

CITY OF TEXAS CITY
REGULAR CALLED CITY COMMISSION MEETING

AGENDA

WEDNESDAY, JUNE 6, 2018- 5:00 P.M.
KENNETH T. NUNN COUNCIL ROOM - CITY HALL
1801 9th Ave. N.
Texas City, TX 77590

PLEASE NOTE: Public comments and matters from the floor are generally limited to 3 minutes in length. If you would like to request to speak, please do so in advance of the meeting by filling out a Request To Address Commission form. All in attendance are required to remove hats and/or sunglasses (dark glasses) during meetings and to also silence all cell phones and electronic devices.

- (1) ROLL CALL
- (2) INVOCATION
- (3) PLEDGE OF ALLEGIANCE
- (4) REPORTS
 - (a) Athletic Division (Recreation and Tourism)
- (5) PUBLIC HEARING
 - (a) Jerome Karam request to rezone from "E" (General Business) to "E-4" (Commercial Warehouse) to renovate an existing building for an indoor mini-warehouse storage facility. Being 3.0 acres out of a 7.155 acre tract known as Lot 3, Mall of the Mainland Plat. Located at 10,000 E.F. Lowry Expressway #3000. (Transportation and Planning)
- (6) PRELIMINARY ZONING APPROVAL
 - (a) Approve or deny request to rezone from "E" (General Business) to "E-4" (Commercial Warehouse) for Jerome Karam. Located at 10,000 E.F. Lowry Expressway #3000. Being 3.0 acres out of a 7.155 ac tract known as Lot 3, Mall of the Mainland Plat. (Transportation and Planning)
- (7) CONSENT AGENDA
 - (a) Approve City Commission Minutes for the May 16, 2018 meeting. (City Secretary)
 - (b) Consider and take action on Resolution No. 18-046, approving RFP # 2018-048 Temporary Employment Services Annual Contract. (Purchasing)

- (c) Consider and take action on Resolution No. 18-047, appointing and/or re-appointing board members to the Houston-Galveston Area Council. (City Secretary)
- (d) Consider and take action on Resolution No. 18-048, approving a contract for the FM 517 Water Plant Phase 1 Project. (Public Works)
- (e) Consider and take action on Resolution No. 18-049, approving an annual contract for Bid # 2018-051 Polymer Annual Contract. (Public Works)
- (f) Consider and take action on Resolution No. 18-050, approving the purchase of eight (8) Police Interceptors. (Police Department)
- (g) Consider and take action on Resolution No. 18-051, approving RFP# 2018-352 Community Development Block Grant – Disaster Recovery Administration – Professional Services. (Purchasing)
- (h) Consider and take action on Resolution No. 18-052, approving the suspension of the Texas-New Mexico Power Electric Company July 5, 2018, effective date. (City Secretary)
- (i) Consider and take action on Resolution No. 18-053, appointing an independent registered Municipal Advisor. (Finance)
- (8) PUBLIC COMMENTS
- (9) MAYOR'S COMMENTS
- (10) COMMISSIONERS' COMMENTS
- (11) ADJOURNMENT

NOTICE OF ANY SUBJECT APPEARING ON THIS AGENDA REGARDLESS OF HOW THE MATTER IS STATED MAY BE ACTED UPON BY THE CITY COMMISSION.

NOTICE: The City of Texas City will furnish free transportation to handicapped individuals via a 4-door sedan for anyone wishing to attend the City Commission meetings. Call 948-3111, City Secretary's Office before noon on Monday preceding the meeting to make arrangements.

I, THE UNDERSIGNED AUTHORITY, DO HEREBY CERTIFY THAT THIS NOTICE OF MEETING WAS POSTED ON THE BULLETIN BOARDS AT CITY HALL, 1801 9TH AVENUE NORTH, TEXAS CITY, TEXAS, AT A PLACE CONVENIENT AND READILY ACCESSIBLE TO THE GENERAL PUBLIC AND ON THE CITY'S WEBSITE ON JUNE 1, 2018 PRIOR TO 5:00 P.M. AND REMAINED SO POSTED CONTINUOUSLY FOR AT LEAST 72 HOURS PRECEDING THE SCHEDULED TIME OF SAID MEETING.

JAMES M. HARTSHORN
CITY SECRETARY

CITY COMMISSION REGULAR MTG

(5) (a)

Meeting Date: 06/06/2018

Rezoning Public Hearing - Karam

Submitted For: Jean Vincent, Transportation and Planning

Submitted By: Jean Vincent, Transportation and Planning

Department: Transportation and Planning

Information

ACTION REQUEST (Brief Summary)

Jerome Karam request to rezone from "E" (General Business) to "E-4" (Commercial Warehouse) to renovate an existing building for an indoor mini-warehouse storage facility. Being 3.0 acres out of a 7.155 acre tract known as Lot 3, Mall of the Mainland Plat. Located at 10,000 E.F. Lowry Expressway #3000.

BACKGROUND

This rezoning request came before the Zoning Commission during a Public Hearing on May 15, 2018. After hearing and reviewing all pertinent information the Zoning Commission unanimously granted approval to the rezone the property to "E-4" (Commercial Warehouse). There was no opposition to the rezoning request.

ANALYSIS

ALTERNATIVES CONSIDERED

Fiscal Impact

Attachments

Cover sheet
Self Storage
preliminary re-plat

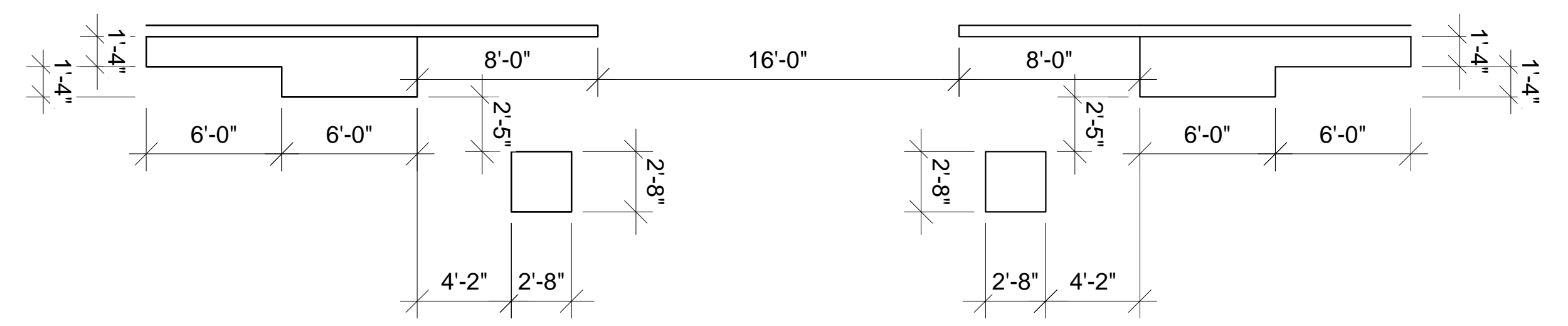

4 ENTRANCE BLOW UP PLAN - RIGHT SIDE
SCALE 1/16" = 1'-0"

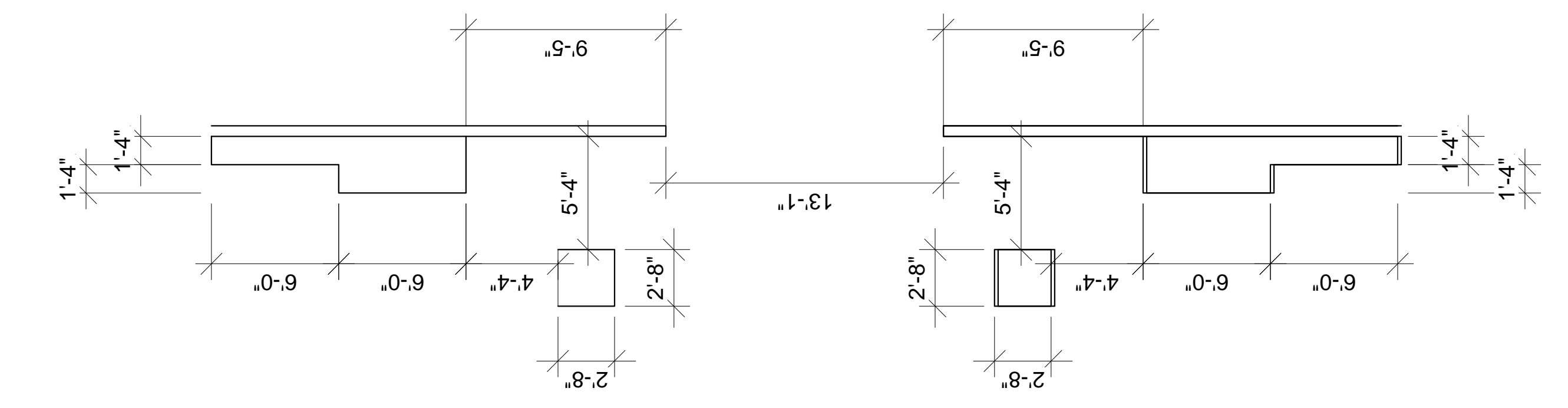

5 ENTRANCE BLOW UP PLAN - LEFT SIDE
SCALE 1/16" = 1'-0"

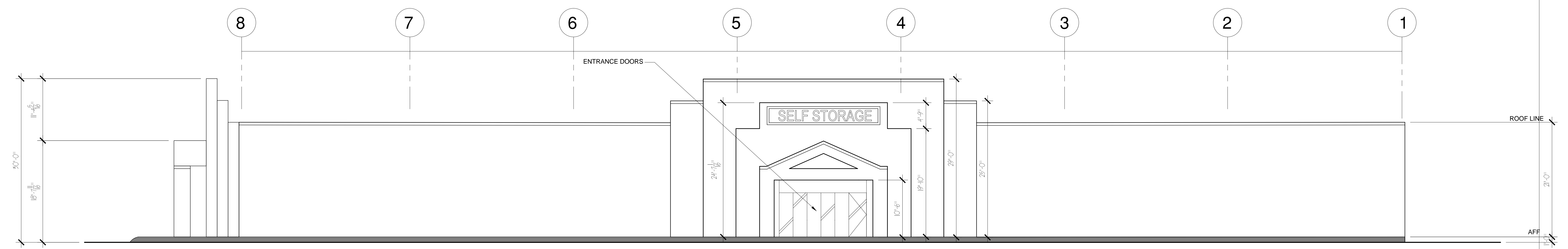

3 RIGHT SIDE ELEVATION
SCALE 3/8" = 1'-0"

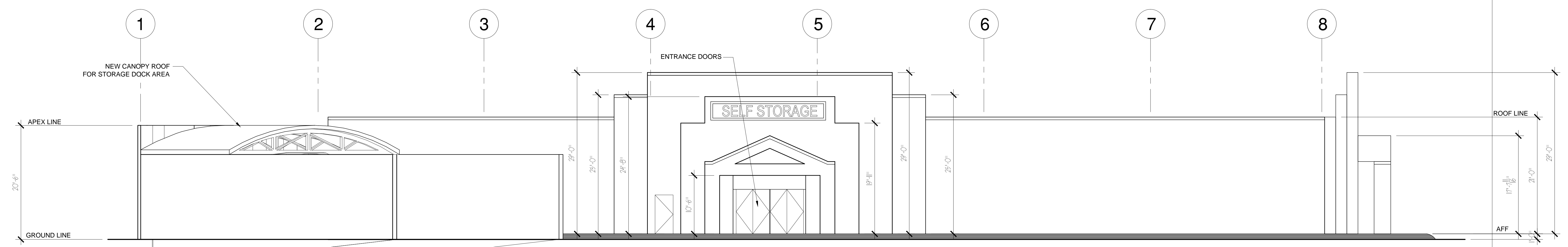

2 LEFT SIDE ELEVATION
SCALE 3/8" = 1'-0"

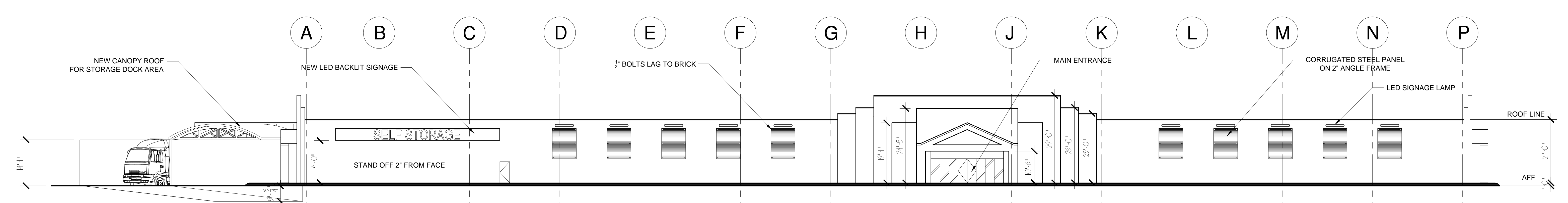

1 FRONT ELEVATION
SCALE 1/16" = 1'-0"

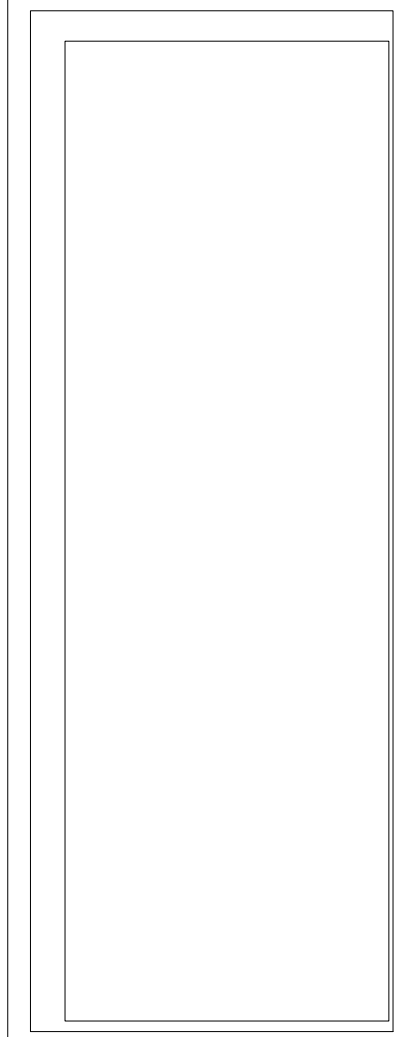

REVISIONS

NO.	DATE	DESCRIPTION

DESIGN ISSUED

DRAWN APPROVED

DESIGN	ISSUED

DRAWN	APPROVED

CONDITIONED STORAGE
TEXAS CITY

sheet title:
BLOW UP PLANS
&
ELEVATIONS
sheet number:
A1-02

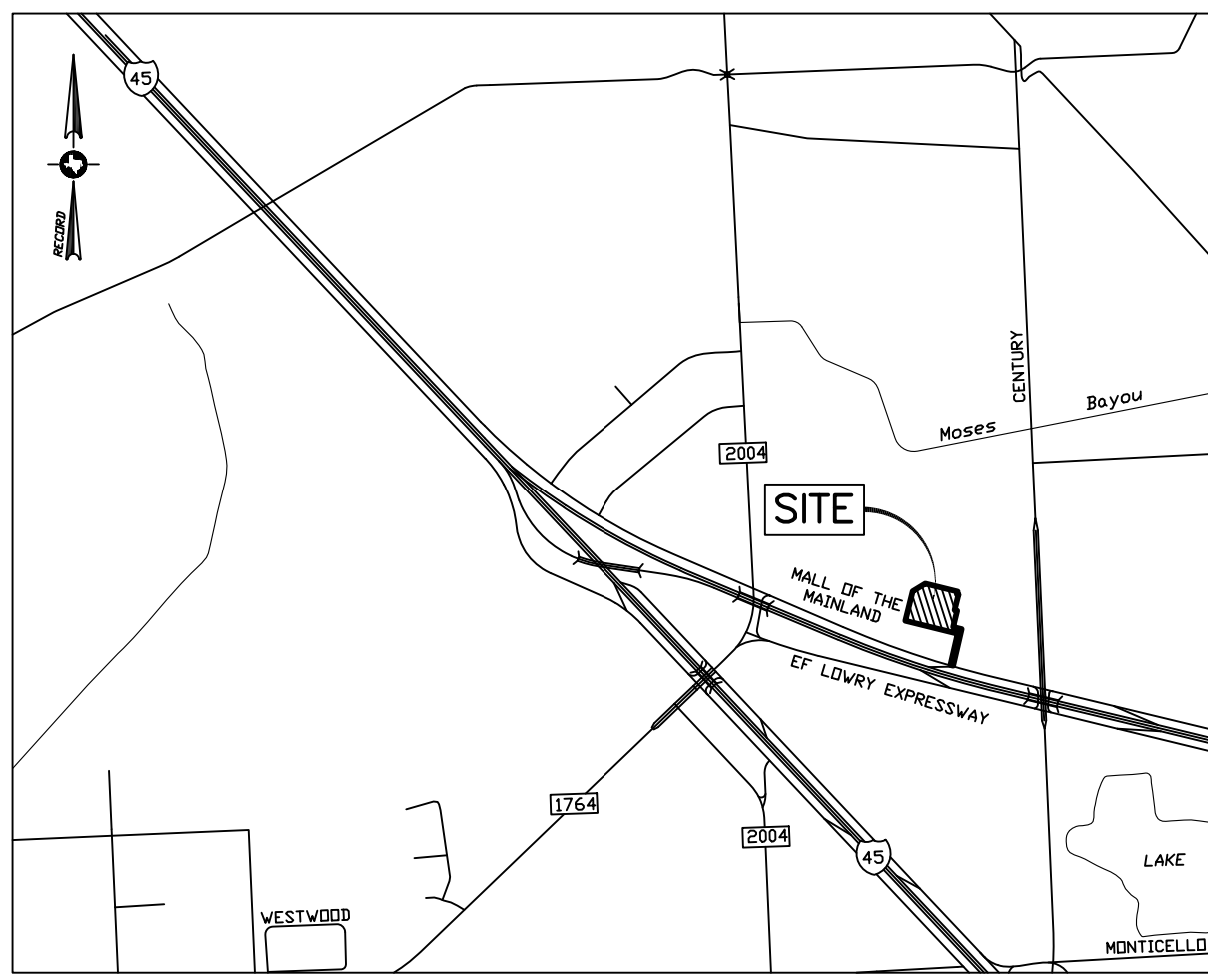

VICINITY MAP
NOT TO SCALE

PRELIMINARY PLAT JMK5 ADDITION NO.1

BEING A REPLAT OF
ALL OF LOT 3 (AKA J.C. PENNEY TRACT), OF MALL OF THE
MAINLAND, A SUBDIVISION IN GALVESTON COUNTY, TEXAS,
ACCORDING TO THE MAP OR PLAT THEREOF RECORDED IN
VOLUME 18, PAGE 446, IN THE OFFICE OF THE COUNTY CLERK
OF GALVESTON COUNTY, TEXAS.

TEXAS CITY, GALVESTON COUNTY, TEXAS
7.155 ACRES (311,672 SQ.FT.)
APRIL, 2018

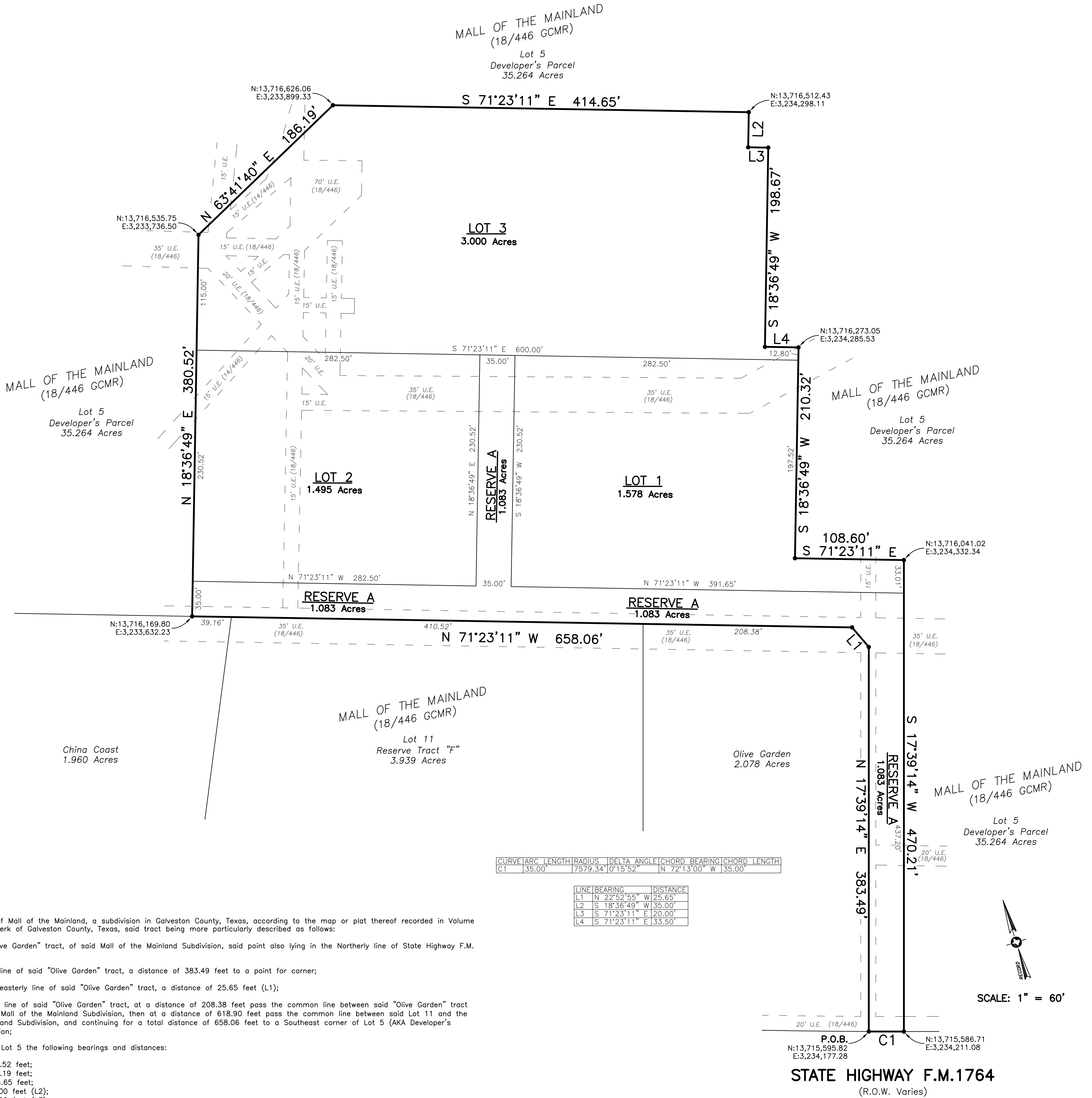

METES AND BOUNDS DESCRIPTION

Being all of Lot 3 (AKA J.C. Penney Tract), of Mall of the Mainland, a subdivision in Galveston County, Texas, according to the map or plat thereof recorded in Volume 18, Page 446, in the Office of the County Clerk of Galveston County, Texas, said tract being more particularly described as follows:

Beginning at the Southeast corner of the "Olive Garden" tract, of said Mall of the Mainland Subdivision, said point also lying in the Northerly line of State Highway F.M. 1764, being a variable width right-of-way;

Thence North 17°39'14" East along the East line of said "Olive Garden" tract, a distance of 383.49 feet to a point for corner;

Thence North 22°52'55" West along the Northeasterly line of said "Olive Garden" tract, a distance of 25.65 feet (L1);

Thence North 71°23'11" West along the North line of said "Olive Garden" tract, at a distance of 208.38 feet pass the common line between said "Olive Garden" tract and Lot 11 (AKA Reserve Tract "F"), of said Mall of the Mainland Subdivision, then a distance of 618.90 feet pass the common line between said Lot 11 and the "China Coast" tract, of said Mall of the Mainland Subdivision, and continuing for a total distance of 658.06 feet to a Southeast corner of Lot 5 (AKA Developer's Parcel), of said Mall of the Mainland Subdivision;

Thence along the Southerly boundary of said Lot 5 the following bearings and distances:

- North 18°36'49" East, a distance of 380.52 feet;
- North 63°41'40" East, a distance of 186.19 feet;
- South 71°23'11" East, a distance of 414.65 feet;
- South 18°36'49" East, a distance of 35.00 feet (L2);
- South 71°23'11" East, a distance of 20.00 feet (L3);
- South 18°36'49" West, a distance of 198.67 feet;
- South 71°23'11" East, a distance of 33.50 feet (L4);
- South 18°36'49" West, a distance of 210.32 feet;
- South 71°23'11" East, a distance of 108.60 feet;
- South 17°39'14" West, a distance of 470.21 feet to a point in the Northerly line of said State Highway F.M. 1764;

Thence along a curve to the left, said curve having a radius of 7579.34 feet, a chord bearing of N72°13'00" West, a chord distance of 35.00 feet, and an arc distance of 35.00 feet to the Point of Beginning of the herein described tract, and containing 7.155 acres of land, more or less.

That Jerome M. Karam, does hereby adopt this plat designating the herein above described property as **JMK5 ADDITION No. 1**, an addition to the City of Texas City, Texas and does hereby dedicate, in fee simple, to the public use forever, the streets, alley, and public use areas, shown hereon, and does hereby dedicate the easements shown on the plat for the purpose indicated to the public use forever, said dedications being free and clear of all liens and encumbrances except shown herein. No buildings, fences, trees, shrubs or other improvements shall be constructed or placed upon, over, or across the easements on said plat. Utility easements may also be used for the mutual use and accommodation of all public utilities desiring to use or using the same unless the easement limits the use to a particular utility or utilities, said use by public utilities being subordinate to the public's and City of Texas City's use thereof. The City of Texas City and any public utility shall have the right to remove and keep removed all or part of any buildings, fences, trees, shrubs, or other improvements or growths which in any way endanger or interfere with the construction, maintenance or efficiency of its respective system on any of the easements. The City of Texas City and any public utility shall at all times have the right of ingress and egress to and from and upon any said easement for the purpose of constructing, reconstructing, inspecting, patrolling, maintaining and adding to or removing all or part of its respective system without the necessity at any time of procuring the permission of anyone.

Jerome M. Karam does hereby bind himself, his successors and assigns to forever warrant and defend all and singular the above described streets, alleys, easements and rights unto the public against every person whomsoever lawfully claiming or to claim the same or any part thereof. This plat approved subject to all plotting ordinances, rules, regulations, and resolutions of the City of Texas City.

WITNESS MY HAND THIS _____ DAY OF _____, 2018.

Jerome M. Karam

KNOW ALL MEN BY THESE PRESENTS: I, the undersigned Stephen C. Blaskey, A Registered Professional Land Surveyor in the State of Texas, hereby certify that this plat is true and correctly made under my supervision and in compliance with City and State survey regulations and laws and made on the ground and that the corner monuments were properly placed under my supervision.

**PRELIMINARY
NOT TO BE RECORDED
FOR ANY PURPOSE**

Stephen C. Blaskey
Registered Professional
Land Surveyor No. 5856

SURVEY DATE: APRIL 16, 2018
FILE No.: 4928-0000-0003-000
DRAFTING: JTK
JOB No.: 18-0325



8017 HARBORSIDE DRIVE
P.O. BOX 16142 (mailing)
GALVESTON, TX 77552
PH (409) 740-1517
Registration Number: 10193855
www.hightidelandsurveying.com

STATE OF TEXAS }}
COUNTY OF GALVESTON }}

I, DWIGHT D. SULLIVAN, County Clerk, Galveston County, Texas, do hereby certify that the written instrument was filed for record in my office on

_____, 2018, at _____ O'Clock, ____M., and duly recorded on

_____, 2018, at _____ O'Clock, ____M., in

Instrument Number _____, Galveston County Records.

Witness my hand and seal of office, at Galveston, Texas, the day and date last above written.

DWIGHT D. SULLIVAN, County Clerk,
Galveston County, Texas

By _____, Deputy

Approval of this Preliminary Plat by the Planning Board and City Commission shall be deemed an expression of approval of the layout submitted on the preliminary plat as a guide to the final engineering of streets, water, sewer and other required improvements and utilities and to the preparation of the final plat. Approval of this preliminary plat shall not constitute automatic approval of the final plat, nor be considered authorization to begin construction or sell lots. Approval of the preliminary plat shall not constitute a guarantee or warranty, either implied or otherwise that all other applicable codes and ordinances of the City of Texas City have been complied with. It shall be the responsibility of the subdivider to ensure that all applicable requirements of the City of Texas City relative to the subdividing and development of property have been met.

On the _____ day of _____, 2018, this plat was duly approved by the Planning Board of the City of Texas City.

Signed: _____
Secretary of the City of Texas City Planning Board

Signed: _____
Chairman of the City of Texas City Planning Board

OWNER/DEVELOPER

Jerome M. Karam
308 W. Parkwood Ave., #104A
Friendswood, Texas 77546
832-282-8451

NOTES

- 1) This property does not lie within the 100 Year Flood Plain, according to FIRM No. 4855140025C, as established by the Federal Emergency Management Agency.
- 2) Bearings are based on Mall of the Mainland Subdivision Plat.
- 3) Coordinates shown are based on the Texas State Coordinate System of 1983, South Central Zone, and are referenced to N.G.S. Monument HGCS 62 (AW5708). All units are expressed in U.S. Survey Feet.
- 4) This property is Zoned as "E" (General Business), according to the City of Texas City's Zoning Ordinance Map.
- 5) Selling a portion of any lot within this addition by metes and bounds is a violation of state law and city ordinance and is subject to fines and withholding of utilities and building permits.

CITY COMMISSION REGULAR MTG

(6) (a)

Meeting Date: 06/06/2018

Preliminary Rezoning for Karam

Submitted For: Jean Vincent, Transportation and Planning

Submitted By: Jean Vincent, Transportation and Planning

Department: Transportation and Planning

Information

ACTION REQUEST (Brief Summary)

Approve or deny request to rezone from "E" (General Business) to "E-4" (Commercial Warehouse) for Jerome Karam. Located at 10,000 E.F. Lowry Expressway #3000. Being 3.0 acres out of a 7.155 ac tract known as Lot 3, Mall of the Mainland Plat.

BACKGROUND

This rezoning request was granted approval by the Zoning Commission during a Public Hearing held on May 15, 2018. There was no opposition to the rezoning request.

ANALYSIS

ALTERNATIVES CONSIDERED

Fiscal Impact

CITY COMMISSION REGULAR MTG

(7) (a)

Meeting Date: 06/06/2018

Submitted By: Rhomari Jackson-Glover, City Secretary

Department: City Secretary

Information

ACTION REQUEST (Brief Summary)

Approve City Commission Minutes for the May 16, 2018 meeting. (City Secretary)

BACKGROUND

ANALYSIS

ALTERNATIVES CONSIDERED

Fiscal Impact

Attachments

Minutes

REGULAR CALLED CITY COMMISSION MEETING

MINUTES

WEDNESDAY, MAY 16, 2018 – 5:00 P.M.
KENNETH T. NUNN COUNCIL ROOM – CITY HALL

A Regular Called Meeting of the City Commission was held on Wednesday, MAY 16, 2018, at 5:00 P.M. in the Kenneth T. Nunn Council Room in City Hall, Texas City, Texas. A quorum having been met, the meeting was called to order at 5:03 p.m. by Mayor Matthew T. Doyle.

1. ROLL CALL

Present: Matthew T. Doyle, Mayor
Phil Roberts, Mayor Pro Tem, Commissioner District 2
Bruce Clawson, Commissioner At-Large
Dee Ann Haney, Commissioner At-Large
Thelma Bowie, Commissioner District 1
Dorthea Jones, Commissioner District 3
Jami Clark, Commissioner District 4

Attendees: Earl Alexander
Abel Garza, Jr.

2. INVOCATION

Led by Pastor Tim Franklin of The Connection Church.

3. PLEDGE OF ALLEGIANCE

The Pledge of Allegiance was led by Commissioner District 1 Thelma Bowie.

The Texas Pledge of Allegiance was led by Commissioner At-Large Dee Ann Haney.

4. CANVASSING ELECTION RETURNS

- a. Consider and take action on Resolution No. 18-039, canvassing the election returns for the City's General Election held on Saturday, May 5, 2018. (City Secretary)

James Hartshorn, City Secretary, presented the Canvass Report conducted by Galveston County-Elections Division.

Motion by Commissioner At-Large Dee Ann Haney, Seconded by Commissioner At-Large Bruce Clawson to approve Resolution No. 18-039, canvassing the election.

Vote: 7 - 0 CARRIED

Commissioner District 1 Thelma Bowie expressed what a privilege and honor it had been to serve the City for 6 years.

Commissioner At-Large Dee Ann Haney stated that she is proud of the work that she and her fellow Commissioners accomplished and that she intends to continue to serve the City in any way that she can.

Mayor Doyle thanked both Thelma Bowie and Dee Ann Haney for the years they dedicated to serving the City. While being presented with flowers, Mayor Doyle announced that each of them will have a bench placed in their honor at Carver Park and Haney Park.

- b. Ceremonial Oath of Office: Each newly sworn in Officer may have a Ceremonial Oath administered by a person of their choosing. (City Secretary)

Commissioner District 1 Earl Alexander was sworn in by his daughter, Kennedy M.D. Alexander.

Commissioner District 2 Abel Garza, Jr. was sworn in by his daughter, Victoria R. Wilkenfeld.

Commissioner District 3 Dorthea Jones was sworn in by former Mayor, Charles Doyle.

Commissioner District 4 Jami Clark was sworn in by her grandchildren, Zane, Alyssa, Addisen and Hailey Clark.

Commissioner At-Large Phil Roberts was sworn in by his wife, Paula Roberts.

Commissioner At-Large Bruce Clawson was sworn in by his grandchildren, Parker and Peyton Garcia.

Mayor Matthew T. Doyle was sworn in by his son, Sean Doyle and granddaughter, Emma Kate Doyle.

- c. Oath of Office: Oath of Office given to candidates who are declared winners from the May 5, 2018, City General Election. (City Secretary)

James Hartshorn, City Secretary, gave the Oath of Office to all of the declared winners of the May 5, 2018, election.

5. Retirements

Mark Moreno	Police	10 years
Mark Pandanell	Fire	24 years
Chet Rich	Police	38 years

Police Chief Robert Burby thanked Corporal Chet Rich for his 38 years of service. Corporal Rich thanked the City for allowing him the honor to serve and his family for their support.

6. PROCLAMATIONS AND PRESENTATIONS

- a. National Police Week 2018 (Police Department)

Police Chief Robert Burby accepted the proclamation on behalf of the Texas City Police Department.

7. CONSENT AGENDA

Motioned by Commissioner At-Large Phil Roberts, Seconded by Commissioner At-Large Bruce Clawson to approve consent items a, d, e, f and g.

- a. Approve City Commission Minutes for May 2, 2018 meeting. (City Secretary)

Vote: 7 - 0 CARRIED

- b. Consider and take action on Resolution No. 18-040, appointing Mayor Pro Tem. (City Secretary)

Item pulled by Commissioner At-Large Bruce Clawson.

Commissioner At-Large Bruce Clawson nominated Phil Roberts to serve as Mayor Pro Tem.

Motioned by Commissioner At-Large Bruce Clawson, Seconded by Commissioner District 2 Abel Garza, Jr.

Vote: 7 - 0 CARRIED

- c. Consider and take action on Resolution No. 18-041, approving an Agreement for Services with ARKK Engineers for design, bidding and construction engineering services associated with the City's Bay Street Shared-Use Path project. (Transportation & Planning)

Item pulled by Mayor Doyle.

Doug Kneupper, City Engineer, stated that the City's Transportation Alternatives Set-Aside program has been accepted for funding through the Texas Transportation Commission. The Federal / State contribution to the project is 80% of the construction cost, which is \$410,154.00, with the City being responsible for 20% of the construction cost, which is \$102,538.00. In addition, the City is responsible for providing the design, environmental clearance, bidding and construction phase services for the project, all of which is included in the Agreement for Services. ARKK Engineers will be utilizing the services of The Goodman Corporation to help navigate through the Federal and State administrative requirements for this project.

Motion by Commissioner At-Large Bruce Clawson, Seconded by Commissioner District 4 Jami Clark

Vote: 7 - 0 CARRIED

- d. Consider and take action on Resolution No. 18-042, approving revisions to the City of Texas City's Personnel Policy. (Human Resources)

Vote: 7 - 0 CARRIED

- e. Consider and take action on Resolution No. 18-043, acceptance of a donated bus. (Recreation & Tourism)

Vote: 7 - 0 CARRIED

- f. Consider and take action on Resolution No. 18-044, approving the execution of an engineering agreement with ARKK Engineers, LLC, for the Sanitary Sewer Rehabilitation - Phase 18A. (Public Works)

Vote: 7 - 0 CARRIED

- g. Consider and take action on Resolution No. 18-045, authorizing the Mayor to enter into an agreement with Aon Risk Solutions, Inc. (Human Resources)

Vote: 7 - 0 CARRIED

8. REGULAR ITEMS

- a. Consider and take action on Ordinance No. 18-12, to amend the City of Texas City Fiscal Year 2017/2018 Budget to create and fund a part-time administrative clerk position in the Fire Department. (Finance)

Laura Boyd, Finance Director, stated that the budget amendment is needed to fund a part-time position for the Fire Department's Emergency Medical Services (EMS) Division.

David Zacherl, Fire Chief, stated that this additional position is necessary to help EMS Administrator, Wendell Wiley, process insurance reports and to provide clerical and secretarial support. The EMS Division processes more than 6,000 reports a year.

Motion by Commissioner District 3 Dorthea Jones, Seconded by Commissioner District 4 Jami Clark

Vote: 7 - 0 CARRIED

- b. Consider and take action on Ordinance No. 18-13, amending the City's fiscal year 2017-2018 budget to appropriate additional funds for the purchase of police vehicles. (Finance)

Laura Boyd, Finance Director, stated that the cost of the vehicles had increased since this was originally approved. The budget amendment is needed to cover the additional cost of replacing 8 police vehicles.

Motioned by Commissioner District 2 Abel Garza, Jr., Seconded by Commissioner At-Large Bruce Clawson.

Vote: 7 - 0 CARRIED

9. STAFF COMMENTS

Jennifer Price, HR Director, congratulated the newly elected Commissioners.

Luke Alvey, Library Director, congratulated the newly elected Commissioners.

Doug Kneupper, City Engineer, stated that Marathon will be opening its first gas station in Texas, Stripes, very soon, along with a Speedy Taco Cafe.

David Zacherl Zacherl, Fire Chief, stated that the annual Firefighter Games on 6th Street will be held on May 18th and 19th.

James Hartshorn, City Secretary, thanked Justin Herter and Rhomari Jackson on their hard work during the election cycle.

Dennis Harris, Recreation and Tourism Director, stated that the registration for their 8 week summer program is now open. Mr. Harris also thanked the City Commissioners for approving Resolution No. 18-043, acceptance of a donated bus from Galveston County Senior Activity, Inc.

Dominick Zavala, Apprentice, congratulated the newly elected Commissioners.

Russell Plackemeier, City Attorney, congratulated the newly elected Commissioners.

PUBLIC COMMENTS

Steven Holmes, Galveston County Commissioner and Board Member of Galveston County Senior Activity, Inc., expressed his gratitude for allowing the board to donate a bus to the Parks, Recreation and Tourism Department.

10. MAYOR'S COMMENTS

Mayor Doyle stated that this will be his final term as Mayor of Texas City. Mayor Doyle thanked his wife and family and all that have supported him throughout the City.

11. COMMISSIONERS' COMMENTS

Commissioner District 1 Earl Alexander thanked Beverley Mitchell for pushing him to run for Commissioner and thanked all voters who supported him.

Commissioner District 2 Abel Garza, Jr. thanked his brother, Carlos Garza, for inspiring him to run for Commissioner and thanked all voters who supported him.

Commissioner District 3 Dorthea Jones stated how honored she is to be a part of the City Commission for another term. Commissioner Jones thanked Mayor Charles Doyle and Galveston County Commissioner Holmes for the wisdom and encouragement they have given her.

Commissioner District 4 Jami Clark thanked her family for their support and stated how happy she is to be able to serve Texas City.

Commissioner At-Large Phil Roberts thanked his wife and the entire City of Texas City for supporting him.

Commissioner At-Large Bruce Clawson stated how delighted he is to continue to work for and with the City.

12. ADJOURNMENT

Having no further business, Commissioner District 3 Dorthea Jones made a MOTION to ADJOURN at 5:56 p.m.; the motion was SECONDED by Commissioner District 2 Abel Garza, Jr. All present voted AYE. MOTION CARRIED.

MATTHEW T. DOYLE, MAYOR

ATTEST:

James M. Hartshorn, City Secretary
Date Approved:

CITY COMMISSION REGULAR MTG

(7) (b)

Meeting Date: 06/06/2018

RFP 2018-048 Temporary Employment Services Annual Contract

Submitted For: Debbie Gurka, Administration

Submitted By: Debbie Gurka,
Administration

Department: Purchasing

Information

ACTION REQUEST (Brief Summary)

Approve and award RFP # 2018-048 Temporary Employment Services Annual Contract.

BACKGROUND

Proposal Packets were mailed to area vendors on April 25, 2018. A proposal tabulation is attached for your review.

The proposals were reviewed by Jennifer Price, HR Director on May 29, 2018.

ANALYSIS

The low responsible proposal meeting all specifications was received by Action Personnel, Inc., in Texas City for the hourly/billing rates proposed.

It is my recommendation and the recommendation of the HR Director to award RFP # 2018-048 Temporary Employment Services Annual Contract to Action Personnel for the hourly/billing rates proposed and that the Mayor be authorized to execute a contract on behalf of the City Commission.

Thank you.

ALTERNATIVES CONSIDERED

Fiscal Impact

Attachments

Resolution

Letter of Recommendation

RFP 2018-048 Bid Tab

RESOLUTION NO. 18-046

A RESOLUTION APPROVING RFP NO. 2018-048 AND AUTHORIZING THE MAYOR TO ENTER INTO AN AGREEMENT FOR TEMPORARY EMPLOYMENT SERVICES ANNUAL CONTRACT; AND PROVIDING THAT THIS RESOLUTION SHALL BECOME EFFECTIVE FROM AND AFTER ITS PASSAGE AND ADOPTION.

WHEREAS, on April 25, 2018, request for proposal packets were mailed to area vendors for Temporary Employment Services Annual Contract, Request for Proposal No. 2018-048; and

WHEREAS, proposals were opened and reviewed by Jennifer Price, Human Resources Director, on Tuesday, May 29, 2018; and

WHEREAS, the lowest proposal meeting all specifications was submitted by Action Personnel, Inc., of Texas City, Texas.

NOW, THEREFORE, BE IT RESOLVED BY THE CITY COMMISSION OF THE CITY OF TEXAS CITY, TEXAS:

SECTION 1: That the City Commission hereby approves that Action Personnel, Inc. be awarded the Temporary Employment Services Annual Contract, RFP No. 2018-048, as recommended by the Human Resources Director and the Purchasing Coordinator.

SECTION 2: That the Mayor is hereby authorized to enter into an agreement with Action Personnel, Inc. for Temporary Employment Services Annual Contract for the total bid amounts as described in **Exhibit "A,"** attached hereto and made a part hereof for all intents and purposes.

SECTION 3: That this Resolution shall be in full force and effect from and after its passage and adoption.

PASSED AND ADOPTED this 6th day of June 2018.

Matthew T. Doyle, Mayor
City of Texas City, Texas

ATTEST:

APPROVED AS TO FORM:

James M. Hartshorn
City Secretary

Russell F. Plackemeier
City Attorney

CITY OF TEXAS CITY, TEXAS

HUMAN RESOURCES • OFFICE (409) 643-5912 • FAX (409) 643-5952



Mayor:
Matthew T. Doyle

Commissioners:
Bruce Clawson
Earl Alexander
Jami Clark
Dorthea Jones
Abel Garza
Philip H. Roberts

May 30, 2018

RE: Temporary Employment Services RFP #2018-048

Mayor and Commissioners:

After reviewing the three submitted proposals for the temporary employment services contract, I am recommending the City move forward with Action Personnel, Inc. based on the proposal tabulation form which details the hourly and billing rates. Action Personnel, Inc. has the current temporary employment services contract and continues to deliver excellent services at competitive and reasonable prices.

Thank you,

A handwritten signature in blue ink that reads "Jennifer Price". The signature is written in a cursive, flowing style.

Jennifer Price, MPA
Human Resources Director
City of Texas City

"QPS – Quality Public Service"

PROPOSAL TABULATION FORM

RFP # 2018-048

TEMPORARY EMPLOYMENT SERVICES ANNUAL CONTRACT

Proposals due: Tuesday, May 29, 2018 at 2:00 p.m.

CATEGORIES OF SERVICES	Spur Employment		Action Personnel		Express Employment	
	Hourly Pay Rates	Billing Rate	Hourly Pay Rates	Billing Rate	Hourly Pay Rates	Billing Rate
Administrative Assistant	12.00	14.64	10.50	15.02	10.00-20.00	15.47-30.94
Clerk/Cashier	8.50	10.37	10.00	14.30	11.00-14.00	17.02-21.66
Deputy Court Clerk	13.00	15.86	10.50	15.02	13.00-26.00	20.11-40.22
Custodian	10.00	12.20	9.50	13.55	11.00-14.00	16.63-21.17
Laborer(General)	10.00	12.20	9.00	12.87	10.00-15.00	15.12-22.68
Network Administrator	32.00	39.04	15.00	21.45	16.00-29.50	25.01-46.11
Hourly & Billing Rate Totals	85.50	104.31	64.50	92.21	71.00-118.50	109.36-182.78

PROPOSAL TABULATION FORM

RFP # 2018-048

TEMPORARY EMPLOYMENT SERVICES ANNUAL CONTRACT

Proposals due: Tuesday, May 29, 2018 at 2:00 p.m.

CATEGORIES OF SERVICES	Spur Employment		Action Personnel		Express Employment	
	Hourly Pay Rates	Billing Rate	Hourly Pay Rates	Billing Rate	Hourly Pay Rates	Billing Rate
Administrative Assistant	12.00	14.64	10.50	15.02	10.00-20.00	15.47-30.94
Clerk/Cashier	8.50	10.37	10.00	14.30	11.00-14.00	17.02-21.66
Deputy Court Clerk	13.00	15.86	10.50	15.02	13.00-26.00	20.11-40.22
Custodian	10.00	12.20	9.50	13.55	11.00-14.00	16.63-21.17
Laborer(General)	10.00	12.20	9.00	12.87	10.00-15.00	15.12-22.68
Network Administrator	32.00	39.04	15.00	21.45	16.00-29.50	25.01-46.11
Hourly & Billing Rate Totals	85.50	104.31	64.50	92.21	71.00-118.50	109.36-182.78

CITY COMMISSION REGULAR MTG

(7) (c)

Meeting Date: 06/06/2018

Submitted By: Rhomari Jackson-Glover, City Secretary

Department: City Secretary

Information

ACTION REQUEST (Brief Summary)

Consider and take action on Resolution No. XX-047, appointing and/or re-appointing board members to the Houston-Galveston Area Council. (City Secretary)

BACKGROUND

Phil Roberts- Representative

Jami Clark- Alternate

ANALYSIS

ALTERNATIVES CONSIDERED

Fiscal Impact

Attachments

Resolution

RESOLUTION 18-047

A RESOLUTION APPOINTING A REPRESENTATIVE AND AN ALTERNATE TO THE BOARD OF DIRECTORS OF THE HOUSTON - GALVESTON AREA COUNCIL; AND PROVIDING THAT THIS RESOLUTION SHALL BECOME EFFECTIVE FROM AND AFTER ITS PASSAGE AND ADOPTION.

WHEREAS, a yearly appointment is necessary for the Board of Directors of the Houston - Galveston Area Council (H-GAC); and

WHEREAS, as a result of the City of Texas City's General Election, new representatives must be appointed; and

WHEREAS, Commissioner At-Large Phil Roberts and Commissioner District 4 Jami Clark have both agreed to serve on the Houston - Galveston Area Council for the calendar year 2018.

NOW, THEREFORE, BE IT RESOLVED BY THE CITY COMMISSION OF THE CITY OF TEXAS CITY, TEXAS:

SECTION 1: That the City Commission of the City of Texas City, Texas, hereby appoints Commissioner At-Large Phil Roberts as the City of Texas City Representative and Commissioner District 4 Jami Clark as Alternate Representative to the Board of Directors of the Houston - Galveston Area Council for the calendar year 2018.

SECTION 2: That this Resolution shall be in full force and effect from and after its passage and adoption.

PASSED AND ADOPTED this 6th day of June 2018.

Matthew T. Doyle, Mayor
City of Texas City, Texas

ATTEST:

APPROVED AS TO FORM:

James M. Hartshorn
City Secretary

Russell F. Plackemeier
City Attorney

**DESIGNATION OF REPRESENTATIVES
HOUSTON-GALVESTON AREA COUNCIL
2018 GENERAL ASSEMBLY
AND
BOARD OF DIRECTORS**

BE IT RESOLVED, by the City Council of Texas City, Texas that the following be and are hereby designated as the representative and alternate of the General Assembly of the Houston-Galveston Area Council for the year 2018:

REPRESENTATIVE Phil Roberts

ALTERNATE Jami Clark

FURTHER THAT, they are hereby, designated as the representative and alternate to the Board of Directors of the Houston-Galveston Area Council for the year 2018.

THAT, the Executive Director of the Houston-Galveston Area Council be notified of the designation of the hereinabove named delegate and alternate.

PASSED AND ADOPTED this 6th day of June 2018.

Matthew T. Doyle, Mayor
City of Texas City, Texas

ATTEST:

APPROVED AS TO FORM:

James M. Hartshorn
City Secretary

Russell F. Plackemeier
City Attorney

CITY COMMISSION REGULAR MTG

(7) (d)

Meeting Date: 06/06/2018

2018-347 FM 517 Water Plant Phase 1 Project

Submitted For: Mike McKinley, Public Works

Submitted By: Mike McKinley, Public Works

Department: Public Works

Information

ACTION REQUEST (Brief Summary)

Consider and take action on Resolution No. 18-048, approving a contract for the FM 517 Water Plant Phase 1 Project. (Public Works)

BACKGROUND

Bid packets were made available to local area vendors on April 17, 2018 bids were received and opened Tuesday, May 8, 2018 at 11:00 a.m.. A bid tabulation and letter of recommendation for your review.

ANALYSIS

The lowest responsible meeting all specifications, was received from W.W. Payton Corporation for a total amount of \$1,550,000.00.

It is the recommendation of the City Engineer and ARKK Engineers, to award Bid # 2018-347 FM 517 Water Plant Phase 1 Project to W.W. Payton Corporation, for the amount of \$1,550,000.00 and that the Mayor be authorized to execute a contract on behalf of the City Commission.

We further request that the Mayor be authorized to approve any change order, not to exceed 25% of the contract amount, without bringing the matter before City Commission.

ALTERNATIVES CONSIDERED

Fiscal Impact

Attachments

Resolution
Exhibit A

RESOLUTION NO. 18-048

A RESOLUTION AWARDING BID NO. 2018-347 FM 517 WATER PLANT PHASE 1 PROJECT AND AUTHORIZING THE MAYOR TO ENTER INTO A CONTRACT WITH W. W. PAYTON CORPORATION; AND PROVIDING THAT THIS RESOLUTION SHALL BECOME EFFECTIVE FROM AND AFTER ITS PASSAGE AND ADOPTION.

WHEREAS, bids were made available to area vendors on April 17, 2018, for Bid No. 2018- 347 FM 517 Water Plant Phase 1 Project; and

WHEREAS, bids were opened on May 8, 2018, and it is the recommendation of ARKK Engineers and the Public Works Department that the bid be awarded to W. W. Payton Corporation, Katy, Texas.

NOW, THEREFORE, BE IT RESOLVED BY THE CITY COMMISSION OF THE CITY OF TEXAS CITY, TEXAS:

SECTION 1: That the City Commission hereby accepts the contract by W. W. Payton Construction for Bid No. 2018-347 FM 517 Water Plant Phase 1 Project.

SECTION 2: That the Mayor is hereby authorized to execute the contract with W. W. Payton Construction for the unit prices bid attached hereto as **Exhibit "A"** and made a part hereof for all intents and purposes.

SECTION 3: That the Mayor is hereby authorized to approve change orders, not to exceed Twenty-Five percent (25.0%) of the total contract amount, without bringing the matter before the City Commission.

SECTION 4: That this Resolution shall be in full force and effect from and after its passage and adoption.

PASSED AND ADOPTED this 6th day of June 2018.

Matthew T. Doyle, Mayor
City of Texas City, Texas

ATTEST:

APPROVED AS TO FORM:

James M. Hartshorn
City Secretary

Russell F. Plackemeier
City Attorney



May 24, 2018

Mr. Doug Kneupper, P.E.
City Engineer
City of Texas City
928 5th Avenue North
Texas City, Texas 77590

Re: **Letter of Recommendation for FM 517 Water Plant Phase 1 Project**
BID #2018-347
City of Texas City
ARKK Job No. 16-033

Dear Mr. Kneupper:

On May 8, 2018, Seven (7) bids were received for the above referenced project. This project involves the rehabilitation of the City's FM 517 Water Plant. The work generally consists of the construction of a potable water booster pump station, a 5,000 gallon hydro pneumatic tank, a 67,500 gallon welded steel ground storage tank, electrical system, building, site work, 150 KW diesel generator, and related items. The project site is located on FM 517, approximately 1.20 miles west of SH 146.

Following is a summary of our bid evaluation:

1. Bid Tabulation Sheet – Seven (7) construction firms participated in the bidding process. The bids were checked for mathematical errors and/or bid irregularities.
2. The bids for the project are as follows:

<u>BIDDER</u>	<u>TOTAL BID</u>
W.W. PAYTON CORPORATION	\$ 1,550,000.00
LONG & SONS INC.	\$ 1,641,012.00
SCHIER CONSTRUCTION COMPANY, INC.	\$ 1,666,994.00
JTR CONSTRUCTIONS, INC	\$ 1,716,000.00
GILLELAND SMITH CONSTRUCTION, INC.	\$ 1,754,646.00
PRINCIPAL PLANT SERVICES LLC	\$ 1,875,450.76
PERSONS SERVICE COMPANY LLC	\$ 2,379,347.96

A copy of the bid tabulation is attached.

References – W.W. Payton Corporation submitted a List of Subcontractors and Major Suppliers for this project. W.W. Payton Corporation is an established contractor in the Houston area. W.W. Payton Corporation is currently working on a project for the Gulf Coast Water Authority (GCWA). GCWA and ARKK Engineers are pleased with their work performance. Some of the references have been contacted previously, and we have received information from these references that W.W. Payton Corporation has performed satisfactorily on these projects.

W.W. Payton Corporation appears to be a responsible firm that is capable of performing the specified work in a satisfactory manner. For these reasons, we recommend that the GCWA award the **FM 517 Water Plant Phase 1 Project to W.W. Payton Corporation for a total amount of \$1,550,000.00**.

If you have any questions, please contact me.

Sincerely,

ARKK ENGINEERS, LLC



Mr. Madhu Kilambi, P.E.
Senior Project Manager

cc: Mr. Corbin Ballast – City of Texas City

ITEM NO.	ITEM DESCRIPTION	UNIT	QUAN.	LOW BIDDER		W.W PAYTON CORPORATION		LONG AND SONS INC.		SCHIER CONSTRUCTION COMPANY, INC.		JTR CONSTRUCTORS, INC.		GILLELAND SMITH CONSTRUCTION, INC.		PRINCIPAL PLANT SERVICES LLC		PERSONS SERVICE COMPANY LLC		
A. BASE BID UNIT PRICE																				
1	Mobilization, Complete in Place, the Sum of:	LS	1	\$ 30,000.00	\$ 30,000.00	\$ 30,000.00	\$ 30,000.00	\$ 30,000.00	\$ 30,000.00	\$ 30,000.00	\$ 30,000.00	\$ 100,000.00	\$ 100,000.00	\$ 30,000.00	\$ 30,000.00	\$ 30,000.00	\$ 30,000.00	\$ 28,429.66	\$ 28,429.66	
2	Traffic Control and Regulation, Complete in Place, the Sum of:	LS	1	\$ 500.00	\$ 500.00	\$ 3,250.00	\$ 3,250.00	\$ 4,000.00	\$ 4,000.00	\$ 4,000.00	\$ 4,000.00	\$ 500.00	\$ 500.00	\$ 500.00	\$ 500.00	\$ 10,000.00	\$ 10,000.00	\$ 16,126.34	\$ 16,126.34	
3	Implementation of Stormwater Pollution Prevention Plan and SWPPP Compliance for a Small Construction Site (< 5 acres), includes silt fencing, construction exits, inlet protection barriers, jobsite postings, filing of Small Construction Site Notice, Complete in Place, the Sum of:	LS	1	\$ 1,000.00	\$ 1,000.00	\$ 6,200.00	\$ 6,200.00	\$ 6,900.00	\$ 6,900.00	\$ 6,900.00	\$ 6,900.00	\$ 2,600.00	\$ 2,600.00	\$ 2,000.00	\$ 2,000.00	\$ 5,000.00	\$ 5,000.00	\$ 15,211.56	\$ 15,211.56	
4	Right-of-Way Preparation for 3.0 acre limits of construction, includes clearing and grubbing, Complete in Place, the Sum of:	LS	1	\$ 2,000.00	\$ 2,000.00	\$ 5,100.00	\$ 5,100.00	\$ 13,800.00	\$ 13,800.00	\$ 13,800.00	\$ 13,800.00	\$ 2,000.00	\$ 2,000.00	\$ 1,000.00	\$ 1,000.00	\$ 75,000.00	\$ 75,000.00	\$ 4,257.30	\$ 4,257.30	
5	Site Grading, per Site Grading Plan, includes site fill (Embankment), drainage ditches and swales, topsoil, and all related earthwork items as shown on the design drawings, Complete in Place, the Sum of:	LS	1	\$ 25,000.00	\$ 25,000.00	\$ 20,000.00	\$ 20,000.00	\$ 63,400.00	\$ 63,400.00	\$ 63,400.00	\$ 63,400.00	\$ 30,000.00	\$ 30,000.00	\$ 60,000.00	\$ 60,000.00	\$ 104,000.00	\$ 104,000.00	\$ 62,669.17	\$ 62,669.17	
6	Construct a 67,500 Gallon Welded Steel Ground Storage Tank, including coatings, pipe connections, drain, control valve, splash pad, access ladders, railings, foundation system, level probes, testing, disinfection, labor and equipment for a fully functioning and operational potable water Ground Storage Tank, Complete in Place, the Sum of:	LS	1	\$ 317,000.00	\$ 317,000.00	\$ 254,000.00	\$ 254,000.00	\$ 246,500.00	\$ 246,500.00	\$ 246,500.00	\$ 246,500.00	\$ 250,000.00	\$ 250,000.00	\$ 260,000.00	\$ 260,000.00	\$ 438,150.00	\$ 438,150.00	\$ 450,111.69	\$ 450,111.69	
7	Construct One (1) 5,000 Gallon Welded Steel Hydropneumatic Tank System, including coatings, tank supports & foundation, air compressor, FRP air compressor building, air piping, connections, labor and equipment for a fully functioning and operational hydropneumatic Tank, Complete in Place, the Sum of:	LS	1	\$ 100,000.00	\$ 100,000.00	\$ 68,400.00	\$ 68,400.00	\$ 89,300.00	\$ 89,300.00	\$ 89,300.00	\$ 89,300.00	\$ 50,000.00	\$ 50,000.00	\$ 85,000.00	\$ 85,000.00	\$ 133,150.00	\$ 133,150.00	\$ 132,061.16	\$ 132,061.16	
8	Construct a Booster Pump Station, includes three (3) vertical turbine pump installations, couplings, valves, 25'-2" x 20' concrete pad and pump foundation, pipe supports, labor and equipment for a fully functioning and operational booster pump station, Complete in Place, the Sum of:	LS	1	\$ 50,000.00	\$ 50,000.00	\$ 132,950.00	\$ 132,950.00	\$ 134,500.00	\$ 134,500.00	\$ 134,500.00	\$ 134,500.00	\$ 129,322.00	\$ 129,322.00	\$ 150,000.00	\$ 150,000.00	\$ 149,100.00	\$ 149,100.00	\$ 224,599.41	\$ 224,599.41	
9	Construct a Fully Functional and Operational CMU Building having dimensions of 20' x 8'-8" x 10' height, includes doors, wall penetrations, roof, concrete foundation, restroom equipment to include porcelain toilet, porcelain urinal, wall mirror, buried plumbing, floor drain, porcelain sink, mirror, SS soap dispenser, SS handrails, SS toilet paper dispenser, SS hand towel dispenser, 3' long SS shelf, ADA Complaint restroom, Complete in Place, the Sum of:	LS	1	\$ 60,000.00	\$ 60,000.00	\$ 72,300.00	\$ 72,300.00	\$ 89,400.00	\$ 89,400.00	\$ 89,400.00	\$ 89,400.00	\$ 75,000.00	\$ 75,000.00	\$ 150,000.00	\$ 150,000.00	\$ 90,650.00	\$ 90,650.00	\$ 81,261.56	\$ 81,261.56	
10	Chlorination System, includes FRP Bleach Storage Building, FRP LAS Storage Building, chemical line piping, four (4) chemical feed pumps, four (4) injection points, One (1) eyewash station, foundation/slabs, appurtenances, labor and equipment for a fully functioning and operational Chlorination System, Owner will Provide and Place the Chemical Tanks, Complete in Place, the Sum of:	LS	1	\$ 50,000.00	\$ 50,000.00	\$ 47,250.00	\$ 47,250.00	\$ 52,700.00	\$ 52,700.00	\$ 52,700.00	\$ 52,700.00	\$ 32,000.00	\$ 32,000.00	\$ 50,000.00	\$ 50,000.00	\$ 38,650.00	\$ 38,650.00	\$ 69,613.92	\$ 69,613.92	
11	Construct a fully functional and operational Water Plant Yard Piping System, includes all above ground and buried potable water pipe, surface preparation and coatings, valves, labor, and equipment, Complete in Place, the Sum of:	LS	1	\$ 100,000.00	\$ 100,000.00	\$ 97,250.00	\$ 97,250.00	\$ 80,600.00	\$ 80,600.00	\$ 80,600.00	\$ 80,600.00	\$ 275,000.00	\$ 275,000.00	\$ 125,000.00	\$ 125,000.00	\$ 84,000.00	\$ 84,000.00	\$ 92,059.32	\$ 92,059.32	
12	12-inch wet connections into existing 12-inch water lines, Complete in Place, the Sum of:	EA	2	\$ 1,000.00	\$ 2,000.00	\$ 600.00	\$ 1,200.00	\$ 1,500.00	\$ 3,000.00	\$ 3,000.00	\$ 3,000.00	\$ 500.00	\$ 1,000.00	\$ 500.00	\$ 1,000.00	\$ 2,000.00	\$ 4,000.00	\$ 2,356.28	\$ 4,712.56	
13	Sanitary Sewer System, includes E-One Package Grinder Pump Station, 4" Piping and Connections to Building Plumbing, Sched 40 1.25" Force Main, One (1) 1.25" Lateral Assembly, Cased road bore across FM 517, One (1) 1.25" force main clean out, and One (1) 1.25" force main plug, fittings, bends, and appurtenances, Complete in Place, the Sum of:	LS	1	\$ 20,160.00	\$ 20,160.00	\$ 29,400.00	\$ 29,400.00	\$ 34,000.00	\$ 34,000.00	\$ 34,000.00	\$ 34,000.00	\$ 20,000.00	\$ 20,000.00	\$ 25,000.00	\$ 25,000.00	\$ 37,200.00	\$ 37,200.00	\$ 43,536.06	\$ 43,536.06	
14	Stormwater Pump Station and Force Main System, includes 8' dia basin, two (2) submersible pumps, fittings, protective coatings, 467 LF of 12" PVC Storm Water Force Main Pipe, penetration of safety end treatment at outfall, fittings, bends, and appurtenances, Complete in Place, the Sum of:	LS	1	\$ 85,000.00	\$ 85,000.00	\$ 91,700.00	\$ 91,700.00	\$ 71,300.00	\$ 71,300.00	\$ 71,300.00	\$ 71,300.00	\$ 50,000.00	\$ 50,000.00	\$ 60,000.00	\$ 60,000.00	\$ 67,050.00	\$ 67,050.00	\$ 67,672.12	\$ 67,672.12	
15	Storm Sewer Culvert Pipes and Drains, includes 136 LF of 24" RCP Storm Sewers, 145 LF of 18" Storm	LS	1	\$ 50,000.00	\$ 50,000.00	\$ 26,850.00	\$ 26,850.00	\$ 45,000.00	\$ 45,000.00	\$ 45,000.00	\$ 45,000.00	\$ 30,000.00	\$ 30,000.00	\$ 50,000.00	\$ 50,000.00	\$ 47,475.00	\$ 47,475.00	\$ 85,875.35	\$ 85,875.35	
16	Provide and install all work shown on plans and described in specifications including as follows; Electrical service, transfer switch, Motor Control Center, lighting and receptacles, pump motor feeders and terminal boxes and electrical service equipment. Provide conduits and circuits for autosensory control panel and other instruments as provided by O'Day Instruments, and provide all required appurtenances as shown on plans and as described in specifications for a complete operating system for a lump sum of::	LS	1	\$ 250,000.00	\$ 250,000.00	\$ 343,550.00	\$ 343,550.00	\$ 342,200.00	\$ 342,200.00	\$ 342,200.00	\$ 342,200.00	\$ 320,000.00	\$ 320,000.00	\$ 325,000.00	\$ 325,000.00	\$ 152,000.00	\$ 152,000.00	\$ 504,338.40	\$ 504,338.40	
17	Diesel Auxiliary Power Generator and base tank per Electrical Drawings and Specifications, includes generator, WP enclosure, transfer switch, concrete pad, connections, labor and equipment for a fully functioning and operational auxiliary diesel generator, Complete in Place, the Sum of:	LS	1	\$ 70,000.00	\$ 70,000.00	\$ 67,350.00	\$ 67,350.00	\$ 46,400.00	\$ 46,400.00	\$ 46,400.00	\$ 46,400.00	\$ 45,000.00	\$ 45,000.00	\$ 65,000.00	\$ 65,000.00	\$ 54,500.00	\$ 54,500.00	\$ 67,212.57	\$ 67,212.57	
18	Allowance for Texas New Mexico Power Electrical Service, as Approved by the Engineer, Exact amount will be reimbursed to Contractor upon submittal of invoice from Electric Service Provider.	AL	1	\$ 15,000.00	\$ 15,000.00	\$ 15,000.00	\$ 15,000.00	\$ 15,000.00	\$ 15,000.00	\$ 15,000.00	\$ 15,000.00	\$ 15,000.00	\$ 15,000.00	\$ 15,000.00	\$ 15,000.00	\$ 15,000.00	\$ 15,000.00	\$ 15,000.00	\$ 15,000.00	
19	Instrumentation & Controls: Provide and install Autosensory control panel, flow control valve instrumentation & controls, GST and Hydrotank controls, and all other instrumentation referenced on plans and/or described in specifications. Materials are to be provided, and work is to be performed, exclusively by O'Day Instruments LLC (ph 979-583-1441); for a lump sum of:	LS	1	\$ 170,000.00	\$ 170,000.00	\$ 166,250.00	\$ 166,250.00	\$ 167,500.00	\$ 167,500.00	\$ 167,500.00	\$ 167,500.00	\$ 147,000.00	\$ 147,000.00	\$ 150,000.00	\$ 150,000.00	\$ 173,516.00	\$ 173,516.00	\$ 207,423.86	\$ 207,423.86	
20	HMAC Surface Course, 2-inches thick for Driveway, Complete in Place, the Sum of:	SY	740	\$ 60.00	\$ 44,400.00	\$ 34.00	\$ 25,160.00	\$ 23.00	\$ 17,020.00	\$ 23.00	\$ 17,020.00	\$ 19.00	\$ 14,060.00	\$ 12.00	\$ 8,880.00	\$ 80.00	\$ 59,200.00	\$ 26.88	\$ 19,891.20	
21	Crushed Stone Base Material for Driveway, 12-inches thick compacted per specifications, Complete in Place, the Sum of:	SY	940	\$ 25.00	\$ 23,500.00	\$ 46.00	\$ 43,240.00	\$ 29.00	\$ 27,260.00	\$ 29.00	\$ 27,260.00	\$ 46.00	\$ 43,240.00	\$ 60.00	\$ 56,400.00	\$ 20.00	\$ 18,800.00	\$ 66.59	\$ 62,594.60	
22	Concrete Pavement for Parking Area, 6-inches reinforced concrete, Complete in Place, the Sum of:	SY	224	\$ 80.00	\$ 17,920.00	\$ 115.00	\$ 25,760.00	\$ 95.00	\$ 21,280.00	\$ 95.00	\$ 21,280.00	\$ 90.00	\$ 20,160.00	\$ 50.00	\$ 11,200.00	\$ 50.00	\$ 11,200.00	\$ 89.56	\$ 20,061.44	

ITEM NO.	ITEM DESCRIPTION	UNIT	QUAN.	LOW BIDDER															
				W.W PAYTON CORPORATION		LONG AND SONS INC.		SCHIER CONSTRUCTION COMPANY, INC.		JTR CONSTRUCTORS, INC.		GILLELAND SMITH CONSTRUCTION, INC.		PRINCIPAL PLANT SERVICES LLC		PERSONS SERVICE COMPANY LLC			
23	Crushed Stone Base Material for Parking Area, 6-inches thick compacted per specifications, Complete in Place, the Sum of:	SY	252	\$ 20.00	\$ 5,040.00	\$ 22.50	\$ 5,670.00	\$ 25.00	\$ 6,300.00	\$ 30.00	\$ 7,560.00	\$ 50.00	\$ 12,600.00	\$ 15.00	\$ 3,780.00	\$ 69.20	\$ 17,438.40		
24	6" Concrete Curbs, Complete in Place, the Sum of:	LF	160	\$ 20.00	\$ 3,200.00	\$ 6.00	\$ 960.00	\$ 6.00	\$ 960.00	\$ 5.00	\$ 800.00	\$ 10.00	\$ 1,600.00	\$ 15.00	\$ 2,400.00	\$ 25.51	\$ 4,081.60		
25	4" Thick Concrete Walkways, Complete in Place, the Sum of:	SF	526	\$ 12.00	\$ 6,312.00	\$ 15.00	\$ 7,890.00	\$ 7.00	\$ 3,682.00	\$ 4.00	\$ 2,104.00	\$ 6.00	\$ 3,156.00	\$ 20.00	\$ 10,520.00	\$ 9.12	\$ 4,797.12		
26	Concrete Ramp, Complete in Place, the Sum of:	SF	40	\$ 25.00	\$ 1,000.00	\$ 80.00	\$ 3,200.00	\$ 20.00	\$ 800.00	\$ 5.00	\$ 200.00	\$ 8.00	\$ 320.00	\$ 20.00	\$ 800.00	\$ 59.88	\$ 2,395.20		
27	Painted Steel Bollard pole, Complete in Place, the Sum of:	EA	4	\$ 500.00	\$ 2,000.00	\$ 600.00	\$ 2,400.00	\$ 450.00	\$ 1,800.00	\$ 400.00	\$ 1,600.00	\$ 300.00	\$ 1,200.00	\$ 500.00	\$ 2,000.00	\$ 320.25	\$ 1,281.00		
28	Trench Safety System for all Water Plant Yard Piping, Drainage Piping, and Sanitary Sewer Piping, greater than 5-feet deep, Complete in Place, the Sum of:	LS	1	\$ 1,000.00	\$ 1,000.00	\$ 1,700.00	\$ 1,700.00	\$ 500.00	\$ 500.00	\$ 1,500.00	\$ 1,500.00	\$ 500.00	\$ 500.00	\$ 500.00	\$ 500.00	\$ 7,095.50	\$ 7,095.50		
29	PVC Coated Chain Link Fencing and all Gates, per Design Drawings and Details, Complete in Place, the Sum of:	LF	1,226	\$ 18.00	\$ 22,068.00	\$ 17.00	\$ 20,842.00	\$ 17.00	\$ 20,842.00	\$ 19.00	\$ 23,294.00	\$ 20.00	\$ 24,520.00	\$ 18.76	\$ 22,999.76	\$ 23.78	\$ 29,154.28		
30	PVC Coated Rolling Gate, 18' Opening, per Design Drawings and Details, Complete in Place, the Sum of:	EA	1	\$ 1,500.00	\$ 1,500.00	\$ 1,300.00	\$ 1,300.00	\$ 1,400.00	\$ 1,400.00	\$ 1,500.00	\$ 1,500.00	\$ 2,500.00	\$ 2,500.00	\$ 5,000.00	\$ 5,000.00	\$ 5,902.86	\$ 5,902.86		
31	PVC Coated Double Swing Gate, 18' Opening, per Design Drawings and Details, Complete in Place, the Sum of:	EA	2	\$ 1,000.00	\$ 2,000.00	\$ 1,025.00	\$ 2,050.00	\$ 1,000.00	\$ 2,000.00	\$ 2,000.00	\$ 4,000.00	\$ 1,000.00	\$ 2,000.00	\$ 1,250.00	\$ 2,500.00	\$ 1,980.52	\$ 3,961.04		
32	Barbed Wire Fence, Complete in Place, the Sum of:	LF	280	\$ 5.00	\$ 1,400.00	\$ 8.00	\$ 2,240.00	\$ 5.00	\$ 1,400.00	\$ 2.00	\$ 560.00	\$ 14.00	\$ 3,920.00	\$ 7.00	\$ 1,960.00	\$ 7.93	\$ 2,220.40		
33	Hydromulch Seeding all Disturbed Areas, Complete in Place, the Sum of:	LS	1	\$ 1,000.00	\$ 1,000.00	\$ 2,250.00	\$ 2,250.00	\$ 7,900.00	\$ 7,900.00	\$ 1,500.00	\$ 1,500.00	\$ 3,000.00	\$ 3,000.00	\$ 5,000.00	\$ 5,000.00	\$ 4,886.65	\$ 4,886.65		
34	Miscellaneous Allowance, as Approved by the Engineer, Complete in Place, the Sum of:	AL	1	\$ 15,000.00	\$ 15,000.00	\$ 15,000.00	\$ 15,000.00	\$ 15,000.00	\$ 15,000.00	\$ 15,000.00	\$ 15,000.00	\$ 15,000.00	\$ 15,000.00	\$ 15,000.00	\$ 15,000.00	\$ 15,000.00	\$ 15,000.00		
TOTAL PAVING & DRAINAGE BASE BID ITEMS:					\$ 1,545,000.00		\$ 1,637,662.00		\$ 1,663,644.00		\$ 1,711,500.00		\$ 1,751,296.00		\$ 1,870,100.76		\$ 2,372,933.30		
B. Extra Unit Price Table																			
35	Wet condition bedding, all sizes, all depths, Complete in Place, the Sum of:	LF	50	\$ 20.00	\$ 1,000.00	\$ 20.00	\$ 1,000.00	\$ 20.00	\$ 1,000.00	\$ 20.00	\$ 1,000.00	\$ 20.00	\$ 1,000.00	\$ 30.00	\$ 1,500.00	\$ 27.51	\$ 1,375.50		
36	Installation and removal of piezometer, complete in place, the Sum of:	EA	1	\$ 100.00	\$ 100.00	\$ 100.00	\$ 100.00	\$ 100.00	\$ 100.00	\$ 100.00	\$ 100.00	\$ 100.00	\$ 100.00	\$ 100.00	\$ 100.00	\$ 390.75	\$ 390.75		
37	Extra cement stabilized sand backfill, complete in place, the Sum of:	CY	50	\$ 36.00	\$ 1,800.00	\$ 15.00	\$ 750.00	\$ 15.00	\$ 750.00	\$ 38.00	\$ 1,900.00	\$ 15.00	\$ 750.00	\$ 30.00	\$ 1,500.00	\$ 47.48	\$ 2,374.00		
38	Well pointing system, all depths, Complete in Place, the Sum of:	LF	50	\$ 32.00	\$ 1,600.00	\$ 20.00	\$ 1,000.00	\$ 20.00	\$ 1,000.00	\$ 20.00	\$ 1,000.00	\$ 20.00	\$ 1,000.00	\$ 25.00	\$ 1,250.00	\$ 31.24	\$ 1,562.00		
39	Brace, support, and protect utility structures, Complete in Place, the Sum of:	EA	1	\$ 500.00	\$ 500.00	\$ 500.00	\$ 500.00	\$ 500.00	\$ 500.00	\$ 500.00	\$ 500.00	\$ 500.00	\$ 500.00	\$ 1,000.00	\$ 1,000.00	\$ 712.41	\$ 712.41		
TOTAL WATER ITEMS BASE BID:					\$ 5,000.00		\$ 3,350.00		\$ 3,350.00		\$ 4,500.00		\$ 3,350.00		\$ 5,350.00		\$ 6,414.66		
TOTAL EXTRA UNIT PRICE:					\$ 5,000.00		\$ 3,350.00		\$ 3,350.00		\$ 4,500.00		\$ 3,350.00		\$ 5,350.00		\$ 6,414.66		
TOTAL PROPOSAL PRICE (BASE BID PRICE + EXTRA UNIT PRICE) :					\$ 1,550,000.00		\$ 1,641,012.00		\$ 1,666,994.00		\$ 1,716,000.00		\$ 1,754,646.00		\$ 1,875,450.76		\$ 2,379,347.96		
MATHEMATICAL ERROR CORRECTED BY ENGINEER																			

CITY COMMISSION REGULAR MTG

(7) (e)

Meeting Date: 06/06/2018

Bid # 2018-051 Polymer Annual Contract

Submitted For: Mike McKinley, Public Works

Submitted By: Mike McKinley, Public Works

Department: Public Works

Information

ACTION REQUEST (Brief Summary)

Consider and take action on Resolution No. 18-049, approving an annual contract for Bid # 2018-051 Polymer Annual Contract. (Public Works)

BACKGROUND

On May 15,2018 the Notice To Bidders was advertised in the local area paper and bid packets were mailed out. Bids were opened at 2 p.m. on May 29, 2018.

A bid tabulation is attached for your review.

ANALYSIS

The low responsible bid meeting all City specification was received from Polydyne Inc., in Riceboro, Georgia, for the unit price bid.

It is the recommendation of the Public Works Department to award an annual contract for Bid # 2017-051 Polymer Annual Contract to Polydyne Inc., for the unit price bid and that the Mayor is authorized to execute a contract on behalf of the City Commission.

Thank you.

ALTERNATIVES CONSIDERED

Fiscal Impact

Attachments

Resolution
Exhibit A

RESOLUTION NO. 18-049

A RESOLUTION AWARDED BID NO. 2018-051 AND AUTHORIZING THE MAYOR TO ENTER INTO AN ANNUAL CONTRACT FOR THE PURCHASE AND DELIVERY OF POLYMER; AND PROVIDING THAT THIS RESOLUTION SHALL BECOME EFFECTIVE FROM AND AFTER ITS PASSAGE AND ADOPTION.

WHEREAS, on May 15, 2018, a Notice to Bidders was advertised in the Galveston Daily Newspaper and bid packets were made available to area vendors for Bid No. 2018-051 Polymer Annual Contract; and

WHEREAS, bids opened on May 29, 2018, and the lowest bid received meeting all specifications was submitted by Polydyne, Inc., of Riceboro, Georgia.

NOW, THEREFORE, BE IT RESOLVED BY THE CITY COMMISSION OF THE CITY OF TEXAS CITY, TEXAS:

SECTION 1: That the City Commission hereby accepts the contract by Polydyne, Inc. for Bid No. 2018-051 Polymer Annual Contract.

SECTION 2: That the Mayor is hereby authorized to enter into an annual contract with Polydyne, Inc. for the respective unit prices bid in **Exhibit "A,"** as attached hereto and incorporated herein for all intents and purposes.

SECTION 3: That this Resolution shall be in full force and effect from and after its passage and adoption.

PASSED AND ADOPTED this 6th day of June 2018.

Matthew T. Doyle, Mayor
City of Texas City, Texas

ATTEST:

APPROVED AS TO FORM:

James M. Hartshorn
City Secretary

Russell F. Plackemeier
City Attorney

BID TABULATION

**Bid # 2018-051
POLYMER
ANNUAL CONTRACT**

Bid Opening: Tuesday, May 29, 2018 at 2:00 p.m.

VENDOR	UNIT PRICE PER LB.	LBS. PER 300 GALLON TOTE	UNIT PRICE PER TOTE
Polydyne Inc. Riceboro, GA	\$1.18	2300	\$2,714.00

CITY COMMISSION REGULAR MTG

(7) (f)

Meeting Date: 06/06/2018

Purchase of Eight (8) Police Interceptors

Submitted For: Robert Burby, Police Department

Submitted By: Robert Burby, Police Department

Department: Police Department

Information

ACTION REQUEST (Brief Summary)

Consider and take action on Resolution No. 18-050, approving the purchase of eight (8) Police Interceptors. (Police Department)

BACKGROUND

ANALYSIS

ALTERNATIVES CONSIDERED

Fiscal Impact

Attachments

Resolution

Police Vehicles

RESOLUTION NO. 18-050

A RESOLUTION APPROVING PURCHASE OF EIGHT (8) POLICE VEHICLES THROUGH BUYBOARD-LOCAL GOVERNMENT PURCHASING COOPERATIVE FOR THE POLICE DEPARTMENT; AND PROVIDING THAT THIS RESOLUTION SHALL BECOME EFFECTIVE FROM AND AFTER ITS PASSAGE AND ADOPTION.

WHEREAS, the Police Department desires to purchase eight (8) police vehicles through BuyBoard- Local Government Purchasing Cooperative; and

WHEREAS, funds are available in the Capital Equipment Replacement – Police Department.

NOW, THEREFORE, BE IT RESOLVED BY THE CITY COMMISSION OF THE CITY OF TEXAS CITY, TEXAS:

SECTION 1: That the City Commission of the City of Texas City hereby approves the purchase of eight (8) police vehicles through BuyBoard - Local Government Purchasing Cooperative; as set out in **Exhibit “A,”** attached hereto and incorporated herein for all intents and purposes.

SECTION 2: That the Mayor is authorized to execute any documentation necessary for the purchase of the police vehicles.

SECTION 3: That this Resolution shall be in full force and effect from and after its passage and adoption.

PASSED AND ADOPTED this 6th day of June 2018.

Matthew T. Doyle, Mayor
City of Texas City, Texas

ATTEST:

APPROVED AS TO FORM:

James M. Hartshorn
City Secretary

Russell F. Plackemeier
City Attorney



TEXAS CITY POLICE DEPARTMENT

ROBERT J. BURBY

Chief of Police

PERF Graduate – Session 53 • FBI N.A. Graduate - Session 229



"First in Texas"

DATE: May 16, 2018

TO: City Secretary Office

FROM: Chief Robert J. Burby

RE: Purchase Request for Eight (8) Ford Explorer Interceptors

With the budget amendment approved by the City Commission on May 15th, 2018, request the purchase of eight (8) new fleet vehicles. that we put on the agenda a total of eight Ford explorer interceptors. This purchase will require the total of \$367,840.62.

This will cover the cost for the complete vehicle purchase as well as the purchase of eight additional hand held LIDAR units and the in dash camera system for each of the eight new vehicles purchased.

Regards,

"102 Years of Dedicated Service"

1004 9th Avenue North, Texas City, TX 77590-7407
www.texas-city-tx.org (409) 948-2525

CITY COMMISSION REGULAR MTG

(7) (g)

Meeting Date: 06/06/2018

2018-352 CDBG-DR Administration Professional Services

Submitted For: Debbie Gurka, Administration

Submitted By: Debbie Gurka,
Administration

Department: Finance

Information

ACTION REQUEST (Brief Summary)

Approve and award RFP # 2018-352 CDBG-DR Administration-Professional Services Contract.

BACKGROUND

Proposal Packets were emailed to vendors on May 14, 2018. The proposal was reviewed by the Selection Review Committee on May 30, 2018.

ANALYSIS

The responsible proposal meeting all specifications was received by GrantWorks in Austin, Texas.

It is the recommendation of the Selection Review Committee to award RFP# 2018-352 CDBG-DR Administration-Professional Services Contract to GrantWorks for the Cost of Services for Infrastructure rates proposed and that the Mayor be authorized to execute a contract on behalf of the City Commission.

Thank you.

ALTERNATIVES CONSIDERED

Fiscal Impact

Attachments

Resolution

Letter of Recommendation

RESOLUTION NO. 18-051

A RESOLUTION APPROVING RFP NO. 2018-352 COMMUNITY DEVELOPMENT BLOCK GRANT - DISASTER RECOVERY ADMINISTRATION - PROFESSIONAL SERVICES CONTRACT AND AUTHORIZING THE MAYOR TO ENTER INTO AN AGREEMENT WITH GRANTWORKS; AND PROVIDING THAT THIS RESOLUTION SHALL BECOME EFFECTIVE FROM AND AFTER ITS PASSAGE AND ADOPTION.

WHEREAS, the Community Development Block Grant – Disaster Recovery Administration – Professional Services (CDBG – DR Administration – Professional Services) contract requires implementation by professionals experienced in the administration of federally-funded disaster recovery projects; and

WHEREAS, in order to identify qualified and responsive providers for these services a Request for Proposals (RFP) process for administration services has been completed in accordance with the Texas General Land Office – Community Development Revitalization (GLO-CDR) requirements; and

WHEREAS, on May 14, 2018, proposal packets were mailed to area vendors for RFP No. 2018-352 CDBG - DR Administration - Professional Services; and

WHEREAS, the proposals received by the due date have been reviewed to determine the most qualified and responsive providers for each professional service giving consideration to ability to perform successfully under the terms and conditions of the proposed procurement, integrity, compliance with public policy, record of past performance and financial and technical resources; and

WHEREAS, proposals were opened and reviewed by the Selection Review Committee on May 30, 2018; and

WHEREAS, the bid proposal meeting all specifications was submitted by GrantWorks of Austin, Texas.

NOW, THEREFORE, BE IT RESOLVED BY THE CITY COMMISSION OF THE CITY OF TEXAS CITY, TEXAS:

SECTION 1: That the City Commission hereby accepts the contract by GrantWorks to provide CDBG application and project-related administration services for RFP No. 2018-352 CDBG - DR Administration - Professional Services.

SECTION 2: That any and all project-related services contracts and commitments made with the above named service provider are dependent on the successful negotiation of a contract with the service provider.

SECTION 3: That the Mayor is hereby authorized to enter into an agreement with GrantWorks for the Cost of Services for Infrastructures rates proposed as described in **Exhibit “A,”** attached hereto and made a part hereof for all intents and purposes.

SECTION 4: That this Resolution shall be in full force and effect from and after its passage and adoption.

PASSED AND ADOPTED this 6th day of June 2018.

Matthew T. Doyle, Mayor
City of Texas City, Texas

ATTEST:

APPROVED AS TO FORM:

James M. Hartshorn
City Secretary

Russell F. Plackemeier
City Attorney

CITY OF TEXAS CITY

PURCHASING DEPARTMENT • OFFICE (409) 643-5950 • FAX (409) 942-1073



Mayor:
Matthew T. Doyle

Commissioners:
Phil Roberts
Bruce Clawson
Earl Alexander
Abel Garza Jr.
Dorthea Jones
Jami Clark

RE: City of Texas City RFP 2018-352 for CDBG-Disaster Recovery Administrative Services

Mayor and Commissioners:

After reviewing the RFP 2018-352 proposal on May 30, 2018 the Selection Review Committee recommends the City move forward with GrantWorks based on the Infrastructure Cost of Services submitted and from past experience with the GrantWorks.

Thank you on behalf of the Selection Review Committee



Thomas Munoz
Emergency Management Coordinator

“QPS-Quality Public Service”

CITY COMMISSION REGULAR MTG

(7) (h)

Meeting Date: 06/06/2018

Submitted For: Nick Finan, Management Services

Submitted By: Rhomari Jackson-Glover, City Secretary

Department: City Secretary

Information

ACTION REQUEST (Brief Summary)

Consider and take action Resolution No. 2018-052, approving the suspension of the TNMP July 5th effective date. (City Secretary)

BACKGROUND

TNMP is seeking a rate adjustment of 16% for all customers in Texas served by TNMP. The suspension allows us to review their request to the PUC and make comments. As you will see in the sample staff report provided by our Coalition's attorney (Model Staff Report) it details more specifics on what the rate case request for street lights and operational costs, etc.

ANALYSIS

ALTERNATIVES CONSIDERED

Fiscal Impact

Attachments

Resolution

Staff Report

RESOLUTION NO. 18-052

RESOLUTION OF THE CITY OF TEXAS CITY SUSPENDING THE JULY 5, 2018 EFFECTIVE DATE OF TEXAS-NEW MEXICO POWER COMPANY'S (TNMP'S) REQUESTED RATE CHANGE TO PERMIT THE CITY TIME TO STUDY THE REQUEST AND TO ESTABLISH REASONABLE RATES; APPROVING COOPERATION WITH OTHER TNMP CITIES; HIRING LLOYD GOSSELINK ATTORNEYS AND CONSULTING SERVICES TO NEGOTIATE WITH THE COMPANY AND DIRECT ANY NECESSARY LITIGATION AND APPEALS; FINDING THAT THE MEETING AT WHICH THIS RESOLUTION IS PASSED IS OPEN TO THE PUBLIC AS REQUIRED BY LAW; REQUIRING NOTICE OF THIS RESOLUTION TO THE COMPANY AND LEGAL COUNSEL AND PROVIDING THAT THIS RESOLUTION SHALL BECOME EFFECTIVE FROM AND AFTER ITS PASSAGE AND ADOPTION.

WHEREAS, on or about May 30, 2018, Texas-New Mexico Power Company (TNMP), pursuant to PURA §§ 33.001 and 36.001 filed with the City of Texas City a Statement of Intent to change electric delivery rates in all municipalities exercising original jurisdiction within its service area effective July 5, 2018; and

WHEREAS, the City of Texas City is a member of the coalition of TNMP Cities and will cooperate with the other similarly situated city members and other city participants in conducting a review of the Company's application and to hire and direct legal counsel and consultants to prepare a common response and to negotiate with the Company and direct any necessary litigation; and

WHEREAS, PURA § 36.108 grants local regulatory authorities the right to suspend the effective date of proposed rate changes for ninety (90) days after the date the rate change would otherwise be effective; and

WHEREAS, PURA § 33.023 provides that costs incurred by Cities in ratemaking activities are to be reimbursed by the regulated utility.

NOW, THEREFORE, BE IT ORDAINED BY THE CITY COMMISSION OF THE CITY OF TEXAS CITY, TEXAS:

SECTION 1: That the July 5, 2018 effective date of the rate request submitted by TNMP on or about May 30, 2018, be suspended for the maximum period allowed by law to permit adequate time to review the proposed changes and to establish reasonable rates.

SECTION 2: That the City is authorized to cooperate with other cities served by TNMP to coordinate efforts to protect the interests of the City and protect the interests of TNMP's end-

use customers residing and conducting business within municipal limits.

SECTION 3: Subject to the right to terminate employment at any time, the City of Texas City hereby authorizes the hiring of Thomas Brocato and Christopher Brewster of the law firm of Lloyd Gosselink and consultants to negotiate with the Company, make recommendations regarding reasonable rates and to direct any necessary administrative proceedings or court litigation associated with an appeal of a rate ordinance and the rate case filed with the City or Public Utility Commission.

SECTION 4: That the City's reasonable rate case expenses shall be reimbursed by TNMP.

SECTION 5: That it is hereby officially found and determined that the meeting at which this Resolution is passed is open to the public as required by law and the public notice of the time, place, and purpose of said meeting was given as required.

SECTION 6: A copy of this Resolution shall be sent to TNMP, care of Scott Seamster, Corporate Counsel, 225 E. John Carpenter Freeway, Suite 1500, Irving, Texas 75062-2282 and to Thomas Brocato, at Lloyd Gosselink Rochelle & Townsend, P.C., 816 Congress Avenue, Suite 1900, Austin, Texas 78701.

PASSED AND ADOPTED this 6th day of June 2018.

Matthew T. Doyle, Mayor
City of Texas City, Texas

ATTEST:

APPROVED AS TO FORM:

James M. Hartshorn
City Secretary

Russell F. Plackemeier
City Attorney

MODEL STAFF REPORT

*****ACTION MUST BE TAKEN TO SUSPEND THE EFFECTIVE DATE ON OR BEFORE JULY 5, 2018*****

PURPOSE

Texas-New Mexico Power Company (TNMP or the Company) filed an application on May 30, 2018 with cities retaining original jurisdiction seeking to increase system-wide transmission and distribution rates by \$33.3 million. The Company asks the City to approve a 23.4% increase in residential rates and a 11.8% increase in street lighting rates. Monthly rates would increase by approximately \$12.21 for an average residential customer.

The resolution suspends the July 5, 2018 effective date of the Company's rate increase for the maximum period permitted by law to allow the City, working in conjunction with other cities served by TNMP, to evaluate the filing, determine whether the filing complies with law, and if lawful, to determine what further strategy, including settlement, to pursue.

The law provides that a rate request made by an electric utility cannot become effective until at least 35 days following the filing of the application to change rates. The law permits the City to suspend the rate change for 90 days after the date the rate change would otherwise be effective. **If the City fails to take some action regarding the filing before the effective date, TNMP's rate request is deemed approved.**

DISCUSSION

The City of _____ is a member of a coalition of cities known alternatively as the Cities Served by TNMP and the Gulf Coast Coalition of Cities (TNMP Cities). The Coalition has been in existence since the early 1990s. TNMP Cities have been the primary public interest advocate before the Public Utility Commission, the Courts, and the Legislature on electric utility regulation matters for over 20 years.

Explanation of "Be It Resolved" Paragraphs:

Section 1. The city is authorized to suspend the rate change for 90 days after the date that the rate change would otherwise be effective for any legitimate purpose. Time to study and investigate the application is always a legitimate purpose. Please note that the resolution refers to the suspension period as "the maximum period allowed by law" rather than ending by a specific date. This is because the Company controls the effective date and can extend the deadline for final city action to increase the time that the City retains jurisdiction if necessary to reach settlement on the case. If the suspension period is not otherwise extended by the Company, the City must take final action on TNMP's request to raise rates by October 3, 2018.

Section 2. This provision authorizes the City to participate in a coalition of cities served by TNMP in order to more efficiently represent the interests of the City and their citizens.

Section 3. This provision authorizes the hiring of Lloyd Gosselink and consultants to represent the City in this matter. It also provides authority for the attorneys and consultants to act on behalf of the City at the local level in settlement discussions, in preparation of a rate ordinance, on appeal of the rate ordinance to the PUC, and on appeal to the Courts. Negotiating clout and efficiency are enhanced by the City cooperation in a common review and common purpose. Additionally, rate case expenses are minimized when cities hire one set of attorneys and experts who work under the guidance and control of the cities.

Section 4. The Company will reimburse the cities for their reasonable rate case expenses. Legal counsel and consultants approved by the TNMP Cities will submit monthly invoices that will be forwarded to TNMP for reimbursement. No individual city incurs liability for payment of rate case expenses by adopting a suspension resolution.

Section 5. This section merely recites that the resolution was passed at a meeting that was open to the public and that the consideration of the Resolution was properly noticed.

Section 6. This section provides that both TNMP's counsel and counsel for the cities will be notified of the City's action by sending a copy of the approved and signed resolution to certain designated individuals.

CITY COMMISSION REGULAR MTG

(7) (i)

Meeting Date: 06/06/2018

Appointing an independent registered municipal financial advisor

Submitted For: Laura Boyd, Finance

Submitted By: Laura Boyd, Finance

Department: Finance

Information

ACTION REQUEST (Brief Summary)

Consider and take action on Resolution No. 18-053, appointing an independent registered municipal advisor. (Finance)

BACKGROUND

The City will be represented by and rely upon this specified municipal advisor to provide advice on proposals from financial services firms concerning the issuance of municipal securities and municipal financial products including investments of bond proceeds and escrow investments.

We recommend appointing Drew Masterson of Masterson Advisors, LLC as the City's municipal advisor. Mr. Masterson is the managing director of Masterson Advisors and will serve as primary contact.

ANALYSIS

ALTERNATIVES CONSIDERED

Fiscal Impact

Attachments

Resolution

RESOLUTION NO. 18-053

**A RESOLUTION APPOINTING DREW MASTERSON OF
MASTERSON ADVISORS, LLC AS AN INDEPENDENT ADVISOR TO
THE TEXAS CITY; AND PROVIDING THAT THIS RESOLUTION
SHALL BECOME EFFECTIVE FROM AND AFTER ITS PASSAGE
AND ADOPTION.**

WHEREAS, the City has determined that it is necessary to appoint an independent registered Municipal Advisor to provide advice on proposals from financial services firms concerning the issuance of municipal securities and municipal financial products including investments of bond proceeds and escrow investments; and

WHEREAS, it is recommended that Drew Masterson of Masterson Advisors, LLC, be appointed as the City's Municipal Advisor.

**NOW, THEREFORE, BE IT RESOLVED BY THE CITY COMMISSION OF
THE CITY OF TEXAS CITY, TEXAS:**

SECTION 1: That the City Commission of the City of Texas City, Texas, hereby appoints Drew Masterson as a Municipal Advisor to the City of Texas City.

SECTION 2: That this Resolution shall be in full force and effect from and after its passage and adoption.

PASSED AND ADOPTED this 6th day of June 2018.

Matthew T. Doyle, Mayor
City of Texas City, Texas

ATTEST:

APPROVED AS TO FORM:

James M. Hartshorn
City Secretary

Russell F. Plackemeier
City Attorney