



The Brandt Companies, LLC

8848 N. Sam Houston Parkway W., Houston, TX 77064, (832) 714-3200, TACLA15221C/TECL20109/M40211

Proposal Date: February 1, 2022 Proposal#: P-20220203-0010-A

24 Hour Service Dispatch: (832) 714-3300 Reference: Option 1- Installation of Viessman Boiler

Customer: Marcell Favalora Service Site: Marcell Favalora
City of Texas City Pool City of Texas City Pool
1900 Fifth Ave N. 1900 Fifth Ave N.
Texas City, Tx 77590 Texas City, Tx 77590

X Repair work proposals are for the scope as listed on the following page.

Equipment replacement proposals are for the scope of work as listed on the following page.

The Brandt Companies, LLC is pleased to submit the following price and general scope of work to be performed,
(at the above-referenced service site), in the amount of: \$ 75,423.90
\$ - plus any applicable taxes. Price is good for 30 Days.
\$ 75,423.90 Total

Remit To: The Brandt Companies, LLC, P.O.Box 227351, Dallas, TX 75222-7351 - Tax EIN: 37-1652957

• Austin • Dallas • Fort Worth • Houston • San Antonio • Waco

We appreciate the opportunity to provide you with our services. Upon receipt of a signed proposal, we will begin mobilizing material orders and contact you to coordinate the repairs. Our terms are net ten days from the invoice date, and past due after thirty days. This contract is not valid without attachment and signature of customer on Service Descriptions Page and Terms and conditions.

Best Regards,

Martha Wethington

Service Account Manager

Cell: 346-426-5934

Fax: 832-714-3500

Email: martha.wethington@brandt.us

Customer Acceptance

Accepted By: _____
Name: _____
Title: _____
Company: _____
Date: _____
Purchase Order Number: _____

The Brandt Companies, LLC

Accepted By: _____
Name: _____
Title: _____
The Brandt Companies, LLC
Date: _____

www.brandt.us



The Brandt Companies, LLC

8848 N. Sam Houston Parkway W., Houston, TX 77064, (832) 714-3200, TACLA15221C/TECL20109/M40211

Proposal Date: February 1, 2022

Proposal#:

P-20220203-0010-A

24 Hour Service Dispatch: (832) 714-3300

Reference:

Option 1- Installation of Viessman Boiler

Scope of Work:

- Mobilize to job site and check in with the customer
- Core drill two holes towards back of outside mechanical room and create penetration on roof for new boiler vent
- Install new Viessman Rack system in outside mechanical room and Bowan pool shell and tube heat exchanger
- Tie in to existing gas line and water line
- Run 2" CPVC Piping from mechanical room to pool pump room
- Tie in to new Bowan pool shell and tube heat exchanger and existing pool pumps
- Install new expansion tank inside mechanical room
- Install carbon monoxide monitor in mechanical room
- Tie in electrical to heat exchangers, boiler and pumps
- Install new CPVC vent stack from the new boiler and out the new roof penetration
- Start boiler and check for operation and leaks
- Call for final inspection with the City of Texas City
- Check out with customer and demobilize from job site
- Install new insulation on new hot water lines

• ***Add on Option 1: Fiberglass unistrut and clamps: ADD \$1500

Accepted By Customer: _____ Brandt: _____

Building a sustainable future
for the communities we serve



The Brandt Companies, LLC

8848 N. Sam Houston Parkway W., Houston, TX 77064, (832) 714-3200, TACLA15221C/TECL20109/M40211

Proposal Date: February 1, 2022

Proposal#: P-20220203-0010-A

24 Hour Service Dispatch: (832) 714-3300

Reference: Option 1- Installation of Viessman Boiler

Exclusions for Services Offered:

- Anything not listed in the scope of work.
- Overtime Work.

Accepted By Customer: _____ Brandt: _____

The Brandt Companies, LLC

8848 N. Sam Houston Parkway W., Houston, TX 77064, (832) 714-3200, TACLA15221C/TECL20109/M40211

Proposal Date: February 1, 2022 Proposal#: P-20220203-0010-A

24 Hour Service Dispatch: (832) 714-3300 Reference: Option 1- Installation of Viessman Boiler

Brandt's Service Proposal # P-20220203-0010-A. Proposal is conditioned upon the following terms and conditions, which

are incorporated by reference and, together with the Proposal, form the Contract between the parties:

- 1 **Warranty.** Brandt shall furnish to Customer all manufacturers' parts and equipment warranties received by Brandt. For a period of one (1) year from the date of the respective work, repair or installation performed by Brandt, Brandt agrees to repair, replace or otherwise make good to the satisfaction of Customer, any defects in parts or materials supplied by Brandt that are not covered under a manufacturer's warranty and that are adversely affecting the performance of the equipment installed by Brandt, if any. Brandt warrants to Customer that all labor performed or provided shall be performed by licensed personnel, if required by applicable law, and will be performed in a good workman like manner. For a period of ninety (90) days from the date of the respective work, repair or installation performed by Brandt, Brandt agrees to repair, replace or otherwise make good to the satisfaction of Customer, any defects in workmanship that is adversely affecting the performance of the equipment installed by Brandt, if any.
- 2 **Insurance.** So long as any of the Work remains to be completed, Brandt shall, at Brandt's sole cost and expense, carry and maintain in full force and effect, the following insurance coverages:
(A) Workers' compensation insurance coverage on all individuals employed upon or about the Property according to the requirements of the laws of the State of Texas;
(B) General liability insurance coverage with the limits maintained by Brandt at the time of this Proposal (which are: \$1M each occurrence; \$1M personal/advertising injury; \$10M general aggregate; \$2M products/completed operations aggregate; \$10,000 medical expense (any one person)).

The policies will be issued by companies reasonably acceptable to Customer. In the event of any covered loss, or upon Customer's reasonable request, Brandt shall deliver to Customer copies of the insurance policies. Brandt and Customer mutually agree to a waiver by their respective insurer(s) of any and all rights to subrogation.
- 3 **General Limitations on Scope of Work.** Notwithstanding any other provision to the contrary in this Contract, including the incorporated Proposal, the Mechanical Service scope excludes:
(a.) Maintenance or repair of Equipment cabinets;
(b.) Ductwork and air distribution devices;
(c.) Water supply or drain beyond the Equipment;
(d.) Repair or replacement of heat exchangers in gas fired furnaces and duct heaters;
(e.) Repair or replacement of metal tubes in condensers, chiller, boilers or any other heat exchanger;

(f.) Moving or relocation of the subject equipment;
(g.) Repairs due to freezing;
(h.) Work made necessary by the enforcement of government codes, building and union regulations or as recommended by insurance companies;
(i.) Damage of any kind due to corrosion, erosion, electrolytic actions, acts of God, power failure, vandalism, or any other cause whatsoever beyond the
(j.) Electrical components associated with the Equipment including: disconnect switches, fuses, circuit breakers, and electrical wiring not specifically
(k.) Water treatment; and
(l.) Piping systems of any nature.
- 4 **Hoisting/Rigging Operations.** Prior to the use of heavy commercial hoisting or rigging equipment that could potentially cause damage to the Property or injury, Brandt will notify Customer in writing and shall not proceed without Customer's prior written consent. While all precautions will be exercised to protect Customer's Property, Brandt will not accept any responsibility for damage to parking lots, driveways, or landscaping that may occur as a result of normal hoisting and rigging operations, except to the extent that the damage is caused by Brandt's gross negligence or willful misconduct.
- 5 **Work Hours.** Unless indicated otherwise, all pricing is based upon work being performed during regular working hours of 8:00 am to 5:00 pm, Monday through Friday, except holidays. If work is required at times other than normal working hours, Customer agrees to pay the Brandt's standard overtime charge rates.
- 6 **Payments.** Customer agrees to pay Brandt all sums due with respect to this Proposal in accordance with the terms specified. Payments are due upon receipt of invoice. In the event payment is not received by Brandt within thirty (30) days following billing, such payment shall be considered past due. Beginning with the thirty-first (31st) day following billing, such payment shall bear interest at the maximum rate allowable by law until payment is received. If default is made in the payment of any sums due hereunder and it becomes necessary that this Contract be placed in the hands of an attorney for collection, Customer agrees to pay to Brandt all costs of collection, including reasonable attorney's fee. Brandt shall have the right to cancel this Contract at any time, upon five (5) business days' written notice, if payments as called for herein are not made.
- 7 **Cancellation.** This Contract may be cancelled by either party upon thirty (30) day written notice. In the event of cancellation by the Customer, Brandt reserves the right to invoice and be paid for work performed thru cancellation date.

Accepted By Customer: _____ Brandt: _____



The Brandt Companies, LLC

8848 N. Sam Houston Parkway W., Houston, TX 77064, (832) 714-3200, TACLA15221C/TECL20109/M40211

Proposal Date: February 1, 2022 Proposal#: P-20220203-0010-A

24 Hour Service Dispatch: (832) 714-3300 Reference: Option 1- Installation of Viessman Boiler

- 8 No Liability from System Design or Existing Equipment Installation. Unless Brandt was the engineer of record for the existing system design under a prior and separate construction/design-build contract or system design is expressly included within the scope of the Proposal (and, in either case, to the extent of that design), Customer acknowledges and stipulates that Brandt did not select, advise Customer regarding, engineer, design or install the system, equipment or any component part thereof to be maintained under this Contract. Accordingly, Brandt shall not be liable in any capacity, under any theory of recovery for any claims or damages related to or originating from prior or existing defects, deficiencies, injuries, or damage (whether to the system, equipment or Property) associated therewith or as a result of prior ineffective maintenance. Brandt agrees, however, to advise the Customer about the existence of such conditions upon discovery in accordance with the terms of the Contract.
- 9 No Liability for Incidental Microbiological Growth/Mold. Customer acknowledges that the Heating, Ventilation, and Air-Conditioning equipment and systems repaired or serviced as a part of this Contract may, under certain conditions, become conducive to or incidentally support microbiological growth. Brandt assumes no liability for nor warrants its work to protect against, eliminate or inhibit any type of incidental microbiological growth including, but not limited to, molds, fungi and other related matter, in or around duct systems, HVAC and related equipment or areas. Brandt agrees, however, to advise the Customer about the existence of such conditions upon discovery and to take measures to discourage such growth as required and in accordance with the terms of the Contract.
- 10 Limitation of Damages for Breach of Contract. The full extent of Brandt's liability and Customer's exclusive remedy for damages from any breach of this Contract, including, but not limited to, nonperformance or misrepresentation, and regardless of the form of action, shall be limited to the annual Contract fee of the current year.
- 11 Mutual Waiver of Consequential and Punitive Damages. Notwithstanding any other provision to the contrary, Brandt and Customer mutually waive all claims against each other for any and all consequential/special/indirect/incidental and, to the extent allowable by law, all punitive/exemplary damages arising out of or relating to this Contract. This mutual waiver includes, but is not limited to, damages incurred for rental expenses, loss of use, lost revenue or profit, lost opportunity, loss of goodwill, loss of management or employee productivity, cost of capital, and cost of substitute facilities, services or goods regardless of the foreseeability of such damages. If Customer is a property manager or other legal agent or representative of the property owner, Customer represents and warrants that it has the express requisite authority to waive claims for and recovery of such damages on behalf of the property owner as well as for itself.
- 12 Indemnity. To the fullest extent permitted by law, to the PROPORTIONATE extent OF CUSTOMER'S AND Brandt's RESPECTIVE negligence and except as otherwise limited herein, CUSTOMER AND BRANDT agree to indemnify, defend, and hold ONE ANOTHER AND THEIR RESPECTIVE officers, directors, agents, assigns, successors and employees HARMLESS against all claims and damages, losses and expenses (including, but not limited to, REASONABLE attorney's fees) arising out of OR RELATED TO the performance of this contract. NOTWITHSTANDING THE FOREGOING PROVISION, THIS INDEMNITY IS SUBJECT TO THE LIMITATIONS OF LIABILITY IN SECTIONS 8-11 ABOVE.
- 13 Hazardous Materials. If Brandt encounters asbestos, polychlorinated biphenyl (PCB) or other hazardous materials on the Property, Brandt will immediately stop work and report in writing the evidence of such to Customer. Brandt will not resume work in the affected area until the hazardous material has been removed or determined harmless by a qualified laboratory at Customer's expense.
- 14 Dispute Resolution and Governing Law. This Contract shall be interpreted and construed according to the laws of the State of Texas. Any disputes arising out of or related to this Contract will be resolved by agreement through a meeting of executive representatives of each party. If no resolution can be reached, the dispute will be resolved through binding arbitration before an arbitrator experienced in construction law and according to the rules promulgated by the American Arbitration Association. The parties agree that the arbitration will be commenced within sixty (60) days of occurrence of the meeting of executive representatives. This Contract shall be governed by the laws of the State of Texas without regard to conflicts of laws principles.
- 15 Property Manager. If Customer is a property manager or other legal agent or representative of the property owner, Customer represents and warrants that it has the express requisite authority to enter into all of the terms of this Contract including, without limitation, the authority to waive claims for and recovery of consequential (special/indirect/incidental) and punitive damages on behalf of the property owner as well as for itself.
- 16 Entire Agreement. This Contract constitutes the entire agreement and is not assignable by either party without the express written consent of the other party. This Contract may be modified or amended only by written agreement of both parties.

Accepted By Customer: _____ Brandt: _____

CN-XL Series - Pool Heat Exchangers

The CN-XL series of heat exchangers was designed specifically for commercial sized swimming pools. They provide a simplified and practical means of indirectly heating both commercial and municipal pools. The vast majority of hotels, YMCAs, municipal arenas, community centers, universities/colleges and condominiums already utilize boilers for makeup air and domestic water heating. Typically these boilers are oversized and are not in operation on a continuous basis even during the winter months. Utilizing this excess capacity also ensures a more continuous operation of the boiler which reduces cycling.

The CN-XL series heat exchangers are available in capacities ranging to 3,000,000 Btu/hr and are therefore suitable for large Olympic size swimming pools. In addition to providing sufficient surface area to facilitate high rates of heat transfer these units are also designed to handle a flow rate of 400 USGPM of pool water with a pressure loss of only 3.2 psi (7.5 feet water).

Please contact us with the design parameters so that we can size a suitable unit and provide a data sheet with the design criteria and flow characteristics - as these are engineered products it is important that they are correctly sized for your application. .



- Applications**
- Large Scale Pools
 - Hot Tubs
 - Geothermal Pool Heating
 - Solar Pool Heating

* Removable tubestacks for easy cleaning

Features

- High Heat Transfer Capacities
- Rugged Design
- Resistant to Corrosion from Both Chlorinated and Salt Water Pools
- Removable Tubestacks Enables Easy Cleaning
- Quick Delivery from Stock

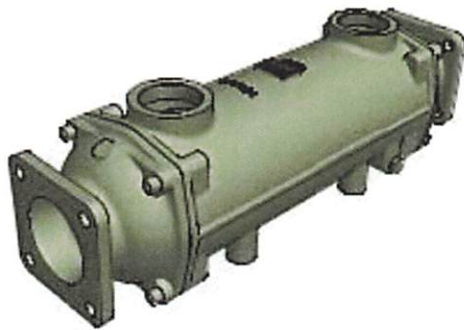

Standard Material

Tube side (Pool Water): Cupro Nickel
 Shell Side (Boiler Water): Cast Iron Steel

Maximum Pressure

Hot Side: 90 psig
 Cold Side: 90 psig

Maximum Temperature

250 °F

Approvals

CRN



Manufactured under ISO 9001-2008 quality guidelines

Made in England

CN-XL Quick Reference Chart (based on boiler water temperature 180°F)

Part Number	Pool Capacity USG	Pool Water Flow GPM	Boiler Water Flow GPM	Boiler Capacity BTU/Hr	Connections	
					Hot	Cold
CN650	60000	127	31.7	650,000	1 1/2" NPT	3" NPT
CN1000	120000	222	54.5	1,000,000	2" NPT	3" Flange
CN1500	200000	330	84.5	1,500,000	2 1/2" NPT	4" Flange
CN2000	240000	500	126	2,650,000	3" NPT	5" Flange

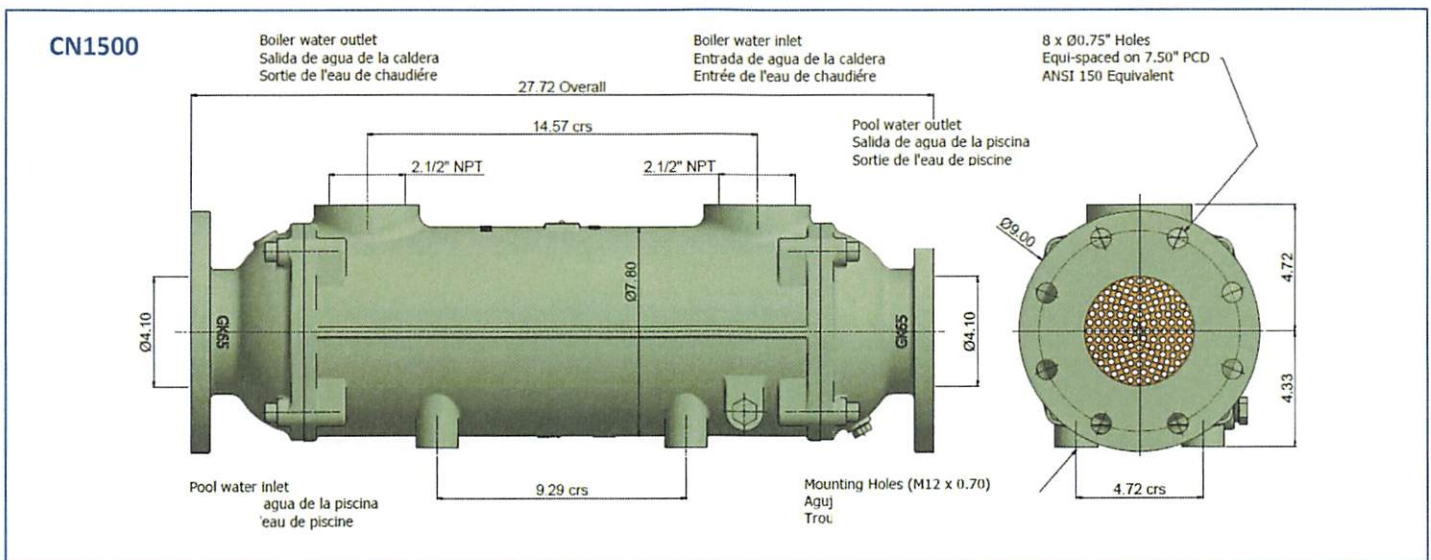
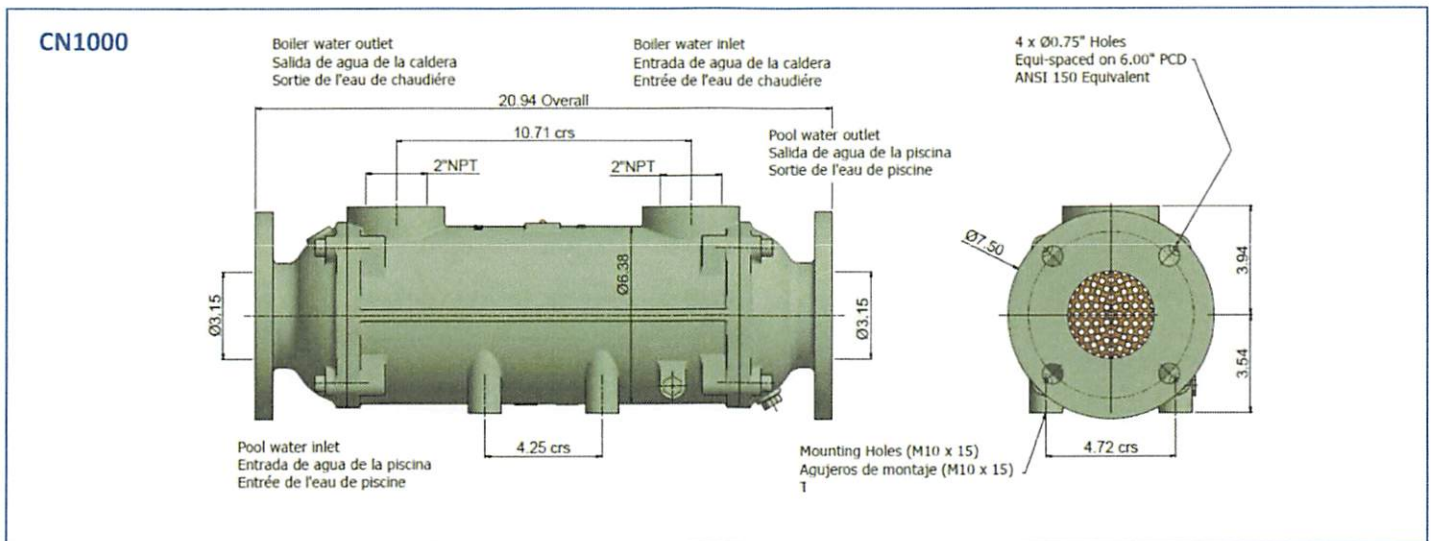
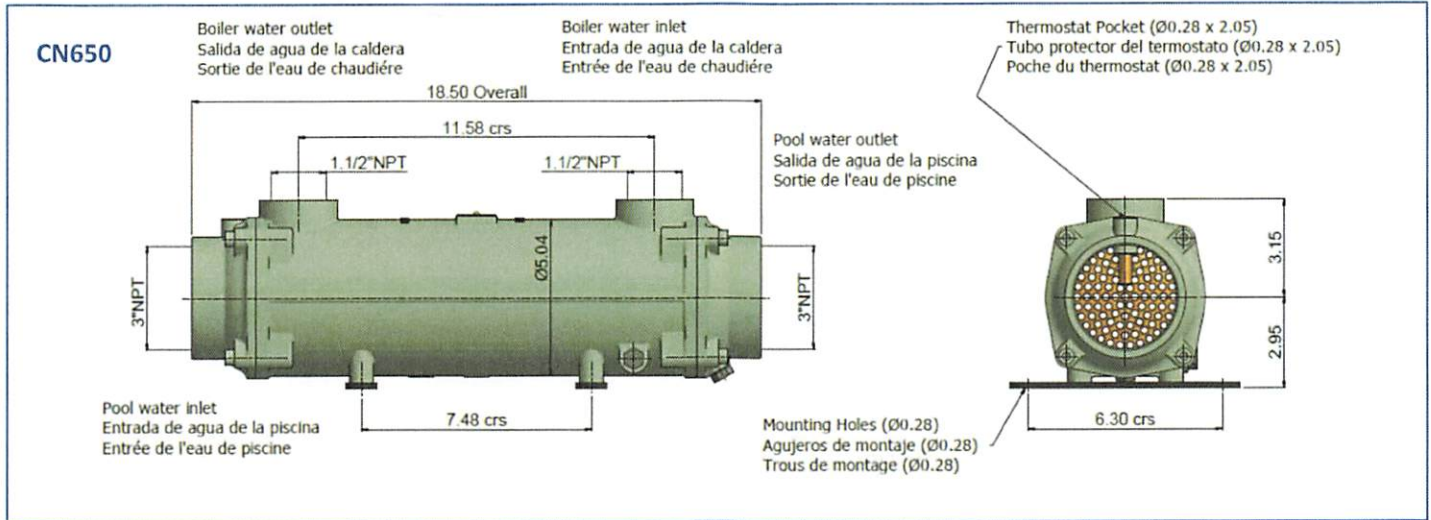

Stocking Distributors for North America



Toll Free: 1-877-751-9414

Web: valutechinc.com

eMail: info@valutechinc.com

Dealer:

VISSMANN MANUFACTURING COMPANY (U.S.) INC. ("Viessmann")

STANDARD LIMITED WARRANTY

For Hydronic Heating Boilers - Gas-Fired Condensing Stainless Steel Boilers Only (the "Standard Warranty" or the "Warranty")

TERMS AND CONDITIONS OF WARRANTY

Viessmann provides this Warranty only to the original end user purchaser (the "Owner") of a Viessmann Stainless Steel Hydronic Heating Boiler of less than 530,000 BTU output purchased after September 1, 2016, in the United States of America for installations in the United States (the "Boiler"), provided the Owner uses the Boiler at the site of original installation in accordance with the terms hereof.

This Warranty provides specific legal rights. You may have other rights which vary from State to State in the United States of America. The rights in this Warranty are conditioned upon: (a) the proper installation of the Boiler in accordance with all applicable rules, regulations, industry standards and Viessmann instructions by a mechanical contractor or installer whose principal occupation is the sale and installation of heating, plumbing, and/or air conditioning equipment and who is properly licensed under all relevant and/or applicable laws of the jurisdiction in which the Boiler is installed ("Contractor"); (b) proper operation, and maintenance of the Boiler by a Contractor in accordance with the product manuals; (c) the original and continuous installation and use of the Boiler by an Owner within the United States of America; and (d) performance of warranted part replacements or repairs by a Contractor.

WARRANTY AND WARRANTY PERIODS

Viessmann's obligation under this Warranty is limited to the repair or replacement, at the sole discretion of Viessmann, of any goods or parts which do not conform to the express Warranty provided herein. Labor and all other costs for the examination, removal and/or re-installation of defective parts, and transportation costs for defective or replacement parts, are not covered by this Warranty.

LIMITED TWO (2) YEAR WARRANTY

Viessmann warrants that the Boiler enclosure, burner, controls, and other accessories Viessmann provides as standard equipment on the Boiler will be free from defects in material and workmanship for TWO (2) YEARS from the Date of Original Installation of the Boiler.

LIMITED FIVE (5) YEAR WARRANTY FOR RESIDENTIAL APPLICATIONS

If the Owner uses the Boiler exclusively for personal, family and household purposes in a single family dwelling or a residential building where Boiler services only the Owner's residence ("Residential Applications") Viessmann warrants that the Boiler enclosure, burner, controls, and other accessories that Viessmann provides as standard equipment on the Boiler will be free from defects in material and workmanship for FIVE (5) YEARS from the Date of Original Installation of the Boiler.

LIMITED TEN (10) YEAR WARRANTY FOR THE PRESSURE VESSEL

Viessmann warrants that the pressure vessel of the Boiler will be free from defects in materials and workmanship resulting in a leak for TEN (10) YEARS from the Date of Original Installation of the Boiler.

LIMITED LIFETIME WARRANTY FOR THE PRESSURE VESSEL AFTER THE TENTH (10TH) YEAR FOR RESIDENTIAL APPLICATIONS

If the Owner uses the Boiler exclusively in a Residential Application, Viessmann warrants that the pressure vessel will remain free from defects in materials and workmanship resulting in a leak during the life time of the boiler. Repair or replacement of a pressure vessel defective in material or workmanship after the tenth year in Residential Applications will be made only upon the Owner's payment of a proportionate charge based upon the length of time the pressure vessel has been installed.

The proportionate charge is the percentage of the then current Viessmann list price of the pressure vessel when the warranty claim is made, determined as follows: 11th year - Owner 20%, Viessmann 80%; 12th year - Owner 40%, Viessmann 60%; 13th year - Owner 50%, Viessmann 50%; 14th year - Owner 60%, Viessmann 40%; 15th year and beyond - Owner 75%, Viessmann 25%.

If a pressure vessel for the Boiler is no longer available when the warranty claim is made, Viessmann will provide a new condensing Boiler at the then current retail price subject to the following: The Owner must pay the then current retail price for the replacement boiler less a credit based upon (1) the percentage the list price of the pressure vessel of the new boiler bears to the list price of the entire boiler, and (2) Viessmann's share of the proportionate charge detailed above. By way of example, if the pressure vessel fails in the 14th year and the list price of the pressure vessel is 30% of the list price of the new boiler, the Owner will receive a credit of 12% of the retail list price of the new boiler (30% of Viessmann's 40% share of proportionate charge in the 14th year).

REPLACEMENT PARTS

Replacement or repaired parts provided under this Warranty are warranted for the applicable unexpired period of this Warranty, or the term of Viessmann's Parts Warranty, whichever is longer.

COMMENCEMENT OF WARRANTY PERIODS

The Warranty Periods commence on the date the Boiler is installed (the "Date of Original Installation"). In the event of a dispute as to the Date of Original Installation, the shipping date from the Viessmann facility, as recorded in the books and records of Viessmann, shall be deemed to be the Date of Original Installation.

WARRANTY EXPRESSLY EXCLUDES THE FOLLOWING

1. THE REMEDY PROVIDED IN THIS WARRANTY IS THE EXCLUSIVE REMEDY OF THE OWNER. VIESSMANN SHALL NOT BE RESPONSIBLE FOR ANY PUNITIVE, SPECIAL, INDIRECT, INCIDENTAL OR CONSEQUENTIAL DAMAGES (INCLUDING WITHOUT LIMITATION LOSS OF USE AND LOST PROFITS). VIESSMANN'S MAXIMUM CUMULATIVE LIABILITY SHALL NOT EXCEED THE ACTUAL PURCHASE PRICE THE ORIGINAL END-USER PURCHASER PAID FOR THE BOILER. Some States do not allow the exclusion or limitation of incidental or consequential damages, so the above limitation or exclusion may not apply to you.

2. THIS WARRANTY IS GIVEN IN LIEU OF ALL OTHER WARRANTIES. VIESSMANN MAKES NO OTHER WARRANTIES OR GUARANTEES, EXPRESS OR IMPLIED, INCLUDING, WITHOUT LIMITATION, ANY WARRANTY OF MERCHANTABILITY OR FITNESS FOR ANY PARTICULAR PURPOSE. ANY SUCH WARRANTY IMPOSED BY LAW IS LIMITED TO THE PERIOD OF THE LIMITED WARRANTY PROVIDED HEREIN. NO WARRANTY ARISING BY USAGE, CUSTOM, COURSE OF DEALING OR COURSE OF PERFORMANCE IS GIVEN BY VIESSMANN OR SHALL ARISE IN CONNECTION WITH THIS WARRANTY. Some States do not allow limitations on how long an implied warranty lasts, so the above limitation may not apply to you.

3. Liability or damages caused by improper installation or unsuitable or improper use or operation of the Boiler, incorrect Boiler start-up, incorrect or careless handling, improper control adjustment or control strategy, incorrect burner adjustment, disregard of the operating and maintenance instructions or any other instructions supplied with the Boiler, alteration of the Boiler, or use of unauthorized replacement parts.

4. The workmanship of the Contractor and repairs or replacement of parts required due to poor workmanship of the Contractor.

5. Components and parts not furnished by Viessmann.

6. (a) Damage caused by improper care or maintenance, including, but not limited to improper removal of Boiler condensate, and (b) failure to inspect and service the Boiler in accordance with Viessmann's product manuals. The Boiler and its burner must be operated, serviced, inspected and cleaned in accordance with the product manuals.

7. Damage to the Boiler or any of its parts caused by matters outside the control of Viessmann, including excessive temperatures or pressures, unsuitable fuels, fuel impurities, improper fuel mixture, fuel or gas explosion, electrical, chemical or electrochemical reaction, water impurities, unsuitable water conditions as per system design guidelines, water conditions causing unusual deposits within the water side and heat exchanger combustion area of the pressure vessel within the Boiler, water treatment chemicals, electrical failures and surges, acts of God, combustion air contaminated externally, air impurities, sulfur or sulfuric action or reaction, dust particles, corrosive vapors, oxygen corrosion, situating the Boiler in an unsuitable location or continuing use of the Boiler after onset of a malfunction or discovery of a defect.

8. Damage to the Boiler or any of its original or authorized replacement parts caused by a water conditioning system in the building in which the Boiler is installed not conforming to Viessmann specifications.

9. Wear and tear and/or consumption of parts including, but not limited to, fuses, gaskets, ignitors, electrodes, combustion chamber linings, and parts in direct contact with the open flame.

NON- ASSIGNABILITY

No Viessmann warranties are assignable.

ARBITRATION

IN THE EVENT OF ANY DISPUTE BETWEEN VIESSMANN AND THE OWNER ARISING OUT OF THE INTERPRETATION OR PERFORMANCE OF THIS WARRANTY, OR THE PARTS AND EQUIPMENT COVERED HEREUNDER, SUCH DISPUTE SHALL BE SUBMITTED TO BINDING ARBITRATION ADMINISTERED BY THE AMERICAN ARBITRATION ASSOCIATION ("AAA"). THE ARBITRATION SHALL BE CONDUCTED BY THREE (3) ARBITRATORS, ONE OF WHOM SHALL BE NOMINATED BY VIESSMANN, ONE BY THE OWNER AND THE THIRD BY THE FIRST TWO NOMINEES IF THEY CAN AGREE AND OTHERWISE IN ACCORDANCE WITH THE RULES OF THE AAA. ALL CLAIMS OR DISPUTES SHALL BE BROUGHT IN THE PARTIES' INDIVIDUAL CAPACITY AND NOT AS A PLAINTIFF OR CLASS MEMBER IN ANY PURPORTED CLASS OR REPRESENTATIVE PROCEEDING. THERE SHALL BE NO RIGHT OR AUTHORITY FOR ANY CLAIMS OR DISPUTES TO BE ARBITRATED ON A CLASS ACTION BASIS.

HOW TO MAKE A WARRANTY CLAIM

For prompt warranty service, notify the Contractor who installed your Boiler. If this action does not result in warranty service, contact Viessmann directly at the address below.

The obligations of Viessmann under this Warranty apply only when the Owner promptly notifies the Contractor of the issue giving rise to the claim and in no event later than fourteen (14) days after its occurrence.

Viessmann Manufacturing Company (U.S.) Inc.
45 Access Road Warwick, Rhode Island • 02886 • USA
Telephone: (401) 732-0667 • Fax: (401) 732-0590
www.viessmann-us.com