



September 26, 2024

Gus' Restaurant
1514 13th Ave. N.
Texas City, TX 77590
Attn: Melissa Tucker

Sent via email: mtucker30@comcast.net

RE: Gus' Restaurant - 3503 Palmer Hwy. Texas City, TX 77590 – Texas City Bay

Dear Tenant:

This letter serves as Landlord approval of your building sign included on the following page. The sign renderings are in line with the Brixmor Sign Criteria package. Please proceed with having the sign placed on your storefront. I am also approving replacing the carpet and plumbing upgrades in your space.

If you have any questions or concerns, please do not hesitate to reach out directly Melissa McNeely 713.660.4343 or via email melissa.mcneely@brixmor.com. If I am not available, please contact my assistant, Rosy Arias at 713-660-4340 or via email at rosy.aria@brixmor.com.

Sincerely,

Melissa McNeely

Melissa McNeely
Associate Property Manager
Melissa.mcneely@brixmor.com
Direct: 713.660.4343
Cell: 713.208.4084

SCOPE OF WORK:

Fabricate & install 1 set of LED internally lit channel letters as shown for Gus' restaurant located at:

3503 Palmer Hwy
Texas City, TX



TYPICAL FABRICATION DIAGRAMS

LED CHANNEL LETTER FRONT VIEW

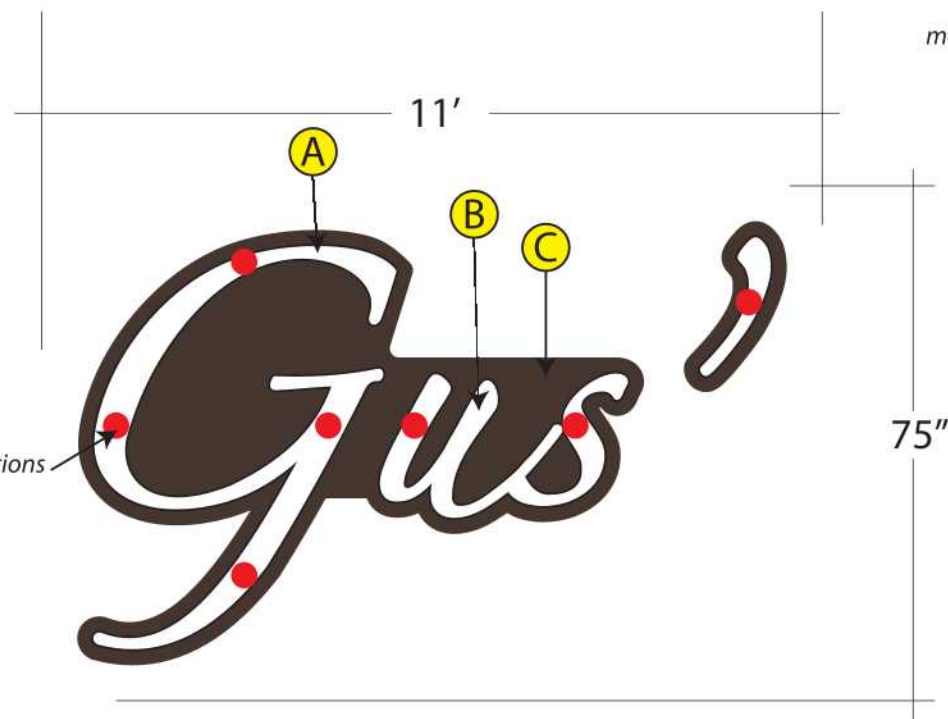
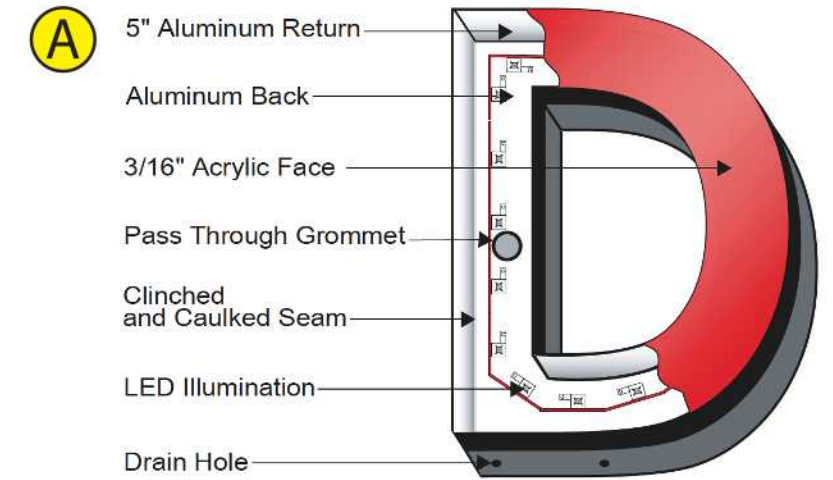

Red Dots are fastener locations

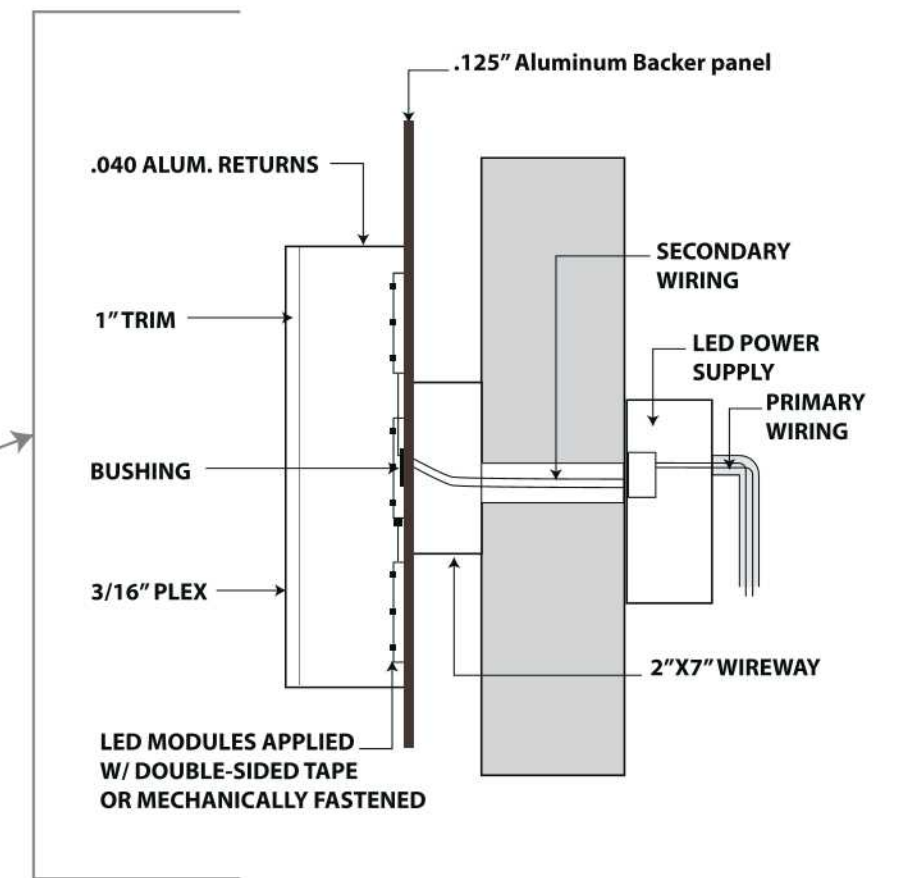
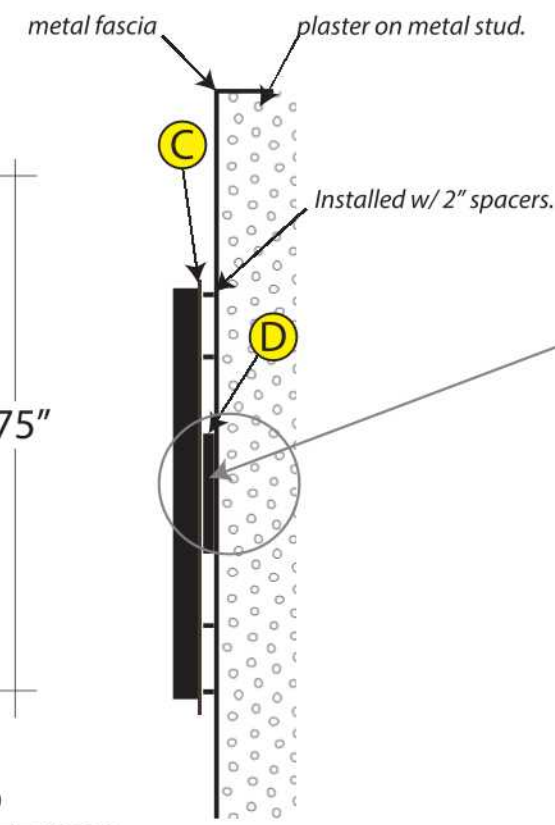

- A: 6' 3" TALL "G" - internally lit with LED, 6400K white
- B: 24" TALL "us" - internally lit with LED, 6400K white
- C: 3" BORDER, .125 ALUMINUM PAINTED DARK BRONZE #313
- D: 2" X 7" WIREWAY.

Approved 9/25/24

Melissa McNeely

Associate Property Manager
Brixmor Property Group
Direct: 713.660.4343

Installation Information: Assembly installed with 3/8" all-thread, through letter & raceway, with 2" spacers at 7 fastener locations.



Ph: 409-945-7446
Fx: 409-945-7445
2212 Palmer Hwy
Texas City, Texas 77590