



January 6, 2026

City of Springfield  
Development Services  
Planning Division  
225 5<sup>th</sup> Street  
Springfield, Oregon 97477

RE: International Way Annexation (202501)  
**Annexation application – Cover Letter**

**Project Address:** Not Yet Assigned (International Way, Springfield, Oregon 97478)  
**Assessor's Map & Tax Lots:** Map 17-03-15-00, Tax Lot 5400 and Map 17-03-15-30, Tax Lot 400  
**Property Owner:** Lane County

125 East 8<sup>th</sup> Avenue  
Eugene, Oregon 97401  
Contact: Steve Mokrohisky  
541.682.3688  
steve.mokrohisky@lanecountyor.gov

**Applicants:**

Lane CountyPeaceHealth  
125 East 8<sup>th</sup> Avenue  
Eugene, Oregon 97401  
Contact: Steve Mokrohisky  
541.682.3688  
steve.mokrohisky@lanecountyor.gov

3333 RiverBend Drive  
Springfield, Oregon 97477  
Contact: Grady Layman  
503.522.4385  
GLayman@peacehealth.org

**Applicant's Representative:**

TBG Community Planning Group LLC  
132 East Broadway, Suite 200  
Eugene, Oregon 97401  
Kristen Taylor or Zach Galloway  
541.687.1010 ext. 115 or 122  
ktaylor@tbg-arch.com or zgalloway@tbg-arch.com

On behalf of the applicant Lane County, enclosed is an Annexation application for newly acquired County property located adjacent to and north of International Way. In accordance with the Annexation submittal requirements, the following attachments are provided for review by the City staff and City Council:

Annexation Application – 1 Copy

Annexation Attachments – 1 Copy

- Written Statement
- ATTACHMENT A Petition for Annexation Form
- ATTACHMENT B Owners Worksheet
- ATTACHMENT C Supplemental Information Form
- ATTACHMENT D Property Deed

City of Springfield – Annexation  
January 6, 2026  
Page 2 of 2

ATTACHMENT E	Preliminary Title Report
ATTACHMENT F	Legal Description
ATTACHMENT G	Tax Assessor's Cadastral Map
ATTACHMENT H	ORS 222.173 Waiver Form
ATTACHMENT I	<u>Metro Plan</u> , Plan Diagram
ATTACHMENT J	City of Springfield – All TSP Projects Map
ATTACHMENT K	Lane County Partition Plat 94-P0499
ATTACHMENT L	Lane County Partition Plat 99-P1243
ATTACHMENT M	Ordinance No. 6104 (Emergency)
ATTACHMENT N	Existing and Conceptual Utility Plan by KPFF Consulting Engineers
ATTACHMENT O	Proposed Street Cross Section Technical Memorandum, prepared by Kelly Sandow, PE, Sandow Engineering, dated October 3, 2025
ATTACHMENT P	Transportation Planning Rule Analysis, prepared by Kelly Sandow, PE, Sandow Engineering, dated December 11, 2025
ATTACHMENT Q	Draft Annexation Agreement

Plan drawings – 1 Copy  
Cadastral Map (18" x 20")

If you have any questions, please do not hesitate to call me or Kristen Taylor at your convenience. Thank you for your time and consideration of this proposal.

Sincerely,

Zach Galloway, AICP  
Principal Planner

ZG/kt

cc: Anne Davies, *Lane County*  
Emily Vario, *Lane County*  
Grady Layman, *PeaceHealth*  
Mike Reeder, *Oregon Land Use Law*  
Matt Keenan, PE, *KPFF Consulting Engineers*  
Kelly Sandow, PE *Sandow Engineering LLC*  
Jay Blomme, PLS, *Lane County*

Z:\PROJ\202501 Lane County International Way\Corresp\Agency\Annexation\202501-AX\_CvrLtr.docx

January 6, 2026

City of Springfield  
Development Services  
Planning Division  
225 5<sup>th</sup> Street  
Springfield, Oregon 97477

RE: International Way Annexation  
**Annexation application – Written Statement**

**Project Address:** Not Yet Assigned (International Way, Springfield, Oregon 97478)  
**Assessor's Map & Tax Lots:** Map 17-03-15-00, Tax Lot 5400 and Map 17-03-15-30, Tax Lot 400  
**Property Owner:** Lane County  
125 East 8<sup>th</sup> Avenue  
Eugene, Oregon 97401  
Contact: Steve Mokrohisky  
541.682.3688  
steve.mokrohisky@lanecountyor.gov

**Applicants:** Lane County  
125 East 8<sup>th</sup> Avenue  
Eugene, Oregon 97401  
Contact: Anne Davies and Emily Vario  
541.682.3301 and 541.682.3728  
anne.davies@lanecountyor.gov and emily.vario@lanecountyor.gov

PeaceHealth  
3333 RiverBend Drive  
Springfield, Oregon 97477  
Contact: Grady Layman  
503.522.4385  
GLayman@peacehealth.org

**Applicant's Representative:** TBG Community Planning Group LLC  
PO Box 10248  
Eugene, Oregon 97440  
Contacts: Kristen Taylor or Zach Galloway  
541.687.1010 ext. 115 or 122  
ktaylor@tbg-arch.com or zgalloway@tbg-arch.com

## WRITTEN STATEMENT

In accordance with the Annexation application procedures and requirements, this written statement and associated attachments describe the proposal and demonstrate that the proposed Annexation complies with the applicable criteria listed under Springfield Development Code (SDC) Section 5.7.100.

The Annexation application process is subject to the Type IV application procedures, without required Planning Commission consideration. As recognized in SDC 5.7.115, this Annexation application is prepared for review and approval by the Springfield City Council.

City of Springfield – Annexation  
January 6, 2026  
Page 2 of 18

## I. Annexation Request

The property Owner, Lane County, and PeaceHealth (together the “Applicants”) request approval of an Annexation application for property located adjacent to and north of International Way. The request is for parcels identified as Tax Lot 400 on Assessor’s Map 17-03-15-30 and Tax Lot 5400 on Assessor’s Map 17-03-15-00 (the “site”). The SDC 5.7.125 outlines the submittal requirements and SDC 5.7.140 provides the Annexation approval criteria.

As demonstrated in Section IV, below, the annexation request meets all applicable criteria in effect at the time of filing, and the application should be approved as proposed.

### ***Project Team:***

#### Property Owner

Lane County  
125 East 8<sup>th</sup> Avenue  
Eugene, Oregon 97401  
Contacts: Steve Mokrohisky  
541.682.3688  
steve.mokrohisky@lanecountyor.gov

#### Applicants

Lane County  
125 East 8<sup>th</sup> Avenue  
Eugene, Oregon 97401  
Contacts: Anne Davies & Emily Vario  
541.682.3301 & 541.682.3728  
anne.davies@lanecountyor.gov &  
emily.vario@lanecountyor.gov

#### PeaceHealth

3333 RiverBend Drive  
Springfield, Oregon 97477  
Contact: Grady Layman  
503.522.4385  
GLayman@peacehealth.org

#### Planner & Applicant’s Representative

TBG Community Planning Group LLC  
375 West 4th Avenue, Suite 204  
Eugene, Oregon 97401  
Contact: Kristen Taylor or Zach Galloway, AICP  
541.687.1010 Ext. 115  
ktaylor@tbg-arch.com or zgalloway@tbg-arch.com

#### Surveyor

Lane County Surveyor’s Office  
3050 N. Delta Hwy,  
Eugene, Oregon 97408  
Contact: Mikeal (Jay) Blomme, PLS  
541.682.6997  
mikeal.blomme@lanecountyor.gov

#### Civil Engineer

KPFF Consulting Engineers  
800 Willamette Street, Suite 400  
Eugene, Oregon 97401  
Contact: Matt Keenan, PE  
541.684.4902  
matt.keenan@kpff.com

#### Transportation Engineer

Sandow Engineering LLC  
60 Madison Street, Suite A  
Eugene, Oregon 97402  
Contact: Kelly Sandow, PE  
541.513.3376  
kellysandow@sandowengineering.com

City of Springfield – Annexation  
January 6, 2026  
Page 3 of 18

## II. Site Description

### A. Location and Site Context

The site is located on the north side of International Way, approximately 1,500 feet east of the Gateway Street intersection. The site is identified as Tax Lot 400 on Assessor's Map 17-03-15-30 and Tax Lot 5400 on Assessor's Map 17-03-15-00. The site is approximately 17.99 acres or 783,644 square feet.

The site is located within the Urban Growth Boundary (UGB) per the Springfield Comprehensive Plan, and it is currently in unincorporated Lane County. On the Metro Plan diagram, the site is designated Campus Industrial. The site is within the Gateway Refinement Plan (a City of Springfield adopted "neighborhood" refinement plan) boundary. The site is currently zoned Campus Industrial with the Urbanizable Fringe Overlay zone (CI/UF-10). Per SDC 5.7.150, the UF-10 Overlay District will be removed automatically following an Annexation approval. Abutting parcels to the east, south, and west are designated Campus Industrial (CI). The abutting parcels to the north are designated Agriculture.

### B. Access and Streets

The City of Springfield 2035 Transportation System Plan (TSP) classifies International Way as a Major Collector street and the adjacent Sports Way is a Minor Collector street. Both streets are under City of Springfield jurisdiction. The site has frontage on International Way. An improved segment of Maple Island Road terminates near the northwest corner of the site.

There is a "Potential Future 60' Right of Way, 7' Public Utility Easement (PUE) & Slope Easement. Inst. No. 9880454" illustrated on the attached approved Lane County Partition Plat 99-P1243 that extends this existing Maple Island Road terminus across the northern portion of the site generally along the existing slough to the eastern edge of the site. This extension of the Maple Island Road right-of-way is consistent with the TSP, which refers to the project as the North Gateway Collector (TSP project no. R-1). Project R-1 is included in the 20-year project list within the "as development occurs" category, not a "priority project." Although there are no other adopted TSP roadway projects in the immediate area abutting the site, the Applicants propose as part of this Annexation application incorporating a local street connection consistent with the requirements of SDC 4.2.105(D)(4) as discussed in more detail below.

## III. Relevant Land Use History

The 17.99-acre site is in unincorporated Lane County. Per available County records, the subject parcels were created by partition. Current Tax Lot 400 was created through Lane County Partition Plat 94-P0499, and current Tax Lot 5400 was created through Lane County Partition Plat 99-P1243. Both are legal, buildable lots. The lots are currently in agricultural use (i.e., orchards). There are no other prior land use applications associated with the two subject lots.

City of Springfield – Annexation  
January 6, 2026  
Page 4 of 18

#### IV. Annexation Approval Criteria – Supporting Facts and Findings

This section is organized by the applicable approval criteria per SDC 5.7.140. Applicable approval criteria are outlined in ***bold italics*** below and then followed by proposed findings in normal text.

A. SDC 5.7.120

***5.7.120 Development Initiation Meeting***

***The applicant must schedule and attend a Development Initiation Meeting prior to submitting an annexation application where staff will inform the applicant of the annexation application submittal requirements and procedures specified in this section, unless waived by the Director.***

Finding: The Applicants applied for a Development Initiation Meeting (DIM) prior to submitting the Annexation application. The DIM was held on August 21, 2025. The criterion is met.

B. SDC 5.7.140(A)

***5.7.140 Criteria.***

***An annexation application may be approved only if the City Council finds that the proposal conforms to the following criteria:***

***(A) The affected territory proposed to be annexed is within the City’s urban growth boundary; and is***

***(1) Contiguous to the city limits; or***

***(2) Separated from the City only by a public right-of-way or a stream, lake or other body of water.***

Finding: As noted above, the site is located within the City of Springfield UGB. The UGB is adopted in the Springfield Comprehensive Plan. See attachments for the adopted UGB map.

The proposed annexation is also contiguous to the Springfield City limits, as the abutting lots to the west, south, and east (Tax Lots 1100 and 600 of Assessor’s Map 17-03-15-30; Tax Lot 1001 of Assessor’s Map 17-03-15-00; Tax Lot 600 of Assessor’s Map 17-03-15-40) are inside the City limits. See the attachments for the contiguous City limits. Therefore, the criterion is met.

C. SDC 5.7.140(B)

***(B) The proposed annexation is consistent with applicable policies in the Springfield Comprehensive Plan, Metro Plan, and in any applicable refinement plans or Plan Districts;***

City of Springfield – Annexation  
January 6, 2026  
Page 5 of 18

Finding:

1. Context

The procedural posture of the proposed Annexation request is unique, as a consequence of recent legislation at the State level. On July 24, 2025, House Bill 2005 (HB 2005), a copy of which is attached herein, became effective. Among other things, this commonly-called “supersiting” bill requires a local jurisdiction – and in this case, with this application, the City of Springfield – to allow a crisis stabilization center co-located with a mental or psychiatric hospital (e.g., behavioral health facility) without requiring a “plan amendment, zone change, or conditional use permit” if the property is zoned for employment or industrial uses and is within the urban growth boundary (UGB). The proposed annexation involves properties within the UGB that are designated Campus Industrial on both the Metro Plan and Gateway Refinement Plan, and which are zoned Campus Industrial. HB 2005 preempts the application of plan policies that would otherwise apply within the context of a plan amendment, zone change or conditional use approval. Because HB 2005 removes local government authority to require a plan amendment, zone change, or conditional use permit in these circumstances, the exercise of determining whether future development, as opposed to annexation of the property, aligns with plan policies is superseded. Stated another way, the criterion of SDC 5.7.140(B) is met with regard to policies that address the actual development because, pursuant to HB 2005, there are no such applicable policies in the Springfield Comprehensive Plan, Metro Plan or the Gateway Refinement Plan. That said, it should be noted that nothing in HB 2005 preempts the City’s annexation process or application of annexation approval criteria found in the City’s Development Code, as those criteria apply to the annexation itself so long as such criteria are not interpreted to require compliance of the development with any Comprehensive Plan, Metro Plan or Gateway Refinement Plan policies. Accordingly, it is not a mandatory requirement for the applicant to provide the plan policy analysis below that addresses the potential development. The Applicants provide such analysis as a precaution only.

The Applicants acknowledge that some Metro Plan and Springfield Comprehensive Plan policies apply to this property. The adopted policies of both the Metro Plan and the Springfield Comprehensive Plan encourage annexation of lands within the UGB and orderly extension of urban services. The proposed annexation is for a site within the Springfield UGB, and urban services can be provided to the site via the abutting, previously dedicated 70-foot right-of-way (see the attached Ordinance No. 6104 and Public Dedication Description Exhibit A) on the south side of Tax Lot 1001 and from International Way. See the attached draft Existing and Conceptual Utility Plan for the required connections to the existing infrastructure, including water, wastewater, stormwater, and public streets.

Once again, out of an extreme abundance of caution, the Applicants have chosen to address the policies that the City Attorney’s Office cited in a memo the Applicants received after the DIM on August 22, 2025. As described in the findings below, many of the policies cited in the City Attorney’s memo are focused on development, not the currently proposed Annexation application. The following findings demonstrate that many of the policies are potentially applicable to a discrete development proposal and therefore, they are not applicable to this Annexation application. Where the Applicant has determined that the policy would be applicable to the proposed Annexation application absent HB 2005, the findings demonstrate that the proposal is consistent with the policy directive.

City of Springfield – Annexation  
January 6, 2026  
Page 6 of 18

## 2. Consistency with Metro Plan

The following Metro Plan policies apply directly to most Annexation applications<sup>1</sup>, as opposed to potential future development. Pursuant to HB 2005 these policies are not applicable to this application, but the applicant addresses them out of an extreme abundance of caution.

### Growth Management Element

*Policy C-8: Land within the UGB may be converted from urbanizable to urban only through annexation to a city when it is found that:*

- a. A minimum level of key urban facilities and services can be provided to the area in an orderly and efficient manner.*
- b. There will be a logical area and time within which to deliver urban services and facilities. Conversion of urbanizable land to urban shall also be consistent with the Metro Plan.*

Findings: The Applicants propose to annex the subject site into the City of Springfield. As demonstrated here and in the attached documentation, the key urban facilities and services are available in close proximity and can be extended in an orderly and efficient manner. The site abuts properties that are within the incorporated City limits and currently served by key urban facilities and services. As noted above, key urban facilities and services can be provided to the site via the abutting, previously developed Tax Lot 1001 to the west within the dedicated 70-foot right-of-way (see attached Ordinance No. 6104 and Public Dedication Description Exhibit A) on the south side of Tax Lot 1001 and from International Way. The Applicants intend to extend the necessary urban services and facilities in a logical timeframe at the time of the proposed future development project. As described above and shown on the attached Existing and Conceptual Utility Plan, the site is proposed to be connected to both City and SUB facilities via the abutting Sports Way and International Way public rights-of-way. The proposed annexation is consistent with this policy.

*Policy C-10: Annexation to a city through normal processes shall continue to be the highest priority.*

Findings: The Applicants propose to annex into the City of Springfield. The proposal is consistent with this policy.

*Policy C-15: Ultimately, land within the UGB shall be annexed to a city and provided with the required minimum level of urban facilities and services. While the time frame for annexation may vary, annexation should occur as land transitions from urbanizable to urban.*

Findings: The site is within the Springfield UGB, as established in the Springfield Comprehensive Plan. The Applicants propose to annex the subject site into the City of Springfield. The Applicants anticipate extending the urban facilities and services to the site via the abutting, previously developed Tax Lot 1001 to the west within the dedicated 70-foot right-of-way (see attached Ordinance No. 6104 and Public

---

<sup>1</sup> Annexations that are not subject to the requirements of HB 2005.

City of Springfield – Annexation  
January 6, 2026  
Page 7 of 18

Dedication Description Exhibit A) on the south side of Tax Lot 1001 and from International Way within a logical timeframe at the time of proposed future development project. The proposed annexation is consistent with this policy.

The proposed annexation is consistent with and advances the policy directives of the Metro Plan.

### 3. Consistency with Springfield Comprehensive Plan

The City of Springfield adopted the local Springfield Comprehensive Plan in July 2022, which includes a City-specific UGB. The site is within the UGB. The Metro Plan diagram remains applicable within the Springfield UGB. The Metro Plan designates the site Campus Industrial.

The Preface to the Springfield Comprehensive Plan includes a User Guide section that describes how the plan is intended to be used and the audience to which the plan is directed. The User Guide includes a general description of the plan as a “policy document that the City must follow when coordinating the delivery of services and when considering many decisions about land use.” Additionally, the guide offers a definition of policies as an adopted statement that provides “a consistent course of action for the jurisdictions to which the policy applies, moving the community toward attainment of its goals.” In both statements, the implied audience and entity responsible for implementation is the City, not a private property owner or a developer. These policies are not to be interpreted as approval criteria for land use applications.

Nevertheless, to ensure compliance with the codified criterion, the Applicants offer the following findings that demonstrate the proposed Annexation is consistent with those policies of the Springfield Comprehensive Plan that are applicable to an Annexation application. Also, certain policies included here are development specific and not applicable to annexation (even without the passage of HB 2005). The Applicant is choosing to address these policies out of an extreme abundance of caution because the City Attorney’s Office memo cited the policy at the DIM on August 21, 2025.

#### Economic Element

*Policy E-3: Work with property owners and their representatives to ensure that prime development and redevelopment sites throughout Springfield and its Urban Growth Boundary that are designated for employment use are preserved for future employment needs and are not subdivided or used for non-employment uses.*

**Findings:** This policy is directed at the City to carry out a proposed action. It is not applicable to the proposed annexation. To the extent it is relevant, the site is within the UGB, and as noted above in the Metro Plan policy section, annexation is a priority action for parcels within the UGB. The proposed annexation applies to two legal, buildable lots that total about 17.99 acres. No land division is proposed.

City of Springfield – Annexation  
January 6, 2026  
Page 8 of 18

Urbanization Element

*Policy UG-1: Urbanizable lands within the 2030 UGB shall be converted to urban uses as shown in the Metro Plan Diagram and as more particularly described in neighborhood refinement plans, other applicable area-specific plans, and the policies of this Plan.*

Findings: The proposed annexation advances this policy by bringing a site that is within the UGB into the incorporated limits of the City of Springfield. Annexation is a required part of the conversion process to urban uses.

*Policy UG-29: Annexation shall continue to be a prerequisite for urban development and the delivery of City services in accordance with the Springfield Comprehensive Plan and Springfield Development Code.*

Findings: The proposed annexation advances this policy by bringing the site into the incorporated limits of the City of Springfield prior to urban development and the extension of public facilities and services. The Applicants understand that any future potential development will be required to connect to public facilities and services.

*Policy UG-30: Unincorporated land within the Springfield UGB may be developed with permitted uses at maximum density only upon annexation to the City when it is found that key urban facilities and services can be provided to the area to be annexed in an orderly and efficient manner. Provision of these services to the area proposed for annexation is consistent with the timing and location for such extension, where applicable, in the City's infrastructure plans — such as the Public Facilities and Services Plan; the Springfield Transportation System Plan; the City's Capital Improvement Program; and the urbanization goals, policies and implementation strategies of this Element — or a logical time within which to deliver these services has been determined, based upon demonstrated need and budgetary priorities.*

Findings: The proposed annexation advances this policy by bringing the site that is within the UGB into the incorporated limits of the City of Springfield. Annexation is a prerequisite to the extension of public facilities and services. As demonstrated in the attached Existing and Conceptual Utility Plan, key utility services are available within the abutting International Way and Sports Way (via the 70-foot dedicated right-of-way on Tax Lot 1001) rights-of-way. Annexation of the site will result in all lots on the north side of International Way being within the incorporated limits, which allows for an orderly and efficient extension of those facilities and services. Key urban facilities and services also include the transportation system. The site proposed for annexation has frontage on two improved public rights-of-way, International Way to the south and Maple Island Road to the northwest. Existing prior agreements and current development standards require future development to connect to and/or extend the streets that terminate at the property lines.

As noted above, the Applicants propose a local street connection consistent with SDC 4.2.105(D)(4). Specifically, the Applicants propose a 30-foot-wide right-of-way dedication along the west property line on the subject Tax Lot 400 adjacent to the existing 30-foot-wide potential future dedicated right-of-way on Tax

City of Springfield – Annexation  
January 6, 2026  
Page 9 of 18

Lot 1100 (Assessor's Map 17-03-15-30). The Applicants propose to construct a 60-foot local street within this total dedicated right-of-way and if required, provide a 7-foot PUE to extend public utilities from International Way to the site at the time of the development proposal.

Although not required, the Owner also proposes a potential future 60-foot-wide right-of-way dedication along the entire southern property line of the subject Tax Lot 5400 to accommodate a potential future local street. At the time of the development proposal, the Owner will also provide an additional 7-foot PUE along the proposed 60-foot right-of-way dedication if required to extend utilities to Tax Lot 5400 from Sports Way via the existing 70-foot-wide right-of-way located along the southern property line of the adjacent Tax Lot 1001.

Lastly, although not required, the Owner proposes a 31-foot-wide right-of-way dedication along the western property line of the subject Tax Lot 5400 to accommodate one-half of a potential future 62-foot-wide collector street. When development to the north necessitates the full connection, the City of Springfield will need to secure the additional 31-foot dedication from Tax Lot 1001 (Assessor's Map 17-03-15-00). Collectively, these dedications will establish the potential future collector street connection between the Sports Way extension and Maple Island Road, which currently terminates at the upper west side of the site. This proposed dedication will help facilitate the orderly extension of public utilities to serve future development of properties located north of the site. See the attached Existing and Conceptual Utility Plan by KPFF, and the Transportation Study and Transportation Planning Rule Analysis (TPRA) and Proposed Street Cross Section Technical Memorandum by Sandow Engineering.

As outlined above, key urban facilities and services can be provided to the site in an orderly and efficient manner consistent with the applicable City-adopted plans and policies and proportional to site specific annexation request.

*Policy UG-31: For the purposes of land use planning and annexation approval, the Springfield Comprehensive Plan defines key urban facilities and services as: wastewater service; stormwater service; transportation; solid waste management; water service; fire and emergency medical services; police protection; citywide park and recreation programs; electric service; land use controls; communication facilities; and public schools on a district- wide basis.*

*Policy UG-32: Urban services provided by the City upon annexation to Springfield include storm and sanitary sewer; water; transportation systems; police and fire protection; planning, building, code enforcement and library services; and public infrastructure maintenance of City-owned or operated facilities.*

Findings: Per available public records and as shown in the attachments, stormwater, water, and wastewater lines are located in the International Way and Sports Way rights-of-way, as follows.

City of Springfield – Annexation  
January 6, 2026  
Page 10 of 18

#### International Way

- Existing 8-inch wastewater main
- Existing 18-inch stormwater main
- Existing 12-inch water line

#### Sports Way

- Existing 8-inch wastewater main
- Existing 48-inch stormwater main
- Existing 12-inch water line

#### Maple Island Road (north of former Royal Caribbean site)

- Existing 15-inch stormwater main
- Existing 8-inch water line

These existing key urban facilities in the abutting rights-of-way enable an orderly and efficient extension of and connection to the necessary infrastructure to support future potential development.

The area streets – International Way, Sports Way, and Maple Island Road – are under the jurisdictional responsibility of the City of Springfield. The abutting existing streets – International Way and Maple Island Road – are improved to urban standards. As noted above, there is also dedicated unimproved 70-foot right-of-way along the south side of Tax Lot 1001 that connects Sports Way to the site (see attached Ordinance No. 6104 and Public Dedication Description Exhibit A).

Each of the following urban services is provided on a City- or district-wide basis, as applicable.

- As a member of the Metropolitan Wastewater Management Commission, the City provides wastewater services.
- The City also provides police protection, land use controls, and public streets.
- The Willamalane Park and Recreation District provides Citywide parks and recreation programs.
- Eugene-Springfield Fire provides fire and emergency medical services.
- The Springfield Utility Board provides water and electrical services.
- The site is within the Eugene School District 4J boundary. Area schools include Holt Elementary School, Monroe Middle School, and Sheldon High School.
- Numerous service providers have Citywide communication facilities.
- Sanipac is the franchised hauler for solid waste management, yard debris, and recycling.

*Policy UG-41: Protect, conserve, and enhance the natural, scenic, environmental, and economic qualities of the McKenzie and Willamette River and waterway corridors as Springfield grows and develops.*

*Policy UG-44: New development that locates along river corridors and waterways shall be designed to enhance natural, scenic and environmental qualities of those water features.*

City of Springfield – Annexation  
January 6, 2026  
Page 11 of 18

Findings: The proposed annexation advances these policies by bringing the site into the incorporated limits of the City. Annexation will result in the site being within the jurisdiction's land use controls, which include stormwater standards, floodplain development permitting, and additional setbacks from the slough/waterway along the northern property boundary of Tax Lot 5400, all of which are intended to address natural resources in the area.

*Policy UG-46: Continue efforts to provide increased opportunities for public access to the Willamette River Greenway and the McKenzie River through comprehensive planning, development standards, annexation agreements, the land use permitting process, and through partnerships with Willamalane, Springfield Utility Board and property owners.*

Findings: Policy UG-46 was also cited in the City Attorney's Office memo after the DIM. Similar to other policy directives here, the City jurisdiction is the intended audience. The policy is not applicable to annexation, except that the City can only act on the policy directive for those parcels within the City limits. In that limited application, the proposed annexation advances this policy.

As demonstrated in the findings above, the proposed annexation is consistent with and advances the policy directives of the Springfield Comprehensive Plan, or the policies are not applicable to annexation.

#### 4. Consistency with Gateway Refinement Plan

##### Industrial Element

Findings: The Gateway Refinement Plan includes a section entitled Plan Organization. This section includes a passage that describes the content and use of the plan, as follows.

“Goals are broad statements of philosophy that describe the hopes of the people with respect to the future of the Gateway Refinement Plan area. Policies and implementation actions are statements adopted as part of the Refinement Plan to provide specific courses of action in attainment of goals, and are based on finding of fact.”

The Applicants note that the goals are not intended to “provide specific courses of action.” Rather, they are broad statements of policy meant to guide the adoption of specific policies and implementation actions. Although the City Attorney memo cites Industrial Element Goals 7 through 11, the Applicants find that the refinement plan goals are not applicable to the proposed annexation pursuant to HB 2005 and because Goals 7 through 11 are based on the different, specific description of the goals and policies, as well as the criterion language, which states “the proposed annexation is consistent with applicable policies in ... any applicable refinement plans”. The following findings address adopted policies and articulate whether the particular policy is one which the applicant is required, in this Annexation application, to demonstrate compliance with.

City of Springfield – Annexation  
January 6, 2026  
Page 12 of 18

*7.0 Ensure that McKenzie-Gateway SLI Site development achieves a high level of aesthetics and amenity, consistent with the intent of the Metro Plan SLI designation and with the “campus industrial” concept.*

Findings: Since Policy 7.0 addresses development it is not applicable to this annexation request.

*8.0 Provide for an efficient and flexible transportation system for the McKenzie-Gateway SLI Site.*

Findings: The proposed annexation advances this policy by bringing the site into the incorporated limits of the City. As noted above, annexation is the necessary prerequisite to the extension of public facilities, the transportation system, or site development within the UGB. The proposed annexation allows for a more efficient transportation system by creating development opportunities in an area of the City that is currently served by existing streets and creating future opportunities for interconnections.

There is a “Potential Future 60’ Right of Way, 7’ PUE & Slope Easement. Inst. No. 9880454” illustrated on the attached approved plat that proposes extending Maple Island Road from the terminus at the northwest corner of the subject site, across the northern portion of the site along the existing slough to the eastern edge of the site. This extension of the Maple Island Road right-of-way is consistent with the TSP, which refers to the project as the North Gateway Collector (TSP project no. R-1). Project R-1 is included in the 20-year project list within the “as development occurs” category, not a “priority project.” Although there are no other adopted TSP roadway projects in the immediate area abutting the site, as noted above, the Applicants propose as part of this Annexation application, a 30-foot wide dedication from International Way to the north end of Tax Lot 400 aligned with the existing 30-foot wide right-of-way dedication located along the east property line of Tax Lot 1100. The applicant proposes to construct this total 60-foot right-of-way dedication as a local street at the time of future development consistent with the requirements of SDC 4.2.105(D)(4). Additionally, the Applicants propose an east-west 60-foot right-of-way dedication to accommodate a potential future local street along the south property line of Tax Lot 5400, and a 31-foot right-of-way dedication running north-south along the western property line of the subject Tax Lot 5400 to accommodate one-half of a potential future 62-foot-wide collector, connecting to Maple Island Road.

*9.0 Improve the appearance and effectiveness of the main approaches to the McKenzie-Gateway SLI Site. These main approaches include: Belt Line Road from I-5 to Game Farm Road South; Game Farm Road South from Belt Line Road to Game Farm Road East; Game Farm Road North from Belt Line to International Way; and International Way from Game Farm Road North to the site boundary.*

Findings: Of the street segments referenced in Policy 9.0, the site has frontage on International Way. International Way is fully improved to urban standards. At the time of a future potential site development, an applicant will be required to comply with the codified City standards related to access connections and landscaping. The policy is not applicable to the proposed annexation.

City of Springfield – Annexation  
January 6, 2026  
Page 13 of 18

*11.0 Ensure that development plans adequately consider the site's natural landscape features and amenities, and provide for the development needs of future developers.*

Findings: The proposed Annexation application is a necessary step that precedes any development plans. The implementation actions nested under this policy invoke Site Plan Review process as the appropriate vehicle for implementation of the policy. The policy is not applicable to the proposed Annexation application. Furthermore, the Policy 11.0 implementation actions (11.1-11.4) use the terms “encourage” and “emphasize.” These are not mandatory actions. The policy is not applicable to the proposed annexation.

*12.0 Encourage the preservation and/or enhancement of reminders of the area's rich agricultural heritage, which are found in the McKenzie-Gateway SLI area.*

Findings: As noted above, the proposed Annexation application is a necessary step that precedes any development proposal. At the time of future potential site development, an Applicant will be required to address applicable codified City standards. However, it is worth noting that both the policy and the implementation actions use the terms “encourage.” These are not mandatory actions. The policy is not applicable to the proposed annexation, in any event.

In conclusion, there are no policies in the Gateway Refinement Plan that preclude approval of or are directly applicable to the proposed Annexation application.

## 5. Other Refinement and Functional Plans

Both the Public Facilities and Services Plan (PFSP) and the Transportation System Plan (TSP) are functional plans that are considered refinements of the Metro Plan and comprehensive plan, respectively. The TSP is incorporated through a cross reference in the Springfield Comprehensive Plan.

Policy G.9 of the PFSP states that the City and Springfield Utility Board (SUB) “shall ultimately be the water service providers within the urban growth boundary.” This reinforces the priority given to serving land and development within the UGB with key urban services and facilities. It also assigns responsibility for providing the service to the City and SUB, which suggests those lands within the UGB are annexed.

- As shown on the attached Existing and Conceptual Utility Plan, the site is proposed to be connected to both City and SUB facilities via the abutting Sports Way and International Way public rights-of-way.

Further review of the Public Facilities and Services Plan (PFSP) and the Transportation System Plan (TSP) does not identify policies that are applicable to the proposed Annexation application. Furthermore, City staff and the City Attorney have not identified any PFSP or TSP policies that they believe are applicable.

City of Springfield – Annexation  
January 6, 2026  
Page 14 of 18

## 6. Policy Review Conclusion

The following plan policies address annexation and are therefore applicable to this Annexation application:

### Metro Plan Policies:

- C-8
- C-10
- C-15

### Springfield Comprehensive Plan Policies:

- E-3
- UG-1
- UG-29
- UG-30
- UG-31
- UG-32

As discussed above, the proposed annexation request is consistent with those applicable plan policies.

The remainder of plan policies called out by the City Attorney are not applicable for the reasons discussed above. Alternatively, those policies that are not listed directly above, even if applicable, are satisfied.

Thus, the excerpted policies and provided findings demonstrate that the proposed Annexation application is consistent with the applicable plan policies, and that no policies would preclude or otherwise prohibit the proposed annexation.

### D. 5.7.140(C)

**(C) *The proposed annexation will result in a boundary in which the minimum level of key urban facilities and services, as defined in the Springfield Comprehensive Plan, can be provided in an orderly, efficient and timely manner; and***

**Finding:** As noted above, the site is within the Springfield UGB and contiguous to parcels within the City limits. The abutting parcels to the east, south, and west are developed, and each development has key urban facilities and services. The Springfield Comprehensive Plan defines key urban facilities and services as wastewater (sewer), stormwater, transportation, solid waste management, water, fire, and emergency medical, police, Citywide park, and recreation programs, electric, land use controls, communication facilities, and public schools. See Springfield Comprehensive Plan Policy UG-31, quoted and discussed below.

City of Springfield – Annexation  
January 6, 2026  
Page 15 of 18

Per available public records and as shown in the attachments, stormwater, water, and wastewater lines are located in the International Way and Sports Way rights-of-way as follows.

International Way

- Existing 8-inch wastewater main
- Existing 18-inch stormwater main
- Existing 12-inch water line

Sports Way, which as noted above, can be connected to via the dedicated unimproved 70-foot right-of-way (see attached Ordinance No. 6104 and Public Dedication Description Exhibit A) that runs along the southern property line of the adjacent Royal Caribbean parcel (Tax Lot 1001 of Assessor's Map 17-03-15-00).

- Existing 8-inch wastewater main
- Existing 48-inch stormwater main
- Existing 12-inch water line

Maple Island Road (north of former Royal Caribbean site)

- Existing 15-inch stormwater main
- Existing 8-inch water line

These existing key urban facilities in the abutting street rights-of-way (and dedicated right-of-way) enable an orderly and efficient extension of and connection to the necessary infrastructure to support future potential development.

Each of the following urban services is provided on a City- or district-wide basis, as applicable.

- The City of Springfield, as a member of the Metropolitan Wastewater Management Commission, provides wastewater services.
- The City also provides police protection, land use controls, and public streets.
- The Willamalane Park and Recreation District provides citywide parks and recreation programs.
- Eugene-Springfield Fire provides fire and emergency medical services.
- The Springfield Utility Board provides water and electrical services.
- The site is within the Eugene School District 4J boundary. Area schools include Holt Elementary School, Monroe Middle School, and Sheldon High School.
- Numerous service providers have Citywide communication facilities.
- Sanipac is the franchised hauler for solid waste management yard debris, and recycling.

The existing area streets – International Way, Sports Way, and Maple Island Road – are under the jurisdictional responsibility of the City of Springfield. The abutting streets – International Way and Maple Island Road – are improved to urban standards. As noted above, there is an existing dedicated unimproved 70-foot right-of-way located along the south side of Tax Lot 1001 that connects Sports Way to the site (see attached Ordinance No. 6104 and Public Dedication Description Exhibit A).

City of Springfield – Annexation  
January 6, 2026  
Page 16 of 18

In addition, as noted above, the attached approved Lane County Partition Plat 99-1243 illustrates a “Potential Future 60-foot Right-of-Way, 7-foot PUE, and Slope Easement (Inst. No. 9880454)” that extends Maple Island Road from the west of the site across the northern portion of the property along the existing slough to the eastern edge of the site. This extension of the Maple Island Road right-of-way is consistent with the Transportation System Plan (TSP), which identifies the project as the North Gateway Collector (TSP Project No. R-1). Project R-1 is included in the 20-year project list under the “as development occurs” category, rather than as a “priority project.” No other adopted TSP roadway projects directly about the site.

The Applicants propose a local street connection consistent with SDC 4.2.105(D)(4). Specifically, the Applicant proposes a 30-foot-wide right-of-way dedication along the west property line on the subject Tax Lot 400 adjacent to the existing 30-foot-wide potential future dedicated right-of-way on Tax Lot 1100 (Assessor’s Map 17-03-15-30). The Owner proposes to construct a 60-foot local street within this total dedicated right-of-way and if required, provide a 7-foot PUE to extend public utilities from International Way to the site at the time of the development proposal.

Although not required, the Owner also proposes a potential future 60-foot-wide right-of-way dedication along the southern property line of the subject Tax Lot 5400 abutting the FedEx property (Tax Lot 1100) to accommodate a potential future local street. At the time of the development proposal, the Owner will also provide an additional 7-foot PUE along the proposed 60-foot right-of-way dedication if required to extend utilities to Tax Lot 5400 from Sports Way via the existing 70-foot-wide right-of-way located along the southern property line of the adjacent Tax Lot 1001.

Lastly, although not required, the Owner proposes a north-south 30-foot-wide right-of-way dedication along the western property line of the subject Tax Lot 5400 to accommodate one-half of a potential future 62-foot-wide collector street. When development to the north necessitates the full connection, the City of Springfield will need to secure the additional 31-foot dedication from Tax Lot 1001 (Assessor’s Map 17-03-15-00). Collectively, these dedications will establish the potential future collector street connection between the Sports Way extension and Maple Island Road, which currently terminates at the upper west side of the site. This proposed dedication will help facilitate the orderly extension of public utilities to serve future development of properties located north of the site.

As described above, the proposed street network is designed to allow for orderly, efficient, and timely extension of rights-of-way and public utilities as applicable at the time of development of the site and/or adjacent parcels. See the Proposed Street Cross Section Technical Memorandum by Sandow Engineering and Existing and Conceptual Utility Plan by KPFF.

The Applicants have provided the attached Transportation Planning Rule Analysis (TPRA) by Sandow Engineering to analyze the available capacity of the surrounding transportation system as required for Annexation application. A Zone Change application from the existing Urbanizable Fringe Overlay zone (CI/UF-10) to Campus Industrial (CI) will not be required for this site and the proposed use (see the HB 2005 – FACILITY SITING AMENDMENTS TO ORS CHAPTER 197A section below). See the attached Transportation Planning Rule Analysis, which concluded the following.

City of Springfield – Annexation  
January 6, 2026  
Page 17 of 18

- The addition of development trips does not trigger any intersections to not meet the LOS standards.
- The intersection of Gateway Street at Beltline Road currently operates at LOS F during the PM peak hour. The City has identified improvements at this intersection, which are reasonably assumed to be constructed within the 20-year planning horizon. With these improvements, the intersection will meet the mobility standards through the year 2035.
- The addition of development traffic does not substantially increase queuing conditions.
- There is no off-site mitigation needed for the zone change proposal.

Based on the findings provided above, the criterion is met.

E. SDC 5.7.140(D)

***(D) Where applicable, fiscal impacts to the City have been mitigated through an Annexation Agreement or other mechanism approved by the City Council.***

Finding: As noted above, the Applicants propose the following improvements and dedications as part of an Annexation Agreement should the City Council determine that an Annexation Agreement is required.

The Applicants propose a local street connection consistent with SDC 4.2.105(D)(4). Specifically, the Applicants propose a 30-foot-wide right-of-way dedication along the west property line on the subject Tax Lot 400 adjacent to the existing 30-foot-wide potential future dedicated right-of-way on Tax Lot 1100 (Assessor's Map 17-03-15-30). The Applicants propose to construct a 60-foot local street within this total dedicated right-of-way and if required, provide a PUE to extend public utilities from International Way to the site at the time of the development proposal.

Although not required, the Owner also proposes a potential future 60-foot-wide right-of-way dedication along the southern property line of the subject Tax Lot 5400 abutting the FedEx property (Tax Lot 1100) to accommodate a potential future local street. At the time of the development proposal, the Owner will also provide an additional 7-foot PUE along the proposed 60-foot right-of-way dedication if required to extend utilities to Tax Lot 5400 from Sports Way via the existing 70-foot-wide right-of-way located along the southern property line of the adjacent Tax Lot 1001.

Lastly, although not required, the Owner proposes a 30-foot-wide right-of-way dedication along the western property line of the subject Tax Lot 5400 to accommodate one-half of a potential future 62-foot-wide collector street. When development to the north necessitates the full connection, the City of Springfield will need to secure the additional 31-foot dedication from Tax Lot 1001 (Assessor's Map 17-03-15-00). Collectively, these dedications will establish the potential future collector street connection between the Sports Way extension and Maple Island Road, which currently terminates at the upper west side of the site. This proposed dedication will help facilitate the orderly extension of public utilities to serve future development of properties located north of the site.

City of Springfield – Annexation  
January 6, 2026  
Page 18 of 18

As described above, the proposed street network is designed to allow for orderly, efficient, and timely extension of rights-of-way and public utilities as applicable at the time of development of the site and/or adjacent parcels. See the Proposed Street Cross Section Technical Memorandum by Sandow Engineering and Existing and Conceptual Utility Plan by KPFF.

## **VI. Conclusion**

Based on the information and findings contained in this written statement, associated attachments and drawings, the proposed Annexation application meets the criteria of approval contained in the Springfield Development Code. Therefore, the Applicants request that the City Council approve the proposed annexation as presented. Both the Applicants and the Applicants' representative are available for questions, as necessary.

If you have any questions about the above application, please contact Kristen Taylor or Zach Galloway at TBG Community Planning Group LLC (541.687.1010).

ZG/KT

Z:\PROJ\202501 Lane County International Way\Corresp\Agency\Annexation\202501-AX\_WrtnState.docx

## MEMORANDUM

---

TO: Andy Limbird, Senior Planner

FROM: Kristen Taylor and Zach Galloway, AICP

DATE: April 3, 2026

SUBJECT: International Way Annexation(202501) – Supplemental Information submittal

---

### INTRODUCTION

The property owners, Lane County and PeaceHealth, (together the “Applicants”) are providing supplemental information and documentation in response to ongoing coordination with City staff regarding the Annexation application, City File No. 811-26-000004-TYP4. The Applicants’ request approval of the Annexation application for two parcels located adjacent to and north of International Way. The request is for parcels identified as Tax Lot 400 on Assessor’s Map 17-03-15-30 and Tax Lot 5400 on Assessor’s Map 17-03-15-00 (together the “site”). The proposed Annexation complies with the applicable criteria listed under Springfield Development Code (SDC) Section 5.7.100.

### SUPPLEMENTAL INFORMATION

The following documentation is submitted to supplement or replace (as noted) the existing materials in the records for review and consideration by the City Council.

- This Memorandum.
- Springfield Comprehensive Plan Map, dated March 2024.

Replace the existing documents with the following updated documents.

- Transportation Planning Rule Analysis, prepared by Kelly Sandow, PE, Sandow Engineering LLC, dated March 20, 2026.
- Existing and Conceptual Utility Plan, prepared by KPFF Consulting Engineers, dated March 25, 2026.
- PeaceHealth purchased Tax Lot 400 from Lane County – see the attached updated Statutory Warranty Deed dated March 13, 2026, and the other associated updated documents below.
  - Annexation Application Type IV Form
  - Owner-Consent/Double Majority Petition
  - Ownership Worksheet
  - Consent To Annexation for Tax Lot 5400
  - Consent To Annexation for Tax Lot 400
  - Summary of Urban Service Provision
  - Census Information Sheet – CONFIDENTIAL (Not Applicable)
  - Waiver Of One Year Time Limit For Annexation for Tax Lot 5400 (Remains unchanged, copy from original submittal provided)
  - Waiver Of One Year Time Limit For Annexation for Tax Lot 400
  - Preliminary Title Report, Supplemental

## MEMORANDUM

April 3, 2026

Page 2 of 4

### WRITTEN STATEMENT REVISIONS

The following passages are excerpted from the January 6, 2026, application submittal. The original, unrevised text is shown in normal font. The page number of the excerpted passage in the original written statement is noted in the heading. The revised text is shown in **bold text** with ~~strikethrough~~ and underline applied to distinguish the deleted and replaced text, respectively from the new revised text.

#### REVISED TEXT: PAGE 9 OF 18

Although not required, the **Owner Applicants** also proposes a potential future ~~60~~ 62-foot-wide right-of-way dedication along the entire southern property line of the subject Tax Lot 5400 to accommodate a potential future local or collector street. At the time of the development proposal, the Owner will also provide an additional 7-foot PUE along the proposed ~~60~~ 62-foot right-of-way dedication if required to extend utilities to Tax Lot 5400 from Sports Way via the existing 70-foot-wide right-of-way located along the southern property line of the adjacent Tax Lot 1001.

Lastly, although not required, the Owner proposes a ~~31~~ 62-foot-wide right-of-way dedication along the western property line of the subject Tax Lot 5400 to accommodate ~~one-half of~~ a potential future 62-foot-wide local or collector street. ~~When development to the north necessitates the full connection, the City of Springfield will need to secure the additional 31-foot dedication from Tax Lot 1001 (Assessor's Map 17-03-15-00). Collectively,~~ these This dedications will establish the potential future ~~collector~~ street connection between the Sports Way extension and Maple Island Road, which currently terminates at the upper west side of the site. This proposed dedication will help facilitate the orderly extension of public utilities to serve future development of properties located north of the site. See the attached Existing and Conceptual Utility Plan by KPFF, and the Transportation Study and Transportation Planning Rule Analysis (TPRA) and Proposed Street Cross Section Technical Memorandum by Sandow Engineering.

#### REVISED TEXT: PAGE 12 OF 18

There is a "Potential Future 60' Right of Way, 7' PUE & Slope Easement. Inst. No. 9880454" illustrated on the attached approved plat that proposes extending Maple Island Road from the terminus at the northwest corner of the subject site, across the northern portion of the site along the existing slough to the eastern edge of the site. This extension of the Maple Island Road right-of-way is consistent with the TSP, which refers to the project as the North Gateway Collector (TSP project no. R-1). Project R-1 is included in the 20-year project list within the "as development occurs" category, not a "priority project." Although there are no other adopted TSP roadway projects in the immediate area abutting the site, as noted above, the Applicants propose as part of this Annexation application, a 30-foot wide dedication from International Way to the north end of Tax Lot 400 aligned with the existing 30-foot wide right-of-way dedication located along the east property line of Tax Lot 1100. The applicant proposes to construct this total 60-foot right-of-way dedication as a local street at the time of future development consistent with the requirements of SDC 4.2.105(D)(4). Additionally, the Applicants propose an east-west ~~60~~ 62-foot right-of-way dedication to accommodate a potential future local or collector street along the south property line of Tax Lot 5400, and a ~~31~~ 62-foot right-of-way dedication running north-south

## MEMORANDUM

April 3, 2026

Page 3 of 4

along the western property line of the subject Tax Lot 5400 to accommodate ~~one-half of~~ a potential future ~~62-foot-wide local or~~ collector street, connecting to Maple Island Road.

### REVISED TEXT: PAGE 16 OF 18

Although not required, the **Owner Applicants** also proposes a potential future ~~60~~ 62-foot-wide right-of-way dedication along the southern property line of the subject Tax Lot 5400 abutting the FedEx property (Tax Lot 1100) to accommodate a potential future local or collector street. At the time of the development proposal, the Owner will also provide an additional 7-foot PUE along the proposed ~~60~~ 62-foot right-of-way dedication if required to extend utilities to Tax Lot 5400 from Sports Way via the existing 70-foot-wide right-of-way located along the southern property line of the adjacent Tax Lot 1001.

Lastly, although not required, the Owner proposes a north-south ~~30~~ 62-foot-wide right-of-way dedication along the western property line of the subject Tax Lot 5400 to accommodate ~~one-half of~~ a potential future ~~62-foot-wide local or~~ collector street. ~~When development to the north necessitates the full connection, the City of Springfield will need to secure the additional 31-foot dedication from Tax Lot 1001 (Assessor's Map 17-03-15-00). Collectively,~~ these **This** dedications will establish the potential future local or collector street connection between the Sports Way extension and Maple Island Road, which currently terminates at the upper west side of the site. This proposed dedication will help facilitate the orderly extension of public utilities to serve future development of properties located north of the site.

### REVISED TEXT: PAGE 16-17 OF 18

**Although not required for the subject application,** ~~T~~the Applicants have provided the attached Transportation Planning Rule Analysis (TPRA) by Sandow Engineering to analyze the available capacity of the surrounding transportation system as required for Annexation application. A Zone Change application from the existing Urbanizable Fringe Overlay zone (CI/UF-10) to Campus Industrial (CI) will not be required for this site and the proposed use (see the HB 2005 – FACILITY SITING AMENDMENTS TO ORS CHAPTER 197A section below). See the attached Transportation Planning Rule Analysis, which concluded the following:

- The addition of development trips does not trigger any intersections to not meet the LOS standards.
- The intersection of Gateway Street at Beltline Road currently operates at LOS F during the PM peak hour. The City has identified improvements at this intersection, which are reasonably assumed to be constructed within the 20-year planning horizon. With these improvements, the intersection will meet the mobility standards through the year 2035.
- The addition of development traffic does not substantially increase queuing conditions **with the TSP improvement projects in place.**
- There is no off-site mitigation needed for the **zone change annexation** proposal.
- **As stated above, although not required, the Applicants' TPR findings demonstrate that the TPR requirements are met.**

## MEMORANDUM

April 3, 2026

Page 4 of 4

### REVISED TEXT: PAGE 17 OF 18

Although not required, the **Owner Applicants** also proposes a potential future **60 62**-foot-wide right-of-way dedication along the southern property line of the subject Tax Lot 5400 abutting the FedEx property (Tax Lot 1100) to accommodate a potential future local **or collector** street. At the time of the development proposal, the Owner will also provide an additional 7-foot PUE along the proposed **60 62**-foot right-of-way dedication if required to extend utilities to Tax Lot 5400 from Sports Way via the existing 70-foot-wide right-of-way located along the southern property line of the adjacent Tax Lot 1001.

Lastly, although not required, the Owner proposes a **30 62**-foot-wide right-of-way dedication along the western property line of the subject Tax Lot 5400 to accommodate ~~one-half of~~ a potential future **62-foot-wide local or** collector street. ~~When development to the north necessitates the full connection, the City of Springfield will need to secure the additional 31-foot dedication from Tax Lot 1001 (Assessor's Map 17-03-15-00). Collectively,~~ these **This** dedications will establish the potential future **collector** street connection between the Sports Way extension and Maple Island Road, which currently terminates at the upper west side of the site. This proposed dedication will help facilitate the orderly extension of public utilities to serve future development of properties located north of the site.

## CONCLUSION

Please accept the supplemental information provided herein and the revisions to the Written Statement. Both the previously submitted findings and the revised materials demonstrate consistency with the applicable annexation approval criteria.

If you have any questions about the supplemental information described here, please contact TBG Community Planning Group LLC at 541.687.1010.



ZG/KT/AD/EV/MR

Z:\PROJ\202501 Lane County International Way\Corresp\Agency\Annexation\202501-SI-Memo.docx

City of Springfield  
Development & Public Works  
225 Fifth Street  
Springfield, OR 97477



## Annexation Application Type 4

<b>Application Type</b>		<b>(Applicant: Check one)</b>	
<b>Annexation Application Completeness Check:</b>		<input type="checkbox"/>	
<b>Annexation Application Submittal:</b>		<input checked="" type="checkbox"/>	
<b>Required Proposal Information</b>		<b>(Applicant: Complete This Section)</b>	
<b>Property Owner:</b> Steve Mokrohisky, Co. Administrator, Lane County Government and Grady Layman, Director - Oregon Network, PeaceHealth		<b>Phone:</b> (Co.) 541.682.3942 & (PH) 503-522-4385	
<b>Address:</b> (Co.) 125 East 8th Avenue, Eugene, OR 97401 & (PH) 1255 Hilyard St, Eugene, OR 97401		<b>E-mail:</b> (Co.) steve.mokrohisky@lanecountyor.gov & (PH) GLayman@peacehealth.org	
<b>Owner Signature:</b>		 Digitally signed by Steve Mokrohisky, County Administrator Date: 2026.04.02 13:13:08 -07'00'	
<b>Owner Signature:</b>		Grady Layman  Digitally signed by Grady Layman DN: CN = Grady Layman email = glayman@peacehealth.org C = AD O = PeaceHealth Date: 2026.03.27 09:52:48 -07'00'	
<b>Agent Name:</b> Kristen Taylor & Zach Galloway		<b>Phone:</b> 541.687.1010	
<b>Company:</b> TBG Community Planning Group LLC		<b>E-mail:</b> ktaylor@tbg-arch.com & zgalloway@tbg-arch.com	
<b>Address:</b> PO Box 10248, Eugene, Oregon 97440			
<b>Agent Signature:</b>		Kristen G Taylor  Digitally signed by Kristen G Taylor DN: C=US, E=ktaylor@tbg-arch.com, O=TBG Community Planning Group LLC, CN=Kristen G Taylor Date: 2026.03.28 16:05:47-07'00'	
If the applicant is other than the owner, the owner hereby grants permission for the applicant to act in his or her behalf, except where signatures of the owner of record are required, only the owner may sign the petition.			
<b>ASSESSOR'S MAP NO:</b> 17-03-15-00 & 17-03-15-30		<b>TAX LOT NO(S):</b> 5400 & 400	
<b>Property Address:</b> Not yet assigned (International Way)			
<b>Area of Request:</b>	<b>Acres:</b> +/- 17.95	<b>Square Feet:</b> +/- 781,902	
<b>Existing Use(s):</b> Vacant		<b>Proposed Use:</b> Crisis Stabilization Center/Behavioral Health Facility	
<b>Required Property Information</b>		<b>(City Intake Staff: Complete This Section)</b>	
<b>Case No.:</b>		<b>Date:</b>	<b>Reviewed By:</b>
<b>Project No.:</b>	<b>Admin Fee:</b>	<b>Comp. Planning Fee:</b>	
<b>Application Fee Deposit:</b> \$7000.00		<b>Total Fee:</b>	
<b>*A deposit is collected and charged for Actual Cost of Service (COS)</b>		<b>Placard:</b>	

## Owner Signatures

This application form is used for both the required completeness check meeting and subsequent complete application submittal. Owner signatures are required at both stages in the application process.

### Submittal

I represent this application to be complete for submittal to the City. Consistent with the completeness check performed on this application at the Completeness Check Meeting, I affirm the information identified by the City as necessary for processing the application is provided herein or the information will not be provided if not otherwise contained within the submittal, and the City may begin processing the application with the information as submitted. This statement serves as written notice pursuant to the requirements of ORS 227.178 pertaining to a complete application.

Owner:



Digitally signed by Steve Mokrohisky,  
County Administrator  
Date: 2026.04.02 13:13:30 -07'00'

4/2/2026

**Signature**

**Date**

Steve Mokrohisky

**Print**

### Submittal

I represent this application to be complete for submittal to the City. Consistent with the completeness check performed on this application at the Completeness Check Meeting, I affirm the information identified by the City as necessary for processing the application is provided herein or the information will not be provided if not otherwise contained within the submittal, and the City may begin processing the application with the information as submitted. This statement serves as written notice pursuant to the requirements of ORS 227.178 pertaining to a complete application.

Owner:

Grady Layman  
**Signature**

Digitally signed by: Grady Layman  
DN: CN = Grady Layman email =  
glayman@peacehealth.org C = AD O =  
PeaceHealth  
Date: 2026.03.27 09:54:31 -07'00'

**Date** 3.27.26

**Print** Grady Layman

Application #: C SP 2009 -

**OWNER-CONSENT/DOUBLE MAJORITY PETITION**

**Petition Signature Sheet  
Annexation by Individuals**

We, the following property owners/electors, consent to the annexation of the following territory to the City of Springfield

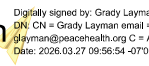
<i>Signature</i>	Date Signed m/d/y	Print Name	Residence Address <i>(street, city, zip code)</i>	Map and Tax Lot Number <i>(example: 17-04-03-00-00100)</i>	✓ Land Owner	✓ Reg Voter	Acres <i>(qty)</i>
1.  Digitally signed by Steve Mokrohisky, County Administrator Date: 2026.04.02 13:13:55 -07'00'	4/2/26	Steve Mokrohisky	125 E 8th Ave, Eugene, OR 97401	17-03-15-00-05400	<input checked="" type="checkbox"/>	<input checked="" type="checkbox"/>	12.07
2. Grady Layman  Digitally signed by Grady Layman DN: CN = Grady Layman email = g.layman@peacehealth.org C = AD O = PeaceHealth Date: 2026.03.27 09:56:54 -07'00'	3.27.26	Grady Layman	123 International Way Springfield, Or 97477	17-03-15-30-00400	<input checked="" type="checkbox"/>	<input checked="" type="checkbox"/>	5.88
3.					<input type="checkbox"/>	<input type="checkbox"/>	
4.					<input type="checkbox"/>	<input type="checkbox"/>	
5.					<input type="checkbox"/>	<input type="checkbox"/>	

Note: With the above signature(s), I am attesting that I have the authority to consent to annexation on my own behalf or on behalf of my firm or agency. *(Attach evidence of such authorization when applicable.)*

I, \_\_\_\_\_ *(printed name of circulator)*, hereby certify that every person who signed this sheet did so in my presence.

**X** \_\_\_\_\_ *(signature of circulator)*

**CERTIFICATION OF PROPERTY OWNERS**

The total landowners in the proposed annexation are 2 (qty). This petition reflects that 2 (qty) landowners (or legal representatives) listed on this petition represent a total 100 (%) of the landowners and 100 (%) of the acres as determined by the map and tax lots attached to the petition. *A&T is not responsible for subsequent deed activity which may not yet be reflected on the A&T computerized tax roll.*

D. [Signature]  
Lane County Department of Assessment and Taxation  
4/2/20  
Date Certified

**CERTIFICATION OF ELECTORS**

The total active registered voters in the proposed annexation are \_\_\_\_\_ (qty). I hereby certify that this petition includes valid signatures representing \_\_\_\_\_ of the total active registered voters that are registered in the proposed annexation.

\_\_\_\_\_  
Lane County Department of Assessment and Taxation  
\_\_\_\_\_  
Date Certified

### OWNERSHIP WORKSHEET

(This form is **NOT** the petition)

Please include the name and address of ALL owners regardless of whether they signed an annexation petition or not.

#### OWNERS

Property Designation (Map/lot number)	Name of Owner	Acres	Assessed Value	Imp. Y / N	Signed Yes	Signed No
17-03-15-00-05400	Lane County Govenment	12.07	\$13,380	N	✓	
17-03-15-30-00400	PeaceHealth	5.88	\$6,661	N	✓	
TOTALS:		~17.9	\$20,041	N	Yes	

TOTAL NUMBER OF OWNERS IN THE PROPOSAL	2
NUMBER OF OWNERS WHO SIGNED	2
PERCENTAGE OF OWNERS WHO SIGNED	100%
TOTAL ACREAGE IN PROPOSAL	~17.9 Acres
ACREAGE SIGNED FOR	~17.9 Acres
PERCENTAGE OF ACREAGE SIGNED FOR	100%
TOTAL VALUE IN THE PROPOSAL	\$20,041
VALUE CONSENTED FOR	\$20,041
PERCENTAGE OF VALUE CONSENTED FOR	100%

**CONSENT TO ANNEXATION**

Consent is hereby given to the annexation by the City of Springfield, Oregon of the following described real property:

Map and Tax Lot: 17-03-15-00-05400 Address: Not Yet Assigned (International Way)

Legal Description: (see below signatures for complete legal description)

Parcel 2 of Land Partition Plat No. 99-P1243, as platted and recorded in Lane County Oregon Partition Records, in Lane County, Oregon.

In the corporate limits of said city, which is owned by the undersigned DATED this \_\_\_\_\_ day of \_\_\_\_\_, 20\_\_.



Digitally signed by Steve Mrokohisky, County Administrator  
Date: 2026.04.02 13:14:29 -07'00'

Grady Layman

Digitally signed by Grady Layman  
DN: CN = Grady Layman email = glayman@peacehealth.org C = AD O = PeaceHealth  
Date: 2026.03.27 10:00:29 -07'00'

Two tracts of land located in Section 15, Township 17 South, Range 3 West of the Willamette Meridian, as conveyed to State Investments L.L.C. on that certain Bargain and Sale Deed recorded on Instrument No. 2009-002494, Lane County Oregon Deed Records, Lane County, Oregon, said tracts being more particularly described as follows:

Parcel 1 of Land Partition Plat No. 94-P0499, as platted and recorded in Lane County Oregon Partition Records, in Lane County, Oregon.

And:

Parcel 2 of Land Partition Plat No. 99-P1243, as platted and recorded in Lane County Oregon Partition Records, in Lane County, Oregon.

Said tracts contain 17.96 acres, more or less.

**CONSENT TO ANNEXATION**

Consent is hereby given to the annexation by the City of Springfield, Oregon of the following described real property:

Map and Tax Lot: 17-03-15-30-00400 Address: Not Yet Assigned (International Way)

Legal Description: (see below signatures for complete legal description)

Parcel 1 of Land Partition Plat No. 94-P0499, as platted and recorded in Lane County Oregon Partition Records, in Lane County, Oregon.

In the corporate limits of said city, which is owned by the undersigned DATED this \_\_\_\_\_ day of \_\_\_\_\_, 20\_\_.



Digitally signed by Steve Mrokohisky, County Administrator  
Date: 2026.04.02 13:14:46 -07'00'

Grady Layman

Digitally signed by Grady Layman  
DN: CN = Grady Layman email = glayman@peacehealth.org C = AD O = PeaceHealth  
Date: 2026.03.27 10:01:51 -07'00'

Two tracts of land located in Section 15, Township 17 South, Range 3 West of the Willamette Meridian, as conveyed to State Investments L.L.C. on that certain Bargain and Sale Deed recorded on Instrument No. 2009-002494, Lane County Oregon Deed Records, Lane County, Oregon, said tracts being more particularly described as follows:

Parcel 1 of Land Partition Plat No. 94-P0499, as platted and recorded in Lane County Oregon Partition Records, in Lane County, Oregon.

And:

Parcel 2 of Land Partition Plat No. 99-P1243, as platted and recorded in Lane County Oregon Partition Records, in Lane County, Oregon.

Said tracts contain 17.96 acres, more or less.

## **Summary of Urban Service Provision**

This form is intended as a guide to assist applicants in demonstrating that a minimum level of key urban services can be provided to the area proposed for annexation. Space is provided on this form for you to provide detailed information on service provision. Please add additional pages if necessary to provide details of servicing issues related to the area you are annexing. To assist you in providing this information, some contacts are listed below. For large or difficult to serve properties, you may wish to contact a private land use planning consultant to prepare your application.

Property Owner(s) Name:

Lane County Government (Tax lot 5400) and PeaceHealth (Tax Lot 400)

---

Assessor's Map and Tax Lot Numbers for Properties Proposed for Annexation (including the township, section, and range numbers) For example: Map 17-03-19-31, Tax Lot 100

Map 17-03-15-00 Tax Lot 5400 and Map 17-03-15-30 Tax Lot 400

---

The street or site addresses within the affected territory as shown in the Lane County Regional Land Information Database system (RLID)

Not yet assigned - both parcels north of International Way

---

**Wastewater** – All new development must connect to the wastewater (sanitary sewer) system. Is wastewater service available to serve the area proposed for annexation? (For more information, contact the Engineering staff at the City of Springfield Engineering at 541-726-3753.)

The property(ies) in this annexation request: 2

will be served from an existing gravity wastewater line.

Location and size of existing wastewater line: International Way (E) 8-inch wastewater main

Sports Way (E) 8-inch wastewater main

---

will be served by an extension of an existing gravity wastewater line.

Where will a wastewater line be extended from? When will it be extended?

By whom? International Way (PeaceHealth) and Sports Way (Lane County)

---

**Stormwater** –All new development must provide for drainage to an approved system. City approval for storm drainage will be required as part of the development process. (For more information, contact the City of Springfield Engineering at 541-726-3753.)

Is the site currently served by an approved stormwater system? No

---

If yes, location? \_\_\_\_\_

If no, how will stormwater be handled after development? On the sites connecting to  
International Way (E) 18-inch stormwater main, Sports Way (E) 48-inch stormwater main and/or Maple Island Road (north of former Royal Caribbean site) (E) 15-inch stormwater main

---

**Streets** – What existing streets provide access to this site? List existing streets that provide access to this site. International way and and if needed, an extension from Sports Way via a dedication area

---

Will dedication for additional street right-of-way be required upon further development of this site?

Yes                       No                       Unknown

Will existing streets be extended or new streets constructed upon further development of this site?

Yes                       No                       Unknown

**Schools** – Please indicate which school district serves the subject property.

- Eugene School District
- Springfield School District
- Pleasant Hill School District

**Parks, Recreation, and Cultural Services** – Systems Development revenues generated by new development will help to fund future acquisition and development in this area and throughout the Willamalane Park and Recreation District. Please list the parks and recreation facilities that already exist or are planned in the general vicinity of the property(ies) included in this annexation:

(E) Arrow Park (2500 Otto St): (1.5 miles from site) neighborhood park; (E) Weyerhaeuser McKenzie Natural Area (3809 Marcola Rd) (about 3 miles from site) ;

(E) Gamebird Park (1500 Mallard Ave): (about 3 miles from the site) A neighborhood park and (E) Mill Race Path (307 S 5th St): (about 4 miles from the site) A linear pathway for walking and biking

---

Key services, defined by the Willamalane Comprehensive Plan as parks and recreation programs, will be available to residents in this area on an equal basis with residents throughout the Willamalane Park and Recreation District.

### Public Safety

**Police services** – Police protection can be extended to this site upon annexation

consistent with service provision throughout the city.

*Fire and emergency services* (Please indicate which fire district serves subject property.)

- McKenzie Fire & Rescue
- Glenwood Water District
- Rainbow Water and Fire District
- Willakenzie Fire & Rescue

Upon annexation, fire protection will be provided directly by the City of Springfield Fire & EMS Department.

**Emergency medical transport (i.e., ambulance) services** are currently provided on a regional basis by Eugene, Springfield, and Lane Rural Fire/Rescue to central Lane County, including unincorporated areas in Springfield. After annexation, this service will continue to be provided by the current provider. All ambulance service providers have mutual aid agreements and provide back-up service into the other providers' areas.

**Planning and Development Services** - Planning and building permit services are provided to the area outside the city limits but within the urban growth boundary by the City of Springfield. This service would continue after annexation.

**Water and Electric Services** – Springfield Utility Board (SUB) currently provides water and electric service in the Springfield area and can provide service upon annexation. For more information contact EPUD, Glenwood Water District, Rainbow Water and Fire District, or SUB.

*Water and electric services* (Please indicate which utility provider serves the subject property.)

- Emerald People's Utility District (EPUD)
- Glenwood Water District
- Rainbow Water and Fire District
- Springfield Utility Board

**Electric Service** – Which electric company will serve this site? SUB

**Water Service** – Please provide the size and location of the water main closest to your property. International Way (E) 12-inch water line; Sports Way (E) 12-inch water line; and

Maple Island Road (north of former Royal Caribbean site) (E) 8-inch water line

**Solid Waste** – Solid waste collection service is provided by private firms. Regional disposal sites and the Short Mountain Landfill are operated by Lane County.

**Natural Gas** – Northwest Natural Gas can extend service to new development in this area.

**Communications** – A variety of telecommunications providers offer communications services throughout the Eugene/Springfield Area.

## Census Information Sheet – CONFIDENTIAL

Please complete the attached survey and return it with your annexation application. It is not necessary to include the names of all individuals. Addresses and number of people living at each address is essential and sex and age information is helpful. If you have any questions, please contact Planning at 541-726-3753.

City of Springfield                      Address: Not Yet Assigned

<b>HOUSING TYPE</b>		<b>TENURE</b>	
Single Unit Structure	<input type="checkbox"/>	Owner-Occupied	<input type="checkbox"/>
Multiple-Unit Structure	<input type="checkbox"/>	Renter-Occupied	<input type="checkbox"/>
Trailer or Mobile Home Seasonal	<input type="checkbox"/>	Vacant	<input type="checkbox"/>
<b>RESIDENTS</b> N/A			

<b>RESPONDENT</b>	<b>LAST NAME</b>	<b>FIRST NAME</b>	<b>SEX</b>	<b>AGE</b>
1.				
2.				
3.				
4.				
5.				
6.				
7.				
8.				
9.				

Portland State University School of Urban and Public Affairs  
Center for Population Research and Census (503) 725-3922

**FORM 4**

**WAIVER OF ONE YEAR TIME LIMIT  
FOR ANNEXATION PURSUANT TO ORS 222.173**

This waiver of the time limit is for the following described property:

17-03-15-00-05400      Not Yet Assigned  
 Map and Tax Lot Number      Street Address of Property (if address has been assigned)

**ONE WAIVER OF TIME LIMIT FOR EACH PARCEL, PLEASE**

We, the owner(s) of the property described above understand the annexation process can take more than one year but desire to annex to have City services. Therefore, we agree to waive the one-year time limitation on this petition to annex established by Oregon Revised Statutes 222.173, and further agree that this contract shall be effective [ ] indefinitely or [ ] until

\_\_\_\_\_  
Date

**Signatures of Legal Owners**

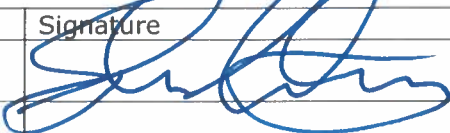
Please print or type name	Signature	Date Signed
Steve Makrohisky		11-3-25

**WAIVER OF ONE YEAR TIME LIMIT  
FOR ANNEXATION PURSUANT TO ORS 222.173**

This waiver of the time limit is for the following described property:

Map 17-03-15-30 Tax Lot 400	Not Yet Assigned
Map and Tax Lot Number (assigned)	Street Address of Property (if address has been assigned)

**ONE WAIVER OF TIME LIMIT FOR EACH PARCEL, PLEASE**

We, the owner(s) of the property described above understand the annexation process can take more than one year but desire to annex to have City services. Therefore, we agree to waive the one-year time limitation on this petition to annex established by Oregon Revised Statutes 222.173, and further agree that this contract shall be effective  indefinitely or  until \_\_\_\_\_.

**Signatures of Legal Owners**

Please print or type name	Signature	Date Signed
<b>Steve Mokrohisky</b>	 <small>Digitally signed by Steve Mokrohisky, County Administrator Date: 2026.04.02 13:15:12 -07'00'</small>	<b>4/2/26</b>
<b>Grady Layman</b>	<b>Grady Layman</b> <small>Digitally signed by: Grady Layman DN: CN = Grady Layman, email = g.layman@peacehealth.org C = AD O = PeaceHealth Date: 2026.03.27 10:04:08 -07'00'</small>	<b>3.27.26</b>

*LCOG: L:\BC\2008 BOUNCHANGE TRANSITION\APPLICATION  
FORMS\SPRINGFIELD\10-03-08 UPDATED FORMS\PRE-SUBMITTAL ANNEXATION  
APPLICATION 10-07-08.DOC  
Last Saved: October 30, 2024*

# Springfield Comprehensive Plan - Illustrative Overview

Refinement Plan Areas\*

Urban Growth Boundary

Overlays  
N N N Nodal Development Area  
  Willamette Greenway

## Comprehensive Plan Designations\*\*

- |  |   |  |   |
|--|---|--|---|
| <span style="background-color: #ffffcc; border: 1px solid black; display: inline-block; width: 15px; height: 10px;"></span> Low Density Residential    | <span style="background-color: #ff6666; border: 1px solid black; display: inline-block; width: 15px; height: 10px;"></span> Major Retail Center             | <span style="background-color: #6666ff; border: 1px solid black; display: inline-block; width: 15px; height: 10px;"></span> Heavy Industrial         | <span style="background-color: #cccccc; border: 1px solid black; display: inline-block; width: 15px; height: 10px;"></span> Mixed Use (general)**           |
| <span style="background-color: #ffcc66; border: 1px solid black; display: inline-block; width: 15px; height: 10px;"></span> Medium Density Residential | <span style="background-color: #ff9999; border: 1px solid black; display: inline-block; width: 15px; height: 10px;"></span> Commercial Mixed Use            | <span style="background-color: #333366; border: 1px solid black; display: inline-block; width: 15px; height: 10px;"></span> Special Heavy Industrial | <span style="background-color: #99ff99; border: 1px solid black; display: inline-block; width: 15px; height: 10px;"></span> Public Land & Open Space        |
| <span style="background-color: #ff9933; border: 1px solid black; display: inline-block; width: 15px; height: 10px;"></span> High Density Residential   | <span style="background-color: #ffcccc; border: 1px solid black; display: inline-block; width: 15px; height: 10px;"></span> Commercial/Industrial Mixed Use | <span style="background-color: #663399; border: 1px solid black; display: inline-block; width: 15px; height: 10px;"></span> Employment Mixed Use     | <span style="background-color: #99cc99; border: 1px solid black; display: inline-block; width: 15px; height: 10px;"></span> Natural Resource                |
| <span style="background-color: #ffcc99; border: 1px solid black; display: inline-block; width: 15px; height: 10px;"></span> Residential Mixed Use      | <span style="background-color: #ffcccc; border: 1px solid black; display: inline-block; width: 15px; height: 10px;"></span> LMI/CC Mixed Use                | <span style="background-color: #993366; border: 1px solid black; display: inline-block; width: 15px; height: 10px;"></span> Booth-Kelly Mixed Use    | <span style="background-color: #cccccc; border: 1px solid black; display: inline-block; width: 15px; height: 10px;"></span> Sand & Gravel                   |
| <span style="background-color: #ffcccc; border: 1px solid black; display: inline-block; width: 15px; height: 10px;"></span> Neighborhood Commercial    | <span style="background-color: #cccccc; border: 1px solid black; display: inline-block; width: 15px; height: 10px;"></span> Light Medium Industrial (LMI)   | <span style="background-color: #ff99cc; border: 1px solid black; display: inline-block; width: 15px; height: 10px;"></span> General Office           | <span style="background-color: #993333; border: 1px solid black; display: inline-block; width: 15px; height: 10px;"></span> Urban Holding Area - Employment |
| <span style="background-color: #ff6666; border: 1px solid black; display: inline-block; width: 15px; height: 10px;"></span> Community Commercial (CC)  | <span style="background-color: #6666ff; border: 1px solid black; display: inline-block; width: 15px; height: 10px;"></span> Campus Industrial               | <span style="background-color: #ff99cc; border: 1px solid black; display: inline-block; width: 15px; height: 10px;"></span> Office Mixed Use         |   |

\*Please click on Refinement Plan label to view the plan designations and document specific to that area.

\*\*Please note that some similar Mixed Use designations are aggregated to simplify readability. Consult the Comprehensive Plan web map for precise designations: [LINK](#)

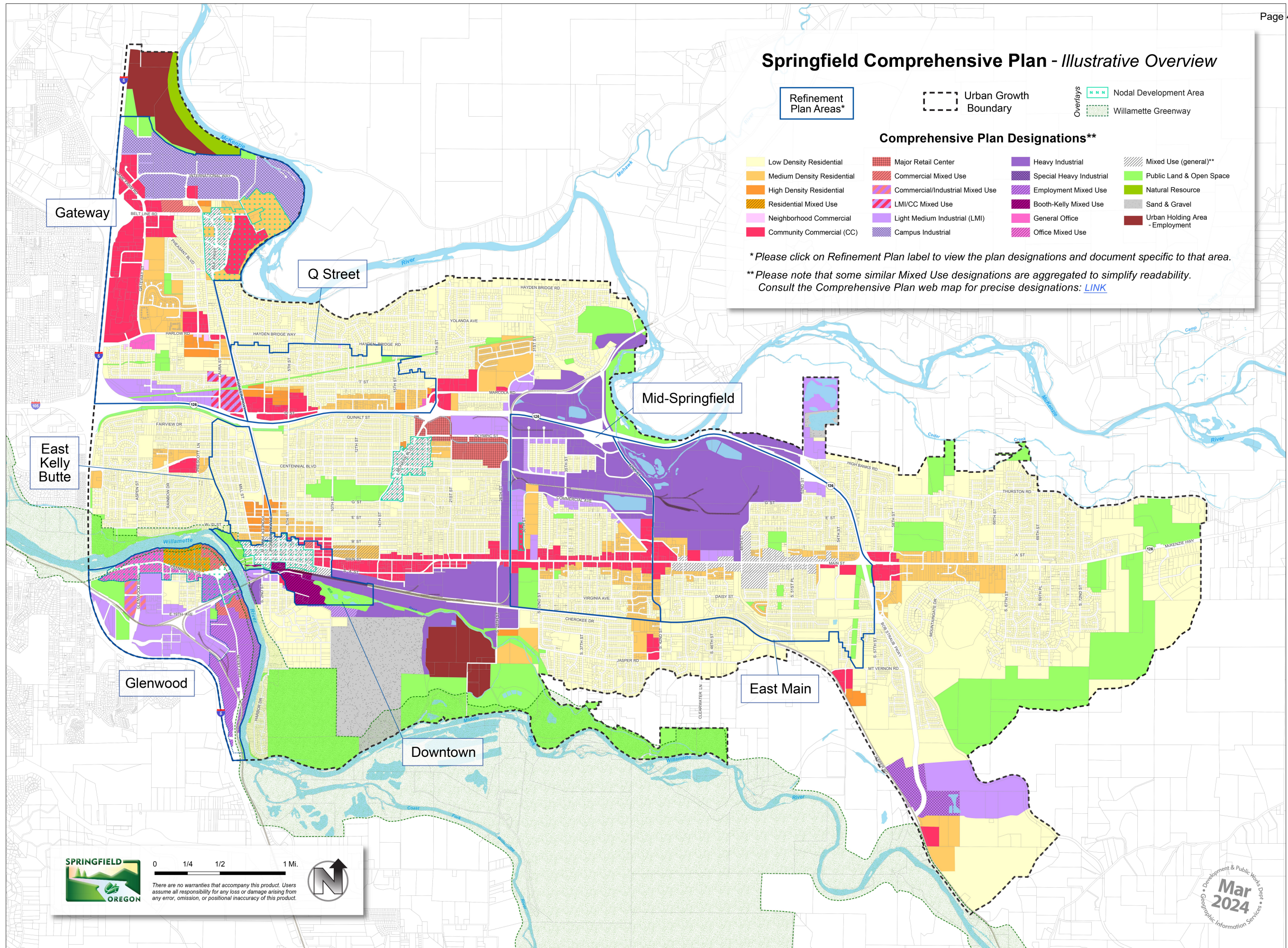

**SPRINGFIELD OREGON**

0 1/4 1/2 1 Mi.

There are no warranties that accompany this product. Users assume all responsibility for any loss or damage arising from any error, omission, or positional inaccuracy of this product.

Development & Public Works Dept.  
**Mar 2024**  
 Geographic Information Services

TRANSPORTATION PLANNING RULE ANALYSIS

INTERNATIONAL WAY ANNEXATION  
TRANSPORTATION PLANNING RULE ANALYSIS

SPRINGFIELD, OR

December 11, 2025

Updated March 20, 2026

777 High Street, Suite 320  
Eugene, Oregon 97401  
541.513.3376

**SANDOW**  
ENGINEERING

# TRANSPORTATION PLANNING RULE ANALYSIS

## INTERNATIONAL WAY ANNEXATION



RENEWAL 06/30/26

Springfield, Oregon

March 20, 2026

Kelly Sandow PE

**SANDOW  
ENGINEERING**  
777 High Street, Suite 320  
Eugene, Oregon 97401  
541.513.3376  
sandowengineering.com

project # 6173

## EXECUTIVE SUMMARY

This report is prepared for the proposed Annexation of Tax Lots 17-03-15-00-05400 and 17-03-15-30-00400 located on International Way between Sports Way and Maple Island Road in Springfield, Oregon. The Annexation request criterion requires a demonstration that the transportation facilities to the site “can be provided in an orderly, efficient, and timely manner”, as per Springfield Development Code (SDC) 5.7.140(C). As demonstrated within this report, the site currently has adequate transportation facilities to the site that are orderly and efficient as required by SDC 5.7.140(C). However, as requested by the applicants, this report uses the Transportation Planning Rule (“TPR”) provisions found at OAR 660-012-0060, out of an extreme abundance of caution, to demonstrate compliance.

The 18.0-acre vacant site is currently located within the urban growth boundary, however, outside of the city limits. The site’s zoning upon Annexation will be Campus Industrial- CI.

## FINDINGS

The following recommendations are based on the information and analysis documented in this report.

- The addition of development trips does not trigger any intersections to not meet the LOS standards.
- The intersection of Gateway St at Beltline Rd currently operates at LOS F during the PM peak hour. The City has identified improvements at this intersection, which are reasonably assumed to be constructed within the 20-year planning horizon. With these improvements, the intersection will meet the mobility standards through the year 2035.
- The addition of development traffic does not substantially increase queuing conditions with the TSP improvement projects in place.
- There is no off-site mitigation needed for the annexation proposal.
- TPR findings demonstrate that the TPR “requirements”<sup>1</sup>are met.

---

<sup>1</sup> See “Executive Summary” discussion above.

## CONTENTS

1.0	BACKGROUND .....	4
1.1	SITE INFORMATION .....	4
1.2	ANALYSIS SCOPE .....	4
	FIGURE 1- VICINITY MAP AND SITE LOCATION .....	5
2.0	ZONING VEHICLE TRIP ESTIMATION .....	6
2.1	EXISTING ZONING TRIP GENERATION .....	6
	TABLE 1: PM PEAK HOUR TRIP GENERATION -CI ZONING .....	7
	TABLE 2: TRIP SPLITS .....	7
	FIGURE 2- PM PEAK HOUR TRIP DISTRIBUTION.....	8
3.0	EXISTING ROADWAY CONDITIONS .....	9
3.1	STREET NETWORK .....	9
	TABLE 3: ROADWAY CHARACTERISTICS WITHIN STUDY AREA .....	9
3.2	STUDY INTERSECTIONS .....	9
	FIGURE 3- INTERSECTION CONTROL AND LANE CONFIGURATION.....	12
4.0	CRASH ANALYSIS .....	13
	TABLE 4: INTERSECTION CRASH RATE.....	13
	TABLE 5: INTERSECTION CRASH PATTERNS .....	14
5.0	IN-PROGRESS TRANSPORTATION IMPROVEMENT PROJECTS.....	15
6.0	BACKGROUND TRAFFIC VOLUMES .....	17
6.1	INTERSECTION COUNTS .....	17
	TABLE 6: TRAFFIC COUNT DATES .....	17
6.2	PIPELINE TRIPS.....	17
6.3	FUTURE YEAR BACKGROUND VOLUMES.....	18
6.4	FINAL TRAFFIC VOLUMES .....	18
	FIGURE 4 –YEAR 2025 PM PEAK HOUR EXISTING TRAFFIC VOLUMES .....	19
	FIGURE 5 – YEAR 2035 PM PEAK HOUR BACKGROUND TRAFFIC VOLUMES .....	20
	FIGURE 6 – YEAR 2035 PM TRAFFIC VOLUMES WITH ANNEXATION-EXISTING ROADWAY .....	21
	FIGURE 7 – YEAR 2035 PM TRAFFIC VOLUMES WITH ANNEXATION-TSP PROJECTS .....	22
7.0	INTERSECTION ANALYSIS.....	23
7.1	PERFORMANCE MEASURES .....	23
	TABLE 7: HCM LEVEL OF SERVICE FOR INTERSECTIONS.....	23
7.2	INTERSECTION ANALYSIS RESULTS.....	24
	TABLE 8: INTERSECTION PERFORMANCE: WEEKDAY PM PEAK HOUR .....	25

7.3 QUEUE ANALYSIS .....	25
TABLE 9: INTERSECTION QUEUING: WEEKDAY PM PEAK HOUR.....	26
8.0 TRANSPORTATION PLANNING RULE FINDINGS .....	28
TABLE 10: EXISTING STREET CLASSIFICATION .....	28
9.0 CONCLUSION .....	30
FINDINGS .....	30

## LIST OF APPENDICES

- APPENDIX A: SCOPE OF WORK
- APPENDIX B: CRASH DATA
- APPENDIX C: TRAFFIC VOLUMES
- APPENDIX D: SYNCHRO OUTPUTS
- APPENDIX E: QUEUING OUTPUTS

## 1.0 BACKGROUND

### 1.1 SITE INFORMATION

The subject site is located on the north side of International Way between Sports Way and Maple Island Road at Tax Lot 5400 of Assessor’s Map 17-03-15-00 and Tax Lot 400 of Assessor’s Map 17-03-15-30. Figure 1 illustrates the site location. The site is approximately 18 acres and is currently vacant.

The subject site is located within the urban growth boundary, however, outside of the city limits. The applicant is proposing Annexation of the tax lots. Upon Annexation, the tax lots will be zoned Campus Industrial-CI, which is consistent with the plan designation in the Comprehensive Plan.

The application includes a new north/south street connection from the site to International Way. For the purposes of this study, all access is assumed via International Way through the new connection.

### 1.2 ANALYSIS SCOPE

This evaluation considers the impacts from the “reasonable worst-case” development potential at the end of the City’s Transportation System Plan planning horizon, year 2035.

The traffic study is performed in accordance with the City of Springfield standards and criteria. Appendix A contains the Scope of Work. An intersection analysis was performed for the adjacent intersections at the following locations:

- International Way at Sports Way
- International Way at Maple Island Road
- Maple Island Road at Game Farm Road
- Game Farm Road at Deadmond Ferry
- Game Farm Road at MLK Jr. Parkway
- Gateway Street at International Way
- Gateway Street at Game Farm Road
- Gateway Street at Beltline Road
- Beltline Road at Hutton Street
- Gateway Street at Harlow Road

The operational analysis was performed at the study area intersections for the weekday PM peak period (4:00-6:00 PM). The operational analysis is performed for the following conditions:

- Existing conditions, year 2025
- End of TSP Planning Horizon, year 2035, with and without proposed annexation.

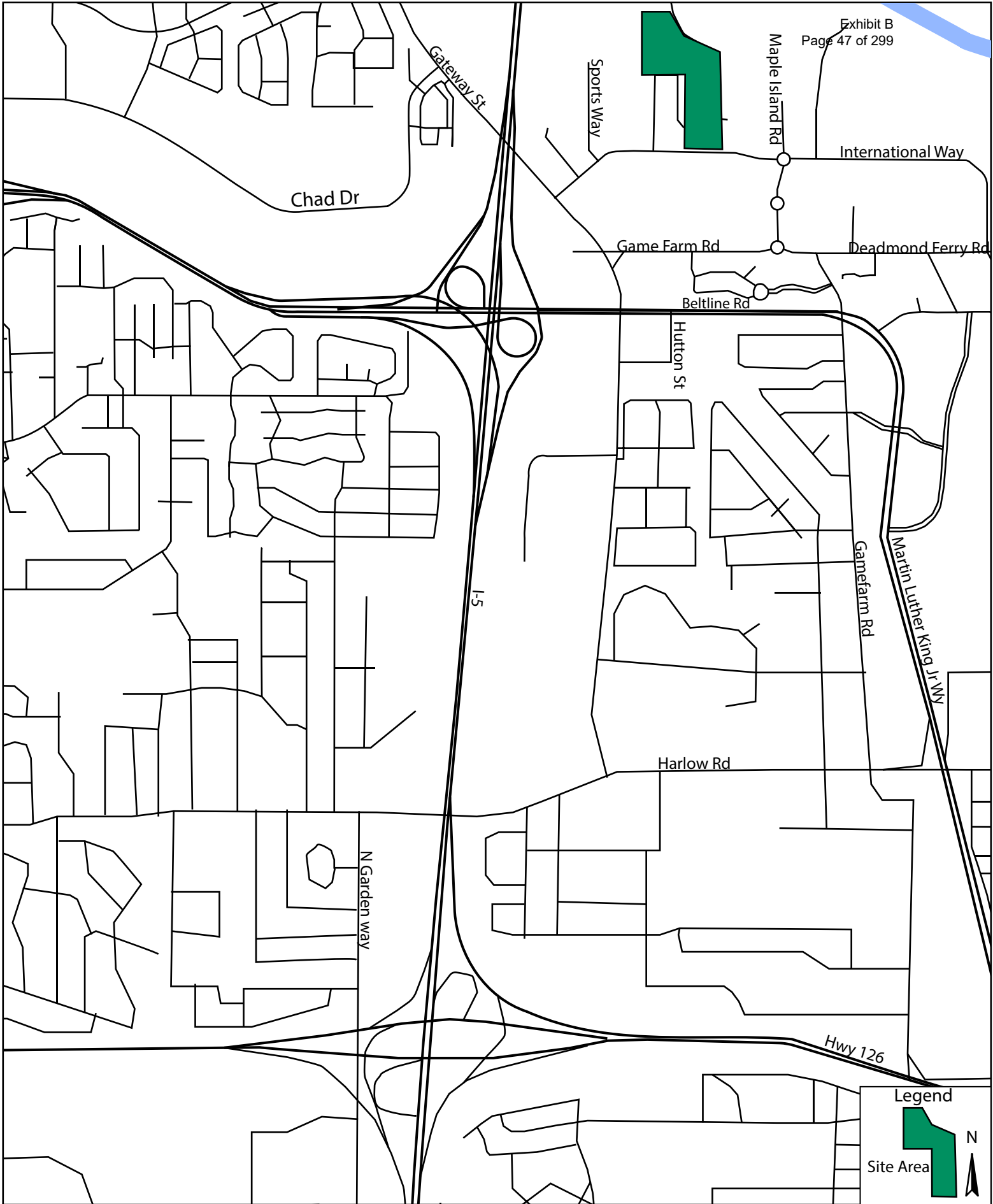

International Way TPR, Springfield, Oregon

Figure 1: Site Location and Vicinity Map

## 2.0 ZONING VEHICLE TRIP ESTIMATION

This report analyzes the traffic generated by the zoning upon Annexation to determine whether the reasonable “worst-case” development scenario would have a “significant effect” on the adjacent transportation system as if OAR 660-012-0010 (the “Transportation Planning Rule” or “TPR”) applied to the Annexation request. This is done by evaluating a reasonable “worst-case” development scenario allowed under the Campus Industrial zoning.

The following provides the reasonable worst-case development potential for the uses allowed under the Campus Industrial zoning.

### 2.1 EXISTING ZONING TRIP GENERATION

The zoning is Campus Industrial-CI. The higher trip-generating uses allowed in the CI zoning are:

- Warehouse and wholesale sales
- Corporate Office/Headquarters
- Business Park

Maximum building height is 45 feet.

Taking into consideration the typical building footprint layout of adjacent properties with CI zoning, it is estimated that a reasonable maximum building footprint is approximately 25% percent of the total site. The remaining 75% is landscaping, parking, drive aisles, and loading areas.

- Total Site= 18.0 acres/784,080 sf
- Building footprint 25%= 196,020 sf -rounded to 200,000 sf
- 2 Stories = 392,040 sf total- rounded to 400,000 sf.

The PM peak hour trip generation is estimated by comparing the uses allowed within the zone. The associated ITE Trip Generation Land Uses with the higher PM peak hour rates are:

- **140 Manufacturing:** The primary activity is manufacturing raw materials into finished products. Buildings typically contain offices, manufacturing areas, and storage areas.
- **156 High-Cube Parcel Hub Warehouse:** buildings primarily devoted to the storage of materials. Land use codes 150 Warehousing, 154 High-Cube Transload and Short-Term Storage, 155 High-Cube Fulfillment Center Warehouse, and 157 High-Cube Storage Warehouse were all evaluated. 156 High-Cube Parcel Hub Warehouse has the highest PM peak hour rates.
- **714 Corporate Headquarters Building:** single-tenant office buildings that house the corporate or headquarters of a company.
- **750 Office Park:** planned unit development that contains general office buildings and support services arranged in a park or campus-like setting.
- **760 Research and Development Center:** a facility devoted to research and development. Buildings contain offices and light fabrication areas.

Table 1 contains the trip generation estimate for each of the ITE land uses allowed within the CI zoning.

TABLE 1: PM PEAK HOUR TRIP GENERATION -CI ZONING

ITE Code	Rate	Trips
<b>140 Manufacturing</b>	$T=0.87(X)-17.5$	331
<b>156 High-Cube Parcel Hub Warehouse</b>	0.64	256
<b>714 Corporate Headquarters Building</b>	$\ln(T)=0.94\ln(x)+0.58$	520
<b>750 Office Park</b>	<b><math>T=1.26(X)+20.98</math></b>	<b>525</b>
<b>760 Research and Development Center</b>	$T=0.84(x)+25.08$	361

The highest PM peak hour generator is 750 Office Park at 525 PM peak hour trips.

The entering and exiting splits are illustrated in Table 2 below for the Office Park use.

TABLE 2: TRIP SPLITS

	Total	In	Out
<b>750 Office Park</b>	525	73	452

The trips are distributed on the street network following the existing travel patterns based on recent traffic counts taken within the study area. The trip distribution is illustrated in Figure 2.

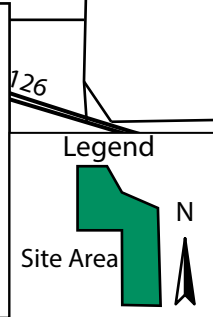
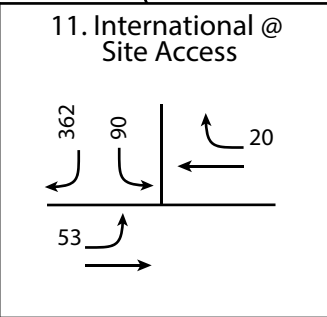
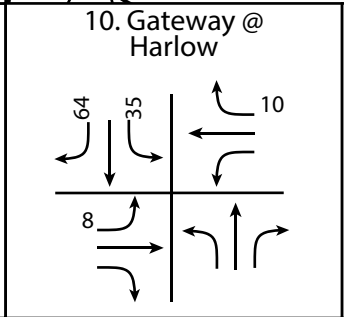
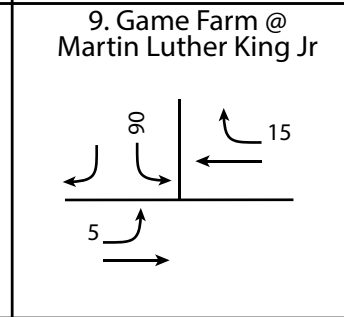
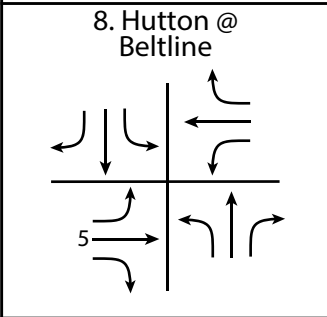
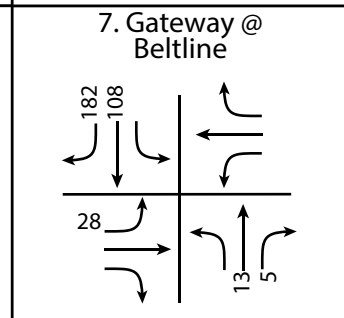
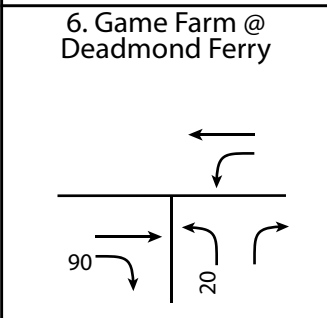
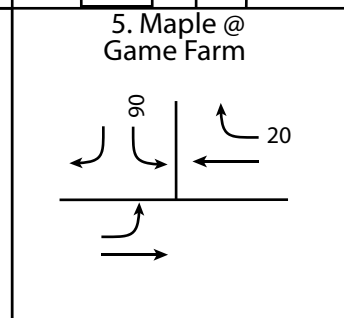
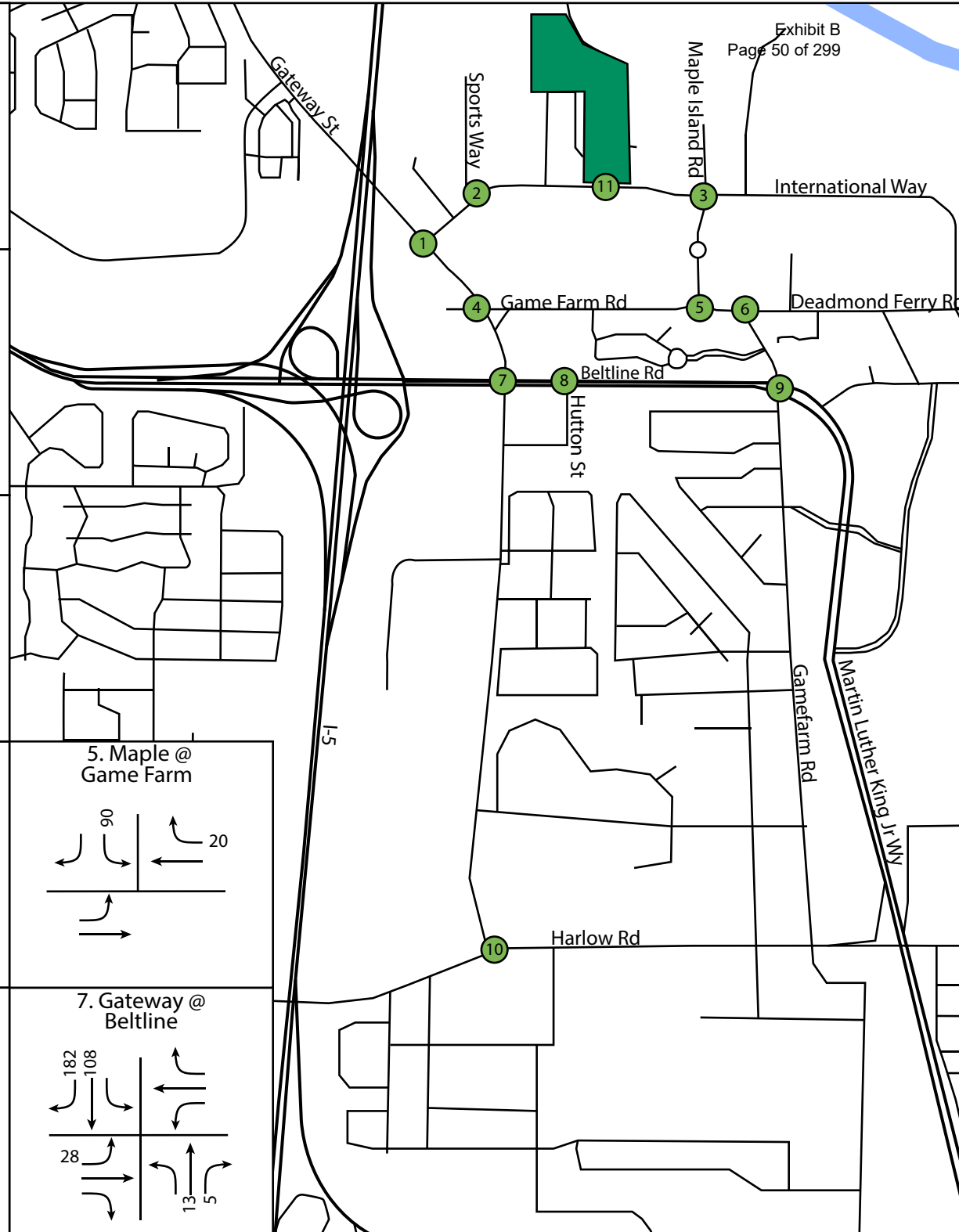
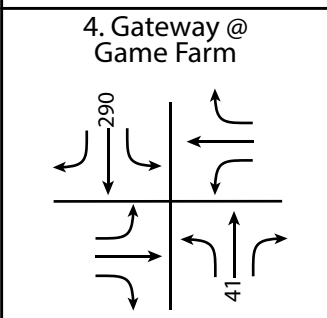
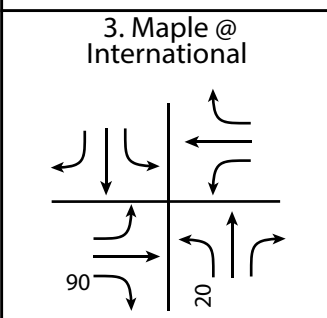
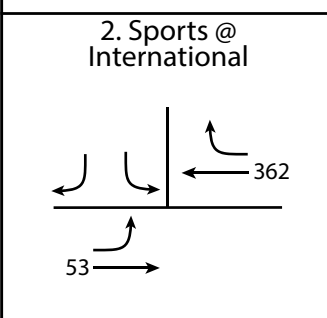
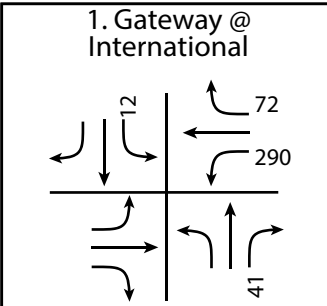

International Way TPR, Springfield, Oregon

Figure 2: Development Trip Distribution

### 3.0 EXISTING ROADWAY CONDITIONS

#### 3.1 STREET NETWORK

Streets included within the study are International Way, Maple Island Road, Game Farm Road, Deadmond Ferry Road, Beltline Road, Gateway Street, and Martin Luther King Jr Parkway. The roadway characteristics within the study area are included in Table 3.

TABLE 3: ROADWAY CHARACTERISTICS WITHIN STUDY AREA

Characteristic	Maple Island Rd	Game Farm Rd	Deadmond Ferry	Beltline Road	MLK Jr Pkwy	Gateway Street	International Way
<b>Jurisdiction</b>	City	City	City	City	City	City	City
<b>Functional Classification</b>	Local	Major Collector	Major Collector	Major/Minor Arterial	Minor Arterial	Minor Arterial	Major Collector
<b>Lanes per Direction</b>	1	1	1	2-3	2	1-2	1-2
<b>Center Left Turn lane</b>	North of International	Yes	Yes	None	None	None	Center BAT Lanes
<b>Restrictions in the Median</b>	Splitter Island	Splitter Island	None	Planter Median	Planter Median	Planter/Concrete Median	Bus Stations
<b>Bikes Lanes Present</b>	Yes	Yes	Yes	Yes	Off-Street Path	Yes	Yes
<b>Sidewalks Present</b>	Yes	Yes	Yes	Yes	Yes	Yes	Yes
<b>Transit Route</b>	None	None	None	Yes	Yes	Yes	Yes
<b>On-Street Parking</b>	None	None	None	None	None	None	None

#### 3.2 STUDY INTERSECTIONS

Intersections included in the study are:

- International Way at Sports Way
- International Way at Maple Island Road
- Maple Island Road at Game Farm Road
- Game Farm Road at Deadmond Ferry
- Game Farm Road at MLK Jr. Parkway
- Gateway Street at International Way

- Gateway Street at Game Farm Road
- Gateway Street at Beltline Road
- Beltline Road at Hutton Street
- Gateway Street at Harlow Road

Figure 3 provides the study area geometry and access control.

**International Way at Sports Way:** This is a stop-controlled 3-legged intersection with the southbound approach as stop-controlled. There are marked crosswalks across the southbound leg and the westbound leg. There is an RRFB across the westbound leg and EmX station in the median. There are BAT lanes along International Way. There are off-street multi-use paths along the north and south sides of International Way.

**Maple Island Road at International Way:** This is a 4-legged intersection with a single-lane roundabout as the control. There are sidewalks and crosswalks on all four approaches. There are BAT lanes along International Way that terminate prior to the roundabout.

**Maple Island Road at Game Farm Road:** This is a 3-legged intersection with a single-lane roundabout as control. There are sidewalks and marked pedestrian crossings on all legs.

**Game Farm Road at Deadmond Ferry Road:** This is a stop-controlled 3-legged intersection with the northbound approach as stop-controlled. There is a marked crosswalk across the northbound leg. There are no marked crosswalks across Game Farm Road. There is no ADA ramp located on the northeast corner of the intersection.

**Game Farm Road at Beltline Road/MLK Jr Parkway:** This is a 3-legged signalized intersection. There are sidewalks and bike lanes/shared paths along all approaches. There are ADA ramps and marked crosswalks along the north and west legs. There is no crosswalk across the east leg.

**International Way at Gateway Street:** This is a 4-legged signalized intersection. The northbound, southbound, and westbound approaches have separate left turn pockets/phases. The westbound approach has a separate left turn lane and left turn phase for the exclusive bus lane. The northbound approach has a separate slip right turn lane with yield control. There are crosswalks on all 4 approaches and bike lanes on Gateway Street.

**Gateway Street at Game Farm Road:** This is a 4-legged signalized intersection. There are separate left turn pockets and phasing for the north, south, and east approaches. The northbound approach is a separate right turn slip lane with yield control. There are sidewalks and striped crosswalks on all 4 approaches. There are striped bike lanes on the Gateway St and East Game Farm Rd approaches.

**Gateway Street at Beltline Road:** This is a 4-legged signalized intersection. All four approaches have separate left turn lanes and phasing. The eastbound approach has a channelized right turn

with signalized control. There are sidewalks, striped pedestrian crossings, and bike lanes on the north, east, and south approaches.

**Beltline Road at Hutton Road:** This is a stop-controlled 3-legged intersection with the northbound approach as stop-controlled. Additionally, there is a private driveway on the north side of the intersection. Beltline Road has separate left turn pockets. There are no marked crosswalks or ADA ramps across Beltline Road. There are marked on-street bike lanes on Beltline Road.

**Gateway Street at Harlow Road:** This is a 4-legged signalized intersection. The south leg is a private driveway. There are separate left turn pockets and phasing for the west and east approaches. The northbound and southbound approaches operate as split phasing. There are sidewalks and striped crosswalks on all 4 approaches. There are striped bike lanes on all approaches.

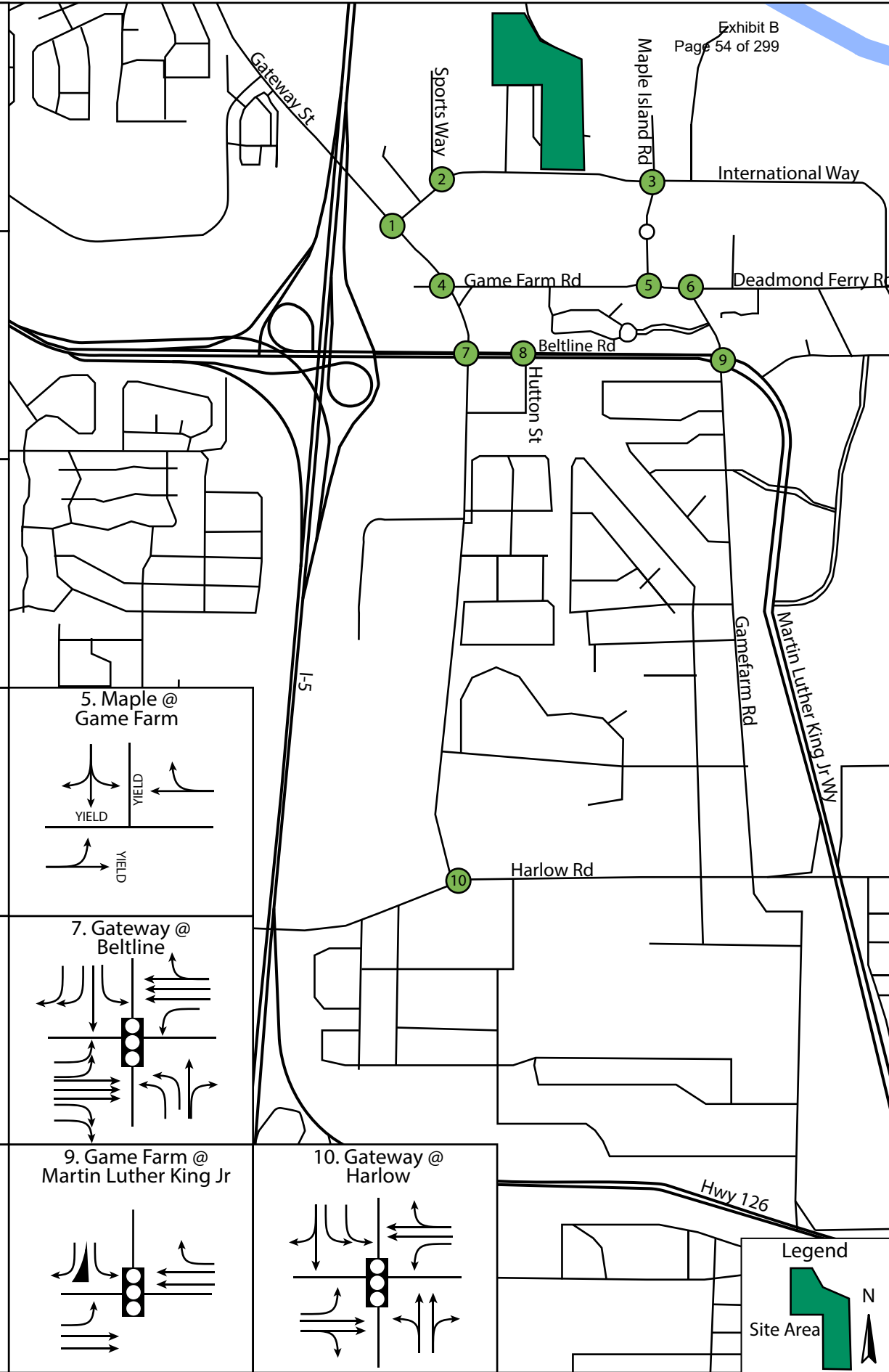
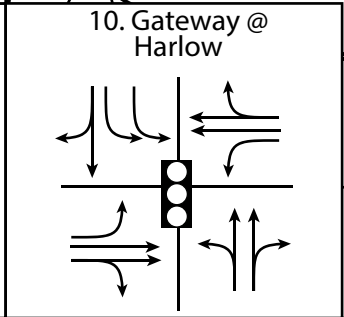
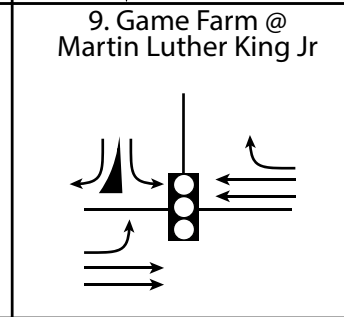
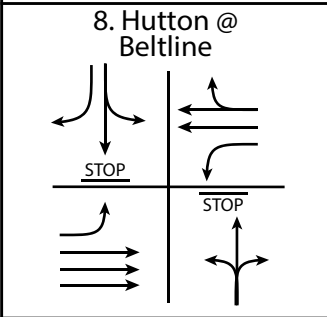
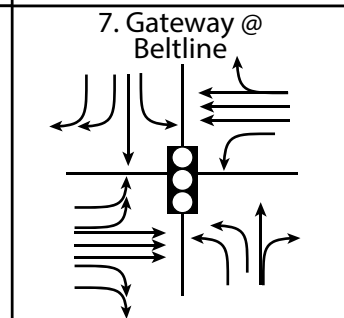
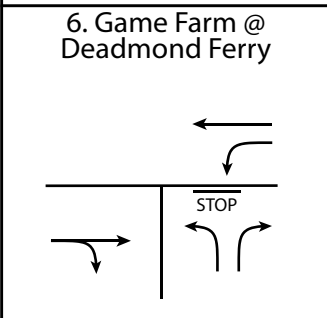
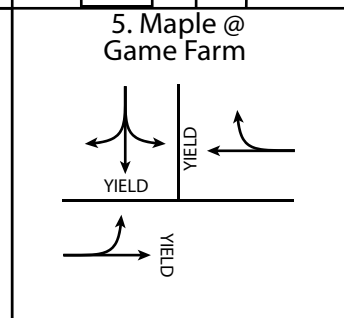
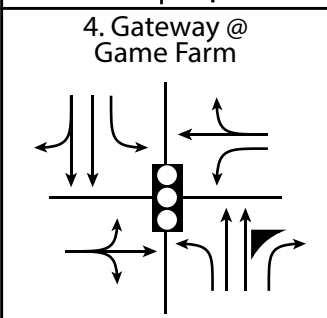
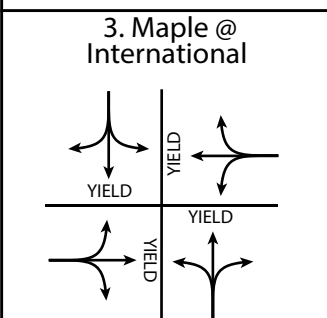
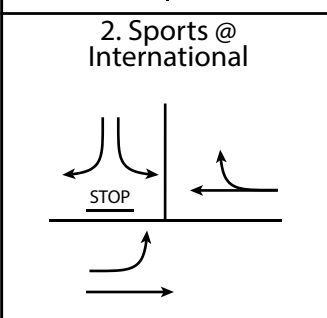
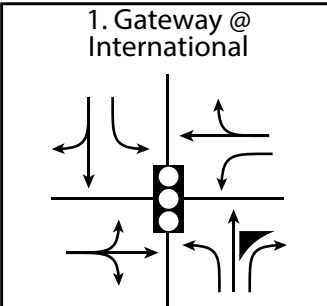

**Legend**

International Way TPR, Springfield, Oregon

Figure 3: Lane Configuration and Traffic Control

## 4.0 CRASH ANALYSIS

A crash evaluation was performed for the study area intersections. The analysis investigates crash data available for the most recent 5 years, 1/1/2019-12/31/2023, to determine the crash rate in crashes per million entering vehicles and the type of crashes that occurred. Year 2024 data is available for injury and fatal crashes. The 2024 data was reviewed for patterns but not included in the crash rate calculations, as the full data for all crash types is not available. The crash analysis follows the Critical Crash Rate methodology outlined in ODOT’s Analysis Procedures Manual. The intersection crash rates are compared to the calculated Critical Crash Rates. If the crash rate exceeds the Critical Crash Rate, the intersection is further evaluated for possible mitigation measures. The crash data is provided in Appendix B. The crash rates are provided in Table 4. Table 5 summarizes the crash data.

TABLE 4: INTERSECTION CRASH RATE

Location	Intersection Type	Number of Crashes	AADT	MEV	Crash Rate	Critical Crash Rate	
<b>Maple Island at International</b>	Roundabout	1	3,040	5.55	0.18	0.98	Under
<b>Maple Island at Game Farm Rd</b>	Roundabout	0	3,900	7.12	0.00	-	-
<b>Game Farm Rd at Deadmond Ferry Rd</b>	Stop	0	5,070	9.25	0.00	-	-
<b>Beltline Rd at Hutton Street</b>	Stop	16	18,500	33.76	0.47	0.63	Under
<b>International Way at Sports Way</b>	Stop	0	3,530	6.44	0.00	-	-
<b>Beltline Rd at Game Farm/MLK</b>	Signal	3	19,600	35.77	0.08	0.55	Under
<b>Gateway St at Game Farm</b>	Signal	5	20,290	37.03	0.14	0.55	Under
<b>Gateway St at Beltline</b>	Signal	50	48,830	89.11	0.56	0.48	Over
<b>Gateway St at International Way</b>	Signal	5	19,310	35.24	0.14	0.55	Under
<b>Gateway St at Harlow Road</b>	Signal	24	20,910	38.16	0.63	0.62	Over

\*(crashes/million vehicles)

The intersections of Gateway Street at Beltline and Gateway Street at Harlow Road have crash rates higher than the Critical Crash Rate for the study area. All other intersections have crash rates under the Critical Crash Rate.

TABLE 5: INTERSECTION CRASH PATTERNS

Location	Number of Crashes	Types of Crashes						Severity		
		Head	Rear	Side	Turn	Other	Ped/Bike	PDO	Injury	Fatal
<b>Maple Island at International</b>	1	0	0	0	0	1	0	1	0	0
<b>Beltline Rd at Hutton Street</b>	16	0	0	0	5	11	0	4	12	0
<b>Beltline Rd at Game Farm/MLK</b>	3	0	1	1	1	0	0	0	3	0
<b>Gateway St at Game Farm</b>	5	0	1	0	1	1	2	0	5	0
<b>Gateway St at Beltline</b>	50	0	21	0	19	10	0	19	31	0
<b>Gateway St at International Way</b>	5	0	1	1	3	0	0	4	1	0
<b>Gateway St at Harlow Road</b>	24	0	4	0	18	0	2	11	13	0

\*(crashes/million entering vehicles)

There was 1 reported crash involving a pedestrian at the Gateway/Game Farm intersection. This crash occurred on Monday, 11/21/2022, at 7 PM. The pedestrian was in the crosswalk on the east side leg of the intersection, traveling northbound. The vehicle was on Game Farm traveling eastbound. The error/cause of the crash is noted as the pedestrian being in the crosswalk during the “don’t walk” indication, and was not visible due to the time of day.

There was 1 reported crash involving a bicyclist at the Gateway/Game Farm intersection. This crash occurred on Wednesday, 7/20/2022, at 8 AM. The bicyclist was traveling westbound on Game Farm Road, and the vehicle was traveling northbound on Gateway Street. The error/cause of the crash was assigned to the vehicle driver for disregarding the traffic signal.

There were 2 reported crashes involving pedestrians occurring at the Gateway/Harlow intersection. One crash occurred on Tuesday, June 12, 2020, at 9 AM. The pedestrian was in the crosswalk traveling eastbound. The vehicle was on Gateway traveling northbound. The error/cause of the crash is noted as the pedestrian being in the crosswalk during the “don’t walk” indication. The other crash occurred on Tuesday, 4/12/22/2020, at 6 PM. The pedestrian was in the crosswalk on the west leg of the intersection, traveling southbound. The vehicle was making a southbound right turn across the crosswalk. The error was assigned to the driver for not yielding the right-of-way to the pedestrian.

The intersection of Gateway Street at Beltline has a crash rate that is over the Critical Crash Rate. A majority of the crashes are classified as rear-end or turn crashes. Of the 22 rear-end collisions, 6 involved southbound vehicles, 6 involved westbound vehicles, 2 involved northbound vehicles, and

8 involved eastbound vehicles. The patterns are consistent with the higher volume/higher congested approaches. Of the 22 turning movement crashes, 8 involved northbound through and southbound left turns. A majority of these types of crashes had the error assigned to the left-turning vehicle. There is no apparent crash pattern with the remainder of the turning crashes.

The intersection of Gateway Street at Harlow Road has a crash rate that is over the critical crash rate. A majority of the crashes were turning movement crashes. Of the 18 turning movement crashes, a majority involved an eastbound or westbound through vehicle colliding with the opposing left turn movement. The left turns operate as protective-permissive. These types of crashes are typical at high-volume intersections with permissive phasing. The City could examine the operational feasibility of running protective-only phasing during peak hours.

## 5.0 IN-PROGRESS TRANSPORTATION IMPROVEMENT PROJECTS

The following projects identified within the TSP are within the study area. The projects described below, as identified in the TSP, are evaluated to determine if the Annexation will have a “significant effect”, as defined in the TPR, on the proposed transportation improvements.

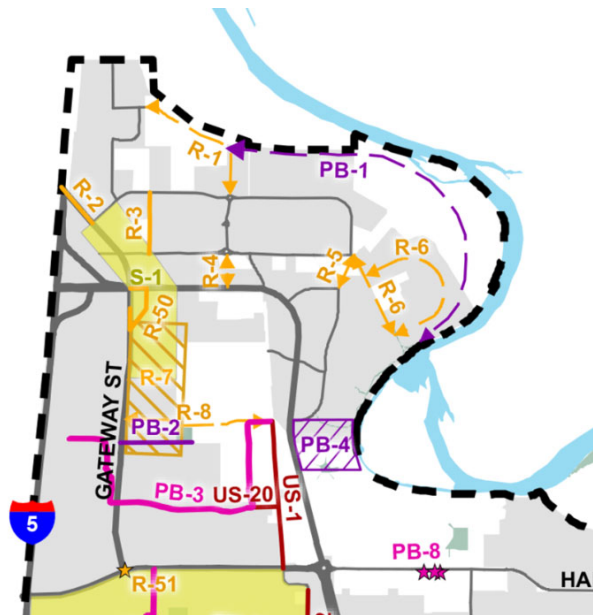

City of Springfield TSP Projects Within Study Area

**Project R-50:** The City of Springfield has identified improvements to the Beltline/Gateway intersection area. The improvements are reasonably anticipated to be completed within the 20-year planning horizon. Therefore, the improvements are assumed to be completed in the year 2035 conditions. The improvements include:

- Converting Gateway into a couplet between the Crossroads Center Access and Beltline Road.
- Divert northbound movements to the couplet, removing all northbound movements at the Gateway and Beltline intersection.
- Signalize Beltline at Hutton St intersection.
- Intersection configuration and layout as per the I-5/Beltline Interchange Area Management Plan

The year 2035 analysis is prepared to evaluate the system with and without the couplet at this intersection to determine if the Annexation impacts the proposed improvement. The evaluation and results are described later in this report.

**Project R-1:** This project includes a new east/west collector street between Royal Caribbean Way and International Way. This project is assumed to be completed as development occurs. While this project may end up constructing the portion of the roadway within their development site, the section to the east of the development site has not been constructed. Therefore, this analysis assumes that the full roadway connection will not be in place by the year 2035, and all development traffic from this proposed Annexation will access the site via a direct connection to International Way. This Annexation proposal will not affect the ability of this project to move forward as proposed.

**Project R-2:** This project includes the construction of a 5-lane section of roadway on Gateway Street between International Way and the UGB. This is an opportunity project and not a priority project for the City. Therefore, it is not assumed to be in place by the year 2035. This Annexation proposal will not affect the ability of this project to move forward as proposed.

**Project R-3:** This project includes a new north/south collector street between Game Farm Road and International Way at approximately the western edge of Tax Lot 600. This is listed as a priority project. However, the right-of-way for this project does not currently exist. Therefore, this project is considered not to be completed prior to the year 2035. This Annexation proposal will not affect the ability of this project to move forward as proposed.

**Project R-4:** This project includes the extension of Maple Island Road south of Game Farm Road to Beltline Road. This project is anticipated to be completed as development occurs. As this site is currently fully developed, this project is considered not to be completed prior to the year 2035. This Annexation proposal will not affect the ability of this project to move forward as proposed.

**Project R-5:** This project includes the extension of Riverbend Drive to International Way. This project is anticipated to be completed as development occurs. As this area is currently fully developed, this project is considered not to be completed prior to the year 2035. This Annexation proposal will not affect the ability of this project to move forward as proposed.

**Project R-7:** This project is a new roadway constructed south of Kruse Way and east of Gateway Street. This is an aspirational project that is anticipated to be completed sometime beyond the year 2035 planning horizon. This Annexation proposal will not affect the ability of this project to move forward as proposed.

**Project R-8:** This project involves updating Mallard Avenue to a 2-lane roadway with typical urban upgrades. This project is anticipated to be completed as development occurs. This Annexation proposal will not affect the ability of this project to move forward as proposed.

**Project R-51:** This project includes traffic control improvements and is listed as a priority project. This study evaluates this intersection, as the Annexation has the potential to add traffic to this intersection. The evaluation is discussed later in this report.

**Project PB-1:** This project includes the construction of a multi-use path between Maple Island Road and the existing path at River Bend Hospital. This project is anticipated to be completed as development occurs. This Annexation proposal will not affect the ability of this project to move forward as proposed.

## 6.0 BACKGROUND TRAFFIC VOLUMES

### 6.1 INTERSECTION COUNTS

Intersection turning movement counts were collected by Sandow Engineering from 4:00-6:00 PM. The peak hour of the system occurs from 4:30 to 5:30 PM. The dates of the traffic counts are provided in Table 6 below. All traffic counts were taken within the past year. The traffic volumes are included in Appendix C.

TABLE 6: TRAFFIC COUNT DATES

Intersection	Count Date
International Way at Sports Way	November 12, 2024
International Way at Maple Island Road	February 13, 2024
Maple Island Road at Game Farm Road	December 4, 2024
Game Farm Road at Deadmond Ferry	December 4, 2024
Game Farm Road at MLK Jr. Parkway	December 4, 2024
Gateway Street at International Way	February 8, 2024
Gateway Street at Game Farm Road	December 4, 2024
Gateway Street at Beltline Road	December 4, 2024
Beltline Road at Hutton Street	December 4, 2024
Gateway Street at Harlow Road	March 3, 2024

### 6.2 PIPELINE TRIPS

Within the study area, Peace Health’s Rehabilitation Hospital, located at Game Farm Road and Maple Island Road, has been approved but not yet completed at the time the traffic counts were

taken. As this project will be completed prior to the year 2035, the trips generated by this development are added to the year 2035 background trips and the year 2035 total trips with the Annexation.

### 6.3 FUTURE YEAR BACKGROUND VOLUMES

Consistent with the TPR criteria, the intersections were evaluated for the 20-year planning horizon, year 2035. An annual growth rate was applied to account for naturally occurring traffic increases between the count year and the future analysis year. The City's standard growth rate of 2% per year was used for this study. The 2.0% per year rate was applied to the year 2024 counts to estimate the year 2025 and year 2035 volumes.

### 6.4 FINAL TRAFFIC VOLUMES

The existing traffic volumes were adjusted according to the methodology described above. Appendix C provides the traffic volume calculations. The Annexation trips are added to the background traffic volumes to represent the “build” conditions. The traffic volumes are provided in the following figures:

- Figure 4- Year 2025 PM Peak Hour Background
- Figure 5- Year 2035 PM Peak Hour Background
- Figure 6- Year 2035 PM Peak Hour with Annexation with Existing Roadway
- Figure 7- Year 2035 PM Peak Hour with Annexation with TSP Projects

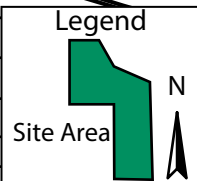
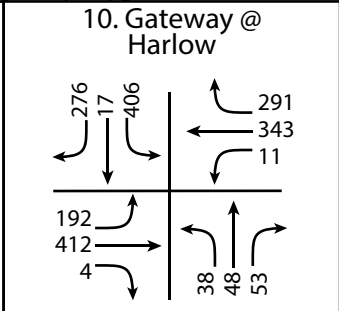
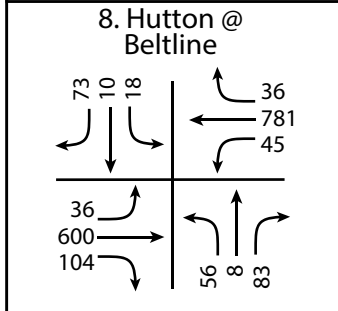
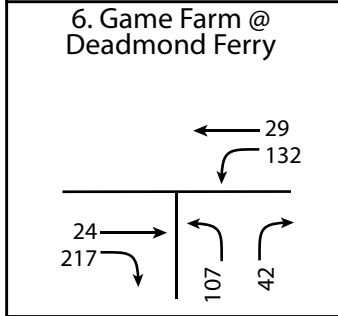
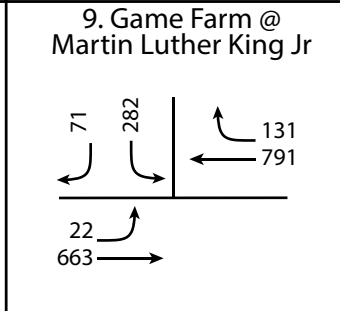
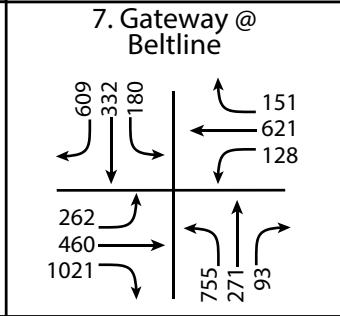
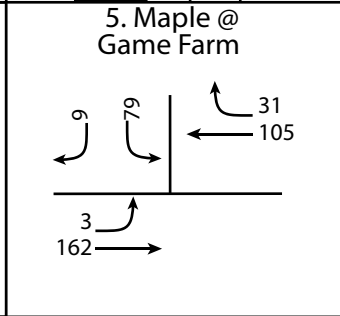
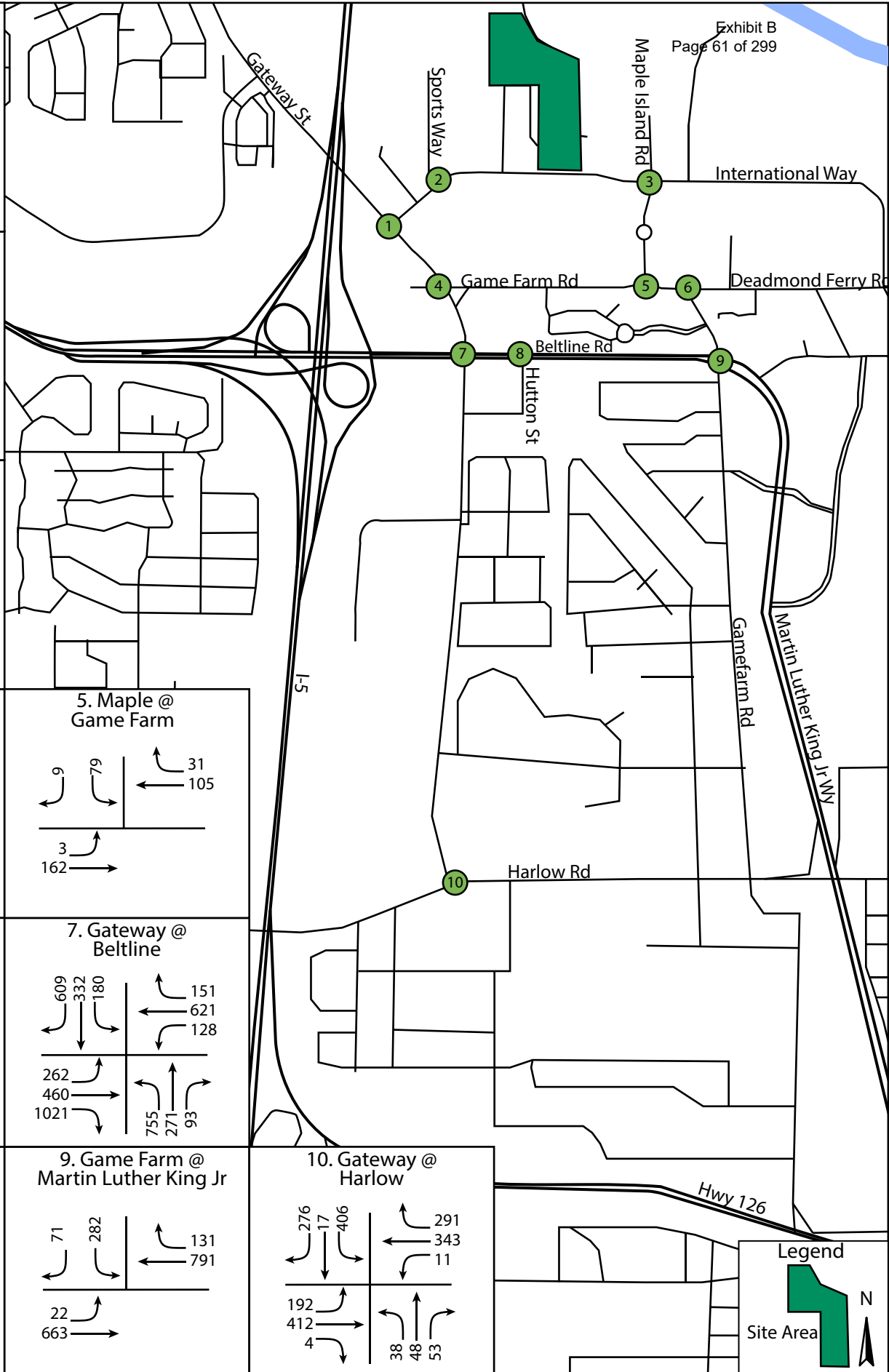
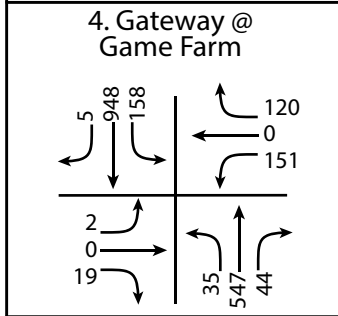
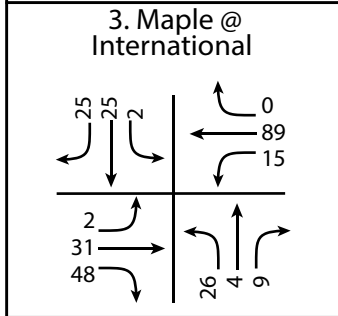
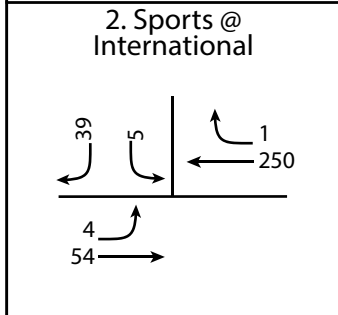
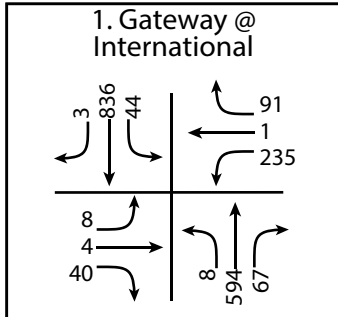

International Way TPR, Springfield, Oregon

Figure 4: Year 2025 Background Traffic Volumes

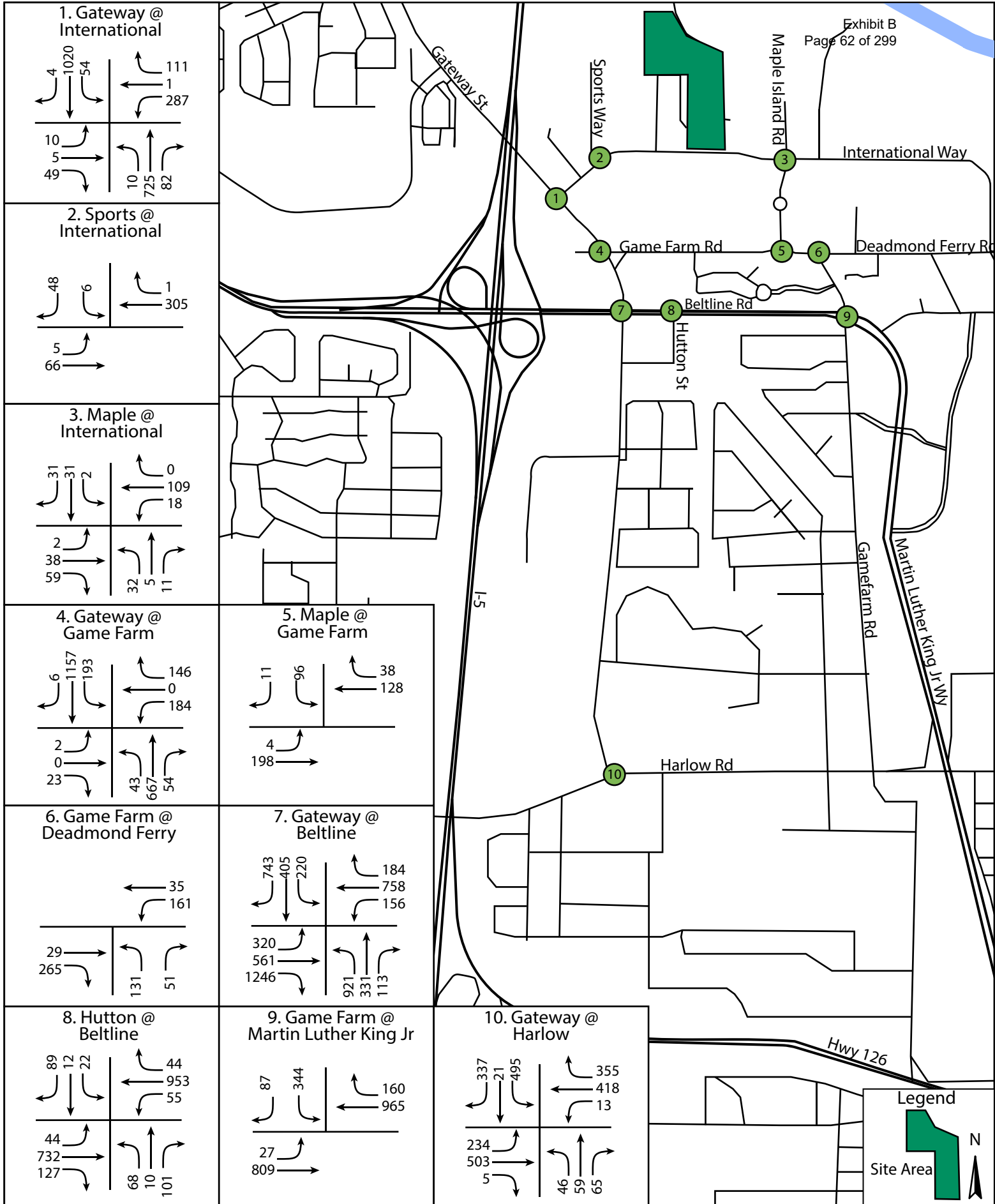

International Way TPR, Springfield, Oregon

Figure 5: Year 2035 Background Traffic Volumes

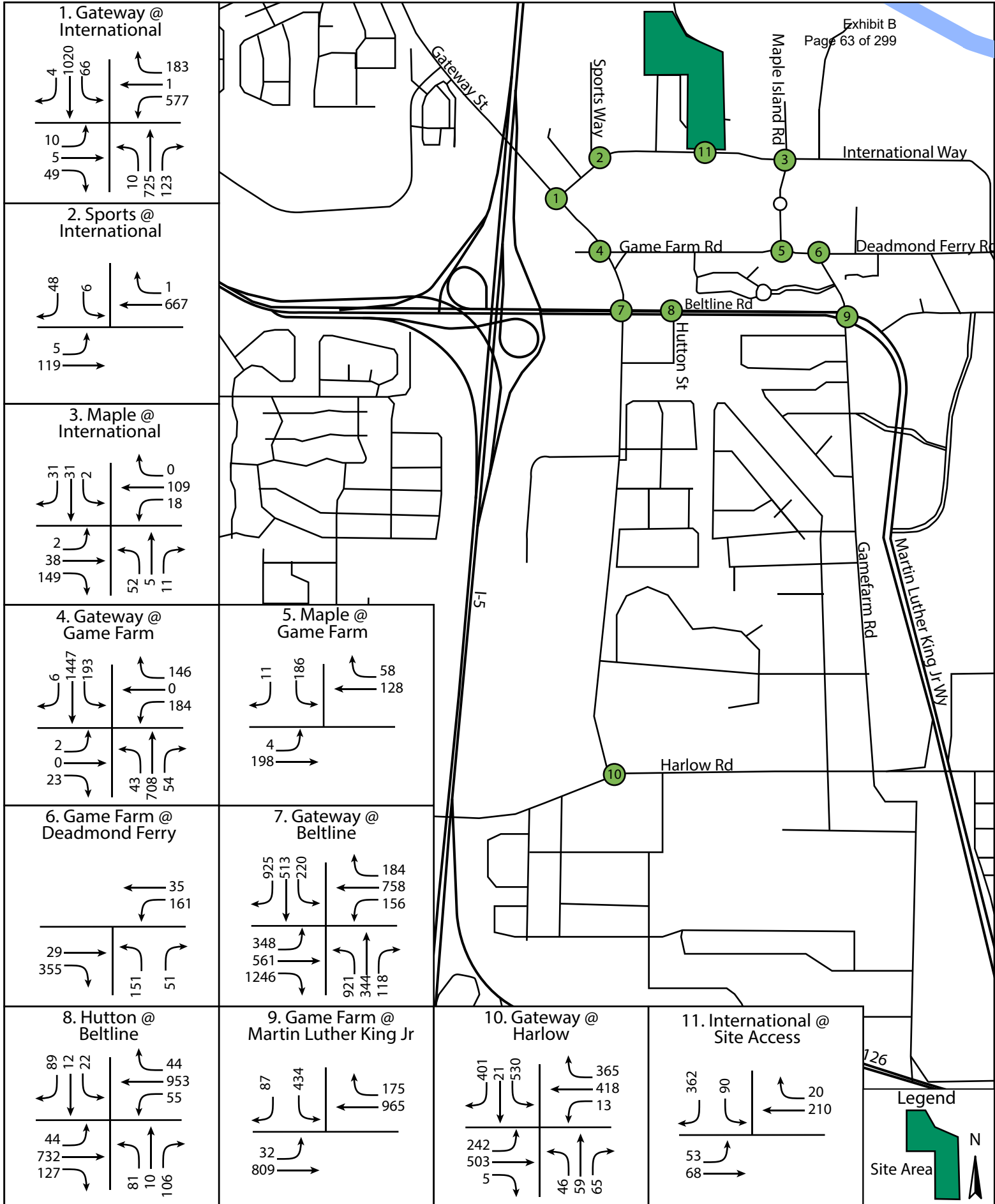

International Way TPR, Springfield, Oregon

Figure 6: 2035 with Annexation Existing Roadway Network

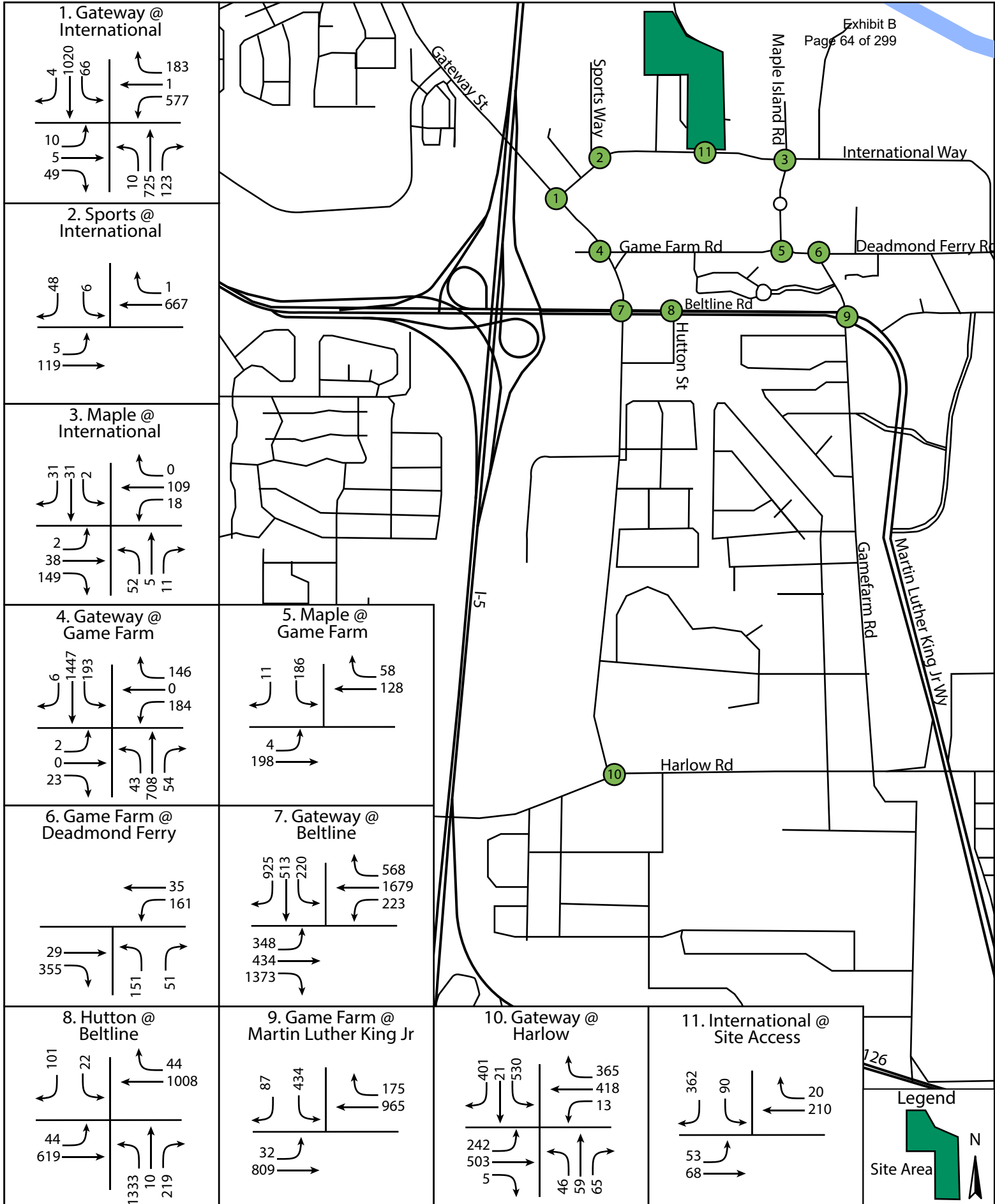

International Way TPR, Springfield, Oregon

Figure 7: Year 2035 with Annexation and TSP Projects

## 7.0 INTERSECTION ANALYSIS

### 7.1 PERFORMANCE MEASURES

The City of Springfield uses a Level of Service (LOS) standard for intersections under the City’s jurisdiction. The LOS standard is based on the Highway Capacity Manual (HCM), defined level of service (LOS). LOS is a concept developed to quantify the degree of comfort (including such elements as travel time, number of stops, total amount of stopped delay, and impediments caused by other vehicles) afforded to drivers as they travel through an intersection or along a roadway segment. It was developed to quantify the quality of service of transportation facilities.

LOS is based on average delay, defined as the average total elapsed time from when a vehicle stops at the end of a queue until the vehicle departs from the stop line. Average delay is measured in seconds per vehicle per hour and is then translated into a grade or “level of service” for each intersection. LOS ranges from A to F, with A indicating the most desirable condition and F indicating the most unsatisfactory condition.

Springfield has a standard of LOS D.

The LOS criteria, as defined by the Highway Capacity Manual (HCM 7) for signalized intersections, are provided in Table 7.

TABLE 7: HCM LEVEL OF SERVICE FOR INTERSECTIONS

	<b>Stopped Delay Per Vehicle (Seconds per Vehicle)</b>	
	<b>Unsignalized Intersections</b>	<b>Signalized Intersections</b>
<b>A</b>	$\leq 10.0$	$\leq 10$
<b>B</b>	$> 10.0$ and $\leq 15.0$	$> 10$ and $\leq 20$
<b>C</b>	$> 15.0$ and $\leq 25.0$	$> 20$ and $\leq 35$
<b>D</b>	$> 25.0$ and $\leq 35.0$	$> 35$ and $\leq 55$
<b>E</b>	$> 35.0$ and $\leq 50.0$	$> 55$ and $\leq 80$
<b>F</b>	$> 50.0$	$> 80$

The City of Springfield has asserted that ODOT’s volume-to-capacity (v/c) standard applies to the intersection of Gateway Street and Beltline Road, as ODOT has jurisdiction of the west leg of the intersection and the intersection is part of the interchange components as per the I-5/Beltline Interchange Area Management Plan. Beltline Highway from I-5 to Gateway Street is designated as a Regional Highway and is located within a Metropolitan Planning Organization (MPO). The v/c standard, as defined within the Oregon Highway Plan, is based on roadway classification and location. Typically, the v/c for intersections with this classification is 0.95. However, the IAMP has

identified the v/c standard to be 0.85. The City has asserted that the v/c standard of 0.85 is to be applied, and so was used in this case out of an extreme abundance of caution.

## 7.2 INTERSECTION ANALYSIS RESULTS

A performance analysis was conducted for the studied intersections for the Years 2025 and 2035 conditions during the PM peak hours. The intersection evaluation was performed using Synchro 12, utilizing the HCM 7 methodology, for the signalized and stop-controlled intersections. ODOT Roundabout Methodology was used to calculate the LOS for the roundabouts. The results are shown in Table 8. The SYNCHRO and roundabout calculation outputs are provided in Appendix D.

The City of Springfield has identified the TSP project R-50: The Gateway/Beltline couplet improvements as a Tier 1 project to be completed within the 20-year planning horizon. As this project is reasonably assumed to be completed, the proposed improvements are an assumed interim project and are evaluated for impacts from the proposed annexation. The Gateway/Beltline IAMP proposed a lane configuration and intersection layout that is used as the lane configuration for this evaluation. The IAMP intersection configuration is illustrated in the following image.

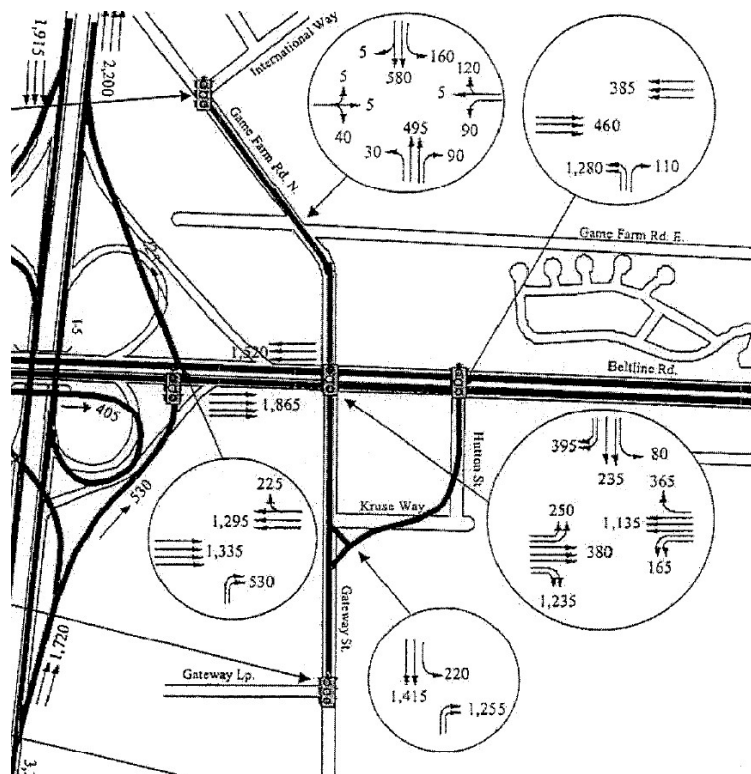

**Gateway Couplet Configuration- Source I-5/Beltline IAMP**

TABLE 8: INTERSECTION PERFORMANCE: WEEKDAY PM PEAK HOUR

Intersection	Mobility Standard	2025 Background	2035 Background	2035 With Annexation
Maple Island Rd at Game Farm Rd	LOS D	A	A	A
International Way at Maple Island Rd	LOS D	A	A	A
Gateway St at Beltline Rd	LOS D v/c 0.85	F 0.76	Without TSP Project=F/0.93 With TSP Project=D/0.64	Without TSP Project=F/1.01 With TSP Project=D/0.67
International Way at Gateway St	LOS D	B	B	D
Gateway Street at Game Farm Rd	LOS D	B	B	B
Game Farm Rd at Deadmond Ferry Road	LOS D	C	C	C
Game Farm Rd at Beltline Rd/Martin Luther King Jr Parkway	LOS D	B	B	B
Beltline at Hutton	LOS D	F	Without TSP Project=F With TSP Project=D	Without TSP Project=F With TSP Project=D
Gateway Street at Harlow Road	LOS D	C	D	D
International Way at Sports Way	LOS D	B	B	C
International Way at Site Access	LOS D	-	-	C

As illustrated in Table 8, the Gateway at Beltline intersection is currently not meeting standards. However, with the city-funded improvement project, the standards will be met in the year 2035. The trips from the proposed annexation do not have a significant impact on the existing and future transportation infrastructure.

### 7.3 QUEUE ANALYSIS

A queuing analysis was conducted for the studied intersections. The adjacent driveways on the north side of International Way were added to the queuing model to evaluate the queuing effects from the site driveway onto International Way. The signalized and stop-controlled queuing analysis was performed using SimTraffic, a microsimulation software tool that uses the HCM-defined criteria to estimate the queuing of vehicles within the study area. ODOT’s Roundabout Methodology was used to calculate the roundabout queues. The average and 95<sup>th</sup> percentile queuing results are illustrated in Table 9 for the PM peak hour. All results are rounded to 25 feet to

represent the total number of vehicles in the queue, as one vehicle typically occupies 25 feet of space. The SimTraffic and roundabout calculation outputs are provided in Appendix E.

TABLE 9: INTERSECTION QUEUING: WEEKDAY PM PEAK HOUR

Intersection			Available Storage (Feet)	2025 Background (Feet)		2035 Background (Feet)		2035 w/Annexation (Feet)	
				95 <sup>th</sup>	Average	95 <sup>th</sup>	Average	95 <sup>th</sup>	Average
<b>Game Farm at Maple Island</b>	EB	LTR	1000+	25	N/A	25	N/A	25	N/A
	WB	ULTR	300	25	N/A	25	N/A	25	N/A
	SB	LTR	300	25	N/A	25	N/A	25	N/A
<b>Maple Island at International</b>	EB	LTR	1000+	25	N/A	25	N/A	25	N/A
	WB	LTR	500+	25	N/A	25	N/A	25	N/A
	NB	LTR	350	25	N/A	25	N/A	25	N/A
	SB	LTR	125	25	N/A	25	N/A	25	N/A
<b>Beltline at Gateway</b>	EB	L	525	200	125	450	250	500	275
	EB	T	700	225	150	475	225	525	275
	EB	R	670	425	300	450	350	425	325
	WB	L	440	175	100	325	150	500	275
	WB	T	440	225	150	475	300	550	425
	WB	TR	400	200	150	425	275	450	375
	NB	L	275	500	350	825	700	850	700
	NB	TR	400	250	150	875	675	950	650
	SB	L	375	200	125	475	325	425	250
	SB	T	470	300	200	575	525	575	375
<b>Beltline at Gateway with TSP Improvements</b>	SB	R	210	150	100	450	225	325	175
	EB	L	525	N/A	N/A	225	125	200	125
	EB	T	700	N/A	N/A	225	100	150	75
	EB	R	670	N/A	N/A	400	300	350	275
	WB	L	440	N/A	N/A	150	100	150	100
	WB	T	440	N/A	N/A	325	225	375	300
	WB	R	400	N/A	N/A	200	100	275	150
	SB	L	375	N/A	N/A	250	175	225	150
	SB	T	470	N/A	N/A	200	150	225	150
<b>Gateway at International</b>	SB	R	210	N/A	N/A	300	200	225	150
	EB	LTR	100	50	25	75	50	100	50
	WB	L	280	150	100	325	300	325	300
	WB	TR	475	75	50	675	475	675	475
	NB	L	140	25	25	75	25	100	25
	NB	T	640	200	125	350	200	475	300
	NB	R	110	0	0	125	25	150	25
	SB	L	200	75	25	275	150	225	100
SB	TR	400	250	150	350	325	350	350	
	EB	LTR	250	25	25	25	25	25	25

<b>Gateway at Game Farm</b>	WB	L	750	125	75	225	150	200	125
	WB	TR	810	50	50	125	275	175	75
	NB	L	120	50	25	100	50	100	25
	NB	T	475	175	100	250	150	225	125
	NB	R	475	0	0	75	25	25	25
	SB	L	240	75	25	225	75	150	50
	SB	T	450	125	50	325	225	250	150
	SB	TR	610	150	75	425	375	425	200
<b>Game Farm at Deadmond Ferry</b>	EB	TR	290	25	25	50	25	25	25
	WB	L	160	50	25	75	50	75	50
	NB	L	140	50	25	100	50	75	50
	NB	R	540	50	25	50	25	50	25
<b>Beltline at Game Farm</b>	EB	L	425	50	25	75	25	75	25
	EB	T	1000+	125	75	175	100	200	100
	WB	T	390	150	100	250	200	275	175
	WB	R	410	75	50	175	75	125	50
	SB	L	150	175	125	250	150	300	200
	SB	R	530	100	25	125	50	150	50
<b>International Way at Site Access</b>	EB	L	825	N/A	N/A	N/A	N/A	25	50
	SB	LR	250	N/A	N/A	N/A	N/A	175	100
<b>Hutton at Beltline</b>	EB	L	130	50	25	75	50	75	25
	EB	T	425	25	25	25	25	25	25
	EB	TR	425	25	25	25	25	25	25
	WB	L	475	50	25	50	25	100	25
	WB	T	1500	25	25	50	25	300	75
	WB	TR	100	50	50	50	25	500	175
	NB	LTR	460	150	75	525	225	700	475
	SB	LT	200	50	25	75	50	75	50
	SB	R	200	75	50	100	50	175	75
<b>Hutton at Beltline with TSP Improvements</b>	EB	L	130	N/A	N/A	125	50	125	50
	EB	T	425	N/A	N/A	225	125	250	175
	WB	T	1500	N/A	N/A	300	225	375	250
	WB	TR	1500	N/A	N/A	325	225	375	275
	NB	L	600	N/A	N/A	450	300	450	300
	NB	TR	600	N/A	N/A	200	75	175	75
	SB	L	200	N/A	N/A	50	25	75	25
	SB	R	200	N/A	N/A	150	75	125	75
<b>Harlow at Gateway</b>	EB	L	225	150	100	275	175	225	150
	EB	T	500	125	75	300	150	225	125
	EB	TR	500	100	50	200	125	175	100
	WB	L	200	50	25	75	25	75	25
	WB	T	475	175	100	325	200	275	175
	WB	TR	475	200	125	400	250	325	200

	NB	LT	225	100	50	150	100	125	75
	NB	TR	225	75	25	100	50	75	50
	SB	L	220	250	150	275	275	325	225
	SB	TR	500	125	75	400	150	225	100

As demonstrated in Table 9, the trips from the proposed Annexation will not significantly alter queuing conditions. Queuing along Gateway Street and Beltline Road is substantially improved with the TSP couplet project.

## 8.0 TRANSPORTATION PLANNING RULE FINDINGS

Consistent with the Transportation Rule (TPR), the following elaborates on how this development meets the TPR requirements.

*Goal 12, (OAR) 660-12-0060 (1) requires that a local government ensures that an amendment to a functional plan, an acknowledged comprehensive plan, or a land-use regulation (including a zoning map) does not significantly affect an existing or planned transportation facility. A plan or land use amendment significantly affects a transportation facility if it would:*

- (a) Change the functional classification of an existing or planned transportation facility (exclusive of correction of map errors in an adopted plan);*

The existing street classification of the study area roadways is illustrated in Table 10.

TABLE 10: EXISTING STREET CLASSIFICATION

Street	Classification
<b>Maple Island Rd</b>	Local
<b>Game Farm Rd</b>	Collector
<b>Beltline Hwy</b>	Minor/Major Arterial
<b>Martin Luther King Jr Parkway</b>	Minor Arterial
<b>Gateway St</b>	Minor Arterial

The City of Springfield Transportation System Plan identifies the factors considered in street classifications. These are land use patterns, roadway volumes, density of accesses, traffic mix and volumes, safety trends, traffic speeds, intersection spacing, and right-of-way availability and constraints.

The traffic mix is anticipated to be a majority of passenger vehicles with infrequent, larger truck deliveries. The mix and levels of traffic are consistent with what is typically found within the types

of streets in the study area. The proposed Annexation and use will not require a change in street classification.

As demonstrated, the levels of traffic added from the proposed Annexation will not change the functional classification of any of the adjacent streets where development traffic will be added.

*(b) Change standards implementing a functional classification system; or*

The standards for implementing a functional classification system are found within the City of Springfield’s Transportation System Plan. The standards are based on street connectivity, spacing of streets, mix and amounts of travel modes, and mobility. The proposed Annexation does not need to modify the standards for the street functional classification system.

*(c) Result in any of the effects listed in paragraphs (A) through (C) of this subsection based on projected conditions measured at the end of the planning period identified in the adopted TSP. As part of evaluating projected conditions, the amount of traffic projected to be generated within the area of the amendment may be reduced if the amendment includes an enforceable, ongoing requirement that would demonstrably limit traffic generation, including, but not limited to, transportation demand management. This reduction may diminish or completely eliminate the significant effect of the amendment.*

*(A) Types or levels of travel or access that are inconsistent with the functional classification of an existing or planned transportation facility;*

Development of the property with the proposed Annexation will mostly consist of passenger cars, pedestrians, and bicycles, with occasional use by delivery vehicles, etc. This type of use is consistent with the types of uses expected on urban streets, especially local and collector streets.

The proposed Annexation will not cause traffic levels, patterns, or access that are inconsistent with the functional classification of an existing or planned transportation facility.

*(B) Degrade the performance of an existing or planned transportation facility such that it would not meet the performance standards identified in the TSP or comprehensive plan;  
 or*

As demonstrated in Section 7.2, the proposed Annexation does not degrade the performance of an existing or planned transportation facility such that it would not meet the performance standards.

*(C) Degrade the performance of an existing or planned transportation facility that is otherwise projected to not meet the performance standards identified in the TSP or comprehensive plan.” OAR 660-12-0060(1)*

The intersection of Beltline Road at Gateway Street is currently not meeting the City’s LOS standard. The City’s TSP priority project of a couplet at relocating northbound trips to Hutton Street will improve the LOS to meet the standards.

## 9.0 CONCLUSION

This report provides the Traffic Impact Analysis and findings prepared for the proposed Annexation of an 18-acre parcel development site located on International Way in Springfield, Oregon. The analysis evaluates the transportation impacts as per the City of Springfield, evaluating adjacent roadway and intersection operation consistent with OAR-660-012-0060, TPR criteria.

### FINDINGS

- The addition of development trips does not trigger any intersections to not meet the LOS standards.
- The intersection of Gateway St at Beltline Rd currently operates at LOS F during the PM peak hour. The City has identified improvements at this intersection, which are reasonably assumed to be constructed within the 20-year planning horizon. With these improvements, the intersection will meet the mobility standards through the year 2035.
- The addition of development traffic does not substantially increase queuing conditions with the TSP improvement projects in place.
- There is no off-site mitigation needed for the annexation proposal.
- The above findings demonstrate that the TPR, if it were applicable, would be met.

## INTERNATIONAL WAY TPR

---

## TECH MEMO

---

DATE: November 25, 2024

TO: Michael Liebler, PE  
City of Springfield

FROM: Kelly Sandow P.E.  
Sandow Engineering

RE: Scope of Work- TPR Tax Lots 5400 and 400 International Way

---

The following provides the trip generation estimate and proposed Scope of Work for the proposed zone change of Tax Lot 5400 and 400 located on International Way between Sports Way and Maple Island Road.

### **Development Proposal**

The site is currently zoned “Campus Industrial” (CI). The applicant is proposing a zone change to “Medical Services” (MS).

### **Site Information**

The development site is comprised of Tax Lots 5400 and 400. The site is approximately 18.0 acres and is currently vacant of any building/development.

The site has frontage on International Way, which is classified as a Major Collector. There is an east/west street that stubs into the northwestern edge of the development site.

For the purposes of the analysis, access will be assumed via a new driveway connection to International Way as there is no other means of access to the public street system that is not through private development.

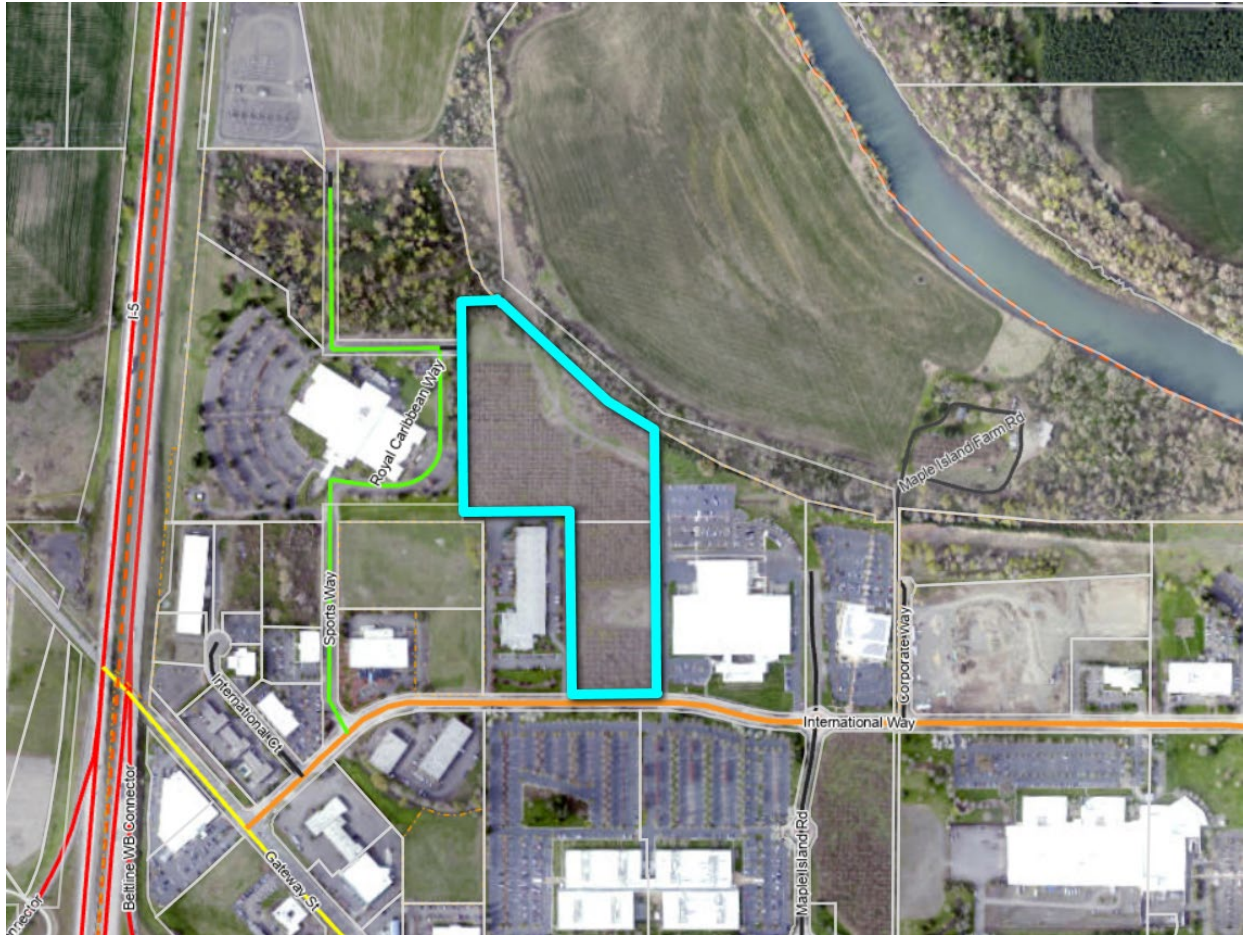

**Site Location and Street Classification**

## **TRANSPORTATION PLANNING RULE ANALYSIS**

### **Existing Zoning Trip Generation**

The existing zoning is Campus Industrial-CI. Uses allowed in the CI zoning are:

- Warehouse and wholesale sales
- Corporate Office/Headquarters
- Business Park

Maximum building height is 45 feet.

Taking into consideration the typical building footprint layout of adjacent properties with C-I zoning, it is estimated that a reasonable maximum building footprint is approximately 25% percent of the total site. The remaining 75% is landscaping, parking, drive aisles, and loading areas.

- Total Site= 18.0 acres/784,080 sf
- Building footprint 25%= 196,020 sf

- 2 Stories = 392,040 sf total

The PM peak hour trip generation is estimated by comparing the uses allowed within the zone. The associated ITE Trip Generation Land Uses with the higher PM peak hour rates are:

- **140 Manufacturing:** primary activity is manufacturing raw materials into finished products. Buildings typically contain offices, manufacturing areas, and storage areas.
- **156 High-Cube Parcel Hub Warehouse:** buildings primarily devoted to the storage of materials. Land use codes 150 Warehousing, 154 High-Cube Transload and Short-Term Storage, 155 High-Cube Fulfillment Center Warehouse, and 157 High-Cube Storage Warehouse were all evaluated. 156 High-Cube Parcel Hub Warehouse has the highest PM peak hour rates.
- **714 Corporate Headquarters Building:** single-tenant office buildings that house the corporate or headquarters of a company.
- **750 Office Park:** planned unit development that contains general office buildings and support services arranged in a park or campus-like setting.
- **760 Research and Development Center:** facility devoted to research and development. Buildings contain offices and light fabrication areas
- **770 Business Park:** group of flex-type or incubator buildings. The space contains a mix of office, manufacturing, retail, and wholesale stores.

Table 1 contains the trip generation estimate for the existing zoning.

TABLE 1: PM PEAK HOUR TRIP GENERATION -EXISTING CI ZONING

ITE Code	Rate	Trips
<b>140 Manufacturing</b>	$T=0.87(X)-17.5$	324
<b>156 High-Cube Parcel Hub Warehouse</b>	0.64	251
<b>714 Corporate Headquarters Building</b>	$\ln(T)=0.94\ln(x)+0.58$	489
<b>750 Office Park</b>	<b><math>T=1.26(X)+20.98</math></b>	<b>515</b>
<b>760 Research and Development Center</b>	$T=0.84(x)+25.08$	354
<b>770 Business Park</b>	$\ln(T)=0.88\ln(x)+0.93$	485

The highest PM peak hour generator is 750 Office Park at 515 PM peak hour trips.

**Potential Zoning**

The proposed zoning is Medical Services-MS. The higher trip-generating uses allowed within the MS zoning are:

- Medical clinic
- Medical office building

- Hospital

For office and medical uses, the building footprint is estimated considering typical parking needs, minimum landscaping at 10%, and building heights. The building footprint is estimated at 33% of the site. The office and clinic use would likely be 2 stories. The building would have a total square footage of approximately 257,000 sf.

The trip generation for each development scenario is illustrated in Table 2.

TABLE 2: PM PEAK HOUR TRIP GENERATION-PROPOSED MS ZONING

Development Potential	ITE Code	Rate	Trips
<b>257,000 sf medical office building</b>	<b>720 Medical Office Building</b>	<b><math>T=4.07(X)-3.17</math></b>	<b>1,044</b>
<b>257,000 sf clinic</b>	630 Clinic	$T=3.53(X)+2.98$	910
<b>257,000 sf hospital</b>	610-Hospital	$\ln(T)=0.64\ln(x)+2.27$	337

The reasonable worst-case development potential under the proposed zoning will generate 1,044 PM peak hour trips.

The entering and exiting splits are illustrated in Table 3 below. As demonstrated, the increase in trips from the zone change will increase the total trips by 528.

	Total	In	Out
Existing Zoning	515	72	443
Proposed Zoning	1,043	313	730
<b>Increase</b>	<b>528</b>	<b>241</b>	<b>287</b>

The increase in trips is distributed on the street network. The trip distribution follows the existing travel patterns based on recent traffic counts taken within the study area.

The trip distribution is shown in the image below.

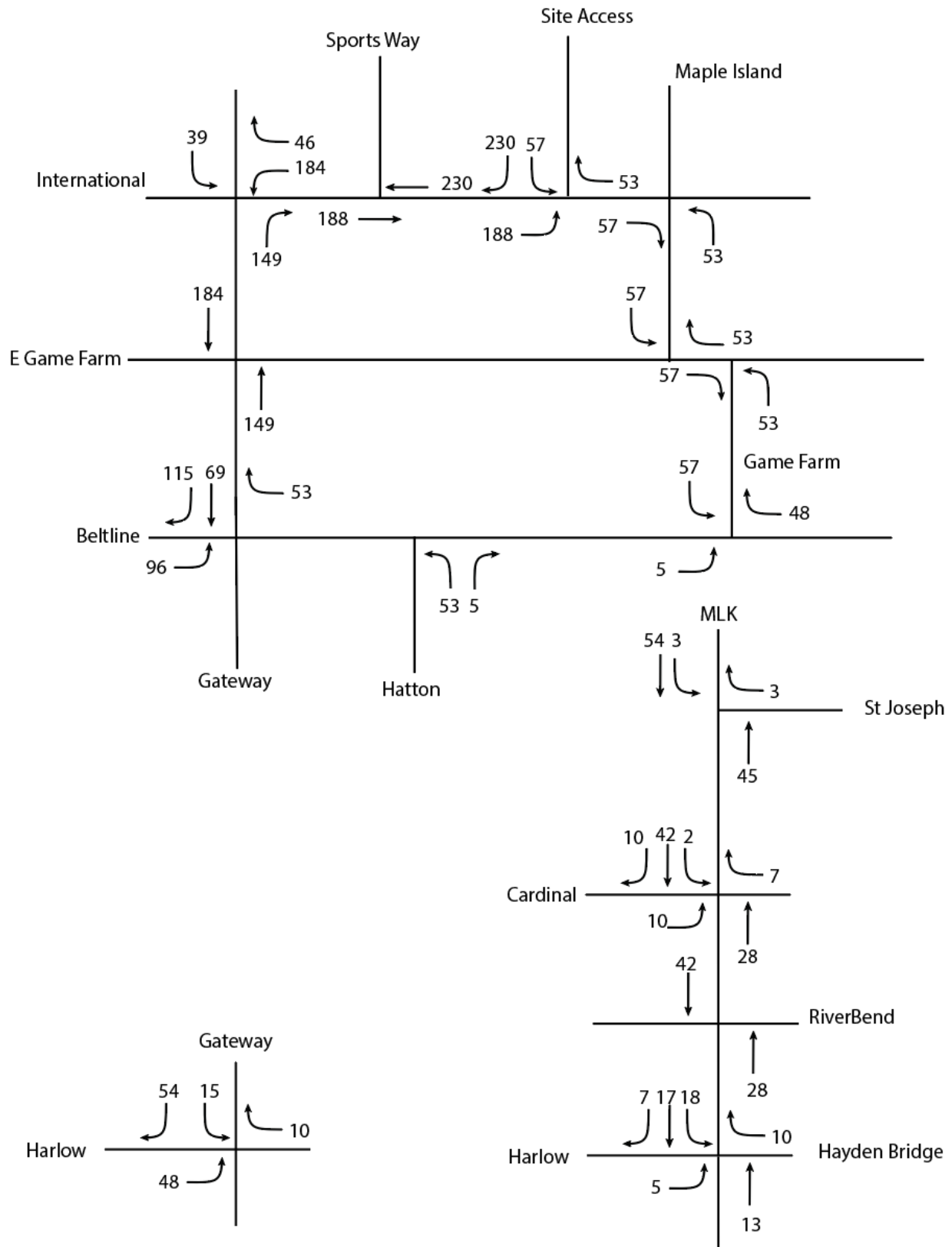

**Trip Distribution TPR Analysis  
 (Trip Differential)**

The following intersections have 20 or more trips added:

- International Way at Sports Way
- International Way at Maple Island
- Maple Island at Game Farm Road
- Game Farm Road at Deadmond Ferry
- Game Farm at MLK JR Parkway
- International Way at Gateway St
- Game Farm at Gateway St
- Gateway Street at Beltline
- Gateway Street at Hatton
- Gateway Street at Harlow
- MLK Jr Parkway at St Joseph
- MLK Jr Parkway at Cardinal Way
- MLK JR Parkway at Riverbend Dr
- MLK JR Parkway at Harlow Road/Hayden Bridge/Pioneer Parkway

\*\* MLK JR Parkway at Harlow Road/Hayden Bridge/Pioneer Parkway intersection will receive more than 25 peak hour trips. However, we recommend not including this intersection in the study, given that there are no further capacity improvements that could be constructed at this location, given the right-of-way restrictions and current roundabout geometry.

\*\* MLK JR Parkway at St Joseph, Cardinal, and Riverbend will have very few turning movements from the site. Therefore, the impact will be insignificant. It is recommended that these intersections not be included in the analysis.

## **ANALYSIS PARAMETERS**

### **TPR Analysis**

- Years
  - 2023- Existing
  - 2035- TSP Horizon
- PM Peak Period 4-6 PM
- Growth Rate: 2%
- Analysis to include:
  - LOS
  - V/c
  - Queuing
  - Crash
  - OAR/TPR Criteria Evaluation/Discussion
- Intersections to be studied
  - International Way at Sports Way

- International Way at Maple Island
- Maple Island at Game Farm Road
- Game Farm Road at Deadmond Ferry
- Game Farm at MLK JR Parkway
- International Way at Gateway St
- Game Farm at Gateway St
- Gateway Street at Beltline
- Gateway Street at Hatton

### **Future TSP Roadway Projects**

The evaluation will

- R-50: 2035 TPR Analysis will include the proposed Gateway couplet as a Tier 1 project.
- R-1: The City's TSP has identified a new roadway project within the project area. North Gateway Collector- Maple Island Road/Royal Caribbean Way to International Way. This project is a new 3-lane roadway with sidewalks and bicycle facilities.

## INTERNATIONAL WAY TPR

CRASH DATA SUMMARY

6173 International Way TPR

Beltline @ Game Farm RD / MLK											
YEAR	PDO	INJURY	FATAL	HEAD	REAR	SIDE	TURN	OTHER	PED	BIKE	TOTAL
2019		1					1				1
2020		2			1	1					2
2021											0
2022											0
2023											0
2024											0
2019-2023	0	3	0	0	1	1	1	0	0	0	3

CHECK
OK
OK
OK
OK
OK
OK
OK

P.M. PEAK HOUR	Number of Years, n	ADT	AVG. ANNUAL MILES (MILLIONS)	AVG. YEARLY CRASHES	CRASH RATE/ MILLION MILES
1960	5	19600	7154000.000	600000.0	0.08
REAR	E-W/E-W				
TURN	SE-NW/NW-N				
BIKE					
OTHER					
SIDE	E-W/E-W				

Gateway @ Game Farm											
YEAR	PDO	INJURY	FATAL	HEAD	REAR	SIDE	TURN	OTHER	PED	BIKE	TOTAL
2019											0
2020		1						1			0
2021											0
2022		3					1		1	1	3
2023		1			1						1
2024		1					1				1
2019-2023	0	5	0	0	1	0	1	1	1	1	5

CHECK
OK
OK
OK
OK
OK
OK
OK

P.M. PEAK HOUR	Number of Years, n	ADT	AVG. ANNUAL MILES (MILLIONS)	AVG. YEARLY CRASHES	CRASH RATE/ MILLION MILES
2029	5	20290	7405850.000	1000000.0	0.14
REAR	SW-NE/SW-NE				
TURN	S-N	E-SE/SE-NW			
SIDE					
BIKE					
OTHER	W-SE	SE-NW/E-W			
PED	W-E/SE-NW				

Gateway @ International Way											
YEAR	PDO	INJURY	FATAL	HEAD	REAR	SIDE	TURN	OTHER	PED	BIKE	TOTAL
2019	1						1				1
2020											0
2021		1						1			1
2022	1				1						1
2023	2					1	1				2
2024	1							1			1
2019-2023	4	1	0	0	1	1	3	0	0	0	5

CHECK
OK
OK
OK
OK
OK
OK
OK

P.M. PEAK HOUR	Number of Years, n	ADT	AVG. ANNUAL MILES (MILLIONS)	AVG. YEARLY CRASHES	CRASH RATE/ MILLION MILES
1931	5	19310	7048150.000	1000000.0	0.14
REAR	NW-SE/NW-SE				
TURN	SE-NW/SE-NE	SW-NE/SE-SW	NE-SE/SE-NW		
SIDE	SE-NW/SE-NW				
OTHER	SE-NW				
PED					

Maple Island @ International Way											
YEAR	PDO	INJURY	FATAL	HEAD	REAR	SIDE	TURN	OTHER	PED	BIKE	TOTAL
2019											0
2020											0
2021	1								1		1
2022											0
2023											0
2024											0
2019-2023	1	0	0	0	0	0	0	1	0	0	1

CHECK
OK
OK
OK
OK
OK
OK
OK

P.M. PEAK HOUR	Number of Years, n	ADT	AVG. ANNUAL MILES (MILLIONS)	AVG. YEARLY CRASHES	CRASH RATE/ MILLION MILES
304	5	3040	1109600.000	200000.0	0.18
REAR					
TURN					
OTHER	E-W/S-N				
SIDE					
BIKE					

Beltline @ Gateway											
YEAR	PDO	INJURY	FATAL	HEAD	REAR	SIDE	TURN	OTHER	PED	BIKE	TOTAL
2019	6	7			4		9				13
2020	4	5			3		4	2			9
2021	2	11			5		2	6			13
2022	6	5			6		4	1			11
2023	1	3			3		3	1			4
2024	2	2			1		3				4
2019-2023	19	31	0	0	21	0	19	10	0	0	50

CHECK
OK
OK
OK
OK
OK
OK
OK

P.M. PEAK HOUR	Number of Years, n	ADT	AVG. ANNUAL MILES (MILLIONS)	AVG. YEARLY CRASHES	CRASH RATE/ MILLION MILES
4883	5	48830	17822950.000	10000000.0	0.56
REAR	5 W-E/W-E	2 N-S/N-S	7 E-W/E-W	6 S-N/S-N	W-E/W-E/S-N/E-S
	E-S/E-S				
TURN	2 W-E/N-E	W-E/W-W	E-N/W-N	2 N-S/S-W	8 S-N/N-E
	W-N/N-S	4 W-E/E-S	E-N/S-N	E-N/W-N	N-W/W-N
	S-W/W-N				
OTHER	W-S	UN-UN	W-E/S-N	3 S-N/E-W	W-E/S-W/S-W
	2 N-S/W-E	W-E/S-N/E-W			

PED  
BIKE  
Side

Beltline @ Hutton											
YEAR	PDO	INJURY	FATAL	HEAD	REAR	SIDE	TURN	OTHER	PED	BIKE	TOTAL
2019		2						2			2
2020	1	2					1	2			3
2021	2	2					1	3			4
2022		5					3	2			5
2023	1	1						2			2
2024	1	1						2			2
2019-2023	4	12	0	0	0	0	5	11	0	0	16

CHECK
OK
OK
OK
OK
OK
OK
OK

P.M. PEAK HOUR	Number of Years, n	ADT	AVG. ANNUAL MILES (MILLIONS)	AVG. YEARLY CRASHES	CRASH RATE/ MILLION MILES
1850	5	18500	6752500.000	3200000.0	0.47
REAR					
TURN	E-N/N-S	2 N-E/W-E	S-W/E-W	N-E/E-W	
OTHER	2 S-N/E-W	S-N/W-E	7 N-S/W-E	W-E/N-S/S-N	E-W/N-S
	W-E/N-S				

PED  
BIKE  
Side

Gateway @ Harlow											
YEAR	PDO	INJURY	FATAL	HEAD	REAR	SIDE	TURN	OTHER	PED	BIKE	TOTAL
2019	3	4			1		6				7
2020	1	3					2		2		4
2021	3	1			1		3				4
2022	3	2					5				5
2023	1	3			2		2				4
2024	1	3			2		2				4
2019-2023	11	13	0	0	4	0	18	0	2	0	24

CHECK
OK
OK
OK
OK
OK
OK
OK

P.M. PEAK HOUR	Number of Years, n	ADT	AVG. ANNUAL MILES (MILLIONS)	AVG. YEARLY CRASHES	CRASH RATE/ MILLION MILES
2091	5	20910	7632150.000	4800000.0	0.63
REAR	N-S/N-S	S-N/S-N	3 W-E/W-E	N-S/N-W	
TURN	E-N/N-S	N-W/N-W	S-W/S-W	4 W-E/E-S	7 E-W/W-N
	2 E-W/E-N	W-E/S-W	S-E/W-E	E-W/W-N/W-E	N-E/W-E
OTHER					

PED  
BIKE  
Side

		# Crashes	ADT	MEV	Crash Rate	Critical Crash Rate	
1	Beltline @ Game Farm RD / MLK	signal	3	19600	35.77	0.08	0.55 under
2	Gateway @ Game Farm	Signal	5	20290	37.03	0.14	0.55 under
3	Gateway @ International Way	Signal	5	19310	35.24	0.14	0.55 under
4	Beltline @ Gateway	Signal	50	48830	89.11	0.56	0.48 over
5	Gateway @ Harlow	Signal	24	20910	38.16	0.63	0.62 over
6	Beltline @ Hutton	Stop	16	18500	33.76	0.47	0.63 under
7	Maple Island @ International Way	Stop	1	3040	5.55	0.18	0.98 under

104

Weighted Average

Signal	87	235	0.369716402
Stop	17	39	0.432454433
	104		

CRASH SUMMARIES BY YEAR BY COLLISION TYPE

BELTLINE RD at MARTIN L KING JR PKY (2), City of Springfield, Lane County, ALL Crashes Severity, ALL Crashes Circumstance, 01/01/2019 to 12/31/2024

COLLISION TYPE	FATAL CRASHES	NON- FATAL CRASHES	PROPERTY DAMAGE ONLY	TOTAL CRASHES	PEOPLE KILLED	PEOPLE INJURED	TRUCKS	DRY SURF	WET SURF	DAY	DARK	INTER- SECTION	SECTION RELATED	OFF- ROAD
<b>YEAR: 2020</b>														
REAR-END	0	1	0	1	0	1	0	1	0	1	0	1	0	0
<b>YEAR 2020 TOTAL</b>	<b>0</b>	<b>1</b>	<b>0</b>	<b>1</b>	<b>0</b>	<b>1</b>	<b>0</b>	<b>1</b>	<b>0</b>	<b>1</b>	<b>0</b>	<b>1</b>	<b>0</b>	<b>0</b>
<b>FINAL TOTAL</b>	<b>0</b>	<b>1</b>	<b>0</b>	<b>1</b>	<b>0</b>	<b>1</b>	<b>0</b>	<b>1</b>	<b>0</b>	<b>1</b>	<b>0</b>	<b>1</b>	<b>0</b>	<b>0</b>

*Disclaimer: The information contained in this report is compiled from individual driver and police crash reports submitted to the Oregon Department of Transportation as required in ORS 811.720. The Crash Analysis and Reporting Unit is committed to providing the highest quality crash data to customers. However, because submittal of crash report forms is the responsibility of the individual driver, the Crash Analysis and Reporting Unit can not guarantee that all qualifying crashes are represented nor can assurances be made that all details pertaining to a single crash are accurate. Note: Legislative changes to DMV's vehicle crash reporting requirements, effective 01/01/2004, may result in fewer property damage only crashes being eligible for inclusion in the Statewide Crash Data File.*

OREGON.. DEPARTMENT OF TRANSPORTATION - TRANSPORTATION DEVELOPMENT DIVISION  
TRANSPORTATION DATA SECTION - CRASH ANALYSIS AND REPORTING UNIT  
URBAN NON-SYSTEM CRASH LISTING

CITY OF SPRINGFIELD, LANE COUNTY

**S GAME FARM RD at BELTLINE RD, City of Springfield, Lane County, ALL Crashes Severity, ALL Crashes Circumstance, 01/01/2019 to 12/31/2024**

1 - 1 of 1 Crash records shown.

SER#	S D M	P R J S W DATE	CLASS	CITY STREET	INT-TYPE	SPCL USE																							
INVEST	E A U I C O DAY	DIST	FIRST STREET	RD CHAR	(MEDIAN)	INT-REL	OFFRD	WTHR	CRASH	TRLR QTY	MOVE																		
RD DPT	E L G N H R TIME	FROM	SECOND STREET	DIRECT	LEGS	TRAF-	RNDBT	SURF	COLL	OWNER	FROM	PRTC	INJ	G E LICNS	PED														
UNLOC?	D C S V L K LAT	LONG	LRS	LOCTN	(#LANES)	CONTL	DRVWY	LIGHT	SVRTY	V# TYPE	TO	P# TYPE	SVRTY	E X RES	LOC	ERROR	ACT	EVENT	CAUSE										
01802	N N N N	06/19/2024	16	S GAME FARM RD	INTER	3-LEG	N	N	UNK	S-STRGHT	01 NONE	9	TURN-R																
NONE		WE	0	BELTLINE RD	NW					TRF SIGNAL	N	UNK	REAR	N/A	N -W					000	00								
N		5P			09	1		N	DAY	PDO			PSNGR CAR		01 DRVR	NONE	00	Unk UNK		000	000	00							
N		44 5 2.63	-123 1																			00							
			58.2																			00							
											02 NONE	9	TURN-R																
											N/A		N -W									000	00						
											PSNGR CAR		01 DRVR	NONE	00	Unk UNK				000	000	00	00						
																						UNK							

Disclaimer: The information contained in this report is compiled from individual driver and police crash reports submitted to the Oregon Department of Transportation as required in ORS 811.720. The Crash Analysis and Reporting Unit is committed to providing the highest quality crash data to customers. However, because submittal of crash report forms is the responsibility of the individual driver, the Crash Analysis and Reporting Unit can not guarantee that all qualifying crashes are represented nor can assurances be made that all details pertaining to a single crash are accurate. Note: Legislative changes to DMV's vehicle crash reporting requirement, effective 01/01/2004, may result in fewer property damage only crashes being eligible for inclusion in the Statewide Crash Data File.

CITY OF SPRINGFIELD, LANE COUNTY

GATEWAY ST at BELTLINE RD, City of Springfield, Lane County, ALL Crashes Severity, ALL Crashes Circumstance, 01/01/2019 to 12/31/2024

1 - 4 of 54 Crash records shown.

SER#	S P R J S W	DATE	CLASS	CITY STREET	INT-TYPE	SPCL USE	ACT	EVENT	CAUSE						
INVEST	E A U I C O DAY		DIST	FIRST STREET	RD CHAR	(MEDIAN) INT-REL	OFFRD WTHR	CRASH	TRLR QTY	MOVE	A S				
RD DPT	E L G N H R TIME		FROM	SECOND STREET	DIRECT	LEGS TRAF-	RNDBT SURF	COLL	OWNER	FROM	PRTC INJ	G E LICNS	PED		
UNLOC?	D C S V L K LAT		LONG	LRS	LOCTN	(#LANES) CONTL	DRVWY LIGHT	SVRTY	V# TYPE	TO	P# TYPE SVRTY	E X RES	LOC	ERROR	
00394	N Y N N N N	02/10/2022	12	BELTLINE RD	INTER	CROSS N	N CLD	S-1STOP	01 NONE 9	STRGHT					29,10
CITY		TH		GATEWAY ST	UN			REAR	N/A	W -E				000	00
N		2P			06	0	N	DAY	PSNGR CAR		01 DRVR	NONE	00 Unk UNK	000	000
N		44 5 2.96	-123 2 29.69	006900100S00					02 NONE 9	STOP					00
									N/A	W -E				012	00
									PSNGR CAR		01 DRVR	NONE	00 Unk UNK	000	000
															00
03714	N N N N N	11/27/2019	12	BELTLINE RD	INTER	CROSS N	N CLD	S-1STOP	01 NONE	STRGHT					29
CITY		WE		GATEWAY ST	N			REAR	PRVTE	N -S				000	00
N		12P			06	1	N	DAY	PSNGR CAR		01 DRVR	NONE	58 M OR-Y	026	000
N		44 5 2.97	-123 2 29.72	006900100S00					02 NONE	STOP					00
									PRVTE	N -S				011	00
									PSNGR CAR		01 DRVR	INJC	50 F OR-Y	000	000
															00
02551	N N N N N N	08/28/2022	16	BELTLINE RD	INTER	CROSS N	N CLR	S-1STOP	01 NONE 0	STRGHT					32,29
CITY		SU	0	GATEWAY ST	N			REAR	PRVTE	N -S				000	00
N		3P			06	0	N	DAY	PSNGR CAR		01 DRVR	NONE	40 F SUSP	052,026	000
N		44 5 2.96	-123 2 29.69						02 NONE 0	STOP					00
									PRVTE	N -S				011	00
									PSNGR CAR		01 DRVR	INJC	34 F OR-Y	000	000
															00
									02 NONE 0	STOP				011	00
									PRVTE	N -S				000	000
									PSNGR CAR		02 PSNG	INJC	38 M	000	000
00219	Y N N N	01/18/2019	12	BELTLINE RD	INTER	CROSS N	N RAIN	S-1STOP	01 NONE	STRGHT					124
NO RPT		FR		GATEWAY ST	E			REAR	PRVTE	E -W				001	124
N		3P			06	1	N	DAY	PSNGR CAR		01 DRVR	NONE	19 F OR-Y	047,026	017
N		44 5 2.96	-123 2 29.7	006900100S00					02 NONE	STOP					00
									PRVTE	E -W				011	00
									PSNGR CAR		01 DRVR	INJC	60 M OR-Y	000	000
															00
									02 NONE	STOP				011	00
									PRVTE	E -W				000	000
									PSNGR CAR		02 PSNG	INJC	60 F	000	000

Disclaimer: The information contained in this report is compiled from individual driver and police crash reports submitted to the Oregon Department of Transportation as required in ORS 811.720. The Crash Analysis and Reporting Unit is committed to providing the highest quality crash data to customers. However, because submittal of crash report forms is the responsibility of the individual driver, the Crash Analysis and Reporting Unit can not guarantee that all qualifying crashes are represented nor can assurances be made that all details pertaining to a single crash are accurate. Note: Legislative changes to DMV's vehicle crash reporting requirement, effective 01/01/2004, may result in fewer property damage only crashes being eligible for inclusion in the Statewide Crash Data File.



CITY OF SPRINGFIELD, LANE COUNTY

GATEWAY ST at BELTLINE RD, City of Springfield, Lane County, ALL Crashes Severity, ALL Crashes Circumstance, 01/01/2019 to 12/31/2024

9 - 12 of 54 Crash records shown.

SER#	P	R	J	S	W	DATE	CLASS	CITY STREET	RD CHAR	INT-TYPE	OFFRD	WTHR	CRASH	SPCL USE	TRLR QTY	MOVE	PRTC	INJ	G	E	LICNS	PED	ACT	EVENT	CAUSE				
UNLOC?	D	C	S	V	L	K	LAT	LRS	LOCTN	(#LANES)	CONTL	DRVWY	LIGHT	SVRTY	V#	TYPE	TO	P#	TYPE	SVRTY	E	X	RES	LOC	ERROR	ACT	EVENT	CAUSE	
														02 NONE	0	STOP													
														PRVTE		E -W										012		00	
														PSNGR CAR				01	DRVR	INJC	28	F	OR-Y		000	000		00	
01054	N	N	N	N		04/09/2022	19	BELTLINE RD	INTER	CROSS	N	N	CLR	S-1STOP	01	NONE	9											29	
NONE						SA	0	GATEWAY ST	E		TRF SIGNAL	N	DRY	REAR	N/A		E -W									000		00	
N						11A			06	0		N	DAY	PDO	PSNGR CAR			01	DRVR	NONE	00	Unk UNK		000	000		00		
N						44 5 2.96	-123 2 29.69																UNK						
														02 NONE	9	STOP													
														N/A		E -W										012		00	
														PSNGR CAR				01	DRVR	NONE	00	Unk UNK		000	000		00		
03122	N	N	N	N		10/23/2023	16	BELTLINE RD	INTER	CROSS	N	N	CLR	S-1STOP	01	NONE	9											29	
NONE						MO	0	GATEWAY ST	E		TRF SIGNAL	N	DRY	REAR	N/A		E -W									000		00	
N						7P			06	1		N	DLIT	PDO	PSNGR CAR			01	DRVR	NONE	00	Unk UNK		000	000		00		
N						44 5 2.96	-123 2 29.69																UNK						
														02 NONE	9	STOP													
														N/A		E -W										011		00	
														PSNGR CAR				01	DRVR	NONE	00	Unk UNK		000	000		00		
02275	N	N	N	N		09/20/2020	11	BELTLINE RD	INTER		N	N	CLR	S-1STOP	01	NONE												29	
NONE						SU		GATEWAY ST	S		TRF SIGNAL	N	DRY	REAR	RENTL		S -N									000		00	
N						3P			06	2		N	DAY	INJ	PSNGR CAR			01	DRVR	NONE	46	F	OR-Y	026	000	000	29		
N						44 5 2.35	-123 2 29.69	0001XK100S00															OR>25						
														02 NONE		STOP											011		00
														PRVTE		S -N			01	DRVR	INJC	46	F	OR-Y	000	000		00	
														PSNGR CAR															
														02 NONE		STOP											011		00
														PRVTE		S -N			02	PSNG	INJC	10	M		000	000		00	
														PSNGR CAR															
														02 NONE		STOP											011		00
														PRVTE		S -N			03	PSNG	INJC	06	F		000	000		00	
														PSNGR CAR															
00229	N	N	N	N		01/20/2020	16	BELTLINE RD	INTER	CROSS	N	N	CLR	S-1STOP	01	NONE	9									013		29	
NONE						MO	0	GATEWAY ST	S		TRF SIGNAL	N	DRY	REAR	N/A		S -N									000		00	
N						12P			06	0		N	DAY	PDO	PSNGR CAR			01	DRVR	NONE	00	Unk UNK		000	000		00		
N						44 5 2.35	-123 2 29.67																UNK						

Disclaimer: The information contained in this report is compiled from individual driver and police crash reports submitted to the Oregon Department of Transportation as required in ORS 811.720. The Crash Analysis and Reporting Unit is committed to providing the highest quality crash data to customers. However, because submittal of crash report forms is the responsibility of the individual driver, the Crash Analysis and Reporting Unit can not guarantee that all qualifying crashes are represented nor can assurances be made that all details pertaining to a single crash are accurate. Note: Legislative changes to DMV's vehicle crash reporting requirement, effective 01/01/2004, may result in fewer property damage only crashes being eligible for inclusion in the Statewide Crash Data File.

CITY OF SPRINGFIELD, LANE COUNTY

GATEWAY ST at BELTLINE RD, City of Springfield, Lane County, ALL Crashes Severity, ALL Crashes Circumstance, 01/01/2019 to 12/31/2024

13 - 17 of 54 Crash records shown.

SER#	P	R	J	S	W	DATE	CLASS	CITY STREET	RD CHAR	INT-TYPE	OFFRD	WTHR	CRASH	SPCL USE	MOVE	A	S	P	T	I	C	LOC	ERROR	ACT	E	C	A			
INVEST	E	A	U	I	C	O	DIST	FIRST STREET	DIRECT	(MEDIAN)	INT-REL	RNDBT	SURF	COLL	TRLR QTY	FROM														
RD DPT	E	L	G	N	H	R	FROM	SECOND STREET		LEGS	TRAF-				OWNER	PRTC	INJ	G	E	LICNS	PED									
UNLOC?	D	C	S	V	L	K	LONG	LRS	LOCTN	(#LANES)	CONTL	DRVWY	LIGHT	SVRTY	V# TYPE	TO	P# TYPE	SVRTY	E	X	RES	LOC	ERROR	ACT	E	C	A			
														02 NONE	9	STOP														
														N/A		S -N														
														PSNGR CAR			01 DRVR	NONE	00	Unk	UNK			000	000		00	00		
02038	N	N	N	N	N	N	08/25/2020	16	BELTLINE RD	INTER	CROSS	N	N	CLR	S-1STOP	01 NONE	9	STRGHT										17,29		
CITY							TU	0	GATEWAY ST	S				TRF SIGNAL	N	DRY	REAR	N/A									000	00		
N							2P			06	0			N	DAY	PDO	PSNGR CAR									000	000	00		
N							44 5 2.75	-123 2																				00	00	
														02 NONE	9	STOP														
														N/A		S -N												011	00	
														PSNGR CAR			01 DRVR	NONE	00	Unk	UNK			000	000		00	00		
00630	N	N	N	N	N	N	03/16/2021	16	BELTLINE RD	INTER	CROSS	N	N	CLR	S-1STOP	01 NONE	0	STRGHT										29		
NO RPT							TU	0	GATEWAY ST	S				TRF SIGNAL	N	DRY	REAR	PRVTE									000	00		
N							5P			06	0			N	DAY	INJ	PSNGR CAR									000	000	29		
N							44 5 2.38	-123 2																				29		
														02 NONE	0	STOP														
														PRVTE		S -N												011	00	
														PSNGR CAR			01 DRVR	INJC	56	F	OR-Y			000	000		00	00		
03219	N	N	N	N	N	N	11/11/2021	16	BELTLINE RD	INTER	CROSS	N	N	CLR	S-1STOP	01 NONE	0	STRGHT										013	10	
CITY							TH	0	GATEWAY ST	S				TRF SIGNAL	N	DRY	REAR	PRVTE									022	00		
N							6P			06	0			N	DUSK	INJ	PSNGR CAR									026	000	10		
N							44 5 2.09	-123 2																				10		
														02 NONE	0	STOP														
														PRVTE		S -N												022	013	00
														PSNGR CAR			01 DRVR	INJB	59	F	OR-Y			000	000		00	00		
														03 NONE	0	STOP														
														PRVTE		S -N												011	00	
														PSNGR CAR			01 DRVR	NONE	49	F	OR-Y			000	000		00	00		
03431	N	N	N	N	N	N	11/16/2022	16	BELTLINE RD	INTER	CROSS	N	N	CLR	S-1STOP	01 NONE	0	STRGHT										27,29		
CITY							WE	0	GATEWAY ST	S				TRF SIGNAL	N	DRY	REAR	RENTL									000	00		
N							11A			06	0			N	DAY	INJ	PSNGR CAR									016,026	038	27,29		
N							44 5 2.96	-123 2																						
														02 NONE	0	STOP														
														PRVTE		S -N												011	00	
														PSNGR CAR			01 DRVR	INJB	36	F	OR-Y			000	000		00	00		

OREGON.. DEPARTMENT OF TRANSPORTATION - TRANSPORTATION DEVELOPMENT DIVISION  
TRANSPORTATION DATA SECTION - CRASH ANALYSIS AND REPORTING UNIT  
URBAN NON-SYSTEM CRASH LISTING

CITY OF SPRINGFIELD, LANE COUNTY

GATEWAY ST at BELTLINE RD, City of Springfield, Lane County, ALL Crashes Severity, ALL Crashes Circumstance, 01/01/2019 to 12/31/2024

18 - 20 of 54 Crash records shown.

SER#	P	R	J	S	W	DATE	CLASS	CITY STREET	INT-TYPE	SPCL USE																												
INVEST	E	A	U	I	C	O	DAY	FIRST STREET	RD CHAR	(MEDIAN)	INT-REL	OFFRD	WTHR	CRASH	TRLR	QTY	MOVE		A	S																		
RD DPT	E	L	G	N	H	R	TIME	SECOND STREET	DIRECT	LEGS	TRAF-	RNDBT	SURF	COLL	OWNER	FROM		PRTC	INJ	G	E	LICNS	PED															
UNLOC?	D	C	S	V	L	K	LAT	LONG	LRS	LOCTN	(#LANES)	CONTL	DRVWY	LIGHT	SVRTY	V#	TYPE	TO	P#	TYPE	SVRTY	E	X	RES	LOC	ERROR	ACT	EVENT	CAUSE									
00124	N	N	N	N	N	N	01/15/2021	12	BELTLINE RD	INTER	CROSS	N	Y	FOG	FIX OBJ	01	NONE	9	TURN-R																054	05		
CITY							FR		GATEWAY ST	SW		TRF SIGNAL	N	WET	FIX		N/A		W	-S														000	00			
N							11P			09	1		N	DARK	PDO		PSNGR CAR		01	DRVR	NONE	00	Unk	UNK			000		000					000	00			
N							44 5 2.96	-123 2	006900100S00																													
01170	N	Y	Y	N	N	N	04/21/2019	12	BELTLINE RD	INTER	CROSS	N	N	CLR	S-1TURN	01	NONE		STRGHT																32,08			
CITY							SU		GATEWAY ST	W		TRF SIGNAL	N	DRY	TURN		PRVTE		W	-E														000	00			
N							5P			06	1		N	DAY	INJ		PSNGR CAR		01	DRVR	INJB	37	F	OR-Y			000		000					000	00			
N							44 5 2.96	-123 2	006900100S00																													
																	01	NONE		STRGHT															000	00		
																	PRVTE		W	-E														000	00			
																	PSNGR CAR		02	PSNG	INJB	26	F				000		000						000	00		
																	01	NONE		STRGHT															000	00		
																	PRVTE		W	-E														000	00			
																	PSNGR CAR		03	PSNG	INJB	03	M				000		000						000	00		
																	02	NONE		U-TURN															000	00		
																	PRVTE		W	-W														051,008	000	000	32,08	
																	PSNGR CAR		01	DRVR	NONE	27	M	OR-Y			051,008		000							OR<25		
00069	N	N	N	N			01/09/2021	12	BELTLINE RD	INTER	CROSS	N	N	FOG	S-1STOP	01	NONE	0	STRGHT																	27,07		
CITY							SA		GATEWAY ST	W		TRF SIGNAL	N	DRY	REAR		PRVTE		W	-E														000	00			
N							6P			06	1		N	DLIT	INJ		PSNGR CAR		01	DRVR	NONE	50	M	OTH-Y			016,043		038							27,07		
N							44 5 2.96	-123 2	006900200S00																													
																	02	NONE	0	STOP																011	00	
																	PRVTE		W	-E															000	000	00	
																	PSNGR CAR		01	DRVR	INJB	29	M	OR-Y			000		000								OR<25	
																	02	NONE	0	STOP																011	00	
																	PRVTE		W	-E															000	000	00	
																	PSNGR CAR		02	PSNG	INJB	31	M				000		000							000	00	
																	02	NONE	0	STOP																011	00	
																	PRVTE		W	-E															000	000	00	
																	PSNGR CAR		03	PSNG	INJB	31	M				000		000							000	000	00
00687	N	N	N	N	N	N	03/17/2023	12	BELTLINE RD	INTER	CROSS	N	N	CLR	S-1STOP	01	NONE	0	STRGHT																013,010	17,27,07		
CITY							FR		GATEWAY ST	W		TRF SIGNAL	N	DRY	REAR		PRVTE		W	-E															000	00		
N							6P			06	0		N	DAY	INJ		PSNGR CAR		01	DRVR	INJB	26	M	OR-Y			016,043		028								17,27,07	
N							44 5 2.96	-123 2	006900100S00																													

Disclaimer: The information contained in this report is compiled from individual driver and police crash reports submitted to the Oregon Department of Transportation as required in ORS 811.720. The Crash Analysis and Reporting Unit is committed to providing the highest quality crash data to customers. However, because submittal of crash report forms is the responsibility of the individual driver, the Crash Analysis and Reporting Unit can not guarantee that all qualifying crashes are represented nor can assurances be made that all details pertaining to a single crash are accurate. Note: Legislative changes to DMV's vehicle crash reporting requirement, effective 01/01/2004, may result in fewer property damage only crashes being eligible for inclusion in the Statewide Crash Data File.

URBAN NON-SYSTEM CRASH LISTING

CITY OF SPRINGFIELD, LANE COUNTY

GATEWAY ST at BELTLINE RD, City of Springfield, Lane County, ALL Crashes Severity, ALL Crashes Circumstance, 01/01/2019 to 12/31/2024

21 - 23 of 54 Crash records shown.

SER#	CLASS	CITY STREET	INT-TYPE	SPCL USE	V#	TYPE	TO	P#	TYPE	SVRTY	E	X	RES	LOC	ERROR	ACT	EVENT	CAUSE
01	NONE	0	STRGHT															
	PRVTE		W -E													000	000	00
	PSNGR	CAR						02	PSNG	INJC	01	M			000	000	00	00
01	NONE	0	STRGHT															
	PRVTE		W -E															
	PSNGR	CAR						03	PSNG	INJC	10	F			000	000	00	00
01	NONE	0	STRGHT															
	PRVTE		W -E															
	PSNGR	CAR						04	PSNG	INJC	05	M			000	000	00	00
02	NONE	0	STOP														011	013,010
	PRVTE		W -E														000	000
	PSNGR	CAR						01	DRVR	INJA	48	M	OR-Y		000			00
													OR<25					00
03	NONE	0	STOP															022
	PRVTE		S -N															000
	PSNGR	CAR						01	DRVR	INJB	42	F	OR-Y		000			000
													OR<25					00
04	NONE	0	TURN-L															
	PRVTE		E -S															
	PSNGR	CAR						01	DRVR	INJB	30	M	OTH-Y		000			000
													OR<25					00
04	NONE	0	TURN-L															
	PRVTE		E -S															
	PSNGR	CAR						02	PSNG	INJC	01	F			000			000
																		00
04	NONE	0	TURN-L															
	PRVTE		E -S															
	PSNGR	CAR						03	PSNG	INJC	07	F			000			000
																		00
03802	Y N N N N N	12/18/2023	12	BELTLINE RD	INTER	CROSS	N	N	CLR	S-1STOP	01	NONE	0	STRGHT				
				GATEWAY ST	W					TRF SIGNAL	N	DRY	REAR	PRVTE	W -E			000
					06	0					N	DAY	INJ	PSNGR CAR				050,016,026
				006900100S00														038
																		30,27,29
																		00
																		00
																		00
01277	N N N N	05/06/2024	12	BELTLINE RD	INTER	CROSS	N	N	RAIN	S-1STOP	01	NONE	9	STRGHT				
				GATEWAY ST	W					TRF SIGNAL	N	WET	REAR	N/A	W -E			000
					06	1					N	DAY	PDO	PSNGR CAR				000
				006900100S00														000
																		000
																		00
																		00
																		00
																		00

Disclaimer: The information contained in this report is compiled from individual driver and police crash reports submitted to the Oregon Department of Transportation as required in ORS 811.720. The Crash Analysis and Reporting Unit is committed to providing the highest quality crash data to customers. However, because submittal of crash report forms is the responsibility of the individual driver, the Crash Analysis and Reporting Unit can not guarantee that all qualifying crashes are represented nor can assurances be made that all details pertaining to a single crash are accurate. Note: Legislative changes to DMV's vehicle crash reporting requirement, effective 01/01/2004, may result in fewer property damage only crashes being eligible for inclusion in the Statewide Crash Data File.

OREGON.. DEPARTMENT OF TRANSPORTATION - TRANSPORTATION DEVELOPMENT DIVISION  
TRANSPORTATION DATA SECTION - CRASH ANALYSIS AND REPORTING UNIT  
URBAN NON-SYSTEM CRASH LISTING

CITY OF SPRINGFIELD, LANE COUNTY

GATEWAY ST at BELTLINE RD, City of Springfield, Lane County, ALL Crashes Severity, ALL Crashes Circumstance, 01/01/2019 to 12/31/2024

24 - 28 of 54 Crash records shown.

SER#	P	R	J	S	W	DATE	CLASS	CITY STREET	INT-TYPE			SPCL USE			A	S		E	LICNS	PED	ERROR	ACT	EVENT	CAUSE								
									(MEDIAN)	INT-REL	OFFRD	WTHR	CRASH	TRLR											QTY	MOVE						
RD DPT	E	L	G	N	H	R	TIME	FROM	SECOND STREET	DIRECT	LEGS	TRAF-	RNDBT	SURF	COLL	OWNER	FROM	PRTC	INJ	G	E	LOC	ERROR	ACT	EVENT	CAUSE						
UNLOC?	D	C	S	V	L	K	LAT	LONG	LRS	LOCTN	(#LANES)	CONTL	DRVWY	LIGHT	SVRTY	V#	TYPE	TO	P#	TYPE	SVRTY	E	X	RES	LOC	ERROR	ACT	EVENT	CAUSE			
00313	N	N	N	N		01/21/2019	12	BELTLINE RD	INTER	CROSS	N	N	N	CLR	ANGL-OTH	01	NONE	9	TURN-R									04				
NONE						MO		GATEWAY ST	CN			TRF SIGNAL	N	DRY	TURN	N/A		E -N									016	00				
N						11A			02	0			N	DAY	PDO		PSNGR CAR		01	DRVR	NONE	00	Unk	UNK		000	000		00			
N						44 5 2.96	-123 2 29.69	006900200S00																								
																02	NONE	9	STRGHT													
																N/A		S -N											000	00		
																PSNGR CAR			01	DRVR	NONE	00	Unk	UNK		000	000		00			
01138	N	N	N	N		04/19/2019	12	BELTLINE RD	INTER	CROSS	N	N	N	CLR	O-1 L-TURN	01	NONE	9	STRGHT									02				
NO RPT						FR		GATEWAY ST	CN			TRF SIGNAL	N	DRY	TURN	N/A		S -N										000	00			
N						10A			04	0			N	DAY	PDO		PSNGR CAR		01	DRVR	NONE	00	Unk	UNK		000	000		00			
N						44 5 2.99	-123 2 29.71	006900100S00																								
																02	NONE	9	TURN-L											000	00	
																N/A		N -E												000	00	
																PSNGR CAR			01	DRVR	NONE	00	Unk	UNK		000	000		000	00		
03247	N	N	N	N	N	10/19/2019	12	BELTLINE RD	INTER	CROSS	N	N	N	RAIN	O-1 L-TURN	01	NONE	9	STRGHT									02				
CITY						SA		GATEWAY ST	CN			TRF SIGNAL	N	WET	TURN	N/A		S -N											000	00		
N						7P			04	0			N	DLIT	PDO		PSNGR CAR		01	DRVR	NONE	00	Unk	UNK		000	000		00			
N						44 5 2.97	-123 2 29.68	006900100S00																								
																02	NONE	9	TURN-L											000	00	
																N/A		N -E													000	00
																PSNGR CAR			01	DRVR	NONE	00	Unk	UNK		000	000		000	00		
03730	N	N	N	N	N	11/27/2019	12	BELTLINE RD	INTER	CROSS	N	N	N	FOG	O-1 L-TURN	01	NONE	9	STRGHT									02				
CITY						WE		GATEWAY ST	CN			TRF SIGNAL	N	WET	TURN	N/A		W -E											000	00		
N						9P			03	1			N	DLIT	PDO		PSNGR CAR		01	DRVR	NONE	00	Unk	UNK		000	000		00			
N						44 5 2.95	-123 2 29.72	006900100S00																								
																02	NONE	9	TURN-L												000	00
																N/A		E -S													000	00
																PSNGR CAR			01	DRVR	NONE	00	Unk	UNK		000	000		000	00		
04141	N	N	N	N		12/31/2019	12	BELTLINE RD	INTER	CROSS	N	N	N	RAIN	O-1 L-TURN	01	NONE	9	STRGHT									02				
CITY						TU		GATEWAY ST	CN			TRF SIGNAL	N	WET	TURN	N/A		W -E											000	00		
N						6P			03	1			N	DLIT	PDO		PSNGR CAR		01	DRVR	NONE	00	Unk	UNK		000	000		00			
N						44 5 2.96	-123 2 29.69	006900100S00																								
																02	NONE	9	TURN-L												000	00
																N/A		E -S													000	00
																PSNGR CAR			01	DRVR	NONE	00	Unk	UNK		000	000		000	00		

Disclaimer: The information contained in this report is compiled from individual driver and police crash reports submitted to the Oregon Department of Transportation as required in ORS 811.720. The Crash Analysis and Reporting Unit is committed to providing the highest quality crash data to customers. However, because submittal of crash report forms is the responsibility of the individual driver, the Crash Analysis and Reporting Unit can not guarantee that all qualifying crashes are represented nor can assurances be made that all details pertaining to a single crash are accurate. Note: Legislative changes to DMV's vehicle crash reporting requirement, effective 01/01/2004, may result in fewer property damage only crashes being eligible for inclusion in the Statewide Crash Data File.







URBAN NON-SYSTEM CRASH LISTING

CITY OF SPRINGFIELD, LANE COUNTY

**GATEWAY ST at BELTLINE RD, City of Springfield, Lane County, ALL Crashes Severity, ALL Crashes Circumstance, 01/01/2019 to 12/31/2024**

42 - 45 of 54 Crash records shown.

SER#	INVEST	RD DPT	UNLOC?	S	D	M	P	R	J	S	W	DATE	CLASS	CITY STREET	RD CHAR	INT-TYPE	INT-REL	OFFRD	WTHR	CRASH	SPCL USE	MOVE	A	S	ACT	EVENT	CAUSE								
	E	A	U	I	C	O	DAY	DIST	FIRST STREET	RD CHAR	(MEDIAN)	INT-REL	OFFRD	WTHR	CRASH	TRLR	QTY																		
	E	L	G	N	H	R	TIME	FROM	SECOND STREET	DIRECT	LEGS	TRAF-	RNDBT	SURF	COLL	OWNER	FROM																		
	D	C	S	V	L	K	LAT	LONG	LRS	LOCTN	(#LANES)	CONTL	DRVWY	LIGHT	SVRTY	V#	TYPE	TO																	
00092	N	N	N	N	N	N	01/10/2022	12	BELTLINE RD	INTER	CROSS	N	N	CLR	O-OTHER	01	NONE	9				TURN-R													
NONE							MO		GATEWAY ST	CN				DRY	TURN	N/A					E -N							000	00						
N							12P			02	0		N	DAY	PDO						PSNGR CAR							000	000	00					
N							44 5 2.96	-123 2 29.69	006900100S00																										
02344	N	N	N	N	N	N	08/07/2022	12	BELTLINE RD	INTER	CROSS	N	N	CLR	S-STRGHT	01	NONE	9				STRGHT													
CITY							SU		GATEWAY ST	CN				DRY	REAR	N/A					W -E						000	00							
N							11A			03	0		N	DAY	PDO						PSNGR CAR						000	000	00						
N							44 5 2.96	-123 2 29.69	006900100S00																										
02913	N	N	N	N	N	N	10/04/2022	12	BELTLINE RD	INTER	CROSS	N	N	CLR	O-1 L-TURN	01	NONE	9				TURN-L													
NONE							TU		GATEWAY ST	CN				DRY	TURN	N/A					E -S					000	00								
N							11A			03	1		N	DAY	PDO						PSNGR CAR					000	000	00							
N							44 5 2.96	-123 2 29.69	006900100S00																										
00982	N	N	N	N	N	N	04/17/2023	12	BELTLINE RD	INTER	CROSS	N	N	CLD	ANGL-OTH	01	NONE	0				STRGHT				013	04,27								
CITY							MO		GATEWAY ST	CN				DRY	ANGL						PRVTE					000	00								
N							7P			04	0		N	DUSK	INJ						PSNGR CAR					020,016	038	04,27							
N							44 5 2.96	-123 2 29.69	006900100S00																										
02184	N	N	N	N	N	N	07/17/2024	12	BELTLINE RD	INTER	CROSS	N	N	CLD	ANGL-OTH	01	NONE	0				TURN-R					11,22,05								
CITY							WE		GATEWAY ST	CN				WET	TURN						PRVTE					000	11,22								
N							7A			01	0		N	DAY	INJ						PSNGR CAR					017	017	05							
N							44 5 2.96	-123 2 29.69	006900100S00																										

Disclaimer: The information contained in this report is compiled from individual driver and police crash reports submitted to the Oregon Department of Transportation as required in ORS 811.720. The Crash Analysis and Reporting Unit is committed to providing the highest quality crash data to customers. However, because submittal of crash report forms is the responsibility of the individual driver, the Crash Analysis and Reporting Unit can not guarantee that all qualifying crashes are represented nor can assurances be made that all details pertaining to a single crash are accurate. Note: Legislative changes to DMV's vehicle crash reporting requirement, effective 01/01/2004, may result in fewer property damage only crashes being eligible for inclusion in the Statewide Crash Data File.

CITY OF SPRINGFIELD, LANE COUNTY

**GATEWAY ST at BELTLINE RD, City of Springfield, Lane County, ALL Crashes Severity, ALL Crashes Circumstance, 01/01/2019 to 12/31/2024**

46 - 50 of 54 Crash records shown.

SER#	INVEST	RD DPT	UNLOC?	S	D	M	P	R	J	S	W	DATE	CLASS	CITY STREET	RD CHAR	INT-TYPE	INT-REL	OFFRD	WTHR	CRASH	SPCL USE	TRLR	QTY	MOVE	A	S	PRTC	INJ	G	E	LICNS	PED	ERROR	ACT	EVENT	CAUSE																		
	E	A	U	I	C	O	DAY	DIST	FIRST STREET	RD CHAR	(MEDIAN)		FROM	SECOND STREET	DIRECT	LEGS	TRAF-	RNDBT	SURF	COLL	OWNER	FROM																																
	E	L	G	N	H	R	TIME	FROM	SECOND STREET	DIRECT	LEGS	TRAF-	RNDBT	SURF	COLL	OWNER	FROM																																					
	D	C	S	V	L	K	LAT	LONG	LRS	LOCTN	(#LANES)	CONTL	DRVWY	LIGHT	SVRTY	V#	TYPE	TO	P#	TYPE	SVRTY	E	X	RES	LOC	ERROR	ACT	EVENT	CAUSE																									
																					02	NONE	0	TURN-L																														
00167	N	N	N	N	N		01/18/2024	12	BELTLINE RD	INTER	CROSS	N						RAIN	ANGL-OTH	01	NONE	9	TURN-L																															
	NONE						TH		GATEWAY ST	CN		TRF	SIGNAL	N				WET	TURN		N/A			N	-E																													
	N						3P			03	1							DAY	PDO		PSNGR	CAR				01	DRVR	NONE	00	Unk	UNK																							
	N						44 5 2.96	-123 2 29.69	006900100S00																																													
01556	N	N	N	N	N		06/02/2024	12	BELTLINE RD	INTER	CROSS	N						RAIN	O-1 L-TURN	01	NONE	0	STRGHT																															
	CITY						SU		GATEWAY ST	CN		TRF	SIGNAL	N				WET	TURN		UNKN			N	-S																													
	N						5P			01	1							DAY	INJ		PSNGR	CAR				01	DRVR	NONE	00	Unk	UNK																							
	N						44 5 2.96	-123 2 29.69	006900100S00																																													
01632	N	Y	Y	N	N	N	06/04/2019	16	BELTLINE RD	INTER	CROSS	N						CLR	O-1 L-TURN	01	NONE		STRGHT																															
	CITY						TU	0	GATEWAY ST	CN		TRF	SIGNAL	N				DRY	TURN		PRVTE			S	-N																													
	N						6P			04	1							DAY	INJ		PSNGR	CAR				01	DRVR	NONE	23	F	OR-Y																							
	N						44 5 2.75	-123 2 29.69																																														
02118	N	N	N	N	N	N	07/16/2019	16	BELTLINE RD	INTER	CROSS	N						CLR	O-1 L-TURN	01	NONE		TURN-L																															
	CITY						TU	0	GATEWAY ST	CN		TRF	SIGNAL	N				DRY	TURN		PRVTE			N	-E																													
	N						11A			04	1							DAY	INJ		PSNGR	CAR				01	DRVR	NONE	54	M	OR-Y																							
	N						44 5 2.75	-123 2 29.69																																														

Disclaimer: The information contained in this report is compiled from individual driver and police crash reports submitted to the Oregon Department of Transportation as required in ORS 811.720. The Crash Analysis and Reporting Unit is committed to providing the highest quality crash data to customers. However, because submittal of crash report forms is the responsibility of the individual driver, the Crash Analysis and Reporting Unit can not guarantee that all qualifying crashes are represented nor can assurances be made that all details pertaining to a single crash are accurate. Note: Legislative changes to DMV's vehicle crash reporting requirement, effective 01/01/2004, may result in fewer property damage only crashes being eligible for inclusion in the Statewide Crash Data File.

CITY OF SPRINGFIELD, LANE COUNTY

GATEWAY ST at BELTLINE RD, City of Springfield, Lane County, ALL Crashes Severity, ALL Crashes Circumstance, 01/01/2019 to 12/31/2024

51 - 54 of 54 Crash records shown.

SER#	P	R	J	S	W	DATE	CLASS	CITY STREET	RD CHAR	INT-TYPE	OFFRD	WTHR	CRASH	SPCL USE	MOVE	A	S	E	L	C	P	ERROR	ACT	EVENT	CAUSE				
INVEST	E	A	U	I	C	DAY	DIST	FIRST STREET	DIRECT	(MEDIAN)	INT-REL	RNDBT	SURF	TRLR QTY	FROM			G	E	L	P								
RD DPT	E	L	G	N	H	R	TIME	SECOND STREET	DIRECT	LEGS	TRAF-	RNDBT	SURF	COLL	OWNER	FROM		P	T	C	I	N	J	G	E	L			
UNLOC?	D	C	S	V	L	K	LAT	LRS	LOCTN	(#LANES)	CONTL	DRVWY	LIGHT	SVRTY	V#	TYPE	TO	P#	TYPE	SVRTY	E	X	RES	LOC	ERROR	ACT	EVENT	CAUSE	
00488	N	N	N	N		02/12/2020	16	BELTLINE RD	INTER	CROSS	N	N	FOG	O-1 L-TURN	01 NONE	9	STRGHT											02	
NO RPT						WE	0	GATEWAY ST	CN		L-GRN-SIG	N	DRY	TURN	N/A		S -N										000	00	
N						6A			04	1		N	DAWN	PDO												000	000	00	
N						44 5 2.75	-123 2 29.69																						00
															02 NONE	9	TURN-L												00
															N/A		N -E												00
															PSNGR CAR			01 DRVR	NONE	00	Unk	UNK			000	000		00	
																													00
03282	N	N	N	N	N	11/16/2021	16	BELTLINE RD	INTER	CROSS	N	N	CLD	ANGL-OTH	01 NONE	0	TURN-L										010	04,27	
CITY						TU	0	GATEWAY ST	CN		TRF SIGNAL	N	DRY	TURN	RENTL		S -W										000	00	
N						10P			02	0		N	DLIT	INJ												020,016	038	04,27	
N						44 5 2.75	-123 2 29.68																						00
															02 NONE	0	TURN-L												00
															PRVTE		W -N												000
															PSNGR CAR			01 DRVR	INJC	24	F	OR-Y			000	000		00	
																													00
																													00
																													00
00572	N	N	N	N	N	02/25/2022	16	BELTLINE RD	INTER	CROSS	N	N	CLR	O-1 L-TURN	01 NONE	0	TURN-L											02,04	
CITY						FR	0	GATEWAY ST	CN		L-GRN-SIG	N	DRY	TURN	PRVTE		E -S										000	00	
N						6P			03	0		N	DLIT	INJ												028,004,097	000	02	
N						44 5 2.75	-123 2 29.69																						00
															01 NONE	0	TURN-L												000
															PRVTE		E -S												000
															PSNGR CAR			02 PSNG	INJC	26	M				000	000		00	
																													00
															02 NONE	0	STRGHT												000
															PRVTE		W -E												000
															PSNGR CAR			01 DRVR	INJC	26	M	OR-Y			000,097	000		00	
																													00
																													00
02209	N	N	N	N	N	07/26/2022	19	BELTLINE RD	INTER	CROSS	N	N	CLR	S-1STOP	01 NONE	9	TURN-L											07	
CITY						TU	0	GATEWAY ST	CN		TRF SIGNAL	N	DRY	REAR	N/A		E -S										000	00	
N						9A			02	0		N	DAY	PDO												000	000	00	
N						44 5 2.96	-123 2 29.69																						00
															02 NONE	9	TURN-L												013
															N/A		E -S												000
															PSNGR CAR			01 DRVR	NONE	00	Unk	UNK			000	000		00	
																													00
																													UNK
																													UNK

Disclaimer: The information contained in this report is compiled from individual driver and police crash reports submitted to the Oregon Department of Transportation as required in ORS 811.720. The Crash Analysis and Reporting Unit is committed to providing the highest quality crash data to customers. However, because submittal of crash report forms is the responsibility of the individual driver, the Crash Analysis and Reporting Unit can not guarantee that all qualifying crashes are represented nor can assurances be made that all details pertaining to a single crash are accurate. Note: Legislative changes to DMV's vehicle crash reporting requirement, effective 01/01/2004, may result in fewer property damage only crashes being eligible for inclusion in the Statewide Crash Data File.

CRASH SUMMARIES BY YEAR BY COLLISION TYPE

GATEWAY ST at BELTLINE RD, City of Springfield, Lane County, ALL Crashes Severity, ALL Crashes Circumstance, 01/01/2019 to 12/31/2024

COLLISION TYPE	FATAL CRASHES	NON- FATAL CRASHES	PROPERTY DAMAGE ONLY	TOTAL CRASHES	PEOPLE KILLED	PEOPLE INJURED	TRUCKS	DRY SURF	WET SURF	DAY	DARK	INTER- SECTION	INTER- SECTION RELATED	OFF- ROAD
<b>YEAR: 2024</b>														
REAR-END	0	0	1	1	0	0	0	0	1	1	0	1	0	0
TURNING MOVEMENTS	0	2	1	3	0	3	0	0	3	3	0	3	0	0
<b>YEAR 2024 TOTAL</b>	<b>0</b>	<b>2</b>	<b>2</b>	<b>4</b>	<b>0</b>	<b>3</b>	<b>0</b>	<b>0</b>	<b>4</b>	<b>4</b>	<b>0</b>	<b>4</b>	<b>0</b>	<b>0</b>
<b>YEAR: 2023</b>														
ANGLE	0	1	0	1	0	1	0	1	0	0	1	1	0	0
REAR-END	0	2	1	3	0	10	0	3	0	2	1	3	0	0
<b>YEAR 2023 TOTAL</b>	<b>0</b>	<b>3</b>	<b>1</b>	<b>4</b>	<b>0</b>	<b>11</b>	<b>0</b>	<b>4</b>	<b>0</b>	<b>2</b>	<b>2</b>	<b>4</b>	<b>0</b>	<b>0</b>
<b>YEAR: 2022</b>														
ANGLE	0	1	0	1	0	1	0	1	0	0	1	1	0	0
REAR-END	0	2	4	6	0	3	0	6	0	6	0	6	0	0
TURNING MOVEMENTS	0	2	2	4	0	3	1	4	0	3	1	4	0	0
<b>YEAR 2022 TOTAL</b>	<b>0</b>	<b>5</b>	<b>6</b>	<b>11</b>	<b>0</b>	<b>7</b>	<b>1</b>	<b>11</b>	<b>0</b>	<b>9</b>	<b>2</b>	<b>11</b>	<b>0</b>	<b>0</b>
<b>YEAR: 2021</b>														
ANGLE	0	4	1	5	0	10	0	4	1	1	4	5	0	0
FIXED / OTHER OBJECT	0	0	1	1	0	0	0	0	1	0	1	1	0	1
REAR-END	0	5	0	5	0	8	0	5	0	1	4	5	0	0
TURNING MOVEMENTS	0	2	0	2	0	3	0	1	1	0	2	2	0	0
<b>YEAR 2021 TOTAL</b>	<b>0</b>	<b>11</b>	<b>2</b>	<b>13</b>	<b>0</b>	<b>21</b>	<b>0</b>	<b>10</b>	<b>3</b>	<b>2</b>	<b>11</b>	<b>13</b>	<b>0</b>	<b>1</b>
<b>YEAR: 2020</b>														
ANGLE	0	1	0	1	0	3	0	1	0	1	0	1	0	0

CRASH SUMMARIES BY YEAR BY COLLISION TYPE

GATEWAY ST at BELTLINE RD, City of Springfield, Lane County, ALL Crashes Severity, ALL Crashes Circumstance, 01/01/2019 to 12/31/2024

COLLISION TYPE	FATAL CRASHES	NON- FATAL CRASHES	PROPERTY DAMAGE ONLY	TOTAL CRASHES	PEOPLE KILLED	PEOPLE INJURED	TRUCKS	DRY SURF	WET SURF	DAY	DARK	INTER- SECTION	SECTION RELATED	OFF- ROAD
FIXED / OTHER OBJECT	0	1	0	1	0	1	0	0	1	0	1	1	0	1
REAR-END	0	1	2	3	0	3	0	3	0	3	0	3	0	0
TURNING MOVEMENTS	0	2	2	4	0	2	0	2	2	1	3	4	0	0
<b>YEAR 2020 TOTAL</b>	<b>0</b>	<b>5</b>	<b>4</b>	<b>9</b>	<b>0</b>	<b>9</b>	<b>0</b>	<b>6</b>	<b>3</b>	<b>5</b>	<b>4</b>	<b>9</b>	<b>0</b>	<b>1</b>
<b>YEAR: 2019</b>														
REAR-END	0	3	1	4	0	4	0	3	1	4	0	4	0	0
TURNING MOVEMENTS	0	4	5	9	0	6	0	6	3	6	3	9	0	0
<b>YEAR 2019 TOTAL</b>	<b>0</b>	<b>7</b>	<b>6</b>	<b>13</b>	<b>0</b>	<b>10</b>	<b>0</b>	<b>9</b>	<b>4</b>	<b>10</b>	<b>3</b>	<b>13</b>	<b>0</b>	<b>0</b>
<b>FINAL TOTAL</b>	<b>0</b>	<b>33</b>	<b>21</b>	<b>54</b>	<b>0</b>	<b>61</b>	<b>1</b>	<b>40</b>	<b>14</b>	<b>32</b>	<b>22</b>	<b>54</b>	<b>0</b>	<b>2</b>

Disclaimer: The information contained in this report is compiled from individual driver and police crash reports submitted to the Oregon Department of Transportation as required in ORS 811.720. The Crash Analysis and Reporting Unit is committed to providing the highest quality crash data to customers. However, because submittal of crash report forms is the responsibility of the individual driver, the Crash Analysis and Reporting Unit can not guarantee that all qualifying crashes are represented nor can assurances be made that all details pertaining to a single crash are accurate. Note: Legislative changes to DMV's vehicle crash reporting requirements, effective 01/01/2004, may result in fewer property damage only crashes being eligible for inclusion in the Statewide Crash Data File.





CRASH SUMMARIES BY YEAR BY COLLISION TYPE

GATEWAY ST at E GAME FARM RD, City of Springfield, Lane County, ALL Crashes Severity, ALL Crashes Circumstance, 01/01/2019 to 12/31/2024

COLLISION TYPE	FATAL CRASHES	NON- FATAL CRASHES	PROPERTY DAMAGE ONLY	TOTAL CRASHES	PEOPLE KILLED	PEOPLE INJURED	TRUCKS	DRY SURF	WET SURF	DAY	DARK	INTER- SECTION	INTER- SECTION RELATED	OFF- ROAD
<b>YEAR: 2024</b>														
TURNING MOVEMENTS	0	1	0	1	0	4	0	1	0	1	0	1	0	0
<b>YEAR 2024 TOTAL</b>	<b>0</b>	<b>1</b>	<b>0</b>	<b>1</b>	<b>0</b>	<b>4</b>	<b>0</b>	<b>1</b>	<b>0</b>	<b>1</b>	<b>0</b>	<b>1</b>	<b>0</b>	<b>0</b>
<b>YEAR: 2023</b>														
REAR-END	0	1	0	1	0	1	0	1	0	1	0	1	0	0
<b>YEAR 2023 TOTAL</b>	<b>0</b>	<b>1</b>	<b>0</b>	<b>1</b>	<b>0</b>	<b>1</b>	<b>0</b>	<b>1</b>	<b>0</b>	<b>1</b>	<b>0</b>	<b>1</b>	<b>0</b>	<b>0</b>
<b>YEAR: 2022</b>														
ANGLE	0	1	0	1	0	1	0	1	0	1	0	1	0	0
PEDESTRIAN	0	1	0	1	0	2	0	1	0	0	1	1	0	0
TURNING MOVEMENTS	0	1	0	1	0	1	0	1	0	1	0	1	0	0
<b>YEAR 2022 TOTAL</b>	<b>0</b>	<b>3</b>	<b>0</b>	<b>3</b>	<b>0</b>	<b>4</b>	<b>0</b>	<b>3</b>	<b>0</b>	<b>2</b>	<b>1</b>	<b>3</b>	<b>0</b>	<b>0</b>
<b>YEAR: 2020</b>														
FIXED / OTHER OBJECT	0	1	0	1	0	1	0	0	1	1	0	1	0	1
<b>YEAR 2020 TOTAL</b>	<b>0</b>	<b>1</b>	<b>0</b>	<b>1</b>	<b>0</b>	<b>1</b>	<b>0</b>	<b>0</b>	<b>1</b>	<b>1</b>	<b>0</b>	<b>1</b>	<b>0</b>	<b>1</b>
<b>FINAL TOTAL</b>	<b>0</b>	<b>6</b>	<b>0</b>	<b>6</b>	<b>0</b>	<b>10</b>	<b>0</b>	<b>5</b>	<b>1</b>	<b>5</b>	<b>1</b>	<b>6</b>	<b>0</b>	<b>1</b>

Disclaimer: The information contained in this report is compiled from individual driver and police crash reports submitted to the Oregon Department of Transportation as required in ORS 811.720. The Crash Analysis and Reporting Unit is committed to providing the highest quality crash data to customers. However, because submittal of crash report forms is the responsibility of the individual driver, the Crash Analysis and Reporting Unit can not guarantee that all qualifying crashes are represented nor can assurances be made that all details pertaining to a single crash are accurate. Note: Legislative changes to DMV's vehicle crash reporting requirements, effective 01/01/2004, may result in fewer property damage only crashes being eligible for inclusion in the Statewide Crash Data File.



URBAN NON-SYSTEM CRASH LISTING

CITY OF SPRINGFIELD, LANE COUNTY

GATEWAY ST at HARLOW RD, City of Springfield, Lane County, ALL Crashes Severity, ALL Crashes Circumstance, 01/01/2019 to 12/31/2024

6 - 8 of 28 Crash records shown.

SER#	S	D	M	P	R	J	S	W	DATE	CLASS	CITY STREET	INT-TYPE	SPCL USE	A	S																
INVEST	E	A	U	I	C	O	DAY	DIST	FIRST STREET	RD CHAR	(MEDIAN)	INT-REL	OFFRD	WTHR	CRASH	TRLR QTY	MOVE	PRTC	INJ	G	E	LICNS	PED								
RD DPT	E	L	G	N	H	R	TIME	FROM	SECOND STREET	DIRECT	LEGS	TRAF-	RNDBT	SURF	COLL	OWNER	FROM	P#	TYPE	SVRTY	E	X	RES	LOC	ERROR	ACT	EVENT	CAUSE			
UNLOC?	D	C	S	V	L	K	LAT	LONG	LRS	LOCTN	(#LANES)	CONTL	DRVWY	LIGHT	SVRTY	V#	TYPE	TO	P#	TYPE	SVRTY	E	X	RES	LOC	ERROR	ACT	EVENT	CAUSE		
03152	N	N	N	N	N	N	N	12/22/2020	16	GATEWAY ST	INTER	CROSS	N	N	CLR	PED	01	NONE	TURN-R												
CITY							TU	0	HARLOW RD	W		TRF SIGNAL	N	WET	PED		PRVTE	N -W								000	000				
N							6P			05	0		N	DLIT	INJ		PSNGR CAR		01	DRVR	NONE	87	F	OR-Y		029	000	02			
N							44 4 14.62	-123 2 31.31																							
03380	N	N	N	N	N	N	N	11/23/2021	16	GATEWAY ST	INTER	CROSS	N	N	CLR	S-1STOP	01	NONE	9	STRGHT											
NONE							TU	0	HARLOW RD	W		TRF SIGNAL	N	DRY	REAR		N/A	W -E								000	000				
N							1P			06	0		N	DAY	PDO		PSNGR CAR		01	DRVR	NONE	00	Unk	UNK		000	000	00			
N							44 4 14.63	-123 2 31.33																							
03591	N	N	N	N	N	N	N	12/02/2022	16	GATEWAY ST	INTER	CROSS	N	N	SLT	S-OTHER	01	NONE	9	TURN-L							124	10			
NONE							FR	0	HARLOW RD	W		TRF SIGNAL	N	ICE	TURN		N/A	S -W								000	000				
N							6A			05	0		N	DLIT	PDO		PSNGR CAR		01	DRVR	NONE	00	Unk	UNK		000	000	00			
N							44 4 14.63	-123 2 31.33																							
00526	N	N	N	N	N	N	N	03/02/2023	16	GATEWAY ST	INTER	CROSS	N	N	CLR	S-1STOP	01	NONE	0	STRGHT											
NONE							TH	0	HARLOW RD	W		TRF SIGNAL	N	DRY	REAR		PRVTE	W -E								000	000				
N							5P			06	0		N	DAY	INJ		PSNGR CAR		01	DRVR	NONE	49	M	OR-Y		016,026	038	27,29			
N							44 4 14.63	-123 2 31.33																							

Disclaimer: The information contained in this report is compiled from individual driver and police crash reports submitted to the Oregon Department of Transportation as required in ORS 811.720. The Crash Analysis and Reporting Unit is committed to providing the highest quality crash data to customers. However, because submittal of crash report forms is the responsibility of the individual driver, the Crash Analysis and Reporting Unit can not guarantee that all qualifying crashes are represented nor can assurances be made that all details pertaining to a single crash are accurate. Note: Legislative changes to DMV's vehicle crash reporting requirement, effective 01/01/2004, may result in fewer property damage only crashes being eligible for inclusion in the Statewide Crash Data File.

OREGON.. DEPARTMENT OF TRANSPORTATION - TRANSPORTATION DEVELOPMENT DIVISION
TRANSPORTATION DATA SECTION - CRASH ANALYSIS AND REPORTING UNIT
URBAN NON-SYSTEM CRASH LISTING

CITY OF SPRINGFIELD, LANE COUNTY

GATEWAY ST at HARLOW RD, City of Springfield, Lane County, ALL Crashes Severity, ALL Crashes Circumstance, 01/01/2019 to 12/31/2024

9 - 13 of 28 Crash records shown.

Table with columns: SER#, S D M, P R J S W DATE, CLASS, CITY STREET, INT-TYPE, SPCL USE, MOVE, A S, RD DPT, E L G N H R TIME, FROM, SECOND STREET, DIRECT, LEGS, TRAF-, RNCBT, SURF, COLL, OWNER, FROM, PRTC, INJ, G E LICNS, PED, UNLOC?, D C S V L K LAT, LONG, LRS, LOCTN, (#LANES), CONTL, DRVWY, LIGHT, SVRTY, V# TYPE, TO, P# TYPE, SVRTY, E X RES, LOC, ERROR, ACT, EVENT, CAUSE. Rows include accident details for dates like 08/22/2023, 11/25/2019, 12/13/2019, and 12/24/2019.

Disclaimer: The information contained in this report is compiled from individual driver and police crash reports submitted to the Oregon Department of Transportation as required in ORS 811.720. The Crash Analysis and Reporting Unit is committed to providing the highest quality crash data to customers. However, because submittal of crash report forms is the responsibility of the individual driver, the Crash Analysis and Reporting Unit can not guarantee that all qualifying crashes are represented nor can assurances be made that all details pertaining to a single crash are accurate. Note: Legislative changes to DMV's vehicle crash reporting requirement, effective 01/01/2004, may result in fewer property damage only crashes being eligible for inclusion in the Statewide Crash Data File.

CITY OF SPRINGFIELD, LANE COUNTY

GATEWAY ST at HARLOW RD, City of Springfield, Lane County, ALL Crashes Severity, ALL Crashes Circumstance, 01/01/2019 to 12/31/2024

14 - 18 of 28 Crash records shown.

SER#	S	D	M	P	R	J	S	W	DATE	CLASS	CITY STREET	INT-TYPE	SPCL USE																							
INVEST	E	A	U	I	C	O	DAY	DIST	FIRST STREET	RD CHAR	(MEDIAN)	INT-REL	OFFRD	WTHR	CRASH	TRLR QTY	MOVE									A	S									
RD DPT	E	L	G	N	H	R	TIME	FROM	SECOND STREET	DIRECT	LEGS	TRAF-	RNDBT	SURF	COLL	OWNER	FROM	PRTC	INJ	G	E	LICNS	PED													
UNLOC?	D	C	S	V	L	K	LAT	LONG	LRS	LOCTN	(#LANES)	CONTL	DRVWY	LIGHT	SVRTY	V#	TYPE	TO	P#	TYPE	SVRTY	E	X	RES	LOC	ERROR	ACT	EVENT	CAUSE							
00359	N	N	N	N	N	N	N	02/02/2019	16	GATEWAY ST	INTER	3-LEG	N	N	CLR	O-1 L-TURN	01	NONE	9	TURN-L																
CITY							SA	0	HARLOW RD	CN		TRF SIGNAL	N	DRY	TURN	N/A		W	-N									000	00							
N							1P			02	0		N	DAY	PDO	PSNGR CAR		01	DRVR	NONE	00	Unk	UNK		000	000	00									
N							44 4 14.63	-123 2 31.33																												
													02	NONE	9	STRGHT																				
													N/A		E	-W																				
													01	DRVR	NONE	00	Unk	UNK		000	000	00														
00870	N	N	N	N	N	N	N	03/22/2019	16	GATEWAY ST	INTER	CROSS	N	N	RAIN	O-1 L-TURN	01	NONE	9	TURN-L																
CITY							FR	0	HARLOW RD	CN		TRF SIGNAL	N	WET	TURN	N/A		E	-S									000	00							
N							11A			03	0		N	DAY	PDO	PSNGR CAR		01	DRVR	NONE	00	Unk	UNK		000	000	00									
N							44 4 14.63	-123 2 31.33																												
													02	NONE	9	STRGHT																				
													N/A		W	-E																				
													01	DRVR	NONE	00	Unk	UNK		000	000	00														
01290	Y	N	N	N	N	N	N	06/02/2020	16	GATEWAY ST	INTER	CROSS	N	N	CLR	O-1 L-TURN	01	NONE		STRGHT																
CITY							TU	0	HARLOW RD	CN		TRF SIGNAL	N	DRY	TURN	PRVTE		W	-E									000	00							
N							4P			03	0		N	DAY	INJ	PSNGR CAR		01	DRVR	INJC	25	F	OR-Y		050	000	30									
N							44 4 14.63	-123 2 31.33																												
													02	NONE		TURN-L																				
													PRVTE		E	-S																				
													01	DRVR	NONE	64	F	OR-Y		004,028	000	00														
00016	N	N	N	N	N	N	N	01/02/2020	16	GATEWAY ST	INTER	CROSS	N	N	CLR	S-1TURN	01	NONE	9	STRGHT																
NONE							TH	0	HARLOW RD	CN		TRF SIGNAL	N	DRY	TURN	N/A		E	-W									000	00							
N							5P			02	0		N	DUSK	PDO	PSNGR CAR		01	DRVR	NONE	00	Unk	UNK		000	000	00									
N							44 4 14.63	-123 2 31.33																												
													02	NONE	9	TURN-R																				
													N/A		E	-N																				
													01	DRVR	NONE	00	Unk	UNK		000	000	00														
01369	N	N	N	N	N	N	N	05/30/2021	16	GATEWAY ST	INTER	3-LEG	N	N	CLR	ANGL-OTH	01	NONE	9	STRGHT																
NONE							SU	0	HARLOW RD	CN		TRF SIGNAL	N	DRY	TURN	N/A		W	-E									000	00							
N							10P			04	0		Y	DLIT	PDO	PSNGR CAR		01	DRVR	NONE	00	Unk	UNK		000	000	00									
N							44 4 14.63	-123 2 31.33																												
													02	NONE	9	TURN-L																				
													N/A		S	-W																				
													01	DRVR	NONE	00	Unk	UNK		000	000	00														

Disclaimer: The information contained in this report is compiled from individual driver and police crash reports submitted to the Oregon Department of Transportation as required in ORS 811.720. The Crash Analysis and Reporting Unit is committed to providing the highest quality crash data to customers. However, because submittal of crash report forms is the responsibility of the individual driver, the Crash Analysis and Reporting Unit can not guarantee that all qualifying crashes are represented nor can assurances be made that all details pertaining to a single crash are accurate. Note: Legislative changes to DMV's vehicle crash reporting requirement, effective 01/01/2004, may result in fewer property damage only crashes being eligible for inclusion in the Statewide Crash Data File.

CITY OF SPRINGFIELD, LANE COUNTY

GATEWAY ST at HARLOW RD, City of Springfield, Lane County, ALL Crashes Severity, ALL Crashes Circumstance, 01/01/2019 to 12/31/2024

19 - 22 of 28 Crash records shown.

SER#	P	R	J	S	W	DATE	CLASS	CITY STREET	INT-TYPE	SPCL USE																				
INVEST	E	A	U	I	C	O	DAY	DIST	FIRST STREET	RD CHAR	(MEDIAN)	INT-REL	OFFRD	WTHR	CRASH	TRLR	QTY	MOVE	A	S										
RD DPT	E	L	G	N	H	R	TIME	FROM	SECOND STREET	DIRECT	LEGS	TRAF-	RNDBT	SURF	COLL	OWNER	FROM	PRTC	INJ	G	E	LICNS	PED							
UNLOC?	D	C	S	V	L	K	LAT	LONG	LRS	LOCTN	(#LANES)	CONTL	DRVWY	LIGHT	SVRTY	V#	TYPE	TO	P#	TYPE	SVRTY	E	X	RES	LOC	ERROR	ACT	EVENT	CAUSE	
03102	N	N	N	N	N	10/30/2021	16	GATEWAY ST	INTER	CROSS	N	N	N	CLR	S-1TURN	01	NONE	9	TURN-R											08,02
NONE						SA	0	HARLOW RD	CN			TRF SIGNAL	N	DRY	TURN		N/A		E -N									000	00	
N						10A			02	0			N	DAY	PDO		PSNGR	CAR			01	DRVR	NONE	00	Unk	UNK		000	000	00
N						44 4 14.63	-123 2 31.33																							
																02	NONE	9	STRGHT											
																	N/A		E -W									000	00	
																	PSNGR	CAR			01	DRVR	NONE	00	Unk	UNK		000	000	00
02391	Y	Y	N	N	N	08/13/2022	16	GATEWAY ST	INTER	CROSS	N	N	N	CLR	ANGL-OTH	01	NONE	0	TURN-R											33,27,02
CITY						SA	0	HARLOW RD	CN			TRF SIGNAL	N	DRY	TURN		PRVTE		S -E									016	00	
N						9P			04	0			N	DLIT	INJ		PSNGR	CAR			01	DRVR	NONE	19	F	OR-Y		051,016,028	038	33,27,02
N						44 4 14.63	-123 2 31.33																							
																	02	NONE	0	STRGHT										
																	PRVTE		W -E										000	00
																	PSNGR	CAR			01	DRVR	INJC	19	F	OR-Y		050	000	30
																	02	NONE	0	STRGHT										
																	PRVTE		W -E										000	00
																	PSNGR	CAR			02	PSNG	INJC	20	M			000	000	00
																	02	NONE	0	STRGHT										
																	PRVTE		W -E										000	00
																	PSNGR	CAR			03	PSNG	INJC	20	F			000	000	00
02418	N	N	N	N	N	08/15/2022	16	GATEWAY ST	INTER	CROSS	N	N	N	CLR	O-1 L-TURN	01	NONE	0	TURN-L											02
CITY						MO	0	HARLOW RD	CN			TRF SIGNAL	N	DRY	TURN		PRVTE		W -N										000	00
N						8A			02	0			N	DAY	INJ		PSNGR	CAR			01	DRVR	NONE	64	F	OR-Y		028,004	000	02
N						44 4 14.63	-123 2 31.33																							
																	02	NONE	0	STRGHT										
																	PRVTE		E -W										000	00
																	PSNGR	CAR			01	DRVR	INJB	27	F	NONE		010	000	00
02401	Y	Y	N	N	N	08/13/2022	16	GATEWAY ST	INTER	CROSS	N	N	N	CLR	O-1 L-TURN	01	NONE	9	STRGHT											30
CITY						SA	0	HARLOW RD	CN			TRF SIGNAL	N	DRY	TURN		N/A		E -W										000	00
N						9P			02	0			N	DLIT	PDO		PSNGR	CAR			01	DRVR	NONE	00	Unk	UNK		000	000	00
N						44 4 14.63	-123 2 31.33																							
																	02	NONE	9	TURN-L										
																	N/A		W -N										000	00
																	PSNGR	CAR			01	DRVR	NONE	00	Unk	UNK		000	000	00

Disclaimer: The information contained in this report is compiled from individual driver and police crash reports submitted to the Oregon Department of Transportation as required in ORS 811.720. The Crash Analysis and Reporting Unit is committed to providing the highest quality crash data to customers. However, because submittal of crash report forms is the responsibility of the individual driver, the Crash Analysis and Reporting Unit can not guarantee that all qualifying crashes are represented nor can assurances be made that all details pertaining to a single crash are accurate. Note: Legislative changes to DMV's vehicle crash reporting requirement, effective 01/01/2004, may result in fewer property damage only crashes being eligible for inclusion in the Statewide Crash Data File.





CRASH SUMMARIES BY YEAR BY COLLISION TYPE

GATEWAY ST at HARLOW RD, City of Springfield, Lane County, ALL Crashes Severity, ALL Crashes Circumstance, 01/01/2019 to 12/31/2024

COLLISION TYPE	FATAL CRASHES	NON- FATAL CRASHES	PROPERTY DAMAGE ONLY	TOTAL CRASHES	PEOPLE KILLED	PEOPLE INJURED	TRUCKS	DRY SURF	WET SURF	DAY	DARK	INTER- SECTION	INTER- SECTION RELATED	OFF- ROAD
<b>YEAR: 2024</b>														
REAR-END	0	1	1	2	0	1	0	0	2	1	1	2	0	0
TURNING MOVEMENTS	0	2	0	2	0	4	0	2	0	1	1	2	0	0
<b>YEAR 2024 TOTAL</b>	<b>0</b>	<b>3</b>	<b>1</b>	<b>4</b>	<b>0</b>	<b>5</b>	<b>0</b>	<b>2</b>	<b>2</b>	<b>2</b>	<b>2</b>	<b>4</b>	<b>0</b>	<b>0</b>
<b>YEAR: 2023</b>														
REAR-END	0	2	0	2	0	5	0	2	0	2	0	2	0	0
TURNING MOVEMENTS	0	1	1	2	0	2	0	1	1	1	1	2	0	0
<b>YEAR 2023 TOTAL</b>	<b>0</b>	<b>3</b>	<b>1</b>	<b>4</b>	<b>0</b>	<b>7</b>	<b>0</b>	<b>3</b>	<b>1</b>	<b>3</b>	<b>1</b>	<b>4</b>	<b>0</b>	<b>0</b>
<b>YEAR: 2022</b>														
TURNING MOVEMENTS	0	2	3	5	0	4	0	4	1	2	3	5	0	0
<b>YEAR 2022 TOTAL</b>	<b>0</b>	<b>2</b>	<b>3</b>	<b>5</b>	<b>0</b>	<b>4</b>	<b>0</b>	<b>4</b>	<b>1</b>	<b>2</b>	<b>3</b>	<b>5</b>	<b>0</b>	<b>0</b>
<b>YEAR: 2021</b>														
REAR-END	0	0	1	1	0	0	0	1	0	1	0	1	0	0
TURNING MOVEMENTS	0	1	2	3	0	1	0	2	1	2	1	3	0	0
<b>YEAR 2021 TOTAL</b>	<b>0</b>	<b>1</b>	<b>3</b>	<b>4</b>	<b>0</b>	<b>1</b>	<b>0</b>	<b>3</b>	<b>1</b>	<b>3</b>	<b>1</b>	<b>4</b>	<b>0</b>	<b>0</b>
<b>YEAR: 2020</b>														
PEDESTRIAN	0	2	0	2	0	2	0	0	2	1	1	2	0	0
TURNING MOVEMENTS	0	1	1	2	0	1	0	2	0	1	1	2	0	0
<b>YEAR 2020 TOTAL</b>	<b>0</b>	<b>3</b>	<b>1</b>	<b>4</b>	<b>0</b>	<b>3</b>	<b>0</b>	<b>2</b>	<b>2</b>	<b>2</b>	<b>2</b>	<b>4</b>	<b>0</b>	<b>0</b>

CRASH SUMMARIES BY YEAR BY COLLISION TYPE

GATEWAY ST at HARLOW RD, City of Springfield, Lane County, ALL Crashes Severity, ALL Crashes Circumstance, 01/01/2019 to 12/31/2024

COLLISION TYPE	FATAL CRASHES	NON- FATAL CRASHES	PROPERTY DAMAGE ONLY	TOTAL CRASHES	PEOPLE KILLED	PEOPLE INJURED	TRUCKS	DRY SURF	WET SURF	DAY	DARK	INTER- SECTION	INTER- SECTION RELATED	OFF- ROAD
<b>YEAR: 2019</b>														
REAR-END	0	1	0	1	0	1	0	1	0	0	1	1	0	0
TURNING MOVEMENTS	0	3	3	6	0	4	1	4	2	6	0	6	0	0
<b>YEAR 2019 TOTAL</b>	<b>0</b>	<b>4</b>	<b>3</b>	<b>7</b>	<b>0</b>	<b>5</b>	<b>1</b>	<b>5</b>	<b>2</b>	<b>6</b>	<b>1</b>	<b>7</b>	<b>0</b>	<b>0</b>
<b>FINAL TOTAL</b>	<b>0</b>	<b>16</b>	<b>12</b>	<b>28</b>	<b>0</b>	<b>25</b>	<b>1</b>	<b>19</b>	<b>9</b>	<b>18</b>	<b>10</b>	<b>28</b>	<b>0</b>	<b>0</b>

Disclaimer: The information contained in this report is compiled from individual driver and police crash reports submitted to the Oregon Department of Transportation as required in ORS 811.720. The Crash Analysis and Reporting Unit is committed to providing the highest quality crash data to customers. However, because submittal of crash report forms is the responsibility of the individual driver, the Crash Analysis and Reporting Unit can not guarantee that all qualifying crashes are represented nor can assurances be made that all details pertaining to a single crash are accurate. Note: Legislative changes to DMV's vehicle crash reporting requirements, effective 01/01/2004, may result in fewer property damage only crashes being eligible for inclusion in the Statewide Crash Data File.



CITY OF SPRINGFIELD, LANE COUNTY

GATEWAY ST at INTERNATIONAL WAY, City of Springfield, Lane County, ALL Crashes Severity, ALL Crashes Circumstance, 01/01/2019 to 12/31/2024

6 - 6 of 6 Crash records shown.

SER#	S	D	M	P	R	J	S	W	DATE	CLASS	CITY STREET	INT-TYPE	SPCL USE																				
INVEST	E	A	U	I	C	O	DAY	DIST	FIRST STREET	RD CHAR	(MEDIAN)	INT-REL	OFFRD	WTHR	CRASH	TRLR QTY	MOVE	A S															
RD DPT	E	L	G	N	H	R	TIME	FROM	SECOND STREET	DIRECT	LEGS	TRAF-	RNDBT	SURF	COLL	OWNER	FROM	PRTC	INJ	G	E	LICNS	PED										
UNLOC?	D	C	S	V	L	K	LAT	LONG	LRS	LOCTN	(#LANES)	CONTL	DRVWY	LIGHT	SVRTY	V#	TYPE	TO	P#	TYPE	SVRTY	E	X	RES	LOC	ERROR	ACT	EVENT	CAUSE				
02755	N	N	N	N	N	N	09/20/2022	16	GATEWAY ST	INTER	3-LEG	N	N	CLR	ANGL-OTH	01	NONE	0	TURN-L														
STATE							TU	0	INTERNATIONAL WAY	CN		TRF SIGNAL	N	DRY	TURN		PRVTE	NE-SE	000 00														
N							9A			02	1		N	DAY	INJ		PSNGR CAR		01	DRVR	INJB	72	M	OTH-Y		020	000	04					
N							44 5 13.9	-123 2 38.57																									
																02	NONE	0	STRGHT														
																	PRVTE	SE-NW															
																	PSNGR CAR		01	DRVR	INJC	27	F	OR-Y		000	000	00					

Disclaimer: The information contained in this report is compiled from individual driver and police crash reports submitted to the Oregon Department of Transportation as required in ORS 811.720. The Crash Analysis and Reporting Unit is committed to providing the highest quality crash data to customers. However, because submittal of crash report forms is the responsibility of the individual driver, the Crash Analysis and Reporting Unit can not guarantee that all qualifying crashes are represented nor can assurances be made that all details pertaining to a single crash are accurate. Note: Legislative changes to DMV's vehicle crash reporting requirement, effective 01/01/2004, may result in fewer property damage only crashes being eligible for inclusion in the Statewide Crash Data File.

CRASH SUMMARIES BY YEAR BY COLLISION TYPE

GATEWAY ST at INTERNATIONAL WAY, City of Springfield, Lane County, ALL Crashes Severity, ALL Crashes Circumstance, 01/01/2019 to 12/31/2024

COLLISION TYPE	FATAL CRASHES	NON- FATAL CRASHES	PROPERTY DAMAGE ONLY	TOTAL CRASHES	PEOPLE KILLED	PEOPLE INJURED	TRUCKS	DRY SURF	WET SURF	DAY	DARK	INTER- SECTION	INTER- SECTION RELATED	OFF- ROAD
<b>YEAR: 2024</b>														
FIXED / OTHER OBJECT	0	0	1	1	0	0	0	0	1	0	1	1	0	1
<b>YEAR 2024 TOTAL</b>	<b>0</b>	<b>0</b>	<b>1</b>	<b>1</b>	<b>0</b>	<b>0</b>	<b>0</b>	<b>0</b>	<b>1</b>	<b>0</b>	<b>1</b>	<b>1</b>	<b>0</b>	<b>1</b>
<b>YEAR: 2023</b>														
SIDESWIPE - OVERTAKING	0	0	1	1	0	0	0	1	0	1	0	1	0	0
TURNING MOVEMENTS	0	0	1	1	0	0	1	1	0	1	0	1	0	0
<b>YEAR 2023 TOTAL</b>	<b>0</b>	<b>0</b>	<b>2</b>	<b>2</b>	<b>0</b>	<b>0</b>	<b>1</b>	<b>2</b>	<b>0</b>	<b>2</b>	<b>0</b>	<b>2</b>	<b>0</b>	<b>0</b>
<b>YEAR: 2022</b>														
REAR-END	0	0	1	1	0	0	0	1	0	1	0	1	0	0
TURNING MOVEMENTS	0	1	0	1	0	2	0	1	0	1	0	1	0	0
<b>YEAR 2022 TOTAL</b>	<b>0</b>	<b>1</b>	<b>1</b>	<b>2</b>	<b>0</b>	<b>2</b>	<b>0</b>	<b>2</b>	<b>0</b>	<b>2</b>	<b>0</b>	<b>2</b>	<b>0</b>	<b>0</b>
<b>YEAR: 2019</b>														
TURNING MOVEMENTS	0	0	1	1	0	0	0	0	1	0	1	1	0	0
<b>YEAR 2019 TOTAL</b>	<b>0</b>	<b>0</b>	<b>1</b>	<b>1</b>	<b>0</b>	<b>0</b>	<b>0</b>	<b>0</b>	<b>1</b>	<b>0</b>	<b>1</b>	<b>1</b>	<b>0</b>	<b>0</b>
<b>FINAL TOTAL</b>	<b>0</b>	<b>1</b>	<b>5</b>	<b>6</b>	<b>0</b>	<b>2</b>	<b>1</b>	<b>4</b>	<b>2</b>	<b>4</b>	<b>2</b>	<b>6</b>	<b>0</b>	<b>1</b>

Disclaimer: The information contained in this report is compiled from individual driver and police crash reports submitted to the Oregon Department of Transportation as required in ORS 811.720. The Crash Analysis and Reporting Unit is committed to providing the highest quality crash data to customers. However, because submittal of crash report forms is the responsibility of the individual driver, the Crash Analysis and Reporting Unit can not guarantee that all qualifying crashes are represented nor can assurances be made that all details pertaining to a single crash are accurate. Note: Legislative changes to DMV's vehicle crash reporting requirements, effective 01/01/2004, may result in fewer property damage only crashes being eligible for inclusion in the Statewide Crash Data File.



CRASH SUMMARIES BY YEAR BY COLLISION TYPE

INTERNATIONAL WAY at MAPLE ISLAND RD, City of Springfield, Lane County, ALL Crashes Severity, ALL Crashes Circumstance, 01/01/2019 to 12/31/2024

COLLISION TYPE	FATAL CRASHES	NON- FATAL CRASHES	PROPERTY DAMAGE ONLY	TOTAL CRASHES	PEOPLE KILLED	PEOPLE INJURED	TRUCKS	DRY SURF	WET SURF	DAY	DARK	INTER- SECTION	SECTION RELATED	OFF- ROAD
<b>YEAR: 2021</b>														
ANGLE	0	0	1	1	0	0	0	0	1	1	0	1	0	0
<b>YEAR 2021 TOTAL</b>	<b>0</b>	<b>0</b>	<b>1</b>	<b>1</b>	<b>0</b>	<b>0</b>	<b>0</b>	<b>0</b>	<b>1</b>	<b>1</b>	<b>0</b>	<b>1</b>	<b>0</b>	<b>0</b>
<b>FINAL TOTAL</b>	<b>0</b>	<b>0</b>	<b>1</b>	<b>1</b>	<b>0</b>	<b>0</b>	<b>0</b>	<b>0</b>	<b>1</b>	<b>1</b>	<b>0</b>	<b>1</b>	<b>0</b>	<b>0</b>

Disclaimer: The information contained in this report is compiled from individual driver and police crash reports submitted to the Oregon Department of Transportation as required in ORS 811.720. The Crash Analysis and Reporting Unit is committed to providing the highest quality crash data to customers. However, because submittal of crash report forms is the responsibility of the individual driver, the Crash Analysis and Reporting Unit can not guarantee that all qualifying crashes are represented nor can assurances be made that all details pertaining to a single crash are accurate. Note: Legislative changes to DMV's vehicle crash reporting requirements, effective 01/01/2004, may result in fewer property damage only crashes being eligible for inclusion in the Statewide Crash Data File.



CRASH SUMMARIES BY YEAR BY COLLISION TYPE

BELTLINE RD at E GAME FARM RD, City of Springfield, Lane County, ALL Crashes Severity, ALL Crashes Circumstance, 01/01/2019 to 12/31/2024

COLLISION TYPE	FATAL CRASHES	NON- FATAL CRASHES	PROPERTY DAMAGE ONLY	TOTAL CRASHES	PEOPLE KILLED	PEOPLE INJURED	TRUCKS	DRY SURF	WET SURF	DAY	DARK	INTER- SECTION	INTER- SECTION RELATED	OFF- ROAD
<b>YEAR: 2020</b>														
SIDESWIPE - OVERTAKING	0	1	0	1	0	1	0	0	1	1	0	1	0	0
<b>YEAR 2020 TOTAL</b>	<b>0</b>	<b>1</b>	<b>0</b>	<b>1</b>	<b>0</b>	<b>1</b>	<b>0</b>	<b>0</b>	<b>1</b>	<b>1</b>	<b>0</b>	<b>1</b>	<b>0</b>	<b>0</b>
<b>YEAR: 2019</b>														
TURNING MOVEMENTS	0	1	0	1	0	2	0	1	0	0	1	1	0	0
<b>YEAR 2019 TOTAL</b>	<b>0</b>	<b>1</b>	<b>0</b>	<b>1</b>	<b>0</b>	<b>2</b>	<b>0</b>	<b>1</b>	<b>0</b>	<b>0</b>	<b>1</b>	<b>1</b>	<b>0</b>	<b>0</b>
<b>FINAL TOTAL</b>	<b>0</b>	<b>2</b>	<b>0</b>	<b>2</b>	<b>0</b>	<b>3</b>	<b>0</b>	<b>1</b>	<b>1</b>	<b>1</b>	<b>1</b>	<b>2</b>	<b>0</b>	<b>0</b>

Disclaimer: The information contained in this report is compiled from individual driver and police crash reports submitted to the Oregon Department of Transportation as required in ORS 811.720. The Crash Analysis and Reporting Unit is committed to providing the highest quality crash data to customers. However, because submittal of crash report forms is the responsibility of the individual driver, the Crash Analysis and Reporting Unit can not guarantee that all qualifying crashes are represented nor can assurances be made that all details pertaining to a single crash are accurate. Note: Legislative changes to DMV's vehicle crash reporting requirements, effective 01/01/2004, may result in fewer property damage only crashes being eligible for inclusion in the Statewide Crash Data File.

CITY OF SPRINGFIELD, LANE COUNTY

BELTLINE RD at E GAME FARM RD, City of Springfield, Lane County, ALL Crashes Severity, ALL Crashes Circumstance, 01/01/2019 to 12/31/2024

1 - 2 of 2 Crash records shown.

SER#	P	R	J	S	W	DATE	CLASS	CITY STREET	INT-TYPE	SPCL USE	A	S																		
INVEST	E	A	U	I	C	O	DAY	DIST	FIRST STREET	RD CHAR	(MEDIAN)	INT-REL	OFFRD	WTHR	CRASH	TRLR QTY	MOVE													
RD DPT	E	L	G	N	H	R	TIME	FROM	SECOND STREET	DIRECT	LEGS	TRAF-	RNDBT	SURF	COLL	OWNER	FROM	PRTC	INJ	G	E	LICNS	PED							
UNLOC?	D	C	S	V	L	K	LAT	LONG	LRS	LOCTN	(#LANES)	CONTL	DRVWY	LIGHT	SVRTY	V#	TYPE	TO	P#	TYPE	SVRTY	E	X	RES	LOC	ERROR	ACT	EVENT	CAUSE	
02472	N	N	N	N	N	N	08/14/2019	16	BELTLINE RD	INTER	3-LEG	N	N	CLR	O-1 L-TURN	01	NONE	STRGHT												
CITY							WE	0	E GAME FARM RD	CN		TRF SIGNAL	N	DRY	TURN		PRVTE	SE-NW									000		00	
N							6A			02	1		N	DAWN	INJ		PSNGR CAR		01	DRVR	INJC	31	M	OTH-Y		000	000		00	
N							44 5 2.63	-123 1 58.2																						
																02	NONE	TURN-L												
																	PRVTE	NW-N									000		00	
																	PSNGR CAR		01	DRVR	INJB	63	F	OR-Y		028,004	000		02	
02250	N	N	N	N	N	N	09/18/2020	16	BELTLINE RD	INTER	3-LEG	N	N	RAIN	S-STRGHT	01	NONE	STRGHT												29
NONE							FR	0	E GAME FARM RD	CN		UNKNOWN	N	WET	SS-O		PRVTE	E -W									000		00	
N							12P			01	0		N	DAY	INJ		PSNGR CAR		01	DRVR	INJC	21	F	OR-Y		026	000		29	
N							44 5 2.63	-123 1 58.22																						
																02	NONE	STOP												
																	PRVTE	E -W										011		00
																	PSNGR CAR		01	DRVR	NONE	59	F	OR-Y		000	000		00	

Disclaimer: The information contained in this report is compiled from individual driver and police crash reports submitted to the Oregon Department of Transportation as required in ORS 811.720. The Crash Analysis and Reporting Unit is committed to providing the highest quality crash data to customers. However, because submittal of crash report forms is the responsibility of the individual driver, the Crash Analysis and Reporting Unit can not guarantee that all qualifying crashes are represented nor can assurances be made that all details pertaining to a single crash are accurate. Note: Legislative changes to DMV's vehicle crash reporting requirement, effective 01/01/2004, may result in fewer property damage only crashes being eligible for inclusion in the Statewide Crash Data File.

CRASH SUMMARIES BY YEAR BY COLLISION TYPE

BELTLINE RD at E GAME FARM RD, City of Springfield, Lane County, ALL Crashes Severity, ALL Crashes Circumstance, 01/01/2019 to 12/31/2024

COLLISION TYPE	FATAL CRASHES	NON- FATAL CRASHES	PROPERTY DAMAGE ONLY	TOTAL CRASHES	PEOPLE KILLED	PEOPLE INJURED	TRUCKS	DRY SURF	WET SURF	DAY	DARK	INTER- SECTION	INTER- SECTION RELATED	OFF- ROAD
<b>YEAR: 2020</b>														
SIDESWIPE - OVERTAKING	0	1	0	1	0	1	0	0	1	1	0	1	0	0
<b>YEAR 2020 TOTAL</b>	<b>0</b>	<b>1</b>	<b>0</b>	<b>1</b>	<b>0</b>	<b>1</b>	<b>0</b>	<b>0</b>	<b>1</b>	<b>1</b>	<b>0</b>	<b>1</b>	<b>0</b>	<b>0</b>
<b>YEAR: 2019</b>														
TURNING MOVEMENTS	0	1	0	1	0	2	0	1	0	0	1	1	0	0
<b>YEAR 2019 TOTAL</b>	<b>0</b>	<b>1</b>	<b>0</b>	<b>1</b>	<b>0</b>	<b>2</b>	<b>0</b>	<b>1</b>	<b>0</b>	<b>0</b>	<b>1</b>	<b>1</b>	<b>0</b>	<b>0</b>
<b>FINAL TOTAL</b>	<b>0</b>	<b>2</b>	<b>0</b>	<b>2</b>	<b>0</b>	<b>3</b>	<b>0</b>	<b>1</b>	<b>1</b>	<b>1</b>	<b>1</b>	<b>2</b>	<b>0</b>	<b>0</b>

Disclaimer: The information contained in this report is compiled from individual driver and police crash reports submitted to the Oregon Department of Transportation as required in ORS 811.720. The Crash Analysis and Reporting Unit is committed to providing the highest quality crash data to customers. However, because submittal of crash report forms is the responsibility of the individual driver, the Crash Analysis and Reporting Unit can not guarantee that all qualifying crashes are represented nor can assurances be made that all details pertaining to a single crash are accurate. Note: Legislative changes to DMV's vehicle crash reporting requirements, effective 01/01/2004, may result in fewer property damage only crashes being eligible for inclusion in the Statewide Crash Data File.

OREGON.. DEPARTMENT OF TRANSPORTATION - TRANSPORTATION DEVELOPMENT DIVISION  
TRANSPORTATION DATA SECTION - CRASH ANAYLYSIS AND REPORTING UNIT  
URBAN NON-SYSTEM CRASH LISTING

CITY OF SPRINGFIELD, LANE COUNTY

BELTLINE RD at E GAME FARM RD, City of Springfield, Lane County, ALL Crashes Severity, ALL Crashes Circumstance, 01/01/2019 to 12/31/2024

1 - 2 of 2 Crash records shown.

SER#	S	D	M	P	R	J	S	W	DATE	CLASS	CITY STREET	INT-TYPE	SPCL USE																						
INVEST	E	A	U	I	C	O	DAY			DIST	FIRST STREET	RD CHAR	(MEDIAN)	INT-REL	OFFRD	WTHR	CRASH	TRLR QTY	MOVE	A	S														
RD DPT	E	L	G	N	H	R	TIME			FROM	SECOND STREET	DIRECT	LEGS	TRAF-	RNDBT	SURF	COLL	OWNER	FROM	PRTC	INJ	G	E	LICNS	PED										
UNLOC?	D	C	S	V	L	K	LAT			LONG	LRS	LOCTN	(#LANES)	CONTL	DRVWY	LIGHT	SVRTY	V#	TYPE	TO	P#	TYPE	SVRTY	E	X	RES	LOC	ERROR	ACT	EVENT	CAUSE				
02472	N	N	N	N	N	N	N	N	08/14/2019	16	BELTLINE RD	INTER	3-LEG	N	N	CLR	O-1 L-TURN	01 NONE	STRGHT																
CITY							WE			0	E GAME FARM RD	CN		TRF SIGNAL	N	DRY	TURN	PRVTE	SE-NW										000		00				
N							6A					02	1		N	DAWN	INJ	PSNGR CAR				01 DRVR	INJC	31	M	OTH-Y		000		000					
N							44 5 2.63			-123 1																									
										58.2								02 NONE	TURN-L																
																		PRVTE	NW-N																
																		PSNGR CAR				01 DRVR	INJB	63	F	OR-Y		028,004		000		02			
02250	N	N	N	N	N	N	N	N	09/18/2020	16	BELTLINE RD	INTER	3-LEG	N	N	RAIN	S-STRGHT	01 NONE	STRGHT																
NONE							FR			0	E GAME FARM RD	CN		UNKNOWN	N	WET	SS-O	PRVTE	E -W											000		00			
N							12P					01	0		N	DAY	INJ	PSNGR CAR				01 DRVR	INJC	21	F	OR-Y		026		000		29			
N							44 5 2.63			-123 1																									
										58.22								02 NONE	STOP																
																		PRVTE	E -W																
																		PSNGR CAR				01 DRVR	NONE	59	F	OR-Y		000		000		00			

Disclaimer: The information contained in this report is compiled from individual driver and police crash reports submitted to the Oregon Department of Transportation as required in ORS 811.720. The Crash Analysis and Reporting Unit is committed to providing the highest quality crash data to customers. However, because submittal of crash report forms is the responsibility of the individual driver, the Crash Analysis and Reporting Unit can not guarantee that all qualifying crashes are represented nor can assurances be made that all details pertaining to a single crash are accurate. Note: Legislative changes to DMV's vehicle crash reporting requirement, effective 01/01/2004, may result in fewer property damage only crashes being eligible for inclusion in the Statewide Crash Data File.





OREGON.. DEPARTMENT OF TRANSPORTATION - TRANSPORTATION DEVELOPMENT DIVISION  
TRANSPORTATION DATA SECTION - CRASH ANALYSIS AND REPORTING UNIT  
URBAN NON-SYSTEM CRASH LISTING

CITY OF SPRINGFIELD, LANE COUNTY

BELTLINE RD at HUTTON ST, City of Springfield, Lane County, ALL Crashes Severity, ALL Crashes Circumstance, 01/01/2019 to 12/31/2024

9 - 13 of 18 Crash records shown.

SER#	S	D	M	P	R	J	S	W	DATE	CLASS	CITY	STREET	RD	CHAR	INT-TYPE	INT-REL	OFFRD	WTHR	CRASH	SPCL USE	MOVE	TRAFFIC	INJ	RES	PED	ACT	EVENT	CAUSE										
INVEST	E	A	U	I	C	O	DAY	DIST	FIRST STREET	RD CHAR	(MEDIAN)	INT-REL	OFFRD	WTHR	CRASH	TRLR QTY	OWNER	FROM	PRTC	INJ	G	E	LICNS	PED	ACT	EVENT	CAUSE											
RD DPT	E	L	G	N	H	R	TIME	FROM	SECOND STREET	DIRECT	LEGS	TRAF-	RNDBT	SURF	COLL	OWNER	FROM	PRTC	INJ	G	E	LICNS	PED	ACT	EVENT	CAUSE												
UNLOC?	D	C	S	V	L	K	LAT	LONG	LRS	LOCTN	(#LANES)	CONTL	DRVWY	LIGHT	SVRTY	V#	TYPE	TO	P#	TYPE	SVRTY	E	X	RES	LOC	ERROR	ACT	EVENT	CAUSE									
																02	NONE	9	STRGHT																			
00181	N	N	N	N	N	N	N		01/20/2022	16	BELTLINE RD		INTER	3-LEG	N	N	N	CLD	ANGL-OTH	01	NONE	0	TURN-L															
CITY							TH	0			HUTTON ST		CN																									
N							11A						01	0																								
N							44 5 2.84	-123 2																														
								22.07																														
01554	N	N	N	N	N	N	N		05/28/2022	16	BELTLINE RD		INTER	3-LEG	N	N	N	RAIN	ANGL-OTH	01	NONE	0	STRGHT															
NO RPT							SA	0			HUTTON ST		CN																									
N							10A						03	0																								
N							44 5 2.84	-123 2																														
								22.07																														
01534	N	N	N	N	N	N	N		05/25/2022	16	BELTLINE RD		INTER	3-LEG	N	N	N	CLR	ANGL-OTH	01	NONE	0	STRGHT															
CITY							WE	0			HUTTON ST		CN																									
N							11A						03	0																								
N							44 5 2.84	-123 2																														
								22.07																														
02403	N	Y	N	N	N	N	N		08/14/2022	16	BELTLINE RD		INTER	3-LEG	N	N	N	CLR	ANGL-OTH	01	NONE	0	TURN-L															
CITY							SU	0			HUTTON ST		CN																									
N							4P						02	0																								
N							44 5 2.84	-123 2																														
								22.07																														

Disclaimer: The information contained in this report is compiled from individual driver and police crash reports submitted to the Oregon Department of Transportation as required in ORS 811.720. The Crash Analysis and Reporting Unit is committed to providing the highest quality crash data to customers. However, because submittal of crash report forms is the responsibility of the individual driver, the Crash Analysis and Reporting Unit can not guarantee that all qualifying crashes are represented nor can assurances be made that all details pertaining to a single crash are accurate. Note: Legislative changes to DMV's vehicle crash reporting requirement, effective 01/01/2004, may result in fewer property damage only crashes being eligible for inclusion in the Statewide Crash Data File.



CRASH SUMMARIES BY YEAR BY COLLISION TYPE

BELTLINE RD at HUTTON ST, City of Springfield, Lane County, ALL Crashes Severity, ALL Crashes Circumstance, 01/01/2019 to 12/31/2024

COLLISION TYPE	FATAL CRASHES	NON- FATAL CRASHES	PROPERTY DAMAGE ONLY	TOTAL CRASHES	PEOPLE KILLED	PEOPLE INJURED	TRUCKS	DRY SURF	WET SURF	DAY	DARK	INTER- SECTION	INTER- SECTION RELATED	OFF- ROAD
<b>YEAR: 2024</b>														
ANGLE	0	1	1	2	0	2	0	0	2	1	1	2	0	0
<b>YEAR 2024 TOTAL</b>	<b>0</b>	<b>1</b>	<b>1</b>	<b>2</b>	<b>0</b>	<b>2</b>	<b>0</b>	<b>0</b>	<b>2</b>	<b>1</b>	<b>1</b>	<b>2</b>	<b>0</b>	<b>0</b>
<b>YEAR: 2023</b>														
ANGLE	0	1	1	2	0	1	0	2	0	2	0	2	0	0
<b>YEAR 2023 TOTAL</b>	<b>0</b>	<b>1</b>	<b>1</b>	<b>2</b>	<b>0</b>	<b>1</b>	<b>0</b>	<b>2</b>	<b>0</b>	<b>2</b>	<b>0</b>	<b>2</b>	<b>0</b>	<b>0</b>
<b>YEAR: 2022</b>														
ANGLE	0	2	0	2	0	2	0	1	1	2	0	2	0	0
TURNING MOVEMENTS	0	3	0	3	0	5	0	2	1	3	0	3	0	0
<b>YEAR 2022 TOTAL</b>	<b>0</b>	<b>5</b>	<b>0</b>	<b>5</b>	<b>0</b>	<b>7</b>	<b>0</b>	<b>3</b>	<b>2</b>	<b>5</b>	<b>0</b>	<b>5</b>	<b>0</b>	<b>0</b>
<b>YEAR: 2021</b>														
ANGLE	0	2	1	3	0	3	0	2	1	2	1	3	0	0
TURNING MOVEMENTS	0	0	1	1	0	0	0	0	1	0	1	1	0	1
<b>YEAR 2021 TOTAL</b>	<b>0</b>	<b>2</b>	<b>2</b>	<b>4</b>	<b>0</b>	<b>3</b>	<b>0</b>	<b>2</b>	<b>2</b>	<b>2</b>	<b>2</b>	<b>4</b>	<b>0</b>	<b>1</b>
<b>YEAR: 2020</b>														
ANGLE	0	2	0	2	0	2	0	0	1	2	0	2	0	0
TURNING MOVEMENTS	0	0	1	1	0	0	0	1	0	1	0	1	0	0
<b>YEAR 2020 TOTAL</b>	<b>0</b>	<b>2</b>	<b>1</b>	<b>3</b>	<b>0</b>	<b>2</b>	<b>0</b>	<b>1</b>	<b>1</b>	<b>3</b>	<b>0</b>	<b>3</b>	<b>0</b>	<b>0</b>

CRASH SUMMARIES BY YEAR BY COLLISION TYPE

BELTLINE RD at HUTTON ST, City of Springfield, Lane County, ALL Crashes Severity, ALL Crashes Circumstance, 01/01/2019 to 12/31/2024

COLLISION TYPE	FATAL CRASHES	NON- FATAL CRASHES	PROPERTY DAMAGE ONLY	TOTAL CRASHES	PEOPLE KILLED	PEOPLE INJURED	TRUCKS	DRY SURF	WET SURF	DAY	DARK	INTER- SECTION	INTER- SECTION RELATED	OFF- ROAD
<b>YEAR: 2019</b>														
ANGLE	0	2	0	2	0	3	0	1	1	2	0	2	0	0
<b>YEAR 2019 TOTAL</b>	<b>0</b>	<b>2</b>	<b>0</b>	<b>2</b>	<b>0</b>	<b>3</b>	<b>0</b>	<b>1</b>	<b>1</b>	<b>2</b>	<b>0</b>	<b>2</b>	<b>0</b>	<b>0</b>
<b>FINAL TOTAL</b>	<b>0</b>	<b>13</b>	<b>5</b>	<b>18</b>	<b>0</b>	<b>18</b>	<b>0</b>	<b>9</b>	<b>8</b>	<b>15</b>	<b>3</b>	<b>18</b>	<b>0</b>	<b>1</b>

*Disclaimer: The information contained in this report is compiled from individual driver and police crash reports submitted to the Oregon Department of Transportation as required in ORS 811.720. The Crash Analysis and Reporting Unit is committed to providing the highest quality crash data to customers. However, because submittal of crash report forms is the responsibility of the individual driver, the Crash Analysis and Reporting Unit can not guarantee that all qualifying crashes are represented nor can assurances be made that all details pertaining to a single crash are accurate. Note: Legislative changes to DMV's vehicle crash reporting requirements, effective 01/01/2004, may result in fewer property damage only crashes being eligible for inclusion in the Statewide Crash Data File.*

INTERNATIONAL WAY TPR

Intersection: 1: Sports Way @ International Way		City: Springfield																					
Counter: Sandow Engineering		Date: Tuesday, November 12, 2024																					
Total of All Vehicles																							
Time Period	Southbound				Westbound				Northbound				Eastbound				15 Minute Volume	Hourly Volume	Pedestrians				
	Right	Thru	Left	Approach Total	Right	Thru	Left	Approach Total	Right	Thru	Left	Approach Total	Right	Thru	Left	Approach Total			SB	WB	NB	EB	
16:00 - 16:15	5	0	1	6	0	56	0	56	0	0	0	0	0	30	3	33	95	0	0	0	0		
16:15 - 16:30	7	0	3	10	0	39	0	39	0	0	0	0	0	20	2	22	71	0	0	0	0		
16:30 - 16:45	7	0	1	8	1	62	0	63	0	0	0	0	0	6	2	8	79	0	1	2	0		
16:45 - 17:00	9	0	0	9	0	34	0	34	0	0	0	0	0	15	0	15	58	0	0	0	0		
17:00 - 17:15	13	0	3	16	0	68	0	68	0	0	0	0	0	23	0	23	107	1	1	1	0		
17:15 - 17:30	10	0	1	11	0	36	0	36	0	0	0	0	0	10	2	12	59	303	0	0	0		
17:30 - 17:45	8	0	0	8	0	64	0	64	0	0	0	0	0	15	0	15	87	311	1	0	0		
17:45 - 18:00	3	0	1	4	0	15	0	15	0	0	0	0	0	7	0	7	26	279	1	0	1		
18:00 - 18:15	0	0	0	0	0	0	0	0	0	0	0	0	0	0	0	0	0	172	0	0	0		
18:15 - 18:30	0	0	0	0	0	0	0	0	0	0	0	0	0	0	0	0	0	113	0	0	0		
18:30 - 18:45	0	0	0	0	0	0	0	0	0	0	0	0	0	0	0	0	0	26	0	0	0		
18:45 - 19:00	0	0	0	0	0	0	0	0	0	0	0	0	0	0	0	0	0	0	0	0	0		
<b>Count Period Total</b>	<b>62</b>	<b>0</b>	<b>10</b>		<b>1</b>	<b>374</b>	<b>0</b>		<b>0</b>	<b>0</b>	<b>0</b>	<b>0</b>	<b>0</b>	<b>126</b>	<b>9</b>		<b>582</b>		<b>3</b>	<b>2</b>	<b>4</b>	<b>0</b>	
PM Peak Hour Count Summary																							
Peak Volumes	Southbound				Westbound				Northbound				Eastbound				Approach	303	Pedestrians				
	Right	Thru	Left	Approach	Right	Thru	Left	Approach	Right	Thru	Left	Approach	Right	Thru	Left	Approach			SB	WB	NB	EB	
	39	0	5	44	1	200	0	201	0	0	0	0	0	54	4	58		1	2	3	0		
PHF	0.75	0.00	0.42	0.69	0.25	0.74	0.00	0.74	0.00	0.00	0.00	0.00	0.00	0.59	0.50	0.63	0.71						
Trucks	0	0	0		0	6	0		0	0	0		0	5	0								
% Trucks	0%	0%	0%		0%	3%	0%		0%	0%	0%		0%	9%	0%								

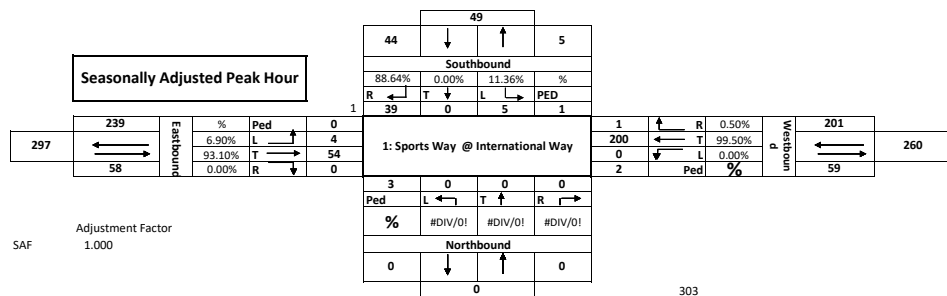



Intersection: 2: West FedEx Access @ International W City: Springfield																						
Counter: Sandow Engineering										Date: Tuesday, November 12, 2024												
Total of All Vehicles																						
Time Period	Southbound				Westbound				Northbound				Eastbound				15 Minute Volume	Hourly Volume	Pedestrians			
	Right	Thru	Left	Approach Total	Right	Thru	Left	Approach Total	Right	Thru	Left	Approach Total	Right	Thru	Left	Approach Total			SB	WB	NB	EB
16:00 - 16:15	7	0	0	7	0	43	0	43	0	0	0	0	0	21	2	23	73	0	0	0	0	
16:15 - 16:30	4	0	1	5	0	35	0	35	0	0	0	0	0	20	2	22	62	0	1	0	0	
16:30 - 16:45	7	0	1	8	1	50	0	51	0	0	0	0	0	8	2	10	69	0	0	0	1	
16:45 - 17:00	6	0	0	6	1	26	0	27	0	0	0	0	0	12	2	14	47	0	0	0	0	
17:00 - 17:15	2	0	1	3	0	61	0	61	0	0	0	0	0	30	0	30	94	0	0	0	0	
17:15 - 17:30	4	0	1	5	0	34	0	34	0	0	0	0	0	9	0	9	48	0	0	0	0	
17:30 - 17:45	2	0	0	2	0	38	0	38	0	0	0	0	0	15	0	15	55	244	0	0	0	1
17:45 - 18:00	0	0	0	0	0	16	0	16	0	0	0	0	0	20	0	20	36	233	0	0	0	0
18:00 - 18:15	0	0	0	0	0	0	0	0	0	0	0	0	0	0	0	0	0	139	0	0	0	0
18:15 - 18:30	0	0	0	0	0	0	0	0	0	0	0	0	0	0	0	0	0	91	0	0	0	0
18:30 - 18:45	0	0	0	0	0	0	0	0	0	0	0	0	0	0	0	0	0	36	0	0	0	0
18:45 - 19:00	0	0	0	0	0	0	0	0	0	0	0	0	0	0	0	0	0	0	0	0	0	0
<b>Count Period Total</b>	<b>32</b>	<b>0</b>	<b>4</b>		<b>2</b>	<b>303</b>	<b>0</b>		<b>0</b>	<b>0</b>	<b>0</b>	<b>0</b>	<b>0</b>	<b>135</b>	<b>8</b>		<b>484</b>	<b>0</b>	<b>1</b>	<b>0</b>	<b>2</b>	
PM Peak Hour Count Summary																						
Peak Volumes	Southbound				Westbound				Northbound				Eastbound				15 Minute Volume	Hourly Volume	Pedestrians			
	Right	Thru	Left	Approach	Right	Thru	Left	Approach	Right	Thru	Left	Approach	Right	Thru	Left	Approach			SB	WB	NB	EB
	19	0	3	22	2	171	0	173	0	0	0	0	0	59	4	63	258	0	0	0	1	
PHF	0.68	0.00	0.75	0.69	0.50	0.70	0.00	0.71	0.00	0.00	0.00	0.00	0.00	0.49	0.50	0.53	0.69					
Trucks	0	0	0		0	4	0		0	0	0		0	8	0							
% Trucks	0%	0%	0%		0%	2%	0%		0%	0%	0%		0%	14%	0%							

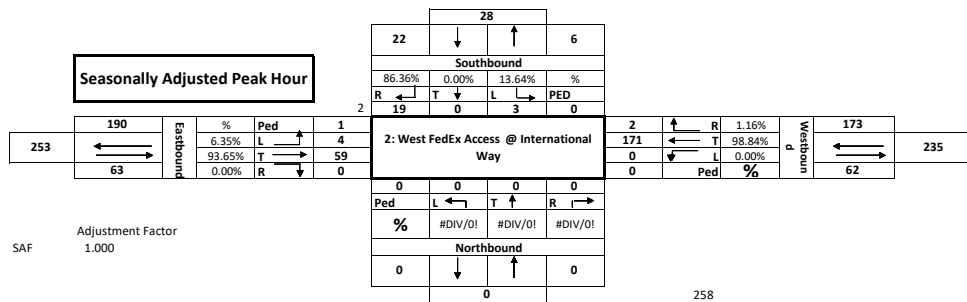



Intersection: 3: East FedEx Access @ International W City: Springfield																						
Counter: Sandow Engineering										Date: Tuesday, November 12, 2024												
Total of All Vehicles																						
Time Period	Southbound				Westbound				Northbound				Eastbound				15 Minute Volume	Hourly Volume	Pedestrians			
	Right	Thru	Left	Approach Total	Right	Thru	Left	Approach Total	Right	Thru	Left	Approach Total	Right	Thru	Left	Approach Total			SB	WB	NB	EB
16:00	16:15	3	0	1	4	0	38	0	38	0	0	0	0	0	19	1	20	62	0	0	0	0
16:15	16:30	3	0	0	3	1	32	0	33	0	0	0	0	0	19	2	21	57	0	0	0	0
16:30	16:45	2	0	0	2	2	47	0	49	0	0	0	0	7	1	8	59	0	0	0	0	
16:45	17:00	1	0	0	1	0	36	0	36	0	0	0	0	11	2	13	50	0	0	0	0	
17:00	17:15	0	0	0	0	0	53	0	53	0	0	0	0	25	3	28	81	0	0	0	0	
17:15	17:30	0	0	0	0	0	29	0	29	0	0	0	0	10	0	10	39	0	0	0	0	
17:30	17:45	0	0	0	0	0	51	0	51	0	0	0	0	13	1	14	65	0	1	0	0	
17:45	18:00	1	0	0	1	0	14	0	14	0	0	0	0	10	0	10	25	0	0	0	0	
18:00	18:15	0	0	0	0	0	0	0	0	0	0	0	0	0	0	0	0	0	0	0	0	0
18:15	18:30	0	0	0	0	0	0	0	0	0	0	0	0	0	0	0	0	0	0	0	0	0
18:30	18:45	0	0	0	0	0	0	0	0	0	0	0	0	0	0	0	0	0	0	0	0	0
18:45	19:00	0	0	0	0	0	0	0	0	0	0	0	0	0	0	0	0	0	0	0	0	0
Count Period Total		10	0	1	3	300	0	0	0	0	0	0	0	0	114	10	0	438	0	1	0	0
PM Peak Hour Count Summary																						
Peak Volumes	Southbound				Westbound				Northbound				Eastbound				15 Minute Volume	Hourly Volume	Pedestrians			
	Right	Thru	Left	Approach	Right	Thru	Left	Approach	Right	Thru	Left	Approach	Right	Thru	Left	Approach			SB	WB	NB	EB
PHF	0.38	0.00	0.00	0.38	0.25	0.78	0.00	0.79	0.00	0.00	0.00	0.00	0.00	0.53	0.50	0.53	229	0.71	0	0	0	0
Trucks	0	0	0	0	0	3	0	0	0	0	0	0	0	3	2	0	0	0	0	0	0	0
% Trucks	0%	0%	0%	0%	0%	2%	0%	0%	0%	0%	0%	0%	0%	6%	33%	0%	0%	0%	0%	0%	0%	0%

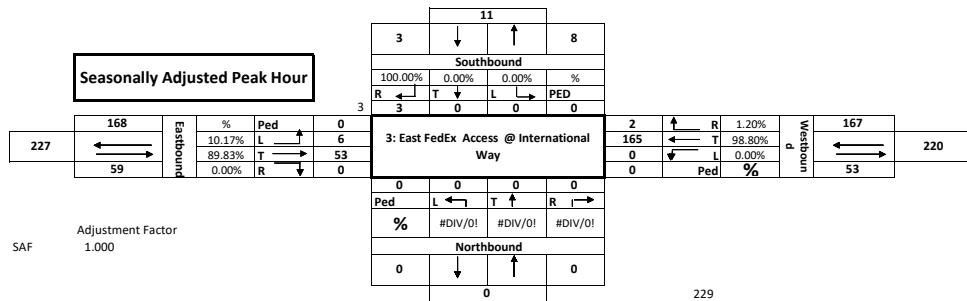



Intersection: 4: Gateway St @ International Way		City: Springfield																					
Counter: Sandow Engineering		Date: Thursday, February 8, 2024																					
Total of All Vehicles																							
Time Period	Southbound				Westbound				Northbound				Eastbound				15 Minute Volume	Hourly Volume	Pedestrians				
	Right	Thru	Left	Approach Total	Right	Thru	Left	Approach Total	Right	Thru	Left	Approach Total	Right	Thru	Left	Approach Total			SB	WB	NB	EB	
16:00	16:15	0	168	11	179	15	0	59	74	19	111	2	132	11	0	1	12	397	0	0	0	0	
16:15	16:30	0	132	8	140	30	0	45	75	14	118	8	140	15	0	0	15	370	0	1	0	0	
16:30	16:45	1	168	13	182	27	0	66	93	22	109	6	137	16	2	3	21	433	0	0	0	0	
16:45	17:00	1	185	11	197	21	0	36	57	17	112	0	129	12	0	3	15	398	1598	1	1	0	0
17:00	17:15	1	184	10	195	24	0	83	107	12	134	0	146	9	1	0	10	458	1659	0	0	0	0
17:15	17:30	0	163	10	173	19	1	50	70	16	140	2	158	3	1	2	6	407	1696	0	1	0	0
17:30	17:45	0	170	5	175	26	0	39	65	6	93	1	100	11	0	3	14	354	1617	0	3	0	0
17:45	18:00	0	115	3	118	11	0	26	37	6	76	1	83	5	0	1	6	244	1463	3	0	0	0
18:00	18:15	0	0	0	0	0	0	0	0	0	0	0	0	0	0	0	0	0	1005	0	0	0	0
18:15	18:30	0	0	0	0	0	0	0	0	0	0	0	0	0	0	0	0	0	598	0	0	0	0
18:30	18:45	0	0	0	0	0	0	0	0	0	0	0	0	0	0	0	0	0	244	0	0	0	0
18:45	19:00	0	0	0	0	0	0	0	0	0	0	0	0	0	0	0	0	0	0	0	0	0	0
Count Period Total		3	1285	71		173	1	404		112	893	20		82	4	13		3061		4	6	0	0
PM Peak Hour Count Summary																							
Peak Volumes	Southbound				Westbound				Northbound				Eastbound				15 Minute Volume	Hourly Volume	Pedestrians				
	Right	Thru	Left	Approach	Right	Thru	Left	Approach	Right	Thru	Left	Approach	Right	Thru	Left	Approach			SB	WB	NB	EB	
	3	700	44	747	91	1	235	327	67	495	8	570	40	4	8	52	1696		1	2	0	0	
PHF	0.75	0.95	0.85	0.95	0.84	0.25	0.71	0.76	0.76	0.88	0.33	0.90	0.63	0.50	0.67	0.62	0.93						
Trucks	0	2	0	0	0	0	2	0	4	2	0	0	0	0	0	0	0						
% Trucks	0%	0%	0%		0%	0%	1%		6%	0%	0%		0%	0%	0%								

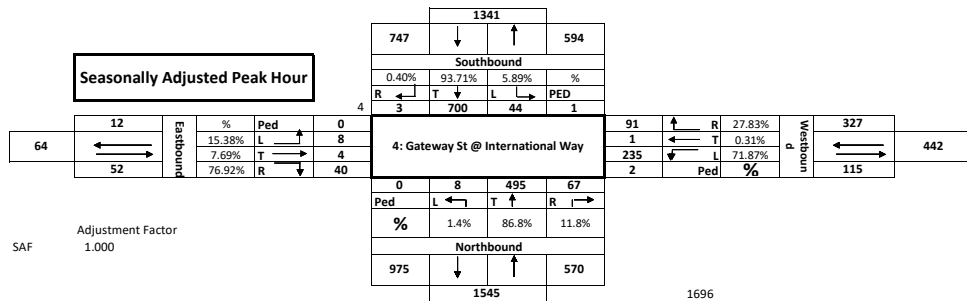



Intersection: 5: Maple Island @ International Way City: Springfield																						
Counter: Sandow Engineering										Date: Tuesday, February 13, 2024												
Total of All Vehicles																						
Time Period	Southbound				Westbound				Northbound				Eastbound				15 Minute Volume	Hourly Volume	Pedestrians			
	Right	Thru	Left	Approach Total	Right	Thru	Left	Approach Total	Right	Thru	Left	Approach Total	Right	Thru	Left	Approach Total			SB	WB	NB	EB
16:00	16:15	8	4	1	13	0	19	1	20	1	0	7	8	9	9	2	24	61	0	0	0	2
16:15	16:30	5	4	0	9	0	20	6	26	3	3	18	24	15	9	0	24	83	0	1	1	0
16:30	16:45	8	5	0	13	0	24	6	30	2	0	5	7	9	8	0	17	67	0	0	0	0
16:45	17:00	2	4	1	7	0	22	2	24	3	2	7	12	9	5	1	15	58	0	0	0	0
17:00	17:15	11	14	0	25	0	28	3	31	0	2	5	7	16	8	0	24	87	0	0	0	0
17:15	17:30	4	2	1	7	0	15	4	19	4	0	9	13	22	10	1	33	72	0	1	0	0
17:30	17:45	5	3	0	8	0	39	9	48	1	0	8	9	8	10	1	19	84	0	0	0	0
17:45	18:00	6	2	0	8	1	16	0	17	5	1	8	14	3	4	1	8	47	0	0	1	0
18:00	18:15	0	0	0	0	0	0	0	0	0	0	0	0	0	0	0	0	0	0	0	0	0
18:15	18:30	0	0	0	0	0	0	0	0	0	0	0	0	0	0	0	0	0	0	0	0	0
18:30	18:45	0	0	0	0	0	0	0	0	0	0	0	0	0	0	0	0	0	0	0	0	0
18:45	19:00	0	0	0	0	0	0	0	0	0	0	0	0	0	0	0	0	0	0	0	0	0
Count Period Total		49	38	3		1	183	31		19	8	67		91	63	6		559	0	2	2	2
PM Peak Hour Count Summary																						
Peak Volumes	Southbound				Westbound				Northbound				Eastbound				15 Minute Volume	Hourly Volume	Pedestrians			
	Right	Thru	Left	Approach	Right	Thru	Left	Approach	Right	Thru	Left	Approach	Right	Thru	Left	Approach			SB	WB	NB	EB
	25	25	2	52	0	89	15	104	9	4	26	39	56	31	2	89	284	0	1	0	0	
PHF	0.57	0.45	0.50	0.52	0.00	0.79	0.63	0.84	0.56	0.50	0.72	0.75	0.64	0.78	0.50	0.67	0.82					
Trucks	1	0	0		0	3	0		0	0	0		0	2	0							
% Trucks	4%	0%	0%		0%	3%	0%		0%	0%	0%		0%	6%	0%							

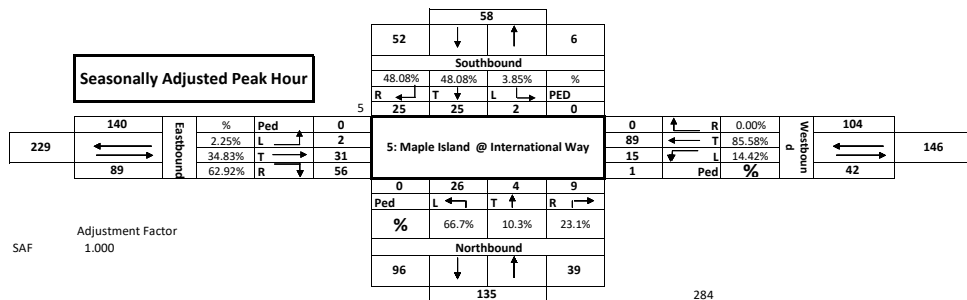



Intersection: 6: Gateway @ Harlow		City: Springfield																					
Counter: Sandow Engineering		Date: Thursday, March 14, 2024																					
Total of All Vehicles																							
Time Period	Southbound				Westbound				Northbound				Eastbound				15 Minute Volume	Hourly Volume	Pedestrians				
	Right	Thru	Left	Approach Total	Right	Thru	Left	Approach Total	Right	Thru	Left	Approach Total	Right	Thru	Left	Approach Total			SB	WB	NB	EB	
16:00 - 16:15	73	9	92	174	80	94	10	184	9	22	15	46	3	112	53	168	572	0	1	0	0		
16:15 - 16:30	67	7	100	174	66	89	1	156	8	13	7	28	3	91	63	157	515	0	0	0	0		
16:30 - 16:45	69	3	87	159	68	81	2	151	7	11	5	23	0	88	34	122	455	0	0	0	0		
16:45 - 17:00	46	3	95	144	78	94	6	178	14	5	7	26	3	94	51	148	496	0	1	0	0		
17:00 - 17:15	81	8	87	176	82	83	3	168	18	21	12	51	0	111	40	151	546	0	0	0	0		
17:15 - 17:30	80	3	137	220	63	85	0	148	14	11	14	39	1	119	67	187	594	2038	1	2	1	2	
17:30 - 17:45	77	8	120	205	81	78	2	161	14	13	9	36	3	91	76	170	572	2208	0	0	0	2	
17:45 - 18:00	67	1	99	167	87	81	2	170	6	11	5	22	1	119	39	159	518	2230	0	2	0	1	
18:00 - 18:15	0	0	0	0	0	0	0	0	0	0	0	0	0	0	0	0	0	1684	0	0	0	0	
18:15 - 18:30	0	0	0	0	0	0	0	0	0	0	0	0	0	0	0	0	0	1090	0	0	0	0	
18:30 - 18:45	0	0	0	0	0	0	0	0	0	0	0	0	0	0	0	0	0	518	0	0	0	0	
18:45 - 19:00	0	0	0	0	0	0	0	0	0	0	0	0	0	0	0	0	0	0	0	0	0	0	
<b>Count Period Total</b>	<b>560</b>	<b>42</b>	<b>817</b>		<b>605</b>	<b>685</b>	<b>26</b>		<b>90</b>	<b>107</b>	<b>74</b>		<b>14</b>	<b>825</b>	<b>423</b>		<b>4268</b>		<b>1</b>	<b>6</b>	<b>1</b>	<b>5</b>	
PM Peak Hour Count Summary																							
Peak Volumes	Southbound				Westbound				Northbound				Eastbound				2091	0.88	Pedestrians				
	Right	Thru	Left	Approach	Right	Thru	Left	Approach	Right	Thru	Left	Approach	Right	Thru	Left	Approach			SB	WB	NB	EB	
	276	17	406	699	291	343	11	645	53	48	38	139	4	412	192	608							
PHF	0.85	0.53	0.74	0.79	0.89	0.91	0.46	0.91	0.74	0.57	0.68	0.68	0.33	0.87	0.72	0.81	0.88						
Trucks	1	0	2		3	1	0		0	0	0		0	3	2								
% Trucks	0%	0%	0%		1%	0%	0%		0%	0%	0%		0%	1%	1%								

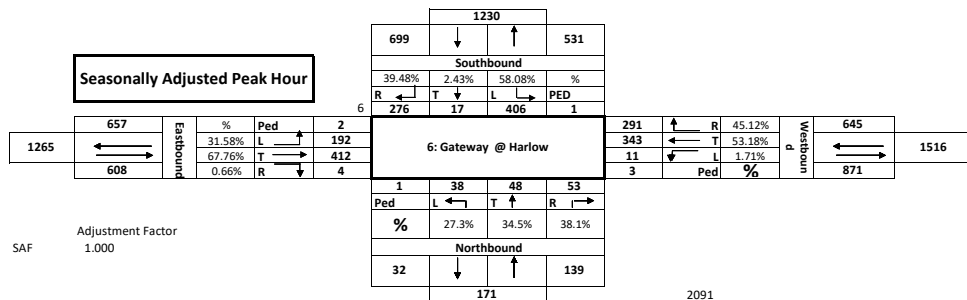



Intersection: 7: Gateway @ Beltline		City: Springfield																					
Counter: Sandow Engineering		Date: Wednesday, December 4, 2024																					
Total of All Vehicles																							
Time Period	Southbound				Westbound				Northbound				Eastbound				15 Minute Volume	Hourly Volume	Pedestrians				
	Right	Thru	Left	Approach Total	Right	Thru	Left	Approach Total	Right	Thru	Left	Approach Total	Right	Thru	Left	Approach Total			SB	WB	NB	EB	
16:00 - 16:15	169	102	42	313	17	188	47	252	12	87	195	294	235	125	68	428	1287	0	0	0	0		
16:15 - 16:30	143	83	49	275	24	136	35	195	19	76	202	297	199	106	50	355	1122	0	0	0	0		
16:30 - 16:45	147	94	34	275	18	150	37	205	16	70	189	275	263	114	76	453	1208	0	0	0	0		
16:45 - 17:00	139	75	36	250	38	138	31	207	20	70	181	271	265	83	59	407	1135	4752	0	0	0	0	
17:00 - 17:15	177	77	52	306	54	169	34	257	29	63	192	284	236	119	44	399	1246	4711	0	0	0	0	
17:15 - 17:30	146	86	58	290	41	164	26	231	28	68	193	289	257	144	83	484	1294	4883	0	0	0	0	
17:30 - 17:45	91	89	40	220	26	121	27	174	25	67	180	272	256	120	83	459	1125	4800	0	0	0	0	
17:45 - 18:00	79	72	37	188	42	93	16	151	18	58	181	257	228	144	48	420	1016	4681	0	0	0	0	
18:00 - 18:15	0	0	0	0	0	0	0	0	0	0	0	0	0	0	0	0	0	3435	0	0	0	0	
18:15 - 18:30	0	0	0	0	0	0	0	0	0	0	0	0	0	0	0	0	0	2141	0	0	0	0	
18:30 - 18:45	0	0	0	0	0	0	0	0	0	0	0	0	0	0	0	0	0	1016	0	0	0	0	
18:45 - 19:00	0	0	0	0	0	0	0	0	0	0	0	0	0	0	0	0	0	0	0	0	0	0	
<b>Count Period Total</b>	<b>1091</b>	<b>678</b>	<b>348</b>		<b>260</b>	<b>1159</b>	<b>253</b>		<b>167</b>	<b>559</b>	<b>1513</b>		<b>1939</b>	<b>955</b>	<b>511</b>		<b>9433</b>	<b>0</b>	<b>0</b>	<b>0</b>	<b>0</b>		
PM Peak Hour Count Summary																							
Peak Volumes	Southbound				Westbound				Northbound				Eastbound				Approach	Total	Pedestrians				
	Right	Thru	Left	Approach	Right	Thru	Left	Approach	Right	Thru	Left	Approach	Right	Thru	Left	Approach			SB	WB	NB	EB	
	609	332	180	1121	151	621	128	900	93	271	755	1119	1021	460	262	1743	4883	0	0	0	0		
PHF	0.86	0.88	0.78	0.92	0.70	0.92	0.86	0.88	0.80	0.97	0.98	0.97	0.96	0.80	0.79	0.90	0.94						
Trucks	2	4	2		0	4	0		0	5	4		3	0	5								
% Trucks	0%	1%	1%		0%	1%	0%		0%	2%	1%		0%	0%	2%								

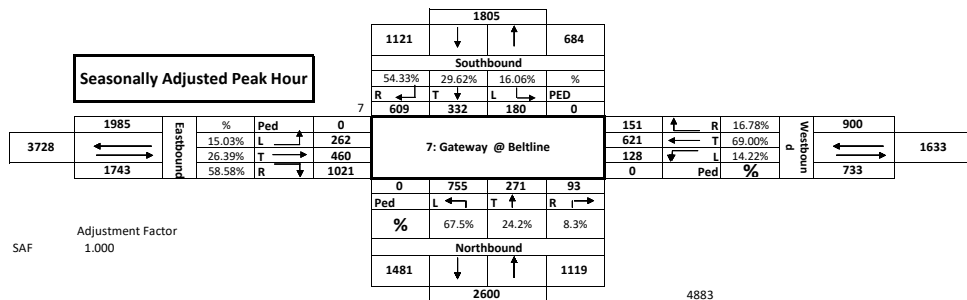



Intersection: <b>8: Hutton @ Beltline</b>		City: <b>Springfield</b>																					
Counter: <b>Sandow Engineering</b>		Date: <b>Wednesday, December 4, 2024</b>																					
<b>Total of All Vehicles</b>																							
Time Period	Southbound				Westbound				Northbound				Eastbound				15 Minute Volume	Hourly Volume	Pedestrians				
	Right	Thru	Left	Approach Total	Right	Thru	Left	Approach Total	Right	Thru	Left	Approach Total	Right	Thru	Left	Approach Total			SB	WB	NB	EB	
16:00 - 16:15	16	1	3	20	13	188	10	211	7	1	14	32	16	136	8	160	423	0	0	0	0		
16:15 - 16:30	16	1	9	26	7	164	12	183	7	2	20	29	22	165	9	196	434	0	0	0	0		
16:30 - 16:45	17	5	6	28	9	195	7	211	19	1	15	35	24	157	8	189	463	0	0	0	0		
16:45 - 17:00	19	2	4	25	4	203	15	222	23	3	14	40	23	154	8	185	472	1792	0	0	0	0	
17:00 - 17:15	23	1	4	28	11	228	8	247	24	1	14	39	28	163	13	204	518	1887	0	0	0	0	
17:15 - 17:30	14	2	4	20	12	192	15	219	17	3	13	33	29	193	7	229	501	1954	0	0	0	0	
17:30 - 17:45	8	1	5	14	2	109	11	122	19	0	27	46	20	138	8	166	348	1839	0	0	0	0	
17:45 - 18:00	11	0	7	18	6	102	10	118	11	1	25	37	26	138	7	171	344	1711	0	0	0	0	
18:00 - 18:15	0	0	0	0	0	0	0	0	0	0	0	0	0	0	0	0	0	1193	0	0	0	0	
18:15 - 18:30	0	0	0	0	0	0	0	0	0	0	0	0	0	0	0	0	0	692	0	0	0	0	
18:30 - 18:45	0	0	0	0	0	0	0	0	0	0	0	0	0	0	0	0	0	344	0	0	0	0	
18:45 - 19:00	0	0	0	0	0	0	0	0	0	0	0	0	0	0	0	0	0	0	0	0	0	0	
<b>Count Period Total</b>	<b>124</b>	<b>13</b>	<b>42</b>		<b>64</b>	<b>1381</b>	<b>88</b>		<b>137</b>	<b>12</b>	<b>142</b>		<b>188</b>	<b>1244</b>	<b>68</b>		<b>3503</b>	<b>0</b>	<b>0</b>	<b>0</b>	<b>0</b>		
<b>PM Peak Hour Count Summary</b>																							
Peak Volumes	Southbound				Westbound				Northbound				Eastbound				15 Minute Volume	Hourly Volume	Pedestrians				
	Right	Thru	Left	Approach	Right	Thru	Left	Approach	Right	Thru	Left	Approach	Right	Thru	Left	Approach			SB	WB	NB	EB	
	73	10	18	101	36	818	45	899	83	8	56	147	104	667	36	807	1954	0	0	0	0		
PHF	0.79	0.50	0.75	0.90	0.75	0.90	0.75	0.91	0.86	0.67	0.93	0.92	0.90	0.86	0.69	0.88	0.94						
Trucks	0	0	1		0	8	0		0	0	0		1	1	3								
% Trucks	0%	0%	6%		0%	1%	0%		0%	0%	0%		1%	0%	8%								

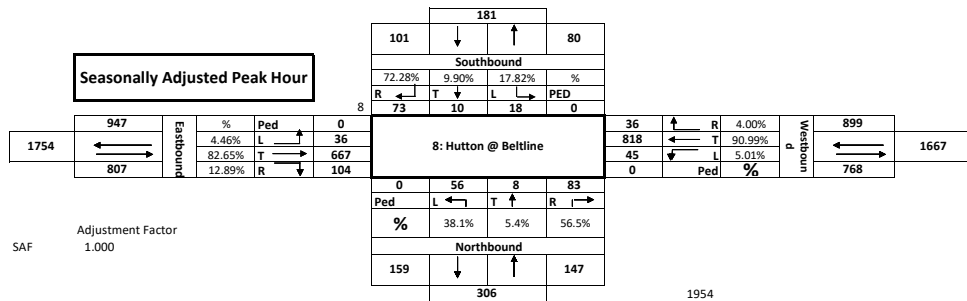



Intersection: 9: Gateway @ Game Farm		City: Springfield																					
Counter: Sandow Engineering		Date: Wednesday, December 4, 2024																					
Total of All Vehicles																							
Time Period	Southbound				Westbound				Northbound				Eastbound				15 Minute Volume	Hourly Volume	Pedestrians				
	Right	Thru	Left	Approach Total	Right	Thru	Left	Approach Total	Right	Thru	Left	Approach Total	Right	Thru	Left	Approach Total			SB	WB	NB	EB	
16:00	16:15	0	245	30	275	27	0	41	68	13	125	6	144	9	0	1	10	497	0	0	0	0	
16:15	16:30	2	248	29	279	28	0	27	55	1	141	8	150	8	0	0	8	492	0	0	0	0	
16:30	16:45	1	254	42	297	19	0	33	52	9	121	11	141	4	0	2	6	496	0	0	0	0	
16:45	17:00	2	235	38	275	45	0	23	68	15	141	6	162	5	0	0	5	510	1995	0	2	1	1
17:00	17:15	0	292	44	336	33	0	39	72	12	133	13	158	3	0	0	3	569	2067	0	2	3	2
17:15	17:30	2	167	34	203	23	0	27	50	8	138	5	151	7	0	0	7	411	1986	3	0	0	3
17:30	17:45	1	201	19	221	19	0	24	43	4	116	8	128	2	0	0	2	394	1884	0	0	1	0
17:45	18:00	0	167	13	180	6	0	13	19	9	133	7	149	5	0	1	6	354	1728	1	0	0	1
18:00	18:15	0	0	0	0	0	0	0	0	0	0	0	0	0	0	0	0	0	1159	0	0	0	0
18:15	18:30	0	0	0	0	0	0	0	0	0	0	0	0	0	0	0	0	0	748	0	0	0	0
18:30	18:45	0	0	0	0	0	0	0	0	0	0	0	0	0	0	0	0	0	354	0	0	0	0
18:45	19:00	0	0	0	0	0	0	0	0	0	0	0	0	0	0	0	0	0	0	0	0	0	0
Count Period Total		8	1809	249		200	0	227		71	1048	64		43	0	4		3723		4	4	5	7
PM Peak Hour Count Summary																							
Peak Volumes	Southbound				Westbound				Northbound				Eastbound				15 Minute Volume	Hourly Volume	Pedestrians				
	Right	Thru	Left	Approach	Right	Thru	Left	Approach	Right	Thru	Left	Approach	Right	Thru	Left	Approach			SB	WB	NB	EB	
	5	948	158	1111	120	0	122	242	44	533	35	612	19	0	2	21	1986		3	4	4	6	
PHF	0.63	0.81	0.90	0.83	0.67	0.00	0.78	0.84	0.73	0.95	0.67	0.94	0.68	0.00	0.25	0.75	0.87						
Trucks	0	12	1		0	0	1		2	8	1		1	0	0								
% Trucks	0%	1%	1%		0%	0%	1%		5%	2%	3%		5%	0%	0%								

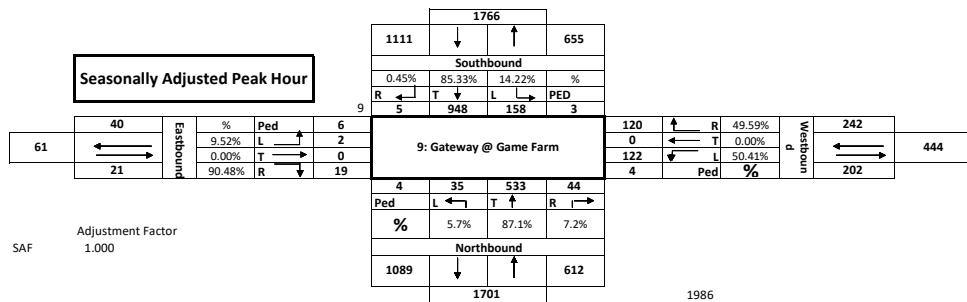



Intersection: 10: Game Farm @ MLK		City: Springfield																					
Counter: Sandow Engineering		Date: Wednesday, December 4, 2024																					
Total of All Vehicles																							
Time Period	Southbound				Westbound				Northbound				Eastbound				15 Minute Volume	Hourly Volume	Pedestrians				
	Right	Thru	Left	Approach Total	Right	Thru	Left	Approach Total	Right	Thru	Left	Approach Total	Right	Thru	Left	Approach Total			SB	WB	NB	EB	
16:00	16:15	12	0	64	76	32	186	0	218	0	0	0	0	0	143	8	151	445	0	0	0	1	
16:15	16:30	15	0	57	72	41	162	0	203	0	0	0	0	0	166	7	173	448	1	0	0	1	
16:30	16:45	15	0	74	89	38	183	0	221	0	0	0	0	0	151	8	159	469	0	0	0	0	
16:45	17:00	14	0	59	73	41	178	0	219	0	0	0	0	0	146	5	151	443	1805	0	0	0	0
17:00	17:15	26	0	90	116	36	207	0	243	0	0	0	0	0	168	6	174	533	1893	0	0	0	0
17:15	17:30	16	0	59	75	16	185	0	201	0	0	0	0	0	198	3	201	477	1922	0	0	0	0
17:30	17:45	6	0	64	70	26	124	0	150	0	0	0	0	0	156	6	162	382	1835	0	0	0	0
17:45	18:00	4	0	18	22	16	118	0	134	0	0	0	0	0	143	4	147	303	1695	0	0	0	0
18:00	18:15	0	0	0	0	0	0	0	0	0	0	0	0	0	0	0	0	0	1162	0	0	0	0
18:15	18:30	0	0	0	0	0	0	0	0	0	0	0	0	0	0	0	0	0	685	0	0	0	0
18:30	18:45	0	0	0	0	0	0	0	0	0	0	0	0	0	0	0	0	0	303	0	0	0	0
18:45	19:00	0	0	0	0	0	0	0	0	0	0	0	0	0	0	0	0	0	0	0	0	0	0
Count Period Total		108	0	485		246	1343	0		0	0	0	0	0	1271	47		3500		1	0	0	2
PM Peak Hour Count Summary																							
Peak Volumes	Southbound				Westbound				Northbound				Eastbound				15 Minute Volume	Hourly Volume	Pedestrians				
	Right	Thru	Left	Approach	Right	Thru	Left	Approach	Right	Thru	Left	Approach	Right	Thru	Left	Approach			SB	WB	NB	EB	
	71	0	282	353	131	753	0	884	0	0	0	0	0	663	22	685	1922		0	0	0	0	
PHF	0.68	0.00	0.78	0.76	0.80	0.91	0.00	0.91	0.00	0.00	0.00	0.00	0.00	0.84	0.69	0.85	0.90						
Trucks	0	0	0		1	6	0		0	0	0		0	13	0								
% Trucks	0%	0%	0%		1%	1%	0%		0%	0%	0%		0%	2%	0%								

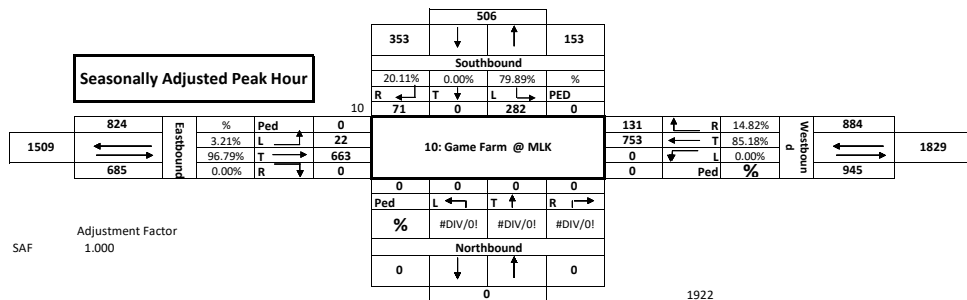



Intersection: 11: Game Farm @ Deadmond Ferry		City: Springfield																					
Counter: Sandow Engineering		Date: Wednesday, December 4, 2024																					
Total of All Vehicles																							
Time Period	Southbound				Westbound				Northbound				Eastbound				15 Minute Volume	Hourly Volume	Pedestrians				
	Right	Thru	Left	Approach Total	Right	Thru	Left	Approach Total	Right	Thru	Left	Approach Total	Right	Thru	Left	Approach Total			SB	WB	NB	EB	
16:00	16:15	0	0	0	0	4	25	29	10	0	22	32	45	4	0	49	110	0	0	0	1		
16:15	16:30	0	0	0	0	10	6	16	9	0	34	43	48	1	0	49	108	0	0	0	1		
16:30	16:45	0	0	0	0	11	34	45	13	0	26	39	53	5	0	58	142	0	0	0	0		
16:45	17:00	0	0	0	0	6	27	33	8	0	41	49	47	9	0	56	138	0	2	0	0		
17:00	17:15	0	0	0	0	4	46	50	14	0	27	41	59	6	0	65	156	0	0	0	0		
17:15	17:30	0	0	0	0	8	25	33	7	0	13	20	51	4	0	55	108	0	1	0	0		
17:30	17:45	0	0	0	0	3	30	33	6	0	21	27	31	3	0	34	94	0	0	0	0		
17:45	18:00	0	0	0	0	11	8	19	9	0	11	20	17	3	0	20	59	0	0	0	0		
18:00	18:15	0	0	0	0	0	0	0	0	0	0	0	0	0	0	0	261	0	0	0	0		
18:15	18:30	0	0	0	0	0	0	0	0	0	0	0	0	0	0	0	153	0	0	0	0		
18:30	18:45	0	0	0	0	0	0	0	0	0	0	0	0	0	0	0	59	0	0	0	0		
18:45	19:00	0	0	0	0	0	0	0	0	0	0	0	0	0	0	0	0	0	0	0	0		
Count Period Total		0	0	0	0	57	201		76	0	195		351	35	0	0	915	0	3	0	2		
PM Peak Hour Count Summary																							
Peak Volumes	Southbound				Westbound				Northbound				Eastbound				15 Minute Volume	Hourly Volume	Pedestrians				
	Right	Thru	Left	Approach	Right	Thru	Left	Approach	Right	Thru	Left	Approach	Right	Thru	Left	Approach			SB	WB	NB	EB	
PHF	0.00	0.00	0.00	0.00	0.00	0.66	0.72	0.81	0.75	0.00	0.65	0.76	0.89	0.67	0.00	0.90	0.87	0	3	0	0		
Trucks	0	0	0	0	0	0	0	0	0	0	1	0	1	0	0	0							
% Trucks	0%	0%	0%	0%	0%	0%	0%	0%	0%	0%	1%	0%	0%	0%	0%	0%							

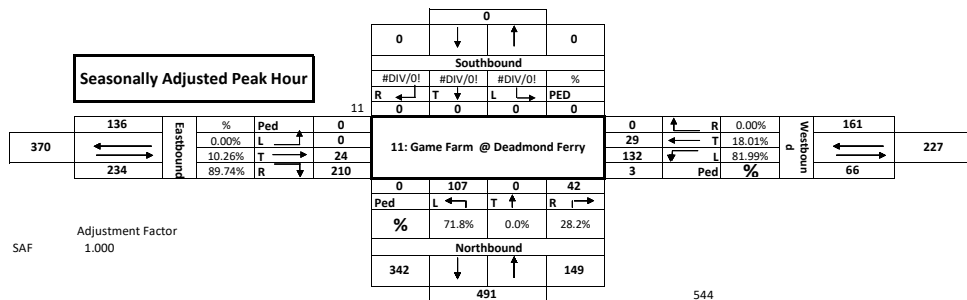

11: Game Farm @ Deadmond Ferry

Pedestrians and Cars

Time Period	Southbound				Westbound				Northbound				Eastbound				15 Minute Volume	Hourly Volume
	Peds	Right	Thru	Left	Peds	Right	Thru	Left	Peds	Right	Thru	Left	Peds	Right	Thru	Left		
4:00 PM							4	25			10	21			45	3	108	
4:15 PM							10	6			9	34	1		47	1	107	
4:30 PM							11	34			13	26			53	5	142	
4:45 PM					2		6	27			8	41			47	9	138	495
5:00 PM							4	46			14	26			58	6	154	541
5:15 PM					1		8	25			7	13			51	4	108	542
5:30 PM							3	30			6	21			31	3	94	494
5:45 PM							11	8			9	11			17	3	59	415
6:00 PM																	0	261
6:15 PM																	0	153
6:30 PM																	0	59
6:45 PM																	0	0
<b>Total</b>	0	0	0	0	3	0	57	201	0	0	76	193	1	0	349	34	0	
<b>Peak Hour</b>	0	0	0	0	3	0	29	132	0	0	42	106	0	0	209	24	0	542 1578

Trucks

Time Period	Southbound			Westbound			Northbound			Eastbound			15 Minute Volume	Hourly Volume
	Right	Thru	Left	Right	Thru	Left	Right	Thru	Left	Right	Thru	Left		
4:00 PM									1			1	2	
4:15 PM													1	
4:30 PM													0	
4:45 PM													0	3
5:00 PM									1			1	2	3
5:15 PM													0	2
5:30 PM													0	2
5:45 PM													0	2
6:00 PM													0	0
6:15 PM													0	0
6:30 PM													0	0
6:45 PM													0	0
<b>Total</b>	0	0	0	0	0	0	0	0	2	0	0	2	1	0
<b>Peak Hour</b>	0	0	0	0	0	0	0	0	1	0	0	1	0	8

Bikes

Time Period	Southbound			Westbound			Northbound			Eastbound			SB	WB	NB	EB
	Right	Thru	Left	Right	Thru	Left	Right	Thru	Left	Right	Thru	Left				
4:00 PM													0	0	0	1
4:15 PM													0	0	0	0
4:30 PM													0	0	0	0
4:45 PM													0	0	0	0
5:00 PM													0	0	0	0
5:15 PM													0	0	0	0
5:30 PM													0	0	0	0
5:45 PM													0	0	0	0
6:00 PM													0	0	0	0
6:15 PM													0	0	0	0
6:30 PM													0	0	0	0
6:45 PM													0	0	0	0
<b>Total</b>	0	0	0	0	0	0	0	0	0	1	0	0	0	0	0	0
<b>Peak Hour</b>	0	0	0	0	0	0	0	0	0	0	0	0	0	0	0	0

Pedestrians

Time Period	NE			NW			SW			SE			SB	WB	NB	EB
	Left	Right	Total	Left	Right	Total	Left	Right	Total	Left	Right	Total				
4:00 PM			0			0			0			0	0	0	0	0
4:15 PM			0			0			0			0	0	0	0	0
4:30 PM			0			0			0			0	0	0	0	0
4:45 PM			0			0			0			0	0	0	0	0
5:00 PM			0			0			0			0	0	0	0	0
5:15 PM			0			0			0			0	0	0	0	0
5:30 PM			0			0			0			0	0	0	0	0
5:45 PM			0			0			0			0	0	0	0	0
6:00 PM			0			0			0			0	0	0	0	0
6:15 PM			0			0			0			0	0	0	0	0
6:30 PM			0			0			0			0	0	0	0	0
6:45 PM			0			0			0			0	0	0	0	0
<b>Total</b>	0	0	0	0	0	0	0	0	0	0	0	0	0	0	0	0

Intersection: 12: Maple Island @ Game Farm Rd		City: Springfield																					
Counter: Sandow Engineering		Date: Wednesday, December 4, 2024																					
Total of All Vehicles																							
Time Period	Southbound				Westbound				Northbound				Eastbound				15 Minute Volume	Hourly Volume	Pedestrians				
	Right	Thru	Left	Approach Total	Right	Thru	Left	Approach Total	Right	Thru	Left	Approach Total	Right	Thru	Left	Approach Total			SB	WB	NB	EB	
16:00	16:15	1	0	10	11	7	19	0	26	0	0	0	0	0	38	2	40	77	0	0	0	1	
16:15	16:30	1	0	20	21	11	29	0	40	0	0	0	0	28	0	28	89	0	0	0	0		
16:30	16:45	4	0	22	26	11	26	0	37	0	0	0	0	39	1	40	103	0	0	0	0		
16:45	17:00	2	0	9	11	9	34	0	43	0	0	0	0	1	47	2	50	104	0	0	0	0	
17:00	17:15	2	0	25	27	6	23	0	29	0	0	0	0	43	0	43	99	395	0	0	0	0	
17:15	17:30	1	0	23	24	5	17	0	22	0	0	0	0	33	0	33	79	385	0	0	0	0	
17:30	17:45	2	0	11	13	6	19	0	25	0	0	0	0	24	0	24	62	344	0	0	0	0	
17:45	18:00	0	0	6	6	5	16	0	21	0	0	0	0	13	5	18	45	285	0	0	0	0	
18:00	18:15	0	0	0	0	0	0	0	0	0	0	0	0	0	0	0	0	186	0	0	0	0	
18:15	18:30	0	0	0	0	0	0	0	0	0	0	0	0	0	0	0	0	107	0	0	0	0	
18:30	18:45	0	0	0	0	0	0	0	0	0	0	0	0	0	0	0	0	45	0	0	0	0	
18:45	19:00	0	0	0	0	0	0	0	0	0	0	0	0	0	0	0	0	0	0	0	0	0	
Count Period Total		13	0	126		60	183	0		0	0	0		1	265	10		658	0	0	0	1	
PM Peak Hour Count Summary																							
Peak Volumes	Southbound				Westbound				Northbound				Eastbound				15 Minute Volume	Hourly Volume	Pedestrians				
	Right	Thru	Left	Approach	Right	Thru	Left	Approach	Right	Thru	Left	Approach	Right	Thru	Left	Approach			SB	WB	NB	EB	
PHF	0.56	0.00	0.79	0.81	0.70	0.74	0.00	0.76	0.00	0.00	0.00	0.00	0.25	0.86	0.38	0.83	385	0.93	0	0	0	0	
Trucks	0	0	0		1	0	0		0	0	0		0	2	0								
% Trucks	0%	0%	0%		3%	0%	0%		0%	0%	0%		0%	1%	0%								

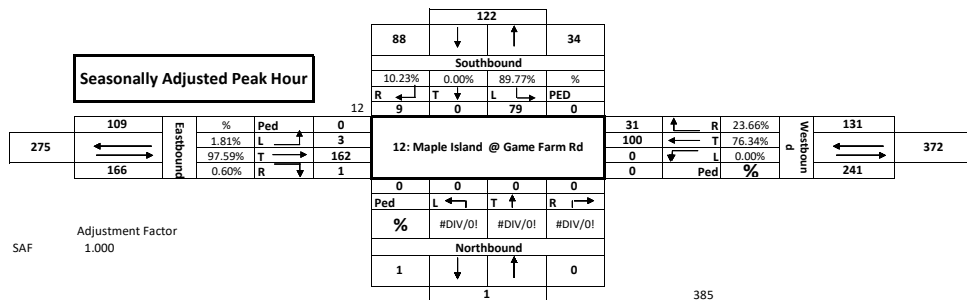



Intersection: 13: Richardsons Site Access @ Internati City: Springfield																						
Counter: Sandow Engineering										Date: Tuesday, February 13, 2024												
Total of All Vehicles																						
Time Period	Southbound				Westbound				Northbound				Eastbound				15 Minute Volume	Hourly Volume	Pedestrians			
	Right	Thru	Left	Approach Total	Right	Thru	Left	Approach Total	Right	Thru	Left	Approach Total	Right	Thru	Left	Approach Total			SB	WB	NB	EB
16:00	16:15	16	0	0	16	0	46	0	46	0	0	1	1	0	8	2	10	73	0	0	0	1
16:15	16:30	6	0	0	6	0	26	0	26	0	0	1	1	0	15	1	16	49	0	0	1	0
16:30	16:45	10	0	1	11	0	30	0	30	0	0	2	2	1	11	1	13	56	0	1	0	0
16:45	17:00	3	0	1	4	0	29	1	30	0	0	3	3	0	16	1	17	54	0	0	0	0
17:00	17:15	8	0	0	8	0	43	0	43	0	0	1	1	0	18	0	18	70	0	0	0	0
17:15	17:30	13	0	0	13	1	39	0	40	0	0	0	0	1	29	1	31	84	0	0	0	1
17:30	17:45	1	0	2	3	0	39	1	40	1	0	0	1	0	15	3	18	62	0	2	0	0
17:45	18:00	2	0	0	2	0	23	0	23	0	0	1	1	0	6	0	6	32	0	0	0	0
18:00	18:15	0	0	0	0	0	0	0	0	0	0	0	0	0	0	0	0	0	0	0	0	0
18:15	18:30	0	0	0	0	0	0	0	0	0	0	0	0	0	0	0	0	0	0	0	0	0
18:30	18:45	0	0	0	0	0	0	0	0	0	0	0	0	0	0	0	0	0	0	0	0	0
18:45	19:00	0	0	0	0	0	0	0	0	0	0	0	0	0	0	0	0	0	0	0	0	0
Count Period Total		59	0	4		1	275	2		1	0	9		2	118	9		480	0	3	1	2
PM Peak Hour Count Summary																						
Peak Volumes	Southbound				Westbound				Northbound				Eastbound				Approach	Hourly Volume	Pedestrians			
	Right	Thru	Left	Approach	Right	Thru	Left	Approach	Right	Thru	Left	Approach	Right	Thru	Left	Approach			SB	WB	NB	EB
	34	0	2	36	1	141	1	143	0	0	6	6	2	74	3	79	264	0	1	0	1	
PHF	0.65	0.00	0.50	0.69	0.25	0.82	0.25	0.83	0.00	0.00	0.50	0.50	0.50	0.64	0.75	0.64	0.79					
Trucks	0	0	0		0	4	1		0	0	0		0	2	0							
% Trucks	0%	0%	0%		0%	3%	100%		0%	0%	0%		0%	3%	0%							

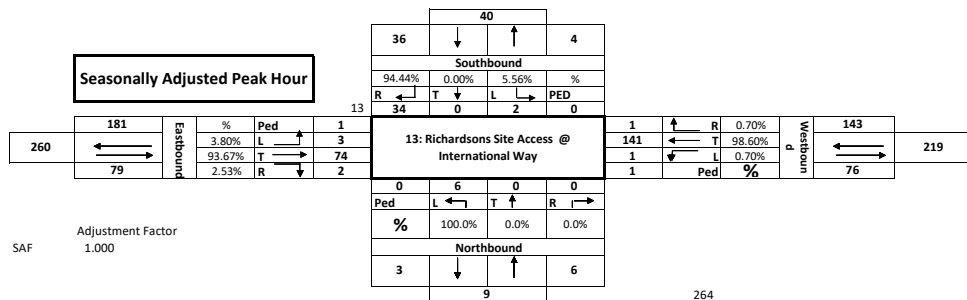



**Global Peak Hour**

		Intersections													
		1: Sports Way @ International Way	2: West FedEx Access @ International Way	3: East FedEx Access @ International Way	4: Gateway St @ International Way	5: Maple Island @ International Way	6: Gateway @ Harlow	7: Gateway @ Beltline	8: Hutton @ Beltline	9: Gateway @ Game Farm	10: Game Farm @ MLK	11: Game Farm @ Deadmond Ferry	12: Maple Island @ Game Farm Rd	13: Richardsons Site Access @ International Way	
Time Period		Volume	Volume	Volume	Volume	Volume	Volume	Volume	Volume	Volume	Volume	Volume	Volume	Volume	Total
4:00 PM	5:00 PM	303	251	228	1,598	269	2,038	4,752	1,792	1,995	1,805	498	373	232	<b>16134</b>
4:15 PM	5:15 PM	315	272	247	1,659	295	2,012	4,711	1,887	2,067	1,893	544	395	229	<b>16526</b>
4:30 PM	5:30 PM	303	258	229	1,696	284	2,091	4,883	1,954	1,986	1,922	544	385	264	<b>16799</b>
4:45 PM	5:45 PM	311	244	235	1,617	301	2,208	4,800	1,839	1,884	1,835	496	344	270	<b>16384</b>
5:00 PM	6:00 PM	279	233	210	1,463	290	2,230	4,681	1,711	1,728	1,695	417	285	248	<b>15470</b>
		315	272	247	1696	301	2230	4883	1954	2067	1922	544	395	270	<b>16799</b>

Peak Hour 4:30 PM  
4:45 PM  
5:00 PM  
5:15 PM

2025

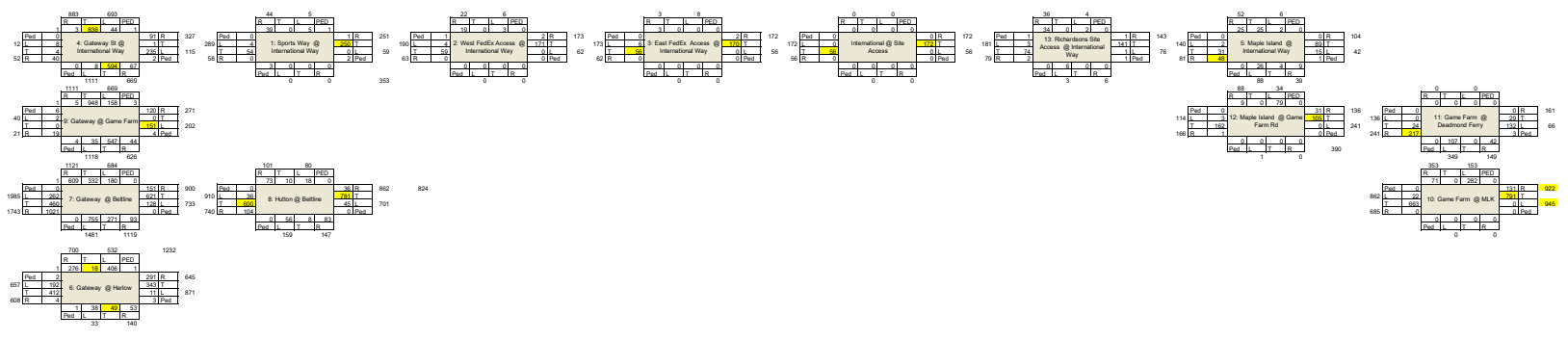

2035 Background

EUIT HIGHLIGHTS	
Base Year	2024
Target Year	2035
Years of Growth	11
Growth Rate Per Yr	0.03
Growth Factor	1.22

Parcel ID	Area (Ac)	Use	2024 Value	2035 Value	2035 Background
14	0.1	4 Gateway @ International Way	112.8	140.8	309
63.4	0.2	1 Sports W @ International Way	262.1	322.1	140
71	0.1	2 West Field Access @ International Way	91.1	111.1	72
274	0.1	3 East Field Access @ International Way	91.1	111.1	211
76	0.1	International @ Site Access	0	0	68
210	0.1	13 Richardson Site Access @ International Way	124.1	154.1	174
171	0.1	5 Maple Island @ International Way	108.1	133.1	127
98.8	0.1	11 Game Farm @ Maple Island @ Game Farm Rd	161.1	196.1	166
130	0.1	12 Maple Island @ Game Farm Rd	154.1	189.1	204
203	0.1	10 Game Farm @ MLK	161.1	196.1	166
84	0.1	Deadwood Ferry	161.1	196.1	81
242	0.1	7 Gateway @ Battine	154.1	189.1	854
219	0.1	8 Matton @ Battine	91.1	111.1	855
80	0.1	6 Gateway @ Harkow	112.8	140.8	787
74	0.1	30	30	30	170

2035 Couplet

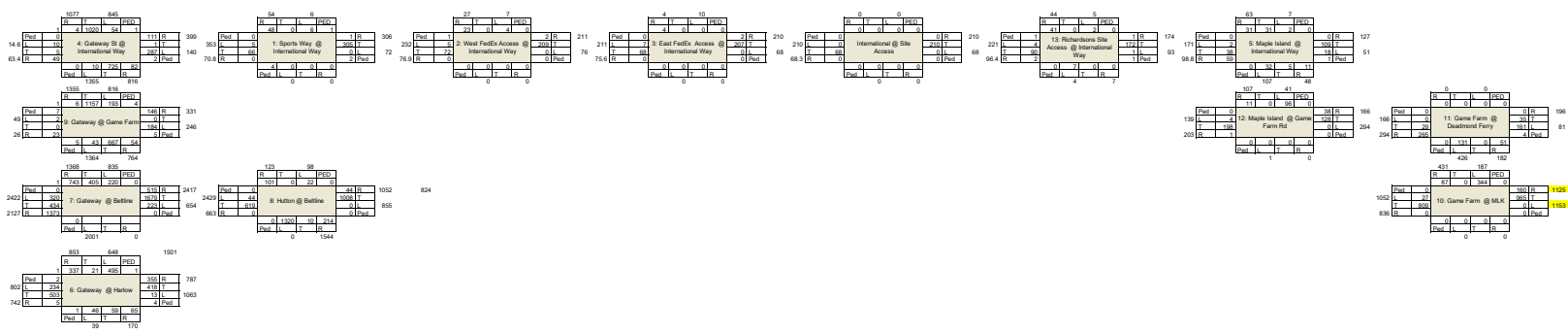































INTERNATIONAL WAY TPR

Gateway at Beltline PM Peak Hour































2025 Background										los	F
Phase	Adj flow	Sat Flow			5,6	0.418					
1 SBL	191	1795	0.106	Prot	1,2	0.323	0.418				
2 NBT	387	1788	0.216								
3 WBL	136	1810	0.075	Prot	3pr,4	0.169		Cycle Length	120		
4 EBT	489	5187	0.094		7pr, 8	0.240	0.240	Lost Time/phase	4		
5 NBL	803	3483	0.231	Prot				# phases	4		
6 SBT	353	1885	0.187					Total Lost Time	16		
7 EBL	279	3456	0.081	Prot							
8 WBT	546	3432	0.159					Critical v/c	0.76		
Critical Pairs										0.658	
2035 Background Existing Configuration										los	F
Phase	Adj flow	Sat Flow			5,6	0.510					
1 SBL	234	1795	0.130	Prot	1,2	0.394	0.510				
2 NBT	472	1789	0.264								
3 WBL	166	1810	0.092	Prot	3pr,4	0.207		Cycle Length	120		
4 EBT	597	5187	0.115		7pr, 8	0.293	0.293	Lost Time/phase	4		
5 NBL	980	3483	0.281	Prot				# phases	4		
6 SBT	431	1885	0.229					Total Lost Time	16		
7 EBL	340	3456	0.098	Prot							
8 WBT	667	3432	0.194					Critical v/c	0.93		
Critical Pairs										0.803	
2035 Background With Couplet										los	D
Phase	Adj flow	Sat Flow			5,6	0.120					
1 SBL	234	1795	0.130	Prot	1,2	0.130	0.130				
3 WBL	237	3510	0.068	Prot	3pr,4	0.157		Cycle Length	120		
4 EBT	462	5187	0.089		7pr, 8	0.445	0.445	Lost Time/phase	4		
6 SBT	431	3582	0.120					# phases	3		
7 EBL	340	3456	0.098	Prot				Total Lost Time	12		
8 WBT	1786	5147	0.347					Critical v/c	0.64		
Critical Pairs										0.576	
2035 Build Existing Configuration										los	F
Phase	Adj flow	Sat Flow			5,6	0.571					
1 SBL	234	1795	0.130	Prot	1,2	0.406	0.571				
2 NBT	492	1788	0.275								
3 WBL	166	1810	0.092	Prot	3pr,4	0.207		Cycle Length	120		
4 EBT	597	5187	0.115		7pr, 8	0.301	0.301	Lost Time/phase	4		
5 NBL	980	3483	0.281	Prot				# phases	4		
6 SBT	546	1885	0.290					Total Lost Time	16		
7 EBL	370	3456	0.107	Prot							
8 WBT	667	3432	0.194					Critical v/c	1.01		
Critical Pairs										0.872	
2035 Build with Couplet										los	D
Phase	Adj flow	Sat Flow			5,6	0.152					
1 SBL	234	1795	0.130	Prot	1,2	0.130	0.152				
3 WBL	237	3510	0.068	Prot	3pr,4	0.157		Cycle Length	120		
4 EBT	462	5187	0.089		7pr, 8	0.454	0.454	Lost Time/phase	4		
6 SBT	546	3582	0.152					# phases	3		
7 EBL	370	3456	0.107	Prot				Total Lost Time	12		
8 WBT	1786	5142	0.347					Critical v/c	0.67		
Critical Pairs										0.607	

# HCM Signalized Intersection Capacity Analysis

## 9: Beltline Rd & Gateway St





















												
Movement	EBL	EBT	EBR	WBL	WBT	WBR	NBL	NBT	NBR	SBL	SBT	SBR
Lane Configurations	 	  	 		  		 					 
Traffic Volume (vph)	262	460	1021	128	621	151	755	271	93	180	332	609
Future Volume (vph)	262	460	1021	128	621	151	755	271	93	180	332	609
Ideal Flow (vphp)	1900	1900	1900	1900	1900	1900	1900	1900	1900	1900	1900	1900
Total Lost time (s)	3.8	3.8	3.8	3.8	3.8		4.0	4.0		4.0	4.0	4.0
Lane Util. Factor	0.97	0.91	0.88	1.00	0.91		0.97	1.00		1.00	1.00	0.88
Frt	1.00	1.00	0.85	1.00	0.97		1.00	0.96		1.00	1.00	0.85
Flt Protected	0.95	1.00	1.00	0.95	1.00		0.95	1.00		0.95	1.00	1.00
Satd. Flow (prot)	3433	5187	2842	1805	4994		3467	1800		1787	1881	2842
Flt Permitted	0.95	1.00	1.00	0.95	1.00		0.95	1.00		0.95	1.00	1.00
Satd. Flow (perm)	3433	5187	2842	1805	4994		3467	1800		1787	1881	2842
Peak-hour factor, PHF	0.94	0.94	0.94	0.94	0.94	0.94	0.94	0.94	0.94	0.94	0.94	0.94
Adj. Flow (vph)	279	489	1086	136	661	161	803	288	99	191	353	648
RTOR Reduction (vph)	0	0	730	0	34	0	0	10	0	0	0	273
Lane Group Flow (vph)	279	489	356	136	788	0	803	377	0	191	353	375
Heavy Vehicles (%)	2%	0%	0%	0%	1%	0%	1%	2%	0%	1%	1%	0%
Turn Type	Prot	NA	Perm	Prot	NA		Prot	NA		Prot	NA	Perm
Protected Phases	7	4		3	8		5	2		1	6	
Permitted Phases			4									6
Actuated Green, G (s)	10.6	26.2	26.2	10.9	26.5		29.0	37.4		16.0	24.4	24.4
Effective Green, g (s)	12.0	27.6	27.6	12.3	27.9		29.5	37.9		16.5	24.9	24.9
Actuated g/C Ratio	0.11	0.25	0.25	0.11	0.25		0.27	0.34		0.15	0.23	0.23
Clearance Time (s)	5.2	5.2	5.2	5.2	5.2		4.5	4.5		4.5	4.5	4.5
Vehicle Extension (s)	2.5	4.0	4.0	2.5	4.0		2.5	2.5		2.5	2.5	2.5
Lane Grp Cap (vph)	374	1302	713	202	1267		930	620		268	426	643
v/s Ratio Prot	c0.08	0.09		0.08	c0.16		c0.23	0.21		0.11	c0.19	
v/s Ratio Perm			0.13									0.13
v/c Ratio	0.75	0.38	0.50	0.67	0.62		0.86	0.61		0.71	0.83	0.58
Uniform Delay, d1	47.5	34.0	35.2	46.9	36.3		38.3	29.8		44.4	40.5	37.9
Progression Factor	1.00	1.00	1.00	1.00	1.00		1.00	1.00		1.00	1.00	1.00
Incremental Delay, d2	7.5	0.2	0.8	7.8	1.1		8.3	1.4		8.1	12.3	1.1
Delay (s)	55.0	34.3	36.0	54.6	37.4		46.6	31.3		52.5	52.7	39.0
Level of Service	D	C	D	D	D		D	C		D	D	D
Approach Delay (s/veh)		38.4			39.9			41.6			45.2	
Approach LOS		D			D			D			D	
<b>Intersection Summary</b>												
HCM 2000 Control Delay (s/veh)			41.0				HCM 2000 Level of Service				D	
HCM 2000 Volume to Capacity ratio			0.77									
Actuated Cycle Length (s)			109.9				Sum of lost time (s)			15.6		
Intersection Capacity Utilization			75.2%				ICU Level of Service			D		
Analysis Period (min)			15									
c Critical Lane Group												

## HCM 7th Signalized Intersection Summary 9: Beltline Rd & Gateway St





















												
Movement	EBL	EBT	EBR	WBL	WBT	WBR	NBL	NBT	NBR	SBL	SBT	SBR
Lane Configurations	 	  	 		  		 					 
Traffic Volume (veh/h)	262	460	1021	128	621	151	755	271	93	180	332	609
Future Volume (veh/h)	262	460	1021	128	621	151	755	271	93	180	332	609
Initial Q (Qb), veh	0	0	0	0	0	0	0	0	0	0	0	0
Lane Width Adj.	1.00	1.00	1.00	1.00	1.00	1.00	1.00	1.00	1.00	1.00	1.00	1.00
Ped-Bike Adj(A_pbT)	1.00		1.00	1.00		1.00	1.00		1.00	1.00		1.00
Parking Bus, Adj	1.00	1.00	1.00	1.00	1.00	1.00	1.00	1.00	1.00	1.00	1.00	1.00
Work Zone On Approach		No			No			No			No	
Adj Sat Flow, veh/h/ln	1870	1900	1900	1900	1885	1900	1885	1870	1900	1885	1885	1900
Adj Flow Rate, veh/h	279	489	1086	136	661	161	803	288	99	191	353	648
Peak Hour Factor	0.94	0.94	0.94	0.94	0.94	0.94	0.94	0.94	0.94	0.94	0.94	0.94
Percent Heavy Veh, %	2	0	0	0	1	0	1	2	0	1	1	0
Cap, veh/h	372	1244	680	185	971	233	908	511	176	244	489	736
Arrive On Green	0.11	0.24	0.24	0.10	0.23	0.22	0.26	0.38	0.38	0.14	0.26	0.26
Sat Flow, veh/h	3456	5187	2834	1810	4143	994	3483	1331	457	1795	1885	2834
Grp Volume(v), veh/h	279	489	1086	136	546	276	803	0	387	191	353	648
Grp Sat Flow(s),veh/h/ln	1728	1729	1417	1810	1716	1706	1742	0	1788	1795	1885	1417
Q Serve(g_s), s	8.9	9.0	27.2	8.3	16.4	16.8	25.1	0.0	19.3	11.7	19.3	24.9
Cycle Q Clear(g_c), s	8.9	9.0	27.2	8.3	16.4	16.8	25.1	0.0	19.3	11.7	19.3	24.9
Prop In Lane	1.00		1.00	1.00		0.58	1.00		0.26	1.00		1.00
Lane Grp Cap(c), veh/h	372	1244	680	185	804	400	908	0	687	244	489	736
V/C Ratio(X)	0.75	0.39	1.60	0.74	0.68	0.69	0.88	0.00	0.56	0.78	0.72	0.88
Avail Cap(c_a), veh/h	372	1244	680	211	853	424	1013	0	687	332	515	775
HCM Platoon Ratio	1.00	1.00	1.00	1.00	1.00	1.00	1.00	1.00	1.00	1.00	1.00	1.00
Upstream Filter(I)	1.00	1.00	1.00	1.00	1.00	1.00	1.00	0.00	1.00	1.00	1.00	1.00
Uniform Delay (d), s/veh	49.1	36.2	43.1	49.4	39.5	40.1	40.3	0.0	27.5	47.4	38.2	40.3
Incr Delay (d2), s/veh	7.9	0.3	276.0	10.1	2.3	5.0	8.5	0.0	0.9	7.0	4.3	10.9
Initial Q Delay(d3), s/veh	0.0	0.0	0.0	0.0	0.0	0.0	0.0	0.0	0.0	0.0	0.0	0.0
%ile BackOfQ(50%),veh/ln	4.1	3.7	35.2	4.2	6.9	7.4	11.6	0.0	8.2	5.6	9.4	9.4
Unsig. Movement Delay, s/veh												
LnGrp Delay(d), s/veh	57.0	36.5	319.1	59.5	41.9	45.1	48.7	0.0	28.4	54.4	42.6	51.2
LnGrp LOS	E	D	F	E	D	D	D		C	D	D	D
Approach Vol, veh/h	1854			958			1190			1192		
Approach Delay, s/veh	205.1			45.3			42.1			49.1		
Approach LOS	F			D			D			D		
Timer - Assigned Phs	1	2	3	4	5	6	7	8				
Phs Duration (G+Y+Rc), s	19.4	47.6	15.4	31.0	33.6	33.4	16.0	30.4				
Change Period (Y+Rc), s	4.5	4.5	5.2	5.2	4.5	4.5	5.2	5.2				
Max Green Setting (Gmax), s	20.5	42.5	11.8	25.8	32.5	30.5	10.8	26.8				
Max Q Clear Time (g_c+I1), s	14.7	21.3	10.3	29.2	27.1	26.9	10.9	18.8				
Green Ext Time (p_c), s	0.3	1.5	0.1	0.0	2.0	2.1	0.0	6.0				
<b>Intersection Summary</b>												
HCM 7th Control Delay, s/veh	102.5											
HCM 7th LOS	F											
<b>Notes</b>												
User approved pedestrian interval to be less than phase max green.												

# HCM Signalized Intersection Capacity Analysis

## 10: Gateway St & International Way

												
Movement	EBL	EBT	EBR	WBL	WBT	WBR	NBL	NBT	NBR	SBL	SBT	SBR
Lane Configurations												
Traffic Volume (vph)	8	4	40	235	1	91	8	594	67	44	836	3
Future Volume (vph)	8	4	40	235	1	91	8	594	67	44	836	3
Ideal Flow (vphp)	1900	1900	1900	1900	1900	1900	1900	1900	1900	1900	1900	1900
Total Lost time (s)		4.0		4.0	4.0		4.0	4.0	4.0	4.0	4.0	
Lane Util. Factor		1.00		1.00	1.00		1.00	1.00	1.00	1.00	1.00	
Frt		0.90		1.00	0.85		1.00	1.00	0.85	1.00	1.00	
Flt Protected		0.99		0.95	1.00		0.95	1.00	1.00	0.95	1.00	
Satd. Flow (prot)		1689		1787	1618		1805	1900	1524	1805	1899	
Flt Permitted		0.96		0.72	1.00		0.15	1.00	1.00	0.32	1.00	
Satd. Flow (perm)		1635		1355	1618		278	1900	1524	604	1899	
Peak-hour factor, PHF	0.93	0.93	0.93	0.93	0.93	0.93	0.93	0.93	0.93	0.93	0.93	0.93
Adj. Flow (vph)	9	4	43	253	1	98	9	639	72	47	899	3
RTOR Reduction (vph)	0	32	0	0	73	0	0	0	29	0	0	0
Lane Group Flow (vph)	0	24	0	253	26	0	9	639	43	47	902	0
Heavy Vehicles (%)	0%	0%	0%	1%	0%	0%	0%	0%	6%	0%	0%	0%
Turn Type	Perm	NA		Perm	NA		Perm	NA	Perm	Perm	NA	
Protected Phases		4			8			2			6	
Permitted Phases	4			8			2		2	6		
Actuated Green, G (s)		13.3		12.8	12.8		30.7	30.7	30.7	30.7	30.7	
Effective Green, g (s)		13.3		13.3	13.3		31.2	31.2	31.2	31.2	31.2	
Actuated g/C Ratio		0.25		0.25	0.25		0.59	0.59	0.59	0.59	0.59	
Clearance Time (s)		4.0		4.5	4.5		4.5	4.5	4.5	4.5	4.5	
Vehicle Extension (s)		2.5		2.5	2.5		4.0	4.0	4.0	4.0	4.0	
Lane Grp Cap (vph)		414		343	409		165	1129	905	358	1128	
v/s Ratio Prot					0.02			0.34				c0.47
v/s Ratio Perm		0.01		c0.19			0.03		0.03	0.08		
v/c Ratio		0.06		0.74	0.06		0.05	0.57	0.05	0.13	0.80	
Uniform Delay, d1		14.9		18.0	14.9		4.5	6.5	4.4	4.7	8.2	
Progression Factor		1.00		1.00	1.00		1.00	1.00	1.00	1.00	1.00	
Incremental Delay, d2		0.0		7.6	0.0		0.2	0.8	0.0	0.2	4.3	
Delay (s)		14.9		25.6	14.9		4.7	7.3	4.5	4.9	12.5	
Level of Service		B		C	B		A	A	A	A	B	
Approach Delay (s/veh)		14.9			22.6			7.0			12.1	
Approach LOS		B			C			A			B	
<b>Intersection Summary</b>												
HCM 2000 Control Delay (s/veh)			12.2				HCM 2000 Level of Service				B	
HCM 2000 Volume to Capacity ratio			0.78									
Actuated Cycle Length (s)			52.5				Sum of lost time (s)				8.0	
Intersection Capacity Utilization			70.5%				ICU Level of Service				C	
Analysis Period (min)			15									
c Critical Lane Group												

## HCM 7th Signalized Intersection Summary 10: Gateway St & International Way





















												
Movement	EBL	EBT	EBR	WBL	WBT	WBR	NBL	NBT	NBR	SBL	SBT	SBR
Lane Configurations												
Traffic Volume (veh/h)	8	4	40	235	1	91	8	594	67	44	836	3
Future Volume (veh/h)	8	4	40	235	1	91	8	594	67	44	836	3
Initial Q (Qb), veh	0	0	0	0	0	0	0	0	0	0	0	0
Lane Width Adj.	1.00	1.00	1.00	1.00	1.00	1.00	1.00	1.00	1.00	1.00	1.00	1.00
Ped-Bike Adj(A_pbT)	1.00		1.00	1.00		1.00	1.00		1.00	1.00		1.00
Parking Bus, Adj	1.00	1.00	1.00	1.00	1.00	1.00	1.00	1.00	1.00	1.00	1.00	1.00
Work Zone On Approach		No			No			No			No	
Adj Sat Flow, veh/h/ln	1900	1900	1900	1885	1900	1900	1900	1900	1811	1900	1900	1900
Adj Flow Rate, veh/h	9	4	43	253	1	98	9	639	0	47	899	3
Peak Hour Factor	0.93	0.93	0.93	0.93	0.93	0.93	0.93	0.93	0.93	0.93	0.93	0.93
Percent Heavy Veh, %	0	0	0	1	0	0	0	0	6	0	0	0
Cap, veh/h	102	58	267	455	4	356	315	1185		485	1180	4
Arrive On Green	0.21	0.21	0.21	0.22	0.22	0.22	0.62	0.62	0.00	0.62	0.62	0.61
Sat Flow, veh/h	105	273	1250	1369	16	1596	628	1900	1535	802	1893	6
Grp Volume(v), veh/h	56	0	0	253	0	99	9	639	0	47	0	902
Grp Sat Flow(s),veh/h/ln	1628	0	0	1369	0	1613	628	1900	1535	802	0	1899
Q Serve(g_s), s	0.0	0.0	0.0	7.2	0.0	2.7	0.5	10.0	0.0	1.8	0.0	17.8
Cycle Q Clear(g_c), s	1.4	0.0	0.0	8.6	0.0	2.7	18.3	10.0	0.0	11.8	0.0	17.8
Prop In Lane	0.16		0.77	1.00		0.99	1.00		1.00	1.00		0.00
Lane Grp Cap(c), veh/h	428	0	0	455	0	360	315	1185		485	0	1184
V/C Ratio(X)	0.13	0.00	0.00	0.56	0.00	0.28	0.03	0.54		0.10	0.00	0.76
Avail Cap(c_a), veh/h	544	0	0	543	0	463	369	1347		554	0	1346
HCM Platoon Ratio	1.00	1.00	1.00	1.00	1.00	1.00	1.00	1.00	1.00	1.00	1.00	1.00
Upstream Filter(I)	1.00	0.00	0.00	1.00	0.00	1.00	1.00	1.00	0.00	1.00	0.00	1.00
Uniform Delay (d), s/veh	16.7	0.0	0.0	18.9	0.0	16.8	13.6	5.6	0.0	8.9	0.0	7.0
Incr Delay (d2), s/veh	0.1	0.0	0.0	0.8	0.0	0.3	0.1	0.5	0.0	0.1	0.0	2.6
Initial Q Delay(d3), s/veh	0.0	0.0	0.0	0.0	0.0	0.0	0.0	0.0	0.0	0.0	0.0	0.0
%ile BackOfQ(50%),veh/ln	0.5	0.0	0.0	2.6	0.0	0.9	0.1	2.5	0.0	0.3	0.0	4.9
Unsig. Movement Delay, s/veh												
LnGrp Delay(d), s/veh	16.8	0.0	0.0	19.7	0.0	17.1	13.7	6.1	0.0	9.0	0.0	9.6
LnGrp LOS	B			B		B	B	A		A		A
Approach Vol, veh/h	56		352				648			949		
Approach Delay, s/veh	16.8		19.0				6.2			9.6		
Approach LOS	B		B				A			A		
Timer - Assigned Phs	2		4				6			8		
Phs Duration (G+Y+Rc), s	36.5		15.6				36.5			15.6		
Change Period (Y+Rc), s	4.5		* 4.5				4.5			4.5		
Max Green Setting (Gmax), s	36.5		* 15				36.5			14.5		
Max Q Clear Time (g_c+I1), s	20.3		3.4				19.8			10.6		
Green Ext Time (p_c), s	8.4		0.1				12.3			0.5		
<b>Intersection Summary</b>												
HCM 7th Control Delay, s/veh			10.4									
HCM 7th LOS			B									
<b>Notes</b>												
User approved pedestrian interval to be less than phase max green.												
* HCM 7th computational engine requires equal clearance times for the phases crossing the barrier.												

## HCM 7th Signalized Intersection Summary 10: Gateway St & International Way

---

Unsignalized Delay for [NBR] is excluded from calculations of the approach delay and intersection delay.

## HCM Signalized Intersection Capacity Analysis 12: Gateway St /Gateway St & EGame Farm Rd

												
Movement	EBL	EBT	EBR	WBL	WBT	WBR	NBL	NBT	NBR	SBL	SBT	SBR
Lane Configurations												
Traffic Volume (vph)	2	0	19	151	0	120	35	547	44	158	948	5
Future Volume (vph)	2	0	19	151	0	120	35	547	44	158	948	5
Ideal Flow (vphp)	1900	1900	1900	1900	1900	1900	1900	1900	1900	1900	1900	1900
Total Lost time (s)		4.0		4.0	4.0		4.0	4.0	4.5	4.0	4.0	
Lane Util. Factor		1.00		1.00	1.00		1.00	0.95	1.00	1.00	0.95	
Frt		0.88		1.00	0.85		1.00	1.00	0.85	1.00	1.00	
Flt Protected		1.00		0.95	1.00		0.95	1.00	1.00	0.95	1.00	
Satd. Flow (prot)		1585		1787	1615		1752	3539	1538	1787	3572	
Flt Permitted		1.00		0.82	1.00		0.21	1.00	1.00	0.31	1.00	
Satd. Flow (perm)		1592		1536	1615		378	3539	1538	586	3572	
Peak-hour factor, PHF	0.87	0.87	0.87	0.87	0.87	0.87	0.87	0.87	0.87	0.87	0.87	0.87
Adj. Flow (vph)	2	0	22	174	0	138	40	629	51	182	1090	6
RTOR Reduction (vph)	0	24	0	0	107	0	0	0	30	0	1	0
Lane Group Flow (vph)	0	0	0	174	31	0	40	629	21	182	1095	0
Heavy Vehicles (%)	0%	0%	5%	1%	0%	0%	3%	2%	5%	1%	1%	0%
Turn Type	Perm	NA		pm+pt	NA		pm+pt	NA	Perm	pm+pt	NA	
Protected Phases		4		3	8		5	2		1	6	
Permitted Phases	4			8			2		2	6		
Actuated Green, G (s)		0.9		11.0	11.0		23.4	21.4	21.4	30.6	25.0	
Effective Green, g (s)		0.9		11.5	11.5		24.4	21.9	21.4	31.6	25.5	
Actuated g/C Ratio		0.02		0.22	0.22		0.47	0.43	0.42	0.61	0.50	
Clearance Time (s)		4.0		4.5	4.5		4.5	4.5	4.5	4.5	4.5	
Vehicle Extension (s)		2.5		2.5	2.5		2.5	4.0	4.0	2.5	4.0	
Lane Grp Cap (vph)		27		375	360		245	1504	639	501	1768	
v/s Ratio Prot				c0.06	0.02		0.01	0.18		c0.04	c0.31	
v/s Ratio Perm		0.00		c0.04			0.07		0.01	0.18		
v/c Ratio		0.02		0.46	0.09		0.16	0.42	0.03	0.36	0.62	
Uniform Delay, d1		24.9		17.2	15.8		7.5	10.3	8.9	4.8	9.5	
Progression Factor		1.00		1.00	1.00		1.00	1.00	1.00	1.00	1.00	
Incremental Delay, d2		0.2		0.7	0.1		0.2	0.3	0.0	0.3	0.7	
Delay (s)		25.0		17.9	15.9		7.8	10.6	8.9	5.1	10.2	
Level of Service		C		B	B		A	B	A	A	B	
Approach Delay (s/veh)		25.0			17.0			10.3			9.5	
Approach LOS		C			B			B			A	
<b>Intersection Summary</b>												
HCM 2000 Control Delay (s/veh)			10.9									B
HCM 2000 Volume to Capacity ratio			0.64									
Actuated Cycle Length (s)			51.5							16.0		
Intersection Capacity Utilization			54.7%									A
Analysis Period (min)			15									
c	Critical Lane Group											

## HCM 7th Signalized Intersection Summary 12: Gateway St /Gateway St & EGame Farm Rd



Movement	EBL	EBT	EBR	WBL	WBT	WBR	NBL	NBT	NBR	SBL	SBT	SBR
Lane Configurations		↔		↖	↗		↖	↑↑	↗	↖	↑↑	
Traffic Volume (veh/h)	2	0	19	151	0	120	35	547	44	158	948	5
Future Volume (veh/h)	2	0	19	151	0	120	35	547	44	158	948	5
Initial Q (Qb), veh	0	0	0	0	0	0	0	0	0	0	0	0
Lane Width Adj.	1.00	1.00	1.00	1.00	1.00	1.00	1.00	1.00	1.00	1.00	1.00	1.00
Ped-Bike Adj(A_pbT)	1.00		1.00	1.00		1.00	1.00		1.00	1.00		1.00
Parking Bus, Adj	1.00	1.00	1.00	1.00	1.00	1.00	1.00	1.00	1.00	1.00	1.00	1.00
Work Zone On Approach		No			No			No			No	
Adj Sat Flow, veh/h/ln	1900	1900	1826	1885	1900	1900	1856	1870	1826	1885	1885	1900
Adj Flow Rate, veh/h	2	0	22	174	0	138	40	629	0	182	1090	6
Peak Hour Factor	0.87	0.87	0.87	0.87	0.87	0.87	0.87	0.87	0.87	0.87	0.87	0.87
Percent Heavy Veh, %	0	0	5	1	0	0	3	2	5	1	1	0
Cap, veh/h	83	8	155	593	0	504	298	1235		495	1491	8
Arrive On Green	0.11	0.00	0.11	0.12	0.00	0.30	0.04	0.35	0.00	0.10	0.41	0.40
Sat Flow, veh/h	60	74	1472	1795	0	1610	1767	3554	1547	1795	3652	20
Grp Volume(v), veh/h	24	0	0	174	0	138	40	629	0	182	534	562
Grp Sat Flow(s),veh/h/ln	1605	0	0	1795	0	1610	1767	1777	1547	1795	1791	1882
Q Serve(g_s), s	0.0	0.0	0.0	4.0	0.0	3.3	0.7	7.2	0.0	3.0	12.9	12.9
Cycle Q Clear(g_c), s	0.7	0.0	0.0	4.0	0.0	3.3	0.7	7.2	0.0	3.0	12.9	12.9
Prop In Lane	0.08		0.92	1.00		1.00	1.00		1.00	1.00		0.01
Lane Grp Cap(c), veh/h	246	0	0	593	0	504	298	1235		495	731	768
V/C Ratio(X)	0.10	0.00	0.00	0.29	0.00	0.27	0.13	0.51		0.37	0.73	0.73
Avail Cap(c_a), veh/h	357	0	0	694	0	693	532	1530		624	771	810
HCM Platoon Ratio	1.00	1.00	1.00	1.00	1.00	1.00	1.00	1.00	1.00	1.00	1.00	1.00
Upstream Filter(I)	1.00	0.00	0.00	1.00	0.00	1.00	1.00	1.00	0.00	1.00	1.00	1.00
Uniform Delay (d), s/veh	20.7	0.0	0.0	14.9	0.0	13.4	10.7	13.2	0.0	8.7	12.7	12.8
Incr Delay (d2), s/veh	0.1	0.0	0.0	0.2	0.0	0.2	0.1	0.5	0.0	0.3	3.7	3.6
Initial Q Delay(d3), s/veh	0.0	0.0	0.0	0.0	0.0	0.0	0.0	0.0	0.0	0.0	0.0	0.0
%ile BackOfQ(50%),veh/ln	0.3	0.0	0.0	1.4	0.0	1.0	0.2	2.4	0.0	0.9	4.8	5.0
Unsig. Movement Delay, s/veh												
LnGrp Delay(d), s/veh	20.9	0.0	0.0	15.1	0.0	13.6	10.8	13.7	0.0	9.1	16.5	16.3
LnGrp LOS	C			B		B	B	B		A	B	B
Approach Vol, veh/h		24			312			669			1278	
Approach Delay, s/veh		20.9			14.4			13.5			15.3	
Approach LOS		C			B			B			B	
Timer - Assigned Phs	1	2	3	4	5	6		8				
Phs Duration (G+Y+Rc), s	9.3	21.8	10.1	9.9	6.2	24.9		20.0				
Change Period (Y+Rc), s	4.5	4.5	4.5	* 4.5	4.5	4.5		4.5				
Max Green Setting (Gmax), s	8.5	21.5	8.5	* 9	8.5	21.5		21.5				
Max Q Clear Time (g_c+I1), s	5.0	9.2	6.0	2.7	2.7	14.9		5.3				
Green Ext Time (p_c), s	0.2	6.4	0.1	0.0	0.0	5.5		0.4				

### Intersection Summary

HCM 7th Control Delay, s/veh	14.7
HCM 7th LOS	B

### Notes

User approved pedestrian interval to be less than phase max green.

\* HCM 7th computational engine requires equal clearance times for the phases crossing the barrier.

## HCM 7th Signalized Intersection Summary 12: Gateway St /Gateway St & EGame Farm Rd

---

Unsignalized Delay for [NBR] is excluded from calculations of the approach delay and intersection delay.

## HCM 7th TWSC 16: Game Farm Rd & Deadmond Ferry

Intersection						
Int Delay, s/veh	5.6					
Movement	EBT	EBR	WBL	WBT	NBL	NBR
Lane Configurations	↻		↻	↑	↻	↻
Traffic Vol, veh/h	24	217	132	29	107	42
Future Vol, veh/h	24	217	132	29	107	42
Conflicting Peds, #/hr	0	0	0	0	0	0
Sign Control	Free	Free	Free	Free	Stop	Stop
RT Channelized	-	None	-	None	-	None
Storage Length	-	-	140	-	115	0
Veh in Median Storage, #	0	-	-	0	0	-
Grade, %	0	-	-	0	0	-
Peak Hour Factor	87	87	87	87	87	87
Heavy Vehicles, %	0	0	0	0	1	0
Mvmt Flow	28	249	152	33	123	48

Major/Minor	Major1	Major2	Minor1			
Conflicting Flow All	0	0	277	0	489	152
Stage 1	-	-	-	-	152	-
Stage 2	-	-	-	-	337	-
Critical Hdwy	-	-	4.1	-	6.41	6.2
Critical Hdwy Stg 1	-	-	-	-	5.41	-
Critical Hdwy Stg 2	-	-	-	-	5.41	-
Follow-up Hdwy	-	-	2.2	-	3.509	3.3
Pot Cap-1 Maneuver	-	-	1298	-	540	899
Stage 1	-	-	-	-	878	-
Stage 2	-	-	-	-	726	-
Platoon blocked, %	-	-	-	-	-	-
Mov Cap-1 Maneuver	-	-	1298	-	477	899
Mov Cap-2 Maneuver	-	-	-	-	477	-
Stage 1	-	-	-	-	878	-
Stage 2	-	-	-	-	641	-

Approach	EB	WB	NB
HCM Ctrl Dly, s/v	0	6.68	13.49
HCM LOS			B

Minor Lane/Major Mvmt	NBLn1	NBLn2	EBT	EBR	WBL	WBT
Capacity (veh/h)	477	899	-	-	1298	-
HCM Lane V/C Ratio	0.258	0.054	-	-	0.117	-
HCM Ctrl Dly (s/v)	15.2	9.2	-	-	8.1	-
HCM Lane LOS	C	A	-	-	A	-
HCM 95th %tile Q(veh)	1	0.2	-	-	0.4	-

## HCM Signalized Intersection Capacity Analysis 17: Beltline Rd /MLK & Game Farm Rd

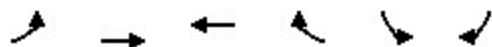

Movement	EBL	EBT	WBT	WBR	SBL	SBR
Lane Configurations						
Traffic Volume (vph)	22	663	791	131	282	71
Future Volume (vph)	22	663	791	131	282	71
Ideal Flow (vphp)	1900	1900	1900	1900	1900	1900
Total Lost time (s)	4.0	4.0	4.0	4.0	4.0	4.0
Lane Util. Factor	1.00	0.95	0.95	1.00	1.00	1.00
Frt	1.00	1.00	1.00	0.85	1.00	0.85
Flt Protected	0.95	1.00	1.00	1.00	0.95	1.00
Satd. Flow (prot)	1805	3539	3574	1599	1805	1615
Flt Permitted	0.95	1.00	1.00	1.00	0.95	1.00
Satd. Flow (perm)	1805	3539	3574	1599	1805	1615
Peak-hour factor, PHF	0.90	0.90	0.90	0.90	0.90	0.90
Adj. Flow (vph)	24	737	879	146	313	79
RTOR Reduction (vph)	0	0	0	92	0	59
Lane Group Flow (vph)	24	737	879	54	313	20
Heavy Vehicles (%)	0%	2%	1%	1%	0%	0%
Turn Type	Prot	NA	NA	Perm	Prot	Perm
Protected Phases	7	4	8		6	
Permitted Phases				8		6
Actuated Green, G (s)	5.9	28.7	17.4	17.4	11.7	11.7
Effective Green, g (s)	7.3	30.1	18.8	18.8	13.1	13.1
Actuated g/C Ratio	0.14	0.59	0.37	0.37	0.26	0.26
Clearance Time (s)	5.4	5.4	5.4	5.4	5.4	5.4
Vehicle Extension (s)	2.5	4.0	4.0	4.0	2.5	2.5
Lane Grp Cap (vph)	257	2080	1312	587	461	413
v/s Ratio Prot	0.01	c0.21	c0.25		c0.17	
v/s Ratio Perm				0.03		0.01
v/c Ratio	0.09	0.35	0.67	0.09	0.68	0.05
Uniform Delay, d1	19.1	5.5	13.6	10.6	17.2	14.4
Progression Factor	1.00	1.00	1.00	1.00	1.00	1.00
Incremental Delay, d2	0.1	0.1	1.4	0.1	3.6	0.0
Delay (s)	19.2	5.6	15.0	10.7	20.7	14.4
Level of Service	B	A	B	B	C	B
Approach Delay (s/veh)		6.1	14.4		19.5	
Approach LOS		A	B		B	
<b>Intersection Summary</b>						
HCM 2000 Control Delay (s/veh)			12.4		HCM 2000 Level of Service	B
HCM 2000 Volume to Capacity ratio			0.63			
Actuated Cycle Length (s)			51.2		Sum of lost time (s)	12.0
Intersection Capacity Utilization			44.2%		ICU Level of Service	A
Analysis Period (min)			15			
c Critical Lane Group						

## HCM 7th Signalized Intersection Summary 17: Beltline Rd /MLK & Game Farm Rd



Movement	EBL	EBT	WBT	WBR	SBL	SBR	
Lane Configurations							
Traffic Volume (veh/h)	22	663	791	131	282	71	
Future Volume (veh/h)	22	663	791	131	282	71	
Initial Q (Qb), veh	0	0	0	0	0	0	
Lane Width Adj.	1.00	1.00	1.00	1.00	1.00	1.00	
Ped-Bike Adj(A_pbT)	1.00			1.00	1.00	1.00	
Parking Bus, Adj	1.00	1.00	1.00	1.00	1.00	1.00	
Work Zone On Approach		No	No		No		
Adj Sat Flow, veh/h/ln	1900	1870	1885	1885	1900	1900	
Adj Flow Rate, veh/h	24	737	879	146	313	79	
Peak Hour Factor	0.90	0.90	0.90	0.90	0.90	0.90	
Percent Heavy Veh, %	0	2	1	1	0	0	
Cap, veh/h	198	2096	1429	637	448	399	
Arrive On Green	0.11	0.59	0.40	0.40	0.25	0.25	
Sat Flow, veh/h	1810	3647	3676	1598	1810	1610	
Grp Volume(v), veh/h	24	737	879	146	313	79	
Grp Sat Flow(s),veh/h/ln	1810	1777	1791	1598	1810	1610	
Q Serve(g_s), s	0.6	5.3	9.6	3.0	7.7	1.9	
Cycle Q Clear(g_c), s	0.6	5.3	9.6	3.0	7.7	1.9	
Prop In Lane	1.00			1.00	1.00	1.00	
Lane Grp Cap(c), veh/h	198	2096	1429	637	448	399	
V/C Ratio(X)	0.12	0.35	0.62	0.23	0.70	0.20	
Avail Cap(c_a), veh/h	331	2453	1527	681	661	588	
HCM Platoon Ratio	1.00	1.00	1.00	1.00	1.00	1.00	
Upstream Filter(I)	1.00	1.00	1.00	1.00	1.00	1.00	
Uniform Delay (d), s/veh	19.8	5.2	11.8	9.8	16.8	14.7	
Incr Delay (d2), s/veh	0.2	0.1	0.8	0.3	1.5	0.2	
Initial Q Delay(d3), s/veh	0.0	0.0	0.0	0.0	0.0	0.0	
%ile BackOfQ(50%),veh/ln	0.2	1.0	2.9	0.8	3.1	0.0	
Unsig. Movement Delay, s/veh							
LnGrp Delay(d), s/veh	20.0	5.4	12.6	10.0	18.3	14.8	
LnGrp LOS	B	A	B	B	B	B	
Approach Vol, veh/h		761	1025		392		
Approach Delay, s/veh		5.8	12.3		17.6		
Approach LOS		A	B		B		
Timer - Assigned Phs				4	6	7	8
Phs Duration (G+Y+Rc), s				33.0	16.2	9.4	23.6
Change Period (Y+Rc), s				5.4	5.4	5.4	5.4
Max Green Setting (Gmax), s				32.6	16.6	7.6	19.6
Max Q Clear Time (g_c+I1), s				7.3	9.7	2.6	11.6
Green Ext Time (p_c), s				14.3	1.1	0.0	6.6
<b>Intersection Summary</b>							
HCM 7th Control Delay, s/veh			11.0				
HCM 7th LOS			B				
<b>Notes</b>							
User approved pedestrian interval to be less than phase max green.							

## HCM 7th TWSC

### 21: International Way & Site access

Intersection						
Int Delay, s/veh	0					
Movement	EBL	EBT	WBT	WBR	SBL	SBR
Lane Configurations		↶	↷		↶	
Traffic Vol, veh/h	0	56	172	0	0	0
Future Vol, veh/h	0	56	172	0	0	0
Conflicting Peds, #/hr	0	0	0	0	0	0
Sign Control	Free	Free	Free	Free	Stop	Stop
RT Channelized	-	None	-	None	-	None
Storage Length	-	-	-	-	0	-
Veh in Median Storage, #	-	0	0	-	0	-
Grade, %	-	0	0	-	0	-
Peak Hour Factor	74	74	74	74	74	74
Heavy Vehicles, %	0	0	0	0	0	0
Mvmt Flow	0	76	232	0	0	0
Major/Minor	Major1	Major2	Minor2			
Conflicting Flow All	232	0	-	0	308	232
Stage 1	-	-	-	-	232	-
Stage 2	-	-	-	-	76	-
Critical Hdwy	4.1	-	-	-	6.4	6.2
Critical Hdwy Stg 1	-	-	-	-	5.4	-
Critical Hdwy Stg 2	-	-	-	-	5.4	-
Follow-up Hdwy	2.2	-	-	-	3.5	3.3
Pot Cap-1 Maneuver	1347	-	-	-	688	812
Stage 1	-	-	-	-	811	-
Stage 2	-	-	-	-	952	-
Platoon blocked, %		-	-	-		
Mov Cap-1 Maneuver	1347	-	-	-	688	812
Mov Cap-2 Maneuver	-	-	-	-	688	-
Stage 1	-	-	-	-	811	-
Stage 2	-	-	-	-	952	-
Approach	EB	WB	SB			
HCM Ctrl Dly, s/v	0	0	0			
HCM LOS				A		
Minor Lane/Major Mvmt	EBL	EBT	WBT	WBR	SBLn1	
Capacity (veh/h)	1347	-	-	-	-	-
HCM Lane V/C Ratio	-	-	-	-	-	-
HCM Ctrl Dly (s/v)	0	-	-	-	-	0
HCM Lane LOS	A	-	-	-	-	A
HCM 95th %tile Q(veh)	0	-	-	-	-	-

HCM 7th TWSC  
24: Hutton & Beltline Rd

Intersection												
Int Delay, s/veh	9.8											
Movement	EBL	EBT	EBR	WBL	WBT	WBR	NBL	NBT	NBR	SBL	SBT	SBR
Lane Configurations	↖ ↑↑↑			↖ ↑↑			↕				↖ ↑	
Traffic Vol, veh/h	36	600	104	45	781	36	56	8	83	18	10	73
Future Vol, veh/h	36	600	104	45	781	36	56	8	83	18	10	73
Conflicting Peds, #/hr	0	0	0	0	0	0	0	0	0	0	0	0
Sign Control	Free	Free	Free	Free	Free	Free	Stop	Stop	Stop	Stop	Stop	Stop
RT Channelized	-	-	None	-	-	None	-	-	None	-	-	None
Storage Length	130	-	-	440	-	-	-	-	-	-	-	0
Veh in Median Storage, #	-	0	-	-	0	-	-	0	-	-	0	-
Grade, %	-	0	-	-	0	-	-	0	-	-	0	-
Peak Hour Factor	94	94	94	94	94	94	94	94	94	94	94	94
Heavy Vehicles, %	8	0	1	0	1	0	0	0	0	6	0	0
Mvmt Flow	38	638	111	48	831	38	60	9	88	19	11	78























Major/Minor	Major1			Major2			Minor1			Minor2		
Conflicting Flow All	869	0	0	749	0	0	1287	1735	374	1282	1771	435
Stage 1	-	-	-	-	-	-	770	770	-	946	946	-
Stage 2	-	-	-	-	-	-	516	965	-	336	826	-
Critical Hdwy	4.26	-	-	5.3	-	-	6.95	6.5	7.1	7.07	6.5	6.9
Critical Hdwy Stg 1	-	-	-	-	-	-	7.3	5.5	-	6.62	5.5	-
Critical Hdwy Stg 2	-	-	-	-	-	-	6.5	5.5	-	6.82	5.5	-
Follow-up Hdwy	2.28	-	-	3.1	-	-	3.65	4	3.9	3.71	4	3.3
Pot Cap-1 Maneuver	734	-	-	523	-	-	147	89	537	141	84	575
Stage 1	-	-	-	-	-	-	298	413	-	267	343	-
Stage 2	-	-	-	-	-	-	499	336	-	607	390	-
Platoon blocked, %	-	-	-	-	-	-	-	-	-	-	-	-
Mov Cap-1 Maneuver	734	-	-	523	-	-	96	76	537	92	72	575
Mov Cap-2 Maneuver	-	-	-	-	-	-	96	76	-	92	72	-
Stage 1	-	-	-	-	-	-	283	391	-	242	311	-
Stage 2	-	-	-	-	-	-	378	305	-	470	369	-

Approach	EB			WB			NB			SB		
HCM Ctrl Dly, s/v	0.49			0.66			97.52			28.29		
HCM LOS							F			D		





















Minor Lane/Major Mvmt	NBLn1	EBL	EBT	EBR	WBL	WBT	WBR	SBLn1	SBLn2
Capacity (veh/h)	174	734	-	-	523	-	-	84	575
HCM Lane V/C Ratio	0.9	0.052	-	-	0.092	-	-	0.356	0.135
HCM Ctrl Dly (s/v)	97.5	10.2	-	-	12.6	-	-	70.2	12.2
HCM Lane LOS	F	B	-	-	B	-	-	F	B
HCM 95th %tile Q(veh)	6.6	0.2	-	-	0.3	-	-	1.4	0.5

# HCM Signalized Intersection Capacity Analysis

## 35: Harlow & Gateway

													
Movement	EBL	EBT	EBR	WBL	WBT	WBR	NBL	NBT	NBR	SBL	SBT	SBR	
Lane Configurations		 			 			 		 			
Traffic Volume (vph)	192	412	4	11	344	291	38	49	53	406	18	276	
Future Volume (vph)	192	412	4	11	344	291	38	49	53	406	18	276	
Ideal Flow (vphp)	1900	1900	1900	1900	1900	1900	1900	1900	1900	1900	1900	1900	
Total Lost time (s)	4.0	4.0		4.0	4.0			3.5		4.0	4.0		
Lane Util. Factor	1.00	0.95		1.00	0.95			0.95		0.97	1.00		
Frt	1.00	1.00		1.00	0.93			0.94		1.00	0.86		
Flt Protected	0.95	1.00		0.95	1.00			0.99		0.95	1.00		
Satd. Flow (prot)	1787	3569		1805	3346			3360		3502	1632		
Flt Permitted	0.95	1.00		0.95	1.00			0.99		0.95	1.00		
Satd. Flow (perm)	1787	3569		1805	3346			3360		3502	1632		
Peak-hour factor, PHF	0.88	0.88	0.88	0.88	0.88	0.88	0.88	0.88	0.88	0.88	0.88	0.88	
Adj. Flow (vph)	218	468	5	13	391	331	43	56	60	461	20	314	
RTOR Reduction (vph)	0	1	0	0	130	0	0	52	0	0	242	0	
Lane Group Flow (vph)	218	472	0	13	592	0	0	107	0	461	92	0	
Heavy Vehicles (%)	1%	1%	0%	0%	0%	1%	0%	0%	0%	0%	0%	0%	
Turn Type	Prot	NA		Prot	NA		Split	NA		Split	NA		
Protected Phases	7	4		3	8		2	2		6	6		
Permitted Phases													
Actuated Green, G (s)	15.8	37.9		1.1	23.2			11.0		19.6	19.6		
Effective Green, g (s)	16.3	38.4		1.6	23.7			11.5		20.1	20.1		
Actuated g/C Ratio	0.19	0.44		0.02	0.27			0.13		0.23	0.23		
Clearance Time (s)	4.5	4.5		4.5	4.5			4.0		4.5	4.5		
Vehicle Extension (s)	2.5	2.5		2.5	2.5			4.0		4.0	4.0		
Lane Grp Cap (vph)	334	1573		33	910			443		808	376		
v/s Ratio Prot	c0.12	0.13		0.01	c0.18			c0.03		c0.13	0.06		
v/s Ratio Perm													
v/c Ratio	0.65	0.30		0.39	0.65			0.24		0.57	0.25		
Uniform Delay, d1	32.8	15.7		42.3	28.0			33.9		29.7	27.3		
Progression Factor	1.00	1.00		1.00	1.00			1.00		1.00	1.00		
Incremental Delay, d2	4.0	0.1		5.6	1.5			0.4		1.2	0.5		
Delay (s)	36.8	15.8		47.8	29.5			34.3		30.8	27.8		
Level of Service	D	B		D	C			C		C	C		
Approach Delay (s/veh)		22.4			29.9			34.3			29.6		
Approach LOS		C			C			C			C		
<b>Intersection Summary</b>													
HCM 2000 Control Delay (s/veh)			27.9									HCM 2000 Level of Service	C
HCM 2000 Volume to Capacity ratio			0.57										
Actuated Cycle Length (s)			87.1									Sum of lost time (s)	16.0
Intersection Capacity Utilization			69.2%									ICU Level of Service	C
Analysis Period (min)			15										
c	Critical Lane Group												

### HCM 7th Signalized Intersection Summary 35: Harlow & Gateway

































												
Movement	EBL	EBT	EBR	WBL	WBT	WBR	NBL	NBT	NBR	SBL	SBT	SBR
Lane Configurations												
Traffic Volume (veh/h)	192	412	4	11	344	291	38	49	53	406	18	276
Future Volume (veh/h)	192	412	4	11	344	291	38	49	53	406	18	276
Initial Q (Qb), veh	0	0	0	0	0	0	0	0	0	0	0	0
Lane Width Adj.	1.00	1.00	1.00	1.00	1.00	1.00	1.00	1.00	1.00	1.00	1.00	1.00
Ped-Bike Adj(A_pbT)	1.00		1.00	1.00		1.00	1.00		1.00	1.00		1.00
Parking Bus, Adj	1.00	1.00	1.00	1.00	1.00	1.00	1.00	1.00	1.00	1.00	1.00	1.00
Work Zone On Approach		No			No			No			No	
Adj Sat Flow, veh/h/ln	1885	1885	1900	1900	1900	1885	1900	1900	1900	1900	1900	1900
Adj Flow Rate, veh/h	218	468	5	13	391	331	43	56	60	461	20	314
Peak Hour Factor	0.88	0.88	0.88	0.88	0.88	0.88	0.88	0.88	0.88	0.88	0.88	0.88
Percent Heavy Veh, %	1	1	0	0	0	1	0	0	0	0	0	0
Cap, veh/h	273	1541	16	33	540	453	115	146	149	934	26	406
Arrive On Green	0.15	0.42	0.42	0.02	0.29	0.28	0.11	0.12	0.11	0.27	0.27	0.26
Sat Flow, veh/h	1795	3630	39	1810	1862	1562	985	1254	1281	3510	97	1528
Grp Volume(v), veh/h	218	231	242	13	379	343	81	0	78	461	0	334
Grp Sat Flow(s),veh/h/ln	1795	1791	1878	1810	1805	1619	1851	0	1669	1755	0	1625
Q Serve(g_s), s	10.4	7.5	7.5	0.6	16.7	16.9	3.6	0.0	3.9	9.8	0.0	16.8
Cycle Q Clear(g_c), s	10.4	7.5	7.5	0.6	16.7	16.9	3.6	0.0	3.9	9.8	0.0	16.8
Prop In Lane	1.00		0.02	1.00		0.96	0.53		0.77	1.00		0.94
Lane Grp Cap(c), veh/h	273	760	797	33	524	470	215	0	194	934	0	432
V/C Ratio(X)	0.80	0.30	0.30	0.40	0.72	0.73	0.38	0.00	0.40	0.49	0.00	0.77
Avail Cap(c_a), veh/h	548	1053	1104	184	694	622	303	0	274	1151	0	533
HCM Platoon Ratio	1.00	1.00	1.00	1.00	1.00	1.00	1.00	1.00	1.00	1.00	1.00	1.00
Upstream Filter(I)	1.00	1.00	1.00	1.00	1.00	1.00	1.00	0.00	1.00	1.00	0.00	1.00
Uniform Delay (d), s/veh	36.2	16.8	16.8	43.0	28.2	28.5	36.2	0.0	36.4	27.4	0.0	30.2
Incr Delay (d2), s/veh	4.0	0.2	0.2	5.7	2.1	2.5	1.5	0.0	1.9	0.6	0.0	6.4
Initial Q Delay(d3), s/veh	0.0	0.0	0.0	0.0	0.0	0.0	0.0	0.0	0.0	0.0	0.0	0.0
%ile BackOfQ(50%),veh/ln	4.7	3.0	3.1	0.3	7.2	6.6	1.7	0.0	1.7	4.0	0.0	7.1
Unsig. Movement Delay, s/veh												
LnGrp Delay(d), s/veh	40.2	17.0	17.0	48.7	30.3	31.0	37.8	0.0	38.3	28.0	0.0	36.7
LnGrp LOS	D	B	B	D	C	C	D		D	C		D
Approach Vol, veh/h		691			735			159				795
Approach Delay, s/veh		24.3			31.0			38.0				31.6
Approach LOS		C			C			D				C
Timer - Assigned Phs		2	3	4		6	7	8				
Phs Duration (G+Y+Rc), s		13.8	5.6	41.5		27.5	17.5	29.7				
Change Period (Y+Rc), s		4.0	4.5	4.5		4.5	4.5	4.5				
Max Green Setting (Gmax), s		14.0	8.5	51.5		28.5	26.5	33.5				
Max Q Clear Time (g_c+I1), s		5.9	2.6	9.5		18.8	12.4	18.9				
Green Ext Time (p_c), s		0.6	0.0	5.6		4.2	0.7	6.2				
<b>Intersection Summary</b>												
HCM 7th Control Delay, s/veh				29.7								
HCM 7th LOS				C								
<b>Notes</b>												
User approved pedestrian interval to be less than phase max green.												

## HCM 7th TWSC 40: International Way & Sports Way

































Intersection						
Int Delay, s/veh	1.4					
Movement	EBL	EBT	WBT	WBR	SBL	SBR
Lane Configurations						
Traffic Vol, veh/h	4	54	250	1	5	39
Future Vol, veh/h	4	54	250	1	5	39
Conflicting Peds, #/hr	0	0	0	0	0	0
Sign Control	Free	Free	Free	Free	Stop	Stop
RT Channelized	-	None	-	None	-	None
Storage Length	175	-	-	-	240	0
Veh in Median Storage, #	-	0	0	-	0	-
Grade, %	-	0	0	-	0	-
Peak Hour Factor	71	71	71	71	71	71
Heavy Vehicles, %	0	9	3	0	0	0
Mvmt Flow	6	76	352	1	7	55
Major/Minor	Major1	Major2	Minor2			
Conflicting Flow All	354	0	-	0	440	353
Stage 1	-	-	-	-	353	-
Stage 2	-	-	-	-	87	-
Critical Hdwy	4.1	-	-	-	6.4	6.2
Critical Hdwy Stg 1	-	-	-	-	5.4	-
Critical Hdwy Stg 2	-	-	-	-	5.4	-
Follow-up Hdwy	2.2	-	-	-	3.5	3.3
Pot Cap-1 Maneuver	1216	-	-	-	578	695
Stage 1	-	-	-	-	716	-
Stage 2	-	-	-	-	941	-
Platoon blocked, %		-	-	-		
Mov Cap-1 Maneuver	1216	-	-	-	575	695
Mov Cap-2 Maneuver	-	-	-	-	575	-
Stage 1	-	-	-	-	712	-
Stage 2	-	-	-	-	941	-
Approach	EB	WB	SB			
HCM Ctrl Dly, s/v	0.55	0	10.7			
HCM LOS			B			
Minor Lane/Major Mvmt	EBL	EBT	WBT	WBR	SBLn1	SBLn2
Capacity (veh/h)	1216	-	-	-	575	695
HCM Lane V/C Ratio	0.005	-	-	-	0.012	0.079
HCM Ctrl Dly (s/v)	8	-	-	-	11.3	10.6
HCM Lane LOS	A	-	-	-	B	B
HCM 95th %tile Q(veh)	0	-	-	-	0	0.3

# HCM Signalized Intersection Capacity Analysis

## 9: Beltline Rd & Gateway St





















													
Movement	EBL	EBT	EBR	WBL	WBT	WBR	NBL	NBT	NBR	SBL	SBT	SBR	
Lane Configurations	 	  	  		  		 	 			 	 	
Traffic Volume (vph)	320	561	1246	156	758	184	921	331	113	220	405	743	
Future Volume (vph)	320	561	1246	156	758	184	921	331	113	220	405	743	
Ideal Flow (vphp)	1900	1900	1900	1900	1900	1900	1900	1900	1900	1900	1900	1900	
Total Lost time (s)	3.8	3.8	3.1	3.8	3.8		4.0	4.0		4.0	4.0	4.0	
Lane Util. Factor	0.97	0.91	0.88	1.00	0.91		0.97	1.00		1.00	1.00	0.88	
Frt	1.00	1.00	0.85	1.00	0.97		1.00	0.96		1.00	1.00	0.85	
Flt Protected	0.95	1.00	1.00	0.95	1.00		0.95	1.00		0.95	1.00	1.00	
Satd. Flow (prot)	3433	5187	2842	1805	4995		3467	1801		1787	1881	2842	
Flt Permitted	0.95	1.00	1.00	0.95	1.00		0.95	1.00		0.95	1.00	1.00	
Satd. Flow (perm)	3433	5187	2842	1805	4995		3467	1801		1787	1881	2842	
Peak-hour factor, PHF	0.94	0.94	0.94	0.94	0.94	0.94	0.94	0.94	0.94	0.94	0.94	0.94	
Adj. Flow (vph)	340	597	1326	166	806	196	980	352	120	234	431	790	
RTOR Reduction (vph)	0	0	198	0	33	0	0	11	0	0	0	326	
Lane Group Flow (vph)	340	597	1128	166	969	0	980	461	0	234	431	464	
Heavy Vehicles (%)	2%	0%	0%	0%	1%	0%	1%	2%	0%	1%	1%	0%	
Turn Type	Prot	NA	pm+ov	Prot	NA		Prot	NA		Prot	NA	Perm	
Protected Phases	7	4	5	3	8		5	2		1	6		
Permitted Phases			4									6	
Actuated Green, G (s)	12.5	21.3	46.9	12.2	21.0		25.6	38.3		17.3	30.0	30.0	
Effective Green, g (s)	13.9	22.7	49.7	13.6	22.4		26.1	38.8		17.8	30.5	30.5	
Actuated g/C Ratio	0.13	0.21	0.46	0.13	0.21		0.24	0.36		0.16	0.28	0.28	
Clearance Time (s)	5.2	5.2	4.5	5.2	5.2		4.5	4.5		4.5	4.5	4.5	
Vehicle Extension (s)	2.5	4.0	2.5	2.5	4.0		2.5	2.5		2.5	2.5	2.5	
Lane Grp Cap (vph)	439	1085	1301	226	1031		833	644		293	528	798	
v/s Ratio Prot	c0.10	0.12	0.22	0.09	c0.19		c0.28	0.26		0.13	c0.23		
v/s Ratio Perm			0.18									0.16	
v/c Ratio	0.77	0.55	0.87	0.73	0.94		1.18	0.72		0.80	0.82	0.58	
Uniform Delay, d1	45.8	38.3	26.4	45.7	42.4		41.2	30.1		43.6	36.4	33.5	
Progression Factor	1.00	1.00	1.00	1.00	1.00		1.00	1.00		1.00	1.00	1.00	
Incremental Delay, d2	8.0	0.7	6.3	11.1	15.6		91.9	3.5		13.6	9.2	0.9	
Delay (s)	53.8	39.1	32.7	56.8	58.0		133.1	33.6		57.3	45.6	34.4	
Level of Service	D	D	C	E	E		F	C		E	D	C	
Approach Delay (s/veh)		37.6			57.8			100.7			41.4		
Approach LOS		D			E			F			D		
<b>Intersection Summary</b>													
HCM 2000 Control Delay (s/veh)			56.6									HCM 2000 Level of Service	E
HCM 2000 Volume to Capacity ratio			0.94										
Actuated Cycle Length (s)			108.5									Sum of lost time (s)	15.6
Intersection Capacity Utilization			88.8%									ICU Level of Service	E
Analysis Period (min)			15										
c	Critical Lane Group												

## HCM 7th Signalized Intersection Summary 9: Beltline Rd & Gateway St

												
Movement	EBL	EBT	EBR	WBL	WBT	WBR	NBL	NBT	NBR	SBL	SBT	SBR
Lane Configurations	 	  	  		  		 				 	  
Traffic Volume (veh/h)	320	561	1246	156	758	184	921	331	113	220	405	743
Future Volume (veh/h)	320	561	1246	156	758	184	921	331	113	220	405	743
Initial Q (Qb), veh	0	0	0	0	0	0	0	0	0	0	0	0
Lane Width Adj.	1.00	1.00	1.00	1.00	1.00	1.00	1.00	1.00	1.00	1.00	1.00	1.00
Ped-Bike Adj(A_pbT)	1.00		1.00	1.00		1.00	1.00		1.00	1.00		1.00
Parking Bus, Adj	1.00	1.00	1.00	1.00	1.00	1.00	1.00	1.00	1.00	1.00	1.00	1.00
Work Zone On Approach		No			No			No			No	
Adj Sat Flow, veh/h/ln	1870	1900	1900	1900	1885	1900	1885	1870	1900	1885	1885	1900
Adj Flow Rate, veh/h	340	597	1326	166	806	196	980	352	120	234	431	790
Peak Hour Factor	0.94	0.94	0.94	0.94	0.94	0.94	0.94	0.94	0.94	0.94	0.94	0.94
Percent Heavy Veh, %	2	0	0	0	1	0	1	2	0	1	1	0
Cap, veh/h	424	1017	1213	214	793	191	782	525	179	283	616	926
Arrive On Green	0.12	0.20	0.20	0.12	0.19	0.18	0.22	0.39	0.39	0.16	0.33	0.33
Sat Flow, veh/h	3456	5187	2834	1810	4138	998	3483	1334	455	1795	1885	2834
Grp Volume(v), veh/h	340	597	1326	166	667	335	980	0	472	234	431	790
Grp Sat Flow(s),veh/h/ln	1728	1729	1417	1810	1716	1705	1742	0	1789	1795	1885	1417
Q Serve(g_s), s	11.1	12.1	22.7	10.3	22.2	22.2	26.0	0.0	25.2	14.6	23.1	30.1
Cycle Q Clear(g_c), s	11.1	12.1	22.7	10.3	22.2	22.2	26.0	0.0	25.2	14.6	23.1	30.1
Prop In Lane	1.00		1.00	1.00		0.59	1.00		0.25	1.00		1.00
Lane Grp Cap(c), veh/h	424	1017	1213	214	657	327	782	0	704	283	616	926
V/C Ratio(X)	0.80	0.59	1.09	0.78	1.01	1.02	1.25	0.00	0.67	0.83	0.70	0.85
Avail Cap(c_a), veh/h	424	1017	1213	222	657	327	782	0	741	310	683	1027
HCM Platoon Ratio	1.00	1.00	1.00	1.00	1.00	1.00	1.00	1.00	1.00	1.00	1.00	1.00
Upstream Filter(I)	1.00	1.00	1.00	1.00	1.00	1.00	1.00	0.00	1.00	1.00	1.00	1.00
Uniform Delay (d), s/veh	49.5	42.3	33.1	49.6	46.8	47.2	44.9	0.0	29.0	47.3	34.0	36.4
Incr Delay (d2), s/veh	10.4	1.1	55.0	14.8	38.9	56.2	124.7	0.0	2.0	14.9	2.5	6.3
Initial Q Delay(d3), s/veh	0.0	0.0	0.0	0.0	0.0	0.0	0.0	0.0	0.0	0.0	0.0	0.0
%ile BackOfQ(50%),veh/ln	5.3	5.1	25.0	5.4	12.7	14.2	24.5	0.0	10.9	7.6	10.8	10.7
Unsig. Movement Delay, s/veh												
LnGrp Delay(d), s/veh	59.8	43.4	88.1	64.4	85.7	103.5	169.6	0.0	31.0	62.2	36.6	42.7
LnGrp LOS	E	D	F	E	F	F	F		C	E	D	D
Approach Vol, veh/h		2263			1168			1452			1455	
Approach Delay, s/veh		72.1			87.8			124.5			44.0	
Approach LOS		E			F			F			D	
Timer - Assigned Phs	1	2	3	4	5	6	7	8				
Phs Duration (G+Y+Rc), s	22.3	49.6	17.5	26.5	30.0	41.9	18.0	26.0				
Change Period (Y+Rc), s	4.5	4.5	5.2	5.2	4.5	4.5	5.2	5.2				
Max Green Setting (Gmax), s	19.5	47.5	12.8	20.8	25.5	41.5	12.8	20.8				
Max Q Clear Time (g_c+I1), s	17.6	27.2	12.3	24.7	28.0	32.1	13.1	24.2				
Green Ext Time (p_c), s	0.2	2.0	0.0	0.0	0.0	5.2	0.0	0.0				
<b>Intersection Summary</b>												
HCM 7th Control Delay, s/veh			80.5									
HCM 7th LOS			F									
<b>Notes</b>												
User approved pedestrian interval to be less than phase max green.												





















# HCM Signalized Intersection Capacity Analysis

## 10: Gateway St & International Way

												
Movement	EBL	EBT	EBR	WBL	WBT	WBR	NBL	NBT	NBR	SBL	SBT	SBR
Lane Configurations												
Traffic Volume (vph)	10	5	49	287	1	111	10	725	82	54	1020	4
Future Volume (vph)	10	5	49	287	1	111	10	725	82	54	1020	4
Ideal Flow (vphp)	1900	1900	1900	1900	1900	1900	1900	1900	1900	1900	1900	1900
Total Lost time (s)		4.0		4.0	4.0		4.0	4.0	4.0	4.0	4.0	
Lane Util. Factor		1.00		1.00	1.00		1.00	1.00	1.00	1.00	1.00	
Frt		0.90		1.00	0.85		1.00	1.00	0.85	1.00	1.00	
Flt Protected		0.99		0.95	1.00		0.95	1.00	1.00	0.95	1.00	
Satd. Flow (prot)		1690		1787	1617		1805	1900	1524	1805	1899	
Flt Permitted		0.96		0.81	1.00		0.10	1.00	1.00	0.24	1.00	
Satd. Flow (perm)		1630		1529	1617		184	1900	1524	459	1899	
Peak-hour factor, PHF	0.93	0.93	0.93	0.93	0.93	0.93	0.93	0.93	0.93	0.93	0.93	0.93
Adj. Flow (vph)	11	5	53	309	1	119	11	780	88	58	1097	4
RTOR Reduction (vph)	0	40	0	0	90	0	0	0	32	0	0	0
Lane Group Flow (vph)	0	29	0	309	30	0	11	780	56	58	1101	0
Heavy Vehicles (%)	0%	0%	0%	1%	0%	0%	0%	0%	6%	0%	0%	0%
Turn Type	Perm	NA		Perm	NA		Perm	NA	Perm	Perm	NA	
Protected Phases		4			8			2		6		6
Permitted Phases	4			8			2		2	6		
Actuated Green, G (s)		16.0		15.5	15.5		40.8	40.8	40.8	40.8	40.8	
Effective Green, g (s)		16.0		16.0	16.0		41.3	41.3	41.3	41.3	41.3	
Actuated g/C Ratio		0.25		0.25	0.25		0.63	0.63	0.63	0.63	0.63	
Clearance Time (s)		4.0		4.5	4.5		4.5	4.5	4.5	4.5	4.5	
Vehicle Extension (s)		2.5		2.5	2.5		4.0	4.0	4.0	4.0	4.0	
Lane Grp Cap (vph)		399		374	396		116	1201	963	290	1201	
v/s Ratio Prot					0.02			0.41			c0.58	
v/s Ratio Perm		0.02		c0.20			0.06		0.04	0.13		
v/c Ratio		0.07		0.83	0.08		0.09	0.65	0.06	0.20	0.92	
Uniform Delay, d1		18.9		23.3	19.0		4.7	7.5	4.6	5.0	10.5	
Progression Factor		1.00		1.00	1.00		1.00	1.00	1.00	1.00	1.00	
Incremental Delay, d2		0.1		13.6	0.1		0.5	1.4	0.0	0.5	11.1	
Delay (s)		19.0		36.9	19.0		5.2	8.9	4.6	5.5	21.6	
Level of Service		B		D	B		A	A	A	A	C	
Approach Delay (s/veh)		19.0			31.9			8.4			20.8	
Approach LOS		B			C			A			C	
<b>Intersection Summary</b>												
HCM 2000 Control Delay (s/veh)			18.3				HCM 2000 Level of Service				B	
HCM 2000 Volume to Capacity ratio			0.89									
Actuated Cycle Length (s)			65.3				Sum of lost time (s)				8.0	
Intersection Capacity Utilization			83.2%				ICU Level of Service				E	
Analysis Period (min)			15									
c Critical Lane Group												

# HCM 7th Signalized Intersection Summary

## 10: Gateway St & International Way





















												
Movement	EBL	EBT	EBR	WBL	WBT	WBR	NBL	NBT	NBR	SBL	SBT	SBR
Lane Configurations												
Traffic Volume (veh/h)	10	5	49	287	1	111	10	725	82	54	1020	4
Future Volume (veh/h)	10	5	49	287	1	111	10	725	82	54	1020	4
Initial Q (Qb), veh	0	0	0	0	0	0	0	0	0	0	0	0
Lane Width Adj.	1.00	1.00	1.00	1.00	1.00	1.00	1.00	1.00	1.00	1.00	1.00	1.00
Ped-Bike Adj(A_pbT)	1.00		1.00	1.00		1.00	1.00		1.00	1.00		1.00
Parking Bus, Adj	1.00	1.00	1.00	1.00	1.00	1.00	1.00	1.00	1.00	1.00	1.00	1.00
Work Zone On Approach		No			No			No			No	
Adj Sat Flow, veh/h/ln	1900	1900	1900	1885	1900	1900	1900	1900	1811	1900	1900	1900
Adj Flow Rate, veh/h	11	5	53	309	1	119	11	780	0	58	1097	4
Peak Hour Factor	0.93	0.93	0.93	0.93	0.93	0.93	0.93	0.93	0.93	0.93	0.93	0.93
Percent Heavy Veh, %	0	0	0	1	0	0	0	0	6	0	0	0
Cap, veh/h	91	59	295	451	3	392	177	1214		377	1209	4
Arrive On Green	0.24	0.24	0.24	0.25	0.25	0.25	0.64	0.64	0.00	0.64	0.64	0.63
Sat Flow, veh/h	128	247	1241	1356	13	1599	520	1900	1535	703	1892	7
Grp Volume(v), veh/h	69	0	0	309	0	120	11	780	0	58	0	1101
Grp Sat Flow(s),veh/h/ln	1616	0	0	1356	0	1612	520	1900	1535	703	0	1899
Q Serve(g_s), s	0.0	0.0	0.0	12.2	0.0	4.2	1.3	17.4	0.0	3.8	0.0	34.5
Cycle Q Clear(g_c), s	2.3	0.0	0.0	14.5	0.0	4.2	35.7	17.4	0.0	21.2	0.0	34.5
Prop In Lane	0.16		0.77	1.00		0.99	1.00		1.00	1.00		0.00
Lane Grp Cap(c), veh/h	445	0	0	451	0	395	177	1214		377	0	1214
V/C Ratio(X)	0.16	0.00	0.00	0.69	0.00	0.30	0.06	0.64		0.15	0.00	0.91
Avail Cap(c_a), veh/h	457	0	0	452	0	396	183	1236		385	0	1235
HCM Platoon Ratio	1.00	1.00	1.00	1.00	1.00	1.00	1.00	1.00	1.00	1.00	1.00	1.00
Upstream Filter(I)	1.00	0.00	0.00	1.00	0.00	1.00	1.00	1.00	0.00	1.00	0.00	1.00
Uniform Delay (d), s/veh	21.0	0.0	0.0	24.9	0.0	21.3	26.1	7.6	0.0	14.1	0.0	10.7
Incr Delay (d2), s/veh	0.1	0.0	0.0	4.0	0.0	0.3	0.2	1.3	0.0	0.3	0.0	10.0
Initial Q Delay(d3), s/veh	0.0	0.0	0.0	0.0	0.0	0.0	0.0	0.0	0.0	0.0	0.0	0.0
%ile BackOfQ(50%),veh/ln	0.9	0.0	0.0	5.0	0.0	1.5	0.2	5.5	0.0	0.6	0.0	13.4
Unsig. Movement Delay, s/veh												
LnGrp Delay(d), s/veh	21.1	0.0	0.0	28.8	0.0	21.6	26.3	8.9	0.0	14.4	0.0	20.7
LnGrp LOS	C			C		C	C	A		B		C
Approach Vol, veh/h		69			429			791			1159	
Approach Delay, s/veh		21.1			26.8			9.2			20.4	
Approach LOS		C			C			A			C	
Timer - Assigned Phs		2		4		6		8				
Phs Duration (G+Y+Rc), s		48.2		21.0		48.2		21.0				
Change Period (Y+Rc), s		4.5		* 4.5		4.5		4.5				
Max Green Setting (Gmax), s		44.5		* 17		44.5		16.5				
Max Q Clear Time (g_c+I1), s		37.7		4.3		36.5		16.5				
Green Ext Time (p_c), s		4.9		0.2		7.3		0.0				
<b>Intersection Summary</b>												
HCM 7th Control Delay, s/veh				17.9								
HCM 7th LOS				B								
<b>Notes</b>												
User approved pedestrian interval to be less than phase max green.												
* HCM 7th computational engine requires equal clearance times for the phases crossing the barrier.												

## HCM 7th Signalized Intersection Summary 10: Gateway St & International Way





















---

Unsignalized Delay for [NBR] is excluded from calculations of the approach delay and intersection delay.

## HCM Signalized Intersection Capacity Analysis 12: Gateway St /Gateway St & EGame Farm Rd

													
Movement	EBL	EBT	EBR	WBL	WBT	WBR	NBL	NBT	NBR	SBL	SBT	SBR	
Lane Configurations													
Traffic Volume (vph)	2	0	23	184	0	146	43	667	54	193	1157	6	
Future Volume (vph)	2	0	23	184	0	146	43	667	54	193	1157	6	
Ideal Flow (vphp)	1900	1900	1900	1900	1900	1900	1900	1900	1900	1900	1900	1900	
Total Lost time (s)		4.0		4.0	4.0		4.0	4.0	4.5	4.0	4.0		
Lane Util. Factor		1.00		1.00	1.00		1.00	0.95	1.00	1.00	0.95		
Frt		0.87		1.00	0.85		1.00	1.00	0.85	1.00	1.00		
Flt Protected		1.00		0.95	1.00		0.95	1.00	1.00	0.95	1.00		
Satd. Flow (prot)		1582		1787	1615		1752	3539	1538	1787	3572		
Flt Permitted		1.00		0.69	1.00		0.15	1.00	1.00	0.24	1.00		
Satd. Flow (perm)		1588		1297	1615		277	3539	1538	450	3572		
Peak-hour factor, PHF	0.87	0.87	0.87	0.87	0.87	0.87	0.87	0.87	0.87	0.87	0.87	0.87	
Adj. Flow (vph)	2	0	26	211	0	168	49	767	62	222	1330	7	
RTOR Reduction (vph)	0	27	0	0	128	0	0	0	36	0	0	0	
Lane Group Flow (vph)	0	1	0	211	40	0	49	767	26	222	1337	0	
Heavy Vehicles (%)	0%	0%	5%	1%	0%	0%	3%	2%	5%	1%	1%	0%	
Turn Type	Perm	NA		pm+pt	NA		pm+pt	NA	Perm	pm+pt	NA		
Protected Phases		4		3	8		5	2		1	6		
Permitted Phases	4			8			2		2	6			
Actuated Green, G (s)		1.8		14.4	14.4		29.4	26.1	26.1	38.9	31.1		
Effective Green, g (s)		1.8		14.9	14.9		30.4	26.6	26.1	39.4	31.6		
Actuated g/C Ratio		0.03		0.24	0.24		0.49	0.43	0.42	0.63	0.51		
Clearance Time (s)		4.0		4.5	4.5		4.5	4.5	4.5	4.5	4.5		
Vehicle Extension (s)		2.5		2.5	2.5		2.5	4.0	4.0	2.5	4.0		
Lane Grp Cap (vph)		45		381	386		225	1511	644	473	1811		
v/s Ratio Prot				c0.08	0.02		0.01	0.22		c0.07	c0.37		
v/s Ratio Perm		0.00		c0.05			0.09		0.02	0.23			
v/c Ratio		0.02		0.55	0.10		0.22	0.51	0.04	0.47	0.74		
Uniform Delay, d1		29.4		20.5	18.5		9.4	13.1	10.7	6.1	12.1		
Progression Factor		1.00		1.00	1.00		1.00	1.00	1.00	1.00	1.00		
Incremental Delay, d2		0.1		1.4	0.1		0.4	0.4	0.0	0.5	1.7		
Delay (s)		29.5		21.9	18.6		9.8	13.4	10.7	6.6	13.8		
Level of Service		C		C	B		A	B	B	A	B		
Approach Delay (s/veh)		29.5			20.4			13.0			12.8		
Approach LOS		C			C			B			B		
<b>Intersection Summary</b>													
HCM 2000 Control Delay (s/veh)			14.0									HCM 2000 Level of Service	B
HCM 2000 Volume to Capacity ratio			0.73										
Actuated Cycle Length (s)			62.3									Sum of lost time (s)	16.0
Intersection Capacity Utilization			62.4%									ICU Level of Service	B
Analysis Period (min)			15										
c	Critical Lane Group												

## HCM 7th Signalized Intersection Summary 12: Gateway St /Gateway St & EGame Farm Rd

												
Movement	EBL	EBT	EBR	WBL	WBT	WBR	NBL	NBT	NBR	SBL	SBT	SBR
Lane Configurations												
Traffic Volume (veh/h)	2	0	23	184	0	146	43	667	54	193	1157	6
Future Volume (veh/h)	2	0	23	184	0	146	43	667	54	193	1157	6
Initial Q (Qb), veh	0	0	0	0	0	0	0	0	0	0	0	0
Lane Width Adj.	1.00	1.00	1.00	1.00	1.00	1.00	1.00	1.00	1.00	1.00	1.00	1.00
Ped-Bike Adj(A_pbT)	1.00		1.00	1.00		1.00	1.00		1.00	1.00		1.00
Parking Bus, Adj	1.00	1.00	1.00	1.00	1.00	1.00	1.00	1.00	1.00	1.00	1.00	1.00
Work Zone On Approach		No			No			No			No	
Adj Sat Flow, veh/h/ln	1900	1900	1826	1885	1900	1900	1856	1870	1826	1885	1885	1900
Adj Flow Rate, veh/h	2	0	26	211	0	168	49	767	0	222	1330	7
Peak Hour Factor	0.87	0.87	0.87	0.87	0.87	0.87	0.87	0.87	0.87	0.87	0.87	0.87
Percent Heavy Veh, %	0	0	5	1	0	0	3	2	5	1	1	0
Cap, veh/h	60	5	126	525	0	451	268	1586		492	1841	10
Arrive On Green	0.08	0.00	0.08	0.13	0.00	0.27	0.04	0.45	0.00	0.10	0.50	0.50
Sat Flow, veh/h	50	64	1490	1795	0	1610	1767	3554	1547	1795	3653	19
Grp Volume(v), veh/h	28	0	0	211	0	168	49	767	0	222	652	685
Grp Sat Flow(s),veh/h/ln	1605	0	0	1795	0	1610	1767	1777	1547	1795	1791	1882
Q Serve(g_s), s	0.0	0.0	0.0	6.9	0.0	5.8	1.0	10.5	0.0	4.1	19.6	19.6
Cycle Q Clear(g_c), s	1.1	0.0	0.0	6.9	0.0	5.8	1.0	10.5	0.0	4.1	19.6	19.6
Prop In Lane	0.07		0.93	1.00		1.00	1.00		1.00	1.00		0.01
Lane Grp Cap(c), veh/h	192	0	0	525	0	451	268	1586		492	902	948
V/C Ratio(X)	0.15	0.00	0.00	0.40	0.00	0.37	0.18	0.48		0.45	0.72	0.72
Avail Cap(c_a), veh/h	263	0	0	525	0	512	423	1747		623	958	1007
HCM Platoon Ratio	1.00	1.00	1.00	1.00	1.00	1.00	1.00	1.00	1.00	1.00	1.00	1.00
Upstream Filter(I)	1.00	0.00	0.00	1.00	0.00	1.00	1.00	1.00	0.00	1.00	1.00	1.00
Uniform Delay (d), s/veh	29.5	0.0	0.0	22.0	0.0	20.2	11.3	13.5	0.0	8.8	13.4	13.4
Incr Delay (d2), s/veh	0.3	0.0	0.0	0.4	0.0	0.4	0.2	0.3	0.0	0.5	2.8	2.7
Initial Q Delay(d3), s/veh	0.0	0.0	0.0	0.0	0.0	0.0	0.0	0.0	0.0	0.0	0.0	0.0
%ile BackOfQ(50%),veh/ln	0.4	0.0	0.0	2.7	0.0	2.1	0.4	3.7	0.0	1.3	7.3	7.6
Unsig. Movement Delay, s/veh												
LnGrp Delay(d), s/veh	29.7	0.0	0.0	22.3	0.0	20.6	11.5	13.8	0.0	9.3	16.2	16.1
LnGrp LOS	C			C		C	B	B		A	B	B
Approach Vol, veh/h		28			379			816			1559	
Approach Delay, s/veh		29.7			21.6			13.7			15.2	
Approach LOS		C			C			B			B	
Timer - Assigned Phs	1	2	3	4	5	6		8				
Phs Duration (G+Y+Rc), s	10.9	34.9	13.0	10.4	6.9	38.8		23.4				
Change Period (Y+Rc), s	4.5	4.5	4.5	* 4.5	4.5	4.5		4.5				
Max Green Setting (Gmax), s	11.5	33.5	8.5	* 9	8.5	36.5		21.5				
Max Q Clear Time (g_c+I1), s	6.1	12.5	8.9	3.1	3.0	21.6		7.8				
Green Ext Time (p_c), s	0.4	11.1	0.0	0.0	0.0	12.7		0.5				
<b>Intersection Summary</b>												
HCM 7th Control Delay, s/veh			15.8									
HCM 7th LOS			B									
<b>Notes</b>												
User approved pedestrian interval to be less than phase max green.												
* HCM 7th computational engine requires equal clearance times for the phases crossing the barrier.												

## HCM 7th Signalized Intersection Summary 12: Gateway St /Gateway St & EGame Farm Rd

---

Unsignalized Delay for [NBR] is excluded from calculations of the approach delay and intersection delay.

HCM 7th TWSC  
16: Game Farm Rd & Deadmond Ferry

Intersection						
Int Delay, s/veh	6.5					
Movement	EBT	EBR	WBL	WBT	NBL	NBR
Lane Configurations	↑		↑	↑	↑	↑
Traffic Vol, veh/h	29	265	161	35	131	51
Future Vol, veh/h	29	265	161	35	131	51
Conflicting Peds, #/hr	0	0	0	0	0	0
Sign Control	Free	Free	Free	Free	Stop	Stop
RT Channelized	-	None	-	None	-	None
Storage Length	-	-	140	-	115	0
Veh in Median Storage, #	0	-	-	0	0	-
Grade, %	0	-	-	0	0	-
Peak Hour Factor	87	87	87	87	87	87
Heavy Vehicles, %	0	0	0	0	1	0
Mvmt Flow	33	305	185	40	151	59

Major/Minor	Major1	Major2	Minor1		
Conflicting Flow All	0	0	338	0	596 186
Stage 1	-	-	-	-	186 -
Stage 2	-	-	-	-	410 -
Critical Hdwy	-	-	4.1	-	6.41 6.2
Critical Hdwy Stg 1	-	-	-	-	5.41 -
Critical Hdwy Stg 2	-	-	-	-	5.41 -
Follow-up Hdwy	-	-	2.2	-	3.509 3.3
Pot Cap-1 Maneuver	-	-	1233	-	468 862
Stage 1	-	-	-	-	849 -
Stage 2	-	-	-	-	672 -
Platoon blocked, %	-	-	-	-	-
Mov Cap-1 Maneuver	-	-	1233	-	398 862
Mov Cap-2 Maneuver	-	-	-	-	398 -
Stage 1	-	-	-	-	849 -
Stage 2	-	-	-	-	571 -

Approach	EB	WB	NB
HCM Ctrl Dly, s/v	0	6.93	16.66
HCM LOS			C

Minor Lane/Major Mvmt	NBLn1	NBLn2	EBT	EBR	WBL	WBT
Capacity (veh/h)	398	862	-	-	1233	-
HCM Lane V/C Ratio	0.379	0.068	-	-	0.15	-
HCM Ctrl Dly (s/v)	19.5	9.5	-	-	8.4	-
HCM Lane LOS	C	A	-	-	A	-
HCM 95th %tile Q(veh)	1.7	0.2	-	-	0.5	-

## HCM Signalized Intersection Capacity Analysis 17: Beltline Rd /MLK & Game Farm Rd

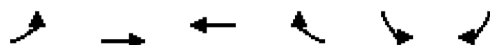

Movement	EBL	EBT	WBT	WBR	SBL	SBR
Lane Configurations						
Traffic Volume (vph)	27	809	965	160	344	87
Future Volume (vph)	27	809	965	160	344	87
Ideal Flow (vphp)	1900	1900	1900	1900	1900	1900
Total Lost time (s)	4.0	4.0	4.0	4.0	4.0	4.0
Lane Util. Factor	1.00	0.95	0.95	1.00	1.00	1.00
Frt	1.00	1.00	1.00	0.85	1.00	0.85
Flt Protected	0.95	1.00	1.00	1.00	0.95	1.00
Satd. Flow (prot)	1805	3539	3574	1599	1805	1615
Flt Permitted	0.95	1.00	1.00	1.00	0.95	1.00
Satd. Flow (perm)	1805	3539	3574	1599	1805	1615
Peak-hour factor, PHF	0.90	0.90	0.90	0.90	0.90	0.90
Adj. Flow (vph)	30	899	1072	178	382	97
RTOR Reduction (vph)	0	0	0	110	0	69
Lane Group Flow (vph)	30	899	1072	68	382	28
Heavy Vehicles (%)	0%	2%	1%	1%	0%	0%
Turn Type	Prot	NA	NA	Perm	Prot	Perm
Protected Phases	7	4	8		6	
Permitted Phases				8		6
Actuated Green, G (s)	6.0	31.2	19.8	19.8	13.5	13.5
Effective Green, g (s)	7.4	32.6	21.2	21.2	14.9	14.9
Actuated g/C Ratio	0.13	0.59	0.38	0.38	0.27	0.27
Clearance Time (s)	5.4	5.4	5.4	5.4	5.4	5.4
Vehicle Extension (s)	2.5	4.0	4.0	4.0	2.5	2.5
Lane Grp Cap (vph)	240	2078	1365	610	484	433
v/s Ratio Prot	0.02	c0.25	c0.30		c0.21	
v/s Ratio Perm				0.04		0.02
v/c Ratio	0.13	0.43	0.79	0.11	0.79	0.07
Uniform Delay, d1	21.2	6.3	15.1	11.1	18.8	15.1
Progression Factor	1.00	1.00	1.00	1.00	1.00	1.00
Incremental Delay, d2	0.2	0.2	3.2	0.1	8.1	0.0
Delay (s)	21.4	6.5	18.4	11.2	26.9	15.2
Level of Service	C	A	B	B	C	B
Approach Delay (s/veh)		7.0	17.3		24.5	
Approach LOS		A	B		C	

### Intersection Summary

HCM 2000 Control Delay (s/veh)	15.0	HCM 2000 Level of Service	B
HCM 2000 Volume to Capacity ratio	0.74		
Actuated Cycle Length (s)	55.5	Sum of lost time (s)	12.0
Intersection Capacity Utilization	52.4%	ICU Level of Service	A
Analysis Period (min)	15		
c Critical Lane Group			

## HCM 7th Signalized Intersection Summary 17: Beltline Rd /MLK & Game Farm Rd

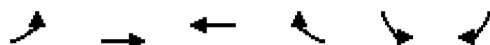

Movement	EBL	EBT	WBT	WBR	SBL	SBR	
Lane Configurations							
Traffic Volume (veh/h)	27	809	965	160	344	87	
Future Volume (veh/h)	27	809	965	160	344	87	
Initial Q (Qb), veh	0	0	0	0	0	0	
Lane Width Adj.	1.00	1.00	1.00	1.00	1.00	1.00	
Ped-Bike Adj(A_pbT)	1.00			1.00	1.00	1.00	
Parking Bus, Adj	1.00	1.00	1.00	1.00	1.00	1.00	
Work Zone On Approach		No	No		No		
Adj Sat Flow, veh/h/ln	1900	1870	1885	1885	1900	1900	
Adj Flow Rate, veh/h	30	899	1072	178	382	97	
Peak Hour Factor	0.90	0.90	0.90	0.90	0.90	0.90	
Percent Heavy Veh, %	0	2	1	1	0	0	
Cap, veh/h	182	2055	1443	644	493	439	
Arrive On Green	0.10	0.58	0.40	0.40	0.27	0.27	
Sat Flow, veh/h	1810	3647	3676	1598	1810	1610	
Grp Volume(v), veh/h	30	899	1072	178	382	97	
Grp Sat Flow(s),veh/h/ln	1810	1777	1791	1598	1810	1610	
Q Serve(g_s), s	0.8	7.7	13.7	4.0	10.4	2.5	
Cycle Q Clear(g_c), s	0.8	7.7	13.7	4.0	10.4	2.5	
Prop In Lane	1.00			1.00	1.00	1.00	
Lane Grp Cap(c), veh/h	182	2055	1443	644	493	439	
V/C Ratio(X)	0.16	0.44	0.74	0.28	0.77	0.22	
Avail Cap(c_a), veh/h	304	2321	1470	656	574	511	
HCM Platoon Ratio	1.00	1.00	1.00	1.00	1.00	1.00	
Upstream Filter(I)	1.00	1.00	1.00	1.00	1.00	1.00	
Uniform Delay (d), s/veh	22.0	6.4	13.6	10.8	18.0	15.1	
Incr Delay (d2), s/veh	0.3	0.2	2.2	0.3	5.2	0.2	
Initial Q Delay(d3), s/veh	0.0	0.0	0.0	0.0	0.0	0.0	
%ile BackOfQ(50%),veh/ln	0.3	1.7	4.5	1.1	4.7	2.5	
Unsig. Movement Delay, s/veh							
LnGrp Delay(d), s/veh	22.3	6.6	15.8	11.1	23.2	15.3	
LnGrp LOS	C	A	B	B	C	B	
Approach Vol, veh/h		929	1250		479		
Approach Delay, s/veh		7.1	15.2		21.6		
Approach LOS		A	B		C		
Timer - Assigned Phs				4	6	7	8
Phs Duration (G+Y+Rc), s				35.0	18.6	9.4	25.6
Change Period (Y+Rc), s				* 5.4	5.4	* 5.4	* 5.4
Max Green Setting (Gmax), s				* 34	15.6	* 7.6	* 21
Max Q Clear Time (g_c+I1), s				9.7	12.4	2.8	15.7
Green Ext Time (p_c), s				16.3	0.8	0.0	4.5
<b>Intersection Summary</b>							
HCM 7th Control Delay, s/veh			13.5				
HCM 7th LOS			B				
<b>Notes</b>							
User approved pedestrian interval to be less than phase max green.							
* HCM 7th computational engine requires equal clearance times for the phases crossing the barrier.							

## HCM 7th TWSC 21: International Way & Site access

Intersection						
Int Delay, s/veh	0					
Movement	EBL	EBT	WBT	WBR	SBL	SBR
Lane Configurations		↔	↔		↔	
Traffic Vol, veh/h	0	68	210	0	0	0
Future Vol, veh/h	0	68	210	0	0	0
Conflicting Peds, #/hr	0	0	0	0	0	0
Sign Control	Free	Free	Free	Free	Stop	Stop
RT Channelized	-	None	-	None	-	None
Storage Length	-	-	-	-	0	-
Veh in Median Storage, #	-	0	0	-	0	-
Grade, %	-	0	0	-	0	-
Peak Hour Factor	74	74	74	74	74	74
Heavy Vehicles, %	0	0	0	0	0	0
Mvmt Flow	0	92	284	0	0	0

Major/Minor	Major1	Major2	Minor2		
Conflicting Flow All	284	0	-	0	376 284
Stage 1	-	-	-	-	284 -
Stage 2	-	-	-	-	92 -
Critical Hdwy	4.1	-	-	-	6.4 6.2
Critical Hdwy Stg 1	-	-	-	-	5.4 -
Critical Hdwy Stg 2	-	-	-	-	5.4 -
Follow-up Hdwy	2.2	-	-	-	3.5 3.3
Pot Cap-1 Maneuver	1290	-	-	-	630 760
Stage 1	-	-	-	-	769 -
Stage 2	-	-	-	-	937 -
Platoon blocked, %		-	-	-	
Mov Cap-1 Maneuver	1290	-	-	-	630 760
Mov Cap-2 Maneuver	-	-	-	-	630 -
Stage 1	-	-	-	-	769 -
Stage 2	-	-	-	-	937 -

Approach	EB	WB	SB
HCM Ctrl Dly, s/v	0	0	0
HCM LOS			A

Minor Lane/Major Mvmt	EBL	EBT	WBT	WBR	SBLn1
Capacity (veh/h)	1290	-	-	-	-
HCM Lane V/C Ratio	-	-	-	-	-
HCM Ctrl Dly (s/v)	0	-	-	-	0
HCM Lane LOS	A	-	-	-	A
HCM 95th %tile Q(veh)	0	-	-	-	-

HCM 7th TWSC  
24: Hutton & Beltline Rd

Intersection												
Int Delay, s/veh	54											
Movement	EBL	EBT	EBR	WBL	WBT	WBR	NBL	NBT	NBR	SBL	SBT	SBR
Lane Configurations	↖ ↑↑↑			↖ ↑↑			↕				↖ ↑	
Traffic Vol, veh/h	44	732	127	55	953	44	68	10	101	22	12	89
Future Vol, veh/h	44	732	127	55	953	44	68	10	101	22	12	89
Conflicting Peds, #/hr	0	0	0	0	0	0	0	0	0	0	0	0
Sign Control	Free	Free	Free	Free	Free	Free	Stop	Stop	Stop	Stop	Stop	Stop
RT Channelized	-	-	None	-	-	None	-	-	None	-	-	None
Storage Length	130	-	-	440	-	-	-	-	-	-	-	0
Veh in Median Storage, #	-	0	-	-	0	-	-	0	-	-	0	-
Grade, %	-	0	-	-	0	-	-	0	-	-	0	-
Peak Hour Factor	94	94	94	94	94	94	94	94	94	94	94	94
Heavy Vehicles, %	8	0	1	0	1	0	0	0	0	6	0	0
Mvmt Flow	47	779	135	59	1014	47	72	11	107	23	13	95























Major/Minor	Major1			Major2			Minor1			Minor2		
Conflicting Flow All	1061	0	0	914	0	0	1570	2118	457	1565	2162	530
Stage 1	-	-	-	-	-	-	940	940	-	1154	1154	-
Stage 2	-	-	-	-	-	-	630	1178	-	410	1007	-
Critical Hdwy	4.26	-	-	5.3	-	-	6.95	6.5	7.1	7.07	6.5	6.9
Critical Hdwy Stg 1	-	-	-	-	-	-	7.3	5.5	-	6.62	5.5	-
Critical Hdwy Stg 2	-	-	-	-	-	-	6.5	5.5	-	6.82	5.5	-
Follow-up Hdwy	2.28	-	-	3.1	-	-	3.65	4	3.9	3.71	4	3.3
Pot Cap-1 Maneuver	618	-	-	437	-	-	95	51	475	90	48	498
Stage 1	-	-	-	-	-	-	227	345	-	199	274	-
Stage 2	-	-	-	-	-	-	428	267	-	547	321	-
Platoon blocked, %	-	-	-	-	-	-	-	-	-	-	-	-
Mov Cap-1 Maneuver	618	-	-	437	-	-	~ 44	41	475	44	38	498
Mov Cap-2 Maneuver	-	-	-	-	-	-	~ 44	41	-	44	38	-
Stage 1	-	-	-	-	-	-	210	319	-	172	237	-
Stage 2	-	-	-	-	-	-	284	231	-	378	297	-

Approach	EB	WB	NB	SB
HCM Ctrl Dly, s/v	0.55	0.76	\$ 619.12	78.48
HCM LOS			F	F

Minor Lane/Major Mvmt	NBLn1	EBL	EBT	EBR	WBL	WBT	WBR	SBLn1	SBLn2
Capacity (veh/h)	90	618	-	-	437	-	-	42	498
HCM Lane V/C Ratio	2.126	0.076	-	-	0.134	-	-	0.867	0.19
HCM Ctrl Dly (s/v)	\$ 619.1	11.3	-	-	14.5	-	-	247.5	13.9
HCM Lane LOS	F	B	-	-	B	-	-	F	B
HCM 95th %tile Q(veh)	16.8	0.2	-	-	0.5	-	-	3.4	0.7

Notes	
~: Volume exceeds capacity	\$: Delay exceeds 300s
+: Computation Not Defined	*: All major volume in platoon

## HCM Signalized Intersection Capacity Analysis 35: Harlow & Gateway

													
Movement	EBL	EBT	EBR	WBL	WBT	WBR	NBL	NBT	NBR	SBL	SBT	SBR	
Lane Configurations		 			 			 		 			
Traffic Volume (vph)	234	503	5	13	418	355	46	59	65	495	21	337	
Future Volume (vph)	234	503	5	13	418	355	46	59	65	495	21	337	
Ideal Flow (vphp)	1900	1900	1900	1900	1900	1900	1900	1900	1900	1900	1900	1900	
Total Lost time (s)	4.0	4.0		4.0	4.0			3.5		4.0	4.0		
Lane Util. Factor	1.00	0.95		1.00	0.95			0.95		0.97	1.00		
Frt	1.00	1.00		1.00	0.93			0.94		1.00	0.86		
Flt Protected	0.95	1.00		0.95	1.00			0.99		0.95	1.00		
Satd. Flow (prot)	1787	3569		1805	3346			3357		3502	1632		
Flt Permitted	0.95	1.00		0.95	1.00			0.99		0.95	1.00		
Satd. Flow (perm)	1787	3569		1805	3346			3357		3502	1632		
Peak-hour factor, PHF	0.88	0.88	0.88	0.88	0.88	0.88	0.88	0.88	0.88	0.88	0.88	0.88	
Adj. Flow (vph)	266	572	6	15	475	403	52	67	74	562	24	383	
RTOR Reduction (vph)	0	1	0	0	128	0	0	66	0	0	292	0	
Lane Group Flow (vph)	266	577	0	15	750	0	0	127	0	563	115	0	
Heavy Vehicles (%)	1%	1%	0%	0%	0%	1%	0%	0%	0%	0%	0%	0%	
Turn Type	Prot	NA		Prot	NA		Split	NA		Split	NA		
Protected Phases	7	4		3	8		2	2		6	6		
Permitted Phases													
Actuated Green, G (s)	19.5	46.4		2.4	29.3			10.9		23.4	23.4		
Effective Green, g (s)	20.0	46.9		2.9	29.8			11.4		23.9	23.9		
Actuated g/C Ratio	0.20	0.47		0.03	0.30			0.11		0.24	0.24		
Clearance Time (s)	4.5	4.5		4.5	4.5			4.0		4.5	4.5		
Vehicle Extension (s)	2.5	2.5		2.5	2.5			4.0		4.0	4.0		
Lane Grp Cap (vph)	355	1663		52	991			380		831	387		
v/s Ratio Prot	c0.15	0.16		0.01	c0.22			c0.04		c0.16	0.07		
v/s Ratio Perm													
v/c Ratio	0.75	0.35		0.29	0.76			0.34		0.68	0.30		
Uniform Delay, d1	37.9	17.1		47.8	32.1			41.1		34.8	31.5		
Progression Factor	1.00	1.00		1.00	1.00			1.00		1.00	1.00		
Incremental Delay, d2	8.0	0.1		2.2	3.2			0.7		2.4	0.6		
Delay (s)	45.9	17.2		50.1	35.3			41.8		37.3	32.0		
Level of Service	D	B		D	D			D		D	C		
Approach Delay (s/veh)		26.2			35.5			41.8			35.1		
Approach LOS		C			D			D			D		
<b>Intersection Summary</b>													
HCM 2000 Control Delay (s/veh)			33.1									HCM 2000 Level of Service	C
HCM 2000 Volume to Capacity ratio			0.68										
Actuated Cycle Length (s)			100.6									Sum of lost time (s)	16.0
Intersection Capacity Utilization			79.5%									ICU Level of Service	D
Analysis Period (min)			15										
c	Critical Lane Group												

## HCM 7th Signalized Intersection Summary 35: Harlow & Gateway

Movement	EBL	EBT	EBR	WBL	WBT	WBR	NBL	NBT	NBR	SBL	SBT	SBR
Lane Configurations												
Traffic Volume (veh/h)	234	503	5	13	418	355	46	59	65	495	21	337
Future Volume (veh/h)	234	503	5	13	418	355	46	59	65	495	21	337
Initial Q (Qb), veh	0	0	0	0	0	0	0	0	0	0	0	0
Lane Width Adj.	1.00	1.00	1.00	1.00	1.00	1.00	1.00	1.00	1.00	1.00	1.00	1.00
Ped-Bike Adj(A_pbT)	1.00		1.00	1.00		1.00	1.00		1.00	1.00		1.00
Parking Bus, Adj	1.00	1.00	1.00	1.00	1.00	1.00	1.00	1.00	1.00	1.00	1.00	1.00
Work Zone On Approach		No			No			No			No	
Adj Sat Flow, veh/h/ln	1885	1885	1900	1900	1900	1885	1900	1900	1900	1900	1900	1900
Adj Flow Rate, veh/h	266	572	6	15	475	403	52	67	74	562	24	383
Peak Hour Factor	0.88	0.88	0.88	0.88	0.88	0.88	0.88	0.88	0.88	0.88	0.88	0.88
Percent Heavy Veh, %	1	1	0	0	0	1	0	0	0	0	0	0
Cap, veh/h	313	1691	18	33	574	486	97	123	129	948	26	413
Arrive On Green	0.17	0.47	0.46	0.02	0.31	0.31	0.09	0.10	0.09	0.27	0.27	0.27
Sat Flow, veh/h	1795	3631	38	1810	1853	1570	978	1235	1303	3510	96	1529
Grp Volume(v), veh/h	266	282	296	15	463	415	98	0	95	562	0	407
Grp Sat Flow(s),veh/h/ln	1795	1791	1878	1810	1805	1617	1851	0	1665	1755	0	1625
Q Serve(g_s), s	15.2	10.5	10.5	0.9	25.1	25.2	5.3	0.0	5.7	14.7	0.0	25.8
Cycle Q Clear(g_c), s	15.2	10.5	10.5	0.9	25.1	25.2	5.3	0.0	5.7	14.7	0.0	25.8
Prop In Lane	1.00		0.02	1.00		0.97	0.53		0.78	1.00		0.94
Lane Grp Cap(c), veh/h	313	834	875	33	559	501	184	0	165	948	0	439
V/C Ratio(X)	0.85	0.34	0.34	0.45	0.83	0.83	0.54	0.00	0.57	0.59	0.00	0.93
Avail Cap(c_a), veh/h	476	933	979	154	616	552	209	0	188	951	0	440
HCM Platoon Ratio	1.00	1.00	1.00	1.00	1.00	1.00	1.00	1.00	1.00	1.00	1.00	1.00
Upstream Filter(I)	1.00	1.00	1.00	1.00	1.00	1.00	1.00	0.00	1.00	1.00	0.00	1.00
Uniform Delay (d), s/veh	42.2	17.9	17.9	51.3	33.8	34.1	45.3	0.0	45.6	33.5	0.0	37.7
Incr Delay (d2), s/veh	7.6	0.2	0.2	7.1	8.2	9.1	3.4	0.0	4.5	1.2	0.0	26.1
Initial Q Delay(d3), s/veh	0.0	0.0	0.0	0.0	0.0	0.0	0.0	0.0	0.0	0.0	0.0	0.0
%ile BackOfQ(50%),veh/ln	7.3	4.2	4.4	0.5	11.9	10.9	2.7	0.0	2.6	6.3	0.0	13.2
Unsig. Movement Delay, s/veh												
LnGrp Delay(d), s/veh	49.9	18.1	18.1	58.4	42.0	43.2	48.8	0.0	50.0	34.7	0.0	63.9
LnGrp LOS	D	B	B	E	D	D	D		D	C		E
Approach Vol, veh/h		844			893			193				969
Approach Delay, s/veh		28.1			42.8			49.4				46.9
Approach LOS		C			D			D				D
Timer - Assigned Phs		2	3	4		6	7	8				
Phs Duration (G+Y+Rc), s		14.0	5.9	53.1		32.5	22.4	36.7				
Change Period (Y+Rc), s		4.0	4.5	4.5		4.5	4.5	4.5				
Max Green Setting (Gmax), s		11.4	8.5	54.5		28.1	27.5	35.5				
Max Q Clear Time (g_c+I1), s		7.7	2.9	12.5		27.8	17.2	27.2				
Green Ext Time (p_c), s		0.4	0.0	7.1		0.2	0.7	5.0				
<b>Intersection Summary</b>												
HCM 7th Control Delay, s/veh			40.3									
HCM 7th LOS			D									
<b>Notes</b>												
User approved pedestrian interval to be less than phase max green.												

## HCM 7th TWSC 40: International Way & Sports Way































Intersection						
Int Delay, s/veh	1.5					
Movement	EBL	EBT	WBT	WBR	SBL	SBR
Lane Configurations	↙	↑	↘		↙	↗
Traffic Vol, veh/h	5	66	305	1	6	48
Future Vol, veh/h	5	66	305	1	6	48
Conflicting Peds, #/hr	0	0	0	0	0	0
Sign Control	Free	Free	Free	Free	Stop	Stop
RT Channelized	-	None	-	None	-	None
Storage Length	175	-	-	-	240	0
Veh in Median Storage, #	-	0	0	-	0	-
Grade, %	-	0	0	-	0	-
Peak Hour Factor	71	71	71	71	71	71
Heavy Vehicles, %	0	9	3	0	0	0
Mvmt Flow	7	93	430	1	8	68

Major/Minor	Major1	Major2	Minor2		
Conflicting Flow All	431	0	-	0	537 430
Stage 1	-	-	-	-	430 -
Stage 2	-	-	-	-	107 -
Critical Hdwy	4.1	-	-	-	6.4 6.2
Critical Hdwy Stg 1	-	-	-	-	5.4 -
Critical Hdwy Stg 2	-	-	-	-	5.4 -
Follow-up Hdwy	2.2	-	-	-	3.5 3.3
Pot Cap-1 Maneuver	1139	-	-	-	508 629
Stage 1	-	-	-	-	660 -
Stage 2	-	-	-	-	922 -
Platoon blocked, %		-	-	-	
Mov Cap-1 Maneuver	1139	-	-	-	505 629
Mov Cap-2 Maneuver	-	-	-	-	505 -
Stage 1	-	-	-	-	656 -
Stage 2	-	-	-	-	922 -

Approach	EB	WB	SB
HCM Ctrl Dly, s/v	0.58	0	11.5
HCM LOS			B

Minor Lane/Major Mvmt	EBL	EBT	WBT	WBR	SBLn1	SBLn2
Capacity (veh/h)	1139	-	-	-	505	629
HCM Lane V/C Ratio	0.006	-	-	-	0.017	0.107
HCM Ctrl Dly (s/v)	8.2	-	-	-	12.3	11.4
HCM Lane LOS	A	-	-	-	B	B
HCM 95th %tile Q(veh)	0	-	-	-	0.1	0.4

## HCM 7th Signalized Intersection Summary 9: Beltline Rd & Gateway St































												
Movement	EBL	EBT	EBR	WBL	WBT	WBR	NBL	NBT	NBR	SBL	SBT	SBR
Lane Configurations	 	  	 	 	  						 	 
Traffic Volume (veh/h)	320	434	1373	223	1679	515	0	0	0	220	405	743
Future Volume (veh/h)	320	434	1373	223	1679	515	0	0	0	220	405	743
Initial Q (Qb), veh	0	0	0	0	0	0				0	0	0
Lane Width Adj.	1.00	1.00	1.00	1.00	1.00	1.00				1.00	1.00	1.00
Ped-Bike Adj(A_pbT)	1.00		1.00	1.00		1.00				1.00		1.00
Parking Bus, Adj	1.00	1.00	1.00	1.00	1.00	1.00				1.00	1.00	1.00
Work Zone On Approach		No			No						No	
Adj Sat Flow, veh/h/ln	1870	1900	1900	1900	1885	1900				1885	1885	1900
Adj Flow Rate, veh/h	340	462	1461	237	1786	548				234	431	790
Peak Hour Factor	0.94	0.94	0.94	0.94	0.94	0.94				0.94	0.94	0.94
Percent Heavy Veh, %	2	0	0	0	1	0				1	1	0
Cap, veh/h	440	3065	1674	336	2878	882				389	776	614
Arrive On Green	0.13	0.59	0.59	0.03	0.18	0.18				0.22	0.22	0.22
Sat Flow, veh/h	3456	5187	2834	3510	5147	1610				1795	3582	2834
Grp Volume(v), veh/h	340	462	1461	237	1786	548				234	431	790
Grp Sat Flow(s),veh/h/ln	1728	1729	1417	1755	1716	1610				1795	1791	1417
Q Serve(g_s), s	11.4	4.8	52.2	8.0	38.4	37.7				14.1	12.9	26.0
Cycle Q Clear(g_c), s	11.4	4.8	52.2	8.0	38.4	37.7				14.1	12.9	26.0
Prop In Lane	1.00		1.00	1.00		1.00				1.00		1.00
Lane Grp Cap(c), veh/h	440	3065	1674	336	2878	882				389	776	614
V/C Ratio(X)	0.77	0.15	0.87	0.70	0.62	0.62				0.60	0.56	1.29
Avail Cap(c_a), veh/h	524	3121	1705	336	2878	882				389	776	614
HCM Platoon Ratio	1.00	1.00	1.00	0.33	0.33	0.33				1.00	1.00	1.00
Upstream Filter(I)	1.00	1.00	1.00	0.48	0.48	0.48				0.66	0.66	0.66
Uniform Delay (d), s/veh	50.7	11.0	20.7	56.4	37.2	37.7				42.3	41.9	47.0
Incr Delay (d2), s/veh	5.4	0.1	6.6	3.0	0.5	1.6				1.5	0.5	137.1
Initial Q Delay(d3), s/veh	0.0	0.0	0.0	0.0	0.0	0.0				0.0	0.0	0.0
%ile BackOfQ(50%),veh/ln	5.1	1.7	16.7	3.8	17.6	16.5				6.4	5.7	20.5
Unsig. Movement Delay, s/veh												
LnGrp Delay(d), s/veh	56.1	11.1	27.3	59.4	37.7	39.3				43.8	42.3	184.1
LnGrp LOS	E	B	C	E	D	D				D	D	F
Approach Vol, veh/h		2263			2571						1455	
Approach Delay, s/veh		28.3			40.0						119.6	
Approach LOS		C			D						F	
Timer - Assigned Phs			3	4		6	7	8				
Phs Duration (G+Y+Rc), s			15.3	74.7		30.0	19.1	70.9				
Change Period (Y+Rc), s			5.2	5.2		4.5	5.2	5.2				
Max Green Setting (Gmax), s			8.8	70.8		25.5	16.8	62.8				
Max Q Clear Time (g_c+I1), s			10.0	54.2		28.0	13.4	40.4				
Green Ext Time (p_c), s			0.0	15.3		0.0	0.5	21.9				
<b>Intersection Summary</b>												
HCM 7th Control Delay, s/veh			54.2									
HCM 7th LOS			D									
<b>Notes</b>												
User approved pedestrian interval to be less than phase max green.												

## HCM 7th Signalized Intersection Summary 24: Hutton & Beltline Rd



































Movement	EBL	EBT	EBR	WBL	WBT	WBR	NBL	NBT	NBR	SBL	SBT	SBR
Lane Configurations												
Traffic Volume (veh/h)	44	619	0	0	1008	44	1320	10	214	22	0	101
Future Volume (veh/h)	44	619	0	0	1008	44	1320	10	214	22	0	101
Initial Q (Qb), veh	0	0	0	0	0	0	0	0	0	0	0	0
Lane Width Adj.	1.00	1.00	1.00	1.00	1.00	1.00	1.00	1.00	1.00	1.00	1.00	1.00
Ped-Bike Adj(A_pbT)	1.00		1.00	1.00		1.00	1.00		1.00	1.00		1.00
Parking Bus, Adj	1.00	1.00	1.00	1.00	1.00	1.00	1.00	1.00	1.00	1.00	1.00	1.00
Work Zone On Approach		No			No			No			No	
Adj Sat Flow, veh/h/ln	1781	1900	0	0	1885	1900	1900	1900	1900	1811	0	1900
Adj Flow Rate, veh/h	47	659	0	0	1072	47	1404	11	228	23	0	107
Peak Hour Factor	0.94	0.94	0.94	0.94	0.94	0.94	0.94	0.94	0.94	0.94	0.94	0.94
Percent Heavy Veh, %	8	0	0	0	1	0	0	0	0	6	0	0
Cap, veh/h	79	1642	0	0	1233	54	1532	29	596	92	0	0
Arrive On Green	0.02	0.10	0.00	0.00	0.24	0.23	0.44	0.39	0.39	0.02	0.00	0.00
Sat Flow, veh/h	1697	5358	0	0	5225	221	3510	75	1547	1725	23	
Grp Volume(v), veh/h	47	659	0	0	727	392	1404	0	239	23	59.6	
Grp Sat Flow(s),veh/h/ln	1697	1729	0	0	1716	1845	1755	0	1622	1725	E	
Q Serve(g_s), s	3.3	14.3	0.0	0.0	24.4	24.5	45.1	0.0	12.8	1.6		
Cycle Q Clear(g_c), s	3.3	14.3	0.0	0.0	24.4	24.5	45.1	0.0	12.8	1.6		
Prop In Lane	1.00		0.00	0.00		0.12	1.00		0.95	1.00		
Lane Grp Cap(c), veh/h	79	1642	0	0	837	450	1532	0	625	92		
V/C Ratio(X)	0.59	0.40	0.00	0.00	0.87	0.87	0.92	0.00	0.38	0.25		
Avail Cap(c_a), veh/h	140	1833	0	0	841	452	1641	0	765	183		
HCM Platoon Ratio	0.33	0.33	1.00	1.00	1.00	1.00	1.00	1.00	1.00	1.00		
Upstream Filter(I)	0.95	0.95	0.00	0.00	1.00	1.00	1.00	0.00	1.00	1.00		
Uniform Delay (d), s/veh	57.9	43.1	0.0	0.0	43.5	43.6	31.8	0.0	26.6	58.6		
Incr Delay (d2), s/veh	4.9	0.2	0.0	0.0	9.9	16.9	8.0	0.0	0.3	1.1		
Initial Q Delay(d3), s/veh	0.0	0.0	0.0	0.0	0.0	0.0	0.0	0.0	0.0	0.0		
%ile BackOfQ(50%),veh/ln	1.5	6.6	0.0	0.0	11.1	12.9	20.6	0.0	5.0	0.7		
Unsig. Movement Delay, s/veh												
LnGrp Delay(d), s/veh	62.8	43.3	0.0	0.0	53.5	60.5	39.8	0.0	26.9	59.6		
LnGrp LOS	E	D			D	E	D		C	E		
Approach Vol, veh/h		706			1119			1643				
Approach Delay, s/veh		44.6			55.9			37.9				
Approach LOS		D			E			D				
Timer - Assigned Phs	1	2		4	5		7	8				
Phs Duration (G+Y+Rc), s	6.6	50.2		42.0	56.9		8.7	33.3				
Change Period (Y+Rc), s	4.5	4.0		* 5.4	4.5		4.5	* 5.4				
Max Green Setting (Gmax), s	8.5	56.6		* 41	56.1		8.5	* 28				
Max Q Clear Time (g_c+I1), s	3.6	14.8		16.3	47.1		5.3	26.5				
Green Ext Time (p_c), s	0.0	1.2		12.5	5.3		0.0	1.4				
<b>Intersection Summary</b>												
HCM 7th Control Delay, s/veh			45.2									
HCM 7th LOS			D									
<b>Notes</b>												
User approved pedestrian interval to be less than phase max green.												
* HCM 7th computational engine requires equal clearance times for the phases crossing the barrier.												

# HCM Signalized Intersection Capacity Analysis

## 9: Beltline Rd & Gateway St





















												
Movement	EBL	EBT	EBR	WBL	WBT	WBR	NBL	NBT	NBR	SBL	SBT	SBR
Lane Configurations	 	  	 		  		 					 
Traffic Volume (vph)	348	561	1246	156	758	184	921	344	118	220	513	925
Future Volume (vph)	348	561	1246	156	758	184	921	344	118	220	513	925
Ideal Flow (vphp)	1900	1900	1900	1900	1900	1900	1900	1900	1900	1900	1900	1900
Total Lost time (s)	3.8	3.8	3.1	3.8	3.8		4.0	4.0		4.0	4.0	4.0
Lane Util. Factor	0.97	0.91	0.88	1.00	0.91		0.97	1.00		1.00	1.00	0.88
Frt	1.00	1.00	0.85	1.00	0.97		1.00	0.96		1.00	1.00	0.85
Flt Protected	0.95	1.00	1.00	0.95	1.00		0.95	1.00		0.95	1.00	1.00
Satd. Flow (prot)	3433	5187	2842	1805	4995		3467	1800		1787	1881	2842
Flt Permitted	0.95	1.00	1.00	0.95	1.00		0.95	1.00		0.95	1.00	1.00
Satd. Flow (perm)	3433	5187	2842	1805	4995		3467	1800		1787	1881	2842
Peak-hour factor, PHF	0.94	0.94	0.94	0.94	0.94	0.94	0.94	0.94	0.94	0.94	0.94	0.94
Adj. Flow (vph)	370	597	1326	166	806	196	980	366	126	234	546	984
RTOR Reduction (vph)	0	0	101	0	35	0	0	10	0	0	0	276
Lane Group Flow (vph)	370	597	1225	166	967	0	980	482	0	234	546	708
Heavy Vehicles (%)	2%	0%	0%	0%	1%	0%	1%	2%	0%	1%	1%	0%
Turn Type	Prot	NA	pm+ov	Prot	NA		Prot	NA		Prot	NA	Perm
Protected Phases	7	4	5	3	8		5	2		1	6	
Permitted Phases			4									6
Actuated Green, G (s)	13.8	21.3	53.8	11.7	19.2		32.5	49.4		18.2	35.1	35.1
Effective Green, g (s)	15.2	22.7	56.6	13.1	20.6		33.0	49.9		18.7	35.6	35.6
Actuated g/C Ratio	0.13	0.19	0.47	0.11	0.17		0.28	0.42		0.16	0.30	0.30
Clearance Time (s)	5.2	5.2	4.5	5.2	5.2		4.5	4.5		4.5	4.5	4.5
Vehicle Extension (s)	2.5	4.0	2.5	2.5	4.0		2.5	2.5		2.5	2.5	2.5
Lane Grp Cap (vph)	434	981	1340	197	857		953	748		278	558	843
v/s Ratio Prot	c0.11	0.12	0.26	0.09	c0.19		c0.28	0.27		0.13	c0.29	
v/s Ratio Perm			0.17									0.25
v/c Ratio	0.85	0.61	0.91	0.84	1.13		1.03	0.64		0.84	0.98	0.84
Uniform Delay, d1	51.3	44.6	29.4	52.4	49.7		43.5	28.0		49.2	41.8	39.5
Progression Factor	1.00	1.00	1.00	1.00	1.00		1.00	1.00		1.00	1.00	1.00
Incremental Delay, d2	14.7	1.2	9.8	26.2	72.6		36.6	1.7		19.7	32.3	7.4
Delay (s)	66.0	45.8	39.2	78.6	122.3		80.1	29.7		68.9	74.1	47.0
Level of Service	E	D	D	E	F		F	C		E	E	D
Approach Delay (s/veh)		45.3			116.1			63.3			58.3	
Approach LOS		D			F			E			E	
<b>Intersection Summary</b>												
HCM 2000 Control Delay (s/veh)			65.0			HCM 2000 Level of Service				E		
HCM 2000 Volume to Capacity ratio			1.00									
Actuated Cycle Length (s)			120.0			Sum of lost time (s)		15.6				
Intersection Capacity Utilization			95.3%			ICU Level of Service		F				
Analysis Period (min)			15									
c Critical Lane Group												

## HCM 7th Signalized Intersection Summary 9: Beltline Rd & Gateway St

												
Movement	EBL	EBT	EBR	WBL	WBT	WBR	NBL	NBT	NBR	SBL	SBT	SBR
Lane Configurations	 	  	  		  		 	 			 	  
Traffic Volume (veh/h)	348	561	1246	156	758	184	921	344	118	220	513	925
Future Volume (veh/h)	348	561	1246	156	758	184	921	344	118	220	513	925
Initial Q (Qb), veh	0	0	0	0	0	0	0	0	0	0	0	0
Lane Width Adj.	1.00	1.00	1.00	1.00	1.00	1.00	1.00	1.00	1.00	1.00	1.00	1.00
Ped-Bike Adj(A_pbT)	1.00		1.00	1.00		1.00	1.00		1.00	1.00		1.00
Parking Bus, Adj	1.00	1.00	1.00	1.00	1.00	1.00	1.00	1.00	1.00	1.00	1.00	1.00
Work Zone On Approach		No			No			No			No	
Adj Sat Flow, veh/h/ln	1870	1900	1900	1900	1885	1900	1885	1870	1900	1885	1885	1900
Adj Flow Rate, veh/h	370	597	1326	166	806	196	980	366	126	234	546	984
Peak Hour Factor	0.94	0.94	0.94	0.94	0.94	0.94	0.94	0.94	0.94	0.94	0.94	0.94
Percent Heavy Veh, %	2	0	0	0	1	0	1	2	0	1	1	0
Cap, veh/h	438	977	1334	199	710	171	958	552	190	281	559	841
Arrive On Green	0.13	0.19	0.19	0.11	0.17	0.16	0.28	0.42	0.41	0.16	0.30	0.30
Sat Flow, veh/h	3456	5187	2834	1810	4138	998	3483	1330	458	1795	1885	2834
Grp Volume(v), veh/h	370	597	1326	166	667	335	980	0	492	234	546	984
Grp Sat Flow(s),veh/h/ln	1728	1729	1417	1810	1716	1705	1742	0	1788	1795	1885	1417
Q Serve(g_s), s	12.6	12.7	22.6	10.8	20.6	20.6	33.0	0.0	26.7	15.2	34.4	35.6
Cycle Q Clear(g_c), s	12.6	12.7	22.6	10.8	20.6	20.6	33.0	0.0	26.7	15.2	34.4	35.6
Prop In Lane	1.00		1.00	1.00		0.59	1.00		0.26	1.00		1.00
Lane Grp Cap(c), veh/h	438	977	1334	199	589	293	958	0	742	281	559	841
V/C Ratio(X)	0.85	0.61	0.99	0.83	1.13	1.14	1.02	0.00	0.66	0.83	0.98	1.17
Avail Cap(c_a), veh/h	438	977	1334	199	589	293	958	0	742	299	559	841
HCM Platoon Ratio	1.00	1.00	1.00	1.00	1.00	1.00	1.00	1.00	1.00	1.00	1.00	1.00
Upstream Filter(I)	1.00	1.00	1.00	1.00	1.00	1.00	1.00	0.00	1.00	1.00	1.00	1.00
Uniform Delay (d), s/veh	51.2	44.7	31.6	52.3	49.7	50.1	43.5	0.0	28.4	49.1	41.8	42.2
Incr Delay (d2), s/veh	13.9	1.3	23.1	24.6	79.4	97.1	35.1	0.0	2.0	16.6	31.9	89.3
Initial Q Delay(d3), s/veh	0.0	0.0	0.0	0.0	0.0	0.0	0.0	0.0	0.0	0.0	0.0	0.0
%ile BackOfQ(50%),veh/ln	6.1	5.4	21.8	6.1	15.0	16.4	18.6	0.0	11.6	8.0	20.6	22.3
Unsig. Movement Delay, s/veh												
LnGrp Delay(d), s/veh	65.1	46.0	54.7	77.0	129.1	147.3	78.6	0.0	30.4	65.7	73.7	131.5
LnGrp LOS	E	D	D	E	F	F	F		C	E	E	F
Approach Vol, veh/h		2293			1168			1472			1764	
Approach Delay, s/veh		54.1			126.9			62.5			104.9	
Approach LOS		D			F			E			F	
Timer - Assigned Phs	1	2	3	4	5	6	7	8				
Phs Duration (G+Y+Rc), s	22.8	53.8	17.0	26.4	37.0	39.6	19.0	24.4				
Change Period (Y+Rc), s	4.5	4.5	5.2	5.2	4.5	4.5	5.2	5.2				
Max Green Setting (Gmax), s	19.5	48.1	11.8	21.2	32.5	35.1	13.8	19.2				
Max Q Clear Time (g_c+I1), s	18.2	28.7	12.8	24.6	35.0	37.6	14.6	22.6				
Green Ext Time (p_c), s	0.1	2.0	0.0	0.0	0.0	0.0	0.0	0.0				
<b>Intersection Summary</b>												
HCM 7th Control Delay, s/veh			82.0									
HCM 7th LOS			F									
<b>Notes</b>												
User approved pedestrian interval to be less than phase max green.												





















# HCM Signalized Intersection Capacity Analysis

## 10: Gateway St & International Way

													
Movement	EBL	EBT	EBR	WBL	WBT	WBR	NBL	NBT	NBR	SBL	SBT	SBR	
Lane Configurations													
Traffic Volume (vph)	10	5	49	577	1	183	10	725	123	66	1020	4	
Future Volume (vph)	10	5	49	577	1	183	10	725	123	66	1020	4	
Ideal Flow (vphp)	1900	1900	1900	1900	1900	1900	1900	1900	1900	1900	1900	1900	
Total Lost time (s)		4.0		4.0	4.0		4.0	4.0	4.0	4.0	4.0		
Lane Util. Factor		1.00		1.00	1.00		1.00	1.00	1.00	1.00	1.00		
Frt		0.90		1.00	0.85		1.00	1.00	0.85	1.00	1.00		
Flt Protected		0.99		0.95	1.00		0.95	1.00	1.00	0.95	1.00		
Satd. Flow (prot)		1690		1787	1616		1805	1900	1524	1805	1899		
Flt Permitted		0.96		0.77	1.00		0.09	1.00	1.00	0.17	1.00		
Satd. Flow (perm)		1628		1449	1616		173	1900	1524	327	1899		
Peak-hour factor, PHF	0.93	0.93	0.93	0.93	0.93	0.93	0.93	0.93	0.93	0.93	0.93	0.93	
Adj. Flow (vph)	11	5	53	620	1	197	11	780	132	71	1097	4	
RTOR Reduction (vph)	0	34	0	0	111	0	0	0	59	0	0	0	
Lane Group Flow (vph)	0	35	0	620	88	0	11	780	73	71	1101	0	
Heavy Vehicles (%)	0%	0%	0%	1%	0%	0%	0%	0%	6%	0%	0%	0%	
Turn Type	Perm	NA		Perm	NA		Perm	NA	Perm	Perm	NA		
Protected Phases		4			8			2		6		6	
Permitted Phases	4			8			2		2	6			
Actuated Green, G (s)		28.0		27.5	27.5		43.5	43.5	43.5	43.5	43.5		
Effective Green, g (s)		28.0		28.0	28.0		44.0	44.0	44.0	44.0	44.0		
Actuated g/C Ratio		0.35		0.35	0.35		0.55	0.55	0.55	0.55	0.55		
Clearance Time (s)		4.0		4.5	4.5		4.5	4.5	4.5	4.5	4.5		
Vehicle Extension (s)		2.5		2.5	2.5		4.0	4.0	4.0	4.0	4.0		
Lane Grp Cap (vph)		569		507	565		95	1045	838	179	1044		
v/s Ratio Prot					0.05			0.41				c0.58	
v/s Ratio Perm		0.02		c0.43			0.06		0.05	0.22			
v/c Ratio		0.06		1.22	0.15		0.12	0.75	0.09	0.40	1.05		
Uniform Delay, d1		17.3		26.0	17.9		8.7	13.7	8.5	10.4	18.0		
Progression Factor		1.00		1.00	1.00		1.00	1.00	1.00	1.00	1.00		
Incremental Delay, d2		0.0		117.0	0.1		0.7	3.1	0.1	2.0	43.4		
Delay (s)		17.3		143.0	18.0		9.4	16.9	8.6	12.3	61.4		
Level of Service		B		F	B		A	B	A	B	E		
Approach Delay (s/veh)		17.3			112.7			15.6			58.4		
Approach LOS		B			F			B			E		
<b>Intersection Summary</b>													
HCM 2000 Control Delay (s/veh)			59.1									HCM 2000 Level of Service	E
HCM 2000 Volume to Capacity ratio			1.12										
Actuated Cycle Length (s)			80.0									Sum of lost time (s)	8.0
Intersection Capacity Utilization			100.1%									ICU Level of Service	G
Analysis Period (min)			15										
c Critical Lane Group													

# HCM 7th Signalized Intersection Summary

## 10: Gateway St & International Way





















												
Movement	EBL	EBT	EBR	WBL	WBT	WBR	NBL	NBT	NBR	SBL	SBT	SBR
Lane Configurations												
Traffic Volume (veh/h)	10	5	49	577	1	183	10	725	123	66	1020	4
Future Volume (veh/h)	10	5	49	577	1	183	10	725	123	66	1020	4
Initial Q (Qb), veh	0	0	0	0	0	0	0	0	0	0	0	0
Lane Width Adj.	1.00	1.00	1.00	1.00	1.00	1.00	1.00	1.00	1.00	1.00	1.00	1.00
Ped-Bike Adj(A_pbT)	1.00		1.00	1.00		1.00	1.00		1.00	1.00		1.00
Parking Bus, Adj	1.00	1.00	1.00	1.00	1.00	1.00	1.00	1.00	1.00	1.00	1.00	1.00
Work Zone On Approach		No			No			No			No	
Adj Sat Flow, veh/h/ln	1900	1900	1900	1885	1900	1900	1900	1900	1811	1900	1900	1900
Adj Flow Rate, veh/h	11	5	53	620	1	197	11	780	0	71	1097	4
Peak Hour Factor	0.93	0.93	0.93	0.93	0.93	0.93	0.93	0.93	0.93	0.93	0.93	0.93
Percent Heavy Veh, %	0	0	0	1	0	0	0	0	6	0	0	0
Cap, veh/h	107	71	419	577	3	561	90	1045		256	1041	4
Arrive On Green	0.34	0.34	0.34	0.35	0.35	0.35	0.55	0.55	0.00	0.55	0.55	0.54
Sat Flow, veh/h	160	208	1219	1356	8	1603	520	1900	1535	703	1892	7
Grp Volume(v), veh/h	69	0	0	620	0	198	11	780	0	71	0	1101
Grp Sat Flow(s),veh/h/ln	1588	0	0	1356	0	1611	520	1900	1535	703	0	1899
Q Serve(g_s), s	0.0	0.0	0.0	25.7	0.0	7.3	0.0	25.1	0.0	6.9	0.0	44.0
Cycle Q Clear(g_c), s	2.3	0.0	0.0	28.0	0.0	7.3	44.0	25.1	0.0	31.9	0.0	44.0
Prop In Lane	0.16		0.77	1.00		0.99	1.00		1.00	1.00		0.00
Lane Grp Cap(c), veh/h	598	0	0	577	0	564	90	1045		256	0	1044
V/C Ratio(X)	0.12	0.00	0.00	1.07	0.00	0.35	0.12	0.75		0.28	0.00	1.05
Avail Cap(c_a), veh/h	608	0	0	577	0	564	90	1045		256	0	1044
HCM Platoon Ratio	1.00	1.00	1.00	1.00	1.00	1.00	1.00	1.00	1.00	1.00	1.00	1.00
Upstream Filter(I)	1.00	0.00	0.00	1.00	0.00	1.00	1.00	1.00	0.00	1.00	0.00	1.00
Uniform Delay (d), s/veh	18.0	0.0	0.0	27.9	0.0	19.3	40.0	13.7	0.0	25.9	0.0	18.0
Incr Delay (d2), s/veh	0.1	0.0	0.0	59.1	0.0	0.3	0.9	3.2	0.0	0.8	0.0	43.3
Initial Q Delay(d3), s/veh	0.0	0.0	0.0	0.0	0.0	0.0	0.0	0.0	0.0	0.0	0.0	0.0
%ile BackOfQ(50%),veh/ln	0.9	0.0	0.0	20.5	0.0	2.6	0.2	10.0	0.0	1.2	0.0	28.5
Unsig. Movement Delay, s/veh												
LnGrp Delay(d), s/veh	18.0	0.0	0.0	87.0	0.0	19.5	40.9	16.9	0.0	26.8	0.0	61.3
LnGrp LOS	B			F		B	D	B		C		F
Approach Vol, veh/h		69			818			791				1172
Approach Delay, s/veh		18.0			70.7			17.3				59.2
Approach LOS		B			E			B				E
Timer - Assigned Phs		2		4		6		8				
Phs Duration (G+Y+Rc), s		48.0		32.0		48.0		32.0				
Change Period (Y+Rc), s		4.5		* 4.5		4.5		4.5				
Max Green Setting (Gmax), s		43.5		* 28		43.5		27.5				
Max Q Clear Time (g_c+I1), s		46.0		4.3		46.0		30.0				
Green Ext Time (p_c), s		0.0		0.2		0.0		0.0				
<b>Intersection Summary</b>												
HCM 7th Control Delay, s/veh				49.9								
HCM 7th LOS				D								
<b>Notes</b>												
User approved pedestrian interval to be less than phase max green.												
* HCM 7th computational engine requires equal clearance times for the phases crossing the barrier.												

## HCM 7th Signalized Intersection Summary 10: Gateway St & International Way

---





















Unsignalized Delay for [NBR] is excluded from calculations of the approach delay and intersection delay.

## HCM Signalized Intersection Capacity Analysis 12: Gateway St /Gateway St & EGame Farm Rd

												
Movement	EBL	EBT	EBR	WBL	WBT	WBR	NBL	NBT	NBR	SBL	SBT	SBR
Lane Configurations												
Traffic Volume (vph)	2	0	23	184	0	146	43	708	54	193	1447	6
Future Volume (vph)	2	0	23	184	0	146	43	708	54	193	1447	6
Ideal Flow (vphp)	1900	1900	1900	1900	1900	1900	1900	1900	1900	1900	1900	1900
Total Lost time (s)		4.0		4.0	4.0		4.0	4.0	4.5	4.0	4.0	
Lane Util. Factor		1.00		1.00	1.00		1.00	0.95	1.00	1.00	0.95	
Frt		0.87		1.00	0.85		1.00	1.00	0.85	1.00	1.00	
Flt Protected		1.00		0.95	1.00		0.95	1.00	1.00	0.95	1.00	
Satd. Flow (prot)		1582		1787	1615		1752	3539	1538	1787	3572	
Flt Permitted		0.96		0.61	1.00		0.08	1.00	1.00	0.26	1.00	
Satd. Flow (perm)		1518		1146	1615		153	3539	1538	481	3572	
Peak-hour factor, PHF	0.87	0.87	0.87	0.87	0.87	0.87	0.87	0.87	0.87	0.87	0.87	0.87
Adj. Flow (vph)	2	0	26	211	0	168	49	814	62	222	1663	7
RTOR Reduction (vph)	0	27	0	0	130	0	0	0	30	0	0	0
Lane Group Flow (vph)	0	1	0	211	38	0	49	814	32	222	1670	0
Heavy Vehicles (%)	0%	0%	5%	1%	0%	0%	3%	2%	5%	1%	1%	0%
Turn Type	Perm	NA		pm+pt	NA		pm+pt	NA	Perm	pm+pt	NA	
Protected Phases		4		3	8		5	2		1	6	
Permitted Phases	4			8			2		2	6		
Actuated Green, G (s)		2.8		20.1	20.1		51.3	47.6	47.6	62.0	53.8	
Effective Green, g (s)		2.8		20.6	20.6		52.3	48.1	47.6	62.5	54.3	
Actuated g/C Ratio		0.03		0.23	0.23		0.57	0.53	0.52	0.69	0.60	
Clearance Time (s)		4.0		4.5	4.5		4.5	4.5	4.5	4.5	4.5	
Vehicle Extension (s)		2.5		2.5	2.5		2.5	4.0	4.0	2.5	4.0	
Lane Grp Cap (vph)		46		356	365		161	1868	803	479	2129	
v/s Ratio Prot				c0.09	0.02		0.01	0.23		c0.05	c0.47	
v/s Ratio Perm		0.00		c0.04			0.16		0.02	0.26		
v/c Ratio		0.02		0.59	0.10		0.30	0.44	0.04	0.46	0.78	
Uniform Delay, d1		42.8		31.0	27.9		12.5	13.2	10.6	6.6	14.0	
Progression Factor		1.00		1.00	1.00		1.00	1.00	1.00	1.00	1.00	
Incremental Delay, d2		0.1		2.2	0.1		0.8	0.2	0.0	0.5	2.1	
Delay (s)		42.9		33.2	28.0		13.3	13.4	10.6	7.2	16.0	
Level of Service		D		C	C		B	B	B	A	B	
Approach Delay (s/veh)		42.9			30.9			13.2			15.0	
Approach LOS		D			C			B			B	
<b>Intersection Summary</b>												
HCM 2000 Control Delay (s/veh)			16.6								HCM 2000 Level of Service	B
HCM 2000 Volume to Capacity ratio			0.76									
Actuated Cycle Length (s)			91.1							16.0		
Intersection Capacity Utilization			70.4%								ICU Level of Service	C
Analysis Period (min)			15									
c	Critical Lane Group											

## HCM 7th Signalized Intersection Summary

### 12: Gateway St /Gateway St & EGame Farm Rd

												
Movement	EBL	EBT	EBR	WBL	WBT	WBR	NBL	NBT	NBR	SBL	SBT	SBR
Lane Configurations												
Traffic Volume (veh/h)	2	0	23	184	0	146	43	708	54	193	1447	6
Future Volume (veh/h)	2	0	23	184	0	146	43	708	54	193	1447	6
Initial Q (Qb), veh	0	0	0	0	0	0	0	0	0	0	0	0
Lane Width Adj.	1.00	1.00	1.00	1.00	1.00	1.00	1.00	1.00	1.00	1.00	1.00	1.00
Ped-Bike Adj(A_pbT)	1.00		1.00	1.00		1.00	1.00		1.00	1.00		1.00
Parking Bus, Adj	1.00	1.00	1.00	1.00	1.00	1.00	1.00	1.00	1.00	1.00	1.00	1.00
Work Zone On Approach		No			No			No			No	
Adj Sat Flow, veh/h/ln	1900	1900	1826	1885	1900	1900	1856	1870	1826	1885	1885	1900
Adj Flow Rate, veh/h	2	0	26	211	0	168	49	814	0	222	1663	7
Peak Hour Factor	0.87	0.87	0.87	0.87	0.87	0.87	0.87	0.87	0.87	0.87	0.87	0.87
Percent Heavy Veh, %	0	0	5	1	0	0	3	2	5	1	1	0
Cap, veh/h	39	3	84	427	0	369	219	2077		511	2283	10
Arrive On Green	0.06	0.00	0.06	0.13	0.00	0.22	0.03	0.58	0.00	0.07	0.62	0.62
Sat Flow, veh/h	53	62	1489	1795	0	1610	1767	3554	1547	1795	3658	15
Grp Volume(v), veh/h	28	0	0	211	0	168	49	814	0	222	814	856
Grp Sat Flow(s),veh/h/ln	1604	0	0	1795	0	1610	1767	1777	1547	1795	1791	1882
Q Serve(g_s), s	0.0	0.0	0.0	11.1	0.0	9.6	1.2	13.1	0.0	4.8	33.2	33.2
Cycle Q Clear(g_c), s	1.7	0.0	0.0	11.1	0.0	9.6	1.2	13.1	0.0	4.8	33.2	33.2
Prop In Lane	0.07		0.93	1.00		1.00	1.00		1.00	1.00		0.01
Lane Grp Cap(c), veh/h	127	0	0	427	0	369	219	2077		511	1118	1175
V/C Ratio(X)	0.22	0.00	0.00	0.49	0.00	0.46	0.22	0.39		0.43	0.73	0.73
Avail Cap(c_a), veh/h	172	0	0	465	0	441	310	2180		617	1183	1244
HCM Platoon Ratio	1.00	1.00	1.00	1.00	1.00	1.00	1.00	1.00	1.00	1.00	1.00	1.00
Upstream Filter(I)	1.00	0.00	0.00	1.00	0.00	1.00	1.00	1.00	0.00	1.00	1.00	1.00
Uniform Delay (d), s/veh	48.0	0.0	0.0	37.5	0.0	35.4	12.7	11.9	0.0	7.9	13.7	13.7
Incr Delay (d2), s/veh	0.6	0.0	0.0	0.7	0.0	0.7	0.4	0.2	0.0	0.4	2.4	2.3
Initial Q Delay(d3), s/veh	0.0	0.0	0.0	0.0	0.0	0.0	0.0	0.0	0.0	0.0	0.0	0.0
%ile BackOfQ(50%),veh/ln	0.7	0.0	0.0	4.9	0.0	3.8	0.4	4.9	0.0	1.7	12.6	13.3
Unsig. Movement Delay, s/veh												
LnGrp Delay(d), s/veh	48.6	0.0	0.0	38.1	0.0	36.0	13.1	12.0	0.0	8.4	16.1	16.0
LnGrp LOS	D			D		D	B	B		A	B	B
Approach Vol, veh/h		28			379			863			1892	
Approach Delay, s/veh		48.6			37.2			12.1			15.2	
Approach LOS		D			D			B			B	
Timer - Assigned Phs	1	2	3	4	5	6		8				
Phs Duration (G+Y+Rc), s	11.8	65.9	17.8	10.5	7.6	70.1		28.3				
Change Period (Y+Rc), s	4.5	4.5	4.5	* 4.5	4.5	4.5		4.5				
Max Green Setting (Gmax), s	13.5	64.5	15.5	* 9	8.5	69.5		28.5				
Max Q Clear Time (g_c+I1), s	6.8	15.1	13.1	3.7	3.2	35.2		11.6				
Green Ext Time (p_c), s	0.4	18.6	0.2	0.0	0.0	30.4		0.6				
<b>Intersection Summary</b>												
HCM 7th Control Delay, s/veh			17.3									
HCM 7th LOS			B									
<b>Notes</b>												
User approved pedestrian interval to be less than phase max green.												
* HCM 7th computational engine requires equal clearance times for the phases crossing the barrier.												

## HCM 7th Signalized Intersection Summary 12: Gateway St /Gateway St & EGame Farm Rd

---

Unsignalized Delay for [NBR] is excluded from calculations of the approach delay and intersection delay.

HCM 7th TWSC  
16: Game Farm Rd & Deadmond Ferry

Intersection						
Int Delay, s/veh	7					
Movement	EBT	EBR	WBL	WBT	NBL	NBR
Lane Configurations	↑		↑	↑	↑	↑
Traffic Vol, veh/h	29	355	161	35	151	51
Future Vol, veh/h	29	355	161	35	151	51
Conflicting Peds, #/hr	0	0	0	0	0	0
Sign Control	Free	Free	Free	Free	Stop	Stop
RT Channelized	-	None	-	None	-	None
Storage Length	-	-	140	-	115	0
Veh in Median Storage, #	0	-	-	0	0	-
Grade, %	0	-	-	0	0	-
Peak Hour Factor	87	87	87	87	87	87
Heavy Vehicles, %	0	0	0	0	1	0
Mvmt Flow	33	408	185	40	174	59

Major/Minor	Major1	Major2	Minor1			
Conflicting Flow All	0	0	441	0	648	237
Stage 1	-	-	-	-	237	-
Stage 2	-	-	-	-	410	-
Critical Hdwy	-	-	4.1	-	6.41	6.2
Critical Hdwy Stg 1	-	-	-	-	5.41	-
Critical Hdwy Stg 2	-	-	-	-	5.41	-
Follow-up Hdwy	-	-	2.2	-	3.509	3.3
Pot Cap-1 Maneuver	-	-	1129	-	437	807
Stage 1	-	-	-	-	804	-
Stage 2	-	-	-	-	672	-
Platoon blocked, %	-	-	-	-	-	-
Mov Cap-1 Maneuver	-	-	1129	-	365	807
Mov Cap-2 Maneuver	-	-	-	-	365	-
Stage 1	-	-	-	-	804	-
Stage 2	-	-	-	-	562	-

Approach	EB	WB	NB
HCM Ctrl Dly, s/v	0	7.24	20.03
HCM LOS			C

Minor Lane/Major Mvmt	NBLn1	NBLn2	EBT	EBR	WBL	WBT
Capacity (veh/h)	365	807	-	-	1129	-
HCM Lane V/C Ratio	0.475	0.073	-	-	0.164	-
HCM Ctrl Dly (s/v)	23.5	9.8	-	-	8.8	-
HCM Lane LOS	C	A	-	-	A	-
HCM 95th %tile Q(veh)	2.5	0.2	-	-	0.6	-

## HCM Signalized Intersection Capacity Analysis 17: Beltline Rd /MLK & Game Farm Rd

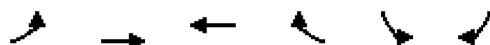

Movement	EBL	EBT	WBT	WBR	SBL	SBR
Lane Configurations	↖	↑↑	↑↑	↑	↘	↘
Traffic Volume (vph)	32	809	965	175	434	87
Future Volume (vph)	32	809	965	175	434	87
Ideal Flow (vphp)	1900	1900	1900	1900	1900	1900
Total Lost time (s)	4.0	4.0	4.0	4.0	4.0	4.0
Lane Util. Factor	1.00	0.95	0.95	1.00	1.00	1.00
Frt	1.00	1.00	1.00	0.85	1.00	0.85
Flt Protected	0.95	1.00	1.00	1.00	0.95	1.00
Satd. Flow (prot)	1805	3539	3574	1599	1805	1615
Flt Permitted	0.95	1.00	1.00	1.00	0.95	1.00
Satd. Flow (perm)	1805	3539	3574	1599	1805	1615
Peak-hour factor, PHF	0.90	0.90	0.90	0.90	0.90	0.90
Adj. Flow (vph)	36	899	1072	194	482	97
RTOR Reduction (vph)	0	0	0	116	0	39
Lane Group Flow (vph)	36	899	1072	78	482	58
Heavy Vehicles (%)	0%	2%	1%	1%	0%	0%
Turn Type	Prot	NA	NA	Perm	Prot	Perm
Protected Phases	7	4	8		6	
Permitted Phases				8		6
Actuated Green, G (s)	6.5	40.4	28.5	28.5	23.5	23.5
Effective Green, g (s)	7.9	41.8	29.9	29.9	24.9	24.9
Actuated g/C Ratio	0.11	0.56	0.40	0.40	0.33	0.33
Clearance Time (s)	5.4	5.4	5.4	5.4	5.4	5.4
Vehicle Extension (s)	2.5	4.0	4.0	4.0	2.5	2.5
Lane Grp Cap (vph)	190	1980	1430	640	601	538
v/s Ratio Prot	0.02	c0.25	c0.30		c0.27	
v/s Ratio Perm				0.05		0.04
v/c Ratio	0.19	0.45	0.75	0.12	0.80	0.11
Uniform Delay, d1	30.5	9.7	19.2	14.1	22.7	17.2
Progression Factor	1.00	1.00	1.00	1.00	1.00	1.00
Incremental Delay, d2	0.4	0.2	2.3	0.1	7.4	0.1
Delay (s)	30.8	9.9	21.5	14.2	30.0	17.3
Level of Service	C	A	C	B	C	B
Approach Delay (s/veh)		10.7	20.4		27.9	
Approach LOS		B	C		C	
<b>Intersection Summary</b>						
HCM 2000 Control Delay (s/veh)			18.7		HCM 2000 Level of Service	B
HCM 2000 Volume to Capacity ratio			0.74			
Actuated Cycle Length (s)			74.7		Sum of lost time (s)	12.0
Intersection Capacity Utilization			57.4%		ICU Level of Service	B
Analysis Period (min)			15			
c Critical Lane Group						

## HCM 7th Signalized Intersection Summary 17: Beltline Rd /MLK & Game Farm Rd

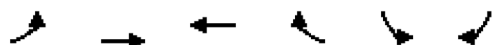

Movement	EBL	EBT	WBT	WBR	SBL	SBR	
Lane Configurations	↶	↷↷	↷↷	↶	↶	↶	
Traffic Volume (veh/h)	32	809	965	175	434	87	
Future Volume (veh/h)	32	809	965	175	434	87	
Initial Q (Qb), veh	0	0	0	0	0	0	
Lane Width Adj.	1.00	1.00	1.00	1.00	1.00	1.00	
Ped-Bike Adj(A_pbT)	1.00			1.00	1.00	1.00	
Parking Bus, Adj	1.00	1.00	1.00	1.00	1.00	1.00	
Work Zone On Approach		No	No		No		
Adj Sat Flow, veh/h/ln	1900	1870	1885	1885	1900	1900	
Adj Flow Rate, veh/h	36	899	1072	194	482	97	
Peak Hour Factor	0.90	0.90	0.90	0.90	0.90	0.90	
Percent Heavy Veh, %	0	2	1	1	0	0	
Cap, veh/h	132	2011	1571	701	589	524	
Arrive On Green	0.07	0.57	0.44	0.44	0.33	0.33	
Sat Flow, veh/h	1810	3647	3676	1598	1810	1610	
Grp Volume(v), veh/h	36	899	1072	194	482	97	
Grp Sat Flow(s),veh/h/ln	1810	1777	1791	1598	1810	1610	
Q Serve(g_s), s	1.4	10.9	17.7	5.7	18.1	3.2	
Cycle Q Clear(g_c), s	1.4	10.9	17.7	5.7	18.1	3.2	
Prop In Lane	1.00			1.00	1.00	1.00	
Lane Grp Cap(c), veh/h	132	2011	1571	701	589	524	
V/C Ratio(X)	0.27	0.45	0.68	0.28	0.82	0.18	
Avail Cap(c_a), veh/h	221	2262	1649	736	858	763	
HCM Platoon Ratio	1.00	1.00	1.00	1.00	1.00	1.00	
Upstream Filter(I)	1.00	1.00	1.00	1.00	1.00	1.00	
Uniform Delay (d), s/veh	32.4	9.3	16.6	13.2	22.9	17.9	
Incr Delay (d2), s/veh	0.8	0.2	1.3	0.3	3.5	0.1	
Initial Q Delay(d3), s/veh	0.0	0.0	0.0	0.0	0.0	0.0	
%ile BackOfQ(50%),veh/ln	0.6	3.3	6.3	1.8	7.9	0.0	
Unsig. Movement Delay, s/veh							
LnGrp Delay(d), s/veh	33.2	9.5	17.9	13.5	26.4	18.0	
LnGrp LOS	C	A	B	B	C	B	
Approach Vol, veh/h		935	1266		579		
Approach Delay, s/veh		10.4	17.2		25.0		
Approach LOS		B	B		C		
Timer - Assigned Phs				4	6	7	8
Phs Duration (G+Y+Rc), s				45.8	28.1	9.4	36.4
Change Period (Y+Rc), s				* 5.4	5.4	* 5.4	* 5.4
Max Green Setting (Gmax), s				* 46	33.6	* 7.6	* 33
Max Q Clear Time (g_c+I1), s				12.9	20.1	3.4	19.7
Green Ext Time (p_c), s				20.5	2.6	0.0	11.3

### Intersection Summary

HCM 7th Control Delay, s/veh	16.5
HCM 7th LOS	B

### Notes

User approved pedestrian interval to be less than phase max green.

\* HCM 7th computational engine requires equal clearance times for the phases crossing the barrier.

## HCM 7th TWSC 21: International Way & Site access

Intersection						
Int Delay, s/veh	11.7					
Movement	EBL	EBT	WBT	WBR	SBL	SBR
Lane Configurations		↕	↕		↕	
Traffic Vol, veh/h	53	68	210	20	90	362
Future Vol, veh/h	53	68	210	20	90	362
Conflicting Peds, #/hr	0	0	0	0	0	0
Sign Control	Free	Free	Free	Free	Stop	Stop
RT Channelized	-	None	-	None	-	None
Storage Length	-	-	-	-	0	-
Veh in Median Storage, #	-	0	0	-	0	-
Grade, %	-	0	0	-	0	-
Peak Hour Factor	90	90	90	90	90	90
Heavy Vehicles, %	0	0	0	0	0	0
Mvmt Flow	59	76	233	22	100	402
Major/Minor	Major1	Major2	Minor2			
Conflicting Flow All	256	0	-	0	438	244
Stage 1	-	-	-	-	244	-
Stage 2	-	-	-	-	193	-
Critical Hdwy	4.1	-	-	-	6.4	6.2
Critical Hdwy Stg 1	-	-	-	-	5.4	-
Critical Hdwy Stg 2	-	-	-	-	5.4	-
Follow-up Hdwy	2.2	-	-	-	3.5	3.3
Pot Cap-1 Maneuver	1321	-	-	-	580	799
Stage 1	-	-	-	-	801	-
Stage 2	-	-	-	-	844	-
Platoon blocked, %		-	-	-		
Mov Cap-1 Maneuver	1321	-	-	-	553	799
Mov Cap-2 Maneuver	-	-	-	-	553	-
Stage 1	-	-	-	-	764	-
Stage 2	-	-	-	-	844	-
Approach	EB	WB	SB			
HCM Ctrl Dly, s/v	3.44	0	19.83			
HCM LOS						C
Minor Lane/Major Mvmt	EBL	EBT	WBT	WBR	SBLn1	
Capacity (veh/h)	788	-	-	-	734	
HCM Lane V/C Ratio	0.045	-	-	-	0.684	
HCM Ctrl Dly (s/v)	7.9	0	-	-	19.8	
HCM Lane LOS	A	A	-	-	C	
HCM 95th %tile Q(veh)	0.1	-	-	-	5.5	

HCM 7th TWSC  
24: Hutton & Beltline Rd

Intersection												
Int Delay, s/veh	84.3											
Movement	EBL	EBT	EBR	WBL	WBT	WBR	NBL	NBT	NBR	SBL	SBT	SBR
Lane Configurations	↖	↕		↖	↕			↕			↕	↗
Traffic Vol, veh/h	44	737	127	55	953	44	81	10	106	22	12	89
Future Vol, veh/h	44	737	127	55	953	44	81	10	106	22	12	89
Conflicting Peds, #/hr	0	0	0	0	0	0	0	0	0	0	0	0
Sign Control	Free	Free	Free	Free	Free	Free	Stop	Stop	Stop	Stop	Stop	Stop
RT Channelized	-	-	None	-	-	None	-	-	None	-	-	None
Storage Length	130	-	-	440	-	-	-	-	-	-	-	0
Veh in Median Storage, #	-	0	-	-	0	-	-	0	-	-	0	-
Grade, %	-	0	-	-	0	-	-	0	-	-	0	-
Peak Hour Factor	94	94	94	94	94	94	94	94	94	94	94	94
Heavy Vehicles, %	8	0	1	0	1	0	0	0	0	6	0	0
Mvmt Flow	47	784	135	59	1014	47	86	11	113	23	13	95





















Major/Minor	Major1			Major2			Minor1			Minor2		
Conflicting Flow All	1061	0	0	919	0	0	1576	2123	460	1645	2167	530
Stage 1	-	-	-	-	-	-	945	945	-	1154	1154	-
Stage 2	-	-	-	-	-	-	630	1178	-	491	1013	-
Critical Hdwy	4.26	-	-	4.1	-	-	7.5	6.5	6.9	7.62	6.5	6.9
Critical Hdwy Stg 1	-	-	-	-	-	-	6.5	5.5	-	6.62	5.5	-
Critical Hdwy Stg 2	-	-	-	-	-	-	6.5	5.5	-	6.62	5.5	-
Follow-up Hdwy	2.28	-	-	2.2	-	-	3.5	4	3.3	3.56	4	3.3
Pot Cap-1 Maneuver	618	-	-	751	-	-	~ 75	51	554	63	48	498
Stage 1	-	-	-	-	-	-	285	343	-	203	274	-
Stage 2	-	-	-	-	-	-	441	267	-	518	319	-
Platoon blocked, %	-	-	-	-	-	-	-	-	-	-	-	-
Mov Cap-1 Maneuver	618	-	-	751	-	-	~ 37	43	554	33	41	498
Mov Cap-2 Maneuver	-	-	-	-	-	-	~ 37	43	-	33	41	-
Stage 1	-	-	-	-	-	-	264	317	-	187	253	-
Stage 2	-	-	-	-	-	-	313	246	-	368	295	-

Approach	EB		WB		NB		SB	
HCM Ctrl Dly, s/v	0.55		0.53		\$ 908.62		99.68	
HCM LOS					F		F	

Minor Lane/Major Mvmt	NBLn1	EBL	EBT	EBR	WBL	WBT	WBR	SBLn1	SBLn2
Capacity (veh/h)	76	618	-	-	751	-	-	36	498
HCM Lane V/C Ratio	2.751	0.076	-	-	0.078	-	-	1.015	0.19
HCM Ctrl Dly (s/v)	\$ 908.6	11.3	-	-	10.2	-	-	\$ 324.2	13.9
HCM Lane LOS	F	B	-	-	B	-	-	F	B
HCM 95th %tile Q(veh)	20.5	0.2	-	-	0.3	-	-	3.7	0.7

Notes	
~: Volume exceeds capacity	\$: Delay exceeds 300s
+: Computation Not Defined	*: All major volume in platoon

## HCM Signalized Intersection Capacity Analysis 35: Harlow & Gateway

													
Movement	EBL	EBT	EBR	WBL	WBT	WBR	NBL	NBT	NBR	SBL	SBT	SBR	
Lane Configurations													
Traffic Volume (vph)	242	503	5	13	418	365	46	59	65	530	21	401	
Future Volume (vph)	242	503	5	13	418	365	46	59	65	530	21	401	
Ideal Flow (vphp)	1900	1900	1900	1900	1900	1900	1900	1900	1900	1900	1900	1900	
Total Lost time (s)	4.0	4.0		4.0	4.0			3.5		4.0	4.0		
Lane Util. Factor	1.00	0.95		1.00	0.95			0.95		0.97	1.00		
Frt	1.00	1.00		1.00	0.93			0.94		1.00	0.86		
Flt Protected	0.95	1.00		0.95	1.00			0.99		0.95	1.00		
Satd. Flow (prot)	1787	3569		1805	3342			3357		3502	1629		
Flt Permitted	0.95	1.00		0.95	1.00			0.99		0.95	1.00		
Satd. Flow (perm)	1787	3569		1805	3342			3357		3502	1629		
Peak-hour factor, PHF	0.88	0.88	0.88	0.88	0.88	0.88	0.88	0.88	0.88	0.88	0.88	0.88	
Adj. Flow (vph)	275	572	6	15	475	415	52	67	74	602	24	456	
RTOR Reduction (vph)	0	1	0	0	129	0	0	66	0	0	345	0	
Lane Group Flow (vph)	275	577	0	15	761	0	0	127	0	602	135	0	
Heavy Vehicles (%)	1%	1%	0%	0%	0%	1%	0%	0%	0%	0%	0%	0%	
Turn Type	Prot	NA		Prot	NA		Split	NA		Split	NA		
Protected Phases	7	4		3	8		2	2		6	6		
Permitted Phases													
Actuated Green, G (s)	20.1	47.6		2.4	29.9			11.3		24.8	24.8		
Effective Green, g (s)	20.6	48.1		2.9	30.4			11.8		25.3	25.3		
Actuated g/C Ratio	0.20	0.46		0.03	0.29			0.11		0.24	0.24		
Clearance Time (s)	4.5	4.5		4.5	4.5			4.0		4.5	4.5		
Vehicle Extension (s)	2.5	2.5		2.5	2.5			4.0		4.0	4.0		
Lane Grp Cap (vph)	355	1657		50	980			382		855	397		
v/s Ratio Prot	c0.15	0.16		0.01	c0.23			c0.04		c0.17	0.08		
v/s Ratio Perm													
v/c Ratio	0.77	0.35		0.30	0.78			0.33		0.70	0.34		
Uniform Delay, d1	39.3	17.7		49.4	33.5			42.3		35.7	32.3		
Progression Factor	1.00	1.00		1.00	1.00			1.00		1.00	1.00		
Incremental Delay, d2	9.7	0.1		2.4	3.8			0.7		2.8	0.7		
Delay (s)	49.0	17.8		51.8	37.2			43.0		38.6	33.0		
Level of Service	D	B		D	D			D		D	C		
Approach Delay (s/veh)		27.9			37.5			43.0			36.1		
Approach LOS		C			D			D			D		
<b>Intersection Summary</b>													
HCM 2000 Control Delay (s/veh)			34.6									HCM 2000 Level of Service	C
HCM 2000 Volume to Capacity ratio			0.70										
Actuated Cycle Length (s)			103.6									Sum of lost time (s)	16.0
Intersection Capacity Utilization			84.2%									ICU Level of Service	E
Analysis Period (min)			15										
c	Critical Lane Group												

## HCM 7th Signalized Intersection Summary 35: Harlow & Gateway

Movement	EBL	EBT	EBR	WBL	WBT	WBR	NBL	NBT	NBR	SBL	SBT	SBR
Lane Configurations												
Traffic Volume (veh/h)	242	503	5	13	418	365	46	59	65	530	21	401
Future Volume (veh/h)	242	503	5	13	418	365	46	59	65	530	21	401
Initial Q (Qb), veh	0	0	0	0	0	0	0	0	0	0	0	0
Lane Width Adj.	1.00	1.00	1.00	1.00	1.00	1.00	1.00	1.00	1.00	1.00	1.00	1.00
Ped-Bike Adj(A_pbT)	1.00		1.00	1.00		1.00	1.00		1.00	1.00		1.00
Parking Bus, Adj	1.00	1.00	1.00	1.00	1.00	1.00	1.00	1.00	1.00	1.00	1.00	1.00
Work Zone On Approach		No			No			No			No	
Adj Sat Flow, veh/h/ln	1885	1885	1900	1900	1900	1885	1900	1900	1900	1900	1900	1900
Adj Flow Rate, veh/h	275	572	6	15	475	415	52	67	74	602	24	456
Peak Hour Factor	0.88	0.88	0.88	0.88	0.88	0.88	0.88	0.88	0.88	0.88	0.88	0.88
Percent Heavy Veh, %	1	1	0	0	0	1	0	0	0	0	0	0
Cap, veh/h	320	1673	18	33	549	479	95	120	127	981	23	431
Arrive On Green	0.18	0.46	0.46	0.02	0.30	0.30	0.09	0.10	0.09	0.28	0.28	0.27
Sat Flow, veh/h	1795	3631	38	1810	1825	1593	978	1235	1303	3510	81	1541
Grp Volume(v), veh/h	275	282	296	15	470	420	98	0	95	602	0	480
Grp Sat Flow(s),veh/h/ln	1795	1791	1878	1810	1805	1613	1851	0	1665	1755	0	1623
Q Serve(g_s), s	16.0	10.8	10.8	0.9	26.4	26.5	5.4	0.0	5.8	16.0	0.0	30.0
Cycle Q Clear(g_c), s	16.0	10.8	10.8	0.9	26.4	26.5	5.4	0.0	5.8	16.0	0.0	30.0
Prop In Lane	1.00		0.02	1.00		0.99	0.53		0.78	1.00		0.95
Lane Grp Cap(c), veh/h	320	825	865	33	543	485	180	0	162	981	0	453
V/C Ratio(X)	0.86	0.34	0.34	0.46	0.87	0.87	0.55	0.00	0.58	0.61	0.00	1.06
Avail Cap(c_a), veh/h	451	867	910	152	572	511	233	0	209	981	0	453
HCM Platoon Ratio	1.00	1.00	1.00	1.00	1.00	1.00	1.00	1.00	1.00	1.00	1.00	1.00
Upstream Filter(I)	1.00	1.00	1.00	1.00	1.00	1.00	1.00	0.00	1.00	1.00	0.00	1.00
Uniform Delay (d), s/veh	42.8	18.5	18.5	52.2	35.5	35.8	46.3	0.0	46.6	33.7	0.0	38.9
Incr Delay (d2), s/veh	10.2	0.2	0.2	7.2	12.4	13.8	3.6	0.0	4.6	1.3	0.0	58.7
Initial Q Delay(d3), s/veh	0.0	0.0	0.0	0.0	0.0	0.0	0.0	0.0	0.0	0.0	0.0	0.0
%ile BackOfQ(50%),veh/ln	7.9	4.4	4.6	0.5	13.2	12.0	2.7	0.0	2.7	6.9	0.0	19.0
Unsig. Movement Delay, s/veh												
LnGrp Delay(d), s/veh	53.0	18.7	18.7	59.4	47.9	49.5	49.9	0.0	51.2	35.0	0.0	97.6
LnGrp LOS	D	B	B	E	D	D	D		D	C		F
Approach Vol, veh/h		853			905			193				1082
Approach Delay, s/veh		29.8			48.9			50.6				62.8
Approach LOS		C			D			D				E
Timer - Assigned Phs		2	3	4		6	7	8				
Phs Duration (G+Y+Rc), s		14.0	5.9	53.5		34.0	23.1	36.3				
Change Period (Y+Rc), s		4.0	4.5	4.5		4.5	4.5	4.5				
Max Green Setting (Gmax), s		13.0	8.5	51.5		29.5	26.5	33.5				
Max Q Clear Time (g_c+I1), s		7.8	2.9	12.8		32.0	18.0	28.5				
Green Ext Time (p_c), s		0.5	0.0	7.0		0.0	0.7	3.3				
<b>Intersection Summary</b>												
HCM 7th Control Delay, s/veh			48.6									
HCM 7th LOS			D									
<b>Notes</b>												
User approved pedestrian interval to be less than phase max green.												

## HCM 7th TWSC 40: International Way & Sports Way































Intersection						
Int Delay, s/veh	1.3					
Movement	EBL	EBT	WBT	WBR	SBL	SBR
Lane Configurations	↙	↑	↘		↙	↗
Traffic Vol, veh/h	5	119	667	1	6	48
Future Vol, veh/h	5	119	667	1	6	48
Conflicting Peds, #/hr	0	0	0	0	0	0
Sign Control	Free	Free	Free	Free	Stop	Stop
RT Channelized	-	None	-	None	-	None
Storage Length	175	-	-	-	240	0
Veh in Median Storage, #	-	0	0	-	0	-
Grade, %	-	0	0	-	0	-
Peak Hour Factor	71	71	71	71	71	71
Heavy Vehicles, %	0	9	3	0	0	0
Mvmt Flow	7	168	939	1	8	68

Major/Minor	Major1	Major2	Minor2
Conflicting Flow All	941	0	0
Stage 1	-	-	940
Stage 2	-	-	182
Critical Hdwy	4.1	-	6.4
Critical Hdwy Stg 1	-	-	5.4
Critical Hdwy Stg 2	-	-	5.4
Follow-up Hdwy	2.2	-	3.5
Pot Cap-1 Maneuver	737	-	230
Stage 1	-	-	383
Stage 2	-	-	854
Platoon blocked, %	-	-	-
Mov Cap-1 Maneuver	737	-	228
Mov Cap-2 Maneuver	-	-	228
Stage 1	-	-	379
Stage 2	-	-	854

Approach	EB	WB	SB
HCM Ctrl Dly, s/v	0.4	0	19.36
HCM LOS			C

Minor Lane/Major Mvmt	EBL	EBT	WBT	WBR	SBLn1	SBLn2
Capacity (veh/h)	737	-	-	-	228	322
HCM Lane V/C Ratio	0.01	-	-	-	0.037	0.21
HCM Ctrl Dly (s/v)	9.9	-	-	-	21.4	19.1
HCM Lane LOS	A	-	-	-	C	C
HCM 95th %tile Q(veh)	0	-	-	-	0.1	0.8

### HCM 7th Signalized Intersection Summary 9: Beltline Rd/Beltline Rd & Gateway St

												
Movement	EBL	EBT	EBR	WBL	WBT	WBR	NBL	NBT	NBR	SBL	SBT	SBR
Lane Configurations	 	  	 	 	  						 	 
Traffic Volume (veh/h)	348	434	1373	223	1679	528	0	0	0	220	513	925
Future Volume (veh/h)	348	434	1373	223	1679	528	0	0	0	220	513	925
Initial Q (Qb), veh	0	0	0	0	0	0				0	0	0
Lane Width Adj.	1.00	1.00	1.00	1.00	1.00	1.00				1.00	1.00	1.00
Ped-Bike Adj(A_pbT)	1.00		1.00	1.00		1.00				1.00		1.00
Parking Bus, Adj	1.00	1.00	1.00	1.00	1.00	1.00				1.00	1.00	1.00
Work Zone On Approach		No			No						No	
Adj Sat Flow, veh/h/ln	1870	1900	1900	1900	1885	1900				1885	1885	1900
Adj Flow Rate, veh/h	370	462	1461	237	1786	562				234	546	984
Peak Hour Factor	0.94	0.94	0.94	0.94	0.94	0.94				0.94	0.94	0.94
Percent Heavy Veh, %	2	0	0	0	1	0				1	1	0
Cap, veh/h	866	3192	1744	328	2357	719				350	697	1241
Arrive On Green	0.25	0.62	0.62	0.06	0.31	0.30				0.06	0.06	0.06
Sat Flow, veh/h	3456	5187	2834	3510	5147	1610				1795	3582	2834
Grp Volume(v), veh/h	370	462	1461	237	1786	562				234	546	984
Grp Sat Flow(s),veh/h/ln	1728	1729	1417	1755	1716	1610				1795	1791	1417
Q Serve(g_s), s	10.8	4.5	49.1	8.0	37.6	38.3				15.3	18.0	11.1
Cycle Q Clear(g_c), s	10.8	4.5	49.1	8.0	37.6	38.3				15.3	18.0	11.1
Prop In Lane	1.00		1.00	1.00		1.00				1.00		1.00
Lane Grp Cap(c), veh/h	866	3192	1744	328	2357	719				350	697	1241
V/C Ratio(X)	0.43	0.14	0.84	0.72	0.76	0.78				0.67	0.78	0.79
Avail Cap(c_a), veh/h	866	3192	1744	328	2367	722				359	716	1256
HCM Platoon Ratio	1.00	1.00	1.00	0.67	0.67	0.67				0.33	0.33	0.33
Upstream Filter(I)	1.00	1.00	1.00	0.47	0.47	0.47				0.65	0.65	0.65
Uniform Delay (d), s/veh	37.7	9.7	18.3	54.7	35.6	36.7				52.4	53.6	36.3
Incr Delay (d2), s/veh	0.2	0.1	5.0	3.5	1.1	4.1				2.8	3.5	2.2
Initial Q Delay(d3), s/veh	0.0	0.0	0.0	0.0	0.0	0.0				0.0	0.0	0.0
%ile BackOfQ(50%),veh/ln	4.5	1.6	15.2	3.7	16.3	16.2				7.6	9.0	3.4
Unsig. Movement Delay, s/veh												
LnGrp Delay(d), s/veh	38.0	9.8	23.3	58.2	36.7	40.8				55.1	57.2	38.6
LnGrp LOS	D	A	C	E	D	D				E	E	D
Approach Vol, veh/h		2293			2585						1764	
Approach Delay, s/veh		23.0			39.5						46.5	
Approach LOS		C			D						D	
Timer - Assigned Phs			3	4		6	7	8				
Phs Duration (G+Y+Rc), s			15.0	77.6		27.4	33.9	58.8				
Change Period (Y+Rc), s			5.2	5.2		4.5	5.2	5.2				
Max Green Setting (Gmax), s			9.8	71.8		23.5	27.8	53.8				
Max Q Clear Time (g_c+I1), s			10.0	51.1		20.0	12.8	40.3				
Green Ext Time (p_c), s			0.0	18.8		2.8	1.4	13.2				
<b>Intersection Summary</b>												
HCM 7th Control Delay, s/veh			35.7									
HCM 7th LOS			D									
<b>Notes</b>												
User approved pedestrian interval to be less than phase max green.												

## HCM 7th Signalized Intersection Summary 24: Hutton & Beltline Rd

Movement	EBL	EBT	EBR	WBL	WBT	WBR	NBL	NBT	NBR	SBL	SBT	SBR
Lane Configurations												
Traffic Volume (veh/h)	44	619	0	0	1008	44	1333	10	219	22	0	101
Future Volume (veh/h)	44	619	0	0	1008	44	1333	10	219	22	0	101
Initial Q (Qb), veh	0	0	0	0	0	0	0	0	0	0	0	0
Lane Width Adj.	1.00	1.00	1.00	1.00	1.00	1.00	1.00	1.00	1.00	1.00	1.00	1.00
Ped-Bike Adj(A_pbT)	1.00		1.00	1.00		1.00	1.00		1.00	1.00		1.00
Parking Bus, Adj	1.00	1.00	1.00	1.00	1.00	1.00	1.00	1.00	1.00	1.00	1.00	1.00
Work Zone On Approach		No			No			No			No	
Adj Sat Flow, veh/h/ln	1781	1900	0	0	1885	1900	1900	1900	1900	1811	0	1900
Adj Flow Rate, veh/h	47	659	0	0	1072	47	1418	11	233	23	0	107
Peak Hour Factor	0.94	0.94	0.94	0.94	0.94	0.94	0.94	0.94	0.94	0.94	0.94	0.94
Percent Heavy Veh, %	8	0	0	0	1	0	0	0	0	6	0	0
Cap, veh/h	79	1703	0	0	1255	55	1536	13	268	398	0	0
Arrive On Green	0.02	0.11	0.00	0.00	0.25	0.24	0.44	0.17	0.17	0.23	0.00	0.00
Sat Flow, veh/h	1697	5358	0	0	5225	221	3510	73	1548	1725	23	
Grp Volume(v), veh/h	47	659	0	0	727	392	1418	0	244	23	36.0	
Grp Sat Flow(s),veh/h/ln	1697	1729	0	0	1716	1845	1755	0	1621	1725	D	
Q Serve(g_s), s	3.3	14.2	0.0	0.0	24.3	24.3	45.7	0.0	17.6	1.2		
Cycle Q Clear(g_c), s	3.3	14.2	0.0	0.0	24.3	24.3	45.7	0.0	17.6	1.2		
Prop In Lane	1.00		0.00	0.00		0.12	1.00		0.95	1.00		
Lane Grp Cap(c), veh/h	79	1703	0	0	852	458	1536	0	281	398		
V/C Ratio(X)	0.59	0.39	0.00	0.00	0.85	0.85	0.92	0.00	0.87	0.06		
Avail Cap(c_a), veh/h	140	1859	0	0	858	461	1624	0	757	398		
HCM Platoon Ratio	0.33	0.33	1.00	1.00	1.00	1.00	1.00	1.00	1.00	1.00		
Upstream Filter(I)	0.95	0.95	0.00	0.00	1.00	1.00	1.00	0.00	1.00	1.00		
Uniform Delay (d), s/veh	57.9	42.3	0.0	0.0	43.0	43.1	31.8	0.0	48.3	36.0		
Incr Delay (d2), s/veh	4.9	0.2	0.0	0.0	8.6	14.9	8.8	0.0	6.1	0.1		
Initial Q Delay(d3), s/veh	0.0	0.0	0.0	0.0	0.0	0.0	0.0	0.0	0.0	0.0		
%ile BackOfQ(50%),veh/ln	1.5	6.6	0.0	0.0	10.9	12.6	21.0	0.0	7.6	0.5		
Unsig. Movement Delay, s/veh												
LnGrp Delay(d), s/veh	62.8	42.4	0.0	0.0	51.6	58.0	40.7	0.0	54.4	36.0		
LnGrp LOS	E	D			D	E	D		D	D		
Approach Vol, veh/h		706			1119			1662				
Approach Delay, s/veh		43.8			53.9			42.7				
Approach LOS		D			D			D				
Timer - Assigned Phs	1	2		4	5		7	8				
Phs Duration (G+Y+Rc), s	32.2	24.8		43.4	57.0		9.6	33.8				
Change Period (Y+Rc), s	4.5	4.0		* 5.4	4.5		* 5.4	* 5.4				
Max Green Setting (Gmax), s	8.5	56.0		* 42	55.5		* 8.5	* 29				
Max Q Clear Time (g_c+I1), s	3.2	19.6		16.2	47.7		5.3	26.3				
Green Ext Time (p_c), s	0.0	1.2		12.7	4.8		0.0	2.1				
<b>Intersection Summary</b>												
HCM 7th Control Delay, s/veh				46.4								
HCM 7th LOS				D								
<b>Notes</b>												
User approved pedestrian interval to be less than phase max green.												
* HCM 7th computational engine requires equal clearance times for the phases crossing the barrier.												

2025 Background PM

Intersection Maple @ Game Farm

	Eastbound			Westbound			Northbound			Southbound		
	Left	Through	Right	Left	Through	Right	Left	Through	Right	Left	Through	Right
Volume	3	162	1	0	105	31	0	0	0	79	0	9
PHF	0.93	0.93	0.93	0.93	0.93	0.93	0.93	0.93	0.93	0.93	0.93	0.93
Adj Volumes	3	174	1	0	113	33	0	0	0	85	0	10
% HV	0.00	0.01	0.00	0.00	0.00	0.03	0.00	0.00	0.00	0.00	0.00	0.00
Fhv	1.00	0.99	1.00	1.00	1.00	0.97	1.00	1.00	1.00	1.00	1.00	1.00
Demand Volume (PCE)	3	176	1	0	113	34	0	0	0	85	0	10
Entry Volume	166		136		0		88					
Entry Lane Volume (adj)	180		147		0		95					
Exiting Flow Rates	123		261		1		38					
Conflicting Flow/Circulating	85		3		264		113					
Entry Capacity	1265		1375		1054		1230					
v/c ratio	0.14		0.10		0.00		0.08					
Delay	4.0		3.4		3.4		3.6					
LOS	A		A		A		A					
95th Percentile Queue (veh)	0.5		0.3		0.0		0.2					
Intersection Delay	3.6									Time		
Intersection v/c	0.11									0.25		

2035 Background PM

Intersection Maple @ Game Farm

	Eastbound			Westbound			Northbound			Southbound		
	Left	Through	Right	Left	Through	Right	Left	Through	Right	Left	Through	Right
Volume	4	198	1	0	128	38	0	0	0	96	0	11
PHF	0.93	0.93	0.93	0.93	0.93	0.93	0.93	0.93	0.93	0.93	0.93	0.93
Adj Volumes	4	213	1	0	138	41	0	0	0	103	0	12
% HV	0.00	0.01	0.00	0.00	0.00	0.03	0.00	0.00	0.00	0.00	0.00	0.00
Fhv	1.00	0.99	1.00	1.00	1.00	0.97	1.00	1.00	1.00	1.00	1.00	1.00
Demand Volume (PCE)	4	215	1	0	138	42	0	0	0	103	0	12
Entry Volume	203			166			0			107		
Entry Lane Volume (adj)	220			180			0			115		
Exiting Flow Rates	149			318			1			46		
Conflicting Flow/Circulating	103			4			323			138		
Entry Capacity	1242			1374			993			1199		
v/c ratio	0.18			0.12			0.00			0.10		
Delay	4.4			3.6			3.6			3.8		
LOS	A			A			A			A		
95th Percentile Queue (veh)	0.6			0.4			0.0			0.3		

Intersection Delay	3.9
Intersection v/c	0.14

Time 0.25

2035 Build PM

Intersection Maple @ Game Farm

	Eastbound			Westbound			Northbound			Southbound		
	Left	Through	Right	Left	Through	Right	Left	Through	Right	Left	Through	Right
Volume	4	198	1	0	128	58	0	0	0	186	0	11
PHF	0.93	0.93	0.93	0.93	0.93	0.93	0.93	0.93	0.93	0.93	0.93	0.93
Adj Volumes	4	213	1	0	138	62	0	0	0	200	0	12
% HV	0.00	0.01	0.00	0.00	0.00	0.03	0.00	0.00	0.00	0.00	0.00	0.00
Fhv	1.00	0.99	1.00	1.00	1.00	0.97	1.00	1.00	1.00	1.00	1.00	1.00
Demand Volume (PCE)	4	215	1	0	138	64	0	0	0	200	0	12
Entry Volume	203			186			0			197		
Entry Lane Volume (adj)	220			202			0			212		
Exiting Flow Rates	149			415			1			69		
Conflicting Flow/Circulating	200			4			419			138		
Entry Capacity	1125			1374			900			1199		
v/c ratio	0.20			0.14			0.00			0.18		
Delay	5.0			3.7			4.0			4.5		
LOS	A			A			A			A		
95th Percentile Queue (veh)	0.7			0.5			0.0			0.6		

Intersection Delay	4.3
Intersection v/c	0.17

Time 0.25

2025 Background PM

Intersection Maple @ International

	Eastbound			Westbound			Northbound			Southbound		
	Left	Through	Right	Left	Through	Right	Left	Through	Right	Left	Through	Right
Volume	2	31	48	15	89	0	26	4	9	2	25	25
PHF	0.82	0.82	0.82	0.82	0.82	0.82	0.82	0.82	0.82	0.82	0.82	0.82
Adj Volumes	2	38	59	18	109	0	32	5	11	2	30	30
% HV	0.00	0.06	0.00	0.00	0.03	0.00	0.00	0.00	0.00	0.00	0.00	0.04
Fhv	1.00	0.94	1.00	1.00	0.97	1.00	1.00	1.00	1.00	1.00	1.00	0.96
<b>Demand Volume (PCE)</b>	<b>2</b>	<b>40</b>	<b>59</b>	<b>18</b>	<b>112</b>	<b>0</b>	<b>32</b>	<b>5</b>	<b>11</b>	<b>2</b>	<b>30</b>	<b>32</b>
Entry Volume	81		104		39		52					
Entry Lane Volume (adj)	101		130		48		65					
Exiting Flow Rates	175		53		107		7					
Conflicting Flow/Circulating	51		39		45		162					
Entry Capacity	1310		1326		1318		1170					
v/c ratio	0.08		0.08		0.04		0.06					
Delay	3.4		3.3		3.0		3.5					
LOS	A		A		A		A					
95th Percentile Queue (veh)	0.3		0.3		0.1		0.2					
<b>Intersection Delay</b>		<b>3.3</b>										
Intersection v/c		0.07						Time 0.25				

2035 Background PM

Intersection Maple @ International

	Eastbound			Westbound			Northbound			Southbound			
	Left	Through	Right	Left	Through	Right	Left	Through	Right	Left	Through	Right	
Volume	2	38	59	18	109	0	32	5	11	2	31	31	
PHF	0.82	0.82	0.82	0.82	0.82	0.82	0.82	0.82	0.82	0.82	0.82	0.82	
Adj Volumes	2	46	72	22	133	0	39	6	13	2	38	38	
% HV	0.00	0.06	0.00	0.00	0.03	0.00	0.00	0.00	0.00	0.00	0.00	0.04	
Fhv	1.00	0.94	1.00	1.00	0.97	1.00	1.00	1.00	1.00	1.00	1.00	0.96	
<b>Demand Volume (PCE)</b>	<b>2</b>	<b>49</b>	<b>72</b>	<b>22</b>	<b>137</b>	<b>0</b>	<b>39</b>	<b>6</b>	<b>13</b>	<b>2</b>	<b>38</b>	<b>39</b>	
Entry Volume		99			127			48			64		
Entry Lane Volume (adj)		124			159			59			80		
Exiting Flow Rates		215			65			132			9		
Conflicting Flow/Circulating		62			48			54			198		
Entry Capacity		1295			1315			1306			1128		
v/c ratio		0.10			0.10			0.04			0.07		
Delay		3.5			3.5			3.1			3.8		
LOS		A			A			A			A		
95th Percentile Queue (veh)		0.3			0.3			0.1			0.2		
<b>Intersection Delay</b>		<b>3.5</b>											
Intersection v/c		0.08								Time		0.25	

2035 Build PM

Intersection Maple @ International

	Eastbound			Westbound			Northbound			Southbound		
	Left	Through	Right	Left	Through	Right	Left	Through	Right	Left	Through	Right
Volume	2	38	149	18	109	0	52	5	11	2	31	31
PHF	0.82	0.82	0.82	0.82	0.82	0.82	0.82	0.82	0.82	0.82	0.82	0.82
Adj Volumes	2	46	182	22	133	0	63	6	13	2	38	38
% HV	0.00	0.06	0.00	0.00	0.03	0.00	0.00	0.00	0.00	0.00	0.00	0.04
Fhv	1.00	0.94	1.00	1.00	0.97	1.00	1.00	1.00	1.00	1.00	1.00	0.96
Demand Volume (PCE)	2	49	182	22	137	0	63	6	13	2	38	39
Entry Volume	189		127		68		64					
Entry Lane Volume (adj)	233		159		83		80					
Exiting Flow Rates	240		65		241		9					
Conflicting Flow/Circulating	62		72		54		222					
Entry Capacity	1295		1282		1306		1100					
v/c ratio	0.18		0.10		0.06		0.07					
Delay	4.3		3.6		3.3		3.9					
LOS	A		A		A		A					
95th Percentile Queue (veh)	0.7		0.3		0.2		0.2					
Intersection Delay	3.8									Time		
Intersection v/c	0.12									0.25		

INTERNATIONAL WAY TPR

Queuing and Blocking Report  
6173 International Way Zone Change

12/20/2024

Intersection: 2: EGame Farm Rd & Maple Island rd, Interval #1

Movement	EB	SB
Directions Served	LTR	LTR
Maximum Queue (ft)	24	30
Average Queue (ft)	8	6
95th Queue (ft)	29	26
Link Distance (ft)	1715	861
Upstream Blk Time (%)		
Queuing Penalty (veh)		
Storage Bay Dist (ft)		
Storage Blk Time (%)		
Queuing Penalty (veh)		

Intersection: 2: EGame Farm Rd & Maple Island rd, Interval #2

Movement	EB	SB
Directions Served	LTR	LTR
Maximum Queue (ft)	40	31
Average Queue (ft)	5	5
95th Queue (ft)	25	23
Link Distance (ft)	1715	861
Upstream Blk Time (%)		
Queuing Penalty (veh)		
Storage Bay Dist (ft)		
Storage Blk Time (%)		
Queuing Penalty (veh)		

Intersection: 2: EGame Farm Rd & Maple Island rd, All Intervals

Movement	EB	SB
Directions Served	LTR	LTR
Maximum Queue (ft)	40	31
Average Queue (ft)	5	5
95th Queue (ft)	26	24
Link Distance (ft)	1715	861
Upstream Blk Time (%)		
Queuing Penalty (veh)		
Storage Bay Dist (ft)		
Storage Blk Time (%)		
Queuing Penalty (veh)		

Queuing and Blocking Report  
6173 International Way Zone Change

12/20/2024

Intersection: 5: Maple Island rd/Maple Island & International Way, Interval #1

Movement	EB	WB	NB	SB
Directions Served	LTR	LTR	LTR	LTR
Maximum Queue (ft)	18	26	12	25
Average Queue (ft)	3	4	2	7
95th Queue (ft)	16	25	13	28
Link Distance (ft)	491	962	861	209
Upstream Blk Time (%)				
Queuing Penalty (veh)				
Storage Bay Dist (ft)				
Storage Blk Time (%)				
Queuing Penalty (veh)				

Intersection: 5: Maple Island rd/Maple Island & International Way, Interval #2

Movement	EB	WB	NB	SB
Directions Served	LTR	LTR	LTR	LTR
Maximum Queue (ft)	23	6	6	29
Average Queue (ft)	1	0	0	2
95th Queue (ft)	11	5	5	17
Link Distance (ft)	491	962	861	209
Upstream Blk Time (%)				
Queuing Penalty (veh)				
Storage Bay Dist (ft)				
Storage Blk Time (%)				
Queuing Penalty (veh)				

Intersection: 5: Maple Island rd/Maple Island & International Way, All Intervals

Movement	EB	WB	NB	SB
Directions Served	LTR	LTR	LTR	LTR
Maximum Queue (ft)	30	26	12	36
Average Queue (ft)	2	1	1	4
95th Queue (ft)	13	13	8	20
Link Distance (ft)	491	962	861	209
Upstream Blk Time (%)				
Queuing Penalty (veh)				
Storage Bay Dist (ft)				
Storage Blk Time (%)				
Queuing Penalty (veh)				

Queuing and Blocking Report  
6173 International Way Zone Change

12/20/2024

Intersection: 6: International Way & Fedex East Side , Interval #1

Movement	SB
Directions Served	LR
Maximum Queue (ft)	31
Average Queue (ft)	4
95th Queue (ft)	22
Link Distance (ft)	294
Upstream Blk Time (%)	
Queuing Penalty (veh)	
Storage Bay Dist (ft)	
Storage Blk Time (%)	
Queuing Penalty (veh)	

Intersection: 6: International Way & Fedex East Side , Interval #2

Movement	EB	SB
Directions Served	L	LR
Maximum Queue (ft)	17	30
Average Queue (ft)	1	3
95th Queue (ft)	11	17
Link Distance (ft)		294
Upstream Blk Time (%)		
Queuing Penalty (veh)		
Storage Bay Dist (ft)	250	
Storage Blk Time (%)		
Queuing Penalty (veh)		

Intersection: 6: International Way & Fedex East Side , All Intervals

Movement	EB	SB
Directions Served	L	LR
Maximum Queue (ft)	17	31
Average Queue (ft)	1	3
95th Queue (ft)	9	18
Link Distance (ft)		294
Upstream Blk Time (%)		
Queuing Penalty (veh)		
Storage Bay Dist (ft)	250	
Storage Blk Time (%)		
Queuing Penalty (veh)		

Queuing and Blocking Report  
6173 International Way Zone Change

12/20/2024

Intersection: 9: Beltline Rd & Gateway St , Interval #1

Movement	EB	EB	EB	EB	EB	EB	WB	WB	WB	WB	NB	NB
Directions Served	L	L	T	T	R	R	L	T	T	TR	L	L
Maximum Queue (ft)	185	170	230	188	446	384	174	206	202	196	284	550
Average Queue (ft)	136	108	165	135	304	248	99	155	152	141	261	385
95th Queue (ft)	199	175	237	198	438	384	178	211	206	191	317	555
Link Distance (ft)			694	694			464	464	464			715
Upstream Blk Time (%)												
Queuing Penalty (veh)												
Storage Bay Dist (ft)	480	480			640	640				360	260	
Storage Blk Time (%)											2	28
Queuing Penalty (veh)											9	111

Intersection: 9: Beltline Rd & Gateway St , Interval #1

Movement	NB	SB	SB	SB	SB
Directions Served	TR	L	T	R	R
Maximum Queue (ft)	236	187	278	144	139
Average Queue (ft)	163	121	198	84	93
95th Queue (ft)	261	194	302	142	151
Link Distance (ft)	715		487	487	
Upstream Blk Time (%)					
Queuing Penalty (veh)					
Storage Bay Dist (ft)		335			190
Storage Blk Time (%)			0	0	
Queuing Penalty (veh)			0	1	

Queuing and Blocking Report  
6173 International Way Zone Change

12/20/2024

Intersection: 9: Beltline Rd & Gateway St , Interval #2

Movement	EB	EB	EB	EB	EB	EB	WB	WB	WB	WB	NB	NB
Directions Served	L	L	T	T	R	R	L	T	T	TR	L	L
Maximum Queue (ft)	191	180	230	213	431	392	171	212	217	210	284	500
Average Queue (ft)	117	100	146	116	290	227	90	141	141	131	244	318
95th Queue (ft)	186	173	218	200	411	379	162	204	204	199	323	450
Link Distance (ft)			694	694			464	464	464			715
Upstream Blk Time (%)												
Queuing Penalty (veh)												
Storage Bay Dist (ft)	480	480			640	640				360	260	
Storage Blk Time (%)											2	17
Queuing Penalty (veh)											6	64

Intersection: 9: Beltline Rd & Gateway St , Interval #2

Movement	NB	SB	SB	SB	SB
Directions Served	TR	L	T	R	R
Maximum Queue (ft)	259	251	318	148	159
Average Queue (ft)	146	121	195	85	87
95th Queue (ft)	242	207	290	136	143
Link Distance (ft)	715		487	487	
Upstream Blk Time (%)					
Queuing Penalty (veh)					
Storage Bay Dist (ft)		335		190	
Storage Blk Time (%)			0	0	
Queuing Penalty (veh)			0	0	

Queuing and Blocking Report  
6173 International Way Zone Change

12/20/2024

Intersection: 9: Beltline Rd & Gateway St , All Intervals

Movement	EB	EB	EB	EB	EB	EB	WB	WB	WB	WB	NB	NB
Directions Served	L	L	T	T	R	R	L	T	T	TR	L	L
Maximum Queue (ft)	198	191	240	215	493	442	190	224	221	216	284	553
Average Queue (ft)	122	102	150	121	293	232	92	144	144	133	248	334
95th Queue (ft)	190	174	224	201	418	381	166	207	205	198	323	484
Link Distance (ft)			694	694			464	464	464			715
Upstream Blk Time (%)												
Queuing Penalty (veh)												
Storage Bay Dist (ft)	480	480			640	640				360	260	
Storage Blk Time (%)											2	20
Queuing Penalty (veh)											7	76

Intersection: 9: Beltline Rd & Gateway St , All Intervals

Movement	NB	SB	SB	SB	SB
Directions Served	TR	L	T	R	R
Maximum Queue (ft)	277	253	327	161	161
Average Queue (ft)	150	121	195	84	88
95th Queue (ft)	247	204	293	137	145
Link Distance (ft)	715		487	487	
Upstream Blk Time (%)					
Queuing Penalty (veh)					
Storage Bay Dist (ft)		335			190
Storage Blk Time (%)			0	0	0
Queuing Penalty (veh)			0	0	0

Intersection: 10: Gateway St & International Way, Interval #1

Movement	EB	WB	WB	NB	NB	SB	SB
Directions Served	LTR	L	TR	L	T	L	TR
Maximum Queue (ft)	49	147	62	29	213	88	269
Average Queue (ft)	26	104	34	8	114	35	166
95th Queue (ft)	53	163	71	31	225	96	282
Link Distance (ft)	271		502		614		314
Upstream Blk Time (%)							1
Queuing Penalty (veh)							0
Storage Bay Dist (ft)		280		160		194	
Storage Blk Time (%)					2		4
Queuing Penalty (veh)					0		2

Queuing and Blocking Report  
6173 International Way Zone Change

12/20/2024

Intersection: 10: Gateway St & International Way, Interval #2

Movement	EB	WB	WB	NB	NB	SB	SB
Directions Served	LTR	L	TR	L	T	L	TR
Maximum Queue (ft)	58	169	67	34	219	82	265
Average Queue (ft)	25	88	33	5	103	23	130
95th Queue (ft)	55	144	62	23	195	62	223
Link Distance (ft)	271		502		614		314
Upstream Blk Time (%)							0
Queuing Penalty (veh)							0
Storage Bay Dist (ft)		280		160		194	
Storage Blk Time (%)					1		1
Queuing Penalty (veh)					0		0

Intersection: 10: Gateway St & International Way, All Intervals

Movement	EB	WB	WB	NB	NB	SB	SB
Directions Served	LTR	L	TR	L	T	L	TR
Maximum Queue (ft)	58	178	72	39	247	128	306
Average Queue (ft)	25	92	33	5	106	26	138
95th Queue (ft)	54	150	65	25	203	72	241
Link Distance (ft)	271		502		614		314
Upstream Blk Time (%)							0
Queuing Penalty (veh)							0
Storage Bay Dist (ft)		280		160		194	
Storage Blk Time (%)					1		2
Queuing Penalty (veh)					0		1

Intersection: 12: Gateway St /Gateway St & EGame Farm Rd, Interval #1

Movement	EB	WB	WB	NB	NB	NB	SB	SB	SB
Directions Served	LTR	L	TR	L	T	T	L	T	TR
Maximum Queue (ft)	8	104	60	56	174	145	54	124	162
Average Queue (ft)	1	68	34	17	104	67	27	59	90
95th Queue (ft)	8	105	61	58	193	145	54	129	157
Link Distance (ft)	249		1715		487	487			614
Upstream Blk Time (%)									
Queuing Penalty (veh)									
Storage Bay Dist (ft)		150		115			224	224	
Storage Blk Time (%)					6	0			0
Queuing Penalty (veh)					2	0			1

Queuing and Blocking Report  
6173 International Way Zone Change

12/20/2024

Intersection: 12: Gateway St /Gateway St & EGame Farm Rd, Interval #2

Movement	EB	WB	WB	NB	NB	NB	SB	SB	SB
Directions Served	LTR	L	TR	L	T	T	L	T	TR
Maximum Queue (ft)	22	138	57	57	166	97	90	150	166
Average Queue (ft)	2	63	31	14	79	30	20	49	71
95th Queue (ft)	12	108	52	47	145	81	62	111	135
Link Distance (ft)	249		1715		487	487			614
Upstream Blk Time (%)									
Queuing Penalty (veh)									
Storage Bay Dist (ft)		150		115			224	224	
Storage Blk Time (%)		0			2		0	0	0
Queuing Penalty (veh)		0			1		0	0	0

Intersection: 12: Gateway St /Gateway St & EGame Farm Rd, All Intervals

Movement	EB	WB	WB	NB	NB	NB	SB	SB	SB
Directions Served	LTR	L	TR	L	T	T	L	T	TR
Maximum Queue (ft)	22	138	65	86	190	145	97	153	180
Average Queue (ft)	2	64	32	15	85	39	21	52	75
95th Queue (ft)	12	108	54	50	160	103	61	116	142
Link Distance (ft)	249		1715		487	487			614
Upstream Blk Time (%)									
Queuing Penalty (veh)									
Storage Bay Dist (ft)		150		115			224	224	
Storage Blk Time (%)		0			3	0	0	0	0
Queuing Penalty (veh)		0			1	0	0	0	0

Intersection: 15: Richardson Access & International Way, Interval #1

Movement	EB	NB	SB
Directions Served	L	LTR	LTR
Maximum Queue (ft)	6	29	30
Average Queue (ft)	1	8	19
95th Queue (ft)	9	30	42
Link Distance (ft)		311	201
Upstream Blk Time (%)			
Queuing Penalty (veh)			
Storage Bay Dist (ft)	145		
Storage Blk Time (%)			
Queuing Penalty (veh)			

Queuing and Blocking Report  
6173 International Way Zone Change

12/20/2024

Intersection: 15: Richardson Access & International Way, Interval #2

Movement	NB	SB
Directions Served	LTR	LTR
Maximum Queue (ft)	30	44
Average Queue (ft)	6	19
95th Queue (ft)	25	45
Link Distance (ft)	311	201
Upstream Blk Time (%)		
Queuing Penalty (veh)		
Storage Bay Dist (ft)		
Storage Blk Time (%)		
Queuing Penalty (veh)		

Intersection: 15: Richardson Access & International Way, All Intervals

Movement	EB	NB	SB
Directions Served	L	LTR	LTR
Maximum Queue (ft)	6	30	44
Average Queue (ft)	0	6	19
95th Queue (ft)	4	26	44
Link Distance (ft)		311	201
Upstream Blk Time (%)			
Queuing Penalty (veh)			
Storage Bay Dist (ft)	145		
Storage Blk Time (%)			
Queuing Penalty (veh)			

Intersection: 16: Game Farm Rd & Deadmond Ferry , Interval #1

Movement	EB	WB	NB	NB
Directions Served	TR	L	L	R
Maximum Queue (ft)	18	52	51	28
Average Queue (ft)	4	30	28	22
95th Queue (ft)	17	62	51	40
Link Distance (ft)	319			554
Upstream Blk Time (%)				
Queuing Penalty (veh)				
Storage Bay Dist (ft)		140	115	
Storage Blk Time (%)				
Queuing Penalty (veh)				

Queuing and Blocking Report  
6173 International Way Zone Change

12/20/2024

Intersection: 16: Game Farm Rd & Deadmond Ferry , Interval #2

Movement	EB	WB	NB	NB
Directions Served	TR	L	L	R
Maximum Queue (ft)	31	43	59	32
Average Queue (ft)	2	22	27	19
95th Queue (ft)	15	48	49	40
Link Distance (ft)	319			554
Upstream Blk Time (%)				
Queuing Penalty (veh)				
Storage Bay Dist (ft)		140	115	
Storage Blk Time (%)				
Queuing Penalty (veh)				

Intersection: 16: Game Farm Rd & Deadmond Ferry , All Intervals

Movement	EB	WB	NB	NB
Directions Served	TR	L	L	R
Maximum Queue (ft)	31	60	60	32
Average Queue (ft)	3	24	27	20
95th Queue (ft)	16	52	49	40
Link Distance (ft)	319			554
Upstream Blk Time (%)				
Queuing Penalty (veh)				
Storage Bay Dist (ft)		140	115	
Storage Blk Time (%)				
Queuing Penalty (veh)				

Intersection: 17: Beltline Rd /MLK & Game Farm Rd, Interval #1

Movement	EB	EB	EB	WB	WB	WB	SB	SB
Directions Served	L	T	T	T	T	R	L	R
Maximum Queue (ft)	47	103	128	154	197	51	184	88
Average Queue (ft)	24	58	72	101	130	33	124	24
95th Queue (ft)	54	115	138	157	197	50	199	98
Link Distance (ft)		1696	1696	878	878		554	
Upstream Blk Time (%)								
Queuing Penalty (veh)								
Storage Bay Dist (ft)	340					275		85
Storage Blk Time (%)							16	0
Queuing Penalty (veh)							13	0

Queuing and Blocking Report  
6173 International Way Zone Change

12/20/2024

Intersection: 17: Beltline Rd /MLK & Game Farm Rd, Interval #2

Movement	EB	EB	EB	WB	WB	WB	SB	SB
Directions Served	L	T	T	T	T	R	L	R
Maximum Queue (ft)	44	130	146	168	217	105	197	110
Average Queue (ft)	14	46	67	80	109	34	102	21
95th Queue (ft)	40	101	116	140	179	82	162	91
Link Distance (ft)		1696	1696	878	878		554	
Upstream Blk Time (%)								
Queuing Penalty (veh)								
Storage Bay Dist (ft)	340					275		85
Storage Blk Time (%)					0		11	0
Queuing Penalty (veh)					0		7	0

Intersection: 17: Beltline Rd /MLK & Game Farm Rd, All Intervals

Movement	EB	EB	EB	WB	WB	WB	SB	SB
Directions Served	L	T	T	T	T	R	L	R
Maximum Queue (ft)	57	132	151	188	228	105	225	110
Average Queue (ft)	17	49	68	85	114	34	108	22
95th Queue (ft)	44	105	122	146	185	76	173	93
Link Distance (ft)		1696	1696	878	878		554	
Upstream Blk Time (%)								
Queuing Penalty (veh)								
Storage Bay Dist (ft)	340					275		85
Storage Blk Time (%)					0		12	0
Queuing Penalty (veh)					0		9	0

Intersection: 21: International Way & Site access , Interval #1

Movement
Directions Served
Maximum Queue (ft)
Average Queue (ft)
95th Queue (ft)
Link Distance (ft)
Upstream Blk Time (%)
Queuing Penalty (veh)
Storage Bay Dist (ft)
Storage Blk Time (%)
Queuing Penalty (veh)

Queuing and Blocking Report  
6173 International Way Zone Change

12/20/2024

Intersection: 21: International Way & Site access , Interval #2

Movement

Directions Served  
Maximum Queue (ft)  
Average Queue (ft)  
95th Queue (ft)  
Link Distance (ft)  
Upstream Blk Time (%)  
Queuing Penalty (veh)  
Storage Bay Dist (ft)  
Storage Blk Time (%)  
Queuing Penalty (veh)

Intersection: 21: International Way & Site access , All Intervals

Movement

Directions Served  
Maximum Queue (ft)  
Average Queue (ft)  
95th Queue (ft)  
Link Distance (ft)  
Upstream Blk Time (%)  
Queuing Penalty (veh)  
Storage Bay Dist (ft)  
Storage Blk Time (%)  
Queuing Penalty (veh)

Intersection: 24: Hutton & Beltline Rd , Interval #1

Movement	EB	WB	WB	NB	SB	SB
Directions Served	L	L	TR	LTR	LT	R
Maximum Queue (ft)	32	55	16	135	69	48
Average Queue (ft)	13	19	2	71	34	27
95th Queue (ft)	35	52	16	132	71	50
Link Distance (ft)			1696	336	170	170
Upstream Blk Time (%)						
Queuing Penalty (veh)						
Storage Bay Dist (ft)	130	440				
Storage Blk Time (%)						
Queuing Penalty (veh)						

Queuing and Blocking Report  
6173 International Way Zone Change

12/20/2024

Intersection: 24: Hutton & Beltline Rd , Interval #2

Movement	EB	EB	EB	WB	WB	NB	SB	SB
Directions Served	L	T	TR	L	TR	LTR	LT	R
Maximum Queue (ft)	51	17	18	52	24	170	50	66
Average Queue (ft)	15	1	1	16	1	68	16	31
95th Queue (ft)	41	10	9	44	13	135	44	58
Link Distance (ft)		464	464		1696	336	170	170
Upstream Blk Time (%)								
Queuing Penalty (veh)								
Storage Bay Dist (ft)	130			440				
Storage Blk Time (%)								
Queuing Penalty (veh)								

Intersection: 24: Hutton & Beltline Rd , All Intervals

Movement	EB	EB	EB	WB	WB	NB	SB	SB
Directions Served	L	T	TR	L	TR	LTR	LT	R
Maximum Queue (ft)	51	17	18	55	32	170	69	66
Average Queue (ft)	14	1	1	17	2	69	21	30
95th Queue (ft)	39	9	8	46	14	134	53	56
Link Distance (ft)		464	464		1696	336	170	170
Upstream Blk Time (%)								
Queuing Penalty (veh)								
Storage Bay Dist (ft)	130			440				
Storage Blk Time (%)								
Queuing Penalty (veh)								

Intersection: 35: Harlow & Gateway , Interval #1

Movement	EB	EB	EB	WB	WB	WB	NB	NB	SB	SB	SB
Directions Served	L	T	TR	L	T	TR	LT	TR	L	L	TR
Maximum Queue (ft)	160	124	117	77	216	243	66	48	189	258	112
Average Queue (ft)	106	71	58	18	140	142	44	28	85	170	74
95th Queue (ft)	177	127	116	84	216	246	75	56	216	284	122
Link Distance (ft)		764	764		802	802	420	420		507	507
Upstream Blk Time (%)											
Queuing Penalty (veh)											
Storage Bay Dist (ft)	215			200					190		
Storage Blk Time (%)	0	0			2				0	7	
Queuing Penalty (veh)	1	0			0				0	15	

Queuing and Blocking Report  
6173 International Way Zone Change

12/20/2024

Intersection: 35: Harlow & Gateway , Interval #2

Movement	EB	EB	EB	WB	WB	WB	NB	NB	SB	SB	SB
Directions Served	L	T	TR	L	T	TR	LT	TR	L	L	TR
Maximum Queue (ft)	159	126	98	39	179	204	104	66	187	252	152
Average Queue (ft)	84	67	42	11	101	97	45	26	64	144	69
95th Queue (ft)	140	115	77	35	158	176	84	56	175	227	120
Link Distance (ft)		764	764		802	802	420	420		507	507
Upstream Blk Time (%)											
Queuing Penalty (veh)											
Storage Bay Dist (ft)	215			200					190		
Storage Blk Time (%)					0				0	2	
Queuing Penalty (veh)					0				0	5	

Intersection: 35: Harlow & Gateway , All Intervals

Movement	EB	EB	EB	WB	WB	WB	NB	NB	SB	SB	SB
Directions Served	L	T	TR	L	T	TR	LT	TR	L	L	TR
Maximum Queue (ft)	186	147	140	86	216	247	104	66	205	280	161
Average Queue (ft)	89	68	46	12	110	108	44	26	69	150	70
95th Queue (ft)	151	118	89	52	178	199	82	56	186	244	120
Link Distance (ft)		764	764		802	802	420	420		507	507
Upstream Blk Time (%)											
Queuing Penalty (veh)											
Storage Bay Dist (ft)	215			200					190		
Storage Blk Time (%)	0	0			0				0	3	
Queuing Penalty (veh)	0	0			0				0	7	

Intersection: 40: International Way & Sports Way , Interval #1

Movement	EB	SB	SB
Directions Served	L	L	R
Maximum Queue (ft)	6	24	30
Average Queue (ft)	1	6	20
95th Queue (ft)	9	23	33
Link Distance (ft)			484
Upstream Blk Time (%)			
Queuing Penalty (veh)			
Storage Bay Dist (ft)	175	240	
Storage Blk Time (%)			
Queuing Penalty (veh)			

Queuing and Blocking Report  
6173 International Way Zone Change

12/20/2024

Intersection: 40: International Way & Sports Way , Interval #2

Movement	EB	SB	SB
Directions Served	L	L	R
Maximum Queue (ft)	12	20	25
Average Queue (ft)	1	3	12
95th Queue (ft)	9	15	27
Link Distance (ft)			484
Upstream Blk Time (%)			
Queuing Penalty (veh)			
Storage Bay Dist (ft)	175	240	
Storage Blk Time (%)			
Queuing Penalty (veh)			

Intersection: 40: International Way & Sports Way , All Intervals

Movement	EB	SB	SB
Directions Served	L	L	R
Maximum Queue (ft)	18	25	35
Average Queue (ft)	1	4	14
95th Queue (ft)	9	17	30
Link Distance (ft)			484
Upstream Blk Time (%)			
Queuing Penalty (veh)			
Storage Bay Dist (ft)	175	240	
Storage Blk Time (%)			
Queuing Penalty (veh)			

Intersection: 42: International Way & Fedex Westside , Interval #1

Movement	EB	SB
Directions Served	L	LR
Maximum Queue (ft)	12	31
Average Queue (ft)	3	19
95th Queue (ft)	19	44
Link Distance (ft)		342
Upstream Blk Time (%)		
Queuing Penalty (veh)		
Storage Bay Dist (ft)	360	
Storage Blk Time (%)		
Queuing Penalty (veh)		

Queuing and Blocking Report  
6173 International Way Zone Change

12/20/2024

Intersection: 42: International Way & Fedex Westside , Interval #2

Movement	EB	SB
Directions Served	L	LR
Maximum Queue (ft)	6	36
Average Queue (ft)	0	15
95th Queue (ft)	5	40
Link Distance (ft)		342
Upstream Blk Time (%)		
Queuing Penalty (veh)		
Storage Bay Dist (ft)	360	
Storage Blk Time (%)		
Queuing Penalty (veh)		

Intersection: 42: International Way & Fedex Westside , All Intervals

Movement	EB	SB
Directions Served	L	LR
Maximum Queue (ft)	18	36
Average Queue (ft)	1	16
95th Queue (ft)	10	41
Link Distance (ft)		342
Upstream Blk Time (%)		
Queuing Penalty (veh)		
Storage Bay Dist (ft)	360	
Storage Blk Time (%)		
Queuing Penalty (veh)		

Network Summary

Network wide Queuing Penalty, Interval #1: 155
Network wide Queuing Penalty, Interval #2: 84
Network wide Queuing Penalty, All Intervals: 102

## Queuing and Blocking Report

11/25/2025

### Intersection: 2: EGame Farm Rd & Maple Island rd, Interval #1

Movement	EB	SB
Directions Served	LTR	LTR
Maximum Queue (ft)	34	31
Average Queue (ft)	6	9
95th Queue (ft)	30	31
Link Distance (ft)	1715	861
Upstream Blk Time (%)		
Queuing Penalty (veh)		
Storage Bay Dist (ft)		
Storage Blk Time (%)		
Queuing Penalty (veh)		

### Intersection: 2: EGame Farm Rd & Maple Island rd, Interval #2

Movement	EB	WB	SB
Directions Served	LTR	LTR	LTR
Maximum Queue (ft)	48	12	35
Average Queue (ft)	7	1	9
95th Queue (ft)	30	7	34
Link Distance (ft)	1715	319	861
Upstream Blk Time (%)			
Queuing Penalty (veh)			
Storage Bay Dist (ft)			
Storage Blk Time (%)			
Queuing Penalty (veh)			

### Intersection: 2: EGame Farm Rd & Maple Island rd, All Intervals

Movement	EB	WB	SB
Directions Served	LTR	LTR	LTR
Maximum Queue (ft)	54	12	35
Average Queue (ft)	6	0	9
95th Queue (ft)	30	6	33
Link Distance (ft)	1715	319	861
Upstream Blk Time (%)			
Queuing Penalty (veh)			
Storage Bay Dist (ft)			
Storage Blk Time (%)			
Queuing Penalty (veh)			

## Queuing and Blocking Report

11/25/2025

### Intersection: 5: Maple Island rd/Maple Island & International Way, Interval #1

Movement	EB	WB	NB	SB
Directions Served	LTR	LTR	LTR	LTR
Maximum Queue (ft)	19	12	12	25
Average Queue (ft)	3	2	2	4
95th Queue (ft)	17	14	14	20
Link Distance (ft)	491	962	861	209
Upstream Blk Time (%)				
Queuing Penalty (veh)				
Storage Bay Dist (ft)				
Storage Blk Time (%)				
Queuing Penalty (veh)				

### Intersection: 5: Maple Island rd/Maple Island & International Way, Interval #2

Movement	EB	WB	NB	SB
Directions Served	LTR	LTR	LTR	LTR
Maximum Queue (ft)	40	34	30	36
Average Queue (ft)	4	3	3	6
95th Queue (ft)	22	22	17	26
Link Distance (ft)	491	962	861	209
Upstream Blk Time (%)				
Queuing Penalty (veh)				
Storage Bay Dist (ft)				
Storage Blk Time (%)				
Queuing Penalty (veh)				

### Intersection: 5: Maple Island rd/Maple Island & International Way, All Intervals

Movement	EB	WB	NB	SB
Directions Served	LTR	LTR	LTR	LTR
Maximum Queue (ft)	40	34	30	36
Average Queue (ft)	4	3	3	5
95th Queue (ft)	21	20	16	25
Link Distance (ft)	491	962	861	209
Upstream Blk Time (%)				
Queuing Penalty (veh)				
Storage Bay Dist (ft)				
Storage Blk Time (%)				
Queuing Penalty (veh)				

## Queuing and Blocking Report

11/25/2025

### Intersection: 6: International Way & Fedex East Side , Interval #1

Movement	EB	SB
Directions Served	L	LR
Maximum Queue (ft)	11	18
Average Queue (ft)	2	3
95th Queue (ft)	16	19
Link Distance (ft)		294
Upstream Blk Time (%)		
Queuing Penalty (veh)		
Storage Bay Dist (ft)	250	
Storage Blk Time (%)		
Queuing Penalty (veh)		

### Intersection: 6: International Way & Fedex East Side , Interval #2

Movement	EB	WB	SB
Directions Served	L	TR	LR
Maximum Queue (ft)	32	10	31
Average Queue (ft)	3	0	5
95th Queue (ft)	19	8	25
Link Distance (ft)		172	294
Upstream Blk Time (%)			
Queuing Penalty (veh)			
Storage Bay Dist (ft)	250		
Storage Blk Time (%)			
Queuing Penalty (veh)			

### Intersection: 6: International Way & Fedex East Side , All Intervals

Movement	EB	WB	SB
Directions Served	L	TR	LR
Maximum Queue (ft)	36	10	31
Average Queue (ft)	2	0	5
95th Queue (ft)	18	7	23
Link Distance (ft)		172	294
Upstream Blk Time (%)			
Queuing Penalty (veh)			
Storage Bay Dist (ft)	250		
Storage Blk Time (%)			
Queuing Penalty (veh)			

## Queuing and Blocking Report

11/25/2025

### Intersection: 9: Beltline Rd & Gateway St , Interval #1

Movement	EB	EB	EB	EB	EB	EB	EB	WB	WB	WB	WB	NB
Directions Served	L	L	T	T	T	R	R	L	T	T	TR	L
Maximum Queue (ft)	280	281	228	179	124	402	380	197	263	252	243	284
Average Queue (ft)	217	216	170	129	83	317	270	127	201	195	187	276
95th Queue (ft)	327	324	232	189	128	429	403	204	274	266	269	313
Link Distance (ft)			1082	1082	1082			459	459	459		
Upstream Blk Time (%)												
Queuing Penalty (veh)												
Storage Bay Dist (ft)	480	480				640	640				360	260
Storage Blk Time (%)												7
Queuing Penalty (veh)												30

### Intersection: 9: Beltline Rd & Gateway St , Interval #1

Movement	NB	NB	SB	SB	SB	SB
Directions Served	L	TR	L	T	R	R
Maximum Queue (ft)	611	634	275	311	325	183
Average Queue (ft)	510	424	174	241	164	132
95th Queue (ft)	766	771	271	348	309	201
Link Distance (ft)	703	703		487	487	
Upstream Blk Time (%)	6	5			0	
Queuing Penalty (veh)	0	0			3	
Storage Bay Dist (ft)			335			190
Storage Blk Time (%)	37		0	1	2	1
Queuing Penalty (veh)	165		0	1	7	3

# Queuing and Blocking Report

11/25/2025

## Intersection: 9: Beltline Rd & Gateway St , Interval #2

Movement	EB	EB	EB	EB	EB	EB	EB	WB	WB	WB	WB	NB
Directions Served	L	L	T	T	T	R	R	L	T	T	TR	L
Maximum Queue (ft)	326	322	376	343	169	502	470	313	345	345	331	285
Average Queue (ft)	238	228	188	151	91	362	317	166	243	234	224	281
95th Queue (ft)	406	411	309	262	155	488	459	292	326	317	314	301
Link Distance (ft)			1082	1082	1082			459	459	459		
Upstream Blk Time (%)												
Queuing Penalty (veh)												
Storage Bay Dist (ft)	480	480				640	640				360	260
Storage Blk Time (%)	1	1								0	0	9
Queuing Penalty (veh)	2	3								2	0	44

## Intersection: 9: Beltline Rd & Gateway St , Interval #2

Movement	NB	NB	SB	SB	SB	SB
Directions Served	L	TR	L	T	R	R
Maximum Queue (ft)	736	726	360	448	359	215
Average Queue (ft)	652	598	193	274	169	152
95th Queue (ft)	842	906	350	410	285	230
Link Distance (ft)	703	703		487	487	
Upstream Blk Time (%)	29	23		0	0	
Queuing Penalty (veh)	0	0		1	0	
Storage Bay Dist (ft)			335			190
Storage Blk Time (%)	45		1	3	3	2
Queuing Penalty (veh)	218		6	8	10	10

## Queuing and Blocking Report

11/25/2025

### Intersection: 9: Beltline Rd & Gateway St , All Intervals

Movement	EB	EB	EB	EB	EB	EB	EB	WB	WB	WB	WB	NB
Directions Served	L	L	T	T	T	R	R	L	T	T	TR	L
Maximum Queue (ft)	342	342	376	343	170	502	470	313	345	345	331	285
Average Queue (ft)	233	225	183	146	89	351	306	157	232	225	215	280
95th Queue (ft)	390	393	294	248	150	478	449	276	318	309	307	305
Link Distance (ft)			1082	1082	1082			459	459	459		
Upstream Blk Time (%)												
Queuing Penalty (veh)												
Storage Bay Dist (ft)	480	480				640	640				360	260
Storage Blk Time (%)	1	1								0	0	8
Queuing Penalty (veh)	1	2								1	0	40

### Intersection: 9: Beltline Rd & Gateway St , All Intervals

Movement	NB	NB	SB	SB	SB	SB
Directions Served	L	TR	L	T	R	R
Maximum Queue (ft)	736	726	360	448	411	215
Average Queue (ft)	618	556	188	266	168	147
95th Queue (ft)	848	897	334	398	291	225
Link Distance (ft)	703	703		487	487	
Upstream Blk Time (%)	23	18		0	0	
Queuing Penalty (veh)	0	0		1	1	
Storage Bay Dist (ft)			335			190
Storage Blk Time (%)	43		1	3	2	2
Queuing Penalty (veh)	205		5	6	10	8

### Intersection: 10: Gateway St & International Way, Interval #1

Movement	EB	WB	WB	NB	NB	NB	SB	SB
Directions Served	LTR	L	TR	L	T	R	L	TR
Maximum Queue (ft)	54	212	57	63	263	182	218	329
Average Queue (ft)	31	147	38	14	171	55	57	240
95th Queue (ft)	60	253	59	40	286	183	169	396
Link Distance (ft)	271		502		614	614		314
Upstream Blk Time (%)								10
Queuing Penalty (veh)								0
Storage Bay Dist (ft)		280		160			194	
Storage Blk Time (%)		3			7			15
Queuing Penalty (veh)		3			1			8

## Queuing and Blocking Report

11/25/2025

### Intersection: 10: Gateway St & International Way, Interval #2

Movement	EB	WB	WB	NB	NB	NB	SB	SB
Directions Served	LTR	L	TR	L	T	R	L	TR
Maximum Queue (ft)	78	291	261	105	333	216	218	329
Average Queue (ft)	37	195	68	14	147	35	70	307
95th Queue (ft)	75	307	235	60	277	148	205	400
Link Distance (ft)	271		502		614	614		314
Upstream Blk Time (%)			0					28
Queuing Penalty (veh)			1					0
Storage Bay Dist (ft)		280		160			194	
Storage Blk Time (%)		5	0		7			30
Queuing Penalty (veh)		7	0		1			17

### Intersection: 10: Gateway St & International Way, All Intervals

Movement	EB	WB	WB	NB	NB	NB	SB	SB
Directions Served	LTR	L	TR	L	T	R	L	TR
Maximum Queue (ft)	78	297	261	105	333	240	218	329
Average Queue (ft)	36	184	61	14	152	40	67	291
95th Queue (ft)	72	299	208	56	280	157	197	412
Link Distance (ft)	271		502		614	614		314
Upstream Blk Time (%)			0					24
Queuing Penalty (veh)			1					0
Storage Bay Dist (ft)		280		160			194	
Storage Blk Time (%)		5	0		7		0	26
Queuing Penalty (veh)		6	0		1		0	15

### Intersection: 12: Gateway St /Gateway St & EGame Farm Rd, Interval #1

Movement	EB	WB	WB	NB	NB	NB	SB	SB	SB
Directions Served	LTR	L	TR	L	T	T	L	T	TR
Maximum Queue (ft)	12	154	58	86	167	144	65	135	140
Average Queue (ft)	2	94	36	24	84	53	33	63	84
95th Queue (ft)	13	155	64	78	174	138	70	141	153
Link Distance (ft)	249		1715		487	487			614
Upstream Blk Time (%)									
Queuing Penalty (veh)									
Storage Bay Dist (ft)		150		115			224	224	
Storage Blk Time (%)		2			3	1			
Queuing Penalty (veh)		3			1	0			

## Queuing and Blocking Report

11/25/2025

### Intersection: 12: Gateway St /Gateway St & EGame Farm Rd, Interval #2

Movement	EB	WB	WB	NB	NB	NB	NB	SB	SB	SB
Directions Served	LTR	L	TR	L	T	T	R	L	T	TR
Maximum Queue (ft)	33	175	373	110	233	216	123	127	188	199
Average Queue (ft)	4	117	99	24	125	91	10	40	79	106
95th Queue (ft)	18	192	314	76	218	187	76	96	151	172
Link Distance (ft)	249		1715		487	487				614
Upstream Blk Time (%)										
Queuing Penalty (veh)										
Storage Bay Dist (ft)		150		115			150	224	224	
Storage Blk Time (%)		18	0		8	1	0		0	0
Queuing Penalty (veh)		30	0		4	1	0		0	0

### Intersection: 12: Gateway St /Gateway St & EGame Farm Rd, All Intervals

Movement	EB	WB	WB	NB	NB	NB	NB	SB	SB	SB
Directions Served	LTR	L	TR	L	T	T	R	L	T	TR
Maximum Queue (ft)	36	175	373	139	233	216	123	127	200	199
Average Queue (ft)	3	112	84	24	115	82	8	38	75	101
95th Queue (ft)	17	185	276	76	212	179	65	90	149	169
Link Distance (ft)	249		1715		487	487				614
Upstream Blk Time (%)										
Queuing Penalty (veh)										
Storage Bay Dist (ft)		150		115			150	224	224	
Storage Blk Time (%)		14	0	0	7	1	0		0	0
Queuing Penalty (veh)		24	0	0	3	1	0		0	0

### Intersection: 15: International Way & Richardson Access , Interval #1

Movement	EB	NB	SB
Directions Served	L	LTR	LTR
Maximum Queue (ft)	6	29	30
Average Queue (ft)	1	7	15
95th Queue (ft)	9	27	39
Link Distance (ft)		311	201
Upstream Blk Time (%)			
Queuing Penalty (veh)			
Storage Bay Dist (ft)	145		
Storage Blk Time (%)			
Queuing Penalty (veh)			

## Queuing and Blocking Report

11/25/2025

### Intersection: 15: International Way & Richardson Access , Interval #2

Movement	EB	NB	SB
Directions Served	L	LTR	LTR
Maximum Queue (ft)	6	30	45
Average Queue (ft)	1	7	28
95th Queue (ft)	7	28	47
Link Distance (ft)		311	201
Upstream Blk Time (%)			
Queuing Penalty (veh)			
Storage Bay Dist (ft)	145		
Storage Blk Time (%)			
Queuing Penalty (veh)			

### Intersection: 15: International Way & Richardson Access , All Intervals

Movement	EB	NB	SB
Directions Served	L	LTR	LTR
Maximum Queue (ft)	12	30	45
Average Queue (ft)	1	7	25
95th Queue (ft)	8	28	47
Link Distance (ft)		311	201
Upstream Blk Time (%)			
Queuing Penalty (veh)			
Storage Bay Dist (ft)	145		
Storage Blk Time (%)			
Queuing Penalty (veh)			

### Intersection: 16: Game Farm Rd & Deadmond Ferry , Interval #1

Movement	EB	WB	NB	NB
Directions Served	TR	L	L	R
Maximum Queue (ft)	30	69	52	28
Average Queue (ft)	5	31	30	22
95th Queue (ft)	27	72	51	39
Link Distance (ft)	319			554
Upstream Blk Time (%)				
Queuing Penalty (veh)				
Storage Bay Dist (ft)		140	115	
Storage Blk Time (%)				
Queuing Penalty (veh)				

## Queuing and Blocking Report

11/25/2025

### Intersection: 16: Game Farm Rd & Deadmond Ferry , Interval #2

Movement	EB	WB	NB	NB
Directions Served	TR	L	L	R
Maximum Queue (ft)	39	83	113	32
Average Queue (ft)	7	41	41	26
95th Queue (ft)	27	70	83	39
Link Distance (ft)	319			554
Upstream Blk Time (%)				
Queuing Penalty (veh)				
Storage Bay Dist (ft)		140	115	
Storage Blk Time (%)			1	
Queuing Penalty (veh)			0	

### Intersection: 16: Game Farm Rd & Deadmond Ferry , All Intervals

Movement	EB	WB	NB	NB
Directions Served	TR	L	L	R
Maximum Queue (ft)	45	91	113	32
Average Queue (ft)	6	39	39	25
95th Queue (ft)	27	71	77	39
Link Distance (ft)	319			554
Upstream Blk Time (%)				
Queuing Penalty (veh)				
Storage Bay Dist (ft)		140	115	
Storage Blk Time (%)			0	
Queuing Penalty (veh)			0	

### Intersection: 17: Beltline Rd /MLK & Game Farm Rd, Interval #1

Movement	EB	EB	EB	WB	WB	WB	SB	SB
Directions Served	L	T	T	T	T	R	L	R
Maximum Queue (ft)	51	127	154	176	183	56	227	110
Average Queue (ft)	19	62	79	111	129	36	137	25
95th Queue (ft)	54	126	141	181	200	64	233	100
Link Distance (ft)		1696	1696	878	878		554	
Upstream Blk Time (%)								
Queuing Penalty (veh)								
Storage Bay Dist (ft)	340					275		85
Storage Blk Time (%)							19	0
Queuing Penalty (veh)							16	0

## Queuing and Blocking Report

11/25/2025

### Intersection: 17: Beltline Rd /MLK & Game Farm Rd, Interval #2

Movement	EB	EB	EB	WB	WB	WB	SB	SB
Directions Served	L	T	T	T	T	R	L	R
Maximum Queue (ft)	70	174	190	230	258	113	285	110
Average Queue (ft)	23	72	90	135	153	41	164	43
95th Queue (ft)	57	139	164	214	231	87	255	129
Link Distance (ft)		1696	1696	878	878		554	
Upstream Blk Time (%)								
Queuing Penalty (veh)								
Storage Bay Dist (ft)	340					275		85
Storage Blk Time (%)					0	0	29	0
Queuing Penalty (veh)					0	0	28	0

### Intersection: 17: Beltline Rd /MLK & Game Farm Rd, All Intervals

Movement	EB	EB	EB	WB	WB	WB	SB	SB
Directions Served	L	T	T	T	T	R	L	R
Maximum Queue (ft)	79	174	190	237	258	113	296	110
Average Queue (ft)	22	69	87	129	147	40	157	38
95th Queue (ft)	56	137	159	208	225	82	252	123
Link Distance (ft)		1696	1696	878	878		554	
Upstream Blk Time (%)								
Queuing Penalty (veh)								
Storage Bay Dist (ft)	340					275		85
Storage Blk Time (%)					0	0	27	0
Queuing Penalty (veh)					0	0	25	0

### Intersection: 21: International Way & Site access , Interval #1

Movement
Directions Served
Maximum Queue (ft)
Average Queue (ft)
95th Queue (ft)
Link Distance (ft)
Upstream Blk Time (%)
Queuing Penalty (veh)
Storage Bay Dist (ft)
Storage Blk Time (%)
Queuing Penalty (veh)

## Queuing and Blocking Report

11/25/2025

### Intersection: 21: International Way & Site access , Interval #2

#### Movement

Directions Served  
 Maximum Queue (ft)  
 Average Queue (ft)  
 95th Queue (ft)  
 Link Distance (ft)  
 Upstream Blk Time (%)  
 Queuing Penalty (veh)  
 Storage Bay Dist (ft)  
 Storage Blk Time (%)  
 Queuing Penalty (veh)

### Intersection: 21: International Way & Site access , All Intervals

#### Movement

Directions Served  
 Maximum Queue (ft)  
 Average Queue (ft)  
 95th Queue (ft)  
 Link Distance (ft)  
 Upstream Blk Time (%)  
 Queuing Penalty (veh)  
 Storage Bay Dist (ft)  
 Storage Blk Time (%)  
 Queuing Penalty (veh)

### Intersection: 24: Hutton & Beltline Rd , Interval #1

Movement	EB	EB	EB	WB	WB	WB	NB	SB	SB
Directions Served	L	T	TR	L	T	TR	LTR	LT	R
Maximum Queue (ft)	51	4	7	55	82	44	184	49	63
Average Queue (ft)	21	0	0	21	18	9	100	19	38
95th Queue (ft)	52	5	4	54	72	41	263	51	65
Link Distance (ft)		459	459		1696	1696	508	334	334
Upstream Blk Time (%)									
Queuing Penalty (veh)									
Storage Bay Dist (ft)	130			440					
Storage Blk Time (%)									
Queuing Penalty (veh)									

## Queuing and Blocking Report

11/25/2025

### Intersection: 24: Hutton & Beltline Rd , Interval #2

Movement	EB	EB	EB	WB	WB	WB	NB	SB	SB
Directions Served	L	T	TR	L	T	TR	LTR	LT	R
Maximum Queue (ft)	74	16	28	59	72	79	301	78	95
Average Queue (ft)	22	1	2	19	6	12	146	27	39
95th Queue (ft)	55	11	13	48	40	50	303	64	69
Link Distance (ft)		459	459		1696	1696	508	334	334
Upstream Blk Time (%)									
Queuing Penalty (veh)									
Storage Bay Dist (ft)	130			440					
Storage Blk Time (%)									
Queuing Penalty (veh)									

### Intersection: 24: Hutton & Beltline Rd , All Intervals

Movement	EB	EB	EB	WB	WB	WB	NB	SB	SB
Directions Served	L	T	TR	L	T	TR	LTR	LT	R
Maximum Queue (ft)	75	18	28	67	98	80	326	83	95
Average Queue (ft)	22	1	2	19	9	12	135	25	39
95th Queue (ft)	55	10	12	50	49	48	297	62	68
Link Distance (ft)		459	459		1696	1696	508	334	334
Upstream Blk Time (%)									
Queuing Penalty (veh)									
Storage Bay Dist (ft)	130			440					
Storage Blk Time (%)									
Queuing Penalty (veh)									

### Intersection: 35: Harlow & Gateway , Interval #1

Movement	EB	EB	EB	WB	WB	WB	NB	NB	SB	SB	SB
Directions Served	L	T	TR	L	T	TR	LT	TR	L	L	TR
Maximum Queue (ft)	193	176	143	74	233	222	115	93	191	243	146
Average Queue (ft)	123	108	70	22	157	154	64	38	108	181	80
95th Queue (ft)	202	188	137	86	242	234	116	91	229	268	142
Link Distance (ft)		764	764		802	802	420	420		507	507
Upstream Blk Time (%)											
Queuing Penalty (veh)											
Storage Bay Dist (ft)	215			200					190		
Storage Blk Time (%)	0	0			3				0	7	
Queuing Penalty (veh)	0	0			0				0	17	

## Queuing and Blocking Report

11/25/2025

### Intersection: 35: Harlow & Gateway , Interval #2

Movement	EB	EB	EB	WB	WB	WB	NB	NB	SB	SB	SB
Directions Served	L	T	TR	L	T	TR	LT	TR	L	L	TR
Maximum Queue (ft)	239	310	215	121	332	459	146	136	215	377	326
Average Queue (ft)	158	135	91	19	217	253	79	45	169	243	147
95th Queue (ft)	239	252	174	72	326	428	133	94	252	342	290
Link Distance (ft)		764	764		802	802	420	420		507	507
Upstream Blk Time (%)											
Queuing Penalty (veh)											
Storage Bay Dist (ft)	215			200					190		
Storage Blk Time (%)	4	0			10				1	18	
Queuing Penalty (veh)	11	1			2				3	51	

### Intersection: 35: Harlow & Gateway , All Intervals

Movement	EB	EB	EB	WB	WB	WB	NB	NB	SB	SB	SB
Directions Served	L	T	TR	L	T	TR	LT	TR	L	L	TR
Maximum Queue (ft)	239	310	215	122	341	459	154	143	215	377	326
Average Queue (ft)	149	128	86	19	203	229	76	44	155	228	131
95th Queue (ft)	234	239	167	76	315	402	130	94	257	334	267
Link Distance (ft)		764	764		802	802	420	420		507	507
Upstream Blk Time (%)											
Queuing Penalty (veh)											
Storage Bay Dist (ft)	215			200					190		
Storage Blk Time (%)	3	0			8				1	15	
Queuing Penalty (veh)	8	1			1				2	42	

### Intersection: 40: International Way & Sports Way , Interval #1

Movement	EB	SB	SB
Directions Served	L	L	R
Maximum Queue (ft)	12	14	25
Average Queue (ft)	2	2	13
95th Queue (ft)	14	13	29
Link Distance (ft)			484
Upstream Blk Time (%)			
Queuing Penalty (veh)			
Storage Bay Dist (ft)	175	240	
Storage Blk Time (%)			
Queuing Penalty (veh)			

## Queuing and Blocking Report

11/25/2025

### Intersection: 40: International Way & Sports Way , Interval #2

Movement	EB	WB	SB	SB
Directions Served	L	TR	L	R
Maximum Queue (ft)	24	25	29	43
Average Queue (ft)	2	2	3	18
95th Queue (ft)	13	21	18	30
Link Distance (ft)		559		484
Upstream Blk Time (%)				
Queuing Penalty (veh)				
Storage Bay Dist (ft)	175		240	
Storage Blk Time (%)				
Queuing Penalty (veh)				

### Intersection: 40: International Way & Sports Way , All Intervals

Movement	EB	WB	SB	SB
Directions Served	L	TR	L	R
Maximum Queue (ft)	30	25	29	43
Average Queue (ft)	2	1	3	17
95th Queue (ft)	13	18	17	31
Link Distance (ft)		559		484
Upstream Blk Time (%)				
Queuing Penalty (veh)				
Storage Bay Dist (ft)	175		240	
Storage Blk Time (%)				
Queuing Penalty (veh)				

### Intersection: 42: International Way & Fedex Westside , Interval #1

Movement	EB	SB
Directions Served	L	LR
Maximum Queue (ft)	6	35
Average Queue (ft)	1	17
95th Queue (ft)	9	43
Link Distance (ft)		342
Upstream Blk Time (%)		
Queuing Penalty (veh)		
Storage Bay Dist (ft)	360	
Storage Blk Time (%)		
Queuing Penalty (veh)		

## Queuing and Blocking Report

11/25/2025

### Intersection: 42: International Way & Fedex Westside , Interval #2

Movement	EB	SB
Directions Served	L	LR
Maximum Queue (ft)	30	45
Average Queue (ft)	2	24
95th Queue (ft)	13	50
Link Distance (ft)		342
Upstream Blk Time (%)		
Queuing Penalty (veh)		
Storage Bay Dist (ft)	360	
Storage Blk Time (%)		
Queuing Penalty (veh)		

### Intersection: 42: International Way & Fedex Westside , All Intervals

Movement	EB	SB
Directions Served	L	LR
Maximum Queue (ft)	30	49
Average Queue (ft)	1	22
95th Queue (ft)	12	48
Link Distance (ft)		342
Upstream Blk Time (%)		
Queuing Penalty (veh)		
Storage Bay Dist (ft)	360	
Storage Blk Time (%)		
Queuing Penalty (veh)		

### Network Summary

Network wide Queuing Penalty, Interval #1: 260
Network wide Queuing Penalty, Interval #2: 463
Network wide Queuing Penalty, All Intervals: 412

# Queuing and Blocking Report

03/19/2026

## Intersection: 9: Beltline Rd & Gateway St , Interval #1

Movement	EB	EB	EB	EB	EB	EB	EB	WB	WB	WB	WB	WB
Directions Served	L	L	T	T	T	R	R	L	L	T	T	T
Maximum Queue (ft)	170	155	157	143	41	361	319	107	122	265	276	275
Average Queue (ft)	102	87	84	50	6	255	215	63	81	189	199	198
95th Queue (ft)	175	164	159	132	46	360	320	110	127	289	300	287
Link Distance (ft)			1076	1076	1076			460	460	460	460	460
Upstream Blk Time (%)												
Queuing Penalty (veh)												
Storage Bay Dist (ft)	480	480				640	640					
Storage Blk Time (%)												
Queuing Penalty (veh)												

## Intersection: 9: Beltline Rd & Gateway St , Interval #1

Movement	WB	SB	SB	SB	SB	SB
Directions Served	R	L	T	T	R	R
Maximum Queue (ft)	184	236	194	208	240	212
Average Queue (ft)	94	143	107	123	151	151
95th Queue (ft)	184	238	192	205	234	217
Link Distance (ft)			468	468	468	
Upstream Blk Time (%)						
Queuing Penalty (veh)						
Storage Bay Dist (ft)	360	335				190
Storage Blk Time (%)					2	1
Queuing Penalty (veh)					7	5

## Queuing and Blocking Report

03/19/2026

### Intersection: 9: Beltline Rd & Gateway St , Interval #2

Movement	EB	EB	EB	EB	EB	EB	EB	WB	WB	WB	WB	WB
Directions Served	L	L	T	T	T	R	R	L	L	T	T	T
Maximum Queue (ft)	221	267	283	174	89	437	423	154	162	305	327	331
Average Queue (ft)	137	129	112	65	8	300	270	73	89	220	231	224
95th Queue (ft)	204	228	223	148	52	414	387	142	154	309	328	315
Link Distance (ft)			1076	1076	1076			460	460	460	460	460
Upstream Blk Time (%)												
Queuing Penalty (veh)												
Storage Bay Dist (ft)	480	480				640	640					
Storage Blk Time (%)												0
Queuing Penalty (veh)												0

### Intersection: 9: Beltline Rd & Gateway St , Interval #2

Movement	WB	SB	SB	SB	SB	SB
Directions Served	R	L	T	T	R	R
Maximum Queue (ft)	242	247	193	193	335	214
Average Queue (ft)	110	172	132	144	193	170
95th Queue (ft)	197	248	193	198	308	233
Link Distance (ft)			468	468	468	
Upstream Blk Time (%)						
Queuing Penalty (veh)						
Storage Bay Dist (ft)	360	335				190
Storage Blk Time (%)					5	4
Queuing Penalty (veh)					18	15

## Queuing and Blocking Report

03/19/2026

### Intersection: 9: Beltline Rd & Gateway St , All Intervals

Movement	EB	EB	EB	EB	EB	EB	EB	WB	WB	WB	WB	WB
Directions Served	L	L	T	T	T	R	R	L	L	T	T	T
Maximum Queue (ft)	221	267	283	180	98	440	423	155	165	305	327	331
Average Queue (ft)	129	119	105	61	8	289	257	71	87	212	223	217
95th Queue (ft)	201	218	210	145	51	405	377	136	148	307	323	310
Link Distance (ft)			1076	1076	1076			460	460	460	460	460
Upstream Blk Time (%)												
Queuing Penalty (veh)												
Storage Bay Dist (ft)	480	480				640	640					
Storage Blk Time (%)												0
Queuing Penalty (veh)												0

### Intersection: 9: Beltline Rd & Gateway St , All Intervals

Movement	WB	SB	SB	SB	SB	SB
Directions Served	R	L	T	T	R	R
Maximum Queue (ft)	243	261	210	209	335	214
Average Queue (ft)	106	165	126	138	183	166
95th Queue (ft)	195	249	196	202	295	231
Link Distance (ft)			468	468	468	
Upstream Blk Time (%)						
Queuing Penalty (veh)						
Storage Bay Dist (ft)	360	335				190
Storage Blk Time (%)					4	3
Queuing Penalty (veh)					15	13

### Intersection: 24: Hutton & Beltline Rd , Interval #1

Movement	EB	EB	EB	EB	WB	WB	WB	NB	NB	NB	SB	SB
Directions Served	L	T	T	T	T	T	TR	L	L	TR	L	R
Maximum Queue (ft)	116	190	180	62	268	271	295	391	381	164	46	130
Average Queue (ft)	50	107	97	17	178	183	194	284	251	74	19	71
95th Queue (ft)	119	193	180	73	267	268	314	412	396	203	53	142
Link Distance (ft)		460	460	460	398	398	398	509	509	509	312	312
Upstream Blk Time (%)							0	0				
Queuing Penalty (veh)							1	0				
Storage Bay Dist (ft)	130											
Storage Blk Time (%)	1	11										
Queuing Penalty (veh)	1	5										

## Queuing and Blocking Report

03/19/2026

### Intersection: 24: Hutton & Beltline Rd , Interval #2

Movement	EB	EB	EB	EB	WB	WB	WB	NB	NB	NB	SB	SB
Directions Served	L	T	T	T	T	T	TR	L	L	TR	L	R
Maximum Queue (ft)	154	257	244	190	304	316	336	490	463	295	63	144
Average Queue (ft)	52	135	123	36	208	217	227	303	268	69	21	77
95th Queue (ft)	117	231	223	133	290	303	319	465	420	179	54	138
Link Distance (ft)		460	460	460	398	398	398	509	509	509	312	312
Upstream Blk Time (%)								0	0	0		
Queuing Penalty (veh)								0	0	0		
Storage Bay Dist (ft)	130											
Storage Blk Time (%)	0	14										
Queuing Penalty (veh)	0	7										

### Intersection: 24: Hutton & Beltline Rd , All Intervals

Movement	EB	EB	EB	EB	WB	WB	WB	NB	NB	NB	SB	SB
Directions Served	L	T	T	T	T	T	TR	L	L	TR	L	R
Maximum Queue (ft)	154	266	245	190	314	320	355	496	463	311	63	164
Average Queue (ft)	52	128	117	31	201	209	219	299	264	70	21	75
95th Queue (ft)	118	224	214	121	287	298	322	453	415	185	54	139
Link Distance (ft)		460	460	460	398	398	398	509	509	509	312	312
Upstream Blk Time (%)								0	0	0		
Queuing Penalty (veh)								0	0	0		
Storage Bay Dist (ft)	130											
Storage Blk Time (%)	0	13										
Queuing Penalty (veh)	0	6										

### Zone Summary

Zone wide Queuing Penalty, Interval #1: 18  
 Zone wide Queuing Penalty, Interval #2: 40  
 Zone wide Queuing Penalty, All Intervals: 35

# Queuing and Blocking Report

11/24/2025

## Intersection: 2: EGame Farm Rd & Maple Island rd, Interval #1

Movement	EB	SB
Directions Served	LTR	LTR
Maximum Queue (ft)	52	36
Average Queue (ft)	19	15
95th Queue (ft)	55	42
Link Distance (ft)	1715	861
Upstream Blk Time (%)		
Queuing Penalty (veh)		
Storage Bay Dist (ft)		
Storage Blk Time (%)		
Queuing Penalty (veh)		

## Intersection: 2: EGame Farm Rd & Maple Island rd, Interval #2

Movement	EB	SB
Directions Served	LTR	LTR
Maximum Queue (ft)	68	50
Average Queue (ft)	17	16
95th Queue (ft)	53	47
Link Distance (ft)	1715	861
Upstream Blk Time (%)		
Queuing Penalty (veh)		
Storage Bay Dist (ft)		
Storage Blk Time (%)		
Queuing Penalty (veh)		

## Intersection: 2: EGame Farm Rd & Maple Island rd, All Intervals

Movement	EB	SB
Directions Served	LTR	LTR
Maximum Queue (ft)	71	50
Average Queue (ft)	17	16
95th Queue (ft)	53	46
Link Distance (ft)	1715	861
Upstream Blk Time (%)		
Queuing Penalty (veh)		
Storage Bay Dist (ft)		
Storage Blk Time (%)		
Queuing Penalty (veh)		

## Queuing and Blocking Report

11/24/2025

### Intersection: 5: Maple Island rd/Maple Island & International Way, Interval #1

Movement	EB	WB	NB	SB
Directions Served	LTR	LTR	LTR	LTR
Maximum Queue (ft)	18	19	12	24
Average Queue (ft)	4	3	2	4
95th Queue (ft)	22	19	13	22
Link Distance (ft)	491	962	861	209
Upstream Blk Time (%)				
Queuing Penalty (veh)				
Storage Bay Dist (ft)				
Storage Blk Time (%)				
Queuing Penalty (veh)				

### Intersection: 5: Maple Island rd/Maple Island & International Way, Interval #2

Movement	EB	WB	NB	SB
Directions Served	LTR	LTR	LTR	LTR
Maximum Queue (ft)	34	36	31	31
Average Queue (ft)	5	5	2	5
95th Queue (ft)	26	24	16	24
Link Distance (ft)	491	962	861	209
Upstream Blk Time (%)				
Queuing Penalty (veh)				
Storage Bay Dist (ft)				
Storage Blk Time (%)				
Queuing Penalty (veh)				

### Intersection: 5: Maple Island rd/Maple Island & International Way, All Intervals

Movement	EB	WB	NB	SB
Directions Served	LTR	LTR	LTR	LTR
Maximum Queue (ft)	40	36	31	31
Average Queue (ft)	5	4	2	5
95th Queue (ft)	25	23	15	23
Link Distance (ft)	491	962	861	209
Upstream Blk Time (%)				
Queuing Penalty (veh)				
Storage Bay Dist (ft)				
Storage Blk Time (%)				
Queuing Penalty (veh)				

# Queuing and Blocking Report

11/24/2025

## Intersection: 9: Beltline Rd & Gateway St , Interval #1

Movement	EB	EB	EB	EB	EB	EB	EB	WB	WB	WB	WB	NB
Directions Served	L	L	T	T	T	R	R	L	T	T	TR	L
Maximum Queue (ft)	350	336	254	218	346	410	376	226	294	294	270	285
Average Queue (ft)	264	256	185	166	145	324	291	157	226	218	201	273
95th Queue (ft)	428	433	271	231	436	427	411	288	324	318	291	319
Link Distance (ft)			1082	1082	1082			459	459	459		
Upstream Blk Time (%)					0							
Queuing Penalty (veh)					0							
Storage Bay Dist (ft)	480	480				640	640				360	260
Storage Blk Time (%)	0									0		6
Queuing Penalty (veh)	0									0		25

## Intersection: 9: Beltline Rd & Gateway St , Interval #1

Movement	NB	NB	SB	SB	SB	SB
Directions Served	L	TR	L	T	R	R
Maximum Queue (ft)	682	665	323	451	405	190
Average Queue (ft)	581	502	198	326	196	140
95th Queue (ft)	818	831	368	492	375	219
Link Distance (ft)	704	704		487	487	
Upstream Blk Time (%)	13	9		2	1	
Queuing Penalty (veh)	0	0		17	11	
Storage Bay Dist (ft)			335			190
Storage Blk Time (%)	43			10	3	2
Queuing Penalty (veh)	193			21	13	9

# Queuing and Blocking Report

11/24/2025

## Intersection: 9: Beltline Rd & Gateway St , Interval #2

Movement	EB	EB	EB	EB	EB	EB	EB	WB	WB	WB	WB	NB
Directions Served	L	L	T	T	T	R	R	L	T	T	TR	L
Maximum Queue (ft)	489	504	909	870	425	537	484	400	425	425	361	285
Average Queue (ft)	412	420	547	487	190	373	332	233	306	299	281	279
95th Queue (ft)	581	601	1199	1104	461	514	470	428	457	458	397	299
Link Distance (ft)			1082	1082	1082			459	459	459		
Upstream Blk Time (%)			9	0	0			2	4	4		
Queuing Penalty (veh)			0	0	0			6	14	14		
Storage Bay Dist (ft)	480	480				640	640				360	260
Storage Blk Time (%)	31	39	0			0				8	6	10
Queuing Penalty (veh)	61	78	0			0				36	17	49

## Intersection: 9: Beltline Rd & Gateway St , Interval #2

Movement	NB	NB	SB	SB	SB	SB
Directions Served	L	TR	L	T	R	R
Maximum Queue (ft)	738	727	359	496	431	215
Average Queue (ft)	714	699	186	314	182	144
95th Queue (ft)	770	856	375	489	352	226
Link Distance (ft)	704	704		487	487	
Upstream Blk Time (%)	44	42		3	1	
Queuing Penalty (veh)	0	0		25	9	
Storage Bay Dist (ft)			335			190
Storage Blk Time (%)	49		0	10	3	2
Queuing Penalty (veh)	241		0	23	13	12

## Queuing and Blocking Report

11/24/2025

### Intersection: 9: Beltline Rd & Gateway St , All Intervals

Movement	EB	EB	EB	EB	EB	EB	EB	WB	WB	WB	WB	NB
Directions Served	L	L	T	T	T	R	R	L	T	T	TR	L
Maximum Queue (ft)	489	504	909	870	427	537	493	403	438	432	362	285
Average Queue (ft)	376	380	460	409	179	361	322	215	286	279	261	277
95th Queue (ft)	574	594	1084	994	457	499	459	404	437	437	385	307
Link Distance (ft)			1082	1082	1082			459	459	459		
Upstream Blk Time (%)			7	0	0			1	3	3		
Queuing Penalty (veh)			0	0	0			5	11	11		
Storage Bay Dist (ft)	480	480				640	640				360	260
Storage Blk Time (%)	23	29	0			0				6	5	9
Queuing Penalty (veh)	46	58	0			0				27	12	43

### Intersection: 9: Beltline Rd & Gateway St , All Intervals

Movement	NB	NB	SB	SB	SB	SB
Directions Served	L	TR	L	T	R	R
Maximum Queue (ft)	738	727	359	508	483	215
Average Queue (ft)	682	651	189	317	185	143
95th Queue (ft)	839	904	373	490	358	224
Link Distance (ft)	704	704		487	487	
Upstream Blk Time (%)	36	34		3	1	
Queuing Penalty (veh)	0	0		23	9	
Storage Bay Dist (ft)			335			190
Storage Blk Time (%)	48		0	10	3	2
Queuing Penalty (veh)	229		0	23	13	11

### Intersection: 10: Gateway St & International Way, Interval #1

Movement	EB	WB	WB	NB	NB	NB	SB	SB
Directions Served	LTR	L	TR	L	T	R	L	TR
Maximum Queue (ft)	54	305	514	61	352	214	218	329
Average Queue (ft)	27	304	502	14	209	64	90	319
95th Queue (ft)	58	308	550	66	390	215	235	378
Link Distance (ft)	271		502		614	614		314
Upstream Blk Time (%)			39					36
Queuing Penalty (veh)			239					0
Storage Bay Dist (ft)		280		160			194	
Storage Blk Time (%)		74	7		15			39
Queuing Penalty (veh)		133	41		2			25

## Queuing and Blocking Report

11/24/2025

### Intersection: 10: Gateway St & International Way, Interval #2

Movement	EB	WB	WB	NB	NB	NB	SB	SB
Directions Served	LTR	L	TR	L	T	R	L	TR
Maximum Queue (ft)	80	305	514	131	491	419	218	329
Average Queue (ft)	34	304	509	15	246	109	105	329
95th Queue (ft)	70	306	514	67	449	333	247	331
Link Distance (ft)	271		502		614	614		314
Upstream Blk Time (%)			36		0	0		47
Queuing Penalty (veh)			363		0	0		0
Storage Bay Dist (ft)		280		160			194	
Storage Blk Time (%)		70	1		18		0	46
Queuing Penalty (veh)		139	5		2		0	33

### Intersection: 10: Gateway St & International Way, All Intervals

Movement	EB	WB	WB	NB	NB	NB	SB	SB
Directions Served	LTR	L	TR	L	T	R	L	TR
Maximum Queue (ft)	83	305	515	131	495	439	218	329
Average Queue (ft)	32	304	507	14	237	98	101	327
95th Queue (ft)	68	304	532	67	437	309	245	357
Link Distance (ft)	271		502		614	614		314
Upstream Blk Time (%)			37		0	0		44
Queuing Penalty (veh)			332		0	0		0
Storage Bay Dist (ft)		280		160			194	
Storage Blk Time (%)		71	2		17		0	44
Queuing Penalty (veh)		137	14		2		0	31

### Intersection: 12: Gateway St /Gateway St & EGame Farm Rd, Interval #1

Movement	EB	WB	WB	NB	NB	NB	NB	SB	SB	SB
Directions Served	LTR	L	TR	L	T	T	R	L	T	TR
Maximum Queue (ft)	13	162	102	139	187	171	70	75	171	187
Average Queue (ft)	2	113	45	35	112	73	5	35	88	117
95th Queue (ft)	13	184	100	116	219	162	53	80	173	200
Link Distance (ft)	249		1715		487	487				614
Upstream Blk Time (%)										
Queuing Penalty (veh)										
Storage Bay Dist (ft)		150		115			150	224	224	
Storage Blk Time (%)		5			6	1				0
Queuing Penalty (veh)		7			3	1				4

## Queuing and Blocking Report

11/24/2025

### Intersection: 12: Gateway St /Gateway St & EGame Farm Rd, Interval #2

Movement	EB	WB	WB	NB	NB	NB	SB	SB	SB
Directions Served	LTR	L	TR	L	T	T	L	T	TR
Maximum Queue (ft)	42	174	337	123	259	228	157	227	388
Average Queue (ft)	4	127	78	36	125	86	43	110	134
95th Queue (ft)	22	190	231	105	240	197	117	208	279
Link Distance (ft)	249		1715		487	487			614
Upstream Blk Time (%)									
Queuing Penalty (veh)									
Storage Bay Dist (ft)		150		115			224	224	
Storage Blk Time (%)		14		0	8	2	0	1	1
Queuing Penalty (veh)		23		0	4	1	0	7	7

### Intersection: 12: Gateway St /Gateway St & EGame Farm Rd, All Intervals

Movement	EB	WB	WB	NB	NB	NB	NB	SB	SB	SB
Directions Served	LTR	L	TR	L	T	T	R	L	T	TR
Maximum Queue (ft)	42	174	337	139	259	228	70	157	235	414
Average Queue (ft)	4	124	70	35	121	83	1	41	104	130
95th Queue (ft)	20	190	208	108	235	190	25	110	201	263
Link Distance (ft)	249		1715		487	487				614
Upstream Blk Time (%)										
Queuing Penalty (veh)										
Storage Bay Dist (ft)		150		115			150	224	224	
Storage Blk Time (%)		12		0	8	2		0	1	1
Queuing Penalty (veh)		19		0	4	1		0	5	6

### Intersection: 15: N Site Access /Richardson Access & International Way, Interval #1

Movement	EB	NB	SB
Directions Served	L	LTR	LTR
Maximum Queue (ft)	11	12	34
Average Queue (ft)	2	3	22
95th Queue (ft)	12	16	45
Link Distance (ft)		310	199
Upstream Blk Time (%)			
Queuing Penalty (veh)			
Storage Bay Dist (ft)	145		
Storage Blk Time (%)			
Queuing Penalty (veh)			

## Queuing and Blocking Report

11/24/2025

### Intersection: 15: N Site Access /Richardson Access & International Way, Interval #2

Movement	EB	NB	SB
Directions Served	L	LTR	LTR
Maximum Queue (ft)	17	30	44
Average Queue (ft)	1	9	25
95th Queue (ft)	8	30	45
Link Distance (ft)		310	199
Upstream Blk Time (%)			
Queuing Penalty (veh)			
Storage Bay Dist (ft)	145		
Storage Blk Time (%)			
Queuing Penalty (veh)			

### Intersection: 15: N Site Access /Richardson Access & International Way, All Intervals

Movement	EB	NB	SB
Directions Served	L	LTR	LTR
Maximum Queue (ft)	22	30	44
Average Queue (ft)	1	7	24
95th Queue (ft)	9	28	45
Link Distance (ft)		310	199
Upstream Blk Time (%)			
Queuing Penalty (veh)			
Storage Bay Dist (ft)	145		
Storage Blk Time (%)			
Queuing Penalty (veh)			

### Intersection: 16: Game Farm Rd & Deadmond Ferry , Interval #1

Movement	EB	WB	NB	NB
Directions Served	TR	L	L	R
Maximum Queue (ft)	30	70	70	32
Average Queue (ft)	12	40	44	22
95th Queue (ft)	35	68	77	42
Link Distance (ft)	319			554
Upstream Blk Time (%)				
Queuing Penalty (veh)				
Storage Bay Dist (ft)		140	115	
Storage Blk Time (%)			0	
Queuing Penalty (veh)			0	

## Queuing and Blocking Report

11/24/2025

### Intersection: 16: Game Farm Rd & Deadmond Ferry , Interval #2

Movement	EB	WB	NB	NB
Directions Served	TR	L	L	R
Maximum Queue (ft)	44	108	124	68
Average Queue (ft)	10	45	47	25
95th Queue (ft)	33	84	90	55
Link Distance (ft)	319			554
Upstream Blk Time (%)				
Queuing Penalty (veh)				
Storage Bay Dist (ft)		140	115	
Storage Blk Time (%)		0	1	
Queuing Penalty (veh)		0	1	

### Intersection: 16: Game Farm Rd & Deadmond Ferry , All Intervals

Movement	EB	WB	NB	NB
Directions Served	TR	L	L	R
Maximum Queue (ft)	50	108	124	68
Average Queue (ft)	11	44	46	24
95th Queue (ft)	34	80	87	53
Link Distance (ft)	319			554
Upstream Blk Time (%)				
Queuing Penalty (veh)				
Storage Bay Dist (ft)		140	115	
Storage Blk Time (%)		0	1	
Queuing Penalty (veh)		0	0	

### Intersection: 17: Beltline Rd /MLK & Game Farm Rd, Interval #1

Movement	EB	EB	EB	WB	WB	WB	SB	SB
Directions Served	L	T	T	T	T	R	L	R
Maximum Queue (ft)	52	176	194	194	214	66	289	104
Average Queue (ft)	25	88	112	128	142	39	189	29
95th Queue (ft)	55	173	192	193	225	66	306	106
Link Distance (ft)		1696	1696	878	878		554	
Upstream Blk Time (%)								
Queuing Penalty (veh)								
Storage Bay Dist (ft)	340					275		85
Storage Blk Time (%)					1		26	0
Queuing Penalty (veh)					2		22	0

## Queuing and Blocking Report

11/24/2025

### Intersection: 17: Beltline Rd /MLK & Game Farm Rd, Interval #2

Movement	EB	EB	EB	WB	WB	WB	SB	SB
Directions Served	L	T	T	T	T	R	L	R
Maximum Queue (ft)	77	212	232	253	258	117	371	110
Average Queue (ft)	24	99	108	149	167	42	207	49
95th Queue (ft)	59	183	202	241	260	90	334	137
Link Distance (ft)		1696	1696	878	878		554	
Upstream Blk Time (%)								
Queuing Penalty (veh)								
Storage Bay Dist (ft)	340					275		85
Storage Blk Time (%)					0		32	0
Queuing Penalty (veh)					1		31	0

### Intersection: 17: Beltline Rd /MLK & Game Farm Rd, All Intervals

Movement	EB	EB	EB	WB	WB	WB	SB	SB
Directions Served	L	T	T	T	T	R	L	R
Maximum Queue (ft)	77	213	232	259	276	125	376	110
Average Queue (ft)	24	96	109	144	161	41	203	44
95th Queue (ft)	59	181	200	231	254	85	328	131
Link Distance (ft)		1696	1696	878	878		554	
Upstream Blk Time (%)								
Queuing Penalty (veh)								
Storage Bay Dist (ft)	340					275		85
Storage Blk Time (%)					0		31	0
Queuing Penalty (veh)					1		29	0

### Intersection: 21: International Way & Site access , Interval #1

Movement	EB	SB
Directions Served	LT	LR
Maximum Queue (ft)	34	134
Average Queue (ft)	10	84
95th Queue (ft)	35	135
Link Distance (ft)	391	399
Upstream Blk Time (%)		
Queuing Penalty (veh)		
Storage Bay Dist (ft)		
Storage Blk Time (%)		
Queuing Penalty (veh)		

## Queuing and Blocking Report

11/24/2025

### Intersection: 21: International Way & Site access , Interval #2

Movement	EB	WB	SB
Directions Served	LT	TR	LR
Maximum Queue (ft)	71	82	414
Average Queue (ft)	22	13	310
95th Queue (ft)	59	64	509
Link Distance (ft)	391	303	399
Upstream Blk Time (%)			46
Queuing Penalty (veh)			0
Storage Bay Dist (ft)			
Storage Blk Time (%)			
Queuing Penalty (veh)			

### Intersection: 21: International Way & Site access , All Intervals

Movement	EB	WB	SB
Directions Served	LT	TR	LR
Maximum Queue (ft)	71	82	414
Average Queue (ft)	19	10	255
95th Queue (ft)	55	55	492
Link Distance (ft)	391	303	399
Upstream Blk Time (%)			34
Queuing Penalty (veh)			0
Storage Bay Dist (ft)			
Storage Blk Time (%)			
Queuing Penalty (veh)			

### Intersection: 24: Hutton & Beltline Rd , Interval #1

Movement	EB	EB	WB	WB	WB	NB	SB	SB
Directions Served	L	TR	L	T	TR	LTR	LT	R
Maximum Queue (ft)	33	1	45	52	38	209	36	55
Average Queue (ft)	15	0	18	9	9	127	18	35
95th Queue (ft)	38	2	47	44	41	233	45	63
Link Distance (ft)		459		1696	1696	522	334	334
Upstream Blk Time (%)								
Queuing Penalty (veh)								
Storage Bay Dist (ft)	130		440					
Storage Blk Time (%)								
Queuing Penalty (veh)								

## Queuing and Blocking Report

11/24/2025

### Intersection: 24: Hutton & Beltline Rd , Interval #2

Movement	EB	EB	EB	WB	WB	WB	NB	SB	SB
Directions Served	L	T	TR	L	T	TR	LTR	LT	R
Maximum Queue (ft)	87	11	16	63	160	172	477	83	102
Average Queue (ft)	25	0	1	21	31	39	273	28	50
95th Queue (ft)	66	9	9	53	143	156	530	66	113
Link Distance (ft)		459	459		1696	1696	522	334	334
Upstream Blk Time (%)							15		
Queuing Penalty (veh)							0		
Storage Bay Dist (ft)	130			440					
Storage Blk Time (%)	0								
Queuing Penalty (veh)	0								

### Intersection: 24: Hutton & Beltline Rd , All Intervals

Movement	EB	EB	EB	WB	WB	WB	NB	SB	SB
Directions Served	L	T	TR	L	T	TR	LTR	LT	R
Maximum Queue (ft)	87	11	18	67	176	172	477	84	110
Average Queue (ft)	22	0	1	20	26	32	238	26	46
95th Queue (ft)	60	8	8	52	126	137	490	62	104
Link Distance (ft)		459	459		1696	1696	522	334	334
Upstream Blk Time (%)							11		
Queuing Penalty (veh)							0		
Storage Bay Dist (ft)	130			440					
Storage Blk Time (%)	0								
Queuing Penalty (veh)	0								

### Intersection: 35: Harlow & Gateway , Interval #1

Movement	EB	EB	EB	WB	WB	WB	NB	NB	SB	SB	SB
Directions Served	L	T	TR	L	T	TR	LT	TR	L	L	TR
Maximum Queue (ft)	200	213	147	31	242	306	107	68	204	260	202
Average Queue (ft)	147	112	70	10	162	175	72	37	142	203	107
95th Queue (ft)	231	201	132	32	229	299	122	72	251	279	216
Link Distance (ft)		764	764		802	802	420	420		507	507
Upstream Blk Time (%)											
Queuing Penalty (veh)											
Storage Bay Dist (ft)	215			200					190		
Storage Blk Time (%)	1	0			3				0	10	
Queuing Penalty (veh)	2	1			0				1	25	

## Queuing and Blocking Report

11/24/2025

### Intersection: 35: Harlow & Gateway , Interval #2

Movement	EB	EB	EB	WB	WB	WB	NB	NB	SB	SB	SB
Directions Served	L	T	TR	L	T	TR	LT	TR	L	L	TR
Maximum Queue (ft)	240	351	243	117	408	477	137	93	215	453	434
Average Queue (ft)	172	143	105	18	227	263	73	39	189	271	180
95th Queue (ft)	254	266	196	81	352	442	122	76	256	397	381
Link Distance (ft)		764	764		802	802	420	420		507	507
Upstream Blk Time (%)										0	0
Queuing Penalty (veh)										0	0
Storage Bay Dist (ft)	215			200					190		
Storage Blk Time (%)	5	0			12				1	25	
Queuing Penalty (veh)	13	1			2				4	76	

### Intersection: 35: Harlow & Gateway , All Intervals

Movement	EB	EB	EB	WB	WB	WB	NB	NB	SB	SB	SB
Directions Served	L	T	TR	L	T	TR	LT	TR	L	L	TR
Maximum Queue (ft)	240	351	253	117	408	477	140	97	215	453	434
Average Queue (ft)	166	136	97	16	211	242	73	39	178	254	162
95th Queue (ft)	251	254	185	72	334	420	122	75	263	380	353
Link Distance (ft)		764	764		802	802	420	420		507	507
Upstream Blk Time (%)										0	0
Queuing Penalty (veh)										0	0
Storage Bay Dist (ft)	215			200					190		
Storage Blk Time (%)	4	0			10				1	21	
Queuing Penalty (veh)	10	1			1				3	63	

### Intersection: 40: International Way & Sports Way , Interval #1

Movement	EB	WB	SB	SB
Directions Served	L	TR	L	R
Maximum Queue (ft)	6	391	15	177
Average Queue (ft)	1	278	3	100
95th Queue (ft)	11	542	16	201
Link Distance (ft)		559		484
Upstream Blk Time (%)		4		
Queuing Penalty (veh)		18		
Storage Bay Dist (ft)	175		240	
Storage Blk Time (%)				4
Queuing Penalty (veh)				0

## Queuing and Blocking Report

11/24/2025

### Intersection: 40: International Way & Sports Way , Interval #2

Movement	EB	WB	SB	SB
Directions Served	L	TR	L	R
Maximum Queue (ft)	25	574	121	451
Average Queue (ft)	2	537	10	349
95th Queue (ft)	13	675	81	610
Link Distance (ft)		559		484
Upstream Blk Time (%)		21		48
Queuing Penalty (veh)		178		0
Storage Bay Dist (ft)	175		240	
Storage Blk Time (%)				67
Queuing Penalty (veh)				5

### Intersection: 40: International Way & Sports Way , All Intervals

Movement	EB	WB	SB	SB
Directions Served	L	TR	L	R
Maximum Queue (ft)	31	574	121	451
Average Queue (ft)	2	475	8	289
95th Queue (ft)	13	729	71	581
Link Distance (ft)		559		484
Upstream Blk Time (%)		16		36
Queuing Penalty (veh)		138		0
Storage Bay Dist (ft)	175		240	
Storage Blk Time (%)				51
Queuing Penalty (veh)				4

### Intersection: 42: International Way & Fedex Westside , Interval #1

Movement	EB	WB	SB
Directions Served	L	TR	LR
Maximum Queue (ft)	23	31	34
Average Queue (ft)	4	15	16
95th Queue (ft)	20	86	43
Link Distance (ft)		391	341
Upstream Blk Time (%)			
Queuing Penalty (veh)			
Storage Bay Dist (ft)	360		
Storage Blk Time (%)			
Queuing Penalty (veh)			

## Queuing and Blocking Report

11/24/2025

### Intersection: 42: International Way & Fedex Westside , Interval #2

Movement	EB	WB	SB
Directions Served	L	TR	LR
Maximum Queue (ft)	18	390	248
Average Queue (ft)	1	241	133
95th Queue (ft)	9	487	312
Link Distance (ft)		391	341
Upstream Blk Time (%)		4	10
Queuing Penalty (veh)		28	0
Storage Bay Dist (ft)	360		
Storage Blk Time (%)			
Queuing Penalty (veh)			

### Intersection: 42: International Way & Fedex Westside , All Intervals

Movement	EB	WB	SB
Directions Served	L	TR	LR
Maximum Queue (ft)	30	390	248
Average Queue (ft)	2	186	105
95th Queue (ft)	12	456	282
Link Distance (ft)		391	341
Upstream Blk Time (%)		3	8
Queuing Penalty (veh)		21	0
Storage Bay Dist (ft)	360		
Storage Blk Time (%)			
Queuing Penalty (veh)			

### Network Summary

Network wide Queuing Penalty, Interval #1: 814
Network wide Queuing Penalty, Interval #2: 1522
Network wide Queuing Penalty, All Intervals: 1345

# Queuing and Blocking Report

03/19/2026

## Intersection: 9: Beltline Rd/Beltline Rd & Gateway St , Interval #1

Movement	EB	EB	EB	EB	EB	EB	EB	WB	WB	WB	WB	WB
Directions Served	L	L	T	T	T	R	R	L	L	T	T	T
Maximum Queue (ft)	160	150	120	114	6	357	321	113	125	368	394	367
Average Queue (ft)	124	103	58	37	2	286	252	72	86	278	291	281
95th Queue (ft)	166	181	117	104	9	366	344	121	137	383	405	382
Link Distance (ft)			1076	1076	1076			460	460	460	460	460
Upstream Blk Time (%)										0	0	
Queuing Penalty (veh)										0	1	
Storage Bay Dist (ft)	480	480				640	640					
Storage Blk Time (%)												1
Queuing Penalty (veh)												5

## Intersection: 9: Beltline Rd/Beltline Rd & Gateway St , Interval #1

Movement	WB	SB	SB	SB	SB	SB
Directions Served	R	L	T	T	R	R
Maximum Queue (ft)	266	197	186	214	171	191
Average Queue (ft)	159	140	141	162	138	149
95th Queue (ft)	279	210	201	221	187	211
Link Distance (ft)			468	468	468	
Upstream Blk Time (%)						
Queuing Penalty (veh)						
Storage Bay Dist (ft)	360	335				190
Storage Blk Time (%)	0				0	1
Queuing Penalty (veh)	0				1	3

Queuing and Blocking Report

03/19/2026

Intersection: 9: Beltline Rd/Beltline Rd & Gateway St , Interval #2

Movement	EB	EB	EB	EB	EB	EB	EB	WB	WB	WB	WB	WB
Directions Served	L	L	T	T	T	R	R	L	L	T	T	T
Maximum Queue (ft)	204	199	174	126	14	374	344	145	161	412	424	420
Average Queue (ft)	108	85	64	35	1	262	230	73	89	275	287	281
95th Queue (ft)	175	167	129	87	8	343	323	126	141	370	383	373
Link Distance (ft)			1076	1076	1076			460	460	460	460	460
Upstream Blk Time (%)										0	0	0
Queuing Penalty (veh)										1	1	0
Storage Bay Dist (ft)	480	480				640	640					
Storage Blk Time (%)												1
Queuing Penalty (veh)												4

Intersection: 9: Beltline Rd/Beltline Rd & Gateway St , Interval #2

Movement	WB	SB	SB	SB	SB	SB
Directions Served	R	L	T	T	R	R
Maximum Queue (ft)	362	251	232	236	271	213
Average Queue (ft)	150	133	138	155	130	135
95th Queue (ft)	263	225	210	224	217	210
Link Distance (ft)			468	468	468	
Upstream Blk Time (%)						
Queuing Penalty (veh)						
Storage Bay Dist (ft)	360	335				190
Storage Blk Time (%)	0				1	1
Queuing Penalty (veh)	0				4	4

## Queuing and Blocking Report

03/19/2026

### Intersection: 9: Beltline Rd/Beltline Rd & Gateway St , All Intervals

Movement	EB	EB	EB	EB	EB	EB	EB	WB	WB	WB	WB	WB
Directions Served	L	L	T	T	T	R	R	L	L	T	T	T
Maximum Queue (ft)	204	199	174	126	14	374	344	145	161	412	424	420
Average Queue (ft)	108	85	64	35	1	262	230	73	89	275	287	281
95th Queue (ft)	175	167	129	87	8	343	323	126	141	370	383	373
Link Distance (ft)			1076	1076	1076			460	460	460	460	460
Upstream Blk Time (%)										0	0	0
Queuing Penalty (veh)										1	1	0
Storage Bay Dist (ft)	480	480				640	640					
Storage Blk Time (%)												1
Queuing Penalty (veh)												4

### Intersection: 9: Beltline Rd/Beltline Rd & Gateway St , All Intervals

Movement	WB	SB	SB	SB	SB	SB
Directions Served	R	L	T	T	R	R
Maximum Queue (ft)	362	251	232	236	271	213
Average Queue (ft)	150	133	138	155	130	135
95th Queue (ft)	263	225	210	224	217	210
Link Distance (ft)			468	468	468	
Upstream Blk Time (%)						
Queuing Penalty (veh)						
Storage Bay Dist (ft)	360	335				190
Storage Blk Time (%)	0				1	1
Queuing Penalty (veh)	0				4	4

### Intersection: 24: Hutton & Beltline Rd , Interval #1

Movement	EB	EB	EB	EB	WB	WB	WB	NB	NB	NB	SB	SB
Directions Served	L	T	T	T	T	T	TR	L	L	TR	L	R
Maximum Queue (ft)	135	224	213	90	338	333	342	442	405	178	52	114
Average Queue (ft)	64	156	152	21	273	289	293	296	258	63	22	75
95th Queue (ft)	151	235	223	87	374	372	390	443	406	155	58	148
Link Distance (ft)		460	460	460	398	398	398	509	509	509	312	312
Upstream Blk Time (%)					1	0	0					
Queuing Penalty (veh)					2	0	1					
Storage Bay Dist (ft)	130											
Storage Blk Time (%)	0	10										
Queuing Penalty (veh)	0	5										

## Queuing and Blocking Report

03/19/2026

### Intersection: 24: Hutton & Beltline Rd , Interval #2

Movement	EB	EB	EB	EB	WB	WB	WB	B2	NB	NB	NB	SB
Directions Served	L	T	T	T	T	T	TR	T	L	L	TR	L
Maximum Queue (ft)	155	262	247	184	368	372	403	10	463	449	268	65
Average Queue (ft)	45	156	152	32	248	257	267	0	280	250	56	20
95th Queue (ft)	119	233	219	115	341	350	372	7	430	408	160	53
Link Distance (ft)		460	460	460	398	398	398	1232	509	509	509	312
Upstream Blk Time (%)					0	0	1		0			
Queuing Penalty (veh)					1	0	2		0			
Storage Bay Dist (ft)	130											
Storage Blk Time (%)	0	12										
Queuing Penalty (veh)	0	5										

### Intersection: 24: Hutton & Beltline Rd , Interval #2

Movement	SB
Directions Served	R
Maximum Queue (ft)	150
Average Queue (ft)	63
95th Queue (ft)	122
Link Distance (ft)	312
Upstream Blk Time (%)	
Queuing Penalty (veh)	
Storage Bay Dist (ft)	
Storage Blk Time (%)	
Queuing Penalty (veh)	

## Queuing and Blocking Report

03/19/2026

### Intersection: 24: Hutton & Beltline Rd , All Intervals

Movement	EB	EB	EB	EB	WB	WB	WB	B2	NB	NB	NB	SB
Directions Served	L	T	T	T	T	T	TR	T	L	L	TR	L
Maximum Queue (ft)	155	262	247	184	368	372	403	10	463	449	268	65
Average Queue (ft)	45	156	152	32	248	257	267	0	280	250	56	20
95th Queue (ft)	119	233	219	115	341	350	372	7	430	408	160	53
Link Distance (ft)		460	460	460	398	398	398	1232	509	509	509	312
Upstream Blk Time (%)					0	0	1		0			
Queuing Penalty (veh)					1	0	2		0			
Storage Bay Dist (ft)	130											
Storage Blk Time (%)	0	12										
Queuing Penalty (veh)	0	5										

### Intersection: 24: Hutton & Beltline Rd , All Intervals

Movement	SB
Directions Served	R
Maximum Queue (ft)	150
Average Queue (ft)	63
95th Queue (ft)	122
Link Distance (ft)	312
Upstream Blk Time (%)	
Queuing Penalty (veh)	
Storage Bay Dist (ft)	
Storage Blk Time (%)	
Queuing Penalty (veh)	

### Zone Summary

Zone wide Queuing Penalty, Interval #1: 19
Zone wide Queuing Penalty, Interval #2: 22
Zone wide Queuing Penalty, All Intervals: 22

# SANDOW ENGINEERING

777 High Street, Suite 320  
Eugene, Oregon 97401  
541.513.3376  
[sandowengineering.com](http://sandowengineering.com)



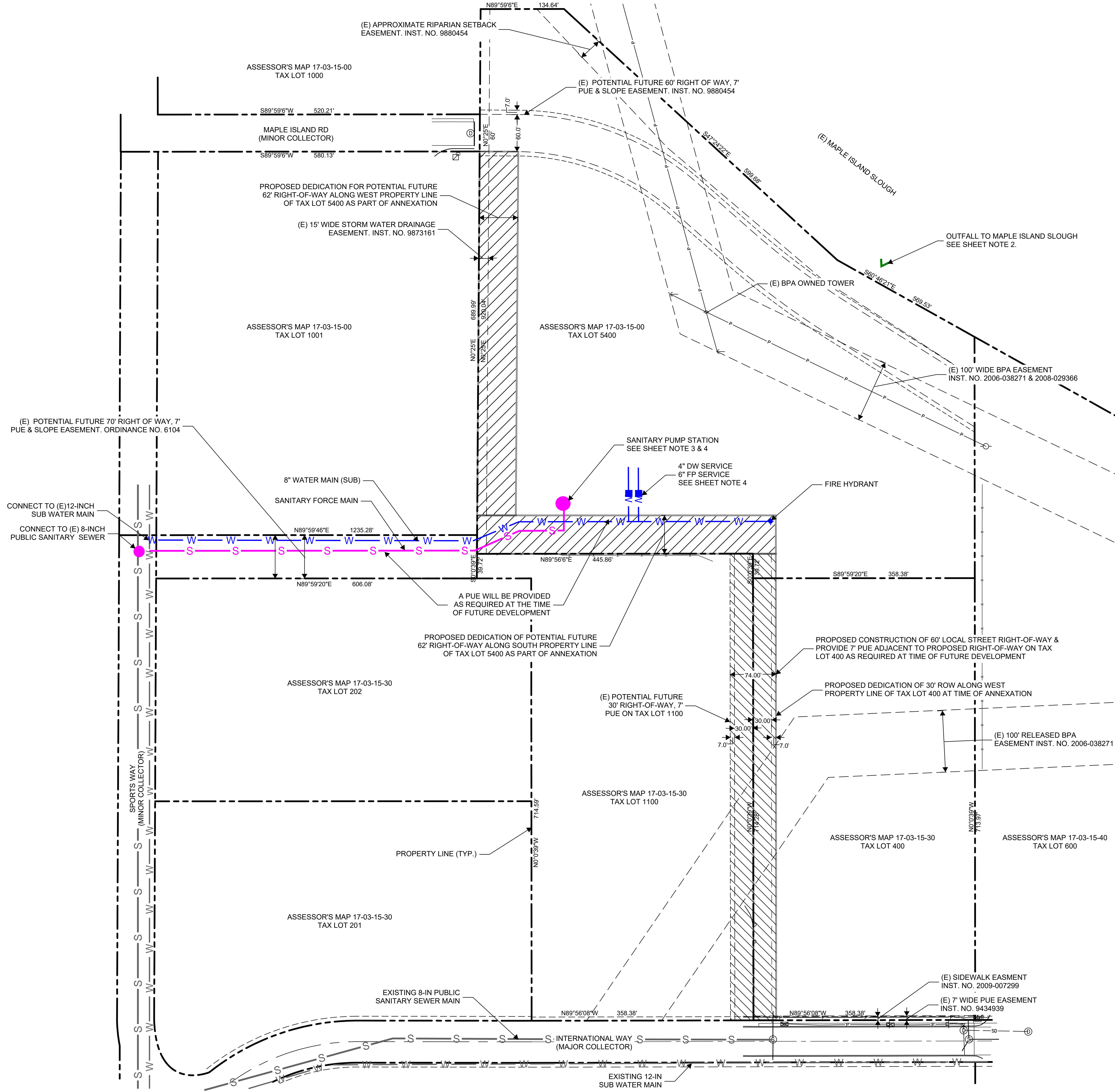

- SHEET NOTES**
1. PER CITY STAFF DURING DIM. STORMWATER PONDS CAN BE UTILIZED TO MEET STORMWATER QUALITY AND QUANTITY REQUIREMENTS. INFILTRATION WILL BE UTILIZED TO THE GREATEST EXTENT FEASIBLE, WHICH IS ENCOURAGED BY THE CITY AND FEMA.
  2. PROPOSED NEW STORM DRAINAGE OUTFALL TO THE MAPLE ISLAND SLOUGH. PUBLIC STORM MAINS ARE LOCATED IN SPORTS WAY AND INTERNATIONAL WAY BUT THE SITE IS TOO LOW TO CONVEY STORM DRAINAGE TO THE PUBLIC STORM LINES. IT IS UNLIKELY THAT THE BUILDING AND SITE COULD BE RAISED ENOUGH TO DRAIN TO THE PUBLIC SYSTEM BECAUSE OF THE CURRENT FEMA REQUIREMENTS FOR BALANCING CUT/FILL.
  3. PROPOSED WASTEWATER FROM DEVELOPMENT WILL NEED TO BE PUMPED TO THE PUBLIC SANITARY SEWER LINES IN SPORTS WAY OR INTERNATIONAL WAY.
  4. UTILITY CONNECTIONS ARE CONCEPTUAL & SHOWN FOR REFERENCE ONLY. SERVICE CONNECTIONS TO BE PROVIDED AT TIME OF SITE PLAN REVIEW AND BUILDING PERMIT APPLICATION SUBMITTALS CONSISTENT WITH CITY REQUIREMENTS AS APPLICABLE TO PROPOSED SITE DESIGN.
  5. METES AND BOUNDS ARE PER RECORDED PLATS, SHOWN FOR REFERENCE ONLY.

**LEGEND**

	PROPERTY LINE
	EXISTING EASEMENT
	EXISTING PUBLIC UTILITY EASEMENT (PUE)
	PROPOSED RIGHT-OF-WAY DEDICATION
	EXISTING CENTERLINE
	EXISTING FENCELINE
	PROPOSED WATER MAIN
	EXISTING WATER SERVICE
	PROPOSED SANITARY MAIN
	EXISTING SANITARY SERVICE
	PROPOSED STORMWATER DESTINATION
	PROPOSED LOCAL STREET ROW CONSTRUCTION AT THE TIME OF FUTURE DEVELOPMENT
	PROPOSED DEDICATION OF POTENTIAL FUTURE 62' ROW

Plotted: 12/26/25 at 3:55pm By: thood

After recording Return to:  
Cascade Title Company  
675 Oak St., Suite 100  
Eugene, OR 97401

EU25-2123  
03508264

Lane County Clerk  
Lane County Deeds & Records

2026-008036

03/13/2026 01:50:45 PM

RPR-DEED      Cnt=1 Stn=1 BLW  
\$20.00 \$11.00 \$10.00 \$61.00

4pages

\$102.00

AFTER RECORDING RETURN TO:

PeaceHealth  
Attn: Tamara Miller  
123 International Way  
Springfield, OR 97477

UNTIL A CHANGE IS REQUESTED, ALL  
TAX STATEMENTS SHALL BE SENT TO:

PeaceHealth  
1115 SE 114th Ave  
Vancouver, WA 98683-9928  
Attn: Legal Dept.

### STATUTORY WARRANTY DEED

THE GRANTOR, LANE COUNTY, a political subdivision of the State of Oregon, for good and valuable consideration, in hand paid, conveys and warrants to PEACEHEALTH, a Washington nonprofit corporation, THE GRANTEE, the following described real estate, situated in the County of Lane, State of Oregon:

SEE EXHIBIT A ATTACHED HERETO AND INCORPORATED  
HEREIN BY THIS REFERENCE.

Subject only to the encumbrances and other items listed on Exhibit B attached hereto and incorporated herein.

The true consideration for this conveyance is \$2,819,020.00.

BEFORE SIGNING OR ACCEPTING THIS INSTRUMENT, THE PERSON TRANSFERRING FEE TITLE SHOULD INQUIRE ABOUT THE PERSON'S RIGHTS, IF ANY, UNDER ORS 195.300, 195.301 AND 195.305 TO 195.336 AND SECTIONS 5 TO 11, CHAPTER 424, OREGON LAWS 2007, SECTIONS 2 TO 9 AND 17, CHAPTER 855, OREGON LAWS 2009, AND SECTIONS 2 TO 7, CHAPTER 8, OREGON LAWS 2010. THIS INSTRUMENT DOES NOT ALLOW USE OF THE PROPERTY DESCRIBED IN THIS INSTRUMENT IN VIOLATION OF APPLICABLE LAND USE LAWS AND REGULATIONS. BEFORE SIGNING OR ACCEPTING THIS INSTRUMENT, THE PERSON ACQUIRING FEE TITLE TO THE PROPERTY SHOULD CHECK WITH THE APPROPRIATE CITY OR COUNTY PLANNING DEPARTMENT TO VERIFY THAT THE UNIT OF LAND BEING TRANSFERRED IS A LAWFULLY ESTABLISHED LOT OR PARCEL, AS DEFINED IN ORS 92.010 OR 215.010, TO VERIFY THE APPROVED USES OF THE LOT OR PARCEL, TO DETERMINE ANY LIMITS ON LAWSUITS AGAINST FARMING OR FOREST PRACTICES, AS DEFINED IN ORS 30.930, AND TO INQUIRE ABOUT THE RIGHTS OF

NEIGHBORING PROPERTY OWNERS, IF ANY, UNDER ORS 195.300, 195.301 AND 195.305 TO 195.336 AND SECTIONS 5 TO 11, CHAPTER 424, OREGON LAWS 2007, SECTIONS 2 TO 9 AND 17, CHAPTER 855, OREGON LAWS 2009, AND SECTIONS 2 TO 7, CHAPTER 8, OREGON LAWS 2010.

Dated March 13, 2026.

**GRANTOR:**

LANE COUNTY,  
a political subdivision of the State of Oregon

By:   
Name: STEVE MOKROHISKY  
Title: COUNTY ADMINISTRATOR

STATE OF OREGON                    )  
  )    ss.  
COUNTY OF Lane                    )

On March 13, 2026, 2026, before me, a notary public, personally appeared STEVE MOKROHISKY, COUNTY ADMINISTRATOR for LANE COUNTY, a political subdivision of the STATE OF OREGON, who proved to me on the basis of satisfactory evidence to be the person(s) whose name is subscribed to the within instrument and acknowledged to me that he/she executed the same in his/her authorized capacity, and that by his/her signature on the instrument the person, or the entity upon behalf of which the person acted, executed the instrument.

WITNESS my hand and official seal.

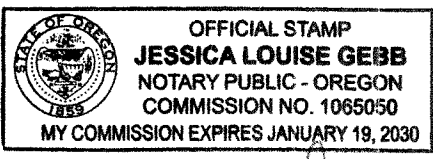



**EXHIBIT A**  
**(Legal Description of the Real Property)**

Parcel 1, LAND PARTITION PLAT NO. 94-P0499, as platted and recorded in Lane County Oregon Plat Records, in Lane County, Oregon

## **EXHIBIT B**

### **(Permitted Exceptions)**

1. Easements, notes, conditions, restrictions and dedications as shown, set forth, and/or delineated on the recorded Plat of Land Partition Plat No. 94-P0499, filed May 6, 1994, reception No. 1994-P0499, Lane County Oregon Plat Records.
2. Notice of Annexation Agreement, including the terms and provisions thereof, recorded May 6, 1994, Reception No. 1994-034937, Lane County Official Records.
3. Waiver of Time Limit on Consent to Annexation an Addendum to the Consent to Annexation Document, including the terms and provisions thereof, recorded May 6, 1994, Reception No. 1994-034938, Lane County Official Records.
4. Conditions for Public Utility Easements (7 Foot), including the terms and provisions thereof, recorded May 6, 1994, Reception No. 1994-034939, Lane County Official Records.
5. Dedication of a Public Road Easement, including the terms and provisions thereof, recorded June 2, 1994, Reception No. 1994-041952, Lane County Official Records.
6. Agreement for Construction of Public Improvement Maple Island Slough Road (Rice/City of Springfield), including the terms and provisions thereof, recorded October 7, 1998, Reception No. 1998-080454, Lane County Official Records.
7. Easement, including the terms and provisions thereof, granted United States of America, Department of Energy, Bonneville Power Administration, by instrument recorded June 2, 2006, Reception No. 2006-038271, Lane County Deeds and Records.
8. Easement, including the terms and provisions thereof, granted City of Springfield, a municipal corporation of the State of Oregon, by instrument recorded February 12, 2009, Reception No. 2009-007299, Lane County Deeds and Records.
9. Easements, conditions, restrictions and matters as disclosed in Warranty Deed, including the terms and provisions thereof, between Harold E. Rice Trustee of the Leona M. Rice Revocable Living Trust dated March 11, 2005, and Merritt Truax, Inc., An Oregon Corporation, recorded January 11, 2007, Reception No. 2007-002512, Lane County Deeds and Records.

READ AND APPROVED

Richard DeCarb



DATE 03/12/2026 08:16 PM EDT

DATE \_\_\_\_\_



**PRELIMINARY TITLE REPORT  
SUPPLEMENTAL**

CASCADE ESCROW  
ATTN: TARA MULLER  
675 OAK ST, SUITE 100  
EUGENE, OR 97401

February 02, 2026  
Report No: 0350864  
Your No: EU25-2123  
Seller: LANE COUNTY  
Buyer: PEACEHEALTH

PRELIMINARY REPORT FOR:

Owner's Standard Policy \$2,819,020.00

PREMIUMS:

Owner's Standard Premium \$3,623.00  
Gov. Lien/Inspect Fee \$35.00

We are prepared to issue 2021 (7/1/2021) ALTA title insurance policy(ies) of OLD REPUBLIC NATIONAL TITLE INSURANCE COMPANY, in the usual form insuring the title to the land described as follows:

Parcel 1, LAND PARTITION PLAT NO. 94-P0499, as platted and recorded in Lane County Oregon Plat Records, in Lane County, Oregon.

Vestee:

LANE COUNTY,  
a political subdivision of the  
STATE OF OREGON

Estate:

FEE SIMPLE

DATED AS OF: JANUARY 28, 2026 at 8:00 A.M.

Schedule B of the policy(ies) to be issued will contain the following general and special exceptions unless removed prior to issuance:

GENERAL EXCEPTIONS (Standard Coverage Policy Exceptions):

1. Taxes or assessments which are not shown as existing liens by the records of any taxing authority that levies taxes or assessments on real property or by the Public Records; proceedings by a public agency which may result in taxes or assessments, or notices of such proceedings, whether or not shown by the records of such agency or by the Public Records.
2. Facts, rights, interests or claims which are not shown by the Public Records but which could be ascertained by an inspection of the Land or by making inquiry of persons in possession thereof.

*No liability is assumed hereunder until policy has been issued and full policy premium has been paid.*

**MAIN OFFICE**  
675 OAK STREET, SUITE 100  
EUGENE, OREGON 97401  
PH: (541) 687-2233 \* FAX: (541) 485-0307

**FLORENCE OFFICE**  
715 HWY 101 \* FLORENCE, OREGON 97439  
MAILING: PO BOX 508 \* FLORENCE, OREGON 97439  
PH: (541) 997-8417 \* FAX: (541) 997-8246

**VILLAGE PLAZA OFFICE**  
4750 VILLAGE PLAZA LOOP, SUITE 100  
EUGENE, OREGON 97401  
PH: (541) 653-8622 \* FAX: (541) 844-1626

Order No. 0350864

Page 2

3. Easements, or claims of easement, not shown by the Public Records; reservations or exceptions in patents or in Acts authorizing the issuance thereof; water rights, claims or title to water.
4. Any encroachment (of existing improvements located on the subject land onto adjoining land or of existing improvements located on adjoining land onto the subject land), encumbrance, violation, variation, or adverse circumstance affecting the title that would be disclosed by an accurate and complete land survey of the subject land.
5. Any lien, or right to a lien, for services, labor, material, equipment rental or workers compensation heretofore or hereafter furnished, imposed by law and not shown by the Public Records.

SPECIAL EXCEPTIONS:

6. DELETED.
7. Easements, notes, conditions, restrictions and dedications as shown, set forth, and/or delineated on the recorded Plat of Land Partition Plat No. 94-P0499, filed May 6, 1994, Reception No. 1994-P0499, Lane County Oregon Plat Records.
8. Notice of Annexation Agreement, including the terms and provisions thereof, recorded May 6, 1994, Reception No. 1994-034937, Lane County Official Records.
9. Waiver of Time Limit on Consent to Annexation an Addendum to the Consent to Annexation Document, including the terms and provisions thereof, recorded May 6, 1994, Reception No. 1994-034938, Lane County Official Records.
10. Conditions for Public Utility Easements (7 Foot), including the terms and provisions thereof, recorded May 6, 1994, Reception No. 1994-034939, Lane County Official Records.
11. Dedication of a Public Road Easement, including the terms and provisions thereof, recorded June 2, 1994, Reception No. 1994-041952, Lane County Official Records.
12. Agreement for Construction of Public Improvement Maple Island Slough Road (Rice/City of Springfield), including the terms and provisions thereof, recorded October 7, 1998, Reception No. 1998-080454, Lane County Official Records.
13. Easement, including the terms and provisions thereof, granted United States of America, Department of Energy, Bonneville Power Administration, by instrument recorded June 2, 2006, Reception No. 2006-038271, Lane County Deeds and Records.
14. Easement, including the terms and provisions thereof, granted City of Springfield, a municipal corporation of the State of Oregon, by instrument recorded February 12, 2009, Reception No. 2009-007299, Lane County Deeds and Records.
15. Easements, conditions, restrictions and matters as disclosed in Warranty Deed, including the terms and provisions thereof, between Harold E. Rice Trustee of the Leona M. Rice Revocable Living Trust dated March 11, 2005, and Merritt Truax, Inc., An Oregon Corporation, recorded January 11, 2007, Reception No. 2007-002512, Lane County Deeds and Records.
16. DELETED.

NOTE: Taxes, Account No. 1518669, Assessor's Map No. 17 03 15 3 0, #400, Code 4-01, 2025-2026, in the amount of \$75.30, PAID IN FULL.

Order No. 0350864

Page 3

NOTE: A judgment search has been made on the above named Vestee(s), and we find NONE except as set forth above.

NOTE: As of the date hereof, there are no matters against PEACEHEALTH, A WASHINGTON NON-PROFIT CORPORATION, which would appear as exceptions in the policy to issue, except as shown herein.

NOTE: The premium amount has been reduced by application of a reissue rate.

NOTE: This report is being supplemented to remove prior exception nos. 6 and 16 to show as "deleted".

This report is preliminary to the issuance of a policy of title insurance and shall become null and void unless a policy is issued and the full premium paid.

**Cascade Title Co.**

rh: Title Officer: KURT BEATY

# CASCADE TITLE CO.

MAP NO.  
17-03-15-30



THIS MAP/PLAT IS BEING FURNISHED AS AN AID IN LOCATING THE HEREIN DESCRIBED LAND IN RELATION TO ADJOINING STREETS, NATURAL BOUNDARIES AND OTHER LAND, AND IS NOT A SURVEY OF THE LAND DEPICTED. EXCEPT TO THE EXTENT A POLICY OF TITLE INSURANCE IS EXPRESSLY MODIFIED BY ENDORSEMENT, IF ANY, THE COMPANY DOES NOT INSURE DIMENSIONS, DISTANCES, LOCATION OF EASEMENTS, ACREAGE OR OTHER MATTERS SHOWN THEREON.