

NOTE:
THIS LAYOUT IS PRELIMINARY
AND FOR EXHIBIT PURPOSES
ONLY. THIS PLAN SHALL NOT BE
USED FOR CONSTRUCTION AND
SHALL NOT BE USED FOR THE
TRANSFER OF REAL PROPERTY.

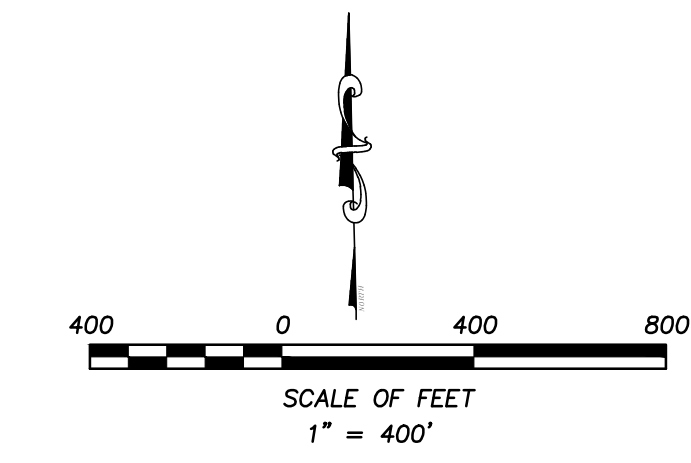

LEGEND

- PROPOSED ROAD R.O.W.
- PROPOSED LOT LINE
- PROPOSED CENTER LINE
- - - - - EXISTING 10' CONTOUR
- 3 = LOT NUMBER
- EXISTING FLOODPLAIN
- UNIT 1
- UNIT 2
- UNIT 3
- UNIT 4
- UNIT 5
- UNIT 6
- UNIT 7
- UNIT 8
- UNIT 9
- UNIT 10

UNIT	ACREAGE	STREET LF	TOTAL LOTS	DENSITY
UNIT-1	65.6	0	92	1.40
UNIT-2	64.0	5,960.18'	69	1.08
UNIT-3	62.5	6,694.64'	56	0.90
UNIT-4	86.8	9,228.15'	74	0.85
UNIT-5	58.5	6,379.17'	65	1.11
UNIT-6	61.0	5,467.12'	74	1.21
UNIT-7	84.7	10,969.11'	81	0.96
UNIT-8	72.4	6,241.98'	87	1.20
UNIT-9	77.8	6,388.50'	92	1.18
UNIT-10	66.0	6,746.13'	71	1.08
TOTAL				
10	±699.3	64,074.98'	761	1.09

DEVELOPMENT PHASING SCHEDULE

UNIT-1	COMPLETION IN Q2 2026 - TBD
UNIT-2	COMPLETION IN Q2 2028 - TBD
UNIT-3	COMPLETION IN Q2 2030 - TBD
UNIT-4	COMPLETION IN Q2 2032 - TBD
UNIT-5	COMPLETION IN Q2 2034 - TBD
UNIT-6	COMPLETION IN Q2 2036 - TBD
UNIT-7	COMPLETION IN Q2 2038 - TBD
UNIT-8	COMPLETION IN Q2 2040 - TBD
UNIT-9	COMPLETION IN Q2 2042 - TBD
UNIT-10	COMPLETION IN Q2 2044 - TBD

CERTIFICATE OF THE PRECINCT COMMISSIONER

I, THE UNDERSIGNED COMMISSIONER IN THE PRECINCT IN WHICH THE LAND SUBDIVIDED ACCORDING TO THE MASTER DEVELOPMENT PLAN TO WHICH THIS CERTIFICATE IS PRESENTED, HEREBY CERTIFY THAT I HAVE REVIEWED THE SAID MASTER DEVELOPMENT AND THAT ALL REQUIREMENTS OF ATASCOSA COUNTY FOR THE PRESENTATION OF THE MASTER DEVELOPMENT FOR FINAL APPROVAL HAVE BEEN FULLY MET TO THE BEST OF MY KNOWLEDGE AND BELIEF.

COMMISSIONER PRECINCT 3 _____

CERTIFICATE OF FINAL APPROVAL

APPROVED BY THE COMMISSIONERS COURT OF ATASCOSA COUNTY, TEXAS,
THIS _____ DAY OF _____, 20__ A.D.

ATASCOSA COUNTY JUDGE _____

COMMISSIONER PRECINCT 1 _____ COMMISSIONER PRECINCT 2 _____

COMMISSIONER PRECINCT 3 _____ COMMISSIONER PRECINCT 4 _____

CERTIFICATE OF THE RURAL DEVELOPMENT DIRECTOR

I, THE UNDERSIGNED RURAL DEVELOPMENT DIRECTOR IN ATASCOSA COUNTY IN WHICH THE LAND SUBDIVIDED ACCORDING TO THE MASTER DEVELOPMENT PLAN TO WHICH THIS CERTIFICATE IS PRESENTED, HEREBY CERTIFY THAT I HAVE REVIEWED THE SAID MASTER DEVELOPMENT PLAN AND THAT ALL REQUIREMENTS OF ATASCOSA COUNTY FOR THE PRESENTATION OF THE MASTER DEVELOPMENT PLAN FOR FINAL APPROVAL HAVE BEEN FULLY MET TO THE BEST OF MY KNOWLEDGE AND BELIEF.

RURAL DEVELOPMENT DIRECTOR _____

ENGINEER & SURVEYOR:
RAKOWITZ ENGINEERING AND SURVEYING
515 W OAKLAWN, SUITE A
PLEASANTON, TX 78064
(830) 281-4060

OWNER:
LONNIE RAKOWITZ
1050 SLOMCHINCKI RD
POTEET, TEXAS 78065

OWNER:
WALT & DAWN RAKOWITZ
1996 WEST CR 304
JOURDANTON, TEXAS 78026

RAKOWITZ
 Engineering & Surveying
 Texas Registered Engineering Firm F-9155
 Texas Registered Surveying Firm T-03812-00
 850-281-4060
 © COPYRIGHT RAKOWITZ ENGINEERING 2024

GRANT ACRES
MASTER DEVELOPMENT PLAN
ATASCOSA COUNTY, TEXAS

THIS DOCUMENT IS
 RELEASED FOR REVIEW
 PURPOSES UNDER THE
 AUTHORIZATION OF
 WALT E. RAKOWITZ, P.E.
 #96538 NOT TO BE USED FOR
 CONSTRUCTION.

REV	DATE	DESCRIPTION

JOB NO.	13-0629
DATE	JUNE 2024
DESIGNER	RLT
CHECKED	WR
DRAWN	RLT

MDP
 SHEET 1 OF 2

Date: Jan 04, 2024, 7:33am User ID: CAD2023-1
 File: N:\Projects\2023\13-0629 Rakowitz-Grant Acres MDP\MDP\RECOVER.dwg

THIS DOCUMENT HAS BEEN PRODUCED FROM ELECTRONICALLY TRANSMITTED OR STORED MATERIAL WHICH MAY HAVE BEEN ALTERED. RELY ONLY ON FINAL HARD COPY MATERIALS BEARING THE ENGINEER'S ORIGINAL SIGNATURE AND SEAL.

UNIT	LOT	ACREAGE
UNIT-1	1	0.74
	2	0.77
	3	0.69
	4	0.69
	5	0.69
	6	0.69
	7	0.69
	8	0.69
	9	0.69
	10	0.69
	11	0.69
	12	0.69
	13	0.69
	14	0.69
	15	0.69
	16	0.69
	17	0.69
	18	0.69
	19	0.70
	20	0.70
	21	0.70
	22	0.70
	23	0.70
	24	0.70
	25	0.70
	26	0.70
	27	0.70
	28	0.70
	29	0.70
	30	0.70
	31	0.70
	32	0.70
	33	0.70
	34	0.70
	35	0.70
	36	0.70
	37	0.70
	38	0.70
	39	0.70
	40	0.70
	41	0.70
	42	0.69
	43	0.69
	44	0.69
	45	0.69
	46	0.69
	47	0.69
	48	0.69
	49	0.69
	50	0.69
	51	0.69
	52	0.69
	53	0.69
	54	0.69
	55	0.69
	56	0.69
	57	0.69
	58	0.69
	59	0.69
	60	0.99
	61	0.70
	62	0.70
	63	0.70
	64	0.70
	65	0.70
	66	0.70
	67	0.70
	68	0.70
	69	0.70
	70	0.70
	71	0.70
	72	0.70
	73	0.70
	74	0.70
	75	0.70
	76	0.70
	77	0.70
	78	0.70
	79	0.70
	80	0.70

UNIT	LOT	ACREAGE
UNIT-1	81	0.70
	82	0.70
	83	0.72
	84	0.72
	85	0.72
	86	0.72
	87	0.72
	88	0.72
	89	0.72
	90	0.72
	91	0.72
	92	0.72

UNIT	LOT	ACREAGE
UNIT-2	93	0.74
	94	0.69
	95	0.69
	96	0.69
	97	0.69
	98	0.69
	99	0.69
	100	0.69
	101	0.69
	102	0.69
	103	0.69
	104	0.69
	105	0.69
	106	0.74
	107	0.69
	108	0.92
	109	0.86
	110	0.69
	111	0.69
	112	0.69
	113	0.69
	114	0.69
	115	0.69
	116	0.69
	117	0.69
	118	0.69
	119	0.69
	120	0.69
	121	0.69
	122	0.69
	123	0.69
	124	0.69
	125	3.17
	126	0.70
	127	0.70
	128	0.70
	129	0.70
	130	0.70
	131	0.70
	132	0.70
	133	0.70
	134	0.94
	135	0.72
	136	0.70
	137	0.70
	138	0.70
	139	0.70
	140	0.70
	141	0.70
	142	0.70
	143	0.70
	144	0.70
	145	0.70
	146	0.73
	147	0.73
	148	0.84
	149	2.43
	150	0.73
	151	0.74
	152	0.74
	153	0.74
	154	0.74
	155	0.74
	156	0.74
	157	0.74
	158	0.74

UNIT	LOT	ACREAGE
UNIT-2	159	0.74
	160	0.74
	161	0.74

UNIT	LOT	ACREAGE
UNIT-3	162	0.71
	163	0.71
	164	0.71
	165	0.71
	166	0.71
	167	0.71
	168	0.71
	169	0.71
	170	0.71
	171	0.71
	172	0.71
	173	0.71
	174	0.71
	175	0.74
	176	0.69
	177	0.69
	178	0.69
	179	0.69
	180	0.69
	181	0.69
	182	0.69
	183	0.69
	184	0.69
	185	0.69
	186	0.69
	187	0.69
	188	1.02
	189	1.02
	190	1.02
	191	1.02
	192	1.02
	193	1.02
	194	1.02
	195	1.02
	196	1.33
	197	1.02
	198	1.02
	199	1.02
	200	1.02
	201	1.02
	202	1.02
	203	1.03
	204	1.03
	205	1.03
	206	1.03
	207	1.03
	208	1.03
	209	1.64
	210	1.01
	211	1.01
	212	1.01
	213	1.01
	214	1.03
	215	1.03
	216	1.03
	217	1.03

UNIT	LOT	ACREAGE
UNIT-4	218	1.41
	219	1.09
	220	1.09
	221	1.09
	222	1.09
	223	1.09
	224	1.09
	225	1.09
	226	1.00
	227	1.00
	228	1.00
	229	1.00
	230	1.00
	231	1.00
	232	1.00
	233	1.00
	234	1.21

UNIT	LOT	ACREAGE
UNIT-4	235	1.32
	236	1.05
	237	1.05
	238	1.05
	239	1.05
	240	1.05
	241	1.05
	242	1.05
	243	1.05
	244	1.05
	245	1.05
	246	1.02
	247	1.02
	248	1.02
	249	1.02
	250	1.02
	251	1.02
	252	1.02
	253	1.02
	254	1.02
	255	1.02
	256	1.02
	257	1.02
	258	0.70
	259	1.02
	260	1.02
	261	1.02
	262	1.02
	263	0.70
	264	0.70
	265	0.70
	266	0.70
	267	0.70
	268	0.77
	269	1.12
	270	0.71
	271	0.71
	272	0.71
	273	0.71
	274	0.71
	275	0.71
	276	0.71
	277	0.70
	278	1.05
	279	1.05
	280	1.05
	281	1.05
	282	1.05
	283	1.05
	284	1.05
	285	1.05
	286	1.05
	287	1.05
	288	1.05
	289	0.77
	290	0.77
	291	0.77

UNIT	LOT	ACREAGE
UNIT-5	292	0.82
	293	0.82
	294	0.82
	295	0.73
	296	0.73
	297	0.73
	298	0.73
	299	0.73
	300	0.73
	301	0.77
	302	0.77
	303	0.77
	304	0.77
	305	0.74
	306	0.74
	307	0.74
	308	0.74
	309	0.74
	310	0.74
	311	0.74
	312	0.69

UNIT	LOT	ACREAGE
UNIT-5	313	0.69
	314	0.69
	315	0.69
	316	0.69
	317	0.69
	318	0.69
	319	0.69
	320	0.69
	321	1.28
	322	0.70
	323	0.70
	324	0.70
	325	0.70
	326	0.70
	327	0.70
	328	0.70
	329	0.70
	330	0.70
	331	0.81
	332	0.93
	333	0.70
	334	0.70
	335	0.70
	336	0.69
	337	0.69
	338	0.69
	339	1.36
	340	0.70
	341	0.70
	342	0.70
	343	0.70
	344	0.70
	345	0.70
	346	0.70
	347	0.70
	348	0.75
	349	0.75
	350	0.75
	351	0.75
	352	0.75
	353	0.75
	354	0.75
	355	0.75
	356	0.75

UNIT	LOT	ACREAGE
UNIT-6	357	0.71
	358	0.71
	359	0.71
	360	0.71
	361	0.71
	362	0.71
	363	0.71
	364	0.71
	365	0.71
	366	0.71
	367	0.72
	368	0.72
	369	0.72
	370	0.72
	371	0.72
	372	0.72
	373	0.72
	374	0.72
	375	0.72
	376	0.73
	377	0.73
	378	0.73
	379	0.73
	380	0.73
	381	0.73
	382	0.73
	383	0.73
	384	0.73
	385	0.71
	386	0.71
	387	0.71
	388	0.71
	389	0.71
	390	0.71

UNIT	LOT	ACREAGE
UNIT-6	391	0.71
	392	0.87
	393	0.71
	394	0.71
	395	0.71
	396	0.71
	397	0.71
	398	0.70
	399	0.70
	400	0.70
	401	0.70
	402	0.70
	403	0.70
	404	0.70
	405	0.70
	406	0.70
	407	0.70
	408	0.70
	409	0.70
	410	0.70
	411	0.70
	412	0.70
	413	0.70
	414	0.70
	415	0.70
	416	0.70
	417	0.73
	418	0.70
	419	0.70
	420	0.70
	421	0.70
	422	0.70
	423	0.69
	424	0.69
	425	0.69
	426	0.69
	427	0.69
	428	0.69
	429	0.69
	430	0.69

UNIT	LOT	ACREAGE
UNIT-7	431	0.69
	432	0.73
	433	0.71
	434	0.71
	435	0.71
	436	0.71
	437	0.71
	438	0.71
	439	0.71
	440	0.71
	441	0.71
	442	0.71
	4	