

# THE EAST BILLINGS URBAN RENEWAL DISTRICT (EBURD) CODE



## EBURD STEERING COMMITTEE MEMBERS:

Project Manager:

Candi Beaudry, AICP  
Director, Planning and Community Services  
Department  
City of Billings

Nicole Cromwell, AICP  
Zoning Coordinator  
City of Billings

Debi Meling, PE  
City Engineer  
City of Billings

Marty Connell, President  
Billings Industrial Revitalization District (BIRD), Inc.

Steve Zeier  
Big Sky Economic Development Authority  
TIF Coordinator, City of Billings

Marshall Knick  
Pacific Steel  
BIRD Board Member

Greg McCall  
McCall Development

Mike Tuss, AIA  
CTA Architects Engineers

## Additional review by:

Terry Smith  
Traffic Engineer  
City of Billings

Stan Jonutis  
Montana Department of Transportation

## CONSULTANTS:

Farr Associates  
53 West Jackson Boulevard, Suite 650  
Chicago, Illinois 60640  
[www.farrside.com](http://www.farrside.com)

Sanderson Stewart  
1300 North Transtech Way  
Billings, Montana 59102  
[www.sandersonstewart.com](http://www.sandersonstewart.com)

Project Manager: Leslie Oberholtzer, AICP, RLA,  
LEED AP

Project Manager: Rick Leuthold, PE, CDP, LEED AP

# TABLE OF CONTENTS

## ADMINISTRATION/OVERVIEW

27-1802.	EBURD Zoning Districts.....	2
27-1803.	Application & Approval Process.....	2
27-1804.	Nonconformances.....	3
27-1805.	Definitions.....	4

## USES

27-1806.	Uses.....	6
----------	-----------	---

## SUSTAINABLE DEVELOPMENT MEASURES

27-1807.	Sustainable Development Measures.....	13
----------	---------------------------------------	----

## FRONTAGE TYPES

27-1808.	Introduction to Frontage Type Requirements.....	15
27-1809.	Entrance Types.....	16
27-1810.	Roof Types.....	18
27-1811.	Explanation of Table Requirements.....	21
27-1812.	Street Facade Materials.....	25
27-1813.	Frontage Types.....	25

## DEVELOPMENT STANDARDS

27-1814.	East Billings Parking Overlay District.....	41
27-1815.	Landscape Standards .....	42
27-1816.	Signage.....	50
27-1817.	Street Types.....	61

# Article 27-1800. East Billings Urban Revitalization District Code

## Sec. 27-1801. Purpose.

The purpose of the East Billings Urban Revitalization District (EBURD) zoning districts and requirements is to provide standards for development as called for in the East Billings Urban Revitalization District Master Plan, adopted by the City of Billings in July 2009. The zoning districts are intended to allow existing uses to continue while integrating new mixed use and residential development appropriately through the use of form-based regulations.

This code will be reviewed and modified as needed on an annual basis by the Billings Industrial Revitalization District, Inc and the City of Billings,

## Sec. 27-1802. EBURD Zoning Districts.

The areas and boundaries of the districts listed below are hereby established to scale as shown on the map entitled Billings Urban Zoning Jurisdiction, available at the City offices.

- (a) EBURD RSV: Rail Spur Village District. The Rail Spur Village District is intended to create a walkable neighborhood focused on residential uses with associated green spaces and commercial businesses with the appropriate form.
- (b) EBURD RSVMS: Rail Spur Village Main Streets District. The Rail Spur Village Main Streets include the extension of the Montana Avenue into the EBURD as well as the North 20th Street corridor from Montana Avenue to 6th Avenue North. This district is intended to create continuous, walkable, shopping & dining corridors with upper floor residential and office uses.
- (c) EBURD CW: Central Works District. The Central Works District is intended to allow a flexible mix of uses, including commercial and light industrial uses.
- (d) EBURD 13th: North 13th Street Main Street District. The North 13th Street Main Street is intended to provide a walkable, shopping & dining corridor with upper floor office and residential adjacent to the Central Works and Industrial Sanctuary districts, while allowing

appropriate craftsman industrial and commercial businesses.

- (e) EBURD IS: Industrial Sanctuary District. The Industrial Sanctuary district is intended to allow a wide mix of industrial businesses within the area with limited form requirements.

## Sec. 27-1803. Application & Approval Process.

- (a) Zoning Approval Required. This Section applies to all EBURD zoning districts defined in BMCC Sec. 27-1802. Any new development, and any remodel which meets the change in associated use test set forth in BMCC Sec. 27-1804 (c) (2) or (3) requires Planning Division approval as part of the City's Building Permit process.
- (b) Content of Application. Each application for development located in any of the EBURD districts shall include the following:
  - (1) The name and address of the property owner and applicant, if different;
  - (2) The legal and general description of the tracts or lots upon which review is sought;
  - (3) A statement of proposed use;
  - (4) A complete site development plan drawn to scale of no less than one (1) inch = forty (40) feet indicating:
    - a. Dimension and location of all existing and proposed buildings, recreation areas, utility and service areas, trash storage area, fire hydrants, access drives, full width of street and adjacent drives, parking areas, existing utility lines, and easements;
    - b. Dimension, location, and description of all other existing and proposed site improvements including fences, walls, walkways, patios, decks, and barriers;
    - c. Plans for landscape development , including irrigation, drainage, grading, and planting detail showing species, size, and spacing of trees, shrubs, and percent of living and non-living material;
    - d. A clear delineation of all area to be paved or surfaced, including a description of surfacing materials to be used;
    - e. Location and description of all off-site improvements and rights-of-way dedication;

# Article 27-1800. East Billings Urban Revitalization District Code

- f. Location and type of lighting, including a scaled or dimensioned elevation of each type of lighting fixture, and the maximum illumination measured in foot-candles at the lot line;
  - g. Building elevations drawn to a scale of no less than one-sixteenth (1/16) inch = one (1) foot for all structures, including architectural plans for proposed buildings complete with exterior finishes and including floor plans and elevations.
  - h. A signage plan indicating the location of all sign bands. This is to be submitted for informational purposes and to verify that the facade will accommodate the sign area allowed in Sec. 27-1816. A separate application and approval is required for all signs;
  - i. A timetable for the proposed construction project;
  - j. Documentation illustrating compliance with sustainable development practices achieved per BMCC Sec. 27-1807.
  - k. Any other information pertinent to the particular project which, in the opinion of the Zoning Coordinator, is determined to be necessary for the review of the project.
- (c) Review Timeline for Application. Within fifteen (15) working days following the submittal of a complete application, the Zoning Coordinator or his/her designee shall approve or deny the application, unless the applicant consents in writing to an extension of the review period. In the event that review exceeds fifteen (15) days, the applicant may seek administrative relief from the Planning Director. If an application is determined to be incomplete, the applicant shall be notified within five (5) days of the submittal. Should the application need corrections, the applicant shall be notified in writing specifying all areas of noncompliance with this Article.

## Sec. 27-1804 Nonconformances.

Refer to BMCC Sec. 27-400 for Nonconforming uses of Land and Nonconforming Structures and uses of Structures in all EBURD districts with the following additions:

- (a) Street Facade Revisions. When a renovation of the front facade occurs with no added building

square footage, the Street Facade Requirements (refer to BMCC Sec. 27-1809(a) through (f)) shall be met when the existing building front or corner facade is located within the build-to zone and the renovation includes any one of the following:

- (1) Installation of additional doors or a change in location of a door.
  - (2) Expansion or change in location of thirty (30) percent of windows by total area on any street façade.
  - (3) Replacement of thirty (30) percent or more of facade materials on any street facing facade with a different facade material.
- (b) Roof Revisions. When the existing building front or corner facade is located within the build-to zone and a renovation of the shape or style of the roof occurs with no added building square footage, the Roof Type Requirements (refer to BMCC Sec. 27-1810) for the frontage type permitted in the district shall be met.
- (c) Nonconforming Site Characteristics. Site characteristics, including impervious site coverage, curb cut quantity and location, parking, signage, landscaping, and other non-structural but physical characteristics of a site, may continue based on the following conditions:
- (1) Ten (10) Percent Exception. A site characteristic is not considered nonconforming if the size of the nonconformance is ten (10) percent or less of any requirement in Article 27-1800.
  - (2) Change in Associated Use. The right to continue shall be terminated if the associated use changes or the number of dwelling units, gross floor area, or capacity increases by fifty (50) percent or more.
    - a. Single or individual business signs within a multiple business center are exempt from this standard. A new tenant is permitted to install an individual business sign even if the signage on the lot as a whole is nonconforming, provided that the new sign does not increase the lot's nonconformance.
  - (3) Change in Associated Structure. The right to continue shall be terminated if the associated structure is altered to increase its gross floor area by fifty (50) percent or more.

# Article 27-1800. East Billings Urban Revitalization District Code

- (4) Abandonment. The right to continue shall be terminated if the associated use or structure, conforming or not, is abandoned for a period of twelve (12) consecutive months.

## Sec. 27-1805 Definitions

Refer to BMCC Sec. 27-200 for general definitions. For the purposes of Article 27-1800, the following terms shall have the following meanings:

**Build-to Zone.** An area in which the front or corner side facade of a building shall be placed; it may or may not be located directly adjacent to a lot line. The zone dictates the minimum and maximum distance a structure may be placed from a lot line. Refer to Figure 27-1805-1 Build-to Zone vs. Setback Line.

**Courtyard.** An outdoor area enclosed by a building on at least two (2) sides and is open to the sky.

**Eave.** The edge of a pitched or flat roof; it typically overhangs beyond the side of a building.

**Entrance Type.** The permitted treatment types of the ground story facade of a Frontage Type. Refer to BMCC Sec. 27-1809 for more information and a list of permitted Entrance Types.

**Expression Line.** An architectural feature consisting of a decorative, three (3) dimensional, linear element, horizontal or vertical, protruding or indented at least two (2) inches from the exterior facade of a building typically utilized to delineate the top or bottom of floors or stories of a building.

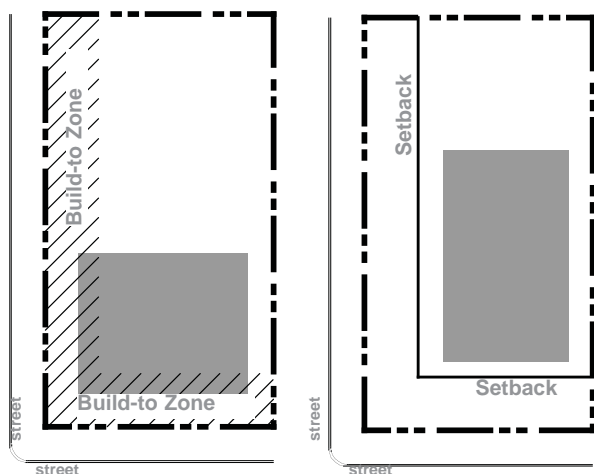

Figure 27-1805-1. Build-to-Zone vs. Setback Line

**Facade.** The exterior face of a building, including but not limited to the wall, windows, windowsills, doorways, and design elements such as expression lines. The front facade is any building face adjacent to the front lot line.

**Frontage Type.** A structure defined by the combination of configuration, form, and function. Refer to BMCC Sec. 27-1808 through 27-1810 for more information and the list of permitted Frontage Types.

**Impervious Site Coverage.** The percentage of a lot developed with principal or accessory structures and impervious surfaces, such as driveways, sidewalks, and patios.

**Landscape Area.** Area on a lot not dedicated to a structure, parking or loading facility, frontage buffer, side and rear buffer, or interior parking lot landscaping.

**Lot Frontage.** The horizontal distance between the side lot lines, measured at the front lot lines.

**Lot Line, Corner.** A boundary of a lot that is approximately perpendicular to the front lot line and is directly adjacent to a public right-of-way, other than an alley or railroad.

**Lot Line, Front.** The boundary abutting a right-of-way, other than an alley, from which the required setback or build-to zone is measured, with the following exceptions.

1. Corner and through lots that abut a primary street (refer to Figure 27-1817(e)-3 Primary Streets Map) shall have the front lot line on that primary street.
2. Corner and through lots that abut two primary streets or do not abut a primary street shall utilize the orientation of the two directly adjacent lots, or shall have the front lot line determined by the Zoning Coordinator.

**Occupied Space.** Interior building space occupied by the building users. It does not include storage areas, utility space, or parking.

**Pedestrianway.** A pathway designed for use by pedestrians; it can be located mid-block allowing pedestrian movement from one street to another without traveling along the block's perimeter.

# Article 27-1800. East Billings Urban Revitalization District Code

**Pervious Surface.** Also referred to as pervious material. A material or surface that allows for the absorption of water into the ground or plant material, such as permeable pavers or a vegetated roof.

**Primary Street.** A street designated on the Zoning Map that receives priority over other streets in terms of setting front lot lines and locating building entrances. Refer to BMCC Sec. 27-1817(e)3.

**Public Improvement.** Any structure incident to servicing or furnishing public facilities for a subdivision or development, such as grading, street surfacing, curbs and gutter, driveway approaches, sidewalks, crosswalks, water mains and lines, sanitary sewers, storm sewers, culverts, bridges, and utilities.

**Roof Type.** The detail at the top of a building that finishes a facade, including a pitch roof with various permitted slopes and a parapet. Refer to BMCC Sec. 27-1810 for more information and a list of the permitted Roof Types.

**Scale.** The relative size of a building, street, sign, or other element of the built environment.

**Semi-Pervious Surface.** Also referred to as semi-pervious material. A material that allows for at least forty (40) percent absorption of water into the ground or plant material, such as pervious pavers, permeable asphalt and concrete, or gravel.

**Setback.** The horizontal distance from a lot line inward, beyond which a structure may be placed. Structures or other impervious surfaces are not permitted within a setback, unless specifically permitted in this article. Refer to Figure 27-1805-1 Build-to Zone vs. Setback Line.

**Solar Reflectance Index (SRI).** A measure of a constructed surface's ability to reflect solar heat, as shown by a small temperature rise. The measure utilizes a scale from 0 to 100 and is defined so that a standard black surface is 0 and a standard white surface is 100. To calculate for a given material, obtain the reflectance value and emittance value for the material; calculate the SRI according to ASTM E 1980-01 or the latest version.

**Stormwater Best Management Practices/Techniques.** Conservation practices or systems of practices and management measures that control soil loss; reduce water quality degradation caused by nutrients, Animal waste, toxins, and sediment; and minimize

adverse impacts to surface water and groundwater flow, circulation patterns, and to chemical, physical, and biological characteristics of wetlands by natural means, including replicating natural systems.

**Story, Ground.** Also referred to as ground floor. The first floor of a building that is level to or elevated above the finished grade on the front and corner facades, excluding basements or cellars.

**Story, Half.** A story either in the base of the building, partially below grade and partially above grade, or a story fully within the roof structure with transparency facing the street.

**Story, Upper.** Also referred to as upper floor. The floors located above the ground story of a building.

**Street Face.** The facade of a building that faces a public right-of-way.

**Street Type.** The permitted and regulated types of streets in this article. Refer to 27-1817 Street Type Standards for more information and a list of the permitted Street Types.

**Streetwall.** The vertical plane created by building facades along a street. A continuous streetwall occurs when buildings are located in a row next to the sidewalk without vacant lots or significant setbacks.

**Visible Basement.** A half story partially below grade and partially exposed above with required transparency on the street facade.

**Yard, Corner Side.** A yard extending from the corner side building facade along a corner side lot line between the front yard and rear lot line.

**Yard, Side.** A yard extending from the side building facade along a side lot line between the front yard and rear lot line.

# Article 27-1800. East Billings Urban Revitalization District Code

## Sec. 27-1806 Uses.

This section outlines the uses of land regulated in this article.

(a) General Provisions. The following general provisions apply to the uses outlined in this section.

- (1) A lot may contain more than one (1) use.
- (2) Each of the uses may function as either a principal use or accessory use on a lot, unless otherwise specified.
- (3) Uses are either permitted by-right in a district, permitted by-right with specific development or design parameters, or require Special Review (refer to BMCC Sec. 27-1503) in order to be developed.
- (4) Each use shall be located within a permitted Frontage Type (Refer to BMCC Sec. 27-1808 through 1810), unless otherwise specified.
- (5) Each use may have both indoor and outdoor facilities, unless otherwise specified.

(b) Organization. The uses are grouped into general categories, which may contain lists of additional uses or clusters of uses.

- (1) Unlisted Similar Use. If a use is not listed but is similar in nature and impact to a use permitted within a zoning district, the Zoning Coordinator may interpret the use as permitted.
  - a. The unlisted use will be subject to any development standards applicable to the similar permitted use.
  - b. If the unlisted use is similar in nature and impact to a use requiring Special Review per BMCC Sec. 27-1503, the Zoning Coordinator may interpret the use as also requiring Special Review.
- (2) Unlisted Dissimilar Use. If a use is not listed and cannot be interpreted as similar in nature and impact to a use within a zoning district that is either permitted or requires Special Review, the use is not permitted and may only be approved through an amendment of this article.

(c) Use Table. Table 27-1806-1: Uses by District outlines the permitted uses in each zoning district. Each use is given one of the following designations for each zoning district in which that use is permitted.

- (1) Permitted (“●”). These uses are permitted by-right in the districts in which they are listed.
- (2) Permitted in Upper Stories Only (“◐”). These uses are permitted by-right in the districts in which they are listed, provided that the uses are located in the upper stories of a structure. These uses may also be located in the ground story provided that they are located beyond a depth of at least thirty (30) feet from the front facade.
- (3) Permitted with Development Standards (“◑”). These uses are permitted by-right in the districts in which they are listed, provided that they are developed utilizing the listed development standards. These standards are intended to alleviate any negative impacts associated with the use, making it appropriate in a district where it otherwise might not have been appropriate.
- (4) Requires a Special Review (“○”). These uses require Special Review by the City Zoning Commission (refer to BMCC Sec. 27-1503) in order to occur in the districts in which they are listed and must follow any applicable development standards associated with the use as well as meet the requirements of the Special Review.
- (5) Uses that are not permitted are indicated by a blank space.

(d) Residential and Lodging Uses. A category of uses that include several residence types.

- (1) Residential. One (1) or more dwelling units located within the principal structure of a lot, in which the units may or may not share a common wall with the adjacent (horizontally or vertically) unit or have individual entrances from the outside.
- (4) Lodging & Residential Care. A facility offering temporary or permanent lodging to the general public consisting of sleeping rooms with or without in-room kitchen facilities. Lodging & residential care includes such uses as hotels, bed and breakfast inns, independent and assisted living facilities, nursing homes, residential care homes, and transitional treatment facilities. Assistance with daily activities may be provided for residents. Secondary service uses may also be provided, such as restaurants and meeting

# Article 27-1800. East Billings Urban Renewal District Code

Uses	EBURD Districts				
	Rail Spur Village Main Street	Rail Spur Village	Central Works	13th Street Main Street	Industrial Sanctuary
<b>KEY</b> ● Permitted ○ Permitted in Upper Stories Only ◐ Permitted with Development Standards ○ Requires a Special Review					
<b>Residential &amp; Lodging</b>					
Residential	○	●	●	○	
Lodging & Residential Care	○	●	●	○	
<b>Civic</b>					
Assembly	○	●	●	○	●
Hospital	○	●	●	○	●
Library/Museum	●	●	●	●	●
Police and Fire	●	●	●	●	●
Post Office	●	●	●	●	●
School	○	●	○	○	●
<b>Retail &amp; Wholesale</b>					
General Retail	●	●	●	●	
Commercial Equipment &		●	●	●	●
Outdoor Sales Lot		◐	●	●	●
<b>Service</b>					
General Service	●	●	●	●	●
Large Scale Entertainment			●	●	●
Vehicle Service	●	◐	●	●	●
<b>Office</b>					
Office	●	●	●	●	○
<b>Industrial</b>					
Craftsman Industrial	◐	●	●	●	●
General Manufacturing			●	●	●
Warehousing & Distribution		●	●	●	●
Heavy Manufacturing					◐
Transportation Facilities			●		●
Sexually Oriented Business			○	○	○
<b>Infrastructure</b>					
Parking Lot	◐	◐	◐	◐	◐
Utility & Infrastructure		○	●	○	●
Wireless Transmission Facility	○	○	○	○	○
Open Space	◐	◐	◐	◐	◐

Uses	EBURD Districts				
	Rail Spur Village Main Street	Rail Spur Village	Central Works	13th Street Main Street	Industrial Sanctuary
<b>Accessory Uses</b>					
Outdoor Storage of Material		●	●	●	●
Employee/Caretaker Units		◐	◐	◐	◐

Table 27-1806-1. Use Table by District.

rooms. Rooms shall be accessed from the interior of the building.

- (e) Civic Uses. A category of uses related to fulfilling the needs of day-to-day community life including assembly, public services, educational facilities, hospitals, and cemeteries.
- (1) Assembly. A facility that has organized services, meetings, or programs to benefit, educate, entertain, or promote discourse amongst the residents of the community in a public or private setting. Assembly includes such uses as a community center, house of worship, and private clubs and lodges. Residential uses accessory to and on the same lot as an assembly use, such as a convent, parish house, or caretaker's home, are also permitted.
  - (2) Hospital. A licensed institution providing medical care and health services to the community. These services may be located in one (1) building or clustered in several buildings and may include laboratories, in- and out-patient facilities, training facilities, medical offices, staff residences, food service, pharmacies, and gift shop.
  - (3) Library/Museum. A structure open to the general public housing educational, cultural, artistic, or historic information, resources, and exhibits. May also include food service and a gift shop.

# Article 27-1800. East Billings Urban Revitalization District Code

- (4) Police and Fire. A facility providing public safety and emergency services; training facilities, locker rooms, and limited overnight accommodations may also be included. Police and fire facilities have the following additional allowances:
- Garage doors are permitted on the front facade.
  - Exempt from maximum driveway widths (refer to BMCC Sec. 6-1208(h)).

- (5) Post Office. A publicly accessed facility for the selling of supplies and mail related products and the small scale collection and distribution of mail and packages. Refer to Warehousing & Distribution (BMCC Sec. 27-1806(o)) for large-scale postal sorting and distribution centers.
- (6) School. An education facility with classrooms and offices, that may also include associated facilities such as ball fields, ball courts, gymnasium, theater, and food service.

General Retail	General Service
Antique & Secondhand	Animal Boarding
Appliance & Electronic Sales & Service	(interior only)
Apparel & Accessory Store	Arcade
Art & Education Supplies	Bank or other Financial Service
Automotive Supply Shop (no service)	Barber Shop, Beauty Salon, & Spa
Bakery	Billiard Hall
Bicycle Sales & Repair	Bowling Alley
Book, Magazine, & Newspaper	Catering
Camera & Photo Supply	Check Cashing
China & Glassware Shop	Day Care
Cigars, Cigarette, & Related	Dry Cleaning & Laundry
Computer Software Sales & Leasing	Eating & Drinking Establishments
Convenience Store	Emergency Care Clinic
Department Store	Fitness, Dance Studio, & Gym
Drug Store/Pharmacy	Framing
Fabric & Craft Store	Funeral Home
Florist	Home Furniture & Equipment Repair
Furniture, Home Furnishings & Accessories	Indoor domestic animal daycare
Gift, Novelty, & Souvenir Shop	Locksmith
Grocery Store	Mailing Services
Gun Shop	Pet Grooming
Hardware Store	Photocopying & Printing
Hobby	Photography Studio & Supplies (on-site processing permitted)
Jewelry Sales & Repair	Repair of Small Goods & Electronics
Luggage & Leather Goods	Shoe Repair
Motorcycle & Motor Scooter Sales	Shooting & Archery Ranges (indoor only)
Music Store	Tailor & Seamstress
Musical Instrument Repair & Sales	Tanning Salon
Office Supply	Tattoo/Piercing Parlor
Optical Goods	Theater
Paint & Wallpaper	Training Center
Party Supply	Travel Agency & Tour Operator
Pawn Shop	Video Rental
Pet & Pet Supply	
Specialty Food Market (Butcher, Candy, Fish Market, Produce, etc.)	
Sporting Goods Sales & Rental	
Stationary & Paper Store	
Toy Shop	
Video/Game Sales & Rental	
Wine & Liquor Shop	

- (f) General Retail. A use involving the sale of goods or merchandise to the general public for personal or household consumption. A use in this category occupies a space of less than 20,000 square feet. Retail includes such uses as those found in Table 27-1806-2.
- (g) Commercial Equipment and Supply. A use involving the large scale sale of goods marketed primarily to commercial or industrial businesses, but may also be available to the general public. This use may include bulk sales and frequent commercial vehicle and consumer traffic. This use is primarily located indoors. Commercial Equipment and Supply includes such uses as:
- Building Materials, Hardware, and Garden Supply
  - Heating, Air Conditioning and Plumbing Supplies, Sales, and Service
  - Cabinet Supply (display only)
  - Machine Sales and Rental
  - Agriculture Equipment and Supply
  - Electrical Supplies
  - Merchandise Vending Machine Operators
  - Medical Supply Store & Sales
  - Exterminating & Disinfecting Service
- (h) Outdoor Sales Lot. A use involving the sale of goods or merchandise to businesses and/or the general public, where the majority of the goods are stored or displayed outdoors. Outdoor sales lots include such uses as the sale and rental of automobiles, trucks, trailers, boats, and recreational vehicles; and the sale of building materials, landscape materials, and garden supplies. In the districts where an outdoor sales lot is permitted with development standards ("C"), the following applies:

Table 27-1806-2. Typical General Retail & General Service Uses.

# Article 27-1800. East Billings Urban Revitalization District Code

- (1) Loose material must be stored in compliance with the standards in BMCC Sec. 27-601(b). Parking and Storage Restrictions.
  - (2) Limited to lots fronting on Boulevard Street Types (1st Avenue N, 4th Avenue N, and 6th Avenue N).
- (i) General Service. A category of uses that provide patrons services and limited retail products related to those services. Visibility and accessibility are important to these uses, as most patrons do not utilize scheduled appointments. A use in this category occupies a space no greater than 20,000 square feet and includes such uses as those found in Table 27-1806-2.
- (j) Large Scale Entertainment. A service use offering entertainment within the community and the region, housed in a large scale facility greater than 20,000 square feet. Large scale entertainment includes such uses as a concert hall, movie theater, casino, or events facility (a facility regularly available for rental by an individual, group, or business for banquets, meetings, conferences, seminars, or lectures). This use may also include support facilities such as eating and drinking establishments. This use may also include outdoor entertainment and recreation opportunities such as batting cages, go-cart tracks, miniature golf, aquatic facilities, and skating rinks.
- (k) Vehicle Service. A business involving the servicing of vehicles and/or the distribution of fuel to residents of the community and region. A convenience store may also be included as a secondary use, as well as the sale of propane and kerosene. Vehicle service includes such uses as automotive filling stations, vehicle repair, car wash facilities, and tire sales and mounting. In the districts where vehicle service is permitted with development standards (“D”), the following apply:
- (1) Use Limitation. Repair and wash facilities for semi-trucks, recreational vehicles, boats, and other oversized vehicles are only permitted in the Industrial Sanctuary district.
  - (2) Service Bays. Vehicular service bays, including garages and car wash bays, shall not be located on the front facade, unless otherwise permitted by the Frontage Type.
  - (3) Outdoor Storage. Disabled or inoperable vehicles and those awaiting pick-up may be stored outdoors if:
    - a. The vehicles are not stored for more than two (2) days.
    - b. The storage area is located in the rear yard screened from view of the front lot line.
    - c. The storage area is screened using the Side & Rear yard buffer outlined in BMCC Sec. 27-1815(j), regardless of the adjacent land uses.
  - (4) Outdoor Activities.
    - a. All repairs or washing activities must occur inside a structure.
    - b. Vacuuming activities may occur in open air, but must be located in the side or rear yards, screened from the front lot line.
    - c. Temporary outdoor display of seasonal items, such as windshield wiper fluid or salt, is permitted during business hours under the canopy and adjacent to the principal structure.

---

## Office Uses

---

**Architecture, Engineering, Planning, & Design**  
**Building Contractor (office only)**  
**Business Consulting**  
**Charitable Institutions**  
**Computer Programming & Support**  
**Detective & Security Services**  
**Educational Services (tutor & testing)**  
**Employment Agency**  
**Financial & Insurance**  
**Government Offices**  
**Professional Membership Organizations**  
**Legal Services**  
**Management Services**  
**Physical Therapy/Physical Rehabilitation**  
**Medical & Dental with Laboratory**  
**PR & Advertising**  
**Property Development**  
**Radio & TV Studio**  
**Real Estate**  
**Recording & Sound Studio**  
**Research & Development**  
**Research Agency**  
**Surveying**  
**Veterinarian**

---

Table 27-1806-3. Typical Office Uses.

- (l) Office Uses. A category of uses for businesses that involve the transaction of affairs of a profession, service, industry, or government. Patrons of these businesses usually have set appointments or meeting times; the businesses do not typically rely on walk-in customers. Office uses include those listed in Table 27-1806-3.

# Article 27-1800. East Billings Urban Revitalization District Code

(m) **Craftsman Industrial.** A use involving small scale manufacturing, production, assembly, and/or repair with little to no noxious by-products that includes a showroom or small retail outlet. Craftsman industrial includes such uses as those found in Table 27-1806-4. This use may also include associated facilities such as offices and small scale warehousing, but distribution is limited. The maximum overall gross floor area is limited to 45,000 square feet, unless otherwise noted. In the districts where a craftsman industrial use is permitted with development standards (“C”), the following apply:

- (1) 20,000 square feet is the maximum permitted overall gross floor area.
- (2) A minimum twenty (20) percent of gross floor area shall be dedicated to a showroom located at the front of the space.
- (3) Outdoor activities and storage of goods are not permitted.

(n) **General Manufacturing.** A manufacturing use involving the assembly, production, and distribution of goods resulting in limited negative external effects. This use may involve the production of goods from raw materials or the assembly of finished products that can

Craftsman Industrial	General Manufacturing	Warehousing & Distribution	Heavy Manufacturing
Apparel & Finished Fabric Products	Aircraft & Railroad Equipment & Parts	Air Freight	Acid
Bakery & Confections	Alcoholic Beverages	Contractor Equipment & Warehouse– Landscape & Construction	Asbestos
Beverages, including Beer, Wine, Liquor, Soft Drinks, Coffee	Apparel, Finished Products from Fabric	Exterminator & Disinfection Services	Asphalt
Botanical Products	Boat Building & Repairing	Fuel Distribution	Battery Manufacturing & Rebuilding
Brooms & Brushes	Cotton Wadding	Mail & Parcel Sorting & Distribution	Biological Product
Canning & Preserving Food	Distilled Water	Mail Order House & Warehousing	Boiler Works
Commercial Scale Copying & Printing	Electrical Machinery & Equipment	Motor Freight Transportation	Celluloid Manufacturing & Treatment
Construction Special Trade Contractors	Electronic Equipment & Component	Newspaper Distribution Facilities	Chemicals
Cut Stone & Cast Stone	Excelsior & Fiber	Packing & Crating	Cement, Concrete, Gypsum, Asbestos
Dairy Products	Fur Dressing & Dying	RV Storage Yard	Dry Cleaning & Dyeing
Electronics Assembly	Internal Combustion Motors	Recycling Center (Collection & Sort)	Foundries
Engraving	Linoleum	Tow or Impound Lot	Industrial Launderers
Electrical Fixtures	Lumber Milling	Truck Terminal or Parking Facilities	Laundry Soap, Chips & Powder
Fabricated Metal Products	Machinery & Tools	Warehousing & Storage (Refrigeration or General)	Meat & Fish Processing & Packaging
Film Making	Mobile/Manufactured Homes Manufacturing	Water Distribution	Motor Vehicle Assembly
Furniture & Fixtures	Motor Testing	Personal & Household Storage	Ordnance & Accessories
Glass	Motor Vehicle Parts & Equipment		Paints, Enamels, Lacquers, & Varnishes & Allied Products
Household Textiles	Motorcycles, Bicycles, & Parts		Paper & Allied Products
Ice	Office & Artist’s Materials		Petroleum & Related Products
Jewelry, Watches, Clocks, & Silverware	Perfume, Cosmetics, Soap, & Other Toiletry Items		Pharmaceuticals
Leather Products	Plumbing & Heating Products		Rock Crushing
Meat & Fish Products, no Processing	Poultry Dressing		Rubber & Plastics
Musical Instruments & Parts	Research & Development with laboratory & testing		Seeding & Grain Milling
Pasta	Rolling, Drawing, Extruding Metal		Smelting
Pottery, Ceramics, & Related Products	Scientific Instruments, including Photographic, Medical & Dental, Surveying, Measuring, and Optical Equipment		Stone & Concrete
Printing, Publishing & Allied Industries	Structural Clay Products		Sugar
Shoes & Boots	Tobacco		Tannery
Signs & Advertising	Vehicle Staging & Storage (Ambulance, Bus, Limousine, Livery, Taxi, etc.)		Tar Distillation
Small Goods Manufacturing			Vegetable, Animal, & Marine Oils & Fats
Smithing			Wax Products Production
Taxidermy			Wool Scouring & Pulling
Textile, Fabric, Cloth			
Toys & Athletic Goods			
Upholstery			
Woodworking			

Table 27-1806-4. Typical Industrial Uses.

# Article 27-1800. East Billings Urban Revitalization District Code

result in some noise and other non-noxious by-products. Associated facilities may also be included such as offices, limited warehousing, limited service bays, and maintenance facilities. Fuel pumps and outdoor storage of goods are defined by the permitted accessory uses. General manufacturing uses include all craftsman industrial uses and such uses as those found in Table 27-1806-4, without the size limitation.

(o) Warehousing and Distribution. A general industrial use involving substantial commercial vehicle access and large-scale indoor or outdoor storage and packing of goods typically between production and the market. Warehousing and Distribution includes such uses as those found in Table 27-1806-4. In the districts where warehousing and distribution is permitted with development standards (“O”), the following apply:

- (1) Truck Access. Truck access is permitted only off a Boulevard Street Type (refer to BMCC Sec. 27-1817 Street Types).
- (2) Loading Bays. Loading bays if permitted by Frontage Type, shall be located directly off a Boulevard Street Type.

(p) Heavy Manufacturing. An industrial use with the potential for significant negative external effects and involving the production of goods from raw materials, often resulting in noise, odor and/or noxious by-products, and involving frequent commercial vehicle access and outdoor storage of materials or products. Heavy industrial includes such uses as those found in Table 27-1806-4. In the districts where a heavy manufacturing use is permitted with development standards (“O”), the following apply:

- (1) Noise, odor, and other noxious by-products shall not be measurable on adjacent properties.
- (2) Waste products shall be disposed of off-site, without entering the sanitary sewer system.

(q) Transportation Facilities. A business involving the transport of passengers that may include a station with offices, food and beverage service and platforms for arrivals and departures. Short and long term parking facilities, maintenance facilities and vehicle storage are not permitted.

Transportation facilities include such uses as bus or rail terminals.

(r) Sexually Oriented Business. A business use that includes the uses defined in BMCC Sec. 27-611 of the Unified Zoning Regulations of the City of Billings. In the districts where a sexually oriented business requires Special Review (BMCC Sec. 27-1503) (“O”), the use shall comply with all requirements set forth in BMCC Sec. 27-611 of the Unified Zoning Regulations of the City of Billings.

(s) Parking Lot. A lot that does not contain a permitted building or Open Space Type and is solely used for the parking of vehicles. In the districts where a parking lot is permitted with development standards (“O”), the following apply:

- (1) Adjacent Parking Lots. Two (2) parking lots cannot be located directly adjacent to one another.
- (2) Single Family. Parking lot cannot be associated with a single family use.
- (3) Distance. Parking lot must be within 1,000 feet of the associated use unless:
  - a. At least seventy-five (75) percent of the spaces are dedicated for public use.
  - b. An approved parking agreement is in place (refer to BMCC Sec. 6-1203 (h) and (i) Joint Use).
  - c. Lot is utilized for commercial vehicles (refer to BMCC Sec. 27-1806(s)(6)) in which case an associated use is not required.
- (4) Pedestrian Access. Must be connected to associated use by a dedicated, public pedestrian pathway.
- (5) Commercial Vehicles. Parking lots for commercial vehicles are only permitted in the Central Works and Industrial Sanctuary districts and are exempt from BMCC Sec. 27-1806(s)(1) through (5).

(t) Utility and Infrastructure. A lot that is primarily utilized for the City’s infrastructure needs. Utility and infrastructure includes such uses as electric or gas services, sewage treatment, water treatment and storage, and energy conversion systems. In the districts where utilities and

# Article 27-1800. East Billings Urban Revitalization District Code

infrastructure require Special Review (“○”), refer to BMCC Sec. 27-1503 for requirements.

(u) Wireless Communication Facility. A use of land that includes unmanned buildings, cabinets, structures, and facilities, including generating and switching stations, repeaters, antennas, transmitters, receivers, towers, and all other buildings and structures relating to low-power mobile voice transmission, data transmission, video transmission, radio transmission, or wireless transmission. In the districts where wireless communication facilities require Special Review (BMCC Sec. 27-1503) (“○”), refer to BMCC Sec. 27-620 for requirements.

(v) Open Space. A use of land for active or passive, public or private, outdoor space, including such uses as parks, plazas, greens, playgrounds, or community gardens. Open space uses may also be utilized to host temporary private or community events, such as a farmer’s market or art fair. In the districts where open space is permitted with development standards (“●”), the following apply:

- (1) Parking. Parking lots are not permitted in open space in any EBURD district.
- (2) Size. All open space in an EBURD district is limited to no greater than 90,000 square feet.
- (3) Treatment. Open space in an EBURD district may include both landscape and hardscape.
- (4) Stormwater Accommodations. Open space that incorporates stormwater management on a site or district scale is encouraged.
  - a. Stormwater facilities shall be designed to accommodate additional uses, such as an amphitheater or a sports field.
  - b. Stormwater facilities shall be designed not to be fenced and shall not impede public use of the land they occupy.
- (5) Active Facilities. Designated ball fields are not permitted. Ball courts and playgrounds are permitted in the Rail Spur Village district only.
- (6) This use may involve small scale food and beverage service, no more than 200 square feet in space, located in a kiosk, with no service access.
- (7) Buildings located directly adjacent to an open space use shall treat facades facing this use with street facade requirements.

(w) Accessory Uses. Accessory uses are regulated by BMCC Sec. 27-600 with the following exceptions:

- (1) Outdoor Storage of Goods. Permanent outdoor storage of goods not typically housed or sold indoors, such as large scale materials and building and landscape supplies. In the districts where outdoor storage of goods is permitted with development standards (“●”), the following development standards apply:
  - a. Within the Central Works and 13th Street Main Street Districts:
    - i. Outdoor storage areas shall be located in the rear or side yard of the lot.
    - ii. Loose materials shall not be stacked higher than six (6) feet.
    - iii. Loose materials shall at a minimum be stored in a three (3) sided shelter and shall be covered.
    - iv. Materials shall be set back a minimum of five (5) feet from any lot line.
    - v. All outdoor storage areas shall be screened from view of adjacent parcels and vehicular rights-of-way using the heavy side or rear buffer, refer to BMCC Section 27-1815(j) Side and Rear Buffer.
- (2) Employee/Caretaker Units. In the districts where employee/caretaker units are permitted with development standards (“●”), the following development standards apply:
  - a. Up to two (2) residential units per 10,000 square feet of gross building floor area.
  - b. Units shall be provided to employees, security personnel, or caretakers, as a benefit to the business only.

# Article 27-1800. East Billings Urban Revitalization District Code

## Sec. 27-1807 Sustainable Development Measures.

The following sustainable development measures process shall be addressed by all developments in the EBURD districts defined by BMCC Sec. 27-1802.

- (a) Review and Approval. Documentation on which measures and total number of points the applicant will achieve shall be indicated on the building permit application submitted to the City for review and approval.
- (b) Requirements. The applicant shall achieve no less than five (5) total points from any combination of the following sustainable development measures. No partial points will be accepted.
- (c) Documentation. The applicant shall submit documentation supporting that the development will achieve the measure.
- (d) Certified Green Buildings Measure (3 points). Certify a new construction building or building undergoing major renovations through a green building rating system requiring review by an independent, third-party certifying body and approved by the Zoning Coordinator.
  - (1) Value. This measure earns the applicant 3 points.
  - (2) Documentation. Required documentation includes registration of the project with the system, payment of all applicable fees for the rating system, and a draft scorecard showing the achieved credits or points.
- (e) Building Energy Efficiency Measure (2 points).
  - (1) New Construction Buildings. Newly constructed buildings must demonstrate an average 10% improvement over the energy code currently in effect in the City.
  - (2) Major Renovation. Building must demonstrate an average 5% improvement over ANSI/ASHRAE/IESNA Standard 90.1-2007.
  - (3) Value. This measure earns the applicant 2 points.
  - (4) Documentation. Required documentation includes an energy model demonstrating that the building(s) will achieve the proposed improvements.
- (f) Building Water Efficiency Measure (2 points). Indoor water use in new buildings and major renovations must be an average 20% less than in baseline buildings. Utilize the baseline water usage for fixtures per the Energy Policy Act of 1992 and subsequent rulings by the United States Department of Energy or a similar method approved by the Zoning Coordinator.
  - (1) Value. This measure earns the applicant 2 points.
  - (2) Documentation. Required documentation includes cut sheets for all water fixtures.
- (g) Water-Efficient Landscaping Measure (2 point). Reduce potable water used for landscape by utilizing all xeriscape plant materials and providing no permanent irrigation system or using only captured rainwater with an irrigation system.
  - (1) Value. This measure earns the applicant 2 points.
  - (2) Documentation. Required documentation includes a landscape and irrigation plan, illustrating the system.
- (h) Renewable Energy Sources Measure (2 points). Incorporate renewable energy generation on-site with production capacity of at least 5% of the building's annual electric and thermal energy, established through an accepted building energy performance simulation tool.
  - (1) The following renewable energy generation sources are applicable:
    - a. Solar thermal or photovoltaics
    - b. Wind
    - c. Geothermal
  - (2) Value. This measure earns the applicant 2 points.
  - (3) Documentation. Required documentation includes specifications and construction details for the installation of the system.
- (i) Green Roof Measure (2 points). Install a vegetated roof for at least 50% of building roof area.
  - (1) Value. This measure earns the applicant 2 points.

# Article 27-1800. East Billings Urban Revitalization District Code

- (2) Documentation. Required documentation includes roof construction plans with drainage and planting details.
- (j) Heat Island Reduction Measure (2 point).
  - (1) Use any combination of the following strategies for 35% of all on-site, non-roof hardscape areas, including sidewalks, plazas, courtyards, parking lots, parking structures, and driveways.
    - a. Tree Canopy Cover. Coverage of the surface at shade tree maturity in 15 years.
    - b. Solar reflective paving & roofing with a SRI (solar reflectance index) of at least 29.
  - (3) Value. This measure earns the applicant 2 point.
  - (2) Documentation. Required documentation includes plans and specifications for installation of the strategy.
- (k) Pervious Pavement Measure (2 points). Install an open grid or pervious pavement system that is at least 40% pervious on 80% of all hardscape surface areas, including sidewalks, plazas, courtyards, parking lots, and driveways.
  - (1) Value. This measure earns the applicant 2 points.
  - (2) Documentation. Required documentation includes plans and specifications for installation of the strategy.
- (l) Enhanced Bicycle Amenities Measure (1 point).
  - (1) Inclusion of two of the following:
    - a. Lockable enclosed bicycle storage. Provide one (1) secure, enclosed bicycle storage space for 10% of planned employee occupancy.
    - b. Employee shower facilities. Provide at least one (1) shower facility and one (1) per 150 employees.
    - c. Increased bicycle parking spaces. Provide bicycle racks at a rate of one (1) per 5000 square feet of gross building area, with no fewer than four (4) bicycle spaces per building.
  - (2) Value. This measure earns the applicant 1 point.
  - (3) Documentation. Required documentation includes site and/or building plans locating the measures included.

# Article 27-1800. East Billings Urban Revitalization District Code

## Sec. 27-1808 Introduction to Frontage Type Requirements

The Frontage Types detailed in BMCC Sec. 27-1813 outline the required building forms for new construction and renovated structures within the EBURD.

- (a) **Applicability.** The Frontage Type standards shall be applied to all new construction and exterior renovation of existing structures. Refer to BMCC Sec. 27-1804 Nonconformances for more information on the continuation of nonconforming structures.
- (b) **General Requirements.** All Frontage Types must meet the following requirements.
  - (1) **Zoning Districts.** Each Frontage Type shall be constructed only within its designated districts (Refer to Table 27-1808-1 Permitted Frontage Types by Districts). Permitted Frontage Types in each zoning district defines which Frontage Types are permitted in which zoning districts. Refer to BMCC Sec. 27-1802 EBURD zoning districts for more information.
  - (2) **Uses.** Each Frontage Type can house a variety of uses depending on the district in which it is located. Refer to BMCC Sec. 27-1806 EBURD uses for general uses permitted per district. Some Frontage Types have additional limitations on permitted uses.
  - (3) **No Other Frontage Types.** All buildings constructed must meet the requirements of one of the Frontage Types permitted within the zoning district of the lot.
  - (4) **Permanent Structures.** All buildings constructed shall be permanent construction without a chassis, hitch, or wheels, or other features that would make the structure mobile, unless otherwise noted.
  - (5) **Accessory Structures.**
    - a. Attached accessory structures are considered part of the principal structure.
    - b. Detached accessory structures are permitted per each Frontage Type and shall comply with all setbacks except the following:
      - i. Detached accessory structures are not permitted in the front yard.
      - ii. Detached accessory structures shall be located behind the principal structure in the corner side yard.
      - iii. Detached accessory structures shall not exceed the height of the principal structure and in no case shall be taller than two and a half (2.5) stories.

		EBURD Districts				
		Rail Spur Village Main Street	Rail Spur Village	Central Works	North 13th Street	Industrial Sanctuary
Frontage Types	<b>Yard Frontage</b>		●			
	<b>General Stoop</b>		●	●		●
	<b>Storefront</b>	●	●	●	●	●
	<b>Limited Bay</b>		●	●	●	●
	<b>Commerce</b>			○		●
	<b>Open Frontage</b>					●
	<b>Civic Frontage</b>	●	●	●	●	●
	<b>Commercial Outdoor Site</b>		○	●	●	●

● = Permitted Boulevard ○ = Permitted Only on Boulevard Street Type

Table 27-1808-1. Permitted Frontage Types by District

# Article 27-1800. East Billings Urban Revitalization District Code

## Sec. 27-1809 Entrance Types

Entrance Type standards apply to the ground story and visible basement of front facades of all Frontage Types as defined in this Section. Refer to BMCC Sec. 27-1813 Frontage Types.

(a) General Provisions. The following provisions apply to all Entrance Types.

- (1) Intent. To guide the design of the ground story of all buildings to relate appropriately to pedestrians on the street. Treatment of other portions of the building facades is detailed in each Frontage Type standard (refer to BMCC Sec. 27-1813(a) through (h)).
- (2) Applicability. The entire ground story street-facing facade(s) of all buildings shall meet the requirements of at least one (1) of the permitted Entrance Types, unless otherwise stated.
- (3) Measuring Transparency. Refer to Sec. 27-1811(d)(1) for information on measuring building transparency.
- (4) Visible Basements. Visible basements, permitted by Entrance Type, are optional. The visible basement shall be a maximum of one-half (1/2) the height of the tallest story.

(b) **Storefront Entrance Type.** (Refer to Figure 27-1809(b)-1). The Storefront Entrance Type is a highly transparent ground story treatment designed to serve primarily as the display area and primary entrance for retail or service uses.

- (1) Transparency. Minimum transparency is required per Frontage Type.

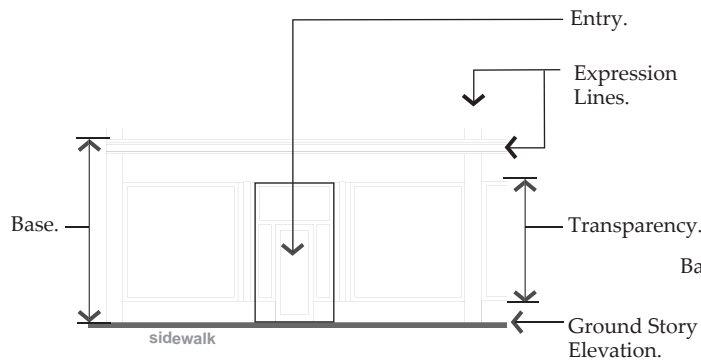

Figure 27-1809(b)-1. Storefront Entrance Type.

- (2) Elevation. Storefront elevation shall be between zero (0) and one (1) foot above sidewalk.
- (3) Visible Basement. A visible basement is not permitted.
- (4) Horizontal Facade Division. Horizontally define the ground story facade from the upper stories.
- (5) Entrance. All entries shall be recessed from the front facade closest to the street.
  - a. Recess shall be a minimum of three (3) feet and a maximum of eight (8) feet deep, measured from the portion of the front facade closest to the street.
  - b. When the recess falls behind the front build-to zone, the recess shall be no wider than eight (8) feet.

(c) **Arcade Entrance Type.** (Refer to Figure 27-1809(c)-1). An Arcade Entrance Type is a covered pedestrian walkway within the recess of a ground story.

- (1) Arcade. An open-air public walkway is required from the face of the building recessed into the building a minimum of eight (8) and a maximum of fifteen (15) feet.
- (2) Recessed or Interior Facade. Storefront Entrance Type is required on the recessed ground story facade.
- (3) Column Spacing. Columns shall be spaced between ten (10) feet and twelve (12) feet on center.
- (4) Column Width. Columns shall be a minimum of 1'-8" and a maximum 2'-4" in width.

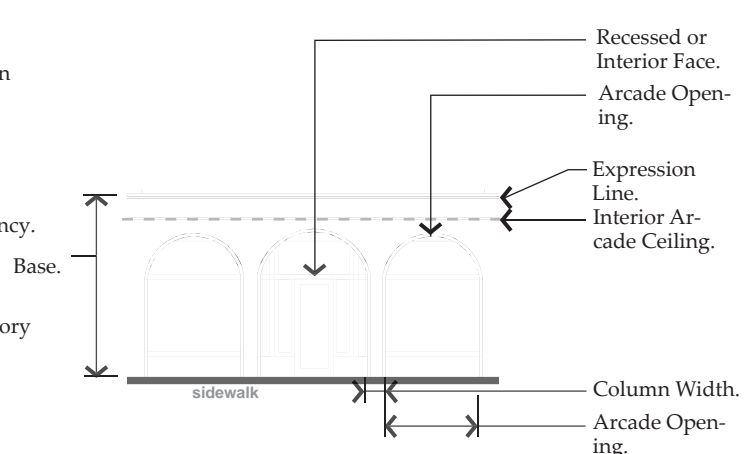

Figure 27-1809(c)-1. Arcade Entrance Type.

# Article 27-1800. East Billings Urban Revitalization District Code

- (5) Arcade Opening. Opening shall not be flush with interior arcade ceiling and may be arched or straight.
  - (6) Horizontal Facade Division. Horizontally define the ground story facade from the upper stories.
  - (7) Visible Basement. A visible basement is not permitted.
- (d) **Stoop Entrance Type.** (Refer to Figure 27-1809(d)-1). A stoop is an unroofed, open platform.
- (1) Transparency. Minimum transparency is required per Frontage Type.
  - (2) Stoop Size. Stoops shall be a minimum of three (3) feet deep and six (6) feet wide.
  - (3) Elevation. Stoop elevation shall be located a maximum of 2'-6" above the sidewalk without visible basement and a maximum of 4'-6" above the sidewalk with a visible basement.
  - (4) Visible Basement. A visible basement is permitted and shall be separated from the ground story by an expression line.
  - (5) Entrance. All entries shall be located off a stoop.
- (e) **Porch Entrance Type.** (Refer to Figure 27-1809(e)-1). A porch is a raised, roofed platform that may or may not be enclosed on all sides.
- (1) Transparency.
    - a. Minimum transparency per Frontage Type is required.
    - b. If enclosed, a minimum of forty (40) percent of the enclosed porch shall be comprised of highly transparent, low reflectance windows.
  - (2) Porch Size. The porch shall be a minimum of (5) feet deep and (8) feet wide.
  - (3) Elevation. Porch elevation shall be located a maximum of 2'-6" above the sidewalk without a visible basement and a maximum of 4'-6" above the sidewalk with a visible basement.
  - (4) Visible Basement. A visible basement is permitted.
  - (5) Height. Porch may be two (2) stories to provide a balcony on the second floor.
  - (6) Entrance. All entries shall be located off a porch.

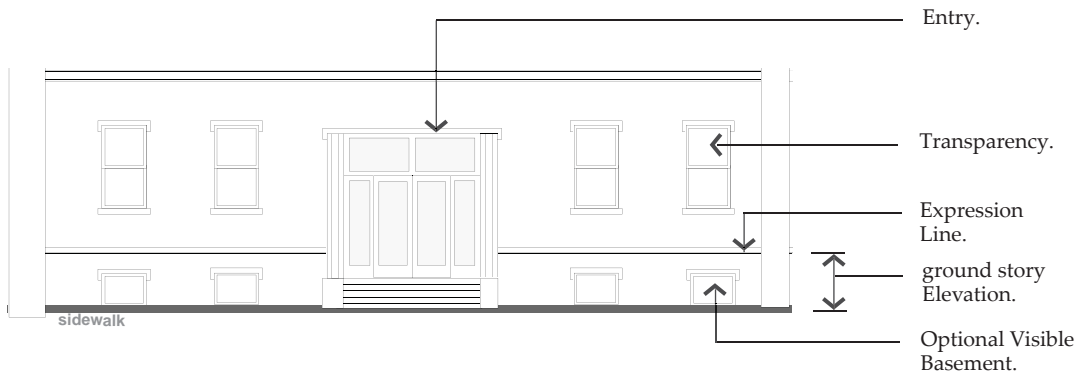

Figure 27-1809(d)-1. Stoop Entrance Type.

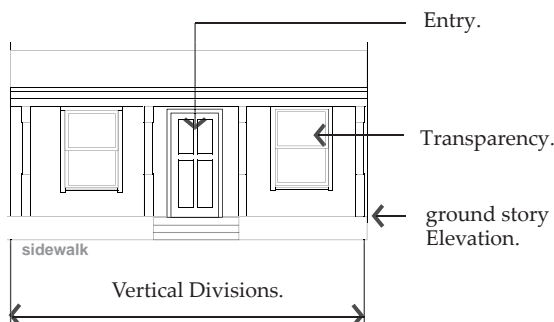

Figure 27-1809(e)-1. Porch Cap

# Article 27-1800. East Billings Urban Revitalization District Code

## Sec. 27-1810 Roof Types

Roof Type standards apply to roof and top of all Frontage Types as required in this Section.

- (a) General Provisions. The following provisions apply to all Roof Types.
- (1) Intent. To guide the design of the cap of all buildings.
  - (2) Applicability. All buildings shall meet the requirements of one of the Roof Types permitted for the Frontage Type.
  - (3) Measuring Height. Refer to BMCC Sec. 27-1811(b) for information on measuring building height.
  - (4) Other Roof Types. Other building caps not listed as a specific type may be requested with the following requirements:
    - a. The height shall not exceed any of the Roof Types permitted for the Frontage Type.
    - b. The cap would not be disruptive to the surrounding area.
    - c. The design of the cap shall be reviewed by the Zoning Coordinator.

- (b) **Parapet Roof Type.** (Refer to Figure 27-1810(b)-1). A parapet is a low wall projecting above a building's roof along the perimeter of the building. It can be utilized with a flat or low pitched roof and also serves to limit the view of roof-top mechanical systems from the street.

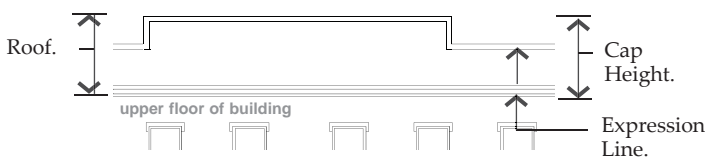

Figure 27-1810(b)-1. Parapet Roof Type.

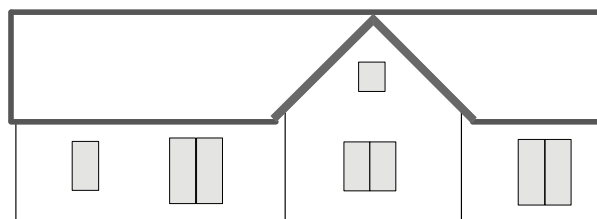

Figure 27-1810(c)-2. Parallel Ridge Line.

- (1) Parapet Height. Height is measured from the top of the upper story to the top of the parapet.
    - a. Minimum height is two (2) feet with a maximum height of six (6) feet.
    - b. Cap shall be high enough to screen the roof and any roof appurtenances from view of the street(s) .
  - (2) Horizontal Expression Lines. An expression line shall define the cap from the upper stories of the building and shall also define the top of the cap.
  - (3) Occupied Space. Occupied space shall not be incorporated behind this Roof Type.
- (c) **Pitched Roof Type.** (Refer to Figure 27-1810(c)-1). This Roof Type has a sloped or pitched roof. Slope is measured with the vertical rise divided by the horizontal span or run.
- (1) Pitch Measure. The roof may not be sloped less than a 4:12 (rise:run) or more than 16:12.
    - a. Slopes less than 4:12 are permitted to occur on second story or higher roofs. (Refer to Figure 27-1810(c)-1).
  - (2) Configurations.

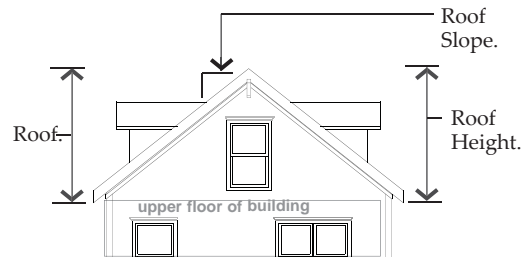
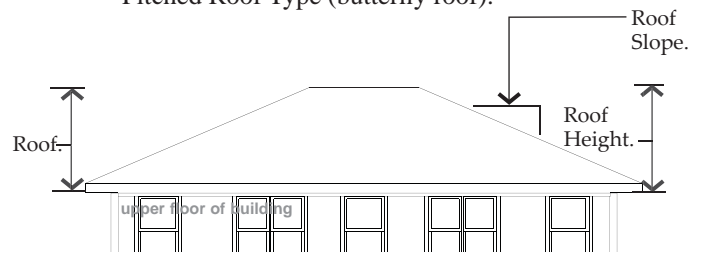
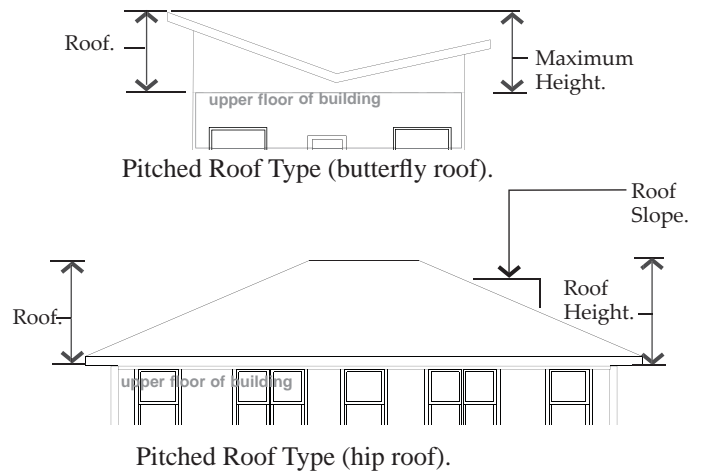
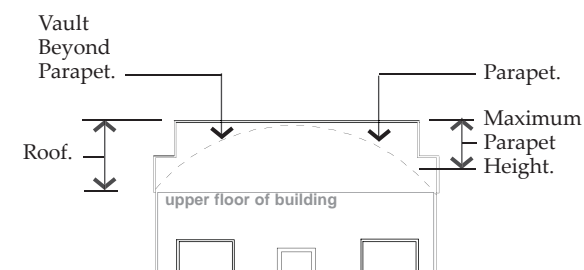

Figure 27-1810(c)-1 Pitched Roof Roof Type.

# Article 27-1800. East Billings Urban Revitalization District Code

- a. Hipped, gabled, and combination of hips and gables with or without dormers are permitted.
  - b. Butterfly roofs (inverted gable roof) are permitted with a maximum height of eight (8) feet, inclusive of overhang.
  - c. Gambrel and mansard roofs are permitted on non-residential Frontage Types (refer to BMCC Sec.27-1813(a) through (h) for Frontage Types). When the ridge runs parallel to the street, one (1) dormer per fifteen (15) feet of street face is required.
- (3) Parallel Ridge Line. A gabled end or perpendicular ridge line shall occur at least every one hundred (100) feet of roof when the ridge line runs parallel to the front lot line. (Refer to Figure 27-1810(c)-3).
  - (4) Roof Height. Roofs without occupied space and/or dormers shall have a maximum height on street-facing facades equal to the maximum floor height permitted for the Frontage Type.
  - (5) Occupied Space. Occupied space may be incorporated behind this Roof Type.

(d) **Barrel Roof Type.** (Refer to Figure 27-1810(d)-1). This Roof Type has a barrel vaulted roof.



Barrel Roof Type with parapet.

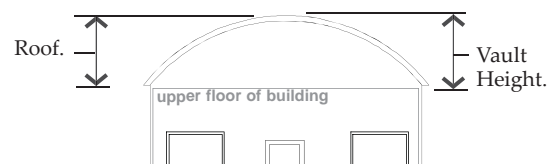

Barrel Roof Type without parapet.

Figure 27-1810(d)-1. Barrel Roof Type.

- (1) Configuration. The barrel vault of the roof shall run perpendicular to the front facade. Eaves may or may not be utilized.
- (2) Vault Height. The vault height shall not exceed half the vault width.
- (3) Parapet. When a parapet wall screens the vault from the street, the parapet shall not extend more than six (6) feet above the barrel vault roof.
- (5) Occupied Space. Occupied space may be incorporated behind this Roof Type.

(e) **Flat Roof Type.** (Refer to Figure 27-1810(e)-1). This Roof Type has a flat roof with overhanging Eaves.

- (1) Configuration. Roofs with no visible slope are acceptable. Eaves are required on all street facing facades.
- (2) Eave Depth. Eave depth is measured from the building facade to the outside edge of the eave. Eaves shall have a depth of at least fourteen (14) inches.
- (3) Eave Thickness. Eave thickness is measured at the outside edge of the eave, from the bottom of the eave to the top of the eave. Eaves shall be a minimum of eight (8) inches thick.
- (4) Interrupting Vertical Walls. Vertical walls may interrupt the eave and extend above the top of the eave with no discernible cap.
  - a. No more than one-half (1/2) of the front facade can consist of an interrupting vertical wall.
  - b. Vertical walls shall extend no more than four (4) feet above the top of the eave.
- (5) Occupied Space. Occupied space shall not be incorporated behind this Roof Type.

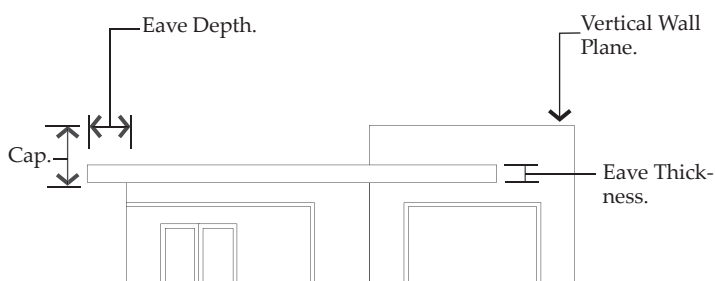

Figure 27-1810(e)-1. Flat Roof Roof Type.

# Article 27-1800. East Billings Urban Revitalization District Code

- (f) **Towers.** (Refer to Figure 27-1810(f)-1). A tower is a rectilinear or cylindrical, vertical element, that must be used with other Roof Types.
- (1) Quantity. All Building Types, with the exception of the Civic Building, are limited to one (1) tower per building.
  - (2) Tower Height. Maximum height, measured from the top of the parapet or eave to the top of the tower, is the equivalent of the height of one (1) upper floor of the building to which the tower is applied.
  - (3) Tower Width. Maximum width along all facades is one-third (1/3) the width of the front facade or thirty (30) feet, whichever is less.
  - (4) Horizontal Expression Lines. An expression line shall define the tower from the upper stories, except on single family or attached house residential Frontage Types (refer to BMCC Sec.27-1813(a) through (h) for Frontage Types).
  - (5) Occupied Space. Towers may be occupied by the same uses allowed in upper stories of the Frontage Type to which it is applied.
  - (6) Application. May be combined with all other Roof Types.
  - (7) Tower Cap. The tower may be capped by the parapet, pitched, low pitched, or flat roof Roof Types, or the spire may cap the tower.

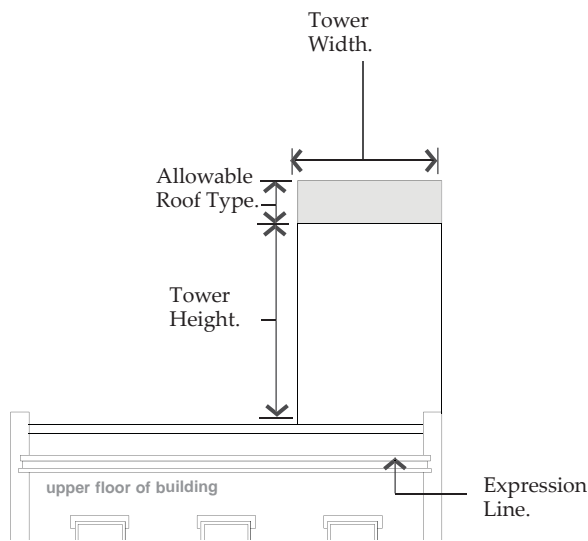

Figure 27-1810(f)-1. Tower.

- (g) **Spire.** (Refer to Figure 27-1810(g)-1). A spire is a long, tapering design element that can be attached to a tower or other Roof Type.
- (1) Permitted Location. Spires are permitted only on civic buildings.
  - (2) Spire Height. Spire height is not limited.
  - (3) Spire Width. Maximum width, measured at the spire base is one-sixth (1/6) the width of the front facade or fifteen (15) feet, whichever is less. A wider spire base, proportionate in height, is subject to the approval the Zoning Coordinator.
  - (4) Occupied Space. Occupied space is not permitted within the spire.
  - (5) Application. May be combined with any other roof type.

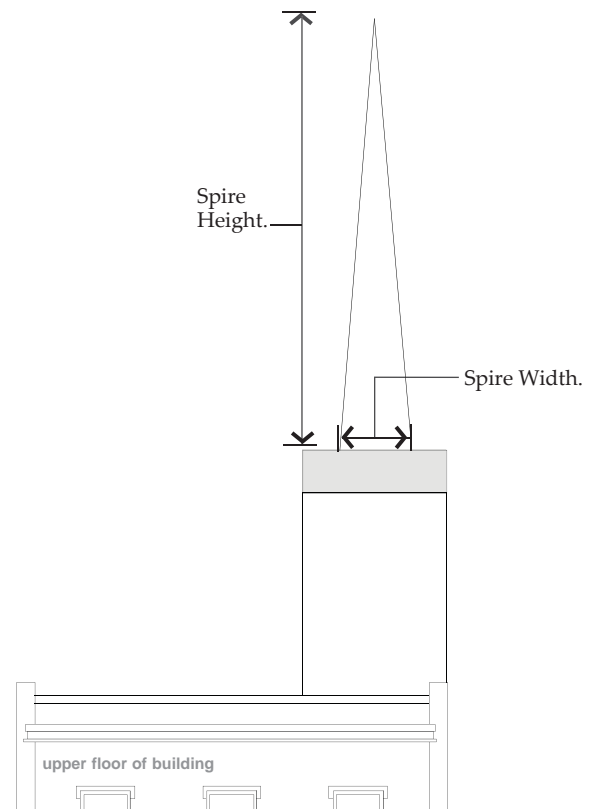

Figure 27-1810(g)-1. Spire.

# Article 27-1800. East Billings Urban Revitalization District Code

## Sec. 27-1811 Explanation of Table Requirements.

The following explains and defines the requirements included in the tables for each Frontage Type, Sections 27-1813(a) through 27-1813(h). Not all line items listed below may appear within each Frontage Type's individual requirements table.

### (a) Building Siting.

#### (1) Street Frontage.

- a. **Multiple Principal Buildings.** The presence of more than one principal structure on a lot.
- b. **Front Lot Line Coverage.** (Refer to Figure 27-1811(a)-1). Measurement defining the minimum percentage of street wall or building facade required along the primary street. (Refer to Figure 27-1817(e)-3 for Primary Street Priority Map.) The width of the principal structure(s) (as measured within the front build-to zone) shall be divided by the maximum width of the front build-to zone (BTZ).
  - i. Some Frontage Types allow side yard parking to be exempted from the front lot line coverage calculation. If such an exemption is permitted,

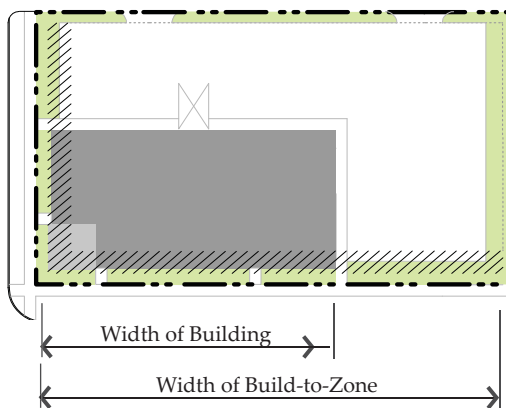

Figure 27-1811(a)-1. Measuring Front Lot Line Coverage.

the width of up to one (1) double loaded aisle of parking, located with the drive perpendicular to the street and including adjacent sidewalks and landscaping, may be exempted, to a maximum of sixty five (65) feet.

- c. **Occupation of Corner.** Occupying the intersection of the front and corner build-to zones with a principal structure.
- d. **Front Build-to Zone or Setback.** The build-to zone or setback parallel to the front lot line.
  - i. All build-to zone and setback areas not covered by building must contain either landscape, patio space, or sidewalk space.
- e. **Corner Build-to Zone or Setback.** The build-to zone or setback parallel to the corner lot line.
  - i. All build-to zone and setback areas not covered by building must contain either landscape, patio space, or sidewalk space.
- f. **Right-of-Way Encroachment.** Specified building components, such as awnings and canopies, may be permitted to extend beyond the front lot line and encroach upon the City right-of-way. If permitted, such building components are

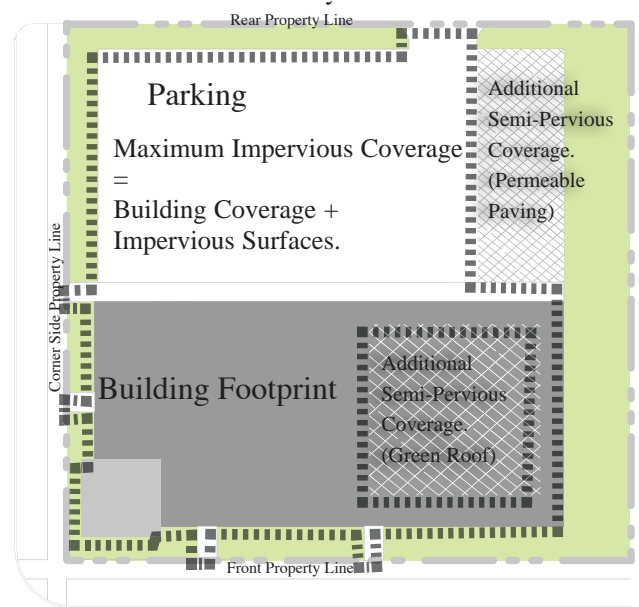

Figure 27-1811(a)-2. Maximum Impervious & Semi-Pervious Coverage.

# Article 27-1800. East Billings Urban Revitalization District Code

permitted to extend to within five (5) feet of the curb, maintaining a minimum of eight (8) feet height clearance along the public sidewalk

(2) Buildable Area.

- a. **Side Yard Setback.** The minimum required setback along a side lot line.
  - i. **Impervious Surfaces Prohibited.** Impervious surfaces within a lot's side yard setback are prohibited except for connections to adjacent parking lots.
  - ii. **Parking Lot Connections.** One (1) drive, maximum 22 feet in width, connecting a lot's parking lot with an adjacent lot's parking lot is permitted.
- b. **Rear Yard Setback.** The minimum required setback along a rear lot line. The rear yard setback applies to principal buildings only.
- c. **Minimum and Maximum Lot Width.** The minimum and maximum width of a lot, measured at the front lot line.
- d. **Maximum Impervious Coverage.** The maximum percentage of a lot permitted to be covered by principal structures, accessory structures, pavement, and other impervious surfaces. Refer to Figure 27-1811(a)-2.
- f. **Additional Semi-Pervious Coverage.** The additional percentage of a lot which may be surfaced in a Semi-Pervious material. A green roof qualifies as a semi-pervious material.

(3) Parking Location, Loading & Access.

- a. **Parking Location.** The yard in which a parking lot or area and associated drive is permitted.
- b. **Service & Loading Facility Location.** The facade of the building on which access is permitted for servicing, loading, and unloading activities related to building uses. Refer to BMCC Sec. 6-1203 for off street loading requirements.
- c. **Entry for Parking within Building.** The facade of the building on which the entrance to interior parking may be located.
- d. **Vehicular Access.** The permitted means of vehicular ingress and egress to the lot.
  - i. Alleys, when present, shall always be the primary means of access. When alleys are not present, driveways may be permitted per Frontage Type and, if an alternative is available, shall not be located off a Primary Street. Refer to Figure 27-1817(e)-3 for a Primary Street Map.

(b) Height.

- (1) **Minimum and Maximum Overall Height.** (Refer to Figure 27-1811(b)-1). A required minimum and maximum overall height is provided for all Frontage Types and is measured as follows:

- a. **Minimum Overall Height.** The minimum overall height for the building shall be located within the build-to zone; stories above the required minimum height may be stepped back from the facade.

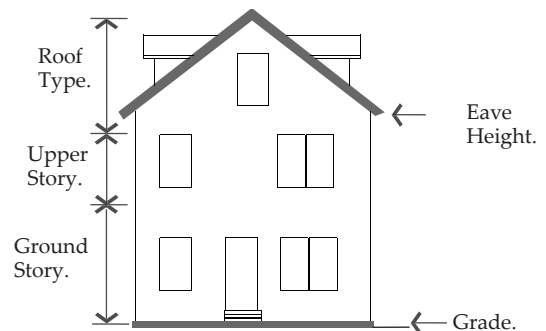
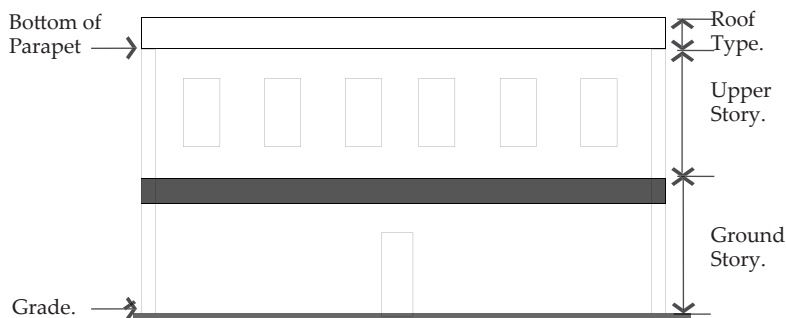

Figure 27-1811(b)-1. Measuring Height.

# Article 27-1800. East Billings Urban Revitalization District Code

- b. **Height in Stories.** The sum of a building's stories.
  - i. Half stories are located either completely within the roof structure with street-facing windows or in a visible basement exposed a maximum of one half (1/2) story above grade.
  - ii. A building incorporating both a half story within the roof and a visible

Measure Percent of Ground Story Storefront Transparency between 2 and 8 feet from the sidewalk.



Measuring Ground Floor transparency on a Storefront base.

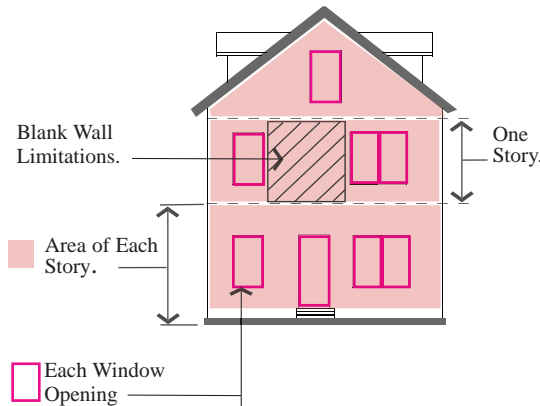

Measuring transparency on all floors.

Figure 27-1811(d)-1. Measuring Transparency per Facade.

- iii. Some Frontage Types require a building facade to step back as its height increases. If required, the upper stories of any building facade with street frontage shall be setback a designated amount beyond the building facade of the lower stories.

- (2) **Ground Story and Upper Story Minimum and Maximum Height.** (Refer to Figure 27-1811(b)-1). Each Frontage Type includes a permitted range of height in feet for each story. Additional information is as follows:
  - a. Floor height is measured in feet between the floor of a story to the floor of the story above it.
  - b. Floor height requirements apply only to street facing facades.
  - c. For single story buildings and the uppermost story of a multiple story building, floor to floor height shall be measured from the floor of the story to the tallest point of the ceiling.

- (c) Uses.
  - (1) **Ground and Upper Story.** The uses or category of uses which may occupy the ground and upper story of a building. Refer to BMCC Sec. 27-1806 Uses.
  - (2) **Parking Within Building.** The area(s) of a building in which parking is permitted within the structure.
  - (3) **Occupied Space.** The area(s) of a building that shall be designed as occupied space (refer to Definitions, BMCC Sec. 27-1805)

- (d) Street Facade Requirements.
  - (1) Transparency. (Refer to Figure 27-1811(d)-1). Measurement of the percentage of a facade that has clear, non-reflective windows.
    - a. **Minimum Transparency.** The minimum amount of transparency permitted on facades with street frontage, measured per story or per facade, depending on the Frontage Type.
    - b. **Blank Wall Limitations.** A restriction of the amount of windowless area permitted on a facade with street frontage. If required, the following shall be met:

# Article 27-1800. East Billings Urban Revitalization District Code

- i. No rectangular area greater than thirty (30) percent of a story's facade, as measured from floor to floor, may be windowless; and
    - ii. No horizontal distance greater than fifteen (15) feet of a story's facade may be windowless.
  - (2) Building Entrance.
    - a. **Principal Entrance Location.** The facade on which the primary building entrance is to be located.
    - b. **Entrance Type.** The Entrance Type(s) permitted on any street facing facade of a given Frontage Type. Refer to BMCC Sec. 27-1809 Entrance Types for specific requirements.
    - b. **Street Facades: Number of Entrances.** The maximum spacing between entrances on a building facade with street frontage.
    - c. **Parking Lot Facades: Number of Entrances.** The maximum spacing between entrances on a building facade that faces a parking lot.
  - (3) Roof Type.
    - a. **Roof Type.** The Roof Type(s) permitted for a given Frontage Type. Refer to BMCC Sec. 27-1810 Roof Types for more specific requirements.
    - b. **Tower.** A vertical building extension that may be permitted in conjunction with another Roof Type on certain Frontage Types. Refer to BMCC Sec. 27-1810 Roof Types.
  - (4) Facade Divisions.
    - a. **Vertical Increments.** The use of a vertically oriented expression line or form to divide the facade into increments no greater than the dimension shown, as measured along the base of the facade. Elements may include a column, pilaster, or other continuous vertical ornamentation a minimum of one and a half inch depth.
    - b. **Horizontal Facade Divisions.** The use of a horizontally oriented expression line or form to divide portions of the facade into horizontal divisions. Elements may include a cornice, belt course, molding, string courses, or other continuous horizontal ornamentation a minimum of one and a half inch depth.
  - (4) **Balconies.** The following requirements pertain to balconies on building facades with street frontage.
    - a. **Size.** The minimum dimensions of a permitted balcony.
    - b. **Facade Coverage.** The percentage of a facade's total area that is permitted to be covered by balconies, including street facing railing and balcony structure.
    - c. **Access to Balcony.** The number of units that are permitted to gain entry to an individual balcony.
    - d. **Structure.** Requirements related to the construction of a balcony. Two types of balcony structures are permitted:
      - i. Independently secured balconies are those that are connected directly to the building and are unconnected to other balconies.
      - ii. Balconies that are integral to the facade are a part of, and built in conjunction with, the building structure.

# Article 27-1800. East Billings Urban Revitalization District Code

## Sec. 27-1812 Street Facade Materials.

The following applies to all facades visible from any street on all Frontage Types with the exception of the Open Frontage Type.

- (a) Permitted Facade Materials. Building materials that are permitted include durable, natural materials such as clay or terracotta tiles, stone, brick, stucco, concrete, and metal. Cast stone is permitted. Painted or stained wood, and burnished and/or split face colored concrete masonry units are permitted as no more than 35% of street facing facade.
- (b) Permitted Upper Story Facade Materials. In addition to the Permitted Facade Materials defined in Sec.27-1812(a), exterior insulation and finishing systems (EIFS) is permitted on upper stories.
- (c) Materials to Avoid. Building materials that are discouraged on any street facing facade include imitation materials intended to look like natural materials; sheet materials intended to look like units; and residential grade windows and doors on all Frontage Types except the Yard Frontage.
- (d) Prohibited Materials on Street Facing Facades. Building materials that are not permitted on building facades that are visible from any street include bricks more than 3-5/8" in height, and untreated wood.

## Sec. 27-1813 Frontage Types.

The Frontage Types on the following pages apply to all development in the EBURD. Refer to Sec. 27-1808 for the Introduction to Frontage Types.

# Article 27-1800. East Billings Urban Revitalization District Code

## Sec. 27-1813(a). Frontage Types:Yard

<b>(1) Building Siting</b>		
a. Street Frontage		
Multiple Principal Buildings	Permitted	
Front Lot Line Coverage	65% minimum <sup>1</sup>	<b>a</b>
Occupation of Corner	Required	
Front Build-to Zone	5' to 15'	<b>b</b>
Corner Build-to Zone	5' to 10'	<b>c</b>
Right-of-Way Encroachment	None	
b. Buildable Area		
Side Yard Setback	0', minimum 10' between buildings or sets of attached units	<b>d</b>
Rear Yard Setback	5'; 0' with Alley	<b>e</b>
Minimum Lot Width	25'	<b>f</b>
Maximum Lot Width	60' for single family only; None for attached	
Maximum Building Length	8 attached units	
Maximum Impervious Coverage	80%	
Additional Semi-Pervious Coverage	15%	
c. Parking Location, Loading & Access		
Parking Location	Rear Yard	<b>g</b>
Loading Facility Location	None	
Entry for Parking within Building	Rear Facade	
Vehicular Access	From Alley; If no Alley exists, up to one (1) driveway per building or set of attached units <sup>2</sup>	<b>h</b>
Notes:		
<sup>1</sup> When townhouses, each attached townhouse unit shall meet all requirements, except one of every five units may front a courtyard with a minimum width of 30'.		
<sup>2</sup> For parcels with a street frontage longer than 300' and no Alley, two (2) driveways are permitted.		
<b>(2) Height</b>		
Minimum Overall Height	1 Story; 2 Stories preferred	<b>i</b>
Maximum Overall Height	3 Stories	<b>j</b>
Stories: Minimum Height	9'	<b>k</b>
Maximum Height	14'	

<b>(3) Uses (refer to BMCC Sec. 27-1806)</b>		
All Stories	Residential, General Service, Office only	<b>l</b>
Parking within Building	Permitted in the rear of all floors and fully in any basement(s)	<b>n</b>
Occupied Space	30' depth space on front facade	<b>o</b>
Accessory Structures	Permitted per Sec. 27-1808(f).	
<b>(4) Street Facade Requirements</b>		
a. Transparency		
Minimum Transparency	15%, per floor	<b>p</b>
Blank Wall Limitations	Required	
b. Building Entrance		
Principal Entrance Location	Front or Corner of Building	<b>q</b>
Entrance Type (refer to Sec. 27-1809)	Stoop, Porch	<b>r</b>
Street Facades: Number of Entrances	Minimum 1 per building	
Parking Lot Facades: Number of Entrances	N/A	
c. Roof Type		
Roof Type (refer to Sec. 27-1810)	Parapet, Flat, or Pitched	<b>s</b>
Tower	Permitted	
d. Facade Divisions		
Vertical Increments	No greater than 50'	
Horizontal Expression Line	None required except by Roof Type	
c. Balconies <b>t</b>		
Size	Minimum 3' deep and 5' wide	
Facade Coverage	Maximum 40% of Front & Corner Side Facades, separately	
Access to Balcony	Maximum one (1) dwelling unit	
Structure	Independently secured and unconnected to other balconies; or integral to the Facade	

# Article 27-1800. East Billings Urban Revitalization District Code

## Sec. 27-1813(a). Frontage Types: Yard

Frontage Type	Permitted in these EBURD Districts				
	Rail Spur Village Main Street	Rail Spur Village	Central Works	North 13th Street	Industrial Sanctuary
Yard Frontage		●			

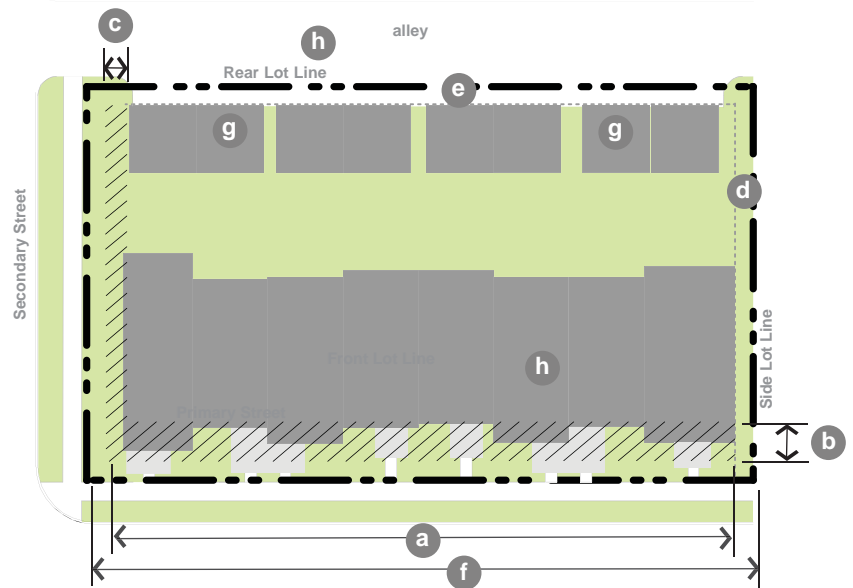

Figure 27-1813(a)-1: Building Siting.

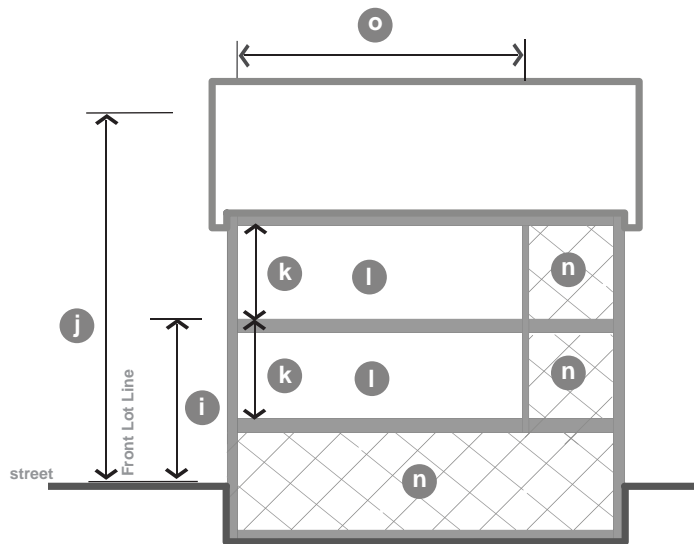

Figure 27-1813(a)-2: Height & Use Requirements.

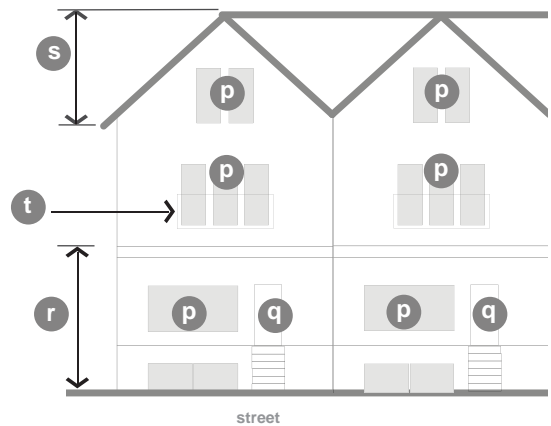

Figure 27-1813(a)-3: Street Facade Requirements.

# Article 27-1800. East Billings Urban Revitalization District Code

## Sec. 27-1813(b). Frontage Types: General Stoop

<b>(1) Building Siting</b>		
a. Street Frontage		
Multiple Principal Buildings	Not Permitted	
Front Lot Line Coverage	85% minimum <sup>1</sup>	<b>a</b>
Occupation of Corner	Required	
Front Build-to Zone	0' to 10'	<b>b</b>
Corner Build-to Zone	0' to 10'	<b>c</b>
Right-of-Way Encroachment	Eaves, Awnings, Canopies	
b. Buildable Area		
Side Yard Setback	3'	<b>d</b>
Rear Yard Setback	5'; 0' with Alley	<b>e</b>
Maximum Impervious Coverage	75%	
Additional Semi-Pervious Coverage	20%	
c. Parking Location, Loading & Access		
Parking Location	Rear Yard	<b>f</b>
Service & Loading Facility Location	Rear Facade	<b>g</b>
Entry for Parking within Building	Rear Facade or Side Facade	
Vehicular Access	From Alley; If no Alley exists, one (1) driveway off a side or corner side yard <sup>2</sup>	<b>h</b>
Notes:		
<sup>1</sup> A courtyard covering up to 35 percent of the front facade is permitted and may contribute to the Front Lot Line Coverage requirement.		
<sup>2</sup> For parcels with a street frontage longer than 300' and no Alley, two (2) driveways are permitted.		
<b>(2) Height</b>		
Minimum Overall Height	2 Stories	<b>i</b>
Maximum Overall Height	6 Stories <sup>3</sup>	<b>j</b>
Floor to Floor Story Height:		
Minimum Height	9'	
Maximum Height	14'	<b>k</b>
Notes:		
<sup>3</sup> Above the fourth story, the upper stories of any building facade with street frontage shall have a step back from the lower Stories that is a minimum of 6' and a maximum of 12'.		
<b>(3) Uses (refer to BMCC Sec. 27-1806)</b>		
Ground and Upper Stories	All permitted uses by district	<b>l</b>
Parking within Building	Permitted in the Rear of all Floors and fully in any Basement(s)	<b>m</b>
Occupied Space	30' depth space on front facing facade	<b>n</b>
Accessory Structures	Permitted per Sec. 27-1808(f).	
<b>(4) Street Facade Requirements</b>		
a. Transparency		
Minimum Transparency	15%, per floor	<b>o</b>
Blank Wall Limitations	Required	
b. Building Entrance		
Principal Entrance Location	Front, Corner Side, or Corner of Building	<b>p</b>
Entrance Type (refer to Sec. 27-1809)	Stoop, minimum 6' wide and 3' deep	<b>q</b>
Street Facades: Number of Entrances	1 per 75' of Facade	
c. Roof Type		
Roof Type (refer to Sec. 27-1810)	Parapet, Flat, or Pitched	<b>r</b>
Tower	Permitted	<b>s</b>
d. Facade Divisions		
Vertical Increments	No greater than 50'	
Horizontal Expression Line	Required within 3' of top of ground story on buildings taller than 3 stories	<b>t</b>
e. Balconies		
Size	Minimum 3' deep and 5' wide	<b>u</b>
Facade Coverage	Maximum 40% of Front & Corner Side Facades, separately	
Access to Balcony	Maximum one (1) dwelling unit	
Structure	Independently secured and unconnected to other balconies; or integral to the Facade	

# Article 27-1800. East Billings Urban Revitalization District Code

## Sec. 27-1813(b). Frontage Type Standards: General Stoop

Frontage Type	Permitted in these EBURD Districts				
	Rail Spur Village Main Street	Rail Spur Village	Central Works	North 13th Street	Industrial Sanctuary
General Stoop		●	●		●

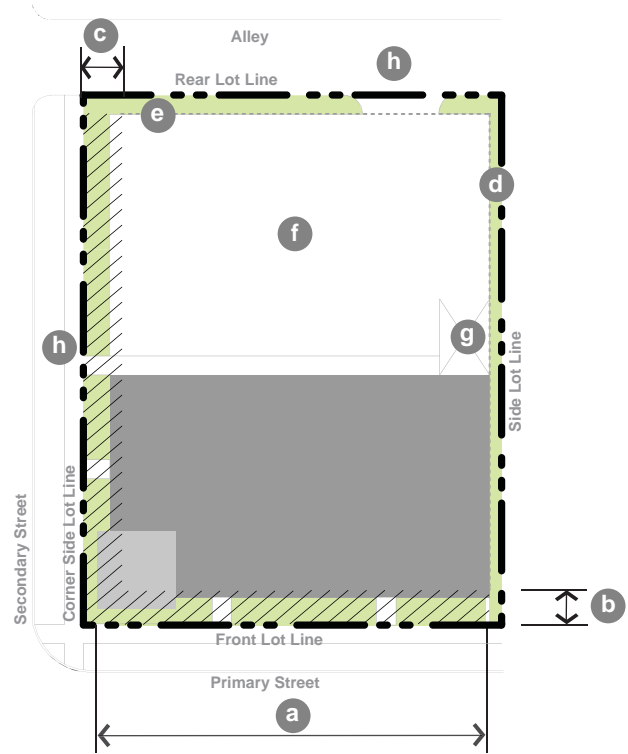

Figure 27-1813(b)-1: Building Siting.

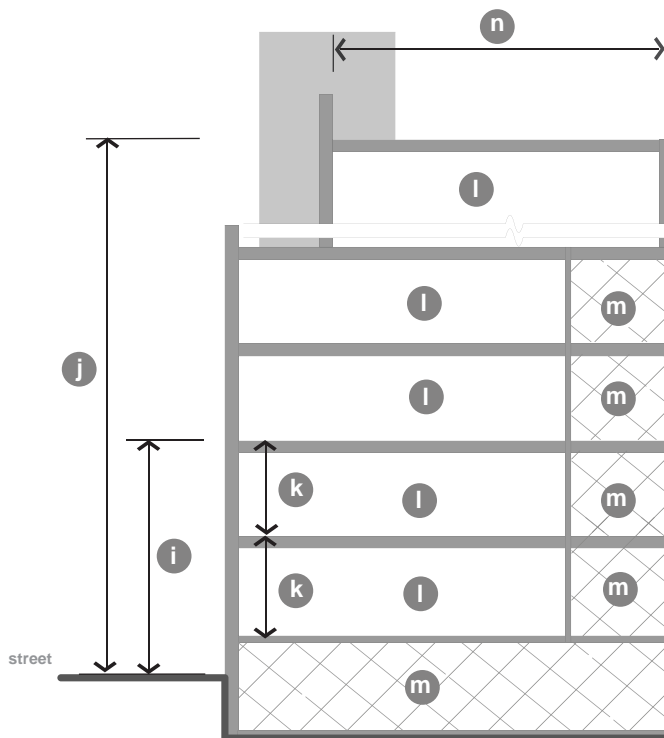

Figure 27-1813(b)-2: Height & Use Requirements.

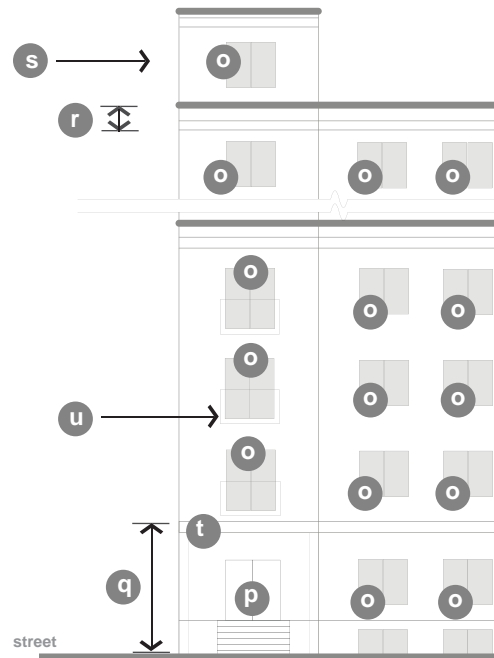

Figure 27-1813(b)-3: Street Facade Requirements.

# Article 27-1800. East Billings Urban Revitalization District Code

## Sec. 27-1813(c). Frontage Type Standards: Storefront

<b>(1) Building Siting</b>		
a. Street Frontage		
Multiple Principal Buildings	Not Permitted	
Front Lot Line Coverage	95% minimum	<b>a</b>
Occupation of Corner	Required	
Front Build-to Zone	0' to 5' <sup>1</sup>	<b>b</b>
Corner Build-to Zone	0' to 5'	<b>c</b>
Right-of-Way Encroachment	Eaves, Awnings, Canopies	
b. Buildable Area		
Side Yard Setback	0'	<b>d</b>
Rear Yard Setback	5'; 0' with Alley	<b>e</b>
Minimum Lot Width	25'	<b>f</b>
Maximum Lot Width	None	
Maximum Impervious Coverage	80%	
Additional Semi-Pervious Coverage	20%	
c. Parking Location, Loading & Access		
Parking Location	Rear Yard	<b>g</b>
Service & Loading Facility Location	Rear Facade	<b>h</b>
Entry for Parking within Building	Rear Facade	
Vehicular Access	From Alley; If no Alley exists, one (1) driveway off a side or corner side yard <sup>2</sup>	<b>i</b>

**Notes:**

<sup>1</sup>Areas within the Front Build-to Zone not occupied by building shall be paved to match adjacent walk.

<sup>2</sup>For parcels with a street frontage longer than 300' and no Alley, two (2) driveways are permitted.

<b>(2) Height</b>		
Minimum Overall Height	2 Stories	<b>j</b>
Maximum Overall Height	6 Stories <sup>3</sup>	<b>k</b>
Ground Story: Minimum Height	14'	<b>l</b>
Maximum Height	24' <sup>4</sup>	
Upper Stories: Minimum Height	9'	<b>m</b>
Maximum Height	14'	

**Notes:**

<sup>3</sup>Above the fourth Story, the Upper Stories of any building Facade with Street Frontage shall have a step back from the lower Stories that is a minimum of 6' and a maximum of 12'.

<sup>4</sup>If 18' or more in height, Ground Story shall count as 2 Stories towards maximum building height.

<b>(3) Uses (refer to BMCC Sec. 27-1806)</b>		
Ground Story	Library/Museum, Post Office, General Retail, General Service, Office, Craftsman Industrial	<b>n</b>
Upper Story	All uses permitted by district	<b>o</b>
Parking within Building	Permitted in the Rear of all Floors and fully in any Basement(s)	<b>p</b>
Occupied Space	30' depth space facing Primary Street	<b>q</b>
Accessory Structures	Permitted per Sec. 27-1808(f).	

<b>(4) Street Facade Requirements</b>		
a. Transparency		
Ground Floor: Minimum Transparency	75%, measured between 2' and 8' from sidewalk elevation	<b>r</b>
Upper Floor: Minimum Transparency	20%, per floor	<b>s</b>
Blank Wall Limitations	Required	

b. Building Entrance		
Principal Entrance Location	Front or Corner of Building	<b>t</b>
Entrance Type (refer to Sec. 27-1809)	Storefront	<b>u</b>
Street Facades: Number of Entrances	1 per 75' of Facade	
Parking Lot Facades: Number of Entrances	N/A	

c. Roof Type		
Roof Type (refer to Sec. 27-1810)	Parapet, Flat, Pitched, or Barrel	<b>v</b>
Tower	Permitted	

d. Facade Divisions		
Vertical Increments	No greater than 30'	
Horizontal Expression Line	Required within 3' of top of ground story	

e. Balconies		
Size	Minimum 3' deep and 5' wide	<b>w</b>
Facade Coverage	Maximum 40% of Front & Corner Side Facades, separately	<b>x</b>
Access to Balcony	Maximum one (1) Dwelling Unit	
Structure	Independently secured and unconnected to other balconies; or integral to the Facade	

# Article 27-1800. East Billings Urban Revitalization District Code

## Sec. 27-1813(c). Frontage Type Standards: Storefront

Frontage Type	Permitted in these EBURD Districts				
	Rail Spur Village Main Street	Rail Spur Village	Central Works	North 13th Street	Industrial Sanctuary
Storefront	●	●	●	●	●

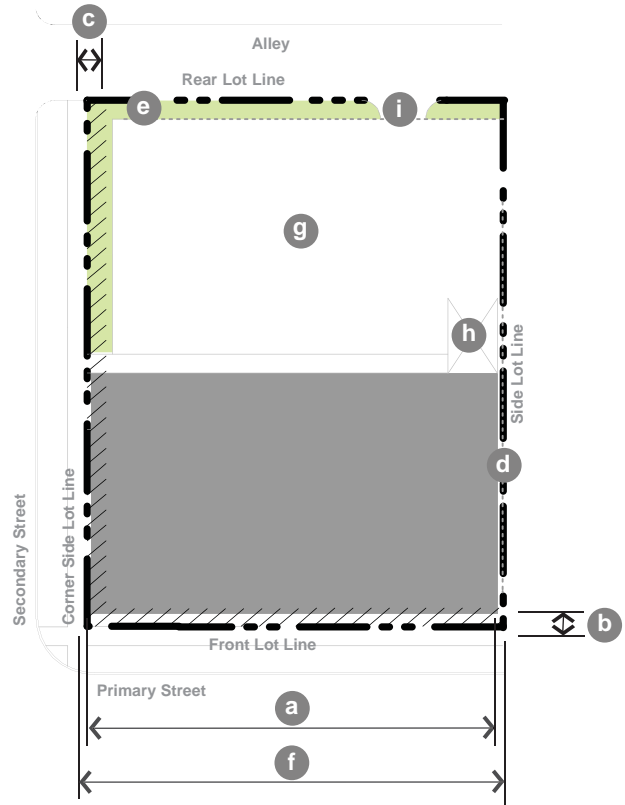

Figure 27-1813(c)-1: Building Siting.

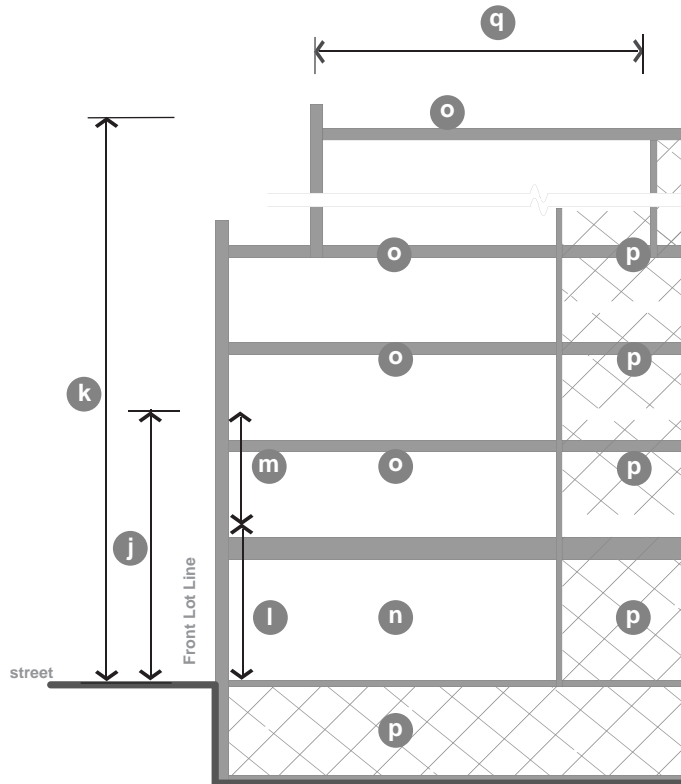

Figure 27-1813(c)-2: Height & Use Requirements.

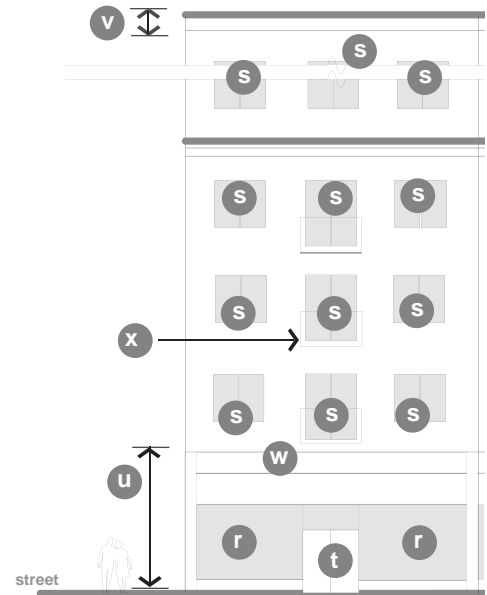

Figure 27-1813(c)-2: Street Facade Requirements.

# Article 27-1800. East Billings Urban Revitalization District Code

## Sec. 27-1813(d). Frontage Type Standards: Limited Bay

<b>(1) Building Siting</b>		
a. Street Frontage		
Multiple Principal Buildings	Not Permitted	
Front Lot Line Coverage	95% minimum, parking exception <sup>1</sup>	<b>a</b>
Occupation of Corner	Required	
Front Build-to Zone	0' to 10'	<b>b</b>
Corner Build-to Zone	0' to 10'	<b>c</b>
Right-of-Way Encroachment	Awnings & canopies	
b. Buildable Area		
Side Yard Setback	0'	<b>d</b>
Rear Yard Setback	5'; 0' with Alley	<b>e</b>
Minimum Lot Width	25'	<b>f</b>
Maximum Lot Width	None	
Maximum Impervious Coverage	90%	
Additional Semi-Pervious Coverage	10%	
c. Parking Location, Loading & Access		
Parking Location	Rear Yard; Limited Side Yard <sup>1</sup>	<b>g</b>
Service & Loading Facility Location	Rear or Side Facade; Limited Front or Corner Side Facade <sup>2</sup>	<b>h</b>
Entry for Parking within Building	Rear & Side Facades; Limited Front or Corner Side Facade <sup>2</sup>	
Vehicular Access	From Alley; or up to one (1) driveway per street frontage <sup>3</sup>	<b>i</b>
Notes:		
<sup>1</sup> Lots wider than 140' are permitted 1 double-loaded aisle of parking (maximum width of 65'), located perpendicular to street, which is exempt from front lot line coverage calculation		<b>n</b>
<sup>2</sup> One bay is permitted on either the front or corner side facade, maximum width 20', for either loading or parking entry.		<b>o</b>
<sup>3</sup> For parcels with a street frontage longer than 300' and no Alley, two (2) driveways are permitted.		
<b>(2) Height</b>		
Minimum Overall Height	1 Story; 2 Stories preferred	<b>j</b>
Maximum Overall Height	6 Stories <sup>4</sup>	<b>k</b>
Ground Story: Minimum Height	15'	
Maximum Height	24' <sup>5</sup>	<b>l</b>
Upper Stories: Minimum Height	9'	
Maximum Height	14'	<b>m</b>
Notes:		
<sup>4</sup> Above the fourth story, the upper stories of any building facade with street frontage shall have a step back from the lower Stories that is a minimum of 6' and a maximum of 12'		
<sup>5</sup> If 18' or more in height, Ground Story shall count as 2 Stories towards maximum building height.		
<b>(3) Uses (refer to Sec. 27-1806)</b>		
Ground and Upper Stories	All uses permitted by district	
Parking within Building	Permitted in the Rear of all Floors and fully in any Basement(s)	<b>p</b>
Occupied Space	30' depth space facing Primary Street	<b>q</b>
Accessory Structures	Permitted per Sec. 27-1808(f).	
<b>(4) Street Facade Requirements</b>		
a. Transparency		
Ground Floor: Minimum Transparency	50%, measured between 2' and 8' from sidewalk elevation	<b>r</b>
Upper Floor Minimum Transparency	20%, per floor	<b>s</b>
Blank Wall Limitations	Required	
b. Building Entrance		
Principal Entrance Location	Front, Corner Side, or Corner of Building	<b>t</b>
Entrance Type (refer to Sec. 27-1809)	Storefront	<b>u</b>
Street Facades: Number of Entrances	1 per 75' of Facade	
Parking Lot Facades: Number of Entrances	1 per 100' of Facade	
c. Roof Type		
Roof Type (refer to Sec. 27-1810)	Parapet, Flat, Pitched, or Barrel	
Tower	Permitted	<b>v</b>
d. Facade Divisions		
Vertical Increments	No greater than 50'	
Horizontal Expression Line	Required within 3' of top of ground story	<b>w</b>
e. Balconies		
Size	Minimum 3' deep and 5' wide	
Facade Coverage	Maximum 40% of Front & Corner Side Facades, separately	
Access to Balcony	Maximum one (1) Dwelling Unit	
Structure	Independently secured and unconnected to other balconies; or integral to the Facade	

# Article 27-1800. East Billings Urban Revitalization District Code

## Sec. 27-1813(d). Frontage Type Standards: Limited Bay

Frontage Type	Permitted in these EBURD Districts				
	Rail Spur Village Main Street	Rail Spur Village	Central Works	North 13th Street	Industrial Sanctuary
Limited Bay		●	●	●	●

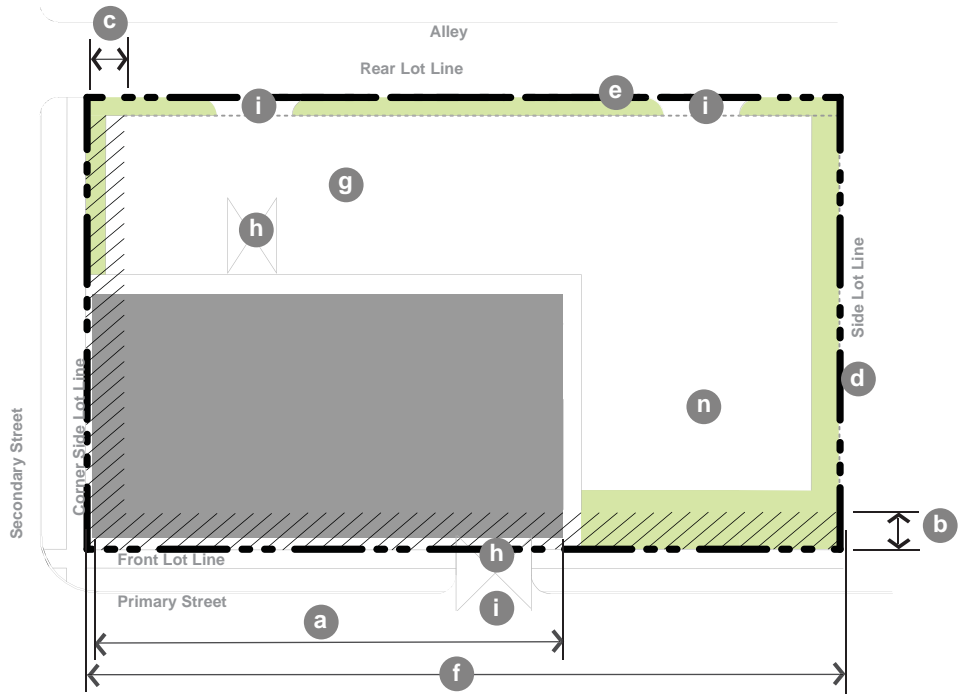

Figure 27-1813(d)-1: Building Siting.

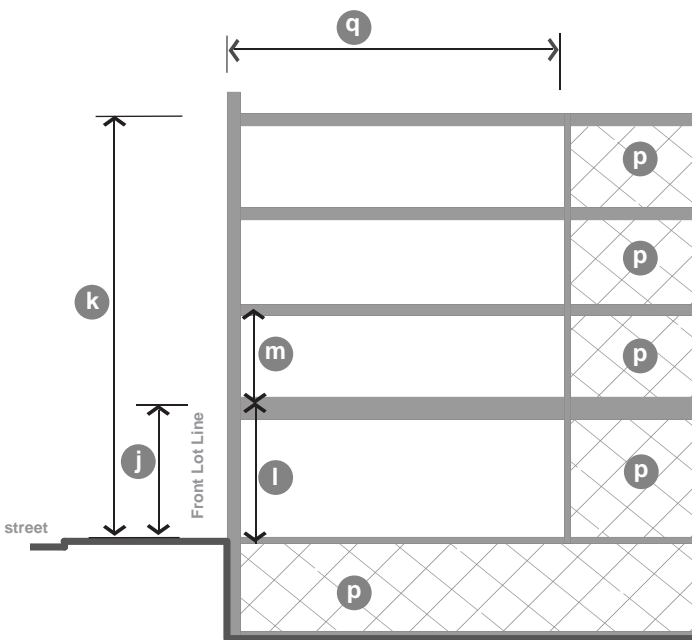

Figure 27-1813(d)-2: Height & Use Requirements.

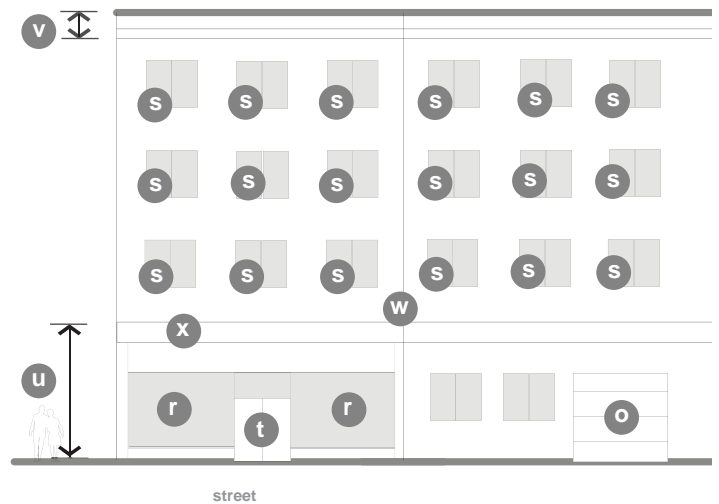

Figure 27-1813(d)-3: Street Facade Requirements.

# Article 27-1800. East Billings Urban Revitalization District Code

## Sec. 27-1813(e). Frontage Type Standards: Commerce

<b>(1) Building Siting</b>		
a. Street Frontage		
Multiple Principal Buildings	Permitted	
Front Lot Line Coverage	45% minimum	<b>a</b>
Occupation of Corner	Required; Fuel stations are exempt	
Front Build-to Zone	5' to 20'	<b>b</b>
Corner Build-to Zone	5' to 20'	<b>c</b>
Right-of-Way Encroachment	None	
b. Buildable Area		
Side Yard Setback	5'	<b>d</b>
Rear Yard Setback	5'; 0' with Alley	<b>e</b>
Minimum Lot Width	50'	
Maximum Lot Width	None	<b>f</b>
Maximum Impervious Coverage	75%	
Additional Semi-Pervious Coverage	15%	
c. Parking Location, Loading & Access		
Parking Location	Rear & Side Yards	<b>g</b>
Service & Loading Facility Location	Rear & Side Facades	<b>h</b>
Entry for Parking within Building	Rear & Side Facades	
Vehicular Access	From Alley; if no Alley exists, one (1) driveway per street frontage <sup>1</sup>	<b>i</b>

Notes:

<sup>1</sup> For parcels with a street frontage longer than 300' and no Alley, two (2) driveways are permitted.

<b>(2) Height</b>		
Minimum Overall Height	1 Story; 2 Stories preferred	<b>j</b>
Maximum Overall Height	6 Stories <sup>2</sup>	<b>k</b>
Ground Story: Minimum Height	15'	
Maximum Height	20' <sup>3</sup>	<b>l</b>
Upper Stories: Minimum Height	9'	
Maximum Height	14'	<b>m</b>

Notes:

<sup>2</sup> Above the fourth story, the upper stories of any building facade with street frontage shall have a step back from the lower Stories that is a minimum of 6' and a maximum of 12'

<sup>3</sup> If 18' or more in height, Ground Story shall count as 2 Stories towards maximum building height

<b>(3) Uses (refer to BMCC Sec. 27-1806)</b>		
Ground and Upper Stories	All uses per district	<b>n</b>
Parking within Building	Permitted in the Rear of all Floors and fully in any Basement(s)	<b>p</b>
Occupied Space	30' depth space facing Primary Street or space on front Facade	<b>q</b>
Accessory Structures	Permitted per Sec. 27-1808(f).	

<b>(4) Street Facade Requirements</b>		
a. Transparency		
Ground Floor: Minimum Transparency	35%, measured between 2' and 8' from sidewalk elevation	<b>r</b>
Upper Floor Minimum Transparency	15%, per floor	<b>s</b>
Blank Wall Limitations	No greater than 50% of facade and no wider than 30'	
b. Building Entrance		
Principal Entrance Location	Front, Corner Side, or Corner of Building	<b>t</b>
Entrance Type (refer to Sec. 27-1809)	Storefront, or Stoop	<b>u</b>
Street Facades: Number of Entrances	1 per 75' of Facade	
Parking Lot Facades: Number of Entrances	1 per 100' of Facade	
c. Roof Type		
Roof Type (refer to Sec. 27-1810)	Parapet, Flat, Pitched, or Barrel	<b>v</b>
Tower	Permitted	<b>w</b>
d. Facade Divisions		
Vertical Increments	No greater than 50'	
Horizontal Expression Line	Required within 3' of top of ground story	<b>x</b>
e. Balconies		
Size	Minimum 3' deep and 5' wide	<b>y</b>
Facade Coverage	Maximum 40% of Front & Corner Side Facades, separately	
Access to Balcony	Maximum one (1) dwelling unit	
Structure	Independently secured and unconnected to other balconies; or integral to the Facade	

# Article 27-1800. East Billings Urban Revitalization District Code

## Sec. 27-1813(e). Frontage Type Standards: Commerce

Frontage Type	Permitted in these EBURD Districts				
	Rail Spur Village Main Street	Rail Spur Village	Central Works	North 13th Street	Industrial Sanctuary
Commerce			○		●

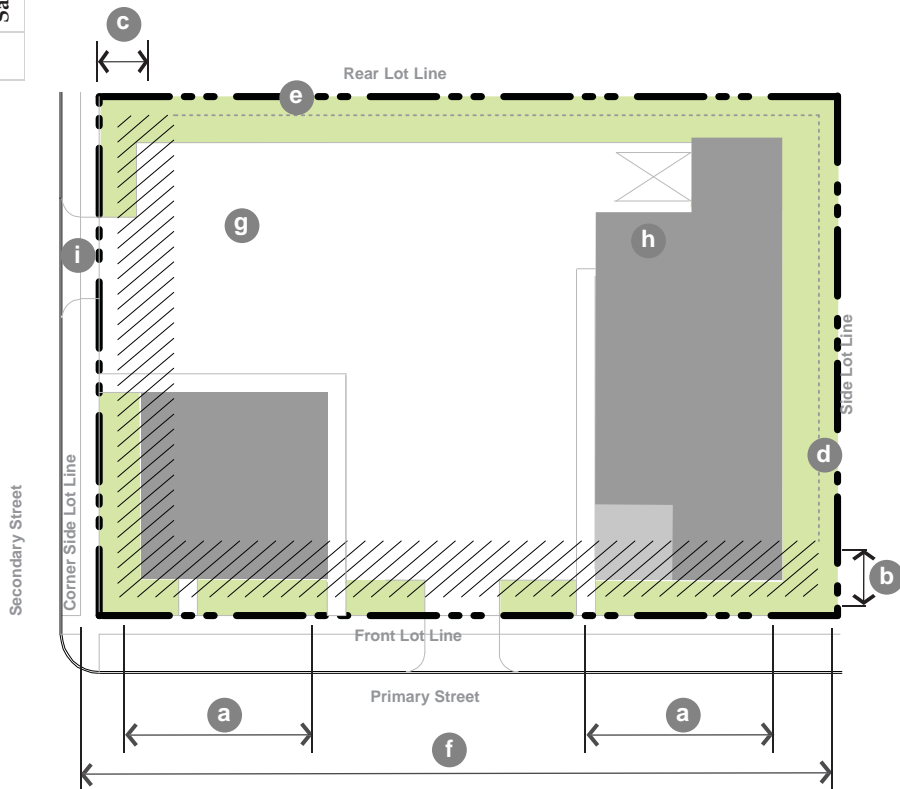

Figure 27-1813(e)-1: Building Siting.

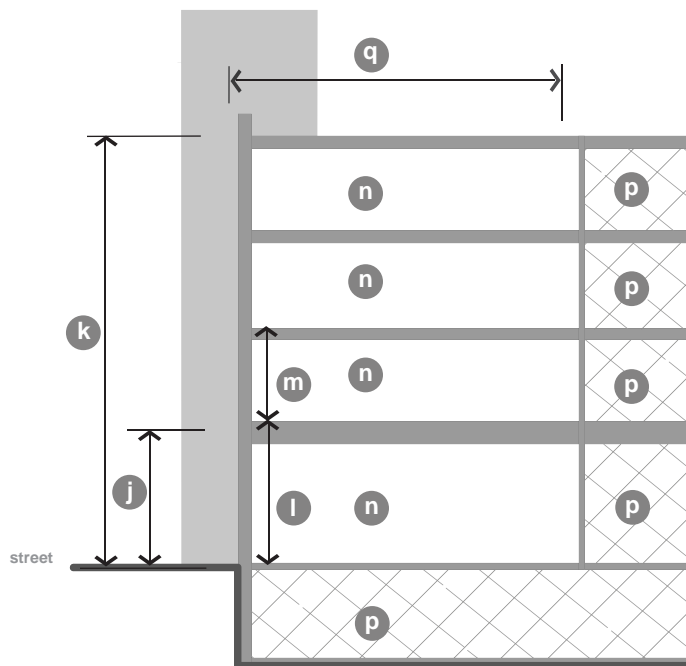

Figure 27-1813(e)-2: Height & Use Requirements.

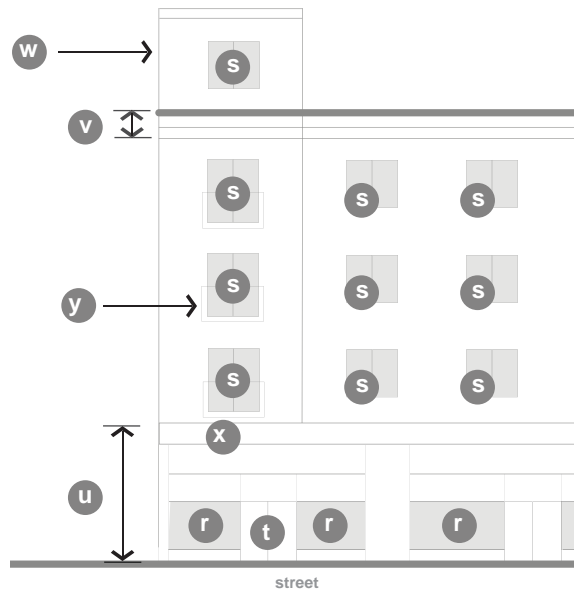

Figure 27-1813(e)-3: Street Facade Requirements.

# Article 27-1800. East Billings Urban Revitalization District Code

## Sec. 27-1813(f). Frontage Type Standards: Open

<b>(1) Building Siting</b>		
a. Street Frontage		
Multiple Principal Buildings	Permitted	
Front Lot Line Coverage	N/A	
Occupation of Corner	Encouraged	
Front Setback	10'	<b>a</b>
Corner Setback	5'	<b>b</b>
Right-of-Way Encroachment	None	
b. Buildable Area		
Side Yard Setback	5'	<b>c</b>
Rear Yard Setback	5'; 0' with Alley	<b>d</b>
Minimum Lot Width	50'	<b>e</b>
Maximum Lot Width	None	
Maximum Impervious Coverage	85%	
Additional Semi-Pervious Cover.	15%	
c. Parking Location, Loading & Access		
Parking Location	All Yards; Rear Yard; & Side Yard preferred	<b>f</b>
Loading Facility Location	Front, Rear & Side Facades	<b>g</b>
Entry for Parking within Building	Front, Rear & Side Facades	
Vehicular Access	From Alley; or up to two (2) driveway per street frontages, minimum 50' apart	<b>h</b>

<b>(2) Height</b>		
Minimum Overall Height	1 Story	<b>i</b>
Maximum Overall Height	6 Stories <sup>1</sup>	<b>j</b>
Ground Story: Minimum Height	9'	<b>k</b>
Maximum Height	20' <sup>2</sup>	
Upper Stories: Minimum Height	9'	<b>l</b>
Maximum Height	15'	

Notes:

<sup>1</sup>Above the fourth story, the upper stories of any building facade with street frontage shall have a step back from the lower Stories that is a minimum of 6' and a maximum of 12'

<sup>2</sup>If 14' or more in height, Ground Story shall count as 2 to Stories towards maximum overall height.

<b>(3) Uses (refer to BMCC Sec. 27-1806)</b>		
Ground and Upper Stories	Only Industrial Uses permitted	<b>m</b>
Parking within Building	Permitted in all floors	<b>n</b>
Occupied Space	30' depth space facing Primary Street	<b>o</b>
Accessory Structures	Permitted per Sec. 27-1808(f).	

<b>(4) Street Facade Requirements</b>		
a. Transparency		
Minimum Transparency	5%	<b>p</b>
Blank Wall Limitations	Not Required	
b. Building Entrance		
Principal Entrance Location	Not Required	
Entrance Type (refer to Sec. 27-1809)	Not Required	
Street Facades: Number of Entrances	Not Required	
Parking Lot Facades: Number of Entrances	Not Required	
c. Roof Type		
Roof Type (refer to Sec. 27-1810)	Not Required	
Tower	Not Permitted	
d. Facade Divisions		
Vertical Increments	Not Required	
Horizontal Expression Line	Not Required	

# Article 27-1800. East Billings Urban Revitalization District Code

## Sec. 27-1813(f). Frontage Type Standards: Open

Frontage Type	Permitted in these EBURD Districts				
	Rail Spur Village Main Street	Rail Spur Village	Central Works	North 13th Street	Industrial Sanctuary
Open Frontage					●

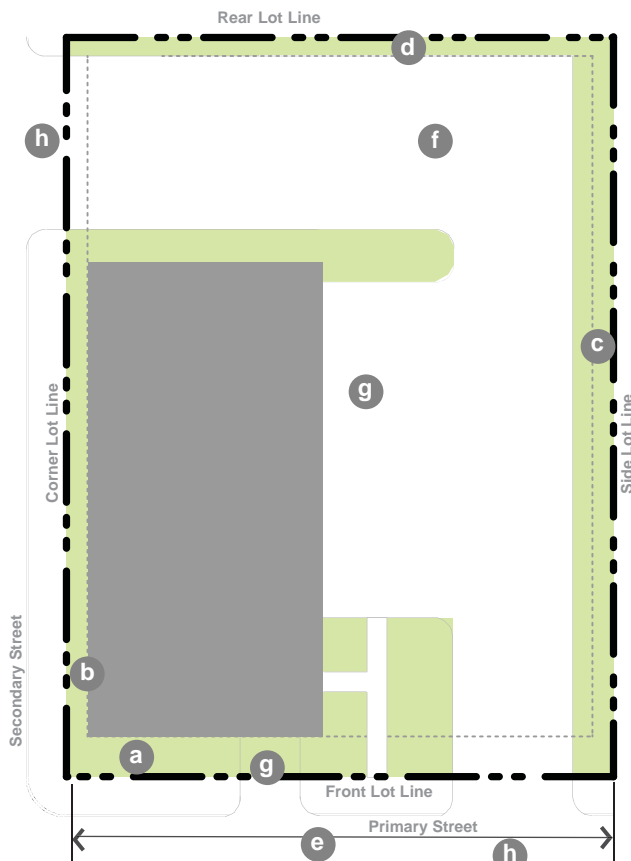

Figure 27-1813(f)-1: Building Siting.

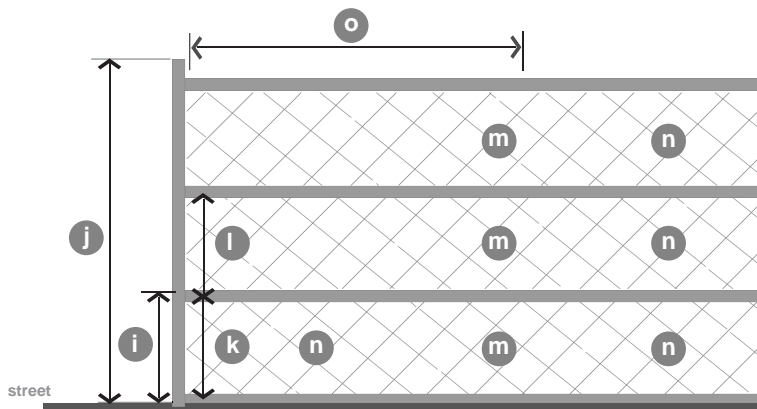

Figure 27-1813(f)-2: Height & Use Requirements.

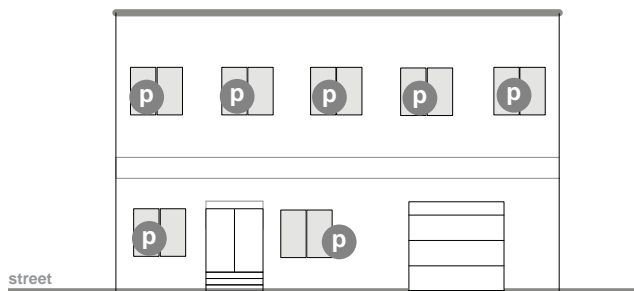

Figure 27-1813(f)-3: Street Facade Requirements.

# Article 27-1800. East Billings Urban Revitalization District Code

## Sec. 27-1813(g). Frontage Type Standards: Civic Building

<b>(1) Building Siting</b>			<b>(3) Uses (refer to BMCC Sec. 27-1806)</b>		
a. Street Frontage			Ground and Upper Stories	Only the Civic and Infrastructure uses are permitted.	<b>m</b>
Multiple Principal Buildings	Permitted		Parking within Building	Permitted in the Rear of all Floors and fully in any Basement(s)	<b>n</b>
Front Lot Line Coverage	N/A		Occupied Space	30' depth space facing on front Facade	<b>o</b>
Occupation of Corner	Required		Accessory Structures	Permitted per Sec. 27-1808(f).	
Front Setback	5'	<b>a</b>			
Corner Setback	5'	<b>b</b>			
Right-of-Way Encroachment	None				
b. Buildable Area			<b>(4) Street Facade Requirements</b>		
Side Yard Setback	5'	<b>c</b>	a. Transparency		
Rear Yard Setback	5'; 0' with Alley	<b>d</b>	Minimum Transparency	15%, per street facade	<b>p</b>
Minimum Lot Width	50'	<b>e</b>	Blank Wall Limitations	Not Required	
Maximum Lot Width	None		b. Building Entrance		
Maximum Impervious Coverage	75%		Principal Entrance Location	Not Required	
Additional Semi-Pervious Cover.	15%		Entrance Type (refer to Sec. 27-1809)	Stoop	<b>q</b>
c. Parking Location, Loading & Access			Street Facades: Number of Entrances	Not Required	
Parking Location	Rear Yard; & Side Yard <sup>1</sup>	<b>f</b>	Parking Lot Facades: Number of Entrances	Not Required	
Loading Facility Location	Rear & Side Facades	<b>g</b>	c. Roof Type <b>r</b>		
Entry for Parking within Building	Rear & Side Facades		Roof Type (refer to Sec. 27-1810)	Parapet, Flat, or Pitched	<b>s</b>
Vehicular Access	From Alley; or up to one (1) driveway per secondary street frontage <sup>2</sup>	<b>h</b>	Tower	Permitted	
Notes:			d. Facade Divisions		
<sup>1</sup> Lots wider than 140' are permitted 1 double-loaded aisle of parking (max. width of 65'), located perpendicular to the street			Vertical Increments	No greater than 30'	
<sup>2</sup> For parcels with a street frontage longer than 300' and no Alley, two (2) driveways are permitted.			Horizontal Expression Line	Not Required	
<b>(2) Height</b>					
Minimum Overall Height	1 Story; 2 Stories preferred	<b>i</b>			
Maximum Overall Height	6 Stories <sup>3</sup>	<b>j</b>			
Ground Story: Minimum Height	9'	<b>k</b>			
Maximum Height	30' <sup>4</sup>				
Upper Stories: Minimum Height	9'	<b>l</b>			
Maximum Height	15'				
Notes:					
<sup>3</sup> Above the fourth Story, the Upper Stories of any building Facade with Street Frontage shall have a step back from the lower Stories that is a minimum of 6' and a maximum of 12'.					
<sup>4</sup> If 20' or more in height, Ground Story shall count as 2 to Stories towards maximum overall height.					

# Article 27-1800. East Billings Urban Revitalization District Code

## Sec. 27-1813(g). Frontage Type Standards: Civic Building

Frontage Type	Permitted in these EBURD Districts				
	Rail Spur Village Main Street	Rail Spur Village	Central Works	North 13th Street	Industrial Sanctuary
Civic Frontage	●	●	●	●	●

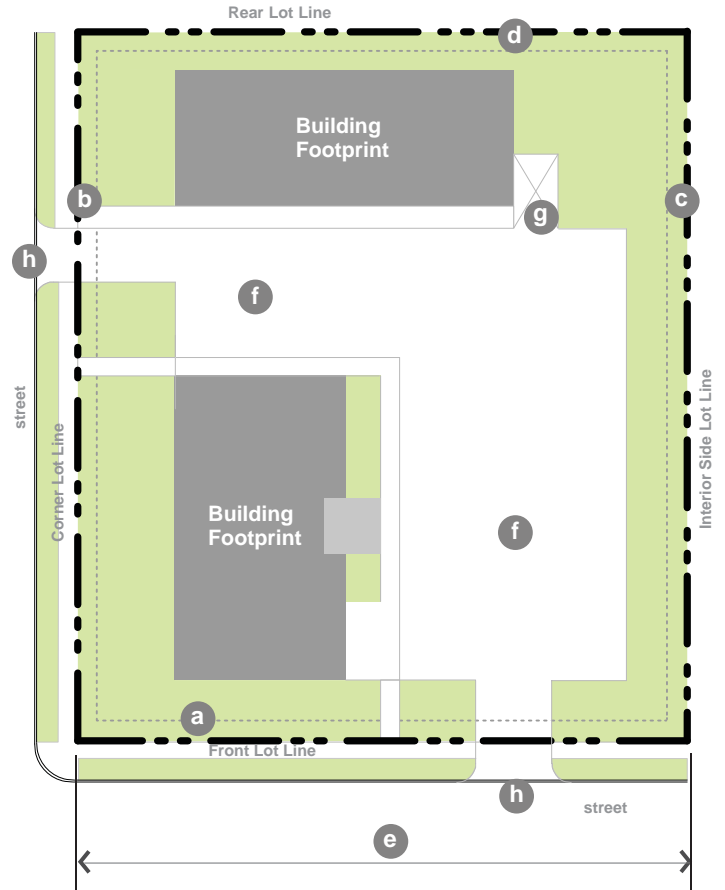

Figure 27-1813(g)-1: Building Siting.

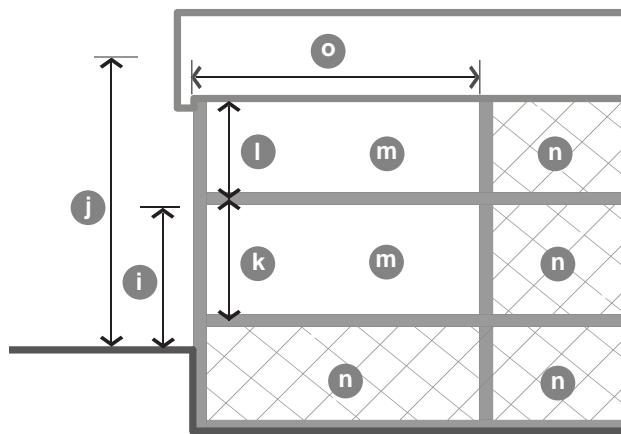

Figure 27-1813(g)-2: Height & Use Requirements.



Figure 27-1813(g)-3: Street Facade Requirements.

# Article 27-1800. East Billings Urban Revitalization District Code

## Sec. 27-1813(h). Frontage Type Standards: Commercial Outdoor Site

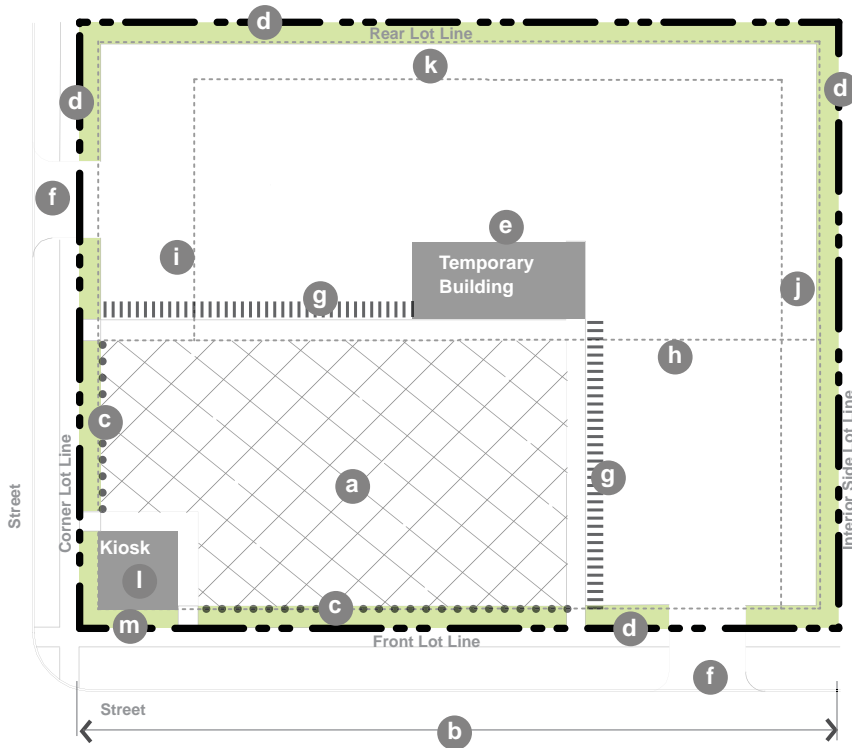

Frontage Type	Permitted in these EBURD Districts				
	Rail Spur Village Main Street	Rail Spur Village	Central Works	North 13th Street	Industrial Sanctuary
Commercial Outdoor Site		○	●	●	●

Figure 27-1813(h)-1: Building Siting.

### (1) Site

**a. Overall Site.** The principal structure is a Patio/Display area.

Minimum Area of Unenclosed, Fully or Partially Paved Outdoor Activity/Display Area 45% of Parcel **a**

Minimum Lot Width none  
Maximum Lot Width 200' **b**

Maximum Impervious Coverage 75%

Required Front & Corner Side Buffer Type Commercial Patio Buffer (Refer to Sec. 27-1815(k) Landscape Standards)<sup>1</sup> **c**

### b. Parking Location, Loading & Access

Parking Setbacks:  
Front 75'  
Corner, Side, Rear 5' **d**

Parking & Loading Facility Location Behind the Rear of the Patio/Display and the Rear Façade of any Building<sup>2</sup> **e**

Vehicular Access One driveway per street frontage **f**

Required Buffer between Parking & Activity/Display Area Frontage Buffer (Refer to Sec. 27-1815(a))<sup>1</sup> **f**

Notes **g**

<sup>1</sup> Exception: Not required for Automobile Sales Use.

<sup>2</sup> One double loaded aisle of parking (to a maximum width of 82 feet) is permitted in the Side Yard.

### B. Accessory Buildings

Number of Permitted Accessory Buildings 2

Maximum Building Coverage 30%

#### 1. Temporary Building

Front Yard Setback 75' **h**

Corner Side Setback 30' **i**

Side Setback 15' **j**

Rear Setback 15' **k**

#### 2. Kiosk Building<sup>3</sup>

Front, Corner, Side, Rear Setback 5' **m**

Maximum Size 500 square feet

Maximum Height 15'

Street Façade Transparency Minimum 20%

Roof Type Pitched

#### Notes

<sup>3</sup> Kiosk is defined as a building with limited space for the proprietor and associated goods and no space for customers to enter the structure with the exception of any bathrooms.

### C. Uses

Permitted Uses Retail & Wholesale Uses, Large Scale Entertainment Use

# Article 27-1800. East Billings Urban Revitalization District Code

## Sec. 27-1814. East Billings Parking Overlay District.

(a) Purpose. The purpose of the East Billings Parking Overlay District is to provide alternative off-street parking standards to encourage the development and re-development of property. The overlay zoning does not alter the category of permitted uses in the underlying zoning.

(b) District Boundaries. The boundaries of the East Billings Parking Overlay District shall be as follows:

Starting at the intersection of Montana Avenue and North 22nd Street, extending north down the centerline of North 22nd to the intersection of 3rd Avenue North, extending westerly down the centerline of 3rd Avenue North to the intersection of North 23rd Street, then northerly along the centerline of North 23rd Street to the intersection of 4th Avenue North, then westerly along the centerline of 4th Avenue North to the intersection of North 25th Street, then northerly along the centerline of North 25th Street to the intersection of 6th Avenue North, then easterly along the centerline of 6th Avenue North to the intersection of North 22nd Street, then northerly along the centerline of to the intersection of 8th Avenue North, extending east down the centerline of 8th Avenue North to the intersection of 8th Avenue North and North 19th Street, extending south down the centerline of North 19th Street to the intersection of North 19th Street and 7th Avenue North, extending east along the centerline of 7th Avenue North to the intersection of North 18th Street and 7th Avenue North, extending south down the centerline of North 18th Street to be perpendicular with the northern most edge of property line of LT 23 & 24 BLK 274 BILLINGS 1ST ADD, extending east along the Northern edge of LT 23 & 24 BLK 274 BILLINGS 1ST ADD, and hence eastward including in their entirety the southern most properties most directly adjacent to 6th Avenue North to the city boundary line including Lots 4-10 of Block 5 and the vacated 20 foot adjacent alley of North Park Subdivision, extending southerly and westerly along the city boundary lines to the northern edge of the rail road tracks,

extending west along the northern edge of the railroad tracks to the centerline of North 22nd Street, extending north along the centerline of North 22nd Street to the ending point at the intersection of Montana Avenue and North 22nd Street. Excluding the non-incorporated land that envelops the Empire Steel property LTS 3 TO 23 & VAC 10FT ADJ ALLEY & E 404T ADJ N 16TH ST BLK 258 & 259.

(c) Application of Regulations. Within this district, the regulations found within BMCC 24-480 and 24-490 as amended shall apply to all property within the East Billings Parking Overlay District. These regulations include but are not limited to the following:

- (1) No minimum off-street parking spaces are required at the time of development, redevelopment, expansion, change of use or addition to public, commercial, industrial or residential property.
- (2) Where off-street parking spaces are developed, the design of such spaces and parking lots shall meet the standards set forth in BMCC 6-1203(o) through 6-1203(u) and other design standards for off-street parking that are adopted policies of the City Engineer.
- (3) These regulations in no way diminish or reduce a property owner's liability or obligation to provide accessibility in compliance with the federal Americans with Disabilities Act (ADA) standards.



Figure 27-1814-1. Map of District Boundaries

# Article 27-1800. East Billings Urban Revitalization District Code

## Sec. 27-1815 Landscape Standards

The following landscape requirements apply to all EBURD districts. Refer to BMCC Sec. 27-1802.

(a) General Compliance. Application of this section to existing Uses shall occur with the following developments.

- (1) The expansion of more than thirty (30) percent of the surface area of an existing parking lot or loading facility, including any associated driveways.
- (2) Alteration to an existing Principal or Accessory Structure that results in a change of fifteen (15) percent or more in the structure's Gross Floor Area.
- (3) When compliance is triggered for existing parking lots, landscape improvements shall take precedence over parking requirements.

(b) General Requirements. Refer to BMCC Sec. 27-1100 for all landscape requirements, including but not limited to the approval process, materials, installation, and maintenance. However, the EBURD specific standards in this section 27-1815 supercede the requirements of subsections 27-1105 and 27-1106.

(c) Landscape Area Vegetation. All unpaved areas shall be covered by one of the following.

- (1) Planting Beds.
  - a. Planting beds may include shrubs, ornamental grasses, ground cover, vines, annuals, or perennials.
  - b. Nonliving materials, such as rocks, gravel, cobbles, pine straw, or mulch, are permitted for up to fifty (50) percent of a bed area.
  - c. Annual beds must be maintained seasonally, replanting as necessary.
- (2) Grass. Seeded, plugged, or sodded grass may be planted throughout landscaped areas, established within ninety (90) days of planting or the area must be reseeded, replugged, or resodded.

(d) Permeable Surface. For each tree preserved or planted, a minimum amount of permeable surface area is recommended, unless otherwise stated in this article.

- (1) Preserved trees should have a permeable surface area equal to the critical root zone. The critical root zone is equal to half of the

radius of the tree's mature canopy, measured from the trunk out to the dripline.

- (2) Planted trees have a suggested minimum permeable area and soil volume based upon tree size; refer to Table 27-1815-1 for details.
- (3) Permeable area for one tree cannot count toward that of another tree.
- (4) Structural Soil. When the critical root zone of an existing tree or the suggested permeable surface area requirement of a newly planted tree extends below any pavement, structural soil is required underneath the pavement.

(e) Street Trees. All new developments or redevelopments shall include the installation of street trees per BMCC Sec. 27-1817 Street Types. The following standards apply to the installation of street trees.

- (1) Clear Branch Height. Minimum clear branch height is eight (8) feet.
- (2) Permitted Street Tree Type. Deciduous Shade and Ornamental Trees per the City of Billings Recommended Plant List are permitted to be installed as street trees. Refer to the current edition of The City of Billings Standard Modifications to the Montana Public Works Standard Specifications for Plant List and other installation specifications. Refer to BMCC Sec. 25-208 for tree species prohibited in the public right-of-way.
- (3) Street Tree Spacing. Street trees shall be planted as follows.
  - a. Each Lot is required to have one (1) tree for every forty (40) feet of street frontage with a minimum of one (1) street tree per street frontage.
  - b. Spacing.
    - i. Shade trees must be spaced a minimum of thirty (30) and a maximum of sixty (60) feet on center.
    - ii. Ornamental trees must be spaced a minimum of twenty (20) and a maximum of forty (40) feet on center.

Tree Type	Soil Volume (cubic ft)	Soil Surface Area (sq ft) with 2.5' Soil Depth	Permeable Surface Area Requirement (sq ft)
	2852	1141 (approx. 34' x 34')	225 (15' x 15')
Shade	6532	2681 (approx. 50' x 50')	400 (20' x 20')

Table 27-1815-1. Minimum Recommended Soil Volumes and Permeable Area per Planted Tree.

# Article 27-1800. East Billings Urban Revitalization District Code

- iii. The location of trees shall take into account the location of signs, wherever it is feasible, so as to not block the view for motorists and still meet the intent of this section.
  - c. Limited Distance from Curb and Sidewalk. Where the distance from the back of the curb to the edge of the Right-of-Way or Lot line is less than nine (9) feet with a sidewalk, Applicant shall work with the City Forester to determine the appropriate tree species. The Zoning Coordinator may waive the street tree requirement in spaces less than nine (9) feet.
- (4) Tree Wells. Where the sidewalk extends from the back of curb to the Lot line, tree wells shall be utilized.
- a. For tree wells adjacent to sidewalks five (5) feet wide or less, an open pit is not permitted.
    - i. The opening must be covered with a tree grate or pervious pavement.
    - ii. The opening in a tree grate for the trunk must be expandable.
- (f) Landscape Area Requirements. These standards apply to all development except single family residential.
- (1) Tree Requirements. One (1) evergreen, ornamental or shade tree is required for every two thousand five hundred (2,500) square feet of Landscape Area.
- a. Existing Tree Canopy may be utilized to meet this requirement.
  - b. If less than 2,500 square feet of Landscape Area exists, tree plantings are not required.
- (2) Planting Bed Requirements. A minimum of forty (40) percent of the Landscape Area of Front and Corner Side Yards not already designated as a frontage or side and rear buffer (refer to BMCC Sec. 27-1815) must be planting beds (refer to BMCC Sec. 27-1815(b)).
- (f) Fences & Walls. These standards apply to all lots in all EBURD Districts. Fences and walls must adhere to the following standards.
- (1) Height. The maximum height of any fence or wall shall be six (6) feet measured from the ground at the base of the fence or wall to the top of the fence boards or wall.
- a. Posts, decorative columns, light fixtures, or other decorative details are permitted to exceed the height limit by up to two (2) foot.
  - b. Fences over four (4) feet in height are not permitted in the front yard.
- c. In the Central Works, the maximum height of any fence or wall shall be eight (8) feet.
  - d. In the Industrial Sanctuary, height limits do not apply.
- (2) Location. All fences and walls must be located within a lot's lot lines.
- (3) Materials.
- a. Permitted Materials. Brick; stone; cast stone; wood; painted, matte finish vinyl; wood composites; or steel are permitted fence and wall materials.
  - b. Prohibited Materials. Barbed wire, chain link, exposed cinder or concrete block, metal mesh, and razor wire and single wire fences and wall are prohibited with the following exceptions.
    - i. In the Industrial Sanctuary districts, chain link, razor wire, and barbed wire fencing are permitted. Sharp fencing must be located 8' above grade.
- (4) Opacity. Fences along the Front Yard or Front Lot line shall have a maximum opacity of fifty (50) percent.
- (g) Buffers. Landscape buffers are required according to the provisions in this section with the following exceptions.
- (1) Shared Driveways. Buffers shall not be required along a lot line where a curb cut or aisle is shared between two adjoining lots.
- (2) Points of Access. Buffering is not required at driveways or other points of access to a lot.

# Article 27-1800. East Billings Urban Revitalization District Code

## (h) Frontage Buffer Requirements

(refer to Figure 27-1815-1)

### (1) Intent & Applicability

Intent	To lessen the visual impact of vehicular areas & outdoor storage visible from the street
General Applicability	Applies to Frontage Types where a vehicular area or outdoor storage is located adjacent to a Right-of-Way
Exceptions	Vehicular areas along alleys, except when a residential district is located across the alley; Single and two family residences

### (2) Buffer Depth & Location <sup>1</sup>

Depth	7'	1
Location on the Site	Between street facing Lot line and parking area <sup>2</sup>	2

### (3) Buffer Landscape Requirements

Uses & Materials	Uses and materials other than those indicated are prohibited in the buffer	
Shade Trees	Medium or large shade tree required at least every 40'; Locate on the street side of the fence; Spacing should alternate with street trees	3
Hedge	Required continuous hedge on street side of fence, between shade trees & in front of vehicular areas	4
Hedge Composition	Individual shrubs with a minimum width of 24", spaced no more than 36" on center	
Existing Vegetation	May be credited toward buffer area	

### (4) Fence

Location	2' from back of curb of vehicular area	5
Materials	Steel or painted, matte finish PVC; Masonry columns (maximum width 2'6") and base (maximum 18" height) permitted	
Minimum Height	3'	
Maximum Height	4'	
Colors	Black, gray, or dark green	
Opacity	Minimum 20%; Maximum 60%	
Gate/Opening	One gate permitted per street frontage; Opening width maximum 6'	

#### Notes:

<sup>1</sup> This screening requirement does not prohibit the installation of or provision for openings necessary for allowable access drives and walkways connecting to the public sidewalk.

<sup>2</sup> In front, corner, and rear yards on a through lot, when the parking area is located adjacent to any building on the lot, the buffer must be located so that it aligns with or is behind the face of the adjacent building back to the vehicular area. The area between the buffer and the lot line must be landscaped.

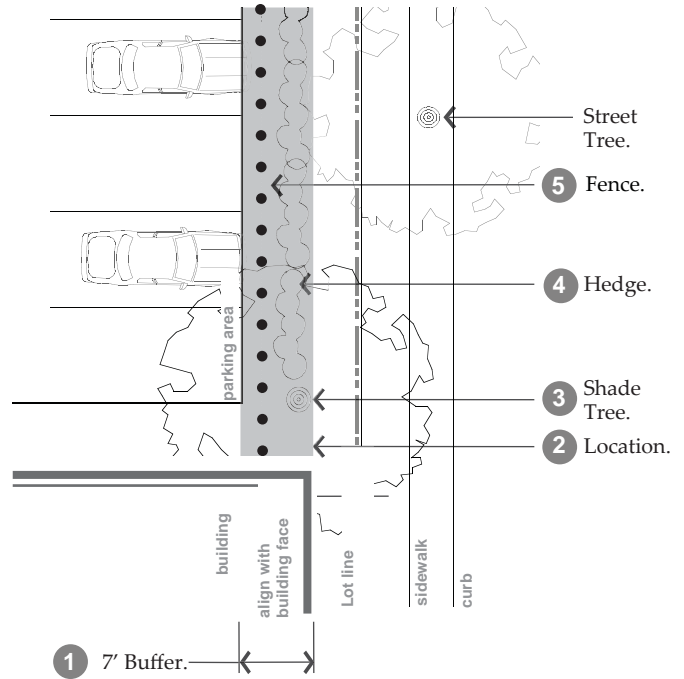

Front Buffer Plan.

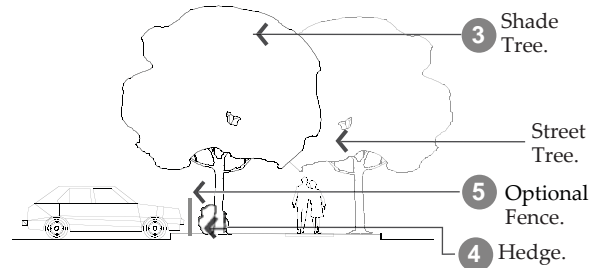

Front Buffer Section.

Figure 27-1815-1. Frontage Buffer Plan and Section.

# Article 27-1800. East Billings Urban Revitalization District Code

## (i) Interior Parking Lot Landscaping Requirements (refer to Figure 27-1815-2)

### (1) Intent & Applicability

**Intent** To provide shade, minimize paving & associated stormwater runoff, & improve the aesthetic look of parking lots

**General Applicability** All open-air, off-street parking lots<sup>1</sup>

**Other Internal Parking Lot Areas** Internal areas not dedicated to parking or drives shall be landscaped with a minimum of one medium or large shade tree for the first 150 square feet and one medium or large shade tree for every 650' thereafter

**Existing Vegetation** Existing vegetation may be credited toward these requirements

### (2) Landscape Island Requirements

**Required Island Locations** Terminal ends<sup>2</sup> of free standing rows or bays of parking; After every ninth parking space for rows of parking greater than 10 spaces in length<sup>4</sup>

**Minimum Width** 5'; Islands less than 15' must utilize structural soil under any paved surface within a tree's recommended permeable surface area requirement (per Table 27-1815-1); Islands under 9' must install an aeration system and utilize permeable pavement

**Required Trees Within Islands** Minimum of 1 medium or large shade tree per island

### (3) Tree Requirements

**Requirements per Parking Space<sup>3</sup>** Each parking space must be located within 50' of a tree planted within parking lot interior; and no more than 8 continuous parking spaces in a row are permitted without a landscape island

Minimum of 1 shade tree must be planted within parking lot interior or within 4' of parking lot's edge for every 3 parking spaces

**Tree Shade** Within 20 years of tree installation, 30% of the interior of the parking lot must be shaded by tree canopy

#### Notes:

<sup>1</sup> Parking lot interior is defined as the area dedicated to parking on a given parcel as measured from the farthest edge of pavement to opposing farthest edge of pavement.

<sup>2</sup> Freestanding rows or bays of parking are those not abutting the parking lot perimeter or building face, and may have a single or double row of parking.

<sup>3</sup> Trees within a designated buffer area may not be utilized to meet these requirements. Trees and landscaping located outside of the parking lot interior, including in the side and rear buffer or frontage buffer, may not be applied to this requirement.

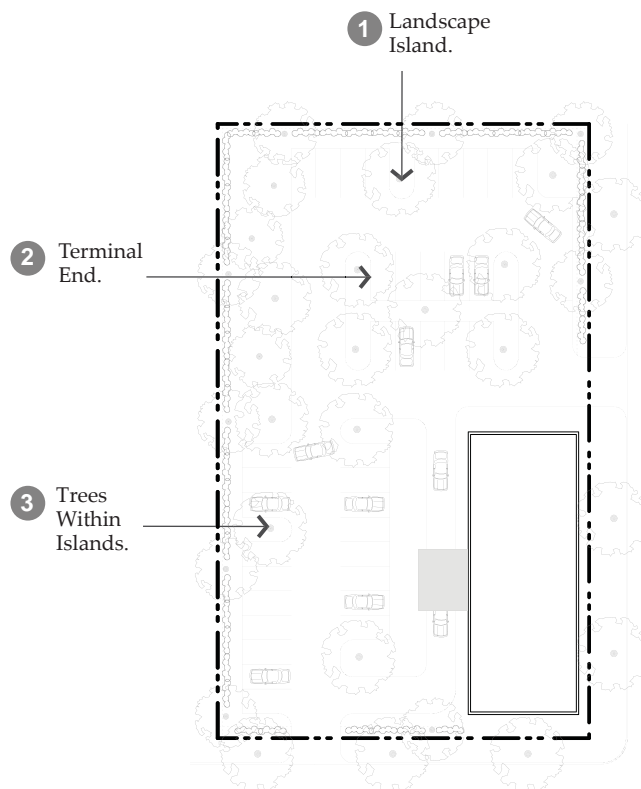

Figure 27-1815-2. Interior Parking Lot Landscaping.

Tree Size	Estimated Canopy at Maturity (sq ft)	Estimated Height at Maturity (ft)
Very Small	150	under 15'
Small	400	15'-25'
Medium	900	25'-40'
Large	1600	40'+

Table 27-1815-3. Estimated Canopy and Height at Maturity.

# Article 27-1800. East Billings Urban Revitalization District Code

## (j) Side & Rear Buffer Requirements

(refer to Figure 27-1815-3)

### A. Intent & Applicability

**Intent** To minimize the impact that one building may have on a neighboring district and to provide a transition between districts

**General** Applies to all directly adjoining properties as outlined in Table 27-1815-4<sup>1</sup>

### B. Required Landscape Screen

**Size** 5' landscape screen in addition to any other buffer landscaping **1**

**Location** Directly adjacent to the Rear or Side Lot line per Table 27-1815-2

**Hedge** Continuous double row of shrubs required between shade trees **2**

**Hedge Composition** Double row of individual shrubs with a minimum width of 24", spaced no more than 36" on center; Mature height in one year of 24"

**Hedge Frequency** Minimum of 15 shrubs per 100' of Lot line is required

**Shade Trees** At least 1 medium or large shade tree per every 40' within the buffer **3**

**Uses and Materials** Uses and materials other than those indicated are prohibited within the buffer

**Existing Vegetation** May be credited toward buffer area **4**

### C. Required Fence

**Permitted Materials** Steel or painted, matte finish PVC for semi-opaque; Wood or masonry for opaque. Chain link not permitted.

**Minimum Height** 6'

**Maximum Height** 8'

**Colors** If steel: black, gray, or dark green

**Opacity** Option 1: Semi-Opaque 20%-60% opacity, hedge required; Option 2: Opaque fence, no hedge required

#### Notes:

<sup>1</sup>Zoning Coordinator may reduce width of buffer, width of landscape screen, or location of landscape screen based on existing landscaping and similarity between uses.

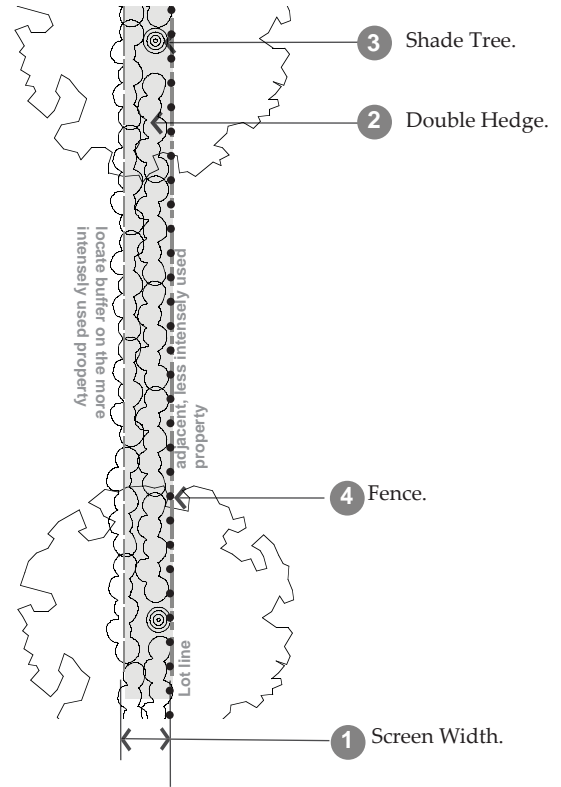

Landscape Screen Plan.

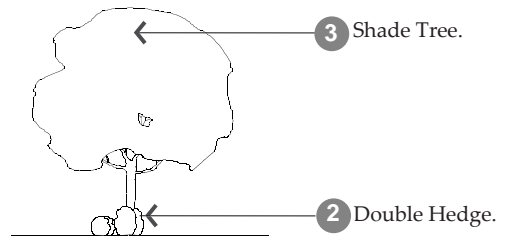

Landscape Screen Section.

Figure 27-1815-3. Landscape Screen within Side & Rear Buffer.

Frontage Types		Buffer	
Buffer Required on Lot	When Lot Line is adjacent to:	Buffer Required	Buffer Width
Open, Commerce, Limited Bay	Yard, General Stoop, Storefront	Side & Rear	5'
General Stoop	Yard	Side Rear	5'

Table 27-1815-4. Side & Rear Buffer Requirements by District.

# Article 27-1800. East Billings Urban Revitalization District Code

## (k) Commercial Patio Frontage

(refer to Figure 27-1815-4)

### (1) Intent & Applicability

<b>Intent</b>	To provide a buffer between outdoor sales uses and street activity
<b>General Applicability</b>	Applies to Commercial Outdoor Site Frontage Type only (refer to BMCC Sec. 27-1813(h))

### (2) Frontage Location

<b>Minimum Depth</b>	7'	1
<b>Location on the Site</b>	Between 5' and 20' from Front and Corner Side Lot line adjacent to patio/display area	2

### (3) Buffer Landscape Requirements<sup>1</sup>

<b>Shade Trees</b>	Medium or large shade tree required at least every 40'; Spacing should alternate with street trees <sup>2</sup>	3
<b>Shrubs</b>	Required continuous shrubs on street side of fence	4
<b>Hedge Composition</b>	Individual shrubs with a minimum width and height of 12", spaced no more than 24" on center	4
<b>Existing Vegetation</b>	May be credited toward buffer area	5

### D. Required Fence

<b>Materials</b>	Steel or painted, matte finish PVC; Masonry base or columns permitted
<b>Minimum Height</b>	18"
<b>Maximum Height</b>	4'
<b>Colors</b>	Black, gray, or dark green for steel or PVC
<b>Opacity<sup>3</sup></b>	Minimum 30 percent; Maximum 60%
<b>Gate/Opening</b>	Two gates permitted per street frontage; Opening width maximum 6'

#### Notes:

<sup>1</sup> This screening requirement does not prohibit the installation of or provision for openings necessary for allowable access drives and walkways connecting to the public sidewalk.

<sup>2</sup> Exception: Trees for Automobile Sales Use may be spaced 90' on center

<sup>3</sup> Fence may be solid if 30" or less in height

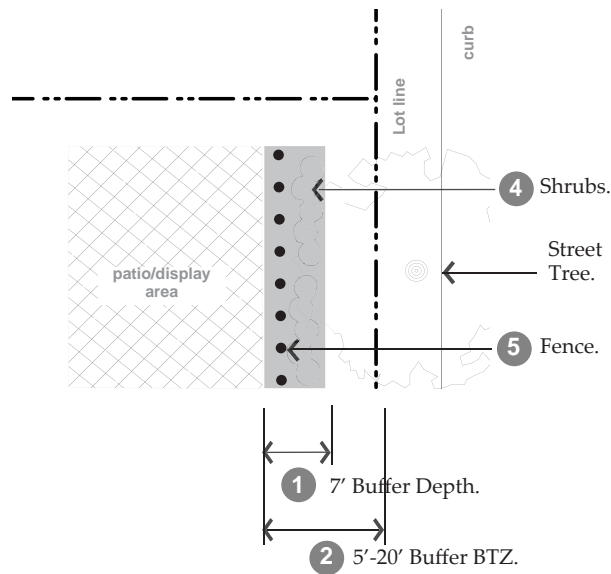

Commercial Patio Frontage Plan.

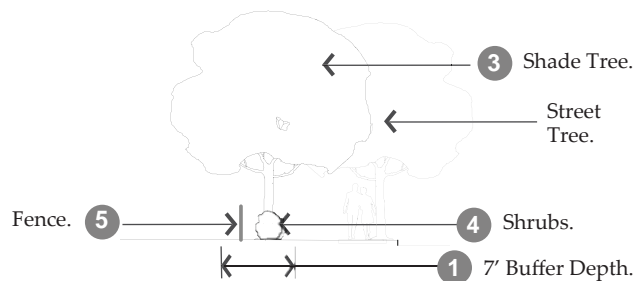

Commercial Patio Frontage Section.

Figure 27-1815-4. Commercial Patio Frontage Plan and Section.

# Article 27-1800. East Billings Urban Revitalization District Code

## (I) Screening of Open Storage, Refuse Areas, & Utility Appurtenances

(refer to Figure 27-1815-5)

### A. Intent & Applicability

**Intent** To reduce the visibility of open storage, refuse areas, and utility appurtenances from public areas and adjacent properties

**General** All dumpsters, open storage, refuse areas, and utility appurtenances

### B. Open Storage & Refuse Area Screening Requirements<sup>1</sup>

**Location on the Site** Not permitted in Front or Corner Side Yards

**Opaque Screen Wall<sup>1</sup>** Required around 3 sides of the dumpster and trash bin area **1**

**Screen Wall Height** Height shall be the higher of the following:  
 1. 6'  
 2. Height of use to be screened  
 3. Height as determined by the Zoning Coordinator to accomplish objective of the screen **2**

**Visible Openings** Openings visible from the public way or adjacent properties must be furnished with opaque gates **2**

**Landscape Requirement** If refuse area is located within larger paved area, such as a parking lot, landscape islands must be located on 3 sides of the area, with at least 1 medium or large shade tree in at least 1 of the landscape areas<sup>2</sup> **3**

### C. Utility Appurtenance Screening Requirements

**Large Private Mechanical Equipment<sup>3</sup>** Shall be fenced with opaque wood or brick-faced masonry on all sides facing Right-of-Way

**Small Private Mechanical Equipment<sup>4</sup>** Shall have landscape screening and a shrub bed containing shrubs spaced no more than 36" on center

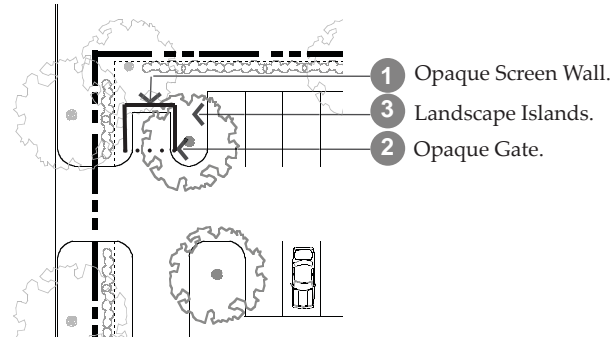

Figure 27-1815-5. Screening of Open Storage & Refuse Areas.

# Article 27-1800. East Billings Urban Revitalization District Code

# Article 27-1800. East Billings Urban Revitalization District Code

## Sec. 27-1816 Signage

Refer to BMCC Sec. 27-700 for sign requirements. The following additional requirements are specific to the EBURD and replaces information in the BMCC Sec. 27-705.

(a) Intent. Commerce is the primary purpose, function and goal of the EBURD. It is the economic engine that funds the City of Billings and Yellowstone County. The functions of signs are to support and enhance that purpose. Regardless of other considerations, the ability of a business to thrive in any given location is the final measure of appropriateness. In a community of our size serving a broad market including Montana, Wyoming and parts of North Dakota, and in a time of growing online commerce, it is increasingly necessary that a business must be able to reach beyond the immediate neighborhood to survive. The ways traffic moves through districts is the most reliable indicator of sign needs and the assurance of success of this purpose. The Billings Industrial Revitalization District Inc. ("BIRD") is the organization that oversees the EBURD and makes recommendations to the City Council.

- (b) The following revises BMCC Sec. 27-706 to incorporate the EBURD.
- (1) Service station and convenience store signage shall adhere to the requirements of this section, BMCC Sec. 27-1816 (b) through (o). BMCC Sec. 27-706(a) does not apply to the EBURD.
  - (2) Billboards shall be permitted only on Boulevards or Avenues within the EBURD (Montana Avenue, 1st Avenue N, 4th Avenue N, 6th Avenue N, and N 13th Street) . All other requirements of BMCC Sec. 27-706(b) shall apply, including the requirements of the existing moratorium.
  - (3) BMCC Sec. 27-706(c) Shopping center or mall signs does not apply to the EBURD.
  - (4) BMCC Sec. 27-706(e) Church, school, and other institutional use signs does not apply to the EBURD. Churches, schools, and other institutions shall adhere to the requirements of this section, BMCC Sec. 27-1816 (b) through (o).
  - (5) All signs that that predate the adoption of this code are legally non conforming until they are completely replaced. At that point, the standards contained within are applicable.

		EBURD Frontage Types							
		Yard Frontage	General Stoop	Storefront	Limited Bay	Commerce	Open	Civic	Outdoor Site
Sign Types	Wall	●	●	●	●	●	●	●	●
	Projecting		●	●	●	●	●	●	●
	Awning	●	●	●	●	●	●	●	●
	Canopy Mounted		●	●	●	●	●	●	●
	Window			●	●	●	●		●
	Monument	●	●		●	●	●	●	●
	Ped. Scale Pole-Mounted	●	●		●	●	●	●	●
	Pole-Mounted					●	●		○
			● = Permitted                      ○ = Permitted Only on Boulevard Street Type						

Table 27-1816-1. Sign Types permitted by Frontage Type.

# Article 27-1800. East Billings Urban Revitalization District Code

- (6) Section 27-705 will be applicable for all Boulevard Street Types.
- (c) Residential Signage. Refer to BMCC Sec. 27-705(a), except: signage for a home occupation are permitted with the following requirements:
  - (1) One (1) home occupation sign per lot is permitted.
  - (2) Home occupation sign shall be a wall sign, flat mounted against the building, or a pedestrian pole mounted sign.
  - (3) Home occupation sign shall be no larger than one (1) square foot in area.
  - (4) Home occupation sign shall not be directly or indirectly illuminated other than by those lights incidental to the residential use of the premises.
- (d) Electronic Message Board Signage. Refer to BMCC Sec. 27-705(c)3 for requirements of all Electronic Message Boards within the EBURD with the following exception:
  - (1) Electronic Message Boards are only permitted on sign types if allowed per BMCC Sec. 27-1816(g) through (o).
- (e) State Routes. In addition to the regulations included in BMCC Sec. 27-1816, off premise signage on parcels abutting a state maintained route are required to obtain an Outdoor Advertising Control sign permit from the

Montana Department of Transportation per the Montana Outdoor Advertising Act. Refer to Figure 27-1816(e)-1 for map of state maintained routes in the EBURD, for reference only.

- (f) Sign Types. Sign types permitted in the EBURD are defined in BMCC Sec. 17-1816(g) through (o).
  - (1) Refer to Table 27-1816-1 for permitted sign types permitted by Frontage Type. Refer to BMCC Sec. 27-1808 for Frontage Type information.
  - (2) Refer to Table 27-1816-2 for the maximum permitted quantity of signage per lot. To calculate this quantity, all sign types on the lot shall be totaled, with the exception of exempt signs, temporary signs, and window signs.



Figure 27-1816(e)-1. Map of State Maintained Routes as of February 2012, for Reference Only.

Frontage Type	Maximum Permitted Quantity of Signage Per Lot
Yard	65 square feet of signage except residential signage (refer to BMCC Sec. 27-1816(c)).
General	
Storefront	3 square feet of signage per 1 linear foot of Lot width with a maximum of 150 square feet
Limited Bay	
Commerce	3 square feet of signage per 1 linear foot of Lot width with a maximum of 200 square feet. An additional 40 square feet per additional tenant over 3 tenants permitted
Open	
Civic	3 square feet of signage per 1 linear foot of lot width with a maximum of 150 square feet

Table 27-1816-2. Total Maximum Permitted Quantity of Signage per Lot by Frontage Type.

# Article 27-1800. East Billings Urban Revitalization District Code

## (g) Wall Sign.

- (1) Description. Wall signs, also known as flat or band signs, are mounted directly to the building face to which the sign is parallel. Refer to Figures 27-1816(g)-1 and 27-1816(g)-2.
- (2) General Requirements. Wall signs shall be developed according to the standards in Table 27-1816(g)-1.
  - a. Building Openings. Wall signs shall not cover windows or other building openings.
  - b. Architectural Features. Wall signs are strongly encouraged not to cover existing architectural building features.
  - c. Murals. Murals, a type of wall sign painted onto the building face displaying the business name or activity, are prohibited on front facades.
- (3) Sign Area is defined as the entire area within any type of perimeter or border which may enclose the outer limits of any writing, representation, emblem, figure or character. The area of the sign having no such perimeter or border shall be computed by enclosing the entire area with parallelograms, triangles or circles of the smallest size sufficient to cover the entire area of the sign and computing the area of

these parallelograms, triangles or circles. The area computed shall be the maximum portion or portions which may be viewed from any one direction

- i. Area Credit. All areas that utilize individual alphanumeric characters or logos (including only those using wood, wood substitute, metal, or masonry) may use a total area of ninety (90) percent of the calculation as outlined above.
- b. Mural Sign. Area is calculated by measuring the area of the smallest square or rectangle that can be drawn around all of the sign elements, including any painted background.

### Wall Sign Requirements

Sign Area	No maximum area for sign type; Refer to Table 27-1816-2 for maximum per lot
Height	No maximum letter or element height
Location on the Building or Site	Permitted on all street facades; Non-illuminated wall signs are permitted on all facades.
Placement on the Building or Site	1' maximum projection from building face
Quantity	1 per tenant per public ROW frontage; 1 per tenant per side or rear facade on a parking lot
Internal Illumination	Permitted
Materials	Solid wood, metal, masonry & neon glass; Plastic & synthetics permitted only as separate alphanumeric characters or logos

Table 27-1816(g)-1. Wall Sign Requirements.

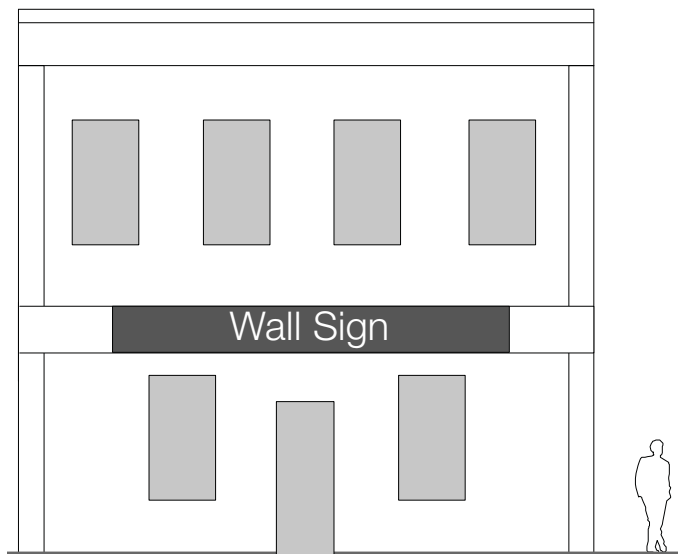

Figure 27-1816(g)-1. Wall Sign.



Figure 27-181(g)-2. Measuring Wall Signs.

# Article 27-1800. East Billings Urban Revitalization District Code

## (h) Projecting Sign.

- (1) Description. A projecting sign is attached to and projects from a building face or hangs from a support structure attached to the building face. Sign faces are typically perpendicular to the building face, but may be at an angle greater than forty-five (45) degrees from the facade. The sign may be vertically or horizontally oriented. Refer to Figure 27-1816(h)-1.
- (2) General Requirements. Projecting signs shall be developed according to the standards in Table 27-1816(h)-1.
- (3) Computation. The area of a projecting sign is equal to the area of one (1) of the sign's faces.
- (4) Permit Required. An encroachment permit shall be obtained from the City Engineering Department for any projecting sign encroaching into the public right-of-way.

Projecting Sign Requirements	
Sign Area	No maximum area for sign type; Refer to Table 27-1816-2 for maximum per lot
Height	8' maximum sign length, 9' minimum clearance to walk required
Location on the Building or Site	Permitted on all facades; sign and structural supports shall not extend above the eave or parapet
Placement on the Building or Site	Shall not project over more than 2/3 the width of the sidewalk. (Refer to BMCC Sec. 27-1816(h)(4) for required permit)
Quantity	1 per tenant per public ROW frontage; 1 per tenant per side or rear facade on a parking lot
Internal Illumination	Permitted
Materials	Solid wood, metal, masonry & neon glass; Plastic & synthetics permitted only as separate alphanumeric characters or logos

Table 27-1816(h)-1. Projecting Sign Requirements.

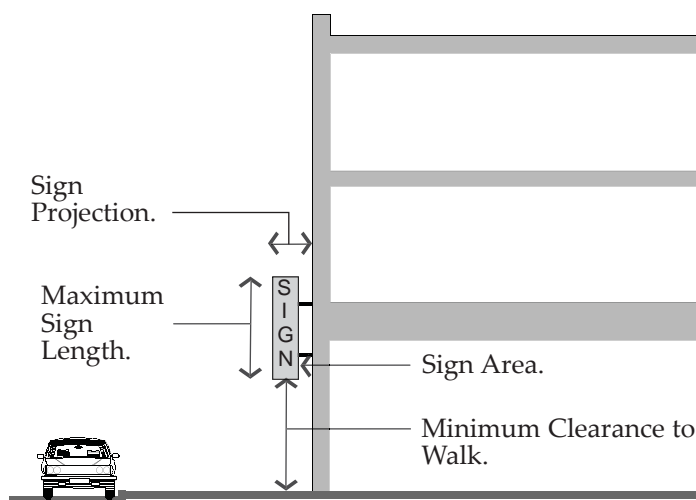

Figure 27-1816(h)-1. Projecting Sign.

# Article 27-1800. East Billings Urban Revitalization District Code

## (i) Awning Sign.

- (1) Description. A sign that is mounted, painted, or otherwise applied on or attached to an awning or canopy. Refer to Figures 27-1816(i)-1 and 27-1816(i)-2.
- (2) General Requirements. Awning signs shall be developed according to the standards in Table 27-1816(i)-1.
- (3) Sign Area. Defined as the entire area within any type of perimeter or border which may enclose the outer limits of any writing, representation, emblem, figure or character. The area of the sign having no such perimeter or border shall be computed by enclosing the entire area with parallelograms, triangles or circles of the smallest size sufficient to cover the entire area of the sign and computing the area of these parallelograms, triangles or circles. The area computed shall be the maximum portion or portions which may be viewed from any one direction.
- (4) Permit Required. An encroachment permit shall be obtained from the City Engineering Department for any projecting sign encroaching into the public right-of-way.

Awning Sign Requirements	
Sign Area	Up to 50% of the awning may be used for signage; Refer to Table 27-1816-2 for maximum per lot
Height	8' minimum clearance to walk required
Location on the Building or Site	Permitted on all facades
Placement on the Building or Site	Maximum projection from building is 6'; Shall not project closer than 2' from back of curb; Shall not block any window, door, or the roof design. (Refer to BMCC Sec. 27-1816(i)(4) for permit)
Quantity	1 per tenant per public ROW frontage; 1 per tenant per side or rear facade on a parking lot
Internal Illumination	Not permitted
Materials	Cloth, canvas, metal, or wood; All supports shall be made of metal or wood

Table 27-1816(i)-1. Awning Sign Requirements.

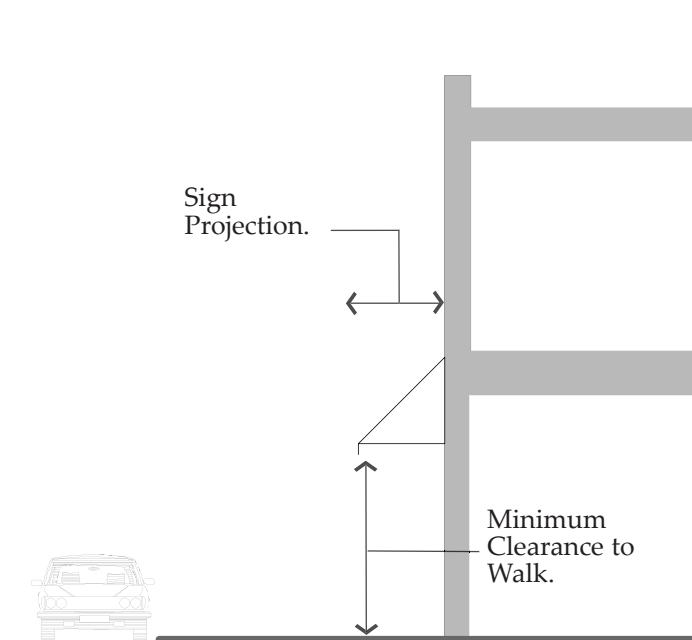

Figure 27-1816(i)-1. Awning Sign.

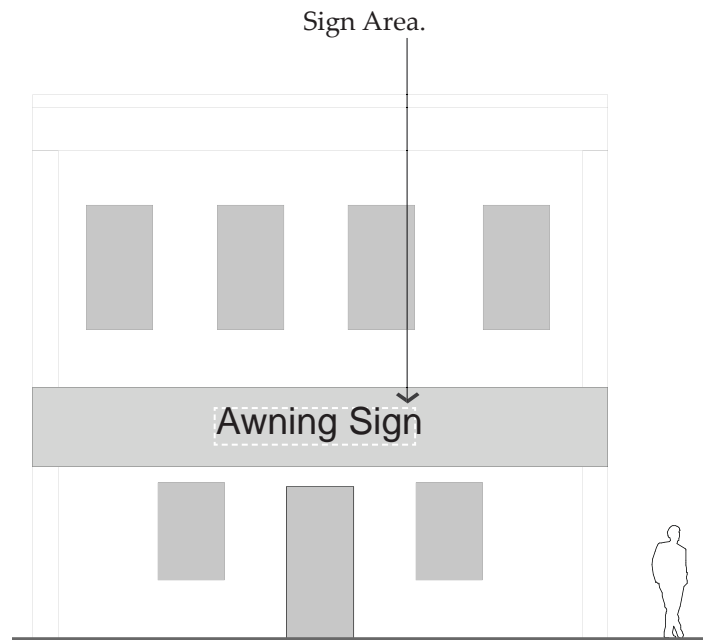

Figure 27-1816(i)-2. Measuring Awning Signs.

# Article 27-1800. East Billings Urban Revitalization District Code

## (j) Canopy-Mounted Sign.

- (1) Description. A sign with individual alphanumeric characters and/or logos that is mounted on top of a permanent canopy. Refer to Figures 27-1816(j)-1 and 27-1816(j)-2.
- (2) General Requirements. Canopy-mounted signs shall be developed according to the standards in Table 27-1816(j)-1.
- (3) Sign Area is defined as the entire area within any type of perimeter or border which may enclose the outer limits of any writing, representation, emblem, figure or character. The area of the sign having no such perimeter or border shall be computed by enclosing the entire area with parallelograms, triangles or circles of the smallest size sufficient to cover the entire area of the sign and computing the area of these parallelograms, triangles or circles. The area computed shall be the maximum portion or portions which may be viewed from any one direction
- (4) Permit Required. An encroachment permit shall be obtained from the City Engineering Department for any projecting sign encroaching into the public right-of-way.

Canopy-Mounted Sign Requirements	
Sign Area	No maximum area for sign type; Refer to Table 2.7-1816-2 for maximum per lot
Height	No maximum letter or element height; Cannot project more than 2' above roof line of canopy
Location on the Building or Site	Permitted on all facades
Placement on the Building or Site	Shall not block any window, door, or the roof design. (Refer to BMCC Sec. 27-1816(j)(4) for permit)
Quantity	1 per tenant per public ROW frontage; 1 per tenant per side or rear facade on a parking lot
Internal Illumination	Permitted
Materials	Solid wood, metal, & neon glass; Plastic & synthetics permitted only as separate alphanumeric characters or logos

Table 27-1816(j)-1. Canopy-Mounted Sign Requirements.

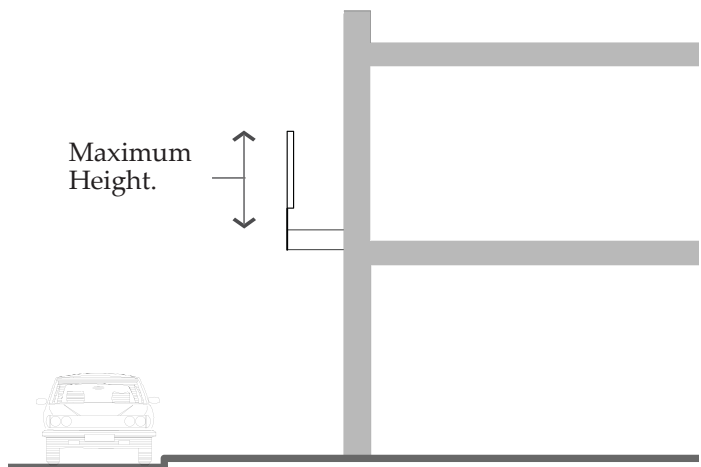

Figure 27-1816(j)-1. Canopy-Mounted Sign.

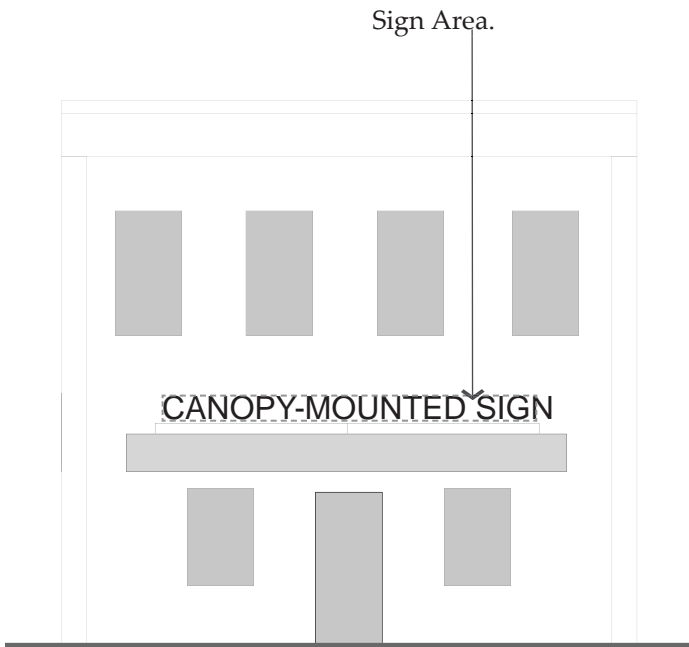

Figure 27-1816(j)-2. Measuring Canopy-Mounted Signs.

# Article 27-1800. East Billings Urban Revitalization District Code

## (k) Window Sign.

- (1) Description. A window sign is posted, painted, placed, or affixed in or on a window exposed for public view or is a sign hung inside the building facing the window for public view. Refer to Figure 27-1816(k)-1.
- (2) General Requirements. Window signs shall be developed according to the standards in Table 27-1816(k)-1.
- (3) Computation. A series of windows that are separated by frames or supporting material of less than six (6) inches in width shall be considered a single window for the purposes of computation.
  - a. Measurement. To measure sign area percentage, divide the total sign area by the total window area, as illustrated in Figure 27-1816(k)-1.
  - b. Maximum Allowance. Window signs are not counted toward a site's maximum signage allowance.
  - c. Exempt signs. Address and hours of operation are considered exempt signs and are not counted in the window sign area calculation. Refer to BMCC Sec. 27-707(b) Exempt signs, with the exception of BMCC Sec. 27-707(b)(23).
  - d. Temporary Window Signs. Temporary window signs must be included in the total percentage of signage per window calculation.
  - e. Window signs may not be internally illuminated except for neon or similar illuminated window signs.

Window Sign Requirements	
Sign Area	Up to 30% of a set of continuous windows may be covered with signage; No more than 50% of any one window panel may be covered with signage
Height	No maximum
Location on the Building or Site	Permitted on all facades
Placement on the Building or Site	Ground or upper story windows; May be affixed to window or hung/mounted behind glass
Quantity	No maximum quantity, based on window sign area for ground story; 1 per tenant per floor for upper stories
Internal Illumination	Not permitted, except on neon or similarly illuminated window signs
Materials	Drawn, painted, or affixed on the glass; Wood, metal, neon glass, plastic, or other similar materials also permitted

Table 27-1816(k)-1. Window Sign Requirements.

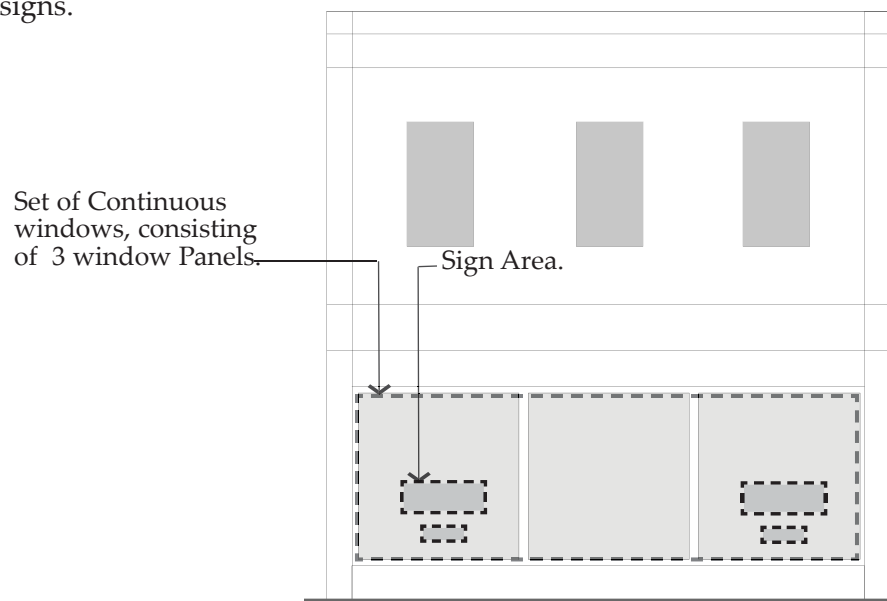

Figure 27-1816(k)-1. Measuring window signs.

# Article 27-1800. East Billings Urban Revitalization District Code

## (l) Monument Sign.

- (1) Description. A monument sign is freestanding; it is located in a front or side yard of a lot. Refer to Figures 27-1816(l)-1 and 27-1816(l)-2.
- (2) General Requirements. Monument signs shall be developed according to the standards in Table 27-1816(l)-1.
  - a.
    - a. Up to two (2) monument signs on one (1) frontage.
    - i. Signs shall be at least one hundred fifty (150) feet apart.
  - b. Display's structure shall be monolithic and fully enclosed.
  - c. Electronic Message Boards. Electronic message boards (EMBs), including such components as light-emitting diodes (LEDs), are permitted on monument signs in the Commerce and Open Frontage Types by-right
  - d. Manually Changeable Copy. The area of any manually changeable copy cannot equal greater than fifty (50) percent of the area of the sign face on which it is located or twenty (20) square feet, whichever is less.
- (3) Sign Area is defined as the entire area within any type of perimeter or border which may enclose the outer limits of any writing, representation, emblem, figure or character. The area of the sign having no such perimeter or border shall be computed by enclosing the entire area with parallelograms, triangles or circles of the smallest size sufficient to cover the entire area of the sign and computing the area of these parallelograms, triangles or circles. The area computed shall be the maximum portion or portions which may be viewed from any one direction
  - a. Measuring Height. Height shall include the sign face, base, cabinet, and ornamental cap.

Monument Sign Requirements	
Sign Area	Maximum 140 sq ft per sign face Refer to Table 27-1816-2 for maximum per lot
Height	Maximum height <del>7'</del> 9'
Location on the Building or Site	Front or corner yards
Placement on the Building or Site	10' Setback from driveways & side lot line; 3' Setback <sup>1</sup> from front & corner lot lines
Quantity	1 per public ROW frontage
Internal Illumination	Permitted
Materials	Solid wood, metal & masonry; Plastic & synthetics permitted on sign face; Electronic Message Board permitted in certain districts <sup>2</sup>

<sup>1</sup>If placed closer than five (5) feet from the front and corner side lot Lines, sign must not be located in a sight triangle extending ten (10) feet from either side of an intersection of a driveway and a vehicular right-of-way or two vehicular rights-of-way.  
<sup>2</sup>Refer to BMCC Sec. 27-1816(d) and 27-1816(l)(2)c for details on Electronic Message Boards

Table 27-1816(l)-1. Monument Sign Requirements.

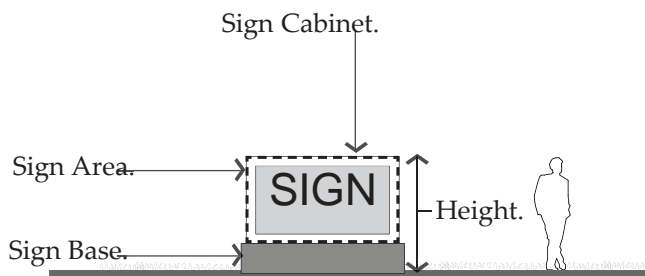

Figure 27-1816(l)-1. Monument Sign.

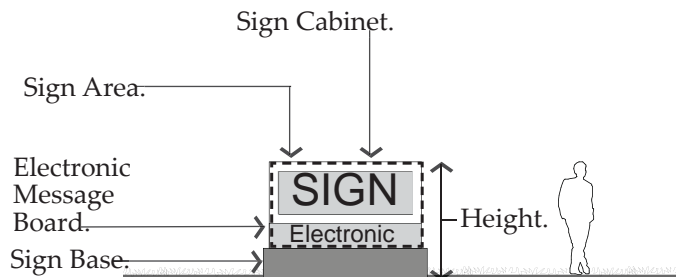

Figure 27-1816(l)-2. Monument Sign with EMB.

# Article 27-1800. East Billings Urban Revitalization District Code

## (m) Ped-Scale Pole-Mounted Sign.

- (1) Description. A ped-scale pole-mounted sign is freestanding and may be mounted on one or two poles. Three (3) configurations are permitted. Refer to Figure 27-1816(m)-1.
  - a. A sign mounted onto a double set of poles.
  - b. A sign mounted on a single pole.
  - c. A sign hanging from a single pole.
- (2) General Requirements. Ped-scale pole-mounted signs shall be developed according to the standards in Table 27-1816(m)-1.
- (3) Computation. The area of a pole-mounted sign is equal to the area of one (1) sign face.

### Ped-Scale Pole-Mounted Sign Requirements

Sign Area	8 sq ft maximum area per sign face; Refer to Table 27-1816-2 for maximum per lot
Height	8' maximum height for sign mounted or hanging on a single pole; 5' for sign mounted on double set of poles; Each pole shall have a maximum diameter of 3 inches
Location on the Building or Site	Front or Corner Yards
Placement on the Building or Site	2' Setback from Front & Corner lot lines; Cannot overhang lot lines
Quantity	1 per lot
Internal Illumination	Permitted
Materials	Solid wood, metal & masonry; Plastic & synthetics permitted on sign face

Table 27-1816(mk)-1. Ped-Scale Pole-Mounted Sign Requirements.

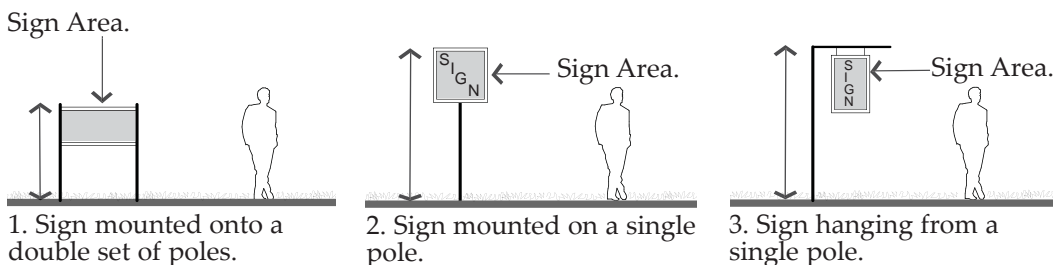

Figure 27-1816(m)-1. Three Types of Ped-Scale Pole-Mounted Signs.

# Article 27-1800. East Billings Urban Revitalization District Code

## (n) Pole-Mounted Sign.

- (1) Description. A pole-mounted sign is freestanding with a one or two-faced sign panel. Three (3) configurations are permitted. Refer to Figure 27-1816(n)-1.
  - a. A sign mounted onto a double set of poles.
  - b. A sign mounted on a single pole.
  - c. A sign hanging from a single pole.
- (2) General Requirements. Pole-mounted signs shall be developed according to the standards in Table 27-1816(n)-1.
  - a. Electronic Message Boards. (Refer to Figure 27-1816(n)-2) Electronic message boards (EMBs), including such components as light-emitting diodes (LEDs), are permitted on pole-mounted signs, provided the following conditions are met:
    - i. The area of the EMB cannot equal greater than forty (40) percent of the area of the sign face on which it is located.
    - ii. One (1) sign containing an EMB is permitted per lot.
    - iii. Refer to BMCC Sec. 27-1816(d) for additional requirements.
  - b. Manually Changeable Copy. The area of any manually changeable copy cannot equal greater than fifty (50) percent of the area of the sign face on which it is located.
  - c. Special Review. Additional height and sign area, per Table 27-1816(n)-1, may be approved by a Special Review under the following conditions.

ii. Street. The sign must front on a Boulevard street

- (3) Computation. The area of a Pole-Mounted sign is equal to the area of one (1) sign face, including the Electronic Message Board.

Pole-Mounted Sign Requirements	
Sign Area	Refer to Table 27-1816-2 for maximum per lot
Height	30' maximum height, not to exceed the height of the principal building
Location on the Building or Site	Front or Corner Yards
Placement on the Building or Site	2' Setback from Front & Corner lot lines; Cannot overhang lot lines
Quantity	1 per lot
Internal Illumination	Permitted
Materials	Solid wood, metal & masonry; Plastic & synthetics permitted on sign face; Electronic Message Board permitted in certain districts <sup>2</sup>

<sup>1</sup>Refer to BMCC Sec. 27-1816(n)(2)c for Special Review conditions.  
<sup>2</sup>Refer to BMCC Sec. 27-1816(d) and 27-1816(n)(2)a for details on Electronic Message Boards

Table 27-1816(n)-1. Pole-Mounted Sign Requirements.

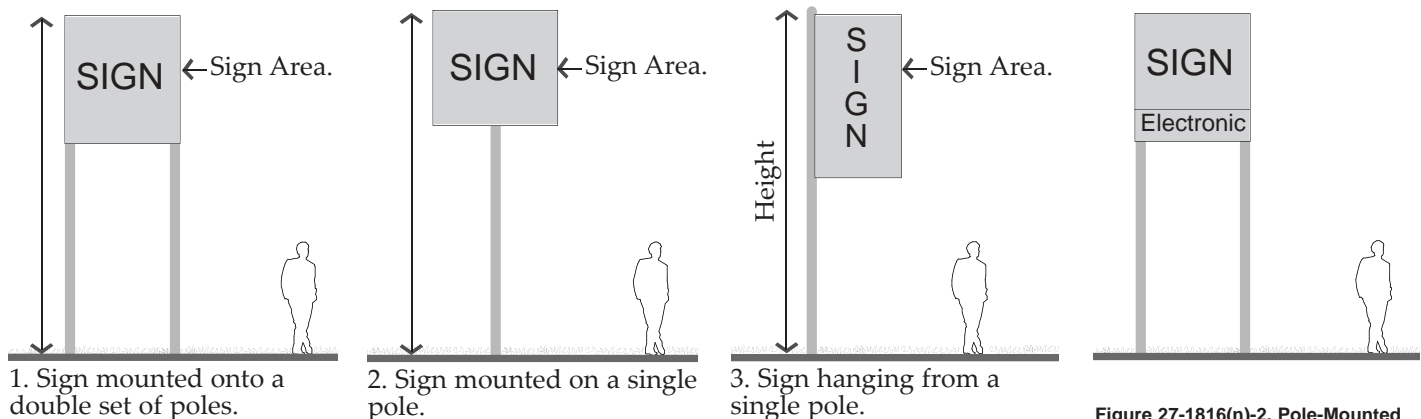

Figure 27-1816(n)-1. Three Types of Pole-Mounted Signs.

Figure 27-1816(n)-2. Pole-Mounted Sign with EMB.

# Article 27-1800. East Billings Urban Revitalization District Code

## (o) Roof Sign

- (1). Description. A roof sign consists of individual letters or elements erected on the roof of a building
  - a. Sign projects above the highest point of the roof line or parapet of the building.
  - b. Typically situated parallel to the adjacent street and does not project beyond the front Facade of the building. Refer to Figures 27-1816(o)-1 and 27-1816(o)-2.
- B. General Requirements. Roof Signs shall be developed according to the standards in Table 27-1816(o)-1.
- C. Sign Area is defined as the entire area within any type of perimeter or border which may enclose the outer limits of any writing, representation, emblem, figure or character. The area of the sign having no such perimeter or border shall be computed by enclosing the entire area with parallelograms, triangles or circles of the smallest size sufficient to cover the entire area of the sign and computing the area of these parallelograms, triangles or circles. The area computed shall be the maximum portion or portions which may be viewed from any one direction.

Roof Sign Requirements	
Sign Area	3 sq ft per 1' building frontage. Refer to Table 27-1816-2 for maximum per lot
Height	Maximum height of letters & elements is 25% of building height.
Location on the Building or Site	Above roof line or parapet.
Placement on the Building or Site	Shall not project beyond the front Facade of the building
Quantity	1 per lot
Illumination	Internal and external illumination permitted.
Materials	Wood, wood substitute, metal, masonry; Plastic & synthetics permitted only as separate alphanumeric characters or logos; Neon glass is permitted provided the neon is not visible from the rear of the sign.

Table 2.5-11(o)-1. Roof Sign Requirements.

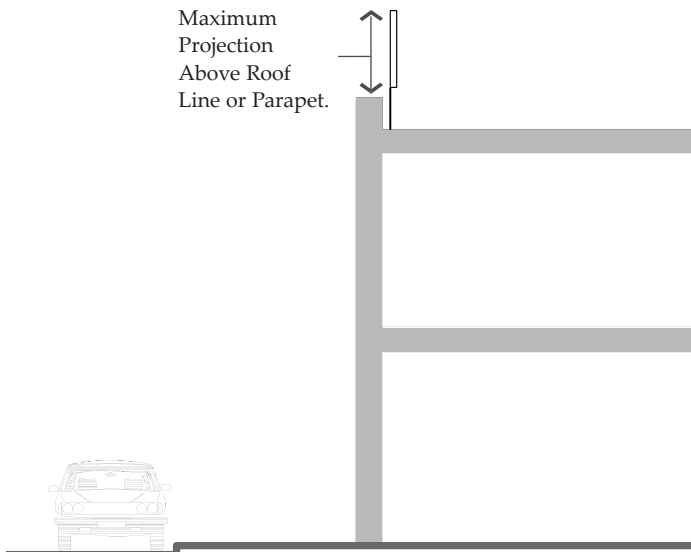

Figure 27-1816(o)-1. Roof Sign.

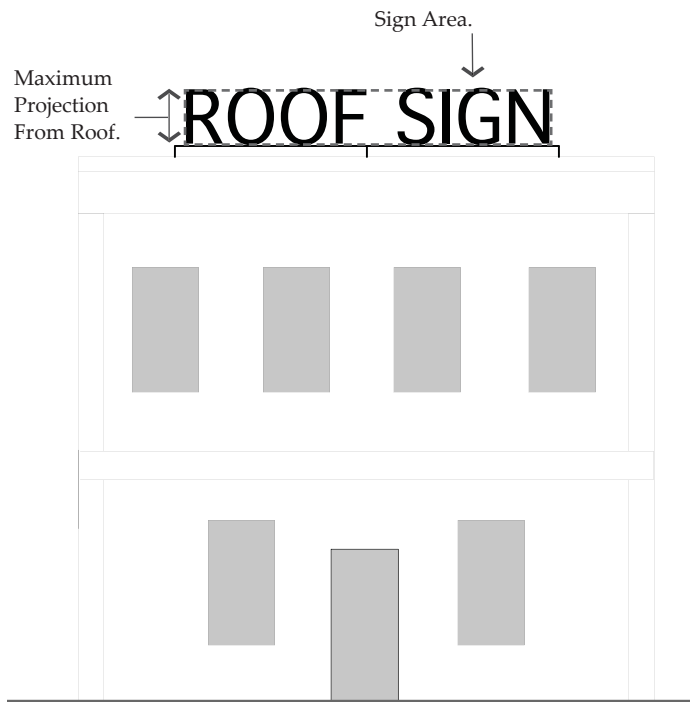

Figure 27-1816(o)-2. Measuring Roof Signs.

# Article 27-1800. East Billings Urban Revitalization District Code

## Sec. 27-1817. Street Type Standards.

### (a) General Requirements.

- (1) Intent. The standards outlined in this section are intended to:
  - a. Create complete streets that address all modes of travel, including pedestrian traffic, bicycle traffic, transit, and vehicular traffic.
  - b. Address all features of the street right-of-way, including sidewalks, parkways, traffic lanes, bicycle lanes, and medians.
  - c. Continue the existing logical and comprehensible system of streets that result in a simple, consistent and understandable pattern of blocks and lots.
  - d. Provide adequate access to all lots for vehicles and pedestrians.
  - e. Create streets that are appropriate for their contexts in residential, commercial, or mixed use districts and are designed to encourage travel at appropriate volumes and speeds.
- (2) Applicability. The standards in this section apply to all vehicular rights-of-way within the EBURD.
- (3) General Requirements. All proposed streets, landscape or furnishings zones, and sidewalks shall be located in dedicated vehicular rights-of-way as required by this article.
  - a. Street Types. All new vehicular rights-of-way shall match one of the street types, refer to BMCC Sec. 27-1817(g) through

27-1817(k), whether publicly dedicated or privately held.

- b. Public Use. All streets shall be available for public use at all times. Gated streets and streets posted as private are not permitted.

- (4) Master Plans. Refer to any adopted City of Billings master plans for additional information, such as the current Bikeway and Trail Master Plan.
- (5) Street Construction Specifications. All construction in the right-of-way shall follow specifications defined by the Department of Public Works, Engineering Division.

### (b) General Street Type Standards.

- (1) Street Types. Street Types defined in this section outline acceptable street configurations. New streets should be designed using the principles and characteristics defined by each Street Type. The Department of Public Works, Engineering Division, or the Montana Department of Transportation, as applicable (refer to Figure 27-1817(e)-2), may require additional right-of-way, pavement width, or additional street elements depending on specific site characteristics.
- (2) Summary Street Type Tables. Table 27-1817(f)-1 summarizes the requirements of each Street Type.
- (3) Graphics. The graphics provided, illustrating each Street Type, are samples of recommendations and illustrate only one possible configuration of that Street Type. By applying the guidelines outlined and working with the Department of Public Works, Engineering Division, other configurations can be determined acceptable.
- (4) Typical Street Elements. Typical elements of a vehicular right-of-way are divided into the vehicular and pedestrian realm. Each Street Type detailed in this article outlines which facilities are applicable. Refer to Figure 27-1817(b)-1: Typical Right-of-Way Elements.
  - a. Vehicular Realm. The vehicular realm is comprised of the travel lanes, bicycle lanes, and parking lanes.
  - b. Pedestrian Realm. The pedestrian realm is comprised of pedestrian facilities, such as sidewalk, path/trail, or off-street bicycle path. A buffer area that serves to

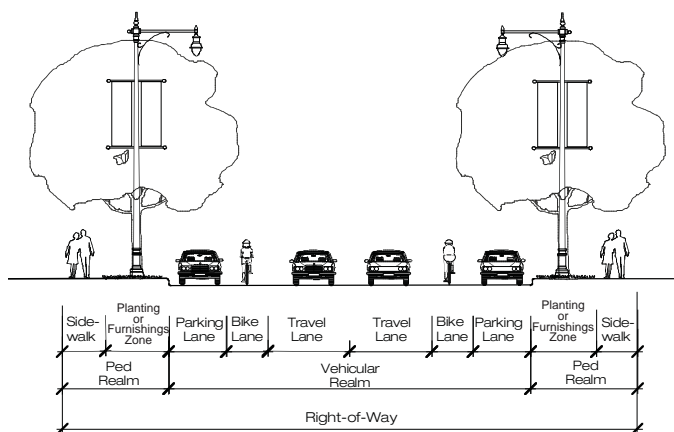

Figure 27-1817(b)-1: Typical Right-of-Way Elements.

# Article 27-1800. East Billings Urban Revitalization District Code

buffer pedestrians or bicyclists from the movements of higher speed vehicles in the vehicular realm shall consist of one of the following:

- i. Landscape Zone. A landscape area between the back of curb to the sidewalk in which street trees, stormwater swales, lighting, and signage may be located. Typically used adjacent to residential ground floor uses.
  - ii. Furnishings Zone. A hardscape area that extends from the sidewalk to the back of curb, in which street trees, street furniture, lighting, and signage may be located. Typically used adjacent to commercial or office ground floor uses.
- (5) Bicycle Facilities. The following types of bicycle accommodations are permitted in the vehicular realm. Refer to Figure 27-1817(b)-2.
- a. Dedicated Bicycle Lane. Dedicated bicycle lanes are striped lanes on the outside of the outermost travel lanes that are designated for only bicycle use. This lane occurs on both sides of the street and shall be four (4) to five (5) feet wide.
  - b. Designated Shared Lane. A designated shared lane is a lane that is shared between vehicles and bicycles. This lane is typically wider than a standard vehicular lane, minimum thirteen (13) feet, in order to accommodate both types of users, and includes a painted bicycle marker combined with a double arrow (known as a “sharrow”). This improvement occurs on both directions.
- c. Shared Lane. A shared lane refers to a street that does not have bicycle lanes or a designated shared lane, but the speed and configuration of the street is such that bicycles could comfortably share lanes with traffic.
  - d. Cycle Track. A cycle track is a separate on-road bike facility that is typically adjacent to, but physically separated from, vehicular traffic and parking by a barrier.
- (6) Vehicular On-Street Parking. On-street parking, as permitted on designated Street Types, must meet the following requirements.
- a. Parallel and back-in diagonal parking is permitted on designated Street Types.
  - b. Vehicular On-Street Parking Space Dimensions.
    - i. The appropriate stall depth for back-in diagonal on-street parking spaces are defined for each Street Type (refer to BMCC Sec. 27-1817(g) through (k).
    - ii. The width of an on-street parking space shall be measured from the center of a stripe, minimum eight and a half (8.5) feet, unless otherwise noted.
    - iii. Back-in diagonal on-street parking shall be at sixty (60) degrees.

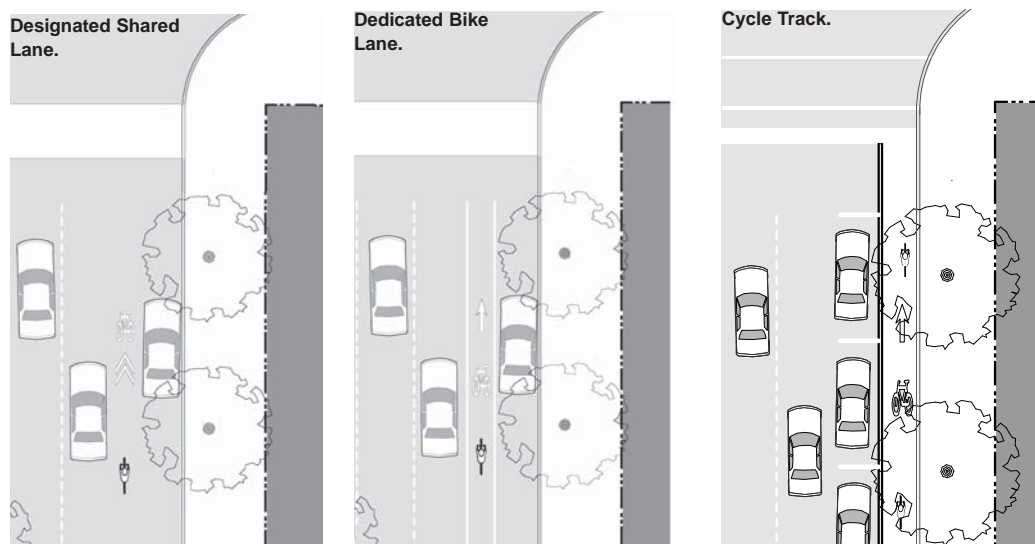

Figure 27-1817(b)-2: On-Street Bicycle Facilities.

# Article 27-1800. East Billings Urban Revitalization District Code

- (7) Stormwater Management. Incorporation of stormwater management best practices into the right-of-way design is encouraged, such as incorporating drainage swales into the landscape zone or permeable paving in the parking lane. Refer to Figure 27-1817(b)-4 and the City's Stormwater Management Manual.
  - (8) Street Trees. Street trees are required along all street frontages, refer to BMCC Sec. 27-1815(e). Street trees shall be located in either a Landscape Zone (within a planting bed or lawn) or a Furnishings Zone (in trees wells with grate as required), refer to BMCC Sec. 27-1817(b)(4)b.
- (c) General Street Layout Requirements. The following standards apply to new streets or newly platted vehicular rights-of-way.
- (1) Interconnected Street Pattern. The network of streets shall form an interconnected pattern with multiple intersections with the following features:
    - a. Street Network. The arrangement of streets shall provide for the continuation of existing streets from adjoining areas into new subdivisions or developments.
    - b. Block Pattern. To the maximum extent possible, the existing block pattern shall be continued and reinforced, and the following encouraged:
      - i. Avoid the closure of existing streets so as to maintain the existing network.
      - ii. As railway tracks are abandoned or larger sites redevelop, new streets should be introduced to extend the existing pattern, incorporating the existing block sizes.
    - c. Bulb shaped cul-de-sac streets are not permitted.
    - d. New deadends should be avoided.
- (d) Intersection Design. The following section outlines the regulations for developing and reconstructing intersections.
- (1) Applicability. The regulations outlined in this section shall apply to all planned intersections and may serve as guidance for reconfiguration of existing intersections.
  - (2) Curb Radii. The following curb radii shall be utilized unless otherwise authorized by the Department of Public Works, Engineering Division.
    - a. Intersections should be designed for actual turning radius of the typical design vehicle as opposed to the maximum design vehicle. Small curb radii at intersections shorten pedestrian crossing distances and reduce vehicle turning speeds, thereby balancing the ease of travel of the vehicles and pedestrians. Refer to Figure 27-1817(d)-1.
    - b. Alley, Neighborhood, and Connector Streets. At the intersection of any street with an Alley, Neighborhood, or a Connector Street, the following curb radii shall be utilized.
      - i. With on-street parking on both streets and no bulb-out, a five (5) foot radius is required.

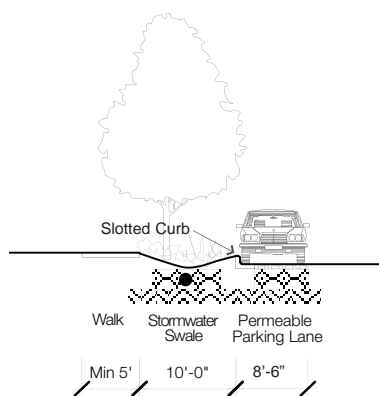

Figure 27-1817(b)-4. Stormwater Management Best Practices incorporated in the Right-of-Way.

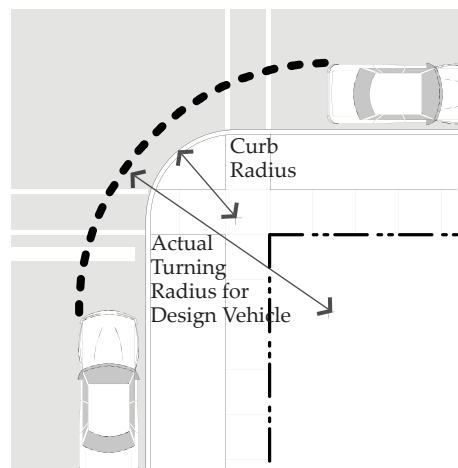

Figure 27-1817(d)-1. Actual Right Turn Radius with On-Street Parking.

# Article 27-1800. East Billings Urban Revitalization District Code

- ii. Without on-street parking, a fifteen (15) foot radius is required.
  - c. Avenues and Boulevards. At the intersection of Avenues with either another Avenue or a Boulevard, the following curb radii shall be utilized.
    - i. With on-street parking on both streets and no bulb-out, a twelve (12) foot radius is required.
    - ii. Without on-street parking on either streets, a twenty five (25) foot radius is required.
  - d. Larger Radius. When the design vehicle requires a larger curb radius, a larger radius may be utilized with approval of the Public Works, Engineering Division.
- (4) Crosswalks. Crosswalks shall be required at all intersections involving Montana Avenue, N 20th Street, and N 13th Street.
  - a. Dimensions. Crosswalks shall be minimum eight (8) feet in width, measured from mid-stripe to mid-stripe, per City standards.
  - b. Markings. Crosswalks shall be appropriately indicated on the finished street surface with painted markings and/or textured or colored pavement.
  - c. Crossing Distances. To encourage pedestrian activity, typical crosswalks shall not extend over thirty-eight (38) feet without a landscape median, bulb-outs, and/or other pedestrian refuge to mitigate the effects of vehicular traffic on crossing and increase pedestrian safety and comfort.
  - d. Bulb-outs. To shorten pedestrian crossing distances, bulb-outs should be utilized at all intersections, unless otherwise required by the Department of Public Works or the Montana Department of Transportation as applicable (refer to Figure 27-1817(e)-2 for State Maintained Routes).
    - i. The depth of the bulb-out shall match the utilized on-street parking, either the width of the parallel space or the depth of the diagonal space.
    - ii. The radius of the bulb-out shall match the requirements for the intersection. Refer to BMCC Sec. 27-1817(d).
- (5) Accessible Ramps and Warning Panels. Accessible ramps and warning panels, per the American Disabilities Act or any more stringent state requirement, are required where all sidewalks or trails terminate at a crosswalk or curb.
  - a. Ramp Orientation. Ramps should be generally oriented perpendicular to traffic, requiring two (2) ramps per corner at intersecting streets.

# Article 27-1800. East Billings Urban Revitalization District Code

- (e) Maps of Street Types. Refer to the maps on the following pages.
- (1) Street Type Map. Refer to Figure 27-1817(e)-1. To provide context for any future platted rights-of-way and guidance for future improvements to existing rights-of-way, existing streets within EBURD are mapped in accordance with the Street Types outlined in BMCC Sec. 27-1817(g) through 27-1817(k).
  - (2) State Maintained Routes. For reference purposes only, a map of routes currently maintained by the State Department of Transportation is included. Refer to Figure 27-1817(e)-2.
  - (3) Primary Street Map. Refer to Figure 27-1817(e)-3.
    - a. Primary Streets are defined as the higher priority street at an intersection, designating the front property line as well as establishing the higher level of pedestrian orientation with limited sidewalk interruptions from driveways.
    - b. At the intersection of any two streets, the street with the highest level designation is considered the Primary Street. For example, at the intersection of 2nd Avenue N and N 19th Street, N 19th Street is designated as Street 1, a higher priority street, and is therefore the Primary Street. The front property line of a building on this corner would be on N 19th Street.
    - c. When a corner is located at the intersection of two streets of the same priority level, either street may be chosen as the Primary Street.





# Article 27-1800. East Billings Urban Revitalization District Code

## Vehicular Realm

	Typical Right-of-Way Width (feet)	Travel Lanes	Lane Width (feet)	Allowable Turn Lanes	Parking Lanes	Pavement Width (feet) Back of Curb to Back of Curb
Alley	20'	1 yield lane	16' (yield)	None	Prohibited	Minimum 16', Maximum 20'
Neighborhood Street	80'	1 yield lane	20' (yield)	None	Parallel or back-in diagonal both sides	37'-48'
Connector	80'	1 lane in each direction	11'	Permitted in place of parking at intersections	Parallel or back-in diagonal both sides	39'-52'
Avenue	80'	Per the Department of Public Works, Engineering Division, or Montana Department of Transportation	12'	Permitted in place of parking at intersections	Parallel or back-in diagonal both sides	41'-54'
Boulevard	80'	Per the Department of Public Works, Engineering Division, or Montana Department of Transportation	11'	Permitted in place of parking at intersections	Both sides, parallel only	50'-60'

Table 27-1817(f)-1: Street Type Summary Table.

(f) Street Type Summary Table.

- (1) Refer to Table 27-1817(f)-1 for a summary table of all Street Types requirements defined in 27-1817(g) through 27-1817(k).

# Article 27-1800. East Billings Urban Revitalization District Code

Vehicular Realm			Pedestrian Realm	
Curbs	Permitted Median	Bicycle Facilities	Pedestrian Facilities	Buffer
None, ribbon or vertical	Prohibited	Shared	Shared	None required
Vertical	Prohibited	Shared	Minimum 5' wide clear sidewalk on both sides	Minimum 11' wide planting zone or furnishings zone, both sides
Vertical	Permitted	Shared, Designated Shared, Dedicated, or Cycle Track	Minimum 5' wide clear sidewalk on both sides	Minimum 9' wide planting or furnishings zone, both sides
Vertical	Permitted	Designated Shared, Dedicated, or Cycle Track	Minimum 5' wide clear sidewalk on both sides	Minimum 8' wide planting zone or furnishings zone, both sides
Vertical	Permitted	Designated Shared, Dedicated, or Cycle Track	Minimum 5' wide clear sidewalk on both sides	Minimum 5' wide planting zone or furnishings zone, both sides

# Article 27-1800. East Billings Urban Revitalization District Code

(g) **Alley.**

- (1) Intent. The Alley is a very low capacity drive located at the rear of parcels. From the Alley, access to parking facilities, loading facilities, and service areas, such as refuse and utilities is possible without a curb cut or driveway interrupting a Street Type. Refer to the typical plan and section in Figure 27-1817(g)-1.
- (2) General Requirements. Alleys shall be developed using the guidelines in Table 27-1817(g)-1.
  - a. The Department of Public Works, Engineering Division, may require additional right-of-way, pavement width, or street elements depending on specific site characteristics.

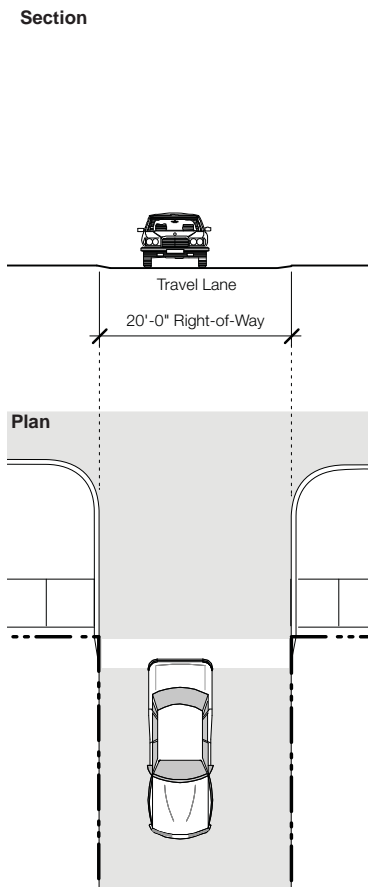

<b>Alley Guidelines</b>	
Location	Permitted adjacent to all Zoning Districts
Typical Right-of-Way Width	20'
<b>a. Vehicular Realm</b>	
Travel Lanes	1 yield lane
Lane Width	Minimum 16' (two way yield lane)
Allowable Turn Lanes	Not applicable
Parking Lanes	Not applicable
Pavement Width	Minimum 16' Maximum 20'
Curbs	None, ribbon, or vertical
Median	Prohibited
Bicycle Facilities <sup>1</sup>	Shared
<b>b. Pedestrian Realm</b>	
Pedestrian Facilities	Shared; travel lanes are shared among drivers, pedestrians and bicyclists
Buffer	None required

<sup>1</sup> Reference BMCC Sec. 27-1817(c)(5) for bicycle facility types and requirements

Figure 27-1817(g)-1: Typical Sample Alley.

Table 27-1817(g)-1: Alley Guidelines.

# Article 27-1800. East Billings Urban Revitalization District Code

## (h) Neighborhood Street.

- (1) Intent. The Neighborhood Street is a low capacity street designed for slow speeds with a standard right-of-way. It primarily serves those residences or businesses directly adjacent to it. Refer to the typical plan and section, Figure 27-1817(h)-1.
- (2) General Requirements. The Neighborhood Street shall be developed using the guidelines in Table 27-1817(h)-1.
  - a. The Department of Public Works, Engineering Division, may require additional right-of-way, pavement width, or street elements depending on specific site characteristics.

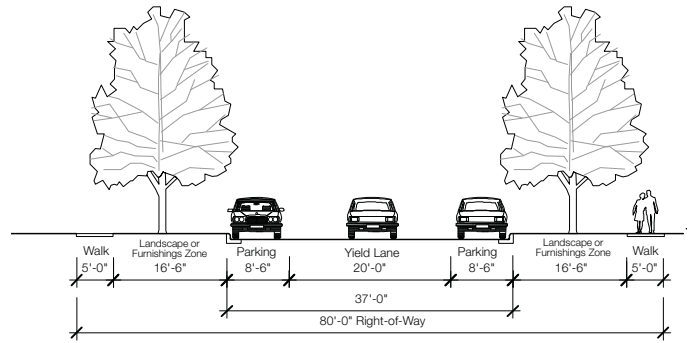

Figure 27-1817(h)-2: Alternative Sample Neighborhood Street.

### Section

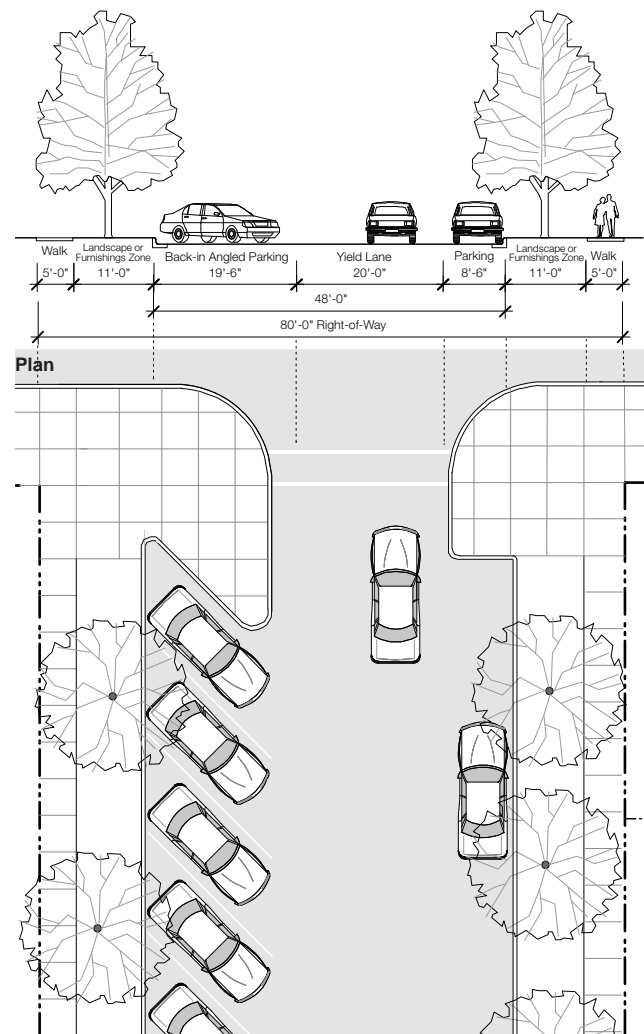

Figure 27-1817(h)-1: Typical Sample Neighborhood Street.

### Neighborhood Street Guidelines

Location	Permitted adjacent to all districts
Typical Right-of-Way Width	80'
<b>a. Vehicular Realm</b>	
Travel Lanes	1 yield lane
Lane Width	20' (two way yield)
Allowable Turn Lanes	Permitted in place of parking and bulb out at intersections
Parking Lanes <sup>1</sup>	Parallel or back-in diagonal on both sides
Pavement Width	37'-48'
Curbs	Vertical
Median	Prohibited
Bicycle Facilities <sup>2</sup>	Shared
<b>b. Pedestrian Realm</b>	
Pedestrian Facilities	Minimum 5 feet wide clear sidewalk on both sides with bulbouts
Buffer	Minimum 11' wide Planting Zone or Furnishings Zone both sides (refer to BMCC Sec. 27-1817((b)(4)b).

<sup>1</sup>Reference BMCC Sec. 27-1817(c)(7) for on-street parking requirements

<sup>2</sup>Reference BMCC Sec. 27-1817(c)(5) for bicycle facility types and requirements

Table 27-1817(h)-1: Neighborhood Street Guidelines.

# Article 27-1800. East Billings Urban Revitalization District Code

## (i) Connector Street.

(1) Intent. The Connector Street is a medium capacity Street for slow speeds with a standard right-of-way. It primarily serves as a through street within the neighborhood and connects Neighborhood Streets to Avenues or Boulevards. Refer to the typical plan and section, Figure 27-1817(i)-1.

(2) General Requirements. Connectors shall be developed using the guidelines in Table 27-1817(i)-1.

a. The Department of Public Works, Engineering Division, may require additional right-of-way, pavement width, or street elements depending on specific site characteristics.

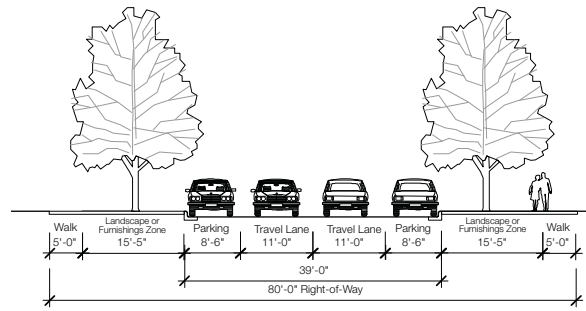

Figure 27-1817(i)-2: Alternative Sample Connector

## Section

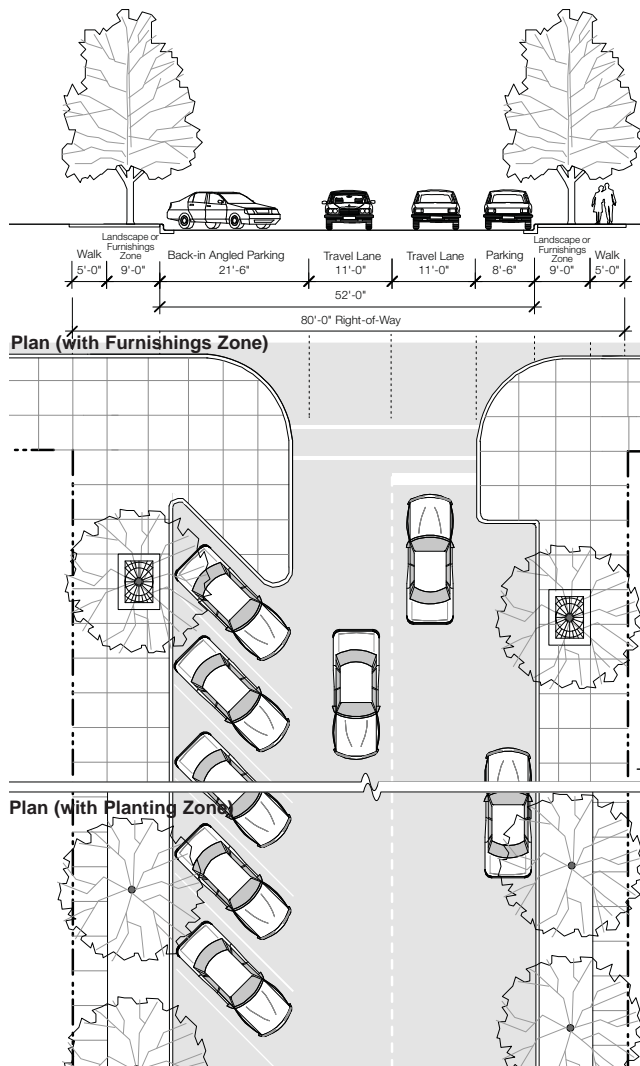

Figure 27-1817(i)-1: Typical Sample Connector.

## Connector Street Guidelines

Location	Permitted adjacent to all districts
Typical Right-of-Way Width	80'
<b>a. Vehicular Realm</b>	
Travel Lanes	1 lane in each direction
Lane Width	11'
Allowable Turn Lanes	Permitted in place of parking and bulb out at intersections
Parking Lanes <sup>1</sup>	Parallel or back-in diagonal both sides
Pavement Width	39'-52'
Curbs	Vertical
Median	Permitted
Bicycle Facilities <sup>2</sup>	Shared, Designated Shared Lane, or Cycle Track
<b>b. Pedestrian Realm</b>	
Pedestrian Facilities	Minimum 5' wide clear sidewalk on both sides with bulbouts
Buffer	Minimum 9' wide landscape zone or furnishings zone, both sides (refer to BMCC Sec. 27-1817((b)(4)b)

<sup>1</sup>Reference BMCC Sec. 27-1817(c)(7) for on-street parking requirements

<sup>2</sup>Reference BMCC Sec. 27-1817(c)(5) for bicycle facility types and requirements

Table 27-1817(i)-1: Connector Guidelines.

# Article 27-1800. East Billings Urban Revitalization District Code

(j) **Avenue.**

- (1) Intent. The Avenue is a high capacity street for higher speeds with a wider right-of-way. It serves all types of development and provides crosstown connections. Refer to the typical plan and section in Figure 27-1817(j)-1.
- (2) General Requirements. Avenues shall be developed using the guidelines in Table 27-1817(j)-1.
  - a. The Department of Public Works, Engineering Division, or Montana Department of Transportation, may require additional right-of-way, pavement width, or street elements depending on specific site characteristics.

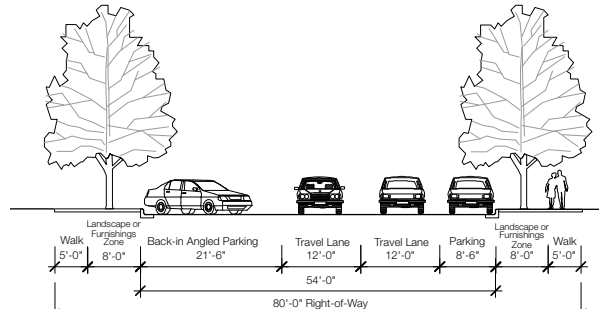
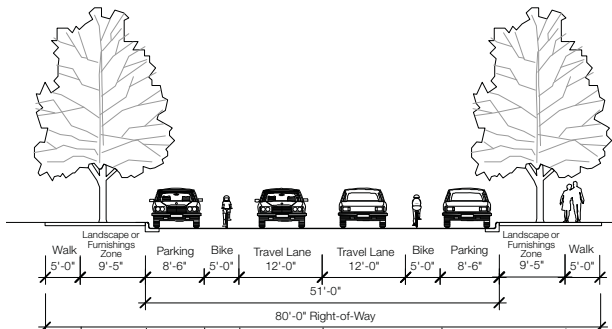

Figure 27-1817(j)-2: Alternative Sample Avenue.

**Section**



**Plan**

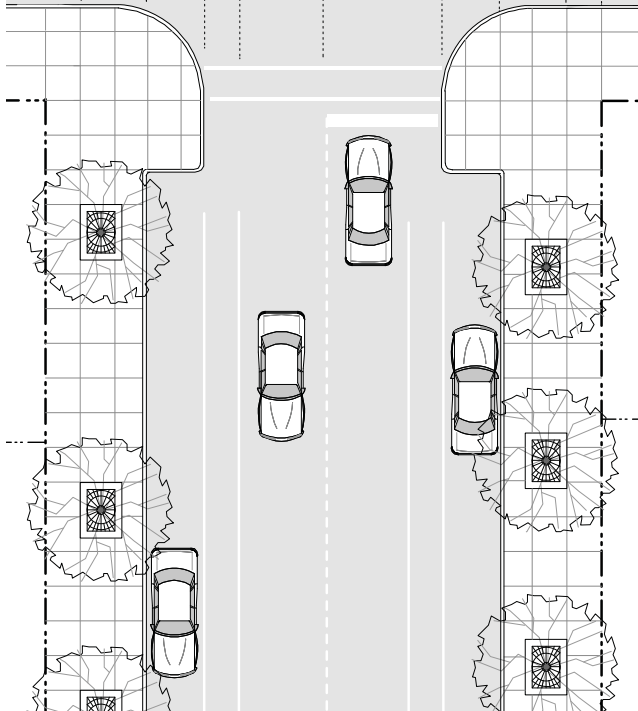

Figure 27-1817(j)-1: Typical Sample Avenue.

**Avenue Guidelines**

Location	Permitted adjacent to all districts
Typical Right-of-Way Width	80'
<b>a. Vehicular Realm</b>	
Travel Lanes	Per the Department of Public Works, Engineering Division, or Montana Department of Transportation
Lane Width	Maximum 12'
Allowable Turn Lanes	Permitted in place of parking at intersections
Parking Lanes <sup>1</sup>	Parallel or back-in diagonal both sides
Pavement Width	41'-54'
Curbs	Vertical
Median	Permitted
Bicycle Facilities <sup>2</sup>	Designated Shared, Dedicated Lane, or Cycle Track
<b>b. Pedestrian Realm</b>	
Pedestrian Facilities	Minimum 5' wide clear sidewalk on both sides with bulbouts
Street Buffer	Minimum 8' wide landscape or furnishings zone, both sides (refer to BMCC Sec. 27-1817((b)(4)b)

<sup>1</sup>Reference BMCC Sec. 27-1817(c)(7) for on-street parking requirements

<sup>2</sup>Reference BMCC Sec. 27-1817(c)(5) for bicycle facility types and requirements

Table 27-1817(j)-1: Avenue Guidelines.

# Article 27-1800. East Billings Urban Revitalization District Code

## (k) Boulevard.

(1) Intent. The Boulevard is a high capacity street for higher speeds with a wider right-of-way, one way only in this case. It serves all types of development and provides crosstown connections. Refer to the typical plan and section, Figure 27-1817(k)-1.

(2) General Requirements. Boulevards shall be developed using the guidelines in Table 27-1817(k)-1.

a. The Department of Public Works, Engineering Division, or Montana Department of Transportation, may require additional right-of-way, pavement width, or street elements depending on specific site characteristics.

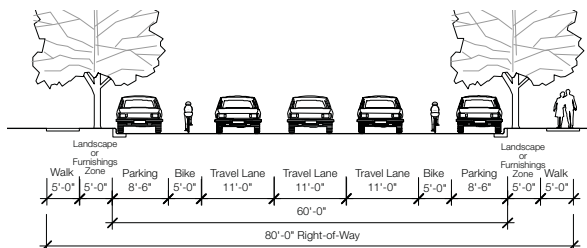

Figure 27-1817(k)-3: Sample One Way Boulevard - 4th Street

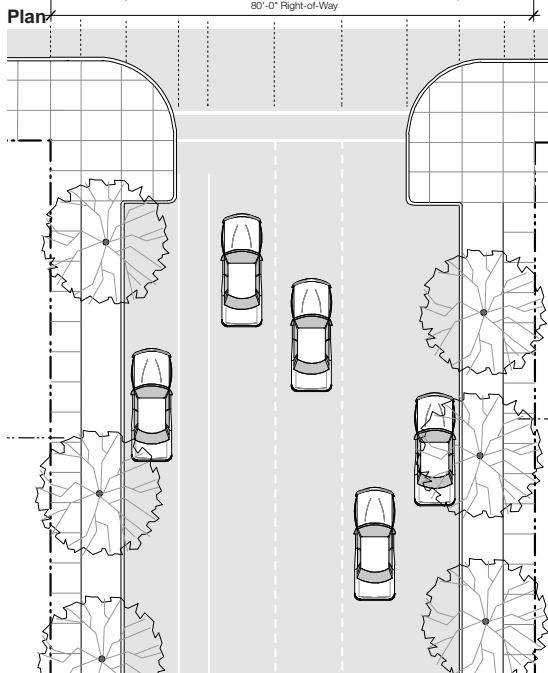
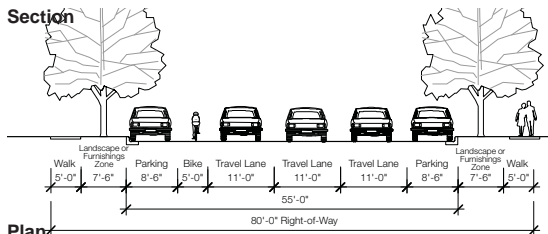

Figure 27-1817(k)-1: Typical Sample One Way Boulevard - 6th Street & Portions of 1st Street

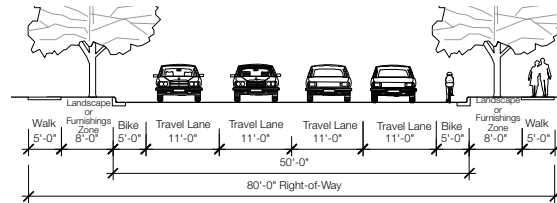

Figure 27-1817(k)-2: Sample Two Way Boulevard

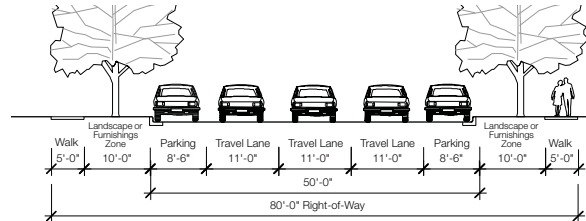

Figure 27-1817(k)-4: Sample One Way Boulevard

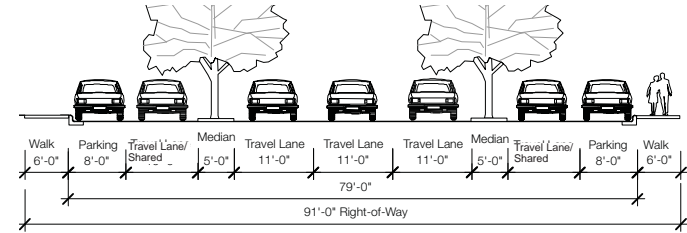

Figure 27-1817(k)-5: Sample One Way Blvd w/Access Rd

### Boulevard Guidelines

Location	Permitted adjacent to all districts
Typical Right-of-Way Width	80'

#### a. Vehicular Realm

Travel Lanes	Per the Department of Public Works, Engineering Division, or Montana Department of Transportation
Lane Width	11'
Allowable Turn Lanes	Permitted in place of parking and bulb out at intersections
Parking Lanes <sup>1</sup>	Both sides, parallel only
Pavement Width	50'-60'
Curbs	Vertical
Median	Permitted, minimum 5' wide, preferably 9' wide
Bicycle Facilities <sup>2</sup>	Designated Shared, Dedicated Lane, or Cycle Track

#### b. Pedestrian Realm

Pedestrian Facilities	Minimum 5' wide clear sidewalk on both sides with bulbouts
Buffer	Minimum 5' wide landscape zone or furnishings zone, both sides (refer to BMCC Sec. 27-1817(b)(4)b)

<sup>1</sup>Reference BMCC Sec. 27-1817(c)(7) for on-street parking requirements

<sup>2</sup>Reference BMCC Sec. 27-1817(c)(5) for bicycle facility types and requirements

Table 27-1817(k)-1: Boulevard Guidelines.