

CITY OF BILLINGS

CITY OF BILLINGS VISION STATEMENT:

**“THE MAGIC CITY: A DIVERSE, WELCOMING COMMUNITY WHERE
PEOPLE PROSPER AND BUSINESS SUCCEEDS.”**

AGENDA

COUNCIL CHAMBERS

October 27, 2014

6:30 P.M.

CALL TO ORDER: Mayor Hanel

PLEDGE OF ALLEGIANCE: Mayor Hanel

INVOCATION: Councilmember Pitman

ROLL CALL: Councilmembers present on roll call were:

MINUTES: October 14, 2014

COURTESIES: Park Department Awards

PROCLAMATIONS:

ADMINISTRATOR REPORTS - TINA VOLEK

PUBLIC COMMENT on “NON-PUBLIC HEARING” Agenda Items: #1 ONLY. Speaker sign-in required. (Comments offered here are limited to one (1) minute. Please sign in at the cart located at the back of the council chambers or at the podium. Comment on items listed as public hearing items will be heard ONLY during the designated public hearing time for each respective item. For Items not on this agenda, public comment will be taken at the end of the agenda.)

1. CONSENT AGENDA -- Separations:

A. Contract for Professional Services with KLJ for design and construction administration of W.O. 15-07, Orchard Lane Reconstruction - King Avenue East to State Avenue (curb and gutter, sidewalk, and street); \$241,000.

- B. Contract for Professional Services** with Sanderson Stewart for design and construction administration of W.O. 15-01, Schedule 3, 2015 Water and Sanitary Sewer Main Replacement Projects (17th Street West from Ave. D to Staples Pump Station north of Rimrock Road); not to exceed \$551,055.
- C. Contract for Professional Services** with Hellas Construction for reconstruction of seven tennis courts in Pioneer and Castlerock Parks; \$57,000.
- D. Contract for Professional Services** with HDR Engineering, Inc., for W.O. 15-10, Water Treatment Plant Chemical Building/Disinfection Improvements; \$1,193,100.
- E. Contract** with Municipal Services Bureau for Court Collection Services (5-year); 27% commission rate on amount collected.
- F. Compensation Agreement** with Trails West Homes for 2,050 feet of 20" water main in 56th Street West south of Grand Avenue; \$403,101.56.
- G. Approval** of Scheduled Airline Operating Agreements and Terminal Building Leases with Alaska/Horizon, Allegiant, Cape Air, Delta, and United Airlines (7/1/13-6/30/19); estimated annual revenue - \$3,000,000.
- H. Recommendation of approval** to the Policy Coordinating Committee for the ZooMontana to Riverfront Park Trail Feasibility Study.
- I. Acknowledging Receipt of Petition to Annex #14-05:** approximately 2.5 acres located at 659 Lincoln Lane in the Billings Heights; Lary and Judy Garrison, owners and petitioners; and setting a public hearing date of November 10, 2014.
- J. Resolution of Intent** to create the downtown Business Improvement District No. 0001 and set a public hearing date for November 24, 2014.
- K. Second/Final Reading Ordinance expanding Ward V (Annexation #14-03 - Shiloh Conservation Area)** for an approximate 69 acres located on the west side of Shiloh Road at the northwest corner of Shiloh Crossing Boulevard and South Shiloh Road; City of Billings, owner.
- L. Preliminary Subsequent Minor Plat** of Amended Lot 9A, Block 9, Circle Fifty Subdivision, generally located on the north side of Avenue C just west of 38th Street West; Tvetene Kenmark, LLC, owner; Mark Allen, managing partner; Meridian Surveying, representing surveyor; conditional approval and adoption of the Findings of Fact.
- M. Bills and Payroll:**

1. September 22, 2014
2. September 29, 2014
3. July 1, 2014 - September 30, 2014 - Municipal Court

REGULAR AGENDA:

2. **PUBLIC HEARING AND FIRST READING ORDINANCE FOR ZONE CHANGE #926:** A zone change from Residential 9,600 to Residential 6,000 on property legally described as Lots 21-24, Block 12, College Subdivision, 3rd Filing, and addressed as 1247 Princeton Avenue; Vaughn and Marla Rohrdanz, owners. Zoning Commission recommends approval of the zone change and adoption of the determinations of the 10 criteria. (Action: approval or disapproval of Zoning Commission recommendation.)
3. **PUBLIC HEARING AND RESOLUTION** approving and adopting First Quarter Budget Amendments for Fiscal Year 2014/2015. Staff recommends approval. (Action: approval or disapproval of staff recommendation.)

PUBLIC COMMENT on Non-Agenda Items -- Speaker Sign-in required. (Restricted to ONLY items not on this printed agenda. Comments here are limited to 3 minutes. Please sign in at the cart located at the back of the council chambers or at the podium.)

COUNCIL INITIATIVES

ADJOURN

Additional information on any of these items is available in the City Clerk's Office.

Reasonable accommodations will be made to enable individuals with disabilities to attend this meeting. Please notify Cari Martin, City Clerk, at 657-8210.

Regular City Council Meeting

Meeting Date: 10/27/2014

TITLE: WO 15-07 Orchard Lane Contract for Professional Services

PRESENTED BY: David Mumford, Public Works Director

Department: Public Works

PROBLEM/ISSUE STATEMENT

The purpose of this project is to reconstruct Orchard Lane from King Avenue East to State Avenue. The typical section will include 2 travel lanes, curb and gutter, and sidewalks on both sides. On-street parking, two-way-left-turn-lane, and on-street bike lanes will be evaluated during design. Staff requested the services of an engineering firm to provide design and construction administration services for the project, and KLJ was selected through the Request for Proposals (RFP) process. Other firms considered were DOWL HKM and Sanderson Stewart. The contract amount is \$241,000.

ALTERNATIVES ANALYZED

The Council may:

- Award the Contract for Professional Services to KLJ; or
- Do not award the contract. If the contract is not awarded, the reconstruction of the road will be delayed.

FINANCIAL IMPACT

The funding for the design is provided by the SBURD TIF and is included in the FY15 budget. The cost of design services is \$241,000.

RECOMMENDATION

Staff recommends that Council authorize the Mayor to execute a Contract for Professional Services with KLJ for \$241,000 for engineering design.

APPROVED BY CITY ADMINISTRATOR

Contract for Professional Engineering Services

Contract for Professional Architectural and Engineering Services

Project Work Order 15-07 Orchard Lane

In consideration of the mutual promises herein, City of Billings and Kadrmas, Lee & Jackson, Inc. agree as follows. This Contract consists of:

Part I, consisting of 15 Sections of Special Provisions;

Part II, consisting of 11 Sections of General Provisions;

Appendix A consisting of 12 pages (Basic Services of Contractor);

Appendix B consisting of 1 page (Methods and Times of Payment);

Appendix C consisting of 1 page (Additional Services of Contractor);

Appendix D consisting of 2 pages (Schedule of Professional Fees);

Appendix E consisting of 1 page (Project Schedule);

Appendix F consisting of 1 page (Certificate(s) of Insurance); and

PART I SPECIAL PROVISIONS

Section 1. Definitions.

In this Contract:

- A. "Administrator" means the City Engineer of the Engineering Division of the Public Works Department or his designee.
- B. "Billings" means the City of Billings.
- C. "Contractor" means Kadrmas, Lee & Jackson, Inc..

Section 2. Scope of Services.

- A. The Contractor shall perform professional services in accordance with Appendix A, which is attached hereto and incorporated in this Section by reference.
- B. Billings shall pay the Contractor in accordance with the Schedule of Professional Fees attached as Appendix D and incorporated herein by reference for services actually performed under this Contract.

- C. Billings shall not allow any claim for services other than those described in this Section. However, the Contractor may provide, at its own expense, any other services that are consistent with this Contract.
- D. The Contractor shall provide as-built drawings on mylars and in digital format, as approved by the City of Billings, to the Administrator within 30 days after the project completion date. Final payment will be withheld until the as-built drawings are received by the City of Billings.
- E. The Contractor shall provide certified construction payrolls to the Administrator stating in writing that the payrolls have been reviewed and are acceptable.

Section 3. Time for Performance.

- A. This Contract becomes effective when signed on behalf of Billings.
- B. The Contractor shall commence performance of the Work described in Section 2 on receipt of written Notice to Proceed and complete that performance in accordance with the schedule set forth in Appendix E.
- C. This Contract shall terminate at midnight on April 30, 2016.

Section 4. Compensation; Method of Payment.

- A. Each month, or at the conclusion of each phase of the Work for which payment is due, as negotiated on a per-task basis, the Contractor shall present a bill to the Administrator describing the Work for which it seeks payment and documenting expenses and fees to the satisfaction of the Administrator. If any payment is withheld because the Contractor's performance is unsatisfactory, the Administrator must, within ten (10) days of the payment denial, notify the Contractor of the payment denial and set forth, with reasonable specificity, what was unsatisfactory and why. Billings will pay Contractor within 30 days of receiving an acceptable invoice.
- B. The Contractor is not entitled to any compensation under this Contract, other than is expressly provided for in this Section.
- C. As a condition of payment, the Contractor shall have paid all City taxes currently due and owing by the Contractor.

Section 5. Termination of the Contractor's Services.

The Contractor's services under Section 2 of this Part may be terminated:

- A. By mutual consent of the parties.
- B. For the convenience of Billings, provided that Billings notifies the Contractor in writing of its intent to terminate under this paragraph at least 10 days prior to the effective date of the termination.
- C. For cause, by either party where the other party fails in any material way to perform its obligations under this Contract. Termination under this Subsection is subject to the condition that the terminating party notifies the other party of its intent to terminate, stating with reasonable specificity the grounds therefor, and the other party fails to cure the default within 30 days after receiving the notice.

Section 6. Duties Upon Termination

- A. If Billings terminates the Contractor's services for convenience, Billings shall pay the Contractor for its actual costs reasonably incurred in performing before termination and Billings shall pay for services rendered prior to termination. Payment under this Subsection shall never exceed the total compensation allowable under Section 4 of this Part. All finished and unfinished documents and materials prepared by the Contractor shall become the property of Billings.
- B. If the Contractor's services are terminated for cause, Billings shall pay the Contractor the reasonable value of the services satisfactorily rendered prior to termination, less any damages suffered by Billings because of the Contractor's failure to perform satisfactorily. The reasonable value of the services rendered shall never exceed ninety percent (90%) of the total compensation allowable under Section 4 of this Part. Any finished or unfinished documents or materials prepared by the Contractor under this Contract shall become the property of Billings at its option.
- C. If the Contractor receives payments exceeding the amount to which it is entitled under Subsections A or B of this Section, he shall remit the excess to the Administrator within 30 days of receiving notice to do so.
- D. The Contractor shall not be entitled to any compensation under this Section until the Contractor has delivered to the Administrator all documents, records, Work product, materials and equipment owned by Billings and requested by the Administrator.
- E. If the Contractor's services are terminated for whatever reason the Contractor shall not claim any compensation under this Contract, other than that allowed under this Section.
- F. If a final audit has not been performed before the Contractor's services are terminated, Billings may recover any payments for costs disallowed as a result of the final audit.
- G. Except as provided in this Section, termination of the Contractor's services under Section 5 of this Part does not affect any other right or obligation of a party under this Contract.

Section 7. Insurance.

- A. The Contractor shall maintain in good standing the insurance described in Subsection B of this Section. Before rendering any services under this Contract, the Contractor shall furnish the Administrator with proof of insurance in accordance with Subsection B of this Section.
- B. The Contractor shall provide the following insurance:
 - 1. Workers' compensation and employer's liability coverage as required by Montana law.
 - 2. Commercial general liability, including contractual and personal injury coverage's -- \$1,500,000 per occurrence.
 - 3. Commercial automobile liability -- \$1,500,000 per accident.
 - 4. Professional liability in the amount of \$1,500,000 per occurrence.

- C. Each policy of insurance required by this Section shall provide for no less than 30 days' advance notice to Billings prior to cancellation.
- D. Billings SHALL be listed as an additional insured on all policies except Professional Liability and Worker's Compensation Policies. In addition, all policies except Professional Liability and Worker's Compensation shall contain a waiver of subrogation against Billings.

Section 8. Assignments.

Unless otherwise allowed by this Contract or in writing by the Administrator, any assignment by the Contractor of its interest in any part of this Contract or any delegation of duties under this Contract shall be void, and an attempt by the Contractor to assign any part of its interest or delegate duties under this Contract shall give Billings the right immediately to terminate this Contract without any liability for Work performed.

Section 9. Ownership; Publication, Reproduction and Use of Material.

- A. Except as otherwise provided herein, all data, documents and materials produced by the Contractor under this Contract shall be the property of Billings, which shall retain the exclusive right to publish, disclose, distribute and otherwise use, in whole or in part, any such data, documents, or other materials. Exclusive rights shall not be attributed to portions of such materials presently in the public domain or which are not subject to copyright. Contractor shall retain rights to pre-existing proprietary property including but not limited to interactive models. The Contractor shall have the right to include photographic or artistic representations of the design and construction of the Project among the Contractor's promotional and professional materials. The Contractor's materials shall not include Billings' confidential or proprietary information regardless of whether Billings has previously advised the Contractor in writing of the specific information considered by Billings to be confidential and proprietary.
- B. Equipment purchased by the Contractor with Contract funds: See Appendix A, Section 3. Scope of Work.
- C. Should Billings elect to reuse Work products provided under this Contract for other than the original project and/or purpose, Billings will indemnify and hold harmless the Contractor from any and all claims, demands and causes of action of any kind or character arising as a result of reusing the documents developed under this contract. Additionally, any reuse of design drawings or specifications provided under this Contract must be limited to conceptual or preliminary use for adaptation, and the original Contractor's or subcontractor's signature, professional seals and dates removed. Such reuse of drawings and specifications, which require professional seals and dates removed, will be signed, sealed, and dated by the professional who is in direct supervisory control and responsible for adaptation.

Section 10. Notices.

Any notice required pertaining to the subject matter of this Contract shall be either sent via facsimile (FAX) or mailed by prepaid first class registered or certified mail, return receipt requested to the following addresses:

Billings: City Engineer (Debi Meling)
City of Billings
Public Works - Engineering
2224 Montana Avenue
Billings, Montana 59101 FAX: (406) 237-6291

Contractor: Carl Jackson
Kadmas, Lee & Jackson Inc.
2611 Gabel Road
Billings, MT 59102 FAX: (855) 288-8055

Notices are effective upon the earlier of receipt, proof of good transmission (facsimiles only), or 5 days after proof of proper posting.

Section 11. Contract Budget.

In connection with its performance under this Contract, the Contractor shall not make expenditures other than as provided in line items in the Contract budget.

Section 12. Force Majeure.

- A. Any failure to perform by either party due to force majeure shall not be deemed a violation or breach hereof.
- B. As used in this Contract, force majeure is an act or event of substantial magnitude, beyond the control of the delayed party, which delays the completion of this Contract, including without limitation:
 - 1. Any interruption, suspension or interference resulting solely from the act of Billings or neglect of Billings not otherwise governed by the terms of this Contract.
 - 2. Strikes or Work stoppages.
 - 3. Any interruption, suspension or interference with the project caused by acts of God, or acts of a public enemy, wars, blockades, insurrections, riots, arrests or restraints of governments and people, civil disturbances or similar occurrences.
 - 4. Order of court, administrative agencies or governmental officers other than Billings.

Section 13. Financial Management System.

The Contractor shall establish and maintain a financial management system that:

- A. Provides accurate, current, and complete disclosure of all financial transactions relating to the Contract;
- B. Maintains separate accounts by source of funds for all revenues and expenditures and identifies the source and application of funds for the Contractor's performance under this Contract, including information pertaining to subcontracts, obligations, unobligated balances, assets, liabilities, outlays and income;
- C. Effectively controls and accounts for all municipal funds and Contract property;

- D. Compares actual expenditures with budgeted amounts and relates financial information to performance or productivity data including unit cost information where applicable;
- E. Allocates administrative costs to direct service delivery units;
- F. Minimizes the time between receipt of funds from Billings and their disbursement by the Contractor;
- G. Provides accounting records supported by source documentation; and
- H. Provides a systematic method assuring the timely and appropriate resolution of audit findings and recommendations.

Section 14. Funding Requirements.

In the event that any funding source for this Contract should impose additional requirements upon Billings for the use of those funds, the Contractor agrees to abide by those additional requirements immediately upon receipt of written notice thereof from Billings.

Section 15. Subcontracts.

The Contractor may enter into subcontracts for the purchase of goods and services necessary for the performance of this Contract, provided:

- A. Every subcontract shall be reduced to writing and contain a precise description of the services or goods to be provided and the nature of the consideration paid therefor.
- B. Every subcontract under which the Contractor delegates the provision of services shall be subject to review and approval by the Administrator before it is executed by the Contractor.
- C. Every subcontract in an amount exceeding \$1,000 shall require reasonable access to business records of the subcontractor relating to the purchase of goods or services pursuant to the subcontract.

PART II
GENERAL CONTRACT PROVISIONS

Section 1. Relationship of Parties.

The Contractor shall perform its obligations hereunder as an independent Contractor of Billings. Billings may administer the Contract and monitor the Contractor's compliance with its obligations hereunder. Billings shall not supervise or direct the Contractor other than as provided in this Section.

Section 2. Nondiscrimination.

- A. The Contractor will not discriminate against any employee or applicant for employment because of race, color, religion, national origin, ancestry, age, sex, or marital status or who is a "qualified individual with a disability" (as that phrase is defined in the Americans With Disabilities Act of 1990). The Contractor will take affirmative action to ensure that applicants are employed and that employees are treated during employment without regard to their race, color, religion, or mental or physical impairment/disability. Such action shall include, without limitation, employment, upgrading, demotion or transfer, recruitment or recruiting advertising, layoff or termination, rates of pay or other forms of compensation, and selection for training including apprenticeship. The Contractor agrees to post, in conspicuous places available to employees and applicants for employment, notices setting forth the provisions of this non-discrimination clause.
- B. The Contractor shall state, in all solicitations or advertisements for employees to Work on Contract jobs, that all qualified applicants will receive equal consideration for employment without regard to race, color, religion, national origin, ancestry, age, sex or marital status, or mental or physical impairment/disability.
- C. The Contractor shall comply with any and all reporting requirements that may apply to it which the City of Billings may establish by regulation.
- D. The Contractor shall include the provisions of Subsections A through C of this Section in every subcontract or purchase order under this Contract, so as to be binding upon every such subcontractor or vendor of the Contractor under this Contract.
- E. The Contractor shall comply with all applicable federal, state, and city laws concerning the prohibition of discrimination.

Section 3. Permits, Laws, and Taxes.

The Contractor shall acquire and maintain in good standing all permits, licenses and other entitlements necessary to its performance under this Contract. All actions taken by the Contractor under this Contract shall comply with all applicable statutes, ordinances, rules and regulations. The Contractor shall pay all taxes pertaining to its performance under this Contract.

Section 4. Nonwaiver.

The failure of either party at any time to enforce a provision of this Contract shall in no way constitute a waiver of the provision, nor in any way affect the validity of this Contract or any part hereof, or the right of such party thereafter to enforce each and every provision hereof.

Section 5. Amendment.

- A. This Contract shall only be amended, modified or changed by a writing, executed by authorized representatives of the parties, with the same formality as this Contract was executed.
- B. For the purposes of any amendment modification or change to the terms and conditions of this Contract, the only authorized representatives of the parties are:

Contractor: Director or Authorized Designee

Billings: City Council or Authorized Designee

- C. Any attempt to amend, modify, or change this Contract by either an unauthorized representative or unauthorized means shall be void.

Section 6. Jurisdiction; Choice of Law.

Any civil action rising from this Contract shall be brought in the District Court for the Thirteenth Judicial District of the State of Montana, Billings. The law of the State of Montana shall govern the rights and obligations of the parties under this Contract.

Section 7. Severability.

Any provision of this Contract decreed invalid by a court of competent jurisdiction shall not invalidate the remaining provisions of the Contract.

Section 8. Integration.

This instrument and all appendices and amendments hereto embody the entire agreement of the parties. There are no promises, terms, conditions or obligations other than those contained herein; and this Contract shall supersede all previous communications, representations or agreements, either oral or written, between the parties hereto.

Section 9. Liability.

The Contractor shall indemnify, defend, save, and hold Billings harmless from any and all claims, causes of action, lawsuits, damages, judgments, liabilities, and litigation costs and expenses including reasonable attorneys' fees and costs, arising from any wrongful or negligent act, error or omission of the Contractor or any agent, employee or subcontractor as a result of the Contractor's or any subcontractor's performance pursuant to this Contract.

- A. The Contractor shall not indemnify, defend, save and hold Billings harmless from claims, causes of action, lawsuits, damages, judgments, liabilities, and litigation costs and expenses or attorneys' fees and costs arising from wrongful or negligent acts, error or omission solely of Billings occurring during the course of or as a result of the performance of the Contract.
- B. Where claims, lawsuits or liability, including attorneys' fees and costs arise from wrongful or negligent act of both Billings and the Contractor, the Contractor shall indemnify, defend, save, and hold Billings harmless from only that portion of claims, causes of action, lawsuits, damages, judgments, liabilities, and litigation costs and expenses including attorneys' fees and costs, which result from the Contractor's or any subcontractor's wrongful or negligent acts occurring as a result from the Contractor's performance pursuant to this Contract.

Section 10. Inspection and Retention of Records.

The Contractor shall, at any time during normal business hours and as often as Billings may deem necessary, make available to Billings, for examination, all of its records with respect to all matters covered by this Contract for a period ending three years after the date the Contractor is to complete performance in accordance with Section 2 of the Special Provisions. Upon request, and within a reasonable time, the Contractor shall submit such other information and reports relating to its activities under this Contract, to Billings, in such form and at such times as Billings may reasonably require. The Contractor shall permit Billings to audit, examine and make copies of such records, and to make audits of all invoices, materials, payrolls, records of personnel, and other data relating to all matters covered by this Contract. Billings may, at its option, permit the Contractor to submit its records to Billings in lieu of the retention requirements of this Section.

Section 11. Availability of Funds.

Payments under this Contract may require funds from future appropriations. If sufficient funds are not appropriated for payments required under this Contract, this Contract shall terminate without penalty to Billings; and Billings shall not be obligated to make payments under this Contract beyond those which have previously been appropriated.

IN WITNESS WHEREOF, the parties have executed this Contract on the date and at the place shown below.

City of Billings

Contractor

City Council or Designee

Date: _____

Name: _____

Title: _____

Date: _____

ATTEST:

IRS Tax ID # _____

City Clerk

APPROVED AS TO FORM:

Date: _____

By _____

BRENT BROOKS, City Attorney

STATE OF MONTANA)
 :ss.
COUNTY OF YELLOWSTONE)

On this ____ day of _____, 20__, before me, the undersigned, a Notary Public for the State of Montana, personally appeared _____, known to me to be the _____ of _____, and acknowledged to me that they executed the foregoing instrument on behalf of said corporation having first been authorized to do so.

IN WITNESS WHEREOF, I have hereunto set my hand and affixed my Notarial Seal the day and year first above written.

Notary Public for the State of Montana
Residing at Billings, Montana
My Commission Expires: _____

Note: Final contract documents will require the Contractor's signature to be notarized.

Appendix A

Basic Services of Engineer

Engineer's Rights and Duties.

- A. To furnish all labor, materials, equipment, supplies, and incidentals necessary to conduct and complete the Engineer's portion of the project as defined in the scope of work and to prepare and deliver to Billings all plans, specifications, bid documents, and other material as designated herein.
- B. Ascertain such information as may have a bearing on the work from local units of government, utility companies, and private organizations and shall be authorized to procure information from other authorities besides Billings, but shall keep Billings advised as to the extent of these contacts and the results thereof.
- C. Prepare and present such information as may be pertinent and necessary in order for Billings to pass critical judgment on the features of the work. The Engineer shall make changes, amendments or revisions in the detail of the work as may be required by Billings. When alternates are being considered, Billings shall have the right of selection.
- D. Engineer's work shall be in accordance with the standards of sound engineering and present City, State, and National standards and policies currently in use.
- E. Conform to the requirements of the Montana Code Annotated Title 18 "Public Contracts" and more particularly Sections 18-2-121 and 18-2-122, and all other codes of the State of Montana applicable to providing professional services including codes and standards nationally recognized.
- F. The Engineer shall certify with the submission of final plans that the plans are in conformance with applicable sections of Title 69, Chapter 4, Part 5, of the Montana Code Annotated as pertaining to existing utilities.
- G. To perform professional services in connection with the project and will serve as Billings' representative in those phases of the project to which this agreement applies.
- H. Where Federal funds are involved, the necessary provisions to meet all requirements will be complied with and documents secured and placed in the bidding documents.
- I. Submit an estimated progress schedule as to time and costs at the beginning of the work, and bi-weekly progress reports thereafter until complete. The reports will include any problems, potential problems, and delays as foreseen by the Engineer. Reports will be submitted in a timely manner to permit prompt resolution of problems.
- J. Name a Task Director who shall be the liaison between Billings and the Engineer. For this project, the Task Director designated for the Engineer is Carl Jackson, PE.

Billings Rights and Duties.

- A. To furnish all labor, materials, equipment, supplies, and incidentals necessary to conduct and complete Billings' portion of the project as designated in the scope of work.
- B. Name a Task Director who shall be the liaison between the Engineer and Billings. For this project, the Task Director designated is Ken Ard, P.E.

Scope of Work.

I. DESCRIPTION

The Orchard Lane reconstruction project entails professional engineering services for design and bidding of Orchard Lane improvements between State Avenue and King Avenue East. In summary, the project consists of design survey and right-of-way mapping, public involvement, preliminary design, final design plans and bidding document preparation. The goal of this project is to reconstruct and widen Orchard Lane between State Avenue and King Avenue East.

The following list summarizes the general objective of this scope of work.

- Engineer's services will primarily entail design of road improvements including widening, curb & gutter, pedestrian facilities, and storm drain.
- Traffic operations analysis is not included. The final cross section will be provided by the City. Posted speed limit will remain. Signalized or alternative intersection design is not included. Existing stop controlled intersections will remain. New pedestrian refuge islands are not anticipated. Postal delivery turn outs are not included.
- The Orchard Lane signalized intersections at State Avenue and King Avenue East will remain as presently constructed with no changes to the traffic signal equipment or operations. Engineer will evaluate approach lane configurations and make recommendations if pavement marking modifications are deemed appropriate. Designing and bidding improvements to State Avenue and King Avenue East is not included.
- On-street parking is to be determined. Depending on the final cross section determination, right-of-way constraints may preclude on-street parking altogether. Engineer's services do not include conducting parking studies. Engineer will not proceed with design until after a parking determination is made.
- At the City's direction, Engineer will incorporate a shared-use path in lieu of sidewalk on one side. Right-of-way constraints may preclude incorporating a shared-use path.
- Impacts to adjacent properties will be minimized and will be identified during preliminary design.
- Existing fences, landscaping or other private property features adjacent to the road will likely be impacted. Since the extent of potential impacts is undetermined, this scope of work does not include design of repairing or replacing adjacent private property features. If required, Engineer's related effort would be considered Additional Services and would be negotiated at a later date. Fences and irrigation systems damaged as a result of the project will be the construction contractor's responsibility to design, relocate and/or reconstruct and will be incorporated as such in Engineer's bid documents. Retaining wall design and construction is not anticipated, and is not

included in this project. Other landscape improvements (gardens, planters, etc.) will be the property owner's responsibility to remove or relocate prior to construction, coordination of which will be the City's responsibility.

- Buffers between pedestrian and vehicular traffic, if applicable, will be paved hardscape. Vegetation establishment is limited to re-seeding grass in properties outside of the typical section that are disturbed by construction. Landscape design, including evaluating and preparing a planting and irrigation plan, is not included.
- The project will be designed and plans produced with AutoCAD and Civil3D software using Engineer's plan preparation (CADD) standards.
- It is anticipated that a subsequent Additional Services agreement will be executed between the City and Engineer for construction staking, on-call construction observation, and project close-out and record drawings.

II. SERVICES TO BE PERFORMED

100 PROJECT MANAGEMENT

Project management addresses and allocates resources on a wide range of activities from conception to completion of a project, including: developing a project work plan and a project team; defining project goals and objectives; specifying tasks and resources; and creating budgets and timelines. The project manager handles all day to day activities and coordination for all actions throughout the duration of the project. The project manager also ensures quality control procedures are on-going throughout the project.

One of the most critical components of project management is communication with the client and project team. Essentially, the project manager is the liaison between external parties and the Engineer team. It is the project manager's responsibility to notify the client of any issues, problems, or concerns regarding the project. The project manager also delegates all activities to the project team and coordinates the progress and completion of these activities. In addition, if any items arise during the duration of the project that are outside this scope of work, the project manager will address them with the City. Ultimately, the project manager is accountable for delivering a successful project.

101 Work Plan

Prepare a work plan to include communication protocol, scope of work, time entry guidelines, schedules, and other guidelines and standards used by the project team.

102 Kick-off Meeting and Project Schedule

Conduct a kick-off meeting to review final task items and establish schedule milestones. At the kick-off meeting the work products and the schedule sequence and information needs will be refined. Following the kick-off meeting, the schedule will be modified to include milestone dates for the major work items. The schedule will be reviewed and adjusted as necessary to incorporate changes in the work concept and progress to-date.

103 Project Coordination

Project coordination will include communication with City staff, Engineer project staff, utility owners, South Billings Urban Renewal District (SBURD) and other stakeholders.

104 Schedule and Budget Monitoring / Progress Reports

Manage the timeline and budget, and prepare invoices and progress reports according to City requirements.

105 Unscheduled Meetings

Attend periodic unscheduled meetings with the City or other stakeholders. Provide meeting documentation. Ten (10) unscheduled meetings are included in Engineer's fee.

106 Milestone Field Reviews

Conduct milestone field reviews with representatives from City of Billings. Time has been included for three (3) field review meetings. The first, following completion of preliminary engineering (30%); the second following City review of the 70% plans and specifications submittal; and the third following submittal of 90% construction documents and prior to bidding. Minutes will be provided for all meetings.

200 PUBLIC INVOLVEMENT

The City will coordinate with news media as needed. The City will develop a landowner mailing list, arrange and facilitate all public meetings, and will coordinate with the City Council and City departments as needed.

201 Landowner Letter

Using the City's mailing list, Engineer will prepare an initial letter to all adjacent property owners as notification that the project is commencing. The letter will request permission to survey private property and also provide contact information should anyone have questions about the project, moving forward.

202 Landowner Coordination Meetings

The Engineer will field calls from property owners. Upon request, Engineer will meet with individual landowners to discuss proposed improvements and probable impacts, and to answer questions. Engineer will provide exhibits and preliminary drawings to assist with the discussion. A record of conversation will be completed for each meeting. Ten (10) individual landowner meetings are included in Engineer's fee.

203 Neighborhood Meetings

Two (2) neighborhood meetings are included to provide a project status update and receive comments from the public. Engineer will provide design exhibits (or sketches) for and attend one meeting at the project onset and a second following the 90% phase. Exhibits will consist of typical roadway sections and plan view drawings, and will be provided on display boards or PowerPoint according to the City's discretion. Preparation of 3-D renderings or similar artistic graphical displays is not included.

300 PRELIMINARY ENGINEERING AND SURVEY

Preliminary engineering and survey tasks are intended to complete the preliminary analysis and design necessary for preparing technical memoranda. Technical memoranda will be provided for project decisions that require action or direction from the City. Design tasks that

do not require action or direction from the City will not begin until 70% design engineering and will not be included in the preliminary engineering phase.

Preliminary design drawings will be conceptual in nature, at the level of detail required to accompany technical memoranda when needed. Engineer will only provide preliminary drawings or sketches of design elements necessary for decisions required by the City; the first complete set of drawings will be submitted following the 70% design stage.

301 Land Ownership Research

Verify the property ownership listing provided to Engineer by the City and include names and addresses on the base drawing. Engineer will document discrepancies and assist with developing a new listing, as required.

302 Right-of-Way Survey and Mapping

Research property boundaries based on plats and certificates of survey obtained from public records. The right-of-way survey is projected to include ties only to existing Public Land Survey System monuments along Orchard Lane in order to allow survey maps on each side to be computed and attached to the base drawing. This procedure is anticipated to be sufficiently accurate to reasonably determine the existing right-of-way and decide if right-of-way acquisition should be evaluated in greater detail. If acquisition is necessary, subject properties likely will require individual surveys and lot lines verified, the work associated with which is not included in this scope of work and will be addressed as Additional Services.

303 Topographic/Design Survey

Complete and furnish preliminary ground survey of project limits to include site contours, existing surface features, and above- and below-ground utilities. Topographic survey will generally be bounded within right-of-way limits, and occasionally beyond as needed to verify grades, adjacent features, and structures. The topographic survey will be accomplished by conventional survey methods. Primary control points will be established as Montana NAD83 (2002) OPUS corrected State Plane Coordinates or City of Billings Coordinates Datum if available. Prior to beginning topographic data collection a level network will be run through all control points and tied to the published City of Billings Vertical Datum. As topographic data is collected an ongoing QC-QA process will verify all data and make sure pertinent features are included on the map.

304 Base Drawing Preparation

Create a base drawing depicting calculated parcel boundaries, topographic survey data, and record drawings provided by the City and other utility owners.

305 Cross Section Alternatives Analysis

The cross section will be determined by the City. After right-of-way limits are defined, the cross section will be evaluated along the corridor. During this time, Engineer will identify areas that preclude the preferred section and also determine if additional features can be considered for the final cross section. This analysis will include consideration of adjacent property impacts, business access, auxiliary lanes, shared-

use paths, bike lanes, accessibility, parking, and impacts from lighting, mailboxes, and utilities.

Engineer will also evaluate adjacent properties for impacts to features such as landscaping, retaining walls, fences, etc. for the City's consideration. This scope of work does not include designing or specifying repairing or replacing adjacent features referenced above that are impacted as a result of the project. If required, these services would be considered extra work and would be negotiated at a later date

It is anticipated that a technical memorandum will be prepared to address the preferred cross section. The technical memorandum will summarize preliminary design results, offer recommendations, and identify action items requiring feedback from the City.

306 Evaluate Existing Utilities

Research and document existing public and privately-owned utilities, and evaluate if existing or potential conflicts necessitate utility relocation. Provide a technical memorandum with conclusions and recommendations. Completion of a Subsurface Utility Engineering (SUE) survey is not included in this scope of work.

307 Geotechnical Evaluation

Engineer's subconsultant will provide geotechnical recommendations, including pavement design and underground utility construction considerations. Engineer will coordinate with the geotechnical engineer to meet project objectives.

400 ENVIRONMENTAL DOCUMENTATION AND PERMITTING

Environmental documentation and permitting is not anticipated, and related services are not included in this scope of work. If required, these services would be considered extra work and would be negotiated at a later date.

500 70% DESIGN ENGINEERING AND REVIEWS

Seventy-percent design engineering and reviews includes design and preliminary construction document preparation, culminating with the City's review and comment period. The intent of this milestone is to finalize any unanswered questions and identify significant changes required by the City prior to proceeding to 90% construction document preparation.

Project decisions, identified during preliminary design that requires written direction from the City, will be finalized prior to commencing with the related tasks below. If the City's subsequent direction requires services that Engineer determines is beyond the scope of work defined below, a contract supplement will be negotiated and approved before proceeding.

It is anticipated that the second public meeting will be held following completion of the City's 70% design review process, prior to commencing with the next stage.

501 Private Utility Coordination

Based on preliminary engineering results, Engineer will coordinate private utility relocations with utility owners, and provide drawings and exhibits as necessary to

show location of proposed improvements. This task includes facilitating one (1) utility coordination meeting to provide technical data and project requirements to utility companies.

502 Pick Up Survey and Base Drawing Updates

Complete additional survey and update the base drawing as required based on preliminary design discoveries and final direction provided by the City.

503 Storm Drain Design

Prepare a preliminary analysis of on-site stormwater facilities to identify if there are any local deficiencies with the on-site system. Evaluate the condition of existing on-site drainage inlets. Evaluate the ability to extend the existing storm drain system to serve all portions of the project as needed and identify any grade constraints. Provide a written summary for City's consideration, giving recommendations for any needed replacements and repairs, summary of sizing for new stormwater infrastructure and recommendation for upgrades to the existing on-site system if needed.

504 Sanitary Sewer Services Design

Approximately 20 new sanitary sewer services will be designed and specified by Engineer, in locations provided by the City. The new services will be shown on the road and storm drain plan and profile drawings.

505 Typical Sections

Develop typical sections based on the preferred cross section verified during preliminary design. Based on a review of the geotechnical report completed by others, and an analysis of the existing pavement condition, segments of the project suitable for pavement overlay will be identified separately from those requiring full-depth reconstruction.

506 Geometric Design

Design horizontal and vertical alignment. Coordinate alignment and grade with storm drain and adjacent property constraints. Evaluate cut sections for impacts to existing utilities, which may create a conflict due to shallow bury depth.

This task also includes grading design at each intersection along the corridor. Intersection grading design will generally stop within approximately 25 feet of the side street curb radius point, or less, to provide adequate transitions necessary for accommodating accessibility ramps and appropriate curb tie-ins.

507 Driveway Design

Evaluate driveways for grades and pedestrian accommodations. If multiple approaches exist at a single property, coordinate with the City and property owner to determine if access can be provided at a single location.

508 Pedestrian Facility Design

Design pedestrian facilities in accordance with local and federal guidelines. Design hardscape buffer when applicable; hardscape buffer will be designed consistently

throughout the project when needed and hardscape design for individual property owners is not included. Evaluate intersections for accessibility accommodations.

509 Typical Sections and Cross Section Drawings

Create typical section and cross section drawings. This task includes the iterative process of evaluating cross sections in detail to design driveway and adjacent property tie-in grades.

510 Road and Storm Drain Plan & Profile Drawings

Create plan & profile drawings showing the proposed roadway and storm drain improvements, as well as other pertinent design elements described herein.

511 Traffic Control Plans

Develop plans for permanent traffic control signs and pavement markings based on local requirements and Manual on Uniform Traffic Control Devices guidelines. Create a sign summary sheet depicting materials, quantities, and locations.

512 Lighting Coordination (Design Not Included)

Existing lighting is assumed to be owned by City of Billings and/or NorthWestern Energy. Although lighting design is not included in this contract, Engineer will coordinate necessary removal or relocation with the owner(s) during the road design process.

513 Detail Drawings

Create detail drawings of intersection grading and other supplemental design information required for construction.

514 Construction Traffic Control Specifications

Engineer will include required construction traffic control provisions in the specifications. Designing construction traffic control plans is not included and will be the contractor's responsibility.

515 Permanent Easements

Determine extents of, and prepare preliminary exhibits depicting locations of, easements required for construction of sidewalks and accessibility ramps. Negotiations for permanent easements will be conducted by the City. Assist the City with easement negotiations.

516 Temporary Construction Easements

Determine extents of, and prepare preliminary exhibits depicting locations of, temporary easements required for construction. Negotiations for temporary construction easements will be conducted by the City. Assist the City with easement negotiations.

517 Technical Specifications and Special Provisions

Prepare draft technical specifications and special provisions for review based on design to-date.

518 Quantities and Opinion of Cost

Complete quantity take-offs and opinion of probable construction cost and provide with the 70% completion submittal.

519 Preliminary Construction Documents Submittal (70% Completion)

Submit construction drawings, special provisions, and opinion of probable cost to the City for review and comment, prior to commencing with additional design.

600 90% DESIGN ENGINEERING AND REVIEWS

It is anticipated that 90% design engineering and reviews tasks will not commence until the preliminary construction documents review meeting is complete, and comments are received from the City accordingly.

The City's 90% design review below is intended to address routine comments or corrections. As such, material changes to the design or drawing format as required by the City should be disclosed during the 70% design review meeting. Engineer does not intend to proceed with 90% design engineering until any question(s) regarding potential material changes is resolved with the City.

601 Private Utility Coordination

Provide revised drawings and exhibits as necessary to show location of proposed improvements. Assist with determining location of relocated utilities, if necessary.

602 Storm Drain Design

Refine storm drain design based on 70% review comments received from the City, and incorporate changes into final construction plans and specifications. Prepare a Comprehensive Drainage Plan in accordance with the City standards to support the sizing and other design decisions for all on-site stormwater facilities constructed with the project.

603 Geometric Design

Refine geometric design based on 70% review comments received from the City, and incorporate changes into final construction plans and specifications.

604 Driveway Design

Refine driveway design based on 70% review comments received from the City, and incorporate changes into final construction plans and specifications.

605 Pedestrian Facility Design

Refine pedestrian facility design based on 70% review comments received from the City, and incorporate changes into final construction plans and specifications.

606 Typical Sections and Cross Section Drawings

Refine typical section and cross section drawings.

607 Road and Storm Drain Plan & Profile Drawings

Refine plan & profile drawings showing the proposed roadway and storm drain improvements, as well as other pertinent design elements described herein.

608 Water Main Plan & Profile Drawings

Refine plan & profile drawings for water main reconstruction.

609 Traffic Control Plans

Refine plans for permanent traffic control signs and pavement markings. Refine the sign summary sheet as necessary.

610 Detail Drawings

Refine detail drawings of intersection grading and other supplemental design information required for construction.

611 Temporary Erosion Control Analysis and Construction Measures

Evaluate the proposed improvements and construction activities for temporary erosion control measures. Incorporate recommended practices in a temporary erosion control plan. Preparing and payment of a MPDES construction permit application is not included.

612 Permanent and Temporary Easements

Finalize easement exhibits. Negotiations for easements will be conducted by the City. Assist the City with easement negotiations.

613 Specifications and Project Manual

Complete the project manual, technical specifications, and special provisions based on the required information to proceed with bidding and construction.

614 Quantities and Opinion of Cost

Update quantity take-offs and opinion of probable construction cost and provide with the 90% completion submittal.

615 Quality Assurance Review

Conduct internal quality assurance review according to Engineer quality assurance and quality control procedures.

616 MT DEQ Submittal and Certification

Prepare a submittal to Montana Department of Environmental Quality as appropriate to utility design. Applicable fees will be paid by the City.

617 Construction Documents Submittal (90% Completion)

Submit construction drawings, special provisions, and opinion of probable cost to the City for review and comment, prior to commencing with preparation of bid documents.

700 100% DESIGN AND BIDDING

701 Final Drawings, Specifications, and Project Manual Revisions

Address comments from 90% completion review. Prepare, review, and seal final bid documents.

702 Final Quantities and Opinion of Construction Cost

After completing final changes to drawings and specifications, and prior to bidding, update the quantity take-offs and opinion of probable construction cost.

703 Prepare Bid Documents

Assemble bid documents and coordinate with the City and other entities required for the advertisement and bidding periods.

704 Bid Assistance

Respond to contractor questions, maintain a plan holders list, and assemble and distribute addenda as appropriate to clarify the contract documents.

705 Conduct Pre-Bid Meeting

Prepare an agenda, facilitate the pre-bid meeting and respond to questions as needed.

706 Attend Bid Opening

Attend the bid opening and collect copies of the bids.

707 Prepare Bid Tabulation and Award Recommendation

Review the bids received, prepare a tabulation of bids, and based on conformance with the contract requirements prepare a Notice of Award recommendation to the City.

708 Prepare and Circulate Contract Documents

Upon dissemination of the Notice of Award assemble, distribute, and coordinate execution of the contract documents.

709 Issue Conformed Drawings and Project Manual

Produce the appropriate number of conformed drawings and project manual copies requested by the City and contractor.

800 RIGHT-OF-WAY

Right-of-way acquisition services are not included in this scope of work. This includes all survey, title work, appraisals, exhibits, legal descriptions and other acquisition services. If required, these services would be considered extra work and would be negotiated at a later date.

900 CONSTRUCTION ADMINISTRATION

Construction administration services are not included in this scope of work. If required, these services would be considered extra work and would be negotiated at a later date.

III. DELIVERABLES

The following deliverables will ultimately be provided by Engineer.

- Meeting minutes and other appropriate documentation
- Meeting display materials
- Technical memoranda
- Comprehensive Drainage Plan at 90% design
- 70%, 90% and final drawings and specifications
- Temporary construction easement descriptions and exhibits
- Quantities and opinion of costs (3 iterations)
- Bid tabulation and award recommendation
- Contract documents
- Conformed drawings and specifications

IV. EXCLUSIONS

This scope of work contains specific information regarding tasks, number of iterations, and deliverables included in the Agreement. Additional services beyond this scope of work are extra and will be addressed as a contract supplement. In addition to those specifically identified in the above tasks, the following list, which is not intended to be exclusive, summarizes exclusions.

- Permits applications other than MT DEQ permit for water main or sanitary sewer construction
- 3-D/Artistic renderings
- Subsurface Utility Engineering
- Design of stormwater detention or treatment facilities
- Analysis of or designing upgrades for off-site stormwater facilities
- Sanitary sewer main analysis and design
- Water distribution system analysis and design
- Hydraulic modeling
- Retaining wall design
- Tasks associated with creating a Special Improvement District (SID) or Special Improvement Light Maintenance District (SILMD)
- Landscaping and irrigation system design
- Structural design
- Traffic analysis, reporting and intersection design other than as indicated above
- Archaeology/Cultural/Historic/etc. impacts research, field work, reporting, and mitigation plans
- Preparation of environmental document, including Categorical Exclusion, Environmental Assessment, or Environmental Impact Statement
- Legal testimony arising out of litigation regarding project decisions
- Record drawings and construction certifications

Appendix B

Methods and Times of Payment

Section 1. Payments for Basic Services.

Billings shall authorize payment to the Engineer for services performed under Appendix A of this Agreement. Partial payment shall be due the Engineer upon receipt of the Engineer's pay estimate, said estimate being proportioned to the work completed by the Engineer.

Partial payment shall be made to the Engineer upon receipt of the Engineer's pay estimate, said estimate being proportioned to the work completed by the Engineer. Billings shall deduct five percent (5%) from each monthly pay estimate to be held until the completion of the final scope of work. The final payment shall be made only after acceptance of final documents by Billings, and determination that the scope of work has been satisfactorily completed.

- A. For services rendered prior to construction, Appendix A, the Engineer shall be paid based upon actual time accrued, but not to exceed the following amounts:

Design Services	\$241,000.00
-----------------	--------------

- B. Final payment shall be the above stated basic fee less all previous payments.

Section 2. Payments for Extra Services when Authorized by Billings.

Requests made or conditions identified by interested groups at the agency or public meetings, which are beyond the scope and intent of this study shall be paid for on an hourly basis at the applicable fees in Appendix D.

Section 3. Corrections.

Costs of Billings work that is required for corrections to the Engineer's work which requires redoing by Billings shall be deducted from any payments due the Engineer, if the Engineer fails to make the required corrections.

Section 4. Fee Increases

For contracts and services that are expected to require more than one (1) year to complete, the above stated basic services payments may be reviewed and adjusted annually by mutual agreement of the parties, based upon documented evidence that the Engineer's costs and hourly rates as shown in Appendix D have increased for all comparable clients.

Appendix C

Additional Services of Engineer

Additional Services of the Engineer will be paid only with written prior authorization by Billings.

1. Field and laboratory testing and reports.
2. Resetting lost or destroyed monuments after construction.
3. Construction inspection.
4. Construction inspection after expiration of the construction contract completion time.
5. Preparation of change orders, which do require additional engineering design or construction review.
6. Requests made or conditions identified by interested groups, which are in excess of basic services.
7. Revisions or additions when such revisions or additions are inconsistent with written approvals or instructions previously given, required by enactment or revisions of codes, laws, or regulations, or are due to other causes not solely within control of the Engineer.
8. As may be requested by Billings, additional design services not included in the original scope of work as outlined in Appendix A.
9. Additional time and/or services resulting from additional requirements imposed by any funding source for use of those funds, as outlined in Part I, Section 14 of this Contract.

Appendix D

Schedule of Professional Fees

Current agreements for engineering services stipulate that the standard hourly rates are subject to review and adjustments. Hourly rates for services effective on the date of this Agreement are included below.

The itemized schedule provided below includes direct labor costs, normal payroll and overhead costs, transportation, furnishing equipment and materials normally required for performance of the work and reasonable profit.

Appendix E

Project Schedule

Based on a written notice to proceed by no later than November 30, 2014, the completion date, including agency reviews, for the Engineer's work through final design shall be:

1. Preliminary Design – April 2015
2. 90% Design Submittal – October 2015
3. Final Design Submittal – January 2016

Delays affecting the completion of the work within the time specified of more than ninety (90) days, not attributable to or caused by the Parties hereto, may be considered as cause for the renegotiation or termination of this Contract.

If the Engineer is behind on this Contract due to no fault of Billings, then the Engineer hereby acknowledges the right of Billings to withhold future Contracts to the Engineer in addition to any other remedy until this Contract is brought back on schedule or otherwise resolved.

Appendix F
Certificates of Insurance

See attached Certificates of Insurance.

Regular City Council Meeting

Meeting Date: 10/27/2014

TITLE: W.O. 15-01, Schedule 3, 17th Street West Water Main Replacement Project Professional Services Contract

PRESENTED BY: David Mumford, Public Works Director

Department: Public Works

PROBLEM/ISSUE STATEMENT

The City Council is asked to consider awarding a professional engineering services contract to Sanderson Stewart in the amount of \$551,055.00 for design, bidding and construction administration services on Schedule 3 of the 2015 Water and Sanitary Sewer Main Replacement projects. The Schedule 3 project consists of approximately 5,500 linear feet of 20-inch water main replacement in 17th Street West from Avenue D to Staples Pump Station, north of Rimrock Road.

Sanderson Stewart was selected based on City staff review of project proposals submitted by prequalified firms. Other firms considered for the work were DOWL HKM and Morrison Maierle, Inc.

The City replaces and upgrades its water utilities as part of an annual maintenance program. As underground water utilities approach the end of their useful life, the City's maintenance costs and potential liabilities from system failures increase. Corroding water main and leaking joints cause water loss and reduced service capacity. Water main breaks often cause public and private property damage.

ALTERNATIVES ANALYZED

City Council may:

- Approve award of the engineering contract to Sanderson Stewart; or
- Do not approve award of the engineering contract to Sanderson Stewart. If the project is not constructed, the City's water distribution system in this area will continue to experience ongoing maintenance problems and expenses.

FINANCIAL IMPACT

Funding for this project has been approved by City Council in the Capital Improvement Program (CIP). Funding is sufficient for the engineering design and construction administration portion of the project which is now under consideration, as well as for the project construction planned for bidding to contractors in April, 2015. The Schedule 3 project will use water funds:

	Water Replacements
Project Budget	\$6,600,000
Previously Encumbered	\$0
This Contract	\$551,055
Budget Remaining	\$6,048,945

RECOMMENDATION

Staff recommends that Council award a professional engineering services contract for the design and construction administration of Schedule 3 of the 2015 Water and Sanitary Sewer Main Replacement Projects to Sanderson Stewart in the amount not to exceed \$551,055.00.

APPROVED BY CITY ADMINISTRATOR

WO 15-01, Sch 3, PES Contract

WO 15-01, Sch 3, PES Contract Appendices

Appendix A

Basic Services of Engineer

W.O. 15-01, Schedule 3, 17th Street West Water Main Replacement Project

Section 1. Engineer's Rights and Duties.

- A. To furnish all labor, materials, equipment, supplies, and incidentals necessary to conduct and complete the Engineer's portion of the project as defined in the scope of work and to prepare and deliver to Billings all plans, specifications, bid documents, and other material as designated herein.
- B. Ascertain such information as may have a bearing on the work from local units of government, utility companies, and private organizations and shall be authorized to procure information from other authorities besides Billings, but shall keep Billings advised as to the extent of these contacts and the results thereof.
- C. Prepare and present such information as may be pertinent and necessary in order for Billings to pass critical judgment on the features of the work. The Engineer shall make changes, amendments or revisions in the detail of the work as may be required by Billings. When alternates are being considered, Billings shall have the right of selection.
- D. Engineer's work shall be in accordance with the standards of sound engineering and present City, State, and National standards and policies currently in use.
- E. Conform to the requirements of the Montana Code Annotated Title 18 "Public Contracts" and more particularly Sections 18-2-121 and 18-2-122, and all other codes of the State of Montana applicable to providing professional services including codes and standards nationally recognized.
- F. The Engineer shall certify with the submission of final plans that the plans are in conformance with applicable sections of Title 69, Chapter 4, Part 5, of the Montana Code Annotated as pertaining to existing utilities.
- G. To perform professional services in connection with the project and will serve as Billings' representative in those phases of the project to which this agreement applies.
- H. Where Federal funds are involved, the necessary provisions to meet all requirements will be complied with and documents secured and placed in the bidding documents.
- I. Submit an estimated progress schedule as to time and costs at the beginning of the work, and monthly progress reports thereafter until complete. The reports will include any problems, potential problems, and delays as foreseen by the Engineer. Reports will be submitted in a timely manner to permit prompt resolution of problems.

- J. Name a Task Director who shall be the liaison between Billings and the Engineer. For this project, the Task Director designated for the Engineer is Mac Fogelsong, PE working under the Principal-in-Charge, Dennis Randall, PE.

Section 2. Billings Rights and Duties.

- A. To furnish all labor, materials, equipment, supplies, and incidentals necessary to conduct and complete Billings' portion of the project as designated in the scope of work.
- B. Name a Task Director who shall be the liaison between the Engineer and Billings. For this project, the Task Director designated is Randy Straus, PE working under the City Engineer, Debi Meling, PE.

Section 3. Scope of Work.

The scope of work covered by this agreement is described hereafter:

The project consists of the design and bidding services for the W.O. 15-01, Schedule 1 - Water Main Replacement which includes one water main within 17th Street West from Avenue D to Rimrock Road to the Staples Pump Station, generally following the existing 20-inch diameter route. An alternate route for the new replacement pipe will be considered in Rimrock Road at the intersection of Rimrock Road/17th Street West east to Radcliffe Drive and then north in Radcliffe Drive, north and west to the Staples Pump Station. Professional services include design of a water main replacement for the existing 20-inch water main, preparation of contract plans and specifications, contract plan and specification interpretation during construction, review of contractor pay estimates, construction staking, and inspection of construction for these water mains more specifically described below. Engineer will coordinate work efforts with other related improvement projects expected to be completed concurrently in the project area.

Phase 100. Project Initiation

- Task 1. Attend meeting with City officials to determine project scope.
- Task 2. Review available information and studies.
- Task 3. Review routes in field walkthrough.
- Task 4. Discuss design basis with the City.

Phase 200. Preliminary Design Services

- Task 1. Project management and coordination
- Task 2. Review alignments with respect to other utilities. Review alignment and replacement route potential in Radcliffe Drive. Review alignment with respect to the existing 16-inch parallel water main in 17th Street West with local contractors for constructability.
- Task 3. Review existing as-built drawings and water service records provided to Sanderson Stewart by the City.
- Task 4. Review work done to date and determine problems with preliminary alignment.

- Task 5. Research existing City, County, State, and Federal studies and reports to determine potential conflicts.
- Task 6. Based on selected City-performed hydrant flow tests, review pipe sizes and/or hydrant lead sizes. Review City master plan for hydrant deficiencies in the project area that may affect design pipe size(s).
- Task 7. Determine locations where additional right-of-way must be secured and coordinate obtaining necessary construction permits if any.
- Task 8. Review existing valve operation near critical intersections to determine if certain valves require replacement. Estimate, based on valve operation, if Contractor will likely experience significant water flows during construction and present information in bidding documents based on findings. City of Billings shall operate all valves.
- Task 9. Assemble existing available plat, certificate of survey, easement and ownership information along the chosen alignment and draw in existing parcels from plats and field survey.
- Task 10. Attend up to six periodic design review meetings with the City and two design review meetings with MDOT personnel (for Rimrock Road east of 17th Street).
- Task 11. Meet with BBWA and Hi-Ditch Officials for ditch crossing requirements. (up to 4 meetings).
- Task 12. Review BBWA Canal Crossing options including boring versus open cut and route across the canal.
- Task 13. Obtain field location of existing utilities and incorporate this information into the construction plans. Utility locates will be requested for the project corridor using the One-Call service and surveyed for the corridor selected by the City.
- Task 14. Perform survey measure downs for existing water, sewer, and storm for 17th Street West from Avenue D to the Staples Pump Station including a portion of Rimrock Road east of 17th Street West, including Radcliffe Drive. Traffic control included for items out-in-traffic areas.
- Task 15. Set control network for 17th Street West from Avenue D to Staples Pump Station, including a portion of Rimrock Road from 17th Street to Radcliffe Drive and Radcliffe Drive to Staples Pump Station.
- Task 16. Property corner search for the area described in Task 15.
- Task 17. Field topographic survey of 17th Street West from Avenue D to Staples Pump Station, including a portion of Rimrock Road from 17th Street to Radcliffe Drive and Radcliffe Drive to Staples Pump

Station. Topographic survey includes up to 4 days of traffic control set-up for 17th Street West.

- Task 18. Geotechnical Investigation of 17th Street West from Avenue D to Staples Pump Station, including a portion of Rimrock Road from 17th Street to Radcliffe Drive and Radcliffe Drive to Staples Pump Station. Begin geotechnical investigation based on alignment as selected by the City. Geotechnical engineering shall include field sampling, laboratory testing and review of subsurface soils to determine appropriate pavement section design alternatives, subgrade treatment, groundwater conditions, and foundations for utility installations. Recommendations associated with crossing the BBWA canal. Recommendations for specific construction materials and groundwater management established in this review will be included in the project plans and specifications. Geotechnical investigation includes traffic control during boring operations. 13 borings about 10 feet deep and two borings 20 feet deep at BBWA Canal.
- Task 19. Miscellaneous geotechnical design review, including geotechnical review of plans and specifications and review of adjacent pipeline/utility stability.
- Task 20. Perform literature review of documented environmental issues (preliminary site analysis) of the project route. No in-field drilling, testing, or environmental sampling is included in this literature review.
- Task 21. Review one trenchless alternate (feasibility level) for replacement of the 20-inch water main in 17th Street West.
- Task 22. Review alternate construction timing methods for the project limits (primarily 17th Street West and/or Rimrock Road). Review of night work/weekend work, 24 hour 7-day a week work hours). Include findings in memorandum with alternate construction methods from Task 21.
- Task 23. Traffic Analysis of 17th Street West from Avenue D to Rimrock Road including Rimrock Road from 17th Street to Radcliffe Drive. Begin analysis and data collection of traffic and related issues to determine if they affect alignment or other design factors. Data collection for up to six (6) impacted intersections in one peak hour (AM or PM).
- Task 24. Design of temporary water system performance specifications for all project areas and flushing design for any 20 to 24-inch diameter water main piping. Review how construction start area affects flushing requirements and project feed water.
- Task 25. Design of temporary private fire suppression system performance specifications as required during construction. Meet with City of Billings Fire Marshall to review affected buildings with fire

- suppression requirements, primarily for commercial businesses along 17th Street West.
- Task 26. Meet with local contractors and suppliers to discuss constructability and traffic control issues.
- Task 27. Identify potential staging areas, disruptions to private access and parking.
- Task 28. Develop a public involvement plan which shall include an educational outreach component and two (2) public informational meetings. Meet with affected businesses/residential owners and present results and provide design charette at one meeting.
- Task 29. Coordinate the identification and potential relocation of private utilities including, overhead and underground power, cable TV, underground telephone and communications, petroleum oil, and natural gas.
- Task 30. Send preliminary construction plans to the private utilities for review and comment, and hold subsequent coordination meetings with the private utilities to assemble and evaluate comments (up to three (3) meetings).
- Task 31. Identify areas to perform subsurface utility "potholing" at identified pipe line or utility crossings to identify specific pipe elevations or private utility locations. Survey said pipe elevations in the field for incorporation into the design. Scope of work assumes Sanderson Stewart will provide a "vacuum" truck via subcontract to remove material in order to survey said utilities. Scope of work includes up to four (4) full 8-hour days of subcontract "potholing". Temporarily backfill holes with cold-mix asphalt. Provide filling of holes during construction by Contractor with hot-mix asphalt. Scope of work includes traffic control.
- Task 32. Meet with City engineering, and public utilities department (PUD) two times for plan review and water service coordination. Attend one meeting with PUD regarding the Staples Pump Station operation and piping connections.
- Task 33. Prepare preliminary traffic control plans and specifications for the project area and submit for review by the City of Billings and MDOT. Coordinate with other City construction projects known in the vicinity of this project.
- Task 34. Quality control review of plans.
- Task 35. Prepare Preliminary Plans and Specifications (70% design level) using all data gathered and input received.
- Task 36. Prepare opinion of probable cost with 15 percent contingency included.
- Task 37. Submit Preliminary Plans and Specifications (70% design level)

for review to all interested parties as determined by the City of Billings and Sanderson Stewart, to include submittals to the BBWA canal and the Hi-Ditch Company.

Phase 200 Deliverables:

Memorandum Discussing Construction Alternate and Scheduling Alternates for project area, Preliminary Geotechnical Report, Preliminary Alignment and Grade Plans (70%), Preliminary Opinion of Probable Cost with 15% contingency; Deliverables include up to five (5) sets of 24x36-inch size preliminary plans and specifications.

Phase 300. Final Design and Bidding Services

- Task 1. Project management, and coordination.
- Task 2. Assemble all preliminary plan review comments and redlines for incorporation into final plans.
- Task 3. Match street restoration grades with proposed development in adjacent properties as required. Design new ADA Ramps where required (Up to 8 ramps).
- Task 4. Coordinate final design with other public utilities within the selected project corridor.
- Task 5. Incorporate recommendations of geotechnical report into final plans and specifications, including the QA/QC recommendations for materials testing during construction.
- Task 6. 17th Street West: Incorporate recommended traffic control plans into final plan set. Plans shall include required detours, required signing, and applicable construction phasing.
- Task 7. Complete final plan and specification sets for submittal, review, and approval by the City of Billings and the Department of Environmental Quality. The City shall pay DEQ review fees direct to DEQ (fees not included in this contract).
- Task 8. Apply for permits, licenses, and approvals necessary to construct the project.
- Task 9. Submittal of two (2) copies of the project specifications, two (2) half-size plan sets, contract-bidding documents, design report and certified water and sewer checklist to Montana Department of Environmental Quality (MDEQ) for approval.
- Task 10. Receive final redline comments from the City and the Department of Environmental Quality and incorporate said comments in final plans and specifications. Final plans and specifications will be prepared in accordance with the Montana Public Works Standard Specifications, Sixth Edition, April 2010 and the current adopted City of Billings Standard Modifications to the Sixth Ed. Stamp and sign all plans and specifications with seal of Professional Engineer in charge.

- Task 11. Calculate bid quantities and prepare bid proposal and contract documents. Update Engineer's Opinion of Probable cost based upon final plan quantities. This scope of work anticipates up to two bid packages—one for a BBWA canal crossing in early Spring of 2015 and a second contract in the summer of 2015 for the remainder of the water main work.
- Task 12. Assist in preparation of bid advertisement and provide documents to prospective bidders and suppliers. Bid advertisement text will be provided to the City for publication. Up to 2 bid packages.
- Task 13. Attend up to two pre-bid meetings.
- Task 14. Answer bid questions and issue addendums as required (assumes up to two contracts).
- Task 15. Attend bid opening, tabulate bids, and make recommendation to the City for award. (Assumes up to two contracts).
- Task 16. Assist in City procurement of final contract agreement, verification of insurance and bonds, and issue notice to proceed. (Assumes up to two contracts).
- Task 17. Quality control review.

Phase 300 Deliverables:

Plans and specifications for review and bidding, Final Opinion of Probable Cost, Bid Tabulations, and Recommendation of Award.

Phase 400. Construction Services and Contract Administration

- Task 1. Project management and coordination.
- Task 2. Schedule and conduct pre-construction conference prior commencement of work at the site. Issue pre-construction meeting minutes to Contractor and City.
- Task 3. Implement and coordinate QA/QC testing program for materials testing developed in the design phase of the project.
- Task 4. Take preconstruction photos of proposed work areas.
- Task 5. Prepare weekly website informational update content for distribution to the City of Billings. Sanderson Stewart will maintain a project website for project construction updates.
- Task 6. Review Contractor shop drawing submittals in conformance with the information given in contract documents. Also review valve requests and temporary water plans. Review does not include review of any dewatering plans, and said review shall not extend to Contractor means, methods, techniques, sequences, or procedures of construction or Contractor safety programs.
- Task 7. Attend weekly construction meetings during construction, including up to 6 meetings for a separate BBWA canal crossing

project.

- Task 8. Make visits to the site at intervals appropriate to various stages of construction to observe as an experienced and qualified design professional the progress of the Contractor's executed work. Visits by Engineer shall be limited to spot checking and similar methods of general observation of the work as assisted by the Resident Project Representative.
- Task 9. Meet as required during construction with businesses and affected residential owners. Provide up to 1.5 hours per week for business or residential meetings for a 150-day construction contract.
- Task 10. Attend random business/public meetings during construction. Up to 2 meetings.
- Task 11. Respond to Contractor requests for information. Issue necessary clarifications and interpretations of the Contract Documents as appropriate consistent with the intent and reasonably inferable from the Contract Documents. Engineer may issue Field Orders authorizing minor variations in the Work from the requirements of the Contract Documents.
- Task 12. Recommend and prepare Change Orders and Work Change Directives to City as appropriate.
- Task 13. Establish schedules, chain-of-command, and communication priorities for all parties involved in construction.
- Task 14. Provide field staking to give the Contractor measurements, lines, locations, and grades necessary for construction. Field staking shall include grade stakes or slope stakes for excavation and fill, subgrade bluetops (if requested), base gravel bluetops (if required), off-sets and grades for the water main and appurtenances thereto, off-sets and grades for manholes and inlets, off-sets for curb and gutter, and miscellaneous concrete replacement (if required).
- Task 15. Coordinate and schedule quality control testing during all phases of construction.
- Task 16. Provide full-time construction observation during construction utilizing a Resident Project Representative (RPR) to assist Engineer in observing progress and quality of the Work assuming a separate 30 calendar day construction contract for a BBWA Canal Crossing Contract and a 120 calendar day construction contract for the remainder of the project work. RPR shall report to Engineer when clarifications and interpretations of the Contract Documents are needed and transmit to Contractor said clarifications and interpretations as issued by Engineer. RPR will prepare daily inspection reports, and daily diaries for the term of construction activity.

In addition to review of major work items, inspection activities shall include general review of traffic control set-up and sediment and erosion control. Major work items include, but are not limited to: water, sanitary sewer, storm drain, irrigation utilities, subgrade preparation, gravel base course preparation, concrete work, paving, signals, lighting, and striping. No night inspection is included in scope of work.

- Task 17. Review and recommend payment and contract requests in accordance with City of Billings format.
- Task 18. Coordinate daily traffic control changes and prepare media releases as required.
- Task 19. Keep track of actual in-place materials, locations, and quantities and transfer to field plans for preparation of record drawings.
- Task 20. Coordinate testing of final water installations and recommend approval or adjustments as necessary.
- Task 21. Conduct final inspection and assist in project closeout. Engineer will provide two (2) paper copies and one (1) pdf file of the record drawings based on record drawings of the Contractor with:
- Offset distances measured from the centerline of the right-of-way to all public water mains.
 - Invert elevations marked for each manhole, structure, and each connection thereto, as well as at the end of each stubbed water main, stubbed water service line and stubbed fire line.
 - Locations of water and sewer services (if any) based on measurements from property lines.
 - Elevations indicating the depth of bury of all public water mains. These elevations shall be shown at each street or right-of-way intersection and at such intervals along the public water mains as may be deemed appropriate by the City Engineer.
 - Permanent bench marks shown.
- Task 22. Prepare reproducible construction record drawings for City of Billings files from records prepared by Contractor.
- Task 23. Conduct one-year inspection with City of Billings staff and Contractor.

Phase 400 Deliverables:

One (1) 11x17-inch set of record drawings submitted to the Department of Environmental Quality, two (2) sets of 24x36-inch record drawings provided to the City of Billings, one (1) set of electronic files (pdf format) provided to the City of Billings, one (1) copy of materials and water main testing records, and final record of project construction cost.

Appendix B

Methods and Times of Payment W.O. 15-01, Schedule 3, 17th Street West Water Main Replacement Project

Section 1. Payments for Basic Services.

Billings shall authorize payment to the Engineer for services performed under Appendix A of this Agreement. Partial payment shall be due the Engineer upon receipt of the Engineer's pay estimate, said estimate being proportioned to the work completed by the Engineer.

Billings shall deduct five percent (5%) from each monthly pay estimate to be held until the completion of the final scope of work. The final payment shall be made only after acceptance of final documents by Billings, and determination that the scope of work has been satisfactorily completed.

- A. For services rendered prior to construction, Appendix A, the Engineer shall be paid based upon actual time accrued, but not to exceed \$551,055.00 (Five Hundred Fifty One Thousand Fifty Five and 00/100 dollars) based on the following tasks:

Phase 100	Project Initiation	<u>\$4,920.00</u>
Phase 200	Preliminary Design	<u>\$210,705.00</u>
Phase 300	Final Design	<u>\$89,520.00</u>
Phase 400	Construction/Contract Administration	<u>\$245,910.00</u>

- B. Final payment shall be the above stated basic fee less all previous payments.

Section 2. Payments for Extra Services when Authorized by Billings.

Work requests made or conditions identified by interested groups at the agency or public meetings which are beyond the scope and intent of this project shall be paid for on an hourly basis at the applicable fees in Appendix D or by an addendum to the agreement.

Section 3. Corrections.

Costs of Billings' work that is required for the purpose of correcting the Engineer's work shall be deducted from any payments due the Engineer if the Engineer fails to make the required corrections.

Section 4. Fee Increases

For contracts and services that are expected to require more than one (1) year to complete, the above stated basic services payments may be reviewed and adjusted annually by mutual agreement of the parties, based upon documented evidence that the Engineer's costs and hourly rates as shown in Appendix D have increased for all comparable clients.

Appendix C

Additional Services of Engineer W.O. 15-01, Schedule 3, 17th Street West Water Main Replacement Project

Extra Services of the Engineer will be paid only with written prior authorization by Billings.

- A. Requests made or conditions identified which are beyond the scope and intent of the services identified under Appendix A.

Appendix D

Schedule of Professional Fees

W.O. 15-01, Schedule 3, 17th Street West Water Main Replacement Project

Current agreements for engineering services stipulate that the standard hourly rates are subject to review and adjustments. Hourly rates for services effective on the date of this Agreement are included below.

The itemized schedule provided below includes direct labor costs, normal payroll and overhead costs, transportation, furnishing equipment and materials normally required for performance of the work and reasonable profit. Direct project costs not itemized herein shall be paid for at actual cost.

Rate changes may be made to the fee schedule by the Engineer to reflect increased salaries and other business costs. Engineer shall submit a revised rate schedule at the time of the change if requested by the Owner. Rate schedule changes made by the Engineer during the term of this Contract shall not alter the maximum project professional fee set forth in the Contract. Changes that alter the maximum project professional fee are covered in Appendix B.

The cost of Professional Liability Insurance coverage is included in the hourly rates of personnel.

CHARGE OUT RATES EFFECTIVE JUNE 1, 2014

At Sanderson Stewart, we strive to provide great customer service and value. While we can offer the traditional method of billing by hourly charge rates, we strongly encourage our current and prospective clients to consider a fixed-fee arrangement in determining your overall project compensation. Fixed-fee projects can result in substantial savings over our posted hourly billing rates and provide a level of certainty at the outset of your project.

STAFF PERSONNEL SERVICES

Expert Witness/Special Consultant	\$ 250.00 /hour
Principal	\$ 180.00 /hour
Senior Engineer	\$ 150.00 /hour
Project Manager	\$ 140.00 /hour
Project Engineer	\$ 105.00 /hour
Staff Engineer	\$ 90.00 /hour
Field Engineer	\$ 90.00 /hour
Engineer Intern	\$ 65.00 /hour
Senior Environmental Scientist	\$ 150.00 /hour
Land Planner/Landscape Architect	\$ 115.00 /hour
Landscape Designer	\$ 80.00 /hour
Senior Professional Land Surveyor	\$ 125.00 /hour
Professional Land Surveyor	\$ 105.00 /hour
Staff Surveyor	\$ 95.00 /hour
Field Survey Technician	\$ 75.00 /hour
Marketing Director	\$ 120.00 /hour
Graphic Artist	\$ 100.00 /hour
Photographer	\$ 180.00 /hour
Designer	\$ 85.00 /hour

Web Developer	\$ 80.00 /hour
CADD Technician	\$ 75.00 /hour
Senior Construction Engineering Technician	\$ 105.00 /hour
Construction Engineering Technician	\$ 75.00 /hour
Construction Inspector	\$ 90.00 /hour
Project Administrator	\$ 65.00 /hour
Administrative/Clerical	\$ 65.00 /hour

SURVEY CREW SERVICES

1-man Crew/2-man Crew	\$ Per Job
-----------------------	------------

OUTSIDE CONSULTANTS

- 1) At cost if independently billed direct to client.
- 2) Cost plus 5% if billed through us.

INDEPENDENT LABORATORIES

- 1) At cost if independently billed direct to client.
- 2) Cost plus 5% if billed through us.

ADMINISTRATIVE EXPENSES

Administrative expenses (including copies, prints, phone, postage, materials, and travel) based on professional services only 3.5% *

* *unless modified by contract*

Appendix E

Project Schedule W.O. 15-01, Schedule 3, 17th Street West Water Main Replacement Project

Based on a notice to proceed by Billings date no later than October 27, 2014, the completion date for the Engineer's work through final design shall be:

1. Preliminary Engineering Services (30% Design): December 12, 2014
2. Preliminary Engineering Services (70% Design): January 30, 2015
3. Preliminary Engineering Services (90% Design): February 27, 2015
4. Final Engineering Services (100% Design): March 16, 2015
5. Construction Services to be based on Contractor Schedule.

Delays affecting the completion of the work within the time specified of more than ninety (90) days, not attributable to or caused by the Parties hereto, may be considered as cause for the renegotiation or termination of this Contract.

If the Engineer is behind on this Contract due to no fault of Billings, then the Engineer hereby acknowledges the right of Billings to withhold future Contracts to the Engineer in addition to any other remedy until this Contract is brought back on schedule or otherwise resolved.

Appendix F

Certificate(s) of Insurance

W.O. 15-01, Schedule 3, 17th Street West Water Main Replacement Project

Attach Certificate(s) of Insurance

Appendix A

Basic Services of Engineer

W.O. 15-01, Schedule 3, 17th Street West Water Main Replacement Project

Section 1. Engineer's Rights and Duties.

- A. To furnish all labor, materials, equipment, supplies, and incidentals necessary to conduct and complete the Engineer's portion of the project as defined in the scope of work and to prepare and deliver to Billings all plans, specifications, bid documents, and other material as designated herein.
- B. Ascertain such information as may have a bearing on the work from local units of government, utility companies, and private organizations and shall be authorized to procure information from other authorities besides Billings, but shall keep Billings advised as to the extent of these contacts and the results thereof.
- C. Prepare and present such information as may be pertinent and necessary in order for Billings to pass critical judgment on the features of the work. The Engineer shall make changes, amendments or revisions in the detail of the work as may be required by Billings. When alternates are being considered, Billings shall have the right of selection.
- D. Engineer's work shall be in accordance with the standards of sound engineering and present City, State, and National standards and policies currently in use.
- E. Conform to the requirements of the Montana Code Annotated Title 18 "Public Contracts" and more particularly Sections 18-2-121 and 18-2-122, and all other codes of the State of Montana applicable to providing professional services including codes and standards nationally recognized.
- F. The Engineer shall certify with the submission of final plans that the plans are in conformance with applicable sections of Title 69, Chapter 4, Part 5, of the Montana Code Annotated as pertaining to existing utilities.
- G. To perform professional services in connection with the project and will serve as Billings' representative in those phases of the project to which this agreement applies.
- H. Where Federal funds are involved, the necessary provisions to meet all requirements will be complied with and documents secured and placed in the bidding documents.
- I. Submit an estimated progress schedule as to time and costs at the beginning of the work, and monthly progress reports thereafter until complete. The reports will include any problems, potential problems, and delays as foreseen by the Engineer. Reports will be submitted in a timely manner to permit prompt resolution of problems.

- J. Name a Task Director who shall be the liaison between Billings and the Engineer. For this project, the Task Director designated for the Engineer is Mac Fogelsong, PE working under the Principal-in-Charge, Dennis Randall, PE.

Section 2. Billings Rights and Duties.

- A. To furnish all labor, materials, equipment, supplies, and incidentals necessary to conduct and complete Billings' portion of the project as designated in the scope of work.
- B. Name a Task Director who shall be the liaison between the Engineer and Billings. For this project, the Task Director designated is Randy Straus, PE working under the City Engineer, Debi Meling, PE.

Section 3. Scope of Work.

The scope of work covered by this agreement is described hereafter:

The project consists of the design and bidding services for the W.O. 15-01, Schedule 1 - Water Main Replacement which includes one water main within 17th Street West from Avenue D to Rimrock Road to the Staples Pump Station, generally following the existing 20-inch diameter route. An alternate route for the new replacement pipe will be considered in Rimrock Road at the intersection of Rimrock Road/17th Street West east to Radcliffe Drive and then north in Radcliffe Drive, north and west to the Staples Pump Station. Professional services include design of a water main replacement for the existing 20-inch water main, preparation of contract plans and specifications, contract plan and specification interpretation during construction, review of contractor pay estimates, construction staking, and inspection of construction for these water mains more specifically described below. Engineer will coordinate work efforts with other related improvement projects expected to be completed concurrently in the project area.

Phase 100. Project Initiation

- Task 1. Attend meeting with City officials to determine project scope.
- Task 2. Review available information and studies.
- Task 3. Review routes in field walkthrough.
- Task 4. Discuss design basis with the City.

Phase 200. Preliminary Design Services

- Task 1. Project management and coordination
- Task 2. Review alignments with respect to other utilities. Review alignment and replacement route potential in Radcliffe Drive. Review alignment with respect to the existing 16-inch parallel water main in 17th Street West with local contractors for constructability.
- Task 3. Review existing as-built drawings and water service records provided to Sanderson Stewart by the City.
- Task 4. Review work done to date and determine problems with preliminary alignment.

- Task 5. Research existing City, County, State, and Federal studies and reports to determine potential conflicts.
- Task 6. Based on selected City-performed hydrant flow tests, review pipe sizes and/or hydrant lead sizes. Review City master plan for hydrant deficiencies in the project area that may affect design pipe size(s).
- Task 7. Determine locations where additional right-of-way must be secured and coordinate obtaining necessary construction permits if any.
- Task 8. Review existing valve operation near critical intersections to determine if certain valves require replacement. Estimate, based on valve operation, if Contractor will likely experience significant water flows during construction and present information in bidding documents based on findings. City of Billings shall operate all valves.
- Task 9. Assemble existing available plat, certificate of survey, easement and ownership information along the chosen alignment and draw in existing parcels from plats and field survey.
- Task 10. Attend up to six periodic design review meetings with the City and two design review meetings with MDOT personnel (for Rimrock Road east of 17th Street).
- Task 11. Meet with BBWA and Hi-Ditch Officials for ditch crossing requirements. (up to 4 meetings).
- Task 12. Review BBWA Canal Crossing options including boring versus open cut and route across the canal.
- Task 13. Obtain field location of existing utilities and incorporate this information into the construction plans. Utility locates will be requested for the project corridor using the One-Call service and surveyed for the corridor selected by the City.
- Task 14. Perform survey measure downs for existing water, sewer, and storm for 17th Street West from Avenue D to the Staples Pump Station including a portion of Rimrock Road east of 17th Street West, including Radcliffe Drive. Traffic control included for items out-in-traffic areas.
- Task 15. Set control network for 17th Street West from Avenue D to Staples Pump Station, including a portion of Rimrock Road from 17th Street to Radcliffe Drive and Radcliffe Drive to Staples Pump Station.
- Task 16. Property corner search for the area described in Task 15.
- Task 17. Field topographic survey of 17th Street West from Avenue D to Staples Pump Station, including a portion of Rimrock Road from 17th Street to Radcliffe Drive and Radcliffe Drive to Staples Pump

Station. Topographic survey includes up to 4 days of traffic control set-up for 17th Street West.

- Task 18. Geotechnical Investigation of 17th Street West from Avenue D to Staples Pump Station, including a portion of Rimrock Road from 17th Street to Radcliffe Drive and Radcliffe Drive to Staples Pump Station. Begin geotechnical investigation based on alignment as selected by the City. Geotechnical engineering shall include field sampling, laboratory testing and review of subsurface soils to determine appropriate pavement section design alternatives, subgrade treatment, groundwater conditions, and foundations for utility installations. Recommendations associated with crossing the BBWA canal. Recommendations for specific construction materials and groundwater management established in this review will be included in the project plans and specifications. Geotechnical investigation includes traffic control during boring operations. 13 borings about 10 feet deep and two borings 20 feet deep at BBWA Canal.
- Task 19. Miscellaneous geotechnical design review, including geotechnical review of plans and specifications and review of adjacent pipeline/utility stability.
- Task 20. Perform literature review of documented environmental issues (preliminary site analysis) of the project route. No in-field drilling, testing, or environmental sampling is included in this literature review.
- Task 21. Review one trenchless alternate (feasibility level) for replacement of the 20-inch water main in 17th Street West.
- Task 22. Review alternate construction timing methods for the project limits (primarily 17th Street West and/or Rimrock Road). Review of night work/weekend work, 24 hour 7-day a week work hours). Include findings in memorandum with alternate construction methods from Task 21.
- Task 23. Traffic Analysis of 17th Street West from Avenue D to Rimrock Road including Rimrock Road from 17th Street to Radcliffe Drive. Begin analysis and data collection of traffic and related issues to determine if they affect alignment or other design factors. Data collection for up to six (6) impacted intersections in one peak hour (AM or PM).
- Task 24. Design of temporary water system performance specifications for all project areas and flushing design for any 20 to 24-inch diameter water main piping. Review how construction start area affects flushing requirements and project feed water.
- Task 25. Design of temporary private fire suppression system performance specifications as required during construction. Meet with City of Billings Fire Marshall to review affected buildings with fire

- suppression requirements, primarily for commercial businesses along 17th Street West.
- Task 26. Meet with local contractors and suppliers to discuss constructability and traffic control issues.
- Task 27. Identify potential staging areas, disruptions to private access and parking.
- Task 28. Develop a public involvement plan which shall include an educational outreach component and two (2) public informational meetings. Meet with affected businesses/residential owners and present results and provide design charette at one meeting.
- Task 29. Coordinate the identification and potential relocation of private utilities including, overhead and underground power, cable TV, underground telephone and communications, petroleum oil, and natural gas.
- Task 30. Send preliminary construction plans to the private utilities for review and comment, and hold subsequent coordination meetings with the private utilities to assemble and evaluate comments (up to three (3) meetings).
- Task 31. Identify areas to perform subsurface utility "potholing" at identified pipe line or utility crossings to identify specific pipe elevations or private utility locations. Survey said pipe elevations in the field for incorporation into the design. Scope of work assumes Sanderson Stewart will provide a "vacuum" truck via subcontract to remove material in order to survey said utilities. Scope of work includes up to four (4) full 8-hour days of subcontract "potholing". Temporarily backfill holes with cold-mix asphalt. Provide filling of holes during construction by Contractor with hot-mix asphalt. Scope of work includes traffic control.
- Task 32. Meet with City engineering, and public utilities department (PUD) two times for plan review and water service coordination. Attend one meeting with PUD regarding the Staples Pump Station operation and piping connections.
- Task 33. Prepare preliminary traffic control plans and specifications for the project area and submit for review by the City of Billings and MDOT. Coordinate with other City construction projects known in the vicinity of this project.
- Task 34. Quality control review of plans.
- Task 35. Prepare Preliminary Plans and Specifications (70% design level) using all data gathered and input received.
- Task 36. Prepare opinion of probable cost with 15 percent contingency included.
- Task 37. Submit Preliminary Plans and Specifications (70% design level)

for review to all interested parties as determined by the City of Billings and Sanderson Stewart, to include submittals to the BBWA canal and the Hi-Ditch Company.

Phase 200 Deliverables:

Memorandum Discussing Construction Alternate and Scheduling Alternates for project area, Preliminary Geotechnical Report, Preliminary Alignment and Grade Plans (70%), Preliminary Opinion of Probable Cost with 15% contingency; Deliverables include up to five (5) sets of 24x36-inch size preliminary plans and specifications.

Phase 300. Final Design and Bidding Services

- Task 1. Project management, and coordination.
- Task 2. Assemble all preliminary plan review comments and redlines for incorporation into final plans.
- Task 3. Match street restoration grades with proposed development in adjacent properties as required. Design new ADA Ramps where required (Up to 8 ramps).
- Task 4. Coordinate final design with other public utilities within the selected project corridor.
- Task 5. Incorporate recommendations of geotechnical report into final plans and specifications, including the QA/QC recommendations for materials testing during construction.
- Task 6. 17th Street West: Incorporate recommended traffic control plans into final plan set. Plans shall include required detours, required signing, and applicable construction phasing.
- Task 7. Complete final plan and specification sets for submittal, review, and approval by the City of Billings and the Department of Environmental Quality. The City shall pay DEQ review fees direct to DEQ (fees not included in this contract).
- Task 8. Apply for permits, licenses, and approvals necessary to construct the project.
- Task 9. Submittal of two (2) copies of the project specifications, two (2) half-size plan sets, contract-bidding documents, design report and certified water and sewer checklist to Montana Department of Environmental Quality (MDEQ) for approval.
- Task 10. Receive final redline comments from the City and the Department of Environmental Quality and incorporate said comments in final plans and specifications. Final plans and specifications will be prepared in accordance with the Montana Public Works Standard Specifications, Sixth Edition, April 2010 and the current adopted City of Billings Standard Modifications to the Sixth Ed. Stamp and sign all plans and specifications with seal of Professional Engineer in charge.

- Task 11. Calculate bid quantities and prepare bid proposal and contract documents. Update Engineer's Opinion of Probable cost based upon final plan quantities. This scope of work anticipates up to two bid packages—one for a BBWA canal crossing in early Spring of 2015 and a second contract in the summer of 2015 for the remainder of the water main work.
- Task 12. Assist in preparation of bid advertisement and provide documents to prospective bidders and suppliers. Bid advertisement text will be provided to the City for publication. Up to 2 bid packages.
- Task 13. Attend up to two pre-bid meetings.
- Task 14. Answer bid questions and issue addendums as required (assumes up to two contracts).
- Task 15. Attend bid opening, tabulate bids, and make recommendation to the City for award. (Assumes up to two contracts).
- Task 16. Assist in City procurement of final contract agreement, verification of insurance and bonds, and issue notice to proceed. (Assumes up to two contracts).
- Task 17. Quality control review.

Phase 300 Deliverables:

Plans and specifications for review and bidding, Final Opinion of Probable Cost, Bid Tabulations, and Recommendation of Award.

Phase 400. Construction Services and Contract Administration

- Task 1. Project management and coordination.
- Task 2. Schedule and conduct pre-construction conference prior commencement of work at the site. Issue pre-construction meeting minutes to Contractor and City.
- Task 3. Implement and coordinate QA/QC testing program for materials testing developed in the design phase of the project.
- Task 4. Take preconstruction photos of proposed work areas.
- Task 5. Prepare weekly website informational update content for distribution to the City of Billings. Sanderson Stewart will maintain a project website for project construction updates.
- Task 6. Review Contractor shop drawing submittals in conformance with the information given in contract documents. Also review valve requests and temporary water plans. Review does not include review of any dewatering plans, and said review shall not extend to Contractor means, methods, techniques, sequences, or procedures of construction or Contractor safety programs.
- Task 7. Attend weekly construction meetings during construction, including up to 6 meetings for a separate BBWA canal crossing

project.

- Task 8. Make visits to the site at intervals appropriate to various stages of construction to observe as an experienced and qualified design professional the progress of the Contractor's executed work. Visits by Engineer shall be limited to spot checking and similar methods of general observation of the work as assisted by the Resident Project Representative.
- Task 9. Meet as required during construction with businesses and affected residential owners. Provide up to 1.5 hours per week for business or residential meetings for a 150-day construction contract.
- Task 10. Attend random business/public meetings during construction. Up to 2 meetings.
- Task 11. Respond to Contractor requests for information. Issue necessary clarifications and interpretations of the Contract Documents as appropriate consistent with the intent and reasonably inferable from the Contract Documents. Engineer may issue Field Orders authorizing minor variations in the Work from the requirements of the Contract Documents.
- Task 12. Recommend and prepare Change Orders and Work Change Directives to City as appropriate.
- Task 13. Establish schedules, chain-of-command, and communication priorities for all parties involved in construction.
- Task 14. Provide field staking to give the Contractor measurements, lines, locations, and grades necessary for construction. Field staking shall include grade stakes or slope stakes for excavation and fill, subgrade bluetops (if requested), base gravel bluetops (if required), off-sets and grades for the water main and appurtenances thereto, off-sets and grades for manholes and inlets, off-sets for curb and gutter, and miscellaneous concrete replacement (if required).
- Task 15. Coordinate and schedule quality control testing during all phases of construction.
- Task 16. Provide full-time construction observation during construction utilizing a Resident Project Representative (RPR) to assist Engineer in observing progress and quality of the Work assuming a separate 30 calendar day construction contract for a BBWA Canal Crossing Contract and a 120 calendar day construction contract for the remainder of the project work. RPR shall report to Engineer when clarifications and interpretations of the Contract Documents are needed and transmit to Contractor said clarifications and interpretations as issued by Engineer. RPR will prepare daily inspection reports, and daily diaries for the term of construction activity.

In addition to review of major work items, inspection activities shall include general review of traffic control set-up and sediment and erosion control. Major work items include, but are not limited to: water, sanitary sewer, storm drain, irrigation utilities, subgrade preparation, gravel base course preparation, concrete work, paving, signals, lighting, and striping. No night inspection is included in scope of work.

- Task 17. Review and recommend payment and contract requests in accordance with City of Billings format.
- Task 18. Coordinate daily traffic control changes and prepare media releases as required.
- Task 19. Keep track of actual in-place materials, locations, and quantities and transfer to field plans for preparation of record drawings.
- Task 20. Coordinate testing of final water installations and recommend approval or adjustments as necessary.
- Task 21. Conduct final inspection and assist in project closeout. Engineer will provide two (2) paper copies and one (1) pdf file of the record drawings based on record drawings of the Contractor with:
- Offset distances measured from the centerline of the right-of-way to all public water mains.
 - Invert elevations marked for each manhole, structure, and each connection thereto, as well as at the end of each stubbed water main, stubbed water service line and stubbed fire line.
 - Locations of water and sewer services (if any) based on measurements from property lines.
 - Elevations indicating the depth of bury of all public water mains. These elevations shall be shown at each street or right-of-way intersection and at such intervals along the public water mains as may be deemed appropriate by the City Engineer.
 - Permanent bench marks shown.
- Task 22. Prepare reproducible construction record drawings for City of Billings files from records prepared by Contractor.
- Task 23. Conduct one-year inspection with City of Billings staff and Contractor.

Phase 400 Deliverables:

One (1) 11x17-inch set of record drawings submitted to the Department of Environmental Quality, two (2) sets of 24x36-inch record drawings provided to the City of Billings, one (1) set of electronic files (pdf format) provided to the City of Billings, one (1) copy of materials and water main testing records, and final record of project construction cost.

Appendix B

Methods and Times of Payment W.O. 15-01, Schedule 3, 17th Street West Water Main Replacement Project

Section 1. Payments for Basic Services.

Billings shall authorize payment to the Engineer for services performed under Appendix A of this Agreement. Partial payment shall be due the Engineer upon receipt of the Engineer's pay estimate, said estimate being proportioned to the work completed by the Engineer.

Billings shall deduct five percent (5%) from each monthly pay estimate to be held until the completion of the final scope of work. The final payment shall be made only after acceptance of final documents by Billings, and determination that the scope of work has been satisfactorily completed.

- A. For services rendered prior to construction, Appendix A, the Engineer shall be paid based upon actual time accrued, but not to exceed \$551,055.00 (Five Hundred Fifty One Thousand Fifty Five and 00/100 dollars) based on the following tasks:

Phase 100	Project Initiation	<u>\$4,920.00</u>
Phase 200	Preliminary Design	<u>\$210,705.00</u>
Phase 300	Final Design	<u>\$89,520.00</u>
Phase 400	Construction/Contract Administration	<u>\$245,910.00</u>

- B. Final payment shall be the above stated basic fee less all previous payments.

Section 2. Payments for Extra Services when Authorized by Billings.

Work requests made or conditions identified by interested groups at the agency or public meetings which are beyond the scope and intent of this project shall be paid for on an hourly basis at the applicable fees in Appendix D or by an addendum to the agreement.

Section 3. Corrections.

Costs of Billings' work that is required for the purpose of correcting the Engineer's work shall be deducted from any payments due the Engineer if the Engineer fails to make the required corrections.

Section 4. Fee Increases

For contracts and services that are expected to require more than one (1) year to complete, the above stated basic services payments may be reviewed and adjusted annually by mutual agreement of the parties, based upon documented evidence that the Engineer's costs and hourly rates as shown in Appendix D have increased for all comparable clients.

Appendix C

Additional Services of Engineer W.O. 15-01, Schedule 3, 17th Street West Water Main Replacement Project

Extra Services of the Engineer will be paid only with written prior authorization by Billings.

- A. Requests made or conditions identified which are beyond the scope and intent of the services identified under Appendix A.

Appendix D

Schedule of Professional Fees

W.O. 15-01, Schedule 3, 17th Street West Water Main Replacement Project

Current agreements for engineering services stipulate that the standard hourly rates are subject to review and adjustments. Hourly rates for services effective on the date of this Agreement are included below.

The itemized schedule provided below includes direct labor costs, normal payroll and overhead costs, transportation, furnishing equipment and materials normally required for performance of the work and reasonable profit. Direct project costs not itemized herein shall be paid for at actual cost.

Rate changes may be made to the fee schedule by the Engineer to reflect increased salaries and other business costs. Engineer shall submit a revised rate schedule at the time of the change if requested by the Owner. Rate schedule changes made by the Engineer during the term of this Contract shall not alter the maximum project professional fee set forth in the Contract. Changes that alter the maximum project professional fee are covered in Appendix B.

The cost of Professional Liability Insurance coverage is included in the hourly rates of personnel.

CHARGE OUT RATES EFFECTIVE JUNE 1, 2014

At Sanderson Stewart, we strive to provide great customer service and value. While we can offer the traditional method of billing by hourly charge rates, we strongly encourage our current and prospective clients to consider a fixed-fee arrangement in determining your overall project compensation. Fixed-fee projects can result in substantial savings over our posted hourly billing rates and provide a level of certainty at the outset of your project.

STAFF PERSONNEL SERVICES

Expert Witness/Special Consultant	\$ 250.00 /hour
Principal	\$ 180.00 /hour
Senior Engineer	\$ 150.00 /hour
Project Manager	\$ 140.00 /hour
Project Engineer	\$ 105.00 /hour
Staff Engineer	\$ 90.00 /hour
Field Engineer	\$ 90.00 /hour
Engineer Intern	\$ 65.00 /hour
Senior Environmental Scientist	\$ 150.00 /hour
Land Planner/Landscape Architect	\$ 115.00 /hour
Landscape Designer	\$ 80.00 /hour
Senior Professional Land Surveyor	\$ 125.00 /hour
Professional Land Surveyor	\$ 105.00 /hour
Staff Surveyor	\$ 95.00 /hour
Field Survey Technician	\$ 75.00 /hour
Marketing Director	\$ 120.00 /hour
Graphic Artist	\$ 100.00 /hour
Photographer	\$ 180.00 /hour
Designer	\$ 85.00 /hour

Web Developer	\$ 80.00 /hour
CADD Technician	\$ 75.00 /hour
Senior Construction Engineering Technician	\$ 105.00 /hour
Construction Engineering Technician	\$ 75.00 /hour
Construction Inspector	\$ 90.00 /hour
Project Administrator	\$ 65.00 /hour
Administrative/Clerical	\$ 65.00 /hour

SURVEY CREW SERVICES

1-man Crew/2-man Crew	\$ Per Job
-----------------------	------------

OUTSIDE CONSULTANTS

- 1) At cost if independently billed direct to client.
- 2) Cost plus 5% if billed through us.

INDEPENDENT LABORATORIES

- 1) At cost if independently billed direct to client.
- 2) Cost plus 5% if billed through us.

ADMINISTRATIVE EXPENSES

Administrative expenses (including copies, prints, phone, postage, materials, and travel) based on professional services only 3.5% *

* *unless modified by contract*

Appendix E

Project Schedule W.O. 15-01, Schedule 3, 17th Street West Water Main Replacement Project

Based on a notice to proceed by Billings date no later than October 27, 2014, the completion date for the Engineer's work through final design shall be:

1. Preliminary Engineering Services (30% Design): December 12, 2014
2. Preliminary Engineering Services (70% Design): January 30, 2015
3. Preliminary Engineering Services (90% Design): February 27, 2015
4. Final Engineering Services (100% Design): March 16, 2015
5. Construction Services to be based on Contractor Schedule.

Delays affecting the completion of the work within the time specified of more than ninety (90) days, not attributable to or caused by the Parties hereto, may be considered as cause for the renegotiation or termination of this Contract.

If the Engineer is behind on this Contract due to no fault of Billings, then the Engineer hereby acknowledges the right of Billings to withhold future Contracts to the Engineer in addition to any other remedy until this Contract is brought back on schedule or otherwise resolved.

Appendix F

Certificate(s) of Insurance

W.O. 15-01, Schedule 3, 17th Street West Water Main Replacement Project

Attach Certificate(s) of Insurance

Regular City Council Meeting

Meeting Date: 10/27/2014

TITLE: Professional Engineering Services Contract for Reconstruction of 7 Tennis Courts at Pioneer and Castlerock Parks

PRESENTED BY: Mike Whitaker, Parks, Recreation & Public Lands Director

Department: Parks/Rec/Public Lands

PROBLEM/ISSUE STATEMENT

The reconstruction of 7 tennis courts in Pioneer and Castlerock Parks was planned for the Park District #1 in FY2014. Funding was approved in FY 14 but the last half of the assessments are paid in June, the month that the fiscal year ends. A budget amendment will be requested later this year to include this project in the FY15 budget. This project is intended to re-build the upper 3 Courts at Pioneer Park and 4 courts at Castlerock Park. It is proposed to construct these courts with a post-tensioned concrete surface designed for longevity, reduced maintenance and a superior playing surface. Due to the specialty nature of this work, engineering services are needed. A Request for Proposals was issued and 3 firms responded. A selection committee met to evaluate the submittals and Hellas Construction from Austin Texas was selected. A contract for professional services was negotiated for \$57,000.00. A copy of the contract is available for review in the City Clerk's Office. If the contract is approved, engineering design will commence immediately. Construction is projected to take place in early spring 2015.

ALTERNATIVES ANALYZED

City Council may:

- Approve the contract with Hellas Construction for professional design services, or;
- Disapprove the contract and provide staff with additional guidance.

FINANCIAL IMPACT

This project was approved In the FY14 Budget. Second half of the year assessments funded the project but the expenses could not be committed and encumbered prior to year-end. Staff will request a budget amendment later this year to change the project and its expenses to the FY 15 budget.

RECOMMENDATION

Staff recommends Council approve the contract for professional engineering services with Hellas Construction for \$57,000.

APPROVED BY CITY ADMINISTRATOR

Regular City Council Meeting

Meeting Date: 10/27/2014

TITLE: W.O. 15-10--Water Treatment Plant Chemical Building/Disinfection Improvements, Professional Services Contract with HDR Engineering, Inc.

PRESENTED BY: David Mumford, Public Works Director

Department: Public Works

PROBLEM/ISSUE STATEMENT

This project will renovate and remodel the existing Chemical Building at the City of Billings Water Treatment Plant (WTP), update and enhance the plant's chemical treatment system (including the installation of a new UV disinfection system), and install a second parallel filter effluent line from the Filter Building to the High Service Pump Station transfer pump wetwell. Proposals were requested from qualified consulting firms to provide the required professional services (design, bidding, construction management, etc.). Three firms responded to the RFP, and HDR Engineering was chosen as the preferred consultant.

ALTERNATIVES ANALYZED

The Council may:

- Award a Professional Services Agreement to HDR Engineering (HDR); or
- Do not award an agreement to HDR. If this agreement is not approved, the project will be delayed.

FINANCIAL IMPACT

The project budget includes \$6,523,000 approved in the FY 2015 budget and will be funded with water funds. The contract is in the amount of \$1,193,100.00.

RECOMMENDATION

Staff recommends that Council authorize the Mayor to execute the Professional Services Contract with HDR Engineering, Inc. for W.O. 15-10--Water Treatment Plant Chemical Building/Disinfection Improvements in the amount of \$1,193,100.00.

APPROVED BY CITY ADMINISTRATOR

WO 15-10 HDR Contract

WO 15-10 Appendix A

WO 15-10 Appendix B

WO 15-10 Appendix C

WO 15-10 Appendix D

WO 15-10 Appendix E

WO 15-10 Appendix F

Insurance Certificate

Contract for Professional Architectural and Engineering Services
W.O. 15-10—Water Treatment Plant Chemical Building/Disinfection
Improvements

In consideration of the mutual promises herein, City of Billings and HDR Engineering, Inc. agree as follows. This Contract consists of:

- Part I, consisting of 15 Sections of Special Provisions;
- Part II, consisting of 11 Sections of General Provisions;
- Appendix A consisting of 13 pages (Basic Services of Consultant);
- Appendix B consisting of 2 pages (Methods and Times of Payment);
- Appendix C consisting of 1 pages (Additional Services of Consultant);
- Appendix D consisting of 1 pages (Schedule of Professional Fees);
- Appendix E consisting of 1 pages (Project Schedule);
- Appendix F consisting of 2 pages (Certificate(s) of Insurance); and

PART I
SPECIAL PROVISIONS

Section 1. Definitions.

In this Contract:

- A. "Administrator" means the City Engineer of the Engineering Division of the Public Works Department or his/her designee.
- B. "Billings" means the City of Billings.
- C. "Engineer" and/or "Contractor" means HDR Engineering, Inc.

Section 2. Scope of Services.

- A. The Contractor shall perform professional services in accordance with Appendix A, which is attached hereto and incorporated in this Section by reference.
- B. Billings shall pay the Contractor in accordance with Section 4.
- C. Billings shall not allow any claim for services other than those described in this Section. However, the Contractor may provide, at its own expense, any other services that are consistent with this Contract.
- D. The Contractor shall provide a minimum of one (1) copy of full-size and two (2) copies of half-size hard copy as-built drawings and two (2) CDs containing as-built drawings in digital format, as approved by the City of Billings, to the Administrator

within 30 days after the project completion date. Final payment will be withheld until the as-built drawings are received by the City of Billings.

- E. The Contractor shall provide certified construction payrolls to the Administrator stating in writing that the payrolls have been reviewed and are acceptable.

Section 3. Time for Performance.

- A. This Contract becomes effective when signed on behalf of Billings.
- B. The Contractor shall commence performance of the Work described in Section 2 on receipt of written Notice to Proceed and complete that performance in accordance with the schedule set forth in Appendix E.
- C. This Contract shall terminate at midnight on March 31, 2017.

Section 4. Compensation; Method of Payment.

- A. Subject to the Contractor's satisfactory performance, Billings shall pay the Contractor no more than One Million, One Hundred Ninety Three Thousand, One Hundred and no/100 dollars (\$1,193,100.00) in accordance with this Section and Appendix B.
- B. Each month, or at the conclusion of each phase of the Work for which payment is due, as negotiated on a per-task basis, the Contractor shall present a bill to the Administrator describing the Work for which it seeks payment and documenting expenses and fees to the satisfaction of the Administrator. If any payment is withheld because the Contractor's performance is unsatisfactory, the Administrator must, within ten (10) days of the payment denial, notify the Contractor of the payment denial and set forth, with reasonable specificity, what was unsatisfactory and why. Billings will pay the Engineer for all services provided not under dispute in the invoice. Billings will pay Contractor within 30 days of receiving an acceptable invoice.
- C. The Engineer is not entitled to any compensation under this Contract, other than is expressly provided for in this Section.
- D. As a condition of payment, the Engineer shall have paid all City taxes currently due and owing by the Engineer.

Section 5. Termination of the Contractor's Services.

The Contractor's services under Section 2 of this Part may be terminated:

- A. By mutual consent of the parties.
- B. For the convenience of Billings, provided that Billings notifies the Contractor in writing of its intent to terminate under this paragraph at least 10 days prior to the effective date of the termination.
- C. For cause, by either party where the other party fails in any material way to perform its obligations under this Contract. Termination under this Subsection is subject to the condition that the terminating party notifies the other party of its intent to terminate, stating with reasonable specificity the grounds therefor, and the other party fails to cure the default within 30 days after receiving the notice.

Section 6. Duties Upon Termination

- A. If Billings terminates the Contractor's services for convenience, Billings shall pay the Contractor for its actual costs reasonably incurred in performing before termination and Billings shall pay for services rendered prior to termination. Payment under this Subsection shall never exceed the total compensation allowable under Section 4 of this Part. All finished and unfinished documents and materials prepared by the Contractor shall become the property of Billings.
- B. If the Contractor's services are terminated for cause, Billings shall pay the Contractor the reasonable value of the services satisfactorily rendered prior to termination, less any damages suffered by Billings because of the Contractor's failure to perform satisfactorily. The reasonable value of the services rendered shall never exceed ninety percent (90%) of the total compensation allowable under Section 4 of this Part. Any finished or unfinished documents or materials prepared by the Contractor under this Contract shall become the property of Billings at its option.
- C. If the Contractor receives payments exceeding the amount to which it is entitled under Subsections A or B of this Section, he shall remit the excess to the Administrator within 30 days of receiving notice to do so.
- D. The Contractor shall not be entitled to any compensation under this Section until the Contractor has delivered to the Administrator all documents, records, Work product, materials and equipment owned by Billings and any deliverables prepared by the Engineer as defined in the Scope of Services and requested by the Administrator.
- E. If the Contractor's services are terminated for whatever reason the Contractor shall not claim any compensation under this Contract, other than that allowed under this Section.
- F. If a final audit has not been performed before the Contractor's services are terminated, Billings may recover any payments for costs disallowed as a result of the final audit.
- G. Except as provided in this Section, termination of the Contractor's services under Section 5 of this Part does not affect any other right or obligation of a party under this Contract.

Section 7. Insurance.

- A. The Contractor shall maintain in good standing the insurance described in Subsection B of this Section. Before rendering any services under this Contract, the Contractor shall furnish the Administrator with proof of insurance in accordance with Subsection B of this Section.
- B. The Contractor shall provide the following insurance:
 - 1. Workers' compensation and employer's liability coverage as required by Montana law.
 - 2. Commercial general liability, including contractual and personal injury coverage's -- \$1,500,000 per occurrence.
 - 3. Commercial automobile liability -- \$1,500,000 per accident.
 - 4. Professional liability in the amount of \$1,500,000 per claim.

- C. Each policy of insurance required by this Section shall provide for no less than 30 days' advance notice to Billings prior to cancellation.
- D. Billings SHALL be listed as an additional insured on all policies except Professional Liability and Worker's Compensation Policies. In addition, all policies except Professional Liability and Worker's Compensation shall contain a waiver of subrogation against Billings.

Section 8. Assignments.

Unless otherwise allowed by this Contract or in writing by the Administrator, any assignment by the Contractor of its interest in any part of this Contract or any delegation of duties under this Contract shall be void, and an attempt by the Contractor to assign any part of its interest or delegate duties under this Contract shall give Billings the right immediately to terminate this Contract without any liability for Work performed.

Section 9. Ownership; Publication, Reproduction and Use of Material.

- A. Except as otherwise provided herein, all data, documents and materials produced by the Contractor under this Contract shall be the property of Billings, which shall retain the non-exclusive right to publish, disclose, distribute and otherwise use, in whole or in part, any such data, documents, or other materials. Exclusive rights shall not be attributed to portions of such materials presently in the public domain or which are not subject to copyright. Contractor shall retain rights to pre-existing proprietary property including but not limited to interactive models. The Contractor shall have the right to include photographic or artistic representations of the design and construction of the Project among the Contractor's promotional and professional materials. The Contractor's materials shall not include Billings' confidential or proprietary information regardless of whether Billings has previously advised the Contractor in writing of the specific information considered by Billings to be confidential and proprietary.
- B. Equipment purchased by the Contractor with Contract funds: See Appendix A, Section 3. Scope of Work.
- C. Should Billings elect to reuse Deliverables provided under this Contract for other than the original project and/or purpose, Billings will indemnify and hold harmless the Contractor from any and all claims, demands and causes of action of any kind or character arising as a result of reusing the deliverables developed under this contract. Additionally, any reuse of design drawings or specifications provided under this Contract must be limited to conceptual or preliminary use for adaptation, and the original Contractor's or subcontractor's signature, professional seals and dates removed. Such reuse of drawings and specifications, which require professional seals and dates removed, will be signed, sealed, and dated by the professional who is in direct supervisory control and responsible for adaptation.

Section 10. Notices.

Any notice required pertaining to the subject matter of this Contract shall be either sent via facsimile (FAX), e-mail, or mailed by prepaid first class registered or certified mail, return receipt requested to the following addresses:

Billings: Will Robbins
City of Billings
Public Works Engineering
2224 Montana Avenue
Billings, Montana 59101
e-mail: robbinsw@ci.billings.mt.us
FAX: (406) 237-6291

Contractor: Craig Habben
HDR Engineering, Inc
2913 Millennium Circle
Billings, MT 59102
e-mail: craig.Habben@hdrinc.com
FAX: (406) 652-2758

Notices are effective upon the earlier of receipt, proof of good transmission (facsimiles only), or 5 days after proof of proper posting.

Section 11. Contract Budget.

In connection with its performance under this Contract, the Contractor shall not make expenditures other than as provided in line items in the Contract budget.

Section 12. Force Majeure.

- A. Any failure to perform by either party due to force majeure shall not be deemed a violation or breach hereof.
- B. As used in this Contract, force majeure is an act or event of substantial magnitude, beyond the control of the delayed party, which delays the completion of this Contract, including without limitation:
 - 1. Any interruption, suspension or interference resulting solely from the act of Billings or neglect of Billings not otherwise governed by the terms of this Contract.
 - 2. Strikes or Work stoppages.
 - 3. Any interruption, suspension or interference with the project caused by acts of God, or acts of a public enemy, wars, blockades, insurrections, riots, arrests or restraints of governments and people, civil disturbances or similar occurrences.
 - 4. Order of court, administrative agencies or governmental officers other than Billings.

Section 13. Financial Management System.

The Contractor shall establish and maintain a financial management system that:

- A. Provides accurate, current, and complete disclosure of all financial transactions relating to the Contract;

- B. Maintains separate accounts by source of funds for all revenues and expenditures and identifies the source and application of funds for the Contractor's performance under this Contract, including information pertaining to subcontracts, obligations, unobligated balances, assets, liabilities, outlays and income;
- C. Effectively controls and accounts for all municipal funds and Contract property;
- D. Compares actual expenditures with budgeted amounts and relates financial information to performance or productivity data including unit cost information where applicable;
- E. Allocates administrative costs to direct service delivery units;
- F. Minimizes the time between receipt of funds from Billings and their disbursement by the Contractor;
- G. Provides accounting records supported by source documentation; and
- H. Provides a systematic method assuring the timely and appropriate resolution of audit findings and recommendations.

Section 14. Funding Requirements.

In the event that any funding source for this Contract should impose additional requirements upon Billings for the use of those funds, the Contractor agrees to abide by those additional requirements immediately upon receipt of written notice thereof from Billings.

Section 15. Subcontracts.

The Contractor may enter into subcontracts for professional services necessary for the performance of this Contract, provided:

- A. Every subcontract shall be reduced to writing and contain a precise description of the services to be provided and the nature of the consideration paid therefor.
- B. Every subcontract under which the Contractor delegates the provision of services shall be subject to review and approval by the Administrator before it is executed by the Contractor.
- C. Every subcontract in an amount exceeding \$1,000 shall require reasonable access to business records of the subcontractor relating to the purchase of goods or services pursuant to the subcontract.

PART II
GENERAL CONTRACT PROVISIONS

Section 1. Relationship of Parties.

The Contractor shall perform its obligations hereunder as an independent Contractor of Billings. Billings may administer the Contract and monitor the Contractor's compliance with its obligations hereunder. Billings shall not supervise or direct the Contractor other than as provided in this Section.

Section 2. Nondiscrimination.

- A. The Contractor will not discriminate against any employee or applicant for employment because of race, color, religion, national origin, ancestry, age, sex, or marital status or who is a "qualified individual with a disability" (as that phrase is defined in the Americans With Disabilities Act of 1990). The Contractor will take affirmative action to ensure that applicants are employed and that employees are treated during employment without regard to their race, color, religion, or mental or physical impairment/disability. Such action shall include, without limitation, employment, upgrading, demotion or transfer, recruitment or recruiting advertising, layoff or termination, rates of pay or other forms of compensation, and selection for training including apprenticeship. The Contractor agrees to post, in conspicuous places available to employees and applicants for employment, notices setting forth the provisions of this non-discrimination clause.
- B. The Contractor shall state, in all solicitations or advertisements for employees to Work on Contract jobs, that all qualified applicants will receive equal consideration for employment without regard to race, color, religion, national origin, ancestry, age, sex or marital status, or mental or physical impairment/disability.
- C. The Contractor shall comply with any and all reporting requirements that may apply to it which the City of Billings may establish by regulation.
- D. The Contractor shall include the provisions of Subsections A through C of this Section in every subcontract or purchase order under this Contract, so as to be binding upon every such subcontractor or vendor of the Contractor under this Contract.
- E. The Contractor shall comply with all applicable federal, state, and city laws concerning the prohibition of discrimination.

Section 3. Permits, Laws, and Taxes.

The Contractor shall acquire and maintain in good standing all permits, licenses and other entitlements necessary to its performance under this Contract. All actions taken by the Contractor under this Contract shall comply with all current and applicable statutes, ordinances, rules and regulations at the time of the execution of the Contract. The Contractor shall pay all taxes pertaining to its performance under this Contract.

Section 4. Nonwaiver.

The failure of either party at any time to enforce a provision of this Contract shall in no way constitute a waiver of the provision, nor in any way affect the validity of this Contract or any part hereof, or the right of such party thereafter to enforce each and every provision hereof.

Section 5. Amendment.

- A. This Contract shall only be amended, modified or changed in writing, executed by authorized representatives of the parties, with the same formality as this Contract was executed.
- B. For the purposes of any amendment modification or change to the terms and conditions of this Contract, the only authorized representatives of the parties are:

Contractor: Area Manager
(title of position)

Billings: City Council or Authorized Designee

- C. Any attempt to amend, modify, or change this Contract by either an unauthorized representative or unauthorized means shall be void.

Section 6. Jurisdiction; Choice of Law.

Any civil action arising from this Contract shall be brought in the District Court for the Thirteenth Judicial District of the State of Montana, Billings. The law of the State of Montana shall govern the rights and obligations of the parties under this Contract.

Section 7. Severability.

Any provision of this Contract deemed invalid by a court of competent jurisdiction shall not invalidate the remaining provisions of the Contract.

Section 8. Integration.

This instrument and all appendices and amendments hereto embody the entire agreement of the parties. There are no promises, terms, conditions or obligations other than those contained herein; and this Contract shall supersede all previous communications, representations or agreements, either oral or written, between the parties hereto.

Section 9. Liability.

The Contractor shall indemnify, defend, save, and hold Billings harmless from any and all claims, causes of action, lawsuits, damages, judgments, liabilities, and litigation costs and expenses including reasonable attorneys' fees and costs, arising from any wrongful or negligent act, error or omission of the Contractor or any agent, employee or subcontractor as a result of the Contractor's or any subcontractor's performance pursuant to this Contract.

- A. The Contractor shall not indemnify, defend, save and hold Billings harmless from claims, causes of action, lawsuits, damages, judgments, liabilities, and litigation costs and expenses or attorneys' fees and costs to the extent arising from wrongful or negligent acts, error or omission solely of Billings occurring during the course of or as a result of the performance of the Contract.
- B. Where claims, lawsuits or liability, including attorneys' fees and costs to the extent arise from wrongful or negligent act of both Billings and the Contractor, the Contractor shall indemnify, defend, save, and hold Billings harmless from only that portion of claims, causes of action, lawsuits, damages, judgments, liabilities, and litigation costs and expenses including attorneys' fees and costs, which to the extent result from the Contractor's or any subcontractor's wrongful or negligent acts occurring as a result from the Contractor's performance pursuant to this Contract.

Billings shall indemnify, defend, save, and hold the Engineer harmless from any and all claims, causes of action, lawsuits, damages, judgments, liabilities, and litigation costs and expenses including reasonable attorneys' fees and costs, arising from any wrongful or negligent act, error or omission of Billings or any agent, employee or subcontractor as a result of Billings' or any subcontractor's performance pursuant to this Contract.

- A. Billings shall not indemnify, defend, save and hold the Engineer harmless from claims, causes of action, lawsuits, damages, judgments, liabilities, and litigation costs and expenses or attorneys' fees and costs arising from wrongful or negligent acts, error or omission solely of the Engineer occurring during the course of or as a result of the performance of the Contract.
- B. Where claims, lawsuits or liability, including attorneys' fees and costs arise from wrongful or negligent act of both Billings and the Engineer, Billings shall indemnify, defend, save, and hold the Engineer harmless from only that portion of claims, causes of action, lawsuits, damages, judgments, liabilities, and litigation costs and expenses including attorneys' fees and costs, which result from Billings' or any subcontractor's wrongful or negligent acts occurring as a result from Billings' performance pursuant to this Contract.

Section 10. Inspection and Retention of Records.

The Contractor shall, at any time during normal business hours and as often as Billings may deem necessary, make available to Billings, for examination, all of its records with respect to all matters covered by this Contract for a period ending three years after the date the Contractor is to complete performance in accordance with Section 2 of the Special Provisions. Upon request, and within a reasonable time, the Contractor shall submit such other information and reports relating to its activities under this Contract, to Billings, in such form and at such times as Billings may reasonably require. The Contractor shall permit Billings to audit, examine and make copies of such records, and to make audits of all invoices, materials, payrolls, records of personnel, and other data relating to all matters covered by this Contract. Billings may, at its option, permit the Contractor to submit its records to Billings in lieu of the retention requirements of this Section.

Section 11. Availability of Funds.

Payments under this Contract may require funds from future appropriations. If sufficient funds are not appropriated for payments required under this Contract, this Contract shall terminate without penalty to Billings; and Billings shall not be obligated to make payments under this Contract beyond those which have previously been appropriated.

IN WITNESS WHEREOF, the parties have executed this Contract on the date and at the place shown below.

City of Billings

Contractor

THOMAS W. HANEL, Mayor

HDR Engineering, Inc.

Date: _____

Name: _____

ATTEST:

Title: _____

Date: _____

Cari Martin, City Clerk

IRS Tax ID # 47-0680568

Date: _____

APPROVED AS TO FORM:

By _____
BRENT BROOKS, City Attorney

Date: _____

STATE OF MONTANA)
)
) :ss.
COUNTY OF _____)

On this ____ day of _____, 20__, before me, the undersigned, a Notary Public for the State of Montana, personally appeared _____, known to me to be the _____ of _____, and acknowledged to me that they executed the foregoing instrument on behalf of said corporation having first been authorized to do so.

IN WITNESS WHEREOF, I have hereunto set my hand and affixed my Notarial Seal the day and year first above written.

Notary Public for the State of Montana
Residing at _____, Montana
My Commission Expires: _____

Note: Final contract documents will require the Contractor's signature to be notarized.

Appendix A
Basic Services of Engineer
W.O. 15-10—Water Treatment Plant Chemical Building/Disinfection
Improvements

Section 1. Engineer's Rights and Duties.

- A. To furnish all labor, materials, equipment, supplies, and incidentals necessary to conduct and complete the Engineer's portion of the project as defined in the scope of work and to prepare and deliver to Billings all plans, specifications, bid documents, and other material as designated herein.
- B. Ascertain such information as may have a bearing on the work from local units of government, utility companies, and private organizations and shall be authorized to procure information from other authorities besides Billings, but shall keep Billings advised as to the extent of these contacts and the results thereof.
- C. Prepare and present such information as may be pertinent and necessary in order for Billings to pass critical judgment on the features of the work. The Engineer shall make changes, amendments or revisions in the detail of the work as may be required by Billings. When alternates are being considered, Billings shall have the right of selection.
- D. Engineer's work shall be in accordance with the standards of sound engineering and present City, State, and National standards and policies currently in use.
- E. Conform to the requirements of the Montana Code Annotated Title 18 "Public Contracts" and more particularly Sections 18-2-121 and 18-2-122, and all other codes of the State of Montana applicable to providing professional services including codes and standards nationally recognized.
- F. The Engineer shall certify with the submission of final plans that the plans are in conformance with applicable sections of Title 69, Chapter 4, Part 5, of the Montana Code Annotated as pertaining to existing utilities.
- G. To perform professional services in connection with the project and will serve as Billings' representative in those phases of the project to which this agreement applies.
- H. Where Federal funds are involved, the necessary provisions to meet all requirements will be complied with and documents secured and placed in the bidding documents.
- I. Submit an estimated progress schedule as to time and costs at the beginning of the work, and monthly progress reports thereafter until complete. The reports will include any problems, potential problems, and delays as foreseen by the Engineer. Reports will be submitted in a timely manner to permit prompt resolution of problems.

- J. Contract administration duties will include review of contractor certified payrolls for wage rate compliance. Discrepancies in certified payrolls will be resolved with the Contractor. A signed Engineer's Payroll Check Sheet (included in the Standard Modifications to MPWSS) will be submitted as proof of this review with one copy of each payroll.
- K. Name a Task Director who shall be the liaison between Billings and the Engineer. For this project the Task Director designated for the Engineer is Craig Habben working under the Principal-in-Charge, Amanda McInnis.

Section 2. Billings Rights and Duties.

- A. To furnish all labor, materials, equipment, supplies, and incidentals necessary to conduct and complete Billings' portion of the project as designated in the scope of work.
- B. Name a Task Director who shall be the liaison between the Engineer and Billings. For this project, the Task Director designated is Will Robbins, working under the City Engineer, Debi Meling.

Section 3. Scope of Work.

The project consists of engineering services for the design, bidding, construction, operation and maintenance manual, training and startup phases for the City of Billings Water Treatment Plant (WTP) Chemical Building/UV Improvements Project. The project is based on recommendations from the Water Treatment Facility Chemical Building and Disinfection Improvements – Chemical/Disinfection Systems Evaluation Report (HDR, 2014) for the chemical system and the City's preference to move forward with the ultraviolet (UV) disinfection system as well as chlorine upgrades and sodium hypochlorite provisions for a temporary system. The project also includes a second parallel filter effluent line from the Filter Building to the High Service Pump Station Transfer Pump Wetwell.

The scope of work is summarized below:

Chemical System

- Chemical Building
 - Locate all chemical facilities on the ground floor
 - Replace windows and doors
 - Perform minor repairs to building exterior
 - Provide exterior improvements to steps, landings and handrails
 - Replace boiler and accessories with new boiler and hot water heat system
 - Separate room drains and floor drains. Route floor drains to sewer collection system.
 - Replace 120 volt electrical system
 - Repair elevator
 - Provide adequate containment for all tanks
 - Remove unused piping, valves and equipment
- Bulk Chemical Building
 - Route sump pump discharge to sewer
 - Route chemical flush lines to new sump discharge line

- Chemicals
 - Remove equipment, piping, valves and tanks for carbon system, potassium permanganate, coagulant polymer, orthophosphate, caustic soda and ammonia.
 - PACL – continue use and replace all equipment, day tanks, valves and piping in the Chemical Building.
 - Chlorine – continue use. Expand chlorine feed room and provide improvements to monorail hoist system. Rearrange chlorinators in expanded room and reroute associated piping.
 - Filter Aid – continue use of dry filter aid. Locate all facilities on the ground floor. Replace all equipment, piping and valves.
 - Ferric Chloride – locate tote and metering pump on Ground Floor of Chemical Building.
 - Future Chemical/Piloting – provide a location for a chemical tote and metering pump location for experimenting with a future chemical or new blend of existing chemical.
 - Replace site piping and piping and valves at feed locations.

Disinfection System

- Chlorine
 - Continue current practice with the improvements described above. Also include piping to High Service Pump Station (HSPS) with feed point to adjust residual if needed.
 - Evaluate the need to dose chlorine following UV disinfection.
- Sodium Hypochlorite
 - Provide piping and valving that would allow for bulk sodium hypochlorite to be stored and fed from bulk tanks on the west side of the Bulk Chemical Building. No equipment would be provided at this time.
- UV
 - Provide a UV disinfection system on the discharge of the HSPS Transfer Pumps.
 - Evaluate UV reactor types to determine the most cost effective, reliable and maintainable system for Billings.
 - Pre-purchase UV system to provide a single design for the selected manufacturer.
 - Provide above ground building to house UV system. Building walls to be precast wall panels and roof to be precast hollow core panels.
 - Provide site piping to connect into existing Transfer Pump discharge piping. Evaluate and recommend level of redundancy of tie-in points.

Filter Effluent Waterline

- Route 60-inch pipe from stub-out south of the Filter Building to the east Transfer Pump Wetwell at HSPS.
- Repair landscaping and site to existing conditions.

Support Service

- Provide architectural design services:
 - Include repairs and improvements to Chemical Building.

- Provide architecture of new UV Building to compliment existing plant architecture.
- Provide structural design services:
 - Include repairs and improvements to Chemical Building.
 - Provide structural services for new UV Building.
- Provide mechanical design services:
 - Include replacement of boiler system in Chemical Building with a hot water system.
 - Provide heating and ventilation of UV Building.
 - Provide plumbing systems for UV Building.
- Provide electrical design services:
 - Provide new 120 volt electrical in Chemical Building. Provide electrical to new Chemical System equipment.
 - Provide electrical system for new UV system and UV Building with appropriate reliability. Provide new Transformer T3-1 to serve 480 volt switchboard in the HSPS.
- Provide instrumentation and controls to support identified upgrades and new UV system.
- Provide bidding services
 - Bidding services based on pre-purchasing UV system and one construction bid package.
- Construction services
 - Provide construction services for Chemical System Improvements, new UV System and filter effluent waterline.
- Training, Startup and O&M assistance:
 - Coordinate training of new equipment with staff. Work with staff to develop protocol for operation of UV system including normal operation, backup operation and startup/operation on backup power.
 - Work with manufacturers and contractor to verify proper installation of chemical equipment and UV system. Verify new systems are functioning properly.
 - Develop electronic Operations Manual (eOM) for new UV system. Review and provide typical hard copies and electronic copy of equipment O&Ms.

DETAILED SCOPE OF SERVICES

The scope of services that will be utilized on the Water Treatment Plant Chemical Building/Disinfection Improvements is presented in the summaries for Tasks 100 through 600. The scope of services is organized as follows:

<u>Task Series</u>	<u>Description</u>
100	Project Initiation, Coordination and Management
200	Preliminary Design Phase
300	Final Design Phase
400	Bid Phase
500	Construction Phase
600	Training, Startup and eOM

TASK SERIES 100

101 – Project Initiation

The purpose of this task is to kick off the project externally and internally. A project management plan (PMP) and all the support paperwork will be developed for all team members to have available to understand the project, the project team and the project requirements. The PMP is updated with significant changes in the project. The project will be kicked off with the City with pertinent staff from the City and HDR to review the project components, schedule and the process for completing the design.

- Deliverables – Half day meeting with City, agenda and meeting minutes.

102 – Meetings with City Staff

During the preliminary design and final design phases of the project, key members of the Consultant design team will meet with the City staff to review the project. Meeting minutes will be prepared and distributed to all parties attending the meeting. Meetings will be approximately once a month with a review meeting at the completion of the draft Design Report, 60% Submittal and 95% Submittal. Ten total meetings are planned for design phase. Bidding and construction phase meetings are described elsewhere. Meetings to be held at the WTP Conference Room.

- Deliverables – Meeting minutes and decision log updated for each meeting

103 – Design, Bidding and Construction Services Project Management

As part of this task, the Engineer's Project Manager will lead coordination of the design team with the City as well as supervise the design team. Project Manager and Accountant will monitor project status, maintain project schedule and prepare financial documents.

- Deliverable – Monthly invoices

TASK SERIES 200 – PRELIMINARY DESIGN PHASE

This task series will further develop recommendations from the Chemical/Disinfection Evaluation as well as select a UV system for detailed design. The tasks associated with the preliminary design includes the following:

201 – Geotechnical Investigations

A soils consultant will perform geotechnical investigations to determine the structural design requirements and limitations for the UV Building and new waterlines.

- Deliverable – Geotechnical Report

202 – Perform Design Surveys

The overall scope is to provide topographic survey of the area from the Filter Building south to Belknap Ave and west to the clearwells. Survey will also include the area west and south of the Chemical Building for the new sump discharge to the sewer. The topographic survey will verify the location of structures and above ground appurtenances.

- The existing datum of the WTP will not be continued.
- The horizontal coordinates will be Montana coordinate system NAD 83 and the vertical will be NAVD 88.

- The existing control provided by the City will be verified.
- Control will be densified to accommodate topographic survey with robotic total station.
- City responsibility – provide utility locates and pertinent GPS information.

203 – Prepare Request for Qualifications (RFQ) Process for UV Equipment

Work with the City to identify reactors types and manufacturers that would be applicable for the Billings conditions. Prepare a RFQ for UV Systems and distribute to the potential manufacturers. Evaluate the qualifications received, call references, and create a shortlist of manufacturers.

- Deliverables – RFQ Package, Evaluation of qualifications received.

204 – Site Visits

Coordinate and travel with City personnel to evaluate existing UV systems on the City's shortlist. A maximum of four installations will be visited.

- Deliverables – Summary of observations from trip.

205 – Perform Procurement Process for UV Equipment

From the RFQ process and site visits, determine shortlist of manufacturers. Prepare procurement documents to send to shortlist of manufacturers. Documents to include front end specifications and technical specifications specific to purchasing UV equipment. Generic layout drawings, P&IDs and electrical one line drawings shall be included. Draft documents will be circulated to shortlisted bidders for review and comment. The bid form will incorporate a life cycle calculation that includes: capital cost, power cost, replacement costs and other future O&M costs. The bid documents shall include a prioritized preference factor on items important to the City and a detailed specification on warranty. HDR will distribute documents to shortlisted bidders, answer questions during bidding (a pre-bid meeting is not anticipated to be required), evaluate bids and supply the City with a recommendation for award. Services associated with a protest of award by a manufacturer is not included in the budget.

- Deliverables – Procurement Package, Addenda, Bid Recommendation.

206 – Montana Department of Environmental Quality (MDEQ) Coordination for UV Equipment

Coordinate with MDEQ and the selected manufacturer to obtain approval of recommended manufacturer from Procurement Bid.

- Deliverables – Support information for MDEQ review
- Assumptions – One trip to Helena for coordination meeting. The recommended UV manufacturer will be approved by MDEQ.

207 – UV Equipment Shop Drawings

HDR will receive, review and coordinate shop drawings with the selected and approved UV manufacturer.

208 - Develop a Lamp Break Response Plan

Develop a lamp break response plan that may be required for MDEQ approval for the project.

209 – Construction Cost Estimate

The estimated capital costs for the project will be updated from the Evaluation Report.

- Deliverable – Summary of Cost Estimate by facility.

210 – Prepare a Design Report

Prepare a design report that describes the project and the planned improvements. The report will include a section on construction sequencing and constructability. Preliminary drawings will be developed showing plan views of proposed improvements and key sections. A Building Information Management (BIM) 3D model will be used for the new UV Building. The Chemical System and Filter Effluent waterline will be produced in 2D. The cost estimate from the Evaluation will be updated as well as the project schedule. The report shall address DEQ design criteria.

- Deliverable – Draft Design Report (electronic copies of chapters as completed).
- Deliverable – BIM model to the City for review of basic layouts of UV facility at the 30% level.

211 – Review Design Report (30% Review)

Conduct internal reviews of Design Report. Incorporate review comments and submit to City for review. Conduct review meeting with the City.

- Deliverable – Draft Design Report (4 hard copies and one electronic copy).

212 – Finalize Design Report

Incorporate City review comments and finalize design report.

- Deliverable – Final Design Report (5 hard copies and one electronic copy).

213 – Internal Team Meetings

Regular conference calls will be conducted to coordinate between team members and to communicate information received from the City as well as obtain questions or decisions needed from the City.

TASK SERIES 300 – FINAL DESIGN

In this task, the Preliminary Design will be developed into more detailed engineered project elements. The design will be taken from the 30% Design Report level to 60% design level and then 95% level before being finalized for bid documents. The BIM model will be regularly shared with project staff and the City in digital format using Navisworks™ reader software for model communication. Specifications will be prepared for 95% review and then finalized for bid. Specific tasks will include the following:

301 – Prepare 60% BIM Model and Drawings

The BIM models will be further developed for all disciplines providing structural sizing, equipment location, piping routing and major electrical facility location. Chemical System Improvements to be shown on 2D drawings utilizing photos as much as possible to indicate demolition and repairs. 2D site drawings, P&IDs drawings and electrical one-line drawings will be updated from preliminary design.

- Deliverable – See Task 302.

302 – Internal and External 60% Review

BIM models and 2D drawings will be reviewed internally by HDR. Review comments will be resolved and applicable comments incorporated in the City's review set. BIM model of the UV Building will be reviewed with City as well as the improvements developed on 2D drawings. City review comments will be resolved and applicable comments will be carried forward into the 95% design.

- Deliverables – BIM model and 2D drawings (4 half sized sets) for review. List of City review comments and how the comments were resolved.
- City responsibility – Provide one set of review comments.

303 – Prepare 95% BIM Model and Drawings

The BIM models for all disciplines will be fully developed showing details necessary for construction. Plan and section drawings will be extracted from the Building Information Model. Notes and additional details will be added to the drawings to complete the design. Existing facility 2D drawings will be further detailed. 2D site drawings, P&IDs drawings and 2D electrical drawings will be detailed for construction.

- Deliverable – See Task 305.

304 – Prepare Detailed Specifications

Final detailed specifications suitable for bidding and construction will be developed. These detailed specifications will be incorporated with the City's front-end documents.

- Deliverable – See Task 305.

305 – Internal and External 95% Review

BIM model, 2D drawings and specifications will be reviewed internally by HDR. Review comments will be resolved and applicable comments incorporated in the City's review set. BIM model will be reviewed with City as well as the 2D drawing set. Key components for the specifications will be reviewed with the City. City review comments will be resolved and applicable comments will be carried forward into the final bid set.

- Deliverables – BIM model, 2D drawing set and specifications for review. List of City review comments and how the comments were resolved.
- City responsibility – Provide one set of review comments.

306 – Finalize Design

Based on review comments, update BIM model and finalize 2D drawings and specifications.

- Deliverable – Bid Documents for advertisement. 4 sets (half-sized drawings) for the City and one set for each plan room.

307 – MDEQ Coordination for Construction Contract

HDR will coordinate all portions of the design with MDEQ to obtain a permit to construct. Any variances that will be needed will be requested from MDEQ.

- Deliverables – Two hard-copy review contract document sets to MDEQ and any variance requests.
- Assumptions – One trip to Helena.

308 – Building Permit

Assist the City in submitting building permit application.

- Deliverables – Building permit application and backup information.
- If necessary, any resubmittal information that may be required by Building Division.

309 – Construction Cost Estimate

The estimated capital costs for the project will be updated from the preliminary design.

- Deliverable – Summary of Cost Estimate by facility.

310 – Internal Team Meetings

Regular conference calls will be conducted to coordinate between team members and to communicate information received from the City as well as obtain questions or decisions needed from the City.

TASK SERIES 400 – BID PHASE

401 – Bidding Administrative Assistance

Produce and distribute bid documents to owner, prospective bidders and plan rooms. Answer bidder questions and prepare addenda as needed. Conduct pre-bid meeting. Attend Bid opening.

- Deliverable – Bid Documents, Advertisement, Pre-Bid Meeting Minutes and Addendums.

402 – Post-Bid Administrative Assistance

Receive, evaluate and tabulate bids. Assess completeness of bids. Review qualifications of bidders. Check references for two lowest bidders. Make recommendations to the City on award of contract.

- Deliverable – Summary of Bidder Qualifications and Recommendation of Award.

TASK SERIES 500 – CONSTRUCTION PHASE

Construction Phase scope of work is based on 52 week construction period, after which time only minor punch list items would need to be completed.

501 – Construction Initiation Services

The Consultant shall prepare construction contracts, conduct a preconstruction conference and prepare minutes summarizing the conference. The Consultant will provide the owner with three sets and the contractor one pdf of “Issue for Construction” plans and specifications.

502 – Office Assistance and Administration

During the construction phase of the project, the Consultant will provide office assistance to the City on the administration of the project. This effort will include review and preparation of change orders, shop drawing review, interpretation of drawings and specifications including answering requests for information (RFI), monitoring of compliance with procedure requirements on the project, coordinating with the contractor, evaluation of pay estimates, review for compliance of certified pay-rolls, and conducting weekly (or as needed) construction meetings.

503 – Field Services

The Consultant will provide half-time on-site construction observation services. A resident project representative will provide up to 1000 hours of construction observations and 500 hours of related tasks including travel to the plant. The resident project representative will monitor the project for compliance with contract documents.

504 – Construction Wrap-Up and Acceptance

Upon completion of the construction of the improvements, the Consultant will schedule and hold a final project walk-through and assist the City in the final wrap-up of the project, including preparing record drawings, preparation of a punch list, preparation of Certificate of Substantial Completion, information review and recommendation of final acceptance.

505 – Post-Construction Warranty Services

After final acceptance, the Consultant will provide warranty item consultation, assist in the eleven-month warranty inspection, and provide warranty follow-up.

TASK SERIES 600 – TRAINING, STARTUP AND ELECTRONIC OPERATIONS MANUAL PHASE (eOM)

601 – Training

Coordinate training of new equipment with manufacturers and the City. Work with staff to develop protocol for operation of UV system including normal operation, backup operation and startup/operation on backup power.

602 – Startup

Work with manufacturers and contractor to verify proper installation of chemical equipment and UV system. Coordinate startup of equipment with Contractor, manufacturer representative and the City. Verify new systems are functioning properly.

603 – eO&M

HDR will develop an Electronic Operations Manual (eOM) for the new UV Disinfection System. The eOM will provide the Owner's staff a graphical user interface to the information necessary to operate and maintain the plant facilities in an efficient and reliable manner. The eOM content will include facility and equipment descriptions, design criteria, process control narratives, design drawings, and vendor supplied equipment O&M manuals. The eOM will provide a permanent archive of the information. HDR will provide an eOM web site structure for the entire plant but will only provide content for the UV disinfection portion of the eOM at this time.

The eOM will be developed as a web application in the Microsoft ASP.net web environment and will function on the City's Windows-based server. The eOM will be internally accessible via Internet Explorer but will not be accessible by the general public. An HTML text editor will be embedded in the eOM web pages to enable easy text editing by City staff without having to know HTML. HDR owns the HTML editor enterprise license which allows FREE distribution provided the editor software is only used in HDR's eOM application. The recommended minimum hardware and software that the City will need to provide to host the eOM on the City server includes:

eOM Web Server Minimum Requirements

1. Microsoft Windows Server 2008 R2 Standard Edition or greater
2. 2 GHz dual/quad processor or better
3. 4 GB of RAM
4. 40 GB of hard drive space

eOM Client (End User) Machine - Software Minimum Requirements

1. Internet Explorer
2. Adobe Acrobat Reader
3. IIS (Internet Information Services 6.0 or higher)
4. Microsoft.NET Framework 3.5

Recommended Tools for Content Authors

1. Microsoft Office
2. Adobe Acrobat Standard - to modify new or scanned equipment O&M manuals in PDF format

The following items will be provided by the City:

1. Network server, network and personal computers, including standard Microsoft network software as described above.
2. Path to and necessary server space on the City's network server to host the eOM application.
3. Ancillary software on the City's computers necessary to run the eOM, including Microsoft Internet Explorer, Windows, and SQL Server.

A four hour kickoff workshop will be held to discuss general eOM content and the schedule for developing and implementing the eOM. The purpose of the workshop is to prepare a final web site map to illustrate the eOM layout and structure. HDR will prepare a draft web site map of the entire plant for review and comment prior to the workshop. The final web site map developed at the workshop will be emailed to City staff after the workshop for final approval. HDR will only prepare content for the UV disinfection portion of the eOM at this time.

The draft web site map will illustrate how and where the following will be organized:

1. The information structure, organization and level of detail.
2. How the navigation between each section will function.
3. What plant general reference information to include.
4. The unit process content detail to be provided.
5. How the equipment O&M manual hyperlinks will function.
6. An eOM content management guide.

The web site map will be developed in coordination with City staff, and will be specifically tailored to meet the requirements and needs of the plant staff.

- **Deliverables** – Meeting agenda and minutes for one four hour workshop.

- **Deliverables** – Draft eOM web site map prior to workshop.
- **Deliverables** – Final eOM web site map after the workshop for approval.

HDR will prepare the eOM manual structure for each unit process shown in the web site map but will provide content only for the UV disinfection section at this time. Example content definitions are shown in the following table. Note that content definitions for this project will be specific and customized to those sub-sections agreed upon and defined by the web site map developed with the plant staff.

Example Unit Process Content Pages	
Section	Text
Overview	This section will include the following narratives and photos: Purpose Theory Equipment Equipment Photos with a Detailed Description List
Process Flow Diagrams	Process flow diagrams to communicate the design intent to the plant staff. The diagrams will be created in Microsoft Visio and saved as PDF files. Both the Visio and PDF files will be included in the eOM. A total of 5 process flow diagrams are anticipated. In addition, HDR will incorporate the plant as-built drawings into the eOM Plant Reference section in PDF file format and provide hyperlinks to the drawings.
Design Criteria	Tabular listing of unit process sizes, loadings, and other design criteria.
Equipment	Hyperlinks to vendor supplied equipment manuals in PDF file format. Existing equipment O&M manuals that are only available in hard copy will be scanned into PDF files and hyperlinked within the eOM application
Controls	A description of manual and automatic equipment controls.
System Procedures	A list of general procedures for starting up and shutting down the process.
Troubleshooting	A compilation of both process and specific equipment troubleshooting guides.
Safety	General and process specific safety considerations.

HDR will provide the City with access to the draft eOM over the Internet for review approximately 30 days prior to startup of the unit process. Procurement of and hyperlinking to as-built equipment photographs will occur after startup and removal of all contractor equipment and materials. The draft eOM will be accessible by City staff as the unit process is started up. The final eOM will be delivered approximately 30 days following receipt of as-built drawings in PDF file format.

- **Deliverables** – Draft eOM accessible by plant staff via the Internet.
- **Deliverables** – Final eOM downloadable to City network server.

HDR will develop the draft and final eOM on an HDR server. Upon completion HDR will coordinate installation of the final eOM on the City's server with the City's information technology (IT) staff. The final eOM will be downloaded to the City's network server.

HDR will schedule a meeting with the plant staff, and facilitate two one-hour training sessions for the plant staff on how to use and maintain the eOM. The first one-hour training session will provide general instruction and use of the eOM. The second one-hour training session will provide instruction on how the plant staff can edit and revise the eOM.

- **Deliverables** – Coordinate with the City's IT staff to download and install final eOM.
- **Deliverables** – Provide two one-hour training sessions at plant to City O&M staff.

Appendix B

Methods and Times of Payment W.O. 15-10—Water Treatment Plant Chemical Building/Disinfection Improvements

Section 1. Payments for Basic Services.

Billings shall authorize payment to the Engineer for services performed under Appendix A of this Agreement. Partial payment shall be due the Engineer upon receipt of the Engineer's pay estimate, said estimate being proportioned to the work completed by the Engineer.

Billings shall deduct five percent (5%) from each monthly pay estimate to be held until the completion of the final scope of work. The final payment shall be made only after acceptance of final documents by Billings, and determination that the scope of work has been satisfactorily completed.

- A. For services rendered under Appendix A of this Agreement, the Engineer shall be paid based upon actual time accrued, but not to exceed the following amounts:

1. Project Initiation, Coordination and Management	\$57,600.00
2. Preliminary Design Phase	\$202,400.00
3. Final Design	\$543,600.00
4. Bid Phase	\$17,700.00
5. Construction Phase	\$297,900.00
6. Startup Phase	\$73,900.00

TOTAL: \$ 1,193,100.00

- B. Final payment shall be the above stated basic fee less all previous payments.

Section 2. Payments for Extra Services when Authorized by Billings.

Requests made or conditions identified by interested groups at the agency or public meetings, which are beyond the scope and intent of the services to be performed under Appendix A shall be paid for based on a negotiated fee.

Section 3. Corrections.

Costs of Billings work that is required for corrections to the Engineer's work which requires redoing by Billings shall be deducted from any payments due the Engineer, if the Engineer fails to make the required corrections.

Section 4. Fee Increases

For contracts and services that are expected to require more than one (1) year to complete, the above stated basic services payments may be reviewed and adjusted annually by mutual agreement of the parties, based upon documented evidence that the Engineer's costs have increased for all comparable clients.

Appendix C

Additional Services of Engineer W.O. 15-10—Water Treatment Plant Chemical Building/Disinfection Improvements

Extra Services of the Engineer will be paid only with written prior authorization by Billings.

- A. Field and laboratory testing of materials and reports.
- B. Requests made or conditions identified by interested groups at the agency or public meetings, which are beyond the scope and intent of this study.

Appendix D

Schedule of Professional Fees W.O. 15-10—Water Treatment Plant Chemical Building/Disinfection Improvements

Not Used

Appendix E

Project Schedule W.O. 15-10—Water Treatment Plant Chemical Building/Disinfection Improvements

Based on a notice to proceed by Billings dated no later than October 28, 2014, the completion date for the Engineer's work shall be:

- A. Preliminary Design
 - 1. RFQ Process Complete – December 2014
 - 2. Preliminary Selection of UV Equipment Supplier – February 2015
 - 3. Target DEQ approval of UV Equipment Supplier – April 2015
 - 4. Design Report Complete – May 2015
- B. Design
 - 1. 60% Design Complete – July 2015
 - 2. 95% Design Complete – September 2015
 - 3. Final Design Complete – October 2015
- C. Bid – November 2015
- D. Award – December 2015
- E. Construction Substantial Completion – October, 2016

Delays affecting the completion of the work within the time specified of more than ninety (90) days, not attributable to or caused by the Parties hereto, may be considered as cause for the renegotiation or termination of this Contract.

If the Engineer is behind on this Contract due to no fault of Billings, then the Engineer hereby acknowledges the right of Billings to withhold future Contracts to the Engineer in addition to any other remedy until this Contract is brought back on schedule or otherwise resolved.

Appendix F

Certificate(s) of Insurance W.O. 15-10—Water Treatment Plant Chemical Building/Disinfection Improvements

Certificate(s) of Insurance attached.



CERTIFICATE OF LIABILITY INSURANCE

6/1/2015

DATE (MM/DD/YYYY)

5/28/2014

THIS CERTIFICATE IS ISSUED AS A MATTER OF INFORMATION ONLY AND CONFERS NO RIGHTS UPON THE CERTIFICATE HOLDER. THIS CERTIFICATE DOES NOT AFFIRMATIVELY OR NEGATIVELY AMEND, EXTEND OR ALTER THE COVERAGE AFFORDED BY THE POLICIES BELOW. THIS CERTIFICATE OF INSURANCE DOES NOT CONSTITUTE A CONTRACT BETWEEN THE ISSUING INSURER(S), AUTHORIZED REPRESENTATIVE OR PRODUCER, AND THE CERTIFICATE HOLDER.

IMPORTANT: If the certificate holder is an ADDITIONAL INSURED, the policy(ies) must be endorsed. If SUBROGATION IS WAIVED, subject to the terms and conditions of the policy, certain policies may require an endorsement. A statement on this certificate does not confer rights to the certificate holder in lieu of such endorsement(s).

PRODUCER Lockton Companies 444 W. 47th Street, Suite 900 Kansas City MO 64112-1906 (816) 960-9000	CONTACT NAME:	
	PHONE (A/C, No, Ext):	FAX (A/C, No):
	E-MAIL ADDRESS:	
	INSURER(S) AFFORDING COVERAGE	
	INSURER A : Hartford Fire Insurance Company	19682
	INSURER B : Travelers Property Casualty Co of America	25674
	INSURER C : New Hampshire Insurance Company	23841
	INSURER D : Lexington Insurance Company	19437
	INSURER E : National Union Fire Ins Co Pittsburgh PA	19445
	INSURER F :	

COVERAGES HDRIN01 **CERTIFICATE NUMBER:** 2824447 **REVISION NUMBER:** XXXXXXXX

THIS IS TO CERTIFY THAT THE POLICIES OF INSURANCE LISTED BELOW HAVE BEEN ISSUED TO THE INSURED NAMED ABOVE FOR THE POLICY PERIOD INDICATED. NOTWITHSTANDING ANY REQUIREMENT, TERM OR CONDITION OF ANY CONTRACT OR OTHER DOCUMENT WITH RESPECT TO WHICH THIS CERTIFICATE MAY BE ISSUED OR MAY PERTAIN, THE INSURANCE AFFORDED BY THE POLICIES DESCRIBED HEREIN IS SUBJECT TO ALL THE TERMS, EXCLUSIONS AND CONDITIONS OF SUCH POLICIES. LIMITS SHOWN MAY HAVE BEEN REDUCED BY PAID CLAIMS.

INSR LTR	TYPE OF INSURANCE	ADDL INSD	SUBR WVD	POLICY NUMBER	POLICY EFF (MM/DD/YYYY)	POLICY EXP (MM/DD/YYYY)	LIMITS
A	<input checked="" type="checkbox"/> COMMERCIAL GENERAL LIABILITY <input type="checkbox"/> CLAIMS-MADE <input checked="" type="checkbox"/> OCCUR <input checked="" type="checkbox"/> CONTRACTUAL LIAB GEN'L AGGREGATE LIMIT APPLIES PER: <input type="checkbox"/> POLICY <input checked="" type="checkbox"/> PROJECT <input checked="" type="checkbox"/> LOC OTHER:	Y	Y	37CSEQU0950	6/1/2014	6/1/2015	EACH OCCURRENCE \$ 1,000,000 DAMAGE TO RENTED PREMISES (Ea occurrence) \$ 300,000 MED EXP (Any one person) \$ 10,000 PERSONAL & ADV INJURY \$ 1,000,000 GENERAL AGGREGATE \$ 2,000,000 PRODUCTS - COMP/OP AGG \$ 2,000,000 \$
A A A	<input checked="" type="checkbox"/> AUTOMOBILE LIABILITY <input checked="" type="checkbox"/> ANY AUTO <input type="checkbox"/> ALL OWNED AUTOS <input type="checkbox"/> SCHEDULED AUTOS <input checked="" type="checkbox"/> HIRED AUTOS <input checked="" type="checkbox"/> NON-OWNED AUTOS	Y	Y	37CSEQU0951 (AOS) 37CSEQU0952 (HI) 37CSE1160 (MA)	6/1/2014 6/1/2014 6/1/2014	6/1/2015 6/1/2015 6/1/2015	COMBINED SINGLE LIMIT (Ea accident) \$ 2,000,000 BODILY INJURY (Per person) \$ XXXXXXXX BODILY INJURY (Per accident) \$ XXXXXXXX PROPERTY DAMAGE (Per accident) \$ XXXXXXXX \$ XXXXXXXX
B	<input checked="" type="checkbox"/> UMBRELLA LIAB <input checked="" type="checkbox"/> OCCUR <input type="checkbox"/> EXCESS LIAB <input type="checkbox"/> CLAIMS-MADE DED RETENTION \$	N	N	ZUP-10R64084-14-NF (EXCLUDES PROF. LIAB)	6/1/2014	6/1/2015	EACH OCCURRENCE \$ 2,000,000 AGGREGATE \$ 2,000,000 \$ XXXXXXXX
C C E	<input checked="" type="checkbox"/> WORKERS COMPENSATION AND EMPLOYERS' LIABILITY ANY PROPRIETOR/PARTNER/EXECUTIVE OFFICER/MEMBER EXCLUDED? (Mandatory In NH) If yes, describe under DESCRIPTION OF OPERATIONS below	Y/N	N/A	027527762 (AOS) 027527764 (ME) 027527763 (CA)	7/1/2014 7/1/2014 7/1/2014	7/1/2015 7/1/2015 7/1/2015	<input checked="" type="checkbox"/> PER STATUTE <input type="checkbox"/> OTH-ER E.L. EACH ACCIDENT \$ 1,000,000 E.L. DISEASE - EA EMPLOYEE \$ 1,000,000 E.L. DISEASE - POLICY LIMIT \$ 1,000,000
D	ARCHS & ENGS PROFESSIONAL LIABILITY	N	N	061853691	6/1/2014	6/1/2015	PER CLAIM: \$2,000,000. AGG: \$2,000,000.

DESCRIPTION OF OPERATIONS / LOCATIONS / VEHICLES (ACORD 101, Additional Remarks Schedule, may be attached if more space is required)

RE: CLIENT #000194: ALL PROJECTS. CITY OF BILLINGS, ITS OFFICIALS, OFFICERS, EMPLOYEES & AGENTS ARE NAMED AS ADDITIONAL INSUREDS AS RESPECTS GENERAL & AUTOMOBILE LIABILITY, AS PER WRITTEN CONTRACT. WAIVER OF SUBROGATION APPLIES.

CERTIFICATE HOLDER**CANCELLATION**

2824447 CITY OF BILLINGS PUBLIC WORKS DEPARTMENT ATTN: DAVE MUMFORD 2224 MONTANA AVE 2ND FLOOR BILLINGS MT 59101	SHOULD ANY OF THE ABOVE DESCRIBED POLICIES BE CANCELLED BEFORE THE EXPIRATION DATE THEREOF, NOTICE WILL BE DELIVERED IN ACCORDANCE WITH THE POLICY PROVISIONS. AUTHORIZED REPRESENTATIVE 
---	---

© 1988-2014 ACORD CORPORATION. All rights reserved.

Regular City Council Meeting

Meeting Date: 10/27/2014

TITLE: Awarding Court Collections Services Contract

PRESENTED BY: Sheila Kolar, Municipal Court Judge

Department: Court

PROBLEM/ISSUE STATEMENT

The City of Billings is currently seeking an independent agency for Municipal Court Collections. The previous contract with Municipal Services Bureau is expired. The City of Billings Municipal Court places an average of 297 new accounts and \$95,000 of outstanding judgments in collections per month.

A detailed RFP was prepared and advertised on the City of Billing website. Nine proposals were received and reviewed by the selection committee. Each proposal was first reviewed to ensure the minimum qualifications were met. The proposals were then evaluated for responsiveness to the RFP, court collection experience, effectiveness of collection efforts, reporting capabilities, and ability to exchange data electronically.

The review committee determined Municipal Services Bureau rated the highest of the nine RFP proposals. Municipal Court Collections specializes in court collections, and they have over 23 years of court experience. The company uses a state of the art collection system with the ability to readily accept data electronically from the city, has a 28.49% collection rate effectiveness and has a reasonable fee for the defendants to pay. This is the current collection system that the Municipal Court utilizes. Reference calls were also made on Municipal Court Services Bureau including Yellowstone County Justice Court and the City of Bozeman.

ALTERNATIVES ANALYZED

City Council may:

- Approve the five (5) year contract, with up to three (3) annual renewals, with MSB, or;
- Disapprove the contract and provide alternative guidance to staff.

FINANCIAL IMPACT

Montana law provides the cost of collection may be assessed against the person who has failed to pay the fine imposed upon them by the Municipal Court. Municipal Services Bureau has agreed to collect a commission rate of 27% for all citations referred by the City of Billings. The Municipal Court places an average of 297 / \$95,000 of new accounts with collections per month, and in 2013 received an average of \$25,000 in payment from collection services.

RECOMMENDATION

Staff recommends that Council award a Municipal Court Collections Services contract to Municipal Services Bureau.

APPROVED BY CITY ADMINISTRATOR

Collections Contract

CONSULTANT AGREEMENT

THIS AGREEMENT is made and entered into this 1 day of October, 2014, by and between the **CITY OF BILLINGS, MONTANA**, a municipal corporation organized and existing under the laws of the State of Montana, P.O. Box 1178, Billings, Montana 59103, hereinafter referred to as "**CITY**," and Gila Corporation, d/b/a Municipal Services Bureau (hereinafter, "**MSB**"), 8325 Tuscany Way Building 4 Austin, TX 78754, hereinafter referred to as "**CONSULTANT**."

WITNESSETH:

WHEREAS, the **CITY** proposes to contract with MSB for Court Collection Services and desires to hire **CONSULTANT** as an independent contractor to perform the services as described in the Scope of Work attached hereto as Exhibit "A" and by this reference made a part hereof.

WHEREAS, the **CITY** has authority to contract for such services, and;

WHEREAS, the **CONSULTANT** represents that he/she is fully qualified to perform such services personally and is in compliance with the Montana Statutes relating to the provisions of such services.

NOW THEREFORE, in consideration of the mutual covenants and agreements herein contained, the receipt and sufficiency whereof being hereby acknowledged, the parties hereto agree as follows:

1. **PURPOSE:** **CITY** agrees to hire **CONSULTANT** as an independent contractor to perform the services as described in the Scope of Work attached hereto as Exhibit "A" and by this reference made a part hereof. In performing these services, the **CONSULTANT** shall at all times comply with all federal, state and local statutes, rules and ordinances applicable. These services and all duties incidental or necessary therefore, shall be performed diligently and completely and in accordance with professional standards of conduct and performance.

2. **TERM:** This **AGREEMENT** shall be for a period of 5 years, from the execution of this **AGREEMENT**. This **AGREEMENT** may be extended for 3 one year options by mutual agreement of both parties, in writing, thirty (30) days prior to termination.

3. **PAYMENT:** In consideration of the services provided by the **CONSULTANT** under this **AGREEMENT**, the **CITY** agrees of a basic commission rate to the **CONSULTANT**. For all citations referred by the City to MSB for collection or resolution for which the City is paid (in whole or in part), regardless of whether payment is accepted directly by the City or MSB on the City's behalf, MSB will collect a 27% percent commission rate on the amount collected. MSB is not due a fee of any kind if the case is resolved by a law enforcement agency. It is expressly understood and agreed between the parties that Montana law provides the cost of collection may be assessed against the person who has failed to pay the fine imposed upon

them by the Municipal Court. Municipal Court will include all such recoverable costs in any claims turned over for the collection and MSB will be paid these sums only as they are recovered from the person who owes them. If the full amount of the claim is not recovered, MSB will receive a pro rata portion of their fee based on the percentage of the amount claimed due which is recovered, including the portion of the costs of collection that are recovered.

In the event scope of work issues arise, the **CONSULTANT** shall immediately discuss them with the Project Manager for the **CITY**. It is understood that the Consultant will not perform any work that the **CITY** deems outside the scope prior to receiving written approval from the **CITY**, and at a rate agreed upon by both parties. Any payment for work not agreed upon by the **CITY** shall be denied.

4. INDEPENDENT CONTRACTOR STATUS: The parties agree that **CONSULTANT** is an independent Contractor for purposes of this **AGREEMENT** and is not to be considered an employee of the **CITY** for any purpose. **CONSULTANT** is not subject to the terms and provisions of the **CITY's** personnel policies handbook and may not be considered a **CITY** employee for workers' compensation or any other purpose. **CONSULTANT** is not authorized to represent the **CITY** or otherwise bind the **CITY** in any dealings between **CONSULTANT** and any third parties.

5. INDEMNITY AND INSURANCE:

- A. The Consultant agrees to indemnify, defend and save City, its officers, agents and employees harmless from any and all losses, damage and liability occasioned by, growing out of, or in any way arising or resulting from any intentional or negligent act on the part of Consultant or its agents or employees.
- B. The Consultant shall not indemnify, defend, save and hold Billings harmless from claims, causes of action, lawsuits, damages, judgments, liabilities, and litigation costs and expenses or attorneys' fees and costs arising from wrongful or negligent acts, error or omission solely of Billings occurring during the course of or as a result of the performance of the **AGREEMENT**.
- C. Where claims, lawsuits or liability, including attorneys' fees and costs arise from wrongful or negligent act of both Billings and the Consultant, the Consultant shall indemnify, defend, save, and hold Billings harmless from only that portion of claims, causes of action, lawsuits, damages, judgments, liabilities, and litigation costs and expenses including attorneys' fees and costs, which result from the Consultant's or any subcontractor's wrongful or negligent acts occurring as a result from the Consultant's performance pursuant to this **AGREEMENT**.
- D. The **CONSULTANT** shall maintain in good standing the insurance described in this Section. Before rendering any services under this **AGREEMENT**, the **CONSULTANT** shall furnish the **CITY** with proof of insurance in accordance with this Section.

The **CONSULTANT** shall provide the following insurance:

- 1. Workers' compensation and employer's liability coverage as required by Montana law.
- 2. Commercial general liability, including contractual and personal injury coverage's -- \$750,000 per claim and \$1,500,000 per occurrence.
- 3. Commercial automobile liability -- \$1,500,000 per accident.
- 4. Professional liability in the amount of \$1,500,000 per claim.

Each policy of insurance required by this Section shall provide for no less than 30 days' advance written notice to the **CITY** prior to cancellation.

The **CITY** shall be listed as an additional insured on all policies except Professional Liability and Worker's Compensation Policies.

In addition, all policies except Professional Liability and Worker's Compensation shall contain a waiver of subrogation against Billings.

CONSULTANT shall comply with the applicable requirements of the Workers' Compensation Act, Title 39, Chapter 71, MCA, and the Occupational Disease Act of Montana, Title 39, Chapter 71, MCA. **CONSULTANT** shall maintain workers' compensation insurance coverage for all members and employees of **CONSULTANT's** business, except for those members who are exempted as independent **CONSULTANTS** under the provisions of §39-71-401, MCA.

CONSULTANT shall furnish **CITY** with copies showing one of the following: (1) proof of registration as a registered Contractor under Title 39, Chapter 9, MCA; (2) a binder for workers' compensation coverage by an insurer licensed and authorized to provide workers' compensation insurance in the State of Montana; or (3) proof of exemption from workers' compensation granted by law for independent Contractors.

6. **AGREEMENTS OF CONSULTANT:** As an inducement to the execution of this **AGREEMENT** by the **CITY** and in consideration of the agreements to be performed by the **CITY**, the **CONSULTANT** agrees that:

A. Qualifications

The **CONSULTANT** is qualified to perform the services to be furnished under this **AGREEMENT** and is permitted by law to perform such services, and all personnel engaged in the work shall be qualified and so permitted to do the work they perform.

B. Solicitation of Agreement

The **CONSULTANT** has not employed any person to solicit this **AGREEMENT** and has not made, and will not make, any payment or any agreement for the payment of any commission, percentage, brokerage, contingent fee, or other compensation in connection with the procurement of this **AGREEMENT**.

C. Facilities and Personnel

The **CONSULTANT** has and will continue to have proper facilities and personnel to perform the services and work agreed to be performed.

D. Subcontracting

None of the work or services covered by this **AGREEMENT** shall be subcontracted without the prior approval of the **CITY**.

E. Affidavits of Compliance

The **CONSULTANT** will, if requested by the **CITY**, furnish the **CITY** affidavits certifying compliance with the provisions of this Section.

7. **AGREEMENTS OF CITY:**

- A. To furnish all labor, materials, equipment, supplies, and incidentals necessary to conduct and complete the City of Billings' portion of the project as designated in the scope of work.
- B. Name a Project Manager who shall be the liaison between the Consultant and the City of Billings. For this project, the Project Manager for **CONSULTANT** designated is _____ and the Project Manager for **CITY** designated is _____.

8. **NONDISCRIMINATION:**

- A. The **CONSULTANT** will not discriminate against any employee or applicant for employment because of race, color, religion, national origin, ancestry, age, sex, or marital status or who is a "qualified individual with a disability" (as that phrase is defined in the Americans With Disabilities Act of 1990). The **CONSULTANT** will take affirmative action to ensure that applicants are employed and that employees are treated during employment without regard to their race, color, religion, or mental or physical impairment/disability. Such action shall include, without limitation, employment, upgrading, demotion or transfer, recruitment or recruiting advertising, layoff or termination, rates of pay or other forms of compensation, and selection for training including apprenticeship. The **CONSULTANT** agrees to post, in conspicuous places available to employees and applicants for employment, notices setting forth the provisions of this non-discrimination clause.
- B. The **CONSULTANT** shall state, in all solicitations or advertisements for employees to work on jobs, that all qualified applicants will receive equal consideration for employment without regard to race, color, religion, national origin, ancestry, age, sex or marital status, or mental or physical impairment/disability.
- C. The **CONSULTANT** shall comply with any and all reporting requirements that may apply to it that the **CITY** may establish by regulation.
- D. The **CONSULTANT** shall include the provisions of Subsections A through C of this Section in every subcontract or purchase order under this **AGREEMENT**, so as to be binding upon every such sub-consultant or vendor of the **CONSULTANT** under this **AGREEMENT**.
- E. The **CONSULTANT** shall comply with all applicable federal, state, and city laws concerning the prohibition of discrimination.

9. **PERMITS, LAWS, AND TAXES:** The **CONSULTANT** shall acquire and maintain in good standing all permits, licenses and other entitlements necessary to its performance under this **AGREEMENT**. All actions taken by the **CONSULTANT**

under this **AGREEMENT** shall comply with all applicable statutes, ordinances, rules and regulations. The **CONSULTANT** shall pay all taxes pertaining to its performance under this **AGREEMENT**.

10. **NONWAIVER:** The failure of either party at any time to enforce a provision of this **AGREEMENT** shall in no way constitute a waiver of the provision, nor in any way affect the validity of this **AGREEMENT** or any part hereof, or the right of such party thereafter to enforce each and every provision hereof.
11. **DECLARATION OF NO FINANCIAL INTEREST:** The **CONSULTANT** hereby declares that he does not have any interest (including that of real estate agent or broker), direct or indirect, present or prospective, in any property described in Section 1 or in its sale, or any other interest, whether or not in connection with the property, which would conflict in any manner or degree with the performance of the services and the submission of impartial reports, and has not employed and will not employ, in connection with the services to be furnished under this **AGREEMENT**, any person having any such interest. Until the property is acquired by the **CITY** or excluded from its project by resolution of its governing body, the **CONSULTANT** and any employees of the **CONSULTANT**, so long as they are employed by the **CONSULTANT**, will not acquire any such interests and will not, for their own account or for other than the **CITY**, negotiate for any of the property, perform services in connection with the property, or testify voluntarily as a witness in a condemnation or other proceeding with respect to the property.
12. **SUCCESSORS AND ASSIGNS:** This **AGREEMENT** and all of the covenants hereof shall inure to the benefit of and be binding upon the **CITY** and the **CONSULTANT** respectively and his partners, successors, assigns, and legal representatives. Neither the **CITY** nor the **CONSULTANT** shall have the right to assign, transfer, or sublet his interest or obligations hereunder without written consent of the other party.
13. **CHANGES IN WORK:** Any change in the scope of **CONSULTANT'S** services as stated in this **AGREEMENT** for whatever reason, will be negotiated between the **CITY** and the **CONSULTANT** and an amendment to this **AGREEMENT** will be issued with the appropriate change of services and **AGREEMENT** fee noted.
14. **LEGAL RELATIONS:** The **CONSULTANT** shall comply with all Federal, State, and local laws and ordinances applicable to the work to be done.
15. **TERMINATION OF AGREEMENT:** The right is reserved by the **CITY** to terminate this **AGREEMENT** at any time upon not less than thirty (30) days written notice to the **CONSULTANT**.

In the event the **CITY** terminates this **AGREEMENT**, the **CONSULTANT** shall be paid for the amount of work performed or services rendered to date of termination per the **AGREEMENT** fee.
16. **ENDORSEMENTS:** The **CONSULTANT** shall furnish signatures, statements, or other suitable means to signify responsible endorsement of work on all reports furnished by him.
17. **OWNERSHIP OF DOCUMENTS:** All information relating to the project and prepared under the terms of this **AGREEMENT**, including reports, data,

recommendations, exhibits, analyses, and plans shall be deemed the property of the **CITY**. Reproduces of all notes, reports, and plans shall be made available at the **CITY'S** request.

18. **PUBLIC INFORMATION:** The **CONSULTANT** shall not issue any statements, releases, or information for public dissemination without prior written approval of the **CITY**.
19. **PROPRIETARY RIGHTS:** If patentable discoveries or inventions should result from work required herein, all rights accruing from such discoveries or inventions shall be the property of the **CITY**.
20. **RECORDS:** The **CONSULTANT** shall maintain accounting records and other evidence pertaining to the cost incurred and to make the records available at all times during the **AGREEMENT** term and for three (3) years from the date of final payment. Such accounting records and other evidence pertaining to the cost incurred will be made available for inspections authorized by the **CITY** and copies thereof shall be furnished if requested.
21. **ATTORNEY'S FEES AND COSTS:** That in the event it becomes necessary for either Party to this **AGREEMENT** to retain an attorney to enforce any of the terms or conditions of the **AGREEMENT** or to give any notice required herein, then the prevailing Party or the Party giving notice shall be entitled to reasonable attorney's fees and costs.
22. **LITIGATION LOCATION:** The parties agree that this **AGREEMENT** shall be governed in all respects by the laws of the state of Montana, and the parties expressly agree that venue shall be in the Montana Thirteenth Judicial District County for Yellowstone County and there shall be no other venue for resolution of disputes arising from the **AGREEMENT** or the performance of its terms.
23. **MODIFICATION AND AMENDMENTS:** That any amendment or modification of this **AGREEMENT** or any provisions herein shall be made in writing and executed in the same manner as this original document and shall after execution become a part of this **AGREEMENT**.

IN WITNESS WHEREOF, the parties hereto have executed this instrument the day and year first above written.

CITY OF BILLINGS, MONTANA

CONSULTANT (Print Name Above)

By _____
THOMAS W. HANEL, MAYOR

By _____

Print Name _____

Print Title _____

APPROVED AS TO FORM:

By _____
BRENT BROOKS, CITY Attorney

Exhibit A

Scope of Work: Consultant will provide the City of Billings Municipal Court with successful collection services.

The consultant shall accept new collection accounts placed by the Municipal Court and will use its best efforts to collect said accounts utilizing means legal, necessary and proper.

The Municipal Court shall provide information needed for the collection. Further, the Municipal Court shall make its own efforts at collection and written demands prior to turnover and will inform the debtor of the consequences of his/her failure to make payments.

The consultant shall provide routine, detailed account information to the Municipal Court each month and shall provide summary information to the Municipal Court as required.

Municipal Court shall provide the consultant with information on payments made directly to it on accounts assigned to the collection agency or consultant, and will pay the collection fee on these accounts.

The consultant shall not initiate legal proceedings on an account without prior authorization by the Municipal Court. All attorney fees, court costs, and other expenses incurred with legal collection proceedings authorized by Municipal Court shall be borne by the consultant.

Accounts may not be compromised by the consultant except pursuant to specific written approval from the City on a case by case basis.

The Municipal Court shall pay no fee to the consultant for the balance due has been reduced resulting from Municipal Court action such as application of refund, security deposit or credit adjustment.

Records developed as a result of an agreement are City records and subject to access, scheduling and disposition approved by the City and Municipal Court.

The consultant shall follow the applicable provisions of federal and state law regulating debt collections.

Regular City Council Meeting

Meeting Date: 10/27/2014

TITLE: Compensation Agreement for P-693, construction of a 20" water main in 56th Street West

PRESENTED BY: David Mumford, Public Works Director

Department: Public Works

PROBLEM/ISSUE STATEMENT

In order for the Trails West Subdivision to continue with development of future phases of the subdivision, 2,050 feet of 20" water main needs to be extended in 56th Street West, south of Grand Avenue. The 20" water main is sized in accordance with the Water Facilities Master Plan. The extension was not a planned project in the current CIP, so the Trails West Homes developer will pay the entire cost of the project. The City's Rules and Regulations for Water and Sanitary Sewer include compensation to developers for the entire cost of constructing water mains over 12" in size. As such, the developer desires to be compensated for these costs in full and the Public Works Department proposes that such compensation be accomplished through the attached agreement.

ALTERNATIVES ANALYZED

City Council may:

- Accept the compensation agreement; or
- Do not accept the compensation agreement. Rejecting the agreement would be contrary to the City's policy which compensates developers who install large diameter public mains as part of their development.

FINANCIAL IMPACT

Based on the lowest bid price for the installation of the public water main, it has been determined that the eligible cost recovery by the developer is \$403,101.56. The timing of the City's participation in the project cost is determined in conformance with the budget approved by the City Council.

RECOMMENDATION

Staff recommends that Council authorize the Mayor to execute the attached compensation agreement. Compensation shall be based on the final water utility costs.

APPROVED BY CITY ADMINISTRATOR

Compensation Agreement

Bid Tab

Overall Exhibit

COMPENSATION AGREEMENT

THIS AGREEMENT entered into this _____ day of _____, 2014 between THE CITY OF BILLINGS, Billings, Montana, hereinafter referred to as the "CITY", and TRAILS WEST HOMES, LLC, 5807 Mountain Front Avenue, Billings, Montana, 59106, hereinafter referred to as "DEVELOPER".

WITNESSETH

WHEREAS, the CITY'S Water/Wastewater Extension Policy outlines the procedure and criteria the CITY uses in approving extensions of the public water and wastewater systems; and

WHEREAS, the CITY'S Utilities Fee Practice outlines how the CITY participates in construction of various water and wastewater facilities and applies water and wastewater construction fees and system development fees to developments; and

WHEREAS, no person, developer, customer, or applicant shall acquire any vested rights under the terms and provisions of this agreement; and

WHEREAS, DEVELOPER has agreed to extend or replace water and/or wastewater facilities for the purpose of providing service through plans and specifications approved by the City on the 24th day of September, 2014. Said plans and specifications generally provide for the construction of water facilities which are specifically described in Exhibit 1, attached hereto; and

WHEREAS, DEVELOPER is desirous of obtaining compensation for a portion of the water main extension in 56th Street West south of Grand Avenue; and

WHEREAS, the CITY is desirous of compensating the DEVELOPER for a portion of such water and/or wastewater facilities.

NOW, THEREFORE, CITY and DEVELOPER, in consideration of their mutual promises to each other hereinafter stated, agree as follows:

1. The water and/or wastewater facilities which are eligible for compensation to the extent set forth in this Agreement are specifically described in Exhibit 1, attached hereto, and by this reference incorporated herein as if fully set out.

2. With respect to DEVELOPER'S entitlement to compensation, the CITY and DEVELOPER agree that the conditions set forth hereinafter, must be met before DEVELOPER is entitled to or will receive any compensation. Said conditions are:

- (a) The extent, timing, and manner of the CITY'S participation in a water and/or wastewater facilities extension is determined in conformance with the CITY'S Water/Wastewater Extension Policy, the CITY'S Utilities Fees Practice, and the DEVELOPER'S compliance with city, state, and federal laws, rules, and regulations. These policies require necessary funds to be included in the current, approved Capital Improvements Projects (CIP) budget in order to be eligible for

compensation back to the DEVELOPER. The DEVELOPER may choose to proceed with an extension or replacement project without waiting for funds to be made available in the CIP budget; in this case, the DEVELOPER is responsible for paying the entire cost of the construction. Extensions or replacements not eligible for compensation according to these CITY policies and practices must be constructed by the DEVELOPER at his expense.

- (b) DEVELOPER shall provide to the CITY sufficient verifiable cost data to determine the appropriate amount of compensation within thirty (30) days of final inspection of the water and/or wastewater facilities and approval and acceptance by the CITY that all construction was completed according to the approved plans and specifications.
- (c) DEVELOPER shall enter into a compensation agreement with the CITY at the time the CITY approves the DEVELOPER'S application for extension of water and/or wastewater facilities or, in the case of a replacement project, prior to submittal of preliminary plans and specifications by the DEVELOPER.
- (d) Upon completion of the extension or replacement of the water and/or wastewater facilities, the DEVELOPER must convey all right, title, and interest in the facilities to the CITY.
- (e) DEVELOPER shall, at all times, provide to the CITY a current address for purposes of mailing compensation to DEVELOPER.
- (f) Extension or replacement of water facilities must be done in compliance with all rules, regulations, resolutions, and ordinances of the CITY, including but not limited to standards for design and construction of the facilities, competitive bidding, and contract requirements for cities, prevailing wage rates, non-discrimination requirements, etc.

DEVELOPER agrees that it will not be entitled to any compensation whatsoever until the above conditions have been completely satisfied. DEVELOPER'S violation of any of the conditions set forth herein may, at the option of the CITY, result in denial of any and all compensation to the DEVELOPER.

3. In addition, it is expressly agreed that any compensation is conditioned upon the following:

- (a) Compensation is limited to costs attributable to water and/or wastewater facilities described in Exhibit 1, less all administrative costs incurred by the CITY. In no event will compensation exceed the actual cost to the DEVELOPER of extending or replacing the water and/or wastewater facilities.
- (b) Compensation shall not include any interest charges.

Acceptance of the water facilities for purposes of compensation as set forth in this agreement shall be evidenced by written notice of a letter from the Public Works Department of the CITY and directed to the DEVELOPER at the address set forth in the first paragraph of this agreement.

4. The CITY, by this agreement, is not guaranteeing that full compensation by the CITY to the DEVELOPER will be made. The CITY is only agreeing that it will develop a plan under its Water/Wastewater Extension Policy and Utilities Fees Practice that will recommend that compensation for water and/or wastewater facilities which have been extended or replaced at the DEVELOPER'S expense will be made as set forth herein.

Compensation does not apply to additional extensions or replacements of the water facilities. Compensation shall be based upon the final total project costs.

5. The address for mailing compensation to the DEVELOPER shall be that address specified in the first paragraph of this agreement. Any change in address of the DEVELOPER shall be sent to the Public Works Director of the City of Billings at P.O. Box 1178, Billings, Montana 59103. The designation of a new address shall be accompanied by a copy of this agreement.

6. This agreement shall be binding upon and shall inure to the benefit of the parties hereto, and their successors and assigns.

DATED this 15th day of OCTOBER, 2014.

TRAILS WEST HOMES, LLC

By: Rod Wilson

Its: Member

STATE OF MONTANA)
: ss
County of Yellowstone)

On this 15th day of October, 2014, before me, a Notary Public in and for the State of Montana, personally appeared Rod Wilson known to me to be the Member of Trails West Homes, LLC, the person who signed the foregoing instrument and acknowledged to me that they executed the same.

IN WITNESS WHEREOF, I have hereunto set my hand and affixed my Notarial Seal the day and year herein above written.

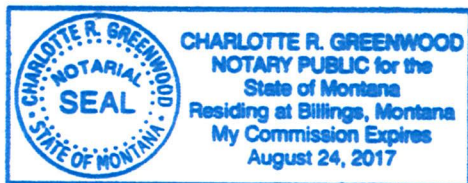

Charlotte R. Greenwood
Notary Public in and for the State of Montana
Printed name: _____
Residing at: _____
My commission expires: _____

EXHIBIT 1

**City of Billings Monetary Compensation for
Private Contract No. 693 – 56th Street West Water Main Extension**

Project Description: Private Contract No. 693 consists of extending 2,050 lineal feet of 20-inch water main and associated appurtenances in 56th Street West south of Grand Avenue

Schedule I – 56th Street West Water Main Extension

Williams Civil Division, Inc. Total Bid Price: \$ 340,716.00
(see attached bid tabs)

DEQ Review Fee

Fee Amount: \$ 510.50

Private Contract Fee

3.5% of Total Bid Price: \$ 11,925.06

Engineering Fees & Construction Administration Services

Total Cost: \$ 49,950.00

Grand Total: \$ 403,101.56

City Compensation to Trails West Homes, LLC \$ 403,101.56

PROJECT: **P693 - 56th Street West Water Main Extension Project**
 S.S. PROJECT NO.: **05051.11**

BID DATE: **October 10, 2014**
 BID TIME: **2:00 PM MST**

BID DATE: **October 10, 2014**
 BID TIME: **2:00 PM MST**

BID DATE: **October 10, 2014**
 BID TIME: **2:00 PM MST**

BID DATE: **October 10, 2014**
 BID TIME: **2:00 PM MST**

BID DATE: **October 10, 2014**
 BID TIME: **2:00 PM MST**

BY: Sanderson Stewart
 FOR: Trails West Homes, LLC

Engineer's Opinion of Probable Cost

Williams Civil Construction

COP Construction LLC

Western Municipal Construction, Inc.

Castlerock Excavating, Inc.

Wilson Bros. Construction, Inc.

ITEM NO.	EST. QTY.	UNIT	DESCRIPTION	UNIT PRICE \$	TOTAL PRICE \$	UNIT PRICE \$	TOTAL PRICE \$	UNIT PRICE \$	TOTAL PRICE \$	UNIT PRICE \$	TOTAL PRICE \$	UNIT PRICE \$	TOTAL PRICE \$	UNIT PRICE \$	TOTAL PRICE \$
101	1	LS	Mobilization and Insurance	\$26,879.20 / LS =	26,879.20	\$10,000.00 / LS =	10,000.00	\$38,000.00 / LS =	38,000.00	\$11,000.00 / LS =	11,000.00	\$21,500.00 / LS =	21,500.00	\$40,000.00 / LS =	40,000.00
102	1	LS	Taxes, Bonds, Insurance	\$16,799.50 / LS =	16,799.50	\$4,500.00 / LS =	4,500.00	\$5,000.00 / LS =	5,000.00	\$9,000.00 / LS =	9,000.00	\$6,600.00 / LS =	6,600.00	\$6,500.00 / LS =	6,500.00
103	6	EA	Pre-Construction Structure Survey (If Dewatering is Required)	\$1,200.00 / EA =	7,200.00	\$1,000.00 / EA =	6,000.00	\$101.00 / EA =	606.00	\$100.00 / EA =	600.00	\$2,500.00 / EA =	15,000.00	\$1,500.00 / EA =	9,000.00
104	1	LS	Stormwater Management and Erosion Control	\$3,000.00 / LS =	3,000.00	\$4,500.00 / LS =	4,500.00	\$4,000.00 / LS =	4,000.00	\$500.00 / LS =	500.00	\$5,000.00 / LS =	5,000.00	\$3,500.00 / LS =	3,500.00
105	1	LS	Traffic Control During Construction	\$30,000.00 / LS =	30,000.00	\$21,000.00 / LS =	21,000.00	\$11,000.00 / LS =	11,000.00	\$12,000.00 / LS =	12,000.00	\$19,450.00 / LS =	19,450.00	\$20,000.00 / LS =	20,000.00
106	1	EA	Connect to Existing 20-inch Water Main with 20x20x20-inch Tee	\$10,000.00 / EA =	10,000.00	\$6,000.00 / EA =	6,000.00	\$13,000.00 / EA =	13,000.00	\$15,500.00 / EA =	15,500.00	\$15,035.00 / EA =	15,035.00	\$10,000.00 / EA =	10,000.00
107	2,050	LF	20-inch Ductile Iron Water Main	\$105.00 / LF =	215,250.00	\$97.00 / LF =	198,850.00	\$108.00 / LF =	221,400.00	\$138.00 / LF =	282,900.00	\$113.98 / LF =	233,659.00	\$151.00 / LF =	309,550.00
108	3	EA	20-inch Butterfly Valve	\$6,000.00 / EA =	18,000.00	\$5,950.00 / EA =	17,850.00	\$5,000.00 / EA =	15,000.00	\$5,700.00 / EA =	17,100.00	\$4,333.33 / EA =	12,999.99	\$7,000.00 / EA =	21,000.00
109	2	EA	20x20x6-inch Hydrant Tee	\$3,000.00 / EA =	6,000.00	\$2,475.00 / EA =	4,950.00	\$2,000.00 / EA =	4,000.00	\$1,500.00 / EA =	3,000.00	\$1,250.00 / EA =	2,500.00	\$2,000.00 / EA =	4,000.00
110	1	EA	20x20x8-inch Hydrant Tee	\$3,500.00 / EA =	3,500.00	\$2,750.00 / EA =	2,750.00	\$2,000.00 / EA =	2,000.00	\$1,700.00 / EA =	1,700.00	\$1,600.00 / EA =	1,600.00	\$2,000.00 / EA =	2,000.00
111	1	EA	20-inch Plug and Thrust Block	\$2,500.00 / EA =	2,500.00	\$1,300.00 / EA =	1,300.00	\$1,500.00 / EA =	1,500.00	\$1,000.00 / EA =	1,000.00	\$917.50 / EA =	917.50	\$1,000.00 / EA =	1,000.00
112	1	EA	8-inch Plug and Thrust Block	\$1,800.00 / EA =	1,800.00	\$900.00 / EA =	900.00	\$500.00 / EA =	500.00	\$250.00 / EA =	250.00	\$505.00 / EA =	505.00	\$850.00 / EA =	850.00
113	2	EA	Fire Hydrant Assembly (Includes 6-inch Gate Valve, Pipe, and Extension to Grade)	\$4,500.00 / EA =	9,000.00	\$3,950.00 / EA =	7,900.00	\$5,800.00 / EA =	11,600.00	\$4,500.00 / EA =	9,000.00	\$3,602.50 / EA =	7,205.00	\$7,500.00 / EA =	15,000.00
114	20	LF	Waterline Insulation	\$100.00 / LF =	2,000.00	\$28.00 / LF =	560.00	\$15.00 / LF =	300.00	\$27.00 / LF =	540.00	\$15.00 / LF =	300.00	\$30.00 / LF =	600.00
115	50	LF	Flowable Fill Backfill (If Required)	\$50.00 / LF =	2,500.00	\$48.00 / LF =	2,400.00	\$32.00 / LF =	1,600.00	\$121.00 / LF =	6,050.00	\$40.50 / LF =	2,025.00	\$75.00 / LF =	3,750.00
116	10	EA	Underground Utility Crossings, Less Than 18-inch Diameter	\$400.00 / EA =	4,000.00	\$350.00 / EA =	3,500.00	\$600.00 / EA =	6,000.00	\$420.00 / EA =	4,200.00	\$600.00 / EA =	6,000.00	\$500.00 / EA =	5,000.00
117	5	EA	Bentonite Cut-off Wall	\$1,000.00 / EA =	5,000.00	\$2,335.00 / EA =	11,675.00	\$700.00 / EA =	3,500.00	\$800.00 / EA =	4,000.00	\$465.00 / EA =	2,325.00	\$500.00 / EA =	2,500.00
118	460	CY	Type 2 Bedding	\$20.00 / CY =	9,200.00	\$22.00 / CY =	10,120.00	\$15.00 / CY =	6,900.00	\$1.00 / CY =	460.00	\$20.70 / CY =	9,522.00	\$24.00 / CY =	11,040.00
119	2,050	LF	Geotextile Trench Fabric	\$3.50 / LF =	7,175.00	\$2.50 / LF =	5,125.00	\$1.40 / LF =	2,870.00	\$0.50 / LF =	1,025.00	\$2.58 / LF =	5,289.00	\$3.00 / LF =	6,150.00
120	53	LF	Relocate Existing 15-inch RCP Culvert with FETS	\$30.00 / LF =	1,590.00	\$22.00 / LF =	1,166.00	\$28.00 / LF =	1,484.00	\$10.00 / LF =	530.00	\$47.17 / LF =	2,500.01	\$100.00 / LF =	5,300.00
121	1	LS	Relocate Existing Irrigation Drain Ditch	\$4,000.00 / LS =	4,000.00	\$3,500.00 / LS =	3,500.00	\$1,250.00 / LS =	1,250.00	\$2,300.00 / LS =	2,300.00	\$5,750.00 / LS =	5,750.00	\$7,500.00 / LS =	7,500.00
122	1	LS	Re-Grade Existing Borrow Ditch, Restore Existing Gravel Emergency Road, and Reseed Disturbed Areas	\$10,000.00 / LS =	10,000.00	\$7,200.00 / LS =	7,200.00	\$5,000.00 / LS =	5,000.00	\$7,000.00 / LS =	7,000.00	\$22,620.00 / LS =	22,620.00	\$3,000.00 / LS =	3,000.00
123	1,550	SY	SC150 Erosion Control Blanket	\$4.00 / SY =	6,200.00	\$1.40 / SY =	2,170.00	\$3.70 / SY =	5,735.00	\$0.80 / SY =	1,240.00	\$3.03 / SY =	4,696.50	\$3.00 / SY =	4,650.00
124	40	SY	Asphalt Restoration in Grand Avenue (Includes Geogrid, 14-inch Base Course, and 6-inch Asphalt Section)	\$100.00 / SY =	4,000.00	\$170.00 / SY =	6,800.00	\$156.00 / SY =	6,240.00	\$175.00 / SY =	7,000.00	\$405.50 / SY =	16,220.00	\$100.00 / SY =	4,000.00
TOTAL BID					\$405,593.70		\$340,716.00		\$368,485.00		\$397,895.00		\$419,219.00		\$495,890.00

c: Engineer, Owner, Bid Tabs Book

Percent Over Engineer's Estimate	-19.0%	-10.1%	-1.9%	3.3%	18.2%
----------------------------------	--------	--------	-------	------	-------

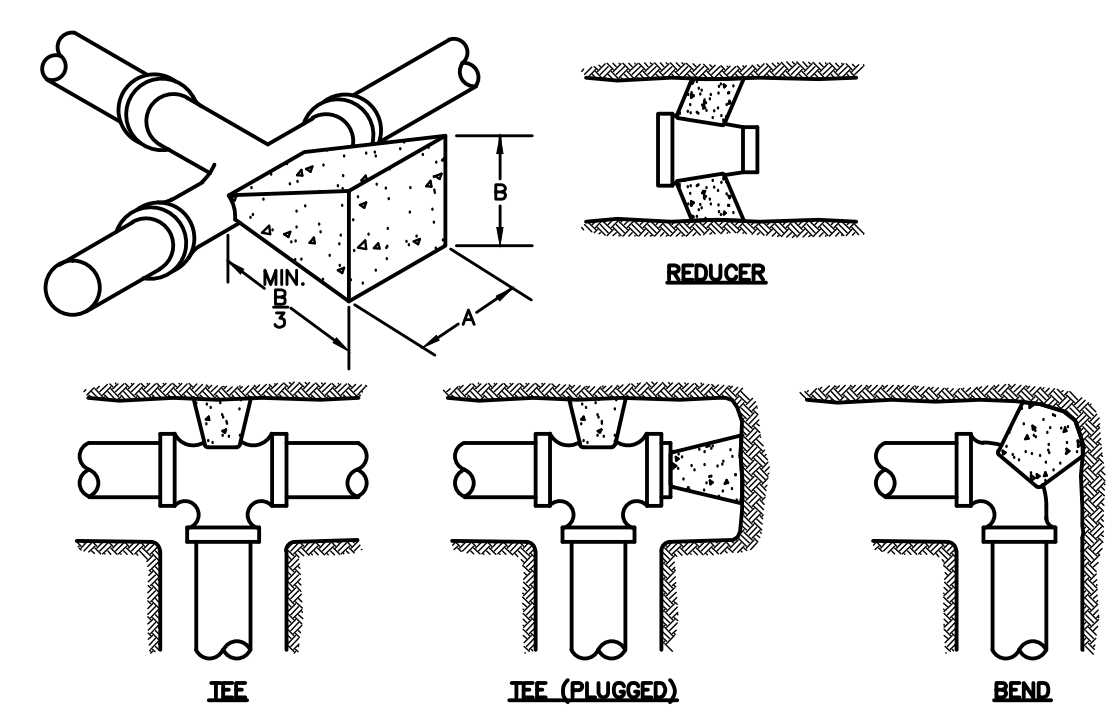
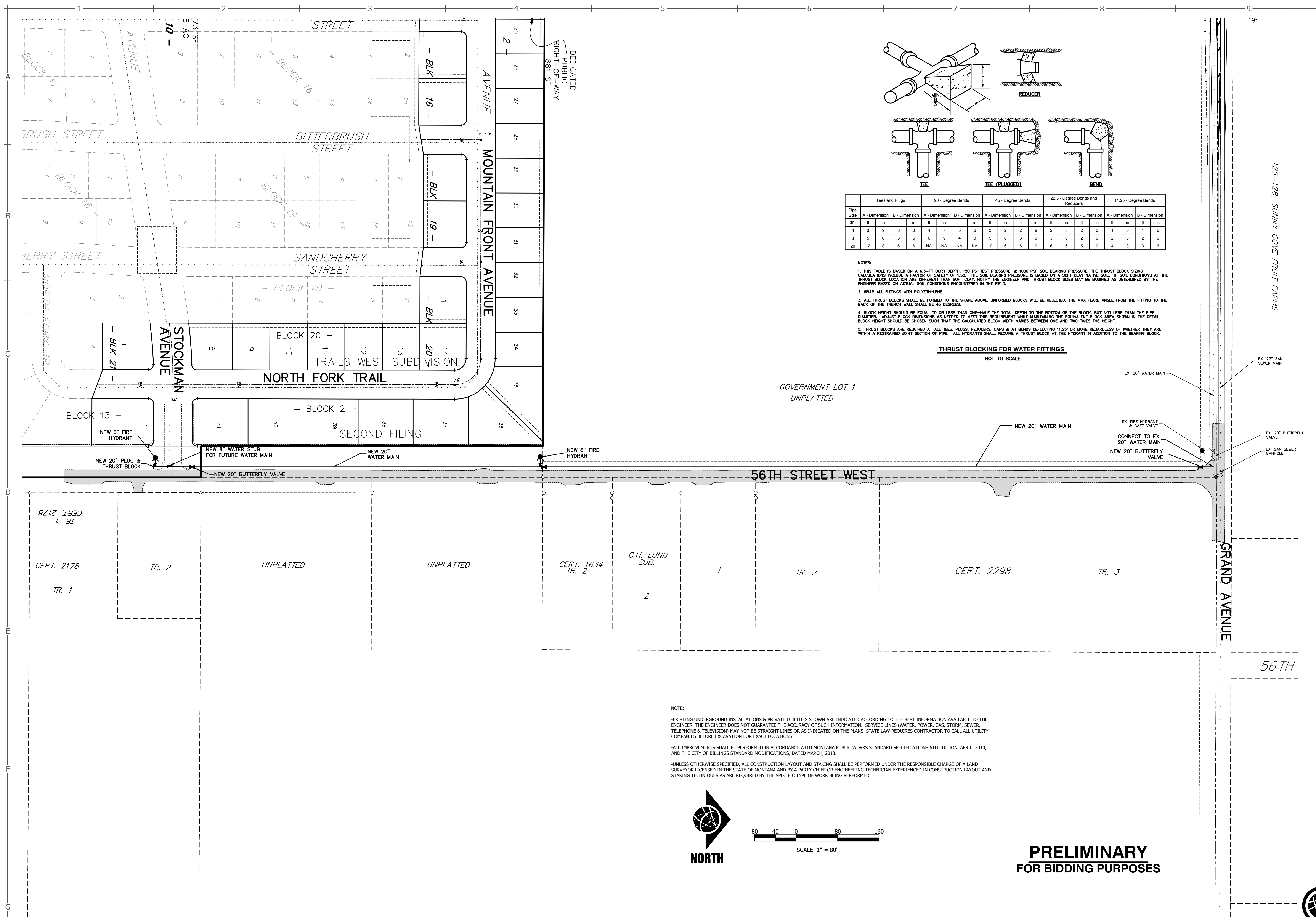

Pipe Size (in)	Tees and Plugs		90 - Degree Bends		45 - Degree Bends		22.5 - Degree Bends and Reducers		11.25 - Degree Bends											
	A - Dimension	B - Dimension	A - Dimension	B - Dimension	A - Dimension	B - Dimension	A - Dimension	B - Dimension	A - Dimension	B - Dimension										
6	3	9	3	0	4	7	3	6	3	2	9	2	3	2	0	1	6	1	6	
8	5	6	3	6	6	9	4	0	5	0	3	0	2	6	2	0	2	0	2	0
20	12	8	6	6	NA	NA	NA	NA	10	6	6	0	6	6	5	0	4	8	3	6

- NOTES:
- THIS TABLE IS BASED ON A 6.5-FT BURY DEPTH, 150 PSI TEST PRESSURE, & 1000 PSF SOIL BEARING PRESSURE. THE THRUST BLOCK SIZING CALCULATIONS INCLUDE A FACTOR OF SAFETY OF 1.50. THE SOIL BEARING PRESSURE IS BASED ON A SOFT CLAY NATIVE SOIL. IF SOIL CONDITIONS AT THE THRUST BLOCK LOCATION ARE DIFFERENT THAN SOFT CLAY, NOTIFY THE ENGINEER AND THRUST BLOCK SIZES MAY BE MODIFIED AS DETERMINED BY THE ENGINEER BASED ON ACTUAL SOIL CONDITIONS ENCOUNTERED IN THE FIELD.
 - WRAP ALL FITTINGS WITH POLYETHYLENE.
 - ALL THRUST BLOCKS SHALL BE FORMED TO THE SHAPE ABOVE. UNFORMED BLOCKS WILL BE REJECTED. THE MAX FLARE ANGLE FROM THE FITTING TO THE BACK OF THE TRENCH WALL SHALL BE 45 DEGREES.
 - BLOCK HEIGHT SHOULD BE EQUAL TO OR LESS THAN ONE-HALF THE TOTAL DEPTH TO THE BOTTOM OF THE BLOCK, BUT NOT LESS THAN THE PIPE DIAMETER. ADJUST BLOCK DIMENSIONS AS NEEDED TO MEET THIS REQUIREMENT WHILE MAINTAINING THE EQUIVALENT BLOCK AREA SHOWN IN THE DETAIL. BLOCK HEIGHT SHOULD BE CHOSEN SUCH THAT THE CALCULATED BLOCK WIDTH VARIES BETWEEN ONE AND TWO TIMES THE HEIGHT.
 - THRUST BLOCKS ARE REQUIRED AT ALL TEES, PLUGS, REDUCERS, CAPS & AT BENDS DEFLECTING 11.25° OR MORE REGARDLESS OF WHETHER THEY ARE WITHIN A RESTRAINED JOINT SECTION OF PIPE. ALL HYDRANTS SHALL REQUIRE A THRUST BLOCK AT THE HYDRANT IN ADDITION TO THE BEARING BLOCK.

THRUST BLOCKING FOR WATER FITTINGS
NOT TO SCALE

- NOTE:
- EXISTING UNDERGROUND INSTALLATIONS & PRIVATE UTILITIES SHOWN ARE INDICATED ACCORDING TO THE BEST INFORMATION AVAILABLE TO THE ENGINEER. THE ENGINEER DOES NOT GUARANTEE THE ACCURACY OF SUCH INFORMATION. SERVICE LINES (WATER, POWER, GAS, STORM, SEWER, TELEPHONE & TELEVISION) MAY NOT BE STRAIGHT LINES OR AS INDICATED ON THE PLANS. STATE LAW REQUIRES CONTRACTOR TO CALL ALL UTILITY COMPANIES BEFORE EXCAVATION FOR EXACT LOCATIONS.
 - ALL IMPROVEMENTS SHALL BE PERFORMED IN ACCORDANCE WITH MONTANA PUBLIC WORKS STANDARD SPECIFICATIONS 6TH EDITION, APRIL, 2010, AND THE CITY OF BILLINGS STANDARD MODIFICATIONS, DATED MARCH, 2013.
 - UNLESS OTHERWISE SPECIFIED, ALL CONSTRUCTION LAYOUT AND STAKING SHALL BE PERFORMED UNDER THE RESPONSIBLE CHARGE OF A LAND SURVEYOR LICENSED IN THE STATE OF MONTANA AND BY A PARTY CHIEF OR ENGINEERING TECHNICIAN EXPERIENCED IN CONSTRUCTION LAYOUT AND STAKING TECHNIQUES AS ARE REQUIRED BY THE SPECIFIC TYPE OF WORK BEING PERFORMED.

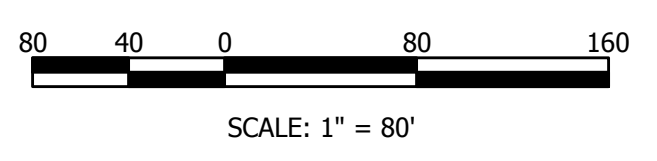
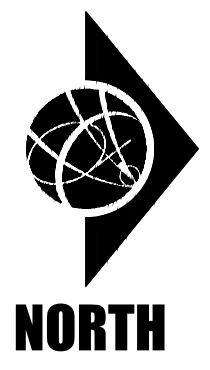

**PRELIMINARY
FOR BIDDING PURPOSES**

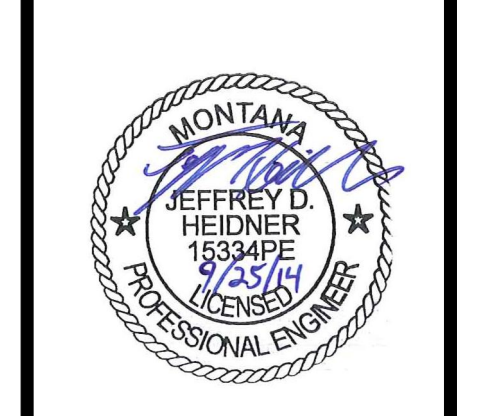

DATE: 09/25/2014

FILE: 05051_11_BASE.DWG

PROJECT NO: 05051.11

CAD: JAS/BEG

QUALITY ASSURANCE: DR 09/23/14

DATE	DESCRIPTION
09/18/14	PRELIM FOR REVIEW

Regular City Council Meeting

Meeting Date: 10/27/2014

TITLE: Scheduled Airline Operating Agreement and Terminal Building Lease at Billings Logan International Airport

PRESENTED BY: Tom Binford, Director of Aviation & Transit

Department: Airport

PROBLEM/ISSUE STATEMENT

The staff at the Billings Logan International Airport has been negotiating a new Scheduled Airline Operating Agreement and Terminal Building Lease (Agreement) with the Airport's five airline tenants for over one year. Recently, consensus was reached between all parties and a six year Agreement was agreed to. This Agreement lays out the terms for a passenger airline to operate at the Billings Logan International Airport and to lease space in the Terminal Building. This Agreement also dictates the financial arrangement that is in place between the City and the airlines. The previous agreement had not been significantly updated since 1996 and this new Agreement updates the language to reflect the realities of the airline/airport world today. The airlines that have signed the Agreement are Alaska/Horizon, Allegiant, Cape Air, Delta, and United. The Agreement term is July 1, 2013 to June 30, 2019. A copy of the Agreement is on file in the City Clerk's Office.

ALTERNATIVES ANALYZED

City Council may:

- Approve, the Scheduled Airline Operating Agreement and Terminal Building Lease with the five airlines serving the Billings market; or
- Disapprove the Scheduled Airline Operating Agreement and Terminal Building Lease, and provide staff with guidance on how to proceed.

FINANCIAL IMPACT

The five airlines that have signed this Agreement provide the Airport with an estimated \$3,000,000 in revenues annually. Since the amount the airlines pay is dependent on contributions from other revenue sources and the amount of expenses in a given year, their rentals and fees can vary from year to year. The Agreement's rate making methodology ensures that the Airport will have the funding it needs to operate each year.

RECOMMENDATION

Staff recommends that City Council approve and the Mayor execute the five Scheduled Airline Operating Agreement and Terminal Building Leases with the airlines that currently serve Billings.

APPROVED BY CITY ADMINISTRATOR

Regular City Council Meeting

Meeting Date: 10/27/2014

TITLE: ZooMontana to Riverfront Park Trail Feasibility Study

PRESENTED BY: Candi Millar, Planning & Community Services Department Director

Department: Planning & Community Services

PROBLEM/ISSUE STATEMENT

The Planning Division is presenting to the City Council the ZooMontana to Riverfront Park Trail Feasibility Study with the intent to have the Council make a recommendation to the Policy Coordinating Committee (PCC). The Council received information regarding this study at its October 20 work session. At the October 27 meeting, the City Council is expected to take action on the study to forward a recommendation to PCC.

This study is intended to determine the feasibility of building an approximately 4 mile greenway trail connecting existing trail segments that terminate at ZooMontana and Riverfront Park. This study describes various potential alignment alternatives with a recommended implementation approach. This study also makes recommendations for the trail and related improvements such as trailheads and interpretive sites. For this study, a greenway is defined as “a corridor of land that connects people and nature together” and a trail is defined as “a linear facility for non-motorized transportation and recreation.” The trail is intended to serve primarily as a shared-use path for pedestrians and bicyclists for recreation and commuting separated from motorized traffic. However, many alignment alternatives will parallel existing roadways with varying levels of vehicle traffic.

The proposed trail alignments that would complete this corridor offer options to the community for pedestrian and bicycle travel, improved mobility for residents living south of I-90, a safe route to access Elysian Elementary School, close-to-home outdoor activities, potential economic development, and health benefits. These opportunities can help residents be more active and healthy, provide additional transportation options for work and play, and encourage environmental stewardship in trail users of all ages.

The development of the study was managed by a project steering committee comprised of representatives from Planning, ZooMontana, City Parks, County Public Works, Montana Department of Transportation, Yellowstone River Parks Association, the Bicycle and Pedestrian Advisory Committee, Chamber of Commerce, BikeNet, and McCall Development. The planning process included a public participation element that hosted two public open houses on the context and goals of the study. Participants were able to review the history of the corridor and the proposed alignments and the theory behind those alignments. Comment cards were provided and the consultant team of Alta Planning + Design and Peaks to Plains were able to use these comment cards to input additional information into the study.

The study is located at the following link or hard copies may be provided to the City Council through the Planning Division: <http://www.ci.billings.mt.us/DocumentCenter/View/26344>

ALTERNATIVES ANALYZED

City Council may:

- Approve the ZooMontana to Riverfront Park Trail Feasibility Study and forward the recommendation to the Policy Coordinating Committee through the City's PCC representative; or
- Approve the ZooMontana to Riverfront Park Trail Feasibility Study with modifications and forward the recommendation to the Policy Coordinating Committee through the City's PCC representative; or
- Disapprove the ZooMontana to Riverfront Park Trail Feasibility and forward the recommendation to the Policy Coordinating Committee through the City's PCC representative.

FINANCIAL IMPACT

There should be no direct financial impact from the adopting this study. However, it will assist with alignment identification and prioritization for near and long-term bike/pedestrian improvements for the corridor, making future project planning and design more efficient and cost effective.

RECOMMENDATION

Staff recommends that the City Council approve the ZooMontana to Riverfront Park Trail Feasibility Study and forward this recommendation to the Policy Coordinating Committee at its meeting on November 18, 2014.

APPROVED BY CITY ADMINISTRATOR

Regular City Council Meeting

Meeting Date: 10/27/2014

TITLE: Annexation #14-05: Acknowledge receipt of petition and set a public hearing date

PRESENTED BY: Candi Millar, Planning & Community Services Department Director

Department: Planning & Community Services

PROBLEM/ISSUE STATEMENT

Owners Lary and Judy Garrison submitted a petition to annex land to the City of Billings under Section 7-2-4600, MCA. The subject property is a parcel totaling about 2.5 acres. The property is located at 659 Lincoln Lane in the Billings Heights. The property is developed with the Lincoln Lane Assisted Living business. The property owner is requesting annexation in order to obtain City services. The property is currently zoned Residential Professional on approximately the western quarter of the property and the remaining three quarters is zoned Residential-6000.

The property is located within the five-year annexation area of the City's Limits of Annexation Map and appears to meet many of the City's criteria in its Annexation Policy. A detailed review and analysis of the Annexation Policy criteria will be provided in the Council's public hearing memo. The City Council's policy is to consider annexations at two separate Council meetings. At the first meeting, the Council acknowledges receipt of a petition and sets a public hearing date. At the second meeting, the Council conducts the hearing and decides if it will annex the property.

ALTERNATIVES ANALYZED

Section 7-2-4600, MCA, allows owners of more than 50% of the property to petition the City for annexation. The only alternative that is consistent with City Council policy is to acknowledge receipt of the petition and set a public hearing date.

FINANCIAL IMPACT

Analysis by City staff of how City services may be provided to this property and a recommendation on the annexation will be prepared and presented at the public hearing.

RECOMMENDATION

Staff recommends that the City Council acknowledge receipt of the annexation petition and schedule a public hearing for November 10, 2014 to consider annexing this property.

APPROVED BY CITY ADMINISTRATOR

Annexation Petition

Annexation Exhibit

Annexation Legal Description

PETITION FOR ANNEXATION TO THE CITY OF BILLINGS

NOTICE TO PETITIONER

This is a Petition to the City of Billings requesting the annexation of property to the City, pursuant to MCA Title 7, Chapter 2, Part 46. Procedures for annexation are governed by the Statutes of the State of Montana. This Petition requires the signatures of more than 50% of the Resident Freeholder Electors to be considered for annexation.

INSTRUCTIONS

1. All items must be completed or provided. Please type or print. You may attach additional pages if more space is needed.
2. Prepare a map drawn to a scale adequate and legible to show the property requesting annexation and all other property within one-quarter (1/4) mile.

The map must show:

- a. The present and proposed boundaries of the municipality;
 - b. The present streets, major trunk water mains and sewer mains;
 - c. The zoning of the property requesting annexation and the property immediately adjacent to it.
3. The Petition should be submitted to the Planning Department, Monday through Friday between the hours of 8:00 a.m. and 5:00 p.m., located on the 4th Floor of Parnly Billings Library at 510 North Broadway, Billings, Montana. Upon presentation, the Petition will be checked for completeness. Once accepted, the Petition will be routed to the following City Departments: Public Works, City-County Planning, Public Utilities, Fire Department, City Attorney, Police Department, and Finance Department. If no problems with the Petition have been noted by the departments, the City Clerk will schedule the Petition for City Council action.
 4. By filing the petition for annexation, the Petitioner(s) agree that only those City services which are available to the general area shall be provided to Petitioner, and that additional services as may become available to the general area shall be made available to Petitioner(s) in the same manner as said services are made available to other residents of the City. Petitioner(s) specifically waive the right to the report and plans for extension of services as provided in MCA Title 7, Chapter 2, Part 47.
 5. A description of the territory to be annexed to the City is legally described on a document attached hereto.

RESIDENT FREEHOLDER ELECTORS

Date	Print Name	Name Signature	Address
Sept 17, 2014	LARY H. GARRISON	<i>Larry H. Garrison</i>	703 Conway St.
Sept 17, 2014	JUDY K. GARRISON	<i>Judy K. Garrison</i>	703 Conway St.

(continued on separate page)

(Should be completed prior to obtaining signatures of resident freeholder electors)

DESCRIPTION OF THE TERRITORY TO BE ANNEXED TO THE CITY OF BILLINGS

Legal Description	Tax Code	Address of General Location	Use of Property	Legal Property Owners	Address	Phone
		659 Lincoln Lane	Assisted Living	Larry & Judy Garrison	1103 Conway St.	896-1746

ALL ITEMS BELOW SHALL BE COMPLETED BY STAFF

Date Submitted: 9/17/14

Received By: [Signature]

Petition Number: AN14-05

Fee Paid: 1,019.00

P2-14-00212

Deposit \$45.00

EXHIBIT "A"

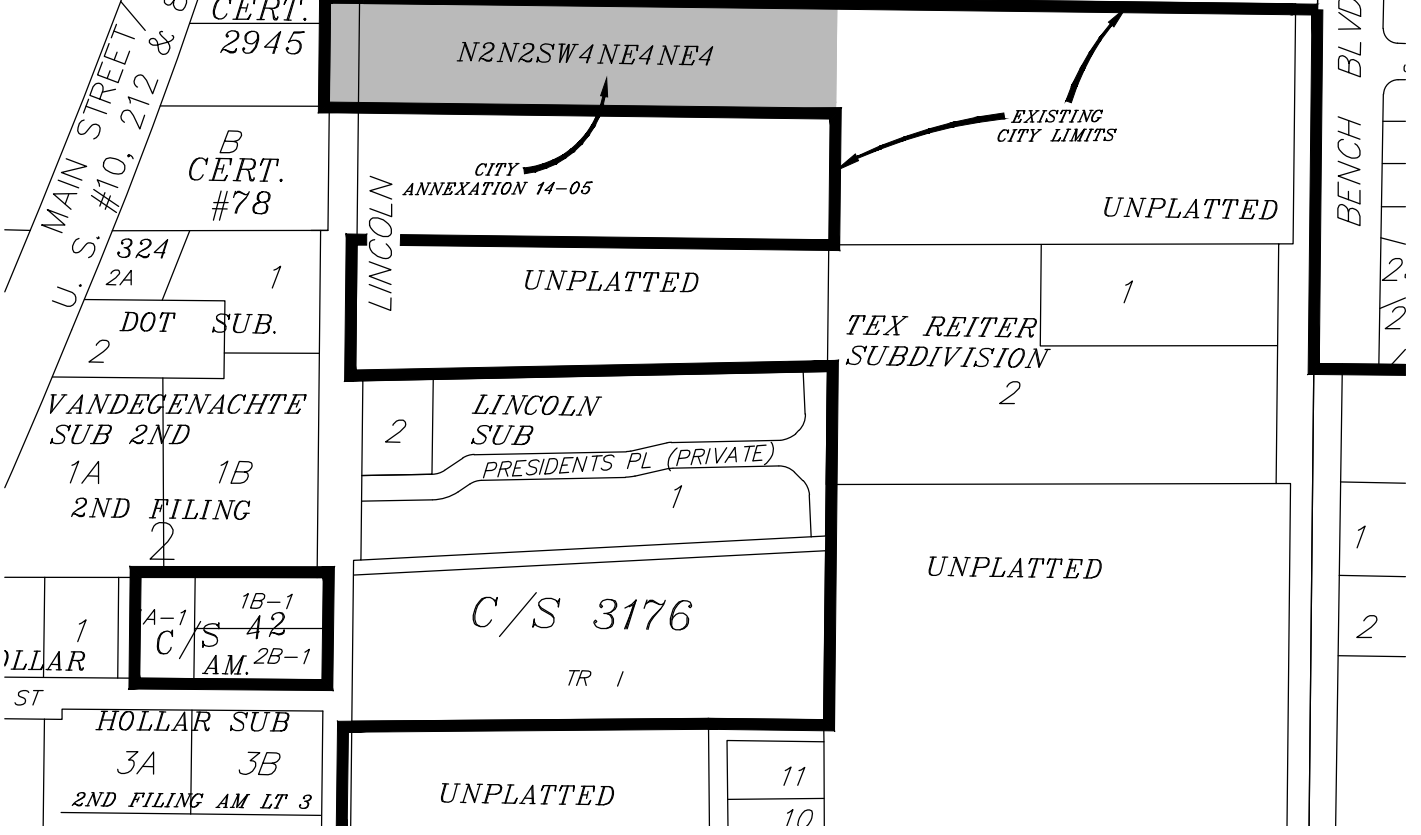
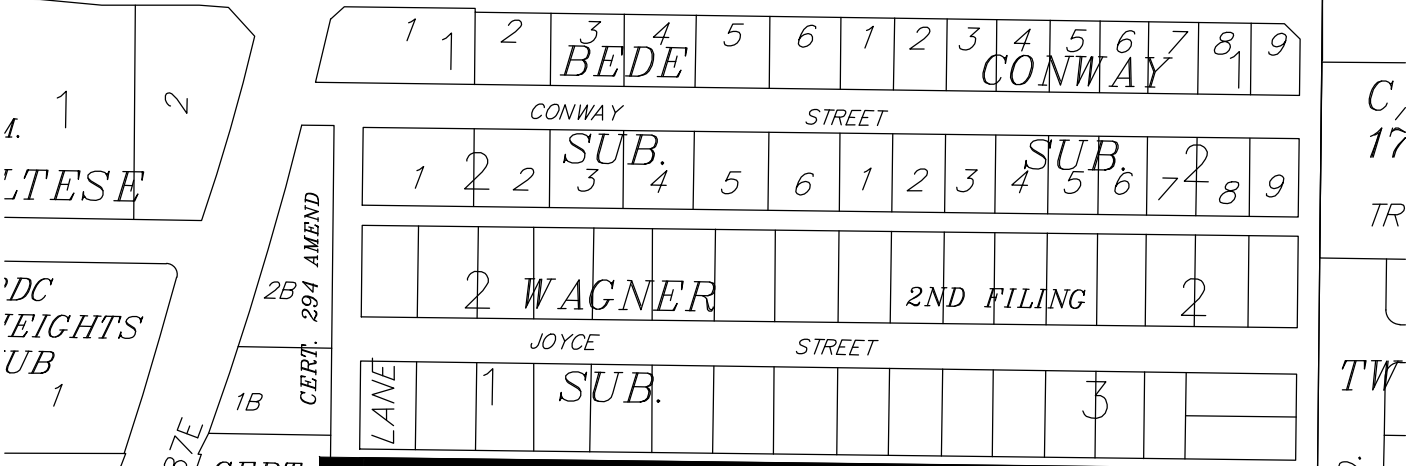
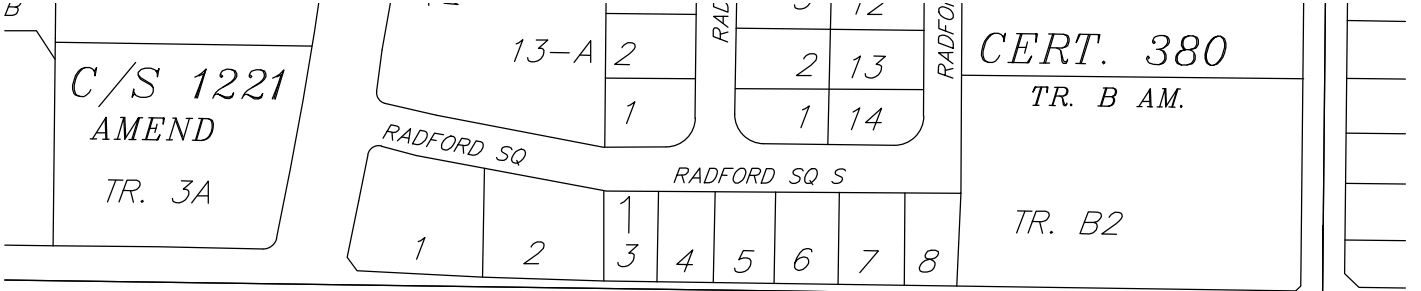

13-A 2
1

RADFORD SQ

RADFORD SQ S

CERT. 380
TR. B AM.

TR. B2

1 1 2 3 4 5 6 1 2 3 4 5 6 7 8 9

BEDE CONWAY

CONWAY STREET

1 2 2 3 4 5 6 1 2 3 4 5 6 7 8 9

SUB. SUB.

2 WAGNER 2ND FILING 2

JOYCE STREET

LANE 1 SUB. 3

CERT. 2945

B CERT. #78

324 2A 1

DOT SUB. 2

VANDEGENACHTE SUB 2ND 1A 1B 2ND FILING 2

1 1B-1 42 AM. 2B-1

HOLLAR SUB 3A 3B 2ND FILING AM LT 3

N2N2SW4NE4

CITY ANNEXATION 14-05

EXISTING CITY LIMITS

UNPLATTED

LINCOLN SUBDIVISION 2

LINCOLN SUB 2

PRESIDENTS PL (PRIVATE) 1

C/S 3176 TR 1

UNPLATTED

UNPLATTED

11 10

ANNEXATION # 14-05

Legal Description of Property to be annexed

A tract of land situated in the NE1/4 of Section 27, T.1N., R.26E., P.M.M., Yellowstone County, Montana, more particularly described as:

Being the N1/2 N1/2 SW1/4 NE1/4 NE1/4, and described as follows per Warranty Deed Document Number 3409606, of record and on file in the office the Yellowstone County, Clerk and Recorder's:

That part of the SW1/4 NE1/4 NE1/4 of Section 27. T. 1 N., R. 26 E., P.M.M., in Yellowstone County, Montana described as follows:

Beginning at a point which is 1291.44 feet West and 660 feet South of the Northeast corner of said Section 27; thence running East a distance of 628.15 feet; thence running South a distance of 165 feet; thence running West a distance of 627.51 feet; thence running North a distance of 165 feet to the point of beginning.

Including all adjacent Right-Of-Way of Lincoln Lane.

Containing 2.530 gross and 2.378 net acres more or less.

(# 14-05) See Exhibit "A" Attached

Regular City Council Meeting

Meeting Date: 10/27/2014

TITLE: Resolution of Intent to Create Downtown Business Improvement District 1

PRESENTED BY: Bruce McCandless, Assistant City Administrator

Department: City Hall Administration

PROBLEM/ISSUE STATEMENT

The City Council created the downtown Business Improvement District (BID) No. 0001 in August, 2005. State law sunsets districts after 10 years and re-creating them requires the same procedure as the original. Owners of at least 60% of the proposed district property must sign and submit a petition to initiate a district. Downtown and east Billings property owners have submitted a petition with signatures that represent 61.1% of the property within the proposed district. The first step toward re-creating this district is for the City Council to accept the petition and adopt a Resolution of Intent to create the BID. The resolution also sets a public hearing for November 24, 2014. If the Council adopts the resolution, present BID managers will send all owners of property within the district a notice regarding the Council's intentions and that they may submit written comments or verbal testimony at the hearing.

ALTERNATIVES ANALYZED

City Council may:

- Approve the resolution stating the Council's intent to create a downtown BID and setting a public hearing for November 24, or;
- Disapprove the resolution. The present BID will terminate in August 2015 and the City will not charge tax year 2015 assessments against the downtown properties. The BID services such as downtown police officers, snow removal, trash service and landscaping maintenance will be terminated as soon as the tax year 2014 assessments and any reserves are expended.

FINANCIAL IMPACT

If the Council creates the new district, the City's properties will be assessed equally with private property. The BID assessment for tax year 2014 will be approximately \$30,000. Tax year 2015 assessments should be similar. The City's Finance Department prepares the assessments for the BID, sends that information to the County for billing and collection and then distributes the funds to the BID. By State law, Finance may not recover its costs by charging the BID.

RECOMMENDATION

Staff recommends that the City Council adopt the Resolution of Intent to create the downtown Business Improvement District No. 0001 and setting a public hearing for November 24, 2014.

APPROVED BY CITY ADMINISTRATOR

Resolution

Boundary description

Map

Assessment

RESOLUTION 14-_____

A RESOLUTION DECLARING IT TO BE THE INTENTION OF THE CITY COUNCIL TO CREATE A BUSINESS IMPROVEMENT DISTRICT FOR THE PURPOSE OF PROVIDING CERTAIN SAFETY SERVICES AND MAINTAINING THE COMMON AREA IMPROVEMENTS AND OTHER PORTIONS OF IMPROVEMENTS MADE IN DOWNTOWN, CITY OF BILLINGS, MONTANA

BE IT RESOLVED by the City Council of the City of Billings (the "City"), Montana, as follows:

Section 1. Proposed Business Improvement District (B.I.D.); Intention To Create Business Improvement District. The B.I.D. proposes to maintain certain special improvements and safety services to benefit certain property located in the City of Billings, Montana. The purpose of this B.I.D. is to provide funding for the purposes and powers that will serve a public use; will promote the health, safety, prosperity, security, and general welfare of the inhabitants thereof and of the people of this state; and will be of special benefit to the property within the boundaries of any district created pursuant to the provisions of Montana Code annotated, Title 7, Chapter 12, Part 11, as amended.

Section 2. Number of District. The District, if the same shall be created and established, shall be known and designated as the Business Improvement District No. 0001 of the City of Billings, Montana.

Section 3. Boundaries and Benefit Zones of District. The limits and boundaries of the District are depicted on a map attached as "Exhibit A" hereto (which is hereby incorporated herein and made a part hereof) and more particularly described on "Exhibit B" hereto (which is hereby incorporated herein and made a part hereof), which boundaries are designated and confirmed as the boundaries of the District. A listing of each of the properties in the District is shown on "Exhibit C" hereto.

Section 4. Benefited Property. The District and territory included within the limits and boundaries described in Section 3 and as shown on Exhibit "A" are hereby declared to be the Business Improvement District and the territory which will benefit and be benefited by and will be assessed for a portion of the costs of the maintenance and services as described in Section 1.

Section 5. General Character of the Service and Maintenance to be Performed. The general character of the maintenance and service includes public sidewalk sweeping, security and safety services, public sidewalk pedestrian passage management of snow accumulation and graffiti removal and abatement and maintaining other sidewalk furniture, equipment and improvements installed in the public areas NOT including city streets, private property or alleyways.

Section 6. Assessment Methods; Property To Be Assessed. All properties within the District are to be assessed for a portion of the costs of safety services and maintaining the sidewalk Public Area Improvements in Business Improvement District, as specified herein. And, pursuant to 7-12-1133 subsection (f), M.C.A. the District, in the first year, shall

subsection (b); AND \$0.0007020 per dollar of taxable value as prescribed in Section 7-12-1133, subsection (c); AND \$0.02288 per square foot of the building above the first floor as prescribed in Section 7-12-1133, subsection (d), M.C.A. And the assessments to fund the work plan for the Safe Zone Classification, for the first year are to be the total amount derived by one of the following methods: a single \$150 flat rate fee for all residential condominium properties proportionate to the percentage of unit ownership of the whole OR a \$150 flat rate fee divided by the number of taxcodes if the total ownership is less than 33,333 sq. ft. as prescribed in Section 7-12-1133, subsection (c), M.C.A. OR \$0.00249 per square foot of total area of all owned parcels within the classified area is more than 3 Million square feet, OR \$0.00319 per square foot of total area of all owned parcels within the classified area is more than 2 Million square feet and less than 3 Million square feet, OR \$0.00224 per square foot of total area of all owned parcels within the classified area is more than 1.1 Million square feet and less than 2 Million square feet, OR \$0.00450 per square foot of total area of all owned parcels within the classified area is more than 33,333 square feet and less than 1.1 Million square feet as prescribed in Section 7-12-1133, subsection (d), M.C.A.

Section 8. Payment of Assessments. The assessments for the costs of maintaining the services provided by the Business Improvement District shall be payable, as prescribed in Section 7-12-1133 subsection (e), M.C.A.

Section 9. Duration of District. The duration of the B. I. D. shall be for a period of 10 years as prescribed in Section 7-12-1141, M.C.A.

Section 10. Public Hearing; Protests. At any time within fifteen (15) days from and after the date of the first publication of the notice of the passage and approval of this resolution, any owner of real property within the proposed District subject to assessment and taxation for the cost and expense of maintaining the Business Improvement District may make and file with the City Clerk until 5:00 p.m., M.T., on the expiration date of said 15-day period from October 31, 2014 through November 14, 2014, written protest against the proposed Business Improvement District, and this Council will at its next regular meeting after the expiration of the fifteen (15) days in which such protests in writing can be made and filed, proceed to hear all such protests so made and filed; which said regular meeting will be held on Monday, November 24, 2014 at 6:30p.m., in the Council Chambers, located on the Second Floor of the City Hall-Police Department at 220 North 27th Street, in Billings, Montana.

Section 11. Notice of Passage of Resolution of Intention. The City Clerk is hereby authorized and directed to publish or cause to be published a copy of a Notice of the passage of this Resolution in the Billings Times, a newspaper of general circulation in the County on Thursday, October 30, 2014, and Thursday, November 6, 2014, in the form and manner prescribed by law, and to mail or cause to be mailed a copy of said Notice to every person, firm, corporation, or the agent of such person, firm, or corporation having real property within the proposed district listed in his or her name upon the last completed assessment roll for State, County, and school district taxes, at his last-known address, on or before the same day such notice is first published.

Section 12. Effective Date: This resolution shall become effective on August 22, 2015.

APPROVED by the City Council of the City of Billings, Montana, this 27th of

Exhibit A

Contiguous to and surrounding the current boundaries of BID No. 0001 the new boundary is described as follows:

Beginning at the centerline intersection of 6th Avenue North and North 32nd Street; Thence along said 6th Avenue North centerline in a northeasterly direction to the centerline intersection with the alley centerline between North 31st Street and North 30th Street; thence along said alley centerline in a northwesterly direction to the centerline intersection with 12th Avenue North; thence along said 12th Avenue North centerline in a northeasterly direction to the centerline intersection with North 30th Street; thence along said North 30th Street centerline in a northwesterly direction to the centerline intersection with the centerlines of Elevation Avenue and Grandview Boulevard; thence along said Grandview Boulevard centerline in a westerly direction to the centerline intersection with Locust Street; thence along said Locust Street centerline in a northerly direction to the centerline intersection with Poly Drive; thence along said Poly Drive Centerline in an easterly direction to the centerline intersection with North 27th Street;





thence along said North 27th Street centerline in a southeasterly direction to the centerline intersection of 10th Avenue North; thence along said 10th Avenue North centerline in a northeasterly direction to the centerline intersection with North 25th Street; thence along said North 25th Street centerline in a southeasterly direction to the centerline intersection with 9th Avenue North; thence along said 9th Avenue North centerline in a southwesterly direction to the centerline intersection with North 26th Street; thence along said North 26th Street centerline in a southeasterly direction to the centerline intersection with 7th Avenue North; thence along said 7th Avenue North centerline in a northeasterly direction to the centerline intersection with North 25th Street; thence along said North 25th Street centerline in a southeasterly direction to the centerline intersection with 6th Avenue North; thence along said 6th Avenue North centerline in a northeasterly direction to the centerline intersection with North 22nd Street; thence along said North 22nd Street centerline in a northwesterly direction to the centerline intersection with 8th Avenue North; thence along said 8th Avenue North centerline in a northeasterly direction to the centerline intersection with North 19th Street; thence along said North 19th Street centerline in a southeasterly direction to the centerline intersection with 6th Avenue North; thence along said 6th Avenue North centerline in a northeasterly direction to the centerline intersection with North 18th Street; thence along said North 18th Street centerline in a southeasterly direction to a point on the northerly right-of-way line of Burlington Northern – Montana Rail Link spur line; thence along said northerly right-of-way line of Burlington Northern – Montana Rail Link spur line in a southwesterly direction to the centerline intersection with North 20th Street; thence along said North 20th Street centerline in a northwesterly direction to the intersection of the projected southerly alley right-of-way line of the northeasterly/southwesterly alley of Blocks 262 and 263 of Billings Original Town, Recorded September 1, 1884, under Document No. 16312, Records of Yellowstone County; thence along said southerly alley right-of-way line in a southwesterly direction for an approximate distance of 570 feet to the projected alley centerline of the northwesterly/southeasterly alley of said Block 263; thence along said alley centerline in a southeasterly direction to a point on the southerly right-of-way line of Burlington Northern –

Montana Rail Link spur line, point also being the alley centerline of Block 14 of said Billings Original Town; thence along said the northerly line of Block 14 in a southwesterly direction to the northwesterly corner of Lot 13, of said Block 14; thence along the westerly line of said Block 14 to the centerline intersection with 4th Avenue North; thence along said 4th Avenue North Centerline in a northeasterly direction to the intersection of the projected east lot lines of Lots 1A – 12A, Block 38 of Amended Plat of a Portion of Lots 1 through 12, Block 38, Town Of Billings, Recorded November 1, 1973, under Document No. 947494, Records of Yellowstone County; thence along said east lot lines of Lots 1A – 12A in a southeasterly direction to the centerline intersection with 3rd Avenue North; thence along said 3rd Avenue North centerline in a southwesterly direction to the centerline intersection with North 22nd Street; thence along said North 22nd Street centerline in a southeasterly direction to the centerline intersection with 2nd Avenue North; thence along said 2nd Avenue North centerline in a northeasterly direction to the centerline intersection with North 20th Street; thence along said North 20th Street centerline in a southeasterly direction to the centerline intersection with 1st Avenue North; thence along said 1st Avenue North centerline in a northeasterly direction to the northwesterly/southeasterly alley centerline intersection of Block 118 of said Billings Original Town; thence along said alley centerline in a southeasterly direction to the southwesterly/northeasterly alley centerline of said Block 118; thence along said alley centerline in a southwesterly direction through said Block 118 and also Block 117 of said Billings Original Town to the centerline intersection with North 20th Street; thence along said North 20th Street centerline in a southeasterly direction to the centerline intersection with Montana Avenue; thence along said Montana Avenue centerline in a southwesterly direction to a point, said point being perpendicular to the most southeast lot corner of Lot 1, Block 115 of said Billings Original Town; thence along a line, said line being perpendicular to Montana Avenue centerline in a southeasterly direction to the most southeasterly corner represented by Tax Code Parcel D12271; thence along a line, said line being more or less parallel to the centerline of Montana Avenue in a southwesterly direction and encompassing said Tax Code Parcel D12271, and Tax Code Parcels D12017A, I00251A, D12017, and D12018 to the east right-of-way line of South 27th Street; thence along said east right-of-way line in a southeasterly direction to the most northwest lot corner represented by Tax Code Parcel D12514; thence along a line, said line being more or less parallel to the centerline of Minnesota Avenue in a northeasterly direction for an approximate distance of 1720 feet to a point, said point being perpendicular to the centerline of said Minnesota Avenue; thence along a line, said line being perpendicular to Minnesota Avenue in a southeasterly direction to the centerline intersection of Minnesota Avenue; thence along said Minnesota Avenue centerline in a northeasterly direction to the centerline intersection with South 21st Street; thence along said South 21st Street centerline in a southeasterly direction to a point on the east section line of Section 3, Township 1 South, Range 26 East, Yellowstone County Montana, P.M.M., thence along said west section line in a southerly direction to the centerline intersection with 8th Avenue South; thence along said 8th Avenue South centerline in a southwesterly direction to the centerline intersection with South 31st Street; thence along said South 31st Street centerline in a northwesterly direction to the centerline intersection with 6th Avenue South; thence along said 6th Avenue South centerline in a northeasterly direction to the centerline intersection with South 28th Street; thence along said South 28th Street centerline in a northwesterly direction to the centerline intersection with 5th Avenue South; thence along said 5th Avenue South centerline in a northeasterly direction to the alley centerline intersection of Block 183 of said Billings Original Town; thence along said alley centerline in a northwesterly direction through said Block 183 and

Block 169 of Billings Original Town to the centerline intersection with 3rd Avenue South; thence along said 3rd Avenue South centerline in a northeasterly direction to the centerline intersection with South 27th Street; thence along said South 27th Street centerline in a northwesterly direction to the centerline intersection with 2nd Avenue South; thence along said 2nd Avenue South centerline in a southwesterly direction to the centerline intersection with South 33rd Street; thence along said South 33rd Street centerline in a northwesterly direction to a point, said point being on the northerly right-of-way line of 1st Avenue South; thence along said northerly right-of-way line in a northeasterly direction to the southwest corner of Lot 1-A, Block 1 of Amended Plat of Lot 1, Block 1, Barnard Subdivision, Recorded October 27, 2010, under Document No. 3567881, Records of Yellowstone County; thence along the boundary of said Lot 1-A the following course, N 34°36'30" W for a distance of 143.00 feet, N 55°23'30" E for a distance of 277.00 feet, S 34°36'30" E for a distance of 12.00 feet, N 55°23'30" E for a distance of 58.00 feet to a point on the westerly right-of-way line of South 30th Street; thence N 55°23'30" E for a distance of 40.00 feet to the centerline of said South 30th Street; thence along said South 30th Street centerline in a northwesterly direction to the centerline intersection with Minnesota Avenue; thence along said Minnesota Avenue centerline in a northeasterly direction to a point, point being perpendicular to the most southwest lot corner represented by Tax Code Parcel D12019; thence along a line, said line being perpendicular to the centerline of Minnesota Avenue in a northwesterly direction to the most southwest lot corner represented by Tax Code Parcel D12019; thence along a line, said line being more or less parallel to the centerline of Minnesota Avenue in a northeasterly direction to a point, said point being on the west right-of-way line of South 27th Street; thence along said west right-of-way line in a northwesterly direction to the most southeast lot corner represented by Tax Code Parcel A29916; thence along a line, said line being more or less parallel to the centerline of Montana Avenue in a southwesterly direction to the centerline intersection with North 29th Street; thence along said North 29th Street centerline in a northwesterly direction to the centerline intersection with Montana Avenue; thence along said Montana Avenue centerline in a southwesterly direction to the centerline intersection with North 32nd Street; thence along said North 32nd Street centerline in a northwesterly direction to the centerline intersection with 6th Avenue North, said centerline intersection being the Point of Beginning, inclusive of all known tax codes in the expanded area herein.

BID 2014 Resolution

Legend

-  BID 2014 boundary
-  Identified parcel within boundary
-  Central Assessed or GSA not in BID
-  "D" Code Locally Assessed
-  Clean & Safe Zone Classification



BID 0001 2014 assessments

Taxcode	Amount
A00001	\$ 150.00
A00004	\$ 29.21
A00005	\$ 75.00
A00006	\$ 75.00
A00007	\$ 150.00
A00008	\$ 75.00
A00009	\$ 75.00
A00010	\$ 150.00
A00011	\$ 126.04
A00016	\$ 188.96
A00041	\$ 126.04
A00042	\$ 176.42
A00042A	\$ 50.57
A00043	\$ 140.55
A00048	\$ 48.61
A00050	\$ 150.00
A00051	\$ 124.08
A00056	\$ 157.41
A00062	\$ 150.00
A00063	\$ 316.97
A00064	\$ 150.00
A00065	\$ 150.00
A00066	\$ 15.68
A00066A	\$ 78.80
A00067	\$ 94.48
A00068A	\$ 150.00
A00069	\$ 62.92
A00070	\$ 75.00
A00071	\$ 150.00
A00072	\$ 150.00
A00073	\$ 150.00
A00073A	\$ 150.00
A00073B	\$ 150.00
A00074	\$ 150.00
A00075	\$ 150.00
A00075B	\$ 150.00
A00196B	\$ 292.86
A00202	\$ 150.00
A00203	\$ 75.00
A00204	\$ 75.00
A00206	\$ 75.00
A00207	\$ 150.00
A00208	\$ 22.37
A00209	\$ 16.81

A00210	\$	16.81
A00211	\$	22.37
A00212	\$	50.00
A00213	\$	50.00
A00214	\$	50.00
A00215	\$	44.61
A00216	\$	89.35
A00217	\$	75.00
A00218	\$	75.00
A00219	\$	75.00
A00222	\$	75.00
A00223	\$	50.00
A00224	\$	50.00
A00225	\$	157.41
A00235	\$	157.41
A00236	\$	50.00
A00241	\$	75.00
A00242	\$	75.00
A00243	\$	150.00
A00244	\$	150.00
A00246	\$	75.00
A00247	\$	150.00
A00251	\$	189.00
A00252	\$	150.00
A00254	\$	150.00
A00255	\$	150.00
A00256	\$	150.00
A00257	\$	150.00
A00258	\$	623.14
A00260	\$	464.57
A00261	\$	1,651.74
A00262	\$	2,301.36
A00263	\$	1,198.70
A00264	\$	4,870.89
A00269	\$	1,073.89
A00270	\$	192.08
A00271	\$	10,813.85
A00273	\$	188.96
A00276	\$	31.56
A00277	\$	75.00
A00278	\$	75.00
A00279	\$	150.00
A00280	\$	150.00
A00282	\$	126.04
A00285	\$	188.96
A00290	\$	78.80
A00292	\$	150.00

A00342	\$	31.56
A00343	\$	47.24
A00344	\$	62.92
A00345	\$	47.24
A00346	\$	188.96
A00347	\$	75.00
A00348	\$	75.00
A00349	\$	108.01
A00351	\$	2,276.29
A00352	\$	4,169.13
A00357	\$	31.56
A00359	\$	150.00
A00360	\$	6,023.77
A00362	\$	284.25
A00363	\$	541.45
A00364	\$	1,872.59
A00365	\$	1,296.19
A00366	\$	3,429.68
A00367	\$	1,158.59
A00367A	\$	245.78
A00367B	\$	236.15
A00367C	\$	481.93
A00368	\$	3,570.91
A00372	\$	2,114.84
A00373	\$	646.79
A00374	\$	625.60
A00375	\$	2,963.18
A00376	\$	1,279.00
A00379	\$	31.56
A00382	\$	188.96
A00383	\$	137.98
A00389	\$	94.48
A00394	\$	75.00
A00395	\$	31.56
A00396	\$	31.56
A00397	\$	31.56
A00398	\$	150.00
A00399	\$	150.00
A00400	\$	150.00
A00401	\$	126.04
A00402	\$	31.56
A00406	\$	150.00
A00407	\$	150.00
A00408	\$	150.00
A00409	\$	150.00
A00410	\$	150.00
A00411	\$	150.00

A00412	\$	31.56
A00413	\$	31.56
A00414	\$	62.92
A00416	\$	50.00
A00417	\$	50.00
A00418	\$	50.00
A00419	\$	30.00
A00420	\$	30.00
A00421	\$	30.00
A00422	\$	150.00
A00423	\$	150.00
A00424	\$	30.00
A00425	\$	30.00
A00426	\$	150.00
A00429	\$	75.00
A00430	\$	75.00
A00431	\$	150.00
A00432	\$	150.00
A00433	\$	75.00
A00434	\$	75.00
A00435	\$	150.00
A00566	\$	188.96
A00566B	\$	150.00
A00567	\$	62.92
A00568	\$	126.04
A00569	\$	75.00
A00570	\$	75.00
A00571	\$	150.00
A00572	\$	150.00
A00573	\$	150.00
A00574	\$	150.00
A00576	\$	150.00
A00577	\$	37.50
A00578	\$	75.00
A00579	\$	150.00
A00580	\$	37.50
A00583	\$	37.50
A00584	\$	37.50
A00585	\$	37.50
A00586	\$	75.00
A00587	\$	75.00
A00588	\$	150.00
A00589	\$	75.00
A00590	\$	75.00
A00591	\$	75.00
A00592	\$	75.00
A00593	\$	75.00

A00594	\$	150.00
A00598	\$	150.00
A00599	\$	150.00
A00600	\$	150.00
A00601	\$	37.50
A00602	\$	37.50
A00603	\$	37.50
A00604	\$	37.50
A00605	\$	150.00
A00606	\$	75.00
A00607	\$	75.00
A00609	\$	150.00
A00610	\$	75.00
A00611	\$	908.68
A00612	\$	412.95
A00613	\$	1,224.74
A00616	\$	424.62
A00617	\$	211.88
A00618	\$	2,674.12
A00620	\$	6,827.80
A00624	\$	9,324.15
A00630	\$	2,850.44
A00630A	\$	412.95
A00631	\$	280.57
A00632	\$	211.88
A00633	\$	416.61
A00634	\$	635.99
A00635	\$	750.70
A00636	\$	875.01
A00637	\$	1,359.68
A00638	\$	585.27
A00639	\$	796.47
A00640A	\$	175.40
A00640B	\$	81.66
A00640C	\$	117.87
A00640D	\$	169.75
A00640E	\$	90.98
A00640F	\$	754.74
A00640H	\$	218.76
A00640I	\$	211.87
A00640J	\$	190.70
A00640K	\$	263.44
A00640L	\$	125.21
A00640N	\$	179.65
A00640O	\$	187.46
A00640P	\$	157.64
A00640Q	\$	146.30

A00640R	\$	132.83
A00640S	\$	165.88
A00640T	\$	132.40
A00640U	\$	107.58
A00640V	\$	161.81
A00641	\$	790.03
A00642A	\$	718.14
A00642B	\$	1,271.14
A00642C	\$	38.10
A00643	\$	1,027.03
A00644	\$	1,014.37
A00645	\$	1,233.75
A00647	\$	1,082.73
A00648	\$	436.44
A00648A	\$	414.97
A00649	\$	548.79
A00650	\$	654.50
A00651	\$	1,418.23
A00652	\$	150.00
A00653	\$	75.00
A00654	\$	75.00
A00655	\$	150.00
A00656	\$	150.00
A00658	\$	150.00
A00659	\$	150.00
A00660	\$	150.00
A00663	\$	31.56
A00664	\$	62.92
A00665	\$	150.00
A00667	\$	126.04
A00671	\$	75.00
A00673	\$	75.00
A00676	\$	31.56
A00677	\$	31.56
A00678	\$	31.56
A00679	\$	150.00
A00740	\$	150.00
A00741	\$	38.03
A00742	\$	64.30
A00744	\$	29.21
A00745	\$	150.00
A00746	\$	150.00
A00747	\$	47.24
A00748	\$	15.68
A00749	\$	150.00
A00753	\$	150.00
A00755	\$	150.00

A00756	\$	43.91
A00757	\$	31.56
A00758	\$	150.00
A00759	\$	150.00
A00760	\$	150.00
A00762	\$	150.00
A00763	\$	601.78
A00765	\$	357.77
A00766	\$	418.58
A00768	\$	544.69
A00769	\$	221.53
A00770	\$	352.24
A00771	\$	252.40
A00773	\$	150.00
A00774	\$	75.00
A00775	\$	761.82
A00776	\$	632.98
A00778	\$	680.85
A00780	\$	847.59
A00781	\$	698.58
A00782	\$	625.44
A00783	\$	693.21
A00786	\$	1,095.16
A00787	\$	3,938.87
A00789	\$	2,518.92
A00792	\$	1,041.16
A00794	\$	893.84
A00795	\$	6,727.88
A00796A	\$	372.94
A00796B	\$	262.89
A00796C	\$	110.65
A00796D	\$	198.41
A00796E	\$	112.04
A00796F	\$	212.14
A00796G	\$	99.31
A00796H	\$	57.31
A00796I	\$	55.52
A00796J	\$	57.71
A00796K	\$	37.61
A00796L	\$	51.94
A00796N	\$	50.75
A00796O	\$	57.31
A00796P	\$	55.52
A00796Q	\$	57.71
A00796R	\$	37.61
A00796S	\$	51.94
A00796T	\$	50.75

A00801A	\$	167.67
A00804	\$	15,324.10
A00806	\$	1,023.91
A00807	\$	345.35
A00808	\$	348.93
A00809	\$	267.52
A00810	\$	1,042.10
A00811	\$	387.38
A00812	\$	316.74
A00813	\$	789.72
A00814	\$	787.78
A00815	\$	1,108.40
A00816	\$	1,556.78
A00817	\$	1,067.46
A00818	\$	337.59
A00820	\$	844.43
A00821	\$	349.46
A00822	\$	366.52
A00823	\$	554.11
A00824	\$	789.22
A00825	\$	350.53
A00826	\$	1,339.29
A00827	\$	277.89
A00828	\$	564.05
A00830	\$	377.33
A00831	\$	377.71
A00832	\$	921.26
A00832A	\$	480.02
A00833	\$	1,042.81
A00834	\$	701.43
A00835	\$	1,287.59
A00836	\$	1,208.41
A00837	\$	150.00
A00838	\$	933.97
A00839	\$	4,168.55
A00840	\$	1,286.04
A00842	\$	87.03
A00843	\$	150.00
A00844	\$	150.00
A00845	\$	75.00
A00846	\$	150.00
A00846A	\$	150.00
A00847	\$	150.00
A00849	\$	75.27
A00851	\$	150.00
A00854	\$	150.00
A00855A	\$	150.00

A00883	\$	188.57
A00884	\$	175.44
A00885	\$	94.48
A00886	\$	175.44
A00886A	\$	94.48
A00887	\$	150.00
A00888	\$	175.44
A00889	\$	150.00
A00891	\$	15.68
A00892	\$	73.12
A00894	\$	150.00
A00895	\$	29.21
A00896	\$	150.00
A00897	\$	62.92
A00900	\$	15.68
A00901	\$	150.00
A00902	\$	75.00
A00908	\$	150.00
A00909	\$	75.00
A00910	\$	75.00
A00911	\$	150.00
A00912	\$	150.00
A00913	\$	75.00
A00914	\$	75.00
A00915	\$	150.00
A00916	\$	150.00
A00917	\$	75.00
A00918	\$	75.00
A00920A	\$	12.50
A00920B	\$	12.50
A00920C	\$	12.50
A00920D	\$	12.50
A00920E	\$	12.50
A00920F	\$	12.50
A00920G	\$	12.50
A00920H	\$	12.50
A00920I	\$	12.50
A00920J	\$	12.50
A00920K	\$	12.50
A00920L	\$	12.50
A00921	\$	75.00
A00922	\$	75.00
A00923	\$	150.00
A00923A	\$	75.00
A00924	\$	75.00
A00925	\$	150.00
A00926	\$	150.00

A00927	\$	150.00
A00928	\$	150.00
A00931	\$	150.00
A00939	\$	374.40
A00949	\$	836.81
A00953	\$	94.48
A00954	\$	15.68
A00956	\$	15.68
A00957	\$	62.92
A00959	\$	202.49
A00963	\$	150.00
A00964	\$	150.00
A00966	\$	75.00
A00967	\$	75.00
A00968	\$	150.00
A00970	\$	150.00
A00971	\$	150.00
A00976	\$	50.00
A00977	\$	50.00
A00981	\$	150.00
A00982	\$	150.00
A00985	\$	150.00
A00986	\$	150.00
A00987	\$	150.00
A00988	\$	50.00
A00995	\$	151.13
A01010	\$	63.00
A01012	\$	31.56
A01013	\$	50.00
A01014	\$	50.00
A01015	\$	50.00
A01019	\$	75.00
A01019A	\$	75.00
A01022	\$	150.00
A01024	\$	75.00
A01028	\$	157.50
A01030	\$	150.00
A01032	\$	50.00
A01035	\$	75.00
A01041	\$	188.96
A01043	\$	37.50
A01044	\$	37.50
A01045	\$	150.00
A01046	\$	50.00
A01047	\$	50.00
A01048	\$	50.00
A01049	\$	150.00

A01050	\$	75.00
A01057	\$	50.00
A01058	\$	50.00
A01059	\$	50.00
A01123	\$	62.92
A01124	\$	94.48
A01125	\$	150.00
A01131	\$	150.00
A01132	\$	150.00
A01133	\$	150.00
A01134	\$	31.56
A01135	\$	31.56
A01136A	\$	15.68
A01137	\$	47.24
A01138	\$	31.56
A01142	\$	31.56
A01144	\$	47.25
A01145	\$	150.00
A01146	\$	31.56
A01147B	\$	64.49
A01151A	\$	61.35
A01152	\$	75.00
A01153	\$	75.00
A01155	\$	150.00
A01161	\$	75.00
A01163	\$	75.00
A01164	\$	75.00
A01165	\$	75.00
A01168	\$	150.00
A01170	\$	150.00
A01171	\$	150.00
A01172	\$	150.00
A01180	\$	2,849.35
A01191	\$	150.00
A01191A	\$	150.00
A01192	\$	150.00
A01193	\$	150.00
A01194	\$	150.00
A01195	\$	150.00
A01195A	\$	75.00
A01196	\$	75.00
A01197	\$	150.00
A01198	\$	150.00
A01200	\$	150.00
A01201	\$	150.00
A01202	\$	150.00
A01203	\$	150.00

A01204	\$	75.00
A01205	\$	150.00
A01206	\$	75.00
A01207	\$	150.00
A01208	\$	150.00
A01209	\$	150.00
A01210	\$	150.00
A01212	\$	188.96
A01218	\$	24.70
A01219	\$	37.50
A01220	\$	31.56
A01221	\$	150.00
A01222	\$	31.56
A01223	\$	31.56
A01224	\$	31.56
A01225	\$	62.92
A01226	\$	126.04
A01231	\$	14.31
A01232	\$	150.00
A01233	\$	22.37
A01234	\$	22.37
A01235	\$	150.00
A01236	\$	150.00
A01237	\$	37.50
A01238	\$	150.00
A01239	\$	11.12
A01240	\$	11.12
A01241	\$	22.37
A01242	\$	150.00
A01243	\$	150.00
A01245	\$	22.37
A01246	\$	377.93
A01249	\$	228.95
A01250	\$	47.24
A01251	\$	47.24
A01252	\$	47.24
A01253	\$	150.00
A01254	\$	23.72
A01256	\$	108.79
A01258	\$	83.31
A01259	\$	66.14
A01264	\$	150.00
A01266	\$	10.42
A01273	\$	150.00
A01274	\$	66.98
A01279	\$	62.92
A01280	\$	150.00

A01281	\$	50.00
A01283	\$	50.00
A01284	\$	150.00
A01285	\$	150.00
A01287	\$	150.00
A01288	\$	150.00
A01289	\$	75.00
A01291	\$	75.66
A01292	\$	18.82
A01293	\$	150.00
A01294	\$	146.23
A01298	\$	29.21
A01299	\$	41.17
A01300	\$	53.32
A01301	\$	150.00
A01302	\$	150.00
A01303	\$	75.00
A01304	\$	87.82
A01305	\$	77.63
A01308	\$	10.19
A01309	\$	150.00
A01310	\$	75.00
A01311	\$	75.00
A01534	\$	188.96
A01539	\$	133.95
A01540	\$	31.56
A01541	\$	63.00
A01545	\$	94.50
A01548	\$	75.00
A01549	\$	150.00
A01550	\$	75.00
A01551	\$	75.00
A01552	\$	150.00
A01553	\$	150.00
A01554	\$	189.00
A01560	\$	189.00
A01567	\$	404.98
A01688	\$	2,299.31
A01689	\$	33.49
A01690	\$	22.37
A01691	\$	33.49
A01692	\$	150.00
A01694	\$	150.00
A01696	\$	150.00
A01699	\$	701.95
A01711	\$	115.38
A01909	\$	786.04

A01916	\$	150.00
A01918	\$	29.21
A01919	\$	29.21
A01921	\$	58.41
A01926	\$	175.44
A01932	\$	31.56
A01933	\$	15.68
A01933A	\$	76.64
A01933B	\$	245.61
A01935	\$	8.89
A01936	\$	37.50
A01937	\$	37.50
A01938	\$	37.50
A01939	\$	150.00
A01940	\$	150.00
A01941	\$	150.00
A01943	\$	150.00
A01944	\$	150.00
A01945	\$	75.00
A01946	\$	75.00
A01947	\$	150.00
A01951	\$	50.00
A01953	\$	50.00
A01954	\$	30.00
A01955	\$	30.00
A01956	\$	30.00
A01957	\$	30.00
A01958	\$	30.00
A01959	\$	150.00
A01960	\$	75.00
A01962	\$	75.00
A01963	\$	50.00
A01963A	\$	72.53
A01964	\$	150.00
A01966	\$	150.00
A01967	\$	15.68
A01968	\$	78.80
A02005A	\$	2,150.63
A05968	\$	4,593.03
A07113	\$	34.82
A07115	\$	204.84
A07116	\$	150.00
A07119	\$	150.00
A07120	\$	104.58
A07125	\$	126.04
A07129	\$	31.56
A07130	\$	17.46

A07131	\$	478.33
A07141	\$	25.49
A07142	\$	150.00
A07149	\$	104.56
A07152	\$	26.14
A07153	\$	17.46
A07154	\$	26.14
A07155	\$	150.00
A07179	\$	150.00
A07180	\$	150.00
A07181	\$	150.00
A07182	\$	150.00
A07191	\$	75.00
A07192	\$	15.84
A07193	\$	26.14
A07194	\$	26.14
A07195	\$	26.14
A07196	\$	87.10
A07201	\$	75.00
A07212	\$	104.58
A07212A	\$	138.44
A07225	\$	150.00
A07226	\$	150.00
A07227	\$	150.00
A07228	\$	150.00
A07229	\$	75.00
A07230	\$	75.00
A07233	\$	150.00
A07234	\$	150.00
A07249	\$	316.57
A07258	\$	150.00
A07260	\$	150.00
A07262	\$	220.52
A07265	\$	75.00
A07266	\$	75.00
A07267	\$	150.00
A07272	\$	17.46
A07273	\$	69.74
A07273A	\$	8.72
A07276	\$	34.82
A07277	\$	7.48
A07278	\$	18.66
A07279	\$	26.14
A07281	\$	150.00
A07282	\$	26.15
A07283	\$	150.00
A07284	\$	150.00

A07285	\$	150.00
A07286	\$	150.00
A07287	\$	75.00
A07288	\$	17.46
A07289	\$	17.46
A07290	\$	25.05
A07291	\$	27.23
A07293	\$	150.00
A07295	\$	150.00
A07296	\$	75.00
A07297	\$	75.00
A07317	\$	239.34
A07324	\$	293.83
A07331	\$	44.61
A07332	\$	75.00
A07332A	\$	75.00
A07333	\$	150.00
A07334	\$	150.00
A07335	\$	150.00
A07336	\$	31.56
A07337	\$	31.56
A07338	\$	150.00
A07339	\$	62.92
A07341	\$	66.98
A07341A	\$	52.66
A07343	\$	22.37
A07344	\$	22.37
A07345	\$	98.66
A07347	\$	34.88
A07348	\$	31.56
A07349	\$	31.56
A07350	\$	78.80
A07352	\$	150.00
A07353	\$	150.00
A07355	\$	47.24
A07356	\$	150.00
A07356A	\$	118.20
A07356C	\$	102.13
A07357	\$	150.00
A07361	\$	150.00
A07362	\$	75.00
A07363	\$	75.00
A07364	\$	511.61
A07366	\$	6,778.86
A07369	\$	150.00
A07370	\$	150.00
A07371A	\$	75.00

A07371B	\$	75.00
A07372	\$	512.99
A07375	\$	31.56
A07376A	\$	150.00
A07376B	\$	47.71
A07376C	\$	47.71
A07376D	\$	75.00
A07376E	\$	37.50
A07376S	\$	37.50
A07376T	\$	37.50
A07376U	\$	37.50
A07376V	\$	47.71
A07376W	\$	47.71
A07379	\$	78.75
A07381	\$	150.00
A08170B	\$	379.35
A11334	\$	18.83
A11335	\$	48.10
A11336	\$	150.00
A11341	\$	50.93
A11351	\$	174.46
A11353	\$	17.76
A11354	\$	110.16
A11355	\$	31.32
A11543	\$	143.17
A11550	\$	74.73
A11554	\$	156.80
A11563	\$	15.71
A11564	\$	150.00
A11565	\$	570.81
A11583	\$	62.74
A11584	\$	150.00
A11585	\$	15.71
A11586	\$	23.52
A11587	\$	15.71
A11588	\$	15.71
A11589	\$	15.71
A11592	\$	54.84
A11605	\$	150.00
A11606	\$	17.46
A11608	\$	150.00
A11609	\$	150.00
A11610	\$	17.46
A11611	\$	17.46
A11612	\$	17.46
A11613	\$	150.00
A11614	\$	15.71

A11615	\$	15.71
A11630	\$	17.46
A11631	\$	17.46
A11632	\$	17.46
A11633	\$	26.14
A11635	\$	150.00
A11636	\$	17.46
A11637	\$	31.56
A11638	\$	141.72
A12102	\$	448.18
A12146	\$	174.30
A12156	\$	75.00
A12157	\$	75.00
A12158	\$	26.14
A12159	\$	17.46
A12160	\$	52.28
A12163	\$	17.46
A12164	\$	17.46
A12165	\$	17.46
A12166	\$	17.46
A12167	\$	13.67
A12168	\$	29.83
A12169	\$	261.40
A12176	\$	168.02
A12194	\$	18.66
A12195	\$	18.66
A12196	\$	18.66
A12197	\$	18.66
A12198	\$	18.66
A12199	\$	18.66
A12200	\$	18.66
A12201	\$	150.00
A12202	\$	17.46
A12203	\$	15.71
A12204	\$	17.46
A12205	\$	150.00
A12210	\$	203.83
A12216	\$	78.35
A12217	\$	15.71
A12218	\$	86.26
A12226	\$	149.00
A12229	\$	47.03
A12233	\$	145.58
A12241	\$	15.71
A12242	\$	15.71
A12243	\$	15.71
A12244	\$	15.71

A12245	\$	15.71
A12246	\$	31.32
A12248	\$	13.46
A12249	\$	15.71
A12250	\$	15.71
A12251	\$	15.71
A12252	\$	15.71
A12253	\$	15.71
A12254	\$	15.71
A12255	\$	15.71
A12256	\$	15.71
A12257	\$	15.71
A12258	\$	15.71
A12259	\$	15.71
A12260	\$	15.71
A12261	\$	15.71
A12262	\$	15.71
A12263	\$	15.71
A12264	\$	15.71
A16450	\$	1,301.47
A18733	\$	150.00
A18734	\$	150.00
A18735	\$	150.00
A18736	\$	150.00
A18737	\$	75.00
A18738	\$	75.00
A18740	\$	75.00
A18741	\$	75.00
A18742	\$	150.00
A18743	\$	150.00
A18744	\$	150.00
A18745	\$	377.93
A26786	\$	10.00
A26787	\$	10.00
A26788	\$	10.00
A26789	\$	10.00
A26790	\$	10.00
A26791	\$	10.00
A26792	\$	10.00
A26793	\$	10.00
A26794	\$	10.00
A26795	\$	10.00
A26796	\$	10.00
A26797	\$	10.00
A26798	\$	10.00
A26799	\$	10.00
A26800	\$	150.00

A27701	\$	62.78
A27702	\$	150.00
A29602	\$	115.85
A29857	\$	12.74
A29916A	\$	356.06
A29916B	\$	206.33
A29916C	\$	107.14
A29916D	\$	78.87
A29916E	\$	103.08
A29916F	\$	89.30
A29916G	\$	107.53
A29916H	\$	74.81
A29916I	\$	108.37
A29916J	\$	107.60
A29916K	\$	109.13
A29916L	\$	108.14
A29916N	\$	108.88
A29916O	\$	108.49
A29917	\$	2,217.63
A31251	\$	212.44
A31251A	\$	75.00
A33292	\$	832.98
A33974	\$	385.71
A34212A	\$	150.00
A34212B	\$	31.66
A34212C	\$	59.51
A34212D	\$	15.25
A34212E	\$	31.06
A34212F	\$	15.18
A34212G	\$	19.39
A34212H	\$	19.23
A34212I	\$	21.05
A34212J	\$	19.06
A34212K	\$	14.92
A34212L	\$	93.03
A34212N	\$	31.66
A34212O	\$	42.27
A34212P	\$	31.83
A34212Q	\$	16.24
A34212R	\$	85.53
A34212S	\$	23.54
A34212T	\$	14.59
A34212U	\$	23.54
A34212V	\$	15.58
A34212W	\$	333.58
A34212X	\$	136.79
A34212Y	\$	210.28

A34225A	\$	3.57
A34225B	\$	3.57
A34225C	\$	3.57
A34225D	\$	3.57
A34225E	\$	3.57
A34225F	\$	3.57
A34225G	\$	3.57
A34225H	\$	3.57
A34225I	\$	3.57
A34225J	\$	3.57
A34225K	\$	3.57
A34225L	\$	3.57
A34225N	\$	3.57
A34225O	\$	3.57
A34225P	\$	3.57
A34225Q	\$	3.57
A34225R	\$	3.57
A34225S	\$	3.57
A34225T	\$	3.57
A34225U	\$	3.57
A34225V	\$	3.57
A34225W	\$	3.57
A34225X	\$	3.57
A34226A	\$	3.57
A34226B	\$	3.57
A34226C	\$	3.57
A34226D	\$	3.57
A34226E	\$	3.57
A34226F	\$	3.57
A34226G	\$	3.57
A34226H	\$	3.57
A34226I	\$	3.57
A34226J	\$	3.57
A34226K	\$	3.57
A34226L	\$	3.57
A34226M	\$	3.57
A34226N	\$	3.57
A34226O	\$	3.57
A34226P	\$	3.57
A34226Q	\$	3.57
A34226R	\$	3.57
A34226S	\$	3.57
A34620	\$	75.00
D01207	\$	26.86
D05764	\$	75.00
D12010	\$	42.73
D12013	\$	79.97

D12014	\$	135.65
D12015	\$	207.00
D12017	\$	26.27
D12017A	\$	103.30
D12018	\$	93.11
D12019	\$	54.00
D12021	\$	64.80
D12037	\$	71.74
D12039	\$	111.54
D12044	\$	63.23
D12048	\$	172.50
D12049	\$	103.89
D12051	\$	45.67
D12052	\$	135.06
D12053	\$	62.92
D12055	\$	8.04
D12056	\$	6.08
D12058	\$	68.85
D12059	\$	135.00
D12060	\$	38.54
D12061	\$	133.65
D12062	\$	175.95
D12267	\$	75.00
D12268	\$	11.17
D12269	\$	48.42
D12270	\$	21.56
D12271	\$	457.51
D12436	\$	19.28
D12514	\$	53.91
D13071	\$	50.38
D13072	\$	67.82
D13111	\$	63.12
D13161	\$	29.52
I00048	\$	150.00
I00063	\$	150.00
I00064	\$	59.32
I00078B	\$	114.22
I00140	\$	76.05
I00144	\$	148.68
I00153	\$	318.40
I00154	\$	1,210.72
I00196	\$	150.00
I00199	\$	150.00
I00203	\$	150.00
I00221	\$	150.00
I00230	\$	75.00
I00236	\$	150.00

I00241	\$	150.00
I00250	\$	150.00
I00250B	\$	150.00
I00251	\$	150.00
I00251A	\$	150.00
I00254	\$	150.00
I00263	\$	150.00
I00270B	\$	150.00
I00270C	\$	150.00
I00272	\$	75.00
I00278	\$	150.00
I00593	\$	50.00
I00602	\$	150.00
I00603	\$	50.00
I00621	\$	50.00
I00622	\$	50.00
I00623	\$	50.00
I00624	\$	150.00
I00648	\$	132.51
I00649	\$	148.22
I00650	\$	198.42
I00651	\$	71.38
I00763	\$	50.00
I00797	\$	6,354.17
I00877	\$	150.00
I00878	\$	150.00
I01016	\$	150.00
I01018	\$	150.00
I01060	\$	150.00
I01104	\$	150.00

Regular City Council Meeting

Meeting Date: 10/27/2014

TITLE: Ward Ordinance Second Reading - Annexation #14-03

PRESENTED BY: Candi Millar, Planning & Community Services Department Director

Department: Planning & Community Services

PROBLEM/ISSUE STATEMENT

City election ward boundaries must be adjusted to conform to city limit amendments resulting from annexation of property into the City. The City Council approved the annexation of City-owned property located west of Shiloh Road and north of Shiloh Crossing Boulevard (The Shiloh Conservation Area, Annexation #14-03) on September 8, 2014. This requires a change in the boundaries of Ward V. Two readings are required for this action. The first reading of the ordinance was approved on October 14, 2014, after a public hearing was conducted. The second reading is scheduled for this meeting.

ALTERNATIVES ANALYZED

City Council may approve or not approve the ordinance to amend the boundaries of Ward V on first reading.

- Approving the ordinance will modify the boundaries of Ward V to include the property located west of Shiloh Road and north of Shiloh Crossing Boulevard.
- Denying the ordinance will not modify the boundaries of Ward V and create a problem where property inside the City Limits is not within one of the City Ward Boundaries.

FINANCIAL IMPACT

There is no budget/financial impact from this action.

RECOMMENDATION

Staff recommends that Council approve this ordinance on second reading adding recently annexed property to Ward V.

APPROVED BY CITY ADMINISTRATOR

Ward Ordinance

ORDINANCE NO. 14-_____

AN ORDINANCE OF THE CITY OF BILLINGS, AMENDING BILLINGS MUNICIPAL CODE, CHAPTER 11, ELECTIONS, IN PARTICULAR, SECTION 11-102(c), WARD BOUNDARIES; AND CHANGING THE WARD BOUNDARIES ESTABLISHED THEREIN BY ADDING CERTAIN NEWLY ANNEXED REAL PROPERTY TO WARD V PROVIDING FOR CERTIFICATION AND REPEALING OF ALL ORDINANCES AND RESOLUTIONS INCONSISTENT THEREWITH.

BE IT RESOLVED BY THE CITY COUNCIL OF THE CITY OF BILLINGS, MONTANA:

1. AMENDMENT. Pursuant to Billings Municipal Code, Section 11-102(c) and the State Law, Billings Municipal Code, Section 11-102(c) Ward Boundaries is hereby amended by adding to Ward V the following described real property:

A tract of land situated in the NE1/4 of Section 15, T. 1 S., R. 25 E., P.M.M., Yellowstone County, Montana, more particularly described as follows:

Lot 5A, of the Plat Of Amended Lot 5, Block 1, Long Subdivision, Recorded April 19, 2011, under Document Number 3585198, of record and on file in the office the Yellowstone County, Clerk and Recorder's. Including all adjacent Right-Of-Way of the Access Road to Yellowstone County Junk Vehicle Yard, as dedicated per said Plat Of Amended Lot 5, Block 1, Long Subdivision, Shiloh Drain and Shiloh Road.

Containing 69.665 gross and 66.893 net acres more or less.
(# 14-03) See Exhibit "A" Attached

2. CERTIFICATION. Pursuant to M.C.A. Section 13-3-103, the above change and alteration is hereby certified to the election administrator by the City Council, and the City Administrator or his designee is hereby directed to certify the changes and alterations and to deliver a map showing the boundaries of the ward, the streets, avenues and alleys by name and the ward by number, to the election administrator not more than ten (10) days after the effective date of this ordinance.
3. REPEALER. All other ordinances, sections of the Billings Municipal Code and ordinances inconsistent herewith are hereby repealed.

PASSED by the City Council on the first reading this 14th day of October, 2014.

PASSED by the City Council on the second reading this 27th day of October, 2014.

THE CITY OF BILLINGS:

Thomas W. Hanel, MAYOR

ATTEST:

BY: _____
Cari Martin, CITY CLERK

(AN 14-03)

EXHIBIT "A"

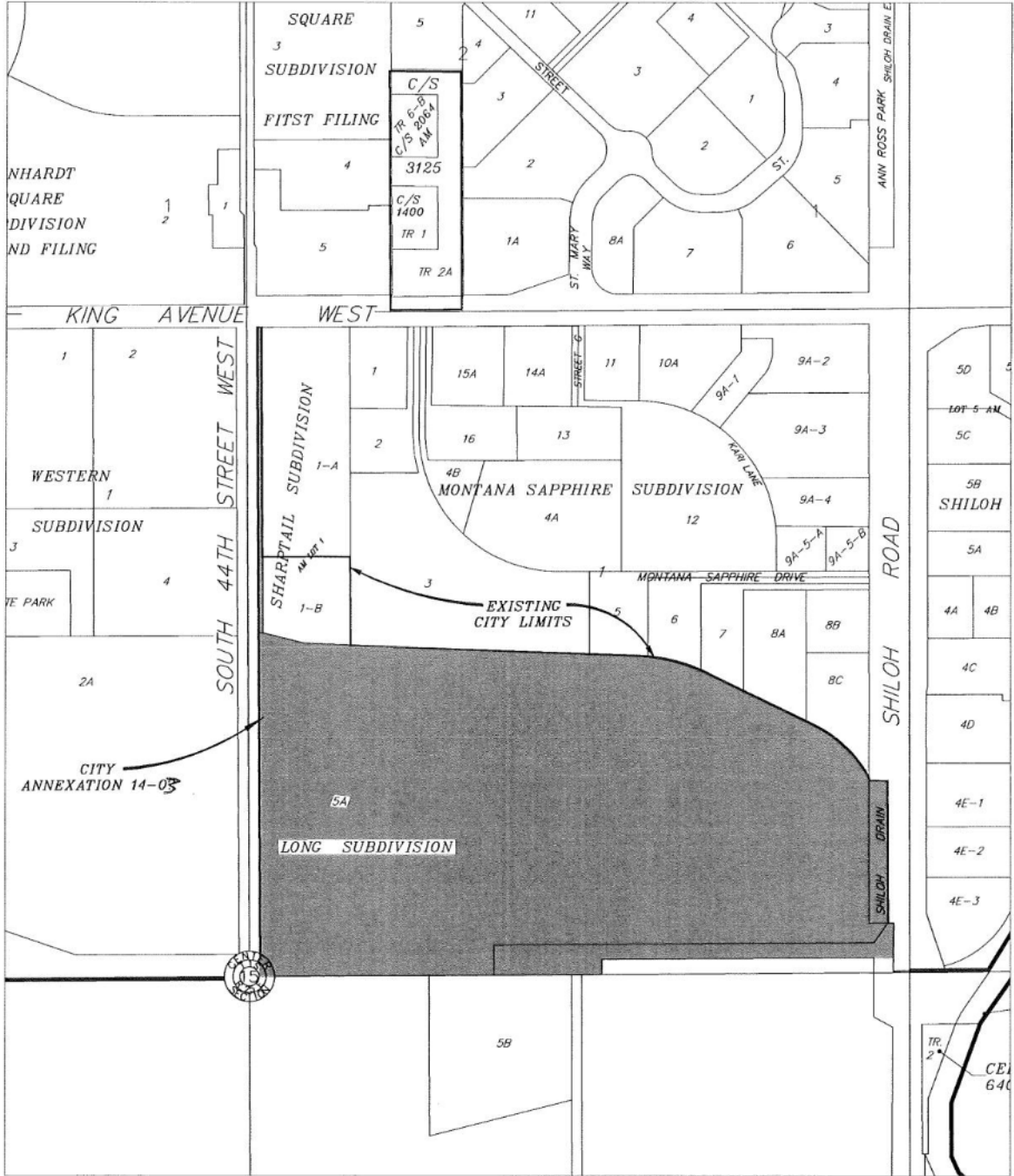

Regular City Council Meeting

Meeting Date: 10/27/2014

TITLE: Circle Fifty Subdivision, Amended Lot 9A, Block 9, Subsequent Minor Subdivision Preliminary Plat

PRESENTED BY: Candi Millar, Planning & Community Services Department Director

Department: Planning & Community Services

PROBLEM/ISSUE STATEMENT

On September 15, 2014, the Planning Division received an application for preliminary plat approval for Amended Lot 9A, Block 9, Circle Fifty Subdivision. The plat contains 2 lots on approximately 19,200 square feet of land generally located on the north side of Avenue C, just west of 38th Street West. The property currently has one duplex residence under construction on what will become Lot 9A-1. The proposal splits the lot in half, and a second duplex is proposed. Access to the new lots would be from Avenue C. The owner is Tvetene Kenmark, LLC., Mark Allen, managing partner, and the representing surveyor is Meridian Surveying.

ALTERNATIVES ANALYZED

In accordance with state law, the City Council has 35 working days to act upon this preliminary subsequent minor plat. The 35 working day review period for the proposed plat ends on November 3, 2014. State and City subdivision regulations also require that preliminary plats be reviewed using specific criteria, as stated within this report. The City may not unreasonably restrict an owner's ability to subdivide land if the subdivider provides evidence that any identified adverse effects can be mitigated. Within the 35-day review period, the City Council is required to:

1. Approve;
2. Conditionally Approve; or
3. Deny the Preliminary Plat

FINANCIAL IMPACT

If the City Council approves the preliminary plat, the subject property may further develop under private ownership, resulting in additional tax revenues.

BACKGROUND

General location: North side of Avenue C, just west of 38th St. West

Legal Description: Lot 9-A, Block 9, Circle Fifty Subdivision

Owner/Subdivider: Tvetene Kenmark, LLC; Mark Allen, Managing Partner

Engineer and Surveyor: Meridian Surveying

Existing Zoning: Residential-7000

Existing land use: one duplex

Proposed land use: two duplexes

Gross/net area: 19,213 square feet

Proposed number of lots: 2

Lot sizes: 9,609 square feet each

Parkland requirements: Parkland is not required as this subdivision is only creating one additional lot.

STAKEHOLDERS

A public hearing is not scheduled for the City Council meeting; however nearby property owners may attend the meeting. The Planning Division has received no public comments or questions regarding the proposed subdivision.

CONSISTENCY WITH ADOPTED POLICIES OR PLANS

Consistency with the Growth Policy, the 2014 Transportation Plan, and the Billings Area Bikeway and Trail Master Plan are discussed within the Findings of Fact.

SUMMARY

RECOMMENDATION

Staff recommends that the City Council conditionally approve the preliminary subsequent minor plat of Amended Lot 9A, Block 9, Circle Fifty Subdivision based on the Findings of Fact as presented in the staff report.

Recommended Conditions of Approval:

1. To ensure the provision of easements, the subdivider shall provide utility easements on the final plat as requested by the private utility companies.
2. Minor changes may be made in the SIA and final documents, as requested by the Planning, Legal or Engineering Departments to clarify the documents and bring them into the standard acceptable format.
3. The final plat shall comply with all requirements of the City of Billings Subdivision Regulations, rules, regulations, policies, and resolutions of City of Billings, and the laws and Administrative Rules of the State of Montana.

APPROVED BY CITY ADMINISTRATOR

[Preliminary Plat](#)

[Findings of Fact](#)

[Aerial photo](#)

Mayor's letter

PRELIMINARY

PRELIMINARY PLAT

AMENDED PLAT OF LOT 9-A, BLOCK 9, of AMENDED PLAT OF LOTS 3, 4, 8 & 9, BLOCK 9, CIRCLE FIFTY SUBDIVISION

LOCATED IN THE SOUTHEAST QUARTER (SE1/4) OF SECTION 33, TOWNSHIP 1 NORTH,
RANGE 25 EAST, P.M.M. CITY OF BILLINGS, YELLOWSTONE COUNTY, MONTANA.

FOR: TVETENE KENMARK LLC.

DATE: MAY 2014

BY: MONTANA MERIDIAN SURVEYING

BASIS OF BEARING: South line of Lot 9-A, Block 9, of AMENDED PLAT of
LOTS 3, 4, 8 & 9, BLOCK 9, CIRCLE FIFTY SUBDIVISION



VICINITY MAP



SCALE 1" = 30'
0 30 60

BLOCK 10
CIRCLE FIFTY SUBDIVISION

LEGEND

- SET REBAR WITH YELLOW PLASTIC CAP MERIDIAN SURVEYING 15035L3
- FOUND REBAR WITH YELLOW PLASTIC CAP MERIDIAN SURVEYING 15035L5
- FOUND ENGINEERING INC. YELLOW PLASTIC CAP 8307L5

AVENUE D

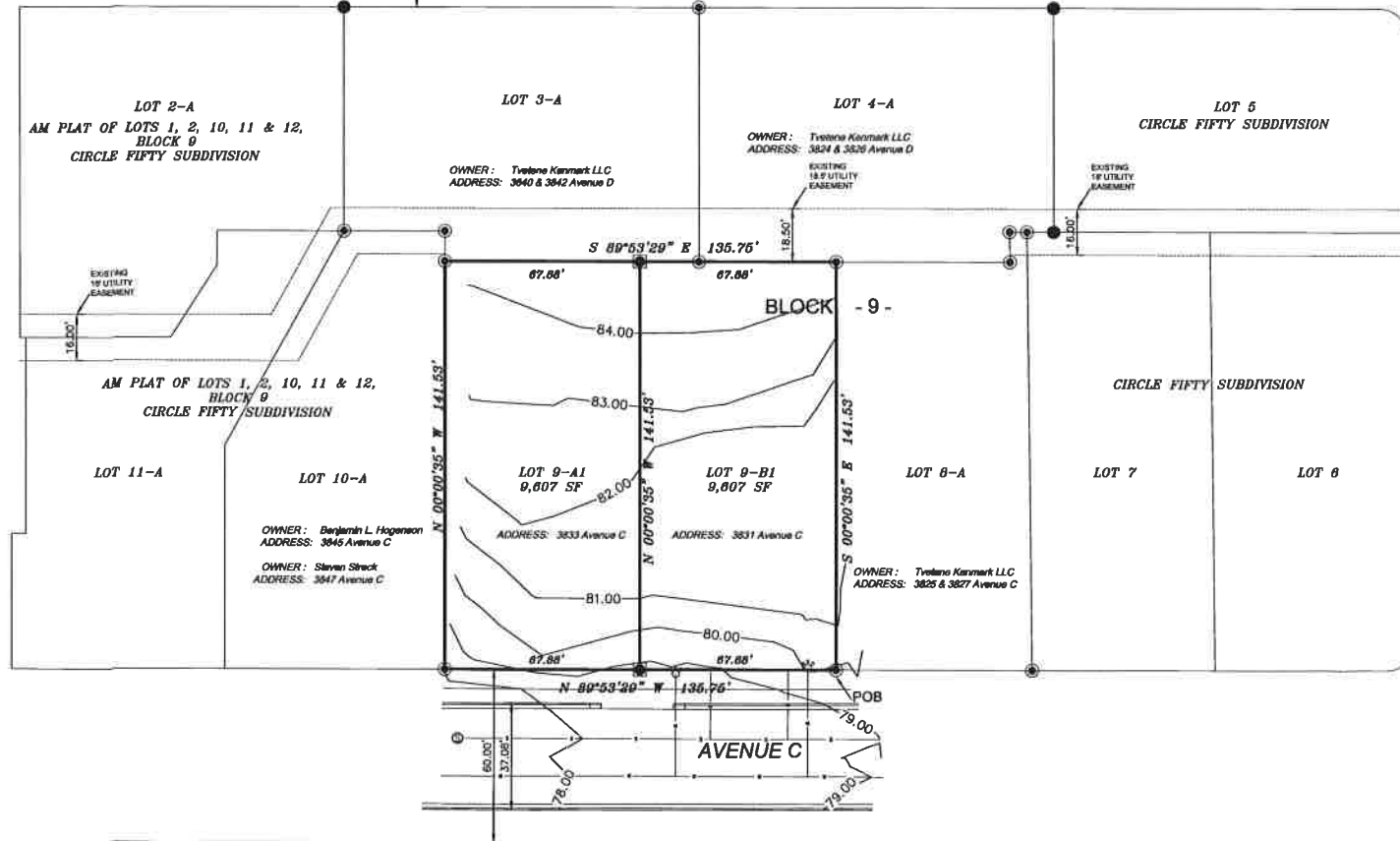

38th STREET WEST

SITE DATA

Number of Lots:	2
Maximum lot area:	9,607 SF
Minimum lot area:	9,607 SF
Area of Parkland:	N/A
Linear feet of streets:	N/A
Net and gross acreage of land:	9,607 SF
Existing Zoning:	R70
Existing land use:	Residential

LOT 7
BLOCK 3
CIRCLE FIFTY SUBDIVISION
OWNER: Alpine Townhomes
ADDRESS: 3838 & 3838 Avenue C

LOT 8 & 9
BLOCK 3
CIRCLE FIFTY SUBDIVISION
OWNER: Alpine Townhomes
ADDRESS: 3816, 3820, 3824 & 3828 Avenue C

Findings of Fact
Amended Lot 9-A, Block 9, Circle Fifty Subdivision

Staff is forwarding the recommended Findings of Fact for Amended Lot 9-A, Block 9, Circle Fifty Subdivision for review and approval by the City Council. These findings are based on the preliminary plat application and supplemental documents and address the review criteria required by the Montana Subdivision and Platting Act (76-3-608, MCA) and the Billings Subdivision Regulations (Section 23-303(H), BMCC).

A. What are the effects on agriculture, local services, the natural environment, wildlife, wildlife habitat, and public health, safety and welfare? [MCA 76-3-608 (3)(a) and BMCC 23-303(H)(1)]

1. Effect on agriculture and agricultural water user facilities

The subject property is within an urbanized residential development. It has not been used for agricultural purposes for many years and has no irrigation facilities serving it. Development of this vacant property within an existing urbanized area may help prevent further development of nearby agricultural lands.

2. Effect on local services

- a. **Utilities** – Water service for the proposed lots will be from the existing water main in Avenue C. One service exists for Lot 9B-1, and one additional service will be installed for Lot 9A-1. Lot owners will be responsible for connection to these services at the time of lot development.

Sewer services for the proposed lots will also be provided from the existing sewer main in Avenue B. One service exists for Lot 9B-1, and one additional service will be installed for Lot 9A-1. Lot owners will be responsible for final connection to the services at the time of lot development.

Private utilities such as electric and gas are available to the lots upon development. An existing utility easement was provided on the previous plats adjacent to this property. Additional easements may be requested on this property according to comments received by Northwestern Energy. Therefore it is recommended as a condition of approval that the subdivider provide utility easements on the final plat as requested by the private utility companies (**Condition #1**).

- b. **Storm water** –All drainage improvements shall comply with the provisions of the City of Billings Storm Water Management Manual and Chapter 28, BMCC. Storm water will be contained on-site in accordance with a storm water management plan to be reviewed and approved at the time of lot development. No new connections to City’s storm drain system will be allowed for this subdivision.
- c. **Solid waste** - The City of Billings will provide solid waste collection and disposal. Dumpster location and design will be evaluated at the time of individual site development. The City’s landfill has adequate capacity for this waste.

- d. **Streets** – The subject property has frontage on Avenue C and currently has one curb cut for a drive approach centered on the southern property line. Individual drive approaches are likely to be requested for the new lots. The new approach proposal will be evaluated and approved by City Engineering at the time of lot development.
- e. **Emergency services** - The Billings Police and Fire Departments will respond to emergencies within the proposed subdivision. The nearest emergency service station is located at Grand Avenue and 54th St. West (Station #7). The subdivision is located within the ambulance service area of American Medical Response.

There are existing fire hydrants to provide fire suppression for the subdivision.

- f. **Schools** –This two-lot subdivision should have a minimal effect on schools. Children living on the property will go to Burlington Elementary, Will James Middle, and West High schools.
- g. **Parks and Recreation** - Parkland dedication is not required for this subdivision, as it is a subdivision creating one additional lot and parkland requirements were met with the original subdivision.
- h. **Mail Delivery** - The United States Postal Service has requested a Central Box Unit (CBU). At the time of lot development and establishment of mail delivery, the location of the CBU shall be reviewed and approved by the post office.

3. Effect on the natural environment

The proposed subdivision should have only minor effects on the natural environment. There will be short term air and noise pollution associated with construction on the property. Storm water shall be managed in compliance with an approved plan and the property is outside of the flood plain. New development proposals will need to prepare and submit a project-specific geotechnical analysis to minimize any potential impacts from soil and groundwater conditions.

4. Effect on wildlife and wildlife habitat

The proposed subdivision should not affect wildlife or habitat. There are no known endangered or threatened species on the property and the property is nearby a very busy commercial development node.

5. Effect on the public health, safety and welfare

The subdivision should not negatively affect public health or safety. The subject property is not within a mapped floodway or flood zone. A geotechnical survey will be required prior to construction to ensure appropriate foundation designs are installed based on the subsurface conditions. There are no obvious threats to public health, safety or welfare.

B. Was an Environmental Assessment required? [MCA 76-3-616 and BMCC 23-901]

The proposed subdivision is exempt from the requirement for an Environmental Assessment pursuant to Section 76-3-616, MCA and 23-901, BMCC.

C. Does the subdivision conform to the Yellowstone County-City of Billings 2008 Growth Policy Update, the 2014 Billings Area Long Range Transportation Plan, and the Billings Area Bikeway and Trails Master Plan? [BMCC 23-303(H)(3)]

1. Yellowstone County-City of Billings 2008 Growth Policy Update

The proposed subdivision is consistent with the following goals of the Growth Policy:

- a. **Goal:** Predictable land use decisions that are consistent with neighborhood character and preferred land use patterns identified in neighborhood plans (p. 6).
- b. **Goal:** New developments that are sensitive to and compatible with the character of adjacent city neighborhoods and County townsites (p.6).
- c. **Goal:** Contiguous development focused in and around existing population centers separated by open space (p. 6).
- d. **Goal:** More housing and business choices within each neighborhood (p. 6).

2. 2014 Billings Urban Area Long Range Transportation Plan

The proposed subdivision adheres to the goals and objectives of the 2014 Transportation Plan and preserves the street network and street hierarchy specified within the plan.

3. Billings Area Bikeway and Trail Master Plan

The Billings Area Bikeway and Trail Master Plan does not identify any bike facilities along the Avenue B frontage of this property. The property is four blocks from Shiloh Road which has an existing multi-use path.

D. Does the subdivision conform to the Montana Subdivision and Platting Act and to local subdivision regulations? [MCA 76-3-608(3)(b), BMCC 23-303(H)(2)]

The proposed subdivision satisfies the requirements of the Montana Subdivision and Platting Act and conforms to the design standards specified in the local subdivision regulations. The subdivider and the local government have complied with the subdivision review and approval procedures set forth in the local and state subdivision regulations.

E. Does the proposed subdivision conform to all requirements of the zoning in effect? [BMCC 23-303(H)(2)(e)]

The subject property is located in the Residential-7000 zoning district. All development shall comply with the standards set forth in Section 27-1001, BMCC. Final zoning compliance will be determined at the time of the building permits for each lot.

F. Does the proposed plat provide easements for the location and installation of any utilities? [MCA 76-3-608(3)(c) and BMCC 23-303(H)(2)(b)]

The plat shows existing easements adjacent to the north of the property for natural gas utility services. Additional easements may be needed as requested by Northwestern Energy. It is recommended as a condition of approval that the subdivider provide utility easements on the final plat as requested by the private utility companies (**Condition #1**).

G. Does the proposed plat provide legal and physical access to each parcel within the subdivision and notation of that access on the plat? [MCA 76-3-608(3)(d) and BMCC 23-303(H)(2)(c)]

Access to the subdivision shall be from Avenue C.

CONCLUSIONS OF FINDING OF FACT

- The preliminary plat of Lot 9-A, Block 9, Circle Fifty Subdivision, does not create any adverse impacts that warrant denial of the subdivision.
- The proposed subdivision conforms to several goals and policies of the 2008 Growth Policy, and does not conflict with the 2014 Long-Range Transportation Plan or the Trail Plan.
- The proposed subdivision complies with state and local subdivision regulations, local zoning, and sanitary requirements, and provides legal and physical access to each lot.
- Any potential negative or adverse impacts will be mitigated with the proposed conditions of approval.

Approved by the Billings City Council, October 27, 2014.

Thomas W. Hanel, Mayor



Subject Property

Mayor's Approval Letter— Amended Lot 9A, Block 9, Circle Fifty Subdivision

October 28, 2014

Mark Allen
2139 Broadwater Ave.
Billings, MT 59102

Dear Property Owner:

On October 27, 2014, the Billings City Council conditionally approved the preliminary plat of Amended Lot 9A, Block 9, Circle Fifty Subdivision, subject to the following conditions of approval:

1. To ensure the provision of easements, the subdivider shall provide utility easements on the final plat as requested by the private utility companies.
2. Minor changes may be made in the SIA and final documents, as requested by the Planning, Legal or Engineering Departments to clarify the documents and bring them into the standard acceptable format.
3. The final plat shall comply with all requirements of the City of Billings Subdivision Regulations, rules, regulations, policies, and resolutions of City of Billings, and the laws and Administrative Rules of the State of Montana.

Should you have questions please contact Juliet Spalding at (406) 247-8684 or by email at spaldingj@ci.billings.mt.us

Sincerely,

Thomas W. Hanel, Mayor

Pc: Montana Meridian Surveying

Regular City Council Meeting

Meeting Date: 10/27/2014

TITLE: Payment of Claims September 22, 2014

PRESENTED BY: Patrick M. Weber, Finance Director

Department: City Hall Administration

PROBLEM/ISSUE STATEMENT

Claims in the amount of \$4,005,359.64 have been audited and are presented for City Council payment approval. A complete listing of the claims dated September 22, 2014 is available in the Finance Department.

ALTERNATIVES ANALYZED

No other alternatives were analyzed.

FINANCIAL IMPACT

Claims have a varying impact on department budgets, but are submitted by the departments and reviewed by Finance staff before being sent to the Council.

RECOMMENDATION

Staff recommends that Council approve the Payment of Claims.

APPROVED BY CITY ADMINISTRATOR

Council Report 09-22

Check Date	Check	Name	Amount	Account	Item Desc
09/22/2014	778586	A & E Architects, PC	\$4,439.08	4980-55360-409390	New Library Building - Construction Management Services
09/22/2014	778588	Ace Electric Inc	\$2,613.16	2110-31320-403590	install street light service at McKinley school
09/22/2014	778593	Alfa Laval	\$6,905.59	5020-00000-141000	WASTEWATER PARTS & SUPPLY PO NUM 296253
09/22/2014	778595	Alfa Planning & Design Inc	\$6,295.60	2400-43010-407214	inv 2014-113-4
09/22/2014	778597	Archie Cochrane	\$17,813.32	6300-17530-407310	Parks Truck #1607 Inv. #826907/1 #2014-057
09/22/2014	778597	Archie Cochrane	\$6.42	1500-21120-402320	5135660
09/22/2014	778597	Archie Cochrane	\$10.26	2110-31320-402320	5135715
09/22/2014	778597	Archie Cochrane	\$119.25	1500-21120-402320	5136400
09/22/2014	778597	Archie Cochrane	\$12.23	1500-21120-402320	5136502
09/22/2014	778597	Archie Cochrane	\$2,213.36	0100-51210-402320	682870/1
09/22/2014	778597	Archie Cochrane	\$5,681.16	6300-17530-407310	Slade 2009 Jeep Library Hail Damage #12870/Chartier 2009 Ford F150 #12897/Vladic 2012 Hyundai Genesis #12893
09/22/2014	778597	Archie Cochrane	\$4,149.42	6300-17530-407310	Slade 2009 Jeep Library Hail Damage #12870/Chartier 2009 Ford F150 #12897/Vladic 2012 Hyundai Genesis #12893
09/22/2014	778597	Archie Cochrane	\$830.89	6300-17530-407310	Invoice #828483-1 BPD 1503 #2014-202
09/22/2014	778598	Artcraft Printers Of Billings	\$4,180.00	2400-43010-407214	32706MP-IN
09/22/2014	778599	Atlantic Signal LLC	\$8,625.00	1500-21120-402120	Item #ACH.VGN.47, Comtac ACH Single Comm Headset: (Vertical Frame: OD Green)
09/22/2014	778599	Atlantic Signal LLC	\$750.00	1500-21120-402120	Item #XRY.GEL, Peltor Gel Cups (Pair)
09/22/2014	778599	Atlantic Signal LLC	\$2,475.00	1500-21120-402120	Item #PTT.SFV.47, 'SF' Push to Talk Assembly w/Volume Control
09/22/2014	778599	Atlantic Signal LLC	\$600.00	1500-21120-402120	Item #CTR.KL1.ST, 6 Pin Hirose Keyload: Straight Cabled Connector
09/22/2014	778599	Atlantic Signal LLC	\$75.00	1500-21120-402120	Freight
09/22/2014	778601	Automatic Doors Of Montana Inc	\$4,400.00	5610-71120-403660	Invoice #3520. Replace caulking on terminal face windows
09/22/2014	778610	Billings Depot Inc	\$5,366.67	6600-31100-405310	Rent
09/22/2014	778610	Billings Depot Inc	\$8,050.00	6700-31410-405310	Rent
09/22/2014	778617	Business Tax Section	\$21.63	0100-00000-201100	Final payment-retainage release on tax.
09/22/2014	778617	Business Tax Section	\$44.80	5620-71200-409290	Car Rental & Airline Ticket Counters Upgrade Project
09/22/2014	778617	Business Tax Section	\$48.29	5620-00000-201100	Retainage Release
09/22/2014	778617	Business Tax Section	\$3,041.95	4050-71250-409683	AIP-47 Security Access Gates - Federal Share
09/22/2014	778617	Business Tax Section	\$337.99	4050-71250-409684	AIP-47 Security Access Gates - Local Share
09/22/2014	778617	Business Tax Section	\$8,296.47	5030-75910-409340	WO 08-25 Zone 3 Chapple Reservoir Expansion
09/22/2014	778617	Business Tax Section	\$2,053.15	8400-31840-409310	WO 14-01 2014 Storm Drain Sch 1A
09/22/2014	778617	Business Tax Section	\$3,104.57	5130-85910-409340	WO 14-01 Sanitary Sewer Main Replacement Schedule 2
09/22/2014	778617	Business Tax Section	\$888.79	8400-31840-409310	WO 14-01 Sanitary Sewer Main Replacement Schedule 2
09/22/2014	778617	Business Tax Section	\$4,003.69	1990-15050-409340	WO 14-05 SBURD Sewer Phase 1
09/22/2014	778617	Business Tax Section	\$753.07	5030-75910-409340	WO 14-05 SBURD Sewer Phase 1
09/22/2014	778617	Business Tax Section	\$104.48	2050-31310-409390	WO 12-03 2012 City Chip Seal Sch1; CO#3 07/18/13
09/22/2014	778617	Business Tax Section	\$4,489.56	5030-75910-409340	WO 14-01 2014 Water Main Replacement and Storm Drain Project Sch 1A
09/22/2014	778621	Carquest Auto Parts	\$71.69	6010-00000-141000	1910-320286 PO NUM 295754
09/22/2014	778621	Carquest Auto Parts	\$11.76	6010-00000-141000	1910-320550 PO NUM 295754
09/22/2014	778621	Carquest Auto Parts	\$60.80	6010-00000-141000	1910-320550 PO NUM 295754
09/22/2014	778621	Carquest Auto Parts	\$6.98	6010-00000-141000	1910-320643 PO NUM 295754
09/22/2014	778621	Carquest Auto Parts	\$35.66	6010-00000-141000	1910-320726 PO NUM 295754
09/22/2014	778621	Carquest Auto Parts	\$3.22	5120-85000-402320	NONSTOCKING ITEMS-P.U.D.
09/22/2014	778621	Carquest Auto Parts	\$57.54	1500-21120-402320	1910-320683
09/22/2014	778621	Carquest Auto Parts	\$9.77	5020-74000-402320	NONSTOCKING ITEMS-P.U.D.
09/22/2014	778621	Carquest Auto Parts	\$32.69	5020-73140-402410	Torx bit set, valve lapper
09/22/2014	778621	Carquest Auto Parts	\$10.90	5120-83140-402410	Torx bit set, valve lapper
09/22/2014	778621	Carquest Auto Parts	\$98.69	5020-75000-402320	NONSTOCKING ITEMS-P.U.D.
09/22/2014	778621	Carquest Auto Parts	\$4.99	6500-15660-402450	Fluid Lubricant Pump for Compressor in Street shop
09/22/2014	778621	Carquest Auto Parts	\$31.81	5020-75000-402320	1910-320268
09/22/2014	778621	Carquest Auto Parts	\$39.58	5020-74000-402320	1910-320271
09/22/2014	778621	Carquest Auto Parts	\$21.95	5020-74000-402320	1910-320286
09/22/2014	778621	Carquest Auto Parts	\$18.33	5410-31220-402320	1910-320521
09/22/2014	778621	Carquest Auto Parts	\$6.90	6500-15660-402320	1910-320559
09/22/2014	778621	Carquest Auto Parts	\$130.19	5020-75000-402320	1910-320564
09/22/2014	778621	Carquest Auto Parts	\$18.69	0100-51420-402320	1910-320632
09/22/2014	778621	Carquest Auto Parts	\$33.59	1500-21120-402320	1910-320666
09/22/2014	778621	Carquest Auto Parts	\$165.51	2110-31320-402320	1910-320688
09/22/2014	778621	Carquest Auto Parts	\$37.16	2110-31320-402320	1910-320708
09/22/2014	778621	Carquest Auto Parts	\$6.61	6010-15530-402650	1910-320745
09/22/2014	778621	Carquest Auto Parts	\$20.78	0100-51120-402320	1910-320777
09/22/2014	778621	Carquest Auto Parts	\$8.15	0100-51120-402320	1910-320785
09/22/2014	778621	Carquest Auto Parts	\$51.46	2090-44520-402320	1910-320855
09/22/2014	778621	Carquest Auto Parts	\$32.75	0100-51120-402320	1910-318548
09/22/2014	778621	Carquest Auto Parts	\$41.88	6010-15530-402650	1910-318772
09/22/2014	778621	Carquest Auto Parts	\$11.16	0100-51120-402320	1910-319119
09/22/2014	778621	Carquest Auto Parts	\$1.90	5020-74000-402320	1935-356202
09/22/2014	778621	Carquest Auto Parts	\$11.24	5710-71470-402320	AUTO & TRUCK MAINT.ITEMS
09/22/2014	778621	Carquest Auto Parts	\$96.54	6010-00000-141000	1910-319163 PO NUM 295754
09/22/2014	778621	Carquest Auto Parts	\$51.10	6010-00000-141000	1910-319311 PO NUM 295754
09/22/2014	778621	Carquest Auto Parts	\$13.00	6010-00000-141000	1910-319414 PO NUM 295754
09/22/2014	778621	Carquest Auto Parts	\$20.10	6010-00000-141000	1910-319414 PO NUM 295754

Check Date	Check	Name	Amount	Account	Item Desc
09/22/2014	778621	Carquest Auto Parts	\$229.20	6010-00000-141000	1910-319414 PO NUM 295754
09/22/2014	778621	Carquest Auto Parts	\$2.20	6010-00000-141000	1910-319553 PO NUM 295754
09/22/2014	778621	Carquest Auto Parts	\$36.04	6010-00000-141000	1910-319604 PO NUM 295754
09/22/2014	778621	Carquest Auto Parts	\$199.30	6010-00000-141000	1910-319621 PO NUM 295754
09/22/2014	778621	Carquest Auto Parts	\$22.39	6010-00000-141000	1910-319686 PO NUM 295754
09/22/2014	778621	Carquest Auto Parts	\$55.85	2110-31320-402320	1910-318758
09/22/2014	778621	Carquest Auto Parts	\$9.95	2110-31320-402320	1910-318873
09/22/2014	778621	Carquest Auto Parts	\$9.63	2110-31320-402320	1910-318873
09/22/2014	778621	Carquest Auto Parts	\$48.35	1500-21120-402320	1910-318932
09/22/2014	778621	Carquest Auto Parts	\$14.00	1500-21120-402320	1910-319072
09/22/2014	778621	Carquest Auto Parts	\$10.31	5410-31230-402320	1910-319084
09/22/2014	778621	Carquest Auto Parts	\$241.52	0100-51120-402320	1910-319176
09/22/2014	778621	Carquest Auto Parts	\$16.16	5410-31230-402320	1910-319178
09/22/2014	778621	Carquest Auto Parts	\$25.73	5410-31230-402320	1910-319194
09/22/2014	778621	Carquest Auto Parts	\$6.87	0100-51120-402320	1910-319245
09/22/2014	778621	Carquest Auto Parts	\$51.46	2090-44520-402320	1910-319257
09/22/2014	778621	Carquest Auto Parts	\$1.00	6010-15530-402650	1910-319386
09/22/2014	778621	Carquest Auto Parts	\$16.32	2110-31320-402320	1910-319422
09/22/2014	778621	Carquest Auto Parts	\$33.00	1500-21120-402320	1910-319423
09/22/2014	778621	Carquest Auto Parts	\$31.32	5410-31220-402320	1910-319494
09/22/2014	778621	Carquest Auto Parts	\$7.81	6010-15530-402320	1910-319608
09/22/2014	778621	Carquest Auto Parts	\$13.35	6700-31410-402320	1910-319809
09/22/2014	778621	Carquest Auto Parts	\$131.00	2110-31320-402320	1910-319842
09/22/2014	778621	Carquest Auto Parts	\$15.46	0100-51120-402320	1910-319845
09/22/2014	778621	Carquest Auto Parts	\$22.69	0100-51120-402320	1910-319849
09/22/2014	778621	Carquest Auto Parts	\$49.76	5410-31220-402320	1910-319961
09/22/2014	778621	Carquest Auto Parts	\$12.48	5020-00000-141000	WATER PARTS AND SUPPLIES PO NUM 296067
09/22/2014	778621	Carquest Auto Parts	\$32.89	5120-84000-402320	NONSTOCKING ITEMS-P.U.D.
09/22/2014	778621	Carquest Auto Parts	\$10.25	5020-75000-402320	NONSTOCKING ITEMS-P.U.D.
09/22/2014	778621	Carquest Auto Parts	-\$23.52	6010-00000-141000	1910-319405 PO NUM 295754
09/22/2014	778621	Carquest Auto Parts	\$94.80	6010-00000-141000	1935-357229 PO NUM 295754
09/22/2014	778621	Carquest Auto Parts	\$26.77	5410-31220-402320	1910-319773
09/22/2014	778621	Carquest Auto Parts	-\$26.77	5410-31220-402320	1910-319847
09/22/2014	778621	Carquest Auto Parts	\$64.88	5410-31220-402320	1910-320071
09/22/2014	778621	Carquest Auto Parts	\$61.29	5020-74000-402320	NONSTOCKING ITEMS-P.U.D.
09/22/2014	778624	Chicago Title of Montana LLC	\$10,000.00	2830-65810-407277	FTHB Jeremy Meyers & Rose Poppler 206 13th Street West
09/22/2014	778630	Connor's Garage Door Service	\$3,700.00	5610-71120-403660	Invoice #3640. Replace exit door at baggage make up
09/22/2014	778630	Connor's Garage Door Service	\$695.00	5610-71120-403660	Invoice #3641. Replace broken springs at entrance door drop off baggage area
09/22/2014	778630	Connor's Garage Door Service	\$155.00	5610-71120-403660	Invoice #3731. Temporary repairs to baggage make up entrance door
09/22/2014	778632	Cop Construction Co	\$307,352.25	5130-85910-409340	WO 14-01 Sanitary Sewer Main Replacement Schedule 2
09/22/2014	778632	Cop Construction Co	\$87,990.63	8400-31840-409310	WO 14-01 Sanitary Sewer Main Replacement Schedule 2
09/22/2014	778632	Cop Construction Co	\$396,365.08	1990-15050-409340	WO 14-05 SBURD Sewer Phase 1
09/22/2014	778632	Cop Construction Co	\$74,553.93	5030-75910-409340	WO 14-05 SBURD Sewer Phase 1
09/22/2014	778634	CTA Inc	\$195.00	2600-55180-403590	Invoice 3826
09/22/2014	778634	CTA Inc	\$4,128.45	0100-14110-403546	City of Billings Facilities Master Plan
09/22/2014	778634	CTA Inc	\$577.09	5620-71200-409290	Amendment 1 Engineers for Architectural Services for the Terminal Hot Water Boiler Replacement
09/22/2014	778634	CTA Inc	\$4,050.64	4050-71250-409683	AIP-47 Security Access Gates - Federal Share
09/22/2014	778634	CTA Inc	\$450.07	4050-71250-409684	AIP-47 Security Access Gates - Local Share
09/22/2014	778639	DataProse LLC	\$9,647.92	5020-73110-403110	Statement processing and mailing
09/22/2014	778639	DataProse LLC	\$3,062.41	5020-73110-403111	Statement processing and mailing
09/22/2014	778639	DataProse LLC	\$6,431.94	5120-83110-403110	Statement processing and mailing
09/22/2014	778639	DataProse LLC	\$2,041.61	5120-83110-403111	Statement processing and mailing
09/22/2014	778643	Dell Computer L P	\$4,917.55	5120-84300-402925	WWTP Elec Laptop
09/22/2014	778649	Edge Construction Supply	\$94.50	5120-84300-402360	Unistrut channel
09/22/2014	778649	Edge Construction Supply	\$3,937.25	5120-84000-402450	Adjustable mast/floor mount sleeve
09/22/2014	778665	Galles Filter Service	\$29.43	5020-00000-141000	WATER PARTS AND SUPPLIES PO NUM 296216
09/22/2014	778665	Galles Filter Service	-\$20.66	6010-00000-141714	313036 PO NUM 295755
09/22/2014	778665	Galles Filter Service	\$9.12	0100-51420-402320	314667
09/22/2014	778665	Galles Filter Service	\$13.68	0100-51120-402320	314861
09/22/2014	778665	Galles Filter Service	\$5.48	2400-43010-402320	314909
09/22/2014	778665	Galles Filter Service	\$58.06	6010-00000-141714	314657 PO NUM 295755
09/22/2014	778665	Galles Filter Service	\$427.70	6010-00000-141000	314663 PO NUM 295755
09/22/2014	778665	Galles Filter Service	\$344.30	6010-00000-141000	314885 PO NUM 295755
09/22/2014	778665	Galles Filter Service	\$7.87	6010-00000-141000	314928 PO NUM 295755
09/22/2014	778665	Galles Filter Service	\$102.70	5410-31230-402320	314654
09/22/2014	778665	Galles Filter Service	\$7.24	5710-71440-402320	314657
09/22/2014	778665	Galles Filter Service	\$1.81	5710-71440-402320	313004
09/22/2014	778665	Galles Filter Service	\$1.81	5710-71440-402320	313601
09/22/2014	778665	Galles Filter Service	\$5.43	5710-71440-402320	314127
09/22/2014	778665	Galles Filter Service	\$61.23	2110-31320-402320	314313
09/22/2014	778665	Galles Filter Service	\$29.59	2110-31320-402320	314560
09/22/2014	778665	Galles Filter Service	\$12.83	5020-74000-402320	NONSTOCKING ITEMS-P.U.D.
09/22/2014	778665	Galles Filter Service	\$189.84	6010-00000-141714	313004 PO NUM 295755

Check Date	Check	Name	Amount	Account	Item Desc
09/22/2014	778665	Galles Filter Service	\$101.39	6010-00000-141714	313601 PO NUM 295755
09/22/2014	778665	Galles Filter Service	\$39.86	6010-00000-141714	314127 PO NUM 295755
09/22/2014	778665	Galles Filter Service	\$337.00	6010-00000-141000	314130 PO NUM 295755
09/22/2014	778665	Galles Filter Service	\$217.31	6010-00000-141000	314322 PO NUM 295755
09/22/2014	778665	Galles Filter Service	\$121.54	5020-00000-141000	WATER PARTS AND SUPPLIES PO NUM 296068
09/22/2014	778665	Galles Filter Service	\$449.78	6010-00000-141000	313009 PO NUM 295755
09/22/2014	778665	Galles Filter Service	\$9.64	0100-51120-402320	313228
09/22/2014	778665	Galles Filter Service	\$5.90	1500-21120-402320	313804
09/22/2014	778665	Galles Filter Service	\$9.64	2110-31320-402320	313805
09/22/2014	778665	Galles Filter Service	\$13.82	2110-31320-402320	13.82
09/22/2014	778665	Galles Filter Service	\$296.03	6010-00000-141000	313226 PO NUM 295755
09/22/2014	778665	Galles Filter Service	\$89.84	6010-00000-141000	313507 PO NUM 295755
09/22/2014	778665	Galles Filter Service	\$471.86	6010-00000-141000	313608 PO NUM 295755
09/22/2014	778665	Galles Filter Service	\$8.61	6010-00000-141000	313728 PO NUM 295755
09/22/2014	778665	Galles Filter Service	\$352.02	6010-00000-141000	313804 PO NUM 295755
09/22/2014	778665	Galles Filter Service	\$12.14	0100-51120-402320	313461
09/22/2014	778668	Gillig Corporation	\$370.72	6010-00000-141714	40035348 PO NUM 296318
09/22/2014	778668	Gillig Corporation	\$2,869.74	6010-00000-141714	40040673 PO NUM 296318
09/22/2014	778668	Gillig Corporation	\$338.56	6010-00000-141714	40042602 PO NUM 296318
09/22/2014	778668	Gillig Corporation	\$21.16	5710-71440-402320	40042602
09/22/2014	778669	Great West Engineering, Inc	\$10,564.83	5440-31230-409390	WO 12-29 Solid Waste Management Amend#2
09/22/2014	778671	Hardrives Construction Inc	\$10,343.43	2050-31310-409390	WO 12-03 2012 City Chip Seal Sch 1; CO#3 07/18/13
09/22/2014	778677	Iaff	\$4,485.35	9000-00000-209920	Payroll Summary
09/22/2014	778678	Ingram Library Services Inc.	\$30.66	2600-55190-403226	Inv 80135357
09/22/2014	778678	Ingram Library Services Inc.	\$4.79	2600-55190-403226	Inv 80135358
09/22/2014	778678	Ingram Library Services Inc.	\$62.49	2600-55190-403241	Inv 80135359
09/22/2014	778678	Ingram Library Services Inc.	\$37.80	2600-55190-403226	Inv 80135360
09/22/2014	778678	Ingram Library Services Inc.	\$110.12	2600-55190-403241	Inv 80135360
09/22/2014	778678	Ingram Library Services Inc.	\$27.49	2600-55190-403242	Inv 80135360
09/22/2014	778678	Ingram Library Services Inc.	\$32.44	2600-55190-403226	Inv 80135361
09/22/2014	778678	Ingram Library Services Inc.	\$45.88	2600-55190-403227	Inv 80135362
09/22/2014	778678	Ingram Library Services Inc.	\$538.20	2600-55110-407930	Inv 80290027
09/22/2014	778678	Ingram Library Services Inc.	\$49.26	2600-55190-403226	Inv 80290028
09/22/2014	778678	Ingram Library Services Inc.	\$8.25	2600-55190-403333	Inv 80290029
09/22/2014	778678	Ingram Library Services Inc.	\$9.59	2600-55190-403227	Inv 80290030
09/22/2014	778678	Ingram Library Services Inc.	\$37.96	2600-55190-403241	Inv 80290031
09/22/2014	778678	Ingram Library Services Inc.	\$18.86	2600-55190-403333	Inv 80290032
09/22/2014	778678	Ingram Library Services Inc.	\$71.96	2600-55190-403227	Inv 80290033
09/22/2014	778678	Ingram Library Services Inc.	\$11.99	2600-55190-403226	Inv 80290034
09/22/2014	778678	Ingram Library Services Inc.	\$143.89	2600-55190-403227	Inv 80290035
09/22/2014	778678	Ingram Library Services Inc.	\$1,220.56	2600-55190-403226	Inv 80290036
09/22/2014	778678	Ingram Library Services Inc.	\$112.71	2600-55190-403222	Inv 80290037
09/22/2014	778678	Ingram Library Services Inc.	\$107.43	2600-55190-403226	Inv 80290037
09/22/2014	778678	Ingram Library Services Inc.	\$477.69	2600-55190-403227	Inv 80290037
09/22/2014	778678	Ingram Library Services Inc.	\$16.60	2600-55190-403255	Inv 80290037
09/22/2014	778678	Ingram Library Services Inc.	\$2.99	2600-55190-403333	Inv 80290037
09/22/2014	778678	Ingram Library Services Inc.	\$17.11	2600-55190-403382	Inv 80290037
09/22/2014	778678	Ingram Library Services Inc.	\$10.17	2600-55190-403227	iNV 80290038
09/22/2014	778678	Ingram Library Services Inc.	\$1,077.60	2600-55110-407930	iNV 80340699
09/22/2014	778678	Ingram Library Services Inc.	\$5.99	2600-55190-403227	iNV 80340700
09/22/2014	778678	Ingram Library Services Inc.	\$31.57	2600-55190-403333	iNV 80340701
09/22/2014	778678	Ingram Library Services Inc.	\$38.47	2600-55190-403222	iNV 80340702
09/22/2014	778678	Ingram Library Services Inc.	\$86.30	2600-55190-403227	iNV 80340702
09/22/2014	778678	Ingram Library Services Inc.	\$158.33	2600-55190-403241	iNV 80340702
09/22/2014	778678	Ingram Library Services Inc.	\$53.84	2600-55190-403242	iNV 80340702
09/22/2014	778678	Ingram Library Services Inc.	\$728.18	2600-55190-403333	Inv. 80340703
09/22/2014	778678	Ingram Library Services Inc.	\$67.77	2600-55190-403227	Inv 80340704
09/22/2014	778678	Ingram Library Services Inc.	\$5.39	2600-55190-403255	Inv 80340704
09/22/2014	778678	Ingram Library Services Inc.	\$60.28	2600-55190-403241	Inv 80340705
09/22/2014	778678	Ingram Library Services Inc.	\$8.24	2600-55190-403242	Inv 80340705
09/22/2014	778678	Ingram Library Services Inc.	\$8.70	2600-55190-403333	Inv 80340706
09/22/2014	778678	Ingram Library Services Inc.	\$63.60	2600-55190-403227	Inv 80340707
09/22/2014	778678	Ingram Library Services Inc.	\$33.91	2600-55190-403241	Inv 80340707
09/22/2014	778678	Ingram Library Services Inc.	\$538.20	2600-55110-407930	Inv 80400816
09/22/2014	778678	Ingram Library Services Inc.	\$10.62	2600-55190-403255	Inv 80400817
09/22/2014	778678	Ingram Library Services Inc.	\$35.96	2600-55190-403227	Inv 80400818
09/22/2014	778678	Ingram Library Services Inc.	\$42.58	2600-55190-403241	Inv 80400818
09/22/2014	778678	Ingram Library Services Inc.	\$10.02	2600-55190-403255	Inv 80400819
09/22/2014	778678	Ingram Library Services Inc.	\$16.51	2600-55190-403241	Inv 80400820
09/22/2014	778678	Ingram Library Services Inc.	\$261.23	2600-55190-403226	Inv 80400821
09/22/2014	778678	Ingram Library Services Inc.	\$24.93	2600-55190-403227	Inv 80400822
09/22/2014	778678	Ingram Library Services Inc.	\$9.60	2600-55190-403226	Inv 80400823
09/22/2014	778678	Ingram Library Services Inc.	\$68.32	2600-55190-403227	Inv 80400824
09/22/2014	778678	Ingram Library Services Inc.	\$68.32	2600-55190-403241	Inv 80400824
09/22/2014	778678	Ingram Library Services Inc.	\$17.08	2600-55190-403255	Inv 80400824
09/22/2014	778678	Ingram Library Services Inc.	\$85.40	2600-55190-403333	Inv 80400824

Check Date	Check	Name	Amount	Account	Item Desc
09/22/2014	778678	Ingram Library Services Inc.	\$39.57	2600-55190-403227	Inv 80400825
09/22/2014	778678	Ingram Library Services Inc.	\$11.99	2600-55190-403227	Inv 80400826
09/22/2014	778678	Ingram Library Services Inc.	\$39.54	2600-55140-402280	Inv 80400827
09/22/2014	778678	Ingram Library Services Inc.	\$22.53	2600-55190-403241	Inv 80441654
09/22/2014	778678	Ingram Library Services Inc.	\$10.61	2600-55190-403255	Inv 80441655
09/22/2014	778678	Ingram Library Services Inc.	\$15.33	2600-55190-403226	Inv 80441656
09/22/2014	778678	Ingram Library Services Inc.	\$16.49	2600-55190-403227	Inv 80441657
09/22/2014	778678	Ingram Library Services Inc.	\$8.99	2600-55190-403226	Inv 80441658
09/22/2014	778679	Interstate Power Systems, Inc.	\$4,227.18	5710-71440-402320	AUTO &TRUCK MAINT.ITEMS
09/22/2014	778679	Interstate Power Systems, Inc.	\$422.44	5710-71440-402320	AUTO &TRUCK MAINT.ITEMS
09/22/2014	778680	J & H Office Equipment Inc.	\$4,974.00	2400-43010-402925	inv 425134 Canon IRC2225 Advance Serial #LYD53891
09/22/2014	778680	J & H Office Equipment Inc.	\$1,490.00	2400-43010-402925	Inv 45133 Savin Printer CLP37DN Serial #S934101115
09/22/2014	778680	J & H Office Equipment Inc.	\$124.96	2400-43010-403240	Inv 424120
09/22/2014	778680	J & H Office Equipment Inc.	\$29.00	2400-43010-403240	inv 68405
09/22/2014	778689	Kimley-Horn and Associates	\$28,675.66	5210-15210-403590	Downtown Parking Strategic Plan
09/22/2014	778691	Knife River (JTL Group Inc.)	\$709.17	2110-31320-404520	3" crushed base
09/22/2014	778691	Knife River (JTL Group Inc.)	\$2,530.28	2110-31320-404710	asphalt
09/22/2014	778691	Knife River (JTL Group Inc.)	\$7,534.11	2110-31320-404710	asphalt
09/22/2014	778691	Knife River (JTL Group Inc.)	\$314.76	2110-31320-404710	asphalt
09/22/2014	778694	L N Curtis & Sons	\$4,250.00	1500-22260-402320	3150911.00
09/22/2014	778694	L N Curtis & Sons	\$276.34	1500-22260-402320	3150911.00
09/22/2014	778697	M-B Companies, Inc.	\$580,012.00	4070-71280-409497	High Speed Rotary Snow Blower
09/22/2014	778700	Midland West Manufacturing Co	\$3,500.00	5410-31220-402320	15632
09/22/2014	778703	Montana CSED	\$4,282.11	9000-00000-209926	Payroll Summary
09/22/2014	778708	Montana State Fireman's Assoc	\$3,368.92	9000-00000-209924	Payroll Summary
09/22/2014	778710	Morrison Maierle Inc	\$52,193.15	8400-31840-409310	WO 12-31 East End Industrial Storm Drain
09/22/2014	778717	NorMont Equipment Company	\$121.05	2110-31320-402290	orange/white and return of yellow paint
09/22/2014	778717	NorMont Equipment Company	\$1,332.50	2110-31320-402420	telspar and star anchors
09/22/2014	778717	NorMont Equipment Company	\$162.24	2110-31320-402410	round and square shovels
09/22/2014	778717	NorMont Equipment Company	\$312.00	2110-31320-402320	gutter wire for sweeper brooms
09/22/2014	778717	NorMont Equipment Company	\$1,289.60	2110-31320-402320	gutter wire for sweeper brooms
09/22/2014	778718	Northwest Pipe Fittings	\$246.14	5120-84000-402450	Parts for basin drain pumps
09/22/2014	778718	Northwest Pipe Fittings	\$105.06	5030-75910-409340	Elbow
09/22/2014	778718	Northwest Pipe Fittings	\$92.46	5120-84000-402450	Slipon weld flange
09/22/2014	778718	Northwest Pipe Fittings	\$184.70	5120-84000-402450	Flip flange, clear primer
09/22/2014	778718	Northwest Pipe Fittings	\$990.00	5020-73120-403660	Repairs on CE handheld
09/22/2014	778718	Northwest Pipe Fittings	\$107.70	5020-73120-402380	Roof mount antenna
09/22/2014	778718	Northwest Pipe Fittings	-\$125.98	5120-84000-402450	Return - Flange
09/22/2014	778718	Northwest Pipe Fittings	\$17,522.30	5020-73120-402380	Antennas/collectors/ac power ups
09/22/2014	778718	Northwest Pipe Fittings	\$278.64	5120-84000-402450	Flange/elbow
09/22/2014	778718	Northwest Pipe Fittings	\$24.96	5020-00000-141000	SYSTEMS PO NUM 296080
09/22/2014	778718	Northwest Pipe Fittings	\$58.27	5020-74000-402450	Boiler parts
09/22/2014	778718	Northwest Pipe Fittings	\$2.97	5020-74000-402450	Gasket
09/22/2014	778718	Northwest Pipe Fittings	\$86.34	5020-74000-402450	Parts for gas line
09/22/2014	778718	Northwest Pipe Fittings	\$138.62	5020-74000-402450	Check valve
09/22/2014	778718	Northwest Pipe Fittings	\$329.04	5020-74000-402450	Check valve
09/22/2014	778718	Northwest Pipe Fittings	\$54.67	5120-84000-402450	Parts for aerator
09/22/2014	778718	Northwest Pipe Fittings	\$2,128.07	5020-00000-141000	WATER PARTS AND SUPPLIES PO NUM 296027
09/22/2014	778718	Northwest Pipe Fittings	\$266.88	5020-00000-141000	SYSTEMS PO NUM 296027
09/22/2014	778718	Northwest Pipe Fittings	\$266.90	5020-00000-141000	WATER PARTS AND SUPPLIES PO NUM 296029
09/22/2014	778718	Northwest Pipe Fittings	\$102.08	5020-00000-141000	WATER PARTS AND SUPPLIES PO NUM 296033
09/22/2014	778718	Northwest Pipe Fittings	\$8,887.50	5020-00000-141000	WATER PARTS AND SUPPLIES PO NUM 296034
09/22/2014	778718	Northwest Pipe Fittings	\$12,854.40	5020-00000-141000	WATER PARTS AND SUPPLIES PO NUM 296061
09/22/2014	778718	Northwest Pipe Fittings	\$67.34	5020-00000-141000	SYSTEMS PO NUM 296063
09/22/2014	778718	Northwest Pipe Fittings	\$37.90	5020-00000-141000	WATER PARTS AND SUPPLIES PO NUM 296064
09/22/2014	778718	Northwest Pipe Fittings	\$99.84	5020-00000-141000	WATER PARTS AND SUPPLIES PO NUM 296065
09/22/2014	778718	Northwest Pipe Fittings	\$231.21	5020-74000-402450	Niplle, tees, couplings
09/22/2014	778718	Northwest Pipe Fittings	\$219.03	5020-74000-402450	Elbows, pipe
09/22/2014	778718	Northwest Pipe Fittings	\$438.48	5020-74000-402450	Couplings, tees, valves, elbows
09/22/2014	778718	Northwest Pipe Fittings	\$18.95	5020-00000-141000	WATER PARTS AND SUPPLIES PO NUM 296138
09/22/2014	778718	Northwest Pipe Fittings	\$1,175.10	5020-00000-141000	SYSTEMS PO NUM 296138
09/22/2014	778718	Northwest Pipe Fittings	\$400.46	5020-00000-141000	SYSTEMS PO NUM 296190
09/22/2014	778718	Northwest Pipe Fittings	\$316.10	5020-00000-141000	SYSTEMS PO NUM 296191
09/22/2014	778718	Northwest Pipe Fittings	\$118.08	5020-00000-141000	SYSTEMS PO NUM 296195
09/22/2014	778718	Northwest Pipe Fittings	\$48.80	5020-00000-141000	SYSTEMS PO NUM 296196
09/22/2014	778718	Northwest Pipe Fittings	\$189.80	5020-00000-141000	SYSTEMS PO NUM 296201
09/22/2014	778720	NorthWestern Energy	\$1,415.84	0100-51270-403410	07123870
09/22/2014	778720	NorthWestern Energy	\$144.44	0100-51220-403410	07125362
09/22/2014	778720	NorthWestern Energy	\$533.05	1500-22210-403410	07125370
09/22/2014	778720	NorthWestern Energy	\$95.64	0100-51220-403410	07126832
09/22/2014	778720	NorthWestern Energy	\$24.31	5710-71480-403410	07127640
09/22/2014	778720	NorthWestern Energy	\$36.45	0100-51220-403410	07208184
09/22/2014	778720	NorthWestern Energy	\$2,114.55	0100-51260-403410	07208218
09/22/2014	778720	NorthWestern Energy	\$417.61	1500-22210-403410	07208408
09/22/2014	778720	NorthWestern Energy	\$2,316.95	5020-74000-403410	07222524
09/22/2014	778720	NorthWestern Energy	\$14,180.00	5020-74000-403410	07222649

Check Date	Check	Name	Amount	Account	Item Desc
09/22/2014	778720	NorthWestern Energy	\$43.17	0100-51120-403410	07222870
09/22/2014	778720	NorthWestern Energy	\$8,618.26	5020-74000-403410	07230402
09/22/2014	778720	NorthWestern Energy	\$802.54	0100-51120-403410	07230451
09/22/2014	778720	NorthWestern Energy	\$7.40	5020-74000-403410	07230592
09/22/2014	778720	NorthWestern Energy	\$13,295.10	5020-74000-403410	07222649
09/22/2014	778720	NorthWestern Energy	\$6,064.91	5020-74000-403410	3116 17th St West
09/22/2014	778720	NorthWestern Energy	\$6,064.92	5020-74000-403410	3116 17th St West
09/22/2014	778720	NorthWestern Energy	\$1,277.41	5120-85000-403410	2750 Bitterroot Dr
09/22/2014	778720	NorthWestern Energy	\$61,296.23	5120-84000-403410	725 HWY 87 East
09/22/2014	778720	NorthWestern Energy	\$27.73	5610-71130-403410	1647695-4. De-Icer. September 2014
09/22/2014	778720	NorthWestern Energy	\$2,488.88	5610-71130-403410	0100483-7. Runway Lights. September 2014
09/22/2014	778720	NorthWestern Energy	\$1,627.89	5610-71130-403410	0100484-5. ARFF Facility. September 2014
09/22/2014	778720	NorthWestern Energy	\$52.57	5610-71170-403410	1138926-9. Aero Interiors. September 2014
09/22/2014	778720	NorthWestern Energy	\$9.25	5610-71170-403410	1264299-7. Old Hertz Car Wash. September 2014
09/22/2014	778720	NorthWestern Energy	\$27.87	5610-71170-403410	1341288-7. Old National/Alamo Car Wash. September 2014
09/22/2014	778720	NorthWestern Energy	\$7.74	5610-71170-403410	1341289-5. Old Thrifty/Dollar Car Wash. September 2014
09/22/2014	778720	NorthWestern Energy	\$27.60	5610-71170-403410	1341291-1. Old Enterprise Car Wash. September 2014
09/22/2014	778720	NorthWestern Energy	\$182.86	5610-71170-403410	1341295-2. Big Sky Ground Support. September 2014
09/22/2014	778720	NorthWestern Energy	\$777.18	5610-71170-403410	1669567-8. TSA Office. September 2014
09/22/2014	778720	NorthWestern Energy	\$1,870.22	5610-71190-403410	1993430-6. Car Wash. September 2014
09/22/2014	778720	NorthWestern Energy	\$372.86	5610-71190-403410	2001846-1. Mud Wash. September 2014
09/22/2014	778720	NorthWestern Energy	\$266.56	5610-71190-403410	2001848-7. Detail Bay 1 Hertz
09/22/2014	778720	NorthWestern Energy	\$287.57	5610-71190-403410	2001855-2. Detail Bay 2 National/Alamo. September 2014
09/22/2014	778720	NorthWestern Energy	\$178.17	5610-71190-403410	2001862-8. Detail Bay 3 Enterprise. September 2014
09/22/2014	778720	NorthWestern Energy	\$212.90	5610-71190-403410	2001865-1. Detail Bay 4 Avis/Budget. September 2014
09/22/2014	778720	NorthWestern Energy	\$129.27	5610-71190-403410	2001867-7. Detail Bay 5 Thrifty/Dollar. September 2014
09/22/2014	778720	NorthWestern Energy	\$1,610.71	5020-74000-403410	Airport Rd/17th St W/Hwy 3/Waldo
09/22/2014	778720	NorthWestern Energy	\$270.17	5120-85000-403410	822 Shiloh Crossing
09/22/2014	778720	NorthWestern Energy	\$7.40	0100-51120-403410	08317026
09/22/2014	778720	NorthWestern Energy	\$560.35	1500-22210-403410	08715468
09/22/2014	778720	NorthWestern Energy	\$316.31	0100-51120-403410	09254962
09/22/2014	778720	NorthWestern Energy	\$559.13	6500-15660-403410	09758087
09/22/2014	778720	NorthWestern Energy	\$319.20	8720-51980-403410	10590933
09/22/2014	778720	NorthWestern Energy	\$1,078.38	5020-74000-403410	11164522
09/22/2014	778720	NorthWestern Energy	\$180.98	5020-74000-403410	11422532
09/22/2014	778720	NorthWestern Energy	\$550.82	0100-51120-403410	11914041
09/22/2014	778720	NorthWestern Energy	\$0.20	2110-31320-403410	17403577
09/22/2014	778720	NorthWestern Energy	\$0.50	2110-31320-403410	17488966
09/22/2014	778720	NorthWestern Energy	\$33.62	0100-51120-403410	18366666
09/22/2014	778720	NorthWestern Energy	\$1,820.01	5210-15940-403410	30674162
09/22/2014	778719	NorthWestern Energy	\$10,561.84	2110-31320-403410	Signal Bills
09/22/2014	778719	NorthWestern Energy	\$487.19	8100-31830-403410	SILMD 008 ACCT# 0712544-6
09/22/2014	778719	NorthWestern Energy	\$498.76	8100-31830-403410	SILMD 009 ACCT# 0712545-3
09/22/2014	778719	NorthWestern Energy	\$1,373.40	8100-31830-403410	SILMD 010 ACCT# 0712546-1
09/22/2014	778719	NorthWestern Energy	\$4,112.18	8100-31830-403410	SILMD 013 ACCT# 0721276-4
09/22/2014	778719	NorthWestern Energy	\$2,025.47	8100-31830-403410	SILMD 014 ACCT# 0721277-2
09/22/2014	778719	NorthWestern Energy	\$1,196.84	8100-31830-403410	SILMD 017 ACCT# 0712553-7
09/22/2014	778719	NorthWestern Energy	\$95.42	8100-31830-403410	SILMD 018 ACCT# 0712554-5
09/22/2014	778719	NorthWestern Energy	\$12,942.34	8100-31830-403410	SILMD 097 ACCT# 0712557-8
09/22/2014	778719	NorthWestern Energy	\$1,590.63	8100-31830-403410	SILMD 099 ACCT# 0712558-6
09/22/2014	778719	NorthWestern Energy	\$2,598.30	8100-31830-403410	SILMD 100 ACCT# 0712559-4
09/22/2014	778719	NorthWestern Energy	\$1,695.19	8100-31830-403410	SILMD 107 ACCT# 0712560-2
09/22/2014	778719	NorthWestern Energy	\$4,251.42	8100-31830-403410	SILMD 109 ACCT# 0712561-0
09/22/2014	778719	NorthWestern Energy	\$180.02	8100-31830-403410	SILMD 113 ACCT# 0712562-8
09/22/2014	778719	NorthWestern Energy	\$914.87	8100-31830-403410	SILMD 114 ACCT# 0712563-6
09/22/2014	778719	NorthWestern Energy	\$215.27	8100-31830-403410	SILMD 115 ACCT# 0712564-4
09/22/2014	778719	NorthWestern Energy	\$565.06	8100-31830-403410	SILMD 116 ACCT# 0712565-1
09/22/2014	778719	NorthWestern Energy	\$3,122.44	8100-31830-403410	SILMD 117 ACCT# 0712566-9
09/22/2014	778719	NorthWestern Energy	\$227.19	8100-31830-403410	SILMD 118 ACCT# 0712567-7
09/22/2014	778719	NorthWestern Energy	\$150.28	8100-31830-403410	SILMD 119 ACCT# 0712568-5
09/22/2014	778719	NorthWestern Energy	\$2,421.70	8100-31830-403410	SILMD 121 ACCT# 0712570-1
09/22/2014	778719	NorthWestern Energy	\$184.23	8100-31830-403410	SILMD 122 ACCT# 0712571-9
09/22/2014	778719	NorthWestern Energy	\$322.89	8100-31830-403410	SILMD 123 ACCT# 0712572-7
09/22/2014	778719	NorthWestern Energy	\$941.75	8100-31830-403410	SILMD 124 ACCT# 0712573-5
09/22/2014	778719	NorthWestern Energy	\$376.71	8100-31830-403410	SILMD 125 ACCT# 0712574-3
09/22/2014	778719	NorthWestern Energy	\$188.35	8100-31830-403410	SILMD 126 ACCT# 0712575-0
09/22/2014	778719	NorthWestern Energy	\$690.83	8100-31830-403410	SILMD 127 ACCT# 0712576-8
09/22/2014	778719	NorthWestern Energy	\$483.58	8100-31830-403410	SILMD 128 ACCT# 0712577-6
09/22/2014	778719	NorthWestern Energy	\$322.89	8100-31830-403410	SILMD 129 ACCT# 0712578-4
09/22/2014	778719	NorthWestern Energy	\$122.62	8100-31830-403410	SILMD 130 ACCT# 0712579-2
09/22/2014	778719	NorthWestern Energy	\$834.14	8100-31830-403410	SILMD 131 ACCT# 0712580-0
09/22/2014	778719	NorthWestern Energy	\$227.72	8100-31830-403410	SILMD 133 ACCT# 0712581-8
09/22/2014	778719	NorthWestern Energy	\$525.54	8100-31830-403410	SILMD 134 ACCT# 0712582-6
09/22/2014	778719	NorthWestern Energy	\$506.61	8100-31830-403410	SILMD 135 ACCT# 0712583-4
09/22/2014	778719	NorthWestern Energy	\$448.04	8100-31830-403410	SILMD 136 ACCT# 0712584-2
09/22/2014	778719	NorthWestern Energy	\$366.24	8100-31830-403410	SILMD 137 ACCT# 0712585-9

Check Date	Check	Name	Amount	Account	Item Desc
09/22/2014	778719	NorthWestern Energy	\$726.51	8100-31830-403410	SILMD 138 ACCT# 0712586-7
09/22/2014	778719	NorthWestern Energy	\$242.18	8100-31830-403410	SILMD 139 ACCT# 0712587-5
09/22/2014	778719	NorthWestern Energy	\$559.20	8100-31830-403410	SILMD 143 ACCT# 0712588-3
09/22/2014	778719	NorthWestern Energy	\$26.63	8100-31830-403410	SILMD 144 ACCT# 0712589-1
09/22/2014	778719	NorthWestern Energy	\$460.56	8100-31830-403410	SILMD 145 ACCT# 0712590-9
09/22/2014	778719	NorthWestern Energy	\$349.79	8100-31830-403410	SILMD 146 ACCT# 0712591-7
09/22/2014	778719	NorthWestern Energy	\$455.40	8100-31830-403410	SILMD 147 ACCT# 0712592-5
09/22/2014	778719	NorthWestern Energy	\$1,440.64	8100-31830-403410	SILMD 149 ACCT# 0712593-3
09/22/2014	778719	NorthWestern Energy	\$736.89	8100-31830-403410	SILMD 150 ACCT# 0712594-1
09/22/2014	778719	NorthWestern Energy	\$618.88	8100-31830-403410	SILMD 151 ACCT# 0712595-8
09/22/2014	778719	NorthWestern Energy	\$4,213.37	8100-31830-403410	SILMD 152 ACCT# 0712596-6
09/22/2014	778719	NorthWestern Energy	\$529.64	8100-31830-403410	SILMD 153 ACCT# 0712597-4
09/22/2014	778719	NorthWestern Energy	\$1,197.45	8100-31830-403410	SILMD 154 ACCT# 0712598-2
09/22/2014	778719	NorthWestern Energy	\$484.33	8100-31830-403410	SILMD 155 ACCT# 0712599-0
09/22/2014	778719	NorthWestern Energy	\$898.09	8100-31830-403410	SILMD 157 ACCT# 0712600-6
09/22/2014	778719	NorthWestern Energy	\$780.33	8100-31830-403410	SILMD 158 ACCT# 0712601-4
09/22/2014	778719	NorthWestern Energy	\$730.64	8100-31830-403410	SILMD 159 ACCT# 0712602-2
09/22/2014	778719	NorthWestern Energy	\$699.60	8100-31830-403410	SILMD 160 ACCT# 0712603-0
09/22/2014	778719	NorthWestern Energy	\$1,036.24	8100-31830-403410	SILMD 161 ACCT# 0712604-8
09/22/2014	778719	NorthWestern Energy	\$59.76	8100-31830-403410	SILMD 162 ACCT# 0712605-5
09/22/2014	778719	NorthWestern Energy	\$657.42	8100-31830-403410	SILMD 163 ACCT# 0712606-3
09/22/2014	778719	NorthWestern Energy	\$368.44	8100-31830-403410	SILMD 164 ACCT# 0712607-1
09/22/2014	778719	NorthWestern Energy	\$861.05	8100-31830-403410	SILMD 165 ACCT# 0712608-9
09/22/2014	778719	NorthWestern Energy	\$230.27	8100-31830-403410	SILMD 167 ACCT# 0712609-7
09/22/2014	778719	NorthWestern Energy	\$552.66	8100-31830-403410	SILMD 171 ACCT# 0712610-5
09/22/2014	778719	NorthWestern Energy	\$525.53	8100-31830-403410	SILMD 172 ACCT# 0712611-3
09/22/2014	778719	NorthWestern Energy	\$1,151.39	8100-31830-403410	SILMD 173 ACCT# 0712612-1
09/22/2014	778719	NorthWestern Energy	\$967.18	8100-31830-403410	SILMD 174 ACCT# 0712613-9
09/22/2014	778719	NorthWestern Energy	\$322.39	8100-31830-403410	SILMD 175 ACCT# 0712614-7
09/22/2014	778719	NorthWestern Energy	\$42.68	8100-31830-403410	SILMD 176 ACCT# 0712615-4
09/22/2014	778719	NorthWestern Energy	\$253.31	8100-31830-403410	SILMD 178 ACCT# 0712616-2
09/22/2014	778719	NorthWestern Energy	\$506.61	8100-31830-403410	SILMD 179 ACCT# 0712617-0
09/22/2014	778719	NorthWestern Energy	\$345.40	8100-31830-403410	SILMD 180 ACCT# 0712618-8
09/22/2014	778719	NorthWestern Energy	\$1,641.38	8100-31830-403410	SILMD 181 ACCT# 0712619-6
09/22/2014	778719	NorthWestern Energy	\$575.68	8100-31830-403410	SILMD 182 ACCT# 0712620-4
09/22/2014	778719	NorthWestern Energy	\$1,151.39	8100-31830-403410	SILMD 183 ACCT# 0712621-2
09/22/2014	778719	NorthWestern Energy	\$368.44	8100-31830-403410	SILMD 184 ACCT# 0712622-0
09/22/2014	778719	NorthWestern Energy	\$138.17	8100-31830-403410	SILMD 185 ACCT# 0712623-8
09/22/2014	778719	NorthWestern Energy	\$614.97	8100-31830-403410	SILMD 186 ACCT# 0712624-6
09/22/2014	778719	NorthWestern Energy	\$230.27	8100-31830-403410	SILMD 187 ACCT# 0712625-3
09/22/2014	778719	NorthWestern Energy	\$276.33	8100-31830-403410	SILMD 188 ACCT# 0712626-1
09/22/2014	778719	NorthWestern Energy	\$230.27	8100-31830-403410	SILMD 189 ACCT# 0712627-9
09/22/2014	778719	NorthWestern Energy	\$1,197.45	8100-31830-403410	SILMD 190 ACCT# 0712628-7
09/22/2014	778719	NorthWestern Energy	\$411.44	8100-31830-403410	SILMD 191 ACCT# 0712629-5
09/22/2014	778719	NorthWestern Energy	\$299.35	8100-31830-403410	SILMD 192 ACCT# 0712630-3
09/22/2014	778719	NorthWestern Energy	\$736.89	8100-31830-403410	SILMD 193 ACCT# 0712631-1
09/22/2014	778719	NorthWestern Energy	\$254.48	8100-31830-403410	SILMD 194 ACCT# 0712632-9
09/22/2014	778719	NorthWestern Energy	\$212.09	8100-31830-403410	SILMD 195 ACCT# 0712633-7
09/22/2014	778719	NorthWestern Energy	\$68.05	8100-31830-403410	SILMD 196 ACCT# 0712634-5
09/22/2014	778719	NorthWestern Energy	\$68.05	8100-31830-403410	SILMD 197 ACCT# 0712635-2
09/22/2014	778719	NorthWestern Energy	\$115.13	8100-31830-403410	SILMD 198 ACCT# 0712636-0
09/22/2014	778719	NorthWestern Energy	\$72.60	8100-31830-403410	SILMD 200 ACCT# 0712637-8
09/22/2014	778719	NorthWestern Energy	\$483.58	8100-31830-403410	SILMD 201 ACCT# 0712638-6
09/22/2014	778719	NorthWestern Energy	\$783.10	8100-31830-403410	SILMD 202 INV# 0712639-4
09/22/2014	778719	NorthWestern Energy	\$18.15	8100-31830-403410	SILMD 203 ACCT# 0712640-2
09/22/2014	778719	NorthWestern Energy	\$364.38	8100-31830-403410	SILMD 204 ACCT# 0712641-0
09/22/2014	778719	NorthWestern Energy	\$34.15	8100-31830-403410	SILMD 205 ACCT# 0712642-8
09/22/2014	778719	NorthWestern Energy	\$322.39	8100-31830-403410	SILMD 206 ACCT# 0712643-6
09/22/2014	778719	NorthWestern Energy	\$368.44	8100-31830-403410	SILMD 207 ACCT# 0712644-4
09/22/2014	778719	NorthWestern Energy	\$145.26	8100-31830-403410	SILMD 208 ACCT# 0712645-1
09/22/2014	778719	NorthWestern Energy	\$529.64	8100-31830-403410	SILMD 209 ACCT# 0712646-9
09/22/2014	778719	NorthWestern Energy	\$81.67	8100-31830-403410	SILMD 210 ACCT# 0712647-7
09/22/2014	778719	NorthWestern Energy	\$45.37	8100-31830-403410	SILMD 211 ACCT# 0712648-5
09/22/2014	778719	NorthWestern Energy	\$45.37	8100-31830-403410	SILMD 212 ACCT# 0712649-3
09/22/2014	778719	NorthWestern Energy	\$27.23	8100-31830-403410	SILMD 213 ACCT# 0712650-1
09/22/2014	778719	NorthWestern Energy	\$463.36	8100-31830-403410	SILMD 214 ACCT# 0712651-9
09/22/2014	778719	NorthWestern Energy	\$138.17	8100-31830-403410	SILMD 216 ACCT# 0712652-7
09/22/2014	778719	NorthWestern Energy	\$378.22	8100-31830-403410	SILMD 217 ACCT# 0712653-5
09/22/2014	778719	NorthWestern Energy	\$176.88	8100-31830-403410	SILMD 220 ACCT# 0712654-3
09/22/2014	778719	NorthWestern Energy	\$8.54	8100-31830-403410	SILMD 221 ACCT# 0712655-0
09/22/2014	778719	NorthWestern Energy	\$71.77	8100-31830-403410	SILMD 222 ACCT# 0712656-8
09/22/2014	778719	NorthWestern Energy	\$108.90	8100-31830-403410	SILMD 223 ACCT# 0712657-6
09/22/2014	778719	NorthWestern Energy	\$1,794.20	8100-31830-403410	SILMD 224 ACCT# 0712658-4
09/22/2014	778719	NorthWestern Energy	\$347.59	8100-31830-403410	SILMD 225 ACCT# 0712659-2
09/22/2014	778719	NorthWestern Energy	\$292.27	8100-31830-403410	SILMD 226 ACCT# 0712660-0
09/22/2014	778719	NorthWestern Energy	\$591.24	8100-31830-403410	SILMD 227 ACCT# 0712661-8

Check Date	Check	Name	Amount	Account	Item Desc
09/22/2014	778719	NorthWestern Energy	\$780.33	8100-31830-403410	SILMD 228 ACCT# 0712662-6
09/22/2014	778719	NorthWestern Energy	\$403.60	8100-31830-403410	SILMD 229 ACCT# 0712663-4
09/22/2014	778719	NorthWestern Energy	\$941.78	8100-31830-403410	SILMD 230 ACCT# 0712664-2
09/22/2014	778719	NorthWestern Energy	\$565.06	8100-31830-403410	SILMD 231 ACCT# 0712665-9
09/22/2014	778719	NorthWestern Energy	\$2,448.61	8100-31830-403410	SILMD 232 ACCT# 0712666-7
09/22/2014	778719	NorthWestern Energy	\$793.74	8100-31830-403410	SILMD 233 ACCT# 0712667-5
09/22/2014	778719	NorthWestern Energy	\$468.16	8100-31830-403410	SILMD 234 ACCT# 0712668-3
09/22/2014	778719	NorthWestern Energy	\$499.99	8100-31830-403410	SILMD 235 ACCT# 0712669-1
09/22/2014	778719	NorthWestern Energy	\$159.03	8100-31830-403410	SILMD 236 ACCT# 0712670-9
09/22/2014	778719	NorthWestern Energy	\$391.47	8100-31830-403410	SILMD 237 ACCT# 0712671-7
09/22/2014	778719	NorthWestern Energy	\$14.57	8100-31830-403410	SILMD 238 ACCT# 0712672-5
09/22/2014	778719	NorthWestern Energy	\$92.11	8100-31830-403410	SILMD 239 ACCT# 0712673-3
09/22/2014	778719	NorthWestern Energy	\$381.72	8100-31830-403410	SILMD 240 ACCT# 0712674-1
09/22/2014	778719	NorthWestern Energy	\$605.92	8100-31830-403410	SILMD 241 ACCT# 0712675-8
09/22/2014	778719	NorthWestern Energy	\$80.73	8100-31830-403410	SILMD 242 ACCT# 0712676-6
09/22/2014	778719	NorthWestern Energy	\$107.63	8100-31830-403410	SILMD 244 ACCT# 0712677-4
09/22/2014	778719	NorthWestern Energy	\$84.46	8100-31830-403410	SILMD 245 ACCT# 0712678-2
09/22/2014	778719	NorthWestern Energy	\$322.89	8100-31830-403410	SILMD 246 ACCT# 0712679-0
09/22/2014	778719	NorthWestern Energy	\$1,136.39	8100-31830-403410	SILMD 247 ACCT# 0712680-8
09/22/2014	778719	NorthWestern Energy	\$2,407.20	8100-31830-403410	SILMD 248 ACCT# 0712681-6
09/22/2014	778719	NorthWestern Energy	\$2,663.87	8100-31830-403410	SILMD 249 ACCT# 0718734-7
09/22/2014	778719	NorthWestern Energy	\$0.75	8100-31830-403410	SILMD 250 ACCT# 1301786-8
09/22/2014	778719	NorthWestern Energy	\$193.41	8100-31830-403410	SILMD 250 ACCT# 0719001-0
09/22/2014	778719	NorthWestern Energy	\$3,827.47	8100-31830-403410	SILMD 251 ACCT# 0718801-4
09/22/2014	778719	NorthWestern Energy	\$538.16	8100-31830-403410	SILMD 252 ACCT# 0719162-0
09/22/2014	778719	NorthWestern Energy	\$1,890.16	8100-31830-403410	SILMD 253 ACCT# 0719644-7
09/22/2014	778719	NorthWestern Energy	\$143.54	8100-31830-403410	SILMD 254 ACCT# 0719763-5
09/22/2014	778719	NorthWestern Energy	\$136.73	8100-31830-403410	SILMD 255 ACCT# 0720813-5
09/22/2014	778719	NorthWestern Energy	\$837.55	8100-31830-403410	SILMD 257 ACCT# 0720360-7
09/22/2014	778719	NorthWestern Energy	\$2,544.16	8100-31830-403410	SILMD 258 ACCT# 0720606-3
09/22/2014	778719	NorthWestern Energy	\$1.00	8100-31830-403410	SILMD 259 ACCT# 1301786-8
09/22/2014	778719	NorthWestern Energy	\$1,253.96	8100-31830-403410	SILMD 259 ACCT# 0720810-1
09/22/2014	778719	NorthWestern Energy	\$484.33	8100-31830-403410	SILMD 261 ACCT# 0720705-3
09/22/2014	778719	NorthWestern Energy	\$3,057.72	8100-31830-403410	SILMD 262 ACCT# 0720937-2
09/22/2014	778719	NorthWestern Energy	\$905.42	8100-31830-403410	SILMD 263 ACCT# 0720716-0
09/22/2014	778719	NorthWestern Energy	\$156.60	8100-31830-403410	SILMD 264 ACCT# 0721427-3
09/22/2014	778719	NorthWestern Energy	\$339.87	8100-31830-403410	SILMD 265 ACCT# 0721556-9
09/22/2014	778719	NorthWestern Energy	\$39.11	8100-31830-403410	SILMD 266 ACCT# 0721684-9
09/22/2014	778719	NorthWestern Energy	\$74.21	8100-31830-403410	SILMD 269 ACCT# 0833098-7
09/22/2014	778719	NorthWestern Energy	\$417.58	8100-31830-403410	SILMD 270 ACCT# 0906944-4
09/22/2014	778719	NorthWestern Energy	\$974.96	8100-31830-403410	SILMD 271 ACCT# 0995095-7
09/22/2014	778719	NorthWestern Energy	\$2,730.07	8100-31830-403410	SILMD 272 ACCT# 0905005-5
09/22/2014	778719	NorthWestern Energy	\$195.95	8100-31830-403410	SILMD 273 ACCT# 0926386-4
09/22/2014	778719	NorthWestern Energy	\$63.62	8100-31830-403410	SILMD 274 ACCT# 0907926-0
09/22/2014	778719	NorthWestern Energy	\$458.91	8100-31830-403410	SILMD 276 ACCT# 0961926-3
09/22/2014	778719	NorthWestern Energy	\$801.36	8100-31830-403410	SILMD 277 ACCT# 1058710-3
09/22/2014	778719	NorthWestern Energy	\$222.66	8100-31830-403410	SILMD 278 ACCT# 1087619-1
09/22/2014	778719	NorthWestern Energy	\$59.91	8100-31830-403410	SILMD 279 ACCT# 1124127-0
09/22/2014	778719	NorthWestern Energy	\$697.58	8100-31830-403410	SILMD 280 ACCT# 1045653-1
09/22/2014	778719	NorthWestern Energy	\$63.62	8100-31830-403410	SILMD 281 ACCT# 1079722-3
09/22/2014	778719	NorthWestern Energy	\$360.27	8100-31830-403410	SILMD 283 ACCT# 1172743-5
09/22/2014	778719	NorthWestern Energy	\$330.26	8100-31830-403410	SILMD 285 ACCT# 1206985-2
09/22/2014	778719	NorthWestern Energy	\$230.87	8100-31830-403410	SILMD 286 ACCT# 1296582-8
09/22/2014	778719	NorthWestern Energy	\$92.95	8100-31830-403410	SILMD 287 ACCT# 1246537-3
09/22/2014	778719	NorthWestern Energy	\$1,733.52	8100-31830-403410	SILMD 288 ACCT# 1303978-9
09/22/2014	778719	NorthWestern Energy	\$317.49	8100-31830-403410	SILMD 289 ACCT# 1685375-6
09/22/2014	778719	NorthWestern Energy	\$115.48	8100-31830-403410	SILMD 290 ACCT# 1433921-2
09/22/2014	778719	NorthWestern Energy	\$591.97	8100-31830-403410	SILMD 292 ACCT# 1481532-8
09/22/2014	778719	NorthWestern Energy	\$230.27	8100-31830-403410	SILMD 293 ACCT# 1481534-4
09/22/2014	778719	NorthWestern Energy	\$460.56	8100-31830-403410	SILMD 294 ACCT# 1481535-1
09/22/2014	778719	NorthWestern Energy	\$107.63	8100-31830-403410	SILMD 295 ACCT# 1481536-9
09/22/2014	778719	NorthWestern Energy	\$1,220.48	8100-31830-403410	SILMD 296 ACCT# 1481537-7
09/22/2014	778719	NorthWestern Energy	\$207.26	8100-31830-403410	SILMD 297 ACCT# 1481539-3
09/22/2014	778719	NorthWestern Energy	\$184.23	8100-31830-403410	SILMD 298 ACCT# 1481540-1
09/22/2014	778719	NorthWestern Energy	\$391.41	8100-31830-403410	SILMD 300 ACCT# 1662840-6
09/22/2014	778719	NorthWestern Energy	\$1,732.03	8100-31830-403410	SILMD 301 ACCT# 1687005-7
09/22/2014	778719	NorthWestern Energy	\$179.10	8100-31830-403410	SILMD 302 ACCT# 1607534-3
09/22/2014	778719	NorthWestern Energy	\$685.31	8100-31830-403410	SILMD 305 ACCT# 1695873-8
09/22/2014	778719	NorthWestern Energy	\$201.58	8100-31830-403410	SILMD 306 ACCT# 1740353-6
09/22/2014	778719	NorthWestern Energy	\$2,269.95	8100-31830-403410	SILMD 307 ACCT# 2049005-8
09/22/2014	778719	NorthWestern Energy	\$230.92	8100-31830-403410	SILMD 308 ACCT# 2072459-7
09/22/2014	778719	NorthWestern Energy	\$317.79	8100-31830-403410	SILMD 309 ACCT# 2001311-6
09/22/2014	778719	NorthWestern Energy	\$289.24	8100-31830-403410	SILMD 310 ACCT# 2060519-2
09/22/2014	778719	NorthWestern Energy	\$211.72	8100-31830-403410	SILMD 311 ACCT# 3014475-2
09/22/2014	778719	NorthWestern Energy	\$52.51	8100-31830-403410	SILMD 320 ACCT# 0712569-3
09/22/2014	778725	Peaks To Plains Design	\$765.00	6500-15660-403990	Quarry Rock Selection/Design Development Inv. 1223

Check Date	Check	Name	Amount	Account	Item Desc
09/22/2014	778725	Peaks To Plains Design	\$8,518.00	2120-43700-409390	inv 1224
09/22/2014	778726	Peterson Office Furniture	\$3,894.46	2990-65010-407270	WSCA Contract #MA147 office desk
09/22/2014	778728	Pierce Mobile Homes & Rvs	\$7,687.50	1500-21400-403822	8 X 20 WWT Containers, Quantity 2
09/22/2014	778735	Qwest Communications	\$50.33	2250-22320-403450	Qwest 406-245-2296 911 Qwest
09/22/2014	778735	Qwest Communications	\$45.65	2250-22320-403450	Qwest 406-245-3107 911 Qwest
09/22/2014	778735	Qwest Communications	\$45.65	2250-22320-403450	Qwest 406-245-3108 911 Qwest
09/22/2014	778735	Qwest Communications	\$39.44	5020-74000-403450	Qwest 406-245-3659 PUD Alarm Water Tower
09/22/2014	778735	Qwest Communications	\$45.66	5610-71100-403450	Qwest 406-245-5834 Airport Alarm
09/22/2014	778735	Qwest Communications	\$119.32	1500-22250-403450	Qwest 406-245-7469 Fire
09/22/2014	778735	Qwest Communications	\$45.66	1500-21110-403450	Qwest 406-245-7481 Police
09/22/2014	778735	Qwest Communications	\$228.20	6060-19310-403450	Qwest 406-248-3049 Main System T1 City/County Tie
09/22/2014	778735	Qwest Communications	\$311.26	6070-22350-403450	Qwest 406-248-3635 Fire Airport Radio Tower WCK
09/22/2014	778735	Qwest Communications	\$311.26	6070-22350-403450	Qwest 406-248-3636 Fire Airport Radio Tower Jellison
09/22/2014	778735	Qwest Communications	\$47.13	6010-15500-403450	Qwest 406-256-5047 Motor Pool
09/22/2014	778735	Qwest Communications	\$45.44	5610-71100-403450	Qwest 406-256-7070 Airport
09/22/2014	778735	Qwest Communications	\$31.01	5120-85000-403450	Qwest 406-259-2328 PUD Sahara Sand Lift Station
09/22/2014	778735	Qwest Communications	\$46.92	2110-31320-403450	Qwest 406-259-3298 PW Traffic 3728 McDougall
					Qwest 406-259-7758 Measured Lines Depot
					60% 6700 31410 403450
09/22/2014	778735	Qwest Communications	\$53.41	6600-31100-403450	40% 6600 31100 403450
					Qwest 406-259-7758 Measured Lines Depot
					60% 6700 31410 403450
09/22/2014	778735	Qwest Communications	\$80.10	6700-31410-403450	40% 6600 31100 403450
09/22/2014	778735	Qwest Communications	\$118.32	1500-22250-403450	Qwest 406-373-3742 Fire RR Crossing Alarm
09/22/2014	778735	Qwest Communications	\$45.63	2250-22320-403450	Qwest 406-651-0282 Fire 5 911 Line
09/22/2014	778735	Qwest Communications	\$31.01	2400-43010-407214	Qwest 406-656-9578 Planning Traffic Central Broadwater
09/22/2014	778735	Qwest Communications	\$31.01	2400-43010-407214	Qwest 406-656-9604 Planning Traffic Central 9th
09/22/2014	778735	Qwest Communications	\$50.01	5610-71170-403450	Qwest 406-256-6014 Airport P9 Building
09/22/2014	778735	Qwest Communications	\$311.26	2250-22320-403450	Qwest 406-245-7101 9-1-1 Center Landfill #2
09/22/2014	778735	Qwest Communications	\$311.26	2250-22320-403450	Qwest 406-245-7102 9-1-1 Center Fox Reservoir #2
					Qwest 406-256-7001 Solid Waste Scale House
09/22/2014	778735	Qwest Communications	\$46.92	5410-31230-403450	5410 31230 403450
					Qwest 406-259-7450 Empire Garage Measured Lines
09/22/2014	778735	Qwest Communications	\$97.36	5210-15940-403450	406-259-7001 406-259-7717
09/22/2014	778738	Rimrock Foundation	\$4,176.82	2460-12530-403590	State August Rimrock
09/22/2014	778738	Rimrock Foundation	\$3,736.72	7380-12640-403590	August IOP
09/22/2014	778738	Rimrock Foundation	\$2,742.43	7380-12640-403990	August Case Manager
09/22/2014	778738	Rimrock Foundation	\$4,628.78	7380-12640-403590	August Day Treatment
09/22/2014	778738	Rimrock Foundation	\$3,845.31	7380-12640-403590	August IOP
09/22/2014	778738	Rimrock Foundation	\$3,618.09	7380-12640-403590	August IOP
					Invoice #8243. Remove and dispose of mudded fittings from
09/22/2014	778742	Safetech, Inc	\$4,250.00	5620-71200-409290	lower boiler room in order to facilitate a new boiler
09/22/2014	778743	Schutz Foss Architects	\$3,939.75	2030-15130-409224	Empire Garage services regarding condo documents
09/22/2014	778747	Skycon Inc	\$4,582.50	5610-71120-403660	Invoice #798. Service and Repair Jet Bridges
09/22/2014	778753	Square One Cabinets	\$4,435.20	5620-71200-409290	Car Rental & Airline Ticket Counters Upgrade Project
09/22/2014	778753	Square One Cabinets	\$4,780.71	5620-00000-201100	Retainage Release
09/22/2014	778756	Sunset Excavation	\$3,850.00	5050-75150-403671	751 Wyoming Ave
09/22/2014	778756	Sunset Excavation	\$4,975.00	5050-75150-403671	2920 Minnesota Ave
09/22/2014	778759	Teledyne Isco Inc	\$12,969.50	5120-84300-402360	Headworks sensor set ADFM flow meter
09/22/2014	778762	TNT Springs Inc	\$399.44	6010-00000-141000	018159 PO NUM 296331
09/22/2014	778762	TNT Springs Inc	\$256.84	6010-00000-141000	137665 PO NUM 296331
09/22/2014	778762	TNT Springs Inc	\$227.50	6010-00000-141000	137791 PO NUM 296331
09/22/2014	778762	TNT Springs Inc	\$1,824.59	6010-00000-141000	137916 PO NUM 296331
09/22/2014	778762	TNT Springs Inc	\$82.92	6010-00000-141000	138464 PO NUM 296331
09/22/2014	778762	TNT Springs Inc	\$120.57	2110-31320-402320	137625
09/22/2014	778762	TNT Springs Inc	\$218.32	5410-31220-402320	137657
09/22/2014	778762	TNT Springs Inc	\$10.08	2110-31320-402320	137664
09/22/2014	778762	TNT Springs Inc	\$14.08	5410-31220-402320	137791
09/22/2014	778762	TNT Springs Inc	\$572.00	5410-31220-402320	138334
09/22/2014	778762	TNT Springs Inc	\$399.00	5410-31220-402320	138464
09/22/2014	778765	Town & Country Supply Association	\$21,268.80	5710-00000-141000	BUS MET PO NUM 296324
09/22/2014	778765	Town & Country Supply Association	\$360.23	5020-00000-141000	WATER PARTS AND SUPPLIES PO NUM 296269
09/22/2014	778765	Town & Country Supply Association	\$9,295.09	6010-00000-141000	202223 PO NUM 296294
09/22/2014	778766	Tractor & Equipment Co.	\$51.51	5410-31230-402320	high pressure fuel line
09/22/2014	778766	Tractor & Equipment Co.	\$221.70	5020-75000-402320	NONSTOCKING ITEMS-P.U.D.
09/22/2014	778766	Tractor & Equipment Co.	\$93.88	5410-31230-402320	BLCS0579056
09/22/2014	778766	Tractor & Equipment Co.	\$11,211.35	5410-31230-402320	BLW00149708
09/22/2014	778766	Tractor & Equipment Co.	\$1,345.91	2110-31320-402320	BLW00149969
09/22/2014	778766	Tractor & Equipment Co.	\$2,038.51	5410-31230-402320	BLW00150016
09/22/2014	778766	Tractor & Equipment Co.	\$456.37	5410-31220-402320	BLW00150072
09/22/2014	778766	Tractor & Equipment Co.	\$4,332.66	5410-31220-402320	BLW00150075
09/22/2014	778766	Tractor & Equipment Co.	\$380.52	5410-31230-402320	jumper cables
09/22/2014	778777	Western Municipal Construction Inc	\$821,350.42	5030-75910-409340	WO 08-25 Zone 3 Chapple Reservoir Expansion
					WO 14-01 2014 Water Main Replacement and Storm Drain
09/22/2014	778777	Western Municipal Construction Inc	\$444,465.79	5030-75910-409340	Project Sch 1A
09/22/2014	778777	Western Municipal Construction Inc	\$203,261.60	8400-31840-409310	WO 14-01 2014 Storm Drain Project Sch 1A

Check Date	Check	Name	Amount	Account	Item Desc
09/22/2014	778780	Yellowstone County Finance Dpt	\$894.88	5210-00000-229161	County lot agreement. 1/2 meter collection.
09/22/2014	778780	Yellowstone County Finance Dpt	\$7,600.00	1500-21110-403590	August 2014 Inmate Billing
09/22/2014	778781	Yellowstone Electric Co	\$301,152.45	4050-71250-409683	AIP-47 Security Access Gates - Federal Share
09/22/2014	778781	Yellowstone Electric Co	\$33,461.38	4050-71250-409684	AIP-47 Security Access Gates - Local Share
09/22/2014	778782	Yellowstone Valley Animal Shelter	\$21,712.67	1500-21700-403990	city contract 6-22-14\7-21-14

Regular City Council Meeting

Meeting Date: 10/27/2014

TITLE: Payment of Claims September 29, 2014

PRESENTED BY: Patrick M. Weber, Finance Director

Department: City Hall Administration

PROBLEM/ISSUE STATEMENT

Claims in the amount of \$2,271,542.98 have been audited and are presented for City Council payment approval. A complete listing of the claims dated September 29, 2014 is available in the Finance Department.

ALTERNATIVES ANALYZED

No other alternatives were analyzed.

FINANCIAL IMPACT

Claims have a varying impact on department budgets, but are submitted by the departments and reviewed by Finance staff before being sent to the Council.

RECOMMENDATION

Staff recommends that Council approve the Payment of Claims.

APPROVED BY CITY ADMINISTRATOR

Council Report 09-29

Check Date	Check	Name	Amount	Account	Item Desc
09/29/2014	778792	Asphalt Plus Inc	\$233,001.99	5630-71220-409310	Demolish Hangar, Fence & Pave New Employee Parking Lot
09/29/2014	778793	Automotive Service Equipment LLC	\$6,680.00	6010-15520-402120	Tire changer and balancer
09/29/2014	778799	Billings Gazette	\$159.44	5020-73110-402190	Water Dept 102-00012285
09/29/2014	778799	Billings Gazette	\$106.28	5120-83110-402190	Water Dept 102-00012285
09/29/2014	778799	Billings Gazette	\$356.20	2600-55190-403380	Billings Library 102-00003728
09/29/2014	778799	Billings Gazette	\$265.72	0100-51400-403330	Mountview Cemetery 102-00003765
09/29/2014	778799	Billings Gazette	\$247.65	0100-51120-403290	Parks & Rec 102-00012461
09/29/2014	778799	Billings Gazette	\$914.00	0100-14110-403310	July Library 102-60001620
09/29/2014	778799	Billings Gazette	\$1,336.90	0100-14110-403310	August Finance 102-60001620
09/29/2014	778799	Billings Gazette	\$914.00	2600-55110-403360	July Library 102-60003259
09/29/2014	778799	Billings Gazette	\$739.00	2600-55110-403360	August Library 102-60003259
09/29/2014	778799	Billings Gazette	\$1,542.32	0100-17500-403370	July HR 102-60010385
09/29/2014	778799	Billings Gazette	\$565.06	2110-31320-403310	July HR 102-60010385
09/29/2014	778799	Billings Gazette	\$840.01	5020-72110-403310	July HR 102-60010385
09/29/2014	778799	Billings Gazette	\$146.83	5120-82110-403310	July HR 102-60010385
09/29/2014	778799	Billings Gazette	\$278.18	5610-71100-403210	July HR 102-60010385
09/29/2014	778799	Billings Gazette	\$4,517.61	0100-17500-403370	August HR 102-60010385
09/29/2014	778799	Billings Gazette	\$343.99	5410-31220-403310	August HR 102-60010385
09/29/2014	778799	Billings Gazette	\$611.30	5610-71100-403210	August HR 102-60010385
09/29/2014	778800	Bison Ford	\$59,899.75	9000-00000-229000	Bid security refund for city vehicles
09/29/2014	778801	Border States Electric	\$33.03	5020-74000-402190	Thermo transfer print cleaning kit
09/29/2014	778801	Border States Electric	\$17.40	5120-84300-402360	Shipping for blower
09/29/2014	778801	Border States Electric	\$39.29	2110-31320-402430	butt connectors for traffic signals
09/29/2014	778801	Border States Electric	\$124.48	6010-15530-402650	907808843 Tools for service truck
09/29/2014	778801	Border States Electric	\$2,462.10	5120-84300-402360	Blower protection PLC card
09/29/2014	778801	Border States Electric	\$24,658.00	5120-84300-403590	Arc Flash Services - Inspection, SKM Modeling, Report and Labeling
09/29/2014	778801	Border States Electric	\$2,950.00	5120-84300-403590	Arc Flash 3-4 hour training class
09/29/2014	778801	Border States Electric	\$1,411.00	5120-84300-403590	AutoCAD One-Line Drawings
09/29/2014	778805	Brenntag Pacific Inc	\$4,716.50	5120-84000-402220	Trans 10K FG Silicone Antifoam
09/29/2014	778808	Business Tax Section	\$2,353.56	5630-71220-409310	Demolish Hangar, Fence & Pave New Employee Parking Lot
09/29/2014	778808	Business Tax Section	\$2,562.80	4050-71250-409685	AIP-46 Air Carrier Ramp - Federal Share
09/29/2014	778808	Business Tax Section	\$284.76	4050-71250-409686	AIP-46 Air Carrier Ramp - Local Share
09/29/2014	778808	Business Tax Section	\$4.46	2050-00000-201100	WO 09-20 Rimrock Road Forsythia to Shiloh
09/29/2014	778808	Business Tax Section	\$55.04	8450-00000-201100	WO 09-20 Rimrock Road Forsythia to Shiloh
09/29/2014	778808	Business Tax Section	\$30.00	7020-00000-201100	WO 12-03 City Chip Seal
09/29/2014	778808	Business Tax Section	\$29.41	2050-00000-201100	WO 12-03 2012 City Chip Seal Sch 1
09/29/2014	778808	Business Tax Section	\$5,616.36	5030-75910-409340	WO 14-01 2014 Water Projects Sch 1B & 1C
09/29/2014	778808	Business Tax Section	\$57.01	5020-75000-403680	Concrete driveway approach - GRT
09/29/2014	778808	Business Tax Section	\$38.00	5120-85000-403680	Concrete driveway approach - GRT
09/29/2014	778812	CMT	\$3,141.00	5030-74910-409390	Side Mount Antennas for SCADA System
09/29/2014	778813	Cop Construction Co	\$556,019.14	5030-75910-409340	WO 14-01 2014 Water Projects Sch 1B & 1C
09/29/2014	778816	CTA Inc	\$7,134.12	4070-71280-409497	Amendment 3-Airport Operations Building Emergency Generator Replacement
09/29/2014	778820	Doppstadt US	\$53,063.00	9000-00000-229000	bid security refund for landfill grinder
09/29/2014	778825	Ebms	\$1,660.00	6270-17520-403511	October 2014 Fee Breakdown
09/29/2014	778825	Ebms	\$23,167.50	6270-17520-403512	October 2014 Fee Breakdown
09/29/2014	778825	Ebms	\$42,667.04	6270-17520-403515	October 2014 Fee Breakdown
09/29/2014	778825	Ebms	\$570.50	6270-17520-403517	October 2014 Fee Breakdown
09/29/2014	778825	Ebms	\$3,367.00	6270-17520-405161	October 2014 Fee Breakdown
09/29/2014	778828	EnvisionWare, Inc	\$2,662.19	2600-55190-403381	Inv INV-US-18346
09/29/2014	778831	Facts On File Inc	\$9,692.28	2600-55190-403381	Invoice 252931
09/29/2014	778835	Fremont Motors	\$41,441.40	9000-00000-229000	bid security refund for city vehicles
09/29/2014	778842	Hansers Wrecker Service	\$3,732.50	6300-17530-407310	SWD Truck #0166. #2014-185
09/29/2014	778844	Hardrives Construction Inc	\$4,916.40	5630-71220-409310	Invoice #4238. Chip Sealing IP-5
09/29/2014	778844	Hardrives Construction Inc	\$2,912.06	2050-00000-201100	WO 12-03 2012 City Chip Seal Sch 1
09/29/2014	778844	Hardrives Construction Inc	\$2,970.00	7020-00000-201100	WO 12-03 2012 City Chip Seal
09/29/2014	778845	HDR, Inc.	\$1,288.92	5120-82110-403540	WO 12-15 IWPI WWTF Plan; Discharge Permit Re-Application Assistance Amendment #2 06/06/14
09/29/2014	778845	HDR, Inc.	\$95,688.36	5130-84910-409390	WO 14-11 WWTP Nutrient Upgrade Expansion & Improvements;6/30/14 Moved fund from 4210 to 5130
09/29/2014	778846	High Point Networks LLC	\$15,848.00	6200-19110-409480	Veeam Backup Management Suite Enterprise for VMware
09/29/2014	778852	Ingram Library Services Inc.	\$11.20	2600-55190-403255	Inv 80469562
09/29/2014	778852	Ingram Library Services Inc.	\$22.98	2600-55190-403333	Inv 80469563
09/29/2014	778852	Ingram Library Services Inc.	\$21.24	2600-55190-403241	Inv 80469564
09/29/2014	778852	Ingram Library Services Inc.	\$91.92	2600-55190-403226	Inv 80469565
09/29/2014	778852	Ingram Library Services Inc.	\$84.96	2600-55190-403226	Inv 80469566
09/29/2014	778852	Ingram Library Services Inc.	\$236.48	2600-55190-403222	Inv 80469567
09/29/2014	778852	Ingram Library Services Inc.	\$316.48	2600-55190-403226	Inv 80469567
09/29/2014	778852	Ingram Library Services Inc.	\$486.76	2600-55190-403227	Inv 80469567
09/29/2014	778852	Ingram Library Services Inc.	\$15.34	2600-55190-403241	Inv 80469567

Check Date	Check	Name	Amount	Account	Item Desc
09/29/2014	778852	Ingram Library Services Inc.	\$122.62	2600-55190-403242	Inv 80469567
09/29/2014	778852	Ingram Library Services Inc.	\$14.38	2600-55190-403333	Inv 80469567
09/29/2014	778852	Ingram Library Services Inc.	\$76.57	2600-55190-403382	Inv 80469567
09/29/2014	778852	Ingram Library Services Inc.	\$10.17	2600-55190-403227	Inv 804695687
09/29/2014	778852	Ingram Library Services Inc.	\$13.79	2600-55190-403227	Inv 80469569
09/29/2014	778852	Ingram Library Services Inc.	\$13.74	2600-55190-403242	Inv 80583482
09/29/2014	778852	Ingram Library Services Inc.	\$52.40	2600-55190-403333	Inv 80583483
09/29/2014	778852	Ingram Library Services Inc.	\$21.38	2600-55190-403227	Inv 80583484
09/29/2014	778852	Ingram Library Services Inc.	\$15.92	2600-55190-403241	Inv 80583485
09/29/2014	778852	Ingram Library Services Inc.	\$142.37	2600-55190-403226	Inv 80583486
09/29/2014	778852	Ingram Library Services Inc.	\$46.55	2600-55190-403227	Inv 80583487
09/29/2014	778852	Ingram Library Services Inc.	\$15.34	2600-55190-403226	Inv 80583488
09/29/2014	778852	Ingram Library Services Inc.	\$12.00	2600-55190-403227	Inv 80583488
09/29/2014	778852	Ingram Library Services Inc.	\$32.99	2600-55190-403222	Inv 80583489
09/29/2014	778852	Ingram Library Services Inc.	\$88.74	2600-55190-403227	Inv 80583490
09/29/2014	778852	Ingram Library Services Inc.	\$96.00	2600-55190-403226	Inv 80583491
09/29/2014	778852	Ingram Library Services Inc.	\$32.97	2600-55190-403222	Inv 80583492
09/29/2014	778852	Ingram Library Services Inc.	\$273.13	2600-55190-403226	Inv 80583492
09/29/2014	778852	Ingram Library Services Inc.	\$530.49	2600-55190-403227	Inv 80583492
09/29/2014	778852	Ingram Library Services Inc.	\$10.61	2600-55190-403241	Inv 80583492
09/29/2014	778852	Ingram Library Services Inc.	\$31.23	2600-55190-403241	Inv 80583492
09/29/2014	778852	Ingram Library Services Inc.	\$65.99	2600-55190-403242	Inv 80583492
09/29/2014	778852	Ingram Library Services Inc.	\$185.09	2600-55190-403255	Inv 80583492
09/29/2014	778854	Jones Construction	\$5,864.00	6300-17530-407310	Water Damage repairs at City Hall #2014-211
09/29/2014	778857	Knife River (JTL Group Inc.)	\$208.35	5120-84000-402290	Crushed base
09/29/2014	778857	Knife River (JTL Group Inc.)	\$440.75	2050-00000-201100	WO 09-20 Rimrock Road Forsythia to Shiloh
09/29/2014	778857	Knife River (JTL Group Inc.)	\$5,449.75	8450-00000-201100	WO 09-20 Rimrock Road Forsythia to Shiloh
09/29/2014	778857	Knife River (JTL Group Inc.)	\$253,717.51	4050-71250-409685	AIP-46 Air Carrier Ramp - Federal Share
09/29/2014	778857	Knife River (JTL Group Inc.)	\$28,190.83	4050-71250-409686	AIP-46 Air Carrier Ramp - Local Share
09/29/2014	778860	L N Curtis & Sons	\$11,554.00	1500-22290-402490	HOSE: 1.75"X50-FT NAFH DURA-BUILT HOSE YELLOW, ULTRA-SHIELD COATED, NH RED HEAD ANODIZED ALUM COUPLINGS. HOSES TO BE STENCILED WITH SEQUENTIAL NUMBERS. (quoted prices include freight)
09/29/2014	778860	L N Curtis & Sons	\$0.00	1500-22290-402490	HOSE: 2.5"X50-FT, NAFH DURA-BUILT HOSE, YELLOW ULTRA-SHIELD COATED, NH RED HEAD ANODIZED ALUM COUPLINGS. HOSES TO BE STENCILED WITH SEQUENTIAL NUMBERS.
09/29/2014	778860	L N Curtis & Sons	\$0.00	1500-22290-402490	ALL AMERICAN HOSE, WHITE QUICK DRAW, 5/8"X50FT, COUPLED 3/4" GHT BRASS.
09/29/2014	778860	L N Curtis & Sons	\$0.00	1500-22290-402490	HOSE: 1.75"X50-FT NAFH DURA-BUILT HOSE YELLOW, ULTRA-SHIELD COATED, NH RED HEAD ANODIZED ALUM COUPLINGS. HOSES TO BE STENCILED WITH SEQUENTIAL NUMBERS. (quoted prices include freight)
09/29/2014	778860	L N Curtis & Sons	\$17,625.00	1500-22290-402490	HOSE: 2.5"X50-FT, NAFH DURA-BUILT HOSE, YELLOW ULTRA-SHIELD COATED, NH RED HEAD ANODIZED ALUM COUPLINGS. HOSES TO BE STENCILED WITH SEQUENTIAL NUMBERS.
09/29/2014	778860	L N Curtis & Sons	\$0.00	1500-22290-402490	ALL AMERICAN HOSE, WHITE QUICK DRAW, 5/8"X50FT, COUPLED 3/4" GHT BRASS.
09/29/2014	778862	Liquid Engineering Corporation	\$1,050.00	5020-74000-403660	Exterior/interior in-service dive assess
09/29/2014	778862	Liquid Engineering Corporation	\$1,050.00	5020-74000-403660	Exterior/interior in-service dive assess
09/29/2014	778862	Liquid Engineering Corporation	\$1,400.00	5020-74000-403660	Exterior/interior in-service dive assess
09/29/2014	778865	M R Concrete	\$5,643.29	5020-75000-403680	Concrete driveway approach
09/29/2014	778865	M R Concrete	\$3,762.20	5120-85000-403680	Concrete driveway approach
09/29/2014	778867	Mallory Safety and Supply LLC	\$30,800.00	6400-22420-409460	FLICO 635010201, CAMERA THERMAL IMAGE 320X240 KIT INCL TIC HARD CASE (2) LiION BATTERIES TABLETOP CHARGER W/POWER SUPPLY USB CABLE RETRACTABLE LANYARD NECK STRAP TRIPOD ADAPTER TOOLS SOFTWARE
09/29/2014	778867	Mallory Safety and Supply LLC	\$5,200.00	6400-22420-409460	FLICO T198322 CHARGER, TRUCK MOUNT
09/29/2014	778869	Marketing Specialties Inc	\$1,115.00	1500-22260-402310	VEEDER-ROOT TLS 300 TANK MONITOR (USED. EXISTING VEEDER-ROOT MONITOR HAS FAILED.
09/29/2014	778869	Marketing Specialties Inc	\$1,743.00	1500-22260-402310	MAG PLUS PROBE
09/29/2014	778869	Marketing Specialties Inc	\$252.00	1500-22260-402310	PROBE FLOAT KIT
09/29/2014	778869	Marketing Specialties Inc	\$100.00	1500-22260-402310	MT DEQ PERMIT
09/29/2014	778869	Marketing Specialties Inc	\$690.00	1500-22260-402310	LABOR
09/29/2014	778869	Marketing Specialties Inc	\$563.98	1500-22260-402310	FIRE3: REPL'D DIESEL PUMP RE-SET SWITCH
09/29/2014	778871	MES-NW	\$3,209.70	1500-22290-402290	SCOTT/SCBA PARTS - SALES ORDER 473392
09/29/2014	778871	MES-NW	\$11.17	1500-22210-403110	SHIPPING

Check Date	Check	Name	Amount	Account	Item Desc
09/29/2014	778876	Miller Trois LLC	\$1,801.32	0100-43210-405311	I15-005253 Planning & Community Services October Rent, Miller Building.
09/29/2014	778876	Miller Trois LLC	\$5,908.86	2090-44510-405311	I15-005253 Planning & Community Services October Rent, Miller Building.
09/29/2014	778876	Miller Trois LLC	\$3,918.84	2400-43010-405311	I15-005253 Planning & Community Services October Rent, Miller Building.
09/29/2014	778876	Miller Trois LLC	\$3,851.45	2740-67800-405310	I15-005253 Planning & Community Services October Rent, Miller Building.
09/29/2014	778876	Miller Trois LLC	\$798.55	2900-65010-405310	I15-005253 Planning & Community Services October Rent, Miller Building.
09/29/2014	778880	Montana Dakota Utilities Co	\$335.61	5610-71190-403440	889 b373 1000 6. Car Wash. September 2014
09/29/2014	778880	Montana Dakota Utilities Co	\$317.85	5610-71190-403440	129 573 1000 1. Mud Wash. September 2014
09/29/2014	778880	Montana Dakota Utilities Co	\$17.22	5610-71190-403440	229 573 1000 0. Detail Bay 1 Hertz. September 2014
09/29/2014	778880	Montana Dakota Utilities Co	\$36.47	5610-71190-403440	185 580 1000 7. Detail Bay 2 National/Alamo. September 2014
09/29/2014	778880	Montana Dakota Utilities Co	\$21.66	5610-71190-403440	329 573 1000 9. Detail Bay 3 Enterprise. September 2014
09/29/2014	778880	Montana Dakota Utilities Co	\$23.13	5610-71190-403440	429 573 1000 8. Detail Bay 4 Avis/Budget. September 2014
09/29/2014	778880	Montana Dakota Utilities Co	\$20.19	5610-71190-403440	529 573 1000 7. Detail Bay 5 Thrifty/Dollar. September 2014
09/29/2014	778880	Montana Dakota Utilities Co	\$12.80	5610-71170-403440	295 580 1000 4. Aero Interiors. September 2014
09/29/2014	778880	Montana Dakota Utilities Co	\$46.09	5610-71170-403440	185 580 1000 7. TSA Building. September 2014
09/29/2014	778880	Montana Dakota Utilities Co	\$351.65	1500-21710-403440	1692331000 3
09/29/2014	778880	Montana Dakota Utilities Co	\$208.32	5610-71130-403440	2855801000 6
09/29/2014	778880	Montana Dakota Utilities Co	\$7.13	5020-74000-403440	3735801000 9
09/29/2014	778880	Montana Dakota Utilities Co	\$7.14	5020-74000-403440	3735801000 9
09/29/2014	778880	Montana Dakota Utilities Co	\$37.88	0100-51270-403440	4377801000 9
09/29/2014	778880	Montana Dakota Utilities Co	\$18.28	0100-51120-403410	5014731000 2
09/29/2014	778880	Montana Dakota Utilities Co	\$94.57	1500-22210-403440	5336531000 1
09/29/2014	778880	Montana Dakota Utilities Co	\$12.80	5020-74000-403440	5413801000 1
09/29/2014	778880	Montana Dakota Utilities Co	\$40.93	6600-31100-403440	5953731000 1
09/29/2014	778880	Montana Dakota Utilities Co	\$61.39	6700-31410-403440	5953731000 1
09/29/2014	778880	Montana Dakota Utilities Co	\$506.48	5610-71120-403440	5955801000 1
09/29/2014	778880	Montana Dakota Utilities Co	\$26.37	5120-85000-403440	5967331000 5
09/29/2014	778880	Montana Dakota Utilities Co	\$209.09	5610-71170-403440	7065801000 7
09/29/2014	778880	Montana Dakota Utilities Co	\$25.37	5120-85000-403440	7354531000 2
09/29/2014	778880	Montana Dakota Utilities Co	\$12.80	5610-71170-403440	8065801000 6
09/29/2014	778880	Montana Dakota Utilities Co	\$107.51	1500-22210-403440	8858801000 4
09/29/2014	778880	Montana Dakota Utilities Co	\$26.37	5020-74000-403440	9215801000 6
09/29/2014	778880	Montana Dakota Utilities Co	\$27.84	5120-85000-403440	9550431000 4
09/29/2014	778880	Montana Dakota Utilities Co	\$385.58	5710-71430-403440	9628801000 0
09/29/2014	778880	Montana Dakota Utilities Co	\$81.80	5610-71130-403440	06882310003 / 31454601
09/29/2014	778881	Montana Law Enforcement Academy	\$1,500.00	1500-21400-403822	Invoice 7853 - Montana Law Enforcement Academy for Nick Lam
09/29/2014	778881	Montana Law Enforcement Academy	\$1,500.00	1500-21400-403822	Invoice 7855 - Montana Law Enforcement Academy for Brandon Lange
09/29/2014	778885	Morbark Inc	\$67,500.00	9000-00000-229000	Bid security refund for landfill grinder
09/29/2014	778886	Morrison Maierle Inc	\$23,025.44	4050-71250-409685	Amendment 10 - AIP 46 Air Carrier Ramp - CA - Federal Share
09/29/2014	778886	Morrison Maierle Inc	\$2,558.38	4050-71250-409686	Amendment 10 - AIP 46 Air Carrier Ramp - CA - Local Share
09/29/2014	778886	Morrison Maierle Inc	\$458.50	5630-71220-409390	Amendment 7 Engineering Services for West End Sanitary Sewer Improvements - TSA CA
09/29/2014	778886	Morrison Maierle Inc	\$305.67	5630-71220-409390	Amendment 7 Engineering Services for West End Sanitary Sewer Improvements - Executive Hangar CA
09/29/2014	778886	Morrison Maierle Inc	\$668.66	4060-71190-409310	Transfer Parking Lot - CA
09/29/2014	778886	Morrison Maierle Inc	\$86.46	5620-71200-409310	Reconstruct Terminal Circle - CA
09/29/2014	778886	Morrison Maierle Inc	\$5,059.29	4050-71250-409685	Environmental Assessment RW10R - Federal
09/29/2014	778886	Morrison Maierle Inc	\$562.14	4050-71250-409686	Environmental Assessment RW10R - Local Share
09/29/2014	778886	Morrison Maierle Inc	\$13,557.03	5630-71220-409310	Amendment 9 Engineering Services to Construct a New Airport Employee Parking Lot - Const. Admin.
09/29/2014	778890	Napa Auto Parts	-\$82.32	6010-00000-141000	551081 PO NUM 296355
09/29/2014	778890	Napa Auto Parts	\$12.88	6010-00000-141000	551654 PO NUM 296355
09/29/2014	778890	Napa Auto Parts	\$123.58	6010-00000-141000	553636 PO NUM 296355
09/29/2014	778890	Napa Auto Parts	\$16.94	6010-00000-141000	553668 PO NUM 296355
09/29/2014	778890	Napa Auto Parts	\$12.00	6010-00000-141000	553668 PO NUM 296355
09/29/2014	778890	Napa Auto Parts	\$27.86	6010-00000-141000	553760 PO NUM 296355
09/29/2014	778890	Napa Auto Parts	\$365.42	6010-00000-141000	553760 PO NUM 296355
09/29/2014	778890	Napa Auto Parts	\$10.40	1500-21120-402320	551045
09/29/2014	778890	Napa Auto Parts	\$145.01	0100-51120-402320	551140
09/29/2014	778890	Napa Auto Parts	\$56.02	2110-31320-402320	551155

Check Date	Check	Name	Amount	Account	Item Desc
09/29/2014	778890	Napa Auto Parts	\$10.55	2110-31320-402320	551395
09/29/2014	778890	Napa Auto Parts	\$7.51	5410-31220-402320	551419
09/29/2014	778890	Napa Auto Parts	\$5.45	5410-31220-402320	551443
09/29/2014	778890	Napa Auto Parts	\$37.29	2110-31320-402320	551557
09/29/2014	778890	Napa Auto Parts	\$5.73	5410-31220-402320	551654
09/29/2014	778890	Napa Auto Parts	\$8.61	5410-31220-402320	551669
09/29/2014	778890	Napa Auto Parts	\$104.53	6200-19110-402320	551672
09/29/2014	778890	Napa Auto Parts	\$142.60	2090-44520-402320	551751
09/29/2014	778890	Napa Auto Parts	-\$5.73	5410-31220-402320	551954
09/29/2014	778890	Napa Auto Parts	\$163.76	5020-73120-402320	552002
09/29/2014	778890	Napa Auto Parts	\$40.23	6010-15530-402320	552069
09/29/2014	778890	Napa Auto Parts	\$20.18	6010-15530-402320	552100
09/29/2014	778890	Napa Auto Parts	\$48.23	2090-44520-402320	552203
09/29/2014	778890	Napa Auto Parts	-\$16.35	6010-15530-402320	552321
09/29/2014	778890	Napa Auto Parts	\$24.99	6500-15660-402320	552990
09/29/2014	778890	Napa Auto Parts	\$89.89	0100-51120-402320	553236
09/29/2014	778890	Napa Auto Parts	\$252.52	1500-21120-402320	553334
09/29/2014	778890	Napa Auto Parts	\$5.31	1500-21120-402320	553366
09/29/2014	778890	Napa Auto Parts	\$34.09	5410-31220-402320	553513
09/29/2014	778890	Napa Auto Parts	\$71.04	5410-31220-402320	553520
09/29/2014	778890	Napa Auto Parts	\$50.72	1500-21120-402320	553649
09/29/2014	778890	Napa Auto Parts	\$47.84	5410-31220-402320	553809
09/29/2014	778890	Napa Auto Parts	\$17.78	6010-15530-402650	553999
09/29/2014	778890	Napa Auto Parts	\$6.72	0100-51120-402320	554311
09/29/2014	778890	Napa Auto Parts	\$76.27	6010-00000-141000	550962 PO NUM 296354
09/29/2014	778890	Napa Auto Parts	\$48.00	6010-00000-141000	550962 PO NUM 296354
09/29/2014	778890	Napa Auto Parts	\$11.55	5410-31220-402320	549950
09/29/2014	778890	Napa Auto Parts	\$27.31	2110-31320-402320	550464
09/29/2014	778890	Napa Auto Parts	\$100.00	2110-31320-402320	550961
09/29/2014	778890	Napa Auto Parts	\$10.00	6010-15530-402650	550961
09/29/2014	778890	Napa Auto Parts	\$105.30	6010-15530-402650	550962
09/29/2014	778890	Napa Auto Parts	\$46.83	5410-31220-402320	551018
09/29/2014	778890	Napa Auto Parts	\$200.00	1500-21120-402320	551052
09/29/2014	778890	Napa Auto Parts	\$100.00	2110-31320-402320	551052
09/29/2014	778890	Napa Auto Parts	\$100.00	5410-31220-402320	551052
09/29/2014	778890	Napa Auto Parts	\$590.00	6010-15530-402650	551052
09/29/2014	778892	Network Information Systems	\$4,919.00	5020-73120-403660	Stewart Park equipment installation
09/29/2014	778893	NorthWestern Energy	\$431.41	1500-22210-403410	FIRE6: MONTHLY ELECTRIC SERVICE FY2015
09/29/2014	778893	NorthWestern Energy	\$3,066.11	1500-22210-403410	FIRE1: MONTHLY ELECTRIC SERVICE CHARGES FY2015 0100476-1
09/29/2014	778893	NorthWestern Energy	\$367.20	5610-71170-403410	0712792-1. IP-7. September 2014
09/29/2014	778893	NorthWestern Energy	\$16.69	5610-71170-403410	0712799-6. IP-8. September 2014
09/29/2014	778893	NorthWestern Energy	\$1,244.29	5610-71170-403410	0712800-2. IP-9. September 2014
09/29/2014	778893	NorthWestern Energy	\$16.49	5610-71170-403410	0712817-6. IP-House. September 2014
09/29/2014	778893	NorthWestern Energy	\$60.30	5610-71130-403410	0719616-5. ARFF Facility Light. September 2014
09/29/2014	778893	NorthWestern Energy	\$13,370.38	2600-55120-403410	Electricity for Library
09/29/2014	778893	NorthWestern Energy	\$9,909.45	2600-55120-403410	Electricity for Library
09/29/2014	778893	NorthWestern Energy	\$1,179.21	5210-15920-403410	07208341
09/29/2014	778893	NorthWestern Energy	\$167.56	6070-22350-403410	07215809
09/29/2014	778893	NorthWestern Energy	\$13.53	0100-51120-403410	07222375
09/29/2014	778893	NorthWestern Energy	\$7.40	0100-51120-403410	07222474
09/29/2014	778893	NorthWestern Energy	\$239.89	0100-51120-403410	07222516
09/29/2014	778893	NorthWestern Energy	\$0.21	0100-51120-403410	07222540
09/29/2014	778893	NorthWestern Energy	\$92.93	0100-51120-403410	07222557
09/29/2014	778893	NorthWestern Energy	\$369.95	0100-51120-403410	07222573
09/29/2014	778893	NorthWestern Energy	\$258.92	0100-51120-403410	07222607
09/29/2014	778893	NorthWestern Energy	\$42.28	0100-51120-403410	07222615
09/29/2014	778893	NorthWestern Energy	\$32.52	0100-51120-403410	07222623
09/29/2014	778893	NorthWestern Energy	\$58.20	0100-51120-403410	07222631
09/29/2014	778893	NorthWestern Energy	\$147.72	0100-51120-403410	07222656
09/29/2014	778893	NorthWestern Energy	\$43.06	0100-51120-403410	07222664
09/29/2014	778893	NorthWestern Energy	\$17.87	0100-51120-403410	07222680
09/29/2014	778893	NorthWestern Energy	\$12.06	0100-51120-403410	07222698
09/29/2014	778893	NorthWestern Energy	\$11.96	0100-51120-403410	07222920
09/29/2014	778893	NorthWestern Energy	\$54.67	0100-51120-403410	07222938
09/29/2014	778893	NorthWestern Energy	\$8.53	0100-51120-403410	07229057
09/29/2014	778893	NorthWestern Energy	\$300.10	0100-51120-403410	07230352
09/29/2014	778893	NorthWestern Energy	\$8.86	0100-51120-403410	07230360
09/29/2014	778893	NorthWestern Energy	\$190.29	0100-51120-403410	07230378
09/29/2014	778893	NorthWestern Energy	\$40.09	0100-51120-403410	07230386
09/29/2014	778893	NorthWestern Energy	\$43.28	0100-51120-403410	07230428
09/29/2014	778893	NorthWestern Energy	\$106.47	0100-51120-403410	07230485
09/29/2014	778893	NorthWestern Energy	\$129.85	0100-51120-403410	07230501
09/29/2014	778893	NorthWestern Energy	\$11.32	0100-51120-403410	07230519
09/29/2014	778893	NorthWestern Energy	\$34.06	0100-51120-403410	07230527
09/29/2014	778893	NorthWestern Energy	\$508.18	0100-51120-403410	07230543

Check Date	Check	Name	Amount	Account	Item Desc
09/29/2014	778893	NorthWestern Energy	\$22.05	0100-51120-403410	07230550
09/29/2014	778893	NorthWestern Energy	\$73.94	0100-51120-403410	07230568
09/29/2014	778893	NorthWestern Energy	\$9.34	0100-51120-403410	07230576
09/29/2014	778893	NorthWestern Energy	\$31.46	0100-51120-403410	07230584
09/29/2014	778893	NorthWestern Energy	\$325.28	0100-51120-403410	07229339
09/29/2014	778893	NorthWestern Energy	\$9.25	0100-51120-403410	07230907
09/29/2014	778893	NorthWestern Energy	\$7.40	0100-51120-403410	07231624
09/29/2014	778893	NorthWestern Energy	\$1,067.71	0100-51120-403410	07231707
09/29/2014	778893	NorthWestern Energy	\$7.40	0100-51120-403410	07236441
09/29/2014	778893	NorthWestern Energy	\$7.40	0100-51120-403410	07236458
09/29/2014	778893	NorthWestern Energy	\$7.40	8720-51980-403410	07238405
09/29/2014	778893	NorthWestern Energy	\$25.10	0100-51120-403410	07894371
09/29/2014	778893	NorthWestern Energy	\$7.63	2110-31320-403410	08554040
09/29/2014	778893	NorthWestern Energy	\$5,592.66	5020-73140-403410	2251 Belknap Ave
09/29/2014	778893	NorthWestern Energy	\$29,827.54	5020-74000-403410	2251 Belknap Ave
09/29/2014	778893	NorthWestern Energy	\$111,853.25	5020-74000-403410	2251 Belknap Ave
09/29/2014	778893	NorthWestern Energy	\$1,864.22	5120-83140-403410	2251 Belknap Ave
09/29/2014	778893	NorthWestern Energy	\$5,250.28	1500-22210-403410	FIRE1: MONTHLY ELECTRIC SERVICE CHARGES FY2015 0100476-1
09/29/2014	778893	NorthWestern Energy	\$1,105.36	6500-15660-403410	11608023
09/29/2014	778893	NorthWestern Energy	\$1,855.90	6500-15660-403410	11608049
09/29/2014	778893	NorthWestern Energy	\$7.40	0100-51120-403410	12422226
09/29/2014	778893	NorthWestern Energy	\$4,142.45	6500-15660-403410	12693917
09/29/2014	778893	NorthWestern Energy	\$1.15	0100-51120-403410	14093942
09/29/2014	778893	NorthWestern Energy	\$1,049.65	5210-15910-403410	15942824
09/29/2014	778893	NorthWestern Energy	\$403.38	6600-31100-403410	17413147
09/29/2014	778893	NorthWestern Energy	\$605.06	6700-31410-403410	17413147
09/29/2014	778893	NorthWestern Energy	\$165.13	5710-71480-403410	17847567
09/29/2014	778893	NorthWestern Energy	\$6.27	8720-51980-403410	20558177
09/24/2014	778785	Petty Cash CCSIU	\$4,477.75	7180-21600-407910	Reimbursement of PE/PI money for September, 2014.
09/29/2014	778901	Polydyne Inc	\$2,646.00	5120-84000-402220	Clarifloc C-4430
09/29/2014	778901	Polydyne Inc	\$3,234.00	5120-84000-402220	Flospense 30
09/29/2014	778905	Public Utilities	\$40.14	4280-65900-409180	Account #97315-10146900 9/18/14 - 502 S 33rd - Water/Sewer/Garbage
09/29/2014	778905	Public Utilities	\$1,044.42	5120-84000-403420	187212152
09/29/2014	778905	Public Utilities	\$1,688.32	8720-51980-403420	11498915890
09/29/2014	778905	Public Utilities	\$4,553.72	8720-51980-403420	11498915891
09/29/2014	778905	Public Utilities	\$2,758.24	8720-51980-403420	11828118660
09/29/2014	778905	Public Utilities	\$2,698.54	8720-51980-403420	13019519760
09/29/2014	778905	Public Utilities	\$136.08	8720-51980-403420	13019521993
09/29/2014	778905	Public Utilities	\$1,434.47	8720-51980-403420	13592326953
09/29/2014	778905	Public Utilities	\$12.22	8720-51980-403420	13592722571
09/29/2014	778905	Public Utilities	\$203.68	8720-51980-403420	13592526964
09/29/2014	778905	Public Utilities	\$679.80	5120-85000-403420	671274846
09/29/2014	778905	Public Utilities	\$162.64	2110-31320-403420	671294847
09/29/2014	778910	Rimrock Foundation	\$4,218.48	2460-12530-403590	Rimrock State
09/29/2014	778910	Rimrock Foundation	\$3,646.04	7380-12640-403590	Sep. IOP Counselor
09/29/2014	778910	Rimrock Foundation	\$2,521.95	7380-12640-403990	Sep. Case Manager
09/29/2014	778910	Rimrock Foundation	\$3,846.10	7380-12640-403590	Sep. Day Treatment
09/29/2014	778910	Rimrock Foundation	\$3,845.02	7380-12640-403590	Sep IOP
09/29/2014	778910	Rimrock Foundation	\$3,579.15	7380-12640-403590	Sep IOP
09/29/2014	778913	Sanderson Stewart	\$9,853.20	2400-43010-407214	Invoice 38110
09/29/2014	778913	Sanderson Stewart	\$5,414.89	5030-75910-409340	WO 14-13 Mallowney/Elysian Water & Sewer Ext
09/29/2014	778913	Sanderson Stewart	\$8,122.34	5130-85910-409340	WO 14-13 Mallowney/Elysian Water & Sewer Ext
09/29/2014	778913	Sanderson Stewart	\$5,037.15	5130-85910-409340	WO 14-15 Bench Boulevard North Sanitary Sewer Ext
09/29/2014	778913	Sanderson Stewart	\$101,012.84	5030-75910-409340	WO 14-01 2014 Water & Sewer Projects - Sch 1 Water
09/29/2014	778913	Sanderson Stewart	\$2,987.36	8400-31840-409310	WO 14-01 2014 Water & Sewer Projects - Sch 1 Water; CO#3 Storm Drain 8/11/14
09/29/2014	778919	Skyline Services, Inc	\$4,950.00	5610-71120-402450	Invoice #35342. Restore door canopies painted surfaces
09/29/2014	778919	Skyline Services, Inc	\$1,627.50	5610-71120-403660	FY15 - 4 Months Window Cleaning Maintenance
09/29/2014	778927	Stewart Title Company	\$10,000.00	2830-65810-407277	FTHB Christine Haslip 505 Terry Avenue 59101
09/29/2014	778930	Town & Country Supply Association	\$1,316.45	1500-22260-402310	206397: FIRE5 - DIESEL DELIVERED 9/2/2014
09/29/2014	778930	Town & Country Supply Association	\$1,097.04	1500-22260-402310	206398: FIRE3 - DIESEL DELIVERED 9/2/2014
09/29/2014	778930	Town & Country Supply Association	\$0.01	1500-22260-402310	DECIMAL PT CORRECTION
09/29/2014	778930	Town & Country Supply Association	\$1,337.99	1500-22260-402310	203898: FIRE1 UNLEADED DELIVERED 9/5/2014
09/29/2014	778930	Town & Country Supply Association	\$1,519.21	1500-22260-402310	203898: FIRE1 DIESEL DELIVERED 9/5/2014
09/29/2014	778930	Town & Country Supply Association	\$75.18	1500-22310-402310	203898: FIRE 5 DIESEL
09/29/2014	778930	Town & Country Supply Association	\$502.40	1500-22260-402310	203933: FIRE1 UNLEADED DELIVERED 9/10/2014
09/29/2014	778930	Town & Country Supply Association	\$645.83	1500-22260-402310	203933: FIRE 3 - DIESEL DELIVERED 9/10/2014

Check Date	Check	Name	Amount	Account	Item Desc
09/29/2014	778930	Town & Country Supply Association	\$599.70	1500-22260-402310	203933: FIRE 5 - DIESEL DELIVERED 9/10/2014
09/29/2014	778930	Town & Country Supply Association	\$335.98	1500-22260-402310	203933: FIRE 5 - UNLEADED DELIVERED 9/10/2014
09/29/2014	778930	Town & Country Supply Association	\$1,217.86	1500-22260-402310	203933: FIRE6 - DIESEL DELIVERED 9/10/2014
09/29/2014	778930	Town & Country Supply Association	\$307.54	1500-22310-402310	203933: FIRE1 - DIESEL DELIVERED 9/10/2014
09/29/2014	778930	Town & Country Supply Association	\$0.03	1500-22260-402310	DECIMAL PT CORRECTION
09/29/2014	778930	Town & Country Supply Association	\$23,436.85	6010-00000-141000	203375 PO NUM 296335
09/29/2014	778930	Town & Country Supply Association	\$618.61	5020-00000-141000	WATER PARTS AND SUPPLIES PO NUM 296301
09/29/2014	778930	Town & Country Supply Association	\$12,045.20	6010-00000-141000	203987 PO NUM 296389
09/29/2014	778930	Town & Country Supply Association	\$27,549.05	6010-00000-141000	203392 PO NUM 296390
09/29/2014	778930	Town & Country Supply Association	\$251.63	1500-22310-402310	200953: FIRE 6 - DIESEL DELIVERED 9/24/2014
09/29/2014	778930	Town & Country Supply Association	\$680.89	1500-22260-402310	200953: FIRE 1 - DIESEL DELIVERED 9/24/2014
09/29/2014	778930	Town & Country Supply Association	\$458.86	1500-22260-402310	200953: FIRE 3 - DIESEL DELIVERED 9/24/2014
09/29/2014	778930	Town & Country Supply Association	\$840.75	1500-22260-402310	200953: FIRE 5 - DIESEL DELIVERED 9/24/2014
09/29/2014	778930	Town & Country Supply Association	\$604.59	1500-22260-402310	200954: FIRE 1 - UNLEADED DELIVERED 9/24/2014
09/29/2014	778930	Town & Country Supply Association	\$0.02	1500-22260-402310	DECIMAL PT CORRECTION
09/29/2014	778936	Verizon Wireless	\$531.65	5610-71100-403450	Airport
09/29/2014	778936	Verizon Wireless	\$149.21	1500-21700-403450	Animal Shelter
09/29/2014	778936	Verizon Wireless	\$99.08	7170-21660-403450	CCSIU
09/29/2014	778936	Verizon Wireless	\$54.31	0100-16110-403450	Legal
09/29/2014	778936	Verizon Wireless	\$52.54	1500-22250-403450	Comm Center 911
09/29/2014	778936	Verizon Wireless	\$72.17	6500-15650-403450	Facilites BOC Plus 70% of 406-672-3027
09/29/2014	778936	Verizon Wireless	\$84.81	6500-15670-403450	Facilities City Hall Plus 30% of 406-672-3027
09/29/2014	778936	Verizon Wireless	\$101.88	0100-15120-403450	Finance Pat Weber
09/29/2014	778936	Verizon Wireless	\$838.46	1500-22210-403450	Fire Department
09/29/2014	778936	Verizon Wireless	\$80.34	0100-17500-403450	Human Resources
09/29/2014	778936	Verizon Wireless	\$13.15	6200-19130-403450	ITD GIS
09/29/2014	778936	Verizon Wireless	\$13.13	6200-19110-403450	ITD
09/29/2014	778936	Verizon Wireless	\$26.26	2600-55170-403450	Library Outreach
09/29/2014	778936	Verizon Wireless	\$345.82	2600-55120-403450	Library
09/29/2014	778936	Verizon Wireless	\$42.81	0100-11000-403450	Mayor
09/29/2014	778936	Verizon Wireless	\$57.43	6010-15500-403450	Motor Pool
09/29/2014	778936	Verizon Wireless	\$193.27	0100-12200-403450	Drug Court
09/29/2014	778936	Verizon Wireless	\$88.96	0100-12120-403450	Municipal Court Judge
09/29/2014	778936	Verizon Wireless	\$13.13	2400-43010-403450	Planning
09/29/2014	778936	Verizon Wireless	\$3,083.74	1500-21110-403450	Police
09/29/2014	778936	Verizon Wireless	\$90.57	2510-21870-403450	Police Forensic 406-794-6880 406-698-7323
09/29/2014	778936	Verizon Wireless	\$679.14	1500-21110-403450	Police Resource Officers
09/29/2014	778936	Verizon Wireless	\$28.15	2490-21960-403450	Police DV 406-698-1391
09/29/2014	778936	Verizon Wireless	\$127.75	5210-15210-403450	Parking
09/29/2014	778936	Verizon Wireless	\$233.67	0100-51100-403450	PRPL Admin
09/29/2014	778936	Verizon Wireless	\$273.47	0100-51210-403450	PRPL Recreation
09/29/2014	778936	Verizon Wireless	\$336.26	0100-51210-403450	PRPL Seasonal
09/29/2014	778936	Verizon Wireless	\$70.30	0100-51400-403450	Cemetery
09/29/2014	778936	Verizon Wireless	\$43.89	0100-51120-403450	Parks PMD
09/29/2014	778936	Verizon Wireless	\$1,026.63	0100-51120-403450	Parks
09/29/2014	778936	Verizon Wireless	\$219.63	0100-51120-403450	Parks Irrigation
09/29/2014	778936	Verizon Wireless	\$125.54	6600-31100-403450	Public Works Admin
09/29/2014	778936	Verizon Wireless	\$143.84	2090-44510-403450	Building
09/29/2014	778936	Verizon Wireless	\$262.23	6700-31410-403450	Engineering
09/29/2014	778936	Verizon Wireless	\$206.86	5410-31210-403450	Solid Waste
09/29/2014	778936	Verizon Wireless	\$380.69	2110-31320-403450	Streets
09/29/2014	778936	Verizon Wireless	\$245.91	5410-31230-403450	Solid Waste On Call
09/29/2014	778936	Verizon Wireless	\$473.49	5020-75000-403450	Distribution & Collection 60% 5020-75000-403450
09/29/2014	778936	Verizon Wireless	\$315.67	5120-85000-403450	Distribution & Collection 40\$ 5120-85000-403450
09/29/2014	778936	Verizon Wireless	\$658.00	5020-74000-403450	Distribution & Collection 40\$ 5120-85000-403450
09/29/2014	778936	Verizon Wireless	\$441.91	5020-73120-403450	Water Treatment PWBelknap-WT
09/29/2014	778936	Verizon Wireless	\$69.67	5020-73110-403450	PWBLKNP MTRSHOP Belknap Office 60% 5020-73110-403450
09/29/2014	778936	Verizon Wireless	\$46.45	5120-83110-403450	Belknap Office 40\$ 5120-83110-403450 Belknap Office 60% 5020-73110-403450

Check Date	Check	Name	Amount	Account	Item Desc
09/29/2014	778936	Verizon Wireless	\$87.09	5020-73140-403450	PWBLKNP STORES 75% 5020-73140-403450
09/29/2014	778936	Verizon Wireless	\$29.03	5120-83140-403450	PWBLKNP STORES 25% 5120-83140-403450
09/29/2014	778936	Verizon Wireless	\$946.55	5120-84000-403450	PWBLKNP STORES 75% 5020-73140-403450
09/29/2014	778936	Verizon Wireless	\$23.17	6060-19310-403450	Wastewater Treatment Plant
09/29/2014	778936	Verizon Wireless	\$92.21	5710-71420-403160	TeleComm Manager
09/29/2014	778936	Verizon Wireless	\$36.44	5710-71410-403450	On Call MET
09/29/2014	778936	Verizon Wireless	\$91.95	0100-43210-403450	MET Transit
09/29/2014	778936	Verizon Wireless	\$836.83	0100-51120-403450	Code Enforcement
09/29/2014	778936	Verizon Wireless	\$211.49	5020-74000-403450	Parks Seasonal
09/29/2014	778936	Verizon Wireless	\$211.50	5120-84300-403450	PWB ELECTRICIANS 50%/50%
09/29/2014	778936	Verizon Wireless	\$200.05	1500-21700-403450	50% 5020-74000-403450
09/29/2014	778936	Verizon Wireless	\$520.77	7170-21660-403450	50% 5120-84300-403450
09/29/2014	778936	Verizon Wireless	\$40.01	7170-21660-403450	PWB ELECTRICIANS 50%/50%
09/29/2014	778936	Verizon Wireless	\$80.02	7170-21660-403450	50% 5020-74000-403450
09/29/2014	778936	Verizon Wireless	\$40.01	0100-13130-403450	50% 5120-84300-403450
09/29/2014	778936	Verizon Wireless	\$80.02	0100-43210-403450	Animal Shelter MDT
09/29/2014	778936	Verizon Wireless	\$40.01	1500-22210-403450	7170-21660-403450
09/29/2014	778936	Verizon Wireless	\$40.01	2200-22330-402410	CCSIU Cell/PTT
09/29/2014	778936	Verizon Wireless	\$711.19	1500-22210-403450	CCSIU Air Card
09/29/2014	778936	Verizon Wireless	\$116.16	6200-19110-403450	CCSIU RAVEN
09/29/2014	778936	Verizon Wireless	\$236.19	2600-55170-403450	City Administration 406-839-4295 Bruce
09/29/2014	778936	Verizon Wireless	\$4,036.01	1500-21110-403450	McCandless
09/29/2014	778936	Verizon Wireless	\$470.28	5710-71470-403160	iPad
09/29/2014	778936	Verizon Wireless	\$40.01	1500-21110-403450	Code Enforcement Air Cards
09/29/2014	778936	Verizon Wireless	\$40.01	1500-21110-403450	Fire MiFi 406-839-3253
09/29/2014	778936	Verizon Wireless	\$154.69	1500-21110-403450	2200-22330-402410
09/29/2014	778936	Verizon Wireless	\$40.01	1500-21110-403450	Fire HAZMAT MDT 406-670-1284
09/29/2014	778936	Verizon Wireless	\$240.06	2090-44510-403450	Fire MDT
09/29/2014	778936	Verizon Wireless	\$192.04	5020-75000-403450	ITD
09/29/2014	778936	Verizon Wireless	\$128.04	5120-85000-403450	Library Outreach Air Cards
09/29/2014	778936	Verizon Wireless	\$100.05	6700-31410-403450	60% 5020-75000-403450
09/29/2014	778936	Verizon Wireless	\$70.03	2110-31320-403450	PW-Distribution Collection Tablets 60%/40%
09/29/2014	778936	Verizon Wireless	\$18.02	5020-75000-403450	40% 5120-85000-403450
09/29/2014	778936	Verizon Wireless	\$12.00	5120-85000-403450	60% 5020-75000-403450
09/29/2014	778936	Verizon Wireless	-\$18.04	0100-51290-403450	PW-Distribution Collection Tablets 60%/40%
09/29/2014	778936	Verizon Wireless	\$80.02	7170-21660-403450	60% 5020-75000-403450
09/29/2014	778936	Verizon Wireless	\$240.06	2110-31320-403450	40% 5120-85000-403450
09/29/2014	778936	Verizon Wireless	\$24.00	5020-75000-403450	PW-Engineering
09/29/2014	778936	Verizon Wireless	\$16.01	5120-85000-403450	PW-Streets 406-697-0361 iPad
09/29/2014	778937	Viking Communications & Electronics Inc	\$7,898.00	1500-22270-402481	406-633-1991 iPad
09/29/2014	778937	Viking Communications & Electronics Inc	\$72.60	1500-22270-402481	PWBELKNAP-AIR 60% 40%
09/29/2014	778937	Viking Communications & Electronics Inc	\$4,118.40	1500-22270-402481	60% 5020-75000-403450
09/29/2014	778937	Viking Communications & Electronics Inc	\$4,752.00	1500-22270-402290	40% 5120-85000-403450
09/29/2014	778937	Viking Communications & Electronics Inc	\$900.90	1500-22270-402481	40% 5120-85000-403450
09/29/2014	778937	Viking Communications & Electronics Inc	\$166.00	1500-22270-402481	PWBELKNAP-AIR 60% 40%
09/29/2014	778940	Wastequip Washington	\$5,345.00	5020-00000-141000	60% 5020-75000-403450
09/29/2014	778946	Yellowstone E-Waste Solutions	\$3,000.00	9000-00000-229000	40% 5120-85000-403450
09/29/2014	778948	Yellowstone Valley Elec	\$59.00	5120-84000-403410	PW-DIS-COLL CITY WORKK 60%/40%
09/29/2014	778948	Yellowstone Valley Elec	\$2,585.29	5020-74000-403410	40% 5120-85000-403450
09/29/2014	778948	Yellowstone Valley Elec	\$364.67	8100-31830-403410	60% 5020-75000-403450
					PRPL-PARKS PMD Air Card
					406-794-6977
					PW-Building Air Cards
					PW-Distribution Collection Tablets 60%/40%
					60% 5020-75000-403450
					40% 5120-85000-403450
					PW-Distribution Collection Tablets 60%/40%
					60% 5020-75000-403450
					40% 5120-85000-403450
					PW-Engineering
					PW-Streets 406-697-0361 iPad
					406-633-1991 iPad
					PWBELKNAP-AIR 60% 40%
					60% 5020-75000-403450
					40% 5120-85000-403450
					PWBELKNAP-AIR 60% 40%
					60% 5020-75000-403450
					40% 5120-85000-403450
					PRPL-REC-AIR-CARD
					406-698-3835 Rose Park
					406-794-2586 Batting Cage
					CCSIU MDT
					2110-31320-403450
					PW-Streets CITY WORKS
					PW-DIS-COLL CITY WORKK 60%/40%
					60% 5020-75000-403450
					40% 5120-85000-403450
					PW-DIS-COLL CITY WORKK 60%/40%
					60% 5020-75000-403450
					40% 5120-85000-403450
					40% 5120-85000-403450
					GP5102XP PORTABLE RADIO (RADIO ONLY)
					LAA0820 ANTENNA
					LAA0380 GANG CHARGER FOR LI-ION (5-UNIT
					RAPID CHARGER)
					BATTERIES (LI-ION) 2200 mAh
					LLA0139 CLAMSHELL (ORANGE)
					FREIGHT (ESTIMATED)
					WASTEWATER PARTS & SUPPLY PO NUM
					296300
					Bid for E-Waste collection - Solid Waste
					Briarwood/O'Shea
					Thomas Pump Station
					SILMD 299 Vintage Estates

Check Date	Check	Name	Amount	Account	Item Desc
09/29/2014	778948	Yellowstone Valley Elec	\$706.62	1500-22210-403410	4179013: ELECTRICAL SERVICE/FIRE STATION #7/PD3 FY2015
09/29/2014	778948	Yellowstone Valley Elec	\$147.62	6070-22350-403410	4179002: LANDFILL 800MHZ RADIO TOWER SITE - ELECTRIC SERVICE - FY2015
09/29/2014	778948	Yellowstone Valley Elec	\$0.00	6070-22350-403410	4179002: TANK "FOX" TOWER SITE - ELECTRIC - FY2015
09/29/2014	778948	Yellowstone Valley Elec	\$0.00	6070-22350-403410	4179002: LANDFILL 800MHZ RADIO TOWER SITE - ELECTRIC SERVICE - FY2015
09/29/2014	778948	Yellowstone Valley Elec	\$169.72	6070-22350-403410	4179002: TANK "FOX" TOWER SITE - ELECTRIC - FY2015

Regular City Council Meeting

Meeting Date: 10/27/2014

TITLE: Payment of Claims - July 1, 2014 through September 30, 2014

PRESENTED BY: Sheila Kolar, Municipal Court Judge

Department: Court

PROBLEM/ISSUE STATEMENT

Claims in the amount of \$439,656.39 have been audited and presented for Council approval. Claims include payments to the general fund, County Treasurer, individual victims and businesses for restitution, disbursement of surcharges and revenues and return of bonds posted to ensure court appearance. A complete listing of claims dated July 1, 2014 through September 30, 2014 is attached to this memo and is on file in the Municipal Court.

ALTERNATIVES ANALYZED

City Council may:

- Approve, or;
- Disapprove

FINANCIAL IMPACT

This results in \$285,146.66 payment to the General Fund and \$154,509.73 in payments to the County Treasurer, individuals and businesses for bond returns, restitution and victims.

RECOMMENDATION

Staff recommends the Council approve the Municipal Court Payment of Claims.

APPROVED BY CITY ADMINISTRATOR

Payment of Claims

Check Register

Bank: US BANK - Account: 150095602101

Date Range: From 07/01/2014 to 09/30/2014

All Check Types

Sorted by Check Number

Check Number	Date	Payee	Amount	Status	Cleared
19671	07/11/2014	Casa Village	15.73	Cleared	07/31/2014
19672	07/11/2014	Shopko	50.00	Cleared	07/31/2014
19673	07/11/2014	State Farm	50.00	Cleared	08/31/2014
19674	07/11/2014	Austin Colt Fallang	15.00	Outstanding	
19675	07/11/2014	Billings Parks, Recreation and Land	25.00	Cleared	07/31/2014
19676	07/11/2014	Billings Public Schools	25.00	Cleared	07/31/2014
19677	07/11/2014	C.jay Deeney	50.00	Cleared	07/31/2014
19678	07/11/2014	City Of Billings	481.22	Cleared	07/31/2014
19679	07/11/2014	City Of Billings - Street/Traffic Dept	25.00	Cleared	08/31/2014
19680	07/11/2014	City of Billings	30.00	Cleared	07/31/2014
19681	07/11/2014	Cody Harris	5.34	Outstanding	
19682	07/11/2014	Community Solutions Inc	25.00	Cleared	07/31/2014
19683	07/11/2014	Community Solutions Inc	50.00	Cleared	07/31/2014
19684	07/11/2014	Crime Victim Compensation Program	50.00	Cleared	07/31/2014
19685	07/11/2014	Crystal Lounge	390.00	Cleared	07/31/2014
19686	07/11/2014	Daniel Lee Peterson	15.00	Cleared	07/31/2014
19687	07/11/2014	Daniel S Repka	50.00	Cleared	07/31/2014
19688	07/11/2014	Dave Welch	62.50	Cleared	08/31/2014
19689	07/11/2014	David Rudolph	100.00	Cleared	07/31/2014
19690	07/11/2014	Desiree Beth Kroll	15.00	Cleared	08/31/2014
19691	07/11/2014	Donna Forbes	50.00	Cleared	07/31/2014
19692	07/11/2014	Dustin Allen Lavelle	1080.00	Cleared	07/31/2014
19693	07/11/2014	Edward Eugene Hauber S	200.00	Cleared	07/31/2014
19694	07/11/2014	Edward R Hawthorne	25.00	Cleared	08/31/2014
19695	07/11/2014	First National Pawn	20.00	Cleared	07/31/2014
19696	07/11/2014	First National Pawn	38.00	Cleared	07/31/2014
19697	07/11/2014	Gina Lynn Kingstad	25.00	Cleared	07/31/2014
19698	07/11/2014	Greg Gordon	50.00	Cleared	07/31/2014
19699	07/11/2014	Hallie Gray	2000.00	Cleared	07/31/2014
19700	07/11/2014	Jace Michael Davidson	15.00	Cleared	07/31/2014
19701	07/11/2014	Jack Ross	50.00	Cleared	07/31/2014
19702	07/11/2014	Jarrett Wanner	100.00	Cleared	07/31/2014
19703	07/11/2014	Jennifer Baldner	120.00	Cleared	07/31/2014
19704	07/11/2014	John Matthew Krebs	100.00	Cleared	08/31/2014
19705	07/11/2014	John WildIn Hahn	15.00	Cleared	08/31/2014
19706	07/11/2014	Joshua Miller	12.50	Cleared	07/31/2014

Check Register

Bank: US BANK - Account: 150095602101

Date Range: From 07/01/2014 to 09/30/2014

All Check Types

Sorted by Check Number

Check Number	Date	Payee	Amount	Status	Cleared
19707	07/11/2014	June Ortman	50.00	Cleared	07/31/2014
19708	07/11/2014	Katherine Irigoien	6758.00	Cleared	07/31/2014
19709	07/11/2014	Kathy Eder	100.00	Cleared	07/31/2014
19710	07/11/2014	Kaycee Elaine Bradley	15.00	Cleared	08/31/2014
19711	07/11/2014	Keri Wilson	35.00	Cleared	07/31/2014
19712	07/11/2014	Kohl's Corporate Loss Prevention	50.00	Cleared	07/31/2014
19713	07/11/2014	Kynzee Mann	15.00	Cleared	08/31/2014
19714	07/11/2014	Laura Michelle Gabaldon	20.00	Cleared	07/31/2014
19715	07/11/2014	Leon Stephen Goodell Jr	855.00	Cleared	07/31/2014
19716	07/11/2014	Les Benner	50.00	Cleared	07/31/2014
19717	07/11/2014	Linda Oistad	9.27	Cleared	08/31/2014
19718	07/11/2014	Luke Taylor Daly	55.00	Cleared	08/31/2014
19719	07/11/2014	Mandi Toews	200.00	Cleared	07/31/2014
19720	07/11/2014	Memri Spottedelk	50.00	Cleared	07/31/2014
19721	07/11/2014	Michael Mury	195.00	Outstanding	
19722	07/11/2014	Michael Rawlins	50.00	Cleared	07/31/2014
19723	07/11/2014	Miguel Elisco Valdez	50.00	Cleared	07/31/2014
19724	07/11/2014	Mika N Orr	540.00	Outstanding	
19725	07/11/2014	Mika N Orr	720.00	Cleared	07/31/2014
19726	07/11/2014	Morlene Vogel	870.00	Cleared	07/31/2014
19727	07/11/2014	Motel 6	50.00	Cleared	07/31/2014
19728	07/11/2014	NAPA Distribution Center Attn: Loren Zoë	50.00	Cleared	07/31/2014
19729	07/11/2014	Nickalas Sammartino	195.00	Cleared	07/31/2014
19730	07/11/2014	Peter Andrew Egge	110.00	Outstanding	
19731	07/11/2014	Richard James Brown	50.00	Cleared	07/31/2014
19732	07/11/2014	Robert Raymond Hill	50.00	Cleared	07/31/2014
19733	07/11/2014	Roger Hill	12.50	Cleared	07/31/2014
19734	07/11/2014	Rosco Lagge	12.50	Cleared	07/31/2014
19735	07/11/2014	Russell Gilmer	300.00	Cleared	08/31/2014
19736	07/11/2014	Shaun Michael Hoover	510.00	Outstanding	
19737	07/11/2014	Shawna Coleman	80.00	Cleared	07/31/2014
19738	07/11/2014	Speak Easy Casino	50.00	Outstanding	
19739	07/11/2014	Steven Ross Johnson	22.50	Cleared	07/31/2014
19740	07/11/2014	Tammy Zemliska	1015.00	Cleared	07/31/2014
19741	07/11/2014	Tammy Kleinrok	595.00	Cleared	08/31/2014
19742	07/11/2014	Target AP Recovery	50.00	Cleared	07/31/2014

Check Register

Bank: US BANK - Account: 150095602101

Date Range: From 07/01/2014 to 09/30/2014

All Check Types

Sorted by Check Number

Check Number	Date	Payee	Amount	Status	Cleared
19743	07/11/2014	Taylor Ita	19.66	Cleared	08/31/2014
19744	07/11/2014	Tom Cummings	100.00	Cleared	07/31/2014
19745	07/11/2014	Treatment Court	25.00	Outstanding	
19746	07/11/2014	Walmart	50.00	Cleared	07/31/2014
19747	07/11/2014	Wesley Glen	50.00	Cleared	07/31/2014
19748	07/11/2014	Westley Fuchs	200.00	Cleared	07/31/2014
19749	07/11/2014	Zachary R Burns	50.00	Cleared	08/31/2014
19750	07/18/2014	Northwestern Energy	25.00	Cleared	07/31/2014
19751	07/18/2014	Assurant Health	55.00	Cleared	08/31/2014
19752	07/18/2014	Big Horn Resort	50.00	Cleared	07/31/2014
19753	07/18/2014	Brent Sterrett	100.00	Cleared	08/31/2014
19754	07/18/2014	Christopher Bumgarner	1135.00	Cleared	07/31/2014
19755	07/18/2014	City Of Billings-c/o JoLynn Yerger	25.00	Cleared	07/31/2014
19756	07/18/2014	City of Billings Animal Shelter	75.00	Cleared	08/31/2014
19757	07/18/2014	Crime Victim Compensation Program	25.00	Cleared	07/31/2014
19758	07/18/2014	Crime Victim Compensation Program	25.00	Cleared	07/31/2014
19759	07/18/2014	Donna Huffman	100.00	Cleared	07/31/2014
19760	07/18/2014	Elizabeth Barrett	2.50	Cleared	07/31/2014
19761	07/18/2014	Ervallynn Nomee	50.00	Outstanding	
19762	07/18/2014	First Interstate Bank Attn: Brian Brown	25.00	Cleared	07/31/2014
19763	07/18/2014	Hobby Lobby	50.00	Cleared	08/31/2014
19764	07/18/2014	Jesse Stapleton	640.00	Cleared	08/31/2014
19765	07/18/2014	Karen Geraldine Zaso	20.00	Cleared	08/31/2014
19766	07/18/2014	Kathleen Green	55.00	Outstanding	
19767	07/18/2014	Kyle David Shambo	500.00	Cleared	07/31/2014
19768	07/18/2014	Lana Cummings	870.00	Cleared	07/31/2014
19769	07/18/2014	Lawrence James Bell	50.00	Cleared	07/31/2014
19770	07/18/2014	Mandy Maxwell	25.00	Cleared	08/31/2014
19771	07/18/2014	Neil Kiner	350.00	Cleared	08/31/2014
19772	07/18/2014	Paul Rosales	50.00	Cleared	08/31/2014
19773	07/18/2014	Ralph Daniels	545.00	Cleared	07/31/2014
19774	07/18/2014	Roberta Fallsdown	195.00	Cleared	08/31/2014
19775	07/18/2014	Ryan Hamman	16.50	Cleared	07/31/2014
19776	07/18/2014	Samson Lloyd Romero	15.00	Cleared	07/31/2014
19777	07/18/2014	Sandra Sukin	8.50	Cleared	07/31/2014
19778	07/18/2014	Stacie M Warehime	25.00	Cleared	08/31/2014

Check Register

Bank: US BANK - Account: 150095602101

Date Range: From 07/01/2014 to 09/30/2014

All Check Types

Sorted by Check Number

Check Number	Date	Payee	Amount	Status	Cleared
19779	07/18/2014	Susanne Biglake Hill	50.00	Cleared	07/31/2014
19780	07/18/2014	Terrill Frank Stoltz	1715.00	Cleared	07/31/2014
19781	07/18/2014	Tim Masbruch	100.00	Cleared	08/31/2014
19782	07/18/2014	Timothy Jack Wagner	1000.00	Cleared	07/31/2014
19783	07/18/2014	Tyler Holliday	25.00	Cleared	08/31/2014
19784	07/18/2014	Wynn Pippin	195.00	Cleared	08/31/2014
19785	07/25/2014	South Forty	12.50	Cleared	08/31/2014
19786	07/25/2014	State Farm	50.00	Cleared	08/31/2014
19787	07/25/2014	Ashley P Wacker	68.25	Outstanding	
19788	07/25/2014	Ashley P Wacker	290.00	Outstanding	
19789	07/25/2014	Barry Donald Stevens	110.00	Cleared	08/31/2014
19790	07/25/2014	Bryan Paul Ulledalen	15.00	Cleared	08/31/2014
19791	07/25/2014	Carol Ann Laforge	50.00	Cleared	08/31/2014
19792	07/25/2014	City Of Billings Police Dept	12.50	Cleared	07/31/2014
19793	07/25/2014	Courtney Hudson	1000.00	Cleared	07/31/2014
19794	07/25/2014	Crime Victim Compensation Program	50.00	Cleared	08/31/2014
19795	07/25/2014	Crime Victim Compensation Program	100.00	Cleared	08/31/2014
19796	07/25/2014	Daniel S Repka	50.00	Cleared	08/31/2014
19797	07/25/2014	Darcie Kay Addington	500.00	Cleared	08/31/2014
19798	07/25/2014	Derek Harper	1000.00	Cleared	08/31/2014
19799	07/25/2014	Douglas Golden	50.00	Cleared	07/31/2014
19800	07/25/2014	Gary Lawrence Shayne	294.75	Cleared	07/31/2014
19801	07/25/2014	Golden Recycling	50.00	Cleared	08/31/2014
19802	07/25/2014	Ioapo Napeli Jr	245.00	Cleared	08/31/2014
19803	07/25/2014	Ioapo Napeli Jr	445.00	Cleared	08/31/2014
19804	07/25/2014	Jerry B Moore	230.00	Cleared	08/31/2014
19805	07/25/2014	Kenneth Romero	20.00	Cleared	08/31/2014
19806	07/25/2014	Kevin Gillen	20.00	Cleared	08/31/2014
19807	07/25/2014	Lake Hills Golf Course	50.00	Cleared	08/31/2014
19808	07/25/2014	Mallory Elaine Keyes	50.00	Outstanding	
19809	07/25/2014	Mary Valley	50.00	Cleared	07/31/2014
19810	07/25/2014	Michael D Adams	295.00	Cleared	08/31/2014
19811	07/25/2014	Pete Portra	50.00	Cleared	08/31/2014
19812	07/25/2014	Platinum Plus Pawn	50.00	Cleared	08/31/2014
19813	07/25/2014	Robert A Spadt Jr	25.00	Cleared	08/31/2014
19814	07/25/2014	Roy D Kessler	25.00	Cleared	08/31/2014

Check Register

Bank: US BANK - Account: 150095602101

Date Range: From 07/01/2014 to 09/30/2014

All Check Types

Sorted by Check Number

Check Number	Date	Payee	Amount	Status	Cleared
19815	07/25/2014	Samuel Post	195.00	Cleared	07/31/2014
19816	07/25/2014	Sears	108.00	Outstanding	
19817	07/25/2014	Shilo Shae Cox	15.00	Outstanding	
19818	07/25/2014	TJ Yzaguirre	25.00	Cleared	08/31/2014
19819	07/25/2014	Virginia M Trent	295.00	Cleared	08/31/2014
19820	08/01/2014	State Farm Insurance	30.94	Cleared	08/31/2014
19821	08/01/2014	Walmart	60.00	Cleared	08/31/2014
19822	08/01/2014	Albertsons	25.00	Outstanding	
19823	08/01/2014	Alexander Gregory Michels	15.00	Cleared	08/31/2014
19824	08/01/2014	Allen R. Peabody	1045.00	Cleared	08/31/2014
19825	08/01/2014	Amanda Major	1040.00	Cleared	08/31/2014
19826	08/01/2014	Andrew Cooper	50.00	Cleared	08/31/2014
19827	08/01/2014	Billings Clinic	50.00	Cleared	08/31/2014
19828	08/01/2014	Billings Machinery Welding	63.25	Cleared	08/31/2014
19829	08/01/2014	Brenda Drewry	200.00	Outstanding	
19830	08/01/2014	Brent Nelson	295.00	Cleared	08/31/2014
19831	08/01/2014	Brent Nelson	990.00	Cleared	08/31/2014
19832	08/01/2014	Carlos Navarro Jr	15.00	Cleared	08/31/2014
19833	08/01/2014	Christopher Hartly-Galt	1045.00	Cleared	08/31/2014
19834	08/01/2014	City Treasurer	154810.94	Cleared	08/31/2014
19835	08/01/2014	Crystle Marie Weise	15.00	Outstanding	
19836	08/01/2014	Ginnie Burgess	50.00	Outstanding	
19837	08/01/2014	Greg & Lani Monical	50.00	Cleared	08/31/2014
19838	08/01/2014	Ivet Tiana Rivera	15.00	Cleared	08/31/2014
19839	08/01/2014	Jack Ross	50.00	Cleared	08/31/2014
19840	08/01/2014	Jacob Brotzler	50.00	Outstanding	
19841	08/01/2014	James Novotny	19.06	Cleared	08/31/2014
19842	08/01/2014	Jamie Nixdorf	50.00	Cleared	08/31/2014
19843	08/01/2014	Jason Romell Dix	50.00	Cleared	08/31/2014
19844	08/01/2014	John Post	1090.00	Cleared	08/31/2014
19845	08/01/2014	Joshua Paul Stewart	15.00	Outstanding	
19846	08/01/2014	Kara Rachelle Allen	15.00	Cleared	08/31/2014
19847	08/01/2014	Kathleen Mollett	1045.00	Cleared	08/31/2014
19848	08/01/2014	Keri Lynn Siewert	50.00	Cleared	08/31/2014
19849	08/01/2014	Leanne Yucha	50.00	Cleared	08/31/2014
19850	08/01/2014	Leonard E Kenney	30.00	Cleared	08/31/2014

Check Register

Bank: US BANK - Account: 150095602101

Date Range: From 07/01/2014 to 09/30/2014

All Check Types

Sorted by Check Number

Check Number	Date	Payee	Amount	Status	Cleared
19851	08/01/2014	Mark Hilario Sr	275.00	Outstanding	
19852	08/01/2014	Mitchel Robert Fleharty	1500.00	Outstanding	
19853	08/01/2014	Mitchell Olson	15.00	Outstanding	
19854	08/01/2014	Municipal Services Bureau	7335.24	Cleared	08/31/2014
19855	08/01/2014	NAPA Distribution Center Attn: Loren Zoë	50.00	Cleared	08/31/2014
19856	08/01/2014	Nina Guitierrez	750.00	Cleared	08/31/2014
19857	08/01/2014	Nona Main	50.00	Outstanding	
19858	08/01/2014	Orlando Christopher Mota	50.00	Cleared	08/31/2014
19859	08/01/2014	Peter Prevost	50.00	Cleared	08/31/2014
19860	08/01/2014	Raann Gibson	720.00	Cleared	08/31/2014
19861	08/01/2014	Reece Kalfell	50.00	Cleared	08/31/2014
19862	08/01/2014	Ron Allen Grimsrud	100.00	Cleared	08/31/2014
19863	08/01/2014	Ron Allen Grimsrud	295.00	Cleared	08/31/2014
19864	08/01/2014	Scott Summers	720.00	Cleared	08/31/2014
19865	08/01/2014	Sears	50.00	Outstanding	
19866	08/01/2014	Seth Jacob Bernhardt	15.00	Cleared	08/31/2014
19867	08/01/2014	Target AP Recovery	50.00	Cleared	08/31/2014
19868	08/01/2014	Thomas Paul Kosche	50.00	Cleared	08/31/2014
19869	08/01/2014	Tom Cummings	100.00	Cleared	08/31/2014
19870	08/01/2014	Walmart	50.00	Cleared	08/31/2014
19871	08/01/2014	Walmart	60.00	Cleared	08/31/2014
19872	08/01/2014	Yellowstone County Treasurer	10584.44	Cleared	08/31/2014
19873	08/08/2014	Casa Village	50.00	Cleared	08/31/2014
19874	08/08/2014	Sears	64.00	Outstanding	
19875	08/08/2014	St. Vincent's Healthcare	100.00	Cleared	08/31/2014
19876	08/08/2014	Target	60.00	Cleared	08/31/2014
19877	08/08/2014	Altimus Distributing	50.00	Cleared	08/31/2014
19878	08/08/2014	Assurant Health	55.00	Cleared	08/31/2014
19879	08/08/2014	Billings Police	200.00	Cleared	08/31/2014
19880	08/08/2014	Billings School District #2	50.00	Cleared	08/31/2014
19881	08/08/2014	Cindi Oberg	595.00	Outstanding	
19882	08/08/2014	City Of Billings - Street/Traffic Dept	50.00	Cleared	08/31/2014
19883	08/08/2014	City of Billings	50.00	Cleared	08/31/2014
19884	08/08/2014	Community Solutions Inc	10.57	Cleared	08/31/2014
19885	08/08/2014	Community Solutions Inc	25.00	Cleared	08/31/2014
19886	08/08/2014	Crime Victim Compensation Program	50.00	Cleared	08/31/2014

Check Register

Bank: US BANK - Account: 150095602101

Date Range: From 07/01/2014 to 09/30/2014

All Check Types

Sorted by Check Number

Check Number	Date	Payee	Amount	Status	Cleared
19887	08/08/2014	Daniel Cox	50.00	Cleared	08/31/2014
19888	08/08/2014	David Rudolph	50.00	Cleared	08/31/2014
19889	08/08/2014	Douglas B Williams	100.00	Cleared	08/31/2014
19890	08/08/2014	Emori Sage Dodson	100.00	Outstanding	
19891	08/08/2014	Ervin Schwiebert	50.00	Cleared	08/31/2014
19892	08/08/2014	First National Pawn	24.18	Cleared	08/31/2014
19893	08/08/2014	Gina Lynn Kingstad	100.00	Cleared	08/31/2014
19894	08/08/2014	John Matthew Krebs	209.30	Outstanding	
19895	08/08/2014	Julie Sullivan	25.00	Cleared	08/31/2014
19896	08/08/2014	June Ortman	50.00	Cleared	08/31/2014
19897	08/08/2014	Kathy Eder	200.00	Cleared	08/31/2014
19898	08/08/2014	Kohl's Corporate Loss Prevention	50.00	Cleared	08/31/2014
19899	08/08/2014	Mandi Toews	55.00	Outstanding	
19900	08/08/2014	Margaret Racheal Romero	80.00	Cleared	08/31/2014
19901	08/08/2014	Melanie Marie Cornell	100.00	Cleared	08/31/2014
19902	08/08/2014	Memri Spottedelk	50.00	Cleared	08/31/2014
19903	08/08/2014	Michael Rawlins	50.00	Cleared	08/31/2014
19904	08/08/2014	Paul Rosales	50.00	Cleared	08/31/2014
19905	08/08/2014	Philip Trunkle	50.00	Cleared	08/31/2014
19906	08/08/2014	Portia Viall Hoverson	100.00	Outstanding	
19907	08/08/2014	Richard James Brown	50.00	Cleared	08/31/2014
19908	08/08/2014	Robert Burton	50.00	Cleared	08/31/2014
19909	08/08/2014	Robert Roy Vincent	445.00	Cleared	08/31/2014
19910	08/08/2014	Scott Aaron Laber	105.00	Cleared	08/31/2014
19911	08/08/2014	Scott Collins	50.00	Cleared	08/31/2014
19912	08/08/2014	Steve Salazar	300.00	Cleared	08/31/2014
19913	08/08/2014	Steven Ross Johnson	25.00	Cleared	08/31/2014
19914	08/08/2014	Steven Sullivan	40.00	Cleared	08/31/2014
19915	08/08/2014	Taylor Ita	50.00	Outstanding	
19916	08/08/2014	Tenille Dahlin	14.43	Cleared	08/31/2014
19917	08/08/2014	Tim R Howe	50.00	Cleared	08/31/2014
19918	08/08/2014	Tyler Holliday	25.00	Cleared	08/31/2014
19919	08/08/2014	Vyron Ray Duncan	125.00	Voided	08/31/2014
19920	08/08/2014	Walmart	50.00	Cleared	08/31/2014
19921	08/08/2014	Western Pawn	50.00	Outstanding	
19922	08/08/2014	Westley Fuchs	200.00	Cleared	08/31/2014

Check Register

Bank: US BANK - Account: 150095602101

Date Range: From 07/01/2014 to 09/30/2014

All Check Types

Sorted by Check Number

Check Number	Date	Payee	Amount	Status	Cleared
19923	08/08/2014	William Stumpf	15.00	Cleared	08/31/2014
19924	08/08/2014	Zachary R Burns	50.00	Outstanding	
19925	08/15/2014	Barbara Powelson	50.00	Cleared	08/31/2014
19926	08/15/2014	Caleb James Brush	110.00	Cleared	08/31/2014
19927	08/15/2014	Christina Taurman	250.00	Cleared	08/31/2014
19928	08/15/2014	City Of Billings-c/o JoLynn Yerger	25.00	Cleared	08/31/2014
19929	08/15/2014	Dept Of Fish, Wildlife & Parks	470.94	Cleared	08/31/2014
19930	08/15/2014	Douglas Owen Morgan J	100.00	Cleared	08/31/2014
19931	08/15/2014	Ervalynn Nomee	50.00	Outstanding	
19932	08/15/2014	James O'Tremba	125.00	Cleared	08/31/2014
19933	08/15/2014	Ladonna Sanderson	25.00	Cleared	08/31/2014
19934	08/15/2014	Lawrence James Bell	20.00	Cleared	08/31/2014
19935	08/15/2014	Les Benner	50.00	Cleared	08/31/2014
19936	08/15/2014	Lester G Roberts	100.00	Outstanding	
19937	08/15/2014	Marcus Pitsch	720.00	Cleared	08/31/2014
19938	08/15/2014	Motel 6	50.00	Cleared	08/31/2014
19939	08/15/2014	Rhonda Roberts	720.00	Cleared	08/31/2014
19940	08/15/2014	Rosalind Brush	25.00	Outstanding	
19941	08/15/2014	Scott Aaron Laber	50.00	Cleared	08/31/2014
19942	08/15/2014	Subrogation Unit	50.00	Cleared	08/31/2014
19943	08/15/2014	Susanne Biglake Hill	50.00	Cleared	08/31/2014
19944	08/15/2014	Tony Perry	442.04	Cleared	08/31/2014
19945	08/15/2014	Victims Crime Comp	954.54	Outstanding	
19946	08/15/2014	Wendi Noelle Largent	100.00	Cleared	08/31/2014
19947	08/15/2014	Zachary Lee	9338.59	Cleared	08/31/2014
19948	08/22/2014	South Forty	25.00	Outstanding	
19949	08/22/2014	State Farm	50.00	Outstanding	
19950	08/22/2014	Allison Roe French	500.00	Outstanding	
19951	08/22/2014	Andrew Cooper	50.00	Outstanding	
19952	08/22/2014	Big Horn Resort	50.00	Cleared	08/31/2014
19953	08/22/2014	Brad Hawley	322.97	Cleared	08/31/2014
19954	08/22/2014	Brandon Dennis Walter	150.00	Outstanding	
19955	08/22/2014	Brenda Hemming Ostermiller	15.00	Outstanding	
19956	08/22/2014	C.jay Deeney	100.00	Cleared	08/31/2014
19957	08/22/2014	Carol Ann Laforge	50.00	Outstanding	
19958	08/22/2014	Cash King Pawn	37.50	Cleared	08/31/2014

Check Register

Bank: US BANK - Account: 150095602101

Date Range: From 07/01/2014 to 09/30/2014

All Check Types

Sorted by Check Number

Check Number	Date	Payee	Amount	Status	Cleared
19959	08/22/2014	City Of Billings-c/o JoLynn Yerger	20.00	Cleared	08/31/2014
19960	08/22/2014	Cold Smoke Tobacco	50.00	Outstanding	
19961	08/22/2014	Crime Victim Compensation Program	25.00	Outstanding	
19962	08/22/2014	Crime Victim Compensation Program	25.00	Outstanding	
19963	08/22/2014	Crime Victim Compensation Program	50.00	Outstanding	
19964	08/22/2014	Curtis William Cortez	195.00	Outstanding	
19965	08/22/2014	Daniel Cox	25.00	Outstanding	
19966	08/22/2014	Dawn Hampton	50.00	Outstanding	
19967	08/22/2014	Debbie Johnerson	835.00	Outstanding	
19968	08/22/2014	First National Pawn	18.75	Cleared	08/31/2014
19969	08/22/2014	First National Pawn	25.00	Cleared	08/31/2014
19970	08/22/2014	Gorden Gildard	50.00	Outstanding	
19971	08/22/2014	Isabella King	110.00	Outstanding	
19972	08/22/2014	Jacob Adkison	250.00	Outstanding	
19973	08/22/2014	Jacob Adkison	545.00	Outstanding	
19974	08/22/2014	Jeannie Boslough	490.00	Cleared	08/31/2014
19975	08/22/2014	Jennifer Jill Vasseur	50.00	Cleared	08/31/2014
19976	08/22/2014	Jennifer Michelle Walker	15.00	Outstanding	
19977	08/22/2014	Joshua Miller	50.00	Outstanding	
19978	08/22/2014	Karen Geraldine Zaso	20.00	Outstanding	
19979	08/22/2014	Karli Lynn Gross	1045.00	Outstanding	
19980	08/22/2014	Kathleen Segmiller	85.00	Cleared	08/31/2014
19981	08/22/2014	Kathy Segmiller	135.00	Cleared	08/31/2014
19982	08/22/2014	Kindra Lloyd	95.00	Outstanding	
19983	08/22/2014	Lake Hills Golf Course	50.00	Outstanding	
19984	08/22/2014	Lawrence James Bell	30.00	Cleared	08/31/2014
19985	08/22/2014	Leonard E Kenney	20.00	Outstanding	
19986	08/22/2014	Mandy Maxwell	50.00	Outstanding	
19987	08/22/2014	Marilyn Lefler	110.00	Outstanding	
19988	08/22/2014	Marina Fitzpatrick	195.00	Cleared	08/31/2014
19989	08/22/2014	Nona Main	50.00	Outstanding	
19990	08/22/2014	Pete Portra	50.00	Cleared	08/31/2014
19991	08/22/2014	Rebecca Phillips	1090.00	Outstanding	
19992	08/22/2014	Robert A Spadt Jr	50.00	Cleared	08/31/2014
19993	08/22/2014	Scott Aaron Laber	25.81	Outstanding	
19994	08/22/2014	Sears	50.00	Outstanding	

Check Register

Bank: US BANK - Account: 150095602101

Date Range: From 07/01/2014 to 09/30/2014

All Check Types

Sorted by Check Number

Check Number	Date	Payee	Amount	Status	Cleared
19995	08/22/2014	Stacie M Warehime	25.00	Outstanding	
19996	08/22/2014	Steven Jens Ladefoged	1310.00	Outstanding	
19997	08/22/2014	Stori Jo Stanaway	15.00	Outstanding	
19998	08/22/2014	Target AP Recovery - (TK-2013-7412)	50.00	Outstanding	
19999	08/22/2014	Thomas Bonogofsky	540.00	Outstanding	
20000	08/22/2014	Tony Perry	265.00	Cleared	08/31/2014
20001	08/22/2014	Wall Mart	42.70	Outstanding	
20002	08/22/2014	Walmart	15.00	Outstanding	
20003	08/22/2014	Walmart	51.00	Outstanding	
20004	08/22/2014	Wayne Bird	2000.00	Outstanding	
20005	08/29/2014	Adam Heimbuck	50.00	Outstanding	
20006	08/29/2014	Beau Taylor Zygmund	605.00	Outstanding	
20007	08/29/2014	Billings Clinic	12.96	Outstanding	
20008	08/29/2014	Billings Parks, Recreation and Land	25.00	Outstanding	
20009	08/29/2014	City Treasurer	130335.72	Outstanding	
20010	08/29/2014	Cordelia Bigman	110.00	Outstanding	
20011	08/29/2014	Crime Victim Compensation Program	100.00	Outstanding	
20012	08/29/2014	Donald Kolstad	1000.00	Outstanding	
20013	08/29/2014	Donna Keller	1000.00	Outstanding	
20014	08/29/2014	Douglas Golden	25.00	Outstanding	
20015	08/29/2014	Duane Youngren	720.00	Outstanding	
20016	08/29/2014	Flori Meyer	15.00	Outstanding	
20017	08/29/2014	Greg & Lani Monical	25.00	Outstanding	
20018	08/29/2014	Greg Gordon	50.00	Outstanding	
20019	08/29/2014	Jared Mcgee	50.00	Outstanding	
20020	08/29/2014	Jason Romell Dix	50.00	Outstanding	
20021	08/29/2014	Jazlyn Schnabl	1960.00	Outstanding	
20022	08/29/2014	Jennifer Baldner	100.00	Outstanding	
20023	08/29/2014	Julie Sullivan	50.00	Outstanding	
20024	08/29/2014	Leanne Yucha	50.00	Outstanding	
20025	08/29/2014	Mary Fisher	1095.00	Outstanding	
20026	08/29/2014	Municipal Services Bureau	7139.86	Outstanding	
20027	08/29/2014	NAPA Distribution Center Attn: Loren Zoë	50.00	Outstanding	
20028	08/29/2014	Platinum Plus Pawn	34.00	Outstanding	
20029	08/29/2014	Rainbow Property Management	11.06	Outstanding	
20030	08/29/2014	Rena Meier	86.70	Outstanding	

Check Register

Bank: US BANK - Account: 150095602101

Date Range: From 07/01/2014 to 09/30/2014

All Check Types

Sorted by Check Number

Check Number	Date	Payee	Amount	Status	Cleared
20031	08/29/2014	Richard Medeiros	250.00	Outstanding	
20032	08/29/2014	Roy D Kessler	50.00	Outstanding	
20033	08/29/2014	Sidney Ayers	50.00	Outstanding	
20034	08/29/2014	Speak Easy Casino	50.00	Outstanding	
20035	08/29/2014	Steven Sullivan	55.00	Outstanding	
20036	08/29/2014	Thomas Bonogofsky	1500.00	Outstanding	
20037	08/29/2014	Trent Fuhrman	40.00	Outstanding	
20038	08/29/2014	Wesley Glen	50.00	Outstanding	
20039	08/29/2014	William James Dodds	15.00	Outstanding	
20040	08/29/2014	William Richard Funk	200.00	Outstanding	
20041	08/29/2014	Yellowstone County Treasurer	10474.56	Outstanding	
20042	09/05/2014	State Farm Insurance	30.94	Outstanding	
20043	09/05/2014	Alexandra Plotner	15.00	Outstanding	
20044	09/05/2014	Ashley Dawn Weis	15.00	Outstanding	
20045	09/05/2014	Assurant Health	55.00	Outstanding	
20046	09/05/2014	Billings Police	19.73	Outstanding	
20047	09/05/2014	Billings Public Schools	100.00	Outstanding	
20048	09/05/2014	Billings School District #2	25.00	Outstanding	
20049	09/05/2014	Brent Sterrett	100.00	Outstanding	
20050	09/05/2014	Cold Smoke Tobacco	57.67	Outstanding	
20051	09/05/2014	Crime Victim Compensation Program	25.00	Outstanding	
20052	09/05/2014	Denny's	25.74	Outstanding	
20053	09/05/2014	Douglas Golden	50.00	Outstanding	
20054	09/05/2014	Edward Eugene Hauber S	105.00	Outstanding	
20055	09/05/2014	Emori Sage Dodson	50.00	Outstanding	
20056	09/05/2014	First Interstate Bank Attn: Brian Brown	25.00	Outstanding	
20057	09/05/2014	Holiday Station	25.01	Outstanding	
20058	09/05/2014	Jacob Brotzler	50.00	Outstanding	
20059	09/05/2014	James Joseph O'tremba	150.00	Outstanding	
20060	09/05/2014	James Novotny	19.06	Outstanding	
20061	09/05/2014	June Ortman	50.00	Outstanding	
20062	09/05/2014	Karen Gossett	706.00	Outstanding	
20063	09/05/2014	Karla Dababneh	156.50	Outstanding	
20064	09/05/2014	Kathy Eder	175.00	Outstanding	
20065	09/05/2014	Kevin Foster	50.00	Outstanding	
20066	09/05/2014	Les Benner	50.00	Outstanding	

Check Register

Bank: US BANK - Account: 150095602101

Date Range: From 07/01/2014 to 09/30/2014

All Check Types

Sorted by Check Number

Check Number	Date	Payee	Amount	Status	Cleared
20067	09/05/2014	Mandi Toews	100.00	Outstanding	
20068	09/05/2014	Mary Valley	50.00	Outstanding	
20069	09/05/2014	Megan Taylor	15.00	Outstanding	
20070	09/05/2014	Memri Spottedelk	50.00	Outstanding	
20071	09/05/2014	Motel 6	50.00	Outstanding	
20072	09/05/2014	Nial Wayne Bretz	195.00	Outstanding	
20073	09/05/2014	Peter Prevost	50.00	Outstanding	
20074	09/05/2014	Reece Kalfell	50.00	Outstanding	
20075	09/05/2014	Richard James Brown	25.00	Outstanding	
20076	09/05/2014	Robert Burton	50.00	Outstanding	
20077	09/05/2014	Scheels	32.00	Outstanding	
20078	09/05/2014	Scheels	50.00	Outstanding	
20079	09/05/2014	Scott Carlson	50.00	Outstanding	
20080	09/05/2014	Sean P Erhard	54.90	Outstanding	
20081	09/05/2014	Shawna Coleman	40.00	Outstanding	
20082	09/05/2014	St. Vincent Healthcare	100.00	Outstanding	
20083	09/05/2014	Steven Ross Johnson	50.00	Outstanding	
20084	09/05/2014	Thomas Paul Kosche	50.00	Outstanding	
20085	09/05/2014	Tim R Howe	60.00	Outstanding	
20086	09/05/2014	Tomas Alexander Delao	15.00	Outstanding	
20087	09/05/2014	Walmart	50.00	Outstanding	
20088	09/05/2014	Westley Fuchs	200.00	Outstanding	
20089	09/09/2014	Erin Fink, JP/City Judge	100.00	Voided	
20090	09/12/2014	Shopko	5.64	Outstanding	
20091	09/12/2014	Walmart	74.96	Outstanding	
20092	09/12/2014	1st National Pawn	60.00	Outstanding	
20093	09/12/2014	Altimus Distributing	100.00	Outstanding	
20094	09/12/2014	Ashley Buyse	1045.00	Outstanding	
20095	09/12/2014	Carrie Forton	103.95	Outstanding	
20096	09/12/2014	City Of Billings - Street/Traffic Dept	50.00	Outstanding	
20097	09/12/2014	Cody Harris	25.00	Outstanding	
20098	09/12/2014	Community Solutions Inc	50.00	Outstanding	
20099	09/12/2014	Crime Victim Compensation Program	100.00	Outstanding	
20100	09/12/2014	Darrel Locken	1000.00	Outstanding	
20101	09/12/2014	David Allen Long	25.00	Outstanding	
20102	09/12/2014	David Corteguera	95.00	Outstanding	

Check Register

Bank: US BANK - Account: 150095602101

Date Range: From 07/01/2014 to 09/30/2014

All Check Types

Sorted by Check Number

Check Number	Date	Payee	Amount	Status	Cleared
20103	09/12/2014	David Corteguera	1065.00	Outstanding	
20104	09/12/2014	Destinee Gondara	50.00	Outstanding	
20105	09/12/2014	Donna Forbes	50.00	Outstanding	
20106	09/12/2014	Donna Huffman	100.00	Outstanding	
20107	09/12/2014	Ervallynn Nomee	50.00	Outstanding	
20108	09/12/2014	First National Pawn	25.00	Outstanding	
20109	09/12/2014	Hartland Realty Investors, Inc.	15.00	Outstanding	
20110	09/12/2014	Jarrett Wanner	50.00	Outstanding	
20111	09/12/2014	John Matthew Krebs	100.00	Outstanding	
20112	09/12/2014	Josh Glen	900.00	Outstanding	
20113	09/12/2014	Kurt Charles Stickney	595.00	Outstanding	
20114	09/12/2014	Kurt Charles Stickney	1000.00	Outstanding	
20115	09/12/2014	Kurt Charles Stickney	2000.00	Outstanding	
20116	09/12/2014	Lawrence James Bell	50.00	Outstanding	
20117	09/12/2014	Li-Ya Huang	750.00	Outstanding	
20118	09/12/2014	Linda Oistad	50.00	Outstanding	
20119	09/12/2014	Lonnie R Peterson	100.00	Outstanding	
20120	09/12/2014	Monica Marie Hauk	10.00	Outstanding	
20121	09/12/2014	Robert Taylor	195.00	Outstanding	
20122	09/12/2014	Sears	39.99	Outstanding	
20123	09/12/2014	Target AP Recovery	50.00	Outstanding	
20124	09/12/2014	Taylor Ita	25.00	Outstanding	
20125	09/12/2014	Timilynn Kisling	720.00	Outstanding	
20126	09/12/2014	Tom Cummings	100.00	Outstanding	
20127	09/12/2014	Walmart	44.97	Outstanding	
20128	09/12/2014	Wei Chen Chuang	750.00	Outstanding	
20129	09/12/2014	Western Pawn	50.00	Outstanding	
20130	09/12/2014	Will Livingston	1045.00	Outstanding	
20131	09/12/2014	Zachary R Burns	200.60	Outstanding	
20132	09/19/2014	State Farm	50.00	Outstanding	
20133	09/19/2014	Target	50.00	Outstanding	
20134	09/19/2014	Adam Barkhuff	195.00	Outstanding	
20135	09/19/2014	Andrew Cooper	25.00	Outstanding	
20136	09/19/2014	Barbara Powelson	50.00	Outstanding	
20137	09/19/2014	Big Horn Resort	50.00	Outstanding	
20138	09/19/2014	Cenex Zip Trip	63.84	Outstanding	

Check Register

Bank: US BANK - Account: 150095602101

Date Range: From 07/01/2014 to 09/30/2014

All Check Types

Sorted by Check Number

Check Number	Date	Payee	Amount	Status	Cleared
20139	09/19/2014	City of Billings	50.00	Outstanding	
20140	09/19/2014	Community Solutions Inc	8.46	Outstanding	
20141	09/19/2014	Community Solutions Inc	50.00	Outstanding	
20142	09/19/2014	Crime Victim Compensation Program	25.00	Outstanding	
20143	09/19/2014	Crime Victim Compensation Program	25.00	Outstanding	
20144	09/19/2014	Crystal Ann McKnight	500.00	Outstanding	
20145	09/19/2014	David Anderson	50.00	Outstanding	
20146	09/19/2014	Donna Kennedy	100.00	Outstanding	
20147	09/19/2014	Dupree Arnell Scott	150.00	Outstanding	
20148	09/19/2014	Ervin Schwiegert	50.00	Outstanding	
20149	09/19/2014	Felicis Caylon	100.00	Outstanding	
20150	09/19/2014	Gina Lynn Kingstad	50.00	Outstanding	
20151	09/19/2014	Gordon Gildroy	50.00	Outstanding	
20152	09/19/2014	Heidi Sikveland	1120.00	Outstanding	
20153	09/19/2014	Jack Ross	50.00	Outstanding	
20154	09/19/2014	Jamie Nixdorf	50.00	Outstanding	
20155	09/19/2014	Jennifer Baldner	100.00	Outstanding	
20156	09/19/2014	Jennifer Jill Vasseur	25.00	Outstanding	
20157	09/19/2014	Karen Geraldine Zaso	20.00	Outstanding	
20158	09/19/2014	Kimberly Kolstad	720.00	Outstanding	
20159	09/19/2014	Ladonna Sanderson	50.00	Outstanding	
20160	09/19/2014	Lorenzo Hernandez	500.00	Outstanding	
20161	09/19/2014	Lorenzo Hernandez	1000.00	Outstanding	
20162	09/19/2014	Mindy Alexis Schamp	5.00	Outstanding	
20163	09/19/2014	Nancy Hodson	50.00	Outstanding	
20164	09/19/2014	Reece Kalfell	50.00	Outstanding	
20165	09/19/2014	Rio Montoya Wofford	110.00	Outstanding	
20166	09/19/2014	Scott Aaron Laber	300.00	Outstanding	
20167	09/19/2014	Stacie M Warehime	25.00	Outstanding	
20168	09/19/2014	Steve Smart	275.00	Outstanding	
20169	09/19/2014	Susanne Biglake Hill	50.00	Outstanding	
20170	09/19/2014	Tanner Schilling	250.00	Outstanding	
20171	09/19/2014	Target AP Recovery - (TK-2013-7412)	50.00	Outstanding	
20172	09/19/2014	Tenille Dahlin	11.54	Outstanding	
20173	09/19/2014	Treasure County Justice Court	100.00	Outstanding	
20174	09/19/2014	Walmart	50.00	Outstanding	

Check Register

Bank: US BANK - Account: 150095602101

Date Range: From 07/01/2014 to 09/30/2014

All Check Types

Sorted by Check Number

Check Number	Date	Payee	Amount	Status	Cleared
20175	09/19/2014	Walmart	50.00	Outstanding	
20176	09/26/2014	South Forty	25.00	Outstanding	
20177	09/26/2014	Target	50.00	Outstanding	
20178	09/26/2014	Andrew Sulser	500.00	Outstanding	
20179	09/26/2014	Billings School District #2	50.00	Outstanding	
20180	09/26/2014	Bryce Lane Saunders	15.00	Outstanding	
20181	09/26/2014	City Of Billings-c/o JoLynn Yerger	20.00	Outstanding	
20182	09/26/2014	Community Crisis Center	120.00	Outstanding	
20183	09/26/2014	Community Solutions Inc	25.00	Outstanding	
20184	09/26/2014	Crime Victim Compensation Program	4.54	Outstanding	
20185	09/26/2014	Daniel S Repka	50.00	Outstanding	
20186	09/26/2014	Dianna Lyne Nuernberger	15.00	Outstanding	
20187	09/26/2014	Douglas Barkemeyer	1045.00	Outstanding	
20188	09/26/2014	Edward R Hawthorne	40.00	Outstanding	
20189	09/26/2014	Emori Sage Dodson	100.00	Outstanding	
20190	09/26/2014	First Interstate Bank Attn: Brian Brown	12.50	Outstanding	
20191	09/26/2014	Frank Rollifson	50.00	Outstanding	
20192	09/26/2014	Greg & Lani Monical	50.00	Outstanding	
20193	09/26/2014	Heather Edwards	500.00	Outstanding	
20194	09/26/2014	Helen Kendall	1000.00	Outstanding	
20195	09/26/2014	Jacob Brotzler	50.00	Outstanding	
20196	09/26/2014	Jason Thomas Hafner	15.00	Outstanding	
20197	09/26/2014	Jeanette Hathaway	1000.00	Outstanding	
20198	09/26/2014	Julie Anna Hrubes	2000.00	Outstanding	
20199	09/26/2014	Julie Allen	59.98	Outstanding	
20200	09/26/2014	Kevin Gillen	183.58	Outstanding	
20201	09/26/2014	Lake Hills Golf Course	25.00	Outstanding	
20202	09/26/2014	Leanne Yucha	50.00	Outstanding	
20203	09/26/2014	Mandy Maxwell	50.00	Outstanding	
20204	09/26/2014	Marie Sharona Sewell	220.00	Outstanding	
20205	09/26/2014	Omar Mohammed Alaquil	275.00	Outstanding	
20206	09/26/2014	Pamela Jean Murray	15.00	Outstanding	
20207	09/26/2014	Paul Rosales	50.00	Outstanding	
20208	09/26/2014	Rayne Dabel	920.02	Outstanding	
20209	09/26/2014	Roy D Kessler	50.00	Outstanding	
20210	09/26/2014	Sidney Ayers	465.00	Outstanding	

Check Register

Bank: US BANK - Account: 150095602101

Date Range: From 07/01/2014 to 09/30/2014

All Check Types

Sorted by Check Number

Check Number	Date	Payee	Amount	Status	Cleared
20211	09/26/2014	Soco Marketing attn: Michelle Stocktin	50.00	Outstanding	
20212	09/26/2014	Step Inc	40.00	Outstanding	
20213	09/26/2014	TJ Yzaguirre	50.00	Outstanding	
20214	09/26/2014	Tawnya Lee Hamlin	275.00	Outstanding	
20215	09/26/2014	Treatment Court	25.00	Outstanding	
20216	09/26/2014	Wall Mart	25.00	Outstanding	

Number checks: 546

Total

439656.39

Regular City Council Meeting

Meeting Date: 10/27/2014

TITLE: Zone Change 926- Public Hearing and 1st reading

PRESENTED BY: Candi Millar, Planning & Community Services Department Director

Department: Planning & Community Services

PROBLEM/ISSUE STATEMENT

The City Council initiated this map amendment and zone change at the request of the property owner to correct an error made in 1972 when the City undertook a city-wide re-zoning program. The property is currently zoned Residential 9,600 (R-96) but previously was zoned R-3-R, a zone analogous to the current Residential 6,000 (R-60) zoning district. The Council proposal is to change the zoning to R-60. The legal description of the property is Lots 21-24, Block 12, College Subdivision 3rd Filing. The property is a 14,000 square foot parcel of land. The property is owned by Vaughn and Marla Rohrdanz. The Zoning Commission is recommending approval and adoption of the findings of the 10 criteria on a 5-0 vote.

ALTERNATIVES ANALYZED

State law at Section 76-2-304, MCA, requires that all zone changes be reviewed in accordance with 10 criteria. Using the 10 criteria to determine the appropriateness of the zone change request, the City Council may:

1. Approve the zone change request
2. Deny the zone change request
3. Allow withdrawal of the application
4. Delay action for up to thirty (30) days

FINANCIAL IMPACT

If the zone change is approved, the taxable value of the property will be stabilized by assuring continued property maintenance and improvements. The new zoning will increase the city fees assessed based on zoning (arterial construction and storm water).

BACKGROUND

In 1970, Mr. Rohrdanz received a zone change for the property to R-3-R - a designation that allowed multi-family dwellings. In 1970-1971, Mr. Rohrdanz had a 6-unit multifamily dwelling constructed on the property in conformance with the R-3-R zoning in place. In May 1972, soon after the apartment building was completed, the City changed all the existing zoning districts within the city limits. This neighborhood was changed to Residential 9,600 - a single family zoning district. This city-wide re-zoning resulted in non-conforming use status for Mr. Rohrdanz property. This allows the use to continue but since multi-family uses are no longer allowed, the property could not be re-built in the event it was destroyed. Mr. Rohrdanz was unaware of the city-wide zoning change in 1972 and did not know the zone change he received in 1970 was no longer valid for this property.

Mr. Rohrdanz visited with the Planning staff in July and August of this year to discuss options for either re-zoning the property or obtaining a variance from the current zoning regulations. Use variances are not allowed under local code and state law so the only option to correct the zoning for the property is to re-zone. Mr. Rohrdanz contacted Council Ward IV representatives Jani McCall and Al Swanson to inquire whether the Council would initiate a corrective zone change for the property. Council member Jani McCall informed the Council of the situation at a work session in August 2014, and the Council subsequently initiated the map amendment and zone change on September 22, 2014.

The Planning staff reviewed the zone change and the surrounding neighborhood for nonconforming uses such as two-family dwellings or multi-family dwellings. Most of College Subdivision was developed prior to the 1972 city-wide re-zoning that adopted R-96 as the zoning for this area. The College Subdivision consists of three filings that developed in 1945 and 1946. Many homes were built with "in-law" living quarters in the basement or developed with a front house and rear house to accommodate relatives. The post-war housing demand saw this type of development throughout the city. Planning staff reviewed Department of Revenue records and City records to determine the average conformance with R-96 zoning in the neighborhood. Approximately 30 percent of the homes in the 3 ½ blocks on the west end of College Subdivision do not conform to the single-family only zoning. This is a high percentage of non conformance. There may be additional nonconforming two-family dwellings in the area. Most of these nonconforming properties contain dwelling units for two families on a "single-family" only lot. Two properties, the subject property and property at 1229 Poly Drive, have multi-family dwellings.

The property to the north is a two-family dwelling on a lot of 3,500 square feet. The lot to the south had two single family dwellings on a lot of 10,500 square feet (1 was destroyed by fire and demolished by the City in 2010). The lot to the south is under new ownership and may request a lot area variance to re-establish 2 single family dwellings. The City Board of Adjustment (BOA) has issued several lot area variances in the College Subdivision to allow single family dwelling units to continue or to be re-built on lots less than required by the current zoning. The BOA cannot issue variances for two-family attached dwelling units since this is not allowed in the R-96 zoning district.

STAKEHOLDERS

The Zoning Commission conducted a public hearing on October 7, 2014, and received the staff recommendation. No other persons provided testimony. Member Barbara Hawkins made a motion to recommend approval and adoption of the findings of the 10 criteria for Zone Change 926. The motion was seconded by Dan Wagner. The motion was approved on a 5-0 vote.

CONSISTENCY WITH ADOPTED POLICIES OR PLANS

The Planning Division reviewed this application and recommended approval to the Zoning Commission based on the ten (10) criteria for zone changes. The subject property is adjacent to a minor arterial street and has been an established part of the neighborhood fabric for more than 40 years. The property is currently well-maintained and fits with the variety of housing types available in the College Subdivision. The proposed zoning, R-60, will allow the use to become a conforming use so it will continue to be part of the neighborhood now and in the future. Any re-development of the property requires compliance with the new zoning and the ability to meet site development requirements and traffic safety standards. The 2008 Growth Policy encourages predictable land use decisions that are consistent with neighborhood character and land use patterns. The existing use and proposed zoning are consistent with this neighborhood and land use pattern.

Prior to any decision on the zone change by the City Council, it shall consider the findings of the following 10 criteria:

1. Is the new zoning designed in accordance with the Growth Policy?

The proposed zone change is consistent with the following goals of the Growth Policy:

- *Predictable land use decisions that are consistent with neighborhood character and land use patterns. (Land Use Element Goal, page 6)* The proposed zoning would permit the existing multi-family apartment to continue in conformity with the zoning. The development has fit in well with the existing neighborhood for more than 40 years, continued investment in the property will preserve the neighborhood integrity. The proposed zoning, R-60, is consistent with the neighborhood character and land use patterns between 13th Street West and Wisconsin Street to the east.
- *More housing and business choices with each neighborhood. (Land Use Element Goal, page 6)* The existing zoning is restricted to single-family only residential uses. The proposed zoning will allow the retention of the apartments on 13th Street West. This will allow the housing choice in this neighborhood to remain diverse.

2. Is the new zoning designed to secure from fire and other dangers?

The new zoning requires minimum setbacks, open and landscaped areas and building separations. The new zoning, as do all zoning districts, provides adequate building separations and density limits to provide security from fire and other dangers.

3. Whether the new zoning will promote public health, public safety and general welfare?

Public health, safety and general welfare will be promoted by the proposed zoning. The nonconforming zoning discourages investment in the property.

4. Will the new zoning will facilitate the adequate provision of transportation, water, sewerage, schools, parks and other public requirement?

Transportation: The proposed zoning should have no impact on transportation.

Water and Sewer: The City provides water and sewer services to the property.

Schools and Parks: There should not be any impact to schools from the proposed zone change.

Fire and Police: The subject property is currently served by the city Public Safety Services.

5. *Will the new zoning provide adequate light and air?*

The proposed zoning provides for sufficient setbacks to allow for adequate separation between structures and adequate light and air.

6. *Will the new zoning effect motorized and non-motorized transportation?*

Traffic generation from the apartments will not change since the maximum number of units on the lot has existed since 1971.

7. *Will the new zoning will promote compatible urban growth?*

The new zoning does promote compatibility with urban growth. The new zoning will allow investment in the property increasing property value over time.

8. *Does the new zoning consider the character of the district and the peculiar suitability of the property for particular uses?*

The proposed zoning does consider the character of district and the suitability of the property

for multi-family uses. The location of the property on a minor arterial street at an intersection makes it suitable for this use.

9. *Will the new zoning conserve the value of buildings?*

The existing multi-family apartment value will be conserved by the new zoning.

10. *Will the new zoning encourage the most appropriate use of land throughout the City of Billings?*

The proposed zoning will permit an existing housing type in the neighborhood to continue and is the most appropriate use of the property.

RECOMMENDATION

The Zoning Commission recommends approval and adoption of the findings of the 10 criteria for Zone Change 926 on a 5-0 vote.

APPROVED BY CITY ADMINISTRATOR

[Zoning Map](#)

[Site photos](#)

[Zone Change documents 1970 1971](#)

[Ordinance](#)

Attachment A: Surrounding Zoning
Zone Change #926 – 2707 13th St West

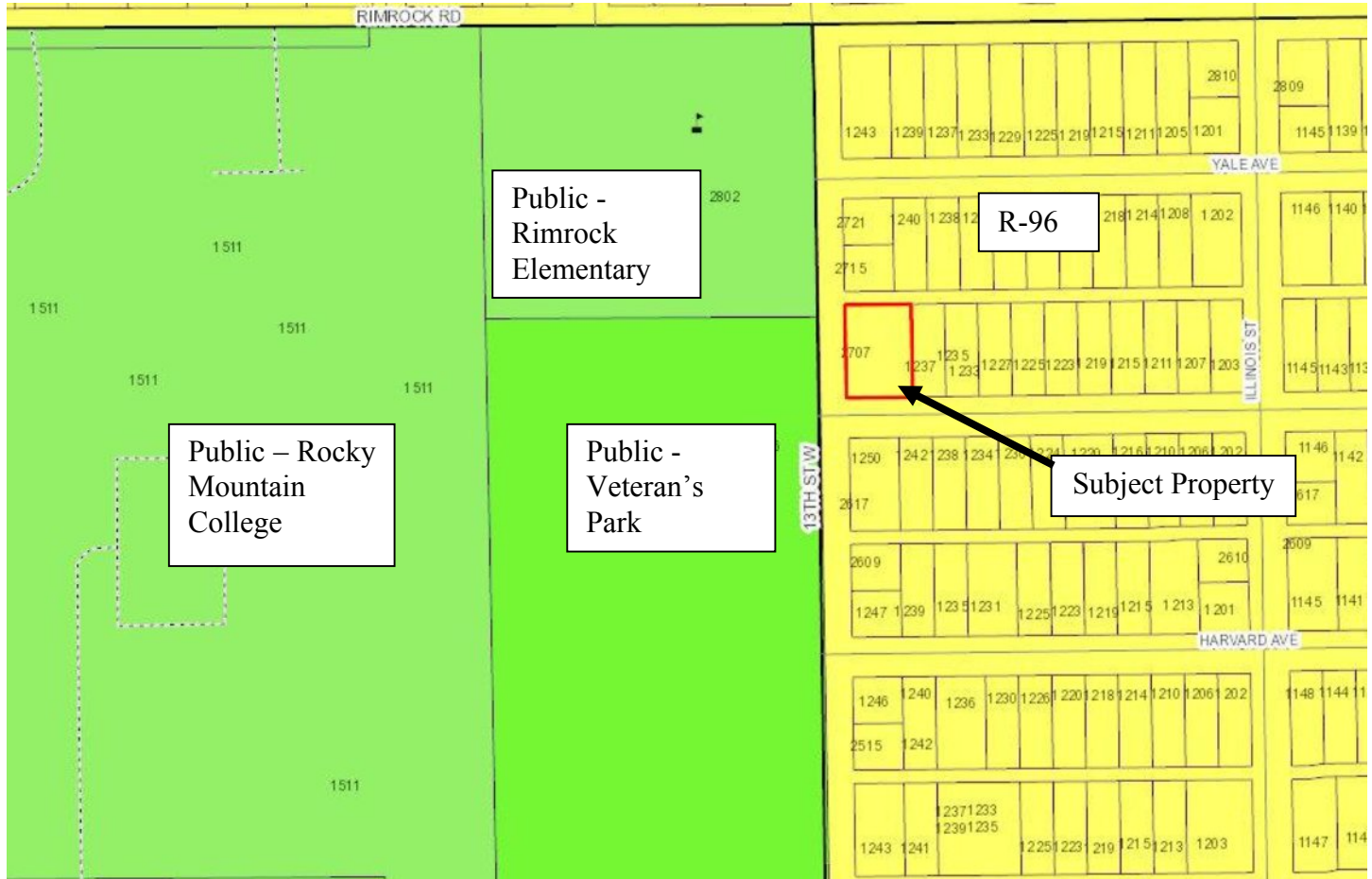

Attachment B
Site Photographs, Zone Change #926 – 2707 13th St West



Subject Property



Aerial Map

Attachment B, continued
Site Photographs, Zone Change #926 – 2707 13th St West



View to the east across 13th Street West – Subject Property



View north across Princeton Avenue

Attachment B, continued
Site Photographs, Zone Change #926 – 2707 13th St West



View of covered parking access from alley north of apartment building



View north of subject property along 13th St West

Attachment C

1971 City Code and related documents – 2707 13th St West (aka 1247 Princeton Avenue)

All bids other than by or on behalf of the State Board of Land Commissioners of the State of Montana must be accompanied by a certified check in the sum of \$2,780.00 payable to the Clerk and Recorder of Yellowstone County, Montana, which will be forfeited by the successful bidder, in the event he shall fail or refuse to complete the purchase of said bonds in accordance with the terms of his bid. Checks of unsuccessful bidders shall be returned promptly.

All bids shall be addressed to the Board of County Commissioners of Yellowstone County, Montana, and delivered to the Clerk and Recorder of said County.

Dated this 28th day of July, 1970.

E. F. CARLSON
Chairman of the Board of County Commissioners of Yellowstone County, Montana.

Attest:

MERRILL H. KLUNDT
Clerk and Recorder of Yellowstone County, Montana, and Ex-officio Clerk of the Board of County Commissioners of said County.

Hendrickson & Bishop
320 Hart-Albin Building
Billings, Montana
Attorneys for the District
(July 30; Aug. 6, 13, 20, 1970)

NOTICE OF TIME SET FOR HEARING PETITION FOR CHANGE OF NAME No. 56082

In the District Court of the Thirteenth Judicial District of the State of Montana, in and for the County of Yellowstone.

In the Matter of the Application of Tina Cherriese Brown, a Minor, for Change of Name.

Notice Is Hereby Given, That a Petition for Change of Name of Tina Cherriese Brown to Tina Cherriese White, has been filed in this Court; and that the 21st day of August, 1970, at 10:00 o'clock a.m., in the Courtroom in the Courthouse in Billings, Yellowstone County, Montana, has been set as the time and place of hearing of said Petition, and that at such time an application will be made for the relief sought in the said petition.

Dated this 27th day of July, 1970. (Seal)

HARDIN E. TODD

Clerk

By: DOROTHY OLSON

Deputy Clerk

(July 30; Aug. 6, 13, 20, 1970)

Whereas hereby given that the Zoning Commission of the City of Billings, Montana, has filed with the City Council of said City its report recommending:

1. That the petition to change the zone classification of Lots 1, 2, and the north 10 feet of 3, Block 15, Central Heights Sub., from Multiple Residential (R-3) to Commercial Limited be held for further study. This property is located on 24th Street West just south of Eldorado Drive.
2. That the petition to change the zone classification of Lot 1 and the east 15 feet of Lot 2, Block 1, Grand Vista Sub., from Commercial Limited Zone (C-L) to Commercial General zone (C-G) be deferred to next regular meeting because of lack of quorum voting. This property is located at 2101 Grand Avenue.
3. That the petition to change the zone classification of Tract 13 C, Lot 13, Flanagan Sub. Amended, from Residential One Family (R-1) to Multiple Residential (R-3) be denied. The Commission further recommends the City Council to initiate a zone change for the whole area to Commercial General. This property is located on both sides of Pricket Lane south of Central Ave.
4. That the request to construct two multiple apartment buildings on lots 21, 22, 23 and 24, Blk. 12, College Sub., be granted to the extent that they will not exceed 6 units total and contingent on the City Council passing of the proposed ordinance establishing a Multiple Family Restrictive (R-3-R) zone. This property is located at 1247 Princeton Ave.
5. That the request for 4 more units making a total of 12 units be denied. However, the Commission did agree that 4 of the 8 units approved July 28, 1969, could be located on the new proposed site. This property is located at 1006 Poly Drive.

The City Council has designated August 24, 1970, at 7:30 p.m., in the City Council Chambers of the City Hall, Billings, Montana, as the time and place for hearing the report of the Zoning Commission. All persons for or against such proposed recommendations may appear and be heard.

Dated this 6th day of August, 1970.

WM. J. FRY, JR.

City Clerk

(Aug. 6, 20, 1970)

The Billings Times 5

Thursday, August 6, 1970

City Council
Minutes from Aug. 24, 1970

4369

(c) That the request to construction 2 multiple apartment buildings on Lots 21, 22, 23 and 24, Block 12, College Sub. be granted to the extent that they will not exceed 6 units total and contingent on the City Council passing of the proposed ordinance establishing a multiple family restrictive "R-3-R" zone. This property is located at 1247 Princeton Ave. Moved by alderman Leuthold, seconded by alderman Yates that the recommendation be approved. Motion carried.

(d) That the request for 4 more units making a total of 12 units be denied. However, the Commission did agree that 4 of the 8 units approved July 28, 1969 could be located on the new proposed site. This property is located at 1006 Poly Drive. Moved by alderman Leuthold, seconded by alderman Baker that the recommendation be approved for the new location. Motion carried.

PETITION to transfer business license for the Lobby Cafe from Isabelle McFarren to Ernest E. Clark. This petition having been approved by the City Treasurer, Police Department, Building Department, Health Department and Fire Department, it was moved by alderman Glenn, seconded by alderman Yates that the petition to transfer the license be approved. Motion carried.

DEPARTMENTAL CHARGES for the month of August were presented for approval. Moved by alderman Glenn, seconded by alderman Baker that the charges be approved. Motion passed on roll call.

PROPOSED AMENDMENT TO JOB CLASSIFICATION ORDINANCE was presented. This was referred by the Mayor to the Budget & Finance Committee.

ANNUAL APPROPRIATION ORDINANCE NO. 3483 for the City of Billings was presented for consideration of the Council. Moved by alderman Smith, seconded by alderman Todd adoption of the Ordinance. Passed on roll call.

RESOLUTION Proposing to extend the boundaries of the city to include Tract 1A, 1B, and the south 10 Ft. of Lot 5, all of Lots 6 and 7, Thomas Subdivision, was presented. This was referred by the Mayor to the Planning & Improvements Committee.

SURETY BONDS having been approved as to form by the City Attorney were presented for approval as follows: United Electric Co., electrical bond, \$5,000, written by the General Insurance Co. of America. Treasure State Plumbing & Heating, Sewer Bond, \$ 3,000, written by the Firemen's Fund Insurance Co. Quality Concrete Co., \$ 2,000, excavation bond, written by the U. S. Fidelity & Guaranty Co. APCOA Division, ITT Consumer Services Corp., \$ 4800.00 Performance Bond, written by the American Insurance Co. Moved by alderman Glenn, seconded by alderman Jovanovich that the bonds be accepted and placed on file. Motion carried.

The Clerk presented items that did not appear on the Agenda. Moved by alderman Smith that these items be considered individually.

REQUEST OF CHIEF OF POLICE to place Francis Maler on the inactive Police Reserve List with a medical retirement, effective September 1, 1970. Moved by alderman Baker, seconded by alderman Leuthold that this item receive unanimous consent for consideration. Motion carried. Moved by alderman Baker, seconded by alderman Riedl that the request be granted. Motion carried.

VARIOUS CLAIMS were presented. Moved by alderman Smith, seconded by alderman Baker that these claims receive unanimous consent for consideration. Motion carried.

COP Construction Co., Estimate # 5 and final, Airport April Improvements, \$ 9,997.29
Montana State Board of Equalization, Airport Construction, Estimate No. 4, \$ 100.98
Barry O'Leary, Inc., Sprinkling Fund, \$ 38,990.44
State Board of Equalization, Sprinkling Fund, \$ 393.84
Long Construction Co., 1971 Curb-Gutter warrants, \$ 6,340.75

Moved by alderman Smith, seconded by alderman Glenn that the claims be allowed and paid. Passed on roll call.

COMMITTEE REPORT, GROUP INSURANCE The Committee requests additional time to study the bids. Moved by alderman Smith, seconded by alderman Glenn approval of the Committee report. Motion carried.

ZONING

City Code 1971

Title 26

ZONING¹

Chapters:

- 26.04 Short Title and Interpretation
- 26.08 Definitions
- 26.12 District Designation and Boundaries
- 26.16 RR Residential-Rural District Regulations
- 26.18 RS Residential-Suburban District Regulations
- 26.20 RST Residential-Suburban-Trailer District Regulations
- 26.22 R1 Residential One-Family District Regulations
- 26.24 R1R Residential One-Family Restricted District Regulations
- 26.26 R2 Residential Two-Family District Regulations
- 26.27 R3R Multiple-Family Restricted-Regulations
- 26.28 R3 Residential Multiple-Family District Regulations
- 26.30 RP Residential-Professional District Regulations
- 26.31 Parking Restrictions in Residential Districts
- 26.32 NCL Neighborhood Commercial Limited District Regulations
- 26.36 CL Commercial-Limited District Regulations
- 26.38 CC Commercial-Central District Regulations
- 26.40 CG Commercial-General District Regulations
- 26.42 CH Commercial Highway District Regulations
- 26.46 M1 Light Industrial District Regulations
- 26.48 M2 Heavy Industrial District Regulations
- 26.52 General Use, Area and Yard Provisions
- 26.56 Exceptions to Height Area, and Yard Provisions
- 26.60 Nonconforming Uses
- 26.64 Conditional Uses
- 26.68 Administration and Enforcement
- 26.72 Amendments and Changes In Districts
- 26.76 Zoning Commission and Board of Adjustment

1. For state law authorizing the enactment of zoning regulations see R.C.M. 1947, §§ 11-2701 – 11-2709.

For state law empowering a city to regulate and restrict the use of land, see R.C.M. 1929, § 11-2701.

RESIDENTIAL MULTIPLE FAMILY RESTRICTED 26.26.050–26.27.010

26.26.050 Side yard. Side yard requirements shall be the same as “R.R.” zoning district. (Ord. 3177 § 6 (part), 1965; Ord. 3000 § 9 (part), 1963; Ord. 2677 Art. 10 (part), 1959).

26.26.060 Rear yard. There shall be a rear yard of not less than twenty feet in depth, except where a house is built at the rear of a corner lot. (Ord. 2713 § 2, 1960; Ord. 2677 Art. 10 (part), 1959).

26.26.070 Lot area. Every lot shall have a minimum average width of sixty feet and a minimum area of seven thousand square feet. The minimum lot area per dwelling unit shall be three thousand five hundred square feet.

Provided, that where a lot has a width of less than sixty feet or an area of less than seven thousand square feet and was held under separate ownership or was of record at the time this title chapter became effective, such lot may be occupied by any use permitted in this chapter. In no case, however, shall a two family dwelling have a lot area of less than three thousand square feet per dwelling unit. (Ord. 2677 Art. 9 (part), 1959).

26.26.080 Percentage of lot coverage. All buildings including accessory buildings shall not cover more than forty percent of the area of the lot. (Ord. 2713 § 2, 1960; Ord. 2677 Art. 10 (part), 1959).

Chapter 26.27

R3R RESIDENTIAL MULTIPLE FAMILY

RESTRICTED – REGULATIONS

Sections:

- 26.27.010 Uses permitted.
- 26.27.020 Height.
- 26.27.030 Area.
- 26.27.040 Front yard.
- 26.27.050 Side yard.
- 26.27.060 Rear yard.
- 26.27.070 Lot area.
- 26.27.080 Percentage of lot coverage.
- 26.27.090 Off-street parking.

26.27.010 Uses permitted. No building, structure or land shall be hereafter used and no building or structure shall be hereafter erected, structurally altered, or enlarged except for the following uses:

- (1) Any uses permitted in “R-2” residential two family district;
- (2) Multiple dwellings not to exceed six units, or two stories in height;
- (3) Signs and nameplates, same as “R-1” zoning district. (Ord. 3478 § 4 (part), 1970).

26.27.020–26.27.090 ZONING

26.27.020 Height. No building or structure nor the enlargement of any building or structure shall be hereafter erected to exceed two stories or twenty-five feet above the average grade. (Ord. 3478 § 4 (part), 1970).

26.27.030 Area. No building or structure nor the enlargement of any building or structure shall be hereafter erected unless the following yards and lot areas are provided and maintained in connection with such building, structure, or enlargement. (Ord. 3478 § 4 (part), 1970).

26.27.040 Front yard. There shall be a front yard of not less than twenty feet. Provided, however, that where lots comprising forty percent or more of the frontage (excluding key and reversed corner lots) between intersecting streets, are developed with buildings having front yards with a variation of not more than six feet in depth, the average of such front yard shall establish the front yard depth; buildings located entirely on the rear one-half of a lot shall not be counted. (Ord. 3478 § 4 (part), 1970).

26.27.050 Side yard. Except as provided in Chapters 26.52 and 26.56 every portion of the basic structure of a main building shall have a side yard of not less than five feet or one-third of the height of such portion, whichever is greater. A side yard abutting upon a side street shall be not less than ten feet. (See Section 26.52.150 for garages.) (Ord. 3478 § 4 (part), 1970).

26.27.060 Rear yard. There shall be a rear yard of not less than twenty feet for interior lots nor fifteen feet for corner lots. (Ord. 3478 § 4 (part), 1970).

26.27.070 Lot area. Every lot shall have a minimum average width of sixty feet and minimum area of seven thousand square feet. Provided, that where a lot has a width of less than sixty feet or an area of less than seven thousand square feet and was held under separate ownership or was of record at the time the ordinance codified in this chapter became effective, such lot may be occupied by any use permitted in this chapter. In no case, however, shall more than two dwelling units be permitted where such lot has an area of less than four thousand four hundred square feet. (Ord. 3478 § 4 (part), 1970).

26.27.080 Percentage of lot coverage. All buildings including accessory buildings shall not cover more than fifty-five percent of the area of the lot. (Ord. 3478 § 4 (part), 1970).

26.27.090 Off-street parking. Off-street parking regulations are as provided in Chapter 26.52.050. (Ord. 3478 § 4 (part), 1970).

ORDINANCE NO. 14-_____

AN ORDINANCE AMENDING THE ZONE CLASSIFICATION FOR Lots 21-24, Block 12, College Subdivision, 3rd Filing, a 14,000 square foot parcel of land, generally located at 2707 13th Street West

BE IT ORDAINED BY THE CITY COUNCIL OF THE CITY OF BILLINGS, MONTANA:

1. RECITALS. *Title 76, Chapter 2, Part 3, MCA, and Sections 27-302 and 27-1502, BMCC,* provide for amendment to the City Zoning Map from time to time. The City Zoning Commission and staff have reviewed the proposed zoning for the real property hereinafter described. The Zoning Commission and staff have considered the ten (10) criteria required by Title 76, Chapter 2, Part 3, MCA. The recommendations of the Zoning Commission and staff have been submitted to the City Council, and the City Council, in due deliberation, has considered the ten (10) criteria required by state law.
2. DESCRIPTION That Lots 21-24, Block 12, College Subdivision, 3rd Filing, a 14,000 square foot parcel of land, generally located at 2707 13th Street West is presently zoned **Residential 9,600 (R-96)** and is shown on the official zoning maps within these zones.
3. ZONE AMENDMENT. The official zoning map is hereby amended and the zoning for **the above described parcel** is hereby changed from **Residential 9,600 (R-96) to Residential 6,000 (R-60)** and from the effective date of this ordinance, shall be subject to all the rules and regulations pertaining to **Residential 6,000 (R-60)** as set out in the Billings, Montana City Code.
4. REPEALER. All ordinances or parts of ordinances in conflict herewith are hereby repealed.
5. EFFECTIVE DATE. This ordinance shall be effective from and after final passage and as provided by law.

PASSED by the City Council on first reading October 27, 2014.

PASSED, ADOPTED AND APPROVED on second reading November 10, 2014.

CITY OF BILLINGS:

BY: _____
Thomas W. Hanel, Mayor

ATTEST:

BY: Cari Martin, City Clerk
Zone Change #926 – 2707 13th Street West

Regular City Council Meeting

Meeting Date: 10/27/2014

TITLE: Public Hearing and Resolution for FY15 First Quarter Budget Amendments

PRESENTED BY: Patrick M. Weber, Finance Director

Department: City Hall Administration

PROBLEM/ISSUE STATEMENT

Public Hearing and Resolution for FY15 First Quarter Budget Amendments:

Fund 6200-Information Technology

Information Technology is requesting a budget amendment for the Capital fund to support the purchase of software, licenses, and tapes necessary to support a new data backup and disaster/recovery solution. In an age where anything and everything is stored electronically, routine data backups and disaster/recovery solutions are mission critical and a top priority for IT. Through an unfortunate series of events, IT lost confidence in our current solution. Reserves will be used to fund this amendment.

Funds 0100-14-Non-Departmental, 2740-CDBG

Community Development did not budget enough for rent to be paid by the General Fund which will make the total 48,127. Reserves will be used to fund this amendment.

[2740-67800-405310](#) 14,127 Rent

[2740-67800-307515](#) 14,127 Transfer from General Fund

[0100-14120-408264](#) 14,127 Transfer to CDBG

ALTERNATIVES ANALYZED

The Council may: Approve the requested budget amendments; or Not approve the requested budget amendments, which would put the City in violation of Montana Code Annotated.

FINANCIAL IMPACT

The requested budget amendments will be funded by current reserves.

RECOMMENDATION

Staff recommends that the City Council conduct a public hearing and approve the resolution approving and adopting the first quarter budget amendments for Fiscal Year 2014/2015.

APPROVED BY CITY ADMINISTRATOR

Resolution

Exhibit

RESOLUTION 14-

A RESOLUTION TO MAKE **FISCAL YEAR 2014/2015** ADJUSTMENTS TO APPROPRIATIONS PURSUANT TO M.C.A. 7-6-4006 AS AMENDED, AND PROVIDING TRANSFERS AND REVISIONS WITHIN THE GENERAL CLASS OF SALARIES AND WAGES, MAINTENANCE AND SUPPORT AND CAPITAL OUTLAY.

WHEREAS, M.C.A. 7-6-4006 provides that the City Council, upon proper resolution, adopted by said Council at a regular meeting and entered into its Minutes, may transfer or revise appropriations within the general class of salaries and wages, maintenance and support, and capital outlay, and

WHEREAS, based upon a Budget Review (**FY 2014/2015**), it is necessary to alter and change said appropriations.

NOW, THEREFORE, BE IT RESOLVED BY THE CITY COUNCIL OF THE CITY OF BILLINGS, MONTANA:

That the attached transfers or revisions are hereby adopted.

(SEE EXHIBIT A)

PASSED AND APPROVED by the City Council, this 27th day of October, 2014.

THE CITY OF BILLINGS:

BY: _____
Thomas W. Hanel, MAYOR

ATTEST:

BY: _____
Cari Martin, CITY CLERK

EXHIBIT A

Revenue Expenditure

Fund 6200-Information Technology

Information Technology is requesting a budget amendment for our Capital fund to support the purchase of software, licenses, and tapes necessary to support a new data backup and disaster/recovery solution. In an age where anything and everything is stored electronically, routine data backups and disaster/recovery solutions are mission critical and a top priority for IT. Through an unfortunate series of events, we lost total confidence in our current solution. Reserves will be used to fund this amendment.

6200-19120-409480	44,000	Capital
-------------------	--------	---------

Funds 0100-14-Non-Departmental, 2740-CDBG

Community Development did not budget enough for rent to be paid by the General Fund which will make the total 48,127. Reserves will be used to fund this amendment.

2740-67800-405310		14,127	Rent
2740-67800-307515	14,127		Transfer from General Fund
0100-14120-408264		14,127	Transfer to CDBG