

CITY OF BILLINGS

CITY OF BILLINGS VISION STATEMENT:

“THE MAGIC CITY: A DIVERSE, WELCOMING COMMUNITY WHERE PEOPLE PROSPER AND BUSINESS SUCCEEDS.”

AGENDA

COUNCIL CHAMBERS

April 11, 2016

6:30 P.M.

CALL TO ORDER: Mayor Hanel

PLEDGE OF ALLEGIANCE: Mayor Hanel

INVOCATION: Councilmember Sullivan

ROLL CALL: Councilmembers present on roll call were:

MINUTES: March 28, 2016

COURTESIES:

PROCLAMATIONS: National Service Recognition Day; Crime Victims' Rights Week; Telecommunicators' Week

ADMINISTRATOR REPORTS - TINA VOLEK

PUBLIC COMMENT on “NON-PUBLIC HEARING” Agenda Items: #1 ONLY. Speaker sign-in required. (Comments offered here are limited to one (1) minute for one item, or three (3) minutes for multiple items. Please sign in at the cart located at the back of the council chambers or at the podium. Comment on items listed as public hearing items will be heard ONLY during the designated public hearing time for each respective item. For Items not on this agenda, public comment will be taken at the end of the agenda.)

1. **CONSENT AGENDA** -- Separations:

A. **Bid Awards:**

1. **W.O. 16-04 2016 ADA Ramp Replacement Project.** (Opened 3/29/2016)
Recommend J&J Concrete, Inc., \$212,900.
 2. **W.O. 16-07 Interstate 90 Water Main Crossing Project.** (Opened 03/29/2016)
Recommend delay of award until April 25, 2016.
- B. Professional Services Contract** for 2016 Integrated Water Plan; HDR Engineering, Inc.; \$507,000.
- C. Acknowledging Receipt of Petition to Annex # 16-03:** a 4 acre portion of an 89 acre parcel described as the N1/2NE1/4, SWNE1/4, Section 31, Township 1 North, Range 25 East, generally located south of Rimrock Road at the southwest corner of the intersection of 54th Street West and Trail Creek Drive; Yellowstone Meadows Partners, LLC, petitioner; and setting a public hearing date for May 9, 2016.
- D. Confirmation of Probationary Police Officers** - Michael Beechie, Jairo Solorio, and Chad Wildin.
- E. Acceptance of Warranty Deed** for a street tract for Grand Avenue and 56th Street West from School District #2.
- F. Acceptance of Donation** to the Parks, Recreation and Public Lands Department from Bright n' Beautiful for tree purchasing and planting at Lillis and Descro Parks; \$5,000.
- G. Acceptance of Donation** to the Parks, Recreation and Public Lands Department from Bright n' Beautiful for Amend Park Community Garden Greenhouse; \$5,000.
- H. Revolving Loan Fund** to Singh Contracting, \$110,000.
- I. Approval** of Tax Increment Financing Assistance from East Billings Urban Renewal District Tax Increment Funds to Eggart Enterprises, LLC for new concrete sidewalks and approaches, landscaping, and public utilities at 1711 6th Avenue North; \$49,000.
- J. Approval** of Tax Increment Financing Assistance from East Billings Urban Renewal District Tax Increment Funds to North Park Properties for demolishing a structure at 504 N. 20th Street; \$7,200.
- K. Approval** of the purchase of a new wireless managed solution from High Point Networks and Extreme Wireless, \$75,342.

- L. **Law Enforcement Officer Reimbursement Agreement #HSTS02-16-H-SLR604** with Transportation Security Administration accepting partial reimbursement, including the accompanying Statement of Joint Objectives.
- M. **Resolution** authorizing application for Land Water Conservation Funding (LWCF) to improve Hawthorne Park Playground.
- N. **Final Plat** of Moody Subdivision, 2nd filing.
- O. **Resolution** adopting Montana Municipal Records Retention Schedule 8 and Schedule 10.
- P. **Bills and Payroll:**
 - 1. March 14, 2016
 - 2. March 21, 2016

REGULAR AGENDA:

- 2. **PUBLIC HEARING AND RESOLUTION** approving FY2017-FY2021 Capital Improvement Plan (CIP), FY2017 Equipment Replacement Plan (ERP) and FY2017 Technology Replacement Plan (TRP). Staff recommends approval. (Action: approval or disapproval of staff recommendation.)
- 3. **PUBLIC HEARING AND RESOLUTION** creating SILMD 322, Orchard Lane street lights. Staff recommends approval. (Action: approval or disapproval of staff recommendation.)

PUBLIC COMMENT on Non-Agenda Items -- Speaker Sign-in required. *(Restricted to ONLY items not on this printed agenda. Comments here are limited to 3 minutes. Please sign in at the cart located at the back of the council chambers or at the podium.)*

COUNCIL INITIATIVES

ADJOURN

Additional information on any of these items is available in the City Clerk's Office. Reasonable accommodations will be made to enable individuals with disabilities to attend this meeting. Please notify Billie Guenther, City Clerk, at 657-8210.

Regular City Council Meeting

Meeting Date: 04/11/2016

TITLE: Bid Award: W.O. 16-04; 2015 ADA Ramp Replacement Project

PRESENTED BY: David Mumford, Public Works Director

Department: Public Works

PROBLEM/ISSUE STATEMENT

W.O. 16-04, 2016 ADA Ramp Replacement Project, is a project consisting of Americans with Disabilities Act (ADA) accessible ramp construction on the street corners where the City will soon be completing pavement overlays and chip seals and on other corners at various locations throughout Billings.

The annual ramp construction project is in accordance with the City’s agreement with the Department of Justice to install/upgrade ramps along streets constructed or reconstructed after 1992 and in specific areas identified by need. A portion of the ramps will be constructed within the South Side Triangle due to property owner requests and ahead of the 2017 chip seal. The other miscellaneous ramp locations were selected based upon neighborhood requests.

The project was advertised on March 17th and March 24th in the Billings Times and on the City's Website. Bids were opened on March 29, 2016 and three bids were received. J&J Concrete, Inc. submitted the lowest responsible bid.

ALTERNATIVES ANALYZED

The Council may:

- Award Work Order 16-04, 2016 ADA Ramp Replacement Project to J&J Concrete, Inc. in the amount of \$212,900; or
- Do not award Work Order 16-04. If not awarded, the City would need to re-bid or cancel the project and construct the ramps in a subsequent year.

FINANCIAL IMPACT

The following bids were received and evaluated:

Contractor	Total Bid
J&J Concrete, Inc.	\$212,900
CMG Construction	\$235,532
EHC, LLC	\$299,236

The funding for this project is included in the approved budget for fiscal year 2016. Gas Tax funds will be used for this project.

Budget	\$250,000
Previously Encumbered	\$0
This contract	\$212,900

Remaining Budget

\$37,100

RECOMMENDATION

Staff recommends that Council award W.O. 16-04, 2016 ADA Ramp Replacement Project to J&J Concrete, Inc. in the amount of \$212,900.

APPROVED BY CITY ADMINISTRATOR

Regular City Council Meeting

Meeting Date: 04/11/2016

TITLE: W.O. 16-07, Interstate 90 Water Main Crossing Project

PRESENTED BY: David Mumford, Public Works Director

Department: Public Works

PROBLEM/ISSUE STATEMENT

W.O. 16-07, Interstate 90 Water Main Crossing Project, will install approximately 3,000 lineal feet of 24-inch diameter trunk water main from the intersection of Gabel Road and South 24th Street West to the intersection of Elysian Road and East Lane. Bid options include installing a casing pipe by either the jack and bore or the directional drilling method for crossing under Hogan Slough, MRL railroad tracks, Interstate 90 and the South Frontage Road. Alternates for different casing and carrier pipe materials are also bid options.

After being advertised in the Billings Times and on the City website March 10, 17 and 24, staff opened bids on March 29. Staff recommends that City Council delay awarding a contract until the April 25 meeting date in order to give staff additional time to review the bids.

ALTERNATIVES ANALYZED

There is no viable alternative to delaying the contract award. Staff is not prepared to make its award recommendation and needs more time to evaluate bids for this complex project. State law requires the Council to take action on bids at the first meeting following the bid opening and delaying the award until the following meeting meets that requirement.

FINANCIAL IMPACT

Funding for this water main extension project has been approved by City Council in the Capital Improvement Program (CIP). Funding is sufficient for the engineering design and construction administration portion of the project as well as for project construction. The project will use water funds.

	Water Main Extension
Project Budget	\$1,900,000
Previously Encumbered	\$349,620
This Contract	to be determined
Budget Remaining	to be determined

RECOMMENDATION

Staff recommends that the City Council delay awarding a contract for the Interstate 90 water main crossing project until the April 25 meeting in order to give staff additional time to review the bids.

APPROVED BY CITY ADMINISTRATOR

Regular City Council Meeting

Meeting Date: 04/11/2016

TITLE: 2016 Integrated Water Plan - Contract for Professional Engineering Services

PRESENTED BY: David Mumford, Public Works Director

Department: Public Works

PROBLEM/ISSUE STATEMENT

This Council memorandum and contract is a follow-up to the Council work session held on March 21, 2016. In October, 2009, Council approved a professional services contract with HDR Engineering, Inc. to begin preparing an integrated water plan (IWP) for the City of Billings. The result of that contract was the development of six alternate strategies for the plan that explored water conservation issues, water reuse opportunities, identified resource efficiencies, incorporated environmental protection elements, and provided continual learning opportunities and best practices models. Following the public participation portion of this planning process, staff selected a preferred alternate consisting of a hybrid mixture of three of the original strategies. This was the goal of the original contract for the Integrated Water Plan and it was completed by the City in 2011 (IWP2011).

Staff desired to wait until this time for the 2016 Integrated Water Plan Contract to proceed with the next phase of the IWP because it will use the growth projections recently completed by the Planning Department. In addition, staff was waiting for closure from the Montana Department of Environmental Quality regarding the nutrient standards and the subsequent requirements. The final product of the contract referenced in this memorandum will provide a clear and detailed action plan, in essence a business plan for the next 20 years for the City regarding water. This business plan will be used to define water resource CIP projects and their timing that will support the overall goals and objectives of the City and focus on an integrated approach to the City's water-related needs and operations. The timing of this contract and work product is critical considering the water rights limitations facing the City in the future. In addition, this plan will define a water conservation program plan and will also address the vulnerability of the single point source of water currently in use.

ALTERNATIVES ANALYZED

The City Council may:

Approve this contract for the Integrated Water Use Plan Contract for Professional Engineering Services; or

Not approve this contract. If not approved, the direction and results from the original contract for the integrated water plan will not move forward.

FINANCIAL IMPACT

Funding for this amendment is included in the FY 2016 Capital Improvement Plan (CIP) approved by Council on March 23, 2015 for the project titled "Integrated Water Plan and New Water Treatment Plant Land Analysis" for \$1,000,000. This funding is also included in the approved FY 2016 budget for the Public Works Department. The total cost for this project is \$507,000 that includes approximately \$307,000 for preliminary engineering and \$200,000 for site evaluations.

RECOMMENDATION

Staff recommends that the City Council approve this contract for the 2016 Integrated Water Plan Contract for Professional Engineering Services with HDR Engineering, Inc. for \$507,000.

APPROVED BY CITY ADMINISTRATOR

Attachments

IWP Contract

Contract for Professional Architectural and Engineering Services

City of Billings W.O. _____ – Integrated Water Plan II

In consideration of the mutual promises herein, City of Billings and HDR Engineering, Inc. agree as follows. This Contract consists of:

Part I, consisting of 15 Sections of Special Provisions;

Part II, consisting of 11 Sections of General Provisions;

Appendix A consisting of 14 pages (Basic Services of Consultant);

Appendix B consisting of 2 pages (Methods and Times of Payment);

Appendix C consisting of 1 pages (Additional Services of Consultant);

Appendix D consisting of 1 pages (Schedule of Professional Fees);

Appendix E consisting of 1 pages (Project Schedule);

Appendix F consisting of 2 pages (Certificate(s) of Insurance); and

PART I SPECIAL PROVISIONS

Section 1. Definitions.

In this Contract:

- A. "Administrator" means the Public Works Director or his/her designee.
- B. "Billings" means the City of Billings.
- C. "Engineer" and/or "Contractor" means HDR Engineering, Inc.

Section 2. Scope of Services.

- A. The Contractor shall perform professional services in accordance with Appendix A, which is attached hereto and incorporated in this Section by reference.
- B. Billings shall pay the Contractor in accordance with Section 4.
- C. Billings shall not allow any claim for services other than those described in this Section. However, the Contractor may provide, at its own expense, any other services that are consistent with this Contract.
- D. The Contractor shall provide a minimum of ten (10) copies of the Integrated Water Plan II report and two (2) CD's containing the document in PDF format to the Administrator within 30 days after the project completion date. Final payment will be withheld until the documents are received by the City of Billings.

Section 3. Time for Performance.

- A. This Contract becomes effective when signed on behalf of Billings.
- B. The Contractor shall commence performance of the Work described in Section 2 on receipt of written Notice to Proceed and complete that performance in accordance with the schedule set forth in Appendix E.
- C. This Contract shall terminate at midnight on December 31, 2017.

Section 4. Compensation; Method of Payment.

- A. Subject to the Contractor's satisfactory performance, Billings shall pay the Contractor no more than Five Hundred and Seven Thousand and no/100 dollars (\$507,000.00) in accordance with this Section and Appendix B.
- B. Each month, or at the conclusion of each phase of the Work for which payment is due, as negotiated on a per-task basis, the Contractor shall present a bill to the Administrator describing the Work for which it seeks payment and documenting expenses and fees to the satisfaction of the Administrator. If any payment is withheld because the Contractor's performance is unsatisfactory, the Administrator must, within ten (10) days of the payment denial, notify the Contractor of the payment denial and set forth, with reasonable specificity, what was unsatisfactory and why. Billings will pay the Contractor for all services provided not under dispute in the invoice. Billings will pay Contractor within 30 days of receiving an acceptable invoice.
- C. The Contractor is not entitled to any compensation under this Contract, other than is expressly provided for in this Section.
- D. As a condition of payment, the Contractor shall have paid all City taxes currently due and owing by the Contractor.

Section 5. Termination of the Contractor's Services.

The Contractor's services under Section 2 of this Part may be terminated:

- A. By mutual consent of the parties.
- B. For the convenience of Billings, provided that Billings notifies the Contractor in writing of its intent to terminate under this paragraph at least 10 days prior to the effective date of the termination.
- C. For cause, by either party where the other party fails in any material way to perform its obligations under this Contract. Termination under this Subsection is subject to the condition that the terminating party notifies the other party of its intent to terminate, stating with reasonable specificity the grounds therefor, and the other party fails to cure the default within 30 days after receiving the notice.

Section 6. Duties Upon Termination

- A. If Billings terminates the Contractor's services for convenience, Billings shall pay the Contractor for its actual costs reasonably incurred in performing before termination and Billings shall pay for services rendered prior to termination. Payment under this Subsection shall never exceed the total compensation allowable under Section 4 of this Part. All finished and unfinished documents and materials prepared by the Contractor shall become the property of Billings.

- B. If the Contractor's services are terminated for cause, Billings shall pay the Contractor the reasonable value of the services satisfactorily rendered prior to termination, less any damages suffered by Billings because of the Contractor's failure to perform satisfactorily. The reasonable value of the services rendered shall never exceed ninety percent (90%) of the total compensation allowable under Section 4 of this Part. Any finished or unfinished documents or materials prepared by the Contractor under this Contract shall become the property of Billings at its option.
- C. If the Contractor receives payments exceeding the amount to which it is entitled under Subsections A or B of this Section, he shall remit the excess to the Administrator within 30 days of receiving notice to do so.
- D. The Contractor shall not be entitled to any compensation under this Section until the Contractor has delivered to the Administrator all documents, records, Work product, materials and equipment owned by Billings and any deliverables prepared by the Engineer as defined in the Scope of Services and requested by the Administrator.
- E. If the Contractor's services are terminated for whatever reason the Contractor shall not claim any compensation under this Contract, other than that allowed under this Section.
- F. If a final audit has not been performed before the Contractor's services are terminated, Billings may recover any payments for costs disallowed as a result of the final audit.
- G. Except as provided in this Section, termination of the Contractor's services under Section 5 of this Part does not affect any other right or obligation of a party under this Contract.

Section 7. Insurance.

- A. The Contractor shall maintain in good standing the insurance described in Subsection B of this Section. Before rendering any services under this Contract, the Contractor shall furnish the Administrator with proof of insurance in accordance with Subsection B of this Section.
- B. The Contractor shall provide the following insurance:
 - 1. Workers' compensation and employer's liability coverage as required by Montana law.
 - 2. Commercial general liability, including contractual and personal injury coverage's -- \$1,500,000 per occurrence.
 - 3. Commercial automobile liability -- \$1,500,000 per accident.
 - 4. Professional liability in the amount of \$1,500,000 per claim.
- C. Each policy of insurance required by this Section shall provide for no less than 30 days' advance notice to Billings prior to cancellation.
- D. Billings SHALL be listed as an additional insured on all policies except Professional Liability and Worker's Compensation Policies. In addition, all policies except Professional Liability and Worker's Compensation shall contain a waiver of subrogation against Billings.

Section 8. Assignments.

Unless otherwise allowed by this Contract or in writing by the Administrator, any assignment by the Contractor of its interest in any part of this Contract or any delegation of duties under this Contract shall be void, and an attempt by the Contractor to assign any part of its interest or delegate duties under this Contract shall give Billings the right immediately to terminate this Contract without any liability for Work performed.

Section 9. Ownership; Publication, Reproduction and Use of Material.

- A. Except as otherwise provided herein, all data, documents and materials produced by the Contractor under this Contract shall be the property of Billings, which shall retain the non-exclusive right to publish, disclose, distribute and otherwise use, in whole or in part, any such data, documents, or other materials. Exclusive rights shall not be attributed to portions of such materials presently in the public domain or which are not subject to copyright. Contractor shall retain rights to pre-existing proprietary property including but not limited to interactive models. The Contractor shall have the right to include photographic or artistic representations of the design and construction of the Project among the Contractor's promotional and professional materials. The Contractor's materials shall not include Billings' confidential or proprietary information regardless of whether Billings has previously advised the Contractor in writing of the specific information considered by Billings to be confidential and proprietary.
- B. Equipment purchased by the Contractor with Contract funds: See Appendix A, Section 3. Scope of Work.
- C. Should Billings elect to reuse Deliverables provided under this Contract for other than the original project and/or purpose, Billings will indemnify and hold harmless the Contractor from any and all claims, demands and causes of action of any kind or character arising as a result of reusing the deliverables developed under this contract. Additionally, any reuse of design drawings or specifications provided under this Contract must be limited to conceptual or preliminary use for adaptation, and the original Contractor's or subcontractor's signature, professional seals and dates removed. Such reuse of drawings and specifications, which require professional seals and dates removed, will be signed, sealed, and dated by the professional who is in direct supervisory control and responsible for adaptation.

Section 10. Notices.

Any notice required pertaining to the subject matter of this Contract shall be either sent via facsimile (FAX), e-mail, or mailed by prepaid first class registered or certified mail, return receipt requested to the following addresses:

Billings: David Mumford
City of Billings
Public Works Engineering
2224 Montana Avenue
Billings, Montana 59101

e-mail: MumfordD@ci.billings.mt.us
FAX: (406) 237-6291

Contractor: Craig Caprara
HDR Engineering, Inc

700 SW Higgins Ave., Suite 200
Missoula, MT 59803

e-mail: craig.caprara@hdrinc.com
FAX: (406) 532-2205

Notices are effective upon the earlier of receipt, proof of good transmission (facsimiles only), or 5 days after proof of proper posting.

Section 11. Contract Budget.

In connection with its performance under this Contract, the Contractor shall not make expenditures other than as provided in line items in the Contract budget.

Section 12. Force Majeure.

- A. Any failure to perform by either party due to force majeure shall not be deemed a violation or breach hereof.
- B. As used in this Contract, force majeure is an act or event of substantial magnitude, beyond the control of the delayed party, which delays the completion of this Contract, including without limitation:
 - 1. Any interruption, suspension or interference resulting solely from the act of Billings or neglect of Billings not otherwise governed by the terms of this Contract.
 - 2. Strikes or Work stoppages.
 - 3. Any interruption, suspension or interference with the project caused by acts of God, or acts of a public enemy, wars, blockades, insurrections, riots, arrests or restraints of governments and people, civil disturbances or similar occurrences.
 - 4. Order of court, administrative agencies or governmental officers other than Billings.

Section 13. Financial Management System.

The Contractor shall establish and maintain a financial management system that:

- A. Provides accurate, current, and complete disclosure of all financial transactions relating to the Contract;
- B. Maintains separate accounts by source of funds for all revenues and expenditures and identifies the source and application of funds for the Contractor's performance under this Contract, including information pertaining to subcontracts, obligations, unobligated balances, assets, liabilities, outlays and income;
- C. Effectively controls and accounts for all municipal funds and Contract property;
- D. Compares actual expenditures with budgeted amounts and relates financial information to performance or productivity data including unit cost information where applicable;
- E. Allocates administrative costs to direct service delivery units;
- F. Minimizes the time between receipt of funds from Billings and their disbursement by the Contractor;
- G. Provides accounting records supported by source documentation; and
- H. Provides a systematic method assuring the timely and appropriate resolution of audit findings and recommendations.

Section 14. Funding Requirements.

In the event that any funding source for this Contract should impose additional requirements upon Billings for the use of those funds, the Contractor agrees to abide by those additional requirements immediately upon receipt of written notice thereof from Billings.

Section 15. Subcontracts.

The Contractor may enter into subcontracts for professional services necessary for the performance of this Contract, provided:

- A. Every subcontract shall be reduced to writing and contain a precise description of the services to be provided and the nature of the consideration paid therefor.
- B. Every subcontract under which the Contractor delegates the provision of services shall be subject to review and approval by the Administrator before it is executed by the Contractor.
- C. Every subcontract in an amount exceeding \$1,000 shall require reasonable access to business records of the subcontractor relating to the purchase of goods or services pursuant to the subcontract.

PART II GENERAL CONTRACT PROVISIONS

Section 1. Relationship of Parties.

The Contractor shall perform its obligations hereunder as an independent Contractor of Billings. Billings may administer the Contract and monitor the Contractor's compliance with its obligations hereunder. Billings shall not supervise or direct the Contractor other than as provided in this Section.

Section 2. Nondiscrimination.

- A. The Contractor will not discriminate against any employee or applicant for employment because of race, color, religion, national origin, ancestry, age, sex, or marital status or who is a "qualified individual with a disability" (as that phrase is defined in the Americans With Disabilities Act of 1990). The Contractor will take affirmative action to ensure that applicants are employed and that employees are treated during employment without regard to their race, color, religion, or mental or physical impairment/disability. Such action shall include, without limitation, employment, upgrading, demotion or transfer, recruitment or recruiting advertising, layoff or termination, rates of pay or other forms of compensation, and selection for training including apprenticeship. The Contractor agrees to post, in conspicuous places available to employees and applicants for employment, notices setting forth the provisions of this non-discrimination clause.
- B. The Contractor shall state, in all solicitations or advertisements for employees to Work on Contract jobs, that all qualified applicants will receive equal consideration for employment without regard to race, color, religion, national origin, ancestry, age, sex or marital status, or mental or physical impairment/disability.
- C. The Contractor shall comply with any and all reporting requirements that may apply to it which the City of Billings may establish by regulation.
- D. The Contractor shall include the provisions of Subsections A through C of this Section in every subcontract or purchase order under this Contract, so as to be binding upon every such subcontractor or vendor of the Contractor under this Contract.
- E. The Contractor shall comply with all applicable federal, state, and city laws concerning the prohibition of discrimination.

Section 3. Permits, Laws, and Taxes.

The Contractor shall acquire and maintain in good standing all permits, licenses and other entitlements necessary to its performance under this Contract. All actions taken by the Contractor under this Contract shall comply with all current and applicable statutes, ordinances, rules and regulations at the time of the execution of the Contract. The Contractor shall pay all taxes pertaining to its performance under this Contract.

Section 4. Nonwaiver.

The failure of either party at any time to enforce a provision of this Contract shall in no way constitute a waiver of the provision, nor in any way affect the validity of this Contract or any part hereof, or the right of such party thereafter to enforce each and every provision hereof.

Section 5. Amendment.

- A. This Contract shall only be amended, modified or changed in writing, executed by authorized representatives of the parties, with the same formality as this Contract was executed.
- B. For the purposes of any amendment modification or change to the terms and conditions of this Contract, the only authorized representatives of the parties are:

Contractor: Area Manager
(title of position)

Billings: City Council or Authorized Designee

- C. Any attempt to amend, modify, or change this Contract by either an unauthorized representative or unauthorized means shall be void.

Section 6. Jurisdiction; Choice of Law.

Any civil action rising from this Contract shall be brought in the District Court for the Thirteenth Judicial District of the State of Montana, Billings. The law of the State of Montana shall govern the rights and obligations of the parties under this Contract.

Section 7. Severability.

Any provision of this Contract decreed invalid by a court of competent jurisdiction shall not invalidate the remaining provisions of the Contract.

Section 8. Integration.

This instrument and all appendices and amendments hereto embody the entire agreement of the parties. There are no promises, terms, conditions or obligations other than those contained herein; and this Contract shall supersede all previous communications, representations or agreements, either oral or written, between the parties hereto.

Section 9. Liability.

The Contractor shall indemnify, defend, save, and hold Billings harmless from any and all claims, causes of action, lawsuits, damages, judgments, liabilities, and litigation costs and expenses including reasonable attorneys' fees and costs, arising from any wrongful or negligent act, error or omission of the Contractor or any agent, employee or subcontractor as a result of the Contractor's or any subcontractor's performance pursuant to this Contract.

- A. The Contractor shall not indemnify, defend, save and hold Billings harmless from claims, causes of action, lawsuits, damages, judgments, liabilities, and litigation costs and expenses or attorneys' fees and costs to the extent arising from wrongful or negligent acts, error or omission solely of Billings occurring during the course of or as a result of the performance of the Contract.
- B. Where claims, lawsuits or liability, including attorneys' fees and costs to the extent arise from wrongful or negligent act of both Billings and the Contractor, the Contractor shall indemnify, defend, save, and hold Billings harmless from only that portion of claims, causes of action, lawsuits, damages, judgments, liabilities, and litigation costs and expenses including attorneys' fees and costs, which to the extent result from the Contractor's or any subcontractor's wrongful or negligent acts occurring as a result from the Contractor's performance pursuant to this Contract.

Billings shall indemnify, defend, save, and hold the Engineer harmless from any and all claims, causes of action, lawsuits, damages, judgments, liabilities, and litigation costs and expenses including reasonable attorneys' fees and costs, arising from any wrongful or negligent act, error or omission of Billings or any agent, employee or subcontractor as a result of Billings' or any subcontractor's performance pursuant to this Contract.

- A. Billings shall not indemnify, defend, save and hold the Engineer harmless from claims, causes of action, lawsuits, damages, judgments, liabilities, and litigation costs and expenses or attorneys' fees and costs arising from wrongful or negligent acts, error or omission solely of the Engineer occurring during the course of or as a result of the performance of the Contract.
- B. Where claims, lawsuits or liability, including attorneys' fees and costs arise from wrongful or negligent act of both Billings and the Engineer, Billings shall indemnify, defend, save, and hold the Engineer harmless from only that portion of claims, causes of action, lawsuits, damages, judgments, liabilities, and litigation costs and expenses including attorneys' fees and costs, which result from Billings' or any subcontractor's wrongful or negligent acts occurring as a result from Billings' performance pursuant to this Contract.

Section 10. Inspection and Retention of Records.

The Contractor shall, at any time during normal business hours and as often as Billings may deem necessary, make available to Billings, for examination, all of its records with respect to all matters covered by this Contract for a period ending three years after the date the Contractor is to complete performance in accordance with Section 2 of the Special Provisions. Upon request, and within a reasonable time, the Contractor shall submit such other information and reports relating to its activities under this Contract, to Billings, in such form and at such times as Billings may reasonably require. The Contractor shall permit Billings to audit, examine and make copies of such records, and to make audits of all invoices, materials, payrolls, records of personnel, and other data relating to all matters covered by this Contract. Billings may, at its option, permit the Contractor to submit its records to Billings in lieu of the retention requirements of this Section.

Section 11. Availability of Funds.

Payments under this Contract may require funds from future appropriations. If sufficient funds are not appropriated for payments required under this Contract, this Contract shall terminate without penalty to Billings; and Billings shall not be obligated to make payments under this Contract beyond those which have previously been appropriated.

IN WITNESS WHEREOF, the parties have executed this Contract on the date and at the place shown below.

City of Billings

Contractor

THOMAS W. HANEL, Mayor

HDR Engineering, Inc.

Date: _____

Name: _____

ATTEST:

Title: _____

Date: _____

City Clerk

IRS Tax ID # 47-0680568

Date: _____

APPROVED AS TO FORM:

By _____
BRENT BROOKS, City Attorney

Date: _____

STATE OF MONTANA)
)
) :ss.
COUNTY OF _____)

On this _____ day of _____, 2016, before me, the undersigned, a Notary Public for the State of Montana, personally appeared _____, known to me to be the _____ of _____, and acknowledged to me that they executed the foregoing instrument on behalf of said corporation having first been authorized to do so.

IN WITNESS WHEREOF, I have hereunto set my hand and affixed my Notarial Seal the day and year first above written.

Notary Public for the State of Montana
Residing at _____, Montana
My Commission Expires: _____

Note: Final contract documents will require the Contractor's signature to be notarized.

Appendix A
Basic Services of Engineer
City of Billings – Integrated Water Plan II

Section 1. Engineer's Rights and Duties.

- A. To furnish all labor, materials, equipment, supplies, and incidentals necessary to conduct and complete the Engineer's portion of the project as defined in the scope of work and to prepare and deliver to Billings all plans, specifications, bid documents, and other material as designated herein.
- B. Ascertain such information as may have a bearing on the work from local units of government, utility companies, and private organizations and shall be authorized to procure information from other authorities besides Billings, but shall keep Billings advised as to the extent of these contacts and the results thereof.
- C. Prepare and present such information as may be pertinent and necessary in order for Billings to pass critical judgment on the features of the work. The Engineer shall make changes, amendments or revisions in the detail of the work as may be required by Billings. When alternates are being considered, Billings shall have the right of selection.
- D. Engineer's work shall be in accordance with the standards of sound engineering and present City, State, and National standards and policies currently in use.
- E. Conform to the requirements of the Montana Code Annotated Title 18 "Public Contracts" and more particularly Sections 18-2-121 and 18-2-122, and all other codes of the State of Montana applicable to providing professional services including codes and standards nationally recognized.
- F. The Engineer shall certify with the submission of final plans that the plans are in conformance with applicable sections of Title 69, Chapter 4, Part 5, of the Montana Code Annotated as pertaining to existing utilities.
- G. To perform professional services in connection with the project and will serve as Billings' representative in those phases of the project to which this agreement applies.
- H. Where Federal funds are involved, the necessary provisions to meet all requirements will be complied with and documents secured and placed in the bidding documents.
- I. Submit an estimated progress schedule as to time and costs at the beginning of the work, and monthly progress reports thereafter until complete. The reports will include any problems, potential problems, and delays as foreseen by the Engineer. Reports will be submitted in a timely manner to permit prompt resolution of problems.

- J. Contract administration duties will include review of contractor certified payrolls for wage rate compliance. Discrepancies in certified payrolls will be resolved with the Contractor. A signed Engineer's Payroll Check Sheet (included in the Standard Modifications to MPWSS) will be submitted as proof of this review with one copy of each payroll.
- K. Name a Task Director who shall be the liaison between Billings and the Engineer. For this project the Task Director designated for the Engineer is Craig Caprara working under the Principal-in-Charge, Amanda McInnis.

Section 2. Billings Rights and Duties.

- A. To furnish all labor, materials, equipment, supplies, and incidentals necessary to conduct and complete Billings' portion of the project as designated in the scope of work.
- B. Name a Task Director who shall be the liaison between the Engineer and Billings. For this project, the Task Director designated is Craig Caprara, working under the Public Works Director David Mumford.

Section 3. Scope of Work.

PHASE 1

TASK 100 – BASIS OF PLAN

Objective:

This Integrated Water Plan Supplement (IWPS) is intended to update the Integrated Water Plan completed by the City of Billings (City) in 2011 (IWP2011) and incorporate pertinent findings from the IWP follow-up studies and the Drinking Source Water Study to form an all encompassing document relevant to long-term planning of the City's water resources. It is intended to ultimately provide a series of actions, programs, and projects that the City can implement that will support the overall goals and objectives toward an integrated approach to the City's water-related operations. An overarching objective of the IWPS and the IWP2011 is assessing future drinking water, wastewater, and storm water challenges and opportunities while balancing consideration of economic, environmental, risk, and societal factors.

The scope of work under this Agreement is divided into Phase 1 and Phase 2 as follows:

Phase 1: Includes Tasks 100 through 700.

Phase 2: Includes Task 800 with initiation of this task at the direction of the City.

Task 900, Additional Services, is not part of this Agreement. Work under this task is to be authorized by subsequent amendment or modification to this Agreement.

The scope of work is summarized below:

Subtask 101 – Develop Goals/Drivers/Approach

The work effort to-date includes:

- Developed a history and background of past efforts, status of the IWP, and development of the City's mission and values associated with the IWP.
- HDR senior planning staff met with City staff to assist in developing IWPS approach.

This information is compiled in the Introduction to the IWPS, which will be included in the final IWPS report. The City has reviewed and generally concurred with the draft Introduction.

Additional work effort anticipated includes:

- Further refinement of these factors once various options are better developed with the areas to be addressed to include, but not be limited to:
 - Water rights
 - Impact of Numeric Nutrient Standards/TMDL on wastewater and storm water
 - Limitations of new wastewater discharge for additional treatment facilities
 - Future wastewater demands and treatment/infrastructure requirements for an estimated service population potentially reaching 200,000 to 260,000 (20 year projection)
 - Increased potable water infrastructure needs to accommodate projected growth, such as transmission capacity to Heights, additional reservoir needs and other areas that may be identified
 - Wastewater collection system capacity limitations, primarily interceptors entering the existing Wastewater Reclamation Facility (WRF)
 - Develop draft goals/drivers for IWPS based on discussions with city staff, including past correspondence.
- Goals will include consideration of:
 - Potable water system and reduction of demands through other means, such as conservation and alternative water sources
 - Consideration of need for West-End WTP
 - Alternative source of raw water for potable water supply, such as groundwater
 - Off-channel storage of raw water or treated wastewater for use in potable water system or alternative non-potable water source
 - Wastewater system and redirection of effluent through reuse
 - Satellite wastewater treatment/reuse/disposal
 - Sources of alternative water, such as ditches, groundwater, storm water, and wastewater effluent
 - More direct reuse options, such as internal plumbing and direct potable reuse (DPR)
 - Service area, based primarily on the City's adopted annexation map

This task also includes the following:

- One on-site meeting with HDR project staff and senior HDR planning staff to discuss the IWPS program elements and approach, and
- One on-site meeting with stakeholders

Subtask 102 – Develop Evaluation Criteria

Evaluation criteria were identified in the development of the IWP2011 and will be reviewed for applicability to the various options identified in the IWPS.

Additional work effort anticipated includes:

- Review, modify, and incorporate IWP2011 criteria as deemed appropriate into the IWPS and develop additional draft criteria for evaluating various options to be identified in IWPS. It is anticipated that criteria will include, but not be limited to:
 - City priorities, such as customer benefits, alternative water sources, supply resiliency/risk, conservation, voluntary vs. mandatory practices, alternative use volumes, user rates, and water rights impact.

Subtask 103 – Confirm Goals/Drivers/Criteria

Meet with city staff/stakeholders to discuss and confirm goals and drivers and evaluation criteria. This task also includes one on-site meeting with HDR project staff.

Task 200 – EVALUATE WATER/WASTEWATER DEMANDS

Objective:

Determine present and projected demands and rate of growth (1.5%, 2%, and 3% annually) as the basis for establishing the time available for the implementation of identified alternatives.

Subtask 201 – Evaluate Water/Wastewater Demands

The work effort to-date includes:

- Reviewing near-term historic maximum day and per capita potable water demand along with demand projections at the various rates of growth mentioned above.
- Evaluation of residential and selected commercial customer demands have been reviewed to determine the potential peak demand reduction by replacement with alternate sources of water.
- Various aspects of ditch water, groundwater, and reclaimed wastewater to reduce peak water demands have been reviewed as alternative sources of irrigation water.
- The October 2011 Water Conservation Plan developed for the City has been reviewed for current relevancy and incorporation into the IWPS.
- The Water Reclamation Facility (WRF) design flows have been compared to and reasonably reconciled with the flow projections developed in the Integrated Water Plan Implementation, Wastewater Collection System Study conducted by Dowl HKM.

Additional work effort anticipated includes:

- Determine service areas as they relate to satellite facilities and resulting water/wastewater demands. In addition, determine the capacity of the existing water treatment plant (WTP) to assess when it will reach capacity and the modifications and cost to upgrade its capacity.
 - Potable water demands - It is anticipated that the City will provide the potable water demands by pressure zone from the Integrated Water Plan Distribution Study water study conducted by Morrison-Maierle. It is anticipated that this will include the regional population projections as well as projections by pressure zone. Update demand projections to reflect a 1.5%, 2%, and 3% growth rate.
 - Wastewater demands – It is anticipated that the information from the Integrated Water Plan Wastewater Collection System Study conducted by Dowl HKM will be used for overall demands. In addition, these overall demands will be broken down

into the subareas within the service area as identified in the Dowl HKM study to provide a basis for evaluating various wastewater reuse alternatives, potential wastewater satellite plant siting and feasibility and interceptor capacity. Update demand projections to reflect a 1.5%, 2%, and 3% growth rate.

It is anticipated that a range of demands (high/low) will be developed as a basis for developing an adaptive management plan approach. In addition and as a comparison, a single growth rate within this range will be used to develop a non-adaptive plan.

Subtask 202 – Evaluate Impact of Demands on Water Rights

The work effort to-date includes:

- Reviewing and updating the water rights discussion included in the 2006 Water and Wastewater Facilities Master Plan (Master Plan) conducted by HDR Engineering.

Additional work effort anticipated includes:

- Determine the impact of the varying growth rates on the longevity of the City's apparent water rights of 172 cubic feet per second (cfs). It is anticipated that the evaluation will be conducted with and without demand reductions potentially achieved through alternative means. The evaluation will be based on the City's latest water rights settlement agreement and water rights information available through the DNRC website. The evaluation will also reflect the City's water reservation, which is to be reviewed by DNRC by July 1, 2016.

Subtask 203 – Evaluate Capacity of Water System to Deliver more Treated Water to the West-End and Heights from Existing WTP

The 2006 Master Plan evaluated the requirements for the existing WTP to treat 80 mgd. The evaluation was based on expanding the Filter Building. For the IWPS, the evaluation will be based on not expanding the Filter Building or High Service Pump Station (HSPS).

The work effort to-date includes:

- Evaluation of the distribution system to deliver more treated water without any additional major transmission mains.
- Evaluation of the capacity of the existing WTP without expanding the Filter Building or HSPS.
- Providing rough cost estimate for WTP expansion requirements.

Additional work effort anticipated includes:

- Use existing water distribution system model to determine maximum capacity of the water system to deliver water primarily to the West-End and Heights through Zone 2 and Zone 2E directly from HSPS and from Zone 1. It is anticipated that Morrison-Maierle will function as a subconsultant to HDR Engineering to provide the current water system modeling results and additional modeling needed to evaluate the transmission system aspects of this task.
- The plant evaluation will look at finding a cost effective treatment capacity for expanding the existing plant within the upgrade limitations noted above.

Subtask 204 – Develop Timeline of Demand vs. Capacity

Develop a timeline of demand vs. available WTP capacity. It is anticipated that this will be used to identify both the amount and timing of potable demand reduction necessary to eliminate the need for a West-End WTP.

Subtask 205 – Evaluate Capacities of Interceptor Sewers

The work effort to-date includes:

- Development of design flows for the WRF as identified in the Wastewater Treatment Facilities Plan and hydraulic flow profile for the WRF based on the proposed design for the Nutrient Project.
- Provided flow information and coordinated, reviewed, and reasonably reconciled flows with Dowl HKM regarding flows in individual plant influent sewers.

Additional work effort anticipated includes:

- Assess the capacities of the existing interceptor sewer lines that convey wastewater to the existing WRF as they relate to the various IWPS options. It is anticipated that Dowl HKM will function as a subconsultant to HDR Engineering to provide the current wastewater collection system modeling results and additional modeling needed to evaluate the collection system aspects of this task.

The three lines to be evaluated include the Heights Interceptor, 48-inch Mid-Town Interceptor, and West-End Interceptor. This information will be used to:

- Determine the timing of when these facilities will reach their respective capacity
- To what extent flows will need to be reduced to increase their service life
- How the various IWPS options to be evaluated impact these sewers

It is anticipated that the City will provide the flow information from the Integrated Water Plan Implementation Wastewater Collection System Study Master Plan conducted by Dowl HKM.

Subtask 206 – Evaluate Storm Water MS4 Implications

The work effort to-date includes:

- Summary of the existing storm water system and outfalls
- Review of water quality data and storm water TMDL implications

Additional work effort anticipated includes:

- Discussion of new MS4 permit implications for City and new TMDL implications
- Evaluation of site(s) for pilot project(s) of low-impact development techniques
- Evaluation of the Sindelar Pit site for storm water storage/treatment

Task 300 – DEVELOP INTEGRATED PLANNING OPTIONS

Objective:

Identify options potentially available to:

- Reduce potable water demands
- Enhance anticipated water rights and develop water reservations
- Increase reliability of water system supply with alternate or enhanced source
- Reduce wastewater flows to existing WRF

- Manage storm water in conformance with MS4 permit and in conjunction with water and wastewater options where feasible
- Identify the estimated potable water demand reduction that can be feasibly achieved by implementing the options.

Develop a planning document that will provide:

- A project-specific management plan to the maximum extent practicable (most likely based on a single rate-of-growth) while incorporating adaptive management aspects where beneficial to allow flexibility to address changing circumstances within the range of estimated demands.

Subtask 301 – Water Options

The work effort to-date includes:

- Reviewing the 2011 water conservation program developed for the City by HDR Engineering to determine its applicability to the IWPS
- Estimating the amount of peak water demand that can be reasonably reduced by expanding the use of non-potable water for irrigation
- Evaluation of off-channel storage
- Evaluation of groundwater as a source of raw water
- Evaluating non-potable water system sources and arrangements using ditch water, groundwater, or reclaimed wastewater

Additional work effort anticipated includes:

- Identify additional demand-side and supply-side measures beyond those included in the Billings 2011 Conservation Plan that can be considered by the City for inclusion in a water conservation program.
- Refine options available for reducing potable water demands. Identify the pros and cons of each option, which include:
 - Low hanging fruit; i.e., education, conservation program, water-efficient landscaping, incentives
 - Ditch water
 - Groundwater
 - Wastewater effluent reuse
 - Storm water

Subtask 302 – Non-potable Water Distribution System

Identify options available for a non-potable water distribution system that utilizes ditch water, groundwater, and/or reclaimed wastewater. Identify the pros and cons of each option. Options to be considered include:

- Non-potable water system for all or a portion of the existing water customers
- Non-potable water system for new development

Subtask 303– Source Water Options

Identify options available for enhancing the City’s existing water rights, developing the existing water reservation, and developing an alternate raw water source, to include:

- Summarize the off-channel storage and groundwater source aspects of the Drinking Source Water Study and evaluate any new options of source water since the study. Include the pros and cons of each option in the summary
- Identify additional potential options for enhancing water rights beyond those already identified in this scope, such as purchases or statute changes
- Discussion of Direct Potable Reuse (DPR) as a potential future option as a potable raw water source and identification of the issues and steps needed to establish a system for allowing the implementation of DPR.

Subtask 304 – Wastewater Options

The work effort to-date includes:

- Evaluation of the options available for an aquifer recharge alternative in a West Billings location
- Preliminary draft Integrated Water Plan Implementation Reuse and Reclamation Study (Reuse Study) conducted by HDR Engineering

Additional work effort anticipated includes:

Identify options available for reducing wastewater flows to the existing WRF and identify the pros and cons of each option. It is anticipated that these options will include:

- Evaluation of a satellite facility in Billings Heights to divert flow from the existing WRF. It is anticipated that the evaluation will consist of a water feature development in the Sindelar Pit located adjacent to the Yellowstone River south of Dover Road at the intersection with Pioneer Road.

The evaluation will include consideration of:

- MPDES permit requirements, nondegradation, and other disposal alternatives
- Site development requirements/considerations
- Estimated flow diversion capability as it relates to the flow capacity of the existing Heights Interceptor Sewer
- Evaluation of alternatives for flow diversion, other than the Sindelar Pit. It is anticipated this will include consideration of:
 - Wastewater reuse, such as for lawn or agricultural irrigation
 - Flow management, such as flow equalization facilities or in-line storage
- Evaluation of a satellite facility located in the west-end of the service area that will consider both wastewater and storm water along with potential groundwater disposal
- Further evaluation and a site-specific investigation to determine the feasibility of developing an aquifer recharge facility and the rate of recharge possible at a specific West Billings site. The scope related to this effort is detailed in Task 400

It is anticipated that information from the preliminary draft Reuse Study will be used to develop:

- Estimated irrigation and associated storage demands
- Recommended West-End and Heights satellite treatment facility locations
- Recommendations for utilizing groundwater disposal/recharge

Subtask 305 – Initial Screening of Options

Develop a list of potential options with preliminary priorities based on non-economic criteria. Meet with City to review and discuss the preliminary option evaluation. Based on this input, further refine those options to be considered further.

Subtask 306 – Develop Cost Estimates for Options

Develop estimates of capital and operational costs for each of the options identified in Subtask 305 for further consideration. The City has expressed a desire to utilize a simplified cost approach for the initial evaluation phase that does not include a Triple Bottom Line (TBL) approach. Further detailed cost analysis, potentially using the TBL model, may be conducted if it is later deemed necessary and desirable and as directed by the City. These detailed analyses are identified herein under Task 900, ADDITIONAL SERVICES.

Subtask 307 – Evaluate the Impact of Options on Improvements in Existing CIP

Estimate the potential reduction in size or need for planned improvements in CIP. It is anticipated that this estimate will include those facilities that are more reasonably determined at this level of planning and detail, such as reservoirs and pumping stations.

TASK 400 – GROUNDWATER DISPOSAL EVALUATION – WEST BILLINGS

Objective

To identify and select sites at a West Billings location for further evaluation and a site-specific investigation to determine the feasibility of developing an aquifer recharge facility and the rate of recharge that may be possible at the site.

Subtask 401 – Identify Properties for Site Investigation

The work effort to-date includes:

- Evaluation of the options available for a wastewater aquifer recharge alternative at a West Billings location.

Additional work effort anticipated includes:

- Identify up to five potential properties within the West Billings area for a potential site investigation. Locate the areas on a map and using tax parcel information provide a table listing owner name, acreage and contact information. This information will be submitted to the City in the form of a technical memorandum. It is assumed that the City will then contact property owners and obtain permission for entry to one of the properties to conduct a site-specific feasibility assessment.

Subtask 402 – Site-Specific Feasibility Investigation

Conduct a site investigation to identify the feasibility of the selected site for an aquifer recharge facility to include:

- Excavate Test Pits – Up to ten pits will be excavated in potential recharge areas to a depth of about 20 feet to characterize the near-surface lithology across the site. The test pits will be excavated using a track-mounted excavator with an extended shovel arm. The locations of the test pits will be determined using a hand-held GPS unit. The soil at the test pits will be classified according to the Unified Soil Classification procedure and logged by a field geologist. Up to two soil samples will be collected from the parent geologic material (under the C soil horizon) and submitted to Terracon

for grain-size analysis from each test pit. The test pits will be backfilled after soil samples are collected.

- Install Soil Borings and Monitoring Wells – Up to three soil borings will be drilled on the site to a depth of 50 feet or until bedrock is encountered, whichever is first. The purpose of the borings/monitoring wells is to determine the type, extent, thickness and depth of the subsurface deposits and to assess whether they are suitable for aquifer recharge. The boring will be drilled using a hollow-stem auger truck-mounted drilling rig with 6-inch diameter inner and outer steel casing and continuous soil sampling. Soil samples will be logged in the field according to the Unified Soil Classification procedure. Up to four soil samples will be collected per boring (12 samples total maximum) from representative layers (including fine-grained layers) and submitted for grain-size analysis and porosity. Hydraulic conductivity will be calculated from the grain-size and porosity data for each sample.

Monitoring wells will be completed in each of the three soil borings. The monitoring wells will be constructed of 2-inch diameter Schedule 40 PVC. Well screens will be screened across the groundwater table so wells can later be used for groundwater quality compliance monitoring and to account for future mounding that may occur if the site moves forward. A surveyor will be retained to survey the location and elevations of the monitoring well casings.

A recording pressure transducer will be placed in one of the monitoring wells to record groundwater levels on a daily basis. These instruments will be downloaded once during a subsequent site visit. One sample will be collected from each of the three wells and submitted for laboratory analysis of metals, chloride, total dissolved solids, nitrate, nitrite and Total Kjeldahal Nitrogen and total organic carbon. Field parameters (conductivity, temperature and pH) will also be measured.

- Develop Simple Groundwater Model to Evaluate Recharge Feasibility - A simple groundwater model will be developed to evaluate the potential groundwater mounding that may occur during aquifer recharge on the site. The model will be developed using MODFLOW and will be based on the site conditions encountered during field investigations. Aquifer parameters assigned to the model will be based on calculated hydraulic conductivity.

Subtask 403 – Meetings

This task includes one project meeting for two persons with City. Assumes one person (Project Manager) will be in person and one person will attend by phone.

Subtask 404 – Task Management

Manage, administer, and provide ongoing oversight and progress reports for the project.

Assumptions:

- City will obtain formal permission needed to access off-site properties and will handle real-estate services needed to obtain access.

- Drilling costs are approximate and based on the two bids obtained at the time of preparation of the proposal. The drilling cost assumes that permission to access drilling sites has been obtained by City and the sites are accessible by a truck-mounted drilling rig for monitoring wells. Other site preparation costs are not included. Water hauling is included assuming water is available within a 5-mile radius from site. Soil cuttings and drilling water is assumed to be disposed of at the drilling location. Drilling costs assumes “clean” site conditions without hazardous/regulated contaminants. Lost or damaged tooling as a result of difficult or unforeseen drilling conditions that is charged in the drilling firms invoices is not included in this proposal and will be charged based on actual costs.
- Cost estimates for HDR field staff during drilling includes time necessary to log the soil samples and to provide input to the driller on where to place the well screen during installation, but does not include continuous field observation of all drilling activities. It is assumed that the driller will be able to independently manage the drilling and well installation without HDR staff being present continuously.
- The cost estimate does not include services to abandon the monitoring wells at the conclusion of the study. It is assumed that wells will remain in-place to be used during project design and operation.
- The project cost for instrumentation rented or purchased for the project is based on cost estimates from vendors. Laboratory analytical costs are based on normal turn-around times from the date of receipt and upon a written quote. If the actual cost at the time of purchase varies from the cost estimate, we will inform City and receive permission to purchase or rent. Actual cost will be billed.
- It is assumed that City will compile comments on draft documents into one set. Comments will be provided in a timely manner as needed to meet the project schedule.
- Permit fees or other regulatory fees, if needed, are not included in this cost estimate.
- The budget provided for these services is based on our best understanding of the current conditions. Some of the information available to determine the actual cost is unknown. HDR will update City as the project details are updated and will request authorization if additional budget is required.

Deliverables:

- Technical memorandum identifying five properties in West Billings Area for potential site investigation (draft and final)
- Site-Specific Feasibility Evaluation Technical Memorandum for West Billings Area (draft and final)

References:

- HDR Engineering, 2013. Reclaimed Water Aquifer Recharge Feasibility Study. Prepared for City of Billings, MT.

Schedule:

Investigation of the locations in Tasks 400 and 800 is anticipated to require approximately 9 months to complete. This assumes that the City will review and provide comments on draft technical memorandum within 2 weeks of receiving the draft. This also assumes the City will

obtain permission to access a property for detailed site investigations within 1 month of obtaining a list of potential site investigation properties.

TASK 500 – EVALUATE IDENTIFIED OPTIONS

Objective:

Evaluate the options using the agreed upon criteria, prioritize the identified options, and develop recommended implementation strategies and schedules.

Subtask 501 – Prioritize Options

Develop a numerical rating approach to reflect the relative importance of each criterion, including cost. Assign ratings for each option and develop a matrix of identified options reflecting the ratings and showing the comparative ranking.

Develop a summary of rankings and recommended approach and implementation schedule. Meet with City to review draft findings and recommendations. It is anticipated the recommended approach will incorporate a phased approach to include public education, conservation, landscaping practices, alternative water sources for irrigation, and satellite wastewater/storm water facilities that incorporate wetlands.

This task includes two on-site meetings; one to present findings to Public Works Board and one City Council presentation.

TASK 600 – IWPS REPORT

Objective:

Produce report of findings and recommendations meeting client needs and expectations.

Subtask 601 – Develop Report

Develop a draft and final IWPS report documenting the findings and recommendations. It is anticipated that the report will be produced as a supplement to the IWP2011. Submit an electronic version of the draft report for city review. Meet with City to discuss and review their input. Revise draft report to incorporate agreed upon revisions and produce final report. Provide ten (10) hard copies and one (1) electronic version of final report.

TASK 700 PROJECT MANAGEMENT

Objective:

Plan and execute the IWPS in accordance with an established schedule and budget while meeting quality expectations for the project.

Subtask 701 – Project Coordination Meetings

Meet monthly with the City to review status of the planning effort. A total of six on-site meetings will be budgeted in addition to other scheduled meetings and workshops identified separately in specific tasks.

Subtask 702 – Project Execution Plan

The Project Execution Plan will set forth project procedures and will clearly define individual responsibilities, task schedules, milestones, deliverables and task budgets. The Project Execution Plan will contain project objectives; organization and roles of the project team, Agreement work plan, management tools and techniques; sub consultant management; coordination with the City and other participating agencies; Quality Assurance and Quality Control Plan; monitoring; reporting and administrative procedures. At the onset of the project, a project team meeting will be conducted to develop communication channels and form the basis for a comprehensive Project Execution Plan.

Subtask 703 – Monitoring

Monitor project progress, including work completed and remaining, budget expended, schedule and estimated cost of work remaining and estimated cost at completion. Manage activities within task budgets. Prepare and submit a brief monthly progress memorandum and invoice using the project management tools prepared in Subtask 702.

Subtask 704 – Quality Control

Review all work activities and project deliverables for conformance with quality control requirements and project standards. Monitor project activities for potential changes, anticipate changes whenever possible, and with the City's approval, modify project tasks and approach to keep the overall project within budget and on schedule.

PHASE 2

The Phase 2 scope of services includes Task 800 below and is included in this Agreement. Work that is part of this task will be undertaken only with the approval of the City.

TASK 800 GROUNDWATER DISPOSAL EVALUATION – EAST BILLINGS

Objective:

To identify and select sites at an East Billings location for further evaluation and a site-specific investigation to determine the feasibility of developing an aquifer recharge facility and the rate of recharge that may be possible at the site.

Subtask 801– Evaluate East Billings Area Hydrogeology

Review existing geologic, hydrogeologic and geotechnical reports on the geology/hydrogeology of the East Billings area to assess if the area is appropriate for a reclaimed water aquifer recharge facility. Download well logs for the area to determine feasibility. A site-specific examination is not included. Aquifer thickness, depth to ground water and subsurface permeability will be determined and evaluated. A technical memorandum will be developed to describe the feasibility of the East Billings area for aquifer recharge and to present findings and recommendations.

If the East Billings area is determined to be inappropriate for an aquifer recharge facility, no further investigation will be completed for this area.

Subtasks 802–805 – Additional Evaluation of East Billings Area

If the evaluation under Subtask 801 determines the hydrogeology is appropriate, additional investigation will be conducted following the scope of services described in Subtasks 401 through 404.

Deliverables:

- East Billings Hydrogeology Evaluation Technical Memorandum (draft and final)
- Technical memorandum identifying five properties in East Billings Area for potential site investigation (draft and final)
- Site-Specific Feasibility Evaluation Technical Memorandum for East Billings Area (draft and final)

Schedule:

Investigation of the locations in Task 800 is anticipated to require approximately 9 months to complete. This assumes that the City will review and provide comments on draft technical

memorandum within 2 weeks of receiving the draft. This also assumes the City will obtain permission to access a property for detailed site investigations within 1 month of obtaining a list of potential site investigation properties.

TASK 900 ADDITIONAL SERVICES

It is anticipated that additional or modified work tasks may be needed for the completion of this project. Such tasks will be added/modified by amendment to this Agreement. Potential tasks may include, but not be limited to:

- Cost analysis incorporating Triple Bottom Line methodology.
- Evaluate impact on existing water and wastewater rate structure; develop estimated rate structure for alternative water sources.
- Other tasks as may be identified and agreed upon.

Appendix B

Methods and Times of Payment City of Billings – Integrated Water Plan II

Section 1. Payments for Basic Services.

Billings shall authorize payment to the Engineer for services performed under Appendix A of this Agreement. Partial payment shall be due the Engineer upon receipt of the Engineer's pay estimate, said estimate being proportioned to the work completed by the Engineer.

Billings shall deduct five percent (5%) from each monthly pay estimate to be held until the completion of the final scope of work. The final payment shall be made only after acceptance of final documents by Billings, and determination that the scope of work has been satisfactorily completed.

A. For services rendered under Appendix A of this Agreement, the Engineer shall be paid based upon actual time accrued, but not to exceed the following amounts:

1. Basis of Plan	\$43,000.00
2. Evaluate Water/Wastewater Demands	\$80,000.00
3. Develop Integrated Planning Goals	\$92,000.00
4. Groundwater Disposal Evaluation – West Billings	\$95,000.00
5. Evaluate Identified Options	\$20,000.00
6. IWPS Report	\$37,000.00
7. Project Management	\$34,000.00
8. Groundwater Disposal Evaluation – East Billings	\$106,000.00

TOTAL: \$507,000.00

B. Final payment shall be the above stated basic fee less all previous payments.

Section 2. Payments for Extra Services when Authorized by Billings.

Requests made or conditions identified by interested groups at the agency or public meetings, which are beyond the scope and intent of the services to be performed under Appendix A shall be paid for based on a negotiated fee.

Section 3. Corrections.

Costs of Billings work that is required for corrections to the Engineer's work which requires redoing by Billings shall be deducted from any payments due the Engineer, if the Engineer fails to make the required corrections.

Section 4. Fee Increases

For contracts and services that are expected to require more than one (1) year to complete, the above stated basic services payments may be reviewed and adjusted annually by mutual agreement of the parties, based upon documented evidence that the Engineer's costs have increased for all comparable clients.

Appendix C

Additional Services of Engineer City of Billings – Integrated Water Plan II

Extra Services of the Engineer will be paid only with written prior authorization by Billings.

- A. Field and laboratory testing of materials and reports.
- B. Requests made or conditions identified which are beyond the scope and intent of the services identified under Appendix A.

Appendix D

Schedule of Professional Fees City of Billings – Integrated Water Plan II

Not Used

Appendix E

Project Schedule City of Billings – Integrated Water Plan II

Based on a notice to proceed by Billings dated no later than April 15, 2016, the completion date for the Engineer's work shall be:

A. Integrated Water Plan Report

1. Draft Integrated Water Plan Report: January 2017
2. Final Integrated Water Plan Report: April 2017

Delays affecting the completion of the work within the time specified of more than ninety (90) days, not attributable to or caused by the Parties hereto, may be considered as cause for the renegotiation or termination of this Contract.

If the Engineer is behind on this Contract due to no fault of Billings, then the Engineer hereby acknowledges the right of Billings to withhold future Contracts to the Engineer in addition to any other remedy until this Contract is brought back on schedule or otherwise resolved.

Appendix F

Certificate(s) of Insurance City of Billings – Integrated Water Plan II

Certificate(s) of Insurance attached.

Regular City Council Meeting

Meeting Date: 04/11/2016

TITLE: Annexation #16-03: Acknowledge receipt of petition and set a public hearing date

PRESENTED BY: Candi Millar, Planning & Community Services Department Director

Department: Planning & Community Services

PROBLEM/ISSUE STATEMENT

Yellowstone Meadows Partners, LLC submitted a petition to annex land it owns using the provisions of Section 7-2-4600, MCA. The subject property is currently described as a 4 acre portion of an 89 acre parcel described as the N1/2NE1/4, SWNE1/4 in Section 31, Township 1 North, Range 25 East. The petitioner is currently moving forward with a lot line relocation to define the 4 acre parcel. A metes and bounds description will be provided and used for this annexation when it comes to the City Council for the public hearing and consideration. The property is located south of Rimrock Road at the southwest corner of the intersection of 54th Street West and Trail Creek Drive. The property is vacant and has been used for agricultural. The owner is requesting annexation in order to develop the property in the City for a new church meeting house. The owner has submitted a Special Review in the City to allow the church use on the property in the Residential-9600 zoning district. The annexation schedule is designed to ensure the Special Review application comes to the Council after the annexation has been acted upon.

The property is located within the five-year annexation area of the City's Limits of Annexation Map and appears to meet some of the City's criteria in its Annexation Policy. A detailed review and analysis of the Annexation Policy criteria will be provided in the Council's public hearing memo. The City Council's policy is to consider annexations at two separate Council meetings. At the first meeting, the Council acknowledges receipt of a petition and sets a public hearing date. At the second meeting, the Council conducts the hearing and takes action on the annexation petition.

ALTERNATIVES ANALYZED

Section 7-2-4600, MCA, allows owners of more than 50% of the property to petition the City for annexation. The only alternative that is consistent with City Council policy is to acknowledge receipt of the petition and set a public hearing date.

FINANCIAL IMPACT

Analysis by City staff of how City services may be provided to this property and a recommendation on the annexation will be prepared and presented at the public hearing.

RECOMMENDATION

Staff recommends that the City Council acknowledge receipt of the annexation petition and schedule a public hearing for May 9, 2016 to consider annexing this property.

APPROVED BY CITY ADMINISTRATOR

Attachments

Annexation Petition

Annexation Exhibit

PETITION FOR ANNEXATION TO THE CITY OF BILLINGS

NOTICE TO PETITIONER

This is a Petition to the City of Billings requesting the annexation of property to the City, pursuant to MCA Title 7, Chapter 2, Part 46. Procedures for annexation are governed by the Statutes of the State of Montana. This Petition requires the signatures of more than 50% of the Resident Freeholder Electors to be considered for annexation.

INSTRUCTIONS

1. All items must be completed or provided. Please type or print. You may attach additional pages if more space is needed.
2. Prepare a map drawn to a scale adequate and legible to show the property requesting annexation and all other property within one-quarter (1/4) mile.

The map must show:

- a. The present and proposed boundaries of the municipality;
 - b. The present streets, major trunk water mains and sewer mains;
 - c. The zoning of the property requesting annexation and the property immediately adjacent to it.
3. The Petition should be submitted to the Planning Department, Monday through Friday between the hours of 8:00 a.m. and 5:00 p.m., located on the 4th Floor of Parnly Billings Library at 510 North Broadway, Billings, Montana. Upon presentation, the Petition will be checked for completeness. Once accepted, the Petition will be routed to the following City Departments: Public Works, City-County Planning, Public Utilities, Fire Department, City Attorney, Police Department, and Finance Department. If no problems with the Petition have been noted by the departments, the City Clerk will schedule the Petition for City Council action.
 4. By filing the petition for annexation, the Petitioner(s) agree that only those City services which are available to the general area shall be provided to Petitioner, and that additional services as may become available to the general area shall be made available to Petitioner(s) in the same manner as said services are made available to other residents of the City. Petitioner(s) specifically waive the right to the report and plans for extension of services as provided in MCA Title 7, Chapter 2, Part 47.
 5. A description of the territory to be annexed to the City is legally described on a document attached hereto.

RESIDENT FREEHOLDER ELECTORS

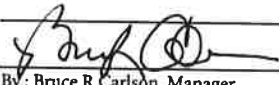
Date	Print Name	Name Signature	Address
March 12, 2016	Yellowstone Meadows Partners LLC	 By: Bruce R Carlson, Manager	3524 Spalding Avenue, Billings, MT 59106

(continued on separate page)

(Should be completed prior to obtaining signatures of resident freeholder electors)
DESCRIPTION OF THE TERRITORY TO BE ANNEXED TO THE CITY OF BILLINGS

Legal Description	Tax Code	Address of General Location	Use of Property	Legal Property Owners	Address	Phone
UNSEGREGATED PORTION OF PARCEL A (4.03 ACRES); PARCEL A, S31, T01 N, R25 E, N2NE4, SWNE4 89.98 ACRES. TO INCLUDE TRAIL CREEK DRIVE.	D04647	PARCEL LOCATED SOUTH WEST OF INTERSECTION AT TRAIL CREEK DRIVE AND 54TH STREET WEST. TO INCLUDE TRAIL CREEK DRIVE	R9600	YELLOWSTONE MEADOWS PARTNERS LLC	3524 SPALDING AVE, Billings	406 869-0565
						c/o Blaine Poppler

ALL ITEMS BELOW SHALL BE COMPLETED BY STAFF

Date Submitted: 3/16/16
 Fee Paid: ✓ 13946 \$1064.00

Received By: [Signature]
[Signature]

Petition Number: AN 16-03
P2-16-0042



EXHIBIT A - PROPERTY REQUESTING ANNEXATION

ANNEXATION MAP
WITHIN
BILLINGS, MONTANA

UNSEGREGATED PORTION OF PARCEL A (4.03 ACRES); PARCEL A, S31, T01 N, R25 E, N2NE4, SWNE4 89.98 ACRES.
CURRENT ZONING: R 9800
PROPOSED ZONING: SPECIAL REVIEW - CHURCH



PREPARED BY : SANDERSON STEWART

MARCH 2016
BILLINGS, MONTANA

300 150 0 150 300
SCALE: 1" = 300'

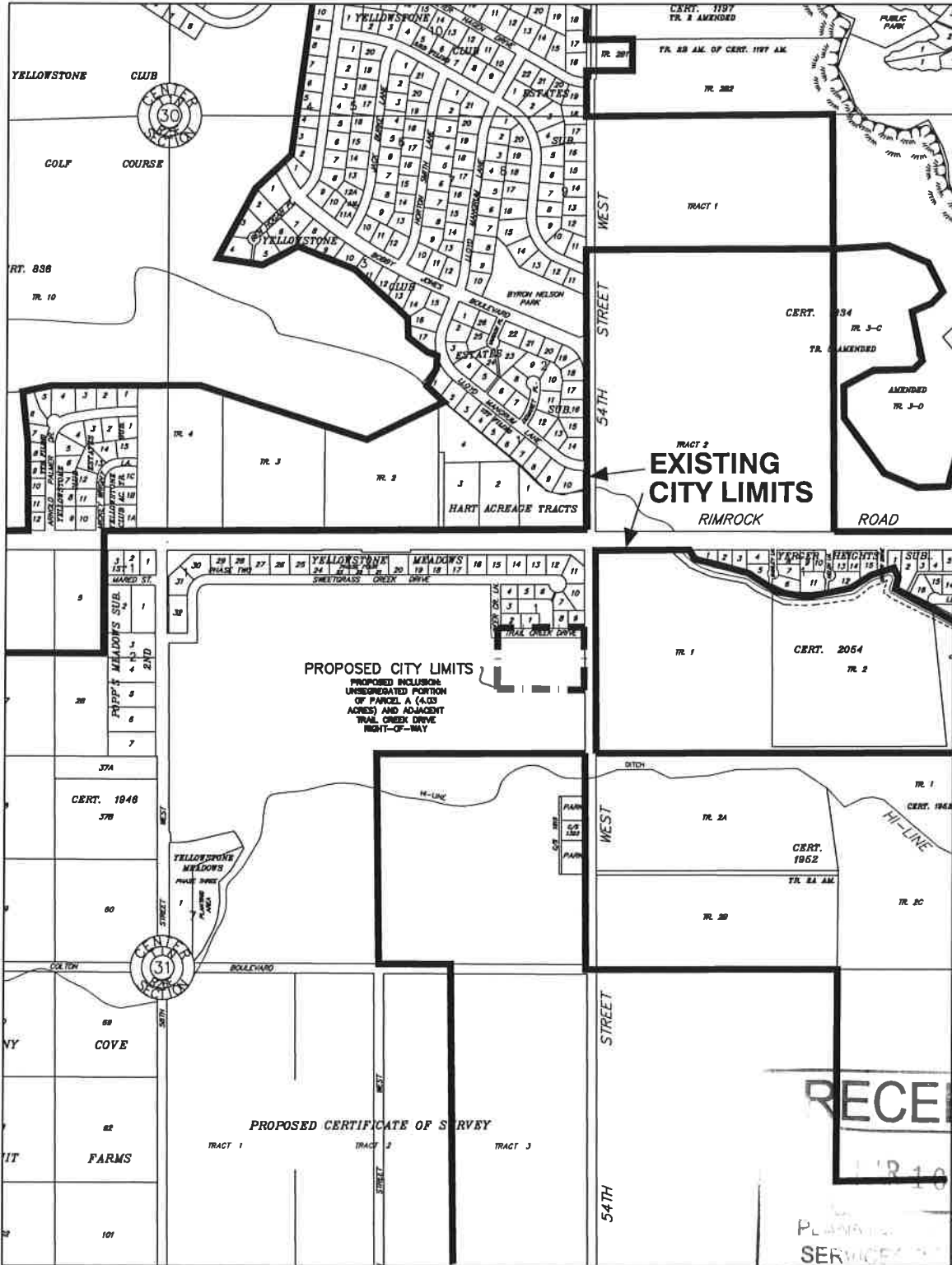

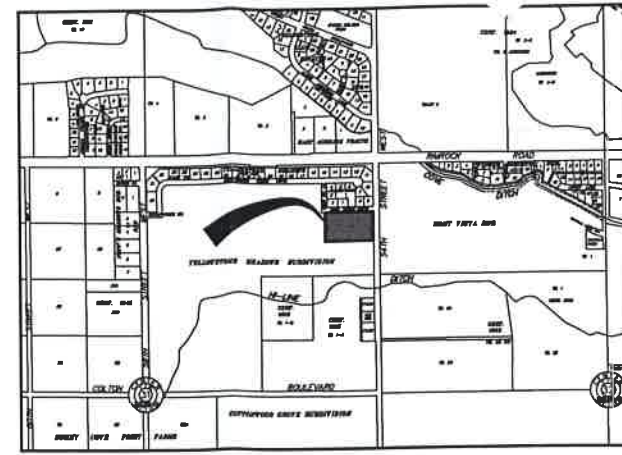

VICINITY MAP

LEGEND

- SET REBAR WITH CAP MARKED "SANDERSON STEWART"
- FOUND CORNER MONUMENT, AS NOTED
- ⊙ POWER POLE
- ⊠ ELECTRIC SERVICE
- ⊞ GAS SERVICE
- ⊕ SAN SEWER MH
- ⊗ STORM DRAIN MH
- CATCH BASIN
- ⊞ WATER VALVE
- ⊕ FIRE HYDRANT
- ⊞ SIGN
- ⊞ TELEPHONE RISER
- SS — SANITARY SEWER MAIN
- SD — STORM DRAIN
- W — WATER MAIN
- G — GAS LINE

The underground utilities shown have been located from field survey information and existing drawings. The surveyor makes no guarantees that the underground utilities shown comprise all such utilities in the area, either in service or abandoned. The surveyor further does not warrant that the underground utilities shown are in the exact location indicated although he does certify that they are located as accurately as possible from the information available. The surveyor has not physically located the underground utilities.

PROJECT SURVEY CONTROL

Point #	Northing	Easting	Elevation	Description
1	169204.00	595917.10	3363.84	CP 1/2" ACR SS CTL MON
2	169197.16	595448.00	3360.80	CP 1/2" ACR SS CTL MON
3	168750.08	595653.73	3353.97	CP 1/2" ACR SS CTL MON

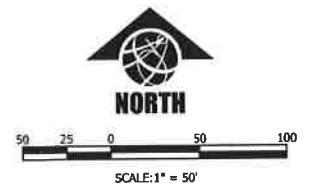

BASIS OF BEARING: DETERMINED BY GPS OBSERVATIONS USING SURVEY GRADE RECEIVERS. DISTANCES SHOWN ARE GROUND.

ZONING NOTE

ZONING INFORMATION NOT PROVIDED BY INSURER. SANDERSON STEWART IS NOT AN EXPERT IN THE INTERPRETATION OF COMPLEX ZONING ORDINANCES. COMPLIANCE IS BEYOND THE SCOPE OF THIS SURVEY. ANY USER OF THE FOLLOWING INFORMATION IS URGED TO CONTACT THE LOCAL AGENCY DIRECTLY.

As disclosed by Yellowstone County property tax records, the subject property is zoned as follows: **Residential 9600**.

As indicated in the zoning regulations for the City of Billings and Yellowstone County the subject property has the following zoning requirements:

- Minimum Yard Requirements:**
- Front: = 20 feet
 - Side: = 5 feet
 - Side Adjacent to Street = 10 feet
 - Rear: = 20 feet
- Maximum Allowable Building Height = 30 feet**
Maximum Allowable Lot Coverage = 30%

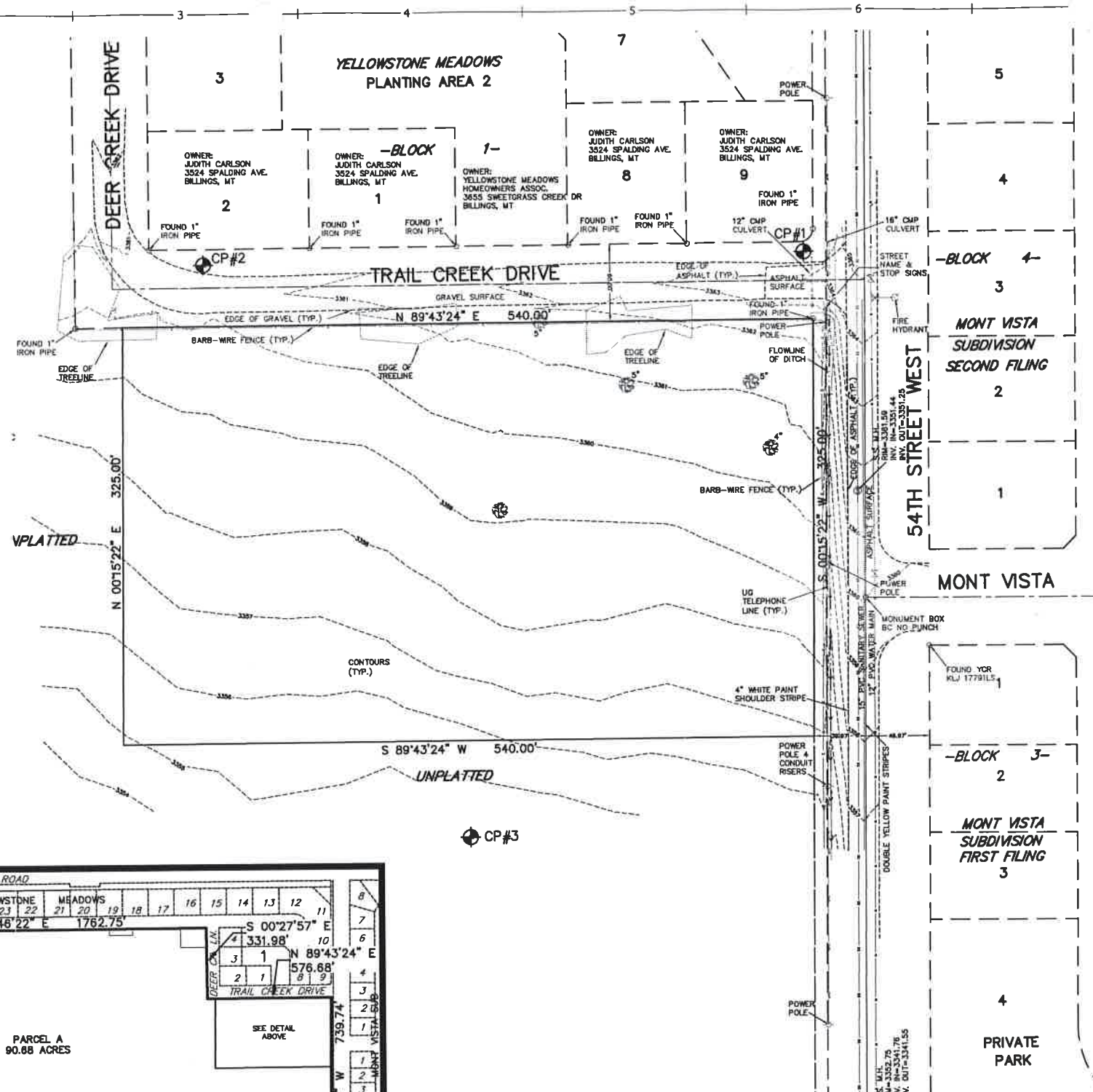
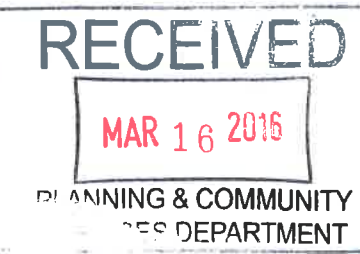

Curve Table

Curve #	Length	Radius	Delta	Chord Direction	Chord Length
C1	102.29	405.07	14.47	S02°37'06"E	102.02
C2	18.71	10.00	80.00	S64°23'05"E	14.14
C3	171.42	720.00	13.64	N43°28'08"E	171.29
C4	18.71	10.00	90.00	N44°18'22"E	14.14

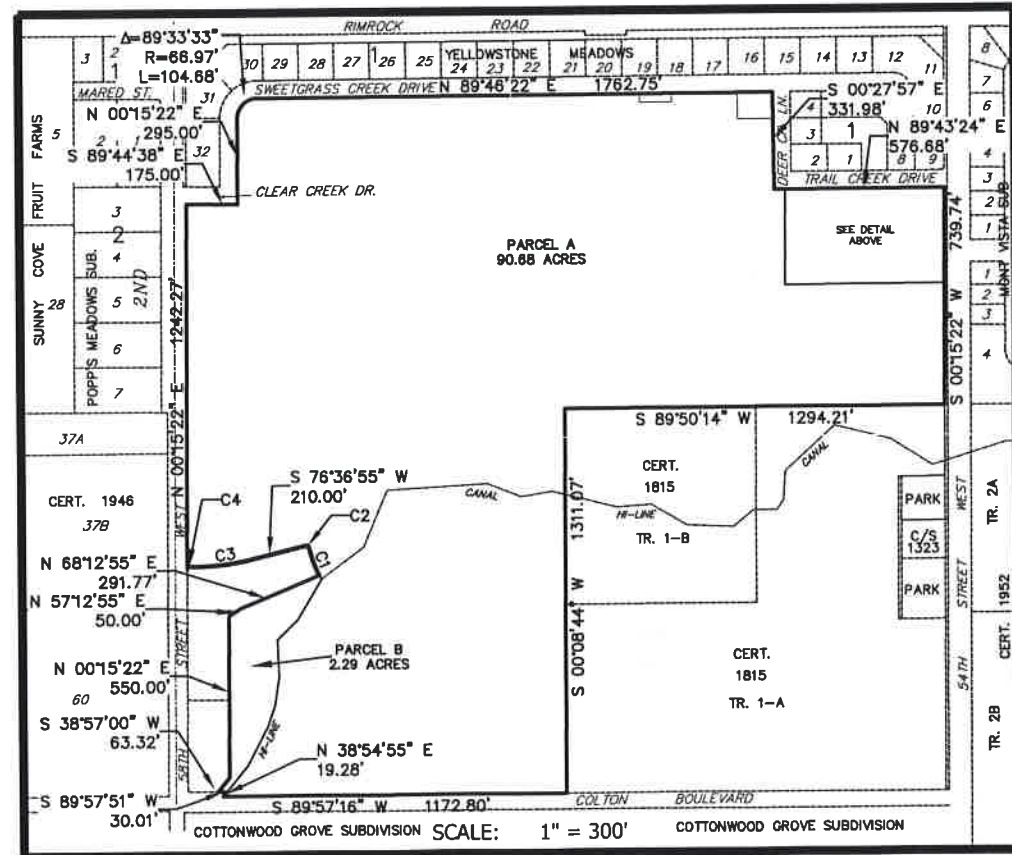

COTTONWOOD GROVE SUBDIVISION SCALE: 1" = 300'

ANNEXATION REQUEST
NE 1/4 SECTION 31, T. 1 N., R. 25 E., P.M.M.
YELLOWSTONE COUNTY, MONTANA

PREPARED FOR: YELLOWSTONE MEADOWS PARTNERS, LLC ON BEHALF OF THE CORPORATION OF THE PRESIDING BISHOP OF THE CHURCH OF JESUS CHRIST OF LATTER-DAY SAINTS

Regular City Council Meeting

Meeting Date: 04/11/2016

TITLE: Confirmation of Probationary Police Officers

PRESENTED BY: Rich St. John, Police Chief

Department: Police

PROBLEM/ISSUE STATEMENT

On March 30, 2015, Officers Michael Beechie, Jairo Solorio & Chad Wildin were hired by the Billings Police Department as probationary police officers. According to MCA 7-32-4113, the probation period is for one year from the date of hire. The officers have completed their one-year probation and, according to state statute, their names are to be submitted to City Council for confirmation. All of the supervisor comments concerning the officers' performance are positive and recommend confirmation.

ALTERNATIVES ANALYZED

Council may:

- Confirm the probationary police officers; or
- Do not confirm the probationary police officers. If the Council chooses to not confirm the officers, it may direct any questions or concerns to the Police Chief and table the item until the next Council meeting.

FINANCIAL IMPACT

There is no financial impact from this action.

RECOMMENDATION

Staff recommends that the City Council confirm Officers Michael Beechie, Jairo Solorio & Chad Wildin as Billings Police Officers.

APPROVED BY CITY ADMINISTRATOR

Regular City Council Meeting

Meeting Date: 04/11/2016

TITLE: Warranty Deed for Right of Way for Grand Avenue and 56th Street West

PRESENTED BY: David Mumford, Public Works Director

Department: Public Works

PROBLEM/ISSUE STATEMENT

School District 2 recently completed a Certificate of Survey which splits off a street tract for Grand Avenue and 56th Street West, adjacent to the new Ben Steel Middle School. The District is deeding this tract to the City. The Certificate of Survey will be assigned a number once it is filed and that information will be written into the warranty deed.

ALTERNATIVES ANALYZED

There is no viable alternative to accepting the warranty deed because the street exists within it.

FINANCIAL IMPACT

There is no significant financial impact with acceptance of the warranty deed.

RECOMMENDATION

Staff recommends Council accept the warranty deed for the street tract for Grand Avenue and 56th Street West.

APPROVED BY CITY ADMINISTRATOR

Attachments

Warranty Deed
Subdivision Plat

Return to:
City of Billings
P.O. Box 1178
Billings, MT 59103

WARRANTY DEED

THIS INDENTURE, made this 27th day of January, 2016.

FOR VALUABLE CONSIDERATION, lawful money of the United States to them in hand paid by the CITY OF BILLINGS, THE receipt whereof is acknowledged, **WITNESSTH THAT:**

Billings School District No. 2,
415 North 30th Street
Billings, MT 59101

does hereby **GRANT, BARGAIN, SELL CONVEY, WARRANT AND CONFIRM** unto the **CITY OF BILLINGS** for the benefit and use of **The Public** the following described real property, to wit:

A tract of land situated the NE1/4 of Section 5, T. 1 S., R. 25 E., P.M.M. described as Tract 2, Certificate of Survey No _____, on file and of record in the office of the Clerk and Recorder of Yellowstone County, Montana, under Document No. _____ more particularly described as follows:

Beginning at a point which is the northeast corner of Section 5, T. 1 S., R. 25 E., P.M.M.; thence, from said point of beginning, S 00°08'22" E a distance of 1,296.43 feet; thence N 89°56'27" W a distance of 60.00 feet; thence N 00°08'22" W a distance of 1206.51 feet; thence along a curve to the left with a central angle of 89°49'06" and a radius of 30.00 feet a distance of 47.03 feet; thence N 89°57'28" W a distance of 888.19 feet; thence N 89°57'35" W a distance of 325.65 feet; thence N 00°06'11" W a distance of 60.00 feet; thence S 89°57'35" E a distance of 325.81 feet; thence S 89°57'28" E a distance of 977.91 feet to the Point of Beginning; containing an area of 3.5033 acres, more or less.

PURPOSE OF ACQUISITION is to create a right-of way parcel for construction and use of public road, utility and related appurtenant structures, pursuant to 76-3-201(1)(h) M.C.A. and A.R.M. 24.183.1104 as a division of land that creates rights-of-way or utility sites.

EXCEPTING AND RESERVING, however, all gas and oil, beneath the surface of the above described and conveyed premises, together with the right to extract the same, provided that in the exercise of such right the surface thereof shall not be disturbed, interfered with, or in anyway damaged.

FURTHER EXCEPTING AND RESERVING, unto the grantors, their successors and assigns all water, water rights, ditches, canals, irrigation systems, existing or as relocated, if any, including but not limited to, water stock or shares, bonds, certificates, contracts and any and all other indicia, of water, water right and ditch ownership, or any interest therein, appurtenant to the land described herein.

TO HAVE AND TO HOLD the above described and conveyed premises, with all the reversions, remainders, tenements, hereditaments and appurtenances thereto, unto the **CITY OF BILLINGS**, and to its successors and assigns forever.

IN WITNESS WHEREOF, the undersigned have executed these premises the day and year first above written.

Billings School District No. 2

By: *[Signature]*
Title: Supt.

STATE OF MONTANA)
County of Yellowstone) :ss

On this 27th day of January, 2016 before me the undersigned Notary Public for the State of Montana, personally appeared Terry Nelson Boush known to me to be the person who signed the foregoing instrument as Superintendent of Billings School District No. 2, and who acknowledged to me that he executed the same. Witness my hand and seal the day and year herein above written.

[Signature]
Signature of Notary Public



ACKNOWLEDGMENT AND ACCEPTANCE OF CONVEYANCE

The Mayor and City Council of the City of Billings acknowledges receipt of this deed and hereby accepts the property interest conveyed through this instrument.

Mayor, City of Billings Date

City Clerk

ATTEST: _____

STATE OF MONTANA)
County of Yellowstone) :SS

On this _____ day of _____, 20____, before me, a Notary Public in and for the State of Montana, personally appeared _____ as Mayor and _____ City Clerk of Billings known to me to be the persons who signed, respectively, and acknowledge to me that they executed the foregoing instrument. **IN WITNESS WHEREOF**, I have hereunto set my hand and my seal the day and year herein above written.

Signature of Notary Public

CERTIFICATE OF SURVEY No. _____

SITUATED IN THE NE1/4 OF SECTION 5,
TOWNSHIP 1 SOUTH, RANGE 25 EAST, P.M.M.
IN THE CITY OF BILLINGS, YELLOWSTONE COUNTY, MONTANA

PREPARED FOR : BILLINGS SCHOOL DISTRICT No. 2

PREPARED BY : SANDERSON STEWART

JANUARY 2016
BILLINGS, MONTANA

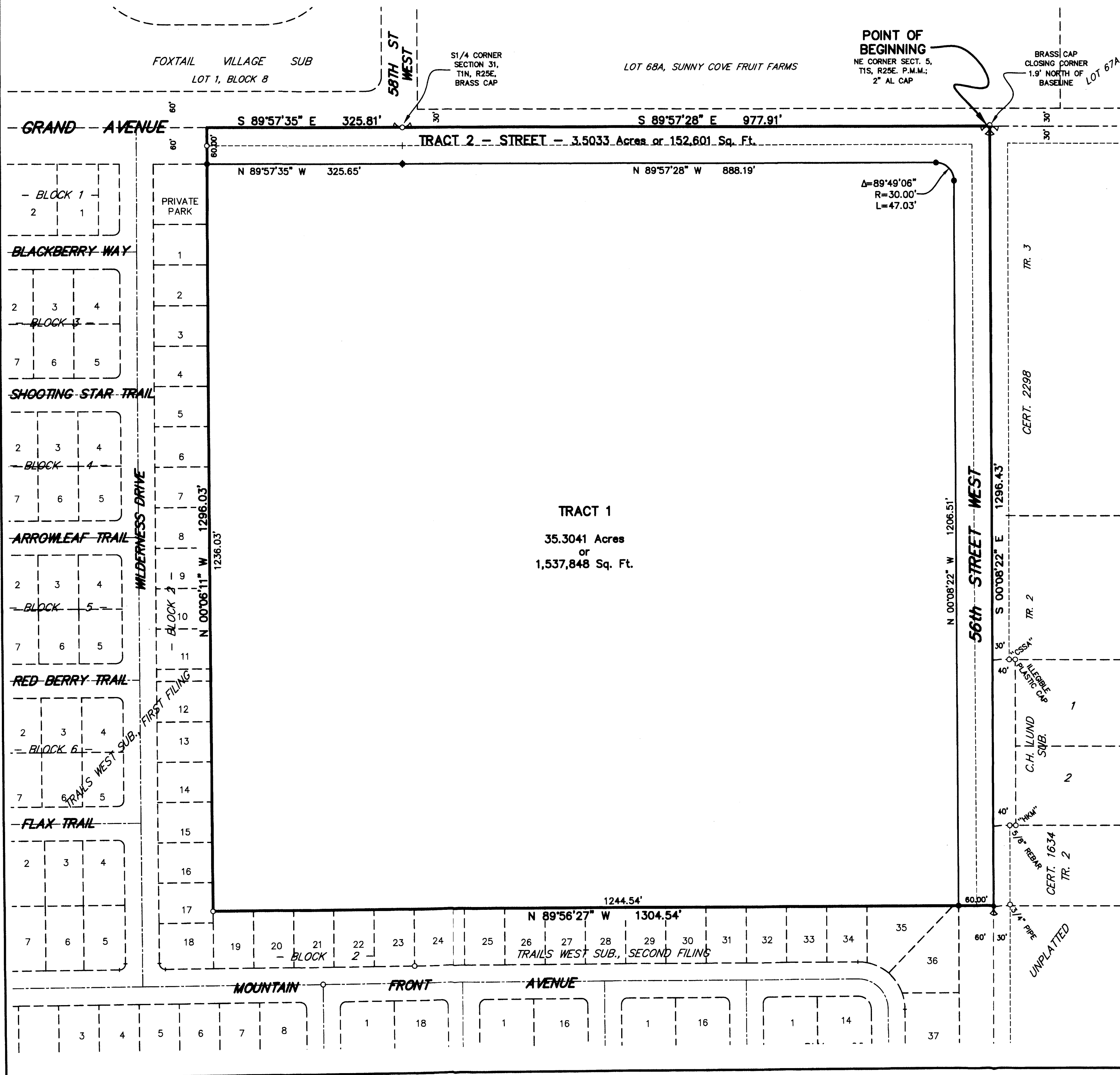
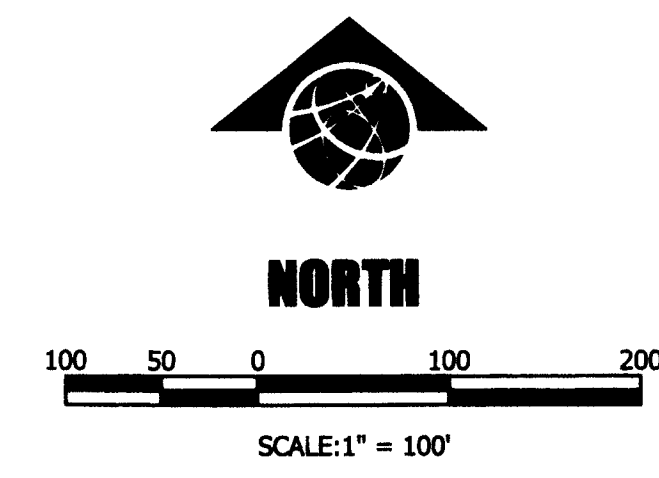
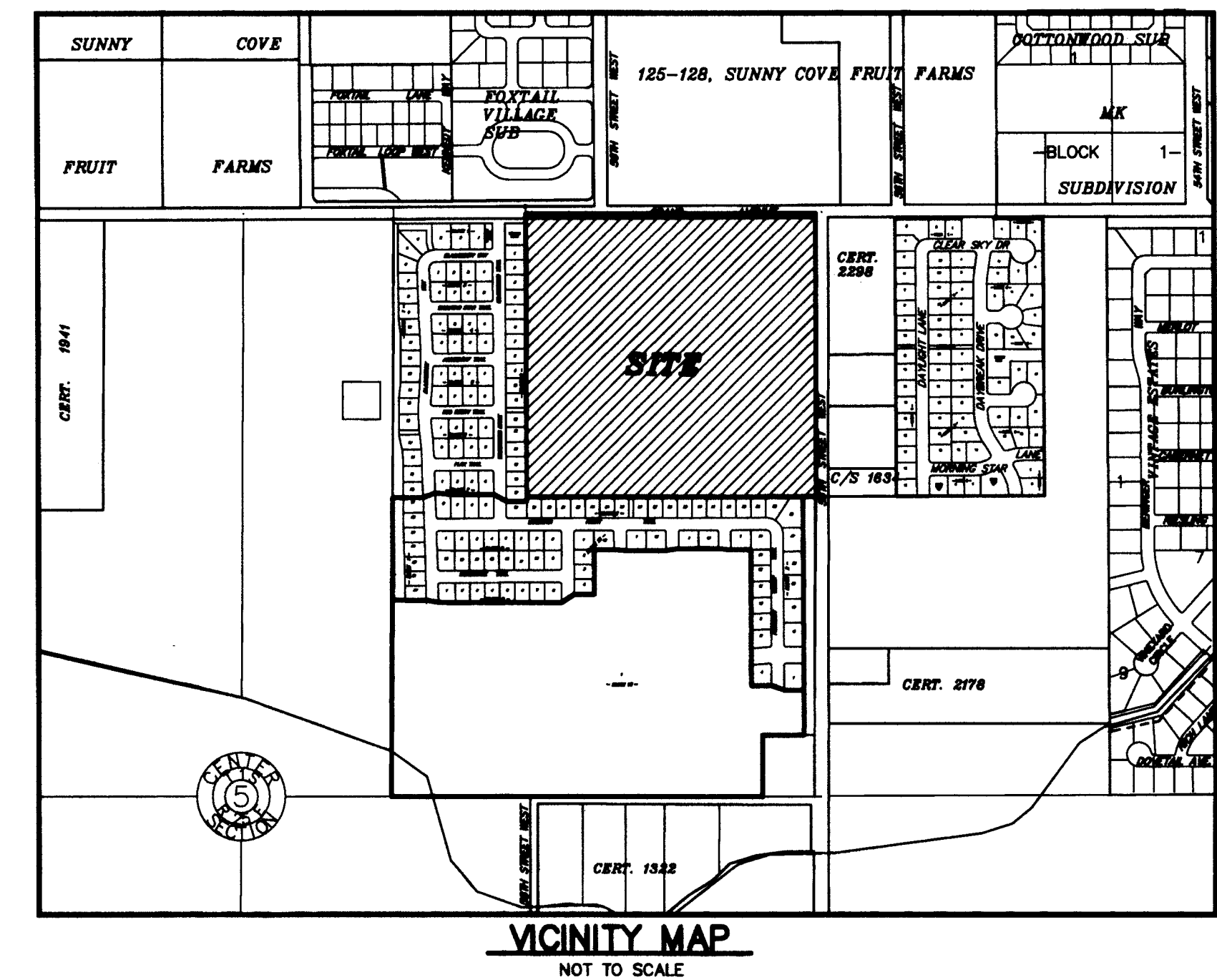

THE BASIS OF BEARINGS FOR THIS SURVEY HAS BEEN DERIVED FROM GPS OBSERVATIONS AND IS BASED ON A NAD 83, LAMBERT CONFORMAL CONIC, SINGLE PARALLEL, LOW DISTORTION PROJECTION FOR THE CITY OF BILLINGS; HAVING A POINT OF ORIGIN AT 45°47'00"N LATITUDE AND 108°25'00"W LONGITUDE WITH A SCALE FACTOR OF 1.0001515.

DISTANCES ARE GRID, INTERNATIONAL FEET.
GRID TO GROUND COMBINED SCALE FACTOR IS 0.9999948

THE CONVERGENCE ANGLE AT THE NORTHEAST CORNER OF SECTION 5 = -00°10'26"

- FOUND SURVEY MONUMENT, REBAR WITH "SANDERSON STEWART" CAP OR AS NOTED.
- SET 5/8" REBAR MARKED WITH THE LICENSE NUMBER OF THE UNDERSIGNED LAND SURVEYOR AND "SANDERSON STEWART".

ERRORS AND OMISSIONS REVIEW

I hereby certify that I have examined the annexed and foregoing certificate of survey for errors and omissions in computations and drafting.

Sandra A. Stewart
Examining Land Surveyor

Date: 02/05/2016

CERTIFICATE OF CITY ATTORNEY

This document has been reviewed by the City Attorney's office and is acceptable as to form.

DATED: _____

Reviewed by: _____

CERTIFICATE OF COUNTY TREASURER

I hereby certify that all real property taxes and special assessments have been paid per 76-3-611(1)(b) / 76-3-207(3), M.C.A.

Date: _____

Yellowstone County Treasurer

BY: _____
Deputy

DEED

DOCUMENT No. _____

PURPOSE OF SURVEY - RETRACE EXISTING BOUNDARY - CREATE ROAD TRACT

The undersigned hereby certifies that the purpose of this survey is to retrace the outside boundary of a tract of land described in a deed recorded under Document No 3103388, records of Yellowstone County, Montana and to create TRACT 2 as shown hereon for transfer to the City of Billings for right-of-way purposes.

This survey has been prepared pursuant to Section 76-3-404(1)(a), M.C.A. to "provide material evidence not appearing on any map filed with the county Clerk and Recorder or contained in the records of the United States Bureau of Land Management" and is exempt from review as a subdivision pursuant to Section 76-3-201(1)(h), M.C.A. for a division of land that "is created for rights-of-way or utility sites".

As shown hereon, TRACT 1 is not subject to review by the Department of Environmental Quality since it is greater than 20 acres in size and TRACT 2 is not subject to review pursuant to Section 76-4-125(2)(a), M.C.A. for right-of-way tracts.

BILLINGS SCHOOL DISTRICT No. 2

By: *Terry Nelson Bouch*
Title: Supt.

STATE OF MONTANA)
County of Yellowstone) ss.

On this 27th day of January, 2016, before me, a Notary Public in and for the State of Montana, personally appeared Terry Nelson Bouch known to me to be the person who signed the foregoing instrument as Supt. of Billings School District No. 2 and who acknowledged to me that he executed the same. Witness my hand and seal the day and year herein above written.

T. Nelson Bouch
Signature of Notary

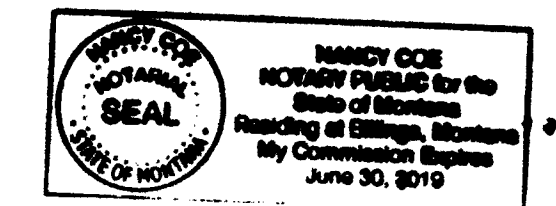

CERTIFICATE OF SURVEYOR

STATE OF MONTANA)
County of Yellowstone) ss.

The undersigned, a Montana Registered Land Surveyor, being first duly sworn, deposes and says that during the month of January 2016, a survey was performed under his supervision of a tract of land situated in the NE1/4 of Section 5, T. 1 S., R. 25 E., P.M.M., in the City of Billings, Yellowstone County, Montana, said tract being more particularly described as follows, to wit:

Beginning at a point which is the northeast corner of Section 5, T. 1 S., R. 25 E., P.M.M.; thence from said point of beginning, along the east line of said Section 5, S 00°08'22" E a distance of 1296.43 feet; thence along the north line of Block 2 in Trails West Subdivision, Second Filing, N 89°56'27" W a distance of 1304.54 feet to the northwest corner of Lot 19 in said Block 2; thence along the east line of Block 2 in Trails West Subdivision First Filing, N 00°06'11" W a distance of 1296.03 feet to a point on the north line of said Section 5; thence, along the north line of said Section 5, S 89°57'35" E a distance of 325.81 feet to the south quarter corner of Section 31, T. 1 N. R. 25 E., P.M.M.; thence, continuing along the north line of said Section 5, S 89°57'28" E a distance of 977.91 feet to the point of beginning; said described tract containing an area of 38.8074 acres, more or less, subject to all easements of record or apparent on the ground.

That the monuments found and set are of the character and occupy the positions shown hereon, that said survey and the plat hereof shows true and correct dimensions and that the plat conforms with the work on the ground.

SANDERSON STEWART

By: *Peter B. Knapp*
Peter B. Knapp

Montana Registration No. 8377-S

Date: January 28, 2016



Return to:
City of Billings
P.O. Box 1178
Billings, MT 59103

AS SUBMITTED
w/ M&M'S

WARRANTY DEED

THIS INDENTURE, made this 27th day of January, 2016.

FOR VALUABLE CONSIDERATION, lawful money of the United States to them in hand paid by the CITY OF BILLINGS, THE receipt whereof is acknowledged, WITNESSTH THAT:

Billings School District No. 2,
415 North 30th Street
Billings, MT 59101

does hereby GRANT, BARGAIN, SELL CONVEY, WARRANT AND CONFIRM unto the CITY OF BILLINGS for the benefit and use of The Public the following described real property, to wit:

A tract of land situated the NE1/4 of Section 5, T. 1 S., R. 25 E., P.M.M. described as Tract 2, Certificate of Survey No _____, on file and of record in the office of the Clerk and Recorder of Yellowstone County, Montana, under Document No. _____ more particularly described as follows:

Beginning at a point which is the northeast corner of Section 5, T. 1 S., R. 25 E., P.M.M.; thence, from said point of beginning, S 00°08'22" E a distance of 1,296.43 feet; thence N 89°56'27" W a distance of 60.00 feet; thence N 00°08'22" W a distance of 1206.51 feet; thence along a curve to the left with a central angle of 89°49'06" and a radius of 30.00 feet a distance of 47.03 feet; thence N 89°57'28" W a distance of 888.19 feet; thence N 89°57'35" W a distance of 325.65 feet; thence N 00°06'11" W a distance of 60.00 feet; thence S 89°57'35" E a distance of 325.81 feet; thence S 89°57'28" E a distance of 977.91 feet to the Point of Beginning; containing an area of 3.5033 acres, more or less.

PURPOSE OF ACQUISITION is to create a right-of way parcel for construction and use of public road, utility and related appurtenant structures, pursuant to 76-3-201(1)(h) M.C.A. and A.R.M. 24.183.1104 as a division of land that creates rights-of-way or utility sites.

EXCEPTING AND RESERVING, however, all gas and oil, beneath the surface of the above described and conveyed premises, together with the right to extract the same, provided that in the exercise of such right the surface thereof shall not be disturbed, interfered with, or in anyway damaged.

FURTHER EXCEPTING AND RESERVING, unto the grantors, their successors and assigns all water, water rights, ditches, canals, irrigation systems, existing or as relocated, if any, including but not limited to, water stock or shares, bonds, certificates, contracts and any and all other indicia, of water, water right and ditch ownership, or any interest therein, appurtenant to the land described herein.

Regular City Council Meeting

-- **Meeting Date:** 04/11/2016

TITLE: Bright n' Beautiful \$5,000 UPS Community Foundation Tree Planting Grant

PRESENTED BY: Mike Whitaker, Parks, Recreation & Public Lands Director

Department: Parks/Rec/Public Lands

PROBLEM/ISSUE STATEMENT

Billings Parks and Recreation staff propose that Council accept a \$5,000 donation from Bright n' Beautiful to purchase and plant trees in Lillis and Descro Parks. Bright n' Beautiful, in cooperation with the Parks Department staff, prepared and submitted the grant application to the UPS Community Foundation. If Council accepts the \$5,000, 25-30 trees will be planted on April 15th at the aforementioned parks. As per grant requirement, volunteers from UPS will join Bright n' Beautiful representatives and Park/Forestry staff to plant the trees. These trees will provide benefits to the park such as additional shade and aesthetic enhancement of the landscape.

ALTERNATIVES ANALYZED

City Council may:

- Approve and accept the \$5,000 donation from Bright n' Beautiful for purchasing and planting trees at Lillis and Descro Parks, or;
- Do not accept the donation and provide staff with additional guidance.

FINANCIAL IMPACT

The financial impact to the city will be limited to staff time to assist with the planting the trees on April 15th. The \$5,000 grant will cover the cost of purchasing the trees and supplies such as fence posts and protective fencing.

RECOMMENDATION

Staff recommends that the City Council accept the \$5,000 donation from Bright n' Beautiful for purchasing and planting trees at Lillis and Descro Parks.

APPROVED BY CITY ADMINISTRATOR

Regular City Council Meeting

-- **Meeting Date:** 04/11/2016

TITLE: \$5,000 Bright n' Beautiful Greenhouse Grant

PRESENTED BY: Mike Whitaker, Parks, Recreation & Public Lands Director

Department: Parks/Rec/Public Lands

PROBLEM/ISSUE STATEMENT

Billings Parks and Recreation staff propose that Council accept a \$5,000 donation from Bright n' Beautiful for a greenhouse at the Amend Park Community Garden. The Lowe's Community Foundation awarded the \$5,000 to Bright n' Beautiful in cooperation with the Parks Department. The greenhouse will be used by participants at the Amend Park Community Garden to start plants earlier in the season for their garden plots. The greenhouse will also be used as an education tool by the Parks Department to engage local schools in hands-on learning about gardening. Lastly, the greenhouse will be used by non-profit agencies that assist in maintaining the communal areas of the Amend Park Community Garden by starting seeds to be grown in the communal plots.

ALTERNATIVES ANALYZED

City Council may:

- Approve and accept the \$5,000 from Bright n' Beautiful for the Amend Park Community Garden Greenhouse, or,
- Not accept the grant and give staff additional guidance..

FINANCIAL IMPACT

The financial impact of accepting the greenhouse is limited to staff time is assembling the interior shelving and irrigation system at the greenhouse. The \$5,000 grant covers the cost of the greenhouse along with basic materials such as soils, pots and seeds.

BACKGROUND

In 2014, The Billings Parks and Recreation Department, in conjunction with the Billings Metro VISTA Project opened Billings' first city-owned community garden at Amend Park. The Department recognized the benefits of a community garden, including education, empowerment and food security. The garden received a citation of merit award from the Montana Trails, Recreation and Parks Association for Agency Excellence in 2015. The garden has 44 plots ranging in size from 10' x 10' to 20' x 20'. Additionally, there are four raised beds that are 3' x 6'. In 2015, the gardeners harvested over 2000 lbs of produce. The garden served clients of all ages, income levels and gardening experience.

RECOMMENDATION

Staff recommends that the City Council accept the \$5,000 donation from the Lowe's Community Foundation to construct a greenhouse at the Amend Park Community Garden.

APPROVED BY CITY ADMINISTRATOR

Regular City Council Meeting

Meeting Date: 04/11/2016

TITLE: Approval of Downtown Revolving Loan Fund Recommendation for Singh Construction

PRESENTED BY: Patrick M. Weber, Finance Director

Department: City Hall Administration

PROBLEM/ISSUE STATEMENT

The Downtown Revolving Loan Committee met on March 14, 2016 and agreed to conditionally approve a \$110,000 loan to Singh Contracting. Singh Contracting is requesting this loan to help purchase a building located at 313 N. Broadway. The applicant met all conditions set by the committee. Mr. Singh is investing a substantial down-payment and there will be a bank loan that is superior to the City's position. The building is currently owned by BOBKATZ, Inc and the asking price was \$550,000. The county website appraised it at \$628,000. Mr. Singh will continue to run it as a restaurant until the current renter's lease expires in October. The tenant will have the first chance to rent the space again. If the current renters do not renew, Mr. Singh will run the restaurant and bar. Mr. Singh plans on cleaning and updating the building as well as some remodeling.

ALTERNATIVES ANALYZED

The Council may approve or disapprove the loan. If Council does not approve the loan, the building purchase may be delayed.

FINANCIAL IMPACT

The Revolving Loan Fund does not owe any money to the banks at this time. The entire loan amount would come from City money in the downtown loan fund.

RECOMMENDATION

The Downtown Revolving Loan Fund Committee recommends that the City Council approve a \$110,000 loan to Singh Contracting.

APPROVED BY CITY ADMINISTRATOR

Attachments

Singh Contracting

Downtown Revolving Loan Fund loan request

Monday, March 14, 2016

Singh Contracting loan terms are as follows:

Loan:	\$110,000
Interest Rate:	2.25% adjusted annually
Term:	Amortized over 15 years
Payments:	Minimum payments calculated at a rate of 2.25% over a 5 year term with a balloon payment.
Collateral:	2 nd position after Yellowstone Bank
Disbursement:	The City will disburse funds after it receives City Council approval.

The purpose of this loan is to partially fund purchase of building at 313 N. Broadway.

Regular City Council Meeting

Meeting Date: 04/11/2016

TITLE: EBURD TIF Assistance Request - Eggart Enterprises LLC

PRESENTED BY: Candi Millar, Planning & Community Services Department Director

Department: Planning & Community Services

PROBLEM/ISSUE STATEMENT

The Billings Industrial Revitalization District (BIRD) Board of Directors is recommending approval of \$49,000.00 in tax increment assistance from the East Billings Urban Renewal District (EBURD) paid to Eggart Enterprises LLC for public improvements. The funding will be used to reimburse the cost of installing new concrete sidewalks and approaches, landscaping and public utilities at 1711 6th Avenue North, Billings, Montana. This project is consistent with the East Billings Urban Renewal District Master Plan. The application for TIF Assistance was recommended for approval by the BIRD Board of Directors on February 19, 2016 in the amount of \$49,000.00.

ALTERNATIVES ANALYZED

The City Council may either approve or deny the recommendation from the BIRD on the expenditure of these funds.

FINANCIAL IMPACT

The amount of the request is for a total of \$49,000.00 to be paid in one payment to Eggart Enterprises LLC. The funds are payable upon approval of the project by the City and submittal of an invoice to the City. There are sufficient funds budgeted in the FY 2016 EBURD budget for payment of this development incentive.

RECOMMENDATION

The Billings Industrial Revitalization District (BIRD) Board of Directors recommends that the City Council approve a reimbursement for new concrete sidewalks and approaches, landscaping and public utilities totaling \$49,000.00 from the East Billings Urban Renewal District tax increment district funds to Eggart Enterprises LLC.

APPROVED BY CITY ADMINISTRATOR

Attachments

Eggart TIF Assistance Application



City of Billings
East Billings Urban Renewal District

**T.I.F.D Project Information and
Application**
Increment Generating Development Projects
Effective June 1st, 2014

Billings Industrial Revitalization District (BIRD)
1413 4th Ave N, Suite C
Billings, MT 59101
406.545.7007

**TAX INCREMENT FINANCING APPLICATION PROCESS FOR POTENTIAL
PUBLIC INFRASTRUCTURE ASSISTANCE VIA A DEVELOPMENT
AGREEMENT AND POSSIBLE ISSUANCE OF TIFD BONDS**

IMPORTANT: The material below outlines the Tax Increment Development Agreement application process and the responsibilities of the person or firm requesting TIF fund assistance (hereinafter known as APPLICANT) and the Billings Industrial Revitalization District, Inc. (hereinafter known as BIRD). Please review this information carefully before submitting the application or finalizing your development plans.

INTRODUCTION

The BIRD is responsible for advising the City of Billings (hereinafter known as CITY), of the East Billings Tax Increment District, pursuant to Montana Urban Renewal Law (Title 7 Chapter 15 part 42 Montana Code Annotated, “Urban Renewal.” Tax Increment Financing (TIF) is an important element of the program as it provides a means to finance public urban renewal activities that assist and enhance private development within the district. A TIF program operates by first establishing a base year taxable value for all properties within the urban renewal district. Property taxes continue to be paid to all taxing jurisdictions on the basis of the base year valuation. All increases in property taxes above this base valuation due to new development or reappraisals are assigned to the TIF District (TIFD.) They are then invested in district revitalization activities.

Consideration of TIFD assistance is available to private developers for public infrastructure (See Schedule “A” attached) components of projects within the boundaries of the East Billings TIFD.

ELIGIBLE ACTIVITIES

As specified by Title 7 Chapter 15 Part 4288 Montana Code Annotated, TIF may be used to finance certain urban renewal activities. The BIRD will review applications and make recommendations to the CITY Council for assistance to projects eligible under this statute. Requests are evaluated on criteria outlined in the “Criteria for Review” section below. Special emphasis will be placed on those projects that exemplify the East Billings Urban Renewal District (EBURD) Master Plan. This plan is available for download at the BIRD website, www.billingsbird.com.

Projects requesting TIFD funds will either be increment generating where development will contribute to increased tax revenue for the TIF District, or non-increment generating projects that improve the aesthetics, character, safety and/or quality of life in the area.

This application is intended for eligible increment generating projects (see Appendix A for guidelines on TIF eligible projects.) All requests for TIFD funds are subject to approval by the Billings CITY Council and TIFD fund availability.

APPLICATION PROCESS AND TIMELINE

Anyone seeking TIF assistance from the BIRD must submit a written application for each TIF-assisted project. The following procedure has been developed to expedite the review of TIF funding requests.

1. Initial Contact. Contact Kelly McCarthy, BIRD Development Director, 1413 4th Avenue North, Suite C Billings, MT 59101, 406-545-7007, to discuss the project and determine preliminary eligibility for TIF assistance.
2. Prepare a Written Application. The APPLICANT must prepare a written application for each project assistance request. Applications must be received by the BIRD staff in advance of work on the project. Development Agreements must be approved and signed prior to commencement of construction (see #6 below.) Waiver of this requirement can be considered when public safety or other factors warrant. For all TIF requests, the APPLICANT must complete a “Developer’s Statement of Qualification and Financial Responsibility” which includes submittal of personal financial statements.
3. Staff Review. Upon submittal of all necessary information, the BIRD staff will review the project and the need for funding. At any point in the review process the staff or Board may request more information of the APPLICANT or solicit comment on the project from other public agencies. Items included in personal financial statements become public documents and are subject to public review or presentation to or comment by other agencies.
4. East District Development Review Team (BIRD BOARD MEMBERSHIP) Review. The BIRD Board serves as the review committee and will evaluate the application and staff recommendations. The review committee reserves the right to seek additional project review from supporting committees of the BIRD and from other public agencies. The review committee will issue preliminary approval/disapproval of the assistance request or any part thereof and will make a recommendation to the Billings CITY Council.
5. CITY Council Review. Projects will be forwarded to the Billings CITY Council for final approval and consideration of a Development Agreement that will clearly spell out the public investment required to be applied towards public infrastructure and/or development improvements within the public right of way. CITY Council approval is required before the BIRD and the CITY enter a Development Agreement with the APPLICANT.
6. Development Agreement. The BIRD, the CITY and the APPLICANT must execute a mutual agreeable legally binding Development Agreement which establishes the terms and conditions of TIF assistance. Sample Development Agreements are available at our office for reference. The Development Agreement may include, but is not limited to, the following:
 - Complete architectural design specifications and site plan

- Time frame for project development, construction and completion
 - Specifications for release of funds related to public infrastructure
 - Cash flow and pro forma statements for a minimum of five years of the development
 - Terms and conditions of the various financings
 - Commitment letters and loan documents related to the various financings
 - Ownership of completed development
 - Events of default; remedies
 - Zoning approval
 - Tenant commitments
 - Non-liability of CITY officials and BIRD
 - Cause for termination
7. Timing. Following the above process for approval, the APPLICANT can expect a minimum of 60 days between submitting an application to the BIRD and receiving a decision from the CITY Council.

COMMITMENT OF FUNDS

Upon CITY Council approval of a project, the BIRD will commit funds to the project from the annual East Billings TIFD project budget subject to availability of funds and/or potential for Tax Increment Bond issuance. Committed funds will be encumbered for a period of 180 days, by which time construction must have commenced. Commencement of construction means the date on which the first building permit is issued. Projects that have not commenced construction within 180 days risk losing the committed funds. Funds will be released only if the project is developed and constructed as presented in the Development Agreement. Funds will be released as specified by the Development Agreement or following project's receipt of a Certificate of Occupancy from the City of Billings if not specified. When necessary, the BIRD will encumber funds for additional fiscal years to accommodate construction schedules.

CRITERIA FOR REVIEW

Materials contained in TIF applications are used to assess the merits of projects in relation to the goals and objectives of the EBURD Master Plan. The BIRD evaluates projects based on the following criteria. Please prepare written response and provide supporting documentation for each of the applicable criteria areas.

1. Relevance to the EBURD Master Plan – Documentation of the project's impact in relation to the goals and objectives of the EBURD Master Plan, particularly mixed-use development. Urban design elements will also be considered, including pedestrian emphasis, quality of design, and Billings' personality.
2. Economic Stimulus – The amount of economic activity to be generated by the project is assessed, as well as the leverage ratio of public to private investment. Applications

should contain credible, measurable information substantiating APPLICANT claims of economic stimulus.

3. Tax Generation – The increase in taxable value due to new construction/rehabilitation is estimated by the County Assessor’s office or State Department of Revenue to determine tax increment generation.
4. Employment Generation – Total employment generated by the project assessed in terms of new permanent and part-time jobs, and construction jobs.
5. Elimination of Blight – The project’s direct and indirect impact on the physical and fiscal deterioration within the Tax Increment District and the community.
6. Special or Unique Opportunities – The extent to which the project represents a unique opportunity, meets a special need, or addresses specific BIRD or community goals. The restoration of historic property or the provision of an unmet community need, are examples of special and unique opportunities.
7. Impact Assessment – The extent of both positive and negative environmental impacts, appropriateness of the project design, and impact on existing businesses or residents.
8. Financial Assistance – Other forms of financing available to the APPLICANT, i.e. lender participation and state and federal grant monies, are examined to assess the need for TIF assistance.
9. Project Feasibility – A determination of feasibility is made on the strength of the APPLICANT’s demonstration of market demand for the project as contained primarily on the pro forma and financing commitments.
10. Developer Ability to Perform – An assessment of the APPLICANT’s capability to undertake the relative complexities of the project based on past performance on similar or comparable projects.
11. Timely Completion – The feasibility of completing the project according to the APPLICANT’s project schedule.
12. Payment of Taxes – All property taxes, special improvement district assessments, and other assessments on the project property must be paid to date



BILLINGS INDUSTRIAL REVITALIZATION DISTRICT, INC.
EAST DISTRICT TAX INCREMENT FINANCING (TIF) APPLICATION

Project Name: 1711 6th Ave North Remodel Date Submitted: 02-09-2016

APPLICANT INFORMATION

1. Name: Eggart Enterprises LLC
2. Address: 720 Lohwest Lane, Billings, MT 59106
3. Telephone Number: 406-839-9151

PROJECT INFORMATION

1. Building Address: 1711 6th Ave North, Billings, MT 59101
2. Legal Description: Billings First Add, S33, T01 N, R26 E, Block 274, Lot 1-12
3. Ownership: Eggart Enterprises LLC
Address: 720 Lohwest Lane, Billings, MT 59106

4. If property is not owned by the APPLICANT, list leasehold interests (Attach evidentiary materials.)
Name: _____
Address: _____

5. Existing/Proposed Businesses: Both Suite One & Suite Two are TBD
Business Description: TBD

6. Employment: Existing FTE Jobs Both Suite One & Suite Two are TBD
New Permanent FTE Jobs created by project 2+ Construction FTE Jobs 2+

7. Architectural Firm: EEC, INC
Address: 720 Lohwest Lane, Billings, MT 59106

Representative: Sara Mackie, AIA

8. Description of Project: (Attach narrative explanation.)

See attachment A

9. Rehabilitation/construction Plans: (Attach schematics, site and landscaping plans.)

See attachment B

10. Project Schedule: (Attach time line or schedule through completion.)

See attachment C

PROJECT COSTS

Land and Site Improvements (Itemized)

1. Equity in Land and Buildings	\$ <u>684,000.00</u>
2.	\$ _____
3.	\$ _____
4.	\$ _____

Subtotal \$ 684,000.00

Construction/Rehabilitation Costs (Use general construction trade divisions)

1. GENERAL: DEMO, STAKING, CLEANING	\$ <u>48,952.15</u>
2. SITEWORK	\$ <u>165,932.60</u>
3. CONCRETE & MASONRY	\$ <u>7,700.00</u>
4. METALS	\$ <u>126,472.23</u>
5. FRAMING & FINISHES	\$ <u>87,384.00</u>
6. THERMAL & MOISTURE PROTECTION	\$ <u>47,300.00</u>
7. DOORS & WINDOWS	\$ <u>45,764.00</u>
8. PLUMBING SYSTEMS	\$ <u>29,150.00</u>
9. HVAC	\$ <u>28,380.00</u>
10. ELECTRICAL	\$ <u>72,022.50</u>
11. SITE WORK - ROW	\$ <u>70,638.39</u>

Subtotal \$ 729,695.87

*See attachment D for cost breakdown

Fees

1. Architectural design/Supervision	\$ <u>18,700.00</u>
2. Permits <u>Bldg Permit & Plan Review Fee</u>	\$ <u>3,763.10</u>
3. Other fees <u>Insurance</u>	\$ <u>7,104.24</u>
Subtotal	\$ <u>29,567.34</u>
Total Project Development Costs	\$ <u>1,443,263.21</u>

PROJECT FINANCING

Please complete Sources of Funds detail and summarize below.

Developer Equity

Cash Invested	\$ <u>136,800.00</u>
Land & Buildings <u>FIB loan</u>	\$ <u>547,200.00</u>
Other (Specify) <u>FIB Construction loan</u>	\$ <u>550,900.00</u>
_____	\$ _____
Subtotal	\$ <u>1,234,900.00</u>

Lender Commitments (Attach evidence i.e. Letters of Credit or other documentation.)

Lender	Loan Amount	Interest	Term	Payment/Period
<u>FIB - Original</u>	\$ <u>547,200</u>	<u>5.5</u> %	<u>1</u> yrs	<u>Interest</u> \$ <u>Only</u> /Month
<u>FIB - Construction</u>	\$ <u>550,900</u>	<u>5.5</u> %	<u>1</u> yrs	<u>Interest</u> \$ <u>Only</u> /Month
Total Loan Amount				\$ <u>Interest Only</u>

TIF Request FOR improvements within the Public Right of Way

Eligible Improvements (See Narrative)	\$ _____
<u>*See attachment D for cost breakdown & attachment E for hard bids</u>	\$ _____

\$ _____

\$ _____

Subtotal \$ 70,638.39

Sources of Funds Summary (Post totals from above.)

Developer Equity \$ 136,800.00

Lender Commitments \$ 1,098,100.00

TIF Request \$ 70,638.39

Other Funds (Specify) _____ \$ _____

Total Project Financing \$ 1,305,538.39

DEVELOPER STATEMENT OF QUALIFICATIONS AND FINANCIAL RESPONSIBILITY

APPLICANT

1. Name: Eggart Enterprises, LLC

Address: 720 Lohwest Lane, Billings, MT 59106

2. If the APPLICANT is not an individual doing business under his/her own name, the APPLICANT has the status indicated below and is organized or operating under the laws of MT.

3.

A corporation.

_____ A nonprofit or charitable institution or corporation

_____ A partnership known as _____

_____ Other (explain): _____

Date of organization: 10-09-13

4. Names, address, title of position (if any), and nature and extent of the interest of the officers and principal members, principal shareholders, investors, or partners of the APPLICANT.

Name and Address	Nature and Extent of Interest
Quentin Eggart; 720 Lohwest Lane, Billings, MT 59106;	Sole Member

Financial Condition

1. Provide a current financial statement for each private entity involved in the project. Documentation of financial capacity may include net worth statements, balance sheets, and/or profit and loss statements.

See attachment F

2. Has the APPLICANT or any individual or entity affiliated with the development of this project been adjudged bankrupt, either voluntary or involuntary, within the past ten years?

No Yes _____ If yes, give date, place, and under what name

3. Has the APPLICANT or any individual or entity affiliated with the development of this project been indicted for or convicted of any felony within the past ten years:

No Yes _____ If yes, give date, charge, place, court and action taken for each case.

CONSTRUCTION CONTRACTOR

1. Identify the construction contractor or builder who will undertake this project.

Name: EEC, INC

Address: 720 Lohwest Lane, Billings, MT 59106

2. Has named contractor or builder ever failed to qualify as a responsible bidder, refused to enter into a contract after an award has been made, or failed to complete a construction or development contract within the last ten years?

No Yes _____ If yes, explain.

CERTIFICATION

I (we), Eggart Enterprises, LLC (please print),
certify that the statements and estimates within this Application as well as any and all
documentation submitted as attachments to this Application or under separate cover are true and
correct to the best of my (our) knowledge and belief. I/We certify that I/We will make no
application for any other tax abatement that may be available for this real property or building.

Signature _____

Signature _____

Title Quentin Eggart, Sole member

Title _____

Address 720 Lohwest Lane, Billings, MT 59106

Address _____

Date _____

Date _____



Appendix A

Examples of TIF-Eligible Public Infrastructure Improvements

Demolition and Abatement

Relocation

Sidewalks, Curbs, Gutters

Public Utilities - Water, Wastewater, Storm Water

Private Utilities - Electrical, Natural Gas, Telecommunications

Intersection Signals

Street Surface Improvements

Crosswalks

Landscaping

Green Space

Improvement of Pedestrian Areas

Historical Restorations

Off Street Parking

Bridges

Pollution Reduction

ATTACHMENT - A

(8) Description of Project:

The existing structure at 1711 6th Ave North was a Sign shop with a paint booth. The structure will be remodeled to create two leasable suites.

Suite one will be classified as Mercantile has yet to be leased.

Suite two is classified as office/warehouse space and is yet to be leased.

The existing site is to be completely redone. Boulder pits for storm water will be added. The front parking lot will be paved. The remaining land will consist of a gravel yard, landscape rock and grass. Trees and grass are to be planted in the ROW. A new, 6' tall architectural metal panel fence will enclose the back gravel yard. Sidewalks, new approaches, and ADA ramps are all to be added.

The building will get a new roof, new siding in most areas, upgraded insulation, upgrading lighting and heating, new ADA compliant restrooms, new doors and windows, and architectural appearance upgrades including two new canopies.

Eggart Enterprises is only requesting funding for work done in the Right of Way. Engineering and design is not included in the requested dollar amount.

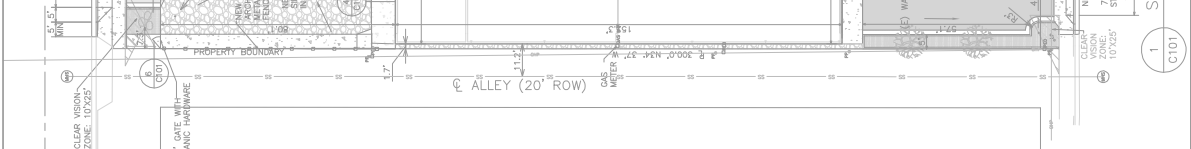
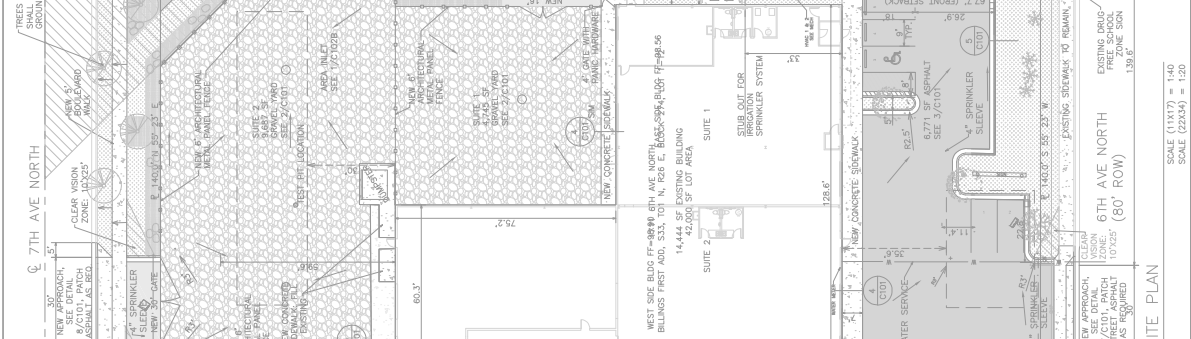
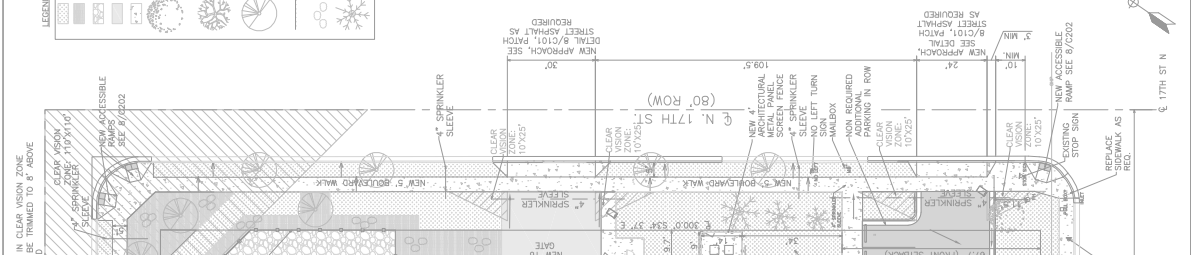
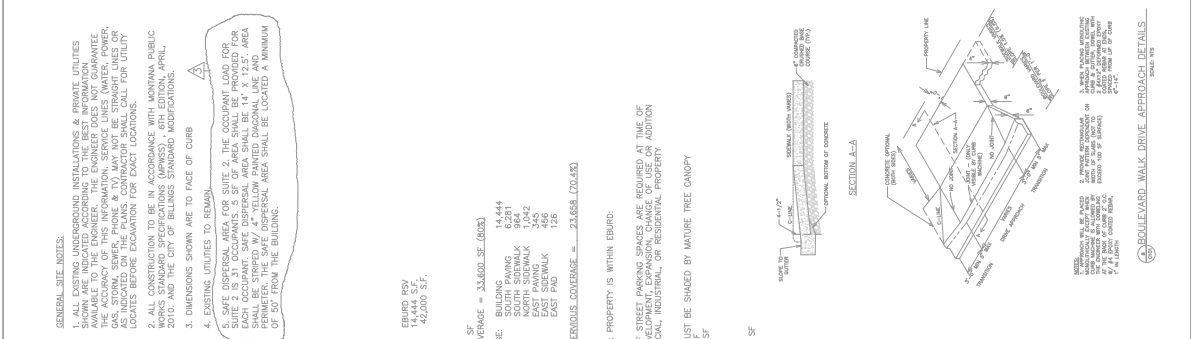
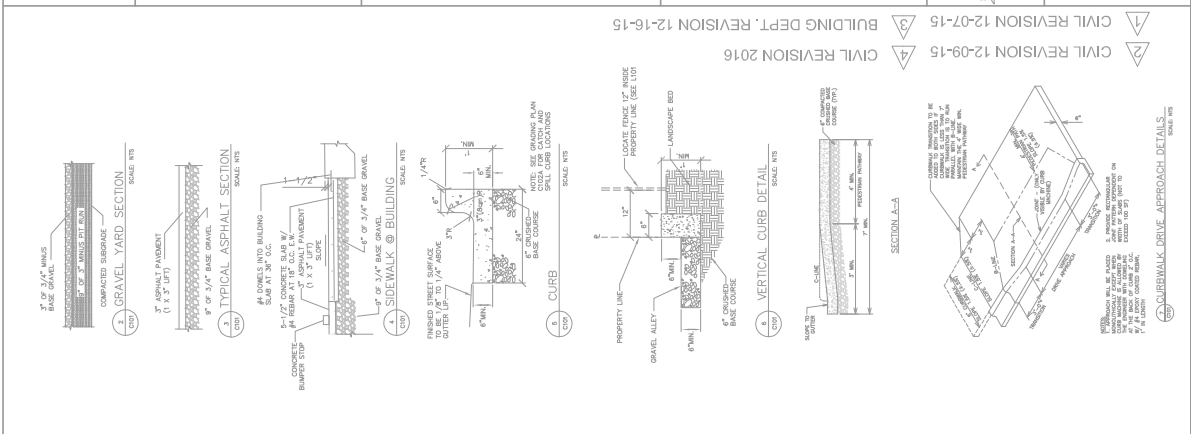

Drawn By: SM
 Checked By: QWE
 Date: 12-09-2015
 Project #: _____
 Cadd file: _____



ENGINEERS • ARCHITECTS
 SURVEYORS • BUILDERS
 BILLINGS, MT
 OFFICE: 406-839-9151 FAX: 406-839-9150

1711 6TH AVE NORTH REMODEL
 BILLINGS FIRST ADD, S33
 T01 N, R26 E, BLOCK 274,
 LOT 1-12
 SHEET#: C102A
 PERMIT

- 1 CIVIL REVISION 12-07-15
- 2 CIVIL REVISION 12-09-15
- 3 BUILDING DEPT. REVISION 12-16-15

GENERAL NOTES

1. CONTRACTOR SHALL VERIFY ALL EXISTING CONDITIONS AND DIMENSIONS. CONTRACTOR SHALL NOTIFY ENGINEER IMMEDIATELY FOR ANY DISCREPANCIES SHOWN ON THE PLANS.
2. CONTRACTOR TO PROTECT ALL EXISTING UTILITIES, AND STRUCTURES INDICATED OR INFERRED TO REMAIN AND REPAIR BACK TO ORIGINAL CONDITION IF DAMAGE HAS OCCURRED DURING CONSTRUCTION.
3. CONTRACTOR TO VERIFY ALL PERMITS, MATERIALS, TO BE REQUIRED FOR NEW CONSTRUCTION WHETHER OR NOT IT IS SPECIFICALLY NOTED.
4. REFER TO SHEET C103 FOR UTILITIES.
5. ALL DIMENSIONS ARE TO FACE OF CURB UNLESS OTHERWISE INDICATED.
6. EXTERIOR FOUNDATION BACKFILL AND BACKFILL BELOW CONCRETE SLABS, DRIVEWAYS, SIDEWALKS AND ALL OTHER CONCRETE ARE TO BE COMPACTED TO 95% OF MAXIMUM DRY DENSITY AS MEASURED BY ASTM D 698. IT IS THE CONTRACTOR'S RESPONSIBILITY TO OBTAIN PROPER DEBRIS, ORGANICS, FROZEN LUMPS AND OTHER DELETERIOUS MATERIALS. SEE SOILS REPORT FOR ADDITIONAL INFORMATION.

LEGEND

- FC FINISH GROUND
- TC TOP OF CURB
- EC EDGE OF CONCRETE
- EW EDGE OF SIDEWALK
- TW TOP OF WALL OR THICKENED EDGE SW
- FL FLOW LINE
- EXISTING CONTOUR
- GRADE BREAK
- SPILL CURB (SHOWN SHADED)

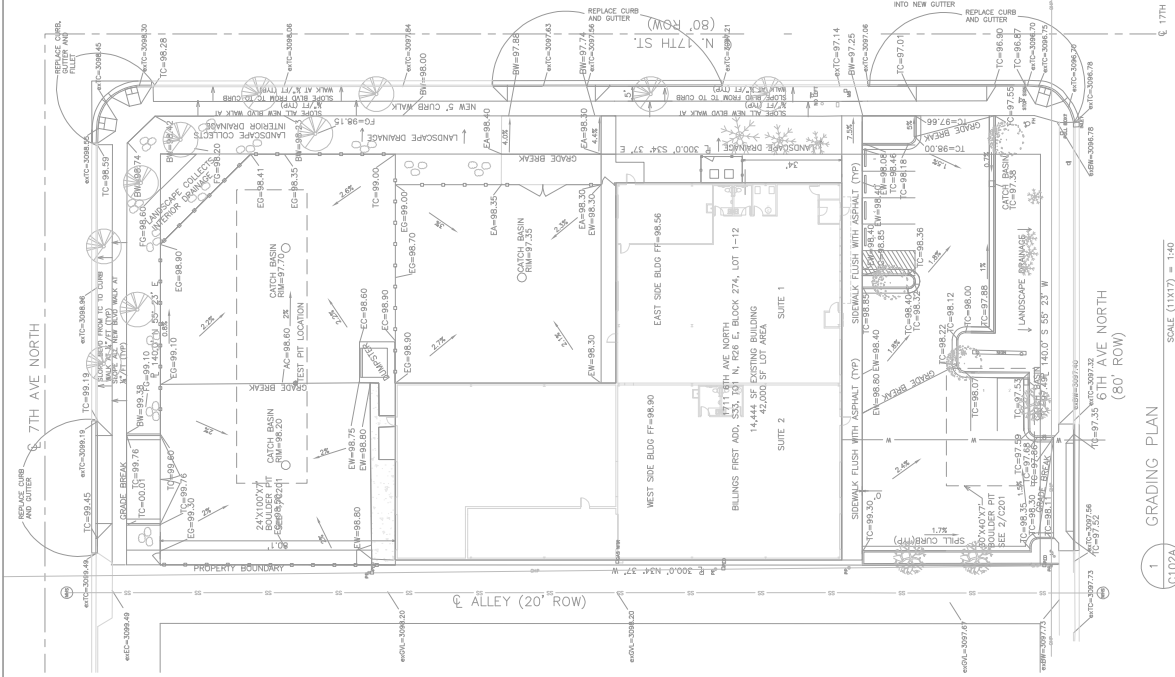

1 GRADING PLAN
 C102A
 SCALE (1:1X17) = 1:40
 SCALE (2:2X4) = 1:20



- 1 CIVIL REVISION 12-07-15
- 2 CIVIL REVISION 12-09-15
- 3 BUILDING DEPT. REVISION 12-16-15



GENERAL NOTES

1. CONTRACTOR SHALL VERIFY ALL EXISTING CONDITIONS AND UTILITIES PRIOR TO CONSTRUCTION. CONTRACTOR SHALL NOTIFY ENGINEER IMMEDIATELY FOR ANY DISCREPANCIES SHOWN ON THE PLANS.
2. CONTRACTOR TO PROTECT ALL EXISTING UTILITIES, AND STRUCTURES INDICATED OR REFERRED TO. REPAIR AND REPAIR BACK TO ORIGINAL CONDITION IF DAMAGE HAS OCCURRED DURING CONSTRUCTION.
3. CONTRACTOR TO VERIFY ALL DIMENSIONS, INCLUDING TO OR FROM EXISTING OR NEW CONSTRUCTION WHETHER OR NOT IT IS SPECIFICALLY NOTED.
4. REFER TO SHEET C103 FOR UTILITIES.
5. ALL DIMENSIONS ARE TO FACE OF CURB UNLESS OTHERWISE INDICATED.
6. EXISTING FOUNDATION BACKFILL AND BACKFILL BELOW CONCRETE SLABS, DRIVEWAYS, SEWELINKS AND ALL OTHER CONCRETE ARE TO BE REMOVED AND REPLACED WITH MAXIMUM DRY DENSITY AS MEASURED BY ASTM D 698. IT IS THE CONTRACTOR'S RESPONSIBILITY TO OBTAIN ALL NECESSARY DEBRIS ORDINANCES, FROZEN LUMPS AND OTHER DELETERIOUS MATERIALS. SEE SOILS REPORT FOR ADDITIONAL INFORMATION.

LEGEND

- FC FINISH GROUND
- TC TOP OF CURB
- EC EDGE OF CONCRETE
- EW EDGE OF SIDEWALK
- TW TOP OF WALL OR THICKENED EDGE SW
- FL FLOW LINE
- 3.000 EXISTING CONTOUR
- GRADE BREAK
- SPILL CURB (SHOWN SHAGED)

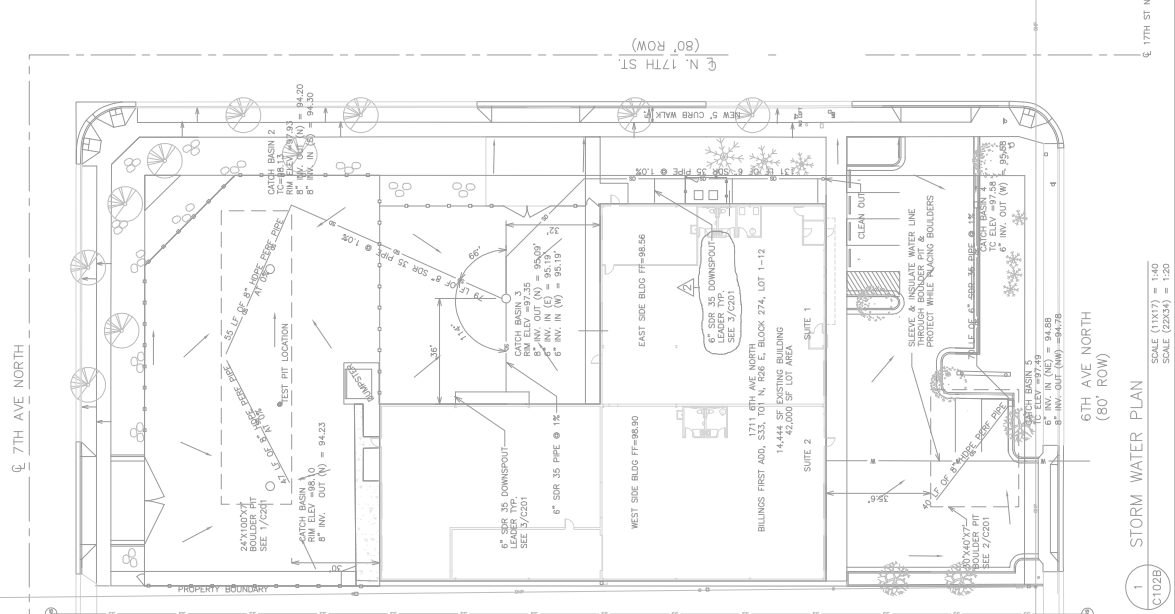

1 STORM WATER PLAN
 SCALE (1:1X17) = 1:40
 SCALE (2:2X34) = 1:50

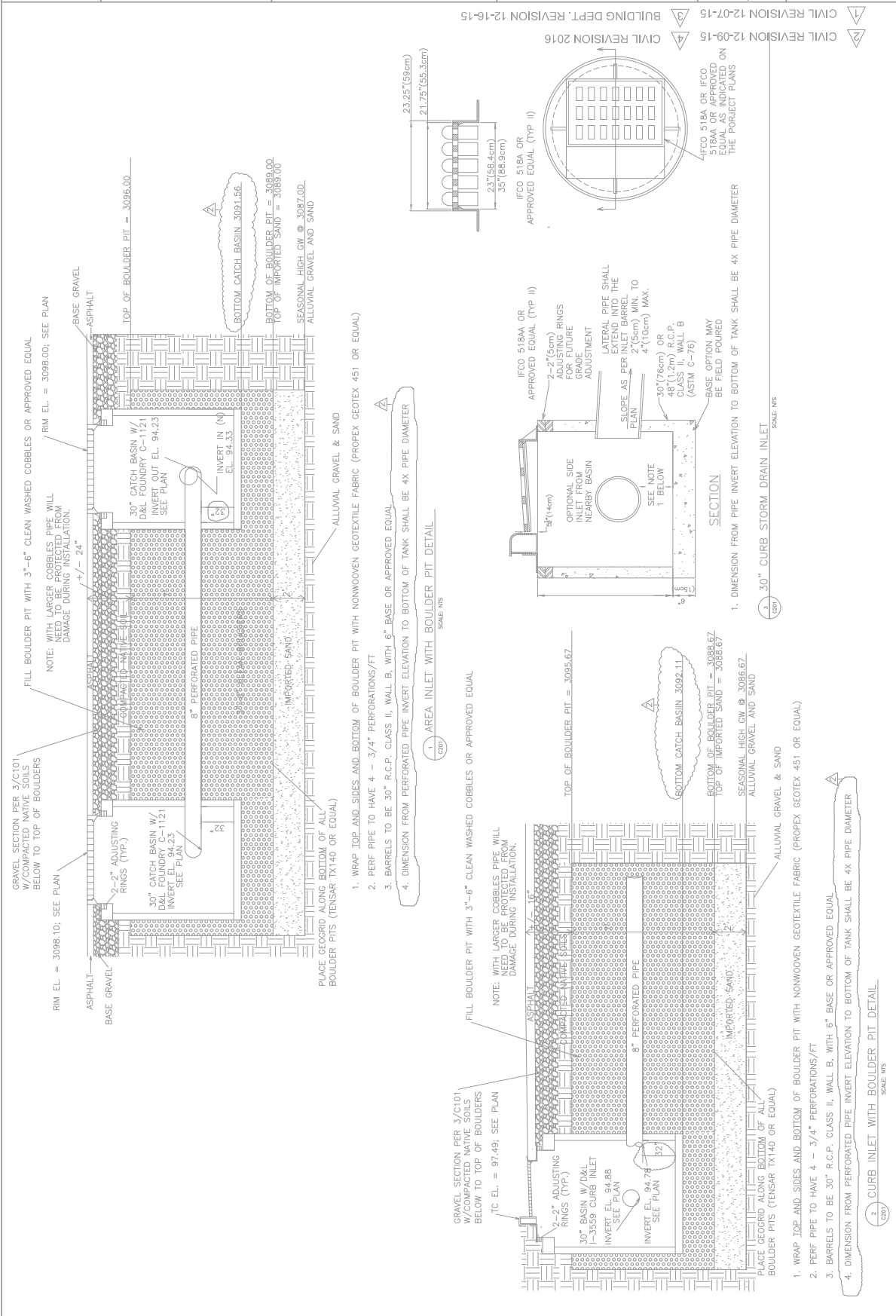

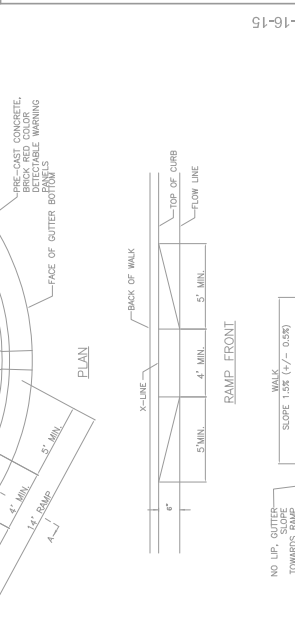
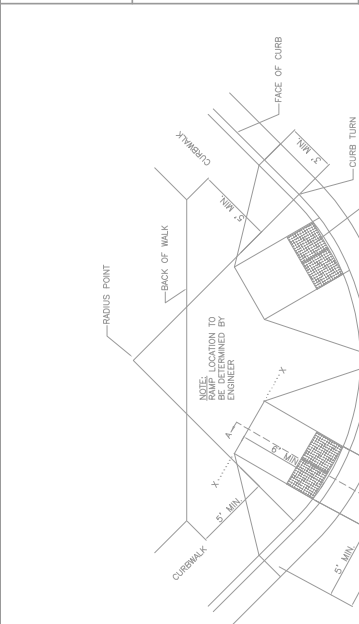

NOTES:
 1. NOT ALL INTERSECTIONS WILL HAVE TWO RAMPS PER CORNER, ENGINEER SHALL DECIDE IF TWO RAMPS ARE REQUIRED.
 2. PLACE TWO(2) ADA RAMPS AT UNCONTROLLED INTERSECTIONS.
 3. DIAGONAL OR MID-RADIUS RAMPS ARE NOT ALLOWED.
 4. DOWN WALK AND GUTTER WITH 2"(60cm) MAX. ON CENTER, EPOXY COATED #4 REBAR, 1"(25cm) IN LENGTH REFER TO SECTION 2320, "STREET EDUCATION, BACKFILL & COMPACTION OF THE IMPASS FOR SUBCUTTING / REPLACEMENT DUE TO UNSUITABLE SURGRADE MATERIAL."
 5. THIS DRAWING IDENTIFIES THE GENERAL CONCEPT OF RAMP CONSTRUCTION FOR THIS CONDITION, DETAILS MAY NEED TO BE MODIFIED TO FIT ACTUAL CONDITIONS. ALL SUCH MODIFICATIONS MUST BE APPROVED BY THE CITY ENGINEER'S OFFICE PRIOR TO USE.

ACCESSIBILITY RAMP DETAIL
 SCALE: NTS

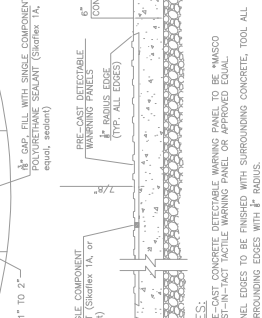
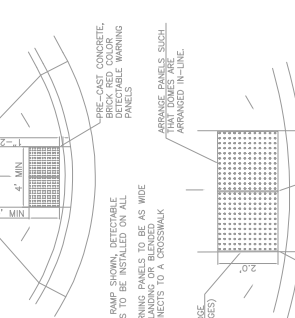
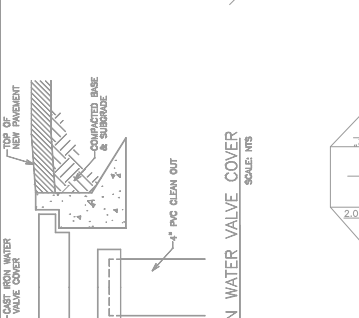

NOTES:
 1. PRE-CAST CONCRETE DETECTABLE WARNING PANEL TO BE "MANCO CAST-IN-FACT FACILE WARNING PANEL OR APPROVED EQUAL."
 2. PANEL EDGES TO BE FINISHED WITH SURROUNDING CONCRETE, TOOL ALL SURROUNDING EDGES WITH # RODS.
 3. CLEAN PANELS TO ENSURE NEAT APPEARANCE.
 4. PANELS TO BE INSTALLED FOLLOWING MANUFACTURER'S RECOMMENDATIONS.

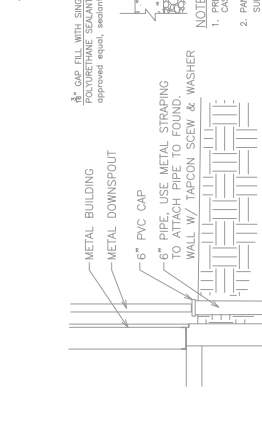
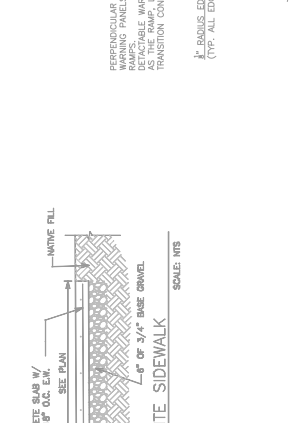
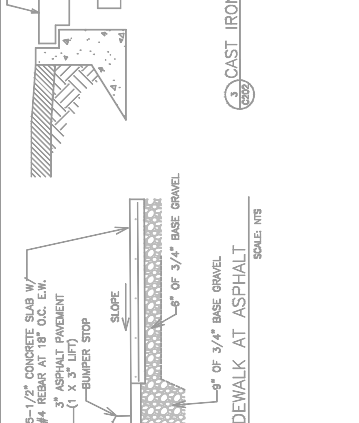

NOTE: AT ENDS OF LINES USE 90° BEND RATHER THAN TEE.
ROOF LEADER CONNECTION DETAIL
 SCALE: NTS

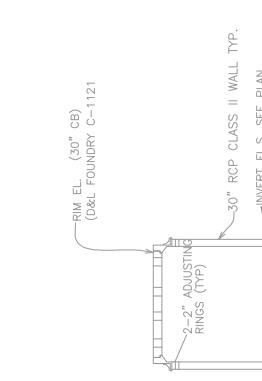
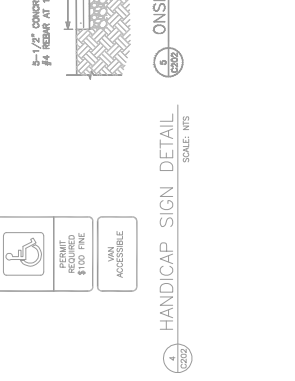
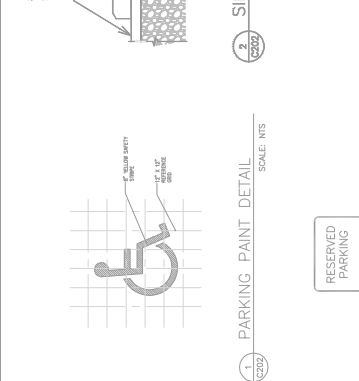

**30\"/>
 SCALE: NTS**

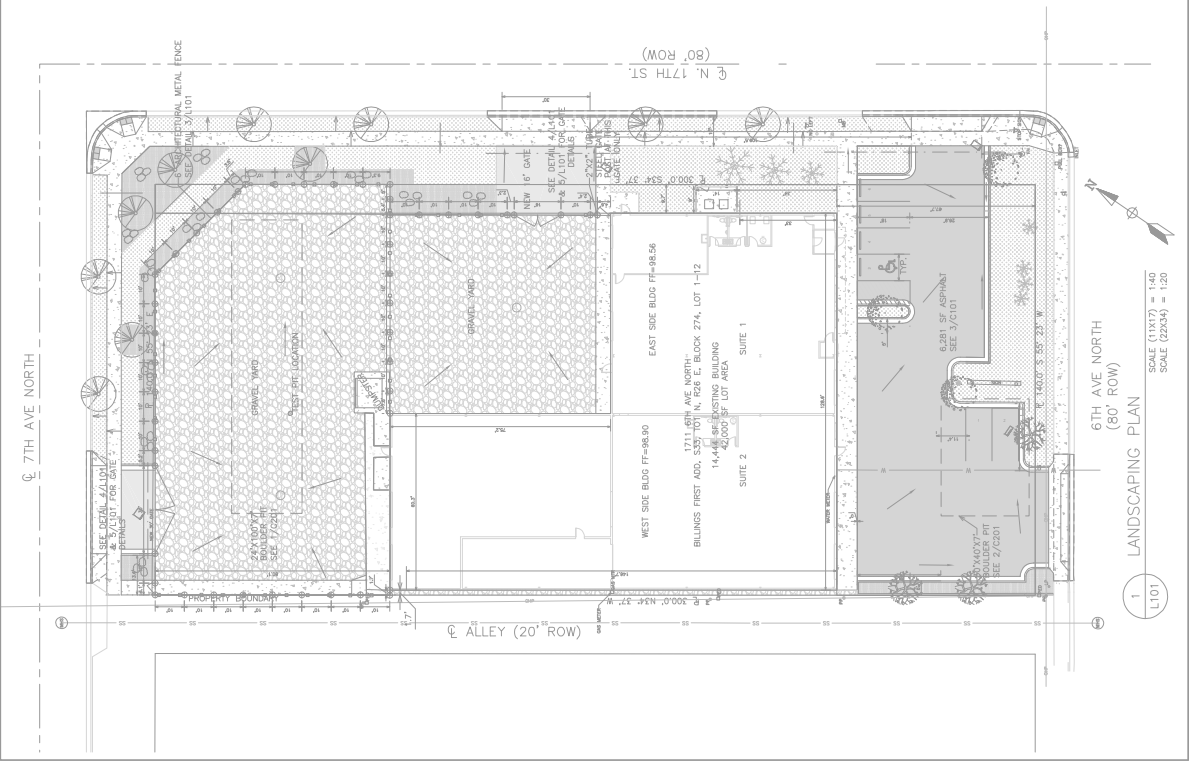
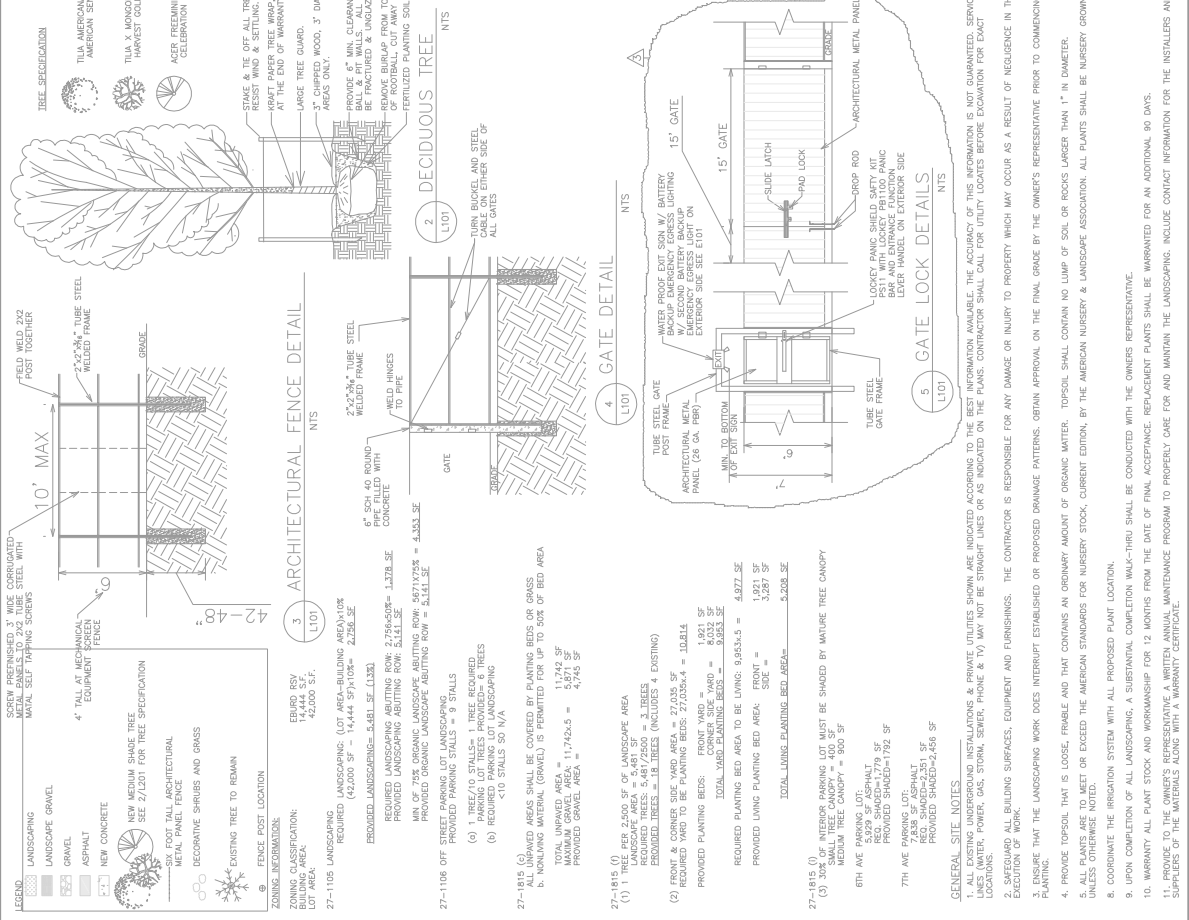

1 LANDSCAPING PLAN
 SCALE (1:12.5) = 1/4" = 1'-0"
 SCALE (2:24.5) = 1/2" = 1'-0"



PERMIT REVISION 12/16/2015

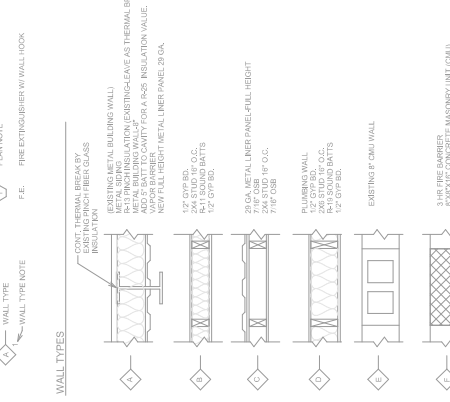

ITEM	CONSTRUCTION	MINIMUM FINISHED THICKNESS (INCHES)
1	EGGART CLASS 0.04 JULIE 0.04	0.04
2	EGGART CLASS 0.04 JULIE 0.04	0.04
3	EGGART CLASS 0.04 JULIE 0.04	0.04
4	EGGART CLASS 0.04 JULIE 0.04	0.04
5	EGGART CLASS 0.04 JULIE 0.04	0.04
6	EGGART CLASS 0.04 JULIE 0.04	0.04

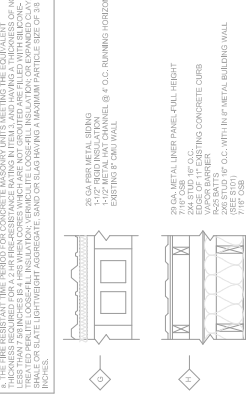

- WALL TYPE NOTES**
- EXISTING 2X4 WALL IS A PLUMBING WALL
 - 1/2" GYP ONLY ONE SIDE (BATHROOM SIBE)
 - 1 1/2" OSB & 20 GA METAL LINER PANEL, SALES ROOM SIDE OF WALL IN PLACE OF GYP.
 - 1 1/2" OSB IN PLACE OF GYP BO. ON STORAGE ROOM SIDE OF WALL HEIGHT
 - 20 GA METAL LINER PANEL BOTH SIDES OF BEHIND WALL-FULL HEIGHT

- PLAN NOTES**
- GIVE WITH FRAME HARDWARE, FRAME HARDWARE TO BE 1/2" DIA. W/ 1/4" THICKNESS.
 - INSTALL NEW DOOR W/ OPERATOR IN EXISTING OPENING.
 - 30" DIA. CEMENT TO INCREASE EXISTING COLUMNS AND CHASE FOR ELECTRICAL WIRING.
 - FOR THE EXISTING METAL BUILDING HOOP AND ADD FULL HEIGHT METAL LINER PANEL TO EXISTING METAL BUILDING.
 - BOTTLED WATER DISPENSER LOCATION

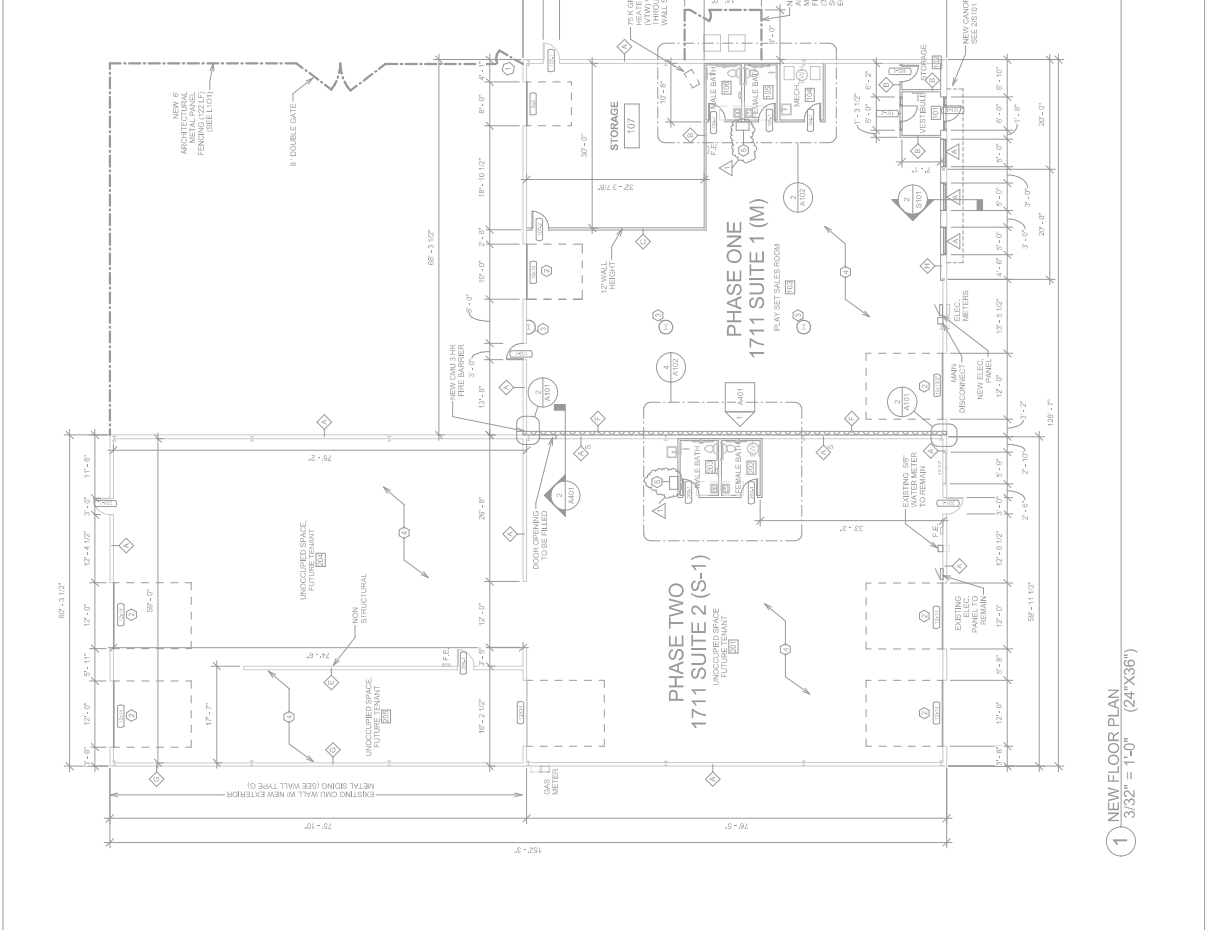
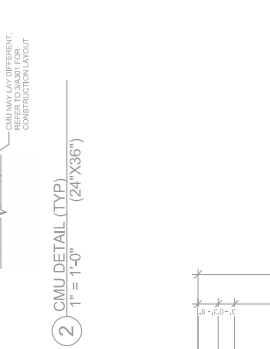
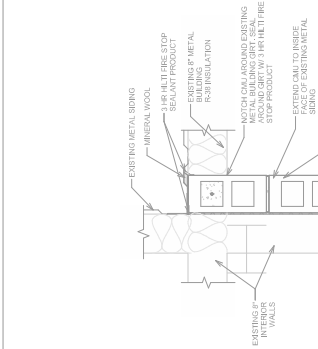

1 NEW FLOOR PLAN
3/32" = 1'-0" (24\"/>



PERMIT REVISION 12/16/2015

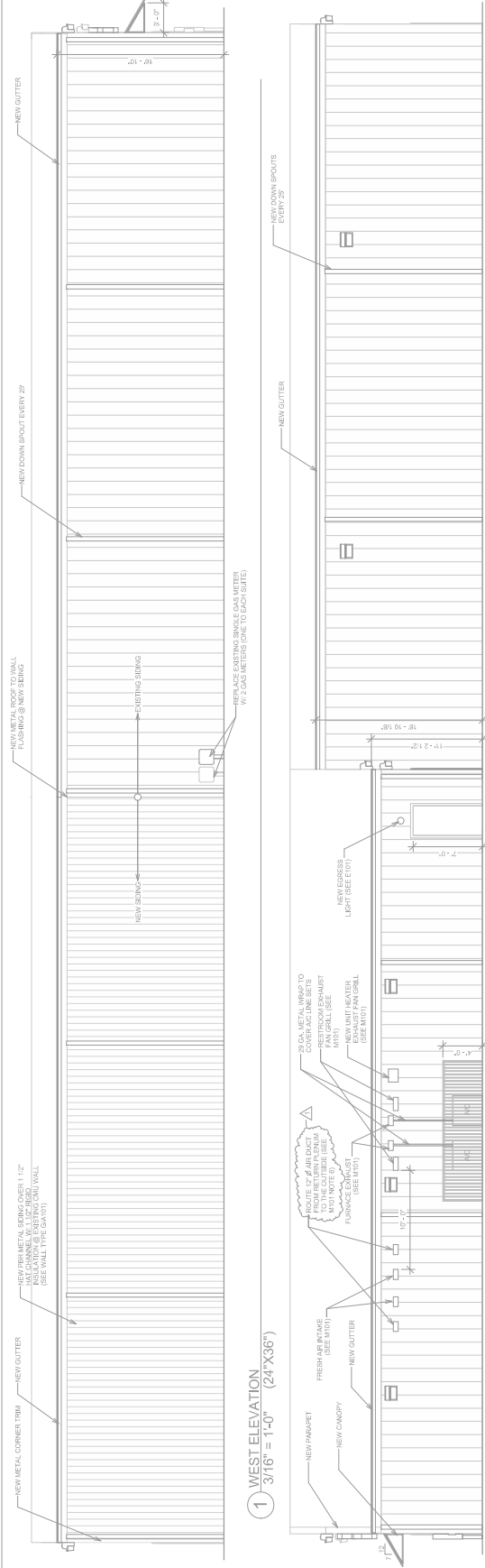

1 WEST ELEVATION
3/16" = 1'-0" (24'X36')

2 EAST ELEVATION
3/16" = 1'-0" (24'X36')

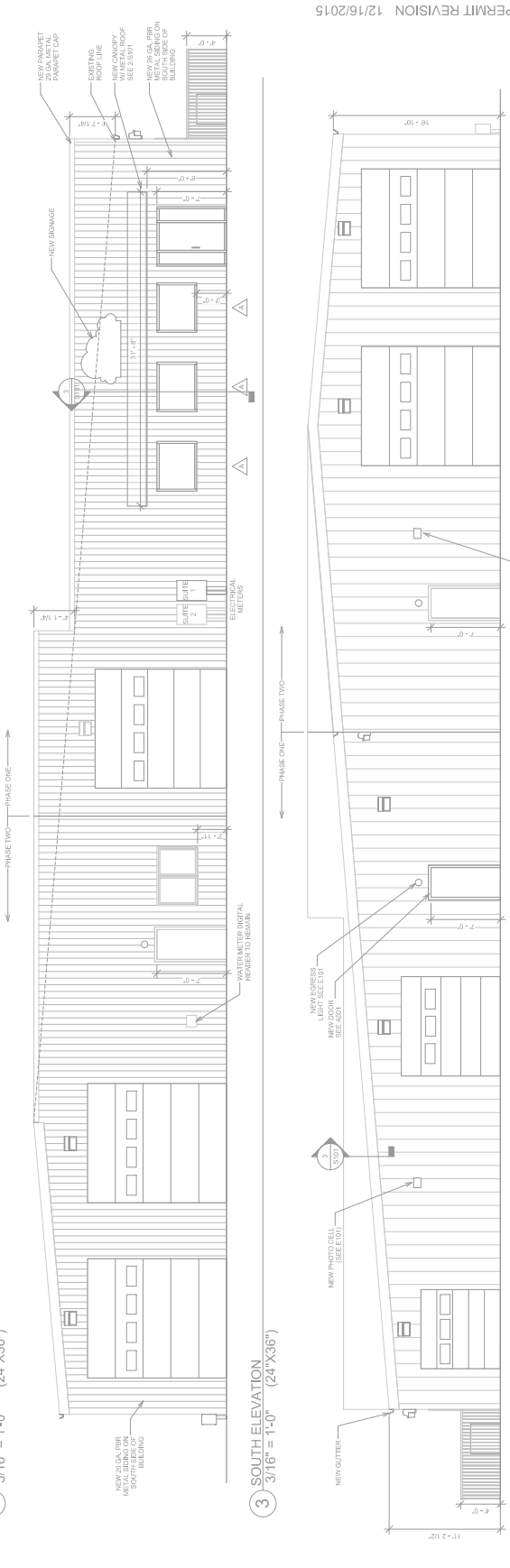

3 SOUTH ELEVATION
3/16" = 1'-0" (24'X36')

4 NORTH ELEVATION
3/16" = 1'-0" (24'X36')

PERMIT
A301

EGGART ENGINEERING COMPANY
1711 BUILDING REMODEL
BILLINGS, MT 59101

EGGART ENGINEERING COMPANY
720 LOHWEST LANE
BILLINGS, MT 59106
OFFICE: 406-839-9151 FAX: 406-839-9150



DRAWN BY: HS
CHECKED BY: SM, QWE
DATE: 12/15/2015
PROJECT#: 15-001

PERMIT REVISION 12/16/2015

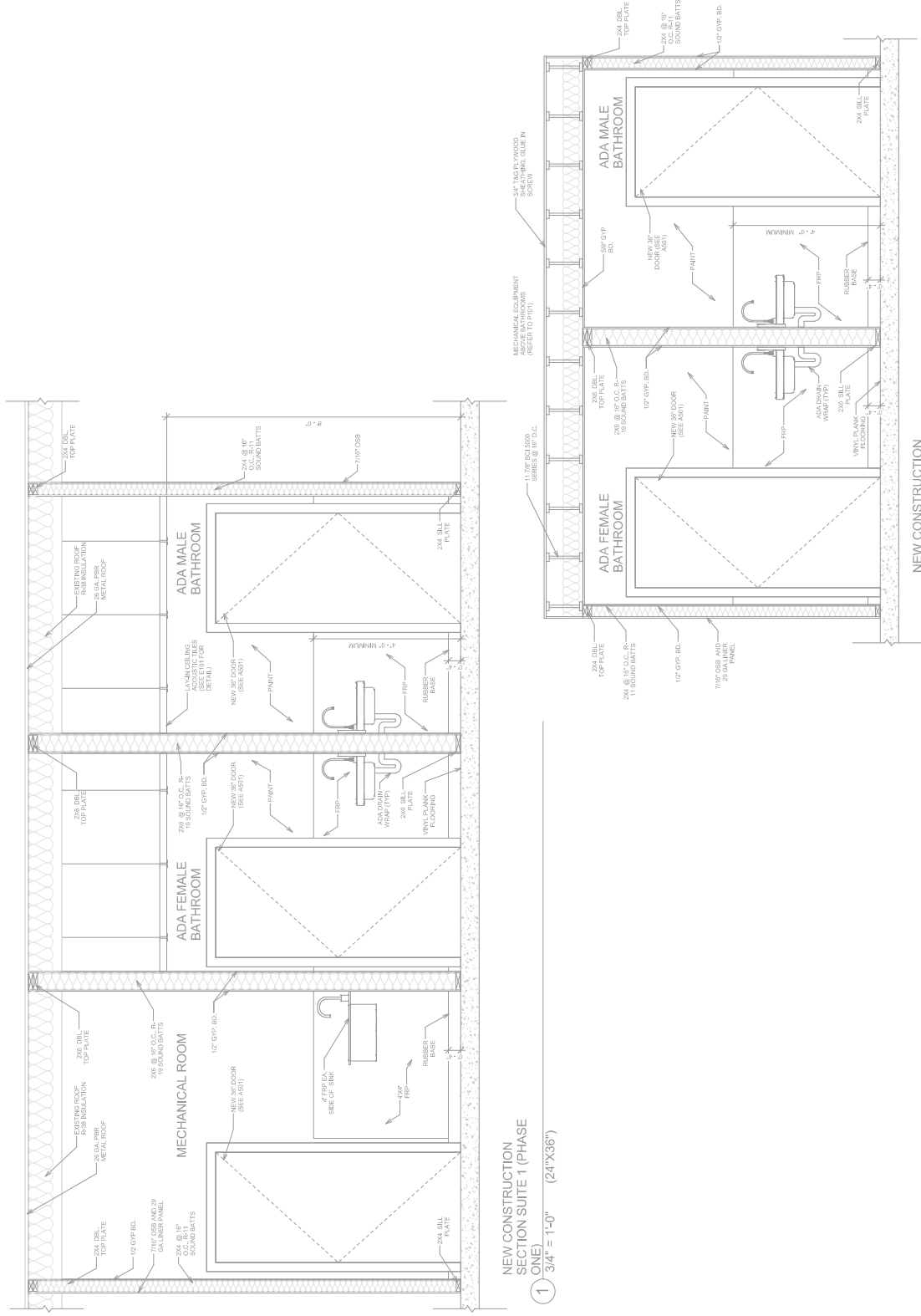

NEW CONSTRUCTION
SECTION SUITE 1 (PHASE ONE)
① 3/4" = 1'-0" (24"X36")

NEW CONSTRUCTION
SECTION SUITE 2 (PHASE TWO)
② 3/4" = 1'-0" (24"X36")

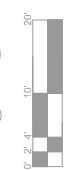
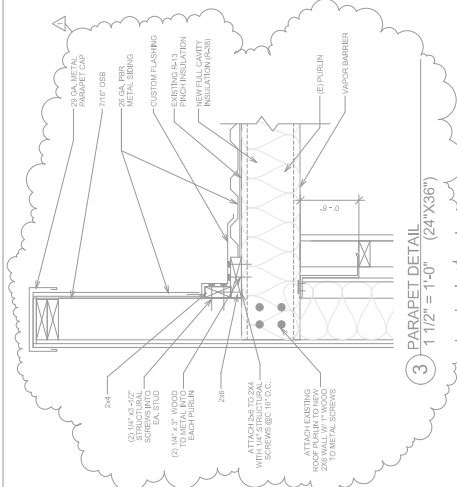
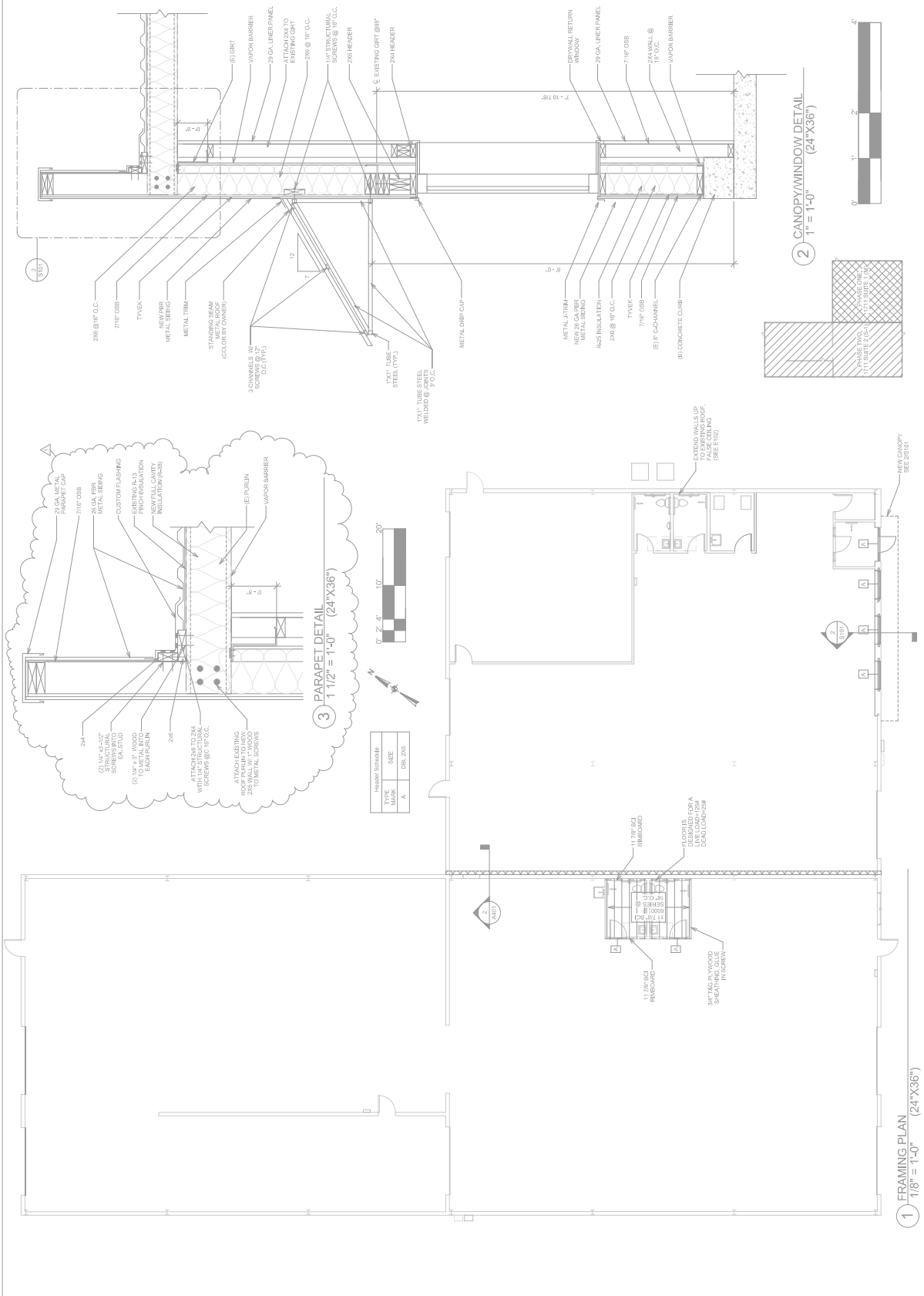

Header Schedule	
TYPE	SIZE
A	2x6
B	2x6

1 FRAMING PLAN
 1/8" = 1'-0" (24" X 36")

3 PARAPET DETAIL
 1/12 = 1'-0" (24" X 36")

2 CANOPY/WINDOW DETAIL
 1/4 = 1'-0" (24" X 36")

GENERAL NOTES

- 1) ALL WORK SHALL BE PERFORMED BY OR DIRECTLY SUPERVISED BY AN EXPERIENCED AND SKILLED CRAFTSMAN IN THE TRADE. ALL WORK SHALL BE NEAT, CLEAN AND COMPLETED IN ACCORDANCE WITH THE INSTALLATION IDENTIFIED BY OWNER. GC SHALL REPLACE AT THE CONTRACTOR'S EXPENSE WITHOUT IMPACT TO THE CONSTRUCTION SCHEDULE.
- 2) NEW EQUIPMENT MANUFACTURER & MODEL NUMBERS LISTED IN SCHEDULES & NOTES DEFINE PERFORMANCE REQUIREMENTS. CONTRACTOR SHALL VERIFY EQUIPMENT OR EXCEED THOSE REQUIREMENTS PRIOR TO OBTAINING APPROVAL FROM THE CITY OF GERMANTOWN. CONTRACTOR SHALL VERIFY ALL GM & OWNER FOR ALL TERMINATE EQUIPMENT AND DEVICES.
- 3) WORKMANSHIP SHALL COMPLY WITH THE CURRENT CODES AND ALL OTHER LOCAL CODES AND ORDINANCES.
- 4) ALL NEW SEWER PIPE SHALL SLOPE A MIN 1/4" PER FOOT.

DOMESTIC WATER HEATER SCHEDULE

TAGS	HEATER TYPE	TANK	5	ELECTRIC	1	110	94	140	3.0	200-1	ELEC DATA	TRAP RECOVERY	TRAP P	HW	MCOP	MANUFACTURER	MANUFACTURER	NOTES	
EW-1	TANK	5	ELECTRIC	1	110	94	140	3.0	200-1	---	---	---	---	---	---	---	---	STATE ESB OR EQUAL	1

1. SET WATER HEATER IN BRICK PAN AND PIPE PAN TO FLOOR DRAIN

PLUMBING FIXTURE AND EQUIPMENT SCHEDULE

TAGS	FIXTURE	MANUFACTURER	TRIM	SUPPLIES	TRAP/WASTE	RVN	CW	HW/TD/P	WASTE	VENT	NOTES/REMARKS
FD-1	FLOOR DRAIN	SINK/CHIEF	---	---	DEEP SEAL	---	---	---	---	---	1.12 ROUND NECK
LD-1	LAVATORY W/ ADA	PROFLO	ACER	WITH STOPS	OFFSET TRAP	---	---	---	---	---	1.12 ADA INSUL. REDUCER
WC-1	WATER CLOSET W/ ADA	PROFLO	ACER	WITH STOPS	---	---	---	---	---	---	1.12 ADA INSUL. REDUCER
U-1	URINAL	CRANE	SEAT	WITH STOPS	---	---	---	---	---	---	1.12 ADA INSUL. REDUCER
BP-1	BP BACKFLOW PREVENTER	MEANS	---	---	---	---	---	---	---	---	1.12 PRESSURE LABEL

NOTES

- 1) PAINTED ESCUTCHEONS, ADA INSULATION ON SAN, CW, & HW. COVER-PLATE FOR FAUCET HOLES IN LAY INSTALL TRAP PRIMER TAIL PIECE CHIEF 215-490.
- 1.12 ROUTE CONTINUOUS OFFSET COPPER TUBING OR PEX FROM TAIL PIECE ON IN WALL TO FD-1 PRIMER CONNECTION. TUBING SHALL HAVE NO JOINTS FROM TAIL PIECE TO FD-1.
- 3) PROVIDE WALL CARRIER FOR FIXTURE
- 4) PROVIDE SHOCK ABSORBER ON COLD WATER LINE TO URINALS

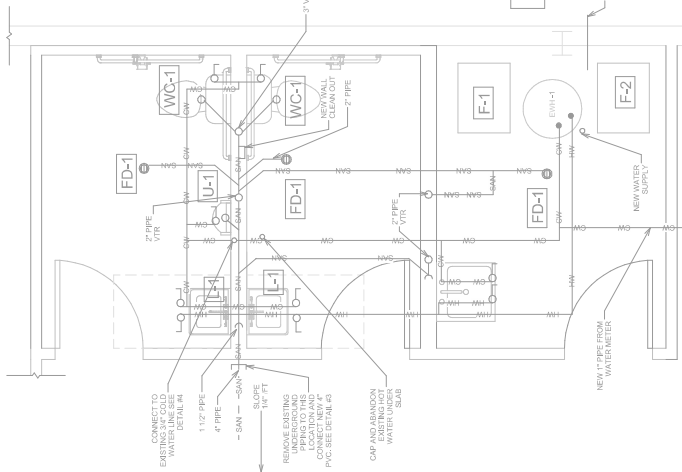

1) PLUMBING NEW CONSTRUCTION BATH SUITE 1 (PHASE ONE) 1/2" = 1'-0" (24" X 36")

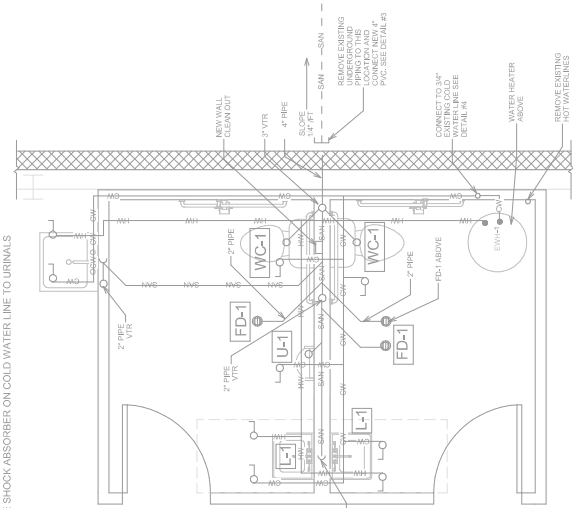

2) PLUMBING NEW CONSTRUCTION BATH SUITE 2 (PHASE TWO) 1/2" = 1'-0" (24" X 36")

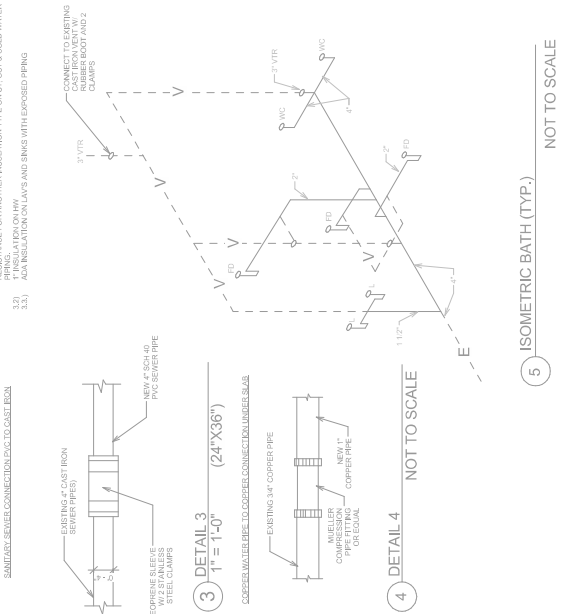

5) ISOMETRIC BATH (TYP.) NOT TO SCALE

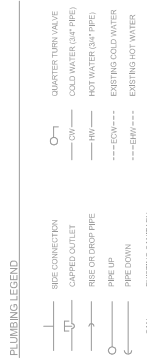

PLUMBING NOTES

- 1) CONNECT VENTS TOGETHER IN WALL A MIN 4" ABOVE THE HIGHEST FLOOR RM.
- 2) VENTS SHALL BE 1/2" ABOVE THE HIGHEST FLOOR RM.
- 3) VENTS SHALL BE 1/2" ABOVE THE HIGHEST FLOOR RM.
- 4) VENTS SHALL BE 1/2" ABOVE THE HIGHEST FLOOR RM.

INSULATION

- 1) INSULATION SHALL BE FORMALDEHYDE FREE
- 2) INSULATION PRODUCT IS SHALL BE UL LISTED OR EQUAL
- 3) INSULATION SHALL BE 1/2" THICK
- 4) INSULATION SHALL BE 1/2" THICK
- 5) INSULATION SHALL BE 1/2" THICK

EGGART ENGINEERING COMPANY
720 LOWEST LANE
BILLINGS, MT 59106
OFFICE: 406-839-9151 FAX: 406-839-9150

EGGART ENGINEERING COMPANY
720 LOWEST LANE
BILLINGS, MT 59106
OFFICE: 406-839-9151 FAX: 406-839-9150

EGGART ENGINEERING COMPANY
720 LOWEST LANE
BILLINGS, MT 59106
OFFICE: 406-839-9151 FAX: 406-839-9150

EGGART ENGINEERING COMPANY
720 LOWEST LANE
BILLINGS, MT 59106
OFFICE: 406-839-9151 FAX: 406-839-9150

EGGART ENGINEERING COMPANY
720 LOWEST LANE
BILLINGS, MT 59106
OFFICE: 406-839-9151 FAX: 406-839-9150

EGGART ENGINEERING COMPANY
720 LOWEST LANE
BILLINGS, MT 59106
OFFICE: 406-839-9151 FAX: 406-839-9150

COMMERCIAL SPECIFICATIONS

SECTION 16009 - GENERAL PROVISIONS FOR ELECTRICAL WORK

1.01 GENERAL
 A. Contractor shall provide labor, materials, equipment, items, articles, operations and methods listed, above, scheduled, or mentioned on the drawing, and/or specified, including all incidents required for their completion.

1.02 MATERIALS, SUBSTITUTION AND APPROVAL
 A. All items in this DIVISION are eligible for substitution. The final decision as to whether or not a substitute item will be approved shall be made by the Architect in the presence of the Contractor. The substitute item shall fit into the space allocated and that the item can be installed and function as intended. Should changes in the work of any Contractor become necessary as a result of any substitutions, the Contractor shall be responsible for the cost of such changes and for the design of the DIVISION, such changes shall be integrated and paid for by the Contractor.

1.03 CODES, REGULATIONS AND PERMITS
 A. Comply with the National Electrical Code, National Electrical Safety Code, local state Electrical Code, International Building Code, and all other applicable codes, ordinances, laws, rules, regulations, codes, specifications and standards. Obtain all permits and approvals required for the execution of the work.

1.04 INTENT OF DRAWINGS
 A. Rules and other diagrams are schematic only and not to scale. They are intended only to show sizes or relative arrangement of conduit and equipment shown elsewhere in plan view.

1.05 RESPONSIBILITY
 A. The Contractor is responsible for the installation of satisfactory and complete pieces of equipment and materials in accordance with the drawings and specifications. Consult all drawings for project to predetermine work and equipment will fit as planned.

1.06 MECHANICAL WORK
 A. Make electrical provisions for all equipment where it is the responsibility of this Contractor.

1.07 COMPLETION AND TESTING
 A. Complete and test each system and leave in proper operation, free of faults, shorts and ground faults. Obtain all necessary permits and approvals, under this contract, for continuity and grounds before energizing any system.

1.08 GROUNDING
 A. Excess wires specifically indicated otherwise, all excess noncurrent-carrying metallic parts of electrical equipment and neutral conductor of the wiring system shall be grounded.

1.09 RECORD DRAWINGS
 A. Maintain a separate set of electrical drawings at the job at all times to be used as a record of the work. The drawings shall be the drawings as shown on the drawings and additions in the construction and/or electrical systems made thereon. Deliver to the Engineer at the completion of the job. This set of drawings shall be kept neat and clean.

1.10 SHOP DRAWINGS
 A. Submit shop drawings for approval before ordering. Contractor check, submit drawings and specifications. Shop drawing submissions revised, changed, and/or resubmitted until acceptable and approved by the Engineer.
 B. The Contractor shall be responsible for the design and construction of all shop drawings from responsibility for errors in shop drawings or literature.
 C. One copy each approved shop drawing retained by Contractor and bound in Binder or Equipment.

SECTION 16111 - CONDUIT

PART 1-GENERAL
1.01 WORK INCLUDED
 A. Conduit and couplings

PART 2-PRODUCTS
2.01 MATERIALS AND COMPONENTS
 A. Conduit run underground to be schedule 40 pvc with schedule 80 pre elbows
 B. Conduit in building to be EMT with steel sets screw fittings.
 C. Flex conduits shall be galvanized, flexible steel in dry areas & rubber or MC type covered neoprene type (suitable with moisture tight fittings in wet locations)
 D. MC type covered neoprene type (suitable with moisture tight fittings in wet locations, device where allowed in N.E.C. & the local jurisdiction.

2.02 TYPE
 A. Utilize conduit in concrete.
 B. For underground conduit, use Schedule 40 PVC with Schedule 80 PVC elbows.

PART 3-EXECUTION
3.01 INSTALLATION
 A. Plug ends to prevent entry of dirt or moisture.
 B. Clean out conduit before installation of conductor.

SECTION 16120 - WIRES AND CABLES

PART 1-GENERAL
1.01 WORK INCLUDED
 A. Wires and cables.

1.01 GENERAL
 A. Contractor shall provide labor, materials, equipment, items, articles, operations and methods listed, above, scheduled, or mentioned on the drawing, and/or specified, including all incidents required for their completion.

1.02 MATERIALS, SUBSTITUTION AND APPROVAL
 A. All items in this DIVISION are eligible for substitution. The final decision as to whether or not a substitute item will be approved shall be made by the Architect in the presence of the Contractor. The substitute item shall fit into the space allocated and that the item can be installed and function as intended. Should changes in the work of any Contractor become necessary as a result of any substitutions, the Contractor shall be responsible for the cost of such changes and for the design of the DIVISION, such changes shall be integrated and paid for by the Contractor.

1.03 CODES, REGULATIONS AND PERMITS
 A. Comply with the National Electrical Code, National Electrical Safety Code, local state Electrical Code, International Building Code, and all other applicable codes, ordinances, laws, rules, regulations, codes, specifications and standards. Obtain all permits and approvals required for the execution of the work.

1.04 INTENT OF DRAWINGS
 A. Rules and other diagrams are schematic only and not to scale. They are intended only to show sizes or relative arrangement of conduit and equipment shown elsewhere in plan view.

1.05 RESPONSIBILITY
 A. The Contractor is responsible for the installation of satisfactory and complete pieces of equipment and materials in accordance with the drawings and specifications. Consult all drawings for project to predetermine work and equipment will fit as planned.

1.06 MECHANICAL WORK
 A. Make electrical provisions for all equipment where it is the responsibility of this Contractor.

1.07 COMPLETION AND TESTING
 A. Complete and test each system and leave in proper operation, free of faults, shorts and ground faults. Obtain all necessary permits and approvals, under this contract, for continuity and grounds before energizing any system.

1.08 GROUNDING
 A. Excess wires specifically indicated otherwise, all excess noncurrent-carrying metallic parts of electrical equipment and neutral conductor of the wiring system shall be grounded.

1.09 RECORD DRAWINGS
 A. Maintain a separate set of electrical drawings at the job at all times to be used as a record of the work. The drawings shall be the drawings as shown on the drawings and additions in the construction and/or electrical systems made thereon. Deliver to the Engineer at the completion of the job. This set of drawings shall be kept neat and clean.

1.10 SHOP DRAWINGS
 A. Submit shop drawings for approval before ordering. Contractor check, submit drawings and specifications. Shop drawing submissions revised, changed, and/or resubmitted until acceptable and approved by the Engineer.
 B. The Contractor shall be responsible for the design and construction of all shop drawings from responsibility for errors in shop drawings or literature.
 C. One copy each approved shop drawing retained by Contractor and bound in Binder or Equipment.

SECTION 16141 - WALL SWITCHES
PART 1-GENERAL
1.01 WORK INCLUDED
 A. Wall Switches.

1.02 RELATED WORK
 A. Section 16134: Device Boxes.

PART 2-PRODUCTS
2.01 ACCEPTABLE MANUFACTURERS
 A. Leviton
 B. Bryant
 C. G.E.

2.02 MATERIALS
 A. 120 Volt Switches: Quiet slow make, slow break design, toggle handle, with totally enclosed case, rated 20 ampere, commercial grade. Provide matching outlet boxes for prewired 2-way switches.
 B. Color Match required.

3.01 INSTALLATION
 A. Switch mounting height to match existing.
 B. Switches shall be installed in accordance with manufacturer's instructions.
 C. It is the electrical contractor's responsibility to assure switches are located at each side of doors.

SECTION 16145 - RECEPTACLES

PART 1-GENERAL
1.01 WORK INCLUDED
 A. Receptacles

1.02 RELATED WORK
 A. Section 16134: Device Boxes
 B. Section 16147: Plate Covers
 C. Section 16161: Grounding.

1.01 GENERAL
 A. Contractor shall provide labor, materials, equipment, items, articles, operations and methods listed, above, scheduled, or mentioned on the drawing, and/or specified, including all incidents required for their completion.

1.02 MATERIALS, SUBSTITUTION AND APPROVAL
 A. All items in this DIVISION are eligible for substitution. The final decision as to whether or not a substitute item will be approved shall be made by the Architect in the presence of the Contractor. The substitute item shall fit into the space allocated and that the item can be installed and function as intended. Should changes in the work of any Contractor become necessary as a result of any substitutions, the Contractor shall be responsible for the cost of such changes and for the design of the DIVISION, such changes shall be integrated and paid for by the Contractor.

1.03 CODES, REGULATIONS AND PERMITS
 A. Comply with the National Electrical Code, National Electrical Safety Code, local state Electrical Code, International Building Code, and all other applicable codes, ordinances, laws, rules, regulations, codes, specifications and standards. Obtain all permits and approvals required for the execution of the work.

1.04 INTENT OF DRAWINGS
 A. Rules and other diagrams are schematic only and not to scale. They are intended only to show sizes or relative arrangement of conduit and equipment shown elsewhere in plan view.

1.05 RESPONSIBILITY
 A. The Contractor is responsible for the installation of satisfactory and complete pieces of equipment and materials in accordance with the drawings and specifications. Consult all drawings for project to predetermine work and equipment will fit as planned.

1.06 MECHANICAL WORK
 A. Make electrical provisions for all equipment where it is the responsibility of this Contractor.

1.07 COMPLETION AND TESTING
 A. Complete and test each system and leave in proper operation, free of faults, shorts and ground faults. Obtain all necessary permits and approvals, under this contract, for continuity and grounds before energizing any system.

1.08 GROUNDING
 A. Excess wires specifically indicated otherwise, all excess noncurrent-carrying metallic parts of electrical equipment and neutral conductor of the wiring system shall be grounded.

1.09 RECORD DRAWINGS
 A. Maintain a separate set of electrical drawings at the job at all times to be used as a record of the work. The drawings shall be the drawings as shown on the drawings and additions in the construction and/or electrical systems made thereon. Deliver to the Engineer at the completion of the job. This set of drawings shall be kept neat and clean.

1.10 SHOP DRAWINGS
 A. Submit shop drawings for approval before ordering. Contractor check, submit drawings and specifications. Shop drawing submissions revised, changed, and/or resubmitted until acceptable and approved by the Engineer.
 B. The Contractor shall be responsible for the design and construction of all shop drawings from responsibility for errors in shop drawings or literature.
 C. One copy each approved shop drawing retained by Contractor and bound in Binder or Equipment.

SECTION 16200 - BUILDING LIGHTING
PART 1-GENERAL
1.01 WORK INCLUDED
 A. Installation of lighting fixtures, luminaires, supports and accessories, and supply of plaster frames, trim rings and backboxes for plaster or drywall ceilings or concrete.

1.02 RELATED WORK
 A. Section 16120: Wires and Cables

2.01 LUMINAIRES
 A. See drawings for electrical and lighting schedule.
 B. See drawings for electrical and lighting schedule.

3.01 LUMINARY SCHEDULE
 A. See drawings for electrical and lighting schedule.
 B. See drawings for electrical and lighting schedule.

3.02 RELATED WORK
 A. Section 16120: Wires and Cables

SECTION 16800 - IDENTIFICATION

1. PROVIDE ELECTRICAL IDENTIFICATION:
 A. All junction box covers and receptacle coverplates to have panel, circuit and service labels.
 B. All panels to have new type written registers.
 C. Provide laminated plastic nameplates on each panel, motor control center and electrical equipment. State use of each contractor, where not obvious.
 D. Panel shall be labeled for voltage of cover with:
 VOLTAGE/PHASE
 WIRING COLOR DESIGNATIONS.
 E. Additionally, on outside of circuit breaker door place N.E.C. 70% warning label for arc flash.

PERMIT

1711 BUILDING REMODEL

1711 6TH AVE NORTH
 BILLINGS, MT 59101

E001

EGGART ENGINEERING COMPANY
 720 LOWWEST LANE
 BILLINGS, MT 59106
 OFFICE: 406-839-9151 FAX: 406-839-9150

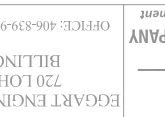
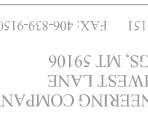

DATE: 12/15/2015
 CHECKED BY: GWE
 DRAWN BY: KKL
 PROJECT#: 15-001

PERMIT REVISION 12/16/2015

▲ PERMIT REVISION 12/16/2015

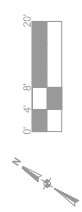
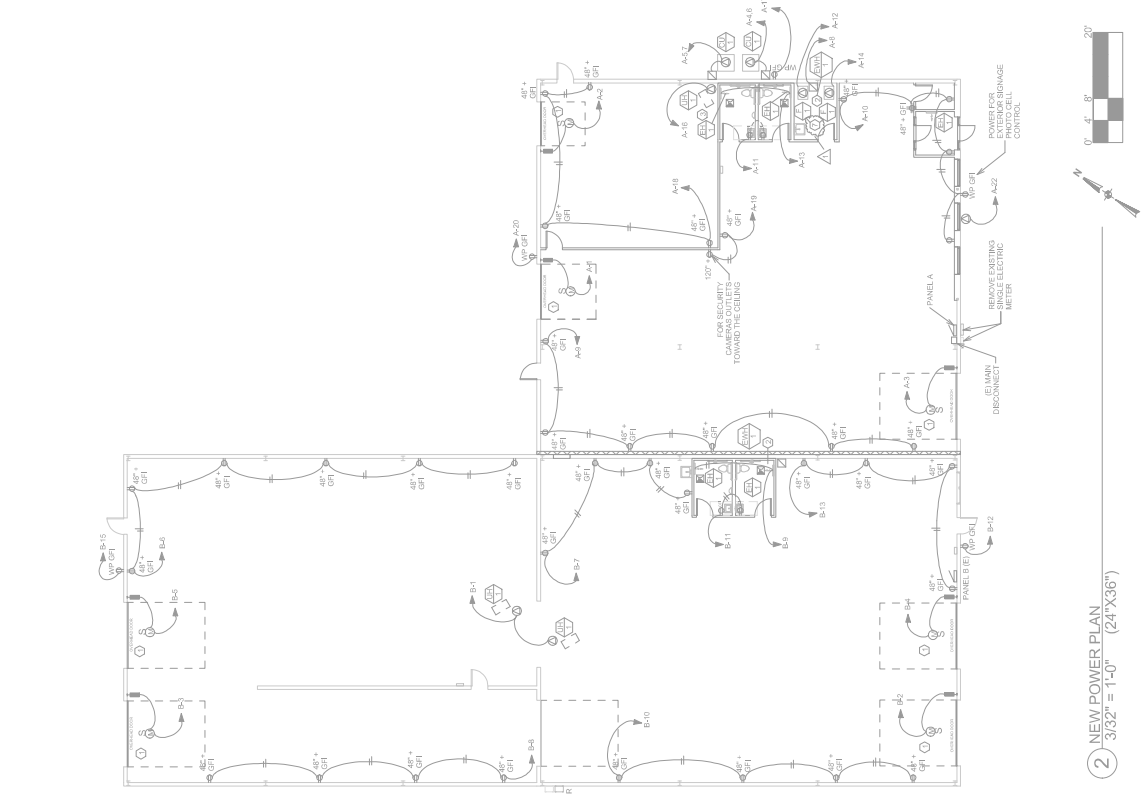

2 NEW POWER PLAN
3/32" = 1'-0" (24"X36")

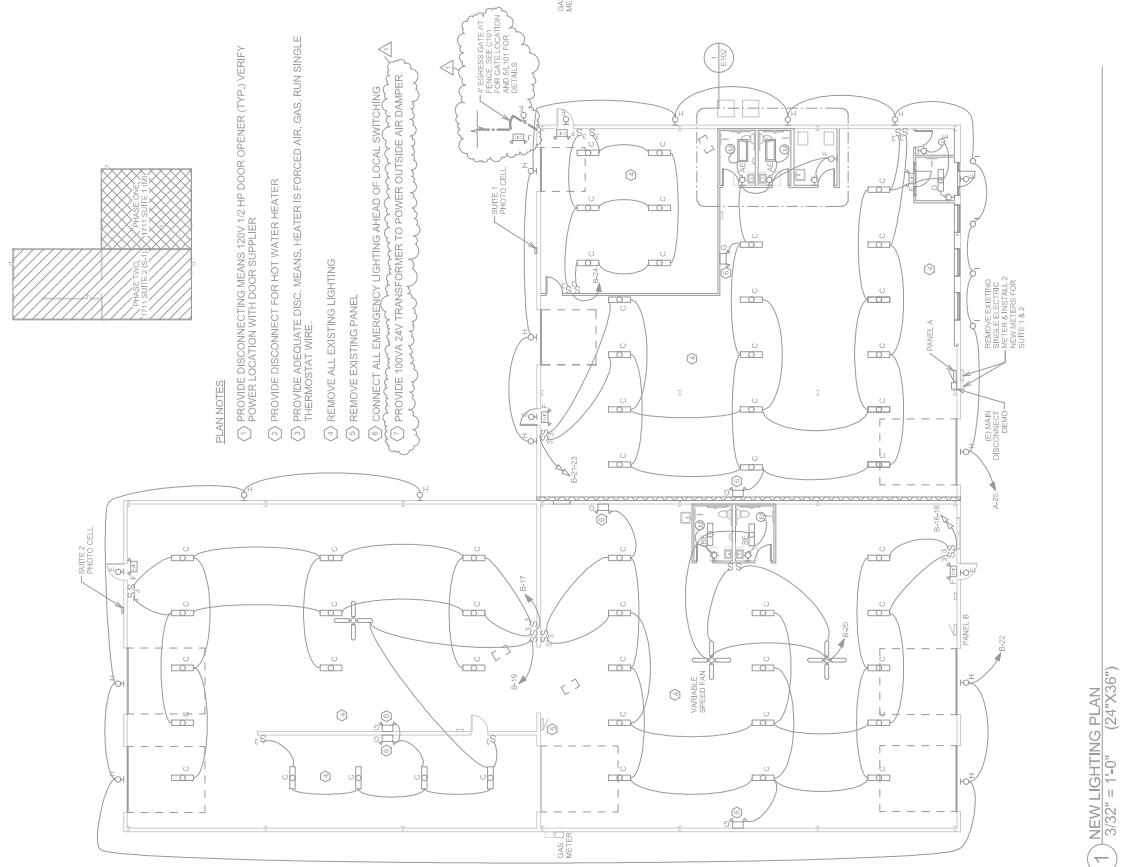

- PLAN NOTES**
- 1 PROVIDE DISCONNECT MEANS 120V 1/2 HP DOOR OPENER (TYP.) VERIFY POWER LOCATION WITH DOOR SUPPLIER.
 - 2 PROVIDE DISCONNECT FOR HOT WATER HEATER.
 - 3 PROVIDE ADEQUATE DISC. MEANS. HEATER IS FORCED AIR, GAS, RUN SINGLE THERMOSTAT WIRE.
 - 4 REMOVE ALL EXISTING LIGHTING.
 - 5 REMOVE EXISTING PANEL.
 - 6 CONNECT ALL EMERGENCY LIGHTING AHEAD OF LOCAL SWITCHING.
 - 7 PROVIDE 100VA JAV TRANSFORMER TO POWER OUTSIDE AIR DAMPER.

1 NEW LIGHTING PLAN
3/32" = 1'-0" (24"X36")

•	CEILING HEIGHT
-	CEILING FINISH
-	ADDITIONAL NOTES

GENERAL NOTES

1. SEE ELECTRICAL PLAN FOR LIGHTING

CEILING FINISH/NOTES

ACT	ACOUSTICAL CEILING TILE
EXP	EXPOSED TO STRUCTURE ABOVE



1 SUITE ONE REFLECTED CEILING PLAN
1/8" = 1'-0" (24" X 36")

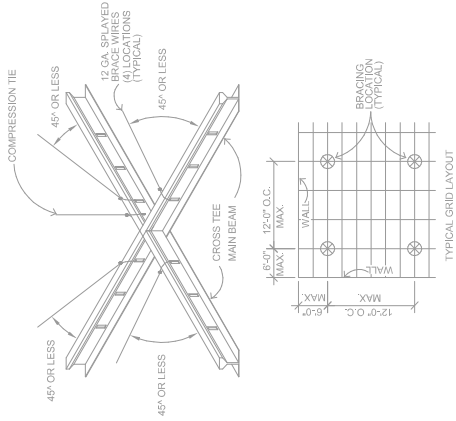

2 LAY-IN CEILING DETAIL
1/8" = 1'-0" (24" X 36")

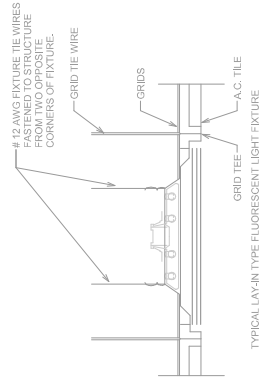
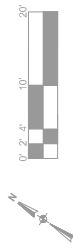

4 LAY-IN FIXTURE MOUNTING DETAIL
NOT TO SCALE

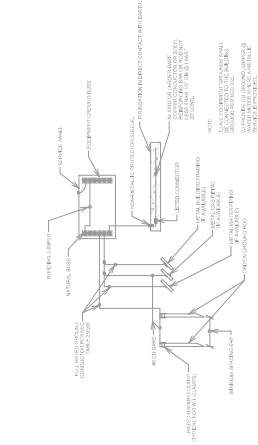

5 ELECTRICAL SERVICE GROUNDING DETAIL
NOT TO SCALE

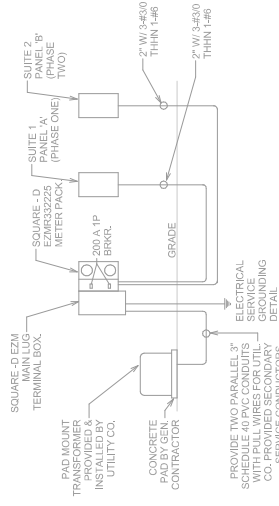

6 NEW ELECTRICAL SERVICE ENTRY DETAIL
NOT TO SCALE

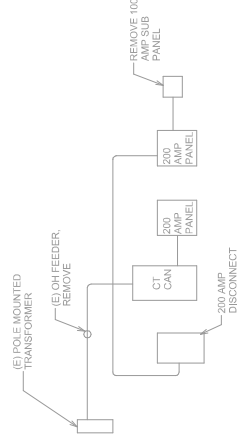

3 DEMO EXISTING SERVICE
NOT TO SCALE

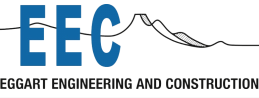

Construciton Site Work Schedule
1711 6th Ave North Remodel

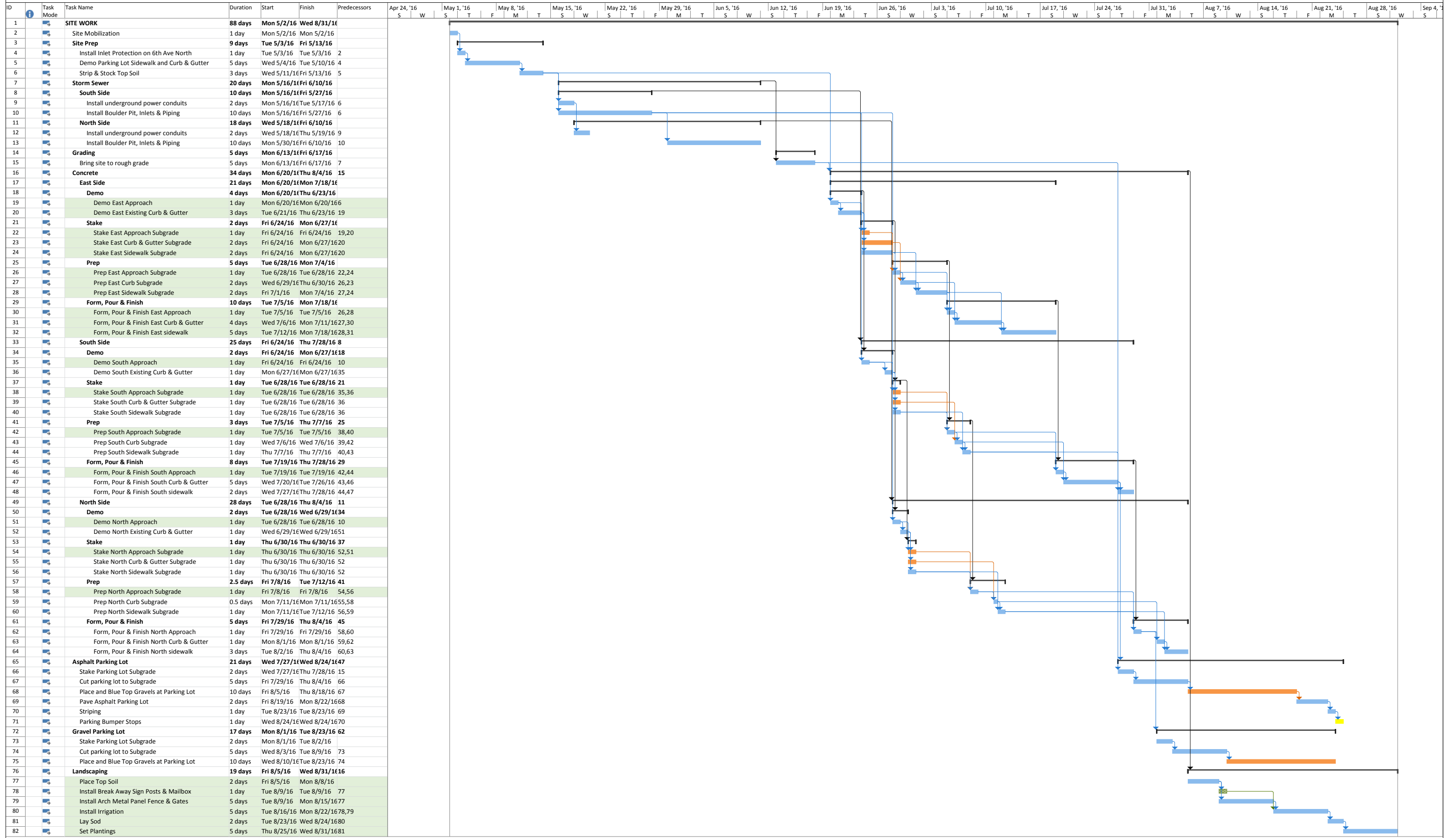



EGGART ENGINEERING & CONSTRUCTION

Project: 6th Avenue North Remodel

Location: 711 6th Avenue North

SITE SF: 42,000

BLDG. SF: 14,552

PRELIMINARY BUDGET-STEEL BUILDING

Total Building SF: 14,552

1-Feb-16

1.0 GENERAL

Item Description	Material Quantity	Units	Material Cost Per Unit	Total Material Cost	Subcontractor Cost	EEC Labor Total	TOTAL MATERIAL & LABOR
Building Permit & Plan Review Fee	1	LS	3763.10	\$0.00	\$3,763.10	\$0.00	3,763.10
Engineering & Design for Permit	1	LS	0	\$0.00	\$0.00	\$8,500.00	8,500.00
Construction Staking	1	LS	0	\$0.00	\$0.00	\$1,700.00	1,700.00
Project Management	1	LS	0	\$0.00	\$0.00	\$10,200.00	10,200.00
Builders Risk Insurance	690	Per \$1,000	1.50	\$0.00	\$1,032.24	\$0.00	1,032.24
General Liability Insurance	690	Per \$1,000	8.8	\$0.00	\$6,072.00	\$0.00	6,072.00
Porta Potty Rental	4	Month	148.50	\$0.00	\$594.00	\$0.00	\$594.00
Final Construction Cleaning	1	LS	0.00	\$0.00	\$0.00	\$2,200.00	\$2,200.00
Division 1.0 - General - Grand Totals				\$0.00	\$11,461.34	\$22,600.00	\$34,061.34

1.1 DEMO

Item Description	Material Quantity	Units	Material Cost Per Unit	Total Material Cost	Subcontractor Cost	EEC Labor Total	TOTAL MATERIAL & LABOR
Demo Existing Interior Framing & Electrical & HVAC	1	LS	0.00	\$0.00	\$0.00	\$33,000.00	33,000.00
Remove Existing Trees & Stumps on East Side of Building	4	EA	2200	\$0.00	\$8,800.00	\$0.00	\$8,800.00
Deliver Roll Off Dumpster	1	Job	60.5	\$0.00	\$60.50	\$0.00	\$60.50
Dumpster Rental per day	30	Days	3.3	\$0.00	\$99.00	\$0.00	\$99.00
Haul off Dumpster	10	EA	160.93	\$0.00	\$1,609.30	\$0.00	\$1,609.30
Landfill Dump Charge per Ton	50	Tons	17.79	\$0.00	\$889.35	\$0.00	\$889.35
Division 1.0 - General - Grand Totals				\$0.00	\$11,458.15	\$33,000.00	\$44,458.15

2.0 SITEWORK

Item Description	Material Quantity	Units	Material Cost Per Unit	Total Material Cost	Subcontractor Cost	EEC Labor Total	TOTAL MATERIAL & LABOR
Strip 4-6" of Existing Gravel Yard	21000	SF	0.44	\$0.00	\$9,240.00	\$0.00	9,240.00
Strip 4-6" of Existing Gravel Yard	8600	SF	0.44	\$1.00	\$3,784.00	\$0.00	3,785.00
Strip 4-6" of Existing Landscaping on East side of Building	1700	SF	0.44	\$2.00	\$748.00	\$0.00	750.00
GRAVEL YARD (21,000 SF)							
6" of Road Base or Asphalt Millings Place, Grade & Compact Gravels	710	TONS	9.19	\$6,521.35	\$0.00	\$0.00	6,521.35
	21000	SF	0	\$0.00	\$0.00	\$11,550.00	11,550.00
ASPHALT PARKING (10,300 SF)							
6" of Gravel Base Under Paving	350	Tons	9.19	\$3,214.75	\$0.00	\$0.00	\$3,214.75
Place, Grade & Compact Gravels	10300	SF	0	\$0.00	\$0.00	\$5,665.00	5,665.00
Mobilization	1	LS	385	\$0.00	\$385.00	\$1,000.00	1,385.00
3" Asphalt Paving	10300	SF	2.20	\$0.00	\$22,660.00	\$0.00	\$22,660.00
Parking Lot Painting	1	LS	495.00	\$0.00	\$495.00	\$0.00	\$495.00
STORMWATER FOR NEW PARKING LOT (CATCHING 17,700 SF OF AREA BETWEEN BUILDING AND PAVING)							
Boulder Pit & Inlets (25'x100'x6')	1	LS	49500.00	\$0.00	\$49,500.00	\$0.00	\$49,500.00
EXTERIOR CONCRETE (130'X7')							
Exterior Concrete Apron @ Front of Building	910	SF	7.15	\$6,506.50	\$0.00	\$0.00	\$6,506.50
UTILITIES							
6" Fire Line From Street to Building (Approx 120')	1	LS	22000.00	\$0.00	\$22,000.00	\$0.00	\$22,000.00
BILLBOARD REHAB							
Rehab	1	LS	5500.00	\$0.00	\$5,500.00	\$0.00	\$5,500.00
FENCING							
6' Chainlink Fencing	510	LF	22.00	\$11,220.00	\$0.00	\$0.00	\$11,220.00
16" Wide Chainlink Gates	3	EA	880.00	\$2,640.00	\$0.00	\$0.00	\$2,640.00
LANDSCAPING							
Clean Up Landscaping Area - Install Sprinklers	1	LS	3300.00	\$0.00	\$3,300.00	\$0.00	\$3,300.00
Division 2.0 - Site work - Grand Totals				\$30,105.60	\$117,612.00	\$18,215.00	\$165,932.60

3.0 CONCRETE & MASONRY

Item Description	Material Quantity	Units	Material Cost Per Unit	Total Material Cost	Subcontractor Cost	EEC Labor Total	TOTAL MATERIAL & LABOR
CUT & REPLACE CONCRETE FOR NEW BATHROOM & MISC PATCHES							
MISC Concrete Cutting & Patching	500	SF	15.40	\$7,700.00	\$0.00	\$0.00	\$7,700.00
Division 3.0 - Concrete - Grand Totals				\$7,700.00	\$0.00	\$0.00	\$7,700.00

5.1 METALS

Item Description	Material Quantity	Units	Material Cost Per Unit	Total Material Cost	Subcontractor Cost	EEC Labor Total	TOTAL MATERIAL & LABOR
DEMIO							
Remove Existing Siding Roofing & Insulation	1	LS	0.00	\$0.00	\$0.00	\$22,000.00	\$22,000.00
ROOFING							
New 24 Ga. Standing Seam Metal Roofing	14550	SF	2.48	\$36,011.25	\$0.00	\$0.00	\$36,011.25
Install New Standing Seam Metal Roofing	14550	SF	2.00	\$0.00	\$0.00	\$29,100.00	\$29,100.00
Eave Trim	310	LF	2.75	\$852.50	\$0.00	\$0.00	\$852.50
Gable Trim	270	LF	3.30	\$891.00	\$0.00	\$0.00	\$891.00
New Seamless Gutters & Downspouts (None on Alley Side)	240	LF	8.80	\$0.00	\$2,112.00	\$0.00	\$2,112.00
NEW SIDING							
New Siding & Trims	8168	SF	1.49	\$12,129.48	\$0.00	\$0.00	\$12,129.48
Hat Channel & Install over CMU Wall	1200	SF	1.10	\$1,320.00	\$0.00	\$1,100.00	\$2,420.00
1.5" Blueboard of CMU	1200	SF	1.10	\$1,320.00	\$0.00	\$0.00	\$1,320.00
Install New Siding	8168	SF	2.00	\$0.00	\$0.00	\$16,336.00	\$16,336.00
Misc Door & Window Trims	1	LS	3300.00	\$3,300.00	\$0.00	\$0.00	\$3,300.00
Division 5.1 - Metals - Grand Totals				\$55,824.23	\$2,112.00	\$68,536.00	\$126,472.23

6.1 FRAMING & FINISHES

Item Description	Material Quantity	Units	Material Cost Per Unit	Total Material Cost	Subcontractor Cost	EEC Labor Total	TOTAL MATERIAL & LABOR
FRAMING & FINISHING OF OFFICES IN WEST UNIT							
Frame & Finish Office Space	1200	SF	38.50	\$46,200.00	\$0.00	\$0.00	46,200.00
FRAMING & FINISHING OF OFFICES IN EAST UNIT							
Framing & Finishing of Office Space	1248	SF	33.00	\$41,184.00	\$0.00	\$0.00	41,184.00
Division 6.1 - Framing & Finishes-Grand Totals				\$87,384.00	\$0.00	\$0.00	\$87,384.00

7.1 THERMAL & MOISTURE PROTECTION

Item Description	Material Quantity	Units	Material Cost Per Unit	Total Material Cost	Subcontractor Cost	EEC Labor Total	TOTAL MATERIAL & LABOR
R-38 Roof & R-25 Wall Simple Saver Insulation System & Install	1	LS	25,300.00	\$25,300.00	\$0.00	\$22,000.00	\$47,300.00
Division 7.1 - Thermal & Moisture Protection - Grand Totals				\$25,300.00	\$0.00	\$22,000.00	\$47,300.00

8.1 DOORS & WINDOWS

Item Description	Material Quantity	Units	Material Cost Per Unit	Total Material Cost	Subcontractor Cost	EEC Labor Total	TOTAL MATERIAL & LABOR
OVERHEAD DOORS							
12'x14' OH Door & Operator	5	EA	4180	\$20,900.00	\$0.00	\$0.00	\$20,900.00
7'X8' OH Door & Operator	1	EA	2420	\$2,420.00	\$0.00	\$0.00	\$2,420.00
7x10 OH Door & Operator	1	EA	2640	\$2,640.00	\$0.00	\$0.00	\$2,640.00
New Exterior Man Doors (Metal Building Doors & Hardware)	3	EA	880	\$2,640.00	\$0.00	\$660.00	\$3,300.00
Storefront Doors & Windows	1	LS	16500	\$4.00	\$16,500.00	\$0.00	\$16,504.00
Division 8.1 - Doors & Windows - Grand Totals				\$2,644.00	\$42,460.00	\$660.00	\$45,764.00

15.1 PLUMBING SYSTEMS

Item Description	Material Quantity	Units	Material Cost Per Unit	Total Material Cost	Subcontractor Cost	EEC Labor Total	TOTAL MATERIAL & LABOR
Reconfigure & finish out 5 Total Bathrooms	5	EA	\$4,950.00	\$0.00	\$24,750.00	\$0.00	\$24,750.00
Gas Line Plumbing	1	LS	\$4,400.00	\$0.00	\$4,400.00	\$0.00	\$4,400.00
Division 15.1 - Plumbing Systems - Grand Totals				\$0.00	\$29,150.00	\$0.00	\$29,150.00

15.3 HEATING VENTILATION & A/C

Item Description	Material Quantity	Units	Material Cost Per Unit	Total Material Cost	Subcontractor Cost	EEC Labor Total	TOTAL MATERIAL & LABOR
300K BTU GFA Unit Heaters in West Unit	2	EA	\$3,850.00	\$0.00	\$7,700.00	\$0.00	\$7,700.00
80K BTU GFA Unit Heater in Middle Unit	1	EA	\$2,200.00	\$0.00	\$2,200.00	\$0.00	\$2,200.00
80 K GFA Unit Heater in East Unit Shop	1	EA	\$2,200.00	\$0.00	\$2,200.00	\$0.00	\$2,200.00
Furnace & AC System for West Unit Offices	1	LS	\$13,200.00	\$0.00	\$13,200.00	\$0.00	\$13,200.00
PTAC Heating & Cooling Unit for Offices are in East Unit	2	EA	\$1,540.00	\$0.00	\$3,080.00	\$0.00	\$3,080.00
Division 15.3 - Heating, Ventilation & AC Grand Totals				\$0.00	\$28,380.00	\$0.00	\$28,380.00

16.1 ELECTRICAL

Item Description	Material Quantity	Units	Material Cost Per Unit	Total Material Cost	Subcontractor Cost	EEC Labor Total	TOTAL MATERIAL & LABOR
Re-Wire Entire Building	14550	SF	\$4.95	\$0.00	\$72,022.50	\$0.00	\$72,022.50
Division 16.1 - Electrical - Grand Totals				\$0.00	\$72,022.50	0.00	\$72,022.50

Total Material Cost	Subcontractor Cost	Total Labor Cost	TOTAL MATERIAL & LABOR
\$208,957.83	\$314,655.99	\$165,011.00	\$688,624.82

BUILDING CONSTRUCTION COST

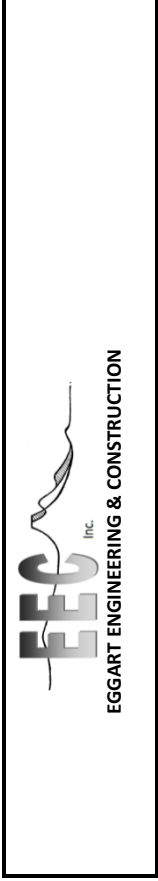

Project: **6th Avenue North Remodel**

Location: **711 6th Avenue North**

SITE SF:	42,000
BLDG: SF:	14,552
	14,552

Total Building SF:

SITEWORK ESTIMATE BASE ON FINAL DESIGN

9-Feb-16

2.0 SITEWORK WITHIN PUBLIC RIGHT OF WAY

	Item Description	Material Quantity	Units	Material Cost Per Unit	Total Material Cost	Subcontractor Cost	EEC Labor Total	TOTAL MATERIAL & LABOR
	DEMO							
For Bid See: Attachment E - 1	Remove Concrete Curbs, Asphalt & Approaches for Install of New Code Compliant	1	LS	4073.04	\$0.00	\$4,073.04	\$0.00	4,073.04
	ASPHALT PATCHING @ NEW CODE COMPLIANT APPROCHES, ADA RAMPS AND CURBS							
Attachment E - 1	Gravel & Prep	1725	SF	1.40	\$0.00	\$2,415.00	\$0.00	2,415.00
Attachment E - 2	3" Asphalt Patching in ROW	1725	SF	3.05	\$0.00	\$5,261.25	\$0.00	5,261.25
	CONCRETE APPROACHES							
Attachment E - 1	Gravel & Prep @ 4 New Concrete Approaches	4	EA	1000.00	\$0.00	\$4,000.00	\$0.00	\$4,000.00
Attachment E - 3	Form, Pour & Finish Concrete Approaches (30' Wide)	3	EA	2010	\$0.00	\$6,030.00	\$0.00	6,030.00
Attachment E - 3	Form, Pour & Finish Concrete Approaches (24' Wide)	1	EA	1620	\$0.00	\$1,620.00	\$0.00	1,620.00
	CONCRETE CURB & GUTTER							
Attachment E - 1	Gravel Prep for New Curb and Gutter in ROW	1	LS	1608.00	\$0.00	\$1,608.00	\$0.00	\$1,608.00
Attachment E - 3	Concrete Curb & Gutter in ROW	111	LF	21.00	\$0.00	\$2,331.00	\$0.00	\$2,331.00
	CITY SIDEWALK & 6" ADA RAMPS							
Attachment E - 1	Gravel & Prep for Sidewalk & ADA Ramps	1	LS	11238.50	\$0.00	\$11,238.50	\$0.00	\$11,238.50
Attachment E - 3	4" Unreinforced City Sidewalk	1	LS	8032.50	\$0.00	\$8,032.50	\$0.00	\$8,032.50
Attachment E - 3	6" ADA Ramps	3	EA	1255.00	\$0.00	\$3,765.00	\$0.00	\$3,765.00
	ROW LANDSCAPING (5,030 GRASS & 1,502 GRAVEL)							
Attachment E - 1	6" of Top Soil in Grass Areas & Final Grading	5030	SF	0.97	\$0.00	\$4,879.10	\$0.00	\$4,879.10
Attachment E - 4	Sod/Irrigation	1	LS	5525.00	\$0.00	\$5,525.00	\$0.00	\$5,525.00
Attachment E - 4	Fabric & Landscape Gravel	1	LS	2710.00	\$0.00	\$2,710.00	\$0.00	\$2,710.00
Attachment E - 4	Feather Reed Grass	30	EA	30.00	\$0.00	\$900.00	\$0.00	\$900.00
Attachment E - 4	2" Caliper Trees	11	EA	450.00	\$0.00	\$4,950.00	\$0.00	\$4,950.00
Attachment E - 4	Landscape Curbing (183 LF)	1	LS	1300.00	\$0.00	\$1,300.00	\$0.00	\$1,300.00
	Division 2.0 - Site work within Public ROW- Grand Totals				\$0.00	\$70,638.39	\$0.00	\$70,638.39



<u>Quote To:</u>	EEC	<u>Job Name:</u>	1711 6th Ave N		
<u>Estimate Date:</u>	1/18/2016	<u>Date of Plans:</u>	12/9/2015		
10 Demolition		1.00	LS	4,073.04	4,073.04
60 Gravel Parking Lot Preparation		14,712.00	SF	1.11	16,330.32
61 Asphalt Parking Lot Preparation		6,633.00	SF	1.40	9,286.20
62 ROW Asphalt Preparation		1,725.00	SF	1.40	2,415.00
70 Site Sidewalks Preparation		2,266.00	SF	2.68	6,072.88
71 Approach Preparation		4.00	EA	1,000.00	4,000.00
72 Curb Preparation		239.00	LF	7.50	1,792.50
75 ROW Concrete Preparation		3,211.00	SF	3.50	11,238.50
76 ROW Curb Preparation		201.00	LF	8.00	1,608.00
80 Final Grade	5,030 SF (ROW)	7,776.00	SF	0.97	7,542.72
90 Site Export		2,250.00	TON	2.39	5,377.50
130 Storm Sewer		1.00	LS	32,189.42	32,189.42
GRAND TOTAL					\$101,926.08

Exclusions:

Asphalt
 Concrete
 Compaction testing
 Site staking

Clarifications:

This estimate includes installing two boulder pits.

Final grade includes importing and placing approximately 6" of topsoil in the landscape areas that receive grass.

Any change made to the design of the structure or performance of this bid outside of the scope of work known to us on the date of this document is subject to a change in bid price in the form of a change order. We reserve the right to stop work until any such issues related to the change are resolved.

We reserve the right to assess a finance charge in the amount of 1.5% per month for any and all late payments.

Estimate is good for 30 days.



Contract

Date	Estimate #
1/6/2016	3831

Name / Address
EEC

Project	
1711 N 6th	

Item	Description	Sq. Ft.	Unit	Total
Mobilization	Mobilization of equipment and employees.	1	200.00	200.00
Pave	Parking Lot-Haul, place and compact 3" type B hot-mix asphalt.	6633	1.78	11,806.00
Pave	ROW-Haul, place and compact 4" type B hot-mix asphalt.	1725	3.05	5,261.00
Striping	Layout and stripe all lines, handicaps and hashmarks.			460.00
Note	Price good till June of 2016 Price doe not include prep Unit price will govern if footage varies ~~~~~ CHANGE ORDER ~~~~~ January 18, 2016 > Decreased price of Pave from \$26,518.00 to \$11,806.00. Changed description of Pave. (-\$14,712.00) > Added 1 Pave. (+\$5,261.00) > Changed description of Note. (+) Total change to estimate -\$9,451.00 ~~~~~			
If any ?'s call Ron @ 406-861-0304		Total		\$17,727.00

Quote is good for 15 days. All material and workmanship carries a 1 year warranty. Work must fit into current working schedule. No guarantee on water drainage on a less than a 2% grade. No guarantee against the growth of vegetation. Not responsible for damage to concrete caused from equipment. Customer agrees to pay all legal fees in the event that it becomes necessary from default of payment of this contract. Customer agrees to pay upon completion of job unless otherwise specified. A \$20.00 late fee will be charged every month account is past due. The above prices, specifications and conditions are satisfactory and are hereby accepted. You are authorized to do work as specified.

Signature _____

Date _____

3962 PA Hollow Trail Billings Mt 59106 P: 406-254-9571 F: 406-254-9572
 WhartonAsphalt@netzero.net WhartonAsphalt.com



M.R. Concrete, Inc.
Matthew Roberts
535 Tumbleweed Drive
Billings, Mt 59105
(406) 861-1634

Concrete Bid

January 14, 2016

EEC: Attn. Scott Swanson

Property: 1711 6th Ave. N - Remodel

5 1/2" Interior Concrete Sidewalk w/ Rebar – 798 SF @ \$5/SF

Curb & Gutter – Interior – 293 LF @ \$21/LF

Vertical Curb – 86 LF @ \$21/LF

Subtotal: \$11,949.00

4" ROW Sidewalk w/out Rebar – 1,785 SF @ \$4/SF

6" ADA Ramps – 3 EA @ \$1,255/EA

30' Concrete Approach – 3 EA @ \$2,010/EA

24' Concrete Approach – 1 EA @ \$1,620/EA

Curb & Gutter in ROW – 111 LF @ \$21/LF

Subtotal: \$20,886.00

Bid includes:

- Concrete & Rebar

Bid Excludes:

- Hauling off dirt/concrete from property
- Removal of curb/concrete sidewalk
- Prep for grade

**Please contact M.R. Concrete, Inc. with any questions you may have
Thank you, Matthew Roberts**



Date: January 25, 2016

From: Jason Albaugh
River Ridge Landscape Company

Re: 1711 6th Ave. North Remodel

Below is our price for the landscaping and sprinkler system at the 1711 6th Ave. Remodel. Our price includes supplying and installing, concrete curbing, weed barrier, 1-1/2" Rock, sod, and the irrigation system as shown on sheet L101 of the construction documents.

Our price assumes the site contractor or others will bring the grade to within plus or minus one inch of all finish grades using suitable topsoil for plant growth. Our price assumes we will be provided with a water source for our sprinklers by others and the projects electrician would provide us power for our controller.

<u>Item</u>	<u>Ont. Private</u>	<u>Bid Private</u>
Sod/Irrigation	2,141 sf	\$4,960.00
Landscape Fabric & 1-1/2" Washed Rock	888 sf	\$1,695.00
Karl Foerster Feather Reed Grass	Qnt. 6	\$180.00
Concrete Curbing	34 lf	\$325.00
2" Caliper Trees	Qnt. 5	\$2,250.00
Total.....		\$9,410.00

<u>Item</u>	<u>Ont. R.O.W</u>	<u>Bid R.O.W</u>
Sod/Irrigation	5,030 sf	\$5,525.00
Landscape Fabric & 1-1/2" Washed Rock	1,502 sf	\$2,710.00
Karl Foerster Feather Reed Grass	Qnt. 30	\$900.00
Concrete Curbing	183 lf	\$1,300.00
2" Caliper Trees	Qnt. 11	\$4,950.00
Total.....		\$15,385.00

Handicap Parking Sign Mounted to the building.....\$80.00

Please let me know if I can answer any further questions.

Sincerely,

Jason Albaugh
jason@riverridgelandscap.com
406-628-7317

Regular City Council Meeting

Meeting Date: 04/11/2016

TITLE: EBURD TIF Assistance Request - North Park Properties

PRESENTED BY: Candi Millar, Planning & Community Services Department Director

Department: Planning & Community Services

PROBLEM/ISSUE STATEMENT

The Billings Industrial Revitalization District (BIRD) Board of Directors is recommending approval of \$7,200.00 in tax increment (TIF) assistance from the East Billings Urban Renewal District (EBURD) paid to North Park Properties, Claren Neal and Donna Braun, owners, for public improvements. The TIF funding will be used to reimburse the cost of demolishing a structure at 504 N. 20th Street in order to eliminate blight. This project is consistent with the East Billings Urban Renewal District Master Plan. The application for TIF Assistance was recommended for approval by the BIRD Board of Directors on February 9, 2016 in the amount of \$7,200.00.

ALTERNATIVES ANALYZED

The City Council may either approve or deny the recommendation from the BIRD on the expenditure of these funds.

FINANCIAL IMPACT

The amount of the request is for a total of \$7,200.00 to be paid in one payment to North Park Properties. The funds are payable upon approval of the project by the City and submittal of an invoice to the City. There are sufficient funds budgeted in the FY 2016 EBURD budget for payment of this development incentive.

RECOMMENDATION

The Billings Industrial Revitalization District (BIRD) Board of Directors recommends that the City Council approve a reimbursement for eliminating blight totaling \$7,200.00 from the East Billings Urban Renewal District tax increment district funds to North Park Properties.

APPROVED BY CITY ADMINISTRATOR

Attachments

N Park TIF Assistance Application



BILLINGS INDUSTRIAL REVITALIZATION DISTRICT

**BILLINGS INDUSTRIAL REVITALIZATION DISTRICT, INC.
EAST DISTRICT TAX INCREMENT FINANCING (TIF) APPLICATION**

Project Name: **DEMOLITION OF FLAT ROOFED ADDITIONS TO WAREHOUSE AT
504 NORTH 20TH STREET** _____ Date Submitted: December 14, 2015

APPLICANT INFORMATION

1. Name: CLAREN NEAL AND DONNA BRAUN _____
2. Address: 725 AVENUE 'D' BILLINGS, MT 59102 _____
3. Telephone Number: CLAREN'S CELL: 698-6325 _____

PROJECT INFORMATION

1. Building Address: 504 NORTH 20TH STREET, BILLINGS, MT _____
2. Legal Description: BILLINGS ORIGINAL TOWNSITE, BLOCK: 262, LOTS: 2-6 AND adjacent vacated north/south alley _____
3. Ownership: CLAREN NEAL AND DONNA BRAUN REVOCABLE TRUST _____
Address: 725 AVENUE 'D' BILLINGS, MT 59102 _____
4. If property is not owned by the APPLICANT, list leasehold interests (Attach evidentiary materials.)
Name: NA _____
5. Existing/Proposed Businesses: MODERN MASONRY, INC. _____

Business Description: local company that does brick, block, stone, and stucco work on residential & commercial buildings _____
6. Employment: Existing FTE Jobs: MODERN MASONRY has from 2 to 6 employees_

New Permanent FTE Jobs created by project: Depends on business growth & economy
Construction FTE Jobs: from two to four during the project
7. Architectural Firm: NA _____
Address: _____

Representative: _____

8. Description of Project: Please read 4 page Letter to Ms. Kennedy dated ~~12/5/2015~~ attached. 01/6/16

9. Rehabilitation/construction Plans: Not Applicable

10. Project Schedule:

Spring of 2015: contact Montana wood recyclers and request bids.

June, 2015: contract w/ Heritage Timber from Missoula to do recycle & demo

July, 2015: Prep building for upcoming recycle & demo

July, 2015: Heritage Timber recycles all reusable items and demolishes the rest. The concrete block walls are left standing as agreed.

August, 2015: ABC Property Services levels block walls and cleans up site.

PROJECT COSTS

Land and Site Improvements (Itemized)

1. Equity in Land and Buildings \$ 185,000 after demo & cleanup_____

2. No loans or liens against property at this time \$ -0-

Subtotal \$ 185,000_____

Construction/Rehabilitation Costs (Use general construction trade divisions)

1. Prep for Demo including getting permit, & terminating all utilities \$ 3,453_____

2. Recycle & Demolish 5000 s.f. of flat roof Building \$14,542_____

3. Knock down concrete block walls, remove and clean everything up \$ 4,496_____

4. Northern Industrial \$ 1,400_____

5. Hygiene, Inc. \$ _____

6. Fradet Gravel & trucking \$ _____

7. \$ 648⁵⁰_____

8. MDU \$ 520⁰⁰_____

9. \$ _____

Subtotal \$ 22,491_____

with additions

\$ 25,059.50

January 6, 2016

(revised on January 6, 2016)

BIRD COMMITTEE THAT REVIEWS TIF APPLICATIONS BILLINGS INDUSTRIAL REVITALIZATION DISTRICT

RE: Demolition of Flat Roofed Additions to Warehouse @ 504 North 20th Street

BIG PICTURE SUMMARY

This is short summary of activities involving a very old and dilapidated building at 504 North 20th Street (originally the Yellowstone Paper Warehouse and later the 504 Artists Warehouse). This summer two thirds of that structure was demolished but the original barrel roofed main building was left standing. This project eliminated a substantial eye sore at that location by tearing down a damaged and blighted structure, enhanced sustainability by recycling most of those materials for other uses and projects, and almost completely avoided any dumping at the city landfill.

HISTORY

The original barrel roofed main building was constructed sometime in the 1930's. It is 30 feet wide and 75 feet long. It has concrete block walls, wooden rib roof trusses, and a square façade on the front. It was built on grade, without footings or foundation. Over the next 20 years, it was added onto several times. Each of the 4 additions was flat roofed with concrete block walls. The last addition spanned the abandoned N/S alley and connected to the neighbor's warehouse. This resulted in an encroachment on both properties, a shared roof and shared end walls in the alley area. The original building was about 2000 sq. ft. and the 4 additions added another 5000 sq. ft., in all about 7000 sq. ft. Originally the building was used as a paper warehouse for Yellowstone Paper.

It was sold in the 1980's and converted into a multi-use building for Wright's Custom Repair and Grafix. After that it was divided up into various size areas for a variety of artists. Over time, Grafix, Kennedy's Stained Glass, the Black Tulip Potters' Group, and many other artists had studios and space there. The tornado in 2010 and the gully washer in 2013 resulted in severe flooding and damage. During that same time the flat roof was deteriorating and the hail storm in 2014 along with significant rains thereafter damaged the flat roof beyond repair. Specifically the roof trusses were weakened and started rotting. The ceilings inside began to fall in as the insulation and sheetrock got soaked. At least two fluorescent light fixtures shorted out due to water in them. A serious problem developed with black mold on the ceiling and walls in several rooms. For safety reasons, all of the renters were asked to leave and relocate. The entire building ended up being vacant.

PROBLEM

The 504 property was a problem with no easy solution. The building could be demolished but then the area would be left with an empty lot sharply reducing tax revenue and contributing nothing to the neighborhood. The entire building could be re-roofed at a huge expense but that would not solve the flooding problem. Until the storm drain system on Sixth Avenue North is enlarged and connected to the main line going to the river, flooding will continue to occur. In the meantime whatever improvements are made will have to be done with the idea something will have to be done with the roof in the near future and somehow the flooding problem needs to be solved. Additionally it was not known whether there was asbestos present. Finally any demolition would require extra time and money since the structures were all connected into one building and the utilities were intertwined. That situation dictated that any demolition would have to be done largely by hand.

DEMOLITION & RECYCLE

Billings had a lot of rain in the spring of 2015 and the roof, ceiling and mold problems got worse. Something had to be done very soon. That spring the building was tested for asbestos and was found to be "clean". In June, after

contacting a number of wood recyclers, Heritage Timber from Missoula, MT agreed to demolish the flat roof parts of the building, recycle all possible materials, and to carefully separate the additions from the original building as well as to remove the encroachment while leaving the neighbor's building undamaged. Heritage acknowledged that the majority of the deconstruction would have to be done by hand and they were agreeable to taking on such a labor intensive project. Heritage Timber agreed to tackle our job in July as they were booked for other jobs throughout the summer.

However as part of the agreement, we were responsible for getting the demolition permit and for terminating all of the utilities before Heritage arrived. See the 3 bills from ABC Property Services in the amount of \$3,453 for all of that preliminary work. Also as part of the agreement, Heritage agreed to recycle and remove everything except the concrete block walls and the concrete floor. Heritage did recycle and demolish everything using hand labor and finished on July 30, 2015. See the contract with Heritage Timber and a copy of the cashier's check in the amount of \$14,542 paying them for their work. In August of 2015, ABC Property Services rented equipment and knocked down all of the concrete walls. The concrete blocks were trucked away and recycled at a private location in the county. The clean blocks were used to prevent washing and erosion. See 3 more bills from ABC Property Services covering that and the final cleanup in the amount of \$4,496.

The total amount for demolition and cleanup amounted to..... \$22,491.00.

SAFETY ISSUES, REPAIR & RE-RENTING

Following the demolition and cleanup, the building was repaired and weather proofed on the outside. It was barely finished before the cold weather hit in November. It had been pre-rented to a masonry company before that and they were waiting to move in. The applicant notes that the guidelines on a TIF Application ask that it be received in advance of the work, that any development agreements be approved and signed before construction begins, and that a

minimum of 60 days be allowed between the submission of the application and getting a decision from the City Council. In this case, that was not possible.

Here due to safety issues involving the integrity of the roof, falling ceilings and wet insulation and the spreading mold, it would not have been prudent to delay the demolition to do paperwork. A delay to process the papers would have put Heritage Timber's employees as well as other local craftsmen and the owner working in the building at far more risk. By going ahead with the deconstruction right away that risk was acceptable at the time and there were no on-the-job injuries or accidents. The new renter is a masonry company. They are local, have several employees, are environmentally friendly, and are building things that last. Therefore we believe that they will contribute to and create a presence which will encourage other business development in the area. Since their product and equipment cannot freeze, the masonry people were anxious to get settled in the warehouse before the cold weather hit. We would not have been able to get them into the building in November if we had been delayed by paperwork during the summer.

CLOSING

Any questions may be directed to the signing partner below. The 504 demolition project exemplifies the EBURD Master Plan by removing blight, improving a building, and getting a solid growing business as a tenant. The Board's favorable consideration of our request would be sincerely appreciated.

Sincerely,

Claren Neal and Donna Braun, Doing business as North Park Properties
725 Avenue 'D' Billings, MT 59102 Cell: 698-6325

Enclosures:

Phase 1: Getting Ready to Begin Demolition---3 bills from ABC totaling \$3453

Deconstruction & Recycle by Heritage Timber totaling \$14,542

Phase 2: Removing Concrete Walls, etc---3 bills from ABC totaling \$4496

Request for BIRD Funds for Demolition of 504 Bldg & History, 1-30-2016 #3

Fees

1. Architectural design/Supervision	\$ Not Applicable _____
2. Permits <u>Demolition X</u>	(\$ 119.00 included in 1. above) _____
3. Other fees _____	\$ _____
Subtotal	\$ _____
Total Project Development Costs	\$ 22,491 _____

PROJECT FINANCING

Please complete Sources of Funds detail and summarize below.

Developer Equity

Cash Invested	\$ 22,491 _____
Land & Buildings	\$ Not Applicable _____
Other (Specify) _____	\$ _____
_____	\$ _____
Subtotal	\$ 22,491 _____

Lender Commitments (Attach evidence i.e. Letters of Credit or other documentation.)

Lender	Loan Amount	Interest	Term	Payment/Period
_____	\$ _____	_____ %	_____ yrs	\$ _____ /Month
_____	\$ _____	_____ %	_____ yrs	\$ _____ /Month

Total Loan Amount NO LOANS WERE TAKEN OUT

TIF Request FOR improvements within the Public Right of Way NOT APPLICABLE

Eligible Improvements (See Narrative)

\$ _____

\$ _____
 \$ _____
 \$ _____
 Subtotal \$ _____

Sources of Funds Summary (Post totals from above.)

Developer Equity \$ 22,491 _____
 Lender Commitments \$ -0- _____
 TIF Request REIMBURSEMENT FOR DEMO-\$22,491
 Other Funds (Specify) _____ \$ _____

Total Project Financing \$ 22,491 _____

DEVELOPER STATEMENT OF QUALIFICATIONS AND FINANCIAL RESPONSIBILITY

APPLICANT

1. Name: CLAREN NEAL AND DONNA BRAUN _____

Address: 725 AVENUE 'D' BILLINGS, MT 59102 _____

2. If the APPLICANT is not an individual doing business under his/her own name, the APPLICANT has the status indicated below and is organized or operating under the laws of MONTANA _____.

3. _____ A corporation.
 _____ A nonprofit or charitable institution or corporation
 _____ A partnership known as NORTH PARK PROPERTIES _____

_____ Other (explain): _____

Date of organization: May 1, 2004 _____

4. Names, address, title of position (if any), and nature and extent of the interest of the officers and principal members, principal shareholders, investors, or partners of the APPLICANT.

Name and Address

Nature and Extent of Interest

CLAREN NEAL 725 AVENUE 'D' BILLINGS, MT 59102 CO-OWNER
50% PARTNERSHIP INTEREST

DONNA BRAUN 333 SOUTH 38TH STREET WEST BILLINGS, MT 59102
CO-OWNER 50% PARTNERSHIP INTEREST

Financial Condition

1. Provide a current financial statement for each private entity involved in the project. Documentation of financial capacity may include net worth statements, balance sheets, and/or profit and loss statements.
SEE ATTACHED FINANCIAL STATEMENT

2. Has the APPLICANT or any individual or entity affiliated with the development of this project been adjudged bankrupt, either voluntary or involuntary, within the past ten years?

No Yes _____ If yes, give date, place, and under what name

3. Has the APPLICANT or any individual or entity affiliated with the development of this project been indicted for or convicted of any felony within the past ten years: No Yes _____ If yes, give date, charge, place, court and action taken for each case.

CONSTRUCTION CONTRACTOR

1. Identify the construction contractor or builder who will undertake this project.

Name: HERITAGE TIMBER, LLC _____

Address: 27341 BLIXIT CREEK ROAD, BONNER, MT 59823 _____

2. Has named contractor or builder ever failed to qualify as a responsible bidder, refused to enter into a contract after an award has been made, or failed to complete a construction or development contract within the last ten years?

No Yes _____ If yes, explain.

CERTIFICATION

I (we), CLAREN NEAL AND DONNA BRAUN (please print), certify that the statements and estimates within this Application as well as any and all documentation submitted as attachments to this Application or under separate cover are true and correct to the best of my (our) knowledge and belief. I/We certify that I/We will make no application for any other tax abatement that may be available for this real property or building.

Signature Claren Neal

Signature Donna Braun

Title CO-OWNER/PARTNER _____

Title CO-OWNER/PARTNER _____

Address 725 AVENUE 'D' _____

Address 333 SOUTH 38TH STREET WEST _____

BILLINGS, MT 59102 _____

BILLINGS, MT 59102 _____

Date DEC. 14, 2015 _____

Date DEC. 14, 2015 _____

ATTACHED:

4 page Letter to Ms. Kennedy dated December 5, 2015

Financial Statement for North Park Properties

BILLS

- 3 BILLS from ABC for initial prep work.....\$3,453
- Contract w/ Heritage Timber and check for\$14,542
- 3 more BILLS from ABC for removing walls & clean up.....\$4,496

Total:

~~\$22,491~~
 \$25,059.50 ✓

+ 1400
 648
 520

 2568

December 12, 2015

FINANCIAL STATEMENT FOR NORTH PARK PROPERTIES

Co-Owners & Partners:

Claren Neal (50%)
725 Avenue 'D'
Billings, MT 59102
Cell: 406-698-6325

Donna Braun (50%)
333 South 38th Street West
Billings, MT 59102

ASSETS

3 Commercial Rentals

Quonset located at 421 North 20th Street

Front/back duplex located at 502 North 20th Street

Barrel roofed Warehouse located at 504 North 20th Street

Quonset @ 421 is 4000 s.f. & rented to: Prince
Telecommunications.....estimated FMV is \$ 90,000

Front/Back duplex @ 502 is 1000 s.f. & rented to: Senior
Citizen in front and another Senior Citizen in the back, and
Barrel roofed Warehouse @ 504 is 2000 s.f. & rented to:
Modern Masonry, Inc...estimated FMV for both after demo &
cleanup is \$ 185,000

LIABILITIES

Taxes for 2015 are \$ 6,276

Insurance for 2016 is estimated to be \$3,000

Utilities have been running about \$ 450 per month

Upkeep & Maintenance varies but averages \$ 150 per month

Management averages about 10% of gross rents

TOTAL EQUITY FOR BOTH OWNERS..... \$ 275,000



Claren Neal - Owner

July 15, 2015

Invoice # 5-2015

TO: North Park Properties
RE: All Work Before De Construction
of Flat Roof 504 Bldg

June 15-17	Get City Demolition paperwork and communicate w/ Heritage	\$46
July 6	Fill out Demo Permit, letter to MT EPA, w/help begin removing fixtures	\$303
July 8	w/help, terminate gas line, terminate water w/new shut off, prep drains for plugging	\$320
July 9	w/help, continue prep for plugging get pallet of redmix concrete, sand & gravel	\$380
July 10	w/help, set up mixer & materials, pour concrete plugs in all drains	\$360
July 13	w/help, shut off main water & cap w/electrician, terminate all electrical into flat roof area, call for inspections	\$300
July 14	w/ Heritage - review work to be done prep for starting deconstruction, etc.	\$145
July 15	work w/ Heritage to begin demo & deconstruction	\$60
Total Time 5.5 hours		\$1914



Claren Neal - Owner July 15, 2015

Invoice # 6-2015

TO: North Park Properties

RE: Extra Labor Expenses Getting
504 Ready for Demolition

HVAC Contractor	July 8-13	23 hrs.	\$ 805
Electrical Contractor	July 13	6 hrs	Labor Trade
Day Laborer 1	July 6 & 9		\$ 75
Day Laborer 2	July 9		\$ 48
Day Laborer 3	July 13		\$ 60
Cleaning Service	July 13		\$ 105
	Total		\$ 1093



PROPERTY SERVICES

Claren Neal - Owner

July 15, 2015

Invoice #7-2015

TO: North Park Properties
RE: Materials for Getting 504
Ready to Demolish

Plumbing Supplies	\$ 31
Pallet of Rechemix Concrete	\$ 140
Roadmix (both sand & gravel)	On Hand
Dye for Concrete	\$ 56
Additional Plumbing Items	\$ 41
Miscellaneous	\$ 58
Demc Permit Fee to City	\$ 120

Total

\$ 446



27341 Blixit Creek Rd.
Bonner, MT 59823
www.HeritageTimberMT.com
406-830-3966

Claren Neal
725 Avenue D
Billings, MT 59102
406-698-6325

Dear Claren,

May 3, 2015

This contract is presented to Claren Neal (herein referred to as "the Client") by Gary Delp of Heritage Timber (herein referred to as "the Contractor"). The scope of work covered by this contract is the deconstruction of the building known as the "Artist Warehouse" located at 504 N 20th St. in Billings, MT. The Contractor will provide all labor, equipment and materials for this project with the following conditions applying:

1. The Contractor will deconstruct and remove all material, salvageable or otherwise, from roofing all the way down to the concrete slab with the following exceptions:
 - a. The Contractor will not be responsible for removing concrete and masonry, including:
 - i. Perimeter block walls
 - ii. Interior east-west block wall
 - iii. Any other concrete block wall
 - iv. Concrete slabs, footings, piers, etc.
 - b. The Contractor will not be responsible for removing any asbestos, oils, paints, liquids, chemicals, or similarly regulated material;
2. The Contractor will retain sole ownership of all salvageable material, including wood, metal, and personal property stored inside building when project commences;
3. The Contractor will require unfettered access to the work site for the duration of this Contract. The Contractor will have access to the south side of the building for parking and to put a dumpster on, and to the fenced area on north side of building for material storage;
4. Client will provide a skid steer with forks for loading a trailer with 24-hours-notice by Contractor;
5. Client will be responsible for terminating all utilities (including gas, water, and power) and securing a demolition permit if one is required before established start date;

6. In a separate contract, the Contractor will remove the lower roof portion of the building that runs east/west and is attached to the south wall of the barrel-trussed building. The additional cost for this will be determined before work on this portion of the project begins. Assuming it is of similar value in salvage materials and of similar cost to dismantle, the cost would be commensurate with the rest of the project (at about \$2.75 a square foot).
7. The Client will pay the Contractor a sum of \$10,500 for the removal of the building.
Payment would be paid in full at the successful completion of the job.
8. The estimated project duration is three weeks;
9. The Contractor will assume full liability for its employees or anyone on site at the Contractor's request;
10. The Contractor will assume no liability for anyone on site without the Contractors knowledge or consent;
11. The Contractor will be able to make sales directly from the site.

Gary Delp

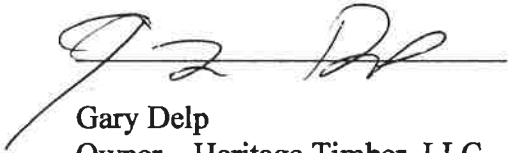

Gary Delp
Owner - Heritage Timber, LLC

5/3/15
Date



Claren Neal

May 15, 2015
Date

Deconstruction is an environmentally friendly alternative to building demolition. Materials are recycled and reused wherever possible, including wood, metals, and household items. This decreases the pressures on the forest, saves energy, conserves landfill space, and honors Montana's history.

1/16" = 1'0"

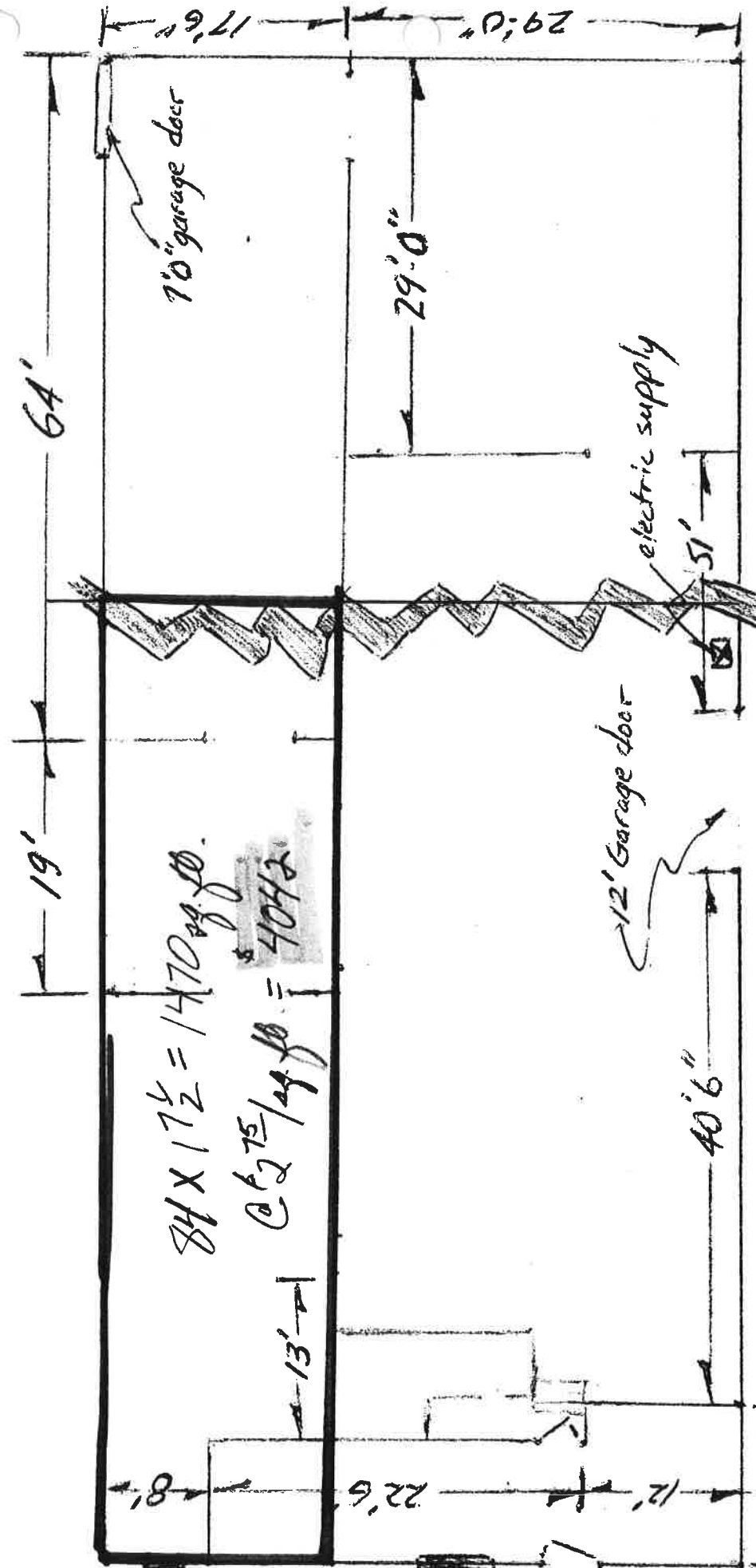

$84 \times 17\frac{1}{2} = 1470 \text{ sq. ft.}$
 $@ \$2.75 / \text{sq. ft.} = \$4042.$

NORTH PARK PROPERTIES - WAREHOUSE

THIS DOCUMENT HAS AN ARTIFICIAL WATERMARK PRINTED ON THE BACK, THE FRONT OF THE DOCUMENT HAS A MICRO-PRINT SIGNATURE LINE. ABSENCE OF THESE FEATURES WILL INDICATE A COPY.



First Interstate Bank
(406) 255-5000
401 N. 31st St. P.O. Box 30918
Billings, Montana 59116
AGENT FOR MONEYGRAM

5071379113

63-541/920

DATE Jul 30, 2015

REMITTER CLAREN NEAL

PAY TO THE ORDER OF HERITAGE TIMBER FOR DECONSTRUCTION 504 FLAT ROOF

\$ 14,542.00

PAY EXACTLY \$14,542 DOL 00 CTS

OFFICIAL CHECK

1142

DRAWER: MONEYGRAM PAYMENT SYSTEMS, INC.
P.O. BOX 9476, MINNEAPOLIS, MN 55480
DRAWEE: FIRST INTERSTATE BANK
BILLINGS, MT

⑆092005411⑆00507 ⑆3791138⑆

014913 / M 3387200



PROPERTY SERVICES

Claren Neal - Owner

Sept 6, 2015

Invoice # 8-2015

TO: North Park Properties

RE: Labor to Finish Demolition

and Clean Up all Debris

July 16	work w/ Heritage	\$40
July 17	w/ help, shut off main water line feeding bldg. w/ skidster load recycled materials	\$60
July 29	incidental work at site w/ skidster and help	\$70
July 30	equipment staging @ site	\$60
July 31	use mini excavator and help, tear down walls	\$240
Aug 1	w/ help, temporarily seal openings in bldg	\$120
Aug 10	use tracked skidster and help, load 3 truckloads of block and pile block	\$200
Aug 21	w/ skidster & help clean up site, move parking bumpers, fill 2 dumpsters	\$160
Aug 25	w/ Surveyor, locate property boundaries, review encroachment and propose solution	\$170



Claren Neal - Owner Sept 6, 2015

Invoice # 8-2015 continued

labor to Finish Demolition & Clean Up

Aug 26	Review and finalize letter agreement to resolve encroachment w/help and walk behind concrete saw cut concrete slab	\$ 227
Aug 27	w/help to concrete saw, cut floor in bldg, remove pieces	\$ 100
Aug 28	w/help to concrete saw, extend and finish all cuts	\$ 87
Sept 1	w/backhoe to help, tear down high back wall, front wall and remaining side wall. pile. haul clean up area	\$ 240
Sept 2	w/shedster to help, clean up all loose blocks and pile, clean up footprint, and surrounding area	\$ 140
Sept 3	w/tracked shedster to help, load 5 truckloads of block & debris	\$ 280
Sept 4	w/shedster to help, load shed and haul to south side Trailer Court	\$ 240
Sept 5	w/shedster, remove remaining stuff, move concrete bumpers, clean up area, expose 4 stamps for grouting	\$ 200
Total time 8.5 hours		\$ 2634

~~PO BOX 22374~~
~~BALTIMORE MD 21244~~



**PROPERTY
SERVICES**

~~410-241-0100~~
~~www.abc-property.com~~

Claren Neal - Owner Sept 6, 2015

Invoice # 9-2015

TO: North Park Properties
RE: Rental Expenses & Materials
to Finish Demolition & Clean Up

Miscellaneous	\$ 23
Rent Mini Excavator	\$ 269
Rent Tracked Skidsteer	\$ 194
Miscellaneous	\$ 9 ⁰⁰
Sawey	\$ 150
Rent Concrete Saw & Blade	\$ 60
Rent Concrete Saw again	\$ 45
Rent Backhoe	\$ 292
Rent Tracked Skidsteer	\$ 220

Total \$ 1262

~~XXXXXXXXXX~~
~~XXXXXXXXXX~~



PROPERTY SERVICES

~~406-245-8100~~
~~406-670-4565~~

Claren Neal - Owner Sept 6, 2015

Invoice # 10-2015

TO: North Park Village

RE: Extra Labor Expenses to Finish
Demolition and Clean Up

Day Laborer 4	July - 4 days Aug - 7 days Sept - 3 days	\$ 540 ⁰⁰
---------------	--	----------------------

Day Laborer 5 (Brother James)	Sept - 1 day	\$ 60
----------------------------------	--------------	-------

Total

\$ 600

RAY Quenzel
 1045 Howard AVE
 Billings MT 59102

Job Invoice

SOLD TO NORTH Park Properties 725 AVE D Billings MT 59101	DATE ORDERED 7-10-2015	ORDER TAKEN BY
	PHONE NO.	CUSTOMER ORDER #
	JOB LOCATION	
	JOB PHONE	STARTING DATE
TERMS		

QTY.	MATERIAL	UNIT	AMOUNT	DESCRIPTION OF WORK
8	Hourly Labor	35.00	280 00	
7-8-15 TO:	TERMINATE Gas LINE TERMINATE Water LINE W/NE Shut OFF + FILL Drains For Plugging			
8	Hourly Labor	35.00	280 00	
7-9-15 TO:	Continue Plugging Drain Lines.			
7				
7-10-15	Hourly Labor TO: Pour concrete Plugs in all drains Shut OFF main Water & cap Line.	35.00	245 00	
			<u>\$805 00</u>	
TOTAL MATERIALS				
		TOTAL LABOR		

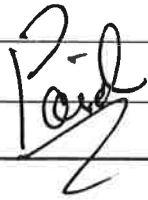
WORK ORDERED		TOTAL LABOR	
DATE ORDERED		TOTAL MATERIALS	
DATE COMPLETED		TOTAL MISCELLANEOUS	
CUSTOMER APPROVAL SIGNATURE _____		SUBTOTAL	
		TAX	

Serafin Electric, Inc.

2830 S 50th St W
Billings MT 59106
Phone 406/245-3056 Cell 406/591-0962

INVOICE # 6022

Date: July 31, 2015

Bill To:
North Park Properties
725 Ave D
Billings, MT 59102

Job Details:
artist warehouse
terminate electrical in areas to be demolished
remove fuses & breakers from main panel
remove 3 phase panel
verify all power off in area to be demolished

Bills due upon receipt- Pursuant to MCA 28-2-2104 bills left unpaid after 30 days will begin to accrue interest at 1 1/2% per month

LABOR/MATERIALS		AMOUNT	
MATERIALS		\$	-
LABOR	6 hours	\$	510.00
TOTAL			\$510.00

PAID

The finest compliment I can receive is a referral from my friends and customers.

Thanks, Alan

Total Rental, Inc.
 (406) 248-9965
 1015 Central Avenue
 Billings, MT 59102

CONTRACT NUMBER T22284 INVOICE NUMBER T36299
 DATE AND TIME IN 09/01/2015 5:19 PM
 DATE AND TIME OUT 09/01/2015 10:30 AM

RENTED AND/OR SOLD TO **Closed Contract/Invoice** ADDRESS AT WHICH EQUIPMENT WILL BE USED

Account #: 25CLA0
 NEAL CLAREN
 725 AVENUE D
 BILLINGS, MT 59102

406-698-6325

WRITTEN BY: JAMES CHECKED IN BY: JAMES AGENT'S NAME: JOB LOCATION:
 CAR LICENSE NUMBER: DRIVER'S LICENSE NUMBER: 12029194XXXX P.O. NO. OR JOB NO.: DATE AND TIME DUE IN: See Details Below

Item #	Description	Qty	Out / In	Rates	M	W	D	H	Date & Time In	Amount
10-BKB-01	BACKHOE 310G JOHN DEERE EXTENDAOE 18'	1		MIN 140.00				6.49	09/01/2015 5:19 PM	140.00
Meter Out: 78.400 Meter In: 81.400 Total Usage: 3.000										
Serial# T0310GX906280										
Quantity Rtn/AmtChgd: 1/ 140.00										
DE-L -00	DELIVERY INSTRUCTIONS	0	1	MIN				6.49	09/01/2015 5:19 PM	0.00
Quantity Rtn/AmtChgd: 1/ 0.00										

DEL TO 504 NO. 20TH ST.

THANK YOU FOR YOUR BUSINESS. WE HOPE TO SEE YOU AGAIN SOON.
 STORE HOURS ARE MONDAY - SATURDAY 8:00_5:30 SUNDAY 10:00-4:00

TOTAL RENTAL INC
 1015 CENTRAL AVE
 BILLINGS, MT 59102
 (406) 248-9965

COPY

09/01/2015 19:41:35

Sale:

Transaction # 27
 Card Type: MasterCard
 Acc: *****6396
 Exp. Date: #/##
 Entry: Manual 30158
 Invoice # 18.00
 Amount:
 Reference No.: 0027
 Auth. Code: 063402
 Response: AP

CUSTOMER COPY

OF RENTAL CHARGE. RENTER MAY, BY INITIALS HEREON, DECLINE BENEFITS OF PARAGRAPH 12, DAMAGE WAIVER, ON REVERSE SIDE OF THIS CONTRACT.

DWC IS NOT INSURANCE.

DECLINES
 (INITIALS)

PROMPT RETURN OF YOUR RENTALS SAVES YOU MONEY. ALL TIME IS CHARGED INCLUDING SATURDAY, SUNDAY AND HOLIDAYS.

MONTANA LAW PROVIDES FOR CRIMINAL PENALTIES FOR FAILURE TO RETURN RENTED OR LEASED PERSONAL PROPERTY.

SEE SECTION 45-6-309, MONTANA CODE ANNOTATED AS REPRINTED ON REVERSE SIDE.

Total Rental 140.00
 Damage Waiver 14.00
 Delivery/Pickup 120.00
 Fuel 18.00
 Subtotal 292.00
 Total 292.00
 Less Deposit 274.00
 Balance Due 18.00
 Amount Out Owed
 EQUIPMENT HAS LIMITED WORKING HOURS.

Renter must pay within 30 minutes of Equipment Failure.

I have read and understand the terms and conditions on both sides of this agreement and certify that those printed on the other side are agreed to as if printed above my signature. There are no oral or other representations not included herein. Unless declined, I also agree to the damage waiver charges. I have received a copy of this agreement.

Lessee's Signature

Written: 09/01/2015, Last Adj.: 09/01/2015, Time: 17:19

Payment: CrCard

Total Rental, Inc.
 (406) 248-9965
 1015 Central Avenue
 Billings, MT 59102

CONTRACT NUMBER 122333 INVOICE NUMBER
 DATE AND TIME IN
 DATE AND TIME OUT 09/03/2015 8:41 AM

RENTED AND/OR SOLD TO

Open Contract

ADDRESS AT WHICH EQUIPMENT WILL BE USED

Account #: 25CLA0
 NEAL, CLAREN
 725 AVENUE D
 BILLINGS, MT 59102

406-698-6325

WRITTEN BY: CHECKED IN BY: RENTER NAME: JOB LOCATION:
 NAMES: DATE AND TIME:
 CAT LICENSE NUMBER: DRIVER LICENSE NUMBER: PO NO OR JOB NO: See Details Below
 12028194XXXX

Item #	Description	ITEMS RENTED AND/OR SOLD				M	W	D	H	Date & Time Due	Amount
		Quantity	Rates								
10-SKN-00	SKIDSTEER 322 TRACK 120.00 Minimum 200.00 Day 200.00 24 Hrs 1000.00 1 Week 3000.00 4 Wks Meter Out: 318.900 Serial# John Deere 322	1	24H 200.00				1		09/04/2015 8.41 AM	200.00	
CHECK UTILITIES DIESEL ONLY CUSTOMER RESPONSIBLE FOR HOSES MACH. HOUR MAX= (24 HRS) 8 DAY, (7 DAYS) 40 WEEK, (28 DAYS) MONTH 170 \$40.00 CLEANING CHARGE IF RETURNED DIRTY!!!											
10-SKF-00	SKIDSTEER BUCKET - SMOOTH 0.00 Minimum 0.00 Day 0.00 24 Hrs 0.00 1 Week 0.00 4 Wks Serial# 7956C87954, 8189C87953	1	24H				1		09/04/2015 8.41 AM	0.00	

THANK YOU FOR YOUR BUSINESS. WE HOPE TO SEE YOU AGAIN SOON.
 STORE HOURS ARE MONDAY - SATURDAY 8:00 - 5:30 SUNDAY 10:00-4:00

TOTAL RENTAL INC
 1015 CENTRAL AVE
 BILLINGS, MT 59102
 (406) 248-9965

COPY
 09/03/2015 11:01:36
 Sale:

Transaction # 6
 Card Type: MasterCard
 Acc: *****6396
 Exp. Date: 09/11/15
 Entry: Swiped
 Invoice # 30188
 Amount: 220.00
 Reference No.: 0006
 Auth. Code: 076882
 Response: AP

CUSTOMER COPY

DAMAGE WAIVER CHARGE (DWC) 10.00
 OF RENTAL CHARGE. RENTER MAY, BY INITIALS HEREON, DECLINE BENEFITS OF PARAGRAPH 12, DAMAGE WAIVER, ON REVERSE SIDE OF THIS CONTRACT.

DWC IS NOT INSURANCE.

DECLINES
 (INITIALS)

PROMPT RETURN OF YOUR RENTALS SAVES YOU MONEY. ALL TIME IS CHARGED INCLUDING SATURDAY, SUNDAY AND HOLIDAYS.

MONTANA LAW PROVIDES FOR CRIMINAL PENALTIES FOR FAILURE TO RETURN RENTED OR LEASED PERSONAL PROPERTY. SEE SECTION 45-6-309, MONTANA CODE ANNOTATED AS REPRINTED ON REVERSE SIDE.

Total Rental 200.00
 Damage Waiver 20.00
 Subtotal 220.00
 Total 220.00
 Total Deposit Required 220.00
 Amount Received 220.00

EVERY DAY IS A RENTAL DAY. WE CHARGE FOR ALL TIME OUT. POWERED EQUIPMENT HAS LIMITED WORKING HOURS.

Renter must call within 30 minutes of Equipment Failure.

I have read and understand the terms and conditions on both sides of this agreement and certify that those printed on the other side are agreed to as if printed above my signature. There are no oral or other representations not included herein. Unless declined, I also agree to the damage waiver charges. I have received a copy of this agreement.

A MINIMUM CHARGE OF \$10.00 IS APPLIED TO RENTAL ITEMS RETURNED DIRTY!!!
 MAKE SURE IT IS CLEAN UPON RETURN!!!
 CUSTOMER RESPONSIBLE FOR HYDRO

Lessee's Signature
 Written: 09/03/2015

Payment: CrCard

Total Rental, Inc.
 (406) 248 - 9965
 1015 Central Avenue
 Billings, MT 59102

CONTRACT NUMBER 122284 INVOICE NUMBER
 DATE AND TIME IN
 DATE AND TIME OUT 09/01/2015 10:30 AM

RENTED AND/OR SOLD TO **Open Contract** ADDRESS AT WHICH EQUIPMENT WILL BE USED

Account #: 25CLA0
 NEAL, CLAREN
 725 AVENUE D
 BILLINGS, MT 59102

406-698-6325

WRITTEN BY: JAMES CHECKED IN BY: AGENT'S NAME: JOB LOCATION:
 CAR LICENSE NUMBER: DRIVER'S LICENSE NUMBER: 12029194XXXX P.O. NO. OR JOB NO.: DATE AND TIME DUE IN: See Details Below

Item #	Description	Quantity	Rates	M	W	D	H	Date & Time Due	Amount
10-BKB-01	BACKHOE 310G JOHN DEERE EXTENDAHOE	1	MIN 140.00				3	09/01/2015 1:30 PM	140.00
	140.00 Minimum 235.00 Day 235.00 24 Hrs 705.00 1 Week 2115.00 4 Wks								

Meter Out: 78.400

Serial# T0310GX906280

CHECK UTILITIES DIESEL ONLY CUSTOMER RESPONSIBLE FOR TIRES AND HOSES MACH. HOUR MAX= 8 DAY 40 WEEK 170 MONTH 4
 OVERNIGHT CUSTOMER RESPONSIBLE FOR FUEL \$50.00 CLEANING CHARGE IF RETURNED DIRTY!!!

DE-L -00	DELIVERY INSTRUCTIONS	1	MIN					09/01/2015 10:30 AM	0.00
	0.00 Minimum 0.00 Day 0.00 24 Hrs 0.00 1 Week 0.00 4 Wks								

CUSTOMER MUST CALL FOR PICKUP. RENT CONTINUES UNTILL RECEIVED.

DEL. TO 504 NO. 20TH ST.

THANK YOU FOR YOUR BUSINESS. WE HOPE TO SEE YOU AGAIN SOON.
 STORE HOURS ARE MONDAY - SATURDAY 8:00_5:30 SUNDAY 10:00-4:00

TOTAL RENTAL INC
 1015 CENTRAL AVE
 BILLINGS, MT 59102
 (406) 248-9965

COPY
 Sale: 09/01/2015 11:24:32

Transaction # 9
 Card Type: MasterCard
 Acc: *****6396
 Exp. Date: MM/YY
 Entry: Swiped
 Invoice # 30141
 Amount: 274.00
 Reference No.: 0009
 Auth. Code: 07238Z
 Response: AP

CUSTOMER COPY

Total Rental	140.00
Damage Waiver	14.00
Delivery/Pickup	120.00
Subtotal	274.00
Total	274.00
Total Deposit Required	274.00
Amount Refused	274.00

EVERY DAY'S RENTAL DAY. WE CHARGE FOR ALL TIME OUT. POWERED EQUIPMENT HAS LIMITED WORKING HOURS.

Renter must call within 30 minutes of Equipment Failure.

SEE SECTION 45-6-309, MONTANA CODE ANNOTATED AS REPRINTED ON REVERSE SIDE OF THIS CONTRACT.

DWC IS NOT INSURANCE.

DECLINES
 (INITIALS)

YOU MONEY. ALL TIME IS CHARGED INCLUDING SATURDAY, SUNDAY AND HOLIDAYS.

MONTANA LAW PROVIDES FOR CRIMINAL PENALTIES FOR FAILURE TO RETURN RENTED OR LEASED PERSONAL PROPERTY.

SEE SECTION 45-6-309, MONTANA CODE ANNOTATED AS REPRINTED ON REVERSE SIDE.

I have read and understand the terms and conditions on both sides of this agreement and certify that those printed on the other side are agreed to as if printed above my signature. There are no oral or other representations not included herein. Unless declined. I also agree to the damage waiver charges. I have received a copy of this agreement.

A MINIMUM CHARGE OF \$10.00 IS APPLIED TO RENTAL ITEMS RETURNED DIRTY!!!
 MAKE SURE IT IS CLEAN UPON RETURN!!!
 CUSTOMER RESPONSIBLE FOR HYDRO

Lessee's Signature
 Written: 09/01/2015

Payment: CrCard

Total Rental, Inc.
 (406) 248 - 9965
 1015 Central Avenue
 Billings, MT 59102

CONTRACT NUMBER 121756

INVOICE NUMBER 135759

DATE AND TIME IN 08/10/2015 5:25 PM

5:25 PM

DATE AND TIME OUT 08/10/2015 12:32 PM

12:32 PM

RENTED AND/OR SOLD TO

Closed Contract/Invoice

ADDRESS AT WHICH EQUIPMENT WILL BE USED

Account #: 25CLAO
 NEAL, CLAREN
 725 AVENUE D
 BILLINGS, MT 59102

406-698-6325



Item #	Description	ITEMS RENTED AND/OR SOLD				Date&Time In	Amount
		Qty	Out / In	Rates	M W D H		
10-SKN-00	SKIDSTEER 322 TRACK	0	1	MN+ 150.00	4.53	08/10/2015 5:25 PM	176.50
Meter Out: 300.100		Meter In: 303.300		Total Usage: 3.200	Allowed: 4.880	Over: 0.000	
Serial# John deere 322		Quantity Rtn'd/AmtChgd: 1/ 176.50					

THANK YOU FOR YOUR BUSINESS. WE HOPE TO SEE YOU AGAIN SOON.
 STORE HOURS ARE MONDAY - SATURDAY 8:00_5:30 SUNDAY 10:00-4:00

TOTAL RENTAL INC
 1015 CENTRAL AVE
 BILLINGS, MT 59102
 (406) 248-9965

COPY
 08/10/2015 19:43:48
 Sale:

Transaction # 36
 Card Type: MasterCard
 Acc: *****6396
 Exp. Date:
 Entry: Swiped
 Invoice # 29634
 Amount: 62.15
 Reference No.: 0036
 Auth. Code: 010362
 Response: AP

CUSTOMER COPY

DAMAGE WAIVER CHARGE (DWC) 10.00%
 OF RENTAL CHARGE. RENTER MAY, BY INITIALS HEREON, DECLINE BENEFITS OF PARAGRAPH 12, DAMAGE WAIVER, ON REVERSE SIDE OF THIS CONTRACT.

DWC IS NOT INSURANCE.

DECLINES
 (INITIALS)

PROMPT RETURN OF YOUR RENTALS SAVES YOU MONEY. ALL TIME IS CHARGED INCLUDING SATURDAY, SUNDAY AND HOLIDAYS.

MONTANA LAW PROVIDES FOR CRIMINAL PENALTIES FOR FAILURE TO RETURN RENTED OR LEASED PERSONAL PROPERTY. SEE SECTION 45-6-308, MONTANA CODE ANNOTATED AS REPRINTED ON REVERSE SIDE.

Total Rental	176.50
Damage Waiver	17.65
Subtotal	194.15
Total	194.15
Less Deposit	132.00
Balance Due	62.15
APPROXIMATE RENTAL DAY. WE CHARGE FOR ALL TIME OUT. POWERED EQUIPMENT HAS LIMITED WORKING HOURS.	62.15
Renter must call within 30 minutes of Equipment Failure.	

I have read and understand the terms and conditions on both sides of this agreement and certify that those printed on the other side are agreed to as if printed above my signature. There are no oral or other representations not included herein. Unless declined, I also agree to the damage waiver charges. I have received a copy of this agreement.

Lessee's Signature: _____
 Written: 08/10/2015, Last Adj.: 08/10/2015, Time: 17:25

Payment: CrCard

Total Rental, Inc.
 (406) 248-9965
 1015 Central Avenue
 Billings, MT 59102

CONTRACT NUMBER 121756

INVOICE NUMBER

DATE AND TIME IN

DATE AND TIME OUT

08/10/2015

12:32 PM

RENTED AND/OR SOLD TO

Open Contract

ADDRESS AT WHICH EQUIPMENT WILL BE USED

Account #: 25CLA0
 NEAL, CLAREN
 725 AVENUE D
 BILLINGS, MT 59102

406-698-6325



Item #	Description	ITEMS RENTED AND/OR SOLD Quantity	Rates	M	W	D	H	Date & Time Due	Amount
10-SKN-00	SKIDSTEER 322 TRACK	1	MIN 120.00					08/10/2015 3:32 PM	120.00
	120.00 Minimum 200.00 Day 200.00 24 Hrs 1000.00 1 Week 3000.00 4 Wks								
	Meter Out: 300.100								
	Serial# john deere 322								

CHECK UTILITIES DIESEL ONLY CUSTOMER RESPONSIBLE FOR HOSES MACH. HOUR MAX= (24 HRS) 8 DAY, (7 DAYS) 40 WEEK, (28 DAYS) MONTH 170 \$40.00 CLEANING CHARGE IF RETURNED DIRTY!!!

THANK YOU FOR YOUR BUSINESS. WE HOPE TO SEE YOU AGAIN SOON.
 STORE HOURS ARE MONDAY - SATURDAY 8:00_5:30 SUNDAY 10:00-4:00

TOTAL RENTAL INC
 1015 CENTRAL AVE
 BILLINGS, MT 59102
 (406) 248-9965

COPY
 08/10/2015 14:51:56

Sale:

Transaction # 15
 Card Type: MasterCard
 Acc: *****6396
 Exp. Date: **/**
 Entry: Swiped
 Invoice # 29614
 Amount: 132.00
 Reference No.: 0015
 Auth. Code: 03320Z
 Response: AP

CUSTOMER COPY

DAMAGE WAIVER CHARGE (DWC) 10.00%
 OF RENTAL CHARGE. RENTER MAY, BY INITIALS HEREON, DECLINE BENEFITS OF PARAGRAPH 12, DAMAGE WAIVER, ON REVERSE SIDE OF THIS CONTRACT.

DWC IS NOT INSURANCE.

DECLINES
 (INITIALS)

PROMPT RETURN OF YOUR RENTALS SAVES YOU MONEY. ALL TIME IS CHARGED INCLUDING SATURDAY, SUNDAY AND HOLIDAYS.

MONTANA LAW PROVIDES FOR CRIMINAL PENALTIES FOR FAILURE TO RETURN RENTED OR LEASED PERSONAL PROPERTY.

SEE SECTION 45-6-309, MONTANA CODE ANNOTATED AS REPRINTED ON REVERSE SIDE.

I have read and understand the terms and conditions on both sides of this agreement and certify that those printed on the other side are agreed to as if printed above my signature. There are no oral or other representations not included herein. Unless declined, I also agree to the damage waiver charges. I have received a copy of this agreement.

Lessee's Signature
 Written: 08/10/2015

Total Rental 120.00
 Damage Waiver 12.00
 Subtotal 132.00
 Total 132.00
 Total Deposit Required 132.00
 Amount Received 132.00

EVERY DAY IS A RENTAL DAY. WE CHARGE FOR ALL TIME OUT. POWERED EQUIPMENT HAS LIMITED WORKING HOURS.

Renter must call within 30 minutes of Equipment Failure.

A MINIMUM CHARGE OF \$10.00 IS APPLIED TO RENTAL ITEMS RETURNED DIRTY!!!
 MAKE SURE IT IS CLEAN UPON RETURN!!!
 CUSTOMER RESPONSIBLE FOR HYDRO

Payment: CrCard

Total Rental, Inc.
 (406) 248-9965
 1015 Central Avenue
 Billings, MT 59102

CONTRACT NUMBER 121526
 DATE AND TIME IN
 DATE AND TIME OUT 07/31/2015 12:00 PM

INVOICE NUMBER
 ADDRESS AT WHICH EQUIPMENT WILL BE USED

RENTED AND/OR SOLD TO

Reservation

Account #: 25CLA0
 NEAL, CLAREN
 725 AVENUE D
 BILLINGS, MT 59102

406-698-6325



Item #	Description	ITEMS RENTED AND/OR SOLD Quantity	Rates	M	W	D	H	Date & Time Due	Amount
BKD -02	BACKHOE MINIX 35D	1	24H 245.00			1		08/01/2015 12:00 PM	245.00
	160.00 Minimum 245.00 Day 245.00 24 Hrs 705.00 1 Week 2115.00 4 Wks								
	Serial# 1FF035DXHCG268270								

CHECK UTILITIES DIESEL ONLY CUSTOMER RESPONSIBLE FOR MACH. TIRES AND HOSES HOURS MAX (24 HRS) 8 DAY, (7 DAY) 40 WEEK, (28 DAY) 170 MONTH 4 OVERNIGHT CUSTOMER RESPONSIBLE FOR FUEL. \$40.00 CLEANING CHARGE IF RETURNED DIRTY!!!

DEL TO 504 NORTH 20TH ST. ACROSS FROM NORTH PARK

THANK YOU FOR YOUR BUSINESS. WE HOPE TO SEE YOU AGAIN SOON.
 STORE HOURS ARE MONDAY - SATURDAY 8:00-5:30 SUNDAY 10:00-4:00

TOTAL RENTAL INC
 1015 CENTRAL AVE
 BILLINGS, MT 59102
 (406) 248-9965

COPY
 07/31/2015 12:15:19
 Sale:

Transaction # 8
 Card Type: MasterCard
 Acc: *****6396
 Exp. Date: #/ #/ #
 Entry: Stiped
 Invoice # 29369
 Amount: 269.50
 Reference No.: 0008
 Auth. Code: 067502
 Response: AP

CUSTOMER COPY

DAMAGE WAIVER CHARGE (DWC) 10.00%
 OF RENTAL CHARGE. RENTER MAY, BY INITIALS HEREON, DECLINE BENEFITS OF PARAGRAPH 12, DAMAGE WAIVER, ON REVERSE SIDE OF THIS CONTRACT.

DWC IS NOT INSURANCE.

DECLINES
 (INITIALS)

PROMPT RETURN OF YOUR RENTALS SAVES YOU MONEY. ALL TIME IS CHARGED INCLUDING SATURDAY, SUNDAY AND HOLIDAYS.

MONTANA LAW PROVIDES FOR CRIMINAL PENALTIES FOR FAILURE TO RETURN RENTED OR LEASED PERSONAL PROPERTY.

SEE SECTION 45-6-309, MONTANA CODE ANNOTATED AS REPRINTED ON REVERSE SIDE.

I have read and understand the terms and conditions on both sides of this agreement and certify that those printed on the other side are agreed to as if printed above my signature. There are no oral or other representations not included herein. Unless declined, I also agree to the damage waiver charges. I have received a copy of this agreement.

Lessee's Signature
 Rsv. Taken: 07/31/2015

Total Rental 245.00
 Damage Waiver 24.50
 Subtotal 269.50
 Total 269.50
 Total Deposit Required 269.50
 Amount Received 269.50

EVERY DAY IS A RENTAL DAY. WE CHARGE FOR ALL TIME OUT. POWERED EQUIPMENT HAS LIMITED WORKING HOURS.

Renter must call within 30 minutes of Equipment Failure.

A MINIMUM CHARGE OF \$10.00 IS APPLIED TO RENTAL ITEMS RETURNED DIRTY!!!
 MAKE SURE IT IS CLEAN UPON RETURN!!!
 CUSTOMER RESPONSIBLE FOR HYDRO

Payment: CrCard

Regular City Council Meeting

Meeting Date: 04/11/2016

TITLE: Managed Wi-Fi Network for City Facilities

PRESENTED BY: Bruce McCandless, Assistant City Administrator

Department: City Hall Administration

PROBLEM/ISSUE STATEMENT

The City currently has a managed Wi-Fi system that provides Wi-Fi for staff, guests, the Emergency Operations Center (EOC), and Council chambers. The Wi-Fi system is seven years old and needs replacement to provide reliable Wi-Fi services to the EOC, to support 2.4Ghz & 5Ghz network coverage simultaneously, to meet current security needs, to provide greater visibility as to who is on our wireless network, to increase the available bandwidth via Wi-Fi for data intensive applications, and to improve the network management capabilities.

The Extreme Wireless solution is being purchased from High Point Networks through an existing State of Montana contract (AR-1470). The wireless upgrade was approved in the FY 2016 Technology Replacement Plan and is budgeted for in the Information Technology FY 2016 budget.

ALTERNATIVES ANALYZED

City Council may:

- Approve purchasing the Extreme Wireless Wi-Fi solution, or
- Disapprove the purchase. Information Technology would have to reassess the options for meeting the organization's technology needs and recommend any viable solutions.

FINANCIAL IMPACT

The FY 2016 Technology Replacement Plan (TRP) and the Information Technology budget includes \$ 80,000 to purchase a new managed wireless solution. The new wireless solution, quoted at \$ 75,342, is within budget and will be funded 100% from the Information Technology budget.

RECOMMENDATION

Staff recommends that the City Council approve purchasing a new wireless managed solution from High Point Networks and Extreme Wireless for the quoted price of \$75,342.

APPROVED BY CITY ADMINISTRATOR

Attachments

High Point-Extreme Proposal
High Point - Authorized Extreme Reseller



Proposal

Prepared for:

City of Billings
David Watterson
210 N. 27th Street
Billings, MT 59102
wattersond@ci.billings.mt.us

Prepared by:

Damon Andrews
High Point Networks, LLC.
Direct/Mobile/Fax: 406-860-5175
damon@highpointnetworks.com

www.highpointnetworks.com

Date prepared:

March 23, 2016

Proposal Name:

Wireless Proposal

Wireless Proposal

Extreme Wireless Hardware

Qty	Item	Description	Price	Ext. Price
3	30135	WS-C35 WLAN Appliance. Manages 50 Access Points, expandable to 125 in 1 or 16 AP increments. Requires Regulatory Domain Key	\$2,698.00	\$8,094.00
83	WS-AP3825i	Dual radio 11ac / 11gn 3X3:3 MIMO indoor access point with integrated antennas and 2xE/N active/active data ports (requires V9 or higher)	\$472.00	\$39,176.00
12	31012	WS-AP3935i-FCC (US Puerto Rico Colombia) - Dual Band Radio 802.11 ac/abgn 4x4:4 MIMO Indoor Wave 2 Access Point with Eight Internal Antenna Array & Active/Active E/N Data Ports (Requires V10.01 or higher)	\$592.00	\$7,104.00
17	WS-AP3805I	Extreme Networks Dual Radio 802.11 ac/abgn, 2x2:2 MIMO (on 5GHz) Indoor Access Point s/ 4 Interanal Antenna Array & Integrated Clips for Flush Rail Drop Ceiling Mounting	\$348.00	\$5,916.00
3	WS-REG9P-NAM	V9 Regulatory Domain Key for the FCC domain. Enables WLAN appliances and access points with appropriate RF settings for associated countries.	\$0.00	\$0.00
3	97004-30135	ExtremeWorks NBD support for WS-C35	\$310.00	\$930.00
			Subtotal:	\$61,220.00

Netsight Advanced

Qty	Item	Description	Price	Ext. Price
1	NMS-ADV-25	NetSight Advanced License for up to 25 devices and 250 thin Aps	\$4,199.00	\$4,199.00
1	97003-S20149	NetSight Advanced - Annual Support	\$2,723.00	\$2,723.00
			Subtotal:	\$6,922.00

Implementation

Qty	Item	Description	Price	Ext. Price
1	PROSERVE-PKG	High Point Networks Professional Services	\$7,200.00	\$7,200.00
			Subtotal:	\$7,200.00

Wireless Proposal

Prepared for:

City of Billings

Attn: David Watterson
210 N. 27th Street IT Division
Billings, MT 59102

Prepared by:

High Point Networks, LLC

Damon Andrews
Direct: 406-860-5175
damon@highpointnetworks.com



Extreme Networks State Contract - AR-1470

Quote Summary

Description	Amount
Extreme Wireless Hardware	\$61,220.00
Netsight Advanced	\$6,922.00
Implementation	\$7,200.00
Total:	\$75,342.00

For questions related to your quotation, please contact us using the information above. By signing below, the undersigned accepts High Point Networks Master Service Agreement and represents that he or she is authorized to execute the agreement on behalf of the customer. Acceptance of the quote online is considered acceptance of an offer and binding. All quotes are subject to shipping costs that may not be listed on the quote. Prices quoted are valid for 30 days from Quotation Date. Limitation of Liability for Consequential Damages. High Point Networks, LLC shall not be liable for any indirect, incidental, consequential, exemplary, or punitive damages of any kind or nature. All IP Telephony and projects exceeding 10 hours of service will require a 50% down payment of the total project due upon acceptance of the quotation and the remainder due within 30 days of completion. Payment for all other orders are due in 30 days subject to credit approval. Credit card usage as a form of payment may be accepted on pre-approval basis and may be subject to a convenience fee. "Optional" items on the above quote are not included in the total pricing at the bottom of the quote. Note: Once product is ordered and shipped there is NO right of return and may be subject to a restocking fee. Product cannot be returned if ordered in error. Product cannot be returned if next generation product has been released.

Signature

Date

Wireless Proposal



Summary

High Point Networks is happy to be providing City of Billings a proposal for an Extreme wireless solution. Our solution details around the professional services associated with this proposal are defined below. If there are any questions or concerns please let us know.

Completion Date: To Be Determined

P.O.C(s): Deb Schmitt

Site Address: City of Billings

Project Brief: City of Billings will be implementing a new Extreme wireless solution to replace a legacy Avaya wireless solution. The new wireless will be implemented methodically over a period of time in order to minimize impact on end users. Netsight software will be implemented to provide reports, maps, and troubleshooting tools.

Scope of Work:

- **HPN Responsibilities:**
 - Configure Extreme wireless controllers
 - Initial 2 areas of deployment will include pre/post install survey of wireless coverage.
 - Work with City of Billings IT staff to develop duplicate SSIDs from existing wireless solution to new Extreme solution.
 - Train City of Billings staff on Extreme wireless management via Netsight Advanced.
 - Provide detailed documentation on final design.

- **Client Responsibilities:**
 - Mounting of all APs
 - New cabling drops, as necessary.
 - Provide necessary network POE switches.

Change Control:

It may become necessary to amend the Scope of Work for reasons including, but not limited to, the following:

- For the avoidance of doubt, High Point Networks is not responsible for providing any services or tasks, hardware, materials or licensing not specifically set forth in this Scope of Work.
- Discretionary changes to the project schedule.
- Requested changes to the work hours of High Point Networks personnel
- Non-availability of products or services that are beyond High Point Networks' control
- Environmental or architectural impediments not previously identified
- Problems associated with the ordering, provisioning, or troubleshooting of goods or services provided by 3rd parties, such as but not limited to: Telco's, ISPs, software vendors, electricians, etc.
- Lack of access to client personnel, data or facilities necessary to complete project

In the event that it is necessary to change this Scope of Work, High Point Networks will initiate contact with the Company Point of Contact to work out these details and any impact to schedules and/or financial commitments.

State of Montana

NASPO ValuePoint Cooperative Purchasing Organization
Data Communications Products and Services 14-19 (Master Agreement AR 1470)

State Contract Details:

Data Communications Products and Services 2014-2019

Address:		State Purchasing Agent:		
State of Montana 125 N. Roberts St. Helena, MT 59620		Rick Dorvall rickdorvall@mt.gov Phone: (406) 444-3366		
Account Team:				
Primary Contact(s):	Account Executive(s):			
	Name	Phone	Website	Notes
	David Sachs	+1-303-506-2422	www.extremeNetworks.com	

Contract(s):

WSCA - AR1470
Price List

Expires:
5/31/19

Resellers for MT, WSCA - AR1470

High Point Networks, LLC

Elmar Cannon

3450 Black Walnut Ct

Loveland, Co 80538

Phone: 978-541-7887

elmar.cannon@highpointnetworks.com

Regular City Council Meeting

Meeting Date: 04/11/2016

TITLE: Approval of Law Enforcement Officer Reimbursement Agreement with the Transportation Security Administration

PRESENTED BY: Kevin Ploehn, Director of Aviation and Transit

Department: Airport

PROBLEM/ISSUE STATEMENT

Since 2002, the Airport has participated in Reimbursement Agreements with the Transportation Security Administration (TSA) to partially reimburse the Aviation and Transit Department for the labor costs associated with providing law enforcement officer (LEO) coverage at the TSA's security passenger screening area. The labor costs eligible for reimbursement include base salary, social security, 457 plans, health, life and disability insurance costs, as well as retirement costs. The current Agreement expired on September 30, 2015 and was extended by the TSA for a 6-month period that ended March 31, 2016. The extension allowed the TSA additional time to evaluate new applications from interested participants. To participate in this next program, airports were once again required to apply via a federal grant process. On August 27, 2015, Billings Logan International Airport submitted an application for participation in the next LEO reimbursement program and recently received notification of the Assistance Award. The program period for the new Agreement consists of a 9-month base funding period, which begins on April 1, 2016 through December 31, 2016, along with two 12-month option periods to end on December 31, 2018. The option periods are to be exercised at the discretion of the TSA, with additional funding for the option periods to be provided on an annual basis, subject to the availability of federal funds.

ALTERNATIVES ANALYZED

City Council may:

- Approve this new LEO reimbursement agreement #HSTS02-16-H-SLR604 with the TSA known as an Other Transaction Agreement (OTA), including the accompanying Statement of Joint Objectives (SOJO), and receive partial reimbursement for the City's labor costs to provide law enforcement support of TSA's passenger screening area, or;
- Disapprove this new LEO reimbursement agreement #HSTS02-16-H-SLR604 with the TSA known as an Other Transaction Agreement (OTA), including the accompanying Statement of Joint Objectives (SOJO). If this option is chosen, the City is still required to provide the law enforcement support and will incur the costs to provide law enforcement support to the security passenger screening area to prevent a disruption of commercial air service in Billings. However, the City would not be reimbursed for any portion of these costs.

FINANCIAL IMPACT

Under the terms of the OTA, the City will be authorized to receive partial reimbursement of the Airport's law enforcement officer's actual eligible wage and benefit costs for the time the officers spend at the passenger screening and checkpoint areas and on other TSA mandated activities. Approximately 35% of the officers' time is spent on these functions. The Airport estimates the labor costs for the 9-month base period at \$141,320.00. The amount to be reimbursed for this 9-month period is \$88,000. With approval of the OTA and accompanying SOJO, the TSA has authorized the first obligation of funds for the Airport in the amount of \$39,040.00 for the funding period April 1, 2016 to July 31, 2016, with the remaining funds for the base period to be unilaterally added by August 1, 2016. Funding for subsequent years of the OTA period is at the option of the TSA and subject to the availability of federal funds. Copies of the OTA and SOJO are on file in the City Clerk's office.

RECOMMENDATION

Staff recommends that City Council approve the OTA with the TSA, along with the accompanying SOJO and accept the associated reimbursement funds.

APPROVED BY CITY ADMINISTRATOR

Attachments

Agreement



Transportation Security Administration

AWARD

1	AWARD TYPE	2	AWARD NUMBER	3	REQUISITION NUMBER
	Other Transaction Agreement		HSTS02-16-H-SLR604		2116206SLR604
4	PARTICIPANT		5	ISSUED BY	
Name & Address: <u>Bill</u> City of Billings DBA Aviation and Transit 1901 Terminal Circle, Rm 216 Billings, Montana 59105-1991 Ms. Marita Herold, 406-237-6284			Name & Address: Transportation Security Administration Credentialing Screening & Intelligence Division (CSID) 701 S. 12 th Street Arlington VA 20598-6025 Kurt Allen, 202-253-4220 email: kurt.allen@tsa.dhs.gov		
6	APPLICATION TITLE & DATE				
Law Enforcement Officer Reimbursement Agreement Program HSTS02-15-R-SLR800					
7	PROGRAM PERIOD		8	FISCAL DATA	
Total Program Period 04/01/2016 through 12/31/2018 Funding/Budget Period: 04/01/2016 to 07/31/2016 Effective Date: Date of Signature by TSA Contracting Officer			Federal Share: \$321,600.00 Appropriation No. 5AV167A000D2016ADE010GE000031006160616SLR-5903001402010000-4101 \$39,040.00 Obligated: \$39,040.00		
9	PARTICIPANT PROGRAM COORDINATOR		10	TSA CONTRACTING OFFICER TECHNICAL REPRESENTATIVE (COR)	
Ms. Marita Herold City of Billings DBA Aviation and Transit 1901 Terminal Circle, Rm 216 Billings, Montana 59105-1991 Ms. Marita Herold, 406-237-6284			Aimee Jackson, Program Manager Transportation Security Administration 601 S. 12th Street, TSA-18 East Tower (E8-206S) Arlington, VA 20598-6018 Telephone: 571-227-1532 e-Mail: aimee.jackson@dhs.gov		
11	ADMINISTRATIVE DATA		12	FAADS DATA	
Program: Chief Operating Officer Legislative Authority: 49 U.S.C. §§ 106(m) and 114(m)(1) Aviation and Transportation Security Act, Pub. L. 107-71, 115 Stat. 597			State Code: Montana Congressional District: 01 EIN: 816001237 DUNS: 184852945		
13 AUTHORIZED SIGNATURES					
Not Required					
Participant's Signature _____ Date _____			Contracting Officer _____		
TYPED NAME AND TITLE _____			TYPED NAME AND TITLE _____		

**DEPARTMENT OF HOMELAND SECURITY
Transportation Security Administration
LAW ENFORCEMENT OFFICER AGREEMENT PROGRAM**

TERMS AND CONDITIONS

PARTICIPANT: City of Billings DBA Aviation and Transit

AGREEMENT NO: HSTS02-16-H-SLR604

ARTICLE I – PARTIES

This Other Transaction Agreement (hereinafter referred to as "Agreement" or "OTA") is entered into between the United States of America (hereinafter referred to as the "Government"), Transportation Security Administration (hereinafter referred to as "TSA") and City of Billings DBA Aviation and Transit. The TSA and the City of Billings DBA Aviation and Transit agree to cooperate in good faith and to perform their respective obligations using good faith efforts in executing the purpose of this Agreement.

ARTICLE II – AUTHORITY

TSA and the City of Billings DBA Aviation and Transit enter into this Agreement under the authority of the Aviation and Transportation Security Act (ATSA), Pub. L. 107-71, 115 Stat. 597, specifically 49 U.S.C. 114(m), and 106(l) and (m), which authorizes agreements and other transactions on such terms and conditions as the Administrator determines necessary.

ARTICLE III – BACKGROUND AND PURPOSE

A. Background

On November 19, 2001, the President and Congress enacted ATSA, which established TSA as a new Federal agency. ATSA provides authority to the Administrator of TSA to carry out chapter 449 of Title 49 United States Code relating to civil aviation security, including responsibility for ordering the deployment of law enforcement personnel at each airport security passenger-screening location to ensure passenger safety and national security.

Pursuant to 49 U.S.C. § 44903(c) and 49 C.F.R. Part 1542, each airport operator is required to establish an air transportation security program that provides a law enforcement presence and capability at the airport that is adequate to ensure the safety of passengers. This Agreement is part of the joint effort of TSA and the airport operator to deploy sufficient LEOs in support of passenger screening activities at the checkpoint to meet their dual responsibility to ensure the safety of passengers and to counter risks to transportation security.

B. Purpose of This Agreement

- I. The Participant agrees to maintain a law enforcement presence and response that is

adequate to support each system for screening persons and accessible property. This law enforcement presence provides for the safety and security of persons and property against an act of criminal violence or aircraft piracy, and assists in preventing the introduction of TSA prohibited items. Both the Participant and TSA recognize that there is a broad range of activities that LEOs engage in at the nation's airports, many of which are outside the scope of this Agreement. Funding under this Agreement is intended to support a dedicated highly visible LEO presence through on-site flexible, fixed, or a combination of the two (hybrid) LEO stationing of the TSA screening checkpoints. For the purposes of this Agreement the acceptable LEO stationing postures are defined as follows:

- a. Fixed Stationing - The on-site LEO is stationed in the TSA passenger screening checkpoint during screening operations.
- b. Flexible Stationing - The on-site LEO is stationed in the vicinity/close proximity of the TSA passenger screening checkpoint, providing an enhanced visible presence/support at the checkpoint.
- c. Hybrid/Combination Stationing - A form of on-site LEO stationing involving both fixed and flexible stationing, which provides a combination of highly visible LEO presence in the checkpoint and in the vicinity/close proximity of the checkpoint

II. At a minimum the Participant will ensure that the Law Enforcement (LE) service provider:

- a. Supports TSA's screening operations, including dealing with attempts to bring prohibited items through the checkpoint, disorderly persons and similar tasks.
- b. Follows an established LE response standard which is mutually acceptable to the FSD, Participant and LE service provider.
- c. Participates in TSA's Layered Security Programs (appropriate level of participation to be determined by the FSD and Participant).

III. The Participant agrees to maintain a sufficient number of LEOs at or in the vicinity/close proximity of the checkpoint(s) during the hours of TSA screening checkpoint operations each day. The specific number of LEOs and the number of hours assigned to provide dedicated support to the passenger screening checkpoints must be identified in the submission.

IV. The Participant will assist in the verification of LEO credentials as requested by the FSD or other TSA representative.

V. The Participant will promptly provide incident reports, police reports, and other information when requested by TSA as part of a regulatory investigation.

VI. The Participant will fully cooperate with regulatory investigations.

VII. The Participant shall coordinate all media releases and other contact with or by media on

the terms and conditions of the LEO Reimbursement Agreement shall be referred to the Contracting Officer.

VIII. **Additional Airport Specific Requirements (these requirements will be mutually defined and accepted by both the FSD and the Participant)**: Describe any specific LEO support to be provided under this Agreement that is not included elsewhere in the Statement of Joint Objectives (SOJO) which supports TSA screening activities. Such support, based on the specific characteristics and security requirements of the airport, could include but is not limited to:

- a. LEO patrol of a particular area.
- b. Unique assistance to local TSA.

Note that such additional activities should only include those which are being performed during periods of TSA screening operations, and which do not interfere with the LEO's ability to provide immediate response to incidents at the screening checkpoints. For the purposes of this Agreement, response times in excess of 5 minutes are unacceptable. If utilizing Flexible Stationing or Hybrid Stationing, Participant must provide a separate document, password-protected, outlining specific LE response time to non-emergency/routine TSA calls for assistance.

ARTICLE IV – AUTHORIZED REPRESENTATIVES

The Contracting Officer is the only TSA official that has the authority to negotiate, administer, and execute all terms and conditions of this Agreement in concurrence with the Program Manager.

A. TSA Contacts:

Contracting Officer (CO)
Kurt Allen
701 S. 12th St. Arlington, VA 20598
Ph: 202-253-4220
Email: kurt.allen@dhs.gov

Program Manager/Contracting Officer's Representative (COR)
Aimee Jackson
TSA/LEO Reimbursement Office
601 S. 12th St. Arlington, VA 20598
Ph: 571-227-1532
Email: aimee.jackson@dhs.gov

The COR is responsible for providing technical direction and administration under this Agreement. The COR is not authorized to change the scope of work, to make any commitment or otherwise obligate the TSA, or authorize any changes which affect the liability of the TSA. The Participant will inform the Contracting Officer in the event that the COR takes any action

which is interpreted by the Participant as a change in scope or liability to either party.

B. PARTICIPANT NAME/CONTACT INFO

ARTICLE V – EFFECTIVE DATE AND TERM

This Agreement consists of a 9 month base funding period (unless otherwise noted), which will begin upon award, and two 12-month option periods, which will be exercised at the sole discretion of the TSA. At the conclusion of the base funding period, it is the TSA's intent to provide additional funding on an annual basis.

ARTICLE VI – FUNDING AND LIMITATIONS

TSA will provide, subject to the availability of funds, partial reimbursement to Participants to offset the cost to carry out aviation LE responsibilities in support of TSA screening activities. The total estimated cost of this agreement over the base and options periods is \$321,600.00

ARTICLE VII – BILLING PROCEDURE AND PAYMENT

A. Payment under this award will be authorized by the reimbursement payment method in compliance with information provided in the Application "Budget Information" with supporting invoice document(s).

B. TSA will reimburse the Participant monthly for amounts expended for the passenger screening checkpoint activities described in this Agreement and the Statement of Joint Objectives (SOJO). Participant is required to provide mandated LE services regardless of funding level or period funding is received.

C. Requests for reimbursement must be submitted to the FSD or FSD Designee for certification by the end of the month following the monthly period of performance (e.g., request for January's period of performance must be submitted no later than February 28th). The Participant will provide monthly invoices to the FSD/TSA designee and/or Contracting Officer's Representative in the format provided by the LEO Reimbursement Program Office, detailing the number of hours of LE services provided, the actual hourly rate, and the total amount requested for reimbursement. It is likely that the TSA will develop a maximum rate that will be used for reimbursement purposes. Reimbursement may be at this rate or at the actual cost, whichever is the lesser of the two. This maximum rate will be based on information that will not be available until the submission review process. The TSA reserves the right to modify the maximum rate during the period of performance as necessary to optimize the impact of the program. Currently the maximum hourly rate for reimbursement is actual costs not-to-exceed \$20.00/hr. Monthly invoicing consists of services provided from the 1st day of the month to the last day of the month. Detailed documentation must be submitted for each item for which reimbursement is requested; for example, checkpoint logs, timesheets, and/or appropriate validation from payroll for each individual LEO's fully burdened salary rate as described in the SOJO. Invoices and documentation supporting amount and number of hours billed will be submitted to the FSD no

later than 45 days after the end of the invoiced period of performance.

D. The final Request for Reimbursement is due within 45 days of the end of the Program Period.

E. Include banking information and Dun & Bradstreet (DUNS) number on all SF270's submitted.

F. Participant must be registered in the System for Award Management (SAM) at <https://www.sam.gov/portal/SAM/#1>. Banking information and DUNS number reflected must match information contained in the Participant's SAM account. Inaccurate information may result in payment delays.

Notwithstanding any other payment clause in this Agreement, the Government shall make invoice payments under the terms and conditions specified in this Article. Payment shall be considered made on the day the check is dated and deposited in the US mail, or an electronic funds transfer is completed. All days referred to in this clause are calendar days, unless otherwise specified.

ARTICLE VIII – AUDITS

TSA shall have the right to examine or audit relevant financial records for each **City of Billings DBA Aviation and Transit** facility, while this Agreement, or any part thereof, remains in force and effect, and for a period of three years after expiration or termination of the terms of this Agreement. For each facility, **City of Billings DBA Aviation and Transit** shall maintain: project records, technology maintenance records, and data associated with the TSA LEO Program while this Agreement, or any part thereof, remains in force and effect, and for a period of three years after the expiration or termination of this Agreement. If this Agreement is completely or partially terminated, the records relating to the work terminated shall be made available for three years after any resulting final termination settlement. Records relating to appeals under the "Disputes" provision in Article X regarding this Agreement shall be made available until such appeals are finally resolved.

As used in this provision, "records" includes books, documents and other data, regardless of type and regardless of whether such items are in written form, in the form of computer or other electronic data, or in any other form that relate to the TSA LEO Program for each facility.

City of Billings DBA Aviation and Transit shall also maintain all records and other evidence sufficient to reflect costs claimed to have been incurred by each facility in the purchase of technologies allowed in the TSA LEO Program, if any. The Contracting Officer, Contracting Officer's Representative, or the authorized representatives of these officers shall have the right to examine and audit those records at any time. This right of examination shall include inspection at all reasonable times at **City of Billings DBA Aviation and Transit's** offices directly responsible for managing the TSA LEO Program.

The Comptroller General of the United States shall also have access to, and the right to examine, any records involving transactions related to this Agreement.

This article shall not be construed to require **City of Billings DBA Aviation and Transit**, or its contractors or subcontractors who are associated with or engaged in activities relating to this OTA, to create or maintain any record that they do not maintain in the ordinary course of

business pursuant to a provision of law, provided that those entities maintain records which conform to generally accepted accounting procedures.

ARTICLE IX – LIMITATIONS OF LIABILITY

A. Subject to the provisions of Federal law, including the Federal Torts Claims Act, each party expressly agrees that it shall be liable for the acts or omissions of its own agents and/or employees and that neither party looks to the other to save or hold it harmless for the consequences of any act or omission on the part of one or more of its own agents or employees, subject to the same conditions provided above.

B. City of Billings DBA Aviation and Transit has the affirmative duty to notify the TSA Contracting Officer in the event that City of Billings DBA Aviation and Transit believes that any act or omission of a TSA agent or employee would increase City of Billings DBA Aviation and Transit costs and cause the City of Billings DBA Aviation and Transit to seek compensation from TSA beyond Article VI (Funding and Limitations). If the City of Billings DBA Aviation and Transit receives any communication which it interprets as instructions to change the work encompassed in this Agreement, or to incur costs not covered by funding obligated at that time, the City of Billings DBA Aviation and Transit must not act on that communication, and must contact the Contracting Officer verbally and in writing immediately.

C. No third party shall assert any rights under this Agreement unless expressly provided herein.

ARTICLE X – DISPUTES

Where possible, disputes shall be resolved by informal discussion between the Contracting Officer for TSA and an authorized representative of City of Billings DBA Aviation and Transit. All disputes arising under or related to this Agreement shall be resolved under this Article. Disputes, as used in this Agreement, mean a written demand or written assertion by one of the parties seeking, as a matter of right, the adjustment or interpretation of Agreement terms, or other relief arising under this Agreement. The dispute shall be made in writing and signed by a duly authorized representative of the City of Billings DBA Aviation and Transit or the TSA Contracting Officer. At a minimum, a dispute under this Agreement shall include a statement of facts, adequate supporting data, and a request for relief. In the event the parties are unable to resolve any disagreement through good faith negotiations, City of Billings DBA Aviation and Transit may submit the dispute to the Deputy Assistant Administrator for Acquisition. The decision of the Deputy Assistant Administrator for Acquisition is final unless it is appealed to the TSA Assistant Administrator for Acquisition or designee within sixty (60) days of receipt of the review and, to the extent permitted by law, is final and binding.

ARTICLE XI – TERMINATION

Either the Participant or TSA may terminate the Agreement by giving written notice to the other party at least thirty (30) calendar days prior to the effective date of the termination. All notices are to be transmitted via registered or certified mail to TSA Contracting Officer, return receipt requested. The Participant's authority to incur new costs will be terminated upon the date of arrival of receipt of the letter or the date set forth in the notice. Any costs incurred up to the earlier of the date of the receipt of the notice or the date of termination set forth in the notice will be negotiated for final payment.

ARTICLE XII – CHANGES AND OR MODIFICATIONS

- A. Changes and/or modifications to this Agreement, with the exception of funding modifications which shall be issued by TSA unilaterally, shall be in writing and signed by the TSA Contracting Officer and Participant. The modification shall cite the Agreement number and shall set forth the exact nature of the change and/or modification. No oral statement by any person shall be interpreted as modifying or otherwise affecting the terms of this Agreement.
- B. All requests for interpretations of this Agreement or modifications to it shall be submitted in writing to the TSA Contracting Officer.
- C. Extensions to the Project Period can only be authorized in writing by the TSA Contracting Officer.

ARTICLE XIII – CONSTRUCTION OF THE AGREEMENT

This Agreement is issued under 49 U.S.C. §106 (l)(6) and §114(m) and is not a procurement contract, grant, cooperative agreement, or other financial assistance. It is not intended to be, nor shall it be construed as, a partnership, corporation, or other business organization. Both parties agree to provide their best efforts to achieve the objectives of this Agreement. The Agreement constitutes the entire agreement between the parties with respect to the subject matter and supersedes all prior agreements, understanding, negotiations and discussions whether oral or written of the parties. Each party acknowledges that there are no exceptions taken or reserved under this Agreement.

This Agreement constitutes the entire agreement between the parties with respect to the subject matter hereof and supersedes all prior agreements, understandings, negotiations and discussions, whether oral or written, of the parties.

In the event that any Article and/or parts of this Agreement are determined to be void, such Article or portions thereof shall lapse. No such lapse will affect the rights, responsibilities, and obligations of the parties under this Agreement, except as provided therein. If either party determines that such lapse has or may have a material effect on the performance of the Agreement, such party shall promptly notify the other party, and shall negotiate in good faith a mutually acceptable amendment to the Agreement if appropriate to address the effect of the lapse.

ARTICLE XIV – PROTECTION OF INFORMATION

The parties agree that they shall take appropriate measures to protect proprietary, privileged, or otherwise confidential information that may come into their possession as a result of this Agreement.

A. RELEASE OF TECHNICAL DATA

No information, oral or written, concerning the scope of this Agreement, shall be published or released to the public without the prior written approval of the TSA Contracting Officer.

B. RECORDS AND RELEASE OF INFORMATION

All Sensitive Security Information (SSI), as defined in 49 CFR Part 1520, shall be handled in accordance with that regulation and TSA policies. All members assigned to work under this Agreement are subject to the provisions of 49 CFR Part 1520, Protection of Sensitive Security Information. SSI may not be disclosed except in accordance with the provisions of that rule.

C. MEDIA

All media releases and other contact with or by media related to this Agreement and in accordance with the terms of this Agreement shall be referred to the Contracting Officer.

ARTICLE XV – CLAUSE INCORPORATED BY REFERENCE

The following is hereby incorporated into this agreement by reference as applicable:

Agreement Application and Assurances contained therein received by TSA on Proposal due date.

For-profit organizations are subject to the provisions of 48 CFR Part 31, "Contract Cost Practices and Procedures."

ARTICLE XVI – CLAUSES INCORPORATED IN FULL TEXT

A. FREEDOM OF INFORMATION ACT (FOIA) REQUESTS

All requests for information relating to the Terms and Conditions or the performance requirements of this Agreement, to include those under FOIA or the Privacy Act, will be forwarded to the TSA Program Manager. The TSA Program Manager will coordinate a response with the TSA FOIA Office.

B. ORGANIZATION STAFFING

The program shall be staffed and organized by the Participant to satisfy its assigned mission and to perform its required functions.

C. INSURANCE

The Participant shall at all times during the duration of this Agreement maintain insurance or be self-insured relating to the program and Participant employees covering property, fire, casualty, liability, life, worker's compensation, and all other forms of insurance customarily obtained by entities in the same industry. The Participant will not insure TSA agents, contractors, or anyone else against any of these risks.

D. PUBLIC AFFAIRS

All public affairs activities related to program(s) sponsored under this award, and its activities must be approved by TSA. This does not preclude the Participant's personnel from participating in public affairs activities not related to program(s) sponsored under this award solely as agents

of the Participant.

E. BUY AMERICAN

The Participant, Sub-recipients and contractors receiving funds from this award shall comply with the Buy American Act (41 U.S.C. § 8302) unless it is determined that it is inconsistent with the public interest, impracticable to comply with such a requirement or that it would unreasonably increase the cost of articles, materials, or supplies. The exception shall be noted in the specifications and documentation to justify the exception will be retained in the file for record.

F. TRAFFICKING IN PERSONS

The Participant and its contractors receiving funds from this agreement must comply with the Trafficking Victims Protection Act of 2000 (TVPA), as amended (22 U.S.C. 7104(g).

ARTICLE XVII – MINIMUM QUALIFICATIONS OF LEO PERSONNEL FOR WHICH PARTICIPANT MAY BE REIMBURSED UNDER THIS AGREEMENT

A. Have authority to arrest, with or without a warrant, while on duty at the airport for the following violations of the criminal laws of the State and local jurisdictions in which the airport is located:

- A crime committed in the presence of the individual; and
- A felony, when the individual has reason to believe that the suspect has committed it.

B. Be identifiable by appropriate indicia of authority.

C. Be armed with a firearm and authorized to use it.

D. Have completed a training program meeting the requirements of 49 C.F.R. § 1542.217(c) and (d), to include training in:

- The use of firearms;
- The courteous and efficient treatment of persons subject to inspection, detention, search, arrest, and other aviation security activities;
- The responsibilities of law enforcement personnel under the security program; and
- Any other subject TSA determines is necessary.

ARTICLE XVIII – PERFORMANCE REVIEWS

A. The Program Manager shall review the monthly Certification sheets submitted by the FSD.

B. An annual performance review may consist of a comparison of the following:

- LEO evaluation/certification results
- Aviation Security Inspector (ASI) Compliance Reports
- Consolidated invoiced and actual cost reports
- Performance and Results Information System (PARIS) Reports

List of Attachments

- Statement of Joint Objectives (SOJO)
- Anticipatory Costs Letter – (if Appropriate)

End of Agreement **HSTS02-16-H-SLR604**

**TRANSPORTATION SECURITY ADMINISTRATION
LAW ENFORCEMENT OFFICER PROGRAM
STATEMENT OF JOINT OBJECTIVES
Calendar Years 2016 - 2018
Attachment 1**

This document defines the responsibilities and conditions that the City of Billings DBA Aviation and Transit, Billings Logan International Airport – BIL (hereinafter referred to as the “Participant”) agrees to as part of the Transportation Security Administration (TSA) Airport Law Enforcement Personnel Reimbursement Program (hereinafter referred to as the “Program.”) This document also defines the responsibilities and participation of the TSA. Nothing in this Agreement diminishes, eliminates, or otherwise affects the Participant’s obligation to adhere to regulatory and other mandated requirements.

The authority to enter into this Agreement is granted by 49 U.S.C. §§ 106(l) and (m), as well as 49 U.S.C. § 114(m). TSA has programmatic authority for the activities undertaken in this Agreement pursuant to 49 U.S.C. §§ 44901(h), 44903(c) and 44922(f), along with 49 C.F.R. §§ 1542.215 and 1544.103. The effective date of the Agreement will be the date of signature by the TSA Contracting Officer.

This Statement of Joint Objectives (SOJO)/Attachment 1 can and should be modified as appropriate to adequately support operational requirements. However, in order for any such modification to be effective, it must be signed by both the Participant and an authorized TSA official. Any modification affecting the funding of this Agreement requires the specific written authorization of the TSA Contracting Officer.

The Participant agrees to provide qualified law enforcement services on-site at BIL during TSA screening checkpoint operating hours, and to provide law enforcement support to the passenger-screening checkpoints in keeping with requirements provided by TSA in accordance with the current Security Directive 1542-01-07 (series), regulations, and other authorities regarding law enforcement services.

Both the Participant and TSA recognize that there is a broad range of activities that Law Enforcement Officers (LEOs) engage in at the nation’s airports, many of which are outside the scope of this Agreement. Funding provided under this Agreement is intended to support a highly visible LEO presence through **on-site** flexible, fixed, or a combination of the two (hybrid)¹ LEO support of the TSA screening checkpoints (as determined by the TSA Federal Security Director (FSD), in consultation with the Participant). The FSD, in consultation with the Participant, may direct a change in how the checkpoint is stationed as necessary based on changes in threat levels, surges, seasonality, and/or other circumstances.

Regardless of their position or title, any individual who provides law enforcement support as outlined in this Agreement must possess all of the qualifications of a LEO set forth at 49 C.F.R. § 1542.217, while on duty at the airport. The TSA will provide partial reimbursement for on-site support of the TSA screening activities pursuant to the terms of this Agreement. At a minimum the Participant will ensure that the Law Enforcement (LE) service provider will:

- Support TSA’s screening operations, including dealing with attempts to bring prohibited items through the checkpoint, disorderly persons and similar tasks.

¹ Refer to LEO Reimbursement Terminology (Attachment 2) for definitions of these terms.

- Follow an established LE response standard which is mutually acceptable to the FSD, Participant and LE service provider.

In addition, the FSD and the Participant will determine, where appropriate, the level of participation in TSA's Layered Security Programs, such as Playbook, Table Top Exercises, Breach Drills, and Joint Vulnerability Assessments (JVAs).

Payment is subject to the availability of appropriated funds and compliance with the requirements of the applicable Security Directive(s), regulations, the Airport Security Program (ASP), and other authorities regarding LE services as noted above. Should the Participant fail to comply with the provisions outlined in this Agreement, it may face full or partial forfeiture of payment and/or sanctions up to removal from the Program. The Participant will be given up to 60 days to take corrective action(s) and rectify any identified compliance issue(s).

TRANSPORTATION SECURITY ADMINISTRATION RESPONSIBILITIES

1. Based on the availability of funds, TSA will provide partial reimbursement to the Participant to offset the cost to carry out Aviation LE responsibilities in support of TSA passenger checkpoint screening and other agreed-upon activities.

TSA will provide partial reimbursement of the actual/direct costs of "fully burdened" Patrol Officers or equivalent salaries, **up to** the established "not-to-exceed" (NTE) ceiling.

Fully Burdened Rate includes:

- Base salary
- Social Security
- 401(k)/403(b)/457 plans
- Disability Insurance
- Health care benefits
- Pension
- Life Insurance

TSA will NOT cover overhead, overtime rates, or administrative costs.

2. TSA will process Participant monthly invoices promptly after obtaining FSD signature certifying that work was performed in accordance with the Agreement.
3. TSA will notify the Participant, promptly and in writing, of any changes in the points of contact for invoicing or other issues involving the Agreement.
4. TSA will provide on an as-needed basis, as determined by the FSD or other TSA representative, training/briefings on relevant security and LE topics.
5. The FSD and/or FSD designee will notify the Program of any operational changes that will impact eligible reimbursement activities during TSA checkpoint hours of operation.

PARTICIPANT RESPONSIBILITIES IN SUPPORT OF TSA PASSENGER CHECKPOINT SCREENING AND OTHER AGREED-UPON ACTIVITIES:

1. The Participant agrees to maintain a law enforcement presence and support that is adequate to support each system for screening persons and accessible property. This law enforcement presence provides for the safety and security of persons and property

against an act of criminal violence or aircraft piracy, and assists in preventing the introduction of TSA prohibited items.

2. The FSD, in consultation with the Participant, has determined that on-site FLEXIBLE LEO stationing is appropriate. Participant agrees to maintain, on a reimbursable basis, ONE LEO to provide visible Law Enforcement presence in the vicinity of the screening checkpoint(s) during the hours of checkpoint operations each day.²

This requirement is subject to change in accordance with the terms outlined in Paragraph #4 on page 1.

3. The Participant will provide monthly invoices to the FSD and to the Contracting Officer's Representative in the format provided by the LEO Reimbursement Program Office, detailing the number of hours of LE services provided, the actual hourly rate, and the total amount requested for reimbursement. Monthly invoicing consists of services provided from the first day of the month to the last day of the month.
4. Invoices must be submitted to the FSD no later than 45 days after the end of the invoiced period of performance.
5. The Participant will notify the FSD, promptly and in writing, of any changes to the points of contact for this Agreement or in the law enforcement agency providing the LE services.
6. The Participant will notify the FSD and LEO Reimbursement Program Office, promptly and in writing, if for any reason the Participant desires to terminate participation in the Program. Resolution of specific details on outstanding issues will be accomplished on a case-by-case basis.
7. The Participant shall coordinate all media releases and other contact with or by media on the terms and conditions of this Agreement with the FSD.
8. The Participant will assist in the verification of LEO credentials as requested by the FSD or other TSA representative.
9. In accordance with Federal, State, and Local statutes, the Participant will promptly furnish on request to any authorized TSA representative incident reports, police reports, and other information dealing with Aviation Security and/or each law enforcement response to transportation security incidents at the airport and in connection with TSA administrative inquiries.
10. The Participant will fully cooperate with regulatory and other TSA investigations.
11. The Participant will notify the Program of any operational changes that will impact eligible reimbursement activities during TSA checkpoint hours of operation.

² If utilizing Flexible Stationing or Hybrid Stationing, Participant must provide a separate document, password-protected, outlining specific LE response time to non-emergency/ routine TSA calls for assistance. Please note that response times in excess of 5 minutes are unacceptable. Additionally, a separate document shall be attached to the SOJO describing, graphically and/or in writing, the area of the airport comprising the "vicinity of the checkpoint."

12. The Participant will participate in security Breach Drills/Exercises as outlined in the Security Directives, ASP, applicable Federal Statute and/or TSA Regulation.
13. The Participant will participate in MANPADS assessments and exercises as outlined in the Security Directives, ASP, applicable federal Statute and/or TSA Regulation.
14. The Participant will participate in new and emerging aviation security programs as outlined in the Security Directives and/or ASP.
15. The Participant will provide support for VIP/Executive Protection Operations as outlined in the applicable Federal Statute and TSA Regulation.
16. LEO patrol of the Checkpoint areas when passengers are processing and patrolling of the Secure Area, SIDA area and AOA during other times.
17. The Participant will consult with Federal Authorities and the Assistant Federal Security Director for Law Enforcement to determine if a case involving an aviation or terrorist incident at the airport will be handled in Federal Jurisdiction.

Note that such additional activities should only include those which are being performed during periods of TSA screening operations, and do not interfere with the LEO's ability to provide immediate response to incidents at the screening checkpoints.

ATTACHMENTS

The TSA may provide administrative and informational updates to the attachments (i.e., updates to the HQ Program Staff listing) without re-issuance of this Agreement. Any new attachment(s) or significant changes to the current attachments will be accomplished through written modifications as provided for in the Terms and Conditions of the Agreement.

PROTECTION OF INFORMATION

The parties agree that they shall take appropriate measures to protect proprietary, privileged, or otherwise confidential information that may come into their possession as a result of this Agreement, including Sensitive Security Information (SSI).

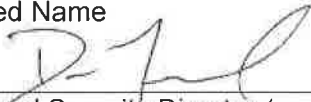
Participant Signature, Authorizing Official	Date
Thomas W. Hanel	Mayor
Typed Name	Title
	March 30, 2016
Federal Security Director (or designee)	Date
Dan Fevold	Federal Security Director
Typed Name	Title



CITY OF BILLINGS
AVIATION AND TRANSIT DEPARTMENT
BILLINGS LOGAN INTERNATIONAL AIRPORT
1901 Terminal Circle, Room 216 • Billings, Montana 59105-1996
(406)657-8495 • (406)657-8438 FAX
www.flybillings.com

BILLINGS LOGAN INTERNATIONAL AIRPORT
VICINITY OF THE CHECKPOINT DEFINITION
FOR STATEMENT OF JOINT OBJECTIVES
Calendar Year 2016–2018

The Billings Logan International Airport Law Enforcement Officers (LEO) will perform routine patrols throughout the Terminal Building during the hours of operations for Screening. During Peak Screening periods, at least one LEO will be in the proximity (within sight/sound) of the Screening area (see Exhibit A and B), providing Law Enforcement visibility and quick response to screening issues. Should other incidents/issues require the LEO to leave the proximity of the Screening area to address other necessary LEO incidents/issues or other items as required by Security Directives or the Airport Security Program, the LEO will return to the proximity of the Screening area once the issue is resolved. In the event of a situation at the Screening checkpoint during the time the LEO is addressing the other incidents/issues, an LEO response to the checkpoint will normally be less than two minutes but not exceed five minutes.



CITY OF BILLINGS
AVIATION AND TRANSIT DEPARTMENT
BILLINGS LOGAN INTERNATIONAL AIRPORT
1901 Terminal Circle, Room 216 • Billings, Montana 59105-1996
(406)657-8495 • (406)657-8438 FAX
www.flybillings.com

BILLINGS LOGAN INTERNATIONAL AIRPORT
FLEXIBLE OR HYBRID STATIONING RESPONSE
FOR STATEMENT OF JOINT OBJECTIVES

Calendar Year 2016–2018

With limited Law Enforcement Officer (LEO) staffing, the Billings Logan International Airport must make the optimum use of the manpower that is available to accomplish all that is required of the LEOs working in the Terminal Building. While a LEO is stationed in the proximity of the checkpoint during peak screening times, the LEO may need to respond to other areas away from the screening area to address other issues, with a LEO then returning to the screening area once the issue is resolved. During non-peak screening times, response from the Security office is less than two minutes. Additionally, there is no location in the Terminal that will take a LEO any more than four to five minutes to respond to the checkpoint.

BILLINGS LOGAN INTERNATIONAL AIRPORT EXHIBIT A

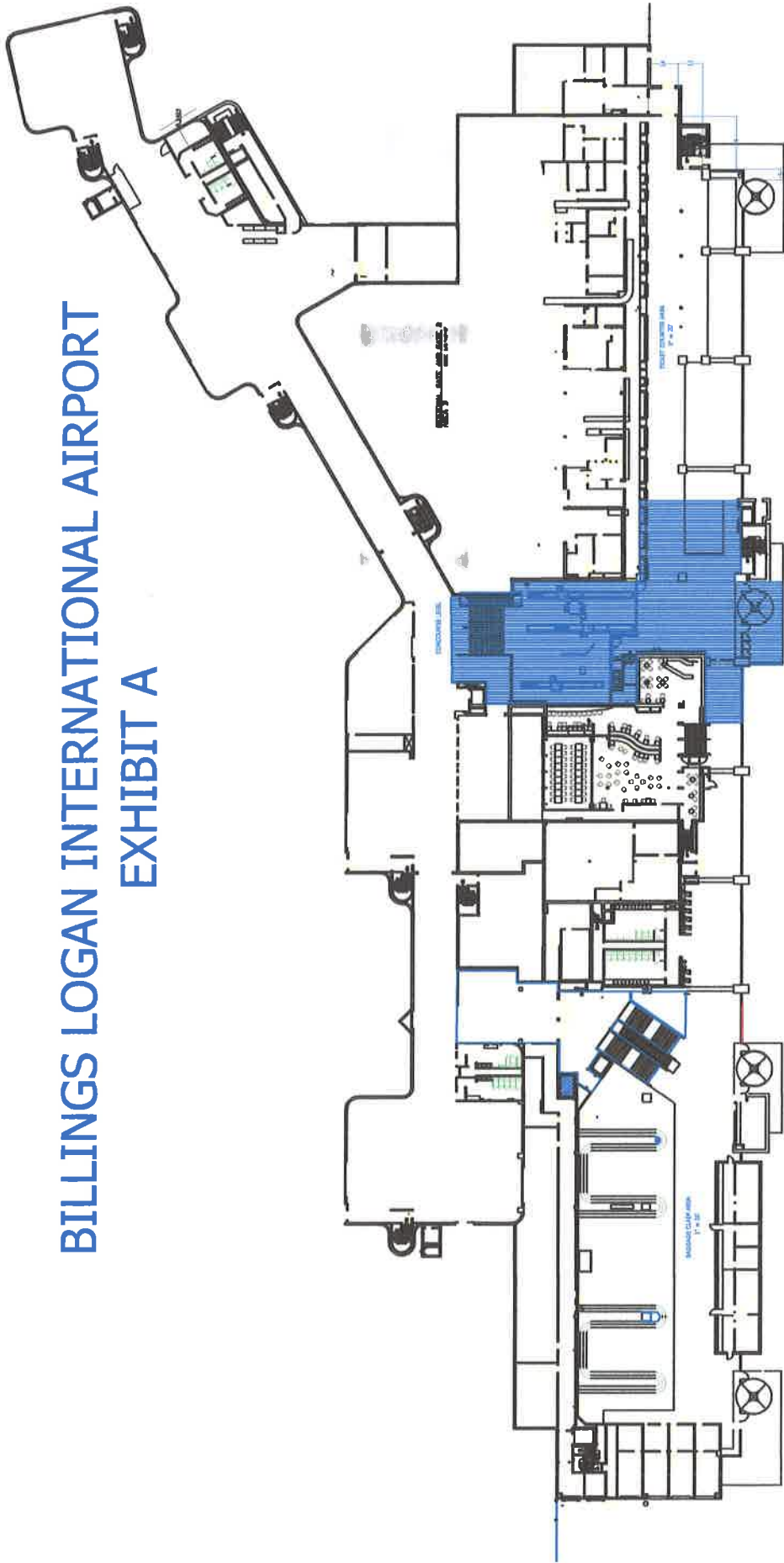

BILLINGS LOGAN INTERNATIONAL AIRPORT EXHIBIT B

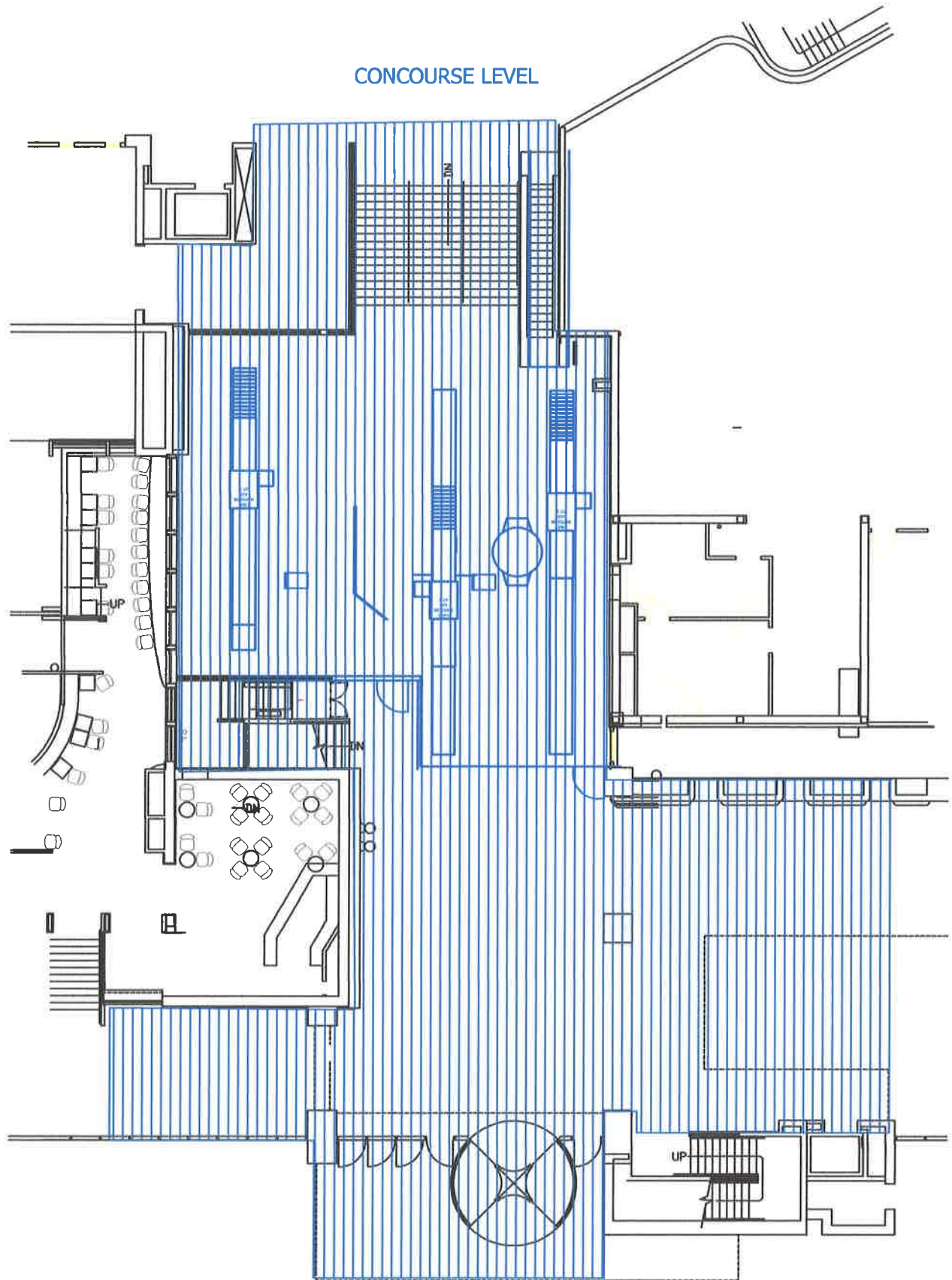

Regular City Council Meeting

Meeting Date: 04/11/2016

TITLE: Resolution for Land Water Conservation Funding (LWCF) Grant

PRESENTED BY: Mike Whitaker, Parks, Recreation & Public Lands Director

Department: Parks/Rec/Public Lands

PROBLEM/ISSUE STATEMENT

Billings Parks and Recreation staff proposes to apply for a Land Water Conservation Funding (LWCF) grant for improvements to the Hawthorne Park Playground. Part of the application requires Council to approve a resolution authorizing application for LWCF assistance; see Attachment A. By applying for this grant, the City may be eligible for up to \$125,000. The Hawthorne Park Playground Replacement project was recommended by the Parks, Recreation and Cemetery Board and was scheduled to be completed during FY16 as part of the City Wide Park Maintenance District (PMD 1) . The PMD 1 budget is \$150,000 and grant proceeds will be used to add equipment or other upgrades to the playground. By seeking grant funds to add to the PMD 1 funds already allocated, the play value of the equipment can be significantly enhanced. The grant has a 50% match requirement, which is met by the City's PMD 1 appropriation. The grant application deadline is Tuesday, April 15, 2016 but the grant award may be as late as winter of 2017. Due to this timeframe, the replacement project will be delayed slightly. As part of the application process, staff contacted stakeholders and surrounding property owners to inform them of the grant opportunity, to solicit letters of support and to receive comments.

ALTERNATIVES ANALYZED

City Council may:

- Approve, the resolution authorizing application for LWCF assistance or;
- Disapprove the resolution and provide staff with additional guidance

FINANCIAL IMPACT

The PMD 1 budget for this project is \$150,000. If the City is awarded a \$125,000 LWCF grant, those funds will be used to purchase additional improvements and upgrades to the Hawthorne Park Playground.

RECOMMENDATION

Staff recommends that the City Council approve the resolution authorizing application for LWCF funding to improve the Hawthorne Park Playground.

APPROVED BY CITY ADMINISTRATOR

Attachments

Attachment A

**Land & Water Conservation Fund
Application Summary Page**

1. Project Sponsor: City of Billings
2. Project Name: Hawthorne Park Playground Replacement
3. Project Contact: Name Mark Jarvis
Address 390 N 23rd St
City Billings Zip 59101
Phone 406-657-8367
Fax 406-247-8641
E-mail jarvism@ci.billings.mt.us
4. Project Type: Acquisition Development Combination
5. Land Ownership: Town County State School
6. Street address for project site: Janie St. and Columbine Dr.
7. Project site Zip Code: 59105 GPS Coordinates (Lat/Long): 45.82/-108.45
8. Township, Range and Section: Township 01 N, Range 26E, Section 14
9. Project Costs: Total Project Costs: \$250,000
Grant Request: \$125,000
(May not Exceed 50% of the total project cost. Grant request not to exceed \$150,000)
Sponsor Share: \$125,000
(Must be at least 50% of the total grant request)
10. Sponsor Share Funding Sources:
Source: City of Billings Amount: \$125,000
Source: _____ Amount: _____
Source: _____ Amount: _____
11. Project Site Previously Funded With LWCF Funds? YES NO
If YES, Provide LWCF Project Number 30 – 00 628-XXX
13. Signature _____ Title _____
(Signature must be from an official with authority to commit funds.)

Regular City Council Meeting

Meeting Date: 04/11/2016

TITLE: Final Plat of Amended Lot 1, Block 4, Moody Subdivision, 2nd Filing

PRESENTED BY: Candi Millar, Planning & Community Services Department Director

Department: Planning & Community Services

PROBLEM/ISSUE STATEMENT

The final plat for Amended Lot 1, Block 4 of Moody Subdivision, 2nd Filing is being presented to City Council for approval. On November 16, 2015, the Planning Division received an application for preliminary plat approval for Amended Lot 1, Block 4 of Moody Subdivision, 2nd Filing. The plat contains two lots on approximately 17,360 square feet of land for residential development. The property is zoned Residential-7000. The proposed subdivision is located on the northeast corner of Bench Blvd. and Ahoy Ave. The lot currently has one single family dwelling and a new single family dwelling is proposed for the second parcel. The owner is Milton, LLC. The representing agent is Sanderson Stewart. Upon City Council approval, these documents are appropriate as to form for filing with the Clerk and Recorder.

ALTERNATIVES ANALYZED

The City Council may approve or deny the final plat of Amended Lot 1, Block 4 of Moody Subdivision, 2nd Filing. If the City Council chooses to deny the final plat, it must base the denial on the criteria outlined in MCA 76-3-611 and BMCC Section 23-307.

FINANCIAL IMPACT

Should the City Council approve the final plat, the subject property may further develop under private ownership, resulting in additional tax revenues.

RECOMMENDATION

Staff recommends the City Council approve the final plat of Amended Lot 1, Block 4 of Moody Subdivision, 2nd Filing.

APPROVED BY CITY ADMINISTRATOR

Attachments

Proposed Final Plat

AMENDED PLAT OF LOT 1, BLOCK 4, MOODY SUBDIVISION 2nd FILING

SITUATED IN THE NW1/4 OF SECTION 23, T. 1 N., R. 26 E., P.M.M.
IN THE CITY OF BILLINGS, YELLOWSTONE COUNTY, MONTANA

PREPARED FOR : KINCAID LAND LLC

FEBRUARY 2016

PREPARED BY : SANDERSON STEWART

BILLINGS, MONTANA

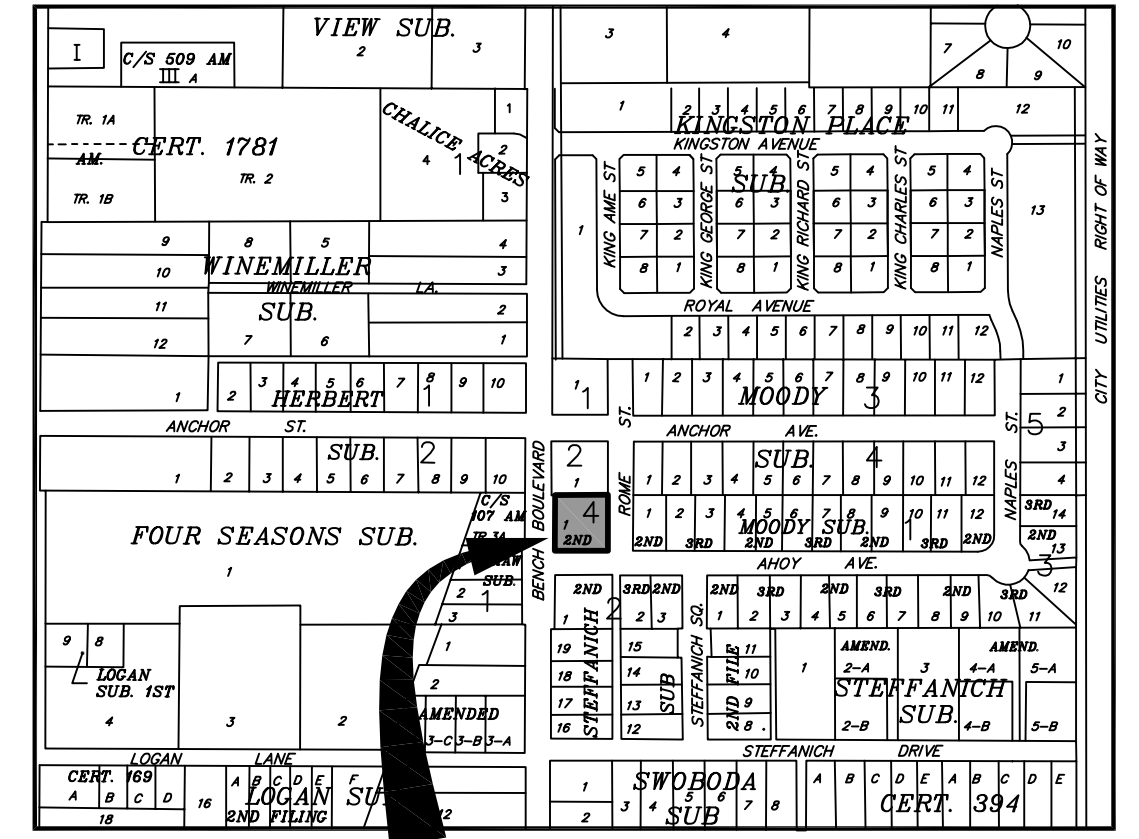
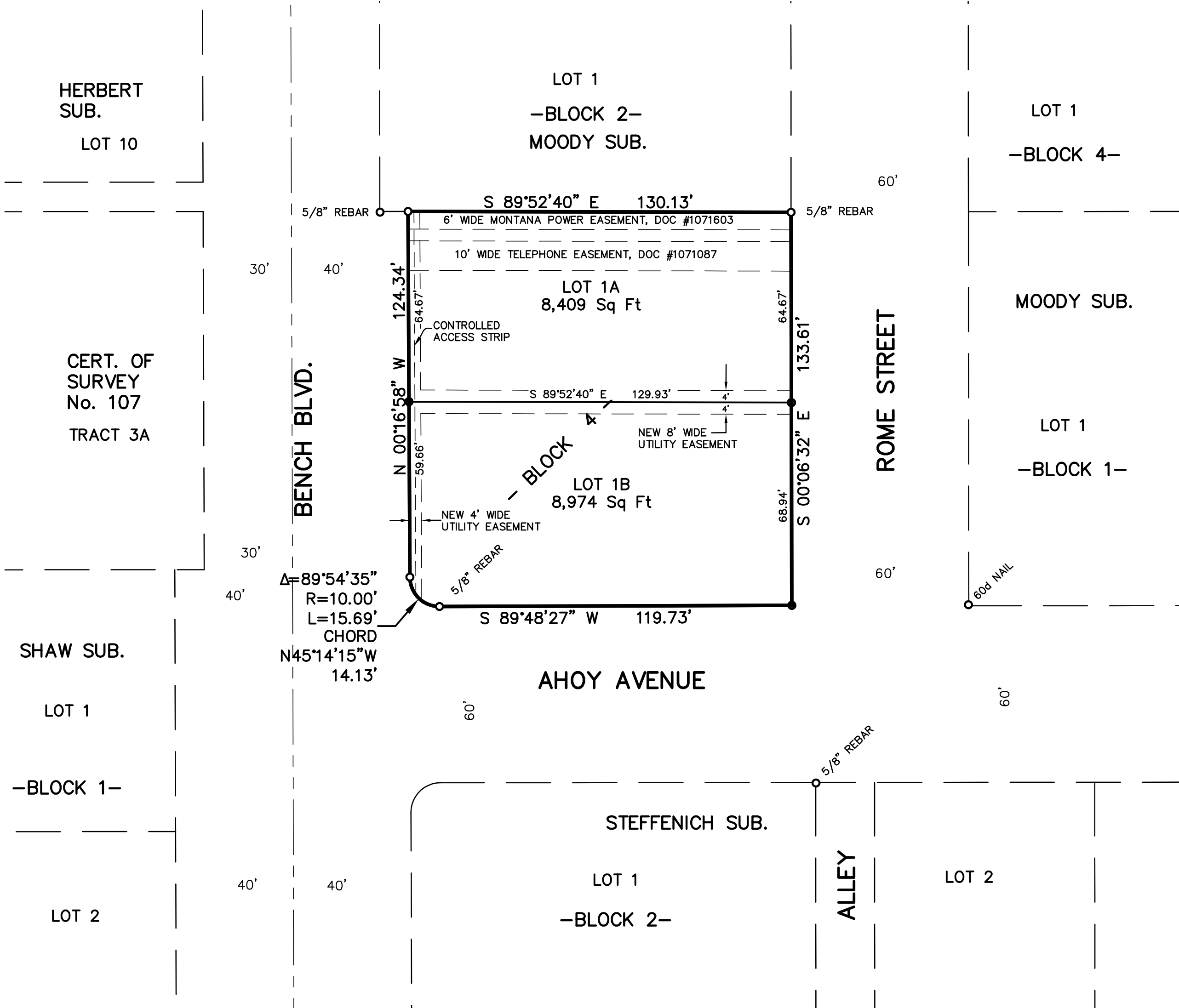

VICINITY MAP
NOT TO SCALE

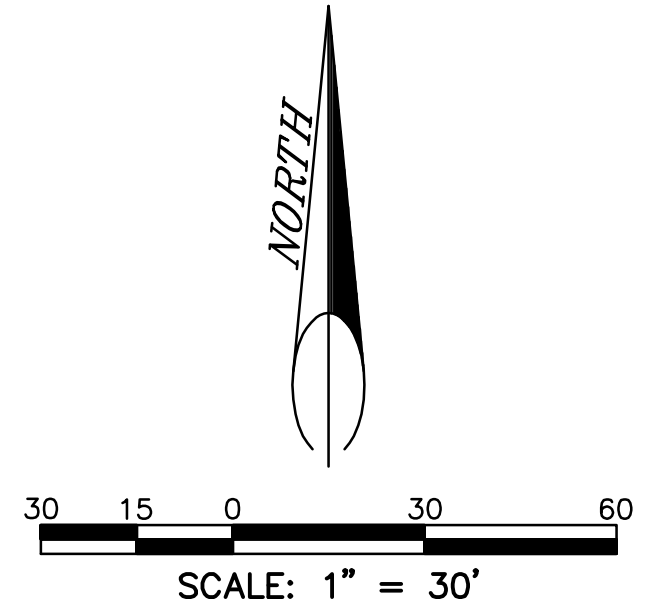

BASIS OF BEARING: THE BASIS OF BEARINGS FOR THIS SURVEY HAS BEEN DERIVED FROM GPS OBSERVATIONS AND IS BASED ON A NAD 83, LAMBERT CONFORMAL CONIC, SINGLE PARALLEL, LOW DISTORTION PROJECTION FOR THE CITY OF BILLINGS; HAVING A POINT OF ORIGIN AT 45°47'00"N LATITUDE AND 108°25'00"W LONGITUDE WITH A SCALE FACTOR OF 1.0001515.

DISTANCES ARE GRID, INTERNATIONAL FEET.

THE GRID TO GROUND COMBINED SCALE FACTOR IS 1.0000022

THE CONVERGENCE ANGLE AT THE SOUTHEAST CORNER OF THIS AMENDED PLAT IS -0°02'05".

- FOUND SURVEY MONUMENT, REBAR WITH "SANDERSON STEWART" CAP OR AS NOTED.
- SET 5/8" X 18" REBAR WITH CAP MARKED WITH THE LICENSE NUMBER OF THE UNDERSIGNED LAND SURVEYOR AND "SANDERSON STEWART".

NOTICE OF APPROVAL

STATE OF MONTANA)
County of Yellowstone) :ss

This plat has been approved for filing by the Yellowstone County Board of Planning and conforms to the recommendations of this board.

Date _____ President _____
Executive Secretary _____

CERTIFICATE OF CITY ENGINEER'S OFFICE

I hereby certify that the annexed and foregoing plat conforms with Section 76-4-125(2)(d), M.C.A., for the removal of sanitary restrictions since the plat is inside a master planning area and said lots will be provided with municipal facilities for the supply of water and the disposal of sewage and solid waste.

IN WITNESS WHEREOF, I have executed this CERTIFICATE OF APPROVAL this _____ day of _____, 20____.

City Engineer's Office

CERTIFICATE OF CITY ATTORNEY

This document has been reviewed by the City Attorney's office and is acceptable as to form.

Date: _____
Reviewed by: _____

ERRORS AND OMISSIONS REVIEW

I hereby certify that I have examined the annexed and foregoing plat for errors and omissions in computations and drafting and find that said plat conforms with the requirements of the laws of the State of Montana, and that said plat conforms to the adjoining additions and plats of the City of Billings already platted as nearly as circumstances will permit.

Examining Land Surveyor _____ Date _____

CERTIFICATE OF COUNTY TREASURER

I hereby certify that all real property taxes and special assessments have been paid per 76-3-611(1)(b)/76-3-207(3), M.C.A.

Date: _____
Yellowstone County Treasurer _____
By: _____
Deputy

CERTIFICATE OF CITY COUNCIL APPROVAL

STATE OF MONTANA)
County of Yellowstone)

We hereby certify that we have examined the annexed and foregoing AMENDED PLAT OF LOT 1, BLOCK 4, MOODY SUBDIVISION, 2nd FILING and find that said plat conforms with the requirements of the laws of the State of Montana, and the requirements of The Yellowstone County Board of Planning. It is therefore approved and the dedication to public use of any and all lands shown on this plat as being dedicated to public use are accepted.

IN WITNESS WHEREOF, we have set our hands and the seal of the CITY OF BILLINGS, MONTANA, this _____ day of _____, 20____.

CITY OF BILLINGS, MONTANA
By: _____ Mayor
Attest: _____ City Clerk

RESERVED FOR CLERK AND RECORDER

SUBDIVISION IMPROVEMENT AGREEMENT
Document No. _____
CONSENT TO PLATTING
Document No. _____

CERTIFICATE OF DEDICATION

STATE OF MONTANA)
County of Yellowstone) :ss

KNOW ALL MEN BY THESE PRESENTS: That the undersigned owner of the following described tract of land, does hereby certify that it has caused to be surveyed, subdivided and platted into lots, blocks and streets as shown on the annexed plat, said tract being situated in the NW1/4 of Section 23, T. 1 N., R. 26 E., P.M.M., in the City of Billings, Yellowstone County, Montana, said tract being described as follows:

LOT 1 IN BLOCK 4 OF MOODY SUBDIVISION, 2nd FILING ACCORDING TO THE OFFICIAL PLAT THEREOF ON FILE IN THE OFFICE OF THE CLERK AND RECORDER OF YELLOWSTONE COUNTY, MONTANA, UNDER DOCUMENT No. 1047927; CONTAINING A GROSS AREA AND A NET AREA OF 17,383 SQUARE FEET.

Pursuant to Section 76-3-621(3)(d), M.C.A. and the City of Billings Subdivision Regulations, there is no park requirement for this subdivision in which only one additional parcel is created.

The undersigned hereby grants unto all utility companies, as such are defined and established by Montana Law, and cable television companies, an easement for the location, maintenance, repair and removal of their lines over, under and across the areas designated on the plat as "UTILITY EASEMENT" to have and hold forever. Said tract to be known and designated as AMENDED PLAT OF LOT 1, BLOCK 4, MOODY SUBDIVISION, 2nd FILING; there is no public land dedication with this plat.

KINCAID LAND, LLC

By: _____
Title: _____

STATE OF MONTANA)
County of Yellowstone) :ss

This instrument was acknowledged before me on _____, 20____, by _____ as _____ of KINCAID LAND, LLC.

Notary Public in and for the State of Montana

CERTIFICATE OF SURVEYOR

STATE OF MONTANA)
County of Yellowstone) :ss

The undersigned, a Montana Registered Land Surveyor being first duly sworn, deposes and says that during the month of February 2016, a survey was performed under his supervision of a tract of land to be known as AMENDED PLAT OF LOT 1, BLOCK 4, MOODY SUBDIVISION, 2nd FILING in accordance with the request of the owner thereof and in conformance with the Montana Subdivision and Platting Act; said subdivision, description of boundaries and dimensions being in accordance with the Certificate of Dedication and as shown on the annexed plat; that the monuments found and set are of the character and occupy the positions shown hereon and that the gross area is 17,383 square feet and the net area is 17,383 square feet.

SANDERSON STEWART

By: _____
Peter B. Knapp
Montana Registration No. _____ 8377-S
Date: _____

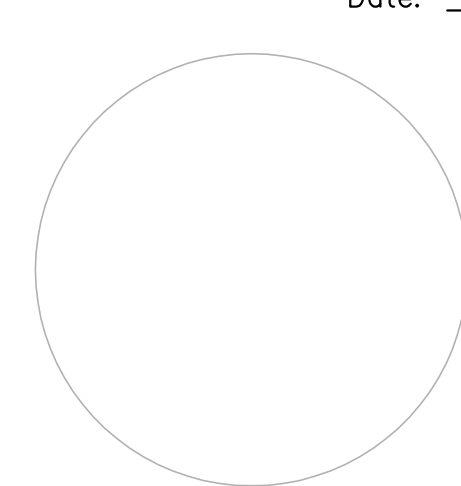

Regular City Council Meeting

Meeting Date: 04/11/2016

TITLE: Resolution Adopting Montana Municipal Records Retention Schedule 8 and Schedule 10 for Municipal Court

PRESENTED BY: Tina Volek, City Administrator

Department: City Hall Administration

PROBLEM/ISSUE STATEMENT

The City of Billings adopted a records management program via Ordinance 97-5034. The City initially adopted records retention schedules via Resolution 97-17257. Many of the adopted schedules have not been updated since their initial adoption. As a result, many retention schedules are not in compliance with State requirements. The Montana Secretary of State's Office has created Schedule 8, which sets retention schedules for local government records. The Secretary of State's Office has also created Schedule 10, which sets retention schedules for courts of limited jurisdiction. Schedule 10 would apply to Municipal Court. The State Local Government Records Committee regularly maintains and updates Schedules 8 and 10. Adopting Schedules 8 and 10 as the City of Billings records retention schedules will ensure compliance with State retention requirements, and will ensure that the schedules are regularly reviewed and updated.

ALTERNATIVES ANALYZED

City Council may:

- Approve, or;
- Disapprove. Disapproval will result in noncompliance of retention requirements for many of the City's records series. Changes in records management requirements from the 2015 legislative session, including the records destruction approval process, necessitate updated records retention schedules.

FINANCIAL IMPACT

There is no financial impact.

RECOMMENDATION

Staff recommends that the City Council approve the resolution adopting Montana Municipal Records Retention Schedule 10 for Municipal Court and Schedule 8 for all other City departments.

APPROVED BY CITY ADMINISTRATOR

Attachments

RESOLUTION NO. 16-_____

A RESOLUTION ADOPTING MONTANA MUNICIPAL RECORDS SCHEDULE 8 AND SCHEDULE 10 FOR MUNICIPAL COURT, PREPARED AND PUBLISHED BY THE MONTANA LOCAL GOVERNMENT RECORDS COMMITTEE, IDENTIFYING THE RETENTION PERIODS FOR ALL RECORDS SERIES CREATED, USED, MAINTAINED, AND STORED BY THE CITY OF BILLINGS.

WHEREAS, it is in the best interest of the City and its citizens to maintain a systematic program of creating, using, maintaining, storing, and eventually disposing of its records; and

WHEREAS, the City Council established a records management program via Ordinance No. 97-5034, which is codified as Article 2-1000 of the Billings Montana City Code; and

WHEREAS, the City initially adopted records retention schedules for its records via Resolution 97-17257, with said schedules dated July 28, 1997; and

WHEREAS, the records management program set forth in Article 2-1000 of Billings Montana City Code requires that the retention schedules be regularly reviewed and updated to reflect changes in local, state, and federal regulations, as they pertain to recordkeeping requirements.

IT IS HEREBY DECLARED TO BE THE INTENT of the City Council of the City of Billings to adopt the entire Montana Courts of Limited Jurisdiction Schedule 10 as the Municipal Court retention schedule, and the entire Montana Municipal Records Schedule 8 retention schedule as the retention schedule for all other City departments, inclusive of the citation/comments sections referring to compliance with state and federal requirements, and the designated records manager is hereby directed to carry out the implementation of the records retention schedules according to the guidelines established by Article 2-1000, Billings Montana City Code.

APPROVED AND ADOPTED this 11th day of April, 2016.

THE CITY OF BILLINGS:

By: _____
Thomas W. Hanel, Mayor

ATTEST:

BY: _____
Billie Guenther, City Clerk

Regular City Council Meeting

Meeting Date: 04/11/2016

TITLE: Payment of Claims March 14, 2016

PRESENTED BY: Patrick M. Weber, Finance Director

Department: City Hall Administration

PROBLEM/ISSUE STATEMENT

Claims in the amount of \$1,072,725.82 have been audited and are presented for City Council payment approval. A complete listing of the claims dated March 14, 2016, is available in the Finance Department.

ALTERNATIVES ANALYZED

No other alternatives were analyzed.

FINANCIAL IMPACT

Claims have a varying impact on department budgets, but are submitted by the departments and reviewed by Finance staff before being sent to the Council.

RECOMMENDATION

Staff recommends that Council approve the Payment of Claims.

APPROVED BY CITY ADMINISTRATOR

Attachments

councilmemo_3.14.2016

Check Date	Check	Name	Amount	Account	Item Desc
03/14/2016	792155	360 Office Solutions Inc	\$ 2,737.00	6600-31100-402120	for pw office space
03/14/2016	792155	360 Office Solutions Inc	\$ 3,749.70	5020-73140-402450	pw office
03/14/2016	792155	360 Office Solutions Inc	\$ 1,249.90	5120-83140-402450	pw office
03/14/2016	792155	360 Office Solutions Inc	\$ 65.94	5020-00000-141000	WATER PARTS AND SUPPLIES PO NUM
03/14/2016	792156	A & I Distributors	\$ 109.45	5710-71440-402320	AUTO &TRUCK MAINT.ITEMS
03/14/2016	792156	A & I Distributors	\$ 4,676.42	6010-00000-141000	2764166 PO NUM 299555
03/14/2016	792156	A & I Distributors	\$ 1,408.00	6010-00000-141000	2759167 PO NUM 299555
03/14/2016	792156	A & I Distributors	\$ 60.00	6010-00000-141000	2759167 PO NUM 299555
03/14/2016	792156	A & I Distributors	\$ 167.88	5410-31230-402310	Oil and Grease for Landfill equipment
03/14/2016	792156	A & I Distributors	\$ 1,852.45	5410-31230-402310	Oil for Landfill Equipment
03/14/2016	792156	A & I Distributors	\$ 576.95	5610-71130-402310	Invoice #2767538. Oil for Equipment
03/14/2016	792156	A & I Distributors	\$ 332.30	2110-31320-402320	55 gal drum blue dep
03/14/2016	792157	ADB Airfield Solutions LLC	\$ 2,908.10	5610-71130-403653	Invoice #24587D-02. Flush mounts-in pavement
03/14/2016	792164	Archie Cochrane	\$ 17,040.00	6400-21650-409440	This is an order Per Attached Quote. Interior color
03/14/2016	792165	Automated Office Inc	\$ 7,224.00	5710-71410-409470	Purchase imageRunner Advance 6285 Copier
03/14/2016	792165	Automated Office Inc	\$ 1,733.00	5710-71410-409470	Staple Finisher P1
03/14/2016	792165	Automated Office Inc	\$ 491.00	5710-71410-409470	External 2/3 Hole Puncher A1
03/14/2016	792165	Automated Office Inc	\$ 6,008.10	6700-31410-409480	Canon imageRUNNER C5240
03/14/2016	792165	Automated Office Inc	\$ 66.35	0100-51100-402190	Ink for copier.
03/14/2016	792165	Automated Office Inc	\$ 66.36	0100-51120-402190	Ink for copier.
03/14/2016	792165	Automated Office Inc	\$ 66.36	0100-51210-402190	Ink for copier.
03/14/2016	792165	Automated Office Inc	\$ 20.75	5710-71410-403630	Monthly maintenance fee for office copier.
03/14/2016	792165	Automated Office Inc	\$ 2.74	2510-21270-402190	C112-27 ICAC
03/14/2016	792165	Automated Office Inc	\$ 7.54	6050-15160-403690	C112-10 Building
03/14/2016	792165	Automated Office Inc	\$ 69.08	6050-15160-403690	C112-19 Court
03/14/2016	792165	Automated Office Inc	\$ 76.06	6050-15160-403690	C112-24
03/14/2016	792165	Automated Office Inc	\$ 118.82	6050-15160-403690	C112-25
03/14/2016	792165	Automated Office Inc	\$ 19.11	6050-15160-403690	C112-26
03/14/2016	792165	Automated Office Inc	\$ 1.07	2510-21270-402190	C112-27 ICAC
03/14/2016	792165	Automated Office Inc	\$ 46.51	6050-15160-403690	C112-29 Court
03/14/2016	792165	Automated Office Inc	\$ 1.33	6050-15160-403690	C112-30 Legal
03/14/2016	792165	Automated Office Inc	\$ 16.92	6050-15160-403690	C112-37 Fleet
03/14/2016	792165	Automated Office Inc	\$ 31.81	5410-31210-403210	Monthly copier cost for duplication
03/14/2016	792167	Beartooth Resource Conservation & Development	\$ 100.00	0100-13130-403350	2016 Board Membership Dues
03/14/2016	792167	Beartooth Resource Conservation & Development	\$ 9,871.54	0100-14110-403951	2016 Assessment Fee
03/14/2016	792174	Bison Motor Company	\$ 38,241.28	5030-74910-409440	Schedule 82016 3/4 ton 4 Wheel Drive Extended Cab 4 door pickup with service body Trade in Unit
03/14/2016	792174	Bison Motor Company	\$ 72,198.56	5030-73910-409440	Schedule 6 2- 2016 3/4 ton 4 Wheel Drive Regular Cab Pickups with Service Badges Replacing units
03/14/2016	792176	Boomers Garage N Shop Supplies	\$ 2,779.30	2110-31320-402420	36" yellow squeeze/bases/anchor for ped

03/14/2016	792178	Brenntag Pacific Inc	\$	5,966.00	2110-31320-404720	hicothaw used to melt snow on streets
03/14/2016	792178	Brenntag Pacific Inc	\$	3,528.00	5120-84000-402220	calcium hypochlorite
03/14/2016	792191	Crescent Electric Supply	\$	8.09	2110-31320-402360	MISC SERVICES
03/14/2016	792191	Crescent Electric Supply	\$	8.02	2110-31320-402360	MISC SERVICES
03/14/2016	792191	Crescent Electric Supply	\$	8.20	2110-00000-141318	STREET LIGHTS PO NUM 299991
03/14/2016	792191	Crescent Electric Supply	\$	4.55	2110-00000-141318	STREET LIGHTS PO NUM 299992
03/14/2016	792191	Crescent Electric Supply	\$	202.54	2110-00000-141318	STREET LIGHTS PO NUM 299993
03/14/2016	792191	Crescent Electric Supply	\$	2.62	2110-00000-141318	STREET LIGHTS PO NUM 299996
03/14/2016	792191	Crescent Electric Supply	\$	407.86	2110-00000-141318	STREET LIGHTS PO NUM 299997
03/14/2016	792191	Crescent Electric Supply	\$	22.51	2110-00000-141318	STREET LIGHTS PO NUM 300068
03/14/2016	792191	Crescent Electric Supply	\$	8.02	2110-00000-141318	STREET LIGHTS PO NUM 300069
03/14/2016	792191	Crescent Electric Supply	\$	211.02	2110-00000-141318	STREET LIGHTS PO NUM 300070
03/14/2016	792191	Crescent Electric Supply	\$	196.64	2110-00000-141318	STREET LIGHTS PO NUM 300071
03/14/2016	792191	Crescent Electric Supply	\$	208.69	2110-00000-141318	STREET LIGHTS PO NUM 300072
03/14/2016	792191	Crescent Electric Supply	\$	55.13	2110-00000-141318	STREET LIGHTS PO NUM 300073
03/14/2016	792191	Crescent Electric Supply	\$	1,500.00	2110-00000-141318	STREET LIGHTS PO NUM 300074
03/14/2016	792191	Crescent Electric Supply	\$	63.55	2110-00000-141318	STREET LIGHTS PO NUM 300075
03/14/2016	792193	Curb Box Specialists Inc.	\$	16,221.15	5050-75150-403671	Repair 13 Various Water Service List 09/04/2015
03/14/2016	792198	DOWL	\$	29,889.88	8450-31860-409310	WO 16-05 Central Ave - Shiloh to 32nd St W
03/14/2016	792198	DOWL	\$	6,274.58	1990-15050-409340	WO 16-06 SBURD Sanitary Sewer - Phase II
03/14/2016	792198	DOWL	\$	10,378.75	5030-75910-409340	WO 16-01 2016 Water/Sewer Main Replc; Sch1
03/14/2016	792199	Dowl Hkm	\$	3,070.39	8450-31860-409310	WO 15-06 Poly Drive - 32nd St West to 38th St
03/14/2016	792201	Dxp/Strategic Supply Inc	\$	1,342.50	1500-22290-402290	SCOTT AV-3000-HT FACE PIECE W/KEVLAR
03/14/2016	792201	Dxp/Strategic Supply Inc	\$	1,342.50	1500-22290-402490	SCOTT AV-3000-HT FACE PIECE W/KEVLAR
03/14/2016	792201	Dxp/Strategic Supply Inc	\$	268.50	1500-22310-402260	SCOTT AV-3000-HT FACE PIECE W/KEVLAR
03/14/2016	792201	Dxp/Strategic Supply Inc	\$	1,208.25	1500-22310-402640	SCOTT AV-3000-HT FACE PIECE W/KEVLAR
03/14/2016	792201	Dxp/Strategic Supply Inc	\$	1,208.25	1500-22310-402690	SCOTT AV-3000-HT FACE PIECE W/KEVLAR
03/14/2016	792201	Dxp/Strategic Supply Inc	\$	1,611.00	1500-22310-402925	SCOTT AV-3000-HT FACE PIECE W/KEVLAR
03/14/2016	792201	Dxp/Strategic Supply Inc	\$	1,118.75	1500-22290-402290	SCOTT AV-3000-HT FACE PIECE W/KEVLAR
03/14/2016	792201	Dxp/Strategic Supply Inc	\$	1,118.75	1500-22290-402490	SCOTT AV-3000-HT FACE PIECE W/KEVLAR
03/14/2016	792201	Dxp/Strategic Supply Inc	\$	1,118.75	1500-22310-402260	SCOTT AV-3000-HT FACE PIECE W/KEVLAR
03/14/2016	792201	Dxp/Strategic Supply Inc	\$	1,118.75	1500-22310-402640	SCOTT AV-3000-HT FACE PIECE W/KEVLAR
03/14/2016	792201	Dxp/Strategic Supply Inc	\$	1,118.75	1500-22310-402690	SCOTT AV-3000-HT FACE PIECE W/KEVLAR
03/14/2016	792201	Dxp/Strategic Supply Inc	\$	1,118.75	1500-22310-402925	SCOTT AV-3000-HT FACE PIECE W/KEVLAR
03/14/2016	792210	Galles Filter Service	\$	100.72	5410-31230-402320	P-58449-01
03/14/2016	792210	Galles Filter Service	\$	167.24	5020-74000-402320	NONSTOCKING ITEMS-P.U.D.
03/14/2016	792210	Galles Filter Service	\$	569.81	5410-31230-402320	Filters for Landfill equipment
03/14/2016	792210	Galles Filter Service	\$	297.96	5710-00000-141714	BUS MET PO NUM 299560
03/14/2016	792210	Galles Filter Service	\$	9.50	5710-71440-402320	AUTO &TRUCK MAINT.ITEMS
03/14/2016	792210	Galles Filter Service	\$	18.44	5410-31230-402320	Filters for landfill equipment
03/14/2016	792210	Galles Filter Service	\$	589.65	5410-31230-402320	Filters for Landfill equipment
03/14/2016	792210	Galles Filter Service	\$	228.11	5410-31230-402320	Filters for Landfill equipment

03/14/2016	792210	Galles Filter Service	\$	295.04	6010-00000-141000	P-57780-01	PO NUM 299560
03/14/2016	792210	Galles Filter Service	\$	288.69	6010-00000-141000	P-57881-01	PO NUM 299560
03/14/2016	792210	Galles Filter Service	\$	201.65	6010-00000-141000	P-57992-01	PO NUM 299560
03/14/2016	792210	Galles Filter Service	\$	161.75	6010-00000-141000	P-58067-01	PO NUM 299560
03/14/2016	792210	Galles Filter Service	\$	333.10	6010-00000-141000	P-58138-01	PO NUM 299560
03/14/2016	792210	Galles Filter Service	\$	200.87	6010-00000-141000	P-58201-01	PO NUM 299560
03/14/2016	792210	Galles Filter Service	\$	118.34	6010-00000-141000	P-58330-01	PO NUM 299560
03/14/2016	792210	Galles Filter Service	\$	326.05	6010-00000-141000	P-58394-01	PO NUM 299560
03/14/2016	792210	Galles Filter Service	\$	44.50	6010-00000-141000	T-57540	PO NUM 299560
03/14/2016	792210	Galles Filter Service	\$	21.49	2110-31320-402320	P-57734-01	
03/14/2016	792210	Galles Filter Service	\$	2.82	2400-43010-402320	P-57774-01	
03/14/2016	792210	Galles Filter Service	\$	63.22	2110-31320-402320	P-57903-01	
03/14/2016	792210	Galles Filter Service	\$	107.45	2110-31320-402320	T-57613	
03/14/2016	792210	Galles Filter Service	\$	346.40	5410-31230-402320		Filters for Landfill equipment
03/14/2016	792210	Galles Filter Service	\$	106.65	5410-31230-402290		measuring containers for oil
03/14/2016	792210	Galles Filter Service	\$	34.97	5410-31230-402320		Filters for Landfill Equipment
03/14/2016	792210	Galles Filter Service	\$	6.79	5410-31220-402320		Filters for Landfill Equipment
03/14/2016	792215	Great West Engineering, Inc	\$	2,895.55	5130-85910-409340	WO 16-01	2016 Water/Sewer Replc; Sch 4 South
03/14/2016	792216	Guardian Security Inc	\$	7,935.24	2600-55120-403574		Invoice 22
03/14/2016	792221	Hardy Construction Co.	\$	37,997.19	5410-31220-409250	WO 15-38	Solid Waste CNG Short-Term Fueling
03/14/2016	792222	HDR, Inc.	\$	277,096.30	5130-84910-409390	WO 14-11	WWTP Nutrient Upgrade Expansion &
03/14/2016	792222	HDR, Inc.	\$	17,219.56	8450-31860-409310	WO 09-15	Grand Avenue Zimmerman Trail to
03/14/2016	792222	HDR, Inc.	\$	6,370.64	8400-31840-403590		MS4 General Permit
03/14/2016	792224	Hose & Rubber Supply Inc	\$	3,362.83	5020-74000-402320		NONSTOCKING ITEMS-P.U.D.
03/14/2016	792229	Ingram Library Services Inc.	\$	107.76	2600-55190-403227		91885041
03/14/2016	792229	Ingram Library Services Inc.	\$	15.64	2600-55190-403227		91885042
03/14/2016	792229	Ingram Library Services Inc.	\$	36.79	2600-55190-403222		91885043
03/14/2016	792229	Ingram Library Services Inc.	\$	14.69	2600-55190-403226		91885043
03/14/2016	792229	Ingram Library Services Inc.	\$	68.36	2600-55190-403227		91885043
03/14/2016	792229	Ingram Library Services Inc.	\$	10.21	2600-55190-403333		91885044
03/14/2016	792229	Ingram Library Services Inc.	\$	8.24	2600-55190-403222		91885045
03/14/2016	792229	Ingram Library Services Inc.	\$	27.51	2600-55190-403226		91885045
03/14/2016	792229	Ingram Library Services Inc.	\$	225.02	2600-55190-403227		91885045
03/14/2016	792229	Ingram Library Services Inc.	\$	15.12	2600-55190-403255		91885045
03/14/2016	792229	Ingram Library Services Inc.	\$	564.26	2600-55190-403333		91885046
03/14/2016	792229	Ingram Library Services Inc.	\$	18.39	2600-55190-403334		91885046
03/14/2016	792229	Ingram Library Services Inc.	\$	10.61	2600-55190-403227		91951277
03/14/2016	792229	Ingram Library Services Inc.	\$	13.56	2600-55190-403226		91951278
03/14/2016	792229	Ingram Library Services Inc.	\$	359.21	2600-55190-403226		91951279
03/14/2016	792229	Ingram Library Services Inc.	\$	75.46	2600-55190-403333		91951280
03/14/2016	792229	Ingram Library Services Inc.	\$	60.12	2600-55190-403241		91951281
03/14/2016	792229	Ingram Library Services Inc.	\$	47.50	2600-55190-403334		91951281

03/14/2016	792229	Ingram Library Services Inc.	\$	16.79	2600-55190-403227	91951282
03/14/2016	792229	Ingram Library Services Inc.	\$	11.37	2600-55190-403227	91951283
03/14/2016	792229	Ingram Library Services Inc.	\$	14.97	2600-55190-403227	91951284
03/14/2016	792229	Ingram Library Services Inc.	\$	10.61	2600-55190-403333	91951285
03/14/2016	792229	Ingram Library Services Inc.	\$	9.57	2600-55190-403227	91951286
03/14/2016	792229	Ingram Library Services Inc.	\$	38.48	2600-55190-403222	92020587
03/14/2016	792229	Ingram Library Services Inc.	\$	438.62	2600-55190-403226	92020587
03/14/2016	792229	Ingram Library Services Inc.	\$	541.68	2600-55190-403227	92020587
03/14/2016	792229	Ingram Library Services Inc.	\$	96.20	2600-55190-403241	92020587
03/14/2016	792229	Ingram Library Services Inc.	\$	67.07	2600-55190-403241	92020587
03/14/2016	792229	Ingram Library Services Inc.	\$	60.48	2600-55190-403242	92020587
03/14/2016	792229	Ingram Library Services Inc.	\$	51.16	2600-55190-403255	92020587
03/14/2016	792229	Ingram Library Services Inc.	\$	927.16	2600-55190-403333	92020587
03/14/2016	792229	Ingram Library Services Inc.	\$	13.86	2600-55190-403334	92020587
03/14/2016	792229	Ingram Library Services Inc.	\$	17.99	2600-55190-403227	92020588
03/14/2016	792229	Ingram Library Services Inc.	\$	11.79	2600-55190-403226	92020589
03/14/2016	792229	Ingram Library Services Inc.	\$	14.97	2600-55190-403226	92020590
03/14/2016	792229	Ingram Library Services Inc.	\$	29.38	2600-55190-403227	92020590
03/14/2016	792229	Ingram Library Services Inc.	\$	279.70	2600-55190-403226	92020591
03/14/2016	792229	Ingram Library Services Inc.	\$	47.65	2600-55190-403227	92020592
03/14/2016	792229	Ingram Library Services Inc.	\$	20.21	2600-55190-403226	92028621
03/14/2016	792229	Ingram Library Services Inc.	\$	19.95	2600-55190-403227	92028621
03/14/2016	792229	Ingram Library Services Inc.	\$	74.59	2600-55190-403226	92057801
03/14/2016	792229	Ingram Library Services Inc.	\$	112.47	2600-55190-403227	92057801
03/14/2016	792229	Ingram Library Services Inc.	\$	32.97	2600-55190-403241	92057801
03/14/2016	792229	Ingram Library Services Inc.	\$	5.99	2600-55190-403255	92057801
03/14/2016	792229	Ingram Library Services Inc.	\$	339.30	2600-55190-403333	92057801
03/14/2016	792229	Ingram Library Services Inc.	\$	19.24	2600-55190-403334	92057801
03/14/2016	792229	Ingram Library Services Inc.	\$	4.79	2600-55190-403226	92057802
03/14/2016	792229	Ingram Library Services Inc.	\$	9.59	2600-55190-403227	92057803
03/14/2016	792229	Ingram Library Services Inc.	\$	23.87	2600-55190-403333	92057804
03/14/2016	792229	Ingram Library Services Inc.	\$	9.19	2600-55190-403226	92057805
03/14/2016	792229	Ingram Library Services Inc.	\$	63.92	2600-55190-403227	92057806
03/14/2016	792229	Ingram Library Services Inc.	\$	1,286.07	2600-55190-403333	92057807
03/14/2016	792229	Ingram Library Services Inc.	\$	31.14	2600-55190-403226	92057808
03/14/2016	792229	Ingram Library Services Inc.	\$	247.97	2600-55190-403227	92057808
03/14/2016	792229	Ingram Library Services Inc.	\$	20.68	2600-55190-403226	92062820
03/14/2016	792229	Ingram Library Services Inc.	\$	49.40	2600-55190-403333	92062821
03/14/2016	792229	Ingram Library Services Inc.	\$	10.02	2600-55190-403333	92062822
03/14/2016	792229	Ingram Library Services Inc.	\$	58.82	2600-55190-403222	92062823
03/14/2016	792229	Ingram Library Services Inc.	\$	91.90	2600-55190-403226	92062823
03/14/2016	792229	Ingram Library Services Inc.	\$	482.78	2600-55190-403227	92062823

03/14/2016	792229	Ingram Library Services Inc.	\$	62.51	2600-55190-403255	92062823
03/14/2016	792229	Ingram Library Services Inc.	\$	17.95	2600-55190-403226	92064044
03/14/2016	792229	Ingram Library Services Inc.	\$	81.28	2600-55190-403227	92064044
03/14/2016	792230	Integra Telecom Holding Inc	\$	39.49	5610-71130-403450	Airport 2948370 Airport Alarm
03/14/2016	792230	Integra Telecom Holding Inc	\$	3,990.52	6060-19310-403450	Main Bill New Account # 330046 Old Acct
03/14/2016	792230	Integra Telecom Holding Inc	\$	230.86	6060-19310-403450	Main Bill T-1 New Account #330047 Old Account
03/14/2016	792230	Integra Telecom Holding Inc	\$	40.10	1500-21110-403450	CPC line 247-8592 New Account # 330183 Old
03/14/2016	792230	Integra Telecom Holding Inc	\$	46.00	0100-51120-403450	Dehler Park line 867-7275
03/14/2016	792230	Integra Telecom Holding Inc	\$	79.95	6200-19110-403452	IT Internet Connection New Account # 330046
03/14/2016	792230	Integra Telecom Holding Inc	\$	40.10	2910-65010-403450	Community Development Services FAX 406-294-
03/14/2016	792230	Integra Telecom Holding Inc	\$	40.10	2090-44510-403450	Building FAX 406-657-8252 New Account #
03/14/2016	792230	Integra Telecom Holding Inc	\$	40.10	2400-43010-403450	Planning FAX 406-657-8327 New Account #
03/14/2016	792234	Johnson's Welding	\$	2,580.00	1500-22240-402450	FIRE:BURN BUILDING CUSTOM WELDING FEB
03/14/2016	792237	Kadrmass Lee & Jackson	\$	67,971.31	1990-15050-409310	WO 15-07 Orchard Lane
03/14/2016	792245	Machinery Power & Equipment Co	\$	2,572.60	2110-31320-405333	rental of model 316E for Ryan storm drain project
03/14/2016	792249	MGM Targets	\$	1,699.99	1500-21400-402270	ReCon-2T - Recon Target, pneumatic self
03/14/2016	792249	MGM Targets	\$	1,277.33	1500-21400-402270	ATTACK - MGM ATTACK TARGET COMPLETE
03/14/2016	792249	MGM Targets	\$	320.27	1500-21400-402270	SNAP - Snapper, dual shot actuated Hostage
03/14/2016	792249	MGM Targets	\$	186.80	1500-21400-402270	MGM-VATA KD Target - VATA Knock Down
03/14/2016	792249	MGM Targets	\$	251.16	1500-21400-402270	DROPTRN - Drop Turner
03/14/2016	792249	MGM Targets	\$	312.65	1500-21400-402270	SWI - Swinger
03/14/2016	792249	MGM Targets	\$	-	1500-21400-402270	Shipping - LIFTGATE REQUIRED (No shipping
03/14/2016	792253	Montana Municipal Interlocal Authority	\$	23,138.98	6300-17530-407311	Deductible Recovery Invoice 3/7/2016 #216003
03/14/2016	792258	National Business Furniture	\$	1,718.40	1500-21500-402120	Item 11998 - Left Desk Left Return
03/14/2016	792258	National Business Furniture	\$	76.80	1500-21500-402120	Item 91681 - Keyboard Tray
03/14/2016	792258	National Business Furniture	\$	612.48	1500-21500-402120	Item 31754 - Two Door Hutch 66" W
03/14/2016	792258	National Business Furniture	\$	431.04	1500-21500-402120	Item 12001 - Single Pedestal Desk 48W
03/14/2016	792258	National Business Furniture	\$	306.24	1500-21500-402120	Item 31754 - Two Door Hutch 66" W
03/14/2016	792258	National Business Furniture	\$	485.21	1500-21500-402120	Shipping
03/14/2016	792258	National Business Furniture	\$	(316.08)	1500-21500-402120	Adjustment
03/14/2016	792261	NorMont Equipment Company	\$	510.00	2110-31320-402410	extend forks for cleaning ditches
03/14/2016	792261	NorMont Equipment Company	\$	2,473.31	2110-31320-402320	brooms for sweepers
03/14/2016	792265	NorthWestern Energy	\$	111.43	5610-71130-403410	0712533-9. Airport Entrance. February 2016
03/14/2016	792265	NorthWestern Energy	\$	237.20	5610-71130-403410	0712535-4. Employee Parking. February 2016
03/14/2016	792265	NorthWestern Energy	\$	25.19	5610-71130-403410	0712791-3. Gate 16. February 2016
03/14/2016	792265	NorthWestern Energy	\$	29.84	5610-71130-403410	0712795-4. Gate 17. February 2016
03/14/2016	792265	NorthWestern Energy	\$	18.40	5610-71130-403410	0712797-0. Gate 9. February 2016
03/14/2016	792265	NorthWestern Energy	\$	12.44	5610-71130-403410	0712813-5. Burn Pit. February 2016
03/14/2016	792265	NorthWestern Energy	\$	23.64	5610-71130-403410	0719759-3. Gate 12. February 2016
03/14/2016	792265	NorthWestern Energy	\$	22.21	5610-71130-403410	0719760-1. Gate 14. February 2016
03/14/2016	792265	NorthWestern Energy	\$	15.54	5610-71130-403410	0719761-9. Gate 15. February 2016
03/14/2016	792265	NorthWestern Energy	\$	7.55	5610-71130-403410	0719762-7. Gate 13. February 2016

03/14/2016	792265	NorthWestern Energy	\$	21.02	5610-71130-403410	0720296-3. Gate 29. February 2016
03/14/2016	792265	NorthWestern Energy	\$	29.29	5610-71130-403410	2114868-9. Runway Weather System. February
03/14/2016	792265	NorthWestern Energy	\$	14.00	5610-71170-403410	0712805-1. IP-10. February 2016
03/14/2016	792265	NorthWestern Energy	\$	14.37	1500-22210-403410	0712532-1
03/14/2016	792265	NorthWestern Energy	\$	153.02	0100-51410-403410	0712538-8
03/14/2016	792265	NorthWestern Energy	\$	307.97	1500-22210-403410	0720817-6
03/14/2016	792265	NorthWestern Energy	\$	149.93	0100-51260-403410	0720841-6
03/14/2016	792265	NorthWestern Energy	\$	7.67	0100-51120-403410	0722253-2
03/14/2016	792265	NorthWestern Energy	\$	216.96	0100-51120-403410	0722256-5
03/14/2016	792265	NorthWestern Energy	\$	9.75	0100-51120-403410	0722258-1
03/14/2016	792265	NorthWestern Energy	\$	16.39	0100-51120-403410	0722259-9
03/14/2016	792265	NorthWestern Energy	\$	9.57	0100-51120-403410	0722272-2
03/14/2016	792265	NorthWestern Energy	\$	6.37	8720-51980-403410	0722272-2
03/14/2016	792265	NorthWestern Energy	\$	158.09	0100-51120-403410	0722273-0
03/14/2016	792265	NorthWestern Energy	\$	13.16	0100-51120-403410	0722274-8
03/14/2016	792265	NorthWestern Energy	\$	108.69	0100-51120-403410	0722275-5
03/14/2016	792265	NorthWestern Energy	\$	38.77	0100-51120-403410	0722277-1
03/14/2016	792265	NorthWestern Energy	\$	31.82	0100-51120-403410	0722278-9
03/14/2016	792265	NorthWestern Energy	\$	16.64	0100-51120-403410	0722279-7
03/14/2016	792265	NorthWestern Energy	\$	7.67	0100-51120-403410	0722280-5
03/14/2016	792265	NorthWestern Energy	\$	7.67	0100-51120-403410	0722281-3
03/14/2016	792265	NorthWestern Energy	\$	7.67	0100-51120-403410	0722283-9
03/14/2016	792265	NorthWestern Energy	\$	7.67	0100-51120-403410	0722284-7
03/14/2016	792265	NorthWestern Energy	\$	16.64	0100-51120-403410	0722808-3
03/14/2016	792265	NorthWestern Energy	\$	10.06	0100-51120-403410	0722852-1
03/14/2016	792265	NorthWestern Energy	\$	9.75	0100-51120-403410	0722862-0
03/14/2016	792265	NorthWestern Energy	\$	165.13	0100-51120-403410	0722901-6
03/14/2016	792265	NorthWestern Energy	\$	9.09	0100-51120-403410	0722976-8
03/14/2016	792265	NorthWestern Energy	\$	128.25	0100-51120-403410	0722995-8
03/14/2016	792265	NorthWestern Energy	\$	81.86	0100-51120-403410	0723005-5
03/14/2016	792265	NorthWestern Energy	\$	7.67	0100-51120-403410	0723025-3
03/14/2016	792265	NorthWestern Energy	\$	-	0100-51120-403410	0723039-4
03/14/2016	792265	NorthWestern Energy	\$	7.55	0100-51120-403410	0723046-9
03/14/2016	792265	NorthWestern Energy	\$	7.55	0100-51120-403410	0723049-3
03/14/2016	792265	NorthWestern Energy	\$	12.32	0100-51120-403410	0723053-5
03/14/2016	792265	NorthWestern Energy	\$	19.27	0100-51120-403410	0723064-2
03/14/2016	792265	NorthWestern Energy	\$	19.27	0100-51120-403410	0723065-9
03/14/2016	792265	NorthWestern Energy	\$	7.67	8720-51980-403410	0723384-4
03/14/2016	792265	NorthWestern Energy	\$	9.37	8720-51980-403410	0723385-1
03/14/2016	792265	NorthWestern Energy	\$	9.37	8720-51980-403410	0723386-9
03/14/2016	792265	NorthWestern Energy	\$	9.37	8720-51980-403410	0723387-7
03/14/2016	792265	NorthWestern Energy	\$	9.37	8720-51980-403410	0723388-5

03/14/2016	792265	NorthWestern Energy	\$	5.17	0100-51120-403410	0723391-9
03/14/2016	792265	NorthWestern Energy	\$	3.45	8720-51980-403410	0723391-9
03/14/2016	792265	NorthWestern Energy	\$	9.37	8720-51980-403410	0723392-7
03/14/2016	792265	NorthWestern Energy	\$	8.27	8720-51980-403410	0723393-5
03/14/2016	792265	NorthWestern Energy	\$	7.67	8720-51980-403410	0723394-3
03/14/2016	792265	NorthWestern Energy	\$	7.67	8720-51980-403410	0723395-0
03/14/2016	792265	NorthWestern Energy	\$	7.67	8720-51980-403410	0723396-8
03/14/2016	792265	NorthWestern Energy	\$	7.67	8720-51980-403410	0723397-6
03/14/2016	792265	NorthWestern Energy	\$	7.67	8720-51980-403410	0723398-4
03/14/2016	792265	NorthWestern Energy	\$	7.67	8720-51980-403410	0723835-5
03/14/2016	792265	NorthWestern Energy	\$	9.75	8720-51980-403410	0723836-3
03/14/2016	792265	NorthWestern Energy	\$	7.55	8720-51980-403410	0723840-5
03/14/2016	792265	NorthWestern Energy	\$	14.47	8720-51980-403410	0723879-3
03/14/2016	792265	NorthWestern Energy	\$	8.16	8720-51980-403410	0723883-5
03/14/2016	792265	NorthWestern Energy	\$	114.19	0100-51120-403410	0723884-3
03/14/2016	792265	NorthWestern Energy	\$	8.27	8720-51980-403410	0723885-0
03/14/2016	792265	NorthWestern Energy	\$	19.27	0100-51120-403410	0723887-6
03/14/2016	792265	NorthWestern Energy	\$	42.68	0100-51120-403410	0813489-2
03/14/2016	792265	NorthWestern Energy	\$	7.90	2110-31320-403410	0855404-0
03/14/2016	792265	NorthWestern Energy	\$	9.11	8720-51980-403410	0881455-0
03/14/2016	792265	NorthWestern Energy	\$	0.87	8720-51980-403410	0971824-8
03/14/2016	792265	NorthWestern Energy	\$	17.58	0100-51120-403410	0978917-3
03/14/2016	792265	NorthWestern Energy	\$	7.55	0100-51290-403410	0999807-1
03/14/2016	792265	NorthWestern Energy	\$	0.43	8720-51980-403410	1045813-1
03/14/2016	792265	NorthWestern Energy	\$	51.75	2110-31320-403410	1045820-6
03/14/2016	792265	NorthWestern Energy	\$	7.80	0100-51120-403410	1156527-2
03/14/2016	792265	NorthWestern Energy	\$	7.55	5020-74000-403410	1160807-2
03/14/2016	792265	NorthWestern Energy	\$	1,342.58	1500-21710-403410	1183483-5
03/14/2016	792265	NorthWestern Energy	\$	7.55	0100-51120-403410	1242222-6
03/14/2016	792265	NorthWestern Energy	\$	-	8720-51980-403410	1265177-4
03/14/2016	792265	NorthWestern Energy	\$	0.65	8720-51980-403410	1312707-1
03/14/2016	792265	NorthWestern Energy	\$	8.08	5020-74000-403410	1346673-5
03/14/2016	792265	NorthWestern Energy	\$	1.31	0100-51120-403410	1409394-2
03/14/2016	792265	NorthWestern Energy	\$	-	8720-51980-403410	1513796-1
03/14/2016	792265	NorthWestern Energy	\$	19.48	8720-51980-403410	1513800-1
03/14/2016	792265	NorthWestern Energy	\$	30.69	8720-51980-403410	1513802-7
03/14/2016	792265	NorthWestern Energy	\$	16.62	8720-51980-403410	1513804-3
03/14/2016	792265	NorthWestern Energy	\$	8.62	8720-51980-403410	1514388-6
03/14/2016	792265	NorthWestern Energy	\$	8.27	8720-51980-403410	1564209-3
03/14/2016	792265	NorthWestern Energy	\$	60.44	2090-44510-403963	1569631-3
03/14/2016	792265	NorthWestern Energy	\$	7.55	0100-51120-403410	1588262-4
03/14/2016	792265	NorthWestern Energy	\$	0.87	0100-51120-403410	1692666-9

03/14/2016	792265	NorthWestern Energy	\$	11.96	5120-85000-403410	1704025-4
03/14/2016	792265	NorthWestern Energy	\$	29.27	5120-85000-403410	1704030-4
03/14/2016	792265	NorthWestern Energy	\$	13.27	2110-31320-403410	1738989-1
03/14/2016	792265	NorthWestern Energy	\$	72.24	0100-51120-403410	1849408-8
03/14/2016	792265	NorthWestern Energy	\$	7.55	5020-74000-403410	1867265-9
03/14/2016	792265	NorthWestern Energy	\$	8.86	0100-51120-403410	1902257-3
03/14/2016	792265	NorthWestern Energy	\$	66.95	0100-51120-403410	1904944-4
03/14/2016	792265	NorthWestern Energy	\$	13.54	0100-51120-403410	1941243-6
03/14/2016	792265	NorthWestern Energy	\$	0.97	8720-51980-403410	1948667-9
03/14/2016	792265	NorthWestern Energy	\$	1.20	8720-51980-403410	2041362-1
03/14/2016	792265	NorthWestern Energy	\$	8.38	2110-31320-403410	2047007-6
03/14/2016	792265	NorthWestern Energy	\$	8.98	2110-31320-403410	2047010-0
03/14/2016	792265	NorthWestern Energy	\$	8.62	2110-31320-403410	2047013-4
03/14/2016	792265	NorthWestern Energy	\$	8.86	2110-31320-403410	2047017-5
03/14/2016	792265	NorthWestern Energy	\$	8.86	2110-31320-403410	2047018-3
03/14/2016	792265	NorthWestern Energy	\$	8.62	2110-31320-403410	2047019-1
03/14/2016	792265	NorthWestern Energy	\$	6.31	8720-51980-403410	2055817-7
03/14/2016	792265	NorthWestern Energy	\$	7.55	0100-51120-403958	3178260-0
03/14/2016	792265	NorthWestern Energy	\$	102.78	5120-85000-403410	62nd st w ironwood sub lift station
03/14/2016	792265	NorthWestern Energy	\$	1,506.98	5020-74000-403410	5809 canyonwoods dr
03/14/2016	792265	NorthWestern Energy	\$	5,000.89	2600-55120-403410	Electric usage
03/14/2016	792265	NorthWestern Energy	\$	2,378.32	5610-71130-403410	0719543-1. Airport Parking Lot Lights. February
03/14/2016	792265	NorthWestern Energy	\$	3,387.47	5710-71430-403410	Electricity at Metroplex 1/26/16 to 2/25/16
03/14/2016	792265	NorthWestern Energy	\$	476.79	5710-71430-403410	07192255
03/14/2016	792272	Public Utilities	\$	44.27	2910-66980-407275	FORECLOSURE: 3921 Chamberlain Account
03/14/2016	792272	Public Utilities	\$	5,430.48	5610-71100-403420	136516
03/14/2016	792272	Public Utilities	\$	16.34	8720-51980-403420	148398
03/14/2016	792272	Public Utilities	\$	310.63	6500-15660-403420	158260
03/14/2016	792273	Public Works-Administration	\$	6,934.80	5050-75150-403671	PWU Feb 2016 Engineering Permits - WSRP
03/14/2016	792273	Public Works-Administration	\$	3,112.00	5020-75000-403680	PWU Feb 2016 Engineering Permits - Watermain
03/14/2016	792274	Qwest Communications	\$	44.67	5610-71190-403450	Bill Date: Feb 28, 2016. QTA Phone
03/14/2016	792274	Qwest Communications	\$	33.36	5610-71120-403450	Qwest 406-245-1044 Airport Terminal Power M
03/14/2016	792274	Qwest Communications	\$	49.34	5710-71470-403450	Qwest 406-245-1789 Transit STS
03/14/2016	792274	Qwest Communications	\$	60.17	5410-31230-403450	Qwest 406-245-7193 Solid Waste Landfill
03/14/2016	792274	Qwest Communications	\$	104.02	5410-31230-403450	Qwest 406-245-9820 Solid Waste Landfil
03/14/2016	792274	Qwest Communications	\$	33.36	2110-31320-403450	Qwest 406-245-9906 PW Traffic Signal 4th 27
03/14/2016	792274	Qwest Communications	\$	191.92	5610-71120-403450	Qwest 406-252-9412 Airport
03/14/2016	792274	Qwest Communications	\$	49.34	5710-71410-403450	Qwest 406-254-7038 MET Transit
03/14/2016	792274	Qwest Communications	\$	7,319.72	2250-22320-403450	Qwest 406-255-9700 E911
03/14/2016	792274	Qwest Communications	\$	47.98	1500-22250-403450	Qwest 406-655-0728 Fire Maintenance Shop
03/14/2016	792274	Qwest Communications	\$	33.36	0100-51120-403450	Qwest 406-657-3014 Parks 3890 Stillwater
03/14/2016	792274	Qwest Communications	\$	2,694.31	6060-19310-403450	Qwest 406-657-8377 Main System Centrex

03/14/2016	792274	Qwest Communications	\$	73.94	6060-19310-403450	Qwest 406-248-9124 Met Measured Lines 406-248-
03/14/2016	792274	Qwest Communications	\$	68.60	6060-19310-403450	Qwest 406-248-3329 Airport Measured Lines 406-
03/14/2016	792274	Qwest Communications	\$	105.29	6060-19310-403450	Qwest 406-657-3009 PUD Measured Lines 406-
03/14/2016	792274	Qwest Communications	\$	40.38	1500-21110-403450	Qwest 406-245-6600 Crime Prevention Alarm
03/14/2016	792274	Qwest Communications	\$	33.42	5210-15920-403450	Qwest 406-657-3054 Park 1 Elevator Phone
03/14/2016	792274	Qwest Communications	\$	71.91	6060-19310-403450	Qwest BOC Measured Lines 406-252-3774 406-
03/14/2016	792274	Qwest Communications	\$	144.35	2600-55120-403450	Qwest 406-245-1579 Library 6 lines (4) Library
03/14/2016	792274	Qwest Communications	\$	63.08	6060-19310-403450	Qwest 406-245-1579 Library 6 lines (4) Library
03/14/2016	792274	Qwest Communications	\$	34.61	6200-19110-403450	Qwest 406-245-4437 Kenco Security Alarm IT
03/14/2016	792274	Qwest Communications	\$	34.30	1500-22210-403450	Qwest 406-245-1743 Fire Elevator 1500-22210-
03/14/2016	792275	RDO Equipment Co.	\$	16,416.00	5410-31230-405333	Excavator for the the clean out of the retention
03/14/2016	792277	Routeware Inc	\$	130,882.50	5410-31220-409480	Routeware hardware and software for the Solid
03/14/2016	792280	Saint Vincent Occupational Health	\$	789.59	1500-22240-403510	48085: BRANGER, PATRICK - PRE-
03/14/2016	792280	Saint Vincent Occupational Health	\$	789.59	1500-22240-403510	48085: CARLSON JAMES PRE-EMPLOYMENT
03/14/2016	792280	Saint Vincent Occupational Health	\$	814.59	1500-22240-403510	48085: EKBLAD ANDREW PRE-EMPLOYMENT
03/14/2016	792280	Saint Vincent Occupational Health	\$	789.59	1500-22240-403510	48085: HEMINGER RYAN PRE-EMPLOYMENT
03/14/2016	792280	Saint Vincent Occupational Health	\$	814.59	1500-22240-403510	48085: O'BRIEN SHAWN PRE-EMPLOYMENT
03/14/2016	792280	Saint Vincent Occupational Health	\$	789.59	1500-22240-403510	48085: O'TOOLE ANDREW PRE-EMPLOYMENT
03/14/2016	792280	Saint Vincent Occupational Health	\$	789.59	1500-22240-403510	48085: SHEEHAN MICHAEL PRE-EMPLOYMENT
03/14/2016	792280	Saint Vincent Occupational Health	\$	789.59	1500-22240-403510	48085: SMITH RYAN PRE-EMPLOYMENT FIRE
03/14/2016	792280	Saint Vincent Occupational Health	\$	789.59	1500-22240-403510	48085: TINNES KEVIN PRE-EMPLOYMENT FIRE
03/14/2016	792280	Saint Vincent Occupational Health	\$	621.96	1500-22290-403510	47943: DILLON GREGORY ANNUAL FIRE
03/14/2016	792280	Saint Vincent Occupational Health	\$	621.96	1500-22290-403510	47943: KINKEAD TODD ANNUAL FIRE
03/14/2016	792281	Sanderson Stewart	\$	7,750.00	8730-51990-409370	Consultant fees for Yellowstone Kelly Interpretative
03/14/2016	792300	TNT Springs Inc	\$	79.74	2110-31320-402320	154606
03/14/2016	792300	TNT Springs Inc	\$	223.86	6010-00000-141000	154385 PO NUM 300060
03/14/2016	792300	TNT Springs Inc	\$	889.94	5410-31220-402320	W-023438
03/14/2016	792300	TNT Springs Inc	\$	1,032.00	1500-22260-402320	154208
03/14/2016	792300	TNT Springs Inc	\$	68.70	1500-22260-402320	154208
03/14/2016	792300	TNT Springs Inc	\$	233.80	1500-22260-402320	154329
03/14/2016	792300	TNT Springs Inc	\$	183.00	5410-31220-402320	154412
03/14/2016	792301	Town & Country Supply Association	\$	4,135.83	6010-00000-141000	218943 PO NUM 300061
03/14/2016	792301	Town & Country Supply Association	\$	9,766.47	6010-00000-141000	218418 PO NUM 300062
03/14/2016	792301	Town & Country Supply Association	\$	12,501.33	5610-71180-402313	Invoice #218921. QTA Car Rental Fuel
03/14/2016	792304	Tristan Sophia PSYD	\$	5,850.00	1500-22240-403510	PRE-EMPLOYMENT EVALUATIONS: O'BRIEN,
03/14/2016	792304	Tristan Sophia PSYD	\$	225.00	1500-22240-403510	PRE-EMPLOYMENT EVALUATIONS: 3-TEST RE-
03/14/2016	792305	Tyler Technologies Inc	\$	4,130.00	6200-19120-403870	Aegis 2016 Customer Conference Barb McRae,
03/14/2016	792305	Tyler Technologies Inc	\$	2,065.00	6200-19130-403870	Aegis 2016 Customer Conference Barb McRae,
03/14/2016	792309	Weiss Electrical Service	\$	1,216.00	1500-22260-402450	FIRE7: SERVICE CALL. REPLD BALLAST AND
03/14/2016	792309	Weiss Electrical Service	\$	2,193.00	1500-22290-402290	FIRE4: ELECTRICAL TO RELOCATE SCBA AIR
03/14/2016	792315	Xylem Dewatering Solutions Inc	\$	7,555.10	5120-85000-403660	repaired FLYGT Model 3153 pump
03/14/2016	792316	Yellowstone County Finance Dpt	\$	7,800.00	1500-21110-403590	Jail Borders for February 2016

03/14/2016	792319	Border States Electric	\$	93.08	5120-84300-402360	3p dist block,power dist safety cover
03/14/2016	792319	Border States Electric	\$	7,357.59	5020-74000-403553	2nd year of 3 year contract tech connect
03/14/2016	792319	Border States Electric	\$	7,357.60	5120-84000-403553	2nd year of 3 year contract tech connect

Regular City Council Meeting

Meeting Date: 04/11/2016

TITLE: Payment of Claims March 21, 2016

PRESENTED BY: Patrick M. Weber, Finance Director

Department: City Hall Administration

PROBLEM/ISSUE STATEMENT

Claims in the amount of \$1,049,572.36 have been audited and are presented for City Council payment approval. A complete listing of the claims dated March 21, 2016, is available in the Finance Department.

ALTERNATIVES ANALYZED

No other alternatives were analyzed.

FINANCIAL IMPACT

Claims have a varying impact on department budgets, but are submitted by the departments and reviewed by Finance staff before being sent to the Council.

RECOMMENDATION

Staff recommends that Council approve the Payment of Claims.

APPROVED BY CITY ADMINISTRATOR

Attachments

councilmemo_3.21.2016

Check Date	Check	Name	Amount	Account	Item Desc
03/21/2016	792337	Bcs Scrip	\$ 9,650.00	0100-17500-403365	2016 Employee Service Awards
03/21/2016	792342	Billings Depot Inc	\$ 5,648.67	6600-31100-405310	Rent
03/21/2016	792342	Billings Depot Inc	\$ 8,473.00	6700-31410-405310	Rent
03/21/2016	792355	Civicplus	\$ 5,049.56	6200-19110-403552	4th Quarterly Fees for Hosting and Support
03/21/2016	792355	Civicplus	\$ 248.75	6200-19110-403552	4th Quarterly Fees CivicSend IT6200-19110-403552
03/21/2016	792355	Civicplus	\$ 248.75	5610-71100-403961	4th Quarterly Fees Airport CivicSend5610-71110-403961
03/21/2016	792363	CTA Inc	\$ 1,783.92	8730-51990-409370	Construction documents for the South Park splash pad.
03/21/2016	792363	CTA Inc	\$ 1,205.00	6300-17530-407310	CTA Services to BOC Salt Barn damaged by winds
03/21/2016	792366	Dell Computer L P	\$ 1,439.85	6200-19110-402925	(1) Dell OptiPlex 7040
03/21/2016	792366	Dell Computer L P	\$ 1,662.46	2090-44510-402925	(2) Dell OptiPlex 3020
03/21/2016	792366	Dell Computer L P	\$ 401.88	2090-44510-402925	(2) Dell 22 inch Monitors
03/21/2016	792366	Dell Computer L P	\$ 3,407.00	6700-31410-402925	(4) Dell OptiPlex 3040
03/21/2016	792366	Dell Computer L P	\$ 2,472.96	6700-31410-402925	(2) Dell OptiPlex 7040
03/21/2016	792366	Dell Computer L P	\$ 959.04	6700-31410-402925	(6) Dell 22 Monitor
03/21/2016	792367	Diversified Inspections/ITL Inc	\$ 800.00	0100-51120-402320	261053
03/21/2016	792367	Diversified Inspections/ITL Inc	\$ 1,600.00	2110-31320-402320	261053
03/21/2016	792367	Diversified Inspections/ITL Inc	\$ 400.00	5020-75000-402320	261053
03/21/2016	792376	Executive Cleaning Co Inc	\$ 1,012.35	6500-15660-403660	Inv. 51090 February 2016 2. hours per night/clean additional areas of the building
03/21/2016	792376	Executive Cleaning Co Inc	\$ 1,963.50	6500-15660-403660	Inv. 51091 February 2016 Janitorial Services/Floor and carpet
03/21/2016	792382	First Congregational United Church of Christ	\$ 6,000.00	2030-15130-407968	Pocket Park TIF project
03/21/2016	792391	Iaff	\$ 4,387.76	9000-00000-209920	Payroll Summary
03/21/2016	792394	Insight Public Sector	\$ 1,519.50	2110-31320-403660	10NMX25 NetMotion Premium Technical Support 6/3/2014-6/2/2017
03/21/2016	792394	Insight Public Sector	\$ 253.24	5020-73120-403660	10NMX25 NetMotion Premium Technical Support6/3/2014-6/2/2017
03/21/2016	792394	Insight Public Sector	\$ 759.75	5020-75000-403660	10NMX25 NetMotion Premium Technical Support6/3/2014-6/2/2017
03/21/2016	792394	Insight Public Sector	\$ 506.50	5120-85000-403660	10NMX25 NetMotion Premium Technical Support6/3/2014-6/2/2017
03/21/2016	792394	Insight Public Sector	\$ 2,815.92	6200-19110-405370	10NMX25 NetMotion Premium Technical Support6/3/2014-6/2/2017
03/21/2016	792396	Johnson Controls Inc.	\$ 2,525.00	5610-71140-402290	Invoice #1-31236589320. Badging Cards
03/21/2016	792404	Labor Ready Northwest, Inc.	\$ 2,960.32	5410-31230-403581	Paper Pickers for the Landfill
03/21/2016	792404	Labor Ready Northwest, Inc.	\$ 2,556.64	5410-31230-403581	Paper Pickers for the Landfill
03/21/2016	792407	Machinery Power & Equipment Co	\$ 4,168.00	2110-31320-405333	rental of model 316e excavator for Ryan ave
03/21/2016	792416	Miller Trois LLC	\$ 1,837.00	0100-43210-405311	I16-019133
03/21/2016	792416	Miller Trois LLC	\$ 6,029.00	2090-44510-405311	I16-019133

03/21/2016	792416	Miller Trois LLC	\$	3,997.00	2400-43010-405311	I16-019133
03/21/2016	792416	Miller Trois LLC	\$	4,734.00	2740-67800-405310	I16-019133
03/21/2016	792418	Montana CSED	\$	3,959.09	9000-00000-209926	Payroll Summary
03/21/2016	792419	Montana Dakota Utilities	\$	3,455.34	6010-00000-141000	022616 PO NUM 300080
03/21/2016	792426	Montana State Fireman's Assoc	\$	3,292.32	9000-00000-209924	Payroll Summary
03/21/2016	792430	MPPA Montana Police Protective Association	\$	2,505.73	9000-00000-209923	Payroll Summary
03/21/2016	792435	NorMont Equipment Company	\$	1,344.00	2110-31320-404710	tote of emulsion for road patcher
03/21/2016	792435	NorMont Equipment Company	\$	189.00	2110-31320-402290	orange locate paint
03/21/2016	792435	NorMont Equipment Company	\$	556.50	2110-31320-402320	sweeper brooms
03/21/2016	792435	NorMont Equipment Company	\$	918.75	2110-31320-402320	gutter wire for sweeper brooms
03/21/2016	792435	NorMont Equipment Company	\$	101.31	2110-31320-402410	forks for cleaning ditches
03/21/2016	792437	Northern Tool & Equipment	\$	7,499.99	8730-51990-402920	Trailer for Parks Department. Invoice is part of the attached email. Supporting quote is also attached.
03/21/2016	792438	NorthWestern Energy	\$	15.06	8100-31830-403410	SILMD 238 ACCT# 0712672-5
03/21/2016	792438	NorthWestern Energy	\$	94.30	8100-31830-403410	SILMD 239 ACCT# 0712673-3
03/21/2016	792438	NorthWestern Energy	\$	403.10	8100-31830-403410	SILMD 240 ACCT# 0712674-1
03/21/2016	792438	NorthWestern Energy	\$	623.00	8100-31830-403410	SILMD 241 ACCT# 0712675-8
03/21/2016	792438	NorthWestern Energy	\$	82.54	8100-31830-403410	SILMD 242 ACCT# 0712676-6
03/21/2016	792438	NorthWestern Energy	\$	110.06	8100-31830-403410	SILMD 244 ACCT# 0712677-4
03/21/2016	792438	NorthWestern Energy	\$	55.31	8100-31830-403410	SILMD 320 Acct# 0712569-3
03/21/2016	792438	NorthWestern Energy	\$	384.28	8100-31830-403410	SILMD 309 ACCT# 2001311-6
03/21/2016	792438	NorthWestern Energy	\$	405.61	8100-31830-403410	SILMD 310 ACCT# 2060519-2
03/21/2016	792438	NorthWestern Energy	\$	292.96	8100-31830-403410	SILMD 311 ACCT# 3014475-2
03/21/2016	792438	NorthWestern Energy	\$	304.32	8100-31830-403410	SILMD 312 ACCT# 3146127-0
03/21/2016	792438	NorthWestern Energy	\$	3,240.46	8100-31830-403410	SILMD 316 Acct# 3291842-7
03/21/2016	792438	NorthWestern Energy	\$	89.32	8100-31830-403410	SILMD 317 Acct# 3253826-6
03/21/2016	792438	NorthWestern Energy	\$	2,384.84	8100-31830-403410	SILMD 301 ACCT# 1687005-7
03/21/2016	792438	NorthWestern Energy	\$	279.36	8100-31830-403410	SILMD 302 ACCT# 1607534-3
03/21/2016	792438	NorthWestern Energy	\$	895.02	8100-31830-403410	SILMD 305 ACCT# 1695873-8
03/21/2016	792438	NorthWestern Energy	\$	280.90	8100-31830-403410	SILMD 306 ACCT# 1740353-6
03/21/2016	792438	NorthWestern Energy	\$	3,156.73	8100-31830-403410	SILMD 307 ACCT# 2049005-8
03/21/2016	792438	NorthWestern Energy	\$	261.50	8100-31830-403410	SILMD 308 ACCT# 2072459-7
03/21/2016	792438	NorthWestern Energy	\$	471.48	8100-31830-403410	SILMD 294 ACCT# 1481535-1
03/21/2016	792438	NorthWestern Energy	\$	110.06	8100-31830-403410	SILMD 295 ACCT# 1481536-9
03/21/2016	792438	NorthWestern Energy	\$	1,249.43	8100-31830-403410	SILMD 296 ACCT# 1481537-7
03/21/2016	792438	NorthWestern Energy	\$	212.16	8100-31830-403410	SILMD 297 ACCT# 1481539-3
03/21/2016	792438	NorthWestern Energy	\$	188.59	8100-31830-403410	SILMD 298 ACCT# 1481540-1
03/21/2016	792438	NorthWestern Energy	\$	399.76	8100-31830-403410	SILMD 300 ACCT# 1662840-6
03/21/2016	792438	NorthWestern Energy	\$	132.11	8100-31830-403410	SILMD 287 ACCT# 1246537-3
03/21/2016	792438	NorthWestern Energy	\$	1,769.08	8100-31830-403410	SILMD 288 ACCT# 1303978-9
03/21/2016	792438	NorthWestern Energy	\$	224.60	8100-31830-403410	SILMD 289 ACCT# 1685375-6

03/21/2016	792438	NorthWestern Energy	\$	155.88	8100-31830-403410	SILMD 290 ACCT# 1433921-2
03/21/2016	792438	NorthWestern Energy	\$	605.31	8100-31830-403410	SILMD 292 ACCT# 1481532-8
03/21/2016	792438	NorthWestern Energy	\$	235.74	8100-31830-403410	SILMD 293 ACCT# 1481534-4
03/21/2016	792438	NorthWestern Energy	\$	61.39	8100-31830-403410	SILMD 279 ACCT# 1124127-0
03/21/2016	792438	NorthWestern Energy	\$	736.68	8100-31830-403410	SILMD 280 ACCT# 1045653-1
03/21/2016	792438	NorthWestern Energy	\$	67.18	8100-31830-403410	SILMD 281 ACCT# 1079722-3
03/21/2016	792438	NorthWestern Energy	\$	382.50	8100-31830-403410	SILMD 283 ACCT# 1172743-5
03/21/2016	792438	NorthWestern Energy	\$	338.64	8100-31830-403410	SILMD 285 ACCT# 1206985-2
03/21/2016	792438	NorthWestern Energy	\$	235.67	8100-31830-403410	SILMD 286 ACCT# 1296582-8
03/21/2016	792438	NorthWestern Energy	\$	2,787.43	8100-31830-403410	SILMD 272 ACCT# 0905005-5
03/21/2016	792438	NorthWestern Energy	\$	200.21	8100-31830-403410	SILMD 273 ACCT# 0926386-4
03/21/2016	792438	NorthWestern Energy	\$	67.18	8100-31830-403410	SILMD 274 ACCT# 0907926-0
03/21/2016	792438	NorthWestern Energy	\$	484.82	8100-31830-403410	SILMD 276 ACCT# 0961926-3
03/21/2016	792438	NorthWestern Energy	\$	817.68	8100-31830-403410	SILMD 277 ACCT# 1058710-3
03/21/2016	792438	NorthWestern Energy	\$	212.74	8100-31830-403410	SILMD 278 ACCT# 1087619-1
03/21/2016	792438	NorthWestern Energy	\$	165.23	8100-31830-403410	SILMD 264 ACCT# 0721427-3
03/21/2016	792438	NorthWestern Energy	\$	346.87	8100-31830-403410	SILMD 265 ACCT# 0721556-9
03/21/2016	792438	NorthWestern Energy	\$	51.48	8100-31830-403410	SILMD 266 ACCT# 0721684-9
03/21/2016	792438	NorthWestern Energy	\$	78.39	8100-31830-403410	SILMD 269 ACCT# 0833098-7
03/21/2016	792438	NorthWestern Energy	\$	440.70	8100-31830-403410	SILMD 270 ACCT# 0906944-4
03/21/2016	792438	NorthWestern Energy	\$	1,000.74	8100-31830-403410	SILMD 271 ACCT# 0995095-7
03/21/2016	792438	NorthWestern Energy	\$	2,607.34	8100-31830-403410	SILMD 258 ACCT# 0720606-3
03/21/2016	792438	NorthWestern Energy	\$	26.29	8100-31830-403410	SILMD 259 ACCT# 1301786-8
03/21/2016	792438	NorthWestern Energy	\$	1,382.32	8100-31830-403410	SILMD 259 ACCT# 0720810-1
03/21/2016	792438	NorthWestern Energy	\$	495.25	8100-31830-403410	SILMD 261 ACCT# 0720705-3
03/21/2016	792438	NorthWestern Energy	\$	3,130.03	8100-31830-403410	SILMD 262 ACCT# 0720937-2
03/21/2016	792438	NorthWestern Energy	\$	986.11	8100-31830-403410	SILMD 263 ACCT# 0720716-0
03/21/2016	792438	NorthWestern Energy	\$	3,880.08	8100-31830-403410	SILMD 251 ACCT# 0718801-4
03/21/2016	792438	NorthWestern Energy	\$	550.28	8100-31830-403410	SILMD 252 ACCT# 0719162-0
03/21/2016	792438	NorthWestern Energy	\$	1,941.40	8100-31830-403410	SILMD 253 ACCT# 0719644-7
03/21/2016	792438	NorthWestern Energy	\$	151.46	8100-31830-403410	SILMD 254 ACCT# 0719763-5
03/21/2016	792438	NorthWestern Energy	\$	163.79	8100-31830-403410	SILMD 255 ACCT# 0720813-5
03/21/2016	792438	NorthWestern Energy	\$	884.80	8100-31830-403410	SILMD 257 ACCT# 0720360-7
03/21/2016	792438	NorthWestern Energy	\$	87.23	8100-31830-403410	SILMD 245 ACCT# 0712678-2
03/21/2016	792438	NorthWestern Energy	\$	330.16	8100-31830-403410	SILMD 246 ACCT# 0712679-0
03/21/2016	792438	NorthWestern Energy	\$	1,174.53	8100-31830-403410	SILMD 247 ACCT# 0712680-8
03/21/2016	792438	NorthWestern Energy	\$	2,486.00	8100-31830-403410	SILMD 248 ACCT# 0712681-6
03/21/2016	792438	NorthWestern Energy	\$	2,723.87	8100-31830-403410	SILMD 249 ACCT# 0718734-7
03/21/2016	792438	NorthWestern Energy	\$	230.66	8100-31830-403410	SILMD 250 ACCT# 0719001-0
03/21/2016	792438	NorthWestern Energy	\$	504.19	8100-31830-403410	SILMD 008 ACCT# 0712544-6
03/21/2016	792438	NorthWestern Energy	\$	515.16	8100-31830-403410	SILMD 009 ACCT# 0712545-3
03/21/2016	792438	NorthWestern Energy	\$	1,420.86	8100-31830-403410	SILMD 010 ACCT# 0712546-1

03/21/2016	792438	NorthWestern Energy	\$	4,399.36	8100-31830-403410	SILMD 013 ACCT# 0721276-4
03/21/2016	792438	NorthWestern Energy	\$	2,132.84	8100-31830-403410	SILMD 014 ACCT# 0721277-2
03/21/2016	792438	NorthWestern Energy	\$	1,230.71	8100-31830-403410	SILMD 017 ACCT# 0712553-7
03/21/2016	792438	NorthWestern Energy	\$	92.38	8100-31830-403410	SILMD 018 ACCT# 0712554-5
03/21/2016	792438	NorthWestern Energy	\$	471.52	8100-31830-403410	SILMD 095 ACCT# 0712556-0
03/21/2016	792438	NorthWestern Energy	\$	13,453.61	8100-31830-403410	SILMD 097 ACCT# 0712557-8
03/21/2016	792438	NorthWestern Energy	\$	1,653.91	8100-31830-403410	SILMD 099 ACCT# 0712558-6
03/21/2016	792438	NorthWestern Energy	\$	2,695.92	8100-31830-403410	SILMD 100 ACCT# 0712559-4
03/21/2016	792438	NorthWestern Energy	\$	1,733.37	8100-31830-403410	SILMD 107 ACCT# 0712560-2
03/21/2016	792438	NorthWestern Energy	\$	4,347.18	8100-31830-403410	SILMD 109 ACCT# 0712561-0
03/21/2016	792438	NorthWestern Energy	\$	189.77	8100-31830-403410	SILMD 113 ACCT# 0712562-8
03/21/2016	792438	NorthWestern Energy	\$	935.47	8100-31830-403410	SILMD 114 ACCT# 0712563-6
03/21/2016	792438	NorthWestern Energy	\$	220.11	8100-31830-403410	SILMD 115 ACCT# 0712564-4
03/21/2016	792438	NorthWestern Energy	\$	577.79	8100-31830-403410	SILMD 116 ACCT# 0712565-1
03/21/2016	792438	NorthWestern Energy	\$	3,196.19	8100-31830-403410	SILMD 117 ACCT# 0712566-9
03/21/2016	792438	NorthWestern Energy	\$	234.33	8100-31830-403410	SILMD 118 ACCT# 0712567-7
03/21/2016	792438	NorthWestern Energy	\$	155.58	8100-31830-403410	SILMD 119 ACCT# 0712568-5
03/21/2016	792438	NorthWestern Energy	\$	2,476.24	8100-31830-403410	SILMD 121 ACCT# 0712570-1
03/21/2016	792438	NorthWestern Energy	\$	188.59	8100-31830-403410	SILMD 122 ACCT# 0712571-9
03/21/2016	792438	NorthWestern Energy	\$	330.16	8100-31830-403410	SILMD 123 ACCT# 0712572-7
03/21/2016	792438	NorthWestern Energy	\$	962.98	8100-31830-403410	SILMD 124 ACCT# 0712573-5
03/21/2016	792438	NorthWestern Energy	\$	385.18	8100-31830-403410	SILMD 125 ACCT# 0712574-3
03/21/2016	792438	NorthWestern Energy	\$	192.61	8100-31830-403410	SILMD 126 ACCT# 0712575-0
03/21/2016	792438	NorthWestern Energy	\$	707.22	8100-31830-403410	SILMD 127 ACCT# 0712576-8
03/21/2016	792438	NorthWestern Energy	\$	495.05	8100-31830-403410	SILMD 128 ACCT# 0712577-6
03/21/2016	792438	NorthWestern Energy	\$	330.16	8100-31830-403410	SILMD 129 ACCT# 0712578-4
03/21/2016	792438	NorthWestern Energy	\$	125.83	8100-31830-403410	SILMD 130 ACCT# 0712579-2
03/21/2016	792438	NorthWestern Energy	\$	852.94	8100-31830-403410	SILMD 131 ACCT# 0712580-0
03/21/2016	792438	NorthWestern Energy	\$	233.65	8100-31830-403410	SILMD 133 ACCT# 0712581-8
03/21/2016	792438	NorthWestern Energy	\$	539.19	8100-31830-403410	SILMD 134 ACCT# 0712582-6
03/21/2016	792438	NorthWestern Energy	\$	518.63	8100-31830-403410	SILMD 135 ACCT# 0712583-4
03/21/2016	792438	NorthWestern Energy	\$	467.72	8100-31830-403410	SILMD 136 ACCT# 0712584-2
03/21/2016	792438	NorthWestern Energy	\$	378.40	8100-31830-403410	SILMD 137 ACCT# 0712585-9
03/21/2016	792438	NorthWestern Energy	\$	742.87	8100-31830-403410	SILMD 138 ACCT# 0712586-7
03/21/2016	792438	NorthWestern Energy	\$	247.62	8100-31830-403410	SILMD 139 ACCT# 0712587-5
03/21/2016	792438	NorthWestern Energy	\$	575.48	8100-31830-403410	SILMD 143 ACCT# 0712588-3
03/21/2016	792438	NorthWestern Energy	\$	27.39	8100-31830-403410	SILMD 144 ACCT# 0712589-1
03/21/2016	792438	NorthWestern Energy	\$	471.48	8100-31830-403410	SILMD 145 ACCT# 0712590-9
03/21/2016	792438	NorthWestern Energy	\$	357.67	8100-31830-403410	SILMD 146 ACCT# 0712591-7
03/21/2016	792438	NorthWestern Energy	\$	467.85	8100-31830-403410	SILMD 147 ACCT# 0712592-5
03/21/2016	792438	NorthWestern Energy	\$	1,551.33	8100-31830-403410	SILMD 149 ACCT# 0712593-3
03/21/2016	792438	NorthWestern Energy	\$	754.36	8100-31830-403410	SILMD 150 ACCT# 0712594-1

03/21/2016	792438	NorthWestern Energy	\$	632.82	8100-31830-403410	SILMD 151 ACCT# 0712595-8
03/21/2016	792438	NorthWestern Energy	\$	4,308.89	8100-31830-403410	SILMD 152 ACCT# 0712596-6
03/21/2016	792438	NorthWestern Energy	\$	542.20	8100-31830-403410	SILMD 153 ACCT# 0712597-4
03/21/2016	792438	NorthWestern Energy	\$	1,225.85	8100-31830-403410	SILMD 154 ACCT# 0712598-2
03/21/2016	792438	NorthWestern Energy	\$	495.25	8100-31830-403410	SILMD 155 ACCT# 0712599-0
03/21/2016	792438	NorthWestern Energy	\$	919.39	8100-31830-403410	SILMD 157 ACCT# 0712600-6
03/21/2016	792438	NorthWestern Energy	\$	797.89	8100-31830-403410	SILMD 158 ACCT# 0712601-4
03/21/2016	792438	NorthWestern Energy	\$	1,105.69	8100-31830-403410	SILMD 159 ACCT# 0712602-2
03/21/2016	792438	NorthWestern Energy	\$	715.35	8100-31830-403410	SILMD 160 ACCT# 0712603-0
03/21/2016	792438	NorthWestern Energy	\$	1,060.80	8100-31830-403410	SILMD 161 ACCT# 0712604-8
03/21/2016	792438	NorthWestern Energy	\$	61.99	8100-31830-403410	SILMD 162 ACCT# 0712605-5
03/21/2016	792438	NorthWestern Energy	\$	694.25	8100-31830-403410	SILMD 163 ACCT# 0712606-3
03/21/2016	792438	NorthWestern Energy	\$	377.18	8100-31830-403410	SILMD 164 ACCT# 0712607-1
03/21/2016	792438	NorthWestern Energy	\$	880.44	8100-31830-403410	SILMD 165 ACCT# 0712608-9
03/21/2016	792438	NorthWestern Energy	\$	235.74	8100-31830-403410	SILMD 167 ACCT# 0712609-7
03/21/2016	792438	NorthWestern Energy	\$	565.77	8100-31830-403410	SILMD 171 ACCT# 0712610-5
03/21/2016	792438	NorthWestern Energy	\$	539.22	8100-31830-403410	SILMD 172 ACCT# 0712611-3
03/21/2016	792438	NorthWestern Energy	\$	1,178.68	8100-31830-403410	SILMD 173 ACCT# 0712612-1
03/21/2016	792438	NorthWestern Energy	\$	990.09	8100-31830-403410	SILMD 174 ACCT# 0712613-9
03/21/2016	792438	NorthWestern Energy	\$	330.02	8100-31830-403410	SILMD 175 ACCT# 0712614-7
03/21/2016	792438	NorthWestern Energy	\$	44.27	8100-31830-403410	SILMD 176 ACCT# 0712615-4
03/21/2016	792438	NorthWestern Energy	\$	259.31	8100-31830-403410	SILMD 178 ACCT# 0712616-2
03/21/2016	792438	NorthWestern Energy	\$	518.63	8100-31830-403410	SILMD 179 ACCT# 0712617-0
03/21/2016	792438	NorthWestern Energy	\$	353.61	8100-31830-403410	SILMD 180 ACCT# 0712618-8
03/21/2016	792438	NorthWestern Energy	\$	1,678.34	8100-31830-403410	SILMD 181 ACCT# 0712619-6
03/21/2016	792438	NorthWestern Energy	\$	589.36	8100-31830-403410	SILMD 182 ACCT# 0712620-4
03/21/2016	792438	NorthWestern Energy	\$	1,178.70	8100-31830-403410	SILMD 183 ACCT# 0712621-2
03/21/2016	792438	NorthWestern Energy	\$	377.18	8100-31830-403410	SILMD 184 ACCT# 0712622-0
03/21/2016	792438	NorthWestern Energy	\$	141.45	8100-31830-403410	SILMD 185 ACCT# 0712623-8
03/21/2016	792438	NorthWestern Energy	\$	649.45	8100-31830-403410	SILMD 186 ACCT# 0712624-6
03/21/2016	792438	NorthWestern Energy	\$	235.74	8100-31830-403410	SILMD 187 ACCT# 0712625-3
03/21/2016	792438	NorthWestern Energy	\$	282.88	8100-31830-403410	SILMD 188 ACCT# 0712626-1
03/21/2016	792438	NorthWestern Energy	\$	235.74	8100-31830-403410	SILMD 189 ACCT# 0712627-9
03/21/2016	792438	NorthWestern Energy	\$	1,225.85	8100-31830-403410	SILMD 190 ACCT# 0712628-7
03/21/2016	792438	NorthWestern Energy	\$	421.20	8100-31830-403410	SILMD 191 ACCT# 0712629-5
03/21/2016	792438	NorthWestern Energy	\$	306.45	8100-31830-403410	SILMD 192 ACCT# 0712630-3
03/21/2016	792438	NorthWestern Energy	\$	754.36	8100-31830-403410	SILMD 193 ACCT# 0712631-1
03/21/2016	792438	NorthWestern Energy	\$	268.74	8100-31830-403410	SILMD 194 ACCT# 0712632-9
03/21/2016	792438	NorthWestern Energy	\$	223.94	8100-31830-403410	SILMD 195 ACCT# 0712633-7
03/21/2016	792438	NorthWestern Energy	\$	71.76	8100-31830-403410	SILMD 196 ACCT# 0712634-5
03/21/2016	792438	NorthWestern Energy	\$	71.76	8100-31830-403410	SILMD 197 ACCT# 0712635-2
03/21/2016	792438	NorthWestern Energy	\$	117.87	8100-31830-403410	SILMD 198 ACCT# 0712636-0

03/21/2016	792438	NorthWestern Energy	\$	92.91	8100-31830-403410	SILMD 200 ACCT# 0712637-8
03/21/2016	792438	NorthWestern Energy	\$	495.05	8100-31830-403410	SILMD 201 ACCT# 0712638-6
03/21/2016	792438	NorthWestern Energy	\$	827.34	8100-31830-403410	SILMD 202 INV# 0712639-4
03/21/2016	792438	NorthWestern Energy	\$	19.14	8100-31830-403410	SILMD 203 ACCT# 0712640-2
03/21/2016	792438	NorthWestern Energy	\$	405.83	8100-31830-403410	SILMD 204 ACCT# 0712641-0
03/21/2016	792438	NorthWestern Energy	\$	35.42	8100-31830-403410	SILMD 205 ACCT# 0712642-8
03/21/2016	792438	NorthWestern Energy	\$	330.02	8100-31830-403410	SILMD 206 ACCT# 0712643-6
03/21/2016	792438	NorthWestern Energy	\$	377.18	8100-31830-403410	SILMD 207 ACCT# 0712644-4
03/21/2016	792438	NorthWestern Energy	\$	270.17	8100-31830-403410	SILMD 208 ACCT# 0712645-1
03/21/2016	792438	NorthWestern Energy	\$	542.20	8100-31830-403410	SILMD 209 ACCT# 0712646-9
03/21/2016	792438	NorthWestern Energy	\$	86.11	8100-31830-403410	SILMD 210 ACCT# 0712647-7
03/21/2016	792438	NorthWestern Energy	\$	47.84	8100-31830-403410	SILMD 211 ACCT# 0712648-5
03/21/2016	792438	NorthWestern Energy	\$	47.84	8100-31830-403410	SILMD 212 ACCT# 0712649-3
03/21/2016	792438	NorthWestern Energy	\$	28.71	8100-31830-403410	SILMD 213 ACCT# 0712650-1
03/21/2016	792438	NorthWestern Energy	\$	476.40	8100-31830-403410	SILMD 214 ACCT# 0712651-9
03/21/2016	792438	NorthWestern Energy	\$	141.45	8100-31830-403410	SILMD 216 ACCT# 0712652-7
03/21/2016	792438	NorthWestern Energy	\$	399.62	8100-31830-403410	SILMD 217 ACCT# 0712653-5
03/21/2016	792438	NorthWestern Energy	\$	261.42	8100-31830-403410	SILMD 220 ACCT# 0712654-3
03/21/2016	792438	NorthWestern Energy	\$	8.84	8100-31830-403410	SILMD 221 ACCT# 0712655-0
03/21/2016	792438	NorthWestern Energy	\$	75.72	8100-31830-403410	SILMD 222 ACCT# 0712656-8
03/21/2016	792438	NorthWestern Energy	\$	114.81	8100-31830-403410	SILMD 223 ACCT# 0712657-6
03/21/2016	792438	NorthWestern Energy	\$	1,861.43	8100-31830-403410	SILMD 224 ACCT# 0712658-4
03/21/2016	792438	NorthWestern Energy	\$	392.58	8100-31830-403410	SILMD 225 ACCT# 0712659-2
03/21/2016	792438	NorthWestern Energy	\$	308.77	8100-31830-403410	SILMD 226 ACCT# 0712660-0
03/21/2016	792438	NorthWestern Energy	\$	624.64	8100-31830-403410	SILMD 227 ACCT# 0712661-8
03/21/2016	792438	NorthWestern Energy	\$	797.89	8100-31830-403410	SILMD 228 ACCT# 0712662-6
03/21/2016	792438	NorthWestern Energy	\$	412.71	8100-31830-403410	SILMD 229 ACCT# 0712663-4
03/21/2016	792438	NorthWestern Energy	\$	962.97	8100-31830-403410	SILMD 230 ACCT# 0712664-2
03/21/2016	792438	NorthWestern Energy	\$	577.79	8100-31830-403410	SILMD 231 ACCT# 0712665-9
03/21/2016	792438	NorthWestern Energy	\$	2,503.75	8100-31830-403410	SILMD 232 ACCT# 0712666-7
03/21/2016	792438	NorthWestern Energy	\$	837.62	8100-31830-403410	SILMD 233 ACCT# 0712667-5
03/21/2016	792438	NorthWestern Energy	\$	494.66	8100-31830-403410	SILMD 234 ACCT# 0712668-3
03/21/2016	792438	NorthWestern Energy	\$	528.23	8100-31830-403410	SILMD 235 ACCT# 0712669-1
03/21/2016	792438	NorthWestern Energy	\$	167.95	8100-31830-403410	SILMD 236 ACCT# 0712670-9
03/21/2016	792438	NorthWestern Energy	\$	400.75	8100-31830-403410	SILMD 237 ACCT# 0712671-7
03/21/2016	792438	NorthWestern Energy	\$	12,523.29	2110-31320-403410	Signal Bills
03/21/2016	792439	NorthWestern Energy	\$	188.63	5020-74000-403410	2251 Belknap AVE It
03/21/2016	792439	NorthWestern Energy	\$	310.61	5120-85000-403410	822 Shiloh Crossing Blvd Lift
03/21/2016	792439	NorthWestern Energy	\$	181.50	5120-87000-403410	EA Electricity
03/21/2016	792439	NorthWestern Energy	\$	2,036.64	5020-74000-403410	1699 High Sierra Blvd Feb 2016
03/21/2016	792439	NorthWestern Energy	\$	80.33	5610-71130-403410	3085107-5. New Employee Parking. March 2016
03/21/2016	792439	NorthWestern Energy	\$	2,695.15	5610-71130-403410	0100483-7. Runway Lights. March 2016

03/21/2016	792439	NorthWestern Energy	\$	1,678.59	5610-71130-403410	0100484-5. ARFF Facility. March 2016
03/21/2016	792439	NorthWestern Energy	\$	75.29	5610-71130-403410	1647695-4. De Icer. March 2016
03/21/2016	792439	NorthWestern Energy	\$	1,498.90	5610-71190-403410	1993430-6. Car Wash. March 2016
03/21/2016	792439	NorthWestern Energy	\$	529.25	5610-71190-403410	2001846-1. Mud Wash. March 2016
03/21/2016	792439	NorthWestern Energy	\$	287.31	5610-71190-403410	2001848-7. Detail Bay 1 Hertz. March 2016
03/21/2016	792439	NorthWestern Energy	\$	281.91	5610-71190-403410	2001855-2. Detail Bay 2 National/Alamo. March 2016
03/21/2016	792439	NorthWestern Energy	\$	172.01	5610-71190-403410	2001862-8. Detail Bay 3 Enterprise. March 2016
03/21/2016	792439	NorthWestern Energy	\$	173.70	5610-71190-403410	2001865-1. Detail Bay 4 Avis/Budget. March 2016
03/21/2016	792439	NorthWestern Energy	\$	189.45	5610-71190-403410	2001867-7. Detail Bay 5 Thrifty/Dollar. March 2016
03/21/2016	792439	NorthWestern Energy	\$	77.88	5610-71170-403410	1138926-9. Aero Interiors. March 2016
03/21/2016	792439	NorthWestern Energy	\$	674.38	5610-71170-403410	1669567-8. TSA Building. March 2016
03/21/2016	792439	NorthWestern Energy	\$	44.65	0100-51270-403410	0712387-0
03/21/2016	792439	NorthWestern Energy	\$	158.08	0100-51220-403410	0712536-2
03/21/2016	792439	NorthWestern Energy	\$	37.95	0100-51220-403410	0720818-4
03/21/2016	792439	NorthWestern Energy	\$	81.09	0100-51260-403410	0720821-8
03/21/2016	792439	NorthWestern Energy	\$	1,811.02	5020-74000-403410	0722264-9
03/21/2016	792439	NorthWestern Energy	\$	35.32	0100-51120-403410	0722287-0
03/21/2016	792439	NorthWestern Energy	\$	35.99	0100-51120-403410	1836666-6
03/21/2016	792439	NorthWestern Energy	\$	641.97	5020-74000-403410	1116452-2
03/21/2016	792439	NorthWestern Energy	\$	844.38	6500-15660-403410	1160802-3
03/21/2016	792439	NorthWestern Energy	\$	2,610.13	6500-15660-403410	1160804-9
03/21/2016	792439	NorthWestern Energy	\$	2,741.61	6500-15660-403410	1269391-7
03/21/2016	792439	NorthWestern Energy	\$	0.32	2110-31320-403410	1740357-7
03/21/2016	792439	NorthWestern Energy	\$	0.55	2110-31320-403410	1748896-6
03/21/2016	792439	NorthWestern Energy	\$	3,984.74	5020-74000-403410	0723040-2
03/21/2016	792439	NorthWestern Energy	\$	91.66	0100-51120-403410	0723045-1
03/21/2016	792439	NorthWestern Energy	\$	14.95	5020-74000-403410	0723059-2
03/21/2016	792439	NorthWestern Energy	\$	633.71	1500-22210-403410	0871546-8
03/21/2016	792439	NorthWestern Energy	\$	155.09	0100-51120-403410	0925496-2
03/21/2016	792439	NorthWestern Energy	\$	514.93	6500-15660-403410	0975808-7
03/21/2016	792439	NorthWestern Energy	\$	33.41	0100-51120-403410	Monthly electrical bill for Pioneer tennis courts.
03/21/2016	792444	Permaletter Sign Co	\$	2,658.00	5410-31220-403620	Decals for the new garbage trucks Units 052 and 053
03/21/2016	792446	Petty Cash CCSIU	\$	3,081.96	7180-21600-407865	Purchase of evidence/information. Receipts on file at the BPD.
03/21/2016	792453	Prorover	\$	8,475.99	0100-51140-403990	Pruning of 62 green ash trees in Mountview Cemetery.
03/21/2016	792459	Rimrock Foundation	\$	3,746.03	7380-12640-403590	Feb. 16 IOP
03/21/2016	792459	Rimrock Foundation	\$	2,557.57	7380-12660-403990	Feb. 2016 Case Manager
03/21/2016	792459	Rimrock Foundation	\$	2,940.60	2480-12620-403560	Feb. 2016 Day Treatment
03/21/2016	792459	Rimrock Foundation	\$	2,879.28	7380-12640-403590	Feb. 2016 IOP
03/21/2016	792459	Rimrock Foundation	\$	644.03	7380-12660-403590	Feb. 2016 IOP
03/21/2016	792459	Rimrock Foundation	\$	1,167.62	7380-12660-403590	Feb. 2016 Coordinator
03/21/2016	792459	Rimrock Foundation	\$	3,028.51	2460-12530-403590	Feb. 16 IOP

03/21/2016	792460	Rimrock Tire Inc	\$	996.28	1500-21120-402320	5-GS98334
03/21/2016	792460	Rimrock Tire Inc	\$	33.28	1500-22260-402320	5-98311
03/21/2016	792460	Rimrock Tire Inc	\$	374.96	0100-51120-402320	5-98314
03/21/2016	792460	Rimrock Tire Inc	\$	1,026.60	2110-31320-402320	5-98341
03/21/2016	792460	Rimrock Tire Inc	\$	156.66	2110-31320-402320	5-98472
03/21/2016	792460	Rimrock Tire Inc	\$	15.95	2110-31320-402320	5-98562
03/21/2016	792460	Rimrock Tire Inc	\$	2,170.62	1500-22260-402320	5-GS98649
03/21/2016	792460	Rimrock Tire Inc	\$	445.08	1500-21120-402320	5-GS98209
03/21/2016	792460	Rimrock Tire Inc	\$	983.44	1500-21120-402320	5-98395
03/21/2016	792463	Rocky Mountain Compost Inc	\$	1,800.00	8730-51990-409370	Playground chips-10424
03/21/2016	792463	Rocky Mountain Compost Inc	\$	1,380.00	8730-51990-409370	Playground chips-10435
03/21/2016	792463	Rocky Mountain Compost Inc	\$	900.00	8730-51990-409370	Playground chips-10438
03/21/2016	792463	Rocky Mountain Compost Inc	\$	640.00	8730-51990-403650	Playground chips
03/21/2016	792463	Rocky Mountain Compost Inc	\$	80.00	8730-51990-409370	Playground chips
03/21/2016	792464	Rocky Mountain Cummins Inc	\$	5,276.00	6300-17530-407310	Repairs to new bookmobile #2016-029
03/21/2016	792467	Sanderson Stewart	\$	5,662.56	2400-43010-407214	Rimrocks to Valley Bike and Pedestrian Feasibility Study
03/21/2016	792467	Sanderson Stewart	\$	1,145.02	2120-43700-409390	Medicine Crow CTEP project
03/21/2016	792467	Sanderson Stewart	\$	10,662.09	2400-43010-407214	West End Multi-Modal Traffic Modeling Project
03/21/2016	792476	Steiner Thuesen PLLC	\$	3,771.30	8730-51990-409370	Veteran's Park irrigation upgrade in 2016.
03/21/2016	792481	Tait Communications	\$	334.50	1500-22270-402481	TAIT HHCH CONTROL FOR MOBILE (HHCH Kit with Full Display Microphone)
03/21/2016	792481	Tait Communications	\$	394.50	1500-22270-402481	TAIT MOBILE REMOTE KIT (Single Control Head Kits)
03/21/2016	792481	Tait Communications	\$	6,975.00	1500-22270-402481	TAIT MOBILE RADIOS (TM9455)00/800 P25 Digital / Analog Dash mount mobiles.
03/21/2016	792481	Tait Communications	\$	288.00	1500-22270-402481	TAIT MOBILE RADIO MICS
03/21/2016	792481	Tait Communications	\$	1,602.00	1500-22270-402481	TAIT HI-ROSE ADAPTERS (PORTABLES)
03/21/2016	792481	Tait Communications	\$	165.00	1500-22270-402481	TAIT PORTABLE ANTENNA TP9455
03/21/2016	792481	Tait Communications	\$	40.55	1500-22270-402481	ESTIMATED SHIPPING/HANDLING
03/21/2016	792485	Titan Machinery Inc	\$	359,828.48	5130-85910-409410	2016 Single Engine Combination Sewer Jet/Vacuum Cleaner
03/21/2016	792485	Titan Machinery Inc	\$	1,703.35	5120-85000-402320	NONSTOCKING ITEMS-P.U.D.
03/21/2016	792485	Titan Machinery Inc	\$	690.00	5120-85000-403620	NONSTOCKING ITEMS-P.U.D.
03/21/2016	792487	Toter Incorporated	\$	30,706.70	5410-31220-404270	Black 96 gallon barrels for residential use
03/21/2016	792488	Town & Country Supply Association	\$	228.92	1500-22260-402310	219030: FIRE 5 - BLENDED DIESEL DELIVERED 3/4/2016 (60 GALLONS #1 AND 140 GALLONS #2)
03/21/2016	792488	Town & Country Supply Association	\$	168.23	1500-22260-402310	219031: FIRE 3 - BLENDED DIESEL DELIVERED 3/4/2016 (44 GALLONS #1 AND 103 GALLONS #2)
03/21/2016	792488	Town & Country Supply Association	\$	212.20	1500-22260-402310	219032: FIRE 1 - UNLEADED DELIVERED 3/4/2016
03/21/2016	792488	Town & Country Supply Association	\$	291.73	1500-22260-402310	219032: FIRE 1 - BLENDED DIESEL DELIVERED 3/4/2016 (76 GALLONS #1 AND 179 GALLONS #2)
03/21/2016	792488	Town & Country Supply Association	\$	114.47	1500-22260-402310	219033: FIRE 2 - BLENDED DIESEL DELIVERED 3/4/2016 (30 GALLONS #1 AND 70 GALLONS #2)

03/21/2016	792488	Town & Country Supply Association	\$	6,644.81	5020-00000-141000	WATER PARTS AND SUPPLIES PO NUM 300053
03/21/2016	792488	Town & Country Supply Association	\$	717.64	1500-22260-402310	219062: FIRE 1 - UNLEADED DELIVERED 3/11/2016
03/21/2016	792488	Town & Country Supply Association	\$	331.83	1500-22260-402310	219062: FIRE 1 - DIESEL #2 DYED DELIVERED 3/11/2016
03/21/2016	792488	Town & Country Supply Association	\$	8,386.79	6010-00000-141000	218433 PO NUM 300121
03/21/2016	792488	Town & Country Supply Association	\$	4,803.20	6010-00000-141000	219123 PO NUM 300122
03/21/2016	792500	Verizon Wireless	\$	200.05	1500-21700-403450	Animal Shelter MDT
03/21/2016	792500	Verizon Wireless	\$	651.52	7170-21660-403450	CCSIU Cell/PTT
03/21/2016	792500	Verizon Wireless	\$	40.01	7170-21660-403450	CCSIU Air Card
03/21/2016	792500	Verizon Wireless	\$	80.02	7170-21660-403450	CCSIU RAVEN
03/21/2016	792500	Verizon Wireless	\$	80.02	0100-43210-403450	Code Enforcement Air Cards
03/21/2016	792500	Verizon Wireless	\$	40.01	1500-22210-403450	Fire MiFi 406-839-3253
03/21/2016	792500	Verizon Wireless	\$	40.01	2200-22330-402410	Fire HAZMAT MDT 406-670-1284
03/21/2016	792500	Verizon Wireless	\$	880.24	1500-22210-403450	Fire MDT
03/21/2016	792500	Verizon Wireless	\$	40.01	6200-19110-403450	ITD
03/21/2016	792500	Verizon Wireless	\$	80.04	2600-55170-403450	Library Outreach Air Cards
03/21/2016	792500	Verizon Wireless	\$	3,975.39	1500-21110-403450	Police MDT Toughbooks
03/21/2016	792500	Verizon Wireless	\$	470.28	5710-71470-403160	MET Transit Tablets
03/21/2016	792500	Verizon Wireless	\$	40.01	1500-21110-403450	Police ICAC 406-690-7347
03/21/2016	792500	Verizon Wireless	\$	40.01	1500-21110-403450	Police MiFi 406-633-0820
03/21/2016	792500	Verizon Wireless	\$	40.01	1500-21110-403450	Police US Marshall Toughbooks
03/21/2016	792500	Verizon Wireless	\$	40.03	0100-51120-403450	PRPL-PARKS PMD Air Card 406-794-6977
03/21/2016	792500	Verizon Wireless	\$	240.06	2090-44510-403450	PW-Building Air Cards
03/21/2016	792500	Verizon Wireless	\$	288.07	5020-75000-403450	PW-Distribution Collection Tablets 60%/40% 60% 5020-75000-40345040% 5120-85000-403450
03/21/2016	792500	Verizon Wireless	\$	192.05	5120-85000-403450	PW-Distribution Collection Tablets 60%/40% 60% 5020-75000-40345040% 5120-85000-403450
03/21/2016	792500	Verizon Wireless	\$	140.06	6700-31410-403450	PW Engineering
03/21/2016	792500	Verizon Wireless	\$	70.03	2110-31320-403450	PW-Streets 406-697-0361 iPad 406-633-1991 iPad
03/21/2016	792500	Verizon Wireless	\$	18.02	5020-75000-403450	PWBELKNAP-AIR 60% 40% 60% 5020-75000-403450 40% 5120-85000-403450
03/21/2016	792500	Verizon Wireless	\$	12.00	5120-85000-403450	PWBELKNAP-AIR 60% 40% 60% 5020-75000-403450 40% 5120-85000-403450
03/21/2016	792500	Verizon Wireless	\$	120.03	7170-21660-403450	CCSIU MDT
03/21/2016	792500	Verizon Wireless	\$	192.04	5020-75000-403450	PW-DIS-COLL CITYWORKS 60%/40% 5020-75000-403450 60% 5120-85000-403450 40%
03/21/2016	792500	Verizon Wireless	\$	128.04	5120-85000-403450	PW-DIS-COLL CITYWORKS 60%/40% 5020-75000-403450 60% 5120-85000-403450 40%
03/21/2016	792500	Verizon Wireless	\$	80.02	1500-21110-403450	POLICE IPAD ST JOHN 406-690-5955 POLICE IPAD HAFNER 406-690-2161 1500-21110-403450
03/21/2016	792500	Verizon Wireless	\$	240.06	2110-31320-403450	PW-STREETS CITY WORKS 2110-31320-403450

03/21/2016	792500	Verizon Wireless	\$	40.01	5210-15210-403450	PARKING 406-690-5822 5210-15210-403450
03/21/2016	792500	Verizon Wireless	\$	280.07	5020-73120-403450	PWBLNP COMM-METER CityWorks/Neptune 5020-73120-403450
03/21/2016	792500	Verizon Wireless	\$	40.11	2510-21870-403450	POLICE-Forensics Tim West 406-794-4826 2510-21870-403450
03/21/2016	792500	Verizon Wireless	\$	40.01	2200-22330-402410	FIRE HAZMAT LAPTOP 406-591-5883 2200-22330-402410
03/21/2016	792501	Verizon Wireless	\$	513.56	5610-71100-403450	Airport
03/21/2016	792501	Verizon Wireless	\$	534.72	1500-21700-403450	Animal Shelter
03/21/2016	792501	Verizon Wireless	\$	186.88	7170-21660-403450	CCSIU
03/21/2016	792501	Verizon Wireless	\$	118.86	0100-16110-403450	Legal
03/21/2016	792501	Verizon Wireless	\$	53.23	1500-22250-403450	Comm Center 911
03/21/2016	792501	Verizon Wireless	\$	70.75	6500-15650-403450	Facilities BOC Plus 70% of 406-672-3027
03/21/2016	792501	Verizon Wireless	\$	51.98	5020-77000-403450	PWBLNP-ENVIRONMENTAL 50% 50% 5020-77000-403450 5120-87000-403450 406-698-1590 406-850-1016
03/21/2016	792501	Verizon Wireless	\$	51.99	5120-87000-403450	PWBLNP-ENVIRONMENTAL 50% 50% 5020-77000-403450 5120-87000-403450 406-698-1590 406-850-1016
03/21/2016	792501	Verizon Wireless	\$	178.44	0100-51120-403450	Parks Seasonal
03/21/2016	792501	Verizon Wireless	\$	225.28	5020-74000-403450	PWVLKNP ELECTRICIANS 50%/50% 50% 5020-74000-403450 50% 5120-84300-403450
03/21/2016	792501	Verizon Wireless	\$	225.28	5120-84300-403450	PWVLKNP ELECTRICIANS 50%/50% 50% 5020-74000-403450 50% 5120-84300-403450
03/21/2016	792501	Verizon Wireless	\$	19.46	5120-83140-403450	PWBLKNP STORES 75% 5020-73140-403450 PWBLKNP STORES 25% 5120-83140-403450
03/21/2016	792501	Verizon Wireless	\$	898.11	5120-84000-403450	Wastewater Treatment Plant
03/21/2016	792501	Verizon Wireless	\$	23.06	6060-19310-403450	TeleComm Manager
03/21/2016	792501	Verizon Wireless	\$	93.07	5710-71420-403160	On Call MET
03/21/2016	792501	Verizon Wireless	\$	78.70	5710-71410-403450	MET Transit
03/21/2016	792501	Verizon Wireless	\$	97.11	0100-43210-403450	Code Enforcement
03/21/2016	792501	Verizon Wireless	\$	293.78	5120-85000-403450	Distribution & Collection 60% 5020-75000-403450 Distribution & Collection 40% 5120-85000-403450
03/21/2016	792501	Verizon Wireless	\$	788.62	5020-74000-403450	Water Treatment PWBelknap-WT
03/21/2016	792501	Verizon Wireless	\$	443.58	5020-73120-403450	PWBLKNP MTRSHOP
03/21/2016	792501	Verizon Wireless	\$	70.05	5020-73110-403450	Belknap Office 60% 5020-73110-403450 Belknap Office 40% 5120-83110-403450
03/21/2016	792501	Verizon Wireless	\$	46.70	5120-83110-403450	Belknap Office 60% 5020-73110-403450 Belknap Office 40% 5120-83110-403450
03/21/2016	792501	Verizon Wireless	\$	58.38	5020-73140-403450	PWBLKNP STORES 75% 5020-73140-403450 PWBLKNP STORES 25% 5120-83140-403450
03/21/2016	792501	Verizon Wireless	\$	238.20	2090-44510-403450	Building
03/21/2016	792501	Verizon Wireless	\$	226.72	6700-31410-403450	Engineering
03/21/2016	792501	Verizon Wireless	\$	113.69	5410-31210-403450	Solid Waste

03/21/2016	792501	Verizon Wireless	\$	340.23	2110-31320-403450	Streets
03/21/2016	792501	Verizon Wireless	\$	234.99	5410-31230-403450	Solid Waste On Call
03/21/2016	792501	Verizon Wireless	\$	440.65	5020-75000-403450	Distribution & Collection 60% 5020-75000-403450 Distribution & Collection 40\$ 5120-85000-403450
03/21/2016	792501	Verizon Wireless	\$	383.72	0100-51210-403450	PRPL Recreation
03/21/2016	792501	Verizon Wireless	\$	80.35	0100-51400-403450	Cemetery
03/21/2016	792501	Verizon Wireless	\$	44.10	0100-51120-403450	Parks PMD
03/21/2016	792501	Verizon Wireless	\$	980.91	0100-51120-403450	Parks
03/21/2016	792501	Verizon Wireless	\$	221.28	0100-51120-403450	Parks Irrigation
03/21/2016	792501	Verizon Wireless	\$	61.91	6600-31100-403450	Public Works Admin
03/21/2016	792501	Verizon Wireless	\$	3,509.95	1500-21110-403450	Police
03/21/2016	792501	Verizon Wireless	\$	126.91	2510-21870-403450	Police Forensic 406-794-6880 406-698-7323
03/21/2016	792501	Verizon Wireless	\$	503.10	1500-21110-403450	Police Resource Officers
03/21/2016	792501	Verizon Wireless	\$	28.61	2490-21960-403450	Police DV 406-698-1391
03/21/2016	792501	Verizon Wireless	\$	115.37	5210-15210-403450	Parking
03/21/2016	792501	Verizon Wireless	\$	162.77	0100-51100-403450	PRPL Admin
03/21/2016	792501	Verizon Wireless	\$	416.05	2600-55120-403450	Library
03/21/2016	792501	Verizon Wireless	\$	42.97	0100-11000-403450	Mayor
03/21/2016	792501	Verizon Wireless	\$	49.73	6010-15500-403450	Motor Pool
03/21/2016	792501	Verizon Wireless	\$	192.80	0100-12200-403450	Drug Court
03/21/2016	792501	Verizon Wireless	\$	88.02	0100-12120-403450	Municipal Court Judge
03/21/2016	792501	Verizon Wireless	\$	13.23	2400-43010-403450	Planning
03/21/2016	792501	Verizon Wireless	\$	91.35	6500-15670-403450	Facilities City Hall Plus 30% of 406-672-3027
03/21/2016	792501	Verizon Wireless	\$	79.31	0100-15120-403450	Finance Pat Weber
03/21/2016	792501	Verizon Wireless	\$	1,261.31	1500-22210-403450	Fire Department
03/21/2016	792501	Verizon Wireless	\$	97.10	0100-17500-403450	Human Resources
03/21/2016	792501	Verizon Wireless	\$	13.23	6200-19110-403450	ITD
03/21/2016	792501	Verizon Wireless	\$	13.82	2600-55170-403450	Library Outreach
03/21/2016	792511	Z & Z Seal Coating Inc	\$	148,841.74	2050-31310-409310	WO 16-03 2016 Overlay/Crack Seal - Contract #1 Crack Seal

Regular City Council Meeting

Meeting Date: 04/11/2016

TITLE: Public Hearing and Resolution Approving the FY 2017 - FY 2021 Capital Improvement Plan and the FY 2017 Equipment and Technology Replacement Plans

PRESENTED BY: David Mumford, Public Works Director

Department: Public Works

PROBLEM/ISSUE STATEMENT

The final draft of the FY 2017-2021 Capital Improvement Plan (CIP), the FY 2017 Equipment Replacement Plan (ERP), and the FY 2017 Technology Replacement Plan (TRP) were presented to the City Council at the March 7, 2016 work session. Council is being asked to hold a public hearing and consider adopting the three plans. Adoption will allow staff to include the FY 2017 projects in next year's proposed budget.

ALTERNATIVES ANALYZED

The City Council may:

- Hold a public hearing and adopt the CIP, ERP, and TRP as presented.
- Hold a public hearing and take no action. Staff will not include the plan elements in the City's proposed FY 17 budget.
- Hold a public hearing, amend the plans to include any desired projects and changes, and adopt the CIP, ERP, and TRP as amended.
- Hold a public hearing and defer action to a later Council meeting.

FINANCIAL IMPACT

The CIP, ERP, and TRP are financial tools that indicate the City's priorities when the City departments prepare their annual budget proposals. For the FY 2017 budget, the proposed CIP shows expenditures totaling \$110,677,992. The ERP recommended rolling stock replacements total \$5,524,662 and \$1,686,629 in supplemental budget requests for a total of \$7,211,291 for FY 2017. The TRP for FY 2017 would result in expenditures totaling \$1,005,923, of which \$626,510 is for capital and \$379,923 for operating and maintenance expenses. Council amendments and the availability of funds in FY 2017 and future years could affect the actual costs of the items in those programs. Copies of the CIP, ERP, and TRP are on file in the City Clerk's Office.

RECOMMENDATION

Staff recommends that the City Council approve the FY 2017 to FY 2021 CIP, the FY 2017 ERP and the FY 2017 TRP.

APPROVED BY CITY ADMINISTRATOR

Attachments

CIP ERP TRP resolution

RESOLUTION 16-_____

A RESOLUTION ADOPTING THE FY 2017–2021 CAPITAL IMPROVEMENT PLAN, FY 2017 EQUIPMENT REPLACEMENT PLAN, AND FY 2017 TECHNOLOGY REPLACEMENT PLAN

WHEREAS, the Capital Improvement Plan (CIP), Equipment Replacement Plan (ERP), and Technology Replacement Plan (TRP) are financial tools adopted by the City Council as an indication of its priorities for funding projects in future budget years; and

WHEREAS, the City Council of the City of Billings was presented on March 7, 2016, with staff recommendations for the Fiscal Year (FY) 2017–2021 CIP, the FY 2017 ERP and the FY2017 TRP; and

WHEREAS, the City Council held a public hearing on the proposed Plans at its April 11, 2016, meeting.

NOW, THEREFORE, BE IT RESOLVED BY THE CITY COUNCIL OF THE CITY OF BILLINGS, MONTANA, AS FOLLOWS:

Section 1: The FY 2017–2021 CIP, the FY 2017 ERP and the FY2017 TRP are hereby adopted as presented by staff on March 7, 2016.

Section 2: City staff is hereby directed to utilize the adopted plans to prepare the FY 2017 departmental budgets that will be incorporated into the comprehensive FY2017 City of Billings budget, which will be presented for City Council review and approval at a future City Council meeting.

APPROVED AND PASSED by the City Council of the City of Billings this 11th day of April 2016.

THE CITY OF BILLINGS:

BY: _____
Thomas W. Hanel, Mayor

ATTEST:

Billie Guenther, City Clerk

Regular City Council Meeting

Meeting Date: 04/11/2016

TITLE: Public Hearing and Resolution Creating SILMD 322, Orchard Lane

PRESENTED BY: David Mumford, Public Works Director

Department: Public Works

PROBLEM/ISSUE STATEMENT

The Engineering Division has a street reconstruction project planned for Orchard Lane in the summer of 2016. The project plan includes installing street lights along those portions of Orchard Lane that do not already have street lighting. Council passed a Resolution of Intention to Create SILMD 322 at its March 14, 2016, meeting and set an April 11, 2016 public hearing on the proposed district. Legal notice of the proposed district and public hearing was published and was mailed to all property owners in the proposed district in accordance with State law.

The new lighting will use steel mastarm style poles with LED lamps and underground wiring. The cost of installing the new lighting will be paid for with funds from the South Billings Urban Renewal District (SBURD). The adjacent property owners will only pay for electrical energy and maintenance, through an assessment on their property taxes. Due to public comments, this district replaces the district originally proposed in January and will be assessed on a frontage basis instead of an area basis as was originally planned. The estimated average annual cost is \$92 per property. Pursuant to 7-12-4327 Montana Code Annotated, properties outside of, but contiguous to, the city limits will be assessed for their share of the energy and maintenance costs for the lighting.

The deadline for written protests is Friday, April 1, 2016. The number and percentage of valid written protests received will be reported at the April 11 Council meeting. As provided in State law, the City Council has the authority to create the district if the legal protest does not exceed 50%.

ALTERNATIVES ANALYZED

The Council may:

- Pass the Resolution creating SILMD 322 to provide a source of funding for operation and maintenance of the streetlights; or
- Do not pass the Resolution creating the district. If the Council does not adopt the Resolution, the property owners cannot be assessed for operation and maintenance of the streetlights and the new lighting will not be installed.

FINANCIAL IMPACT

All costs of maintaining and providing energy for the lighting are paid from assessments against the properties within the light district. There are no City owned properties within the district.

RECOMMENDATION

Staff recommends that the City Council conduct a public hearing and approve the resolution creating SILMD 322 if the valid protest does not exceed 50%.

APPROVED BY CITY ADMINISTRATOR

Attachments

SILMD Resolution Creating
SILMD 322 Exh A--Map

RESOLUTION NO. 16-_____

A RESOLUTION CREATING SPECIAL IMPROVEMENT LIGHTING MAINTENANCE DISTRICT NO. 322 OF THE CITY OF BILLINGS, MONTANA, FOR THE PURPOSE OF SECURING AND PROVIDING ENERGY AND MAINTENANCE FOR NEW STREETLIGHTING, SETTING THE BOUNDARIES THEREOF, STATING THE GENERAL CHARACTER OF THE IMPROVEMENTS TO BE MADE, ESTABLISHING THE ESTIMATED RATE FOR ENERGY AND MAINTENANCE THEREOF, AN APPROXIMATE ESTIMATE OF THE COST OF MAINTAINING SUCH LIGHTS AND SUPPLYING ELECTRICAL CURRENT THEREFORE FOR THE FIRST YEAR, AND THE PROPORTION OF THE COST TO BE ASSESSED AGAINST THE ABUTTING PROPERTY, AND THE METHOD OF ASSESSMENT OF SAID COSTS.

WHEREAS, the City Council of the City of Billings, Montana, on the 14th day of March, 2016, passed Resolution 16-10531, a Resolution of Intention to Create a Special Improvement Lighting Maintenance District designated as No. 322, setting the hearing on the creation of said District and hearing of protests against the extent and creation of said District, or any matter pertaining thereto, and thereafter gave notice by publication and mailing, all as required by law, and at said hearing which was held at the time and place specified in said Notice, all protests were heard and considered; and

WHEREAS, the City Council finds that the protests are insufficient to stop the creation of said district, and the protests are overruled and denied.

NOW, THEREFORE, BE IT RESOLVED BY THE CITY COUNCIL OF THE CITY OF BILLINGS, MONTANA:

SECTION 1:

That the City Council of the City of Billings, Montana does hereby create a District, to be known and designated as Special Improvement Lighting Maintenance District No. 322, hereinafter called the District, for the purpose of securing and providing energy and maintenance for new street lights for lighting said District.

SECTION 2:

That the boundaries of the District are as set forth in Resolution of Intention No. 16-10531, hereinafter called the Resolution, on file in the office of the City Clerk of Billings, Montana, and by this reference is incorporated herein and made a part hereof.

SECTION 3:

That the City Council hereby finds and determines that each property described within the Resolution of Intent, is especially benefited and affected by said improvements, and each of the properties are hereby declared to

be the property to be assessed for the cost and expense of the electrical energy for and maintenance of said District.

SECTION 4:

That the general character of the improvements to be made is hereby declared to be as described in the Resolution and is by this reference incorporated herein and made a part hereof.

SECTION 5:

The City of Billings intends to establish the contract rate for supplying electrical energy in accordance with the rate schedule approved by the Montana Public Service Commission. Said rate is currently estimated at \$6.49 per unit, per month, and that NorthWestern Energy Company shall provide energy to the lighting fixtures. That the City of Billings shall provide normal maintenance to lighting fixtures, poles, cables and other incidental equipment, and shall at all times own said lighting fixtures, poles, cables and other incidental equipment.

SECTION 6:

The estimate of the cost of the District per year, including City administrative costs, is the sum of \$4,600.00; that the entire cost of said District shall be paid by the owners of the property depicted in Exhibit "A" attached hereto, with each lot, parcel or piece of land within the District to be assessed for that portion of the whole cost which its Orchard Lane frontage bears to the total assessable frontage of the entire District, exclusive of public streets, avenues, alleys and other public places. The estimated cost of the District per year for property owners is on the basis of approximately \$0.830775 per lineal foot of property frontage.

SECTION 7:

That pursuant to MCA 7-12-4327, the City of Billings will assess properties outside of, but contiguous to, the city limits of the City of Billings for a portion of the costs of the District.

SECTION 8:

That the entire cost of the District shall be paid by an annual assessment against the property in the District. That all monies derived from the collection of such assessments shall be paid into a fund to be known as the "Special Improvement Lighting Maintenance District No. 322 Maintenance Fund", and warrants shall be drawn on said fund for the payment of such cost of maintaining said lights and supplying electrical current therefore.

SECTION 9:

That reference is hereby made to the Resolution, the maps, specifications, boundaries, perimeter and data pertaining to the District, on file in the offices of the City Clerk and City Engineer, for further particulars, all of which

are made a part hereof.

PASSED by the City Council of the City of Billings, Montana and approved this 11th day of April, 2016.

THE CITY OF BILLINGS:

BY: _____
Thomas W. Hanel MAYOR

ATTEST:

BY: _____
Billie Guenther CITY CLERK

SILMD 322 - Exhibit A

