

**UPDATED AS OF 5/5/2016
CITY OF BILLINGS**

CITY OF BILLINGS VISION STATEMENT:

“THE MAGIC CITY: A DIVERSE, WELCOMING COMMUNITY WHERE PEOPLE PROSPER AND BUSINESS SUCCEEDS.”

AGENDA

City Hall Conf. Room, Council Chamber May 9, 2016 5:45 P.M.

CALL TO ORDER: Mayor Hanel, City Hall Conference Room

PLEDGE OF ALLEGIANCE: Mayor Hanel

INVOCATION: Councilmember Clark

ROLL CALL: Councilmembers present on roll call were:

RECESS TO CLOSED EXECUTIVE SESSION (meeting will be called back to order at 6:30 pm in Council Chamber)

*Note: The closed Executive Session is solely for the purpose of discussing litigation strategy in which the only parties are NOT public bodies or associations, as described in Section 2-3-203(1) and (2). The meeting is closed, as allowed by Section 2-3-303, MCA, "to discuss a strategy to be followed with respect to litigation when an open meeting would have a detrimental effect on the litigating position" of the City of Billings.

MINUTES: April 25, 2016

COURTESIES:

PROCLAMATIONS: Mental Health Month; Pediatric Stroke Awareness Month

ADMINISTRATOR REPORTS - TINA VOLEK

PUBLIC COMMENT on “NON-PUBLIC HEARING” Agenda Items: #1 and #6 ONLY.

Speaker sign-in required. (Comments offered here are limited to one (1) minute for one item, or three (3) minutes for multiple items. Please sign in at the cart located at the back of the council chambers or at the podium. Comment on items listed as public hearing items will be heard ONLY during the designated public hearing time for each respective item. For Items not on this agenda, public comment will be taken at the end of the agenda.)

1. **CONSENT AGENDA** -- Separations:
 - A. **Bid Awards:**
 1. **W.O. 16-01, Schedule 2B, Sanitary Sewer Main Replacement Project.** (Opened 4/26/16) Recommend Western Municipal Construction, Inc., \$1,102,651.60.
 2. **W.O. 16-01, Schedule 3, 17th Street West Water Main Replacement Project Phase 2.** (Opened 4/26/16) Recommend COP Construction, LLC, \$708,102.
 3. **W.O. 16-06, South Billings Urban Renewal District (SBURD) Sanitary Sewer, Phase 2.** (Opened 4/26/16) Recommend COP Construction, LLC, \$729,600.
 4. **Pond D Storm Water Detention and Conveyance System.** (Opened 4/26/16) Recommend COP Construction, LLC, \$2,658,745.10.
 - B. **Professional Services Contract** for W.O. 16-09, Grand Avenue (48th Street West to 58th Street West) Engineering Design; Sanderson Stewart; \$556,900.
 - C. **Professional Services Contract** for Optimist Park master plan; Land Design, Inc.; \$49,615.
 - D. **Development Agreement** with School District 2 for Ben Steele Middle School.
 - E. **Agreement** with Yellowstone County Sheriff's Department to provide New World Public Safety data processing services. FY 2016-2017; annual revenue \$134,521.
 - F. **Acknowledge receipt of petition to vacate** a portion of Montgomery Street near Hansen Lane, Popelka Enterprises, petitioner; and setting a public hearing date of June 13, 2016.
 - G. **Acceptance of Donation** to Billings Fire Department, St. Vincent Healthcare employees, Share Our Spirit Associate Giving Campaign, \$2,500 for the purchase of patient lift devices.

- H. **Recommendation of approval** to the Policy Coordinating Committee for Amendment III of the 2015-2019 Transportation Improvement Program (TIP).
- I. **Resolution** relating to the financing of South Billings Urban Renewal District improvement projects, establishing compliance with Reimbursement Bond Regulations under the Internal Revenue Code.
- J. **Preliminary Subsequent Minor Plat** of 23rd Street Subdivision, Amended Plat of the North 100 feet of Lot 1, Block 8, Sunnyside Subdivision, Second Filing, generally located at 11th Avenue North and North 23rd Street; Mark Wright, owner; Territorial Landworks, Inc., agent; conditional approval and adoption of the findings of fact.
- K. **Bills and Payroll:**
 - 1. April 11, 2016
 - 2. April 18, 2016

REGULAR AGENDA:

- 2. **PUBLIC HEARING AND RESOLUTION** approving and adopting budget amendments for FY16. Staff recommends approval. (Action: approval or disapproval of staff recommendation.)
- 3. **PUBLIC HEARING AND RESOLUTION FOR ANNEXATION #16-03:** a 6.4 acre portion of an 89 acre parcel of land described as the N1/2 NE1/4, SWNE1/4, Section 31, Township 1 North, Range 25 East, generally located south of Rimrock Road at the southwest corner of the intersection of 54th Street West and Trail Creek Drive; Yellowstone Meadows Partners, LLC, petitioner. Staff recommends conditional approval. (Action: approval or disapproval of staff recommendation.)
- 4. **PUBLIC HEARING AND SPECIAL REVIEW #941:** a special review to allow the construction of an LDS Meetinghouse, in a Residential 9,600 (R-96) zone on a 5.6 acre portion of an 89.98 acre un-platted parcel of land described as: the N1/2 NE1/4, SWNE 1/4 in Section 31, Township 1 North, Range 25 East, generally located at 54th Street West at Trail Creek Drive. Scott Nielson, NBW Architects, agent. Zoning Commission recommends conditional approval and adoption of the findings of the 3 criteria. (Action: approval or disapproval of Zoning Commission recommendation.)

5. **PUBLIC HEARING AND FIRST READING ORDINANCE** expanding the boundaries of Ward III to include recently annexed property in Annexation #16-02: located south of Elysian Road and west of the Hogan Slough between Mallowney Lane and East Lane; McCall Development and the Yellowstone Boys and Girls Ranch Foundation, petitioners. Staff recommends approval. (Action: approval or disapproval of staff recommendation.)

6. **AUTHORIZATION OF PROPERTY PURCHASE** by the Downtown Billings Partnership (DBP) at 1st Avenue North and North 29th Street for a price and expenses not to exceed \$850,000; and granting a waiver to the appraisal requirements of Resolution 93-16740. DBP Board recommends authorizing the property purchase by the DBP. Staff recommends approval of the waiver. (Action: approval or disapproval of DBP Board and staff recommendations.)

PUBLIC COMMENT on Non-Agenda Items -- Speaker Sign-in required. *(Restricted to ONLY items not on this printed agenda. Comments here are limited to 3 minutes. Please sign in at the cart located at the back of the council chambers or at the podium.)*

COUNCIL INITIATIVES

ADJOURN

Additional information on any of these items is available in the City Clerk's Office. Reasonable accommodations will be made to enable individuals with disabilities to attend this meeting. Please notify Billie Guenther, City Clerk, at 657-8210.

Consent 1. A. 1.

Regular City Council Meeting

Meeting Date: 05/09/2016

TITLE: Bid Award: W.O. 16-01 Schedule 2B - Sanitary Sewer Main Replacement Project

PRESENTED BY: David Mumford, Public Works Director

Department: Public Works

PROBLEM/ISSUE STATEMENT

W.O. 16-01, Schedule 2B, Sanitary Sewer Replacement Project will replace approximately 4,950 feet of 8-inch sanitary sewer main and reconnect sanitary sewer services in the alleys between Grand Avenue and Lewis Avenue from Division to 4th Street West. The existing sewer is clay tile pipe, which has many breaks and root intrusions and requires frequent maintenance to keep the system functioning. The project was advertised on April 7th, 14th, 21st in the Billings Times and on the City's Website. Bids were opened on April 26, 2016 and the City received 5 bids.

A public agency in Montana shall award a public contract for construction, repair, and public works to the lowest responsible bidder without regard for residency. However, a Montana resident bidder must be allowed a preference on a contract against the bid of a nonresident bidder from any state or country that enforces a preference for resident bidders. The preference given to Montana resident bidders must be equal to the preference given in the other state or country. See §18-1-102(1)(a), MCA.

Wyoming's bid preference statute provides that Wyoming resident bidders will receive preference over nonresident bidders if the nonresident bid is not more than 5% lower than the lowest resident bid. Therefore, although Wyoming's nonresident bidder (Wilson Bros. Construction, LLC) submitted the lowest construction bid and would otherwise be awarded the project, its nonresident bid is not more than 5% lower than the lowest Montana resident bidder (Western Municipal Construction, Inc). In this case, Wilson Bros. Construction was only 3.8% (\$41,902.60) lower than Western Municipal Construction, Inc. Therefore, the City must award this construction to the Montana resident low bidder, Western Municipal Construction, Inc.

After considering preference to resident bidders, Western Municipal Construction, Inc. submitted the lowest responsible bid.

ALTERNATIVES ANALYZED

City Council may:

- Approve the construction contract with Western Municipal Construction, Inc. in the amount of \$1,102,651.60; or,
- Do not approve the construction contract and reject all bids. If the project is not approved, the City will continue to experience ongoing maintenance problems. Future repair costs and property damage claims can be minimized by completing this project.

FINANCIAL IMPACT

The following bids were received and evaluated:

Contractor	Bid Amount
Wilson Bros. Construction	\$1,060,749.00
COP Construction, LLC	\$1,131,346.00
Western Municipal Construction, Inc.	\$1,102,651.60
Pro-Pipe Corp.	\$1,311,190.60
Kinkaid Civil Construction	\$1,136,707.00

Funding for this project will be from Wastewater Funds budgeted in FY16.

Budget	\$3,800,000.00
--------	----------------

Previously Encumbered	\$1,710,301.00
This Project	\$1,102,651.60
Remaining budget	\$268,021.74

RECOMMENDATION

Staff recommends that Council approve a contract with Western Municipal Construction, Inc. for W.O. 16-01, Schedule 2B Sanitary Sewer Replacement Project in the amount of \$1,102,651.60.

APPROVED BY CITY ADMINISTRATOR

Regular City Council Meeting

Meeting Date: 05/09/2016

TITLE: Bid Award: W.O. 16-01 Schedule 3 - 17th Street West Water Main Replacement Project Phase 2

PRESENTED BY: David Mumford, Public Works Director

Department: Public Works

PROBLEM/ISSUE STATEMENT

W.O. 16-01, 17th Street West Water Main Replacement Project, Phase 2, will replace approximately 2,100 feet of 20-inch diameter water main in 17th Street West from Poly Drive to the Staples Pump Station, located at the north end of 17th Street West. The use of PVC water main in lieu of ductile iron was evaluated and determined appropriate for this project. Selection of the PVC bid alternates saves nearly \$35,000 in materials and installation costs.

The project was advertised on April 7th, 14th, and 21st in the Billings Times and on the City's Website. Bids were opened on April 26, 2016, and three bids were received. COP Construction, LLC submitted the lowest responsible bid.

ALTERNATIVES ANALYZED

City Council may:

- Approve the construction contract with COP Construction, LLC in the amount of \$708,102.00, or;
- Do not approve the construction contract. If the project is not constructed, the City's water distribution system will continue to experience ongoing maintenance problems such as the more frequently occurring main breaks in this area. Future repair costs and property damage claims can be minimized by completing this project.

FINANCIAL IMPACT

The following bids were received and evaluated:

Contractor	Bid Amount (with PVC Alternate)
COP Construction, LLC	\$708,102.00
Western Municipal Construction, Inc.	\$775,780.00
Kinkaid Civil Construction, LLC	\$819,770.00

The funding source is water revenues budgeted in FY 16.

Budget	\$3,750,000.00
Previously Encumbered	\$1,767,240.00
This Contract	\$708,102.00
Remaining budget	\$1,274,658.00

RECOMMENDATION

Staff recommends that Council approve a contract with COP Construction, LLC for W.O. 16-01, 17th Street West Main Replacement Project Phase 2, in the amount of \$708,102.00.

APPROVED BY CITY ADMINISTRATOR

Regular City Council Meeting

Meeting Date: 05/09/2016

TITLE: Bid Award: W.O. 16-06 SBURD Sanitary Sewer Phase 2

PRESENTED BY: David Mumford, Public Works Director

Department: Public Works

PROBLEM/ISSUE STATEMENT

Staff opened bids on April 26, 2016, for W.O. 16-06 South Billings Urban Renewal District (SBURD) Sanitary Sewer, Phase 2. The contract was advertised on April 7th, 14th, and 21st in the Billings Times and on the City's website. Six bids were submitted.

A public agency in Montana shall award a public contract for construction, repair, and public works to the lowest responsible bidder without regard for residency. However, a Montana resident bidder must be allowed a preference against the bid of a nonresident bidder from any state or country that enforces a preference for resident bidders. The preference given to Montana resident bidders must be equal to the preference given in the other state or country. See §18-1-102(1)(a), MCA.

Wyoming's bid preference statute provides that Wyoming resident bidders will receive preference over nonresident bidders if the nonresident bid is not more than 5% lower than the lowest resident bid. Therefore, although Wyoming's nonresident bidder (Wilson Bros. Construction, LLC) submitted the lowest construction bid and would otherwise be awarded the project, its nonresident bid is not more than 5% lower than the lowest Montana resident bidder (COP Construction LLC). In this case, Wilson Bros. Construction was only 3.6% (\$26,190.50) lower than COP Construction LLC. Therefore, the City must award this construction contract to the Montana resident bidder, COP Construction LLC.

After considering preference to resident bidders, COP Construction LLC submitted the lowest responsible bid.

This project will construct approximately 3,400 lineal feet of new sewer in areas where there currently is none. The area is bounded north-south by Morgan and Francis Ave and bounded east-west by Jackson St and Hallowell Ln. New mains and sewer service connections to property lines will be installed. The project was bid with one alternative. Add Alternative A is 611 lineal feet of new sewer main which is part of the 3,400 lineal feet but was contingent on obtaining an easement from a property owner at 146 Jackson St. An easement agreement has been signed at no cost to the City and will be presented to Council for approval on May 23.

This project will provide the opportunity for properties in the area to connect to sanitary sewer but the property owners will not be required to connect to sewer unless their septic system fails.

ALTERNATIVES ANALYZED

The Council may:

- Award W.O. 16-06 to COP Construction LLC in the amount of \$729,600.00; or
- Not award the contract to COP Construction LLC and reject all bids. If the contract is not awarded, property owners within the project area will not be able to connect to the City sanitary sewer.

FINANCIAL IMPACT

The following bids were received and evaluated:

Contractor	Base Bid+Add Alternatives A
Dick Anderson Construction, Inc.	\$850,533.00
Wilson Bros. Construction, Inc.	\$703,409.50
EDK Engineering and Construction, Inc.	\$812,578.50
Pro Pipe Corporation	\$749,771.00
COP Construction LLC	\$729,600.00
Western Municipal Construction, Inc.	\$790,396.00

The project funding is budgeted in FY16 and the source is the South Billings Boulevard Tax Increment District.

Project Budget	\$1,555,000
Previously Encumbered	\$297,045
This Contract	\$729,600
Budget Remaining	\$528,355

RECOMMENDATION

Staff recommends that the City Council award a contract for W.O. 16-06 to COP Construction LLC in the amount of \$729,600.00.

APPROVED BY CITY ADMINISTRATOR

Regular City Council Meeting

Meeting Date: 05/09/2016

TITLE: Award of the Pond D Storm Water Detention and Conveyance System Construction Project

PRESENTED BY: Kevin Ploehn, Director of Aviation and Transit

Department: Airport

PROBLEM/ISSUE STATEMENT

One of this year's Airport Capital Improvement Projects is the Pond D Storm Water Detention and Conveyance System. This multiphase project will enhance the Airport's ability to collect and convey storm water from the airfield, specifically the areas between Taxiway A and the main runway, into the new detention Pond D complex and then via pipe into Alkali Creek. During the abnormally large rain events of 2010, 2011, and 2013, so much water fell so fast that the infield area between the main runway and main taxiway filled up and overflowed across the runway for up to 20 minutes after the rain stopped, getting as high as 3 inches deep on the runway. This is an unsafe airfield condition which the Airport is now addressing. In order to get the water from one side of the runway to the other side, the Airport contracted to have two 48 inch tunnels bored under the runway last winter. The Tunnel Boring project was approved by Council on September 14, 2015. The installation of 24 inch storm water piping from the Airport to Alkali Creek is the first construction phase under this contract. This will be followed up with the construction of a new pond structure and the conveyance system from the new tunnel borings to the new Pond D. The estimated construction time to complete this project is about 160 days.

This project was advertised in the *Billings Times* on April 7, 14, and 21, as well as posted on the City's Website. On April 26, 2016, the following bids were received for this project:

CONTRACTOR	BID
COP Construction, LLC	\$2,658,745.10
Western Municipal Construction	\$3,244,746.50
Wilson Brothers Construction	\$3,259,339.50
Dick Anderson Construction	\$3,347,415.00
Nelcon, Inc.	\$3,400,519.70
Montana Civil Contractors, Inc.	\$3,910,849.07

ALTERNATIVES ANALYZED

City Council may:

- Approve the award of the Pond D Storm Water Detention and Conveyance System project;
- or
- Decline to approve the award, reject all bids, and delay the project.

FINANCIAL IMPACT

The total cost of this project is \$2,658,745.10. This project will have multiple funding sources. \$1,752,935.13 of this project will be funded with Airport Improvement Program (AIP) entitlement grant funds with a \$194,770.57 local share match. The balance will be funded with \$711,039.40 of Passenger Facility Charge (PFC) funding. Local share and PFC portions are available in the Airport's capital funds.

RECOMMENDATION

Staff recommends the City Council approve the bid award for the Pond D Storm Water Detention and Conveyance System project to the low bidder COP Construction, LLC, for the amount of \$2,658,745.10.

APPROVED BY CITY ADMINISTRATOR

Regular City Council Meeting

Meeting Date: 05/09/2016

TITLE: WO 16-09 Grand Avenue (48th Street West to 58th Street West)
Contract for Professional Services

PRESENTED BY: David Mumford, Public Works Director

Department: Public Works

PROBLEM/ISSUE STATEMENT

The purpose of this project is to reconstruct/widen Grand Avenue from 48th Street West to 58th Street West. The project includes constructing a traffic signal at the intersection of 54th Street West and Grand Avenue and a pedestrian signal at Ben Steel Middle School. Sidewalk and a multi-use path connecting the nearby neighborhoods to the school will also be constructed. Staff requested the services of an engineering firm to provide design and construction administration services for the project, and Sanderson Stewart was selected through the Request for Proposals (RFP) process. Other firms considered were KLJ, HDR and DOWL. The contract amount is \$556,900. School District 2 will be participating in the funding for design and construction.

ALTERNATIVES ANALYZED

The Council may:

- Award the Contract for Professional Services to Sanderson Stewart; or
- Do not award the contract. If the contract is not awarded, the reconstruction of the road will be delayed.

FINANCIAL IMPACT

The cost of design services is \$556,900. Arterial fees, Gas Tax and School District 2 Funds are budgeted for design and construction.

RECOMMENDATION

Staff recommends that Council authorize the Mayor to execute a Contract for Professional Services with Sanderson Stewart for \$556,900 for Grand Avenue engineering design services.

APPROVED BY CITY ADMINISTRATOR

Attachments

WO 16-09 Contract for Professional Services

**Contract for Professional Architectural and Engineering
Services
Project Work Order 16-09 Grand Avenue (48th to 58th)**

In consideration of the mutual promises herein, City of Billings and Sanderson Stewart agree as follows. This Contract consists of:

- Part I, consisting of 15 Sections of Special Provisions;
- Part II, consisting of 11 Sections of General Provisions;
- Appendix A consisting of 13 pages (Basic Services of Contractor);
- Appendix B consisting of 1 pages (Methods and Times of Payment);
- Appendix C consisting of 1 page (Additional Services of Contractor);
- Appendix D consisting of 2 pages (Schedule of Professional Fees);
- Appendix E consisting of 1 page (Project Schedule);
- Appendix F consisting of 1 page (Certificate(s) of Insurance); and

**PART I
SPECIAL PROVISIONS**

Section 1. Definitions.

In this Contract:

- A. "Administrator" means the City Engineer of the Engineering Division of the Public Works Department or his designee.
- B. "Billings" means the City of Billings.
- C. "Contractor" means Sanderson Stewart.

Section 2. Scope of Services.

- A. The Contractor shall perform professional services in accordance with Appendix A, which is attached hereto and incorporated in this Section by reference.

- B. Billings shall pay the Contractor in accordance with the Schedule of Professional Fees attached as Appendix D and incorporated herein by reference for services actually performed under this Contract.
- C. Billings shall not allow any claim for services other than those described in this Section. However, the Contractor may provide, at its own expense, any other services that are consistent with this Contract.
- D. The Contractor shall provide as-built drawings on mylars and in digital format, as approved by the City of Billings, to the Administrator within 30 days after the project completion date. Final payment will be withheld until the as-built drawings are received by the City of Billings.
- E. The Contractor shall provide certified construction payrolls to the Administrator stating in writing that the payrolls have been reviewed and are acceptable.

Section 3. Time for Performance.

- A. This Contract becomes effective when signed on behalf of Billings.
- B. The Contractor shall commence performance of the Work described in Section 2 on receipt of written Notice to Proceed and complete that performance in accordance with the schedule set forth in Appendix E.
- C. This Contract shall terminate at midnight on December 31, 2018.

Section 4. Compensation; Method of Payment.

- A. Each month, or at the conclusion of each phase of the Work for which payment is due, as negotiated on a per-task basis, the Contractor shall present a bill to the Administrator describing the Work for which it seeks payment and documenting expenses and fees to the satisfaction of the Administrator. If any payment is withheld because the Contractor's performance is unsatisfactory, the Administrator must, within ten (10) days of the payment denial, notify the Contractor of the payment denial and set forth, with reasonable specificity, what was unsatisfactory and why. Billings will pay Contractor within 30 days of receiving an acceptable invoice.
- B. The Contractor is not entitled to any compensation under this Contract, other than is expressly provided for in this Section.
- C. As a condition of payment, the Contractor shall have paid all City taxes currently due and owing by the Contractor.

Section 5. Termination of the Contractor's Services.

The Contractor's services under Section 2 of this Part may be terminated:

- A. By mutual consent of the parties.
- B. For the convenience of Billings, provided that Billings notifies the Contractor in writing of its intent to terminate under this paragraph at least 10 days prior to the effective date of the termination.

- C. For cause, by either party where the other party fails in any material way to perform its obligations under this Contract. Termination under this Subsection is subject to the condition that the terminating party notifies the other party of its intent to terminate, stating with reasonable specificity the grounds therefor, and the other party fails to cure the default within 30 days after receiving the notice.

Section 6. Duties Upon Termination

- A. If Billings terminates the Contractor's services for convenience, Billings shall pay the Contractor for its actual costs reasonably incurred in performing before termination and Billings shall pay for services rendered prior to termination. Payment under this Subsection shall never exceed the total compensation allowable under Section 4 of this Part. All finished and unfinished documents and materials prepared by the Contractor shall become the property of Billings.
- B. If the Contractor's services are terminated for cause, Billings shall pay the Contractor the reasonable value of the services satisfactorily rendered prior to termination, less any damages suffered by Billings because of the Contractor's failure to perform satisfactorily. The reasonable value of the services rendered shall never exceed ninety percent (90%) of the total compensation allowable under Section 4 of this Part. Any finished or unfinished documents or materials prepared by the Contractor under this Contract shall become the property of Billings at its option.
- C. If the Contractor receives payments exceeding the amount to which it is entitled under Subsections A or B of this Section, he shall remit the excess to the Administrator within 30 days of receiving notice to do so.
- D. The Contractor shall not be entitled to any compensation under this Section until the Contractor has delivered to the Administrator all documents, records, Work product, materials and equipment owned by Billings and requested by the Administrator.
- E. If the Contractor's services are terminated for whatever reason the Contractor shall not claim any compensation under this Contract, other than that allowed under this Section.
- F. If a final audit has not been performed before the Contractor's services are terminated, Billings may recover any payments for costs disallowed as a result of the final audit.
- G. Except as provided in this Section, termination of the Contractor's services under Section 5 of this Part does not affect any other right or obligation of a party under this Contract.

Section 7. Insurance.

- A. The Contractor shall maintain in good standing the insurance described in Subsection B of this Section. Before rendering any services under this

Contract, the Contractor shall furnish the Administrator with proof of insurance in accordance with Subsection B of this Section.

- B. The Contractor shall provide the following insurance:
 - 1. Workers' compensation and employer's liability coverage as required by Montana law.
 - 2. Commercial general liability, including contractual and personal injury coverage's -- \$1,500,000 per occurrence.
 - 3. Commercial automobile liability -- \$1,500,000 per accident.
 - 4. Professional liability in the amount of \$1,500,000 per occurrence.
- C. Each policy of insurance required by this Section shall provide for no less than 30 days' advance notice to Billings prior to cancellation.
- D. Billings SHALL be listed as an additional insured on all policies except Professional Liability and Worker's Compensation Policies. In addition, all policies except Professional Liability and Worker's Compensation shall contain a waiver of subrogation against Billings.

Section 8. Assignments.

Unless otherwise allowed by this Contract or in writing by the Administrator, any assignment by the Contractor of its interest in any part of this Contract or any delegation of duties under this Contract shall be void, and an attempt by the Contractor to assign any part of its interest or delegate duties under this Contract shall give Billings the right immediately to terminate this Contract without any liability for Work performed.

Section 9. Ownership; Publication, Reproduction and Use of Material.

- A. Except as otherwise provided herein, all data, documents and materials produced by the Contractor under this Contract shall be the property of Billings, which shall retain the exclusive right to publish, disclose, distribute and otherwise use, in whole or in part, any such data, documents, or other materials. Exclusive rights shall not be attributed to portions of such materials presently in the public domain or which are not subject to copyright. Contractor shall retain rights to pre-existing proprietary property including but not limited to interactive models. The Contractor shall have the right to include photographic or artistic representations of the design and construction of the Project among the Contractor's promotional and professional materials. The Contractor's materials shall not include Billings' confidential or proprietary information regardless of whether Billings has previously advised the Contractor in writing of the specific information considered by Billings to be confidential and proprietary.
- B. Equipment purchased by the Contractor with Contract funds: See Appendix A, Section 3. Scope of Work.

1. Any interruption, suspension or interference resulting solely from the act of Billings or neglect of Billings not otherwise governed by the terms of this Contract.
2. Strikes or Work stoppages.
3. Any interruption, suspension or interference with the project caused by acts of God, or acts of a public enemy, wars, blockades, insurrections, riots, arrests or restraints of governments and people, civil disturbances or similar occurrences.
4. Order of court, administrative agencies or governmental officers other than Billings.

Section 13. Financial Management System.

The Contractor shall establish and maintain a financial management system that:

- A. Provides accurate, current, and complete disclosure of all financial transactions relating to the Contract;
- B. Maintains separate accounts by source of funds for all revenues and expenditures and identifies the source and application of funds for the Contractor's performance under this Contract, including information pertaining to subcontracts, obligations, unobligated balances, assets, liabilities, outlays and income;
- C. Effectively controls and accounts for all municipal funds and Contract property;
- D. Compares actual expenditures with budgeted amounts and relates financial information to performance or productivity data including unit cost information where applicable;
- E. Allocates administrative costs to direct service delivery units;
- F. Minimizes the time between receipt of funds from Billings and their disbursement by the Contractor;
- G. Provides accounting records supported by source documentation; and
- H. Provides a systematic method assuring the timely and appropriate resolution of audit findings and recommendations.

Section 14. Funding Requirements.

In the event that any funding source for this Contract should impose additional requirements upon Billings for the use of those funds, the Contractor agrees to abide by those additional requirements immediately upon receipt of written notice thereof from Billings.

Section 15. Subcontracts.

The Contractor may enter into subcontracts for the purchase of goods and services necessary for the performance of this Contract, provided:

- A. Every subcontract shall be reduced to writing and contain a precise description of the services or goods to be provided and the nature of the consideration paid therefor.
- B. Every subcontract under which the Contractor delegates the provision of services shall be subject to review and approval by the Administrator before it is executed by the Contractor.
- C. Every subcontract in an amount exceeding \$1,000 shall require reasonable access to business records of the subcontractor relating to the purchase of goods or services pursuant to the subcontract.

PART II GENERAL CONTRACT PROVISIONS

Section 1. Relationship of Parties.

The Contractor shall perform its obligations hereunder as an independent Contractor of Billings. Billings may administer the Contract and monitor the Contractor's compliance with its obligations hereunder. Billings shall not supervise or direct the Contractor other than as provided in this Section.

Section 2. Nondiscrimination.

- A. The Contractor will not discriminate against any employee or applicant for employment because of race, color, religion, national origin, ancestry, age, sex, or marital status or who is a "qualified individual with a disability" (as that phrase is defined in the Americans With Disabilities Act of 1990). The Contractor will take affirmative action to ensure that applicants are employed and that employees are treated during employment without regard to their race, color, religion, or mental or physical impairment/disability. Such action shall include, without limitation, employment, upgrading, demotion or transfer, recruitment or recruiting advertising, layoff or termination, rates of pay or other forms of compensation, and selection for training including apprenticeship. The Contractor agrees to post, in conspicuous places available to employees and applicants for employment, notices setting forth the provisions of this non-discrimination clause.
- B. The Contractor shall state, in all solicitations or advertisements for employees to Work on Contract jobs, that all qualified applicants will receive equal consideration for employment without regard to race, color, religion, national origin, ancestry, age, sex or marital status, or mental or physical impairment/disability.
- C. The Contractor shall comply with any and all reporting requirements that may apply to it which the City of Billings may establish by regulation.
- D. The Contractor shall include the provisions of Subsections A through C of this Section in every subcontract or purchase order under this Contract, so as to be binding upon every such subcontractor or vendor of the Contractor under this Contract.
- E. The Contractor shall comply with all applicable federal, state, and city laws concerning the prohibition of discrimination.

Section 3. Permits, Laws, and Taxes.

The Contractor shall acquire and maintain in good standing all permits, licenses and other entitlements necessary to its performance under this Contract.

All actions taken by the Contractor under this Contract shall comply with all applicable statutes, ordinances, rules and regulations. The Contractor shall pay all taxes pertaining to its performance under this Contract.

Section 4. Nonwaiver.

The failure of either party at any time to enforce a provision of this Contract shall in no way constitute a waiver of the provision, nor in any way affect the validity of this Contract or any part hereof, or the right of such party thereafter to enforce each and every provision hereof.

Section 5. Amendment.

- A. This Contract shall only be amended, modified or changed by a written, executed by authorized representatives of the parties, with the same formality as this Contract was executed.
- B. For the purposes of any amendment modification or change to the terms and conditions of this Contract, the only authorized representatives of the parties are:

Contractor: Mac Fogelsong, PE

Billings: City Council or Authorized Designee

- C. Any attempt to amend, modify, or change this Contract by either an unauthorized representative or unauthorized means shall be void.

Section 6. Jurisdiction; Choice of Law.

Any civil action rising from this Contract shall be brought in the District Court for the Thirteenth Judicial District of the State of Montana, Billings. The law of the State of Montana shall govern the rights and obligations of the parties under this Contract.

Section 7. Severability.

Any provision of this Contract decreed invalid by a court of competent jurisdiction shall not invalidate the remaining provisions of the Contract.

Section 8. Integration.

This instrument and all appendices and amendments hereto embody the entire agreement of the parties. There are no promises, terms, conditions or obligations other than those contained herein; and this Contract shall supersede all

previous communications, representations or agreements, either oral or written, between the parties hereto.

Section 9. Liability.

The Contractor shall indemnify, defend, save, and hold Billings harmless from any and all claims, causes of action, lawsuits, damages, judgments, liabilities, and litigation costs and expenses including reasonable attorneys' fees and costs, arising from any wrongful or negligent act, error or omission of the Contractor or any agent, employee or subcontractor as a result of the Contractor's or any subcontractor's performance pursuant to this Contract.

- A. The Contractor shall not indemnify, defend, save and hold Billings harmless from claims, causes of action, lawsuits, damages, judgments, liabilities, and litigation costs and expenses or attorneys' fees and costs arising from wrongful or negligent acts, error or omission solely of Billings occurring during the course of or as a result of the performance of the Contract.
- B. Where claims, lawsuits or liability, including attorneys' fees and costs arise from wrongful or negligent act of both Billings and the Contractor, the Contractor shall indemnify, defend, save, and hold Billings harmless from only that portion of claims, causes of action, lawsuits, damages, judgments, liabilities, and litigation costs and expenses including attorneys' fees and costs, which result from the Contractor's or any subcontractor's wrongful or negligent acts occurring as a result from the Contractor's performance pursuant to this Contract.

Section 10. Inspection and Retention of Records.

The Contractor shall, at any time during normal business hours and as often as Billings may deem necessary, make available to Billings, for examination, all of its records with respect to all matters covered by this Contract for a period ending three years after the date the Contractor is to complete performance in accordance with Section 2 of the Special Provisions. Upon request, and within a reasonable time, the Contractor shall submit such other information and reports relating to its activities under this Contract, to Billings, in such form and at such times as Billings may reasonably require. The Contractor shall permit Billings to audit, examine and make copies of such records, and to make audits of all invoices, materials, payrolls, records of personnel, and other data relating to all matters covered by this Contract. Billings may, at its option, permit the Contractor to submit its records to Billings in lieu of the retention requirements of this Section.

Section 11. Availability of Funds.

Payments under this Contract may require funds from future appropriations. If sufficient funds are not appropriated for payments required under this Contract, this Contract shall terminate without penalty to Billings; and Billings shall not be obligated to make payments under this Contract beyond those which have previously been appropriated.

IN WITNESS WHEREOF, the parties have executed this Contract on the date and at the place shown below.

City of Billings

Contractor

City Council or Designee

Date: _____

Name: _____

Title: _____

Date: _____

ATTEST:

IRS Tax ID # _____

City Clerk

APPROVED AS TO FORM:

Date: _____

By _____

BRENT BROOKS, City Attorney

STATE OF MONTANA)
 :ss.
COUNTY OF YELLOWSTONE)

On this ____ day of _____, 20__, before me, the undersigned, a Notary Public for the State of Montana, personally appeared _____, known to me to be the _____ of _____, and acknowledged to me that they executed the foregoing instrument on behalf of said corporation having first been authorized to do so.

IN WITNESS WHEREOF, I have hereunto set my hand and affixed my Notarial Seal the day and year first above written.

Notary Public for the State of Montana
Residing at Billings, Montana
My Commission Expires: _____

Note: Final contract documents will require the Contractor's signature to be notarized.

Appendix A

Basic Services of Engineer City of Billings W.O. 16-09 Grand Ave – 48th to 58th

Section 1. Engineer's Rights and Duties.

- A. To furnish all labor, materials, equipment, supplies, and incidentals necessary to conduct and complete the Engineer's portion of the project as defined in the scope of work and to prepare and deliver to Billings all plans, specifications, bid documents, and other material as designated herein.
- B. Ascertain such information as may have a bearing on the work from local units of government, utility companies, and private organizations and shall be authorized to procure information from other authorities besides Billings, but shall keep Billings advised as to the extent of these contacts and the results thereof.
- C. Prepare and present such information as may be pertinent and necessary in order for Billings to pass critical judgment on the features of the work. The Engineer shall make changes, amendments or revisions in the detail of the work as may be required by Billings. When alternates are being considered, Billings shall have the right of selection.
- D. Engineer's work shall be in accordance with the standards of sound engineering and present City, State, and National standards and policies currently in use.
- E. Conform to the requirements of the Montana Code Annotated Title 18 "Public Contracts" and more particularly Sections 18-2-121 and 18-2-122, and all other codes of the State of Montana applicable to providing professional services including codes and standards nationally recognized.
- F. The Engineer shall certify with the submission of final plans that the plans are in conformance with applicable sections of Title 69, Chapter 4, Part 5, of the Montana Code Annotated as pertaining to existing utilities.
- G. To perform professional services in connection with the project and will serve as Billings' representative in those phases of the project to which this agreement applies.
- H. Where Federal funds are involved, the necessary provisions to meet all requirements will be complied with and documents secured and placed in the bidding documents.

- I. Submit an estimated progress schedule as to time and costs at the beginning of the work, and monthly progress reports thereafter until complete. The reports will include any problems, potential problems, and delays as foreseen by the Engineer. Reports will be submitted in a timely manner to permit prompt resolution of problems.
- J. Name a Task Director who shall be the liaison between Billings and the Engineer. For this project, the Task Director designated for the Engineer is D.J. Clark, PE, PTOE, working under the Principal-in-Charge, Mac Fogelson, PE.

Section 2. Billings Rights and Duties.

- A. To furnish all labor, materials, equipment, supplies, and incidentals necessary to conduct and complete Billings' portion of the project as designated in the scope of work.
- B. Name a Task Director who shall be the liaison between the Engineer and Billings. For this project, the Task Director designated is Chris Hertz, PE working under the City Engineer, Debi Meling, PE.

Section 3. Scope of Work.

SCOPE OF WORK:

The scope of work covered by this agreement is described hereafter:

The project consists of the design and bidding services for the W.O. 16-09, Grand Ave – 48th to 58th project. The project will generally widen Grand Avenue in segmented locations to implement dedicated turn lanes and/or a two-way left-turn lane (TWLTL) from approximately 48th Street West to 58th Street West, as well as auxiliary turn lanes on the minor approaches of 56th Street West, 54th Street West and 48th Street West to Grand Avenue. The project will also install a traffic signal at the Grand Avenue-54th Street West intersection, a high-intensity activated crosswalk (HAWK) signal on Grand Avenue between 58th Street West and 56th Street West, sidewalk and multi-use path improvements along Grand Avenue and 54th Street West and school zone-related improvements. A storm drain main may be constructed from approximately 58th Street West to 56th Street West along Grand Avenue.

General professional services include field survey, geotechnical investigation, design of utility, roadway and traffic-related improvements, coordination of private utility and irrigation modifications (as required), land owner coordination, public involvement, preparation of contract plans and specifications, permitting and project bidding, more specifically described below. Engineer will coordinate work efforts with other related improvement projects expected to be completed concurrently in the project area, such as the Ben Steele Middle School project.

Phase 100. Project Initiation/Concept (30%) Design Services

- Task 1. General project management and coordination.
- Task 2. Project scoping, including meetings and coordination with sub-consultants and City staff.
- Task 3. Weekly project update e-mails to City staff.
- Task 4. Meetings and correspondence with City of Billings staff.
- Task 5. Preliminary field review and project site reconnaissance. Sanderson Stewart will take photos of key project features such as signs, culverts, irrigation structures, private utility structures and other such features for documentation purposes and use in design.
- Task 6. Review of property ownership and right-of-way/easement designations through online and archived plat, COS and parcel research. Additional review of Subdivision Improvement Agreements (SIAs) for area subdivisions, including Daybreak, Grand Peaks, Vintage Estates, Trails West, MK, Cottonwood Grove, Mont Vista, and Bishop Fox to ensure that no committed improvements described by these SIAs are left out of the project. This task shall also include the field survey and office work necessary to perform and document property corner searches as required. No time for property corner replacement is included for missing or disturbed corners.
- Task 7. Meetings and correspondence with project area property owners to inform them about the project and discuss potential right-of-way dedication considerations. Sanderson Stewart will send one (1) letter to each of the property owners that may be impacted by right-of-way or easement considerations for this project. Sanderson Stewart will also attend up to one (1) meeting with each property to discuss concept-level details about the project and anticipated impacts. Additional ongoing communication will be maintained via phone calls and e-mail correspondence. Negotiations for the purchase of right-of-way or easements are not included in the scope for this contract.
- Task 8. Control and topographic surveys of project corridor utilizing a combination of conventional GPS survey, total station and scanning methods. Survey control will consist of 18"x5/8" rebar with 2 inch aluminum caps clearly stamped SANDERSON STEWART CONTROL MONUMENT with the control point number. Control

points will be spaced no more than 250 feet apart in scanning areas, and no more than 500 feet apart in non-scanning areas. All control points will be double observed to ensure accuracy within 0.04 feet. Scanning will be utilized to collect topographic survey data for hard surface and vertical elements of the project corridor. Conventional GPS survey or total station survey will be utilized to cross section vegetated areas and to fill in additional detail as required.

Task 9. Research and review of records and field-generated information (topographic survey/locates) on private utilities and irrigation facilities that are located within the project corridor. Records shall include atlas maps, online resources and information provided by the private utility and irrigation companies. Sanderson Stewart may also interview ditch users via phone call if necessary.

Task 10. Preliminary geotechnical field investigation and report to be performed by SK Geotechnical. Scope of work for SK Geotechnical includes:

- a. Borehole staking.
- b. Six (6) penetration test borings (10-ft depth) performed via truck-mounted drill rig within limits of existing pavement on Grand Avenue.
- c. Two (2) penetration test borings (25-ft depth) performed via truck-mounted drill rig in likely locations for traffic signal poles.
- d. Fifteen (15) hand auger borings (5-ft depth) performed in locations along Grand Avenue, 56th Street West, 54th Street West and 48th Street West where roadway widening and/or multi-use path/sidewalk construction is planned to occur.
- e. Laboratory tests, including:
 - i. Fifty (50) moisture content
 - ii. Ten (10) classification
 - iii. Three (3) moisture-density curves (Proctors)
 - iv. Three (3) California Bearing Ratio (CBR)
 - v. One (1) consolidation/swell test for signal pole foundations

- f. Summary geotechnical report with recommendations for pavement section design (street and sidewalk/multi-use path), shallow storm drain installation, subgrade treatment and electrical pole foundation design.
- Task 11. Review of as-built drawings and reports for past projects within the project corridor. Known projects include but are not limited to various area subdivision projects (including off-site improvements), the Grand Avenue Trunk Sewer and Water – 2001- Phase I project and the 54th Street Water and Sewer project.
- Task 12. Preliminary storm water analysis including delineation of contributing drainage areas, analysis of peak flows for the existing and proposed improvements for the 10-year, 24-hour design storm, analysis of existing and proposed borrow ditch capacity, analysis of required detention in the borrow ditches to retain the water quality storm for the increased impervious area and limit off-site discharge to the existing peak flows for the 10-year design storm for the projection corridor. Also included is preliminary sizing and plan and profile layout of the proposed storm drain extension from 58th to 56th Street West including associated inlets and lateral piping from the borrow ditches.
- Task 13. Groundwater monitoring for the segment of Grand Avenue where storm drain may be extended (58th Street West to 56th Street West). Monitoring would be conducted once per month from May of 2016 through April of 2017.
- Task 14. Setting up of plan sheets and creation of title sheet.
- Task 15. Processing of topographic survey data, importation into base cadd file and drafting existing conditions features. Unless otherwise directed by the City, the project will use the following coordinate systems:
- a. Billings Low Distortion Projection (NAD83-2011) with horizontal units expressed in international feet.
 - b. Vertical datum will be NAVD88 with GPS elevations derived from GEOID12A and vertical units expressed in U.S. survey feet.
- Task 16. Prepare concept-level (30%) plan and profile design plans.

- Task 17. Prepare concept-level (30%) cross sections.
- Task 18. Prepare concept-level (30%) typical sections and design details.
- Task 19. Perform concept-level (30%) analysis and design for traffic signal at Grand Avenue and 54th Street West, HAWK signal, and intersection lighting. Design-year peak hour capacity analyses will be conducted using traffic volumes projected by Sanderson Stewart though the West End Multi-Modal Planning Study. Lane configurations and geometric details for the intersection will be established through this task.
- Task 20. Prepare right-of-way exhibits for up to eight (8) parcels where City may need to acquire additional right-of-way (as required).
- Task 21. Perform quantity take-off calculations and prepare concept-level (30%) opinions of probable construction cost.
- Task 22. Perform a detailed quality control review of concept-level (30%) plans and opinions of probable cost. Revisions to submittal materials will be made as necessary based on review comments.
- Task 23. Attend one (1) concept design review meeting at City of Billings – Public Works offices.
- Task 24. Meetings and correspondence with each private utility companies to inform them of the project and discuss options for relocation as necessary based on the conceptual design. Sanderson Stewart will schedule and administer up to two (2) meetings for which all of the private utility companies impacted by this project will be invited to attend and discuss impacts and scheduling for rehabilitation or relocation of facilities.
- Task 25. Attendance of one (1) meeting with each individual irrigation company to inform them of the project and discuss options for relocation or modification as necessary based on the conceptual design. Ongoing communication will be accomplished via phone and e-mail correspondence.
- Task 26. Coordinate with City of Billings staff to schedule and administer a concept design-stage informational public meeting. Mailing of notifications and arrangement of venue are assumed to be the responsibility of the City

for the purposes of this scope of work.

- Task 27. Direct reimbursable expenses such as printing and mileage.

Phase 100 Deliverables:

Concept-level (30%) design plans, geotechnical report and opinion of probable construction cost with (15% contingency); Deliverables include up to four (4) full size sets (24x36-inch) and four (4) half size sets (12x18-inch) preliminary plans and specifications.

Phase 200. Preliminary (90%) Design Services

- Task 1. General project management and coordination.
- Task 2. Weekly project update e-mails to City staff.
- Task 3. Additional meetings and correspondence with City of Billings staff.
- Task 4. Up to one (1) additional meeting with each project area property owner, as well as ongoing communication via phone and e-mails. Negotiations for the purchase of right-of-way is not included in the scope for this contract.
- Task 5. Ongoing consultation with geotechnical subconsultant on design-related details and specifications. Preliminary recommendations may be revised based on the development of design details for the project. Once surfacing section, rehabilitation vs. reconstruction strategy and other such details are finalized, SK Geotechnical will revise summary report.
- Task 6. Completion of storm water analysis and design of improvements including borrow ditches, detention ponds (within borrow ditches), storm drain extension from 58th to 56th Street West, inlets, and preparation of Storm water Management Design Report with associated exhibits and details.
- Task 7. Additional pick-up topographic survey (conventional) as required.
- Task 8. Potholing of public and private utilities to verify depth and location within the project corridor. Pothole locations to be determined strategically during conceptual design as alignments and profiles are established.
- Task 9. Prepare preliminary (90%) plan and profile design plans.

- Task 10. Prepare preliminary (90%) cross sections.
- Task 11. Prepare preliminary (90%) typical sections and design details.
- Task 12. Prepare preliminary (90%) traffic signal plans and details, including electrical plans and details for the traffic signal, HAWK signal and intersection lighting.
- Task 13. Perform quantity take-off calculations and prepare preliminary (90%) opinion of probable construction cost.
- Task 14. Prepare preliminary (90%) contract documents and specifications.
- Task 15. Prepare preliminary (90%) traffic control plans and special provisions.
- Task 16. Perform a detailed quality control review of concept-level (90%) plans and cost estimates. Revisions to submittal materials will be made as necessary based on review comments.
- Task 17. Attend one (1) preliminary design review meeting at City of Billings – Public Works offices.
- Task 18. Up to one (1) additional individual meeting with each private utility company, as well as ongoing communication via phone calls and e-mail correspondence.
- Task 19. Up to one (1) additional individual meeting with each irrigation company, as well as ongoing communication via phone calls and e-mail correspondence.
- Task 20. Coordinate with City of Billings staff to schedule and administer a second informational public meeting. Mailing of notifications and arrangement of venue are assumed to be the responsibility of the City for the purposes of this scope of work.
- Task 21. Direct reimbursable expenses such as printing and mileage.

Phase 200 Deliverables:

Preliminary (90%) geotechnical report, storm report, alignment and grade plans, and estimate of probable construction cost (with 15% contingency); Deliverables include up to four (4) full size sets (24x36-inch) and four (4) half size sets (12x18-inch) preliminary plans and specifications.

Phase 300. Final Design and Bidding Services

- Task 1. General project management and coordination.
- Task 2. Weekly project update e-mails to City staff.
- Task 3. Additional meetings and correspondence with City of Billings staff.
- Task 4. Final revisions to design plans and specifications based on City of Billings review comments.
- Task 5. Assist in preparation of bid advertisement and provide documents to prospective bidders and suppliers. Bid advertisement text will be provided to the City for publication.
- Task 6. Attendance of one (1) pre-bid meeting.
- Task 7. Provision of responses to contractor request for information (RFIs) during the bidding process.
- Task 8. Preparation and distribution of bid addenda (as required).
- Task 9. Attendance of public bid opening.
- Task 10. Tabulation of bids and recommendation of award to the City of Billings.
- Task 11. Assistance to City in the procurement of final contract agreement, verification of insurance and bonds, and issue of notice to proceed.
- Task 12. Direct reimbursable expenses such as printing and mileage.

Phase 300 Deliverables:

Final plans and specifications for review and bidding, estimate of probable construction cost, bid tabulations, and Recommendation of Award.

Phase 400. Construction Administration Services (assumes a single 90-day construction contract)

- Task 1. General project management and coordination.
- Task 2. Weekly project update e-mails to City staff.
- Task 3. Attendance of approximately eighteen (18) weekly construction meetings with Contractor and City of Billings staff.
- Task 4. Attendance of one (1) pre-construction meeting.

- Task 5. Site visit to take pre-construction photos for the purpose of documenting project features and conditions prior to the start of construction.
- Task 6. Review of project shop drawings.
- Task 7. Preparation of valve operation requests and submittal to City of Billings for processing. Coordination with Contractor on requests.
- Task 8. Review of traffic control plan proposals as made by Contractor and submittal of proposals to City of Billings with comments and recommendations for revisions and/or approval.
- Task 9. Site visits by the Project Manager or Project Engineer(s) other than for the scheduled weekly meeting with the Contractor.
- Task 10. Meetings with property owners adjacent to the project corridor to address questions or concerns during construction, as well as to notify property owners of progress and impending impacts to private property or access.
- Task 11. Response to contractor-submitted requests for information (RFIs) during construction. This task shall include all necessary time for drafting plan modifications and design revisions as needed to address RFIs.
- Task 12. Review and processing of pay applications and change orders for the project. This task shall include time for verification of bid item quantities both in the office and in the field as necessary to approve pay applications.
- Task 13. Part-time daily observation of construction activities based on an anticipated 90-day construction contract. Sanderson Stewart would provide full-time observation services for any sub-surface sanitary sewer, water or storm drain construction activities. At this time, the only public sub-surface utility work anticipated would be storm drain-related.
- Task 14. Observe storm drain video testing in the field. Review Contractor-provided video log of storm drain pipe and submit to City of Billings with required form.
- Task 15. Coordination of materials testing per City of Billings specifications on frequency and conformance standards. Sanderson Stewart staff will coordinate

schedules for testing and keep detailed records of where tests are performed relative to construction details.

- Task 16. Record project bid item quantities and details in-place for use in evaluating pay applications and the completion of record drawings.
- Task 17. Final walk-through inspection of project once substantial completion is reached. Includes time for summarizing final inspection results via a memo to be sent to the Contractor and the City of Billings.
- Task 18. Preparation of project record drawings for submittal to City of Billings and Montana Department of Environmental Quality (if required).
- Task 19. One-year anniversary warranty inspection of project. Includes time for summarizing final inspection results via a memo to be sent to the Contractor and the City of Billings.
- Task 20. Direct reimbursable expenses such as printing and mileage.

Phase 400 Deliverables:

Weekly project update e-mails, reviewed shop drawings, reviewed pay applications and change orders, storm drain video logs and forms, copies of materials testing records, record drawings, final and one-year warranty walk-through summary memos.

Phase 500. Construction Staking

- Task 1. General project management and coordination of staking requests with Contractor.
- Task 2. Preparation of survey computations in the office prior to field work.
- Task 3. Meetings and consultation with Project Manager and/or Project Engineer.
- Task 4. Preparation of point files and exhibits for staking.
- Task 5. Staking for irrigation-related facilities and structures. Stake all pipes and culverts with double offset hubs with invert grade.
- Task 6. Staking of subgrade. Set grade hubs with tacks every

- 50 feet each side of roadway with a 2-foot offset.
- Task 7. Staking of blue tops for base gravel. Set hubs every 50 feet on centerline of road for finished grade of gravel.
 - Task 8. Staking of miscellaneous surface features for intersection of Grand Avenue and 54th Street West.
 - Task 9. Staking of signing and striping improvements. Stake all actual sign locations. Stake actual striping every 50 feet. Stake miscellaneous striping features at ends, point of curves and point of tangent.
 - Task 10. Staking of sidewalk and multi-use path improvements. Stake every 50 feet on straight portions and 25 feet on curves. Set offset hubs 2-foot offset away from roadway.
 - Task 11. Staking of electrical facilities, including streets lights, pull boxes, power services, cabinets, traffic signals and other related hardware. Stake actual locations of each feature with a 5-foot offset with grade of base.
 - Task 12. Staking of storm drain facilities, including pipe, manholes, culverts and inlets. Stake actual locations of all manholes and ends of culverts with double offsets to invert elevations.
 - Task 13. Direct reimbursable expenses such as printing, stakes and mileage.

Phase 500 Deliverables:

Weekly project update e-mails

Exclusions from Scope of Work

The following work items are excluded from the scope of work for this project and shall be considered as Additional Work. If the City of Billings determines that Additional Work is required, Sanderson Stewart will provide those services for an additional agreed-upon fee.

1. Landscape or landscape irrigation design and specifications – the City of Billings has directed that landscape improvements will not be included in this project. The Contractor will be required to stabilize and re-seed disturbed areas as per the requirements of NPDES regulations.
2. Analysis or design of off-site storm water storage or conveyance facilities. At this time, it is expected that storm water will be stored and conveyed in roadside borrow ditches, except in the segment where a storm drain may be extended

from 58th Street West to 56th Street West. For that segment of the project, storm water would be conveyed via the storm drain main to outfall points in the roadside borrow ditches.

The City of Billings recently released a request for proposal for the W.O. 16-14 – West Billings Stormwater Development Plan project, the intent of which is to develop a viable solution for West End storm water management. Sanderson Stewart acknowledges that the results of that study/project could bring about additional design work or changes for this project contract. If such changes become necessary, the additional design work will be added to the contract via an amendment.

3. Infiltration testing of soils for storm water storage and conveyance purposes.
4. Corridor street lighting design and specifications other than in conjunction with the traffic signal at the Grand Avenue/54th Street West intersection. Since curb and gutter and raised median is not planned for this project, it is not anticipated that street lighting will be constructed except as part of the traffic signal improvements.
5. Design, specifications or permitting related to erosion control and storm water management during construction; this work shall be considered to be the responsibility of the contractor. Sanderson Stewart will be in no way responsible for reviewing, approving or monitoring Contractor-required storm water pollution prevention plan (SWPPP) documentation or installation measures. The Contractor shall be required to prepare and submit for approval the Notice of Intent (NOI), Notice of Termination (NOT) and all related supportive materials.
6. Creation of maintenance of a project website, as well as preparation of weekly e-mails to project constituents. These services can certainly be provided if the City of Billings would like, but they are currently excluded from the Scope of Work.

Appendix B

Methods and Times of Payment

Section 1. Payments for Basic Services.

Billings shall authorize payment to the Engineer for services performed under Appendix A of this Agreement. Partial payment shall be due the Engineer upon receipt of the Engineer's pay estimate, said estimate being proportioned to the work completed by the Engineer.

Partial payment shall be made to the Engineer upon receipt of the Engineer's pay estimate, said estimate being proportioned to the work completed by the Engineer. Billings shall deduct five percent (5%) from each monthly pay estimate to be held until the completion of the final scope of work. The final payment shall be made only after acceptance of final documents by Billings, and determination that the scope of work has been satisfactorily completed.

- A. For services rendered prior to construction, Appendix A, the Engineer shall be paid based upon actual time accrued, but not to exceed the following amounts:

Phase I

i.	30% design services	\$180,245.00
ii.	90% Preliminary Engineering & Design	\$148,130.00

Phase II

i.	Final Design (100%)	\$28,850.00
ii.	<u>Construction Administration and Staking</u>	<u>\$199,675.00</u>
	TOTAL	\$556,900.00

- B. Final payment shall be the above stated basic fee less all previous payments.

Section 2. Payments for Extra Services when Authorized by Billings.

Requests made or conditions identified by interested groups at the agency or public meetings, which are beyond the scope and intent of this study shall be paid for on an hourly basis at the applicable fees in Appendix D.

Section 3. Corrections.

Costs of Billings work that is required for corrections to the Engineer's work which requires redoing by Billings shall be deducted from any payments due the Engineer, if the Engineer fails to make the required corrections.

Section 4. Fee Increases

For contracts and services that are expected to require more than one (1) year to complete, the above stated basic services payments may be reviewed and adjusted annually by mutual agreement of the parties, based upon documented evidence that the Engineer's costs and hourly rates as shown in Appendix D have increased for all comparable clients.

Appendix C

Additional Services of Engineer

Additional Services of the Engineer will be paid only with written prior authorization by Billings.

1. Field and laboratory testing and reports.
2. Resetting lost or destroyed monuments after construction.
3. Construction inspection.
4. Construction inspection after expiration of the construction contract completion time.

5. Preparation of change orders, which do require additional engineering design or construction review.
6. Requests made or conditions identified by interested groups, which are in excess of basic services.
7. Revisions or additions when such revisions or additions are inconsistent with written approvals or instructions previously given, required by enactment or revisions of codes, laws, or regulations, or are due to other causes not solely within control of the Engineer.
8. As may be requested by Billings, additional design services not included in the original scope of work as outlined in Appendix A.
9. Additional time and/or services resulting from additional requirements imposed by any funding source for use of those funds, as outlined in Part I, Section 14 of this Contract.

Appendix D

Schedule of Professional Fees

Current agreements for engineering services stipulate that the standard hourly rates are subject to review and adjustments. Hourly rates for services effective on the date of this Agreement are included below.

The itemized schedule provided below includes direct labor costs, normal payroll and overhead costs, transportation, furnishing equipment and materials normally required for performance of the work and reasonable profit.

1. *Survey Crew Services.*

1-man Crew/2-man Crew

\$ Per Job

- NOTE:
- 1) Charge out rate for travel time to and from the site same as above.
 - 2) Minimum of one-hour charge for field crew time.

2. *Staff Personnel Services.*

Expert Witness/Special Consultant	\$250.00 /hour
Principal	\$180.00 /hour
Senior Engineer	\$135.00 /hour
Project Engineer	\$ 90.00 /hour
Staff Engineer	\$ 85.00 /hour
Engineer Intern	\$ 65.00 /hour
Land Planner/Landscape Architect	\$110.00 /hour
Senior Professional Land Surveyor	\$115.00 /hour
Professional Land Surveyor	\$100.00 /hour
Staff Surveyor	\$ 80.00 /hour
Designer	\$ 80.00 /hour
CADD Technician	\$ 75.00 /hour
Senior Construction Engineering Technician	\$ 95.00 /hour
Construction Engineering Technician	\$ 70.00 /hour
Construction Inspector	\$ 80.00 /hour
Project Administrator	\$ 65.00 /hour
Field Survey Technician	\$ 70.00 /hour
Administrative/Clerical	\$ 60.00 /hour

Outside Consultants:

- 1) At cost if independently billed direct to client.
- 2) Cost plus 5% if billed through us.

Independent Laboratories:

- 1) At cost if independently billed direct to client.
- 2) Cost plus 5% if billed through us.

Appendix E

Project Schedule

Section 1. Design Services.

Based on a written notice to proceed by Billings on May 2, 2016, the completion date, including agency reviews, for the Engineer's work through final design shall be:

- A. 30 percent Design – August, 2016
- B. 90 percent PS&E Package – January, 2017
- C. Final PS&E Package – March, 2017

Delays in the Scope of Work.

Delays affecting the completion of the work within the time specified of more than ninety (90) days, not attributable to or caused by the Parties hereto, may be considered as cause for the renegotiation or termination of this Contract.

If the Engineer is behind on this Contract due to no fault of Billings, then the Engineer hereby acknowledges the right of Billings to withhold future Contracts to the Engineer in addition to any other remedy until this Contract is brought back on schedule or otherwise resolved.

Appendix F
Certificates of Insurance

See attached Certificates of Insurance.

Regular City Council Meeting

Meeting Date: 05/09/2016

TITLE: Optimist Park Master Plan - Contract With Land Design, Inc.

PRESENTED BY: Mike Whitaker, Parks, Recreation & Public Lands Director

Department: Parks/Rec/Public Lands

PROBLEM/ISSUE STATEMENT

Optimist Park is located at Morgan Avenue and Hallowell Lane. On February 11, 2016, staff sent out a Request for Proposals (RFP) seeking responses from qualified firms for professional services to develop an Optimist Park Master Plan. Seven firms responded. A staff team reviewed all of the responses and selected Land Design, Inc. of Billings as the top ranked firm. After meeting with staff to negotiate a contract, a fee of \$49,615.00 was agreed upon. If the contract is approved, work on the master plan will commence immediately.

ALTERNATIVES ANALYZED

City Council may:

- Approve the contract to develop an Optimist Park Master Plan, or;
- Disapprove the contract and provide guidance to staff on the Council's preferred alternative.

FINANCIAL IMPACT

In FY 14 and FY 15, the City Council authorized a total of \$25,000 from the Council Contingency Fund for an Optimist Park Master Plan. \$15,000 was transferred to the PRPL revenue account but \$10,000 wasn't transferred, must be rebudgeted and will be included in a 4th quarter budget amendment that the Council will consider in June. The South Billings Urban Renewal Association recommended and the City Council approved spending \$25,000 from the South Billings Boulevard tax increment fund for the study. The total funding of \$50,000 is sufficient for this contract.

RECOMMENDATION

Staff recommends that the City Council approve the contract for \$49,615 with Land Design, Inc. to create a park master plan for Optimist Park.

APPROVED BY CITY ADMINISTRATOR

Attachments

Contract

Contract for Professional Architectural and Engineering Services For Optimist Park Master Plan

In consideration of the mutual promises herein, City of Billings and Land Design, Inc. agree as follows. This Contract consists of:

Part I, consisting of 15 Sections of Special Provisions;

Part II, consisting of 11 Sections of General Provisions;

Appendix A consisting of 4 pages (Basic Services of Contractor);

Appendix B consisting of 4 pages (Methods and Times of Payment);

Appendix C consisting of 1 page (Additional Services of Contractor);

Appendix D consisting of 1 page (Project Schedule);

Appendix E consisting of ___ pages (Certificate(s) of Insurance); and

PART I SPECIAL PROVISIONS

Section 1. Definitions.

In this Contract:

- A. "Administrator" means the Park Planner of the Parks, Recreation and Public Lands Department or his designee.
- B. "Billings" means the City of Billings.
- C. "Contractor" means Land Design, Inc.

Section 2. Scope of Services.

- A. The Contractor shall perform professional services in accordance with Appendix A, which is attached hereto and incorporated in this Section by reference.
- B. Billings shall pay the Contractor in accordance with the Fee Schedule contained in Appendix B and incorporated herein by reference for services actually performed under this Contract.
- C. Billings shall not allow any claim for services other than those described in this Section. However, the Contractor may provide, at its own expense, any other services that are consistent with this Contract.

- D. The Contractor shall provide as-built drawings on mylars and in digital format, as approved by the City of Billings, to the Administrator within 30 days after the project completion date. Final payment will be withheld until the as-built drawings are received by the City of Billings.
- E. The Contractor shall provide certified construction payrolls to the Administrator stating in writing that the payrolls have been reviewed and are acceptable.

Section 3. Time for Performance.

- A. This Contract becomes effective when signed on behalf of Billings.
- B. The Contractor shall commence performance of the Work described in Section 2 on receipt of written Notice to Proceed and complete that performance in accordance with the schedule set forth in Appendix D.
- C. This Contract shall terminate at midnight on October 31, 2016

Section 4. Compensation; Method of Payment.

- A. Each month, or at the conclusion of each phase of the Work for which payment is due, as negotiated on a per-task basis, the Contractor shall present a bill to the Administrator describing the Work for which it seeks payment and documenting expenses and fees to the satisfaction of the Administrator. If any payment is withheld because the Contractor's performance is unsatisfactory, the Administrator must, within ten (10) days of the payment denial, notify the Contractor of the payment denial and set forth, with reasonable specificity, what was unsatisfactory and why. Billings will pay Contractor within 30 days of receiving an acceptable invoice.
- B. As a condition of payment, the Contractor shall have paid all City taxes currently due and owing by the Contractor.

Section 5. Termination of the Contractor's Services.

The Contractor's services under Section 2 of this Part may be terminated:

- A. By mutual consent of the parties.
- B. For the convenience of Billings, provided that Billings notifies the Contractor in writing of its intent to terminate under this paragraph at least 10 days prior to the effective date of the termination.
- C. For cause, by either party where the other party fails in any material way to perform its obligations under this Contract. Termination under this Subsection is subject to the condition that the terminating party notifies the other party of its intent to terminate, stating with reasonable specificity the grounds therefor, and the other party fails to cure the default within 30 days after receiving the notice.

Section 6. Duties Upon Termination

- A. If Billings terminates the Contractor's services for convenience, Billings shall pay the Contractor for its actual costs reasonably incurred in performing before termination and Billings shall pay for services rendered prior to termination. Payment under this Subsection shall never exceed the total compensation allowable under Section 4 of

this Part. All finished and unfinished documents and materials prepared by the Contractor shall become the property of Billings.

- B. If the Contractor's services are terminated for cause, Billings shall pay the Contractor the reasonable value of the services satisfactorily rendered prior to termination, less any damages suffered by Billings because of the Contractor's failure to perform satisfactorily. The reasonable value of the services rendered shall never exceed ninety percent (90%) of the total compensation allowable under Section 4 of this Part. Any finished or unfinished documents or materials prepared by the Contractor under this Contract shall become the property of Billings at its option.
- C. If the Contractor receives payments exceeding the amount to which it is entitled under Subsections A or B of this Section, he shall remit the excess to the Administrator within 30 days of receiving notice to do so.
- D. The Contractor shall not be entitled to any compensation under this Section until the Contractor has delivered to the Administrator all documents, records, Work product, materials and equipment owned by Billings and requested by the Administrator.
- E. If the Contractor's services are terminated for whatever reason the Contractor shall not claim any compensation under this Contract, other than that allowed under this Section.
- F. If a final audit has not been performed before the Contractor's services are terminated, Billings may recover any payments for costs disallowed as a result of the final audit.
- G. Except as provided in this Section, termination of the Contractor's services under Section 5 of this Part does not affect any other right or obligation of a party under this Contract.

Section 7. Insurance.

- A. The Contractor shall maintain in good standing the insurance described in Subsection B of this Section. Before rendering any services under this Contract, the Contractor shall furnish the Administrator with proof of insurance in accordance with Subsection B of this Section.
- B. The Contractor shall provide the following insurance:
 - 1. Workers' compensation and employer's liability coverage as required by Montana law.
 - 2. Commercial general liability, including contractual and personal injury coverage's -- \$1,500,000 per occurrence.
 - 3. Commercial automobile liability -- \$1,500,000 per accident.
 - 4. Professional liability in the amount of \$1,500,000 per claim.
- C. Each policy of insurance required by this Section shall provide for no less than 30 days' advance notice to Billings prior to cancellation.
- D. Billings SHALL be listed as an additional insured on all policies except Professional Liability and Worker's Compensation Policies. In addition, all policies except Professional Liability and Worker's Compensation shall contain a waiver of subrogation against Billings.

Section 8. Assignments.

Unless otherwise allowed by this Contract or in writing by the Administrator, any assignment by the Contractor of its interest in any part of this Contract or any delegation of duties under this Contract shall be void, and an attempt by the Contractor to assign any part of its interest or delegate duties under this Contract shall give Billings the right immediately to terminate this Contract without any liability for Work performed.

Section 9. Ownership; Publication, Reproduction and Use of Material.

- A. Except as otherwise provided herein, all data, documents and materials produced by the Contractor under this Contract shall be the property of Billings, which shall retain the exclusive right to publish, disclose, distribute and otherwise use, in whole or in part, any such data, documents, or other materials. Exclusive rights shall not be attributed to portions of such materials presently in the public domain or which are not subject to copyright. Contractor shall retain rights to pre-existing proprietary property including but not limited to interactive models. The Contractor shall have the right to include photographic or artistic representations of the design and construction of the Project among the Contractor's promotional and professional materials. The Contractor's materials shall not include Billings' confidential or proprietary information regardless of whether Billings has previously advised the Contractor in writing of the specific information considered by Billings to be confidential and proprietary.
- B. Equipment purchased by the Contractor with Contract funds: See Appendix A, Section 3. Scope of Work.
- C. Should Billings elect to reuse Work products provided under this Contract for other than the original project and/or purpose, Billings will indemnify and hold harmless the Contractor from any and all claims, demands and causes of action of any kind or character arising as a result of reusing the documents developed under this contract. Additionally, any reuse of design drawings or specifications provided under this Contract must be limited to conceptual or preliminary use for adaptation, and the original Contractor's or subcontractor's signature, professional seals and dates removed. Such reuse of drawings and specifications, which require professional seals and dates removed, will be signed, sealed, and dated by the professional who is in direct supervisory control and responsible for adaptation.

Section 10. Notices.

Any notice required pertaining to the subject matter of this Contract shall be either sent via facsimile (FAX) or mailed by prepaid first class registered or certified mail, return receipt requested to the following addresses:

Billings: Mark Jarvis
City of Billings
Parks, Recreation and Public Lands
390 North 23rd Street
Billings, Montana 59101

FAX: (406) 247-8641

Contractor: Stacey Robinson
Land Design, Inc.
3529 Gabel Road
PO Box 81316
Billings, Montana 59108

FAX: (406) 655-3560

Notices are effective upon the earlier of receipt, proof of good transmission (facsimiles only), or 5 days after proof of proper posting.

Section 11. Contract Budget.

In connection with its performance under this Contract, the Contractor shall not make expenditures other than as provided in line items in the Contract budget.

Section 12. Force Majeure.

- A. Any failure to perform by either party due to force majeure shall not be deemed a violation or breach hereof.
- B. As used in this Contract, force majeure is an act or event of substantial magnitude, beyond the control of the delayed party, which delays the completion of this Contract, including without limitation:
 - 1. Any interruption, suspension or interference resulting solely from the act of Billings or neglect of Billings not otherwise governed by the terms of this Contract.
 - 2. Strikes or Work stoppages.
 - 3. Any interruption, suspension or interference with the project caused by acts of God, or acts of a public enemy, wars, blockades, insurrections, riots, arrests or restraints of governments and people, civil disturbances or similar occurrences.
 - 4. Order of court, administrative agencies or governmental officers other than Billings.

Section 13. Financial Management System.

The Contractor shall establish and maintain a financial management system that:

- A. Provides accurate, current, and complete disclosure of all financial transactions relating to the Contract;
- B. Maintains separate accounts by source of funds for all revenues and expenditures and identifies the source and application of funds for the Contractor's performance under this Contract, including information pertaining to subcontracts, obligations, unobligated balances, assets, liabilities, outlays and income;
- C. Effectively controls and accounts for all municipal funds and Contract property;
- D. Compares actual expenditures with budgeted amounts and relates financial information to performance or productivity data including unit cost information where applicable;
- E. Allocates administrative costs to direct service delivery units;
- F. Minimizes the time between receipt of funds from Billings and their disbursement by the Contractor;
- G. Provides accounting records supported by source documentation; and

- H. Provides a systematic method assuring the timely and appropriate resolution of audit findings and recommendations.

Section 14. Funding Requirements.

In the event that any funding source for this Contract should impose additional requirements upon Billings for the use of those funds, the Contractor agrees to abide by those additional requirements immediately upon receipt of written notice thereof from Billings.

Section 15. Subcontracts.

The Contractor may enter into subcontracts for the purchase of goods and services necessary for the performance of this Contract, provided:

- A. Every subcontract shall be reduced to writing and contain a precise description of the services or goods to be provided and the nature of the consideration paid therefor.
- B. Every subcontract under which the Contractor delegates the provision of services shall be subject to review and approval by the Administrator before it is executed by the Contractor.
- C. Every subcontract in an amount exceeding \$1,000 shall require reasonable access to business records of the subcontractor relating to the purchase of goods or services pursuant to the subcontract.

PART II
GENERAL CONTRACT PROVISIONS

Section 1. Relationship of Parties.

The Contractor shall perform its obligations hereunder as an independent Contractor of Billings. Billings may administer the Contract and monitor the Contractor's compliance with its obligations hereunder. Billings shall not supervise or direct the Contractor other than as provided in this Section.

Section 2. Nondiscrimination.

- A. The Contractor will not discriminate against any employee or applicant for employment because of race, color, religion, national origin, ancestry, age, sex, or marital status or who is a "qualified individual with a disability" (as that phrase is defined in the Americans With Disabilities Act of 1990). The Contractor will take affirmative action to ensure that applicants are employed and that employees are treated during employment without regard to their race, color, religion, or mental or physical impairment/disability. Such action shall include, without limitation, employment, upgrading, demotion or transfer, recruitment or recruiting advertising, layoff or termination, rates of pay or other forms of compensation, and selection for training including apprenticeship. The Contractor agrees to post, in conspicuous places available to employees and applicants for employment, notices setting forth the provisions of this non-discrimination clause.
- B. The Contractor shall state, in all solicitations or advertisements for employees to Work on Contract jobs, that all qualified applicants will receive equal consideration for employment without regard to race, color, religion, national origin, ancestry, age, sex or marital status, or mental or physical impairment/disability.
- C. The Contractor shall comply with any and all reporting requirements that may apply to it which the City of Billings may establish by regulation.
- D. The Contractor shall include the provisions of Subsections A through C of this Section in every subcontract or purchase order under this Contract, so as to be binding upon every such subcontractor or vendor of the Contractor under this Contract.
- E. The Contractor shall comply with all applicable federal, state, and city laws concerning the prohibition of discrimination.
- F. The Contractor and subcontractor shall abide by the requirements of 41 CFR 60-300.5(a) and 41 CFR 60-741.5(a), which prohibit discrimination against qualified protected veterans and/or qualified individuals on the basis of disability, and requires affirmative action by covered prime contractors and subcontractors to employ and advance in employment qualified protected veterans and individuals with disabilities.

Section 3. Permits, Laws, and Taxes.

The Contractor shall acquire and maintain in good standing all permits, licenses and other entitlements necessary to its performance under this Contract. All actions taken by the

Contractor under this Contract shall comply with all applicable statutes, ordinances, rules and regulations. The Contractor shall pay all taxes pertaining to its performance under this Contract.

Section 4. Nonwaiver.

The failure of either party at any time to enforce a provision of this Contract shall in no way constitute a waiver of the provision, nor in any way affect the validity of this Contract or any part hereof, or the right of such party thereafter to enforce each and every provision hereof.

Section 5. Amendment.

- A. This Contract shall only be amended, modified or changed by a writing, executed by authorized representatives of the parties, with the same formality as this Contract was executed.
- B. For the purposes of any amendment modification or change to the terms and conditions of this Contract, the only authorized representatives of the parties are:

Contractor: Stacey Robinson
(Principal/Owner)

Billings: City Council or Authorized Designee

- C. Any attempt to amend, modify, or change this Contract by either an unauthorized representative or unauthorized means shall be void.

Section 6. Jurisdiction; Choice of Law.

Any civil action rising from this Contract shall be brought in the District Court for the Thirteenth Judicial District of the State of Montana, Billings. The law of the State of Montana shall govern the rights and obligations of the parties under this Contract.

Section 7. Severability.

Any provision of this Contract decreed invalid by a court of competent jurisdiction shall not invalidate the remaining provisions of the Contract.

Section 8. Integration.

This instrument and all appendices and amendments hereto embody the entire agreement of the parties. There are no promises, terms, conditions or obligations other than those contained herein; and this Contract shall supersede all previous communications, representations or agreements, either oral or written, between the parties hereto.

Section 9. Liability.

The Contractor shall indemnify, defend, save, and hold Billings harmless from any and all claims, causes of action, lawsuits, damages, judgments, liabilities, and litigation costs and expenses including reasonable attorneys' fees and costs, arising from any wrongful or negligent act, error or omission of the Contractor or any agent, employee or subcontractor as a result of the Contractor's or any subcontractor's performance pursuant to this Contract.

- A. The Contractor shall not indemnify, defend, save and hold Billings harmless from claims, causes of action, lawsuits, damages, judgments, liabilities, and litigation costs and expenses or attorneys' fees and costs arising from wrongful or negligent acts, error or omission solely of Billings occurring during the course of or as a result of the performance of the Contract.
- B. Where claims, lawsuits or liability, including attorneys' fees and costs arise from wrongful or negligent act of both Billings and the Contractor, the Contractor shall indemnify, defend, save, and hold Billings harmless from only that portion of claims, causes of action, lawsuits, damages, judgments, liabilities, and litigation costs and expenses including attorneys' fees and costs, which result from the Contractor's or any subcontractor's wrongful or negligent acts occurring as a result from the Contractor's performance pursuant to this Contract.

Section 10. Inspection and Retention of Records.

The Contractor shall, at any time during normal business hours and as often as Billings may deem necessary, make available to Billings, for examination, all of its records with respect to all matters covered by this Contract for a period ending three years after the date the Contractor is to complete performance in accordance with Section 2 of the Special Provisions. Upon request, and within a reasonable time, the Contractor shall submit such other information and reports relating to its activities under this Contract, to Billings, in such form and at such times as Billings may reasonably require. The Contractor shall permit Billings to audit, examine and make copies of such records, and to make audits of all invoices, materials, payrolls, records of personnel, and other data relating to all matters covered by this Contract. Billings may, at its option, permit the Contractor to submit its records to Billings in lieu of the retention requirements of this Section.

Section 11. Availability of Funds.

Payments under this Contract may require funds from future appropriations. If sufficient funds are not appropriated for payments required under this Contract, this Contract shall terminate without penalty to Billings; and Billings shall not be obligated to make payments under this Contract beyond those which have previously been appropriated.

IN WITNESS WHEREOF, the parties have executed this Contract on the date and at the place shown below.

City of Billings

Contractor

City Council or Designee

Date: _____

Name: _____

Title: _____

Date: _____

ATTEST:

IRS Tax ID # _____

City Clerk

APPROVED AS TO FORM:

Date: _____

By _____

BRENT BROOKS, City Attorney

STATE OF MONTANA)
 :ss.
COUNTY OF YELLOWSTONE)

On this _____ day of _____, 2004, before me, the undersigned, a Notary Public for the State of Montana, personally appeared _____, known to me to be the _____ of _____, and acknowledged to me that they executed the foregoing instrument on behalf of said corporation having first been authorized to do so.

IN WITNESS WHEREOF, I have hereunto set my hand and affixed my Notarial Seal the day and year first above written.

Notary Public for the State of Montana
Residing at Billings, Montana
My Commission Expires: _____

Note: **Final contract documents will require the Contractor's signature to be notarized.**

Appendix A

Basic Services of Contractor

Section 1. Contractor's Rights and Duties.

- A. To furnish all labor, materials, equipment, supplies, and incidentals necessary to conduct and complete the Contractor's portion of the project as defined in the scope of work and to prepare and deliver to Billings all plans, specifications, bid documents, and other material as designated herein.
- B. Ascertain such information as may have a bearing on the work from local units of government, utility companies, and private organizations and shall be authorized to procure information from other authorities besides Billings, but shall keep Billings advised as to the extent of these contacts and the results thereof.
- C. Prepare and present such information as may be pertinent and necessary in order for Billings to pass critical judgment on the features of the work. The Contractor shall make changes, amendments or revisions in the detail of the work as may be required by Billings. When alternates are being considered, Billings shall have the right of selection.
- D. Contractor's work shall be in accordance with the standards of sound professional practice and present City, State, and National standards and policies currently in use.
- E. Conform to the requirements of the Montana Code Annotated Title 18 "Public Contracts" and more particularly Sections 18-2-121 and 18-2-122, and all other codes of the State of Montana applicable to providing professional services including codes and standards nationally recognized.
- F. The Contractor shall certify with the submission of final plans that the plans are in conformance with applicable sections of Title 69, Chapter 4, Part 5, of the Montana Code Annotated as pertaining to existing utilities.
- G. To perform professional services in connection with the project and will serve as Billings' representative in those phases of the project to which this agreement applies.
- H. Where Federal funds are involved, the necessary provisions to meet all requirements will be complied with and documents secured and placed in the bidding documents.
- I. Submit an estimated progress schedule as to time and costs at the beginning of the work, and monthly progress reports thereafter until complete. The reports will include any problems, potential problems, and delays as foreseen by the Contractor. Reports will be submitted in a timely manner to permit prompt resolution of problems.
- J. Contract administration duties will include review of contractor certified payrolls for wage rate compliance. Discrepancies in certified payrolls will be resolved with the Contractor. A signed Contractor's Payroll Check Sheet (included in the Standard

Modifications to MPWSS) will be submitted as proof of this review with one copy of each payroll.

- K. Name a Task Director who shall be the liaison between Billings and the Contractor. For this project the Project Leader designated for the Contractor is Michael Verseman working under the Principal-in-Charge, Stacey Robinson.

Section 2. Billings Rights and Duties.

- A. To furnish all labor, materials, equipment, supplies, and incidentals necessary to conduct and complete Billings' portion of the project as designated in the scope of work.
- B. Name a Project Leader who shall be the liaison between the Contractor and Billings. For this project, the Project Leader designated is Mark Jarvis, Park Planner.
- C.

Section 3. Scope of Work.

The following work will be accomplished as part of this contract:

- A. **Needs Assessment Analysis & Base Information Gathering.** We will analyze existing information to ensure the master plan is consistent with the findings of the needs assessments that are guiding the development of our Parks System. This review will include:

- 2014 Citizen Survey Report
- 2009 Needs Assessment Study
- Parks 20/20 Plan
- Demographic Analysis
- Service Provider Analysis
- Market Definition
- Visioning & Core Program Review
- Operational Analysis

We will utilize aerial photography and existing site surveys to develop a foundation for the Optimist Park Master Plan.

- B. **Internal Analysis Review.** We will facilitate meetings with PRPL to review the findings of our analysis. Facility recommendations and operational recommendations will be presented, reviewed and formalized.
- C. **Key Stakeholder Interviews.** PRPL and the Design Team will conduct brief interviews with key stakeholders to gather their initial input related to the existing park, to identify positives, negatives, perceived deficiencies, wants & needs. This information will then be synthesized for use in the Master Plan Program Development.

- D. **Master Plan Program and Operational Standards Development and Review.** We will develop and present the master plan program and operational standards based on information gathered from our stakeholder interviews and our internal review with PRPL.
- E. **Community Outreach and Stakeholder Review.** We will present our analysis findings and recommendations to the community and key stakeholders to solicit comment. Comments will be received in these community and stakeholder meetings as well as through PRPL online resources.
- F. **Concept Master Plan Development and Cost Estimate.** With information in-hand following the internal work sessions and community outreach, we will develop the Concept Master Plan. This plan will illustrate existing conditions and proposed improvements to Optimist Park per our analysis, program and comments received. In addition to the plan, we will develop a cost estimate based on proposed improvements.
- G. **Community Review #1- Concept Master Plan.** We will present the Concept Master Plan and Cost Estimate for review and comment. This will provide another opportunity to receive community input.
- H. **Preliminary Master Plan & Cost Estimate.** Based on comments received in the Community Review, we will make revisions to the Concept Plan and Cost Estimate keeping Community and PRPL goals and objectives in mind.
- I. **Community Review #2- Preliminary Master Plan.** We will present the Preliminary Master Plan and Cost Estimate for public review and comment.
- J. **Final Master Plan & Cost Estimate.** We will make revisions as necessary based on comments received in the Community Review Session. These revisions will be reviewed with PRPL and stakeholders to ensure project goals and objectives have been addressed. The final master plan will include operation and maintenance guidelines for future park operations.
- K. **Community Review #3- Final Master Plan.** We will present the Final Master Plan and Cost Estimate for public review and comment.
- L. **Park Board Presentation.** We will present the Optimist Park Master Plan, Cost Estimate, Operational Standards and Executive Summary to the City of Billings Parks, Recreation and Cemetery Board for final review and comment. The plan will be refined as necessary to the Park Board's satisfaction.

M. **City Council Presentation - Final Master Plan.** We will present the Optimist Park Master Plan Up-Date to City Council for formal approval and adoption in coordination with PRPL.

N. **Master Plan Documentation.** We will create a summary document recording the City Council approved Optimist Park Master Plan and the master planning process. The document will be an 8.5 x 11" format with expanded pages for larger displays. Deliverables will include one bound hard copy and one electronic copy.

Appendix B

Methods and Times of Payment

Section 1. Payments for Basic Services.

- A. Billings shall authorize payment to the Contractor for services performed under Appendix A of this Agreement. Partial payment shall be due the Contractor upon receipt of the Contractor’s pay estimate, said estimate being proportioned to the work completed by the Contractor.
- B. Billings shall deduct ten percent (10%) from each monthly pay estimate to be held until the completion of the final scope of work. The final payment shall be made only after acceptance of final documents by Billings, and determination that the scope of work has been satisfactorily completed.
- C. For services rendered prior to construction, Appendix A, the Contractor shall be paid a total of \$49,615.00 as follows:

FEE SCHEDULE:

**Optimist Park Scoping
Task Estimate**

Proposed Services:

Task	Personnel	Quantity	Units	Rate	Sub-Total
OPTIMIST PARK MASTER PLAN - KICKOFF APRIL 11TH					
a. Needs Assessment & Analysis					
11-Apr Start	Stacey	2	Hrs.	\$130.00	\$260.00
18-Apr End	Michael	16	Hrs.	\$115.00	\$1,840.00
	Ryan	0	Hrs.	\$115.00	\$0.00
	Pros	16	Hrs.	\$160.00	\$2,560.00
SUB-TOTAL DESIGN					\$4,660.00
b. Programming & Operational Standards Development					
18-Apr Start	Stacey	5	Hrs.	\$130.00	\$650.00
29-Apr End	Michael	16	Hrs.	\$115.00	\$1,840.00
	Ryan	0	Hrs.	\$115.00	\$0.00
	Pros	40	Hrs.	\$160.00	\$6,400.00
SUB-TOTAL DESIGN					\$8,890.00
SUBTOTAL					\$13,550.00
CONCEPT MASTER PLAN - MAY 3 - JUNE 2					
a. Develop Master Plan Concepts					
	Stacey	5	Hrs.	\$130.00	\$650.00

Michael	24	Hrs.	\$115.00	\$2,760.00
Ryan	24	Hrs.	\$115.00	\$2,760.00
Pros	5	Hrs.	\$160.00	\$800.00

SUB-TOTAL DESIGN **\$6,970.00**

b. Presentation Graphics

Stacey	2	Hrs.	\$130.00	\$260.00
Michael	8	Hrs.	\$115.00	\$920.00
Ryan	16	Hrs.	\$115.00	\$1,840.00
Pros	0	Hrs.	\$160.00	\$0.00

SUB-TOTAL DESIGN **\$3,020.00**

c. Cost Estimates

Stacey	2	Hrs.	\$130.00	\$260.00
Michael	8	Hrs.	\$115.00	\$920.00
Ryan	15	Hrs.	\$115.00	\$1,725.00

SUB-TOTAL DESIGN **\$2,905.00**

SUBTOTAL **\$12,895.00**

PRELIMINARY MASTER PLAN - JUNE 7 - JULY 7

REFINE CONCEPTS PER PUBLIC COMMENT - COMBINE AS

a. POSSIBLE

Stacey	5	Hrs.	\$130.00	\$650.00
Michael	8	Hrs.	\$115.00	\$920.00
Ryan	16	Hrs.	\$115.00	\$1,840.00
Pros	2	Hrs.	\$160.00	\$320.00

SUB-TOTAL DESIGN **\$3,730.00**

b. Presentation Graphics

Stacey	2	Hrs.	\$130.00	\$260.00
Michael	8	Hrs.	\$115.00	\$920.00
Ryan	16	Hrs.	\$115.00	\$1,840.00
Pros	0	Hrs.	\$160.00	\$0.00

SUB-TOTAL DESIGN **\$3,020.00**

c. Cost Estimates

Stacey	2	Hrs.	\$130.00	\$260.00
Michael	8	Hrs.	\$115.00	\$920.00
Ryan	0	Hrs.	\$115.00	\$0.00

SUB-TOTAL DESIGN **\$1,180.00**

SUBTOTAL	\$7,930.00
-----------------	-------------------

FINAL MASTER PLAN - JULY 12 - JULY 25
--

a. Develop Preferred Concept					
	Stacey	2	Hrs.	\$130.00	\$260.00
	Michael	10	Hrs.	\$115.00	\$1,150.00
	Ryan	20	Hrs.	\$115.00	\$2,300.00
	Pros	1	Hrs.	\$160.00	\$160.00

SUB-TOTAL DESIGN	\$3,870.00
-------------------------	-------------------

b. Presentation Graphics					
	Stacey	1	Hrs.	\$130.00	\$130.00
	Michael	5	Hrs.	\$115.00	\$575.00
	Ryan	8	Hrs.	\$115.00	\$920.00
	Pros	0	Hrs.	\$160.00	\$0.00

SUB-TOTAL DESIGN	\$1,625.00
-------------------------	-------------------

City Council					
c. Presentation					
	Stacey	2	Hrs.	\$130.00	\$260.00
	Michael	8	Hrs.	\$115.00	\$920.00
	Ryan	8	Hrs.	\$115.00	\$920.00
	Pros	0	Hrs.	\$160.00	\$0.00

SUB-TOTAL DESIGN	\$2,100.00
-------------------------	-------------------

d. Cost Estimates					
	Stacey	2	Hrs.	\$130.00	\$260.00
	Michael	5	Hrs.	\$115.00	\$575.00
	Ryan	8	Hrs.	\$115.00	\$920.00

SUB-TOTAL DESIGN	\$1,755.00
-------------------------	-------------------

SUBTOTAL	\$9,350.00
-----------------	-------------------

MASTER PLAN DOCUMENTATION - AUGUST 15-22

a. Master Plan Documentation					
	Stacey	5	Hrs.	\$130.00	\$650.00
	Michael	40	Hrs.	\$115.00	\$4,600.00
	Ryan	0	Hrs.	\$115.00	\$0.00
	Pros	4	Hrs.	\$160.00	\$640.00

SUB-TOTAL DESIGN	\$5,890.00
-------------------------	-------------------

SUBTOTAL	\$5,890.00
-----------------	-------------------

Grand Total	\$49,615.00
--------------------	--------------------

D. Final payment shall be the above stated basic fee less all previous payments.

Section 2. Payments for Extra Services when Authorized by Billings.

Requests made or conditions identified which are beyond the scope and intent of this study shall be paid for on an hourly basis at the applicable fees in Appendix D.

Section 3. Corrections.

Costs of Billings work that is required for corrections to the Contractor's work which requires redoing by Billings shall be deducted from any payments due the Contractor, if the Contractor fails to make the required corrections.

Appendix C

Additional Services of Contractor

Extra Services of the Contractor will be paid only with written prior authorization by Billings.

- A. Requests made or conditions identified by interested groups at the agency or public meetings, which are beyond the scope and intent of this study.

Appendix D

Project Schedule

- A. Based on contract approval by Billings City Council, a Notice to Proceed by Billings date on or about May 18, 2016, the completion date for the Contractor's work through Council approval shall be October 31, 2016.
- B. Upon Notice to Proceed, Contractor shall prepare a Work Plan Schedule demonstrating the approved Project Scope and proposed timeline for the project.
- C. Delays affecting the completion of the work within the time specified of more than ninety (90) days, not attributable to or caused by the Parties hereto, may be considered as cause for the renegotiation or termination of this Contract.
- D. If the Contractor is behind on this Contract due to no fault of Billings, then the Contractor hereby acknowledges the right of Billings to withhold future Contracts to the Contractor in addition to any other remedy until this Contract is brought back on schedule or otherwise resolved.

Appendix E

Certificate(s) of Insurance

(Attach Certificate(s) of Insurance)

Regular City Council Meeting

Meeting Date: 05/09/2016

TITLE: Development Agreement with School District 2 for Ben Steel Middle School

PRESENTED BY: David Mumford, Public Works Director

Department: Public Works

PROBLEM/ISSUE STATEMENT

School District 2 (SD 2) is required to execute a development agreement with the City as a condition of annexing the property for the future Ben Steel Middle School. This development agreement outlines all of the offsite improvements that are required for the construction of the school. In particular, SD 2 will contribute to WO 16-09, which is going to widen Grand Avenue between 48th Street West and 58th Street West and will include traffic signal work and sidewalk construction throughout the area.

ALTERNATIVES ANALYZED

City Council may:

- Approve the development agreement, or;
- Disapprove the development agreement. If disapproved, SD 2 and City staff will negotiate a new development agreement that conforms to City Council directives.

FINANCIAL IMPACT

The development agreement outlines the financial commitment that is required by the school district for off-site improvements.

RECOMMENDATION

Staff recommends that the City Council approve the development agreement with School District 2 for Ben Steel Middle School.

APPROVED BY CITY ADMINISTRATOR

Attachments

Development Agreement

Return to:
Sanderson Stewart
1300 North Transtech Way
Billings, MT 59102

DEVELOPMENT AGREEMENT

THIS DEVELOPMENT AGREEMENT is made this ____ day of _____, 2016, by and between BILLINGS SCHOOL DISTRICT NO. 2, 415 North 30th Street, Billings, Montana, 59101 hereinafter referred to as "District," and THE CITY OF BILLINGS, MONTANA, a municipal corporation, c/o City Hall, 210 North 27th Street, Billings, Montana, 59101, hereinafter referred to as the "CITY."

WHEREAS, District is the owner of certain real property situated in Yellowstone County, Montana, more particularly described as follows:

Certificate of Survey No. 3612, Situated in the NE1/4 of Section 5, T 01S, R 25E, P.M.M., Yellowstone County, Montana hereinafter referred to as "School Tract".

WHEREAS, District has submitted to the City a Petition for Annexation to the City for School Tract; and

WHEREAS, District desires to annex School Tract to the City; and

WHEREAS, CITY has approved the Petition for Annexation for the School Tract contingent that a Development Agreement be executed between CITY and District to identify required off-site infrastructure improvements and timing of those improvements.

NOW THEREFORE, in consideration of the mutual promises and covenants contained herein, the parties do hereby agree as follows:

1. Sanitary Sewer. The School Tract will be served by an existing sanitary sewer main in Grand Avenue. District will be responsible for connecting to the sanitary sewer system at the time of development and shall be responsible for payment of the City wastewater system development fee at the time of connection to the sanitary sewer.

2. Water. The School Tract will be served by an existing water main in 56th Street West. District will be responsible for connecting to the water system at the time of development and shall be responsible for payment of the City water system development fee at the time of connection to the water main.
3. Storm Drain. The District will manage storm drainage on the site in accordance with the City of Billings Stormwater Management Manual (2015).
4. Right of Way. District will be required to dedicate the necessary right of way along Grand Avenue and 56th Street West concurrent with the Certificate of Survey for School Tract. District will not be compensated for the right of way dedication.
5. Street Widening and Curb and Gutter. District will be required to pay for design and construction of 10 feet of widening (including curb and gutter) of Grand Avenue and 56th Street West along their frontage in association with City W.O. 16-09. No other off-site road widening will be required by District.
6. Sidewalks and Multi-Use Paths. Subject to future reimbursement as outlined in Section 10 of this Agreement, District has agreed to pay for design and construction of sidewalks and multi-use paths for School Tract as listed below and as depicted in Exhibit A attached hereto. The design and location of the sidewalks and paths shall be in accordance with final plans and specifications approved in association with City W.O. 16-09.
 - a. Five (5)-foot wide sidewalk on north side of Grand Avenue between 58th Street West and future school pedestrian crossing (HAWK).
 - b. Five (5)-foot wide sidewalk on south side of Grand Avenue along frontage of Hope Church property (Certificate of Survey 2298).
 - c. Five (5)-foot wide sidewalk on south side of Grand Avenue along frontage of unplatted land between Day Break Subdivision and Vintage Estates Subdivision.
 - d. Five (5)-foot wide sidewalk on east side of 54th Street West between Grand Peaks Subdivision and Mont Vista Subdivision.
 - e. Five (5)-foot wide sidewalk on Grand Avenue and 54th Street West adjacent to Bishop Fox Subdivision.
 - f. Five (5)-foot wide sidewalk on north side of Grand Avenue between HAWK signal adjacent to school and 54th Street West.
 - g. Ten (10)-foot wide multi-use path of west side of 54th Street West adjacent to MK Subdivision.

7. High-Intensity Activated Crosswalk (HAWK) Signal. District will be required to pay for design and construction of a High-Intensity Activated Crosswalk (HAWK) signal and related improvements on Grand Avenue adjacent to property. HAWK signal to be constructed in association with City W.O. 16-09. If a similar crossing is needed in the future on 54th Street West near Poly Drive and is specifically warranted due to school age children crossing 54th Street West, the District will be required to pay for design and construction of crossing.
8. Future Intersection Contributions. District will be required to pay for its commensurate share of future intersection improvements, as outlined in the approved Traffic Impact Study (TIS), as follows:
 - a. 2.63 percent of future improvement at 62nd Street West and Grand Avenue
 - b. 2.17 percent of future improvement at 62nd Street West and Rimrock Road
 - c. 2.89 percent of future improvement at 58th Street West and Grand Avenue
 - d. 9.56 percent of future improvement at 56th Street West and Grand Avenue
 - e. 6.40 percent of future improvement at 54th Street West and Grand Avenue
 - f. 3.42 percent of future improvement at 54th Street West and Rimrock Road
 - g. 3.95 percent of future improvement at 48th Street West and Grand Avenue
9. Other Public Improvements. The anticipated time schedule contemplated for construction of public improvements serving the property in sections 5, 6, and 7 will be 2017. For any other improvements not specifically listed in this Agreement, the CITY shall rely on the attached Waiver filed concurrently herewith, to insure the installation of any or all remaining public improvements. Said improvements shall include, but not be limited to, street construction and paving, curb, gutter, sidewalks, driveways, storm drainage, and street lighting. The attached Waiver, waiving the right to protest the creation of one or more Special Improvement Districts, by this reference is expressly incorporated herein and part hereof.
10. Future Reimbursement. CITY agrees to reimburse District in the future for design and construction costs of improvements listed in section 6 of this Agreement. Reimbursement will be required in the event currently undeveloped properties fronting the improvements installed by District are

developed or if the same undeveloped properties are included in a future Special Improvement District (SID) that include items installed by District.

11. Compliance. Nothing herein shall be deemed to exempt the School Tract from compliance with any current or future City laws, rules, regulations, or policies that are applicable to the development, redevelopment, or use of the subject property.
12. Runs with Land. The covenants, agreements, and all statements in this Agreement and in the incorporated and attached Waiver shall run with the land and shall be binding on the heirs, personal representatives, successors, and assigns of the respective parties.
13. Attorney's Fees. In the event it becomes necessary for either party to this Agreement to retain an attorney to enforce any of the terms or conditions of this Agreement or to give any notice required herein, then the prevailing party or the party giving notice shall be entitled to reasonable attorney fees and costs, including those fees and costs of in-house counsel.
14. Amendments and Modifications. Any amendments or modifications of this Agreement shall be made in writing and executed in the same manner as this original document and shall after execution become a part of this Agreement.

This Agreement is hereby approved and accepted by City of Billings, this ____ day of _____, 20____.

“CITY”

CITY OF BILLINGS, MONTANA

By: _____
Mayor

Attest: _____
City Clerk

STATE OF MONTANA)
 :ss
County of Yellowstone)

On this _____ day of _____, 20____, before me, a Notary Public for the State of Montana, personally appeared _____, and _____, known to me to be the Mayor and City Clerk, respectively, of the City of Billings, Montana, whose names are subscribed to the foregoing instrument in such capacity and acknowledged to me that they executed the same on behalf of the City of Billings, Montana.

Notary Public in and for the State of Montana
Printed name: _____
Residing at: _____
My commission expires: _____

Approved as to Form:

City Attorney

WAIVER OF RIGHT TO PROTEST

FOR VALUABLE CONSIDERATION, the undersigned, Owner of the hereinafter described real property, does hereby waive the right to protest the formation of one or more Special Improvement Districts (SID) for the construction, reconstruction or maintenance of streets, curbs, gutter, concrete ribbons, sidewalks, driveways, survey monuments, street name signs, street lights, street light energy and maintenance, traffic control devices on-site and off-site inclusive as determined by an overall traffic accessibility study, specific realignments or relocation of sanitary sewer lines and water lines, valley gutters, culverts, storm sewer lines, if any, either within or without the area And other incidental improvements which the City of Billings may require.

The Waiver and Agreement shall run with the land and shall be binding upon the undersigned, its successors and assigns, and shall be recorded in the office of County Clerk and Recorder of Yellowstone County, Montana.

The real property hereinabove mentioned is more particularly described as follows:

Certificate of Survey No. _____, Situated in the NE1/4 of Section 5, T 01S, R 25E, P.M.M., Yellowstone County, Montana

“DISTRICT”

BILLINGS SCHOOL DISTRICT NO. 2

By: _____
Terry Nelsen Bouck, Superintendent

STATE OF MONTANA)
 :ss.
County of Yellowstone)

On this ____ day of _____, 20____, before me, a Notary Public in and for the State of Montana, personally appeared Terry Nelson Bouck, known to me to be the person who signed the foregoing instrument as the Superintendent of Billings School District No. 2, and who acknowledged to me that said District executed the same.

IN WITNESS WHEREOF, I have hereunto set my hand and affixed my Notarial Seal the day and year hereinabove written.

Notary Public in and for the State of Montana
Printed name: _____
Residing at: _____
My commission expires: _____

Regular City Council Meeting

Meeting Date: 05/09/2016

TITLE: City of Billings/Yellowstone County Agreement to provide Law Enforcement Data Processing

PRESENTED BY: Bruce McCandless, Assistant City Administrator

Department: City Hall Administration

PROBLEM/ISSUE STATEMENT

The City of Billings has contracted with Yellowstone County for many years to provide the Sheriff's Department with New World Public Safety access, disk storage, computer processing, program maintenance and operations to support its data processing requirements. Under an annual agreement, Information Technology bills the Sheriff's Office for the actual resources that were used in the prior calendar year. Council is being asked to approve the FY 2016-2017 agreement in the amount of \$134,521.00

ALTERNATIVES ANALYZED

The City Council may:

- Approve the annual agreement with Yellowstone County Sheriff's Department; or
- Not approve the annual agreement.

FINANCIAL IMPACT

The annual charge for July 1, 2016, through June 30, 2017, is \$134,521. The prior year's charges were \$131,315. The increase is a result of actual usage of the Public Safety System. Information Technology is an internal service fund, whose budget is dependent on charging customers for the services that it provides.

RECOMMENDATION

Staff recommends that Council approve the agreement to provide FY16-17 data processing services for the Yellowstone County Sheriff's Department in the amount of \$134,521

APPROVED BY CITY ADMINISTRATOR

Attachments

Sheriff Agreement Agenda 2016-2017

AGREEMENT

This Agreement, made and entered into on _____, 20____, by and between the Yellowstone County Sheriff, hereinafter called the "SHERIFF", and the City of Billings, Montana, hereinafter called the "CITY".

WITNESSETH:

Whereas, the SHERIFF is desirous of using the CITY's Computer Facility to support their existing law enforcement data processing requirements; and

Whereas, the CITY maintains and operates a Computer Facility with appropriate capabilities, capacity and security; and

Whereas, the CITY is willing to allow the SHERIFF to have access to the Computer Facility at all normal operating times which are seven (7) days a week, twenty-four (24) hours a day except for necessary back-ups and maintenance.

NOW, THEREFORE, IN CONSIDERATION OF THE MUTUAL COVENANTS AND AGREEMENTS between the parties hereto, it is mutually agreed that:

1. The CITY will provide to the Yellowstone County Sheriff's department the following described computer access, magnetic disk storage, computer processing, and maintenance support to support their existing Law Enforcement data processing system:
 - A. Communication capabilities allowing 24 hr computer access;
 - B. Magnetic disk storage shared with Billings Police Dept.;
 - C. Computer processing, program maintenance, operations to support current data processing system;
2. The SHERIFF agrees to pay CITY the sum of One Hundred and Thirty-Four Thousand, Five Hundred and Twenty-one (\$134,521.00) specified in Paragraph Three below. This charge is based on actual computer usage for the period of January 1, 2015 thru December 31, 2015.
3. This Agreement shall be in effect for twelve (12) months beginning July 1, 2016, and continuing until June 30, 2017.
4. Payment shall be made in two equal installments of \$67,260.50. The first installment is due and payable on or before October 20, 2016, and the second is due and payable on or before April 15, 2017.

AGREEMENT DATED _____, 20_____.

YELLOWSTONE COUNTY

CITY OF BILLINGS

BY: [Signature]
Sheriff

Mayor

[Signature]
Chair, County Commissioners

City Clerk

ATTEST: [Signature]
Clerk and Recorder

City Attorney

Approved as to Form:

[Signature]
County Attorney

Regular City Council Meeting

Meeting Date: 05/09/2016

TITLE: Acknowledge Receipt of Petition to Vacate a portion of Montgomery Street and Set a Public Hearing

PRESENTED BY: David Mumford, Public Works Director

Department: Public Works

PROBLEM/ISSUE STATEMENT

Popelka Enterprises had petitioned to vacate a portion of Montgomery Street near Hansen Lane. The property owner is proposing to re-develop the area and the Montgomery Street right of way will be utilized in their development. Montgomery Street only extends a short distance south of Hansen Lane and appears to be a driveway into the Albertsons. Since the street cannot be extended in the future, there is no need to have this portion of street. There is a sanitary sewer main in Montgomery, and it will remain in place and the city will have the same access to it as today per state law. The area of the right of way proposed to be vacated is 3,900 square feet.

ALTERNATIVES ANALYZED

The Council may:

- Approve acknowledgment of petition to vacate the above-mentioned right-of-way and set a public hearing for June 13, 2016; or
- Do not acknowledge the petition and terminate the right-of-way vacation process.

FINANCIAL IMPACT

George Warmer from Coldwell Bankers has established value of the right of way at \$5.05 per square foot. The total value of the right of way is \$19,695.

RECOMMENDATION

Staff recommends City Council acknowledge the receipt of a petition to vacate a portion of Montgomery Street and set a public hearing for June 13, 2016.

APPROVED BY CITY ADMINISTRATOR

Attachments

Exhibit
Valuation Letter

EXHIBIT "A"

PROPOSED RIGHT-OF-WAY VACATION



VICINITY MAP
NOT TO SCALE

DATE:	02/11/2016
FILE:	02161001000
PROJECT NO.:	15002
DATE:	02/11/2016
PROJECT NO.:	15002
DATE:	02/11/2016
PROJECT NO.:	15002
DATE:	02/11/2016
PROJECT NO.:	15002
DATE:	02/11/2016
PROJECT NO.:	15002

MONTGOMERY STREET
 LOT 1A, BLOCK 2 OF HANSEN LANE SUB.
 LOT 1A, BLOCK 2 OF MALTESE SUB.
 BILLINGS, MONTANA
 RIGHT-OF-WAY VACATION EXHIBIT

1.0

SCALE 1" = 40'



TO PLAN AND DESIGN INCLUDING COMMUNITIES...

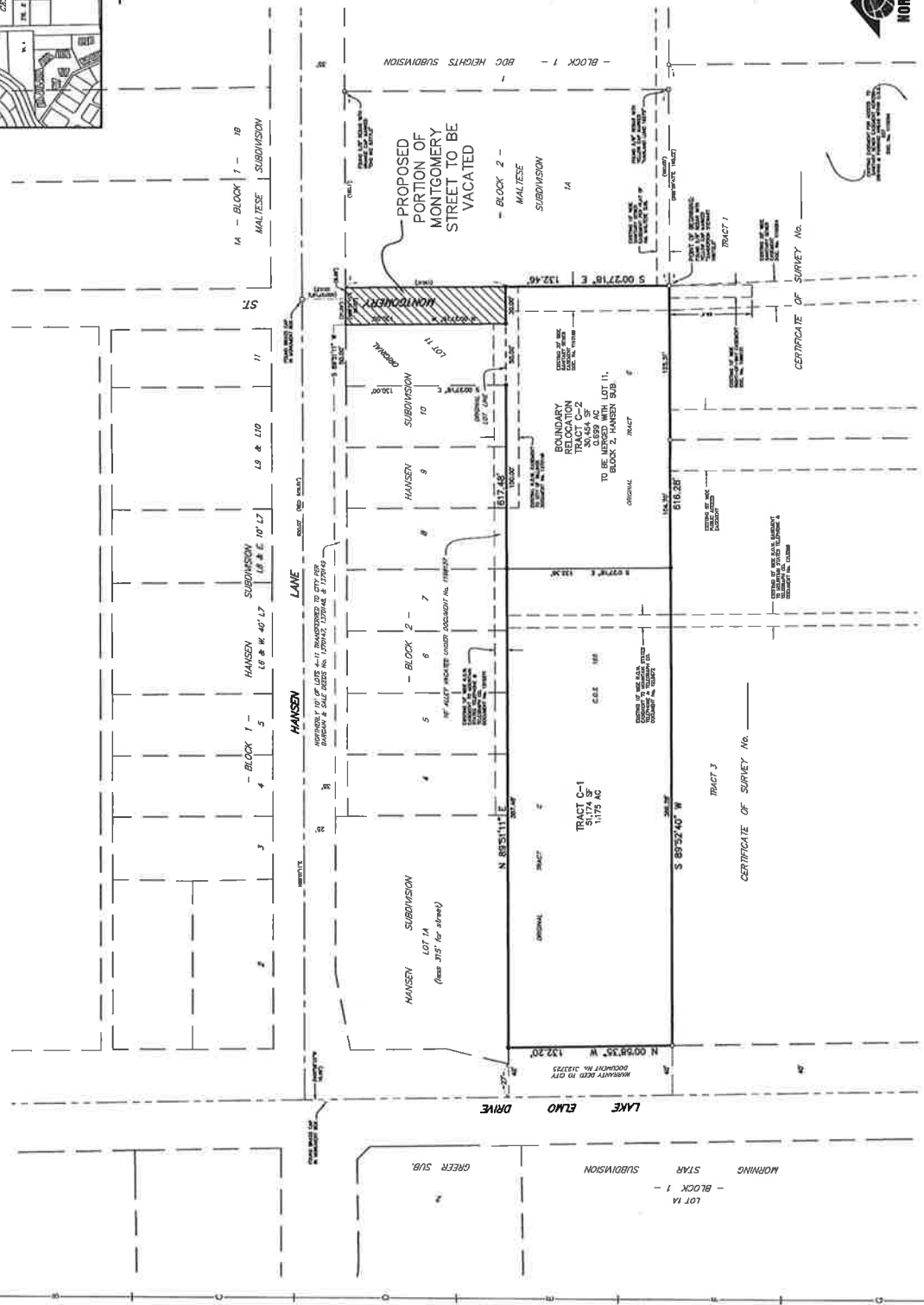



COLDWELL BANKER COMMERCIAL
CBS
1215 24TH STREET WEST
BILLINGS, MT 59102
BUS (406) 656-2001
FAX (866) 795-7999
www.cbcmontana.com

March 28, 2016

Chris Hertz
City of Billings

RE: Broker's Evaluation for the attached lot description:

Dear Chris,

We have evaluated the subject property. It is the intent of the purchaser to use this land for additional parking for the Albertsons store located to the south. Given the limited potential use of this land and further supported by the negotiated price of the 11 acres under contract immediately to the west of the subject property we believe a value of \$5.05 per square foot is reasonable.

Please do not hesitate to contact us should you have additional questions.

Best regards,

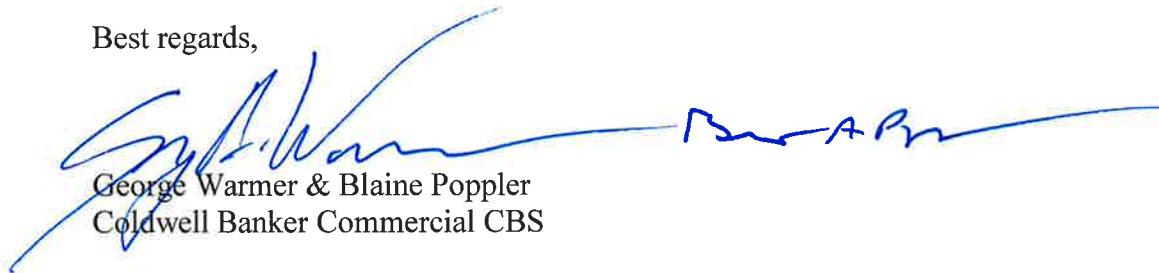
A handwritten signature in blue ink, appearing to read 'George Warmer & Blaine Poppler', written over a horizontal line.

George Warmer & Blaine Poppler
Coldwell Banker Commercial CBS

Regular City Council Meeting

Meeting Date: 05/09/2016

TITLE: Donation \$2500 from St. Vincent Employees - Share Our Spirit

PRESENTED BY: Paul Dextras, Fire Chief

Department: Fire

PROBLEM/ISSUE STATEMENT

The Billings Fire Department has been awarded a grant in the amount of \$2,500 associated with the St. Vincent Hospital "Share Our Spirit" Program. This grant funding comes from internal donations made by employees at St. Vincent that share a desire to help private and public organizations that contribute to the care, wellbeing, and quality of life for citizens and families in our community. The Billings Fire Department responds to hundreds of medical calls that necessitates lifting or moving a patient prior to transport to an area hospital. St. Vincent's "Share Our Spirit" saw this grant as a way to improve overall patient care by funding the purchase of a creative lifting device/equipment that would minimize injuring the patient and enhance firefighter safety associated with lifting injuries.

ALTERNATIVES ANALYZED

City Council may approve or disapprove accepting the \$2,500 donation from St Vincent Healthcare Share Our Spirit Associate's Giving Campaign.

FINANCIAL IMPACT

Accepting this donation will allow the Fire staff to purchase at least three of these patient lift devices which list for \$749.00.

RECOMMENDATION

Staff recommends accepting the \$2,500 donation from the employees of St. Vincent Healthcare under the Share Our Spirit Associate Giving Campaign for the purchase of these new patient lift devices.

APPROVED BY CITY ADMINISTRATOR

Regular City Council Meeting

Meeting Date: 05/09/2016

TITLE: 2015-2019 Transportation Improvement Program (TIP) Amendment III

PRESENTED BY: Candi Millar, Planning & Community Services Department Director

Department: Planning & Community Services

PROBLEM/ISSUE STATEMENT

Federal regulations require that the Billings Metropolitan Planning Organization (MPO) review and update its Transportation Improvement Program (TIP) periodically. Given some funding adjustments with several transportation projects, the current Billings 2015-2019 TIP must be amended to maintain compliance with State and Federal requirements.

The TIP is a short-range program of highway and transit projects in the Billings MPO area and is prepared by City-County Planning Division staff in cooperation with state and local agencies. The purpose of the TIP is to provide the mechanism for scheduling federal funds for surface transportation projects, indicate regional priorities, and demonstrate a short range transportation vision for the area. A secondary purpose of the TIP is to provide information about other transportation projects in the urbanized area that are exempt from the TIP approval process, such as projects that do not utilize federal funds.

This TIP amendment is being presented to the City Council for review due to cost updates to several projects. The projects listed in the TIP that have updates for cost increases include, but are not limited to: 1st Avenue South, Zimmerman Trail, the North Bypass, and several safety projects. Staff has attached the document for reference. The City Council is being asked to review the TIP amendments at this meeting and provide the City Council's designee direction for the Policy Coordinating Committee meeting on May 17, 2016.

ALTERNATIVES ANALYZED

The current TIP includes updates of federal funding for several projects in the Billings area. The City Council may:

- Recommend approval to the Policy Coordinating Committee (PCC) of the 2015-2019 TIP Amendment III as drafted in order to continue the implementation of federally funded transportation projects in the community.
- Recommend modifications to the proposed 2015-2019 TIP Amendment III and present these recommendations to the Policy Coordinating Committee for further consideration.

Not approving the 2015-2019 TIP Amendment III would cause the Billings MPO to be out of compliance with State and Federal requirements and could affect the schedule and completion of transportation projects in the Billings MPO area.

FINANCIAL IMPACT

A range of federal funding sources is available to the Billings Urban Area for the purposes of funding transportation system improvements. A list of those sources is shown in the attached TIP. There is usually no direct impact to City or County funds in budgeting for these projects given the federal funding sources.

RECOMMENDATION

Staff recommends that the City Council review the 2015-2019 TIP Amendment III and forward a recommendation of approval to PCC through its designee. The PCC is scheduled to meet on May 17, 2016 for action on this item.

APPROVED BY CITY ADMINISTRATOR

Attachments

TIP Amendment III
Quick Reference-TIP Amend. III

BILLINGS URBAN AREA

TRANSPORTATION IMPROVEMENT PROGRAM (TIP)



FY 2015-2019

Amendment I - June 23, 2015

Amendment II-December 15, 2015

Amendment III-May 17, 2016

****This document is funded in part through grants from the Federal Highway Administration and Federal Transit Administration, U.S. Department of Transportation. The contents of this document do not necessarily reflect the official views or policy of the U.S. Department of Transportation.**

Prepared by:

Yellowstone County Board of Planning
 Billings Metropolitan Planning Organization

In Cooperation With:

City of Billings
 Yellowstone County
 Yellowstone County Board of Planning
 Montana Department of Transportation
 Federal Highway Administration
 Federal Transit Administration

Reviewed By:	Approval	Amendment I	Amendment II	Amendment III
Technical Advisory Committee	11/25/14	05/21/15	11/05/2015	4/07/16
Yellowstone County Board of Planning	12/09/14	06/09/15	11/24/2015	4/26/16
Billings City Council	11/20/14	06/22/15	11/23/2015	05/09/16
Yellowstone County Commissioners	12/09/14	06/16/15	12/01/2015	05/03/2016
Approved By:				
Billings Policy Coordinating Committee	12/16/14	06/23/15	12/15/2015	05/17/2016
Montana Department of Transportation	01/29/15	01/27/16	01/26/16	
Federal Highway Administration	01/28/15	01/27/16	01/29/16	
Federal Transit Administration	01/28/15	01/27/16	01/29/16	
		01/21/16		
		01/21/16		

TABLE OF CONTENTS

SIGNATURE PAGE..... 1

INTRODUCTION..... 2

FEDERAL REGULATIONS..... 3

FINANCIAL RESOURCES 3

AIR QUALITY CONSISTENCY..... 4

CONFORMITY OF THE BILLINGS AREA TRANSPORTATION IMPROVEMENT PROGRAM
WITH THE 1990 CLEAN AIR ACT 4

TIP CONFORMITY 5

ENERGY CONSERVATION CONSIDERATIONS 6

PROGRAMMING OF NON-URBAN SYSTEM, FEDERAL AID AND STATE FUNDING 6

PRIVATE ENTERPRISE PARTICIPATION..... 12

LIST OF TABLES

TABLE 1: EXEMPT PROJECTS5

TABLE 2: REGIONALLY SIGNIFICANT PROJECTS 6

TABLE 3: TRANSPORTATION REVENUE ESTIMATES (2015-2019)..... 7

TABLES 4A-4C: TRANSPORTATION PRIORITY LIST8-9

TABLE 4D: BENCH BOULEVARD PROJECT 11

TABLE 5: TRANSPORTATION PROJECT PRIORITY LIST FTA SECTIONS 5307, 5309, 5310, 5316, 5317..... 14

TABLE 6: MULTI-YEAR STAGING PROGRAM CALENDAR YEARS 2015-2019 15

TABLE 7: HIGHWAY/TRANSIT MULTI-YEAR IMPROVEMENT PROGRAM FY 2015 16

TABLE 8: HIGHWAY/TRANSIT MULTI-YEAR IMPROVEMENT PROGRAM FY 2016 17

TABLE 9: HIGHWAY/TRANSIT MULTI-YEAR IMPROVEMENT PROGRAM FY 2017 18

TABLE 10: HIGHWAY/TRANSIT MULTI-YEAR IMPROVEMENT PROGRAM FY 2018..... 19

TABLE 11: HIGHWAY/TRANSIT MULTI-YEAR IMPROVEMENT PROGRAM FY 2019.....20

TABLE 12: BIENNIAL ELEMENT JULY 1, 2014-JUNE 30, 2016 (HIGHWAY).....21

TABLE 12: BIENNIAL ELEMENT OCTOBER 1, 2014-SEPTEMBER 30 2016 (TRANSIT).....22

**METROPOLITAN TRANSPORTATION PLANNING PROCESS
SELF-CERTIFICATION**

The Billings Metropolitan Planning Organization for the Billings, Montana, urbanized area hereby certifies that the transportation planning process is addressing the major issues in the metropolitan planning area and is being conducted in accordance with all applicable requirements of:

- I. 49 U.S.C. Section 5303 and 23 U.S.C. 134 and CFR 450.334;
- II. Title VI of the Civil Rights Act of 1964, as amended (42 U.S.C 2000d-1) and 49 CFR, Part 21;
- III. Section 1101(b) of the SAFETEA-LU (Pub. L. 109-59) regarding the involvement of disadvantaged business enterprises in the FHWA and the FTA funded projects (49 CFR part 26);
- IV. The provision of the Americans With Disabilities Act of 1990 (42U.S.C. 12101 *et seq.*) and the U. S. DOT implementing regulation (49 CFR Parts 27, 37 and 38);
- V. The provisions of 49 CFR part 20 regarding restrictions on influencing certain activities; and
- VI. Sections 174 and 176(c) and (d) of the Clean Air Act as amended (42 U.S.C. 7504, 7506(c) and (d)), 40 CFR, part 93.
- VII. 49 U.S.C. 5332, prohibiting discrimination on the basis of race, color, creed, national origin, sex or age in employment or business opportunity.
- VIII. 23 CFR, part 230, regarding the implementation of an equal employment opportunity on Federal & Federal-aid highway construction contracts.
- IX. The Older Americans Act as amended (42 U.S.C. 6101), prohibiting discrimination on the basis of age in program or projects receiving Federal financial assistance.
- X. Section 324 of title 23 U.S.C. regarding the prohibition of discrimination based on gender.
- XI. Section 504 of the Rehabilitation Act of 1973 (29 U.S.C. 794) and 49 CFR, part 27 regarding discrimination against individuals with disabilities.

Billings, Montana

Metropolitan Planning Organization



Richard Clark, President, Yellowstone County Board of Planning

INTRODUCTION

PREFACE

The Yellowstone County Board of Planning (YCBP) is the metropolitan planning organization (MPO) for the Billings metropolitan planning area. The Transportation Improvement Program (TIP) is the funding mechanism for transportation projects requesting federal dollars in the Billings urbanized area. All MPO's are required by the current Federal Highway Bill SAFETEA LU to produce a TIP and update it at least every four years. SAFETEA LU was signed into law by President Bush in 2005, and extended by President Obama through June 2012. The act and extensions authorized highway, highway safety, transit, and other surface transportation programs.

On July 6, 2012 Moving Ahead for Progress in the 21st Century (MAP-21) was signed into law. The law provides federal program funding through the end of Federal Fiscal Year 2014 and brings program structure changes that will be fully addressed in future long range transportation plans and TIPs. This document contains a list of all surface transportation projects requesting the use of federal funds. Local jurisdictions working through the Billings MPO's Policy Coordinating Committee (PCC) determine how the area's transportation system is developed and expanded.

PURPOSE OF THE TIP

The TIP is a short-range program of highway and transit projects in the Billings metropolitan planning area and is prepared by YCBP staff in cooperation with state and local agencies. The basic purpose of the TIP is to provide the mechanism for scheduling federal funds for surface transportation projects, indicating regional priorities, and demonstrating a short range transportation vision for the area. A secondary purpose of the TIP is to provide information about other transportation projects in the planning area that are exempt from the TIP approval process such as projects that do not utilize federal funds.

THE TIP PROCESS

The development of the TIP document is the responsibility of the Billings MPO and provides an opportunity for local officials to determine priorities and spending for federal highway and transit funds. Any transportation project located in the Billings metropolitan planning area must be included in the TIP prior to receiving federal funds. TIP projects must be included in the area's 20 year Transportation Plan, and are proposed for the TIP by local elected officials, transit operating officials, or state highway agencies. The TIP is reviewed and endorsed annually by the Billings MPO's PCC and may be modified through the TIP amendment process. The PCC includes a Billings City Council representative, the Chair of the Yellowstone County Commission, the President of the Yellowstone County Board of Planning and the District Administrator of the Montana Department of Transportation. After PCC endorsement, the TIP is submitted to the Montana Department of Transportation (MDT) and to the Federal Highway Administration and Federal Transit Administration for federal review of the document and approval of conformity and fiscal constraint determination.

FEDERAL REGULATIONS

The Transportation Improvement Program (TIP) is a required planning program for federally assisted highway and transit improvements for the Billings metropolitan planning area and the Montana Department of Transportation (MDT) over a five-year period. The principal focus is given to the first two years of the program, the Biennial Element, which contains projects that could be implemented between July 1, 2015 and June 30, 2017.

The TIP is prepared annually and is in conformance with 23 CFR, Part 450 324-330.

FINANCIAL RESOURCES

A range of federal funding sources is available to the Billings planning area for the purposes of funding transportation system improvements. Following is a list of those sources which, when available to the Billings area, are shown in the Transportation Improvement Program. Project implementation is indicated as expected to occur during the pertinent program year. Billings has had a favorable history of receiving federal earmarks as reflected in the table below.

BILLINGS FEDERAL EARMARK HISTORY – 2003 through 2012

YEAR	EARMARKS
2003	\$ 3,000,000
2004	\$ 2,000,000
2005	\$ 4,960,000
2006	\$ 35,173,900
2007	\$ 0.0
2008	\$ 4,596,200
2009	\$ 4,750,000
2010	\$0.00
2011	\$0.0
2012	\$54,457
TOTAL	\$54,534,557
10 YEAR AVERAGE	\$5,453,455

FUNDING SOURCES

- Surface Transportation Program Urban (STPU)
- Surface Transportation Program Primary (STPP)
- National Highway System (NHS)
- Interstate Maintenance (IM)
- Highway-Railway Crossing Program (RRX)
- Transportation and Community and System Preservation (TCSP)
- Surface Transportation Enhancement (STPE)
- Highway Safety Improvement Program (HSIP)
- Bridge Replacement and Rehabilitation Program (HBRRP)
- Urban Pavement Preservation (UPP)

- Community Transportation Enhancement Program (CTEP)
- State Funded Construction (SFC)
- Congestion Mitigation Air Quality (CMAQ)
- Montana Air Congestion Initiative (MACI)
- FTA Section 5309 (Formerly Sec. 3)
- FTA Section 5307 (Formerly Sec. 9)
- FTA Section 5310 (Formerly Sec. 16)
- Congressionally Directed Funds (MT, NCPD, DEMO)
- Safe Routes to School (SRTS)

AIR QUALITY CONSISTENCY

Billings was designated as a non-attainment area for both Total Suspended Particulates (TSP) and Carbon Monoxide (CO) on March 3, 1978, (Federal Register, Vol. 44, No. 150, page 45421, August 2, 1979). As such, Billings was required to prepare a Transportation Control Plan (TCP). The TCP identified strategies to mitigate the TSP and CO problems. The TCP is the Billings element of Montana's State Implementation Plan (SIP). The TIP is required to be, and is, consistent with the TCP as discussed in the Billings conformity statement.

In 1987 the standard for TSP was dropped, and a new standard for particulate matter under 10 microns in size (PM - 10) was adopted (7/1/87 at 52 FR 24854). The Environmental Protection Agency (EPA), has also adopted the PM 2.5 standard and Billings is considered to be in compliance with both of these new standards.

CONFORMITY OF THE BILLINGS AREA TRANSPORTATION IMPROVEMENT PROGRAM WITH THE 1990 CLEAN AIR ACT

A portion of the Billings Urbanized Area, (Billings), was designated non-attainment for carbon monoxide (CO) on 3/3/78 (43 FR 8962) with a secondary classification of "unclassified". EPA approved the Billings CO Control Plan on 1/16/86 (51 FR 2397). Billings was then re-designated as "Not Classified" on 11/6/91 (56 FR 56697). The area meets the qualifications of the Clean Air Act (CAA) for classification as an attainment area for ozone.

The Billings "not classified" carbon monoxide (CO) nonattainment area was re-designated by the Environmental Protection Agency (EPA) to attainment for the CO National Ambient Air Quality Standards (NAAQS) with an approved limited maintenance plan effective April 22, 2002. Under a CO limited maintenance plan, the motor vehicle emissions budgeted may be treated as essentially non-constraining for the length of the maintenance period because growth would need to exceed reasonable expectations to create a violation of the NAAQS for transportation-related CO. Therefore conformity demonstration using regional emissions analysis is not required; however, individual projects may still be required to conduct "hot spot" analysis.

As demonstrated in the following sections, the Transportation Improvement Program (TIP) satisfactorily meets the requirements established by the 1990 amendments to the CAA regarding the conformity of TIP's.

- The most recent estimates of CO mobile source emissions have been developed by the Analytical Services Section, Montana Department of Environmental Quality and are based upon development and transportation data provided by the Yellowstone County Board of Planning.
- EPA has approved the second 10-year carbon monoxide (CO) maintenance plan for the Billings area. This second 10-year CO maintenance plan meets the requirements of CAA section 175A(b) and is also a Limited Maintenance Plan (as was the maintenance plan with the original 2002 EPA approval.) The second 10-year CO maintenance plan continues to correctly reflect the Limited Maintenance Plan transportation conformity requirements. The EPA-approved Billings second 10-year CO maintenance plan is available at the Planning office.

TRANSPORTATION CONTROL MEASURES

Specific Transportation Control Measures have not been proposed for Billings recently, however, the SIP completed in 1986 included the widening of Exposition Drive (Main Street) and the signalization at Main Street and First Avenue North. Both of these projects were completed in 1983.

There are no Transportation Control Measures (TCM’s) in the State Implementation Plan (SIP) and therefore there are no specific TCM’s recommended for implementation in this TIP.

TIP CONFORMITY

As a prerequisite for receiving Federal-aid transportation funds through the TIP, a determination must be made that the proposed transportation projects do not cause or contribute to violations of the carbon monoxide ambient air quality standards. An analysis, which meets the EPA conformity determination regulations specified in 40 CFR Part 51 was performed in conjunction with the development of the Billings Urban Area 2014 Long Range Transportation Plan. The plan was found to conform at the federal level November 10, 2014. The analysis appears in Section 4, pages 4-24 through 4-27 of the Plan document and is titled "Air Quality/Conformity". As the transportation projects in the TIP are contained in the Transportation Plan's analysis, a separate analysis for the TIP is not necessary.

There are no new regionally significant projects in this 2015-2019 Billings Urban Area TIP.

NEW PROJECTS EXEMPT FROM REGIONAL ANALYSIS-

(Table 1): EXEMPT PROJECTS

Project	Scope	Comments
Exposition Dr & 1 st Ave N-concrete pavement rehab		
27 th St-1 st Ave S to Airport-mill/overlay (pavement preservation)		
2012 Scour Mitigation-Bridge Scour Mitigation (Dick Johnson Bridge)		
I-90 Yellowstone River Bridge-Bridge Replacement		

REGIONALLY SIGNIFICANT PROJECTS

(Table 2): REGIONALLY SIGNIFICANT PROJECTS

Project	Scope	Comments
6 th Avenue/Bench Connection	Reconstruction	Completed, section has functionally classified and added to Urban System
Billings Bypass (aka North Bypass)	Location/Environmental	Ongoing
Bench Boulevard-Billings Phases I and II	Reconstruction	Phase I letting in 2013 Phase II letting anticipated in 2015

ENERGY CONSERVATION CONSIDERATIONS

Energy impact analyses have been conducted as a part of the urban transportation planning process. In addition, increased attention has been given to energy conservation and contingency planning on a project specific basis.

As part of the 2009 update of the Billings Urban Area Transportation Plan, energy conservation was considered in each of the proposed alternative transportation networks.

The City of Billings has a well-developed transit system, and ride-sharing opportunities have been examined. Transit facilities and highway system proposals will continue to be considered in a comprehensive method through the adopted Transportation Planning process.

The detailed energy conservation analysis of specific projects has been conducted for each of the major highway construction projects recommended in the 2009 update of the Billings Urban Area Transportation Plan.

**PROGRAMMING OF NON-URBAN SYSTEM,
FEDERAL AID AND STATE FUNDING**

Proposed projects involving federal-aid funding, other than urban system funding, that are proposed within existing rights-of-way and which are determined to not significantly change traffic patterns, may not be considered to be of appropriate scale to warrant a modification to a currently valid TIP.

When there is knowledge of such projects prior to the annual adoption of the TIP, each project will be included in the program. Generally, projects falling within this category are those which serve to preserve and maintain the integrity of the existing plant or facility such as: overlays to improve or maintain surface conditions; bridge expansion joints and deck repairs necessary to maintain structural and surface sufficiency; slope repair necessary to maintain drainage adequacy; etc. Projects of this nature will be identified by MDT with appropriate justification when requesting program approval of federal highway funds. Local urban area officials will be advised by the Department through the local planning process of the Department's intent to expend federal funds (non-urban system) for such improvements in their area.

(Table 3) -TRANSPORTATION REVENUE ESTIMATES (2015-2019)

BILLINGS, MONTANA																		
YEAR	SURFACE TRANS PROGRAM (STP) (URBAN)*	CMAQ LOCAL	MONTANA AIR CONGESTION INITIATIVE (MACI)*	EARMARKS (MT/NCPD/ DEMO)	SURFACE TRANSPORTATION ENHANCEMENT**	TRANSPORTATION ALTERNATIVES (TA)	NATIONAL HWY SYSTEM (NHS) INTERSTATE MAINTENANCE (IM)	STATE HSP UPP RRP MDT-MACI BR	GAS TAX		TRANSIT SEC 5307		TRANSIT SEC 5310	TRANSIT SEC TRANSADE	TRANSIT SEC 5339	OTHER FUNDS (LOCAL)	TOTAL	
CARRYFORWARD	\$ 12,016,934	\$ 6,232,673	\$ -	\$ 25,141,588	\$ 2,030,301													\$ 45,421,496
2015									CITY	\$ 1,771,687	OPER.	\$ 1,718,629		\$ 70,000		OPER.	\$ 2,421,696	\$ 5,982,012
	\$ 2,489,770	\$ 1,432,171	\$ 589,817			\$ 195,400	\$ 2,674,304	\$ 2,575,215	COUNTY	\$ 291,791	CAP		\$ 160,000		\$ 420,000	CAP	\$ 145,000	\$ 10,973,468
2016									CITY	\$ 1,771,687	OPER.	\$ 1,718,629		\$ 70,000		OPER.	\$ 2,421,696	\$ 5,982,012
	\$ 2,489,770	\$ 1,516,062	\$ 6,289,900			\$ 700,000	\$ 4,478,369	\$ 4,594,176	COUNTY	\$ 291,791	CAP		\$ 160,000		\$ 420,000	CAP	\$ 145,000	\$ 21,085,068
2017									CITY	\$ 1,771,687	OPER.	\$ 1,718,629		\$ 70,000		OPER.	\$ 2,421,696	\$ 5,982,012
	\$ 2,489,770	\$ 1,516,062	\$ 5,253,600			\$ 700,000	\$ 30,235,737	\$ 3,885,397	COUNTY	\$ 291,791	CAP		\$ 160,000		\$ 420,000	CAP	\$ 145,000	\$ 45,097,357
2018									CITY	\$ 1,771,687	OPER.	\$ 1,718,629		\$ 70,000		OPER.	\$ 2,421,696	\$ 5,982,012
	\$ 2,489,770	\$ 1,516,062	\$ 750,000			\$ 700,000	\$ 11,017,916	\$ 43,890,459	COUNTY	\$ 291,791	CAP		\$ 160,000		\$ 420,000	CAP	\$ 145,000	\$ 61,380,998
2019									CITY	\$ 1,771,687	OPER.	\$ 1,718,629		\$ 70,000		OPER.	\$ 2,421,696	\$ 5,982,012
	\$ 2,489,770	\$ 1,516,062	\$ 750,000			\$ 700,000	\$ 10,955,807	\$ 2,293,788	COUNTY	\$ 291,791	CAP		\$ 160,000		\$ 420,000	CAP	\$ 145,000	\$ 19,722,218
TOTAL	\$ 24,465,784	\$ 13,729,092	\$ 13,633,317	\$ 25,141,588	\$ 2,030,301	\$ 2,995,400	\$ 59,362,133	\$ 57,239,035		\$ 10,317,390		\$ 8,593,145	\$ 800,000	\$ 350,000	\$ 2,100,000		\$ 12,833,480	\$ 233,590,665

Given current funding uncertainties and unknown impacts of future congressional or other Federal actions, Federal funding available may affect the programming of projects.

*Includes Non-Federal Match

**Surface Transportation Enhancement (CTEP) funding no longer available after 2015

***Funds to be transferred to 5307

TABLE 4(a) -TRANSPORTATION PRIORITY LIST BILLINGS, MONTANA						
PROJECT	TYPE OF WORK	PROJECT LENGTH	PHASE	ESTIMATED COST	FUNDING SOURCE	
SURFACE TRANSPORTATION PROGRAM-URBAN (STPU)						
BENCH BLVD-US 87 INTERSECTION	Reconstruction		IC	\$195,095	STPU	
			CN	\$264,950	STPU	
			TOTAL	\$460,045		
BENCH BLVD	Reconstruction		RW	\$525,000	STPU	
			IC	\$5,018	STPU	
			TOTAL	\$530,018		
BENCH BLVD HILLTOP/PEMBERTON	Reconstruction		CN	\$3,660,751	STPU	
			TOTAL	\$3,660,751		
BILLINGS BYPASS	New Construction	5	CN	\$9,063,570	STPU	
			TOTAL	\$9,063,570		
CONGESTION MITIGATION AIR QUALITY (CMAQ) Local Match						
BENCH BLVD HILLTOP/PEMBERTON	Reconstruction		CN	\$7,150,649	CMAQ	
			TOTAL	\$7,150,649		
MONTANA AIR CONGESTION INITIATIVE (MACI) State Match						
27th St-1ST AVE S to AIRPORT	Signal Optimization		CN	\$4,503,600	MACI	
			TOTAL	\$4,503,600		
UNDERPASS AVE IMPROVEMENTS	Study		OT	\$309,337	MACI	
			PE	\$0		
			CN	\$0		
			TOTAL	\$309,337		
AIRPORT RD & MAIN ST - BLGS	Study		OT	\$152,503	MACI	
			PE	\$0		
			CN	\$0		
			TOTAL	\$152,503		
BILLINGS SIGNAL UPGRADES	Signal Optimization		OT	\$320,869	MACI	
			TOTAL	\$320,869		
LOCKWOOD SIGNALS - BILLINGS	Signal Optimization		OT	\$18,948	MACI	
			TOTAL	\$18,948		
DOWNTOWN STATE SIGNALS BLGS	Signals		PE	\$250,000	MACI	
			CN	\$6,272,824	MACI	
			TOTAL	\$6,522,824		
1ST AVE SOUTH - ADA(BLGS)	Signals		PE	\$331,111	MACI	
			CN	\$1,499,589	MACI	
			TOTAL	\$1,830,700		
MDT-MACI	Statewide CMAQ - Various		PE/OTHER	\$1,000,000	MACI	
			TOTAL	\$1,000,000		
MDT-MACI	Statewide CMAQ - ADA Compliancy		PE/OTHER	\$1,750,000	MACI	
			TOTAL	\$1,750,000		
HEARINGS/DISCRETIONARY GRANTS						
BENCH BLVD-US 87 INTERSECTION	Reconstruction	3	CN	\$2,114,314	MT	
			TOTAL	\$2,114,314		
ZIMMERMAN TRAIL	Rockfall Mitigation	1	PE	\$571,014	MT	
			CN	\$988,521	MT	
			TOTAL	\$1,559,535		
ZIMMERMAN TRAIL	Roadway Improvements		PE	\$941,150	MT	
			RW	\$119,484	MT	
			CN	\$3,237,320	MT	
			LOCAL	\$880,373	LOCAL	
			TOTAL	\$5,178,327		
BILLINGS BYPASS	New Construction	5	OT/ENV	\$4,689,600	NCPD	
			PE	\$9,909,000	MT/NCPD	
			RW	\$7,847,000	MT	
			TOTAL	\$22,445,600		
INTERSTATE MAINTENANCE (IM)						
VARIOUS PROJECTS	Pavement Preservation		PE/CN	Per Project	IM	
D5 INTERSTATE FENCING (only portion in MPO area)	Fencing		CN	\$700,000	IM	
			TOTAL	\$700,000		
PINEHILLS INTCH-PRYOR CR INTCH (only portion in MPO area)	Pavement Preservation		PE	\$30,307	IM	
			CN	\$857,250	IM	
			TOTAL	\$887,557		

TABLE 4(b)-TRANSPORTATION PRIORITY LIST BILLINGS, MONTANA					
I-90 Yellowstone River-Billings	Replace Bridges		IC	\$386,894	IM
			RW	\$386,894	IM
			CN	\$6,190,400	IM
			TOTAL	\$6,964,188	
NATIONAL HIGHWAY SYSTEM - (NH)					
MDT PREVENTIVE MAINTENANCE	Pavement Preservation		ALL	Per Project	NH
BILLINGS - NW	Pavement Preservation		CN	\$4,946,400	NH
			TOTAL	\$4,946,400	
MAIN ST - BILLINGS	Pavement Preservation		CN	\$7,441,200	NH
			TOTAL	\$7,441,200	
AIRPORT RD - ZIMMERMAN TRAIL	Pavement Preservation		PE	\$75,690	NH
			CN	\$2,227,383	NH
			TOTAL	\$2,303,073	
27th St-1ST AVE S to Airport	Pavement Preservation		RW	\$126,712	NH
			IC	\$126,712	NH
			CN	\$7,661,595	NH
			TOTAL	\$7,915,019	
BILLINGS BYPASS	New Construction	5	IC	\$3,188,004	NH
			TOTAL	\$3,188,004	
EXPOSITION DR & 1ST AVE N BLGS	Pavement Preservation		PE	\$126,989	NH
			CN	\$1,257,185	NH
			TOTAL	\$1,384,174	
MT3-ZIMMERMAN TR INTRSCCT IMPRV	Intersection Improvement		PE	\$716,907	NH
			RW	\$94,032	NH
			IC	\$62,688	NH
			CN	\$2,199,400	NH
			TOTAL	\$3,073,027	
1st AVENUE NORTH - BILLINGS	Major Rehabilitation		PE	\$1,024,945	NH
			RW	\$64,058	NH
			IC	\$64,058	NH
			CN	\$8,455,807	NH
			TOTAL	\$9,608,868	
BRIDGE (BH, BR)					
2012 Scour Mitigation (Yellowstone River (Dick Johnson Bridge))	Mitigation		PE	\$79,000	BH
			CN	\$520,000	STPB
			TOTAL	\$599,000	
I-90 Yellowstone River-Billings	Replace Bridges		PE	\$5,557,600	BR
			CN	\$38,599,300	BR
			TOTAL	\$44,156,900	
SURFACE TRANSPORTATION PROGRAM-URBAN PAVEMENT PRESERVATION (UPP)					
1ST AVE S-MINN AVE-13 ST-BLGS	Pavement Preservation		CN	\$964,700	UPP
			TOTAL	\$964,700	
4TH AVE N-13TH ST TO MAIN-BLG	Pavement Preservation		CN	\$452,300	UPP
			TOTAL	\$452,300	
6TH AVE N- 27TH TO 32ND (BLGS)	Pavement Preservation		PE	\$63,076	UPP
			CN	\$347,900	UPP
			TOTAL	\$410,976	
DIVISION STREET - BILLINGS	Pavement Preservation		PE	\$63,076	UPP
			CN	\$527,100	UPP
			TOTAL	\$590,176	
VARIOUS PROJECTS 2015-2019	Pavement Preservation		PE/CN	Per Project	UPP
HIGHWAY SAFETY (HSIP)					
SF 129-RNDBABOUT KING 56TH	Roundabout		PE	\$705,817	HSIP
			RW	\$165,000	HSIP
			IC	\$308,984	HSIP
			CN	\$3,044,800	HSIP
			TOTAL	\$4,224,601	
SF 139-RNDBABOUT CENTRAL/56TH	Roundabout		PE	\$784,985	HSIP
			RW	\$253,976	HSIP
			IC	\$126,988	HSIP
			CN	\$2,159,737	HSIP
			TOTAL	\$3,325,686	
SF 139 13TH/PARKHILL SIGNAL	Signal		PE	\$65,780	HSIP
			CN	\$445,600	HSIP
			TOTAL	\$511,380	

TABLE 4(c)-TRANSPORTATION PRIORITY LIST BILLINGS, MONTANA				
HIGHWAY SAFETY (HSIP)-CONTINUED				
MT3-ZIMMERMAN TR INTRSTCT IMPRV	Intersection Improvement	CN	\$2,131,422	HSIP
		TOTAL	\$2,131,422	
SF-149 HILLCREST RIGHT TURN LN.	Intersection Improvement	PE	\$30,098	HSIP
		CN	\$300,975	HSIP
		TOTAL	\$331,073	
SF 129 BILLINGS HORIZONTAL CURVE SIGNAGE	Signage	PE/CN	\$1,126,611	HSIP
		TOTAL	\$1,126,611	
SF-149 CLRS BILLINGS NORTH(only portion in MPO)	Centerline Rumble Strips	PE	\$27,851	HSIP
		CN	\$285,000	HSIP
		Total	\$312,851	
SF 149 - KING INTCH SFTY IMPRV	Safety	PE	\$4,114	HSIP
		CN	\$10,275	HSIP
		TOTAL	\$14,389	
SF 149 CLRS BILLINGS SOUTH(only portion in MPO)	Centerline Rumble Strips	PE	\$1,400	HSIP
		CN	\$10,400	HSIP
		TOTAL	\$11,800	
VARIOUS SAFETY PROJECTS	Safety	ALL	\$2,250,000	HSIP
			\$2,250,000	
OTHER FUNDING				
STP ENHANCEMENTS	Various Projects	OTHER	\$2,030,301	CTEP
ANNUAL OPERATION AND MAINTENANCE	Various Projects	OTHER	\$225,000	LOCAL
MDT-MACI	Equipment Purchase	OTHER	\$220,562	CMAQ/LOCAL
TRANSPORTATION ALTERNATIVES PROGRAM	Various Projects	OTHER	Per Project	TA
STATE FUNDED MAINTENANCE	Various Projects	OTHER	\$1,746,000	STATE
		TOTAL	\$4,221,863	
CN Estimates Include CE Costs				

(Table 4d) Bench Blvd

Project	Description	Phase	Program Schedule					Funding Source	State 13.42%	Federal 86.58%
			Pre 2013	2014	2015	2016	2017			
Sponsor	Current TIP Est. Cost									
Bench Blvd <i>UPN6041001</i>	Preliminary Engineering	PE	\$87,892		\$23,684			STPU	\$14,973	\$96,603
		PE	\$2,990,428		\$67,932			MT-Earmark	\$410,432	\$2,647,928
		IC**	\$1,269,416		\$136,668			MT-Earmark	\$188,696	\$1,217,388
		IC			\$502,554			STPU	\$67,443	\$435,111
		RW	\$1,585,000					MT-Earmark	\$212,707	\$1,372,293
		RW			\$525,000			STPU	\$70,455	\$454,545
		CN	\$3,479,201		-\$136,666			MT-Earmark	\$448,568	\$2,893,967
		CN	\$1,629,618		-\$52,153			STPU	\$211,696	\$1,365,769
			\$12,108,574	Total	\$11,041,555	\$0	\$1,067,019	\$0	\$0	\$1,624,971
Bench Blvd <i>UPN6041002</i> BENCH BLVD-US 87 INTERSECTION	Reconstruction of roadway.	IC			\$195,095			STPU	\$26,182	\$168,913
		CN			\$2,114,314			MT-Earmark	\$283,741	\$1,830,573
		CN			\$264,950			STPU	\$35,556	\$229,394
			\$2,574,359	Total	\$0	\$0	\$2,574,359	\$0	\$0	\$345,479
Bench Blvd <i>UPN6041003</i> BENCH BLVD-HILLTOP/PEMBERTON	Reconstruction of roadway and bridge.				\$5,036,394	\$2,114,255		CMAQ/MT*	\$959,617	\$6,191,032
		CN				\$3,660,751		STPU	\$491,273	\$3,169,478
			\$10,811,400	Total	\$0	\$0	\$5,036,394	\$5,775,006	\$0	\$1,450,890
Totals	\$25,494,333		\$11,041,555	\$0	\$8,677,772	\$5,775,006	\$0	\$3,421,339	\$22,072,994	

Funding projections are based on best available information and are subject to change given current funding uncertainties and unknown impacts of future congressional or other federal actions.

*Excess apportionment being spent from CMAQ authority.

** Includes non par funds of \$29,830

ADVANCEMENT OF PROJECTS

It is mutually agreed that the first two years of this program is the best estimate of the project phase that will be undertaken during the Biennial timeframe. Occasionally, projects advance through the design process faster than anticipated. An approved project may accelerate into the next logical phase providing that the funding source does not change from that, which was initially identified in the TIP. Federal, State, and local governments have agreed that a TIP revision is not required in order to accelerate a specific project phase, so long as other planned work is not unduly delayed. The priorities with regard to the FTA Section 5307 projects in the Biennial Element are: 1) Operating Assistance.

- The priorities with regard to the FTA Section 5310 projects in the Biennial Element are: 1) Replacement vehicles for MET Special Transit, 2) Replacement vehicles for MET Special Transit.
- The priorities with regard to the FTA Section 5309 projects are: 1) Livability Grant for ITS.

PRIVATE ENTERPRISE PARTICIPATION

Both the City of Billings and Yellowstone County have locally developed policies and procedures to examine opportunities for private sector participation in the provision of transit services and related support services. The City of Billings adopted resolution 86-15346 which states said policy and provides a process for implementation. The Council approved that resolution on July 7, 1986. Further, a Private Transportation Enterprise Participation Policy (PEP) and implementing procedures were adopted by the MPO's Technical Advisory Committee on April 24, 1986; by the Policy Coordinating Committee on May 8, 1986; and by the Yellowstone County Planning Board on May 13, 1986.

The City's MET Transit Department has examined various opportunities for private sector provision of services. The Department utilizes private tire firms to handle parts of servicing of the tire inventory. The Department also contracts with various private firms for radiator repair, air compressor rebuilds, as well as glass, bodywork on the vehicles, and occasional component rebuilds.

The required TIP documentation related to the PEP process is as follows:

- a) The City of Billings MET Transit System solicited the possible interest or involvement of the private sector in providing leased tires for the MET Transit fleet of coaches. In the spring of 1993, 1996, 2001, 2006 and 2011, a Request for Bids was sent to potentially interested private vendors and was also advertised in a local newspaper and a national transit journal. Bids are evaluated based on cost and ability to perform. Three firms requested bid packages. The current contract for the tire lease is in effect through August 31, 2012 with four additional one-year renewal options.
- b) No other proposals were received from the private sector.
- c) There are no known impediments to holding service out for competition.
- d) There are no known private sector complaints.

The Yellowstone County-City of Billings Planning Division has and will continue to follow its adopted policy and procedures regarding private sector participation. The mailing list of private providers has been updated and used to provide notice about TAC and PCC meetings, including those that deal with the Unified Planning Work Program, (UPWP), projects and process as well as the TIP process. Through these mailings the private providers are aware of the development of the proposed transit capital and operating projects as well as the proposed paratransit capital projects for the five years covered in the TIP.

FEDERAL TRANSIT ADMINISTRATION PROJECTS

The Federal Transit Act funded projects, including FTA Section 5309 grant projects, (Biennial Element) are intended to insure the continued efficient operation, maintenance and administration of the MET Transit system fleet and facilities, including meeting federal regulations such as the Americans with Disabilities Act (ADA). The operating grants are for the fiscal years of July 2015 to June 2016 and July 2015 to June 2016 and the Section 5309 grant projects will permit Bus and Bus Facilities projects in Fiscal Years 2015-2016 through 2015-2016.



The vehicle purchases for MET Special Transit are projects to enable the City to continue providing the required specialized demand-responsive paratransit service for citizens who are unable to use the MET Transit System due to their disabling conditions. The projects to purchase vehicles for other entities will address some of the transportation needs of developmentally impaired or disabled residents.

(Table 5) - TRANSPORTATION PROJECT PRIORITY LIST		
BILLINGS, MONTANA		
SECTION/PROJECT		PROJECT ESTIMATE
FTA SECTION 5307 (INCLUDES LOCAL FUNDS)		
	OPERATING PROJECT (7-1-2014 TO 6-30-2015)	4,140,325
	OPERATING PROJECT (7-1-2015 TO 6-30-2016)	4,140,325
	OPERATING PROJECT (7-1-2016 TO 6-30-2017)	4,140,325
	OPERATING PROJECT (7-1-2017 TO 6-30-2018)	4,140,325
	OPERATING PROJECT (7-1-2018 TO 6-30-2019)	4,140,325
	TOTAL	\$20,701,625
FTA SECTION 5310(INCLUDES LOCAL FUNDS)		
	REPLACEMENT VEHICLES-TRANSIT (FY2015)	192,000
	REPLACEMENT VEHICLES-TRANSIT (FY2016)	192,000
	REPLACEMENT VEHICLES-TRANSIT (FY2017)	192,000
	REPLACEMENT VEHICLES-TRANSIT (FY2018)	192,000
	REPLACEMENT VEHICLES-TRANSIT (FY2019)	192,000
* DEPENDENT ON FUNDING AND APPLICATION APPROVALS BY MDT		
	*TOTAL	\$960,000
FTA SECTION 5311* #Funds transferred to 5307		
	OPERATING PROJECT (2015)	0
	OPERATING PROJECT (2016)	0
	OPERATING PROJECT (2017)	0
FTA SECTION 5339 (INCLUDES LOCAL FUNDS)		
	CAPITAL PROJECTS 2015	525,000
	CAPITAL PROJECTS 2016	525,000
	CAPITAL PROJECTS 2017	525,000
	CAPITAL PROJECTS 2018	525,000
	CAPITAL PROJECTS 2019	525,000
	TOTAL	\$2,625,000
TRANSADE (STATE FUNDED)		
	OPERATING PROJECT (2015)	\$70,000
	OPERATING PROJECT (2016)	\$70,000
	OPERATING PROJECT (2017)	\$70,000
	OPERATING PROJECT (2018)	\$70,000
	OPERATING PROJECT (2019)	\$70,000
	TOTAL	\$350,000
	TOTAL	\$24,636,625

**(Table 6) - MULTI-YEAR STAGING PROGRAM
CALENDAR YEARS 2015-2019
BILLINGS, MONTANA**

PROJECTS	2015	2016	2017	2018	2019	>2019
BENCH BLVD-BILLINGS						
BENCH BLVD-US 87 INTERSECTION						
BENCH BLVD-HILLTOP/PEMBERTON						
BILLINGS BYPASS						
BILLINGS BYPASS						
TRANSPORTATION ALTERNATIVES PROJECTS (VARIOUS)	Per Project-----					
ZIMMERMAN TRAIL						
MT3-ZIMMERMAN TR. INTERSECT. IMPROVE.						
1ST AVENUE NORTH - BILLINGS						
D5 IM FENCING CHAINLINK						
MDT PREVENTIVE MAINTENANCE (NH)	Per Project-----					
MDT PREVENTIVE MAINTENANCE (IM)	Per Project-----					
STP URBAN PAVEMENT PRESERVATION(UPP)	Per Project-----					
ADA COMPLIANCE	Per Project-----					
2012 SCOUR MITIGATION						
I-90 YELLOWSTONE RIVER-BILLINGS						
SF 129-RNDABOUT KING 56TH						
SF 129 BILLINGS HORIZONTAL CURVE SIGNAGE						
SF 139-RNDABOUT CENTRAL/56TH						
SF 139-13TH/PARKHILL SIGNAL						
27TH ST. - 1ST AVE S TO AIRPORT						
4TH AVE N - 13TH ST TO MAIN BLG						
BILLINGS SIGNAL UPGRADES						
LOCKWOOD SIGNALS - BILLINGS						
PINEHILLS INTCH-PRYOR CR INTCH						
AIRPORT RD-ZIMMERMAN TRAIL						
6TH AVE N-27TH TO 32ND (BLGS)						
DIVISION STREET - BILLINGS						
SF-149 HILLCREST RIGHT TURN LN						
SF-149 CLRS BILLINGS NORTH						
SF 149 CLRS BILLINGS SOUTH						
SF-149 KING INTCH SFTY IMPRV						
CTEP - VARIOUS PROJECTS						
DOWNTOWN STATE SIGNALS BLGS						
BILLINGS-NW						
MAIN ST BILLINGS						
EXPOSITION DR & 1ST AVE						
1ST AVE S - MINN AVE 13TH ST BLGS						
1ST AVE S - ADA (BLGS)						

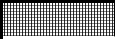
***ALL TIME FRAMES ARE APPROXIMATE

	PRELIMINARY ENGINEERING
	RIGHT OF WAY/UTILITIES
	CONSTRUCTION

(Table 7) - HIGHWAY/TRANSIT MULTI-YEAR IMPROVEMENT PROGRAM FISCAL YEAR 2015
BILLINGS, MONTANA

PROJECT DESCRIPTION	UPN	PHASING	STP URBAN (STPU)	CMAQ LOCAL	MT. AIR CONGESTION INITIATIVE (MACT)	EARMARKS (MT, NCPD, DEMO)	SURFACE TRANSPORTATION PROJECTS STPE	TRANSPORTATION ALTERNATIVES PROGRAM (TA)**	NATIONAL HWY SYSTEM (NHS) INTERSTATE MAINTENANCE (IM)	HSIP UPP RRP BRIDGE	TRANSIT SEC 5307	TRANSIT SEC 5310**	TRANSADA	TRANSIT SEC 5339**	OTHER FUNDS*	TOTAL
Estimated carryover balance			\$ 12,016,934	\$ 6,232,673	\$ -	\$ 25,141,588	\$ 2,030,301	\$ -				\$ 27,000				
Estimated allocation			\$ 2,489,770	\$ 1,432,171	\$ -		\$ -	\$ 195,400	\$ 2,674,304		\$ 1,718,629	\$ 160,000	\$ 70,000	\$ 420,000	\$ 2,566,696	
Estimated beginning balance			\$ 14,506,704	\$ 7,664,844	\$ -	\$ 25,141,588	\$ 2,030,301	\$ 195,400				\$ 187,000				
MT3-ZIMMERMAN TR INTRSCCT IMPRV	8888	PE							\$ 716,907							\$ 716,907
BENCH BOULEVARD-BILLINGS	6041	RW / IC / CN	\$ 851,516													\$ 851,516
BENCH BLVD-US 87 INTERSECTION	6041	IC/CN	\$ 460,045			\$ 2,114,314										\$ 2,574,359
BENCH BLVD-HILLTOP/PEMBERTON	6041	CN		\$ 5,036,394												\$ 5,036,394
BILLINGS BYPASS	4199	PE/RW				\$ 17,755,315										\$ 17,755,315
ZIMMERMAN TRAIL	6040	PE				\$ 941,150										\$ 941,150
BILLINGS SIGNAL UPGRADES	9007	OT			\$ 320,869											\$ 320,869
LOCKWOOD SIGNALS - BILLINGS	9012	OT			\$ 18,948											\$ 18,948
TRAFFIC MITIGATION		ALL			\$ 250,000											\$ 250,000
MDT-PREVENTATIVE MAINTENANCE - IM		ALL							\$ 1,500,000							\$ 1,500,000
PINEHILLS INTCH-PRYOR CR INTCH (only portion in MPO)	8986	PE							\$ 30,307							\$ 30,307
MDT-PREVENTATIVE MAINTENANCE - NH		ALL							\$ 350,000							\$ 350,000
AIRPORT RD - ZIMMERMAN TRAIL	8987	PE							\$ 75,690							\$ 75,690
MDT-URBAN PAVEMENT PRESERVATION (UPP)		ALL							\$ 500,000							\$ 500,000
1ST AVE S-MINN AVE-13 ST-BLGS	8592	CN							\$ 964,700							\$ 964,700
4TH AVE N-13TH ST TO MAIN-BLG	8593	CN							\$ 452,300							\$ 452,300
6TH AVE N- 27TH TO 32ND (BLGS)	9003	PE							\$ 63,076							\$ 63,076
DIVISION STREET - BILLINGS	9004	PE							\$ 63,076							\$ 63,076
ENHANCEMENT PROJECTS-VARIOUS LOCATIONS		ALL														\$ -
STPE PONDEROSA SCHOOL PATH - BILLINGS	8183	CN					\$ 176,800									\$ 176,800
STPE ARROWHEAD SCHOOL PATH - BILLINGS	8184	CN					\$ 82,500									\$ 82,500
STPE SWORDS PARK OUTLET TRAIL - BLGS	8185	CN					\$ 117,900									\$ 117,900
STPE POLY DRIVE SCHOOL WALKS - BLGS	8186	CN					\$ 95,500									\$ 95,500
STPE BROADWATER SCHL LSCAPE - BLGS	8836	CN					\$ 188,795									\$ 188,795
STPE 19TH ST W WALKS - BLGS	8837	PE,CN					\$ 130,956									\$ 130,956
STPE POLY DRIVE BIKE/PED - BLGS	8838	CN					\$ 196,434									\$ 196,434
STPE 44TH ST W WALKS - BLGS	8839	PE,CN					\$ 111,312									\$ 111,312
STPE WICKS LN PATH - BLGS	8841	PE,CN					\$ 278,282									\$ 278,282
STPE BARRETT RD PATH - BLGS	8842	PE,CN					\$ 143,277									\$ 143,277
STPE CALHOUN LN WALKS - BLGS	8843	CN					\$ 188,795									\$ 188,795
STPE JACKSON ST WALKS - BLGS	8822	PE,CN					\$ 236,266									\$ 236,266
STPE KING AVE TRAIL - BLGS	8823	PE,CN					\$ 83,484									\$ 83,484
TRANSPORTATION ALTERNATIVES-VARIOUS LOCATIONS		PE						\$ 150,000								\$ 150,000
TA BROADWATER AVE PATH-BILLINGS	8701	PE						\$ 45,400								\$ 45,400
SAFETY PROJECTS VARIOUS		PE/RW/IC/CN								\$ 250,000						\$ 250,000
SF 129 RNDABOUT KING 56TH	8052	RW/IC								\$ 220,000						\$ 220,000
SF-149 HILLCREST RIGHT TURN LN.	8904	PE								\$ 30,098						\$ 30,098
SF-149 CLRS BILLINGS NORTH(only portion in MPO)	8906	PE								\$ 27,851						\$ 27,851
SF 149 - KING INTCH SFTY IMPRV	8941	PE								\$ 4,114						\$ 4,114
SF 149 CLRS BILLINGS SOUTH(only portion in MPO)	8907	PE						\$ 1,400								\$ 1,400
TRANSIT OPERATING (7/2014-6/2015)										\$ 1,718,629			\$ 70,000		\$ 2,421,696	\$ 4,210,325
REPLACEMENT VEHICLES											\$ 187,000				\$ 40,000	\$ 227,000
TRANSIT CAPITAL (7/2014-6/2015)		CAPITAL												\$ 420,000	\$ 105,000	\$ 525,000
TOTAL			\$ 1,311,561	\$ 5,036,394	\$ 589,817	\$ 20,810,779	\$ 2,030,301	\$ 195,400	\$ 2,674,304	\$ 2,575,215	\$ 1,718,629	\$ 187,000	\$ 70,000	\$ 420,000	\$ 2,566,696	\$ 40,186,096

*Local Match for Transit **Dependent on Funding & Application Approvals by MDT ***FUNDS TO BE TRANSFERRED TO 5307

(Table 8) - HIGHWAY/TRANSIT MULTI-YEAR IMPROVEMENT PROGRAM FISCAL YEAR 2016

BILLINGS, MONTANA														TOTAL	
PROJECT DESCRIPTION	UPN	PHASING	STP URBAN (STPU)	CMAQ LOCAL	MT. AIR CONGESTION INITIATIVE (MACI)	EARMARKS (MT, NCPD, DEMO)	TRANSPORTATION ALTERNATIVES PROGRAM (TA)**	NATIONAL HWY SYSTEM (NHS) INTERSTATE MAINTENANCE (IM)	HSIP UPP RRP BRIDGE	TRANSIT SEC 5307	TRANSIT SEC 5310**	TRANSADA	TRANSIT SEC 5339**	OTHER FUNDS*	TOTAL
Estimated carryover balance			\$ 13,195,143	\$ 2,628,450		\$ 4,330,809	\$ -				\$ -				
Estimated allocation			\$ 2,489,770	\$ 1,516,062	\$ -	\$ -	\$ 697,900	\$ 4,478,369	\$ 4,594,176	\$ 1,718,629	\$ 160,000	\$ 70,000	\$ 420,000	\$ 2,566,696	
Estimated beginning balance			\$ 15,684,913	\$ 4,144,512	\$ -	\$ 4,330,809	\$ 697,900				\$ 160,000				
BENCH BLVD-HILLTOP/PEMBERTON	6041	CN	\$ 3,660,751	\$ 2,114,255											\$ 5,775,006
ADA COMPLIANCE		ALL			\$ 250,000										\$ 250,000
1st AVE SOUTH - ADA (BLGS)	9082	ALL			\$ 1,830,700										\$ 1,830,700
TRAFFIC MITIGATION		ALL			\$ 250,000										\$ 250,000
DOWNTOWN STATE SIGNALS BLGS	8036	IC/RW/CN			\$ 3,959,200										\$ 3,959,200
MDT-PREVENTATIVE MAINTENANCE - IM		ALL						\$ 1,500,000							\$ 1,500,000
D5 IM FENCING - CHAIN LINK (only portion in MPO)	8131	CN						\$ 700,000							\$ 700,000
MDT-PREVENTATIVE MAINTENANCE - NH		ALL						\$ 1,000,000							\$ 1,000,000
27th St-1st Ave S to Airport	7910	IC/RW						\$ 253,424							\$ 253,424
MDT-URBAN PVMT PRES (UPP)		ALL							\$ 500,000						\$ 500,000
TRANSPORTATION ALTERNATIVES-VARIOUS LOCATIONS		ALL					\$ 200,000								\$ 200,000
TA BROADWATER AVE PATH-BILLINGS	8701	CN					\$ 497,900								\$ 497,900
1ST AVENUE NORTH - BILLINGS	9022	PE						\$ 1,024,945							\$ 1,024,945
SAFETY PROJECTS VARIOUS		PE/RW/IC/CN							\$ 500,000						\$ 500,000
SF 129 RNDABOUT KING 56TH	8052	CN							\$ 3,044,800						\$ 3,044,800
SF 139-CENTRAL & 56TH RNDABOUT	8611	RW							\$ 253,976						\$ 253,976
SF 149 CLRS BILLINGS NORTH(only portion in MPO)	8906	CN							\$ 285,000						\$ 285,000
SF 149 CLRS BILLINGS SOUTH(only portion in MPO)	8907	CN							\$ 10,400						\$ 10,400
TRANSIT OPERATING (7/16-6/17)		Operating								\$ 1,718,629		\$ 70,000		\$ 2,421,696	\$ 4,210,325
VEHICLE REPLACEMENTS**		Purchase									\$ 160,000			\$ 40,000	\$ 200,000
TRANSIT CAPITAL (7/16-6/17)		Capital											\$ 420,000	\$ 105,000	\$ 525,000
Adjustments			\$ (881)												\$ (881)
TOTAL			\$ 3,659,870	\$ 2,114,255	\$ 6,289,900	\$ -	\$ 697,900	\$ 4,478,369	\$ 4,594,176	\$ 1,718,629	\$ 160,000	\$ 70,000	\$ 420,000	\$ 2,566,696	\$ 26,769,795

*Local Match for Transit **Dependent on Funding & Application Approvals by MDT

(Table 9) - HIGHWAY/TRANSIT MULTI-YEAR IMPROVEMENT PROGRAM FISCAL YEAR 2017															
BILLINGS, MONTANA															
PROJECT DESCRIPTION	UPN	PHASING	STP URBAN (STPU)	CMAQ LOCAL	MT. AIR CONGESTION INITIATIVE (MACI)	EARMARKS (MT, NCPD, DEMO)	TRANSPORTATION ALTERNATIVES PROGRAM (TA)**	NATIONAL HWY SYSTEM (NHS) INTERSTATE MAINTENANCE (IM)	HSIP UPP RRP BRIDGE	TRANSIT SEC 5307	TRANSIT SEC 5310**	TRANSADA	TRANSIT SEC 5339**	OTHER FUNDS*	TOTAL
Estimated carryover balance			\$ 12,025,043	\$ 2,030,257		\$ 4,330,809	\$ -								
Estimated allocation			\$ 2,489,770	\$ 1,516,062	\$ -	\$ -	\$ 700,000	\$ 30,235,737	\$ 3,885,397	\$ 1,718,629	\$ 160,000	\$ 70,000	\$ 420,000	\$ 2,566,696	
Estimated beginning balance			\$ 14,514,813	\$ 3,546,319	\$ -	\$ 4,330,809	\$ 700,000				\$ 160,000				
BILLINGS BYPASS	4199	IC						\$ 3,188,004							\$ 3,188,004
ZIMMERMAN TRAIL	6040	RW					\$ 119,484								\$ 119,484
MT3-ZIMMERMAN TR INTRCST IMPRV	8888	RW/IC						\$ 156,720							\$ 156,720
ADA COMPLIANCE		ALL			\$ 500,000										\$ 500,000
TRAFFIC MITIGATION		ALL			\$ 250,000										\$ 250,000
MDT-PREVENTATIVE MAINTENANCE - IM		ALL						\$ 1,500,000							\$ 1,500,000
PINEHILLS INTCH-PRYOR CR INTCH (only portion in MPO)	8986	CN						\$ 857,250							\$ 857,250
MDT-PREVENTATIVE MAINTENANCE - NH		ALL						\$ 1,000,000							\$ 1,000,000
BILLINGS - NW	8721	CN						\$ 4,946,400							\$ 4,946,400
MAIN ST - BILLINGS	8717	CN						\$ 7,441,200							\$ 7,441,200
27th St-1st Ave S to Airport	7910	CN			\$ 4,503,600			\$ 7,661,595							\$ 12,165,195
EXPOSITION DR & 1st AVE	7908	CN						\$ 1,257,185							\$ 1,257,185
AIRPORT RD - ZIMMERMAN TRAIL	8987	CN						\$ 2,227,383							\$ 2,227,383
MDT-URBAN PVTM PRES (UPP)		ALL							\$ 500,000						\$ 500,000
6TH AVE N- 27TH TO 32ND (BLGS)	9003	CN						\$ 347,783							\$ 347,783
DIVISION STREET - BILLINGS	9004	CN						\$ 526,951							\$ 526,951
TRANSPORTATION ALTERNATIVES-VARIOUS LOCATIONS		ALL					\$ 700,000								\$ 700,000
SAFETY PROJECTS VARIOUS		PE/RW/IC/CN							\$ 500,000						\$ 500,000
SF 129 BILLINGS HORIZONTAL CURVE SIGNAGE(only portion in	7990	CN						\$ 1,126,700							\$ 1,126,700
SF 139 13TH/PARKHILL SIGNAL	8610	CN						\$ 445,600							\$ 445,600
SF 139-CENTRAL & 56TH RNDABOUT	8611	IC						\$ 126,988							\$ 126,988
SF-149 HILLCREST RIGHT TURN LN.	8904	CN						\$ 300,975							\$ 300,975
SF 149 - KING INTCH SFTY IMPRV	8941	CN						\$ 10,400							\$ 10,400
TRANSIT OPERATING (7/16-6/17)		Operating								\$ 1,718,629		\$ 70,000		\$ 2,421,696	\$ 4,210,325
VEHICLE REPLACEMENTS**		Purchase									\$ 160,000			\$ 40,000	\$ 200,000
TRANSIT CAPITAL (7/16-6/17)		Capital											\$ 420,000	\$ 105,000	\$ 525,000
Adjustments															\$ -
TOTAL			\$ -	\$ -	\$ 5,253,600	\$ 119,484	\$ 700,000	\$ 30,235,737	\$ 3,885,397	\$ 1,718,629	\$ 160,000	\$ 70,000	\$ 420,000	\$ 2,566,696	\$ 45,129,543

*Local Match for Transit and Zimmerman Trail **Dependent on Funding & Application Approvals by MDT

(Table 10) - HIGHWAY/TRANSIT MULTI-YEAR IMPROVEMENT PROGRAM FISCAL YEAR 2018

BILLINGS, MONTANA

PROJECT DESCRIPTION	UPN	PHASING	STP URBAN (STPU)	CMAQ LOCAL	MT. AIR CONGESTION INITIATIVE (MACI)	EARMARKS (MT, NCPD, DEMO)	TRANSPORTATION ALTERNATIVES PROGRAM (TA)**	NATIONAL HWY SYSTEM (NHS) INTERSTATE MAINTENANCE (IM)	HSIP UPP RRP BRIDGE	TRANSIT SEC 5307	TRANSIT SEC 5310**	TRANSADA	TRANSIT SEC 5339**	OTHER FUNDS*	TOTAL
Estimated carryover balance			\$ 14,514,813	\$ 3,546,319		\$ 4,211,325									
Estimated allocation			\$ 2,489,770	\$ 1,516,062	\$ -	\$ -	\$ 700,000	\$ 11,017,916	\$ 43,890,459	\$ 1,718,629	\$ 160,000	\$ 70,000	\$ 420,000	\$ 3,447,069	
Estimated beginning balance			\$ 17,004,583	\$ 5,062,381	\$ -	\$ 4,211,325	\$ 700,000				\$ 160,000				
BILLINGS BYPASS(Five Mile Road)	4199	CN	\$ 4,120,036												\$ 4,120,036
ZIMMERMAN TRAIL	6040	CN				\$ 3,237,300								\$ 880,373	\$ 4,117,673
MT3-ZIMMERMAN TR INTRSC T IMPRV	8888	CN						\$ 2,199,400	\$ 2,131,422						\$ 4,330,822
ADA COMPLIANCE		ALL			\$ 500,000										\$ 500,000
TRAFFIC MITIGATION		ALL			\$ 250,000										\$ 250,000
MDT-PREVENTATIVE MAINTENANCE - IM		ALL						\$ 1,500,000							\$ 1,500,000
MDT-PREVENTATIVE MAINTENANCE - NH		ALL						\$ 1,000,000							\$ 1,000,000
MDT-URBAN PVMT PRES (UPP)		ALL							\$ 500,000						\$ 500,000
TRANSPORTATION ALTERNATIVES-VARIOUS LOCATIONS		ALL					\$ 700,000								\$ 700,000
I-90 YELLOWSTONE R-BILLINGS	7972	CN						\$ 6,190,400	\$ 38,599,300						\$ 44,789,700
1ST AVENUE NORTH - BILLINGS	9022	RW/IC						\$ 128,116							\$ 128,116
SAFETY PROJECTS VARIOUS		PE/RW/IC/CN							\$ 500,000						\$ 500,000
SF 139-CENTRAL & 56TH RNDABOUT	8611	CN							\$ 2,159,737						\$ 2,159,737
TRANSIT OPERATING (7/16-6/17)		Operating								\$ 1,718,629		\$ 70,000		\$ 2,421,696	\$ 4,210,325
VEHICLE REPLACEMENTS**		Purchase									\$ 160,000			\$ 40,000	\$ 200,000
TRANSIT CAPITAL (7/16-6/17)		Capital											\$ 420,000	\$ 105,000	\$ 525,000
TOTAL			\$ 4,120,036	\$ -	\$ 750,000	\$ 3,237,300	\$ 700,000	\$ 11,017,916	\$ 43,890,459	\$ 1,718,629	\$ 160,000	\$ 70,000	\$ 420,000	\$ 3,447,069	\$ 69,531,409

*Local Match for Transit **Dependent on Funding & Application Approvals by MDT

(Table 11) - HIGHWAY/TRANSIT MULTI-YEAR IMPROVEMENT PROGRAM FISCAL YEAR 2019

BILLINGS, MONTANA															
PROJECT DESCRIPTION	UPN	PHASING	STP URBAN (STPU)	CMAQ LOCAL	MT. AIR CONGESTION INITIATIVE (MACI)	EARMARKS (MT, NCPD, DEMO)	TRANSPORTATION ALTERNATIVES PROGRAM (TA)**	NATIONAL HWY SYSTEM (NHS) INTERSTATE MAINTENANCE (IM)	HSIP UPP RRP BRIDGE	TRANSIT SEC 5307	TRANSIT SEC 5310**	TRANSIDE	TRANSIT SEC 5339**	OTHER FUNDS*	TOTAL
Estimated carryover balance			\$ 12,884,547	\$ 5,062,381		\$ 974,025									
Estimated allocation			\$ 2,489,770	\$ 1,516,062	\$ -	\$ -	\$ 700,000	\$ 10,955,807	\$ 2,293,788	\$ 1,718,629	\$ 160,000	\$ 70,000	\$ 420,000	\$ 2,566,696	
Estimated beginning balance			\$ 15,374,317	\$ 6,578,443	\$ -	\$ 974,025	\$ 700,000				\$ 160,000				
BILLINGS BYPASS(South RR Connection)	4199	CN	\$ 4,943,534												\$ 4,943,534
ADA COMPLIANCE		ALL			\$ 500,000										\$ 500,000
TRAFFIC MITIGATION		ALL			\$ 250,000										\$ 250,000
MDT-PREVENTATIVE MAINTENANCE - IM		ALL						\$ 1,500,000							\$ 1,500,000
MDT-PREVENTATIVE MAINTENANCE - NH		ALL						\$ 1,000,000							\$ 1,000,000
MDT-URBAN PVMT PRES (UPP)		ALL							\$ 500,000						\$ 500,000
1ST AVENUE NORTH - BILLINGS	9022	CN						\$ 8,455,807							\$ 8,455,807
TRANSPORTATION ALTERNATIVES-VARIOUS LOCATIONS		ALL					\$ 700,000								\$ 700,000
I-90 YELLOWSTONE R-BILLINGS	7972	RW/IC							\$ 773,788						\$ 773,788
SAFETY PROJECTS VARIOUS		PE/RW/IC/CN							\$ 500,000						\$ 500,000
2012 SCOUR MITIGATION	7960	CN							\$ 520,000						\$ 520,000
TRANSIT OPERATING (7/16-6/17)		Operating								\$ 1,718,629		\$ 70,000		\$ 2,421,696	\$ 4,210,325
VEHICLE REPLACEMENTS**		Purchase									\$ 160,000			\$ 40,000	\$ 200,000
TRANSIT CAPITAL (7/16-6/17)		Capital											\$ 420,000	\$ 105,000	\$ 525,000
TOTAL			\$ 4,943,534	\$ -	\$ 750,000	\$ -	\$ 700,000	\$ 10,955,807	\$ 2,293,788	\$ 1,718,629	\$ 160,000	\$ 70,000	\$ 420,000	\$ 2,566,696	\$ 24,578,454

*Local Match for Transit **Dependent on Funding & Application Approvals by MDT

Table 12) - BIENNIAL ELEMENT OCTOBER 1, 2014 - SEPTEMBER 30, 2016 (HIGHWAY)							
BILLINGS, MONTANA							
PROJECT/PHASE	PROJECT NUMBER	PROJECT DESCRIPTION	TOTAL ESTIMATED COST	FEDERAL FUNDS AND SOURCES	NON-FEDERAL FUNDS AND SOURCES	RECIPIENT OF FUNDS	RESPONSIBLE IMPLEMENTING AGENCY
MT3-ZIMMERMAN TR INTRSCCT IMPRV PE/RW/IC	HSIP/NH UPN8888	INTERSECTION IMPROVEMENT	532,852	479,567 FHWA	53,285 STATE MATCH	MDT	MDT
BENCH BLVD-US 87 INTERSECTION IC/CN	STPU/MT 1036() UPN6041002	RECONSTRUCTION	2,574,359	2,228,880 FHWA	345,479 STATE MATCH	MDT	MDT
BENCH BLVD-HILLTOP/PEMBERTON CN	CM/STPU/MT 1036() UPN6041003	RECONSTRUCTION	10,811,400	9,360,510 FHWA	1,450,890 STATE MATCH	MDT	MDT
BILLINGS BYPASS RW	NCPD-MT56(45) UPN4199	RECONSTRUCTION	7,847,000	6,793,933 FHWA	1,053,067 STATE MATCH	MDT	MDT
TRAFFIC MITIGATION ALL	CM()	SIGNAL OPTIMIZATION	500,000	432,900 FHWA	67,100 STATE MATCH	MDT	MDT
BILLINGS SIGNALS UPDGRADE OT	CM UPN9007	SIGNAL OPTIMIZATION	320,869	277,808 FHWA	43,061 STATE MATCH	MDT	MDT
LOCKWOOD SIGNALS - BILLINGS OT	CM UPN9012	SIGNAL OPTIMIZATION	18,948	16,405 FHWA	2,543 STATE MATCH	MDT	MDT
MDT-PREVENTIVE MAINTENANCE (IM) PE/CN	IM	MAINTENANCE MAINTENANCE	3,000,000	2,597,400 FHWA	402,600 STATE MATCH	MDT	MDT
D-5 IM FENCING - CHAINLINK(only portion in MPO) CN	IM STWD UPN 8131	INTERSTATE FENCING	700,000	606,060 FHWA	93,940 STATE MATCH	MDT	MDT
PINEHILLS INTCH-PRYOR CR INTCH PE	IM UPN 8986	PAVEMENT PRESERVATION	30,307	26,240 FHWA	4,067 STATE MATCH	MDT	MDT
MDT-PREVENTIVE MAINTENANCE (NH) PE/CN	NH	MAINTENANCE MAINTENANCE	1,350,000	1,168,830 FHWA	181,170 STATE MATCH	MDT	MDT
27th St-1st Ave S to AIRPORT IC/RW	NH53-1(29) UPN7910	OVERLAY	253,424	219,414 FHWA	34,010 STATE MATCH	MDT	MDT
MDT-URBAN PVMT PRESERVATION(UPP) ALL	UPP	PAVEMENT PRESERVATION	1,000,000	865,800 FHWA	134,200 STATE MATCH	MDT	MDT
6TH AVE N - 27TH TO 32ND (BLGS) PE	UPP UPN9003	PAVEMENT PRESERVATION	63,076	54,611 FHWA	8,465 STATE MATCH	MDT	MDT
DIVISION STREET - BILLINGS PE	UPP UPN9004	PAVEMENT PRESERVATION	63,076	54,611 FHWA	8,465 STATE MATCH	MDT	MDT
AIRPORT RD - ZIMMERMAN TRAIL PE	NH UPN8987	PAVEMENT PRESERVATION	75,690	65,532 FHWA	10,158 STATE MATCH	MDT	MDT
1ST AVE S-MINN AVE-13 ST-BLGS CN	UPP UPN8592	PAVEMENT PRESERVATION	964,700	835,237 FHWA	129,463 STATE MATCH	MDT	MDT
4TH AVE N-13TH ST TO MAIN-BLG CN	UPP UPN8593	PAVEMENT PRESERVATION	452,300	391,601 FHWA	60,699 STATE MATCH	MDT	MDT
STPE PONDEROSA SCHOOL PATH - BILLINGS CN	STPE UPN8183	BIKE/PED	176,800	153,073 FHWA	23,727 LOCAL MATCH	MDT	LOCAL
STPE ARROWHEAD SCHOOL PATH - BILLINGS CN	STPE UPN8184	BIKE/PED	82,500	71,429 FHWA	11,072 LOCAL MATCH	MDT	LOCAL
STPE SWORDS PARK OUTLET TRAIL - BLGS CN	STPE UPN8185	BIKE/PED	117,900	102,078 FHWA	15,822 LOCAL MATCH	MDT	LOCAL
STPE POLY DRIVE SCHOOL WALKS - BLGS CN	STPE UPN8186	BIKE/PED	95,500	82,684 FHWA	12,816 LOCAL MATCH	MDT	LOCAL
SAFETY PROJECTS VARIOUS ALL	HSIP	SAFETY	500,000	450,000 FHWA	50,000 STATE MATCH	MDT	MDT
SF 129 RNDABOUT KING 56TH RW/IC/CN	HSIP UPN8052	SAFETY	3,182,800	2,864,520 FHWA	318,280 STATE MATCH	MDT	MDT
2012-SCOUR MITIGATION CN	HSIP UPN7960	SCOUR MITIGATION	520,000	468,000 FHWA	52,000 STATE MATCH	MDT	MDT
ZIMMERMAN TRAIL RW	MT1001() UPN6040	ROADWAY IMPROVEMENTS	100,000	86,580 FHWA	13,420 STATE MATCH	MDT	MDT
DOWNTOWN STATE SIGNALS BLGS CN	CMSTWD(100) UPN8036	SIGNAL OPTIMIZATION	6,872,600	5,950,297 FHWA	922,303 STATE MATCH	MDT	MDT
ENHANCEMENT PROJECTS-VARIOUS LOCATIONS ALL	TA()	BIKE/PED TRAILS	700,000	606,060 FHWA	93,940 STATE MATCH	MDT	MDT
SF 139 13TH/PARKHILL SIGNAL CN	HSIP1099() UPN8610	NEW SIGNAL	432,119	388,907 FHWA	43,212 STATE MATCH	MDT	MDT
SF 129 BILLINGS HORIZONTAL CURVE SIGNAGE CN	HSIPSTWD UPN7990	SIGNAGE UPGRADE	1,126,700	1,014,030 FHWA	112,670 STATE MATCH	MDT	MDT
SF 139-CENTRAL & 56TH RNDABOUT RW/IC	HSIP56() UPN8611	INSTALL ROUNDBOUT	380,964	342,868 FHWA	38,096 STATE MATCH	MDT	MDT
SF-149 HILLCREST RIGHT TURN LN. PE/CN	HSIP UPN8904	SIGNAGE UPGRADE	331,073	297,966 FHWA	33,107 STATE MATCH	MDT	MDT
SF-149 CLRS BILLINGS NORTH(only portion in MPO) PE/CN	HSIPSTWD UPN8906	CENTERLINE RUMBLE STRIPS	312,851	281,566 FHWA	31,285 STATE MATCH	MDT	MDT
SF-149 KING INTCH SFTY IMPRV PE	HSIP UPN8941	REFLECTIVE BACKING	4,114	3,703 FHWA	411 STATE MATCH	MDT	MDT
Not all Earmarks require 13.42% match							

(Table 12) - BIENNIAL ELEMENT JULY 1, 2014-JUNE 30, 2016 (TRANSIT)					
BILLINGS MONTANA					
PROJECT/FUNDING SOURCE	TOTAL EST COST	FEDERAL FUNDS AND SOURCES	NON-FEDERAL FUNDS AND SOURCES	RECIPIENT OF FUNDS	RESPONSIBLE IMPLEMENTING AGENCY
FTA SECTION 5307					
OPERATING PROJECT (7-1-14 TO 6-30-15)	4,140,325	1,718,629	2,421,696	CITY	CITY
OPERATING PROJECT (7-1-15 TO 6-30-16)	4,140,325	1,718,629	2,421,696	CITY	CITY
FTA SECTION 5310*					
REPLACEMENT VEHICLES(2015)	160,000	128,000	32,000	STATE	VARIOUS LOCAL
REPLACEMENT VEHICLES (2016)	160,000	128,000	32,000	STATE	VARIOUS LOCAL
FTA SECTION 5311* #Funds transferred to 5307					
OPERATING PROJECT (2015)	-	-	-	CITY	CITY
OPERATING PROJECT (2016)	-	-	-	CITY	CITY
FTA SECTION 5339					
CAPITAL/VEHICLES (2015)	525,000	420,000	105,000	CITY	CITY
CAPITAL/VEHICLES (2016)	525,000	420,000	105,000	CITY	CITY
TransADE State Funded					
OPERATING PROJECT (2015)			70,000	CITY	CITY
OPERATING PROJECT (2016)			70,000	CITY	CITY
*Dependent on Funding & Application Approvals by MDT					

Highlights of 2015-2019 TIP Amendment 3

Overall minor changes for the following projects:

- 4199 Billings Bypass – Five Mile Road
 - CN costs increased
- 6040: Zimmerman Trail
 - RW moved from 2016 to 2017
 - CN moved from 2017 to 2018
- 7972: I-90 Yellowstone River Billings
 - PE increase
- 8036: Downtown State Signals
 - RW added in 2016
 - IC added in 2016
 - CN decrease
- 8052: Roundabout King & 56th
 - IC increase
- 8611: SF 129 – Roundabout Central & 56th
 - PE increase
 - IC moved from 2016 to 2017
 - CN increase

New Projects:

- 9082: 1st Ave South – ADA (BLGS)
 - All phase in 2016 for \$1,830,700
 - Funded with Statewide CMAQ
 - ADA Compliance funding bucket was reduced in 2016 since a project was nominated

Regular City Council Meeting

Meeting Date: 05/09/2016

TITLE: Resolution Establishing Compliance with Reimbursement under Internal Revenue Code for South Billings Urban Renewal District

PRESENTED BY: Patrick M. Weber, Finance Director

Department: City Hall Administration

PROBLEM/ISSUE STATEMENT

The City needs to sell bonds to finance the projects in the South Billings Urban Renewal District described below. The City needs to expend monies related to the project before funds are available from the bond sale proceeds. Under IRS rules, the attached resolution must be adopted in order for the City to reimburse those pre-sale expenses from the bond sale proceeds.

W.O. 15-07 Orchard Lane Reconstruction is a project to reconstruct Orchard between King Ave East and State Avenue. The Council approved a \$4,070,072 construction contract on April 23. The City plans to issue bonds in June to pay for part of the work.

Sanitary Sewer, Phase 2 project will construct approximately 3,400 lineal feet of new sewer in areas where there currently is none. The area is bounded north-south by Morgan and Francis Ave and bounded east-west by Jackson St and Hallowell Lane. New mains and sewer service connections to property lines will be installed.

ALTERNATIVES ANALYZED

The City Council may:

- Approve the resolution and proceed with the projects with the ability to reimburse expenses when the bonds are sold; or
- Not approve the resolution, in which case Public Works will have to suspend work on the project until bonds sell or will have to find alternative ways to pay for the project.

FINANCIAL IMPACT

This Resolution will not result in additional costs to the project.

RECOMMENDATION

Staff recommends that the City Council approve the attached resolution that will allow the City to reimburse expenses related to projects in the South Billings Urban Renewal District that it will incur prior to issuing bonds for the project.

APPROVED BY CITY ADMINISTRATOR

Attachments

SBURD

CERTIFICATE AS TO RESOLUTION AND ADOPTING VOTE

I, the undersigned, being the duly qualified and acting recording officer of the City of Billings, Montana (the "City"), hereby certify that the attached resolution is a true copy of a Resolution No. _____ entitled: "RESOLUTION RELATING TO THE FINANCING OF PROPOSED IMPROVEMENTS WITHIN THE SOUTH BILLINGS BOULEVARD URBAN RENEWAL DISTRICT; ESTABLISHING COMPLIANCE WITH REIMBURSEMENT BOND REGULATIONS UNDER THE INTERNAL REVENUE CODE" (the "Resolution"), on file in the original records of the City in my legal custody; that the Resolution was duly adopted by the City Council of the City at a regular meeting on May 9, 2016, and that the meeting was duly held by the City Council and was attended throughout by a quorum, pursuant to call and notice of such meeting given as required by law; and that the Resolution has not as of the date hereof been amended or repealed.

I further certify that, upon vote being taken on the Resolution at said meeting, the following Council Members voted in favor thereof: _____
_____ ; voted against the same: _____
_____ ; abstained from voting thereon: _____
_____ ; or were absent: _____.

WITNESS my hand and seal officially this 9th day of May, 2016.

(SEAL)

City Clerk

RESOLUTION NO. _____

RESOLUTION RELATING TO THE FINANCING OF
PROPOSED IMPROVEMENTS WITHIN THE SOUTH
BILLINGS BOULEVARD URBAN RENEWAL DISTRICT;
ESTABLISHING COMPLIANCE WITH REIMBURSEMENT
BOND REGULATIONS UNDER THE INTERNAL REVENUE
CODE

BE IT RESOLVED by the City Council of the City of Billings, Montana (the “City”), as follows:

Section 1. Recitals.

1.01 The United States Department of Treasury has promulgated final regulations governing the use of proceeds of tax-exempt bonds, all or a portion of which are to be used to reimburse the City for project expenditures paid by the City prior to the date of issuance of such bonds. Those regulations (Treasury Regulations, Section 1.150-2) (the “Regulations”) require that the City adopt a statement of official intent to reimburse an original expenditure not later than 60 days after payment of the original expenditure. The Regulations also generally require that bonds be issued and the reimbursement allocation be made from the proceeds of such bonds within 18 months (or three years, if the reimbursement bond issue qualifies for the “small issuer” exception from the arbitrage rebate requirement) after the later of (i) the date the expenditure is paid or (ii) the date the project is placed in service or abandoned, but (unless the issue qualifies for the “small issuer” exception from the arbitrage rebate requirement) in no event more than three years after the date the expenditure is paid. The Regulations generally permit reimbursement of capital expenditures and costs of issuance of the bonds.

1.02 The City desires to comply with requirements of the Regulations with respect to certain projects hereinafter identified.

Section 2. Official Intent Declaration.

2.01 The City proposes to undertake certain improvements within the South Billings Boulevard Urban Renewal District (the “District”), consisting of the design, construction and installation of road, curb, gutter, sidewalk and lighting improvements on Orchard Lane and the design, construction and installation of sanitary sewer system improvements in the District (collectively, the “Project”).

2.02 Other than (i) expenditures to be paid or reimbursed from sources other than the Bonds (as hereinafter defined), (ii) expenditures permitted to be reimbursed under the transitional provision contained in Section 1.150-2(j)(2) of the Regulations, (iii) expenditures constituting preliminary expenditures within the meaning of Section 1.150-2(f)(2) of the Regulations, or (iv) expenditures in a “de minimus” amount (as defined in Section 1.150-2(f)(1) of the Regulations), no expenditures for the Project have heretofore been paid by the City and no expenditures will be paid by the City until after the date of this Resolution.

2.03 The City reasonably expects to reimburse some or all of the expenditures made for costs of the Project out of proceeds of bonds to be issued in one or more series in an estimated maximum aggregate principal amount of \$5,300,000 (the "Bonds") after the date of payment of all or a portion of the costs of the Project. All reimbursed expenditures shall be capital expenditures, a cost of issuance of the Bonds or other expenditures eligible for reimbursement under Section 1.150-2(d)(3) of the Regulations.

Section 3. Budgetary Matters. As of the date hereof, there are no City funds reserved, allocated on a long-term basis or otherwise set aside (or reasonably expected to be reserved, allocated on a long-term basis or otherwise set aside) to provide permanent financing for the expenditures related to the Project, other than pursuant to the issuance of the Bonds. The statement of intent contained in this resolution, therefore, is determined to be consistent with the City's budgetary and financial circumstances as they exist or are reasonably foreseeable on the date hereof.

Section 4. Reimbursement Allocations. The City Finance Director shall be responsible for making the "reimbursement allocations" described in the Regulations, being generally the transfer of the appropriate amount of proceeds of the Bonds to reimburse the source of temporary financing used by the City to make prior payment of the costs of the Project. Each allocation shall be evidenced by an entry on the official books and records of the City maintained for the Bonds or the Project and shall specifically identify the actual original expenditure being reimbursed.

PASSED AND APPROVED by the City Council of the City of Billings, Montana, this 9th day of May, 2016.

Mayor

Attest: _____
City Clerk

(SEAL)

Regular City Council Meeting

Meeting Date: 05/09/2016

TITLE: 23rd Street Subdivision Preliminary Subsequent Minor Plat

PRESENTED BY: Candi Millar, Planning & Community Services Department Director

Department: Planning & Community Services

PROBLEM/ISSUE STATEMENT

On March 29, 2016, the Planning Division received an application for preliminary plat approval for the 23rd Street Subdivision, Amended Plat of the North 100' of Lot 1, Block 8 of Sunnyside Subdivision, Second Filing. This subdivision is reviewed as a subsequent minor plat through the minor plat review process. The lot currently has one four-plex dwelling and a new multi-family dwelling is proposed for the second parcel. The owner is Mark Wright. The representing agent is Territorial Landworks, Inc.

ALTERNATIVES ANALYZED

In accordance with state law, the City Council has 35 working days to act upon this subsequent minor preliminary plat. The 35 working day review period for the proposed plat ends on May 16, 2016. State and City subdivision regulations also require that preliminary plats be reviewed using specific criteria, as stated within this report. The City may not unreasonably restrict an owner's ability to develop land if the subdivider provides evidence that any identified adverse effects can be mitigated. Within the review period, the City Council is required to:

1. Approve
2. Conditionally Approve;or
3. Deny the Preliminary Plat

FINANCIAL IMPACT

Should the City Council approve the preliminary plat, the subject property may further develop under private ownership, resulting in additional tax revenues.

BACKGROUND

General location:	11 th Avenue North/North 23 rd Street
Legal Description:	23rd Street Subdivision, Amended Plat of the North 100' of Lot 1, Block 8 of Sunnyside Subdivision, 2 nd Filing
Owner/Subdivider:	Mark Wright
Engineer and Surveyor:	Territorial Landworks, Inc.
Existing Zoning:	Residential Multi-Family Restricted (RMF-R)
Existing land use:	Multi-Family Residential
Proposed land use:	Multi-Family Residential
Gross/net area:	14,000
Proposed number of lots:	2
Lot size:	7,000 sf/ 7,000 sf
Parkland requirements:	None

STAKEHOLDERS

A public hearing is not scheduled for the City Council meeting, however nearby property owners may attend the City Council meeting. The Planning Division has received no public comments or questions regarding the proposed subdivision.

CONSISTENCY WITH ADOPTED POLICIES OR PLANS

Consistency with the 2008 City of Billings and Yellowstone County Growth Policy, the 2014 Transportation Plan Update, the 2011 Billings Area Bikeway and Trail Master Plan, and the North Park Neighborhood Plan are discussed within the Findings of Fact.

RECOMMENDATION

Staff recommends conditional approval of the preliminary subsequent minor plat of of 23rd Street Subdivision, Amended Plat of the North 100' of Lot 1, Block 8 of Sunnyside Subdivision, Second Filing and adoption of the Findings of Fact as presented in the staff report to the City Council.

Recommended Conditions of Approval:

1. To minimize effects on local services and comply with the City of Billings storm water management requirements, prior to final plat approval the applicant will add the standard language regarding provision of a Storm Water Pollution Prevention Plan (SWPPP) in the SIA under the Storm Drainage section.
2. To minimize effects on local services and ensure the provision of easements for utilities, the subdivider shall work with the City Engineering Division and the private utility companies to determine suitable locations for any necessary utility easements. These easements shall be shown on the final plat.
3. The final plat shall comply with all requirements of the City of Billings Subdivision Regulations, rules, regulations, policies, and resolutions of City of Billings, and the laws and Administrative Rules of the State of Montana.

APPROVED BY CITY ADMINISTRATOR

Attachments

Preliminary Plat
Findings of Fact
Mayor's Approval Letter

PRELIMINARY PLAT OF 23RD STREET SUBDIVISION

AMENDED PLAT OF THE NORTH 100' OF LOT 1, BLOCK 8,
SUNNYSIDE SUBDIVISION, SECOND FILING
SITUATED IN THE NE 1/4 OF SECTION 32 T. 1 N., R. 26 E., P.M.M.
YELLOWSTONE COUNTY, MONTANA

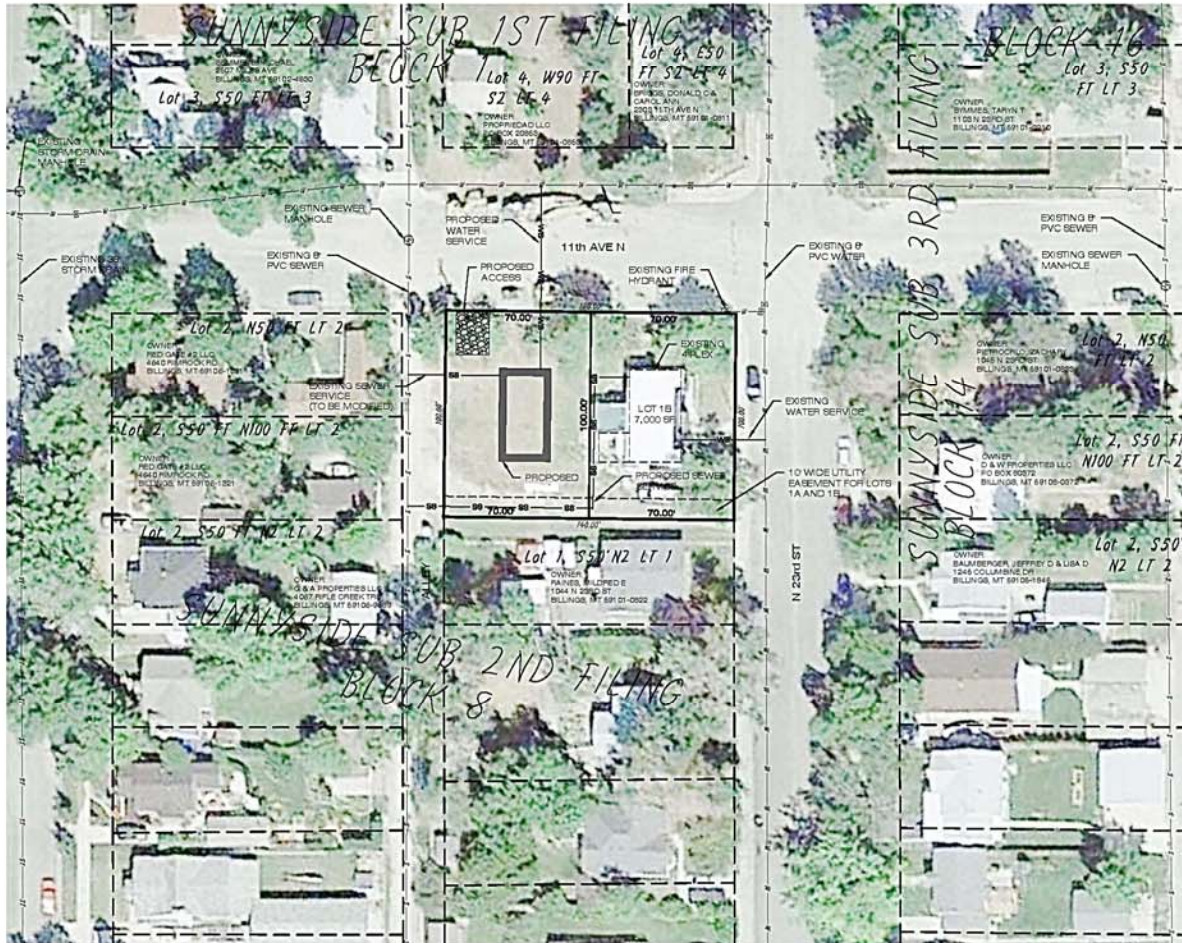

PLAT DATA

GROSS AREA	= 14,000 SF
NET AREA	= 14,000 SF
NUMBER OF LOTS	= 2
MINIMUM LOT SIZE	= 7,000 SF
MAXIMUM LOT SIZE	= 7,000 SF
LINEAL FEET OF STREETS	= N/A
PARKLAND REQUIREMENTS	= N/A
PARKLAND DEDICATION	= N/A
EXISTING ZONING	= R1/FR
SURROUNDING ZONING	=
NORTH	= R70
SOUTH	= R70
EAST	= R70
WEST	= R70
EXISTING LAND USE	= RESIDENTIAL 4-PLEX
PROPOSED LAND USE:	
LOT 1A	= RESIDENTIAL 4-PLEX
LOT 1B	= RESIDENTIAL 4-PLEX

VICINITY MAP

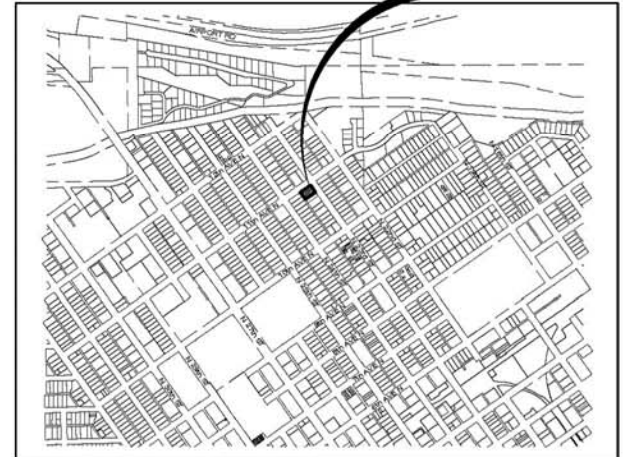

BILLINGS, YELLOWSTONE COUNTY, MT

TERRITORIAL LANDWORKS, INC.
 FULLY LICENSED - RESIDENTIAL - LAND & ESTATE
 1049 N 23RD STREET
 BILLINGS, MT 59102
 PHONE: 406.243.1111
 WWW.TERRITORIALLANDWORKS.COM

DATE	
REVISIONS	
DESIGNED:	
DRAFTED:	
CHECKED:	
DATE:	12/23/23

LOCATION:
 1049 N 23RD STREET
 SECTION 32
 T. 1 N., R. 26 E.
 YELLOWSTONE COUNTY, MONTANA

PREPARED FOR:
 MARK WRIGHT

PROJECT NAME:
 23RD STREET SUBDIVISION

SHEET TITLE:
 PRELIMINARY PLAT

PROJECT NO:
 15-3923

SHEET:
 1 OF 1

PRELIMINARY

Findings of Fact
23rd Street Subdivision

Staff is forwarding the recommended Findings of Fact for 23rd Street Subdivision, Amended Plat of the North 100' of Lot 1, Block 8 of Sunnyside Subdivision, Second Filing for review and approval by the City Council. These findings are based on the preliminary plat application and supplemental documents and address the review criteria required by the Montana Subdivision and Platting Act (76-3-608, MCA) and the Billings Subdivision Regulations (Section 23-303(H), BMCC).

A. What are the effects on agriculture, local services, the natural environment, wildlife, wildlife habitat, and public health, safety and welfare? [MCA 76-3-608 (3)(a) and BMCC 23-303(H)(1)]

1. Effect on agriculture and agricultural water user facilities

The subject property is not used for agriculture, and has no irrigation facilities serving it. There is currently one multi-family dwelling on the subject lot and the owners are proposing to create one additional lot for infill development. The proposal may help alleviate development pressure on existing agricultural areas by creating additional lots on vacant areas already within the urban core. Overall, there is no anticipated negative effect on irrigation facilities or agriculture from this proposal.

2. Effect on local services

- a. **Utilities** – The subdivision is currently served by a public water main located in North 23rd Street. There will be no additional work needed at this time on the water line. Any future connections to the water line will be the lot owners' responsibility at the time of lot development. An easement is being created with this subdivision to ensure the lots can maintain the lines that already exists and for any future repairs or replacement. The development of Lot 1A will require installation of a new water service.
- b. **Sewer** - The existing sewer services are from the sewer mains in 11th Ave North. Development of Lot 1A will require installation of a new sanitary sewer service. No improvement to the existing sewer main is proposed at this time. Lot owners will be responsible for connecting to the services at the time of lot development.

Private utilities such as electric and gas are available to the lots upon development. To ensure the proper utility easements are provided, it is recommended that the developer consult with the utility companies and place the requested easements on the final plat (**Condition #2**).

- c. **Storm water** –All drainage improvements shall comply with the provisions of the current City of Billings Storm Water Management Manual and the standard language regarding provision of a Storm Water Pollution Prevention Plan must be added to the SIA under the Storm Water Drainage section (**Condition #1**).
- d. **Solid waste** - The City of Billings will provide solid waste collection and disposal. The City's landfill has adequate capacity for this waste.

- e. **Streets** – The property currently has an existing access on North 23rd Street. Any additional approaches or modifications to the existing approaches will require approval at time of lot development through the site review and Building Permit process. Approaches shall meet the requirements of the City of Billings site development ordinance.
- f. **Emergency services** - The Billings Police and Fire Departments will respond to emergencies within the proposed subdivision. The nearest emergency service station is located at 2305 8th Avenue North (Station #1), less than a mile from the subject property. The subdivision is located within the ambulance service area of American Medical Response.
- g. **Schools** –This residential subdivision should have a minimal effect on schools since only one additional lot is being created.
- h. **Parks and Recreation** - Parkland dedication is not required for this subdivision.
- i. **Mail Delivery** - The United States Postal Service will provide postal service to the subdivision. Any special requirements will have to be submitted and approved by the Postal Service.

3. Effect on the natural environment

The proposed subdivision should have only minor effects on the natural environment. There will be short term air and noise pollution associated with construction on the property. Storm water shall be managed in compliance with an approved plan and the property is outside of the flood plain. Any new development proposals in the future will need to prepare and submit a project-specific geotechnical analysis to minimize any potential impacts from soil and groundwater conditions.

4. Effect on wildlife and wildlife habitat

The proposed subdivision should not affect wildlife or habitat. There are no known endangered or threatened species on the property.

5. Effect on the public health, safety and welfare

The subdivision should not negatively affect public health or safety. The subject property is not within a mapped floodway or flood zone. A geotechnical survey will be required prior to construction to ensure appropriate foundation designs are installed based on the subsurface conditions. There are no obvious threats to public health, safety or welfare.

B. Was an Environmental Assessment required? [MCA 76-3-616 and BMCC 23-901]

The proposed subdivision is exempt from the requirement for an Environmental Assessment pursuant to Section 76-3-616, MCA and 23-901, BMCC.

C. Does the subdivision conform to the Yellowstone County-City of Billings 2008 Growth Policy Update, the North Park Neighborhood Plan, the Urban Area Transportation Plan, 2009 Update, and the Billings Area Bikeway and Trails Master Plan? [BMCC 23-303(H)(3)]

1. Yellowstone County-City of Billings 2008 Growth Policy Update

The proposed subdivision is consistent with the following goals of the Growth Policy:

- a. **Goal:** Predictable land use decisions that are consistent with neighborhood character and preferred land use patterns identified in neighborhood plans (p. 6).
- b. **Goal:** New developments that are sensitive to and compatible with the character of adjacent city neighborhoods and County townsites (p.6).
- c. **Goal:** Contiguous development focused in and around existing population centers separated by open space (p. 6).
- d. **Goal:** More housing and business choices within each neighborhood (p. 6).

2. 2014 Billings Urban Area Transportation Plan

The proposed subdivision adheres to the goals and objectives of the 2014 Transportation Plan and preserves the street network and street hierarchy specified within the plan.

3. Billings Area Bikeway and Trail Master Plan

The Billings Area Bikeway and Trail Master Plan covers this area. No new improvements will be required with this subdivision to meet the Trail Plan recommendations.

4. The North Park Neighborhood Plan

This proposed subdivision is in compliance with several of the goals and objectives of the North Park Neighborhood Plan including:

- a) **Goal:** Maintain the residential character of the North Park Neighborhood.
- b) **Goal:** Maintain residential parking in the North Park Neighborhood. To preserve neighborhood character and residential parking as new or redevelopment occurs in the neighborhood.
- c) **Goal:** Guide land use decisions within the neighborhood that are consistent with the neighborhood plan and the preferred land use map.
- d) **Goal:** Affordable housing development.
- e) **Goal:** Maintain existing housing. To preserve the existing housing stock and maintain an aesthetic neighborhood.

D. Does the subdivision conform to the Montana Subdivision and Platting Act and to local subdivision regulations? [MCA 76-3-608(3)(b), BMCC 23-303(H)(2)]

The proposed subdivision, with the proposed conditions, satisfies the requirements of the Montana Subdivision and Platting Act and conforms to the design standards specified in the local subdivision regulations. The subdivider and the local government have complied with the subdivision review and approval procedures set forth in the local and state subdivision regulations.

E. Does the proposed subdivision conform to all requirements of the zoning in effect? [BMCC 23-303(H)(2)(e)]

The subject property is located in the Residential Multi Family-Restricted zoning district. All development shall comply with the standards set forth in Section 27-308, BMCC. Additionally, the City Board of Adjustment (BOA) at its April 6, 2016 meeting voted 4-2 to conditionally approve a variance request to allow the existing four-plex on a 7,000 square foot lot (proposed lot 1B). This approval does not include a variance for allowing a new four-plex on the proposed lot 1A. One duplex or two single family dwellings may be constructed on the proposed lot 1A. Final zoning compliance will be determined at the time of the building permit.

F. Does the proposed plat provide easements for the location and installation of any utilities? [MCA 76-3-608(3)(c) and BMCC 23-303(H)(2)(b)]

The plat provides easements for utilities. It is recommended that the developer work with NWE and MDU to show the needed easements on the final plat.

G. Does the proposed plat provide legal and physical access to each parcel within the subdivision and notation of that access on the plat? [MCA 76-3-608(3)(d) and BMCC 23-303(H)(2)(c)]

Access to the subdivision shall be from an existing access on North 23rd Street, with an additional access proposed from 11th Ave. N (noted on plat). Any additional approaches or modifications to the existing approach shall meet the requirements of the City of Billings site development ordinance.

CONCLUSIONS OF FINDING OF FACT

- The preliminary plat for 23rd Street Subdivision, Amended Plat of the North 100' of Lot 1, Block 8 of Sunnyside Subdivision, Second Filing, does not create any adverse impacts that warrant denial of the subdivision.
- The proposed subdivision conforms to several goals and policies of the 2008 Growth Policy, and the North Park Neighborhood Plan, and does not conflict with the 2014 Transportation Plan or the Bikeway and Trail Master Plan.
- The proposed subdivision complies with state and local subdivision regulations, local zoning, and sanitary requirements and provides legal and physical access to each lot.
- Any potential negative or adverse impacts will be mitigated with the proposed conditions of approval.

Approved by the Billings City Council, May 9, 2016

Thomas W. Hanel, Mayor

ATTACHMENT C
Mayor's Approval Letter

May 9, 2016

Mark Wright
P.O. Box 173
Billings, MT 59103-0173

Dear Applicant:

On May 9, 2016, the Billings City Council conditionally approved the preliminary plat of 23rd Street Subdivision, the North 100 feet of Lot 1, Block 8, Sunnyside Subdivision, 2nd Filing, subject to the following conditions of approval:

1. To minimize effects on local services and comply with the City of Billings storm water management requirements, prior to final plat approval the applicant will add the standard language regarding provision of a Storm Water Pollution Prevention Plan (SWPPP) in the SIA under the Storm Drainage section.
2. To minimize effects on local services and ensure the provision of easements for utilities, the subdivider shall work with the City Engineering Division and the private utility companies to determine suitable locations for any necessary utility easements. These easements shall be shown on the final plat.
3. The final plat shall comply with all requirements of the City of Billings Subdivision Regulations, rules, regulations, policies, and resolutions of City of Billings, and the laws and Administrative Rules of the State of Montana.

Should you have questions please contact the Karen Husman at (406) 247-8684 or by email at husmank@ci.billings.mt.us .

Sincerely,

Thomas W. Hanel, Mayor

Pc: Territorial Landworks

Regular City Council Meeting

Meeting Date: 05/09/2016

TITLE: Payment of Claims April 11, 2016

PRESENTED BY: Patrick M. Weber, Finance Director

Department: City Hall Administration

PROBLEM/ISSUE STATEMENT

Claims in the amount of \$2,050,109.69 have been audited and are presented for City Council payment approval. A complete listing of the claims dated April 11, 2016, is available in the Finance Department.

ALTERNATIVES ANALYZED

No other alternatives were analyzed.

FINANCIAL IMPACT

Claims have a varying impact on department budgets, but are submitted by the departments and reviewed by Finance staff before being sent to the Council.

RECOMMENDATION

Staff recommends that Council approve the Payment of Claims.

APPROVED BY CITY ADMINISTRATOR

Attachments

councilmemo_4.11.2016

Check Date	Check	Name	Amount	Account	Item Desc
04/11/2016	45	U.S. Bank PCards	\$ 325.00	2600-55110-403290	Yourmember-Careers - PCard
04/11/2016	45	U.S. Bank PCards	\$ 1,598.00	1500-22210-403630	Xenarc Technologies Corp - PCard
04/11/2016	45	U.S. Bank PCards	\$ 349.00	2600-55180-403690	Www.Logmein.Com - PCard
04/11/2016	45	U.S. Bank PCards	\$ (649.00)	2600-55180-403690	Www.Logmein.Com - PCard
04/11/2016	45	U.S. Bank PCards	\$ 649.00	2600-55180-403690	Www.Logmein.Com - PCard
04/11/2016	45	U.S. Bank PCards	\$ 209.00	1500-21400-403822	Wpy*Online Event By Idaho - PCard
04/11/2016	45	U.S. Bank PCards	\$ 34.47	5210-15930-403650	Kb Commercial Products - PCard
04/11/2016	45	U.S. Bank PCards	\$ 276.71	5410-31230-402290	Kb Commercial Products - PCard
04/11/2016	45	U.S. Bank PCards	\$ 119.25	1500-21710-402240	Kelly Services - PCard
04/11/2016	45	U.S. Bank PCards	\$ 186.75	5210-15910-403650	Kb Commercial Products - PCard
04/11/2016	45	U.S. Bank PCards	\$ 186.80	5210-15920-403650	Kb Commercial Products - PCard
04/11/2016	45	U.S. Bank PCards	\$ 186.75	5210-15930-403650	Kb Commercial Products - PCard
04/11/2016	45	U.S. Bank PCards	\$ 40.41	5210-15910-403650	Kb Commercial Products - PCard
04/11/2016	45	U.S. Bank PCards	\$ 40.42	5210-15920-403650	Kb Commercial Products - PCard
04/11/2016	45	U.S. Bank PCards	\$ 40.42	5210-15930-403650	Kb Commercial Products - PCard
04/11/2016	45	U.S. Bank PCards	\$ 368.46	6600-31100-402120	Kb Commercial Products - PCard
04/11/2016	45	U.S. Bank PCards	\$ 552.68	6700-31410-402120	Kb Commercial Products - PCard
04/11/2016	45	U.S. Bank PCards	\$ (368.46)	6600-31100-402120	Kb Commercial Products - PCard
04/11/2016	45	U.S. Bank PCards	\$ (552.68)	6700-31410-402120	Kb Commercial Products - PCard
04/11/2016	45	U.S. Bank PCards	\$ 284.74	6600-31100-402120	Kb Commercial Products - PCard
04/11/2016	45	U.S. Bank PCards	\$ 427.10	6700-31410-402120	Kb Commercial Products - PCard
04/11/2016	45	U.S. Bank PCards	\$ 164.96	0100-51120-402290	Jares Fence Co - PCard
04/11/2016	45	U.S. Bank PCards	\$ 448.80	5610-71140-403660	Johnson Controls Ss - PCard
04/11/2016	45	U.S. Bank PCards	\$ 668.80	5610-71140-403660	Johnson Controls Ss - PCard
04/11/2016	45	U.S. Bank PCards	\$ 696.80	5610-71190-402450	Johnson Controls Ss - PCard
04/11/2016	45	U.S. Bank PCards	\$ 480.54	5120-84300-402360	Johnstone Supply Billings - PCard
04/11/2016	45	U.S. Bank PCards	\$ 267.03	5610-71120-402240	Kb Commercial Products - PCard
04/11/2016	45	U.S. Bank PCards	\$ 30.18	5610-71120-402450	Hose & Rubber Supply - PCard
04/11/2016	45	U.S. Bank PCards	\$ 41.32	5610-71170-402450	Hose & Rubber Supply - PCard
04/11/2016	45	U.S. Bank PCards	\$ 149.00	0100-15120-403821	Icma Online Purchases - PCard
04/11/2016	45	U.S. Bank PCards	\$ 79.95	0100-51140-403350	Intl Soc Arboriculture - PCard
04/11/2016	45	U.S. Bank PCards	\$ 48.22	0100-51420-402390	Tire Rama 101 Bc - PCard
04/11/2016	45	U.S. Bank PCards	\$ 939.48	0100-51120-402290	Jares Fence Co - PCard
04/11/2016	45	U.S. Bank PCards	\$ 27.07	5120-85000-402410	Hose & Rubber Supply - PCard
04/11/2016	45	U.S. Bank PCards	\$ 4.39	5120-85000-404220	Hose & Rubber Supply - PCard
04/11/2016	45	U.S. Bank PCards	\$ 37.71	5120-85000-404210	Hose & Rubber Supply - PCard
04/11/2016	45	U.S. Bank PCards	\$ 153.72	5120-85000-404210	Hose & Rubber Supply - PCard
04/11/2016	45	U.S. Bank PCards	\$ 31.89	2110-31320-402475	Hose & Rubber Supply - PCard
04/11/2016	45	U.S. Bank PCards	\$ 206.76	0100-51120-402330	Hose & Rubber Supply - PCard
04/11/2016	45	U.S. Bank PCards	\$ 125.58	1500-22260-402240	Hanson Chemical - PCard

Check Date	Check	Name	Amount	Account	Item Desc
04/11/2016	45	U.S. Bank PCards	\$ 125.58	1500-22260-402240	Hanson Chemical - PCard
04/11/2016	45	U.S. Bank PCards	\$ 60.75	1500-22260-402240	Hanson Chemical - PCard
04/11/2016	45	U.S. Bank PCards	\$ 114.27	0100-51120-402240	Hanson Chemical - PCard
04/11/2016	45	U.S. Bank PCards	\$ 78.88	5610-71150-402290	Hose & Rubber Supply - PCard
04/11/2016	45	U.S. Bank PCards	\$ 40.60	5020-75000-402410	Hose & Rubber Supply - PCard
04/11/2016	45	U.S. Bank PCards	\$ 74.95	2600-55120-402120	Hanson Chemical - PCard
04/11/2016	45	U.S. Bank PCards	\$ 40.21	6600-31100-403660	Hanson Chemical - PCard
04/11/2016	45	U.S. Bank PCards	\$ 26.80	6700-31410-403660	Hanson Chemical - PCard
04/11/2016	45	U.S. Bank PCards	\$ 42.24	6600-31100-403660	Hanson Chemical - PCard
04/11/2016	45	U.S. Bank PCards	\$ 63.36	6700-31410-403660	Hanson Chemical - PCard
04/11/2016	45	U.S. Bank PCards	\$ 452.62	1500-22260-402240	Hanson Chemical - PCard
04/11/2016	45	U.S. Bank PCards	\$ 28.00	0100-51120-402240	Hanson Chemical - PCard
04/11/2016	45	U.S. Bank PCards	\$ 76.90	1500-22260-402240	Hanson Chemical - PCard
04/11/2016	45	U.S. Bank PCards	\$ 687.52	6500-15660-402240	Hanson Chemical - PCard
04/11/2016	45	U.S. Bank PCards	\$ 364.98	6500-15670-402240	Hanson Chemical - PCard
04/11/2016	45	U.S. Bank PCards	\$ 476.11	2600-55120-402240	Hanson Chemical - PCard
04/11/2016	45	U.S. Bank PCards	\$ 675.83	2600-55120-402240	Hanson Chemical - PCard
04/11/2016	45	U.S. Bank PCards	\$ 13.36	0100-51270-402450	Graybar Electric - PCard
04/11/2016	45	U.S. Bank PCards	\$ 20.76	5020-73140-402450	Graybar Electric - PCard
04/11/2016	45	U.S. Bank PCards	\$ 6.92	5120-83140-402450	Graybar Electric - PCard
04/11/2016	45	U.S. Bank PCards	\$ 181.79	5120-84000-402223	Hach Company - PCard
04/11/2016	45	U.S. Bank PCards	\$ 92.26	5710-71430-402450	Hanson Chemical - PCard
04/11/2016	45	U.S. Bank PCards	\$ 38.27	5710-71430-402450	Hanson Chemical - PCard
04/11/2016	45	U.S. Bank PCards	\$ 54.80	1500-21120-402261	Galls - PCard
04/11/2016	45	U.S. Bank PCards	\$ 87.33	1500-21120-402260	Galls - PCard
04/11/2016	45	U.S. Bank PCards	\$ 127.89	1500-21120-402260	Galls - PCard
04/11/2016	45	U.S. Bank PCards	\$ 840.00	0100-15120-403350	Government Finance - PCard
04/11/2016	45	U.S. Bank PCards	\$ 28.38	0100-51270-402450	Graybar Electric - PCard
04/11/2016	45	U.S. Bank PCards	\$ 226.80	5610-71190-402450	Graybar Electric - PCard
04/11/2016	45	U.S. Bank PCards	\$ 131.01	1500-21120-402260	Galls - PCard
04/11/2016	45	U.S. Bank PCards	\$ 45.56	1500-21120-402261	Galls - PCard
04/11/2016	45	U.S. Bank PCards	\$ 621.33	1500-21120-402260	Galls - PCard
04/11/2016	45	U.S. Bank PCards	\$ 269.46	1500-21120-402261	Galls - PCard
04/11/2016	45	U.S. Bank PCards	\$ 181.23	1500-21120-402261	Galls - PCard
04/11/2016	45	U.S. Bank PCards	\$ 127.60	1500-21120-402260	Galls - PCard
04/11/2016	45	U.S. Bank PCards	\$ 18.00	7380-12640-403730	City Of Billings Finance - PCard
04/11/2016	45	U.S. Bank PCards	\$ 220.00	5610-71150-402290	Fire Protection Pub-Web - PCard
04/11/2016	45	U.S. Bank PCards	\$ 1,344.00	1500-22240-402280	Fire Protection Pub-Web - PCard
04/11/2016	45	U.S. Bank PCards	\$ 227.95	5610-71140-402260	Galls - PCard
04/11/2016	45	U.S. Bank PCards	\$ 33.81	5610-71130-402260	Galls - PCard

Check Date	Check	Name	Amount	Account	Item Desc
04/11/2016	45	U.S. Bank PCards	\$ 33.84	5610-71130-402260	Galls - PCard
04/11/2016	45	U.S. Bank PCards	\$ 113.40	0100-51120-402290	Fasteners Billings - PCard
04/11/2016	45	U.S. Bank PCards	\$ 1.00	0100-51120-402320	Fasteners Billings - PCard
04/11/2016	45	U.S. Bank PCards	\$ 3.99	5210-15230-402290	Fasteners Billings - PCard
04/11/2016	45	U.S. Bank PCards	\$ 39.74	5610-71120-402450	Fasteners Billings - PCard
04/11/2016	45	U.S. Bank PCards	\$ 3.96	5610-71120-402450	Fasteners Billings - PCard
04/11/2016	45	U.S. Bank PCards	\$ 169.99	5710-71440-402410	Fasteners Billings - PCard
04/11/2016	45	U.S. Bank PCards	\$ 5.83	0100-51140-402410	Fasteners Billings - PCard
04/11/2016	45	U.S. Bank PCards	\$ 10.73	2110-31320-402360	Fasteners Billings - PCard
04/11/2016	45	U.S. Bank PCards	\$ 29.18	2110-31320-402360	Fasteners Billings - PCard
04/11/2016	45	U.S. Bank PCards	\$ 14.16	5410-31220-402290	Fasteners Billings - PCard
04/11/2016	45	U.S. Bank PCards	\$ 13.99	5410-31220-402630	Fasteners Billings - PCard
04/11/2016	45	U.S. Bank PCards	\$ 28.27	5410-31220-402290	Fasteners Billings - PCard
04/11/2016	45	U.S. Bank PCards	\$ 16.26	5610-71130-402410	Fasteners Billings - PCard
04/11/2016	45	U.S. Bank PCards	\$ 39.48	5020-73140-402450	Fasteners Billings - PCard
04/11/2016	45	U.S. Bank PCards	\$ 13.16	5120-83140-402450	Fasteners Billings - PCard
04/11/2016	45	U.S. Bank PCards	\$ 22.08	5020-74000-402450	Fasteners Billings - PCard
04/11/2016	45	U.S. Bank PCards	\$ 4.72	5120-85000-402410	Fasteners Billings - PCard
04/11/2016	45	U.S. Bank PCards	\$ 56.05	0100-51120-402290	Fasteners Billings - PCard
04/11/2016	45	U.S. Bank PCards	\$ 77.96	0100-15120-403210	Econo Print - PCard
04/11/2016	45	U.S. Bank PCards	\$ 58.16	0100-17500-403365	Econo Print - PCard
04/11/2016	45	U.S. Bank PCards	\$ 47.50	5610-71140-403660	Entre Technology Service - PCard
04/11/2016	45	U.S. Bank PCards	\$ 627.64	5020-74000-402220	Environmental Resource - PCard
04/11/2016	45	U.S. Bank PCards	\$ 23.35	0100-51120-402290	Fasteners Billings - PCard
04/11/2016	45	U.S. Bank PCards	\$ 268.47	5610-71130-402320	Fasteners Billings - PCard
04/11/2016	45	U.S. Bank PCards	\$ 199.36	5610-71130-402450	Cummins Rocky Mtn - PCard
04/11/2016	45	U.S. Bank PCards	\$ 1,821.00	8730-51990-402920	Cy Corp Trailer - PCard
04/11/2016	45	U.S. Bank PCards	\$ 25.01	5120-87000-403824	On Your Way #1 - PCard
04/11/2016	45	U.S. Bank PCards	\$ 439.80	1500-21500-403210	Econo Print - PCard
04/11/2016	45	U.S. Bank PCards	\$ 234.27	0100-43210-402190	Econo Print - PCard
04/11/2016	45	U.S. Bank PCards	\$ 290.91	6700-31410-403210	Econo Print - PCard
04/11/2016	45	U.S. Bank PCards	\$ 7.58	5710-71430-402450	Crescent Electric 054 - PCard
04/11/2016	45	U.S. Bank PCards	\$ 188.21	5710-71430-402450	Crescent Electric 054 - PCard
04/11/2016	45	U.S. Bank PCards	\$ 61.78	5120-84300-402360	Crescent Electric 054 - PCard
04/11/2016	45	U.S. Bank PCards	\$ 82.06	5120-84300-402360	Crescent Electric 054 - PCard
04/11/2016	45	U.S. Bank PCards	\$ 372.97	5120-84300-402360	Crescent Electric 054 - PCard
04/11/2016	45	U.S. Bank PCards	\$ 239.14	5120-84300-402360	Crescent Electric 054 - PCard
04/11/2016	45	U.S. Bank PCards	\$ 1,060.00	1500-21120-402261	Creative Monograms Smb - PCard
04/11/2016	45	U.S. Bank PCards	\$ 80.00	1500-21500-402120	Creative Monograms Smb - PCard
04/11/2016	45	U.S. Bank PCards	\$ 91.00	1500-21120-402260	Creative Monograms Smb - PCard

Check Date	Check	Name	Amount	Account	Item Desc
04/11/2016	45	U.S. Bank PCards	\$ 63.00	5210-15230-402260	Creative Monograms Smb - PCard
04/11/2016	45	U.S. Bank PCards	\$ 701.00	5610-71130-402260	Creative Monograms Smb - PCard
04/11/2016	45	U.S. Bank PCards	\$ 37.91	5710-71430-402450	Crescent Electric 054 - PCard
04/11/2016	45	U.S. Bank PCards	\$ 12.55	2600-55140-402190	Brodart Supplies - PCard
04/11/2016	45	U.S. Bank PCards	\$ 12.50	2600-55130-402190	Brodart Supplies - PCard
04/11/2016	45	U.S. Bank PCards	\$ 171.68	2600-55160-402190	Brodart Supplies - PCard
04/11/2016	45	U.S. Bank PCards	\$ 375.00	1500-21150-402285	Billings Chamber Of Co - PCard
04/11/2016	45	U.S. Bank PCards	\$ 12.00	7380-12640-403730	City Of Billings Met - PCard
04/11/2016	45	U.S. Bank PCards	\$ 6.00	1500-21120-402260	Creative Monograms Smb - PCard
04/11/2016	45	U.S. Bank PCards	\$ 54.28	5120-84300-402360	Border States Electric - PCard
04/11/2016	45	U.S. Bank PCards	\$ 215.29	0100-51120-402290	Border States Electric - PCard
04/11/2016	45	U.S. Bank PCards	\$ 14.54	6060-19310-402122	Border States Electric - PCard
04/11/2016	45	U.S. Bank PCards	\$ 1,173.38	5020-73140-402450	Border States Electric - PCard
04/11/2016	45	U.S. Bank PCards	\$ 391.13	5120-83140-402450	Border States Electric - PCard
04/11/2016	45	U.S. Bank PCards	\$ 469.29	2600-55160-402190	Brodart Supplies - PCard
04/11/2016	45	U.S. Bank PCards	\$ 101.50	1500-22240-402450	Billings Const. Supply - PCard
04/11/2016	45	U.S. Bank PCards	\$ 58.80	1500-21110-403330	Lee Newspaper Subscriptio - PCard
04/11/2016	45	U.S. Bank PCards	\$ 10.47	2110-31320-402380	Bloedorn Lumber Billings - PCard
04/11/2016	45	U.S. Bank PCards	\$ 246.96	5020-74000-402360	Border States Electric - PCard
04/11/2016	45	U.S. Bank PCards	\$ 30.56	5020-74000-402360	Border States Electric - PCard
04/11/2016	45	U.S. Bank PCards	\$ 36.41	5020-74000-402360	Border States Electric - PCard
04/11/2016	45	U.S. Bank PCards	\$ 361.00	5410-31230-405333	Billings Const. Supply - PCard
04/11/2016	45	U.S. Bank PCards	\$ 70.00	5610-71130-403660	Billings Const. Supply - PCard
04/11/2016	45	U.S. Bank PCards	\$ 129.92	5610-71130-403650	Billings Const. Supply - PCard
04/11/2016	45	U.S. Bank PCards	\$ 29.80	2110-31320-402410	Billings Const. Supply - PCard
04/11/2016	45	U.S. Bank PCards	\$ 119.65	2110-31320-402290	Billings Const. Supply - PCard
04/11/2016	45	U.S. Bank PCards	\$ 150.24	5120-85000-402290	Billings Const. Supply - PCard
04/11/2016	45	U.S. Bank PCards	\$ 657.60	6500-15670-403690	Big Sky Linen & Uniform - PCard
04/11/2016	45	U.S. Bank PCards	\$ 342.35	6500-15660-402450	Big Sky Linen & Uniform - PCard
04/11/2016	45	U.S. Bank PCards	\$ 21.50	1500-21120-402450	Big Sky Linen & Uniform - PCard
04/11/2016	45	U.S. Bank PCards	\$ 40.30	0100-51270-402450	Big Sky Linen & Uniform - PCard
04/11/2016	45	U.S. Bank PCards	\$ 108.00	2600-55120-402260	Big Sky Linen & Uniform - PCard
04/11/2016	45	U.S. Bank PCards	\$ 41.00	1500-21120-402120	Billings Army Navy Surplu - PCard
04/11/2016	45	U.S. Bank PCards	\$ 452.43	5610-71120-402260	Big Sky Linen & Uniform - PCard
04/11/2016	45	U.S. Bank PCards	\$ 201.01	5610-71130-402260	Big Sky Linen & Uniform - PCard
04/11/2016	45	U.S. Bank PCards	\$ 1,158.50	2110-31320-402260	Big Sky Linen & Uniform - PCard
04/11/2016	45	U.S. Bank PCards	\$ 926.80	2110-31320-402260	Big Sky Linen & Uniform - PCard
04/11/2016	45	U.S. Bank PCards	\$ 7.15	0100-51120-403660	Big Sky Linen & Uniform - PCard
04/11/2016	45	U.S. Bank PCards	\$ 317.01	6010-15530-402260	Big Sky Linen & Uniform - PCard
04/11/2016	45	U.S. Bank PCards	\$ 10.46	6700-31410-403660	Automated Office Systems - PCard

Check Date	Check	Name	Amount	Account	Item Desc
04/11/2016	45	U.S. Bank PCards	\$ 59.00	5020-74000-402190	Badgewest Awards & Eng - PCard
04/11/2016	45	U.S. Bank PCards	\$ 9.48	5020-74000-402450	Motion Industries Mt01 - PCard
04/11/2016	45	U.S. Bank PCards	\$ 1,121.10	5410-31220-402260	Big Sky Linen & Uniform - PCard
04/11/2016	45	U.S. Bank PCards	\$ 692.12	5410-31230-402260	Big Sky Linen & Uniform - PCard
04/11/2016	45	U.S. Bank PCards	\$ 143.19	5610-71120-402240	Big Sky Linen & Uniform - PCard
04/11/2016	45	U.S. Bank PCards	\$ 52.66	2110-31320-403630	Automated Office Systems - PCard
04/11/2016	45	U.S. Bank PCards	\$ 8.12	5020-74000-403660	Automated Office Systems - PCard
04/11/2016	45	U.S. Bank PCards	\$ 454.13	2910-65010-403240	Automated Office Systems - PCard
04/11/2016	45	U.S. Bank PCards	\$ 14.00	6600-31100-403660	Automated Office Systems - PCard
04/11/2016	45	U.S. Bank PCards	\$ 8.11	6700-31410-403660	Automated Office Systems - PCard
04/11/2016	45	U.S. Bank PCards	\$ 26.16	6600-31100-403660	Automated Office Systems - PCard
04/11/2016	45	U.S. Bank PCards	\$ 780.00	5710-71420-403823	American Public Trans Ass - PCard
04/11/2016	45	U.S. Bank PCards	\$ 1,278.00	6700-31410-403350	American Public Works - PCard
04/11/2016	45	U.S. Bank PCards	\$ 319.50	6600-31100-403350	American Public Works - PCard
04/11/2016	45	U.S. Bank PCards	\$ 159.75	2110-31320-403350	American Public Works - PCard
04/11/2016	45	U.S. Bank PCards	\$ 159.75	5020-74000-403350	American Public Works - PCard
04/11/2016	45	U.S. Bank PCards	\$ 288.00	2600-55110-403290	Artcraft Printers Of Bill - PCard
04/11/2016	45	U.S. Bank PCards	\$ 97.90	5210-15920-402450	Air Controls-Billings - PCard
04/11/2016	45	U.S. Bank PCards	\$ 85.00	6500-15670-403690	Air Controls-Billings - PCard
04/11/2016	45	U.S. Bank PCards	\$ 85.00	6500-15670-403690	Air Controls-Billings - PCard
04/11/2016	45	U.S. Bank PCards	\$ 1,225.00	5610-71120-402450	Alpine Plumbing Heating I - PCard
04/11/2016	45	U.S. Bank PCards	\$ 450.00	5610-71150-403822	Aaae - PCard
04/11/2016	45	U.S. Bank PCards	\$ 450.00	5610-71150-403822	Aaae - PCard
04/11/2016	45	U.S. Bank PCards	\$ 831.57	5210-15930-402450	Ace Electric, Inc. - PCard
04/11/2016	45	U.S. Bank PCards	\$ 609.72	5210-15950-402450	Ace Electric, Inc. - PCard
04/11/2016	45	U.S. Bank PCards	\$ 950.00	6500-15660-403990	Ace Electric, Inc. - PCard
04/11/2016	45	U.S. Bank PCards	\$ 484.95	6500-15660-402450	Ace Electric, Inc. - PCard
04/11/2016	45	U.S. Bank PCards	\$ 140.07	6500-15660-402450	Ace Electric, Inc. - PCard
04/11/2016	45	U.S. Bank PCards	\$ 278.62	5210-15950-402450	Air Controls-Billings - PCard
04/11/2016	45	U.S. Bank PCards	\$ 85.00	5020-74000-405333	A-1 Rentals - PCard
04/11/2016	45	U.S. Bank PCards	\$ 18.17	5020-75000-402410	A & H Turf - PCard
04/11/2016	45	U.S. Bank PCards	\$ 12.11	5120-85000-402410	A & H Turf - PCard
04/11/2016	45	U.S. Bank PCards	\$ 8.60	0100-51120-402391	A & H Turf - PCard
04/11/2016	45	U.S. Bank PCards	\$ 145.00	1500-21500-403210	Accent Print Shop, Inc. - PCard
04/11/2016	45	U.S. Bank PCards	\$ 42.00	1500-21700-403210	Accent Print Shop, Inc. - PCard
04/11/2016	45	U.S. Bank PCards	\$ 169.02	5120-84000-402320	Ratco Trailer And Hitch - PCard
04/11/2016	45	U.S. Bank PCards	\$ 3.80	0100-51120-402330	Ratco Trailer And Hitch - PCard
04/11/2016	45	U.S. Bank PCards	\$ 360.53	7090-21910-396620	Radioshack Dea00030676 - PCard
04/11/2016	45	U.S. Bank PCards	\$ 155.10	5120-83110-405333	Pitney Bowes Credit - PCard
04/11/2016	45	U.S. Bank PCards	\$ 232.65	5020-73110-405333	Pitney Bowes Credit - PCard

Check Date	Check	Name	Amount	Account	Item Desc
04/11/2016	45	U.S. Bank PCards	\$ 85.00	5120-83140-405333	A-1 Rentals - PCard
04/11/2016	45	U.S. Bank PCards	\$ 39.39	5610-71130-402450	Sherwin Williams #3203 - PCard
04/11/2016	45	U.S. Bank PCards	\$ 36.00	2600-55160-402290	The Rubber Stamp Shop, In - PCard
04/11/2016	45	U.S. Bank PCards	\$ 27.94	0100-15120-402190	The Rubber Stamp Shop, In - PCard
04/11/2016	45	U.S. Bank PCards	\$ 150.00	2400-43010-403210	The Rubber Stamp Shop, In - PCard
04/11/2016	45	U.S. Bank PCards	\$ 37.50	2600-55130-402190	The Rubber Stamp Shop, In - PCard
04/11/2016	45	U.S. Bank PCards	\$ 43.70	7180-21600-402290	The Rubber Stamp Shop, In - PCard
04/11/2016	45	U.S. Bank PCards	\$ 760.00	5410-31210-402190	Cartridge World Centennia - PCard
04/11/2016	45	U.S. Bank PCards	\$ 28.11	5020-74000-402450	Sipton'S Big R-East - PCard
04/11/2016	45	U.S. Bank PCards	\$ 17.99	0100-51120-402290	Siptons Big R Heights - PCard
04/11/2016	45	U.S. Bank PCards	\$ 34.76	0100-51120-402290	Siptons Big R Heights - PCard
04/11/2016	45	U.S. Bank PCards	\$ 30.00	1500-22260-402340	Sherwin Williams #3203 - PCard
04/11/2016	45	U.S. Bank PCards	\$ 27.00	5610-71130-402450	Sherwin Williams #3203 - PCard
04/11/2016	45	U.S. Bank PCards	\$ 260.00	5210-15230-402310	Permaletter Sign Company - PCard
04/11/2016	45	U.S. Bank PCards	\$ 60.00	5610-71120-402450	Permaletter Sign Company - PCard
04/11/2016	45	U.S. Bank PCards	\$ 210.00	1500-22290-402640	Permaletter Sign Company - PCard
04/11/2016	45	U.S. Bank PCards	\$ 107.25	0100-51120-402290	Agp*Propane Services - PCard
04/11/2016	45	U.S. Bank PCards	\$ 420.00	6500-15670-403690	Stanley Steemer/Blngs - PCard
04/11/2016	45	U.S. Bank PCards	\$ 560.00	6500-15660-403660	Stanley Steemer/Blngs - PCard
04/11/2016	45	U.S. Bank PCards	\$ 68.18	5410-31220-402290	Pacific Steel #02 - PCard
04/11/2016	45	U.S. Bank PCards	\$ 4.50	0100-51120-402290	Pacific Steel #02 - PCard
04/11/2016	45	U.S. Bank PCards	\$ 85.65	5410-31230-402290	Pacific Steel #02 - PCard
04/11/2016	45	U.S. Bank PCards	\$ 138.27	5610-71130-402450	The Paint Center - PCard
04/11/2016	45	U.S. Bank PCards	\$ 45.00	0100-51280-402290	Pepsi-Cola Bottling Co - PCard
04/11/2016	45	U.S. Bank PCards	\$ 759.00	5610-71120-402450	Permaletter Sign Company - PCard
04/11/2016	45	U.S. Bank PCards	\$ 35.80	2110-31320-402380	Pacific Steel #02 - PCard
04/11/2016	45	U.S. Bank PCards	\$ 83.48	5020-74000-402450	Pacific Steel #02 - PCard
04/11/2016	45	U.S. Bank PCards	\$ 26.32	5120-85000-404220	Pacific Steel #02 - PCard
04/11/2016	45	U.S. Bank PCards	\$ 10.95	5020-75000-404220	Pacific Steel #02 - PCard
04/11/2016	45	U.S. Bank PCards	\$ 7.30	5120-85000-404220	Pacific Steel #02 - PCard
04/11/2016	45	U.S. Bank PCards	\$ 20.32	5410-31220-402290	Pacific Steel #02 - PCard
04/11/2016	45	U.S. Bank PCards	\$ 114.72	5020-74000-402220	Northwest Scientific Inc - PCard
04/11/2016	45	U.S. Bank PCards	\$ 514.88	5020-74000-402220	Northwest Scientific Inc - PCard
04/11/2016	45	U.S. Bank PCards	\$ 156.14	5020-74000-402220	Northwest Scientific Inc - PCard
04/11/2016	45	U.S. Bank PCards	\$ 86.13	5120-84000-402223	Northwest Scientific Inc - PCard
04/11/2016	45	U.S. Bank PCards	\$ 118.78	5020-74000-402220	Northwest Scientific Inc - PCard
04/11/2016	45	U.S. Bank PCards	\$ 23.48	5120-84300-402360	Pacific Steel #02 - PCard
04/11/2016	45	U.S. Bank PCards	\$ 53.21	0100-51120-402290	Northwest Pipe Fitting - PCard
04/11/2016	45	U.S. Bank PCards	\$ 143.48	0100-51120-402391	Northwest Pipe Fitting - PCard
04/11/2016	45	U.S. Bank PCards	\$ 178.47	0100-51120-402391	Northwest Pipe Fitting - PCard

Check Date	Check	Name	Amount	Account	Item Desc
04/11/2016	45	U.S. Bank PCards	\$ 74.67	0100-51120-402391	Northwest Pipe Fitting - PCard
04/11/2016	45	U.S. Bank PCards	\$ 91.90	5120-84000-402223	Northwest Scientific Inc - PCard
04/11/2016	45	U.S. Bank PCards	\$ 221.43	5020-74000-402220	Northwest Scientific Inc - PCard
04/11/2016	45	U.S. Bank PCards	\$ 67.83	5020-73120-402410	Northwest Industrial Supp - PCard
04/11/2016	45	U.S. Bank PCards	\$ 473.29	5120-85000-402410	Northwest Industrial Supp - PCard
04/11/2016	45	U.S. Bank PCards	\$ 226.56	2110-31320-402290	Northwest Industrial Supp - PCard
04/11/2016	45	U.S. Bank PCards	\$ 6.01	0100-51120-402290	Northwest Pipe Fitting - PCard
04/11/2016	45	U.S. Bank PCards	\$ 48.16	5610-71150-402290	Northwest Pipe Fitting - PCard
04/11/2016	45	U.S. Bank PCards	\$ 2.42	0100-51120-402290	Northwest Pipe Fitting - PCard
04/11/2016	45	U.S. Bank PCards	\$ 9.11	5020-75000-402410	Northwest Industrial Supp - PCard
04/11/2016	45	U.S. Bank PCards	\$ 6.08	5120-85000-402410	Northwest Industrial Supp - PCard
04/11/2016	45	U.S. Bank PCards	\$ 63.08	5020-75000-402920	Northwest Industrial Supp - PCard
04/11/2016	45	U.S. Bank PCards	\$ 42.06	5120-85000-402920	Northwest Industrial Supp - PCard
04/11/2016	45	U.S. Bank PCards	\$ 5.26	5020-75000-402410	Northwest Industrial Supp - PCard
04/11/2016	45	U.S. Bank PCards	\$ 3.50	5120-85000-402410	Northwest Industrial Supp - PCard
04/11/2016	45	U.S. Bank PCards	\$ 196.00	1500-21120-402320	Northland Automotive - PCard
04/11/2016	45	U.S. Bank PCards	\$ 61.44	5610-71130-402410	Northwest Industrial Supp - PCard
04/11/2016	45	U.S. Bank PCards	\$ 13.84	5020-75000-402410	Northwest Industrial Supp - PCard
04/11/2016	45	U.S. Bank PCards	\$ 9.23	5120-85000-402410	Northwest Industrial Supp - PCard
04/11/2016	45	U.S. Bank PCards	\$ 155.20	5020-75000-402410	Northwest Industrial Supp - PCard
04/11/2016	45	U.S. Bank PCards	\$ 103.47	5120-85000-402410	Northwest Industrial Supp - PCard
04/11/2016	45	U.S. Bank PCards	\$ 12.29	0100-51120-402410	Napa Store 3547001 - PCard
04/11/2016	45	U.S. Bank PCards	\$ 80.63	5410-31220-402290	Napa Store 3547001 - PCard
04/11/2016	45	U.S. Bank PCards	\$ 289.00	0100-51120-402120	Napa Store 3547001 - PCard
04/11/2016	45	U.S. Bank PCards	\$ 39.60	0100-51120-402410	Napa Store 3547001 - PCard
04/11/2016	45	U.S. Bank PCards	\$ 43.16	1500-22260-402320	Napa Store 3547001 - PCard
04/11/2016	45	U.S. Bank PCards	\$ 86.16	5610-71130-402320	Normont Equipment Co - PCard
04/11/2016	45	U.S. Bank PCards	\$ 324.26	1500-21710-403512	Moore Lane Veterinary Hos - PCard
04/11/2016	45	U.S. Bank PCards	\$ 12.78	0100-51120-402290	Napa Store 3547001 - PCard
04/11/2016	45	U.S. Bank PCards	\$ 35.49	5610-71130-402410	Napa Store 3547001 - PCard
04/11/2016	45	U.S. Bank PCards	\$ 5.33	5710-71440-402450	Napa Store 3547001 - PCard
04/11/2016	45	U.S. Bank PCards	\$ 3.46	5710-71430-402450	Napa Store 3547001 - PCard
04/11/2016	45	U.S. Bank PCards	\$ 15.98	0100-51120-402330	Napa Store 3547001 - PCard
04/11/2016	45	U.S. Bank PCards	\$ 50.28	0100-51120-402330	Midland Implement Co - PCard
04/11/2016	45	U.S. Bank PCards	\$ 231.62	0100-51120-402330	Midland Implement Co - PCard
04/11/2016	45	U.S. Bank PCards	\$ 40.90	0100-51120-402391	Midland Implement Co - PCard
04/11/2016	45	U.S. Bank PCards	\$ 429.20	0100-51120-402330	Midland Implement Co - PCard
04/11/2016	45	U.S. Bank PCards	\$ 251.64	8730-51990-403650	Knife River 5601 - PCard
04/11/2016	45	U.S. Bank PCards	\$ 40.00	5610-71100-403210	Midland Printing - PCard
04/11/2016	45	U.S. Bank PCards	\$ 6.42	5410-31230-402290	Marketing Specialtites - PCard

Check Date	Check	Name	Amount	Account	Item Desc
04/11/2016	45	U.S. Bank PCards	\$ 280.35	0100-51420-402290	Midland Implement Co - PCard
04/11/2016	45	U.S. Bank PCards	\$ 215.44	0100-51420-402330	Midland Implement Co - PCard
04/11/2016	45	U.S. Bank PCards	\$ 227.13	0100-51420-402290	Midland Implement Co - PCard
04/11/2016	45	U.S. Bank PCards	\$ 257.10	2110-31320-402320	Midland Implement Co - PCard
04/11/2016	45	U.S. Bank PCards	\$ 235.00	0100-51120-402330	Midland Implement Co - PCard
04/11/2016	45	U.S. Bank PCards	\$ 67.00	1500-21110-403574	Kenco Security And Tec - PCard
04/11/2016	45	U.S. Bank PCards	\$ 26.00	2510-21270-402190	Kenco Security And Tec - PCard
04/11/2016	45	U.S. Bank PCards	\$ 303.94	1500-21150-402285	Kenco Security And Tec - PCard
04/11/2016	45	U.S. Bank PCards	\$ 73.00	2600-55120-403660	Kenco Security And Tec - PCard
04/11/2016	45	U.S. Bank PCards	\$ 36.00	2110-31320-402380	Macon Supply Billi - PCard
04/11/2016	45	U.S. Bank PCards	\$ 17.37	1500-22290-402925	The Mail Drop - PCard
04/11/2016	45	U.S. Bank PCards	\$ 1,166.00	6500-15670-403690	Kenco Security And Tec - PCard
04/11/2016	45	U.S. Bank PCards	\$ 1,417.98	6500-15670-403690	Kenco Security And Tec - PCard
04/11/2016	45	U.S. Bank PCards	\$ 1,753.94	6500-15660-402450	Kenco Security And Tec - PCard
04/11/2016	45	U.S. Bank PCards	\$ 67.00	6500-15660-403660	Kenco Security And Tec - PCard
04/11/2016	45	U.S. Bank PCards	\$ 18.40	6600-31100-403660	Kenco Security And Tec - PCard
04/11/2016	45	U.S. Bank PCards	\$ 27.60	6700-31410-403660	Kenco Security And Tec - PCard
04/11/2016	45	U.S. Bank PCards	\$ 10.05	5120-85000-403660	Kenco Security And Tec - PCard
04/11/2016	45	U.S. Bank PCards	\$ 6.28	5020-73140-403660	Kenco Security And Tec - PCard
04/11/2016	45	U.S. Bank PCards	\$ 2.09	5120-83140-403660	Kenco Security And Tec - PCard
04/11/2016	45	U.S. Bank PCards	\$ 75.00	5210-15930-403970	Kenco Security And Tec - PCard
04/11/2016	45	U.S. Bank PCards	\$ 75.00	5210-15920-403970	Kenco Security And Tec - PCard
04/11/2016	45	U.S. Bank PCards	\$ 37.50	5210-15910-403970	Kenco Security And Tec - PCard
04/11/2016	45	U.S. Bank PCards	\$ (119.25)	1500-21710-402240	Kelly Services - PCard
04/11/2016	45	U.S. Bank PCards	\$ 33.50	5410-31230-403660	Kenco Security And Tec - PCard
04/11/2016	45	U.S. Bank PCards	\$ 19.50	5020-74000-403660	Kenco Security And Tec - PCard
04/11/2016	45	U.S. Bank PCards	\$ 4.88	5020-73140-403660	Kenco Security And Tec - PCard
04/11/2016	45	U.S. Bank PCards	\$ 1.62	5120-83140-403660	Kenco Security And Tec - PCard
04/11/2016	45	U.S. Bank PCards	\$ 15.08	5020-75000-403660	Kenco Security And Tec - PCard
04/11/2016	45	U.S. Bank PCards	\$ 19.95	2600-55190-403225	Msu-Bz-Kusm-Cm - PCard
04/11/2016	45	U.S. Bank PCards	\$ (119.25)	1500-21710-402240	Kelly Services - PCard
04/11/2016	45	U.S. Bank PCards	\$ (159.00)	1500-21710-402240	Kelly Services - PCard
04/11/2016	45	U.S. Bank PCards	\$ (119.25)	1500-21710-402240	Kelly Services - PCard
04/11/2016	45	U.S. Bank PCards	\$ (119.25)	1500-21710-402240	Kelly Services - PCard
04/11/2016	45	U.S. Bank PCards	\$ (159.00)	1500-21710-402240	Kelly Services - PCard
04/11/2016	45	U.S. Bank PCards	\$ 24.57	5020-75000-403660	Ups (800) 811-1648 - PCard
04/11/2016	45	U.S. Bank PCards	\$ 16.38	5120-85000-403660	Ups (800) 811-1648 - PCard
04/11/2016	45	U.S. Bank PCards	\$ 55.07	0100-51420-402290	Oreilly Auto 00015511 - PCard
04/11/2016	45	U.S. Bank PCards	\$ 44.94	5610-71130-402310	Oreilly Auto 00015511 - PCard
04/11/2016	45	U.S. Bank PCards	\$ 649.10	5610-71130-402320	Oreilly Auto 00015511 - PCard

Check Date	Check	Name	Amount	Account	Item Desc
04/11/2016	45	U.S. Bank PCards	\$ 27.57	1500-22240-402450	Oreilly Auto 00043018 - PCard
04/11/2016	45	U.S. Bank PCards	\$ 19.13	1500-21710-402450	Amazon Mktplace Pmts - PCard
04/11/2016	45	U.S. Bank PCards	\$ 57.30	1500-21710-402450	Amazon Mktplace Pmts - PCard
04/11/2016	45	U.S. Bank PCards	\$ 38.22	1500-21500-402120	Amazon Mktplace Pmts - PCard
04/11/2016	45	U.S. Bank PCards	\$ 42.28	1500-21700-402260	Amazon Mktplace Pmts - PCard
04/11/2016	45	U.S. Bank PCards	\$ 94.41	1500-21700-402260	Amazon Mktplace Pmts - PCard
04/11/2016	45	U.S. Bank PCards	\$ 15.82	1500-21700-403110	The Ups Store 2594 - PCard
04/11/2016	45	U.S. Bank PCards	\$ 249.45	2600-55190-403225	Amazon Mktplace Pmts - PCard
04/11/2016	45	U.S. Bank PCards	\$ 13.46	2600-55190-403226	Amazon Mktplace Pmts - PCard
04/11/2016	45	U.S. Bank PCards	\$ 6.97	2600-55190-403226	Amazon Mktplace Pmts - PCard
04/11/2016	45	U.S. Bank PCards	\$ 19.03	2600-55190-403227	Amazon Mktplace Pmts - PCard
04/11/2016	45	U.S. Bank PCards	\$ 58.45	1500-21200-402610	Amazon Mktplace Pmts - PCard
04/11/2016	45	U.S. Bank PCards	\$ 188.88	1500-21710-402450	Amazon Mktplace Pmts - PCard
04/11/2016	45	U.S. Bank PCards	\$ 13.98	2600-55190-403226	Amazon Mktplace Pmts - PCard
04/11/2016	45	U.S. Bank PCards	\$ 8.99	2600-55190-403226	Amazon Mktplace Pmts - PCard
04/11/2016	45	U.S. Bank PCards	\$ 17.96	2600-55190-403222	Amazon Mktplace Pmts - PCard
04/11/2016	45	U.S. Bank PCards	\$ 105.49	2600-55190-403225	Amazon Mktplace Pmts - PCard
04/11/2016	45	U.S. Bank PCards	\$ (5.00)	2600-55190-403225	Amazon Mktplace Pmts - PCard
04/11/2016	45	U.S. Bank PCards	\$ 7.99	2600-55190-403222	Amazon Mktplace Pmts - PCard
04/11/2016	45	U.S. Bank PCards	\$ 19.49	2600-55150-402190	Amazon Mktplace Pmts - PCard
04/11/2016	45	U.S. Bank PCards	\$ 28.99	2600-55190-403225	Amazon Mktplace Pmts - PCard
04/11/2016	45	U.S. Bank PCards	\$ 12.99	2600-55190-403225	Amazon Mktplace Pmts - PCard
04/11/2016	45	U.S. Bank PCards	\$ (21.70)	2600-55190-403382	Amazon Mktplace Pmts - PCard
04/11/2016	45	U.S. Bank PCards	\$ (5.14)	2600-55110-403110	Amazon Mktplace Pmts - PCard
04/11/2016	45	U.S. Bank PCards	\$ 8.49	2600-55190-403226	Amazon Mktplace Pmts - PCard
04/11/2016	45	U.S. Bank PCards	\$ 4.00	2600-55190-403226	Amazon Mktplace Pmts - PCard
04/11/2016	45	U.S. Bank PCards	\$ 15.43	2600-55190-403333	Amazon Mktplace Pmts - PCard
04/11/2016	45	U.S. Bank PCards	\$ 10.98	2600-55190-403222	Amazon Mktplace Pmts - PCard
04/11/2016	45	U.S. Bank PCards	\$ 4.42	2600-55190-403222	Amazon Mktplace Pmts - PCard
04/11/2016	45	U.S. Bank PCards	\$ 33.94	2600-55190-403227	Amazon Mktplace Pmts - PCard
04/11/2016	45	U.S. Bank PCards	\$ 16.50	2600-55190-403225	Amazon Mktplace Pmts - PCard
04/11/2016	45	U.S. Bank PCards	\$ 8.00	2600-55190-403226	Amazon Mktplace Pmts - PCard
04/11/2016	45	U.S. Bank PCards	\$ 21.28	2600-55190-403227	Amazon Mktplace Pmts - PCard
04/11/2016	45	U.S. Bank PCards	\$ 18.85	2600-55190-403255	Amazon Mktplace Pmts - PCard
04/11/2016	45	U.S. Bank PCards	\$ 20.29	2600-55190-403225	Amazon Mktplace Pmts - PCard
04/11/2016	45	U.S. Bank PCards	\$ 10.44	2600-55190-403227	Amazon Mktplace Pmts - PCard
04/11/2016	45	U.S. Bank PCards	\$ 6.94	2600-55190-403226	Amazon Mktplace Pmts - PCard
04/11/2016	45	U.S. Bank PCards	\$ 12.09	6200-19130-402190	Amazon Mktplace Pmts - PCard
04/11/2016	45	U.S. Bank PCards	\$ 12.09	6200-19110-402290	Amazon Mktplace Pmts - PCard
04/11/2016	45	U.S. Bank PCards	\$ 440.09	5610-71120-402450	Amazon Mktplace Pmts - PCard

Check Date	Check	Name	Amount	Account	Item Desc
04/11/2016	45	U.S. Bank PCards	\$ 75.96	2920-65010-402190	Amazon Mktplace Pmts - PCard
04/11/2016	45	U.S. Bank PCards	\$ 18.15	2600-55190-403241	Amazon Mktplace Pmts - PCard
04/11/2016	45	U.S. Bank PCards	\$ 107.85	2600-55190-403225	Amazon Mktplace Pmts - PCard
04/11/2016	45	U.S. Bank PCards	\$ 10.84	2400-43010-403210	Amazon Mktplace Pmts - PCard
04/11/2016	45	U.S. Bank PCards	\$ 30.99	2400-43010-403210	Amazon Mktplace Pmts - PCard
04/11/2016	45	U.S. Bank PCards	\$ 40.60	2400-43010-403210	Amazon Mktplace Pmts - PCard
04/11/2016	45	U.S. Bank PCards	\$ 7.94	5710-71410-402190	Amazon Mktplace Pmts - PCard
04/11/2016	45	U.S. Bank PCards	\$ 37.96	2510-21270-402190	Amazon Mktplace Pmts - PCard
04/11/2016	45	U.S. Bank PCards	\$ 69.22	1500-21200-402610	Amazon Mktplace Pmts - PCard
04/11/2016	45	U.S. Bank PCards	\$ 224.99	5710-71410-402190	Amazon Mktplace Pmts - PCard
04/11/2016	45	U.S. Bank PCards	\$ 33.34	1500-21710-402120	Amazon Mktplace Pmts - PCard
04/11/2016	45	U.S. Bank PCards	\$ 40.19	0100-13140-402120	Amazon Mktplace Pmts - PCard
04/11/2016	45	U.S. Bank PCards	\$ 8.56	0100-13140-402120	Amazon Mktplace Pmts - PCard
04/11/2016	45	U.S. Bank PCards	\$ 10.33	0100-13140-402120	Amazon Mktplace Pmts - PCard
04/11/2016	45	U.S. Bank PCards	\$ 83.49	2650-67720-402290	Amazon Mktplace Pmts - PCard
04/11/2016	45	U.S. Bank PCards	\$ 526.24	5410-31210-403210	Fedexoffice 00022665 - PCard
04/11/2016	45	U.S. Bank PCards	\$ 24.04	2690-67710-403822	Wheat Montana Farms - PCard
04/11/2016	45	U.S. Bank PCards	\$ 19.68	2690-67710-403822	Wheat Montana Farms - PCard
04/11/2016	45	U.S. Bank PCards	\$ 16.17	2690-67710-403822	Wheat Montana Farms - PCard
04/11/2016	45	U.S. Bank PCards	\$ 60.00	0100-51100-403240	Boxwood Technology - PCard
04/11/2016	45	U.S. Bank PCards	\$ 80.00	0100-51100-403240	Boxwood Technology - PCard
04/11/2016	45	U.S. Bank PCards	\$ 800.00	1500-22230-403824	Int'L Code Council - PCard
04/11/2016	45	U.S. Bank PCards	\$ 57.00	2090-44510-402520	Int'L Code Council Inc - PCard
04/11/2016	45	U.S. Bank PCards	\$ 167.57	2400-43010-403920	Cafe Courier - PCard
04/11/2016	45	U.S. Bank PCards	\$ 721.92	0100-14110-403325	Allegra - PCard
04/11/2016	45	U.S. Bank PCards	\$ 18.24	5610-71130-402320	Rdo Equipment Co - PCard
04/11/2016	45	U.S. Bank PCards	\$ 244.68	2110-31320-402320	Rdo Equipment Co - PCard
04/11/2016	45	U.S. Bank PCards	\$ 7.12	5120-85000-402410	Fastenal Company01 - PCard
04/11/2016	45	U.S. Bank PCards	\$ 17.58	5020-75000-402410	Fastenal Company01 - PCard
04/11/2016	45	U.S. Bank PCards	\$ 11.72	5120-85000-402410	Fastenal Company01 - PCard
04/11/2016	45	U.S. Bank PCards	\$ 9.00	5020-74000-402450	Fastenal Company01 - PCard
04/11/2016	45	U.S. Bank PCards	\$ 103.93	5410-31220-402290	Screen Graphics - PCard
04/11/2016	45	U.S. Bank PCards	\$ 600.00	0100-43210-403822	Int'L Code Council - PCard
04/11/2016	45	U.S. Bank PCards	\$ 18.22	6500-15660-402310	Meadow Green Sales - PCard
04/11/2016	45	U.S. Bank PCards	\$ 40.00	1500-22260-402120	Target 00001719 - PCard
04/11/2016	45	U.S. Bank PCards	\$ 1,071.00	2110-31320-402420	3Mprods Tp82882 Credit - PCard
04/11/2016	45	U.S. Bank PCards	\$ 407.75	2110-31320-402420	3Mprods Tp82883 Credit - PCard
04/11/2016	45	U.S. Bank PCards	\$ 396.00	2110-31320-402420	3Mprods Tp83146 Verbal - PCard
04/11/2016	45	U.S. Bank PCards	\$ 10.68	5020-75000-402410	Fastenal Company01 - PCard
04/11/2016	45	U.S. Bank PCards	\$ 4.25	5710-71430-402450	West End Lock And Secur - PCard

Check Date	Check	Name	Amount	Account	Item Desc
04/11/2016	45	U.S. Bank PCards	\$ 3.50	6500-15670-402190	West End Lock And Secur - PCard
04/11/2016	45	U.S. Bank PCards	\$ 182.00	5210-15950-402450	West End Lock And Secur - PCard
04/11/2016	45	U.S. Bank PCards	\$ 723.00	6500-15660-402450	West End Lock And Secur - PCard
04/11/2016	45	U.S. Bank PCards	\$ 78.00	1500-21120-402290	West End Lock And Secur - PCard
04/11/2016	45	U.S. Bank PCards	\$ 567.22	6500-15660-402210	Meadow Green Sales - PCard
04/11/2016	45	U.S. Bank PCards	\$ 1,796.21	5410-31220-402290	Impact Plastics - PCard
04/11/2016	45	U.S. Bank PCards	\$ 729.39	5410-31220-402290	Impact Plastics - PCard
04/11/2016	45	U.S. Bank PCards	\$ 100.00	1500-21110-403170	Franks Towing - PCard
04/11/2016	45	U.S. Bank PCards	\$ 228.50	1500-21200-407910	Lexisnexis Risk Dat - PCard
04/11/2016	45	U.S. Bank PCards	\$ 14.99	0100-12200-402190	Adobe *Acropro Subs - PCard
04/11/2016	45	U.S. Bank PCards	\$ 14.99	1500-22210-403590	Adobe *Acropro Subs - PCard
04/11/2016	45	U.S. Bank PCards	\$ 130.41	0100-51420-402530	Matthews International - PCard
04/11/2016	45	U.S. Bank PCards	\$ 132.53	5710-71440-402450	Kimball Midwest - PCard
04/11/2016	45	U.S. Bank PCards	\$ 51.74	5710-71440-402450	Kimball Midwest - PCard
04/11/2016	45	U.S. Bank PCards	\$ 102.39	5710-71440-402450	Kimball Midwest - PCard
04/11/2016	45	U.S. Bank PCards	\$ 56.00	2400-43010-403310	Billingsgazettethriftync - PCard
04/11/2016	45	U.S. Bank PCards	\$ 112.00	2400-43010-403310	Billingsgazettethriftync - PCard
04/11/2016	45	U.S. Bank PCards	\$ 10.97	1500-22250-402410	Wm Supercenter #2923 - PCard
04/11/2016	45	U.S. Bank PCards	\$ 107.44	2110-31320-402290	Wm Supercenter #2923 - PCard
04/11/2016	45	U.S. Bank PCards	\$ 56.82	1500-21110-401170	Wm Supercenter #4412 - PCard
04/11/2016	45	U.S. Bank PCards	\$ 4.88	2600-55120-402290	Wm Supercenter #4412 - PCard
04/11/2016	45	U.S. Bank PCards	\$ 14.97	2600-55110-402190	Wm Supercenter #4412 - PCard
04/11/2016	45	U.S. Bank PCards	\$ 323.79	1500-21150-402975	Comfort Inns - PCard
04/11/2016	45	U.S. Bank PCards	\$ 19.97	0100-51120-402260	Wm Supercenter #1956 - PCard
04/11/2016	45	U.S. Bank PCards	\$ 8.94	2600-55150-402280	Wm Supercenter #2923 - PCard
04/11/2016	45	U.S. Bank PCards	\$ 23.60	6600-31100-402190	Wm Supercenter #2923 - PCard
04/11/2016	45	U.S. Bank PCards	\$ 35.40	6700-31410-402190	Wm Supercenter #2923 - PCard
04/11/2016	45	U.S. Bank PCards	\$ 56.28	1500-21400-403822	Wm Supercenter #2923 - PCard
04/11/2016	45	U.S. Bank PCards	\$ 11.33	1500-21400-403822	Wm Supercenter #2923 - PCard
04/11/2016	45	U.S. Bank PCards	\$ 10.77	0100-16110-402190	Wal-Mart #2923 - PCard
04/11/2016	45	U.S. Bank PCards	\$ 119.34	0100-51120-402260	Wal-Mart #4412 - PCard
04/11/2016	45	U.S. Bank PCards	\$ 22.17	2600-55140-402290	Walmart.Com 8009666546 - PCard
04/11/2016	45	U.S. Bank PCards	\$ 78.01	5710-71430-402450	Wm Supercenter #1956 - PCard
04/11/2016	45	U.S. Bank PCards	\$ 58.14	5710-71430-402450	Wm Supercenter #1956 - PCard
04/11/2016	45	U.S. Bank PCards	\$ 9.96	5710-71440-402450	Wm Supercenter #1956 - PCard
04/11/2016	45	U.S. Bank PCards	\$ 25.59	5020-74000-402320	Yellowstone County Treas - PCard
04/11/2016	45	U.S. Bank PCards	\$ 24.60	5710-71440-402320	Yellowstone County Treas - PCard
04/11/2016	45	U.S. Bank PCards	\$ 66.00	7380-12660-402290	Community Education Nt - PCard
04/11/2016	45	U.S. Bank PCards	\$ 75.00	5020-74000-403823	Awwa.Org - PCard
04/11/2016	45	U.S. Bank PCards	\$ 13.34	0100-51260-402290	Wal-Mart #2923 - PCard

Check Date	Check	Name	Amount	Account	Item Desc
04/11/2016	45	U.S. Bank PCards	\$ 100.04	7380-12640-402190	Wal-Mart #2923 - PCard
04/11/2016	45	U.S. Bank PCards	\$ 25.63	5020-73120-402320	Yellowstone County Treas - PCard
04/11/2016	45	U.S. Bank PCards	\$ 25.63	1500-21120-402320	Yellowstone County Treas - PCard
04/11/2016	45	U.S. Bank PCards	\$ 25.63	6600-31100-402320	Yellowstone County Treas - PCard
04/11/2016	45	U.S. Bank PCards	\$ 25.62	2090-44520-402320	Yellowstone County Treas - PCard
04/11/2016	45	U.S. Bank PCards	\$ 20.58	5120-85000-402320	Yellowstone County Treas - PCard
04/11/2016	45	U.S. Bank PCards	\$ 25.58	5020-73120-402320	Yellowstone County Treas - PCard
04/11/2016	45	U.S. Bank PCards	\$ 172.78	5120-84300-402290	Batteries Plus #25 - PCard
04/11/2016	45	U.S. Bank PCards	\$ 11.99	1500-22270-402290	Batteries Plus #25 - PCard
04/11/2016	45	U.S. Bank PCards	\$ 537.98	5610-71120-402450	Batteries Plus #25 - PCard
04/11/2016	45	U.S. Bank PCards	\$ 23.15	5610-71100-403390	Albertsons #2041 - PCard
04/11/2016	45	U.S. Bank PCards	\$ 176.22	5410-31220-402320	Yellowstone County Treas - PCard
04/11/2016	45	U.S. Bank PCards	\$ 25.71	2110-31320-402320	Yellowstone County Treas - PCard
04/11/2016	45	U.S. Bank PCards	\$ 80.60	2600-55110-403581	Adecco - PCard
04/11/2016	45	U.S. Bank PCards	\$ 96.28	2600-55110-403581	Adecco - PCard
04/11/2016	45	U.S. Bank PCards	\$ 14.16	0100-51400-402290	Batteries Plus #25 - PCard
04/11/2016	45	U.S. Bank PCards	\$ 272.88	1500-22270-402290	Batteries Plus #25 - PCard
04/11/2016	45	U.S. Bank PCards	\$ 131.96	5120-84300-402290	Batteries Plus #25 - PCard
04/11/2016	45	U.S. Bank PCards	\$ 59.88	6700-31410-407212	Batteries Plus #25 - PCard
04/11/2016	45	U.S. Bank PCards	\$ 29.97	6200-19110-402290	Best Buy 00005926 - PCard
04/11/2016	45	U.S. Bank PCards	\$ 59.99	0100-51100-402190	Best Buy 00005926 - PCard
04/11/2016	45	U.S. Bank PCards	\$ 12.99	5410-31210-402190	Best Buy 00005926 - PCard
04/11/2016	45	U.S. Bank PCards	\$ 87.97	1500-22240-402290	Best Buy 00005926 - PCard
04/11/2016	45	U.S. Bank PCards	\$ 29.11	2600-55110-403581	Adecco - PCard
04/11/2016	45	U.S. Bank PCards	\$ 51.50	2600-55110-403581	Adecco - PCard
04/11/2016	45	U.S. Bank PCards	\$ 11.25	5020-74000-402450	Selby'S - PCard
04/11/2016	45	U.S. Bank PCards	\$ 9.00	2110-31320-402290	Selby'S - PCard
04/11/2016	45	U.S. Bank PCards	\$ 131.15	2600-55190-403382	Tcd*Gale - PCard
04/11/2016	45	U.S. Bank PCards	\$ 141.73	2600-55190-403382	Tcd*Gale - PCard
04/11/2016	45	U.S. Bank PCards	\$ 332.34	2600-55190-403382	Tcd*Gale - PCard
04/11/2016	45	U.S. Bank PCards	\$ 78.38	2600-55190-403382	Tcd*Gale - PCard
04/11/2016	45	U.S. Bank PCards	\$ 15.75	2600-55190-403227	Amazon.Com Amzn.Com/Bill - PCard
04/11/2016	45	U.S. Bank PCards	\$ 60.72	2600-55190-403227	Amazon.Com Amzn.Com/Bill - PCard
04/11/2016	45	U.S. Bank PCards	\$ 8.31	2600-55190-403243	Amazon.Com Amzn.Com/Bill - PCard
04/11/2016	45	U.S. Bank PCards	\$ 152.00	6700-31410-402190	Selby'S - PCard
04/11/2016	45	U.S. Bank PCards	\$ 753.30	6700-31410-402190	Selby'S - PCard
04/11/2016	45	U.S. Bank PCards	\$ 224.84	5710-71460-403210	Selby'S - PCard
04/11/2016	45	U.S. Bank PCards	\$ 201.14	6500-15670-402240	Amazon.Com Amzn.Com/Bill - PCard
04/11/2016	45	U.S. Bank PCards	\$ 41.81	2650-67720-402290	Amazon.Com Amzn.Com/Bill - PCard
04/11/2016	45	U.S. Bank PCards	\$ 31.94	6700-31410-402190	Amazon.Com Amzn.Com/Bill - PCard

Check Date	Check	Name	Amount	Account	Item Desc
04/11/2016	45	U.S. Bank PCards	\$ 89.95	1500-21500-402190	Amazon.Com Amzn.Com/Bill - PCard
04/11/2016	45	U.S. Bank PCards	\$ 143.92	1500-21500-402190	Amazon.Com Amzn.Com/Bill - PCard
04/11/2016	45	U.S. Bank PCards	\$ 11.71	2600-55190-403226	Amazon.Com Amzn.Com/Bill - PCard
04/11/2016	45	U.S. Bank PCards	\$ 176.45	5710-71410-402190	Amazon.Com Amzn.Com/Bill - PCard
04/11/2016	45	U.S. Bank PCards	\$ 44.95	1500-22240-402290	Amazon.Com Amzn.Com/Bill - PCard
04/11/2016	45	U.S. Bank PCards	\$ 26.97	1500-22240-402290	Amazon.Com Amzn.Com/Bill - PCard
04/11/2016	45	U.S. Bank PCards	\$ 53.94	1500-22240-402290	Amazon.Com Amzn.Com/Bill - PCard
04/11/2016	45	U.S. Bank PCards	\$ 127.50	1500-22260-402450	Amazon.Com Amzn.Com/Bill - PCard
04/11/2016	45	U.S. Bank PCards	\$ 155.90	2110-31320-402630	Amazon.Com Amzn.Com/Bill - PCard
04/11/2016	45	U.S. Bank PCards	\$ 14.95	2600-55190-403227	Amazon.Com - PCard
04/11/2016	45	U.S. Bank PCards	\$ 15.37	2600-55190-403334	Amazon.Com - PCard
04/11/2016	45	U.S. Bank PCards	\$ 34.99	2600-55190-403226	Amazon.Com - PCard
04/11/2016	45	U.S. Bank PCards	\$ 53.94	1500-21200-402610	Amazon.Com - PCard
04/11/2016	45	U.S. Bank PCards	\$ 23.35	8730-51990-402410	Amazon.Com - PCard
04/11/2016	45	U.S. Bank PCards	\$ 175.14	1500-21120-402261	Amazon.Com - PCard
04/11/2016	45	U.S. Bank PCards	\$ (16.80)	6700-31410-402190	Amazon.Com - PCard
04/11/2016	45	U.S. Bank PCards	\$ 24.57	6700-31410-402190	Amazon.Com - PCard
04/11/2016	45	U.S. Bank PCards	\$ 55.36	1500-21110-401170	Amazon.Com - PCard
04/11/2016	45	U.S. Bank PCards	\$ 39.95	5610-71120-402450	Amazon.Com - PCard
04/11/2016	45	U.S. Bank PCards	\$ 9.49	2600-55190-403225	Amazon.Com - PCard
04/11/2016	45	U.S. Bank PCards	\$ 24.21	2600-55190-403226	Amazon.Com - PCard
04/11/2016	45	U.S. Bank PCards	\$ 175.00	1500-21120-402320	Aces - PCard
04/11/2016	45	U.S. Bank PCards	\$ 410.00	1500-21120-402320	Aces - PCard
04/11/2016	45	U.S. Bank PCards	\$ 53.94	1500-22240-402290	Amazon.Com - PCard
04/11/2016	45	U.S. Bank PCards	\$ 131.78	6700-31410-402290	Amazon.Com - PCard
04/11/2016	45	U.S. Bank PCards	\$ 33.18	6700-31410-402190	Amazon.Com - PCard
04/11/2016	45	U.S. Bank PCards	\$ 34.88	6700-31410-402190	Amazon.Com - PCard
04/11/2016	45	U.S. Bank PCards	\$ 853.09	6500-15660-402450	Aces - PCard
04/11/2016	45	U.S. Bank PCards	\$ 124.12	5410-31220-402260	Aces - PCard
04/11/2016	45	U.S. Bank PCards	\$ 820.00	1500-21400-402270	Aces - PCard
04/11/2016	45	U.S. Bank PCards	\$ 820.00	1500-21400-402270	Aces - PCard
04/11/2016	45	U.S. Bank PCards	\$ 820.00	1500-21120-402320	Aces - PCard
04/11/2016	45	U.S. Bank PCards	\$ 820.00	1500-21120-402320	Aces - PCard
04/11/2016	45	U.S. Bank PCards	\$ 82.56	1500-22240-402290	Office Depot #450 - PCard
04/11/2016	45	U.S. Bank PCards	\$ 59.65	0100-51420-402290	Dxp Enterprises - PCard
04/11/2016	45	U.S. Bank PCards	\$ 692.25	5610-71150-403660	Dxp Enterprises - PCard
04/11/2016	45	U.S. Bank PCards	\$ 381.82	5610-71150-403660	Dxp Enterprises - PCard
04/11/2016	45	U.S. Bank PCards	\$ 5.30	5210-15230-402290	Dxp Enterprises - PCard
04/11/2016	45	U.S. Bank PCards	\$ 212.70	2600-55190-403382	Center Point Large Print - PCard
04/11/2016	45	U.S. Bank PCards	\$ 25.82	5710-71410-402190	Office Depot #450 - PCard

Check Date	Check	Name	Amount	Account	Item Desc
04/11/2016	45	U.S. Bank PCards	\$ 319.99	5710-71410-402190	Office Depot #450 - PCard
04/11/2016	45	U.S. Bank PCards	\$ 9.99	5710-71410-402190	Office Depot #450 - PCard
04/11/2016	45	U.S. Bank PCards	\$ 134.99	0100-16110-403240	Office Depot #450 - PCard
04/11/2016	45	U.S. Bank PCards	\$ 199.99	5020-74000-402190	Office Depot #450 - PCard
04/11/2016	45	U.S. Bank PCards	\$ 34.97	1500-21200-402610	Office Depot #450 - PCard
04/11/2016	45	U.S. Bank PCards	\$ 9.98	1500-21500-402190	Office Depot #2135 - PCard
04/11/2016	45	U.S. Bank PCards	\$ 39.98	1500-22210-402190	Office Depot #2135 - PCard
04/11/2016	45	U.S. Bank PCards	\$ 24.68	1500-22290-403822	Office Depot #2135 - PCard
04/11/2016	45	U.S. Bank PCards	\$ 8.99	5410-31210-402190	Office Depot #450 - PCard
04/11/2016	45	U.S. Bank PCards	\$ (8.99)	5410-31210-402190	Office Depot #450 - PCard
04/11/2016	45	U.S. Bank PCards	\$ 14.99	6010-15500-402190	Office Depot #450 - PCard
04/11/2016	45	U.S. Bank PCards	\$ 45.12	0100-51120-402290	The Home Depot 3101 - PCard
04/11/2016	45	U.S. Bank PCards	\$ 55.72	1500-21500-402271	The Home Depot 3101 - PCard
04/11/2016	45	U.S. Bank PCards	\$ 86.32	1500-21120-402320	The Home Depot 3101 - PCard
04/11/2016	45	U.S. Bank PCards	\$ 21.99	0100-16110-402190	Office Depot #2135 - PCard
04/11/2016	45	U.S. Bank PCards	\$ 137.40	2400-43010-402190	Office Depot #2135 - PCard
04/11/2016	45	U.S. Bank PCards	\$ 16.29	2600-55140-402190	Office Depot #2135 - PCard
04/11/2016	45	U.S. Bank PCards	\$ 306.20	2110-31320-404160	The Home Depot 3101 - PCard
04/11/2016	45	U.S. Bank PCards	\$ 6.56	0100-51120-402290	The Home Depot 3101 - PCard
04/11/2016	45	U.S. Bank PCards	\$ 19.04	0100-51120-402290	The Home Depot 3101 - PCard
04/11/2016	45	U.S. Bank PCards	\$ 12.20	0100-51120-402290	The Home Depot 3101 - PCard
04/11/2016	45	U.S. Bank PCards	\$ 28.97	0100-51140-402290	The Home Depot 3101 - PCard
04/11/2016	45	U.S. Bank PCards	\$ 55.20	1500-22260-402450	The Home Depot 3101 - PCard
04/11/2016	45	U.S. Bank PCards	\$ 921.92	1500-21500-403630	Dmi* Dell Bus Online - PCard
04/11/2016	45	U.S. Bank PCards	\$ 976.93	1500-21500-402190	Dmi* Dell Bus Online - PCard
04/11/2016	45	U.S. Bank PCards	\$ 349.95	1500-21500-402190	Dmi* Dell Bus Online - PCard
04/11/2016	45	U.S. Bank PCards	\$ 35.82	0100-51120-402290	The Home Depot 3101 - PCard
04/11/2016	45	U.S. Bank PCards	\$ (15.00)	2110-31320-404160	The Home Depot 3101 - PCard
04/11/2016	45	U.S. Bank PCards	\$ (72.80)	2110-31320-404160	The Home Depot 3101 - PCard
04/11/2016	45	U.S. Bank PCards	\$ 150.13	0100-51120-402290	Big Sky Fire Equipment - PCard
04/11/2016	45	U.S. Bank PCards	\$ 228.15	1500-21200-402610	B&H Photo, 800-606-6969 - PCard
04/11/2016	45	U.S. Bank PCards	\$ 60.26	0100-51250-402250	Albertsons #2025 - PCard
04/11/2016	45	U.S. Bank PCards	\$ 44.71	0100-51250-402250	Albertsons #2025 - PCard
04/11/2016	45	U.S. Bank PCards	\$ 20.42	2400-43010-403920	Albertsons #2025 - PCard
04/11/2016	45	U.S. Bank PCards	\$ 64.95	1500-22290-403822	Albertsons #2025 - PCard
04/11/2016	45	U.S. Bank PCards	\$ 265.89	1500-21110-403330	Web*Networksolutions - PCard
04/11/2016	45	U.S. Bank PCards	\$ 53.15	5020-74000-402220	Idexx Distribution Inc - PCard
04/11/2016	45	U.S. Bank PCards	\$ 179.64	5020-74000-402220	Idexx Distribution Inc - PCard
04/11/2016	45	U.S. Bank PCards	\$ 76.45	1500-21710-402120	Big Sky Fire Equipment - PCard
04/11/2016	45	U.S. Bank PCards	\$ 195.84	0100-51120-402290	Big Sky Fire Equipment - PCard

Check Date	Check	Name	Amount	Account	Item Desc
04/11/2016	45	U.S. Bank PCards	\$ 412.41	2600-55130-402190	Big Sky Fire Equipment - PCard
04/11/2016	45	U.S. Bank PCards	\$ 100.00	0100-13140-403350	Associatedemployers - PCard
04/11/2016	45	U.S. Bank PCards	\$ 804.30	5610-71120-402240	Montana Broom Brush Comp - PCard
04/11/2016	45	U.S. Bank PCards	\$ 458.00	6500-15660-402120	Montana Broom Brush Comp - PCard
04/11/2016	45	U.S. Bank PCards	\$ 180.00	5610-71140-402260	Spic And Span Cleaners - PCard
04/11/2016	45	U.S. Bank PCards	\$ 338.50	5610-71150-402220	Emergency Medical Produc - PCard
04/11/2016	45	U.S. Bank PCards	\$ 123.96	5610-71100-402925	Web*Networksolutions - PCard
04/11/2016	45	U.S. Bank PCards	\$ 9.99	0100-51120-402410	Ace Hardware - PCard
04/11/2016	45	U.S. Bank PCards	\$ 29.87	0100-51140-403650	Forestry Suppliers - PCard
04/11/2016	45	U.S. Bank PCards	\$ 10.51	5610-71150-402290	Fei Inc Nd - PCard
04/11/2016	45	U.S. Bank PCards	\$ 16.95	2110-31320-402320	Fei Inc Nd - PCard
04/11/2016	45	U.S. Bank PCards	\$ 75.00	6300-17530-403820	Associatedemployers - PCard
04/11/2016	45	U.S. Bank PCards	\$ 75.00	0100-17500-403820	Associatedemployers - PCard
04/11/2016	45	U.S. Bank PCards	\$ 17.98	0100-51120-402290	Kings Ace Hardware - PCard
04/11/2016	45	U.S. Bank PCards	\$ 19.99	5210-15230-402290	Kings Ace Hardware - PCard
04/11/2016	45	U.S. Bank PCards	\$ 13.98	5210-15230-402290	Kings Ace Hardware - PCard
04/11/2016	45	U.S. Bank PCards	\$ 221.57	5210-15230-402460	Kings Ace Hardware - PCard
04/11/2016	45	U.S. Bank PCards	\$ 105.00	8730-51990-403670	Sprocket'S Mach. & Weld - PCard
04/11/2016	45	U.S. Bank PCards	\$ 80.00	0100-51120-403690	Sprocket'S Mach. & Weld - PCard
04/11/2016	45	U.S. Bank PCards	\$ 19.99	0100-51140-402330	Kings Ace Hardware - PCard
04/11/2016	45	U.S. Bank PCards	\$ 13.98	2110-31320-402320	Kings Ace Hardware - PCard
04/11/2016	45	U.S. Bank PCards	\$ 35.98	2110-31320-402410	Kings Ace Hardware - PCard
04/11/2016	45	U.S. Bank PCards	\$ 14.17	5410-31220-402290	Kings Ace Hardware - PCard
04/11/2016	45	U.S. Bank PCards	\$ 26.37	0100-51120-402330	Kings Ace Hardware - PCard
04/11/2016	45	U.S. Bank PCards	\$ 9.59	0100-51120-402330	Kings Ace Hardware - PCard
04/11/2016	45	U.S. Bank PCards	\$ 8.26	0100-51420-402290	Kings Ace Hardware - PCard
04/11/2016	45	U.S. Bank PCards	\$ 87.81	0100-51120-402410	Kings Ace Hardware - PCard
04/11/2016	45	U.S. Bank PCards	\$ 19.99	0100-51120-402260	Kings Ace Hardware - PCard
04/11/2016	45	U.S. Bank PCards	\$ 19.97	0100-51120-402290	Kings Ace Hardware - PCard
04/11/2016	45	U.S. Bank PCards	\$ 35.99	0100-51120-402410	Kings Ace Hardware - PCard
04/11/2016	45	U.S. Bank PCards	\$ 22.99	0100-51140-402330	Kings Ace Hardware - PCard
04/11/2016	45	U.S. Bank PCards	\$ 8.98	2110-31320-402410	Kings Ace Hardware - PCard
04/11/2016	45	U.S. Bank PCards	\$ 26.95	0100-51410-402450	Kings Ace Hardware - PCard
04/11/2016	45	U.S. Bank PCards	\$ 37.97	0100-51420-402290	Kings Ace Hardware - PCard
04/11/2016	45	U.S. Bank PCards	\$ 18.57	6500-15670-402240	Kings Ace Hardware - PCard
04/11/2016	45	U.S. Bank PCards	\$ 38.32	0100-51410-402450	Kings Ace Hardware - PCard
04/11/2016	45	U.S. Bank PCards	\$ 5.98	0100-51420-402290	Kings Ace Hardware - PCard
04/11/2016	45	U.S. Bank PCards	\$ 28.15	0100-51120-402410	Kings Ace Hardware - PCard
04/11/2016	45	U.S. Bank PCards	\$ 20.65	0100-51120-402290	Kings Ace Hardware - PCard
04/11/2016	45	U.S. Bank PCards	\$ 16.34	0100-51120-402410	Kings Ace Hardware - PCard

Check Date	Check	Name	Amount	Account	Item Desc
04/11/2016	45	U.S. Bank PCards	\$ 25.35	0100-51120-402290	Kings Ace Hardware - PCard
04/11/2016	45	U.S. Bank PCards	\$ 29.99	5020-74000-402450	Kings Ace Hardware - PCard
04/11/2016	45	U.S. Bank PCards	\$ 26.96	5020-74000-402450	Kings Ace Hardware - PCard
04/11/2016	45	U.S. Bank PCards	\$ 3.88	5610-71150-402290	Kings Ace Hardware - PCard
04/11/2016	45	U.S. Bank PCards	\$ 16.57	5610-71150-402290	Kings Ace Hardware - PCard
04/11/2016	45	U.S. Bank PCards	\$ 74.97	5610-71130-402410	Kings Ace Hardware - PCard
04/11/2016	45	U.S. Bank PCards	\$ 40.16	6500-15660-402450	Kings Ace Hardware - PCard
04/11/2016	45	U.S. Bank PCards	\$ 90.13	2400-43010-407214	Kings Ace Hardware - PCard
04/11/2016	45	U.S. Bank PCards	\$ 41.25	5410-31220-402290	Kings Ace Hardware - PCard
04/11/2016	45	U.S. Bank PCards	\$ 8.09	1500-22290-402290	Kings Ace Hardware - PCard
04/11/2016	45	U.S. Bank PCards	\$ 15.29	1500-22260-402360	Kings Ace Hardware - PCard
04/11/2016	45	U.S. Bank PCards	\$ 182.94	1500-22240-402450	Kings Ace Hardware - PCard
04/11/2016	45	U.S. Bank PCards	\$ 31.96	0100-51420-402290	Kings Ace Hardware - PCard
04/11/2016	45	U.S. Bank PCards	\$ 19.35	0100-51420-402290	Kings Ace Hardware - PCard
04/11/2016	45	U.S. Bank PCards	\$ 31.97	0100-51420-402290	Kings Ace Hardware - PCard
04/11/2016	45	U.S. Bank PCards	\$ 26.46	1500-22260-402240	Kings Ace Hardware - PCard
04/11/2016	45	U.S. Bank PCards	\$ 44.03	1500-22260-402450	Kings Ace Hardware - PCard
04/11/2016	45	U.S. Bank PCards	\$ 8.99	1500-22250-402450	Kings Ace Hardware - PCard
04/11/2016	45	U.S. Bank PCards	\$ 23.71	1500-22260-402360	Kings Ace Hardware - PCard
04/11/2016	45	U.S. Bank PCards	\$ 21.86	1500-22270-402481	Kings Ace Hardware - PCard
04/11/2016	45	U.S. Bank PCards	\$ 23.37	1500-22260-402340	Kings Ace Hardware - PCard
04/11/2016	45	U.S. Bank PCards	\$ 335.00	5410-31210-403823	Fredpryor Careertrack - PCard
04/11/2016	45	U.S. Bank PCards	\$ 89.00	1500-21200-402610	Can*Canonusa Fscnj - PCard
04/11/2016	45	U.S. Bank PCards	\$ 125.92	5610-71130-402320	Kings Ace Hardware - PCard
04/11/2016	45	U.S. Bank PCards	\$ 21.56	0100-51120-402290	Kings Ace Hardware - PCard
04/11/2016	45	U.S. Bank PCards	\$ 6.29	0100-51120-402290	Kings Ace Hardware - PCard
04/11/2016	45	U.S. Bank PCards	\$ 35.14	5610-71120-402450	Kings Ace Hardware - PCard
04/11/2016	45	U.S. Bank PCards	\$ 1,805.87	5020-73120-403660	Idu*Insight Public Sec - PCard
04/11/2016	45	U.S. Bank PCards	\$ 135.43	5020-75000-402190	Idu*Insight Public Sec - PCard
04/11/2016	45	U.S. Bank PCards	\$ 90.30	5120-85000-402190	Idu*Insight Public Sec - PCard
04/11/2016	45	U.S. Bank PCards	\$ 250.00	5710-71420-403823	Community Transportati - PCard
04/11/2016	45	U.S. Bank PCards	\$ 900.00	5710-71410-403350	Community Transportati - PCard
04/11/2016	45	U.S. Bank PCards	\$ 200.00	1500-22250-403350	National Academy Of Emd - PCard
04/11/2016	45	U.S. Bank PCards	\$ 597.70	0100-11000-403740	United 0167759887636 - PCard
04/11/2016	45	U.S. Bank PCards	\$ 24.06	0100-13130-403360	Perkins Rest 04136966 - PCard
04/11/2016	45	U.S. Bank PCards	\$ 1,761.65	5410-31220-402310	Farstad Oil Inc - PCard
04/11/2016	45	U.S. Bank PCards	\$ (20.00)	5410-31230-402310	Farstad Oil Inc - PCard
04/11/2016	45	U.S. Bank PCards	\$ 451.61	0100-11000-402925	Idu*Insight Public Sec - PCard
04/11/2016	45	U.S. Bank PCards	\$ 79.43	0100-11000-402925	Idu*Insight Public Sec - PCard
04/11/2016	45	U.S. Bank PCards	\$ 517.70	0100-51140-403823	United 0162484666062 - PCard

Check Date	Check	Name	Amount	Account	Item Desc
04/11/2016	45	U.S. Bank PCards	\$ 517.70	0100-51140-403823	United 0162484666063 - PCard
04/11/2016	45	U.S. Bank PCards	\$ 517.70	0100-51140-403823	United 0162484666064 - PCard
04/11/2016	45	U.S. Bank PCards	\$ 60.00	1500-22230-403824	United 0162602606162 - PCard
04/11/2016	45	U.S. Bank PCards	\$ 60.00	1500-22230-403824	United 0162603003622 - PCard
04/11/2016	45	U.S. Bank PCards	\$ 477.70	0100-13130-403824	United 0167759848864 - PCard
04/11/2016	45	U.S. Bank PCards	\$ 223.08	5020-74000-402450	Russell Industries Inc - PCard
04/11/2016	45	U.S. Bank PCards	\$ 25.00	5610-71130-402450	Sign Pro Billings - PCard
04/11/2016	45	U.S. Bank PCards	\$ 38.00	6500-15660-402450	Sign Pro Billings - PCard
04/11/2016	45	U.S. Bank PCards	\$ 167.32	1500-22230-403824	Guest Services-Unit 3750 - PCard
04/11/2016	45	U.S. Bank PCards	\$ 15.00	5610-71130-402320	Billings Hardware & Se - PCard
04/11/2016	45	U.S. Bank PCards	\$ 8.99	0100-51120-402290	Billings Hardware & Se - PCard
04/11/2016	45	U.S. Bank PCards	\$ 31.11	5020-74000-402190	Cdw Government - PCard
04/11/2016	45	U.S. Bank PCards	\$ 31.12	5120-84300-402190	Cdw Government - PCard
04/11/2016	45	U.S. Bank PCards	\$ 2,423.95	1500-22210-403630	Cdw Government - PCard
04/11/2016	45	U.S. Bank PCards	\$ 695.00	1500-22230-403824	laai - PCard
04/11/2016	45	U.S. Bank PCards	\$ 200.00	1500-22230-403824	laai - PCard
04/11/2016	45	U.S. Bank PCards	\$ 200.00	1500-22230-403824	laai - PCard
04/11/2016	45	U.S. Bank PCards	\$ 15.00	5610-71150-402290	National Registry Emt - PCard
04/11/2016	45	U.S. Bank PCards	\$ 15.00	5610-71150-402290	National Registry Emt - PCard
04/11/2016	45	U.S. Bank PCards	\$ 15.00	5610-71150-402290	National Registry Emt - PCard
04/11/2016	45	U.S. Bank PCards	\$ 383.64	5610-71120-402450	Npc*New Pig Corp - PCard
04/11/2016	45	U.S. Bank PCards	\$ 250.24	6200-19110-402925	Cdw Government - PCard
04/11/2016	45	U.S. Bank PCards	\$ 155.83	1500-21200-402120	Cdw Government - PCard
04/11/2016	45	U.S. Bank PCards	\$ 287.70	2600-55110-403824	Delta Air 0062338670996 - PCard
04/11/2016	45	U.S. Bank PCards	\$ 287.70	2600-55110-403824	Delta Air 0062338670997 - PCard
04/11/2016	45	U.S. Bank PCards	\$ 293.70	2600-55110-403824	Delta Air 0062338928404 - PCard
04/11/2016	45	U.S. Bank PCards	\$ 158.70	1500-21720-403824	Delta Air 0067803547911 - PCard
04/11/2016	45	U.S. Bank PCards	\$ 15.00	5610-71150-402290	National Registry Emt - PCard
04/11/2016	45	U.S. Bank PCards	\$ 15.00	5610-71150-402290	National Registry Emt - PCard
04/11/2016	45	U.S. Bank PCards	\$ 220.70	7380-12660-403824	Delta Air 0062336399749 - PCard
04/11/2016	45	U.S. Bank PCards	\$ 220.70	7380-12660-403824	Delta Air 0062336399750 - PCard
04/11/2016	45	U.S. Bank PCards	\$ 220.70	7380-12660-403824	Delta Air 0062336399751 - PCard
04/11/2016	45	U.S. Bank PCards	\$ 220.70	7380-12660-403824	Delta Air 0062336399752 - PCard
04/11/2016	45	U.S. Bank PCards	\$ 220.70	7380-12660-403824	Delta Air 0062336399753 - PCard
04/11/2016	45	U.S. Bank PCards	\$ 210.70	1500-21400-403822	Delta Air 0062336811832 - PCard
04/11/2016	45	U.S. Bank PCards	\$ 545.67	5210-15910-403660	Kone Inc. - PCard
04/11/2016	45	U.S. Bank PCards	\$ 545.67	5210-15920-403660	Kone Inc. - PCard
04/11/2016	45	U.S. Bank PCards	\$ 545.66	5210-15930-403660	Kone Inc. - PCard
04/11/2016	45	U.S. Bank PCards	\$ 90.15	5210-15910-402450	Kone Inc. - PCard
04/11/2016	45	U.S. Bank PCards	\$ 46.50	2600-55110-403590	Baudville Inc. - PCard

Check Date	Check	Name	Amount	Account	Item Desc
04/11/2016	45	U.S. Bank PCards	\$ 253.20	1500-21400-403822	Delta Air 0062336200894 - PCard
04/11/2016	45	U.S. Bank PCards	\$ 62.20	5610-71130-402450	Critelli Glass - PCard
04/11/2016	45	U.S. Bank PCards	\$ 222.35	8730-51990-402342	Critelli Glass - PCard
04/11/2016	45	U.S. Bank PCards	\$ 1,046.62	2110-31320-402320	Auto Trim Design - PCard
04/11/2016	45	U.S. Bank PCards	\$ 1,382.50	0100-16110-403821	State Bar Of Montana - PCard
04/11/2016	45	U.S. Bank PCards	\$ 1,382.50	0100-16110-403821	State Bar Of Montana - PCard
04/11/2016	45	U.S. Bank PCards	\$ 395.00	0100-12120-403824	State Bar Of Montana - PCard
04/11/2016	45	U.S. Bank PCards	\$ 27.98	5020-74000-402450	Harbor Freight Tools 207 - PCard
04/11/2016	45	U.S. Bank PCards	\$ 71.76	5410-31220-402290	Harbor Freight Tools 207 - PCard
04/11/2016	45	U.S. Bank PCards	\$ 12.48	5020-74000-402410	Harbor Freight Tools 207 - PCard
04/11/2016	45	U.S. Bank PCards	\$ 12.47	5120-84300-402410	Harbor Freight Tools 207 - PCard
04/11/2016	45	U.S. Bank PCards	\$ 5.98	5210-15230-402290	Harbor Freight Tools 207 - PCard
04/11/2016	45	U.S. Bank PCards	\$ 7.98	5210-15230-402290	Harbor Freight Tools 207 - PCard
04/11/2016	45	U.S. Bank PCards	\$ 88.00	1500-22260-402320	Alladin Lock & Security - PCard
04/11/2016	45	U.S. Bank PCards	\$ 247.78	6700-31410-403824	Snow King - PCard
04/11/2016	45	U.S. Bank PCards	\$ 247.78	6700-31410-403824	Snow King - PCard
04/11/2016	45	U.S. Bank PCards	\$ 245.76	5610-71120-402240	House Of Clean, Inc - PCard
04/11/2016	45	U.S. Bank PCards	\$ 522.13	5610-71120-402450	House Of Clean, Inc - PCard
04/11/2016	45	U.S. Bank PCards	\$ 13.99	0100-51120-402290	Harbor Freight Tools 207 - PCard
04/11/2016	45	U.S. Bank PCards	\$ 2.21	5020-75000-402410	Mountain Supply - PCard
04/11/2016	45	U.S. Bank PCards	\$ 1.48	5120-85000-402410	Mountain Supply - PCard
04/11/2016	45	U.S. Bank PCards	\$ 516.00	5610-71130-403650	Redds Prints And Signs In - PCard
04/11/2016	45	U.S. Bank PCards	\$ 41.88	0100-51410-402450	Zigs Bldg Materials - PCard
04/11/2016	45	U.S. Bank PCards	\$ 18.79	0100-51410-402450	Zigs Bldg Materials - PCard
04/11/2016	45	U.S. Bank PCards	\$ 624.21	0100-51410-402450	Zigs Bldg Materials - PCard
04/11/2016	45	U.S. Bank PCards	\$ 48.56	5120-85000-403660	City Of Billings Pud - PCard
04/11/2016	45	U.S. Bank PCards	\$ 86.71	5020-73140-403660	City Of Billings Pud - PCard
04/11/2016	45	U.S. Bank PCards	\$ 24.28	5120-83140-403660	City Of Billings Pud - PCard
04/11/2016	45	U.S. Bank PCards	\$ 9.67	5120-85000-403420	City Of Billings Pud - PCard
04/11/2016	45	U.S. Bank PCards	\$ 160.28	2110-31320-403420	City Of Billings Pud - PCard
04/11/2016	45	U.S. Bank PCards	\$ 350.42	5120-85000-403420	City Of Billings Pud - PCard
04/11/2016	45	U.S. Bank PCards	\$ 34.77	5020-74000-403660	City Of Billings Pud - PCard
04/11/2016	45	U.S. Bank PCards	\$ 1,748.08	5120-84000-403420	City Of Billings Pud - PCard
04/11/2016	45	U.S. Bank PCards	\$ 1,415.28	5120-84000-403420	City Of Billings Pud - PCard
04/11/2016	45	U.S. Bank PCards	\$ 9.67	5120-85000-403420	City Of Billings Pud - PCard
04/11/2016	45	U.S. Bank PCards	\$ 117.93	5020-74000-403660	City Of Billings Pud - PCard
04/11/2016	45	U.S. Bank PCards	\$ 69.37	5020-75000-403660	City Of Billings Pud - PCard
04/11/2016	45	U.S. Bank PCards	\$ 117.93	5020-74000-403660	City Of Billings Pud - PCard
04/11/2016	45	U.S. Bank PCards	\$ 69.37	5020-75000-403660	City Of Billings Pud - PCard
04/11/2016	45	U.S. Bank PCards	\$ 48.56	5120-85000-403660	City Of Billings Pud - PCard

Check Date	Check	Name	Amount	Account	Item Desc
04/11/2016	45	U.S. Bank PCards	\$ 86.71	5020-73140-403660	City Of Billings Pud - PCard
04/11/2016	45	U.S. Bank PCards	\$ 24.28	5120-83140-403660	City Of Billings Pud - PCard
04/11/2016	45	U.S. Bank PCards	\$ 34.77	5020-74000-403660	City Of Billings Pud - PCard
04/11/2016	45	U.S. Bank PCards	\$ 97.23	7180-21600-403870	Best Western Grantree Inn - PCard
04/11/2016	45	U.S. Bank PCards	\$ 388.92	7180-21600-403870	Best Western Grantree Inn - PCard
04/11/2016	45	U.S. Bank PCards	\$ 388.92	7180-21600-403870	Best Western Grantree Inn - PCard
04/11/2016	45	U.S. Bank PCards	\$ 388.92	7180-21600-403870	Best Western Grantree Inn - PCard
04/11/2016	45	U.S. Bank PCards	\$ 1,036.50	2090-44510-403822	Holiday Inns - PCard
04/11/2016	45	U.S. Bank PCards	\$ 194.46	0100-13130-403824	Holiday Inns - PCard
04/11/2016	45	U.S. Bank PCards	\$ 6.56	5020-74000-402450	In *Frontier Fence Compan - PCard
04/11/2016	45	U.S. Bank PCards	\$ 37.92	5410-31220-402290	In *Frontier Fence Compan - PCard
04/11/2016	45	U.S. Bank PCards	\$ 178.00	5210-15910-402450	Firemaster - PCard
04/11/2016	45	U.S. Bank PCards	\$ 125.50	5210-15930-402450	Firemaster - PCard
04/11/2016	45	U.S. Bank PCards	\$ 60.00	5210-15920-402450	Firemaster - PCard
04/11/2016	45	U.S. Bank PCards	\$ 86.00	1500-21710-402450	Firemaster - PCard
04/11/2016	45	U.S. Bank PCards	\$ 19.00	5120-85000-403410	Yellowstone Valley Elect - PCard
04/11/2016	45	U.S. Bank PCards	\$ 257.51	5120-85000-403410	Yellowstone Valley Elect - PCard
04/11/2016	45	U.S. Bank PCards	\$ 33.60	5020-74000-403410	Yellowstone Valley Elect - PCard
04/11/2016	45	U.S. Bank PCards	\$ 1,700.00	8730-51990-409370	Yellowstone Valley Elect - PCard
04/11/2016	45	U.S. Bank PCards	\$ 7.68	0100-51120-402290	In *Frontier Fence Compan - PCard
04/11/2016	45	U.S. Bank PCards	\$ 20.38	2110-31320-402380	In *Frontier Fence Compan - PCard
04/11/2016	45	U.S. Bank PCards	\$ 20.24	8720-51980-403410	Yellowstone Valley Elect - PCard
04/11/2016	45	U.S. Bank PCards	\$ 27.53	5120-84000-403410	Yellowstone Valley Elect - PCard
04/11/2016	45	U.S. Bank PCards	\$ 1,238.33	5020-74000-403410	Yellowstone Valley Elect - PCard
04/11/2016	45	U.S. Bank PCards	\$ 201.13	5120-85000-403410	Yellowstone Valley Elect - PCard
04/11/2016	45	U.S. Bank PCards	\$ 1,275.30	5120-84000-403410	Yellowstone Valley Elect - PCard
04/11/2016	45	U.S. Bank PCards	\$ 179.04	5120-85000-403410	Yellowstone Valley Elect - PCard
04/11/2016	45	U.S. Bank PCards	\$ 300.17	8720-51980-403410	Yellowstone Valley Elect - PCard
04/11/2016	45	U.S. Bank PCards	\$ 168.10	8720-51980-403410	Yellowstone Valley Elect - PCard
04/11/2016	45	U.S. Bank PCards	\$ 8.87	0100-51120-403410	Yellowstone Valley Elect - PCard
04/11/2016	45	U.S. Bank PCards	\$ 40.24	8720-51980-403410	Yellowstone Valley Elect - PCard
04/11/2016	45	U.S. Bank PCards	\$ 65.83	8720-51980-403410	Yellowstone Valley Elect - PCard
04/11/2016	45	U.S. Bank PCards	\$ 19.56	8720-51980-403410	Yellowstone Valley Elect - PCard
04/11/2016	45	U.S. Bank PCards	\$ 252.00	5610-71130-403660	Yellowstone Electric Comp - PCard
04/11/2016	45	U.S. Bank PCards	\$ 252.00	5610-71170-403660	Yellowstone Electric Comp - PCard
04/11/2016	45	U.S. Bank PCards	\$ 141.87	5610-71120-403660	Yellowstone Electric Comp - PCard
04/11/2016	45	U.S. Bank PCards	\$ 5.65	0100-51120-402330	Yellowstone County Implem - PCard
04/11/2016	45	U.S. Bank PCards	\$ 1,115.61	5410-31230-403410	Yellowstone Valley Elect - PCard
04/11/2016	45	U.S. Bank PCards	\$ 129.90	2110-31320-403410	Yellowstone Valley Elect - PCard
04/11/2016	45	U.S. Bank PCards	\$ 9.78	5610-71150-402290	Carquest 3103 - PCard

Check Date	Check	Name	Amount	Account	Item Desc
04/11/2016	45	U.S. Bank PCards	\$ 25.49	0100-51120-402330	Carquest 3104 - PCard
04/11/2016	45	U.S. Bank PCards	\$ 36.07	0100-51120-402410	Carquest 3104 - PCard
04/11/2016	45	U.S. Bank PCards	\$ 1,036.36	0100-16110-403220	Thomson West*Tcd - PCard
04/11/2016	45	U.S. Bank PCards	\$ 1,036.36	0100-16110-403220	Thomson West*Tcd - PCard
04/11/2016	45	U.S. Bank PCards	\$ 33.75	2400-43010-403210	Western Awards & Engravin - PCard
04/11/2016	45	U.S. Bank PCards	\$ 34.00	1500-21110-401170	Universal Awards - PCard
04/11/2016	45	U.S. Bank PCards	\$ 36.00	1500-21110-401170	Universal Awards - PCard
04/11/2016	45	U.S. Bank PCards	\$ 46.00	1500-21110-401170	Universal Awards - PCard
04/11/2016	45	U.S. Bank PCards	\$ 27.62	5610-71130-402410	Carquest 3103 - PCard
04/11/2016	45	U.S. Bank PCards	\$ 35.12	5610-71150-402320	Carquest 3103 - PCard
04/11/2016	45	U.S. Bank PCards	\$ 67.36	5610-71130-402320	Carquest 3103 - PCard
04/11/2016	45	U.S. Bank PCards	\$ 65.98	0100-51120-402390	Tractor-Supply-Co #0303 - PCard
04/11/2016	45	U.S. Bank PCards	\$ 50.00	0100-51120-402330	Tractor-Supply-Co #0303 - PCard
04/11/2016	45	U.S. Bank PCards	\$ 65.98	2110-31320-402320	Tractor-Supply-Co #0303 - PCard
04/11/2016	45	U.S. Bank PCards	\$ 79.98	1500-21120-402120	Tractor-Supply-Co #0303 - PCard
04/11/2016	45	U.S. Bank PCards	\$ 102.96	5610-71120-403660	Usa Communications - PCard
04/11/2016	45	U.S. Bank PCards	\$ 58.50	5610-71130-403660	Usa Communications - PCard
04/11/2016	45	U.S. Bank PCards	\$ 44.99	8730-51990-402260	Shipton'S Big R-West - PCard
04/11/2016	45	U.S. Bank PCards	\$ 5.00	5120-84300-402290	Target 00013334 - PCard
04/11/2016	45	U.S. Bank PCards	\$ 4.99	5020-74000-402290	Target 00013334 - PCard
04/11/2016	45	U.S. Bank PCards	\$ 44.97	2600-55190-403225	Target 00013334 - PCard
04/11/2016	45	U.S. Bank PCards	\$ 369.97	0100-51120-402290	Tractor-Supply-Co #0303 - PCard
04/11/2016	45	U.S. Bank PCards	\$ 256.05	1500-22290-402120	Tractor-Supply-Co #0303 - PCard
04/11/2016	45	U.S. Bank PCards	\$ 190.85	0100-51120-402410	Shipton'S Big R-West - PCard
04/11/2016	45	U.S. Bank PCards	\$ 53.98	2110-31320-402380	Shipton'S Big R-West - PCard
04/11/2016	45	U.S. Bank PCards	\$ 111.40	0100-51120-402290	Shipton'S Big R-West - PCard
04/11/2016	45	U.S. Bank PCards	\$ 40.97	0100-51120-402290	Shipton'S Big R-West - PCard
04/11/2016	45	U.S. Bank PCards	\$ 59.92	0100-51120-402260	Shipton'S Big R-West - PCard
04/11/2016	45	U.S. Bank PCards	\$ 119.99	2110-31320-402920	Shipton'S Big R-West - PCard
04/11/2016	45	U.S. Bank PCards	\$ 41.98	2110-31320-402920	Shipton'S Big R-East - PCard
04/11/2016	45	U.S. Bank PCards	\$ 269.98	2110-31320-402290	Shipton'S Big R-East - PCard
04/11/2016	45	U.S. Bank PCards	\$ 30.99	6060-19310-402122	Shipton'S Big R-East - PCard
04/11/2016	45	U.S. Bank PCards	\$ 15.97	1500-22290-403822	Shipton'S Big R-East - PCard
04/11/2016	45	U.S. Bank PCards	\$ 54.99	0100-51120-402320	Shipton'S Big R-West - PCard
04/11/2016	45	U.S. Bank PCards	\$ 34.99	0100-51120-402290	Shipton'S Big R-West - PCard
04/11/2016	45	U.S. Bank PCards	\$ 11.00	5610-71130-402450	Ww Grainger - PCard
04/11/2016	45	U.S. Bank PCards	\$ 1,042.30	5020-74000-402360	Ww Grainger - PCard
04/11/2016	45	U.S. Bank PCards	\$ 76.54	5020-74000-402360	Ww Grainger - PCard
04/11/2016	45	U.S. Bank PCards	\$ 52.38	5610-71120-402450	Ww Grainger - PCard
04/11/2016	45	U.S. Bank PCards	\$ 6.80	0100-51120-402290	Ww Grainger - PCard

Check Date	Check	Name	Amount	Account	Item Desc
04/11/2016	45	U.S. Bank PCards	\$ 100.00	0100-16110-403822	Eb The Future Is Now - PCard
04/11/2016	45	U.S. Bank PCards	\$ 25.43	5020-74000-402920	Ww Grainger - PCard
04/11/2016	45	U.S. Bank PCards	\$ 25.43	5120-84300-402920	Ww Grainger - PCard
04/11/2016	45	U.S. Bank PCards	\$ 73.30	2600-55120-402360	Ww Grainger - PCard
04/11/2016	45	U.S. Bank PCards	\$ 105.12	2600-55120-403670	Ww Grainger - PCard
04/11/2016	45	U.S. Bank PCards	\$ 35.04	2600-55120-403670	Ww Grainger - PCard
04/11/2016	45	U.S. Bank PCards	\$ 23.50	1500-22260-402450	Ww Grainger - PCard
04/11/2016	45	U.S. Bank PCards	\$ 30.00	0100-13130-403824	Tickets*Metrapark - PCard
04/11/2016	45	U.S. Bank PCards	\$ 275.00	6700-31410-403350	Transp Profcert Brd - PCard
04/11/2016	45	U.S. Bank PCards	\$ 448.38	5410-31230-402290	Ww Grainger - PCard
04/11/2016	45	U.S. Bank PCards	\$ 59.22	0100-51270-402450	Ww Grainger - PCard
04/11/2016	45	U.S. Bank PCards	\$ 31.26	5210-15230-402290	Ww Grainger - PCard
04/11/2016	45	U.S. Bank PCards	\$ 16.36	5410-31230-402630	Ww Grainger - PCard
04/11/2016	45	U.S. Bank PCards	\$ 148.68	7380-12660-403824	Supershuttle Execucarlax - PCard
04/11/2016	45	U.S. Bank PCards	\$ 185.47	5120-84000-402450	Sylvan Nursery & Landscap - PCard
04/11/2016	45	U.S. Bank PCards	\$ 116.79	1500-21120-402320	Tessco Technologies - PCard
04/11/2016	45	U.S. Bank PCards	\$ 49.00	2600-55190-403227	The Collected Works Book - PCard
04/11/2016	45	U.S. Bank PCards	\$ 30.00	0100-11000-403824	Tickets*Metrapark - PCard
04/11/2016	45	U.S. Bank PCards	\$ 30.00	0100-11000-403824	Tickets*Metrapark - PCard
04/11/2016	45	U.S. Bank PCards	\$ 66.30	1500-21400-403822	Sleep Inn & Suites - PCard
04/11/2016	45	U.S. Bank PCards	\$ 169.00	5410-31230-403350	Solid Waste Associa - PCard
04/11/2016	45	U.S. Bank PCards	\$ 507.85	1500-21150-403870	Springhill Suites - PCard
04/11/2016	45	U.S. Bank PCards	\$ 507.85	1500-21150-403870	Springhill Suites - PCard
04/11/2016	45	U.S. Bank PCards	\$ 507.85	1500-21150-403870	Springhill Suites - PCard
04/11/2016	45	U.S. Bank PCards	\$ 4.40	0100-13130-403360	Starbucks #28060 Billings - PCard
04/11/2016	45	U.S. Bank PCards	\$ 80.27	5610-71120-402240	Rubbermaid For Less - PCard
04/11/2016	45	U.S. Bank PCards	\$ 1,233.00	5610-71150-403660	Safe Air Systems Inc - PCard
04/11/2016	45	U.S. Bank PCards	\$ 2.34	2690-67710-403822	Safeway Store 00014860 - PCard
04/11/2016	45	U.S. Bank PCards	\$ 73.46	1500-22250-402450	Samsclub #4805 - PCard
04/11/2016	45	U.S. Bank PCards	\$ 48.00	0100-17500-403330	Send Technology Inc. - PCard
04/11/2016	45	U.S. Bank PCards	\$ 146.58	0100-51120-402410	Sherwin Williams 701710 - PCard
04/11/2016	45	U.S. Bank PCards	\$ 1,600.00	2840-65810-403822	Nan Mckay & Associates - PCard
04/11/2016	45	U.S. Bank PCards	\$ 86.60	5120-87000-403824	O Haire Motor Inn - PCard
04/11/2016	45	U.S. Bank PCards	\$ 23.00	1500-22210-403920	Papa John'S #01945 - PCard
04/11/2016	45	U.S. Bank PCards	\$ 15.00	1500-22210-403920	Papa Murphy'S Mt001 - PCard
04/11/2016	45	U.S. Bank PCards	\$ 9.97	2110-31320-402320	Paypal *Xoxpartner - PCard
04/11/2016	45	U.S. Bank PCards	\$ 144.48	1500-21720-403824	Rio Suites Advance Dep - PCard
04/11/2016	45	U.S. Bank PCards	\$ 1,058.20	5120-84300-402290	Mitchell Instruments C - PCard
04/11/2016	45	U.S. Bank PCards	\$ 1,058.20	5020-74000-402290	Mitchell Instruments C - PCard
04/11/2016	45	U.S. Bank PCards	\$ 375.23	5120-84300-402290	Mitchell Instruments C - PCard

Check Date	Check	Name	Amount	Account	Item Desc
04/11/2016	45	U.S. Bank PCards	\$ 375.22	5020-74000-402290	Mitchell Instruments C - PCard
04/11/2016	45	U.S. Bank PCards	\$ 88.70	1500-21400-403822	My Place Hotel Bismarck - PCard
04/11/2016	45	U.S. Bank PCards	\$ (7.70)	1500-21400-403822	My Place Hotel Bismarck - PCard
04/11/2016	45	U.S. Bank PCards	\$ 71.27	5120-84000-403823	La Quinta Inn - PCard
04/11/2016	45	U.S. Bank PCards	\$ 109.89	5610-71150-403822	Lodge At Whitefish Lake L - PCard
04/11/2016	45	U.S. Bank PCards	\$ 109.89	5610-71150-403822	Lodge At Whitefish Lake L - PCard
04/11/2016	45	U.S. Bank PCards	\$ 149.99	2510-21270-402190	Microsoft *Store - PCard
04/11/2016	45	U.S. Bank PCards	\$ 43.35	5610-71130-403590	Minnesota Trapline Produc - PCard
04/11/2016	45	U.S. Bank PCards	\$ 650.00	5610-71100-403390	Missoula International Ai - PCard
04/11/2016	45	U.S. Bank PCards	\$ 2,265.00	2200-22390-409460	In *Sports Resource Group - PCard
04/11/2016	45	U.S. Bank PCards	\$ 238.99	2600-55110-403360	Janway Company - PCard
04/11/2016	45	U.S. Bank PCards	\$ 76.05	0100-51140-403650	Johnson Lane Materials - PCard
04/11/2016	45	U.S. Bank PCards	\$ 79.18	6700-31410-403823	La Quinta Inn - PCard
04/11/2016	45	U.S. Bank PCards	\$ 71.27	5120-84000-403823	La Quinta Inn - PCard
04/11/2016	45	U.S. Bank PCards	\$ 71.27	5120-84000-403823	La Quinta Inn - PCard
04/11/2016	45	U.S. Bank PCards	\$ 10.00	1500-21700-403824	Golden Nugget Lv - Hot - PCard
04/11/2016	45	U.S. Bank PCards	\$ 168.00	1500-21700-403824	Golden Nugget Lv - Hot - PCard
04/11/2016	45	U.S. Bank PCards	\$ 168.00	1500-21700-403824	Golden Nugget Lv - Hot - PCard
04/11/2016	45	U.S. Bank PCards	\$ 360.00	1500-21400-402270	Gti Inc - PCard
04/11/2016	45	U.S. Bank PCards	\$ 2.95	1500-21110-401170	Gypsy Wind - PCard
04/11/2016	45	U.S. Bank PCards	\$ 952.59	1500-22230-403824	Hyatt Denver Tech Center - PCard
04/11/2016	45	U.S. Bank PCards	\$ 533.50	5610-71130-403660	Emerald Automotive Divis - PCard
04/11/2016	45	U.S. Bank PCards	\$ 3.00	2520-21490-403822	Exxonmobil 47825534 - PCard
04/11/2016	45	U.S. Bank PCards	\$ 100.00	7690-51820-403560	Facebook Hlda59Erv2 - PCard
04/11/2016	45	U.S. Bank PCards	\$ 147.68	0100-51250-403990	Facebook Xe3P79Srf2 - PCard
04/11/2016	45	U.S. Bank PCards	\$ 150.00	2110-31320-403350	Force America Distributin - PCard
04/11/2016	45	U.S. Bank PCards	\$ 600.00	6200-19130-403870	Frontier Precision Inc - PCard
04/11/2016	45	U.S. Bank PCards	\$ 35.00	7380-12660-402290	Cnt*Msu Billings - PCard
04/11/2016	45	U.S. Bank PCards	\$ 788.81	5610-71130-402310	Cross Petroleum Billings - PCard
04/11/2016	45	U.S. Bank PCards	\$ 46.99	1500-21110-401170	Deelynn Designs - PCard
04/11/2016	45	U.S. Bank PCards	\$ 113.76	2600-55110-403824	Eb Maker Faire Bay Ar - PCard
04/11/2016	45	U.S. Bank PCards	\$ 4.99	6500-15670-402240	Echst.Net 866-452-5108 - PCard
04/11/2016	45	U.S. Bank PCards	\$ (4.99)	6500-15670-402240	Echst.Net 866-452-5108 - PCard
04/11/2016	45	U.S. Bank PCards	\$ 1,417.00	0100-51270-402450	Ben Franklin Plumbing - PCard
04/11/2016	45	U.S. Bank PCards	\$ 512.20	1500-21400-403822	Big Horn Resort - PCard
04/11/2016	45	U.S. Bank PCards	\$ 882.00	1500-21110-402274	Big Horn Resort - PCard
04/11/2016	45	U.S. Bank PCards	\$ 90.00	0100-51420-402260	Bighorn Boots - PCard
04/11/2016	45	U.S. Bank PCards	\$ 2,800.00	6060-19310-402122	Cablexpresscorp Cxtex - PCard
04/11/2016	45	U.S. Bank PCards	\$ 126.28	5710-71430-402630	Cintas 60A Sap - PCard
04/11/2016	45	U.S. Bank PCards	\$ 206.34	1500-21200-402610	Americanflagstore.Com - PCard

Check Date	Check	Name	Amount	Account	Item Desc
04/11/2016	45	U.S. Bank PCards	\$ 58.73	6500-15670-402240	Americord - PCard
04/11/2016	45	U.S. Bank PCards	\$ 41.55	0100-13130-403360	Applebees 911945991197 - PCard
04/11/2016	45	U.S. Bank PCards	\$ 4.78	5710-71440-402450	Archie Cochrane Motors - PCard
04/11/2016	45	U.S. Bank PCards	\$ 137.77	5710-71430-402450	Belanger Inc - PCard
04/11/2016	45	U.S. Bank PCards	\$ 451.83	0100-51120-402290	Belzona Rocky Mountain In - PCard
04/11/2016	45	U.S. Bank PCards	\$ 500.00	0100-12120-402190	Billings Ink And Toner In - PCard
04/11/2016	45	U.S. Bank PCards	\$ 412.70	5020-74000-402220	Ge Analytical Instruments - PCard
04/11/2016	45	U.S. Bank PCards	\$ 134.00	2400-43010-403824	Stacked A Montana Grill - PCard
04/11/2016	45	U.S. Bank PCards	\$ 430.00	5710-71440-402320	A Parts - PCard
04/11/2016	45	U.S. Bank PCards	\$ 220.00	6700-31410-403824	Act*Ite Intermtn Meeti - PCard
04/11/2016	45	U.S. Bank PCards	\$ 125.00	5610-71150-402260	Als Bootery And Repair Sh - PCard
04/11/2016	45	U.S. Bank PCards	\$ 1,972.38	5610-71100-403581	E & Jk Enterprises Inc - PCard
04/11/2016	45	U.S. Bank PCards	\$ 1,941.38	5610-71100-403581	E & Jk Enterprises Inc - PCard
04/11/2016	45	U.S. Bank PCards	\$ 1,960.76	5610-71100-403581	E & Jk Enterprises Inc - PCard
04/11/2016	45	U.S. Bank PCards	\$ 1,848.38	5610-71100-403581	E & Jk Enterprises Inc - PCard
04/11/2016	45	U.S. Bank PCards	\$ 141.90	8730-51990-402260	Phillips Feed Montana - PCard
04/11/2016	45	U.S. Bank PCards	\$ 112.00	0100-43210-402190	Billings Ink And Toner In - PCard
04/11/2016	45	U.S. Bank PCards	\$ 10.00	2400-43010-402120	Volgistics Inc - PCard
04/11/2016	45	U.S. Bank PCards	\$ 71.00	8730-51990-403360	Volgistics Inc - PCard
04/11/2016	45	U.S. Bank PCards	\$ 184.00	6270-17520-403516	City Blue Productions, LI - PCard
04/11/2016	45	U.S. Bank PCards	\$ 84.00	1500-21120-402260	Silver Threads - PCard
04/11/2016	45	U.S. Bank PCards	\$ 98.00	1500-21120-402260	Silver Threads - PCard
04/11/2016	45	U.S. Bank PCards	\$ 25.99	5020-74000-403823	Missoula Fresh Market No - PCard
04/11/2016	45	U.S. Bank PCards	\$ 55.00	6500-15670-403690	Sq *Skyline Services, Inc - PCard
04/11/2016	45	U.S. Bank PCards	\$ 26.00	2400-43010-403310	Sq *Yellowstone Cou - PCard
04/11/2016	45	U.S. Bank PCards	\$ 59.95	0100-51270-402290	Charter Comm - PCard
04/11/2016	45	U.S. Bank PCards	\$ 120.00	2600-55110-403590	In *Southeastern Security - PCard
04/11/2016	45	U.S. Bank PCards	\$ 63.21	1500-21120-402220	Firstaidsuppliesonl - PCard
04/11/2016	45	U.S. Bank PCards	\$ 40.00	1500-21150-402285	Volgistics Inc - PCard
04/11/2016	45	U.S. Bank PCards	\$ 17.74	5120-85000-403660	Sq *Billings Office Syste - PCard
04/11/2016	45	U.S. Bank PCards	\$ 200.00	1500-21110-403170	Sq *Maverick Wrecker - PCard
04/11/2016	45	U.S. Bank PCards	\$ 155.00	5610-71190-403660	Sq *Roger Connor - PCard
04/11/2016	45	U.S. Bank PCards	\$ 40.00	5210-15910-402450	Sq *Skyline Services, Inc - PCard
04/11/2016	45	U.S. Bank PCards	\$ 120.00	5210-15920-402450	Sq *Skyline Services, Inc - PCard
04/11/2016	45	U.S. Bank PCards	\$ 30.00	5210-15930-402450	Sq *Skyline Services, Inc - PCard
04/11/2016	45	U.S. Bank PCards	\$ 648.63	0100-51120-402290	Bettymillsc - PCard
04/11/2016	45	U.S. Bank PCards	\$ 278.97	5020-74000-402220	Microbiologics, Inc - PCard
04/11/2016	45	U.S. Bank PCards	\$ 150.00	1500-21110-403170	Sq *Agave Towing - PCard
04/11/2016	45	U.S. Bank PCards	\$ 365.00	5710-71430-402450	Sq *Billings Carpet & Wat - PCard
04/11/2016	45	U.S. Bank PCards	\$ 44.37	6200-19130-402120	Sq *Billings Office Syste - PCard

Check Date	Check	Name	Amount	Account	Item Desc
04/11/2016	45	U.S. Bank PCards	\$ 26.62	5020-75000-403660	Sq *Billings Office Syste - PCard
04/11/2016	45	U.S. Bank PCards	\$ 19.25	5610-71120-402450	Ats Inland Nw - PCard
04/11/2016	45	U.S. Bank PCards	\$ 105.00	1500-21110-403170	Budget Towing - PCard
04/11/2016	45	U.S. Bank PCards	\$ 17.95	0100-51120-402390	Rimrock Tire - PCard
04/11/2016	45	U.S. Bank PCards	\$ 17.95	0100-51120-402390	Rimrock Tire - PCard
04/11/2016	45	U.S. Bank PCards	\$ 28.95	0100-51120-402390	Rimrock Tire - PCard
04/11/2016	45	U.S. Bank PCards	\$ 14.95	0100-51120-402390	Rimrock Tire - PCard
04/11/2016	45	U.S. Bank PCards	\$ 7.49	0100-51120-402290	Autozone #3769 - PCard
04/11/2016	45	U.S. Bank PCards	\$ 17.98	0100-51120-402290	Autozone #3772 - PCard
04/11/2016	45	U.S. Bank PCards	\$ 124.80	0100-51120-402260	Sq *Rocky Mountain Compos - PCard
04/11/2016	45	U.S. Bank PCards	\$ 41.60	0100-51140-403650	Sq *Rocky Mountain Compos - PCard
04/11/2016	45	U.S. Bank PCards	\$ 219.90	6500-15670-402310	Interstate Battery Of - PCard
04/11/2016	45	U.S. Bank PCards	\$ 964.42	5610-71120-402450	Ats Inland Nw - PCard
04/11/2016	45	U.S. Bank PCards	\$ 95.00	1500-21110-403170	Excel Services - PCard
04/11/2016	45	U.S. Bank PCards	\$ 1,123.20	5610-71150-402290	Fire Service Bookstore - PCard
04/11/2016	45	U.S. Bank PCards	\$ 32.85	1500-22290-403822	Bagel Inc - 4Th Ave - PCard
04/11/2016	45	U.S. Bank PCards	\$ 300.00	2510-21270-403450	In *Gibson Advertising, M - PCard
04/11/2016	45	U.S. Bank PCards	\$ 214.00	5020-74000-403330	Uei Water Program - PCard
04/11/2016	45	U.S. Bank PCards	\$ 6.00	0100-51210-403665	Zeecreative - PCard
04/11/2016	45	U.S. Bank PCards	\$ 144.00	5710-71430-402450	Heartland Paper Company - PCard
04/11/2016	45	U.S. Bank PCards	\$ 140.39	5710-71430-402450	Heartland Paper Company - PCard
04/11/2016	45	U.S. Bank PCards	\$ 43.00	6500-15670-403690	Heartland Paper Company - PCard
04/11/2016	45	U.S. Bank PCards	\$ 95.53	6500-15670-402240	Heartland Paper Company - PCard
04/11/2016	45	U.S. Bank PCards	\$ 154.18	6500-15660-402450	Heartland Paper Company - PCard
04/11/2016	45	U.S. Bank PCards	\$ 162.64	0100-51270-402450	Heartland Paper Company - PCard
04/11/2016	45	U.S. Bank PCards	\$ 34.34	2600-55110-402190	360 Office Solutions Inc - PCard
04/11/2016	45	U.S. Bank PCards	\$ 285.99	2600-55130-402190	360 Office Solutions Inc - PCard
04/11/2016	45	U.S. Bank PCards	\$ 18.49	2600-55140-402120	360 Office Solutions Inc - PCard
04/11/2016	45	U.S. Bank PCards	\$ 960.00	1500-22290-402690	Ph & S Products Llc - PCard
04/11/2016	45	U.S. Bank PCards	\$ 16.18	5410-31230-403824	High Country Travel Plaza - PCard
04/11/2016	45	U.S. Bank PCards	\$ 20.30	2400-43010-403720	High Country Travel Plaza - PCard
04/11/2016	45	U.S. Bank PCards	\$ 38.33	2910-65010-402190	360 Office Solutions Inc - PCard
04/11/2016	45	U.S. Bank PCards	\$ 83.19	2600-55130-402190	360 Office Solutions Inc - PCard
04/11/2016	45	U.S. Bank PCards	\$ 52.35	2600-55110-403690	360 Office Solutions Inc - PCard
04/11/2016	45	U.S. Bank PCards	\$ 136.11	2600-55140-403690	360 Office Solutions Inc - PCard
04/11/2016	45	U.S. Bank PCards	\$ 20.94	2600-55130-403690	360 Office Solutions Inc - PCard
04/11/2016	45	U.S. Bank PCards	\$ 7.36	2600-55150-402190	360 Office Solutions Inc - PCard
04/11/2016	45	U.S. Bank PCards	\$ 45.60	2090-44510-402190	360 Office Solutions Inc - PCard
04/11/2016	45	U.S. Bank PCards	\$ 8.88	0100-51120-402190	360 Office Solutions Inc - PCard
04/11/2016	45	U.S. Bank PCards	\$ 434.00	0100-51270-402925	360 Office Solutions Inc - PCard

Check Date	Check	Name	Amount	Account	Item Desc
04/11/2016	45	U.S. Bank PCards	\$ 275.22	0100-17500-402110	360 Office Solutions Inc - PCard
04/11/2016	45	U.S. Bank PCards	\$ 25.99	0100-17500-402110	360 Office Solutions Inc - PCard
04/11/2016	45	U.S. Bank PCards	\$ 676.01	0100-12200-402190	360 Office Solutions Inc - PCard
04/11/2016	45	U.S. Bank PCards	\$ 61.79	1500-21200-402290	360 Office Solutions Inc - PCard
04/11/2016	45	U.S. Bank PCards	\$ 608.26	1500-21500-402190	360 Office Solutions Inc - PCard
04/11/2016	45	U.S. Bank PCards	\$ 61.98	1500-21500-402190	360 Office Solutions Inc - PCard
04/11/2016	45	U.S. Bank PCards	\$ 11.18	1500-21710-402120	360 Office Solutions Inc - PCard
04/11/2016	45	U.S. Bank PCards	\$ 47.46	6200-19110-402290	360 Office Solutions Inc - PCard
04/11/2016	45	U.S. Bank PCards	\$ 10.19	2090-44510-402190	360 Office Solutions Inc - PCard
04/11/2016	45	U.S. Bank PCards	\$ 34.77	0100-15120-402190	360 Office Solutions Inc - PCard
04/11/2016	45	U.S. Bank PCards	\$ 34.90	6050-15160-402160	360 Office Solutions Inc - PCard
04/11/2016	45	U.S. Bank PCards	\$ 253.30	6050-15160-402160	360 Office Solutions Inc - PCard
04/11/2016	45	U.S. Bank PCards	\$ 10.26	0100-15120-402190	360 Office Solutions Inc - PCard
04/11/2016	45	U.S. Bank PCards	\$ 148.60	6050-15160-402160	360 Office Solutions Inc - PCard
04/11/2016	45	U.S. Bank PCards	\$ 405.83	5710-71410-402190	360 Office Solutions Inc - PCard
04/11/2016	45	U.S. Bank PCards	\$ 76.79	6700-31410-402190	360 Office Solutions Inc - PCard
04/11/2016	45	U.S. Bank PCards	\$ 69.80	6050-15160-402160	360 Office Solutions Inc - PCard
04/11/2016	45	U.S. Bank PCards	\$ (34.77)	0100-15120-402190	360 Office Solutions Inc - PCard
04/11/2016	45	U.S. Bank PCards	\$ 14.88	0100-15120-402190	360 Office Solutions Inc - PCard
04/11/2016	45	U.S. Bank PCards	\$ 139.60	6050-15160-402160	360 Office Solutions Inc - PCard
04/11/2016	45	U.S. Bank PCards	\$ 19.58	6050-15160-402160	360 Office Solutions Inc - PCard
04/11/2016	45	U.S. Bank PCards	\$ 399.98	5120-84000-402120	360 Office Solutions Inc - PCard
04/11/2016	45	U.S. Bank PCards	\$ 358.79	5120-84000-402190	360 Office Solutions Inc - PCard
04/11/2016	45	U.S. Bank PCards	\$ 47.82	0100-16110-402190	360 Office Solutions Inc - PCard
04/11/2016	45	U.S. Bank PCards	\$ 118.32	0100-16110-402190	360 Office Solutions Inc - PCard
04/11/2016	45	U.S. Bank PCards	\$ 8.99	0100-16110-402190	360 Office Solutions Inc - PCard
04/11/2016	45	U.S. Bank PCards	\$ 14.97	2400-43010-403210	360 Office Solutions Inc - PCard
04/11/2016	45	U.S. Bank PCards	\$ 7.66	5210-15930-402190	360 Office Solutions Inc - PCard
04/11/2016	45	U.S. Bank PCards	\$ 109.52	5210-15210-402190	360 Office Solutions Inc - PCard
04/11/2016	45	U.S. Bank PCards	\$ 159.08	5020-73110-403630	360 Office Solutions Inc - PCard
04/11/2016	45	U.S. Bank PCards	\$ 106.06	5120-83110-403630	360 Office Solutions Inc - PCard
04/11/2016	45	U.S. Bank PCards	\$ 119.40	5020-73110-402120	360 Office Solutions Inc - PCard
04/11/2016	45	U.S. Bank PCards	\$ 79.60	5120-83110-402120	360 Office Solutions Inc - PCard
04/11/2016	45	U.S. Bank PCards	\$ 29.54	0100-51120-402190	360 Office Solutions Inc - PCard
04/11/2016	45	U.S. Bank PCards	\$ 15.65	0100-51100-402190	360 Office Solutions Inc - PCard
04/11/2016	45	U.S. Bank PCards	\$ 5.04	0100-51120-402190	360 Office Solutions Inc - PCard
04/11/2016	45	U.S. Bank PCards	\$ 52.94	0100-51270-402190	360 Office Solutions Inc - PCard
04/11/2016	45	U.S. Bank PCards	\$ 144.93	0100-51270-402190	360 Office Solutions Inc - PCard
04/11/2016	45	U.S. Bank PCards	\$ 7.66	5210-15920-402190	360 Office Solutions Inc - PCard
04/11/2016	45	U.S. Bank PCards	\$ 23.03	0100-51100-402190	360 Office Solutions Inc - PCard

Check Date	Check	Name	Amount	Account	Item Desc
04/11/2016	45	U.S. Bank PCards	\$ 23.73	0100-51210-402190	360 Office Solutions Inc - PCard
04/11/2016	45	U.S. Bank PCards	\$ 35.09	0100-51100-402190	360 Office Solutions Inc - PCard
04/11/2016	45	U.S. Bank PCards	\$ 66.67	0100-51210-402190	360 Office Solutions Inc - PCard
04/11/2016	45	U.S. Bank PCards	\$ 10.95	0100-51210-402190	360 Office Solutions Inc - PCard
04/11/2016	45	U.S. Bank PCards	\$ 10.95	0100-51100-402190	360 Office Solutions Inc - PCard
04/11/2016	45	U.S. Bank PCards	\$ 32.65	5610-71100-402190	360 Office Solutions Inc - PCard
04/11/2016	45	U.S. Bank PCards	\$ 18.10	5020-75000-402190	360 Office Solutions Inc - PCard
04/11/2016	45	U.S. Bank PCards	\$ 12.06	5120-85000-402190	360 Office Solutions Inc - PCard
04/11/2016	45	U.S. Bank PCards	\$ 11.32	5020-74000-402190	360 Office Solutions Inc - PCard
04/11/2016	45	U.S. Bank PCards	\$ 100.20	2110-31320-402190	360 Office Solutions Inc - PCard
04/11/2016	45	U.S. Bank PCards	\$ 23.04	0100-51120-402190	360 Office Solutions Inc - PCard
04/11/2016	45	U.S. Bank PCards	\$ (10.29)	0100-16110-402190	360 Office Solutions - PCard
04/11/2016	45	U.S. Bank PCards	\$ (41.56)	2600-55130-402190	360 Office Solutions - PCard
04/11/2016	45	U.S. Bank PCards	\$ 87.64	6010-15500-402190	360 Office Solutions Inc - PCard
04/11/2016	45	U.S. Bank PCards	\$ 187.42	6010-15500-402190	360 Office Solutions Inc - PCard
04/11/2016	45	U.S. Bank PCards	\$ 142.98	5020-74000-402190	360 Office Solutions Inc - PCard
04/11/2016	45	U.S. Bank PCards	\$ 74.90	0100-51400-402290	360 Office Solutions Inc - PCard
04/11/2016	45	U.S. Bank PCards	\$ 8.39	5610-71120-402450	Cvs/Pharmacy #08944 - PCard
04/11/2016	45	U.S. Bank PCards	\$ 5.99	6500-15650-402190	Cvs/Pharmacy #08944 - PCard
04/11/2016	45	U.S. Bank PCards	\$ 231.15	1500-21120-402261	High Speed Gear - PCard
04/11/2016	45	U.S. Bank PCards	\$ 29.50	5410-31230-402320	Spencer Fluid Power - PCard
04/11/2016	45	U.S. Bank PCards	\$ 19.18	1500-22240-402280	360 Office Solutions - PCard
04/11/2016	45	U.S. Bank PCards	\$ (19.18)	0100-43210-402190	360 Office Solutions - PCard
04/11/2016	45	U.S. Bank PCards	\$ 148.52	5610-71120-403660	Ecolab, Inc - PCard
04/11/2016	45	U.S. Bank PCards	\$ 148.52	5610-71120-403660	Ecolab, Inc - PCard
04/11/2016	45	U.S. Bank PCards	\$ 148.52	5610-71120-403660	Ecolab, Inc - PCard
04/11/2016	45	U.S. Bank PCards	\$ 165.75	5610-71170-403660	Ecolab, Inc - PCard
04/11/2016	45	U.S. Bank PCards	\$ 342.00	6010-15530-403990	Oil Price Info Serv - PCard
04/11/2016	45	U.S. Bank PCards	\$ 28.40	2690-67710-403822	Holiday Stnstore 0274 - PCard
04/11/2016	45	U.S. Bank PCards	\$ 83.84	5610-71170-403660	Ecolab, Inc - PCard
04/11/2016	45	U.S. Bank PCards	\$ 93.15	5610-71170-403660	Ecolab, Inc - PCard
04/11/2016	45	U.S. Bank PCards	\$ 93.15	5610-71170-403660	Ecolab, Inc - PCard
04/11/2016	45	U.S. Bank PCards	\$ 98.33	5610-71190-403660	Ecolab, Inc - PCard
04/11/2016	45	U.S. Bank PCards	\$ 98.33	5610-71190-403660	Ecolab, Inc - PCard
04/11/2016	45	U.S. Bank PCards	\$ 98.33	5610-71190-403660	Ecolab, Inc - PCard
04/11/2016	45	U.S. Bank PCards	\$ 56.26	5710-71430-403660	Alsco Slbil - PCard
04/11/2016	45	U.S. Bank PCards	\$ 68.63	5710-71480-402450	Alsco Slbil - PCard
04/11/2016	45	U.S. Bank PCards	\$ 141.15	6500-15660-402450	Ecolab, Inc - PCard
04/11/2016	45	U.S. Bank PCards	\$ 141.15	6500-15660-402450	Ecolab, Inc - PCard
04/11/2016	45	U.S. Bank PCards	\$ 83.84	5610-71170-403660	Ecolab, Inc - PCard

Check Date	Check	Name	Amount	Account	Item Desc
04/11/2016	45	U.S. Bank PCards	\$ 83.84	5610-71170-403660	Ecolab, Inc - PCard
04/11/2016	45	U.S. Bank PCards	\$ 2.00	0100-51250-402250	Albertsons #2047 - PCard
04/11/2016	45	U.S. Bank PCards	\$ 50.00	5410-31210-401170	Albertsons #2047 - PCard
04/11/2016	45	U.S. Bank PCards	\$ 5.48	5410-31210-401170	Albertsons #2047 - PCard
04/11/2016	45	U.S. Bank PCards	\$ 70.20	5710-71430-402260	Alsco Sbil - PCard
04/11/2016	45	U.S. Bank PCards	\$ 424.72	5710-71430-402450	Alsco Sbil - PCard
04/11/2016	45	U.S. Bank PCards	\$ 255.28	5710-71440-402260	Alsco Sbil - PCard
04/11/2016	45	U.S. Bank PCards	\$ 65.01	5410-31230-403450	At&T*Bill Payment - PCard
04/11/2016	45	U.S. Bank PCards	\$ 110.00	5120-87000-403824	Msu Northern - Tuition - PCard
04/11/2016	45	U.S. Bank PCards	\$ 29.44	8730-51990-403360	Albertsons #2038 - PCard
04/11/2016	45	U.S. Bank PCards	\$ 25.91	0100-51100-403360	Albertsons #2047 - PCard
04/11/2016	45	U.S. Bank PCards	\$ 15.45	0100-51250-402250	Albertsons #2047 - PCard
04/11/2016	45	U.S. Bank PCards	\$ 12.99	0100-51120-402290	Albertsons #2047 - PCard
04/11/2016	45	U.S. Bank PCards	\$ 1,000.00	5610-71140-403990	Transportation Security - PCard
04/11/2016	45	U.S. Bank PCards	\$ 94.40	0100-51100-403360	Jimmy Johns - 1646 - E - PCard
04/11/2016	45	U.S. Bank PCards	\$ 14.00	1500-22230-403824	Pilot - PCard
04/11/2016	45	U.S. Bank PCards	\$ 54.00	6500-15650-403450	At&T Smd7 15579 - PCard
04/11/2016	45	U.S. Bank PCards	\$ 115.00	6500-15650-403450	At&T Smd7 15579 - PCard
04/11/2016	45	U.S. Bank PCards	\$ (6.40)	6500-15650-403450	At&T Smd7 15579 - PCard
04/11/2016	45	U.S. Bank PCards	\$ 54.42	5410-31230-402320	Norco Inc - PCard
04/11/2016	45	U.S. Bank PCards	\$ 1,205.00	0100-51120-402290	General Shale-Billings - PCard
04/11/2016	45	U.S. Bank PCards	\$ (1,205.00)	0100-51120-402290	General Shale-Billings - PCard
04/11/2016	45	U.S. Bank PCards	\$ 221.50	0100-51120-403650	General Shale-Billings - PCard
04/11/2016	45	U.S. Bank PCards	\$ 50.39	5020-74000-402360	Monoprice Com - PCard
04/11/2016	45	U.S. Bank PCards	\$ 50.39	5120-84300-402360	Monoprice Com - PCard
04/11/2016	45	U.S. Bank PCards	\$ 52.86	5710-71440-402450	Norco Inc - PCard
04/11/2016	45	U.S. Bank PCards	\$ 58.50	5410-31220-402630	Norco Inc - PCard
04/11/2016	45	U.S. Bank PCards	\$ 1,370.00	5020-74000-402410	Norco Inc - PCard
04/11/2016	45	U.S. Bank PCards	\$ 195.00	5020-74000-402220	Norco Inc - PCard
04/11/2016	45	U.S. Bank PCards	\$ 29.49	0100-51140-402410	Norco Inc - PCard
04/11/2016	45	U.S. Bank PCards	\$ 113.38	5410-31230-402290	Norco Inc - PCard
04/11/2016	45	U.S. Bank PCards	\$ 21.00	0100-51120-402330	Norco Inc - PCard
04/11/2016	45	U.S. Bank PCards	\$ 246.45	5610-71130-402370	Norco Inc - PCard
04/11/2016	45	U.S. Bank PCards	\$ 113.48	5610-71130-402370	Norco Inc - PCard
04/11/2016	45	U.S. Bank PCards	\$ 50.24	2110-31320-402290	Norco Inc - PCard
04/11/2016	45	U.S. Bank PCards	\$ 34.14	0100-51120-403660	Norco Inc - PCard
04/11/2016	45	U.S. Bank PCards	\$ 195.00	5020-73120-402410	Norco Inc - PCard
04/11/2016	45	U.S. Bank PCards	\$ 38.00	5410-31220-402290	Industrial Sales And S - PCard
04/11/2016	45	U.S. Bank PCards	\$ 495.00	2510-21270-403822	Dallas Childrens Advocacy - PCard
04/11/2016	45	U.S. Bank PCards	\$ 410.00	2110-31320-402320	Gorman Rupp-Industries - PCard

Check Date	Check	Name	Amount	Account	Item Desc
04/11/2016	45	U.S. Bank PCards	\$ 30.25	0100-13130-403360	The Burger Dive - PCard
04/11/2016	45	U.S. Bank PCards	\$ 270.53	5610-71130-402320	Team Eagle Inc - PCard
04/11/2016	45	U.S. Bank PCards	\$ 76.33	2110-31320-402420	Montana Moulding And S - PCard
04/11/2016	45	U.S. Bank PCards	\$ 520.00	1500-21400-403822	I/O Solutions, Inc. - PCard
04/11/2016	45	U.S. Bank PCards	\$ 110.40	5020-75000-404220	Mt Waterworks, Llc. - PCard
04/11/2016	45	U.S. Bank PCards	\$ 199.00	0100-51120-402330	Industrial Sales And S - PCard
04/11/2016	45	U.S. Bank PCards	\$ 18.00	5410-31220-402290	Industrial Sales And S - PCard
04/11/2016	45	U.S. Bank PCards	\$ 210.00	2110-31320-402920	Industrial Sales And S - PCard
04/11/2016	45	U.S. Bank PCards	\$ 33.25	5410-31220-402290	Industrial Sales And S - PCard
04/11/2016	45	U.S. Bank PCards	\$ 28.35	0100-51120-403660	American Weldi - PCard
04/11/2016	45	U.S. Bank PCards	\$ 46.61	5020-74000-402450	American Weldi - PCard
04/11/2016	45	U.S. Bank PCards	\$ 262.00	5020-74000-402410	American Weldi - PCard
04/11/2016	45	U.S. Bank PCards	\$ 71.68	5020-74000-402450	American Weldi - PCard
04/11/2016	45	U.S. Bank PCards	\$ 63.80	5210-15230-402310	American Weldi - PCard
04/11/2016	45	U.S. Bank PCards	\$ 132.00	1500-21150-402285	Safariland, Llc - PCard
04/11/2016	45	U.S. Bank PCards	\$ 92.50	0100-51120-402260	Snappy Duds - PCard
04/11/2016	45	U.S. Bank PCards	\$ 109.90	0100-51120-402260	Snappy Duds - PCard
04/11/2016	45	U.S. Bank PCards	\$ 58.93	5610-71130-402410	American Weldi - PCard
04/11/2016	45	U.S. Bank PCards	\$ 137.00	5610-71130-402410	American Weldi - PCard
04/11/2016	45	U.S. Bank PCards	\$ 48.75	2110-31320-402420	American Weldi - PCard
04/11/2016	45	U.S. Bank PCards	\$ 178.33	2110-31320-402420	American Weldi - PCard
04/11/2016	45	U.S. Bank PCards	\$ 49.00	5610-71150-402220	Billings Clinic Homeox - PCard
04/11/2016	45	U.S. Bank PCards	\$ 15.00	0100-51210-403665	Plug N Pay Inc - PCard
04/11/2016	45	U.S. Bank PCards	\$ 33.35	0100-51420-402290	Warne Chemical And Equ - PCard
04/11/2016	45	U.S. Bank PCards	\$ 170.14	1500-22290-402640	Legend Data Systems - PCard
04/11/2016	45	U.S. Bank PCards	\$ 97.52	5710-71410-403990	Garda CI - PCard
04/11/2016	45	U.S. Bank PCards	\$ 24.23	5210-15230-402290	Ncs Billings 3 - PCard
04/11/2016	45	U.S. Bank PCards	\$ 19.25	2400-43010-403720	Conomart Iv - PCard
04/11/2016	45	U.S. Bank PCards	\$ 153.77	2550-21430-403822	Embassy Suites - Denver - PCard
04/11/2016	45	U.S. Bank PCards	\$ 147.15	2110-31320-402380	Probuild N #409 - PCard
04/11/2016	45	U.S. Bank PCards	\$ 658.40	0100-51120-402290	Probuild N #409 - PCard
04/11/2016	45	U.S. Bank PCards	\$ 8.80	5210-15230-402120	Probuild N #409 - PCard
04/11/2016	45	U.S. Bank PCards	\$ 564.00	1500-22250-403350	Billings Clinic Ctc - PCard
04/11/2016	45	U.S. Bank PCards	\$ 73.17	5120-84300-402360	Fedex 782506652792 - PCard
04/11/2016	45	U.S. Bank PCards	\$ 21.41	2200-22330-402410	Fedex 782597773114 - PCard
04/11/2016	45	U.S. Bank PCards	\$ 73.85	5120-84300-403660	Fedex 782620333410 - PCard
04/11/2016	45	U.S. Bank PCards	\$ 8.99	2200-22330-402410	Fedex 870186332095 - PCard
04/11/2016	45	U.S. Bank PCards	\$ 38.44	1500-21110-403110	Fedex 98276224 - PCard
04/11/2016	45	U.S. Bank PCards	\$ 37.21	1500-21110-403110	Fedex 98423365 - PCard
04/11/2016	45	U.S. Bank PCards	\$ 935.16	5610-71130-403653	Airside Solutions, Inc - PCard

Check Date	Check	Name	Amount	Account	Item Desc
04/11/2016	45	U.S. Bank PCards	\$ 680.88	5610-71130-403653	Airside Solutions, Inc - PCard
04/11/2016	45	U.S. Bank PCards	\$ (24.00)	0100-51100-403824	Car Airportrentals.Com - PCard
04/11/2016	45	U.S. Bank PCards	\$ 81.75	2510-21270-402190	Tlo Transunion - PCard
04/11/2016	45	U.S. Bank PCards	\$ 350.00	2510-21270-402190	Nli*Sharefile - PCard
04/11/2016	45	U.S. Bank PCards	\$ 101.84	5020-74000-402220	Fedex 19739725 - PCard
04/11/2016	45	U.S. Bank PCards	\$ 354.90	0100-51120-402330	Midwest Sports - PCard
04/11/2016	45	U.S. Bank PCards	\$ 1,349.55	0100-51120-402330	Midwest Sports - PCard
04/11/2016	45	U.S. Bank PCards	\$ 995.00	6200-19110-402290	Sym*Secure Site Ssl - PCard
04/11/2016	45	U.S. Bank PCards	\$ 418.00	7750-51540-407249	International Bronze Plaq - PCard
04/11/2016	45	U.S. Bank PCards	\$ 103.65	5020-74000-403823	Hilton Garden Inn - PCard
04/11/2016	45	U.S. Bank PCards	\$ 1,415.90	5610-71130-403653	Airside Solutions, Inc - PCard
04/11/2016	45	U.S. Bank PCards	\$ 119.85	2400-43010-403210	Pita Pit - 14-025-Mt - PCard
04/11/2016	45	U.S. Bank PCards	\$ 97.35	2400-43010-403210	Pita Pit - 14-025-Mt - PCard
04/11/2016	45	U.S. Bank PCards	\$ 15.47	5020-74000-402360	Provantage Llc - PCard
04/11/2016	45	U.S. Bank PCards	\$ 15.46	5120-84300-402360	Provantage Llc - PCard
04/11/2016	45	U.S. Bank PCards	\$ 26.00	8730-51990-403360	Surveymonkey.Com - PCard
04/11/2016	45	U.S. Bank PCards	\$ 19.00	5410-31210-401170	Walgreens #12155 - PCard
04/11/2016	45	U.S. Bank PCards	\$ 30.91	1500-22230-402290	Lowe's #00319* - PCard
04/11/2016	45	U.S. Bank PCards	\$ 342.96	1500-21400-402270	Lowe's #00319* - PCard
04/11/2016	45	U.S. Bank PCards	\$ 25.80	1500-21120-402120	Lowe's #00319* - PCard
04/11/2016	45	U.S. Bank PCards	\$ 25.75	5020-73120-402410	Edge Construction Supp - PCard
04/11/2016	45	U.S. Bank PCards	\$ 52.50	5610-71190-403660	Northwest Fuel Systems-B - PCard
04/11/2016	45	U.S. Bank PCards	\$ 640.53	5610-00000-141000	Northwest Fuel Systems-K - PCard
04/11/2016	45	U.S. Bank PCards	\$ 53.21	0100-51120-402290	Lowe's #00319* - PCard
04/11/2016	45	U.S. Bank PCards	\$ 118.10	0100-51120-402290	Lowe's #00319* - PCard
04/11/2016	45	U.S. Bank PCards	\$ 61.68	0100-51120-402290	Lowe's #00319* - PCard
04/11/2016	45	U.S. Bank PCards	\$ 24.24	0100-51120-402290	Lowe's #00319* - PCard
04/11/2016	45	U.S. Bank PCards	\$ 116.40	0100-51120-402290	Lowe's #00319* - PCard
04/11/2016	45	U.S. Bank PCards	\$ 89.10	0100-51270-402290	Lowe's #00319* - PCard
04/11/2016	45	U.S. Bank PCards	\$ 21.87	0100-51120-402290	Lowe's #00319* - PCard
04/11/2016	45	U.S. Bank PCards	\$ 65.83	0100-51120-402290	Lowe's #00319* - PCard
04/11/2016	45	U.S. Bank PCards	\$ 47.59	0100-51120-402290	Lowe's #00319* - PCard
04/11/2016	45	U.S. Bank PCards	\$ 69.98	0100-51120-402120	Lowe's #00319* - PCard
04/11/2016	45	U.S. Bank PCards	\$ 36.28	0100-51120-402290	Lowe's #00319* - PCard
04/11/2016	45	U.S. Bank PCards	\$ 36.28	0100-51120-402290	Lowe's #00319* - PCard
04/11/2016	45	U.S. Bank PCards	\$ 6.22	2110-31320-402290	Lowe's #00319* - PCard
04/11/2016	45	U.S. Bank PCards	\$ 20.74	2110-31320-402290	Lowe's #00319* - PCard
04/11/2016	45	U.S. Bank PCards	\$ 42.60	1500-21500-402271	Lowe's #00319* - PCard
04/11/2016	45	U.S. Bank PCards	\$ 9.97	6500-15670-402240	Lowe's #00319* - PCard
04/11/2016	45	U.S. Bank PCards	\$ 286.87	5410-31220-402410	Lowe's #00319* - PCard

Check Date	Check	Name	Amount	Account	Item Desc
04/11/2016	45	U.S. Bank PCards	\$ 20.92	0100-51120-402290	Lowes #00319* - PCard
04/11/2016	45	U.S. Bank PCards	\$ 37.96	6500-15660-402450	Lowes #00319* - PCard
04/11/2016	45	U.S. Bank PCards	\$ (37.96)	6500-15660-402450	Lowes #00319* - PCard
04/11/2016	45	U.S. Bank PCards	\$ 35.12	6500-15660-402450	Lowes #00319* - PCard
04/11/2016	45	U.S. Bank PCards	\$ 17.94	2110-31320-402380	Lowes #00319* - PCard
04/11/2016	45	U.S. Bank PCards	\$ 31.29	2110-31320-402320	Lowes #00319* - PCard
04/11/2016	45	U.S. Bank PCards	\$ 15.19	5410-31220-402290	Lowes #00319* - PCard
04/11/2016	45	U.S. Bank PCards	\$ 36.80	5020-74000-402450	Lowes #00319* - PCard
04/11/2016	45	U.S. Bank PCards	\$ 35.80	0100-51120-402290	Lowes #00319* - PCard
04/11/2016	45	U.S. Bank PCards	\$ 37.76	0100-51120-402320	Lowes #00319* - PCard
04/11/2016	45	U.S. Bank PCards	\$ 40.62	5610-71120-402450	Lowes #00319* - PCard
04/11/2016	45	U.S. Bank PCards	\$ 99.00	0100-51410-402450	Lowes #00319* - PCard
04/11/2016	45	U.S. Bank PCards	\$ 11.92	5610-71130-402450	Lowes #00319* - PCard
04/11/2016	45	U.S. Bank PCards	\$ 214.00	2600-55110-403824	Paypal *Montanalibr - PCard
04/11/2016	45	U.S. Bank PCards	\$ 162.50	2600-55110-403824	Paypal *Montanalibr - PCard
04/11/2016	45	U.S. Bank PCards	\$ 98.00	2600-55110-403824	Paypal *Montanalibr - PCard
04/11/2016	45	U.S. Bank PCards	\$ 143.00	2600-55110-403824	Paypal *Montanalibr - PCard
04/11/2016	45	U.S. Bank PCards	\$ 200.00	2600-55110-403824	Paypal *Montanalibr - PCard
04/11/2016	45	U.S. Bank PCards	\$ 110.50	1500-21200-402610	I D Wholesalers - PCard
04/11/2016	45	U.S. Bank PCards	\$ 10.71	1500-21720-403824	Netflix.Com - PCard
04/11/2016	45	U.S. Bank PCards	\$ (10.71)	1500-21720-403824	Netflix.Com - PCard
04/11/2016	45	U.S. Bank PCards	\$ (145.20)	1500-21720-403824	Orbitz*129384931934 - PCard
04/11/2016	45	U.S. Bank PCards	\$ 145.20	1500-21720-403824	Orbitz*129384931934 - PCard
04/11/2016	45	U.S. Bank PCards	\$ 450.00	5610-71100-403824	Paypal *Afw - PCard
04/11/2016	45	U.S. Bank PCards	\$ 65.00	2400-43010-403350	Paypal *Map - PCard
04/11/2016	45	U.S. Bank PCards	\$ 1,000.00	1500-21500-402925	Portable Computer Systems - PCard
04/11/2016	45	U.S. Bank PCards	\$ 510.00	8730-51990-409370	Bobcat Of Big Sky - PCard
04/11/2016	45	U.S. Bank PCards	\$ 419.96	5610-71150-402290	L A Police Gear Inc - PCard
04/11/2016	45	U.S. Bank PCards	\$ 60.00	7380-12660-403824	Nadcp - PCard
04/11/2016	45	U.S. Bank PCards	\$ 1,800.00	7380-12660-403824	Nadcp - PCard
04/11/2016	45	U.S. Bank PCards	\$ 1,200.00	7380-12660-403824	Nadcp - PCard
04/11/2016	45	U.S. Bank PCards	\$ 89.15	0100-51120-402390	Lisacs Billingstire Sp - PCard
04/11/2016	45	U.S. Bank PCards	\$ 31.50	0100-51120-402390	Lisacs Billingstire Sp - PCard
04/11/2016	45	U.S. Bank PCards	\$ 16.18	5120-84000-403823	Town Pump 5600 Rockr - PCard
04/11/2016	45	U.S. Bank PCards	\$ 19.00	5120-84000-403823	Town Pump 5600 Rockr - PCard
04/11/2016	45	U.S. Bank PCards	\$ 19.20	1500-21400-403822	Town Pump Helena 5 - PCard
04/11/2016	45	U.S. Bank PCards	\$ 199.00	2090-44510-403821	Ncs*Itl Cde Council Ex - PCard
04/11/2016	45	U.S. Bank PCards	\$ 76.25	5410-31230-403420	American Water & Technolo - PCard
04/11/2016	45	U.S. Bank PCards	\$ 9.00	1500-21710-402120	American Water & Technolo - PCard
04/11/2016	45	U.S. Bank PCards	\$ 20.00	5210-15910-403650	Gorham Park Laundry - PCard

Check Date	Check	Name	Amount	Account	Item Desc
04/11/2016	45	U.S. Bank PCards	\$ 20.00	5210-15920-403650	Gorham Park Laundry - PCard
04/11/2016	45	U.S. Bank PCards	\$ 20.00	5210-15930-403650	Gorham Park Laundry - PCard
04/11/2016	45	U.S. Bank PCards	\$ 214.86	2520-21490-403822	Hertz Rent-A-Car - PCard
04/11/2016	45	U.S. Bank PCards	\$ 497.20	1500-21400-403822	Comfort Suites Of Helena - PCard
04/11/2016	45	U.S. Bank PCards	\$ (10.00)	2520-21490-403822	Hotel Monaco Alexandria - PCard
04/11/2016	45	U.S. Bank PCards	\$ 521.84	2520-21490-403822	Hotel Monaco Alexandria - PCard
04/11/2016	45	U.S. Bank PCards	\$ 579.84	2520-21490-403822	Hotel Monaco Alexandria - PCard
04/11/2016	45	U.S. Bank PCards	\$ 23.32	2520-21490-403822	Hotel Monaco Alexandria - PCard
04/11/2016	45	U.S. Bank PCards	\$ (13.32)	2520-21490-403822	Hotel Monaco Alexandria - PCard
04/11/2016	45	U.S. Bank PCards	\$ 233.75	5610-71100-403210	Regional Helpwanted - PCard
04/11/2016	45	U.S. Bank PCards	\$ 7.00	0100-13130-403824	Expedia*1129879946629 - PCard
04/11/2016	45	U.S. Bank PCards	\$ 78.80	5610-71130-402410	Snap-On Tools Eforseth - PCard
04/11/2016	45	U.S. Bank PCards	\$ 55.31	5610-71150-402320	General Safety Equipment - PCard
04/11/2016	45	U.S. Bank PCards	\$ 131.88	2090-44510-402520	Workbook Or Pdf - PCard
04/11/2016	45	U.S. Bank PCards	\$ 497.20	1500-21400-403822	Comfort Suites Of Helena - PCard
04/11/2016	45	U.S. Bank PCards	\$ 134.35	5020-74000-402360	Www.Newegg.Com - PCard
04/11/2016	45	U.S. Bank PCards	\$ 15.99	2090-44510-402925	Www.Newegg.Com - PCard
04/11/2016	45	U.S. Bank PCards	\$ 2,500.00	1500-21500-403967	Bridger Steel Billings - PCard
04/11/2016	45	U.S. Bank PCards	\$ 2,183.25	1500-21500-403967	Bridger Steel Billings - PCard
04/11/2016	45	U.S. Bank PCards	\$ 16.71	8400-31840-403824	Exxonmobil 45940327 - PCard
04/11/2016	45	U.S. Bank PCards	\$ 15.00	1500-22230-403824	Exxonmobil 45948007 - PCard
04/11/2016	45	U.S. Bank PCards	\$ 25.00	1500-21700-403824	Alaska Air 0272189461577 - PCard
04/11/2016	45	U.S. Bank PCards	\$ 25.00	1500-21700-403824	Alaska Air 0272189945750 - PCard
04/11/2016	45	U.S. Bank PCards	\$ 25.00	1500-21700-403824	Alaska Air 0272189945751 - PCard
04/11/2016	45	U.S. Bank PCards	\$ 59.95	5020-74000-402190	Www.Newegg.Com - PCard
04/11/2016	45	U.S. Bank PCards	\$ 59.95	5120-84300-402190	Www.Newegg.Com - PCard
04/11/2016	45	U.S. Bank PCards	\$ 320.97	5020-74000-402120	Www.Newegg.Com - PCard
04/11/2016	45	U.S. Bank PCards	\$ 30.00	5610-71150-402290	Mt Gov Online Trns - PCard
04/11/2016	45	U.S. Bank PCards	\$ 1.99	5610-71150-402290	Fedexoffice 00016089 - PCard
04/11/2016	45	U.S. Bank PCards	\$ 126.00	1500-22310-402520	Fedexoffice 00016089 - PCard
04/11/2016	45	U.S. Bank PCards	\$ 22.99	0100-16110-402190	Fedexoffice 00016089 - PCard
04/11/2016	45	U.S. Bank PCards	\$ 55.96	0100-16110-402190	Fedexoffice 00016089 - PCard
04/11/2016	45	U.S. Bank PCards	\$ 353.05	1500-22240-402290	Fedexoffice 00016089 - PCard
04/11/2016	45	U.S. Bank PCards	\$ 375.00	2090-44510-403822	Mt Gov Online Trns - PCard
04/11/2016	45	U.S. Bank PCards	\$ 2,450.00	5610-71120-403660	Mt Gov Online Trns - PCard
04/11/2016	45	U.S. Bank PCards	\$ 50.00	5610-71150-402290	Mt Gov Online Trns - PCard
04/11/2016	45	U.S. Bank PCards	\$ 30.00	5610-71150-402290	Mt Gov Online Trns - PCard
04/11/2016	45	U.S. Bank PCards	\$ 50.00	5610-71150-402290	Mt Gov Online Trns - PCard
04/11/2016	45	U.S. Bank PCards	\$ 30.00	5610-71150-402290	Mt Gov Online Trns - PCard
04/11/2016	45	U.S. Bank PCards	\$ 35.00	5120-84000-403350	Mt Gov Online Trns - PCard

Check Date	Check	Name	Amount	Account	Item Desc
04/11/2016	45	U.S. Bank PCards	\$ 50.00	1500-22240-403350	Mt Gov Online Trns - PCard
04/11/2016	45	U.S. Bank PCards	\$ 50.00	1500-22240-403350	Mt Gov Online Trns - PCard
04/11/2016	45	U.S. Bank PCards	\$ 100.00	1500-22240-403350	Mt Gov Online Trns - PCard
04/11/2016	45	U.S. Bank PCards	\$ 50.00	1500-22240-403350	Mt Gov Online Trns - PCard
04/11/2016	45	U.S. Bank PCards	\$ 50.00	1500-22240-403350	Mt Gov Online Trns - PCard
04/11/2016	45	U.S. Bank PCards	\$ 50.00	1500-22240-403350	Mt Gov Online Trns - PCard
04/11/2016	45	U.S. Bank PCards	\$ 100.00	1500-22240-403350	Mt Gov Online Trns - PCard
04/11/2016	45	U.S. Bank PCards	\$ 70.00	1500-22240-403350	Mt Gov Online Trns - PCard
04/11/2016	45	U.S. Bank PCards	\$ 50.00	1500-22240-403350	Mt Gov Online Trns - PCard
04/11/2016	45	U.S. Bank PCards	\$ 50.00	1500-22240-403350	Mt Gov Online Trns - PCard
04/11/2016	45	U.S. Bank PCards	\$ 50.00	1500-22240-403350	Mt Gov Online Trns - PCard
04/11/2016	45	U.S. Bank PCards	\$ 50.00	1500-22240-403350	Mt Gov Online Trns - PCard
04/11/2016	45	U.S. Bank PCards	\$ 50.00	1500-22240-403350	Mt Gov Online Trns - PCard
04/11/2016	45	U.S. Bank PCards	\$ 209.00	7080-21180-402120	Wpy*Online Event By Idaho - PCard
04/11/2016	45	U.S. Bank PCards	\$ 118.69	5610-71150-403822	Wingate - PCard
04/11/2016	45	U.S. Bank PCards	\$ 10.00	1500-22230-403824	Wal-Mart #4653 - PCard
04/11/2016	45	U.S. Bank PCards	\$ 16.00	1500-22230-403824	United Pacific 6514 - PCard
04/11/2016	45	U.S. Bank PCards	\$ 27.18	1500-21400-402270	Ww Grainger - PCard
04/11/2016	45	U.S. Bank PCards	\$ 50.00	1500-22240-403350	Mt Gov Online Trns - PCard
04/11/2016	45	U.S. Bank PCards	\$ 209.00	7080-21180-402120	Wpy*Online Event By Idaho - PCard
04/11/2016	45	U.S. Bank PCards	\$ 209.00	7080-21180-402120	Wpy*Online Event By Idaho - PCard
04/11/2016	45	U.S. Bank PCards	\$ 209.00	7080-21180-402120	Wpy*Online Event By Idaho - PCard
04/11/2016	45	U.S. Bank PCards	\$ 209.00	7080-21180-402120	Wpy*Online Event By Idaho - PCard
04/11/2016	45	U.S. Bank PCards	\$ 209.00	7080-21180-402120	Wpy*Online Event By Idaho - PCard
04/11/2016	45	U.S. Bank PCards	\$ 209.00	7080-21180-402120	Wpy*Online Event By Idaho - PCard
04/11/2016	793033	A & I Distributors	\$ 254.40	2110-31320-402320	2773768
04/11/2016	793033	A & I Distributors	\$ 2,999.55	6010-00000-141000	2770734 PO NUM 299555
04/11/2016	793033	A & I Distributors	\$ 1,825.80	5710-00000-141714	BUS MET PO NUM 299555
04/11/2016	793033	A & I Distributors	\$ 361.35	5710-71440-402320	AUTO &TRUCK MAINT.ITEMS
04/11/2016	793033	A & I Distributors	\$ 4,793.24	6010-00000-141000	2777193 PO NUM 299555
04/11/2016	793033	A & I Distributors	\$ 656.70	5410-31220-402310	Blue DEF oil for the garbage trucks
04/11/2016	793033	A & I Distributors	\$ 218.90	5410-31220-402310	Blue DEF for the garbage trucks
04/11/2016	793033	A & I Distributors	\$ 921.42	5410-31230-402310	Oil for Landfill equipment
04/11/2016	793033	A & I Distributors	\$ 40.35	1500-21120-402320	2777193
04/11/2016	793033	A & I Distributors	\$ 39.79	2110-31320-402320	2777193
04/11/2016	793033	A & I Distributors	\$ 39.79	5410-31220-402320	2777193
04/11/2016	793033	A & I Distributors	\$ 13.98	5410-31220-402320	2779156
04/11/2016	793033	A & I Distributors	\$ 383.57	5410-31230-402310	Oil for Landfill Equipment
04/11/2016	793033	A & I Distributors	\$ 657.25	6010-00000-141000	2782400 PO NUM 299555
04/11/2016	793033	A & I Distributors	\$ 194.63	5410-31230-402310	Oil for garbage trucks

Check Date	Check	Name	Amount	Account	Item Desc
04/11/2016	793033	A & I Distributors	\$ 607.06	5610-71130-402310	Invoice #2770052. Oil for equipment-Services on snow
04/11/2016	793035	Advanced Computer Technologies Llc	\$ 15,000.00	0100-12200-403553	Advanced Computer Technologies Hosting and
04/11/2016	793048	Armscor Cartridge Incorporated	\$ 440.00	1500-21120-402261	Part #AC380-2N, .380 ACP, 95 gr, FMJ
04/11/2016	793048	Armscor Cartridge Incorporated	\$ 540.00	1500-21120-402261	Part #AC38-17N, .38 SPL, 158 gr, FMJ
04/11/2016	793048	Armscor Cartridge Incorporated	\$ 285.00	1500-21120-402261	Park #AC10-2N, 10mm, 180 gr, FMJ, New
04/11/2016	793048	Armscor Cartridge Incorporated	\$ 1,380.00	1500-21120-402261	Part #AC40-2N, 40 S&W, 180 gr, FMJ, New
04/11/2016	793048	Armscor Cartridge Incorporated	\$ 228.00	1500-21120-402261	Part #AC300AAC-1N, 300 Blackout, 147 gr, FMJ, New
04/11/2016	793048	Armscor Cartridge Incorporated	\$ 1,925.00	2500-21380-402120	Part #AC223-1N, .223, 55 gr, FMJ, New
04/11/2016	793048	Armscor Cartridge Incorporated	\$ 172.50	1500-21120-402261	Park #N40180VP250, 40 S&W, 180 gr, FMJ, Value
04/11/2016	793054	Bcs Scrip	\$ 3,350.00	6270-17520-401430	Health Incentives April 2016
04/11/2016	793064	Billings Industrial Revitalization District Inc	\$ 42,000.00	2010-15070-407946	BIRD TIF Management 4th Qtr FY2016
04/11/2016	793067	Bobcat Of Big Sky, Inc.	\$ 1,280.00	2110-31320-405333	rental of mini x
04/11/2016	793067	Bobcat Of Big Sky, Inc.	\$ 502.00	5120-85000-402320	NONSTOCKING ITEMS-P.U.D.
04/11/2016	793067	Bobcat Of Big Sky, Inc.	\$ 1,511.96	5120-85000-402390	NONSTOCKING ITEMS-P.U.D.
04/11/2016	793067	Bobcat Of Big Sky, Inc.	\$ 164.37	5120-85000-402320	NONSTOCKING ITEMS-P.U.D.
04/11/2016	793068	Boomers Garage N Shop Supplies	\$ 2,786.60	2110-31320-402420	36" yellow squeeze poles and bases for ped/bike
04/11/2016	793070	Brannan Construction Company	\$ 328,638.56	4050-71250-409687	RW 10L/28R Storm Drain Tunnel Boring Project -
04/11/2016	793070	Brannan Construction Company	\$ 36,515.39	4050-71250-409689	RW 10L/28R Storm Drain Tunnel Boring Project - Local
04/11/2016	793070	Brannan Construction Company	\$ 59,179.79	4050-00000-201100	AIP50 Tunnel Boring Retainage Release
04/11/2016	793072	Bridgestone/Firestone Inc	\$ 2,267.81	5710-71440-402390	AUTO &TRUCK MAINT.ITEMS
04/11/2016	793072	Bridgestone/Firestone Inc	\$ 2,234.03	5710-71440-402390	AUTO &TRUCK MAINT.ITEMS
04/11/2016	793074	Business Tax Section	\$ 3,319.58	4050-71250-409687	RW 10L/28R Storm Drain Tunnel Boring Project -
04/11/2016	793074	Business Tax Section	\$ 368.84	4050-71250-409689	RW 10L/28R Storm Drain Tunnel Boring Project - Local
04/11/2016	793074	Business Tax Section	\$ 295.85	5050-75150-403671	Water Repair List 05.01.15
04/11/2016	793074	Business Tax Section	\$ 83.75	6300-17530-407310	Inv. 18321 1%
04/11/2016	793074	Business Tax Section	\$ 597.78	4050-00000-201100	Retainage Release. AIP50 Tunnel Boring
04/11/2016	793077	Carquest Auto Parts	\$ 96.34	5410-31220-402320	1910-366861
04/11/2016	793077	Carquest Auto Parts	\$ 22.04	5410-31220-402320	1910-366978
04/11/2016	793077	Carquest Auto Parts	\$ 39.40	5410-31220-402320	1910-365808
04/11/2016	793077	Carquest Auto Parts	\$ 6.00	6010-15530-402650	1910-366151
04/11/2016	793077	Carquest Auto Parts	\$ 80.60	5410-31220-402320	1910-366362
04/11/2016	793077	Carquest Auto Parts	\$ 161.20	5410-31230-402320	1910-366362
04/11/2016	793077	Carquest Auto Parts	\$ 8.44	5020-74000-402320	NONSTOCKING ITEMS-P.U.D.
04/11/2016	793077	Carquest Auto Parts	\$ 47.88	5020-74000-402310	NONSTOCKING ITEMS-P.U.D.
04/11/2016	793077	Carquest Auto Parts	\$ 199.90	5020-00000-141000	WATER PARTS AND SUPPLIES PO NUM 300169
04/11/2016	793077	Carquest Auto Parts	\$ 113.22	5020-74000-402320	NONSTOCKING ITEMS-P.U.D.
04/11/2016	793077	Carquest Auto Parts	\$ 29.49	5020-74000-402450	gasket remover aircraft remover ,brakleen cleaner
04/11/2016	793077	Carquest Auto Parts	\$ 38.00	6010-00000-141000	1910-365826 PO NUM 299559
04/11/2016	793077	Carquest Auto Parts	\$ (4.75)	6010-00000-141000	1910-365860 PO NUM 299559
04/11/2016	793077	Carquest Auto Parts	\$ 2.75	6010-00000-141000	1910-366030 PO NUM 299559

Check Date	Check	Name	Amount	Account	Item Desc
04/11/2016	793077	Carquest Auto Parts	\$ 7.70	6010-00000-141000	1910-366031 PO NUM 299559
04/11/2016	793077	Carquest Auto Parts	\$ 299.97	6010-00000-141000	1910-366033 PO NUM 299559
04/11/2016	793077	Carquest Auto Parts	\$ 24.56	6010-00000-141000	1910-366095 PO NUM 299559
04/11/2016	793077	Carquest Auto Parts	\$ 10.66	6010-00000-141000	1910-366151 PO NUM 299559
04/11/2016	793077	Carquest Auto Parts	\$ 78.84	6010-00000-141000	1910-366226 PO NUM 299559
04/11/2016	793077	Carquest Auto Parts	\$ 123.84	6010-00000-141000	1910-366783 PO NUM 299559
04/11/2016	793077	Carquest Auto Parts	\$ 23.52	6010-00000-141000	1910-364897 PO NUM 299559
04/11/2016	793077	Carquest Auto Parts	\$ 10.35	6010-00000-141000	1910-365028 PO NUM 299559
04/11/2016	793077	Carquest Auto Parts	\$ 153.60	1500-21120-402320	1910-364657
04/11/2016	793077	Carquest Auto Parts	\$ 12.03	2090-44520-402320	1910-364840
04/11/2016	793077	Carquest Auto Parts	\$ 19.37	5410-31220-402320	1910-365236
04/11/2016	793077	Carquest Auto Parts	\$ 13.98	5120-84000-402450	ag v belt
04/11/2016	793077	Carquest Auto Parts	\$ 684.16	5020-74000-402290	4 COMMERCIAL BATTERIES
04/11/2016	793077	Carquest Auto Parts	\$ 47.56	5120-85000-402410	tractor lamp
04/11/2016	793077	Carquest Auto Parts	\$ 598.65	5020-00000-141000	WATER PARTS AND SUPPLIES PO NUM 300052
04/11/2016	793077	Carquest Auto Parts	\$ 101.83	5020-75000-402320	NONSTOCKING ITEMS-P.U.D.
04/11/2016	793077	Carquest Auto Parts	\$ 12.82	6010-00000-141000	1910-365442 PO NUM 299559
04/11/2016	793077	Carquest Auto Parts	\$ 31.65	6010-00000-141000	1910-365479 PO NUM 299559
04/11/2016	793077	Carquest Auto Parts	\$ 5.26	6010-00000-141000	1910-365505 PO NUM 299559
04/11/2016	793077	Carquest Auto Parts	\$ 7.12	5020-75000-402320	NONSTOCKING ITEMS-P.U.D.
04/11/2016	793077	Carquest Auto Parts	\$ 186.99	5020-74000-402320	NONSTOCKING ITEMS-P.U.D.
04/11/2016	793077	Carquest Auto Parts	\$ 10.76	5020-74000-402320	spark plug
04/11/2016	793077	Carquest Auto Parts	\$ 11.15	5020-74000-402320	NONSTOCKING ITEMS-P.U.D.
04/11/2016	793077	Carquest Auto Parts	\$ 143.28	5020-00000-141000	WATER PARTS AND SUPPLIES PO NUM 300103
04/11/2016	793077	Carquest Auto Parts	\$ 66.18	5020-74000-402450	spark plugs for lawn equipment
04/11/2016	793077	Carquest Auto Parts	\$ 29.43	5120-84000-402450	Loctite Sleeve
04/11/2016	793077	Carquest Auto Parts	\$ 23.68	5020-74000-402450	air filter
04/11/2016	793077	Carquest Auto Parts	\$ 18.33	6010-15530-402650	1910-365362
04/11/2016	793077	Carquest Auto Parts	\$ 61.58	5410-31220-402320	1910-365479
04/11/2016	793077	Carquest Auto Parts	\$ 8.27	6010-15530-402650	1910-365528
04/11/2016	793077	Carquest Auto Parts	\$ 80.60	5410-31220-402320	1910-365549
04/11/2016	793077	Carquest Auto Parts	\$ 129.59	5020-74000-402320	1910-365670
04/11/2016	793077	Carquest Auto Parts	\$ 8.45	5120-85000-402320	NONSTOCKING ITEMS-P.U.D.
04/11/2016	793085	Cummins Rocky Mountain LLC	\$ 732.61	5410-31220-402320	004-22194
04/11/2016	793085	Cummins Rocky Mountain LLC	\$ (50.00)	5410-31220-402320	004-22204
04/11/2016	793085	Cummins Rocky Mountain LLC	\$ 18.42	5410-31220-402320	004-22207
04/11/2016	793085	Cummins Rocky Mountain LLC	\$ 784.63	2110-31320-402320	004-22302
04/11/2016	793085	Cummins Rocky Mountain LLC	\$ 28.48	2110-31320-402320	004-22332
04/11/2016	793085	Cummins Rocky Mountain LLC	\$ (125.00)	2110-31320-402320	004-22333
04/11/2016	793085	Cummins Rocky Mountain LLC	\$ 3,926.34	5710-71440-403690	AUTO &TRUCK MAINT.ITEMS

Check Date	Check	Name	Amount	Account	Item Desc
04/11/2016	793085	Cummins Rocky Mountain LLC	\$ 300.64	5710-71440-402320	AUTO &TRUCK MAINT.ITEMS
04/11/2016	793085	Cummins Rocky Mountain LLC	\$ (300.64)	5710-71440-402320	AUTO &TRUCK MAINT.ITEMS
04/11/2016	793086	Curb Box Specialists Inc.	\$ 29,289.15	5050-75150-403671	Water Repair List 05.01.15
04/11/2016	793087	Dale & Jax Door & Glass Inc	\$ 8,291.25	6300-17530-407310	Inv. #18321 Window replacement at the Library. #2016-
04/11/2016	793093	Ditch Witch Northwest	\$ 29,346.18	5130-85910-409420	Burst Head assembly 8" IPS Solid Tool Assembly 7" Air Reverse Bursting Hose Lay flat Hose Mole Supply
04/11/2016	793093	Ditch Witch Northwest	\$ (7,000.00)	5130-85910-409420	Trade in of 8" hammer tool and 10" & 12" expanders
04/11/2016	793121	Graphic Imprints Inc.	\$ 4,289.52	0100-51250-402250	City league jackets.
04/11/2016	793123	Guardian Security Inc	\$ 8,999.91	2600-55120-403574	Invoice 35
04/11/2016	793128	HDR, Inc.	\$ 416,233.65	5130-84910-409390	WO 14-11 WWTP Nutrient Upgrade Expansion &
04/11/2016	793133	ICL Performance Products Lp	\$ 4,092.00	1500-22310-402690	10000278: WD881, PHOS-CHEK CLASS 'A' FIRE
04/11/2016	793135	InfoSend Inc	\$ 8,293.52	5020-73110-403110	billing
04/11/2016	793135	InfoSend Inc	\$ 2,071.42	5020-73110-403111	billing
04/11/2016	793135	InfoSend Inc	\$ 5,529.01	5120-83110-403110	billing
04/11/2016	793135	InfoSend Inc	\$ 1,380.94	5120-83110-403111	billing
04/11/2016	793143	Knife River (JTL Group Inc.)	\$ 262.52	2110-31320-404520	3/8" chips
04/11/2016	793143	Knife River (JTL Group Inc.)	\$ 63.56	2110-31320-404520	3/4" bedding rock
04/11/2016	793143	Knife River (JTL Group Inc.)	\$ 855.22	2110-31320-404710	asphalt
04/11/2016	793143	Knife River (JTL Group Inc.)	\$ 2,745.02	2110-31320-404520	1 1/2" crushed base
04/11/2016	793143	Knife River (JTL Group Inc.)	\$ 183.44	2110-31320-404520	1 1/2" crushed base
04/11/2016	793143	Knife River (JTL Group Inc.)	\$ 93.82	2110-31320-404520	3/8" naturals screened
04/11/2016	793143	Knife River (JTL Group Inc.)	\$ 925.01	2110-31320-404520	3/8" chips
04/11/2016	793143	Knife River (JTL Group Inc.)	\$ 499.06	2110-31320-404520	1 1/2" crushed base
04/11/2016	793143	Knife River (JTL Group Inc.)	\$ 30.00	2110-31320-404520	3/4" crushed base
04/11/2016	793143	Knife River (JTL Group Inc.)	\$ 74.84	2110-31320-404520	3/4" crushed base
04/11/2016	793143	Knife River (JTL Group Inc.)	\$ 160.18	2110-31320-404520	1 1/2" crushed base
04/11/2016	793143	Knife River (JTL Group Inc.)	\$ 457.24	2110-31320-404520	1 1/2" crushed base
04/11/2016	793143	Knife River (JTL Group Inc.)	\$ 430.75	2110-31320-404520	1 1/2" crushed base
04/11/2016	793143	Knife River (JTL Group Inc.)	\$ 1,553.05	2110-31320-404520	1 1/2" crushed base
04/11/2016	793143	Knife River (JTL Group Inc.)	\$ 1,348.71	2110-31320-404710	asphalt
04/11/2016	793143	Knife River (JTL Group Inc.)	\$ 1,303.41	2110-31320-404520	3/8" chips
04/11/2016	793143	Knife River (JTL Group Inc.)	\$ 662.36	2110-31320-404520	1 1/2" crushed base
04/11/2016	793143	Knife River (JTL Group Inc.)	\$ 54.15	2110-31320-404520	1 1/2" crushed base
04/11/2016	793143	Knife River (JTL Group Inc.)	\$ 138.79	2110-31320-404520	3/8" chips
04/11/2016	793143	Knife River (JTL Group Inc.)	\$ 234.79	2110-31320-404520	1 1/2" crushed base and 3/8" chips
04/11/2016	793143	Knife River (JTL Group Inc.)	\$ 63.66	2110-31320-404520	1 1/2" crushed base
04/11/2016	793143	Knife River (JTL Group Inc.)	\$ 400.00	2110-31320-402380	concrete on ryan ave
04/11/2016	793145	L N Curtis & Sons	\$ 1,900.00	1500-22230-402925	BH20B PPV 24" FAN, DUAL POWERED, BATTERY
04/11/2016	793145	L N Curtis & Sons	\$ 1,400.00	1500-22310-402925	BH20B PPV 24" FAN, DUAL POWERED, BATTERY
04/11/2016	793146	L P Anderson Tire Co. Inc.	\$ 1,226.30	5020-73120-402390	NONSTOCKING ITEMS-P.U.D.

Check Date	Check	Name	Amount	Account	Item Desc
04/11/2016	793146	L P Anderson Tire Co. Inc.	\$ 602.00	5020-74000-402390	NONSTOCKING ITEMS-P.U.D.
04/11/2016	793146	L P Anderson Tire Co. Inc.	\$ 1,288.00	5020-75000-402390	NONSTOCKING ITEMS-P.U.D.
04/11/2016	793146	L P Anderson Tire Co. Inc.	\$ 62.00	5120-84000-402390	NONSTOCKING ITEMS-P.U.D.
04/11/2016	793146	L P Anderson Tire Co. Inc.	\$ 2,501.20	5120-85000-402390	NONSTOCKING ITEMS-P.U.D.
04/11/2016	793147	Labor Ready Northwest, Inc.	\$ 1,875.43	5410-31230-403581	Paper Pickers for the Landfill
04/11/2016	793147	Labor Ready Northwest, Inc.	\$ 2,825.76	5410-31230-403581	Paper Pickers for the Landfill
04/11/2016	793152	Local 521	\$ 4,875.00	1500-22240-402260	CLOTHING ALLOWANCE: NEW HIRES
04/11/2016	793162	Montana Department Of Environmental	\$ 31,070.30	5410-31230-407635	Quarterly Landfill license payment
04/11/2016	793163	Montana Municipal Interlocal Authority	\$ 406,081.44	9000-00000-209941	Workers' Compensation January 1, 2016 through March
04/11/2016	793168	Morrison Maierle Inc	\$ 8,590.32	4050-71250-409687	AIP-50 Extend East Taxi Lane 400' - Design - Federal
04/11/2016	793168	Morrison Maierle Inc	\$ 954.48	4050-71250-409689	AIP-50 Extend East Taxi Lane 400' - Design - Local
04/11/2016	793168	Morrison Maierle Inc	\$ 10,813.01	4050-71250-409687	48" Micro Tunnel Under RW 10L/28R CA - Federal
04/11/2016	793168	Morrison Maierle Inc	\$ 1,201.44	4050-71250-409689	48" Micro Tunnel Under RW 10L/28R CA - Local Share
04/11/2016	793168	Morrison Maierle Inc	\$ 26,960.11	5130-85910-409340	WO1601 2016 Water/Sewer Replc; Sch 2 Sanitary
04/11/2016	793168	Morrison Maierle Inc	\$ 59,867.77	4050-71250-409687	AIP-50 Pond D Storm Water System - Design - Federal
04/11/2016	793168	Morrison Maierle Inc	\$ 6,651.98	4050-71250-409689	AIP-50 Pond D Storm Water System - Design - Local
04/11/2016	793174	National Research Center	\$ 3,727.00	0100-14110-403587	Citizens Survey
04/11/2016	793178	NorMont Equipment Company	\$ 2,300.00	2110-31320-402320	brooms for sweepers
04/11/2016	793178	NorMont Equipment Company	\$ 559.00	2110-31320-402420	sign stiffeners
04/11/2016	793178	NorMont Equipment Company	\$ 532.44	2110-31320-402410	shovels/lutes
04/11/2016	793179	NorthWestern Energy	\$ 14.41	1500-22210-403410	0712532-1
04/11/2016	793179	NorthWestern Energy	\$ 8.03	0100-51410-403410	0855404-0
04/11/2016	793179	NorthWestern Energy	\$ 18.02	1500-22210-403410	0978917-3
04/11/2016	793179	NorthWestern Energy	\$ 50.51	0100-51260-403410	1045820-6
04/11/2016	793179	NorthWestern Energy	\$ 13.69	0100-51120-403410	1160807-2
04/11/2016	793179	NorthWestern Energy	\$ 1,472.32	0100-51120-403410	1183483-5
04/11/2016	793179	NorthWestern Energy	\$ 7.55	0100-51120-403410	1242222-6
04/11/2016	793179	NorthWestern Energy	\$ 8.00	0100-51120-403410	1346673-5
04/11/2016	793179	NorthWestern Energy	\$ 8.62	0100-51120-403410	1514388-6
04/11/2016	793179	NorthWestern Energy	\$ 7.55	8720-51980-403410	1588262-4
04/11/2016	793179	NorthWestern Energy	\$ 7.67	0100-51120-403410	1867265-9
04/11/2016	793179	NorthWestern Energy	\$ 20.06	0100-51120-403410	1941243-6
04/11/2016	793179	NorthWestern Energy	\$ 7.55	0100-51120-403410	3178260-0
04/11/2016	793179	NorthWestern Energy	\$ 147.54	0100-51260-403410	0720841-6
04/11/2016	793179	NorthWestern Energy	\$ 7.67	0100-51120-403410	0722253-2
04/11/2016	793179	NorthWestern Energy	\$ 217.47	0100-51120-403410	0722256-5
04/11/2016	793179	NorthWestern Energy	\$ 9.77	0100-51120-403410	0722258-1
04/11/2016	793179	NorthWestern Energy	\$ 16.43	0100-51120-403410	0722259-9
04/11/2016	793179	NorthWestern Energy	\$ 9.59	0100-51120-403410	0722272-2
04/11/2016	793179	NorthWestern Energy	\$ 6.39	8720-51980-403410	0722272-2

Check Date	Check	Name	Amount	Account	Item Desc
04/11/2016	793179	NorthWestern Energy	\$ 99.06	0100-51120-403410	0722273-0
04/11/2016	793179	NorthWestern Energy	\$ 13.21	0100-51120-403410	0722274-8
04/11/2016	793179	NorthWestern Energy	\$ 109.05	0100-51120-403410	0722275-5
04/11/2016	793179	NorthWestern Energy	\$ 38.86	0100-51120-403410	0722277-1
04/11/2016	793179	NorthWestern Energy	\$ 31.87	0100-51120-403410	0722278-9
04/11/2016	793179	NorthWestern Energy	\$ 16.69	0100-51120-403410	0722279-7
04/11/2016	793179	NorthWestern Energy	\$ 7.67	0100-51120-403410	0722280-5
04/11/2016	793179	NorthWestern Energy	\$ 7.67	0100-51120-403410	0722281-3
04/11/2016	793179	NorthWestern Energy	\$ 7.67	0100-51120-403410	0722283-9
04/11/2016	793179	NorthWestern Energy	\$ 7.67	0100-51120-403410	0722284-7
04/11/2016	793179	NorthWestern Energy	\$ 16.69	0100-51120-403410	0722808-3
04/11/2016	793179	NorthWestern Energy	\$ 9.96	0100-51120-403410	0722852-1
04/11/2016	793179	NorthWestern Energy	\$ 9.77	0100-51120-403410	0722862-0
04/11/2016	793179	NorthWestern Energy	\$ 53.87	0100-51120-403410	0722901-6
04/11/2016	793179	NorthWestern Energy	\$ 9.47	0100-51120-403410	0722976-8
04/11/2016	793179	NorthWestern Energy	\$ 130.99	0100-51120-403410	0722995-8
04/11/2016	793179	NorthWestern Energy	\$ 81.96	0100-51120-403410	0723005-5
04/11/2016	793179	NorthWestern Energy	\$ 7.67	0100-51120-403410	0723025-3
04/11/2016	793179	NorthWestern Energy	\$ 7.55	0100-51120-403410	0723046-9
04/11/2016	793179	NorthWestern Energy	\$ 7.55	0100-51120-403410	0723049-3
04/11/2016	793179	NorthWestern Energy	\$ 12.36	0100-51120-403410	0723053-5
04/11/2016	793179	NorthWestern Energy	\$ 19.32	0100-51120-403410	0723064-2
04/11/2016	793179	NorthWestern Energy	\$ 19.32	0100-51120-403410	0723065-9
04/11/2016	793179	NorthWestern Energy	\$ 7.67	8720-51980-403410	0723384-4
04/11/2016	793179	NorthWestern Energy	\$ 9.39	8720-51980-403410	0723385-1
04/11/2016	793179	NorthWestern Energy	\$ 9.39	8720-51980-403410	0723386-9
04/11/2016	793179	NorthWestern Energy	\$ 9.39	8720-51980-403410	0723387-7
04/11/2016	793179	NorthWestern Energy	\$ 9.39	8720-51980-403410	0723388-5
04/11/2016	793179	NorthWestern Energy	\$ 5.25	0100-51120-403410	0723391-9
04/11/2016	793179	NorthWestern Energy	\$ 3.50	8720-51980-403410	0723391-9
04/11/2016	793179	NorthWestern Energy	\$ 9.39	8720-51980-403410	0723392-7
04/11/2016	793179	NorthWestern Energy	\$ 8.40	8720-51980-403410	0723393-5
04/11/2016	793179	NorthWestern Energy	\$ 7.67	8720-51980-403410	0723394-3
04/11/2016	793179	NorthWestern Energy	\$ 7.67	8720-51980-403410	0723395-0
04/11/2016	793179	NorthWestern Energy	\$ 7.67	8720-51980-403410	0723396-8
04/11/2016	793179	NorthWestern Energy	\$ 7.67	8720-51980-403410	0723397-6
04/11/2016	793179	NorthWestern Energy	\$ 7.67	8720-51980-403410	0723398-4
04/11/2016	793179	NorthWestern Energy	\$ 7.67	8720-51980-403410	0723835-5
04/11/2016	793179	NorthWestern Energy	\$ 9.77	8720-51980-403410	0723836-3
04/11/2016	793179	NorthWestern Energy	\$ 7.55	8720-51980-403410	0723840-5

Check Date	Check	Name	Amount	Account	Item Desc
04/11/2016	793179	NorthWestern Energy	\$ 14.30	8720-51980-403410	0723879-3
04/11/2016	793179	NorthWestern Energy	\$ 8.03	8720-51980-403410	0723883-5
04/11/2016	793179	NorthWestern Energy	\$ 112.48	0100-51120-403410	0723884-3
04/11/2016	793179	NorthWestern Energy	\$ 8.28	8720-51980-403410	0723885-0
04/11/2016	793179	NorthWestern Energy	\$ 19.32	0100-51120-403410	0723887-6
04/11/2016	793179	NorthWestern Energy	\$ 1.81	0100-51120-403410	0793134-8
04/11/2016	793179	NorthWestern Energy	\$ 0.78	8720-51980-403410	0971824-8
04/11/2016	793179	NorthWestern Energy	\$ 7.55	0100-51290-403410	0999807-1
04/11/2016	793179	NorthWestern Energy	\$ 42.16	0100-51120-403410	1141284-8
04/11/2016	793179	NorthWestern Energy	\$ 7.55	0100-51120-403410	1156527-2
04/11/2016	793179	NorthWestern Energy	\$ 0.66	8720-51980-403410	1312707-1
04/11/2016	793179	NorthWestern Energy	\$ 1.42	0100-51120-403410	1409394-2
04/11/2016	793179	NorthWestern Energy	\$ 8.28	8720-51980-403410	1564209-3
04/11/2016	793179	NorthWestern Energy	\$ 0.88	0100-51120-403410	1692666-9
04/11/2016	793179	NorthWestern Energy	\$ 12.12	5120-85000-403410	1704025-4
04/11/2016	793179	NorthWestern Energy	\$ 29.81	5120-85000-403410	1704030-4
04/11/2016	793179	NorthWestern Energy	\$ 12.96	2110-31320-403410	1738989-1
04/11/2016	793179	NorthWestern Energy	\$ 8.87	0100-51120-403410	1902257-3
04/11/2016	793179	NorthWestern Energy	\$ 1.10	8720-51980-403410	2041362-1
04/11/2016	793179	NorthWestern Energy	\$ 8.51	2110-31320-403410	2047007-6
04/11/2016	793179	NorthWestern Energy	\$ 8.87	2110-31320-403410	2047010-0
04/11/2016	793179	NorthWestern Energy	\$ 8.62	2110-31320-403410	2047013-4
04/11/2016	793179	NorthWestern Energy	\$ 8.75	2110-31320-403410	2047017-5
04/11/2016	793179	NorthWestern Energy	\$ 8.75	2110-31320-403410	2047018-3
04/11/2016	793179	NorthWestern Energy	\$ 8.51	2110-31320-403410	2047019-1
04/11/2016	793179	NorthWestern Energy	\$ -	0100-51120-403410	0723039-4
04/11/2016	793179	NorthWestern Energy	\$ 275.18	5020-74000-403410	805 Constitution Ave
04/11/2016	793179	NorthWestern Energy	\$ 1,939.22	5020-74000-403410	1699 high sierra blvd
04/11/2016	793179	NorthWestern Energy	\$ 11.11	5020-74000-403410	0722249-0
04/11/2016	793179	NorthWestern Energy	\$ 2,526.76	5020-74000-403410	0722270-6
04/11/2016	793179	NorthWestern Energy	\$ 66.38	5120-85000-403410	0723383-6
04/11/2016	793179	NorthWestern Energy	\$ 403.04	5120-85000-403410	0723878-5
04/11/2016	793179	NorthWestern Energy	\$ 164.45	6070-22350-403410	1006915-1
04/11/2016	793179	NorthWestern Energy	\$ 7.55	0100-51120-403410	1230066-1
04/11/2016	793179	NorthWestern Energy	\$ 18.50	8720-51980-403410	1513800-1
04/11/2016	793179	NorthWestern Energy	\$ 28.61	8720-51980-403410	1513802-7
04/11/2016	793179	NorthWestern Energy	\$ 15.87	8720-51980-403410	1513804-3
04/11/2016	793179	NorthWestern Energy	\$ 8.62	2110-31320-403410	2047000-1
04/11/2016	793179	NorthWestern Energy	\$ 8.87	2110-31320-403410	2047011-8
04/11/2016	793179	NorthWestern Energy	\$ 25,138.40	5610-71120-403410	0100482-9. Main Vault. March 2016

Check Date	Check	Name	Amount	Account	Item Desc
04/11/2016	793179	NorthWestern Energy	\$ 111.68	5610-71130-403410	0712533-9. Airport Entrance. March 2016
04/11/2016	793179	NorthWestern Energy	\$ 237.72	5610-71130-403410	0712535-4. Employee Parking. March 2016
04/11/2016	793179	NorthWestern Energy	\$ 23.79	5610-71130-403410	0712791-3. Gate 16. March 2016
04/11/2016	793179	NorthWestern Energy	\$ 26.22	5610-71130-403410	0712795-4. Gate 17. March 2016
04/11/2016	793179	NorthWestern Energy	\$ 17.53	5610-71130-403410	0712797-0. Gate 9. March 2016
04/11/2016	793179	NorthWestern Energy	\$ 20.31	5610-71130-403410	0720296-3. Gate 29. March 2016
04/11/2016	793179	NorthWestern Energy	\$ 26.65	5610-71130-403410	2114868-9. Runway Weather System. March 2016
04/11/2016	793179	NorthWestern Energy	\$ 18.50	5610-71170-403410	0712805-1. IP-10. March 2016
04/11/2016	793179	NorthWestern Energy	\$ 14.89	5610-71130-403410	0712813-5. Burn Pit. March 2016
04/11/2016	793179	NorthWestern Energy	\$ 2,386.25	5610-71130-403410	0719543-1. Parking Lot Light. March 2016
04/11/2016	793179	NorthWestern Energy	\$ 21.99	5610-71130-403410	0719759-3. Gate 12. March 2016
04/11/2016	793179	NorthWestern Energy	\$ 21.50	5610-71130-403410	0719760-1. Gate 14. March 2016
04/11/2016	793179	NorthWestern Energy	\$ 14.53	5610-71130-403410	0719761-9. Gate 15. March 2016
04/11/2016	793179	NorthWestern Energy	\$ 7.55	5610-71130-403410	0719762-7. Gate 13. March 2016
04/11/2016	793186	Public Works-Administration	\$ 10,071.00	5050-75150-403671	PWU March 2016 Engineering Permits - WSRP
04/11/2016	793186	Public Works-Administration	\$ 1,110.00	5020-75000-403680	PWU March 2016 Engineering Permits - Watermain
04/11/2016	793192	River Ridge Landscape Co	\$ 720.00	2600-55120-402925	prune shrubs
04/11/2016	793192	River Ridge Landscape Co	\$ 3,200.00	2600-55120-402925	prune shrubs
04/11/2016	793195	Saint Vincent Occupational Health	\$ 377.75	1500-22290-403510	NEWMAN, LEVI: ANNUAL FIRE PHYSICAL 3/11/2016
04/11/2016	793195	Saint Vincent Occupational Health	\$ 789.59	1500-22240-403510	48133: CLARK, KYLE PRE-EMPLOYMENT FIRE
04/11/2016	793195	Saint Vincent Occupational Health	\$ 764.59	1500-22240-403510	48133: HELLAND, CHRISTIAN PRE-EMPLOYMENT
04/11/2016	793195	Saint Vincent Occupational Health	\$ 789.59	1500-22240-403510	48133: JOHNSON, LORI PRE-EMPLOYMENT FIRE
04/11/2016	793195	Saint Vincent Occupational Health	\$ 789.59	1500-22240-403510	48133: LANDON, CHAD PRE-EMPLOYMENT FIRE
04/11/2016	793195	Saint Vincent Occupational Health	\$ 3,060.00	0100-17500-403572	Drug Testing/On-site Nursing/DOT Physicals/Rabies
04/11/2016	793195	Saint Vincent Occupational Health	\$ 95.00	0100-51120-403510	Drug Testing/On-site Nursing/DOT Physicals/Rabies
04/11/2016	793195	Saint Vincent Occupational Health	\$ 325.00	1500-21710-403510	Drug Testing/On-site Nursing/DOT Physicals/Rabies
04/11/2016	793195	Saint Vincent Occupational Health	\$ 40.00	1500-22250-403510	Drug Testing/On-site Nursing/DOT Physicals/Rabies
04/11/2016	793195	Saint Vincent Occupational Health	\$ 20.00	1500-22290-403510	Drug Testing/On-site Nursing/DOT Physicals/Rabies
04/11/2016	793195	Saint Vincent Occupational Health	\$ 380.00	2110-31320-403510	Drug Testing/On-site Nursing/DOT Physicals/Rabies
04/11/2016	793195	Saint Vincent Occupational Health	\$ 220.00	5020-74000-403510	Drug Testing/On-site Nursing/DOT Physicals/Rabies
04/11/2016	793195	Saint Vincent Occupational Health	\$ 57.00	5020-75000-403510	Drug Testing/On-site Nursing/DOT Physicals/Rabies
04/11/2016	793195	Saint Vincent Occupational Health	\$ 38.00	5120-85000-403510	Drug Testing/On-site Nursing/DOT Physicals/Rabies
04/11/2016	793195	Saint Vincent Occupational Health	\$ 340.00	5410-31230-403510	Drug Testing/On-site Nursing/DOT Physicals/Rabies
04/11/2016	793195	Saint Vincent Occupational Health	\$ 50.00	5610-71120-403510	Drug Testing/On-site Nursing/DOT Physicals/Rabies
04/11/2016	793195	Saint Vincent Occupational Health	\$ 190.00	5610-71150-403510	Drug Testing/On-site Nursing/DOT Physicals/Rabies
04/11/2016	793195	Saint Vincent Occupational Health	\$ 145.00	5710-71420-403510	Drug Testing/On-site Nursing/DOT Physicals/Rabies
04/11/2016	793195	Saint Vincent Occupational Health	\$ 765.00	6270-17520-405160	Drug Testing/On-site Nursing/DOT Physicals/Rabies
04/11/2016	793213	Town & Country Supply Association	\$ 7,208.40	5710-00000-141000	BUS MET PO NUM 300200
04/11/2016	793213	Town & Country Supply Association	\$ 3,064.53	5710-00000-141000	BUS MET PO NUM 300200
04/11/2016	793213	Town & Country Supply Association	\$ 5,081.34	6010-00000-141000	220117 PO NUM 300263

Check Date	Check	Name	Amount	Account	Item Desc
04/11/2016	793213	Town & Country Supply Association	\$ 507.72	1500-22260-402310	219648: FIRE1 - DIESEL DELIVERED 4/1/2016
04/11/2016	793213	Town & Country Supply Association	\$ 253.86	1500-22260-402310	219648: FIRE2 - DIESEL DELIVERED 4/1/2016
04/11/2016	793213	Town & Country Supply Association	\$ 190.40	1500-22260-402310	219648: FIRE3 - DIESEL DELIVERED 4/1/2016
04/11/2016	793213	Town & Country Supply Association	\$ 317.33	1500-22260-402310	219648: FIRE5 - DIESEL DELIVERED 4/1/2016
04/11/2016	793213	Town & Country Supply Association	\$ (0.01)	1500-22260-402310	219648:DECIMAL PT CORRECTION TO INVOICE
04/11/2016	793217	Unemployment Ins Contributions Bureau	\$ 18,347.53	9000-00000-209996	Unemployment Insurance January - March 2016
04/11/2016	793219	Valmont Industries Inc	\$ 2,702.00	2110-00000-141318	STREET LIGHTS PO NUM 299840
04/11/2016	793222	Whelen Engineering Co	\$ 4,676.62	1500-21120-402320	IB8DEDE, Liberty II LED lightbar, WC version, 48"
04/11/2016	793222	Whelen Engineering Co	\$ -	1500-21120-402320	CCSRN36, CenCom Sapphire siren and light controller
04/11/2016	793222	Whelen Engineering Co	\$ 319.20	1500-21120-402320	INV1B, ION V-Series 180 degree LED lighthouse, blue
04/11/2016	793222	Whelen Engineering Co	\$ 319.20	1500-21120-402320	INV1R, ION V-Series 180 degree LED lighthouse, red
04/11/2016	793222	Whelen Engineering Co	\$ 90.00	1500-21120-402320	3SR0CDRR, 3" red nighttime illumination light
04/11/2016	793227	Yellowstone County Finance Dpt	\$ 11,700.00	1500-21110-403590	Jail Boarders for March 2016
04/11/2016	793228	Yellowstone Valley Animal Shelter	\$ 22,855.58	1500-21700-403990	contract 2-22-16\3-21-16

Regular City Council Meeting

Meeting Date: 05/09/2016

TITLE: Payment of Claims April 18, 2016

PRESENTED BY: Patrick M. Weber, Finance Director

Department: City Hall Administration

PROBLEM/ISSUE STATEMENT

Claims in the amount of \$758,885.36 have been audited and are presented for City Council payment approval. A complete listing of the claims dated April 18, 2016, is available in the Finance Department.

ALTERNATIVES ANALYZED

No other alternatives were analyzed.

FINANCIAL IMPACT

Claims have a varying impact on department budgets, but are submitted by the departments and reviewed by Finance staff before being sent to the Council.

RECOMMENDATION

Staff recommends that Council approve the Payment of Claims.

APPROVED BY CITY ADMINISTRATOR

Attachments

councilmemo_4.18.2016

Check						
Date	Check	Name	Amount	Account	Item Desc	
04/18/2016	793242	American Title & Escrow	\$ 110,000.00	7230-65950-405930	DRL for Singh Construction	
04/18/2016	793246	Billings Community Cable	\$ 25,000.00	0100-14110-407266	Quarterly Disbursement January - March 2016	
04/18/2016	793246	Billings Community Cable	\$ 300.00	0100-14110-407265	Work Session Live Broadcasts January - March 2016	
04/18/2016	793247	Billings Gazette	\$ 1,015.00	0100-14110-403310	MARCH PAD	
04/18/2016	793247	Billings Gazette	\$ 1,881.00	0100-14110-403310	8 PG INSERT	
04/18/2016	793247	Billings Gazette	\$ 821.70	0100-14110-403310	8 PAGE INSERT	
04/18/2016	793247	Billings Gazette	\$ 39.00	0100-14110-403310	SEARCH BOOST	
04/18/2016	793247	Billings Gazette	\$ 1,782.00	0100-14110-403310	8PG INSERT	
04/18/2016	793249	Border States Electric	\$ 13,886.80	5120-84300-402360	powerflex,card relay misc	
04/18/2016	793249	Border States Electric	\$ 47.43	2110-31320-402320	910912050	
04/18/2016	793249	Border States Electric	\$ 840.36	5020-00000-141000	ELECTRICAL FOR WTP & WWTP PO NUM 300032	
04/18/2016	793249	Border States Electric	\$ 249.00	5020-00000-141000	WATER PARTS AND SUPPLIES PO NUM 300222	
04/18/2016	793249	Border States Electric	\$ 1,215.44	5020-00000-141000	ELECTRICAL FOR WTP & WWTP PO NUM 300222	
04/18/2016	793264	Crescent Electric Supply	\$ 93.90	2110-00000-141318	STREET LIGHTS PO NUM 300270	
04/18/2016	793264	Crescent Electric Supply	\$ 10.16	2110-00000-141318	STREET LIGHTS PO NUM 300271	
04/18/2016	793264	Crescent Electric Supply	\$ 428.62	2110-00000-141318	STREET LIGHTS PO NUM 300272	
04/18/2016	793264	Crescent Electric Supply	\$ 2,600.00	2110-00000-141318	STREET LIGHTS PO NUM 300273	
04/18/2016	793264	Crescent Electric Supply	\$ 287.50	2110-00000-141318	STREET LIGHTS PO NUM 300274	
04/18/2016	793264	Crescent Electric Supply	\$ 93.90	2110-00000-141318	STREET LIGHTS PO NUM 300275	
04/18/2016	793264	Crescent Electric Supply	\$ 135.43	2110-00000-141318	STREET LIGHTS PO NUM 300276	
04/18/2016	793264	Crescent Electric Supply	\$ 104.82	2110-00000-141318	STREET LIGHTS PO NUM 300277	
04/18/2016	793264	Crescent Electric Supply	\$ 6.29	2110-31320-402430	MISC SERVICES	
04/18/2016	793264	Crescent Electric Supply	\$ 0.53	2110-31320-402360	MISC SERVICES	
04/18/2016	793264	Crescent Electric Supply	\$ 6.50	2110-00000-141318	STREET LIGHTS PO NUM 300308	
04/18/2016	793264	Crescent Electric Supply	\$ 2.24	2110-00000-141318	STREET LIGHTS PO NUM 300309	
04/18/2016	793264	Crescent Electric Supply	\$ 93.90	2110-00000-141318	STREET LIGHTS PO NUM 300310	
04/18/2016	793264	Crescent Electric Supply	\$ 9.51	2110-00000-141318	STREET LIGHTS PO NUM 300311	
04/18/2016	793264	Crescent Electric Supply	\$ 93.90	2110-00000-141318	STREET LIGHTS PO NUM 300313	
04/18/2016	793264	Crescent Electric Supply	\$ 24.59	2110-00000-141318	STREET LIGHTS PO NUM 300314	
04/18/2016	793264	Crescent Electric Supply	\$ 243.62	2110-00000-141318	STREET LIGHTS PO NUM 300315	
04/18/2016	793264	Crescent Electric Supply	\$ 26.94	2110-31320-402360	MISC SERVICES	
04/18/2016	793264	Crescent Electric Supply	\$ 0.55	2110-31320-402360	MISC SERVICES	
04/18/2016	793266	CTA Inc	\$ 66,966.09	4050-71250-409687	AIP-51 Concourse B Remodel - Design Federal Share	
04/18/2016	793266	CTA Inc	\$ 7,440.67	4050-71250-409689	AIP-51 Concourse B Remodel - Design Local Share	
04/18/2016	793267	Cucancic Construction Inc	\$ 7,641.95	0100-16110-409291	City Hall 1st & 2nd Floor Remodel	
04/18/2016	793273	Dell Computer L P	\$ 1,103.51	1500-22210-402925	Dell OptiPlex 3020	
04/18/2016	793273	Dell Computer L P	\$ 1,121.11	1500-22210-402925	Dell OptiPlex 3020 Fire Suppression	
04/18/2016	793273	Dell Computer L P	\$ 1,541.43	1500-22210-402925	(1) Dell Latitude E5450	
04/18/2016	793275	Denny Menholt Frontier Chevrolet	\$ 4,519.43	6300-17530-407310	Public Works Truck #7201 hail storm damage. #2014-215	
04/18/2016	793283	Energy Laboratories Inc	\$ 60.00	5120-84000-403590	wwtp mpdes monitoring	

04/18/2016	793283	Energy Laboratories Inc	\$	3,010.00	5120-84000-403590	WWTP permit pretreatment testing
04/18/2016	793283	Energy Laboratories Inc	\$	25.00	5020-74000-403590	WTP Sdwa monitoring B16040156
04/18/2016	793290	Flathead County Sheriff's Office	\$	2,815.90	2510-21270-403560	Overtime.
04/18/2016	793294	Galles Filter Service	\$	317.58	5410-31230-402320	Filters for Landfill equipment
04/18/2016	793294	Galles Filter Service	\$	111.14	5410-31230-402320	Filters for Landfill Equipment
04/18/2016	793294	Galles Filter Service	\$	192.05	5710-00000-141714	BUS MET PO NUM 299560
04/18/2016	793294	Galles Filter Service	\$	7.60	5710-71470-402320	AUTO &TRUCK MAINT.ITEMS
04/18/2016	793294	Galles Filter Service	\$	34.96	6010-15530-402320	P-58664-01
04/18/2016	793294	Galles Filter Service	\$	31.64	2110-31320-402320	P-58792-01
04/18/2016	793294	Galles Filter Service	\$	8.22	2110-31320-402320	P-58856-01
04/18/2016	793294	Galles Filter Service	\$	5.80	5410-31220-402320	T-58138
04/18/2016	793294	Galles Filter Service	\$	54.00	5410-31220-402320	T-58418
04/18/2016	793294	Galles Filter Service	\$	532.39	5410-31230-402320	Parts for Landfill equipment
04/18/2016	793294	Galles Filter Service	\$	64.13	5020-74000-402320	NONSTOCKING ITEMS-P.U.D.
04/18/2016	793294	Galles Filter Service	\$	267.64	5710-00000-141714	BUS MET PO NUM 299560
04/18/2016	793294	Galles Filter Service	\$	157.84	5710-00000-141714	BUS MET PO NUM 299560
04/18/2016	793294	Galles Filter Service	\$	19.65	5710-71440-402320	AUTO &TRUCK MAINT.ITEMS
04/18/2016	793294	Galles Filter Service	\$	216.51	6010-00000-141000	P-58510-01 PO NUM 299560
04/18/2016	793294	Galles Filter Service	\$	208.07	6010-00000-141000	P-58592-01 PO NUM 299560
04/18/2016	793294	Galles Filter Service	\$	241.48	6010-00000-141000	P-58791-01 PO NUM 299560
04/18/2016	793294	Galles Filter Service	\$	320.82	6010-00000-141000	P-58950-01 PO NUM 299560
04/18/2016	793294	Galles Filter Service	\$	257.05	6010-00000-141000	T-58258 PO NUM 299560
04/18/2016	793294	Galles Filter Service	\$	243.67	5020-00000-141000	WATER PARTS AND SUPPLIES PO NUM 300051
04/18/2016	793294	Galles Filter Service	\$	3,694.66	5020-00000-141000	WASTEWATER PARTS & SUPPLY PO NUM 300051
04/18/2016	793294	Galles Filter Service	\$	136.44	5020-00000-141000	WATER PARTS AND SUPPLIES PO NUM 300166
04/18/2016	793294	Galles Filter Service	\$	9.69	2110-31320-402320	P-58953-01
04/18/2016	793294	Galles Filter Service	\$	77.84	2110-31320-402320	P-59050-01
04/18/2016	793294	Galles Filter Service	\$	23.55	2110-31320-402320	T-58426
04/18/2016	793294	Galles Filter Service	\$	321.57	5410-31230-402320	Filters for Landfill Equipment
04/18/2016	793294	Galles Filter Service	\$	302.79	5410-31230-402320	Filters for Landfill Equipment
04/18/2016	793294	Galles Filter Service	\$	362.62	6010-00000-141000	P-59028-01 PO NUM 299560
04/18/2016	793294	Galles Filter Service	\$	329.75	6010-00000-141000	P-59113-01 PO NUM 299560
04/18/2016	793294	Galles Filter Service	\$	292.10	6010-00000-141000	P-59182-01 PO NUM 299560
04/18/2016	793294	Galles Filter Service	\$	251.12	6010-00000-141000	P-59278-01 PO NUM 299560
04/18/2016	793294	Galles Filter Service	\$	282.69	6010-00000-141000	P-59340-01 PO NUM 299560
04/18/2016	793294	Galles Filter Service	\$	13.37	0100-51120-402320	P-59277-01
04/18/2016	793294	Galles Filter Service	\$	51.98	5410-31220-402320	T-58654
04/18/2016	793298	Graybar Electric Company Inc	\$	3,337.32	5120-84300-402360	Lithonia lighting
04/18/2016	793298	Graybar Electric Company Inc	\$	956.26	5120-85000-402360	starter coil
04/18/2016	793300	Great West Engineering, Inc	\$	6,947.75	5130-85910-409340	WO 16-01 2016 Water/Sewer Replc; Sch 4 South Side Sanitary
04/18/2016	793305	Hardy Construction Co.	\$	26,982.90	5410-00000-201100	WO 15-38 Solid Waste CNG Short-Term Fueling Station
04/18/2016	793307	HDR, Inc.	\$	5,754.93	8450-31860-409310	WO 09-15 Grand Avenue Zimmerman Trail to Shiloh Rd; CO#2

04/18/2016	793307	HDR, Inc.	\$	1,786.78	5410-31220-409250	WO 15-38 Solid Waste CNG Short-Term Fueling Station
04/18/2016	793307	HDR, Inc.	\$	6,019.53	8400-31840-403590	MS4 General Permit
04/18/2016	793309	High Point Networks LLC	\$	3,183.00	6200-19110-405315	(3) R-VS6-OEPL-P-SS-C VMware vSphere 6 3/10/16-3/9/17
04/18/2016	793311	Iaff	\$	4,387.76	9000-00000-209920	Payroll Summary
04/18/2016	793313	Ingram Library Services Inc.	\$	23.66	2600-55190-403333	92427932
04/18/2016	793313	Ingram Library Services Inc.	\$	21.99	2600-55190-403222	92427933
04/18/2016	793313	Ingram Library Services Inc.	\$	30.06	2600-55190-403226	92427933
04/18/2016	793313	Ingram Library Services Inc.	\$	26.14	2600-55190-403226	92427934
04/18/2016	793313	Ingram Library Services Inc.	\$	27.92	2600-55190-403227	92427934
04/18/2016	793313	Ingram Library Services Inc.	\$	8.38	2600-55190-403333	92427934
04/18/2016	793313	Ingram Library Services Inc.	\$	37.44	2600-55190-403227	92427935
04/18/2016	793313	Ingram Library Services Inc.	\$	54.63	2600-55190-403226	92427936
04/18/2016	793313	Ingram Library Services Inc.	\$	4.79	2600-55190-403226	92427937
04/18/2016	793313	Ingram Library Services Inc.	\$	15.92	2600-55190-403226	92427938
04/18/2016	793313	Ingram Library Services Inc.	\$	17.99	2600-55190-403227	92427939
04/18/2016	793313	Ingram Library Services Inc.	\$	221.76	2600-55190-403226	92427940
04/18/2016	793313	Ingram Library Services Inc.	\$	20.04	2600-55190-403333	92427941
04/18/2016	793313	Ingram Library Services Inc.	\$	5.37	2600-55190-403333	92425188
04/18/2016	793313	Ingram Library Services Inc.	\$	52.35	2600-55190-403227	92435189
04/18/2016	793313	Ingram Library Services Inc.	\$	22.00	2600-55190-403222	92435190
04/18/2016	793313	Ingram Library Services Inc.	\$	22.05	2600-55190-403226	92435190
04/18/2016	793313	Ingram Library Services Inc.	\$	23.91	2600-55190-403227	92435190
04/18/2016	793313	Ingram Library Services Inc.	\$	14.38	2600-55190-403333	92435190
04/18/2016	793313	Ingram Library Services Inc.	\$	52.49	2600-55190-403226	92435191
04/18/2016	793313	Ingram Library Services Inc.	\$	169.58	2600-55190-403227	92435191
04/18/2016	793313	Ingram Library Services Inc.	\$	17.20	2600-55190-403255	92435191
04/18/2016	793313	Ingram Library Services Inc.	\$	51.35	2600-55190-403226	92435192
04/18/2016	793313	Ingram Library Services Inc.	\$	373.24	2600-55190-403227	92435192
04/18/2016	793313	Ingram Library Services Inc.	\$	9.57	2600-55190-403241	92512438
04/18/2016	793313	Ingram Library Services Inc.	\$	10.02	2600-55190-403333	92512438
04/18/2016	793313	Ingram Library Services Inc.	\$	47.50	2600-55190-403334	92512438
04/18/2016	793313	Ingram Library Services Inc.	\$	19.25	2600-55190-403222	92512439
04/18/2016	793313	Ingram Library Services Inc.	\$	236.55	2600-55190-403226	92512439
04/18/2016	793313	Ingram Library Services Inc.	\$	31.27	2600-55190-403227	92512439
04/18/2016	793313	Ingram Library Services Inc.	\$	21.99	2600-55190-403222	92512440
04/18/2016	793313	Ingram Library Services Inc.	\$	188.24	2600-55190-403226	92512440
04/18/2016	793313	Ingram Library Services Inc.	\$	15.34	2600-55190-403227	92512440
04/18/2016	793313	Ingram Library Services Inc.	\$	33.53	2600-55190-403226	92512441
04/18/2016	793313	Ingram Library Services Inc.	\$	34.20	2600-55190-403227	92512441
04/18/2016	793313	Ingram Library Services Inc.	\$	14.74	2600-55190-403226	92512442
04/18/2016	793313	Ingram Library Services Inc.	\$	25.51	2600-55190-403226	92512443
04/18/2016	793313	Ingram Library Services Inc.	\$	16.19	2600-55190-403227	92512443

04/18/2016	793313	Ingram Library Services Inc.	\$	16.52	2600-55190-403227	92512444
04/18/2016	793313	Ingram Library Services Inc.	\$	11.79	2600-55190-403226	92512445
04/18/2016	793313	Ingram Library Services Inc.	\$	11.79	2600-55190-403227	92512445
04/18/2016	793313	Ingram Library Services Inc.	\$	10.61	2600-55190-403241	92512445
04/18/2016	793313	Ingram Library Services Inc.	\$	40.09	2600-55190-403227	92512446
04/18/2016	793313	Ingram Library Services Inc.	\$	39.68	2600-55190-403226	92531180
04/18/2016	793313	Ingram Library Services Inc.	\$	21.99	2600-55190-403222	92531181
04/18/2016	793313	Ingram Library Services Inc.	\$	93.74	2600-55190-403226	92531181
04/18/2016	793313	Ingram Library Services Inc.	\$	66.08	2600-55190-403226	92531182
04/18/2016	793313	Ingram Library Services Inc.	\$	38.49	2600-55190-403222	92531183
04/18/2016	793313	Ingram Library Services Inc.	\$	218.10	2600-55190-403226	92531183
04/18/2016	793313	Ingram Library Services Inc.	\$	902.24	2600-55190-403227	92531183
04/18/2016	793313	Ingram Library Services Inc.	\$	237.70	2600-55190-403241	92531183
04/18/2016	793313	Ingram Library Services Inc.	\$	19.25	2600-55190-403242	92531183
04/18/2016	793313	Ingram Library Services Inc.	\$	116.19	2600-55190-403255	92531183
04/18/2016	793313	Ingram Library Services Inc.	\$	790.28	2600-55190-403333	92531183
04/18/2016	793313	Ingram Library Services Inc.	\$	9.59	2600-55190-403226	92531184
04/18/2016	793313	Ingram Library Services Inc.	\$	14.99	2600-55190-403227	92531184
04/18/2016	793313	Ingram Library Services Inc.	\$	34.95	2600-55190-403226	92532073
04/18/2016	793313	Ingram Library Services Inc.	\$	92.33	2600-55190-403227	92532073
04/18/2016	793313	Ingram Library Services Inc.	\$	16.47	2600-55190-403255	92532073
04/18/2016	793313	Ingram Library Services Inc.	\$	14.67	2600-55190-403333	92532073
04/18/2016	793314	Integra Telecom Holding Inc	\$	39.49	5610-71130-403450	Airport 2948370 Airport Alarm
04/18/2016	793314	Integra Telecom Holding Inc	\$	3,990.52	6060-19310-403450	Main Bill New Account # 330046 Old Acct 00001906
04/18/2016	793314	Integra Telecom Holding Inc	\$	230.86	6060-19310-403450	Main Bill T-1 New Account #330047 Old Account 00018768
04/18/2016	793314	Integra Telecom Holding Inc	\$	40.10	1500-21110-403450	CPC line 247-8592 New Account # 330183 Old Account
04/18/2016	793314	Integra Telecom Holding Inc	\$	46.00	0100-51120-403450	Dehler Park line 867-7275
04/18/2016	793314	Integra Telecom Holding Inc	\$	79.95	6200-19110-403452	IT Internet Connection New Account # 330046
04/18/2016	793314	Integra Telecom Holding Inc	\$	40.10	2910-65010-403450	Community Development Services FAX 406-294-7595 New
04/18/2016	793314	Integra Telecom Holding Inc	\$	40.10	2090-44510-403450	Building FAX 406-657-8252 New Account # 330183 Account
04/18/2016	793314	Integra Telecom Holding Inc	\$	40.10	2400-43010-403450	Planning FAX 406-657-8327 New Account # 330183 Account
04/18/2016	793315	Intellisys Inc	\$	1,800.00	5120-84000-403553	2016-16 support contract software
04/18/2016	793315	Intellisys Inc	\$	1,800.00	5020-74000-403553	2016-16 support service renewal contract for software
04/18/2016	793324	Kois Brothers Equipment Co	\$	2,613.68	2110-31320-402320	106264
04/18/2016	793324	Kois Brothers Equipment Co	\$	38.31	2110-31320-402320	106264
04/18/2016	793324	Kois Brothers Equipment Co	\$	2,575.00	2110-31320-402320	MT32685
04/18/2016	793341	Miller Trois LLC	\$	1,837.00	0100-43210-405311	I16-021838
04/18/2016	793341	Miller Trois LLC	\$	6,029.00	2090-44510-405311	I16-021838
04/18/2016	793341	Miller Trois LLC	\$	3,997.00	2400-43010-405311	I16-021838
04/18/2016	793341	Miller Trois LLC	\$	4,734.00	2740-67800-405310	I16-021838
04/18/2016	793345	Montana CSED	\$	4,102.59	9000-00000-209926	Payroll Summary
04/18/2016	793350	Montana Peterbilt LLC	\$	22,007.15	6300-17530-407310	Inv. 260460139 MET Transit Bus #1801 #2015-166

04/18/2016	793351	Montana State Fireman's Assoc	\$	3,520.23	9000-00000-209924	Payroll Summary
04/18/2016	793352	Morrison Maierle Inc	\$	3,507.33	4260-31840-409310	WO 12-31 East End Industrial Storm Drain; Fund trsfr from 8400
04/18/2016	793352	Morrison Maierle Inc	\$	42,720.38	5130-85910-409340	WO1601 2016 Water/Sewer Replc; Sch 2 Sanitary Sewer
04/18/2016	793358	MT DEQ	\$	3,750.00	8400-31840-403590	MTR040001 Outfall Charge
04/18/2016	793358	MT DEQ	\$	562.50	8400-31840-403590	MTG770013 Annual Invoice
04/18/2016	793362	Northwest Pipe Fittings	\$	20,294.40	5020-00000-141000	SYSTEMS PO NUM 300240
04/18/2016	793362	Northwest Pipe Fittings	\$	291.52	5020-00000-141000	WATER PARTS AND SUPPLIES PO NUM 300042
04/18/2016	793362	Northwest Pipe Fittings	\$	198.09	5020-00000-141000	SYSTEMS PO NUM 300042
04/18/2016	793362	Northwest Pipe Fittings	\$	54.00	5020-74000-402450	For Tree farm
04/18/2016	793362	Northwest Pipe Fittings	\$	29.76	5020-74000-402450	ball valve gauge
04/18/2016	793362	Northwest Pipe Fittings	\$	656.00	5020-74000-402450	CLA VALVES
04/18/2016	793362	Northwest Pipe Fittings	\$	45.11	5020-74000-402450	new toilet seat for shop
04/18/2016	793362	Northwest Pipe Fittings	\$	1,938.80	5020-73120-402380	ume for 3" cu ft Hydrant meter
04/18/2016	793362	Northwest Pipe Fittings	\$	29.59	5020-74000-402450	copper refrigeration tubing
04/18/2016	793362	Northwest Pipe Fittings	\$	692.51	2110-31320-402380	storm sewer pipe
04/18/2016	793362	Northwest Pipe Fittings	\$	1,460.31	5020-00000-141000	WATER PARTS AND SUPPLIES PO NUM 300170
04/18/2016	793362	Northwest Pipe Fittings	\$	12,848.00	5020-00000-141000	WATER PARTS AND SUPPLIES PO NUM 300223
04/18/2016	793362	Northwest Pipe Fittings	\$	433.96	5020-00000-141000	WATER PARTS AND SUPPLIES PO NUM 300089
04/18/2016	793362	Northwest Pipe Fittings	\$	16,340.40	5020-00000-141000	WATER PARTS AND SUPPLIES PO NUM 299943
04/18/2016	793362	Northwest Pipe Fittings	\$	19.40	6010-00000-141000	1606208 PO NUM 299566
04/18/2016	793362	Northwest Pipe Fittings	\$	11,900.00	5020-00000-141000	WATER PARTS AND SUPPLIES PO NUM 300102
04/18/2016	793362	Northwest Pipe Fittings	\$	60.44	5020-75000-402410	Rounding tool for copper
04/18/2016	793362	Northwest Pipe Fittings	\$	25.12	5020-00000-141000	WATER PARTS AND SUPPLIES PO NUM 300104
04/18/2016	793362	Northwest Pipe Fittings	\$	7.28	5020-00000-141000	WATER PARTS AND SUPPLIES PO NUM 300149
04/18/2016	793362	Northwest Pipe Fittings	\$	33.80	2110-31320-402380	duck butter lube for ryan storm sewer project
04/18/2016	793362	Northwest Pipe Fittings	\$	26.17	5020-74000-402320	NONSTOCKING ITEMS-P.U.D.
04/18/2016	793362	Northwest Pipe Fittings	\$	197.46	5120-84000-402450	wtr gauge
04/18/2016	793362	Northwest Pipe Fittings	\$	(58.14)	5120-84000-402450	Cr from orginal in 16 019816 strainer
04/18/2016	793364	NorthWestern Energy	\$	97.44	5020-77000-403410	Electricity
04/18/2016	793364	NorthWestern Energy	\$	97.44	5120-87000-403410	Electricity
04/18/2016	793364	NorthWestern Energy	\$	164.13	0100-51410-403410	0712538-8
04/18/2016	793364	NorthWestern Energy	\$	431.94	5710-71430-403410	0719225-5
04/18/2016	793364	NorthWestern Energy	\$	265.16	1500-22210-403410	0720817-6
04/18/2016	793364	NorthWestern Energy	\$	48.47	0100-51120-403410	0813489-2
04/18/2016	793364	NorthWestern Energy	\$	8.39	8720-51980-403410	0881455-0
04/18/2016	793364	NorthWestern Energy	\$	0.45	8720-51980-403410	1045813-1
04/18/2016	793364	NorthWestern Energy	\$	188.77	5020-74000-403410	1142253-2
04/18/2016	793364	NorthWestern Energy	\$	58.33	2090-44510-403963	1569631-3
04/18/2016	793364	NorthWestern Energy	\$	69.87	0100-51120-403410	1849408-8
04/18/2016	793364	NorthWestern Energy	\$	59.99	0100-51120-403410	1904944-4
04/18/2016	793364	NorthWestern Energy	\$	0.98	8720-51980-403410	1948667-9
04/18/2016	793364	NorthWestern Energy	\$	6.20	8720-51980-403410	2055817-7

04/18/2016	793364	NorthWestern Energy	\$	101.72	5120-85000-403410	Ironwood lift station
04/18/2016	793364	NorthWestern Energy	\$	1,158.63	5020-74000-403410	5809 canyonwoods dr
04/18/2016	793370	PoolEquip, LLC	\$	11,990.00	8730-51990-409370	10" Dura Tech PVC T-bar grating, parallel white anchoring
04/18/2016	793372	Premier Vehicle Installation	\$	2,646.32	1500-21120-402320	Invoice 20026 - Patrol Car Parts
04/18/2016	793374	Public Utilities	\$	45.62	4280-65900-409180	Account #236995 4/7/16 - 3921 Chamberlain Dr -
04/18/2016	793374	Public Utilities	\$	5,782.00	5610-71100-403420	136516
04/18/2016	793374	Public Utilities	\$	16.34	8720-51980-403420	148398
04/18/2016	793374	Public Utilities	\$	310.63	6500-15660-403420	158260
04/18/2016	793374	Public Utilities	\$	9.67	5120-85000-403420	180645
04/18/2016	793376	Rimrock Foundation	\$	3,745.95	7380-12640-403590	March IOP
04/18/2016	793376	Rimrock Foundation	\$	2,559.98	7380-12660-403990	March Case Manager
04/18/2016	793376	Rimrock Foundation	\$	3,341.94	2480-12620-403560	March Day Treatment
04/18/2016	793376	Rimrock Foundation	\$	3,030.78	7380-12660-403590	March IOP
04/18/2016	793376	Rimrock Foundation	\$	538.20	7380-12640-403590	March IOP
04/18/2016	793376	Rimrock Foundation	\$	1,167.56	7380-12660-403590	March Coordinator
04/18/2016	793376	Rimrock Foundation	\$	3,483.27	2460-12530-403590	March IOP
04/18/2016	793379	Rocky Mountain Cummins Inc	\$	4,551.98	6300-17530-407310	Repairs to bookmobile #5005. #2016 - 029
04/18/2016	793382	Sam Brown Shield LLC	\$	1,492.50	1500-22290-402640	BILLINGS FIRE: CAPTAIN PASSPORT SHIELDS 6.25" BONRB
04/18/2016	793382	Sam Brown Shield LLC	\$	447.75	1500-22290-402640	BILLINGS FIRE: PROBATIONARY PASSPORT SHIELDS 6.25",
04/18/2016	793382	Sam Brown Shield LLC	\$	1,044.75	1500-22290-402640	BILLINGS FIRE: ENGINEER PASSPORT SHIELDS 6.25",
04/18/2016	793382	Sam Brown Shield LLC	\$	28.80	1500-22210-403110	ESTIMATED SHIPPING
04/18/2016	793382	Sam Brown Shield LLC	\$	82.00	1500-22210-402260	6.25 PASSPORT SHIELD 'DIVISION CHEIF: SAFETY /
04/18/2016	793382	Sam Brown Shield LLC	\$	43.00	1500-22210-402260	6.25" PASSPORT CHIEF 'ASST. CHIEF & AND BATTALION
04/18/2016	793383	Sanderson Stewart	\$	22,814.90	5030-75910-409340	WO 16-07 I-90 Water System Loop
04/18/2016	793383	Sanderson Stewart	\$	13,512.98	2400-43010-407214	West End Multi-Modal Traffic Modeling Project
04/18/2016	793397	Tire-Rama	\$	528.90	5410-31230-402390	Tires for unit #0031 at the Landfill
04/18/2016	793397	Tire-Rama	\$	3,685.50	5410-31230-402390	Tires for Landfill equipment
04/18/2016	793397	Tire-Rama	\$	3,685.50	5410-31230-402390	Tires for Landfill equipment
04/18/2016	793397	Tire-Rama	\$	330.00	5410-31220-402390	Tire repairs for the garbage trucks
04/18/2016	793397	Tire-Rama	\$	4,909.00	5410-31220-402390	Recapped tires for the garbage trucks
04/18/2016	793397	Tire-Rama	\$	420.00	5410-31220-402390	Tire repairs for garbage trucks
04/18/2016	793397	Tire-Rama	\$	40.00	2110-31320-402320	1050265464
04/18/2016	793397	Tire-Rama	\$	80.50	5410-31230-402390	Tire repairs for the landfill equipment
04/18/2016	793397	Tire-Rama	\$	184.00	5410-31220-402390	Tire repairs for the garbage trucks
04/18/2016	793397	Tire-Rama	\$	3,456.50	5410-31220-402390	recapped tires for the garbage trucks
04/18/2016	793397	Tire-Rama	\$	35.00	2110-31320-402320	1030161123
04/18/2016	793397	Tire-Rama	\$	2,188.50	5410-31220-402390	Recapped tires for the garbage trucks
04/18/2016	793397	Tire-Rama	\$	372.50	5410-31220-402390	Tire repairs for the garbage trucks
04/18/2016	793397	Tire-Rama	\$	80.00	5410-31220-402390	Tire repairs for the garbage trucks
04/18/2016	793400	Town & Country Supply Association	\$	10,136.18	5020-00000-141000	WATER PARTS AND SUPPLIES PO NUM 300333
04/18/2016	793400	Town & Country Supply Association	\$	10,600.64	6010-00000-141000	219578 PO NUM 300289
04/18/2016	793407	West Interactive Services Corp, Inc	\$	1,459.52	2250-22320-403450	MARCH 2016: MONTHLY FEE - REVERSE 9-1-1

04/18/2016	793407	West Interactive Services Corp, Inc	\$ 15,000.00	2250-22320-403450	ANNUAL PLAN: APRIL 12, 2016 THRU APRIL 11, 2017.
04/18/2016	793412	Yellowstone County Sheriffs Office	\$ 11,075.00	2500-21360-402120	2015 JAG Grant Expenses.
04/18/2016	793413	Yellowstone Electric Co	\$ 37,157.98	8450-31860-409310	WO 15-12 Gabel Road & 32nd Street W Traffic Signal

Regular City Council Meeting

Meeting Date: 05/09/2016

TITLE: Public Hearing and Resolution for FY16 Budget Amendments

PRESENTED BY: Patrick M. Weber, Finance Director

Department: City Hall Administration

PROBLEM/ISSUE STATEMENT

Montana Code allows local governments to amend their fiscal year budgets by using the same method as used for the original budget adoption: public notice, public hearing and Council adopting a resolution. The following amendments are proposed for the third quarter of FY 2016:

Fund 203 - N 27th Tax Increment District

Because more revenue will be received than predicted, the reimbursements to Stockman Bank and Northern Hotel will also be more than is budgeted. The Downtown Partnership awarded grants for \$179,772. The largest grants went to Martin & Associates LLC, K-B Chemical, BEGE Enterprises and Yellowstone Art Museum. Current revenues will be used for this amendment.

Fund 2010 - East Tax Increment District

Because more revenue will be received than predicted, the reimbursements to First Interstate Bank and Boyer will also be more than is budgeted. BIRD, Inc. also asked Council to approve \$75,878 for Erving Properties, Converse Development, North Park Properties and Eggart Enterprises reimbursements for public improvements. Current revenue will be used for this amendment.

Fund 0100-14110 - General Fund, Non Departmental; 2640 - Community Development
Starting in FY14, rent for Community Development was to be paid by a transfer from the General Fund. The rent for FY14 and FY15 did not get transferred. The transfer for both years will be done in FY16. Reserves will be used for the transfer.

4240 - Rose Park Construction; 8730 - Park District 1

This amendment will allow Parks to start demolition and clean up at Rose Park after the concession stand and pool house was damaged by a fire. The pool house was scheduled to be renovated in FY18, so another project will be moved to FY18 and those funds will pay for the rebuild at Rose Park.

2250 - EOC 911

Purchase of property for the new 911 Center that Council has approved, \$395,000. Demolition of the property is estimated at \$100,000. Design of the new 911 Center building is estimated at \$800,000. Reserves will be used for this amendment.

4980 - Library Construction

Completion of the new Library. Library operating transferred funds to cover the amendment.

1990 - South Tax Increment

The Orchard Lane Reconstruction project will reconstruct Orchard Lane between King Avenue

East and State Avenue. Public Works bid this project in April and the bids came in higher than the budget. The SBURD desired proceeding with the project using Tax Increment Financing (TIF) bond funds to make up the difference. The Orchard Lane project was awarded at the April 25, 2016 Council meeting with the understanding that a budget amendment was forthcoming.

ALTERNATIVES ANALYZED

The Council may: Approve the requested budget amendments; or Not approve the requested budget amendments, which would put the City in violation of Montana law.

FINANCIAL IMPACT

The requested budget amendments will be funded by reserves or current revenue, as described in the budget resolution exhibit and above.

RECOMMENDATION

Staff recommends that the City Council conduct a public hearing and approve the resolution approving and adopting the budget amendments for Fiscal Year 2016.

APPROVED BY CITY ADMINISTRATOR

Attachments

Resolution
Exhibit A

RESOLUTION 16-

A RESOLUTION TO MAKE FISCAL YEAR 2015/2016 ADJUSTMENTS TO APPROPRIATIONS PURSUANT TO M.C.A. 7-6-4006 AS AMENDED, AND PROVIDING TRANSFERS AND REVISIONS WITHIN THE GENERAL CLASS OF SALARIES AND WAGES, MAINTENANCE AND SUPPORT AND CAPITAL OUTLAY.

WHEREAS, M.C.A. 7-6-4006 provides that the City Council, upon proper resolution, adopted by said Council at a regular meeting and entered into its Minutes, may transfer or revise appropriations within the general class of salaries and wages, maintenance and support, and capital outlay, and

WHEREAS, based upon a Budget Review (**FY 2015/2016**), it is necessary to alter and change said appropriations.

NOW, THEREFORE, BE IT RESOLVED BY THE CITY COUNCIL OF THE CITY OF BILLINGS, MONTANA:

That the attached transfers or revisions are hereby adopted.

(SEE EXHIBIT A)

PASSED AND APPROVED by the City Council, this 9th day of May, 2016.

THE CITY OF BILLINGS:

BY: _____
Thomas W. Hanel, MAYOR

ATTEST:

BY: _____
Billie Guenther, CITY CLERK

Regular City Council Meeting

Meeting Date: 05/09/2016

TITLE: Public Hearing and Resolution for Annexation #16-03

PRESENTED BY: Candi Millar, Planning & Community Services Department Director

Department: Planning & Community Services

PROBLEM/ISSUE STATEMENT

Yellowstone Meadows Partners submitted a petition to annex land they own using the provisions of Section 7-2-4600, MCA. The subject property is a portion of an unplatted tract of land at the southwest corner of the intersection of 54th Street West and Trail Creek Drive and totals about 6.4 acres. The property is undeveloped and does not have an address. The owners are requesting annexation in order to begin developing the property in the City for a church meeting house. The property is currently zoned Residential 9600.

The property is located within the five-year annexation area of the City's Limits of Annexation Map and appears to meet some of the City's criteria in its Annexation Policy. The City is able to serve the property and further analysis and discussion is provided in the Consistency with Adopted Plans and Policies section of this memo. The City Council considers this annexation at two separate Council meetings. At the first meeting on April 11, the Council accepted the annexation petition for this property and set a public hearing date for May 9. At this meeting, the Council will conduct the hearing and decide if it will annex the property.

ALTERNATIVES ANALYZED

The City Council may approve or deny a petition submitted by owners of 50% or more of the real property in the area to be annexed (7-2-4601 (3)(b), MCA). The only alternative that is consistent with City Council policy and state law is to conduct a public hearing and review the request before taking action.

FINANCIAL IMPACT

The City is able to provide municipal water and sewer to the subject property via main lines in 54th Street West. Staff is recommending two conditions of approval for this annexation: that a Development Agreement be executed with the City to identify infrastructure improvements and timing of those improvements to serve the property; and/or that a Subdivision Improvement Agreement be signed and recorded between the property owner and the City to identify infrastructure improvements and timing of those improvements to serve the property through a subdivision platting process. Since this property is being developed for use as a church, the City may not realize property tax revenue, but will receive payment for fees and assessments for City services.

BACKGROUND

The subject property totals about 5.6 net acres. It is located at the southwest corner of the intersection of 54th Street West and Trail Creek Drive in West Billings. The property is vacant but the owner has submitted a Special Review application for a church use on the Residential-9600 zoned property. The City Council will review the Special Review for the church use after it acts on the annexation at its meeting on May 9. The property is located within the five year annexation area of the City's Limits of Annexation Map and appears to meet some of the City's criteria in its Annexation Policy. The city limits border the eastern edge of the property.

PROCEDURAL HISTORY

- On March 16, 2016 the annexation petition was submitted to the Planning Division by the owner's agent
- On April 11, the City Council accepted the petition to annex the property and set a public hearing date for May 9
- On May 9, the City Council will conduct the public hearing for the annexation and may take action on the request.
- On May 23, if the resolution to annex is approved by the City Council, a public hearing and first reading of an ordinance to include the property in City Council Ward IV will be conducted.
- On June 13, the City Council will conduct the second and final reading for the ordinance expanding the Ward IV boundary.

STAKEHOLDERS

Annexation by petition does not require notification of adjoining landowners; however, it does require that the City Council conduct a public hearing and post the property with information on the annexation petition and public hearing. Notice of the public hearing was posted on the property on April 22 and published in the Billings Times on April 21. The Planning Division has not received any inquiries about this petition at the time this memo was prepared.

CONSISTENCY WITH ADOPTED POLICIES OR PLANS

Although MCA 7-2-4400-4407 does not require a public services plan, it is the City's custom to have staff prepare a brief analysis of predicted impacts to services and facilities. The proposed annexation complies with the adopted Annexation Policy criteria as follows:

1. The area is located within the Limits of Annexation.
2. The City is able to adequately provide municipal water and sewer services to the property.
3. Any proposed public improvements within the area to be annexed will meet City standards.
4. All property owners within the area to be annexed must sign a Waiver of Right to Protest future Special Improvement Districts. The proposed conditions of annexation in the Resolution that the property owner enter into a Development Agreement or Subdivision Improvement Agreement with the City will ensure that the waiver is signed.
5. If annexed, any proposed land use will comply with the zoning. The property is currently zoned R-9600. The owner is going through a Special Review process for the property to allow a church use in a residential zoning district. The owner has submitted site plans for the church development for the Special Review process that indicates it will comply with zoning and site development regulations as well as any conditions imposed in the Special Review.

Departmental Response: City and County Departments were given the opportunity to comment on this annexation. City departments responded favorably and detailed responses are provided

below. The County Public Works Department responded to verify that the City was annexing all of the Trail Creek Drive right-of-way along the north boundary of the subject property.

City Facilities:

Specific comments from City Departments are provided below:

- **Water:** This property is intended to be served by a water lines currently in 54th Street West. The subject property will be responsible for connecting and extending service lines at the time of development.
- **Sewer:** The property will be served by sewer mains that run in front of the subject property in 54th Street West. The subject property will be responsible for connecting and extending service lines at the time of development.
- **Storm water:** All of the storm water runoff from this property will need to meet the City of Billings requirements for storm water management. Any future development will follow the City of Billings storm water regulations. At the time of preliminary subdivision or development plan submittal, the developer will provide drainage plans and detail the specifics of the sites' storm water system.
- **Transportation:** The subject property may have access via 54th Street West and Trail Creek Drive. The property owner will have to work with City Public Works and Engineering staff to determine approved drive approaches to the property at the time of development or subdivision.
- **Fire Stations:** The subject property is currently served by the Billings Fire Department through the Billings Urban Fire Service Area and the Billings Fire Department will continue to serve the property upon annexation. The Billings Fire Chief stated that as this and other annexations are built out, additional fire department resources will be needed. The nearest fire station is Station #7, located at 1501 54th Street West, about 3/4 of a mile south of the subject property on 54th Street West.
- **Parks:** The subject property is to be developed with a church meeting house and so park land is not likely to be an issue at time of development of this property. However, Cottonwood Park is located less than a 1/4 mile south of the subject property and, when it is developed, will be an amenity users of this property may enjoy.
- **Bicycle and pedestrian facilities:** The property lies within the jurisdiction of the Billings Area Bikeway and Trail Master Plan. The Plan calls for bicycle lanes in the short term along 54th Street West and at the time of road improvements to 54th, the bike lanes could be installed. There is also a plan to construct pedestrian facilities along 54th Street West from Rimrock to Grand Avenue in this area. These improvements are expected to be completed in 2017 and include sidewalks and several pedestrian crossings to help connect the neighborhoods in the area to Cottonwood Park and the new middle school at 56th and Grand.
- **School facilities:** The subject property would be served by Billings School District #2. Billings School District #2 did not respond, but since this property is to be developed for a church use, so there should be no impact to schools in the area.

General City Services: These are the City services that are provided to all residents and businesses in the City, such as police and fire protection, street and storm drain maintenance, and garbage collection and disposal. The service providers that responded did not object to the

annexation of this property, however the Fire Department in its comments above did note its concerns as additional property is annexed into the City.

- Transit: MET transit system operators have no objections to the annexation request. However, there is no bus service in the vicinity of the subject property. MET currently does not provide services west of Shiloh Road, about 1.7 miles east of the subject property.
- Police: The Police Department staff stated that this property is near an existing patrol area and may be served with existing patrol resources.
- Public Utilities: The Public Works-- Distribution and Collection Division had no concerns with the annexation request.
- Public Works -Street and Traffic Division: The Street and Traffic Division stated that it has no concerns with serving the property. However, the road standards that will need to be met for 54th Street West and Trail Creek Drive will be defined in a Development Agreement prior to construction of the church project.
- Public Works-Solid Waste: The Solid Waste Division has no concerns with annexing the property, but pointed out that State Law allows the property owner to choose what garbage hauler may service the property after it is in the City.
- Ambulance Service: The City does not provide ambulance service, however it does dictate the level of service provided by American Medical Response (AMR). By City ordinance, 90% of ambulance calls must be answered within 8 minutes. This property may be within the area of acceptable response time.
- Legal and Finance: General Fund services, such as the Legal and Finance Departments should not be negatively impacted by this annexation, and had no concerns with annexing the property.
- Other Departments: City/County services including Library, Planning, and Environmental Health are only slightly affected by the annexation since they will continue to serve the property whether it is in the City or the County. The Planning Division staff was in support of annexation of the property as it is in the Red Area of Annexation, has access to City services, and has existing City Limits to the north across Rimrock Road, to the east across 54th Street West and to the south along 54th Street West.

Annexation of this property would adhere to the following goals, objectives and policies of the Yellowstone County and City of Billings 2008 Growth Policy:

- Predictable land use decisions that are consistent with neighborhood character and preferred land use patterns identified in neighborhood plans (Land Use Goal, Page 6). *The use of the property as a church fits with neighborhood uses and land uses where churches serve people within residential neighborhoods as well as those from other areas of the community.*
- New developments that are sensitive to and compatible with the character of the adjacent City neighborhoods and County townsites (Land Use Goal, Page 6).

Annexation of this property would adhere to the following goals of the West Billings Plan:

- Ensure that new development is provided with adequate infrastructure and services, including sanitary sewer and storm water control (*Page 24*)
- Condition approval of new development in the West Billings Plan area on the ability to provide infrastructure and public services, including streets, sidewalks, curb, gutter or alternative standards, police fire, public water and sewer services (*Page 26*)
- Create developments in West Billings that are compatible with their surroundings and provide a safe and desirable environment for residents, shoppers, workers, and visitors (*page 38*).

RECOMMENDATION

Staff recommends that the City Council conduct the public hearing and approve the Resolution annexing the subject property.

APPROVED BY CITY ADMINISTRATOR

Attachments

Annexation Petition
Annexation Exhibit
Annexation Resolution
Applicant Site Map

PETITION FOR ANNEXATION TO THE CITY OF BILLINGS

NOTICE TO PETITIONER

This is a Petition to the City of Billings requesting the annexation of property to the City, pursuant to MCA Title 7, Chapter 2, Part 46. Procedures for annexation are governed by the Statutes of the State of Montana. This Petition requires the signatures of more than 50% of the Resident Freeholder Electors to be considered for annexation.

INSTRUCTIONS

1. All items must be completed or provided. Please type or print. You may attach additional pages if more space is needed.
2. Prepare a map drawn to a scale adequate and legible to show the property requesting annexation and all other property within one-quarter (1/4) mile.

The map must show:

- a. The present and proposed boundaries of the municipality;
 - b. The present streets, major trunk water mains and sewer mains;
 - c. The zoning of the property requesting annexation and the property immediately adjacent to it.
3. The Petition should be submitted to the Planning Department, Monday through Friday between the hours of 8:00 a.m. and 5:00 p.m., located on the 4th Floor of Parnly Billings Library at 510 North Broadway, Billings, Montana. Upon presentation, the Petition will be checked for completeness. Once accepted, the Petition will be routed to the following City Departments: Public Works, City-County Planning, Public Utilities, Fire Department, City Attorney, Police Department, and Finance Department. If no problems with the Petition have been noted by the departments, the City Clerk will schedule the Petition for City Council action.
 4. By filing the petition for annexation, the Petitioner(s) agree that only those City services which are available to the general area shall be provided to Petitioner, and that additional services as may become available to the general area shall be made available to Petitioner(s) in the same manner as said services are made available to other residents of the City. Petitioner(s) specifically waive the right to the report and plans for extension of services as provided in MCA Title 7, Chapter 2, Part 47.
 5. A description of the territory to be annexed to the City is legally described on a document attached hereto.

RESIDENT FREEHOLDER ELECTORS

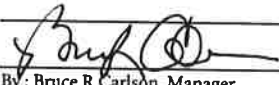
Date	Print Name	Name Signature	Address
March 12, 2016	Yellowstone Meadows Partners LLC	 By: Bruce R Carlson, Manager	3524 Spalding Avenue, Billings, MT 59106

(continued on separate page)

EXHIBIT A - PROPERTY REQUESTING ANNEXATION

ANNEXATION MAP
WITHIN
BILLINGS, MONTANA

UNSEGREGATED PORTION OF PARCEL A (4.03 ACRES); PARCEL A, S31, T01 N, R25 E, N2NE4, SWNE4 89.98 ACRES.
CURRENT ZONING: R 9800
PROPOSED ZONING: SPECIAL REVIEW - CHURCH



PREPARED BY : SANDERSON STEWART

MARCH 2016
BILLINGS, MONTANA

300 150 0 150 300
SCALE: 1" = 300'

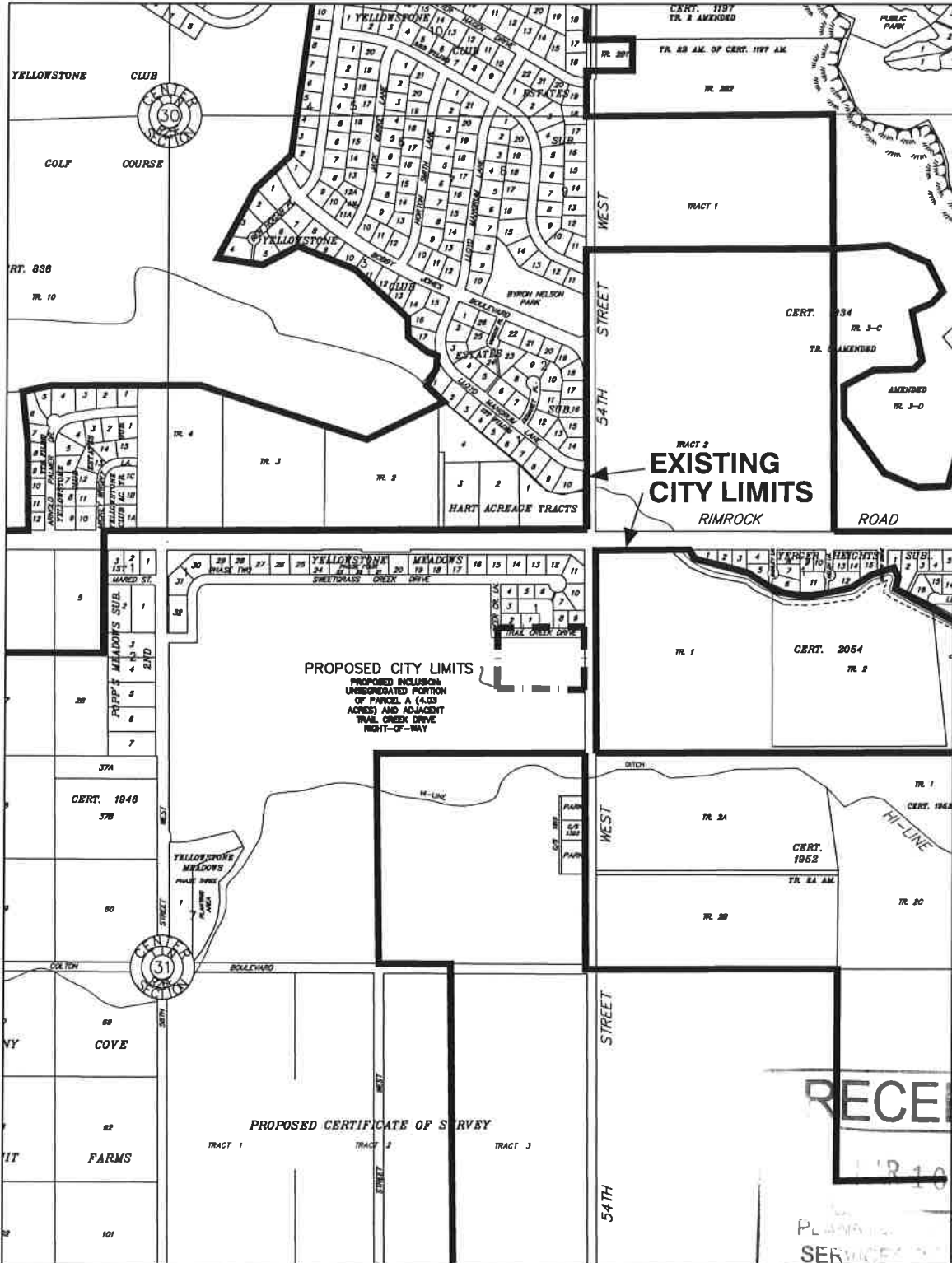

ANNEXATION 16-03 EXHIBIT "A"

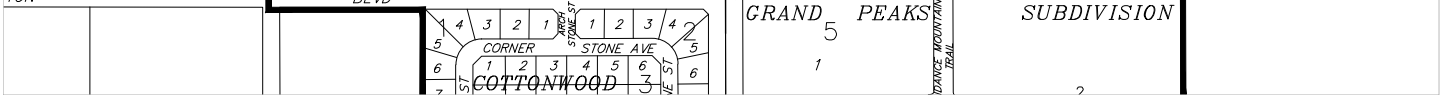
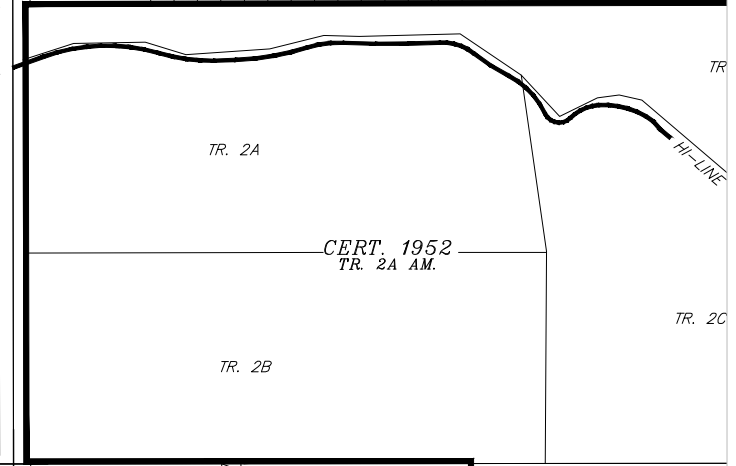
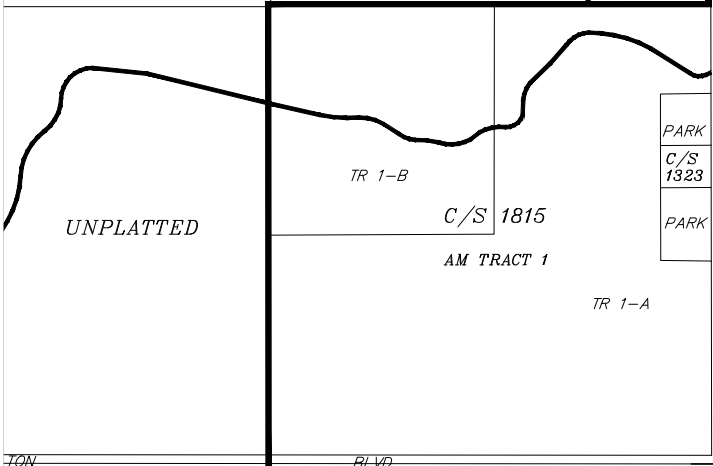
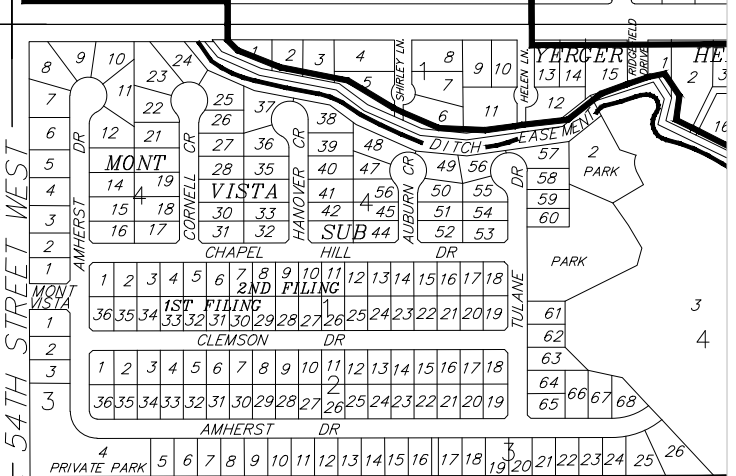
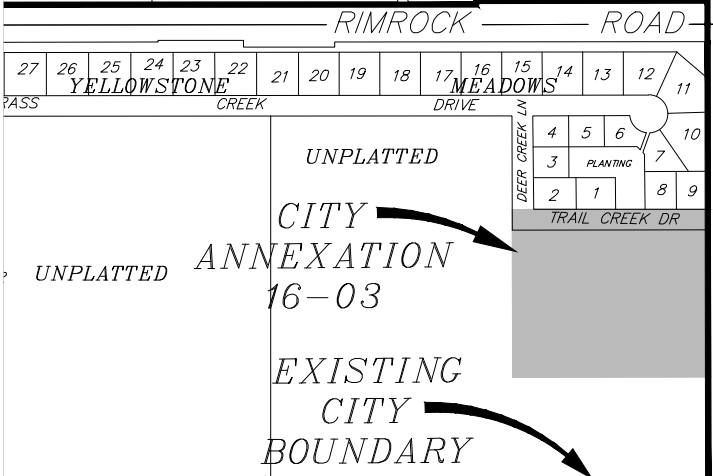
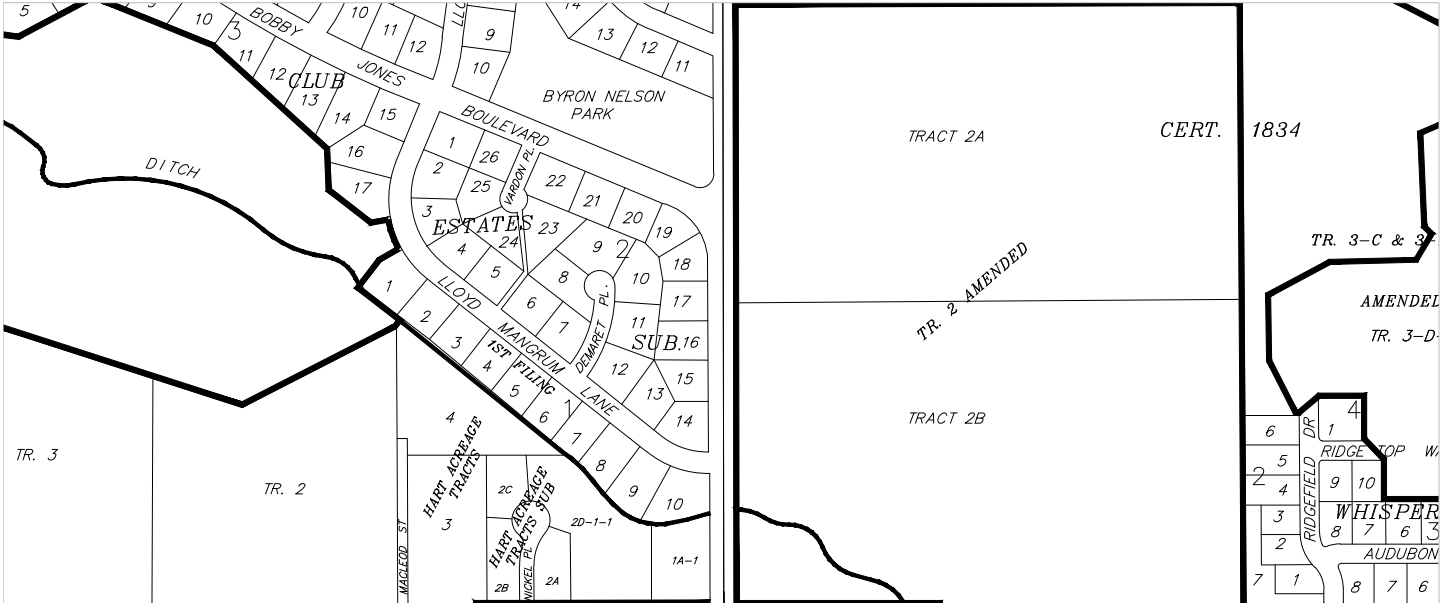

RESOLUTION NO. 16 -

A RESOLUTION OF THE CITY OF BILLINGS APPROVING PETITIONS FOR ANNEXATION AND ANNEXING TERRITORY TO THE CITY.

WHEREAS, one hundred percent (100%) of the freeholders who constitute more than fifty percent (50%) of the resident freeholder electors have petitioned the City for annexation of the territory hereinafter described; and

WHEREAS, the territory was described in the Petition as required by law, and

WHEREAS, annexation of said territory would be in the best interest of the City.

NOW, THEREFORE, BE IT RESOLVED BY THE CITY COUNCIL OF THE CITY OF BILLINGS, MONTANA, AS FOLLOWS:

1. TERRITORY ANNEXED. Pursuant to Petition filed as provided M.C.A., Title 7, Chapter 2, Part 46, the following territory is hereby annexed to the City of Billings:

A tract of unplatted land situated in the NE1/4, NE1/4 of Section 31, T.1N., R.25E., P.M.M., Yellowstone County, Montana, more particularly described as:

Beginning at the southeast corner of Trail Creek Drive of Yellowstone Meadows-Phase One, Recorded December 15, 1970, under Document No. 873104, on file and of record in the Records of Yellowstone County, said Point of Beginning being the southwest corner Right-Of-Way line of Trail Creek Drive and 54th Street West; thence in a southwesterly direction and along the west Right-Of-Way line of said 54th Street West for a distance of 426.00 feet; thence leaving said 54th Street West Right-Of-Way line and in a southwesterly direction and parallel to said Trail Creek Drive for a distance of 576.68 feet to a point; thence in a northeasterly direction and parallel to 54th Street West for a distance of 426.00 feet to a point on the south Right-Of-Way line of Trail Creek Drive, said point being the southwest corner of said Trail Creek Drive of Yellowstone Meadows-Phase One; thence in a northeasterly direction and along said Right-Of-Way line of Trail Creek Drive for a distance of 576.68 feet to the Point of Beginning. Including all adjacent right-of-way of Trail Creek Drive.

Containing 6.434 gross acres and 5.639 net acres more or less.

(#16-03) See Exhibit "A" Attached

2. CONDITIONS. The annexation is approved, subject to the following conditions:
- Prior to site development, a Development Agreement shall be executed between the owner(s) and the City that shall stipulate specific infrastructure improvements, provide guarantees for said improvements, and include a Waiver of Right to Protest the Creation of Special Improvement Districts will be recorded; and/or
 - A Subdivision Improvements Agreement (SIA) and Waiver of Right to Protest the Creation of Special Improvement Districts shall be approved and recorded that will stipulate specific infrastructure improvements, and provide guarantees for such infrastructure improvements.
3. PROCEDURE. All procedures as required under M.C.A., Title 7, Chapter 2, Part 46, have been duly and properly followed and taken.

PASSED by the City Council and APPROVED this 9th day of May, 2016.

THE CITY OF BILLINGS:

BY: _____

Thomas W. Hanel, MAYOR

ATTEST:

BY: _____

Billie Guenther, CITY CLERK

(AN# 16-03)

ANNEXATION 16-03 EXHIBIT "A"

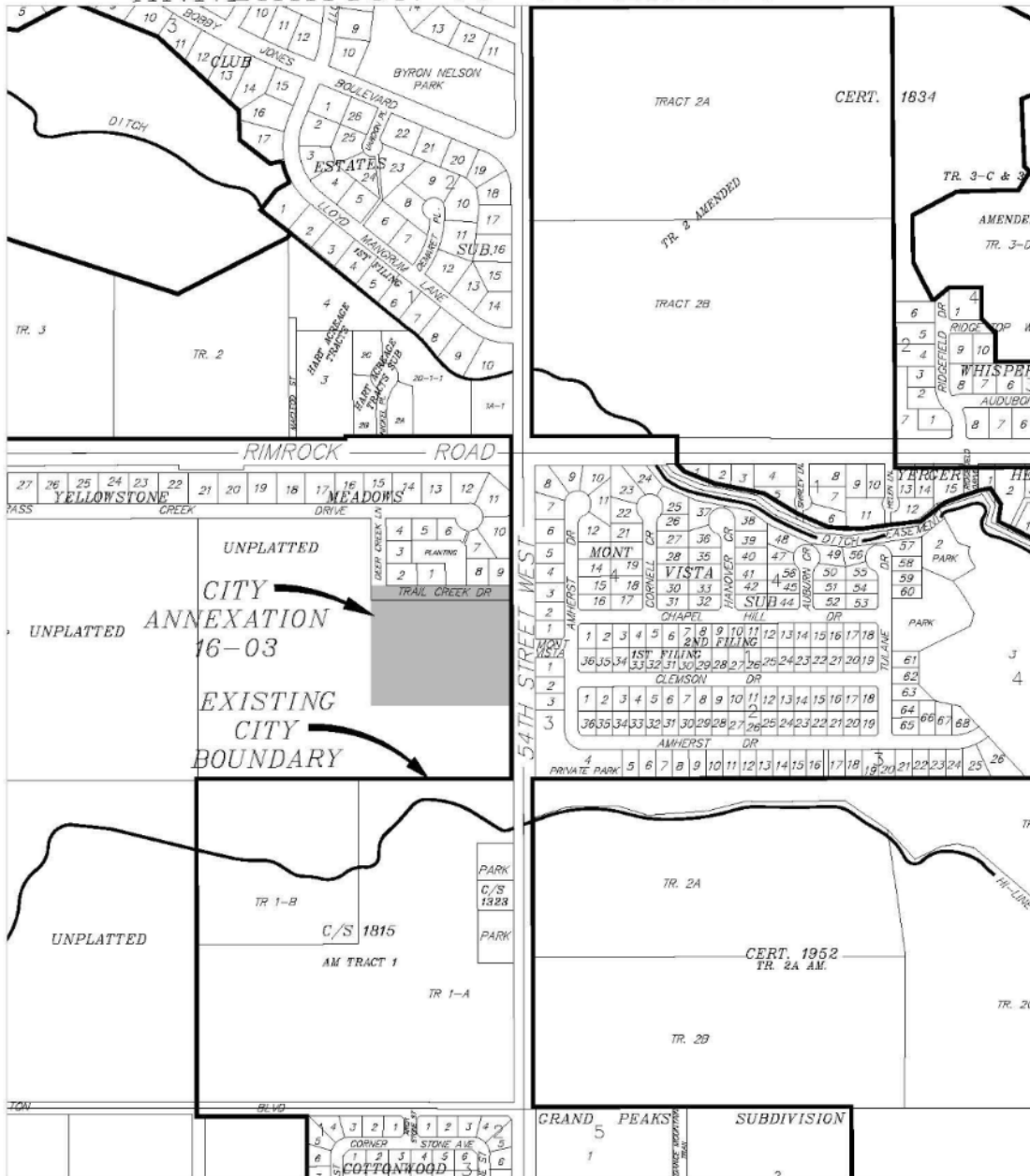

Regular City Council Meeting

Meeting Date: 05/09/2016

TITLE: Special Review 941 - Public Hearing

PRESENTED BY: Candi Millar, Planning & Community Services Department Director

Department: Planning & Community Services

PROBLEM/ISSUE STATEMENT

This is a special review request to allow the construction of a new church, an LDS Meetinghouse, in a Residential 9,600 (R-96) zone on a 5.6 acre portion of an 89.98 acre un-platted parcel of land described as the N1/2NE1/4, SWNE1/4 in Section 31, Township 1 North, Range 25 East. A concurrent annexation of the 5.6 acre parcel has been submitted. The Zoning Commission conducted a public hearing on April 5, 2016, and is forwarding a recommendation of conditional approval.

Special Review applications are reviewed using criteria referenced in the Alternatives Analyzed section of this memo. Special Reviews do not change the zoning of a property. They are tied to specific uses that are permitted in a given zoning district but are subject to a review by the City prior to the use being allowed. Special Review requests, unlike Zone Changes, may be conditioned to mitigate potential impacts from the use on the subject property or surrounding properties.

ALTERNATIVES ANALYZED

City Council may:

- Approve the request
- Conditionally approve the request
- Deny the request
- Allow the applicant to withdraw the request
- Delay action on the request for up to 30 days

The Planning Division reviewed the application and recommended conditional approval to the Zoning Commission based on the findings of the 3 criteria. The Zoning Commission concurred with this recommendation. Before a recommendation of approval or conditional approval can be made, each special review request must demonstrate conformance with three primary criteria: 1) the application complies with all parts of the Unified Zoning Regulations, 2) the application is consistent with the objectives and purposes of the Unified Zoning Regulations, the 2008 Growth Policy including any neighborhood plans, and 3) the proposal is compatible with surrounding land uses and is otherwise screened and separated from adjacent land to minimize adverse impacts.

This application conforms to the first criteria in so far that it is in a zoning district, R-96, where churches and places of worship are allowed by special review approval. The City has conditionally approved similar churches and places of worship in West Billings in the past 10 years as the population in this area has increased. The form of the application is correct and the submitted site plan is in conformance with site development and zoning regulations for the R-96

zoning district. The proposal is consistent with goals of the 2008 Growth Policy, and the West Billings Neighborhood Plan – specifically the goal of encouraging uses that are compatible with the character of the adjacent land use patterns. The property has direct access to a principal arterial street and is not directly adjacent to any existing dwellings. There is a platted but undeveloped residential subdivision to the north and the Mont Vista Subdivision to the east across 54th St West is under construction. The bulk and height of the building are mitigated by the large setbacks from property lines. The proposed landscaping around the building and parking lot will soften the appearance of the building as the plantings mature. There are some impacts from the proposed location that need to be mitigated by conditions of approval, specifically concerning the parking lot lights and the mechanical units. Other recommended conditions are standard conditions applicable to all special review approvals.

PROPOSED CONDITIONS:

1. The special review approval is for the construction of an LDS Meetinghouse of 16,558 square feet with a future addition of 2,510 square feet and a 191-space parking lot, and a future addition of an 81-space parking lot to the south.
2. The approval is limited to a 5.639-acre portion of an 89.98 acre un-platted parcel of land described as the N1/2NE1/4, SWNE1/4 in Section 31, Township 1 North, Range 25 East as shown on the submitted site plan.
3. Increases in the size of the meetinghouse and its future addition or the number of parking spaces by more than 10% of what is shown will require an additional special review.
4. The site will be developed in substantial conformance with the submitted site plan. Minor modifications are acceptable.
5. The applicant will provide a screening wall around each mechanical pad as shown on the site plan to reduce noise and provide continuity with the adjacent building. The screening wall will be compatible in color and materials to the adjacent building.
6. All outdoor light fixtures shall be no taller than 15 feet from grade and have full cut-off shields so no part of the fixture or lens projects below the shielding. Entryway lights shall be recessed within the ceiling of the canopy so no part of the fixture or lens projects below the ceiling.
7. The landscaping, including the enclosures for the dumpster, satellite dish and power transformer, shall be installed as shown on the submitted site plan. The enclosures shall be constructed of similar or complementary materials as the church. No reflective building materials shall be used for the enclosures.
8. There shall be no construction activity after 8 pm or before 7 am daily.
9. These conditions of special review approval shall run with the land described in this authorization and shall apply to all current and subsequent owners, operators, managers, lease holders, heirs and assigns.
10. The proposed development shall comply with all other limitations of Section 27-613 of the Unified Zoning Regulations concerning special review uses, and all other City of Billings, regulations and ordinances that apply.

FINANCIAL IMPACT

The property is currently in the County and does not contribute to the City's tax base. If the property is annexed and development occurs, the City will collect fees for arterial construction, storm water management, street maintenance and other similar fees. Non-profit organizations and religious institutions are usually able to obtain an exemption from taxes, including property taxes. The development may need to contribute to off-site traffic management depending on the approved findings of the traffic accessibility analysis submitted for the City Traffic Engineer's review. Improvements to adjacent right of ways will be required at the time of building permit

submission and approval. Those improvements may also be required through a Development Agreement required by the annexation.

BACKGROUND

A portion of this un-platted parcel received a zone change from the County in 1974 to change the zoning to Residential 15,000. This portion is located south and west of the subject property. The Yellowstone Meadows Subdivision to the north is in the County and zoned R-96. The first phase of the subdivision was filed in 1970, but no dwellings have been constructed. Mont Vista Subdivision to the east was granted a zone change in 2008 at the time of annexation to a Planned Development zone. Mont Vista started construction in 2014. An annexation petition for the 5.639 acres has been submitted. The intent is to have this Special Review application come before the City Council at the same meeting as the Annexation Petition.

This is a special review request to construct a new LDS meetinghouse on a 5.639-acre portion of an un-platted parcel of land west of 54th St West and south of Trail Creek Drive. The property is zoned R-9600 and churches and religious institutions are allowed by special review approval. In 2015, the LDS meetinghouse was proposed for several vacant lots in the Rim Point Subdivision north of Rimrock Road near the LDS Temple. This application was withdrawn.

The Church of Jesus Christ LDS needs additional meetinghouse space to accommodate a growing church membership. The meetinghouse is meant to accommodate everyday worship activities and will be similar in size and construction style as other meetinghouse sites in Billings (such as 912 Wicks Lane, 2929 Belvedere, 3595 Monad Road, 1640 Broadmoor and 1711 6th Street West).

The proposed meetinghouse is a 16,558 square foot building with a planned future addition of 2,510 square feet. The building will be a single story structure with a maximum building height of approximately 28 feet. The church spire will be approximately 64 feet above finished grade. There is also a small 190 square foot storage shed on the west end of the parking lot next to an enclosure for a satellite dish. The dumpster enclosure and enclosure for a power transmission facility are located on the south edge of the proposed 191-stall parking lot that wraps around the church. A future 81-stall parking lot is proposed south of the building. If the meetinghouse has a large enough congregation, it may host occasional regional meetings, requiring a larger parking lot. The site plan shows one drive approach on 54th Street West and one drive approach on Trail Creek Drive to the north. Annexation of the property will require some improvements to Trail Creek Drive. The church is sited 80 feet west of the front property line and the area between the building and the street is scheduled to be landscaped with grass and trees. Storm water control of the run off from the roof and parking area will be handled on site since no City storm water system exists in this area of West Billings. The landscaping plan shows a total of 80 trees to be disbursed throughout the site. The proposed landscaping plan includes 3.73 acres of landscaped area around the building and parking lot or approximately 66% of the total land area. No freestanding sign is proposed - the building will have one un-lit stone engraved sign. The building is proposed as wood construction with a brick exterior. There is no building lighting. The proposed lighting is for the parking and sidewalk areas. Four mechanical pads for air handling units are shown on the site plan - two north of the building and two south of the building. The landscaping plan was designed by local landscape architects so species and plant material will be appropriate for this location. The parking lot lights (8 shown) are on the interior edge of the proposed parking and are full cut-off shield fixtures.

The applicant has provided a full traffic accessibility study for the site. The study concludes the new traffic would not have a significant impact on existing traffic on 54th St West. The City Traffic Engineer, Terry Smith, has not yet approved the conclusions of the study. Any required

mitigation will be determined by Mr. Smith including but not limited to contributions to future traffic management at 54th St West and Rimrock and 54th St West and Grand Avenue, and street frontage improvements on 54th St West and Trail Creek Drive.

STAKEHOLDERS

The Zoning Commission conducted a public hearing on April 5, 2016, and received the staff recommendation, testimony from the applicant's agent, Scott Nielson, of NBW Architects, and from several surrounding property owners. Surrounding property owners testified in opposition to the special review and included the following individuals: David Ryckman, Glen Korf, Peg & Karl Guhn, Bill Felton, Duane Hankel, and Mary & Monti Bonawitz. All of these surrounding owners live on Sweetgrass Creek Drive and Trailcreek Drive in the County subdivision north of the subject property. Several individuals provided testimony in support of the special review including Blaine Poppler, Tamara Zaccardi, Stewart Kirkpatrick, Ken Petersen and Rick Leuthold.

Mr. Scott Nielson provided updated information to the Zoning Commission on the additional area south of the original site plan. He stated the need for the area was to adequately handle storm water runoff from the parking area and roof of the meetinghouse. He stated the additional area may have an 81-stall parking lot in the future if the meetinghouse increases its membership. Mr. Nielson stated the proposed site took into consideration all of the objections from the previous application so they chose a site not within an existing neighborhood with direct arterial street access. He stated the area is larger than the previous site and the landscaping proposed will complement the surrounding area. He stated the church and the agent for the owner, Blaine Poppler, conducted a pre-application meeting with the surrounding owners. He stated there were no great concerns raised at the meeting.

Mr. Poppler stated he was engaged by the church to seek a new site for the meetinghouse on the west end of Billings. He stated they considered several sites and found this property met the client's needs and the property owner is a willing seller. He stated the closest residence to the property line is over 450 feet north on Sweetgrass Creek Drive.

Tamara Zaccardi, a community relations and outreach coordinator for the LDS church in Billings, stated the need for additional space is great in the community. In response to a question from the Commission, she stated choosing local contractors is encouraged by the church.

Ken Petersen testified in favor. He stated he was the co-chair for the church committee that found and developed the site for the LDS temple north of Rimrock Road. He stated all of the church's buildings in the community are quality construction and are well-maintained. He stated the traffic issues have been studied by Bob Marvin and a report submitted to the City for review. He stated the church's withdrawal of the previous application on Rimpoint Drive was the right thing to do. In response to a question from the Commission, Mr. Petersen stated the closest LDS meeting house is on Belvedere Drive south of Grand Avenue. He stated this is a larger congregation than what is proposed at the subject property.

Stewart Kirkpatrick testified in favor of the church location. He stated this area has a mixture of uses already from Grand Avenue north to Rimrock Road. He stated there is a serious amount of green space planned for this site and it will fit with the Billings Westend plan.

Rick Leuthold stated his firm, Sanderson Stewart, is representing the applicant on the site's civil

engineering work. He stated the church has prepared the traffic analysis and there will be contributions required for nearby intersections and the applicant will likely have to sign a waiver of protest against future SIDs for 54th St .West improvements. He stated that Trail Creek Drive would need to have a 3/4 street improvement including curb, gutter and sidewalk from its intersection with 54th St West to the west property line of the subject property. He stated it was unlikely vehicles would use the gravel roads through the County subdivision to the north but would turn right to the intersection at 54th St West. He stated the homes in the County subdivision sit at a much higher grade than the subject property and the visual impact of the 28-foot tall church building would be diminished by distance.

Carl Guhn testified in opposition. He stated his biggest concern was cut-through traffic on Trail Creek and Sweetgrass Creek. He stated the roads are little more than dirt and dust from just a few cars each day. He stated the area is also full of wildlife including deer and pheasant. He stated his preference would be for the church to choose a commercially zoned lot down near Grand Avenue.

Monti Bonawitz testified in opposition. He stated the area is a nice rural subdivision but the potential for even a few more cars using their subdivision roads would not be fair. He stated the roads are not in good condition. He stated some of the homes on the north side Sweetgrass Creek have septic systems that go across the road and he is concerned with the impact to those systems.

Mr. Ryckman testified in opposition. He stated his biggest concern was the impact to the wildlife in the area. He stated there is an albino deer that lives in the field and any disturbance of the area may impact the wildlife. He stated his concern was not based on the faith of the LDS church but with the impact on his viewshed, the wildlife, and the County road.

Glen Korf testified in opposition. He stated people who use Sweetgrass Creek Drive now go too fast. He stated the dust issues were already serious. He stated if the City approves the proposal one of the conditions should be the church re-build the roads in their subdivision to eliminate any traffic issues. He stated he is concerned about losing his view and the open space south of his home. He stated the church is not compatible with surrounding homes.

Mr. Felton testified in opposition. He stated he lives in a County single family subdivision. He stated that allowing the church will allow a commercial use in close proximity to his neighborhood. He stated it would likely lower his property value. He stated the church should go in a commercial zone at Grand Avenue.

Mr. Nielson provide rebuttal testimony. He stated the church is a good neighbor in every residential zone where they are currently located. He stated there is some use of the building during the week but mostly just on Sundays from 9 am to 4 pm. He stated he has worked with the LDS church for more than 45 years and meeting houses are always sited in neighborhoods. Mr. Nielson asked the surrounding owners to work with him to address their concerns over the next few weeks. He stated some of the issues could be addressed by minor modifications of the site plan.

A motion to recommend conditional approval based on the findings of the 3 criteria was made by Commission Member Michael Larson and seconded by Commission Member Dennis Ulvestad. The motion was approved 5-0.

CONSISTENCY WITH ADOPTED POLICIES OR PLANS

Consistency with Adopted Policies and Plans is discussed in the Alternatives Analyzed section above.

RECOMMENDATION

The Zoning Commission recommends conditional approval and adoption of the findings of the 3 criteria on a 5-0 vote.

APPROVED BY CITY ADMINISTRATOR

Attachments

Zoning Map and Site Photos
Site Plan and Applicant Letter
Amended Landscaping Plan
Letter of Opposition

Zoning Map – Special Review #941

54th St W and Trail Creek Dr

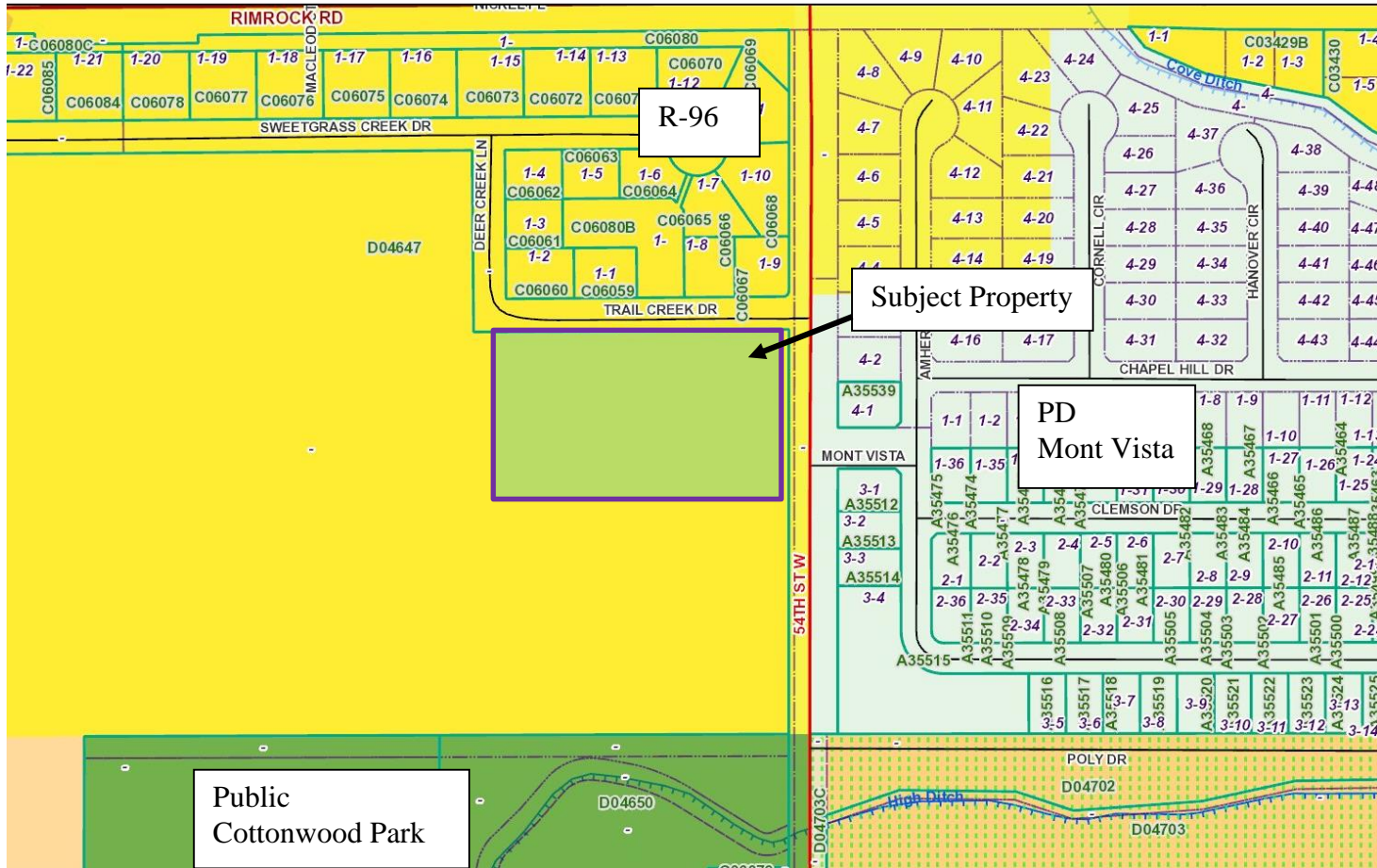

54th St W and Trail Creek Dr

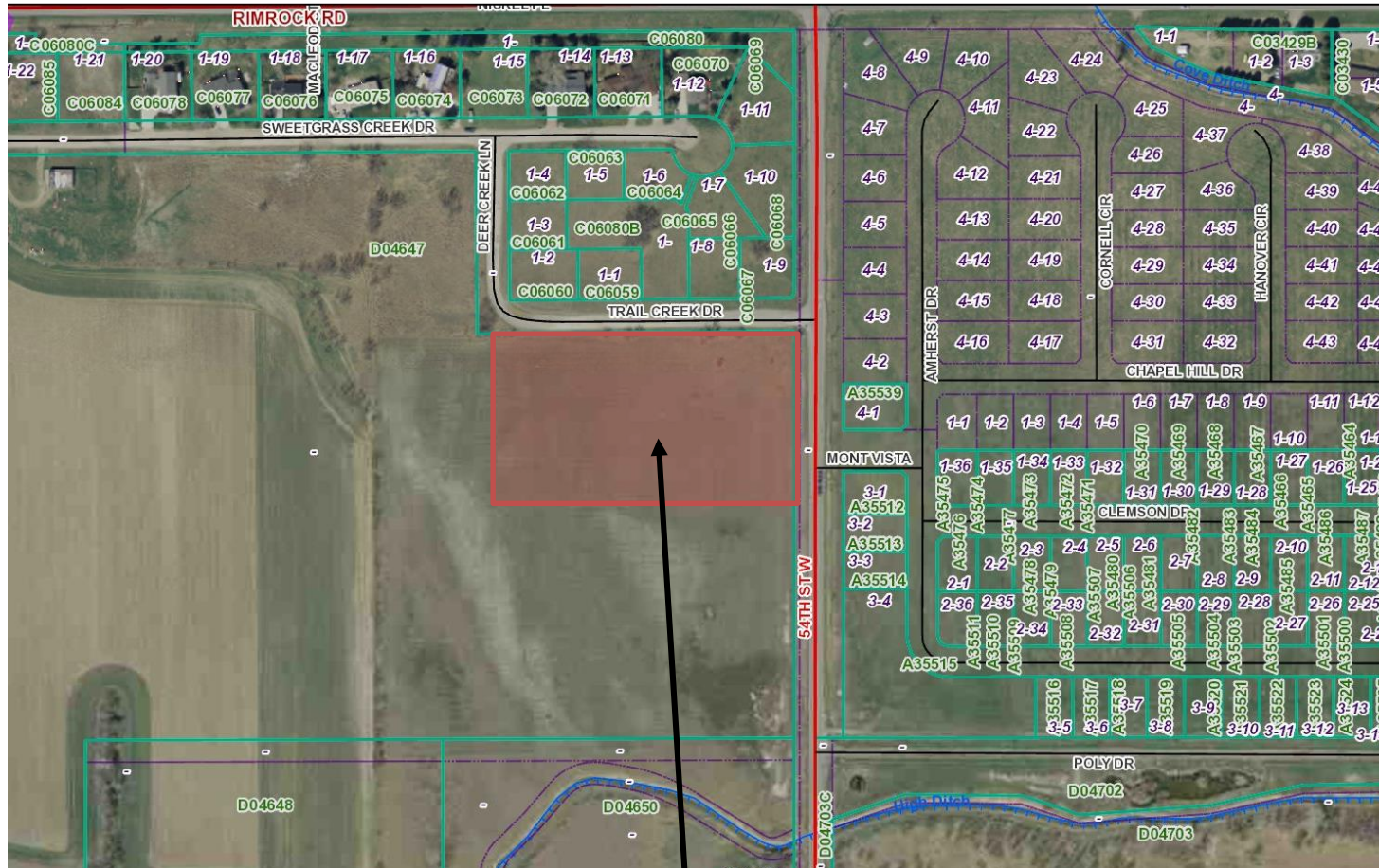

Subject Property



Subject Property – from Trail Creek Drive



View west along Trail Creek Drive



View south from intersection of Trail Creek Drive and 54th St West



View south and east across 54th St West – Mont Vista Subdivision



View north and east across 54th Street West – Mont Vista Subdivision



View south and west across subject property

Special Review 941
Site Plan and Applicant Letter

THE CHURCH OF JESUS CHRIST OF LATTER DAY SAINTS
PROPOSED MEETING HOUSE

SPECIAL REVIEW APPLICATION
INSTRUCTIONS ITEM 1 A

A. *In what ways is your proposal consistent with the goals and policies of the adopted Growth Policy?*

PROPOSAL CONSISTENCY WITH THE PRIMARY GOALS AND OBJECTIVES OF THE 2008 GROWTH POLICY

LAND USE ELEMENT

Issue 1: Neighborhood pressures from development

The type of structure proposed under this application is a prototype building that has been developed by the LDS church primarily for siting in residential areas. Considerations taken are eave heights, overall building height and exterior materials that are not only compatible with but typical of residential structures. This meets the objective of preserving neighborhood integrity. The objective of empowering neighborhood groups does not appear to be applicable in this case other than a cooperative effort between the church and the neighboring properties in terms of property line interface, noise control, lighting scenario etc. These items will be discussed later in this document.

Issue 2: Compatibility of use

As stated above houses of worship are typically sited in residential neighborhoods rather than in commercial, retail or industrial areas. We feel that a house of worship is compatible with the neighborhood and a common occurrence in cities throughout our country.

Issue 3: Rural town-site

This issue does not appear to be applicable in this area since it is located near an established neighborhood in the City of Billings and a large subdivision has been platted to the east of our development.

Issue 4: Urban sprawl

This doesn't appear to be an applicable issue in as much as it is in an established area with existing services. This facility poses no reason for concern for overloading of existing service facilities nor does it threaten the vitality of the city core and downtown area.

Issue 5: Affordable housing

The nature of this facility is not housing oriented and does not propose the development of housing in any way and therefore this issue is not applicable.

Issue 6: Mixed use neighborhoods

While this project is not of the nature to provide mixed use in its true sense it will still allow closer proximity to the members of the LDS church that live in the surrounding neighborhoods thereby lessening travel for them and reducing traffic at meetinghouses at other locations. From that aspect, this project will provide proximal services for the members of the LDS church that currently do not exist in this part of Billings.

ECONOMIC DEVELOPMENT ELEMENT

Issue 1: Focus in economic development

Since the proposed facility is to be constructed in a residential zone and is intended for religious worship it's intention is not related to retail or business development.

Issue 2: Lack of living wage jobs

While this facility will not have the ability to create jobs or enhance income levels of the citizens of Billings it will still represent a significant improvement to what is now an undeveloped vacant piece of property. History has proven that with the nature of the building and landscape that the LDS church typically constructs that the neighborhood then has a tendency to infill with homes of people desiring to live adjacent to these types of facilities. Customarily these have been well constructed and maintained residential properties that enhance the neighborhood. This is the type of growth that cities desire to have. Attracting this type of growth is a positive consideration since these people then assist through property taxes etc. in paying for services, improving infrastructure and so on.

Issue 3: Entryways to the community

This issue would not apply since it is not located at or near an entryway to the community

Issue 4: Government supported programs and improvements are not sufficiently funded.

This project is not funded by any government entity. However, it should be noted that at the time of commencement of construction all funding for the project is in place and committed. This will provide the assurance that the project will be completed as intended and as designed.

Issue 5: Economic viability of downtown Billings

This issue is not applicable to this project

Issue 6: Safety in Downtown Billings

This issue is not applicable to this project

Issue 7: Need for economic development

As stated above, in as much as this is a house of worship the need for economic development will not apply.

Issue 8: Need for higher paying wages

This issue does not apply

Issue 9: Economic Development of Billings Heights is overlooked

This issue does not apply.

Issue 10: Quality of Schools

This project will not impact the quality of schools in any way.

Issue 11: Preserve the character of the neighborhood

As stated above, the facility, site layout, lighting and landscape design are with the intention of blending well into a residential neighborhood. The scale of the building is maintained at a size that will not overwhelm the residential architecture found in a typical neighborhood housing area. Building materials to be used are similar to those used on the residences in this area. Parking is only of a capacity to meet

local zoning requirements and the entire site other than building and hardscapes will be landscaped with attractive plantings that are indigenous to or will grow well in the local climate. Privacy fences will be constructed which will reasonably protect the neighbors from vehicle or pedestrian intrusion and will screen adjacent homes from headlight glare. Lighting is kept at a minimal level in order to avoid over lighting. Lights are placed at locations to avoid light spill over into neighboring properties. Light poles are spaced typically at 80' on center and are relatively short poles at 18 feet. They are shoebox type fixtures with cut off shields as required. They are typically shut off after any evening activities at the building are ended. A photometric layout can be provided upon request. It is the intention of the church to be a good neighbor and they have taken every possible precaution to do so. There will be no recreational facilities such as athletic fields or pavilions at this property. Outdoor activity around the building will be limited to members coming and going to and from the facility for worship and indoor activities

Issue 12: Shortage of skilled workers

This facility will not add to, nor detract from the issue of shortage of skilled workers. Therefore this issue does not apply

AESTHETICS ELEMENT

Issue 1: Some areas in Billings are unattractive and present a poor image of the community

This issue has been largely addressed in item 11 in the preceding topic. This facility will enhance the current setting (vacant lot) and will be of a nature not to diminish the image of the community. The building will have a pleasing design and the choice of materials will not seem out of place with the surrounding homes.

Issue 2: Signs, cell towers and power lines and other structures could reduce the visual quality of the rims.

The only sign that will be utilized on this facility will be an incised letter stone sign incorporated into the front of the building. It is approximately 4' x 3' and will be neither front -lit nor back- lit. There are no cell towers or power lines associated with this project.

NATURAL RESOURCES ELEMENT

Issue 1: Quality of Yellowstone River and associated riparian habitat

This project is not located near the Yellowstone River or in the riparian habitat and it is not envisioned that the project will have impact on either.

Issue 2: Water is an important resource and is becoming more scarce.

This facility will not use large amounts of water. The primary use will be on Sunday and water will be used for toilet rooms and drinking water. The facility does not contain a commercial kitchen or any other amenity that will utilize any excessive amount of water. The landscape will be purposely designed to also minimize the amount of water used. In recent years the LDS church has moved to designs that reduce the amount of sod on the site and to the use of smaller minimal water consuming plant and therefore more drip style irrigation and less rotor or spray head water distribution.

Issue 3: Risk to human life and property from wildfires

In as much as this site will be fully developed it is not anticipated that it will provide fuel for wildfires. All areas of the site will be landscape, hardscape or building and therefore there will be no areas to develop fuel. This property is not viewed as a potential contributor to this issue

Issue 4: Weeds detract from beauty and pose a fire danger – reduce ag production.

Please see the response above

Issue 5: Human encounters with wildlife

This site is currently vacant property and is not seen as a supporter of wild life nor does it provide a suitable habitat for wildlife in its current state. With development the site will be similar to the residential properties around it. It is not anticipated that encounters with wild life will be an issue on this property.

Issue 6: Certain development is damaging to our natural resources.

Once this site is developed the storm water will be controlled per applicable requirements. There are no existing water bodies on site that will be affected or need protection. This development will not negatively affect air quality or productive agricultural land.

OPEN SPACE RECREATION ELEMENT

Issue 1: neighborhood park funding

A neighborhood park is not involved in this project. Therefore, this issue does not apply.

Issue 2: Counties need more major recreation facilities and need to improve existing facilities

This issue does not appear to be related to this particular project.

Issue 3: Private land development sometimes restricts access to public land

The development of this property will not restrict access to public land

Issue 4: County townsites need more multiple use trails

This issue does not appear to pertain to this project

Issue 5: Public access to areas above and below the rimrocks is limited and decreasing

This project will not inhibit access to the subject areas.

Issue 6: Public access to areas along the Yellowstone River is limited and decreasing

This project does not limit access to the Yellowstone River

TRANSPORTATION ELEMENT

Issue 1: Speeding in City neighborhoods and outlying communities

This facility will utilize traffic infrastructure already in place and will meet all necessary access and traffic control requirements. It will not adversely affect the rate at which traffic flows in this area. Location of this building will allow a better pedestrian opportunity to members of the congregation who live in this area and who currently drive to other locations to attend church.

Issue 2: Safe and efficient traffic circulation.

This facility will reduce travel times for members of the LDS church who currently live in this area. As stated above this facility will utilize traffic infrastructure already in place and will meet all necessary access and traffic control requirements.

Issue 3: Lack of adequate traffic control.

At city request, the owner is providing a traffic study of the area and the impact that the construction and use of this facility will have on local traffic. It is the owner's intention to comply with all requirements that are based on the study to provide adequate traffic control.

Issue 4: Design of roads, streets and pedestrian facilities.

This project will utilize the existing street (54th Street West) for an east access drive approach. The road to the north (Trail Creek Drive) is currently a gravel road. The developer will comply with city standards and requirements regarding the development of this road insofar as they apply.

Issue 5: Obstacles to efficient and safe traffic flow

There are no apparent obstacles to efficient and safe traffic flow associated with this project.

Issue 6: Deteriorated condition of city streets and county roads

The developer of this project will meet its obligations to the necessary support of the maintenance, upkeep and improvements to the existing city streets. No county roads are affected.

Issue 7: Resources for transportation improvements should be rationally allocated.

This issue appears to be a function of the governing body charged with the distribution of improvement funds and not the responsibility of this particular developer.

Issue 8: More convenient bus schedules are needed

This issue appears to be the responsibility of the regulating agency and is out of the control of this developer.

Issue 9: Condition of existing sidewalks

Currently there are no existing sidewalks near or adjacent to this development. This developer will respond as required for the installation of new sidewalks along existing streets and roads as required by the city.

Issue 10: Lack of adequate bicycle facilities

This developer will comply with city requirements regarding the development of bicycle facilities insofar as they apply.

Issue 11: MET is underfunded

This issue does not appear to be applicable to this development.

Issue 12: Deterioration of air quality due to vehicle emissions

The LDS church encourages its members to be sensitive to the environment and not to purposely contribute to environmental problems. Nevertheless, these same members will rely on their private transportation as required.

Issue 13: Some bicyclists do not follow traffic laws and can cause unsafe situations

This is a matter of individual prerogative and this developer does not exercise control over individuals and their behavior or choice of mode of transportation in this regard.

Issue 14: There are more motorcycles, bicycles and motor scooters on the roadways

See item 13 above. The same response applies.

Issue 15: Billings needs a cross town demonstration or pilot program to illustrate that public transportation attracts riders

Not under the purview of this developer

PUBLIC FACILITIES AND SERVICES ELEMENT

Issue 1: Residents are not adequately informed of County and City projects

Not under the purview of this developer

Issue 2: Dilapidated and unsafe properties in City neighborhoods and County townsites

There are no such properties as described above at or near this project site.

Issue 3: Safety is a concern in neighborhoods and outlying County townsites.

It is the intention of this developer to provide compliant and safety conscious design for this project for the pedestrians, motorists and general public who will use this facility.

Issue 4: There are safety and functionality issues with City Streets.

A traffic study has been obtained by the owner to identify potential traffic loads generated by this project and will comply with the requirements of that study in conjunction with the interpretation and direction given by the City of Billings engineering department.

Issue 5: Funding for Community facilities and infrastructure is very limited.

This issue is not under the purview of this developer.

Issue 6: Public funds are not distributed rationally throughout City neighborhoods and County townsites

This developer has no control over the distribution of public funds.

Issue 7: There are vacant structures around Billings and in the County that could be re-used

There are no vacant facilities in the area of this project that are existing.

Issue 8: Community services are not always available to everyone.

This issue is not under the purview of this owner and is not applicable to this project.

Issue 9: Reviews of subdivisions, plats and other permit items are not always conducted in a timely manner

This developer is not responsible for those processes and has no control over them.

Issue 10: Maintenance of existing and planning for new educational facilities

This issue is not under the purview of this owner and is not applicable to this project.

Issue 11: Competition for tax dollars by Multiple Community interests

This development is not seeking tax dollars in any form.

CULTURAL AND HISTORIC RESOURCES ELEMENT

Issue 1: Historic landmarks and structures are being lost to development

There are no historic landmarks or structures that are being lost due to this development.

Issue 2: Cities must link economic development with quality of life. Need culturally aware city

This is a matter for city administrators and economic development personnel and is not a function of this development.

Issue 3: Public art is seen as an important part of the Billings landscape.

This development will take place near a residential neighborhood and the developer sees no benefit to create public area in this setting but rather it should be seen in public and common areas.

Issue 4: Archeological surveys.

The creation of a requirement for this type of survey is not under the purview of this developer.

COMMUNITY HEALTH ELEMENT

Issue 1: Existing neighborhood plans lack sufficient detail to address emergency preparedness.

The members of the LDS Church that are involved with the development and use of this facility are willing and able to assist the neighborhood in developing, promoting and maintaining an emergency preparedness plan.

Issue 2: Not all neighborhoods are planned with ways to access nutritious food.

The members of the LDS Church that are involved with the development and use of this facility are willing and able to assist the neighborhood in the endeavor of providing nutritious food.

Issue 3: Some roadways are not designed to accommodate pedestrians and therefore create inconvenient and unsafe conditions.

This project will take place in an undeveloped neighborhood where sidewalks and pedestrian facilities do not exist along roadways. The developer will provide pedestrian access as required.

Issue 4: Physical activity is not seen as a means of getting from place to place.

Church developments usually have sidewalks along the streets to encourage neighborhood residents to walk to the facility as much as possible. This neighborhood has no connecting sidewalks adjacent to the development.

Issue 5: Neighborhoods lack a sense of community, which is contributing to neighborhood decline.

The purpose of this development is for the construction of a place of worship where neighborhood enhancement and unity is a principle that is taught through outreach, cooperation and inclusion.

Issue 6: Some neighborhoods are not safe.

This development will attract church members and new neighbors that desire to live near a church. That type of neighborhood will act to increase safety for all who are there.

Issue 7: Poor housing and lack of living wage jobs puts the health of residents at risk.

This project is not intended to addressing housing issues or wage rates. However, it will attract the type of people as neighbors that will likely construct safe desirable housing and that will contribute economically to the neighborhood.

**SPECIAL REVIEW APPLICATION
INSTRUCTIONS ITEM 1 B**

B. *Why is there a need for the intended use of the property at this location?*

The existing LDS meetinghouse facilities in the Billings area are currently at or above capacity. Growth in general population and therefore LDS population as well in this area has resulted in the number of members of the LDS church to grow over the period of the past number of years. The congregations that meet in the existing area facilities have grown to the point where some of them need to be divided to create more administratively manageable sized congregations. Because of scheduling issues each of the existing meetinghouses are not capable of handling any more congregational units than they currently house and still be able to meet the worship and activity needs of the members. The need is to construct an additional meetinghouse that can accommodate the additional congregation(s) that will be created in the near future.

This particular site was selected due to geographical location for members and the proximity to existing utility services. The geographical location provides short travel times and reduced vehicular involvement for the members who live in this area. It will allow them to avoid longer car trips to reach the other meetinghouses where they currently attend.

The church has investigated other potential sites but the other locations available were not always best suited for access by the members it needs to serve in terms of location. In addition, purchase costs of other properties together with development costs were significantly more prohibitive on most of the sites in comparison to this site primarily with respect to their ownership.

**SPECIAL REVIEW APPLICATION
INSTRUCTIONS ITEM 1 C**

C. *How will the public interest be served if this application is approved?*

The present site is currently vacant undeveloped ground. The development of this site will create an attractive addition to the community of Billings with tasteful architecture and well planned and maintained landscape.

The development will provide a finished site which will be inviting to those who choose to avail themselves of the use of the facility. Studies have shown that the construction of a church facility promotes a better neighborhood environment, more of a safe environment, does away with the ugliness and uselessness of vacant property within a city, and the typical construction of additional single family residences that follow.

**SPECIAL REVIEW APPLICATION
INSTRUCTIONS ITEM 1 D**

D.

Prepare a written statement addressing what is intended to be done with the property, including new construction or changes in the use of the property, and why the special review is being sought.

It is the intention of the LDS church to construct a new meeting house on the subject property. The meeting house is a 16,558 sf building with a sloped roof. It is a frame building with brick veneer. It will be single story with no basement. The remainder of the site will provide city compliant parking and landscaping. All of the property designated for the church will be developed and / or improved with this project. There are no recreational facilities being developed with this site.

The Special Review is being sought because it is being required by the City of Billings for church construction within the R9600 Zone.

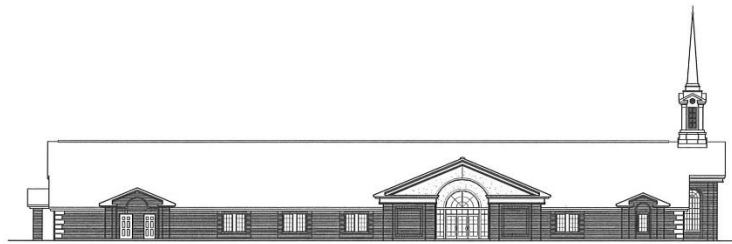

SIDE

ELEV. 192'-0"
TOP OF ROOF

ELEV. 108'-0"
T.O. SIDE WALLS

ELEV. 100'-0"
FINISHED FLOOR

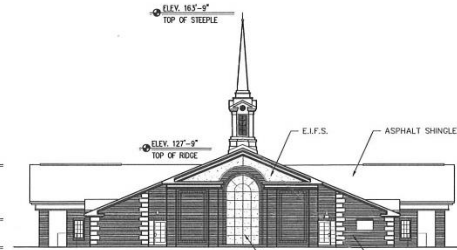

FRONT

ELEV. 185'-2"
TOP OF STEEPLE

ELEV. 192'-0"
TOP OF ROOF

EIFS

ASPHALT SHINGLES

EIFS

BRICK VENEER

BUILDING ELEVATIONS

SCALE: 3/4" = 1'-0"

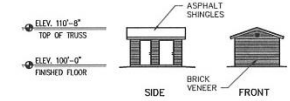
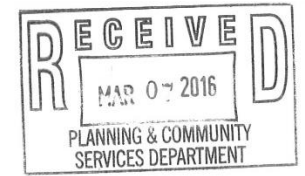

SIDE FRONT

SHED ELEVATIONS

SCALE: 3/4" = 1'-0"

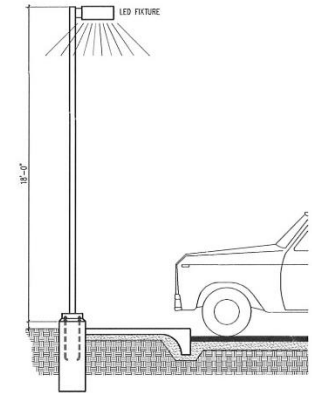

PARKING LOT LIGHTS

SCALE: N.T.S.

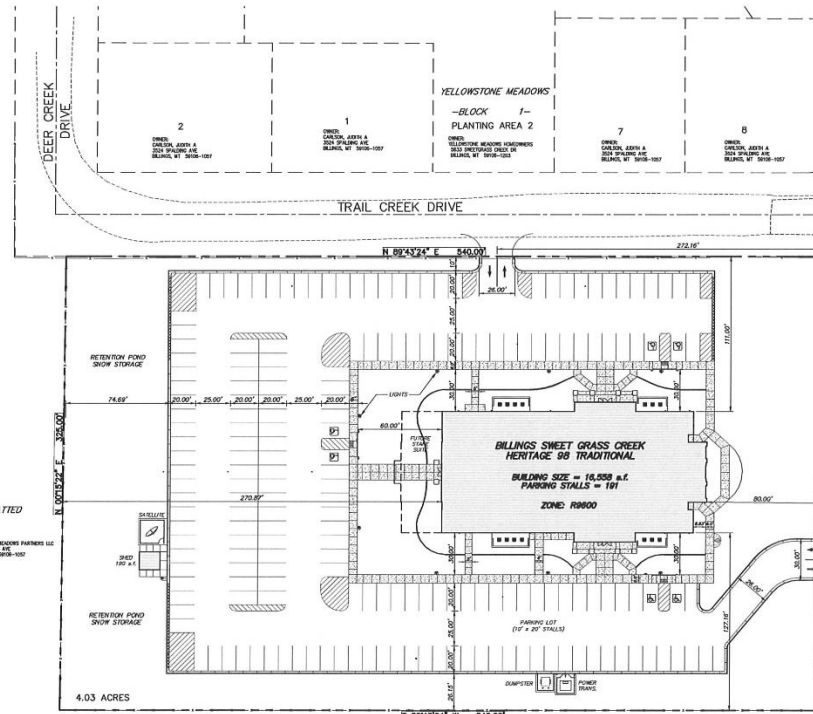

UNPLATTED

OWNER: YELLOWSTONE MEADOWS PARTNERS LLC
5532 BOBBY JONES BLVD
BILLINGS, MT 59106-1130

UNPLATTED
YELLOWSTONE MEADOWS PARTNERS LLC
5532 BOBBY JONES BLVD
BILLINGS, MT 59106-1130

UNPLATTED
OWNER: YELLOWSTONE MEADOWS PARTNERS LLC
5532 BOBBY JONES BLVD
BILLINGS, MT 59106-1130

- LEGEND**
- PROPERTY LINE
 - FENCE LINE
 - SIDEWALK
 - MOW STRIP
 - CONCRETE CURB & GUTTER
 - 6" CONCRETE CURB
 - ROLL BACK CURB

PRELIMINARY SITE LAYOUT

SCALE: 1" = 40'-0"

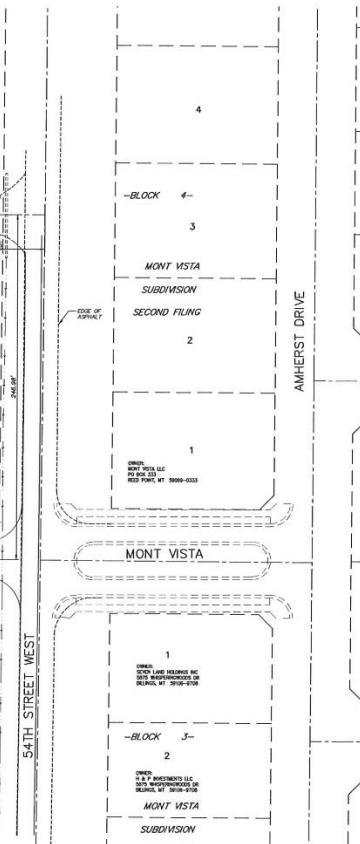

SITE KEY PLAN

SCALE: N.T.S.

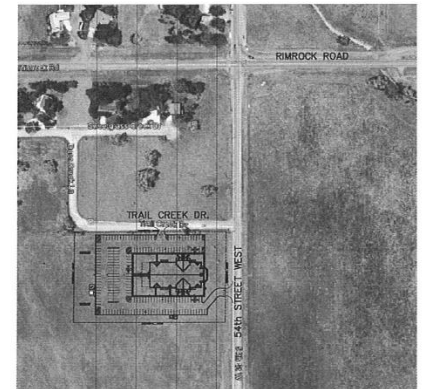

CARLSON, JUDITH A
3524 SPALDING AVE
BILLINGS, MT 59106-1057

3524 SPALDING AVE.
BILLINGS, MT 59106-1057

YELLOWSTONE MEADOWS HOMEOWNERS
5633 SWEETGRASS CREEK DR
BILLINGS, MT 59106-1203

OWNER:
CARLSON, JUDITH A
3524 SPALDING AVE
BILLINGS, MT 59106-1057

OWNER:
CARLSON, JUDITH A
3524 SPALDING AVE
BILLINGS, MT 59106-1057

TRAIL CREEK DRIVE

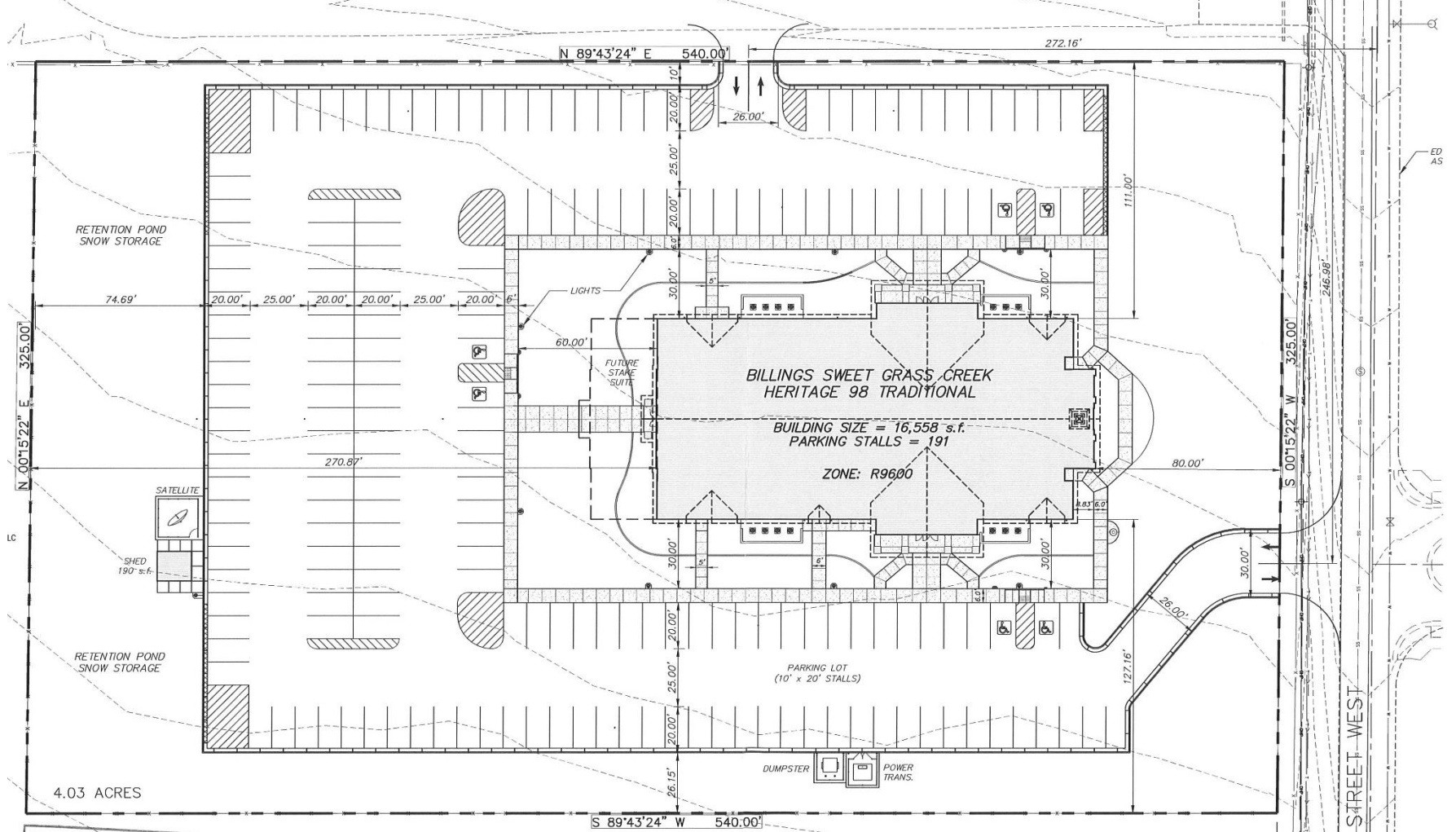

RECEIVED
MAR 07 2016

PRELIMINARY SITE LAYOUT
SCALE: 1" = 20'-0"

UNPLATTED
OWNER:
YELLOWSTONE MEADOWS PARTNERS LLC
3524 SPALDING AVE

LEGEND
PROPERTY LINE
FENCE LINE
SIDEWALK
CONCRETE CURB & GUTTER
6" CONCRETE CURB
ROLL BACK CURB
MOW STRIP

54TH STREET WEST

RECEIVED
 MAR 07 2016
 PLANNING & COMMUNITY SERVICES DEPARTMENT

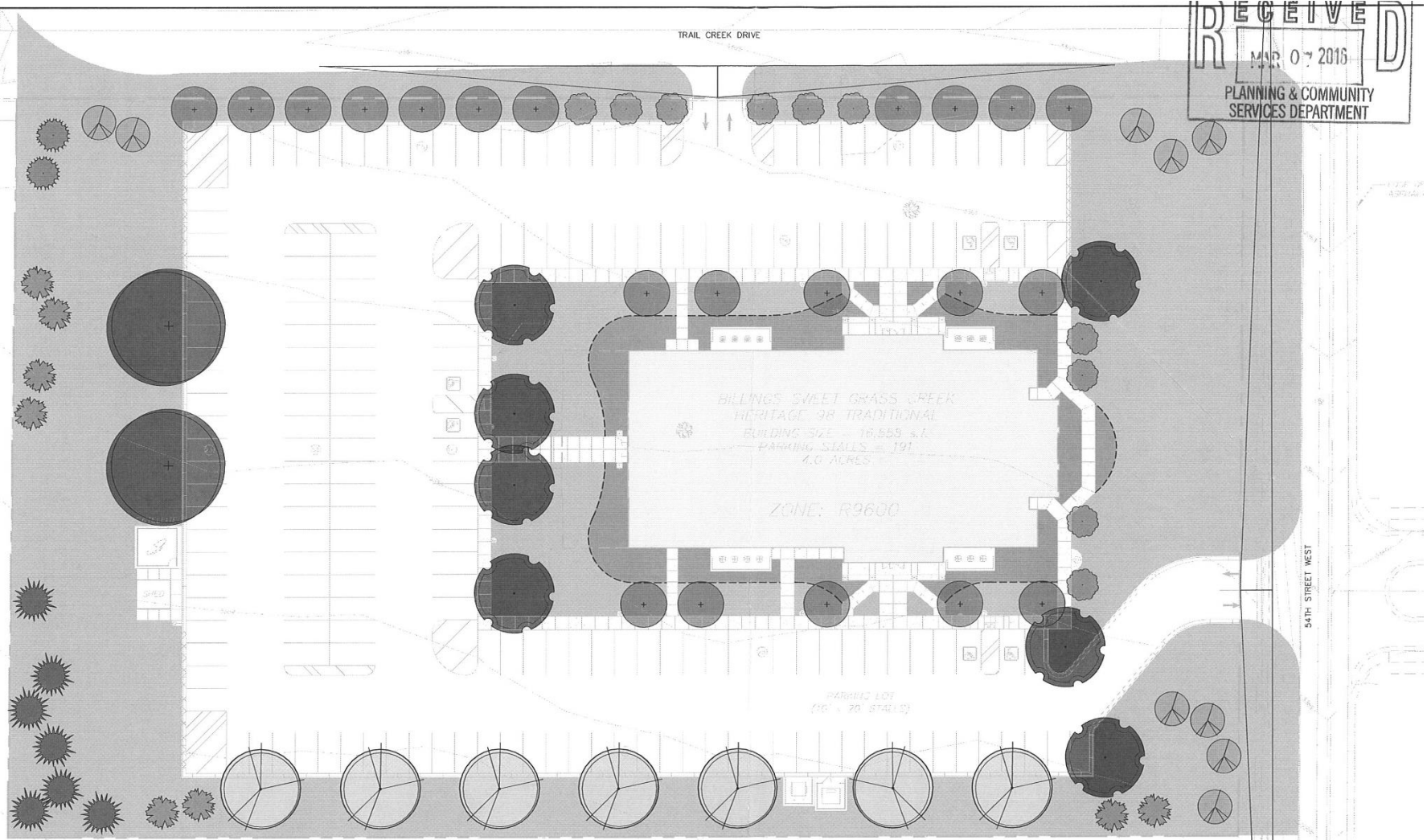

DESIGN CRITERIA

CLIMATE	U.S. HARDNESS ZONE 4
ZONING ORDINANCE	CITY OF BILLINGS ARTICLE 27-1100 LANDSCAPING
WATER AVAILABILITY	T.B.D. P.S.I. AND G.P.M.
SOIL TYPE	T.B.D. PER TOPSOIL TEST REPORT/INDICATE IF IMPORT IS NEEDED
SLOPES	NONE
WIND	SOUTHWEST
SETBACKS/EASEMENTS	UNKNOWN
MICROCLIMATES	SHADE ON NORTH SIDE OF BUILDING
SOIL PH	T.B.D. PER TOPSOIL TEST REPORT
LAWN AREA PERCENTAGE	TBD
UNDEVELOPED PROPERTY	NONE
IRRIGATION SYSTEM	YES -AUTOMATIC

LANDSCAPE DATA

TOTAL SITE AREA	4.4 ACRES
SHRUBS/GROUNDCOVER	6,240 SQ.FT.
TOTAL LANDSCAPE AREA	69,435 SQ.FT.

PLANT COVERAGE

	SHRUBS-MATURE COVERAGE	TREES-MATURE COVERAGE
STREET FRONTAGE	50% - 75%	FRAME BUILDING
ENTRIES	50% - 75%	FRAME ENTRY
BUILDING PERIMETER	40% - 60%	40% - 60%
PERIMETER SIDES	75%	60% - 80%
PERIMETER REAR	75%	40% - 60%

LEGEND:
 --- CONCRETE CURBING, SEE DETAILS
 [Light Gray Box] SOO = 83,195 SQ.FT.
 [Dark Gray Box] PLANTER AREA = 6,240 SQ.FT.

CITY OF BILLINGS LANDSCAPE ORDINANCE REQUIREMENTS:

	TOTAL	REQUIRED	PROVIDED
REQUIRED BUFFERYARD			
STREET FRONTAGE LANDSCAPING: 20' MINIMUM BUFFERYARD AND 1 TREE/40' LF (54th STREET WEST)	325 LF	8.1	8
10' MINIMUM BUFFERYARD AND 2 TREES/40' LF (TRAIL CREEK DRIVE)	395 LF	19.8	20
20' MINIMUM BUFFERYARD AND 1 TREE/40' LF (TRAIL CREEK DRIVE)	145 LF	3.6	4
PERIMETER LANDSCAPING: SOUTH 5' MINIMUM BUFFERYARD AND 1 TREE/40 LF	540 LF	13.5	14
WEST 5' MINIMUM BUFFERYARD AND 1 TREE/40 LF	325 LF	8.1	8
OFF-STREET PARKING LOT LANDSCAPING			
TREES: 1 TREE/10 STALLS	191 STALLS	19.1	19
LANDSCAPE AREA: STEPPED SCALE	191 STALLS	5,120 SF	-

NOTES:
 1. ALL PLANTERS TO RECEIVE ROCK MULCH.

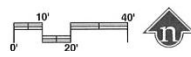

Stamp:
NOT FOR CONSTRUCTION

Billings Sweet Grass Creek
 Heritage 98
 Billings Montana Stake
 ...Trail Creek Drive
 Billings Montana

Project for:
THE CHURCH OF JESUS CHRIST OF LATTER-DAY SAINTS

4 APR 16	REVISED PLAN	Mark	Date (day)	Description

Project Number:
 15047
 Plan Series:
 HER-TRA-98-20
 Property Number:
 **** **

Sheet Title:
PRELIMINARY CONCEPT PLANTING PLAN

Sheet:
L101

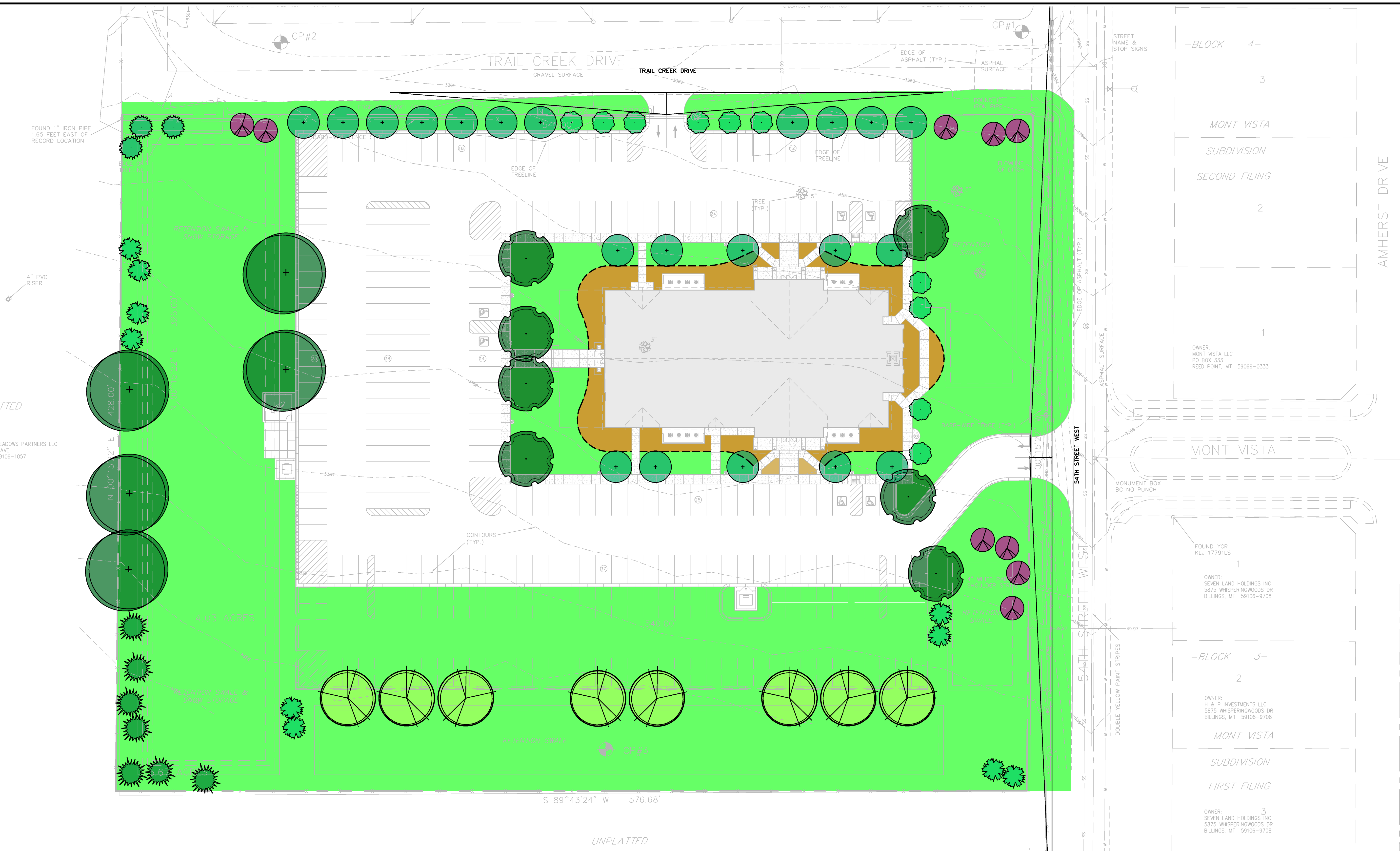
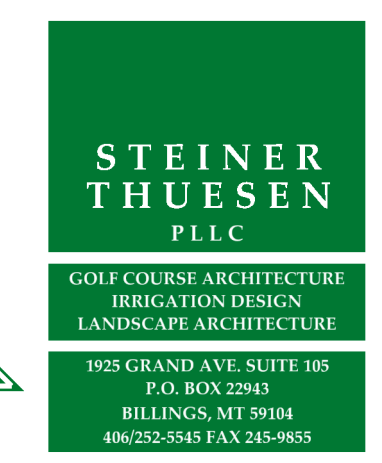

DESIGN CRITERIA

CLIMATE	U.S. HARDINESS ZONE 4
ZONING ORDINANCE	CITY OF BILLINGS ARTICLE 27-1100 LANDSCAPING
WATER AVAILABILITY	T.B.D. P.S.I. AND G.P.M.
SOIL TYPE	T.B.D. PER TOPSOIL TEST REPORT/INDICATE IF IMPORT IS NEEDED
SLOPES	NONE
WIND	SOUTHWEST
SETBACKS/EASEMENTS	UNKNOWN
MICROCLIMATES	SHADE ON NORTH SIDE OF BUILDING
SOIL PH	T.B.D. PER TOPSOIL TEST REPORT
LAWN AREA PERCENTAGE	TBD
UNDEVELOPED PROPERTY	NONE
IRRIGATION SYSTEM	YES -AUTOMATIC

PLANT COVERAGE

	SHRUBS—MATURE COVERAGE	TREES—MATURE COVERAGE
STREET FRONTAGE	50% - 75%	FRAME BUILDING
ENTRIES	50% - 75%	FRAME ENTRY
BUILDING PERIMETER	40% - 60%	40% - 60%
PERIMETER SIDES	75%	60% - 80%
PERIMETER REAR	75%	40% - 60%

LEGEND:
 --- CONCRETE CURBING, SEE DETAILS
 [Green Box] LAWN/NATIVE GRASS = 156,232 SQFT.
 [Brown Box] PLANTER AREA = 6,240 SQFT.

CITY OF BILLINGS LANDSCAPE ORDINANCE REQUIREMENTS:

REQUIRED BUFFERYARD	TOTAL	REQUIRED	PROVIDED
STREET FRONTAGE LANDSCAPING: 20' MINIMUM BUFFERYARD AND 1 TREE/40' LF (54th STREET WEST)	428 LF	10.7	11
10' MINIMUM BUFFERYARD AND 2 TREES/40' LF (TRAIL CREEK DRIVE)	390 LF	19.5	20
20' MINIMUM BUFFERYARD AND 1 TREE/40' LF (TRAIL CREEK DRIVE)	187 LF	4.7	5
PERIMETER LANDSCAPING: SOUTH 5' MINIMUM BUFFERYARD AND 1 TREE/40 LF	577 LF	14.4	14
WEST 5' MINIMUM BUFFERYARD AND 1 TREE/40 LF	428 LF	10.7	11
OFF-STREET PARKING LOT LANDSCAPING	TOTAL	REQUIRED	PROVIDED
TREES: 1 TREE/10 STALLS	191 STALLS	19.1	19
LANDSCAPE AREA: STEPPED SCALE	191 STALLS	5,120 SF	-

NOTES:
 1. ALL PLANTERS TO RECEIVE ROCK MULCH.

LANDSCAPE DATA

TOTAL SITE AREA	5.6 ACRES
SHRUBS/GROUNDCOVER	6,240 SQFT.
TOTAL LANDSCAPE AREA	162,472 SQFT.
TREES ON SITE	80

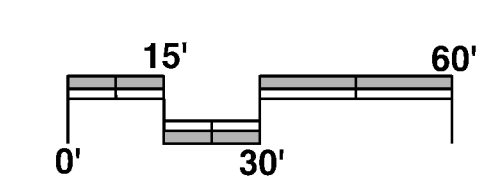

To: Nicole Cromwell

RE: In Protest of Variance 941
Special Review

Hello Nicole,

Can you please submit our letter of protest of Variance 941 to the City Council Meeting of April 4th 2016.

We reside at **5515 Sweetgrass Creek Drive**. The following are the reasons we do not want to see the LDS Meeting House constructed in our residential neighborhood:

- It will consist of an extremely large building--approximate size of a 16,558-square-foot meetinghouse and a 191-stall parking lot- with drive approaches off both 54th Street West and Trail Creek Drive-this will greatly increase the amount of traffic on our small gravel street. We currently have Rimrock Road outside of our back yards and this will make the area across from the front of our homes just as busy and noisy.
- The Meetinghouse will increase traffic on Grand and 54th and Rimrock and 54th Street. These intersections have already become busier with the added subdivisions in this area, so the meetinghouse will drastically increase what have already become unmanageable.
- We chose this area to live in because of its remoteness and the fact there is little traffic across from our homes. It is currently peaceful and quiet-the new meeting hall will make it a hive of activity, thereby eliminating the reason we moved here in the first place
- It will give the residential area a more commercial appearance and will diminish our property values as a result-It will have a large economic impact for those homes that will be closest to it.
- There will be lights illuminating the meetinghouse-it will take away the residential aspect of our neighborhood.
- This area is zoned for Residential Single Family homes

Thank you for submitting and considering our letter.

Please call me with any questions or further information at 406-697-7727.

 4/5/16
Monti Bonawitz

 4/5/16
Mary Bonawitz

Signed Petition in Protest of Variance #941

Marybelle Watters 5525 Sweetgrass Creek Drive
Mary Bonart 5515 Sweetgrass Creek Drive
Gina June Tibbs 5503 Sweetgrass Creek Drive
Pat King 5515 Sweetgrass C. Dr

Regular City Council Meeting

Meeting Date: 05/09/2016

TITLE: Public Hearing for Ward Ordinance First Reading - Annexation #16-02

PRESENTED BY: Candi Millar, Planning & Community Services Department Director

Department: Planning & Community Services

PROBLEM/ISSUE STATEMENT

City election ward boundaries must be adjusted to conform to city limit amendments resulting from annexation of property into the City. The City Council approved the annexation of property owned by McCall Development and the Yellowstone Boys and Girls Ranch Foundation (Annexation #16-02) on April 25, 2016. This requires a change in the boundaries of Ward III. Two readings are required for this action. The first reading of the ordinance is scheduled for May 9, 2016 along with a public hearing, and the second reading is scheduled for May 23.

ALTERNATIVES ANALYZED

City Council may approve or not approve the ordinance to amend the boundaries of Ward III on first reading.

- Approving the ordinance will modify the boundaries of Ward III to include the property owned by McCall Development and the Yellowstone Boys and Girls Ranch.
- Not approving the ordinance will not modify the boundaries of Ward III and create a problem where property inside the City Limits is not within one of the City Ward Boundaries.

FINANCIAL IMPACT

There is no budget/financial impact from this action.

RECOMMENDATION

Staff recommends that the City Council hold a public hearing and approve this ordinance on first reading, adding recently annexed property to Ward III.

APPROVED BY CITY ADMINISTRATOR

Attachments

Ward Ordinance

ORDINANCE NO. 16-_____

AN ORDINANCE OF THE CITY OF BILLINGS, AMENDING BILLINGS MUNICIPAL CODE, CHAPTER 11, ELECTIONS, IN PARTICULAR, SECTION 11-102(c), WARD BOUNDARIES; AND CHANGING THE WARD BOUNDARIES ESTABLISHED THEREIN BY ADDING CERTAIN NEWLY ANNEXED REAL PROPERTY TO WARD III PROVIDING FOR CERTIFICATION AND REPEALING OF ALL ORDINANCES AND RESOLUTIONS INCONSISTENT THEREWITH.

BE IT RESOLVED BY THE CITY COUNCIL OF THE CITY OF BILLINGS, MONTANA:

1. AMENDMENT. Pursuant to Billings Municipal Code, Section 11-102(c) and the State Law, Billings Municipal Code, Section 11-102(c) Ward Boundaries is hereby amended by adding to Ward III the following described real property:

A tract of land situated in the SW1/4 of Section 18, and the NW 1/4 of Section 19 , T.1S., R.26E., P.M.M., Yellowstone County, Montana, more particularly described as: Adam and Mollie Walter Subdivision, First Filing, Lots 1, Block 1, Recorded February 22, 2016, under Document No. 3769605, on file and of record in the Records of Yellowstone County; Tract 1, of Certificate of Survey No. 3594, Recorded July 29, 2015, under Document No. 3748158, on file and of record in the Records of Yellowstone County; Including all adjacent right-of-way of Elysian Road and Canyon Creek Ditch.

Containing 34.721 gross acres and 33.854 net acres more or less.

(# 16-02) See Exhibit "A" Attached

2. CERTIFICATION. Pursuant to M.C.A. Section 13-3-103, the above change and alteration is hereby certified to the election administrator by the City Council, and the City Administrator or his designee is hereby directed to certify the changes and alterations and to deliver a map showing the boundaries of the ward, the streets, avenues and alleys by name and the ward by number, to the election administrator not more than ten (10) days after the effective date of this ordinance.
3. REPEALER. All other ordinances, sections of the Billings Municipal Code and ordinances inconsistent herewith are hereby repealed.

PASSED by the City Council on the first reading this 9th day of May, 2016.

PASSED by the City Council on the second reading this 23rd day of May, 2016.

THE CITY OF BILLINGS:

Thomas W. Hanel, MAYOR

ATTEST:

BY: _____
Billie Guenther, CITY CLERK

(AN 16-02)

Regular City Council Meeting

Meeting Date: 05/09/2016

TITLE: Authorize the Downtown Billings Partnership (DBP) to purchase property and waive appraisal requirements of Resolution No. 93-16740

PRESENTED BY: Bruce McCandless, Assistant City Administrator

Department: City Hall Administration

PROBLEM/ISSUE STATEMENT

The Downtown Billings Partnership (DBP) has been working for many months with a prospective property developer who is planning a large redevelopment project in the vicinity of N. 29th Street and 1st Avenue North. The developer owns property in the project area and has purchase options for others, including the subject property. The developer plans to transfer the option to the DBP if Council approves purchasing this property. The DBP Board of Directors requests that the City Council approve purchasing the property with downtown tax increment funds (TIF) for a price and expenses not to exceed \$850,000. Additional explanations and justifications for the purchase are contained in the attachments provided by the DBP. City Resolution #93-16740 establishes the requirements for property purchases. According to the resolution, property with value exceeding \$200,000 should be appraised by two qualified appraisers and a third appraiser should review them and determine the final appraised value. The Resolution's Paragraph H allows the City Administrator to request a variance to that policy if the project demands it. There isn't enough time to perform two long form appraisals and a review before the purchase option's expiration on May 9. The DBP obtained one appraisal for the property and the appraiser substantiated the proposed purchase price. Therefore, if the Council allows the DBP to purchase this property, it should waive the appraisal requirements of Resolution No. 93-16740.

ALTERNATIVES ANALYZED

City Council may:

- Approve the DBP's request to use TIF funds to purchase property, including expenses, for up to \$850,000 and waive Resolution No. 93-16740 appraisal guidelines; or,
- Not approve the request, or
- Request additional information from the DBP and delay a final decision until a future meeting.

FINANCIAL IMPACT

The downtown Tax Increment District (TID) has sufficient funds for the purchase. The 2015 statewide property re-appraisal and continued strong downtown business activity increased the downtown district's taxable value by almost \$2 million; from \$3,067,000 in tax year 2014 to \$4,960,000 in tax year 2015. The TID Fund has about \$2 million of un-obligated cash and the County Treasurer will collect and distribute second half property taxes in June.

RECOMMENDATION

The Downtown Billings Partnership Board of Directors recommends that the City Council authorize the DBP to purchase property at 1st Ave. North and North 29th Street for a price and expenses not to exceed \$850,000. Staff recommends that Council waive the appraisal requirements of Resolution No. 93-16740.

APPROVED BY CITY ADMINISTRATOR

Attachments

Project description

FAQ

Reso. No. 93-16740

City Council Action Request:

On April 22, 2019 the Board of Directors approved the purchase of property legally described as BILLINGS ORIGINAL TOWNSITE, S03, T01 S, R26 E, BLOCK 94, Lot 1 - 3 located at 102 N. 29th St. by the Downtown Billings Partnership, Inc. (DBP) and to request full funding for that purchase up to \$850,000.00 from Urban Renewal Fund 203, the Expanded North 27th St. Tax Increment District. Further, due to timely transfer and execution of a Buy Sell contract, the DBP request placement on the Regular Agenda for May 9, 2016.

For almost two years, the Downtown Alliance staff has been working on a potential large development site that could include a 40 to 50 K square foot conference center for the City of Billings. At the very least, we anticipate a development that will increase the building density on N. 29th Street in Downtown. Our charge has been to add to the street level activity and meet the demand for housing units downtown. At this time, the DBP Board feels that our best chance to seize on this opportunity is to purchase property within a footprint that could be expanded to provide green space, housing, parking, conference space, and other commercial uses. The best purchase at this time would be at 102 N. 29th St. This property has been for sale for several years. Further, the current owner has not paid property taxes on this site since December of 2013. Delinquent taxes have been paid by a 3rd party and with this purchase, the current owner will be required to satisfy that debt including penalties and interest out of the purchase proceeds. A qualified development entity currently has an active Buy/Sell agreement on this property that will expire on May 9, 2016. They have offered, at no additional expense, to transfer this Buy/Sell to the DBP. Pending approval tonight for funding, the DBP has accepted that offer and has scheduled closing on Friday, May 20, 2016. The DBP has given this development entity until July 2016 to make a major decision to go public with an urban renewal project that would dramatically increase the taxable value of the area and, with Council Approval, agreed to purchase this parcel within the development and hold it until they are ready to announce and commit. That commitment will require significantly more TIFD investment and a Development Agreement between the development entity and the City of Billings. This project has the potential to satisfy our goals and bring a development valued at over \$100 Million.

If Council approves this request, the DBP will manage and maintain the property (the DBP has an history of doing this for the City) for as long as it takes to enter into a development agreement with this developer. We have agreed to give them 1 year from tonight (May 9th) to propose an acceptable plan for this site that could include construction of a City owned parking structure, a city plaza on N. 29th and a Conference Center. If Council does not approve of the proposal, the DBP will either continue to hold the property, transfer ownership to the City, or sell the property at market value and return the proceeds of the sale to the TIFD fund 203.

Fund 203 has sufficient unencumbered funds to execute this request.

Mixed Use Development on N. 29th St.

Pending Council Action Scheduled for May 9th – DBP is requesting up to \$850,000 from the TIFD Fund to purchase a building on 29th.

Q: What is mixed use and why is that important?

A: The Central Business District has the most valuable real estate in the city and as such, economies of scale entice developers to efficiently use the footprint of land. Mixed use in one vertical structure is far more efficient and valuable as a taxable property than several single story buildings surrounded by parking lots and roads.

Q: Why does the Developer need the DBP to help assemble land?

A: The Developer has already put over \$1,000,000.00 cash into this project. They are working through due diligence on three more parcels, not including the property to be purchased by the DBP, using TIFD resources. In addition, they have committed significant financial resources to preliminary design using a local firm.

Q: Can we afford it?

A: The Expanded N. 27th Street TIFD, due to several high value projects, and the new re-appraisal cycle, has been dramatically successful. That's good because there is much yet to be done. Our bond payment on the Empire Garage is just under \$1 Million per year, and we receive roughly \$3 Million per year. And, as of today, we have over \$2 Million in the fund that is unencumbered and available for investment.

Q: Why don't we simply transfer that "surplus" into the General Fund or return it to the other taxing entities?

A: TIFD funds can only be used to implement the urban renewal plan within the boundaries of the district. It would be unwise to suspend all urban renewal projects before all blight has been eliminated and all opportunities have been explored and completed. **In 1987 the City suspended urban renewal in the previous TIFD and within 4 years the taxable value of the TIFD dropped by 53% and was on a path that could have placed committed bond payments into real jeopardy.**

Q: What's the rush and has the property been appraised?

A: The "rush" is due to a buy/sell document that requires that the property be committed to a purchase on May 9th or the Buy/Sell instrument expires. It is likely that will increase the price tag dramatically and the fragile development opportunity will disappear. The appraisal is taking place and should be completed before we commit to the purchase. With a steady gross cash flow of about \$11-\$12K per month, it should appraise for at least \$850,000.

NORTH 29TH BETWEEN 1ST AVE. N. AND 3RD AVE N. HAS HAD VERY LITTLE REDEVOPMENT SINCE 2005. THE BUILDING DENSITY IS VERY LOW COMPARED TO N. BROADWAY. THUS, A MAJORITY OF THE STOREFRONTS ARE VACANT AND VERY DIFFICULT TO FILL. FURTHER, THE CURBS, GUTTERS AND SIDE WALKS, IN MANY PLACES, ARE IN NEED OF REPAIR.



RESOLUTION NO. 93 - 16740

A RESOLUTION REPEALING RESOLUTION 86-15515, AND ESTABLISHING A POLICY OF THE CITY OF BILLINGS, MONTANA AS IT RELATES TO THE ACQUISITION OF PROPERTY.

WHEREAS, from time to time the City of Billings has need to acquire property in order to carry out the programs and projects adopted by the City Council; and

WHEREAS, the city is desirous of developing a uniform guide to determine the number and type of appraisals in the acquisition of real property.

NOW THEREFORE, BE IT RESOLVED BY THE CITY COUNCIL OF THE CITY OF BILLINGS, MONTANA, AS FOLLOWS:

Resolution No. 86-15515 is hereby repealed.

GUIDE TO DETERMINE THE NUMBER AND TYPE OF APPRAISALS:

Since these matters are largely governed by the magnitude of the appraised compensation for each parcel, the following rules are set forth on this basis. If these differ from requirements tied to a specific funding source, then the more rigorous standards will be used.

- A. RANGE OF VALUE: LESS THAN \$100,000:
 - 1. Appraisals required: One.
 - 2. Type of Appraisal: Short form
- B. RANGE OF VALUE FROM \$100,000 to \$200,000:
 - 1. Appraisals required: One.
 - 2. Type of Appraisal: Long form
- C. RANGE OF VALUE OVER \$200,000:
 - 1. Appraisals required: Two.
 - 2. Type of Appraisal: Long form
- D. APPRAISALS FOR PROPERTY \$100,000 AND OVER IN VALUE MUST BE REVIEWED BY A QUALIFIED REVIEW APPRAISER SELECTED BY THE CITY OF BILLINGS ACCORDING TO REQUIREMENTS SET FORTH FOR REVIEW APPRAISERS, WHICH ARE MADE A PART OF THIS RESOLUTION.
 - 1. After the review appraiser has reviewed the appraisals and arrived at a fair market value of the property being appraised, the city staff will

present the review appraisal to the City Council for the purpose of establishing the fair market value.

2. For appraisals less than \$100,000 in value, the staff will present the appraisal as reviewed by staff to the City Council for the purpose of establishing fair market value.
3. In any case, after the appraisals have been completed and reviewed, city staff may enter into contingent acquisition negotiations with the property owner prior to presenting the appraisals to the City Council to establish fair market value. However, city staff shall not acquire or enter into a binding agreement to acquire the property prior to the establishment of the fair market value by the City Council.

E. **NEGOTIATING FLEXIBILITY:** In cases of extreme need where expeditious decisions are critical to the success of the development of a public improvement project, the city administrator may authorize an offer over the fair market value established by the City Council. The offer may not exceed 5% of the fair market value or \$10,000, whichever is less.

F. **MINIMUM PAYMENT POLICY:** It is the City of Billings' policy to employ the minimum payments described below whenever the estimated just compensation, based on recognized appraisal techniques, is less than these amounts, including those instances where the estimated compensation is zero. In these cases, the appraisal report should show the property values as estimated using recognized techniques and in addition, the report should show the applicable minimum payment as described below.

1. **MINIMUM PAYMENT FOR PERMANENT PROPERTY INTERESTS:** The minimum payment for any property interest acquired by deed or easement will be \$300.
2. **MINIMUM PAYMENT FOR TEMPORARY USE OF PROPERTY:** The minimum payment for the temporary right to occupy and use property during construction, e.g., streets, waterlines, sewer lines, traffic signals, will be \$150.

Minimum payment appraisal is limited to those parcels where total compensation is \$500 or less.

G. **QUALIFICATION OF FEE AND REVIEW APPRAISERS:** The City of Billings will maintain a current list of contract fee and review appraisers in the office of the director of development services who have been approved for an appraisal assignment. Before an appraiser can be approved, they must first submit a demonstration appraisal of his/her current appraisal work which will be used to evaluate their knowledge of appraisal theory and principles and the clarity of their written communication. As a minimum, fee and review appraisers must be Montana Certified Appraisers with two or more full-time years of appraisal experience. In addition, appraisers with higher qualifications may be retained 1) to meet the needs of projects involving federal, state or local grant conditions, 2)

to participate in projects anticipated to involve eminent domain proceedings, or
3) to meet other special requirements, situations and conditions.

Appraisers meeting the above criteria will be hired as would any other
professional service provider.

- H. THIS RESOLUTION IS INTENDED TO PROVIDE A SET OF GUIDELINES.
IN CASES WHERE THE DEMANDS OF A PROJECT REQUIRE A
VARIANCE FROM THESE GUIDELINES, THE CITY ADMINISTRATOR
MAY COME TO THE CITY COUNCIL TO REQUEST A VARIANCE.

APPROVED AND PASSED by the City Council of the City of Billings this 13th day of
September 1993.

THE CITY OF BILLINGS:

BY: _____
MAYOR

ATTEST:

CITY CLERK