



BICYCLE PEDESTRIAN COMMITTEE AGENDA
City of Billings & Yellowstone County
MEETING AGENDA



October 24, 2017 MEETING TIME: 11:30 a.m.
1st Floor Conference Room, Miller Building
2825 3rd Avenue North, Billings, Montana 59101

1. Call to Order: Chairman

2. **PUBLIC COMMENT PERIOD** – As required (minute maximum per person.) *Any member of the public may be heard on any subject that is not on the agenda. The Bicycle Pedestrian Committee will not take any action on these items at this time, but could choose to add an item to the next meeting's agenda for discussion.*

Attendees: Please sign in on the provided meeting attendance sheet.
 - a. **Comments on items not on the agenda and requests to add items to future agendas.**

 - b. **Comments on items on the non-public agenda items.**

3. Motion. Approval of the minutes of: August and September 2017

4. Old Business
 - a. Discussion. Bike Parking Update, Kristi Drake, Ed Gulick.

 - b. Discussion. New Funding Sources and Strategies. Ed Gulick.

 - c. Discussion. Letter to MDT-North 27th Street Reconstruction, Kristi Drake, Planning Staff.

5. New Business
 - a. Update/Discussion. Household Travel Survey Results. Planning Staff

 - b. Update/Discussion. Complete Streets Progress Report. Planning Staff.

6. Other Business

- a. Discussion.Next BPAC meeting: November 28, 2017?

7. Future Agenda Items

- a. --Alignment of Bike and Parks Plan, Jolene Rieck
--Joint meeting with Traffic Control Board

8. Adjournment

Bicycle Pedestrian Advisory Committee

3.

Meeting Date: 10/24/2017

Subject

Motion. Approval of the minutes of: August and September 2017

Attachments

2017-August 22_BPAC_Minutes-Draft
17.09.26_BPAC minutes



BICYCLE AND PEDESTRIAN ADVISORY COMMITTEE

City of Billings & Yellowstone County



MEETING MINUTES

Tuesday, August 22, 2017 MEETING TIME: 11:30 am
1st Floor Conference Room, Miller Building
2825 3rd Avenue North, Billings, MT 59101

Draft to be approved at next meeting.

Call to order: Ed Gulick, Chair, called the meeting to order at 11:37 a.m.

Members present: Kristi Drake, City Council; Ed Gulick, Planning Board, Amber Sundsted, City Council; Jane Van Dyk, City Council

Others present: Lora Mattox, Transportation Planner; Mark Jarvis, Park Planner, PRPL

Public Comment Period:

- a. **Comments on items not on the agenda and request to add items to future agendas** – none
- b. **Comments on items on the non-public agenda items** – none

Motion. Approval of the meeting minutes of: July 17, 2017: Amber motioned for the approval of the July 17, 2017 minutes, seconded by Jane. Approved.

New Business: Out of courtesy to Mark Jarvis, this item was moved before Old Business.

- a. **Park Signage (Mark Jarvis)** – Mark started this presentation with a discussion on how the Signage Framework Plan was completed during the Phase II of the Swords Park Path development. The plan included design guidelines for a variety of sign types:
 - Entry Markers and Site Signs – Two types, Monumental (large and small) and Secondary Site Signs
 - Wayfinding Signs – Mile Markers and Decision point signage
 - Interpretation and Education Signs

Kristi asked about implementation of the sign plan? Mark stated that it is really dependent on prioritization and funding. Kristi suggests Mark identify the priority areas and submit a list of potential projects to Billings TrailNet as a potential funding source. Ed thanked Mark for his informative presentation.

Old Business:

- a. **Bike Parking Update (Ed Gulick and Kristi Drake)** – Members from the board met with DBA, specifically Lisa and Joe regarding bike parking downtown. The sponsors are requesting a more decorative bike rack be purchased with funds donated. After discussion, Kristi sent out a poll asking for a simple vote on type of rack. The top three selected are:



Lora is checking with Erin on the choices to see if Engineering has an issue with any of them. Erin stated that the designs are not a concern but would like to see the dimensions not exceed what is currently approved. The current bike parking guidelines state:

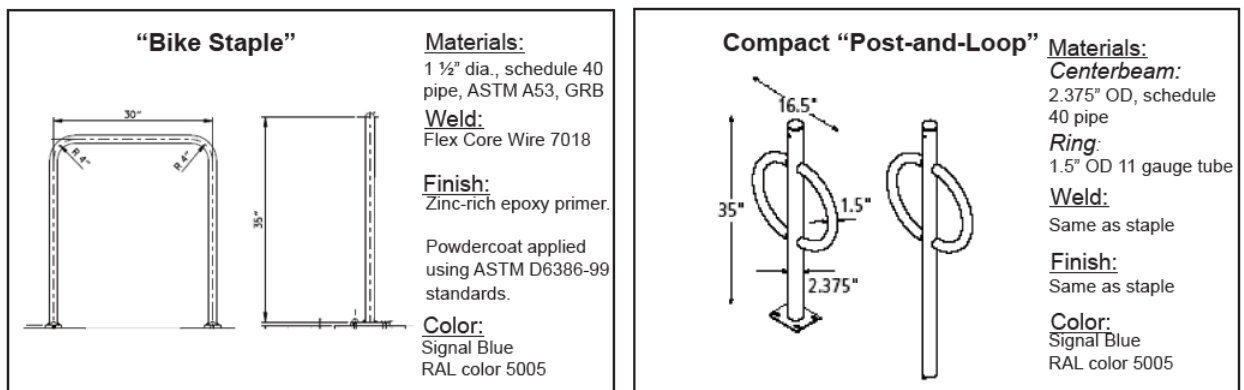

The guidelines also state that decorative and art racks will need approval from the Planning and Engineering Division.

Kristi states that a decision needs to be made to ensure racks for installation in October. Montana Ironworks has expressed an interest in donating time/materials to the project. Kristi will look to see if a design of the #1 choice can be found online to provide to Montana Ironworks for a quote.

- b. **BPAC Presentation to Governing Bodies (Ed Gulick)** – Since the last meeting, Ed and members of the board have presented BPAC information to both the County Commissioners and the City Council. Both presentations went very well with good interaction between BPAC and the governing body representatives. One of the questions asked by Commissioner Pitman was regarding non-city trails, county trails. The trails around MetraPark are a good example of county trails. Councilman Brown asked about

the percentage of residents that bike? According to the American Community Survey, the number is around 1.5–2 percent.

- c. **Downtown Traffic Study Update (Lora)** – Ed asked Lora for an update on the Downtown Transportation Study, specifically how it will work with the update to the Downtown Framework Plan being undertaken by DBA. Lora stated that the study will be developed with two different phases. The first phase will be completed by Engineering. Engineering will be able to include infrastructure engineering within their contract and will include data analysis including crash data, traffic modeling of scenarios and the preliminary design of projects. The second phase will be completed by the Planning Division who will be able to take this initial information provided by Engineering and complete the planning side that will include significant property owner interaction. Engineering’s contract will go first. More information will be provided as the project develops.

Other Business: Jane discussed that at the last Rimrocks Neighborhood Task Force, the task force discussed being in opposition of a trail along Zimmerman Trail. More information will need to be gathered on their concerns.

Future Agenda Items:

- a. **Bike Parking (September)**
- b. **Letter to MDT – RE: North 27th Street Reconstruction (September)**
- c. **Household Travel Survey Results (October)**
- d. **New funding sources (September)**
- e. **Complete Streets Progress Report (October)**
- f. **Invite Jolene Rieck from Peaks to Plains – Alignment of Bike Plan and Park Plans (October)**
- g. **Joint meeting with the Traffic Control Board (November/December)**

Adjournment: 1.02 p.m.

BPAC minutes
September 26, 2017

Present: Zach Hassler (Yellowstone County), Ed Gulick (Chair), Scott Walker (City/County Planning), Jane Van Dyk, (City Rep), Ian (Vista).

Public Comment:

None

Approval of minutes of August – delayed:

No Quorum

Old Business

Park Signage Plan:

Ed mentioned that there has been conversation with Mark Jarvis (PRPL) about the Signage Plan. There still needs to be some work done on the priorities of where to place signs and their general make-up. Ed mentioned that Amber was looking into funding options from the Relators Association.

Jane mentioned some fund raising options for the signage and there was discussion on BPAC's involvement with fund raising.

Bike parking:

Jane spoke of her trip to Anaconda and the Bike parking there, very attractive! BPAC will follow-up with business partners.

Other business:

Group discussion on:

- N. 27th Street rehab project; sidewalk rehab, ADA ramps and road resurfacing
- Funding sources and strategies; Transportation Alternative Grant, Urban and CMAQ funding, Trail District, GO Bond, Gas Tax, Billings TrailNet and Chamber of Commerce

Bike/Ped. Funding needs to diversify.

Next Meeting, October 24th.