



# BILLINGS SAFE ROUTES TO SCHOOL Plan Update



DRAFT - June 2022



# Acknowledgements

Elyse Monat, Billings MPO, Active Transportation Planner & Project Manager

## Project Oversight Committee

### Billings City Council

- Bill Cole, Mayor
- Pam Purinton, City Council, Ward 4

### Billings Public Schools

- Keith Adams, Billings School District
- Sondra Baker, Billings Public Schools
- Brenda Koch, Billings Public Schools
- Pam Meier, Arrowhead Elementary School
- Joe Walsh, Newman Elementary School

### City of Billings and Metropolitan Planning Agency

- Mac Fogelsong, Billings Public Works
- Lora Mattox, Billings MPO
- Dakota Martonen, Billings Public Works
- Scott Walker, Billings MPO

## Community Organizations and Advocates

- Kathy Aragon, Community Advocate
- Jed Barton, Living Independently for Today and Tomorrow
- Melissa Henderson, Healthy By Design Coalition
- Morgan Miller, RiverStone Health
- Elaine Archer, Advocate and Crossing Guard

## Consultant Team:

### Toole Design

- Sara Schooley, Project Manager
- Kerry Aszklar
- Sonia Haeckel
- Carly Haithcock
- Lisa Johnston-Smith
- Fernando Olivera
- Megan Seib

Information contained in this document is for planning purposes and should not be used for final design of any project. All results, recommendations, concept drawings, cost opinions, and commentary contained herein are based on limited data and information and on existing conditions that are subject to change. Further analysis and engineering design are necessary prior to implementing any of the recommendations contained herein.



# Contents

<b>1. Introduction .....</b>	<b><a href="#">1</a></b>	Highland.....	<a href="#">48</a>
1.1 Goals of this Plan .....	<a href="#">1</a>	McKinley.....	<a href="#">51</a>
1.2 How to Use this Plan .....	<a href="#">2</a>	Meadowlark.....	<a href="#">54</a>
1.3 History of Billings’ Safe Routes to School Program .....	<a href="#">3</a>	Miles Avenue.....	<a href="#">57</a>
1.4 Moving Forward.....	<a href="#">3</a>	Newman.....	<a href="#">60</a>
<b>2. Programmatic Recommendations.....</b>	<b><a href="#">4</a></b>	Orchard .....	<a href="#">63</a>
2.1 Creating an Equitable Safe Routes to School Program in Billings.....	<a href="#">4</a>	Poly Drive .....	<a href="#">66</a>
2.2 Using this Chapter .....	<a href="#">5</a>	Ponderosa .....	<a href="#">69</a>
2.3 Recommended Strategies .....	<a href="#">5</a>	Rose Park.....	<a href="#">72</a>
<b>3. Project Recommendations .....</b>	<b><a href="#">13</a></b>	Sandstone .....	<a href="#">75</a>
3.1 Methodology.....	<a href="#">13</a>	Washington.....	<a href="#">78</a>
3.2 How to Use This Chapter.....	<a href="#">13</a>	<b>4. Infrastructure Toolbox.....</b>	<b><a href="#">81</a></b>
3.3 Project List and School-Specific Project Location Recommendations .....	<a href="#">14</a>	<b>5. Project Impact.....</b>	<b><a href="#">107</a></b>
Alkali Creek.....	<a href="#">15</a>	5.1 Impact Score Criteria .....	<a href="#">107</a>
Arrowhead.....	<a href="#">18</a>	5.2 Implementation.....	<a href="#">108</a>
Beartooth .....	<a href="#">21</a>	5.3 High Impact Project List.....	<a href="#">110</a>
Bench.....	<a href="#">24</a>	5.4 Medium Impact Project List .....	<a href="#">112</a>
Big Sky.....	<a href="#">27</a>	5.5 Low Impact Project List .....	<a href="#">114</a>
Bitterroot.....	<a href="#">30</a>	<b>6. School Walking Maps .....</b>	<b><a href="#">116</a></b>
Boulder.....	<a href="#">33</a>	<b>Appendix A. Existing Safe Routes to School Plans, Policies, and Program Review .....</b>	<b><a href="#">140</a></b>
Broadwater .....	<a href="#">36</a>	<b>Appendix B: School Summaries.....</b>	<b><a href="#">144</a></b>
Burlington .....	<a href="#">39</a>	<b>Appendix C. Webmap Summary .....</b>	<b><a href="#">252</a></b>
Central Heights .....	<a href="#">42</a>		
Eagle Cliffs.....	<a href="#">45</a>		

THIS PAGE INTENTIONALLY LEFT BLANK

# 1. Introduction

The Billings Safe Routes to School Plan Update (“the Plan”) is an effort led by the Billings-Yellowstone County Metropolitan Planning Organization (Billings MPO). This effort builds off previous Safe Routes to School (SRTS) work, including a plan adopted in 2011<sup>1</sup> and additional efforts that have focused on encouraging students and their families walk and bike to school. This updated plan was completed collaboratively by Billings MPO staff and a consultant team, who were advised by a Project Oversight Committee (POC) consisting of MPO staff, school district staff, stakeholder organizations, and members of the public.

## 1.1 Goals of this Plan

Walking and biking are fun and healthy ways for students to get to school in Billings, and can also help reduce air pollution, build a sense of community, encourage more physical activity, promote safety, and save money. Unfortunately, many students and their families don't feel safe walking or biking to school because of busy streets, lack of sidewalks, unmarked crossings, or other issues.

This plan aims to recommend policy and programmatic changes, as well as identify and prioritize infrastructure projects that improve safety and accessibility for, and increase the number of, children walking and rolling to school in Billings.

The goals of this plan are as follows:

- Evaluate current walking and biking conditions for students in the region
- Identify barriers or issues that might discourage students from walking or biking
- Recommend policy or programmatic changes that would encourage more students to walk or bike to school
- Develop a list of prioritized projects that can be built to improve walking and biking conditions for students
- Create walking route maps for all 22 public elementary schools in Billings

<sup>1</sup> The 2011 City of Billings Safe Routes to School Study can be found at <https://www.billingsmtpublicworks.gov/DocumentCenter/View/180/SRTS-Report---FINAL-082411-PDF?bidId>



## 1.2 How to Use this Plan

This Plan, like the SRTS program in general, has many audiences, all of which play important roles in making Billings a healthy place where students and their families can and want to walk or roll to school. This plan should be used by a variety of audiences and is organized to help each audience quickly and easily understand how the information can be applied. The following is a list of SRTS stakeholders and how they may use the plan. It should be noted that there may be more ways the plan can be used by additional community stakeholders that are not outlined below:

- **Billings MPO Staff.** The Billings MPO is the lead agency for SRTS infrastructure and planning policy efforts. Billings MPO staff should use **Section 2. Programmatic Recommendations** to evaluate their current SRTS programming and policies to identify opportunities to build a more holistic SRTS program that incorporates all Six E's of the SRTS program, as well as identify funding opportunities to ensure that the program is sustainable. Billings MPO staff can use **Section 3. Project Recommendations** to create project lists for the next 10 years and strategize the most effective use of funding opportunities that may align with identified SRTS projects.
- **City of Billings Public Works Department.** The Billings Public Works department is the main implementer of roadway projects, street maintenance, and traffic engineering. **Section 3. Project Recommendations, Section 4. Infrastructure Toolkit, and Section 5. Project Impact,** would be the most applicable and important pieces of this plan for Public Works as they look for identified SRTS project locations, design guidance, and project scheduling to inform their overall projections and planning for transportation improvements into the future.
- **Yellowstone County Safe Routes to School Committee.** The Yellowstone County Safe Routes to School Committee can use this document to work collaboratively towards programmatic and policy changes. The section most applicable to this committee is **Section 2. Programmatic Recommendations,** which can give the group and its member organizations direction and collaboration opportunities to continue to grow the program, as well as more equitably implement existing program elements.
- **School Staff (Principals, Administration, Crossing Guards).** School staff can use this document to better understand SRTS efforts that may impact their school and students, as well as track and advocate for on-the-ground improvements near their school. They can use **Section 2. Programmatic Recommendations** to evaluate whether any programs may be appropriate for their students and **Section 3. Project Recommendations** to become educated on what projects are on the list near their school. **Section 6: School Walking Maps** may be the most useful section for school staff, as they can be sent directly to students and their families to help them decide on their best route to school.
- **Community Advocates.** Community advocates are often interested in understanding what programs or projects have been identified to better meet their goals for the community, whether those goals are around public health, reducing congestion, or getting more residents walking and biking. All the sections in this plan may be useful for community advocates in order to know what projects are upcoming and help them plan for how they can use their support or sway in community to move projects or other efforts forward.
- **Families and students.** While families and students are welcome to read and use any part of this plan, they will get the most value out of **Section 3. Project Recommendations** and **Section 6. School Walking Maps.** These sections include information about potential projects at their specific school, as well as user-friendly walking and biking maps to help plan trips to and from school.



## 1.3 History of Billings' Safe Routes to School Program

SRTS is an international movement that uses programs, policies, and infrastructure to encourage children to walk and bicycle to school. SRTS programs seek to improve safety conditions near schools and encourage more walking and bicycling when it is safe to do so. Nationally, walking and bicycling to school has declined dramatically, from nearly 50% of K-8th grade students in the 1960s to only 11% as of 2017. SRTS programs seek to reverse this decline by promoting walking and bicycling through a holistic set of strategies known as the six “Es”<sup>2</sup> shown at right.

In 2011, the City of Billings completed a SRTS plan that identified projects that could increase safety for students walking and biking to school. In addition, this plan highlighted “preferred neighborhood walking routes,” for each of the 22 elementary schools in Billings. This plan can be found at <https://www.billingsmtpublicworks.gov/DocumentCenter/View/131/Safe-Routes-to-School-SRTS---Figures-PDF?bidId=>.

## 1.4 Moving Forward

This Safe Routes to School Plan Update looks to build on the work of the city's past SRTS efforts to expand programmatic opportunities to all students and prioritize on-the-ground roadway improvements that make walking and biking to school a more comfortable, preferred, and safer way to get to school.

To keep up to date on Billings SRTS efforts, visit <https://ci.billings.mt.us/2160/Getting-to-School>

### The 6 Es of Safe Routes to School



**Engagement.** Listening and involving students, families, teachers, and school leaders, and working with existing community organizations to build intentional, ongoing engagement opportunities into the program structure.



**Equity.** Ensuring that Safe Routes to School initiatives are benefiting all demographic groups, with particular attention to ensuring safe, healthy, and fair outcomes for low-income students, students of color, students of all genders, students with disabilities, and others.



**Engineering.** Creating physical improvements to streets and neighborhoods that make walking and bicycling safer, more comfortable, and more convenient.



**Encouragement.** Generating enthusiasm and increased walking and bicycling for students through events, activities, and programs.



**Education.** Providing students and the community with the skills to walk and bicycle safely, educating them about benefits of walking and bicycling, and teaching them about the broad range of transportation choices.



**Evaluation.** Assessing which approaches are more or less successful, ensuring that programs and initiatives are supporting equitable outcomes, and identifying unintended consequences or opportunities to improve the effectiveness of each approach.

<sup>2</sup> In June 2020, the Safe Routes Partnership removed Enforcement as one of the Es of Safe Routes to School and added Engagement. More about the reasons behind this change can be found at <https://www.saferoutespartnership.org/blog/dropping-enforcement-safe-routes-school-6-e%E2%80%99s-framework>

## 2. Programmatic Recommendations

As mentioned in the plan introduction, effective and comprehensive SRTS programs address all the six Es: Engagement, Equity, Engineering, Encouragement, Education, and Evaluation. Chapter 3 of this plan addresses Engineering. This chapter addresses the non-infrastructure efforts— all the “other Es”—that are important for sustaining a SRTS program and increasing the number of students who can walk or bicycle safely to school.

The program and policy recommendations in this Plan were developed through a variety of efforts— the completion of a plan and policy review memo at the beginning of this planning effort (Appendix A); advice and feedback from the Project Oversight Committee, conversations with RiverStone Health and Healthy By Design staff, public input from an online webmap that was open in Fall 2021; and interviews with principals at 21 of the 22 elementary schools in Billings Public Schools system. The input from these sources, combined with national best practices, helped to inform the following recommended strategies.

### 2.1 Creating an Equitable Safe Routes to School Program in Billings

Billings, like many other jurisdictions across the country, is starting to institutionalize equity into their work, whether it's reevaluating how services are distributed, how public engagement is done, or how projects are prioritized to ensure that those who were historically disenfranchised by government policies - are getting the benefits of public investments that were disproportionately lost on them in the past This includes low-income families, families of color, differently-abled individuals, and families who speak languages other than English.

Many families within these demographic groups use active modes of transportation, often at higher-than-average rates. National research has shown that children from low-income families are twice as likely as those from wealthier families to walk to school, but disproportionately encounter traffic and safety issues on the trip to school.<sup>3</sup> Low-income and urban students are more likely to have to cross busy streets to get to school and may be impacted by personal safety issues. Those in rural settings often lack sidewalks and bike infrastructure, may have to cross highways, and often have longer distances to school. Emphasizing equity as a framework in SRTS programming ensures that all children and adults have opportunities to choose active modes going to and from school, regardless of the barriers they face.



<sup>3</sup> Safe Routes to School National Partnership. Implementing Safe Routes to School in Low-Income Schools and Communities: A Resource Guide for Volunteers and Professionals. Retrieved from <https://www.saferoutespartnership.org/sites/default/files/pdf/LowIncomeGuide.pdf>



## 2.2 Using this Chapter

Most non-infrastructure SRTS efforts in Billings are done either collaboratively by the Billings-Yellowstone County MPO, RiverStone Health, the Healthy By Design Coalition, and/or the schools themselves. This approach, using multiple staff and agency resources, has its benefits, but can also result in confusion about what role(s) individuals or organizations can or should play when advancing SRTS efforts.

This chapter will help guide and focus the efforts of Billings MPO staff, stakeholders, liaisons, and advocates. The strategies that follow are high-level statements that offer broad direction on how to meet program goals, followed by associated actions. The actions provide more detail about how each strategy could be accomplished.

This chapter also includes metrics to regularly check as the program develops to help the SRTS team decide when the work on each action should be continued, adjusted, or stopped. This chapter should be seen and used as a community resource – school administrators can use it to understand the future of SRTS programming in their schools; or as a jumping off point to get involved in SRTS efforts; families can review it to see how programs they participate in may be updated or improved; and community partners can see where they may be involved in SRTS programming into the future.



## 2.3 Recommended Strategies

The policies and programs recommendations in this chapter are grouped into four broad strategies:



**1. Build, define, and leverage partnerships**



**2. Create a Billings SRTS toolkit**



**3. Build an inclusive education campaign to encourage walking and biking to school**



**4. Consider impacts on students walking and biking when creating and updating school policies**



## Strategy 1. Build, Define, and Leverage Partnerships

The Billings SRTS program is a collective effort between multiple organizations and individuals. While this diversity in groups, expertise, and individuals brings strength and depth to the program, it can also cause confusion about who does what, especially to school staff, parents, and students. The following actions will help create a SRTS program with transparent participants and responsibilities.

### Action 1.1 Expand and define current relationships

The following organizations have historic and current roles within the Billings SRTS program. These relationships could be formalized through a SRTS organization and responsibility framework, memorandums of understanding, and/or a coalition contract. This formalization of roles and responsibilities would be led by the Yellowstone County Safe Routes to School Committee.

- **Billings MPO.** The Billings MPO is the region's lead for roadway planning and infrastructure, including SRTS efforts. The MPO also leads grant writing efforts to complete projects.
- **Billings Public Works.** Public Works implements SRTS infrastructure projects, as well as responds to stakeholder concerns. Public Works staff conduct speed and traffic volume studies, and implement interventions as appropriate.
- **Healthy by Design.** Healthy by Design is fundamental to building a coalition around SRTS and its mission. They are connected to Billings' two hospitals and helped lead the effort with Billings TrailNet to get dedicated funding for SRTS. In addition, they helped get the City's first Complete Streets Policy<sup>4</sup> passed and continue to support Complete Streets design principles, many of which align with SRTS goals. Lastly, they play a role in communications, getting the word out about SRTS efforts via Facebook and their e-newsletter.
- **Riverstone Health.** Riverstone Health houses staff that support programmatic SRTS work – walking school buses, encouragement campaigns, etc. – and pushes for SRTS-supportive policies, systems, and environmental change. They also organize and facilitate the Yellowstone County SRTS Committee.
- **Kids in Motion.** Kids In Motion is a collaborative active transportation program facilitated by School District #2, Education Foundation for Billings Public Schools, the City of Billings, and other community partners. The program combines volunteer-coordinated events with in-class education to empower youth with the skills and confidence needed to walk and ride their bicycle every day.
- **Billings School District.** The school district hires and places crossing guards, creates and implements the district's safety bussing policy, and distributes SRTS materials and communications. They also support Kids in Motion efforts, often using the program's education curriculum in health enhancement classes.
- **Billings Police Department.** The police department helps with enforcement of school zones as able or requested. Due to limited staff, these enforcement operations are very limited.
- **Billings TrailNet.** Billings TrailNet is a non-profit, 501c3, grass-roots organization that supports urban trails in and around the Billings. They worked, in the past, with Healthy By Design to try to secure dedicated funding for SRTS.
- **St. Vincent Healthcare.** St Vincent's is one of the two major hospital providers in the community. They are the presenting sponsor for Kids in Motion and provide low-cost helmets for kids. They also provided grant funds to further discount helmets.
- **Education Foundation for Billings Public Schools.** The Education Foundation is the fiscal agent for Kids in Motion and manages the grants from St. Vincent Healthcare.

<sup>4</sup> Billings Complete Streets Policy can be found at <https://www.billingsmtpublicworks.gov/DocumentCenter/View/200/RES-11-19097-Adopting-Complete-Streets-Policy-PDF?bidId=>

### Action 1.2 Identify and establish new partnership opportunities

In order for the Billings SRTS program to continue to grow and equitably serve additional students and families, especially those who have not been involved in the past, it will need to establish new relationships. The following groups and organizations have missions that align with the SRTS program, but have not been regularly or officially integrated into SRTS efforts to date.

- **Parent-Teacher Organizations (PTOs).** PTOs are formal organizations that can include parents, teachers, and school staff. These groups work to promote school success and community through fundraising, events, and general support. Currently, the Billings MPO communicates with schools' PTOs through email and/or social media with varying amounts of success, often because PTOs at schools, if they exist at all, tend to be small. As possible, one member of each school's PTO should be a liaison to the Billings SRTS program, in order to have consistent communication at every school. For schools without PTOs, an alternate person (e.g., interested parent, school staff member, etc.) should be the formalized contact.
- **Billings Bicycle and Pedestrian Advisory Committee.** The Billings Bicycle and Pedestrian Advisory Committee advises City Council, the Mayor, County Commissioners, Planning Board, and all departments and boards of the City and County with regard to walking and biking projects, plans, and efforts. In the past, the committee has not been overtly active on SRTS efforts and could play a more formalized role in the future.
- **Living Independently for Today and Tomorrow (LIFTT).** LIFTT is a Billings-based non-profit that works to empower persons with disabilities to live freely and equally. In the past, LIFTT assisted with inclusive walk audits. There are opportunities to continue this work as well as partner with LIFTT to further education efforts.
- **Billings Urban Indian Health and Wellness Center (BUIHWC).**<sup>5</sup> The BUIHWC's has a model of healing that holistically involves the body, mind, and spirit. This organization has deep ties to Native families in Billings and is a trusted source of information about living healthier lives. They have a youth program that may have clear interest in supporting more kids and their families living healthier, active lives through methods planned and encouraged by the SRTS program.
- **Bicycle shops and groups.** For many families, especially low-income families, the largest barrier to bicycling is physically having a bike that works and/or having someplace to safely store the bike. Some bicycle shops around the country have "earn-a-bike" programs<sup>6</sup> where students learn about bicycle repair and fix up a donated bicycle with shop staff for themselves. Bicycle groups or clubs also tend to have outdated (to them) gear, such as bikes, bike parts, or locks that could be perfect for students. In the past, there was a local earn-a-bike program in Billings that was focused mostly on adults, but it is not currently active.
- **Older adult groups.** Older adults are often the eyes and ears of their neighborhoods, especially if they have lived in the neighborhood for years and/or have children that they raised in the area. In addition, older adults are often looking for ways to give back to the community and stay active – crossing guard positions may be the perfect fit. There is currently a shortage of crossing guards in Billings and across the country, and creating a formal program between older adult groups in Billings and the SRTS program may be an approach that is sustainable and can staff more locations than the current conditions. Working with Senior Programs at the Billings Parks and Recreation Department or the Adult Resource Alliance may be a promising first step.

<sup>5</sup> <http://billingsurbanindianhealth.org/>

<sup>6</sup> Neighborhood Bike Works in Philadelphia has a Earn-A-Bike class where students learn basic bike repair and maintenance by fixing up a donated bike. Once a student completes the class, they are able to keep the bike they've refurbished, as well as earn a lock and helmet. More information can be found at <https://neighborhoodbikeworks.org/youth-programs>

**Action 1.3 Identify partners to present pedestrian and bike safety education in non-school settings**

Bicycle and pedestrian safety education is most effective when it is taught over multiple sessions. Out-of-school-programs such as camps and after-school programs can offer a natural time and place for more in-depth bicycle education, without the logistics of fitting it into a school day. The Billings SRTS program should approach the following partners to discuss bike safety education:

- **Afterschool care providers.** Nearly every elementary school in Billings has an afterschool care option, either at the school or at a location that students bus, providing an opportunity for students to learn about walking and biking safely in smaller groups. In addition, some of these providers may offer “camps” over school institute days or breaks that could be appropriate for longer safety lessons, walks, or bike rides.

- **Billings Parks and Recreation.** Billings Parks and Recreation hosts a variety of youth sports, activities, and summer camps for children in the County. Currently, Kids In Motion partners with Parks on a summer cycling camp. It has historically had a strong focus on mountain biking because of who the counselors have been and what the kids enjoy, but there is a component of the camp focused on road safety. Increased formalization of this program and the information presented could increase the number of youth in Billings who have received bike safety education.
- **Cycling clubs and shops.** Billings has a number of bicycle shops and clubs/riding groups that offer rides for bicyclists of varying skill, as well as for families. These groups often have employees or members that are interested in spreading bicycling amongst youth and would be able to lead or promote bicycle education in the community.

Action	Timeline	Metric	Potential Partners	Engagement	Equity	Encouragement	Engineering	Education	Evaluation
Action 1.1 Expand and define current relationships	0-2 years	Formalization of current partnerships versus future	MPO, RiverStone Health	x	x	x	x	x	
Action 1.2 Identify and establish new partnership opportunities	2-5 years	Number of new established partnerships	PTOs, Billings Bicycle and Pedestrian Advisory Committee, LIFTT, BUIHW, bicycle shops and groups, older adult groups	x	x	x		x	
Action 1.3 Identify and implement pedestrian and bike safety education in non-school settings	2-5 years	Creation of new programs	RiverStone Health, MPO, Kids In Motion, afterschool care providers, Billings Parks and Recreation, cycling clubs and shops	x	x	x		x	



## Strategy 2. Create a Billings SRTS Toolkit

Safe Routes to School toolkits come in a variety of forms – some are for specific events (e.g., International Walk and Roll to School Day<sup>7</sup>) while some are a one-stop-shop for all the programs’ offerings.<sup>8</sup> Either way, toolkits are clear communication tools for staff, stakeholders, families, and students to help them learn about the program and how they can get involved. A toolkit is an important documentation tool for SRTS program staff and can reduce issues due to staff turnover and/or consistency of program expectations. The following actions build a suite of toolkits for the Billings SRTS program.

### Action 2.1 Create a programmatic toolkit that documents roles and responsibilities, and parts of the Billings SRTS Program

Currently, there is not one singular place for a Billings MPO staffer or community member to go to learn about all the facets of the SRTS program. A programmatic toolkit should outline the program pieces, including who is responsible for each piece, what the scope of each project part is, and contact information for the lead agency or staff (if applicable). This toolkit should also clearly tie its narrative to the 6 E’s of SRTS to ensure that the program is transparently meeting its mission.

### Action 2.2 Create a communications toolkit

Part of a program’s success is making it known by and needed in a community. Currently, there is no unified direction on how to talk about the program, promote the organization, or advertise what it does. A communications toolkit is a way to create consistent messaging, such as about the program’s vision, goals, program description, and other elements. If the responsibility and roles of the Billings SRTS program remain dispersed as they are now, a communications toolkit is essential to create a “one-program” feel for staff and the community.

This toolkit should also create standards and a schedule for regular communications – newsletters, flyers, social media, etc. – to ensure they reach a diverse population. These standards may involve translation efforts, accessible writing, or other measures.

### Action 2.3 Create toolkits for specific events

The Billings SRTS program helps support and/or organize a variety of events – International Walk and Roll to School Day, Walking School Buses, Kids in Motion, etc. At the moment, these events rely heavily on organizational staff and, perhaps, a parent or school staff member that has time and expertise. Event toolkits serve as a step-by-step guide for how to plan for an event, from inception through evaluation. These toolkits allow those with less time or history with the program to organize events easily and, over time, rely less on limited staff to run successful and sustainable events. To begin, it is recommended that the Billings SRTS program creates toolkits for International Walk and Roll to School Day. RiverStone Health has already begun work on a Walking School Bus toolkit.

Action	Timeline	Metric	Potential Partners	Engagement	Equity	Encouragement	Engineering	Education	Evaluation
Action 2.1 Create a programmatic toolkit that documents roles and responsibilities, and parts of the Billings SRTS Program	0-2 years	Creation of programmatic toolkit	MPO, RiverStone Health, Billings Public Schools	x	x	x	x	x	x
Action 2.2 Create a communications toolkit	0-2 years	Creation of communications protocol	MPO, RiverStone Health	x	x	x			
Action 2.3 Create toolkit for specific events	2-5 years	Creation of toolkits	MPO, RiverStone Health	x	x	x		x	x

7 The Alameda County Safe Routes to Schools International Walk and Roll to School Day toolkit is an example of an event toolkit and can be found at [https://alamedacounty2s.org/wp-content/uploads/2021/09/International-Walk-and-Roll-to-School-Day\\_Toolkit\\_2021.pdf](https://alamedacounty2s.org/wp-content/uploads/2021/09/International-Walk-and-Roll-to-School-Day_Toolkit_2021.pdf)

8 The Wisconsin Safe Routes to School Toolkit an example of a program-wide toolkit can be found at <https://wisconsin.gov/Documents/doing-bus/local-gov/astnce-pgms/aid/safe-routes/toolkit.pdf>



### Strategy 3. Build an Inclusive Education Campaign to Encourage Walking and Biking to School

Branding and education campaigns are essential ways to make an organization visible and recognizable to students, families, school staff, and the Billings community as a whole. This task would help to solidify knowledge of the program by stakeholders and would be used as a tool for all aspects of the SRTS program.

#### Action 3.1. Create a SRTS brand

The SRTS program, historically, has not had a singular brand, with each of the organizations that participate doing their own branding and materials. This leads to discontinuity in the visuals and the materials shared by the program, and can lead to stakeholders getting confused about what the program really is and who runs it.

A logo was recently developed for the Billings Safe Routes to School Program. Using the logo as a starting point, a brand should be created to include a color palette, typography, document templates, and design elements (e.g., the logos that go on each material, any pieces of graphics that should be universally used, etc.). The brand should emphasize kids walking and rolling to school, as well as have the “feel” of Billings.

#### Action 3.2 Roll-out a safety and encouragement campaign focusing on walking and biking to school

Along with the visibility that a brand can achieve, a campaign process can help draw attention to up to three messages. It is recommended that every year, the SRTS campaign decides on its three (or fewer) main messages – other safety tips can be used in lengthier communications.

This allows students, families, and the community to quickly focus on sound bites and behaviors that they can do to increase the number of kids walking and biking to school, as well as make it safer. Campaigns are also fundamental to decreasing “perceived safety” issues because the campaign, if done right, can emphasize that the community is behind these behavior changes and that everybody can and should be able to walk or bike to school safely.

#### Action 3.3 Evaluate SRTS campaign bi-annually

Evaluation is a fundamental part of any SRTS program, allowing the program to analyze what works, what doesn’t, and where changes should be made. Evaluation of a SRTS campaign is especially important in the early years of campaign development as stakeholders are first being exposed to the campaign and have less base knowledge about the program.

Evaluations can become very complicated and data heavy, but do not necessarily have a proportional level of benefit for the complexity. As such, it is recommended that evaluations remain fairly qualitative, asking stakeholders about their thoughts via a quick survey and keeping track of the methods that the campaign was distributed through.



Billings SRTS Logo Designed in 2022

Action	Timeline	Metric	Potential Partners	Engagement	Equity	Encouragement	Engineering	Education	Evaluation
Action 3.1. Create a SRTS brand	0-2 years	Creation of brand toolkit	MPO, RiverStone Health	x	x	x		x	
Action 3.2 Roll-out a safety and encouragement campaign focusing on walking and biking to school	2-5 years	Presence of safety campaign	MPO, RiverStone Health, Billings Public Schools, Billings TrailNet	x	x	x		x	
Action 3.3 Evaluate SRTS campaign bi-annually	2-5 years	Evaluation report	MPO, RiverStone Health, Healthy By Design						x



## Strategy 4. Consider Impacts on Students Walking and Biking When Creating and Updating School Policies

If a community wants more of its students to walk or bike to school, walking and biking must be easy and convenient, as well as safe. Some of the Billings School District policies may inadvertently make walking and biking difficult or, at minimum, less convenient for parents deciding whether their children should walk and/or bike. The following are a few of the school district's policies that have direct implications on the convenience of walking and biking.

### Action 4.1 Evaluate safety busing policy for impacts to student walking and biking

The district's safety busing policy mostly focuses on whether students need to cross busy roads. If students are required to cross a busy road and there is not a safe sidewalk or path to walk on, crosswalk guards, or stoplights where necessary, a bus is (often) available.

Safety busing standards are not completely quantitative, though, and principal or parent feedback can impact the presence or absence of a safety busing route. Many schools are located fairly close to busy roads, so some students that are safety busing are within easy walking or biking distance. The presence of buses could be discouraging for students when making the choice whether to walk or bike.

Currently, families are asked to pay \$75 per student per semester (although not at Title schools) to use safety busing; each bus costs approximately \$53,000 per year for the district to operate. The district estimates they recuperate \$6,000 - \$8,000 per year for each bus. Safety busing routes should be evaluated for where a walking school bus could be a replacement. This would result in an increase in walking and biking, as well as cost savings for the district. If possible, walking school bus leaders should be paid to ensure consistency and reliability for parents and students.

### Action 4.2 Participate in discussion of school dismissal time policies

Every public elementary school in Billings has two dismissal times – kindergarten through 3<sup>rd</sup> grade dismisses 45 minutes before 4<sup>th</sup> and 5<sup>th</sup> graders. This time differential poses a few challenges to students and families looking to walk or bike home from school.

The largest challenges are for families who have multiple children and one in either K-3<sup>rd</sup> and another in 4<sup>th</sup> – 5<sup>th</sup>. Many families will drive to pick up their first child and then simply wait in the car for 45 minutes until the second student is dismissed, with the idea that 45 minutes may not be enough to go back and forth or that they might as well wait since they're already there.

In addition, older kids – those in 4<sup>th</sup> or 5<sup>th</sup> grades – are most likely to be able to walk independently. They are also able to walk or bike with younger sibling, neighbors, or friends, and provide extra “eyes on the street.” The gap in time between the younger and older students' dismissals removes this opportunity.

Given that more students walk or bike home, versus to school (because of the relative “rush” in the morning and/or parents dropping their students off on their way to work), the district should evaluate whether it might make more sense to delay the start time in the morning for K-3<sup>rd</sup> and then have one dismissal in the afternoon. This change could provide multiple benefits for families looking to walk or bike to school more, and create more of a culture around walking or biking home at dismissal.

During Project Oversight Committee meeting discussions, Billings Public Schools noted that the availability of buses is one of the constraints that requires two dismissal times. They are working to make busing more efficient and may be able to move to one dismissal time in the future.

### Action 4.3 Reevaluate “visual check” policy for students at dismissal

Schools have a “visual check” policy for their younger students where the teacher needs to make eye contact with a parent before releasing their student at the end of the day. This discourages any independent walking or biking home, which may be feasible for 2<sup>nd</sup> or 3<sup>rd</sup> graders if their parents are comfortable with it. This also makes the idea of a “park-and-walk” area more challenging since students are not allowed to walk off campus without a parent in sight.

Many schools have parents fill out a “dismissal procedure” form at the beginning of the school year that specifies who can pick up the student and if a student can leave independently. The independent choice should be allowed for all students 2<sup>nd</sup> grade and above. There should also be an option that specifies that the parent will be parking at a “park-and-walk” location a few blocks from the school. As possible, school staff or parents can be posted along the way between the school and the location to supervise students. This method can significantly decrease the chaos of school pick-ups, which are shown to decrease walking and biking rates – often, parents see the area immediately in front of the school as too unsafe for walking and biking because of drop-off/pick-up patterns. Another option to stagger students would be to add a 5-minute early release for students who are walking or biking to the remote pick-up location, especially if a staff member is able to assist.

**Action 4.4 Consider decreasing school zone speed limits based on City Policy and State Law**

Most school zones in Billings are signed at 25mph, (some are signed at 20mph) but some may be able to be reduced according to City policy and State law. Crossing guards and principals that were interviewed as part of this plan regularly mentioned that they feel

speeds were excessive in front of their schools, especially if the schools were on a major route to or from a nearby high school, with the assumption that high school students were prone to speeding.

Irrespective of who is driving, setting the school zone speed limit to the lowest speed allowed by the City of Billings State law would slow drivers down, decrease stopping times, and make school zones safer for students walking and biking. In addition, many principals noted that school zone signs with flashing warnings were often broken – signage should be regularly tested to ensure that they effectively signal the presence of a school zone to drivers.

**Action 4.5 Incorporate walking and biking criteria into school siting and redistricting processes**

The location of a school compared to where students live has an enormous impact on whether students can and will walk and bicycle to school. School district redistricting and siting policies should include evaluating if and establishing criteria on how new boundaries would impact the ability of students to walk and bike to school, as well as the potential changes to safety bussing that would be required. Example school siting policies can be found at <https://www.changelabsolutions.org/product/smart-school-siting>.

Action	Timeline	Metric	Potential Partners	Engagement	Equity	Encouragement	Engineering	Education	Evaluation
Action 4.1 Evaluate safety busing policy for impacts to student walking and biking	0-2 years	Updated safety busing policies	Billings Public Schools		x	x			x
Action 4.2 Participate in discussion of school dismissal time policies	5-10 years	Updated school dismissal policies	Billings Public Schools		x	x			x
Action 4.3 Reevaluate “visual check” policy for students at dismissal	2-5 years	Updated student release policies	Billings Public Schools		x	x			x
Action 4.4 Consider decreasing standard school zone speed limits based on City Policy and State Law	2-5 years	School zone speed limit change	City of Billings		x	x	x		x
Action 4.5 Incorporate walking and biking criteria into school siting and redistricting processes	5-10 years	Updated school siting and redistricting processes	Billings Public Schools		x	x			



## 3. Project Recommendations

While programs and policies set the groundwork for more students to walk and bike to school safely and comfortably, infrastructure projects are what will make Billings roads safer and more attractive to students and their families. This section provides recommendations on locations where it is most important to improve the walking and biking in Billings for students and their families.

The following sections detail project locations per school, as well as pinpoint potential concerns for students walking and biking that were identified through site visits, stakeholder input, principal interviews, or staff comments. It should be noted that the exact project infrastructure proposed at the locations is not specified because additional engineering analysis will need to be conducted before a specific remedy can be proposed.

That said, **4. Infrastructure Toolbox** and, specifically, the Safety Infrastructure Tool Selection Matrix found on **page 104**, can and should be used to guide the selection of the safety infrastructure tool(s) that could be used. **Appendix B: School Summaries** provides additional summary information that was used to develop the project location recommendations, including preliminary proposed project infrastructure recommendations. **Appendix B: School Summaries** should be reviewed as projects locations move forward into the design phase.

### 3.1 Methodology

The Billings SRTS project team used a combination of methods to develop the project list. These methods included:

- **School site audits.** Toole Design, Billings MPO staff, and volunteers conducted site audits at all 22 elementary schools in Billings the week of September 20, 2022. These audits included interviews with school principals to ask about their concerns and observations on students getting to and from school, conversations with crossing guards, and walking audits of streets within a 1/2-mile radius of the school. All issues and observations from the walking audits were loaded into the Fulcrum mapping app, allowing project staff to categorize issues, leave comments, and take photos.
- **Online webmap.** In the fall of 2021, residents and stakeholders could input where they currently walk or bike, where they have identified issues, and where they see

opportunities to encourage walking and biking to school. The webmap also had an introductory survey that asked respondents about their walking and biking habits, which school(s) they are affiliated with, and demographics. There were nearly 300 respondents who submitted 360 comments. A summary of the webmap results can be found in **Appendix C. Webmap Summary**.

- **2011 Safe Routes to School Plan.** The 2011 Plan was reviewed for projects to ensure that projects identified, but not yet completed, were moved forward into this effort if they were still applicable.
- **Billings MPO and City of Billings staff review.** Staff reviewed a draft project list to ensure that the list offered an appropriate level of detail about the project and that all proposed projects were feasible in the proposed time frame. Some projects were also added or removed during this review phase.
- **Project Oversight Committee (POC) Review.** The POC reviewed a draft project list to offer additional knowledge about specific project that may increase its ability to be implemented and/or garner support from the school and community.

### 3.2 How to Use This Chapter

Each of the 22 elementary schools has a cover page with a photo of the school, an existing conditions map showing existing sidewalks, shared use paths, pedestrian/bike crashes in the area, proposed improvements from other plans, and a heatmap of student addresses as of the 2021-2022 school year. The following proposed projects map shows areas of concern as either a line, a point, or an area. Each project area has a number that corresponds with the table below. Projects are numbered for identification only; numbers do not indicate implementation priority. The table below the map shows what observed and reported safety concerns there are in each area.

The types of concerns in each area can then be matched with the infrastructure toolkit in Chapter 4 to determine potential infrastructure interventions to improve these areas. Not every tool will be applicable to every location.

As discussed further in Chapter 5, upon adoption of this plan, the City of Billings Engineering Division will conduct additional internal analysis to determine what types of projects will be implemented in each location. While exact interventions may change

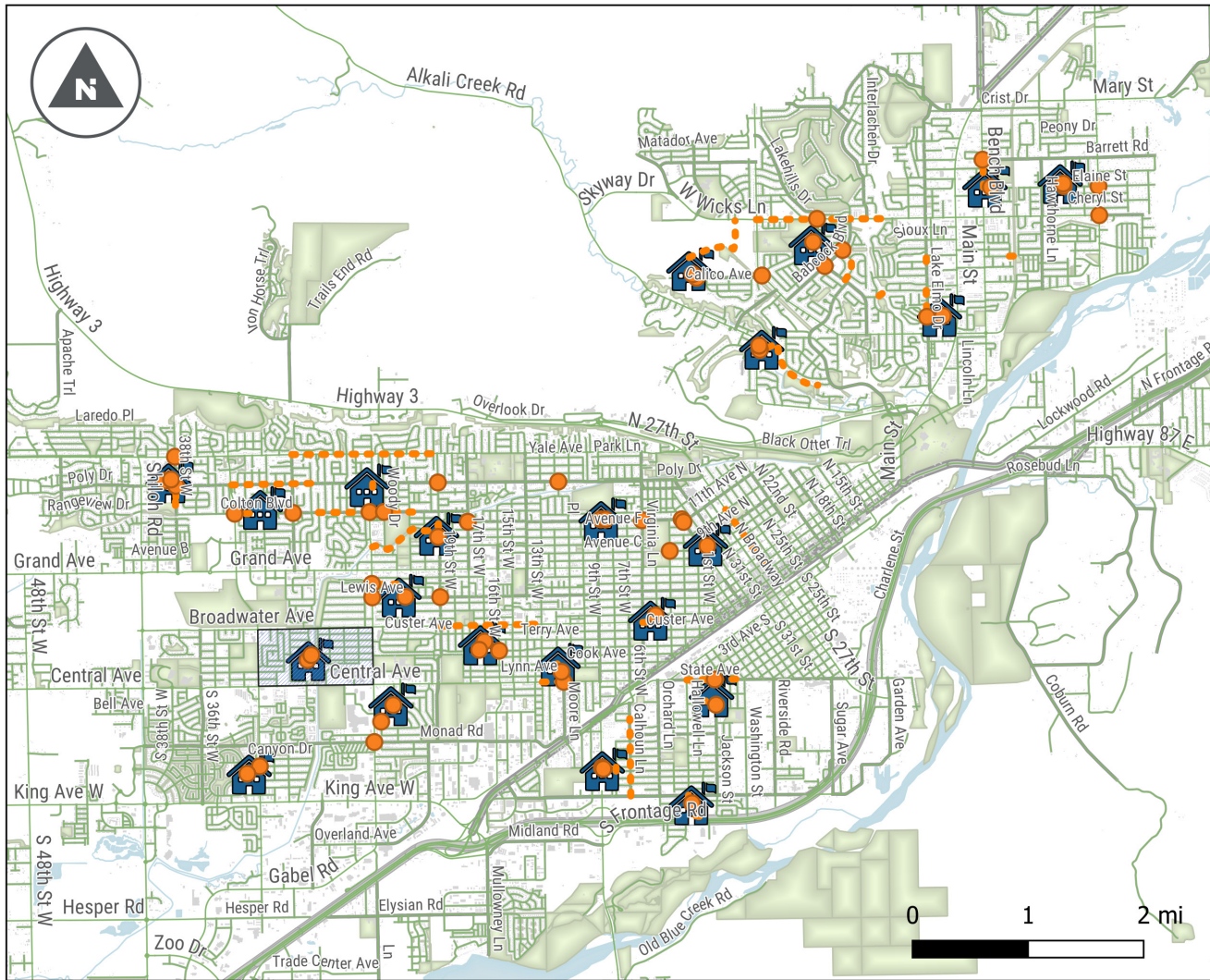

- Spot Recommendations
- Segment Recommendations
- ▭ Area Recommendations

from those identified in Appendix B, the City of Billings Engineering Division is committed to carefully considering each location to make it safer for children to walk and bike to school.

### 3.3 Project List and School-Specific Project Location Recommendations



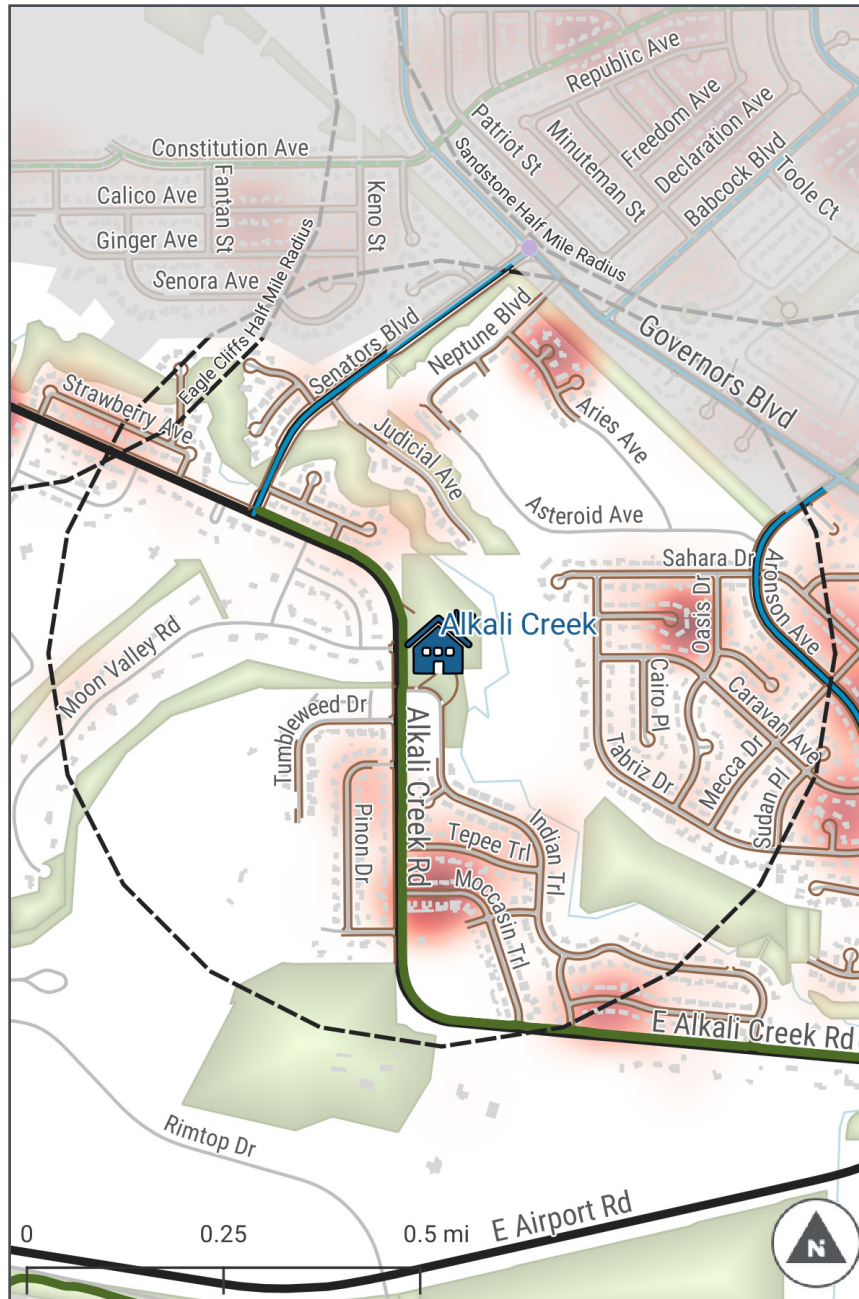

The following is an all-inclusive list, by school, of the projects identified for Billings SRTS. The map to the left shows the locations of all the projects. The following pages detail school specific locations and projects.

# Alkali Creek







### Key Safety and Mobility Considerations for Alkali Creek Elementary

-  Student Address Heatmap
-  School Half Mile Buffer
-  Outside School Boundary
-  Pedestrian Crash (2016-2020)
-  Speed Limit 35 mph or Greater

#### Existing

-  Shared Use Path
-  Existing Bike Lane
-  Sidewalk

#### Proposed

-  Bike Lane

### Proposed Safe Routes to School Projects for Alkali Creek Elementary

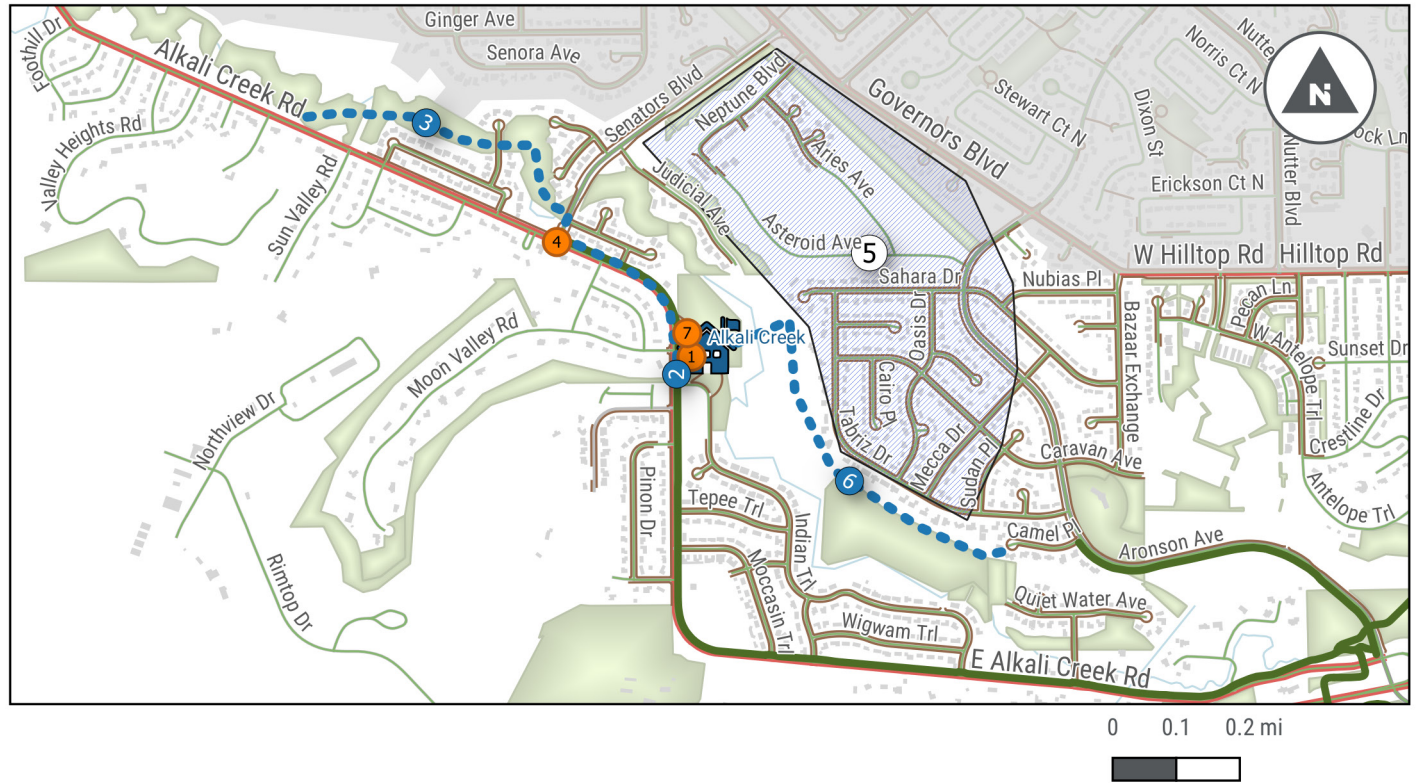







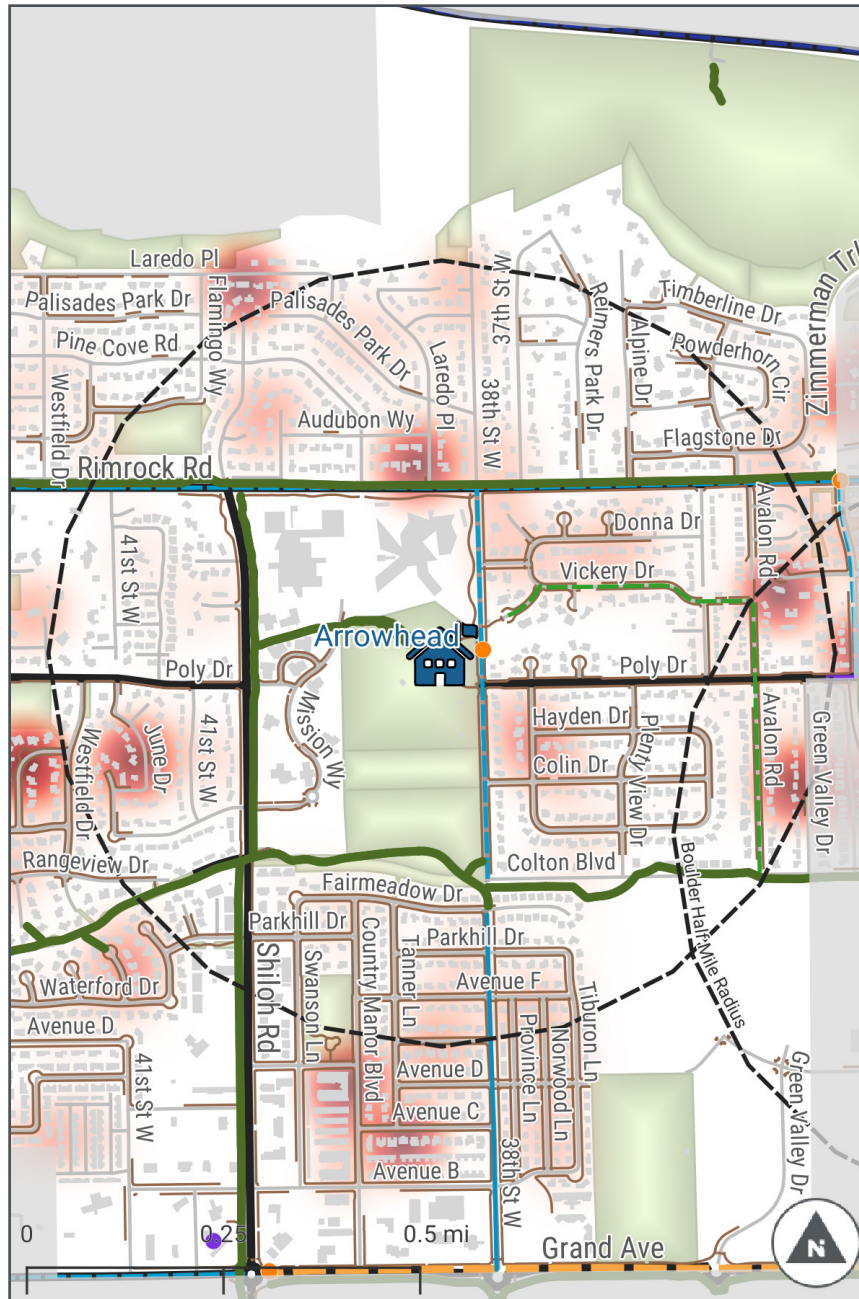





Project #	Proposed Project Type	Observed and Reported Safety Concerns at Project Location											
		Motor vehicle speeding	Long crossing distances	Turning vehicles not yielding	Poor pedestrian access and/or comfort	Poor bicycle access and/or comfort	Crosswalks blocked during arrival/dismissal	Pedestrians crossing mid-block	Poor visibility	Drivers not yielding to pedestrians in crosswalks	Insufficient separation from traffic	Illegal U-turns	Constrained school site/few access points
1	Parking Procedures			x	x		x		x	x			
2	Crossing Improvement							x					
3	Sidewalk/Side path				x	x					x		
4	Crossing Improvement	x	x	x	x				x	x			
5	Safety Busing				x	x							
6	Shared Use Path				x	x							x
7	Bicycle Parking					x							

# Arrowhead





### Key Safety and Mobility Considerations for Arrowhead Elementary

-  Student Address Heatmap
  -  School Half Mile Buffer
  -  Outside School Boundary
  -  Bike Crash (2016-2020)
  -  Pedestrian Crash (2016-2020)
  -  Speed Limit 35 mph or Greater
- Existing**
-  Shared Use Path
  -  Existing Bike Lane
  -  Existing Shared Lane
  -  Sidewalk
- Proposed**
-  Neighborhood Bikeway
  -  Bike Lane

## Proposed Safe Routes to School Projects for Arrowhead Elementary

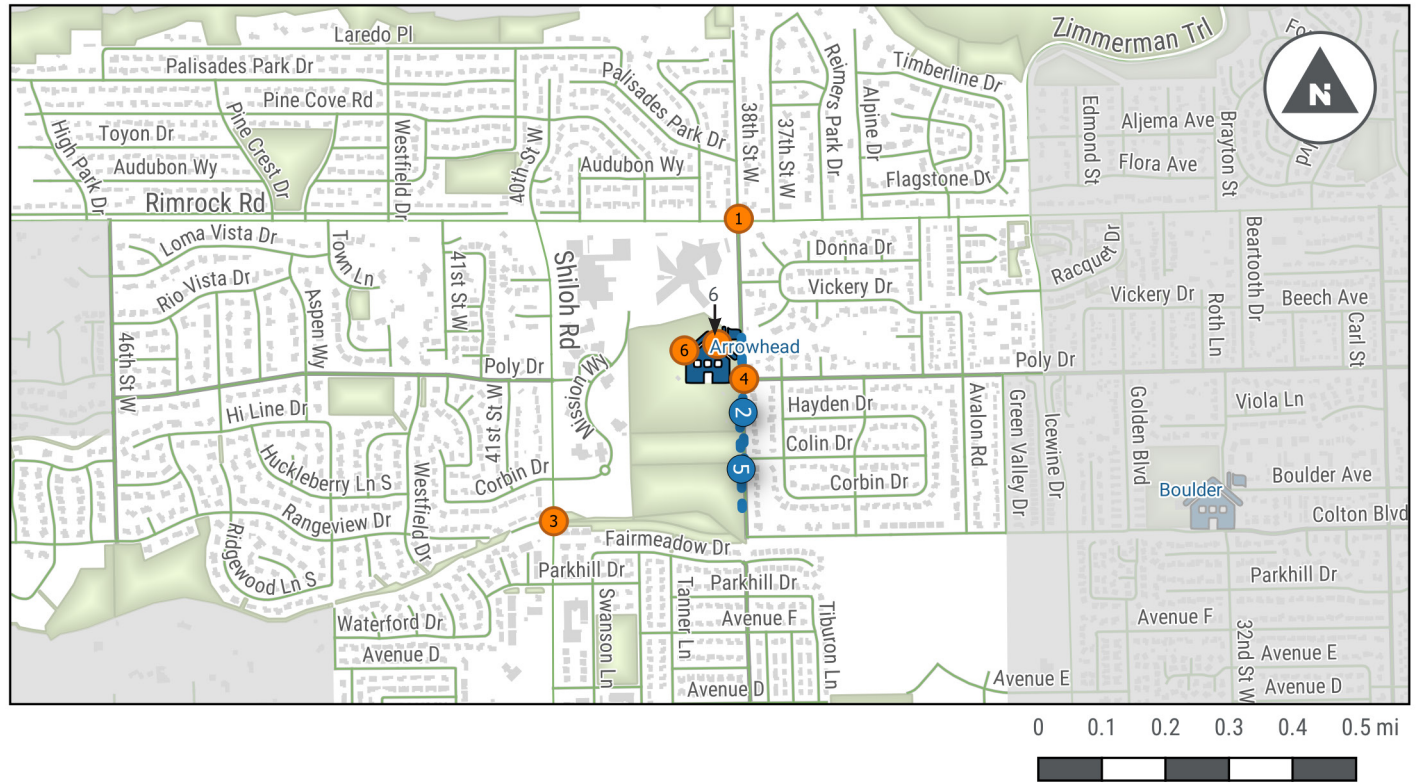

Project #	Proposed Project Type	Observed and Reported Safety Concerns at Project Location											
		Motor vehicle speeding	Long crossing distances	Turning vehicles not yielding	Poor pedestrian access and/or comfort	Poor bicycle access and/or comfort	Crosswalks blocked during arrival/dismissal	Pedestrians crossing mid-block	Poor visibility	Drivers not yielding to pedestrians in crosswalks	Insufficient separation from traffic	Illegal U-turns	Constrained school site/ few access points
1	Crossing	x	x		x	x							x
2	Arrival/Dismissal Behavior				x	x							x
3	Crossing				x	x							
4	Crossing				x	x							x
5	Sidewalk/Sidepath				x	x						x	
6	Bicycle Parking (2 locations)					x							







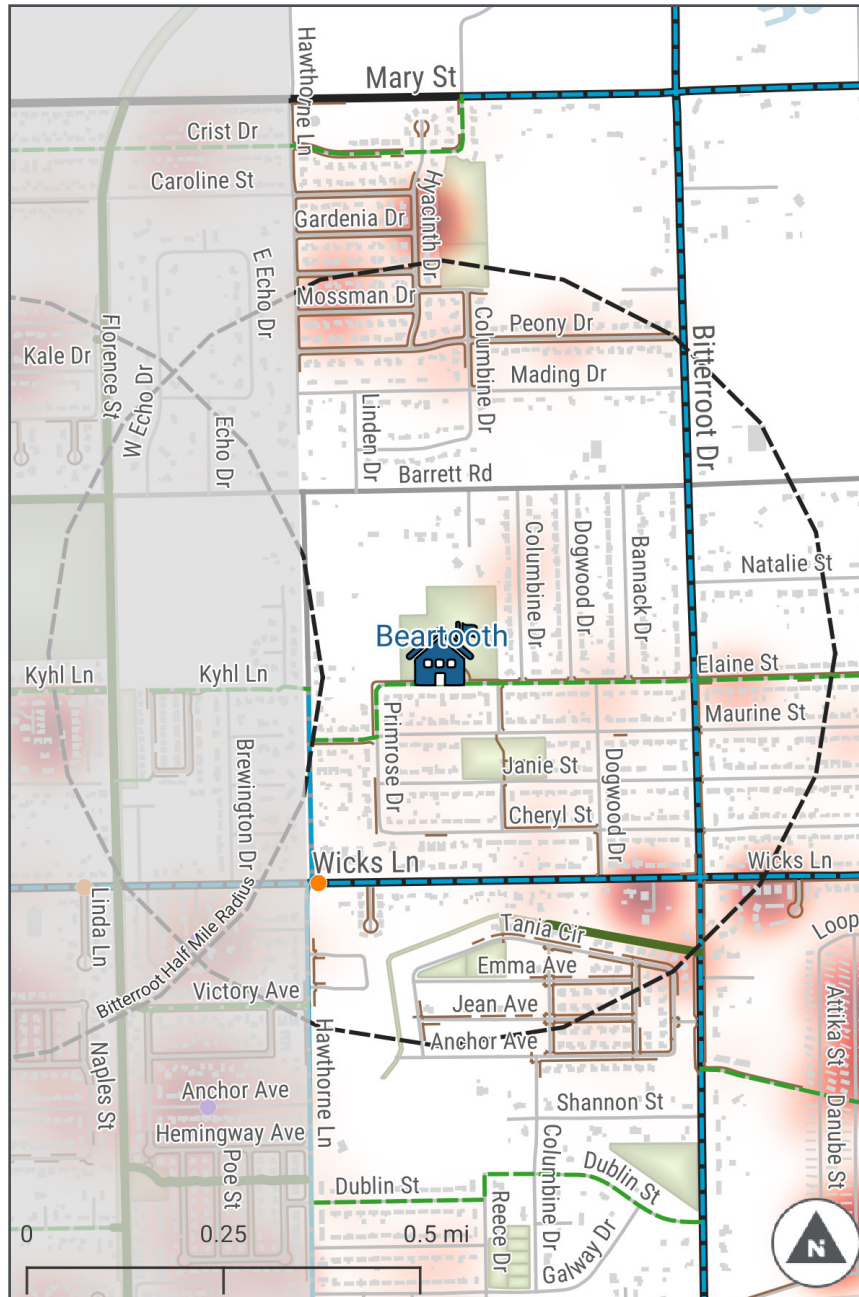

# Beartooth









### Key Safety and Mobility Considerations for Beartooth Elementary

-  Student Address Heatmap
-  School Half Mile Buffer
-  Outside School Boundary
-  Bike Crash (2016-2020)
-  Pedestrian Crash (2016-2020)
-  Speed Limit 35 mph or Greater

#### Existing

-  Shared Use Path
-  Sidewalk

#### Proposed

-  Neighborhood Bikeway
-  Bike Lane

## Proposed Safe Routes to School Projects for Beartooth Elementary

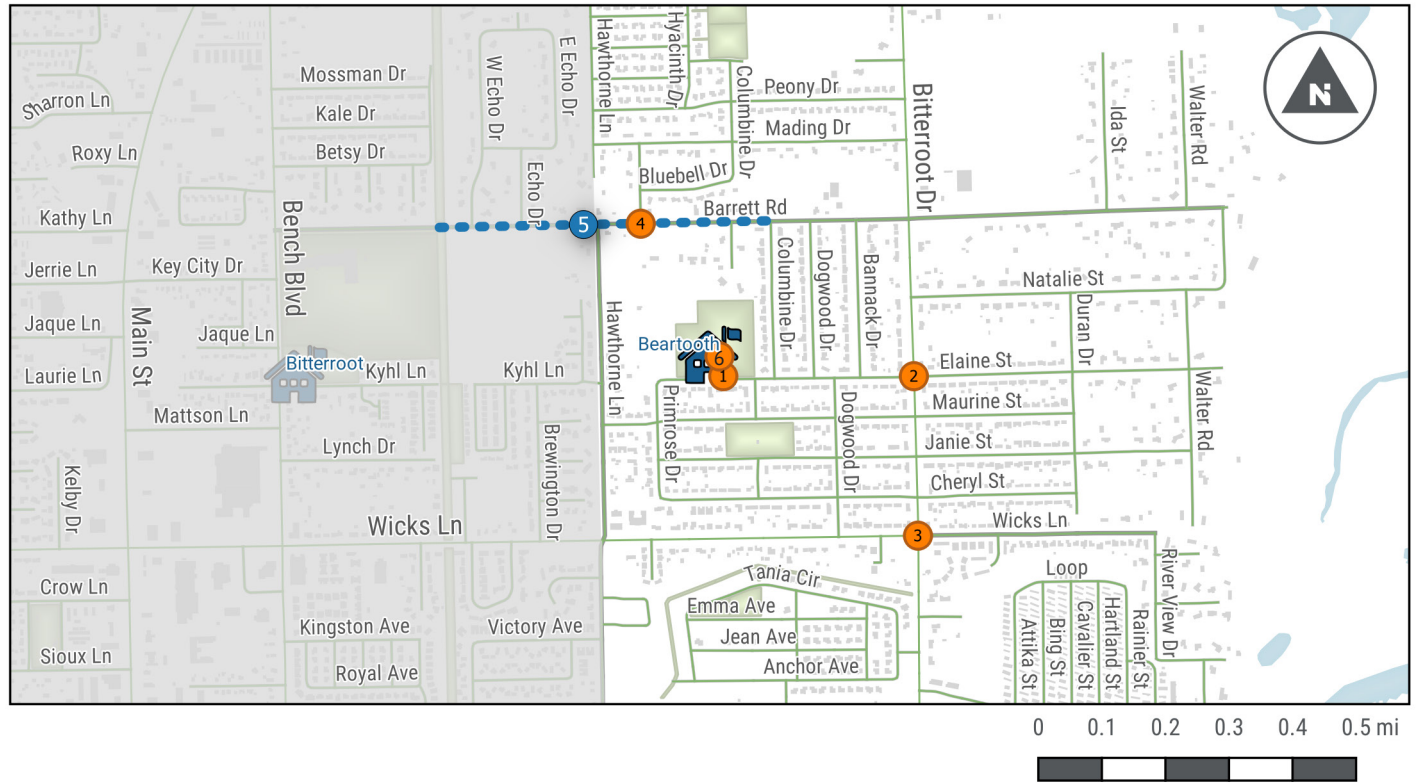





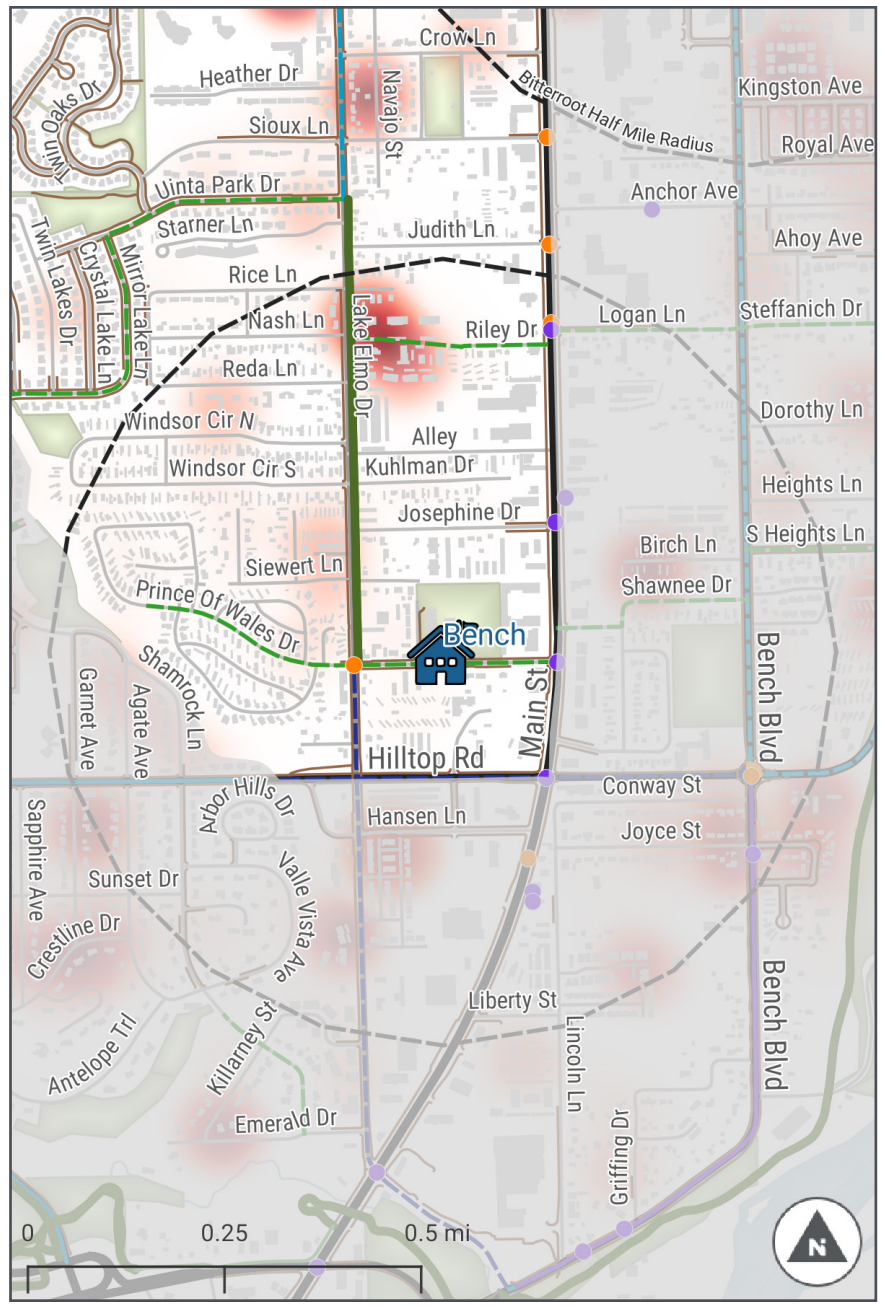

Project #	Proposed Project Type	Observed and Reported Safety Concerns at Project Location											
		Motor vehicle speeding	Long crossing distances	Turning vehicles not yielding	Poor pedestrian access and/or comfort	Poor bicycle access and/or comfort	Crosswalks blocked during arrival/dismissal	Pedestrians crossing mid-block	Poor visibility	Drivers not yielding to pedestrians in crosswalks	Insufficient separation from traffic	Illegal U-turns	Constrained school site/ few access points
1	Parking Procedures			x	x	x		x					x
2	Crossing				x					x			
3	Crossing	x			x					x			
4	Crossing				x								
5	Sidewalk/Sidepath				x							x	
6	Bicycle Parking					x							

# Bench









### Key Safety and Mobility Considerations for Bench Elementary

-  Student Address Heatmap
-  School Half Mile Buffer
-  Outside School Boundary
-  Bike Crash (2016-2020)
-  Pedestrian Crash (2016-2020)
-  Speed Limit 35 mph or Greater

**Existing**

-  Shared Use Path
-  Existing Bike Lane
-  Existing Shared Lane
-  Sidewalk

**Proposed**

-  Neighborhood Bikeway
-  Bike Lane
-  Buffered Bike Lane
-  Visionary Long Range Bikeway

## Proposed Safe Routes to School Projects for Bench Elementary

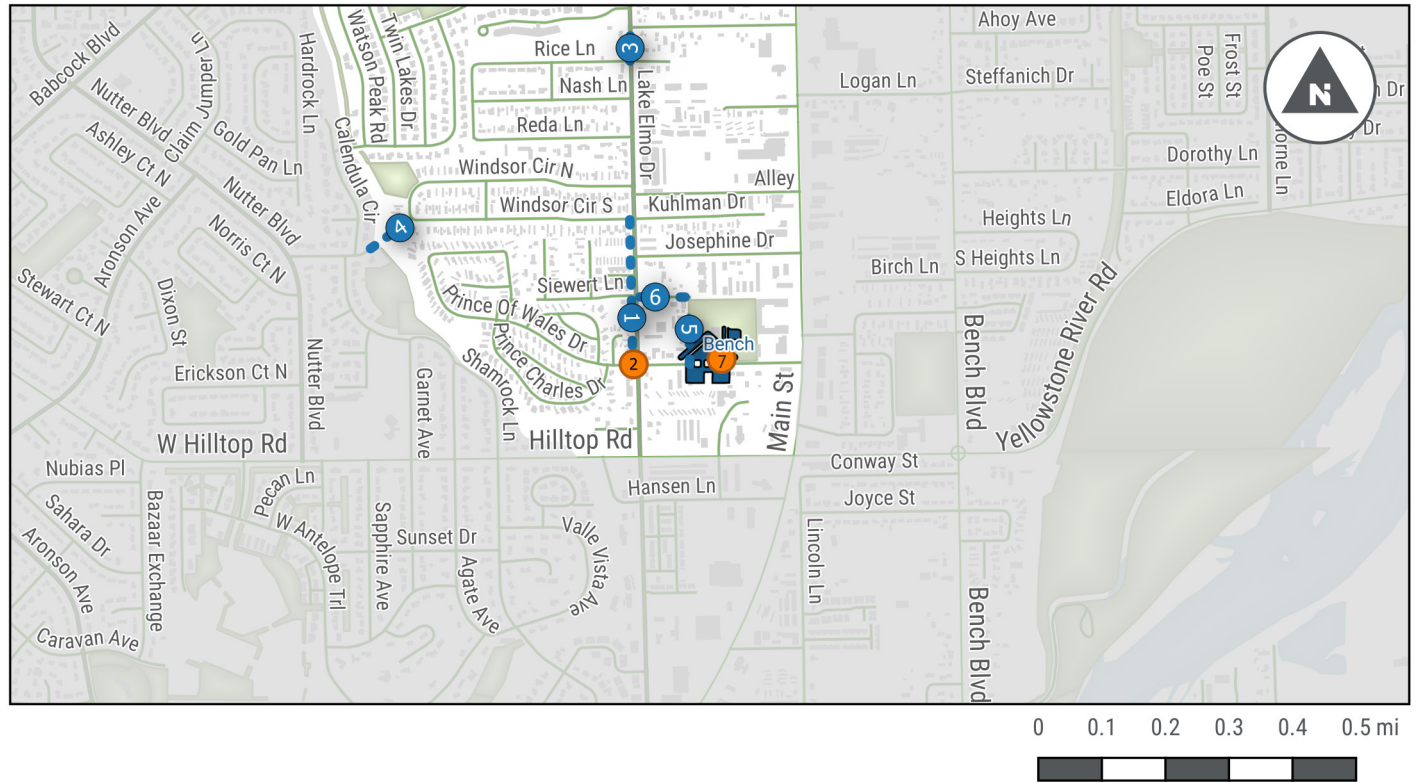







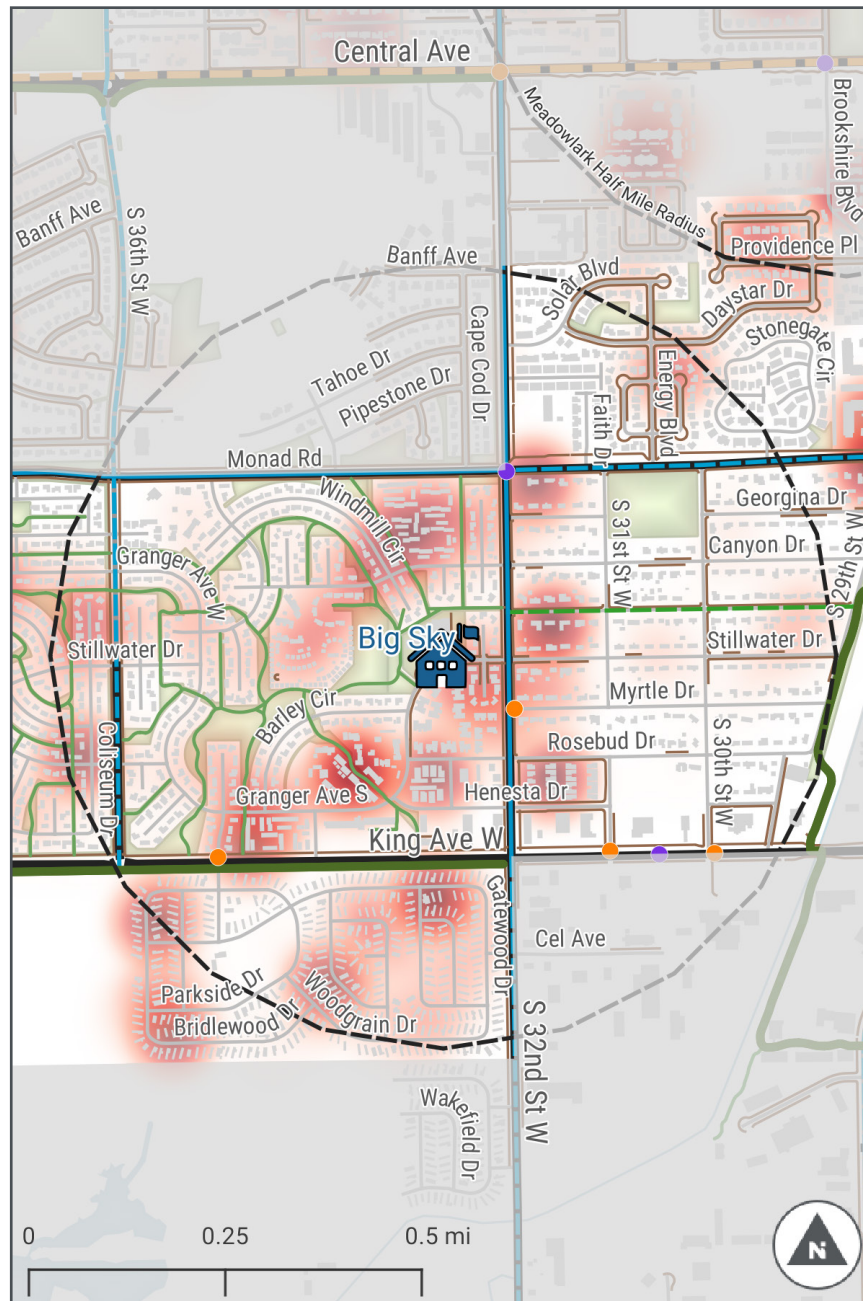



Project #	Proposed Project Type	Observed and Reported Safety Concerns at Project Location											
		Motor vehicle speeding	Long crossing distances	Turning vehicles not yielding	Poor pedestrian access and/or comfort	Poor bicycle access and/or comfort	Crosswalks blocked during arrival/dismissal	Pedestrians crossing mid-block	Poor visibility	Drivers not yielding to pedestrians in crosswalks	Insufficient separation from traffic	Illegal U-turns	Constrained school site/ few access points
1	Sidewalk/Sidepath	x			x							x	
2	School Zone Signage	x			x								
3	Sidewalks				x						x		
4	Shared Use Path				x	x							x
5	Sidewalks				x						x		
6	Shared Use Path				x	x							x
7	Bicycle Parking					x							

# Big Sky





### Key Safety and Mobility Considerations for Big Sky Elementary

-  Student Address Heatmap
  -  School Half Mile Buffer
  -  Outside School Boundary
  -  Bike Crash (2016-2020)
  -  Pedestrian Crash (2016-2020)
  -  Speed Limit 35 mph or Greater
- Existing**
-  Shared Use Path
  -  Existing Bike Lane
  -  Sidewalk
- Proposed**
-  Neighborhood Bikeway
  -  Bike Lane



### Proposed Safe Routes to School Projects for Big Sky Elementary

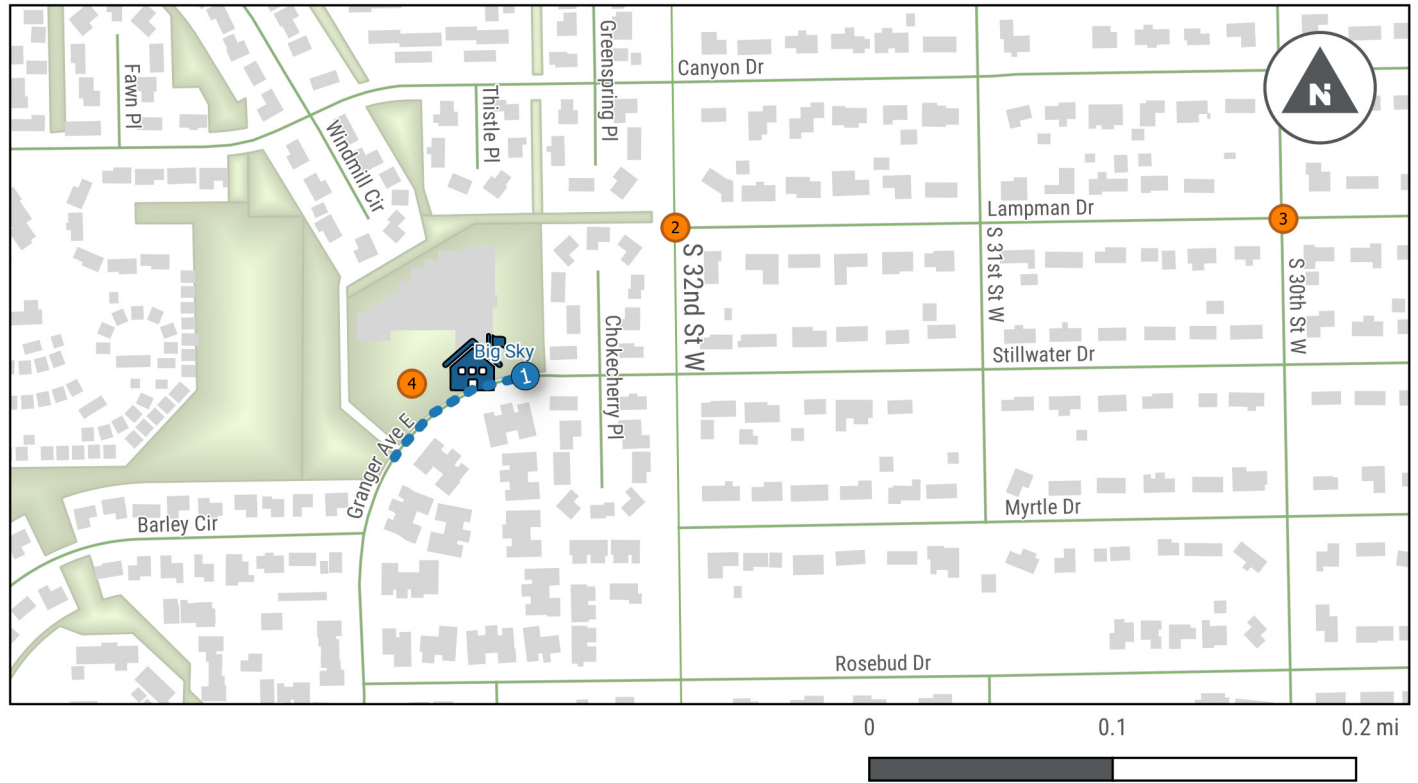

Project #	Proposed Project Type	Observed and Reported Safety Concerns at Project Location											
		Motor vehicle speeding	Long crossing distances	Turning vehicles not yielding	Poor pedestrian access and/or comfort	Poor bicycle access and/or comfort	Crosswalks blocked during arrival/dismissal	Pedestrians crossing mid-block	Poor visibility	Drivers not yielding to pedestrians in crosswalks	Insufficient separation from traffic	Illegal U-turns	Constrained school site/ few access points
1	Arrival/Dismissal Behavior				x	x		x					
2	Crossing				x	x				x			
3	Crossing				x	x				x			
4	Bicycle Parking					x							

# Bitterroot



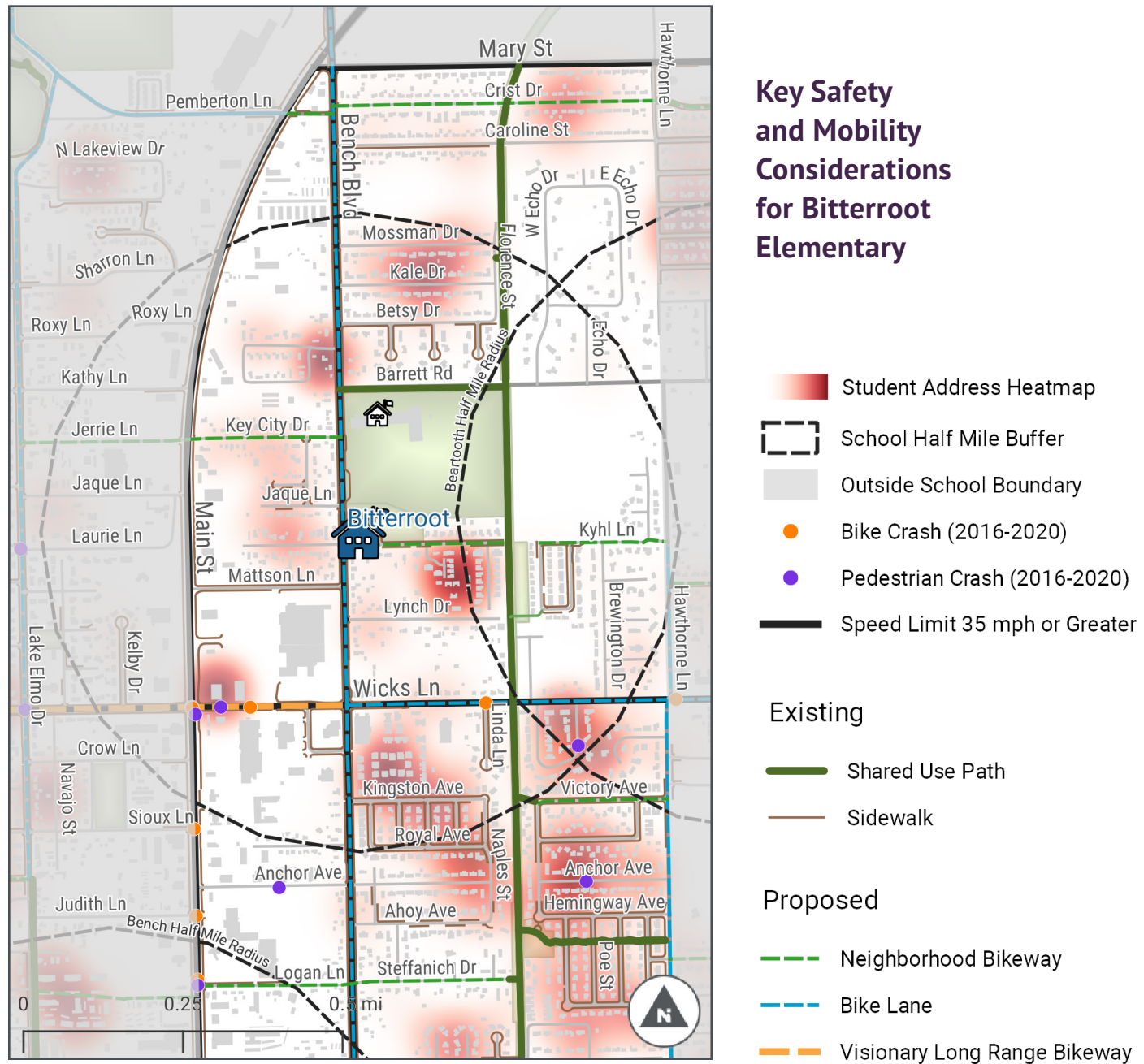

### Proposed Safe Routes to School Projects for Bitterroot Elementary



Project #	Proposed Project Type	Observed and Reported Safety Concerns at Project Location											
		Motor vehicle speeding	Long crossing distances	Turning vehicles not yielding	Poor pedestrian access and/or comfort	Poor bicycle access and/or comfort	Crosswalks blocked during arrival/dismissal	Pedestrians crossing mid-block	Poor visibility	Drivers not yielding to pedestrians in crosswalks	Insufficient separation from traffic	Illegal U-turns	Constrained school site/ few access points
1	Arrival/Dismissal Behavior				x	x		x					
2	Sidewalk				x						x		
3	Crossing		x		x		x			x			
4	Trail Connections					x	x						x
5	Sidewalk/Sidepath				x	x					x		
6	Bicycle Parking					x							

# Boulder





### Proposed Safe Routes to School Projects for Boulder Elementary

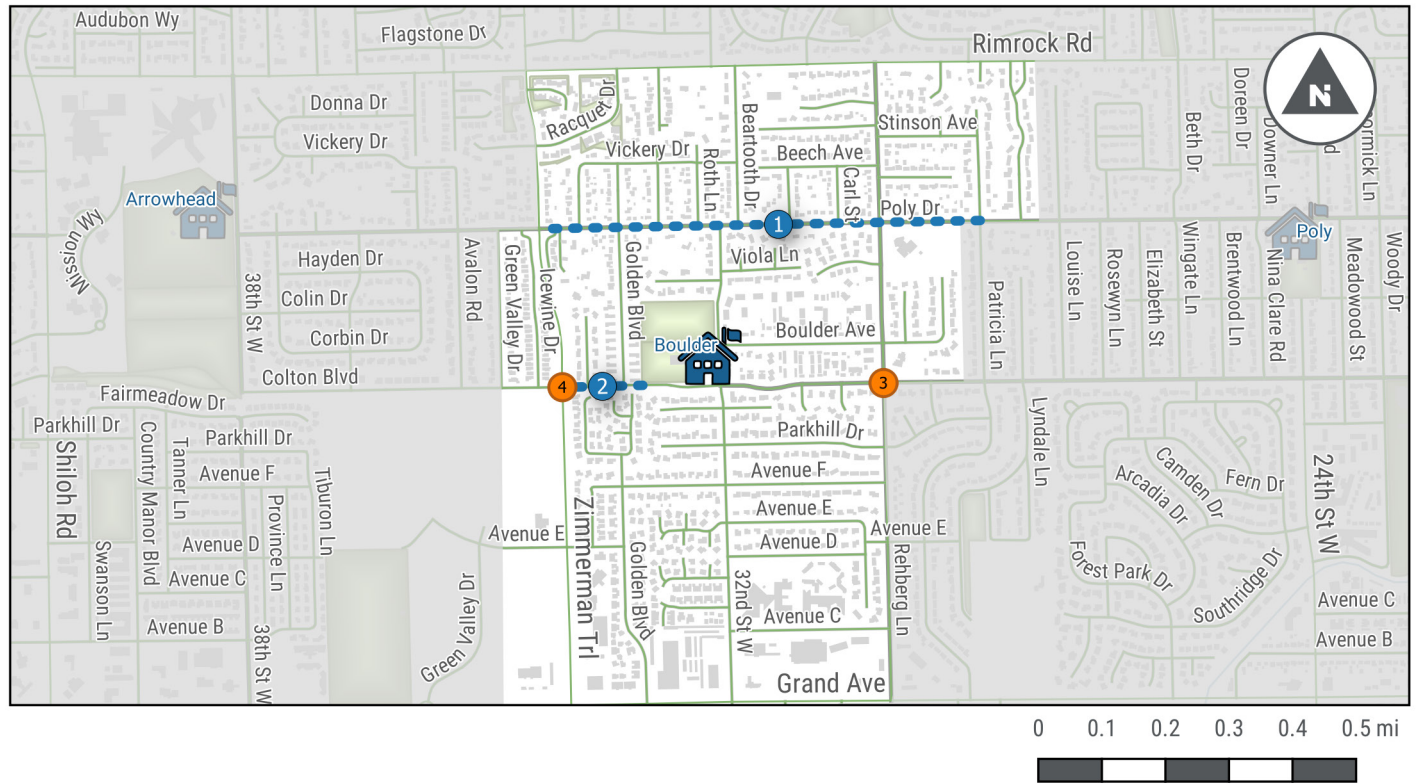

Project #	Proposed Project Type	Observed and Reported Safety Concerns at Project Location											
		Motor vehicle speeding	Long crossing distances	Turning vehicles not yielding	Poor pedestrian access and/or comfort	Poor bicycle access and/or comfort	Crosswalks blocked during arrival/dismissal	Pedestrians crossing mid-block	Poor visibility	Drivers not yielding to pedestrians in crosswalks	Insufficient separation from traffic	Illegal U-turns	Constrained school site/ few access points
1	Speeding	x			x	x							
2	Connectivity				x	x							x
3	Crossing	x	x	x	x								
4	Crossing		x		x					x			







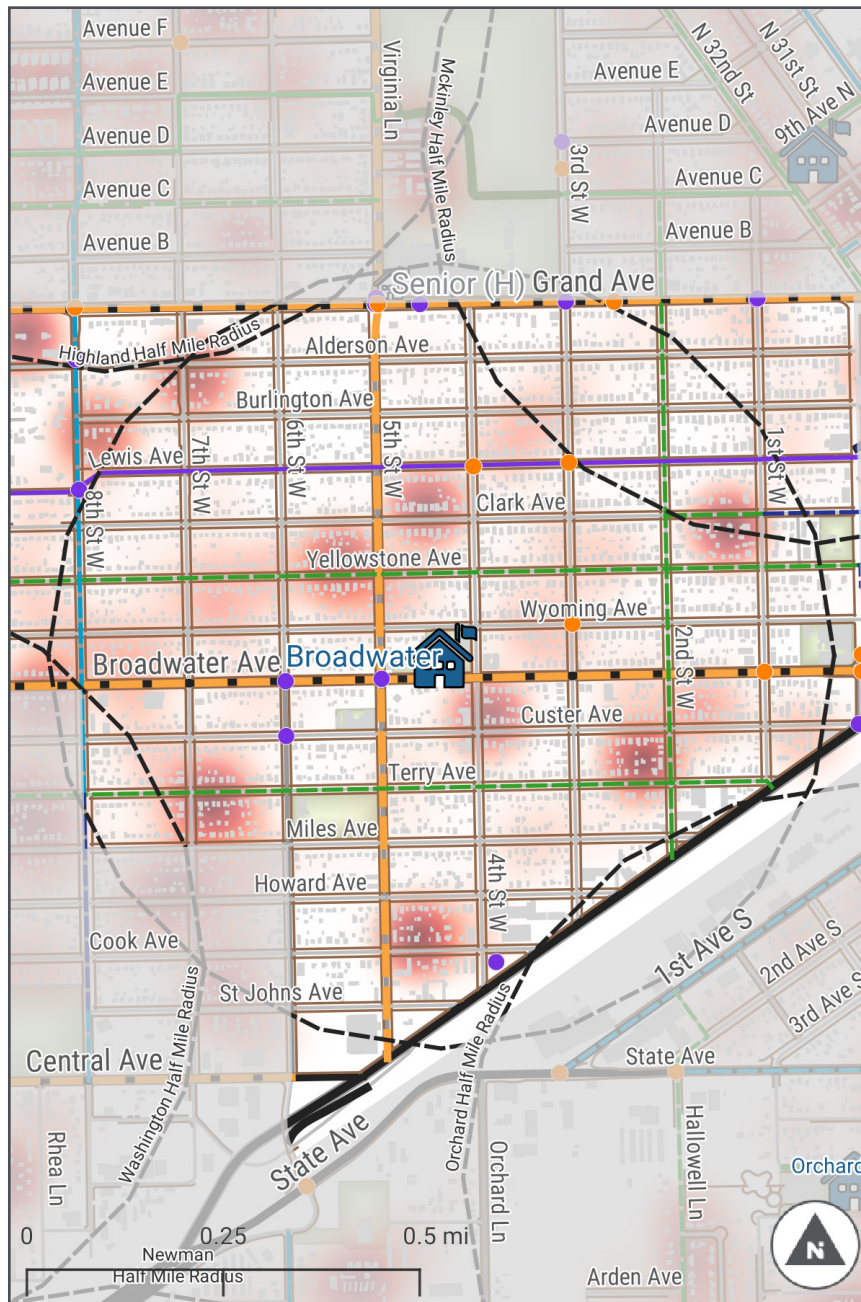





# Broadwater







### Key Safety and Mobility Considerations for Broadwater Elementary

-  Student Address Heatmap
  -  School Half Mile Buffer
  -  Outside School Boundary
  -  Bike Crash (2016-2020)
  -  Pedestrian Crash (2016-2020)
  -  Speed Limit 35 mph or Greater
- Existing**
-  Existing Shared Lane
  -  Sidewalk
- Proposed**
-  Neighborhood Bikeway
  -  Bike Lane
  -  Buffered Bike Lane
  -  Shared Lane Marking
  -  Visionary Long Range Bikeway

### Proposed Safe Routes to School Projects for Broadwater Elementary

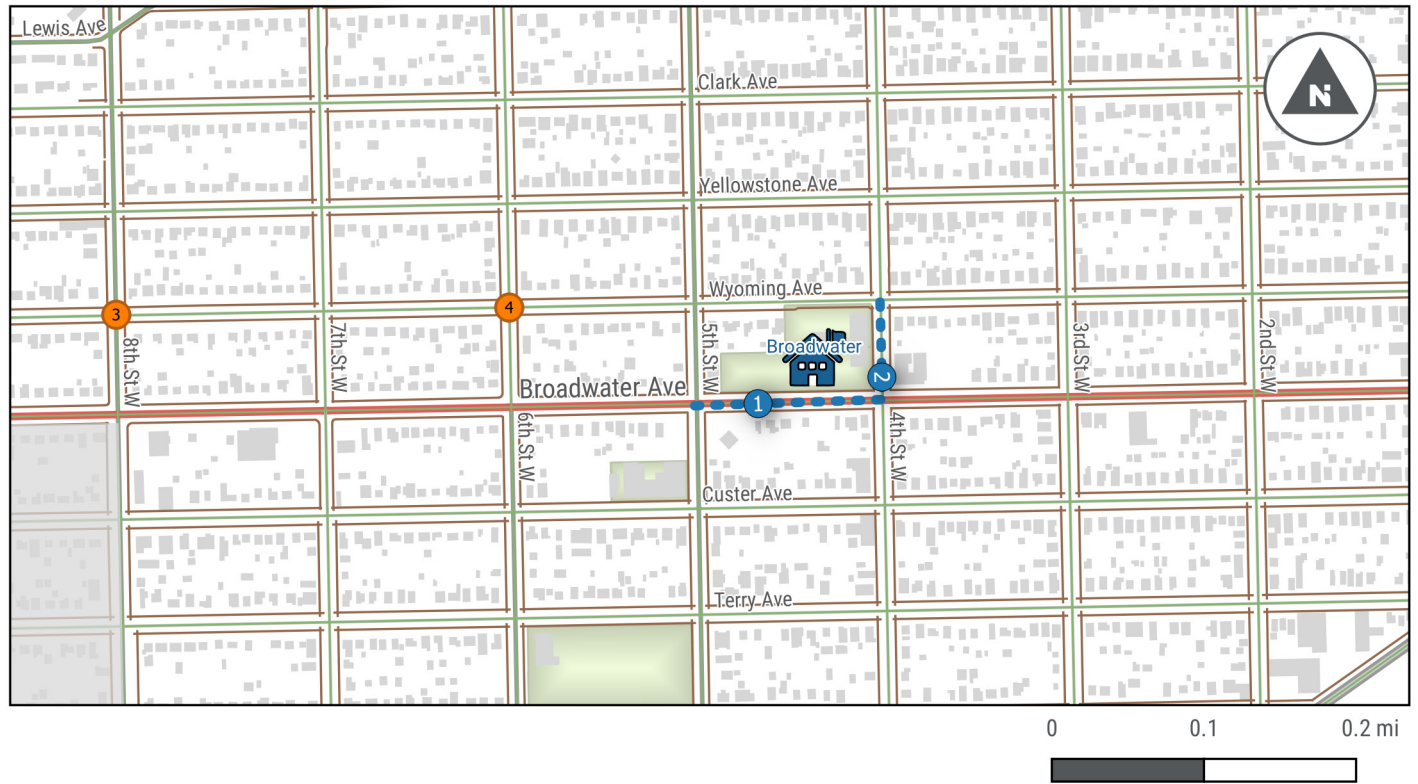







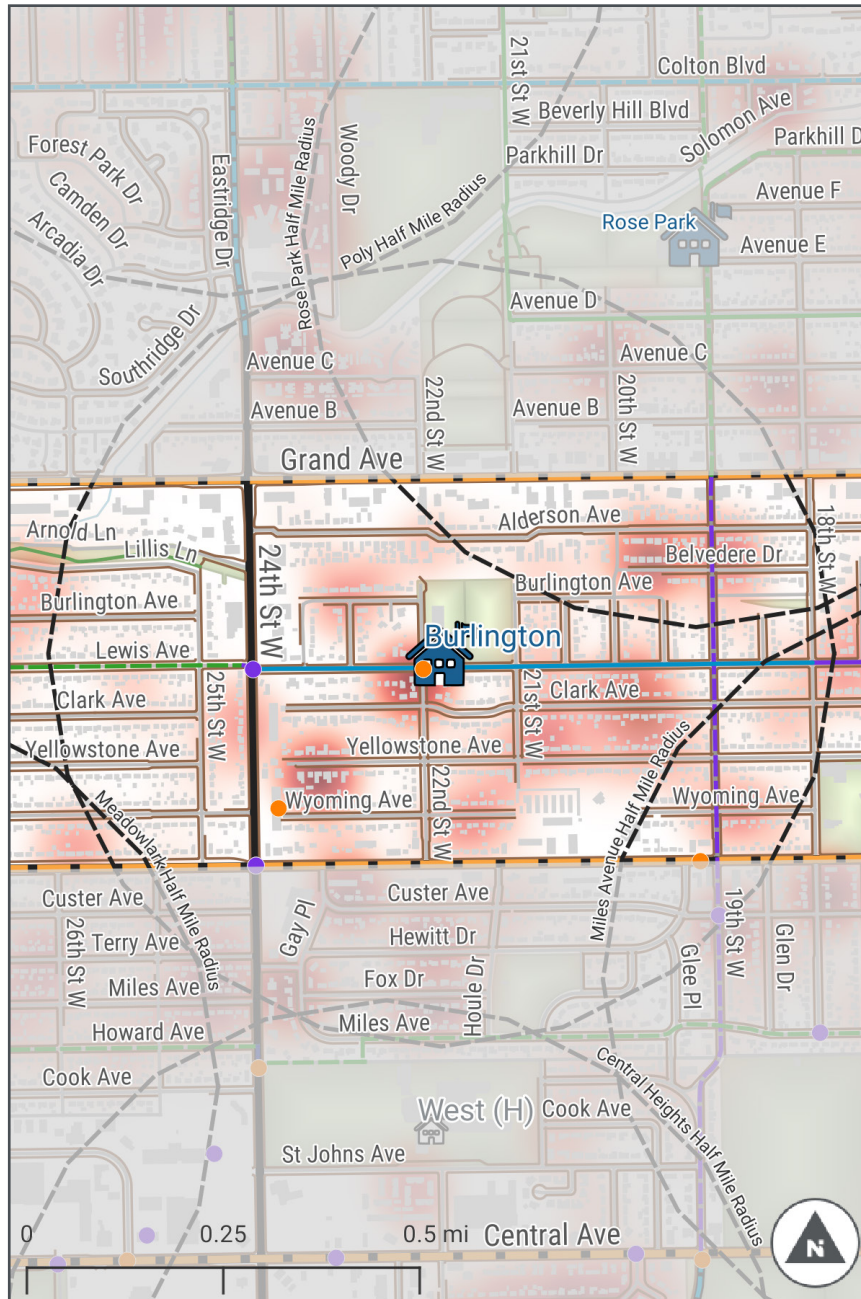







Project #	Proposed Project Type	Observed and Reported Safety Concerns at Project Location											
		Motor vehicle speeding	Long crossing distances	Turning vehicles not yielding	Poor pedestrian access and/or comfort	Poor bicycle access and/or comfort	Crosswalks blocked during arrival/dismissal	Pedestrians crossing mid-block	Poor visibility	Drivers not yielding to pedestrians in crosswalks	Insufficient separation from traffic	Illegal U-turns	Constrained school site/ few access points
1	Speeding	x			x	x							
2	Arrival/Dismissal Behavior				x	x						x	
3	Crossing				x						x		
4	Crossing				x						x		

# Burlington





### Key Safety and Mobility Considerations for Burlington Elementary

-  Student Address Heatmap
-  School Half Mile Buffer
-  Outside School Boundary
-  Bike Crash (2016-2020)
-  Pedestrian Crash (2016-2020)
-  Speed Limit 35 mph or Greater
- Existing**
  -  Existing Bike Lane
  -  Existing Shared Lane
  -  Sidewalk
  -  Neighborhood Bikeway
- Proposed**
  -  Neighborhood Bikeway
  -  Bike Lane
  -  Shared Lane Marking
  -  Visionary Long Range Bikeway

## Proposed Safe Routes to School Projects for Burlington Elementary

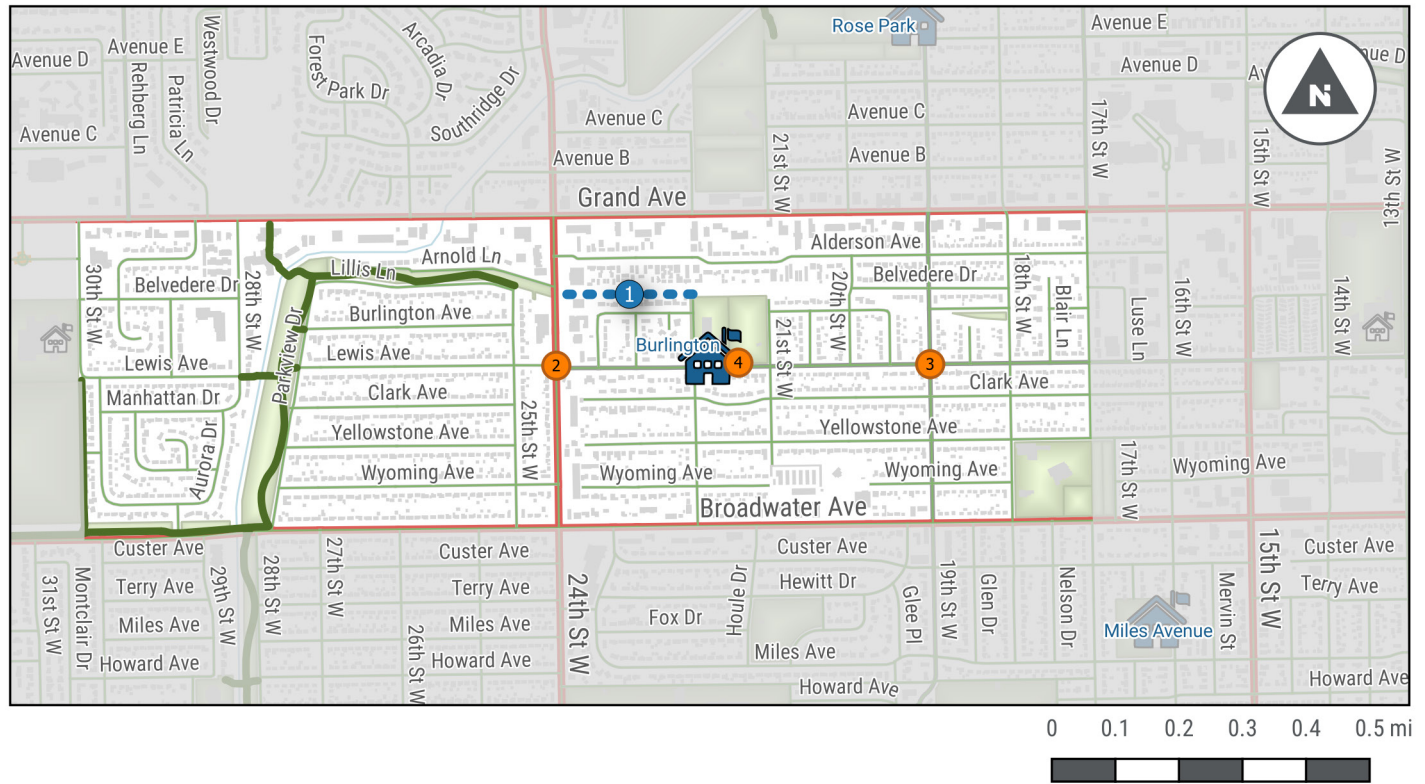





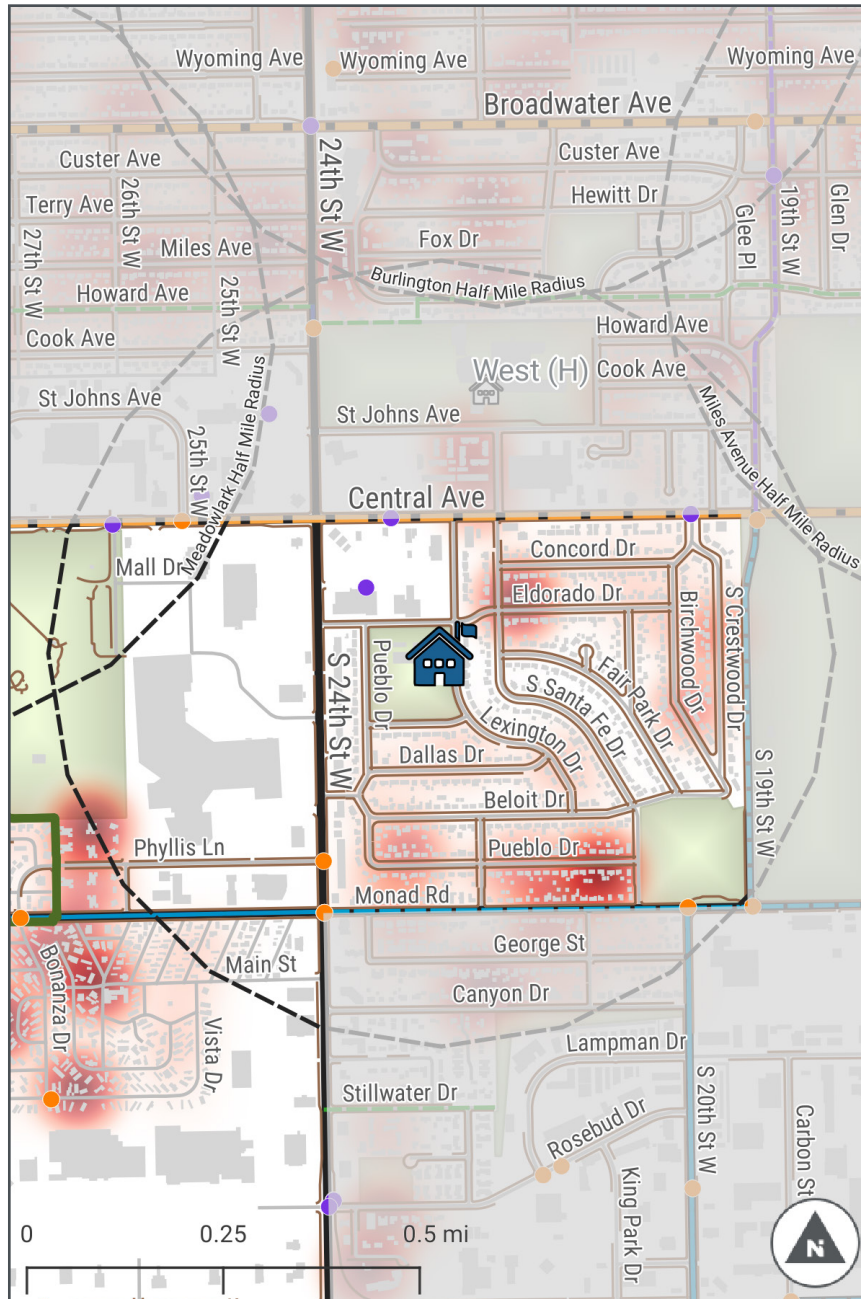

Project #	Proposed Project Type	Observed and Reported Safety Concerns at Project Location											
		Motor vehicle speeding	Long crossing distances	Turning vehicles not yielding	Poor pedestrian access and/or comfort	Poor bicycle access and/or comfort	Crosswalks blocked during arrival/dismissal	Pedestrians crossing mid-block	Poor visibility	Drivers not yielding to pedestrians in crosswalks	Insufficient separation from traffic	Illegal U-turns	Constrained school site/ few access points
1	Trail/Path				x	x							x
2	Crossing			x									x
3	Crossing												x
4	Bicycle parking					x							

# Central Heights









### Key Safety and Mobility Considerations for Central Heights Elementary

-  Student Address Heatmap
-  School Half Mile Buffer
-  Outside School Boundary
-  Bike Crash (2016-2020)
-  Pedestrian Crash (2016-2020)
-  Speed Limit 35 mph or Greater

Existing

-  Existing Bike Lane

Proposed

-  Neighborhood Bikeway
-  Bike Lane
-  Buffered Bike Lane
-  Shared Lane Marking
-  Visionary Long Range Bikeway

### Proposed Safe Routes to School Projects for Central Heights Elementary

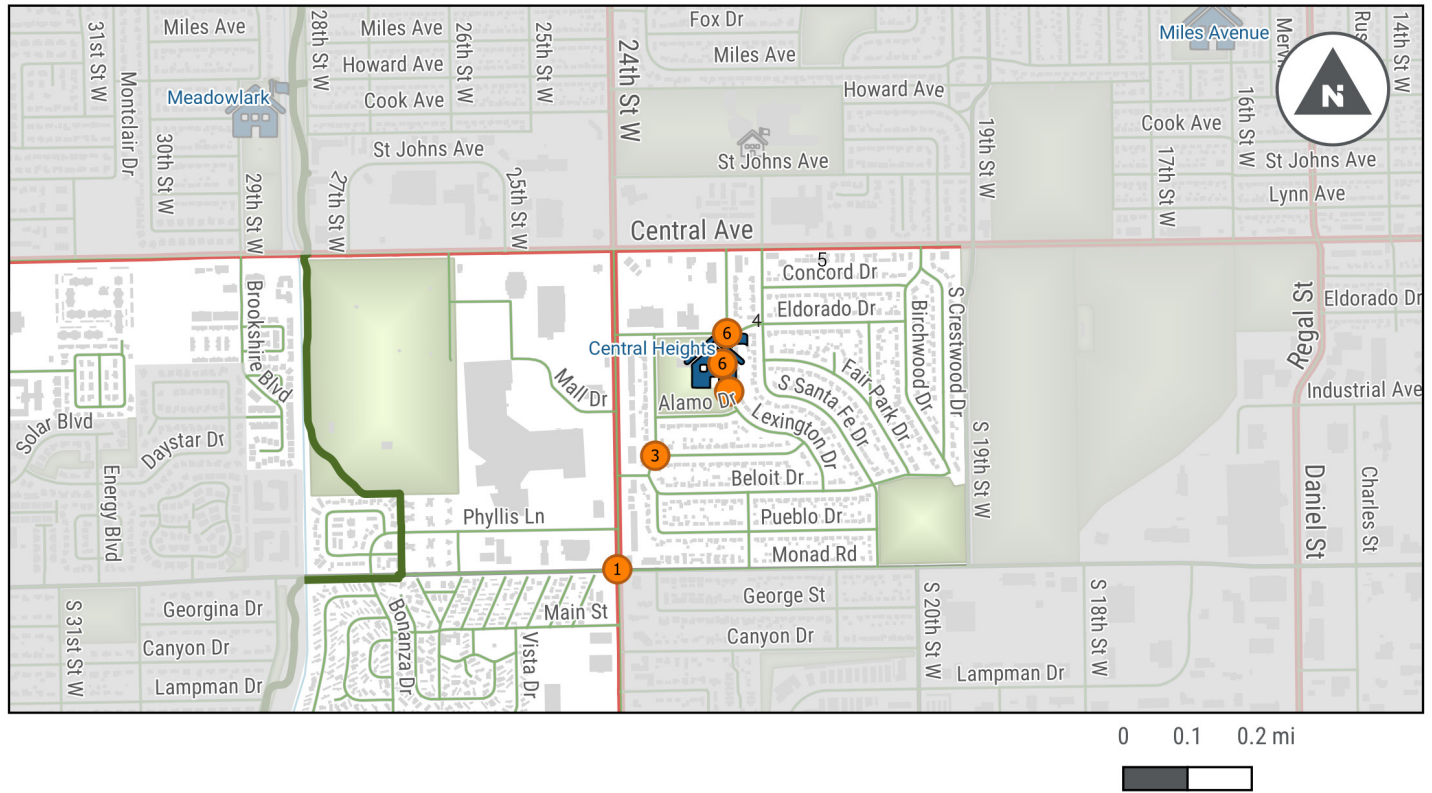

Project #	Proposed Project Type	Observed and Reported Safety Concerns at Project Location											
		Motor vehicle speeding	Long crossing distances	Turning vehicles not yielding	Poor pedestrian access and/or comfort	Poor bicycle access and/or comfort	Crosswalks blocked during arrival/dismissal	Pedestrians crossing mid-block	Poor visibility	Drivers not yielding to pedestrians in crosswalks	Insufficient separation from traffic	Illegal U-turns	Constrained school site/ few access points
1	Crossing		x		x								
2	Arrival/Dismissal Behavior				x	x						x	
3	Accessibility				x								
4	Crossing		x		x	x				x			
5	Crossing		x		x	x				x			
6	Bicycle Parking					x							





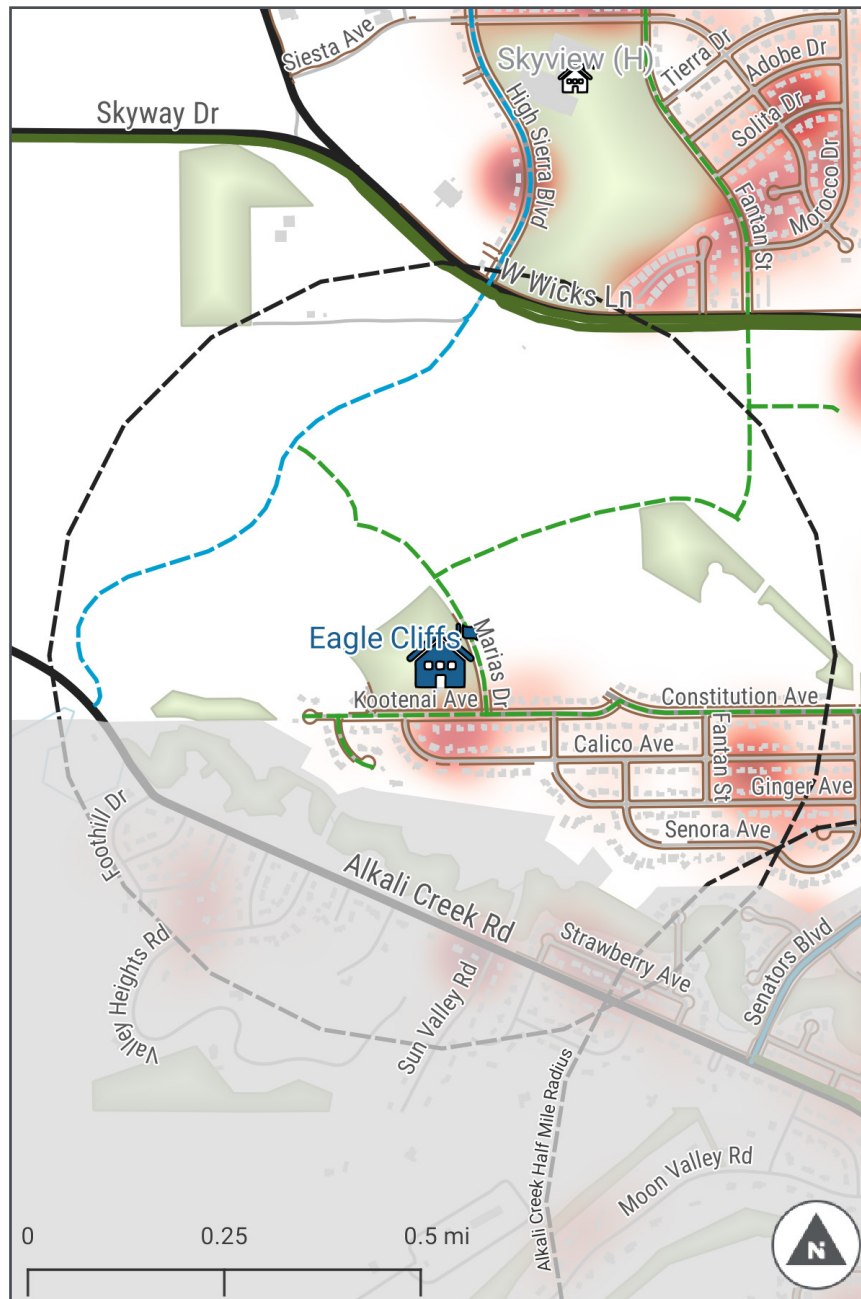

# Eagle Cliffs









### Key Safety and Mobility Considerations for Eagle Cliffs Elementary

-  Student Address Heatmap
-  School Half Mile Buffer
-  Outside School Boundary
-  Speed Limit 35 mph or Greater

#### Existing

-  Shared Use Path
-  Sidewalk

#### Proposed

-  Neighborhood Bikeway
-  Bike Lane

## Proposed Safe Routes to School Projects for Eagle Cliffs Elementary

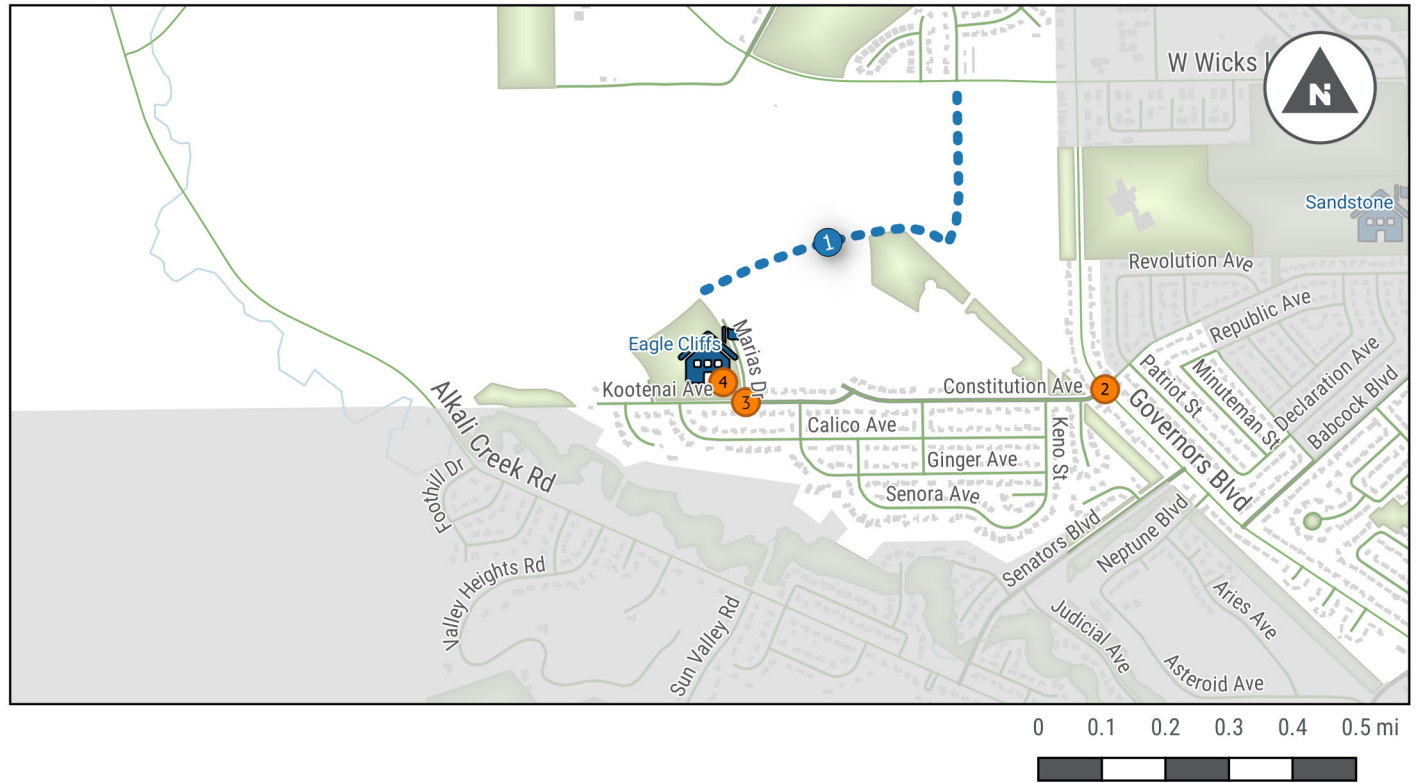







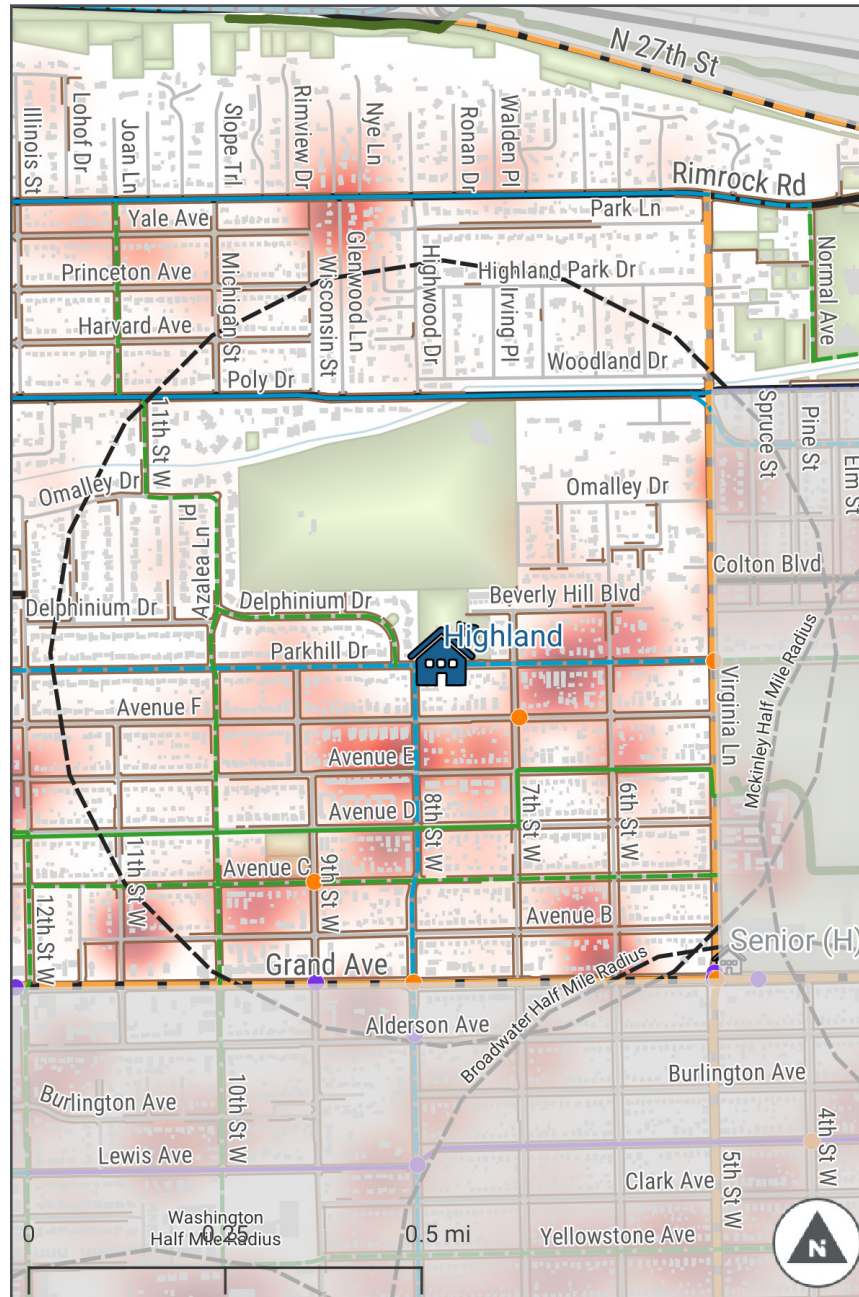







Project #	Proposed Project Type	Observed and Reported Safety Concerns at Project Location											
		Motor vehicle speeding	Long crossing distances	Turning vehicles not yielding	Poor pedestrian access and/or comfort	Poor bicycle access and/or comfort	Crosswalks blocked during arrival/dismissal	Pedestrians crossing mid-block	Poor visibility	Drivers not yielding to pedestrians in crosswalks	Insufficient separation from traffic	Illegal U-turns	Constrained school site/ few access points
1	Trail/Path				x	x							x
2	Crossing			x						x			
3	Crossing				x	x							
4	Bicycle Parking					x							

# Highland





### Key Safety and Mobility Considerations for Highland Elementary

-  Student Address Heatmap
  -  School Half Mile Buffer
  -  Outside School Boundary
  -  Bike Crash (2016-2020)
  -  Pedestrian Crash (2016-2020)
  -  Speed Limit 35 mph or Greater
- Existing**
-  Shared Use Path
  -  Existing Bike Lane
  -  Sidewalk
  -  Neighborhood Bikeway
- Proposed**
-  Neighborhood Bikeway
  -  Bike Lane
  -  Buffered Bike Lane
  -  Visionary Long Range Bikeway

## Proposed Safe Routes to School Projects for Highland Elementary

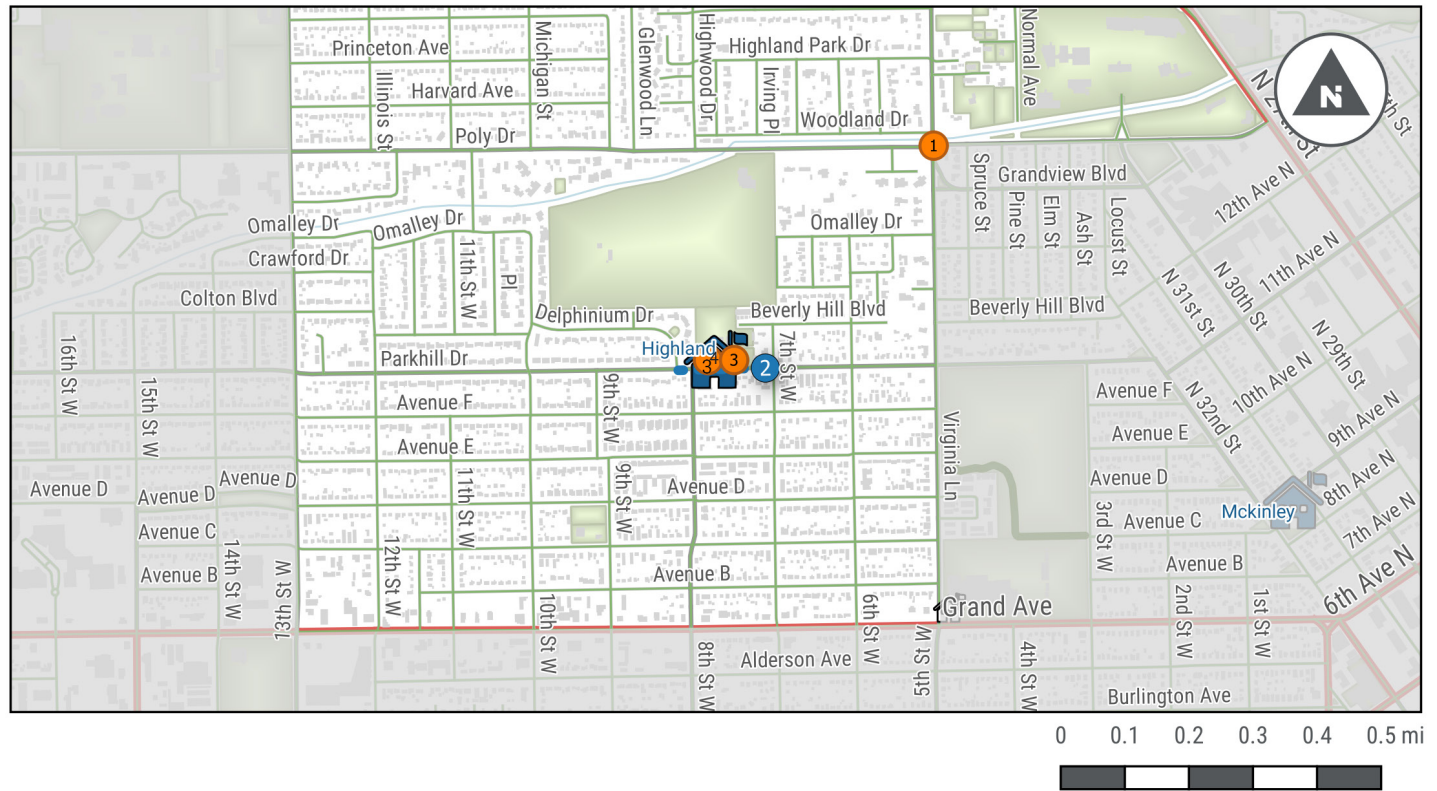







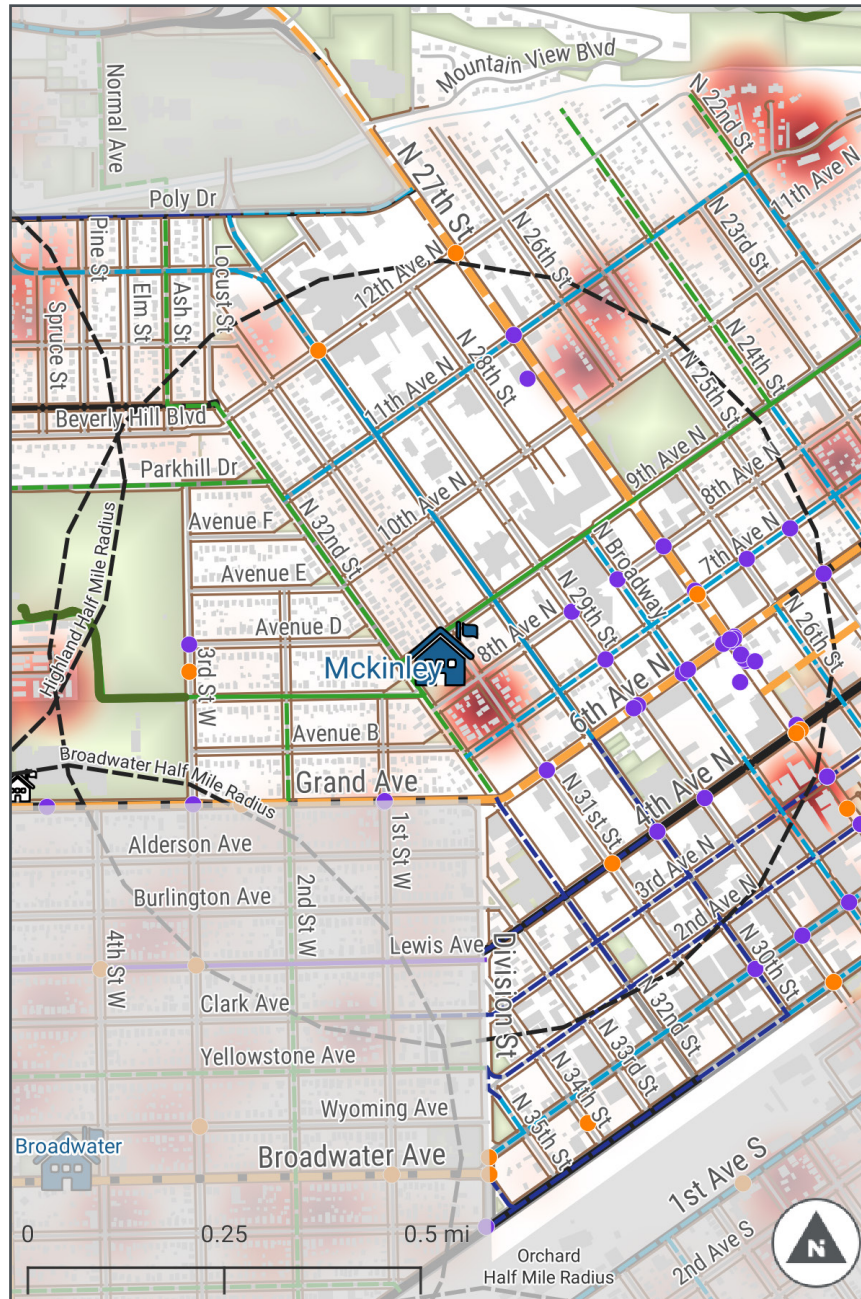







Project #	Proposed Project Type	Observed and Reported Safety Concerns at Project Location											
		Motor vehicle speeding	Long crossing distances	Turning vehicles not yielding	Poor pedestrian access and/or comfort	Poor bicycle access and/or comfort	Crosswalks blocked during arrival/dismissal	Pedestrians crossing mid-block	Poor visibility	Drivers not yielding to pedestrians in crosswalks	Insufficient separation from traffic	Illegal U-turns	Constrained school site/ few access points
1	Crossing				x								
2	Arrival/Dismissal Behavior							x					x
3	Bicycle Parking					x							

# McKinley





### Key Safety and Mobility Considerations for McKinley Elementary

-  Student Address Heatmap
-  School Half Mile Buffer
-  Outside School Boundary
-  Bike Crash (2016-2020)
-  Pedestrian Crash (2016-2020)
-  Speed Limit 35 mph or Greater
- Existing**
  -  Shared Use Path
  -  Existing Bike Lane
  -  Existing Shared Lane
  -  Sidewalk
- Proposed**
  -  Neighborhood Bikeway
  -  Bike Lane
  -  Buffered Bike Lane
  -  Shared Lane Marking
  -  Visionary Long Range Bikeway



### Proposed Safe Routes to School Projects for McKinley Elementary

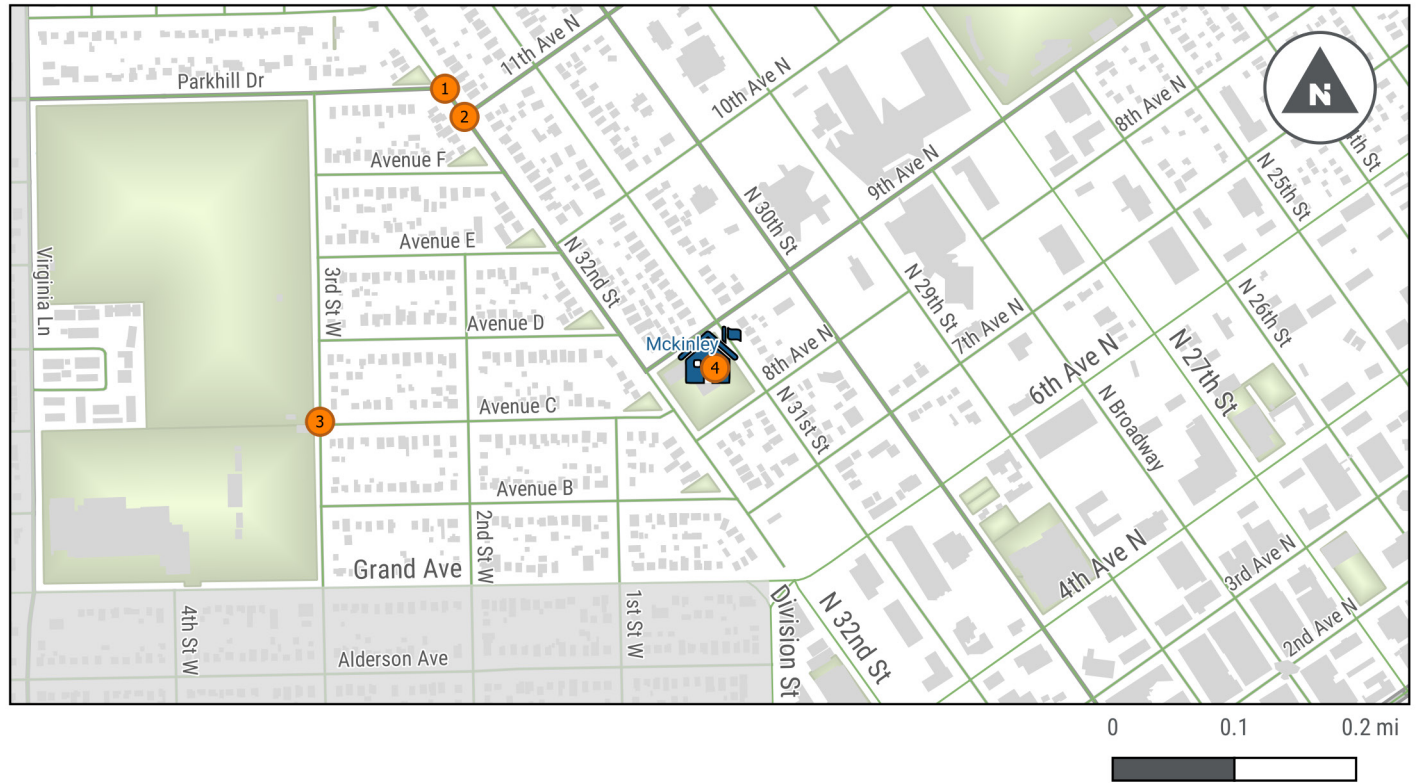





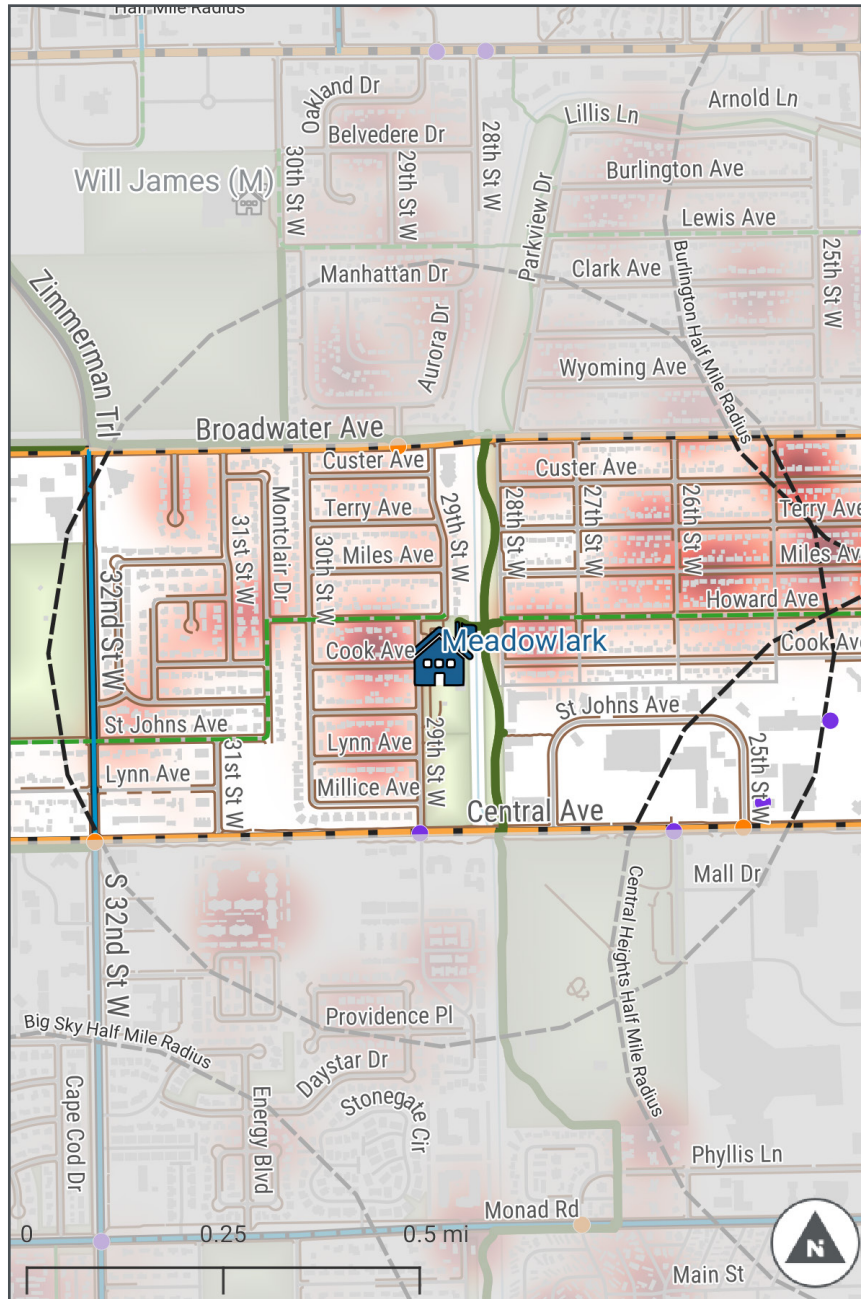

Project #	Proposed Project Type	Observed and Reported Safety Concerns at Project Location											
		Motor vehicle speeding	Long crossing distances	Turning vehicles not yielding	Poor pedestrian access and/or comfort	Poor bicycle access and/or comfort	Crosswalks blocked during arrival/dismissal	Pedestrians crossing mid-block	Poor visibility	Drivers not yielding to pedestrians in crosswalks	Insufficient separation from traffic	Illegal U-turns	Constrained school site/ few access points
1	Crossing			x	x	x							x
2	Crossing		x	x	x								x
3	Speeding and Volume	x	x		x	x							
4	Crossing	x			x	x							

# Meadowlark









### Key Safety and Mobility Considerations for Meadowlark Elementary

-  Student Address Heatmap
-  School Half Mile Buffer
-  Outside School Boundary
-  Bike Crash (2016-2020)
-  Pedestrian Crash (2016-2020)
-  Speed Limit 35 mph or Greater

#### Existing

-  Shared Use Path
-  Existing Bike Lane
-  Sidewalk

#### Proposed

-  Neighborhood Bikeway
-  Visionary Long Range Bikeway

### Proposed Safe Routes to School Projects for Meadowlark Elementary

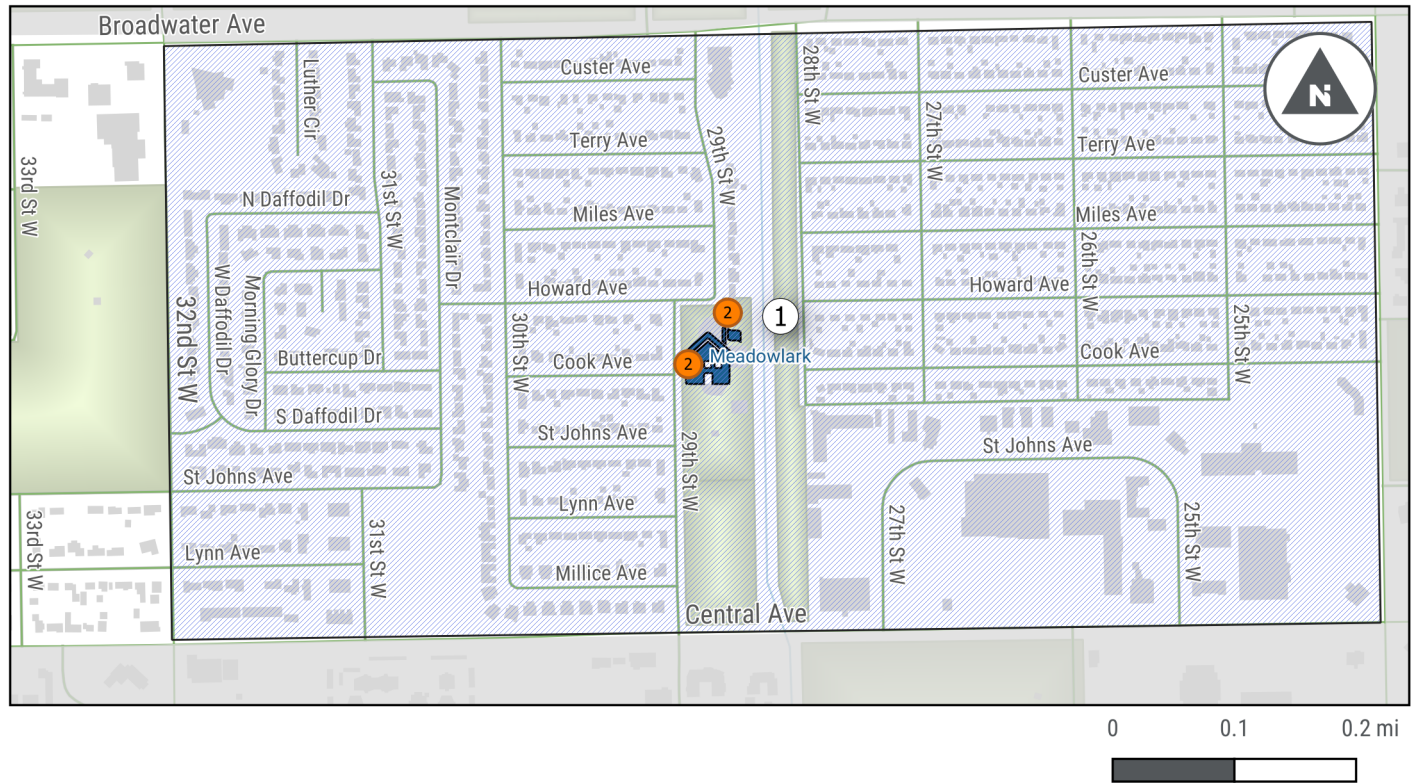

Project #	Proposed Project Type	Observed and Reported Safety Concerns at Project Location											
		Motor vehicle speeding	Long crossing distances	Turning vehicles not yielding	Poor pedestrian access and/or comfort	Poor bicycle access and/or comfort	Crosswalks blocked during arrival/dismissal	Pedestrians crossing mid-block	Poor visibility	Drivers not yielding to pedestrians in crosswalks	Insufficient separation from traffic	Illegal U-turns	Constrained school site/ few access points
1	Sidewalk				x							x	
2	Bicycle parking					x							

# Miles Avenue



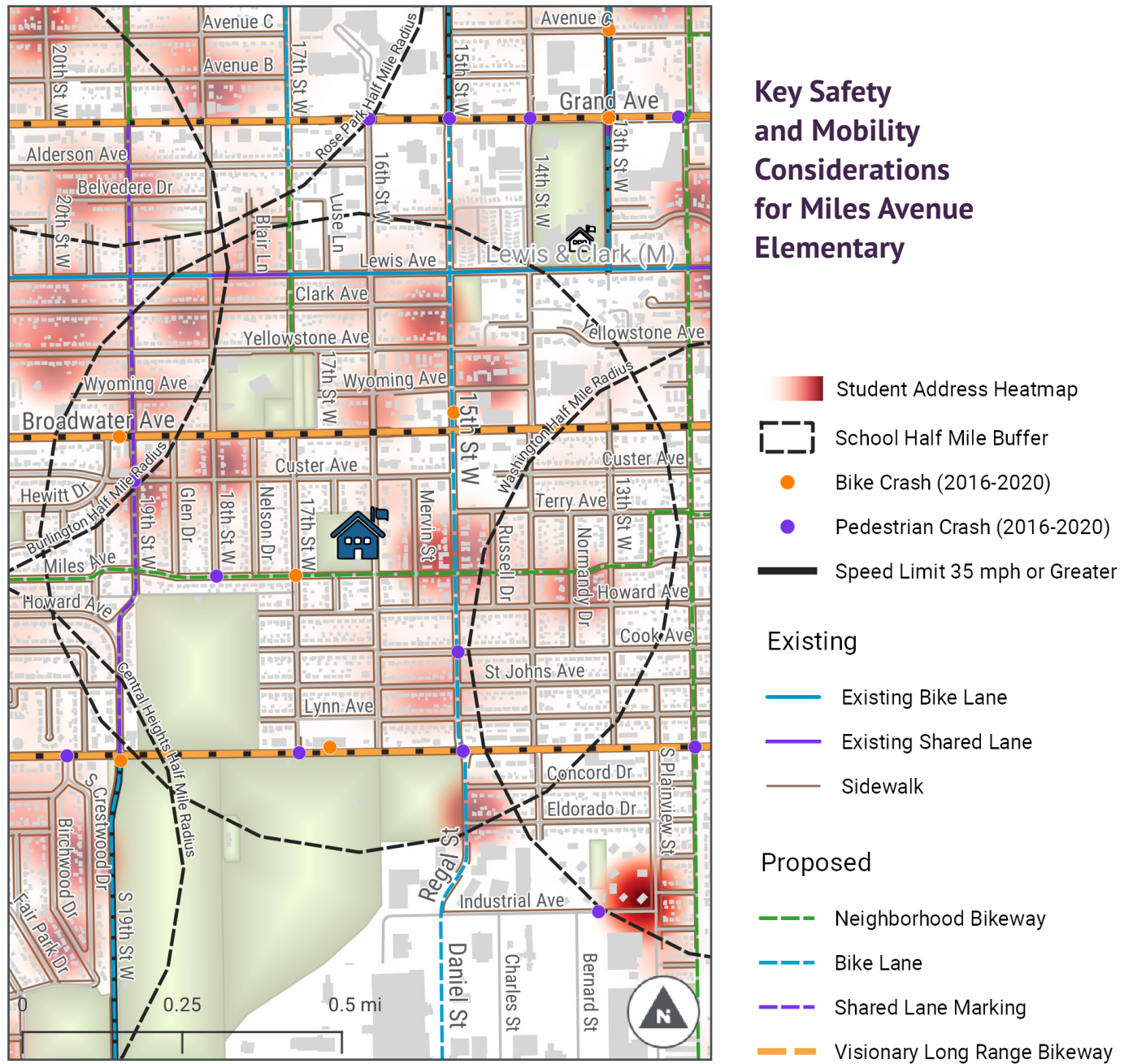

## Proposed Safe Routes to School Projects for Miles Avenue Elementary

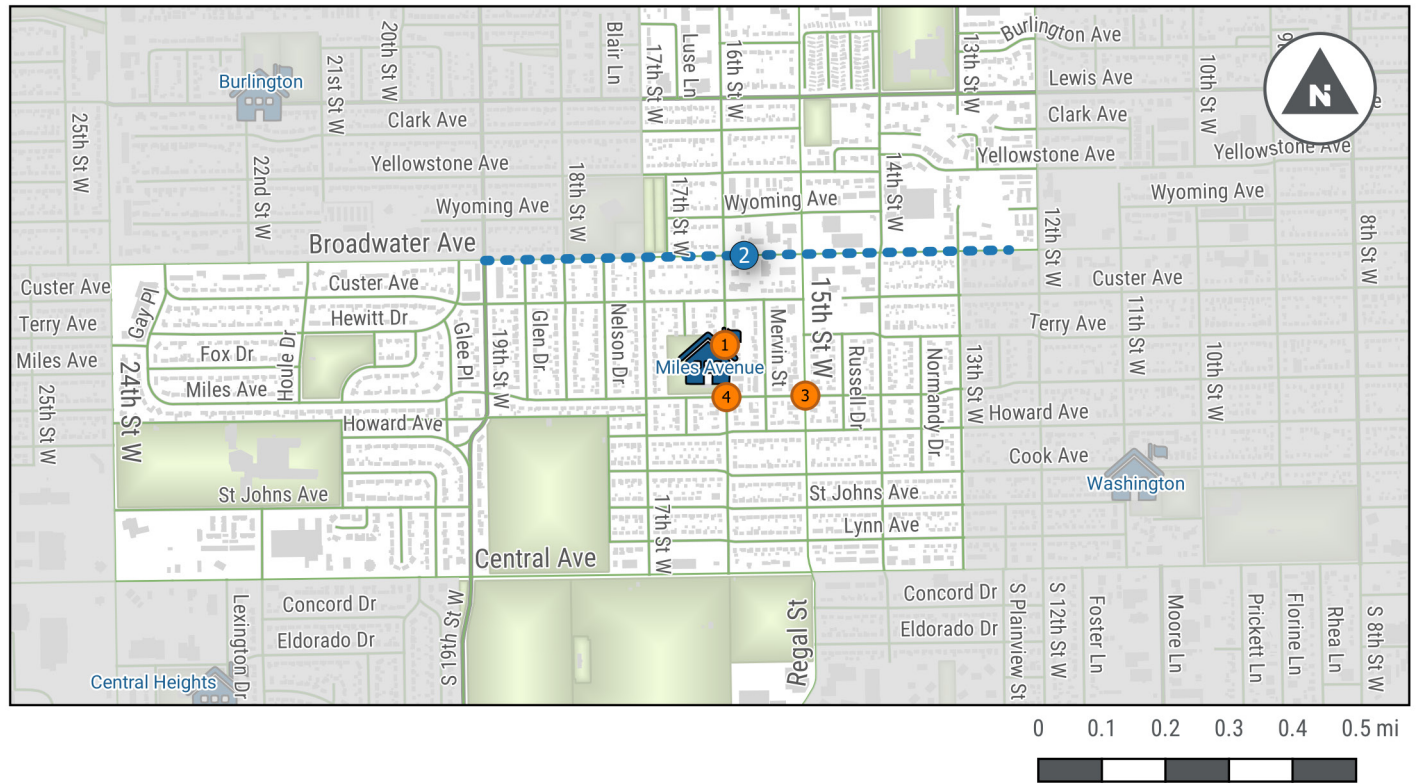

Project #	Proposed Project Type	Observed and Reported Safety Concerns at Project Location											
		Motor vehicle speeding	Long crossing distances	Turning vehicles not yielding	Poor pedestrian access and/or comfort	Poor bicycle access and/or comfort	Crosswalks blocked during arrival/dismissal	Pedestrians crossing mid-block	Poor visibility	Drivers not yielding to pedestrians in crosswalks	Insufficient separation from traffic	Illegal U-turns	Constrained school site/ few access points
1	Crossing				x								x
2	Crossing	x	x		x								x
3	Speeding/Volume	x			x	x							
4	Bicycle Parking												

# Newman





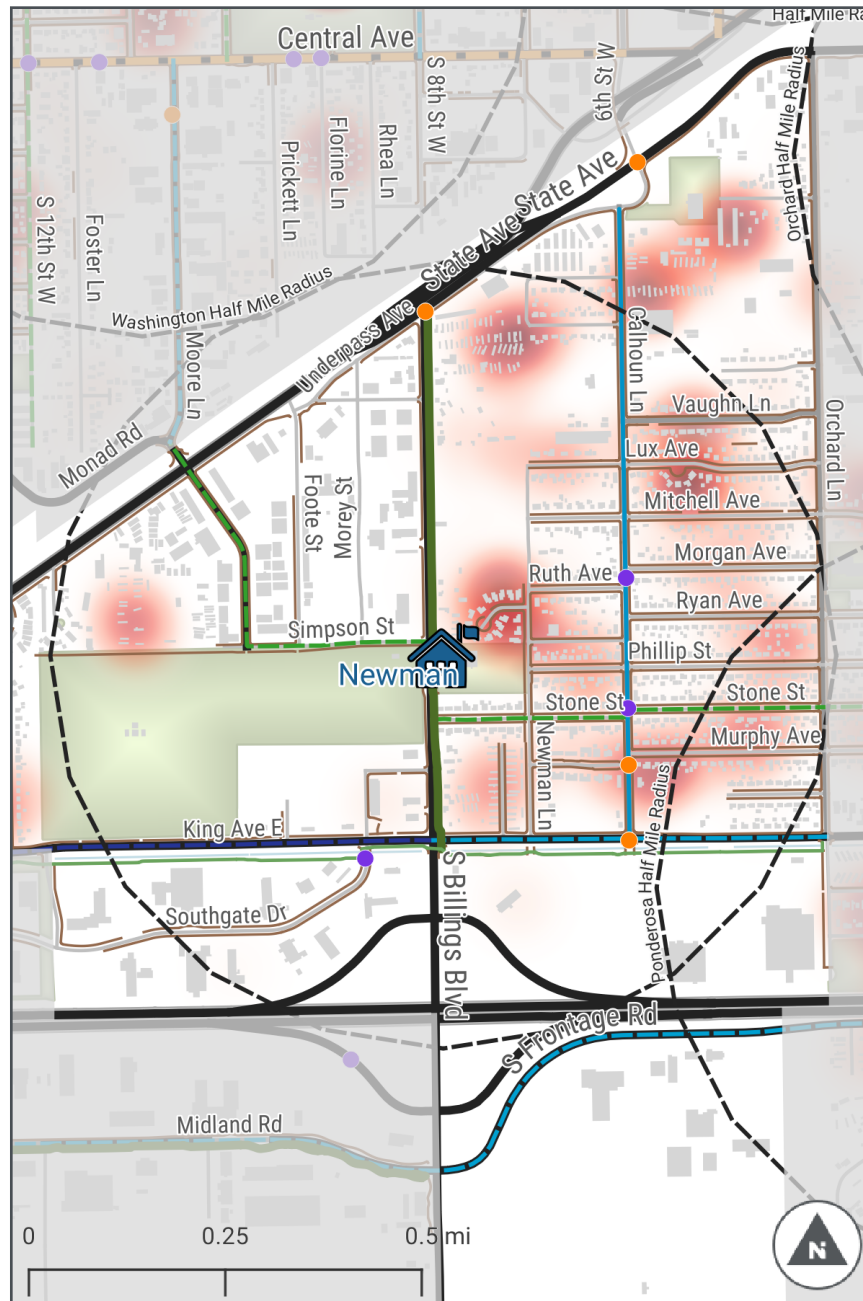

### Key Safety and Mobility Considerations for Newman Elementary

- Student Address Heatmap
- School Half Mile Buffer
- Outside School Boundary
- Bike Crash (2016-2020)
- Pedestrian Crash (2016-2020)
- Speed Limit 35 mph or Greater

#### Existing

- Shared Use Path
- Existing Bike Lane
- Sidewalk

#### Proposed

- Neighborhood Bikeway
- Bike Lane
- Buffered Bike Lane

### Proposed Safe Routes to School Projects for Newman Elementary

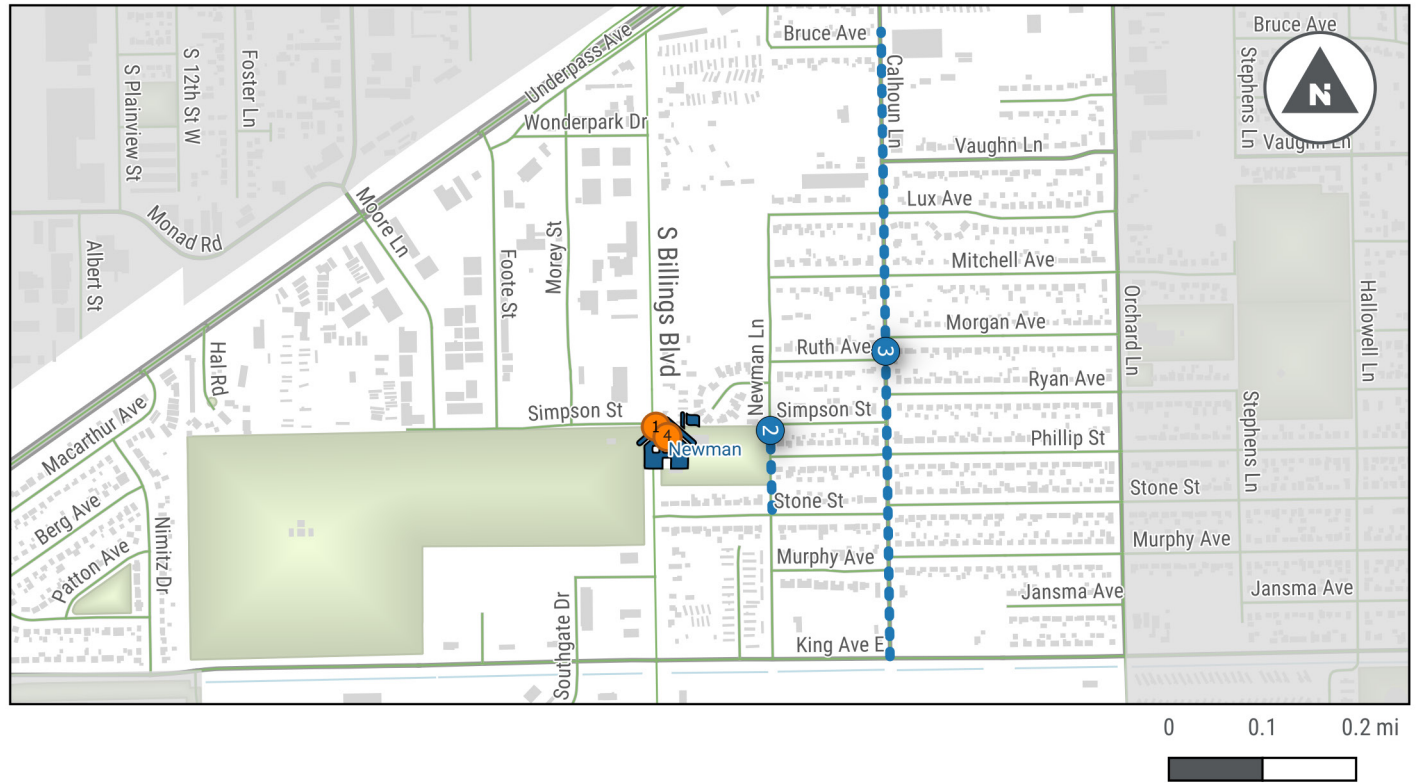





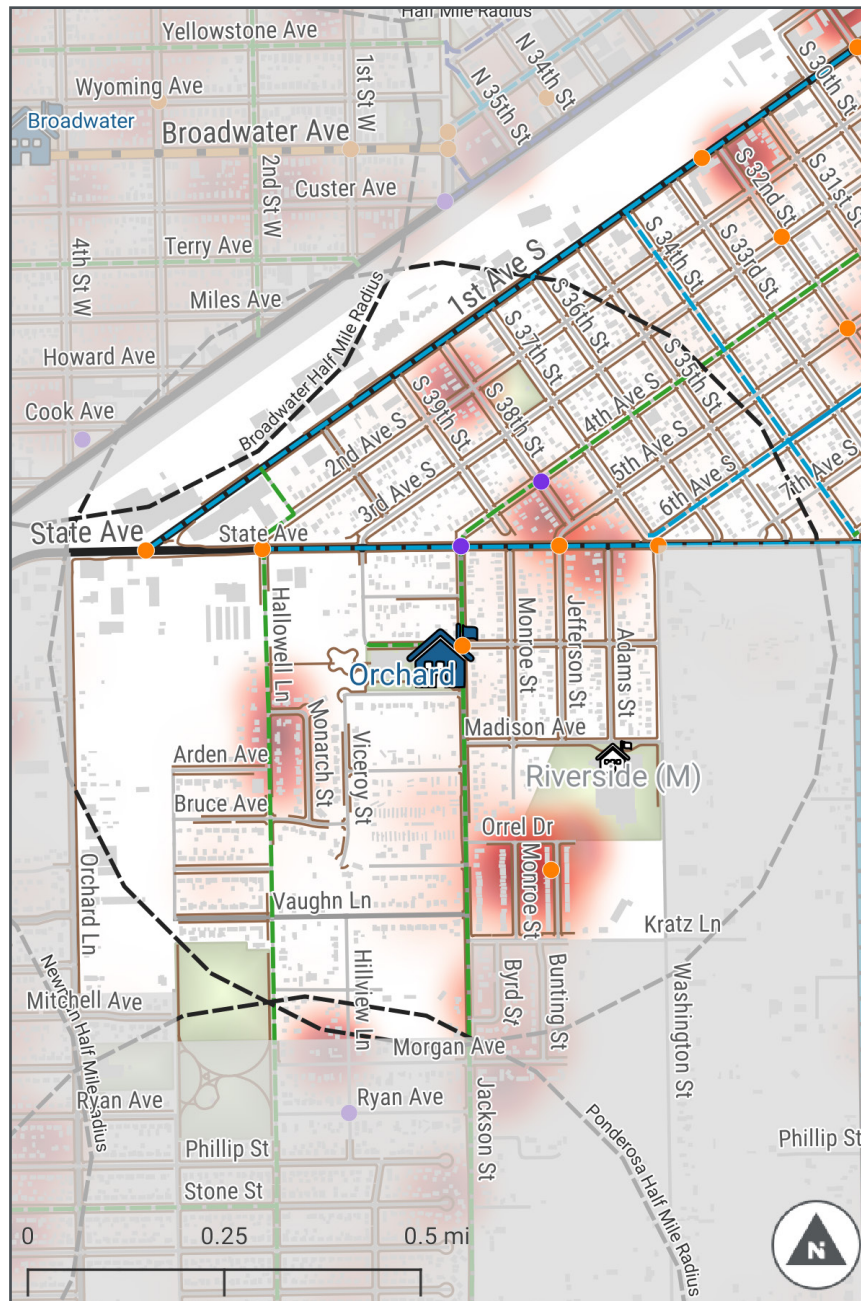

Project #	Proposed Project Type	Observed and Reported Safety Concerns at Project Location											
		Motor vehicle speeding	Long crossing distances	Turning vehicles not yielding	Poor pedestrian access and/or comfort	Poor bicycle access and/or comfort	Crosswalks blocked during arrival/dismissal	Pedestrians crossing mid-block	Poor visibility	Drivers not yielding to pedestrians in crosswalks	Insufficient separation from traffic	Illegal U-turns	Constrained school site/ few access points
1	Crossing		x		x								
2	Arrival/Dismissal Behavior				x	x							x
3	Sidewalks				x						x		
4	Bicycle Parking					x							

# Orchard







### Key Safety and Mobility Considerations for Orchard Elementary

-  Student Address Heatmap
-  School Half Mile Buffer
-  Outside School Boundary
-  Bike Crash (2016-2020)
-  Pedestrian Crash (2016-2020)
-  Speed Limit 35 mph or Greater

#### Existing

-  Sidewalk

#### Proposed

-  Neighborhood Bikeway
-  Bike Lane

### Proposed Safe Routes to School Projects for Orchard Elementary

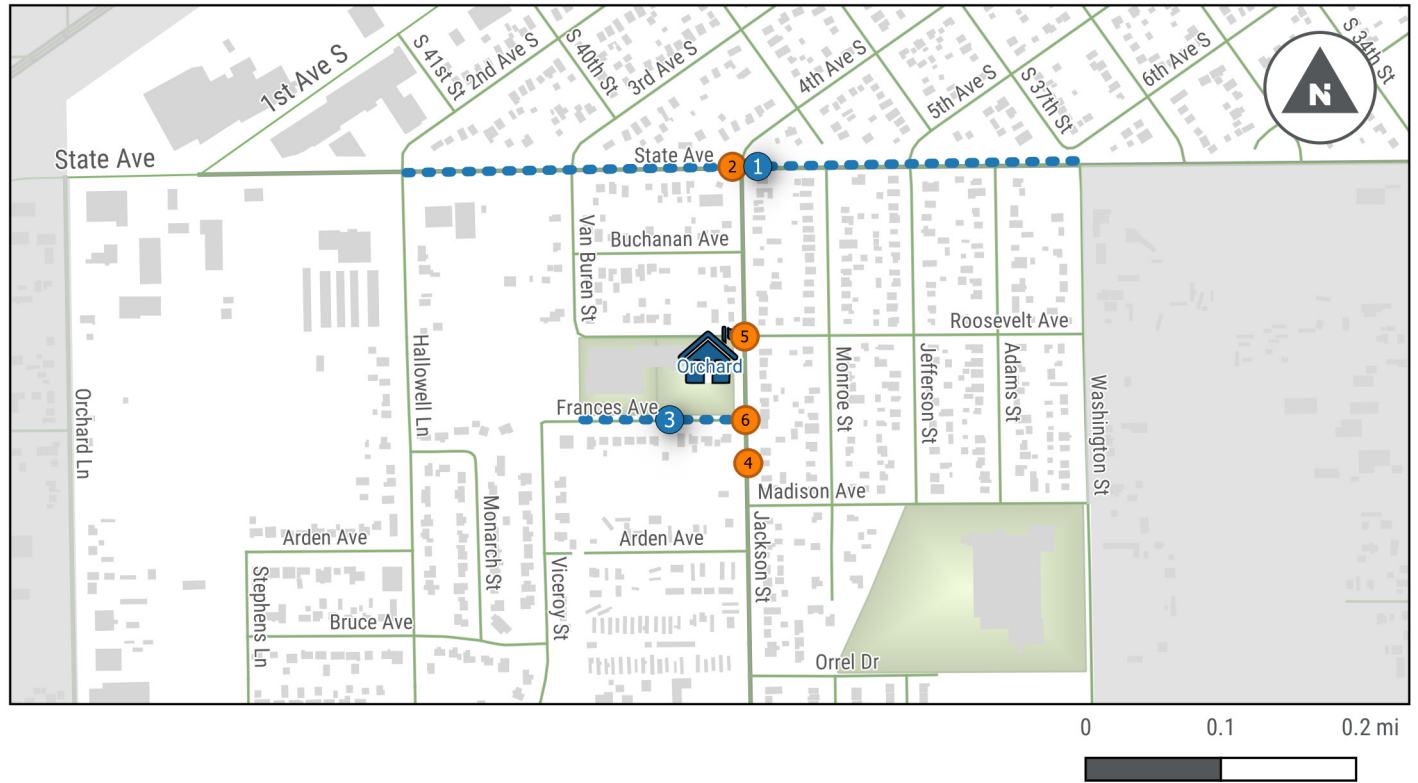



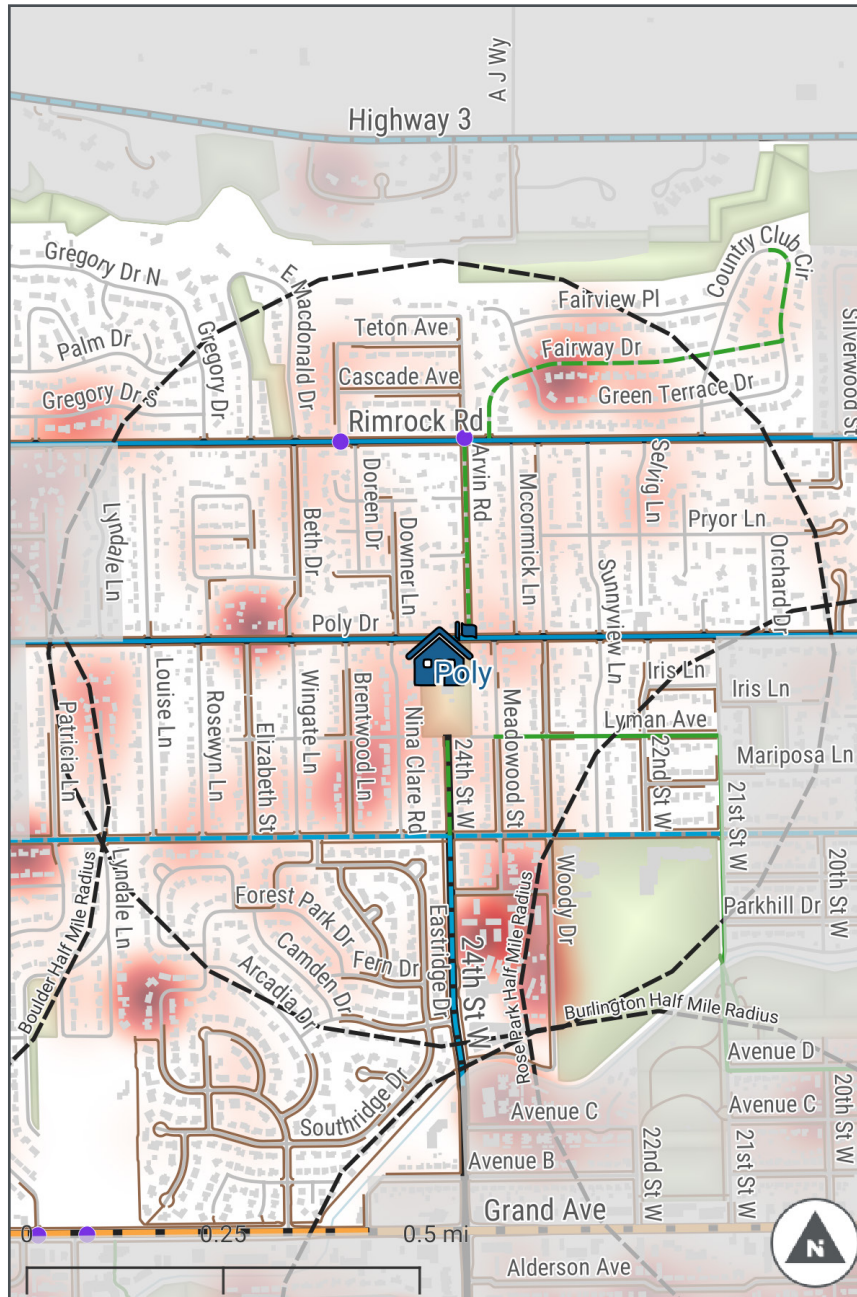

Project #	Proposed Project Type	Observed and Reported Safety Concerns at Project Location											
		Motor vehicle speeding	Long crossing distances	Turning vehicles not yielding	Poor pedestrian access and/or comfort	Poor bicycle access and/or comfort	Crosswalks blocked during arrival/dismissal	Pedestrians crossing mid-block	Poor visibility	Drivers not yielding to pedestrians in crosswalks	Insufficient separation from traffic	Illegal U-turns	Constrained school site/ few access points
1	Speeding/Volume	x			x	x							
2	Accessibility				x								
3	Arrival/Dismissal behavior							x				x	
4	School zone signage								x				
5	Crossing				x							x	
6	Crossing				x							x	

# Poly Drive









### Key Safety and Mobility Considerations for Poly Drive Elementary

-  Student Address Heatmap
-  School Half Mile Buffer
-  Outside School Boundary
-  Pedestrian Crash (2016-2020)
-  Speed Limit 35 mph or Greater

#### Existing

-  Existing Bike Lane
-  Sidewalk
-  Neighborhood Bikeway

#### Proposed

-  Neighborhood Bikeway
-  Bike Lane

### Proposed Safe Routes to School Projects for Poly Drive Elementary

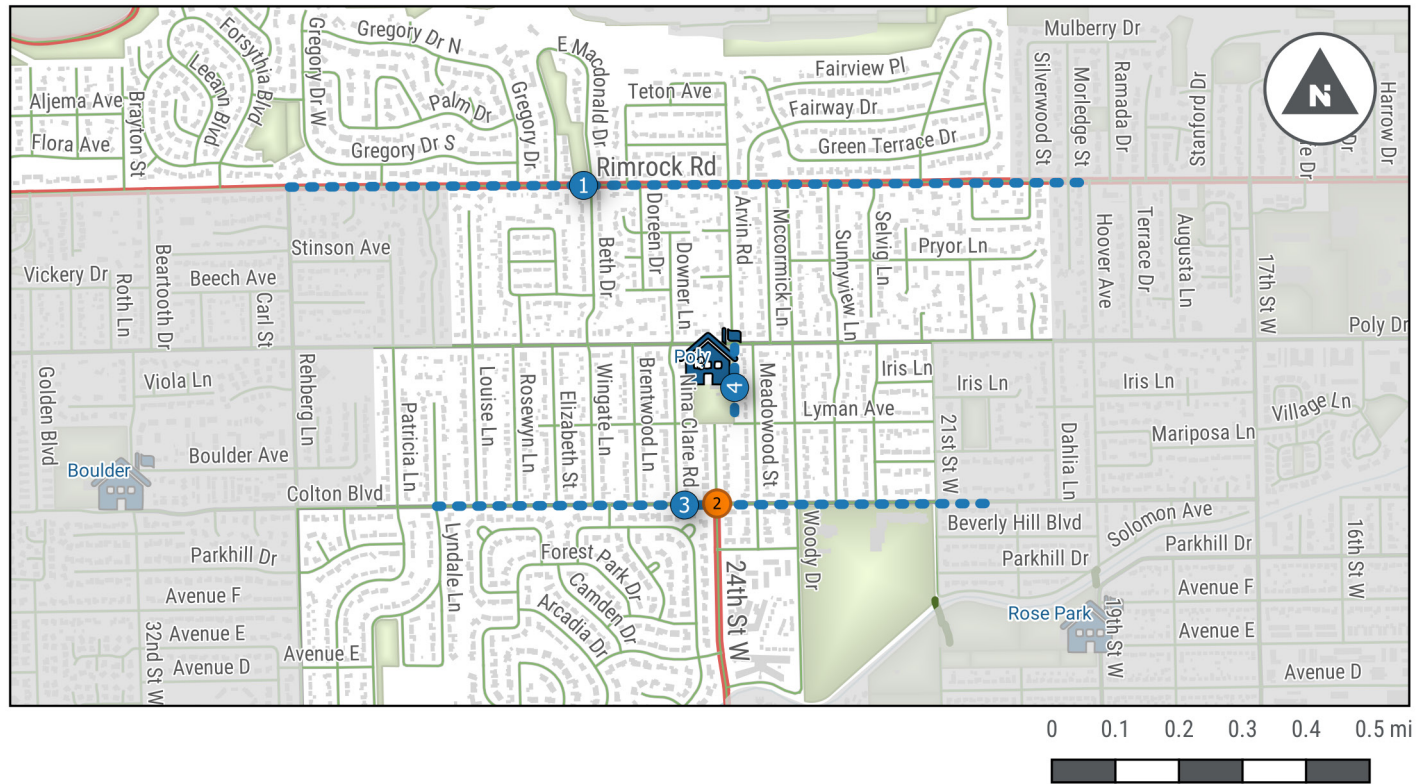

Project #	Proposed Project Type	Observed and Reported Safety Concerns at Project Location											
		Motor vehicle speeding	Long crossing distances	Turning vehicles not yielding	Poor pedestrian access and/or comfort	Poor bicycle access and/or comfort	Crosswalks blocked during arrival/dismissal	Pedestrians crossing mid-block	Poor visibility	Drivers not yielding to pedestrians in crosswalks	Insufficient separation from traffic	Illegal U-turns	Constrained school site/ few access points
1	School Zone Signage	x								x			
2	Crossing	x	x	x	x	x							
3	School Zone Signage	x								x			
4	Trail/Path				x	x							







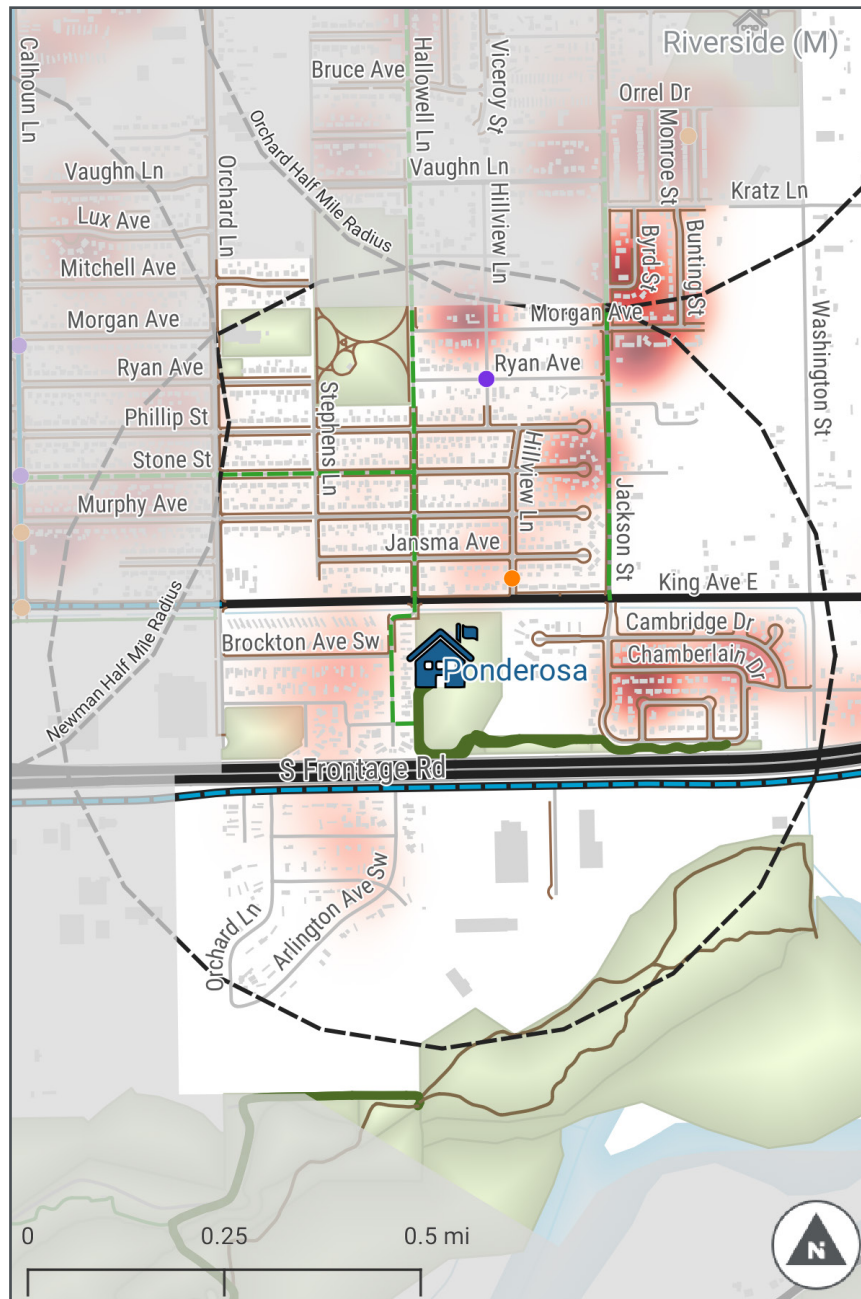

# Ponderosa









### Key Safety and Mobility Considerations for Ponderosa Elementary

-  Student Address Heatmap
-  School Half Mile Buffer
-  Outside School Boundary
-  Bike Crash (2016-2020)
-  Pedestrian Crash (2016-2020)
-  Speed Limit 35 mph or Greater

**Existing**

-  Shared Use Path
-  Sidewalk

**Proposed**

-  Neighborhood Bikeway
-  Bike Lane

### Proposed Safe Routes to School Projects for Ponderosa Elementary

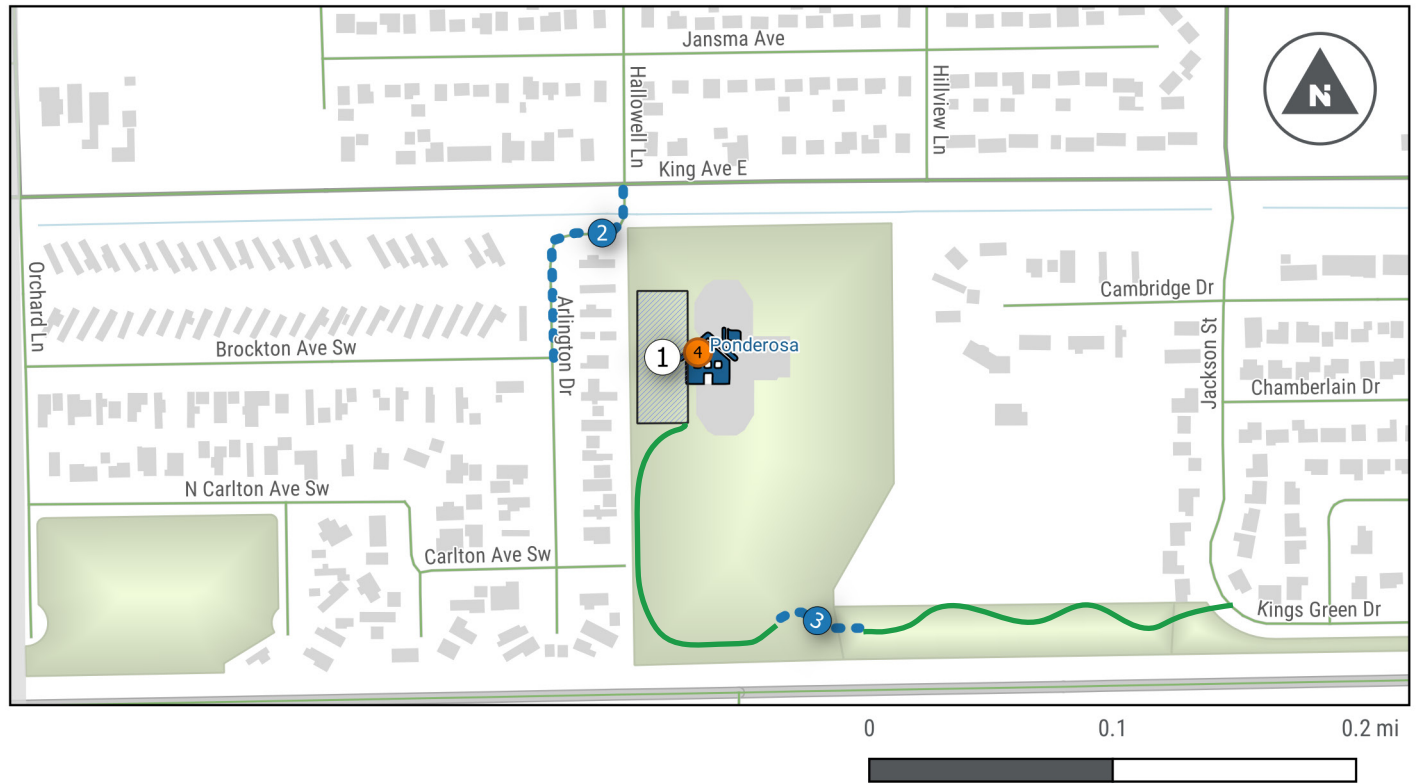

Project #	Proposed Project Type	Observed and Reported Safety Concerns at Project Location											
		Motor vehicle speeding	Long crossing distances	Turning vehicles not yielding	Poor pedestrian access and/or comfort	Poor bicycle access and/or comfort	Crosswalks blocked during arrival/dismissal	Pedestrians crossing mid-block	Poor visibility	Drivers not yielding to pedestrians in crosswalks	Insufficient separation from traffic	Illegal U-turns	Constrained school site/ few access points
1	Arrival/Dismissal Behavior				x	x						x	
2	Congestion				x	x							x
3	Hazardous/Illicit Activity				x	x							
4	Bicycle Parking					x							

# Rose Park



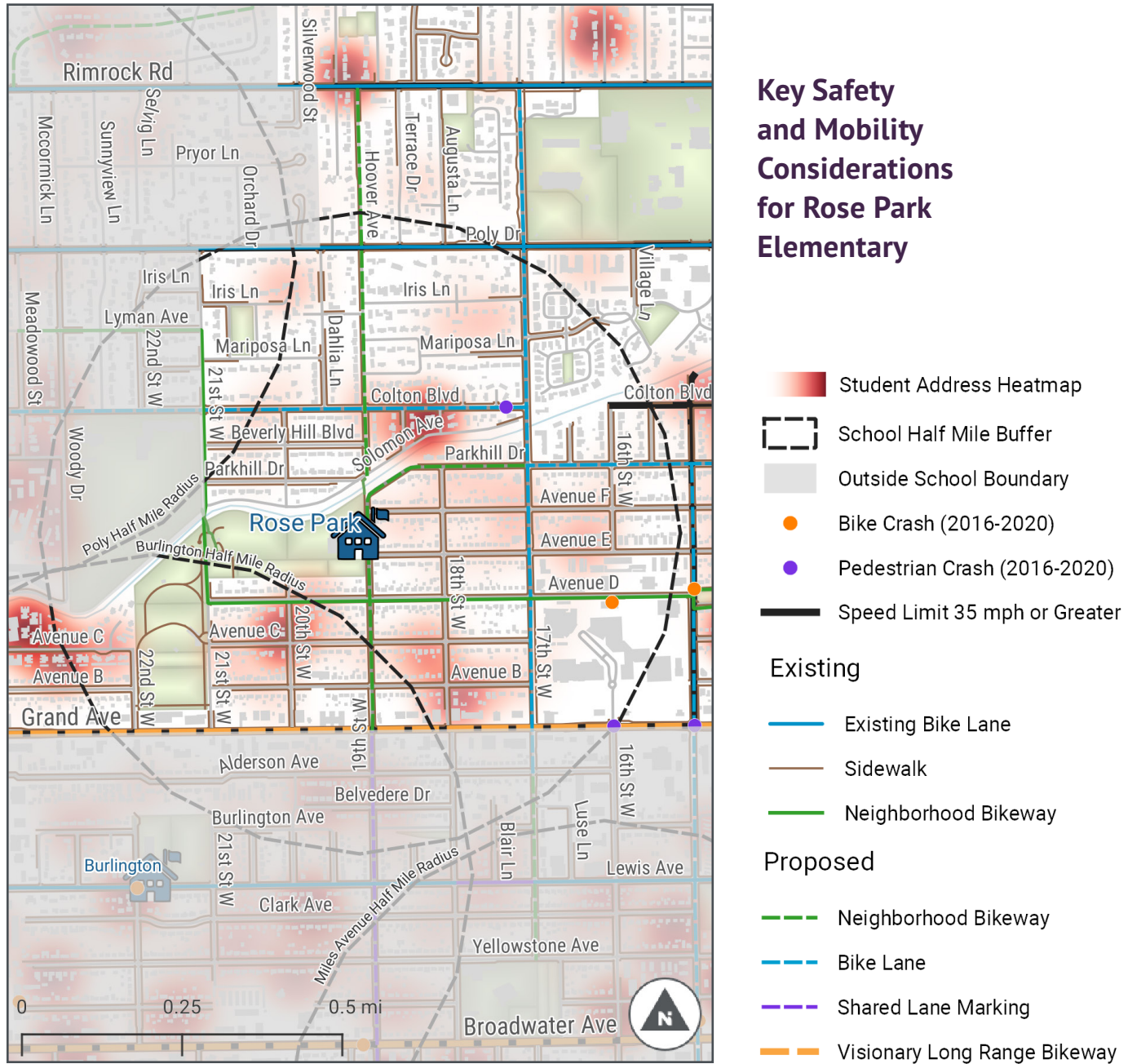

### Proposed Safe Routes to School Projects for Rose Park Elementary

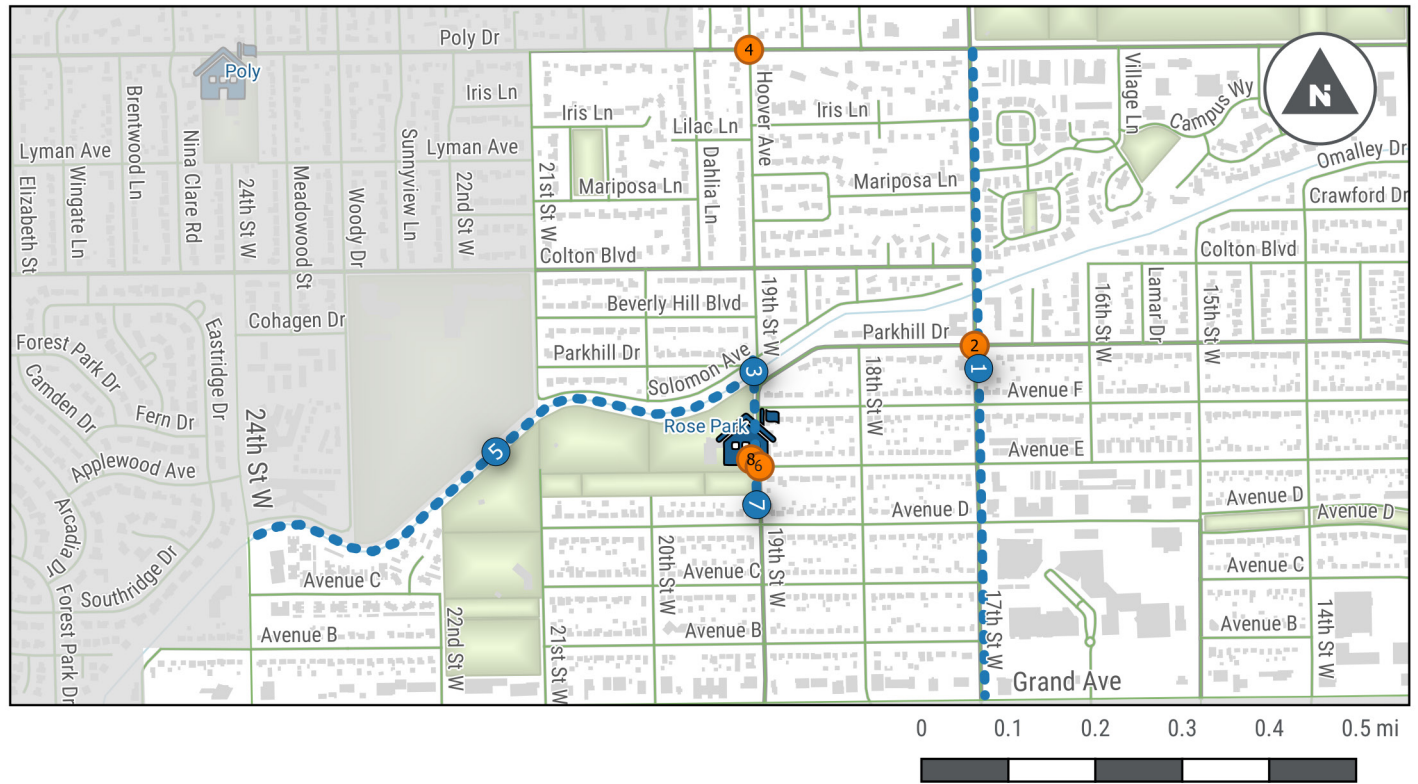





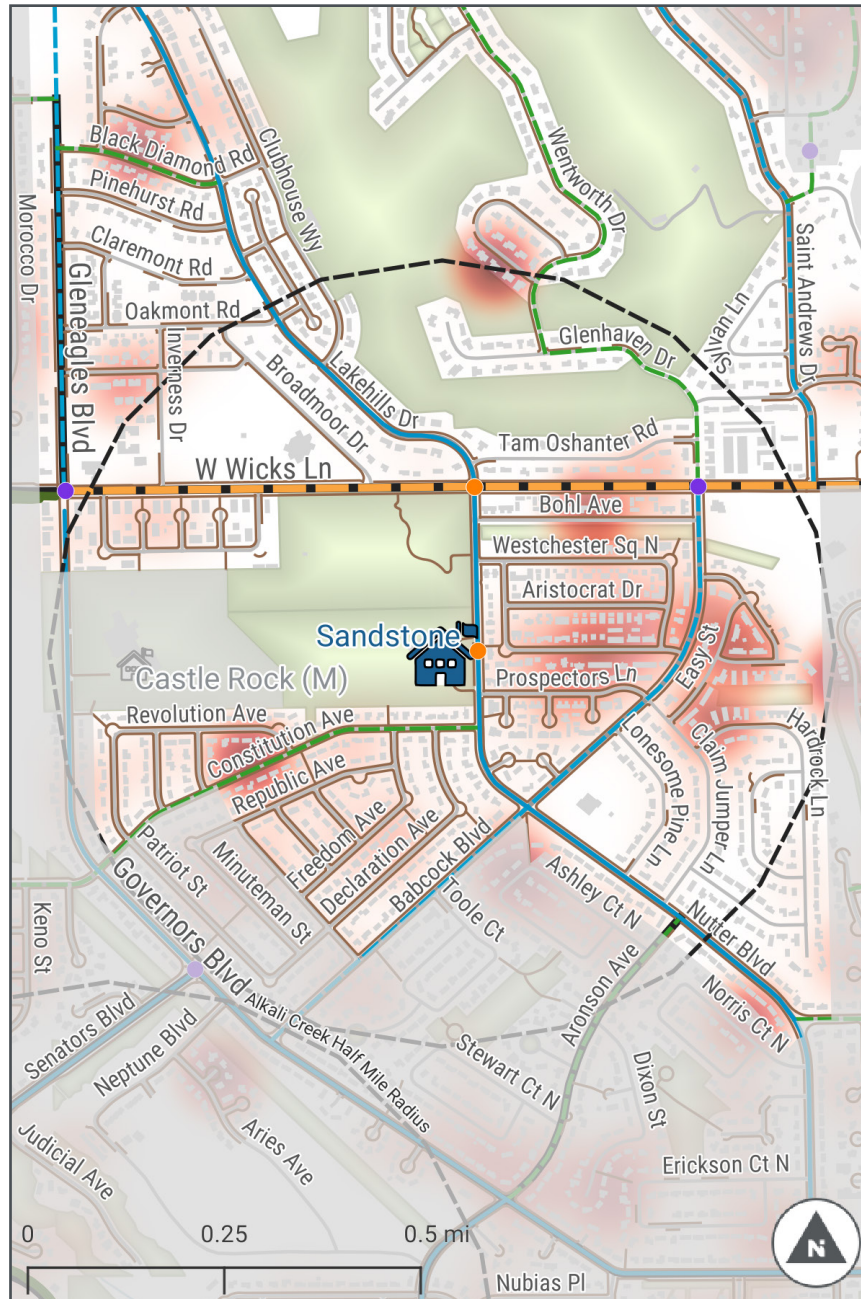

Project #	Proposed Project Type	Observed and Reported Safety Concerns at Project Location											
		Motor vehicle speeding	Long crossing distances	Turning vehicles not yielding	Poor pedestrian access and/or comfort	Poor bicycle access and/or comfort	Crosswalks blocked during arrival/dismissal	Pedestrians crossing mid-block	Poor visibility	Drivers not yielding to pedestrians in crosswalks	Insufficient separation from traffic	Illegal U-turns	Constrained school site/ few access points
1	Speed/volume	x			x	x					x		
2	Crossing				x				x	x			
3	Shared Use Path				x	x							
4	Crossing				x	x				x			
5	Shared Use Path				x	x							x
6	Crossing				x	x			x	x			
7	Speed/volume	x			x	x					x		
8	Bicycle parking					x							

# Sandstone









### Key Safety and Mobility Considerations for Sandstone Elementary

-  Student Address Heatmap
-  School Half Mile Buffer
-  Outside School Boundary
-  Bike Crash (2016-2020)
-  Pedestrian Crash (2016-2020)
-  Speed Limit 35 mph or Greater

#### Existing

-  Existing Bike Lane
-  Sidewalk

#### Proposed

-  Neighborhood Bikeway
-  Bike Lane
-  Visionary Long Range Bikeway



### Proposed Safe Routes to School Projects for Sandstone Elementary

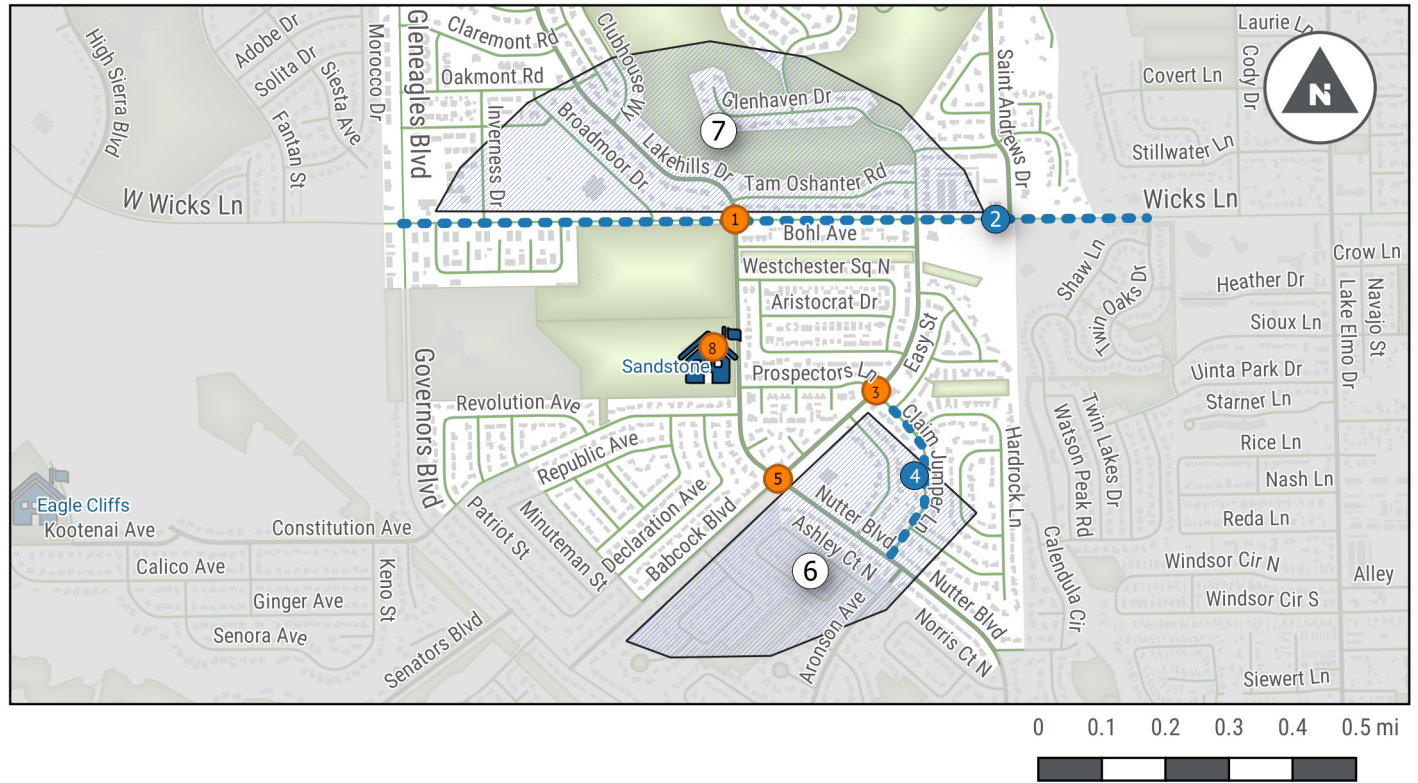





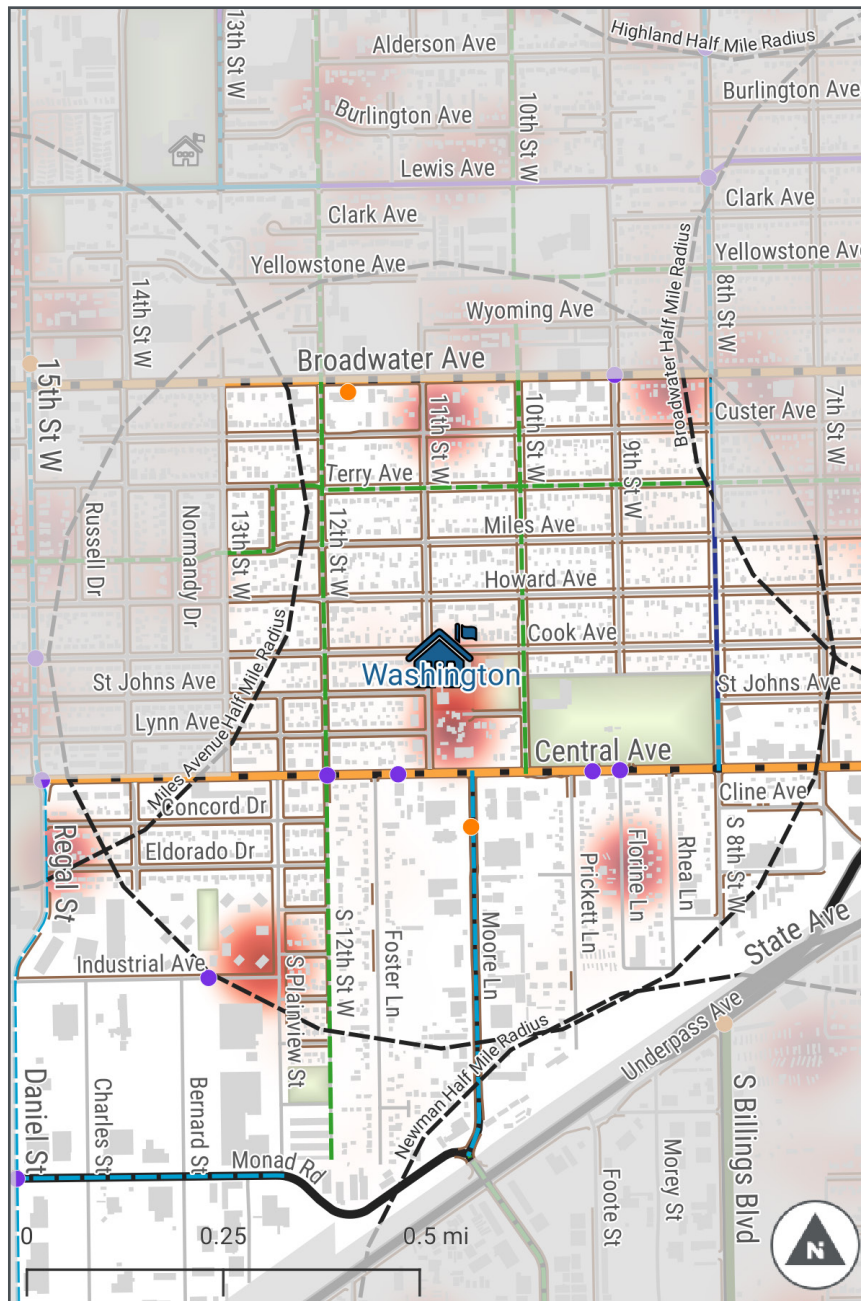

Project #	Proposed Project Type	Observed and Reported Safety Concerns at Project Location											
		Motor vehicle speeding	Long crossing distances	Turning vehicles not yielding	Poor pedestrian access and/or comfort	Poor bicycle access and/or comfort	Crosswalks blocked during arrival/dismissal	Pedestrians crossing mid-block	Poor visibility	Drivers not yielding to pedestrians in crosswalks	Insufficient separation from traffic	Illegal U-turns	Constrained school site/ few access points
1	Crossing		x										x
2	Speeding	x			x	x							
3	Crossing		x		x								
4	Sidewalks				x							x	
5	Crossing		x		x								
6	Sidewalks				x							x	
7	Sidewalks				x							x	
8	Bicycle racks					x							

# Washington









### Key Safety and Mobility Considerations for Washington Elementary

-  Student Address Heatmap
-  School Half Mile Buffer
-  Outside School Boundary
-  Bike Crash (2016-2020)
-  Pedestrian Crash (2016-2020)
-  Speed Limit 35 mph or Greater

#### Existing

-  Sidewalk

#### Proposed

-  Neighborhood Bikeway
-  Bike Lane
-  Buffered Bike Lane
-  Visionary Long Range Bikeway

### Proposed Safe Routes to School Projects for Washington Elementary

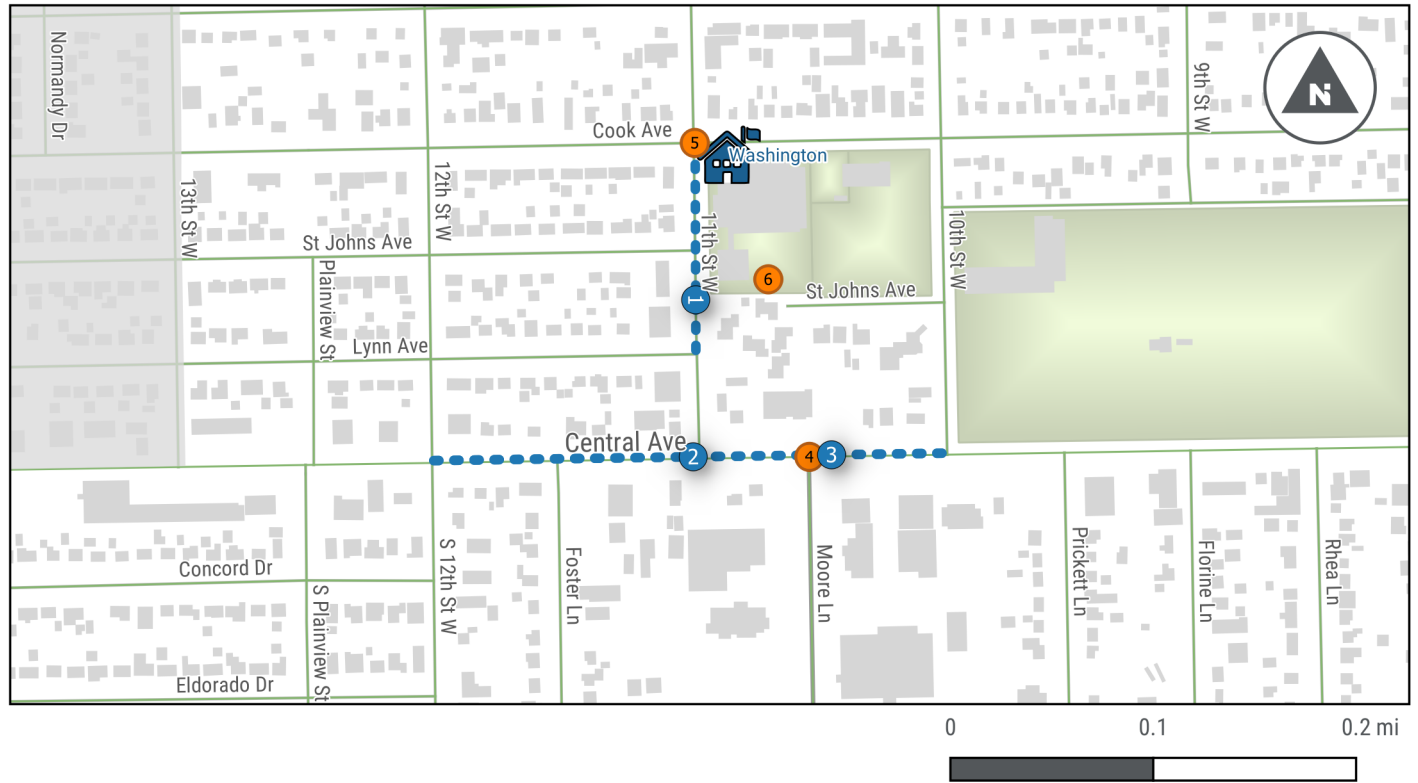

Project #	Proposed Project Type	Observed and Reported Safety Concerns at Project Location											
		Motor vehicle speeding	Long crossing distances	Turning vehicles not yielding	Poor pedestrian access and/or comfort	Poor bicycle access and/or comfort	Crosswalks blocked during arrival/dismissal	Pedestrians crossing mid-block	Poor visibility	Drivers not yielding to pedestrians in crosswalks	Insufficient separation from traffic	Illegal U-turns	Constrained school site/ few access points
1	Arrival/Dismissal behavior					x	x					x	
2	Speeding/volume	x			x	x							
3	Sidewalks				x						x		
4	Crossing		x						x	x			
5	Crossing		x						x	x			
6	Bicycle parking					x							

# 4. Infrastructure Toolbox

This infrastructure toolbox was developed to support the Billings Safe Routes to School program and its implementation partners when deciding what types of infrastructure treatments should be considered to address which sorts of issues. It presents the most common engineering treatments used to improve pedestrian and bicyclist safety, with a focus on supporting healthy, safe, and active travel to school.

While this toolbox represents common engineering solutions that can be used, it is not an exhaustive list of every design solution that may be applicable. Solutions to specific local challenges must be evaluated by City staff through field work and, when appropriate, engineering studies and/or public engagement. All projects will be designed using applicable City, State and Federal design manuals and guidelines. Toolbox suggestions may have trade-offs in certain situations. For example, while speed humps slow vehicle traffic, they may also cause unwanted noise for nearby residents. Street reconfigurations may involve trade-offs between roadway capacity, speed, parking, and the safety of people walking and biking. During the implementation phase, the Engineering Division will evaluate the trade-offs involved in each solution. Not every tool in the toolbox will work at every location.

Many of the treatments described below are from the FHWA's 2018 Guide for Improving Pedestrian Safety at Uncontrolled Crossing Locations. This document, and its associated Safe Transportation for Every Pedestrian (STEP) matrix, suggest countermeasures that can be applied at uncontrolled crossing locations depending on roadway and traffic features (see table to the right). The countermeasures are assigned specific roadway types based on safety research, best practices, and established national guidelines. More information on the STEP guidance can be found at [https://safety.fhwa.dot.gov/ped\\_bike/step](https://safety.fhwa.dot.gov/ped_bike/step).

Roadway Configuration	Posted Speed Limit and AADT								
	Vehicle AADT <9,000			Vehicle AADT 9,000–15,000			Vehicle AADT >15,000		
	≤30 mph	35 mph	≥40 mph	≤30 mph	35 mph	≥40 mph	≤30 mph	35 mph	≥40 mph
<b>2 lanes</b> (1 lane in each direction)	① 2 4 5 6	① 5 6 7 9	① ②	① 4 5 6 7 9	① 5 6 7 9	① ②	① 4 5 6 7 9	① 5 6 7 9	① ②
<b>3 lanes with raised median</b> (1 lane in each direction)	① 2 3 4 5	① 5 7 9	① ② ③	① 3 4 5	① 5 7 9	① ② ③	① 3 4 5	① 5 7 9	① ② ③
<b>3 lanes w/o raised median</b> (1 lane in each direction with a two-way left-turn lane)	① 2 3 4 5 6	① 5 6 7 9	① ② ③	① 3 4 5 6	① 5 6 7 9	① ② ③	① 3 4 5 6	① 5 6 7 9	① ② ③
<b>4+ lanes with raised median</b> (2 or more lanes in each direction)	① ② ③ 4 5 6	① 5 7 8 9	① ② ③	① ③ 4 5 6	① 5 7 8 9	① ② ③	① ③ 4 5 6	① 5 7 8 9	① ② ③
<b>4+ lanes w/o raised median</b> (2 or more lanes in each direction)	① ② ③ 4 5 6	① ② ③ 4 5 6 7 8 9	① ② ③	① ③ 4 5 6 7 8 9	① ② ③ 4 5 6 7 8 9	① ② ③	① ③ 4 5 6 7 8 9	① ② ③ 4 5 6 7 8 9	① ② ③

Given the set of conditions in a cell,  
 # Signifies that the countermeasure is a candidate treatment at a marked uncontrolled crossing location.  
 ● Signifies that the countermeasure should always be considered, but not mandated or required, based upon engineering judgment at a marked uncontrolled crossing location.  
 ○ Signifies that crosswalk visibility enhancements should always occur in conjunction with other identified countermeasures.\*  
 \*The absence of a number signifies that the countermeasure is generally not an appropriate treatment, but exceptions may be considered following engineering judgment.

- High-visibility crosswalk markings, parking restrictions on crosswalk approach, adequate nighttime lighting levels, and crossing warning signs
- Raised crosswalk
- Advance Yield Here To (Stop Here For) Pedestrians sign and yield (stop) line
- In-Street Pedestrian Crossing sign
- Curb extension
- Pedestrian refuge island
- Rectangular Rapid-Flashing Beacon (RRFB)\*\*
- Road Diet
- Pedestrian Hybrid Beacon (PHB)\*\*

Application of Pedestrian Crash Countermeasures by Roadway Feature. (Source: [https://safety.fhwa.dot.gov/ped\\_bike/step/](https://safety.fhwa.dot.gov/ped_bike/step/))

**Crossing Treatments** ..... **82**

    Curb Ramps ..... **82**

    Curb Extensions ..... **83**

    Pedestrian Refuge Islands ..... **84**

    Marked Crosswalks ..... **85**

**Street Treatments** ..... **87**

    Sidewalks ..... **87**

    Speed Humps ..... **88**

    Right-Turn Redesign ..... **89**

    Lane Reconfiguration ..... **90**

**Signs and Markings** ..... **92**

    Stop Signs ..... **92**

    Yield Signs and Advanced Yield Markings ..... **93**

Parking Restriction Signs ..... **95**

School Zones ..... **96**

**Signals** ..... **97**

    Traffic Signals ..... **97**

        Leading Pedestrian Intervals (LPI) ..... **98**

        Right Turn on Red Restrictions ..... **99**

    Pedestrian Hybrid Beacons ..... **100**

    Rectangular Rapid Flashing Beacons ..... **101**

**Other** ..... **102**

    Bicycle Parking ..... **102**

    Shared Use Paths ..... **103**

    Arrival-Dismissal Traffic Safety Plan ..... **104**

## CROSSING TREATMENTS

### Curb Ramps

Curb ramps are sloped areas located at intersection corners and crossings that connect the street to the sidewalk. They create a barrier-free environment for everyone when crossing streets that have curbs and sidewalks.



Curbs limit universal accessibility and are barriers for transitioning from the sidewalk to the street



A sidewalk retrofitted with a curb ramp and a tactile warning strip



Each corner should have two curb ramps, one for each crossing

#### What is the purpose of a curb ramp?

- Provides a comfortable transition from the street to the sidewalk for all people, including people with disabilities, kids on bikes, and caretakers pushing strollers.

#### Where can curb ramps be installed?

- To the extent that resources are available, new curb ramp installations are coordinated with sidewalk rehabilitation and applicable street alterations. Curb ramps are the standard on all new construction.
- The Billings Urban Area Long-Range Transportation Plan, Safe Routes to School Plan on the ground observations, GIS data, comments from the public, and the Capital Improvement Program list are all used to select and prioritize curb ramp retrofits.

#### How much does a new curb ramp cost?

**\$-\$-\$:** The Federal Americans with Disabilities Act (ADA) lays out very specific requirements for how curb ramps must be constructed, including level landings and gentle grades. The cost of a curb ramp may vary depending on what existing conditions need to be changed to meet these requirements, whether adding a curb ramp requires stormwater improvements, and/or whether cost can be saved by doing multiple curb ramps on the same intersection at a time.

#### How long does it take to install a curb ramp?

**Varies:** If a curb ramp is a small scale, stand-alone project, it can be completed within several months. If it is part of a larger resurfacing or reconstruction project, it can take a year or more.

#### References and Resources

- [United States Access Board Proposed Guidelines for Pedestrian Facilities in the Public Right-of-Way \(PROWAG\)](https://www.access-board.gov/prowag/). <https://www.access-board.gov/prowag/>
- [ADA Accessibility Survey Instructions: Curb Ramps](#)

## Curb Extensions

Curb extensions are created by extending the curb line into the roadway at a corner or mid-block. They shorten the distance for people walking across the street and improve visibility between people walking and driving. By visually and physically narrowing the roadway, curb extensions also help reduce speeding.



Mid-block curb extension



Easy-to-install materials such as paint, turtle bumps, and flex posts may be used to create curb extensions



Curb extensions may provide space for landscaping

### What is the purpose of a curb extension?

- Improves safety by reducing the distance and time required to cross the street.
- Improves visibility between people driving and people walking across the street.
- Provides additional space in constrained locations for installing curb ramps.
- Improves safety at corners by slowing turning motorists through a tighter turning radius.
- Prevents people from parking too close to a crosswalk, which could limit visibility, or from blocking a curb ramp or crosswalk.
- Provides space for seating, public art, bike racks, rain gardens or other public amenities.

### Where can curb ramps be installed?

- Curb extensions are considered at locations that would benefit from improved visibility between people walking and driving, such as at school crosswalks.
- Curb extensions can be installed:
  - » at most locations with a legal crosswalk, whether marked or unmarked, provided there is adequate width, and
  - » on streets with all day on-street parking.

### How much does a curb extension cost?

**\$\$-\$\$\$:** Curb extensions typically involve roadway and sidewalk removal and may require replacement / relocation of stormwater drainage inlets. Installing curb extensions as part of larger capital projects such as street repaving, or when using low cost materials such as paint and pre-fabricated platforms (a.k.a. turtle bumps), costs can be reduced.

### How long does it take to install a curb extension?

**1–2 years:** Typically, design is completed in 6–12 months and construction is completed by a contractor the following year.

### References and Resources

- [Pedestrian Safety Guide and Countermeasure Selection System: Curb Extensions](#)
- [NACTO Urban Street Design Guide: Curb Extensions](#)
- [AASHTO Guide for the Planning, Design and Operation of Pedestrian Facilities, 2015](#)

## Pedestrian Refuge Islands

Pedestrian refuge islands (also called pedestrian refuges or center islands) are delineated or raised areas in the middle of the street at intersections or mid-block crossings that provide a designated place for people walking and biking to wait for an opportunity to cross the other half of the street.

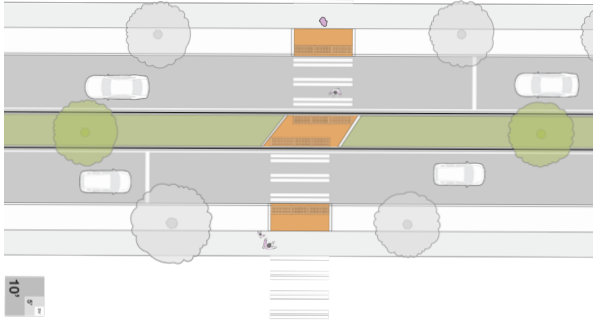

Typical crossing island



A pedestrian refuge island assists people crossing Broadwater Ave.



Pedestrian refuge islands also help people on bicycles cross the street

### What is the purpose of a pedestrian refuge island?

- Makes the crossing more visible to people driving.
- Allows people to cross the street in two stages, making it easier to find gaps in traffic by only having to cross one direction of travel at a time.
- Reduces the amount of time a person crossing the street is exposed to traffic by providing a designated place to wait in the middle of the crossing.
- Makes the street easier to cross for kids, older adults, people with disabilities, and others who may need more time to cross or have more difficulty judging gaps in traffic.
- Reduces speeding due to perceived road width narrowing at the crossing.

### Where can pedestrian refuge islands be installed?

- Pedestrian refuge islands may be an effective crossing treatment in situations where it is difficult to cross the street due to long crossing distances or few gaps in traffic.
- There must be adequate width (6-ft minimum) in

the middle of the road to install the refuge island. Generally, streets with a two-way center turn lane or few or no left turns by people driving provide opportunities to install a pedestrian refuge island.

- Additional safety improvements like crossing beacons are often installed along with the refuge island to make the crossing even more visible to people driving. Any added vegetation should be low-lying as to not affect sight distance.
- At crossings frequently used by people on bikes, such as neighborhood bikeway crossings, crossings that separate people biking and people walking may be created.
- Analysis is needed at each intersection before a pedestrian refuge island is installed.

### How much does a pedestrian refuge island cost?

**\$\$-\$\$\$:** A small asphalt or concrete pedestrian refuge island can be fairly inexpensive, typically in the range of \$10K to \$20K to install. Lower cost materials such as flexible posts can also be used to delineate the

pedestrian refuge island in certain situations. Larger projects that include landscaping and drainage structures can increase construction and maintenance costs.

### How long does it take to install a pedestrian refuge island?

**1–2 years or less:** A simple project can be designed in six months and constructed easily by City crews. More time is required to design larger pedestrian refuge islands or pedestrian refuge islands at busy intersections.

### References and Resources

- [Pedestrian Safety Guide and Countermeasure Selection System \(PEDSAFE\): Refuge islands](#)
- NACTO Urban Bikeway Design Guide: Median Refuge Island
- [FHWA Proven Safety Countermeasures: Medians and Pedestrian Refuge islands](#)

### Example in Billings

- Broadwater crossing



## Marked Crosswalks

Legal crossings exist at every intersection, (except where prohibited by signage) whether marked or unmarked. Marked crosswalks are used to raise driver awareness of people crossing the street and to direct people who are walking to the best place to cross the street.



Marked ladder style crosswalk at an intersection



Raised crosswalks slow down people driving



Advanced stop bars increase visibility of people crossing the street

### What is the purpose of a marked crosswalk?

- Direct school kids who are walking to the best place to cross the street.
- Indicate the walking route to school.
- People driving are made more aware of where to expect school kids to cross the street.

### Where are crosswalks marked?

- Crosswalks will generally be marked at signals and at intersections downtown.
- Crosswalks will typically be marked at stop-controlled locations if there is high vehicular volume, and will be marked if feasible at uncontrolled locations if they satisfy the criteria outlined on this page.

- The following factors are considered when deciding whether to mark a crosswalk at uncontrolled locations. It should be noted that different jurisdictions (City, County, and MDT) have different policies:
  - » Average hourly traffic over 300 vehicles per hour in any hour
  - » Adequate stopping or sight distance
  - » More than 20 pedestrian crossings in any one hour of the day, or more than 10 children or elderly persons in any one hour
  - » There is no existing marked crosswalk within 300-ft of the location in question
  - » The crosswalk is located on a trail, shared-use path, designated safe route to school, or provides direct access to a transit stop, or other pedestrian destinations
  - » Presence of curb ramps
  - » Presence of lighting

### Raised Crosswalks

- Raised crosswalks keep the crosswalk at the same height as the sidewalk.
- They act as a speed table and slow people driving as they approach the crosswalk.
- They also make people walking more visible to people driving.
- Raised crosswalks may require modifications to stormwater drainage structures in the street, increasing construction costs.

### Raised Intersections

- Raised intersections slow people driving and encourage them to yield to people walking across the street.
- Raised intersections can be installed in neighborhood intersections to make the public space more comfortable and inviting for people to walk and bike.

## Marked Crosswalks (continued)

- Other considerations include:
  - » The total distance a person walking would have to cross. If there is more than one lane of traffic in each direction, additional features may be added to supplement the crosswalk and minimize the potential multiple threat. These treatments could include elements like crossing beacons, pedestrian signals, refuge islands, curb extensions, or advanced stop lines.
  - » Volume and speed of people driving. If the street is very busy and speeds are high, additional features may be added to supplement the marked crosswalk.
- New crosswalks are often accompanied by new crosswalk signs. If it's a crosswalk mostly used by kids, the marked crosswalk will be a school crosswalk with school crosswalk signs. Otherwise, regular crosswalk signs are used. Flexible in-street bollards may also be used to draw additional attention to the crossing.
- Durable and reflective materials are used to mark crosswalks. Over time, the crosswalk markings may need to be refreshed. Crosswalk maintenance is prioritized based on the condition of all the crosswalks in the city.

### How long does it take to install a marked crosswalk?

**Varies.** In some cases, it can take 1–2 months or less to install a new marked crosswalk. If new curb ramps or other safety improvements need to be installed in addition to the marked crosswalk, then it can take 1–2 years or longer to complete the work.

### How much does a new marked crosswalk cost?

**\$:** If a potential new marked crosswalk location does not require any additional safety treatments, then marking the crosswalk is relatively inexpensive and straightforward.

**\$\$:** If other safety improvements are needed at the crosswalk the cost can be higher.

### References and Resources

- [Marking and Signing Crosswalks \(Safe Routes to School Guide\)](#)
- [Manual on Uniform Traffic Control Devices \(MUTCD\) Chapter 7C.03 Crosswalk Markings](#)

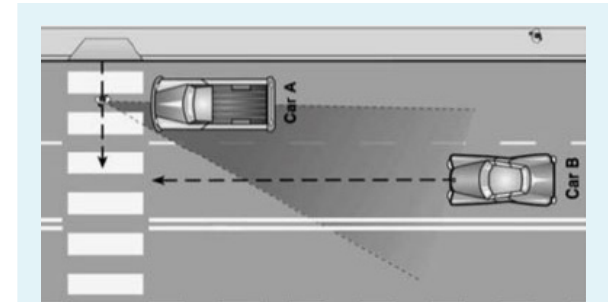

### Multiple Threat

A multiple threat is a situation where a driver in one lane (car A) stops for a person crossing the street, but the driver in the next lane (car B) doesn't see the person and doesn't stop. If a crosswalk is marked on a street with multiple traffic lanes or high traffic volumes, additional safety improvements like crossing beacons, pedestrian signals, refuge islands, curb extensions, or advanced stop lines are considered to minimize the multiple threat.

## STREET TREATMENTS

### Sidewalks

Sidewalks are the building blocks of the pedestrian network. While many neighborhoods in Billings have built-out sidewalk networks, many areas in the city do not have sidewalks at all. Sidewalks provide the greatest benefit to people when they are wide enough for two people to walk side-by-side, maintained in good condition with few bumps or cracks, kept clear of debris and overgrowing plants, and built with curbs.



Severe cracking creates uneven and hazardous walking surfaces



New sidewalk remains level across driveway



Alternative sidewalk design

#### What is the purpose of a sidewalk?

- Improves safety and comfort of people walking by separating pedestrians from people moving faster on bikes or in cars.
- Provides a dedicated space away from car traffic for children to walk, play, and learn to ride a bike.

#### Where are new sidewalks installed?

- The Billings Urban Area Long-Range Transportation Plan, the Safe Routes to School Plan, and the Capital Improvement Plan identify locations for new sidewalk construction and existing sidewalk repair and rehabilitation projects.
- Developers often have to build new sidewalks or repair existing sidewalks with new development.
- Ideally, existing neighborhoods should have sidewalks on at least one side of residential streets. New developments in the City, (with the exception of parcels developed via master site plans (i.e. apartments

or condos all on the same lot) are required to have sidewalks on both sides of the street. School routes may be locations where sidewalks should be installed on both sides of residential streets to provide for direct access from homes to school, as well as to areas used for off-site drop-off and pick-up.

- Along existing sidewalks, opportunities are identified to remove barriers such as light poles or other obstructions, aiming to maintain a 4-ft clear zone. Opportunities to limit or narrow driveways (a.k.a. curb cuts) may also be identified, which can create conflicts between people walking and people driving.

#### How much does a new sidewalk cost?

**\$\$-\$\$\$\$:** Building new sidewalks can be an expensive and challenging engineering project. Often, coordination must be done with nearby property owners. In addition, driveways connecting to private property may need to be redesigned and rebuilt, encroachments of private property onto public property removed, and new

stormwater infrastructure constructed.

#### How long does it take to get a new sidewalk installed?

**1–2 Years:** Design and outreach must be completed before construction can begin.

#### Additional Information

When building conventional sidewalks is not feasible, other strategies may be considered for creating safer walking routes to school, such as Shared Streets, reallocating road space to create dedicated walking space, and alternative surfacing materials.

#### References and Resources

- [United States Access Board Proposed Guidelines for Pedestrian Facilities in the Public Right-of-Way \(PROWAG\)](#)

## Speed Humps

Speed humps are traffic calming features that encourage people driving to slow down. Speed humps are raised areas that extend across the street with wheel cutouts to allow large vehicles, like buses or emergency vehicles, to pass through unaffected.



Speed hump



Speed humps help with traffic calming on streets that have high numbers of bicyclists



Speed humps installed on hills help slow traffic coming downhill

### What is the purpose of speed humps?

- Slow people driving to make streets safer and more comfortable for people walking and biking.
- Speed humps are usually installed on neighborhood streets.

### Where are speed humps installed?

- The City of Billings currently does not have a funding source for neighborhood traffic calming. Therefore, it falls on the individual neighborhoods to fund a localized project. Typically, this funding is raised through a Special Improvement District (SID).
- There is a City-approved design template for speed humps that should be used to ensure consistency across the City.

### How much does a speed hump cost?

⌘: Speed humps are low-cost ways to slow people driving.

### How long does it take to install a speed hump?

1–2 years: Priority streets with high speeds are usually identified one year and construction happens the next year.

### References and Resources

- [NACTO Urban Street Design Guide](#)

## Right-Turn Redesign

Intersections should be designed to accommodate safe pedestrian crossings using tight curb radii, pedestrian corner islands, and other tools. This is especially the case where right-turn slip lanes are present, many of which were designed to promote fast, and unimpeded vehicles travel, which can be unsafe for crossing pedestrians.



Slip lanes with added signs and raised crosswalks bring attention to pedestrians



Curb radii can be adjusted to lower vehicle turning speeds



Temporary turn wedges can be installed to test turning radii

### What is the purpose of right turn redesign?

- Separate right-turning traffic
- Slow turning vehicle speeds and improve safety.
- Allow drivers to see approaching cross street traffic more clearly.

### Where are right-turn redesigns installed?

- Right lane redesign can be used at intersections with high volumes of pedestrians and conflicting turning vehicles.
- Vehicle turning speeds are evaluation to determine whether a decrease in turning radius would reduce speeds

### How much do right-turn redesign restrictions cost?

**\$\$-\$\$\$:** Depending on the location, right-turn redesigns include reconfiguring the roadway, adding striping and/or constructing an island.

### How long does it take to install a right turn redesign?

**1-2 years:** Traffic studies must be completed before installation can begin. Additional time may be needed if traffic islands are constructed.

### References and Resources

- [AASHTO Guide for the Planning, Design, and Operation of Pedestrian Facilities](#)
- [AASHTO Guide for the Development of Bicycle Facilities](#)
- [ITE Context Sensitive Solutions in Designing Major Urban Thoroughfares for Walkable Communities](#)

## Lane Reconfiguration

On multi-lane streets, a lane reconfiguration can improve safety for all roadway users. Lane reconfiguration could be reducing the number of lanes, reducing the width of the lanes, or modifying parking. Modification of on-street parking can also give flexibility to constrained streets. Depending on the needs of the street, which are determined by careful analysis, a strong public process, and its general purpose, parking or turn lanes may be repurposed for other uses such as wider sidewalks, street trees, bike lanes, or more efficient transit.



Street before lane reconfiguration



Street after lane reconfiguration



Street after lane reconfiguration

### What is the purpose of a lane reconfiguration?

- Makes it easier and safer for people to cross busy streets by reducing the number of traffic lanes a person has to cross. When people cross streets with more than one lane in each direction they encounter a 'multiple threat.'
- Reallocates space on the street to widen sidewalks, plant street trees, add curb extensions, or install protected bike lanes.
- Slows people driving, which makes the street safer for everyone. When there's one lane in each direction, a person driving can only go as fast as the person in front of them.
- Makes it safer for people driving to make a left turn when a center turn lane is added, and a single lane of traffic helps manage drivers cutting in and out of lanes, which helps reduce collisions.
- Narrowing the width of travel lanes can also slow people driving and create space on the street to make it safer and more comfortable for people walking and biking.

### Where are lane reconfigurations done?

- When a street is being resurfaced or reconstructed, there is an opportunity to change the configuration of lanes on the street. Traffic conditions and crash records are evaluated to identify whether a road or lane diet is needed and if parking can be modified.
- Streets that are good candidates for lane reconfigurations typically have lower volumes than would be expected for a street with the existing configuration.
- For all lane reconfiguration projects, the flow of traffic is carefully analyzed to make sure a lane reduction wouldn't cause back-ups at traffic signals, and a public process is conducted to discuss tradeoffs with the public.
- For parking lane reconfigurations, parking use and supply is carefully studied and inform the proposed designs that are vetted through a public process before moving forward.
- Any modifications made for lane reconfigurations are designed by an engineer.

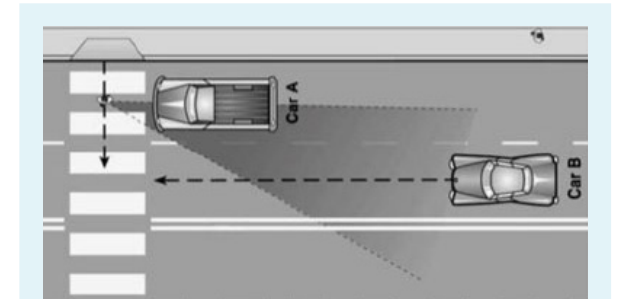

### Multiple Threat

A multiple threat is a situation where a driver in one lane (car A) stops for a person crossing the street, but the driver in the next lane (car B) doesn't see the person and doesn't stop. If a crosswalk is marked across more than two lanes of traffic, additional safety improvements like crossing beacons, pedestrian signals, refuge islands, curb extensions, or advanced stop lines may be installed to minimize the multiple threat.

Lane Reconfiguration (continued)



A three-lane to two-lane reconfiguration



Lane reconfiguration



Center turn lane narrowed to provide space for bike lanes

**How much does a lane reconfiguration cost?**

**\$-\$\$\$\$:** The cost of a lane reconfiguration is highly variable; it may involve removing the lane lines from the street and repainting new lane lines, which is often done at night or on weekends to minimize traffic disruptions. When a lane reduction is done as part of a larger project to resurface or reconstruct a street, it can be accomplished for relatively low costs.

**How long does it take to do a lane reconfiguration?**

**>1 year:** Community input is gathered through presentations and public comment at the local governing bodies which influences design decisions in the first year, and construction typically follows the year after.

**References and Resources**

- [FHWA Proven Safety Countermeasures: Road Diet \(Roadway Reconfiguration\)](#)

## SIGNS AND MARKINGS

### Stop Signs

Stop signs are a traffic control device used at intersections with three or more approaches, and where application of the normal right-of-way rule would not be expected to provide reasonable compliance with the law.



Stop sign with stop line at an all-way stop



Stop sign oriented to traffic crossing a neighborhood bikeway



Stop sign at intersection between a neighborhood street and a busier street

#### What is the purpose of a stop sign?

- Controls traffic movements between people driving, walking, and biking by assigning right of way at an intersection.
- May be used to control one direction of traffic while allowing the other direction to flow freely or can be used to control all directions of traffic.

#### Where are stop signs installed?

- The MUTCD determines if the safety of an intersection would be improved by controlling one or more directions of traffic with a stop sign. The MUTCD outlines certain minimum thresholds of motorist, pedestrian, and bicyclist traffic and collisions that should be considered before installing a stop sign.

- If the volumes of people driving, walking, and biking at each direction of the intersection are approximately equal and meet the minimum thresholds established in the MUTCD, stop signs may be installed for all directions of travel.
- If the volumes of people driving, walking, and biking from each direction are unequal, the street with the lower volume of people traveling should be stop-controlled unless there are reasons to provide an advantage to one direction of travel (e.g. neighborhood bikeways).
- Other considerations include:
  - » direction of school walking routes,
  - » visibility and sight distance on different sides of the intersection, and
  - » providing advantage to one direction of travel over another, e.g. neighborhood bikeway or major trail connection.

- Stop signs may be accompanied by stop lines, which indicate to people driving where to stop their car before the intersection.

#### How much does a stop sign cost?

⌘: Stop signs are a relatively low-cost and effective way of controlling traffic at intersections.

#### How long does it take to install a stop sign?

<1 year: If it is determined that an intersection should have one or more new stop signs, they can be installed relatively quickly.

#### References and Resources

- [FHWA Manual for Uniform Traffic Control Devices](#)
- [AASHTO Guide for the Development of Bicycle Facilities](#)



## Yield Signs and Advanced Yield Markings

Advance yield lines are pavement markings placed in advance of an uncontrolled and unsignalized crosswalk and are used in conjunction with YIELD HERE TO PEDESTRIANS signs. This treatment increases the distance between where motorists yield and the crosswalk, which improves the visibility of people in the crosswalk and helps reduce multiple-threat crashes. Multiple-threat crashes occur when a driver in one lane yields for a person in the crosswalk and a driver in an adjacent lane does not, striking the person in the crosswalk.



Yield signage in combination with crossing infrastructure increases visibility



Yield signage can vary with application



Bike-specific yield markings and signs may be necessary depending on the situation

### What is the purpose of yield signs and advanced yield markings?

- Increases visibility between people driving, walking, and bicycling.
- Reduces multiple-threat crashes.

### Where are yield signs and advanced yield markings installed?

- Advance yield markings should be considered on four-lane (or wider) streets at uncontrolled intersections where adult school crossing guards are posted.
- Yield signs and markings are used at midblock crossings, crosswalks at free-flow ramps, and roundabouts.

- Parking should be prohibited in the area between the yield line and the crosswalk to allow for increased visibility for pedestrians and motorists

### How much do yield signs and advanced yield markings cost?

\$: Yield signs and advanced yield markings are typically added where there is already a marked crosswalk, so the cost is minimal.

### How long does it take to install a right turn redesign?

<1 year: If it is determined that a crossing needs a yield sign and markings, they can be installed relatively quickly.

### References and Resources

- [AASHTO Guide for the Planning, Design, and Operation of Pedestrian Facilities](#)
- [Zerger, C., C. Lyon, R. Srinivasan, B. Persaud, B. Lan, and S. Smith. 2017. "Development of Crash Modification Factors for Uncontrolled Pedestrian Crossing Treatments." \*Transportation Research Record: Journal of the Transportation Research Board\* 2636. \[Transportation Research Board of the National Academies, Washington, D.C.\]\(#\)](#)

## Parking Restriction Signs

Parking provides access to businesses, residences, and other community resources, and it can also have a traffic calming effect by acting as a buffer between moving motor vehicles and people walking or biking. However, on-street parking can reduce visibility between drivers and people walking, especially at intersections and crosswalks.



Signage communicating time restrictions



Parking signage can indicate drop off only instructions



Signage can also be temporary and removable

### What is the purpose of parking restriction signs?

- Parking restriction signs can be used to provide space for and communicate the right locations for school drop-off and pick-up activities.
- Removing parking space(s) at an intersection can improve the visibility of the crosswalk

### Where are parking restriction signs installed?

- Signs are installed on approaches to intersections and crossings where parked vehicles could block visibility of pedestrians, or where stopped motorists block curb ramps or crosswalks.
- In some cases, physical street barriers to prevent

motorists from parking near crosswalks, such as curb extensions, or interim measures such as planters or vertical flexible delineators are used to supplement parking restriction signs.

- Parking restrictions can either be implemented on a permanent basis or during certain times of day.
- Parking restrictions intended to improve crossing visibility are tailored to the speed of the street. The Federal Highway Administration (FHWA) recommends extending parking restrictions 20 feet from the crosswalk on 20 to 30 mph streets, 50 feet from the crosswalk on 35 to 45 mph streets, and 100 feet from the crosswalk on streets with posted speeds above 45 mph.

### How much do parking restriction signs cost?

⌚: parking restriction signs can be quickly fabricated and installed, so the cost is minimal.

### How long does it take to install parking restriction signs?

<1 year: Once the area and type of parking restriction is decided upon, they can be installed relatively quickly. The amount of time may increase as additional stakeholders (e.g., businesses) are impacted by parking restrictions.

### References and Resources

- [FHWA MUTCD Chapter 2](#)

## School Zones

School Zones are designated on the immediate blocks around a school with reduced speed limits and pedestrian crossing signage to facilitate safer crossings for children walking and biking to school.



Trained crossing guards improve school zone safety



School crossing sign



In road signage reinforces pedestrian priority at school crossings

### What is the purpose of a school zone?

A School Zone is an area around a school that may have a reduced speed limit. This lower speed limit and associated signage serves to alert drivers that there will be students walking and/or biking in the area.

### What treatments define a school zone?

- School zone signs with flashing lights are used to reduce speed limits during school arrival and dismissal hours.
- School crossing signs should be used on key crossings located within the school zone. Other enhanced crossing treatments may be appropriate, depending on the volumes of pedestrian and motor vehicle traffic.
- Signs may include School Crossing, Speed Limit, and/or School Bus Stop signs.
- Beacons may be used to supplement signage.

### What other treatments should also be considered to improve safety in a school zone?

- Adequate sidewalks and crosswalk markings.
- Crossing guards with proper equipment and training.
- Traffic control devices including pedestrian activated signals.

### Where are school zones implemented?

- The beginning point of a reduced school speed limit zone should be at least 200-ft in advance of the school grounds, a school crossing, or other school related activities; however, this 200-ft distance should be increased if the reduced school speed limit is 30 mph or higher.
- School zone locations are governed by MUTCD and engineering evaluation.

- Signage and pavement markings are not frequently used on neighborhood streets, though it does speed of traffic and anticipated number of students walking along the route. This also applies if the approach is a state highway or major arterial.
- Additional information on school zone signage and markings can be found in the MUTCD.

### How much do school zone improvements cost?

⌘: Pavement markings and signage are relatively inexpensive. Costs increase if sidewalk construction, road alterations, and traffic signals are also needed.

### References and Resources

- [MUTCD Traffic Control for School Areas](#)
- [New Jersey School Zone Design Guide](#)
- [Arizona Traffic Safety for School Zones Manual](#)

## SIGNALS

### Traffic Signals

Traffic signals coordinate the flow of traffic at intersections, including people driving, walking, and biking.



Gary Kavanaugh via Flickr

Bicycle signal detection



Reflective back plate makes the signal more visible



“No Turn on Red” sign

#### What is the purpose of a traffic signal?

- Controls the flow of traffic and provides coordinated movement of people driving, walking, and biking.
- Provides a safer, more comfortable environment for people walking and biking to cross the street or streets with high traffic volumes or speeds. People driving have to completely stop at red signals when it's the pedestrian's or bicyclist's turn to cross the street.
- When there is a steady stream of traffic, it can be difficult for people walking or biking to find a gap in traffic to cross the street. Traffic signals create gaps in traffic that allow people biking or walking to cross the street.

#### Where are traffic signals installed?

- The MUTCD is used to determine whether the safety and traffic flow at an intersection would be improved by installing a new traffic signal. The MUTCD outlines

minimum thresholds for vehicle and pedestrian traffic and collisions that should be considered before installing a traffic signal.

- A traffic engineering study would be conducted to determine if a location meets the MUTCD thresholds, further analyze traffic patterns, and conclude whether a new signal would improve safety or the flow of traffic.
- At some intersections near schools, signal timing and flashing pattern during school arrival and dismissal hours can be adjusted to create fewer conflicts between people walking and people driving.
- Providing a dedicated phase for people to cross the street followed by a separate phase for left turning vehicles reduces potential conflicts between pedestrians and motorists. By prohibiting left turns during the WALK phase, pedestrians in the crosswalk do not have to worry about turning motorists yielding to them.

- » At some intersections, including some locations in downtown, people driving aren't allowed to make a right turn when the traffic signal is red. This design makes it safer for people walking across the street by reducing the number of potential conflicts with people turning right on red.
- » Traffic signals are more convenient for people walking when the WALK sign is displayed automatically when it's their turn to cross the street, a strategy referred to as automatic recall. Signals in areas of Billings with high pedestrian volumes are programmed to show the walk signal automatically. In situations with very low pedestrian volumes, this design may not be appropriate, so many traffic signals have push buttons for people to activate the WALK phase.
- » At intersections that are frequently used by people on bikes, equipment can be installed to detect

## Traffic Signals continued

when a bicyclist is present. Many new traffic signals in Billings are being controlled by GRIDSMART video controllers that automatically detect bikes in the road. In addition, old induction loops are being replaced with these new controllers.

### How much does a traffic signal cost?

**\$\$\$\$:** Installing a new traffic signal is a very costly safety improvement. When possible, more cost-effective safety improvements that achieve the same safety objectives are considered so that more can be achieved with limited city resources.

### How long does it take to install a traffic signal?

- **2–4 years:** A limited number of new signals are installed every year because they are so costly. They take a long time to design and construct because they are complex systems.
- **4+ years:** If the new signal is on a state route, then the City coordinates with the Montana Department of Transportation, which adds time to the process.

### References and Resources

- [FHWA Manual on Uniform Traffic Control Devices](#)
- [Federal Highway Administration Proven Safety Countermeasures](#)

## Leading Pedestrian Intervals (LPI)

A Leading Pedestrian Interval (LPI) gives people walking the WALK indication 3–5 seconds before people driving in the same direction get a green signal. Because people walking are already in the crosswalk when people driving begin to turn left or right, people driving are more likely to yield to people walking.

### What is the purpose of an LPI?

- The LPI signal timing technique allows pedestrians to establish themselves in the intersection in front of turning vehicles, increasing visibility between all modes.

### How does Billings decide where to implement an LPI?

- The LPI can be used at intersections with high volumes of pedestrians and conflicting turning vehicles and at locations with a large population of elderly or school children who tend to walk more slowly.
- The LPI should be at least three seconds to allow pedestrians to cross at least one lane of traffic to establish their position ahead of turning traffic.

### How much do LPIs cost?

**\$:** An LPI is typically added where there is already a signal, so the cost is minimal.



With a Leading Pedestrian Interval, motorists have a red signal for the first 3–5 seconds of the WALK phase.

### How long does it take to install an LPI?

**A few months.** An LPI is typically added where there is already a signal, so this reflects the time to redesign the signal cycle and time for a technician to adjust it at the control center or in the field.

Traffic Signals continued

## Right Turn on Red Restrictions

A Right Turn on Red Restriction (RTOR Restriction) prohibits motorists from taking right turns at signals if the light is red. The standard MUTCD sign states “NO TURN ON RED.” For areas where RTOR restrictions may only be needed during certain times of the day (e.g., school arrival and dismissal times), time-of day restrictions may be appropriate.

### What is the purpose for RTOR restrictions?

- RTOR restrictions allow pedestrians to have a specific phase where they can walk aligned with a green light without conflict from right turning vehicles
- NO TURN ON RED restrictions remind drivers of their obligation to yield to people walking and biking in the crosswalk.

### How does Billings decide where to implement RTOR restrictions?

- RTOR restrictions can be used at intersections with high volumes of pedestrians and conflicting turning vehicles or in areas with visibility concerns.

- Signs should be clearly visible to right-turning motorists stopped in the curb lane at the crosswalk.
- There is no available research to support whether installing NO TURN ON RED signs is an effective tool at decreasing crashes with pedestrians. Therefore, it is recommended that such signs be used in conjunction with LPs

### How much do RTOR restrictions cost?

**\$:** An RTOR restriction is typically added where there is already a signal, so the cost is minimal. If an electronic sign is desired, that can significantly increase the cost.

### How long does it take to install an RTOR restriction?

**A few months.** An RTOR restriction is usually added to an already-existing signal pole, so the timing is dependent on how long the intersection analysis and evaluation would take. More time would be needed for electronic signs to allow a technician to adjust the signal timing at the control center or in the field.

## Pedestrian Hybrid Beacons

Pedestrian Hybrid Beacons (PHB) are pedestrian-activated traffic control devices which help pedestrians safely cross major roadways where there is no traffic signal. PHBs are also known as High Intensity Activated Crosswalks, or HAWK, signals.



Pedestrian hybrid beacon



Pedestrian hybrid beacon on a divided roadway



Pedestrian hybrid beacon on a downtown street

### What is the purpose of a PHB?

Makes the presence of a person trying to cross the street known to people driving, since the beacon is only activated when someone pushes the button.

### How does a PHB work?

- The beacon consists of two red lights above a single yellow light. The beacon head is “dark,” or unilluminated, until a pedestrian activates the device. The pedestrian pushes a button that activates the beacon. After displaying brief flashing and then steady yellow intervals, the device displays a steady red indication to drivers and a “WALK” indication to pedestrians, allowing them to cross while traffic is stopped.
- The solid red signal face on a PHB has the same meaning as and should be treated like a traffic signal showing a red light. Once the red light starts flashing it should be treated like a stop sign, where the driver is to stop and make sure it is clear before proceeding.

### Where are PHBs installed?

- The City follows the Federal Highway Administration’s Manual on Uniform Traffic Control Devices (MUTCD) guidelines and warrants when studying a location for a PHB.
- Data is used to understand the volume and speed of people driving on the street as well as the number of traffic lanes a person has to cross.
- The safety history of the crossing is considered in addition to environmental and community issues at a given location.
- PHB must be located more than 300-ft from existing signals.
- PHB should be reserved for roads with at least three travel lanes.
- PHB can be installed at crosswalks that have other safety improvements, like a crossing island.

### How much does a PHB cost?

\$\$\$\$: Relatively expensive due to electrical components that often require temporarily removing sidewalk to access underground electrical lines and the reconstruction of any sidewalk removed during construction. The cost can range from \$75,000 to \$150,000.

### How long does it take to install a PHB?

1–2 years: Traffic studies and signal design must be completed before installation can begin.

### References and Resources

- [Pedestrian Safety Guide and Countermeasure Selection System: Pedestrian Hybrid Beacon](#)
- [FHWA Intersection Safety Technologies](#)
- [Federal Highway Administration’s Manual on Uniform Traffic Control Devices \(MUTCD\)](#)

## Rectangular Rapid Flashing Beacons

Rectangular Rapid Flashing Beacons (RRFB) are pedestrian-activated flashing lights on the side of the street that make a crosswalk more visible to people driving and alert them to the presence of a person trying to cross the street.



RRFB with passive detection



RRFB with push button at a school crosswalk



RRFB at a neighborhood bikeway crossing

### What is the purpose of a RRFB?

- Makes the presence of a person trying to cross the street known to people driving, since they only flash when someone pushes the button or activates an automatic sensor.
- Studies have shown that people driving are more likely to stop for people trying to cross the street when they activate a rectangular rapid flashing beacon. The highly visible flash of RRFBs is very eye-catching to motorists.

### Where are RRFBs installed?

- The Federal Highway Administration (FHWA) provides guidance for the installation of RRFBs. For more information, see [https://mutcd.fhwa.dot.gov/resources/interim\\_approval/ialistreq.htm#ia11](https://mutcd.fhwa.dot.gov/resources/interim_approval/ialistreq.htm#ia11)

- The City of Billings considers the volume and speed of traffic on the street as well as the total distance a person walking or biking has to cross.
- RRFBs can be installed at crosswalks that have other safety improvements, like a crossing island.

### How much does a RRFB cost?

\$\$: RRFBs are a relatively inexpensive way to improve safety for people crossing the street. The cost to install RRFBs can increase if the crossing doesn't already have a marked crosswalk with curb ramps that meet Federal Americans with Disabilities Act requirements.

### How long does it take to install a RRFB?

*Varies.* If the existing crossing already has marked crosswalks and curb ramps that meet ADA requirements, RRFB can be installed in a few months. If other improvements are needed at the location, it may take 1–2 years.

### References and Resources

- [Interim Approval for Optional Use of RRFBs \(FHWA\)](#)
- [Pedestrian Safety Guide and Countermeasure Selection System: RRFB](#)
- [FHWA Intersection Safety Technologies](#)



**OTHER**

**Bicycle Parking**

Bicycle parking can be a single rack or a group of racks and can be installed on school grounds, on the sidewalk, or in the street.



Bike racks on the sidewalk



Bike corral



Covered bike parking

**What is the purpose of bicycle parking near schools?**

- Gives students and school staff a place to secure their bike during the day while they're at school.
- Encourages students and school staff to ride their bikes to school.
- When located near the main entrance, bike parking makes it inviting for people who get to school by bike.
- Sends the message that the school encourages bicycling.

**Where is bike parking installed?**

- Every school should have enough bike parking to meet the day-to-day needs of students and staff. Bike parking at schools is currently the responsibility of the school district.
- When deciding where to install bike racks, the school district facilities group considers locations where the racks will be:

- » noticeable immediately when arriving at school,
- » visible from nearby windows and the street to make sure bikes are secure, and
- » publicly accessible.
- The Billings Area Bikeway and Trail Master Plan specifies three preferred bicycle rack types - the "Inverted U," cost hanger rack, and post and loop rack.

**How much does bike parking cost?**

💰: Bike parking is relatively inexpensive.

**How long does it take to install bike parking?**

< 1 year: New bike parking can generally be installed at a school in less than one year.

**Bike corrals**

Sometimes the best place to install bike parking is on the street. A bike corral can be installed in place of on-street parking and can provide parking for 6 to 12 bikes in place of one car.

A corral can also be placed in locations where parking isn't allowed, like 30 feet from an intersection or marked crosswalk. This helps make the crosswalk safer by ensuring no one parks their car illegally and blocks visibility of the crosswalk or intersection, while also adding parking spaces for people on bikes.

**References and Resources**

- [Billings Area Bikeway and Trail Master Plan](#)
- [Safe Routes to School National Partnership](#)

- [City of Billings Bike Parking Guidelines](#)
- [Association of Pedestrian and Bicycle Professionals: Bicycle Parking Guidelines](#)

## Shared Use Paths

Shared use paths create active transportation corridors that provide expanded travel choices. Shared use paths can be built independent from the road network or alongside a roadway where traffic volumes and speeds are too high, or where there is not sufficient space for bicycle lanes in the existing street space.



Multi-use paths in Alexandria, VA



Multi-use path in Billings



Multi-use path in Austin, TX

### What is the purpose of a shared use path?

- Serves both transportation and recreation users.
- Can accommodate two-way pedestrian and bicycle use.
- May include connections to the on-street bicycle and sidewalk network.
- Should be aesthetically appealing and feel safe to use.
- May provide opportunities for economic development along the path corridor.

### Where are shared use paths built?

- Prioritization criteria based on proximity to destinations, residential populations, connectivity, and community support all contribute to the trail-siting process.
- Opportunities to integrate shared use paths in proposed development projects are consistently looked for, as well as outreach and education opportunities for local bicycle, pedestrian, and environmental advocacy groups.

- A 10 ft-wide hard surface path is ideal, but may need to narrow the trail under constrained circumstances.
- Shared use paths are constructed as part of the construction or reconstruction of arterial roads within the City of Billings. On arterials, shared use path are being built on one side with a standard sidewalk on the other.

### How much does a shared use path cost?

\$\$\$: Costs for shared use paths vary, but are typically among the most expensive types of bicycle and pedestrian facilities. Components of multi-use path design and construction include:

- » Right-of-way
- » Surface material
- » Lighting
- » Landscaping
- » Terrain grading
- » Retaining walls
- » Pavement markings
- » Fencing/rails
- » Multi-use bridges
- » Maps and signage

- » Trail furniture
- » Wayfinding signage

### How long does it take to install a shared use path?

**Varies.** Planning, public input, design, engineering, and construction are all components of the installation process. Many urban trails will take 5 to 10 years to be fully implemented. However, shorter segments that close gaps in the network or eliminate barriers can often be installed in a shorter timeframe. Public Works constructs about 1 mile of shared use paths per year and developers who develop on arterial streets may have to build shared use paths.

### References and Resources

- [Billings Area Bikeway and Trail Master Plan](#)
- [NACTO Urban Bikeway Design Guide](#)
- [AASHTO Guide for the Development of Bicycle Facilities](#)
- [City of Billings Subdivision Regulations](#)

## Arrival-Dismissal Traffic Safety Plan

Many parents cite traffic and confusion at pick-up and drop-off as one of the reasons they choose to drive their children to or from school. Arrival and dismissal plans aim to help document formal and organized procedures for students and families using all modes of transportation - walking, biking, driving, and taking the bus - upon arrival and dismissal to help limit the chaos and confusion.



Arrival and dismissal plans communicate the preferred locations for buses and personal vehicles



Crossing guards should be involved in creating arrival and dismissal plans



Arrival and dismissal plans can encourage walking and biking to school by managing behavior expectations

### What is the purpose of an arrival-dismissal traffic safety plan?

- Gives parents and caregivers consistent expectations of how to behave at drop-off and pick-up to maintain safety for people walking, biking, driving, and bussing.
- Allows the school to address campus-specific issues and challenging local street networks.

### How are arrival-dismissal traffic safety plans developed?

- Currently, each school develops their own arrival-dismissal traffic safety plan. These plans, for most schools, were updated for the 2021–2022 school year to address COVID-19 precautions.

- Traffic safety plans should be revised regularly to address changes in travel behaviors, identified safety concerns, availability of staff to supervise, or safety bussing changes.
- Arrival-dismissal traffic safety plans should be revisited prior to the school year and sent to parents and staff with welcome materials. The plans should be revisited throughout the school year to address any issues that arise.

### How much does an arrival-dismissal traffic safety plan cost?

**\$:** Plans are a relatively low-cost and effective way to manage drop-off and pick-up times. Additional costs may be incurred implementing the plan, dependent on whether additional staff are needed to assist.

### How long does it take to implement an arrival-dismissal traffic safety plan?

**<1 month:** The plan is sent to parents and staff via email and in student folders. Additionally, school staff and administrators should regularly monitor arrival and dismissal times to continually remind and educate parents, students, and staff on the plan expectations.

### References and Resources

- [Safe Routes to School National Partnership. Keep Calm and Carry on to School: Improving Arrival and Dismissal for Walking and Biking](#)
- [Feet First. Improve your School Arrival and Departure Procedures: A Toolkit for School Safety Committees](#)

## 4.1 Safety Infrastructure Tool Selection Matrix

With so many tools available, it can be difficult to know which one(s) will have the greatest safety benefits. The table below will help in selecting the right tool for addressing common safety concerns near schools in Billings. The tools can be used together, and often greater safety gains can be expected when more than one tool is used.

COMMON SAFETY CONCERNS NEAR SCHOOLS												
	Motor vehicle speeding	Long crossing distances	Turning vehicles not yielding	Poor pedestrian access and/or comfort	Poor bicycle access and/or comfort	Crosswalks blocked during arrival/dismissal	Pedestrians crossing mid-block	Poor visibility	Drivers not yielding to pedestrians in crosswalks	Insufficient separation from traffic	Illegal U-turns	Constrained school site/few access points
<b>Capital Improvements</b>												
Sidewalks				x	x		x					x
Curb Ramps				x								
Curb Extensions	x	x	x	x			x	x	x			
Pedestrian Refuge Islands	x	x		x		x		x	x			
Speed Humps	x				x							
Raised Crosswalks	x	x		x	x	x			x			
Right-Turn Redesign	x	x	x	x	x							
Shared-Use Paths				x	x					x		x
<b>Signs &amp; Markings</b>												
Lane Width Reduction	x	x		x	x							
Lane Reconfiguration	x	x		x	x							
Marked Crosswalks		x	x	x		x			x			

Continued on the next page

COMMON SAFETY CONCERNS NEAR SCHOOLS												
	Motor vehicle speeding	Long crossing distances	Turning vehicles not yielding	Poor pedestrian access and/or comfort	Poor bicycle access and/or comfort	Crosswalks blocked during arrival/dismissal	Pedestrians crossing mid-block	Poor visibility	Drivers not yielding to pedestrians in crosswalks	Insufficient separation from traffic	Illegal U-turns	Constrained school site/ few access points
Advance Yield Markings	x	x	x	x	x			x	x			
Stop Signs	x			x	x				x			
Parking Restriction Signs				x	x	x	x	x	x		x	x
Turning Vehicles Yield to Pedestrian Signs			x	x	x			x	x			
School Zones and School Crossing Signs	x	x		x	x	x		x				
<b>Signals</b>												
Leading Pedestrian Intervals		x	x	x					x			
Protected Left Turns		x	x	x	x			x	x			
Right Turn on Red Restrictions		x	x	x	x			x	x	x		
Pedestrian Hybrid Beacons	x	x		x	x	x	x	x	x			
Rectangular Rapid Flashing Beacons	x	x		x	x	x	x	x	x			
<b>Other</b>												
Bicycle Parking					x							
Arrival-Dismissal Traffic Safety Plan	x	x	x	x	x	x	x	x	x	x	x	x

## 5. Project Impact

All of the project locations identified in Section 3 cannot be implemented immediately for a variety of reasons – funding constraints, staff availability, political support, etc. As such, it is important to prioritize the projects to evaluate the potential impact of each project. While the City of Billings will try to implement projects by category of impact, projects will not be implemented in the exact order of impact. For example, the City of Billings will try to implement high impact projects before medium or low impact projects.

Project implementation order may differ from project impact score based on external factors such as the opportunity to combine a SRTS project with other construction, the need to acquire right-of-way or easements, the types or amount of funding available, etc. In addition, not all projects are under City of Billings jurisdiction. Some may need to be installed, constructed, or implemented by other entities.

### 5.1 Impact Score Criteria

The project locations identified in this plan were evaluated for their level of impact using a set of criteria that represents both the values and realities of the SRTS program and its stakeholders in Billings. The criteria are:

- **Traffic Safety.** This criteria represents the safety of the roadway as evaluated by a variety of factors – speed limit, roadway classification – that impact the safety of people walking or biking on, alongside, and/or crossing the roadway. For all three of these factors, higher amounts (e.g., a higher speed limit) increase the criteria's score since having higher amounts, in turn, create a less safe – both actual and perceived – environment for people walking and biking.
- **Feasibility.** This criteria represents the likelihood and/or ease of the project getting built based on available funding and documented support. There are three factors that contribute to the feasibility score a project location would receive – whether the project is related to pedestrian crossings, sidewalk, or ADA improvement (there is a dedicated annual funding source for these types of projects); whether the project is specified in the City's 5-year Capital Improvement Plan; and whether a project at the location is identified in a citywide or regional plan.
- **Demand.** Demand is based on the potential use of an improvement at the location if it were to be built. This criteria is measured by the number of students within a ¼-radius of the location.

- **Equity.** The Billings School District is consistently looking for ways to be more equitable, whether in or out of the classroom. The equity criteria that is being applied to the project locations are criteria that each school gathers and includes the percentage of students eligible for Free or Reduced Lunch and the percent students of color. Each project location is “assigned” these numbers based on the school that it is associated with.



## 5.2 Implementation

Implementation is an important part of any SRTS plan. After identifying areas of concern based on geographic data, comments from principals, crossing guards, and the public as well as professional expertise from City of Billings, MPO, and Toole Design staff, the locations above were identified as areas of concern. Improving these areas should help make it safer, easier, and more appealing for children to walk and bike to school.

Upon adoption of this plan, the City of Billings Public Works Department will evaluate the planning-level project suggestions on an engineering level to determine the feasibility of each tool suggested. The tool(s) used to address each project may change at this point due to other constraints, but the City of Billings will consider how to make walking and biking for students safer at each of these locations.

The City of Billings currently has dedicated funding sources available each year to construct new sidewalks, add accessible ramps to intersections, and to improve crossings. Other funding sources, such as gas tax, arterial fees, developer contributions, special improvement district bonds, street maintenance fees, and tax increment financing district revenues may be able to be used for some of these projects. Others may be funded by grant funding that the City of Billings applies for in the future.

In order to be programmed for construction, all infrastructure projects over \$25,000 must be programmed into the City of Billings Capital Improvement Plan (CIP). The CIP is a five-year program that identifies the needs for construction of capital projects or improvements to the City's infrastructure. Each update is create with input from the public and direction from the City Council.



Table 1 summarizes the criteria, metrics, and weights used to prioritize the project locations.

Table 1. Criteria Table for Plan

Criteria	Metric	Maximum Points per Metric	Point Assignment	Overall Criteria Score
Traffic Safety	Posted Speed Limit <sup>1</sup>	50	25mph = 10 30mph = 20 35mph = 30 40mph = 40 45+mph = 50	100
	Roadway Classification	50	Street = 10 Collector = 30 Minor Arterial = 40 Principal Arterial = 50	
Feasibility	Project is for Pedestrian Crossing, Sidewalk, or ADA Improvement	30	Yes = 30 No = 0	100
	In 5-Year Capital Improvement Plan	50	Yes = 50 No = 0	
	Documented in Adopted Plan	20	Yes = 20 No = 0	
Demand	Number of Students Living Within ¼-mile of the Project	100	<110 students = 120 110-139 students = 240 140-159 students = 360 160-199 students = 480 200+ students = 50100	100
Equity	Free and Reduced Lunch Percentage at School	50	Free and Reduced Lunch Percentage x 50	100
	Percent Students of Color	50	Percent Students of Color x 50	
TOTAL POINTS AVAILABLE:				400

<sup>1</sup> Posted speed limits used are not reflective of any "School Zone" temporal speed limit (e.g., 20mph when school speed limit sign is flashing) and only represent the regularly signed speed on the roadway.



### 5.3 High Impact Project List

Using the criteria and scoring detailed on page 109, the project locations are scored as follows:

School	Project Number	Location	Project Type	Impact Scoring Criteria Category																				Overall Score
				Traffic Safety					Feasibility					Demand			Equity							
				Posted Speed Limit	Points Assigned	Roadway Classification	Points Assigned	Total Traffic Safety Score	Ped Crossing, Sidewalk, ADA	Points Assigned	Specified in the 5-year CIP	Points Assigned	Documented in Adopted Plan	Points Assigned	Total Feasibility Score	Number of Students Living Within .25 mi	Points Assigned	Total Demand Score	Free & Reduced Lunch Percentage at School	Points Assigned	% Students of Color	Points Assigned	Total Equity Score	
ORCHARD	6	Jackson St and Francis Ave	Crossing	30	20	Collector	30	50	Y	30	N	0	Y	20	50	208	100	100	100%	50	58%	29	79	279
MILES AVE	2	Broadwater Ave between 12th and 19th	Crossing	35	30	Principal Arterial	50	80	Y	30	N	0	Y	20	50	357	100	100	52%	26	31%	15	41	271
NEWMAN	3	Calhoun Ln	Sidewalk	35	30	Minor Arterial	40	70	Y	30	N	0	N	0	30	240	100	100	100%	50	39%	20	70	270
BOULDER	1	Poly Dr	Speeding	35	30	Principal Arterial	50	80	N	0	Y	50	Y	20	70	369	100	100	13%	7	14%	7	13	263
ALKALI CREEK	3	Alkali Creek Rd from Sandstone Trail to Moon Valley Rd	Sidewalk	35	30	Principal Arterial	50	80	Y	30	N	0	Y	20	50	226	100	100	34%	17	26%	13	30	260
SANDSTONE	3	Babcock Blvd and Prospectors Ln/ Claim Jumper Ln	Crossing	25	10	Collector	30	40	Y	30	Y	50	N	0	80	269	100	100	38%	19	28%	14	33	253
ORCHARD	5	Jackson St and Roosevelt Ave	Crossing	25	10	Collector	30	40	Y	30	N	0	Y	20	50	161	80	80	100%	50	58%	29	79	249
ORCHARD	1	State Ave	Speeding	35	30	Minor Arterial	40	70	N	0	N	0	N	0	0	223	100	100	100%	50	58%	29	79	249
BENCH	1	Lake Elmo Dr sidepath	Sidewalk	35	30	Collector	30	60	Y	30	N	0	N	0	30	267	100	100	57%	29	43%	21	50	240
BENCH	3	Lake Elmo Dr north of Rice Ln	Sidewalk	35	30	Collector	30	60	Y	30	N	0	N	0	30	218	100	100	57%	29	43%	21	50	240
BIG SKY	2	S 32nd St W and Lampman Dr	Crossing	35	30	Principal Arterial	50	80	Y	30	N	0	Y	20	50	150	60	60	47%	23	36%	18	41	231
BROADWATER	1	Broadwater Ave between 4th and 5th St W	Speeding	35	30	Principal Arterial	50	80	N	0	N	0	Y	20	20	191	80	80	56%	28	32%	16	44	224
WASHINGTON	4	Central Ave and Moore Ln	Crossing	35	30	Principal Arterial	50	80	Y	30	N	0	N	0	30	123	40	40	100%	50	47%	24	74	224
WASHINGTON	3	Central Ave and from 10th to 12th St	Sidewalk	35	30	Principal Arterial	50	80	Y	30	N	0	N	0	30	121	40	40	100%	50	47%	24	74	224
ORCHARD	3	Frances Ave	Arrival/Dissmissal Behavior	25	10	Collector	30	40	N	0	N	0	N	0	0	222	100	100	100%	50	58%	29	79	219
ORCHARD	4	Jackson St	School Speed Zone	25	10	Collector	30	40	N	0	N	0	N	0	0	231	100	100	100%	50	58%	29	79	219
POLY DRIVE	2	Colton Blvd and 24th St W	Crossing	35	30	Principal Arterial	50	80	Y	30	N	0	Y	20	50	151	60	60	25%	13	21%	11	23	213

Continued on the next page

School	Project Number	Location	Project Type	Impact Scoring Criteria Category																				Overall Score
				Traffic Safety					Feasibility					Demand			Equity							
				Posted Speed Limit	Points Assigned	Roadway Classification	Points Assigned	Total Traffic Safety Score	Ped Crossing, Sidewalk, ADA	Points Assigned	Specified in the 5-year CIP	Points Assigned	Documented in Adopted Plan	Points Assigned	Total Feasibility Score	Number of Students Living Within .25 mi	Points Assigned	Total Demand Score	Free & Reduced Lunch Percentage at School	Points Assigned	% Students of Color	Points Assigned	Total Equity Score	
BOULDER	4	Zimmerman Trail	Crossing	35	30	Principal Arterial	50	80	Y	30	Y	50	Y	20	100	87	20	20	13%	7	14%	7	13	213
SANDSTONE	2	W Wicks Ln	Speeding	35	30	Principal Arterial	50	80	N	0	N	0	N	0	0	490	100	100	38%	19	28%	14	33	213
BURLINGTON	1	Belvedere Dr	Shared Use Path	35	30	Principal Arterial	50	80	N	0	N	0	Y	20	20	172	80	80	42%	21	24%	12	33	213
CENTRAL HEIGHTS	1	Monad Rd and 24th St W	Crossing	35	30	Principal Arterial	50	80	Y	30	N	0	Y	20	50	114	40	40	42%	21	36%	18	39	209
ORCHARD	2	State Ave and Jackson St	Curb Ramps	35	30	Minor Arterial	40	70	N	0	N	0	N	0	0	142	60	60	100%	50	58%	29	79	209
ROSE PARK	7	19th St W between Avenue F and Avenue D	Speeding	30	20	Collector	30	50	N	0	N	0	Y	20	20	206	100	100	48%	24	26%	13	37	207
POLY DRIVE	1	Rimrock Rd and Arvin Rd	School Speed Zone	35	30	Principal Arterial	50	80	N	0	N	0	N	0	0	436	100	100	25%	13	21%	11	23	203
POLY DRIVE	3	Colton Blvd between Lyndell and 20th St W	School Speed Zone	35	30	Principal Arterial	50	80	N	0	N	0	N	0	0	358	100	100	25%	13	21%	11	23	203
SANDSTONE	5	Nutter Blvd and Babcock Blvd	Crossing	25	10	Collector	30	40	Y	30	N	0	N	0	30	240	100	100	38%	19	28%	14	33	203
SANDSTONE	4	Claim Jumper Ln	Sidewalk	25	10	Street	10	20	Y	30	N	0	Y	20	50	387	100	100	38%	19	28%	14	33	203
SANDSTONE	6	Neighborhoods southeast of Babcock Blvd	Sidewalk	25	10	Street	10	20	Y	30	N	0	Y	20	50	204	100	100	38%	19	28%	14	33	203
SANDSTONE	7	Neighborhoods north of Wicks Lane	Sidewalk	25	10	Street	10	20	Y	30	N	0	Y	20	50	300	100	100	38%	19	28%	14	33	203
BURLINGTON	3	19th St and Lewis Ave	Crossing	25	10	Collector	30	40	Y	30	N	0	Y	20	50	162	80	80	42%	21	24%	12	33	203
PONDEROSA	2	King Ave and Arlington Ave SW	Congestion	35	30	Minor Arterial	40	70	N	0	N	0	N	0	0	151	60	60	100%	50	44%	22	72	202
NEWMAN	1	S Billings Blvd and Simpson	Crossing	35	30	Principal Arterial	50	80	Y	30	N	0	N	0	30	72	20	20	100%	50	39%	20	70	200
BROADWATER	3	8th St W and Wyoming	Crossing	25	10	Collector	30	40	Y	30	N	0	N	0	30	182	80	80	56%	28	32%	16	44	194
WASHINGTON	2	Central Ave and from 10th to 12th St	Speeding	35	30	Principal Arterial	50	80	N	0	N	0	N	0	0	121	40	40	100%	50	47%	24	74	194
EAGLE CLIFFS	2	Constitution Ave and Governors Blvd	Crossing	35	30	Principal Arterial	50	80	Y	30	N	0	N	0	30	144	60	60	26%	13	17%	8	21	191
BIG SKY	3	S 30th St W and Lampman Dr	Crossing	25	10	Street	10	20	Y	30	N	0	Y	20	50	188	80	80	47%	23	36%	18	41	191
BENCH	2	Lake Elmo Dr and Milton Rd	School Speed Zone	35	30	Collector	30	60	N	0	N	0	N	0	0	162	80	80	57%	29	43%	21	50	190

Continued on the next page

## 5.4 Medium Impact Project List

Using the criteria and scoring detailed on page 109, the project locations are scored as follows:

School	Project Number	Location	Project Type	Impact Scoring Criteria Category																				Overall Score
				Traffic Safety					Feasibility					Demand			Equity							
				Posted Speed Limit	Points Assigned	Roadway Classification	Points Assigned	Total Traffic Safety Score	Ped Crossing, Sidewalk, ADA	Points Assigned	Specified in the 5-year CIP	Points Assigned	Documented in Adopted Plan	Points Assigned	Total Feasibility Score	Number of Students Living Within .25 mi	Points Assigned	Total Demand Score	Free & Reduced Lunch Percentage at School	Points Assigned	% Students of Color	Points Assigned	Total Equity Score	
BEARTOOTH	3	Wicks Ln and Bitterroot Dr	Crossing	35	30	Principal Arterial	50	80	Y	30	N	0	N	0	30	139	40	40	46%	23	28%	14	37	187
BROADWATER	2	4th St W between Broadwater Ave & Wyoming Ave	Arrival/Dismissal Behavior	25	10	Street	10	20	N	0	N	0	Y	20	20	223	100	100	56%	28	32%	16	44	184
WASHINGTON	5	Cook Ave and 11th St	Crossing	25	10	Street	10	20	Y	30	N	0	Y	20	50	126	40	40	100%	50	47%	24	74	184
SANDSTONE	1	W Wicks Ln and Nutter Blvd	Crossing	35	30	Principal Arterial	50	80	Y	30	N	0	Y	20	50	106	20	20	38%	19	28%	14	33	183
BURLINGTON	2	24th St W and Lewis	Crossing	35	30	Principal Arterial	50	80	Y	30	N	0	Y	20	50	101	20	20	42%	21	24%	12	33	183
MCKINLEY	1	Parkhill Dr and N 32nd St	Crossing	25	10	Collector	30	40	Y	30	N	0	Y	20	50	91	20	20	100%	50	40%	20	70	180
MCKINLEY	2	11th Ave N and N 32nd St	Crossing	25	10	Collector	30	40	Y	30	N	0	Y	20	50	95	20	20	100%	50	40%	20	70	180
ROSE PARK	2	Parkhill Dr and 17th St W	Crossing	35	30	Minor Arterial	40	70	Y	30	N	0	Y	20	50	97	20	20	48%	24	26%	13	37	177
ROSE PARK	4	Poly Drive and Hoover Ave	Crossing	35	30	Minor Arterial	40	70	Y	30	N	0	Y	20	50	83	20	20	48%	24	26%	13	37	177
ROSE PARK	6	Avenue E and 19th St W	Crossing	30	20	Collector	30	50	Y	30	N	0	Y	20	50	113	40	40	48%	24	26%	13	37	177
ROSE PARK	5	Multifamily housing near Avenue C and 22nd St W	Shared Use Path	25	10	Street	10	20	N	0	N	0	Y	20	20	254	100	100	48%	24	26%	13	37	177
BROADWATER	4	6th St W and Wyoming	Crossing	25	10	Street	10	20	Y	30	N	0	N	0	30	188	80	80	56%	28	32%	16	44	174
WASHINGTON	1	11th St W	Arrival/Dismissal Behavior	25	10	Street	10	20	N	0	N	0	Y	20	20	142	60	60	100%	50	47%	24	74	174
BITTERROOT	3	Barrett Rd and Bench Blvd	Crossing	35	30	Principal Arterial	50	80	Y	30	N	0	N	0	30	68	20	20	48%	24	29%	14	39	169
MEADOWLARK	1	Throughout neighborhood	Sidewalk	25	10	Street	10	20	Y	30	N	0	N	0	30	719	100	100	20%	10	16%	8	18	168
BEARTOOTH	2	Elaine St and Bitterroot Dr	Crossing	35	30	Principal Arterial	50	80	Y	30	N	0	N	0	30	79	20	20	46%	23	28%	14	37	167
ARROWHEAD	3	Shiloh Road at Arrowhead School Path crossing	Crossing	45	50	Principal Arterial	50	100	Y	30	N	0	N	0	30	54	20	20	17%	8	15%	7	16	166
POLY DRIVE	4	Side alley to east of school property	Shared Use Path	25	10	Street	10	20	N	0	N	0	Y	20	20	358	100	100	25%	13	21%	11	23	163

Continued on the next page

School	Project Number	Location	Project Type	Impact Scoring Criteria Category																				Overall Score
				Traffic Safety					Feasibility					Demand			Equity							
				Posted Speed Limit	Points Assigned	Roadway Classification	Points Assigned	Total Traffic Safety Score	Ped Crossing, Sidewalk, ADA	Points Assigned	Specified in the 5-year CIP	Points Assigned	Documented in Adopted Plan	Points Assigned	Total Feasibility Score	Number of Students Living Within .25 mi	Points Assigned	Total Demand Score	Free & Reduced Lunch Percentage at School	Points Assigned	% Students of Color	Points Assigned	Total Equity Score	
BOULDER	3	Rehberg Ln and Colton Blvd	Crossing	35	30	Collector	30	60	Y	30	N	0	N	0	30	142	60	60	13%	7	14%	7	13	163
MILES AVE	3	Miles Ave and 15th St W	Speeding	35	30	Principal Arterial	50	80	N	0	N	0	N	0	0	125	40	40	52%	26	31%	15	41	161
ALKALI CREEK	2	Front of school along Alkali Creek Rd	Crossing	35	30	Principal Arterial	50	80	Y	30	N	0	N	0	30	81	20	20	34%	17	26%	13	30	160
ALKALI CREEK	4	Alkali Creek Road and Senators Blvd	Crossing	35	30	Principal Arterial	50	80	Y	30	N	0	N	0	30	64	20	20	34%	17	26%	13	30	160
CENTRAL HEIGHTS	2	Lexington Dr	Arrival/Dismissal Behavior	25	10	Street	10	20	N	0	N	0	Y	20	20	175	80	80	42%	21	36%	18	39	159
BITTERROOT	1	Bench Blvd from Kyhl Ln to Barrett Rd	Arrival/Dismissal Behavior	35	30	Principal Arterial	50	80	N	0	N	0	N	0	0	121	40	40	48%	24	29%	14	39	159
BITTERROOT	4	Heritage/Kiwanis Trail at Ahoy Avenue and Naples Street	Shared Use Path	25	10	Street	10	20	N	0	N	0	N	0	0	230	100	100	48%	24	29%	14	39	159
HIGHLAND	1	Poly Dr and Virginia Ln	Crossing	35	30	Minor Arterial	40	70	Y	30	N	0	N	0	30	82	20	20	39%	20	27%	14	33	153
BENCH	4	Ulnita Park/Twin Oaks neighborhood	Shared Use Path	25	10	Street	10	20	N	0	N	0	N	0	0	173	80	80	57%	29	43%	21	50	150
BEARTOOTH	4	Barrett Rd and Linden Dr	Crossing	25	10	Collector	30	40	Y	30	N	0	Y	20	50	71	20	20	46%	23	28%	14	37	147
BEARTOOTH	5	Barrett Rd from Kiwanis Trail to Columbine Dr	Sidewalk	25	10	Collector	30	40	Y	30	N	0	Y	20	50	59	20	20	46%	23	28%	14	37	147
ARROWHEAD	1	Rimrock Rd and 38th St W	Crossing	35	30	Principal Arterial	50	80	Y	30	N	0	N	0	30	107	20	20	17%	8	15%	7	16	146
ARROWHEAD	5	38th St W, south of school	Sidewalk	25	10	Collector	30	40	Y	30	N	0	N	0	30	149	60	60	17%	8	15%	7	16	146
EAGLE CLIFFS	1	Marias Dr/Wicks Ln	Shared Use Path	35	30	Principal Arterial	50	80	N	0	N	0	N	0	0	136	40	40	26%	13	17%	8	21	141
BIG SKY	1	Front of school	Arrival/Dismissal Behavior	25	10	Street	10	20	N	0	N	0	N	0	0	199	80	80	47%	23	36%	18	41	141
BENCH	5	Rex Ln north of Milton Rd	Sidewalk	25	10	Street	10	20	Y	30	N	0	Y	20	50	103	20	20	57%	29	43%	21	50	140
MCKINLEY	3	Pioneer Park path, 3rd St W, and Ave C	Crossing	25	10	Street	10	20	Y	30	N	0	N	0	30	82	20	20	100%	50	40%	20	70	140

Continued on the next page

## 5.5 Low Impact Project List

Using the criteria and scoring detailed on page 109, the project locations are scored as follows:

School	Project Number	Location	Project Type	Impact Scoring Criteria Category																			Overall Score	
				Traffic Safety					Feasibility					Demand			Equity							
				Posted Speed Limit	Points Assigned	Roadway Classification	Points Assigned	Total Traffic Safety Score	Ped Crossing, Sidewalk, ADA	Points Assigned	Specified in the 5-year CIP	Points Assigned	Documented in Adopted Plan	Points Assigned	Total Feasibility Score	Number of Students Living Within .25 mi	Points Assigned	Total Demand Score	Free & Reduced Lunch Percentage at School	Points Assigned	% Students of Color	Points Assigned		Total Equity Score
ROSE PARK	3	Pedestrian bridge over canal at 19th St W	Shared Use Path	25	10	Collector	30	40	N	0	N	0	Y	20	20	123	40	40	48%	24	26%	13	37	137
ARROWHEAD	4	38th St W and Poly Dr	Crossing	35	30	Minor Arterial	40	70	Y	30	N	0	N	0	30	79	20	20	17%	8	15%	7	16	136
BOULDER	2	Colton Blvd	Connectivity	35	30	Principal Arterial	50	80	N	0	N	0	N	0	0	117	40	40	13%	7	14%	7	13	133
HIGHLAND	2	Parkhill Dr	Arrival/Dismissal Behavior	25	10	Collector	30	40	N	0	N	0	N	0	0	156	60	60	39%	20	27%	14	33	133
SANDSTONE	8	School site	Bicycle Parking	N/A	0	N/A	0	0	N	0	N	0	N	0	0	204	100	100	38%	19	28%	14	33	133
MILES AVE	1	School crossing along 16th St W near the school	Crossing	25	10	Street	10	20	Y	30	N	0	N	0	30	118	40	40	52%	26	31%	15	41	131
ALKALI CREEK	1	School front parking lot	Parking Procedures	35	30	Principal Arterial	50	80	N	0	N	0	N	0	0	73	20	20	34%	17	26%	13	30	130
ALKALI CREEK	6	Alkali Creek from Camel Pl to school site	Shared Use Path	35	30	Principal Arterial	50	80	N	0	N	0	N	0	0	69	20	20	34%	17	26%	13	30	130
BENCH	6	Lola Ln from Lake Elmo Dr to school property	Shared Use Path	N/A	0	N/A	0	0	N	0	N	0	Y	20	20	142	60	60	57%	29	43%	21	50	130
CENTRAL HEIGHTS	4	Lexington Dr north of Alamo Dr	Crossing	25	10	Street	10	20	Y	30	N	0	Y	20	50	0	20	20	42%	21	36%	18	39	129
CENTRAL HEIGHTS	5	Eldorado Dr and Lexington Dr	Crossing	25	10	Street	10	20	Y	30	N	0	Y	20	50	33	20	20	42%	21	36%	18	39	129
ROSE PARK	1	Parkhill Dr and 17th St W	Speeding	35	30	Minor Arterial	40	70	N	0	N	0	N	0	0	0	20	20	48%	24	26%	13	37	127
PONDEROSA	3	Shared use path south of Ponderosa Elementary	Hazardous/Illicit Activity	N/A	0	Street	10	10	N	0	N	0	N	0	0	124	40	40	100%	50	44%	22	72	122
BIG SKY	4	School playground area	Bicycle Parking	N/A	0	N/A	0	0	N	0	N	0	N	0	0	186	80	80	47%	23	36%	18	41	121
WASHINGTON	6	Front of school	Bicycle Parking	N/A	0	N/A	0	0	N	0	N	0	N	0	0	119	40	40	100%	50	47%	24	74	114
PONDEROSA	1	School parking lot	Arrival/Dismissal Behavior	N/A	0	N/A	0	0	N	0	N	0	N	0	0	138	40	40	100%	50	44%	22	72	112
PONDEROSA	4	School site	Bicycle Parking	N/A	0	N/A	0	0	N	0	N	0	N	0	0	138	40	40	100%	50	44%	22	72	112

Continued on the next page

School	Project Number	Location	Project Type	Impact Scoring Criteria Category																				Overall Score
				Traffic Safety					Feasibility					Demand			Equity							
				Posted Speed Limit	Points Assigned	Roadway Classification	Points Assigned	Total Traffic Safety Score	Ped Crossing, Sidewalk, ADA	Points Assigned	Specified in the 5-year CIP	Points Assigned	Documented in Adopted Plan	Points Assigned	Total Feasibility Score	Number of Students Living Within .25 mi	Points Assigned	Total Demand Score	Free & Reduced Lunch Percentage at School	Points Assigned	% Students of Color	Points Assigned	Total Equity Score	
EAGLE CLIFFS	3	Constitution Ave and Marias Dr	Crossing	25	10	Collector	30	40	Y	30	N	0	N	0	30	58	20	20	26%	13	17%	8	21	111
ALKALI CREEK	5	North and east of the school	Safety Busing	N/A	0	N/A	0	0	N	0	N	0	N	0	0	160	80	80	34%	17	26%	13	30	110
BENCH	7	Bicycle rack in school parking lot	Bicycle Parking	N/A	0	N/A	0	0	N	0	N	0	N	0	0	150	60	60	57%	29	43%	21	50	110
NEWMAN	2	Newman Ln	Arrival/Dissmissal Behavior	25	10	Street	10	20	N	0	N	0	N	0	0	107	20	20	100%	50	39%	20	70	110
CENTRAL HEIGHTS	3	Dallas Dr and Pueblo Dr (west to east leg)	Crossing	25	10	Street	10	20	Y	30	N	0	N	0	30	109	20	20	42%	21	36%	18	39	109
BITTERROOT	2	Kyhl Ln in front of school	Sidewalk	25	10	Street	10	20	Y	30	N	0	N	0	30	75	20	20	48%	24	29%	14	39	109
BITTERROOT	5	Barrett Rd from Kiwanis Trail to Columbine Dr	Sidewalk	25	10	Street	10	20	Y	30	N	0	N	0	30	59	20	20	48%	24	29%	14	39	109
MILES AVE	4	South of school	Bicycle Parking	25	10	Street	10	20	N	0	N	0	N	0	0	114	40	40	52%	26	31%	15	41	101
ARROWHEAD	2	Front of school along 38th St W	Arrival/Dissmissal Behavior	25	10	Collector	30	40	N	0	N	0	N	0	0	130	40	40	17%	8	15%	7	16	96
BURLINGTON	4	Bicycle racks	Bicycle Parking	N/A	0	N/A	0	0	N	0	N	0	N	0	0	140	60	60	42%	21	24%	12	33	93
MCKINLEY	4	Bicycle racks	Bicycle Parking	N/A	0	N/A	0	0	N	0	N	0	N	0	0	71	20	20	100%	50	40%	20	70	90
NEWMAN	4	School site	Bicycle Parking	N/A	0	N/A	0	0	N	0	N	0	N	0	0	71	20	20	100%	50	39%	20	70	90
CENTRAL HEIGHTS	6	School property	Bicycle Parking	25	10	Street	10	20	N	0	N	0	N	0	0	33	20	20	42%	21	36%	18	39	79
BEARTOOTH	1	Elaine St immediately in front of school	Parking Procedures	25	10	Street	10	20	N	0	N	0	N	0	0	86	20	20	46%	23	28%	14	37	77
ROSE PARK	8	School site	Bicycle Parking	N/A	0	N/A	0	0	N	0	N	0	N	0	0	116	40	40	48%	24	26%	13	37	77
HIGHLAND	3	School property	Bicycle Parking	N/A	0	N/A	0	0	N	0	N	0	N	0	0	118	40	40	39%	20	27%	14	33	73
ALKALI CREEK	7	Behind school	Bicycle Parking	N/A	0	N/A	0	0	N	0	N	0	N	0	0	130	40	40	34%	17	26%	13	30	70
BITTERROOT	6	Southwest corner of school blacktop	Bicycle Parking	N/A	0	N/A	0	0	N	0	N	0	N	0	0	72	20	20	48%	24	29%	14	39	59
MEADOWLARK	2	On-site bicycle racks	Bicycle Parking	N/A	0	N/A	0	0	N	0	N	0	N	0	0	126	40	40	20%	10	16%	8	18	58
BEARTOOTH	6	Front of school	Bicycle Parking	N/A	0	N/A	0	0	N	0	N	0	N	0	0	90	20	20	46%	23	28%	14	37	57
EAGLE CLIFFS	4	Front of school	Bicycle Parking	N/A	0	N/A	0	0	N	0	N	0	N	0	0	48	20	20	26%	13	17%	8	21	41
ARROWHEAD	6	Front, back, and south of school	Bicycle Parking	N/A	0	N/A	0	0	N	0	N	0	N	0	0	58	20	20	17%	8	15%	7	16	36

## 6. School Walking Maps

Students and families are more likely to walk or bike to school if they feel that there is a safe route to do so. As part of the SRTS plan update, the project team created “suggested walking route” maps for each school. The suggested walking routes were created by analyzing where students live, evaluating whether street segments were appropriate for walking (e.g., presence of sidewalks, low speed roadways, etc.), and identifying crossings suitable for young children (e.g., presence of crossing guard, signals, stop signs, low traffic volumes).

Ideally, students and families would receive these maps at the beginning of the school year as they are deciding on how they will travel to school. The maps should also be available on the school and the City’s websites for continuous use. In addition, these maps can be used to create walking school bus routes and handed out at events such as International Walk and Roll to School Day.

The maps are intended for informational purposes only. The City of Billings or Billings Public Schools cannot and does not guarantee the safety of these routes, and assumes no responsibility or liability. Families and students should use to use this map to explore options for going to and from school, but each family is responsible for choosing the most appropriate option based upon their knowledge of route conditions and the specific needs and/or experience level of their student.

The maps are designed to be handed out as a two-sided flyer with the suggested route map on one side and walking and biking tips on the other side. The tip sheet is shown on the following page, and each individual school’s walking map is shown in the remainder of this section.



Walking school buses allow children to walk to school with friends and trusted adults.



# Billings Safe Routes to School

## WALKING AND BIKING TIPS

Walking and bicycling to and from school are great ways to get a jump start to your day!

Walking or bicycling to school improves children’s concentration, boosts moods and alertness, and enhances memory, creativity, and overall learning. Here are a few tips to make sure you get to school safely, no matter how you choose to travel:

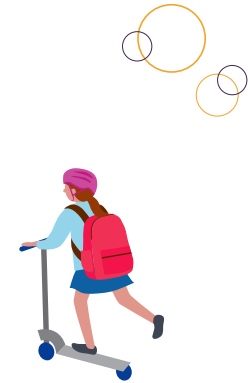

### If you’re walking...

- Look before you cross – look left, right, and left again before crossing the street.
- Cross at corners or at a marked crosswalk. If you can, cross where there’s a crossing guard – they love to help!
- Don’t assume that vehicles will stop for you. Use eye contact and hand signals to communicate before crossing, and make sure to wait until all lanes of traffic are clear or stopped before you cross.
- If you can, walk with a parent or a friend (it’s safer and more fun!).

### If you’re biking...

- Always wear your helmet and buckle it every time. To best protect your head, your helmet must fit properly – snug and level on your head, just above your eyebrows.
- Be predictable. Follow the same rules of the road as drivers when riding your bike. This includes obeying ALL stop signs and traffic signals, as well as yielding to pedestrians.
- Talk with your parents about where you can ride on the street and where you should ride on the sidewalk. When riding on the street, ride on the right-hand side of the road, in the same direction as traffic. Watch out for turning cars and cars coming out of driveways. If you are riding on the sidewalk, slow down for pedestrians and give them priority.

### If you’re driving...

- Slow down in school zones or when students are nearby.
- Do not use your cell phone while driving, even hands-free.
- Yield to people walking and biking, and always follow the directions of crossing guards.
- Make sure students enter and exit the vehicle on the curb side of the street. Have student walk to the nearest intersection to cross.
- Avoid making U-turns, double-parking, blocking crosswalks and other unsafe movements.
- Stop for school buses with red flashing lights on both sides of the street.
- Consider parking a few blocks away and walking your student the rest of the way to school. This reduces congestion around the school and adds a little exercise to your day!



Want to learn more about the Billings Safe Routes to School Program?  
 VISIT: <https://tinyurl.com/BillingsSRTS>  
 and join the movement!





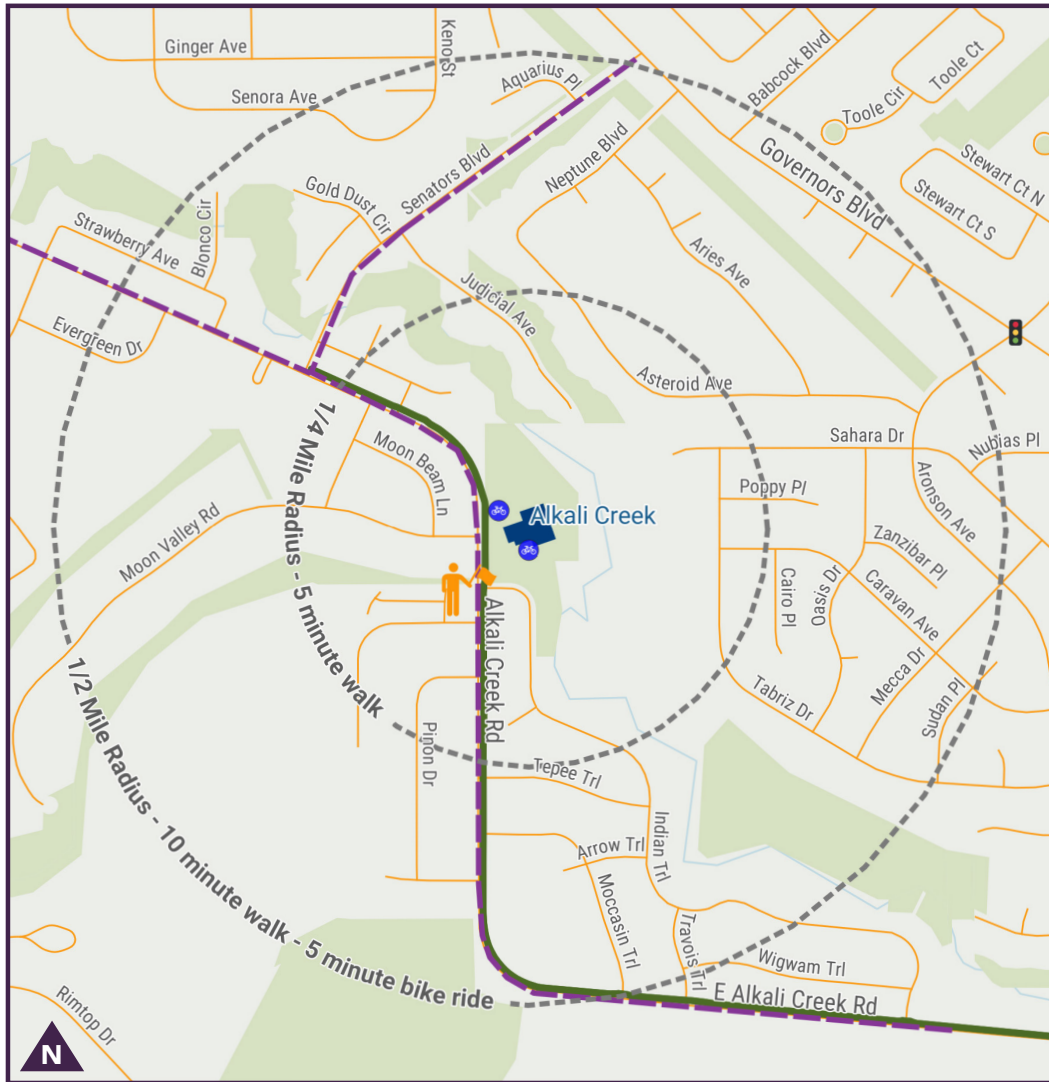

# ALKALI CREEK ELEMENTARY SCHOOL

## SUGGESTED WALKING ROUTES TO SCHOOL



### LEGEND

-  Suggested Walking Route
-  Crossing Guard
-  Traffic Signal
-  Bike Rack
-  Shared Use Path





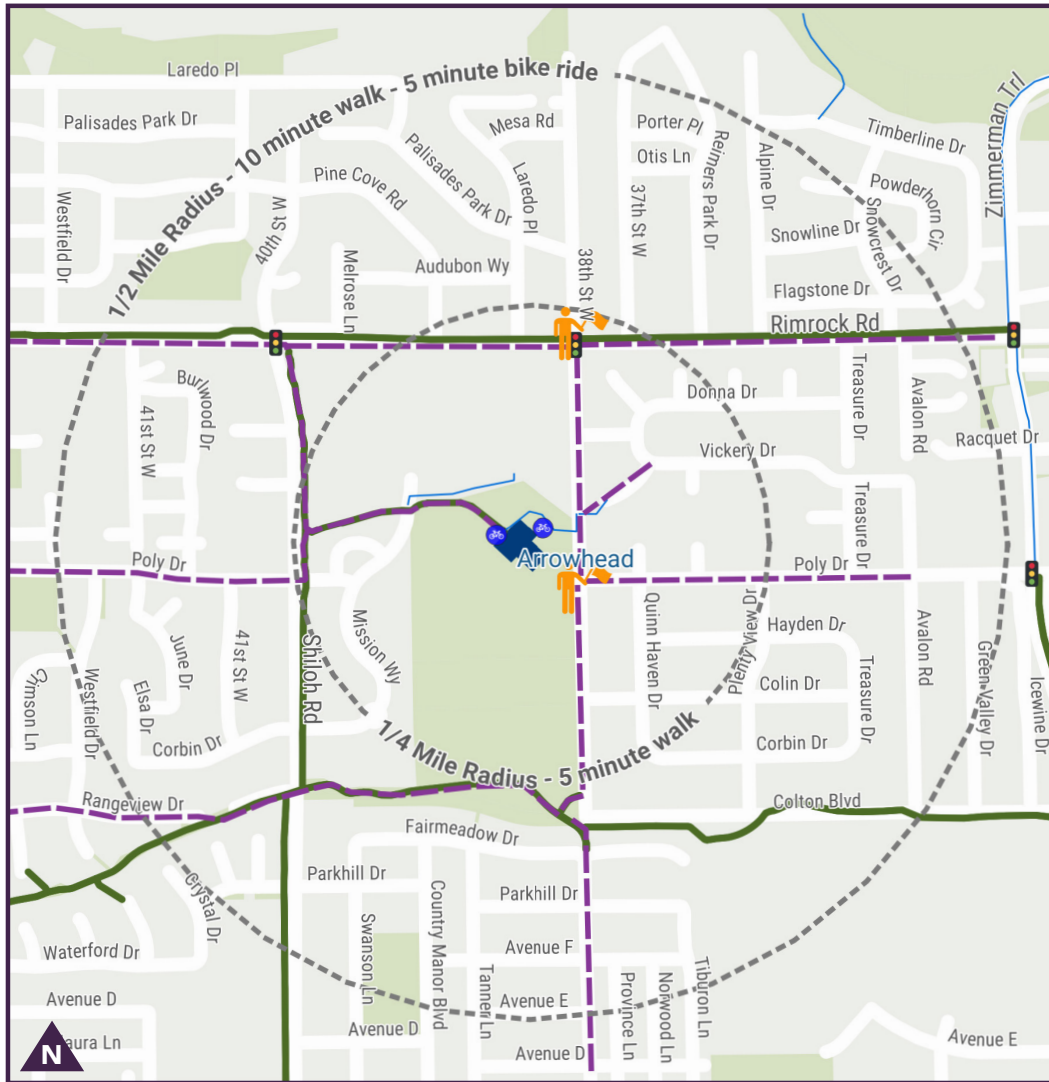

This map is intended for informational purposes only. The City of Billings or Billings Public Schools cannot and does not guarantee the safety of these routes, and assumes no responsibility or liability. We encourage families and students to use this map to explore options for going to and from school, but each family is responsible for choosing the most appropriate option based upon their knowledge of route conditions and the specific needs and/or experience level of their student.

# ARROWHEAD ELEMENTARY SCHOOL

## SUGGESTED WALKING ROUTES TO SCHOOL



### LEGEND

-  Suggested Walking Route
-  Crossing Guard
-  Traffic Signal
-  Bike Rack
-  Shared Use Path





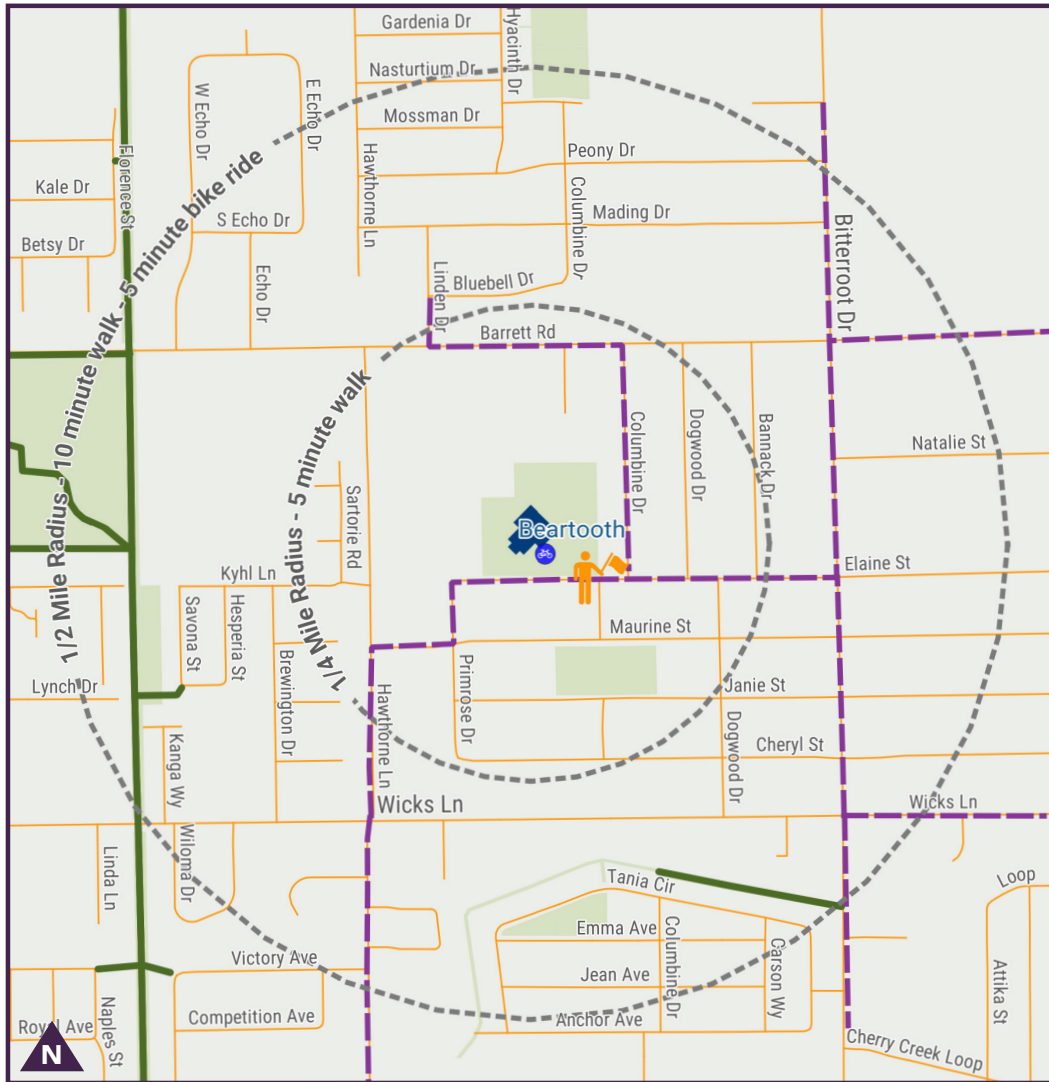

This map is intended for informational purposes only. The City of Billings or Billings Public Schools cannot and does not guarantee the safety of these routes, and assumes no responsibility or liability. We encourage families and students to use this map to explore options for going to and from school, but each family is responsible for choosing the most appropriate option based upon their knowledge of route conditions and the specific needs and/or experience level of their student.

# BEARTOOTH ELEMENTARY SCHOOL

## SUGGESTED WALKING ROUTES TO SCHOOL



### LEGEND

-  Suggested Walking Route
-  Crossing Guard
-  Traffic Signal
-  Bike Rack
-  Shared Use Path



This map is intended for informational purposes only. The City of Billings or Billings Public Schools cannot and does not guarantee the safety of these routes, and assumes no responsibility or liability. We encourage families and students to use this map to explore options for going to and from school, but each family is responsible for choosing the most appropriate option based upon their knowledge of route conditions and the specific needs and/or experience level of their student.

# BENCH ELEMENTARY SCHOOL

## SUGGESTED WALKING ROUTES TO SCHOOL

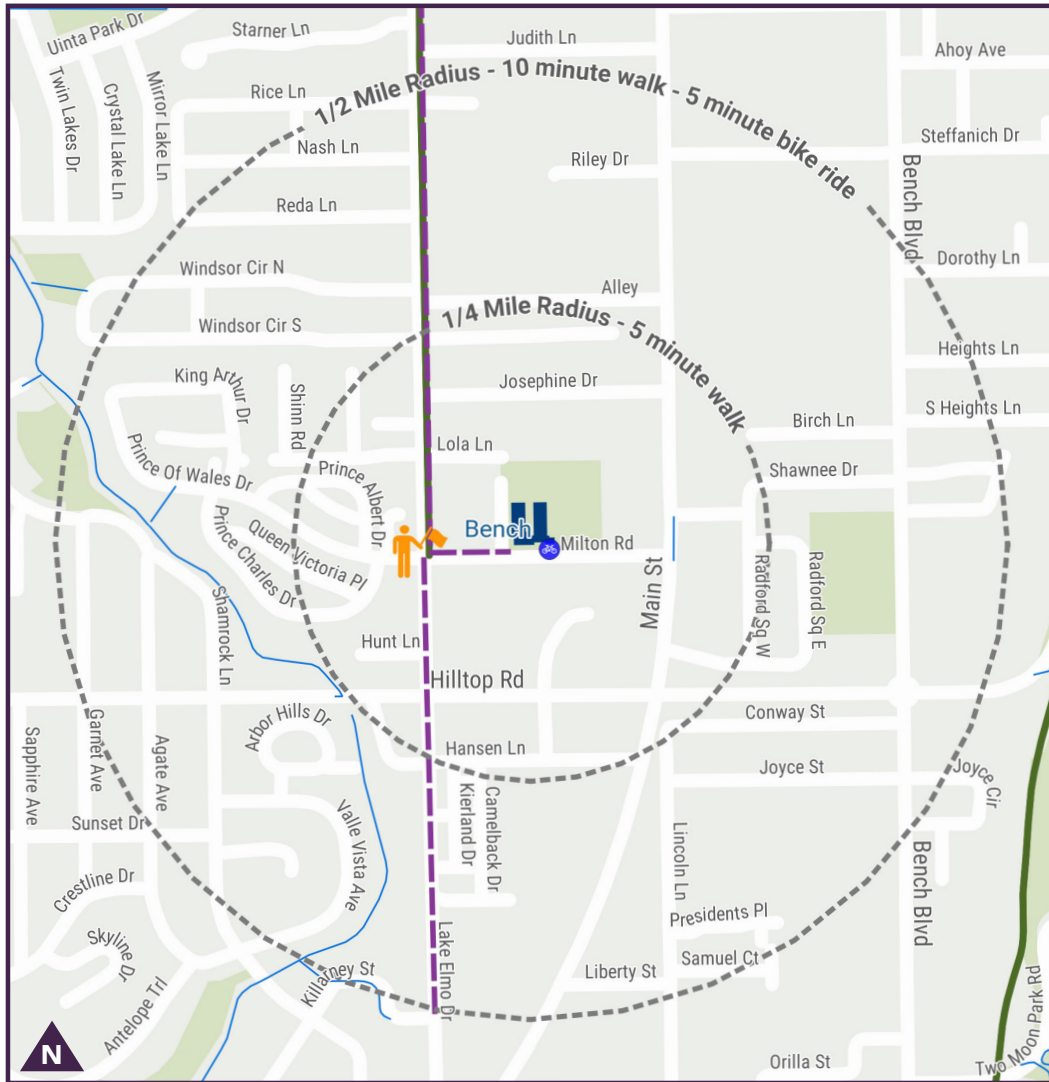



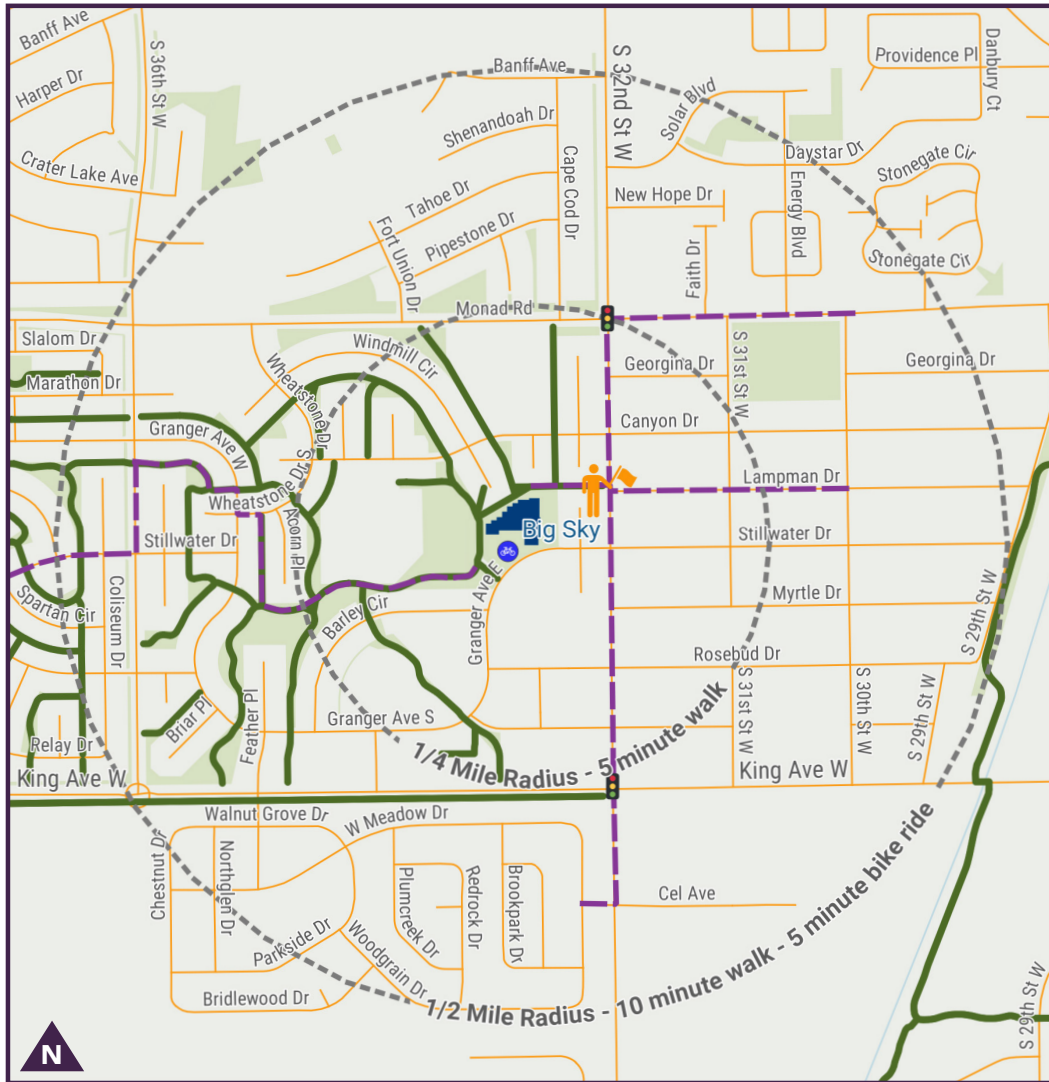

This map is intended for informational purposes only. The City of Billings or Billings Public Schools cannot and does not guarantee the safety of these routes, and assumes no responsibility or liability. We encourage families and students to use this map to explore options for going to and from school, but each family is responsible for choosing the most appropriate option based upon their knowledge of route conditions and the specific needs and/or experience level of their student.

# BIG SKY ELEMENTARY SCHOOL

## SUGGESTED WALKING ROUTES TO SCHOOL



### LEGEND

-  Suggested Walking Route
-  Crossing Guard
-  Traffic Signal
-  Bike Rack
-  Shared Use Path





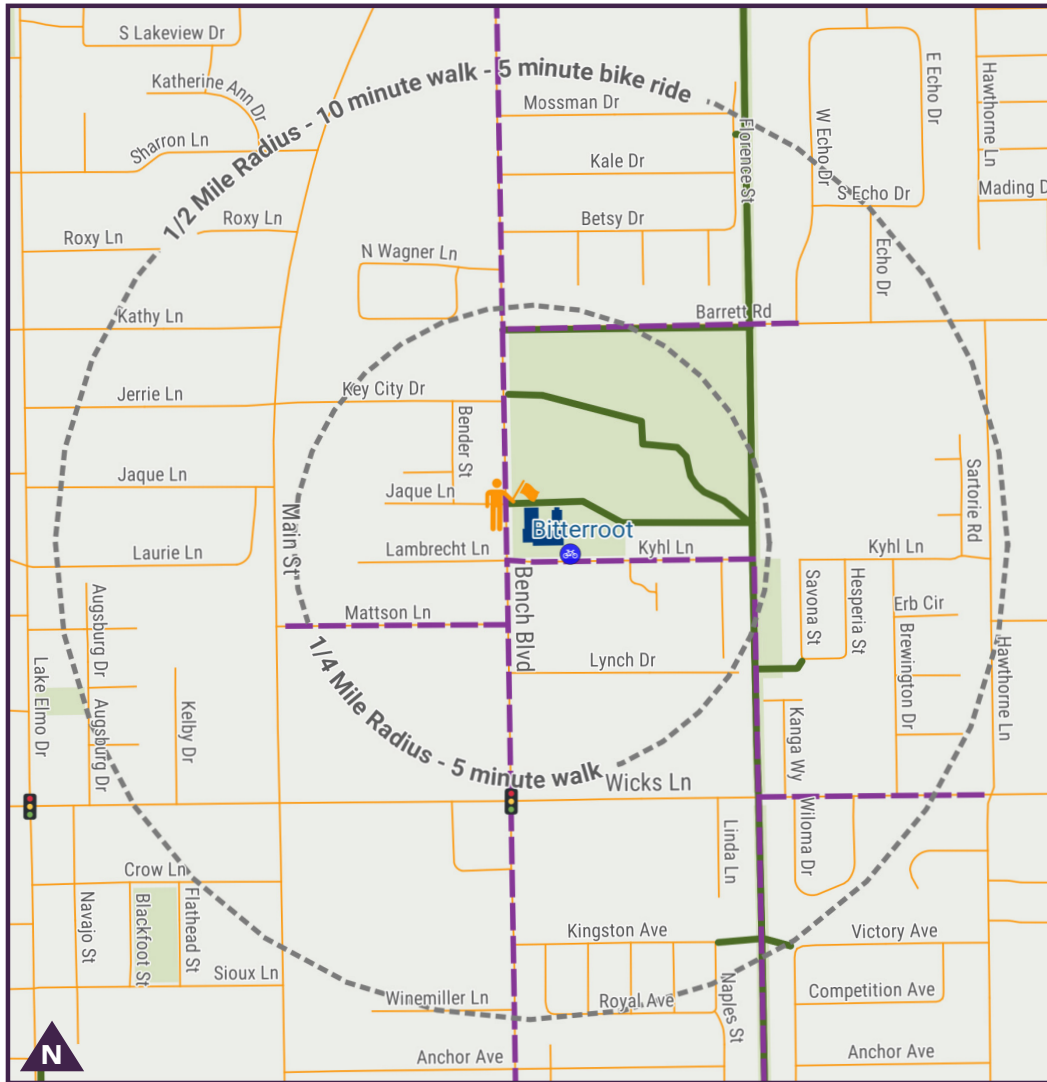

This map is intended for informational purposes only. The City of Billings or Billings Public Schools cannot and does not guarantee the safety of these routes, and assumes no responsibility or liability. We encourage families and students to use this map to explore options for going to and from school, but each family is responsible for choosing the most appropriate option based upon their knowledge of route conditions and the specific needs and/or experience level of their student.

# BITTERROOT ELEMENTARY SCHOOL

## SUGGESTED WALKING ROUTES TO SCHOOL



### LEGEND

-  Suggested Walking Route
-  Crossing Guard
-  Traffic Signal
-  Bike Rack
-  Shared Use Path





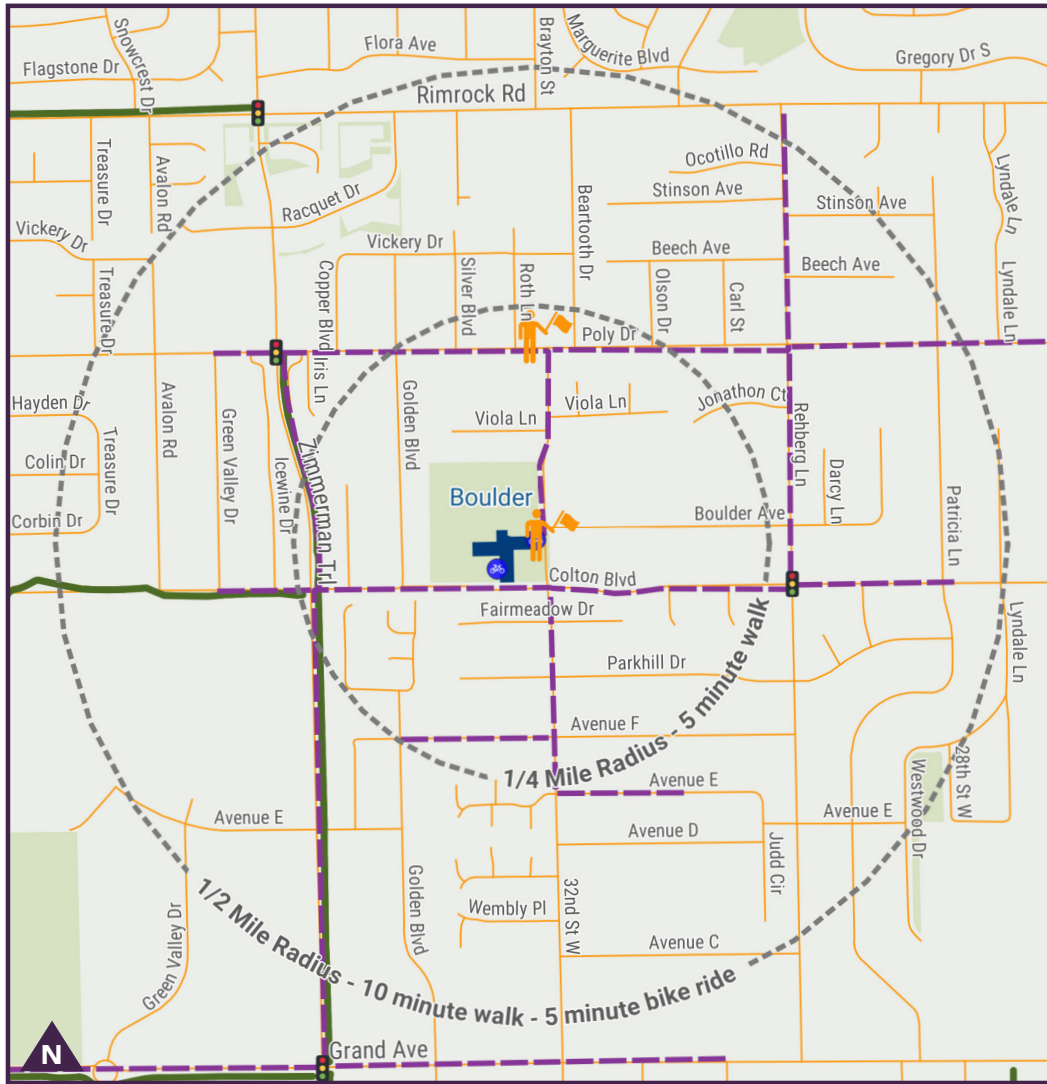

This map is intended for informational purposes only. The City of Billings or Billings Public Schools cannot and does not guarantee the safety of these routes, and assumes no responsibility or liability. We encourage families and students to use this map to explore options for going to and from school, but each family is responsible for choosing the most appropriate option based upon their knowledge of route conditions and the specific needs and/or experience level of their student.

# BOULDER ELEMENTARY SCHOOL

## SUGGESTED WALKING ROUTES TO SCHOOL



### LEGEND

-  Suggested Walking Route
-  Crossing Guard
-  Traffic Signal
-  Bike Rack
-  Shared Use Path





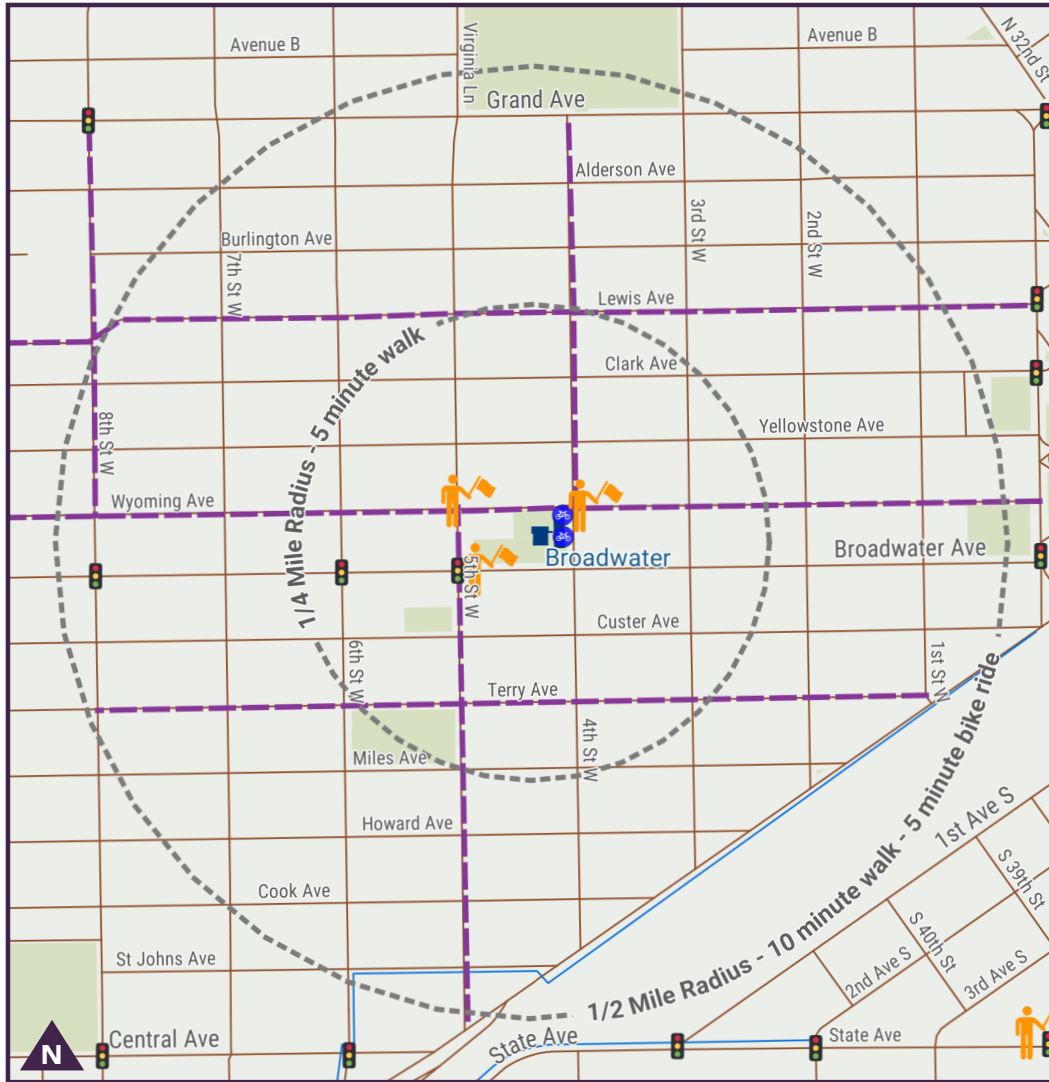

This map is intended for informational purposes only. The City of Billings or Billings Public Schools cannot and does not guarantee the safety of these routes, and assumes no responsibility or liability. We encourage families and students to use this map to explore options for going to and from school, but each family is responsible for choosing the most appropriate option based upon their knowledge of route conditions and the specific needs and/or experience level of their student.

# BROADWATER ELEMENTARY SCHOOL

## SUGGESTED WALKING ROUTES TO SCHOOL



### LEGEND

-  Suggested Walking Route
-  Crossing Guard
-  Traffic Signal
-  Bike Rack
-  Shared Use Path



This map is intended for informational purposes only. The City of Billings or Billings Public Schools cannot and does not guarantee the safety of these routes, and assumes no responsibility or liability. We encourage families and students to use this map to explore options for going to and from school, but each family is responsible for choosing the most appropriate option based upon their knowledge of route conditions and the specific needs and/or experience level of their student.





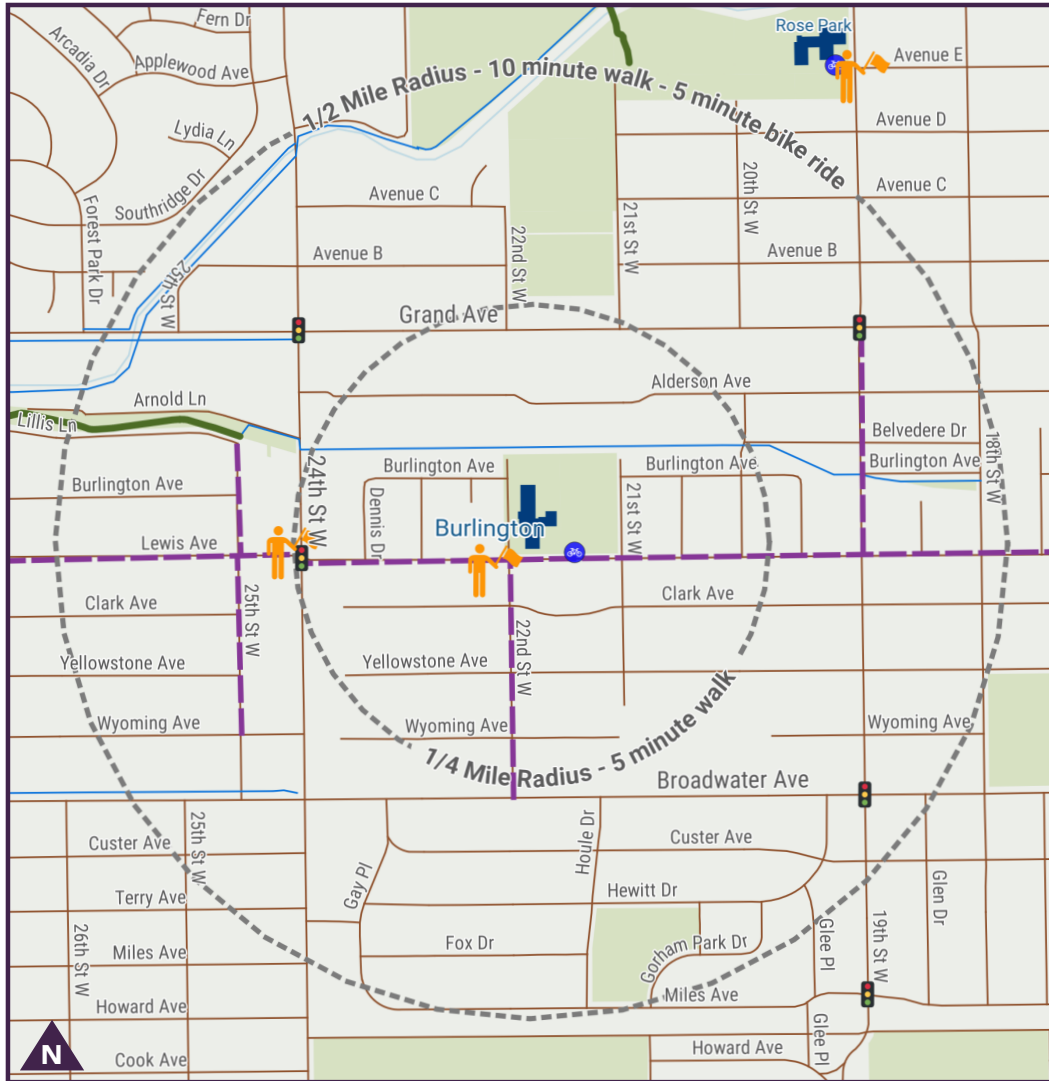

# BURLINGTON ELEMENTARY SCHOOL

## SUGGESTED WALKING ROUTES TO SCHOOL



### LEGEND

-  Suggested Walking Route
-  Crossing Guard
-  Traffic Signal
-  Bike Rack
-  Shared Use Path





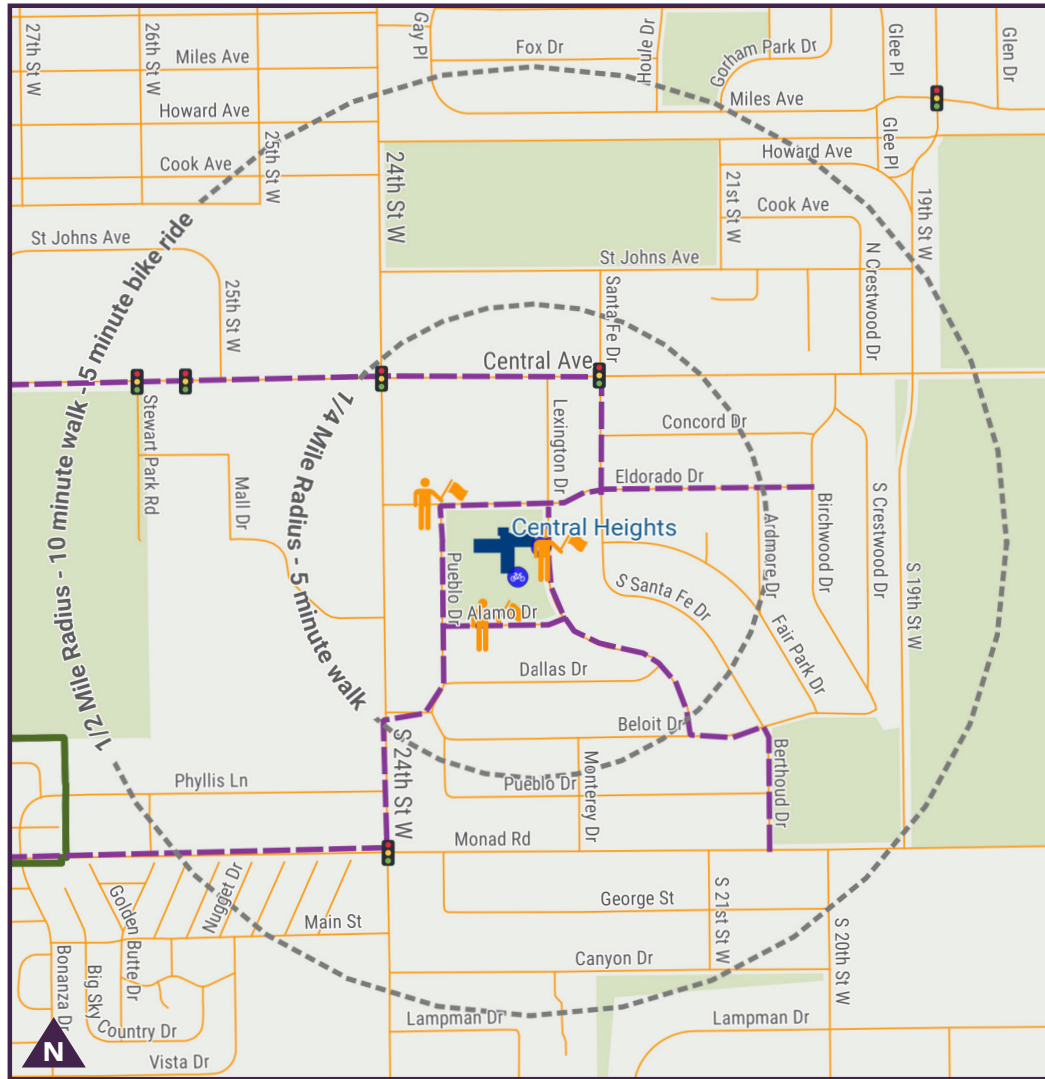

This map is intended for informational purposes only. The City of Billings or Billings Public Schools cannot and does not guarantee the safety of these routes, and assumes no responsibility or liability. We encourage families and students to use this map to explore options for going to and from school, but each family is responsible for choosing the most appropriate option based upon their knowledge of route conditions and the specific needs and/or experience level of their student.

# CENTRAL HEIGHTS ELEMENTARY SCHOOL

## SUGGESTED WALKING ROUTES TO SCHOOL



### LEGEND

-  Suggested Walking Route
-  Crossing Guard
-  Traffic Signal
-  Bike Rack
-  Shared Use Path





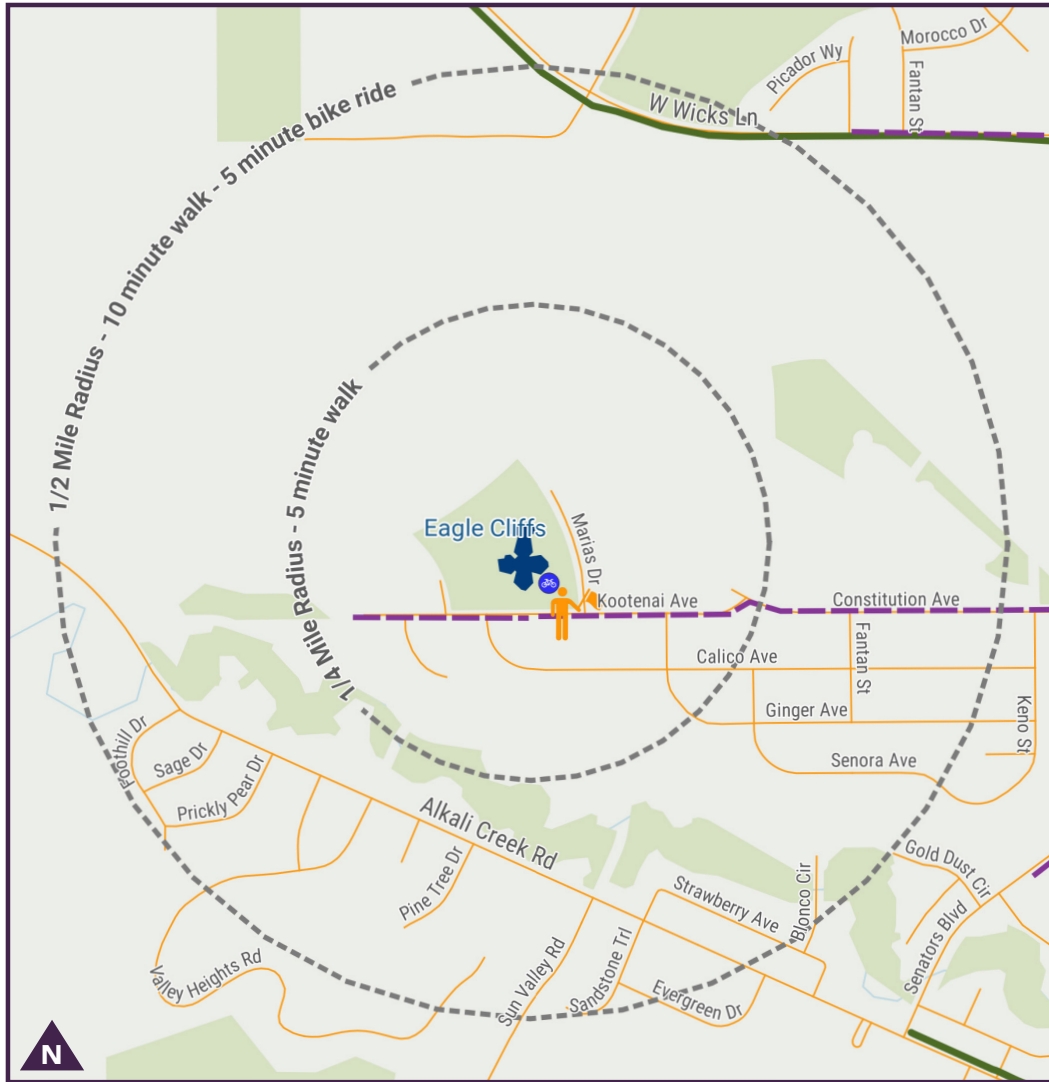

This map is intended for informational purposes only. The City of Billings or Billings Public Schools cannot and does not guarantee the safety of these routes, and assumes no responsibility or liability. We encourage families and students to use this map to explore options for going to and from school, but each family is responsible for choosing the most appropriate option based upon their knowledge of route conditions and the specific needs and/or experience level of their student.

# EAGLE CLIFFS ELEMENTARY SCHOOL

## SUGGESTED WALKING ROUTES TO SCHOOL



### LEGEND

-  Suggested Walking Route
-  Crossing Guard
-  Traffic Signal
-  Bike Rack
-  Shared Use Path





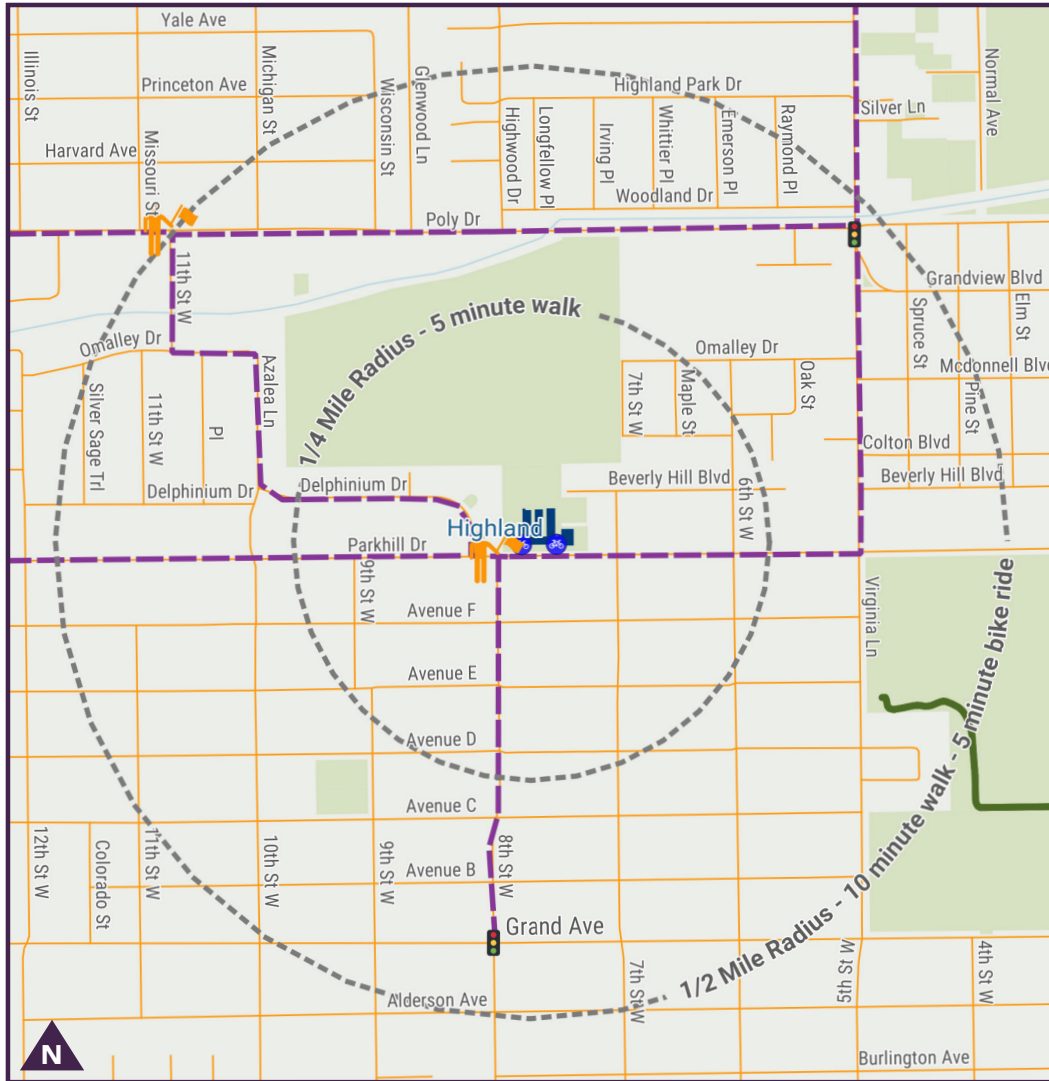

This map is intended for informational purposes only. The City of Billings or Billings Public Schools cannot and does not guarantee the safety of these routes, and assumes no responsibility or liability. We encourage families and students to use this map to explore options for going to and from school, but each family is responsible for choosing the most appropriate option based upon their knowledge of route conditions and the specific needs and/or experience level of their student.

# HIGHLAND ELEMENTARY SCHOOL

## SUGGESTED WALKING ROUTES TO SCHOOL



### LEGEND

-  Suggested Walking Route
-  Crossing Guard
-  Traffic Signal
-  Bike Rack
-  Shared Use Path





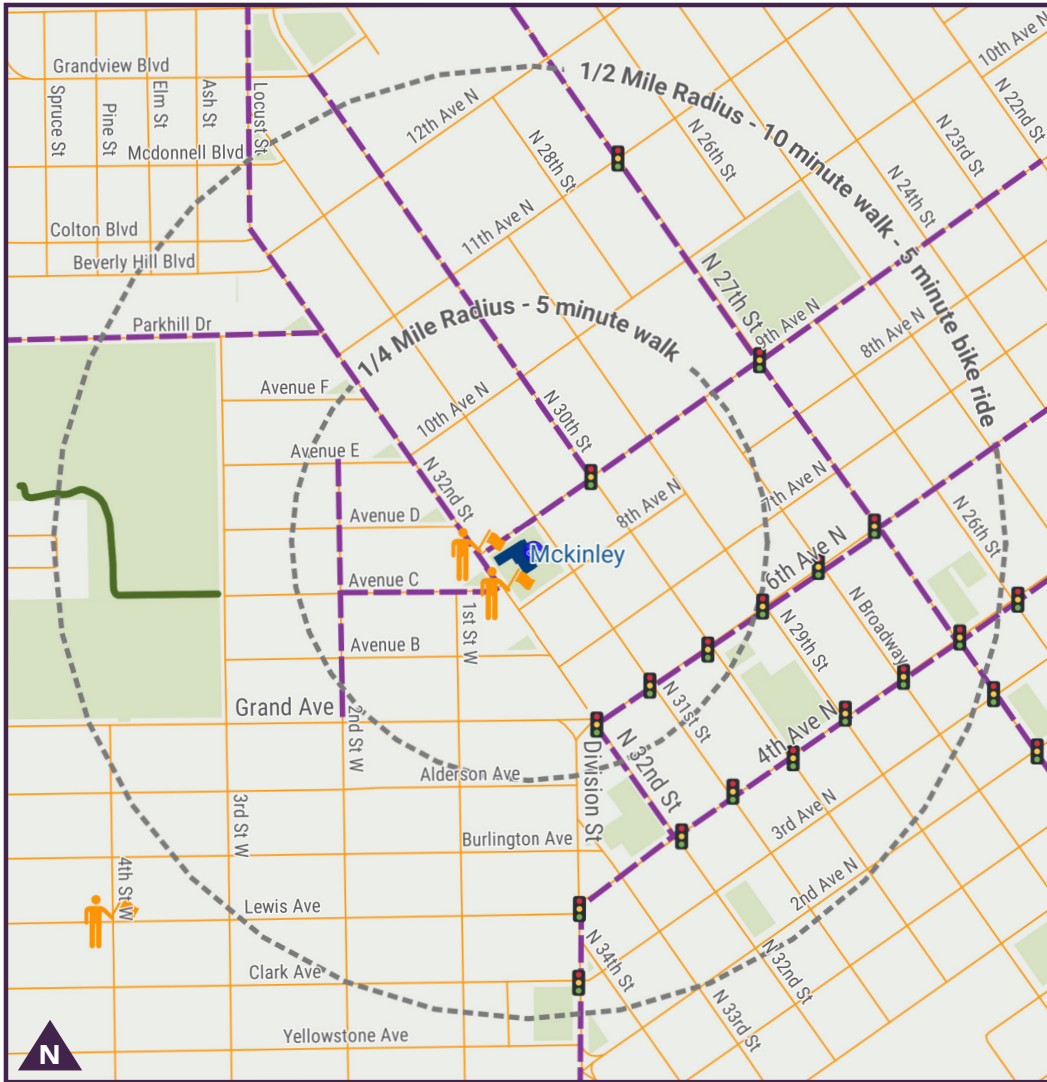

This map is intended for informational purposes only. The City of Billings or Billings Public Schools cannot and does not guarantee the safety of these routes, and assumes no responsibility or liability. We encourage families and students to use this map to explore options for going to and from school, but each family is responsible for choosing the most appropriate option based upon their knowledge of route conditions and the specific needs and/or experience level of their student.

# MCKINLEY ELEMENTARY SCHOOL

## SUGGESTED WALKING ROUTES TO SCHOOL



### LEGEND

-  Suggested Walking Route
-  Crossing Guard
-  Traffic Signal
-  Bike Rack
-  Shared Use Path





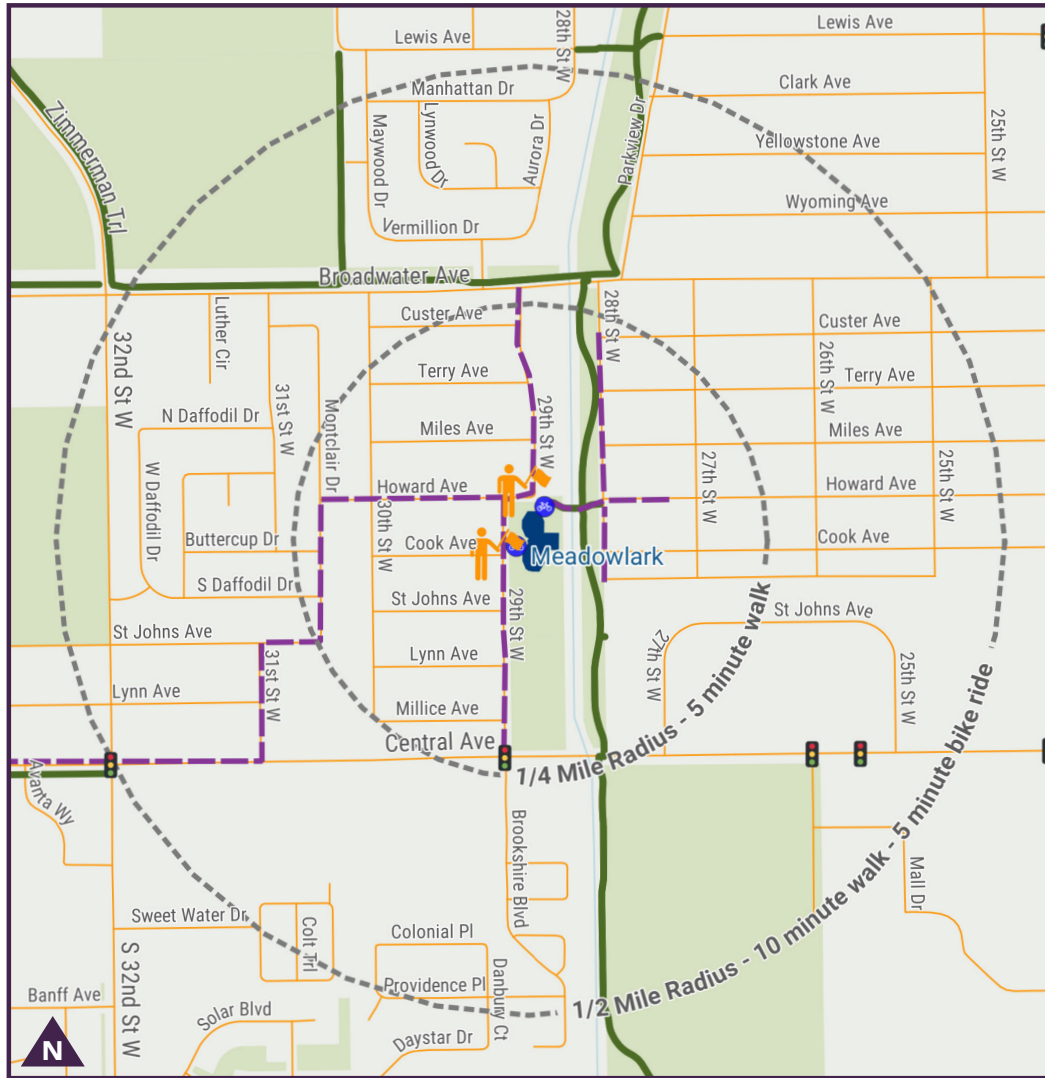

This map is intended for informational purposes only. The City of Billings or Billings Public Schools cannot and does not guarantee the safety of these routes, and assumes no responsibility or liability. We encourage families and students to use this map to explore options for going to and from school, but each family is responsible for choosing the most appropriate option based upon their knowledge of route conditions and the specific needs and/or experience level of their student.

# MEADOWLARK ELEMENTARY SCHOOL

## SUGGESTED WALKING ROUTES TO SCHOOL



### LEGEND

-  Suggested Walking Route
-  Crossing Guard
-  Traffic Signal
-  Bike Rack
-  Shared Use Path





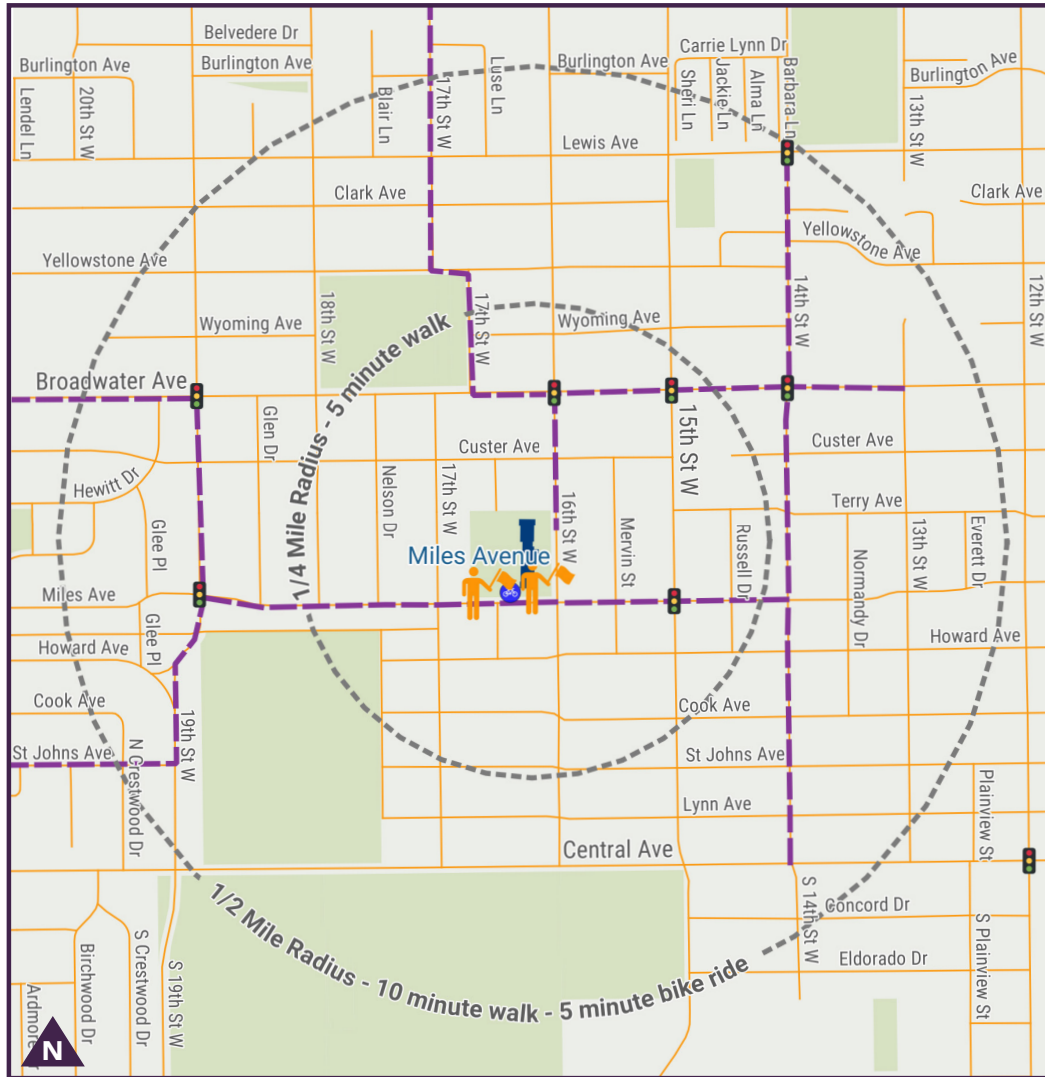

This map is intended for informational purposes only. The City of Billings or Billings Public Schools cannot and does not guarantee the safety of these routes, and assumes no responsibility or liability. We encourage families and students to use this map to explore options for going to and from school, but each family is responsible for choosing the most appropriate option based upon their knowledge of route conditions and the specific needs and/or experience level of their student.

# MILES AVENUE ELEMENTARY SCHOOL

## SUGGESTED WALKING ROUTES TO SCHOOL



### LEGEND

-  Suggested Walking Route
-  Crossing Guard
-  Traffic Signal
-  Bike Rack
-  Shared Use Path





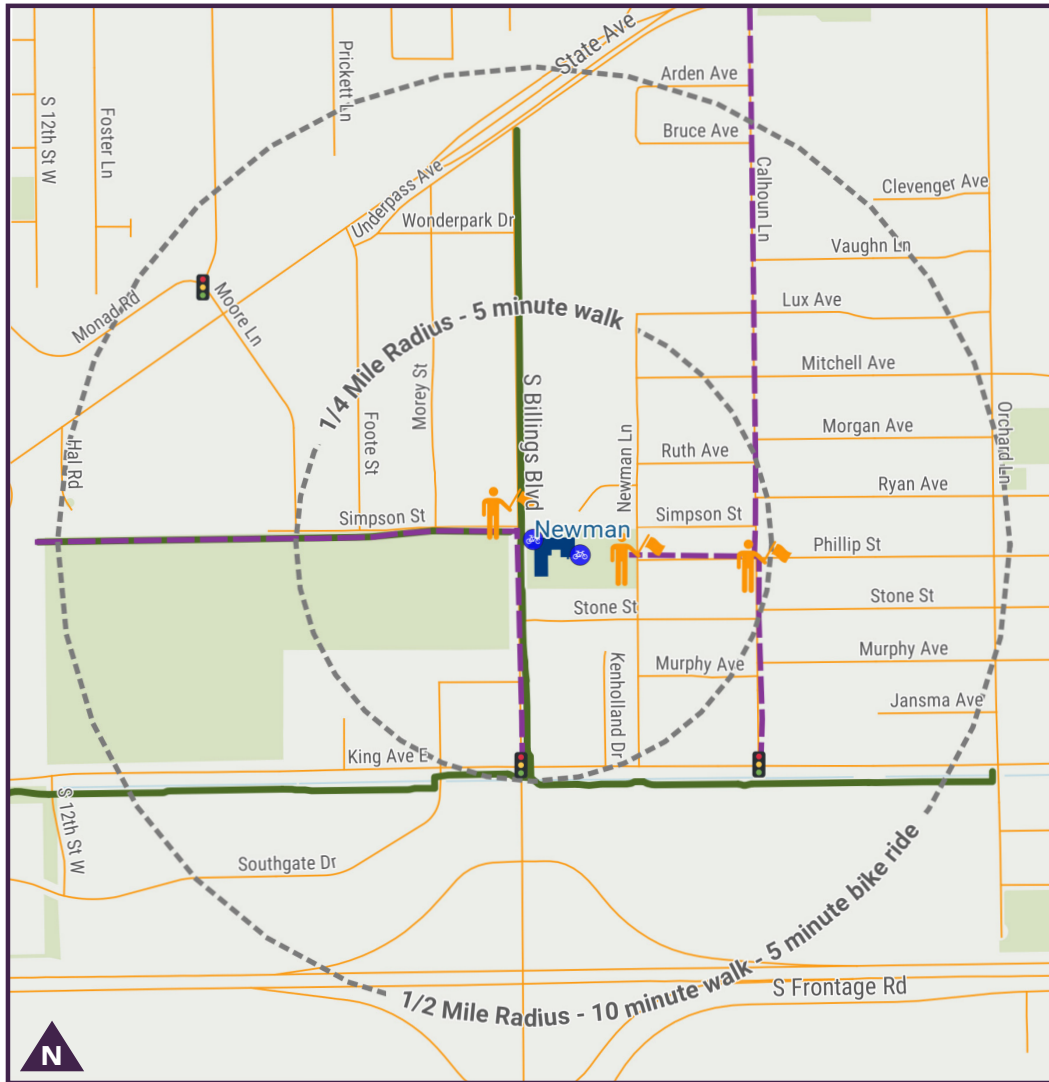

This map is intended for informational purposes only. The City of Billings or Billings Public Schools cannot and does not guarantee the safety of these routes, and assumes no responsibility or liability. We encourage families and students to use this map to explore options for going to and from school, but each family is responsible for choosing the most appropriate option based upon their knowledge of route conditions and the specific needs and/or experience level of their student.

# NEWMAN ELEMENTARY SCHOOL

## SUGGESTED WALKING ROUTES TO SCHOOL



### LEGEND

-  Suggested Walking Route
-  Crossing Guard
-  Traffic Signal
-  Bike Rack
-  Shared Use Path



This map is intended for informational purposes only. The City of Billings or Billings Public Schools cannot and does not guarantee the safety of these routes, and assumes no responsibility or liability. We encourage families and students to use this map to explore options for going to and from school, but each family is responsible for choosing the most appropriate option based upon their knowledge of route conditions and the specific needs and/or experience level of their student.



# ORCHARD ELEMENTARY SCHOOL

## SUGGESTED WALKING ROUTES TO SCHOOL

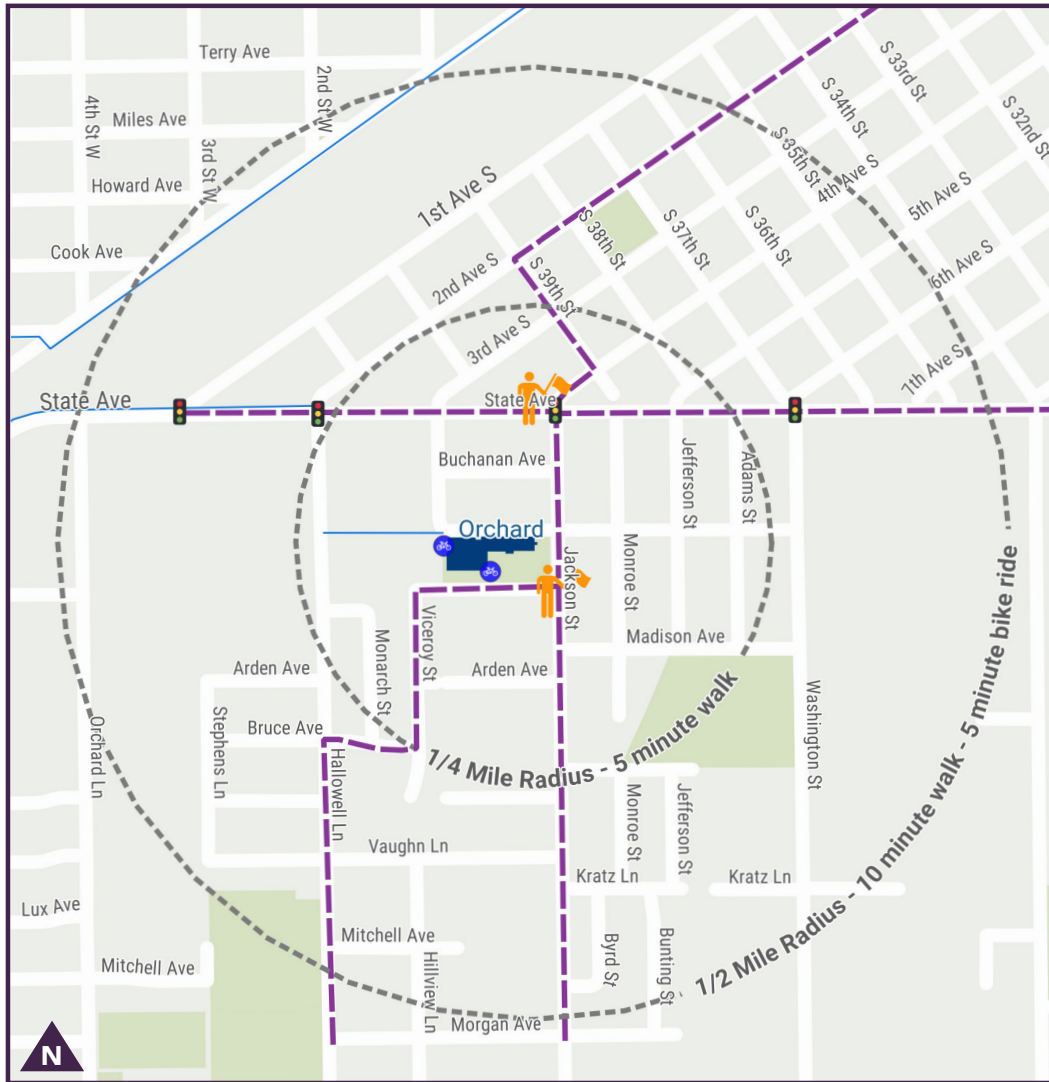

### LEGEND

- Suggested Walking Route
- Crossing Guard
- Traffic Signal
- Bike Rack
- Shared Use Path



This map is intended for informational purposes only. The City of Billings or Billings Public Schools cannot and does not guarantee the safety of these routes, and assumes no responsibility or liability. We encourage families and students to use this map to explore options for going to and from school, but each family is responsible for choosing the most appropriate option based upon their knowledge of route conditions and the specific needs and/or experience level of their student.

# POLY ELEMENTARY SCHOOL

## SUGGESTED WALKING ROUTES TO SCHOOL

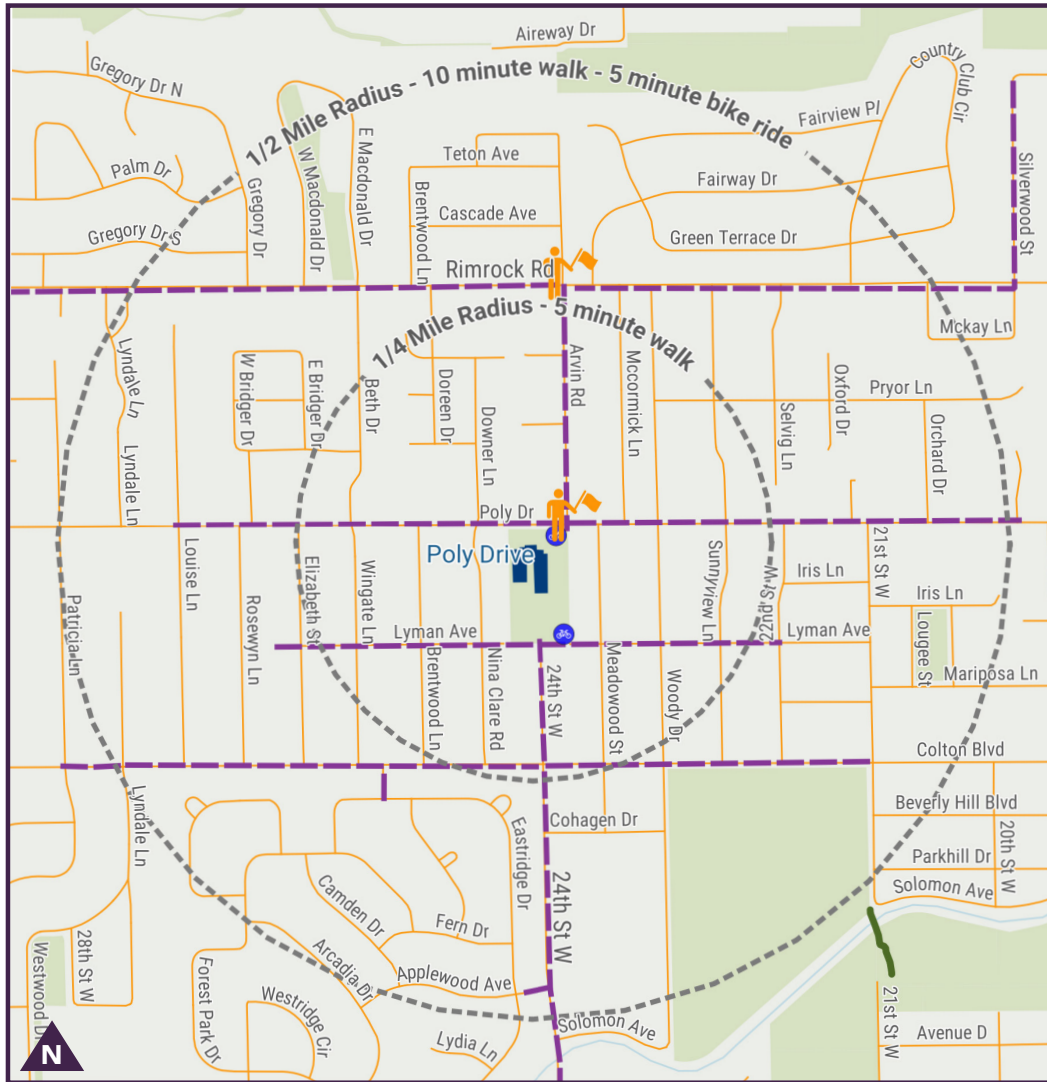

### LEGEND

- Suggested Walking Route
- Crossing Guard
- Traffic Signal
- Bike Rack
- Shared Use Path





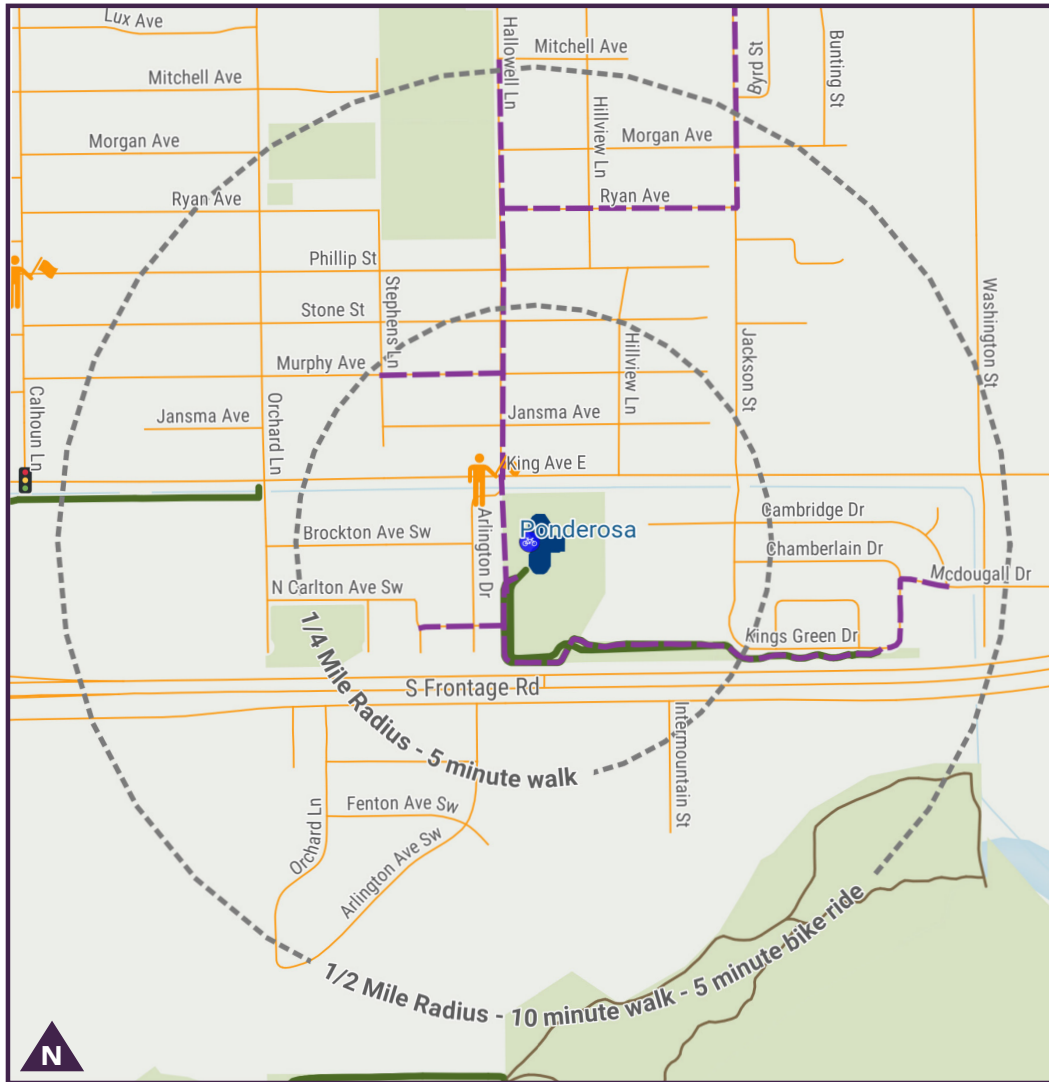

This map is intended for informational purposes only. The City of Billings or Billings Public Schools cannot and does not guarantee the safety of these routes, and assumes no responsibility or liability. We encourage families and students to use this map to explore options for going to and from school, but each family is responsible for choosing the most appropriate option based upon their knowledge of route conditions and the specific needs and/or experience level of their student.

# PONDEROSA ELEMENTARY SCHOOL

## SUGGESTED WALKING ROUTES TO SCHOOL



### LEGEND

-  Suggested Walking Route
-  Crossing Guard
-  Traffic Signal
-  Bike Rack
-  Shared Use Path



This map is intended for informational purposes only. The City of Billings or Billings Public Schools cannot and does not guarantee the safety of these routes, and assumes no responsibility or liability. We encourage families and students to use this map to explore options for going to and from school, but each family is responsible for choosing the most appropriate option based upon their knowledge of route conditions and the specific needs and/or experience level of their student.

# ROSE PARK ELEMENTARY SCHOOL

## SUGGESTED WALKING ROUTES TO SCHOOL

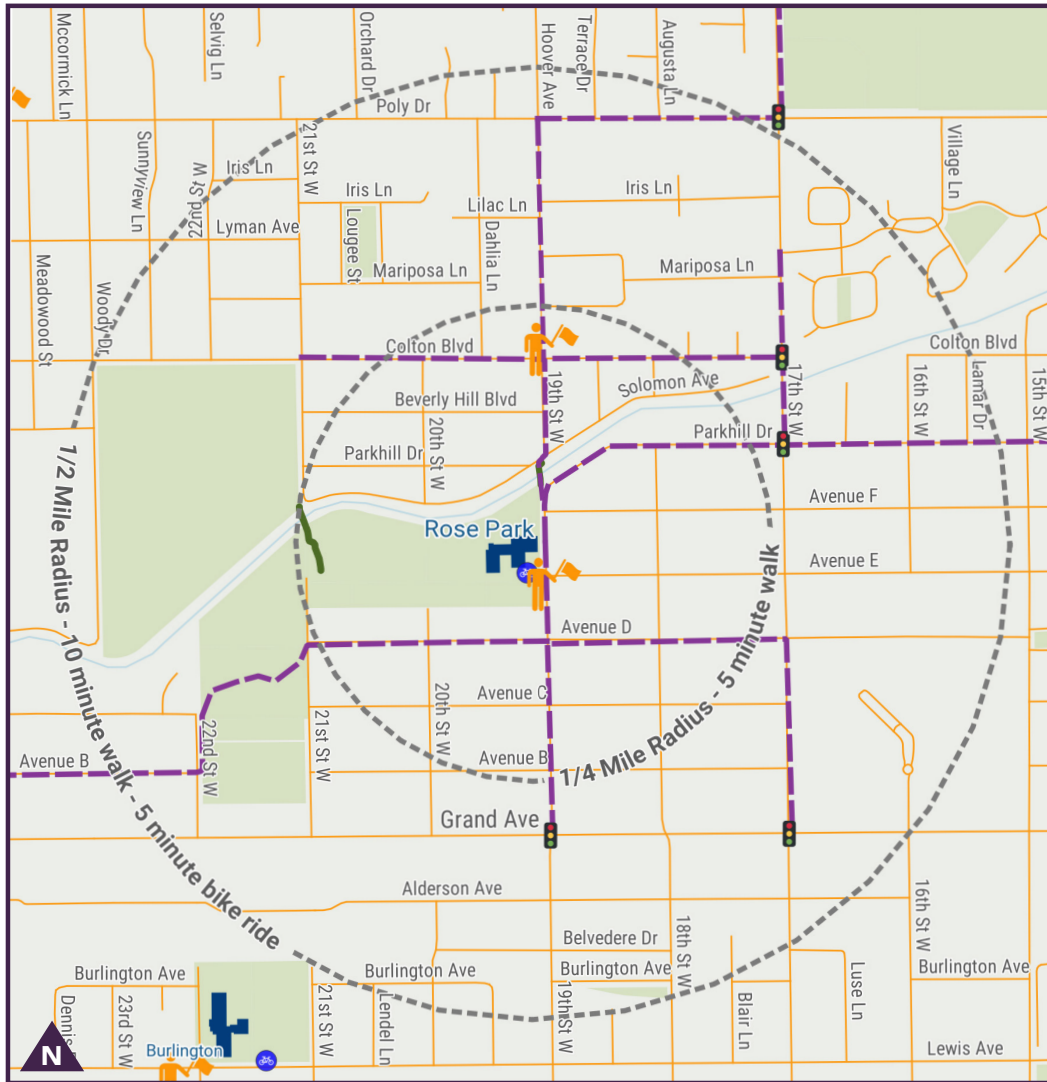

### LEGEND

- Suggested Walking Route
- Crossing Guard
- Traffic Signal
- Bike Rack
- Shared Use Path





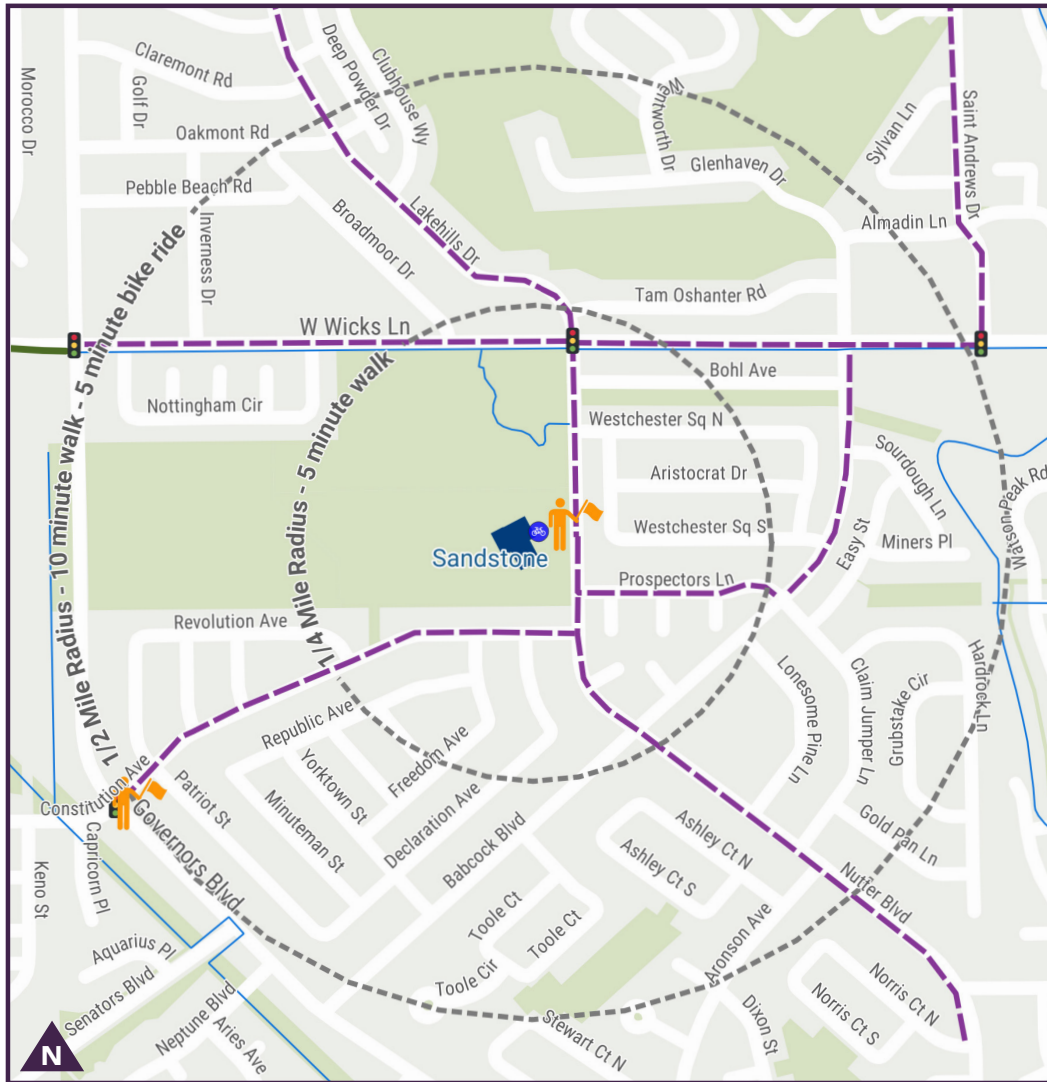

This map is intended for informational purposes only. The City of Billings or Billings Public Schools cannot and does not guarantee the safety of these routes, and assumes no responsibility or liability. We encourage families and students to use this map to explore options for going to and from school, but each family is responsible for choosing the most appropriate option based upon their knowledge of route conditions and the specific needs and/or experience level of their student.

# SANDSTONE ELEMENTARY SCHOOL

## SUGGESTED WALKING ROUTES TO SCHOOL



### LEGEND

-  Suggested Walking Route
-  Crossing Guard
-  Traffic Signal
-  Bike Rack
-  Shared Use Path





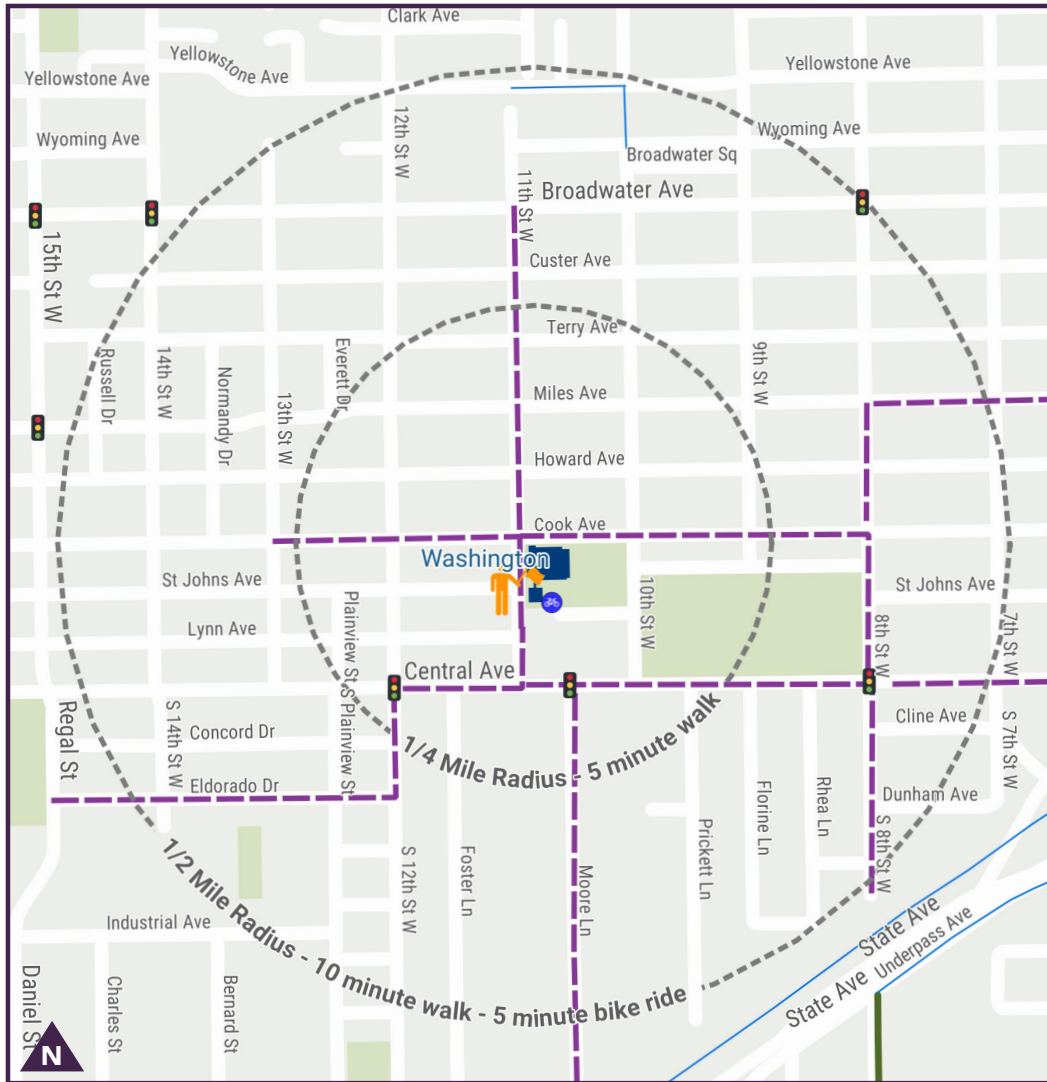

This map is intended for informational purposes only. The City of Billings or Billings Public Schools cannot and does not guarantee the safety of these routes, and assumes no responsibility or liability. We encourage families and students to use this map to explore options for going to and from school, but each family is responsible for choosing the most appropriate option based upon their knowledge of route conditions and the specific needs and/or experience level of their student.

# WASHINGTON ELEMENTARY SCHOOL

## SUGGESTED WALKING ROUTES TO SCHOOL



### LEGEND

-  Suggested Walking Route
-  Crossing Guard
-  Traffic Signal
-  Bike Rack
-  Shared Use Path



This map is intended for informational purposes only. The City of Billings or Billings Public Schools cannot and does not guarantee the safety of these routes, and assumes no responsibility or liability. We encourage families and students to use this map to explore options for going to and from school, but each family is responsible for choosing the most appropriate option based upon their knowledge of route conditions and the specific needs and/or experience level of their student.

# Appendix A. Existing Safe Routes to School Plans, Policies, and Program Review





122 W. WASHINGTON AVENUE  
SUITE 550  
MADISON, WI 53703

608.643.8082  
TOOLEDESIGN.COM

**MEMORANDUM**

August 17, 2021

To: Elyse Monat

Organization: Billings MPO

From: Kerry Aszklar and Sara Schooley, Toole Design

Project: Billings Safe Routes to School Study Update

**Re: Plan and Policy Review**

This memorandum reviews materials as they pertain to the Billings Safe Routes to Schools Study Update. This review included city, county, and state materials that ranged from plans, policies, resources, and data summaries. A summary of these reviewed items is in Table 1.

**Table 1: Summary of Reviewed Items**

Item	Year	Organization
City of Billings Safe Routes to School Study	2011	City
Billings Bikeway and Trails Master Plan	2017	City
Walking Route Maps for Billings Elementary Schools	2018	City
Billings • Yellowstone County Metropolitan Planning Organization Public Participation Plan	2018	City/County
Billings Urban Area Long Range Transportation	2018	County
Safe Routes to Schools Reports	2018	City-County Health Department
Montana Department of Transportation Crash Data	2010-2019	State
City of Billings Transportation Planning Resources	2011-2020	City
Billings Area Wayfinding Signage Plan	2020	City
City of Billings Complete Streets Progress Report	2020	City
Kids In Motion	Ongoing	City



122 W. WASHINGTON AVENUE  
SUITE 550  
MADISON, WI 53703

608.643.8082  
TOOLEDESIGN.COM

*City of Billings Safe Routes to School Study - 2011*

The 2011 Safe Routes to School Study provides a foundation for Billing’s SRTS program. The study builds the case for Safe Routes to School by providing national trends on school travel and provides a data inventory of school sites and school-specific findings and recommendations.

The study also breaks down recommended strategies to improve routes to schools based on the “Es”: enforcement, education, encouragement, and evaluation. This report identifies “big picture” issues impacting students’ ability and desire to walk or bike to school, and provides recommendations to address them. Lastly, the study includes implementation strategies for projects, such as listing priority projects, budget-level cost estimates, and potential funding sources.

Link: <https://ci.billings.mt.us/2219/Walking-Route-Maps>

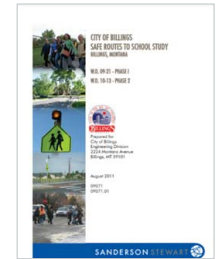

*Billings Area Bikeway And Trails Master Plan Update - 2017*

The Billings Area Bikeway and Trails Master Plan Update provides a vision, recommendations, and implementation plan to create a safe, convenient, and connected active transportation network of bikeways, trails, streets, and sidewalks. The plan incorporates an all-ages-and-abilities mentality for utilitarian trips and recreational trips.

Regarding the Safe Routes to School Study Update, the Plan includes implementing comprehensive education and encouragement programs as a goal, and specifically calls for the continued support of the Safe Routes to School program to encourage healthy walking and bicycling habits at an early age. Additionally, routes to schools are identified as key connections for short-term projects. The plan recommends implementing these routes with the annual city budget. Lastly, the Bikeway and Trails Master Plan Update calls for regional coordination of Safe Routes to School through a new program.

Link: <https://ci.billings.mt.us/DocumentCenter/View/34091/Billings-Bikeway-and-Trails-Master-Plan?bidId=>





**Walking Route Maps for Billings Elementary Schools - 2018**

Each elementary school in the City of Billings has a walking route map to illustrate recommended routes to schools. Included with each map is information on the Safe Routes to School program and an explanation of each of the six E's – education, encouragement, enforcement, evaluation, engineering, and equity. Neighborhood aerial maps for each school display the school location, school boundaries before and after 2017, traffic signals, pedestrian hybrid beacon, school speed zones, school crossing, and crossing guards. The preferred neighborhood walking routes are displayed in arrows.

Link: <https://ci.billings.mt.us/2219/Walking-Route-Maps>

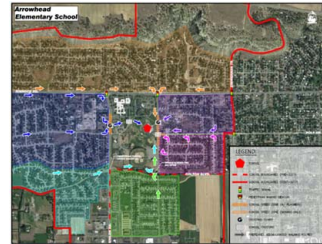

Sample map, Arrowhead Elementary School.

**Billings & Yellowstone County Metropolitan Planning Organization Public Participation Plan - 2018**

The purpose of the Billings and Yellowstone County Public Participation Plan is to clarify when and how members of the public can engage in projects in the Metropolitan Planning Organization. It outlines participants, products, strategies, and evaluation for public participation.

It defines what a metropolitan planning organization is and explains the various governmental boards and committees that often engage with the public. It also outlines the process that transportation projects go through for federal aid and the "products" – the long-range transportation plan, the transportation improvement program, the unified planning work program, and special plans and studies.

This plan relates to Billings' Safe Routes to School Study Update by providing guidance for Billings staff and for community members on how to engage with the Billings MPO in planning processes.

Link: [https://ci.billings.mt.us/DocumentCenter/View/37536/Public-Participation-Plan\\_final-08-30-2018](https://ci.billings.mt.us/DocumentCenter/View/37536/Public-Participation-Plan_final-08-30-2018)



**Billings Urban Area Long Range Transportation Plan - 2018**

The Billings Urban Area Long Range Transportation Plan is a guide to the transportation projects and investments in the Billings area. The projects cover the land within the Yellowstone County Metropolitan Planning Organization and areas just outside the MPO boundary. The plan includes land use, streets and highways, public transit, freight, rail services, pedestrian and bicycle facilities, safety, and security.

Specific to the Safe Routes to School Study Update, the Plan mentions the Safe Routes program as a pedestrian and bicycle program, and also notes the completion of nine studies for elementary schools by RiverStone Health. Safe Routes projects are listed by school name as pedestrian projects, with estimated planning-level costs. The Plan recommends supporting the Safe Routes program as a strategy to incorporate through the planning and implementation process.

Link: <https://ci.billings.mt.us/DocumentCenter/View/37388/2018-Transportation-Plan-Update>



**RiverStone Health Safe Routes To Schools Reports – 2018**

The Yellowstone City-County Health Department (dba RiverStone Health) produced several Safe Routes to Schools reports for Billings specific to schools and their neighborhood and demographic contexts. Along with a short description, program history, and role of the project team in Safe Routes in Yellowstone County, each report includes:

- A school profile with start and dismissal times, demographics, and percentages of students receiving free or reduced lunch,
- A map with crossing guard locations
- A neighborhood profile with walking routes and other key information
- Assessment methods
- Key findings from walk and bike audits, behavioral observations, and key informant interviews
- School recommendations based on the five Es of encouragement, education, environmental change, evaluation, and enforcement.

These reports provide a crucial foundation for the Safe Routes to School Study Update.

**Montana Department Of Transportation Crash Data – 2010-2019**

The Montana Department of Transportation (MDT) provides disaggregated crash data by city, county, and reservation. Data is categorized and summarized by a variety of topics, including non-motorists of all ages, within the crash report, "Problem Identification: 2019 Data." This report summarizes crash patterns, including crash data, demographics, and state traffic safety emphasis areas as part of the state's Vision Zero effort.

Data on crashes involving non-motorists in Billings reveals a fluctuation over time with a general downward trend. Serious injury crashes peaked in 2014 with 11 crashes but have decreased since then and remain low. Fatal crashes remain low but peaked in 2018 with six people killed.

Specific to the Safe Routes to School Study Update, this crash data will inform recommended interventions based on the severity of crashes involving non-motorists and based on the crash locations. See the figure below for a high-level summary of crash types involving non-motorists.

Link: <https://www.mdt.mt.gov/publications/datatats/crashdata.shtml>

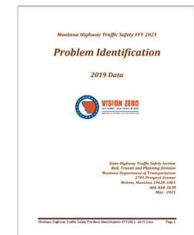
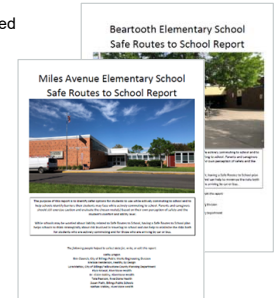

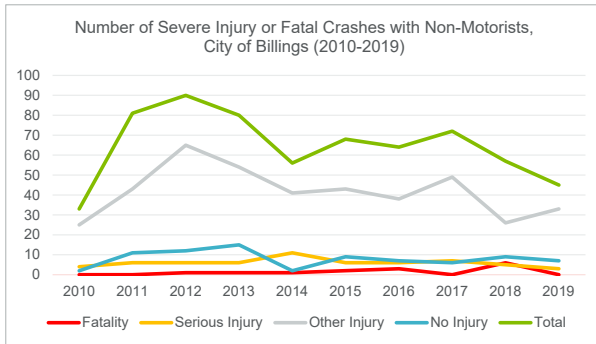

**City Of Billings Transportation Planning Resources - Ongoing**

The City of Billings has many resources for transportation planning that can contribute to the Safe Routes to School Study Update. These transportation planning resources include:

- Traffic count maps from 2011 – 2020
- Non-motorized transportation, including the proposed bikeway and trail network, the 2011 Trail Asset Management Plan, trail counts from 2014 – 2020, bicycle counts from 2017 – 2020
- The current Transportation Improvement Plan for 2020-2024
- The Unified Planning Work Plan
- Long-Range Transportation Plans and Studies, such as corridor studies, the Complete Streets policy and progress report, household travel survey, public participation plans, the Wayfinding Signage Plan, and more,
- The Downtown Traffic Plan and the Billings Bike and Scooter Share Feasibility Study

While all resources contribute to the transportation system in Billings, the traffic count maps and the non-motorized transportation resources provide a snapshot of current travel habits near schools.

Link: <https://ci.billings.mt.us/2336/Transportation-Resources>

**Billings Area Wayfinding Signage Plan - 2020**

The Billings Area Wayfinding Signage Plan outlines the importance and design aspects of wayfinding specific to Billings. It addresses the barrier of pedestrian- and bicycle-specific navigation by providing a comprehensive wayfinding system. The Plan outlines the benefits of wayfinding, best practices, different purposes and designs of signage, destination selection and programming, placement guidance, and implementation.



The Plan notes middle schools as secondary destinations, and elementary schools as tertiary destinations within the destination hierarchy.

Link: <https://ci.billings.mt.us/DocumentCenter/View/41706/Final-Billings-Wayfinding-Signage-Plan>

**City of Billings Complete Streets Progress Report – 2020**

The Complete Streets Progress Report provides updated information regarding the implementation and application of the City of Billings' 2011 adopted Complete Streets policy. The report walks through the progress of improving walking and rolling, bicycling, transit, and automobiles by outlining each mode's context, what it's like to use that mode in Billings, a timeline, milestones, and performance measures. The inclusion of connectivity, community health, economics, and the future as stand-alone sections is noteworthy to mention.

Safe Routes to Schools is included in the walking and rolling mode. The report spotlights RiverStone Health and the revival of the Safe Routes program in 2017 with walk audit of 10 elementary schools.

Link: <https://ci.billings.mt.us/DocumentCenter/View/43311/Final-Complete-Streets-Progress-Report-2020>



**Kids In Motion - Ongoing**

Kids in Motion (KIM) is a program run by St. Vincent's Healthcare, School District #2, the Education Foundation for Billings Public Schools, the City of Billings, and community partners that focuses on engaging and encouraging youth to walking and bicycling. It organizes events such as bicycle tune-up clinics, rotating through elementary schools, and offers lesson plans so that Health Enhancement Teachers (a combination of health and physical education teachers) can teach the curriculum if they so wish. These lesson plans include a curriculum for a traffic skills class, as well as educational resources, printable materials, and certificates.

KIM relates to the Billings Safe Routes to School Study Update by engaging with students on how to walk and bike to school.

Link: <https://kidsinmotionvolunt.wixsite.com/kimbillings>



## Appendix B: School Summaries

This appendix includes summaries for all 22 public elementary schools in Billings. These summaries should be referenced and used when selecting, prioritizing, and designing projects. Much of the information on the following pages was gathered through site visits, interviews with school principals, and feedback from an online interactive webmap.

At the end of each school summary there is a “Proposed Projects” table that recommends specific mitigation strategies for locations and issues. Many of the engineering recommendations are informed by FHWA’s 2018 Guide for Improving Pedestrian Safety at Uncontrolled Crossing Locations, this document, and its associated Safe Transportation for Every Pedestrian (STEP) matrix, suggest countermeasures that can be applied at uncontrolled crossing locations depending on roadway and traffic features. The countermeasures are assigned specific roadway types based on safety research, best practices, and established national guidelines. More information on the STEP guidance can be found at [https://safety.fhwa.dot.gov/ped\\_bike/step/](https://safety.fhwa.dot.gov/ped_bike/step/).

In addition, all the following information contained in this appendix is for planning purposes and should not be used for final design of any project. Further analysis and engineering design are necessary prior to implementing any of the recommendations contained herein.

While many of these projects may be completed by the City of Billings, there are several that fall outside of the City’s jurisdiction including all bike rack replacements. Bike rack replacements would be the responsibility of Billings Public Schools. Some road projects may fall under the jurisdiction of the Montana Department of Transportation or of Yellowstone County.

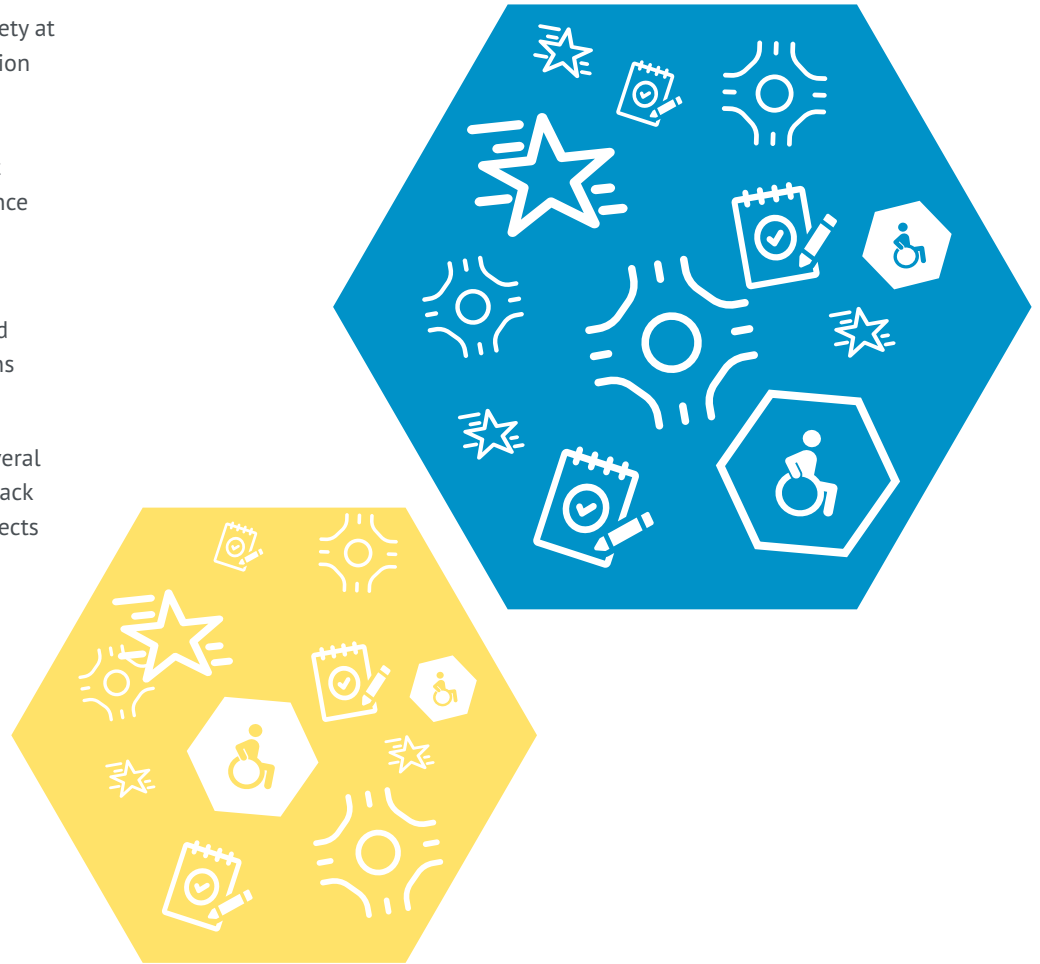

# Alkali Creek Elementary

## Existing Conditions

About the School	
Address	681 Alkali Creek Rd
Number of Students	Approximately 340
Percentage of Students Eligible for Free and Reduced Lunch	34%
Arrival / Dismissal Times	8:25 AM / 2:20 and 3:05 PM

Major Streets and Highways	Annual Average Daily Traffic (AADT) <sup>c</sup>
Alkali Creek Rd	<ul style="list-style-type: none"> <li>1,500 (at Senators Blvd)</li> <li>3,300 (east of Black Pine St)</li> </ul>
Senators Blvd	1,500 (at Governors Blvd)

<sup>c</sup>Source: MDOT Interactive Traffic Web Map

## Existing Conditions Map



- |                               |                    |                 |
|-------------------------------|--------------------|-----------------|
| Student Address Heatmap       | <b>Existing</b>    | <b>Proposed</b> |
| School Half Mile Buffer       | Shared Use Path    | Bike Lane       |
| Outside School Boundary       | Existing Bike Lane |                 |
| Pedestrian Crash (2016-2020)  | Sidewalk           |                 |
| Speed Limit 35 mph or Greater |                    |                 |

## Known Safety Concerns at Alkali Creek Elementary

Source of Concern	Safety Concern or Comment
Principal	<ul style="list-style-type: none"> <li>Families will park on east side of Alkali Creek Rd to pick-up, creating a pinch point for traffic.</li> <li>Families will also park on Moon Valley Rd, encouraging students to cross at undesignated crossing rather than walk down to Indian Trail intersection and cross with crossing guard.</li> </ul>
Webmap Survey	<p>There were four comments for the Alkali Creek catchment area.</p> <ul style="list-style-type: none"> <li>One comment about crossing Senators Blvd and Alkali Creek Rd</li> <li>One comment about fast traffic on Senators Blvd</li> <li>Two route drawings on Alkali Creek Rd from Moon Valley Rd to Woodland Trail.</li> </ul>
Crossing Guard	<ul style="list-style-type: none"> <li>Students cross the street without an adult at Moon Valley Rd, which is not a crossing guard location.</li> </ul>
Safety Busing Concern	<ul style="list-style-type: none"> <li>Safety busing is provided for students living within Alkali Creek's boundaries east of Main St.</li> <li>Safety busing is recommended for students living east of the school on top of bluff.</li> </ul>

## Dismissal Observations

Observation Details	
Observation Date	<b>The consultant team observed dismissal on Thursday, September 23.</b>
School Bus Loading	<ul style="list-style-type: none"> <li>School buses lined up along the sidewalk outside the front of the school.</li> <li>Day care buses also picked up in this area.</li> </ul>
Family Vehicles	<ul style="list-style-type: none"> <li>At the first dismissal, families in vehicles picked up students from the front of the building. Family drivers parked in the field south of Indian Trail and walk to the school entrance.</li> <li>At the second dismissal, there were fewer family vehicles. Most families parked along Alkali Creek Rd or on Moon Valley Rd and waited for their children in the car.</li> </ul>
School Staff Roles	<ul style="list-style-type: none"> <li>School staff led their classes outside to meet their families. Two staff members were present at the front of the school building to assist with traffic control and to help load students onto buses.</li> </ul>
Adult Crossing Guards	<ul style="list-style-type: none"> <li>A school crossing guard was posted at Indian Trail and Alkali Creek Rd.</li> </ul>
Students Walking and Biking	<ul style="list-style-type: none"> <li>Some students were observed walking and biking on the path along Alkali Creek Road.</li> <li>No students were observed using the trail along Alkali Creek.</li> </ul>

## Priority Concerns at Alkali Creek Elementary

The numbered observations and recommendations in the table below correspond to the points in the Existing Conditions Map (shown on previous page).

#	Location	Observations
1	School front parking lot	<ul style="list-style-type: none"> <li>During the first dismissal, families would park in the front parking lot and have difficulty backing up to leave with the presence of families and students crossing and the bus leaving.</li> <li>Recommend back-in angled parking to improve circulation issues.</li> <li>Recommend aligning crosswalk with curb ramp.</li> </ul>
2	School front parking lot; Indian Trail	<ul style="list-style-type: none"> <li>During the first dismissal, families would park in the lot south of Indian Trail as well as in school parking spots on the semicircle. Due to these two locations of parking, motor vehicles would back up in the school parking lot and prevent the bus from exiting.</li> <li>Recommend prohibiting parking in school parking lot to address bottleneck at Indian Trail intersection.</li> </ul>
3	Alkali Creek Rd (~260' north of Moon Valley Rd and at Tumbleweed Dr)	<ul style="list-style-type: none"> <li>Anecdotal evidence from the principal revealed that occasionally the School Zone flashing beacons do not come on during arrival or dismissal times.</li> <li>Recommend coordinating with school to ensure school zone flashing beacons consistently work.</li> </ul>
4	Alkali Creek Rd and Moon Valley Rd	<ul style="list-style-type: none"> <li>Currently, families park on the west and east side of Alkali Creek Rd north of Indian Trail, as well as on Moon Valley Rd, incentivizing students to cross Alkali Creek Rd at non-designated crossing locations.</li> <li>Recommend extending the motor vehicle parking on Alkali Creek Rd and adding bollards in sections where parking is not allowed. This could incentivize families to park on one side of the road rather than park on local streets across the road, and reducing the need for students to cross Alkali Creek Rd. A further evaluation and/or pilot pop-up project should be used to evaluate the effectiveness of any new on-street parking restriction.</li> <li>Recommend reinforcing students crossing at the crossing guard crosswalk.</li> </ul>
5	Alkali Creek	<ul style="list-style-type: none"> <li>The lack of a formalized pathway along Alkali Creek is a barrier to students living on Quiet Water Ave and Black Pine St. Currently, the Billings Bike Map identifies an existing pathway there, but none currently exist.</li> <li>Recommend designing and building a paved path along Alkali Creek with signage.</li> </ul>
6	Area north and east of the school	<ul style="list-style-type: none"> <li>Topographical challenges create a barrier for students living east of the school on the bluff, despite their proximity to school. Connection could connect to the Alkali Creek trail, Pow Wow Park, and the future trail under the powerlines that parallels Governors Blvd, as well as future homes on Aries Ave and Asteroid Ave.</li> <li>Recommend designing and building a walking and biking connection to this residential area.</li> <li>A shared use path is proposed to connect behind the school from Alkali Creek Rd to the Alkali Creek pathway.</li> <li>A shared use path is proposed, running under the powerlines south of Governors Blvd.</li> </ul>
7	Bicycle Racks at Alkali Creek Elementary	<ul style="list-style-type: none"> <li>Bike racks were present on the south and west of the school. Racks to the south were not used, likely due to its location close to K-3<sup>rd</sup> grade classrooms. Racks to the west had roughly five to eight bikes parked on the day of observation and were located close to the 4<sup>th</sup> and 5<sup>th</sup> grade classrooms.</li> </ul>

## Proposed Projects at Alkali Creek Elementary

The numbered observations and recommendations in the table below correspond to the points in the Proposed Projects Map (shown on final page of school profile).

#	Location	Topic	Issue	Recommendation
1	School front parking lot	Parking Procedures	<ul style="list-style-type: none"> <li>Families parking in the front parking lot create a hazard for people walking and biking.</li> </ul>	<ul style="list-style-type: none"> <li>Add signage designating back-in only parking in the afternoons. Communicate changes in parking procedure to families via email, text, windshield flyers, and backpack mail.</li> <li>Align and mark crosswalk with curb ramp; and install new curb ramp.</li> </ul>
2	Front of school along Alkali Creek Rd	Crossing	<ul style="list-style-type: none"> <li>Students cross at an unmarked location.</li> </ul>	<ul style="list-style-type: none"> <li>Install fencing along Alkali Creek Rd between the northern section of the school and Indian Trail Rd to discourage students crossing from the west side, and to encourage crossing at the crossing guard location at Indian Trail.</li> </ul>
3	Alkali Creek Rd from Sandstone Trail to Moon Valley Rd	Sidewalk and Shared Use Path	<ul style="list-style-type: none"> <li>Alkali Creek Road is signed at 35mph</li> <li>Missing sidewalks present a barrier to walking and bicycling to school.</li> </ul>	<ul style="list-style-type: none"> <li>Construct sidewalks on west side of Alkali Creek Road.</li> <li>Trail component of project is identified in the Billings Area Bikeway and Trails Master Plan.</li> </ul>
4	Alkali Creek Road and Senators Blvd	Crossing	<ul style="list-style-type: none"> <li>Comments on the webmap indicated concerns about traffic on Senators Boulevard.</li> </ul>	<ul style="list-style-type: none"> <li>Install curb extensions or a traffic island to slow turning traffic and increase safety and visibility of people crossing.</li> </ul>
5	North and east of the school	Safety Busing	<ul style="list-style-type: none"> <li>Topographical challenges create a barrier for students living east of the school on the bluff, despite their proximity to school. The school district does not provide safety busing to this area.</li> </ul>	<ul style="list-style-type: none"> <li>The school district should offer a paid bus option for students living in this area, to reduce the amount of family vehicles around the school during arrival and dismissal.</li> </ul>
6	Aronson Ave. to Quiet Water Ave.	Shared Use Path	<ul style="list-style-type: none"> <li>Build a paved shared use path from Aronson Ave. to Quiet Water Ave. and from Quiet Water Ave. to the school site.</li> </ul>	<ul style="list-style-type: none"> <li>Build a paved path along Alkali Creek.</li> <li>Trail is currently identified in Billings Area Bikeway and Trails Master Plan.</li> </ul>
7	Behind School	Bicycle Parking	<ul style="list-style-type: none"> <li>Racks to the west had roughly five to eight bikes parked on the day of observation and were located close to the 4<sup>th</sup> and 5<sup>th</sup> grade classrooms. Existing type of bicycle racks can damage bikes and make it difficult to securely lock bicycles.</li> </ul>	<ul style="list-style-type: none"> <li>Replace the bike racks behind the school with new racks that support the bike frame in at least two places and that enable secure locking.</li> </ul>

### Proposed Projects Map

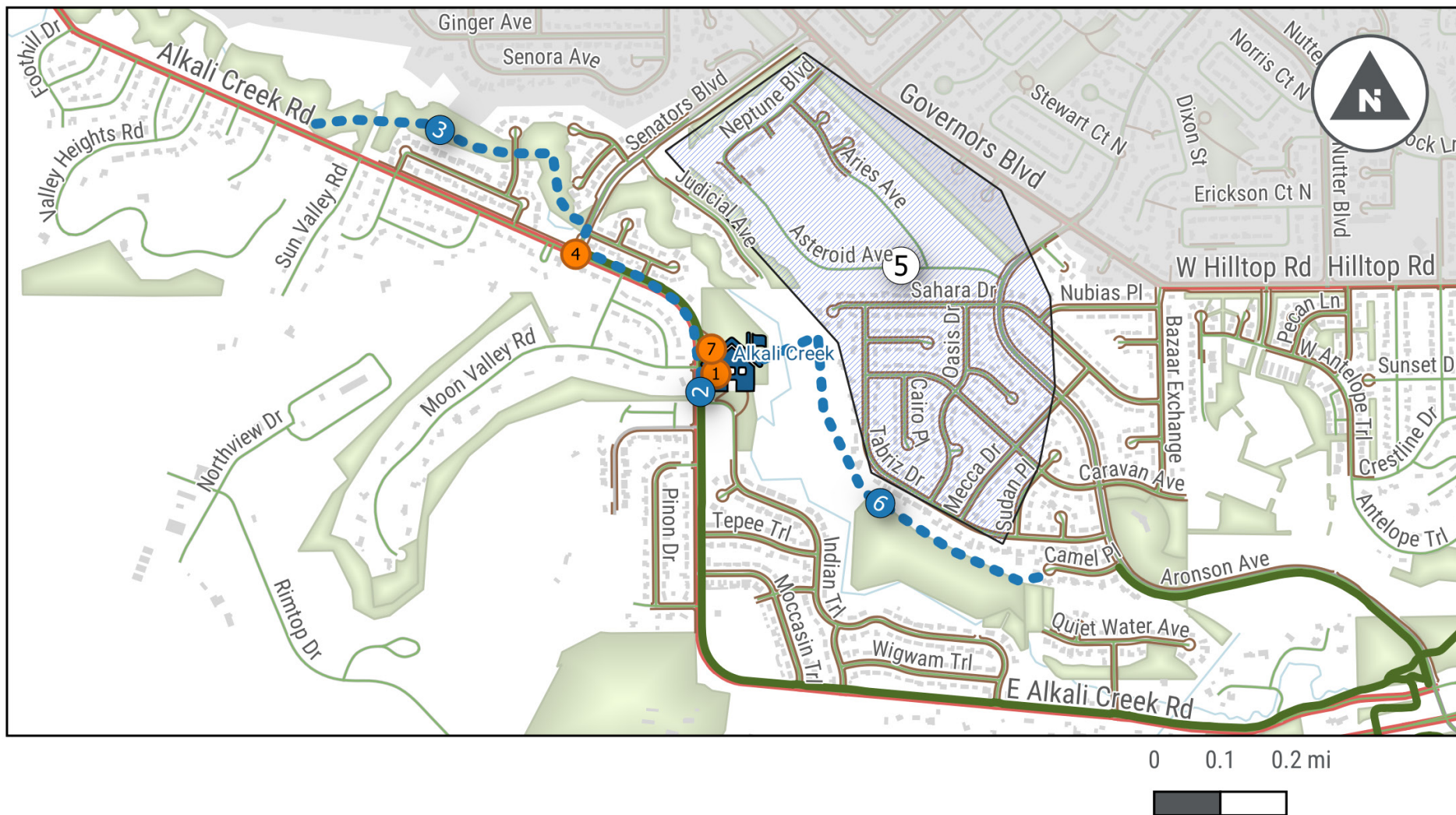



# Arrowhead Elementary

## Existing Conditions

About the School	
Address	2510 38th St W
Number of Students	Approximately 427
Percentage of Students Eligible for Free and Reduced Lunch	17%
Arrival / Dismissal Times	8:20 AM / 2:15 and 3:00 PM

Major Streets and Highways	Annual Average Daily Traffic (AADT) <sup>c</sup>
Shiloh Rd	10,400
Rimrock Rd	<ul style="list-style-type: none"> <li>12,800 (W of 38th St)</li> <li>11,700 (E of 38th St)</li> </ul>
Poly Dr	1,400

<sup>c</sup>Source: MDOT Interactive Traffic Web Map

## Existing Conditions Map

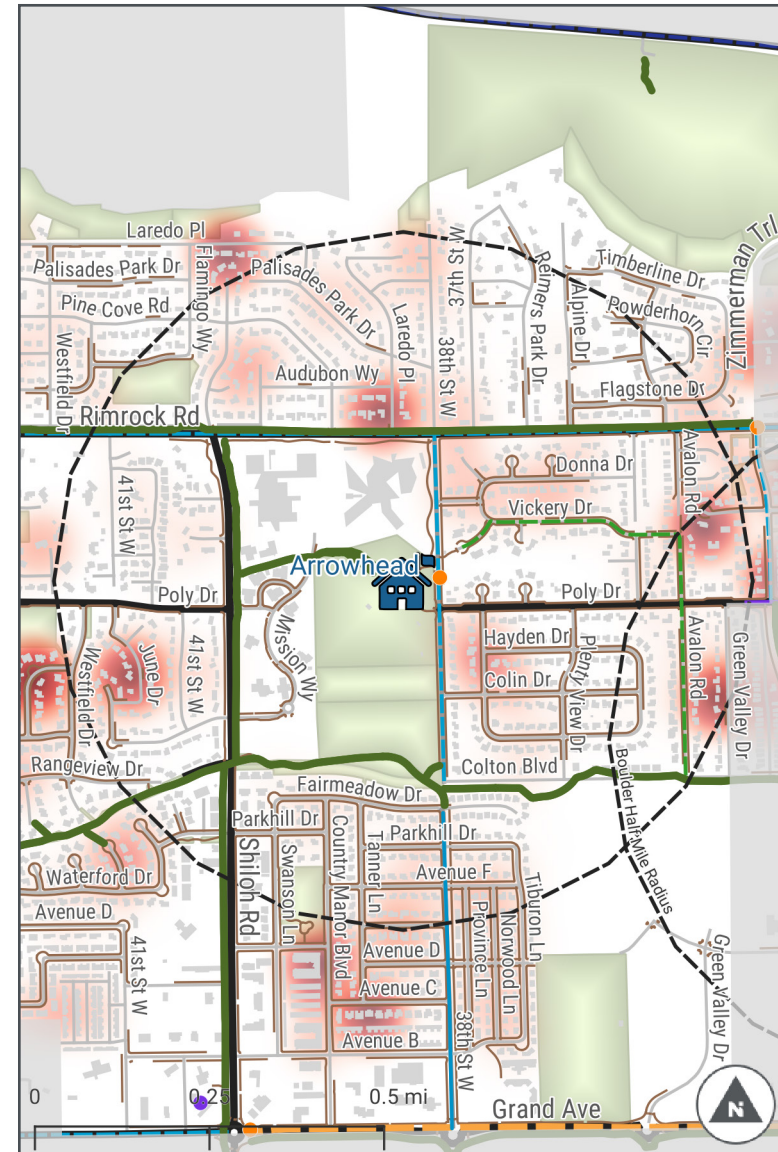

- |  |                               |  |                          |  |                               |
|--|-------------------------------|--|--------------------------|--|-------------------------------|
|  | Student Address Heatmap       |  | Existing Shared Use Path |  | Proposed Neighborhood Bikeway |
|  | School Half Mile Buffer       |  | Existing Bike Lane       |  | Proposed Bike Lane            |
|  | Outside School Boundary       |  | Existing Shared Lane     |  | Sidewalk                      |
|  | Bike Crash (2016-2020)        |  |                          |  |                               |
|  | Pedestrian Crash (2016-2020)  |  |                          |  |                               |
|  | Speed Limit 35 mph or Greater |  |                          |  |                               |

## Known Safety Concerns at Arrowhead Elementary

Source of Concern	Safety Concern or Comment
Principal	<ul style="list-style-type: none"> <li>Rimrock Rd and Shiloh Rd are safety concerns, as well as parents parking at St. Johns United to drop off and pick-up.</li> </ul>
Webmap Survey	<p>There were over 30 comments for the Arrowhead Elementary catchment area. Most comments were north and west of the school</p> <ul style="list-style-type: none"> <li>Lack of crossing guard on Shiloh Rd at Arrowhead School Path</li> <li>Lack of safe bicycling conditions on 38th St, causing conflicts on the sidewalk between people walking and bicycling and creating unsafe biking conditions with parked cars.</li> <li>Fast vehicular traffic on Rimrock Rd creates unsafe crossing conditions, requests for school zone signage.</li> <li>Lack of curb cuts on Poly Dr west of the school are a hindrance to walking and bicycling.</li> <li>Families cited lack of sidewalks or narrow sidewalks throughout the neighborhood.</li> <li>Lighting was also an issue for walking on Rimrock Rd and 38th St W.</li> </ul>
Crossing Guard	<ul style="list-style-type: none"> <li>Family vehicles make u-turns near the crossing guard crosswalk.</li> <li>High traffic volumes on 38th St W during drop-off.</li> </ul>
Safety Busing Concern	<ul style="list-style-type: none"> <li>No safety busing is provided.</li> </ul>

## Arrival Observations

Observation Details	
Observation Date	<b>The consultant team observed arrival on Monday, September 20.</b>
School Bus Loading	<ul style="list-style-type: none"> <li>School buses dropped off on the north side of the parking lot loop. Daycare vans also pick up here.</li> </ul>
Family Vehicles	<ul style="list-style-type: none"> <li>[For arrival] Families dropped off students by car on 38th St W in front of the school; mostly on the west side, but also on the east side of the street.</li> </ul>
School Staff Roles	<ul style="list-style-type: none"> <li>No school staff were involved during the arrival period.</li> </ul>
Adult Crossing Guards	<ul style="list-style-type: none"> <li>A school crossing guard is posted at 38th St W and Poly Drive, and another at 38th St W and Rimrock Rd. Both crossing guards are school employees.</li> <li>An additional crossing guard used to be located at Shiloh Rd at Arrowhead School Path crossing.</li> </ul>
Students Walking and Biking	<ul style="list-style-type: none"> <li>Many students were observed walking and biking from the north and east of the school. Students also walked or biked from the south, possibly from the shared use path south of Poly Vista Park.</li> <li>Many bicycles were parked the day of observation.</li> </ul>

## Priority Concerns at Arrowhead Elementary

The numbered observations and recommendations in the table below correspond to the points in the Existing Conditions Map (shown on previous page).

#	Location	Observations
1	Rimrock Rd and 38th St W	<ul style="list-style-type: none"> <li>Students and families were observed crossing Rimrock Rd at 38th St W with a crossing guard. Rimrock has higher traffic volumes and speeds than would be preferred for a student crossing location.</li> <li>Bike lanes are proposed on Rimrock Rd from the Zimmerman Trail to 48th St W.</li> </ul>
2	Front of school - 38th St W and Poly Dr	<ul style="list-style-type: none"> <li>Families dropping off students by car on 38th St W were observed doing u-turns in the road.</li> <li>Bike lanes are proposed on 38th St W from Poly Dr to Rimrock Rd.</li> </ul>
3	Shiloh Rd at Arrowhead School Path crossing	<ul style="list-style-type: none"> <li>There used to be a crossing guard posted at Shiloh Road and the Arrowhead School Path crossing. Shiloh Rd has higher traffic volumes and speeds than would be preferred for a student crossing location.</li> </ul>
4	38th St W and Poly Dr	<ul style="list-style-type: none"> <li>Cars turning left from 38th St W on to Poly Dr are not required to stop. This intersection only has yield pavement markings on 38th St W. This caused crossing hesitation with families and students who crossed 38th St W on the south side of the intersection.</li> </ul>
5	38th St W south of school	<ul style="list-style-type: none"> <li>The existing sidewalk on 38th is not wide enough for a biking facility, causing conflicts on the sidewalk between people walking and bicycling and creating unsafe biking conditions with parked cars.</li> </ul>
6	Bicycle racks	<ul style="list-style-type: none"> <li>Existing bicycle racks are two different sizes, and larger bikes are unable to be locked to the smaller racks. However, the larger racks are located near the entrances to the K-3 classrooms, thus younger students with smaller bikes are using racks for larger bikes. This leaves limited bike parking options for older students. Students who bike to school from the shared use path on the south reported difficulties getting through the staff parking lot to the bike racks behind the school.</li> </ul>

## Proposed Projects at Arrowhead Elementary

The numbered observations and recommendations in the table below correspond to the points in the Proposed Projects Map (shown on final page).

#	Location	Topic	Issue	Recommendation
1	Rimrock Rd and 38th St W	Crossing	<ul style="list-style-type: none"> <li>Parents and staff report that this crossing is dangerous and discourages students from walking and biking.</li> </ul>	<ul style="list-style-type: none"> <li>Reduce travel lane widths to shorten crossing distance and/or add curb extensions.</li> </ul>
2	Front of school along 38th St W	Arrival/Dismissal Behavior	<ul style="list-style-type: none"> <li>Some families were observed making u-turns in front of the school.</li> </ul>	<ul style="list-style-type: none"> <li>Develop a school drop off/pick up plan that can be shared with families. Communicate expected drop off and pick up procedures to families via email, text, windshield flyers, and backpack mail.</li> </ul>
3	Shiloh Road at Arrowhead School Path crossing	Crossing	<ul style="list-style-type: none"> <li>There used to be a crossing guard posted at Shiloh Road and the Arrowhead School Path crossing.</li> <li>Shiloh Rd is signed at 45mph</li> <li>Shiloh Rd has an ADT of 13,620</li> </ul>	<ul style="list-style-type: none"> <li>Post crossing guard at Shiloh Road and Arrowhead School Path crossing.</li> </ul>
4	38th St W and Poly Dr	Crossing	<ul style="list-style-type: none"> <li>Many students cross the street at this intersection and drivers don't always yield to pedestrians in the crosswalk (crossing guard is present).</li> </ul>	<ul style="list-style-type: none"> <li>Use in-street yield to pedestrian signs.</li> </ul>
5	38th St W, south of school	Sidewalk/Sidepath	<ul style="list-style-type: none"> <li>There is a lack of safe bicycling facilities on 38th St and the current sidewalk isn't wide enough for pedestrians and bicyclists to pass each other.</li> </ul>	<ul style="list-style-type: none"> <li>Construct a minimum 10-foot-wide sidewalk or path on the west side of 38th St W between the school and the path to the south or consult with school to determine if a separated, buffered, or regular bike lane would be sufficient on 38th St. W. 2017 Billings Area Bikeway and Trails Master plan recommends a bike lane.</li> </ul>
6	Front, back and south of School	Bicycle Parking	<ul style="list-style-type: none"> <li>Existing bicycle racks are two different sizes, and larger bikes are unable to be locked to the smaller racks. However, the larger racks are located near the entrances to the K-3 classrooms, thus younger students with smaller bikes are using racks for larger bikes. This leaves limited bike parking options for older students. Students who bike to school from the shared use path on the south reported difficulties getting through the staff parking lot to the bike racks behind the school.</li> </ul>	<ul style="list-style-type: none"> <li>Replace the existing bike racks in front of, and behind school with new racks that support the bike frame in at least two places and that enable secure locking. Add new bike racks to the south of the school (possibly in staff parking lot) for students biking from the shared use path to the south.</li> </ul>

## Proposed Projects Map

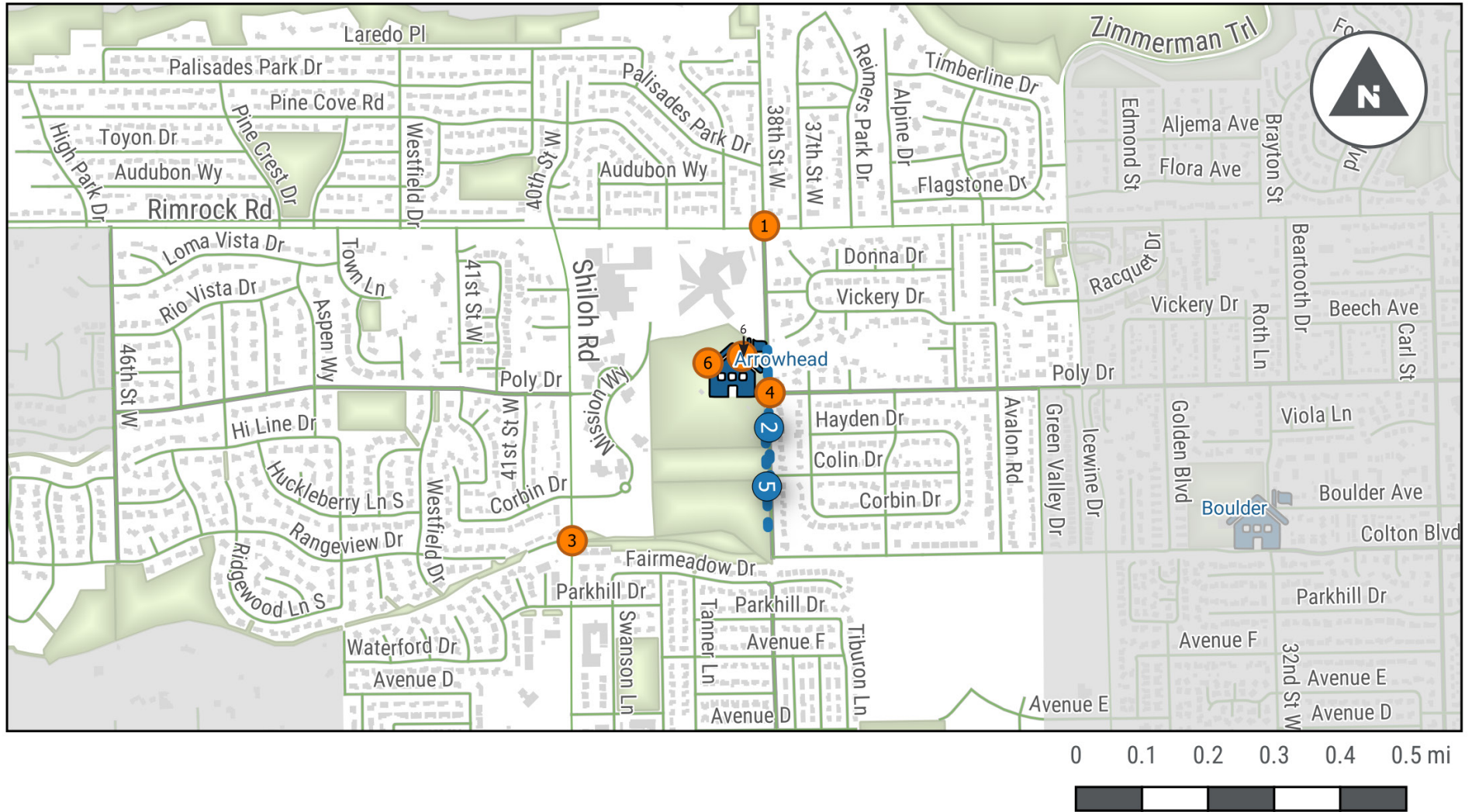

# Beartooth Elementary

## Existing Conditions

About the School	
Address	1345 Elaine St
Number of Students	360
Percentage of Students Eligible for Free and Reduced Lunch	46%
Arrival / Dismissal Times	8:25 AM / 2:00 and 3:15 PM

Major Streets and Highways	Annual Average Daily Traffic (AADT) <sup>c</sup>
Bitterroot Dr	<ul style="list-style-type: none"> <li>• 2,500 (south of Barrett)</li> <li>• 700 (north of Barrett)</li> </ul>
Wicks Ln	2,400
Hawthorne Ln	1,000

<sup>c</sup>Source: MDOT Interactive Traffic Web Map

## Existing Conditions Map

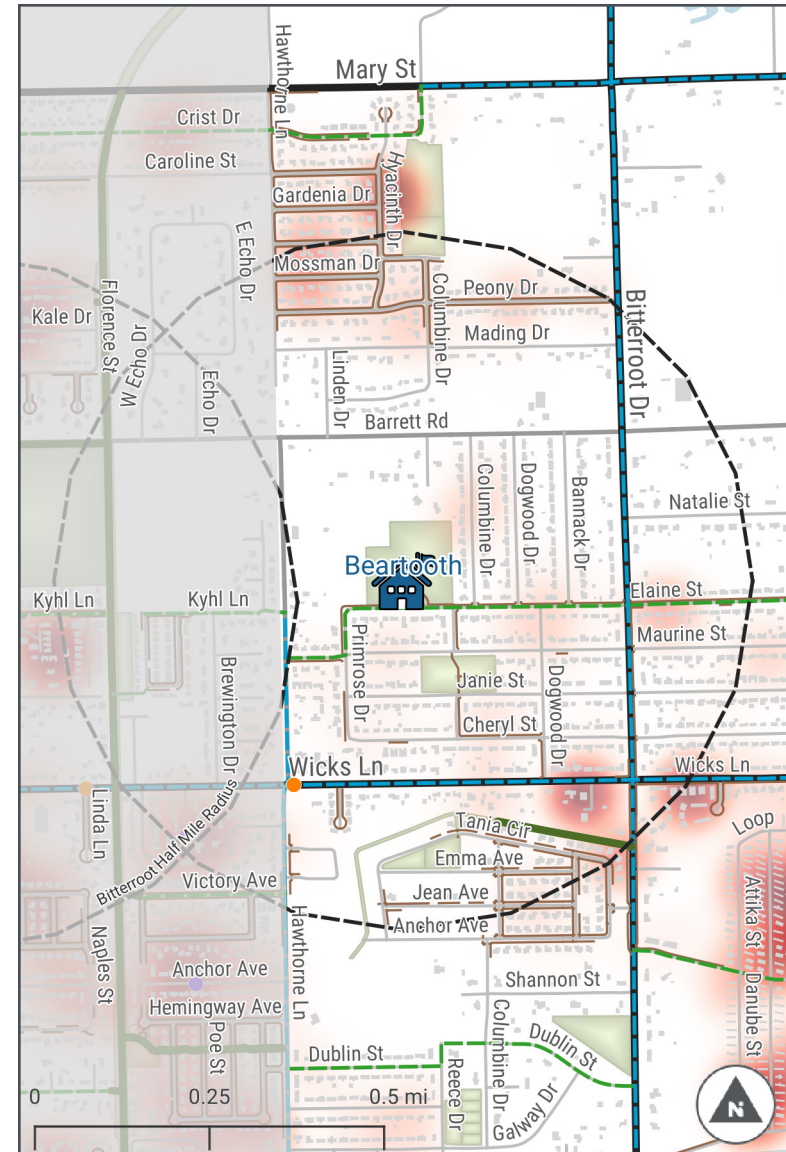

- |                               |                 |                      |
|-------------------------------|-----------------|----------------------|
| Student Address Heatmap       | <b>Existing</b> | <b>Proposed</b>      |
| School Half Mile Buffer       | Shared Use Path | Neighborhood Bikeway |
| Outside School Boundary       | Sidewalk        | Bike Lane            |
| Bike Crash (2016-2020)        |                 |                      |
| Pedestrian Crash (2016-2020)  |                 |                      |
| Speed Limit 35 mph or Greater |                 |                      |

## Known Safety Concerns at Beartooth Elementary

Source of Concern	Safety Concern or Comment
Principal	<ul style="list-style-type: none"> <li>Because of high driving rates and limited parking in front of the school, a lot of parents will drop off students wherever they can and then students run across Elaine.</li> <li>There are students, primarily those that live to the southeast of the school, that are regular bikers to school and have limited vehicle access. When it snows, it is not unusual for these students to not come to school because they can't get there by bike.</li> <li>Crossing at Elaine St and Bitterroot Dr is uncomfortable for students because of high vehicle volumes and limited traffic control.</li> </ul>
Webmap Survey	<p>There were over 20 comments in the Beartooth Elementary catchment area:</p> <ul style="list-style-type: none"> <li>Many comments about Barrett Rd regarding lighting, lack of sidewalks, speeding traffic, and dangerous crossing conditions.</li> <li>Surrounding neighborhood has lack of sidewalks</li> <li>Bitterroot Dr has very little lighting and no sidewalks in some areas.</li> <li>Lack of lighting on Wicks Ln creates dangerous walking and bicycling conditions.</li> <li>The Elaine St and Bitterroot Dr intersection is a dangerous crossing.</li> <li>The Wicks Ln and Bitterroot Dr intersection is dangerous to cross.</li> </ul>
Crossing Guard	<ul style="list-style-type: none"> <li>Most kids who cross are crossing to get to a parked car with their parents.</li> <li>A lot of vehicles, but generally good behavior</li> </ul>
Safety Busing	<ul style="list-style-type: none"> <li>There are special needs buses and the bus for students experiencing homelessness.</li> </ul>

## Dismissal Observations

Observation Details	
Observation Date	<b>The consultant team observed dismissal on Wednesday, September 23.</b>
School Bus Loading	<ul style="list-style-type: none"> <li>School buses parked in the driveway/lot on the south side of the school.</li> </ul>
Before/Aftercare Vans	<ul style="list-style-type: none"> <li>Before/aftercare vans parked in the driveway/lot on the south side of the school.</li> </ul>
Family Vehicles	<ul style="list-style-type: none"> <li>At the first dismissal, families in vehicles picked up students mostly from the front of the building. Family drivers either stay in the vehicle and queue to pick up directly at the school entrance, or park on side streets (many cross at Columbine Dr) and walk to the school entrance. Some families park in the alley to the east of the school.</li> <li>At the second dismissal, families in vehicles picked up students mostly from the front of the building. Family drivers either stay in the vehicle and queue to pick up directly at the school entrance, or park on side streets (many cross at Columbine Dr) and walk to the school entrance. Some families park in the alley to the east of the school.</li> <li>For both dismissals, a fair number of families pull in and park in the areas clearly marked for bus and daycare only parking.</li> <li>Many families make a "loop" when picking up students, driving west on Elaine St, south on Primrose Dr, east on Maurine St, and north on Columbine Dr.</li> </ul>
School Staff Roles	<ul style="list-style-type: none"> <li>Teachers go out with students to watch for parents.</li> </ul>
Adult Crossing Guards	<ul style="list-style-type: none"> <li>A school crossing guard is posted at Elaine St and Columbine Dr.</li> </ul>
Bike Rack Locations and Use	<ul style="list-style-type: none"> <li>There is one extended bike rack at the school, located on the southeast side.</li> </ul>
Students Walking and Biking	<ul style="list-style-type: none"> <li>Some students were headed either into the neighborhoods immediately to the south of the school, or east on Elaine St.</li> <li>Students were observed biking/walking east on Elaine St to Bitterroot Dr and then south on Bitterroot Dr to the Cherry Creek Loop.</li> </ul>

## Priority Concerns at Beartooth Elementary

The numbered observations and recommendations in the table below correspond to the points in the Existing Conditions Map (shown on previous page).

#	Location	Observations
1	Elaine St. immediately in front of school	<ul style="list-style-type: none"> <li>Some families were observed parking on the non-school side, double-parking, asking students to cross the street without an adult at non-intersection locations, making u-turns in front of the school, and parking in the bus parking locations.</li> </ul>
2	Elaine St. and Bitterroot Dr.	<ul style="list-style-type: none"> <li>Many/some students cross the street at this intersection and drivers don't always yield to pedestrians in the crosswalk.</li> <li>Parents and staff feel that this crossing is dangerous and discourages students from walking and biking.</li> <li>The intersection is not within a reduced speed limit school zone.</li> <li>Vehicles appear to exceed the posted speed limit on Bitterroot Dr. during school arrival and dismissal times.</li> </ul>
3	Wicks Ln and Bitterroot	<ul style="list-style-type: none"> <li>Bitterroot Dr has higher traffic volumes and speeds than would be preferred for a student crossing location.</li> <li>Some students cross the street at this intersection and drivers don't always yield to pedestrians in the crosswalk.</li> <li>Crossings of Wicks Ln at Bitterroot Dr are expected to increase because of increased development.</li> </ul>
4	Neighborhoods to the north of Beartooth Elementary	<ul style="list-style-type: none"> <li>Complete lack of connectivity between neighborhoods north of Barrett Rd and the school. Potential link through an alley to the east of the school or the discontinuous Carroll Heights Circle.</li> </ul>
5	Bicycle Racks at Beartooth Elementary	<ul style="list-style-type: none"> <li>Existing bicycle racks can damage bikes and make it difficult to securely lock bicycles. Few bicycles were parked the day of observation.</li> </ul>



## Proposed Projects at Beartooth Elementary

The numbered observations and recommendations in the table below correspond to the points in the Proposed Projects Map (shown on final page).

#	Location	Topic	Issue	Recommendation
1	Elaine St immediately in front of school	Parking Procedures	<ul style="list-style-type: none"> <li>Some families were observed parking on the non-school side, asking students to cross the street without an adult at non-intersection locations, and making u-turns in front of the school.</li> <li>Families park in designated bus parking, create a hazard for people walking and biking.</li> </ul>	<ul style="list-style-type: none"> <li>Add signage designating bus-only parking. Communicate changes in parking procedures via email, text, windshield flyers, and backpack mail.</li> <li>Provide/continue staff monitoring of arrival and dismissal, and provide/continue communicating expectations for family vehicles at arrival and dismissal.</li> <li>Encourage more families to walk or bicycle to school to reduce the number of vehicles during arrival and dismissal</li> <li>Move all pick-up and drop-off to the school side of the street, or, at a minimum, in locations with safe crossings. Add on-street parking restrictions to facilitate school-side drop off/pick up and crossing at safe locations.</li> <li>A further evaluation and/or pilot pop-up project should be used to evaluate the effectiveness of any new on-street parking restriction.</li> </ul>
2	Elaine St and Bitterroot Dr	Crossing	<ul style="list-style-type: none"> <li>Many/Some students cross the street at this intersection and drivers don't always yield to pedestrians in the crosswalk.</li> <li>Parents and staff report that this crossing is dangerous and discourages students from walking and biking.</li> </ul>	<ul style="list-style-type: none"> <li>Add high visibility crosswalk markings, and adequate nighttime lighting levels.</li> <li>Consider using in-street yield to pedestrian signs.</li> <li>Add additional traffic calming measures to accentuate Elaine St as a future neighborhood bikeway in the 2017 Billings Urban Area Bikeway + Trails Master Plan Update.</li> <li>Installing RRFB in 2022.</li> </ul>
3	Wicks Ln and Bitterroot Dr	Crossing	<ul style="list-style-type: none"> <li>Bitterroot Dr has a posted speed limit of 35mph.</li> <li>ADT on Bitterroot Dr is 3,610 and 3,840 (north and south of intersection, respectively).</li> <li>Some students cross the street at this intersection and drivers don't always yield to pedestrians in the crosswalk.</li> <li>Crossings of Wicks Ln at Bitterroot Dr are expected to increase because of increased development.</li> </ul>	<ul style="list-style-type: none"> <li>Add high visibility crosswalk markings, parking restrictions on the crosswalk approach, and ensure there is adequate nighttime lighting. A further evaluation and/or pilot pop-up project should be used to evaluate the effectiveness of any new on-street parking restriction.</li> <li>Study further to find an infrastructure intervention to make it safer and more comfortable for school children to cross Wicks. Solution must be compatible with future bike lanes..</li> </ul>
4	Barrett Rd and Linden Dr	Crossing	<ul style="list-style-type: none"> <li>Some students cross the street at this intersection when walking from northern neighborhoods.</li> <li>No crossing infrastructure exists at this location.</li> </ul>	<ul style="list-style-type: none"> <li>Install new crosswalk across Barrett</li> </ul>
5	Barrett Rd from Kiwanis Trail to Columbine Dr	Sidewalk/Sidepath	<ul style="list-style-type: none"> <li>Currently no sidewalk that allows separated facilities for walking and biking along Barrett Rd.</li> </ul>	<ul style="list-style-type: none"> <li>Install new sidewalk or trail along south side of Barrett Rd. Should coordinate with crossing at Barrett Rd and Linden Dr.</li> </ul>
6	Front of School	Bicycle Parking	<ul style="list-style-type: none"> <li>Existing bicycle racks make it difficult to securely lock bicycles.</li> </ul>	<ul style="list-style-type: none"> <li>Replace the existing bike racks with new racks that support the bike frame in at least two places and that enable secure locking.</li> </ul>

### Proposed Projects Map

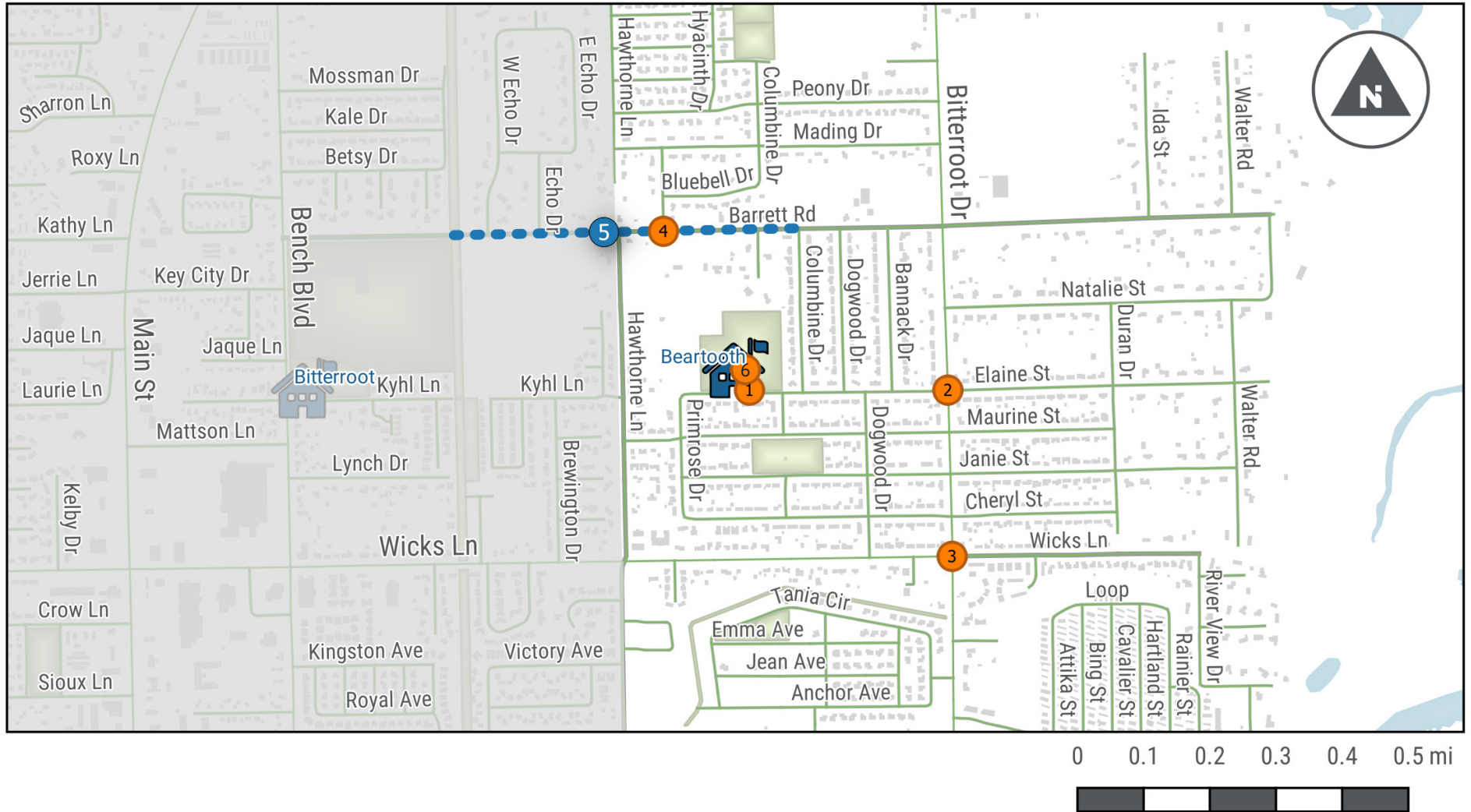

# Bench Elementary

## Existing Conditions

### About the School

Address	505 Milton Rd
Number of Students	Approximately 320
Percentage of Students Eligible for Free and Reduced Lunch	57%
Arrival / Dismissal Times	8:10 AM / 2:15 and 3:00 PM

### Major Streets and Highways

Major Streets and Highways	Annual Average Daily Traffic (AADT) <sup>c</sup>
Lake Elmo Drive	10,500
Main Street (US Hwy 87)	<ul style="list-style-type: none"> <li>• 24,000 (at Wicks Ln)</li> <li>• 29,000 (at Hilltop Rd)</li> </ul>

<sup>c</sup>Source: MDOT Interactive Traffic Web Map

## Existing Conditions Map

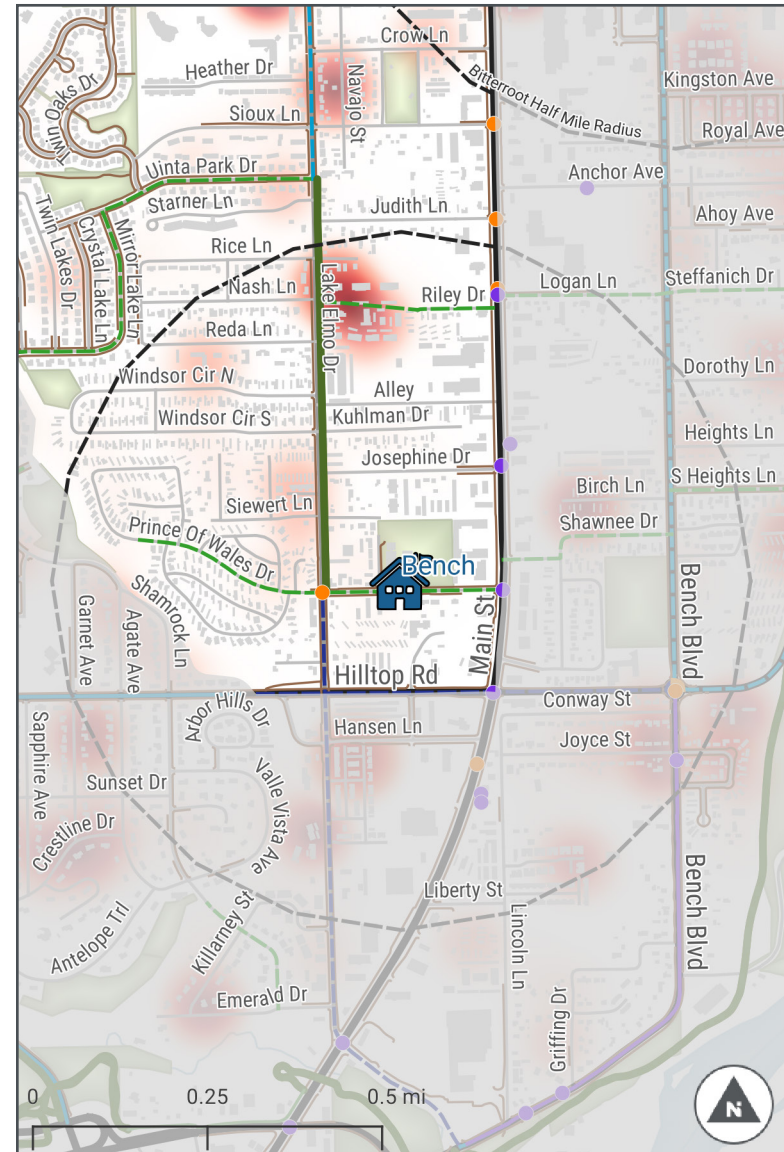

## Known Safety Concerns at Bench Elementary

Source of Concern	Safety Concern or Comment
Principal	<ul style="list-style-type: none"> <li>Students living across Lake Elmo Dr are supposed to cross at the rapid flashing beacon at Milton Rd. The principal noted that beacon has occasionally been out of order.</li> <li>In the past, students who walk to or from school got into physical fights. As a result, the school district provides safety busing to students north of Josephine Dr.</li> </ul>
Webmap Survey	<p>Comments revealed:</p> <ul style="list-style-type: none"> <li>Support for a canal path west of the school following the creek.</li> <li>Concerns about snow piles narrowing the sidewalk width</li> <li>Paving an existing cut-through route from Mirror Lake Ln to Reda Ln/Broadview Dr.</li> </ul>
Crossing Guard	<ul style="list-style-type: none"> <li>Most motorists on Lake Elmo Dr <i>do</i> stop for the flashing beacon. However, the day of observation, one motorist almost did not stop.</li> <li>High speeds on Lake Elmo Dr.</li> </ul>
Safety Busing	<ul style="list-style-type: none"> <li>The school district provides safety busing for students that live in the northern part of the attendance area.</li> <li>Safety busing was supposed to be eliminated once sidewalks went in on Lake Elmo but Lincoln Center Administration requested that safety busing continue after sidewalks were in place.</li> </ul>

## Dismissal Observations

Observation Details	
Observation Date	<b>The consultant team observed dismissal on Tuesday, September 21.</b>
School Bus Loading	<ul style="list-style-type: none"> <li>School buses lined up in the pull-out loop on Milton Rd.</li> </ul>
Before/Aftercare Vans	<ul style="list-style-type: none"> <li>No before/aftercare vans were observed.</li> </ul>
Family Vehicles	<ul style="list-style-type: none"> <li>During both dismissals, family members parked on Rex Ln, opposite the school on Milton Rd, and in the school parking lot. Family members then walk to the designated meeting spot for the teachers.</li> </ul>
School Staff Roles	<ul style="list-style-type: none"> <li>Each teacher is responsible for their own classroom students. Teachers wait with their students at their assigned door and ensure that students get on the correct bus.</li> </ul>
Adult Crossing Guards	<ul style="list-style-type: none"> <li>A school crossing guard waits for all the students to be dismissed, then assists students crossing Rex Ln and Lake Elmo Dr.</li> </ul>
Bike Rack Locations and Use	<ul style="list-style-type: none"> <li>There is one bike rack at the school, located in the parking lot. One bicycle was parked the day of observation.</li> </ul>
Students Walking and Biking	<ul style="list-style-type: none"> <li>Few students were observed walking. About 10-20 students crossed Lake Elmo Dr with the crossing guard; most of those who crossed there entered the Windsor Estates.</li> </ul>

## Priority Concerns at Bench Elementary

The numbered observations and recommendations in the table below correspond to the points in the Existing Conditions Map (shown on previous page).

#	Location	Observations	Webmap comment?
1	Lake Elmo Dr sidepath	<ul style="list-style-type: none"> <li>Lake Elmo Dr higher traffic volumes and speeds than would be preferred for road students would need to cross.</li> <li>The sidepath (or trail) on the east side of Lake Elmo Dr is not comfortable because there is no vertical barrier such as a curb that provides separation from motor vehicles. Parking is allowed in the buffer zone between the street and the trail.</li> <li>No crosswalks are marked where the sidepath crosses side streets.</li> <li>Lake Elmo Dr is recommended to have on-street bicycle facilities to the north and south of the existing trail in the 2017 Billings Area Bikeway and Trails Master Plan Update.</li> </ul>	No
2	Lake Elmo Dr and Milton Rd	<ul style="list-style-type: none"> <li>A crossing guard is posted at this intersection. The north leg of the intersection has a high-visibility crosswalk marking, yield markings, a Rectangular Rapid Flashing Beacon (RRFB) that is used by the crossing guard. School crossing assemblies are present on both the north and south approaches.</li> <li>The intersection is not within a reduced speed limit school zone and lacks school zone speed limit flashing beacons.</li> </ul>	No
3	Lake Elmo Dr north of Rice Ln	<ul style="list-style-type: none"> <li>Missing sidewalks along the west side of Lake Elmo Dr present a barrier to walking and bicycling to school.</li> </ul>	No
4	Ulnita Park/Twin Oaks neighborhood	<ul style="list-style-type: none"> <li>Students living in the Uinta Park/Twin Oaks neighborhood have a circuitous path to school due to a lack of street and path connections in the neighborhood.</li> <li>A shared-use path is recommended along the irrigation canal in the Billings Area Bikeway and Trails Master Plan Update.</li> </ul>	Yes
5	Many streets in the neighborhood	<ul style="list-style-type: none"> <li>Unpaved streets and missing sidewalks throughout the neighborhood present a barrier to walking and bicycling to school.</li> </ul>	Yes
6	Bicycle Racks at Bench Elementary	<ul style="list-style-type: none"> <li>Existing bicycle racks can damage bikes and make it difficult to securely lock bicycles. One bicycle was locked to the rack the day of observation.</li> </ul>	No

## Proposed Projects at Bench Elementary

The numbered observations and recommendations in the table below correspond to the points in the Proposed Projects Map (shown on final page).

#	Location	Topic	Issue	Recommendation
1	Lake Elmo Dr sidepath	Sidewalk/Sidepath	<ul style="list-style-type: none"> <li>Vehicles appear to exceed the posted speed limit during school arrival and dismissal times.</li> </ul>	<ul style="list-style-type: none"> <li>Add vertical barrier such as a curb or other buffer to provide separation from motor vehicles and to prohibit vehicles from parking in the buffer zone. A further evaluation and/or pilot pop-up project should be used to evaluate the effectiveness of any new on-street parking restriction.</li> </ul>
2	Lake Elmo Dr and Milton Rd	School Speed Zone	<ul style="list-style-type: none"> <li>The intersection of Lake Elmo Dr and Milton Rd is not within a reduced speed limit school zone and lacks school zone speed limit flashing beacons.</li> </ul>	<ul style="list-style-type: none"> <li>Install curb extensions to slow traffic and increase the visibility of students as they cross.</li> </ul>
3	Lake Elmo Dr north of Rice Ln	Sidewalks	<ul style="list-style-type: none"> <li>Missing sidewalks along the west side of Lake Elmo Dr present a barrier to walking and bicycling to school.</li> <li>Lack of vertical barrier between motorized traffic and shared use path users decreases comfort for students walking and biking to school.</li> </ul>	<ul style="list-style-type: none"> <li>Pave streets and construct sidewalks on the west side of the street.</li> <li>Study further to find an infrastructure intervention to slow speeds on Lake Elmo and increase separation of shared use path users from traffic to make it safer, easier, and more comfortable for children to walk and bike to school.</li> </ul>
4	Ulnita Park/Twin Oaks neighborhood	Shared Use Path	<ul style="list-style-type: none"> <li>Students living in the Uinta Park/Twin Oaks neighborhood have a circuitous path to school due to a lack of street and path connections in the neighborhood. A shared-use path is recommended along the irrigation canal in the Billings Area Bikeway and Trails Master Plan Update.</li> </ul>	<ul style="list-style-type: none"> <li>Build a shared-use path along the irrigation canal. Provide connections to the path through City-owned land off of Windsor Cir. and north of Hilltop Rd.</li> </ul>
5	Rex Ln north of Milton Rd	Sidewalks	<ul style="list-style-type: none"> <li>Missing sidewalks along the west side of Rex Ln presents a barrier to walking and bicycling to school.</li> </ul>	<ul style="list-style-type: none"> <li>Construct sidewalks on the west side of the street.</li> </ul>
6	Lola Ln from Lake Elmo Dr to school property	Shared Use Path	<ul style="list-style-type: none"> <li>Missing pedestrian connection along Lola Ln presents a barrier to walking and bicycling to school.</li> </ul>	<ul style="list-style-type: none"> <li>Install east-west sidewalk or trail connection to north end of school property along Lola Ln.</li> </ul>
7	Bicycle rack in school parking lot	Bicycle Parking	<ul style="list-style-type: none"> <li>Existing bicycle rack can damage bikes and make it difficult to securely lock bicycles.</li> </ul>	<ul style="list-style-type: none"> <li>Replace the existing bike rack with new racks that support the bike frame in at least two places and that enable secure locking.</li> </ul>

### Proposed Projects Map

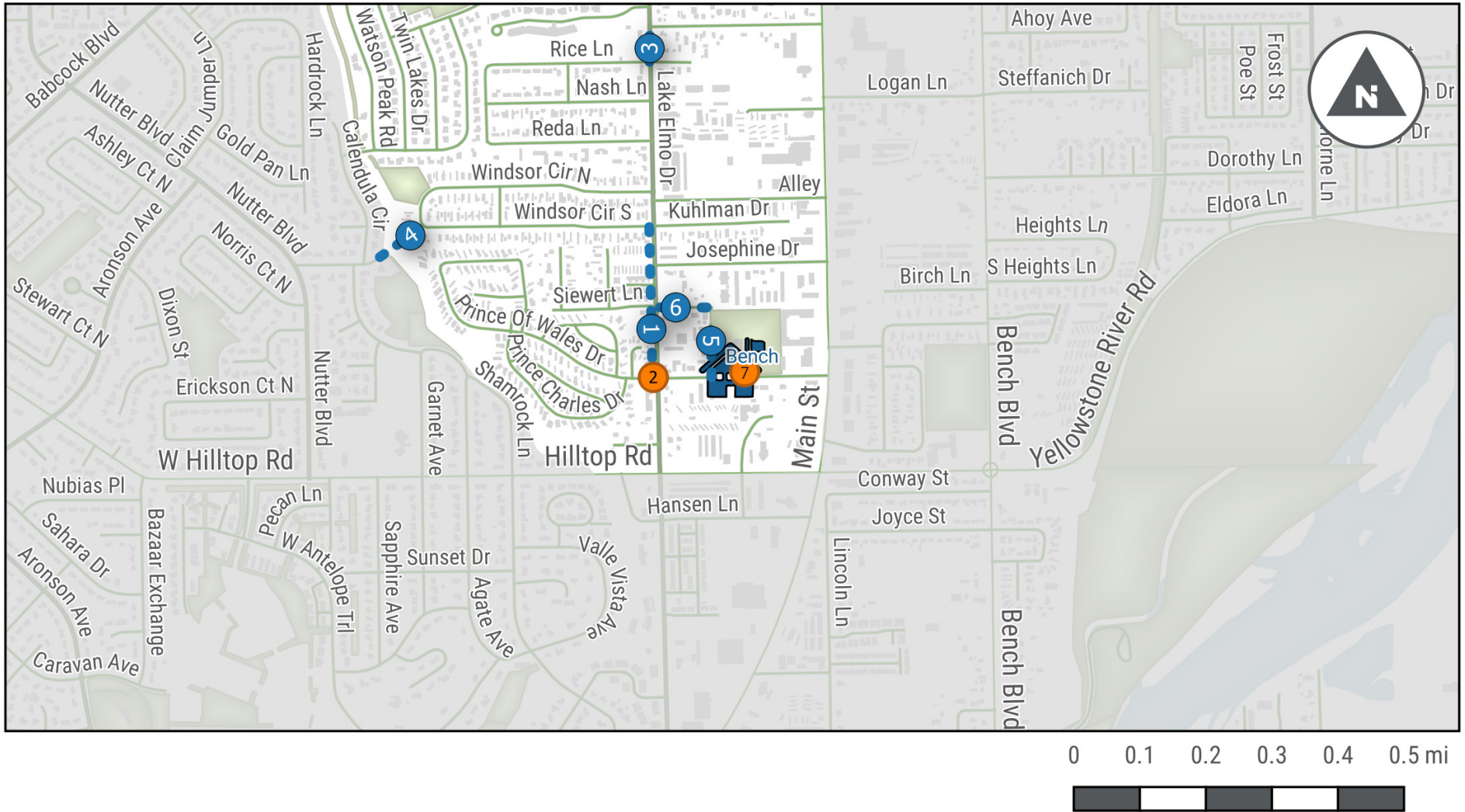

# Big Sky Elementary

## Existing Conditions

About the School	
Address	3231 Granger Ave E
Number of Students	Approximately 360
Percentage of Students Eligible for Free and Reduced Lunch	47%
Arrival / Dismissal Times	8:10 AM / 2:15 and 3:00 PM

Major Streets and Highways	Annual Average Daily Traffic (AADT) <sup>c</sup>
S 32 <sup>nd</sup> St W	<ul style="list-style-type: none"> <li>10,000 (north of King Ave)</li> <li>7,650 (south of King Ave)</li> </ul>
King Ave W	15,000 (west of S 32 <sup>nd</sup> St W)
Monad Rd	5,700 (west of S 32 <sup>nd</sup> Ave W)

<sup>c</sup>Source: MDOT Interactive Traffic Web Map

## Existing Conditions Map



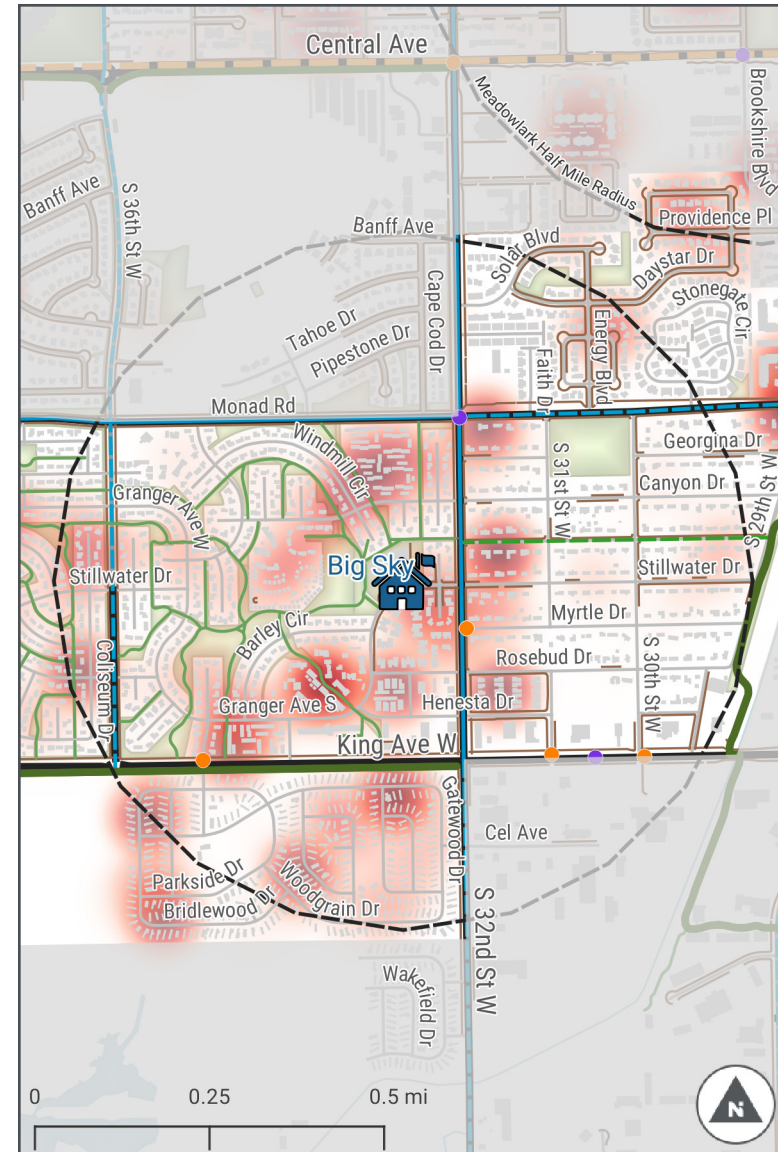

## Known Safety Concerns at Big Sky Elementary

Source of Concern	Safety Concern or Comment
Principal	<ul style="list-style-type: none"> <li>32<sup>nd</sup> St W is a high-trafficked street.</li> <li>Principal also stated the “change in housing population” in the neighborhood was a concern. He also mentioned the presence of sex offenders and drug homes in the area.</li> </ul>
Webmap Survey	<p>There were four comments in the Big Sky Elementary catchment area:</p> <ul style="list-style-type: none"> <li>Lack of nearby crossings encourages unsafe crossings on King Ave W near 36<sup>th</sup> St.</li> <li>Drivers do not stop for people crossing S 32<sup>nd</sup> St between Stillwater Dr and Lampman Dr.</li> <li>Unsafe bicycling conditions crossing Shiloh Rd.</li> </ul>
Crossing Guard	<ul style="list-style-type: none"> <li>Positioned at Lampman Dr. at the midblock crossing. However, families will cross one block south at Granger Ave E/Stillwater Dr, where there isn't any crossing infrastructure.</li> </ul>
Safety Busing Concern	<ul style="list-style-type: none"> <li>Safety busing is provided to students living in Golden Meadows Trailer Park.</li> </ul>

## Dismissal Observations

Observation Details	
Observation Date	<b>The consultant team observed dismissal on Wednesday, September 22.</b>
School Bus Loading	<ul style="list-style-type: none"> <li>School buses lined up along the loop to the south of the school on Granger Ave E.</li> <li>Daycare vans also picked-up in this location.</li> </ul>
Family Vehicles	<ul style="list-style-type: none"> <li>At both dismissals, families parked along Granger Ave E. Some would exit cars to wait near school playground; others would stay in cars. Many family vehicles were parked illegally, and created challenging sight line issues around the bend of Granger Ave E.</li> </ul>
School Staff Roles	<ul style="list-style-type: none"> <li>School staff (including principal, councilor, and teachers) walked students outside to make eye contact with parents before releasing students.</li> <li>One staff member per grade is involved in morning drop off.</li> </ul>
Adult Crossing Guards	<ul style="list-style-type: none"> <li>One crossing guard at Lampman St.</li> </ul>
Students Walking and Biking	<ul style="list-style-type: none"> <li>Many students were observed walking and biking in all directions. Students traveling alone used the paved off-street paths. Students being picked up by family went to the street.</li> </ul>

## Priority Concerns at Big Sky Elementary

The numbered observations and recommendations in the table below correspond to the points in the Existing Conditions Map (shown on previous page).

#	Location	Observations	Webmap Comments?
1	School frontage on Granger Ave E	<ul style="list-style-type: none"> <li>Many families parked on both sides of Grange Ave E to pick-up students. Some families walked with their students in the street during the busy dismissal time, and some families walked in between cars and the drainage ditch. Neither side of the street has sidewalks, exposing students and families to moving traffic.</li> <li>With families parked on both sides of Grange Ave E, at the curve of the street, sightlines were significantly impacted. This created a pinch point and unsafe crossing situations for families and students.</li> <li>A minor trailhead improvement is planned at this location for Granger Ave E, north of Barley Circle.</li> </ul>	No
2	S 32 <sup>nd</sup> St W and Lampman Dr	<ul style="list-style-type: none"> <li>Students and families crossed S 32<sup>nd</sup> St W at the marked crossing at Lampman Dr, where a crossing guard was present. Students were also seen crossing one block south, at Grange Ave E, with no crosswalk or crossing guard.</li> <li>A future bike boulevard is planned for Lampman Dr.</li> </ul>	Yes
3	King Ave and Meadowbrook Dr/Feather Pl	<ul style="list-style-type: none"> <li>Some students and families live south of King Ave in the Golden Meadows mobile home area. However, crossing King Ave W is difficult.</li> </ul>	Yes
4	Bicycle Racks at Big Sky Elementary	<ul style="list-style-type: none"> <li>Existing bicycle racks were located near the playground. Additional racks were located nearby, but were empty, or were used to prop the storage shed door open.</li> </ul>	No

## Proposed Projects at Big Sky Elementary

The numbered observations and recommendations in the table below correspond to the points in the Proposed Projects Map (shown on final page).

#	Location	Topic	Issue	Recommendation
1	Front of school	Arrival/Dismissal Behavior	<ul style="list-style-type: none"> <li>Some families were observed parking on the non-school side and asking students to cross the street without an adult.</li> </ul>	<ul style="list-style-type: none"> <li>Provide staff monitoring of arrival and dismissal, and communicate expectations for family vehicles at arrival and dismissal.</li> <li>Encourage more families to walk or bicycle to school to reduce the number of vehicles during arrival and dismissal.</li> <li>Add on-street parking restrictions to facilitate school-side drop off/pick up and crossing at safe locations. Ideally, all pick-up and drop-off occurs on the school side of the street, or, at a minimum, in locations with safe crossings.</li> </ul>
2	S 32 <sup>nd</sup> St W and Lampman Dr	Crossing	<ul style="list-style-type: none"> <li>Students cross at an unmarked location.</li> </ul>	<ul style="list-style-type: none"> <li>Refresh crosswalk markings and yield markings.</li> <li>A crossing guard is posted at this intersection. Add a Rectangular Rapid Flashing Beacon to further improve the safety of the crossing.</li> <li>Installing RRFB in 2022.</li> </ul>
3	S 30 <sup>th</sup> St W and Lampman Dr	Crossing	<ul style="list-style-type: none"> <li>Students cross at an unmarked location.</li> </ul>	<ul style="list-style-type: none"> <li>Reduce effective turn radii at north, south, and east legs of the intersection or install curb extensions on all legs of the intersection.</li> <li>Install new curb ramps that line up with crosswalks at all corners.</li> </ul>
4	School playground area	Bicycle Parking	<ul style="list-style-type: none"> <li>Existing bicycle racks can damage bikes and make it difficult to securely lock bicycles. Some bicycles were parked the day of observation.</li> </ul>	<ul style="list-style-type: none"> <li>Replace the existing bike racks with new racks that support the bike frame in at least two places and that enable secure locking.</li> </ul>

### Proposed Projects Map

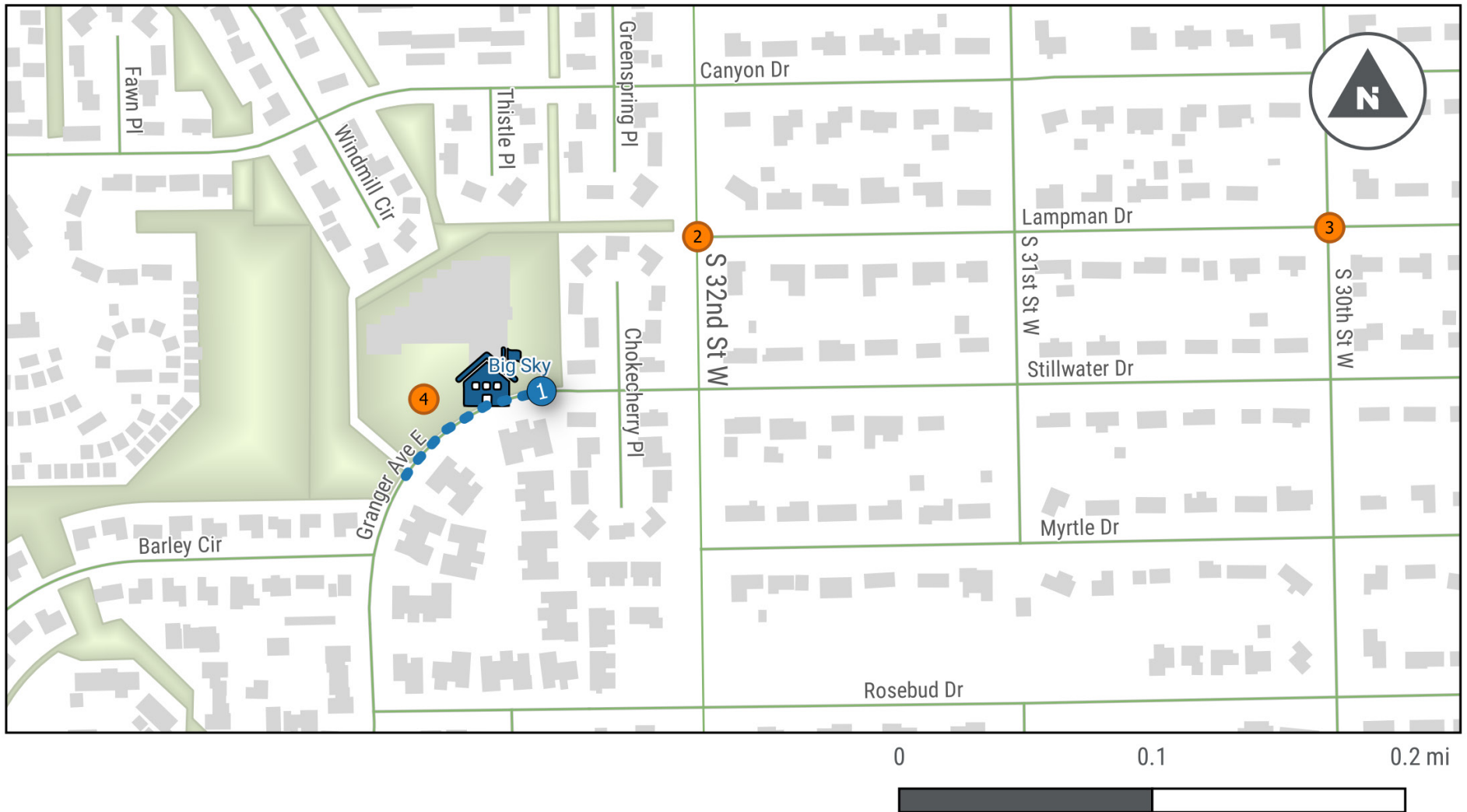

# Bitterroot Elementary

## Existing Conditions

About the School	
Address	1801 Bench Blvd
Number of Students	Approximately 295
Percentage of Students Eligible for Free and Reduced Lunch	48%
Arrival / Dismissal Times	8:05 AM / 2:20 and 3:05 PM

Major Streets and Highways	Annual Average Daily Traffic (AADT) <sup>c</sup>
Bench Blvd	<ul style="list-style-type: none"> <li>5,500 (north of Wicks Ln)</li> <li>3,400 (north of Barrett Rd)</li> </ul>
Wicks Ln	<ul style="list-style-type: none"> <li>10,500 (west of Bench Blvd)</li> <li>4,000 (east of Bench Blvd)</li> </ul>

<sup>c</sup>Source: MDOT Interactive Traffic Web Map

## Existing Conditions Map

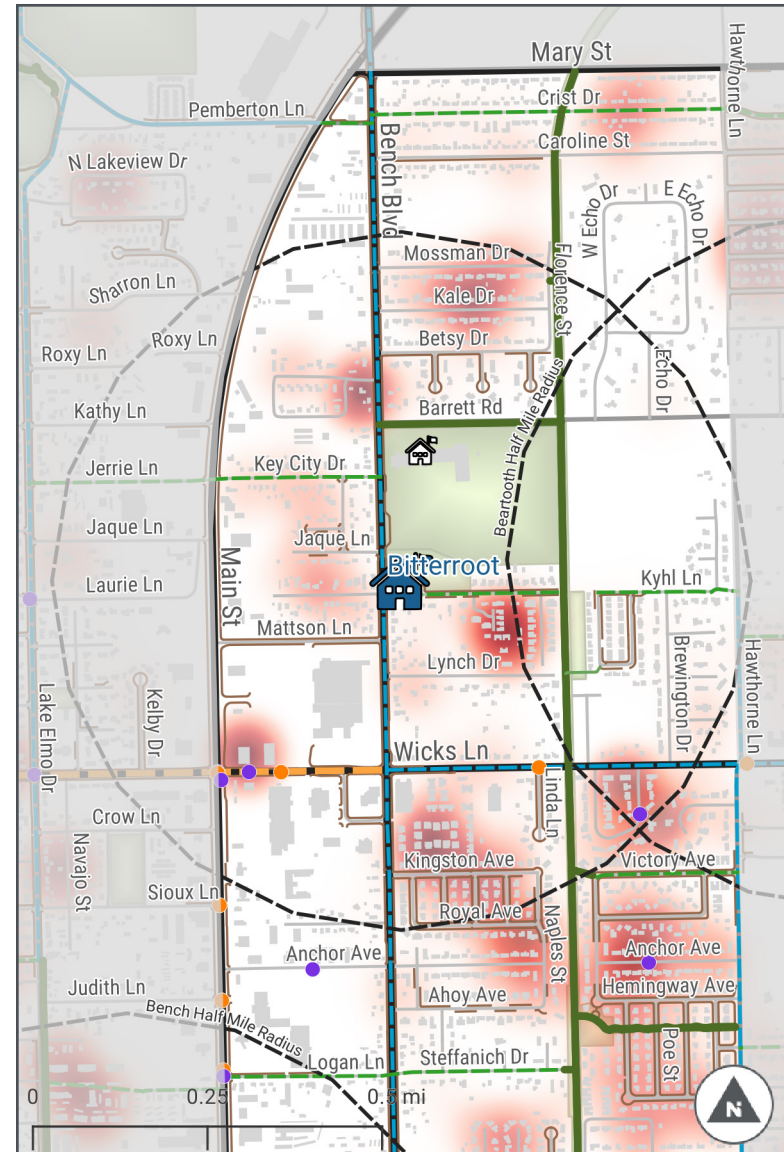

Student Address Heatmap	<b>Existing</b>	<b>Proposed</b>
School Half Mile Buffer	Shared Use Path	Neighborhood Bikeway
Outside School Boundary	Sidewalk	Bike Lane
Bike Crash (2016-2020)		Visionary Long Range Bikeway
Pedestrian Crash (2016-2020)		
Speed Limit 35 mph or Greater		

## Known Safety Concerns at Bitterroot Elementary

Source of Concern	Safety Concern or Comment
Principal	<ul style="list-style-type: none"> <li>Drop-off and pick-up area for parents along Bench Blvd was a concern due to high traffic volumes and students crossing at undesignated crosswalks. Parents parked across the street and waited for student to cross.</li> </ul>
Webmap Survey	<p>There were over 20 comments in the Bitterroot Elementary catchment area:</p> <ul style="list-style-type: none"> <li>Many concerns about Barrett Rd and the lack of sidewalks and street lighting. Some comments regarding vehicular congestion at Bench Blvd and Barrett Rd.</li> <li>Comments also noted the difficulty crossing Wicks Ln.</li> <li>Concerns about sidewalk clearing and high traffic on Bench Blvd.</li> </ul>
Crossing Guard	<ul style="list-style-type: none"> <li>Family vehicles make u-turns near the crossing guard crosswalk</li> <li>Families ask students to cross the street without an adult all along Bench Blvd.</li> <li>Some drivers/Turning drivers do not stop for crossing guard.</li> <li>High speeds and/or high traffic volumes on Bench Blvd.</li> </ul>
Safety Busing Concern	<ul style="list-style-type: none"> <li>No busing of any kind is provided.</li> </ul>

## Dismissal Observations

Observation Details	
Observation Date	<b>The consultant team observed dismissal on Monday, September 20.</b>
School Bus Loading	<ul style="list-style-type: none"> <li>School buses lined up along the school-side of Bench Blvd.</li> </ul>
Family Vehicles	<ul style="list-style-type: none"> <li>At the first dismissal, families waited for students on the westside of the building on school property to walk them to the car. Family drivers parked on the street to pick up directly at the school entrance or in the angled parking.</li> <li>Second dismissal aligned with the Medicine Crow Middle School dismissal, increasing the number of cars on the west side of Bench Blvd and increasing the number of students crossing (either at the crosswalk or not).</li> <li>For both dismissal periods, a few families would park on Kyhl Ln. School has explicitly said to not do this.</li> </ul>
School Staff Roles	<ul style="list-style-type: none"> <li>A few school staff were present, supervising students on the playground.</li> </ul>
Adult Crossing Guards	<ul style="list-style-type: none"> <li>A school crossing guard is posted at Bench Blvd and the midblock crossing north of Kyhl Ln/Lambrech Ln.</li> <li>Missing crossing guard due to labor shortages at Bench Blvd and Barrett Rd.</li> </ul>
Students Walking and Biking	<ul style="list-style-type: none"> <li>Few students were observed walking or biking. A handful of students walked or biked east to the Heritage Trail/Kiwanis Trail.</li> </ul>

## Priority Concerns at Bitterroot Elementary

The numbered observations and recommendations in the table below correspond to the points in the Existing Conditions Map (shown on previous page).

#	Location	Observations	Webmap Comments?
1	Bench Blvd from Kyhl Ln to Barrett Rd	<ul style="list-style-type: none"> <li>ADT on Bench Blvd is 7,090 just north of Wicks and 4,280 just north of Barrett</li> <li>Some families were observed parking on the non-school side and asking middle school students to cross the street without an adult.</li> </ul>	Yes
2	Kyhl Ln in front of school	<ul style="list-style-type: none"> <li>Drainage issues and walking infrastructure concerns were observed in front of the school.</li> <li>There is no sidewalk on the north side of Kyhl Ln, along the parking median.</li> <li>A future neighborhood bikeway is planned for Kyhl Ln from Bench Blvd to the Heritage Trail/Kiwanis Trail.</li> </ul>	No
3	Barrett Rd and Bench Blvd	<ul style="list-style-type: none"> <li>During dismissal, students crossed Barrett Rd along Bench Blvd.</li> <li>This intersection has significant vehicle congestion at arrival and dismissal due to the proximity of the two schools.</li> </ul>	Yes
4	Heritage Trail/Kiwanis Trail	<ul style="list-style-type: none"> <li>The Kiwanis Trail offers a great off-street walking and biking connection; however it appears to be underutilized by students and families at both Bitterroot and Medicine Crow.</li> <li>Neighborhood sidewalk connections to the Heritage Trail/Kiwanis Trail were lacking.</li> <li>Many students live south of the school near the trail.</li> </ul>	Yes
5	Southwest corner of school blacktop	<ul style="list-style-type: none"> <li>Existing bicycle racks were located on the blacktop adjacent to Kyhl Ln. Bike parking was a third- to a half-full.</li> </ul>	No

## Proposed Projects at Bitterroot Elementary

The numbered observations and recommendations in the table below correspond to the points in the Proposed Projects Map (shown on final page).

#	Location	Topic	Issue	Recommendation
1	Bench Blvd from Kyhl Ln to Barrett Rd	Arrival/Dismissal Behavior	<ul style="list-style-type: none"> <li>Some families were observed parking on the non-school side and asking students to cross the street without an adult.</li> <li>ADT on Bench Blvd is 7,090 just north of Wicks and 4,280 just north of Barrett.</li> </ul>	<ul style="list-style-type: none"> <li>Encourage more families to walk or bicycle to school to reduce the number of vehicles during arrival and dismissal.</li> <li>Ideally, all pick-up and drop-off occurs on the school side of the street, or, at a minimum, in locations with safe crossings. Develop a school drop off/pick up plan that can be shared with Bitterroot and Medicine Crow families. Communicate expected drop off and pick up procedures to families via email, text, windshield flyers, and backpack mail.</li> <li>Reduce travel lane widths to install bike lanes and slow traffic on Bench Blvd.</li> <li>A further evaluation and/or pilot pop-up project should be used to evaluate the effectiveness of any new on-street parking restriction.</li> </ul>
2	Kyhl Ln in front of school	Sidewalk	<ul style="list-style-type: none"> <li>Drainage issues and walking infrastructure concerns were observed in front of the school. There is no sidewalk on the north side of Kyhl Ln, along the parking median.</li> </ul>	<ul style="list-style-type: none"> <li>Construct sidewalk in front of the school along the parking median.</li> </ul>
3	Barrett Rd and Bench Blvd	Crossing	<ul style="list-style-type: none"> <li>During dismissal, students crossed Barrett Rd along Bench Blvd. This intersection has significant vehicle congestion at arrival and dismissal due to the proximity of the two schools.</li> </ul>	<ul style="list-style-type: none"> <li>Install curb extensions to shorten pedestrian crossing distance and improve visibility of pedestrians.</li> </ul>
4	Heritage/Kiwanis Trail at Ahoy Avenue and Naples Street	Trail Connections	<ul style="list-style-type: none"> <li>Neighborhood sidewalk connections to the Heritage Trail/Kiwanis Trail were lacking.</li> <li>Many students live south of the school near the trail.</li> </ul>	<ul style="list-style-type: none"> <li>Recommend building a sidewalk and neighborhood street access connections along the Heritage/Kiwanis Trail, with accompanying wayfinding.</li> <li>Organize a walk/bike to school event (such as a weekly walking school bus or a walk to school day) from Walden Grove Park to one or both schools.</li> </ul>
5	Barrett Rd from Kiwanis Trail to Columbine Dr	Sidewalk/Sidepath	<ul style="list-style-type: none"> <li>Currently no sidewalk that allows separated facilities for walking and biking along Barrett Rd.</li> </ul>	<ul style="list-style-type: none"> <li>Install new sidewalk or trail along south side of Barrett Rd.</li> </ul>
6	Southwest corner of school blacktop	Bicycle Parking	<ul style="list-style-type: none"> <li>Existing bicycle racks can damage bikes and make it difficult to securely lock bicycles. Some bicycles were parked the day of observation.</li> </ul>	<ul style="list-style-type: none"> <li>Replace the existing bike racks with new racks that support the bike frame in at least two places and that enable secure locking. (Short Term)</li> </ul>



### Proposed Projects Map



# Boulder Elementary

## Existing Conditions

About the School	
Address	2202 32nd St W, Billings, MT 59102
Number of Students	Approximately 500
Percentage of Students Eligible for Free and Reduced Lunch	13%
Arrival / Dismissal Times	8:00 and 8:20 AM / 2:20 and 3:00 PM

Major Streets and Highways	Annual Average Daily Traffic (AADT) <sup>c</sup>
Poly Drive	<ul style="list-style-type: none"> <li>4,700 (west of Rehberg Ln)</li> <li>5,000 (east of Rehberg Ln)</li> </ul>
Colton Boulevard	2,800
Grand Avenue	<ul style="list-style-type: none"> <li>13,200 (west of Rehberg Ln) to</li> <li>16,000 (east of Rehberg Ln)</li> </ul>
Rehberg Lane	<ul style="list-style-type: none"> <li>2,600 (north of Cotton Blvd)</li> <li>5,300 (south of Cotton Blvd)</li> </ul>

<sup>c</sup>Source: MDOT Interactive Traffic Web Map

## Existing Conditions Map

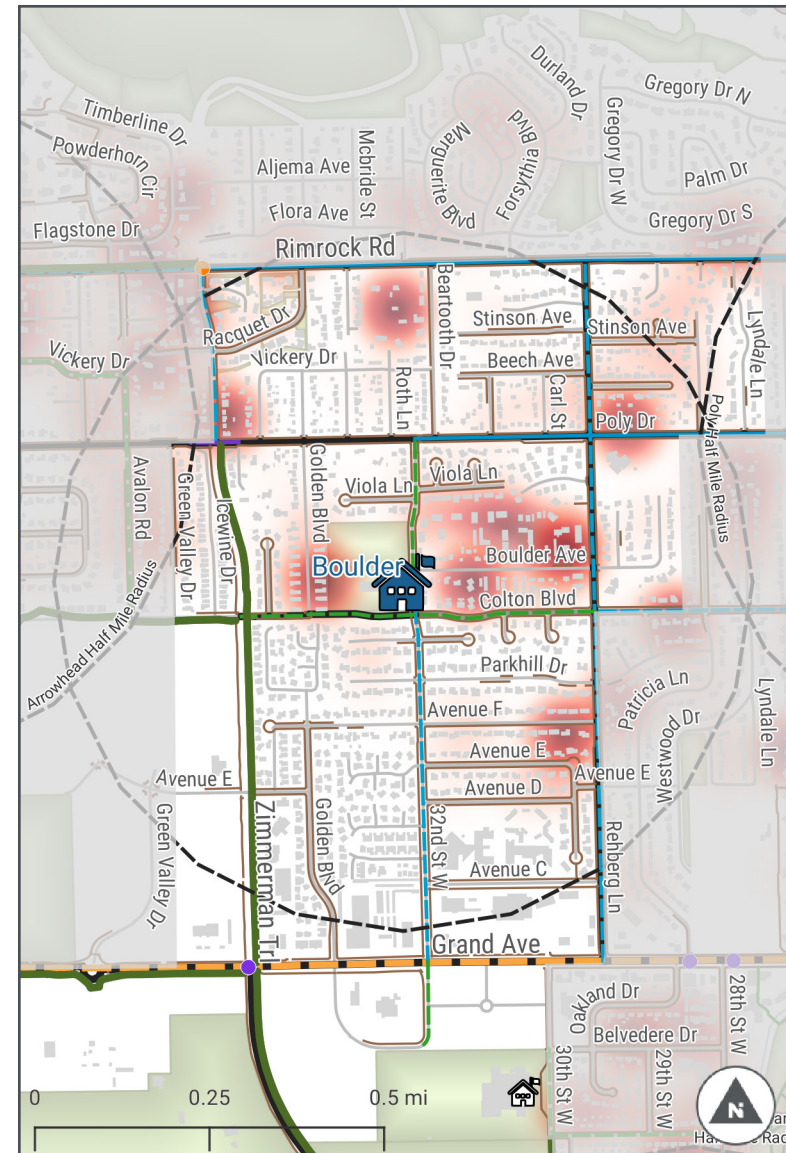

## Known Safety Concerns at Boulder Elementary

Source of Concern	Safety Concern or Comment
Principal	<ul style="list-style-type: none"> <li>No significant safety concerns.</li> </ul>
Webmap Survey	<p>There are approximately 10 comments in the Boulder Elementary catchment area:</p> <ul style="list-style-type: none"> <li>Gate prohibiting people walking and biking on trail connection to Zimmerman Trail.</li> <li>Speeding traffic on Poly Dr is a concern, especially at the 32<sup>nd</sup> St W intersection and the lack of a crossing guard.</li> <li>Speeding traffic and lack of street lighting create dangerous conditions to walk and bike.</li> <li>Canal path.</li> <li>Sidewalk conditions.</li> </ul>
Crossing Guard	<ul style="list-style-type: none"> <li>Family vehicles make u-turns near the crossing guard crosswalk.</li> <li>Some drivers/Turning drivers do not stop for crossing guard.</li> </ul>
Safety Busing	<ul style="list-style-type: none"> <li>No safety busing is provided.</li> </ul>

## Dismissal Observations

Observation Details	
Observation Date	<b>The consultant team observed dismissal on Thursday, September 23.</b>
School Bus Loading	<ul style="list-style-type: none"> <li>School buses lined up along side of the school on Colton Blvd inside of school limits. Buses enter a gate area protected with fences with gates for kids entering the buses according to grades.</li> </ul>
Before/Aftercare Vans	<ul style="list-style-type: none"> <li>Before/aftercare vans picked up students in front of school at 32nd Ave W.</li> </ul>
Family Vehicles	<ul style="list-style-type: none"> <li>For first and second dismissal, families in vehicles picked up students from the front of the building. Family drivers either stay in the vehicle and queue to pick up directly at the school entrance, or park in perpendicular streets (Boulder Ave and Colton Blvd) and walk to the school entrance.</li> </ul>
School Staff Roles	<ul style="list-style-type: none"> <li>School staff loaded students onto the correct buses.</li> <li>School staff were present supervising students on the playground and outside the front door.</li> </ul>
Adult Crossing Guards	<ul style="list-style-type: none"> <li>A school crossing guard is posted in front on the school crossing at Boulder Ave.</li> <li>School crossing guard recently quit at Poly Dr and 32nd St W.</li> </ul>
Bike Rack Locations and Use	<ul style="list-style-type: none"> <li>There are two bike racks around the school, located at 32nd St W in front of the school and south side of the school near Colton Blvd.</li> <li>Most of the bicycles were parked at 32nd St W.</li> </ul>
Students Walking and Biking	<ul style="list-style-type: none"> <li>Few students were observed walking and biking.</li> </ul>

## Priority Concerns at Boulder Elementary

The numbered observations and recommendations in the table below correspond to the points in the Existing Conditions Map (shown on previous page).

#	Location	Observations	Webmap Comments?
1	Poly Dr	<ul style="list-style-type: none"> <li>• Poly Dr has higher traffic volumes and speeds than would be preferred for a student crossing location.</li> <li>• Crossings of Poly Dr and 32nd St W are uncomfortable because crossing distances are long, and pedestrians have no median crossing islands.</li> <li>• Some students cross the street at this location. This intersection used to have a crossing guard, but the guard quit just prior to observation. The consultant team observed that drivers don't always yield to pedestrians in the crosswalk.</li> <li>• Sidewalks are in poor conditions and there are permanent obstructions, including cracks, breakings, and mailboxes.</li> <li>• Existing bike lane on Poly Dr.</li> </ul>	Yes
2	Boulder Ave	<ul style="list-style-type: none"> <li>• Missing sidewalks on the south side sides of the street.</li> <li>• Families park and walk to pick up their students.</li> </ul>	No
3	Colton Blvd	<ul style="list-style-type: none"> <li>• Colton Blvd between 32nd St and Golden Blvd, which directly borders the school to the south, is gated and locked except for when busses arrive. This is a key connector to students who live west of school.</li> <li>• Bus arrival/dismissal with open gates for each bus.</li> <li>• The Billings Area Bikeway and Trails Master plan includes the following projects on Colton Blvd.:                             <ul style="list-style-type: none"> <li>• A neighborhood bikeway on Colton Blvd from Zimmerman Trail to Rehberg Ln.</li> <li>• A bike lane from Rehberg Ln to 17th St W.</li> <li>• Spot improvements at intersections of Zimmerman Trail, 32nd St W and Rehberg Ln.</li> <li>• Major trailhead improvements for Colton Blvd and 38th St W.</li> </ul> </li> </ul>	Yes
4	Zimmerman Trail	<ul style="list-style-type: none"> <li>• Crossing distances are long and, although there are medians, they do not extend through the crosswalks and are not designed to be used as median crossing islands.</li> </ul>	No
5	32 <sup>nd</sup> St W	<ul style="list-style-type: none"> <li>• Sidewalks measure less than the recommended width of 5' and have inadequate buffer.</li> <li>• Families parking in prohibited parking zone. Some families complained about the parking regulation.</li> <li>• Second crosswalk is a block apart front of the school.</li> <li>• 32nd St W is recommended to be a neighborhood bikeway from Poly Dr to Colton Blvd, and a bike lane from Colton Blvd to Grand Ave in the Billings Area Bikeway and Trails Master Plan.</li> </ul>	Yes
6	Rehberg Ln	<ul style="list-style-type: none"> <li>• Crossings are uncomfortable because of wide corner radii, which encourages fast vehicular turns.</li> <li>• Rehberg Ln is recommended to be a bike lane in the Billings Area Bikeway and Trails Master Plan.</li> </ul>	Yes

## Proposed Projects at Boulder Elementary

The numbered observations and recommendations in the table below correspond to the points in the Proposed Projects Map (shown on final page).

#	Location	Topic	Issue	Recommendation
1	Poly Dr	Speeding	<ul style="list-style-type: none"> <li>Vehicles appear to exceed the posted speed limit during school arrival and dismissal times.</li> </ul>	<ul style="list-style-type: none"> <li>Install driver speed feedback sign on both approaches to Poly Dr at 32<sup>nd</sup> St.</li> <li>Install curb extensions at 32<sup>nd</sup> and school flashing beacon.</li> <li>Installing RRFB in 2022.</li> </ul>
2	Colton Blvd	Connectivity	<ul style="list-style-type: none"> <li>Private development fencing restricts access of students to school.</li> </ul>	<ul style="list-style-type: none"> <li>Build a path from where the sidewalk ends on Aronson to the cul-de-sac on Quiet Water Ave on City owned land.</li> <li>Work with property owners to discuss easement and access possibilities.</li> </ul>
3	Rehberg Ln and Colton Blvd	Crossing	<ul style="list-style-type: none"> <li>Crossings are uncomfortable because of wide corner radii, which encourages fast vehicular turns.</li> </ul>	<ul style="list-style-type: none"> <li>Install curb extensions to shorten crossing distance.</li> </ul>
4	Zimmerman Trail	Crossing	<ul style="list-style-type: none"> <li>Some students cross the street at this intersection, and drivers don't always yield to pedestrians in the crosswalk.</li> </ul>	<ul style="list-style-type: none"> <li>Install high-visibility crosswalk</li> <li>Install curb extensions, pedestrian refuge island, and rectangular rapid-flashing beacon or pedestrian hybrid beacon.</li> <li>Installing RRFB in 2022.</li> </ul>

## Proposed Projects Map

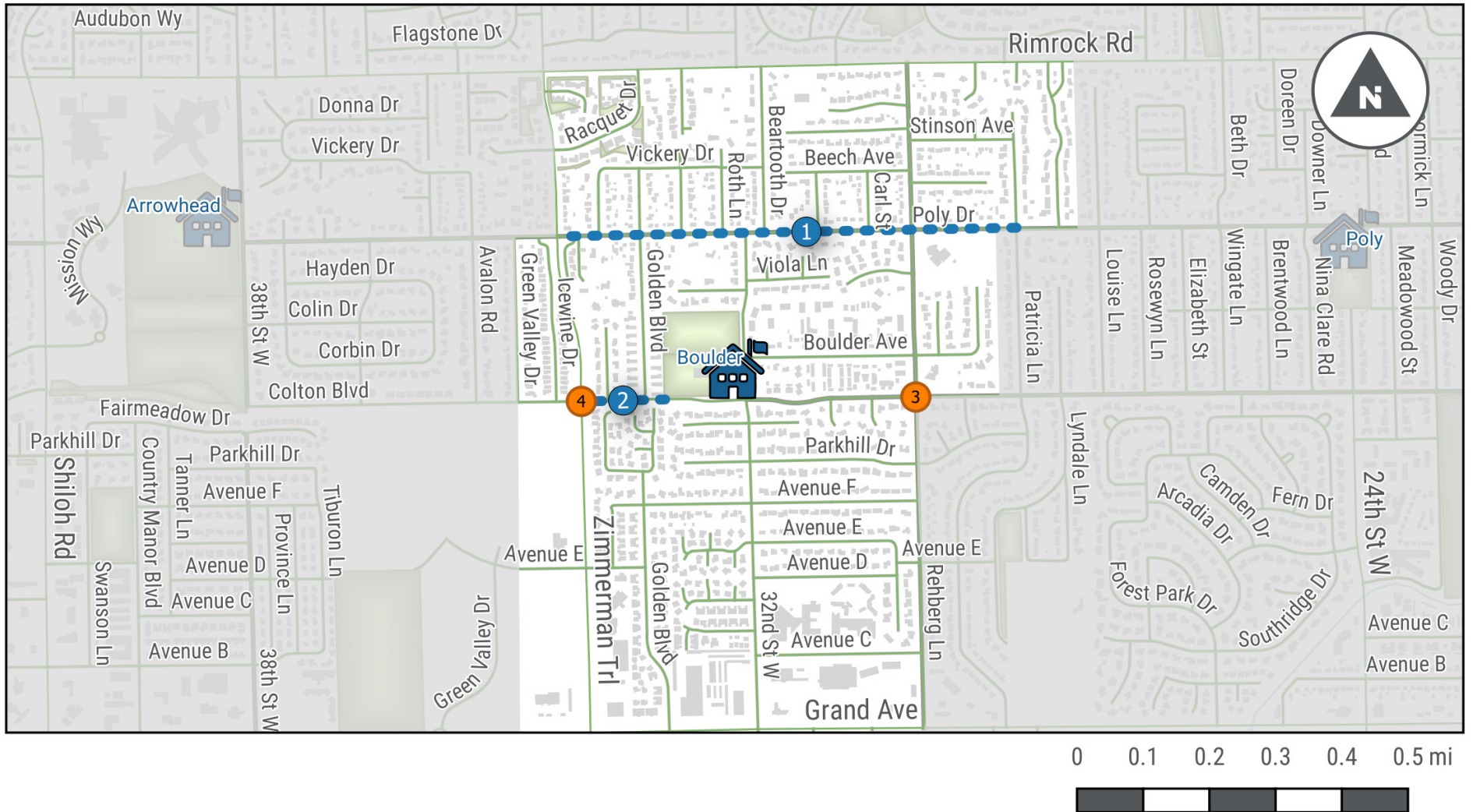

# Broadwater Elementary

## Existing Conditions

About the School	
Address	415 Broadwater Ave
Number of Students	325
Percentage of Students Eligible for Free and Reduced Lunch	56%
Arrival / Dismissal Times	8:15 AM / 2:10 and 2:50 PM

Major Streets and Highways	Annual Average Daily Traffic (AADT) <sup>c</sup>
Broadwater Ave	13,500
5 <sup>th</sup> St	<ul style="list-style-type: none"> <li>6,000 (north of Broadwater Ave)</li> <li>4,200 (south of Broadwater Ave)</li> </ul>
6 <sup>th</sup> St	8,500
Lewis Ave	3,300
7 <sup>th</sup> St	5,300
8 <sup>th</sup> St	5,100

<sup>c</sup>Source: MDOT Interactive Traffic Web Map

## Existing Conditions Map

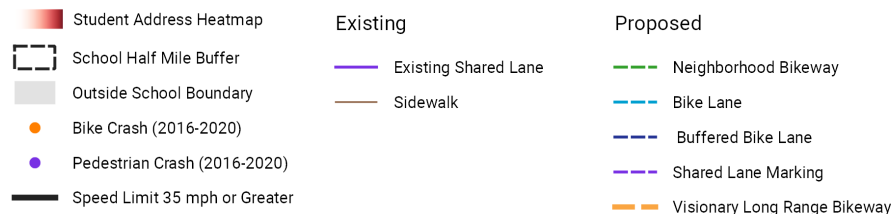
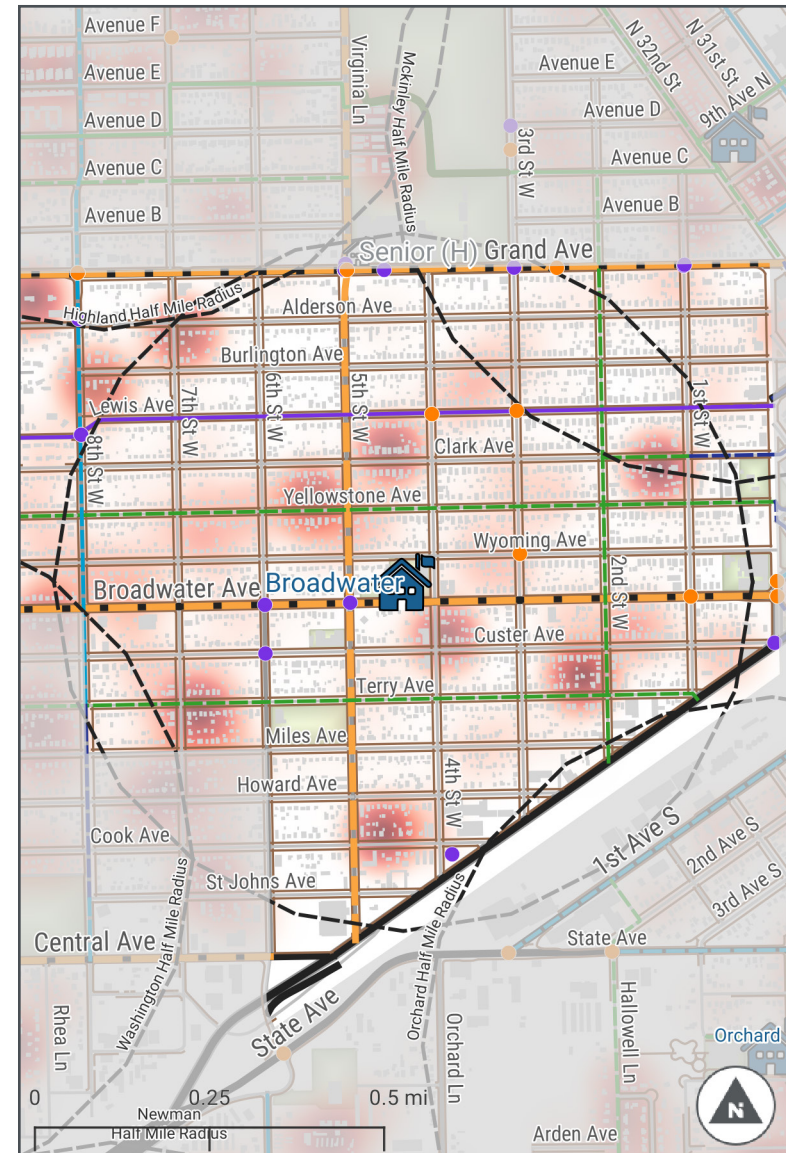

## Known Safety Concerns at Broadwater Elementary

Source of Concern	Safety Concern or Comment
Principal	<ul style="list-style-type: none"> <li>Drop-off and pick-up are chaotic, mostly between Broadwater Ave and Wyoming Ave on 4<sup>th</sup> St W.</li> <li>Crossing Broadwater Ave is risky. There is only one crossing guard at the intersection of Broadwater Ave and 5<sup>th</sup> St W not at 4<sup>th</sup> St W where some students (not many) sometimes try to cross.</li> </ul>
Webmap Survey	<p>There are approximately 15 comments in the Broadwater Elementary catchment area:</p> <ul style="list-style-type: none"> <li>Concerns of speeding traffic and crossings on Lewis Ave.</li> <li>Other comments noted fast traffic on 3<sup>rd</sup> St W and 1<sup>st</sup> St W.</li> <li>Comments showed support for Alderson Ave and Yellowstone Ave as bike routes.</li> <li>Concerns about Lewis Ave at 8<sup>th</sup> St and 4<sup>th</sup> St.</li> <li>Some additional comments pertained to safety at Senior High School, including a pedestrian crossing at 4<sup>th</sup> St W and Grand Ave.</li> </ul>
Crossing Guard	<p>At Broadwater Ave and 5th St W:</p> <ul style="list-style-type: none"> <li>Drivers turning on red do not see kids/guard.</li> <li>Speeding in the morning and running the red light.</li> </ul> <p>At 4th St W and Wyoming Ave:</p> <ul style="list-style-type: none"> <li>Arrival and dismissal are usually a mess – too many people, vehicles, and buses packed into one block on 4th between Wyoming and Broadwater.</li> <li>High school students speeding down 4th St W in the morning on their way to school.</li> </ul>
Safety Busing	<ul style="list-style-type: none"> <li>No safety busing is provided.</li> </ul>

## Dismissal Observations

Observation Details	
Observation Date	<b>The consultant team observed dismissal on Tuesday, September 21.</b>
School Bus Loading	<ul style="list-style-type: none"> <li>School buses line up along 4<sup>th</sup> St between Wyoming Ave and Broadwater Ave.</li> </ul>
Before/Aftercare Vans	<ul style="list-style-type: none"> <li>Before/Aftercare vans park along 4<sup>th</sup> St between Wyoming Ave and Broadwater Ave.</li> </ul>
Family Vehicles	<ul style="list-style-type: none"> <li>At dismissal, families park on neighborhood streets (primarily Wyoming Ave north of the school property) and then walk to the front or the side of the school to meet their children.</li> <li>At dismissal, families can also park in the church parking lot to the east of the school and cross 4<sup>th</sup> St to meet their children. They are supposed to cross at 4<sup>th</sup> St W and Broadwater Ave, but often cross mid-block at the parking lot driveway.</li> </ul>
School Staff Roles	<ul style="list-style-type: none"> <li>School staff have “door duty” near the doors by the buses, but do not have specific direction.</li> </ul>
Adult Crossing Guards	<p>A school crossing guard is posted at the following three locations:</p> <ul style="list-style-type: none"> <li>4<sup>th</sup> St. and Wyoming Ave</li> <li>Broadwater Ave and 5<sup>th</sup> St W</li> <li>4<sup>th</sup> and Lewis Ave (AM only)</li> </ul> <p>Principal noted that a guard was supposed to be located at Wyoming Ave and 5<sup>th</sup> St W, but no guard was there during the observation.</p>
Bike Rack Locations and Use	<ul style="list-style-type: none"> <li>There are two bike racks around the school – one at Wyoming Ave near 4<sup>th</sup> St W, and the other on 4<sup>th</sup> St W at the school entrance,</li> <li>Most of the bicycles were parked at the rack on 4<sup>th</sup> St W.</li> </ul>
Students Walking and Biking	<ul style="list-style-type: none"> <li>Most of the student biking were traveling toward neighborhoods to the north of the school, either along 4<sup>th</sup> or east/west along Wyoming Ave.</li> <li>Some students were observed leaving the school property at the SW campus entrance/exit fence gate and crossing at Broadwater St W and 5<sup>th</sup> St W.</li> </ul>



## Priority Concerns at Broadwater Elementary

The numbered observations and recommendations in the table below correspond to the points in the Existing Conditions Map (shown on previous page).

#	Location	Observations	Webmap Comments?
1	Broadwater Ave at 4 <sup>th</sup> St W	<ul style="list-style-type: none"> <li>Broadwater Ave has higher traffic volumes and speeds than would be preferred for a road students walk along without a wide sidewalk.</li> <li>The relatively wide street and/or multiple travel lanes encourages speeding.</li> <li>Broadwater Ave and 4th St W is unsignalized, yet is a logical crossing for students heading to neighborhoods to the south.</li> <li>Drivers take right turns on red while students are crossing.</li> <li>The corners offer very little waiting space for groups of students (Broadwater Ave is all curbside).</li> </ul>	No
2	Broadwater Ave and 5 <sup>th</sup> St W	<ul style="list-style-type: none"> <li>Broadwater Ave has higher traffic volumes and speeds than would be preferred for a student crossing location.</li> <li>The relatively wide street and/or multiple travel lanes encourages speeding.</li> </ul>	No
3	4th St W between Broadwater Ave and Wyoming Ave	<ul style="list-style-type: none"> <li>This block serves too many functions during drop-off/pick-up, including bus parking, daycare parking, parent parking, parent and family crossing from the church parking lot to the east.</li> <li>Drivers may take 4<sup>th</sup> St W to avoid the high traffic streets like 5th and 6th Sts W to get to the nearby high school (this is also a route to the high school, so there are student drivers).</li> </ul>	Yes
4	4th St and Lewis Ave	<ul style="list-style-type: none"> <li>Lewis Ave has higher traffic volumes and speeds than would be preferred for a student crossing location</li> </ul>	Yes
5	Broadwater Ave between 4th and 5th	<ul style="list-style-type: none"> <li>Narrow sidewalks with minimal buffer next to a busy, 4-lane arterial creates an uncomfortable walking/cycling environment.</li> </ul>	No
6	Bicycle Racks at Broadwater	<ul style="list-style-type: none"> <li>There are two bike racks around the school – one at Wyoming Ave near 4<sup>th</sup> St W, and the other on 4<sup>th</sup> St W at the school entrance,</li> <li>Most of the bicycles were parked at the rack on 4<sup>th</sup> St W.</li> </ul>	No

## Proposed Projects at Broadwater Elementary

The numbered observations and recommendations in the table below correspond to the points in the Proposed Projects Map (shown on final page).

#	Location	Topic	Issue	Recommendation
1	Broadwater Ave between 4 <sup>th</sup> and 5 <sup>th</sup> St W	Speeding	<ul style="list-style-type: none"> <li>The relatively wide street and/or multiple travel lanes encourage(s) speeding.</li> </ul>	<ul style="list-style-type: none"> <li>Install driver speed feedback sign on both approaches to the (intersection, school, etc.).</li> <li>Study further to find an infrastructure intervention to make crossing safer and more comfortable for school children and to deter speeding.</li> </ul>
2	4th St W between Broadwater Ave and Wyoming Ave	Arrival/Dismissal Behavior	<ul style="list-style-type: none"> <li>Some families were observed parking on the non-school side/ double-parking/asking students to cross the street without an adult.</li> <li>Vehicles were observed making u-turns in front of the school.</li> </ul>	<ul style="list-style-type: none"> <li>Provide/continue staff monitoring of arrival and dismissal, and provide/continue communicating expectations for family vehicles at arrival and dismissal.</li> <li>Close 4<sup>th</sup> St W between Wyoming and Broadwater to personal vehicles during drop-off and pick-up, only allowing busses. The closure would occur with temporary barricades only, and would begin as a pilot project to allow for evaluation.</li> <li>Encourage more families to walk or bicycle to school to reduce the number of vehicles during arrival and dismissal.</li> <li>Ideally, all pick-up and drop-off occurs on the school side of the street, or, at a minimum, in locations with safe crossings. Add on-street parking restrictions to facilitate school-side drop off/pick up and crossing at safe locations.</li> <li>A further evaluation and/or pilot pop-up project should be used to evaluate the effectiveness of any new on-street parking restriction.</li> </ul>
3	Wyoming Ave at 8th St W	Crossing	<ul style="list-style-type: none"> <li>Some students cross the street at this intersection and drivers don't always yield to pedestrians in the crosswalk.</li> <li>Preference is for students to walk east/west on Wyoming instead of Broadwater.</li> </ul>	<ul style="list-style-type: none"> <li>Install high-visibility crosswalk.</li> <li>Add crossing guard to this location if crossing after crossing infrastructure is added.</li> <li>Install curb extensions to shorten crossing distance.</li> </ul>
4	Wyoming Ave at 6th St W	Crossing	<ul style="list-style-type: none"> <li>Some students cross the street at this intersection and drivers don't always yield to pedestrians in the crosswalk.</li> <li>Preference is for students to walk east/west on Wyoming instead of Broadwater.</li> </ul>	<ul style="list-style-type: none"> <li>Install high-visibility crosswalk.</li> <li>Add crossing guard to this location if crossing after crossing infrastructure is added.</li> <li>Install curb extensions to shorten crossing distance.</li> </ul>

## Proposed Projects Map

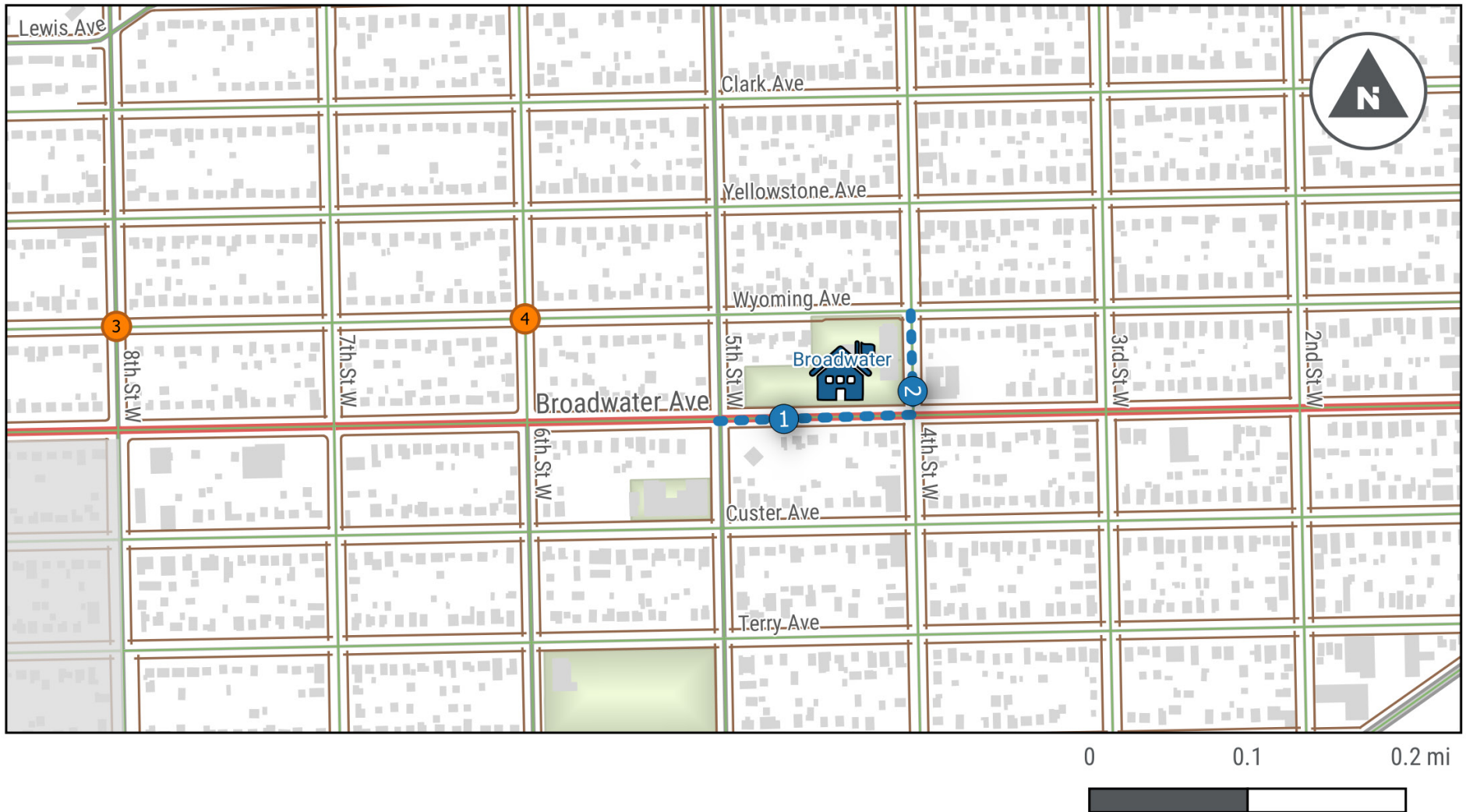

# Burlington Elementary

## Existing Conditions

About the School	
Address	2135 Lewis Ave
Number of Students	Approximately 230
Percentage of Students Eligible for Free and Reduced Lunch	42%
Arrival / Dismissal Times	7:45 and 8:25 AM / 2:25 and 3:15 PM

Major Streets and Highways	Annual Average Daily Traffic (AADT) <sup>c</sup>
Grand Ave	<ul style="list-style-type: none"> <li>16,000 (between Rehberg Ln and 24th St W)</li> <li>14,100 (between 24th St W and 19th St W)</li> <li>17,000 (between 19th St W and 17th St W)</li> </ul>
Lewis Ave	<ul style="list-style-type: none"> <li>4,800 (west of 19th Street W)</li> <li>3,300 (east of 19th Street W)</li> </ul>
Broadwater Ave	<ul style="list-style-type: none"> <li>9,400 (between Vermillion Dr and 24th St W)</li> <li>11,700 (between 24th St W and 19th St W)</li> <li>12,900 (between 19th St W and 16th St W)</li> </ul>
24th St W	<ul style="list-style-type: none"> <li>17,300 (north of Lewis Ave)</li> <li>15,600 (south of Lewis Ave)</li> </ul>
19th Ave	<ul style="list-style-type: none"> <li>6,200 (between Grand Ave and Broadwater Ave)</li> </ul>

<sup>c</sup>Source: MDOT Interactive Traffic Web Map

## Existing Conditions Map

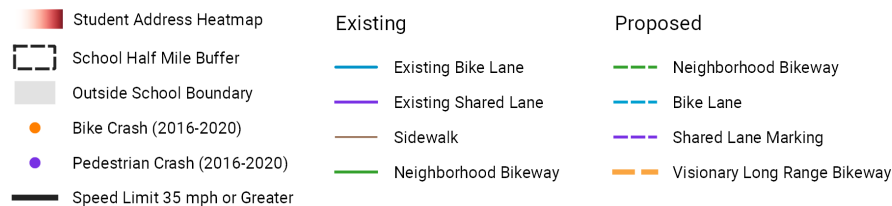
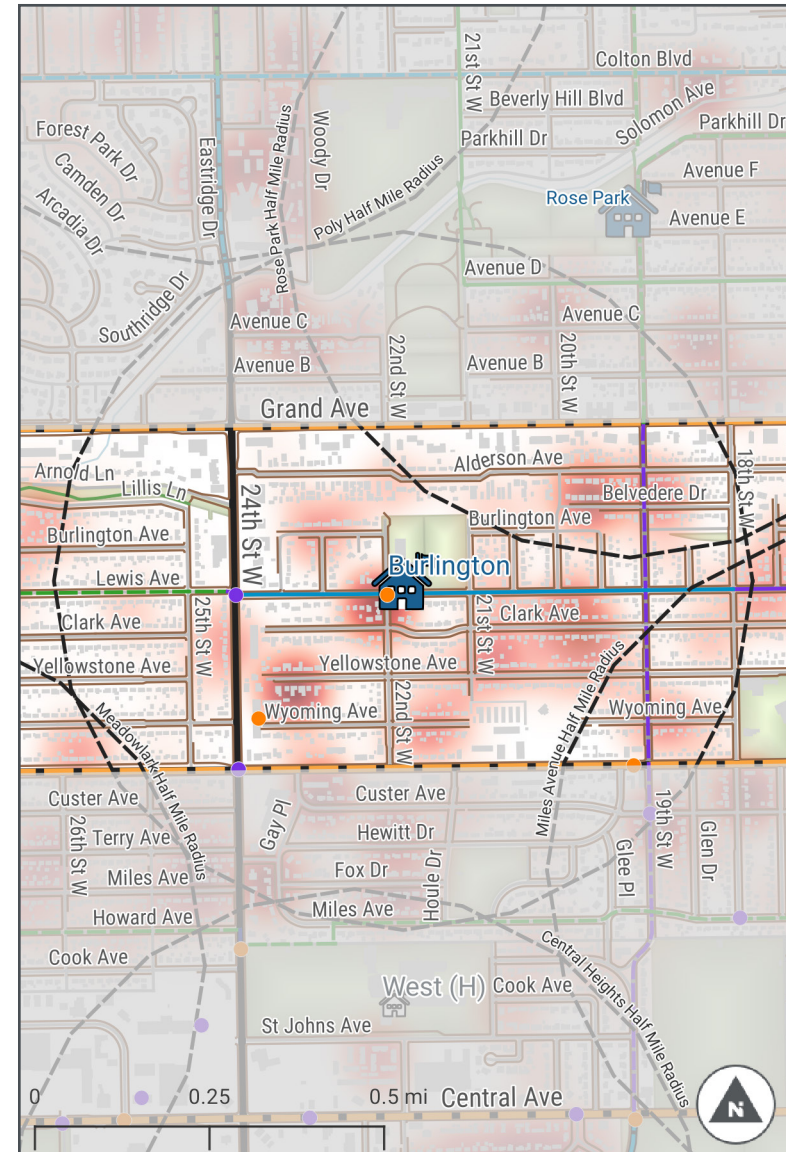

## Known Safety Concerns at Burlington Elementary

Source of Concern	Safety Concern or Comment
Principal	<ul style="list-style-type: none"> <li>Lewis Ave has high traffic volumes and high speeds.</li> </ul>
Webmap Survey	<p>There are approximately 10 comments in the Burlington Ave catchment area.</p> <ul style="list-style-type: none"> <li>24<sup>th</sup> St is difficult to cross.</li> <li>Lewis Ave is high traffic.</li> <li>Crossing 24<sup>th</sup> St at Arnold Ln.</li> <li>24<sup>th</sup> St and Lewis is a difficult intersection to cross.</li> <li>Snow plowing on 22<sup>nd</sup> makes crossings and drop-off difficult.</li> </ul>
Crossing Guard	<ul style="list-style-type: none"> <li>Family vehicles make u-turns near the crossing guard crosswalk.</li> <li>Families ask students to cross the street without an adult in front of the school.</li> <li>Some drivers do not stop for crossing guard.</li> <li>High speeds and high traffic volumes on Lewis Ave.</li> </ul>
Safety Busing	<ul style="list-style-type: none"> <li>No safety busing is provided.</li> </ul>

## Arrival Observations

Observation Details	
Observation Date	<b>The consultant team observed arrival on Tuesday, September 21.</b>
School Bus Loading	<ul style="list-style-type: none"> <li>School buses lined up along the middle sidewalk at 22nd St W in front of the school.</li> </ul>
Before/Aftercare Vans	<ul style="list-style-type: none"> <li>No before/aftercare vans were observed.</li> </ul>
Family Vehicles	<ul style="list-style-type: none"> <li>Families dropped off students in front of the school on Lewis Ave or dropped off near the crossing guard so students crossed the street with the crossing guard at 22nd Ave W.</li> </ul>
School Staff Roles	<ul style="list-style-type: none"> <li>No school staff were involved during the arrival period.</li> </ul>
Adult Crossing Guards	<ul style="list-style-type: none"> <li>Two school crossing guards are posted at 22nd Ave W and 24th Ave W.</li> </ul>
Bike Rack Locations and Use	<ul style="list-style-type: none"> <li>There is one bike rack located on 22nd Ave in front of the school. The rack was moderately full.</li> </ul>
Students Walking and Biking	<ul style="list-style-type: none"> <li>Some students were observed walking and biking.</li> </ul>

## Priority Concerns at Burlington Elementary

The numbered observations and recommendations in the table below correspond to the points in the Existing Conditions Map (shown on previous page).

#	Location	Observations	Webmap Comments?
1	Belvedere Dr	<ul style="list-style-type: none"> <li>Missing sidewalks present a barrier to walking and bicycling to school.</li> <li>Sidewalks throughout the neighborhood need repair or replacement to provide a safe pedestrian route for all users. Some existing sidewalks measure less than the recommended width of 5'. Curb ramps are missing throughout the neighborhood.</li> </ul>	No
2	Arnold Ln	<ul style="list-style-type: none"> <li>Unpaved streets and missing sidewalks throughout the neighborhood present a barrier to walking and bicycling to school. There is an existing shared use path from Parkview Dr to 24th St W. Providing a crossing at 24th St W and Arnold Ln could unlock access to neighborhoods west of 24th St.</li> <li>Arnold Ln is recommended to be a shared use path from 24th St W to 18th St W, and recommended to have a spot improvement at Arnold Ln and 24th Ave St W in the Billings Area Bikeway and Trails Master Plan.</li> </ul>	Yes
3	Lewis Ave	<ul style="list-style-type: none"> <li>Lewis Ave has higher traffic volumes and speeds than would be preferred for a student crossing location.</li> <li>Some families were observed parking on the non-school side. Students understood to cross at 22nd St with the crossing guard.</li> <li>Sidewalks throughout the neighborhood need repair or replacement to provide a safe pedestrian route for all users. Some existing sidewalks measure less than the recommended width of 5'. Curb ramps are missing throughout the neighborhood. Vegetation, posts, and mailboxes in the sidewalk further impede users.</li> <li>A directional curb ramp is missing on the southwest corner of Lewis Ave and 21st St W.</li> <li>Vegetation and trees cover the school sign, reducing visibility.</li> <li>Lewis Ave has an existing bike lane.</li> <li>Lewis Ave and 24th St W is recommended to be a spot improvement in the Billings Area Bikeway and Trails Master Plan.</li> </ul>	Yes
4	Clark Ave	<ul style="list-style-type: none"> <li>There are no curb ramps at Clark Ave and 22nd St W, even though there are sidewalks.</li> </ul>	No
5	Yellowstone Ave	<ul style="list-style-type: none"> <li>There are no curb cuts at Yellowstone Ave and 21st St W, even though there are sidewalks.</li> <li>Sidewalks measure less than the recommended width of 5'.</li> </ul>	Yes
6	Broadwater Ave	<ul style="list-style-type: none"> <li>Broadwater Ave is recommended to be a visionary long-range bikeway in the Billings Area Bikeway and Trails Master Plan.</li> </ul>	No
7	24th St W	<ul style="list-style-type: none"> <li>24th St W has higher traffic volumes and speeds than would be preferred for a student crossing location.</li> <li>Crossing distances across 24th St are long and there are no median crossing islands for pedestrians.</li> <li>Crossings are uncomfortable because of wide corner radii, encouraging fast vehicular turns.</li> <li>The utility box on the northeast corner of 24th St and Lewis Ave blocks the sight vision of vehicles, causing visibility issues.</li> </ul>	Yes
8	22nd St W	<ul style="list-style-type: none"> <li>Some families were observed parking on the non-school side and making u-turns in front of the school.</li> <li>Narrow sidewalks create an uncomfortable walking environment.</li> <li>There are no marked crossings at 22nd St W and Burlington Ave.</li> <li>Curb ramps are missing at 22nd St W and Burlington Ave.</li> <li>Bicycle racks are located on the southwest corner of the school; a few bicycles were parked the day of observation.</li> </ul>	Yes
9	19th St W	<ul style="list-style-type: none"> <li>Sidewalks measure less than the recommended width of 5'. Posts and mailboxes in the sidewalk further impede users.</li> <li>The principal mentioned the need for a crossing guard at the intersection of 19 St W and Lewis Ave.</li> </ul>	No
10	17th St W	<ul style="list-style-type: none"> <li>17th A St W is recommended to be a visionary long-range bikeway from Colton Boulevard to Alderson Ave, and a future neighborhood bikeway is recommended from Alderson Ave to Yellowstone Ave in the Billings Area Bikeway and Trails Master Plan.</li> </ul>	No

## Proposed Projects at Burlington Elementary

The numbered observations and recommendations in the table below correspond to the points in the Proposed Projects Map (shown on final page).

#	Location	Topic	Issue	Recommendation
1	Belvedere Dr	Trail/path	<ul style="list-style-type: none"> <li>Connections to the Arnold shared use path from Burlington Elementary are limiting.</li> </ul>	<ul style="list-style-type: none"> <li>Install a shared use path parallel to the Arnold drain from Burlington Elementary to 24<sup>th</sup> St W. Add treatments that prohibit vehicular driving on the path. Check public ROW ownership for lot south of the Montana Rescue Mission West End Bargain Center.</li> </ul>
2	24 <sup>th</sup> St W and Lewis	Crossing	<ul style="list-style-type: none"> <li>Crossing is uncomfortable because of wide corner radii, which encourages fast vehicular turns.</li> </ul>	<ul style="list-style-type: none"> <li>Study further to find an infrastructure intervention that deters speeding and makes crossing safer and more comfortable for school children.</li> </ul>
3	19 <sup>th</sup> St and Lewis Ave	Crossing	<ul style="list-style-type: none"> <li>No crosswalk is marked on all intersection legs.</li> </ul>	<ul style="list-style-type: none"> <li>Add a high-visibility crosswalk on all legs of the intersection.</li> </ul>
4	Bicycle racks	Bicycle parking	<ul style="list-style-type: none"> <li>Existing bicycle racks can damage bikes and make it difficult to securely lock bicycles. Some bicycles were parked the day of observation.</li> </ul>	<ul style="list-style-type: none"> <li>Replace the existing bike racks with new racks that support the bike frame in at least two places and that enable secure locking.</li> </ul>

### Proposed Projects Map

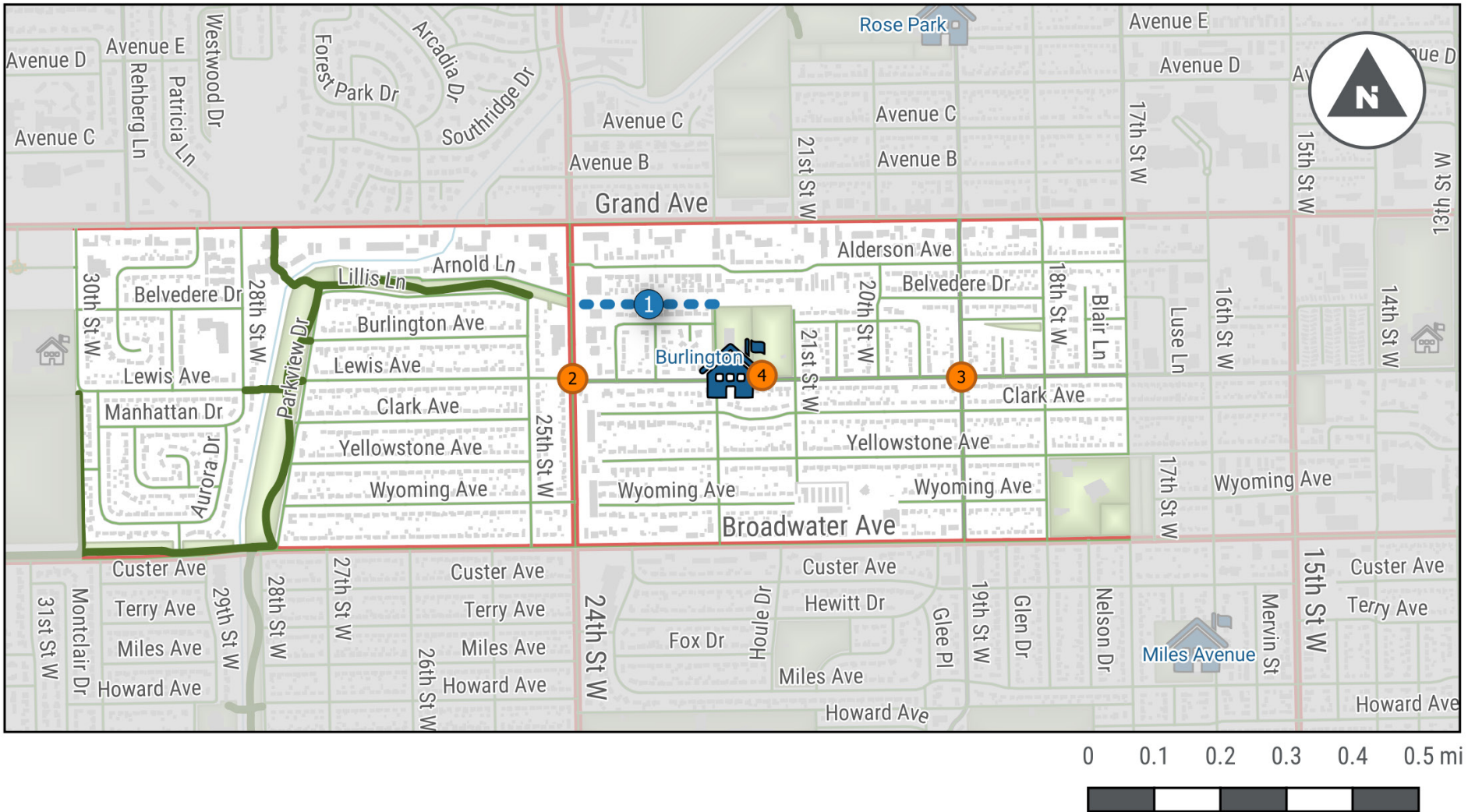



# Central Heights Elementary

## Existing Conditions

About the School	
Address	120 Lexington Dr, Billings, MT 59102
Number of Students	Approximately 305
Percentage of Students Eligible for Free and Reduced Lunch	42%
Arrival / Dismissal Times	7:45 AM / 2:25 and 3:05 PM

Major Streets and Highways	Annual Average Daily Traffic (AADT) <sup>c</sup>
Central Ave	<ul style="list-style-type: none"> <li>17,400 (west of 24th St W)</li> <li>13,400 (east of 24th St W)</li> </ul>
Monad Rd	7,700
24th St W	<ul style="list-style-type: none"> <li>24,800 (north of Monad Rd)</li> <li>17,800 (east of Monad Rd)</li> </ul>

<sup>c</sup>Source: MDOT Interactive Traffic Web Map

## Existing Conditions Map

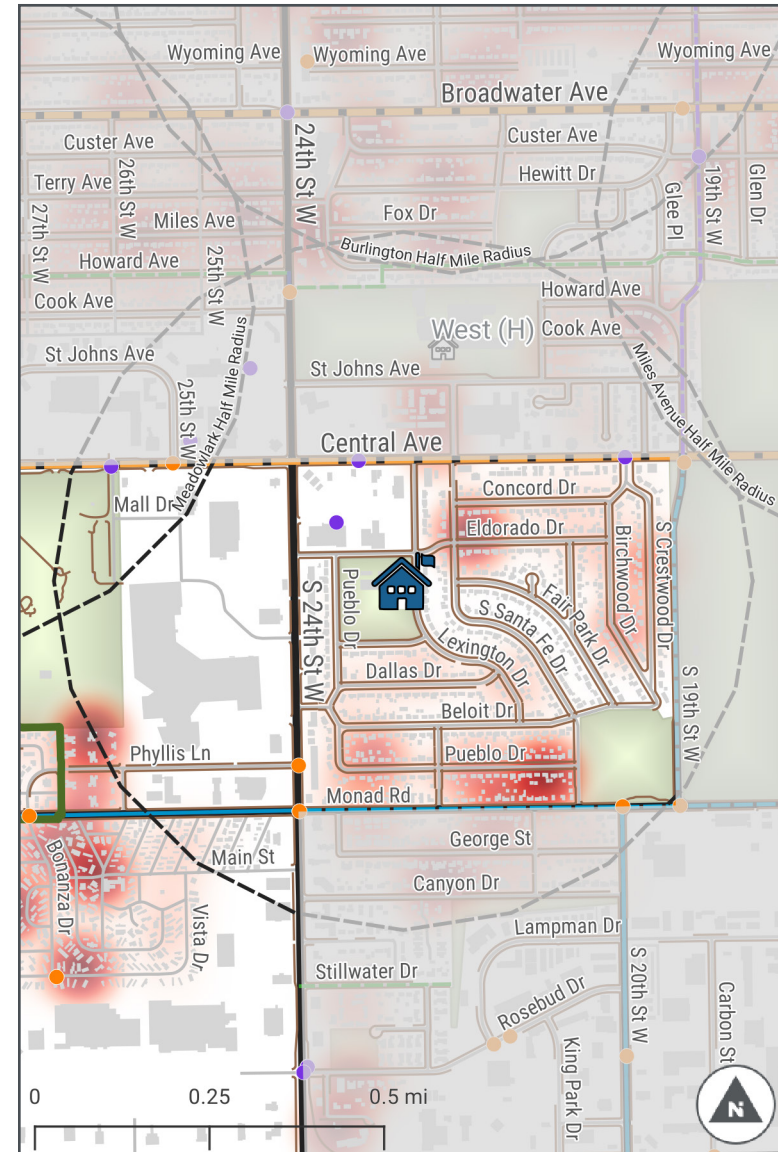

Student Address Heatmap	<b>Existing</b>	<b>Proposed</b>
School Half Mile Buffer	Existing Bike Lane	Neighborhood Bikeway
Outside School Boundary	Sidewalk	Bike Lane
Bike Crash (2016-2020)		Buffered Bike Lane
Pedestrian Crash (2016-2020)		Shared Lane Marking
Speed Limit 35 mph or Greater		Visionary Long Range Bikeway

## Known Safety Concerns at Central Heights Elementary

Source of Concern	Safety Concern or Comment
Principal	<ul style="list-style-type: none"> <li>Concerned with offenders. Principal has no information but said that families are concerned.</li> <li>Street network is confusing surrounding the school area.</li> <li>Concerned with morning rush and high-speed vehicles.</li> <li>Principal doesn't encourage lower grades to walk to school. The only exception is if they are with families.</li> </ul>
Webmap Survey	<p>There are approximately three comments in the Central Heights Elementary catchment area:</p> <ul style="list-style-type: none"> <li>Speeding traffic on 24<sup>th</sup> St and Central Ave.</li> <li>Dangerous walking conditions on Central Ave.</li> </ul>
Crossing Guard	<ul style="list-style-type: none"> <li>Some drivers/turning drivers do not stop for crossing guard.</li> <li>High speeds and/or high traffic volumes on Lexington Dr and Eldorado Dr.</li> </ul>
Safety Busing	<ul style="list-style-type: none"> <li>The school district provides safety busing for students that live west of S 24th St W.</li> </ul>

## Dismissal Observations

Observation Details	
Observation Date	<b>The consultant team observed dismissal on Tuesday, September 21.</b>
School Bus Loading	<ul style="list-style-type: none"> <li>School buses lined up along the Pueblo Dr.</li> </ul>
Before/Aftercare Vans	<ul style="list-style-type: none"> <li>Before/aftercare vans picked up students at Pueblo Dr.</li> </ul>
Family Vehicles	<ul style="list-style-type: none"> <li>At the first dismissal, grades K-2, families in vehicles picked up students at Alamo Dr south of the building or on Lexington Dr, and 3rd grades on Pueblo Dr. Family drivers either stayed in the vehicle and queued to pick up directly at the school entrance, or parked in the parking lot and walked to the school entrances.</li> <li>At the second dismissal, grades 4-5, families in vehicles picked up students at Pueblo Dr west of the building. Family drivers either stayed in the vehicle and queued to pick up directly at the school entrance, or parked in the parking lot and walk to the school entrances.</li> </ul>
School Staff Roles	<ul style="list-style-type: none"> <li>School staff were present to help students onto the correct buses.</li> <li>School staff were present supervising students on the playground and outside the front door.</li> </ul>
Adult Crossing Guards	<ul style="list-style-type: none"> <li>A school crossing guard for the first dismissal is posted at the midblock crossing on Lexington Dr and at the midblock crossing on Alamo Dr.</li> <li>One crossing guard transitions to the intersection of Eldorado Dr and Pueblo Dr for the second dismissal.</li> </ul>
Bike Rack Locations and Use	<ul style="list-style-type: none"> <li>There are two bike racks around the school, located in front of the school at Lexington Dr and back of the school near Pueblo Dr.</li> </ul>
Students Walking and Biking	<ul style="list-style-type: none"> <li>Few students were observed walking and biking.</li> </ul>

## Priority Concerns at Central Heights Elementary

The numbered observations and recommendations in the table below correspond to the points in the Existing Conditions Map (shown on previous page).

#	Location	Observations	Webmap Comments?
1	Central Ave	<ul style="list-style-type: none"> <li>Central Ave is recommended to be a Visionary Long Range Bikeway in the Billings Area Bikeway and Trails Master Plan.</li> </ul>	Yes
2	Eldorado Dr	<ul style="list-style-type: none"> <li>Curb ramps are missing at crosswalks at Pueblo Dr, creating a hazard for people biking, pushing strollers, or using wheelchairs.</li> </ul>	No
3	Alamo Dr	<ul style="list-style-type: none"> <li>Some families were observed parking on the non-school or on top of the curb asking students to cross the street.</li> <li>Narrow sidewalks with minimal buffer and permanent obstruction creating an uncomfortable walking/cycling environment. Posts and mailboxes in the sidewalk further impede users.</li> <li>There are no curb cuts at the midblock crossing in front of the school and at the intersections with Pueblo Dr and with Lexington Dr, even though there are sidewalks.</li> <li>No crosswalk is marked on any leg at the Pueblo Dr intersection.</li> <li>Missing sidewalks present a barrier to walking and bicycling to school. School staff park their vehicles on Alamo Dr, obstructing the sidewalk.</li> </ul>	No
4	Lexington Dr	<ul style="list-style-type: none"> <li>Some families were observed parking on the non-school side, asking students to cross the street without an adult, and making u-turns in front of the school.</li> <li>There are missing curb ramps at the mid-block crossing.</li> <li>No crosswalk is marked on any leg at the Alamo Dr intersection.</li> <li>Sidewalks need repairs or replacement to provide a smooth and trip-free route for all users.</li> <li>Sidewalks measure less than the recommended width of 5'. Sidewalk abruptly gets narrower in front of the school and the presence of a fence where the sidewalk decreases the width. Posts, mailboxes and trash bin in the sidewalk further impede users.</li> </ul>	No
5	Dallas Dr/Beloit Dr/ Pueblo Dr (west to east leg)	<ul style="list-style-type: none"> <li>Uncontrolled intersection on the three intersections of Dallas Dr, Pueblo Dr and Beloit Dr.</li> <li>Sidewalks throughout the neighborhood need repair or replacement to provide a safe pedestrian route for all users. Some existing sidewalks measure less than the recommended width of 5'.</li> <li>Curb ramps are missing throughout the neighborhood.</li> <li>Pueblo Dr is a relatively wide street, which encourages speeding.</li> </ul>	No
6	Monad Rd	<ul style="list-style-type: none"> <li>Monad Rd and 24th St W has higher traffic volumes and speeds than would be preferred for a student crossing location.</li> <li>Crossing distances are long and there are no median crossing islands for pedestrians.</li> <li>Crosswalk markings across Monad Rd and 24th St W, and at Monad Rd and Monterey Dr, are faded.</li> <li>Curb ramps are missing at crosswalks at some legs of 24<sup>th</sup> St and at Monad Rd and Monterey Dr, creating a hazard for people biking, pushing strollers, or using wheelchairs.</li> </ul>	No
7	Pueblo Dr (north to south leg)	<ul style="list-style-type: none"> <li>Sidewalks throughout the neighborhood need installment, repair, or replacement to provide a safe pedestrian route for all users. Some existing sidewalks measure less than the recommended width of 5'.</li> <li>Curb ramps are missing along Pueblo Dr, creating a hazard for people biking, pushing strollers, or using wheelchairs.</li> <li>There is a lack of parking signage, and the "NO PARKING" sign is damaged in the bus pick-up locations.</li> </ul>	No

## Proposed Projects at Central Heights Elementary

The numbered observations and recommendations in the table below correspond to the points in the Proposed Projects Map (shown on final page).

#	Location	Topic	Issue	Recommendation
1	Monad Rd and 24 <sup>th</sup> St W	Crossing	<ul style="list-style-type: none"> <li>The crossings on all legs lack high-visibility markings.</li> <li>Crossing distances are long.</li> <li>There are not curb cuts at all legs of 24<sup>th</sup> St and at Monad Rd and Monterey Dr, even though there are sidewalks.</li> </ul>	<ul style="list-style-type: none"> <li>Repaint crossing with high-visibility markings.</li> <li>Add pedestrian refuge islands in the Monad Rd and 24th St W to shorten crossing distances and improve pedestrian safety. Study further to find an infrastructure intervention to make crossing safer and more comfortable for school children.</li> <li>Install ADA compliant curb ramps.</li> </ul>
2	Lexington Dr	Arrival/dismissal behavior	<ul style="list-style-type: none"> <li>Some families were observed parking on the non-school side, asking students to cross the street without an adult, and making u-turns in front of the school.</li> </ul>	<ul style="list-style-type: none"> <li>Continue staff monitoring of arrival and dismissal, and continue communicating expectations for family vehicles at arrival and dismissal.</li> <li>Encourage more families to walk or bicycle to school to reduce the number of vehicles during arrival and dismissal</li> <li>Ideally, all pick-up and drop-off occurs on the school side of the street, or, at a minimum, in locations with safe crossings. Add on-street parking restrictions to facilitate school-side drop off/pick up and crossing at safe locations.</li> <li>A further evaluation and/or pilot pop-up project should be used to evaluate the effectiveness of any new on-street parking restriction.</li> </ul>
3	Dallas Dr and Pueblo Dr (west to east leg)	Crossing	<ul style="list-style-type: none"> <li>Crossings are uncomfortable because of wide corner radii, which encourages fast vehicular turns.</li> <li>Intersections without any control (stop signs, yield signs, etc.) create unpredictable traffic patterns and create difficult crossing conditions.</li> <li>There are not curb cuts at all the intersections of Pueblo Dr, Beloit Dr, and Dallas Dr, even though there are sidewalks.</li> </ul>	<ul style="list-style-type: none"> <li>Tighten the curb radii on the legs of the intersection and install new curb ramps that line up with crosswalks at all corners.</li> <li>Install high-visibility crosswalk markings, parking restrictions on crosswalk approach, adequate nighttime lighting levels, crossing warning signs, in-street pedestrian crossing sign, curb extensions, and pedestrian refuge island at all three intersections.</li> <li>Install ADA compliant curb ramps.</li> <li>A further evaluation and/or pilot pop-up project should be used to evaluate the effectiveness of any new on-street parking restriction.</li> </ul>
4	Lexington Dr north of Alamo Dr	Crossing	<ul style="list-style-type: none"> <li>Missing curb ramps at crosswalks create a hazard for people biking, pushing strollers, or using wheelchairs.</li> </ul>	<ul style="list-style-type: none"> <li>Install ADA compliant curb ramps.</li> </ul>
5	Eldorado Dr and Lexington Dr	Crossing	<ul style="list-style-type: none"> <li>Crossings are uncomfortable because of wide corner radii, which encourages fast vehicular turns.</li> <li>Curb extensions at corners can shorten crossing distances and increase pedestrian visibility.</li> </ul>	<ul style="list-style-type: none"> <li>Install curb extensions at all four corners of the intersection.</li> </ul>
6	School property	Bicycle Parking	<ul style="list-style-type: none"> <li>Existing bicycle racks can damage bikes and make it difficult to securely lock bicycles. Few bicycles were parked the day of observation.</li> </ul>	<ul style="list-style-type: none"> <li>Replace the existing bike racks with new racks that support the bike frame in at least two places and that enable secure locking.</li> </ul>

### Proposed Projects Map

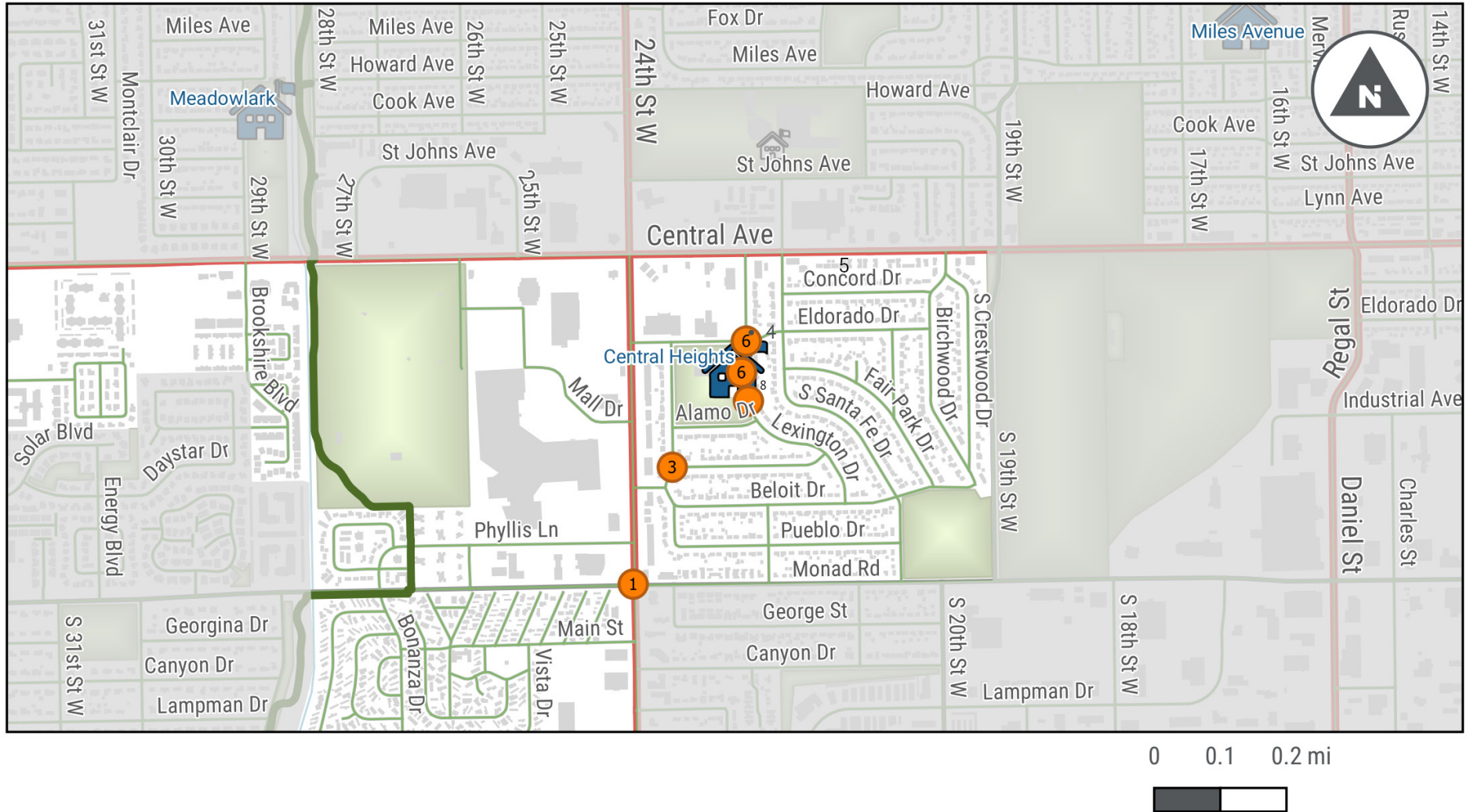

# Eagle Cliffs Elementary

## Existing Conditions

### About the School

Address	1201 Kootenai Ave
Number of Students	Approximately 420
Percentage of Students Eligible for Free and Reduced Lunch	26%
Arrival / Dismissal Times	8:05 AM / 2:15 and 3:15 PM

### Major Streets and Highways

Major Streets and Highways	Annual Average Daily Traffic (AADT) <sup>c</sup>
Governors Blvd	5,300
W Wicks Ln	4,400 (west of Governors Blvd)

<sup>c</sup>Source: MDOT Interactive Traffic Web Map

## Existing Conditions Map

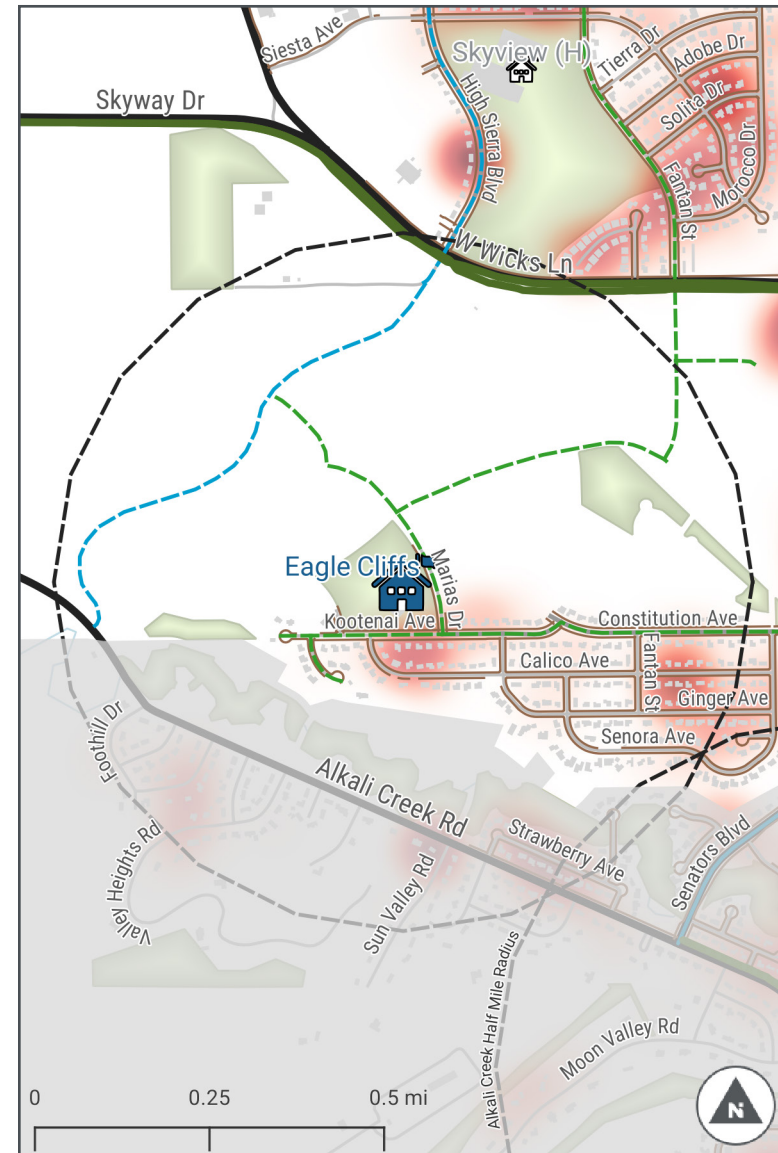

- Student Address Heatmap
- School Half Mile Buffer
- Outside School Boundary
- Speed Limit 35 mph or Greater
- Existing Shared Use Path
- Existing Sidewalk
- Proposed Neighborhood Bikeway
- Proposed Bike Lane

## Known Safety Concerns at Eagle Cliffs Elementary

Source of Concern	Safety Concern or Comment
Principal	<ul style="list-style-type: none"> <li>• Significant safety concerns on Constitution Ave as the only street to the school.</li> <li>• Constitution Ave and Governors Blvd intersection is a significant safety concern due to tight sidewalk corners and lack of protected left turns.</li> <li>• Principal states they need a better connection to the housing coming from north of Wicks Lane.</li> </ul>
Webmap Survey	<p>There are approximately 10 comments in the Eagle Cliffs catchment area regarding:</p> <ul style="list-style-type: none"> <li>• Traffic congestion on Constitution Ave</li> <li>• The Governors Blvd and Constitution Ave intersection</li> <li>• Sidewalks on Governors Blvd</li> </ul>
Crossing Guard	<ul style="list-style-type: none"> <li>• Some turning drivers do not stop for crossing guard.</li> <li>• High speeds and/or high traffic volumes on Governors Blvd.</li> <li>• Crossing guard at Constitution Ave and Marias Dr is concerned about traffic circulation. Sometimes will stop traffic on Constitution Ave to let automobiles on Marias Dr turn left.</li> </ul>
Safety Busing Concern	<ul style="list-style-type: none"> <li>• No safety busing is provided.</li> </ul>

## Arrival Observations

Observation Details	
Observation Date	<b>The consultant team observed arrival on Thursday, September 23.</b>
School Bus Loading	<ul style="list-style-type: none"> <li>• School buses dropped off in the school parking lot off of Marias Dr.</li> </ul>
Family Vehicles	<ul style="list-style-type: none"> <li>• Families dropped off students in the loading/unloading driveway loop off of Constitution Ave, and also drop off along Constitution Ave. Cars waiting to enter the unloading loop occasionally spilled into Constitution Ave, creating crossing challenges on the west side of the intersection.</li> <li>• Families also dropped off on Marias Dr on both sides of the street.</li> </ul>
School Staff Roles	<ul style="list-style-type: none"> <li>• School staff were present supervising students on the playground and outside the front door.</li> </ul>
Adult Crossing Guards	<ul style="list-style-type: none"> <li>• Two school crossing guards are posted at Constitution Ave and Marias Dr and at Constitution Ave and Governors Blvd.</li> </ul>
Students Walking and Biking	<ul style="list-style-type: none"> <li>• Many students were observed walking and biking from Governors Blvd.</li> </ul>

## Priority Concerns at Eagle Cliffs Elementary

The numbered observations and recommendations in the table below correspond to the points in the Existing Conditions Map (shown on previous page).

#	Location	Observations	Webmap Comments?
1	Marias Dr/Wicks Ln	<ul style="list-style-type: none"> <li>With only one street connecting Eagle Cliffs to other neighborhoods, Governors Blvd was observed as highly trafficked by motor vehicles. Families living north of Wicks Ln are required to use Governors Blvd, despite Eagle Cliffs being within walking distance. No existing, direct walking or bicycling infrastructure exists.</li> <li>A neighborhood bikeway is planned to connect part-way to Wicks Ln and will be intersected with a planned bike lane.</li> </ul>	Yes
2	Constitution Ave and Governors Blvd	<ul style="list-style-type: none"> <li>This intersection has higher traffic volumes and speeds than would be preferred for a student crossing location, especially during the morning hours.</li> <li>Constitution Ave, from Eagle Cliffs Elementary to Nutter Blvd, is recommended as a neighborhood bikeway.</li> <li>Without a protected left turn, motor vehicles are required to find gaps in on-coming traffic to turn on to Constitution Ave. This behavior can detract from driver attention to students walking and bicycling.</li> </ul>	Yes
3	Constitution Ave and Marias Dr	<ul style="list-style-type: none"> <li>Families drop off students at both the "drop-off and pick-up only" area to the south of the school and Marias Dr. This creates motor vehicle congestion at the intersection of Constitution Ave and Marias Dr. Crossing. Challenging intersection for a crossing guard to control.</li> <li>Recommend a three-way stop intersection.</li> </ul>	Yes
4	Bicycle racks at Eagle Cliffs Elementary	<ul style="list-style-type: none"> <li>Existing bicycle racks blocked the pedestrian through zone by the drop-off area. Most students chose to use the larger bike rack.</li> </ul>	No



## Proposed Projects at Eagle Cliffs Elementary

The numbered observations and recommendations in the table below correspond to the points in the Proposed Projects Map (shown on final page).

#	Location	Topic	Issue	Recommendation
1	Marias Dr/Wicks Ln	Trail/path	<ul style="list-style-type: none"> <li>A discontinuous street network between Wicks Ln and Marias Dr discourages walking and biking trips.</li> </ul>	<ul style="list-style-type: none"> <li>Construct a walking and bicycling path to connect Marias Dr and Wicks Ln. This will alleviate motor vehicle traffic on Governors Blvd while also creating a direct walking and bicycling connection for students. This path could connect to the existing off-street path on the southside of Wicks Ln.</li> <li>Install a neighborhood bikeway from Marias Dr to a future street, and a shared use path to run parallel to existing power lines – this is in the Billings Area Bikeway and Trails Master Plan.</li> </ul>
2	Constitution Ave and Governors Blvd	Crossing	<ul style="list-style-type: none"> <li>Crossings are uncomfortable because of wide corner radii, which encourages fast vehicular turns.</li> <li>Crossings are uncomfortable because left-turning vehicles may not yield to pedestrians in the crosswalk.</li> </ul>	<ul style="list-style-type: none"> <li>Tighten the curb radii on the north, south, and east legs of the intersection and install new curb ramps that line up with crosswalks at all corners.</li> <li>Install a dedicated left-turn signal from Governors Blvd to Constitution Ave. Convert to flashing yellow arrow for left turns from Governors.</li> <li>Restrict permissive left turns during school travel times.</li> </ul>
3	Constitution Ave and Marias Dr	Crossing	<ul style="list-style-type: none"> <li>The lack of traffic control devices (yield sign, stop sign, etc.) creates a challenge for vehicles turning left from Marias Dr onto Constitution Ave.</li> </ul>	<ul style="list-style-type: none"> <li>Conduct additional analysis to investigate installing a three-way stop at the intersection.</li> </ul>
4	Front of school	Bicycle parking	<ul style="list-style-type: none"> <li>Existing bicycle racks can damage bikes and make it difficult to securely lock bicycles. Some bicycles were parked the day of observation.</li> </ul>	<ul style="list-style-type: none"> <li>Replace the existing bike racks with new racks that support the bike frame in at least two places and that enable secure locking. Place racks in location that does not impede pedestrian route.</li> </ul>

## Proposed Projects Map

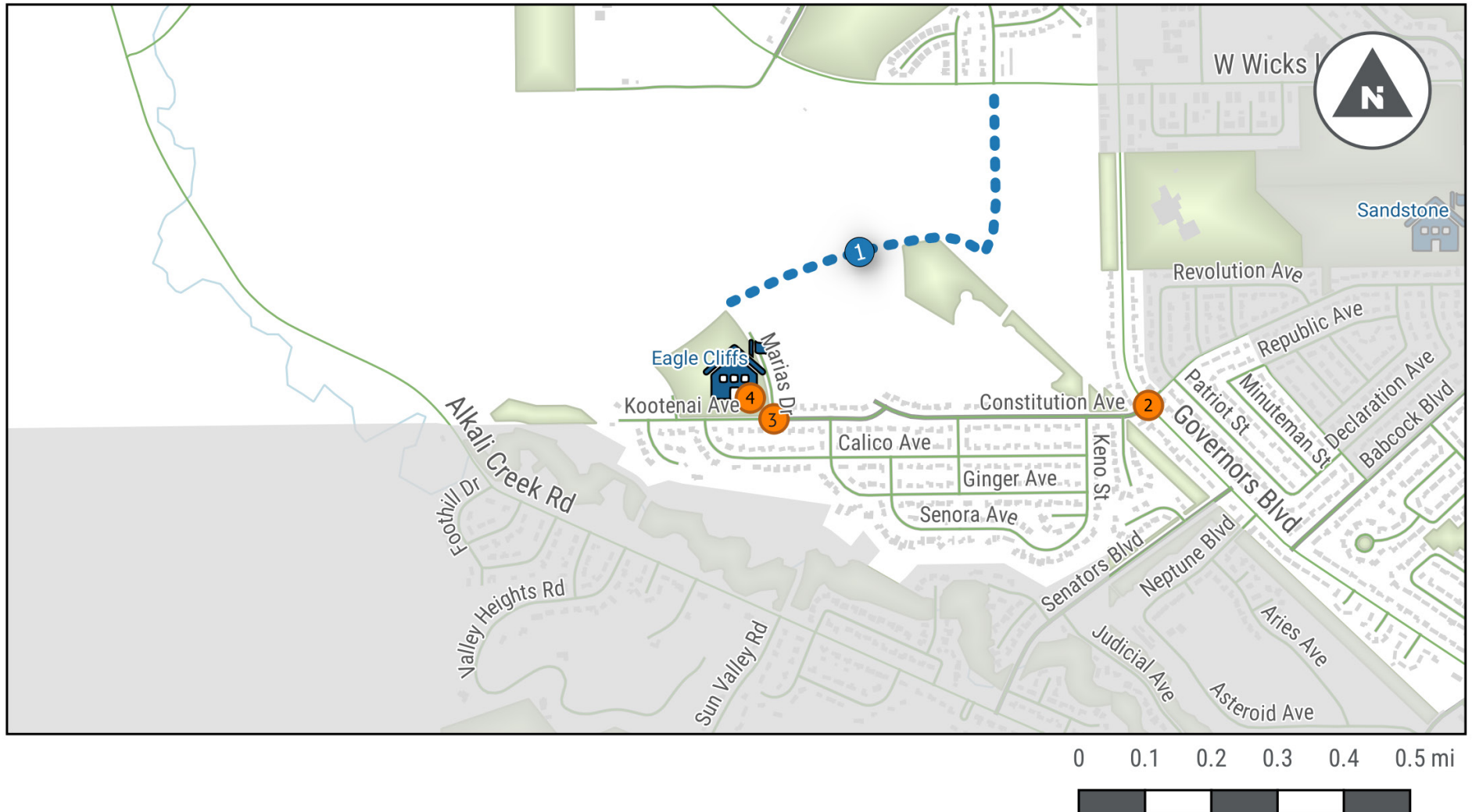

# Highland Elementary

## Existing Conditions

About the School	
Address	729 Parkhill Dr
Number of Students	Approximately 250
Percentage of Students Eligible for Free and Reduced Lunch	39%
Arrival / Dismissal Times	7:45 and 8:20 AM / 2:15 and 3:00 PM

Major Streets and Highways	Annual Average Daily Traffic (AADT) <sup>c</sup>
Rimrock Road	9,200
Poly Drive	7,900
Parkhill Drive	<ul style="list-style-type: none"> <li>2,800 (west of 10th St W)</li> <li>3,820 (east of 10th St W)</li> </ul>
Grand Avenue	<ul style="list-style-type: none"> <li>22,000 (west of 8th St W)</li> <li>16,986 (east of 8th St W)</li> </ul>
13th St W	<ul style="list-style-type: none"> <li>5,300 (north of Parkhill Drive)</li> <li>6,315 (south of Parkhill Drive)</li> </ul>
8th St W	5,000
7th St W	5,300
6th St W	8,500
Virginia Ln	<ul style="list-style-type: none"> <li>3,400 (north of Parkhill Drive)</li> <li>6,000 (south of Parkhill Drive)</li> </ul>

<sup>c</sup>Source: MDOT Interactive Traffic Web Map

## Existing Conditions Map

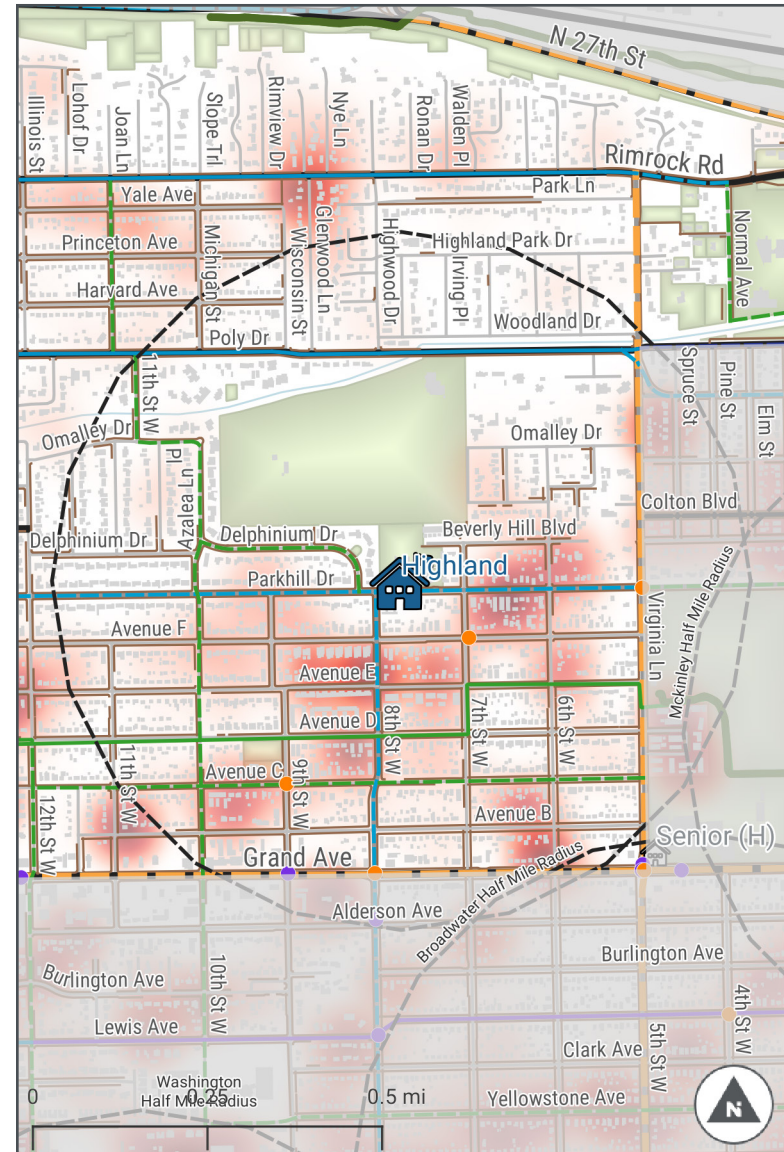

Student Address Heatmap	<b>Existing</b>	<b>Proposed</b>
School Half Mile Buffer	Shared Use Path	Neighborhood Bikeway
Outside School Boundary	Existing Bike Lane	Bike Lane
Bike Crash (2016-2020)	Sidewalk	Buffered Bike Lane
Pedestrian Crash (2016-2020)	Neighborhood Bikeway	Visionary Long Range Bikeway
Speed Limit 35 mph or Greater		

## Known Safety Concerns at Highland Elementary

Source of Concern	Safety Concern or Comment
Principal	<ul style="list-style-type: none"> <li>Traffic doesn't always stop for the crossing guard. Parents avoiding the crosswalk are dropping kids off and having them run across the street.</li> <li>AAA Safety Patrol has approached about leadership opportunities for students to relieve the pressure on school staff.</li> <li>School has an active Walking School Bus with four different routes.</li> </ul>
Webmap Survey	<p>There are approximately 20 comments in the Highland Elementary catchment area regarding:</p> <ul style="list-style-type: none"> <li>Crossings and sidewalks on or intersecting Poly Dr.</li> <li>Lack of intersection control on streets intersecting Poly Dr.</li> <li>Lighting, crossings, speeding, lack of sidewalks, and bike lanes on Parkhill Dr.</li> <li>Lack of sidewalks and curb ramps on neighborhood streets.</li> <li>Parkhill Dr and 11<sup>th</sup> St W have speeding traffic.</li> <li>Speeding traffic on Virginia Ln deters walking and biking.</li> </ul>
Crossing Guard	<ul style="list-style-type: none"> <li>Family vehicles make U-turns near the crossing guard crosswalk.</li> <li>Some drivers/turning drivers do not stop for crossing guard.</li> <li>High speeds and/or high traffic volumes on Parkhill Dr.</li> </ul>
Safety Busing	<ul style="list-style-type: none"> <li>No safety busing is provided.</li> </ul>

## Arrival Observations

Observation Details	
Observation Date	<b>The consultant team observed arrival on Thursday, September 23.</b>
School Bus Loading	<ul style="list-style-type: none"> <li>No school buses were observed.</li> </ul>
Before/Aftercare Vans	<ul style="list-style-type: none"> <li>No before/aftercare vans were observed.</li> </ul>
Family Vehicles	<p>Families pick up and dropped off students in the following entrances/exits:</p> <ul style="list-style-type: none"> <li>1st Grade &amp; K/1 Combo will enter through the gym (exit 7).</li> <li>K and 2nd grade will enter the main doors (exit 1).</li> <li>3rd, 4th &amp; 5th grade will enter the breezeway doors (exit 8).</li> <li>Principal mentioned that they hope to dismiss everyone at the back of the school.</li> </ul>
School Staff Roles	<ul style="list-style-type: none"> <li>School staff were present supervising students on the playground and outside the front door.</li> </ul>
Adult Crossing Guards	<ul style="list-style-type: none"> <li>A school crossing guard is posted at Parkhill Drive and 8th St W, and Poly Dr and 11<sup>th</sup> St W.</li> </ul>
Bike Rack Locations and Use	<ul style="list-style-type: none"> <li>There are two bike racks around the school, located on the west and east sides of the school.</li> </ul>
Students Walking and Biking	<ul style="list-style-type: none"> <li>Many students were observed walking and biking in/from all directions.</li> </ul>

## Priority Concerns at Highland Elementary

The numbered observations and recommendations in the table below correspond to the points in the Existing Conditions Map (shown on previous page).

#	Location	Observations	Webmap Comments?
1	Poly Dr	<ul style="list-style-type: none"> <li>• Poly Dr has higher traffic volumes and speeds than would be preferred for students walking without a wide sidewalk or crossing.</li> <li>• Crossing distances are long and there are no median crossing islands for pedestrians.</li> <li>• Narrow sidewalks with minimal buffer next to a busy street, creating an uncomfortable walking/cycling environment. Posts and mailboxes in the sidewalk further impede users.</li> <li>• Pedestrian signal heads are present at Virginia Ln but require people to push a button to get a pedestrian phase. The pedestrian timing did not appear to provide enough time for pedestrians to clear the crosswalk.</li> <li>• There is an existing bike lane.</li> </ul>	Yes
2	Delphinium Dr	<ul style="list-style-type: none"> <li>• Sidewalks need repairs or replacement to provide a trip-free route for all users.</li> <li>• There are very few curb cuts even though there are sidewalks.</li> </ul>	Yes
3	Parkhill Dr	<ul style="list-style-type: none"> <li>• Parkhill Dr has higher traffic volumes and speeds than would be preferred for a student crossing location.</li> <li>• Crossing distances are long and there are no median crossing islands for pedestrians.</li> <li>• Some families were observed parking on the non-school side and double parking, asking students to cross the street without an adult, and making U-turns in front of the school. Students were observed jay walking to get to the school side. Families dropping off on school side back up to get out of traffic.</li> <li>• Narrow sidewalks with minimal buffer next to a busy street, creating an uncomfortable walking/cycling environment. Posts and mailboxes in the sidewalk further impede users.</li> <li>• Existing bicycle racks in poor conditions on the east side of the school.</li> <li>• Parkhill Dr is recommended to have a bike lane in the Billings Area Bikeway and Trails Master Plan.</li> </ul>	Yes
4	7th St W	<ul style="list-style-type: none"> <li>• Missing sidewalks present a barrier to walking and bicycling to school. Where the side path/street over the creek ends north of O'Malley Dr, a golf course and houses obstruct a direct connection to Poly Dr.</li> </ul>	Yes
5	Virginia Ln	<ul style="list-style-type: none"> <li>• Narrow sidewalks with minimal buffer next to a busy street, creating an uncomfortable walking/cycling environment. Posts, mailboxes, and vegetation in the sidewalk further impede users.</li> <li>• Crossings along Virginia Ln are worn down.</li> <li>• Unpaved streets and missing sidewalks at the intersection with Woodland Dr, where Virginia Ln crosses the creek, present a barrier to walking and bicycling to school.</li> <li>• Virginia Ln is recommended to have a Visionary Long-Range Bikeway in the Billings Area Bikeway and Trails Master Plan.</li> </ul>	Yes

## Proposed Projects at Highland Elementary

The numbered observations and recommendations in the table below correspond to the points in the Proposed Projects Map (shown on final page).

#	Location	Topic	Issue	Recommendation
1	Poly Dr and Virginia Ln	Crossing	<ul style="list-style-type: none"> <li>• Pedestrian signal heads are present but require people to push a button to get a pedestrian phase.</li> </ul>	<ul style="list-style-type: none"> <li>• Add leading pedestrian interval at signal.</li> <li>• Consider automatic pedestrian signal recall, especially if motor vehicle signal phase is already long enough to accommodate a pedestrian crossing.</li> </ul>
2	Parkhill Dr	Arrival/Dismissal Behavior	<ul style="list-style-type: none"> <li>• Some families were observed parking on the non-school side and double-parking, asking students to cross the street without an adult, and making U-turns in front of the school.</li> </ul>	<ul style="list-style-type: none"> <li>• Continue staff monitoring of arrival and dismissal, and continue communicating expectations for family vehicles at arrival and dismissal. Ideally, all pick-up and drop-off occurs on the school side of the street, or, at a minimum, in locations with safe crossings.</li> <li>• Encourage more families to walk or bicycle to school to reduce the number of vehicles during arrival and dismissal.</li> <li>• Add on-street parking restrictions to facilitate school-side drop off/pick up and crossing at safe locations.</li> <li>• Parkhill Dr is a planned bike lane route in the Billings Area Bikeways and Trails Master Plan.</li> <li>• A further evaluation and/or pilot pop-up project should be used to evaluate the effectiveness of any new on-street parking restriction.</li> </ul>
3	School property (2 locations)	Bicycle Parking	<ul style="list-style-type: none"> <li>• Existing bicycle racks can damage bikes and make it difficult to securely lock bicycles. Few bicycles were parked the day of observation.</li> </ul>	<ul style="list-style-type: none"> <li>• Replace the existing bike racks with new racks that support the bike frame in at least two places and that enable secure locking.</li> </ul>

### Proposed Projects Map

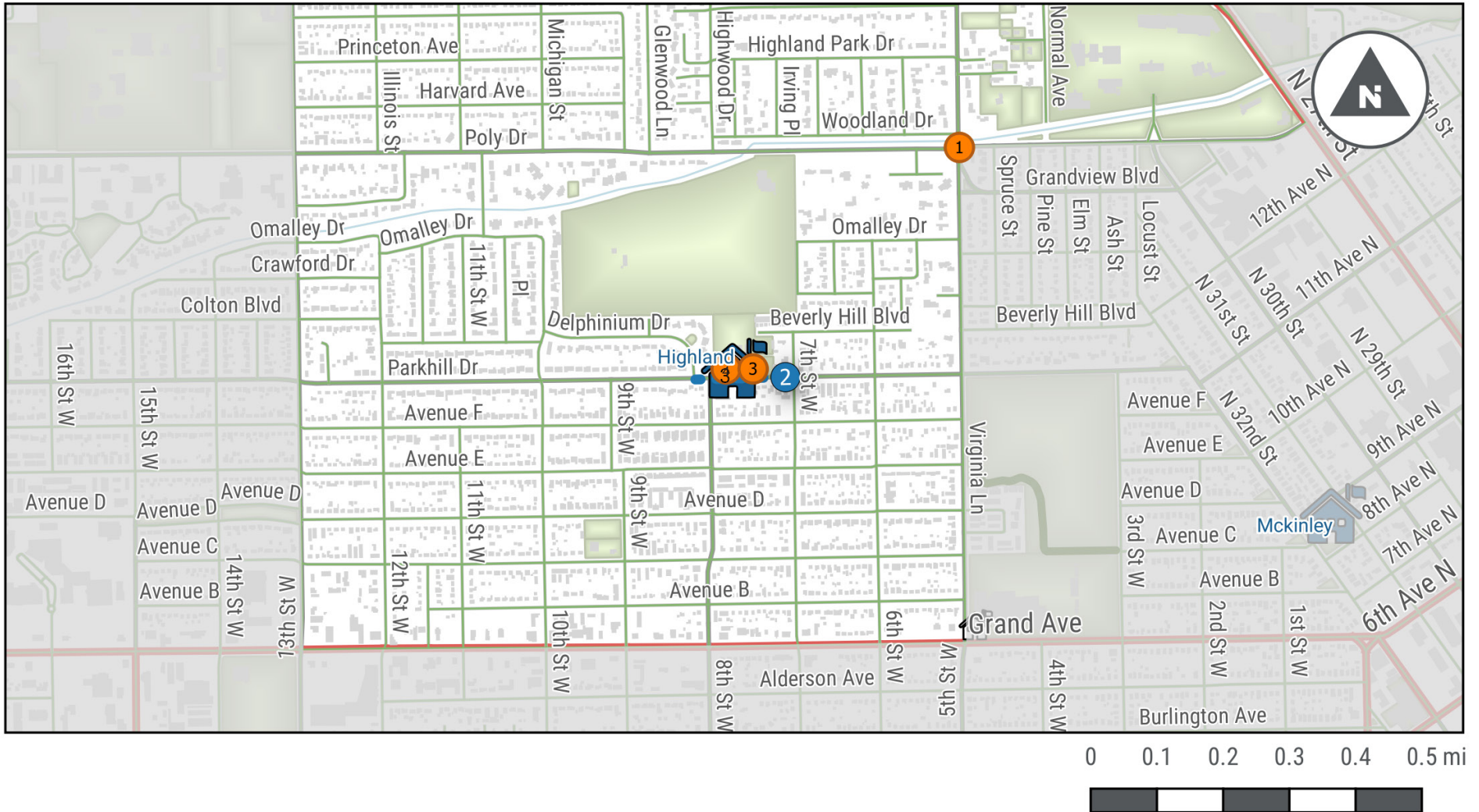





## Known Safety Concerns at McKinley Elementary

Source of Concern	Safety Concern or Comment
School Secretary	<ul style="list-style-type: none"> <li>There are some homeless people that sleep on the streets in downtown Billings, which is the main concern that parents express about walking or biking to school.</li> </ul>
Webmap Survey	<p>There were approximately eight comments in the McKinley Elementary catchment area regarding:</p> <ul style="list-style-type: none"> <li>Drivers not stopping for pedestrians and challenging crossing conditions on N 30<sup>th</sup> St, N 32<sup>nd</sup> St, and Parkhill Dr</li> <li>Parkhill Dr and 11<sup>th</sup> Ave N as a challenging intersection to navigate by walking or biking</li> <li>A linear park on 5<sup>th</sup> Ave N</li> </ul>
Walking School Bus Leaders	<ul style="list-style-type: none"> <li>Many drivers use the intersection of Parkhill Dr, N 32<sup>nd</sup> St and 11<sup>th</sup> Ave N as a route through town. Drivers roll through yield signs posted at intersections and do not stop for pedestrians.</li> <li>At the intersection of Parkhill Dr and 3<sup>rd</sup> St W by Pioneer Park, high school drivers turn quickly onto 3<sup>rd</sup> St from Parkhill in the mornings and do not always yield to pedestrians. Also, drivers on 3<sup>rd</sup> St W approaching Parkhill Dr have poor sight lines and must block the crosswalk in order to see oncoming traffic.</li> </ul>
Crossing Guard	<ul style="list-style-type: none"> <li>Family vehicles park or stop near the crossing guard crosswalk on the non-school side of N 32<sup>nd</sup> St (in the no-parking zones), reducing the visibility of the crosswalk for southbound drivers</li> <li>Some drivers do not stop for crossing guards.</li> </ul>
Safety Busing	<ul style="list-style-type: none"> <li>The school district provides safety busing for most students in the school attendance area: all students living east of N 27<sup>th</sup> St and south of 6<sup>th</sup> Ave N are bussed.</li> </ul>

## Arrival Observations

Observation Details	
Observation Date	<b>The consultant team observed arrival on Wednesday, September 22.</b>
School Bus Loading	<ul style="list-style-type: none"> <li>School buses lined up next to the entrance gate on N 32<sup>nd</sup> St.</li> </ul>
Before/Aftercare Vans	<ul style="list-style-type: none"> <li>No before care vans were observed.</li> </ul>
Family Vehicles	<ul style="list-style-type: none"> <li>Most families dropped off students on N 32<sup>nd</sup> St, parking on both sides of N 32<sup>nd</sup> St and crossing with the crossing guards. Some family vehicles were observed using the bus loading area near the entrance gate on N 32<sup>nd</sup> St.</li> <li>Some families dropped off students at the school entrance on 9<sup>th</sup> Ave N, mostly after the first bell rang and the doors in back of the school are locked.</li> </ul>
School Staff Roles	<ul style="list-style-type: none"> <li>One school staff person is posted at the back door of the school where students entering from the entrance gate on N 32<sup>nd</sup> St enter.</li> </ul>
Adult Crossing Guards	<ul style="list-style-type: none"> <li>School crossing guards are posted at N 32<sup>nd</sup> St and 9<sup>th</sup> Ave N, and at N 32<sup>nd</sup> St and Ave C.</li> </ul>
Bike Rack Locations and Use	<ul style="list-style-type: none"> <li>There is 1 bike rack at the school, located near the back door.</li> </ul>
Students Walking and Biking	<ul style="list-style-type: none"> <li>A group of students and families were observed arriving in a walking school bus that approached the school from N 32<sup>nd</sup> St. Other than that group, few students were observed walking. No students arrived on bicycle the day of observation.</li> </ul>

## Priority Concerns at McKinley Elementary

The numbered observations and recommendations in the table below correspond to the points in the Existing Conditions Map (shown on previous page).

#	Location	Observations	Webmap Comments?
1	Parkhill Dr, N 32 <sup>nd</sup> St and 11th Ave N	<ul style="list-style-type: none"> <li>Many drivers use the intersection of Parkhill Dr, N 32<sup>nd</sup> St and 11th Ave N as a route through central Billings. Drivers roll through yield signs posted at intersections and do not stop for pedestrians.</li> <li>Crossing N 32<sup>nd</sup> St at this intersection is uncomfortable because of wide corner radii, which encourages fast vehicular turns.</li> <li>One of the McKinley walking school buses traverses this intersection.</li> <li>Both Parkhill Dr and N 32<sup>nd</sup> St are recommended for bicycle boulevards in the Billings Area Bikeways and Trails Master Plans.</li> </ul>	Yes
2	N 32 <sup>nd</sup> St and 9 <sup>th</sup> Ave N	<ul style="list-style-type: none"> <li>A crossing guard is posted at this intersection.</li> <li>Family vehicles park or stop near the crossing guard crosswalk on the west side of N 32<sup>nd</sup> St (in the no-parking zones) reducing the visibility of the crosswalk for southbound drivers. Curb extensions on the east side of N 32<sup>nd</sup> St and on both legs of 9<sup>th</sup> Ave N shorten crossing distances and increase pedestrian visibility.</li> <li>Both N 32<sup>nd</sup> St and 9<sup>th</sup> Ave N are recommended for bicycle boulevards in the Billings Area Bikeways and Trails Master Plans.</li> </ul>	No
3	N 27 <sup>th</sup> St and 9 <sup>th</sup> Ave N	<ul style="list-style-type: none"> <li>N 27<sup>th</sup> St is has higher traffic volumes and speeds than would be preferred for a student crossing location.</li> <li>Crossing distances are long and there are no median crossing islands for pedestrians. Safety busing is currently provided to families that live on the other side of N 27<sup>th</sup> St.</li> <li>9<sup>th</sup> Ave N is recommended for a bicycle boulevard in the Billings Area Bikeways and Trails Master Plans.</li> </ul>	No
4	Parkhill Dr and 3 <sup>rd</sup> St W	<ul style="list-style-type: none"> <li>At the intersection of Parkhill Dr and 3<sup>rd</sup> St W, drivers on 3<sup>rd</sup> St W approaching Parkhill Dr have poor sight lines and must block the crosswalk in order to see oncoming traffic.</li> <li>Parkhill Dr is recommended for a bicycle boulevard in the Billings Area Bikeways and Trails Master Plan.</li> </ul>	No
5	Pioneer Park path, 3 <sup>rd</sup> St W, and Ave C	<ul style="list-style-type: none"> <li>Pioneer Park is a popular park which sees high levels of use by the community.</li> <li>The path in Pioneer Park is in very poor condition.</li> <li>One of the McKinley Walking School Buses traverses Pioneer Park along the path.</li> <li>At the intersection of the path and 3<sup>rd</sup> St W, there are no detectable warnings on the west leg of the intersection. There are no marked crosswalks, and the intersection lacks connecting curb ramps on the east leg. Community members state that some high school drivers rushing to get to school have nearly hit people crossing to or from the park at this intersection.</li> <li>The path through Pioneer Park is a proposed connection to a bicycle boulevard on Ave C in the Billings Area Bikeways and Trails Master Plan.</li> </ul>	No
6	Bicycle Racks at McKinley Elementary	<ul style="list-style-type: none"> <li>Existing bicycle racks can damage bikes and make it difficult to securely lock bicycles. No bicycles were parked the day of observation.</li> </ul>	No

## Proposed Projects at McKinley Elementary

The numbered observations and recommendations in the table below correspond to the points in the Proposed Projects Map (shown on final page).

#	Location	Topic	Issue	Recommendation
1	Parkhill Dr and N 32 <sup>nd</sup> St	Crossing	<ul style="list-style-type: none"> <li>Many drivers use the intersection of Parkhill Dr, N 32<sup>nd</sup> St and 11th Ave N as a route through central Billings. Drivers roll through yield signs posted at intersections and do not stop for pedestrians.</li> <li>Crossing N 32<sup>nd</sup> St at this intersection is uncomfortable because of wide corner radii, which encourages fast vehicular turns.</li> <li>Both Parkhill Dr and N 32<sup>nd</sup> St are recommended for bicycle boulevards in the Billings Area Bikeways and Trails Master Plans.</li> </ul>	<ul style="list-style-type: none"> <li>Conduct an engineering study to determine if stop sign is warranted.</li> <li>Install a curb extension on the south leg of the intersection of Parkhill Dr and N 32<sup>nd</sup> St to slow turning traffic and shorten pedestrian crossing distance.</li> </ul>
2	11 <sup>th</sup> Ave N and N 32 <sup>nd</sup> St	Crossing	<ul style="list-style-type: none"> <li>Many drivers use the intersection of Parkhill Dr, N 32<sup>nd</sup> St and 11th Ave N as a route through central Billings. Drivers roll through yield signs posted at intersections and do not stop for pedestrians.</li> <li>There are no curb ramps on the south leg of the intersection.</li> </ul>	<ul style="list-style-type: none"> <li>Install a STOP sign and high visibility markings on the west leg of the intersection, to make drivers stop for pedestrians.</li> </ul>
3	Pioneer Park path, 3rd St W, and Ave C	Crossing	<ul style="list-style-type: none"> <li>No crosswalk is marked on the north, south, or east legs.</li> <li>Community members state that some high school drivers rushing to get to school have nearly hit people crossing to or from the park at this intersection.</li> <li>The path through Pioneer Park is a connection to a neighborhood bikeway on Ave C in the Billings Area Bikeways and Trails Master Plan.</li> <li>Non-ADA curb ramps at crosswalks on the east leg, creating a hazard for people biking, pushing strollers, or using wheelchairs.</li> </ul>	<ul style="list-style-type: none"> <li>Add a high-visibility crosswalk on the north and east legs of the intersection.</li> <li>Install parking restrictions on crosswalk approach, adequate nighttime lighting levels, crossing warning signs, and either a raised crosswalk or curb extension.</li> <li>Install ADA compliant curb ramps.</li> <li>A further evaluation and/or pilot pop-up project should be used to evaluate the effectiveness of any new on-street parking restriction.</li> </ul>
4	Bicycle racks at McKinley Elementary	Bicycle parking	<ul style="list-style-type: none"> <li>Existing bicycle racks can damage bikes and make it difficult to securely lock bicycles. No bicycles were parked the day of observation.</li> </ul>	<ul style="list-style-type: none"> <li>Replace the existing bike racks with new racks that support the bike frame in at least two places and that enable secure locking.</li> </ul>

## Proposed Projects Map

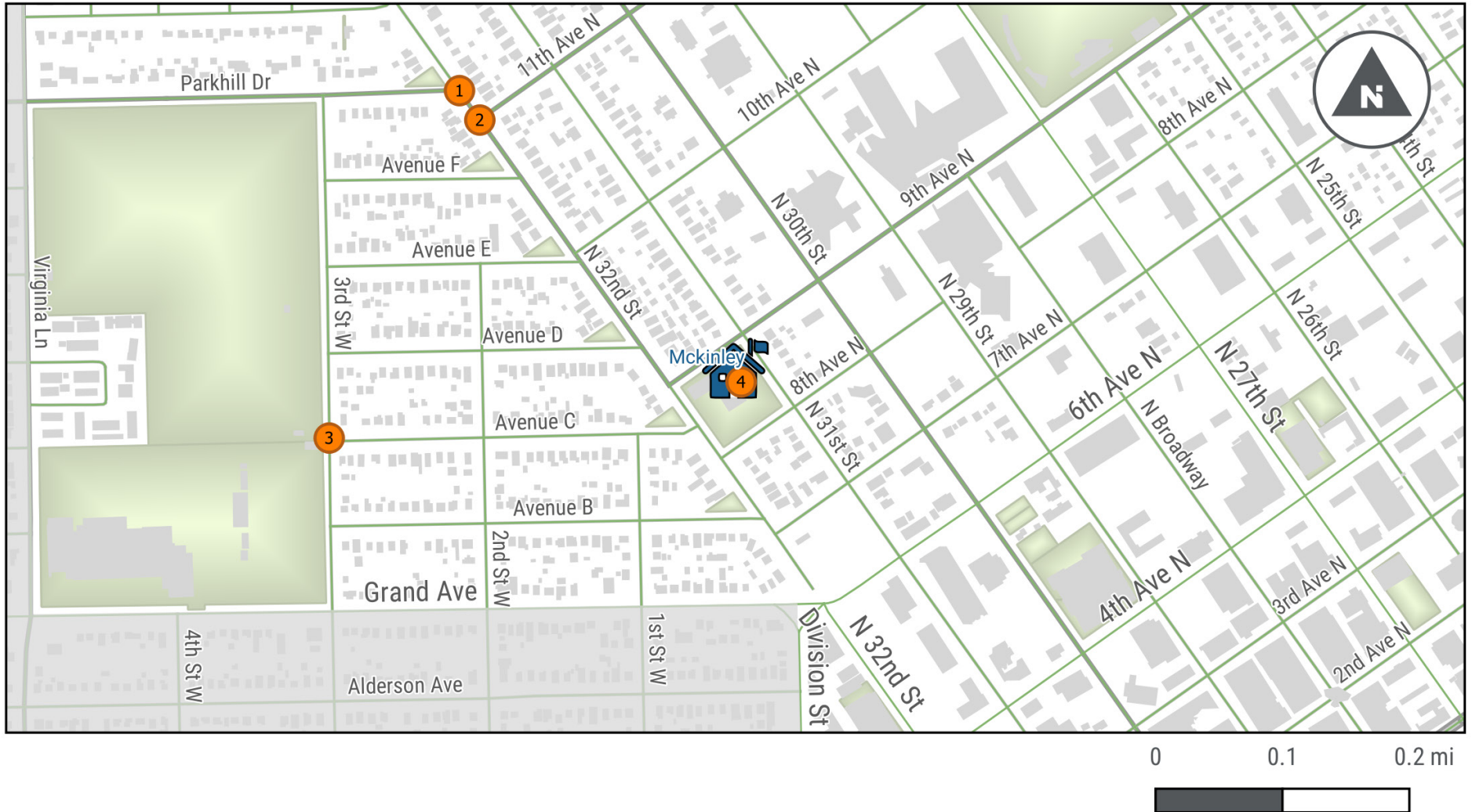

# Meadowlark Elementary

## Existing Conditions

About the School	
Address	221 29th St W
Number of Students	Approximately 520
Percentage of Students Eligible for Free and Reduced Lunch	20%
Arrival / Dismissal Times	8:30 AM / 2:30 and 3:15 PM

Major Streets and Highways	Annual Average Daily Traffic (AADT) <sup>c</sup>
32 <sup>nd</sup> St W	13,100
Central Ave	17,400

<sup>c</sup>Source: MDOT Interactive Traffic Web Map

## Existing Conditions Map

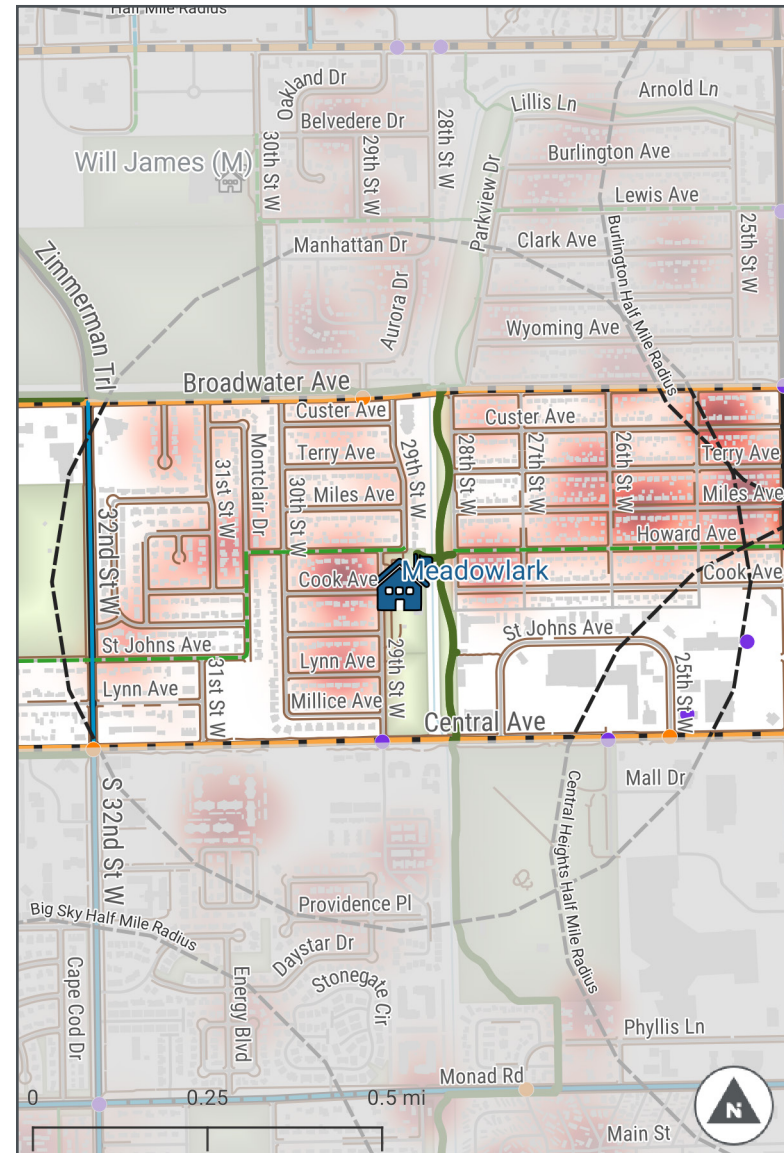

- |  |                               |  |                          |  |                                       |
|--|-------------------------------|--|--------------------------|--|---------------------------------------|
|  | Student Address Heatmap       |  | Existing Shared Use Path |  | Proposed Neighborhood Bikeway         |
|  | School Half Mile Buffer       |  | Existing Bike Lane       |  | Proposed Visionary Long Range Bikeway |
|  | Outside School Boundary       |  | Sidewalk                 |  |                                       |
|  | Bike Crash (2016-2020)        |  |                          |  |                                       |
|  | Pedestrian Crash (2016-2020)  |  |                          |  |                                       |
|  | Speed Limit 35 mph or Greater |  |                          |  |                                       |

## Known Safety Concerns at Meadowlark Elementary

Source of Concern	Safety Concern or Comment
Principal	<ul style="list-style-type: none"> <li>Largest issue is students being dropped off in the traffic lane in front of school on 29<sup>th</sup> St W.</li> <li>Principal serves as a “driveway guard” to stop the kids walking so buses can exit the parking lot/drop-off zone.</li> <li>With the school boundary change, the school transitioned from most of the students being within walking distance to most being safety bussed.</li> <li>Largest safety concern from the parents is personal safety in the neighborhood, although the principal thinks it is a very safe neighborhood for walking and biking.</li> </ul>
Webmap Survey	<p>There are approximately six comments in the Meadowlark Elementary catchment area regarding:</p> <ul style="list-style-type: none"> <li>Unsafe crossing at 32<sup>nd</sup> St W and Central Ave and at 29<sup>th</sup> St W and Broadwater Ave.</li> <li>Unsafe walking conditions along Central Ave.</li> </ul>
Crossing Guard	<ul style="list-style-type: none"> <li>Much of the faster driving is from students heading through the neighborhood on 29<sup>th</sup> St to the nearby high school.</li> <li>Need to maintain coordination between students walking, parents driving, and busses entering and exiting parking lot.</li> <li>Parents are not supposed to use parking lot to drop off children (there used to be three cones blocking the lot, but since some families and staff need to use the lot for accessibility, they left an opening that some parents have started to use.)</li> </ul>
Safety Busing	<ul style="list-style-type: none"> <li>The school district provides safety busing for students that live west of 32<sup>nd</sup> Ave.</li> </ul>

## Arrival Observations

Observation Details	
Observation Date	<b>The consultant team observed arrival on Tuesday, September 21.</b>
School Bus Loading	<ul style="list-style-type: none"> <li>School buses pull into a lot along the southwest side of the school. This lot is only for school bus loading and unloading. The principal stands at the school bus loop exit to hold back students walking in order to keep buses moving along.</li> </ul>
Before/Aftercare Vans	<ul style="list-style-type: none"> <li>No before/aftercare vans were observed.</li> </ul>
Family Vehicles	<ul style="list-style-type: none"> <li>Most families dropped off students in front of the school on 29<sup>th</sup> St W.</li> <li>Some families dropped children off on Howard Ave or 29<sup>th</sup> St W and used crossing guard at 29<sup>th</sup> St W.</li> <li>Some families dropped off on Cook Ave, and then students would cross at the crossing guard location.</li> <li>Families coming from the east are encouraged to drop off students on 28<sup>th</sup> St W to use the pedestrian and bike bridge that goes onto the school property.</li> </ul>
School Staff Roles	<ul style="list-style-type: none"> <li>School staff are assigned to “bus duty” for both arrival and dismissal (in the morning, it is a school counselor, in the afternoon, it is teachers).</li> <li>Students have color-coded tags on their backpacks that correspond to their specific bus.</li> <li>Principal serves as “driveway guard” before school.</li> </ul>
Adult Crossing Guards	<ul style="list-style-type: none"> <li>There are two school crossing guards posted at Cook Ave and 29<sup>th</sup> St W, and at Howard Ave and the school’s north entrance.</li> </ul>
Bike Rack Locations and Use	<ul style="list-style-type: none"> <li>There are two bike racks around the school, located at the school main entrance on 29<sup>th</sup> St W and Howard Ave.</li> <li>Most of the bicycles were parked at the rack on Howard Ave.</li> </ul>
Students Walking and Biking	<ul style="list-style-type: none"> <li>Very few students were observed walking – most were walking after being dropped off a half block away.</li> <li>Some students were observed walking and biking over the pedestrian and bike bridge to the east of the school.</li> </ul>

## Priority Concerns at Meadowlark Elementary

The numbered observations and recommendations in the table below correspond to the points in the Existing Conditions Map (shown on previous page).

#	Location	Observations	Webmap Comments?
1	Throughout the neighborhood	<ul style="list-style-type: none"> <li>The neighborhoods and streets within the school's catchment area and ½-mile are very walkable and low-speed, but there are sections with missing sidewalks.</li> </ul>	No
2	Bike racks	<ul style="list-style-type: none"> <li>Existing bicycle racks can damage bikes and make it difficult to securely lock bicycles. Few bicycles were parked the day of observation.</li> </ul>	No

## Proposed Projects at Meadowlark Elementary

The numbered observations and recommendations in the table below correspond to the points in the Proposed Projects Map (shown on final page).

#	Location	Topic	Issue	Recommendation
1	Throughout neighborhood	Sidewalks	<ul style="list-style-type: none"> <li>Missing sidewalks throughout the neighborhood present a barrier to walking and bicycling to school.</li> </ul>	<ul style="list-style-type: none"> <li>Pave streets and construct sidewalks along at least one side of the street. (Long term)</li> </ul>
2	On-site bicycle racks	Bicycle parking	<ul style="list-style-type: none"> <li>Existing bicycle racks can damage bikes and make it difficult to securely lock bicycles. Few bicycles were parked the day of observation.</li> </ul>	<ul style="list-style-type: none"> <li>Replace the existing bike racks with new racks that support the bike frame in at least two places and that enable secure locking. (Short term)</li> </ul>

### Proposed Projects Map

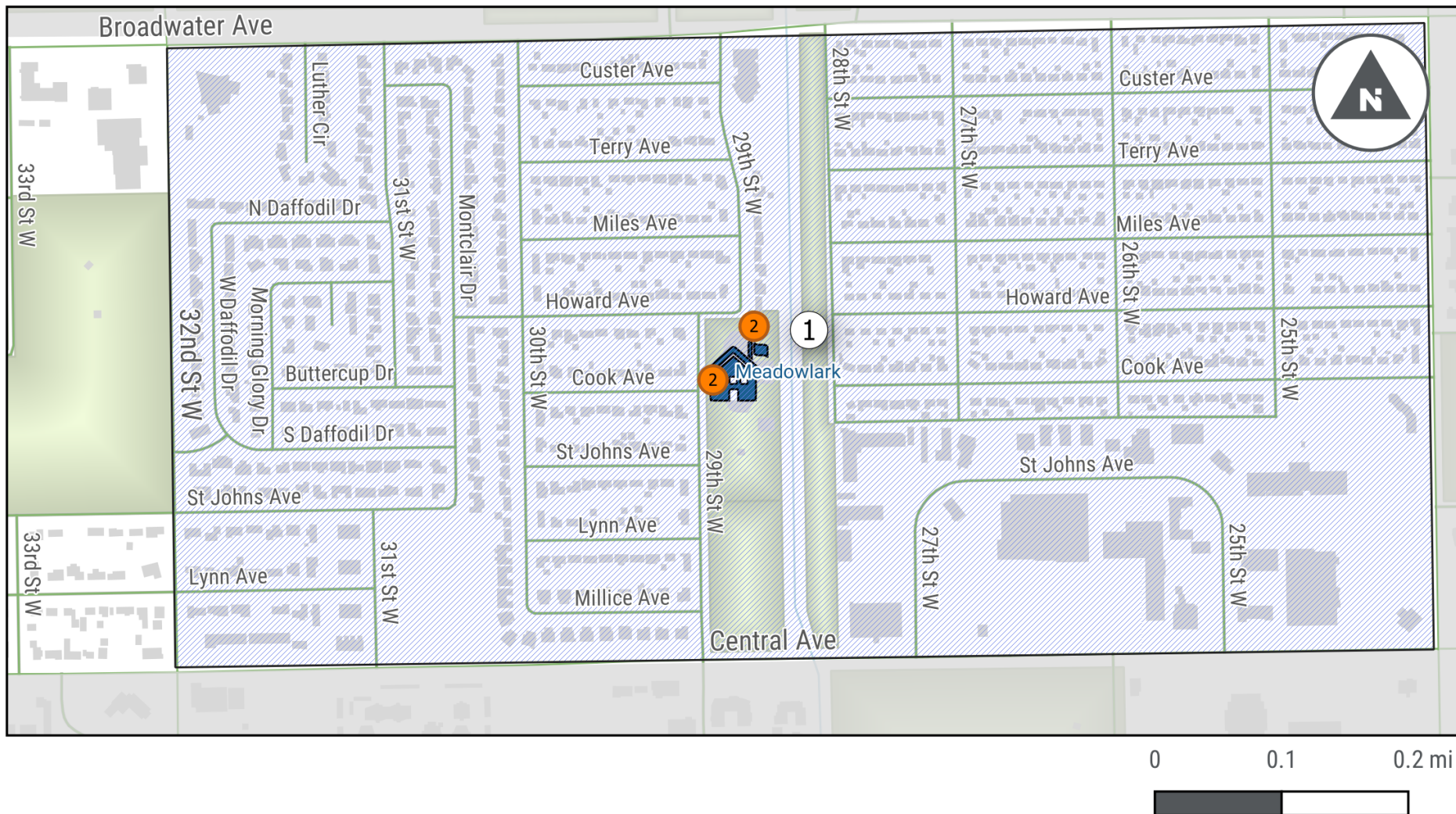



# Miles Avenue Elementary

## Existing Conditions

About the School	
Address	1601 Miles Ave
Number of Students	270
Percentage of Students Eligible for Free and Reduced Lunch	52%
Arrival / Dismissal Times	8:15 AM / 2:15 and 3:10 PM

Major Streets and Highways	Annual Average Daily Traffic (AADT) <sup>c</sup>
Central Ave	17,600
Broadwater Ave	12,900
15 <sup>th</sup> St W	6,000
16 <sup>th</sup> St W	2,000
19 <sup>th</sup> St W	9,300

<sup>c</sup>Source: MDOT Interactive Traffic Web Map

## Existing Conditions Map

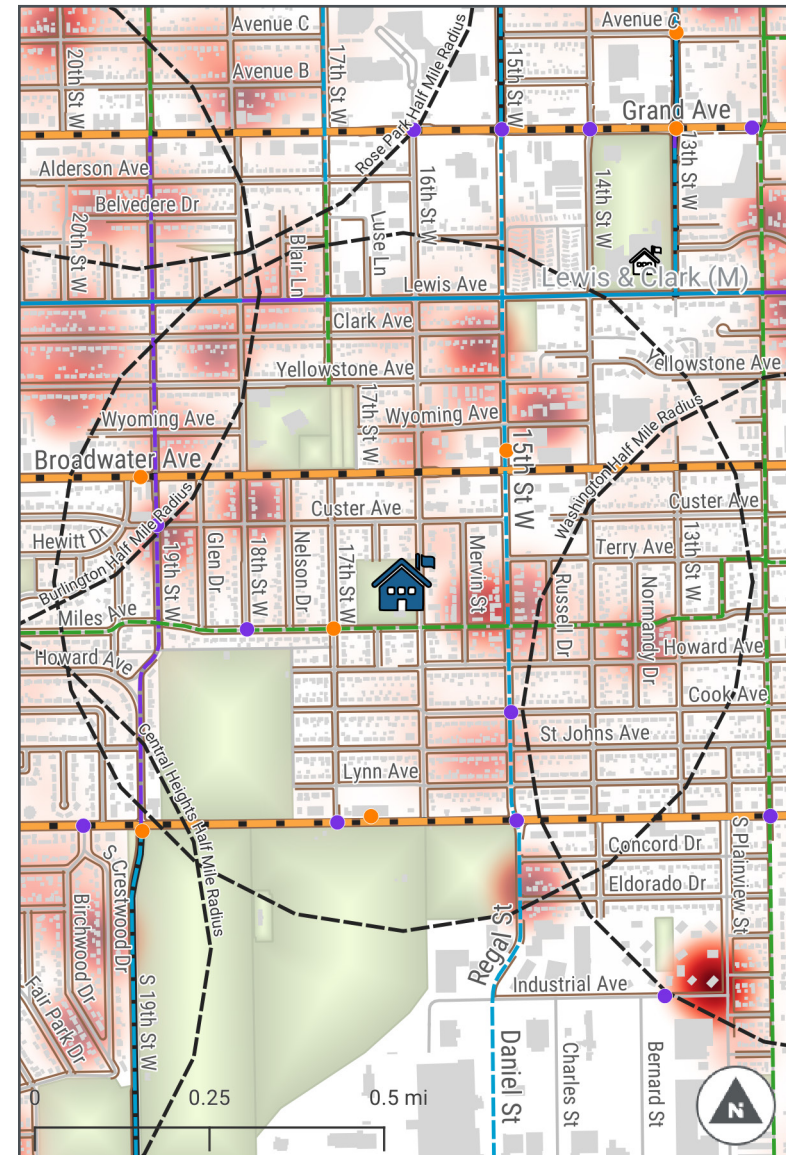

- |                               |                      |                              |
|-------------------------------|----------------------|------------------------------|
| Student Address Heatmap       | <b>Existing</b>      | <b>Proposed</b>              |
| School Half Mile Buffer       | Existing Bike Lane   | Neighborhood Bikeway         |
| Bike Crash (2016-2020)        | Existing Shared Lane | Bike Lane                    |
| Pedestrian Crash (2016-2020)  | Sidewalk             | Shared Lane Marking          |
| Speed Limit 35 mph or Greater |                      | Visionary Long Range Bikeway |

## Known Safety Concerns at Miles Ave Elementary

Source of Concern	Safety Concern or Comment
Principal	<ul style="list-style-type: none"> <li>Most concerns are about the crosswalks in from of the school. There is a crossing guard at 16<sup>th</sup> St W and Miles Ave, but not one at the crosswalk on 16<sup>th</sup> St at the north side of the school.</li> <li>Believes that the neighborhood is a relatively safe place to walk in terms of personal safety. Personal safety is a concern for families south of Terry and east of 13<sup>th</sup> St W.</li> </ul>
Webmap Survey	<p>There was one comment in the Miles Ave Elementary catchment area regarding:</p> <ul style="list-style-type: none"> <li>Curb ramps on Miles Ave</li> </ul>
Crossing Guard	<ul style="list-style-type: none"> <li>Parents are pretty good at slowing down and stopping.</li> <li>Concerned about the crosswalk without a crossing guard on the north side of the school.</li> </ul>
Safety Busing	<ul style="list-style-type: none"> <li>Safety busing is provided for students living south of Monad between S 20th St W and S 24th St W.</li> </ul>

## Arrival Observations

Observation Details	
Observation Date	<b>The consultant team observed arrival on Wednesday, September 22.</b>
School Bus Loading	<ul style="list-style-type: none"> <li>School buses lined up and dropped off in the pull-in driveway along 16<sup>th</sup> St W.</li> </ul>
Before/Aftercare Vans	<ul style="list-style-type: none"> <li>Before/aftercare vans buses lined up and dropped off in the pull-in driveway along 16<sup>th</sup> St W.</li> </ul>
Family Vehicles	<ul style="list-style-type: none"> <li>Families dropped off students in front of the school along 16th St W, many pulling into the same driveway loop as the busses</li> <li>Families would also drop off students along Miles Ave. There are cones put near the crosswalk to discourage parents from parking too close and limiting visibility.</li> <li>A limited number of families dropped off students in the alley behind (west of) the school. There are a number of breaks in the fence to allow students to enter the school property from that direction.</li> </ul>
School Staff Roles	<ul style="list-style-type: none"> <li>School staff do not assist with arrival. Students either go straight to the lunchroom for breakfast and then to their class or enter at their classroom door from the outside.</li> <li>In the afternoon dismissal, teachers bring students to their busses.</li> </ul>
Adult Crossing Guards	<ul style="list-style-type: none"> <li>A school crossing guard is posted at 16<sup>th</sup> St W and Miles Ave.</li> <li>A school crossing guard is posted at Miles Ave and Van Bramer Dr.</li> </ul>
Bike Rack Locations and Use	<ul style="list-style-type: none"> <li>There are 3 adjacent bike racks at the school, located on school property (inside the fence) along Miles Ave.</li> <li>Families notes that there was always bike parking available.</li> </ul>
Students Walking and Biking	<ul style="list-style-type: none"> <li>Many students were observed walking, mostly coming from the west along Miles Ave.</li> <li>Some students were observed getting to the school by walking south along 16<sup>th</sup> St W.</li> <li>Few students were observe using the openings in the fence to the north side of the school.</li> </ul>

## Priority Concerns at Miles Ave Elementary

The numbered observations and recommendations in the table below correspond to the points in the Existing Conditions Map (shown on previous page).

#	Location	Observations	Webmap Comments?
1	School crossing along 16 <sup>th</sup> St W north of school the school	<ul style="list-style-type: none"> <li>Some students cross at the marked crossing at the school driveway entrance to the north of the school. There is no crossing guard here, and drivers don't always yield to pedestrians in the crosswalk. The marked crosswalk to the school should be eliminated to consolidate crossings.</li> </ul>	No
2	Broadwater Ave and 15 <sup>th</sup> St W	<ul style="list-style-type: none"> <li>Crossing distances are long and there are no median crossing islands for pedestrians.</li> <li>Broadwater Ave and 15th St W have higher traffic volumes and speeds than would be preferred for a student crossing location.</li> <li>The relatively wide street and/or multiple travel lanes encourage(s) speeding.</li> <li>All crosswalk markings across are faded.</li> </ul>	No
3	Miles Ave and 15 <sup>th</sup> St W	<ul style="list-style-type: none"> <li>15th St W is has higher traffic volumes and speeds than would be preferred for a student crossing location.</li> <li>Parents and staff report that this crossing is dangerous and discourages students from walking and biking.</li> </ul>	No
5	Bicycle Racks at Miles Ave School	<ul style="list-style-type: none"> <li>Existing bicycle racks can damage bikes and make it difficult to securely lock bicycles. Many bicycles were parked the day of observation.</li> </ul>	No

## Proposed Projects at Miles Ave Elementary

The numbered observations and recommendations in the table below correspond to the points in the Proposed Projects Map (shown on final page).

#	Location	Topic	Issue	Recommendation
1	School crossing along 16 <sup>th</sup> St W near the school	Crossing	<ul style="list-style-type: none"> <li>Some students cross the street at this intersection and drivers don't always yield to pedestrians in the crosswalk.</li> </ul>	<ul style="list-style-type: none"> <li>Consider using in-street yield to pedestrian signs.</li> </ul>
2	Broadwater Ave between 12 <sup>th</sup> St W and 19th St W	Crossing	<ul style="list-style-type: none"> <li>Crossing distances are long and there are no median crossing islands for pedestrians.</li> <li>The crossings on all legs lack high-visibility markings.</li> </ul>	<ul style="list-style-type: none"> <li>Add pedestrian refuge islands to shorten crossing distances and improve pedestrian safety.</li> <li>Add high-visibility crosswalk markings at 16<sup>th</sup> and Broadwater.</li> <li>Install driver speed feedback sign on both approaches to the intersection.</li> </ul>
3	Miles Ave and 15 <sup>th</sup> St W	Speeding/Volume	<ul style="list-style-type: none"> <li>15<sup>th</sup> St W is posted at 35 mph at this location.</li> <li>ADT on 15th St W is 8,390 at this location.</li> </ul>	<ul style="list-style-type: none"> <li>curb extensions with parking lanes to slow traffic and increase the visibility of crossing students.</li> </ul>
4	Miles Ave and 16 <sup>th</sup> St W	Crossing	<ul style="list-style-type: none"> <li>Curb extensions shorten crossing distances and increase pedestrian visibility.</li> </ul>	<ul style="list-style-type: none"> <li>Install curb extensions at all corners of the intersection.</li> </ul>
4	South of school	Bicycle parking	<ul style="list-style-type: none"> <li>Existing bicycle racks can damage bikes and make it difficult to securely lock bicycles. Some bicycles were parked the day of observation.</li> </ul>	<ul style="list-style-type: none"> <li>Replace the existing bike racks with new racks that support the bike frame in at least two places and that enable secure locking.</li> </ul>

### Proposed Projects Map

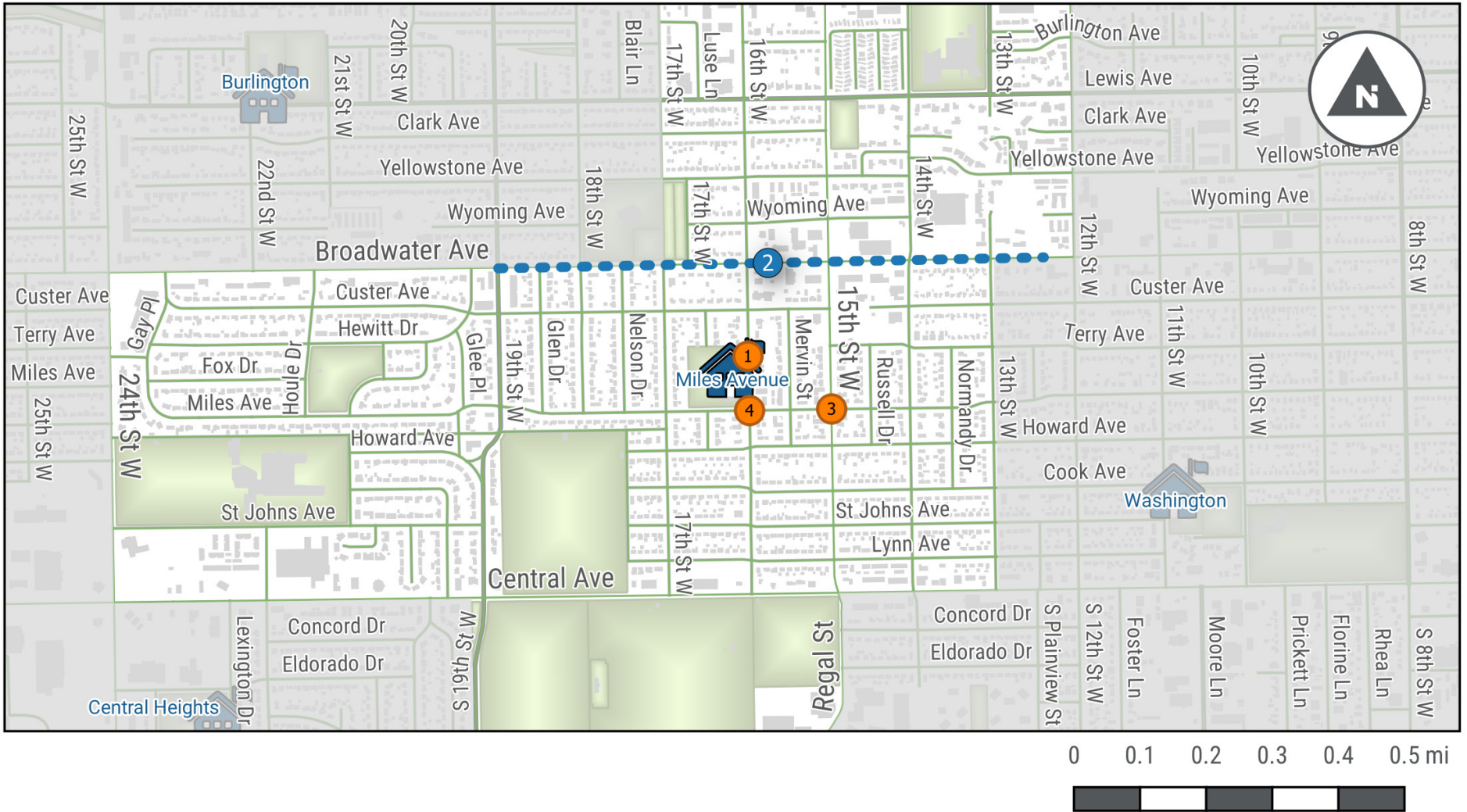

# Newman Elementary

## Existing Conditions

About the School	
Address	605 S Billings Boulevard
Number of Students	Approximately 230
Percentage of Students Eligible for Free and Reduced Lunch	100%
Arrival / Dismissal Times	7:30 and 8:10 AM / 2:00 and 3:00 PM

Major Streets and Highways	Annual Average Daily Traffic (AADT) <sup>c</sup>
Underpass Ave	13,200
State Ave	<ul style="list-style-type: none"> <li>18,700 (between King Ave and Underpass Ave)</li> <li>14,700 (between Underpass Ave and Central Ave)</li> </ul>
King Ave	<ul style="list-style-type: none"> <li>3,400 (west of Billings Blvd)</li> <li>10,700 (between Billings Blvd and Orchard Ln)</li> </ul>
Billings Blvd	<ul style="list-style-type: none"> <li>7,400 (north of Simpson St)</li> <li>6,400 (south of Simpson St)</li> </ul>
Calhoun Ln	<ul style="list-style-type: none"> <li>3,900 (north of Lux Ave)</li> <li>2,300 (south of Lux Ave)</li> </ul>
Orchard Ln	<ul style="list-style-type: none"> <li>3,500 (north of Phillip St)</li> <li>2,200 (south of Phillip St)</li> </ul>

<sup>c</sup>Source: MDOT Interactive Traffic Web Map

## Existing Conditions Map

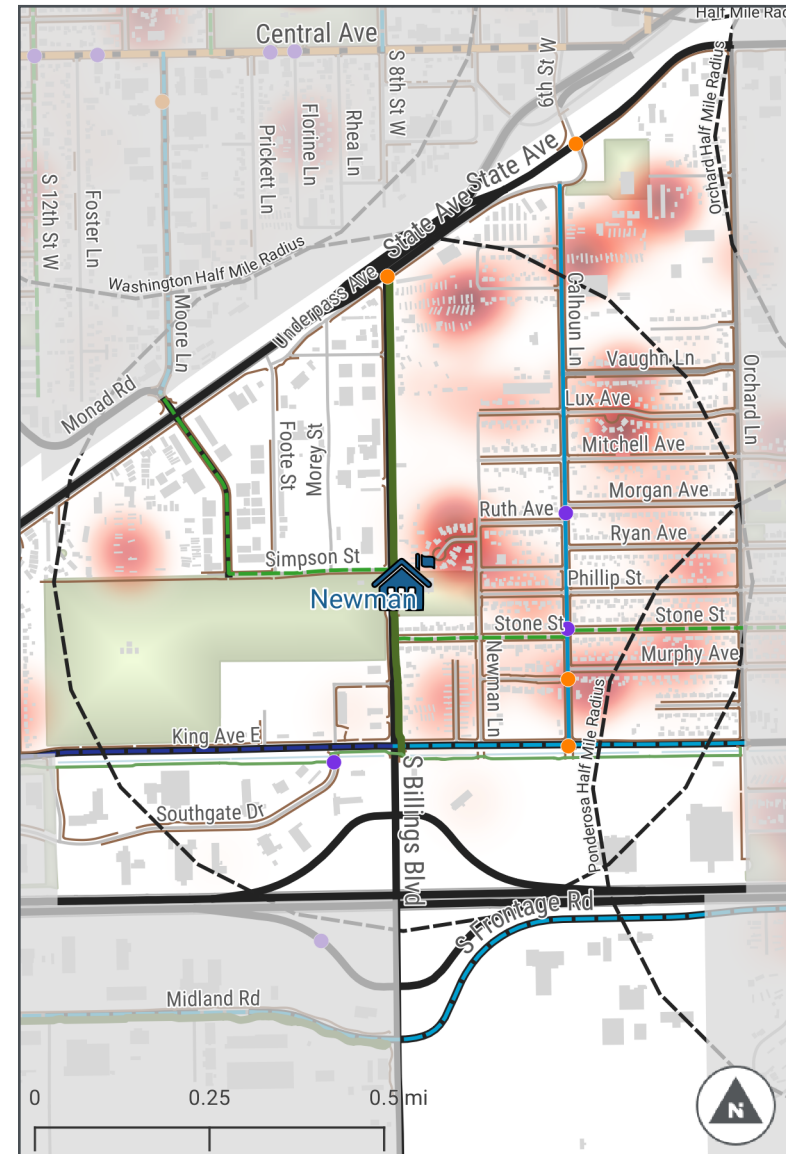

## Known Safety Concerns at Newman Elementary

Source of Concern	Safety Concern or Comment
Principal	<ul style="list-style-type: none"> <li>No significant safety concerns.</li> </ul>
Webmap Survey	<p>There are approximately six comments in the Newman Elementary catchment area regarding:</p> <ul style="list-style-type: none"> <li>Walking conditions and safety on Simpson St</li> <li>Crossing and a road diet on S Billings Blvd</li> <li>Conditions on King Ave E</li> <li>An off-street canal path</li> </ul>
Crossing Guard	<ul style="list-style-type: none"> <li>Mentioned that students cross from all directions and crossing guard can't see the ones crossing behind her.</li> <li>Crossing guard parks vehicle near the crosswalk to guide parents to park close to her car.</li> </ul>
Safety Busing	<ul style="list-style-type: none"> <li>Safety busing is provided for students who live in Meadowlark Trailer Court.</li> </ul>

## Arrival Observations

Observation Details	
Observation Date	<b>The consultant team observed arrival on Monday, September 20.</b>
School Bus Loading	<ul style="list-style-type: none"> <li>School buses lined up along the front of the school on S Billings Blvd.</li> </ul>
Before/Aftercare Vans	<ul style="list-style-type: none"> <li>Before/aftercare vans picked up students in front door of the school.</li> </ul>
Family Vehicles	<ul style="list-style-type: none"> <li>Families dropped off and pick up students in front of the school on S Billings Blvd and in the back of the school on Newman Ln.</li> </ul>
School Staff Roles	<ul style="list-style-type: none"> <li>School staff were present supervising students on the playground and outside the front door.</li> </ul>
Adult Crossing Guards	<ul style="list-style-type: none"> <li>A school crossing guard is posted at intersections of Simpson and S Billings Blvd, Newman Ln and Phillip St, and Calhoun Ln and Phillip St.</li> </ul>
Bike Rack Locations and Use	<ul style="list-style-type: none"> <li>There are two bike racks around the school, located in front of the school on S Billings Blvd, and on the back of the school.</li> </ul>
Students Walking and Biking	<ul style="list-style-type: none"> <li>Few students were observed walking and biking.</li> </ul>

## Priority Concerns at Newman Elementary

The numbered observations and recommendations in the table below correspond to the points in the Existing Conditions Map (shown on previous page).

#	Location	Observations	Webmap Comments?
1	S Billings Blvd	<ul style="list-style-type: none"> <li>S Billings Blvd has higher traffic volumes and speeds than would be preferred for a student crossing location.</li> <li>Crossing distances are long and there are no median crossing islands for pedestrians.</li> <li>Some families were observed parking on the non-school side and double parking, asking students to cross the street without an adult, and making u-turns in front of the school.</li> <li>Missing sidewalks present a barrier to walking and bicycling to school.</li> <li>Junkyards are located on both sides of S Billings Blvd, generating high volume of trucks which is creating a barrier for students to walk to school.</li> <li>Existing off street trail on school side of S Billings Blvd</li> </ul>	No
2	Newman Ln	<ul style="list-style-type: none"> <li>Some families were observed parking on the non-school side and double parking, asking students to cross the street without an adult, and making u-turns in front of the school.</li> <li>Sidewalks need repairs or replacement to provide a trip-free route for all users.</li> <li>Students walk to the back gate fence which is offset from the crossing guard – some students cross at this location instead of walking to the marked crossing. This may have to be closed.</li> </ul>	No
3	Calhoun Ln	<ul style="list-style-type: none"> <li>Crossing distances are long and there are no median crossing islands for pedestrians.</li> <li>Narrow sidewalks with minimal buffer next to a busy street, creating an uncomfortable walking/cycling environment. Posts and mailboxes in the sidewalk further impede users.</li> <li>Crosswalk markings across Phillip St are faded.</li> <li>There is an existing bike lane on Calhoun Ln.</li> </ul>	No

## Proposed Projects at Newman Elementary

The numbered observations and recommendations in the table below correspond to the points in the Proposed Projects Map (shown on final page).

#	Location	Topic	Issue	Recommendation
1	S Billings Blvd and Simpson	Crossing	<ul style="list-style-type: none"> <li>Crossing distances are long and there are no median crossing islands for pedestrians.</li> </ul>	<ul style="list-style-type: none"> <li>Add pedestrian refuge island to shorten crossing distances and improve pedestrian safety.</li> <li>Installing RRFB in 2022.</li> </ul>
2	Newman Ln	Arrival/Dismissal Behavior	<ul style="list-style-type: none"> <li>Some families were observed parking on the non-school side, double-parking, asking students to cross the street without an adult, and making u-turns in front of the school.</li> </ul>	<ul style="list-style-type: none"> <li>Provide staff monitoring of arrival and dismissal, and provide communication expectations for family vehicles at arrival and dismissal.</li> <li>Ideally, all pick-up and drop-off occurs on the school side of the street, or, at a minimum, in locations with safe crossings. Add on-street parking restrictions to facilitate school-side drop off/pick up and crossing at safe locations.</li> <li>A further evaluation and/or pilot pop-up project should be used to evaluate the effectiveness of any new on-street parking restriction.</li> </ul>
3	Calhoun Ln	Sidewalks	<ul style="list-style-type: none"> <li>Sidewalks measure less than the recommended width of 5'. Posts and mailboxes in the sidewalk further impede users.</li> </ul>	<ul style="list-style-type: none"> <li>Reconstruct sidewalks to provide a wider surface.</li> </ul>
4	School site	Bicycle parking	<ul style="list-style-type: none"> <li>Existing bicycle racks can damage bikes and make it difficult to securely lock bicycles. Few bicycles were parked the day of observation.</li> </ul>	<ul style="list-style-type: none"> <li>Replace the existing bike racks with new racks that support the bike frame in at least two places and that enable secure locking.</li> </ul>

### Proposed Projects Map

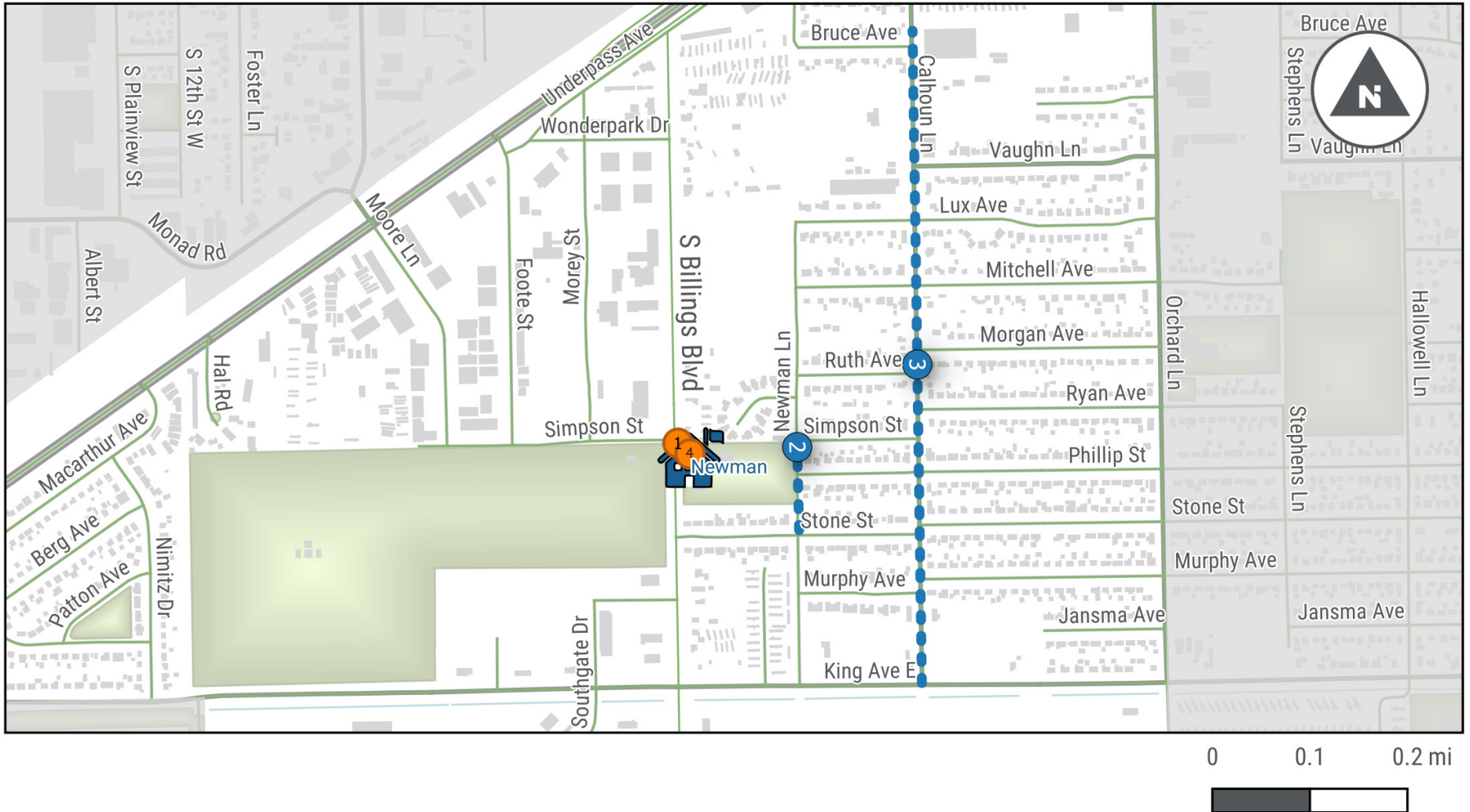



# Orchard Elementary

## Existing Conditions

About the School	
Address	120 Jackson St
Number of Students	Approximately 285
Percentage of Students Eligible for Free and Reduced Lunch	100%
Arrival / Dismissal Times	7:30 and 8:00 AM / 2:00 and 3:00 PM

Major Streets and Highways	Annual Average Daily Traffic (AADT) <sup>c</sup>
1st Ave South	<ul style="list-style-type: none"> <li>8,300 (between State Ave and 35th St)</li> <li>7,900 (between 35th St and 30th St)</li> <li>7,900 (between 30th St and 27th St)</li> </ul>
State Ave	10,800 (between 1st Ave South and Jackson St) 9,146 (between Jackson St and Riverside Road)
Orchard Ln	<ul style="list-style-type: none"> <li>3,500 (north of Phillip St)</li> <li>2,200 (south of Phillip St)</li> </ul>
Jackson St	<ul style="list-style-type: none"> <li>3,400 (north of Vaughn Ln)</li> <li>1,300 (south of Vaughn Ln)</li> </ul>

<sup>c</sup>Source: MDOT Interactive Traffic Web Map

## Existing Conditions Map

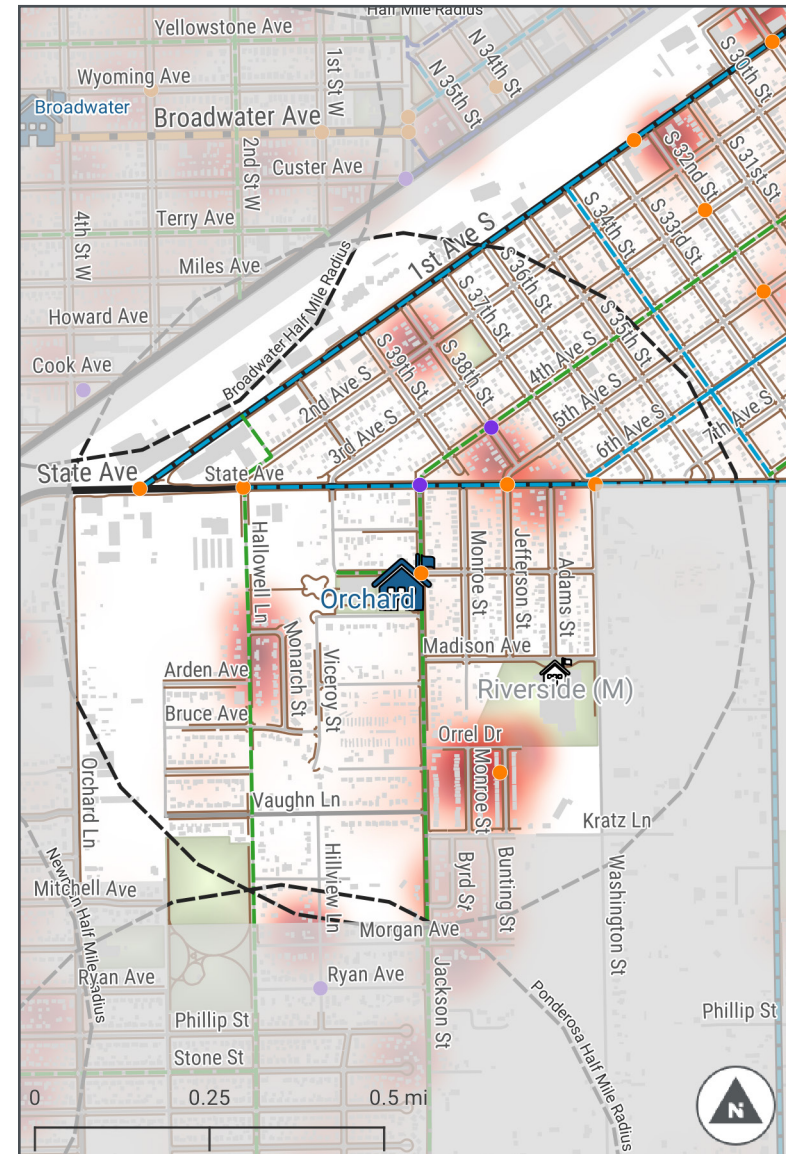

Student Address Heatmap	<b>Existing</b>	<b>Proposed</b>
School Half Mile Buffer	Sidewalk	Neighborhood Bikeway
Outside School Boundary		Bike Lane
Bike Crash (2016-2020)		
Pedestrian Crash (2016-2020)		
Speed Limit 35 mph or Greater		

## Known Safety Concerns at Orchard Elementary

Source of Concern	Safety Concern or Comment
Principal	<ul style="list-style-type: none"> <li>Principal is concerned with dismissal, high traffic volume of family vehicles.</li> <li>Principal is concerned with community perceptions, neighborhood offenders, and students misbehaving on the walk home.</li> </ul>
Webmap Survey	<p>There are approximately ten comments in the Orchard Elementary catchment area regarding:</p> <ul style="list-style-type: none"> <li>Speeding near Highland Park</li> <li>Difficult crossing conditions due to driver behavior on Jackson St</li> <li>A shared use path along a canal</li> <li>Safe walking facilities and difficulty crossing 4<sup>th</sup> Ave S</li> <li>Lack of intersection control on Roosevelt Ave</li> <li>Difficulty crossing State Ave</li> </ul>
Crossing Guard	<ul style="list-style-type: none"> <li>Family vehicles make u-turns near the crossing guard crosswalk.</li> <li>Some drivers/turning drivers do not stop for crossing guard.</li> <li>High speeds and/or high traffic volumes on Jackson St.</li> </ul>
Safety Busing	<ul style="list-style-type: none"> <li>No safety busing is provided.</li> </ul>

## Dismissal Observations

Observation Details	
Observation Date	<b>The consultant team observed dismissal on Monday, September 20.</b>
School Bus Loading	<ul style="list-style-type: none"> <li>Buses pick up on Roosevelt Ave.</li> </ul>
Before/Aftercare Vans	<ul style="list-style-type: none"> <li>Aftercare vans picked up students at the north side of the school</li> </ul>
Family Vehicles	<p>Families dropped off and pick up students:</p> <ul style="list-style-type: none"> <li>Kindergarten – Door #1</li> <li>1st Grade – Door #2</li> <li>2nd Grade – Door #3</li> <li>3rd Grade – Door #4</li> <li>4th Grade – Door #5</li> <li>5th Grade – Door #6</li> </ul>
School Staff Roles	<ul style="list-style-type: none"> <li>No school staff were involved during the arrival period.</li> </ul>
Adult Crossing Guards	<ul style="list-style-type: none"> <li>A school crossing guard is posted at the intersection of Jackson St and State Ave, and Jackson St and Frances Ave.</li> </ul>
Bike Rack Locations and Use	<ul style="list-style-type: none"> <li>There are two bike racks around the school, located in front of the school at Frances Ave, and at the west side of the school.</li> </ul>
Students Walking and Biking	<ul style="list-style-type: none"> <li>Students were observed walking and biking from all directions.</li> </ul>

## Priority Concerns at Orchard Elementary

The numbered observations and recommendations in the table below correspond to the points in the Existing Conditions Map (shown on previous page).

#	Location	Observations	Webmap Comments?
1	State Ave	<ul style="list-style-type: none"> <li>State Ave has higher traffic volumes and speeds than would be preferred for a student crossing location.</li> <li>Crossing distances are long and there are no median crossing islands for pedestrians.</li> <li>There are no curb cuts at the intersection of State Ave and Jackson St even though there are sidewalks.</li> <li>State Ave is recommended to be a bike lane from Hallowell Ln to Sugar Ave in the Billings Area Bikeway and Trails Master Plan.</li> </ul>	Yes
2	Frances Ave	<ul style="list-style-type: none"> <li>Some families were observed parking on the non-school side and double parking, asking students to cross the street without an adult, and making u-turns in front of the school.</li> <li>There are no marked crossings in front of the school at the intersection of Frances Ave and Jackson St.</li> <li>Several families parked at 45 degrees in front of the school, causing pedestrian conflicts.</li> <li>Students were observed jay walking between vehicles to families parking on the non-school side.</li> <li>No presence of school signage.</li> </ul>	No
3	Van Buren St	<ul style="list-style-type: none"> <li>Missing sidewalks present a barrier to walking and bicycling to school.</li> </ul>	No
4	Hallowell Ln	<ul style="list-style-type: none"> <li>Hallowell Ln is recommended to be a neighborhood bikeway from State Ave to King Ave, and a major trailhead improvement in the Billings Area Bikeway and Trails Master Plan.</li> </ul>	No
5	Jackson St	<ul style="list-style-type: none"> <li>Sidewalks throughout the neighborhood need repair or replacement to provide a safe pedestrian route for all users.</li> <li>Some existing sidewalks measure less than the recommended width of 5'.</li> <li>Narrow sidewalks with minimal buffer are present. Curb ramps are missing throughout the neighborhood. Posts and mailboxes in the sidewalk further impede users.</li> <li>School and crosswalk signage and flashing light not visible, vegetation obstruction.</li> <li>Vehicles on both sides for pick up. A lot of on-street parking mixed with people picking up.</li> <li>There are no marked crossings across Roosevelt at the intersection of Roosevelt Ave and Jackson St.</li> <li>Jackson St is recommended to be a neighborhood bikeway from State Ave to King Ave in the Billings Area Bikeway and Trails Master Plan.</li> </ul>	Yes

## Proposed Projects at Orchard Elementary

The numbered observations and recommendations in the table below correspond to the points in the Proposed Projects Map (shown on final page).

#	Location	Topic	Issue	Recommendation
1	State Ave	Speeding/Volume	<ul style="list-style-type: none"> <li>State Ave has a posted speed limit of 35mph</li> <li>State street has an ADT of 8,250 at this location.</li> </ul>	<ul style="list-style-type: none"> <li>State St is a planned bicycle lane in the Billings Area Bikeway and Trails Master Plan.</li> <li>Study further to find an infrastructure intervention slow speeds on State Ave. to make it safer and more comfortable for school children walking and biking to school. Solution must be compatible with future bike lane.</li> </ul>
2	State Ave and Jackson St	Curb Cuts	<ul style="list-style-type: none"> <li>There are no curb cuts at the intersection of State Ave and Jackson St even though there are sidewalks.</li> </ul>	<ul style="list-style-type: none"> <li>Install ADA compliant curb ramps.</li> </ul>
3	Frances Ave	Arrival/Dismissal Behavior	<ul style="list-style-type: none"> <li>Some families were observed parking on the non-school side and double parking, asking students to cross the street without an adult, and making u-turns in front of the school.</li> </ul>	<ul style="list-style-type: none"> <li>Provide staff monitoring of arrival and dismissal, and provide expectations for family vehicles at arrival and dismissal.</li> <li>Ideally, all pick-up and drop-off occurs on the school side of the street, or, at a minimum, in locations with safe crossings.</li> <li>Add on-street parking restrictions to facilitate school-side drop off/pick up and crossing at safe locations.</li> <li>A further evaluation and/or pilot pop-up project should be used to evaluate the effectiveness of any new on-street parking restriction.</li> </ul>
4	Jackson St	Signage	<ul style="list-style-type: none"> <li>School and crosswalk signage and flashing light are not visible due to vegetation obstruction.</li> </ul>	<ul style="list-style-type: none"> <li>Trim vegetation to allow improved visibility for the signage and flashing light on Jackson St.</li> </ul>
5	Jackson St and Roosevelt Ave	Crossing	<ul style="list-style-type: none"> <li>Curb extensions shorten crossing distances and increase pedestrian visibility.</li> </ul>	<ul style="list-style-type: none"> <li>Install curb extensions to align with marked crosswalk.</li> </ul>
6	Jackson St and Francis Ave	Crossing	<ul style="list-style-type: none"> <li>Curb extensions shorten crossing distances and increase pedestrian visibility.</li> </ul>	<ul style="list-style-type: none"> <li>Install curb extensions to align with marked crosswalk</li> </ul>

## Proposed Projects Map

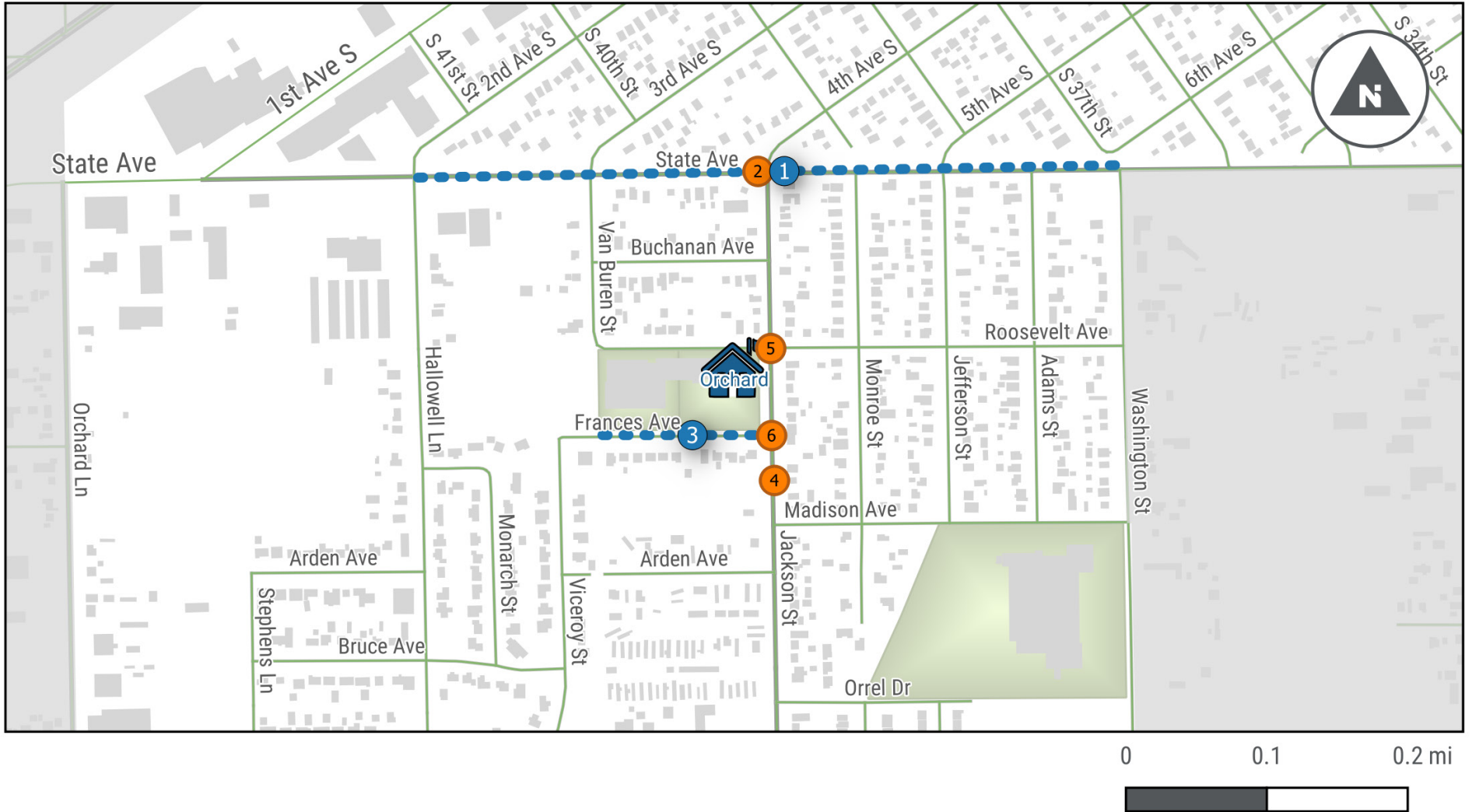

# Poly Drive Elementary

## Existing Conditions

About the School	
Address	2410 Poly Dr
Number of Students	Approximately 310
Percentage of Students Eligible for Free and Reduced Lunch	25%
Arrival / Dismissal Times	8:25 AM / 2:20 and 3:05 PM

Major Streets and Highways	Annual Average Daily Traffic (AADT) <sup>c</sup>
Poly Dr	5,000
Rimrock Rd	8,300
Colton Blvd	2,800
Rehberg Ln	<ul style="list-style-type: none"> <li>2,600 (north of Colton Blvd)</li> <li>5,300 (south of Colton Blvd)</li> </ul>
24 <sup>th</sup> Ave	4,900

<sup>c</sup>Source: MDOT Interactive Traffic Web Map

## Existing Conditions Map

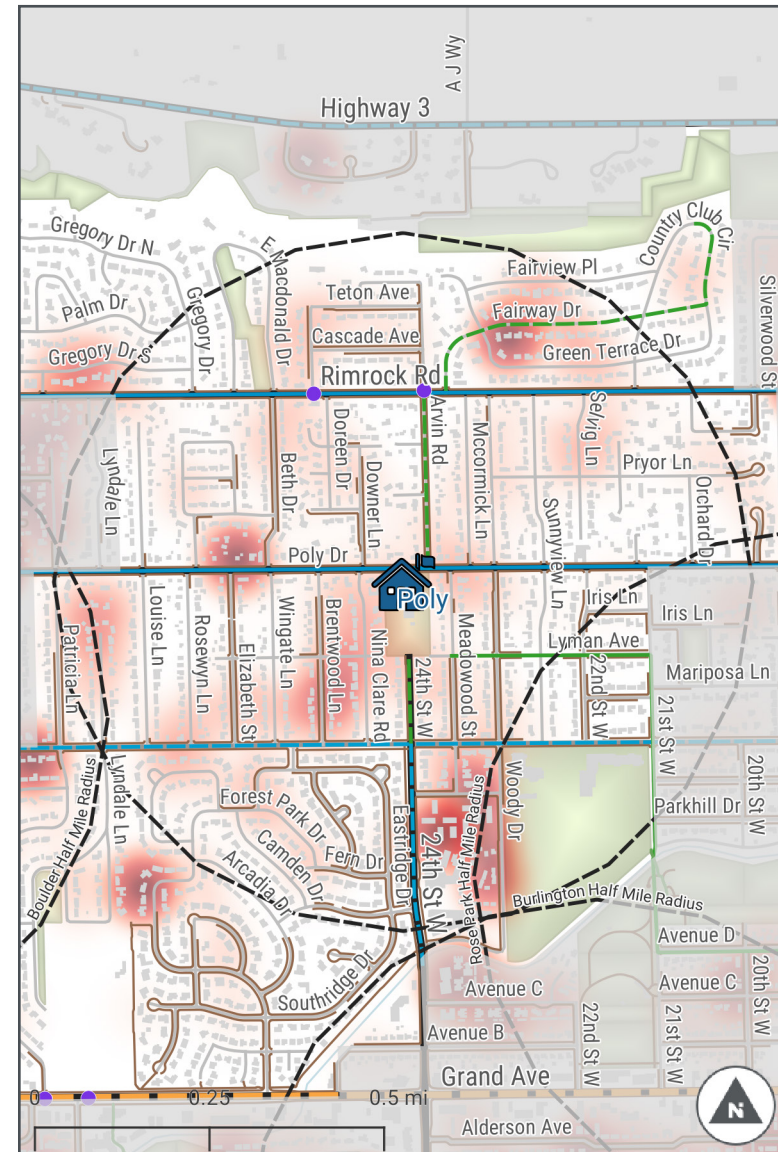

- |                               |                      |                      |
|-------------------------------|----------------------|----------------------|
| Student Address Heatmap       | <b>Existing</b>      | <b>Proposed</b>      |
| School Half Mile Buffer       | Existing Bike Lane   | Neighborhood Bikeway |
| Outside School Boundary       | Sidewalk             | Bike Lane            |
| Pedestrian Crash (2016-2020)  | Neighborhood Bikeway |                      |
| Speed Limit 35 mph or Greater |                      |                      |

## Known Safety Concerns at Poly Drive Elementary

Source of Concern	Safety Concern or Comment
Principal	<ul style="list-style-type: none"> <li>No significant safety concerns. Slightly concerned about Rehberg Ln as a high-volume street, which is slightly more than ½ mile to the west.</li> </ul>
Webmap Survey	<p>There are approximately 15 comments in the Poly Dr Elementary catchment area regarding:</p> <ul style="list-style-type: none"> <li>Nina Clare Rd sidewalk presence and driver behavior</li> <li>Traffic and crossing challenges on Rimrock Rd</li> <li>Canal path</li> <li>Colton Blvd crossing challenges</li> <li>Neighborhood traffic calming</li> <li>Poly Dr traffic conditions, bike lane facility, and crossings</li> </ul>
Crossing Guard	<ul style="list-style-type: none"> <li>Motor vehicles speed on Rimrock Rd going east. Morning light causes visibility concern.</li> <li>Snow removal creates crossing barriers due to plows using the median on Rimrock Rd to store the snow. This also blocks the crossing on the median, forcing students and families to cross more towards the center of the intersection.</li> </ul>
Safety Busing Concern	<ul style="list-style-type: none"> <li>No safety busing is provided. One bus is reserved for special circumstances.</li> </ul>

## Arrival Observations

Observation Details	
Observation Date	<b>The consultant team observed arrival on Friday, September 24.</b>
School Bus Loading	<ul style="list-style-type: none"> <li>One school bus was lined up along the school-side of Poly Dr.</li> </ul>
Family Vehicles	<ul style="list-style-type: none"> <li>Families dropped off students in front of the school on Poly Dr, and in the side alley. Parents are not allowed to pull into the school parking lot.</li> </ul>
School Staff Roles	<ul style="list-style-type: none"> <li>School staff were present at school entrance and outside the front door.</li> <li>A staff member serves as the crossing guard at Arvin Rd and Poly Dr.</li> </ul>
Adult Crossing Guards	<ul style="list-style-type: none"> <li>A paid school crossing guard is posted at Rimrock Rd.</li> <li>Another crossing guard was posted at Arvin Rd and Poly Drive; the responsibility for this crossing guard rotates between staff members.</li> </ul>
Students Walking and Biking	<ul style="list-style-type: none"> <li>Many students were observed walking and biking to school.</li> </ul>

## Priority Concerns at Poly Drive Elementary

The numbered observations and recommendations in the table below correspond to the points in the Existing Conditions Map (shown on previous page).

#	Location	Observations	Webmap Comments?
1	Rimrock Rd and Arvin Rd	<ul style="list-style-type: none"> <li>Rimrock Rd is a highly-used road for morning commuting. At certain times of the year, the sun causes visibility issues with drivers in the morning.</li> </ul>	Yes
2	Colton Blvd and 24 <sup>th</sup> St W	<ul style="list-style-type: none"> <li>Colton Blvd is a popular morning commute route. The intersection at 24<sup>th</sup> St W is a four-way stop, with a high-visibility crossing on the west and north legs of the intersection, and a painted crossing on the south and east legs.</li> <li>Bike lanes are proposed on Colton Blvd from Rehberg Ln to 17<sup>th</sup> St W, and on Rehberg Ln.</li> </ul>	Yes
3	Woody Dr and Colton Blvd	<ul style="list-style-type: none"> <li>Students from apartment complexes south of Colton Blvd often cross at Woody Dr without any crossing infrastructure (aside from curb ramps) and not at 24<sup>th</sup> St W with existing marked crossing.</li> <li>A neighborhood bikeway is proposed on Lynman Ave and on 24<sup>th</sup> St (north of Colton Blvd).</li> </ul>	No
4	Side alley to east of school property	<ul style="list-style-type: none"> <li>This gravel side alley provides a key off-street connection to Poly Dr Elementary.</li> <li>A shared use path is proposed in the side alley next to the school. This alley is adjacent to parking for the school.</li> </ul>	No
5	Arvin Rd from Rimrock Rd to Poly Dr	<ul style="list-style-type: none"> <li>Arvin Rd serves as a key north-south connection to residents north of Rimrock Rd. With the existing crosswalk, median, and crossing guard, this intersection has a high number of students crossing.</li> <li>Sidewalk curb ramps are not consistent on Arvin Rd between Rimrock Rd and Poly Dr.</li> <li>Spot improvements are proposed at Poly Drive and Arvin Rd.</li> </ul>	Yes
6	Bicycle Racks at Poly Drive Elementary	<ul style="list-style-type: none"> <li>Bike racks were located in a small plaza area in the northeast corner of the school grounds, adjacent to Poly Drive. Bike parking racks were approximately a quarter full on day of observation.</li> <li>Additional bike racks were located in the southeast corner of the school grounds, on the playing field near a break in the fencing. Racks were too close to the fence to use and were empty on day of observation.</li> </ul>	No



## Proposed Projects at Poly Dr Elementary

The numbered observations and recommendations in the table below correspond to the points in the Proposed Projects Map (shown on final page).

#	Location	Topic	Issue	Recommendation
1	Rimrock Rd and Arvin Rd	School Zone signage	<ul style="list-style-type: none"> <li>Rimrock Rd has a posted speed limit of 35mph.</li> <li>This location is halfway in between traffic counts on Rimrock and Rehberg (10,900 ADT), and Rimrock and 17th (12,380 ADT)</li> </ul>	<ul style="list-style-type: none"> <li>Add school zone flashing beacon on Rimrock Rd.</li> <li>Study further to find an infrastructure intervention to slow speeds on Rimrock Rd.</li> </ul>
2	Colton Blvd and 24 <sup>th</sup> St W	Crossing	<ul style="list-style-type: none"> <li>Colton Blvd has a posted speed limit of 35mph.</li> <li>ADT counts nearby include 5,070 at Colton Blvd and 19th, and 4,030 east of Colton Blvd and Lyndale.</li> </ul>	<ul style="list-style-type: none"> <li>Remove left turn lane on Colton Blvd turning north on to 24<sup>th</sup> St W.</li> <li>Install curb extensions for the west and south legs with lane width reduction.</li> <li>Construct proposed bike lanes on Colton Blvd from Rehberg Ln to 17<sup>th</sup> St, and on Rehberg Ln.</li> </ul>
3	Colton Blvd between Lyndele and 20 <sup>th</sup> St W	School Zone signage	<ul style="list-style-type: none"> <li>Colton Blvd has a posted speed limit of 35mph.</li> <li>ADT counts nearby include 5,070 at Colton Blvd and 19th, and 4,030 east of Colton Blvd and Lyndale.</li> </ul>	<ul style="list-style-type: none"> <li>Install a school zone flashing beacon on Colton Blvd.</li> <li>Implement traffic calming and/or road diet to slow traffic on Colton Blvd.</li> </ul>
4	Side alley to east of school property	Trail/path	<ul style="list-style-type: none"> <li>Connection from Poly Dr to Lyman Ave is unpaved.</li> </ul>	<ul style="list-style-type: none"> <li>Formalize side alley as a paved shared use path.</li> </ul>

### Proposed Projects Map

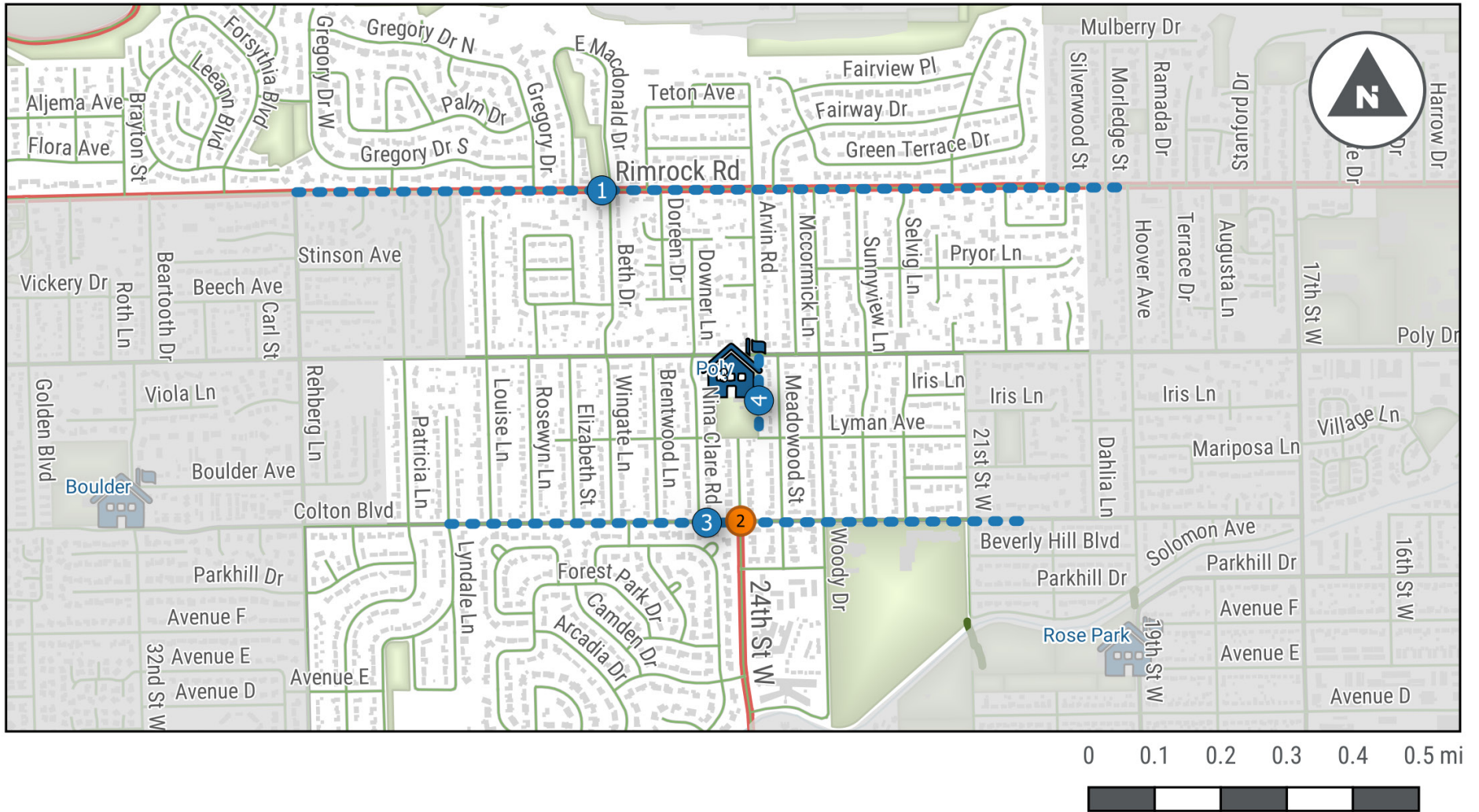

# Ponderosa Elementary

## Existing Conditions

About the School	
Address	4188 King Ave E
Number of Students	Approximately 286
Percentage of Students Eligible for Free and Reduced Lunch	100%
Arrival / Dismissal Times	7:40 AM / 2:00 and 2:45 PM

Major Streets and Highways	Annual Average Daily Traffic (AADT) <sup>c</sup>
King Ave E	4,500

<sup>c</sup>Source: MDOT Interactive Traffic Web Map

## Existing Conditions Map

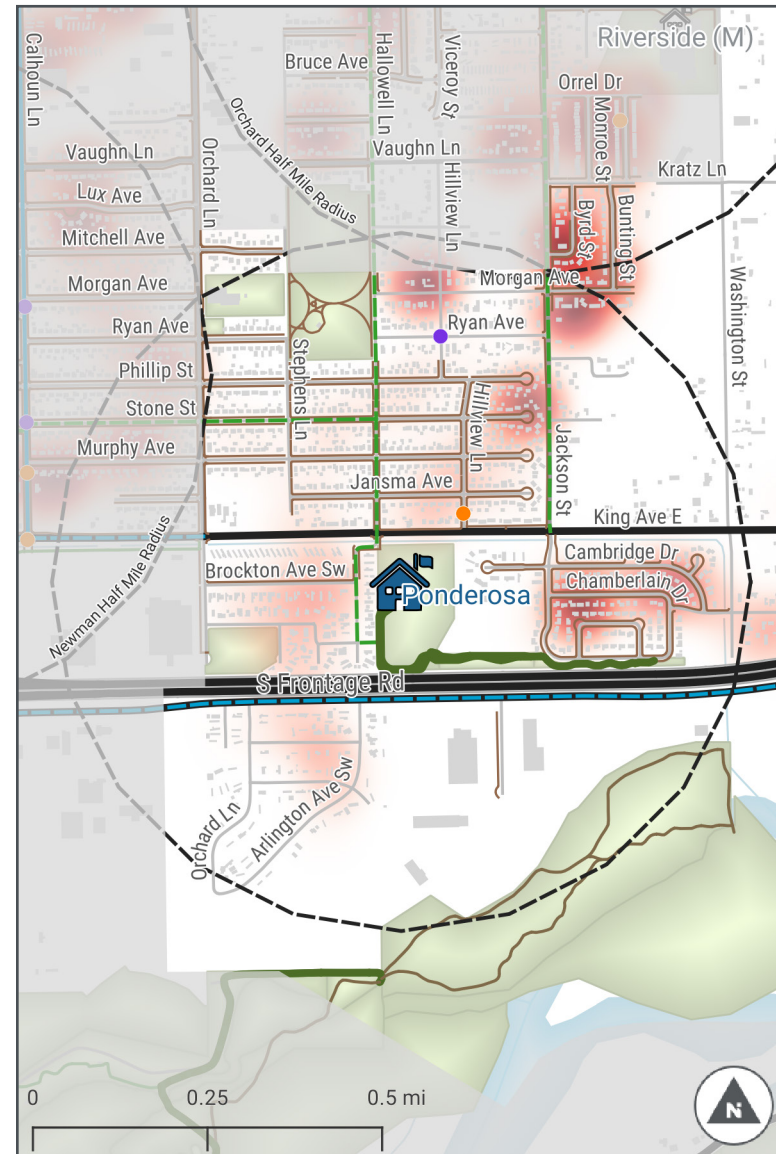

- |                               |                 |                      |
|-------------------------------|-----------------|----------------------|
| Student Address Heatmap       | <b>Existing</b> | <b>Proposed</b>      |
| School Half Mile Buffer       | Shared Use Path | Neighborhood Bikeway |
| Outside School Boundary       | Sidewalk        | Bike Lane            |
| Bike Crash (2016-2020)        |                 |                      |
| Pedestrian Crash (2016-2020)  |                 |                      |
| Speed Limit 35 mph or Greater |                 |                      |

## Known Safety Concerns at Ponderosa Elementary

Source of Concern	Safety Concern or Comment
Principal	<ul style="list-style-type: none"> <li>The shared-use path on King Ave E has helped greatly with safety.</li> <li>Principal also expressed safety concerns with shared-use path south of the school regarding dangerous behaviors in a grove of trees.</li> </ul>
Webmap Survey	<p>There are approximately 11 comments in the Ponderosa Elementary catchment area regarding:</p> <ul style="list-style-type: none"> <li>School site traffic congestion and drop-off zone</li> <li>Shared use path south of school property</li> <li>Crossing challenges on Hallowell Ln</li> <li>A canal path</li> <li>Driver behavior compliance</li> <li>Crossing at Jackson St and King Ave E</li> </ul>
Crossing Guard	<ul style="list-style-type: none"> <li>No feedback.</li> </ul>
Safety Busing Concern	<ul style="list-style-type: none"> <li>Students who live along Frontage Road, to the south of I-90, are safety bused.</li> </ul>

## Arrival Observations

Observation Details	
Observation Date	<b>The consultant team observed arrival on Wednesday, September 22.</b>
School Bus Loading	<ul style="list-style-type: none"> <li>School buses entered through the east entrance, separate from car drop-off.</li> </ul>
Family Vehicles	<ul style="list-style-type: none"> <li>Families dropped off students in front of the school in the parking lot loop. School staff set out orange cones to denote an unloading area to discourage families parking. Some families would still park and unload outside of designated areas.</li> </ul>
School Staff Roles	<ul style="list-style-type: none"> <li>School staff were present supervising arrival at the front door and at the bus drop-off area.</li> </ul>
Adult Crossing Guards	<ul style="list-style-type: none"> <li>A school crossing guard is posted at King Ave E and Hallowell Ln.</li> </ul>
Students Walking and Biking	<ul style="list-style-type: none"> <li>Some students were observed walking and biking with their family on the path along King Ave.</li> </ul>

## Priority Concerns at Ponderosa Elementary

The numbered observations and recommendations in the table below correspond to the points in the Existing Conditions Map (shown on previous page).

#	Location	Observations	Webmap Comments?
1	School parking lot	<ul style="list-style-type: none"> <li>Drop-off in the school parking lot created circulation issues. School staff set out orange cones parallel to the front of the school, creating a drop-off area. Some families were observed double-parking, asking students to cross the street without an adult, creating potential conflicts with motor vehicles as they back up.</li> </ul>	Yes
2	King Ave and Arlington Ave SW	<ul style="list-style-type: none"> <li>During drop-off, congestion leaving the school due to difficult left turns onto King Ave caused a back-up into the school parking lot and into Arlington Ave SW.</li> <li>A spot improvement is proposed for King Ave and Hallowell Ln.</li> </ul>	No
3	Shared use path south of Ponderosa Elementary	<ul style="list-style-type: none"> <li>South of the school grounds is a wide, clean, and new shared use path. However, parents felt unsafe allowing their students to use it due to a grove of trees where hazardous behaviors occurred.</li> </ul>	Yes
4	Cambridge Dr and Jackson St	<ul style="list-style-type: none"> <li>Jackson St is a key outlet to many families living in the neighborhood. The Cambridge Dr and Jackson St intersection is overbuilt, though, with yellow bollards acting as traffic separation.</li> </ul>	No
5	Shared use path from Jackson St to Arlington Ave SW	<ul style="list-style-type: none"> <li>A wide, asphalt, recently constructed shared use path provides a key connection to neighborhoods on the south side of King Ave E. However, there is no buffer between the path and the road, and people walking may feel exposed to vehicular traffic.</li> <li>A shared use path is proposed on King Ave to Sugar Ave. At the time of this report, the path had not extended all the way to Sugar Ave.</li> </ul>	No
6	Hallowell Ln from King Ave to Simpson St	<ul style="list-style-type: none"> <li>Hallowell Ln serves as a key neighborhood connection; however, sidewalks were narrow and curb radii were wide.</li> <li>A major trailhead improvement is planned for Morgan Ave and Hallowell Ln.</li> <li>A neighborhood bikeway is proposed for Hallowell Ln to State Ave.</li> </ul>	Yes
7	Bicycle Racks at Ponderosa Elementary	<ul style="list-style-type: none"> <li>Existing bicycle racks were located in front area of school. Roughly five bikes were parked on the day of observation.</li> </ul>	No

## Proposed Projects at Ponderosa Elementary

The numbered observations and recommendations in the table below correspond to the points in the Proposed Projects Map (shown on final page).

#	Location	Topic	Issue	Recommendation
1	School parking lot	Arrival/Dismissal Behavior	<ul style="list-style-type: none"> <li>Some families were observed double-parking, asking students to cross the street without an adult, making dangerous back-ups.</li> </ul>	<ul style="list-style-type: none"> <li>Provide staff monitoring of arrival and dismissal, and provide expectations for family vehicles at arrival and dismissal. (Short term)</li> <li>Encourage more families to walk or bicycle to school to reduce the number of vehicles during arrival and dismissal. (Short term)</li> <li>Reserve all parking spots for school staff and to reinforce the drop-off area. (Short term)</li> </ul>
2	King Ave and Arlington Ave SW	Congestion	<ul style="list-style-type: none"> <li>Vehicular traffic backs up into school parking lot, and traffic volumes on King Ave (6,230 ADT) encourage fast turns during breaks in traffic.</li> </ul>	<ul style="list-style-type: none"> <li>Encourage more families to walk or bicycle to school to reduce the number of vehicles during arrival and dismissal. (Short term)</li> </ul>
3	Shared use path south of Ponderosa Elementary	Hazardous/illicit activity	<ul style="list-style-type: none"> <li>School community does not feel safe near tree grove along path.</li> </ul>	<ul style="list-style-type: none"> <li>Investigate ownership of land and follow up with actions to clean up area and discourage hazardous activities. (Short term)</li> </ul>
4	School site	Bicycle Parking	<ul style="list-style-type: none"> <li>Existing bicycle racks can damage bikes and make it difficult to securely lock bicycles. Few bicycles were parked the day of observation.</li> </ul>	<ul style="list-style-type: none"> <li>Replace the existing bike racks with new racks that support the bike frame in at least two places and that enable secure locking. (Short term)</li> </ul>

### Proposed Projects Map

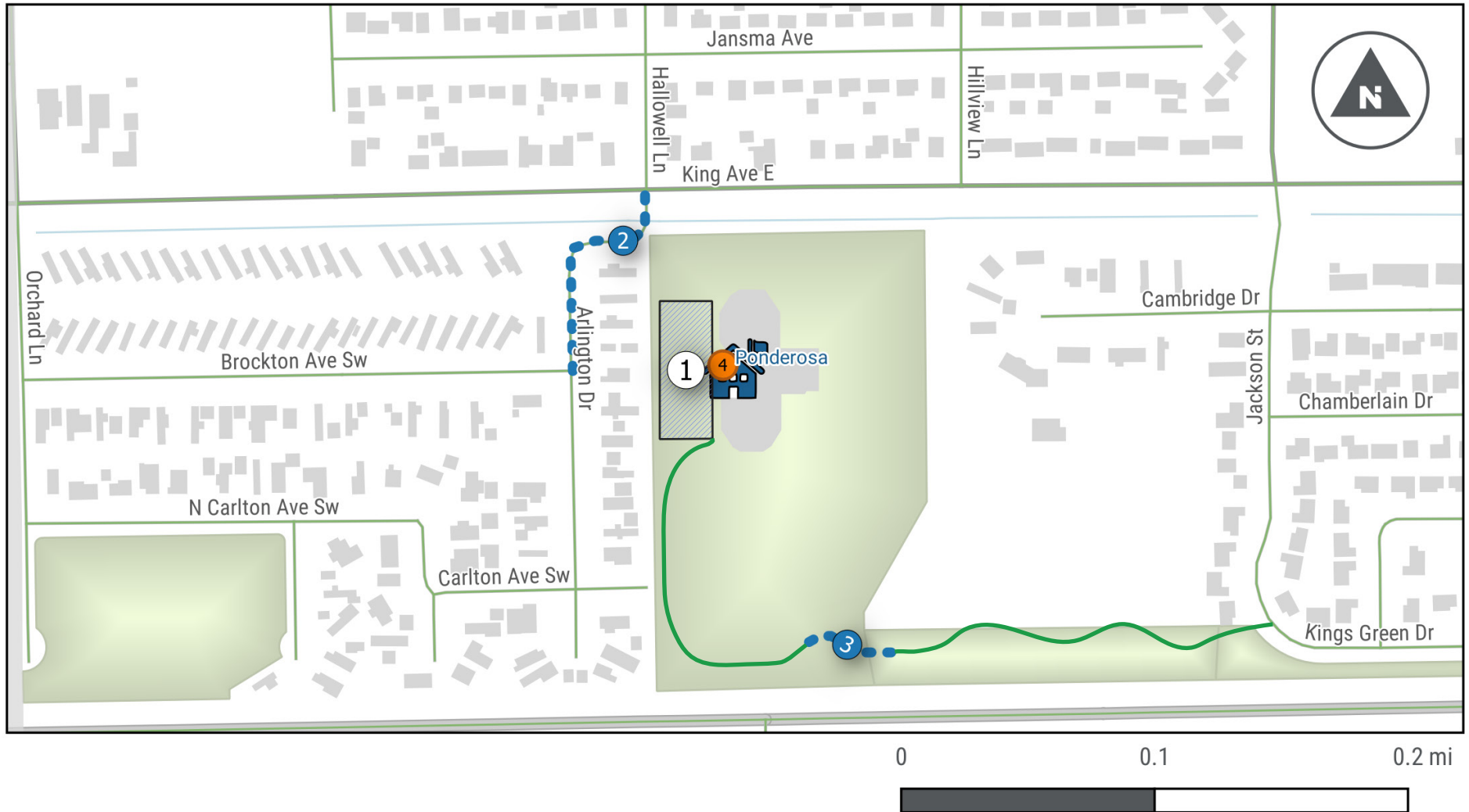

# Rose Park Elementary

## Existing Conditions

About the School	
Address	1812 19th St W
Number of Students	Approximately 245
Percentage of Students Eligible for Free and Reduced Lunch	48%
Arrival / Dismissal Times	8:15 AM / 2:20 and 3:05 PM

Major Streets and Highways	Annual Average Daily Traffic (AADT) <sup>c</sup>
19 <sup>th</sup> St W	<ul style="list-style-type: none"> <li>1,600 (in front of school)</li> <li>2,000 (at Grand Ave)</li> </ul>
17 <sup>th</sup> St W	8,900
Colton Blvd	3,600
Poly Dr	6,400

<sup>c</sup>Source: MDOT Interactive Traffic Web Map

## Existing Conditions Map

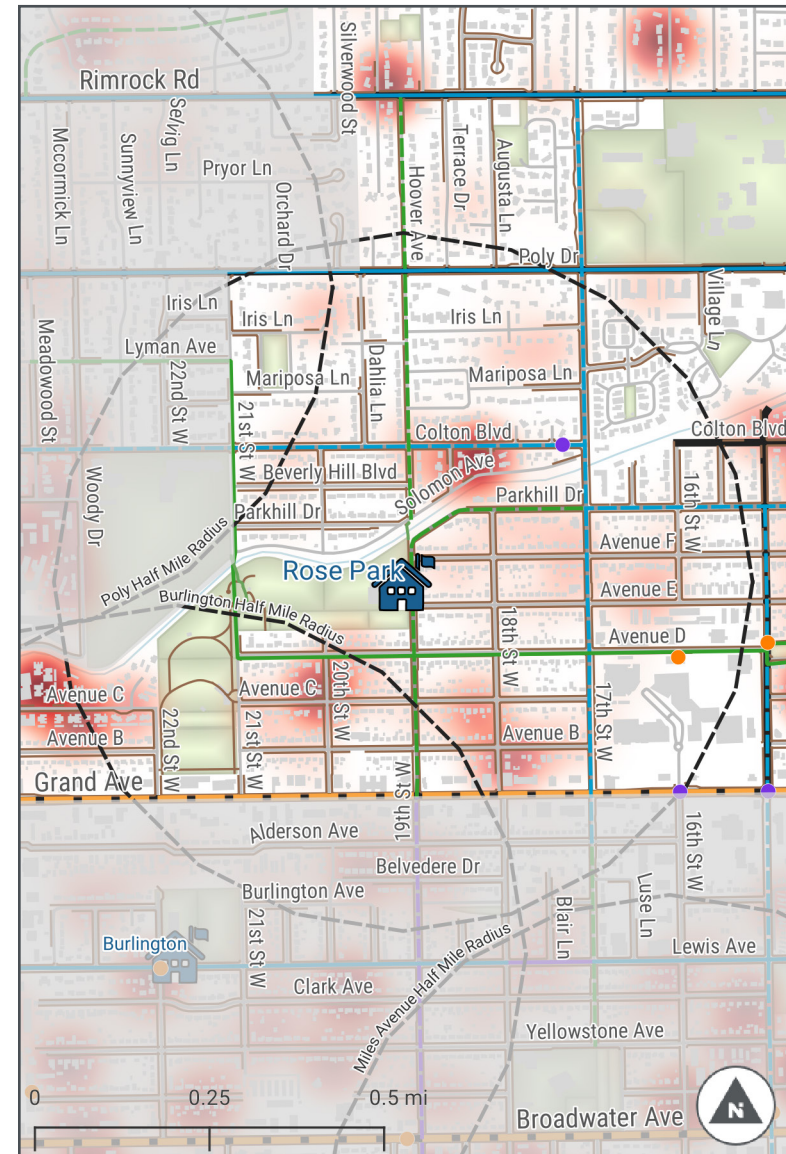

Student Address Heatmap	<b>Existing</b>	<b>Proposed</b>
School Half Mile Buffer	Existing Bike Lane	Neighborhood Bikeway
Outside School Boundary	Sidewalk	Bike Lane
Bike Crash (2016-2020)	Neighborhood Bikeway	Shared Lane Marking
Pedestrian Crash (2016-2020)		Visionary Long Range Bikeway
Speed Limit 35 mph or Greater		



## Known Safety Concerns at Rose Park Elementary

Source of Concern	Safety Concern or Comment
School Secretary	<ul style="list-style-type: none"> <li>Families jaywalk across the street in front of the school instead of crossing with the crossing guard.</li> <li>Families park in the bus zone to drop off or pick up students.</li> </ul>
Webmap Survey	<p>There are approximately 16 comments in the Rose Park Elementary catchment area regarding:</p> <ul style="list-style-type: none"> <li>An additional bridge over the canal</li> <li>Continuing the canal path east past 17<sup>th</sup> St W</li> <li>Colton Blvd</li> <li>Poly Dr and 17<sup>th</sup> St crossing</li> <li>Traffic control at Parkhill Dr and shared use path at 21<sup>st</sup> St W</li> </ul>
Crossing Guard	<ul style="list-style-type: none"> <li>Families jaywalk across the street in front of the school instead of crossing with the crossing guard.</li> <li>Some drivers go at high speeds on 19<sup>th</sup> St W</li> </ul>
Safety Busing	<ul style="list-style-type: none"> <li>No safety busing is provided.</li> </ul>

## Dismissal Observations

Observation Details	
Observation Date	<b>The consultant team observed dismissal on Wednesday, September 22.</b>
School Bus Loading	<ul style="list-style-type: none"> <li>One school bus was observed in front of the school on 19<sup>th</sup> St W in the marked BUS STOP area.</li> </ul>
Before/Aftercare Vans	<ul style="list-style-type: none"> <li>Aftercare vans picked up students in front of the school on 19<sup>th</sup> St W in the marked BUS STOP area</li> </ul>
Family Vehicles	<ul style="list-style-type: none"> <li>At the first dismissal, families in vehicles picked up students from the south entrances of the school. Most family drivers parked in the parking lot or the alley and walked to the school entrance.</li> <li>At first dismissal, some families parked on 19<sup>th</sup> St W in front of the school in the areas marked LOADING AND UNLOADING. One or two families parked or stopped in areas they were not supposed to use in front of the school (in the BUS STOP area) or too close to the crosswalk at Ave E.</li> <li>At the second dismissal, there were fewer family vehicles. Most family vehicles waited on 19<sup>th</sup> St W near the north entrance.</li> </ul>
School Staff Roles	<ul style="list-style-type: none"> <li>School staff loaded students onto the correct buses; and</li> <li>School staff walks up to the bridge over the canal to make sure students cross the bridge safely; and</li> <li>School staff supervise students on the playground as they wait for parents to pick up.</li> </ul>
Adult Crossing Guards	<ul style="list-style-type: none"> <li>A school crossing guard is posted at the intersection of 19<sup>th</sup> St W and Ave E.</li> <li>An additional school crossing guard is posted at the intersection of Colton Boulevard and 19<sup>th</sup> St W.</li> <li>In previous years, there has been a school crossing guard posted at the intersection of Parkhill Dr and 17<sup>th</sup> St West; however, the school has had trouble finding staff for that intersection and it was unfilled the day of observation.</li> </ul>
Bike Rack Locations and Use	<ul style="list-style-type: none"> <li>There are 6 bike racks at the school, located in the main parking lot in front of the school. About 10 bikes were parked in the racks the day of observation.</li> </ul>
Students Walking and Biking	<ul style="list-style-type: none"> <li>Some students were observed walking and biking from school. Some students went west on Ave E, some went north across the canal, and others walked northwest along Parkhill Dr.</li> </ul>

## Priority Concerns at Rose Park Elementary

The numbered observations and recommendations in the table below correspond to the points in the Existing Conditions Map (shown on previous page).

#	Location	Observations	Webmap Comments?
1	Parkhill Drive at 19 <sup>th</sup> St W	<ul style="list-style-type: none"> <li>A gap in the sidewalk on the north side of Parkhill Drive near the canal presents a safety concern. The turn in the street reduces the visibility of pedestrians to drivers at this location. Students were observed walking on the grass next to the street.</li> </ul>	Yes
2	Parkhill Drive and 17 <sup>th</sup> St W	<ul style="list-style-type: none"> <li>17<sup>th</sup> St W has higher traffic volumes and speeds than would be preferred for a student crossing location, with two travel lanes and a wide center turn lane.</li> <li>A crossing guard has been posted at this intersection in previous years.</li> <li>Crossing distances on 17<sup>th</sup> St W are long and there are no median crossing islands for pedestrians.</li> <li>Crosswalks are marked but lack high-visibility markings and advance school crossing signs.</li> <li>17<sup>th</sup> St W is recommended for a "visionary long range bikeway" in the Billings Area Bikeway and Trails Master Plan.</li> </ul>	Yes
3	Pedestrian bridge over canal at 19 <sup>th</sup> St W	<ul style="list-style-type: none"> <li>The bridge is narrow, measuring 5' across with railings on either side. The design does not allow sufficient space for two pedestrians to pass each other comfortably with shy space, and is not wide enough to serve as a bicycle facility.</li> <li>19<sup>th</sup> St W/Hoover Ave is recommended for a neighborhood bikeway in the Billings Area Bikeway and Trails Master Plan, with a connection across the canal.</li> </ul>	Yes
4	Poly Drive and Hoover Ave	<ul style="list-style-type: none"> <li>Poly Drive has higher traffic volumes and speeds than would be preferred for a student crossing location, with bike lanes and two parking lanes.</li> <li>No crosswalks are marked and no school crossing signs are present.</li> <li>Some students cross the street at this intersection and drivers don't always yield to pedestrians.</li> <li>19<sup>th</sup> St W/Hoover Ave is recommended for a neighborhood bikeway in the Billings Area Bikeway and Trails Master Plan, with a connection across Poly Drive.</li> <li>One curb ramp is missing on the southwest corner of the intersection.</li> </ul>	No
5	Multifamily housing near Avenue C and 22 <sup>nd</sup> St W	<ul style="list-style-type: none"> <li>Students living in the multifamily housing units on Avenue C lack a direct route to school due to lack of convenient path connections across Rose Park. A shared-use path is recommended along the irrigation canal in the Billings Area Bikeway and Trails Master Plan.</li> </ul>	Yes
6	Rose Park Neighborhood	<ul style="list-style-type: none"> <li>In general, the Rose Park is in an excellent neighborhood for walking and biking to school, with few major existing issues. Sidewalks throughout the neighborhood do need repair or replacement to provide a safe pedestrian route for all users. Most existing sidewalks measure less than the recommended width of 5'. Curb ramps are missing throughout the neighborhood. Posts and mailboxes in the sidewalk further impede users.</li> </ul>	No
7	Bicycle Racks at Rose Park Elementary	<ul style="list-style-type: none"> <li>Existing bicycle racks can damage bikes and make it difficult to securely lock bicycles. About 10 bicycles were parked the day of observation.</li> </ul>	No

## Proposed Projects at Rose Park Elementary

The numbered observations and recommendations in the table below correspond to the points in the Proposed Projects Map (shown on final page).

#	Location	Topic	Issue	Recommendation
1	Parkhill Dr and 17 <sup>th</sup> St W	Speeding/volume	<ul style="list-style-type: none"> <li>17th St W has a posted speed limit of 35mph.</li> <li>This location along 17th St has an ADT of 9,910.</li> <li>17th St W is a planned Visionary Long Range Bikeway in the Billings Area Bikeway and Trails Master Plan</li> </ul>	Reconfigure 17 <sup>th</sup> St W to reduce travel lane width and add sidepath or separated bike lane.
2	Parkhill Dr and 17 <sup>th</sup> St W	Crossing	<ul style="list-style-type: none"> <li>A crossing guard has been posted at this intersection in previous years.</li> <li>Crosswalks are marked but lack high-visibility markings and advance school crossing signs</li> </ul>	<ul style="list-style-type: none"> <li>Add high visibility crosswalk markings.</li> <li>Post crossing guard at intersection.</li> </ul>
3	Pedestrian bridge over canal at 19 <sup>th</sup> St W	Multi Use Path	<ul style="list-style-type: none"> <li>The bridge is narrow, measuring 5' across with railings on either side. The design does not allow sufficient space for two pedestrians to pass each other comfortably with shy space, and is not wide enough to serve as a bicycle facility.</li> <li>19<sup>th</sup> St W/Hoover Ave is recommended for a neighborhood bikeway in the Billings Area Bikeway and Trails Master Plan, with a connection across the canal.</li> </ul>	<ul style="list-style-type: none"> <li>Reconstruct the bridge with a minimum 14' width to accommodate 2-way bicycle and pedestrian traffic.</li> </ul>
4	Poly Drive and Hoover Ave	Crossing	<ul style="list-style-type: none"> <li>No crosswalks are marked and no school crossing signs are present.</li> <li>Some students cross the street at this intersection and drivers don't always yield to pedestrians.</li> <li>19<sup>th</sup> St W/Hoover Ave is recommended for a neighborhood bikeway in the Billings Area Bikeway and Trails Master Plan, with a connection across Poly Drive.</li> </ul>	<ul style="list-style-type: none"> <li>Add high visibility crosswalk markings and adequate nighttime lighting levels for Hoover Ave/Poly Dr.</li> <li>When the 19<sup>th</sup> St W/Hoover Ave bicycle boulevard is constructed, install curb extensions or pedestrian refuge island to improve driver yielding. Consider adding a Rectangular Rapid Flashing Beacon to further improve the safety of the crossing.</li> </ul>
5	Multifamily housing near Avenue C and 22 <sup>nd</sup> St W	Multi Use Path	<ul style="list-style-type: none"> <li>Students living in the multifamily housing units on Ave C lack a direct route to school due to lack of convenient path connections across Rose Park.</li> </ul>	<ul style="list-style-type: none"> <li>Build a share-use path along the irrigation canal. Provide connections to the path to ensure it can be used by students getting to and from school.</li> </ul>
6	Avenue E and 19 <sup>th</sup> St W	Crossing	<ul style="list-style-type: none"> <li>Curb extensions shorten crossing distances and increase pedestrian visibility.</li> <li>Crosswalk markings across 19th St W are faded.</li> </ul>	<ul style="list-style-type: none"> <li>Install curb extensions to reduce crossing distances.</li> <li>Refresh crosswalk markings.</li> </ul>
7	19 <sup>th</sup> St W between Avenue F and Avenue D	Speed/Volume	<ul style="list-style-type: none"> <li>The relatively wide street encourages speeding.</li> </ul>	<ul style="list-style-type: none"> <li>Study street further to determine if traffic calming improvements are necessary to slow traffic speeds.</li> </ul>
8	School site	Bicycle Parking	<ul style="list-style-type: none"> <li>Existing bicycle racks can damage bikes and make it difficult to securely lock bicycles. Some bicycles were parked the day of observation.</li> </ul>	<ul style="list-style-type: none"> <li>Replace the existing bike racks with new racks that support the bike frame in at least two places and that enable secure locking.</li> </ul>

## Proposed Projects Map

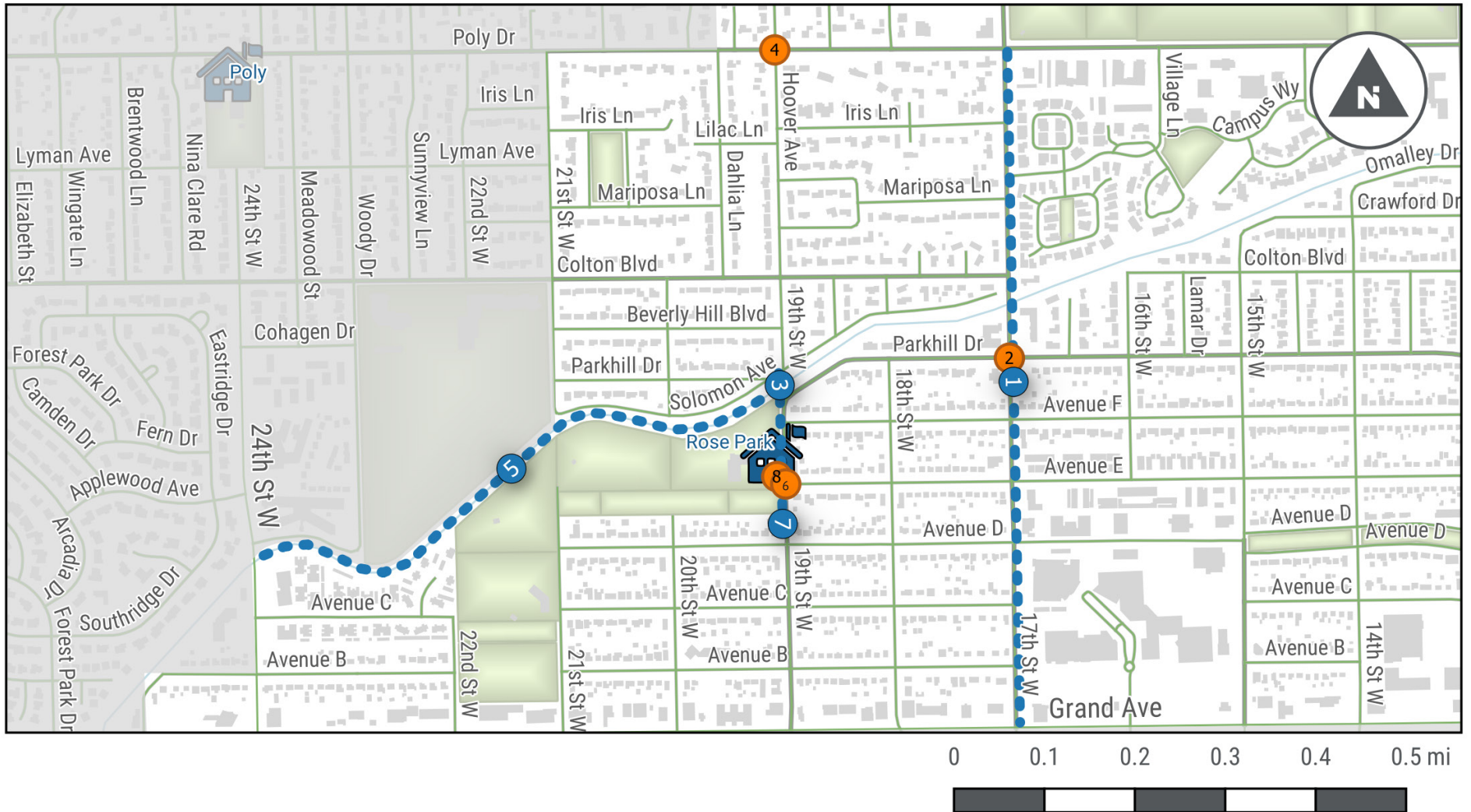

# Sandstone Elementary

## Existing Conditions

About the School	
Address	1440 Nutter Blvd
Number of Students	Approximately 420
Percentage of Students Eligible for Free and Reduced Lunch	38%
Arrival / Dismissal Times	8:20 AM / 2:25 and 3:10 PM

Major Streets and Highways	Annual Average Daily Traffic (AADT) <sup>c</sup>
W Wicks Ln	<ul style="list-style-type: none"> <li>9,200 (east of Nutter Blvd) to</li> <li>4,800 (west of Nutter Blvd)</li> </ul>
Nutter Blvd near Wicks Ln	2,100
Babcock Blvd near Wicks Ln	3,700
Saint Andrew's Drive	3,800

<sup>c</sup>Source: MDOT Interactive Traffic Web Map

## Existing Conditions Map

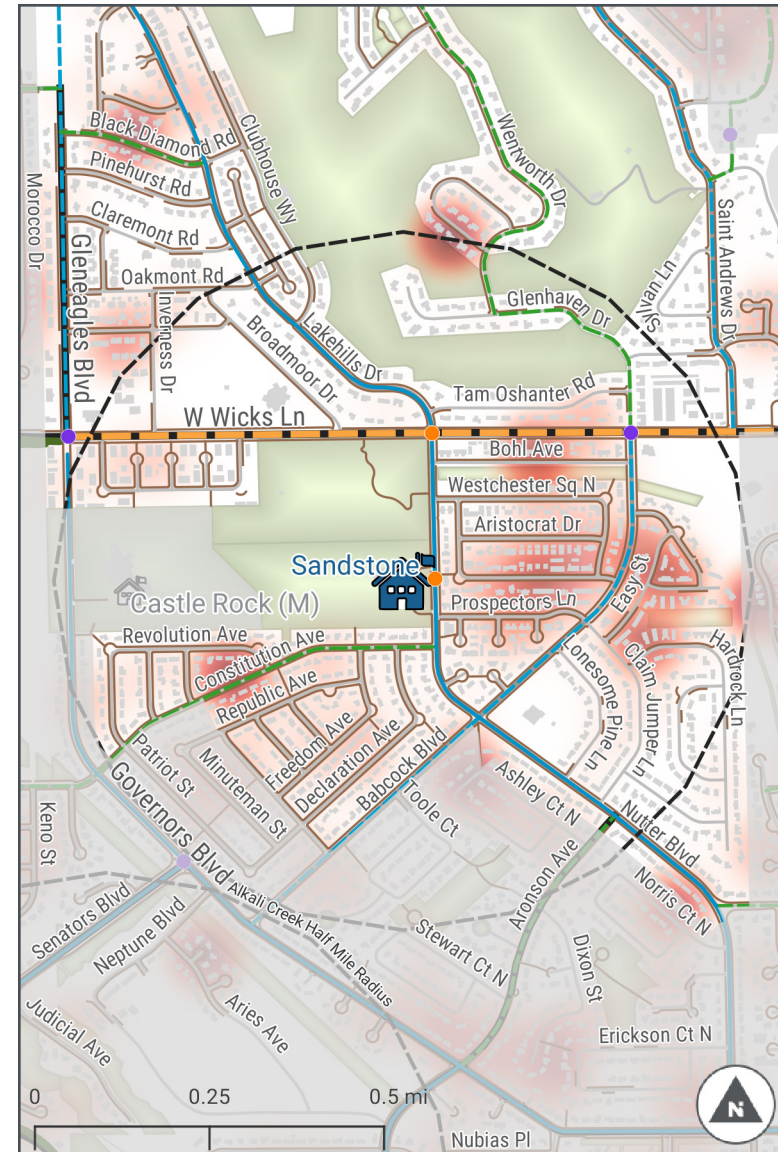

- |                               |                    |                              |
|-------------------------------|--------------------|------------------------------|
| Student Address Heatmap       | <b>Existing</b>    | <b>Proposed</b>              |
| School Half Mile Buffer       | Existing Bike Lane | Neighborhood Bikeway         |
| Outside School Boundary       | Sidewalk           | Bike Lane                    |
| Bike Crash (2016-2020)        |                    | Visionary Long Range Bikeway |
| Pedestrian Crash (2016-2020)  |                    |                              |
| Speed Limit 35 mph or Greater |                    |                              |

## Known Safety Concerns at Sandstone Elementary

Source of Concern	Safety Concern or Comment
Principal	<ul style="list-style-type: none"> <li>The intersection of Wicks Ln and Nutter Blvd has a traffic light. Wicks Ln is a high-speed street and at dismissal, some of the students from nearby Skyview High School drive on Wicks Ln in a reckless manner. The principal has assisted students crossing at that intersection due to difficulties in hiring a crossing guard for that location.</li> <li>Many of the students who do walk to school live in Westchester Square, an affordable housing development across Nutter Blvd from the school.</li> <li>Some parents have expressed frustration with the traffic in the front parking loop and have helped direct traffic in the past.</li> </ul>
Webmap Survey	<p>There are approximately 18 comments in the Sandstone Elementary catchment area regarding:</p> <ul style="list-style-type: none"> <li>Traffic conditions and crossing challenges on Governors Blvd at various locations</li> <li>Claim Jumper Ln: a lack of sidewalks, and a dangerous crossing at Babcock Boulevard</li> <li>A north-south canal path</li> <li>Crossing challenges and snow piles on sidewalks on Wicks Ln</li> <li>Dangerous crossing at Nutter Blvd and Babcock Blvd</li> </ul>
Safety Busing	<ul style="list-style-type: none"> <li>No safety busing is provided.</li> </ul>

## Arrival Observations

Observation Details	
Observation Date	<b>The consultant team observed arrival on Tuesday, September 21.</b>
School Bus Loading	<ul style="list-style-type: none"> <li>No school buses were observed.</li> </ul>
Before/Aftercare Vans	<ul style="list-style-type: none"> <li>Beforecare childcare vans dropped off students in the front loop.</li> </ul>
Family Vehicles	<ul style="list-style-type: none"> <li>Most families dropped off students in the front parking loop. Some families also dropped off students on Nutter Blvd, either on the school side, or near the crossing guard so students crossed the street with the crossing guard.</li> </ul>
School Staff Roles	<ul style="list-style-type: none"> <li>School staff were present supervising students outside the front door.</li> </ul>
Adult Crossing Guards	<ul style="list-style-type: none"> <li>A school crossing guard is posted on Nutter Blvd at the entrance to the front parking loop.</li> <li>An additional school crossing guard is supposed to be posted at the intersection of Nutter Blvd and Wicks Ln but that position was unfilled the day of observation due to the labor staffing shortage.</li> </ul>
Bike Rack Locations and Use	<ul style="list-style-type: none"> <li>There are two bike racks at the school, located near the front door.</li> <li>There were about 15 bikes parked at the racks the day of observation.</li> </ul>
Students Walking and Biking	<ul style="list-style-type: none"> <li>Some students were observed walking and biking along Nutter Blvd and coming from the sidewalk cut through from the Westchester Square apartments.</li> </ul>

## Priority Concerns at Sandstone Elementary

The numbered observations and recommendations in the table below correspond to the points in the Existing Conditions Map (shown on previous page).

#	Location	Observations	Webmap Comments?
1	W Wicks Ln	<ul style="list-style-type: none"> <li>W Wicks Ln is a wide, three-lane street with parking lanes that have very little use. The relatively wide street encourages speeding.</li> <li>Vehicles appear to exceed the posted speed limit during school arrival and dismissal times.</li> <li>W Wicks Ln is recommended to have a shared-use path and “visionary long-range bikeway” when the roadway is reconstructed in the Billings Area Bikeway and Trails Master Plan.</li> <li>The principal said that students from Skyview High School drive recklessly on W Wicks Ln at around the same time that Sandstone Elementary students are walking home from school.</li> </ul>	Yes
2	W Wicks Ln and Nutter Blvd	<ul style="list-style-type: none"> <li>W Wicks Ln has higher traffic volumes and speeds than would be preferred for a student crossing location.</li> <li>Crossings distances are long due to multiple turn lanes.</li> <li>A crossing guard is supposed to be posted at this intersection. The crossings on the north and south legs lack high-visibility markings. There are no advance school crossing signs on any of the approaches to the intersection.</li> <li>The pedestrian timing did not appear to provide enough time for a crossing guard and child pedestrians to clear the crosswalk.</li> </ul>	Yes
3	Nutter Blvd and Babcock Blvd	<ul style="list-style-type: none"> <li>Nutter Blvd is a relatively wide street with low use of on-street parking. The relatively wide street encourages speeding.</li> <li>Crossing distances are long and there are no median crossing islands or curb extensions to lower the speed of traffic on Nutter Blvd.</li> </ul>	Yes
4	Babcock Blvd and Prospector’s Ln/Claim Jumper Ln	<ul style="list-style-type: none"> <li>Babcock Blvd is a relatively wide street with low use of on-street parking. The relatively wide street encourages speeding.</li> <li>The intersection of Babcock Blvd and Prospector’s Ln is marked with a high-visibility crosswalk and school crossing signs on the southwest leg.</li> <li>Crossing distances across Babcock Blvd are long and there are no median crossing islands or curb extensions to lower the speed of traffic on Babcock Blvd.</li> </ul>	Yes
5	Claim Jumper Ln	<ul style="list-style-type: none"> <li>Missing sidewalks on Claim Jumper Ln present a barrier to walking and biking to school for students living in this neighborhood.</li> </ul>	Yes
6	Bicycle Racks at Sandstone Elementary	<ul style="list-style-type: none"> <li>Existing bicycle racks can damage bikes and make it difficult to securely lock bicycles. 15 bicycles were parked the day of observation.</li> </ul>	No

## Proposed Projects at Sandstone Elementary

The numbered observations and recommendations in the table below correspond to the points in the Proposed Projects Map (shown on final page).

#	Location	Topic	Issue	Recommendation
1	W Wicks Ln and Nutter Blvd	Crossing	<ul style="list-style-type: none"> <li>Crossings distances are long due to multiple turn lanes.</li> <li>A crossing guard is supposed to be posted at this intersection but currently is not due to staffing shortages.</li> <li>The crossings on the north and south legs lack high-visibility markings. There are no advance school crossing signs on any of the approaches to the intersection.</li> </ul>	<ul style="list-style-type: none"> <li>Post a crossing guard at the intersection.</li> <li>Install high-visibility markings and advance school crossing signs on the approaches to the intersection.</li> <li>Conduct additional analysis to consider removing right turn lanes on the west and east legs of Wicks Ln and construct curb extensions or pedestrian refuge islands to shorten crossing distances and improve pedestrian safety.</li> </ul>
2	W Wicks Ln	Speeding	<ul style="list-style-type: none"> <li>W Wicks Ln as a posted speed limit of 35mph.</li> <li>W Wicks Ln as an ADT of 9,910 at this location.</li> <li>W Wicks Ln is recommended to have a shared-use path and "visionary long-range bikeway" when the roadway is reconstructed in the Billings Area Bikeway and Trails Master Plan.</li> </ul>	<ul style="list-style-type: none"> <li>Reduce the number of lanes on W Wicks Ln to slow down traffic.</li> </ul>
3	Babcock Blvd and Prospectors Ln/Claim Jumper Ln	Crossing	<ul style="list-style-type: none"> <li>Crossing distances across Babcock Blvd are long and there are no median crossing islands or curb extensions to lower the speed of traffic on Babcock Blvd.</li> </ul>	<ul style="list-style-type: none"> <li>Add curb extensions or pedestrian refuge islands to the north and south legs of Babcock Blvd to shorten crossing distances and improve pedestrian safety.</li> </ul>
4	Claim Jumper Ln	Sidewalks	<ul style="list-style-type: none"> <li>Missing sidewalks on Claim Jumper Ln present a barrier to walking and biking to school for students living in this neighborhood.</li> </ul>	<ul style="list-style-type: none"> <li>Build sidewalk on at least one side of the street.</li> </ul>
5	Nutter Blvd and Babcock Blvd	Crossing	<ul style="list-style-type: none"> <li>Crossing distances are long and there are no median crossing islands or curb extensions to lower the speed of traffic on Nutter Blvd.</li> </ul>	<ul style="list-style-type: none"> <li>Add curb extensions or pedestrian refuge islands on all legs to shorten crossing distances and improve pedestrian safety.</li> </ul>
6	Neighborhoods southeast of Babcock Blvd	Sidewalks	<ul style="list-style-type: none"> <li>Missing sidewalks present a barrier to walking and bicycling to school.</li> </ul>	<ul style="list-style-type: none"> <li>Construct sidewalks on neighborhood streets.</li> </ul>
7	Neighborhoods north of Wicks Lane	Sidewalks	<ul style="list-style-type: none"> <li>Missing sidewalks present a barrier to walking and bicycling to school.</li> </ul>	<ul style="list-style-type: none"> <li>Construct sidewalks on neighborhood streets.</li> </ul>
8	School site	Bicycle Racks	<ul style="list-style-type: none"> <li>Existing bicycle racks can damage bikes and make it difficult to securely lock bicycles.</li> </ul>	<ul style="list-style-type: none"> <li>Replace the existing bike racks with new racks that support the bike frame in at least two places and that enable secure locking.</li> </ul>



### Proposed Projects Map

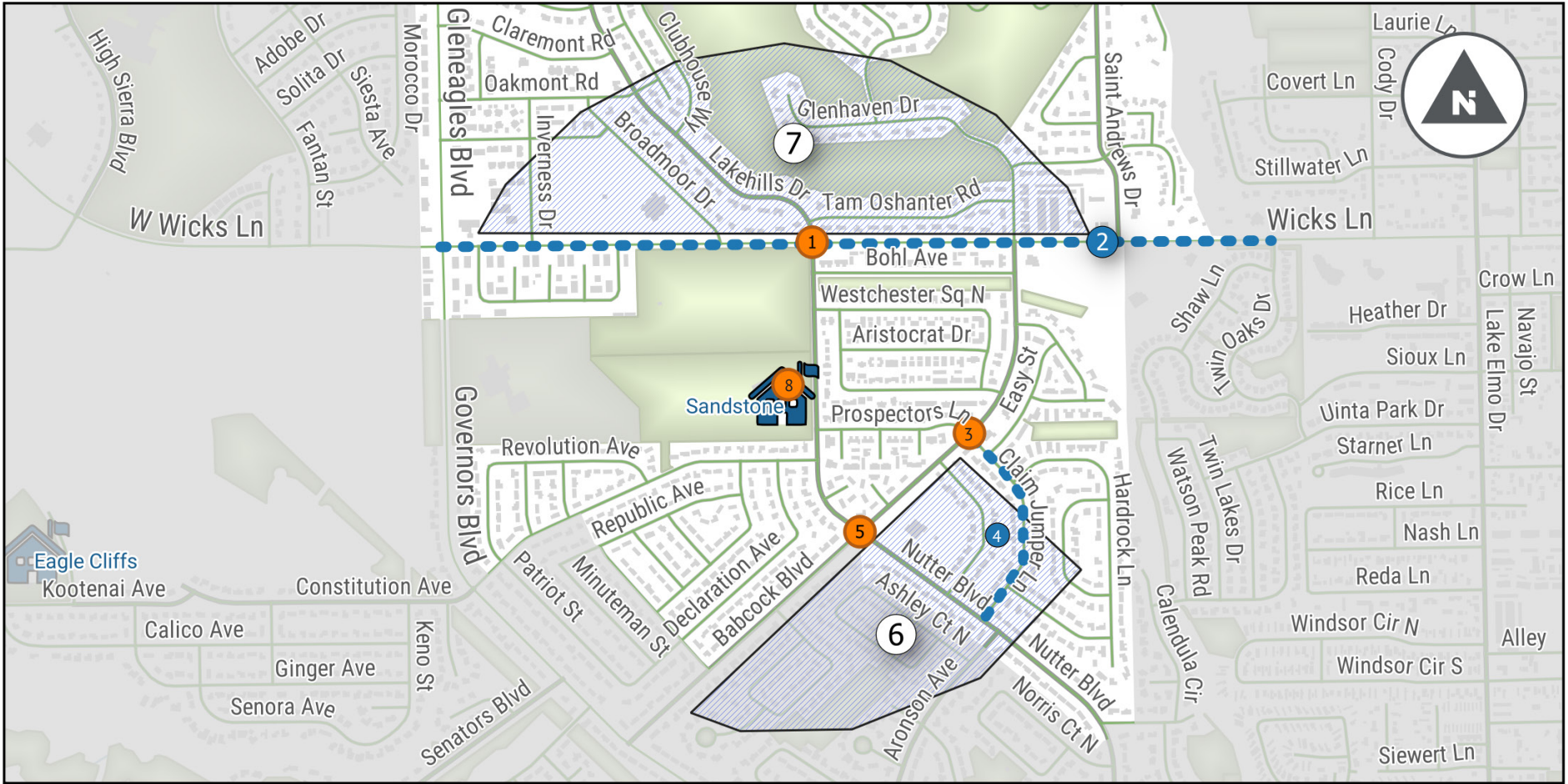

# Washington Elementary

## Existing Conditions

About the School	
Address	1044 Cook Ave
Number of Students	Approximately 250
Percentage of Students Eligible for Free and Reduced Lunch	100%
Arrival / Dismissal Times	7:30 and 8:15 AM / 2:05 and 3:05 PM

Major Streets and Highways	Annual Average Daily Traffic (AADT) <sup>c</sup>
Broadwater Ave	19,900
Central Ave	<ul style="list-style-type: none"> <li>13,500 (west of 12th St W)</li> <li>20,300 (east of 12th St W)</li> </ul>
8th St W	5,100
7th St W	5,300

<sup>c</sup>Source: MDOT Interactive Traffic Web Map

## Existing Conditions Map

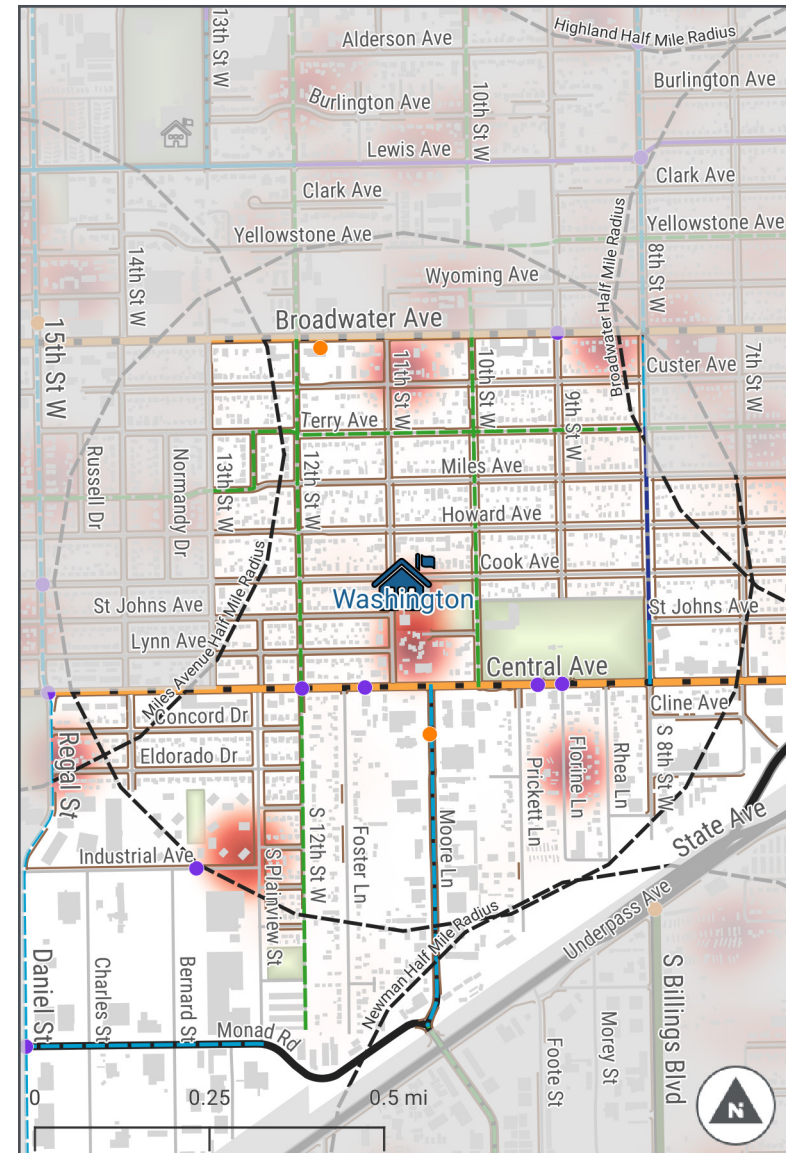

Student Address Heatmap	<b>Existing</b>	<b>Proposed</b>
School Half Mile Buffer	Sidewalk	Neighborhood Bikeway
Outside School Boundary		Bike Lane
Bike Crash (2016-2020)		Buffered Bike Lane
Pedestrian Crash (2016-2020)		Visionary Long Range Bikeway
Speed Limit 35 mph or Greater		

## Known Safety Concerns at Washington Elementary

Source of Concern	Safety Concern or Comment
Principal	<ul style="list-style-type: none"> <li>The principal is concerned about the neighborhood. He feels that some parts of the neighborhood is unsafe for students to walk and bike to school.</li> </ul>
Webmap Survey	<p>There are approximately five comments in the Washington Elementary catchment area regarding:</p> <ul style="list-style-type: none"> <li>Crossing Central Ave</li> <li>Crossing opportunities along 8<sup>th</sup> St W</li> <li>Crossing Broadwater Ave</li> </ul>
Crossing Guard	<ul style="list-style-type: none"> <li>Family vehicles make u-turns near the crossing guard crosswalk.</li> <li>Some drivers/turning drivers do not stop for crossing guard.</li> <li>High speeds and/or high traffic volumes on 11th St W.</li> </ul>
Safety Busing	<ul style="list-style-type: none"> <li>No safety busing is provided.</li> </ul>

## Arrival Observations

Observation Details	
Observation Date	<b>The consultant team observed arrival on Friday, September 24.</b>
School Bus Loading	<ul style="list-style-type: none"> <li>School buses lined up in front of the school on 11th St W.</li> </ul>
Before/Aftercare Vans	<ul style="list-style-type: none"> <li>No before/aftercare vans were observed.</li> </ul>
Family Vehicles	<ul style="list-style-type: none"> <li>For dismissal, families pick up students from the exit closest to their classrooms.</li> <li>Families dropped off students in front of the school on 11th St W or dropped off near the crossing guard at 11<sup>th</sup> St W and St Johns Ave so students crossed the street with the crossing guard.</li> </ul>
School Staff Roles	<ul style="list-style-type: none"> <li>No school staff were involved during the arrival period.</li> </ul>
Adult Crossing Guards	<ul style="list-style-type: none"> <li>A school crossing guard is posted at the intersection of 11th St W and St. Johns Ave.</li> </ul>
Bike Rack Locations and Use	<ul style="list-style-type: none"> <li>There is one bike rack around the school, located at the southeast corner of the school in the back.</li> </ul>
Students Walking and Biking	<ul style="list-style-type: none"> <li>Few students were observed walking and biking.</li> </ul>

## Priority Concerns at Washington Elementary

The numbered observations and recommendations in the table below correspond to the points in the Existing Conditions Map (shown on previous page).

#	Location	Observations	Webmap Comments?
1	Cook Ave	<ul style="list-style-type: none"> <li>School staff appears to be parked on the north side of the school. This area should prohibit parking to allow families to drop off on the school side.</li> <li>There is an uncontrolled intersection at Cook Ave and 11th St W.</li> <li>Crosswalk markings across 10th St W and 11th St W are faded.</li> </ul>	No
2	St Johns Ave and 11 <sup>th</sup> St W	<ul style="list-style-type: none"> <li>Some families were observed parking on the non-school side and double parking, making U-turns in front of the school.</li> <li>No crosswalk is marked on the St Johns Ave leg.</li> <li>No visible school signage; vegetation obstruction.</li> </ul>	No
3	Central Ave and 11 <sup>th</sup> St W	<ul style="list-style-type: none"> <li>Central Ave is a high speed and high-volume street.</li> <li>Crossing distances are long and there are no median crossing islands for pedestrians.</li> <li>There are no curb cuts at the intersection of 11th St W even though there are sidewalks.</li> <li>Narrow sidewalks with minimal buffer next to a busy street, creating an uncomfortable walking/cycling environment. Posts and mailboxes in the sidewalk further impede users.</li> <li>Crossings are uncomfortable because of wide corner radii, which encourages fast vehicular turns.</li> </ul>	Yes
4	Plainview St	<ul style="list-style-type: none"> <li>Street network is confusing. Two parallel two-way streets separated by a median. Vehicles seen driving in the wrong directions.</li> </ul>	No
5	11th St W	<ul style="list-style-type: none"> <li>Some families were observed parking on the non-school side and double parking, making U-turns in front of the school.</li> <li>Sidewalks are wide without buffer in front of the school.</li> </ul>	No
6	8th St W	<ul style="list-style-type: none"> <li>Crossing distances are long and there are no median crossing islands for pedestrians.</li> <li>Crossings are uncomfortable because of wide corner radii, which encourages fast vehicular turns.</li> <li>There is a temporary feedback sign on 8<sup>th</sup> St at the northeast corner of Central Park.</li> </ul>	Yes

## Proposed Projects at Washington Elementary

The numbered observations and recommendations in the table below correspond to the points in the Proposed Projects Map (shown on final page).

#	Location	Topic	Issue	Recommendation
1	11th St W	Arrival/Dismissal Behavior	<ul style="list-style-type: none"> <li>Some families were observed parking on the non-school side, double-parking, and making U-turns in front of the school.</li> </ul>	<ul style="list-style-type: none"> <li>Provide staff monitoring of arrival and dismissal and provide expectations for family vehicles at arrival and dismissal.</li> <li>Ideally, all pick-up and drop-off occurs on the school side of the street, or, at a minimum, in locations with safe crossings. Add on-street parking restrictions to facilitate school-side drop off/pick up and crossing at safe locations.</li> <li>A further evaluation and/or pilot pop-up project should be used to evaluate the effectiveness of any new on-street parking restriction.</li> </ul>
2	Central Ave and from 10 <sup>th</sup> to 12 <sup>th</sup> St	Speeding/volume	<ul style="list-style-type: none"> <li>Central Ave has a posted speed limit of 35mph.</li> <li>Central Ave has an ADT of 21,080 at this location.</li> </ul>	<ul style="list-style-type: none"> <li>Study further to find an infrastructure intervention that deters speeding and makes crossings safer and more comfortable for school children.</li> <li>Central Ave is recommended as a Visionary Long-Range Bikeway in the Billings Area Bikeway and Trail Master Plan.</li> </ul>
3	Central Ave and from 10 <sup>th</sup> to 12 <sup>th</sup> St	Sidewalks	<ul style="list-style-type: none"> <li>Narrow sidewalks with minimal buffer next to a busy street, creating an uncomfortable walking/cycling environment. Posts and mailboxes in the sidewalk further impede users.</li> </ul>	<ul style="list-style-type: none"> <li>Widen sidewalk and provide a wider buffer between the roadway and the sidewalk to encourage children to walk or cycle to school.</li> </ul>
4	Central Ave and Moore Ln	Crossings	<ul style="list-style-type: none"> <li>Crossing distances are long and there is limited visibility for both drivers and pedestrians.</li> </ul>	<ul style="list-style-type: none"> <li>At Central Ave and Moore Ln, add high visibility crosswalk markings, parking restrictions on the crosswalk approach, and ensure there is adequate nighttime lighting.</li> <li>Add pedestrian refuge islands in the Central Ave to shorten crossing distances and improve pedestrian safety.</li> <li>Study further to find another infrastructure intervention to make crossing safer and more comfortable for school children.</li> </ul>
5	Cook Ave and 11 <sup>th</sup> St	Crossing	<ul style="list-style-type: none"> <li>Crosswalk markings across 10th St W and 11th St W are faded.</li> <li>Some students cross the street at this intersection and drivers don't always yield to pedestrians in the crosswalk.</li> </ul>	<ul style="list-style-type: none"> <li>Evaluate the need for traffic control improvements and consider an additional crossing guard.</li> </ul>
6	Front of school	Bicycle parking	<ul style="list-style-type: none"> <li>Existing bicycle racks can damage bikes and make it difficult to securely lock bicycles. Few bicycles were parked the day of observation.</li> </ul>	<ul style="list-style-type: none"> <li>Replace the existing bike racks with new racks that support the bike frame in at least two places and that enable secure locking. Add additional bike racks at front of school to accommodate more bicycles.</li> </ul>

### Proposed Projects Map

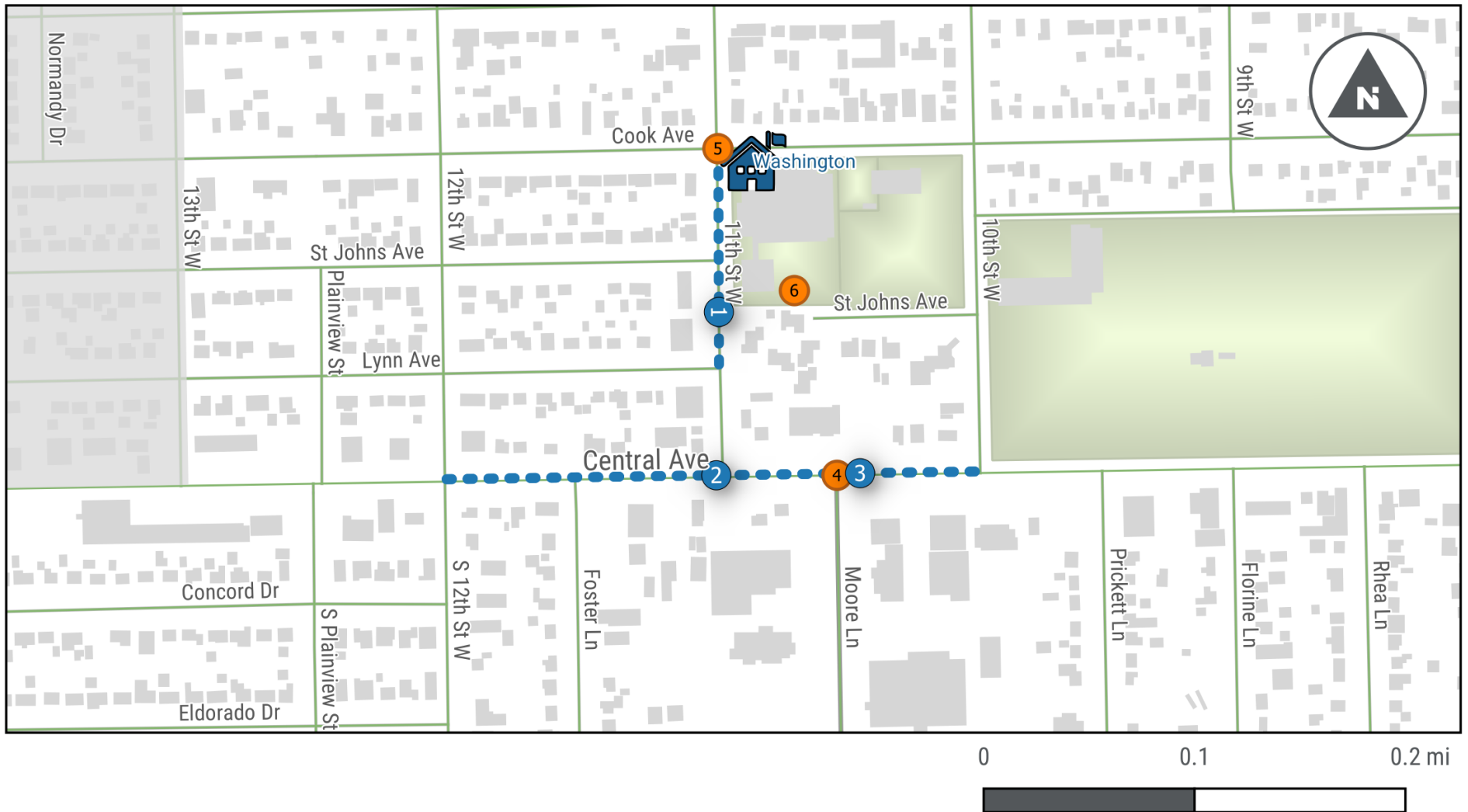

# Appendix C. Webmap Summary

An interactive webmap was created to gather feedback from students, families, and other community stakeholders about specific locations that may make walking and biking difficult for students and their families. Over 300 respondents used the webmap between October and December 2021, and they left just over 360 comments. These comments were used to help form the project recommendations and are summarized in more detail on the following pages.

The webmap was publicized and distributed through the following means:

- Direct emails and/or Facebook messages to all elementary school PTOs
- Article in the Billings Gazette
- In-person visits to several Title schools by Billings MPO staff
- Emails to all elementary school principals
- Flyers put into student's folders on Walk to School Day
- Morning segment on KTVQ news

The following maps show the distribution and types of comments posted to the webmap.

## Students should be able to walk, bike, or roll to school in Billings.

**The Billings Safe Routes to School Study is going to help make that possible.**

Walking, biking, scooting, and skating are fun and healthy ways for students to get to school in Billings, and can also

- help reduce air pollution,
- build a sense of community,
- encourage and promote safety,
- and save money.

Unfortunately, many students and their families don't feel safe getting to school in these ways because of busy streets, lack of sidewalks, unmarked crossings, or other issues.

The Billings Metropolitan Planning Organization (MPO) is kicking off a Safe Routes to School Study to identify ways to improve walking, biking, and rolling conditions for elementary school students in Billings.

**This study has four major tasks:**

1. Evaluate current walking, biking, and rolling conditions for students in the region
2. Identify barriers or issues that might discourage students from walking, biking, and rolling
3. Develop a list of prioritized projects that can be built to improve walking, biking, and rolling conditions for students
4. Create walking route maps for all 22 public elementary schools in Billings

**We need you!**

**Your experience and knowledge can take this plan from good to great.**

Give us input on the project webmap. Head to [tinyurl.com/BillingsSRTS-plan](https://tinyurl.com/BillingsSRTS-plan) to let us know where you currently walk, where you think there are issues, and what you would need to walk or bike to school more.







Cut here and use as a bookmark!

**Color me in!**

Use your favorite colors, and add in your own unique elements, like flowers in the basket, streamers, a bike horn – whatever you like!

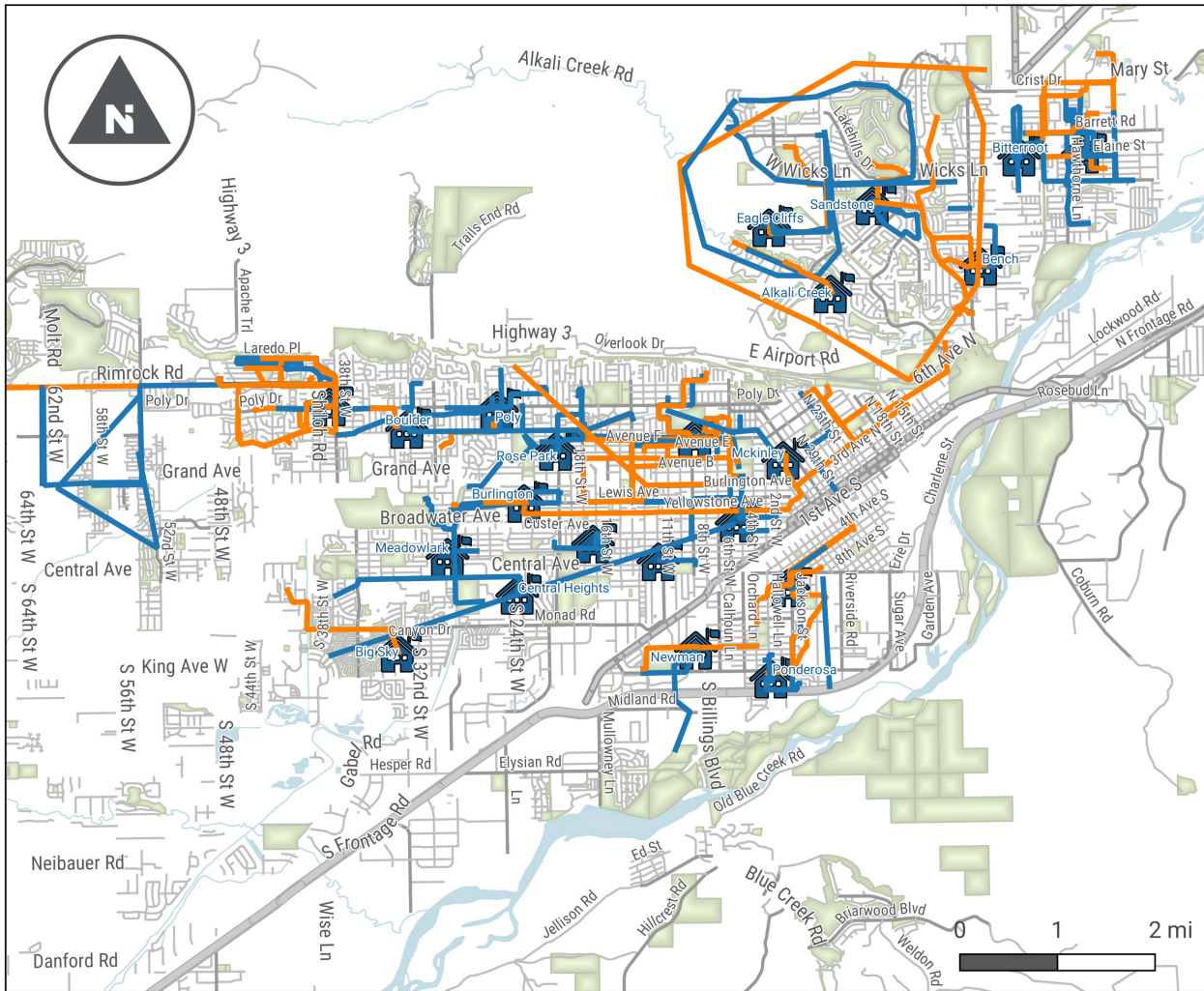

Flyers were handed out to students at all elementary schools to encourage parents to contribute to the interactive webmap.



Types of Routes Detailed on the Billings Interactive Webmap

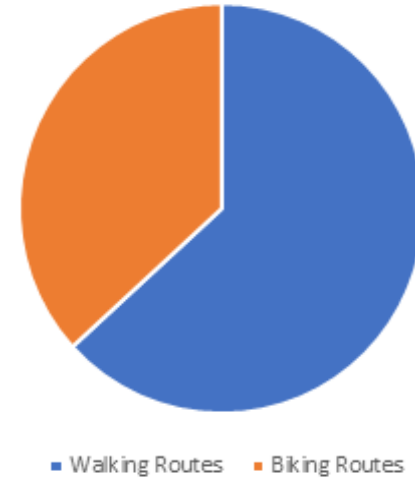

Interactive Webmap Inputs - Lines

- Routes where I bike or would like to bike
- Routes where I walk or would like to walk



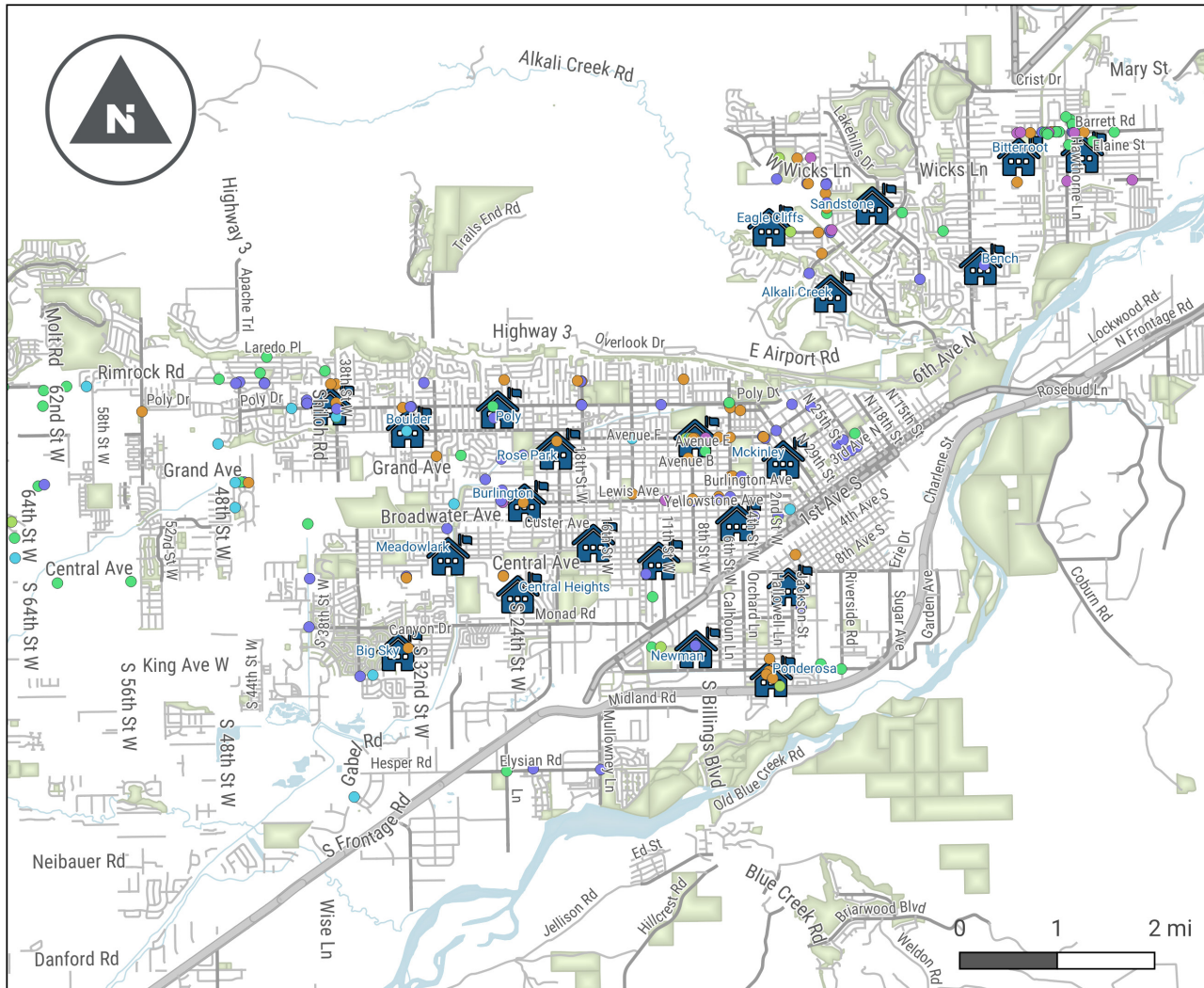

Types of Concerns posted on the Billings Interactive Webmap

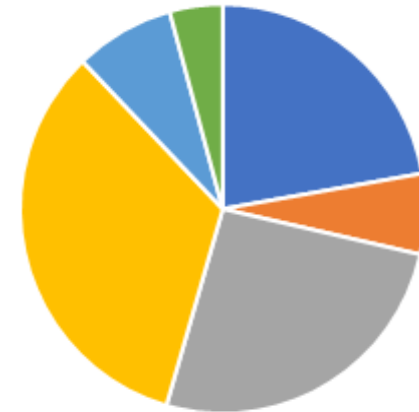

- Sidewalk   ■ Lighting   ■ Traffic
- Crossing   ■ Biking   ■ Other

Interactive Webmap Inputs - Points

- Cycling Concern   ● Sidewalk Concern
- Crossing Concern   ● Traffic Concern
- Lighting Concern   ● Other Concern

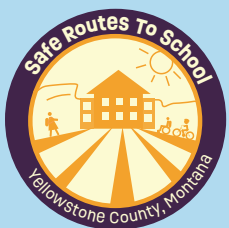

# **BILLINGS SAFE ROUTES TO SCHOOL**

Plan Update

**DRAFT June 2022**

