



**ADJOURNED MEETING OF THE
CANYON LAKE CITY COUNCIL**

**Wednesday, July 12, 2017
Closed Session – 5:00 P.M.,
Open Session – 6:30 P.M.**

**City Council Chambers
31516 Railroad Canyon Road
Canyon Lake, CA 92587**

Please turn off your cell phones during the meeting

Closed Session - 5:00 p.m.

- 1. Call to Order**
- 2. Roll Call:** Council Members Ehrenkranz, Greene, Haggerty, Mayor Pro Tem Warren, Mayor Bonner
- 3. Public Comments** – Any person wishing to address the City Council on any matter on this agenda, is asked to complete a “Speaker Request Form” available on the back counter. The completed form is to be submitted to the City Clerk prior to an individual being heard by the City Council. The City Council has adopted a time limitation of three (3) minutes per person. If you are commenting on the agenda item, your comments will be heard at the time that particular item is scheduled on the agenda.
- 4. Closed Session**
 - a. Closed session pursuant to govt. code section 54957 – Public Employment; Public Employee Evaluation - City Manager
 - b. Return/Report from Closed Session

OPEN SESSION – 6:30 P.M.

- 1. Call Open Session to Order**
- 2. Invocation**
Flag Salute

3. **Roll Call:** Council Members Ehrenkranz, Greene, Haggerty, Mayor Pro Tem Warren, Mayor Bonner

4. **Approval of City Council Agenda**

5. **Special Presentations and Proclamations**

5.1 **Introduction of Executive Director, Neil Trent, with Animal Friends of the Valley**

5.2 **PACE Program Presentation**

5.3 **Chamber of Commerce Announcements**

6. **Public Comments** – Any person wishing to address the City Council on any matter within the jurisdiction of the City, whether or not it appears on this agenda, is asked to complete a “Speaker Request Form” available on the back counter. The completed form is to be submitted to the City Clerk prior to an individual being heard by the City Council. The City Council has adopted a time limitation of three (3) minutes per person. If you are commenting on the agenda item, your comments will be heard at the time that particular item is scheduled on the agenda. *Please note that if you are addressing the City Council on items NOT on the agenda, the Brown Act does not allow discussion of such items. Therefore, the City Council may only do the following: refer the matter to staff, ask for additional information or request a report back, or give a very limited factual response.*

7. **Consent Calendar:**

All items listed on the Consent Calendar are considered to be routine matters, status reports or documents covering previous City Council action. The items listed on the Consent Calendar may be enacted in one motion. With the concurrence of the City Council, a Council Member may request that an item be removed for further discussion. Staff recommends approval of all items.

7.1 **Waiver of Reading in Full of all Ordinances by Title Only**

7.2 **Adoption of Resolution No. 2017-07, Approving Claims and Demands of the City** **Pg. 7**

7.3 **Adoption of Resolution No. 2017-12, Approving Claims and Demands of the City** **Pg. 20**

7.4 **City Council Meeting Minutes**

7.4.1 June 1, 2017 – Adjourned Minutes **Pg. 32**

7.4.2 June 1, 2017 – Special Minutes **Pg. 42**

7.4.3 June 7, 2017 – Canceled Minutes **Pg. 44**

- 7.4.4 June 20, 2017 - Special Minutes **Pg. 46**
- 7.4.5 July 5, 2017 – Adjourned Minutes **Pg. 54**
- 7.5 **Adoption of Resolution No. 2017-13, Approving 2017 Agency and Committee Assignments and Appointments **Pg. 56****
- 7.6 **Adoption of Resolution No. 2017-14, Support for the National Park System **Pg. 62****
- 7.7 **Approval of Annual Payment to Trauma Intervention Programs (TIP) **Pg. 66****
- 8. **Pulled Consent Calendar Items**
- 9. **Schedule of Future Events:**
 - 9.1 Administration, Finance, and Planning Committee Meeting
Tuesday, August 1, 2017 at 8:00 a.m., City Council Chambers
 - 9.2 Public Safety Committee Meeting
Tuesday, August 1, 2017 at 9:30 a.m., City Council Chambers
 - 9.3 Canyon Lake City Council Meeting
Wednesday, August 2, 2017 at 6:30 p.m., City Council Chambers
 - 9.4 Water Committee Meeting
Thursday, September 21, 2017 at 9:00 a.m., City Council Chambers
 - 9.5 Veterans Committee Meeting
Meeting Date to Be Determined
- 10. **Business Items**
 - 10.1 **Presentation by Mark Norton, Discussion and Possible Direction given Regarding City’s Annual Fee to LESJWA **Pg. 72****
 - 10.2 **Presentation and possible direction to staff for Landscape Plant Replacement **Pg. 74****
 - 10.3 **Amendments to City Solid Waste Collection **Pg. 98****
 - 10.3.1 Approve Fourth Amendment to the Franchise Agreement between the City of Canyon Lake and CR&R Incorporated.
 - 10.3.2 Adopt Urgency Ordinance No. 172 - AN URGENCY ORDINANCE OF THE CITY COUNCIL OF THE CITY OF CANYON LAKE REVISING CERTAIN PROVISIONS OF CANYON LAKE MUNICIPAL CODE CHAPTER 6.01: INTEGRATED WASTE MANAGEMENT PERTAINING TO THE CHANGES IN STATE LAW EFFECTING SOLID, RECYCLABLE

AND ORGANIC WASTE COLLECTION AND DIVERSION AS NECESSARY FOR PRESERVING PUBLIC PEACE, HEALTH, AND SAFETY

10.3.3 Hold First Reading and Introduce Ordinance No. 173 - AN ORDINANCE OF THE CITY COUNCIL OF THE CITY OF CANYON LAKE REVISING CERTAIN PROVISIONS OF CANYON LAKE MUNICIPAL CODE CHAPTER 6.01: INTEGRATED WASTE MANAGEMENT PERTAINING TO THE CHANGES IN STATE LAW EFFECTING SOLID, RECYCLABLE AND ORGANIC WASTE COLLECTION AND DIVERSION

10.4 League of California Cities (LOCC) Voting Delegate for Annual Conference Pg. 130

10.5 Discussion and possible direction by Council to return City Hall to full operating hours Monday through Friday. Pg. 138

11. Public Hearing

11.1 Public Hearing – Approve Resolution No. 2017-08 - A RESOLUTION OF THE CITY COUNCIL OF THE CITY OF CANYON LAKE INCREASING AND SETTING SOLID AND ORGANIC WASTE COLLECTION RATES FOR THE 2017-2018 FISCAL YEAR AND PROVIDING FOR COLLECTION OF RESIDENTIAL SERVICE ON THE PROPERTY TAX ROLL Pg. 140

- a. Public Hearing Opened
- b. Staff Presentation
- c. Questions to Staff by City Council
- d. Testimony by Proponents
- e. Testimony by Opponents
- f. Rebuttal by Proponents
- g. Public Hearing Closed
- h. Discussion by City Council
- i. Action by City Council

12. Announcements

The next regular City Council meeting is scheduled for **August 2, 2017 at 5:30 for closed session and 6:30 p.m. for Open Session.**

13. Closed Session

- a. Closed session pursuant to govt. code section 54957 – Public Employment; Public Employee Evaluation - City Manager
- b. Return/Report from closed session

14. Adjournment

VISION STATEMENT

The vision of the City of Canyon Lake is to be a City that provides a quality of life that makes Canyon Lake the premier place to live in Southern California.

ATTENTION RESIDENTS:

Supporting documents, including staff reports, are available for review at City Hall in the City Clerk's Office or on the City's website at www.cityofcanyonlake.org once the agenda has been publicly posted. Any written materials relating to an item on this agenda submitted to the City Council after distribution of the agenda packet are available for public inspection in the City Clerk's Office during normal business hours. In addition, such writings or documents will be made available for public review at the respective public meeting. It is the intention of the City of Canyon Lake to comply with the Americans with Disabilities Act (ADA) in all respects. If, as an attendee or participant at this meeting, you will need special assistance beyond what is normally provided, the City of Canyon Lake will attempt to accommodate you in every reasonable manner. Please contact Ariel M. Hall, City Clerk, at least 48 hours prior to the meeting to inform us of your particular needs and to determine if accommodation is feasible. Please advise us at that time if you will need accommodations to attend or participate in meetings on a regular basis.

July 12, 2017 Adjourned City Council Meeting

**STATE OF CALIFORNIA }
COUNTY OF RIVERSIDE } SS. AFFIDAVIT OF POSTING
CITY OF CANYON LAKE }**

I, Stephanie N. Roseen, being duly sworn, depose and say that I am the duly appointed and qualified Deputy City Clerk of the City of Canyon Lake and that on July 6, 2017 before the hour of 5:00 p.m., I caused the above notice to be posted as required by Resolution 2015-36 of the City Council of the City of Canyon Lake.

**Stephanie N. Roseen
Deputy City Clerk**

**City of Canyon Lake
City Council
Staff Report**

TO: Mayor and City Council
FROM: Kayla Malin, Accountant
DATE: July 12, 2017
SUBJECT: List of Demands

Recommendation:

That the City Council adopts a resolution entitled: RESOLUTION NO. 2017-07

**A RESOLUTION OF THE CITY COUNCIL OF THE
CITY OF CANYON LAKE ALLOWING CERTAIN
CLAIMS AND DEMANDS AS SET FORTH IN EXHIBIT A**

Background:

All claims and demands are reported and summarized for review and approval by the City Council on a routine basis at each City Council meeting. The attached claims represent the paid claims and demands since the City Council meeting of June 1, 2017.

Budget (or Fiscal) Impact:

All claims and demands are paid from appropriated funds or authorized resources of the City and have been recorded in accordance with the City's policies.

Attachments:

Resolution
List of Demands

RESOLUTION NO. 2017-07

A RESOLUTION OF THE CITY COUNCIL OF THE CITY OF CANYON LAKE, CALIFORNIA, ALLOWING CERTAIN CLAIMS AND DEMANDS AS SET FORTH IN EXHIBIT A

The City Council of the City of Canyon Lake does hereby resolve as follows:

Demands are approved as shown on the Demand/Warrant Register of July 12th, in the amount of \$761,702.85 as follows:

Payroll Earnings (Gross)	\$	41,745.67	(2nd Half of April & 1st Half of May)
Payroll Taxes - Employer	\$	832.73	(2nd Half of April & 1st Half of May)
On-line Retirement		4,239.85	(2nd Half of April & 1st Half of May)
On-line Health		730.41	(For the Month of May)
General		714,154.19	(Accounts Payable)
TOTAL	\$	<u>761,702.85</u>	

PASSED, APPROVED AND ADOPTED this 12th day of July 2017.

Randall P. Bonner, Mayor

ATTEST:

Stephanie Roseen, Deputy City Clerk

Note: Due to system crash around 5/17/17, check numbers 23078-23082 are not in the accounting system. Further research will be done after all data has been entered into MIP. These missing checks will be accounted for at a later date. - Kayla Malin, Accountant

State of California
County of Riverside) ss
City of Canyon Lake)

I, Stephanie Roseen, Deputy City Clerk of the City of Canyon Lake, California, DO HEREBY CERTIFY, that the foregoing is a true and correct copy of the Resolution No. 2017-07 adopted by the City Council of the City of Canyon Lake, California, at an adjourned meeting thereof, held on July 12, 2017, by the following vote:

AYES:
NOES:
ABSTAIN:
ABSENT:

Stephanie Roseen, Deputy City Clerk

City of Canyon Lake
Check/Voucher Register - Council Report - Expenditures
From 5/11/2017 Through 5/11/2017

Check Num...	Matching Docum... Date	Vendor Name	Transaction Description	Check Amount	Fund Code	Fund Short Title
23083	5/11/2017	AMERICAN FORENSIC NURSES INC	Sheriff's Dept Blood Draws, April 2017	200.00	10	GENERAL
Total 23083	5/11/2017			200.00		
23084	5/11/2017	ANIMAL FRIENDS OF THE VALLEYS	Animal Control Services for February 2017	3,500.00	10	GENERAL
Total 23084	5/11/2017			3,500.00		
23085	5/11/2017	ALLIED UNIVERSAL SECURITY SERVICES	Overpayment of Business License Application, 4/26/17	121.00	10	GENERAL
Total 23085	5/11/2017			121.00		
23086	5/11/2017	CHARLES ABBOTT ASSOCIATES, INC.	Building & Safety - Permit & Plan Review, April 2017	14,097.64	10	GENERAL
Total 23086	5/11/2017			14,097.64		
23087	5/11/2017	Corelogic Information Solutions, INC.	Database for Code Enforcement, April 2017	1.25	10	GENERAL
Total 23087	5/11/2017			1.25		
23088	5/11/2017	Cota Cole LLP	Attorney Services, General - Zaitz, April 2017	10,554.17	10	GENERAL
23088	5/11/2017	Cota Cole LLP	Attorney Services, Marina Landscape Maint. vs. CL; April '17	206.00	10	GENERAL
Total 23088	5/11/2017			10,760.17		
23089	5/11/2017	CTAI PACIFIC GREENSCAPE	Canyon Lake Fire Station Landscape Maint for April 2017	250.00	10	GENERAL
23089	5/11/2017	CTAI PACIFIC GREENSCAPE	Tree Trimming at Fire Station, 4/21/17	390.00	10	GENERAL

City of Canyon Lake
 Check/Voucher Register - Council Report - Expenditures
 From 5/11/2017 Through 5/11/2017

Check Num...	Matching Docum... Date	Vendor Name	Transaction Description	Check Amount	Fund Code	Fund Short Title
23089	5/11/2017	CTAI PACIFIC GREENSCAPE	Weed Abatement at Fire Station, 4/19/17	500.00	10	GENERAL
23089	5/11/2017	CTAI PACIFIC GREENSCAPE	Median & Parkways Landscape Maint for April 2017	5,200.00	20	GAS TAX
23089	5/11/2017	CTAI PACIFIC GREENSCAPE	Railroad Canyon Rd Median Light Repair, 4/27/17	200.00	20	GAS TAX
23089	5/11/2017	CTAI PACIFIC GREENSCAPE	Railroad Canyon Rd Median Light Repair, Invoice Date:3/28/17	100.00	20	GAS TAX
23089	5/11/2017	CTAI PACIFIC GREENSCAPE	Tree Replacement in Median, Invoice Date: 4/17/17	315.00	20	GAS TAX
Total 23089	5/11/2017			6,955.00		
23090	5/11/2017	DATA TICKET	FTB Payment & Hearing Decision, Invoice Date 5/10/17	448.15	10	GENERAL
Total 23090	5/11/2017			448.15		
23091	5/11/2017	Department of Justice Accounting Office	Fingerprint Apps, April 2017	32.00	10	GENERAL
Total 23091	5/11/2017			32.00		
23092	5/11/2017	DFM ASSOCIATES	2017 Ca Elections Code Book	54.38	10	GENERAL
Total 23092	5/11/2017			54.38		
23093	5/11/2017	ELSINORE VALLEY MUNI WATER DIS	Water & Sewer Bill for City Hall	110.52	10	GENERAL
23093	5/11/2017	ELSINORE VALLEY MUNI WATER DIS	Water & Sewer for Fire Station; Period: 3/27/17 to 4/27/17	100.33	10	GENERAL
23093	5/11/2017	ELSINORE VALLEY MUNI WATER DIS	Irrigation; Billing Period: 3/27/17 to 4/27/17	1,530.80	20	GAS TAX
Total 23093	5/11/2017			1,741.65		

City of Canyon Lake
Check/Voucher Register - Council Report - Expenditures
From 5/11/2017 Through 5/11/2017

Check Num...	Matching Docum... Date	Vendor Name	Transaction Description	Check Amount	Fund Code	Fund Short Title
23094	5/11/2017	THE GAS COMPANY	Gas Bill; Billing Period: 3/29/17 to 4/27/17	5.04	10	GENERAL
Total 23094	5/11/2017			5.04		
23095	5/11/2017	Jani-King of California, Inc. L.A./Col Region	Cleaning Services for May 2017	720.37	10	GENERAL
Total 23095	5/11/2017			720.37		
23096	5/11/2017	Joe's Hardware	Supplies for Special Enforcement, April 2017	16.36	10	GENERAL
Total 23096	5/11/2017			16.36		
23097	5/11/2017	Millar Heating & Air	Assessment of HVAC unit at CL Fire Station, 4/25/17	250.00	10	GENERAL
Total 23097	5/11/2017			250.00		
23098	5/11/2017	Redlands Arbitration & Mediation Services	Mediation for CL vs. Marina, 2/2/17	1,000.00	10	GENERAL
Total 23098	5/11/2017			1,000.00		
23099	5/11/2017	Rogers, Anderson, Malody & Scott, LLP	Accounting Services for February 2017	6,700.00	10	GENERAL
Total 23099	5/11/2017			6,700.00		
23100	5/11/2017	COUNTY OF RIVERSIDE-TLMA	SLF Costs - March 2017	46.80	20	GAS TAX
Total 23100	5/11/2017			46.80		
23101	5/11/2017	SOUTHERN CALIFORNIA EDISON	Electricity for Traffic Signals; 3/23/17 to 4/24/17	88.72	20	GAS TAX

City of Canyon Lake
Check/Voucher Register - Council Report - Expenditures
From 5/11/2017 Through 5/11/2017

Check Numb...	Matching Docum... Date	Vendor Name	Transaction Description	Check Amount	Fund Code	Fund Short Title
Total 23101	5/11/2017			88.72		
23102	5/11/2017	Sparkletts	Water Service for City Hall; April 2017	60.15	10	GENERAL
Total 23102	5/11/2017			60.15		
23103	5/11/2017	STAPLES	Office Supplies, 4/22/17	79.49	10	GENERAL
Total 23103	5/11/2017			79.49		
23104	5/11/2017	Synoptek	IT Services for May 2017	1,910.00	10	GENERAL
Total 23104	5/11/2017			1,910.00		
23105	5/11/2017	Windwild Group	19 Engraved Bricks for Veteran's Park, Inv Date: May 2, 2017	410.40	10	GENERAL
Total 23105	5/11/2017			410.40		
Report Total				49,198.57		

City of Canyon Lake
 Check/Voucher Register - Council Report - Expenditures
 From 5/31/2017 Through 5/31/2017

Check Num...	Matching Docum... Date	Vendor Name	Transaction Description	Check Amount	Fund Code	Fund Short Title
23106	5/31/2017	AMERICAN FORENSIC NURSES INC	Sheriff's Dept DUI Blood Draw April 2017	200.00	10	GENERAL
Total 23106	5/31/2017			200.00		
23107	5/31/2017	BIO-TOX LABORATORIES	Sheriff's Dept Blood Testing	658.10	10	GENERAL
Total 23107	5/31/2017			658.10		
23108	5/31/2017	Canyon Lake Pest Control	Pest Control City Hall	100.00	10	GENERAL
23108	5/31/2017	Canyon Lake Pest Control	Pest Control Storage Unit	90.00	10	GENERAL
Total 23108	5/31/2017			190.00		
23109	5/31/2017	CR&R	Refuse FY 16-17	515,354.07	50	AGENCY
Total 23109	5/31/2017			515,354.07		
23110	5/31/2017	DATA TICKET	Monthly Citation Processing April 2017	100.00	10	GENERAL
Total 23110	5/31/2017			100.00		
23111	5/31/2017	DownStream Services, Inc.	Scheduled Stormwater Maintenance, Date of service 03/01/17	3,139.32	20	GAS TAX
Total 23111	5/31/2017			3,139.32		
23112	5/31/2017	Eastport Market	City Vehicle Fuel 10/1/16 - 05/17/17	1,160.01	10	GENERAL
Total 23112	5/31/2017			1,160.01		
23113	5/31/2017	FRIDAY FLYER	Notice of Budget Adoption	19.50	10	GENERAL

City of Canyon Lake
 Check/Voucher Register - Council Report - Expenditures
 From 5/31/2017 Through 5/31/2017

Check Num...	Matching Docum... Date	Vendor Name	Transaction Description	Check Amount	Fund Code	Fund Short Title
23113	5/31/2017	FRIDAY FLYER	Notice of Public Hearing	55.50	10	GENERAL
Total 23113	5/31/2017			75.00		
23114	5/31/2017	Frontier Communications	City Hall Internet 05/10/17-06/09/17	81.12	10	GENERAL
23114	5/31/2017	Frontier Communications	Phones 05/10/17-06/09/17	127.74	10	GENERAL
23114	5/31/2017	Frontier Communications	Phones 05/13/17-06/12/17	341.34	10	GENERAL
Total 23114	5/31/2017			550.20		
23115	5/31/2017	GOLDING PUBLICATIONS	Blank Stock for City License Card	102.36	10	GENERAL
Total 23115	5/31/2017			102.36		
23116	5/31/2017	H2 Environmental	Microbial Assessment Fire Station	1,162.00	10	GENERAL
Total 23116	5/31/2017			1,162.00		
23117	5/31/2017	ParkWest Tree Care, Inc.	Tree Trimming	5,330.00	10	GENERAL
Total 23117	5/31/2017			5,330.00		
23118	5/31/2017	Pitney Bowes Global Financial Services, LLC	Postage Lease 3/13/17-06/12/17	175.14	10	GENERAL
Total 23118	5/31/2017			175.14		
23119	5/31/2017	Rogers, Anderson, Malody & Scott, LLP	Accounting Service March 2017	6,700.00	10	GENERAL
23119	5/31/2017	Rogers, Anderson, Malody & Scott, LLP	Accounting Services April 2017	6,700.00	10	GENERAL
Total 23119	5/31/2017			13,400.00		

City of Canyon Lake
Check/Voucher Register - Council Report - Expenditures
From 5/31/2017 Through 5/31/2017

Check Num...	Matching Docum... Date	Vendor Name	Transaction Description	Check Amount	Fund Code	Fund Short Title
23 120	5/31/2017	JOHN REGUS	Rent for Library July 2017	1,012.95	10	GENERAL
Total 23 120	5/31/2017			1,012.95		
23 121	5/31/2017	JOHN REGUS	Rent Conference Room June 2017	250.00	10	GENERAL
Total 23 121	5/31/2017			250.00		
23 122	5/31/2017	RIV. CO. SHERIFF'S DEPT., Acctg & Fin	Contract Law Enforcement Facility Expenses FY 16/17	53,200.08	10	GENERAL
Total 23 122	5/31/2017			53,200.08		
23 123	5/31/2017	RIV. CO. SHERIFF'S DEPT., Acctg & Fin	Contract Law Enforcement Rate Adjustment FY 16-17	55,657.03	10	GENERAL
Total 23 123	5/31/2017			55,657.03		
23 124	5/31/2017	COUNTY OF RIVERSIDE-TLMA	SLF Costs April 2017	2,379.25	20	GAS TAX
Total 23 124	5/31/2017			2,379.25		
23 125	5/31/2017	Southern California Association of Government	Dues Assessment for FY 17/18	1,198.00	10	GENERAL
Total 23 125	5/31/2017			1,198.00		
23 126	5/31/2017	SOUTHERN CALIFORNIA EDISON	Electricity Bill for City Hall 04/17/17 - 05/16/17	934.27	10	GENERAL
23 126	5/31/2017	SOUTHERN CALIFORNIA EDISON	Electricity Bill for Fire Station 04/17/17 - 05/16/17	134.24	10	GENERAL
23 126	5/31/2017	SOUTHERN CALIFORNIA EDISON	Electricity Bill for Office Lease 4/21/17-5/22/17	35.96	10	GENERAL
23 126	5/31/2017	SOUTHERN CALIFORNIA EDISON	Electricity Bill for Pump Station 04/10/17 - 05/10/17	258.19	20	GAS TAX

City of Canyon Lake
 Check/Voucher Register - Council Report - Expenditures
 From 5/31/2017 Through 5/31/2017

Check Num...	Matching Docum... Date	Vendor Name	Transaction Description	Check Amount	Fund Code	Fund Short Title
23126	5/31/2017	SOUTHERN CALIFORNIA EDISON	Electricity Bill for Traffic Control 03/22/17 - 04/21/17	12.52	20	GAS TAX
23126	5/31/2017	SOUTHERN CALIFORNIA EDISON	Electricity Bill for Traffic Control 04/17/17 - 05/16/17	191.55	20	GAS TAX
23126	5/31/2017	SOUTHERN CALIFORNIA EDISON	Electricity Bill for Traffic Control 4/24/17-5/23/17	78.65	20	GAS TAX
Total 23126	5/31/2017			1,645.38		
23127	5/31/2017	Special District Risk Management Authority	Dental and Vision June 2017	275.50	10	GENERAL
Total 23127	5/31/2017			275.50		
23128	5/31/2017	STATE COMP. INS. FUND	Workers Comp June 2017	1,538.68	10	GENERAL
Total 23128	5/31/2017			1,538.68		
23129	5/31/2017	Synoptek, LLC	Server Warranty Renewal	261.45	10	GENERAL
Total 23129	5/31/2017			261.45		
23130	5/31/2017	TPx Communications	City Hall Phone Systems 05/16/17 - 06/15/17	548.59	10	GENERAL
Total 23130	5/31/2017			548.59		
23131	5/31/2017	Toshiba Financial Services	Monthly Copier Lease, April and May 2017	1,496.64	10	GENERAL
Total 23131	5/31/2017			1,496.64		
23132	5/31/2017	TWO BROS. LOCKSMITH	Service Call/Open Door City Hall	60.00	10	GENERAL
Total 23132	5/31/2017			60.00		
23133	5/31/2017	U. S. Bank	Fast Signs, Supplies, etc	969.77	10	GENERAL

City of Canyon Lake
 Check/Voucher Register - Council Report - Expenditures
 From 5/31/2017 Through 5/31/2017

Check Numb...	Matching Docum... Date	Vendor Name	Transaction Description	Check Amount	Fund Code	Fund Short Title
23133	5/31/2017	U. S. Bank	Fast Signs, Supplies, etc	1,231.62	40	CAP. PROJ.
Total 23133	5/31/2017			2,201.39		
23134	5/31/2017	VERIZON CALIFORNIA	Cell Phone Service 05/04/17-06/03/17	331.68	10	GENERAL
23134	5/31/2017	VERIZON CALIFORNIA	iPads Service 05/04/17-06/03/17	239.10	10	GENERAL
Total 23134	5/31/2017			570.78		
23135	5/31/2017	XEROX	Copier Lease April 2017	512.57	10	GENERAL
23135	5/31/2017	XEROX	Copier Meter Usage 3/22/17-4/13/17	176.08	10	GENERAL
Total 23135	5/31/2017			688.65		
23136	5/31/2017	JOHN ZAITZ	December 2016 Reimbursement	178.84	10	GENERAL
Total 23136	5/31/2017			178.84		
23137	5/31/2017	NANCY GREENHALGH	Retiree Health Insurance for June 2017	196.21	10	GENERAL
Total 23137	5/31/2017			196.21		
Report Total				664,955.62		

**City of Canyon Lake
City Council
Staff Report**

TO: Mayor and City Council
FROM: Kayla Malin, Accountant
DATE: July 12, 2017
SUBJECT: List of Demands

Recommendation:

That the City Council adopts a resolution entitled: RESOLUTION NO. 2017-12

A RESOLUTION OF THE CITY COUNCIL OF THE
CITY OF CANYON LAKE ALLOWING CERTAIN
CLAIMS AND DEMANDS AS SET FORTH IN EXHIBIT A

Background:

All claims and demands are reported and summarized for review and approval by the City Council on a routine basis at each City Council meeting. The attached claims represent the paid claims and demands since the City Council meeting of June 1, 2017.

Budget (or Fiscal) Impact:

All claims and demands are paid from appropriated funds or authorized resources of the City and have been recorded in accordance with the City's policies.

Attachments:

Resolution
List of Demands

RESOLUTION NO. 2017-12

A RESOLUTION OF THE CITY COUNCIL OF THE CITY OF CANYON LAKE, CALIFORNIA, ALLOWING CERTAIN CLAIMS AND DEMANDS AS SET FORTH IN EXHIBIT A

The City Council of the City of Canyon Lake does hereby resolve as follows:

Demands are approved as shown on the Demand\Warrant Register of July 12th, in the amount of \$182,290.35 as follows:

Payroll Earnings (Gross)	\$	40,967.12	(2nd Half of May & 1st Half of June)
Payroll Taxes - Employer	\$	692.17	(2nd Half of May & 1st Half of June)
On-line Retirement		4,113.76	(2nd Half of May & 1st Half of June)
On-line GASB 68 Reporting		475.00	
On-line Health		730.41	(For the Month of June)
General		135,311.89	(Accounts Payable)
TOTAL	\$	<u>182,290.35</u>	

PASSED, APPROVED AND ADOPTED this 12th day of July 2017.

Randall P. Bonner, Mayor

ATTEST:

Stephanie Roseen, Deputy City Clerk

State of California
County of Riverside) ss
City of Canyon Lake)

I, Stephanie Roseen, Deputy City Clerk of the City of Canyon Lake, California, DO HEREBY CERTIFY, that the foregoing is a true and correct copy of the Resolution No. 2017-12 adopted by the City Council of the City of Canyon Lake, California, at an adjourned meeting thereof, held on July 12, 2017, by the following vote:

AYES:
NOES:
ABSTAIN:
ABSENT:

Stephanie Roseen, Deputy City Clerk

City of Canyon Lake
 Check/Voucher Register - Council Report - Expenditures
 From 6/1/2017 Through 6/30/2017

Check Numb...	Matching Docum... Date	Vendor Name	Transaction Description	Check Amount	Fund Code	Fund Short Title
23138	6/8/2017	Aflac	Aflac Supplemental Insurance May 2017	325.70	10	GENERAL
Total 23138	6/8/2017			325.70		
23139	6/8/2017	Avenet, LLC	Gov Office - City Website	4,755.00	10	GENERAL
Total 23139	6/8/2017			4,755.00		
23140	6/8/2017	Charles Abbott Associates, Inc.	Engineering Services April 2017	6,852.00	10	GENERAL
23140	6/8/2017	Charles Abbott Associates, Inc.	Gas Tax and Planning/PZL April 2017	8,568.17	10	GENERAL
23140	6/8/2017	Charles Abbott Associates, Inc.	Gas Tax and Planning/PZL April 2017	5,921.00	20	GAS TAX
Total 23140	6/8/2017			21,341.17		
23141	6/8/2017	Corelogic Information Solutions, INC.	Database for Code Enforcement May 2017	38.25	10	GENERAL
Total 23141	6/8/2017			38.25		
23142	6/8/2017	CTAI Pacific Greenscape	Canyon Lake Fire Station Landscape Maintenance May 2017	250.00	10	GENERAL
23142	6/8/2017	CTAI Pacific Greenscape	Median & Parkways Landscape Maintenance for May 2017	5,200.00	20	GAS TAX
Total 23142	6/8/2017			5,450.00		
23143	6/8/2017	DATA TICKET	Monthly Citation Processing May 2017	100.00	10	GENERAL
Total 23143	6/8/2017			100.00		
23144	6/8/2017	Jani-King of CA, Inc.	City Hall Cleaning Service June 2017	720.37	10	GENERAL

City of Canyon Lake
Check/Voucher Register - Council Report - Expenditures
From 6/1/2017 Through 6/30/2017

Check Num...	Matching Docum... Date	Vendor Name	Transaction Description	Check Amount	Fund Code	Fund Short Title
Total 23144	6/8/2017			720.37		
23145	6/8/2017	L.C.C - Riverside Division	Division Meeting 05/08/17	90.00	10	GENERAL
Total 23145	6/8/2017			90.00		
23146	6/8/2017	Pure Solar & Electric	Refund on Permit 2017-133	80.25	10	GENERAL
Total 23146	6/8/2017			80.25		
23147	6/8/2017	SOUTHERN CALIFORNIA EDISON	Electricity, Traffic Signals 3/30/17 - 05/31/17	742.52	20	GAS TAX
Total 23147	6/8/2017			742.52		
23148	6/8/2017	Sparkletts	Water for City Hall, May 2017	60.15	10	GENERAL
Total 23148	6/8/2017			60.15		
23149	6/8/2017	STAPLES	Office Supplies	208.90	10	GENERAL
Total 23149	6/8/2017			208.90		
23150	6/8/2017	TWO BROS. LOCKSMITH	Rekey Lever Lock City Hall	94.85	10	GENERAL
Total 23150	6/8/2017			94.85		
23151	6/21/2017	Canyon Lake Mattress and More	Fire Station 60 rehab-bedding supplies for 6 mattresses	801.66	10	GENERAL
Total 23151	6/21/2017			801.66		
23152	6/21/2017	Charles Abbott Associates, Inc.	Engineering Services May 2017	17,954.50	10	GENERAL

City of Canyon Lake
 Check/Voucher Register - Council Report - Expenditures
 From 6/1/2017 Through 6/30/2017

Check Numb...	Matching Docum... Date	Vendor Name	Transaction Description	Check Amount	Fund Code	Fund Short Title
23152	6/21/2017	Charles Abbott Associates, Inc.	Permit and Plan Review May 2017	18,993.06	10	GENERAL
23152	6/21/2017	Charles Abbott Associates, Inc.	Public Works and Planning, May 2017	2,354.63	10	GENERAL
23152	6/21/2017	Charles Abbott Associates, Inc.	Public Works and Planning, May 2017	6,315.00	20	GAS TAX
Total 23152	6/21/2017			45,617.19		
23153	6/21/2017	C.L.CHAMBER OF COMMERCE	Annual Membership	110.00	10	GENERAL
Total 23153	6/21/2017			110.00		
23154	6/21/2017	Cota, Cola and Huber, LLP	Attorney Services May 2017	7,754.75	10	GENERAL
Total 23154	6/21/2017			7,754.75		
23155	6/21/2017	DATA TICKET	Monthly Citation Processing May 2017	100.00	10	GENERAL
Total 23155	6/21/2017			100.00		
23156	6/21/2017	STATE OF CA DEPT. OF JUSTICE	Fingerprints May 2017	384.00	10	GENERAL
Total 23156	6/21/2017			384.00		
23157	6/21/2017	ELSINORE VALLEY MUNI WATER DIS	Water, City Hall 4/24/17 - 5/25/17	113.70	10	GENERAL
23157	6/21/2017	ELSINORE VALLEY MUNI WATER DIS	Irrigation 4/27/17 - 5/26/17	1,025.58	20	GAS TAX
Total 23157	6/21/2017			1,139.28		
23158	6/21/2017	FRIDAY FLYER	Notice of Budget Adoption June 2017	19.50	10	GENERAL

City of Canyon Lake
 Check/Voucher Register - Council Report - Expenditures
 From 6/1/2017 Through 6/30/2017

Check Num...	Matching Docum... Date	Vendor Name	Transaction Description	Check Amount	Fund Code	Fund Short Title
Total 23158	6/21/2017			19.50		
23159	6/21/2017	Frontier Communications	Internet 6/10/17 - 7/9/17	149.49	10	GENERAL
23159	6/21/2017	Frontier Communications	Phones 6/10/17 - 7/9/17	63.87	10	GENERAL
23159	6/21/2017	Frontier Communications	Phones 6/13/17 - 7/12/17	354.28	10	GENERAL
Total 23159	6/21/2017			567.64		
23160	6/21/2017	THE GAS COMPANY	Gas, 04/27/17 - 05/26/17	5.08	10	GENERAL
Total 23160	6/21/2017			5.08		
23161	6/21/2017	NANCY GREENHALGH	Retiree Health Insurance July 2017	196.21	10	GENERAL
Total 23161	6/21/2017			196.21		
23162	6/21/2017	Purchase Power	Postage May 2017	201.00	10	GENERAL
Total 23162	6/21/2017			201.00		
23163	6/21/2017	Priority 1 Property Preservation, Inc.	Residential Hazard Abatement Case	4,592.00	10	GENERAL
Total 23163	6/21/2017			4,592.00		
23164	6/21/2017	Rogers, Anderson, Malody & Scott, LLP	Accounting Services May 2017	6,700.00	10	GENERAL
Total 23164	6/21/2017			6,700.00		
23165	6/21/2017	JOHN REGUS	Rent for Library August 2017	1,012.95	10	GENERAL
Total 23165	6/21/2017			1,012.95		

City of Canyon Lake
 Check/Voucher Register - Council Report - Expenditures
 From 6/1/2017 Through 6/30/2017

Check Num...	Matching Docum... Date	Vendor Name	Transaction Description	Check Amount	Fund Code	Fund Short Title
23166	6/21/2017	JOHN REGUS	Rent for Conference Room August 2017	250.00	10	GENERAL
Total 23166	6/21/2017			250.00		
23167	6/21/2017	Round Up Jr. Mart	City Vehicle Fuel 10/1/16 - 05/17/17	1,160.01	10	GENERAL
Total 23167	6/21/2017			1,160.01		
23168	6/21/2017	REGISTRAR OF VOTERS	Election Services November 8, 2016	14,497.65	10	GENERAL
Total 23168	6/21/2017			14,497.65		
23169	6/21/2017	SOUTHERN CALIFORNIA EDISON	Electricity, City Hall 05/16/17 - 06/15/17	1,246.90	10	GENERAL
23169	6/21/2017	SOUTHERN CALIFORNIA EDISON	Electricity, Fire Station 05/16/17 - 06/15/17	131.59	10	GENERAL
23169	6/21/2017	SOUTHERN CALIFORNIA EDISON	Electricity, Pump Station 05/10/17 - 6/9/17	374.96	20	GAS TAX
23169	6/21/2017	SOUTHERN CALIFORNIA EDISON	Electricity, Traffic Control 4/21/17 - 5/22/17	12.62	20	GAS TAX
23169	6/21/2017	SOUTHERN CALIFORNIA EDISON	Electricity, Traffic Control 5/16/17 - 6/15/17	197.32	20	GAS TAX
Total 23169	6/21/2017			1,963.39		
23170	6/21/2017	Special District Risk Management Authority	Dental and Vision July 2017	275.50	10	GENERAL
Total 23170	6/21/2017			275.50		
23171	6/21/2017	Speedy Vehicle Registration	Live Scans May 2017	300.00	10	GENERAL
Total 23171	6/21/2017			300.00		
23172	6/21/2017	STAPLES	Office Supplies	166.65	10	GENERAL

City of Canyon Lake
 Check/Voucher Register - Council Report - Expenditures
 From 6/1/2017 Through 6/30/2017

Check Num...	Matching Docum... Date	Vendor Name	Transaction Description	Check Amount	Fund Code	Fund Short Title
Total 23172	6/21/2017			166.65		
23173	6/21/2017	STATE COMP. INS. FUND	Worker's Comp Premium - Annual 06/1/18	1,717.72	10	GENERAL
Total 23173	6/21/2017			1,717.72		
23174	6/21/2017	STATE COMP. INS. FUND	Worker's Comp July 2017	1,265.42	10	GENERAL
Total 23174	6/21/2017			1,265.42		
23175	6/21/2017	Synoptek, LLC	IT Service June 2017	2,225.00	10	GENERAL
Total 23175	6/21/2017			2,225.00		
23177	6/21/2017	TWO BROS. LOCKSMITH	Service Call, Open Door at City Hall	94.85	10	GENERAL
Total 23177	6/21/2017			94.85		
23178	6/21/2017	Tyco Integrated Security LLC	Security City Hall 7/1/17 - 09/30/17	181.02	10	GENERAL
Total 23178	6/21/2017			181.02		
23179	6/21/2017	U. S. Bank	Candy for Fiesta Day, Supplies, Dinner for Council Meeting	942.00	10	GENERAL
Total 23179	6/21/2017			942.00		
23180	6/21/2017	Total Compensation Systems, Inc.	GASB68 Reporting Service FY 16/17	475.00	10	GENERAL
23180	6/21/2017	Verizon Wireless	Cell Phones 06/04/17-07/03/17	473.59	10	GENERAL
23180	6/21/2017	Verizon Wireless	Ipads, 06/04/17-07/03/17	161.67	10	GENERAL

City of Canyon Lake
Check/Voucher Register - Council Report - Expenditures
From 6/1/2017 Through 6/30/2017

Check Numb...	Matching Docum... Date	Vendor Name	Transaction Description	Check Amount	Fund Code	Fund Short Title
Total 23180	6/21/2017			1,110.26		
23181	6/28/2017	Regional Conservation Authority	MSHCP Fees June 2017	1,992.00	50	AGENCY
Total 23181	6/28/2017			1,992.00		
23182	6/28/2017	WRCOG	TUMF Fees June 2017	4,437.00	50	AGENCY
Total 23182	6/28/2017			4,437.00		
Report Total				135,786.89		

**MINUTES
ADJOURNED MEETING OF THE
CANYON LAKE CITY COUNCIL
THURSDAY, JUNE 1, 2017
Open Session - 6:00 p.m.**

**City Council Chambers
31516 Railroad Canyon Road
Canyon Lake, CA 92587**

1. Call Open Session to Order

Mayor Pro Tem Warren called the meeting to order at 6:11 p.m.

2. Invocation

The Invocation was led by Pastor Pete with Canyon Lake Community Church.

Flag Salute

The Flag Salute was led by City Accountant, Terry Shea.

3. Roll Call

Present: Council Member Bonner, Council Member Ehrenkranz, Council Member Greene, Council Member Haggerty, Mayor Pro Tem Warren

4. Approval of the City Council Agenda

Moved by Bonner, seconded by Haggerty, to approve the agenda as presented.

Motion carried 5-0 with Council Members Bonner, Ehrenkranz, Greene, Haggerty and Mayor Pro Tem Warren voting aye.

5. Statement regarding reimbursement issues

Aaron Palmer, City Manager, apologized on behalf of City staff regarding reimbursement issues.

Council Member Haggerty made a statement in regards to the reimbursement issues.

Mayor Pro Tem Warren made a statement in regards to the Ad Hoc Committee and reimbursement issues.

Resident John Zaitz made a public comment regarding the reimbursement issue.

6. Selection of Mayor

Office Specialist Hunter asked for nominations for appointment to the Mayor seat.

Mayor Pro Tem Warren nominated Council Member Bonner for Mayor.

Council Member Ehrenkranz nominated Council Member Haggerty for Mayor.

There were no further nominations, Office Specialist Hunter conducted a roll call vote.

Council Member Ehrenkranz made a statement regarding the current reimbursement issue and his nomination of Council Member Haggerty.

Mayor Pro Tem Warren made a statement regarding her nomination of Council Member Bonner.

Resident Paul Queen discussed the reimbursement form, placement for signature, and his support for Council Member Haggerty.

Resident John Guzman discussed his support for Council Member Haggerty.

Resident Jack Wamsley discussed the current reimbursement issue.

Resident Paul Chenette discussed his support for Council Member Haggerty.

Resident Eric Spitzer discussed his support for Council Member Haggerty.

Resident Daryl France discussed the current reimbursement issue.

Council Member Greene discussed the difference between a stipend and a reimbursement.

Resident Karen Bevans discussed the current reimbursement issue and her support for Council Member Bonner.

Resident Ted Horton discussed the current reimbursement issue and his support for Council Member Bonner.

Resident Joe Washle discussed the current reimbursement issue and his support for the Council.

Resident John Zaitz discussed the current reimbursement issues.

Resident Rick Garcia discussed moving on from the current issues and support of the Council.

Council Member Greene discussed the current reimbursement issues.

There were no further nominations, Office Specialist Hunter conducted a roll call vote.

Council Member Bonner, Greene and Mayor Pro Tem Warren voted for Council Member Bonner.

Council Member Ehrenkranz and Haggerty voted for Council Member Haggerty.

Council Member Bonner was appointed as Mayor.

Mayor Bonner made a statement regarding the reimbursement issue.

7. Selection of Mayor Pro Tem

Office Specialist Hunter asked for nominations for appointment to the Mayor Pro Tem seat.

Mayor Bonner nominated Council Member Warren.

Council Member Haggerty nominated Council Member Ehrenkranz.

Mayor Bonner stated his appreciation for Council Member Ehrenkranz.

Council Members Bonner, Ehrenkranz, Greene, Haggerty and Warren voted for Council Member Warren.

Mayor Pro Tem called for a recess at 7:14 pm

Mayor Bonner called the meeting back to order at 7:27 pm

8. Special Presentations and Proclamations

8.1 Chamber of Commerce Announcements

Jim Randle, Chamber of Commerce President, discussed the Annual Golf Tournament, and the new “Business Spotlight” program.

Mayor Bonner discussed the next Round Table Meeting in regards to the town center that would take place June 13th.

9. Public Comments

There were no public comments

10. Consent Calendar

10.1 Waiver of Reading in Full of all Ordinances by Title Only

10.2 City Council Meeting Minutes

- 10.2.1 April 5, 2017 – Council Meeting
- 10.2.2 April 20, 2017 – Special Meeting
- 10.2.3 April 26, 2017 – Special Meeting
- 10.2.4 May 3, 2017 – Adjourned Minutes

10.3 Adoption of Resolution No. 2017-05, Approving Claims and Demands of the City

10.4 Adoption of Resolution No. 2017-06, Updating and Re-establishing City Council Committees, Committee Functions, and setting Committee Meeting dates and times.

10.5 Approval of an Amendment of the Current Cafeteria Plan Benefit Policy

Moved by Ehrenkranz, seconded by Haggerty, to approve the Consent Calendar as presented.

Motion carried 5-0 with Council Members Ehrenkranz, Greene, Haggerty, Mayor Pro Tem Warren, and Mayor Bonner voting aye.

11. Pulled Consent Calendar Items

There were no pulled Consent Calendar Items.

12. Schedule of Future Events

Mayor Bonner stated that due to the 4th of July holiday the next City Council Meeting would be held Wednesday, July 12th and the next Public Safety and Administration, Finance and Planning Meeting would be held Tuesday, July 11th. Mayor Bonner also stated the next Water Subcommittee Meeting would be on September 21st and the Veteran's Committee Meeting would be determined.

13. Public Hearing

13.1 Public Hearing – Approve Resolution No. 2017-08 – Increasing and setting solid waste collection rates for the 2017-2018 fiscal year and providing for collection of residential service on the property tax roll

Office Specialist, Stephanie Hunter, introduced the item.

Mayor Bonner opened the Public Hearing at 7:32 p.m.

Alex Braicovich, Senior Regional Vice President for CR&R, discussed the annual rate adjustment increase for CR&R regarding county disposal costs and that there would be an average increase of .45 for residential customers.

There were no Council comments.

There were no comments from the public.

Alex Braicovich gave a presentation regarding the CR&R Anaerobic Digestion Facility.

There was discussion regarding the gas pipe that pumps to SoCal Gas was located eight feet below ground.

There was discussion regarding the equipment for the Anaerobic Digester was not available in the USA.

It was discussed that 83,000 gallons of natural gas was produced between January and April 30th.

There was discussion that there would not be a need for another residential trash bin and organic waste could go in the green waste container and a kitchen pail would be provided to residents to collect organic waste.

There was discussion regarding the use of horse manure and there is not enough energy value.

Council Member Haggerty discussed her visit to CR&R and the tour of the Anaerobic Digestive System.

There was discussion regarding the safety precautions that were in place.

Mayor Bonner closed the Public Hearing at 7:54 pm.

There was discussion regarding how the City of Canyon Lake would start participating in the Anaerobic Digestive System.

There was discussion regarding having this item brought back to the council and continuing the public hearing to July 12, 2017.

Moved by Haggerty, seconded by Greene to continue the public hearing on July 12, 2017.

Motion carried 5-0 with Council Members Ehrenkranz, Greene, Haggerty, Mayor Pro Tem Warren, and Mayor Bonner voting aye.

14. Business Items

14.1 Award of Contract – Wrought Iron Fence Repair Project #2016-03

Margaret Monson, Public Works Department, discussed the Wrought Iron Fence Repair Project #2016-03

Council Member Greene discussed the bids and condition of the fencing that would need repair.

There was discussion regarding the 25 percent contingency that would compensate for the additional work that was not originally included in the contract.

There was discussion regarding the cost listed for Charles Abbott was not an additional cost to the City and was for budgeting purposes.

There was discussion regarding cost recovery from drivers who had damaged the fencing.

Moved by Greene, seconded by Ehrenkranz to accept the bid for the replacement of the wrought iron fencing, authorize City Manager to execute the contract for AB Fence Co. in the amount of \$64,444, authorize the amounts of \$16,500 for contingency and \$7,000 for construction contract administration the project budget in the amount of \$87,944, and approve the plans and specifications as presented.

Motion carried 5-0 with Council Members Ehrenkranz, Greene, Haggerty, Mayor Pro Tem Warren, and Mayor Bonner voting aye.

14.2 Award of Contracts – Fire Station 60 Rehabilitation

14.2.1 Award of Contract – Fire Station Shower Repair and Water Heater Closet Repair Project #2017-02 and Fire Station ADA Retrofit Project #2017-07

Margaret Monson, Public Works Department, discussed the Fire Station Shower Repair and Water Heater Closet Repair Project # 2017-02 and Fire Station ADA Retrofit Project # 2017-07.

There was discussion regarding hiring local plumbers.

There was discussion regarding getting the interior repairs done first then working on the exterior repairs.

Moved by Greene, seconded by Warren to authorize City Manager to execute the contract for Masterline Plumbing, Inc. in the amount of \$8,690 for Project #2017-02, authorize the amounts of \$1,500 for contingency and \$1,000 for construction contract administration, staff time and inspection for a total project budget of \$11,190 for the Fire

Station Shower Repair and Water Heater Closet Door Project #2017-02, authorize City Manager to execute the contract for Masterline Plumbing, Inc. in the amount of \$7,425 for Project #2017-07, authorize the amounts of \$1,500 for contingency and \$1,000 for construction contract administration, staff time and inspection for a total project budget of \$9,925 for the Fire Station ADA Retrofit Project #2017-07.

Motion carried 5-0 with Council Members Ehrenkranz, Greene, Haggerty, Mayor Pro Tem Warren, and Mayor Bonner voting aye.

14.3 Review and Discussion of 2017/2018 Proposed City Budget

14.3.1 Resolution No. 2017-09, adopting the City's Fiscal Year 2017/2018 Budget and Appropriations Limit

14.3.2 Resolution No. 2017-10, approving the salary and wage Schedule for employees of the City for FY 2017-2018

14.3.3 Set date for adoption of 2017/2018 City Budget

Terry Shea, Accountant, gave the staff report.

There was discussion regarding the 8-10% increase for the sheriff department.

There was discussion regarding the Gas Tax and Measure A Funds in relation to the Available Fund Balance.

There was discussion regarding City vehicles that are currently used on the BLM Land and the AVA Grant that would pay for 60% of a new vehicle.

There was discussion regarding the proposed Code Enforcement Tech position.

There was discussion regarding the need for coverage on BLM Land.

There was discussion regarding the budget for Animal Friends of the Valley.

There was discussion regarding the promotion of Gina Dickson to Senior Special Enforcement Officer with the recent resignation of Special Enforcement Officer Ivan Henry.

There was discussion regarding the budget for the new Special Enforcement Vehicle and 60% of that cost would be covered through the AVA Grant.

There was discussion regarding slurry seal to Railroad Canyon Road.

There was discussion regarding the use of \$200,000 to assist the City of Lake Elsinore with their portion of Railroad Canyon Road.

Resident Nancy Horton discussed the option of the developers that have been building new homes in the City of Lake Elsinore along Railroad Canyon Road, contribute to the cost of fixing Railroad Canyon Road.

There was discussion regarding leaving the full \$500,000 in the budget for the repair of Railroad Canyon Road within the City of Canyon Lake boundaries.

There was discussion regarding the repayment of the RCTC (Riverside County Transportation Commission) loan.

There was discussion regarding the budgeted exhaust system for Fire Station 60 and the possibility of AQMD (Air Quality Management District) Funds and other fire grants that could help pay for repairs to Fire Station 60 and that staff would be looking into those options.

There was discussion regarding obtaining a scope of work from the Public Works Department to assess where the City was in projects that needed to be caught up and future work.

There was discussion regarding the overall Operations and Maintenance budget that had increased over a million dollars due to Fire increase of \$311,000, Police increase of \$135,000 and the amount of \$530,000 for the slurry seal to repair Railroad Canyon Road.

There was a discussion regarding holding a special meeting Tuesday, June 20, 2017 at 12:00 p.m. to approve the budget.

There was discussion regarding a budget for the Chamber of Commerce.

There was discussion regarding the Veteran's Day Committee Budget.

There was further discussion regarding the budget for the Chamber of Commerce.

There was discussion regarding a possible budget for research regarding the BLM Land.

14.4 Ratification of the City's Fire Contract with the County of Riverside

14.4.1 Ratification of A COOPERATIVE AGREEMENT TO PROVIDE FIRE PROTECTION, FIRE PREVENTION, RESCUE AND MEDICAL

EMERGENCY SERVICES FOR THE CITY OF CANYON LAKE between the City of Canyon Lake and the County of Riverside for Fiscal Year 2017/2018.

City Manager Palmer introduced the item.

There was discussion regarding the current shape of the fire engine.

14.4.2 Discussion regarding celebration of the reopening of Station 60 in Canyon Lake

There was discussion regarding having a ribbon cutting for the opening of Fire Station 60.

Moved by Haggerty, seconded by Ehrenkranz to ratify a cooperative agreement with Riverside County Fire for fire services at Station 60.

Motion carried 5-0 with Council Members Ehrenkranz, Greene, Haggerty, Mayor Pro Tem Warren, and Mayor Bonner voting aye.

15. City Manager Comments

There were no City Manager Comments.

16. Committee and Council Reports/Comments

16.1 Council Member Ehrenkranz

Council Member Ehrenkranz stated he had no reports.

16.2 Council Member Greene

Council member Greene discussed a reported electrical shock to a resident with an aluminum paddle and the City's authority on electrical use on docks.

16.3 Council Member Haggerty

Council Member Haggerty discussed meetings she had attended.

16.4 Mayor Pro Tem Warren

Mayor Pro Tem Warren stated she had no reports.

16.5 Mayor Bonner

Mayor Bonner stated he had no reports.

17. Announcements

It was discussed there would be a special City Council meeting on Tuesday, June 20th.

The next regular City Council meeting that was scheduled for July 5, 2017 was adjourned to July 12, 2017 at 5:00 p.m. for closed session and 6:30 p.m. for open session.

18. Closed Session

Council did not return to closed session.

19. Adjournment

The meeting was adjourned at 9:10 p.m.

Respectfully submitted,

Stephanie Roseen
Deputy City Clerk

**MINUTES
SPECIAL MEETING OF THE
CANYON LAKE CITY COUNCIL
Tuesday, June 1, 2017
Closed Session – 5:15 p.m.**

**City Council Chambers
31516 Railroad Canyon Road
Canyon Lake, CA 92587**

Closed Session – 5:15 p.m.

1. Call to Order

Mayor Pro Tem Warren called the meeting to order at 5:26 p.m.

2. Roll Call

Present: Council Members Bonner, Ehrenkranz, Greene, Haggerty and Mayor Pro Tem Warren

3. Public Comments

There were no public comments.

4. Closed Session

- a. Closed Session pursuant to Govt. Code Section 54957 – Public employment; Public employee performance evaluation – City Manager
- b. Closed Session with Legal Counsel regarding existing litigation pursuant to Govt. Code Section 54956.9(d)(1): Zaitz v. City of Canyon Lake
- c. Return/Report from Closed Session.

The City Council returned from Closed Session around 6:00 p.m. with no reportable action.

Respectfully submitted,

Stephanie Roseen,
Deputy City Clerk

MINUTES
REGULAR MEETING OF THE CANYON LAKE
CITY COUNCIL
Wednesday, June 7, 2017

City Council Chambers
31516 Railroad Canyon Road
Canyon Lake, CA 92587

**THE REGULAR MEETING OF THE CITY COUNCIL OF THE CITY OF CANYON LAKE
SCHEDULED FOR JUNE 7, 2017 HAD BEEN CANCELLED.**

Respectfully Submitted,

Stephanie Hunter
Office Specialist

**MINUTES
SPECIAL MEETING OF THE
CANYON LAKE CITY COUNCIL
Tuesday, June 20, 2017
Open Session - 12:00 p.m.**

**City Council Chambers
31516 Railroad Canyon Road
Canyon Lake, CA 92587**

Open Session – 12:00 p.m.

1. Call Open Session to Order

Mayor Bonner called the meeting to order at 12:00 p.m.

2. Flag Salute

Flag Salute was led by Alex Braicovich

3. Roll Call

Present: Council Members Ehrenkranz, Greene, Mayor Pro Tem Warren, and Mayor Bonner.

Absent: Council Member Haggerty was excused as absent.

4. Approval of the City Council Agenda

Moved by Greene, seconded by Warren, to approve the agenda as presented.

Motion carried 4-0-1 with Council Members Ehrenkranz, Greene, Mayor Pro Tem Warren, and Mayor Bonner voting aye, and Council Member Haggerty absent.

5. Public Comment

There were no public comments.

6. Consent Calendar

6.1 Waiver of Reading in Full of all Ordinances by Title Only

6.2 Cooperative Agreement with Riverside County Economic Development Agency (EDA) for Urban County Qualification

Moved by Warren, seconded by Greene to approve the Consent Calendar as presented.

Motion carried 4-0-1 with Council Members Ehrenkranz, Greene, Mayor Pro Tem Warren, and Mayor Bonner voting aye, and Council Member Haggerty absent.

7. Business Items

7.1 Presentation regarding CR&R Anaerobic Digestive System; possible direction to staff to include the additional \$1.95/month in the overall solid waste cost and notice the continued public hearing for residential tax roll collection to use that amount

Aaron Palmer, City Manager, introduced Alex Braicovich with CR&R who would be making the presentation.

Mr. Braicovich and his staff made a presentation on the newly constructed Anaerobic Digester and the new legislation on recycling organic waste.

There was discussion regarding how innovative and proprietary the facility is.

There was discussion regarding the impact on the City if the City decided not to participate in increasing the rates and using the facility.

Jack Wamsley, resident, spoke about how supportive of the community CR&R had been. He was in support of participating in the program.

Moved by Ehrenkranz, seconded by Greene to direct staff to review the amendment to the CR&R Franchise Agreement to participate in the Anaerobic Digester program, and to incorporate the new increased rate.

Motion carried 4-0-1 with Council Members Ehrenkranz, Greene, Mayor Pro Tem Warren and Mayor Bonner voting aye, and Council Member Haggerty absent.

7.2 Approval of 2017/2018 Proposed City Budget

7.2.1 Resolution No. 2017-09, adopting the City's Fiscal Year 2017/2018 Budget and Appropriations Limit

City Manager Palmer stated that the budget as presented showed a deficit, and he proposed removing the proposed exhausted system for the fire station out of the budget to bring the budget back into a surplus. The exhaust system could be addressed later and put back into the budget if/when grant funding was received.

Mayor Pro Tem Warren stated that she had questions and concerns that she wanted to have addressed prior to starting to move items around.

Accountant Shea stated that he had adjusted the Sheriff's budget because there was previously a miscalculation between what the Sheriff and the City had projected, and the City Attorney budget had been lowered. He added that there was also an adjustment to cover the cost of the City's server crashing. Those adjustments brought the projected deficit down significantly.

There was discussion regarding the significant amount of changes that were done after the Finance Committee initially reviewed the proposed budget.

There was a discussion regarding what was causing the deficit. It was discussed that removing the exhaust system could remove the deficit, and that the item could be added back in later with a budget amendment once grant funding was obtained for it.

Mayor Pro Tem Warren expressed concerns and staff provided explanations regarding the Christmas Lighting budget being higher than in the past.

Mayor Pro Tem Warren stated that the City had a healthy fund currently and she didn't want staff and Council to look at that healthy fund as something that could be raided. She stated that funding would not be the same in a few years and the budget needed to reflect what funding would be in the future.

There was discussion to reduce the funding for the Christmas Lighting to \$1,000.

There was discussion regarding the amount of funding projected for the Veteran's Day event.

Mayor Pro Tem Warren expressed concern that there were increases in budget items that were for celebrations, and there was discussion about removing an exhaust system for the fire station to make up for the budget difference.

There was discussion regarding increasing the budget for the contribution to the Lake Elsinore San Jacinto Watershed Authority to \$20,000 in order to have the City making the same contribution as the other members of the Authority.

City Manager Palmer stated that he would contact Mark Norton with LESJWA to see if Mr. Norton was available to make a presentation to the City Council at the July 12, 2017 meeting.

There was discussion regarding the cost of the new vehicle listed in the budget for Code Enforcement, and the vehicle listed in the budget that

AQMD would be covering with a grant. There was additional discussion regarding the rotation of vehicles.

There was discussion regarding the staff positions listed in Code Enforcement and Special Enforcement.

There was discussion regarding cost recovery efforts in the City.

There was additional discussion regarding staffing for Code Enforcement and for staffing the front office.

There was discussion regarding removing the City Clerk position from the budget.

Mayor Pro Tem Warren asked that an Ad Hoc Committee be formed to review the budget issues and to delay approving the budget.

There was discussion regarding the request for the Ad Hoc Committee. It was decided to not delay approval and form an Ad Hoc Committee.

There was additional discussion regarding the changes in the City Clerk staffing, removing the City Clerk position from the budget, giving the title of City Clerk to the City Manager, and promoting Stephanie Hunter to Deputy City Clerk. There was discussion regarding the timing of the switch in the City Clerk position, and what staffing had been reviewed by the Finance Committee.

Mayor Pro Tem Warren stated that she had not had the opportunity to meet with the City Manager to review her concerns about the budget.

There was discussion regarding what was listed on the City Manager's budget for support services.

There was discussion regarding the increase in salary for the Administrative Services Manager and whether or not that person was off of their probationary period.

There was discussion regarding the increase in Public Works service costs.

There was additional discussion regarding the increase in staffing costs for Code/Special Enforcement.

There was discussion regarding furniture in the budget for the employee break room.

There was discussion regarding the increase in costs for landscaping.

There was discussion regarding the changes in the budget and the effect on the deficit.

There was discussion regarding the speed calming signs in the budget.

There was discussion regarding weed abatement issues and how that particular issue was not addressed in the budget. Mayor Bonner expressed concerns about the process that brought about changes in how weed abatement was handled.

Mayor Bonner also expressed concerns about handling Harmful Algae Bloom testing and the potential cost to the City, which was not addressed in the budget.

City Manager Palmer stated that staff was looking at how many lots needed weed abatement and would then be looking at the budget issue.

There was discussion regarding what was happening with weed abatement and what the City's role with weed abatement was. Council Member Greene spoke about his experience with weed abatement issues and the processes and documents that the City needed to have in place before trying to enforce weed abatement.

There was additional discussion on the roles of the POA and the City in weed abatement.

There was discussion regarding the roles of various agencies in testing for harmful/toxic algae in the lake.

Barry Talbot, resident, stated that he sensed a good attitude about trying to keep the budget balanced and asked that the Council consider doing something to build the City's reserves for when the existing Utility Users Tax expires and needs to be renewed. He stated that the way the Council and Staff acted in budgeting would show the citizens whether or not the City could be counted on when asking to renew the Utility Users Tax. He also went on to say that weed abatement and algae testing should have some sort of cost recovery to it so it wouldn't negatively effect the budget. Mr. Talbot spoke about the City's history with the Chamber of Commerce and why the City had stopped contributing to the Chamber. He went on to speak about the projected cost of the car, and the entryway monument on Goetz Road being in Menifee. He asked that those issues be resolved and the City have a balanced budget before approving it.

There was discussion regarding what items could have cost recovery in the future.

Jack Wamsley, resident, spoke about the history of LESJWA and how the cost sharing happened with all of the member agencies. Mr. Wamsley spoke about LESJWA's previous involvement in testing for and treating algae in the lake, and stated that the City should approach LESJWA regarding the issue because the lake was an important drinking water basin. Mr. Wamsley also spoke about the previous process for weed abatement.

Administrative Services Manager Borja clarified that the budget line that he had previously stated was for furniture in the employee break room was actually for the issue with server in addition to the furniture for the employee break room.

Council Member Warren stated that the issue with the server had been budgeted somewhere else and it was still unclear what the budget item was for. Mr. Borja stated that this particular item was for data recovery on the crashed server, in addition to purchasing new equipment to power the servers. Council Member Warren asked that the budget item be moved to the proper place so it was clear what the budget was for.

There was discussion on what changes would be included when the budget was adopted. There was discussion that the exhaust system for the fire station was not a necessity, but would be good to have if a grant could be received. There was additional discussion regarding what other items in the budget were going to be covered with grants.

There was discussion regarding the City Clerk position and whether or not the City Manager could hold both titles.

There was additional discussion regarding the public works budget.

Accountant Shea stated that City staff should be commended for balancing the budget with the biggest costs increasing an average of 14% for the upcoming year.

Moved by Ehrenkranz, seconded by Greene to approve the budget with the proposed changes to lower the Christmas Lighting Event Budget, breaking out the line item in the budget for the server issue to separate it from the break room furniture, to change the description for the "speed study", and to remove the exhaust system for the fire station.

Motion carried 4-0-1 with Council Members Ehrenkranz, Greene, Mayor Pro Tem Warren, and Mayor Bonner voting aye, Council Member Haggerty absent, and Council Member Ehrenkranz abstaining from page 43 of the budget for the Chamber of Commerce

7.2.2 Resolution No. 2017-10, approving the salary and wage schedule for employees of the City for FY 2017-2018

Council Member Ehrenkranz stepped away from the dais at 1:39 p.m.

City Manager Palmer introduced the item and explained that the salaries did not change and the Code Enforcement technician position had been added.

Council Member Ehrenkranz returned to the dais at 1:41 p.m.

Moved by Greene, seconded by Ehrenkranz to approve the resolution at presented.

Motion carried 4-0-1 with Council Members Ehrenkranz, Greene, Mayor Pro Tem Warren, and Mayor Bonner voting aye and Council Member Haggerty absent.

8. Announcements

The next regular City Council meeting was scheduled for August 2, 2017 at 6:30 p.m. For Open Session. There would be an adjourned meeting July 12, 2017 at 6:30 p.m.

9. Closed Session

The City Council recessed to Closed Session at 1:44 p.m.

- A. Closed session pursuant to govt. code section 54957 – Public Employment; Public Employee Evaluation – City Manager
- B. Closed Session with Legal Counsel regarding existing litigation pursuant to Govt. Code Section 54956.9(d)(1): Zaitz v. City of Canyon Lake
- C. Return/Report from closed session

Mayor Pro Tem Warren left the meeting at 2:30 p.m.

The City Council returned from Closed Session at 2:32 p.m. with no reportable action.

10. Adjournment

Mayor Bonner adjourned the meeting at 2:32 p.m.

Respectfully submitted,

Ariel Hall
City Clerk

**MINUTES
REGULAR MEETING OF THE CANYON LAKE
CITY COUNCIL
Wednesday, July 5, 2017**

**City Council Chambers
31516 Railroad Canyon Road
Canyon Lake, CA 92587**

**THE REGULAR MEETING OF THE CITY COUNCIL OF THE CITY OF CANYON LAKE
SCHEDULED FOR JULY 5, 2017 HAD BEEN ADJOURNED FOR LACK OF A QUORUM
AND WAS RESCHEDULED TO WEDNESDAY, JULY 12, 2017.**

Respectfully Submitted,

Stephanie Roseen
Deputy City Clerk

**City of Canyon Lake
City Council
Staff Report**

TO: Honorable Mayor and Respectable Members of the City Council

FROM: Aaron Palmer, City Manager

BY: Stephanie Roseen, Deputy City Clerk

DATE: July 12, 2017

SUBJECT: Approval of Updated 2017 Agency and Committee Assignments and Appointments.

Recommendation

It is recommended that the City Council: Review and approve the updated 2017 Agency and Committee Assignments and Appointments.

Background

At the March 1st 2017 Council Meeting, Council voted to approve the updated 2017 Agency and Committee Assignments and Appointments. The Mayor has since requested to change the Administration, Finance and Planning Committee to reflect Council Member Greene as Chair and Mayor Bonner as Member, Public Safety to reflect Mayor Bonner as Chair and Council Member Greene as Member. Also change the Representative for Riverside County Transportation Commission (RCTC) to reflect Mayor Bonner as the Representative. Representative for the Regional Conservation Authority (RCA) Agency to reflect Council Member Greene and Mayor Pro Tem Warren as the Alternate. Also to reflect Mayor Bonner as Alternate for SCFA – JPA (Animal Services) and Mayor Bonner as the Alternate for Western Riverside Council of Governments (WRCOG.)

The City Clerk’s Department has posted a Form 806, so action may be taken by the entire City Council on the appointments as a whole.

Budget (or Fiscal) Impact

There is no impact.

Attachments

1. Previously adopted Committee Roster **Pg. 58**
2. Proposed Committee Roster **Pg. 60**

2017 Agency and Committee Assignments; and Appointments

Committee	Per Meeting Stipend	Chair	Member	Meeting Date	Time	Place
Administration, Finance and Planning Committee		Greene, Bonner		Tuesday before Regular Council Meeting	8:00 AM	Municipal Building
Public Safety Committee		Bonner, Greene		Last Wednesday of the Month*	9:30 AM	Municipal Building
Public Works Committee		Warren	Ehrenkranz	As Needed		Municipal Building
Water Committee		Warren	Ehrenkranz	Every Other Month as Needed	9:00 AM	Rotate Between City and EVMWD
Veterans Committee		Warren	Ehrenkranz	As Needed		Municipal Building
Econ Dev and Healthy Cities Committee		Warren		As Needed		Municipal Building
Agency		Designee	Alternate	Meeting Date	Time	Place
Lake Elsinore San Jacinto Watersheds Authority (LESJWA)	\$100	Warren	Green	Third Thursday	3:00 PM	EVMWD, 31315 Chaney St, Lake Elsinore
Riverside County Transportation Commission	\$100	Haggerty	Ehrenkranz	Second Wednesday	9:30 AM	4080 Lemon St, Riverside, 1st Floor
Riverside Transit Agency (RTA)	\$150	Haggerty	Bonner	Fourth Thursday	2:00 PM	4080 Lemon St, Riverside, 1st Floor
SCFA - JPA (Animal Friends)	None	Warren		As Needed		33751 Mission Trail, Wildomar
Western Riverside Council of Governments (WRCOG) - Executive Committee	\$150	Ehrenkranz	Warren	First Monday	2:00 PM	4080 Lemon St, Riverside, 1st Floor
Western Riverside County - Regional Conservation Authority (RCA)	\$100	Warren	Bonner	First Monday	1:00 PM	4080 Lemon St., 1st Floor, Riverside
Southwest Cities Coalition		Mayor	Mayor Pro Tem	Quarterly	Lunch	Rotates Cities
League of California Cities		Mayor	Mayor Pro Tem			Rotates Cities
Murrieta/Temecula Group (Open to anyone)		Warren		First Friday	7:30 AM	Varies
Regional Task Force on Health				As Needed		Murrieta City Hall, 1 Town Square, Murrieta
South Coast Air Quality Management District (SCAQMD)		Mayor	Mayor Pro Tem			21865 Copley Drive, Diamond Bar
Northwest Mosquito and Vector Control District	\$100	Ehrenkranz	Greene	Third Thursday	3:00 PM	1966 Compton Ave., Corona
Appointment by Agency		Member	Member	Meeting Date	Time	Place
Public Entity Risk Management Authority		City Manager	Admin Serv Mgr	6 times per year		Rancho Mirage
San Jacinto Valley Environmental Coalition (501C3)		Warren	Bonner			
County Free Library Advisory Committee		Ginger Harris	Sandra Brautigam	Quarterly, Thursdays	10:00 AM	Rotates Riverside County
League of California Cities Riverside Division		Warren				Rotates Cities

2017 Agency and Committee Assignments; and Appointments

Committee	Per Meeting Stipend	Chair	Member	Meeting Date	Time	Place
Agency		Designee	Alternate	Meeting Date	Time	Place
Administration, Finance and Planning Committee		Greene	Bonner	Tuesday before Regular Council Meeting	8:00 AM	Municipal Building
Public Safety Committee		Bonner	Greene	Tuesday before Regular Council Meeting	9:30 AM	Municipal Building
Public Works Committee		Warren	Ehrenkranz	As Needed		Municipal Building
Water Committee		Warren	Ehrenkranz	Quarterly, Third Thursday	9:00 AM	Municipal Building
Veterans Committee		Warren	Ehrenkranz	As Needed		Municipal Building
Agency		Designee	Alternate	Meeting Date	Time	Place
Lake Elsinore San Jacinto Watersheds Authority (LESJWA)	\$100	Warren	Green	Third Thursday	3:00 PM	EVMWD, 31315 Chaney St, Lake Elsinore
Riverside County Transportation Commission	\$100	Bonner	Ehrenkranz	Second Wednesday	9:30 AM	4080 Lemon St, Riverside, 1st Floor
Riverside Transit Agency (RTA)	\$150	Haggerty	Bonner	Fourth Thursday	2:00 PM	4080 Lemon St, Riverside, 1st Floor
SCFA - JPA (Animal Friends)	None	Warren	Bonner	As Needed		33751 Mission Trail, Wildomar
Western Riverside Council of Governments (WRCOG) - Executive Committee	\$150	Ehrenkranz	Bonner	First Monday	2:00 PM	4080 Lemon St, Riverside, 1st Floor
Western Riverside County - Regional Conservation Authority (RCA)	\$100	Greene	Warren	First Monday	1:00 PM	4080 Lemon St., 1st Floor, Riverside
Southwest Cities Coalition		Mayor	Mayor Pro Tem	Quarterly	Lunch	Rotates Cities
League of California Cities		Mayor	Mayor Pro Tem			Rotates Cities
Murrieta/Temecula Group (Open to anyone)		Warren		First Friday	7:30 AM	Varies
Regional Task Force on Health				As Needed		Murrieta City Hall, 1 Town Square, Murrieta
South Coast Air Quality Management District (SCAQMD)		Mayor	Mayor Pro Tem			21865 Copley Drive, Diamond Bar
Northwest Mosquito and Vector Control District	\$100	Ehrenkranz	Greene	Third Thursday	3:00 PM	1966 Compton Ave., Corona
Appointment by Agency		Member	Member	Meeting Date	Time	Place
Public Entity Risk Management Authority		City Manager	Admin Serv Mgr	6 times per year		Rancho Mirage
San Jacinto Valley Environmental Coalition (501C3)		Warren	Bonner			
County Free Library Advisory Committee		Ginger Harris	Sandra Brautigam	Quarterly, Thursdays	10:00 AM	Rotates Riverside County
League of California Cities Riverside Division		Warren				Rotates Cities

**City of Canyon Lake
City Council
Staff Report**

TO: Honorable Mayor and Members of the City Council
FROM: Aaron Palmer, City Manager
DATE: July 12, 2017
SUBJECT: Approval of Resolution 2017-14 Supporting National Parks System

Recommendation

Approval of Resolution 2017-14 supporting the National Parks System.

Background

The Pew Charitable Trust is asking Cities in the 42nd Congressional District to pass a resolution in support of the National Parks Service. The resolution is asking Congress to address the backlogged maintenance issues surrounding the National Parks Service.

Budget (or Fiscal) Impact

None

Attachments

Resolution 2017-14 **Pg. 64**

RESOLUTION NO. 2017-14

**RESOLUTION OF THE CITY COUNCIL OF THE CITY OF CANYON LAKE, CALIFORNIA,
SUPPORT FOR THE NATIONAL PARK SYSTEM**

WHEREAS, America’s National Park System is a living testament to our citizens’ valor, our nation’s hardships, our victories, and our traditions as Americans, and has been called "America’s Best Idea;" and

WHEREAS, the National Park System preserves the diversity, culture, and heritage of all Americans, and serves as a living classroom for future generations; and

WHEREAS, in 2016, the National Park Service is celebrating its centennial and currently manages 410 nationally significant sites and an invaluable collection of more than 75,000 natural and cultural assets that span 84 million acres across all 50 states, the District of Columbia, and several U.S. territories and insular areas; and

WHEREAS, the National Park Service’s mission is to “to conserve the scenery and the natural and historic objects and the wild life therein and to provide for the enjoyment of the same in such manner and by such means as will leave them unimpaired for the enjoyment of future generations;" and

WHEREAS, in 2015, the National Park System had more than 305 million visits; and

WHEREAS, in 2014, National Park Service estimates indicate that park visitors spent more than \$15 billion at the sites and in the states and local communities adjacent to national parks; and

WHEREAS, the National Park Service has the obligation to preserve our nation’s history; promote access to national parks for all citizens; stimulate revenue to sustain itself and nearby communities; educate the public about America’s natural, cultural and historical resources, and provide safe facilities and environs to enjoy these resources; and

WHEREAS, in 2016, the National Park Service estimated a deferred maintenance backlog of nearly \$12 billion, which includes repairs to aging historical structures, trails, sewers, drainage, thousands of miles of roads, bridges, tunnels, and other vital infrastructure; and

WHEREAS, it is the responsibility of Congress to maintain America’s national parks to ensure our natural places and our history is preserved and documented for future generations, and for the adjacent communities that rely on the direct and indirect economic benefits generated by visits to national park sites.

NOW, THEREFORE, BE IT RESOLVED that the City of Canyon Lake strongly encourages Congress to create a reliable, predictable stream of resources to address deferred maintenance needs in America’s National Park System.

PASSED, APPROVED, and ADOPTED on this 12 day of July, 2017.

Randall P. Bonner, Mayor

ATTEST:

Stephanie Roseen
Deputy City Clerk

State of California)
County of Riverside) ss
City of Canyon Lake)

I, Stephanie Roseen, Deputy City Clerk of the City of Canyon Lake, California, do hereby certify that the foregoing is a true and correct copy of the Resolution No. 2017-14 adopted by the City Council of the City of Canyon Lake, California, at an adjourned meeting held on the 12th day of July, 2017, by the following vote:

AYES:

NOES:

ABSTAIN:

ABSENT:

Stephanie Roseen,
Deputy City Clerk

**City of Canyon Lake
City Council
Staff Report**

TO: Honorable Mayor and Members of the City Council
FROM: Aaron Palmer, City Manager
DATE: July 12, 2017
SUBJECT: Approval of Annual Payment to Trauma Intervention Programs (TIP)

Recommendation

Approval of annual payment of \$1,500 to Trauma Intervention Programs (TIP).

Background

Trauma Intervention Programs Inc. (TIP) is a national non-profit organization founded in 1985. TIP has 14 affiliates serving over 250 cities across the nation. Each affiliate uses specially trained citizen volunteers to respond to traumatic incidents to support victims and their families in the first few hours following a tragedy.

The County Chapter of TIP was founded in 1993. There are currently 24 volunteers serving 7 jurisdictions, 5 hospitals, and 5 public safety agencies. The Chapter receives support and guidance from TIP National.

TIP Volunteers are available 24 hours a day, 365 days a year. They are called by police officers, firefighters, paramedics, and hospital personnel to assist family members and friends following a natural or unexpected death; victims of violent crime including rape, assault, robbery, or burglary; victims of fire; disoriented or lonely elderly persons; people involved in motor vehicle accidents; people who are distraught and seeking immediate support; and survivors of suicide.

The City has participated in this program since 2013.

Budget (or Fiscal) Impact

The City's approved budget for FY 2017-2018 has the \$1,500 that was requested by TIP in account 100-6830.

Attachments

Letter from TIP requesting annual funding from the City **Pg. 68**
TIP Invoice **Pg. 70**



Trauma Intervention Programs Inc.

Southwest Riverside County Chapter
Trauma Intervention Programs, Inc.
P.O. Box 585
Murrieta, California 92564-0585
www.tipswrc.org
EIN: 20-5389457

"Citizens helping citizens in crisis"

Board Members

Reginald Wadlington
City of Murrieta Commissioner
Chairman

Chief Scott Ferguson
Murrieta Fire Chief
Vice-Chairman

Kim Cousins
Treasurer
CEO Lake Elsinore Chamber
President and CEO

Jennifer Lee, RN BSN
Secretary
Southwest Healthcare System
Director of Clinical Resource
Project Management

Mike Norkin
Cherished Memories Photography

Gary Brown
City of Wildomar
Planning Commissioner

Mike Lassig
CHP Public Information Officer

Dr. Pranav Kachhi
Temecula Valley Hospital

Tonya Burke
City of Perris Councilwoman

Jonathan Ingram
Mayor Pro Tem
City of Murrieta

June 5, 2017

City Manager Aaron Palmer
City of Canyon Lake
31516 Railroad Canyon Rd
Canyon Lake, CA 92587

Re: Request for Continued Funding for Trauma Intervention Services

Dear Mr. Palmer,

As the city begins to refine its budget projection and expenditures for the upcoming 2017/2018 fiscal year we once again respectfully request the Council's support of our program.

Last year City Council generously provided us \$1,500 in funds, which went directly to Southwest County residents and visitors. As our part of the county continues to grow so does the need for the services our program provides. With the support of your city, the Sheriff's Department, and First Responders throughout Southwest Riverside County we can continue to service the needs of our community.

Recognizing the current economic climate we respectfully request your consideration and support for the same funding level as approved last year.

Should you require any additional information from our program I am happy to make myself available to answer any questions or to address the council directly. Again we appreciate your support in the past and hope we can continue to count on it in the future.

Sincerely,

Magda Stewart

Magda Stewart
CEO

Cc: Mayor and City Council



Trauma Intervention Programs
Southwest Riverside County
PO Box 585
Murrieta, CA 92564
Phone: 951-698-2453
Fax: 866-304-2141
Non-Profit EIN: 20-5389457

July 6, 2017

To:

City of Canyon Lake
31516 Railroad Canyon Rd.
Canyon Lake, CA 92587
Attn: Aaron Palmer

From:

Trauma Intervention Programs (TIP)
Southwest Riverside County
Magda Stewart

INVOICE# CL2017-18

Annual Services

Assisting the on scene First Responders by providing emotional support and trauma services to the survivors and families involved with Traumatic Events.

\$1,500

**City of Canyon Lake
City Council
Staff Report**

TO: Honorable Mayor and Members of the City Council
FROM: Aaron Palmer, City Manager
DATE: July 12, 2017
SUBJECT: Presentation, Discussion and Possible Direction given
Regarding City's Annual Fee to LESJWA

Recommendation

Discussion and possible direction from the City Council regarding the City's annual fee to Lake Elsinore San Jacinto Watershed Authority (LESJWA).

Background

The Lake Elsinore and San Jacinto Watershed covers over 720 square miles, starting in the San Jacinto Mountains, running westerly through Canyon Lake and ending in Lake Elsinore. Therefore, this makes the City of Canyon Lake a stakeholder. Currently, the City's annual membership fee is ten thousand dollars (\$10,000). LESJWA has asked Canyon Lake to increase their annual membership fee to twenty thousand dollars (\$20,000).

Budget (or Fiscal) Impact

The City's approved budget for FY 2017-2018 has the \$10,000 annual membership fee for LESJWA in account 515-6520. If the City Council decides to increase their annual membership fee to \$20,000, the City will have to take the additional \$10,000 from reserves.

Attachments

None

**City of Canyon Lake
City Council
Staff Report**

TO: Honorable Mayor and Members of the City Council

FROM: Aaron Palmer, City Manager

BY: Margaret Monson, Associate Engineer

DATE: July 12, 2017

SUBJECT: Landscape Plant Replacement

Recommendation

That the City Council:

1. Review the existing Landscape Planting Plans and the Proposed Shrub Replacement Plans; and
2. Direct staff as appropriate regarding the quantity and variety of planting; and
3. Authorize staff to prepare bid package and advertise for installation of Proposed Shrub Replacement, as directed.

Background

The City of Canyon Lake widened Railroad Canyon Road in 2012 and installed planting based on landscape plans approved by City Council as a part of the entire road widening project. The 2012 contracted landscape company installed the plants and were also contracted to maintain the planting for one year following the acceptance of installation, however, the contractor abandoned the project. The City received a settlement agreement for the replacement of plants that had died as a result.

The City Manager directed engineering staff to begin with tree replacements starting February 2016. Charles Abbott Associates' Landscape Architect and Certified Arborist, Steve Frenken, conducted a tree survey for health and maintenance, completed in July 2016. This resulted in scheduling for tree trimming in the dormant growth season and occurred in March 2017. Steve Frenken reviewed the existing 2012 planting plans, inspected the entirety of Railroad Canyon Road, prepared replacement tree planting plans based on the State water conservation ordinance requiring drought tolerant planting in municipal applications. He met with the City's contract landscape maintenance company, CTAI, who completed the tree replacement installation in December 2016. This was following the numerous, required repairs and replacements to the existing irrigation and lighting systems.

Steve Frenken will present the Proposed Shrub Replacement Plans here today to assist the Council in directing staff regarding the planting replacement.

Fiscal Impact

Proposed Plant Replacement, at the same quantity level as specified on the existing plans, where plant death has occurred, is as specified on the estimate prepared by Steve Frenken using the unit prices agreed to by contract with CTAI Pacific Greenscape, Inc., the City's contract landscape maintenance company. See the attached estimate.

Staff is requesting direction relating to the quantity of plant replacement. If preferred, staff will revise the plans and estimate to the quantity level the Council determines. Staff is also requesting direction in advertising for public bidding outside of the Council authorized landscape maintenance contract under the supervision of Public Works or as bid by the landscape maintenance contractors in the up-coming landscape maintenance contract.

Attachments

Existing Planting Plans **Pg. 76**
Proposed Planting Plans **Pg. 85**
Planting Estimate **Pg. 96**

EXISTING PLANTING PLANS

CITY OF CANYON LAKE

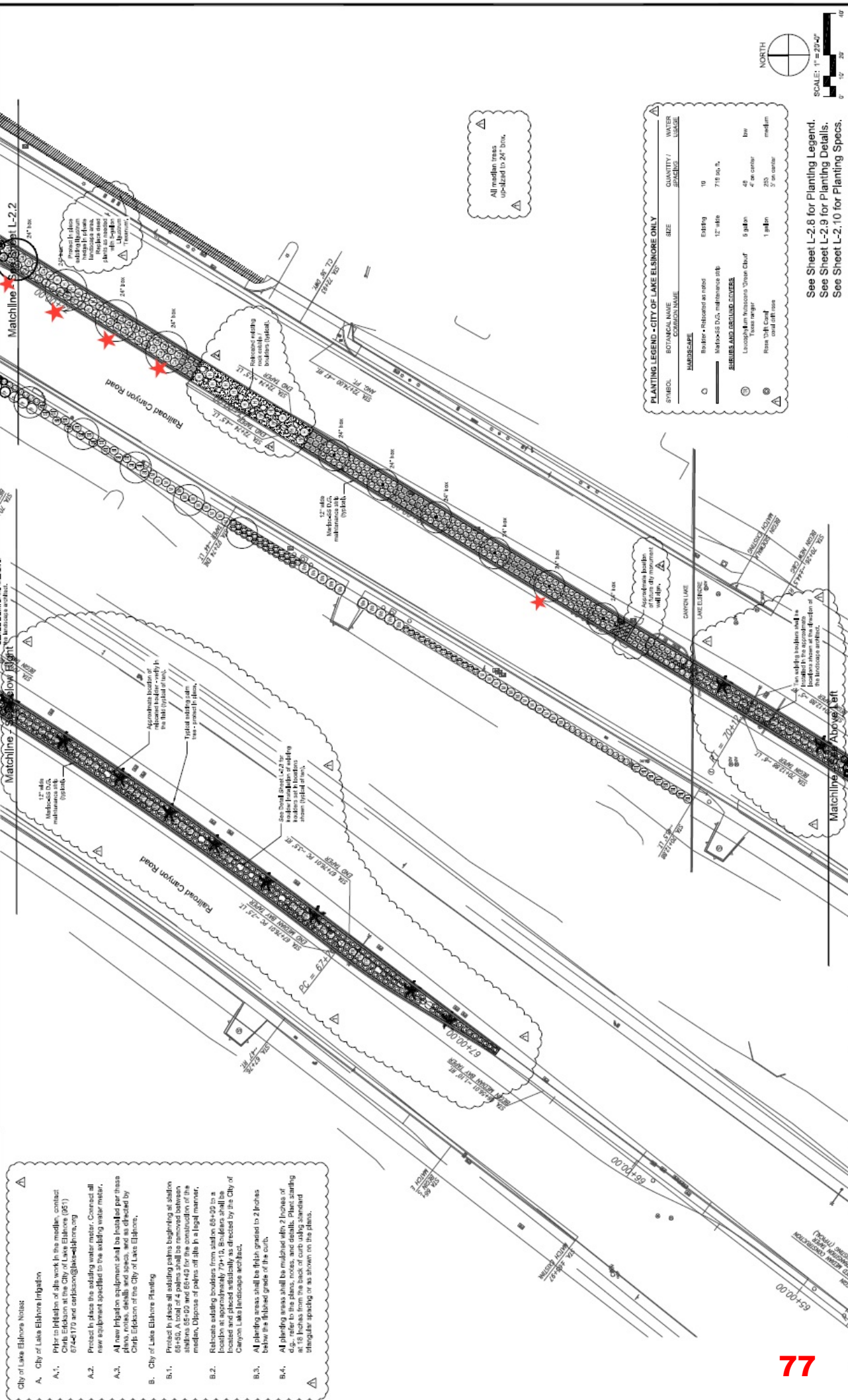

- City of Lake Elsinore Notes**
- A. City of Lake Elsinore Irrigation
 - A.1. Riprap installation at site work in the median, contact City of Lake Elsinore Irrigation Department (951) 674-6170 and carlson@lakeelsinore.org
 - A.2. Protect in place the existing water meter. Connect all new equipment specified to the existing water meter.
 - A.3. All new irrigation equipment shall be installed per these plans, notes, details and specs, and as directed by Chris Erickson of the City of Lake Elsinore.
 - B. City of Lake Elsinore Planting
 - B.1. Protect in place all existing palms beginning at station 68+50. A total of 4 palms shall be removed between station 65+00 and 68+40 for the construction of the median. Dispose of palms off site in a legal manner.
 - B.2. Retain existing bougainvillea from station 68+00 to a location at approximately 70+10. Bougainvillea shall be located and placed artistically as directed by the City of Canyon Lake landscape architect.
 - B.3. All planting areas shall be fully graded to 2 inches below the finished grade of the curb.
 - B.4. All planting areas shall be mulched with 2 inches of d.g., refer to the plans, notes, and details. Plant staking at 18 inches from the back of curb using standard triangular spacing or as shown on the plans.

All median trees updated to 24" box.

PLANTING LEGEND - CITY OF LAKE ELSINORE ONLY

SYMBOL	BOTANICAL NAME / COMMON NAME	SIZE	QUANTITY / SPACING	WATER USAGE
○	Red Pine • Retained as noted	Existing	10	
○	Manzanita • 65 D.C. maintenance tree	12" W.B.	718 sq. ft.	
○	SHRUBS AND GROUND COVERS			
○	Leucophyllum frutescens • Orange Churn	5 palm	48	low
○	Yucca angustifolia	1 palm	255	0 to none
○	Rose of Sharon	1 palm	255	0 to none
○	Calliandra	1 palm	255	0 to none

See Sheet L-2.8 for Planting Legend.
See Sheet L-2.9 for Planting Details.
See Sheet L-2, 10 for Planting Specs.

CITY OF CANYON LAKE, CALIFORNIA
RAILROAD CANYON ROAD
 WIDENING PROJECT
Landscape Plans
 Planting Plan

LAURIE LEVINE
 Landscape Architect
 17003 Boca Vista Circle
 Menlo Park, CA 94025
 Phone (951) 696-0122
 Fax (951) 696-0185
 laurielevine@earthlink.net

APPROVED BY: _____ DATE: _____
FOR ENGINEER: _____
 SCALE: **BENCHMARK** ELEV. = 443.05
 1" = 20'-0"
 DATE: 7/23/11

REVISIONS:

NO.	DATE	DESCRIPTION
1	11/19/12	Added Lake Elsinore / Misc. Site Changes
2	11/19/12	Additional Site Changes

DIG ALERT
 DIAL TOLL FREE
 1-800-227-2800
 48 HOURS PER DAY
 24 HOURS PER YEAR

77

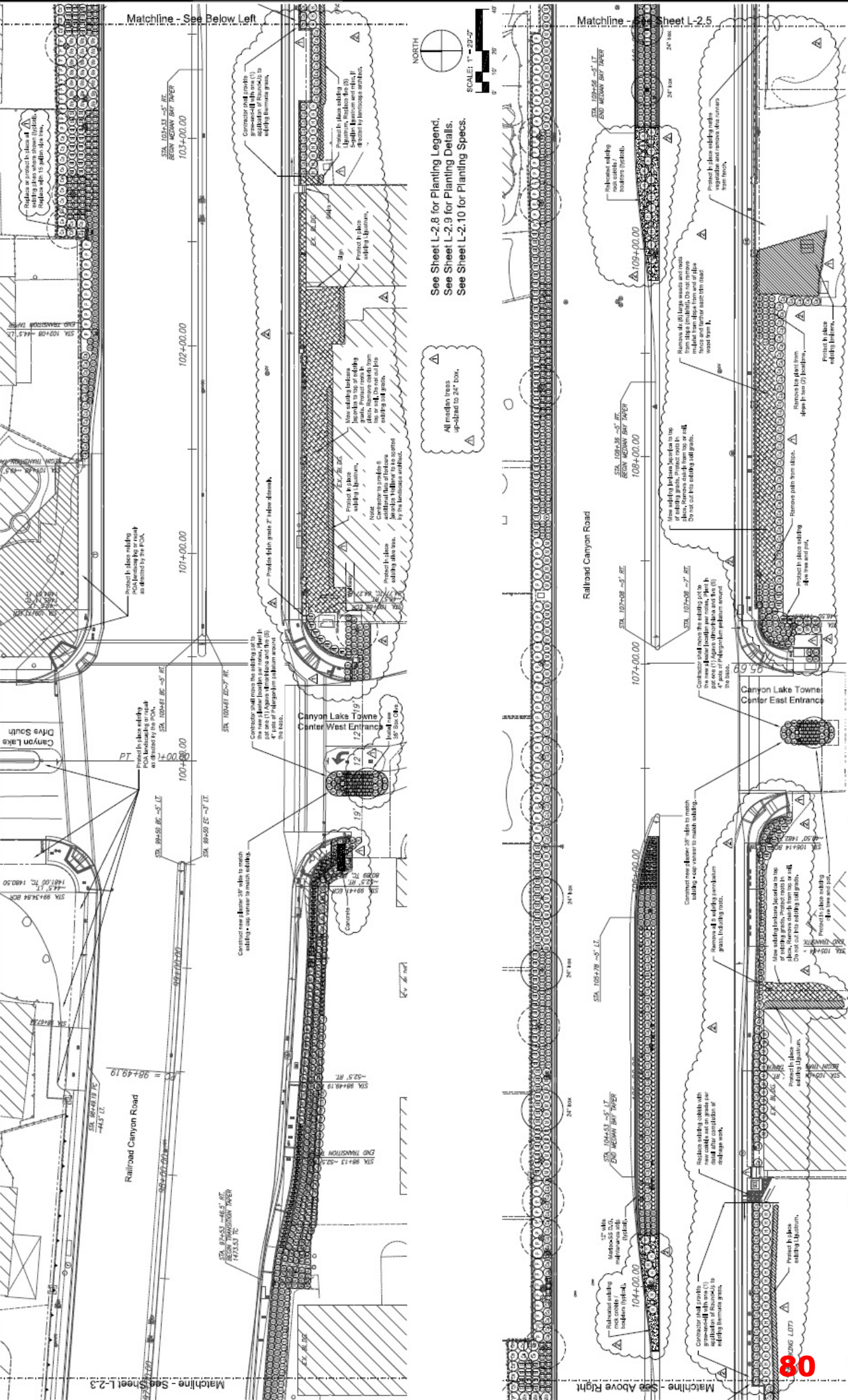

See Sheet L-2.8 for Planting Legend.
 See Sheet L-2.9 for Planting Details.
 See Sheet L-2.10 for Planting Specs.

All median trees
 specified to 24" DIA.

NOI, BIDDING AND INVESTIGATION CLARIS Contractor agrees to assume full responsibility for the job site conditions during the course of the construction of this project, including safety of all workers and the public. The contractor shall be responsible for obtaining all necessary permits, and for the safety of all workers and the public. The contractor shall be responsible for the safety of all workers and the public. The contractor shall be responsible for the safety of all workers and the public.		DIG ALERT DIAL TOLL FREE 1-800-227-2600 AT LEAST 72 HRS BEFORE ANY DIGGING		UNDESIGNED SERVICE ALERT OR SOUTHWEST CALIFORNIA (DESIGNED BY: L.L./J.L.C. DRAWN BY: J.L.C. CHECKED BY: L.L./J.L.C.)	
APPROVED BY: DATE: 7/13/11 SCALE: 1" = 20'-0" BENCHMARK: ELEV = 483.05 CITY OF CANYON LAKE CIVIL ENGINEER		SEAL: CIVIL ENGINEER J.L. CROOK 10/15/12		ADDITIONAL: DATE: 11/15/12 APPRO. DATE: 11/15/12 REVISIONS:	
LAURIE LEVINE Landscape Architect 37803 Bean View Circle Murietta, CA 92562 phone (951) 694-0122 fax (951) 694-0105 laurielevine@comcast.net		CITY OF CANYON LAKE W.G. CL-009 CL-009 OF 34 SHEETS FILE NO. 971071		CITY OF CANYON LAKE, CALIFORNIA RAILROAD CANYON ROAD WIDENING PROJECT Landscape Plans Planting Plan L-2.4	

80

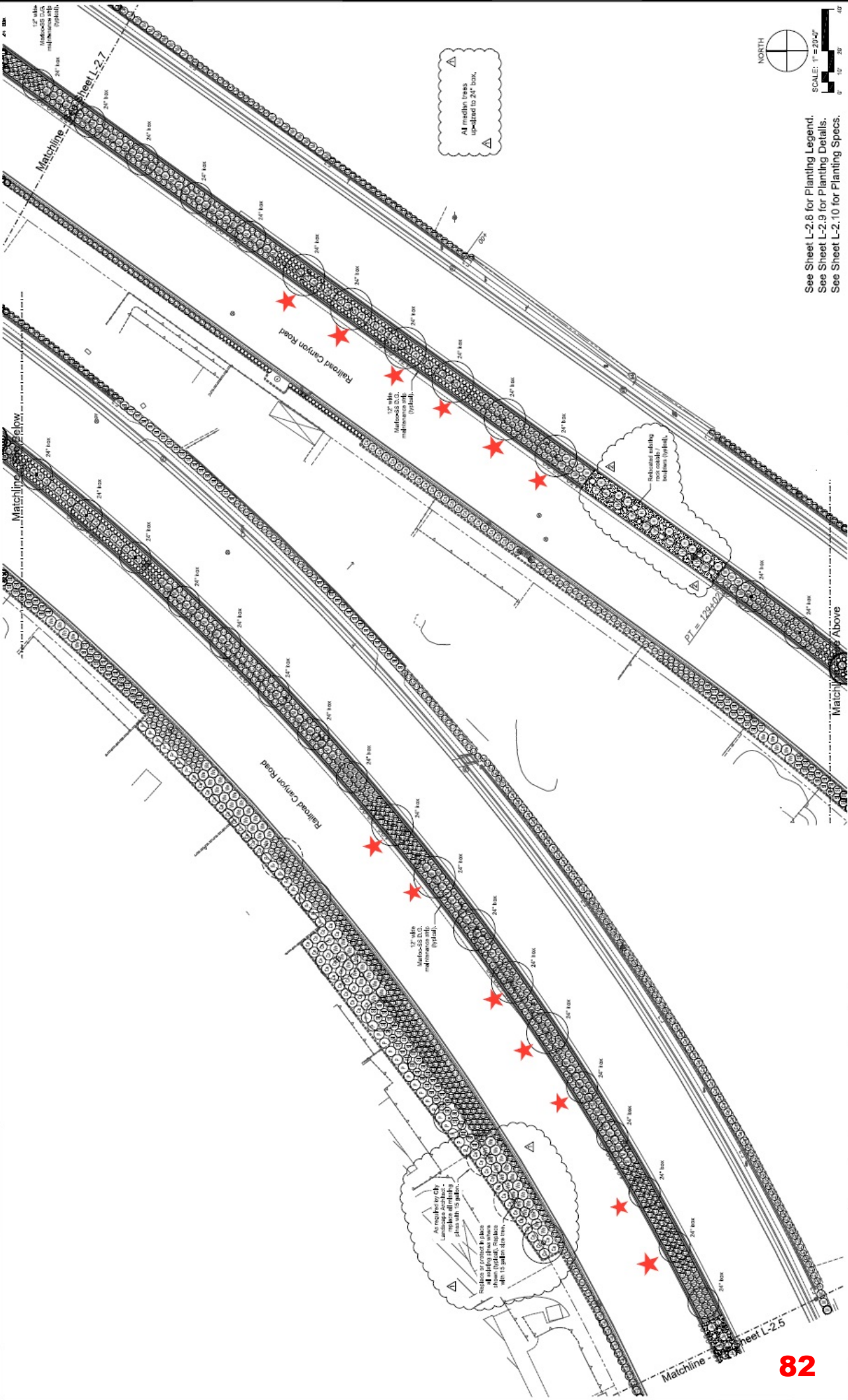

See Sheet L-2.8 for Planting Legend.
 See Sheet L-2.9 for Planting Details.
 See Sheet L-2.10 for Planting Specs.

CITY OF CANYON LAKE, CALIFORNIA
RAILROAD CANYON ROAD
 WIDENING PROJECT
 Landscape Plans
 Planting Plan

FWP: CITY OF CANYON LAKE W.C. CL-009
 SHEET NO. **L-2.6**
 OF 34 SHEETS
 FILE NO. CL-009
 7/11/11

Laurie Levine
 Landscape Architect
 37803 Ross View Circle
 Murietta, CA 95662
 phone (951) 694-0122
 fax (951) 694-0105
 laurielevine@comcast.net

APPROVED BY: _____ DATE: _____
 CITY ENGINEER: _____
 SCALE NO. 35183
 SCALE 1" = 20' 0"
 DATE 7/13/11

LOGSHEET NO. _____
 SHEET NO. _____
 DATE 7/13/11

DATE	APPROVED BY	REVISIONS
10/12/12	DR. L.L./J.L.C.	ADJUSTED
11/15/12	DR. L.L./J.L.C.	ADJUSTED

DIG ALERT
 DIAL TOLL FREE
 1-800-227-2600
 AT LEAST 720 HRS
 BEFORE YOU DIG

UNIVERSITY SERVICE ALERT OF SOUTHERN CALIFORNIA

HOLD HARMLESS AND INDEMNIFICATION CLAUSES
 Contractor agrees to assume full responsibility for the job site conditions and the consequences of this project, including safety of all workers and the public. The City and County of Canyon Lake, California, its officers, employees, and the City and County of Canyon Lake shall not be held liable for any damages, claims, or expenses incurred in connection with the project, except to the extent that such damages, claims, or expenses are caused by the negligence of the City or the County of Canyon Lake.

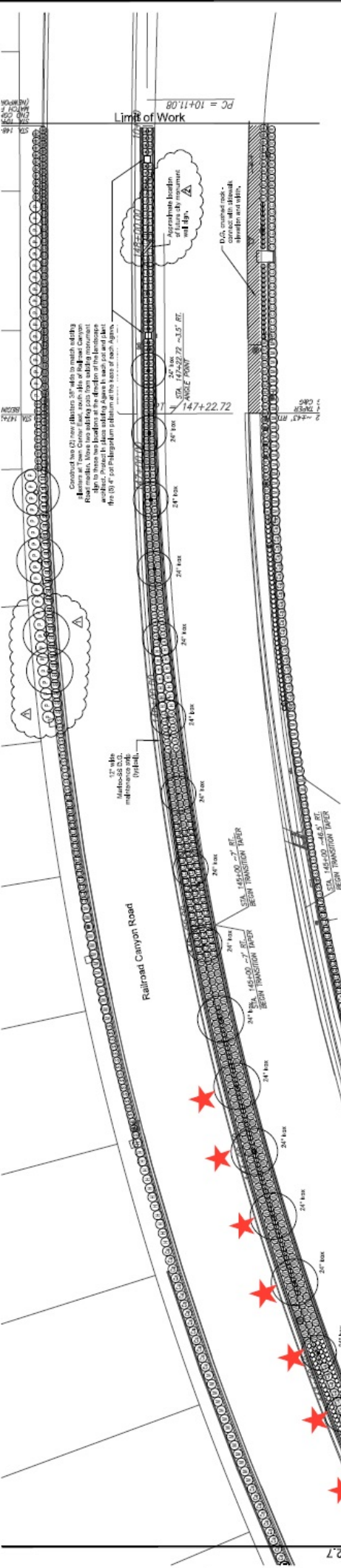

PLANTING LEGEND

SYMBOL	BOTANICAL NAME / COMMON NAME	SIZE	QUANTITY / SPACING	WATER USAGE
⊙	Dalea bicolor ssp. conf. / Golden Dalea	1 gallon	200	low
⊙	Callisiphon utriusque / Dyer's Bushclover	5 gallon	840	low
⊙	Ceanothus 'Coville' / California Blue	5 gallon	108	low
⊙	Coryphantha mollis / Dumbbells	1 gallon	648	low
⊙	Clusia x palmeriana 'Sunset' / Magnolia Redrope	1 gallon	1025	low
⊙	Gaura 'Nimbus Falls' PKC / Gaura	1 gallon	324	medium
⊙	Hesperandor caniflorus / Red Yucca	1 gallon	256	low
⊙	Urmonium parvifolium / Sea Lavender	1 gallon	678	medium
⊙	Mertensia 'Mentocor' / Blue Star	1 gallon	1798	low
⊙	Muhlenbergia ssp. 'Black Royal Hair' / Regal Hair-Pink Moth	1 gallon	753	low
⊙	Phacelia arbutifolia / Phacelia	1 gallon	81	medium
⊙	Penstemon 'Mariana Blight N Tiger' / Light N Tiger Corolla Larkspur	5 gallon	328	low
⊙	Rosa 'Duff Red' / Duff Rose	1 gallon	1384	medium
⊙	Rosa 'Duff White' / Duff Rose	1 gallon	504	medium
⊙	Rosa 'White Snow Rose' / White Snow Rose	5 gallon	16	medium
⊙	Sedum 'gracile' 'Fernando's Reef' / Fernando's Reef	1 gallon	1032	low
⊙	Sedum 'Innocent' 'Suzanne Barkley' / Suzanne Barkley	1 gallon	528	low
⊙	Westringera 'Eubonia Wandell' / Low Coast Rosemary	1 gallon	178	low
▲	Monardella unguiculata / Cutsicle	5 gallon	63	low

PLANTING LEGEND

SYMBOL	BOTANICAL NAME / COMMON NAME	SIZE	QUANTITY / SPACING	WATER USAGE
▲	Arctostaphylos 'Marquez' / Strawberry Tree	15 gallon	5	low
●	Cercis ssp. 'Redwood' / Redwood Redbud	15 gallon	16	low
■	Lagerströmia indica 'Dynamite' / Crown of Thorns	24" box	48	low
○	Citrus aurantium / Citrus	36" box	1	low
⊙	Phlox subulata 'Mantilla Pink' / Mantilla Pink	15 gallon	3	low
⊙	Red-tipped Yucca (Plant reduced on the street to be 24" tall.)	15 gallon	18	low
○	Bradford Pear	12" x 48"	6,795 sq. ft.	low

All median trees upsized to 24" box.

See Sheet L-2.8 for Planting Legend.
See Sheet L-2.9 for Planting Details.
See Sheet L-2.10 for Planting Specs.

CITY OF CANYON LAKE, CALIFORNIA
RAILROAD CANYON ROAD
 WIDENING PROJECT
 Landscape Plans
 Planting Plan

Laurie Levine
 Landscape Architect
 371931 Beat Vista Court
 Murietta, CA 92562
 phone: (951) 694-0122
 fax: (951) 694-0105
 laurielevine@verizon.net

APPROVED BY: DATE: 7/13/11
SEAL: REGISTERED PROFESSIONAL ENGINEER IN THE STATE OF CALIFORNIA
 No. 0119
 EXPIRES 6/30/12

DIG ALERT:
 DIAL TOLL FREE
 1-800-227-2600
 AT LEAST TWO DAYS BEFORE YOU DIG
 UNDESIRABLE SERVICE ALERT OF SANJUAN CALIFORNIA

NO. 2 UNDESIRABLE SERVICE ALERT:
 CONTRACTOR agrees to assume sole responsibility for the job site conditions and to be responsible for the safety of the public and the contractor's employees. We shall be held liable for any and all damages, including but not limited to, property damage, personal injury, and death, resulting from any and all accidents, incidents, or events occurring on the job site, whether or not caused in whole or in part by the contractor's negligence or the City of San Juan, California.

10/12/12 Add Job Elevation / Misc. Site Changes
11/15/12 Additional Site Changes

DATE: **MARK:** **APPR. DATE:**
APPROVE: **REVISIONS:** **CHECKED BY:** L.L./J.L.C. **DRAWN BY:** J.L.C.

SCALE: 1" = 20'-0"
BENCHMARK: DEVI = 483.05
 6.56' (10' 5" 1/2") TO CORNER OF RAILROAD CANYON ROAD AND CANYON LAKE DRIVE
DATE: 7/13/11 **DATE:** 7/13/11 **DATE:** 7/13/11

FILE NO.: CL-009
SHEET NO.: L-2.8
 OF 34 SHEETS

84

PROPOSED PLANTING PLANS

CITY OF CANYON LAKE

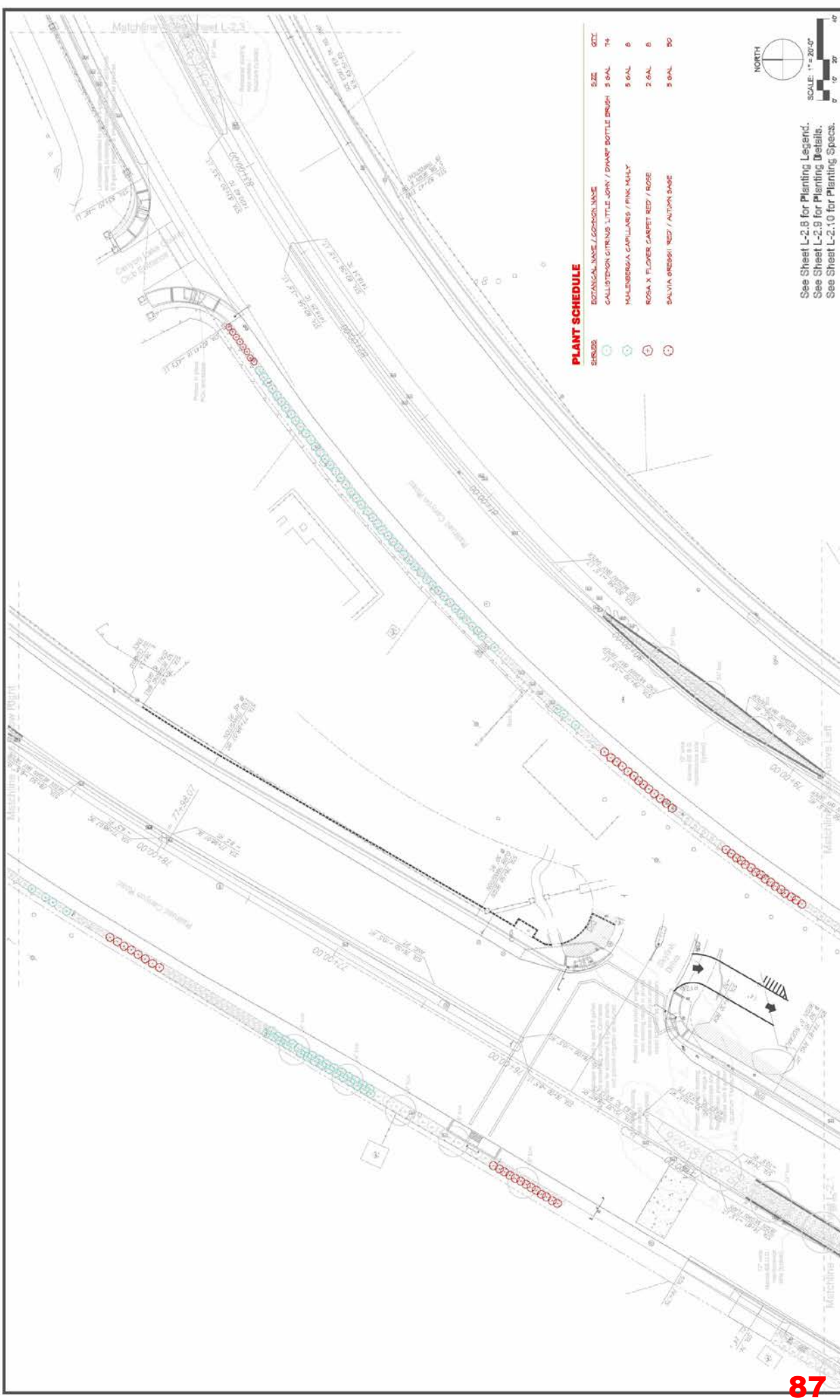

PLANT SCHEDULE

SYMBOL	BOTANICAL NAME / COMMON NAME	SIZE	QTY
	CALLISTEMON CITRINUS / LITTLE JOHN / DWARF BOTTLE BRUSH	3 GAL	74
	HALENDERA CAPILLARIS / PINK MARY	3 GAL	6
	ROSA X FLORES CARPET RED / ROSE	2 GAL	6
	SALVIA GRESCHII RED / AUTUMN BAZE	3 GAL	30



See Sheet L-2.8 for Planting Legend.
 See Sheet L-2.9 for Planting Details.
 See Sheet L-2.10 for Planting Specs.

CITY of CANYON LAKE	SHEET NO.
RAILROAD CANYON ROAD	L-2.2
PLANT REPLACEMENT	OF 11 SHEETS
PLANTING PLAN	FILE NO.
CITY of CANYON LAKE, R.G.	

APPROVED BY:	DATE:	ACCEPTED:	DATE:
FILE NO.	CITY ENGINEER	FILE NO.	CITY ENGINEER
SCALE	BENCHMARK	ELV. = 1483.09	DN
DATE	DATE	1-15-10 (CITY OF CANYON LAKE) BENCHMARK	DATE
		TRANS 503 S E 1/4 CORNER	

DATE	APPROVAL DATE	CITY
ARCHITECT	CHECKED BY	
DESIGNED BY		

DIS ALERT
 DIAL TOLL FREE
 1-800-227-2500
 ARCHITECT: [Signature]
 DESIGNER: [Signature]

NO OBSTRUCTION
 UNDERGROUND SERVICE ALERT OF SOUTHWEST CALIFORNIA

THE ENGINEER HAS BEEN INFORMED THAT THE CONTRACTOR SHALL BE RESPONSIBLE FOR THE PROTECTION OF ALL UTILITIES AND STRUCTURES LOCATED ON THE PROJECT. THE CONTRACTOR SHALL BE RESPONSIBLE FOR THE PROTECTION OF ALL UTILITIES AND STRUCTURES LOCATED ON THE PROJECT. THE CONTRACTOR SHALL BE RESPONSIBLE FOR THE PROTECTION OF ALL UTILITIES AND STRUCTURES LOCATED ON THE PROJECT.

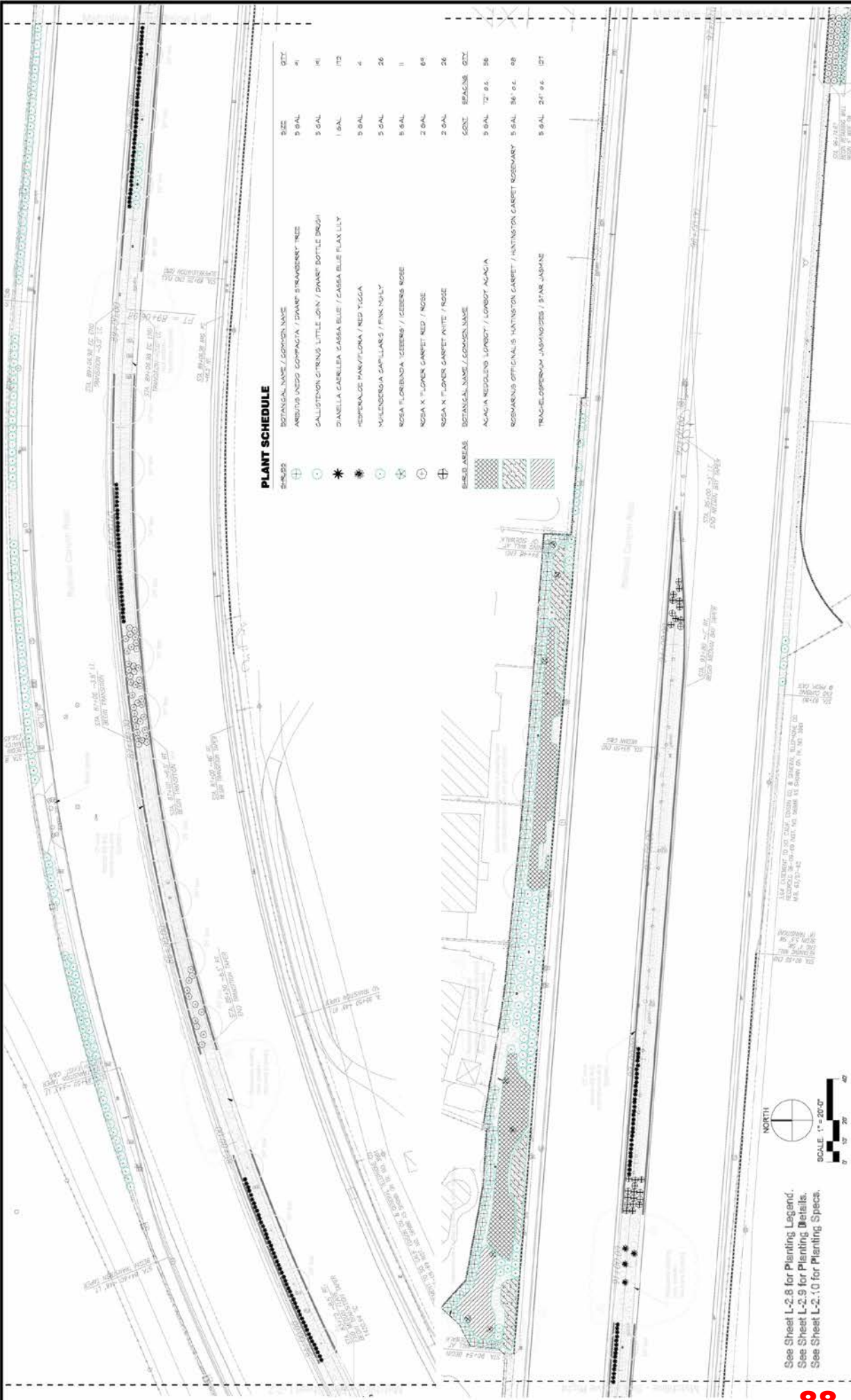

PLANT SCHEDULE

SYMBOL	BOTANICAL NAME / COMMON NAME	SIZE	QTY
⊕	ARJUNUS UNDO COPAQUA / DWARF SPANANEM* TREE	5 GAL	4
⊙	GALLIUM CRINUS LITTLE JOIN / DWARF BOTTLE BRUSH	5 GAL	161
✱	DANELLA CABELLA CARBA BLUE / CARBA BLUE FLX LILY	1 GAL	173
✱	HEPERANGE PAN/FLOKA / RED YUCCA	5 GAL	4
⊙	MALDENBIA CAPITILLAS / PINK NOLLY	5 GAL	26
⊙	ROSA T. LOREANDA / GREENS ROSE	5 GAL	11
⊙	NOSSA X *LOWER CARPET NITE / ROSE	2 GAL	84
⊕	NOSSA X *LOWER CARPET NITE / ROSE	2 GAL	26
BASIC AREAS			
[Cross-hatch pattern]	BOTANICAL NAME / COMMON NAME	SIZE	SPACING QTY
[Cross-hatch pattern]	ACACIA NEDELOD LONGOCT / LONGOCT ACACIA	5 GAL	72 5'x 5'
[Cross-hatch pattern]	ROSMARINUS OFFICINALIS HANTINGTON CARPET / HANTINGTON CARPET ROSEMARY	5 GAL	30' 5'x 5'
[Cross-hatch pattern]	TRACHYLOPERGON LANGSHANDES / STAR JASMINE	5 GAL	24' 5'x 5'

See Sheet L-2.8 for Planting Legend.
 See Sheet L-2.9 for Planting Details.
 See Sheet L-2.10 for Planting Specs.



HOURLY RATES AND INFORMATION CAUTION:
 The City of Canyon Lake is not responsible for the accuracy of the information provided in this plan. The City of Canyon Lake is not responsible for the accuracy of the information provided in this plan. The City of Canyon Lake is not responsible for the accuracy of the information provided in this plan.

SHEET NO. **L-2.3**
 OF 11 SHEETS
 FILE NO. _____

CITY of CANYON LAKE
RAILROAD CANYON ROAD
PLANT REPLACEMENT
PLANTING PLAN
 CITY of CANYON LAKE, R.G.

APPROVED BY: _____ DATE: _____
 CITY ENGINEER

ACCEPTED: _____ DATE: _____

SCALE: 1"=20'-0"

DATE: 06/09/2017
 ARCHITECT: [Signature]
 CHECKED: [Signature]

DIS ALERT
 0941 TOLL FREE
 1-800-227-2600
 4800 N. 100th St.
 SUITE 200
 EDWARDS, CALIFORNIA 92627

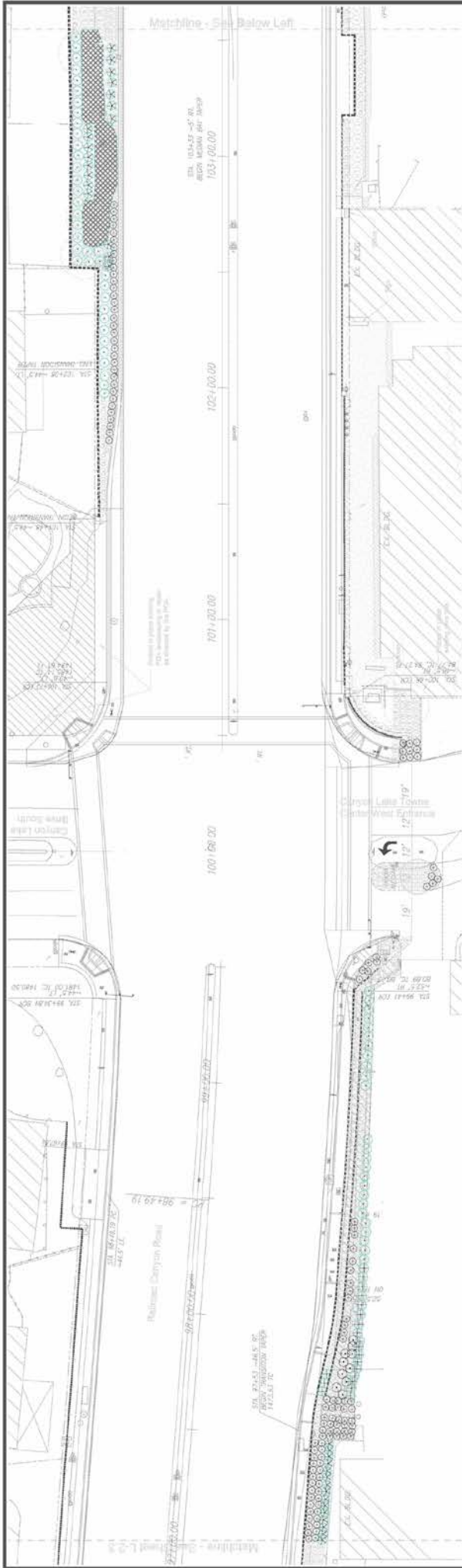

See Sheet L-2.8 for Planting Legend.
 See Sheet L-2.8 for Planting Details.
 See Sheet L-2.10 for Planting Specs.

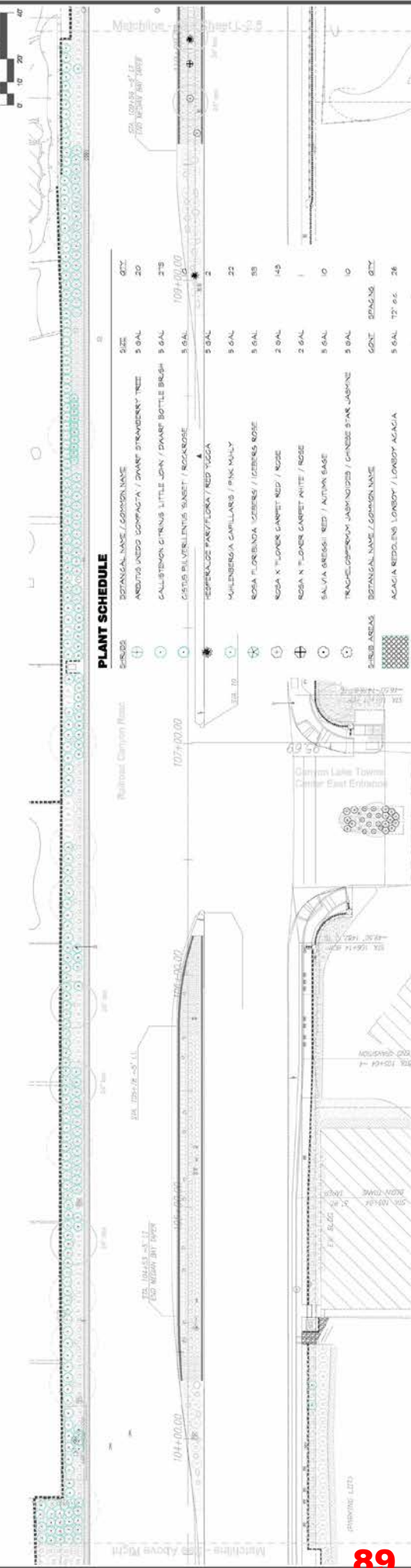

PLANT SCHEDULE

SYMBOL	BOTANICAL NAME / COMMON NAME	SIZE	QTY
①	ANDROMEDA DORRICA / DWARF STAMBECK TREE	5 GAL	20
②	CALLISTEMON CITRINUS LITTLE SPK / DWARF BOTTLE BRUSH	5 GAL	25
③	CISTUS PALMERIUS SANIT / ROCK ROSE	5 GAL	10
④	ESPERANZA PINK / FLOKA / RED YUCCA	5 GAL	2
⑤	MALENESSA CAPILLARIS / PINK MULLY	5 GAL	22
⑥	ROSA FLORINDA / GREENS / ICEBERG ROSE	5 GAL	35
⑦	ROSA X T-LONER CARPET RED / ROSE	2 GAL	145
⑧	ROSA X T-LONER CARPET WHITE / ROSE	2 GAL	1
⑨	SALVA GREGGII RED / AUTUMN SAGE	5 GAL	10
⑩	TRICHOLOPERON JASMINOIDES / CHINESE STAR JASMINE	5 GAL	10
⑪	BOTANICAL NAME / COMMON NAME	60% SPACING	QTY
⑫	ACACIA REDOLENS LONSOBY / LONSOBY ACACIA	5 GAL	127 @ 6. 26

NO STOPPING OR PARKING

NOIS ALERT
 DIAL TOLL FREE
 1-800-227-2600
 9:00 AM - 5:00 PM

HOURLY SERVICE INFORMATION CALL:
 For more information on the project, including the location of the project, the schedule of the project, and the location of the project, please call the City and County of Southern California at 1-800-227-2600. The City and County of Southern California is not responsible for the performance of any contractor or subcontractor on the project, nor for the accuracy of any information provided by any contractor or subcontractor. The City and County of Southern California is not responsible for the performance of any contractor or subcontractor on the project, nor for the accuracy of any information provided by any contractor or subcontractor.

APPROVED BY: CITY ENGINEER
DATE: 3/15/2017

SCALE: 1" = 20'0"

PROJECT: RAILROAD CANYON ROAD
DATE: 3/15/2017

CITY: CITY OF CANYON LAKE
PROJECT: RAILROAD CANYON ROAD
DATE: 3/15/2017

PROJECT: RAILROAD CANYON ROAD
DATE: 3/15/2017

PROJECT: RAILROAD CANYON ROAD
DATE: 3/15/2017



See Sheet L-2.8 for Planting Legend.
 See Sheet L-2.9 for Planting Details.
 See Sheet L-2.10 for Planting Specs.

PLANT SCHEDULE

SYMBOL	BOTANICAL NAME / COMMON NAME	SIZE	QTY
+	BETANICAL NAME / COMMON NAME	5 GAL	62
○	ANDRIS LINDO COPACASTA / DWARF STRAWBERRY TREE	5 GAL	24
○	SALLUSTION CITRINUS LITTLE JOHN / DWARF BOTTLE BRUSH	5 GAL	5
○	CISTUS PULVERULENTUS SUNSET / ROCKROSE	5 GAL	12
*	DIANELLA CADRELLA CASSA BLUE / CASSA BLUE FLAX LILY	1 GAL	2
○	HEPSTRALOE PARVIFLORA / RED YUCCA	1 GAL	25
○	LYNCHUM FERREI / STAVE	5 GAL	71
○	MALENSINGIA CAPILLARIS / PINK MILLY	2 GAL	22
○	ROSA X FLOWER CARPET RED / ROSE	2 GAL	39
○	ROSA X FLOWER CARPET WHITE / ROSE	5 GAL	21
○	SALVIA BRUNSA / RED / AUTUMN SAGE	5 GAL	30
○	MYRTINARIA FRUTICOSA / COAST ROSEMARY		

DIS ALERT
 DIAL TOLL FREE
 1-800-227-2600
 ARCHITECT
 1680P
 DATE

APPROVED BY: _____ DATE: _____
 CITY ENGINEER
 BENCHMARK: ELEV. = 1483.09
 1-16-70 (CITY OF CANYON LAKE) BUILDING DEPARTMENT
 5/19/2007 DATE

DRAWN BY: SP
 CHECKED BY: SP

ACCEPTED
 DATE: _____
 BY: _____
 DATE: _____

CITY OF CANYON LAKE
RAILROADS CANYON ROAD L-2.5
 PLANT REPLACEMENT
 PLANTING PLAN
 CITY OF CANYON LAKE, R.C.

HOLD THESE PLANS AND INFORMATION CLAUSE:
 THE CONTRACTOR SHALL BE RESPONSIBLE FOR OBTAINING ALL NECESSARY PERMITS AND APPROVALS FROM ALL AFFECTED AGENCIES AND AGENCIES INVOLVED IN THE PROJECT. THE CONTRACTOR SHALL BE RESPONSIBLE FOR OBTAINING ALL NECESSARY PERMITS AND APPROVALS FROM ALL AFFECTED AGENCIES AND AGENCIES INVOLVED IN THE PROJECT. THE CONTRACTOR SHALL BE RESPONSIBLE FOR OBTAINING ALL NECESSARY PERMITS AND APPROVALS FROM ALL AFFECTED AGENCIES AND AGENCIES INVOLVED IN THE PROJECT.

PLANT SCHEDULE

SYMBOL	BOTANICAL NAME / COMMON NAME	SIZE	QTY
⊕	ANUBIS UNDO COPPACTA / DWARF STAMBERY TREE	5 GAL	12
⊙	CALLISTEMON CITRINUS LITTLE JOHN / DWARF BOTTLE BRUSH	5 GAL	46
⊙	CISTIS PALMERIENSIS WARET / ROSEBUSH	5 GAL	28
*	DIANELLA GARRULEA DASSA BLUE / CASSIA BLUE FLAX LILY	1 GAL	11
⊙	HEPESALZE PINK/FLORA / RED YOGA	5 GAL	4
⊙	LIMONUM PEREZI / STATICE	1 GAL	14
⊙	MANFRIDA X BLOODSPOT / BLOODSPOT MANGAVE	1 GAL	7
⊙	MALINDOGA CAPILLARE / PINK MILLY	5 GAL	64
⊙	ROSA X FLOWER CARPET RED / ROSE	5 GAL	18
⊙	SALVIA GRESEI RED / AUTUMN SHADE	5 GAL	104
⊙	ROSMARINUS OFFICINALIS HUNTINGTON CARPET / HUNTINGTON CARPET ROSEMARY	5 GAL	84
⊙	ROSMARINUS OFFICINALIS HUNTINGTON CARPET / HUNTINGTON CARPET ROSEMARY	5 GAL	84

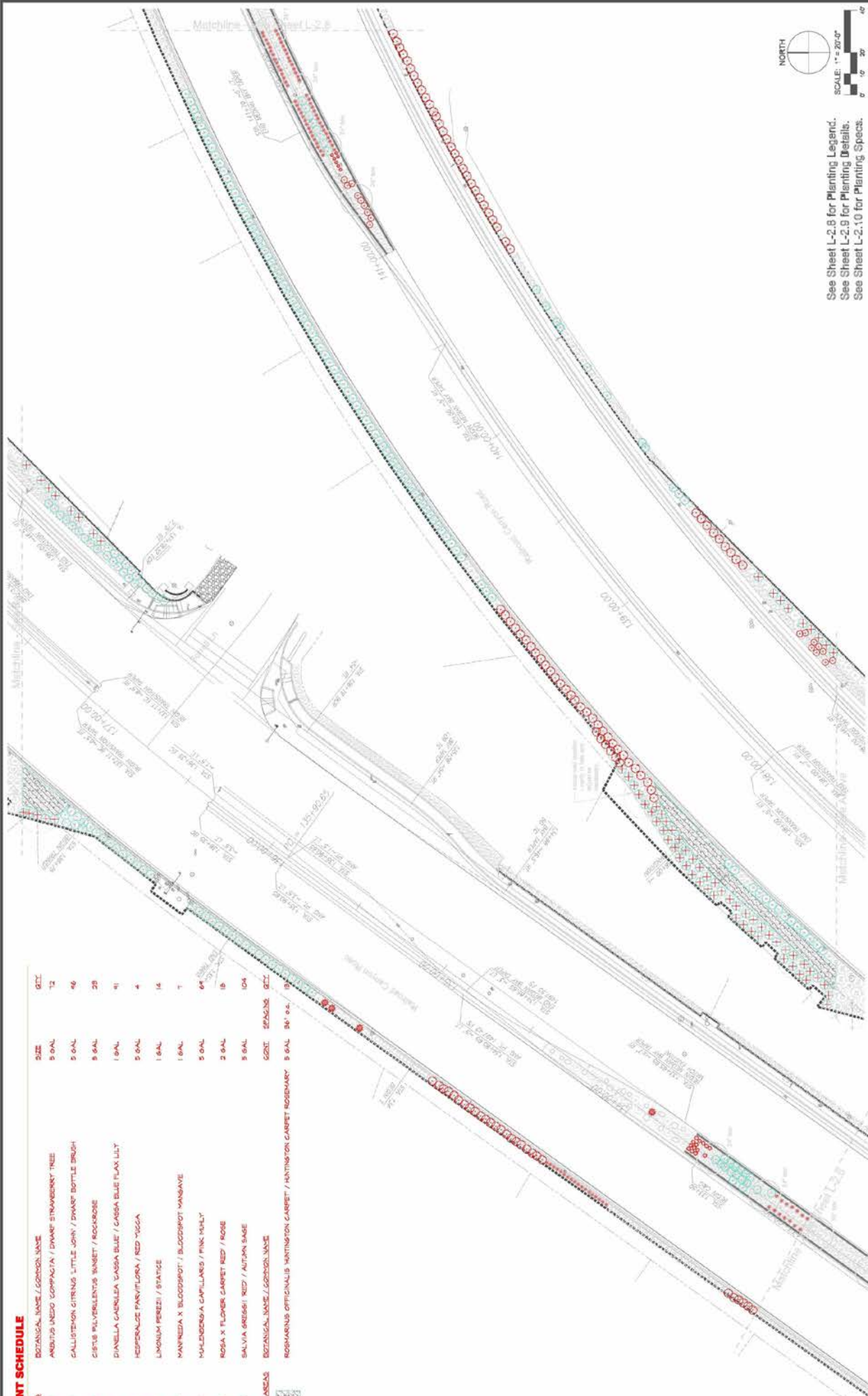

See Sheet L-2.8 for Planting Legend.
 See Sheet L-2.9 for Planting Details.
 See Sheet L-2.10 for Planting Specs.

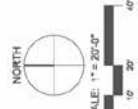

CITY of CANYON LAKE
RAILROAD CANYON ROAD L-2.7
 PLANT REPLACEMENT
 PLANTING PLAN
 FOR CITY of CANYON LAKE, R.G.

APPROVED BY: _____ DATE: _____
 CITY ENGINEER
 BENCHMARK: ELEV. = 1483.00
 SCALE: 1" = 20'
 DATE: 11/20/2017
 DRAWN BY: _____ DATE: _____
 CHECKED BY: _____ DATE: _____

ACCEPTED: _____ DATE: _____
 CITY ENGINEER
 BENCHMARK: ELEV. = 1483.00
 SCALE: 1" = 20'
 DATE: 11/20/2017
 DRAWN BY: _____ DATE: _____
 CHECKED BY: _____ DATE: _____

SCALE: 1" = 20'
 CITY ENGINEER
 BENCHMARK: ELEV. = 1483.00
 SCALE: 1" = 20'
 DATE: 11/20/2017
 DRAWN BY: _____ DATE: _____
 CHECKED BY: _____ DATE: _____

BIS ALERT
 1-800-227-2600
 ARCHITECT: _____ CITY: _____
 CHECKED BY: _____ DATE: _____

FOR INFORMATION AND INFORMATION CALL: _____
 1-800-227-2600
 ARCHITECT: _____ CITY: _____
 CHECKED BY: _____ DATE: _____

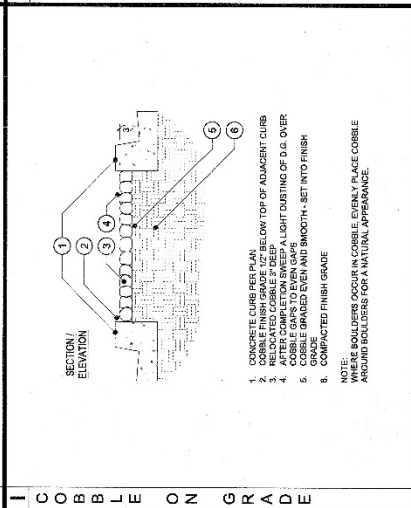
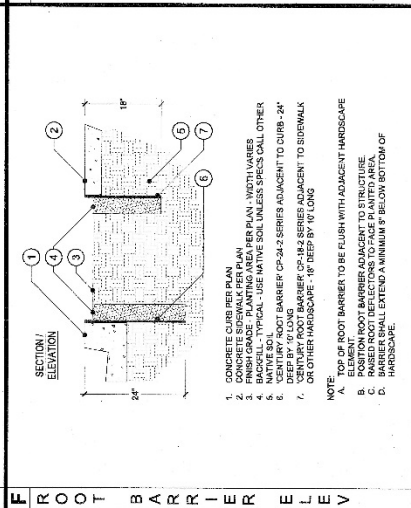
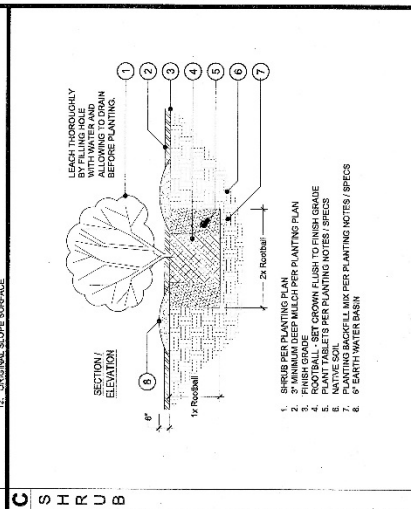
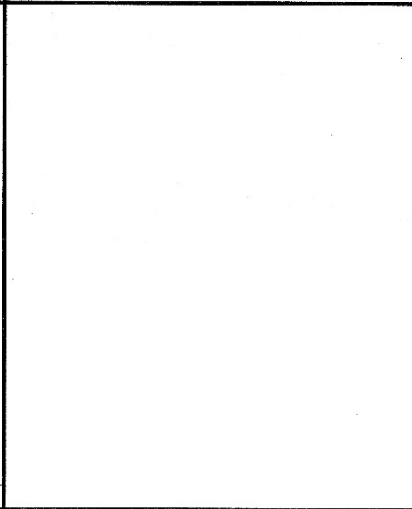
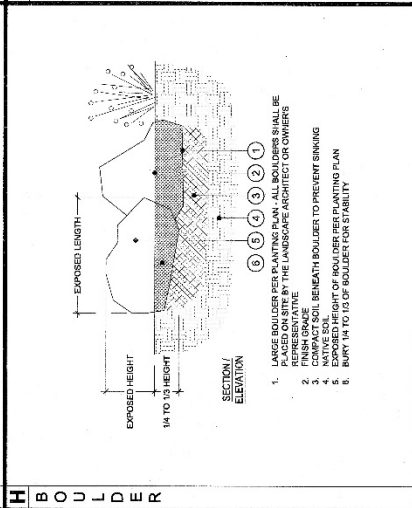
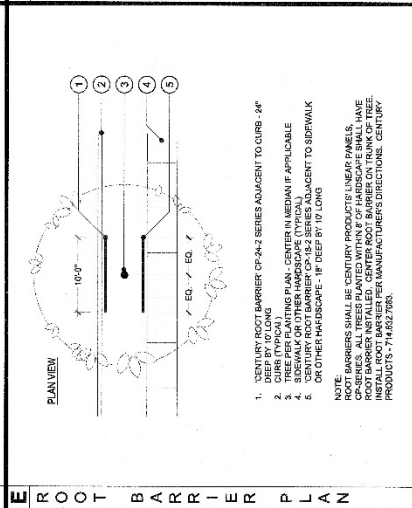
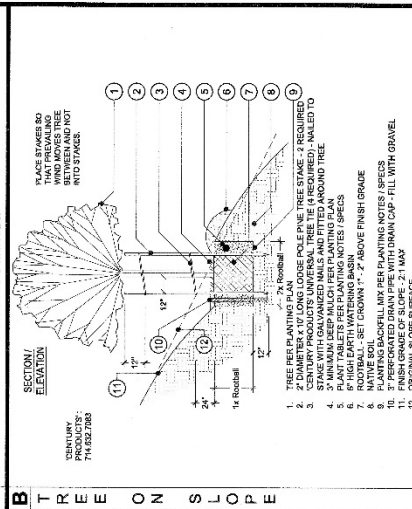
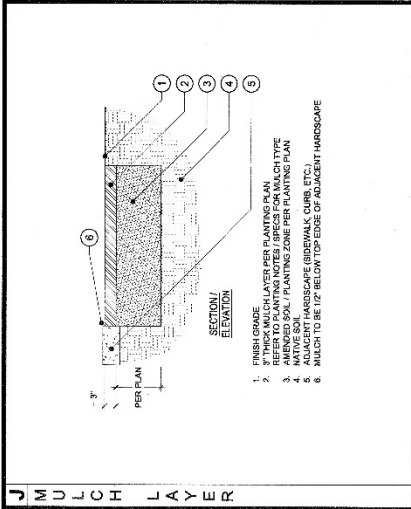
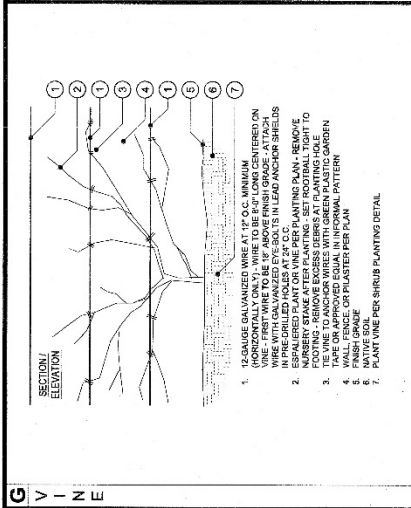
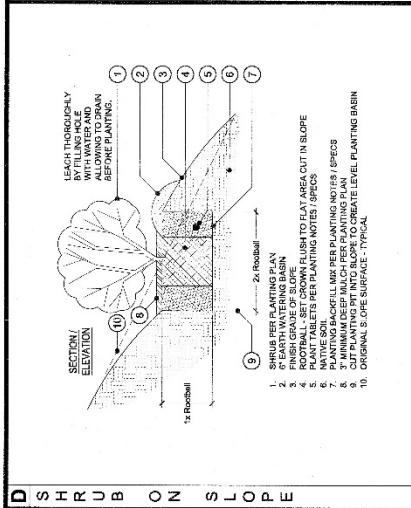
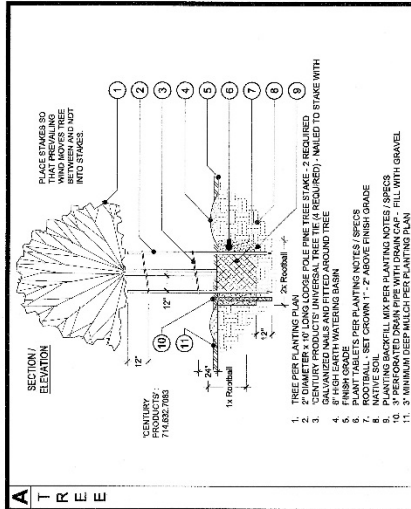

CITY OF CANYON LAKE, CALIFORNIA
RAILROAD CANYON ROAD
WIDENING PROJECT
Landscape Details
Planting Details
 FOR CITY OF CANYON LAKE W.O. CL-069

Laurie Levine
 Landscape Architect
 37805 Basin View Circle
 San Diego, CA 92121
 Phone (951) 684-4444
 Fax (951) 684-0115
 laurielevine.com

APPROVED BY: DATE: _____
 By: _____
 S.E.C. NO. 35167
 SCALE: 1" = 20'-0"
 DATE: 7/13/11
 BENCHMARK: ELEV. = 163.05
 C-15-2 (CITY OF CANYON LAKE) MARKED
 5'-0" BENCH MARK
 30'-0" BENCH MARK

DIG ALERT
 DIAL TOLL FREE
 1-800-227-2000
 BEFORE YOU DIG
 UNDERGROUND SERVICE ALERT OF SOUTHERN CALIFORNIA

HOLD-HARMLESS AND INDEMNIFICATION CLAUSE
 Contractor agrees to assume sole responsibility for the job for the conditions during the course of the completion of this project, including safety of all workers, and to defend, indemnify and hold the City and County of Canyon Lake harmless from and against all claims, damages, losses, and expenses, including reasonable attorneys' fees, that may be asserted against the City and County of Canyon Lake and its employees, officers, directors, agents, contractors, subcontractors, or any other person or entity arising from the performance of work on this project, arising from liability arising from the sole negligence of the City or the County of Canyon Lake.

City of Canyon Lake

RAILROAD CANYON ROAD

SHRUB REPLACEMENT (per plan vs proposed)		Landscape Drawing Sheet Number																						
Plan symbol	Botanical Name	Common Name	Size	total	L-2.1		L-2.2		L-2.3		L-2.4		L-2.5		L-2.6		L-2.7		L-2.8		Contract Unit Cost	Proposed		
				Original	Proposed	Original	Proposed	Original	Proposed	Original	Proposed	Original	Proposed	Original	Proposed	Original	Proposed	Original	Proposed	Original	Proposed	Original	Proposed	
1	Acacia redolens 'Lowboy Acacia'	Lowboy Acacia	5 gallon		82						56	26										\$18.50	\$1,517.00	
2	Arbutus unedo 'Compacta'	Compact Strawberry	5 gallon		336						91	20											\$18.50	\$6,216.00
3	Callistemon 'Little John'	Little John Bottle Brush	5 gallon	56	895					74	8	31	273	2	124	50	91	72	15	87		\$18.50	\$1,036.00	\$16,557.50
4	Ceanothus 'Concha'	California Lilac	5 gallon	145							46	23			33		43					\$18.50	\$2,682.50	
5	Chrysactinia mexicana	Damianita	1 gallon	413		12				144				166	49	30						\$8.50	\$3,510.50	
6	Cistus x pulverulentus 'Sunset'	Magenta Rockrose	5 gallon	357	105	14				146		75	10	3	35	23	23	61	34			\$18.50	\$6,604.50	\$1,942.50
7	Dalea capitata 'Sierra Gold'	Golden Dalea	1 gallon	92						41					27	24						\$8.50	\$782.00	
8	Dianella caerulea 'Cassa Blue'	Cassa Blue Flax Lily	1 gallon		860						172	6		172	354	91						\$12.00	\$10,320.00	
9	Gaura 'Karalee Petite Pink'	Gaura	1 gallon	161						35					120							\$8.50	\$1,368.50	
10	Helianthemum nummularium 'Annabel'	Sunrose	1 gallon		30																	\$8.50	\$255.00	
11	Hesperaloe parviflora	Red Yucca	5 gallon	47	71	8				4	4	2	2	12	12	4	4	4	13	37		\$18.50	\$869.50	\$1,313.50
12	Limonium perezii	Sea Lavender	1 gallon	340	49					93		55		25	25	14	14	10	10			\$8.50	\$2,890.00	\$416.50
13	Manfreda 'Bloodspot'	Bloodspot Mangave	1 gallon	946	7					245				303	243	84	7	71				\$18.50	\$17,501.00	\$129.50
14	Muhlenbergia capillaris 'Pink Muhly'	Pink Muhly	5 gallon	254	211	24				8	8	22	22	96	71	3	3	26	23	12		\$18.50	\$4,699.00	\$3,903.50
15	Prunus carolina Monus 'Bright N Tight'	Bright N Tight Carolina Laurel	5 gallon	227	5					30		78		62	14	38		5	5			\$18.50	\$4,199.50	\$92.50
16	Rosa 'Flower Carpet'	Flower Carpet White	2 gallon		158						26	1		52	13							\$18.50	\$2,923.00	
17	Rosa 'Drift White'	Drift Rose	2 gallon	311						38		76		109	13			66				\$18.50	\$5,753.50	
18	Rosa 'Drift Red'	Drift Rose	2 gallon	374	11					47		62	11	92	56	64		41				\$18.50	\$6,919.00	\$203.50
19	Rosa floribunda 'Iceberg'	Iceberg Rose	5 gallon		44					11		33										\$18.50	\$814.00	
20	Rosa 'Flower Carpet'	Flower Carpet Red	2 gallon		489					8		69	143	122	56			18				\$18.50	\$9,046.50	
21	Rosmarinus officinalis 'Huntington Carpet'	Huntington Carpet Rosemary	5 gallon		229						98							131				\$18.50	\$4,236.50	
22	Salvia greggii Red	Autumn Sage	5 gallon	686	272	54	42			50	39	159	10	117	21	124	45	80	28			\$18.50	\$12,691.00	\$5,032.00
23	Salvia leucantha	Mexican Sage	5 gallon	384	52	25	28			51		107	18	18	70	24	103	10				\$18.50	\$7,104.00	\$962.00
24	Trachelospermum jasminoides	Star Jasmine	5 gallon		137						127	10										\$18.50	\$2,534.50	
25	Westringea fruticosa	Coast Rosemary	5 gallon	195	126	6	52			52		26		30	42	44	69					\$18.50	\$3,607.50	\$2,331.00
			total plants	4,988	4,169																		\$82,218.00	\$70,746.50

**City of Canyon Lake
City Council
Staff Report**

TO: Honorable Mayor and Members of the City Council
FROM: Aaron Palmer, City Manager
BY: Elizabeth Martyn, City Attorney
DATE: July 12, 2017
SUBJECT: Amendments to City Solid Waste Collection

Recommendation

It is recommended that the City Council 1) Approve the Fourth Amendment to the Franchise Agreement between the City of Canyon Lake and CR&R Incorporated and authorize the Mayor to execute the agreement, and 2) adopt Urgency Ordinance No. 172 to revise and update the Solid Waste Chapter of the City’s Municipal Code as an urgency ordinance by 4/5ths vote, and 3) introduce and hold first reading of Ordinance No. 173 to revise and update the Solid Waste Chapter of the City’s Municipal Code and schedule for second reading at the August City Council meeting.

Please Note: Placing residential solid waste fees on the tax roll is a separate public hearing to be conducted after the consideration and approval of this item.

Background

On June 20, 2017, the City Council considered and approved the proposed residential organics recycling program, and directed staff to place the proposed amended franchise agreement on the next City Council agenda along with the necessary revisions to the Solid Waste Ordinance so that the cost of the City’s participation in the organics recycling program can be included in the amount placed on the tax roll for residences. For background, please see the staff report from June 20, 2017 included as an attachment here.

Attached to this report as Attachment A is the Fourth Amendment to the Franchise Agreement, which makes the following changes:

- 1) Effective immediately, CR&R will direct all Residential Organic Waste generated within the City Limits to its Anaerobic Digester Processing Facility (AD Facility) located in Perris, California.
- 2) CR&R also will provide kitchen food scrap pails at no cost to those residential customers who wish to pick them up.
- 3) CR&R will provide a container at the library for household battery disposal.

- 4) The cost of participating in the residential organics recycling program will be included in the rate schedule for residential rates to be collected on the tax roll. That action is a separate public hearing.
- 5) CR&R will implement voluntary recycling and organic diversion programs for commercial entities in accordance with the requirements of AB 341 (Mandatory Commercial Recycling) and AB 1826 (Organic Waste)
- 6) Residential refuse service will include collection of recyclable materials and organic waste in three separate containers furnished by CR&R along with instructions for their use.
- 7) All other terms and conditions of the franchise remain the same.

Attached to this report as Attachment B is Ordinance No. 173 to revise and update the Solid Waste Chapter of the City's Municipal Code. Chapter 6 of the City Code has been updated and amended to refer to organic waste as a separate type of solid waste; organic waste includes green waste and other waste that will be taken to the AD Facility.

Because the City and CR&R have agreed to implement the organics recycling program immediately, and the tax roll deadline for collection of solid waste charges is August 10, 2017, the City Council needs to adopt the updated ordinance in two different ways: first, as an urgency ordinance to take effect immediately to provide the authority for that action at this meeting; second, as a regular ordinance with a second reading at the August meeting so that the regular ordinance takes effect 30 days from August 6, 2017. The regular ordinance will replace the urgency ordinance when the regular ordinance becomes effective.

Staff believes that the Fourth Amendment will enable the City to meet the requirements of AB341, AB1826 (Organic Waste), and AB1594 (Green Waste Diversion).

Budget (or Fiscal) Impact

There is no anticipated fiscal impact to the City of Canyon Lake General Fund.

Attachments

- A) Fourth Amendment to the Franchise Agreement between the City of Canyon Lake and CR&R Incorporated **Pg. 100**
- B) Urgency Ordinance No. 172 **Pg. 106**
- C) Ordinance No. 173 **Pg. 116**
- D) June 20, 2017 Staff Report **Pg. 126**

AMENDMENT NUMBER FOUR TO THE AGREEMENT BETWEEN THE CITY OF CANYON LAKE AND CR&R INCORPORATED, FOR THE COLLECTION, TRANSPORTATION, RECYCLING, COMPOSTING AND DISPOSAL OF SOLID WASTE, RECYCLABLES, COMPOSTABLES AND YARD WASTE AND TEMPORARY ROLLOFF BINS/ROLL-OFF SERVICES

This Fourth Amendment to the Franchise Agreement is entered into as of _____, 2017, by and between the City of Canyon Lake, a Municipal Corporation (“City”) and CR&R Incorporated, a California Corporation (“Grantee”). In consideration of the mutual covenants and conditions set forth herein, the parties agree as follows:

Recitals. This Amendment Number Four is made with respect to the following facts and purposes, which each party agrees to be true and correct:

- A. Whereas on January 14, 1992 the City and Grantee entered into that certain agreement entitled “Agreement Between the City of Canyon Lake and CR&R Incorporated, for the Collection, Transportation, Recycling, Composting, and Disposal of Solid Waste, Recyclables, Compostables and Yard Waste and Temporary Roll-Off /Roll-Off Services”.
- B. Whereas on January 14, 1992 the City and Grantee entered into that certain Amendment Number One in which the Bay Cities Litigation between the City and Grantee was settled and concluded; and
- C. Whereas on January 14, 1992 the City and Grantee entered into that certain Amendment Number Two in which Grantee agreed to postpone a contractual CPI Increase; and
- D. Whereas on March 16, 1994 the City and Grantee entered into that certain Amendment Number Three in which special “weekender service” and Residential Tax Roll charges were implemented as part of the contract terms; and
- E. Whereas Grantee is undertaking the design and construction of an Anaerobic Digester Facility in Perris, California (AD Facility), in which municipally collected organic materials will be processed and converted into a Renewable Natural Gas (RNG) and Organic Compost Material (OCM); and
- F. Whereas City and Grantee desire to further amend this Franchise Agreement with a Fourth Amendment in order to provide for the enhanced collection of organic materials and other service enhancements in the manner hereinafter set forth.

Now, therefore, in consideration of the foregoing, and other good and valuable consideration, the receipt and sufficiency of which are hereby acknowledged, the parties agree as follows:

1. **Definitions.** Section II of this Franchise Agreement is hereby amended to read as follows:

I. Item “F” shall be deleted and replaced with the following:

F. "Solid Waste" shall mean all discarded putrescible and non-putrescible solid and semi-solid wastes, including refuse, construction and demolition debris, bulky items, recyclable materials, greenwaste or any combination thereof which are permitted to be disposed of in a Class III Landfill, and which are included in the definition of "Non-Hazardous Solid Waste" set forth in the California Code of Regulations.

II. Item G. shall be added as follows:

G. "Organic Waste" shall mean food waste, green waste, landscape and pruning waste, compostables, nonhazardous wood waste and minimal amounts of soiled paper waste that is mixed in with food waste. Organic Waste does not include waste types specified as "Special Wastes" or "Hazardous Waste" as defined by California regulations.

2. Amend Section V. Services Provided by Grantee.

Section V.C. (1) is hereby deleted and replaced as follows:

1. Weekly Service. Once each week before 8:00 p.m. and after 7 a.m. Grantee shall collect the solid waste, organics and recyclables (except bulky items and household hazardous waste) which have been placed, kept or accumulated in containers at single family residences that are serviced by the Grantee within the Franchise Area and placed at curbside prior to Grantee's normal weekly collection time. All solid waste, organics and recyclables must be placed within containers curbside or in alleys without obstructions so as to permit safe and efficient collection.
2. When necessary, Grantee shall collect solid waste, organic waste or recyclables placed for collection in bundles, bags or boxes placed next to the containers and shall clean-up any refuse spilled or dropped around containers, whether or not spilled by Grantee. Notwithstanding, the additional can rate shall apply where additional capacity is needed on a regular basis.
3. Grantee shall provide special manual carry-out services for those residents determined to have difficulty doing so themselves, due to physical disabilities and/or the configuration of their property. Grantee shall not receive special payment for this service. However, in the event such service is requested by an otherwise capable resident, solely for the convenience of such resident, Grantee shall retain the right to negotiate with such resident an additional charge.
4. Standard residential service shall include providing, maintaining and replacing three (3) 60-gallon containers with lids and per residence.
5. Grantee shall notify customers in advance in writing of the acceptable contents of each container and shall notify customers of any change in that system. In general, waste shall be separated and disposed of as follows:

Blue/Grey Container: Processed at Perris MRF or other certified recycling facility

Glass Containers
Cans (Aluminum/tin)
Newspaper
Cardboard

Junk Mail
Phone Books
Waste Paper
P.E.T. Plastic
H.D.P.E. Plastic
Other Metals
Cartons (Cereal boxes, shoe boxes, etc.)

Green Container: Processed at Perris Anaerobic Digester

Grass Clippings
Leaves
Twigs
Tree Trimmings
Weeds
Lumber
Manure
Food waste

Black Container: Landfill

All other solid waste (including non-recyclable plastics)

Section V.C. (6) is hereby added as follows:

6. Effective October 1, 2017 Grantee shall direct all Residential Organic Waste generated within the City Limits to its Anaerobic Digester Processing Facility (AD Facility) located in Perris, California. All Organic Waste processed in the AD Facility shall be diverted from the landfill and receive diversionary credit. Costs for this service shall be as outlined in Exhibit C-Schedule of Rates. Grantee shall also make available a Kitchen Food Scrap Pail at two agreed upon distribution events. Food scrap pails will be made available to single family residential service recipients only. The first Food Scrap Pail will be provided at no cost to the resident. Additional Food Scrap Pails, above and beyond the first pail, will be charged as outlined in Exhibit C-Schedule of Rates.

Section V.C. (7) is hereby added as follows:

7. Effective October 1, 2017 Grantee shall provide a used household battery recycling service. The service shall consist of one (1) BatteryTracker container located at the Public Library where residents of Canyon Lake can drop off their used household batteries (sizes AAA, AA, C, D and watch batteries). City will notify the Contractor or battery recycling vendor when the container is full in order to arrange for a replacement with an empty used battery container. The annual cost to Contractor to provide this service shall not exceed one thousand five hundred dollars (\$1500.00).

Section V.E. (1) is hereby amended as follows:

1. Multi-Family Weekly Service. Not less often than once per week, and more frequently if required to handle the waste stream and insure the health and safety of the premises where bins are located, Grantee shall collect the solid waste (including bulky items which have been placed in a closed bin), organics and recyclables (except household hazardous waste) which have been placed for collection in the appropriate bins. Grantee shall maintain and replace commercial bins as necessary in order to provide customers with the appropriate containers.

Section V.E. (3) is hereby amended as follows:

1. Commercial and Industrial Weekly Service. Not less often than once per week, and more frequently if required to handle the waste stream and protect the health and safety of the premises where bins are located, Grantee shall collect the solid waste, organics and recyclables (except hazardous waste) which have been placed for collection in the appropriate bins. Grantee shall maintain and replace commercial bins as necessary in order to provide customers with the appropriate containers. Bulky items which have been placed in a closed bin may be collected.

Section V.E. (4) is hereby added as follows:

4. Effective October 1, 2017, Multi-Family, Commercial and Industrial customers shall have the option of diverting their organic waste through a Grantee provided Organics Recycling Program. These services will require a separate, Grantee provided, bin or cart depending upon the individual customer's organic waste generation rates. All Organic Waste will be collected in separate Organic Waste collection vehicles. Organic Waste will be processed at Grantee's Anaerobic Digestion Facility located in Perris, California. Organic waste shall be diverted from the landfill and receive full diversionary credit. These new services will meet all State of California Organics Recycling requirements as outlined within Assembly Bill 1826. The costs for these services shall be charged as outlined in Exhibit "C"- Schedule of Rates.

3. Amend Section VI. AB 939 Compliance

Section VI. B. Composting is hereby deleted and replaced as follows:

B. Organic Recycling. Grantee shall collect all Organic Waste set out for collection and shall deliver all such materials to Grantee's Anaerobic Digestion Facility located in Perris, California. The process shall meet all requirements under AB 1826 and AB 1594.

4. **Amendment of Exhibit C, Schedules of Rates.** The Franchise Agreement is hereby amended by deleting Exhibit C, Schedule of Rates, and in its place substituting a new Exhibit C, which is attached hereto as Attachment 1 and incorporated herein as though set forth in full.
5. **Continuation of Franchise Terms.** Except as specifically amended by this Amendment Number Four, the terms of the Franchise Agreement remain in full force and effect.

IN WITNESS WHEREOF, the parties hereto have executed this Agreement as of the date first above written.

CITY OF CANYON LAKE

CR&R INCORPORATED

By: _____

Mayor

Date: _____

Date: _____

ATTEST:

By: _____

City Clerk

Date: _____

Date: _____

APPROVED AS TO FORM:

City Attorney

Date: _____

URGENCY ORDINANCE NO. 172

**AN URGENCY ORDINANCE OF THE CITY COUNCIL OF THE CITY OF CANYON LAKE
REVISING CERTAIN PROVISIONS OF CANYON LAKE MUNICIPAL CODE CHAPTER 6.01:
INTEGRATED WASTE MANAGEMENT PERTAINING TO THE CHANGES IN STATE LAW
EFFECTING SOLID, RECYCLABLE AND ORGANIC WASTE COLLECTION AND DIVERSION AS
NECESSARY FOR PRESERVING PUBLIC PEACE, HEALTH, AND SAFETY**

NOW THEREFORE, THE CITY COUNCIL OF THE CITY OF CANYON LAKE DOES HEREBY ORDAIN AS FOLLOWS:

Section 1. Chapter 6.01 of the Canyon Lake Municipal Code is amended as follows:

- 6.01.010 Purpose. protection of the public health, safety and welfare and to mitigate any health hazards within the City.
- 6.01.020 Delegation of authority. **6.01.020 Delegation of authority.**
The Riverside County Department of Health Services shall act as the Health Officer for the City and shall enforce all health-related standards. The City of Canyon Lake shall enforce all non-health related standards (unless otherwise preempted by state law) including but not limited to the use of containers, ownership of recyclables or waste, and responsibility of the operator for containers furnished.
- 6.01.030 Reserved. **6.01.030 - 6.01.050 Reserved.**
- 6.01.040 Reserved. **6.01.060 Definitions.**
The following words and phrases shall, for the purposes of this Chapter, be defined as following, unless it is clearly apparent from the context that another meaning is intended.
- 6.01.050 Reserved.
- 6.01.060 Definitions.
- 6.01.070 Service to be provided by the City.
- 6.01.080 Mandatory subscription.
- 6.01.090 Collection of fees.
- 6.01.100 Refuse collection fee a debt.
- 6.01.110 Collection procedure for delinquent accounts creation of lien.
- 6.01.120 Standby assessment on vacant parcels.
- 6.01.130 Solid waste collection schedules.
- 6.01.140 Placement of containers.
- 6.01.150 Condition of waste for collection.
- 6.01.160 Ownership of waste materials.
- 6.01.170 Solid waste and recyclable containers.
- 6.01.180 Vehicles and contractor’s employees.
- 6.01.190 Complaint service.
- 6.01.200 Compliance with Solid Waste Legislation.
- 6.01.210 Penalties for violation.

Cross-reference:
Requirements for pet waste disposal see Chapter 15.02

6.01.010 Purpose.

The purpose of this Chapter is to provide for the collection, removal and disposal of recyclable material, and solid waste as well as related services in accordance with state standards, laws and regulations and to otherwise provide for the determination and regulation of a solid waste contractor. This Chapter is necessary for the

(a) “Collection” means the act of collecting solid waste, recyclables, or organic recyclables at the place of generation by an approved public or private collection agency and is distinguished from “removal.”

(b) “Container” means any metallic or plastic vessel, can or receptacle with a close-fitting lid or cover, appropriate for collecting solid wastes, recyclables, or organic recyclables for removal, whether owned by the City, approved collection agent, property owner, tenant or other person in control of the premises.

(c) “Contractor” or “approved collection agent” or “collector” or “collection service” means any person, persons, firm, corporation or partnership that has been issued a contract or franchise by the City Council for the purpose of collecting, transporting and disposing of refuse.

(d) “Disposal” means the complete operation of treating as required and disposing of the accumulation of garbage, rubbish, waste and the product or residue arising from any such treatment.

(e) “Organic Waste” shall mean food waste, green waste, landscape and pruning waste, compostables, nonhazardous wood waste and minimal amounts of soiled paper waste that is mixed in with food waste. Organic Waste includes organic recyclables. Organic Waste does not include waste types specified as “Special Wastes” or “Hazardous Waste” as defined by California regulations.

(f) “Recyclable material” includes but is not limited to glass, newsprint, newspaper, aluminum, cardboard, certain plastics or metal.

(g) “Removal” means the act of taking solid wastes, recyclables, or organic waste from the place of generation by an approved collection agent or by a person in control of the premises.

(h) “Solid Waste” shall mean all discarded putrescible and non-putrescible solid and semi-solid wastes, including refuse, construction and demolition debris, bulky items, recyclable materials, organic waste or any combination thereof which are permitted to be disposed of in a Class III Landfill, and which are included in the definition of “Non-Hazardous Solid Waste” set forth in the California Code of Regulations but excludes:

- (1) Discarded home or industrial appliances;
- (2) Sewage collected and treated in a municipal or regional sewerage system;
- (3) Recyclable material, or organic recyclables or other materials or substances that have been separated for reuse or resale;
- (4) Hazardous refuse including household hazardous wastes and any compound,

mixture, substance or article defined as hazardous under state or federal law or which if improperly used, handled, transplanted, processed or stored may constitute a hazard to health or cause property damage or contamination or which is explosive, flammable, poisonous, corrosive, radioactive or otherwise harmful to the environment and includes household batteries; and

(5) Discarded (as distinguished from abandoned) automobile or truck parts or bodies, dirt, sod, rock, manure or stable waste or waste from building or construction operations.

(6) Special waste as defined by state law.

6.01.070 Service to be provided by the City.

(a) The City shall provide the service of collecting solid waste and recyclables within the City, either through its own employees or through an entity under exclusive or non-exclusive franchise or contract with the City for a term determined by the City. In the event the City determines to contract for such service, the City shall seek competitive bids and determine the standards for an exclusive contractor to collect both solid waste and recyclables. So long as the City provides such service either through its own employees or by contract or franchise, it shall be unlawful for any person to engage in the business of collecting solid waste or recyclables within the City unless such person has a valid franchise or contract with the City to do so. The City reserves its right to regulate aspects of solid waste handling including, but not limited to, level of services, times of collection, frequency of collection and waste diversion requirements.

(b) The approved contractor awarded a franchise or contract by the City shall comply with all local governmental licenses, permits, or written approval requirements applicable to the City as well as with any and all state or federal requirements for the collection and removal of solid waste, recyclable material, organic waste, hazardous waste or other waste as agreed between the City and approved contractor. The contractor also may be required to assist in meeting the requirements of AB 939, AB 32, AB 341, AB 1826, AB 1594 and other laws and regulations which have been or will be imposed upon the City.

(c) No franchise contract or subscription shall be required for: (i) the removal of vegetative cuttings or other solid waste not containing garbage or manure to a legal place of disposal as a part of gardening or horticulture or for composting; (ii) contractors or builders removing debris, rubbish and trash from construction sites; (iii) any person removing large or oversized items from his or her premises; (iv) any person removing infectious or hazardous waste from his/her premises. All solid or hazardous waste self-hauled shall be contained, tied or enclosed to prevent leaking, spilling or blowing and shall be deposited only in a duly authorized location.

(d) In accordance with state regulations, the following items are required before a franchise or contract shall be awarded by the City:

(1) The filing of a faithful performance or surety bond with the City in an amount determined by the City unless otherwise waived by the City Council.

(2) Evidence that the collector has experience and assets sufficient to meet the needs of the customers within the jurisdiction.

(3) Acquisition of a permit for waste collection from the County of Riverside.

(4) The filing of insurance certificates from a company or companies acceptable to the City Manager showing the City as an additional named insured, where such insurance is primary and not contributing and is in an amount of at least \$10,000,000 combined single limit aggregate bodily injury and property damage, \$5,000,000 vehicle liability insurance, and workers compensation in an amount as required by law. Such insurance shall remain in full force and effect during the term of any agreement and the City shall be given 30 days advance notice of any modification, termination or suspension.

6.01.080 Mandatory subscription.

(a) Except as set out in Section 6.01.070(c) it shall be unlawful for any occupant or person in possession, charge or control of any residential premises within the City from which ordinary

household garbage, solid waste, organic waste, or recyclables are or may be created, accumulated or produced, to fail to subscribe for the collection service provided by the City. When the joint or multiple use of solid waste containers is provided on the residential premises, it shall be unlawful for the person in possession, charge or control of such containers, to fail to subscribe to the City's collection service.

(b) It shall be unlawful for any occupant and/or any contractor doing business on any premises or any person in possession, charge, or control of any nonresidential premises within the City from which solid waste, recyclables, or organic waste, are or may be created, accumulated or produced to fail to subscribe for collection of solid waste, recyclable material, or organic waste, with anyone other than the City's collection service, except as set out in Section 6.01.070(c).

(c) It is the duty of the approved collection agent to collect all solid waste, recyclable material, or organic waste, from premises within the City that subscribe to such service and to deposit such materials at the appropriate facility.

(d) Notwithstanding the foregoing, or Section 6.01.130 hereof, should conditions warrant at any residential, commercial, industrial or multi-residential unit, the City or the Health Officer may require increased frequency of collection. No accumulation of solid waste shall be allowed to create a public nuisance and such accumulation shall be a public nuisance where detrimental to public health and safety.

(e) The owner or occupant of any premises may contract for additional collection services in excess of those required or provided by contractor hereunder.

6.01.090 Collection of fees.

(a) Every person in the City who has the occupancy, charge or control of any place or premises, within the City where any ordinary household garbage, solid waste, recyclables, or organic waste accumulates or may accumulate, shall pay, or cause to be paid, to the City or its agent a charge in such amounts and in such manner as shall be established by the City for the service of having

such ordinary household garbage, recyclables, or organic waste solid waste, collected and removed from the place or premises by the exclusive contractor. In the case of residential and commercial rental units, the property owner of record ultimately shall be responsible for such charge.

(b) Nothing in this Section is intended to prevent an arrangement, or the continuance of an existing arrangement, under which payments of refuse collection fees are made by a tenant or tenants, or any agent, on behalf of the owner. However, any such arrangement will not affect the property owner's obligation to the contractor.

(c) All fees for service shall be proposed by the contractor and approved by the City Council by resolution. Fees shall be based on the type of occupancy or use of the place or premises.

(d) All fees (and any penalty) for collection services shall be billed and collected in accordance with rules and regulations proposed by the contractor and established and adopted by the City Council. The City Council may collect residential fees on the tax roll pursuant to Section 6.01.110.

6.01.100 Refuse collection fee a debt.

The refuse collection fee shall be a civil debt owing the contractor and the City from the owner, occupant or person in possession, charge or control of the premises. A penalty may be charged for late payment. Should any person fail, refuse or neglect to pay a collection bill within 30 days after received, without a valid dispute therefore, the contractor may refuse to collect solid waste, organic waste or recyclables from the premises until the bill is paid or the matter otherwise is resolved.

6.01.110 Collection procedure for delinquent accounts - creation of lien.

Fees authorized pursuant to this Chapter, including those owing prospectively as well as those which remain unpaid as of April 1 of any year may be collected on the property tax roll by the City as provided in this Section.

(a) Annually, on or before July 1, of each year, the City shall cause a written report to be prepared and filed with the City Clerk. The report

shall describe each parcel in the city receiving solid waste collection services and the charge for such services for the next fiscal year. For collection of delinquent accounts, the contractor shall cause a report of delinquent fees or charges to be prepared annually after April 1. The report may contain both prospective and delinquent charges. Charges may be placed on the tax rolls for residential and/or commercial property.

(b) The Council shall fix a time, date and place for a hearing on the report and any objections or protests thereto.

(c) The City Council shall cause written notice of such hearing to be mailed to the landowners listed on the report not less than 15 days prior to the date of the hearing.

(d) At the hearing, the City Council shall hear any objections or protests of landowners liable to be assessed for fees and may make such revisions or corrections to the report as it deems just, after which, by resolution, the report may be confirmed. The City Clerk shall file the report with the County Auditor before August 10 of each year.

(e) The fees set forth in the report as confirmed shall constitute special assessments against the respective parcels of land, and are a lien on the property for the amount of such delinquent fees plus administrative costs. A certified copy of the confirmed report shall be filed with the County Auditor for amounts of the respective parcels of land as they appear on the current assessment roll. The lien created attaches upon recordation, in the office of the County recorder, of a certified copy of the resolution of confirmation. The assessment may be collected at the same time and subject to the same procedures including sale in case of delinquency as provided for such taxes. All laws applicable to the levy, collection and enforcement of ad valorem property taxes shall be applicable to such assessments, except that if any real property to which such fees or charges relate has been transferred or conveyed to a bona fide purchaser for value, or if a lien of a bona fide encumbrancer for value has been created and attaches thereon, prior to the date on which the first installment of such taxes would become delinquent, then the lien which would otherwise be imposed shall not attach to such real

property and the fees or charges and interest shall be transferred to the unsecured roll for collection.

6.01.120 Standby assessment on vacant parcels.

Pursuant to the authority set out in Health & Safety Code Sections 5470 et seq., the City may by 4/5ths vote adopt an ordinance, levy and collect an annual standby charge on unimproved property for solid waste capacity and collection and to meet obligations under AB 939, as it may be revised from time to time. By resolution approved by 4/5ths vote of the City Council, such charges may be collected in the same manner, by the same persons and at the same time and together with real property general taxes. In such event, the City Council shall:

(a) Annually cause a written report to be filed with the City Clerk, describing each parcel and the amount of the charge;

(b) Give notice of the charge and a hearing thereon shall be given as set out in Health & Safety Code Section 5473.1;

(c) At the time of the hearing, hear and consider any and all protests to the report. In the event of a protest by the owners of a majority of separate parcels, the report shall not be approved;

(d) Absent a majority protest, approve the report and file it with the County Auditor as set out in Section 5473.4 of the Health & Safety Code; and

(e) The charges set out in the report shall constitute a lien on the property in the same manner as real property taxes.

All laws applicable to the levy, collection and enforcement of general taxes of the entity, including, but not limited to, those pertaining to the matters of delinquency, correction, cancellation, refund and redemption, are applicable to such charges, except that if any real property to which such charges relate has been transferred or conveyed to a bona fide purchaser for value, or if a lien of a bona fide encumbrancer for value has been created and attaches thereon, prior to the date on which the first installment of such taxes would become delinquent, then the lien which would otherwise be imposed shall

not attach to such real property and the charges relating to such property shall be transferred to the unsecured roll of collection.

6.01.130 Solid waste collection schedules.

(a) Residential, industrial and commercial solid waste and recyclable material shall be collected at least once weekly. Collections shall not be made between 8 p.m. and 7 a.m. unless otherwise agreed in advance in writing by the City Manager. Organic waste shall be collected on the same schedule or as determined to be necessary by the City and the Contractor. Collections of discarded automobile or truck bodies or other bulky or heavy objects, dirt, sod, rock, manure or waste from any stable, and material resulting from building or construction charges shall occur within seven days from receipt of request for such collection unless needed sooner for health and safety reasons. Subject to such limitations as may be agreed to by the City and waste hauler, dead animals shall be removed without charge within 24 hours after oral request for such removal. Special clean-up shall occur as set out in Section 6.01.150(d). Neither bulky waste nor dead animals shall be set out for collection except as set out in Section 6.01.150(b).

(b) The contractor also may be required to provide at its expense waste collection bins or containers within City facilities or other public areas, including but not limited to Section 26 (the BLM parcel).

6.01.140 Placement of containers.

(a) Residential: Unless other appropriate arrangements are made between an owner/agent and the approved collector, due to special circumstances, all containers shall be placed for collection along the curb or paved alley as directed by the City. On streets without curbs, containers shall be placed in the parkway but not in the local flowline. No person shall place any solid waste, organic waste or recyclable material or any container containing such material at any place of collection before 5:00 p.m. of the day preceding its scheduled collection, or leave any such container at the place of collection after 9:00 p.m. on the day of actual collection.

(b) Industrial, commercial and multiple dwelling units: Industrial, commercial and multiple dwelling residential solid waste containers or containers for recyclable materials or organic waste installed outdoors shall be screened and located in compliance with City zoning regulations.

(c) Public nuisance of containers prohibited: When not placed for collection, solid waste containers shall be kept in an area which is not visible from the street and which will not be offensive to neighboring property so far as it is reasonably practicable to do so. Recyclable containers and Organic Waste containers shall be placed in the same manner.

6.01.150 Condition of waste for collection

(a) Solid waste in containers. Waste shall be kept and placed for collection in sturdy containers with tight-fitting lids which shall be of a size, type and number agreed to by the City and the contractor; but shall not exceed 50 lbs. in weight when placed for pickup.

(b) Waste not in containers.

(1) Single bulky items of solid waste or items not in containers shall be collected provided that no item exceeds three feet in length and one foot in diameter, or weighs over 50 pounds.

(2) Solid waste or organic waste in bundles shall be collected provided that each bundle is tied and does not exceed three feet in length and one foot in diameter, or weigh over 50 pounds, not to exceed three bundles in any one pick-up day.

(3) Bulky household items such as stoves, refrigerators, furniture, water heaters and similar material shall be collected according to the collection policies of the waste collector for such items.

(4) Cardboard or empty cardboard boxes shall be collected and not returned to property owners or tenants.

(5) Magazines shall be securely tied in bundles if not placed in containers.

(6) Fluorescent lamp tubes must be broken prior to pickup.

(7) When any refuse is not collected by the approved collection agent, he shall leave a tag, provided at its cost, at least 2" x 6" in size, on which is specifically stated the reason for the refusal to collect and stating the City regulation or provision of the agreement which has been violated. Such tag shall contain thereon the name, address and telephone number of the approved collection agent and shall be securely fastened to the container or article. The approved collection agent shall maintain a record of the location where all and any such tags have been placed. In the event the reason for non-collection is not remedied or cured by the date of the next regular pickup for the location, the approved collection agent shall provide the City with written notice thereof, stating the full particulars of the reason for no collection and location thereof.

(c) Recyclables in containers: All recyclable materials shall be placed in containers provided by the approved collection agent specifically for that purpose. In the event that such containers are filled, additional recyclable material may be placed adjacent to the recycling container in another container, bag or box.

(d) The approved collection agent agrees to assist and cooperate, at least twice per year, at no additional cost, in a clean-up operation on dates to be mutually determined.

6.01.160. Ownership of waste materials.

Solid wastes subject to collection by the approved collection agent shall become the property of that agent. Recyclable materials, and organic wastes, shall become property of the City. No person other than the person generating the materials, City employees or the contractor acting within the scope of his or her agency or employment shall remove such materials once placed for collection.

6.01.170 Solid waste and recyclable containers.

(a) Care of all containers: All containers shall be returned upright to the curb where found. Containers or lids shall not be deposited in the street or on adjoining property. Collectors shall not in any way throw or roughly handle any container so as to cause damage. The approved collection agent shall

return all bins, roll-off boxes and the like utilized for business establishments hereunder, to the enclosure(s) provided therefor on the property. In the event that a business establishment fails to utilize such enclosures, or if said enclosures are rendered unusable, the approved collection agent shall request the business establishment to make the enclosure usable for bins, roll-off boxes and the like. If the business establishment fails or refuses to correct the situation, the approved collection agent shall notify the City.. The contractor immediately shall remove any and all material that is spilled.

(b) Replacement of faulty containers: Where the property owner or occupant provides the container, any container that leaks and is not watertight shall be replaced by the owner within ten (10) days after notice from the collector, stating the condition of such container. Such notice from the collector shall be made by attaching a tag to the container indicating its defective condition.

(c) Operator responsibility: Where the approved collection agent furnishes containers (whether for solid waste or recyclables), he is responsible for maintaining the containers in good condition, ordinary wear and tear excepted, unless they are furnished under other terms, conditions or agreements.

(d) Use of container: No person shall tamper with, modify, remove from or deposit recyclables, solid wastes or organic waste in any container which has not been provided for his use without the permission of the container owner.

6.01.180 Vehicles and contractor's employees.

(a) The approved collection agent shall own or lease and maintain at its expense all equipment necessary to perform its duties as provided for under the Agreement, including sufficient radio equipment for office-to-field equipment communication.

(b) The contractor shall maintain all trucks and equipment used within the City in good mechanical condition and the same shall be clean and uniformly painted and numbered. All trucks and equipment shall have painted thereon, or affixed thereto, in letters and numerals at least six inches in height, the name and telephone number of the contractor, which name and telephone number shall

be clearly visible at all times. Each vehicle utilized by the contractor shall be identified by numerals at least six inches in height in a location or locations on such vehicles to be specified by the City. A current list showing each vehicle so identified shall be supplied to the City at least annually.. All trucks and equipment used in the performance of the agreement shall be available for and subject to inspection by the City. If the City finds that any truck or equipment requires correction of defects, it shall not be used by the contractor in the performance of the agreement until corrected to the reasonable satisfaction of the City. The contractor shall cause its vehicles to be inspected annually by the California Highway Patrol and the report of any and all California Highway Patrol inspections (annual or otherwise) shall be provided to the City within one week thereafter.

All truck bodies used by the contractor shall be watertight and leak-proof and so constructed as to prevent odors or falling, leaking or spilling refuse unless special arrangements are approved by the City for certain areas. Each piece of equipment used by Contractor shall carry at all times a broom and shovel to be used for the immediate removal of any spilled material as well as a fire extinguisher and first aid kit.

Each vehicle used within the City shall be washed at least once a week and steam-cleaned once a month and shall at no time constitute a nuisance or menace to public welfare, health and safety.

(c) The contractor at all times shall comply with state, federal and local rules and regulations applicable to its employees. All employees working within the City shall be bonded.

6.01.190 Complaint service.

(a) The approved collection agent shall maintain a telephone service with a local exchange area telephone number for the purpose of handling complaints or emergency service calls. The telephone service shall be operated between the hours of 8:00 a.m. and 5:00 p.m. of each day of the week during which collections are made.

(b) Complaints received by the approved collection agent shall be recorded in a log established for that purpose and shall specify the date and time of the complaint and the substance thereof. The disposition of the complaint and the date of

disposition shall be recorded and a copy of said log shall be provided to the City monthly. The contractor shall use its best efforts to resolve all complaints within 48 hours from the time received.

(c) The approved collection agent shall have available, during the hours while the approved collection agent's telephone service is in operation, an emergency service vehicle to attend to complaints or emergency calls.

(d) The approved collection agent shall visit the City offices at such times as the City shall designate for the purpose of discussing any matters relating to, or any complaints which may be involved with, the performance of the agreement. The approved collection agent shall report back as directed on any action taken with reference to subject matter so discussed. Coordination of such check-in meetings is to be arranged by the City.

(e) Every effort will be made to provide a good quality of complaint service and follow up in the community.

6.01.200 Compliance with Solid Waste Legislation.

Section 2. To the extent the provisions of the Canyon Lake Municipal Code as amended by this Ordinance are substantially the same as the provisions of that Code as they read immediately prior to the adoption of this Ordinance, then those provisions shall be construed as continuations of the earlier provisions and not as new enactments.

Section 3. This ordinance shall take effective immediately.

PASSED, APPROVED AND ADOPTED by at least a 4/5th vote this 12th day of July, 2017.

(a) The approved collection agent shall reimburse the City for the cost of developing a Source Reduction and Recycling Element (SRRE) and Household Hazardous Waste Element (HHWE) that meets all requirements of AB 939. The contractor shall collect with its bills the cost of implementing the SRRE and HHWE as set by the City. The contractor also shall provide a specific and detailed program approved by the City for such implementation in order to meet the waste-reduction goals of AB 939 including the financing of such program.

(b) The approved collection agent shall provide for the City to comply with all applicable current and future solid waste laws and regulations.

6.01.210 Penalties for violation.

Violations of this Chapter shall be punishable as an infraction in accordance with the Canyon Lake Municipal Code. Fines for such infractions shall be within the limits established by the Canyon Lake Municipal Code. In addition, any violation of this Chapter is deemed to be a public nuisance that may be abated by administrative or criminal action.

Randall P. Bonner, Mayor

Approved as to form:

Attest:

Stephanie Roseen, Deputy City Clerk

Elizabeth Martyn, City Attorney

State of California)
County of Riverside)ss
City of Canyon Lake)

I, Stephanie Roseen, Deputy City Clerk of the City of Canyon Lake, California do hereby certify that the foregoing Urgency Ordinance No. 172 was duly adopted by the City Council of the City of Canyon Lake, California, at an adjourned meeting held on the 12th day of July, 2017, by the following vote:

AYES:

NOES:

ABSENT:

ABSTAIN:

Stephanie Roseen, Deputy City Clerk

ORDINANCE NO. 173

AN ORDINANCE OF THE CITY COUNCIL OF THE CITY OF CANYON LAKE REVISING CERTAIN PROVISIONS OF CANYON LAKE MUNICIPAL CODE CHAPTER 6.01: INTEGRATED WASTE MANAGEMENT PERTAINING TO THE CHANGES IN STATE LAW EFFECTING SOLID, RECYCLABLE AND ORGANIC WASTE COLLECTION AND DIVERSION

NOW THEREFORE, THE CITY COUNCIL OF THE CITY OF CANYON LAKE DOES HEREBY ORDAIN AS FOLLOWS:

Section 1. Chapter 6.01 of the Canyon Lake Municipal Code is amended as follows:

- 6.01.010 Purpose.
- 6.01.020 Delegation of authority.
- 6.01.030 Reserved.
- 6.01.040 Reserved.
- 6.01.050 Reserved.
- 6.01.060 Definitions.
- 6.01.070 Service to be provided by the City.
- 6.01.080 Mandatory subscription.
- 6.01.090 Collection of fees.
- 6.01.100 Refuse collection fee a debt.
- 6.01.110 Collection procedure for delinquent accounts creation of lien.
- 6.01.120 Standby assessment on vacant parcels.
- 6.01.130 Solid waste collection schedules.
- 6.01.140 Placement of containers.
- 6.01.150 Condition of waste for collection.
- 6.01.160 Ownership of waste materials.
- 6.01.170 Solid waste and recyclable containers.
- 6.01.180 Vehicles and contractor’s employees.
- 6.01.190 Complaint service.
- 6.01.200 Compliance with Solid Waste Legislation.
- 6.01.210 Penalties for violation.

6.01.020 Delegation of authority.

The Riverside County Department of Health Services shall act as the Health Officer for the City and shall enforce all health-related standards. The City of Canyon Lake shall enforce all non-health related standards (unless otherwise preempted by state law) including but not limited to the use of containers, ownership of recyclables or waste, and responsibility of the operator for containers furnished.

6.01.030 - 6.01.050 Reserved.

6.01.060 Definitions.

The following words and phrases shall, for the purposes of this Chapter, be defined as following, unless it is clearly apparent from the context that another meaning is intended.

(a) “Collection” means the act of collecting solid waste, recyclables, or organic recyclables at the place of generation by an approved public or private collection agency and is distinguished from “removal.”

(b) “Container” means any metallic or plastic vessel, can or receptacle with a close-fitting lid or cover, appropriate for collecting solid wastes, recyclables, or organic recyclables for removal, whether owned by the City, approved collection agent, property owner, tenant or other person in control of the premises.

(c) “Contractor” or “approved collection agent” or “collector” or “collection service” means any person, persons, firm, corporation or partnership that has been issued a contract or franchise by the

Cross-reference:
Requirements for pet waste disposal see Chapter 15.02

6.01.010 Purpose.

The purpose of this Chapter is to provide for the collection, removal and disposal of recyclable material, and solid waste as well as related services in accordance with state standards, laws and regulations and to otherwise provide for the determination and regulation of a solid waste contractor. This Chapter is necessary for the protection of the public health, safety and welfare and to mitigate any health hazards within the City.

City Council for the purpose of collecting, transporting and disposing of refuse.

(d) "Disposal" means the complete operation of treating as required and disposing of the accumulation of garbage, rubbish, waste and the product or residue arising from any such treatment.

(e) "Organic Waste" shall mean food waste, green waste, landscape and pruning waste, compostables, nonhazardous wood waste and minimal amounts of soiled paper waste that is mixed in with food waste. Organic Waste includes organic recyclables. Organic Waste does not include waste types specified as "Special Wastes" or "Hazardous Waste" as defined by California regulations.

(f) "Recyclable material" includes but is not limited to glass, newsprint, newspaper, aluminum, cardboard, certain plastics or metal.

(g) "Removal" means the act of taking solid wastes, recyclables, or organic waste from the place of generation by an approved collection agent or by a person in control of the premises.

(h) "Solid Waste" shall mean all discarded putrescible and non-putrescible solid and semi-solid wastes, including refuse, construction and demolition debris, bulky items, recyclable materials, organic waste or any combination thereof which are permitted to be disposed of in a Class III Landfill, and which are included in the definition of "Non-Hazardous Solid Waste" set forth in the California Code of Regulations but excludes:

(1) Discarded home or industrial appliances;

(2) Sewage collected and treated in a municipal or regional sewerage system;

(3) Recyclable material, or organic recyclables or other materials or substances that have been separated for reuse or resale;

(4) Hazardous refuse including household hazardous wastes and any compound, mixture, substance or article defined as hazardous under state or federal law or which if improperly used, handled, transplanted, processed or stored may constitute a hazard to health or cause property

damage or contamination or which is explosive, flammable, poisonous, corrosive, radioactive or otherwise harmful to the environment and includes household batteries; and

(5) Discarded (as distinguished from abandoned) automobile or truck parts or bodies, dirt, sod, rock, manure or stable waste or waste from building or construction operations.

(6) Special waste as defined by state law.

6.01.070 Service to be provided by the City.

(a) The City shall provide the service of collecting solid waste and recyclables within the City, either through its own employees or through an entity under exclusive or non-exclusive franchise or contract with the City for a term determined by the City. In the event the City determines to contract for such service, the City shall seek competitive bids and determine the standards for an exclusive contractor to collect both solid waste and recyclables. So long as the City provides such service either through its own employees or by contract or franchise, it shall be unlawful for any person to engage in the business of collecting solid waste or recyclables within the City unless such person has a valid franchise or contract with the City to do so. The City reserves its right to regulate aspects of solid waste handling including, but not limited to, level of services, times of collection, frequency of collection and waste diversion requirements.

(b) The approved contractor awarded a franchise or contract by the City shall comply with all local governmental licenses, permits, or written approval requirements applicable to the City as well as with any and all state or federal requirements for the collection and removal of solid waste, recyclable material, organic waste, hazardous waste or other waste as agreed between the City and approved contractor. The contractor also may be required to assist in meeting the requirements of AB 939, AB 32, AB 341, AB 1826, AB 1594 and other laws and regulations which have been or will be imposed upon the City.

(c) No franchise contract or subscription shall be required for: (i) the removal of vegetative cuttings or other solid waste not containing garbage or

manure to a legal place of disposal as a part of gardening or horticulture or for composting; (ii) contractors or builders removing debris, rubbish and trash from construction sites; (iii) any person removing large or oversized items from his or her premises; (iv) any person removing infectious or hazardous waste from his/her premises. All solid or hazardous waste self-hauled shall be contained, tied or enclosed to prevent leaking, spilling or blowing and shall be deposited only in a duly authorized location.

(d) In accordance with state regulations, the following items are required before a franchise or contract shall be awarded by the City:

(1) The filing of a faithful performance or surety bond with the City in an amount determined by the City unless otherwise waived by the City Council.

(2) Evidence that the collector has experience and assets sufficient to meet the needs of the customers within the jurisdiction.

(3) Acquisition of a permit for waste collection from the County of Riverside.

(4) The filing of insurance certificates from a company or companies acceptable to the City Manager showing the City as an additional named insured, where such insurance is primary and not contributing and is in an amount of at least \$10,000,000 combined single limit aggregate bodily injury and property damage, \$5,000,000 vehicle liability insurance, and workers compensation in an amount as required by law. Such insurance shall remain in full force and effect during the term of any agreement and the City shall be given 30 days advance notice of any modification, termination or suspension.

6.01.080 Mandatory subscription.

(a) Except as set out in Section 6.01.070(c) it shall be unlawful for any occupant or person in possession, charge or control of any residential premises within the City from which ordinary household garbage, solid waste, organic waste, or recyclables are or may be created, accumulated or produced, to fail to subscribe for the collection service provided by the City. When the joint or

multiple use of solid waste containers is provided on the residential premises, it shall be unlawful for the person in possession, charge or control of such containers, to fail to subscribe to the City's collection service.

(b) It shall be unlawful for any occupant and/or any contractor doing business on any premises or any person in possession, charge, or control of any nonresidential premises within the City from which solid waste, recyclables, or organic waste, are or may be created, accumulated or produced to fail to subscribe for collection of solid waste, recyclable material, or organic waste, with anyone other than the City's collection service, except as set out in Section 6.01.070(c).

(c) It is the duty of the approved collection agent to collect all solid waste, recyclable material, or organic waste, from premises within the City that subscribe to such service and to deposit such materials at the appropriate facility.

(d) Notwithstanding the foregoing, or Section 6.01.130 hereof, should conditions warrant at any residential, commercial, industrial or multi-residential unit, the City or the Health Officer may require increased frequency of collection. No accumulation of solid waste shall be allowed to create a public nuisance and such accumulation shall be a public nuisance where detrimental to public health and safety.

(e) The owner or occupant of any premises may contract for additional collection services in excess of those required or provided by contractor hereunder.

6.01.090 Collection of fees.

(a) Every person in the City who has the occupancy, charge or control of any place or premises, within the City where any ordinary household garbage, solid waste, recyclables, or organic waste accumulates or may accumulate, shall pay, or cause to be paid, to the City or its agent a charge in such amounts and in such manner as shall be established by the City for the service of having such ordinary household garbage, recyclables, or organic waste solid waste, collected and removed from the place or premises by the exclusive contractor. In the case of residential and commercial

rental units, the property owner of record ultimately shall be responsible for such charge.

(b) Nothing in this Section is intended to prevent an arrangement, or the continuance of an existing arrangement, under which payments of refuse collection fees are made by a tenant or tenants, or any agent, on behalf of the owner. However, any such arrangement will not affect the property owner's obligation to the contractor.

(c) All fees for service shall be proposed by the contractor and approved by the City Council by resolution. Fees shall be based on the type of occupancy or use of the place or premises.

(d) All fees (and any penalty) for collection services shall be billed and collected in accordance with rules and regulations proposed by the contractor and established and adopted by the City Council. The City Council may collect residential fees on the tax roll pursuant to Section 6.01.110.

6.01.100 Refuse collection fee a debt.

The refuse collection fee shall be a civil debt owing the contractor and the City from the owner, occupant or person in possession, charge or control of the premises. A penalty may be charged for late payment. Should any person fail, refuse or neglect to pay a collection bill within 30 days after received, without a valid dispute therefore, the contractor may refuse to collect solid waste, organic waste or recyclables from the premises until the bill is paid or the matter otherwise is resolved.

6.01.110 Collection procedure for delinquent accounts - creation of lien.

Fees authorized pursuant to this Chapter, including those owing prospectively as well as those which remain unpaid as of April 1 of any year may be collected on the property tax roll by the City as provided in this Section.

(a) Annually, on or before July 1, of each year, the City shall cause a written report to be prepared and filed with the City Clerk. The report shall describe each parcel in the city receiving solid waste collection services and the charge for such services for the next fiscal year. For collection of delinquent accounts, the contractor shall cause a

report of delinquent fees or charges to be prepared annually after April 1. The report may contain both prospective and delinquent charges. Charges may be placed on the tax rolls for residential and/or commercial property.

(b) The Council shall fix a time, date and place for a hearing on the report and any objections or protests thereto.

(c) The City Council shall cause written notice of such hearing to be mailed to the landowners listed on the report not less than 15 days prior to the date of the hearing.

(d) At the hearing, the City Council shall hear any objections or protests of landowners liable to be assessed for fees and may make such revisions or corrections to the report as it deems just, after which, by resolution, the report may be confirmed. The City Clerk shall file the report with the County Auditor before August 10 of each year.

(e) The fees set forth in the report as confirmed shall constitute special assessments against the respective parcels of land, and are a lien on the property for the amount of such delinquent fees plus administrative costs. A certified copy of the confirmed report shall be filed with the County Auditor for amounts of the respective parcels of land as they appear on the current assessment roll. The lien created attaches upon recordation, in the office of the County recorder, of a certified copy of the resolution of confirmation. The assessment may be collected at the same time and subject to the same procedures including sale in case of delinquency as provided for such taxes. All laws applicable to the levy, collection and enforcement of ad valorem property taxes shall be applicable to such assessments, except that if any real property to which such fees or charges relate has been transferred or conveyed to a bona fide purchaser for value, or if a lien of a bona fide encumbrancer for value has been created and attaches thereon, prior to the date on which the first installment of such taxes would become delinquent, then the lien which would otherwise be imposed shall not attach to such real property and the fees or charges and interest shall be transferred to the unsecured roll for collection.

6.01.120 Standby assessment on vacant parcels.

Pursuant to the authority set out in Health & Safety Code Sections 5470 et seq., the City may by 4/5ths vote adopt an ordinance, levy and collect an annual standby charge on unimproved property for solid waste capacity and collection and to meet obligations under AB 939, as it may be revised from time to time. By resolution approved by 4/5ths vote of the City Council, such charges may be collected in the same manner, by the same persons and at the same time and together with real property general taxes. In such event, the City Council shall:

(a) Annually cause a written report to be filed with the City Clerk, describing each parcel and the amount of the charge;

(b) Give notice of the charge and a hearing thereon shall be given as set out in Health & Safety Code Section 5473.1;

(c) At the time of the hearing, hear and consider any and all protests to the report. In the event of a protest by the owners of a majority of separate parcels, the report shall not be approved;

(d) Absent a majority protest, approve the report and file it with the County Auditor as set out in Section 5473.4 of the Health & Safety Code; and

(e) The charges set out in the report shall constitute a lien on the property in the same manner as real property taxes.

All laws applicable to the levy, collection and enforcement of general taxes of the entity, including, but not limited to, those pertaining to the matters of delinquency, correction, cancellation, refund and redemption, are applicable to such charges, except that if any real property to which such charges relate has been transferred or conveyed to a bona fide purchaser for value, or if a lien of a bona fide encumbrancer for value has been created and attaches thereon, prior to the date on which the first installment of such taxes would become delinquent, then the lien which would otherwise be imposed shall not attach to such real property and the charges relating to such property shall be transferred to the unsecured roll of collection.

6.01.130 Solid waste collection schedules.

(a) Residential, industrial and commercial solid waste and recyclable material shall be collected at least once weekly. Collections shall not be made between 8 p.m. and 7 a.m. unless otherwise agreed in advance in writing by the City Manager. Organic waste shall be collected on the same schedule or as determined to be necessary by the City and the Contractor. Collections of discarded automobile or truck bodies or other bulky or heavy objects, dirt, sod, rock, manure or waste from any stable, and material resulting from building or construction charges shall occur within seven days from receipt of request for such collection unless needed sooner for health and safety reasons. Subject to such limitations as may be agreed to by the City and waste hauler, dead animals shall be removed without charge within 24 hours after oral request for such removal. Special clean-up shall occur as set out in Section 6.01.150(d). Neither bulky waste nor dead animals shall be set out for collection except as set out in Section 6.01.150(b).

(b) The contractor also may be required to provide at its expense waste collection bins or containers within City facilities or other public areas, including but not limited to Section 26 (the BLM parcel).

6.01.140 Placement of containers.

(a) Residential: Unless other appropriate arrangements are made between an owner/agent and the approved collector, due to special circumstances, all containers shall be placed for collection along the curb or paved alley as directed by the City. On streets without curbs, containers shall be placed in the parkway but not in the local flowline. No person shall place any solid waste, organic waste or recyclable material or any container containing such material at any place of collection before 5:00 p.m. of the day preceding its scheduled collection, or leave any such container at the place of collection after 9:00 p.m. on the day of actual collection.

(b) Industrial, commercial and multiple dwelling units: Industrial, commercial and multiple dwelling residential solid waste containers or containers for recyclable materials or organic waste installed outdoors shall be screened and located in compliance with City zoning regulations.

(c) Public nuisance of containers prohibited: When not placed for collection, solid waste containers shall be kept in an area which is not visible from the street and which will not be offensive to neighboring property so far as it is reasonably practicable to do so. Recyclable containers and Organic Waste containers shall be placed in the same manner.

6.01.150 Condition of waste for collection

(a) Solid waste in containers. Waste shall be kept and placed for collection in sturdy containers with tight-fitting lids which shall be of a size, type and number agreed to by the City and the contractor; but shall not exceed 50 lbs. in weight when placed for pickup.

(b) Waste not in containers.

(1) Single bulky items of solid waste or items not in containers shall be collected provided that no item exceeds three feet in length and one foot in diameter, or weighs over 50 pounds.

(2) Solid waste or organic waste in bundles shall be collected provided that each bundle is tied and does not exceed three feet in length and one foot in diameter, or weigh over 50 pounds, not to exceed three bundles in any one pick-up day.

(3) Bulky household items such as stoves, refrigerators, furniture, water heaters and similar material shall be collected according to the collection policies of the waste collector for such items.

(4) Cardboard or empty cardboard boxes shall be collected and not returned to property owners or tenants.

(5) Magazines shall be securely tied in bundles if not placed in containers.

(6) Fluorescent lamp tubes must be broken prior to pickup.

(7) When any refuse is not collected by the approved collection agent, he shall leave a tag, provided at its cost, at least 2" x 6" in size, on which is specifically stated the reason for the refusal to collect and stating the City regulation or provision of

the agreement which has been violated. Such tag shall contain thereon the name, address and telephone number of the approved collection agent and shall be securely fastened to the container or article. The approved collection agent shall maintain a record of the location where all and any such tags have been placed. In the event the reason for non-collection is not remedied or cured by the date of the next regular pickup for the location, the approved collection agent shall provide the City with written notice thereof, stating the full particulars of the reason for no collection and location thereof.

(c) Recyclables in containers: All recyclable materials shall be placed in containers provided by the approved collection agent specifically for that purpose. In the event that such containers are filled, additional recyclable material may be placed adjacent to the recycling container in another container, bag or box.

(d) The approved collection agent agrees to assist and cooperate, at least twice per year, at no additional cost, in a clean-up operation on dates to be mutually determined.

6.01.160. Ownership of waste materials.

Solid wastes subject to collection by the approved collection agent shall become the property of that agent. Recyclable materials, and organic wastes, shall become property of the City. No person other than the person generating the materials, City employees or the contractor acting within the scope of his or her agency or employment shall remove such materials once placed for collection.

6.01.170 Solid waste and recyclable containers.

(a) Care of all containers: All containers shall be returned upright to the curb where found. Containers or lids shall not be deposited in the street or on adjoining property. Collectors shall not in any way throw or roughly handle any container so as to cause damage. The approved collection agent shall return all bins, roll-off boxes and the like utilized for business establishments hereunder, to the enclosure(s) provided therefor on the property. In the event that a business establishment fails to utilize such enclosures, or if said enclosures are rendered unusable, the approved collection agent shall request

the business establishment to make the enclosure usable for bins, roll-off boxes and the like. If the business establishment fails or refuses to correct the situation, the approved collection agent shall notify the City.. The contractor immediately shall remove any and all material that is spilled.

(b) Replacement of faulty containers: Where the property owner or occupant provides the container, any container that leaks and is not watertight shall be replaced by the owner within ten (10) days after notice from the collector, stating the condition of such container. Such notice from the collector shall be made by attaching a tag to the container indicating its defective condition.

(c) Operator responsibility: Where the approved collection agent furnishes containers (whether for solid waste or recyclables), he is responsible for maintaining the containers in good condition, ordinary wear and tear excepted, unless they are furnished under other terms, conditions or agreements.

(d) Use of container: No person shall tamper with, modify, remove from or deposit recyclables, solid wastes or organic waste in any container which has not been provided for his use without the permission of the container owner.

6.01.180 Vehicles and contractor's employees.

(a) The approved collection agent shall own or lease and maintain at its expense all equipment necessary to perform its duties as provided for under the Agreement, including sufficient radio equipment for office-to-field equipment communication.

(b) The contractor shall maintain all trucks and equipment used within the City in good mechanical condition and the same shall be clean and uniformly painted and numbered. All trucks and equipment shall have painted thereon, or affixed thereto, in letters and numerals at least six inches in height, the name and telephone number of the contractor, which name and telephone number shall be clearly visible at all times. Each vehicle utilized by the contractor shall be identified by numerals at least six inches in height in a location or locations on such vehicles to be specified by the City. A current list showing each vehicle so identified shall be supplied to the City at least annually.. All trucks and

equipment used in the performance of the agreement shall be available for and subject to inspection by the City. If the City finds that any truck or equipment requires correction of defects, it shall not be used by the contractor in the performance of the agreement until corrected to the reasonable satisfaction of the City. The contractor shall cause its vehicles to be inspected annually by the California Highway Patrol and the report of any and all California Highway Patrol inspections (annual or otherwise) shall be provided to the City within one week thereafter.

All truck bodies used by the contractor shall be watertight and leak-proof and so constructed as to prevent odors or falling, leaking or spilling refuse unless special arrangements are approved by the City for certain areas. Each piece of equipment used by Contractor shall carry at all times a broom and shovel to be used for the immediate removal of any spilled material as well as a fire extinguisher and first aid kit.

Each vehicle used within the City shall be washed at least once a week and steam-cleaned once a month and shall at no time constitute a nuisance or menace to public welfare, health and safety.

(c) The contractor at all times shall comply with state, federal and local rules and regulations applicable to its employees. All employees working within the City shall be bonded.

6.01.190 Complaint service.

(a) The approved collection agent shall maintain a telephone service with a local exchange area telephone number for the purpose of handling complaints or emergency service calls. The telephone service shall be operated between the hours of 8:00 a.m. and 5:00 p.m. of each day of the week during which collections are made.

(b) Complaints received by the approved collection agent shall be recorded in a log established for that purpose and shall specify the date and time of the complaint and the substance thereof. The disposition of the complaint and the date of disposition shall be recorded and a copy of said log shall be provided to the City monthly. The contractor shall use its best efforts to resolve all complaints within 48 hours from the time received.

(c) The approved collection agent shall have available, during the hours while the approved collection agent's telephone service is in operation, an emergency service vehicle to attend to complaints or emergency calls.

(d) The approved collection agent shall visit the City offices at such times as the City shall designate for the purpose of discussing any matters relating to, or any complaints which may be involved with, the performance of the agreement. The approved collection agent shall report back as directed on any action taken with reference to subject matter so discussed. Coordination of such check-in meetings is to be arranged by the City.

(e) Every effort will be made to provide a good quality of complaint service and follow up in the community.

6.01.200 Compliance with Solid Waste Legislation.

(a) The approved collection agent shall reimburse the City for the cost of developing a

Source Reduction and Recycling Element (SRRE) and Household Hazardous Waste Element (HHWE) that meets all requirements of AB 939. The contractor shall collect with its bills the cost of implementing the SRRE and HHWE as set by the City. The contractor also shall provide a specific and detailed program approved by the City for such implementation in order to meet the waste-reduction goals of AB 939 including the financing of such program.

(b) The approved collection agent shall provide for the City to comply with all applicable current and future solid waste laws and regulations.

6.01.210 Penalties for violation.

Violations of this Chapter shall be punishable as an infraction in accordance with the Canyon Lake Municipal Code. Fines for such infractions shall be within the limits established by the Canyon Lake Municipal Code. In addition, any violation of this Chapter is deemed to be a public nuisance that may be abated by administrative or criminal action.

Section 2. To the extent the provisions of the Canyon Lake Municipal Code as amended by this Ordinance are substantially the same as the provisions of that Code as they read immediately prior to the adoption of this Ordinance, then those provisions shall be construed as continuations of the earlier provisions and not as new enactments.

Section 3. This ordinance shall take effective 30 days from the date of its adoption.

PASSED, APPROVED AND ADOPTED this XX day of August, 2017.

Randall P. Bonner, Mayor

Approved as to form:

Attest:

Stephanie Roseen, Deputy City Clerk

Elizabeth Martyn, City Attorney

State of California)
County of Riverside)ss
City of Canyon Lake)

I, Stephanie Roseen, Deputy City Clerk of the City of Canyon Lake, California do hereby certify that the foregoing Ordinance No. 167 was introduced at an adjourned meeting of the City Council held on the 12th day of July, 2017 and was duly adopted by the City Council of the City of Canyon Lake, California, at a regular meeting held on the XXst day of August, 2017, by the following vote:

AYES:

NOES:

ABSENT:

ABSTAIN:

Stephanie Roseen, Deputy City Clerk

**City of Canyon Lake
City Council
Staff Report**

TO: Honorable Mayor and Members of the City Council

FROM: Aaron Palmer, City Manager

BY: Ariel M Hall, City Clerk

DATE: June 20, 2017

SUBJECT: Consider information and presentation, and instruct staff whether to proceed to include participation in the CR&R organic recycling program

Recommendation

It is recommended that the City Council: consider information and the CR&R presentation regarding the proposed residential and commercial organic recycling program specifically including the anaerobic digester facility.

“Organic materials” means food waste, green waste, landscape and pruning waste, compostables, nonhazardous wood waste and minimal amounts of soiled paper waste that is mixed in with food waste. Organic materials include those now used as covering for landfills.

The Council then should determine if the City wishes to proceed to consider participation at an added cost for residences of \$1.95 per month. If the decision is to participate then the City Council should a) direct the City Attorney to revise the solid waste ordinance to address organic waste as required by recent legislation; and

b) direct staff to review Amendment No. 4 to the Franchise Agreement with CR&R;

c) incorporate the rate for Residential Organics Recycling Program into the monthly solid waste disposal rates to be placed on the tax bill and re-advertise the public hearing to adopt such rates (with CR&R to include an optional commercial organic recycling program; and

d) instruct staff set a July 12, 2017 public hearing on the increased rates and tax roll collected, re-advertise those increased rates and provide the franchise amendment and revised ordinance for that July 12 meeting.

Background

Upon incorporation, the City of Canyon Lake entered into a franchise agreement with CR&R to provide for the collection, transportation, recycling, composting, and disposal of solid waste and construction debris, and for providing temporary bin/roll-off services in commercial, residential, construction, and industrial areas within the City of Canyon Lake.

The agreement has been amended periodically to reflect new legislative requirements and changes in services. Recent legislation regarding the removal of organic waste from materials to be landfilled has prompted solid waste haulers and the agencies they serve to consider new methods for the processing of organic and address the change in the use of green waste for daily cover. The following provides additional background regarding State legislation and the proposed Residential Organics Recycling Program.

Statewide Policies and Legislative Mandates:

There are five legislative actions that drive the current and future solid waste and recycling efforts regarding organic waste diversion from landfills.

1. Assembly Bill 939 – Required that cities and counties met solid waste diversion goals of 25% by 1995 and 50% by 2000. If these diversion goals are not met by a city, CalRecycle may impose administrative civil penalties up to \$10,000 per day.
2. Assembly Bill 32 – Requires California to reduce its greenhouse gas emissions to 1990 levels by 2020 (a reduction of approximately 15 percent below emissions expected under a “business as usual” scenario). In response to Assembly Bill 32, the California Air Resources Board developed the Seeping Plan that contains the main strategies California will use to reduce the greenhouse gases that cause climate change. The Seeping Plan focuses on six major sections: 1) transportation and fuels; 2) energy generation; 3) waste; 4) water; 5) natural lands; and 6) agriculture.
3. Assembly Bill 341 – Requires that businesses that generate more than four cubic yards of commercial solid waste per week or is a multi family residential dwelling of five units or more to arrange for recycling services, on and after July 1, 2012. AB341 also set a declaration that it is the policy goal of the State that not less than 75% of solid waste generated be source reduced, recycled, or composted by the year 2020.
4. Assembly Bill 1826 – Requires that on or after April 1, 2016, a business that generates eight cubic yards or more of organic waste per week shall arrange for recycling services specifically for organic waste.
5. Assembly Bill 1594 – Commencing January 1, 2020, green waste material used as alternative daily cover (ADC) at landfills no longer constitutes diversion through recycling and shall be considered disposal. Commencing on August 1, 2018, local

jurisdictions are required to report on how they intend to divert material being used as ADC.

Potential Impact To The City of Canyon Lake:

The City of Canyon Lake residents obviously generate green waste, a portion of which is used as alternative daily cover. As mentioned above, by year 2020 green waste will no longer count toward diversion is used for ADC, and there is the potential that non-composted green waste will not be allowed for land application on agricultural land, or at the least, more stringent regulations regarding the quality of the end product and land application will be implemented. Additionally, as other cities throughout California take action to find outlets for their green waste, composting facilities will reach their permitting capacity. This will result in the need to find suitable outlets for the organic material, which may include transporting green waste material farther distances away. These factors negatively impact the City's ability to meet its diversion goals as mandated by CalRecycle.

Currently, non-composted green waste used for land application is the least expensive means to divert green waste from the landfill and continue to receive diversion credit toward meeting State mandates; however, with looming environmental concerns regarding this practice, it is expected that the cost will increase as more stringent regulations are considered. The practice of using green waste as ADC at the landfills is the next least expensive practice, however, pursuant to AB1594, this practice will no longer help the City toward meeting its diversion mandates. The proposed Residential Organics Recycling Program will cost an additional \$1.95 per parcel per month and will result in a product that is environmentally preferred for land application and qualifies for full diversion credit toward meeting the State diversion mandates.

Franchise Agreement Amendment and Rate Adjustment:

Should the City Council choose to implement the CR&R proposed residential organics recycling program, the existing Franchise Agreement with CR&R will need to be amended. The Franchise Agreement amendment would be brought to the City Council for consideration at the July 12 Council Meeting along with a revision to the solid waste ordinance. Additionally, the proposed rate increase of \$1.95 per parcel per month will need to be incorporated into Exhibit "C" of the Franchise Agreement (Schedule of Rates for Trash and Recycling) and the rate hearing re-advertised and conducted at that meeting.

Budget (or Fiscal) Impact

There is no anticipated fiscal impact to the City of Canyon Lake General Fund.

No Attachments

**City of Canyon Lake
City Council
Staff Report**

TO: Mayor and City Council

FROM: Aaron Palmer, City Manager

BY: Stephanie Roseen, Deputy City Clerk

DATE: July 12, 2017

SUBJECT: Designation of Voting Delegate and Alternates at League of California Cities Annual Conference – Sept. 13th – 15th 2017 in Sacramento

Recommendation:

Appoint a voting delegate and alternate(s) to the League of California Cities Annual Conference Business Meeting on Friday, September 15, 2017; and direct City Staff to complete and file the necessary paperwork.

Background:

Consistent with the League of California Cities' bylaws, a City's voting delegate and up to two alternates must be designated by the City Council at a City Council Meeting. In the past the Mayor has been appointed the voting delegate and the Mayor Pro Tem as the voting alternate. The voting delegate and alternates must be registered to attend the conference. In order to cast a vote, at least one person must be present at the Business Meeting and in possession of the voting delegate card.

Budget (or Fiscal) Impact:

Registration and expenses for the League of California Cities Annual Conference attendance was included in the Fiscal Year 2017/2018 Budget.

Attachments:

1. Letter from the League of California Cities regarding Designation of Voting Delegates and Alternates **Pg. 132**

MAY 15 2017

BY: SH

1400 K Street, Suite 400 • Sacramento, California 95814
Phone: 916.658.8200 Fax: 916.658.8240
www.cacities.org

Council Action Advised by July 31, 2017

May 3, 2017

TO: Mayors, City Managers and City Clerks

**RE: DESIGNATION OF VOTING DELEGATES AND ALTERNATES
League of California Cities Annual Conference – September 13 – 15, Sacramento**

The League's 2017 Annual Conference is scheduled for September 13 – 15 in Sacramento. An important part of the Annual Conference is the Annual Business Meeting (during General Assembly), scheduled for 12:30 p.m. on Friday, September 15, at the Sacramento Convention Center. At this meeting, the League membership considers and takes action on resolutions that establish League policy.

In order to vote at the Annual Business Meeting, your city council must designate a voting delegate. Your city may also appoint up to two alternate voting delegates, one of whom may vote in the event that the designated voting delegate is unable to serve in that capacity.

Please complete the attached Voting Delegate form and return it to the League's office no later than Friday, September 1, 2017. This will allow us time to establish voting delegate/alternate records prior to the conference.

Please note the following procedures that are intended to ensure the integrity of the voting process at the Annual Business Meeting.

- **Action by Council Required.** Consistent with League bylaws, a city's voting delegate and up to two alternates must be designated by the city council. When completing the attached Voting Delegate form, please attach either a copy of the council resolution that reflects the council action taken, or have your city clerk or mayor sign the form affirming that the names provided are those selected by the city council. Please note that designating the voting delegate and alternates must be done by city council action and cannot be accomplished by individual action of the mayor or city manager alone.
- **Conference Registration Required.** The voting delegate and alternates must be registered to attend the conference. They need not register for the entire conference; they may register for Friday only. To register for the conference, please go to our website: www.cacities.org. In order to cast a vote, at least one voter must be present at the

Business Meeting and in possession of the voting delegate card. Voting delegates and alternates need to pick up their conference badges before signing in and picking up the voting delegate card at the Voting Delegate Desk. This will enable them to receive the special sticker on their name badges that will admit them into the voting area during the Business Meeting.

- **Transferring Voting Card to Non-Designated Individuals Not Allowed.** The voting delegate card may be transferred freely between the voting delegate and alternates, but *only* between the voting delegate and alternates. If the voting delegate and alternates find themselves unable to attend the Business Meeting, they may *not* transfer the voting card to another city official.
- **Seating Protocol during General Assembly.** At the Business Meeting, individuals with the voting card will sit in a separate area. Admission to this area will be limited to those individuals with a special sticker on their name badge identifying them as a voting delegate or alternate. If the voting delegate and alternates wish to sit together, they must sign in at the Voting Delegate Desk and obtain the special sticker on their badges.

The Voting Delegate Desk, located in the conference registration area of the Sacramento Convention Center, will be open at the following times: Wednesday, September 13, 8:00 a.m. – 6:00 p.m.; Thursday, September 14, 7:00 a.m. – 4:00 p.m.; and Friday, September 15, 7:30 a.m.– Noon. The Voting Delegate Desk will also be open at the Business Meeting on Friday, but will be closed during roll calls and voting.

The voting procedures that will be used at the conference are attached to this memo. Please share these procedures and this memo with your council and especially with the individuals that your council designates as your city's voting delegate and alternates.

Once again, thank you for completing the voting delegate and alternate form and returning it to the League office by Friday, September 1. If you have questions, please call Carly Shelby at (916) 658-8279.

Attachments:

- Annual Conference Voting Procedures
- Voting Delegate/Alternate Form

Annual Conference Voting Procedures

1. **One City One Vote.** Each member city has a right to cast one vote on matters pertaining to League policy.
2. **Designating a City Voting Representative.** Prior to the Annual Conference, each city council may designate a voting delegate and up to two alternates; these individuals are identified on the Voting Delegate Form provided to the League Credentials Committee.
3. **Registering with the Credentials Committee.** The voting delegate, or alternates, may pick up the city's voting card at the Voting Delegate Desk in the conference registration area. Voting delegates and alternates must sign in at the Voting Delegate Desk. Here they will receive a special sticker on their name badge and thus be admitted to the voting area at the Business Meeting.
4. **Signing Initiated Resolution Petitions.** Only those individuals who are voting delegates (or alternates), and who have picked up their city's voting card by providing a signature to the Credentials Committee at the Voting Delegate Desk, may sign petitions to initiate a resolution.
5. **Voting.** To cast the city's vote, a city official must have in his or her possession the city's voting card and be registered with the Credentials Committee. The voting card may be transferred freely between the voting delegate and alternates, but may not be transferred to another city official who is neither a voting delegate or alternate.
6. **Voting Area at Business Meeting.** At the Business Meeting, individuals with a voting card will sit in a designated area. Admission will be limited to those individuals with a special sticker on their name badge identifying them as a voting delegate or alternate.
7. **Resolving Disputes.** In case of dispute, the Credentials Committee will determine the validity of signatures on petitioned resolutions and the right of a city official to vote at the Business Meeting.

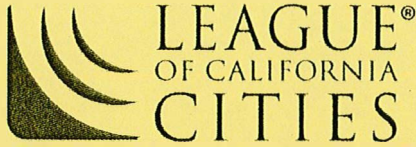

CITY: _____

2017 ANNUAL CONFERENCE
VOTING DELEGATE/ALTERNATE FORM

Please complete this form and return it to the League office by Friday, September 1, 2017. Forms not sent by this deadline may be submitted to the Voting Delegate Desk located in the Annual Conference Registration Area. Your city council may designate one voting delegate and up to two alternates.

In order to vote at the Annual Business Meeting (General Assembly), voting delegates and alternates must be designated by your city council. Please attach the council resolution as proof of designation. As an alternative, the Mayor or City Clerk may sign this form, affirming that the designation reflects the action taken by the council.

Please note: Voting delegates and alternates will be seated in a separate area at the Annual Business Meeting. Admission to this designated area will be limited to individuals (voting delegates and alternates) who are identified with a special sticker on their conference badge. This sticker can be obtained only at the Voting Delegate Desk.

1. VOTING DELEGATE

Name: _____

Title: _____

2. VOTING DELEGATE - ALTERNATE

Name: _____

Title: _____

3. VOTING DELEGATE - ALTERNATE

Name: _____

Title: _____

PLEASE ATTACH COUNCIL RESOLUTION DESIGNATING VOTING DELEGATE AND ALTERNATES.

OR

ATTEST: I affirm that the information provided reflects action by the city council to designate the voting delegate and alternate(s).

Name: _____ E-mail _____

Mayor or City Clerk _____ Phone: _____
(circle one) (signature)

Date: _____

Please complete and return by Friday, September 1, 2017

League of California Cities
ATTN: Carly Shelby
1400 K Street, 4th Floor
Sacramento, CA 95814

FAX: (916) 658-8240
E-mail: cshelby@cacities.org
(916) 658-8279

**City of Canyon Lake
City Council
Staff Report**

TO: Honorable Mayor and Members of the City Council
FROM: Aaron Palmer, City Manager
DATE: July 12, 2017
SUBJECT: Discussion and Possible Direction Regarding Changing City Hall's Operating Hours

Recommendation

Discussion and Possible Direction Regarding Changing City Hall's Operating Hours.

Background

Mayor Pro Tem Warren has requested a discussion, by the City Council, of City Hall operating hours. If during that discussion, the Council desires to explore further changing City Hall operating hours, they can direct staff as how to proceed.

Budget (or Fiscal) Impact

None

Attachments

None

**City of Canyon Lake
City Council
Staff Report**

TO: Mayor and City Council

FROM: Aaron Palmer, City Manager

BY: Stephanie Roseen, Deputy City Clerk

DATE: July 12, 2017

SUBJECT: Resolution No. 2017-08 - Approving Annual Rate Adjustment and Confirmation of Collection of Residential Solid and Organic Waste Charges on the Tax Rolls

Recommendation:

Adopt Resolution No. 2017-08 approving the annual rate adjustment for all solid and organic waste services and placement of residential solid and organic waste fees on the tax roll for collection for the 2017-2018 fiscal year.

Background:

A public hearing was noticed before the City Council on June 1, 2017 to review documentation from CR&R, the franchise holder, for the annual rate adjustment for solid waste fees. The rates are recommended to the City by CR&R based upon their actual costs for service, which include adjustments for the Consumer Price Index (CPI) and Landfill costs. The franchise agreement requires that CR&R annually provide evidence of the CPI adjustment to the City Manager for review and approval.

At the June 1, 2017 meeting Alex Braicovich provided a presentation on the CR&R Inc. Anaerobic Digestive System and invited Canyon Lake's participation. The Council then initially discussed whether the City was interested in participating, as there would be an additional \$1.95 a month per resident fee added to the tax roll as a disposal pass-through cost. The hearing on tax roll collection of fees was continued to June 12.

At the June 20, 2017 meeting Council voted to participate in the Anaerobic Digestive System Program and to incorporate the new increased rate. The hearing on tax roll collection of fees was re-noticed to include the additional amount for the July 12 date.

Since Canyon Lake has mandatory trash collection, the City Council has adopted an ordinance that allows solid waste collection fees to be collected on the property tax roll for residential services. Tax roll collection minimizes delinquencies and thus helps keep rates down. This ordinance now has been amended by urgency action to allow inclusion of the cost of organic recycling in tax roll collection.

As provided in the contract with CR&R, there are automatic pass through components for service (CPI) and landfill (disposal) costs. The April 17, 2017 letter from J. Alex Braicovich of CR&R and 2016 Annual Price Adjustment reflect an increase of 36 cents per month for CPI and an increase in the Riverside County Landfill component of 9 cents per month for a total increase of 45 cents per month; from \$21.90 to \$22.35 a month for residential standard service. As set out in the revised letter, that amount now will include the \$1.95 for organic recycling.

Similarly, for commercial, industrial and multi-family residential refuse service, the typical three cubic yard bin will increase by \$2.32 from \$123.35 to \$125.67 per month. These are minimum increases that will help defray the increased cost of operations and maintain the level of service.

Budget (or Fiscal) Impact:

Revenue Neutral – this is a pass-through rate

Attachments:

1. Resolution No. 2017-08 **Pg. 142**
2. Letter from CR&R dated April 17, 2017 **Pg. 152**
3. Notice of Continued Public Hearing **Pg. 155**

RESOLUTION NO. 2017-08

A RESOLUTION OF THE CITY COUNCIL OF THE CITY OF CANYON LAKE INCREASING AND SETTING SOLID AND ORGANIC WASTE COLLECTION RATES FOR THE 2017-2018 FISCAL YEAR AND PROVIDING FOR COLLECTION OF RESIDENTIAL SERVICE ON THE PROPERTY TAX ROLL

WHEREAS, pursuant to the provisions of State law, including but not limited to Health & Safety Code Sections 5470 et seq., the City of Canyon Lake may adopt and implement fees and charges to cover the cost of collection of solid and organic waste within the City and, when adopted, may collect such fees for residential service on the property tax rolls; and

WHEREAS, because of increased costs, the City's franchise hauler has informed the City that such fees must be increased by \$0.45 per month per single family residence and \$2.32 per month for commercial, industrial and multi-family residential refuse service, and has provided a report explaining the reasons for such increase, which report has been on file at the City offices; and

WHEREAS, based upon the requirements of AB 341, AB 1826 and AB 1594 for removal of organic waste from the waste stream, the franchise holder has constructed an additional facility for the disposal of such organic waste and the City has determined to participate in that program for organic waste recycling; and

WHEREAS, the additional residential cost of that required change in disposal is \$1.95/month, subject to the annual CPI increase; and

WHEREAS, the proposed increased fees are set out on Exhibit "A", attached and incorporated hereto; and

WHEREAS, the City has published notice of the collection of such residential fees on the property tax roll in the same manner, at the same time and subject to the same penalties as property taxes; and

WHEREAS, as additional information for such tax roll collection, a written report of prospective solid and organic waste collection fees for the fiscal year 2017-2018 has been prepared and filed with the City Clerk; and

WHEREAS, on July 12, 2017, the City Council conducted a duly noticed public hearing and heard all comments/protests regarding the fee increase; and

WHEREAS, the City Council finds from such reports that the amount of fees is the reasonable cost of service provided, plus direct and indirect overhead; that amounts collected will be used only for immediately available (and not standby) solid waste collection services; that such fees and charges are proportionate to the amount of service received, and that such fees and charges are not for traditional governmental services such as police or libraries; and

WHEREAS, the City Council further finds that this increase in rates is for the purpose of meeting operating expenses, including wage rates and fringe benefits, required for the collection of solid waste within the City pursuant to its existing franchise, and that such action therefore is statutorily exempt from CEQA under Public Resources Code Section 21080 (b) and Section 15273 of the CEQA guidelines.

NOW, THEREFORE, THE CITY COUNCIL OF CANYON LAKE RESOLVES AND ORDERS AS FOLLOWS:

SECTION 1. RECITALS: The Recitals set out above are true and correct.

SECTION 2. CEQA EXEMPTION: The adoption of fees as set out here is statutorily exempt from CEQA and staff is directed to take all necessary actions to prepare and file a Notice of Exemption.

SECTION 3. FEES DETERMINED: The solid waste collection fees are increased in the amounts set out on Exhibit "C". Such increase shall be effective on July 12, 2017.

SECTION 4. TAX ROLL COLLECTION: Such residential fees shall be collected on the property tax rolls. The City Clerk is directed to file a certified copy of this resolution and of the report with the County Auditor. The County Auditor is designated and empowered to collect the assessment as set out here as necessary. For purpose of tax roll collection, the fees set forth in the report shall be deemed to constitute special assessments against the respective parcels on which they are levied without regard to property valuation. The Assessment shall be collected at the same time and subject to the same procedures provided for such taxes. All laws applicable to the levy, collection and enforcement of ad valorem property taxes shall be applicable to such assessments, except that if any real property to which such fees

or charges relate has been transferred or conveyed to a bona fide purchaser for value, or if a lien of a bona fide encumbrancer for value has been created and attached thereon, prior to the date on which the first installment of such taxes would become delinquent, then the lien which would otherwise be imposed shall not attach to such real property and the fees or charges and interest shall be transferred to the unsecured roll for collection.

PASSED, APPROVED AND ADOPTED the 12st day of July, 2017.

Randall P. Bonner, Mayor

ATTEST:

Stephanie Roseen, Deputy City Clerk

State of California)
County of Riverside) ss
City of Canyon Lake)

I, Stephanie Roseen, Deputy City Clerk of the City of Canyon Lake, California, DO HEREBY CERTIFY that the foregoing is a true and correct copy of Resolution No. 2017-08 adopted by the City Council of the City of Canyon Lake, California, at an adjourned meeting thereof, held on July 12, 2017 by the following vote:

AYES:

NOES:

ABSENT:

ABSTAIN:

Stephanie Roseen, Deputy City Clerk

Dated: July 12, 2017

City of Canyon Lake Organics Recycling Rate Schedule
2017-2018

Residential Monthly Organics Recycling Rate

Rate per Home per Month: \$1.95
 Additional Food Scrap Pail: \$7.00 each

Anaerobic Digester Processing Component Calculations (Greenwaste Only):

Non - Food Disposal Rates are based on an average of 200 pounds per cubic yard
 Anaerobic Digester Disposal Rate of \$72.50 per ton

Two Cubic Yard Commercial Bins - Greenwaste Only			
Frequency	Service	Digester	Total Rate
1x per Week	\$ 127.21	\$ 47.09	\$ 174.30
2xPer Week	\$ 248.70	\$ 94.18	\$ 342.88
3x per Week	\$ 372.20	\$ 141.27	\$ 513.47
4x per Week	\$ 495.69	\$ 188.36	\$ 684.05
5x per Week	\$ 619.20	\$ 235.45	\$ 854.65
6x Per Week	\$ 742.70	\$ 282.54	\$ 1,025.24

Anaerobic Digester Processing Component Calculations (Food Establishment):

Food Disposal Rates are based on an average of 400 pounds per cubic yard
 Anaerobic Digester Disposal Rate of \$72.50 per ton

Two Cubic Yard Commercial Bins - Foodwaste Included			
Frequency	Service	Digester	Total Rate
1x per Week	\$ 127.21	\$ 94.18	\$ 221.39
2xPer Week	\$ 248.70	\$ 188.36	\$ 437.06
3x per Week	\$ 372.20	\$ 282.54	\$ 654.74
4x per Week	\$ 495.69	\$ 376.72	\$ 872.41
5x per Week	\$ 619.20	\$ 470.90	\$ 1,090.10
6x Per Week	\$ 742.70	\$ 565.08	\$ 1,307.78

Commercial Organics Cart Rates (Small Generator):

Four carts per account Maximum

64 Gallon Cart			
Frequency	Service	Digester	Total Rate
1x per Week	\$ 28.80	\$ 22.48	\$ 51.28
2xPer Week	\$ 58.76	\$ 44.96	\$ 103.72
3x per Week	\$ 88.14	\$ 67.44	\$ 155.58
4x per Week	\$ 117.52	\$ 89.92	\$ 207.44

5x per Week	\$ 146.90	\$ 112.40	\$ 259.30
6x Per Week	\$ 176.28	\$ 134.88	\$ 311.16

Rolloff Rates:

Disposal will be \$72.50 per ton plus the proposed Haul Rate for 2017-2018

*All Rates include 8% Franchise Fee

CITY OF CANYON LAKE

EXHIBIT "C"

Schedule of Rates
(effective July 1, 2017)

2 Fully automated single family residential collection, fully mechanized recycling, composting, transfer and disposal:		
Monthly Rate:	\$	22.35
3 Fully automated single family residential additional refuse, recycling or composting container:		
Monthly Rate Per Container:	\$	9.45
4 Single family residential additional bulky item pick up:		
Per Pick Up (two items per pick up):	\$	10.02
5 Commercial, industrial, and multi-family residential refuse monthly bin rates (one 3 cubic yard bin) with the following pick ups per week:		
	1 x week	\$ 125.67
	2 x week	\$ 249.16
	3 x week	\$ 372.66
	4 x week	\$ 496.15
	5 x week	\$ 619.66
	6 x week	\$ 743.16
6 Commercial, industrial, and multi-family residential recycle monthly bin rates (one 3 cubic yard bin) with the following pick ups per week:		
	1 x week	\$ 54.28
	2 x week	\$ 108.54
	3 x week	\$ 162.82
	4 x week	\$ 217.11
	5 x week	\$ 271.36
	6 x week	\$ 325.63
7 Temporary 3 cubic yard bin rate:	\$	95.29 per bin
8 Redeliver and reinstatement rate:	\$	43.75 per occurrence
9 40 cubic yard roll-off bin rate:	\$	229.57 + MRF/landfill fees
10 10 cubic yard roll-off/lowboy bin rate:	\$	229.57 + MRF/landfill fees

**CANYON LAKE
2017 ANNUAL PRICE ADJUSTMENT**

	New	Previous				
1. All Urban Consumers (Oct)	251.10	245.81	2.15%	86.0%		1.85%
2. Urban Wage Earners (Oct)	241.93	237.47	1.88%	14.0%		0.26%
						2.110%

	New	Previous			
Landfill	\$ 29.08	\$ 28.52	\$	0.56	1.96%
MRF	\$ 49.03	\$ 48.08	\$	0.95	1.98%

CPI *
1.97% * Provided by County Waste Manag

	Service Component				
	Previous Rate	Contract	CPI Change	Rate Change	Unit Measure
2 Standard service	\$ 21.90	78.0%	2.11%	\$ 0.36	per month
3 Additional Cart	\$ 9.21	78.0%	2.11%	\$ 0.15	per month
4 Additional Bulky pick up	\$ 9.77	78.0%	2.11%	\$ 0.16	per month
5 Refuse Bin rate - 3 cubic yard	\$ 123.35	71.5%	2.11%	\$ 1.86	per month
6 Recycle Bin rate - 3 cubic yard	\$ 53.47	71.5%	2.11%	\$ 0.81	per month
7 Temporary 3 cubic yard bin	\$ 93.42	71.5%	2.11%	\$ 1.41	per load
8 Re-deliver and re-instatement	\$ 42.85	100.0%	2.11%	\$ 0.90	per occurrence
9 40 cubic yard roll-off	\$ 224.83	100.0%	2.11%	\$ 4.74	per load
10 10 cubic yard roll-off	\$ 224.83	100.0%	2.11%	\$ 4.74	per load

Landfill Component			
Contract	Diversion	Landfill Fee Increase per Ton	Rate Change
\$ 0.21	20.2%	\$ 0.56	\$ 0.09
\$ 0.21	20.2%	\$ 0.56	\$ 0.09
\$ 0.21	20.2%	\$ 0.56	\$ 0.09
\$ 0.91	10.6%	\$ 0.56	\$ 0.46
\$ 0.91	10.6%	\$ 0.56	\$ 0.46

Total Rate Change	Previous Rate	Proposed Rate	Net % Change
\$ 0.45	\$ 21.90	\$ 22.35	2.1%
\$ 0.24	\$ 9.21	\$ 9.45	2.6%
\$ 0.25	\$ 9.77	\$ 10.02	2.6%
\$ 2.32	\$ 123.35	\$ 125.67	1.9%
\$ 0.81	\$ 53.47	\$ 54.28	1.5%
\$ 1.87	\$ 93.42	\$ 95.29	2.0%
\$ 0.90	\$ 42.85	\$ 43.75	2.1%
\$ 4.74	\$ 224.83	\$ 229.57	2.1%
\$ 4.74	\$ 224.83	\$ 229.57	2.1%

	Service Component				
	Previous Rate	Contract	CPI Change	Rate Change	Unit Measure
5 Complete Refuse 3 yd Bin Rates					
1 x week	\$ 123.35	71.5%	2.11%	\$ 1.86	per month
2 x week	\$ 245.00	71.5%	2.11%	\$ 3.70	per month
3 x week	\$ 366.67	71.5%	2.11%	\$ 5.53	per month
4 x week	\$ 488.32	71.5%	2.11%	\$ 7.37	per month
5 x week	\$ 610.00	71.5%	2.11%	\$ 9.20	per month
6 x week	\$ 731.66	71.5%	2.11%	\$ 11.04	per month
6 Complete Recycle Bin Rates					
1 x week	\$ 53.47	71.5%	2.11%	\$ 0.81	per month
2 x week	\$ 106.93	71.5%	2.11%	\$ 1.61	per month
3 x week	\$ 160.40	71.5%	2.11%	\$ 2.42	per month
4 x week	\$ 213.88	71.5%	2.11%	\$ 3.23	per month
5 x week	\$ 267.33	71.5%	2.11%	\$ 4.03	per month
6 x week	\$ 320.79	71.5%	2.11%	\$ 4.84	per month

Landfill Component			
Contract	Diversion	Landfill Fee Increase per Ton	Rate Change
\$ 0.91	10.6%	\$ 0.56	\$ 0.46
\$ 0.91	10.6%	\$ 0.56	\$ 0.46
\$ 0.91	10.6%	\$ 0.56	\$ 0.46
\$ 0.91	10.6%	\$ 0.56	\$ 0.46
\$ 0.91	10.6%	\$ 0.56	\$ 0.46

Total Rate Change	Previous Rate	Proposed Rate	Net % Change
\$ 2.32	\$ 123.35	\$ 125.67	1.9%
\$ 4.16	\$ 245.00	\$ 249.16	1.7%
\$ 5.99	\$ 366.67	\$ 372.66	1.6%
\$ 7.83	\$ 488.32	\$ 496.15	1.6%
\$ 9.66	\$ 610.00	\$ 619.66	1.6%
\$ 11.50	\$ 731.66	\$ 743.16	1.6%
\$ 0.81	\$ 53.47	\$ 54.28	1.5%
\$ 1.61	\$ 106.93	\$ 108.54	1.5%
\$ 2.42	\$ 160.40	\$ 162.82	1.5%
\$ 3.23	\$ 213.88	\$ 217.11	1.5%
\$ 4.03	\$ 267.33	\$ 271.36	1.5%
\$ 4.84	\$ 320.79	\$ 325.63	1.5%

Databases, Tables & Calculators by Subject

SHARE ON: FONT SIZE:

Change Output Options: From: To: **GO**
 include graphs include annual averages

[More Formatting Options](#)

Data extracted on: March 13, 2017 (2:00:35 PM)

Consumer Price Index - All Urban Consumers

Series Id: CUURA421SA0
 Not Seasonally Adjusted
Area: Los Angeles-Riverside-Orange County, CA
Item: All items
Base Period: 1982-84=100

Download: [.xlsx](#)

Year	Jan	Feb	Mar	Apr	May	Jun	Jul	Aug	Sep	Oct	Nov	Dec	Annual	HALF1	HALF2
2007	212.584	214.760	216.500	217.845	218.596	217.273	217.454	217.330	217.697	218.696	219.943	219.373	217.338	216.260	218.416
2008	220.918	221.431	223.606	224.625	226.651	229.033	229.886	228.484	227.449	226.159	222.229	219.620	225.008	224.377	225.638
2009	220.719	221.439	221.376	221.693	222.522	223.906	224.010	224.507	225.226	225.264	224.317	223.643	223.219	221.943	224.495
2010	224.610	224.620	225.483	225.916	226.438	225.877	225.991	226.373	226.048	226.794	225.941	226.639	225.894	225.491	226.298
2011	228.652	229.729	232.241	233.319	233.367	232.328	231.303	231.833	233.022	233.049	232.731	231.567	231.928	231.606	232.251
2012	233.441	234.537	236.941	236.866	237.032	236.025	235.776	237.222	238.104	240.111	237.675	236.042	236.648	235.807	237.488
2013	238.015	239.753	239.995	239.043	239.346	239.223	238.920	239.219	239.611	239.940	238.677	238.742	239.207	239.229	239.185
2014	239.857	241.059	242.491	242.437	243.362	243.528	243.727	243.556	243.623	243.341	241.753	240.475	242.434	242.122	242.746
2015	239.724	241.297	243.738	243.569	246.093	245.459	247.066	246.328	245.431	245.812	245.711	245.357	244.632	243.313	245.951
2016	247.155	247.113	247.873	248.368	249.554	249.789	249.784	249.700	250.145	251.098	250.185	250.189	249.246	248.309	250.184
2017	252.373														

12-Month Percent Change

Series Id: CUURA421SA0
 Not Seasonally Adjusted
Area: Los Angeles-Riverside-Orange County, CA
Item: All items
Base Period: 1982-84=100

Download: [.xlsx](#)

Year	Jan	Feb	Mar	Apr	May	Jun	Jul	Aug	Sep	Oct	Nov	Dec	Annual	HALF1	HALF2
2007	3.2	3.5	3.8	3.5	2.9	2.9	2.9	2.6	2.3	3.5	4.2	4.2	3.3	3.3	3.2
2008	3.9	3.1	3.3	3.1	3.7	5.4	5.7	5.1	4.5	3.4	1.0	0.1	3.5	3.8	3.3
2009	-0.1	0.0	-1.0	-1.3	-1.8	-2.2	-2.6	-1.7	-1.0	-0.4	0.9	1.8	-0.8	-1.1	-0.5
2010	1.8	1.4	1.9	1.9	1.8	0.9	0.9	0.8	0.4	0.7	0.7	1.3	1.2	1.6	0.8
2011	1.8	2.3	3.0	3.3	3.1	2.9	2.4	2.4	3.1	2.8	3.0	2.2	2.7	2.7	2.6
2012	2.1	2.1	2.0	1.5	1.6	1.6	1.9	2.3	2.2	3.0	2.1	1.9	2.0	1.8	2.3
2013	2.0	2.2	1.3	0.9	1.0	1.4	1.3	0.8	0.6	-0.1	0.4	1.1	1.1	1.5	0.7
2014	0.8	0.5	1.0	1.4	1.7	1.8	2.0	1.8	1.7	1.4	1.3	0.7	1.3	1.2	1.5
2015	-0.1	0.1	0.5	0.5	1.1	0.8	1.4	1.1	0.7	1.0	1.6	2.0	0.9	0.5	1.3
2016	3.1	2.4	1.7	2.0	1.4	1.8	1.1	1.4	1.9	2.2	1.8	2.0	1.9	2.1	1.7
2017	2.1														

RECOMMEND THIS PAGE USING: Facebook Twitter LinkedIn

TOOLS

[Areas at a Glance](#)
[Industries at a Glance](#)
[Economic Releases](#)

CALCULATORS

[Inflation](#)
[Location Quotient](#)
[Injury And Illness](#)

HELP

[Help & Tutorials](#)
[FAQs](#)
[Glossary](#)

INFO

[What's New](#)
[Careers @ BLS](#)
[Find It! DOL](#)

RESOURCES

[Inspector General \(OIG\)](#)
[Budget and Performance](#)
[No Fear Act](#)

Databases, Tables & Calculators by Subject

SHARE ON: FONT SIZE:

Change Output Options: From: To: **GO**
 include graphs include annual averages

[More Formatting Options](#)

Data extracted on: March 20, 2017 (6:31:56 PM)

Consumer Price Index - Urban Wage Earners and Clerical Workers

Series Id: CWURA421SA0
 Not Seasonally Adjusted
 Area: Los Angeles-Riverside-Orange County, CA
 Item: All items
 Base Period: 1982-84=100

Download: [.xlsx](#)

Year	Jan	Feb	Mar	Apr	May	Jun	Jul	Aug	Sep	Oct	Nov	Dec	Annual	HALF1	HALF2
2007	204.498	206.632	208.929	210.195	211.145	209.614	209.444	209.240	209.849	211.259	212.844	212.282	209.661	208.502	210.820
2008	213.825	214.231	216.493	217.914	219.702	222.435	223.245	221.230	220.285	218.726	214.083	211.007	217.765	217.433	218.096
2009	212.454	213.234	213.013	213.405	214.446	216.145	216.128	216.628	217.302	217.474	216.618	216.233	215.257	213.783	216.730
2010	217.290	217.090	218.157	218.475	218.787	218.222	218.367	218.752	218.427	219.339	218.694	219.619	218.435	218.004	218.866
2011	221.540	222.814	225.770	227.051	226.842	225.461	224.277	224.665	226.096	226.116	225.786	224.444	225.072	224.913	225.231
2012	226.245	227.585	230.281	230.023	230.180	228.917	228.446	230.229	231.085	233.431	230.426	228.940	229.649	228.872	230.426
2013	230.651	232.983	233.200	232.030	232.387	232.378	232.190	232.245	232.817	232.735	231.598	231.594	232.234	232.271	232.197
2014	232.578	233.886	235.500	235.717	236.647	236.880	236.963	236.504	236.451	235.921	233.896	232.330	235.273	235.201	235.344
2015	231.063	232.975	235.991	235.697	238.816	237.792	239.889	238.755	237.324	237.472	237.190	236.787	236.646	235.389	237.903
2016	238.609	238.262	239.146	239.536	240.320	240.522	240.580	240.267	240.851	241.932	240.809	240.846	240.140	239.399	240.881
2017	242.735	244.254													

12-Month Percent Change

Series Id: CWURA421SA0
 Not Seasonally Adjusted
 Area: Los Angeles-Riverside-Orange County, CA
 Item: All items
 Base Period: 1982-84=100

Download: [.xlsx](#)

Year	Jan	Feb	Mar	Apr	May	Jun	Jul	Aug	Sep	Oct	Nov	Dec	Annual	HALF1	HALF2
2007	3.1	3.4	4.0	3.6	3.0	2.7	2.4	2.1	2.2	3.8	4.7	4.6	3.3	3.3	3.3
2008	4.6	3.7	3.6	3.7	4.1	6.1	6.6	5.7	5.0	3.5	0.6	-0.6	3.9	4.3	3.5
2009	-0.6	-0.5	-1.6	-2.1	-2.4	-2.8	-3.2	-2.1	-1.4	-0.6	1.2	2.5	-1.2	-1.7	-0.6
2010	2.3	1.8	2.4	2.4	2.0	1.0	1.0	1.0	0.5	0.9	1.0	1.6	1.5	2.0	1.0
2011	2.0	2.6	3.5	3.9	3.7	3.3	2.7	2.7	3.5	3.1	3.2	2.2	3.0	3.2	2.9
2012	2.1	2.1	2.0	1.3	1.5	1.5	1.9	2.5	2.2	3.2	2.1	2.0	2.0	1.8	2.3
2013	1.9	2.4	1.3	0.9	1.0	1.5	1.6	0.9	0.7	-0.3	0.5	1.2	1.1	1.5	0.8
2014	0.8	0.4	1.0	1.6	1.8	1.9	2.1	1.8	1.6	1.4	1.0	0.3	1.3	1.3	1.4
2015	-0.7	-0.4	0.2	0.0	0.9	0.4	1.2	1.0	0.4	0.7	1.4	1.9	0.6	0.1	1.1
2016	3.3	2.3	1.3	1.6	0.6	1.1	0.3	0.6	1.5	1.9	1.5	1.7	1.5	1.7	1.3
2017	1.7	2.5													

RECOMMEND THIS PAGE USING: Facebook Twitter LinkedIn

TOOLS

Areas at a Glance
 Industries at a Glance
 Economic Releases

CALCULATORS

Inflation
 Location Quotient
 Injury And Illness

HELP

Help & Tutorials
 FAQs
 Glossary

INFO

What's New
 Careers @ BLS
 Find It! DOL

RESOURCES

Inspector General (OIG)
 Budget and Performance
 No Fear Act



April 17, 2017

Mr. Aaron Palmer
City Manager
City of Canyon Lake
31532 Railroad Canyon Road
Suite 101/103
Canyon Lake, CA 92587

Re: Annual Consumer Price Index Rate Adjustment and Organic Waste Rate Structure

Dear Aaron,

Pursuant to our current agreement to provide Solid Waste and Recycling Services to the City of Canyon Lake, CR&R Incorporated respectfully submits the attached information which outlines our Annual Rate Adjustment request for fiscal year 2017-2018. As provided for in the contract between the City of Canyon Lake and CR&R Incorporated, the rates illustrated in Exhibit "C" shall be adjusted annually to reflect the change in the Consumer Price Index (CPI).

In reviewing the data from the Bureau of Labor Statistics (BLS) for October 2016, the CPI for All Urban Consumers has increased by 1.85% and the CPI for Urban Wage Earners increased by .26%. In addition, the County of Riverside's Waste Management Department has indicated that they will adjust their disposal rate by 1.97% from \$28.52 per ton to \$29.08 per ton. Therefore, based upon the data supplied by both the BLS and the County of Riverside, we have prepared the attached rate schedules which pass these adjustments through to the various rates. We have also prepared a new Exhibit "C" to reflect the incremental increases that will become effective July 1, 2017.

As an example, the new rate for standard residential service will increase from \$21.90 per month to \$22.35 per month; an increase of 2.1% or .45 cents per month. Your typical 3 cubic yard commercial bin will increase from \$123.35 per month to \$125.67 per month; an increase of 1.9% or \$2.32 per month. These are minimum increases which help to defray our increased cost of operations and maintain the level of service your community has come to expect.

In addition to our standard rate adjustments, CR&R is proposing to add a new rate structure for Organic Recycling services. As you are aware, the State of California passed recent legislation (AB 1594 and AB 1826) which impacts the way our industry will be required to process "organic waste". Organic waste is mainly comprised of food and yard waste as well as compostable products. These two new pieces of legislation will begin impacting your City by requiring businesses, multi-family complexes and residential customers to recycle their organics in order to divert this material from the landfill.

Given these critical changes in State Law, CR&R has embarked on the construction of a new Anaerobic Digester Facility (AD Facility) at our regional headquarters in the City of Perris. Our AD Facility will help your City address the new State mandates in a cost effective and environmentally conscious manner. We have included the new rates for this service in this rate adjustment request for your consideration and eventual City Council approval. We look forward to your City's participation in the very near future.

We sincerely appreciate our long standing relationship with the City of Canyon Lake as well as the opportunity that we have had to be of service to your residents and businesses. It continues to be a privilege to be of service to your City. Please do not hesitate to call if you have any questions or comments. We look forward to any further assistance that we can provide.

Sincerely,

A handwritten signature in blue ink, appearing to read "J. Alex Braicovich", with a large, stylized flourish extending to the right.

J. Alex Braicovich
Senior Vice President

Cc: David Fahrion

This space for filing stamp only

RECEIVED

JUN 27 2017

BY: SH

THE FRIDAY FLYER
PROOF OF PUBLICATION

(2010, 2015.5)
STATE OF CALIFORNIA
County of Riverside

CITY OF CANYON LAKE
31516 Railroad Canyon Road
Canyon Lake, CA 92587

**CITY OF CANYON LAKE
NOTICE OF CONTINUED PUBLIC HEARING TO JULY 12, 2017**

**City of Canyon Lake
NOTICE OF CONTINUED PUBLIC HEARING TO JULY**

I am a citizen of the United States and a resident of the County aforesaid; I am over the age of eighteen years, and not a party to or interested in the above entitled matter. I am an authorized representative of THE FRIDAY FLYER, a newspaper of general circulation, printed and published weekly in the City of Canyon Lake, County of Riverside, and which newspaper has been adjudicated a newspaper of general circulation by the Superior Court of the County of Riverside, State of California, under date of April 29, 1996, Case Number 279205; that the notice, of which the annexed is a printed copy, has been published in each regular and entire issue of said newspaper and not in any supplement thereof on the following dates, to-wit:

6/16/2017

6/23/2017

I certify (or declare) under penalty of perjury that the foregoing is true and correct.

Dated 6/23/2017
at Canyon Lake, California by

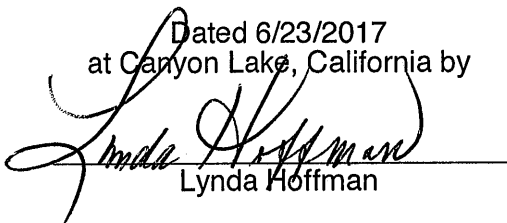
Lynda Hoffman

Notice is hereby given that on June 1, 2017, the City Council of the City of Canyon Lake continued the Public Hearing on the annual adjustment of solid waste fees and residential collection on the annual tax roll for the fiscal year 2017-2018 to July 12, 2017 during the course of the Adjourned City Council meeting that begins at 6:30 p.m., at the Canyon Lake City Hall, Council Chambers, 31516 Railroad Canyon Road, Canyon Lake, CA 92587, pertaining to the annual adjustment of solid waste fees and residential collection on the annual tax roll for the fiscal year 2017-2018. As provided for in the contract between the City of Canyon Lake and CR&R Incorporated, the rates are adjusted annually to reflect the change in the Consumer Price Index (CPI) and in the landfill costs since the publication of the Notice for the June 1, 2017, hearing did not include notice of increased pass-through of landfill/disposal costs that were not known at that time.
Annual CPI Increase for Solid Waste Collection Services: The CPI increase for solid waste collection services remains the same. The rate for basic service for a single family dwelling will increase 45 cents a month from \$21.90 to \$22.35. Similarly, refuse service for a typical 3 cubic yard commercial container will increase \$2.32 per month from \$123.35 to \$125.67 per month.
In addition, the franchise agreement with the solid waste hauler provides that landfill and disposal costs shall be passed through to all customers (residential and commercial) in addition to the cost of solid waste collection services. Based upon the requirements of AB 341, AB 1826 and AB 1594 for removal of organic waste from the waste stream, the franchise holder has constructed an additional facility for the disposal of such organic waste. The additional residential cost of that required change in disposal is \$1.95/month, subject to the annual CPI increase.
Residential solid waste fees including the additional disposal fee for organic wastes will be placed on the tax roll for fiscal year 2017-2018. All such fees will be collected at the same time and in the same manner as County property taxes. The description of each lot or parcel is part of the records of the Assessor of the County of Riverside.
Commercial rates shall be increased by the CPI increase. Organic waste removal services are available for purchase by commercial customers at the rates established by the franchise holder. Commercial rates are not collected on the tax roll.
Anyone wishing to protest this action must file a written response or may appear personally at the public hearing. Prior to the hearing, written comments in favor or against should be sent to the Canyon Lake City Hall, City Clerk's Office at 31516 Railroad Canyon Road, Canyon Lake, CA 92587. If you challenge any project or fee in court, you may be held to raising only those issues you or someone else raised at the public hearing or in written correspondence to the City Clerk at or prior to the public hearing as described in this notice.
For additional information contact City Hall at (951) 244-2955 or at 31516 Railroad Canyon Road, Canyon Lake, CA 92587. City Hall is open Monday through Thursday from 8 a.m. to 5 p.m.
The Friday Flyer
Stephanie Hunter, Office Specialist
City of Canyon Lake

Published: 6/16/2017, 6/23/2017