



CITY OF CANYON LAKE

City Hall
31516 Railroad Canyon Road
Canyon Lake, CA 92587

Website: www.cityofcanyonlake.org

Mayor Larry Greene
Mayor Pro Tem Jordan Ehrenkranz

Council Members:

Randy Bonner
Kasey Castillo
Jeremy Smith

City Manager Chris Mann
City Attorney Steven Graham
Deputy City Clerk Ana V. Sauseda

AGENDA

Regular Meeting of the Canyon Lake City Council
Wednesday, August 7, 2019
Closed Session 5:30 P.M.
Open Session 6:30 P.M.

COUNCIL CHAMBER

CLOSED SESSION – 5:30 P.M.

CLOSED SESSION CALLED TO ORDER

ROLL CALL Councilmember Bonner, Councilmember Castillo, Mayor Pro Tem Ehrenkranz,
Councilmember Smith, Mayor Greene

PUBLIC COMMENT

Limit 3 Minutes

Any person wishing to address the City Council on any matter within the jurisdiction of the City, whether or not it appears on this agenda, is asked to complete a "Speaker Request Form" available on the back counter. The completed form is to be submitted to the City Clerk prior to an individual being heard by the City Council. The City Council has adopted a time limitation of three (3) minutes per person. If you are commenting on the agenda item, your comments will be heard at the time that particular item is scheduled on the agenda. Please note that if you are addressing the City Council on items NOT on the agenda, the Brown Act does not allow discussion of such items. Therefore, the City Council may only do the following: refer the matter to staff, ask for additional information or request a report back, or give a very limited factual response.

A. CONFERENCE WITH LEGAL COUNSEL - ANTICIPATED LITIGATION - Significant exposure to litigation pursuant to paragraph (2) of subdivision (d) of Section 54956.9 - 1 case

CLOSED SESSION REPORT

OPEN SESSION - 6:30 P.M.

OPEN SESSION CALLED TO ORDER

INVOCATION - Pastor Dave Dick - Canyon Lake Community Church

FLAG SALUTE

ROLL CALL Councilmember Bonner, Councilmember Castillo, Mayor Pro Tem Ehrenkranz, Councilmember Smith, Mayor Greene

APPROVAL OF CITY COUNCIL AGENDA

CEREMONIAL MATTERS *Presentations, Awards, Proclamations*

- Chamber of Commerce Announcement
- Introduction of New City Employees

PUBLIC COMMENT

Limit 3 Minutes

Any person wishing to address the City Council on any matter within the jurisdiction of the City, whether or not it appears on this agenda, is asked to complete a "Speaker Request Form" available on the back counter. The completed form is to be submitted to the City Clerk prior to an individual being heard by the City Council. The City Council has adopted a time limitation of three (3) minutes per person. If you are commenting on the agenda item, your comments will be heard at the time that particular item is scheduled on the agenda. Please note that if you are addressing the City Council on items NOT on the agenda, the Brown Act does not allow discussion of such items. Therefore, the City Council may only do the following: refer the matter to staff, ask for additional information or request a report back, or give a very limited factual response.

CONSENT CALENDAR

All items listed on the Consent Calendar are considered to be routine matters, status reports or documents covering previous City Council action. The items listed on the Consent Calendar may be enacted in one motion. With the concurrence of the City Council, a Council Member may request that an item be removed for further discussion. Staff recommends approval of all items.

- (1) Waive Full Reading, Read all Ordinances by Title Only
- (2) Adoption of Resolution No. 2019-23 and 2019-24 - Approving Claims and Demands of the City
- (3) Approval of City Council Meeting Minutes
 - May 08, 2019 - Special Meeting
 - May 15, 2019 - Special Meeting
 - June 05, 2019 - Regular Meeting
 - June 05, 2019 - Special Meeting
 - June 17, 2019 - Special Meeting
 - July 03, 2019 - Regular Meeting
- (4) Second Reading of Ordinance No. 183 – An Ordinance of the City Council of the City of Canyon Lake Amending Article XXI of the City of Canyon Lake Zoning Ordinance and Amending Title 9 to add Chapter 9.27 regarding emergency shelters as well as Chapter 9.28 regarding mandatory uses in all residential zones

PULLED CONSENT CALENDAR ITEMS:

SCHEDULE OF FUTURE EVENTS:

BUSINESS ITEMS

- (5) League of California Cities - Designation of Voting Delegate and Alternates for League of California Cities Annual Conference - October 16th through 18th, 2019, in Long Beach, CA
- (6) CDBG - Discussion and Authorization on Reallocating Remaining Fiscal Year 16/17 & 17/18 Community Development Block Grant Funds
- (7) Railroad Canyon Road Projects Overview - Power Point presentation to provide updates on the projects affecting Railroad Canyon Road
- (8) Resolution - Adoption of Resolution No. 2019-25, Amending the Pass-Through Convenience Fees for Credit Card Payments at City Hall and Eliminating the Charge Limit
- (9) Resolution - Adoption of Resolution 2019-26, Declaring a City-Owned Vessel and Trailer to be Surplus, and Authorizing the City Manager to Execute a Sale Agreement with the Canyon Lake Property Owners Association
- (10) Resolution - Adoption of Resolution No. 2019-27 and Resolution No. 2019-28, Authorizing the City Manager to Submit Letters of Interest to the United States Department of the Interior Bureau of Land Management (BLM) Indicating the **City's Desire to Acquire Two Parcels Currently Managed by the BLM**

PUBLIC HEARINGS

- (11) Resolution - Adoption of Resolution No. 2019-29, Approving Annual Rate Adjustment and Confirmation of Collection of Residential Solid Waste Charges on the Tax Rolls
 - Public Hearing Opened
 - Staff Presentation
 - Questions to Staff by City Council
 - Testimony by Proponents
 - Testimony by Opponents
 - Response by Proponents
 - Public Hearing Closed
 - Discussion by City Council
 - Tabulation of Written Protests by City Clerk
 - Action by City Council
- (12) Resolution - Adoption of Resolution No. 2019-30 – Approving Variance No. 19-33 (Pitts Backyard Pool) located at 30211 Cove View Drive, Canyon Lake, CA 92587
 - Public Hearing Opened
 - Staff Presentation
 - Questions to Staff by City Council

- Testimony by Proponents
- Testimony by Opponents
- Response by Proponents
- Public Hearing Closed
- Discussion by City Council
- Action by City Council

CITY MANAGER COMMENTS

COMMITTEE AND COUNCIL REPORTS/COMMENTS:

- Council Member Bonner
- Council Member Castillo
- Mayor Pro Tem Ehrenkranz
- Council Member Smith
- Mayor Greene

ANNOUNCEMENTS

The next regular meeting will be Wednesday, September 4, 2019 at 5:30 for Closed Session & 6:30 p.m. for Open Session

ADJOURNMENT

VISION STATEMENT

The vision of the City of Canyon Lake is to be a City that provides a quality of life that makes Canyon Lake the premier place to live in Southern California.

ATTENTION RESIDENTS:

Supporting documents, including staff reports, are available for review at City Hall in the **City Clerk's Office** or on the **City's website at www.cityofcanyonlake.org once the agenda has been publicly posted.** Any written materials relating to an item on this agenda submitted to the City Council after distribution of the agenda packet are available for public inspection **in the City Clerk's Office during normal business hours. In addition, such writings or documents** will be made available for public review at the respective public meeting. It is the intention of the City of Canyon Lake to comply with the Americans with Disabilities Act (ADA) in all respects. If, as an attendee or participant at this meeting, you will need special assistance beyond what is normally provided, the City of Canyon Lake will attempt to accommodate you in every reasonable manner. Please contact Ana V. Sauseda, Deputy City Clerk, at least 48 hours prior to the meeting to inform us of your particular needs and to determine if accommodation is feasible. Please advise us at that time if you will need accommodations to attend or participate in meetings on a regular basis.

August 7, 2019 City Council Meeting

STATE OF CALIFORNIA }
COUNTY OF RIVERSIDE } SS. AFFIDAVIT OF POSTING
CITY OF CANYON LAKE }

I, Ana V. Sauseda, being duly sworn, depose and say that I am the duly appointed and qualified Deputy City Clerk of the City of Canyon Lake and that on August **2**, 2019 before the hour of 5:00 p.m., I caused the above notice to be posted as required by Resolution 2015-36 of the City Council of the City of Canyon Lake.

Ana V. Sauseda
Deputy City Clerk

City of Canyon Lake
City Council
Staff Report

TO: Honorable Mayor and Members of the City Council
FROM: Chris Mann, City Manager *CM*
BY: Kayla Lozano, Accountant
DATE: July 3, 2019
SUBJECT: List of Demands

Recommendation:

That the City Council adopt a resolution entitled: RESOLUTION NO. 2019-23

A RESOLUTION OF THE CITY COUNCIL OF THE
CITY OF CANYON LAKE ALLOWING CERTAIN
CLAIMS AND DEMANDS AS SET FORTH IN EXHIBIT A

Background:

All claims and demands are reported and summarized for review and approval by the City Council on a routine basis at each City Council meeting. The attached claims represent the paid claims and demands since the City Council meeting of June 5, 2019.

Budget (or Fiscal) Impact:

All claims and demands are paid from appropriated funds or authorized resources of the City and have been recorded in accordance with the City's policies.

Attachments:

1. Resolution No. 2019-23
2. List of Demands

RESOLUTION NO. 2019-23

A RESOLUTION OF THE CITY COUNCIL OF THE CITY OF CANYON LAKE, CALIFORNIA, ALLOWING CERTAIN CLAIMS AND DEMANDS AS SET FORTH IN EXHIBIT A

The City Council of the City of Canyon Lake does hereby resolve as follows:

Demands are approved as shown on the Demand/Warrant Register of August 7th, in the amount of \$879,048.28 as follows:

Payroll Earnings (Gross)	\$ 40,419.80	(2nd Half of May & 1st Half of June)
Payroll Taxes - Employer	736.01	(2nd Half of May & 1st Half of June)
On-line Retirement	4,929.75	(2nd Half of May & 1st Half of June)
On-line Health	969.49	(For the Month of June)
Nationwide Deferred Comp.	341.45	(For the Month of May)
CalPERS Arrears Admin Fee	500.00	(Service Period: 11-6-17 to 10-15-18)
CalPERS Arrears	2,302.60	(Service Period: 11-6-17 to 10-15-18)
General	828,849.18	
TOTAL	<u>\$ 879,048.28</u>	

PASSED, APPROVED AND ADOPTED this 7th day of August, 2019.

Jordan Ehrenkranz, Mayor Pro Tem

ATTEST:

Ana V. Sauseda, Deputy City Clerk

State of California
County of Riverside) ss
City of Canyon Lake)

I, Ana V. Sauseda, Deputy City Clerk of the City of Canyon Lake, California, DO HEREBY CERTIFY, that the foregoing is a true and correct copy of the Resolution No. 2019-23 adopted by the City Council of the City of Canyon Lake, California, at a regular meeting thereof, held on August 7, 2019, by the following vote:

AYES:
NOES:
ABSTAIN:
ABSENT:

Ana V. Sauseda
Deputy City Clerk

Claims and Demands

City of Canyon Lake
 Check/Voucher Register - Council Report - Expenditures
 From 6/1/2019 Through 6/30/2019

Check Num...	Matching Docum... Date	Vendor Name	Transaction Description	Check Amount	Fund Code	Fund Short Title
25093	6/5/2019	AMERICAN FORENSIC NURSES INC	Sheriff's Blood Draws, April 2019	85.00	10	GENERAL
Total 25093	6/5/2019			85.00		
25094	6/5/2019	AMP GLOBAL LLC	Rent for Admin Bldg for the Month of July	2,600.00	10	GENERAL
Total 25094	6/5/2019			2,600.00		
25095	6/5/2019	Randall Bonner	Auto Allowance for the Month of June 2019 - Bonner	100.00	10	GENERAL
Total 25095	6/5/2019			100.00		
25096	6/5/2019	CANYON LAKE PEST CONTROL, Steven E. Young	Quarterly Pest Control PO #09-010, 5/13/19	100.00	10	GENERAL
Total 25096	6/5/2019			100.00		
25097	6/5/2019	Corelogic Information Solutions, INC.	Database for Code Enforcement, May 2019	125.00	10	GENERAL
Total 25097	6/5/2019			125.00		
25098	6/5/2019	CTAI Pacific Greenscape	Irrigation Control Replacement on Railroad Cyn Rd, 5/28/19	960.00	20	GAS TAX
Total 25098	6/5/2019			960.00		
25099	6/5/2019	Robert and Mona Cuicchi	Refund for Plot Plan on 30417 Longhorn Drive	893.00	10	GENERAL
Total 25099	6/5/2019			893.00		

City of Canyon Lake
 Check/Voucher Register - Council Report - Expenditures
 From 6/1/2019 Through 6/30/2019

Check Num...	Matching Docum... Date	Vendor Name	Transaction Description	Check Amount	Fund Code	Fund Short Title
25100	6/5/2019	DATA TICKET	Monthly Code Enforcement, April 2019	100.00	10	GENERAL
25100	6/5/2019	DATA TICKET	Monthly Parking Citations, April 2019	100.00	10	GENERAL
Total 25100	6/5/2019			200.00		
25101	6/5/2019	Delgado Janitorial Services	Janitorial Services for the Month of May 2019	941.50	10	GENERAL
Total 25101	6/5/2019			941.50		
25102	6/5/2019	Jordan Ehrenkranz	Auto Allowance for the Month of June 2019 - Ehrenkranz	100.00	10	GENERAL
Total 25102	6/5/2019			100.00		
25103	6/5/2019	Fast Signs	Front Door City Logo on Admin Bldg & Monument Sign, 5/13/19	983.22	40	CAP. PROJ.
Total 25103	6/5/2019			983.22		
25104	6/5/2019	HINDERLITER, DE LLAMAS & ASSOC	Annual Sales Tax Audit Services FY 18/19	2,135.29	10	GENERAL
Total 25104	6/5/2019			2,135.29		
25105	6/5/2019	Interwest Consulting Group	Building & Safety Services for April 8 - 30	22,950.11	10	GENERAL
25105	6/5/2019	Interwest Consulting Group	Building & Safety SRVCS, Plan Review & Storm Water April 1-7	5,977.20	10	GENERAL
Total 25105	6/5/2019			28,927.31		
25106	6/5/2019	Jeremy Smith	Auto Allowance for the Month of June 2019 - Smith	100.00	10	GENERAL

City of Canyon Lake
 Check/Voucher Register - Council Report - Expenditures
 From 6/1/2019 Through 6/30/2019

Check Num...	Matching Docum... Date	Vendor Name	Transaction Description	Check Amount	Fund Code	Fund Short Title
25106	6/5/2019	Jeremy Smith	Parking at Ontario Airport for LOCC Mtg., 4/19/19	36.00	10	GENERAL
Total 25106	6/5/2019			136.00		
25107	6/5/2019	Kasey Castillo	Auto Allowance for the Month of June 2019 - Castillo	100.00	10	GENERAL
Total 25107	6/5/2019			100.00		
25108	6/5/2019	Larry Greene	Auto Allowance for the Month of June 2019 - Greene	100.00	10	GENERAL
Total 25108	6/5/2019			100.00		
25109	6/5/2019	League of California Cities	Division Mtg 5/13/19;Mann, Greene, Ehrenkranz, Bonner, Smith	250.00	10	GENERAL
Total 25109	6/5/2019			250.00		
25110	6/5/2019	Chris Mann	Reimb. for LOCC Div. Mtg & SCAG Conference May 2019	116.41	10	GENERAL
Total 25110	6/5/2019			116.41		
25111	6/5/2019	Rogers, Anderson, Malody & Scott, LLP	Accounting Services for the Month of April 2019	6,700.00	10	GENERAL
Total 25111	6/5/2019			6,700.00		
25112	6/5/2019	RIV. CO. SHERIFF'S DEPT., Acctg & Fin	Sheriff's Contract Law Enforcement 3/28/19 to 4/24/19	129,118.83	10	GENERAL
Total 25112	6/5/2019			129,118.83		

City of Canyon Lake
 Check/Voucher Register - Council Report - Expenditures
 From 6/1/2019 Through 6/30/2019

Check Num...	Matching Docum... Date	Vendor Name	Transaction Description	Check Amount	Fund Code	Fund Short Title
25113	6/5/2019	Southern California Association of Government	Dues Assessment for FY 19-20	1,294.00	10	GENERAL
Total 25113	6/5/2019			1,294.00		
25114	6/5/2019	STAPLES	Office Supplies for Admin Bldg & City Hall May 2019	1,171.17	10	GENERAL
25114	6/5/2019	STAPLES	Office Supplies for Admin Bldg & City Hall May 2019	547.63	40	CAP. PROJ.
Total 25114	6/5/2019			1,718.80		
25115	6/5/2019	Synoptek, LLC	IT Services for June 2019	2,436.00	10	GENERAL
25115	6/5/2019	Synoptek, LLC	Server Warranty Renewal 5/31/19 to 5/30/2020	146.68	10	GENERAL
Total 25115	6/5/2019			2,582.68		
25116	6/5/2019	Time Warner Cable	Digital Converter for City Hall, 5/22/19 to 6/21/19	5.25	10	GENERAL
Total 25116	6/5/2019			5.25		
25117	6/5/2019	Toshiba Financial Services	Monthly Copier Lease for Admin Bldg & City Hall-5/10 to 6/10	880.89	10	GENERAL
Total 25117	6/5/2019			880.89		
25118	6/19/2019	Abila	Accounting Software Renewal June 2019	838.00	10	GENERAL
Total 25118	6/19/2019			838.00		
25119	6/19/2019	Aflac	Supplemental Insurance June 2019	432.82	10	GENERAL
Total 25119	6/19/2019			432.82		

City of Canyon Lake
 Check/Voucher Register - Council Report - Expenditures
 From 6/1/2019 Through 6/30/2019

Check Num...	Matching Docum... Date	Vendor Name	Transaction Description	Check Amount	Fund Code	Fund Short Title
25120	6/19/2019	AMERICAN FORENSIC NURSES INC	Sheriff's Blood Draws May 2019	55.00	10	GENERAL
Total 25120	6/19/2019			55.00		
25121	6/19/2019	American Legal Publishing	Canyon Lake Ordinances with Custom tabs, 5/15/19	100.82	10	GENERAL
Total 25121	6/19/2019			100.82		
25122	6/19/2019	ANIMAL FRIENDS OF THE VALLEYS	Animal Control Services for April 2019	3,500.00	10	GENERAL
Total 25122	6/19/2019			3,500.00		
25123	6/19/2019	California Newspapers Partnership	Classified Advertising for Public Hearing Notice 5/15/19	283.80	10	GENERAL
Total 25123	6/19/2019			283.80		
25124	6/19/2019	Charles Abbott Associates, Inc.	Code Enforcement Software License and Hosting May 2019	2,050.00	10	GENERAL
Total 25124	6/19/2019			2,050.00		
25125	6/19/2019	CR&R	Refuse 5/20/19	576,351.80	50	AGENCY
Total 25125	6/19/2019			576,351.80		
25126	6/19/2019	CTAI Pacific Greenscape	Landscape Maintenance for Fire Station June 2019	250.00	10	GENERAL
25126	6/19/2019	CTAI Pacific Greenscape	Landscape Maintenance for Median & Parkways June 2019	5,000.00	20	GAS TAX
Total 25126	6/19/2019			5,250.00		

City of Canyon Lake
 Check/Voucher Register - Council Report - Expenditures
 From 6/1/2019 Through 6/30/2019

Check Num...	Matching Docum... Date	Vendor Name	Transaction Description	Check Amount	Fund Code	Fund Short Title
25127	6/19/2019	DIRECTV	Satellite Service, 6/12/19 to 7/11/19	103.09	10	GENERAL
Total 25127	6/19/2019			103.09		
25128	6/19/2019	STATE OF CA DEPT. OF JUSTICE	Fingerprinting Apps, May 2019	160.00	10	GENERAL
Total 25128	6/19/2019			160.00		
25129	6/19/2019	FRIDAY FLYER	Notice of Budget Adoption 5/24/19	20.53	10	GENERAL
25129	6/19/2019	FRIDAY FLYER	Notice of Ordinance Adoption - Ordinance No. 179 - 4/5/19	518.70	10	GENERAL
25129	6/19/2019	FRIDAY FLYER	Notice of Ordinance Intro - Ordinance No. 180, 4/19/19	42.00	10	GENERAL
25129	6/19/2019	FRIDAY FLYER	Notice of Ordinance Intro, Ordinance No. 182, 4/19/19	46.50	10	GENERAL
25129	6/19/2019	FRIDAY FLYER	Notice of Ordinance Intro. - Ordinance No. 181, 4/19/19	43.50	10	GENERAL
25129	6/19/2019	FRIDAY FLYER	Notice of Public Hearing 4/19/19	243.60	10	GENERAL
25129	6/19/2019	FRIDAY FLYER	Notice of Public Hearing 5/24/19	73.50	10	GENERAL
25129	6/19/2019	FRIDAY FLYER	Notice pf Public Hearing 5/24/19	61.95	10	GENERAL
25129	6/19/2019	FRIDAY FLYER	Regarding Ordinance No. 180, 5/10/19	34.50	10	GENERAL
25129	6/19/2019	FRIDAY FLYER	Regarding Ordinance No. 181, 5/10/19	40.50	10	GENERAL
25129	6/19/2019	FRIDAY FLYER	Regarding Ordinance No. 182, 5/10/19	42.00	10	GENERAL
Total 25129	6/19/2019			1,167.28		
25130	6/19/2019	Frontier Communications	City Hall Internet, 6/10/19 to 7/9/19	150.98	10	GENERAL
25130	6/19/2019	Frontier Communications	City Hall Phones, 6/13/19 to 7/12/19	122.05	10	GENERAL

City of Canyon Lake
 Check/Voucher Register - Council Report - Expenditures
 From 6/1/2019 Through 6/30/2019

Check Num...	Matching Docum... Date	Vendor Name	Transaction Description	Check Amount	Fund Code	Fund Short Title
25130	6/19/2019	Frontier Communications	Fire Station Phone & Internet, 6/13/19 to 7/12/19	268.15	10	GENERAL
Total 25130	6/19/2019			541.18		
25131	6/19/2019	THE GAS COMPANY	Gas charges for 4/30/19 to 5/30/19	6.17	10	GENERAL
Total 25131	6/19/2019			6.17		
25132	6/19/2019	NANCY GREENHALGH	Retiree Health Insurance July 2019	163.37	10	GENERAL
Total 25132	6/19/2019			163.37		
25133	6/19/2019	Johnson Controls Security Solutions	Elevator Smoke Test for City Hall, 4/3/19	470.00	10	GENERAL
25133	6/19/2019	Johnson Controls Security Solutions	Security System, 7/1/19 to 9/30/19	220.69	10	GENERAL
Total 25133	6/19/2019			690.69		
25134	6/19/2019	Kasey Castillo	Replace Canceled Check Issued in January 2019	295.64	10	GENERAL
Total 25134	6/19/2019			295.64		
25135	6/19/2019	Nate Volk	Broadcasting for Mtg 6/5/19	575.00	10	GENERAL
Total 25135	6/19/2019			575.00		
25136	6/19/2019	PV Maintenance Inc.	Moved Office Furniture from City Hall to Storage May 2019	357.78	40	CAP. PROJ.
Total 25136	6/19/2019			357.78		
25137	6/19/2019	PZL, Inc.	Planning Services for the month of May 2019	4,650.00	10	GENERAL

City of Canyon Lake
 Check/Voucher Register - Council Report - Expenditures
 From 6/1/2019 Through 6/30/2019

Check Num...	Matching Docum... Date	Vendor Name	Transaction Description	Check Amount	Fund Code	Fund Short Title
Total 25137	6/19/2019			4,650.00		
25138	6/19/2019	Regional Conservation Authority	MSHCP Fees Collected for June 2019	2,104.00	50	AGENCY
Total 25138	6/19/2019			2,104.00		
25139	6/19/2019	JOHN REGUS	Library Lease for August 2019	1,074.62	10	GENERAL
Total 25139	6/19/2019			1,074.62		
25140	6/19/2019	County of Riverside - Registrar of Voters	Election services rendered for the November 6, 2018 election	20,987.37	10	GENERAL
Total 25140	6/19/2019			20,987.37		
25141	6/19/2019	Special District Risk Management Authority	Dental & Vision Ins. for Mann & Sauseda July 2019	101.28	10	GENERAL
Total 25141	6/19/2019			101.28		
25142	6/19/2019	Speedy Vehicle Registration	Live Scans, Emergency Preparedness Committee, May 2019	80.00	10	GENERAL
Total 25142	6/19/2019			80.00		
25143	6/19/2019	STATE COMP. INS. FUND	Workers Comp Annual Premium 6/6/19	1,360.56	10	GENERAL
Total 25143	6/19/2019			1,360.56		
25144	6/19/2019	STATE COMP. INS. FUND	Workers Comp for July 2019	859.87	10	GENERAL
Total 25144	6/19/2019			859.87		

City of Canyon Lake
 Check/Voucher Register - Council Report - Expenditures
 From 6/1/2019 Through 6/30/2019

Check Num...	Matching Docum... Date	Vendor Name	Transaction Description	Check Amount	Fund Code	Fund Short Title
25145	6/19/2019	Synoptek, LLC	Setting up Router in Admin City Hall, May 2019	250.00	40	CAP. PROJ.
Total 25145	6/19/2019			250.00		
25146	6/19/2019	Time Warner Cable	Internet for Fire Station, 6/10/19 to 7/9/19	99.98	10	GENERAL
Total 25146	6/19/2019			99.98		
25147	6/19/2019	Verizon Wireless	Cell Phones, 5/4/19 to 6/3/19	389.06	10	GENERAL
25147	6/19/2019	Verizon Wireless	iPads, 5/4/19 to 6/3/19	207.09	10	GENERAL
Total 25147	6/19/2019			596.15		
25148	6/19/2019	WRCOG	TUMF Fees Collected for June 2019	8,873.00	50	AGENCY
Total 25148	6/19/2019			8,873.00		
25149	6/20/2019	Regional Conservation Authority	Additional MSHCP Fees Collected for June 2019	2,104.00	50	AGENCY
Total 25149	6/20/2019			2,104.00		
25150	6/20/2019	WRCOG	Additional TUMF Fees Collected for June 2019	8,873.00	50	AGENCY
Total 25150	6/20/2019			8,873.00		
EFT11		SOUTHERN CALIFORNIA EDISON	SCE for City Hall 4/15/19 to 5/15/19	698.82	10	GENERAL
Total EFT11				698.82		
EFT12		SOUTHERN CALIFORNIA EDISON	SCE Traffic Signals 4/15/19 to 5/15/19	160.83	20	GAS TAX

City of Canyon Lake
 Check/Voucher Register - Council Report - Expenditures
 From 6/1/2019 Through 6/30/2019

Check Num...	Matching Docum... Date	Vendor Name	Transaction Description	Check Amount	Fund Code	Fund Short Title
Total EFT12				160.83		
EFT13		SOUTHERN CALIFORNIA EDISON	SCE Traffic Signals 4/22/19 to 5/21/19	6.70	20	GAS TAX
Total EFT13				6.70		
EFT14		SOUTHERN CALIFORNIA EDISON	SCE Fire Station 4/15/19 to 5/15/19	303.41	10	GENERAL
Total EFT14				303.41		
EFT15		SOUTHERN CALIFORNIA EDISON	SCE Traffic Signals 4/23/19 to 5/22/19	48.03	20	GAS TAX
Total EFT15				48.03		
EFT16		SOUTHERN CALIFORNIA EDISON	SCE Office Lease May 2019	26.14	10	GENERAL
Total EFT16				26.14		
EFT17		SOUTHERN CALIFORNIA EDISON	SCE Admin City Hall May 2019	127.09	10	GENERAL
Total EFT17				127.09		
EFT18		ELSINORE VALLEY MUNI WATER DIS	EVMWD Fire Detector 4/26/19 to 5/26/19	98.91	10	GENERAL
Total EFT18				98.91		
EFT19		ELSINORE VALLEY MUNI WATER DIS	EVMWD Irrigation 4/29/19 to 5/29/19	652.59	20	GAS TAX
Total EFT19				652.59		

City of Canyon Lake
 Check/Voucher Register - Council Report - Expenditures
 From 6/1/2019 Through 6/30/2019

Check Num...	Matching Docum... Date	Vendor Name	Transaction Description	Check Amount	Fund Code	Fund Short Title
EFT20		ELSINORE VALLEY MUNI WATER DIS	EVMWD Fire Station 4/29/19 to 5/29/19	207.62	10	GENERAL
Total EFT20				207.62		
EFT21		Sparkletts	Sparkletts Drinking Water for City Hall May 2019	66.49	10	GENERAL
Total EFT21				66.49		
EFT22		SOUTHERN CALIFORNIA EDISON	SCE Traffic Signals 4/30/19 to 5/30/19	271.38	20	GAS TAX
Total EFT22				271.38		
EFT23		SOUTHERN CALIFORNIA EDISON	SCE Pump Station 5/9/19 to 6/10/19	91.72	20	GAS TAX
Total EFT23				91.72		
Report Total				828,849.18		

City of Canyon Lake
Invoices Selected for Payment - COUNCIL CHECK REPORT

Vendor ID	Invoice Description	Cash Required
AMERICAN FORENSIC	Sheriff's Blood Draws, April 2019	85.00
AMP	Rent for Admin Bldg for the Month of July	2,600.00
Bonner	Auto Allowance for the Month of June 2019 - Bonner	100.00
CL PEST	Quarterly Pest Control PO #09-010, 5/13/19	100.00
Corelogic	Database for Code Enforcement, May 2019	125.00
CTAI	Irrigation Control Replacement on Railroad Cyn Rd, 5/28/19	960.00
CUICCHI	Refund for Plot Plan on 30417 Longhorn Drive	893.00
DATA TICKET	Monthly Parking Citations, April 2019	100.00
	Monthly Code Enforcement, April 2019	100.00
Delgado	Janitorial Services for the Month of May 2019	941.50
Ehrenkranz	Auto Allowance for the Month of June 2019 - Ehrenkranz	100.00
Fast Signs	Front Door City Logo on Admin Bldg & Monument Sign, 5/13/19	983.22
HINDERLITER	Annual Sales Tax Audit Services FY 18/19	2,135.29
ICG	Building & Safety SRVCS, Plan Review & Storm Water April 1-7	5,977.20
	Building & Safety Services for April 8 - 30	22,950.11
Jeremy Smith	Parking at Ontario Airport for LOCC Mtg., 4/19/19	36.00
	Auto Allowance for the Month of June 2019 - Smith	100.00
Kasey Castillo	Auto Allowance for the Month of June 2019 - Castillo	100.00
Larry Greene	Auto Allowance for the Month of June 2019 - Greene	100.00
LOCC	Division Mtg 5/13/19;Mann, Greene, Ehrenkranz, Bonner, Smith	250.00
MANN	Reimb. for LOCC Div. Mtg & SCAG Conference May 2019	116.41
RAMS	Accounting Services for the Month of April 2019	6,700.00
Riv Co Sheriff Acctg	Sheriff's Contract Law Enforcement 3/28/19 to 4/24/19	129,118.83
SCAG	Dues Assessment for FY 19-20	1,294.00
STAPLES	Office Supplies for Admin Bldg & City Hall May 2019	547.63
	Office Supplies for Admin Bldg & City Hall May 2019	1,171.17
Synoptek	IT Services for June 2019	2,436.00
	Server Warranty Renewal 5/31/19 to 5/30/2020	146.68
Time Warner	Digital Converter for City Hall, 5/22/19 to 6/21/19	5.25
Toshiba	Monthly Copier Lease for Admin Bldg & City Hall-5/10 to 6/10	880.89
Report Total		181,153.18

City of Canyon Lake
Invoices Selected for Payment - COUNCIL CHECK REPORT

Vendor ID	Invoice Description	Cash Required
ABILA	Accounting Software Renewal June 2019	838.00
Aflac	Supplemental Insurance June 2019	432.82
AMERICAN FORENSIC	Sheriff's Blood Draws May 2019	55.00
American Legal	Canyon Lake Ordinances with Custom tabs, 5/15/19	100.82
ANIMAL FRIENDS	Animal Control Services for April 2019	3,500.00
Cali Newspaper Part	Classified Advertising for Public Hearing Notice 5/15/19	283.80
Charles Abbott	Code Enforcement Software License and Hosting May 2019	2,050.00
CR&R	Refuse 5/20/19	576,351.80
CTAI	Landscape Maintenance for Median & Parkways June 2019	5,000.00
	Landscape Maintenance for Fire Station June 2019	250.00
DIRECTV	Satellite Service, 6/12/19 to 7/11/19	103.09
DOJ	Fingerprinting Apps, May 2019	160.00
FRIDAY FLYER	Notice pf Public Hearing 5/24/19	61.95
	Notice of Public Hearing 4/19/19	123.90
	Notice of Public Hearing 5/24/19	73.50
	Notice of Budget Adoption 5/24/19	20.53
	Regarding Ordinance No. 182, 5/10/19	42.00
	Regarding Ordinance No. 181, 5/10/19	40.50
	Notice of Ordinance Intro, Ordinance No. 182, 4/19/19	46.50
	Regarding Ordinance No. 180, 5/10/19	34.50
	Notice of Ordinance Intro - Ordinance No. 180, 4/19/19	42.00
	Notice of Public Hearing 4/19/19	119.70
	Notice of Ordinance Intro. - Ordinance No. 181, 4/19/19	43.50
	Notice of Ordinance Adoption - Ordinance No. 179 - 4/5/19	518.70
Frontier	Fire Station Phone & Internet, 6/13/19 to 7/12/19	268.15
	City Hall Phones, 6/13/19 to 7/12/19	122.05
	City Hall Internet, 6/10/19 to 7/9/19	150.98
GAS CO	Gas charges for 4/30/19 to 5/30/19	6.17
GREENHALGH	Retiree Health Insurance July 2019	163.37
Johnson Controls	Elevator Smoke Test for City Hall, 4/3/19	470.00
	Security System, 7/1/19 to 9/30/19	220.69
Kasey Castillo	Replace Canceled Check Issued in January 2019	295.64
Nate Volk	Broadcasting for Mtg 6/5/19	575.00
PVM	Moved Office Furniture from City Hall to Storage May 2019	357.78
PZL, Inc.	Planning Services for the month of May 2019	4,650.00
RCA	MSHCP Fees Collected for June 2019	2,104.00

City of Canyon Lake
Invoices Selected for Payment - COUNCIL CHECK REPORT

Vendor ID	Invoice Description	Cash Required
REGUS	Library Lease for August 2019	1,074.62
Riv Co Registrar of Voters	Election services rendered for the November 6, 2018 election	20,987.37
SDRMA	Dental & Vision Ins. for Mann & Sauseda July 2019	101.28
Speedy Vehicle	Live Scans, Emergency Preparedness Committee, May 2019	80.00
STATE FUND	Workers Comp for July 2019	859.87
	Workers Comp Annual Premium 6/6/19	1,360.56
Synoptek	Setting up Router in Admin City Hall, May 2019	250.00
Time Warner	Internet for Fire Station, 6/10/19 to 7/9/19	99.98
VerizonW	Cell Phones, 5/4/19 to 6/3/19	389.06
	iPads, 5/4/19 to 6/3/19	207.09
WRCOG	TUMF Fees Collected for June 2019	8,873.00
Report Total		633,959.27

City of Canyon Lake
Invoices Selected for Payment - COUNCIL CHECK REPORT

<u>Vendor ID</u>	<u>Invoice Description</u>	<u>Cash Required</u>
RCA	Additional MSHCP Fees Collected for June 2019	2,104.00
WRCOG	Additional TUMF Fees Collected for June 2019	8,873.00
Report Total		<u>10,977.00</u>

Labor Distribution

City of Canyon Lake
Company (10756)

Check Date: 06/14/2019
Process: 2019061401
Period: 06/01/2019 to 06/15/2019

Department: (20)City Employees

Code	Earning	Hours	Amount	Deduction	Code	Amount	Tax	Code	Amount	Tax	Code	Amount	Taxable	Tax	Amount	Amount
125CO	125 Cash		492.43	PTAXI Pre-Tax P	CA	264.97	California SI	4012.71	CAETT	CA Edu & T		152.05	0.00	0.00	0.00	
102	Reg		3785.25		CASDI	CA SDI - Err	4277.68	CASUI	4277.68	California SI		42.77	0.00	0.00	0.00	Gross
3785.25	Salary				FITW	Federal Inco	4012.71	MED-R	429.50	Medicare - E		429.50	4277.68	62.03	62.03	Tot Liab
					MED	Medicare	4277.68		62.03							Net Amt
		0.00	4277.68	Total Deductions		264.97			686.35	Total Employer Taxes					62.03	

Code	Earning	Hours	Amount	Deduction	Code	Amount	Tax	Code	Amount	Tax	Code	Amount	Taxable	Tax	Amount	Amount
Reg	Regular	53.00	737.23	457B EE	CA	55.29	California SI	681.94	CAETT	CA Edu & T		7.05	737.23	0.00	0.00	
112					CASDI	CA SDI - Err	737.23	CASUI	737.23	California SI		7.37	737.23	45.71	45.71	Gross
13.9100	Rate				FITW	Federal Inco	681.94	MED-R	54.75	Medicare - E		54.75	737.23	10.69	10.69	Tot Liab
					MED	Medicare	737.23	SS-R	10.69	OASDI - Em		10.69	737.23	0.00	0.00	Net Amt
		53.00	737.23	Total Deductions		55.29			79.86	Total Employer Taxes					56.40	

Code	Earning	Hours	Amount	Deduction	Code	Amount	Tax	Code	Amount	Tax	Code	Amount	Taxable	Tax	Amount	Amount
125CO	125 Cash		103.28	PTXPE Pre-Tax P	CA	369.79	California SI	5725.16	CAETT	CA Edu & T		435.63	0.00	0.00	0.00	
111	Auto		75.00		CASDI	CA SDI - Err	6094.95	CASUI	60.95	California SI		60.95	0.00	0.00	0.00	Gross
5916.67	Reg		5916.67		FITW	Federal Inco	5725.16	MED-R	1051.31	Medicare - E		1051.31	6094.95	88.38	88.38	Tot Liab
	Salary				MED	Medicare	6094.95		88.38							Net Amt
		0.00	6094.95	Total Deductions		369.79			1636.27	Total Employer Taxes					88.38	

Code	Earning	Hours	Amount	Deduction	Code	Amount	Tax	Code	Amount	Tax	Code	Amount	Taxable	Tax	Amount	Amount
125CO	125 Cash		499.58	PTXPE Pre-Tax P	CA	118.70	California SI	2280.11	CAETT	CA Edu & T		47.29	0.00	0.00	0.00	
98	Reg	66.50	1661.83		CASDI	CA SDI - Err	2398.81	CASUI	23.99	California SI		23.99	0.00	0.00	0.00	Gross
24.9900	Sick	9.50	237.40		FITW	Federal Inco	2280.11	MED-R	198.45	Medicare - E		198.45	2398.81	34.78	34.78	Tot Liab
	Rate				MED	Medicare	2398.81		34.78							Net Amt
		76.00	2398.81	Total Deductions		118.70			304.51	Total Employer Taxes					34.78	

Code	Earning	Hours	Amount	Deduction	Code	Amount	Tax	Code	Amount	Tax	Code	Amount	Taxable	Tax	Amount	Amount
125CO	125 Cash		527.04	457B EE	CA	66.00	California SI	2180.68	CAETT	CA Edu & T		18.62	0.00	0.00	0.00	
108	Comp	17.00	413.61	PTAXI Pre-Tax P	CASDI	129.44	CA SDI - Err	2376.12	CASUI	California SI		23.76	0.00	0.00	0.00	Gross
24.3300	Reg	59.00	1435.47		FITW	Federal Inco	2180.68	MED-R	123.51	Medicare - E		123.51	2376.12	34.45	34.45	Tot Liab
	Rate				MED	Medicare	2376.12		34.45							Net Amt
		76.00	2398.81	Total Deductions		195.44			200.34	Total Employer Taxes					34.45	

Code	Earning	Hours	Amount	Deduction	Code	Amount	Tax	Code	Amount	Tax	Code	Amount	Taxable	Tax	Amount	Amount
125CO	125 Cash		1622.33	457B EE	CA	121.29	California SI	14880.60	CAETT	CA Edu & T		660.64	737.23	0.00	0.00	
Auto	Auto Allo		75.00	PTAXI Pre-Tax P	CASDI	394.41	CA SDI - Err	15884.79	CASUI	California SI		158.84	737.23	45.71	45.71	Gross
178.50	Reg	17.00	413.61	PTXPE Pre-Tax P	FITW	488.49	Federal Inco	14880.60	MED-R	Medicare - E		1857.52	15884.79	230.33	230.33	Tot Liab
	Sick	9.50	237.40		MED	Medicare	15884.79	SS-R	230.33	OASDI - Em		230.33	737.23	0.00	0.00	Net Amt
	Rate				SS	OASDI	737.23		0.00							276.04
		205.00	15884.79	Total Deductions		1004.19			2907.33	Total Employer Taxes					276.04	

Code	Earning	Hours	Amount	Deduction	Code	Amount	Tax	Code	Amount	Tax	Code	Amount	Taxable	Tax	Amount	Amount
125CO	125 Cash		1622.33	457B EE	CA	121.29	California SI	14880.60	CAETT	CA Edu & T		660.64	737.23	0.00	0.00	
Auto	Auto Allo		75.00	PTAXI Pre-Tax P	CASDI	394.41	CA SDI - Err	15884.79	CASUI	California SI		158.84	737.23	45.71	45.71	Gross
178.50	Reg	17.00	413.61	PTXPE Pre-Tax P	FITW	488.49	Federal Inco	14880.60	MED-R	Medicare - E		1857.52	15884.79	230.33	230.33	Tot Liab
	Sick	9.50	237.40		MED	Medicare	15884.79	SS-R	230.33	OASDI - Em		230.33	737.23	0.00	0.00	Net Amt
	Rate				SS	OASDI	737.23		0.00							276.04
		205.00	15884.79	Total Deductions		1004.19			2907.33	Total Employer Taxes					276.04	

Code	Earning	Hours	Amount	Deduction	Code	Amount	Tax	Code	Amount	Tax	Code	Amount	Taxable	Tax	Amount	Amount
125CO	125 Cash		1622.33	457B EE	CA	121.29	California SI	14880.60	CAETT	CA Edu & T		660.64	737.23	0.00	0.00	
Auto	Auto Allo		75.00	PTAXI Pre-Tax P	CASDI	394.41	CA SDI - Err	15884.79	CASUI	California SI		158.84	737.23	45.71	45.71	Gross
178.50	Reg	17.00	413.61	PTXPE Pre-Tax P	FITW	488.49	Federal Inco	14880.60	MED-R	Medicare - E		1857.52	15884.79	230.33	230.33	Tot Liab
	Sick	9.50	237.40		MED	Medicare	15884.79	SS-R	230.33	OASDI - Em		230.33	737.23	0.00	0.00	Net Amt
	Rate				SS	OASDI	737.23		0.00							276.04
		205.00	15884.79	Total Deductions		1004.19			2907.33	Total Employer Taxes					276.04	

Department: (30)Special Enforcement Team

Code	Earning	Hours	Amount	Deduction	Code	Amount	Tax	Code	Amount	Tax	Code	Amount	Taxable	Tax	Code	Amount	Taxable	Amount
Reg	Regular	52.00	1281.28	457B EE	CA	96.10	California SI	CA	1105.10	CA ETT	CA Edu & T	18.07	0.00	CA	1281.28	0.00	0.00	0.00
				AflacP	CASDI	26.26	CA SDI - Eir	CASDI	1281.28	CASUI	California SI	12.82	0.00	CASUI	0.00	0.00	0.00	0.00
				PTXPE Pre-Tax P	FITW	80.08	Federal Inco	FITW	1105.10	MED-R	Medicare - E	61.34	1281.28	MED-R	18.58	18.58	18.58	18.58
					MED		Medicare		1281.28			18.58						
Total Earnings		52.00	1281.28	Total Deductions		202.44			1105.10	Total Employer Taxes		110.81						18.58
Helgemod Dickson																		
125CO	125 Cash		200.72	PTAXI Pre-Tax P	CA	159.55	California SI	CA	2320.41	CA ETT	CA Edu & T	95.59	0.00	CA ETT	0.00	0.00	0.00	0.00
101	Reg Regular	70.00	2099.30		CASDI	2479.96	CA SDI - Eir	CASDI	2479.96	CASUI	California SI	24.80	0.00	CASUI	0.00	0.00	0.00	0.00
29.9900	Sick Sick	6.00	179.94		FITW	2320.41	Federal Inco	FITW	2320.41	MED-R	Medicare - E	203.28	2479.96	MED-R	35.96	35.96	35.96	35.96
					MED	2479.96	Medicare		2479.96			35.96						
Total Earnings		76.00	2479.96	Total Deductions		159.55			359.63	Total Employer Taxes		359.63						35.96

Department: (30)Special Enforcement Team Total

Code	Earning	Hours	Amount	Deduction	Code	Amount	Tax	Code	Amount	Tax	Code	Amount	Taxable	Tax	Code	Amount	Taxable	Amount
2	125CO 125 Cash		200.72	457B EE	CA	96.10	California SI	CA	3425.51	CA ETT	CA Edu & T	113.66	0.00	CA ETT	0.00	0.00	0.00	0.00
0	Reg Regular	122.00	3380.58	AflacP	CASDI	26.26	CA SDI - Eir	CASDI	3761.24	CASUI	California SI	37.62	0.00	CASUI	0.00	0.00	0.00	0.00
	Sick Sick	6.00	179.94	PTXPE Pre-Tax P	FITW	159.55	Federal Inco	FITW	3425.51	MED-R	Medicare - E	264.62	3761.24	MED-R	54.54	54.54	54.54	54.54
					MED	80.08	Medicare		3761.24			54.54						
Total Earnings		128.00	3761.24	Total Deductions		361.99			470.44	Total Employer Taxes		470.44						54.54

Report Total

Code	Earning	Hours	Amount	Deduction	Code	Amount	Tax	Code	Amount	Tax	Code	Amount	Taxable	Tax	Code	Amount	Taxable	Amount
7	125CO 125 Cash		1823.05	457B EE	CA	217.39	California SI	CA	18306.11	CA ETT	CA Edu & T	774.30	737.23	CA ETT	0.00	0.00	0.00	0.00
2	Auto Auto Allo		75.00	AflacP	CASDI	26.26	CA SDI - Eir	CASDI	19646.03	CASUI	California SI	196.46	737.23	CASUI	45.71	45.71	45.71	45.71
	Comp Comp Tin	17.00	413.61	PTXPE Pre-Tax P	FITW	553.96	Federal Inco	FITW	18306.11	MED-R	Medicare - E	2122.14	19646.03	MED-R	284.87	284.87	284.87	284.87
	Reg Regular	300.50	16917.03	PTXPE Pre-Tax P	MED	568.57	Medicare	SS	19646.03	SS-R	OASDI - Em	284.87	737.23	SS-R	0.00	0.00	0.00	0.00
	Sick Sick	15.50	417.34		SS		OASDI		737.23			0.00						
Total Earnings		333.00	19646.03	Total Deductions		1366.18			3377.77	Total Employer Taxes		3377.77						330.58

Chris Mann
Chris Mann, City Manager
6-17-19
Date

Labor Distribution

City of Canyon Lake

Company (10756)

Check Date: 05/31/2019
Process: 2019053101
Period: 05/16/2019 to 05/31/2019

Department: (20)City Employees

Code	Earning	Hours	Amount	Deduction	Code	Amount	Taxable	Tax	Code	Amount	Taxable	Amount
125CO	125 Cash		492.43	PTAXI Pre-Tax P.	CA	264.97	4012.71	CA Edu & T	CAETT	152.05	0.00	0.00
102	Hol Holiday	9.50	0.00		CASDI CA SDI - Err		4277.68	California SI	CASUI	42.78	0.00	0.00
Salary	Regular		3785.25		FITW Federal Inco		4012.71	Medicare - E	MED-R	429.50	4277.68	62.03
					MED Medicare		4277.68			62.02		Net Amt
					Total Deductions	264.97			Total Employer Taxes	686.35		62.03
Day,	Earning	Hours	Amount	Deduction	Code	Amount	Taxable	Tax	Code	Amount	Taxable	Amount
Sarahel	Regular	13.00	180.83	457B EE	CA	13.56	167.27	CA Edu & T	CAETT	0.00	180.83	0.00
Emp Id					CASDI CA SDI - Err		180.83	California SI	CASUI	1.81	180.83	11.21
Rate					FITW Federal Inco		167.27	Medicare - E	MED-R	0.89	180.83	2.62
					MED Medicare		180.83	OASDI - Err	SS-R	2.62	180.83	0.00
					SS OASDI		180.83			0.00		Net Amt
					Total Deductions	13.56			Total Employer Taxes	5.32		13.83

Code	Earning	Hours	Amount	Deduction	Code	Amount	Taxable	Tax	Code	Amount	Taxable	Amount
125CO	125 Cash		103.28	PTXPE Pre-Tax P.	CA	369.79	5725.16	CA Edu & T	CAETT	435.63	0.00	0.00
111	Auto Auto Allo		75.00		CASDI CA SDI - Err		6094.95	California SI	CASUI	60.95	0.00	0.00
Salary	Hol Holiday	9.50	0.00		FITW Federal Inco		5725.16	Medicare - E	MED-R	1051.31	6094.95	88.38
	Regular		5916.67		MED Medicare		6094.95			88.38		Net Amt
					Total Deductions	369.79			Total Employer Taxes	1636.27		88.38

Code	Earning	Hours	Amount	Deduction	Code	Amount	Taxable	Tax	Code	Amount	Taxable	Amount
125CO	125 Cash		499.58	PTXPE Pre-Tax P.	CA	133.54	2502.67	CA Edu & T	CAETT	57.08	0.00	0.00
98	Hol Holiday	9.50	237.40		CASDI CA SDI - Err		2636.21	California SI	CASUI	26.36	0.00	0.00
Rate	Regular	66.50	1661.83		FITW Federal Inco		2502.67	Medicare - E	MED-R	225.15	2636.21	38.23
	Sick	9.50	237.40		MED Medicare		2636.21			38.23		Net Amt
					Total Deductions	369.79			Total Employer Taxes	346.82		38.23

Code	Earning	Hours	Amount	Deduction	Code	Amount	Taxable	Tax	Code	Amount	Taxable	Amount
125CO	125 Cash		527.04	457B EE	CA	66.00	2395.64	CA Edu & T	CAETT	28.08	0.00	0.00
108	Hol Holiday	9.50	231.14	PTAXI Pre-Tax P.	CASDI CA SDI - Err		2607.26	California SI	CASUI	26.07	0.00	0.00
Rate	Regular	76.00	1849.08		FITW Federal Inco		2395.64	Medicare - E	MED-R	149.31	2607.26	37.81
	Sick	9.50	237.40		MED Medicare		2607.26			37.81		Net Amt
					Total Deductions	133.54			Total Employer Taxes	241.27		37.81

Code	Earning	Hours	Amount	Deduction	Code	Amount	Taxable	Tax	Code	Amount	Taxable	Amount
125CO	125 Cash		1622.33	457B EE	CA	79.56	14803.45	CA Edu & T	CAETT	672.84	180.83	0.00
2	Auto Auto Allo		75.00	PTAXI Pre-Tax P.	CASDI CA SDI - Err		15796.93	California SI	CASUI	157.97	180.83	11.21
Rate	Hol Holiday	38.00	468.54	PTXPE Pre-Tax P.	FITW Federal Inco		14803.45	Medicare - E	MED-R	1856.16	15796.93	229.07
	Regular	155.50	13393.66		MED Medicare		15796.93			229.06	180.83	0.00
	Sick	9.50	237.40		SS OASDI		180.83			0.00		Net Amt
					Total Deductions	993.48			Total Employer Taxes	2916.03		240.28

Code	Earning	Hours	Amount	Deduction	Code	Amount	Taxable	Tax	Code	Amount	Taxable	Amount
125CO	125 Cash		75.00	457B EE	CA	410.59	14803.45	CA Edu & T	CAETT	672.84	180.83	0.00
2	Auto Auto Allo		468.54	PTAXI Pre-Tax P.	CASDI CA SDI - Err		15796.93	California SI	CASUI	157.97	180.83	11.21
Rate	Hol Holiday	38.00	468.54	PTXPE Pre-Tax P.	FITW Federal Inco		14803.45	Medicare - E	MED-R	1856.16	15796.93	229.07
	Regular	155.50	13393.66		MED Medicare		15796.93			229.06	180.83	0.00
	Sick	9.50	237.40		SS OASDI		180.83			0.00		Net Amt
					Total Deductions	993.48			Total Employer Taxes	2916.03		240.28

Code	Earning	Hours	Amount	Deduction	Code	Amount	Taxable	Tax	Code	Amount	Taxable	Amount
125CO	125 Cash		527.04	457B EE	CA	66.00	2395.64	CA Edu & T	CAETT	28.08	0.00	0.00
108	Hol Holiday	9.50	231.14	PTAXI Pre-Tax P.	CASDI CA SDI - Err		2607.26	California SI	CASUI	26.07	0.00	0.00
Rate	Regular	76.00	1849.08		FITW Federal Inco		2395.64	Medicare - E	MED-R	149.31	2607.26	37.81
	Sick	9.50	237.40		MED Medicare		2607.26			37.81		Net Amt
					Total Deductions	133.54			Total Employer Taxes	241.27		37.81

Department: (20)City Employees Total

Code	Earning	Hours	Amount	Deduction	Code	Amount	Taxable	Tax	Code	Amount	Taxable	Amount
125CO	125 Cash		1622.33	457B EE	CA	79.56	14803.45	CA Edu & T	CAETT	672.84	180.83	0.00
2	Auto Auto Allo		75.00	PTAXI Pre-Tax P.	CASDI CA SDI - Err		15796.93	California SI	CASUI	157.97	180.83	11.21
Rate	Hol Holiday	38.00	468.54	PTXPE Pre-Tax P.	FITW Federal Inco		14803.45	Medicare - E	MED-R	1856.16	15796.93	229.07
	Regular	155.50	13393.66		MED Medicare		15796.93			229.06	180.83	0.00
	Sick	9.50	237.40		SS OASDI		180.83			0.00		Net Amt
					Total Deductions	993.48			Total Employer Taxes	2916.03		240.28

Labor Distribution

City of Canyon Lake

Company (10756)

Check Date: 05/31/2019
 Process: 2019053101
 Period: 05/16/2019 to 05/31/2019

Code	Earning	Hours	Amount	Code	Tax	Amount	Code	Tax	Amount	Code	Tax	Amount	Tot Liab	Net Amt
Reg	Regular		300.00	CA	California SI	300.00	CA	CA Edu & Ti	0.00	CA	CA Edu & Ti	0.00		
Emp	103			FITW	Federal Incoi	300.00	FITW	California SI	18.60	FITW	California SI	18.60	Gross	300.00
Salary	300.00			MED	Medicare	300.00	MED-R	Medicare - E	4.35	MED-R	Medicare - E	4.35	Tot Liab	322.95
													Net Amt	295.65
Total Earnings		0.00	300.00	Total Deductions		0.00	Total Employer Taxes		4.35	Total Employer Taxes		22.95		
Code	Earning	Hours	Amount	Code	Tax	Amount	Code	Tax	Amount	Code	Tax	Amount	Tot Liab	Net Amt
Reg	Regular		300.00	CA	California SI	300.00	CA	CA Edu & Ti	0.00	CA	CA Edu & Ti	0.00		
Emp	109			FITW	Federal Incoi	300.00	FITW	California SI	18.60	FITW	California SI	18.60	Gross	300.00
Salary	300.00			MED	Medicare	300.00	MED-R	Medicare - E	4.35	MED-R	Medicare - E	4.35	Tot Liab	322.95
													Net Amt	295.65
Total Earnings		0.00	300.00	Total Deductions		0.00	Total Employer Taxes		4.35	Total Employer Taxes		22.95		

Department: (50) Council Members Total

Code	Earning	Hours	Amount	Code	Tax	Amount	Code	Tax	Amount	Code	Tax	Amount	Tot Liab	Net Amt
1	Reg		1500.00	CA	California SI	1500.00	CA	CA Edu & Ti	0.00	CA	CA Edu & Ti	0.00		
4	Regular			FITW	Federal Incoi	1500.00	FITW	California SI	93.00	FITW	California SI	93.00	Gross	1500.00
				MED	Medicare	1500.00	MED-R	Medicare - E	21.74	MED-R	Medicare - E	21.74	Tot Liab	1614.74
													Net Amt	1478.25
Total Earnings		0.00	1500.00	Total Deductions		0.00	Total Employer Taxes		21.75	Total Employer Taxes		114.74		

Report Total

Code	Earning	Hours	Amount	Code	Tax	Amount	Code	Tax	Amount	Code	Tax	Amount	Tot Liab	Net Amt
6	125CO	125 Cash	1795.75	457B	EE	160.87	CA	California SI	19475.87	CA	CA Edu & Ti	1680.83		
6	Auto	Auto Allo	75.00	AflacP	Aflac Post	26.26	CASDI	CA SDI - Em	19273.77	CASUI	California SI	1680.83	Gross	20773.77
	Holiday		468.54	PTAXI	Pre-Tax P	565.94	FITW	Federal Incoi	19475.87	MED-R	Medicare - E	20773.77	Tot Liab	21179.20
	Regular		18017.14	PTXPE	Pre-Tax P	571.09	MED	Medicare	20773.77	SS-R	OASDI - Em	180.83	Net Amt	16088.10
	Sick	Sick	417.34				SS	OASDI	180.83					
Total Earnings		321.00	20773.77	Total Deductions		1324.16	Total Employer Taxes		3361.51	Total Employer Taxes		405.43		

Chris Mann
 Chris Mann, City Manager

6-6-19
 Date

Skip to: Content | Footer | Welcome Kayla | Help | Contact Us | CalPERS Website | Log out **May 30, 2019**



Home Profile Reporting Person Information Education Other Organizations

Manage Reports Billing and Payments Payroll Schedule Out-of-Class Validation Member Requests Health Reconciliation Retirement Appc

Name: City of Canyon Lake **CalPERS ID:** 3813045770

Payment Request Acceptance

Your request for payment has been accepted

- **To generate the employer payment report, please click the print button.**
- If you need to contact us with questions regarding this payment, please have your Payment Confirmation Number for faster access.
- Your payment will reflect as paid in myCalPERS if your payroll has successfully posted. Once your payment is processed any credits will roll over to the same type of receivable in the next month, after your payroll has been processed.
- Your payment may take longer to post, depending upon your Financial Institution.

Payment Setup Total

Total Payment Amount: \$969.49

Payment Summary

Payment Confirmation Number	Payment Authorization Date	Receivable ID	Receivable Description	Payment Method	Payment Account Nickname	Selected Payment Amount
1001329958	06/03/2019	100000015676332	Health PA Billing - PERS	EFT - Debit	Citizens Business Bank -5402	\$969.49

© Copyright 2019 CalPERS | [Conditions of Use](#) | [Accessibility](#)

Build: v8.0.0.a Baseline: 190503.112600 v8.0.Int.6286 UID: 318

Skip to: Content | Footer | Welcome Kayla | Help | Contact Us | CalPERS Website | Log out June 20, 2019



Home Profile Reporting Person Information Education Other Organizations

Manage Reports Billing and Payments Payroll Schedule Out-of-Class Validation Member Requests Health Reconciliation Retirement App

Name: City of Canyon Lake CalPERS ID: 3813045770

Payment Request Acceptance

Your request for payment has been accepted

- To generate the employer payment report, please click the print button.
- If you need to contact us with questions regarding this payment, please have your Payment Confirmation Number for faster access.
- Your payment will reflect as paid in myCalPERS if your payroll has successfully posted. Once your payment is processed any credits will roll over to the same type of receivable in the next month, after your payroll has been processed.
- Your payment may take longer to post, depending upon your Financial Institution.

Payment Setup Total

Total Payment Amount: \$2,448.64

Payment Summary

Payment Confirmation Number	Payment Authorization Date	Receivable ID	Receivable Description	Payment Method	Payment Account Nickname	Selected Payment Amount
1001342985	06/20/2019	100000015668794	Employer Contribution, Classic, 1684, CalPERS, 06/01/2019 - 06/15/2019	EFT - Debit	Citizens Business Bank -5402	\$1,257.63
1001342986	06/20/2019	100000015668839	Employer Contribution, PEPR, 26189, CalPERS, 06/01/2019 - 06/15/2019	EFT - Debit	Citizens Business Bank -5402	\$1,191.01

© Copyright 2019 CalPERS | Conditions of Use | Accessibility

Build: v8.1 Baseline: 190611 125242 v8.1 Int.8391 UID: 318

Skip to: Content | Footer | Welcome Kayla | Help | Contact Us | CalPERS Website | Log out June 12, 2019



Home Profile Reporting Person Information Education Other Organizations

Manage Reports Billing and Payments Payroll Schedule Out-of-Class Validation Member Requests Health Reconciliation Retirement App

Name: City of Canyon Lake CalPERS ID: 3813045770

Payment Request Acceptance

Your request for payment has been accepted

- To generate the employer payment report, please click the print button.
- If you need to contact us with questions regarding this payment, please have your Payment Confirmation Number for faster access.
- Your payment will reflect as paid in myCalPERS if your payroll has successfully posted. Once your payment is processed any credits will roll over to the same type of receivable in the next month, after your payroll has been processed.
- Your payment may take longer to post, depending upon your Financial Institution.

Payment Setup Total

Total Payment Amount: \$2,481.11

Payment Summary

Payment Confirmation Number	Payment Authorization Date	Receivable ID	Receivable Description	Payment Method	Payment Account Nickname	Selected Payment Amount
1001338951	06/12/2019	100000015643124	Employer Contribution, Classic, 1684, CalPERS, 05/16/2019 - 05/31/2019	EFT - Debit	Citizens Business Bank -5402	\$1,284.83
1001338952	06/12/2019	100000015643158	Employer Contribution, PEPRA, 26189, CalPERS, 05/16/2019 - 05/31/2019	EFT - Debit	Citizens Business Bank -5402	\$1,196.28

© Copyright 2019 CalPERS | [Conditions of Use](#) | [Accessibility](#)

Build: v8.0.0.a Baseline: 190503 112600 v8.0.Int.6288 UID: 318

Handwritten initials "CW"

Skip to: Content | Footer | Welcome Kayla | Help | Contact Us | CalPERS Website | Log out **June 06, 2019**



Home Profile Reporting Person Information Education Other Organizations

Manage Reports Billing and Payments Payroll Schedule Out-of-Class Validation Member Requests Health Reconciliation Retirement App

Name: City of Canyon Lake **CalPERS ID:** 3813045770

Payment Request Acceptance

Your request for payment has been accepted

- **To generate the employer payment report, please click the print button.**
- If you need to contact us with questions regarding this payment, please have your Payment Confirmation Number for faster access.
- Your payment will reflect as paid in myCalPERS if your payroll has successfully posted. Once your payment is processed any credits will roll over to the same type of receivable in the next month, after your payroll has been processed.
- Your payment may take longer to post, depending upon your Financial Institution.

Payment Setup Total

Total Payment Amount: \$500.00

Payment Summary

Payment Confirmation Number	Payment Authorization Date	Receivable ID	Receivable Description	Payment Method	Payment Account Nickname	Selected Payment Amount
1001335220	06/06/2019	100000015684133	Admin Fee - 20283 Arrears, CalPERS	EFT - Debit	Citizens Business Bank -5402	\$500.00

© Copyright 2019 CalPERS | [Conditions of Use](#) | [Accessibility](#)

Build: v8.0.0.a Baseline: 190503 112600 v8.0 Int.6288 UID: 318



P.O. Box 942715 Sacramento, CA 94229-2715
 888 CalPERS (or 888-225-7377) | Fax: (800) 959-6545
 www.calpers.ca.gov

California Public Employees' Retirement System

ADMIN FEE - ARREARS-EMPLOYER PAID (20283)

May 24, 2019

City of Canyon Lake
 Aaron Palmer
 31516 RAILROAD CANYON RD
 CANYON LAKE, CA

Business Unit: 1900
 Business Partner ID: 3813045770
 Receivable ID: 100000015684133
 Invoice Date: May 24, 2019
 Payment Due Date: July 01, 2019

Description	Amount
20283 (Arrears-Employer Paid) Administration Fee	\$500.00
Total Due	\$500.00

Retain this statement for your records, and mail remittance notification below with your payment.

The following provides detailed information related to the 20283 (Arrears-Employer Paid) Administration Fee receivable:

- Participant: Victoria L Day
- Participant CalPERS ID: 2185155590
- Service Period: November 06, 2017 -- October 15, 2018
- Business Partner Name: City of Canyon Lake

Employers can view detailed information related to 20283 (Arrears-Employer Paid) Administration Fee receivables by generating the "Arrears Receivable Detail Report" within my|CalPERS. This report provides participant information pertaining to the receivable.

California Public Employees' Retirement System
 www.calpers.ca.gov

my|CalPERS 2288



Skip to: Content | Footer | Welcome Kayla | Help | Contact Us | CalPERS Website | Log out **June 06, 2019**



Home Profile Reporting Person Information Education Other Organizations

Manage Reports Billing and Payments Payroll Schedule Out-of-Class Validation Member Requests Health Reconciliation Retirement Appc

Name: City of Canyon Lake **CalPERS ID:** 3813045770

Payment Request Acceptance

Your request for payment has been accepted

- **To generate the employer payment report, please click the print button.**
- If you need to contact us with questions regarding this payment, please have your Payment Confirmation Number for faster access.
- Your payment will reflect as paid in myCalPERS if your payroll has successfully posted. Once your payment is processed any credits will roll over to the same type of receivable in the next month, after your payroll has been processed.
- Your payment may take longer to post, depending upon your Financial Institution.

Payment Setup Total

Total Payment Amount: \$2,302.60

Payment Summary

Payment Confirmation Number	Payment Authorization Date	Receivable ID	Receivable Description	Payment Method	Payment Account Nickname	Selected Payment Amount
1001335218	06/06/2019	100000015684134	20283 Arrears, CalPERS	EFT - Debit	Citizens Business Bank -5402	\$2,302.60

© Copyright 2019 CalPERS | [Conditions of Use](#) | [Accessibility](#)

Build: v8.0.0.a Baseline: 190503 112600 v8.0 Int.6288 UID: 318



P.O. Box 942715 Sacramento, CA 94229-2715
 888 CalPERS (or 888-225-7377) | Fax: (800) 959-6545
 www.calpers.ca.gov

California Public Employees' Retirement System

PUBLIC AGENCY ADJUSTMENT INVOICE

City of Canyon Lake
 Aaron Palmer
 31516 RAILROAD CANYON RD
 CANYON LAKE, CA 92587

Business Unit: 1900
 Business Partner ID: 3813045770
 Receivable ID: 100000015684134
 Invoice Date: May 24, 2019
 Payment Due Date: July 01, 2019

Description	Amount
Arrears Contributions	\$2,302.60
Total Due	\$2,302.60

Retain this statement for your records, and mail remittance notification below with your payment.

The following provides detailed information related to the Mandatory and 20283 Arrears receivable:

- Participant: Victoria L Day
- Participant CalPERS ID: 2185155590
- Service Period: November 06, 2017 -- October 15, 2018
- Business Partner Name: City of Canyon Lake

Employers can view detailed information related to Mandatory and 20283 Arrears receivables by generating the "Arrears Receivable Notice Report" within my|CalPERS. This report provides participant information pertaining to the receivable.

my|CalPERS 2235





CITY OF CANYON LAKE
PLAN SPONSOR: 0035273

Acknowledgment

Your payment was successfully submitted. Provided it is in good order, it will process within contractual timeframes.

You can print this acknowledgment for your records.

Plan Name: **CITY OF CANYON LAKE 457**

Plan Number: **0035273001**

Payroll Center: **CITY OF CANYON LAKE OBRA**

Payroll Center Number: ~~004~~ **002**

Payroll Received for Salary Reduction

Submission date: **06/13/2019**

Submission time: **02:35 PM**

Pay period end date: **05/31/2019**

Payment method: **Debit ACH**

Bank routing number: **122234149**

Bank account number: **245125402**

Contributions payment amount: **\$13.56**

Contributions count: **1**

Draft date: **06/14/2019**

Warnings

The following participants are not yet enrolled in this plan. Please submit the appropriate paperwork or have the participant access this website and follow the directions to either self-enroll or contact us.

SSN

Participant

615-19-9085

DAY, SARAH

Nationwide Retirement Solutions and Nationwide Life Insurance Company (collectively "Nationwide") have endorsement relationships with the National Association of Counties, the International Association of Fire Fighters-Financial Corporation, and the National Association of Police Organizations.

Nationwide may receive payments from mutual funds or their affiliates in connection with certain investment options. [Learn more about these payments](#).



CITY OF CANYON LAKE
PLAN SPONSOR: 0035273

Acknowledgment

Your payment was successfully submitted. Provided it is in good order, it will process within contractual timeframes.

You can print this acknowledgment for your records.

Plan Name:**CITY OF CANYON LAKE 457**

Plan Number:**0035273001**

Payroll Center:**CITY OF CANYON LAKE**

Payroll Center Number:**001**

Payroll Received for Salary Reduction

Submission date:**06/13/2019**

Submission time:**02:16 PM**

Pay period end date:**05/31/2019**

Payment method:**Debit ACH**

Bank routing number:**122234149**

Bank account number:**245125402**

Contributions payment amount:**\$132.00**

Contributions count:**1**

Draft date:**06/14/2019**

CM

Nationwide Retirement Solutions and Nationwide Life Insurance Company (collectively "Nationwide") have endorsement relationships with the [National Association of Counties](#), the [International Association of Fire Fighters-Financial Corporation](#), and the [National Association of Police Organizations](#).

Nationwide may receive payments from mutual funds or their affiliates in connection with certain investment options. [Learn more about these payments](#).

Retirement Specialists provide information for educational purposes only. This information is not meant to be used as investment advice. Retirement Specialists are Registered Representatives of Nationwide Investment Services Corporation, member [FINRA](#).



CITY OF CANYON LAKE
PLAN SPONSOR: 0035273

Acknowledgment

Your payment was successfully submitted. Provided it is in good order, it will process within contractual timeframes.

You can print this acknowledgment for your records.

Plan Name: **CITY OF CANYON LAKE 457**

Plan Number: **0035273001**

Payroll Center: **CITY OF CANYON LAKE**

Payroll Center Number: **001**

Payroll Received for Salary Reduction

Submission date: **06/13/2019**

Submission time: **02:27 PM**

Pay period end date: **05/30/2019**

Payment method: **Debit ACH**

Bank routing number: **122234149**

Bank account number: **245125402**

Contributions payment amount: **\$195.89**

Contributions count: **1**

Draft date: **06/14/2019**

Warnings

The following participants are not yet enrolled in this plan. Please submit the appropriate paperwork or have the participant access this website and follow the directions to either self-enroll or contact us.

SSN

Participant

662-07-9007

ECCLEFIELD, DAWN

Nationwide Retirement Solutions and Nationwide Life Insurance Company (collectively "Nationwide") have endorsement relationships with the [National Association of Counties](#), the [International Association of Fire Fighters-Financial Corporation](#), and the [National Association of Police Organizations](#).

Nationwide may receive payments from mutual funds or their affiliates in connection with certain investment options. [Learn more about these payments.](#)

Investment Reports

CITIZENSTRUST™

PO Box 2549
Rancho Cucamonga, CA 91729-2549
Return Service Requested

00000042 MCB1000060619312948 01 000000 42 004



CITY OF CANYON LAKE
31516 RAILROAD CANYON RD
CANYON LAKE CA 92587

RECEIVED
MAY 1 19 2019
BY: *sd*

STATEMENT FOR THE PERIOD FROM 05/01/2019 TO 05/31/2019
ACCOUNT 1035003119

THIS IS YOUR REPORT OF INVESTMENTS AND TRANSACTIONS FOR THE PERIOD. INCLUDED IN THE REPORT ARE

- * PORTFOLIO: SUMMARY GRAPHICAL DISPLAY WITH MARKET VALUE & PERCENT
 - * ACTIVITY SUMMARY: MARKET VALUE WITH TRANSACTION SUMMARY
 - * PORTFOLIO STATEMENT: A LISTING OF COST AND MARKET VALUE OF ASSETS HELD IN THE PORTFOLIO
- COST BASIS APPLICABLE FOR CALCULATING CAPITAL GAINS AND LOSSES.
MARKET VALUE IS THE CURRENT VALUE OF EACH ASSET FOR MOST STOCKS AND BONDS.
MARKETS ARE THE CLOSING PRICES ON THE LAST TRADING DAY OF THE PERIOD.
- * TRANSACTION STATEMENT: A COMPLETE LISTING FOR THE PERIOD GROUPED BY TRANSACTION TYPE.
 - * DISCLOSURES: CITIZENS BUSINESS BANK MAY RECEIVE RESEARCH AND OTHER BENEFITS FROM BROKER DEALERS WHICH MAY BE CONSIDERED COMPENSATION TO US. UPON REQUEST WE WILL DISCLOSE DETAILS OF ANY COMPENSATION RECEIVED.
 - * TO TRUST BENEFICIARIES: UNDER SECTION 17200 OF CALIFORNIA PROBATE CODE, YOU MAY PETITION THE COURT TO OBTAIN A COURT REVIEW OF THE ACCOUNT AND THE ACTS OF THE TRUSTEE. CLAIMS AGAINST THE TRUSTEE FOR BREACH OF TRUST MUST BE MADE WITHIN THREE YEARS FROM THE DATE OF RECEIPT OF AN ACCOUNTING OR OTHER REPORT DISCLOSING FACTS GIVING RISE TO THE CLAIM.



PO Box 2549
 Rancho Cucamonga, CA 91729-2549
 Return Service Requested



Account Statement

Account Number: **1035003119**
 May 01, 2019 To May 31, 2019

CITY OF CANYON LAKE
 31516 RAILROAD CANYON RD
 CANYON LAKE, CA 92587

Account Name:	CITY OF CANYON LAKE CITIZENS BUSINESS BANK
Account Number:	1035003119
Your Relationship Manager Is:	MIKE GARDNER
Phone:	909-483-4390

Investment Portfolio Summary

Market Value As Of	05/01/2019	05/31/2019	% Of Account
 CASH & CASH EQUIVALENTS	352,427.77	354,240.21	13.1%
 FIXED INCOME	2,336,011.25	2,342,572.16	86.9%
Total	2,688,439.02	2,696,812.37	100.0%

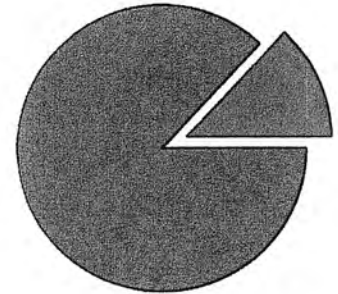

Activity Summary

	This Period	Year To Date	Realized Capital Gains / Losses	
			This Period	Year To Date
Beginning Market Value	2,688,439.02	2,651,935.18		
Income	585.07	22,864.67	Long Term	143.45-
Asset Activity	2,049.29	209,472.47	Total Gains / Losses	143.45-
Fees	821.92-	4,136.99-		
Cash Management	1,812.44-	228,200.15-		
Change In Market Value	8,373.35	44,877.19		
Ending Market Value	2,696,812.37	2,696,812.37		



Account Statement

Account Number: **1035003119**

May 01, 2019 To May 31, 2019

Portfolio Statement

Quantity	Description	Market Value	Cost Basis
Cash & Cash Equivalents			
Cash Equivalents			
Unclassified			
354,240.210	31607A703 FIDELITY GOVERNMENT PORTFOLIO	354,240.21	354,240.21
	Total Unclassified	354,240.21	354,240.21
Total	Cash Equivalents	354,240.21	354,240.21
Total	Cash & Cash Equivalents	354,240.21	354,240.21
Fixed Income			
Taxable			
75,000.000	05531FAU7 BB&T CORPORATION DTD 06/29/15 CALL 2.625% 06/29/2020-2020	75,049.50	75,166.09
100,000.000	05580ACZ5 BMW BANK BANK NORTH AMERICA DTD 09/30/15 MEDIUM-TERM CD 2.2% 09/30/2020	99,713.00	99,980.00
100,000.000	14042RAR2 CAPITAL ONE NA MEDIUM-TERM CD DTD 10/07/2015 2.2% 10/07/2020	99,708.00	99,615.00
100,000.000	24422ERE1 JOHN DEERE CAPITAL CORP SERIES MTN DTD 07/12/2011 3.9% 07/12/2021	102,845.00	105,175.84
100,000.000	29266NS32 ENERBANK USA DTD 10/16/2015 MEDIUM-TERM CD 1.75% 10/16/2020	99,026.00	100,000.00
70,000.000	3130A1CE6 FEDERAL HOME LOAN DTD 03/27/14 2% 12/27/2019	69,855.10	70,231.64
100,000.000	3130A6NA1 FEDERAL HOME LOAN DTD 10/29/15 CALL 1.4% 10/29/2019-2016	99,589.00	100,000.00
50,000.000	3130A8EN9 FEDERAL HOME LOAN BANK DTD 06/14/16 CALL 1.64% 06/14/2021-2016	49,613.50	50,000.00
100,000.000	3130A8NT6 FEDERAL HOME LOAN DTD 07/13/16 CALL 1.48% 07/13/2021-2017	98,792.00	100,000.00
150,000.000	3130ADZ88 FEDERAL HOME LOAN DTD 4/17/18 3% 4/17/23 CALL 3% 04/17/2023-2019	150,009.00	150,000.00
100,000.000	313380FB8 FEDERAL HOME LOAN BANK DTD 08/09/12 1.375% 09/13/2019	99,712.00	99,667.18

Portfolio Statement (Continued)

Quantity	Description	Market Value	Cost Basis
Taxable			
100,000.000	3133EFZ91 FEDERAL FARM CREDIT BANK DTD 04/12/16 CALL 1.62% 04/12/2021-2017	99,310.00	99,909.00
50,000.000	3134GAHK3 FREDDIE MAC DTD 09/30/16 CALL 1.6% 09/30/2021-2016	49,398.00	49,967.50
100,000.000	3134GAZR8 FREDDIE MAC DTD 12/30/2016 CALL 2.05% 12/30/2021-2017	99,793.00	100,000.00
100,000.000	3134GB7F3 FREDDIE MAC DTD 12/29/17 CALL 2.5% 12/29/2022-2018	100,006.00	100,000.00
100,000.000	3134GBZS4 FREDDIE MAC DTD 7/27/2017 CALL 2.15 4/27/2022 2.15% 04/27/2022-2017	100,015.00	100,000.00
150,000.000	3134GSYQ2 FREDDIE MAC DTD 9/27/2018 CALL 3% 09/27/2021-2019	150,417.00	149,902.50
50,000.000	3136G1C98 FANNIE MAE DTD 02/05/13 1.42% 02/05/2020	49,745.50	50,153.00
100,000.000	3136G3J30 FANNIE MAE DTD 07/28/16 CALL 1.6% 07/28/2021-2016	99,292.00	100,000.00
100,000.000	3136G3VG7 FANNIE MAE DTD 06/29/16 CALL 1.5% 09/29/2020-2016	99,358.00	100,000.00
100,000.000	3136G3XZ3 FANNIE MAE DTD 07/28/16 CALL 1.5% 07/28/2021-2016	99,097.00	100,000.00
100,000.000	3136G4EV1 FANNIE MAE DTD 10/28/16 CALL 1.625% 10/28/2021-2017	99,212.00	99,959.00
28,782.470	31398R7H2 FANNIE MAE SERIES 2010-M4 CLASS A3 DTD 07/01/10 3.819% 06/25/2020	29,032.06	30,797.24
200,000.000	69353REW4 PNC BANK NA DTD 04/29/16 CALL 2.15% 04/29/2021-2021	198,680.00	201,644.19
25,000.000	713448BN7 PEPSICO INC DTD 01/14/10 4.5% 01/15/2020	25,304.50	25,682.38
Total	Taxable	2,342,572.16	2,357,850.56
Total	Fixed Income	2,342,572.16	2,357,850.56



Account Statement

Account Number: **1035003119**

May 01, 2019 To May 31, 2019

Portfolio Statement (Continued)

Quantity	Description	Market Value	Cost Basis
Miscellaneous			
Miscellaneous Sundry Assets			
Documents			
1.000	DOC199647 INVESTMENT MANAGEMENT AGREEMENT CITY OF CANYON LAKE A/C# 1035003119	0.00	0.00
Total Documents		0.00	0.00
Total	Miscellaneous Sundry Assets	0.00	0.00
Total	Miscellaneous	0.00	0.00
Grand Total Assets		2,696,812.37	2,712,090.77

Account Activity Summary

	Total Cash	Cost Basis Excluding Cash	Market Value Including Cash
Balances Beginning Of Period	0.00	2,712,471.07	2,696,697.70
Prior Accruals			8,258.68-
Unrealized Appreciation This Period			8,516.80
Current Accruals			12,199.45
Asset Activity	2,049.29	2,192.74-	2,049.29
Cash Management	1,812.44-	1,812.44	1,812.44-
Fees	821.92-	0.00	821.92-
Income	585.07	0.00	585.07
Realized Gain/loss			143.45-
Non Cash Asset Changes			
Balances End Of Period	0.00	2,712,090.77	2,709,011.82

Transaction Statement

Date	Quantity	Description	Transaction Type	Cash	Cost Basis
05/01/19		Beginning Balance		0.00	2,712,471.07
Income					
Interest					
05/01/19		31607A703 FIDELITY GOVERNMENT PORTFOLIO 29266NS32	INTEREST RCVD	337.10	
05/16/19		ENERBANK USA DTD 10/16/2015 MEDIUM-TERM CD 1.75% 10/16/2020	INTEREST RCVD	143.84	
05/28/19		31398R7H2 FANNIE MAE SERIES 2010-M4 CLASS A3 DTD 07/01/10 3.819% 06/25/2020	INTEREST RCVD	98.12	
05/29/19		31398R7H2 FANNIE MAE SERIES 2010-M4 CLASS A3 DTD 07/01/10 3.819% 06/25/2020	INTEREST RCVD	6.01	
Total Interest				585.07	0.00
Total Income				585.07	0.00

Transaction Statement (Continued)

Date	Quantity	Description	Transaction Type	Cash	Cost Basis
Asset Activity					
Assets Sold					
05/28/19	2,049.290-	31398R7H2 FANNIE MAE SERIES 2010-M4 CLASS A3 DTD 07/01/10 3.819% 06/25/2020	NOTE AND MTG PMT	2,049.29	2,192.74-
05/29/19		31398R7H2 FANNIE MAE SERIES 2010-M4 CLASS A3 DTD 07/01/10 3.819% 06/25/2020	NOTE AND MTG PMT		
Total Assets Sold				2,049.29	2,192.74-
Total Asset Activity				2,049.29	2,192.74-
Fees					
05/28/19		MANAGEMENT FEES CITIZENS BUSINESS BANK FOR THE PERIOD ENDING 05/20/2019	DISBURSEMENT	821.92-	
Total Fees				821.92-	0.00
Cash Management					
05/31/19	1,812.440	31607A703 NET CASH MANAGEMENT	NET CASH MGMT	1,812.44-	1,812.44
Total Cash Management				1,812.44-	1,812.44
05/31/19		Ending Balance		0.00	2,712.090.77

Disclosure

DISCLOSURE: CitizensTrust may receive research and benefits from Brokers/Dearlers which may be considered compensation. Upon request we will disclose details. Please contact your Relationship Manager if you have any questions.



**City of Canyon Lake
City Council
Staff Report**

TO: Honorable Mayor and Members of the City Council
FROM: Chris Mann, City Manager
BY: Kayla Lozano, Accountant
DATE: August 7, 2019
SUBJECT: List of Demands

CM

Recommendation:

That the City Council adopt a resolution entitled: RESOLUTION NO. 2019-24

A RESOLUTION OF THE CITY COUNCIL OF THE
CITY OF CANYON LAKE ALLOWING CERTAIN
CLAIMS AND DEMANDS AS SET FORTH IN EXHIBIT A

Background:

All claims and demands are reported and summarized for review and approval by the City Council on a routine basis at each City Council meeting. The attached claims represent the paid claims and demands since the City Council meeting of June 5, 2019.

Budget (or Fiscal) Impact:

All claims and demands are paid from appropriated funds or authorized resources of the City and have been recorded in accordance with the City's policies.

Attachments:

1. Resolution No. 2019-24
2. List of Demands

RESOLUTION NO. 2019-24

A RESOLUTION OF THE CITY COUNCIL OF THE CITY OF CANYON LAKE, CALIFORNIA, ALLOWING CERTAIN CLAIMS AND DEMANDS AS SET FORTH IN EXHIBIT A

The City Council of the City of Canyon Lake does hereby resolve as follows:

Demands are approved as shown on the Demand\Warrant Register of August 7th, in the amount of \$460,349.33 as follows:

Payroll Earnings (Gross)	\$ 43,215.75	(2nd Half of June & 1st Half of July)
Payroll Taxes - Employer	835.34	(2nd Half of June & 1st Half of July)
On-line Retirement	5,302.78	(2nd Half of June & 1st Half of July)
On-line Health	969.49	(For the Month of July)
Nationwide Deferred Comp.	445.86	(For the Month of June)
CalPERS Unfunded Accrued Liability	2,016.04	FY 2019/2020
CalPERS Unfunded Accrued Liability	122.67	FY 2019/2020
General	407,441.40	
TOTAL	<u>\$ 460,349.33</u>	

PASSED, APPROVED AND ADOPTED this 7th day of August, 2019.

Jordan Ehrenkranz, Mayor Pro Tem

ATTEST:

Ana V. Sauseda, Deputy City Clerk

State of California
County of Riverside) ss
City of Canyon Lake)

I, Ana V. Sauseda, Deputy City Clerk of the City of Canyon Lake, California, DO HEREBY CERTIFY, that the foregoing is a true and correct copy of the Resolution No. 2019-24 adopted by the City Council of the City of Canyon Lake, California, at a regular meeting thereof, held on August 7, 2019, by the following vote:

AYES:

NOES:

ABSTAIN:

ABSENT:

Ana V. Sauseda
Deputy City Clerk

Claims and Demands

City of Canyon Lake
 Check/Voucher Register - Council Report - Expenditures
 From 7/1/2019 Through 7/31/2019

Check Num...	Matching Docum... Date	Vendor Name	Transaction Description	Check Amount	Fund Code	Fund Short Title
25151	6/30/2019	ANIMAL FRIENDS OF THE VALLEYS	Animal Control Services for May & June 2019	7,000.00	10	GENERAL
Total 25151	6/30/2019			7,000.00		
25152	6/30/2019	BIO-TOX LABORATORIES	Sheriff's Dept. Blood Draw, May 2019	46.00	10	GENERAL
Total 25152	6/30/2019			46.00		
25153	6/30/2019	Randall Bonner	Reimb. for internet & phone for April 2019, travel for May	127.10	10	GENERAL
Total 25153	6/30/2019			127.10		
25154	6/30/2019	Castaneda & Associates	Housing Needs Assesment June 2019	1,826.99	10	GENERAL
25154	6/30/2019	Castaneda & Associates	Housing Needs Assesment May 2019	5,165.46	10	GENERAL
Total 25154	6/30/2019			6,992.45		
25155	6/30/2019	C.L.CHAMBER OF COMMERCE	Business Membership June - May 2019	110.00	10	GENERAL
Total 25155	6/30/2019			110.00		
25156	6/30/2019	Cole Huber LLP	Attorney Services April 2019	5,000.00	10	GENERAL
25156	6/30/2019	Cole Huber LLP	Attorney Services February 2019	8,320.00	10	GENERAL
25156	6/30/2019	Cole Huber LLP	Attorney Services for June 2019	5,000.00	10	GENERAL
25156	6/30/2019	Cole Huber LLP	Attorney Services March 2019	7,600.00	10	GENERAL
25156	6/30/2019	Cole Huber LLP	Attorney Services May 2019	5,000.00	10	GENERAL
Total 25156	6/30/2019			30,920.00		

City of Canyon Lake
 Check/Voucher Register - Council Report - Expenditures
 From 7/1/2019 Through 7/31/2019

Check Num...	Matching Docum... Date	Vendor Name	Transaction Description	Check Amount	Fund Code	Fund Short Title
25157	6/30/2019	Corelogic Information Solutions, INC.	Database for Code Enforcement - Report June 2019	5.00	10	GENERAL
25157	6/30/2019	Corelogic Information Solutions, INC.	Database for Code Enforcement June 2019	125.00	10	GENERAL
Total 25157	6/30/2019			130.00		
25158	6/30/2019	DATA TICKET	Monthly Code Enforcement, May 2019	100.00	10	GENERAL
25158	6/30/2019	DATA TICKET	Monthly Parking Citations, May 2019	100.00	10	GENERAL
Total 25158	6/30/2019			200.00		
25159	6/30/2019	Delgado Janitorial Services	Cleaning Service for the Month of June 2019	941.50	10	GENERAL
Total 25159	6/30/2019			941.50		
25160	6/30/2019	STATE OF CA DEPT. OF JUSTICE	Fingerprinting Apps, June 2019	96.00	10	GENERAL
Total 25160	6/30/2019			96.00		
25161	6/30/2019	FRIDAY FLYER	Notice of Ordinance No. 183, June 2019	23.25	10	GENERAL
Total 25161	6/30/2019			23.25		
25162	6/30/2019	GOLDING PUBLICATIONS	Business Cards for Nazareno, June 2019	37.71	10	GENERAL
Total 25162	6/30/2019			37.71		
25163	6/30/2019	Interwest Consulting Group	Building & Safety for May 2019	31,936.20	10	GENERAL
Total 25163	6/30/2019			31,936.20		

City of Canyon Lake
 Check/Voucher Register - Council Report - Expenditures
 From 7/1/2019 Through 7/31/2019

Check Numb...	Matching Docum... Date	Vendor Name	Transaction Description	Check Amount	Fund Code	Fund Short Title
25164	6/30/2019	Inland Urgent Care Wildomar	Drug Testing for Sarah Day, 6/5/19	60.00	10	GENERAL
Total 25164	6/30/2019			60.00		
25165	6/30/2019	The Lloyd Pest Control Co. Inc.	Monthly Pest Control at Fire Station, June 2019	36.75	10	GENERAL
Total 25165	6/30/2019			36.75		
25166	6/30/2019	League of California Cities	2019 Local Streets and Roads Needs Assessment	300.00	20	GAS TAX
Total 25166	6/30/2019			300.00		
25167	6/30/2019	CASH	Reimburse Petty Cash June 2019	100.00	10	GENERAL
Total 25167	6/30/2019			100.00		
25168	6/30/2019	PV Maintenance Inc.	Powerwashed Memorial Monument, June 2019	536.67	10	GENERAL
Total 25168	6/30/2019			536.67		
25169	6/30/2019	PZL, Inc.	Planning Services for June 2019	3,877.50	10	GENERAL
Total 25169	6/30/2019			3,877.50		
25170	6/30/2019	Rogers, Anderson, Malody & Scott, LLP	Accounting Services for the month of May 2019	6,700.00	10	GENERAL
Total 25170	6/30/2019			6,700.00		
25171	6/30/2019	Regional Conservation Authority	Additional MSHCP Fees collected for June 2019	2,104.00	50	AGENCY

City of Canyon Lake
 Check/Voucher Register - Council Report - Expenditures
 From 7/1/2019 Through 7/31/2019

Check Num...	Matching Docum... Date	Vendor Name	Transaction Description	Check Amount	Fund Code	Fund Short Title
Total 25171	6/30/2019			2,104.00		
25172	6/30/2019	RIV. CO. SHERIFF'S DEPT., Acctg & Fin	Sheriff's Contract Law 4/25/19 to 5/22/19	128,567.45	10	GENERAL
Total 25172	6/30/2019			128,567.45		
25173	6/30/2019	Riv Co Sheriff Dept Perris Station	Sheriff's Dept Extra Duty for Fiesta Days - May 2019	6,084.58	10	GENERAL
Total 25173	6/30/2019			6,084.58		
25174	6/30/2019	Riv Co Sheriff Dept Perris Station	Sheriff's Dept Extra Duty Siren Crush Concert - June 2019	672.30	10	GENERAL
Total 25174	6/30/2019			672.30		
25175	6/30/2019	Riv Co Sheriff Dept Perris Station	Sheriff's Dept. Extra Duty for Taco Tuesday 6/11 & 6/18/19	1,334.74	10	GENERAL
Total 25175	6/30/2019			1,334.74		
25176	6/30/2019	RIV COUNTY SHERIFF-Dept. Technical Svcs.	Communications Dispatch FY 18-19	7,206.00	10	GENERAL
Total 25176	6/30/2019			7,206.00		
25177	6/30/2019	COUNTY OF RIVERSIDE-TLMA	SLF Costs May 2019	1,160.05	20	GAS TAX
Total 25177	6/30/2019			1,160.05		
25178	6/30/2019	Shred Pros	On Site Pick up for 50 Boxes to shred, May 2019	200.00	10	GENERAL
Total 25178	6/30/2019			200.00		

City of Canyon Lake
 Check/Voucher Register - Council Report - Expenditures
 From 7/1/2019 Through 7/31/2019

Check Num...	Matching Docum... Date	Vendor Name	Transaction Description	Check Amount	Fund Code	Fund Short Title
25179	6/30/2019	STAPLES	Office Supplies for City Hall & Admin Building, June 2019	696.42	10	GENERAL
25179	6/30/2019	STAPLES	Office Supplies for City Hall & Admin Building, June 2019	215.49	40	CAP. PROJ.
Total 25179	6/30/2019			911.91		
25180	6/30/2019	Statewide Traffic Safety & Signs	Blinker Slow Down Sign for Golf Community May 2019	3,328.63	20	GAS TAX
Total 25180	6/30/2019			3,328.63		
25181	6/30/2019	TPx Communications	City Hall Phone System 6/16/19 to 7/15/19	626.19	10	GENERAL
Total 25181	6/30/2019			626.19		
25182	6/30/2019	U. S. Bank	Office Supplies & Furniture for Admin Bldg, CM Mtg, May 2019	2,454.47	10	GENERAL
25182	6/30/2019	U. S. Bank	Office Supplies & Furniture for Admin Bldg, CM Mtg, May 2019	2,398.29	40	CAP. PROJ.
Total 25182	6/30/2019			4,852.76		
25183	6/30/2019	Verizon Wireless	Cell Phones, 6/4/19 to 7/3/19	392.42	10	GENERAL
25183	6/30/2019	Verizon Wireless	iPads, 6/4/19 to 7/3/19	207.09	10	GENERAL
Total 25183	6/30/2019			599.51		
25184	6/30/2019	WRCOG	Additional TUMF Fees collected for June 2019	8,873.00	50	AGENCY
Total 25184	6/30/2019			8,873.00		
25185	7/11/2019	AMP GLOBAL LLC	Rent for Admin Building for the month of August 2019	2,600.00	10	GENERAL

City of Canyon Lake
 Check/Voucher Register - Council Report - Expenditures
 From 7/1/2019 Through 7/31/2019

Check Num...	Matching Docum... Date	Vendor Name	Transaction Description	Check Amount	Fund Code	Fund Short Title
Total 25185	7/11/2019			2,600.00		
25186	7/11/2019	Randall Bonner	Auto Allowance for July 2019 - Bonner	100.00	10	GENERAL
Total 25186	7/11/2019			100.00		
25187	7/11/2019	Jordan Ehrenkranz	Auto Allowance for July 2019 - Ehrenkranz	100.00	10	GENERAL
Total 25187	7/11/2019			100.00		
25188	7/11/2019	GOLDING PUBLICATIONS	Business Cards for Brophy, July 2019	37.71	10	GENERAL
25188	7/11/2019	GOLDING PUBLICATIONS	Business Cards for Manzano & Lopez, July 2019	75.43	10	GENERAL
Total 25188	7/11/2019			113.14		
25189	7/11/2019	Jeremy Smith	Auto Allowance for July 2019 - Smith	100.00	10	GENERAL
Total 25189	7/11/2019			100.00		
25190	7/11/2019	Kasey Castillo	Auto Allowance for July 2019 - Castillo	100.00	10	GENERAL
Total 25190	7/11/2019			100.00		
25191	7/11/2019	Larry Greene	Auto Allowance for July 2019 - Greene	100.00	10	GENERAL
Total 25191	7/11/2019			100.00		
25192	7/11/2019	Maureen Kane & Associates, Inc.	Technical Training for Clerks - Series 200 - Sept. 2019	1,550.00	10	GENERAL
Total 25192	7/11/2019			1,550.00		

City of Canyon Lake
 Check/Voucher Register - Council Report - Expenditures
 From 7/1/2019 Through 7/31/2019

Check Num...	Matching Docum... Date	Vendor Name	Transaction Description	Check Amount	Fund Code	Fund Short Title
25193	7/11/2019	Nate Volk	Video Broadcasting for Meeting on 7/25/19	175.00	10	GENERAL
Total 25193	7/11/2019			175.00		
25194	7/11/2019	Public Entity Risk Management Authority	FY 19-20 Crim Coverage Program Insurance Premium	760.00	10	GENERAL
25194	7/11/2019	Public Entity Risk Management Authority	FY 19-20 Deadly Weapon Response Program Insurance Premium	110.00	10	GENERAL
25194	7/11/2019	Public Entity Risk Management Authority	FY 19-20 Deposit Premium General Liability Program	31,570.00	10	GENERAL
25194	7/11/2019	Public Entity Risk Management Authority	FY 19-20 ERMA Deposit Premium	2,341.00	10	GENERAL
25194	7/11/2019	Public Entity Risk Management Authority	FY 19-20 Property Program Insurance Premium	3,528.00	10	GENERAL
Total 25194	7/11/2019			38,309.00		
25195	7/11/2019	Riverside County Auditor-Controller	LAFCO FY20 Fees & Admin Fees	711.63	10	GENERAL
Total 25195	7/11/2019			711.63		
25196	7/11/2019	County Executive Office	SCFA Quarterly Sheltering Services for July - Sept. 2019	17,220.00	10	GENERAL
Total 25196	7/11/2019			17,220.00		
25197	6/30/2019	Frank Smith	By Pass Donation from Riv. Co. Kevin Jeffries to CLEPC	1,000.00	10	GENERAL
Total 25197	6/30/2019			1,000.00		VOID Check
25198	7/11/2019	Synoptek, LLC	IT Services for July 2019	2,225.00	10	GENERAL
Total 25198	7/11/2019			2,225.00		

City of Canyon Lake
 Check/Voucher Register - Council Report - Expenditures
 From 7/1/2019 Through 7/31/2019

Check Num...	Matching Docum... Date	Vendor Name	Transaction Description	Check Amount	Fund Code	Fund Short Title
25199	7/11/2019	Time Warner Cable	Digital Converter for City Hall, 6/22/19 to 7/21/19	5.25	10	GENERAL
Total 25199	7/11/2019			5.25		
25200	6/30/2019	DATA TICKET	Code Enforcement June 2019	100.00	10	GENERAL
25200	6/30/2019	DATA TICKET	Parking Citations June 2019	100.00	10	GENERAL
Total 25200	6/30/2019			200.00		
25201	6/30/2019	Division of the State Architect	Disability Access & Education Fee Qtr. Ended 6/30	16.80	10	GENERAL
Total 25201	6/30/2019			16.80		
25202	6/30/2019	Johnson Controls Security Solutions	Installation of New Alarm System at Admin Office, 4/26/19	1,289.18	40	CAP. PROJ.
Total 25202	6/30/2019			1,289.18		
25203	6/30/2019	Rogers, Anderson, Malody & Scott, LLP	Accounting services for June 2019	6,700.00	10	GENERAL
Total 25203	6/30/2019			6,700.00		
25204	6/30/2019	County Executive Office	SCFA Miscellaneous Admin Expenses 4th Qtr.	630.00	10	GENERAL
Total 25204	6/30/2019			630.00		
25205	6/30/2019	TRI LAKE CONSULTANTS, INC.	Project List Review & SB-1 Engineering June 2019	420.00	10	GENERAL
Total 25205	6/30/2019			420.00		
25206	6/30/2019	TRI LAKE CONSULTANTS, INC.	Wrought Iron Fencing Repair Project - Engineer June 2019	280.00	10	GENERAL

City of Canyon Lake
 Check/Voucher Register - Council Report - Expenditures
 From 7/1/2019 Through 7/31/2019

Check Num...	Matching Docum... Date	Vendor Name	Transaction Description	Check Amount	Fund Code	Fund Short Title
Total 25206	6/30/2019			280.00		
25207	6/30/2019	TRI LAKE CONSULTANTS, INC.	General Engineering - Exhibit Install & WRCOG Mtg. June 2019	280.00	10	GENERAL
Total 25207	6/30/2019			280.00		
25208	6/30/2019	U. S. Bank	Office Supplies, Code Enf. Classes, CM Conf., etc, June 2019	5,774.52	10	GENERAL
25208	6/30/2019	U. S. Bank	Office Supplies, Code Enf. Classes, CM Conf., etc, June 2019	252.91	40	CAP. PROJ.
Total 25208	6/30/2019			6,027.43		
25209	7/24/2019	Aflac	Supplemental Insurance for July 2019	432.82	10	GENERAL
Total 25209	7/24/2019			432.82		
25210	7/24/2019	CL EMERGENCY PREPARDNESS COMMITTEE	By Pass Donation from Riv. Co. Kevin Jeffries to CLEPC	1,000.00	10	GENERAL
Total 25210	7/24/2019			1,000.00		
25211	7/24/2019	CANYON LAKE PEST CONTROL, Steven E. Young	City Hall Admin General Pest Control - 7/16/2019	55.00	10	GENERAL
Total 25211	7/24/2019			55.00		
25212	7/24/2019	Control Pump	Check for system leak, valve was plugged w/debris 7/19/19	290.00	20	GAS TAX
Total 25212	7/24/2019			290.00		

City of Canyon Lake
 Check/Voucher Register - Council Report - Expenditures
 From 7/1/2019 Through 7/31/2019

Check Num...	Matching Docum... Date	Vendor Name	Transaction Description	Check Amount	Fund Code	Fund Short Title
25213	7/24/2019	CTAI Pacific Greenscape	Landscape Maintenance for Fire Station July 2019	250.00	10	GENERAL
25213	7/24/2019	CTAI Pacific Greenscape	Landscape Maintenance Median & Parkways for July 2019	5,000.00	20	GAS TAX
Total 25213	7/24/2019			5,250.00		
25214	7/24/2019	Delgado Janitorial Services	Janitorial Services for July 2019	941.50	10	GENERAL
Total 25214	7/24/2019			941.50		
25215	7/24/2019	DIRECTV	Satellite Service, 7/12/19 to 8/11/19	103.09	10	GENERAL
Total 25215	7/24/2019			103.09		
25216	7/24/2019	Frontier Communications	City Hall Internet 7/10/19 to 8/9/19	330.38	10	GENERAL
25216	7/24/2019	Frontier Communications	City Hall Phones, 7/13/19 to 8/12/19	6.83	10	GENERAL
25216	7/24/2019	Frontier Communications	Fire Station Phone and Internet, 7/13/19 to 8/12/19	275.71	10	GENERAL
Total 25216	7/24/2019			612.92		
25217	7/24/2019	NANCY GREENHALGH	Retiree Health Insurance August 2019	163.37	10	GENERAL
Total 25217	7/24/2019			163.37		
25218	7/24/2019	Johnson Controls Security Solutions	Security Systems for Admin Bldg 7/1/19 to 9/30/19	179.44	10	GENERAL
Total 25218	7/24/2019			179.44		
25219	7/24/2019	LESJWA	Task Force Contributions FY 19-20	33,754.00	10	GENERAL

City of Canyon Lake
 Check/Voucher Register - Council Report - Expenditures
 From 7/1/2019 Through 7/31/2019

Check Num...	Matching Docum... Date	Vendor Name	Transaction Description	Check Amount	Fund Code	Fund Short Title
Total 25219	7/24/2019			33,754.00		
25220	7/24/2019	MR. WINDOW CLEANING	Window Cleaning Inside and Outside - 7/17/19	75.00	10	GENERAL
Total 25220	7/24/2019			75.00		
25221	7/24/2019	Public Entity Risk Management Authority	FY 19-20 Cyber Liability Coverage Program Insurance	546.00	10	GENERAL
Total 25221	7/24/2019			546.00		
25222	7/24/2019	Regional Conservation Authority	MSHCP Fees Collected for July 2019	2,168.00	50	AGENCY
Total 25222	7/24/2019			2,168.00		
25223	7/24/2019	JOHN REGUS	Library Lease for September 2019	1,074.62	10	GENERAL
Total 25223	7/24/2019			1,074.62		
25224	7/24/2019	RIV. CO. SHERIFF-S DEPT.	Riv Cal-ID FY 19-20 Member Agency Assessment	11,018.00	10	GENERAL
Total 25224	7/24/2019			11,018.00		
25225	7/24/2019	Special District Risk Management Authority	Dental & Vision for Mann & Sauseda August 2019	120.46	10	GENERAL
Total 25225	7/24/2019			120.46		
25226	7/24/2019	STATE COMP. INS. FUND	Workers Comp for August 2019	884.75	10	GENERAL
Total 25226	7/24/2019			884.75		

City of Canyon Lake
 Check/Voucher Register - Council Report - Expenditures
 From 7/1/2019 Through 7/31/2019

Check Num...	Matching Docum... Date	Vendor Name	Transaction Description	Check Amount	Fund Code	Fund Short Title
25227	7/24/2019	Time Warner Cable	Internet for Fire Station 7/10/19 to 8/9/19	99.98	10	GENERAL
Total 25227	7/24/2019			99.98		
25228	7/24/2019	WRCOG	TUMF Fees Collected for July 2019	9,146.00	50	AGENCY
Total 25228	7/24/2019			9,146.00		
EFT24		Sparkletts	Water for City Hall June 2019	64.16	10	GENERAL
Total EFT24				64.16		
EFT25		SOUTHERN CALIFORNIA EDISON	Electricity for City Hall 5/15/19 to 6/14/19	946.34	10	GENERAL
Total EFT25				946.34		
EFT26		SOUTHERN CALIFORNIA EDISON	Electricity for Traffic Signals 5/15/19 to 6/14/19	161.78	20	GAS TAX
Total EFT26				161.78		
EFT27		SOUTHERN CALIFORNIA EDISON	Electricity for Admin City Hall June 2019	170.12	10	GENERAL
Total EFT27				170.12		
EFT28		SOUTHERN CALIFORNIA EDISON	Electricity Traffic Signals 5/24/19 to 6/20/19	6.88	20	GAS TAX
Total EFT28				6.88		
EFT29		SOUTHERN CALIFORNIA EDISON	Electricity for Fire Station 5/15/19 to 6/14/19	392.23	10	GENERAL
Total EFT29				392.23		

City of Canyon Lake
 Check/Voucher Register - Council Report - Expenditures
 From 7/1/2019 Through 7/31/2019

Check Num...	Matching Docum... Date	Vendor Name	Transaction Description	Check Amount	Fund Code	Fund Short Title
EFT30		SOUTHERN CALIFORNIA EDISON	Electricity for Traffic Signals 5/22/19 to 6/21/19	48.35	20	GAS TAX
Total EFT30				48.35		
EFT31		SOUTHERN CALIFORNIA EDISON	Electricity for Traffic Signals 5/30/19 to 6/28/19	270.73	20	GAS TAX
Total EFT31				270.73		
EFT32		ELSINORE VALLEY MUNI WATER DIS	Water for City Hall 5/26/19 to 6/26/19	109.02	10	GENERAL
Total EFT32				109.02		
EFT33		ELSINORE VALLEY MUNI WATER DIS	Water for Irrigation 5/29/19 to 6/29/19	905.88	20	GAS TAX
Total EFT33				905.88		
EFT34		ELSINORE VALLEY MUNI WATER DIS	Water for Fire Station 5/29/19 to 6/29/19	296.43	10	GENERAL
Total EFT34				296.43		
EFT35		SOUTHERN CALIFORNIA EDISON	Electricity for Pump Station 6/10/19 to 7/10/19	209.85	20	GAS TAX
Total EFT35				209.85		
Report Total				408,441.40		
				- 1,000.00		
				<u>\$407,441.40</u>		

City of Canyon Lake
Invoices Selected for Payment - COUNCIL CHECK REPORT

Vendor ID	Invoice Description	Cash Required
ANIMAL FRIENDS	Animal Control Services for May & June 2019	7,000.00
BIO-TOX	Sheriff's Dept. Blood Draw, May 2019	46.00
Bonner	Reimb. for internet & phone for April 2019, travel for May	127.10
Castaneda & Associates	Housing Needs Assessment June 2019	1,826.99
	Housing Needs Assessment May 2019	5,165.46
CL CHAMBER	Business Membership June - May 2019	110.00
Cole Huber	Attorney Services February 2019	8,320.00
	Attorney Services March 2019	7,600.00
	Attorney Services April 2019	5,000.00
	Attorney Services May 2019	5,000.00
	Attorney Services for June 2019	5,000.00
Corelogic	Database for Code Enforcement - Report June 2019	5.00
	Database for Code Enforcement June 2019	125.00
DATA TICKET	Monthly Parking Citations, May 2019	100.00
	Monthly Code Enforcement, May 2019	100.00
Delgado	Cleaning Service for the Month of June 2019	941.50
DOJ	Fingerprinting Apps, June 2019	96.00
FRIDAY FLYER	Notice of Ordinance No. 183, June 2019	23.25
GOLDING	Business Cards for Nazareno, June 2019	37.71
ICG	Building & Safety for May 2019	31,936.20
Inland	Drug Testing for Sarah Day, 6/5/19	60.00
LLOYD	Monthly Pest Control at Fire Station, June 2019	36.75
LOCC	2019 Local Streets and Roads Needs Assessment	300.00
PETTY CASH	Reimburse Petty Cash June 2019	100.00
PVM	Powerwashed Memorial Monument, June 2019	536.67
PZL, Inc.	Planning Services for June 2019	3,877.50
RAMS	Accounting Services for the month of May 2019	6,700.00
RCA	Additional MSHCP Fees collected for June 2019	2,104.00
Riv Co Sheriff Acctg	Sheriff's Contract Law 4/25/19 to 5/22/19	128,567.45
Riv Co Sheriff Dept	Sheriff's Dept Extra Duty Siren Crush Concert - June 2019	672.30
	Sheriff's Dept. Extra Duty for Taco Tuesday 6/11 & 6/18/19	1,334.74
	Sheriff's Dept Extra Duty for Fiesta Days - May 2019	6,084.58
Riv Co Sheriff DTS	Communications Dispatch FY 18-19	7,206.00
Riv Co TLMA	SLF Costs May 2019	1,160.05
SHRED	On Site Pick up for 50 Boxes to shred, May 2019	200.00
STAPLES	Office Supplies for City Hall & Admin Building, June 2019	696.42
	Office Supplies for City Hall & Admin Building, June 2019	215.49
Statewide	Blinker Slow Down Sign for Golf Community May 2019	3,328.63

Date: 7/11/19
12:51:50 PM

Page: 1

City of Canyon Lake
Invoices Selected for Payment - COUNCIL CHECK REPORT

Vendor ID	Invoice Description	Cash Required
TelePacific	City Hall Phone System 6/16/19 to 7/15/19	626.19
US Bank	Office Supplies & Furniture for Admin Bldg, CM Mtg, May 2019	2,398.29
	Office Supplies & Furniture for Admin Bldg, CM Mtg, May 2019	2,454.47
VerizonW	iPads, 6/4/19 to 7/3/19	207.09
	Cell Phones, 6/4/19 to 7/3/19	392.42
WRCOG	Additional TUMF Fees collected for June 2019	8,873.00
Report Total		256,692.25

CM

City of Canyon Lake
Invoices Selected for Payment - COUNCIL CHECK REPORT

Vendor ID	Invoice Description	Cash Required
AMP	Rent for Admin Building for the month of August 2019	2,600.00
Bonner	Auto Allowance for July 2019 - Bonner	100.00
Ehrenkranz	Auto Allowance for July 2019 - Ehrenkranz	100.00
GOLDING	Business Cards for Manzano & Lopez, July 2019	75.43
	Business Cards for Brophy, July 2019	37.71
Jeremy Smith	Auto Allowance for July 2019 - Smith	100.00
Kasey Castillo	Auto Allowance for July 2019 - Castillo	100.00
Larry Greene	Auto Allowance for July 2019 - Greene	100.00
Maureen Kane	Technical Training for Clerks - Series 200 - Sept. 2019	1,550.00
Nate Volk	Video Broadcasting for Meeting on 7/25/19	175.00
PERMA	FY 19-20 Deposit Premium General Liability Program	31,570.00
	FY 19-20 Crim Coverage Program Insurance Premium	760.00
	FY 19-20 ERMA Deposit Premium	2,341.00
	FY 19-20 Deadly Weapon Response Program Insurance Premium	110.00
	FY 19-20 Property Program Insurance Premium	3,528.00
Riv Co Auditor	LAFCO FY20 Fees & Admin Fees	711.63
riv Co Exec	SCFA Quarterly Sheltering Services for July - Sept. 2019	17,220.00
SMITH	By Pass Donation from Riv. Co. Kevin Jeffries to CLEPC	1,000.00 VOID check
Synoptek	IT Services for July 2019	2,225.00
Time Warner	Digital Converter for City Hall, 6/22/19 to 7/21/19	5.25
Report Total		64,409.02 - 1,000.00 <u>\$63,409.02</u> CM

City of Canyon Lake
Invoices Selected for Payment - COUNCIL CHECK REPORT

Vendor ID	Invoice Description	Cash Required
DATA TICKET	Code Enforcement June 2019	100.00
	Parking Citations June 2019	100.00
DSA	Disability Access & Education Fee Qtr. Ended 6/30	16.80
Johnson Controls	Installation of New Alarm System at Admin Office, 4/26/19	1,289.18
RAMS	Accounting services for June 2019	6,700.00
riv Co Exec	SCFA Miscellaneous Admin Expenses 4th Qtr.	630.00
TRI LAKE	Project List Review & SB-1 Engineering June 2019	420.00
	Wrought Iron Fencing Repair Project - Engineer June 2019	280.00
	General Engineering - Exhibit Install & WRCOG Mtg. June 2019	280.00
US Bank	Office Supplies, Code Enf. Classes, CM Conf., etc, June 2019	252.91
	Office Supplies, Code Enf. Classes, CM Conf., etc, June 2019	5,774.52
Report Total		15,843.41

City of Canyon Lake
Invoices Selected for Payment - COUNCIL CHECK REPORT

Vendor ID	Invoice Description	Cash Required
Aflac	Supplemental Insurance for July 2019	432.82
CL EMERGENCY	By Pass Donation from Riv. Co. Kevin Jeffries to CLEPC	1,000.00
CL PEST	City Hall Admin General Pest Control - 7/16/2019	55.00
Control Pump	Check for system leak, valve was plugged w/debris 7/19/19	290.00
CTAI	Landscape Maintenance Median & Parkways for July 2019	5,000.00
	Landscape Maintenance for Fire Station July 2019	250.00
Delgado	Janitorial Services for July 2019	941.50
DIRECTV	Satellite Service, 7/12/19 to 8/11/19	103.09
Frontier	Fire Station Phone and Internet, 7/13/19 to 8/12/19	275.71
	City Hall Phones, 7/13/19 to 8/12/19	6.83
	City Hall Internet 7/10/19 to 8/9/19	330.38
GREENHALGH	Retiree Health Insurance August 2019	163.37
Johnson Controls	Security Systems for Admin Bldg 7/1/19 to 9/30/19	179.44
LESJWA	Task Force Contributions FY 19-20	33,754.00
MR. WINDOW	Window Cleaning Inside and Outside - 7/17/19	75.00
PERMA	FY 19-20 Cyber Liability Coverage Program Insurance	546.00
RCA	MSHCP Fees Collected for July 2019	2,168.00
REGUS	Library Lease for September 2019	1,074.62
Riv Co Cal-ID	Riv Cal-ID FY 19-20 Member Agency Assessment	11,018.00
SDRMA	Dental & Vision for Mann & Sauseda August 2019	120.46
STATE FUND	Workers Comp for August 2019	884.75
Time Warner	Internet for Fire Station 7/10/19 to 8/9/19	99.98
WRCOG	TUMF Fees Collected for July 2019	9,146.00
Report Total		67,914.95

Labor Distribution

City of Canyon Lake
Company (10756)

Check Date: 07/15/2019
Process: 2019071501
Period: 07/01/2019 to 07/15/2019

Department: (20)City Employees

Code	Earning	Hours	Amount	Code	Deduction	Amount	Code	Tax	Amount	Code	Tax	Amount	Taxable	Amount	Taxable	Amount
125CO	125 Cash		492.43	PTAXI	Pre-Tax P	272.39	CA	California SI	4111.28	CAETT	CA Edu & T	0.00	0.00	0.00		
102	Hol	9.50	0.00	CASDJ	CA SDI - Eir	4383.67	CASUJ	California SI	4383.67	CASUJ	California SI	0.00	0.00	4383.67		4383.67
3891.24	Reg		3891.24	FITW	Federal Incoi	4111.28	MED-R	Medicare - E	4383.67	MED-R	Medicare - E	63.56	63.56	4383.67		4447.23
	Reg			MED	Medicare	4383.67										3391.96
	Total Earnings	9.50	4383.67	Total Deductions		272.39	Total Employer Taxes		719.32	Total Employer Taxes		63.56		63.56		
Day,	Earning	Hours	Amount	Code	Deduction	Amount	Code	Tax	Amount	Code	Tax	Amount	Taxable	Amount	Taxable	Amount
Sarah L	Regular	56.00	800.24	457B	457B EE	60.02	CA	California SI	740.22	CAETT	CA Edu & T	0.00	0.00	800.24		800.24
112	Auto		75.00	CASDJ	CA SDI - Eir	800.24	CASUJ	California SI	800.24	CASUJ	California SI	49.61	49.61	800.24		800.24
14,2900	Hol		0.00	FITW	Federal Incoi	740.22	MED-R	Medicare - E	800.24	MED-R	Medicare - E	11.60	11.60	800.24		861.45
	Reg			MED	Medicare	800.24	SS-R	OASDI - Eir	800.24	SS-R	OASDI - Eir	0.00	0.00	800.24		650.53
	Total Earnings	56.00	800.24	Total Deductions		60.02	Total Employer Taxes		89.69	Total Employer Taxes		61.21		61.21		
Christopher F	125CO 125 Cash		103.28	PTXPE	Pre-Tax P	399.38	CA	California SI	5695.57	CAETT	CA Edu & T	0.00	0.00	0.00		
111	Auto		75.00	CASDJ	CA SDI - Eir	6094.95	CASUJ	California SI	6094.95	CASUJ	California SI	0.00	0.00	0.00		6094.95
5916.67	Hol	9.50	0.00	FITW	Federal Incoi	1044.21	MED-R	Medicare - E	5695.57	MED-R	Medicare - E	88.38	88.38	6094.95		6183.33
	Reg		5916.67	MED	Medicare	88.38			6094.95					6094.95		4069.43
	Total Earnings	9.50	6094.95	Total Deductions		399.38	Total Employer Taxes		1626.14	Total Employer Taxes		88.38		88.38		
Sauseda,	Earning	Hours	Amount	Code	Deduction	Amount	Code	Tax	Amount	Code	Tax	Amount	Taxable	Amount	Taxable	Amount
Ana	125CO 125 Cash		527.34	457B	457B EE	66.00	CA	California SI	2450.02	CAETT	CA Edu & T	0.00	0.00	0.00		
108	Hol	9.50	237.60	PTAXI	Pre-Tax P	149.68	CASDJ	CA SDI - Eir	2665.70	CASUJ	California SI	0.00	0.00	0.00		2665.70
25,0100	Reg	76.00	1900.76	FITW	Federal Incoi	2450.02	MED-R	Medicare - E	2665.70	MED-R	Medicare - E	38.65	38.65	2665.70		2704.35
	Reg			MED	Medicare	38.65			2665.70					2665.70		2198.40
	Total Earnings	85.50	2665.70	Total Deductions		215.68	Total Employer Taxes		251.62	Total Employer Taxes		38.65		38.65		

Department: (20)City Employees Total

Code	Earning	Hours	Amount	Code	Deduction	Amount	Code	Tax	Amount	Code	Tax	Amount	Taxable	Amount	Taxable	Amount
4	125CO 125 Cash		1123.05	457B	457B EE	126.02	CA	California SI	12997.09	CAETT	CA Edu & T	0.00	0.00	0.00		
2	Auto		75.00	PTAXI	Pre-Tax P	422.07	CASDJ	CA SDI - Eir	13944.56	CASUJ	California SI	49.61	49.61	800.24		13944.56
2	Hol	28.50	237.60	PTXPE	Pre-Tax P	399.38	FITW	Federal Incoi	12997.09	MED-R	Medicare - E	202.19	202.19	13944.56		14196.36
	Reg	132.00	12508.91	MED	Medicare	202.21	SS-R	OASDI - Eir	13944.56	SS-R	OASDI - Eir	0.00	0.00	800.24		10310.32
	Total Earnings	160.50	13944.56	Total Deductions		947.47	Total Employer Taxes		2686.77	Total Employer Taxes		251.80		251.80		

08-0019-0019 City Council Agenda

Department: (30)Special Enforcement Team

Code	Earning	Hours	Amount	Deduction	Code	Amount	Taxable	Code	Tax	Amount	Taxable	Amount
125CO	125 Cash		250.32	457B EE	CA	50.00	1558.49	CAETT	CA Edu & T	38.97	0.00	0.00
104	Reg	57.50	1456.48	PTXPE Pre-Tax P	CASDI	98.31	1706.80	CASUI	California SI	17.07	0.00	0.00
25.3300	Regular				FITW		1558.49	MED-R	Medicare - E	111.85	1706.80	24.75
					MED		1706.80			24.75		Net Amt
												24.75

Code	Earning	Hours	Amount	Deduction	Code	Amount	Taxable	Code	Tax	Amount	Taxable	Amount
125CO	125 Cash		477.29	PTAXI Pre-Tax P	CA	184.52	2928.74	CAETT	CA Edu & T	154.97	0.00	0.00
101	Comp Tin	9.50	292.89		CASDI		3113.26	CASUI	California SI	31.13	0.00	0.00
30.8300	Regular	76.00	2343.08		FITW		2928.74	MED-R	Medicare - E	276.28	3113.26	45.14
					MED		3113.26			45.14		Net Amt
												45.14

Code	Earning	Hours	Amount	Deduction	Code	Amount	Taxable	Code	Tax	Amount	Taxable	Amount
125CO	125 Cash		328.80	PTAXI Pre-Tax P	CA	23.02	305.78	CAETT	CA Edu & T	0.00	328.80	0.00
113	Reg	12.00			CASDI		328.80	CASUI	California SI	3.29	328.80	20.39
27.4000	Regular				FITW		305.78	MED-R	Medicare - E	14.74	328.80	4.77
					MED		328.80	SS-R	OASDI - Em	4.77	328.80	0.00
												Net Amt
												25.16

Code	Earning	Hours	Amount	Deduction	Code	Amount	Taxable	Code	Tax	Amount	Taxable	Amount
125CO	125 Cash		499.58	PTXPE Pre-Tax P	CA	151.13	2587.35	CAETT	CA Edu & T	60.81	0.00	0.00
98	Reg	74.00	1949.16		CASDI		2738.48	CASUI	California SI	27.38	0.00	0.00
26.3400	Sick	4.50	118.53		FITW		2587.35	MED-R	Medicare - E	235.32	2738.48	39.71
	Vac	6.50	171.21		MED		2738.48			39.71		Net Amt
												39.71

Department: (30)Special Enforcement Team Total

Code	Earning	Hours	Amount	Deduction	Code	Amount	Taxable	Code	Tax	Amount	Taxable	Amount
125CO	125 Cash		1227.19	457B EE	CA	50.00	7380.36	CAETT	CA Edu & T	254.75	328.80	0.00
1	Comp Tin	9.50	292.89	PTAXI Pre-Tax P	CASDI	207.54	7887.34	CASUI	California SI	78.87	328.80	20.39
	Regular	219.50	6077.52	PTXPE Pre-Tax P	FITW	249.44	7380.36	MED-R	Medicare - E	638.19	7887.34	114.37
	Sick	4.50	118.53		MED		7887.34	SS-R	OASDI - Em	114.37	328.80	0.00
	Vac	6.50	171.21									Net Amt
												134.76

Labor Distribution

City of Canyon Lake
Company (10756)

Check Date: 07/15/2019
Process: 2019071501
Period: 07/01/2019 to 07/15/2019

Report Total

Emp	Code	Earning	Hours	Amount	Code	Deduction	Amount	Code	Tax	Amount	Code	Tax	Amount	Code	Taxable	Amount	Taxable	Amount	
Female	5	125CO 125 Cash		2350.24	457B	457B EE	176.02	CA	California SI	20377.45	CAETT	CA Edu & T	886.87	CAETT	1129.04	0.00	1129.04	0.00	
Male	3	Auto Auto Allo		75.00	PTAXI	Pre-Tax P	629.61	CASDJ	CA SDI - Em	21831.90	CASUJ	California SI	218.33	CASUJ	1129.04	70.00	1129.04	70.00	
		Comp Comp Tin	9.50	292.89	PTXPE	Pre-Tax P	648.82	FITW	Federal Incoi	20377.45	MED-R	Medicare - E	2351.17	MED-R	21831.90	316.56	21831.90	316.56	
		Hol Holiday	28.50	237.60				MED	Medicare	21831.90	SS-R	OASDI - Em	316.58	SS-R	1129.04	0.00	1129.04	0.00	
		Reg Regular	351.50	18586.43															
		Sick Sick	4.50	118.53															
		Vac Vacation	6.50	171.21															
Total Earnings				400.50	21831.90	Total Deductions	1454.45	Total Employee Taxes	3772.95	Total Employer Taxes	386.56								

Chris Mann
Chris Mann, City Manager

7-18-19
Date

Labor Distribution

City of Canyon Lake
Company (10756)

Check Date: 06/28/2019
Process: 2019062801
Period: 06/16/2019 to 06/30/2019

Department: (20)City Employees

Code	Earning	Hours	Amount	Deduction	Code	Amount	Taxable	Code	Tax	Amount	Taxable	Amount
125CO	125 Cash		492.43	PTAXI	CA	264.97	4012.71	CAETT	CA Edu & T	152.05	0.00	0.00
102	ADML Admin Le	20.00	0.00		CASD)		4277.68	CASUI	California S	42.78	0.00	0.00
3785.25	Reg Regular		3785.25		FITW		4012.71	MED-R	Medicare - E	429.50	4277.68	62.03
	Sick	9.50	0.00		MED		4277.68			62.02		62.03
	Vac	19.00	0.00									Net Amt
	Total Earnings	48.50	4277.68	Total Deductions		264.97		Total Employer Taxes		686.35		62.03

Code	Earning	Hours	Amount	Deduction	Code	Amount	Taxable	Code	Tax	Amount	Taxable	Amount
Reg	Regular	53.00	737.23	457B EE	CA	55.29	681.94	CAETT	CA Edu & T	7.05	737.23	0.00
112					CASD)		737.23	CASUI	California S	7.37	737.23	45.71
13.9100					FITW		681.94	MED-R	Medicare - E	54.75	737.23	10.69
					MED		737.23	SS-R	OASDI - Em	10.69	737.23	0.00
					SS		737.23			0.00		0.00
	Total Earnings	53.00	737.23	Total Deductions		55.29		Total Employer Taxes		79.86		56.40

Code	Earning	Hours	Amount	Deduction	Code	Amount	Taxable	Code	Tax	Amount	Taxable	Amount
125CO	125 Cash		103.28	PTXPE	CA	369.79	5725.16	CAETT	CA Edu & T	435.63	0.00	0.00
111	Auto Auto Allo		75.00		CASD)		6094.95	CASUI	California S	60.94	0.00	0.00
5916.67	Reg Regular		5916.67		FITW		5725.16	MED-R	Medicare - E	1051.31	6094.95	88.38
					MED		6094.95			88.37		88.38
	Total Earnings	0.00	6094.95	Total Deductions		369.79		Total Employer Taxes		1636.25		88.38

Code	Earning	Hours	Amount	Deduction	Code	Amount	Taxable	Code	Tax	Amount	Taxable	Amount
125CO	125 Cash		499.58	PTXPE	CA	118.70	2280.12	CAETT	CA Edu & T	47.29	0.00	0.00
98	Reg Regular	76.00	1899.24		CASD)		2398.82	CASUI	California S	23.99	0.00	0.00
24.9900					FITW		2280.12	MED-R	Medicare - E	198.45	2398.82	34.78
					MED		2398.82			34.78		34.78
	Total Earnings	76.00	2398.82	Total Deductions		118.70		Total Employer Taxes		304.51		34.78

Code	Earning	Hours	Amount	Deduction	Code	Amount	Taxable	Code	Tax	Amount	Taxable	Amount
125CO	125 Cash		527.04	457B EE	CA	66.00	2180.68	CAETT	CA Edu & T	18.62	0.00	0.00
108	Reg Regular	76.00	1849.08	PTAXI	CASD)	129.44	2376.12	CASUI	California S	23.76	0.00	0.00
24.3300					FITW		2180.68	MED-R	Medicare - E	123.51	2376.12	34.45
					MED		2376.12			34.46		34.45
	Total Earnings	76.00	2376.12	Total Deductions		195.44		Total Employer Taxes		200.35		34.45

Credit Card Review

U S BANK Statement dated 6/6/19

ITEM #	CREDITOR	DESCRIPTION	AMOUNT	ACCOUNT
1	Amazon	Office Supplies for Admin Building - Hanging Folders	\$ 39.93	40-310-6210
2	Amazon	Office Supplies for Admin Building - Hanging Folders	\$ 68.46	40-310-6210
3	Microsoft	Microsoft 365 Monthly Fee	\$ 428.33	10-310-6210
4	Seabreeze Group	Iridium Renewal May 2019 to April 2020 - City Hall Satellite Phones	\$ 1,392.00	10-425-6215
5	Canyon Lake Property Owner	Round Table Monthly Breakfast	\$ 186.91	10-310-6510
6	Home Goods	Office Supplies for Admin Building - Storage Organizer	\$ 24.76	40-310-6210
7	TJ Maxx	Office Supplies for Admin Building - Workspace Organizer	\$ 37.69	40-310-6210
8	Arlo Technologies	Monthly Camera Service - City Hall	\$ 9.99	10-550-6610
9	Staples	Office Supplies for Admin Building - Tea, Cables, Air Freshner, Folders	\$ 238.29	40-310-6210
10	Etsy.com	Personalized Office Wall Sign Name Plates for Council Members	\$ 142.20	40-310-6210
11	Amazon	Office Supplies for Admin Building - Acrylic Wall Mounts	\$ 239.72	40-310-6210
12	Amazon	Ethernet Patch Cable for Admin Office	\$ 10.76	40-310-6210
13	Costco	City Council Candy - Fiesta Day Parade	\$ 215.64	10-100-6830
14	Costco	City Council Pictures	\$ 21.50	40-310-6210
15	Lowes	Texture Outside Front Mat for Admin Office	\$ 19.37	40-310-6210
16	Staples	Office Supplies Admin Office - Hang Wall Files, Wood Desk Organizer	\$ 71.60	40-310-6210
17	Staples	Office Supplies Admin Office - Tape Dispensor, Cable	\$ 41.45	40-310-6210
18	Canyon Lake Market	Plunger for Admin Office	\$ 4.30	40-310-6210
19	Staples	Business Forms - City Seal Embosser	\$ 126.12	40-310-6210
20	Embroidery and More	2 Polos and Jacket for City Manager	\$ 39.87	10-310-6210
21	Embroidery and More	2 Polos and Jacket for City Manager	\$ 19.93	10-310-6210
22	The Canyon Cowboy	Staff Meeting with Code Enforcement	\$ 85.61	10-310-6510
23	Target	Electronics for Admin Office	\$ 19.34	40-310-6210
24	Amazon	Door Mirror for Admin Office	\$ 31.96	40-310-6210
25	Wayfair	Arm Chair for City Manager Office	\$ 340.14	40-310-8007
26	Wayfair	Refund of Arm Chair for City Manager Office	\$ (261.91)	40-310-8007
27	Canyon Lake Property Owner	Lunch Meeting with Murrieta Council Member	\$ 41.21	10-310-6510
28	Zuri Furniture	Hayes Cabinet for City Manager Office	\$ 649.48	40-310-8007
29	Wayfair	Leilla End Table for City Manager Office	\$ 183.16	40-310-8007
30	The Canyon Cowboy	Lunch Meeting Chris and Cal Fire	\$ 34.98	10-310-6510
31	Personalized Paper Store	Note Pads for City Manager Office	\$ 72.13	40-310-6210
32	Wayfair	Table Lamp and Tree Floor Lamp for City Manager Office	\$ 277.84	40-310-8007

		Late Fee	\$ -	10-310-6965
--	--	----------	------	-------------

\$ 4,852.76

Account Breakdown

Capital Projects Office Chair	40-310-8040		
Capital Projects Computer Upgrade	40-310-8010		
Capital Projects Office Furniture	40-310-8007		
Capital Projects Office Supplies	40-310-6210	\$ 1,188.71	
Council Meeting/Travel Expense	10-100-6510	\$ 1,209.58	
Council Special Dept. Expense	10-100-6520		
Promotion and Advertising	10-100-6830		
Office Expense	10-310-6210	\$ 215.64	
Conference/Meeting/Travel Expense	10-310-6510	\$ 488.13	
Professional/Specialized Services	10-310-6610	\$ 348.71	
City Clerk Dues	10-320-6520		
Professional/Specialized Services	10-320-6610		
City Clerk Training and Education	10-320-6710		
Building Dept Expense	10-360-6220		
Fire Station Expenses	10-420-6210		
Emergency Preparedness Supplies	10-425-6215		
Code Enforcement Supplies	10-520-6210	\$ 1,392.00	
Special Enforcement Misc Expense	10-520-6220		
Code Enforcement Vehicle Equipment	10-520-6410		
Vehicle Maintenance	10-520-6415		
Code Enforcement Membership Dues	10-520-6520		
Building & Facilities Maintenance	10-550-6510	\$ 9.99	
		\$ 4,852.76	

*Copies for City Council
as directed by
the Finance Committee*

Check Figure	\$ -
--------------	------

Skip to: Content | Footer | Welcome Kayla | Help | Contact Us | CalPERS Website | Log out **June 27, 2019**



Home Profile Reporting Person Information Education Other Organizations

Manage Reports Billing and Payments Payroll Schedule Out-of-Class Validation Member Requests Health Reconciliation Retirement Appc

Name: City of Canyon Lake **CalPERS ID:** 3813045770

Payment Request Acceptance

Your request for payment has been accepted

- To generate the employer payment report, please click the print button.
- If you need to contact us with questions regarding this payment, please have your Payment Confirmation Number for faster access.
- Your payment will reflect as paid in myCalPERS if your payroll has successfully posted. Once your payment is processed any credits will roll over to the same type of receivable in the next month, after your payroll has been processed.
- Your payment may take longer to post, depending upon your Financial Institution.

Payment Setup Total

Total Payment Amount: \$969.49

Payment Summary

Payment Confirmation Number	Payment Authorization Date	Receivable ID	Receivable Description	Payment Method	Payment Account Nickname	Selected Payment Amount
1001349645	07/01/2019	100000015698374	Health PA Billing - PERS	EFT - Debit	Citizens Business Bank -5402	\$969.49

© Copyright 2019 CalPERS | [Conditions of Use](#) | [Accessibility](#)

Build: v8.1 Baseline: 190611_125242_v8.1_Int.8391 **UID: 318**

CM



Home Profile Reporting Plans My CalPERS Business Other Organizations

Manage Reports Billing & Payments Payroll Schedule Out-of-Class Validation Member Requests Health Reconciliation Retirement App

Name: City of Canyon Lake CalPERS ID: 3813045770

Payment Request Acceptance

Your request for payment has been accepted

- To generate the employer payment report, please click the print button.
- If you need to contact us with questions regarding this payment, please have your Payment Confirmation Number for faster access.
- Your payment will reflect as paid in myCalPERS if your payroll has successfully posted. Once your payment is processed any credits will roll over to the same type of receivable in the next month, after your payroll has been processed.
- Your payment may take longer to post, depending upon your Financial Institution.

Payment Setup Total

Total Payment Amount: \$2,820.50

Payment Summary

Payment Confirmation Number	Payment Authorization Date	Receivable ID	Receivable Description	Payment Method	Payment Account Nickname	Selected Payment Amount
1001365834	07/18/2019	100000015736634	Employer Contribution, Classic, 1684, CalPERS, 07/01/2019 - 07/15/2019	EFT - Debit	Citizens Business Bank -5402	\$1,500.27
1001365835	07/18/2019	100000015741095	Employer Contribution, PEPR, 26189, CalPERS, 07/01/2019 - 07/15/2019	EFT - Debit	Citizens Business Bank -5402	\$1,320.23

© Copyright 2019 CalPERS. Conditions of Use. Privacy Policy

July 18, 2019 10:00 AM (PST) 1001365835_07_18_2019_010 - 010-313

CW

Skip to: Content | Footer | Welcome Kayla | Help | Contact Us | CalPERS Website | Log out **June 27, 2019**



Home Profile Reporting Person Information Education Other Organizations

Manage Reports Billing and Payments Payroll Schedule Out-of-Class Validation Member Requests Health Reconciliation Retirement App

Name: City of Canyon Lake **CalPERS ID:** 3813045770

Payment Request Acceptance

Your request for payment has been accepted

- To generate the employer payment report, please click the print button.
- If you need to contact us with questions regarding this payment, please have your Payment Confirmation Number for faster access.
- Your payment will reflect as paid in myCalPERS if your payroll has successfully posted. Once your payment is processed any credits will roll over to the same type of receivable in the next month, after your payroll has been processed.
- Your payment may take longer to post, depending upon your Financial Institution.

Payment Setup Total

Total Payment Amount: \$2,482.28

Payment Summary

Payment Confirmation Number	Payment Authorization Date	Receivable ID	Receivable Description	Payment Method	Payment Account Nickname	Selected Payment Amount
1001349642	07/01/2019	100000015668818	Employer Contribution, Classic, 1684, CalPERS, 06/16/2019 - 06/30/2019	EFT - Debit	Citizens Business Bank -5402	\$1,271.92
1001349643	07/01/2019	100000015668860	Employer Contribution, PEPPRA, 26189, CalPERS, 06/16/2019 - 06/30/2019	EFT - Debit	Citizens Business Bank -5402	\$1,210.36

© Copyright 2019 CalPERS | [Conditions of Use](#) | [Accessibility](#)

Buld: v8.1 Baseline: 190611_125242_v8.1_Int.8391 **UID: 318**

CM

Skip to Content | Footer | Welcome Kayla | Help | Contact Us | CalPERS Website | July 17, 2019



Home Profile Reporting Person Information Education Other Organizations

Manage Reports Billing and Payments Payroll Schedule Out-of-Class Validation Member Requests Health Reconciliation Retirement App

Name: City of Canyon Lake CalPERS ID: 3813045770

Payment Request Acceptance

Your request for payment has been accepted

- To generate the employer payment report, please click the print button.
- If you need to contact us with questions regarding this payment, please have your Payment Confirmation Number for faster access.
- Your payment will reflect as paid in myCalPERS if your payroll has successfully posted. Once your payment is processed any credits will roll over to the same type of receivable in the next month, after your payroll has been processed.
- Your payment may take longer to post, depending upon your Financial Institution.

Payment Setup Total

Total Payment Amount: \$2,016.04

Payment Summary

Payment Confirmation Number	Payment Authorization Date	Receivable ID	Receivable Description	Payment Method	Payment Account Nickname	Selected Payment Amount
1001364072	07/17/2019	100000015712586	Employer Contributions - Unfunded Accrued Liability, Classic, 1684, CalPERS, 2019/2020	EFT - Debit	Citizens Business Bank -5402	\$2,016.04

© Copyright 2019 CalPERS | [Conditions of Use](#) | [Accessibility](#)
Bundle 19 | 0 3 | Baseline 190703_041313_08 1_incl.pdf | UID: 318

CM

July 17, 2019



Reporting Manage Reports Payroll Schedule Out-of-Class Validation Member Requests Health Reconciliation Retirement Appc

Name: City of Canyon Lake CalPERS ID: 3813045770

Payment Request Acceptance

Your request for payment has been accepted

- To generate the employer payment report, please click the print button.
- If you need to contact us with questions regarding this payment, please have your Payment Confirmation Number for faster access.
- Your payment will reflect as paid in myCalPERS if your payroll has successfully posted. Once your payment is processed any credits will roll over to the same type of receivable in the next month, after your payroll has been processed.
- Your payment may take longer to post, depending upon your Financial Institution.

Payment Setup Total

Total Payment Amount: \$122.67

Payment Summary

Payment Confirmation Number	Payment Authorization Date	Receivable ID	Receivable Description	Payment Method	Payment Account Nickname	Selected Payment Amount
1001364074	07/17/2019	100000015712602	Employer Contributions - Unfunded Accrued Liability, PEPR, 26189, CalPERS, 2019/2020	EFT - Debit	Citizens Business Bank -5402	\$122.67

CW



CITY OF CANYON LAKE
PLAN SPONSOR: 0035273

Acknowledgment

Your payment was successfully submitted. Provided it is in good order, it will process within contractual timeframes.

You can print this acknowledgment for your records.

Plan Name: **CITY OF CANYON LAKE 457**

Plan Number: **0035273001**

Payroll Center: **CITY OF CANYON LAKE**

Payroll Center Number: **001**

Payroll Received for Salary Reduction

Submission date: **07/12/2019**

Submission time: **04:29 PM**

Pay period end date: **06/30/2019**

Payment method: **Debit ACH**

Bank routing number: **122234149**

Bank account number: **245125402**

Contributions payment amount: **\$335.28**

Contributions count: **2**

C M

Draft date: **07/16/2019**

Nationwide Retirement Solutions and Nationwide Life Insurance Company (collectively "Nationwide") have endorsement relationships with the [National Association of Counties](#), the [International Association of Fire Fighters-Financial Corporation](#), and the [National Association of Police Organizations](#).

Nationwide may receive payments from mutual funds or their affiliates in connection with certain investment options. [Learn more about these payments.](#)

Retirement Specialists provide information for educational purposes only. This information is not meant to be used as investment advice. Retirement Specialists are Registered Representatives of Nationwide Investment Services Corporation, member [FINRA](#).



CITY OF CANYON LAKE
PLAN SPONSOR: 0035273

Acknowledgment

Your payment was successfully submitted. Provided it is in good order, it will process within contractual timeframes.

You can print this acknowledgment for your records.

Plan Name: **CITY OF CANYON LAKE 457 OBRA-PST**

Plan Number: **0035273002**

Payroll Center: **CITY OF CANYON LAKE OBRA**

Payroll Center Number: **001**

Payroll Received for Salary Reduction

Submission date: **07/12/2019**

Submission time: **04:26 PM**

Pay period end date: **06/30/2019**

Payment method: **Debit ACH**

Bank routing number: **122234149**

Bank account number: **245125402**

Contributions payment amount: **\$110.58**

CM

Contributions count: **1**

Draft date: **07/16/2019**

Nationwide Retirement Solutions and Nationwide Life Insurance Company (collectively "Nationwide") have endorsement relationships with the [National Association of Counties](#), the [International Association of Fire Fighters-Financial Corporation](#), and the [National Association of Police Organizations](#).

Nationwide may receive payments from mutual funds or their affiliates in connection with certain investment options. [Learn more about these payments](#).

Retirement Specialists provide information for educational purposes only. This information is not meant to be used as investment advice. Retirement Specialists are Registered Representatives of Nationwide Investment Services Corporation, member [FINRA](#).

Investment Reports

CITIZENSTRUST

Member Since 1991

Member Since 1991

Member Since 1991

000000075 MCB1000070819547680 01 00000056005

RECEIVED
JUL 16 2019
BY: _____

CITY OF CANYON LAKE
31516 RAILROAD CANYON RD
CANYON LAKE CA 92587

STATEMENT FOR THE PERIOD FROM 06/01/2019 TO 06/30/2019
ACCOUNT 1035003119

THIS IS YOUR REPORT OF INVESTMENTS AND TRANSACTIONS FOR THE PERIOD. INCLUDED IN THE REPORT ARE

- * PORTFOLIO: SUMMARY GRAPHICAL DISPLAY WITH MARKET VALUE & PERCENT
- * ACTIVITY SUMMARY: MARKET VALUE WITH TRANSACTION SUMMARY
- * PORTFOLIO STATEMENT: A LISTING OF COST AND MARKET VALUE OF ASSETS HELD IN THE PORTFOLIO

COST BASIS APPLICABLE FOR CALCULATING CAPITAL GAINS AND LOSSES.
MARKET VALUE IS THE CURRENT VALUE OF EACH ASSET FOR MOST STOCKS AND BONDS.
MARKETS ARE THE CLOSING PRICES ON THE LAST TRADING DAY OF THE PERIOD.

- * TRANSACTION STATEMENT: A COMPLETE LISTING FOR THE PERIOD GROUPED BY TRANSACTION TYPE.
- * DISCLOSURES: CITIZENS BUSINESS BANK MAY RECEIVE RESEARCH AND OTHER BENEFITS FROM BROKER DEALERS WHICH MAY BE CONSIDERED COMPENSATION TO US. UPON REQUEST WE WILL DISCLOSE DETAILS OF ANY COMPENSATION RECEIVED.
- * TO TRUST BENEFICIARIES: UNDER SECTION 17200 OF CALIFORNIA PROBATE CODE, YOU MAY PETITION THE COURT TO OBTAIN A COURT REVIEW OF THE ACCOUNT AND THE ACTS OF THE TRUSTEE. CLAIMS AGAINST THE TRUSTEE FOR BREACH OF TRUST MUST BE MADE WITHIN THREE YEARS FROM THE DATE OF RECEIPT OF AN ACCOUNTING OR OTHER REPORT DISCLOSING FACTS GIVING RISE TO THE CLAIM.

Account Statement



Account Number: 1035003119

June 01, 2019 To June 30, 2019

CITY OF CANYON LAKE
31516 RAILROAD CANYON RD
CANYON LAKE, CA 92587

Account Name:	CITY OF CANYON LAKE CITIZENS BUSINESS BANK
Account Number:	1035003119
Your Relationship Manager Is:	MIKE GARDNER
Phone:	909-483-4390

Investment Portfolio Summary

Market Value As Of	06/01/2019	06/30/2019	% Of Account
 CASH & CASH EQUIVALENTS	354,240.21	259,092.60	9.6%
 FIXED INCOME	2,342,572.16	2,445,315.02	90.4%
Total	2,696,812.37	2,704,407.62	100.0%

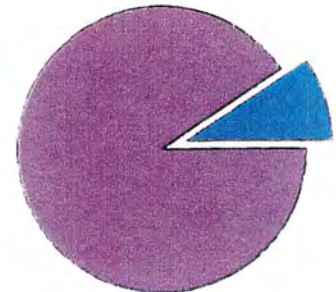

Activity Summary

	This Period	Year To Date	Realized Capital Gains / Losses	
			This Period	Year To Date
Beginning Market Value	2,696,812.37	2,651,935.18		
Income	2,714.43	25,579.10	Long Term	209.11-
Asset Activity	97,012.73-	112,459.74-	Total Gains / Losses	209.11-
Fees	849.31-	4,986.30-		872.19-
Cash Management	95,147.61	133,052.54-		
Change In Market Value	7,595.25	52,472.44		
Ending Market Value	2,704,407.62	2,704,407.62		



Account Statement

Account Number: 1035003119

June 01, 2019 To June 30, 2019

Performance Summary - Total Returns

	Market Value	1 Month	3 Months	1 Year	2 Years	3 Years	Since Inception 03/01/2010
TOTAL FUND	2,721,149	0.51	1.12	4.00	2.07	1.28	1.23
Return On Indexes Fixed GT (95% FX / 5% C)		0.68	1.79	4.99	2.39	1.54	1.77

Return Comparison

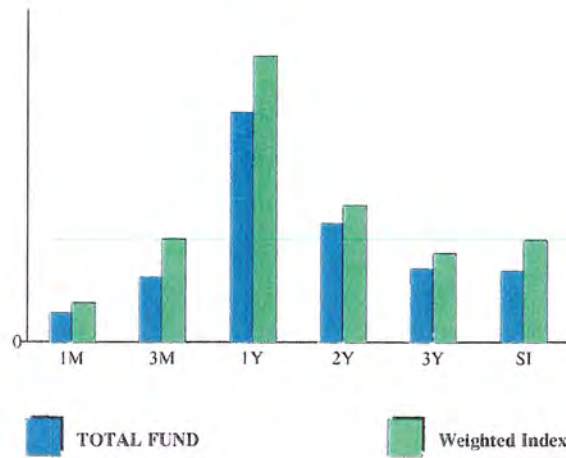

PAST RESULTS ARE NOT INDICATIVE OF FUTURE INVESTMENT RESULTS. FUND DATA IS ON A TRADE DATE BASIS. PERFORMANCE RESULTS ARE GROSS OF MANAGEMENT FEES. RETURNS FOR PERIODS LONGER THAN ONE YEAR ARE ANNUALIZED. MARKET VALUE DOES NOT INCLUDE ACCRUED INCOME.

Account Statement

Account Number: 1035003119

June 01, 2019 To June 30, 2019

Portfolio Statement (Continued)

Quantity	Description	Market Value	Cost Basis
Taxable			
50,000.000	3133EKRS7 FEDERAL FARM CREDIT BANK DTD 06/19/19 CALL 2.3% 06/19/2020-2019	50,005.50	50,000.00
50,000.000	3134GAHK3 FREDDIE MAC DTD 09/30/16 CALL 1.6% 09/30/2021-2016	49,606.00	49,967.50
100,000.000	3134GAZR8 FREDDIE MAC DTD 12/30/2016 CALL 2.05% 12/30/2021-2017	100,022.00	100,000.00
100,000.000	3134GB7F3 FREDDIE MAC DTD 12/29/17 CALL 2.5% 12/29/2022-2018	100,000.00	100,000.00
100,000.000	3134GBZS4 FREDDIE MAC DTD 7/27/2017 CALL 2.15 4/27/2022 2.15% 04/27/2022-2017	100,020.00	100,000.00
150,000.000	3134GSYQ2 FREDDIE MAC DTD 9/27/2018 CALL 3% 09/27/2021-2019	150,381.00	149,902.50
200,000.000	3134GTUV3 FREDDIE MAC DTD 6/17/2019 CALL 2.38% 06/17/2021-2019	200,010.00	200,000.00
50,000.000	3136G1C98 FANNIE MAE DTD 02/05/13 1.42% 02/05/2020	49,806.50	50,153.00
100,000.000	3136G3J30 FANNIE MAE DTD 07/28/16 CALL 1.6% 07/28/2021-2016	99,672.00	100,000.00
100,000.000	3136G3VG7 FANNIE MAE DTD 06/29/16 CALL 1.5% 09/29/2020-2016	99,609.00	100,000.00
100,000.000	3136G3XZ3 FANNIE MAE DTD 07/28/16 CALL 1.5% 07/28/2021-2016	99,482.00	100,000.00
100,000.000	3136G4EV1 FANNIE MAE DTD 10/28/16 CALL 1.625% 10/28/2021-2017	99,632.00	99,959.00
25,795.200	31398R7H2 FANNIE MAE SERIES 2010-M4 CLASS A3 DTD 07/01/10 3.819% 06/25/2020	26,050.07	27,600.86
200,000.000	69353REW4 PNC BANK NA DTD 04/29/16 CALL 2.15% 04/29/2021-2021	199,632.00	201,644.19
25,000.000	713448BN7 PEPSICO INC DTD 01/14/10 4.5% 01/15/2020	25,300.75	25,682.38
Total	Taxable	2,445,315.02	2,454,539.16

Portfolio Statement (Continued)

Quantity	Description	Market Value	Cost Basis
Fixed Income			
Total	Fixed Income	2,445,315.02	2,454,539.16
Miscellaneous			
Miscellaneous Sundry Assets			
Documents			
1.000	DOC199647 INVESTMENT MANAGEMENT AGREEMENT CITY OF CANYON LAKE A/C# 1035003119	0.00	0.00
Total Documents		0.00	0.00
Total	Miscellaneous Sundry Assets	0.00	0.00
Total	Miscellaneous	0.00	0.00
Grand Total Assets		2,704,407.62	2,713,631.76

Account Activity Summary

	Total Cash	Cost Basis Excluding Cash	Market Value Including Cash
Balances Beginning Of Period	0.00	2,712,090.77	2,709,011.82
Prior Accruals			12,199.45-
Unrealized Appreciation This Period			7,804.36
Current Accruals			10,873.87
Asset Activity	97,012.73-	96,803.62	97,012.73-
Cash Management	95,147.61	95,147.61-	95,147.61
Fees	849.31-	0.00	849.31-
Income	2,714.43	115.02-	2,714.43
Realized Gain/loss			209.11-
Non Cash Asset Changes			
Balances End Of Period	0.00	2,713,631.76	2,715,281.49

Transaction Statement

Date	Quantity	Description	Transaction Type	Cash	Cost Basis
06/01/19		Beginning Balance		0.00	2,712,090.77
Income					
Interest					
06/03/19		31607A703 FIDELITY GOVERNMENT PORTFOLIO 3130ADZ88	INTEREST RCVD	696.43	
06/10/19		FEDERAL HOME LOAN DTD 4/17/18 3% 4/17/23 CALL 3% 04/17/2023-2019 3130A8EN9	INTEREST RCVD	662.50	
06/14/19		FEDERAL HOME LOAN BANK DTD 06/14/16 CALL 1.64% 06/14/2021-2016	INTEREST RCVD	410.00	

Account Statement

Account Number: 1035003119

June 01, 2019 To June 30, 2019

Transaction Statement (Continued)

Date	Quantity	Description	Transaction Type	Cash	Cost Basis
06/17/19		29266NS32 ENERBANK USA DTD 10/16/2015 MEDIUM-TERM CD 1.75% 10/16/2020	INTEREST RCVD	148.63	
06/25/19		31398R7H2 FANNIE MAE SERIES 2010-M4 CLASS A3 DTD 07/01/10 3.819%	INTEREST RCVD	91.60	
06/26/19		06/25/2020 31398R7H2 FANNIE MAE SERIES 2010-M4 CLASS A3 DTD 07/01/10 3.819%	INTEREST RCVD	5.27	
06/27/19		06/25/2020 3130A1CE6 FEDERAL HOME LOAN DTD 03/27/14 2% 12/27/2019	INTEREST RCVD	700.00	
Total Interest				2,714.43	0.00
Total Income				2,714.43	0.00
Asset Activity					
Assets Purchased					
06/17/19	200,000.000	3134GTUV3 FREDDIE MAC DTD 6/17/2019 CALL 2.38% 06/17/2021-2019	BUY	200,000.00-	200,000.00
06/19/19	50,000.000	3133EKRS7 FEDERAL FARM CREDIT BANK DTD 06/19/19 CALL 2.3% 06/19/2020-2019	BUY	50,000.00-	50,000.00
Total Assets Purchased				250,000.00-	250,000.00
Assets Sold					
06/10/19	150,000.000-	3130ADZ88 FEDERAL HOME LOAN DTD 4/17/18 3% 4/17/23 CALL 3% 04/17/2023-2019	REDEEMED	150,000.00	150,000.00-
06/25/19	2,987.270-	31398R7H2 FANNIE MAE SERIES 2010-M4 CLASS A3 DTD 07/01/10 3.819%	NOTE AND MTG PMT	2,987.27	3,196.38-
06/26/19		06/25/2020 31398R7H2 FANNIE MAE SERIES 2010-M4 CLASS A3 DTD 07/01/10 3.819%	NOTE AND MTG PMT		
Total Assets Sold				152,987.27	153,196.38-
Total Asset Activity				97,012.73-	96,803.62
Fees					
06/27/19		MANAGEMENT FEES CITIZENS BUSINESS BANK FOR THE PERIOD ENDING 06/20/2019	DISBURSEMENT	849.31-	
Total Fees				849.31-	0.00

Expense Report

City of Canyon Lake
Utility Taxed Summary by Service Period
FY 2018/2019

	July	August	September	October	November	December	January	February	March	April	May	June
Electric												
Calpine Energy Solutions	15.67	21.25	33.37	13.23	19.90	8.18	29.17	28.45	19.14	19.14	37.25	23.21
Constellation New Energy, Inc.	106.00		12.32			80.96	69.03	62.66	114.89	54.32		33.63
East Energy Solutions, Inc.								102.18				
Southern California Edison	36,035.60	59,265.65	48,780.07	40,159.60	27,244.29	31,002.42	40,502.05	40,535.12	47,963.51	34,561.74		25,005.81
Water												
EP&D	2,113.85	2,289.26	2,388.29		2,175.17	1,911.92	1,895.61	1,769.24	1,514.83	1,538.75	1,869.61	2,075.78
EW&D	23,435.10	25,197.99	23,743.40	23,598.72	24,750.61	24,566.09	20,648.40	20,181.16	18,612.66	14,163.78	25,365.93	22,135.22
Water												
City Tax Roll	891.57	957.68	1,206.04									
Sewer												
Gas Company	135.06	149.93	159.56	147.17	162.47	244.81	329.04	349.57	293.35	171.58	187.89	176.56
Gas Energy, LLC												
Agustin, Inc. c/o Arkudin, Inc.												
Arkudin Corp (Split)	33.87	24.06	22.95	25.16	28.75	48.54	24.11	26.00	21.86	22.77	22.01	17.82
CenturyLink Communications Company, LLC	0.75	0.75	0.75	0.64	0.64	0.64	0.64	0.64	0.64	0.64	0.64	0.64
Compliance Solutions, Inc. GreatCall, Inc. dba Jitterbug	39.92	41.60	39.73	38.56	49.97	40.88	37.24	45.83	49.50	36.14	39.96	32.20
Compliance Solutions, Inc. Nextiva, Inc.	20.24	20.40	21.47	21.47	21.67	14.01	12.38	13.73	13.90	13.78	13.00	13.69
Compliance Solutions, Inc. dba Opex	0.35	0.35	0.39	0.38	0.37	0.39						
Compliance Solutions, Inc. Matrix Telecom, Inc.				1.92	1.59	1.59	2.92	1.85	1.76	1.34	1.30	1.50
Compliance Solutions, Inc. Phone.com Inc.									1.73	1.73	1.75	1.75
Compliance Solutions, Inc. Utility Telecom Group LLC	3.04	0.76	0.76	0.76	2.68	0.37		0.31	5.98	0.29	0.31	0.42
Compliance Solutions, Inc. Google North America dba Google Fi		2.36	2.31			3.30		2.83		2.57	2.83	3.80
Compliance Solutions, Inc. Google North America dba Google Fi	0.14	0.13										
Consumer Cellular, Inc.	57.15	61.94	60.59	60.59	65.86	65.90	70.19	83.99	82.65	87.07	93.65	90.91
Crockett Wireless LLC	56.26	57.35	58.78	58.25	56.05	64.52	64.99	68.55	71.27	3.69	5.29	5.66
Flash Wireless, LLC c/o Avallara, Inc. (FKA Extras Services)												
Frontier California Inc. (Split)	1,836.18	1,764.91	1,749.85	1,729.68	1,673.97	1,658.52	1,619.04	1,568.67	1,547.38	1,515.95	1,438.51	1,415.90
Frontier Communications of America	239.39	228.92	240.29	228.34	228.61	220.20	228.96	226.17	202.95	204.60	199.90	200.77
Granite Telecommunications LLC												
Google North America Inc. dba Project Fi by Google	0.34	3.51					3.42					
Google North America Inc. dba Project Fi by Google - Wireline	0.39						0.38					
Google North America Inc. c/o Avallara, Inc.												
Wireless												
ITask Global Communications												
InReach, Inc. c/o Avallara, Inc. (FKA Extras Services)	0.64	0.99	0.99	0.65	0.76	0.65	0.65	0.63	0.63	0.60	0.60	0.60
Level 3 Communications, LLC	0.35	49.14	43.38	43.38	43.68	43.65	43.65	43.72	43.75	44.93	43.17	43.37
Los Angeles SMSG Limited Partnership	3,110.28	3,049.24	3,122.92	3,060.40	3,029.16	3,048.79	2,962.29	2,940.59	3,040.50	3,028.26	2,952.96	2,977.52
MCI Communications Services, Inc.												
MCI Metro Access Transmission Services Corp	1.93	1.93	1.93	1.414	18.29	14.19	13.62	15.11	15.00	14.60	18.27	14.45
Metro PCS California, LLC	50.66	43.93	15.26	14.14	9.01	9.01	9.01	9.01	9.01	8.98	8.98	8.98
Mitel Cloud Services, Inc.	18.00	8.99	8.97	9.04								
New Cingular Wireless PCS LLC	3,681.63	4,020.23	3,541.04	4,010.41	3,217.56	3,519.03	3,399.82	3,996.82	2,235.22	2,022.25	2,157.61	1,600.74
Nuso, LLC												
Ooma, Inc.	13.24	8.11	8.49	8.49	13.72	8.76	8.27	13.23	8.27	11.92	18.13	8.68
OnStar LLC	11.90	15.36	12.87	14.16	12.24	11.14	8.59	11.00	12.26	8.98	18.92	18.92
Pacific Bell Telephone Company AT&T	5.46	5.46	4.65	4.64	4.64	4.64	4.64	4.63	5.33	4.64	5.03	5.05
PHG Telecommunications Inc. c/o Avallara, Inc. (FKA Extras Services)												
Ready Wireless LLC												
Republic Wireless, Inc. Avallara, Inc.	2.00	2.01	2.00	2.01	1.34	1.34	1.34	0.50	0.67	0.67	0.67	0.67
SpectroTel, Inc.												
Spectrum Mobile, LLC												
Spok, Inc.												
SprintCom, Inc.	20.99	17.74	16.08	18.79	15.17	15.83	14.80	14.78	15.31	13.23	13.17	12.07
Sprint Communications												
Sprint Spectrum LP												
Sprint Telephony PCS, LP	879.82	802.96	760.07	826.53	708.01	788.36	743.78	636.77	820.29	739.34	739.34	658.61
Sprint Telephony PCS, LP CA Prepaid												
StarZtur Communications												
T-Mobile USA Inc.	9.51	9.51	9.51	9.54	9.54	9.54		10.13	10.13	10.11	10.11	10.11
T-Mobile West LLC	839.35	829.40	411.40	369.33	396.52	381.15	396.77	401.91	448.36	402.58	449.31	420.59
TWC Digital Phone LLC												
United Office, Inc. Avallara, Inc.												
Utah Telecommunications, Inc. Telepacific Corp.	101.35	98.50	67.82	66.22	70.51	50.15	69.16	70.74	142.96	69.82	70.13	3.75
Utah Telecommunications, Inc. Utility Telephone, Inc.												
Utah Telecommunications, Inc. Utility Telecom Group, LLC												
Verizon Long Distance, LLC												
Virgin Mobile USA, LP	85.36	80.12	79.18	79.29	25.77	85.12	91.09	64.41	78.10	75.99	70.49	71.89
Virgin Mobile USA, LP	57.77	39.68	56.36	44.80	44.62	43.79	43.25	43.90	43.31	43.89	42.81	42.64
Virgin American c/o Avallara, Inc.	40.90	56.91	38.64	39.46	37.84	40.83	40.32	30.92	30.52	31.80	38.69	35.86
Virgin Business Solutions, Inc. c/o Avallara, Inc.												
Video Users												
AT&T Corp (Split)	2,664.72	2,706.49	2,639.86	2,714.88	2,696.10	2,660.03	2,726.93	2,717.53	2,633.32	2,475.80	2,465.40	2,430.22
Frontier California Inc. (Split)												
Frontier California, Inc.	1,462.61	1,443.76	1,449.62	1,444.20	1,395.72	1,393.87	1,327.00	1,333.75	1,327.40	1,276.20	1,054.44	33.69
Time Warner Cable Info Services (CA) LLC	33.73	37.73	33.69	33.69	33.69	33.69	33.69	33.69	33.69	33.69	33.69	33.69
Time Warner Cable Business LLC	44.83	180.98	190.36	317.20	414.79	463.50	400.54	650.15	750.96	769.90	769.90	763.59
DirectTV LLC												
Total	\$ 78,157.20	\$ 103,550.10	\$ 91,037.38	\$ 79,217.48	\$ 68,731.08	\$ 72,502.36	\$ 77,920.89	\$ 76,156.91	\$ 82,135.91	\$ 63,522.18	\$ 40,275.28	\$ 60,457.45

MINUTES
SPECIAL MEETING OF THE
CANYON LAKE CITY COUNCIL
Wednesday, May 8, 2019
Open Session – 5:30 p.m.

City Council Chamber
31516 Railroad Canyon Road
Canyon Lake, CA 92587

OPEN SESSION – 5:30 p.m.

CALL TO ORDER

Mayor Greene called the meeting to order at 5:31 p.m.

FLAG SALUTE

Flag Salute was led by Jack Wamsley

CITY COUNCIL ROLL CALL

Present: Councilmembers Bonner, Castillo, Mayor Pro Tem Ehrenkranz,
Councilmember Smith, and Mayor Greene

PUBLIC COMMENTS

There were no public comments.

GOALS SESSION

- **CONSIDERATION OF 2019 CITY COUNCIL GOALS**

City Manager Mann presented the item. He stated that 18 potential goals had been identified and he requested that each goal be discussed individually to determine the Council's final list of goals for 2019.

Mayor Greene called for the approval of the City Council Agenda.

Motion and Second by Mayor Pro Tem Ehrenkranz/Councilmember Smith to approve the agenda.

Motion carried 5-0, with Councilmembers Bonner, Castillo, Mayor Pro Tem Ehrenkranz, Councilmember Smith, and Mayor Greene voting aye.

City Manager Mann identified the following 18 potential goals and discussed them individually:

- Public Safety Contracts
- Update Computers, Phones, Data Storage and Records Retention
- Adopt and Implement Updated Fees
- Implement Fire Code Enforcement Program
- Update General Plan Housing Element
- Secure BLM Land for Economic Development
- Enhance Relationship with the POA
- Build Positive Regional Relationships
- Contract with a Traffic Engineer
- Add Residential Rentals and/or Short-Term Vacation Rentals to Business License Program
- Establish Internship Program
- Bring on Grants Consultant
- Update General Plan or Zoning Ordinance
- Move the City Council Chamber upstairs
- Update Inventory of City Assets
- Develop and Adopt a Filming Ordinance
- Review Standing Committees
- Put on City Sponsored Movie/Market Nights

The Council had thorough discussion on the items they felt were most important to them.

City Manager Mann wrapped up the Goals Session portion of the meeting by stating that the City has a significant budget challenge with the public safety contracts however, staff is committed to solving the problem. He spoke about the City Council's ongoing commitment to resolving the issues and he also made a commitment to staff that the problem would be resolved. He stated that under no circumstance would the City go under.

Mayor Greene called a recess at 7:14 p.m.

The meeting reconvened at 7:22 p.m.

BUDGET WORKSHOP

- **PRESENTATION AND DISCUSSION OF DRAFT FY 19/20 BUDGET**

Terry Shea, Finance Director, presented the City's proposed budget for Fiscal Year 2019/2020.

The Council had thorough discussion on the items they felt were most important to them.

Finance Director Shea stated that the proposed budget is a draft and welcomed questions and concerns from the Council.

City Manager Mann discussed the Fire Contract and the potential for significant savings by switching from a Municipal Contract to a Non-Municipal Contract.

Mayor Pro Tem Ehrenkranz thanked staff for all their hard work.

ADJOURNMENT

Mayor Greene adjourned the meeting at 8:15 p.m.

Respectfully submitted,

Ana V. Sauseda, Deputy City Clerk

MINUTES
SPECIAL MEETING OF THE
CANYON LAKE CITY COUNCIL
Wednesday, May 15, 2019
Closed Session – 5:30 p.m.
Open Session – 6:00 p.m.

City Council Chamber
31516 Railroad Canyon Road
Canyon Lake, CA 92587

CLOSED SESSION – 5:30 p.m.

CALL TO ORDER

Mayor Pro Tem Ehrenkranz called the meeting to order at 5:30 p.m.

CITY COUNCIL ROLL CALL

Present: Council Members Bonner, Castillo, Smith, and Mayor Pro Tem Ehrenkranz
Absent: Mayor Greene

Also present was Attorney Steven Graham.

PUBLIC COMMENTS

There were no public comments.

CLOSED SESSION

The City Council entered Closed Session at 5:32 p.m.

- A. CLOSED CONFERENCE WITH LEGAL COUNSEL - ANTICIPATED LITIGATION - Significant exposure to litigation pursuant to paragraph (2) of subdivision (d) of Section 54956.9 - 1 case

The City Council returned from Closed Session at 6:15 p.m. with no reportable action.

OPEN SESSION – 6:00 p.m.

CALL TO ORDER

Mayor Pro Tem Ehrenkranz called the meeting to order at 6:17 p.m.

FLAG SALUTE

Flag Salute was led by Councilmember Smith

CITY COUNCIL ROLL CALL

Present: Councilmembers Bonner, Castillo, Smith, and Mayor Pro Tem Ehrenkranz
Absent: Mayor Greene

APPROVAL OF CITY COUNCIL AGENDA

Motion and second by Councilmembers Bonner/Smith to approve the agenda.

Motion carried 4-0-1, with Councilmembers Bonner, Castillo, Smith, and Mayor Pro Tem Ehrenkranz voting aye and Mayor Greene absent.

Mayor Pro Tem Ehrenkranz announced that the Public Hearing regarding the Introduction of Ordinance No. 183 was continued to the June 5th Regular City Council Meeting.

PUBLIC COMMENTS

There were no public comments.

DISCUSSION AND POSSIBLE DIRECTION

- **NOTICE REGARDING STATION 60 STAFFING MODEL**

City Manager Mann presented the item. He discussed the difference between the two staffing models and stated that by switching to a Non-Municipal staffing model, the City would save approximately \$119,862.00 annually. He requested authorization from the Council to move forward with providing notice to the County to change the City's staffing model.

Motion and second by Councilmember Bonner/Smith to approve staff's request and direct the City Manager to send notice to the County regarding the staffing model change.

Motion carried 4-0-1, with Councilmembers Bonner, Castillo, Smith, and Mayor Pro Tem Ehrenkranz voting aye and Mayor Greene absent.

HOUSING ELEMENT

- **DISCUSSION AND DIRECTION REGARDING THE CITY OF CANYON LAKE'S GENERAL PLAN HOUSING ELEMENT**

It was stated that the City received a letter from State HCD advising that the Housing Element for the current cycle was not completed therefore the City was out of compliance.

City Planner Jim Morrissey along with Ralph Castaneda of Castaneda and Associates gave an oral report with PowerPoint presentation providing information to the Council on the obligations, requirements of the law, and examples of what the City had done in the past. They also discussed subsequent steps to prepare and address comments from the state.

Councilmember Bonner stepped away from the dais at 6:27 p.m. and returned at 6:28 p.m.

Mayor Pro Tem Ehrenkranz called for a recess at 7:06 p.m.

The meeting reconvened at 7:09 p.m.

Discussion between the Council, Ralph Castaneda, and City Staff continued.

ADJOURNMENT

Mayor Pro Tem Ehrenkranz adjourned the meeting at 7:32 p.m.

Respectfully submitted,

Ana V. Sauseda, Deputy City Clerk

MINUTES
SPECIAL MEETING OF THE
CANYON LAKE CITY COUNCIL
Wednesday, June 5, 2019
Closed Session – 5:30 p.m.

City Council Chamber
31516 Railroad Canyon Road
Canyon Lake, CA 92587

OPEN SESSION – 5:30 p.m.

CALL TO ORDER

Mayor Pro Tem Ehrenkranz called the meeting to order at 5:31 p.m.

FLAG SALUTE

Flag Salute was led by John Zaitz.

CITY COUNCIL ROLL CALL

Present: Councilmembers Bonner, Castillo, Smith, and Mayor Pro Tem
Ehrenkranz
Absent: Mayor Greene

APPROVAL OF CITY COUNCIL AGENDA

Motion and second by Councilmembers Smith/Castillo to approve the agenda.

Motion carried 4-0-1, with Councilmembers Bonner, Castillo, Smith, and Mayor Pro Tem Ehrenkranz voting aye and Mayor Greene absent.

PUBLIC COMMENTS

There were no public comments.

THE BROWN ACT

- **PRESENTATION AND REVIEW OF THE RALPH M. BROWN ACT**

Attorney Steven Graham gave a Power Point presentation to provide training to the City Council on the provisions of the Ralph M. Brown Act.

John Zaitz, resident, requested that the City Attorney address Section 54952.2 (c)(6) with the City Council. Discussion ensued.

Mr. Zaitz had additional questions and comments regarding the Brown Act.

1

DRAFT

Attorney Graham suggested that Mr. Zaitz be allowed to make his comments as Public Comment however the Council should not engage in back and forth conversation.

ADJOURNMENT

Mayor Pro Tem Ehrenkranz adjourned the meeting at 6:27 p.m.

Respectfully submitted,

Ana V. Sauseda, Deputy City Clerk

**MINUTES
REGULAR MEETING OF THE
CANYON LAKE CITY COUNCIL
Wednesday, June 5, 2019
Open Session - 6:30 p.m.**

**City Council Chamber
31516 Railroad Canyon Road
Canyon Lake, CA 92587**

OPEN SESSION – 6:30 p.m.

CALL OPEN SESSION TO ORDER

Mayor Pro Tem Ehrenkranz called the meeting to order at 6:33 p.m.

INVOCATION

Invocation was led by Nancy Horton

FLAG SALUTE

Flag Salute was led by Travis Montgomery

CITY COUNCIL ROLL CALL

Present: Councilmembers Bonner, Castillo, Smith, and Mayor Pro Tem Ehrenkranz
Absent: Mayor Greene.

APPROVAL OF THE CITY COUNCIL AGENDA

Motion and second by Councilmembers Bonner/Smith to approve the agenda.

Motion carried 4-0-1, with Councilmembers Bonner, Castillo, Smith and Mayor Pro Tem Ehrenkranz voting aye and Mayor Greene absent.

CEREMONIAL MATTERS

Presentations, Awards, Proclamations, Announcements

- Chamber of Commerce Announcement
Jim Randle gave an update on events that occurred since the last Council meeting and upcoming Chamber events.
- Animal Friends of the Valleys

Mayor Pro Tem Ehrenkranz presented Animal Friends of the Valleys with a Certificate of Recognition.

PUBLIC COMMENT

The following members of the public spoke:

- Nancy Horton - Resident

CONSENT CALENDAR

- (1) Waive Full Reading, Read all Ordinances by Title Only
- (2) Adoption of Resolution No. 2019-15 - Approving Claims and Demands of the City
- (3) City Council Meeting Minutes
 - May 1, 2019
- (4) WRCOG – Approval of Amendment to the Joint Powers Agreement and Bylaws of the Western Riverside Council of Governments
- (5) Resolution – Adoption of Resolution 2019-16 to Approve Senate Bill 1 (SB 1) Road Maintenance and Rehabilitation Account Funding and Project List
- (6) Agreement - Authorization of Professional Service Agreement with Tri Lake Consultants, Inc. for City Engineering Services
- (7) Resolution - Adoption of Resolution 2019-17, Repealing Resolution 2019-12 and Replacing it with Revised Language in Support of Balanced Energy Solutions and Local Choice

Motion and second by Councilmembers Bonner/Smith to approve the Consent Calendar.

Motion carried 4-0-1, with Councilmembers Bonner, Castillo, Smith and Mayor Pro Tem Ehrenkranz voting aye and Mayor Greene absent.

PULLED CONSENT CALENDAR ITEMS

SCHEDULE OF FUTURE EVENTS

Chris Mann, City Manager, discussed the next Special Joint Meeting between the City and the POA and proposed Monday, June 24th as the date for the next meeting.

Ana Sauseda, Deputy City Clerk, asked that the Council move Item 8 to the end of the Business Items and discuss Items 9 through 12 first.

BUSINESS ITEMS

(9) Consideration and Adoption of City Budget

- Approval of Resolution No. 2019-18, Adopting the City's Fiscal Year 2019/20 Budget and Appropriations Limit
- Approval of Resolution No. 2019-19, Approving the salary and wage Schedule for employees of the City for FY 2019-2020.

Terry Shea, Finance Director, presented the proposed Budget for Fiscal Year 2019-2020.

John Zaitz, resident, provided a handout to the Council and commented on the City's finances.

Motion and second by Councilmembers Bonner/Castillo to approve Resolution No. 2019-18.

Motion carried 4-0-1, with Councilmembers Bonner, Castillo, Smith and Mayor Pro Tem Ehrenkranz voting aye and Mayor Greene absent.

Motion and second by Councilmembers Bonner/Castillo to approve Resolution No. 2019-19.

Motion carried 4-0-1, with Councilmembers Bonner, Castillo, Smith and Mayor Pro Tem Ehrenkranz voting aye and Mayor Greene absent.

(10) Agreement - Cooperative Agreement with the County of Riverside for Fire Protection Services

City Manager Mann presented the item. He discussed the City's current Cooperative Agreement with the County of Riverside and the impacts to the City's budget because of it.

Council discussed their concerns and reservations in signing the contract.

The following members of the public spoke regarding Item 10:

- Travis Montgomery - Resident
- John Zaitz - Resident
- Jack Wamsley - Resident
- Nancy Horton - Resident
- Jeff Greene, Chief of Staff - Supervisor Kevin Jeffries

- Richard Seems - Resident
- Tod Williams, Deputy Chief - Cal Fire

Discussion between the Council, Staff, and the City Attorney continued.

Motion and second by Councilmembers Castillo/Bonner to hold a Special Meeting on June 17, 2019 to further discuss Agenda Item 10.

Motion carried 4-0-1, with Councilmembers Bonner, Castillo, Smith and Mayor Pro Tem Ehrenkranz voting aye and Mayor Greene absent.

- (11) Resolution - Adoption of Resolution No. 2019-20, Updating City Rates, Charges and User Fees for Commercial Filming Permits along with a CPI Escalator

Mike Borja, Administrative Services Manager, presented the item.

There was brief discussion as to why the fee had increased.

The following members of the public spoke regarding Item 11:

- Dale Welty - Resident
- Jack Wamsley – Resident

Motion and second by Councilmembers Smith/Bonner to Approve Resolution No. 2019-20.

Motion carried 4-0-1, with Councilmembers Bonner, Castillo, Smith and Mayor Pro Tem Ehrenkranz voting aye and Mayor Greene absent.

- (12) Resolution - Adoption of Resolution 2019-21 to Establish Fees and Charges for State Required Fire Inspection Municipal Services

Gina Dickson, Special/Code Enforcement Supervisor, presented the item.

There was brief discussion between Councilmember Smith and Staff.

Motion and second by Councilmembers Smith/Bonner to Approve Resolution No. 2019-21.

Motion carried 4-0-1, with Councilmembers Bonner, Castillo, Smith and Mayor Pro Tem Ehrenkranz voting aye and Mayor Greene absent.

Mayor Pro Tem Ehrenkranz called for a recess at 8:27 p.m.

The meeting reconvened at 8:36 p.m.

- (8) Housing Element - Preliminary Draft Housing Element for Review and Comment

Jim Morrissey, City Planner, presented the item.

Morrissey stated that the Reasonable Accommodation Resolution would be brought back at the June 17th meeting for approval.

Ralph Castaneda, Castaneda and Associates, presented a Power Point presentation and discussed the Preliminary Draft Housing Element.

The following members of the public spoke regarding Item 8:

- Jack Wamsley – Resident

The Council thanked staff for preparing the document in such a short amount of time.

PUBLIC HEARINGS

(13) Public Hearing - Introduction and First Reading of Ordinance No. 183

TIME AND PLACE FIXED FOR A PUBLIC HEARING TO CONSIDER THE INTRODUCTION AND FIRST READING OF ORDINANCE NO. 183 AN ORDINANCE OF THE CITY COUNCIL OF THE CITY OF CANYON LAKE AMENDING ARTICLE XXI OF THE CITY OF CANYON LAKE ZONING ORDINANCE AND AMENDING TITLE 9 TO ADD CHAPTER 9.27 REGARDING EMERGENCY SHELTERS AS WELL AS CHAPTER 9.28 REGARDING MANDATORY USES IN ALL RESIDENTIAL ZONES

- Public Hearing Opened

The Public Hearing was opened at 9:07 p.m.

- Staff Presentation

City Planner Morrissey presented the item.

- Questions to Staff by City Council

Jack Wamsley, resident, commented on the item.

- Testimony by Proponents

There were no comments.

- Testimony by Opponents

There were no comments by opponents, however, City Attorney Graham did clarify that there was an amendment to the draft Ordinance. There were no changes to the language, the City would simply add definitions to an already existing article.

- Response by Proponents

There were no comments.

- Public Hearing Closed

The Public Hearing was closed at 9:11 p.m.

- Discussion by City Council

Deputy City Clerk Sauseda stated that the Proof of Publication for the Public Hearing was on file in the City Clerk's Office.

Staff recommended a categorical exemption as part of the Environmental compliance for the California Environmental Quality Act.

- Action by City Council

Motion and second by Councilmembers Bonner/Castillo to Approve the Introduction and First Reading of Ordinance No. 183.

Motion carried 4-0-1, with Councilmembers Bonner, Castillo, Smith, and Mayor Pro Tem Ehrenkranz voting aye and Mayor Greene absent.

CITY MANAGER COMMENTS

Administrative Services Manager Borja provided the Council with an update on the CDBG project.

City Manager Mann discussed a meeting with Rick Bishop of WRCOG. He discussed attending the League of California Cities Manager's meeting followed by the Division meeting. He attended the WRCOG Technical Advisory Committee meeting and was appointed as the WRCOG Alternate to the Riverside County Emergency Medical Care Committee. He met with the City Manager for the City of Temecula regarding I-15 Taskforce. He attended the Southwest Counties Financing Authority. He met with Councilman Jonathan Ingram from the City of Murrieta to discuss RCA issues in the BLM Land and also spoke of an upcoming meeting with representatives from the Bureau of Land Management. He presented at the Southwest Riverside Association of Realtors breakfast. Lastly, he asked for direction from the Council as to whether they would like to cancel the July City Council Meeting.

The Council unanimously chose to go dark in July.

There was discussion about adding specific water items to the City Council's list of goals.

COMMITTEE AND COUNCIL REPORTS/COMMENTS

- **COUNCILMEMBER BONNER**

Councilmember Bonner discussed attending RCTC. He reminded the audience about the upcoming Roundtable meeting.

- **COUNCILMEMBER CASTILLO**

Councilmember Castillo stated that LESJWA went dark for the month but discussed one of their upcoming projects. She discussed her participation in the RFQ process with the TMDL Taskforce. She attended two of Melissa Melendez's Town Hall meetings. Lastly, she offered assistance if needed on the Veterans Day Committee.

- **COUNCILMEMBER SMITH**

Councilmember Smith offered prayers for Sparrow and Larry Greene. He discussed attending the RTA meeting. He attended the RCA meeting on behalf of Mayor Greene. He discussed the success of the Fiesta Day parade.

- **MAYOR PRO TEM EHRENKRANZ**

Mayor Pro Tem Ehrenkranz offered his thoughts and prayers for Sparrow and Larry Greene and thanked everyone for the opportunity to fill in for Mayor Greene.

ADJOURNMENT

Mayor Pro Tem Ehrenkranz adjourned the meeting at 9:40 p.m.

Respectfully submitted,

Ana V. Sauseda,
Deputy City Clerk

DRAFT

MINUTES
SPECIAL MEETING OF THE
CANYON LAKE CITY COUNCIL
Wednesday, June 17, 2019
Closed Session – 6:30 p.m.

City Council Chamber
31516 Railroad Canyon Road
Canyon Lake, CA 92587

OPEN SESSION – 6:30 p.m.

CALL TO ORDER

Mayor Pro Tem Ehrenkranz called the meeting to order at 6:32 p.m.

FLAG SALUTE

CITY COUNCIL ROLL CALL

Present: Councilmembers Bonner, Castillo, Smith, and Mayor Pro Tem
Ehrenkranz
Absent: Mayor Greene

APPROVAL OF CITY COUNCIL AGENDA

Motion and second by Councilmembers Bonner/Castillo to approve the agenda.

Motion carried 4-0-1, with Councilmembers Bonner, Castillo, Smith, and Mayor Pro Tem Ehrenkranz voting aye and Mayor Greene absent.

CONSENT CALENDAR

- (1) Resolution – Adoption of Resolution No. 2019-22 to Approve the Reasonable Accommodation Policy

Motion and second by Councilmembers Bonner/Smith to approve Resolution No. 2019-22.

Motion carried 4-0-1, with Councilmembers Bonner, Castillo, Smith, and Mayor Pro Tem Ehrenkranz voting aye and Mayor Greene absent.

PUBLIC COMMENTS

There were no public comments.

BUSINESS ITEMS

- (2) Agreement - Discussion and Possible Action on Cooperative Agreement with the County of Riverside for Fire Protection Services

Chris Mann, City Manager, presented the item. A Power Point presentation was used to give an overview of the City's financial struggles due to the fire contract. It was also used to illustrate the different options which staff had already explored in an ongoing effort to fix the City's fiscal deficit and different options which could potentially still be explored.

Discussion regarding some of the different options ensued.

Prior to accepting public comment, Mayor Pro Tem Ehrenkranz asked that the public not repeat comments from those who had spoken before.

The following members of the public spoke regarding Item 2:

- Art Femister
- Jack Wamsley
- Travis Montgomery
- Tim Adams
- Tiffani Paul
- Jesse Dofelmire
- Barry Talbot
- John Zaitz

Councilmember Smith spoke in favor of signing the current contract, however, he urged his colleagues to continue to work diligently to find other solutions as it is crucial for the survival of the City of Canyon Lake.

Mayor Pro Tem Ehrenkranz expressed his appreciation for Cal Fire and clarified that the City is not anti-Cal Fire, however, it would need to find a way to make the contract sustainable in order for it to continue.

Motion and second by Councilmembers Smith/Bonner to Approve the contract and directed the City Manager to explore additional revenue options for the City.

Motion carried 4-0-1, with Councilmembers Bonner, Castillo, Smith, and Mayor Pro Tem Ehrenkranz voting aye and Mayor Greene absent.

ADJOURNMENT

Mayor Pro Tem Ehrenkranz adjourned the meeting at 7:50 p.m.

Respectfully submitted,

Ana V. Sauseda, Deputy City Clerk

DRAFT

2

MINUTES
REGULAR MEETING OF THE CANYON LAKE
CITY COUNCIL
Wednesday, July 3, 2019

City Council Chamber
31516 Railroad Canyon Road
Canyon Lake, CA 92587

THE REGULAR MEETING OF THE CITY COUNCIL OF THE CITY OF CANYON LAKE SCHEDULED FOR JULY 3, 2019 WAS CANCELLED.

Respectfully Submitted,

Ana V. Sauseda
Deputy City Clerk

DRAFT

ORDINANCE NO. 183

AN ORDINANCE OF THE CITY COUNCIL OF THE CITY OF CANYON LAKE AMENDING ARTICLE XXI OF THE CITY OF CANYON LAKE ZONING ORDINANCE AND AMENDING TITLE 9 TO ADD CHAPTER 9.27 REGARDING EMERGENCY SHELTERS AS WELL AS CHAPTER 9.28 REGARDING MANDATORY USES IN ALL RESIDENTIAL ZONES

WHEREAS, State laws have been enacted which require amendments to the City’s Zoning Ordinance. Program 9 and Program 10 of the *2008-2014 Housing Element* describe the amendments to be adopted that include definitions for the following:

- Employee Housing to comply with Government Code Section 65583(c)(1)
- Family to comply with fair housing laws
- Licensed Group Homes to comply with the Welfare and Institutions Code (Lanterman-Petris Act) and Health and Safety Code (Community Care Facilities Act and Residential Care Facilities for the Elderly Act)
- Supportive Housing to comply with Government Code Section 65582(g)
- Target Population to comply with Government Code Section 65582(i)
- Transitional Housing to comply with Government Code Section 65582(j)

WHEREAS, in addition, in 2007, the State adopted legislation, Senate Bill 2 (SB2), that requires local agencies to incorporate provisions in Housing Element updates to provide for Emergency Shelters permitted "by right" within specified zoning districts; and,

WHEREAS, the Riverside County Point-In-Time Homeless Counts conducted in 2015, 2016, 2017 and 2018 have reported zero (0) homeless persons in Canyon Lake; and,

WHEREAS, Government Code Section 65583(a)(4)(A) states: “The identified zone or zones shall include sufficient capacity to accommodate the need for emergency shelter...except that each local government shall identify a zone or zones that can accommodate at least one year-round emergency shelter”; and,

WHEREAS, California Department of Housing and Community Development (HCD) has interpreted this requirement as follows: “Regardless of the extent of need identified in the [housing] element, local governments must provide zoning to allow at least one year round emergency shelter ...”; and,

WHEREAS, the City of Canyon Lake adopted the *2008-2014 Housing Element* on May 31, 2012 that is consistent with SB 2 and includes Program 10 that states the City will allow emergency shelters as a permitted use in the C-1 General Commercial Zone; and,

WHEREAS, the proposed zoning Ordinance is consistent with goals, objectives, policies, and programs of the City’s General Plan, and is necessary and desirable to implement the provisions of the General Plan; and,

WHEREAS, to comply with SB 2, this Zoning Ordinance Amendment proposes to add a definition for Emergency Shelters and identifies Emergency Shelters as permitted uses in the C-1 Zone that encompasses an area that is 23.4 acres in size.

WHEREAS, SB 2 allows the City to apply written, objective development and management standards as described by law that provides the following in an emergency shelter ordinance:

- The maximum number of beds or persons permitted to be housed nightly by the shelter;
- Off-street parking based on demonstrated need;
- The size and location of exterior and interior on-site waiting and client intake areas;
- The provision of on-site management;
- The proximity to other emergency shelters provided that emergency shelters are not required to be more than 300 feet apart;
- The length of stay;
- Lighting;
- Security during hours that the emergency shelter is in operation; and

WHEREAS, the City Council of the City of Canyon Lake conducted a duly noticed public hearing on June 5, 2019, to accept public testimony on the zoning Ordinance and environmental determination.

WHEREAS, the project is exempt from the California Environmental Quality Act (CEQA) as the activity is covered by the common sense exemption set out in CEQA Guidelines Section 15061(b)(3) that provides that where it can be seen with certainty that there is no possibility that the activity in question may have a significant effect on the environment, the activity is not subject to CEQA.

WHEREAS, the public health, safety and welfare would not be adversely affected by approval of the proposed zoning Ordinance; and,

NOW, THEREFORE, THE CITY COUNCIL OF THE CITY OF CANYON LAKE DOES ORDAIN AS FOLLOWS:

SECTION 1. The above recitals and findings are true and correct and incorporated herein by this reference.

SECTION 2. The following definitions are added to Article XXI of the City of Canyon Lake Zoning Ordinance:

“Employee housing” means privately owned housing that is provided by an employer in connection with any work, whether or not rent is involved.

“Family” means one or more persons living together as a single housekeeping unit in a dwelling unit. Family also means the persons living together in a licensed residential facility, as that term is defined in California Health and Safety Code Section 1502(a)(1) serving six or fewer persons, excluding the licensee, the members of the licensee’s

family, and persons employed as facility staff who reside at the facility.

“Licensed group homes” means residential care facilities licensed by the Community Care Licensing Division of the California Department of Social Services (DSS) and include, but are not limited, to Adult Residential Care Facilities and Residential Care Facilities for the Elderly. California law requires that many types of licensed facilities serving six persons or fewer be treated for zoning purposes like single-family homes. Group homes licensed under the provisions of the California Health & Safety Code include:

1. Intermediate care facilities for individuals who have developmental disabilities (Health and Safety Code § 1267.8)
2. Residential facilities for persons with disabilities and for abused children (Health and Safety Code § 1566.3, and Welfare and Institution Code § 5116)
3. Residential care facility for the elderly (Health and Safety Code § 1569.85)
4. Alcoholism and drug treatment facilities (Health and Safety Code § 11834.23)
5. Residential facilities for persons with chronic life threatening illness (Health and Safety Code § 1568.0831)

“Supportive housing” means housing with no limit on length of stay, that is occupied by the target population, and that is linked to an onsite or offsite service that assists the supportive housing resident in retaining the housing, improving his or her health status, and maximizing his or her ability to live and, when possible, work in the community.

“Target population” may include, among other populations, adults, emancipated minors, families with children, elderly persons, young adults aging out of the foster care system, individuals exiting from institutional settings, veterans, and homeless people.

“Transitional housing” means buildings configured as rental housing developments, but operated under program requirements that require the termination of assistance and recirculating of the assisted unit to another eligible program recipient at a predetermined future point in time that shall be no less than six months from the beginning of the assistance.

SECTION 3. Chapter 9.27 is added to the Municipal Code to read as follows:

\\

\\

CHAPTER 9.27 EMERGENCY SHELTERS

Section 9.27.010 Definitions.

“Emergency shelter” means housing with minimal supportive services for homeless persons that is limited to occupancy of six months or less by a homeless person. No individual or household may be denied emergency shelter because of an inability to pay. (See Government Code Section 65582(d) and Health and Safety Code Section 50801(e).)

Section 9.27.020 Emergency shelter(s) is a permitted use in the C-1 General Commercial Zone.

Emergency shelters as defined in Section 9.27.010 are hereby added as a permitted use in the C-1 General Commercial Zone.

Section 9.27.030 Development standards.

Emergency shelters shall comply with all development standards of the C-1 General Commercial Zone and the following standards:

- a. **Maximum Number of Beds.** An emergency shelter or a combination of emergency shelters with five (5) or fewer beds shall be a permitted use in the C-1 Commercial Zone. An emergency shelter with six or more beds or the expansion of an existing shelter to more than five (5) beds are permitted with the approval of a conditional use permit.
- b. **Minimum Separation Distance.** An emergency shelter shall be located at least 300 feet away from another emergency shelter, as measured in a straight line between property lines of each use without regard to intervening structures or objects.
- c. **On-site Waiting Area.** Each emergency shelter shall provide an interior and exterior waiting area adequate to accommodate waiting clients and to prevent queuing into the public right-of-way. An exterior waiting area shall be physically separated and visually screened from the public right-of-way.
- d. **Parking.** The emergency shelter shall provide on-site parking at a rate of one space for every five beds plus one space per each staff member.
- e. **Limited Terms of Stay.** The maximum length of stay for any homeless individual shall not exceed six (6) months in any consecutive twelve-month period.
- f. **Lighting.** Exterior lighting shall be provided on pedestrian pathways and parking lot areas on the property. Lighting shall be stationary, reflect away from residential areas and public streets.
- g. **Supervision.** An emergency shelter shall provide on-site supervision at all times it is open. The operator shall regularly patrol the area surrounding the shelter site during hours

that the shelter is in operation to ensure that homeless persons who have been denied access are not congregating in the neighborhood.

- h. Management. The emergency shelter facility shall provide an on-site resident manager at all times. A management plan is required for an emergency shelter to address management experience, client supervision, client services, and standards to govern expulsions, good neighbor issues, transportation, lights-out, and food services. Such plan shall be submitted to and approved by the City of Canyon Lake Planning Department.
- i. Maintenance of Exterior. The operator of an emergency shelter shall maintain the exterior of the facility, including signs and accessory structures, free of litter and graffiti at all times; provide removal of trash from the premises and abutting walkways within twenty (20) feet of the premises; and remove graffiti within forty-eight (48) hours of discovery.
- j. Toilets/Washbasins. Shelters must provide sufficient toilets and washbasins with warm and cold running water. The resident to toilet ratio must be 1 toilet/5 residents.
- k. Showers. Shelters must provide a reasonable supply of showers. The resident to shower ratio must be 1 showers/5 residents.
- l. Additional Standards. Each emergency shelter shall comply with applicable Building Code requirements, Fire Code requirements, and State Department of Social Services licensing requirements.

SECTION 4. Chapter 9.28 shall be added to read as follows:

MANDATORY USES IN ALL RESIDENTIAL ZONE

9.28.010 Uses in Residential Zone.

Notwithstanding anything to the contrary in the Canyon Lake Zoning Code or regulations,

- a. Employee housing accommodating six or fewer employees is deemed a single-family use and permitted in all zones permitting single-family residential land use. (Health & Safety Code Section 17021.5).
- b. Transitional housing and supportive housing as a proposed residential use and subject only to those restrictions that apply to other residential uses of the same type in the same zone.

SECTION 5. Effective Date. This Ordinance shall be effective 30 days from the date of its adoption.

///

///

SECTION 6. The City Clerk shall certify to the adoption of this Ordinance and shall cause the same to be published as required by law.

PASSED, APPROVED AND ADOPTED this 7th day of August, 2019.

Larry Greene, Mayor

ATTEST:

APPROVED AS TO FORM:

Ana V. Sauseda, Deputy City Clerk

Steven Graham, City Attorney

City of Canyon Lake
City Council
Staff Report

TO: Honorable Mayor and Members of the City Council
FROM: Chris Mann, City Manager
DATE: August 7, 2019
SUBJECT: Designation of Voting Delegate and Alternates for League of California Cities Annual Conference – October. 16th through 18th, 2019, in Long Beach, CA

CM

Recommendation:

That the City Council appoint a voting delegate and up to two alternates to the League of California Cities Annual Conference to be held in Long Beach, CA, October 16th through 18th, 2019, and direct City staff to complete and file the necessary paperwork.

Background:

Consistent with the League of California Cities’ bylaws, the City’s voting delegate and up to two alternates must be designated by the City Council. The voting delegate and alternates must be registered to attend the conference. In order to cast a vote, at least one person must be present and in possession of the voting delegate card at the Business Meeting, scheduled for Friday, October 18th, 2019, at 12:30 P.M.

An email with this information was sent by the City Manager to all members of the City Council on June 13th, 2019. Councilman Smith responded that he plans to attend the conference and would be interested in serving as the City’s delegate. Councilman Bonner subsequently responded that he also plans to be in attendance at the conference and would be willing to serve as either the City’s delegate or as an alternate.

Staff recommends that the Council discuss and appoint a voting delegate and one or two alternates to represent the City at the Business Meeting portion of the League of California Cities Annual Conference.

Fiscal Impact:

Registration and expenses for attendance at the League of California Cities Annual Conference was included in the Fiscal Year 2019/2020 Budget.

Attachments:

1. Letter from the League of California Cities Regarding Designation of Voting Delegates and Alternates

ATTACHMENT 1

Council Action Advised by August 30, 2019

June 10, 2019

TO: Mayors, City Managers and City Clerks

**RE: DESIGNATION OF VOTING DELEGATES AND ALTERNATES
League of California Cities Annual Conference – October 16 - 18, Long Beach**

The League's 2019 Annual Conference is scheduled for October 16 – 18 in Long Beach. An important part of the Annual Conference is the Annual Business Meeting (during General Assembly), scheduled for 12:30 p.m. on Friday, October 18, at the Long Beach Convention Center. At this meeting, the League membership considers and takes action on resolutions that establish League policy.

In order to vote at the Annual Business Meeting, your city council must designate a voting delegate. Your city may also appoint up to two alternate voting delegates, one of whom may vote in the event that the designated voting delegate is unable to serve in that capacity.

Please complete the attached Voting Delegate form and return it to the League's office no later than Friday, October 4. This will allow us time to establish voting delegate/alternate records prior to the conference.

Please note the following procedures are intended to ensure the integrity of the voting process at the Annual Business Meeting.

- **Action by Council Required.** Consistent with League bylaws, a city's voting delegate and up to two alternates must be designated by the city council. When completing the attached Voting Delegate form, please attach either a copy of the council resolution that reflects the council action taken, or have your city clerk or mayor sign the form affirming that the names provided are those selected by the city council. Please note that designating the voting delegate and alternates **must** be done by city council action and cannot be accomplished by individual action of the mayor or city manager alone.
- **Conference Registration Required.** The voting delegate and alternates must be registered to attend the conference. They need not register for the entire conference; they may register for Friday only. To register for the conference, please go to our website: www.cacities.org. In order to cast a vote, at least one voter must be present at the

Business Meeting and in possession of the voting delegate card. Voting delegates and alternates need to pick up their conference badges before signing in and picking up the voting delegate card at the Voting Delegate Desk. This will enable them to receive the special sticker on their name badges that will admit them into the voting area during the Business Meeting.

- **Transferring Voting Card to Non-Designated Individuals Not Allowed.** The voting delegate card may be transferred freely between the voting delegate and alternates, but *only* between the voting delegate and alternates. If the voting delegate and alternates find themselves unable to attend the Business Meeting, they may *not* transfer the voting card to another city official.
- **Seating Protocol during General Assembly.** At the Business Meeting, individuals with the voting card will sit in a separate area. Admission to this area will be limited to those individuals with a special sticker on their name badge identifying them as a voting delegate or alternate. If the voting delegate and alternates wish to sit together, they must sign in at the Voting Delegate Desk and obtain the special sticker on their badges.

The Voting Delegate Desk, located in the conference registration area of the Sacramento Convention Center, will be open at the following times: Wednesday, October 16, 8:00 a.m. – 6:00 p.m.; Thursday, October 17, 7:00 a.m. – 4:00 p.m.; and Friday, October 18, 7:30 a.m.–11:30 a.m.. The Voting Delegate Desk will also be open at the Business Meeting on Friday, but will be closed during roll calls and voting.

The voting procedures that will be used at the conference are attached to this memo. Please share these procedures and this memo with your council and especially with the individuals that your council designates as your city’s voting delegate and alternates.

Once again, thank you for completing the voting delegate and alternate form and returning it to the League’s office by Friday, October 4. If you have questions, please call Darla Yacub at (916) 658-8254.

Attachments:

- Annual Conference Voting Procedures
- Voting Delegate/Alternate Form



Annual Conference Voting Procedures

1. **One City One Vote.** Each member city has a right to cast one vote on matters pertaining to League policy.
2. **Designating a City Voting Representative.** Prior to the Annual Conference, each city council may designate a voting delegate and up to two alternates; these individuals are identified on the Voting Delegate Form provided to the League Credentials Committee.
3. **Registering with the Credentials Committee.** The voting delegate, or alternates, may pick up the city's voting card at the Voting Delegate Desk in the conference registration area. Voting delegates and alternates must sign in at the Voting Delegate Desk. Here they will receive a special sticker on their name badge and thus be admitted to the voting area at the Business Meeting.
4. **Signing Initiated Resolution Petitions.** Only those individuals who are voting delegates (or alternates), and who have picked up their city's voting card by providing a signature to the Credentials Committee at the Voting Delegate Desk, may sign petitions to initiate a resolution.
5. **Voting.** To cast the city's vote, a city official must have in his or her possession the city's voting card and be registered with the Credentials Committee. The voting card may be transferred freely between the voting delegate and alternates, but may not be transferred to another city official who is neither a voting delegate or alternate.
6. **Voting Area at Business Meeting.** At the Business Meeting, individuals with a voting card will sit in a designated area. Admission will be limited to those individuals with a special sticker on their name badge identifying them as a voting delegate or alternate.
7. **Resolving Disputes.** In case of dispute, the Credentials Committee will determine the validity of signatures on petitioned resolutions and the right of a city official to vote at the Business Meeting.



CITY: _____

**2019 ANNUAL CONFERENCE
VOTING DELEGATE/ALTERNATE FORM**

Please complete this form and return it to the League office by Friday, October 4, 2019. Forms not sent by this deadline may be submitted to the Voting Delegate Desk located in the Annual Conference Registration Area. Your city council may designate one voting delegate and up to two alternates.

In order to vote at the Annual Business Meeting (General Assembly), voting delegates and alternates must be designated by your city council. Please attach the council resolution as proof of designation. As an alternative, the Mayor or City Clerk may sign this form, affirming that the designation reflects the action taken by the council.

Please note: Voting delegates and alternates will be seated in a separate area at the Annual Business Meeting. Admission to this designated area will be limited to individuals (voting delegates and alternates) who are identified with a special sticker on their conference badge. This sticker can be obtained only at the Voting Delegate Desk.

1. VOTING DELEGATE

Name: _____

Title: _____

2. VOTING DELEGATE - ALTERNATE

Name: _____

Title: _____

3. VOTING DELEGATE - ALTERNATE

Name: _____

Title: _____

PLEASE ATTACH COUNCIL RESOLUTION DESIGNATING VOTING DELEGATE AND ALTERNATES.

OR

ATTEST: I affirm that the information provided reflects action by the city council to designate the voting delegate and alternate(s).

Name: _____

Email _____

Mayor or City Clerk _____
(circle one) (signature)

Date _____ Phone _____

Please complete and return by Friday, October 4, 2019

League of California Cities
ATTN: Darla Yacub
1400 K Street, 4th Floor
Sacramento, CA 95814

FAX: (916) 658-8240
E-mail: dyacub@cacities.org
(916) 658-8254

**City of Canyon Lake
City Council
Staff Report**

TO: Honorable Mayor and Members of the City Council

FROM: Chris Mann, City Manager *CM*

BY: Mike Borja, Administrative Services Manager

DATE: August 7, 2019

SUBJECT: Discussion and Authorization on Reallocating Remaining Fiscal Year 16/17 & 17/18 Community Development Block Grant Funds

Recommendation

Discussion and recommendation authorizing staff to reallocate previously allocated Community Development Block Grant (CDBG) funding towards City Hall ADA accessibility projects.

Background

At the May 1, 2019 City Council meeting, the City Council gave direction to city staff to re-promote the Home Repair Program towards the City's mobile home community, also known as the Fairway Estates, in hopes of attracting new applications from residents that are looking to benefit from the City's Home Repair Program. City staff contacted Habitat for Humanity Inland Valley, who oversees the Home Repair Program for the City, and directed them to re-promote the program by sending out mailers on June 6th to each of the homes in the Fairway Estates.

With a deadline of June 30th to submit applications, final documentation was then to be submitted from Habitat to County EDA for processing by July 19th. County EDA was notified prior to July 19th that a total of five applications were received by Habitat. However, of the five applications Habitat received, none of them qualified due to the following reasons:

1. Skylink Drive applicant #1 - applicant advised that she is not prepared to fill out the application any longer.
2. Skylink Drive applicant #2 - applicant's income exceeded the guidelines.
3. Skylink Drive applicant #3 - no response to phone messages left.
4. Big Tee Drive applicant #1 - applicant's home is still owned by his father's estate.
5. Big Tee Drive applicant #2 - applicant completed and turned in their application; however, applicant claims no income and that all her expenses are paid by a boyfriend who does not live with her.

Based on the applications received, County EDA didn't approve any of these applicants for the Home Repair Program. Staff's recommendation to the City Council is to reallocate the remaining balances from FY16/17 and FY17/18 towards City Hall ADA projects, as outlined in Accessibility Review Report. As an additional option, County EDA is willing to upfront the total cost of all the

projects listed in the report, if City Council chooses to accept. City staff would determine a total cost estimate to submit to County EDA if accepted.

Fiscal Impact

The City's current remaining CDBG balance is \$25,748.31. This amount is an accumulation left over from FY16/17 & FY17/18 allocation combined, that could be used towards projects listed in the Accessibility Review Report. If the City Council chooses the option to accept County EDA's offer to fund all projects list in the report, a total cost would be determined at that point.

Attachments

1. Accessibility Review Report - Interior Spaces for Canyon Lake City Hall

ATTACHMENT 1

April 9, 2019

PREPARED FOR THE

CITY OF CANYON LAKE

ACCESSIBILITY REVIEW OF INTERIOR SPACES FOR CANYON LAKE CITY HALL



**INTERWEST
CONSULTING
GROUP**

Dave Marcum, CASp, ICC
Building Inspector
15140 Transistor Lane
Huntington Beach, CA 92649

www.interwestgrp.com

April 9, 2019

Accessibility Review of Interior Spaces for Canyon Lake City Hall

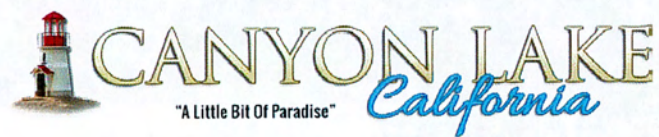

Prepared for the
City of Canyon Lake
31516 Railroad Canyon Road,
Canyon Lake, CA 92587

By
Interwest Consulting Group, Inc.



Dave Marcum, CASp, ICC
Building Inspector
15140 Transistor Lane
Huntington Beach, CA 92649
dmarcum@interwestgrp.com
O: 714.899.9039
C: 714.313.7131

Table of Contents

Scope and Data.....	1
Canyon Lake Map.....	2
City Hall Arial View	3
Building Department Office	4
Police Office	7
Men’s Restroom (Upper Level)	10
Women’s Restroom (Upper Level)	14
Drinking Fountain (Upper Level).....	16
Library	17
Administrative Office	20
Break Room.....	21
Stairs.....	24
Men’s Restroom (Lower Level)	25
Women’s Restroom (Lower Level)	29
Council Chamber	30
Elevator	33
Main Entry Door (amended 4/3/2019).....	34
Lower Level Exit Door (amended 4/3/2019)	35

Canyon Lake City Hall Accessibility Review



Scope: Accessibility review of Canyon Lake City Hall interior spaces.

Address: 31516 Railroad Canyon Road, Canyon Lake, CA 92587

Codes: Based on the 2016 California Building Code, 11-B and the 2010 ADA Standards for Accessible Design.

Building Inspector: Dave Marcum, Interwest Consulting Group
dmarcum@interwestgrp.com 714-594-9458

Date of Inspection: February 20, 2019



Canyon Lake Map

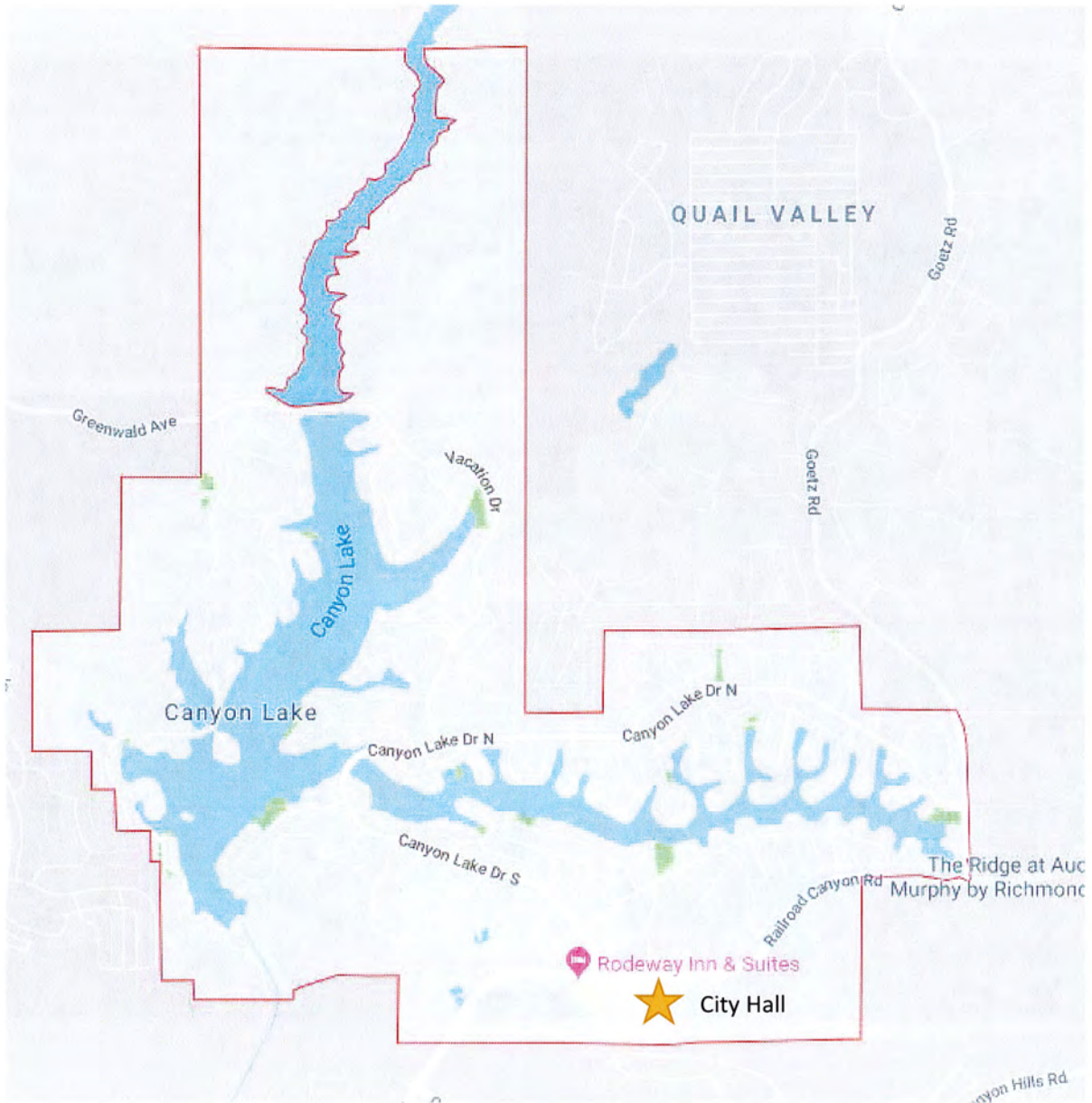

City Hall Aerial View

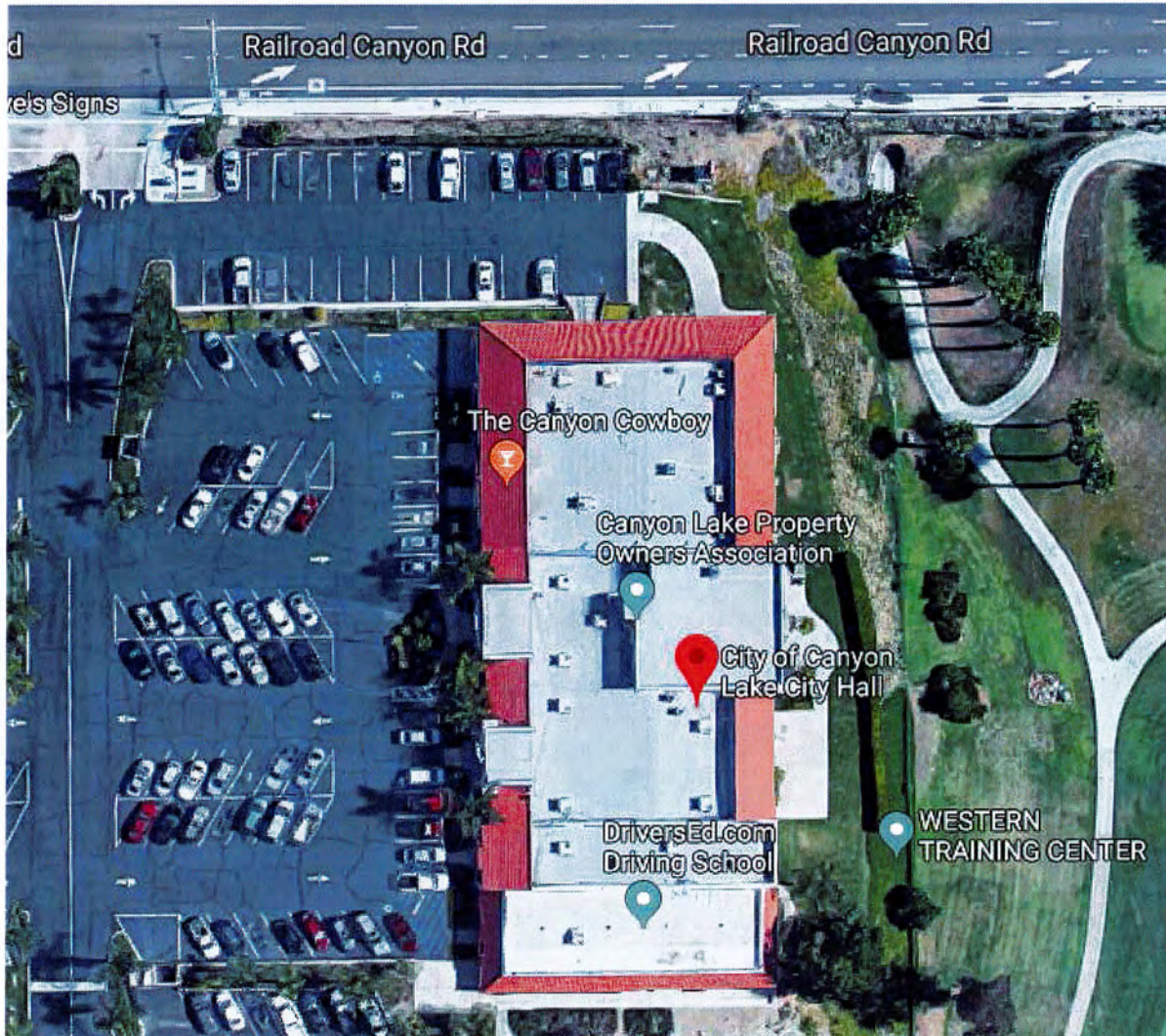

Upper Level

Building Department Office

1. Forward approach accessible countertop requires 36-inch minimum width (**CBC**). 30-inch minimum width (**ADA**). See below.



CBC 11B-904.4 Sales and service counters. Sales counters and service counters shall comply with Section 11B-904.4.1 or 11B-904.4.2. The accessible portion of the counter top shall extend the same depth as the sales or service counter top.

11B-904.4.2 Forward approach. A portion of the counter surface that is 36 inches (914 mm) long minimum and 34 inches (864 mm) high maximum shall be provided. Knee and toe space complying with Section 11B-306 shall be provided under the counter. A clear floor or ground space complying with Section 11B-305 shall be positioned for a forward approach to the counter.

ADA 902.3.904.4 Sales and Service Counters. Sales counters and service counters shall comply with 904.4.1 or 904.4.2. The *accessible* portion of the counter top shall extend the same depth as the sales or service counter top.

904.4.2 Forward Approach. A portion of the counter surface that is 30 inches (760 mm) long minimum and 36 inches (915 mm) high maximum shall be provided. Knee and toe *space* complying with 306 shall be provided under the counter. A clear floor or ground *space* complying with 305 shall be positioned for a forward approach to the counter.

2. Threshold/transition is missing at entry door and appears to exceed one quarter inch allowance.
CBC and ADA concur.

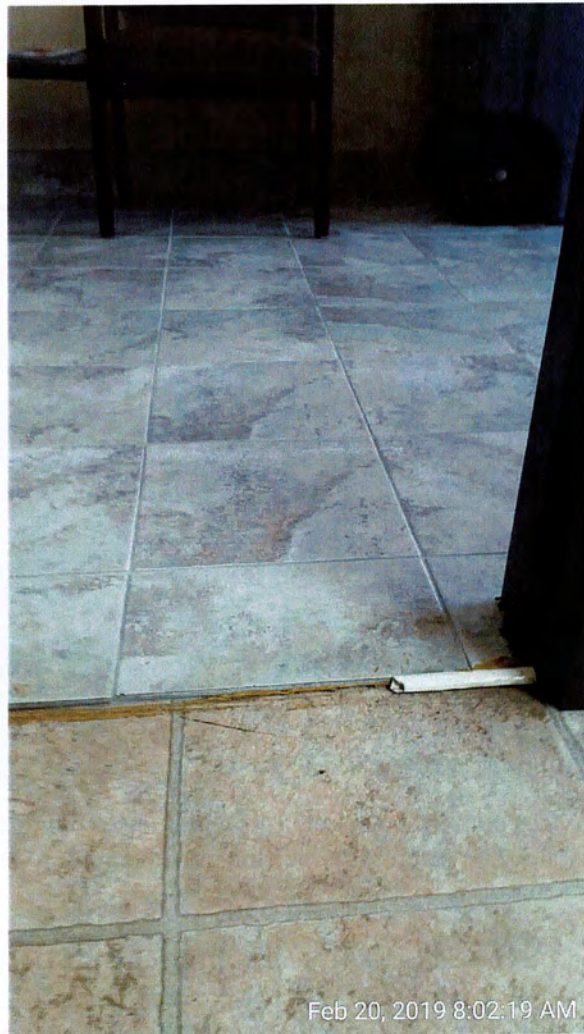

ADA Level 303.1 General. Where changes in level are permitted in floor or ground surfaces, they shall comply with 303.

303.2 Vertical. Changes in level of ¼ inch (6.4 mm) high maximum shall be permitted to be vertical.



ADA 303.3 Beveled. Changes in level between ¼ inch (6.4 mm) high minimum and ½ inch (13 mm) high maximum shall be beveled with a slope not steeper than 1:2.

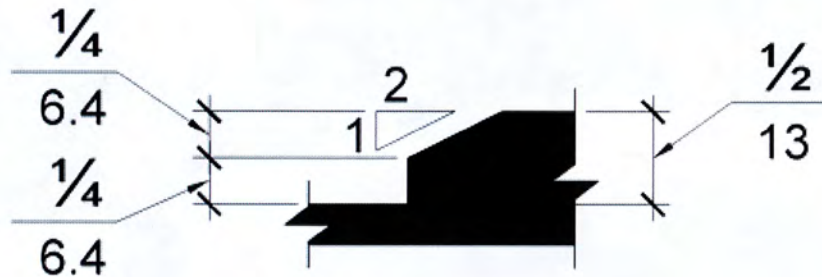

3. Thumbscrew type locks are not accessible.



CBC 11B-309.4 Operation. Operable parts shall be operable with one hand and shall not require tight grasping, pinching, or twisting of the wrist. The force required to activate operable parts shall be 5 pounds (22.2 N) maximum.

Police Department Office

4. Service counter is not accessible.

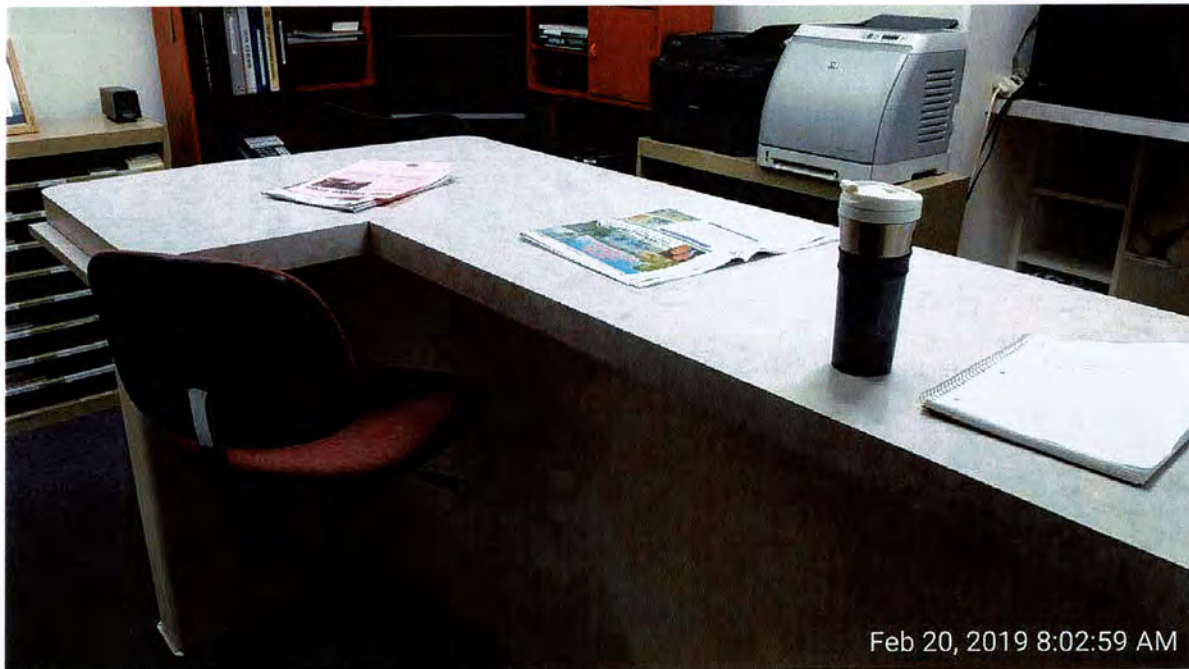

CBC 11B-904.4 Sales and service counters. Sales counters and service counters shall comply with Section 11B-904.4.1 or 11B-904.4.2. The accessible portion of the counter top shall extend the same depth as the sales or service counter top.

11B-904.4.1 Parallel approach. A portion of the counter surface that is 36 inches (914 mm) long minimum and 34 inches (864 mm) high maximum above the finish floor shall be provided. A clear floor or ground space complying with *Section 11B-305* shall be positioned for a parallel approach adjacent to the 36 inch (914 mm) minimum length of counter.

Exception: Where the provided counter surface is less than 36 inches (914 mm) long, the entire counter surface shall be 34 inches (864 mm) high maximum above the finish floor.

11B-904.4.2 Forward approach. A portion of the counter surface that is 36 inches (914 mm) long minimum and 34 inches (864 mm) high maximum shall be provided. Knee and toe space complying with *Section 11B-306* shall be provided under the counter. A clear floor or ground space complying with *Section 11B-305* shall be positioned for a forward approach to the counter.

ADA 904.4.1 Parallel Approach. A portion of the counter surface that is 36 inches (915 mm) long minimum and 36 inches (915 mm) high maximum above the finish floor shall be provided. A clear floor or ground space complying with 305 shall be positioned for a parallel approach adjacent to the 36 inch (915 mm) minimum length of counter. **EXCEPTION:** Where the provided counter surface is less than 36 inches (915 mm) long, the entire counter surface shall be 36 inches (915 mm) high maximum above the finish floor.

904.4.2 Forward Approach. A portion of the counter surface that is 30 inches (760 mm) long minimum and 36 inches (915 mm) high maximum shall be provided. Knee and toe *space* complying with 306 shall be provided under the counter. A clear floor or ground *space* complying with 305 shall be positioned for a forward approach to the counter.

5. Door requires an 18-inch minimum strike side clearance.

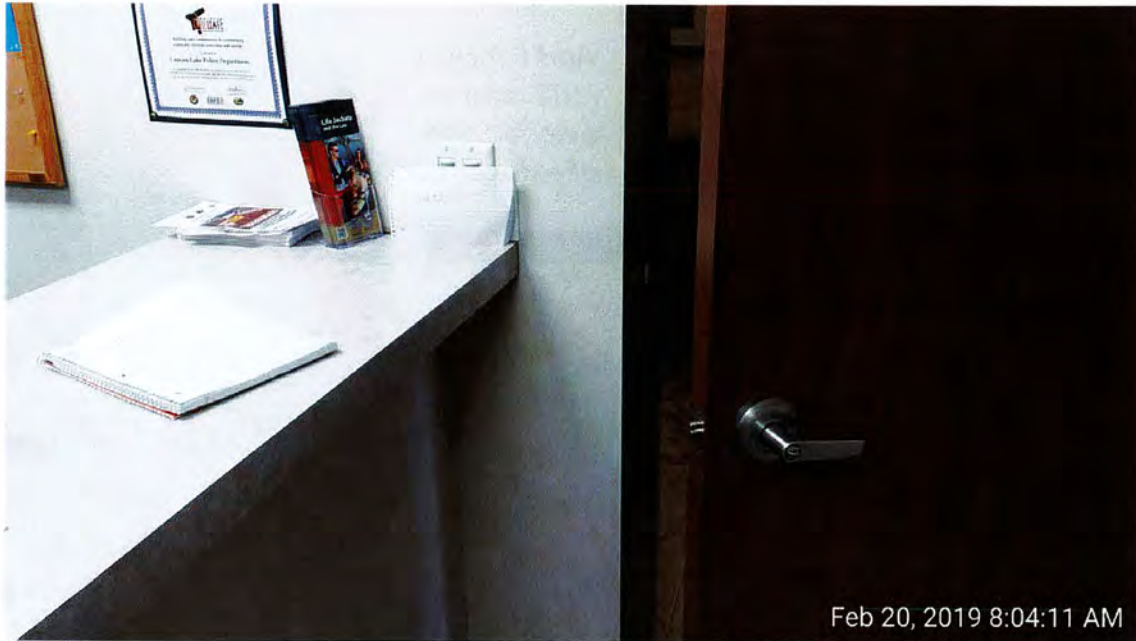

CBC 11B-404.2.4 Maneuvering clearances. Minimum maneuvering clearances at doors and gates shall comply with *Section 11B-404.2.4*. Maneuvering clearances shall extend the full width of the doorway and the required latch side or hinge side clearance.

404.2.4.1 Swinging doors and gates. Swinging doors and gates shall have maneuvering clearances complying with Table *11B-404.2.4.1*.

Table 11B-404.2.4.1 Maneuvering Clearances at Manual Swinging Doors and Gates Type of Use Approach Direction Door or Gate Side

Minimum Maneuvering Clearance

Approach Direction	Door or Gate Side	Perpendicular to Doorway	Parallel to Doorway (beyond latch side unless noted)
From front	Pull	60 inches (1524 mm)	18 inches (457 mm)⁵
From front	Push	48 inches (1219 mm)	0 inches (0 mm) ¹
From hinge side	Pull	60 inches (1524 mm)	36 inches (914 mm)
From hinge side	Push	44 inches (1118 mm) ²	22 inches (559 mm) ³
From latch side	Pull	60 inches (1524 mm)	24 inches (610 mm)
From latch side	Push	44 inches (1118 mm) ⁴	24 inches (610 mm)

1. Add 12 inches (305 mm) if closer and latch are provided.
2. Add 4 inches (102 mm) if closer and latch are provided.
3. Beyond hinge side.
4. Add 4 inches (102 mm) if closer is provided.
5. Add 6 inches (152 mm) at exterior side of exterior doors

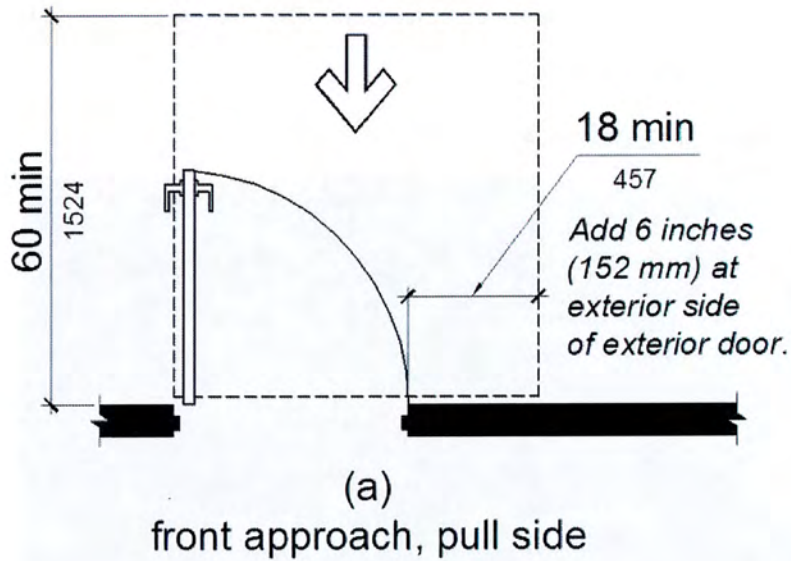

CBC and ADA concur.

6. 36-inch minimum aisle widths to work spaces.



ADA 403.5.1 Clear Width. Except as provided in 403.5.2 and 403.5.3, the clear width of walking surfaces shall be 36 inches (915 mm) minimum.

EXCEPTION: The clear width shall be permitted to be reduced to 32 inches (815 mm) minimum for a length of 24 inches (610 mm) maximum provided that reduced width segments are separated by segments that are 48 inches (1220 mm) long minimum and 36 inches (915 mm) wide minimum.

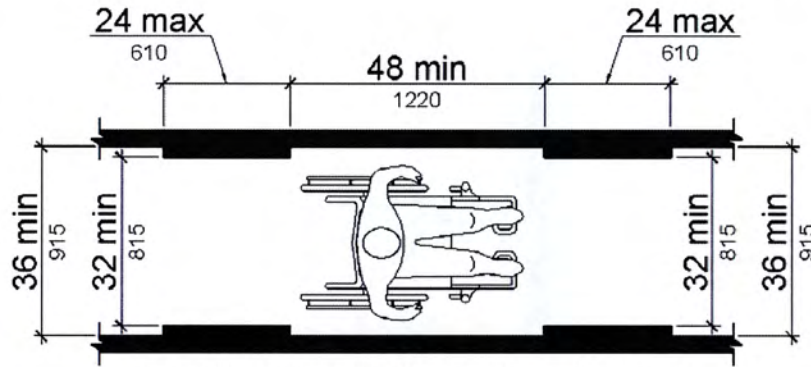
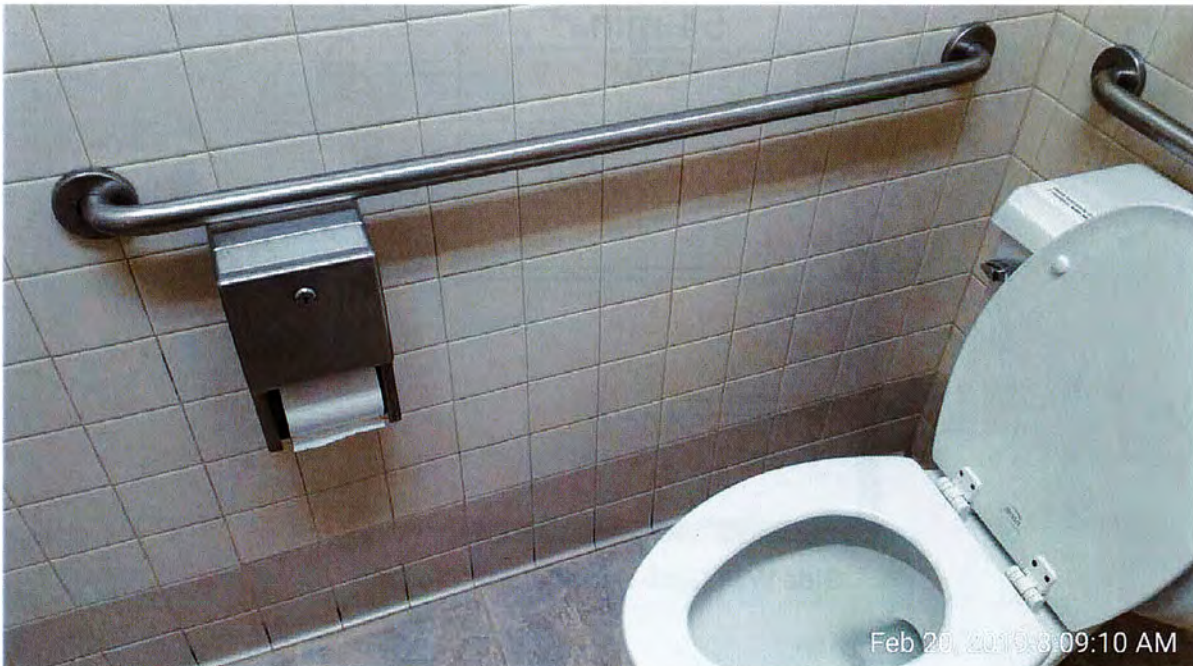

Figure 403.5.1 Clear Width of an Accessible Route

CBC and ADA concur

Upper Level Men's Restroom

7. Side wall grab bar shall project a minimum of 24 inches in front of water closet.



CBC 11B-604.5.1 Side wall. The side wall grab bar shall be 42 inches (1067 mm) long minimum, located 12 inches (305 mm) maximum from the rear wall and extending 54 inches (1372 mm) minimum from the rear wall with the front end positioned 24 inches (610 mm) minimum in front of the water closet.

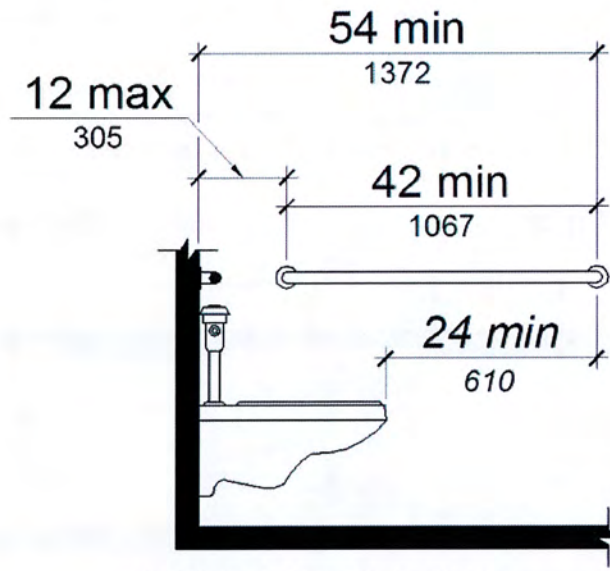

Side Wall Grab Bar at Water Closets

ADA 604.5.1 Side Wall. The side wall grab bar shall be 42 inches (1065 mm) long minimum, located 12 inches (305 mm) maximum from the rear wall and extending 54 inches (1370 mm) minimum from the rear wall. ★

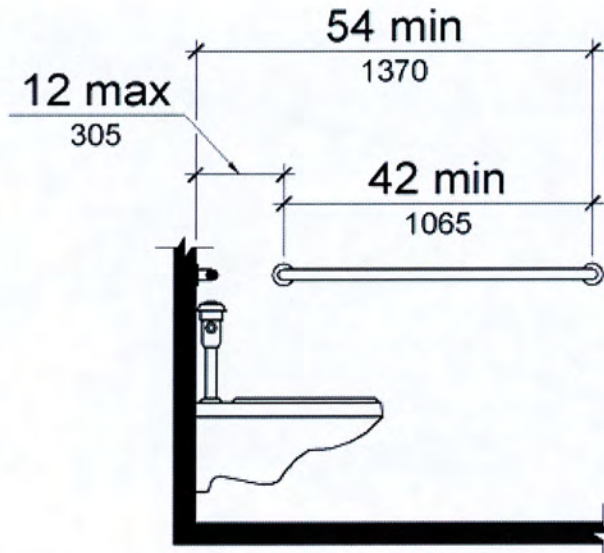

Side Wall Grab Bar at Water Closets

★ *CBC differs slightly from ADA*

7. Toilet paper dispenser impinges on grab bar grip requirement.



11B-609.3 Spacing. The space between the wall and the grab bar shall be 1½ inches (38 mm). The space between the grab bar and projecting objects below and at the ends shall be 1½ inches (38 mm) minimum. The space between the grab bar and projecting objects above shall be 12 inches (305 mm) minimum.

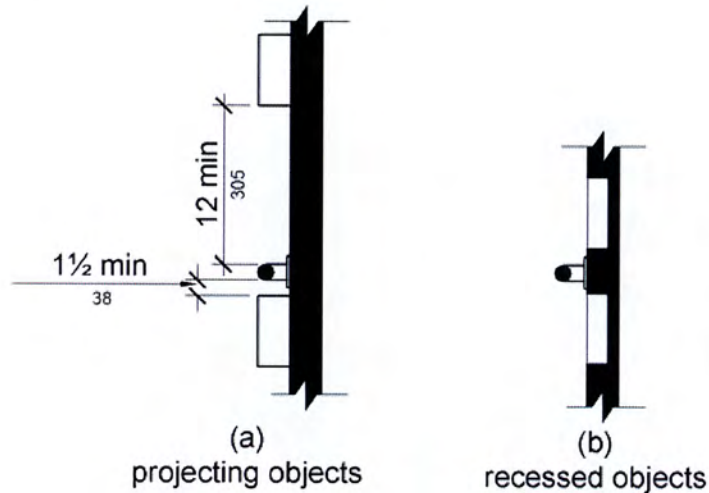

CBC and ADA concur.

8. Flush valve shall be on the open side of water closet compartment.



CBC 11B-604.6 Flush controls. Flush controls shall be hand operated or automatic. Hand operated flush controls shall comply with *Section 11B-309* except they shall be located 44 inches (1118 mm) maximum above the floor. Flush controls shall be located on the open side of the water closet except in ambulatory accessible compartments complying with *Section 11B-604.8.2*.

9. Toilet paper dispenser not dimensioned correctly in from front of toilet.



11B-604.7 Dispensers. Toilet paper dispensers shall comply with *Section 11B-309.4* and shall be 7 inches (178 mm) minimum and 9 inches (229 mm) maximum in front of the water closet measured to the

centerline of the dispenser. The outlet of the dispenser shall be *below the grab bar*, 19 inches (483 mm) *minimum* above the finish floor and shall not be located behind grab bars. Dispensers shall not be of a type that controls delivery or that does not allow continuous paper flow.

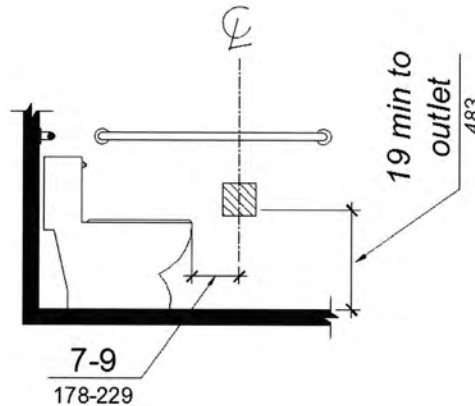

Dispenser Outlet Location

CBC and ADA concur

Upper Level Women's Restroom

The following are the same requirements for men's upper level restroom.

- Grab bar shall project a minimum of 24 inches in front of water closet. Pages 11-12
- Toilet paper dispenser impinges on grab bar grip requirement. Page 13
- Flush valve shall be on the open side of water closet compartment. Page 14
- Toilet paper dispenser in front of water closet dimension. Page 15

Additional requirement:

10. Cabinet impinging on required door maneuvering clearance.

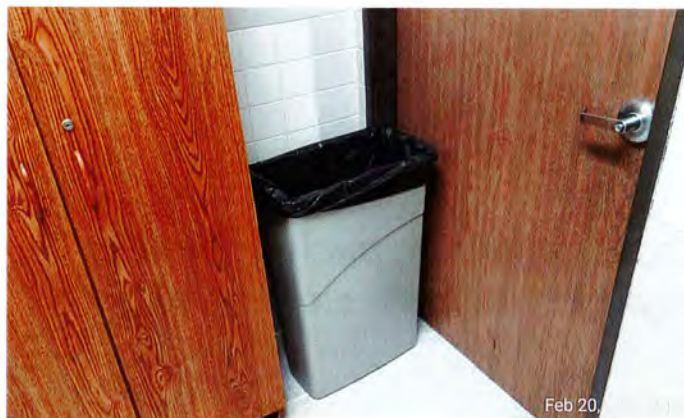

CBC 404.2.4.1 Swinging doors and gates. Swinging doors and gates shall have maneuvering clearances complying with Table 11B-404.2.4.1.

Approach Direction	Door or Gate Side	Minimum Maneuvering Clearance	
		Perpendicular to Doorway	Parallel to Doorway (beyond latch side unless noted)
From front	Pull	60 inches (1524 mm)	18 inches (457 mm) ⁵
From front	Push	48 inches (1219 mm)	0 inches (0 mm)¹
From hinge side	Pull	60 inches (1524 mm)	36 inches (914 mm)
From hinge side	Push	44 inches (1118 mm) ²	22 inches (559 mm) ³
From latch side	Pull	60 inches (1524 mm)	24 inches (610 mm)
From latch side	Push	44 inches (1118 mm) ⁴	24 inches (610 mm)

1. Add 12 inches (305 mm) if closer and latch are provided.
2. Add 4 inches (102 mm) if closer and latch are provided.
3. Beyond hinge side.
4. Add 4 inches (102 mm) if closer is provided.
5. Add 6 inches (152 mm) at exterior side of exterior doors

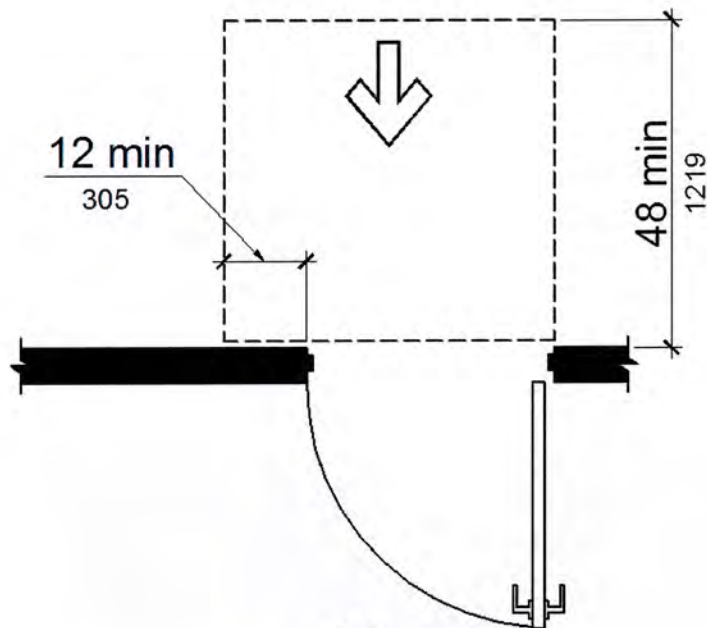

(c)
front approach, push side, door provided with both closer and latch

Upper Level Drinking Fountain

11. Drinking fountain not in alcove.



CBC 11B-602.9 Pedestrian protection. All drinking fountains shall either be located completely within alcoves, positioned completely between wing walls, or otherwise positioned so as not to encroach into pedestrian ways. The protected area within which a drinking fountain is located shall be 32 inches (813 mm) wide minimum and 18 inches (457 mm) deep minimum, and shall comply with Section 11B-305.7. When used, wing walls or barriers shall project horizontally at least as far as the drinking fountain and to within 6 inches (152 mm) vertically from the floor or ground surface.

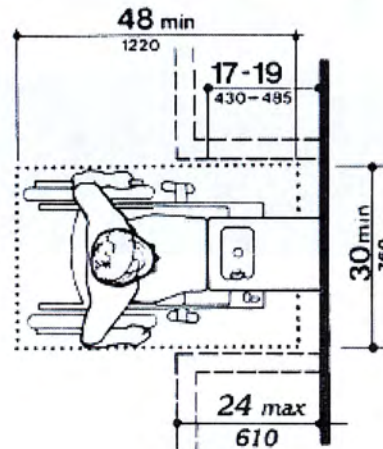

12. ADA requires a high/low style drinking fountain.



ADA 211.211.2 Minimum Number. No fewer than two drinking fountains shall be provided. One drinking fountain shall comply with 602.1 through 602.6 and one drinking fountain shall comply with 602.7.

602.4 Spout Height. Spout outlets shall be 36 inches (915 mm) maximum above the finish floor or ground.

602.7 Drinking Fountains for Standing Persons. Spout outlets of drinking fountains for standing persons shall be 38 inches (965 mm) minimum and 43 inches (1090 mm) maximum above the finish floor or ground.

Library

13. Accessible reception counter requires a 27-inch minimum roll under with a clear floor space.

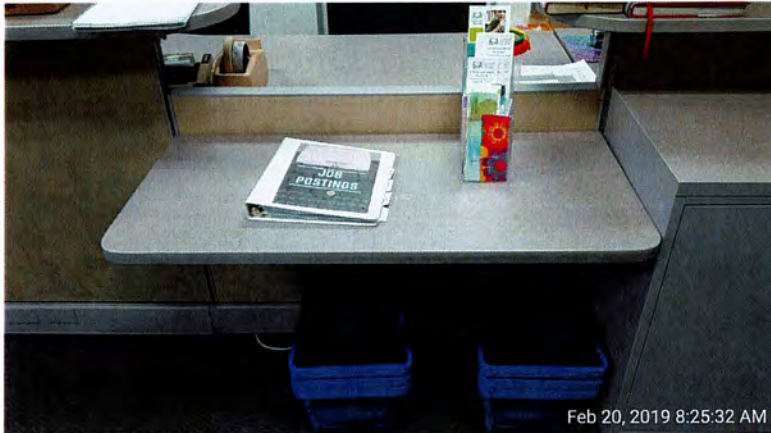

CBC 11B-306.3.3 Minimum required depth. Where knee clearance is required under an element as part of a clear floor space, the knee clearance shall be 11 inches (279 mm) deep minimum at 9 inches (229 mm) above the finish floor or ground, and 8 inches (203 mm) deep minimum at 27 inches (686 mm) above the finish floor or ground.

11B-902.3 Height. The tops of dining surfaces and work surfaces shall be 28 inches (711 mm) minimum and 34 inches (864 mm) maximum above the finish floor or ground.

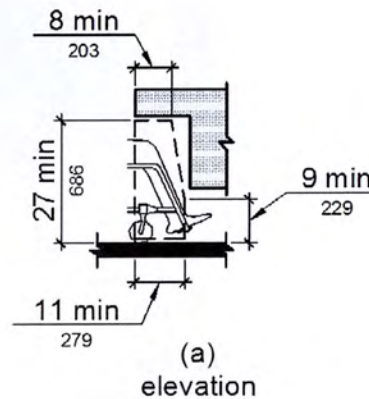

CBC and ADA concur

14. Check aisle widths and reach ranges.



CBC 11B-225.2.3 Library book stacks. Book stacks available for public use shall be 54 inches (1372 mm) maximum above the finish floor.

Exceptions:

1. Book stacks available for public use may be higher than 54 inches (1372 mm) maximum above the finish floor when an attendant is available to assist persons with disabilities.
2. Book stacks restricted to employee use are not required to comply with these requirements.

15. Provide accessible work tables with minimum 27-inch roll under.

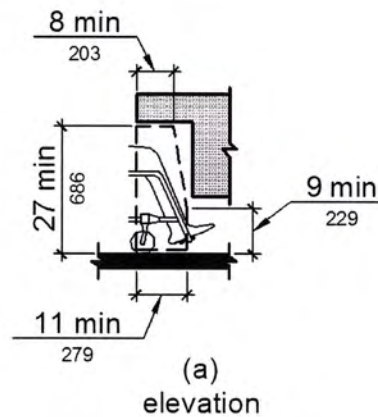

16. Provide tactile exit signs where required.

CBC 1013.4 Raised character and braille exit signs. *Tactile exit signs shall be required at the following locations:*

1. Each grade-level exterior exit door that is required to comply with Section 1013.1, shall be identified by a tactile exit sign with the word, "EXIT"
 2. Each exit door that is required to comply with Section 1013.1, and that leads directly to a grade-level exterior exit by means of a stairway or ramp shall be identified by a tactile exit sign with the following words as appropriate:
 - 2.1. "EXIT STAIR DOWN"
 - 2.2. "EXIT RAMP DOWN"
 - 2.3. "EXIT STAIR UP"
 - 2.4. "EXIT RAMP UP"
 3. Each exit door that is required to comply with Section 1013.1, and that leads directly to a grade-level exterior exit by means of an exit enclosure or an exit passageway shall be identified by a tactile exit sign with the words, "EXIT ROUTE".
 4. Each exit access door from an interior room or area to a corridor or hallway that is required to comply with Section 1013.1, shall be identified by a tactile exit sign with the words "EXIT ROUTE".
 5. Each exit door through a horizontal exit that is required to comply with Section 1013.1, shall be identified by a sign with the words, "TO EXIT".
- Raised character and Braille exit signs shall comply with Chapter 11A, Section 1143A or Chapter 11B, Sections 11B-703.1, 11B-703.2, 11B-703.3 and 11B-703.5.*

CBC 11B-703.4.1 Height above finish floor or ground. *Tactile characters on signs shall be located 48 inches (1219 mm) minimum above the finish floor or ground surface, measured from the baseline of the lowest Braille cells and 60 inches (1524 mm) maximum above the finish floor or ground surface, measured from the baseline of the highest line of raised characters.*

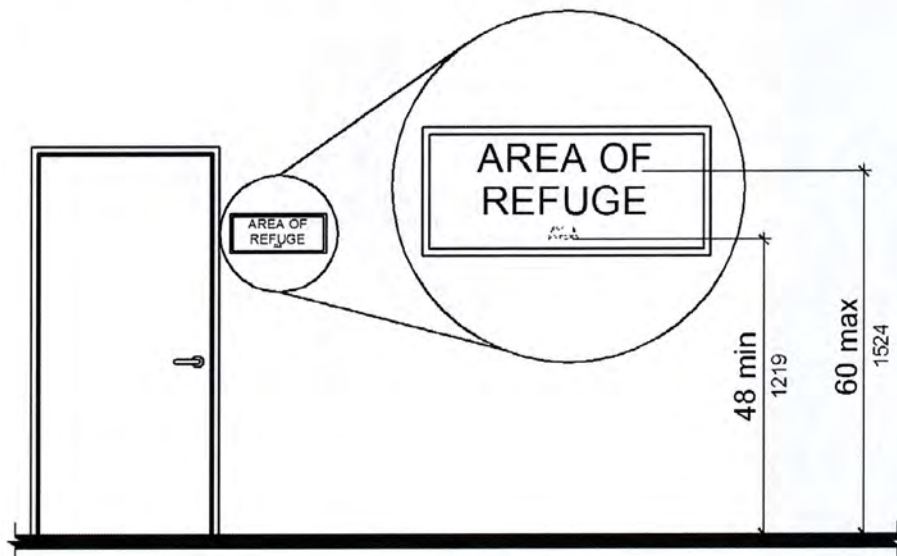

11B-703.4.2 Location. Where a tactile sign is provided at a door, the sign shall be located alongside the door at the latch side. Where a tactile sign is provided at double doors with one active leaf, the sign shall be located on the inactive leaf. Where a tactile sign is provided at double doors with two active leaves, the sign shall be located to the right of the right hand door. Where there is no wall space at the latch side of a single door or at the right side of double doors, signs shall be located on the nearest adjacent wall. Signs containing tactile characters shall be located so that a clear floor space of 18 inches (457 mm) minimum by 18 inches (457 mm) minimum, centered on the tactile characters, is provided beyond the arc of any door swing between the closed position and 45 degree open position. *Where provided, signs identifying permanent rooms and spaces shall be located at the entrance to, and outside of the room or space. Where provided, signs identifying exits shall be located at the exit door when approached in the direction of egress travel.*

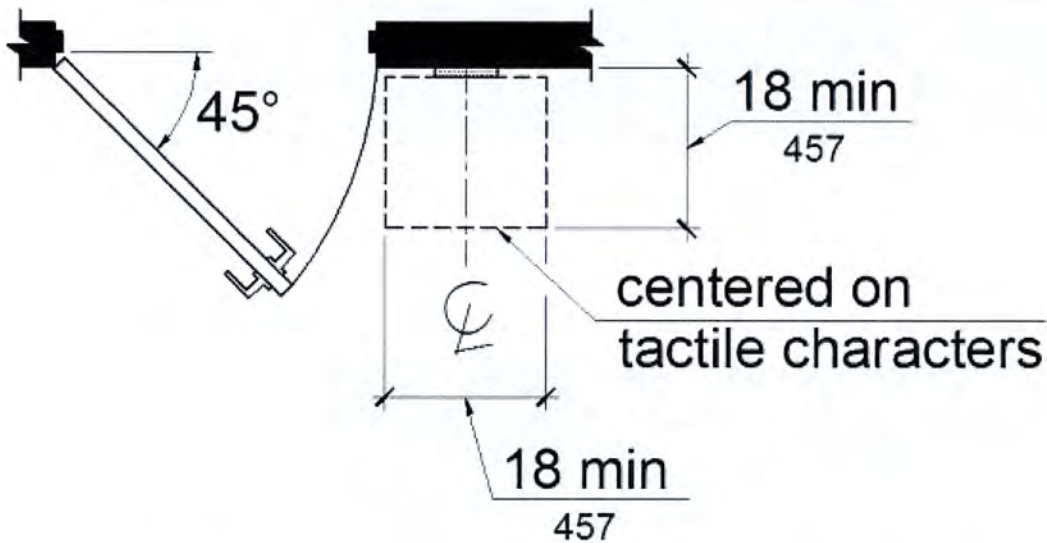

Administrative Office Areas

- 17. "Exit Route" sign at reception to lobby door (strike side). See pages 20 and 21.
- 18. Maintain minimum 36-inch wide passage ways. See diagram and page 11.

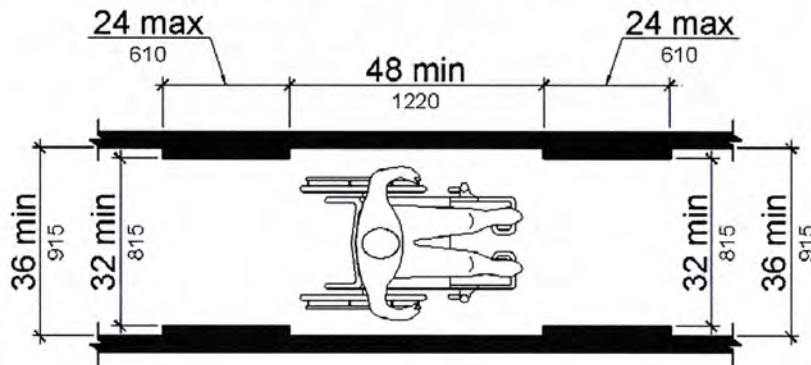

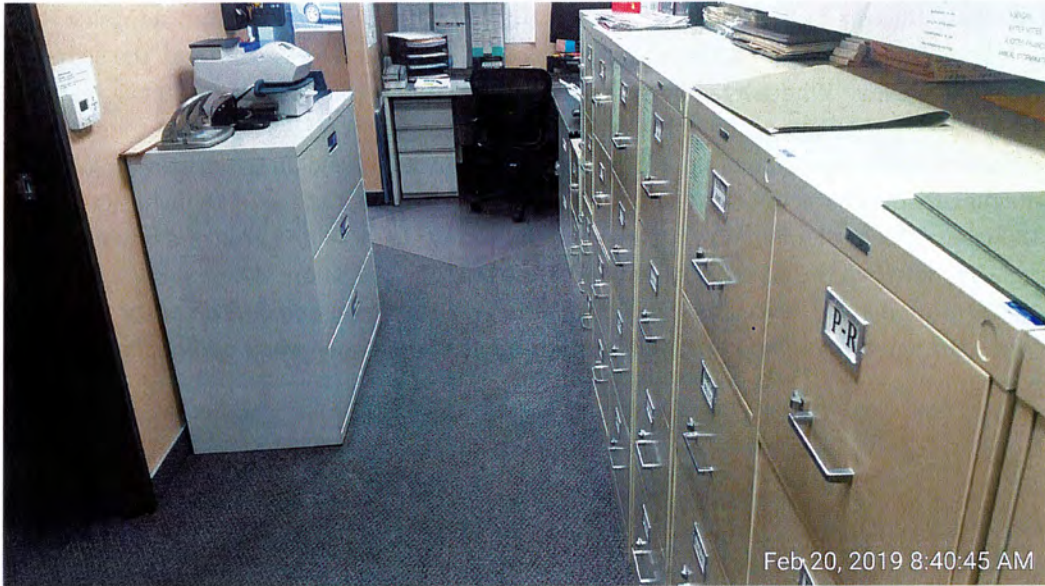

19. Thumbscrew door locks are not accessible. See page 7.

Break Room

20. Clear space “roll-under” required at break room sink area.

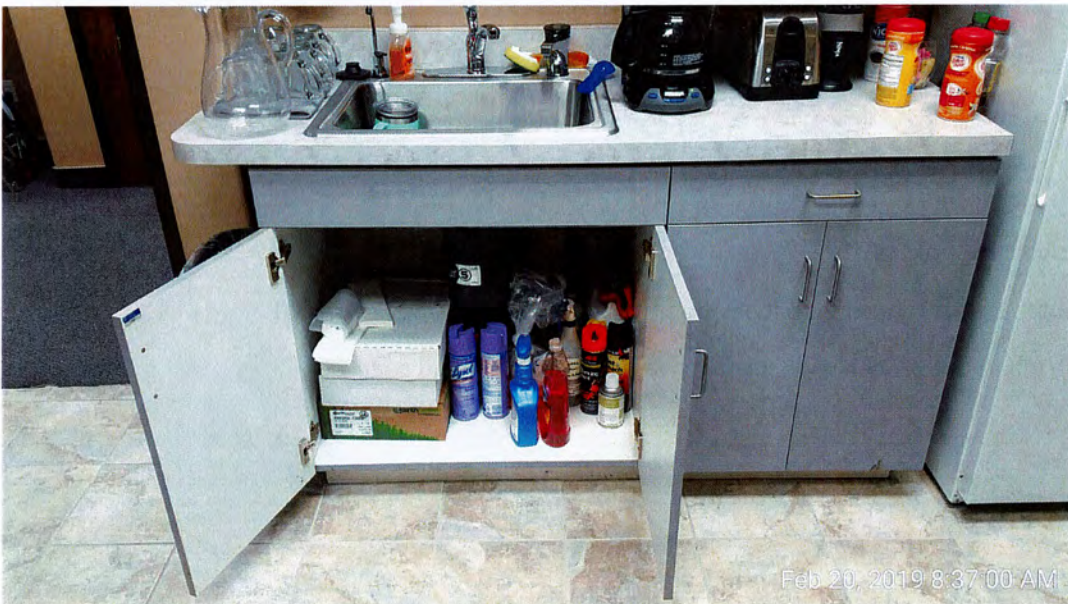

CBC 11B-804.3.1 Clear floor or ground space. A clear floor space complying with *Section 11B-305* positioned for a forward approach shall be provided. The clear floor or ground space shall be centered on the kitchen work surface and shall provide knee and toe clearance complying with *Section 11B-306*. **Exception:** Cabinetry shall be permitted under the kitchen work surface provided that all of the following conditions are met:

- (a) the cabinetry can be removed without removal or replacement of the kitchen work surface;
- (b) the finish floor extends under the cabinetry; and
- (c) the walls behind and surrounding the cabinetry are finished.

CBC 11B-804.3.2 Height. The kitchen work surface shall be 34 inches (864 mm) maximum above the finish floor or ground.

Exception: A counter that is adjustable to provide a kitchen work surface at variable heights, 29 inches (737 mm) minimum and 36 inches (914 mm) maximum, shall be permitted.

21. Maintain appliance reach ranges. (Microwave oven)



11B-308.2 Forward reach.

11B-308.2.1 Unobstructed. Where a forward reach is unobstructed, the high forward reach shall be 48 inches (1219 mm) maximum and the low forward reach shall be 15 inches (381 mm) minimum above the finish floor or ground.

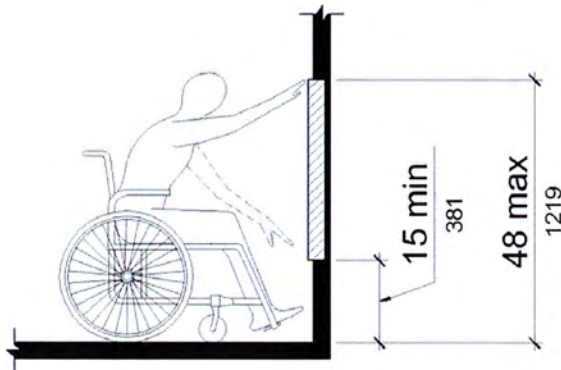

Unobstructed Forward Reach

22. 18-inch minimum strike side clearance required at door.

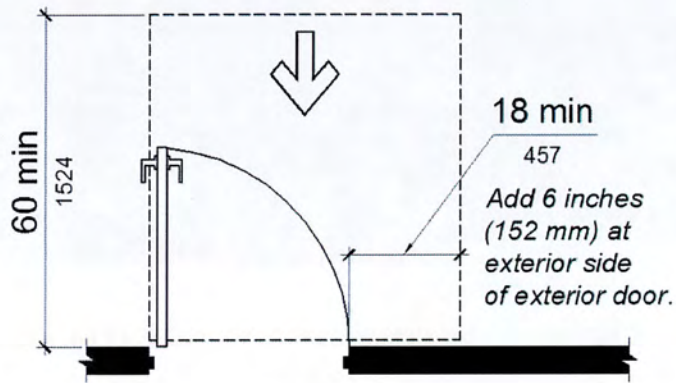
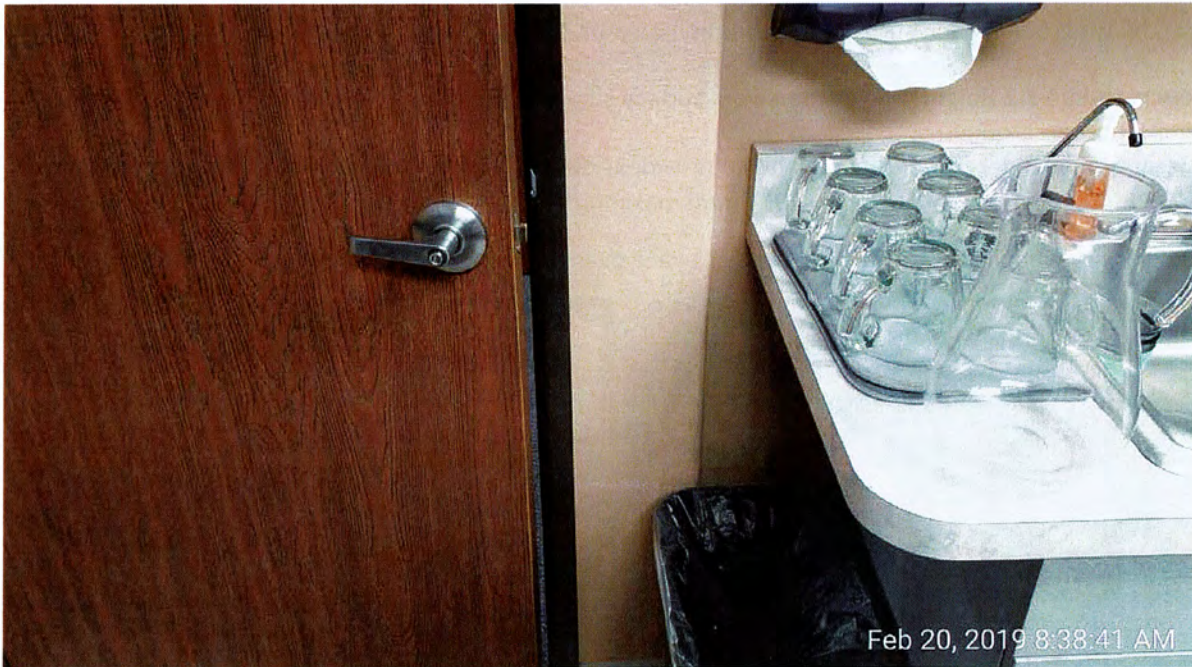

(a)
front approach, pull side

23. Break room table shall be accessible with clear floor area and 27-inch minimum roll under.

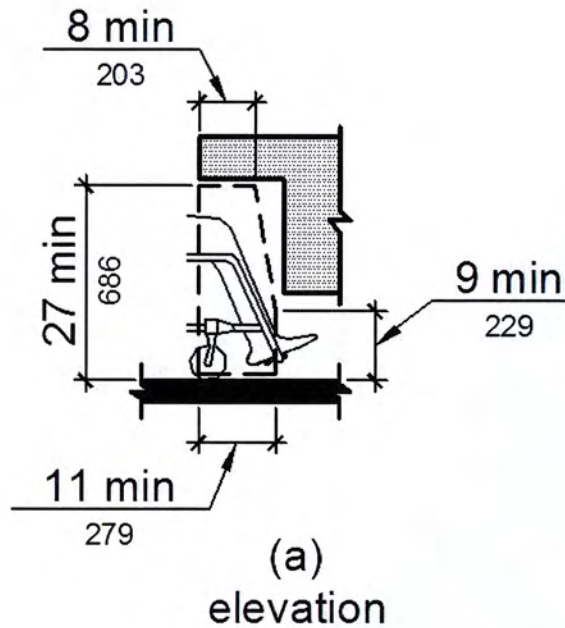

Stairs

24. Inside handrails shall be continuous.



11B-505.3 Continuity. Handrails shall be continuous within the full length of each stair flight or ramp run. Inside handrails on switchback or dogleg stairs and ramps shall be continuous between flights or runs.

25. Contrasting stripe required at top of stairs and bottom tread. (example only)

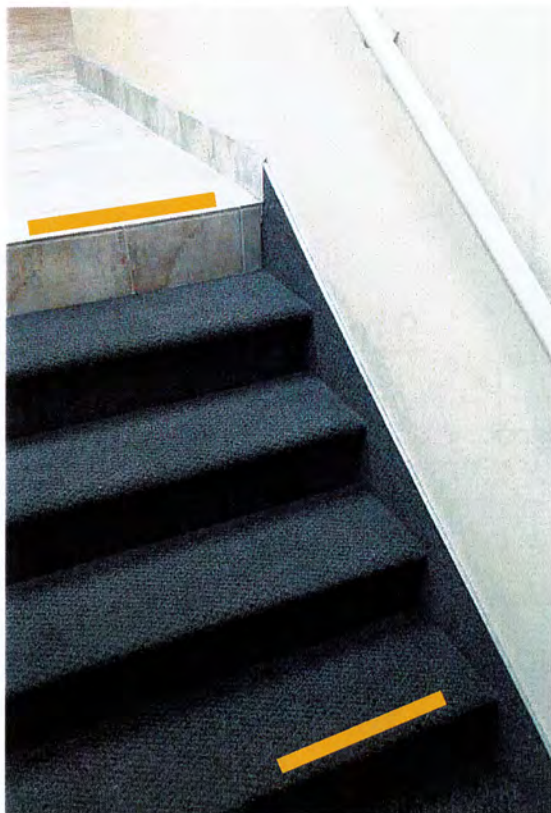

11B-504.4.1 Contrasting stripe. Interior stairs shall have the upper approach and lower tread marked by a stripe providing clear visual contrast. Exterior stairs shall have the upper approach and all treads marked by a stripe providing clear visual contrast. The stripe shall be a minimum of 2 inches (51 mm) wide to a maximum of 4 inches (102 mm) wide placed parallel to, and not more than 1 inch (25 mm) from, the nose of the step or upper approach. The stripe shall extend the full width of the step or upper approach and shall be of material that is at least as slip resistant as the other treads of the stair. A painted stripe shall be acceptable. Grooves shall not be used to satisfy this requirement.

Lower Level

Men's Restroom

26. Grab bar shall extend 24 inches in front of water closet. See page 12.

27. Water closet shall be centered 17-18 inches from finish side wall.



11B-604.2 Location. The water closet shall be positioned with a wall or partition to the rear and to one side. The centerline of the water closet shall be 17 inches (432 mm) minimum to 18 inches (457 mm) maximum from the side wall or partition, except that the water closet shall be 17 inches (432 mm) minimum and 19 inches (483 mm) maximum from the side wall or partition in the ambulatory accessible toilet compartment specified in Section 11B-604.8.2. Water closets shall be arranged for a left-hand or right-hand approach.

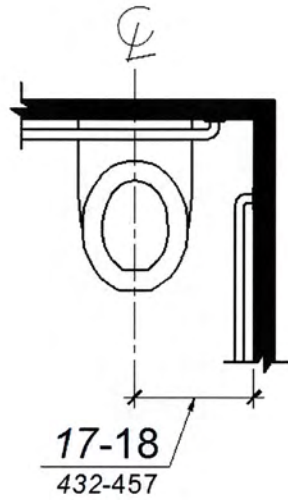

28. Lavatory impinges on required door clearance.



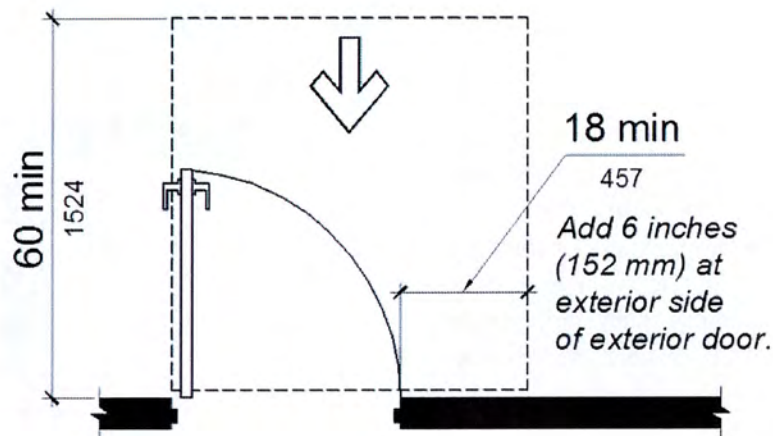

(a)
front approach, pull side

29. Paper towel dispenser reach maximum is 40".



11B-603.5 Accessories. Where towel or sanitary napkin dispensers, waste receptacles, or other accessories are provided in toilet facilities, at least one of each type shall be located on an accessible route. All operable parts, including coin slots, shall be 40 inches (1016 mm) maximum above the finish floor.

30. Toilet paper dispenser dimensions and grab bar extension.

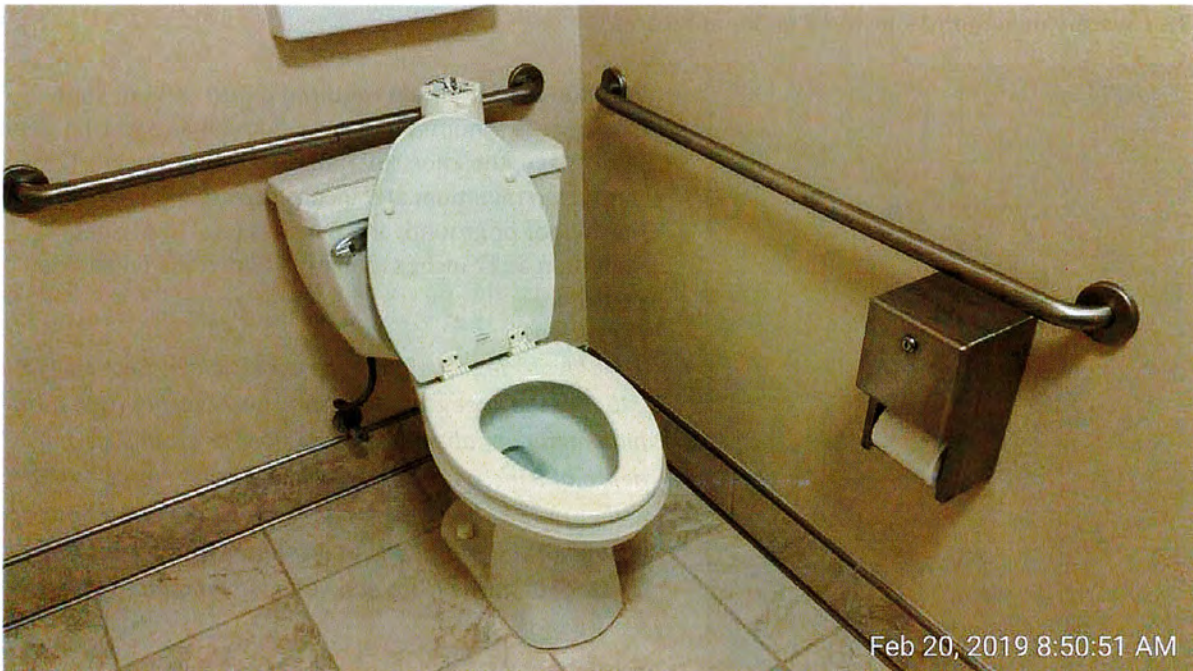

See page 12 and 15.

31. Door signage is not correct.



11B-703.7.2.6.1 Men's toilet and bathing facilities. An equilateral triangle, 1/4 inch (6.4 mm) thick with edges 12 inches (305 mm) long and a vertex pointing upward, shall be located at entrances to men's toilet and bathing facilities. The triangle symbol shall contrast with the door, either light on a dark background or dark on a light background.



Example only

Lower Women's Restroom

32. Lavatory minimum 29-inch roll under at lip area.



11B-306.3.3 Minimum required depth. Where knee clearance is required under an element as part of a clear floor space, the knee clearance shall be 11 inches (279 mm) deep minimum at 9 inches (229 mm) above the finish floor or ground, and 8 inches (203 mm) deep minimum at 27 inches (686 mm) above the finish floor or ground.

Exceptions:

1. At lavatories required to be accessible by Section 11B-213.3.4, the knee clearance shall be 27 inches (686 mm) high minimum above the finish floor or ground at a depth of 8 inches (203 mm) minimum **increasing to 29 inches (737 mm) high minimum above the finish floor or ground at the front edge of a counter with a built-in lavatory or at the front edge of a wall-mounted lavatory fixture**

33. 40- inch maximum reach to soap and paper towel dispensers. See above and page 28.

34. 18-inch minimum strike side clearance at door. See page 24.

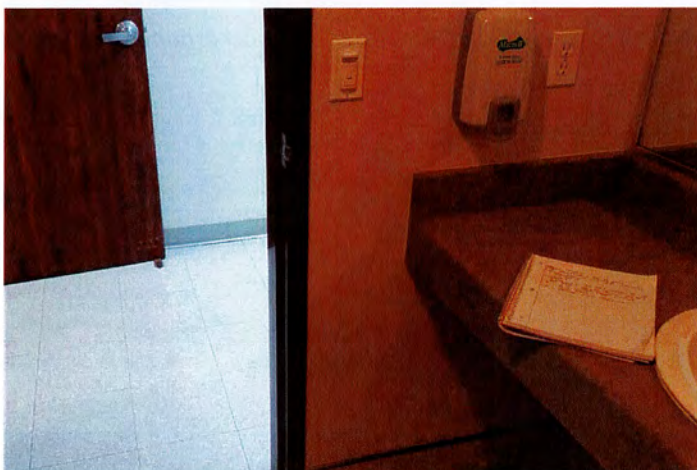

35. Door signage is not correct.

CBC 11B-703.7.2.6.2 Women's toilet and bathing facilities. A circle, 1/4 inch (6.4 mm) thick and 12 inches (305 mm) in diameter, shall be located at entrances to women's toilet and bathing facilities. The circle symbol shall contrast with the door, either light on a dark background or dark on a light background.



Example only

Council Chamber

36. Single dispenser drinking fountain has no alcove. See page 17.

37. Threshold from Council Chambers to stairs appears to be too high.



11B-303.2 Vertical. Changes in level of 1/4 inch (6.4 mm) high maximum shall be permitted to be vertical and without edge treatment.

ADA Level 303.1 General. Where changes in level are permitted in floor or ground surfaces, they shall comply with 303.

303.2 Vertical. Changes in level of $\frac{1}{4}$ inch (6.4 mm) high maximum shall be permitted to be vertical.

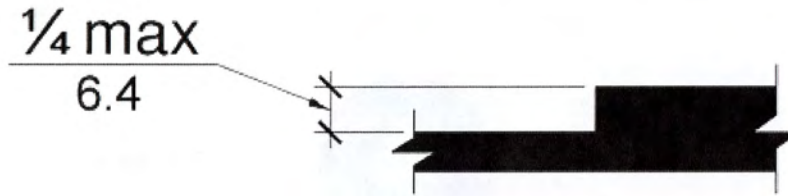

ADA 303.3 Beveled. Changes in level between $\frac{1}{4}$ inch (6.4 mm) high minimum and $\frac{1}{2}$ inch (13 mm) high maximum shall be beveled with a slope not steeper than 1:2.

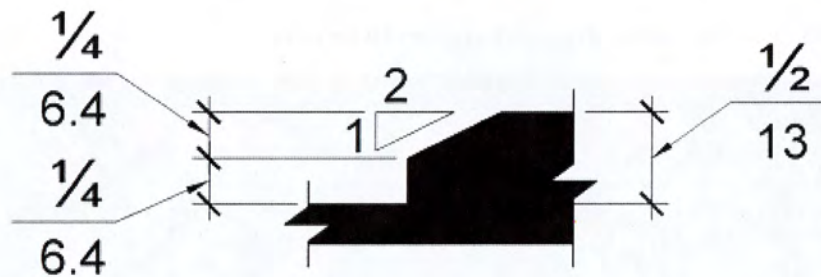

CBC and ADA concur

38. Tactile "Exit" sign to outside missing and Tactile "Exit Stair Up" missing to stairs.



For tactile exit regulations see pages 20 and 21.

Elevator

39. No tactile floor designator at the basement level.



11B-411.2.3.1 Floor designation signs. Floor designation signs complying with Sections 11B-703.2 and 11B-703.4.1 shall be provided on both jambs of elevator hoistway entrances. Signs shall be provided in **both raised characters and Braille**. Raised characters shall be 2 inches (51 mm) high. A raised star placed to the left of the floor designation, shall be provided on both jambs at the main entry level. The outside diameter of the star shall be 2 inches (51 mm) and all points shall be of equal length. Raised characters, including the star, shall be white on a black background. Braille complying with Section 11B-703.3 shall be placed below the corresponding raised characters and the star. The Braille translation for the star shall be "MAIN". Applied plates are acceptable if they are permanently fixed to the jamb.

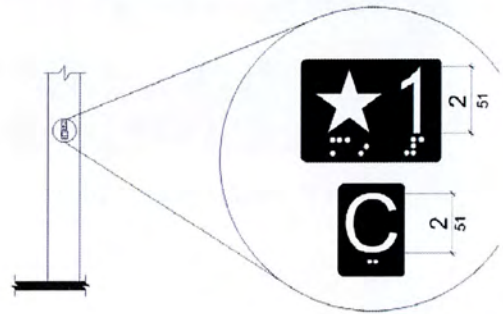

Main Entrance Door

40. Exterior landing at front entry exceeds 1:48 (1/4 inch per foot)



11B-404.2.4.4 Floor or ground surface. Floor or ground surface within required maneuvering

clearances shall comply with Section 11B-302. Changes in level are not permitted.

Exceptions:

1. Slopes not steeper than 1:48 shall be permitted.



41. Pull force at main entry door exceeds 5 pounds of pressure.

11B-404.2.9 Door and gate opening force. The force for pushing or pulling open a door or gate shall be as follows: *Exterior hinged doors: 5 pounds (22.2 N) maximum*

42. Tactile "Exit" sign missing at main entry door. (For tactile exit regulations see pages 20 and 21.)

Lower Level Exit Door

No comment except as mentioned in item 38. (For tactile exit regulations see pages 20 and 21.)

Power Point to be presented at the meeting.

**City of Canyon Lake
City Council
Staff Report**

TO: Honorable Mayor and Members of the City Council

FROM: Chris Mann, City Manager

DATE: August 7, 2019

SUBJECT: Adoption of Resolution No. 2019-25, Amending the Pass-Through Convenience Fees for Credit Card Payments at City Hall and Eliminating the Charge Limit

CM

Recommendation

It is recommended that the City Council approve Resolution No. 2019-25, amending the pass-through convenience fees for credit card payments at City Hall and eliminating the charge limit.

Background

On July 1, 2015, the City Council adopted a pass-through convenience fee for credit card transactions at City Hall of \$3.00, as well as a maximum amount allowed payable by credit card of \$1,500.00, which would be evaluated after 6-months of operating.

On February 3, 2016, the City Council reviewed an analysis of transactions and determined that the City was not fully recovering all fees charged by the credit card processing company.

In an attempt to correct this situation, on March 2, 2016, the City Council adopted revised pass-through convenience fees for credit card transactions at City Hall of \$3.00 for transactions up to \$100.00 and \$6.00 for transactions over \$100.00. In addition, the maximum amount allowed payable by credit card was reduced from \$1,500.00 to \$300.00.

Over the past few months, the City has been transitioning from software provided by Charles Abbott to iWorQ. Staff is now ready to transition from the Square credit card processing system to Payroc, which works in conjunction with iWorQ. Unlike Square, which charged transaction fees to the City, the Payroc system charges customers directly for those fees. Currently those transaction fees are set at 3.5% of the total transaction amount. The City would no longer charge the convenience fees of \$3.00 and \$6.00, as the exact cost of credit card processing would be covered by the customer through the Payroc system. The customer will be informed of the fee prior to authorizing the charge. Should a customer wish to avoid paying the credit card transaction fee, the City also accepts payments via check or cash.

Government Code section 6159(h) expressly authorizes the City to adopt a fee on the use of a credit or debit card for the payments to the City, so long as the fee does not exceed the costs incurred by the City in providing for the payment by credit or debit card.

Fiscal Impact

Minimal fiscal impact anticipated. Slight savings to the General Fund probable.

Attachments

1. Resolution No. 2019-25

ATTACHMENT 1

RESOLUTION 2019-25

A RESOLUTION OF THE CITY COUNCIL OF THE CITY OF CANYON LAKE AMENDING THE PASS-THROUGH CONVENIENCE FEES FOR CREDIT OR DEBIT CARD PAYMENTS AT CITY HALL AND ELIMINATING THE CHARGE LIMIT

WHEREAS, pursuant to the provisions of the California Constitution and the laws of the State of California, the City of Canyon Lake is authorized to adopt and implement pass-through charges for municipal services; provided, however, that such charges do not exceed the estimated reasonable cost of providing such services; and

WHEREAS, the City Council of the City of Canyon Lake desires to make credit and debit card payment options available to the public for convenience; and

WHEREAS, on July 1, 2015, the City Council adopted a pass-through convenience fee for credit card transactions at City Hall of \$3.00, as well as a maximum amount allowed payable by credit card of \$1,500.00, which would be evaluated after 6-months of operating; and

WHEREAS, on March 2, 2016, the City Council adopted revised pass-through convenience fees for credit card transactions at City Hall of \$3.00 for transactions up to \$100.00 and \$6.00 for transactions over \$100.00, as well as a revised maximum amount allowed payable by credit card of \$300.00; and

WHEREAS, the City has transitioned to new software and a new credit card processing system which passes along to customers the exact amount of transaction fees associated with accepting credit card payments (currently 3.5% of the total transaction amount); and

WHEREAS, pursuant to Government Code section 6159, the City Council must approve the City's acceptance of credit or debit cards for payment; and

WHEREAS, pursuant to Government Code section 6159, the City is expressly authorized to impose a fee for the use of a credit or debit card for payment so long as the fee does not exceed the costs incurred by the City in providing for the payment by credit or debit card; and

WHEREAS, the City Council of the City of Canyon Lake finds that this approval of a charge is for the purposes of meeting operating expenses, related to use of credit cards, in that this charge directly reimburses the City for expenses required to process the activity for which the charge is imposed. Accordingly, this action is exempt from CEQA under the provisions of Section 21080 (b) of 8 of the Public Resources Code, and Section 15273 of the CEQA guidelines; and

WHEREAS, all legal prerequisites to the adoption of this Resolution have occurred.

///

///

NOW, THEREFORE, THE CITY COUNCIL OF THE CITY OF CANYON LAKE RESOLVES AND ORDERS AS FOLLOWS:

SECTION 1. CHARGE ESTABLISHED AND ADOPTED

A. As set forth above, the City Council of the City of Canyon Lake hereby authorizes the City to provide for payment to the City by credit or debit card, and further finds and determines that, based upon the data, information, analysis, oral and written documentation presented to this City Council, the charge shall be set at 3.5% of the total transaction amount, or such other percentage as may be charged to the City by the credit card processing vendor in the future, so long as such fee does not exceed the costs incurred by the City in providing for payment by credit or debit card.

B. There shall be no City-established limit to the amount allowed payable by credit or debit card.

C. The fees set forth, hereby are adopted and approved as the fees for providing the use of credit or debit cards at City Hall.

SECTION 2. EFFECTIVE DATE

A. The fees set forth shall be effective immediately after the adoption of this Resolution.

PASSED, APPROVED, AND ADOPTED this 7th day of August 2019.

Larry Greene, Mayor

ATTEST:

Ana V. Sauseda, Deputy City Clerk

State of California
County of Riverside) ss
City of Canyon Lake)

I, Ana V. Sauseda, Deputy City Clerk of the City of Canyon Lake, California, DO HEREBY CERTIFY, that the foregoing is a true and correct copy of the Resolution No. 2019-25 adopted by the City Council of the City of Canyon Lake, California, at a regular meeting thereof, held on August 7, 2019, by the following vote:

AYES:

NOES:

ABSTAIN:

ABSENT:

Ana V. Sauseda, Deputy City Clerk

**City of Canyon Lake
City Council
Staff Report**

TO: Honorable Mayor and Members of the City Council

FROM: Chris Mann, City Manager

DATE: August 7, 2019

SUBJECT: Adoption of Resolution 2019-26, Declaring a City-Owned Vessel and Trailer to be Surplus, and Authorizing the City Manager to Execute a Sale Agreement with the Canyon Lake Property Owners Association CM

Recommendation

That the City Council adopt Resolution 2019-26, declaring a City-owned 2005 Champion 19 Sea Champ boat, Hull Identification Number (“HIN”) GCB9S113J405, and trailer to be surplus, finding that disposition of the vessel and trailer by sale to the Canyon Lake Property Owners Association (POA) to be in the best interests of the City, and authorizing the City Manager to execute a sale agreement with the POA.

Background

In February of 2006, the City purchased two 2005 Champion 19-foot Sea Champ boats with Mercury Marine 150 HP outboard motors. The City has used these boats to patrol and enforce city ordinances in the portion of Canyon Lake commonly referred to as the “North Lake.” The boats have also been used by the City to assist POA Marine Patrol on holidays that attract increased boating activity, such as the Fourth of July. More recently, the boats have also been utilized for diplomatic purposes, as City officials have incorporated the boats into tours of the City.

In recent months it has become evident that the needs of the City have shifted. City enforcement personnel are using the boats less often and have indicated that one boat would be sufficient for most enforcement activities. At the same time, as the City Council has identified improving regional relationships and seeking economic development as major goals, there are increased opportunities to use a boat for diplomatic purposes.

At the budget workshop held on May 8th, 2019, staff suggested that the City consider selling one of the boats and applying the proceeds toward the purchase of a boat that would be more conducive to the increased diplomatic needs of the City. That suggestion was met with a positive response from the Council. Therefore, the Fiscal Year 2019-2020 budget, which was adopted by the Council on June 5th, 2019, included \$18,000, to be added to the proceeds of the sale of one of the boats, for the purchase of a replacement boat.

Staff is recommending that the City move forward with the plan as outlined above. City staff has prepared one of the boats (HIN: GCB9S113J405) for sale and is in the process of determining fair

market value. The enforcement lights have been removed, as have the City logo and enforcement lettering. The PA system will remain with the boat and has been returned to working condition.

While the City could pursue a number of avenues for selling the boat, the POA has expressed an interest in purchasing it for use by their Marine Patrol. Given that enhancing the City's relationship with the POA is an adopted goal of the Council, staff recommends that the City Manager be authorized to enter into negotiations with the POA, and that, if the City Manager successfully negotiates a sales price that provides maximum return to the City, the City Manager be authorized to execute a sale agreement with the POA, along with any other documents necessary to effectuate the sale.

Fiscal Impact

The sale of the boat will result in General Fund revenue. The amount of revenue will be determined by the negotiated sales price. That revenue will then be applied toward the purchase of a replacement boat better suited to the current needs of the City.

Attachments

1. Resolution No. 2019-26
2. Photographs of Boat and Trailer

ATTACHMENT 1

RESOLUTION NO. 2019-26

A RESOLUTION OF THE CITY COUNCIL OF THE CITY OF CANYON LAKE DECLARING A 2005 CHAMPION 19 SEA CHAMP VESSEL AND TRAILER TO BE SURPLUS, FINDING THAT DISPOSITION OF THE VESSEL AND TRAILER BY SALE TO THE CANYON LAKE PROPERTY OWNERS ASSOCIATION (“POA”) TO BE IN THE BEST INTEREST OF THE CITY, AND AUTHORIZING THE CITY MANAGER TO EXECUTE A SALE AGREEMENT WITH THE POA

WHEREAS, the City currently owns two 2005 Champion 19 Sea Champ vessels and trailers used for various City purposes; and,

WHEREAS, pursuant to Government Code section 37350, “[a] city may ... dispose of [property] for the common benefit” and pursuant to Government Code section 37351, “[t]he legislative body may ... dispose of, and convey such property for the benefit of the City.”

NOW, THEREFORE, THE CITY COUNCIL OF THE CITY OF CANYON LAKE RESOLVES AND ORDERS AS FOLLOWS:

SECTION 1. That the 2005 Champion 19 Sea Champ vessel with Hull Identification Number (“HIN”) GCB9S113J405 (“Surplus Vessel”) and trailer, are declared surplus, and the City Council finds that it would be in the public interest and for the common benefit to dispose of the Surplus Vessel and trailer by negotiated sale to the Canyon Lake Property Owners Association (“POA”). The City Manager is authorized and directed to negotiate the sale of the Surplus Vessel and trailer to the POA at a sale price that provides maximum return to the City.

SECTION 2. If the City Manager successfully negotiates a sales price that provides maximum return to the City, then the City Manager is authorized to execute a sale agreement with the POA for the Surplus Vessel and trailer in a form acceptable to the City Attorney, along with any other documents necessary to effectuate the sale.

SECTION 3. If the City Manager is unable to negotiate a sale price with the POA, or if the POA does not purchase the Surplus Vessel and trailer for any other reason, then the City Manager is authorized to dispose of the Surplus Vessel and trailer in the manner authorized by Canyon Lake Municipal Code section 3.08.320.

∥∥
∥∥
∥∥
∥∥
∥∥

SECTION 4. The City Manager shall report the terms of the sale of the Surplus Vessel and trailer, whether under Sections 2 or 3 above, to the Finance Committee within 45 days of sale.

PASSED, APPROVED, AND ADOPTED this 7th day of August 2019.

Larry Greene, Mayor

Attest:

Ana V. Sauseda, Deputy City Clerk

State of California
County of Riverside) ss
City of Canyon Lake)

I, Ana V. Sauseda, Deputy City Clerk of the City of Canyon Lake, California, DO HEREBY CERTIFY, that the foregoing is a true and correct copy of the Resolution No. 2019-26 adopted by the City Council of the City of Canyon Lake, California, at a regular meeting thereof, held on August 7, 2019, by the following vote:

AYES:

NOES:

ABSTAIN:

ABSENT:

Ana V. Sauseda, Deputy City Clerk

ATTACHMENT 2



City of Canyon Lake
City Council
Staff Report

TO: Honorable Mayor and Members of the City Council

FROM: Chris Mann, City Manager

DATE: August 7, 2019

SUBJECT: Resolution No. 2019-27 and Resolution No. 2019-28 – Authorizing the City Manager to Submit Letters of Interest to the United States Department of the Interior Bureau of Land Management (BLM) Indicating the City’s Desire to Acquire Two Parcels Currently Managed by the BLM

CM

Recommendation

It is recommended that the City Council approve Resolution No. 2019-27 and Resolution No. 2019-28, authorizing the City Manager to submit letters of interest to the United States Department of the Interior Bureau of Land Management (BLM) indicating the City’s desire to acquire two parcels (APN: 349-200-012 and APN: 349-290-003) which are currently managed by the BLM.

Background

For several years, the City has discussed pursuing the acquisition of two parcels of public land currently managed by the BLM. These parcels are located within the boundaries of the City, and represent two of only a few remaining areas of the City that could potentially be utilized for economic growth.

On June 19th, 2019, the City Manager met with Doug Herrema, the BLM Field Manager assigned to the region that includes the City of Canyon Lake. Mr. Herrema provided an update of the discussions that have taken place between the City and the BLM in the past, an overview of some of the preliminary work that has been done on the parcels in question, and a summary of what steps could be taken by the City in order to move the process forward.

The first step the City must take to officially begin the process of acquiring land from the BLM is to submit a letter of interest. The letter must indicate the parcels in question, the land uses contemplated by the City, and how the transfer of the property from the BLM to the City would benefit all involved.

City staff has prepared draft letters of interest (one for each parcel in question) for the Council’s consideration, and is asking for authorization to submit the letters to the BLM. In passing Resolution No. 2019-27 and Resolution No. 2019-28, the City would be officially signaling to the

BLM, and to all stakeholders, that it is the City's intention to acquire the parcels in question and to develop portions of those parcels in order to achieve the important public objectives of community expansion and economic development.

Fiscal Impact

No fiscal impact at this time.

Attachments

1. Resolution No. 2019-27
2. Resolution No. 2019-28
3. Draft Letters of Interest for APN 349-200-012 and APN 349-290-003
4. Map of Parcels in Question

ATTACHMENT 1

RESOLUTION NO. 2019-27

A RESOLUTION OF THE CITY COUNCIL OF THE CITY OF CANYON LAKE, AUTHORIZING THE CITY MANAGER TO SUBMIT A LETTER OF INTEREST TO THE UNITED STATES DEPARTMENT OF THE INTERIOR BUREAU OF LAND MANAGEMENT INDICATING THE CITY'S DESIRE TO ACQUIRE PUBLIC LAND KNOWN AS ASSESSOR'S PARCEL NUMBER 349-200-012

WHEREAS, the United States Department of the Interior Bureau of Land Management currently manages public land known as Assessor's Parcel Number 349-200-012, located within the boundaries of the City of Canyon Lake; and

WHEREAS, the City of Canyon Lake has determined that acquisition of the parcel in question is critical for future community expansion and economic development; and

WHEREAS, members of the City Council and the City Manager of the City of Canyon Lake have met with representatives of the Bureau of Land Management in order to express an interest in acquiring the parcel in question and to discuss the steps required to effect a direct sale; and

WHEREAS, the City Council of the City of Canyon Lake formally identified the acquisition of the property known as Assessor's Parcel Number 349-200-012 from the Bureau of Land Management as a top priority at the May 8, 2019, Special Meeting of the City Council.

NOW, THEREFORE, THE CITY COUNCIL OF THE CITY OF CANYON LAKE RESOLVES AND ORDERS AS FOLLOWS:

Section 1. The City Manager is directed to pursue acquisition of the public land known as Assessor's Parcel Number 349-200-012, and is authorized to submit a letter of interest to the United States Department of the Interior Bureau of Land Management.

Section 2. The City Clerk shall certify to the adoption of this Resolution.

PASSED, APPROVED AND ADOPTED the 7th day of August 2019.

Larry Greene, Mayor

ATTEST:

Ana V. Sauseda, Deputy City Clerk

ATTACHMENT 2

RESOLUTION NO. 2019-28

A RESOLUTION OF THE CITY COUNCIL OF THE CITY OF CANYON LAKE, AUTHORIZING THE CITY MANAGER TO SUBMIT A LETTER OF INTEREST TO THE UNITED STATES DEPARTMENT OF THE INTERIOR BUREAU OF LAND MANAGEMENT INDICATING THE CITY'S DESIRE TO ACQUIRE PUBLIC LAND KNOWN AS ASSESSOR'S PARCEL NUMBER 349-290-003

WHEREAS, the United States Department of the Interior Bureau of Land Management currently manages public land known as Assessor's Parcel Number 349-290-003, located within the boundaries of the City of Canyon Lake; and

WHEREAS, the City of Canyon Lake has determined that acquisition of the parcel in question is critical for future community expansion and economic development; and

WHEREAS, members of the City Council and the City Manager of the City of Canyon Lake have met with representatives of the Bureau of Land Management in order to express an interest in acquiring the parcel in question and to discuss the steps required to effect a direct sale; and

WHEREAS, the City Council of the City of Canyon Lake formally identified the acquisition of the property known as Assessor's Parcel Number 349-290-003 from the Bureau of Land Management as a top priority at the May 8, 2019, Special Meeting of the City Council.

NOW, THEREFORE, THE CITY COUNCIL OF THE CITY OF CANYON LAKE RESOLVES AND ORDERS AS FOLLOWS:

Section 1. The City Manager is directed to pursue acquisition of the public land known as Assessor's Parcel Number 349-290-003, and is authorized to submit a letter of interest to the United States Department of the Interior Bureau of Land Management.

Section 2. The City Clerk shall certify to the adoption of this Resolution.

PASSED, APPROVED AND ADOPTED the 7th day of August 2019.

Larry Greene, Mayor

ATTEST:

Ana V. Sauseda, Deputy City Clerk

ATTACHMENT 3



CITY OF CANYON LAKE

August 7, 2019

Mr. Douglas J. Herrema, J.D.
Field Manager, Bureau of Land Management
Palm Springs – South Coast Field Office
1201 Bird Center Drive
Palm Springs, CA 92262

RE: LETTER OF INTEREST TO PURCHASE PUBLIC LAND (APN: 349-200-012) CURRENTLY
MANAGED BY THE U.S. DEPARTMENT OF THE INTERIOR BUREAU OF LAND MANAGEMENT

Dear Mr. Herrema:

At its regularly scheduled meeting held on August 7th, 2019, the City Council of the City of Canyon Lake adopted Resolution No. 2019-27, authorizing me to submit this letter of interest to you, indicating our desire to acquire a parcel of public land (APN: 349-200-012) currently managed by the BLM.

This parcel is located within the boundaries of the City of Canyon Lake, and is one of only a few remaining areas in the City that could potentially be utilized for community expansion and economic development. Without adequate land resources, the City has struggled in recent years to address fiscal challenges that could be solved through economic development, and to meet State of California requirements to provide for additional housing. In addition, City resources have been increasingly required in order to ensure public safety on the BLM managed parcels within the City. Lastly, the City believes that the parcel in question is a tremendous asset within the community which could be maximized for the benefit of the City, the BLM, and the community as a whole.

As the City has limited options for economic growth, and perhaps no other opportunities for community expansion, acquiring the parcel in question has become a top priority for the City and was officially established as a goal by the City Council at a special goals setting meeting held on May 8th, 2019. The City intends to utilize the parcel in question for a combination of residential and open space uses. This will allow the City to expand revenues derived from property taxes, franchise fees, the utility users tax, development fees and business licenses. It will also allow the City to better maintain and patrol the portions of this parcel that will be preserved as open space for habitat conservation, and to enhance recreational opportunities such as hiking, fishing and horseback riding, making them more accessible to the public.

In addition, while the City and the Canyon Lake Property Owners Association have been helping to patrol and clean-up this parcel for several years, unlawful activities such as dumping, camping, off-roading, creating fires and launching personal watercraft have steadily increased as surrounding communities continue to develop. The BLM would benefit from having this responsibility and liability shifted

31516 Railroad Canyon Road, Canyon Lake, CA 92587 · 951-244-2955 · FAX 951-246-2022



CITY OF CANYON LAKE

completely to the City, which is better positioned geographically and has the staffing to more thoroughly patrol and maintain the land.

Through the City Council's adoption of Resolution 2019-27, the City of Canyon Lake is officially indicating its desire to acquire the parcel in question (APN: 349-200-012) from the BLM. We respectfully request that the BLM proceed as expeditiously as possible with the established procedures for a direct purchase.

We appreciate the ongoing positive relationship the City has shared with the BLM, and look forward to working with you throughout this process.

Sincerely,

Chris Mann
City Manager



CITY OF CANYON LAKE

August 7, 2019

Mr. Douglas J. Herrema, J.D.
Field Manager, Bureau of Land Management
Palm Springs – South Coast Field Office
1201 Bird Center Drive
Palm Springs, CA 92262

RE: LETTER OF INTEREST TO PURCHASE PUBLIC LAND (APN: 349-290-003) CURRENTLY
MANAGED BY THE U.S. DEPARTMENT OF THE INTERIOR BUREAU OF LAND MANAGEMENT

Dear Mr. Herrema:

At its regularly scheduled meeting held on August 7th, 2019, the City Council of the City of Canyon Lake adopted Resolution No. 2019-28, authorizing me to submit this letter of interest to you, indicating our desire to acquire a parcel of public land (APN: 349-290-003) currently managed by the BLM.

This parcel is located within the boundaries of the City of Canyon Lake, and is one of only a few remaining areas in the City that could potentially be utilized for community expansion and economic development. Without adequate land resources, the City has struggled in recent years to address fiscal challenges that could be solved through economic development, and to meet State of California requirements to provide for additional housing. In addition, City resources have been increasingly required in order to ensure public safety on the BLM managed parcels within the City. Lastly, the City believes that the parcel in question is a tremendous asset within the community which could be maximized for the benefit of the City, the BLM, and the community as a whole.

As the City has limited options for economic growth, and perhaps no other opportunities for community expansion, acquiring the parcel in question has become a top priority for the City and was officially established as a goal by the City Council at a special goals setting meeting held on May 8th, 2019. The City intends to utilize the parcel in question for a mixed use of residential, boutique hotel resort and spa, and community facilities. This will allow the City to expand revenues derived from property taxes, franchise fees, the utility users tax, development fees, business licenses, transient occupancy tax and sales tax. It will also allow the City to provide greatly enhanced amenities for the public, such as restaurants, meeting facilities, boat and RV storage, and potentially both passive and active parks. The acquisition and development of this parcel will also help the City to comply with State of California mandates pertaining to current and future housing needs.

In addition, while the City and the Canyon Lake Property Owners Association have been helping to patrol and clean-up this parcel for several years, unlawful activities such as dumping, camping, off-roading, creating fires and launching personal watercraft have steadily increased as surrounding communities



CITY OF CANYON LAKE

continue to develop. The BLM would benefit from having this responsibility and liability shifted completely to the City, which is better positioned geographically and has the staffing to more thoroughly patrol and maintain the land.

Through the City Council's adoption of Resolution 2019-28, the City of Canyon Lake is officially indicating its desire to acquire the parcel in question (APN: 349-290-003) from the BLM. We respectfully request that the BLM proceed as expeditiously as possible with the established procedures for a direct purchase.

We appreciate the ongoing positive relationship the City has shared with the BLM, and look forward to working with you throughout this process.

Sincerely,

Chris Mann
City Manager

ATTACHMENT 4

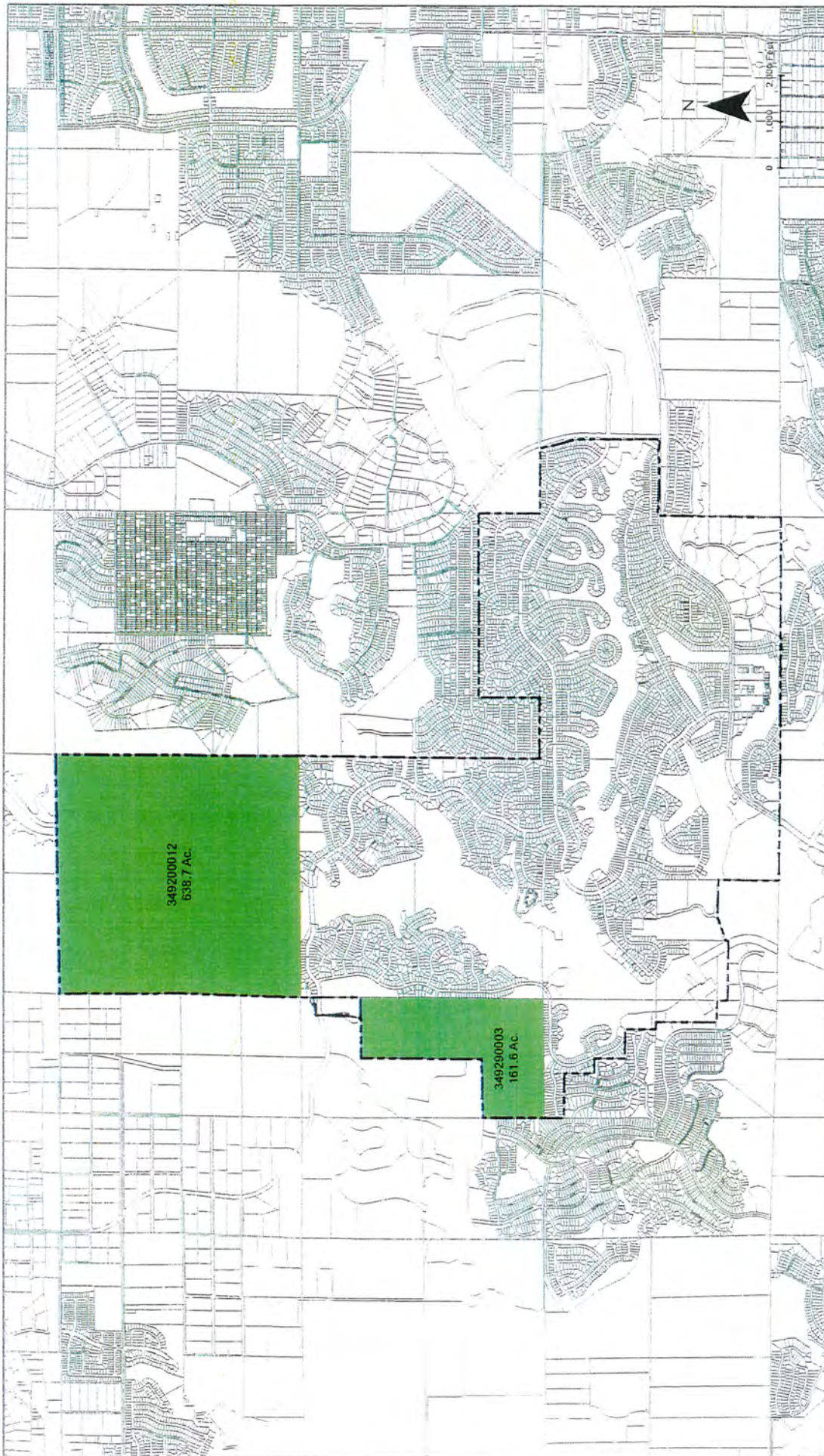

Assessor Parcels

CITY OF CANYON LAKE

**City of Canyon Lake
City Council
Staff Report**

TO: Honorable Mayor and Members of the City Council

FROM: Chris Mann, City Manager

DATE: August 7, 2019

SUBJECT: Adoption of Resolution No. 2019-29, Approving Annual Rate Adjustment and Confirmation of Collection of Residential Solid Waste Charges on the Tax Rolls *CM*

Recommendation:

Conduct a public hearing and adopt Resolution No. 2019-29, approving the annual rate adjustment for all solid waste services and placement of residential solid waste fees on the tax roll for collection for the 2019-2020 fiscal year.

Background:

As provided in the contract with CR&R, the City's franchise solid waste hauler, there are automatic pass through components to the rate based on the actual cost of providing the service, including adjustments tied to the Consumer Price Index (CPI), and County landfill (disposal) costs. In a letter from CR&R Senior Regional Vice President J. Alex Braicovich dated April 30, 2019, CR&R is requesting an Annual Price Adjustment for residential standard service of \$0.25 per month to cover a CPI increase of 1.37%, and an increase of \$0.16 per month to cover a higher disposal rate charged by the Riverside County Landfill.

In addition to these standard rate adjustments, CR&R is also requesting an "extraordinary adjustment" to residential rates of \$0.54 per month. The stated reason for the extraordinary adjustment is to offset loss of revenue caused by China's import ban on recyclables, which has triggered plummeting values for recyclable materials. This adjustment will be reviewed each year. If recycling markets are restored in the future, this fee would be reduced or eliminated.

In all, CR&R is requesting increases totaling \$0.95 per month for residential standard service; from \$23.12 to \$24.07 per month (1.8%). Similarly, for commercial, industrial and multi-family residential refuse service, the typical three cubic yard bin will increase from \$129.59 to \$131.64 per month, an increase of \$2.05 (1.6%).

PROPOSITION 218 COMPLIANCE: Public notice of this proposed rate increase was sent to all property owners and residents within the City's service area on June 24th, 2019. Attachment 3 is a copy of this notice. All documents related to this fee increase have also been made available at the City Clerk's office. To date, the City has received no protests. Any protests received will be presented at the August 7, 2019 hearing.

Fiscal Impact:

As this is a pass-through rate, approval of this item would be largely revenue neutral. However, the City may realize a slight increase in franchise fee and utility user tax revenue.

Attachments:

1. Resolution No. 2019-29
2. Letter from CR&R dated April 30, 2019
3. Notice of Public Hearing

ATTACHMENT 1

RESOLUTION NO. 2019-29

A RESOLUTION OF THE CITY COUNCIL OF THE CITY OF CANYON LAKE INCREASING AND SETTING SOLID WASTE COLLECTION RATES FOR THE 2019-2020 FISCAL YEAR AND PROVIDING FOR COLLECTION OF RESIDENTIAL SERVICE ON THE PROPERTY TAX ROLL

WHEREAS, Proposition 218 was adopted on November 6, 1996, adding Article XIID, Section 6, to the California Constitution; and

WHEREAS, the City of Canyon Lake has adopted an exclusive franchise agreement (“Agreement”) with CR&R Environmental Services, Inc. (“CR&R”); and

WHEREAS, under the Agreement, CR&R provides solid waste collection services for the City of Canyon Lake; and

WHEREAS, pursuant to the provisions of State law, including but not limited to Health & Safety Code Sections 5470 et seq., the City of Canyon Lake may adopt and implement fees and charges to cover the cost of collection of solid waste within the City and, when adopted, may collect such fees for residential service on the property tax rolls; and

WHEREAS, because of increased costs as well as declining value of recyclable materials, CR&R has informed the City that such fees must be increased to cover the costs incurred by CR&R in providing the solid waste collection services and CR&R has provided a report explaining the reasons for such increase, which report is on file with the City Clerk; and

WHEREAS, the proposed increased fees are set out on Exhibit “A”, attached and incorporated hereto; and

WHEREAS, the City has published notice of the collection of such residential fees on the property tax roll in the same manner, at the same time and subject to the same penalties as property taxes; and

WHEREAS, as additional information for such tax roll collection, a written report of prospective solid waste collection fees for the fiscal year 2019-2020 has been prepared and filed with the City Clerk; and

WHEREAS, on August 7, 2019, the City Council conducted a duly noticed public hearing and heard all comments/protests regarding the fee increase; and

WHEREAS, the City Council finds from such reports that the amount of fees is the reasonable cost of service provided, plus direct and indirect overhead; that amounts collected will be used only for immediately available (and not standby) solid waste collection services; that such fees and charges are proportionate to the amount of service received, and that such fees and charges are not for traditional governmental services such as police or libraries; and

WHEREAS, the City Council further finds that this increase in rates is for the purpose of meeting operating expenses, including wage rates and fringe benefits, required for the collection of solid waste within the City pursuant to its existing franchise, and that such action therefore is statutorily exempt from CEQA under Public Resources Code Section 21080(b) and Section 15273 of the CEQA guidelines.

NOW, THEREFORE, THE CITY COUNCIL OF CANYON LAKE RESOLVES AND ORDERS AS FOLLOWS:

SECTION 1. RECITALS

The Recitals set out above are true and correct and are a substantive part of this Resolution.

SECTION 2. FINDINGS

The City Council finds and determines as follows:

- (A) The City of Canyon Lake has provided the required written notice in accordance with Article XIID of the California Constitution. (Cal. Const., art. XIID, § 6(a)(1)).
- (B) The public hearing has occurred not less than 45 days after the mailing of the written notice. (Cal. Const., art. XIID, § 6(a)(2)).
- (C) Revenues derived from the proposed adjustments to the rates do not exceed the funds required to provide the services. (Cal. Const., art. XIID, § 6(b)(1)).
- (D) Revenues derived from the proposed adjustments to the rates are not used for any other purpose other than to provide the services. (Cal. Const., art. XIID, § 6(b)(2)).
- (E) The amount of the proposed adjustments to the rates imposed upon any parcel or person does not exceed the proportional cost of providing the services to that parcel. (Cal. Const., art. XIID, § 6(b)(3)).
- (F) The services are actually used by, or immediately available to, the owner of the parcels subject to the proposed adjustments to the rates. (Cal. Const., art. XIID, § 6(b)(4)).
- (G) The proposed adjustments to the rates are not imposed for general governmental services, where the service is available to the public in substantially the same manner as it is to property owners. (Cal. Const., art. XIID, § 6(b)(5)).
- (H) The City of Canyon Lake has received no timely-filed written protests.
- (I) Of those timely-filed written protests received, no valid protests were submitted by the record owners of one or more of the parcels mailed Proposition 218 notices. No protests were determined not to be valid for one of more of the following reasons: _____

-
- (J) The City Council conducted a fully noticed public hearing on August 7, 2019, at which time the public had the opportunity to provide testimony regarding the proposed increases and the City Council considered the testimony prior to making a final decision to adopt the proposed adjustments to the rates.

SECTION 3. CEQA EXEMPTION

The adoption of this Resolution is exempt from the Requirements of the California Environmental Quality Act (“CEQA”) pursuant to Public Resources Code Section 21080(b) and Section 15273 of the State CEQA Guidelines because the Resolution pertains to the adoption of rates necessary to maintain services within the City’s existing service area.

SECTION 4. DECLARATION OF RESULTS

The total number of valid protests received by the City of Canyon Lake does not constitute a majority of the parcels mailed Proposition 218 notices.

SECTION 5. EFFECT OF PROTESTS

The effect of the results of the protest count as described above in Section 4 is that the City Council is authorized to adopt the proposed adjustments to the rates as described in Exhibit “A” attached hereto and incorporated herein as though set forth in full.

SECTION 6. ADOPTION OF FEE SCHEDULE

The solid waste collection fees are increased in the amounts set out on Exhibit “A” attached hereto and incorporated herein as though set forth in full. Such increase shall be effective as of July 1, 2019.

SECTION 7. ANNUAL CPI ADJUSTMENT

Pursuant to Government Code section 53756, the City Council authorizes automatic adjustments to the rates described in Exhibit “A” beginning July 1, 2020, and continuing annually thereafter, effective on each July 1st through and including July 1, 2023, that pass through the increases tipping fees charged by Riverside County and adjusts for inflation. The rates shall be adjusted upward or downward annually by resolution of the City Council in accordance with the methodology set forth below:

- (A) Service Component: The Service Component comprises eighty percent (75%) of the rate. The Service Component will be adjusted by the percentage increase in the Consumer Price Index (“CPI”), All Urban Consumers, for the Riverside/San Bernardino/Ontario metropolitan area, All Urban Consumers, Index CUURS49CSA0, as published by the United States Department of Labor, Bureau of Labor Statistics, for the March to March period immediately preceding the effective date of the rate adjustment.

- (B) Disposal/Waste Processing Component: The Disposal/Waste Processing Component comprises twenty percent (25%) of the rate. The Disposal Waste Processing Component will be adjusted by the greater of (a) the percentage increase in the CPI for the January to December period immediately preceding the effective date of the rate adjustment; OR (b) the percentage increase in the per ton tipping fee established by the Riverside County Waste Management Department for disposal of Solid Waste generated within Riverside County for the January to December period immediately preceding the effective date of the rate adjustment.
- (C) Adjustments to Ancillary or Other Fees: All Ancillary or Other Fees outlined in the rate schedule that do not have a disposal/waste processing component shall be adjusted on an annual basis each July 1st by applying 100% of the percentage increase in the Consumer Price Index (CPI), All Urban Consumers, for the Riverside/San Bernardino/Ontario metropolitan area, All Urban Consumers, Index CUURS49CSA0, as published by the United States Department of Labor, Bureau of Labor Statistics, for the March to March period immediately preceding the effective date of the rate adjustment.

SECTION 8. TAX ROLL COLLECTION

Such residential fees shall be collected on the property tax rolls. The City Clerk is directed to file a certified copy of this resolution and of the report with the County Auditor. The County Auditor is designated and empowered to collect the assessment as set out here as necessary. For purpose of tax roll collection, the fees set forth in the report shall be deemed to constitute special assessments against the respective parcels on which they are levied without regard to property valuation. The Assessment shall be collected at the same time and subject to the same procedures provided for such taxes. All laws applicable to the levy, collection and enforcement of ad valorem property taxes shall be applicable to such assessments, except that if any real property to which such fees or charges relate has been transferred or conveyed to a bona fide purchaser for value, or if a lien of a bona fide encumbrancer for value has been created and attached thereon, prior to the date on which the first installment of such taxes would become delinquent, then the lien which would otherwise be imposed shall not attach to such real property and the fees or charges and interest shall be transferred to the unsecured roll for collection.

PASSED, APPROVED AND ADOPTED the 7th day of August 2019.

Larry Greene, Mayor

ATTEST:

Ana V. Sauseda, Deputy City Clerk

State of California)
County of Riverside)ss
City of Canyon Lake)

I, Ana V. Sauseda, Deputy City Clerk of the City of Canyon Lake, California, DO HEREBY CERTIFY, that the foregoing is a true and correct copy of Resolution No. 2019-29 adopted by the City Council of the City of Canyon Lake, California, at a regular meeting thereof, held on August 7, 2019 by the following vote:

AYES: Council Members

NOES: None

ABSENT: None

ABSTAIN: None

Ana V. Sauseda, Deputy City Clerk

ATTACHMENT 2



April 30, 2019

Mr. Chris Mann
City Manager
City of Canyon Lake
31532 Railroad Canyon Road
Suite 101/103
Canyon Lake, CA 92587

Re: Annual Consumer Price Index Rate Adjustment

Dear Chris,

Pursuant to our current agreement to provide Solid Waste and Recycling Services to the City of Canyon Lake, CR&R Incorporated respectfully submits the attached information which outlines our Annual Rate Adjustment request for fiscal year 2019-2020. As provided for in the contract between the City of Canyon Lake and CR&R Incorporated, the rates illustrated in Exhibit "C" shall be adjusted annually to reflect the change in the Consumer Price Index (CPI).

In reviewing the data from the Bureau of Labor Statistics (BLS) for March 2019, the CPI for All Urban Consumers has increased by 1.0% and the CPI for Urban Wage Earners increased by .38%. In addition, the County of Riverside's Waste Management Department has indicated that they will adjust their disposal rate by 3.05% from \$30.13 per ton to \$31.05 per ton. Therefore, based upon the data supplied by both the BLS and the County of Riverside, we have prepared the attached rate schedules which pass these adjustments through to the various rates. We have also prepared a new Exhibit "C" to reflect the incremental increases that will become effective July 1, 2019.

In addition to our standard rate adjustments, this year CR&R is respectfully requesting an extraordinary adjustment to our residential rates. This request is being made as a result of the significant impact that China's new recyclables import ban is having on the value of recyclable materials. China's new rules, also known as China Sword, went into effect in January of 2018. Recycling markets world-wide have been devastated by these new trade restrictions. Many haulers have resorted to landfilling recyclable materials due to the collapse of recycling markets. Over 60% of the materials recycled on the West Coast were going to China; those same materials are now flooding a world-wide market that no longer exists.

As a result of China's actions (and now India as well) recycle material values have plummeted all over the world. In our Riverside County region, when compared to 2010, the average value of a ton of recyclable material has declined by 37%. The loss of this revenue, which was used to offset the true cost of our recycling program, has had a

significant impact on our ability to continue operating our recycling program in a "business as usual" mode. Due to these issues, we are asking for a monthly rate adjustment of .50 cents per home plus applicable franchise fees to offset this loss. We have attached a spreadsheet to outline how we have developed this extraordinary request. We anticipate that this adjustment will be reviewed every year.

If recycling markets come back next year or during future annual rate adjustments, we would plan to remove this additional fee. We are hopeful that world-wide markets will eventually rebound but we do not know if or when this will occur. We look forward to your review of our request

We sincerely appreciate our long standing relationship with the City of Canyon Lake as well as the opportunity that we have had to be of service to your residents and businesses. It continues to be a privilege to be of service to your City. Please do not hesitate to call if you have any questions or comments. We look forward to any further assistance that we can provide.

Respectfully,

A handwritten signature in black ink, appearing to read "J. Alex Braicovich". The signature is stylized with large loops and a long horizontal flourish extending to the right.

J. Alex Braicovich
Senior Regional Vice President

Attachments

CANYON LAKE
2019 ANNUAL PRICE ADJUSTMENT

	New	Previous	CPI Change	Rate Change	Unit Measure
1. All Urban Consumers (Mar)	232,548	229,865	1.16%	86.0%	1.00%
2. Urban Wage Earners (Mar)	261,278	254,451	2.68%	14.0%	0.38%
					1.370%

CPI* 3.05% * Provided by County Waste Management Dept

	New	Previous	Rate Change
Landfill	\$ 31.05	\$ 30.13	\$ 0.92
MRF	\$ 52.35	\$ 50.80	\$ 1.55
			3.05%

	Service Component			
	Previous Rate	Contract	CPI Change	Rate Change
2 Standard service	\$ 23.12	78.0%	1.37%	\$ 0.25
3 Additional Cart	\$ 9.88	78.0%	1.37%	\$ 0.11
4 Additional Bulky pick up	\$ 10.47	78.0%	1.37%	\$ 0.11
7 Temporary 3 cubic yard bin	\$ 98.47	71.5%	1.37%	\$ 0.96
8 Re-deliver and re-instatement	\$ 45.24	100.0%	1.37%	\$ 0.62
9 40 cubic yard roll-off	\$ 237.40	100.0%	1.37%	\$ 3.25
10 10 cubic yard roll-off	\$ 237.40	100.0%	1.37%	\$ 3.25
Residential New Account Set up	\$ 25.85	100.0%	1.37%	\$ 0.35
Commercial New Account Set up	\$ 51.71	100.0%	1.37%	\$ 0.71
Rolloff New Account Set up	\$ 51.71	100.0%	1.37%	\$ 0.71

	Landfill Component			
	Contract	Diversion	Landfill Fee Increase per Ton	Rate Change
\$	0.21	19.1%	\$ 0.92	\$ 0.16
\$	0.21	19.1%	\$ 0.92	\$ 0.16
\$	0.91	6.4%	\$ 0.92	\$ 0.78

	Service Component			
	Previous Rate	Contract	CPI Change	Rate Change
5 Complete Refuse 3 yd Bin Rates				
1 x week	\$ 129.59	71.5%	1.37%	\$ 1.27
2 x week	\$ 258.01	71.5%	1.37%	\$ 2.53
3 x week	\$ 386.44	71.5%	1.37%	\$ 3.79
4 x week	\$ 514.84	71.5%	1.37%	\$ 5.04
5 x week	\$ 643.29	71.5%	1.37%	\$ 6.30
6 x week	\$ 771.70	71.5%	1.37%	\$ 7.56
6 Complete Recycle 3 yd Bin Rates				
1 x week	\$ 55.60	71.5%	1.37%	\$ 0.54
2 x week	\$ 111.19	71.5%	1.37%	\$ 1.08
3 x week	\$ 166.79	71.5%	1.37%	\$ 1.63
4 x week	\$ 222.40	71.5%	1.37%	\$ 2.18
5 x week	\$ 277.98	71.5%	1.37%	\$ 2.72
6 x week	\$ 333.57	71.5%	1.37%	\$ 3.27
Recycle 95-gallon cart				
1x week	\$ 34.87	100.0%	1.37%	\$ 0.48
Each additional cart	\$ 28.87	100.0%	1.37%	\$ 0.40

	Landfill Component			
	Contract	Diversion	Landfill Fee Increase per Ton	Rate Change
\$	0.91	6.4%	\$ 0.92	\$ 0.78
\$	0.91	6.4%	\$ 0.92	\$ 1.56
\$	0.91	6.4%	\$ 0.92	\$ 2.34
\$	0.91	6.4%	\$ 0.92	\$ 3.12
\$	0.91	6.4%	\$ 0.92	\$ 3.90
\$	0.91	6.4%	\$ 0.92	\$ 4.68

	Extraordinary Recycling Fee **	Total Rate Change	Previous Rate	Proposed Rate	Net % Change
\$	0.54	\$ 0.410	\$ 23.12	\$ 24.07	1.8%
\$		\$ 0.270	\$ 9.88	\$ 10.15	2.7%
\$		\$ 0.270	\$ 10.47	\$ 10.74	2.6%
\$		\$ 1.740	\$ 98.47	\$ 100.21	1.8%
\$		\$ 0.620	\$ 45.24	\$ 45.86	1.4%
\$		\$ 3.250	\$ 237.40	\$ 240.65	1.4%
\$		\$ 3.250	\$ 237.40	\$ 240.65	1.4%
\$		\$ 0.350	\$ 25.85	\$ 26.20	1.4%
\$		\$ 0.710	\$ 51.71	\$ 52.42	1.4%
\$		\$ 0.710	\$ 51.71	\$ 52.42	1.4%

** includes franchise fee

	Total Rate Change	Previous Rate	Proposed Rate	Net % Change
\$	2,050	\$ 129.59	\$ 131.64	1.6%
\$	4,090	\$ 258.01	\$ 262.10	1.6%
\$	6,130	\$ 386.44	\$ 392.57	1.6%
\$	8,160	\$ 514.84	\$ 523.00	1.6%
\$	10,200	\$ 643.29	\$ 653.49	1.6%
\$	12,240	\$ 771.70	\$ 783.94	1.6%
\$	0.540	\$ 55.60	\$ 56.14	1.0%
\$	1,090	\$ 111.19	\$ 112.28	1.0%
\$	1,630	\$ 166.79	\$ 168.42	1.0%
\$	2,180	\$ 222.40	\$ 224.58	1.0%
\$	2,720	\$ 277.98	\$ 280.70	1.0%
\$	3,270	\$ 333.57	\$ 336.84	1.0%
\$	0.480	\$ 34.87	\$ 35.35	1.4%
\$	0.400	\$ 28.87	\$ 29.27	1.4%

Organic (AD) Rates	Service Component				Digester Component				Total Rate Change	Previous Rate	Proposed Rate	Net % Change	
	Previous Rate	Contract	CPI Change	Rate Change	Unit Measure	Contract	100.0%	Landfill Fee Increase per Ton					Rate Change
Residential Organic AD Rate	\$ 2.02	\$ 1.95	1.37%	\$ 0.03	per month	\$ 75.12	100.0%	3.05%	\$ 2.29	\$ 0.030	\$ 2.02	2.05	1.5%
Additional Food Scrap Pail	\$ 7.24	\$ 7.00	1.37%	\$ 0.10	per pail					\$ 0.100	\$ 7.24	7.34	1.4%
Anaerobic Digester Rate Per Ton	\$ 75.12				per ton					\$ 2.290	\$ 75.12	\$ 77.41	3.0%
7 2-Yard Commercial Food Waste Bin													
1 x week	\$ 229.13	\$ 131.55	1.37%	\$ 1.80	per month	\$ 97.58	100.0%	3.05%	\$ 2.98	\$ 4.780	\$ 229.13	\$ 233.91	2.1%
2 x week	\$ 452.34	\$ 257.18	1.37%	\$ 3.52	per month	\$ 195.16	100.0%	3.05%	\$ 5.95	\$ 9.470	\$ 452.34	\$ 461.81	2.1%
3 x week	\$ 677.63	\$ 384.89	1.37%	\$ 5.27	per month	\$ 292.74	100.0%	3.05%	\$ 8.93	\$ 14.200	\$ 677.63	\$ 691.83	2.1%
4 x week	\$ 902.91	\$ 512.59	1.37%	\$ 7.02	per month	\$ 390.32	100.0%	3.05%	\$ 11.90	\$ 18.920	\$ 902.91	\$ 921.83	2.1%
5 x week	\$ 1,128.21	\$ 640.31	1.37%	\$ 8.77	per month	\$ 487.90	100.0%	3.05%	\$ 14.88	\$ 23.650	\$ 1,128.21	\$ 1,151.86	2.1%
6 x week	\$ 1,353.51	\$ 768.03	1.37%	\$ 10.52	per month	\$ 585.48	100.0%	3.05%	\$ 17.86	\$ 28.380	\$ 1,353.51	\$ 1,381.89	2.1%
11 2-Yard Commercial Green Waste Only Bin													
1 x week	\$ 180.34	\$ 131.55	1.37%	\$ 1.80	per month	\$ 48.79	100.0%	3.05%	\$ 1.49	\$ 3.290	\$ 180.34	\$ 183.63	1.8%
2 x week	\$ 354.76	\$ 257.18	1.37%	\$ 3.52	per month	\$ 97.58	100.0%	3.05%	\$ 2.98	\$ 6.500	\$ 354.76	\$ 361.26	1.8%
3 x week	\$ 531.26	\$ 384.89	1.37%	\$ 5.27	per month	\$ 146.37	100.0%	3.05%	\$ 4.46	\$ 9.730	\$ 531.26	\$ 540.99	1.8%
4 x week	\$ 707.75	\$ 512.59	1.37%	\$ 7.02	per month	\$ 195.16	100.0%	3.05%	\$ 5.95	\$ 12.970	\$ 707.75	\$ 720.72	1.8%
5 x week	\$ 884.26	\$ 640.31	1.37%	\$ 8.77	per month	\$ 243.95	100.0%	3.05%	\$ 7.44	\$ 16.210	\$ 884.26	\$ 900.47	1.8%
6 x week	\$ 1,060.77	\$ 768.03	1.37%	\$ 10.52	per month	\$ 292.74	100.0%	3.05%	\$ 8.93	\$ 19.450	\$ 1,060.77	\$ 1,080.22	1.8%
12 64-gal Food Waste Cart													
1 x week	\$ 53.07	\$ 25.78	1.37%	\$ 0.41	per month	\$ 23.29	100.0%	3.05%	\$ 0.71	\$ 1.120	\$ 53.07	\$ 54.19	2.1%
2 x week	\$ 107.34	\$ 60.76	1.37%	\$ 0.83	per month	\$ 46.58	100.0%	3.05%	\$ 1.42	\$ 2.250	\$ 107.34	\$ 109.59	2.1%
3 x week	\$ 161.02	\$ 91.15	1.37%	\$ 1.25	per month	\$ 69.87	100.0%	3.05%	\$ 2.13	\$ 3.380	\$ 161.02	\$ 164.40	2.1%
4 x week	\$ 214.70	\$ 121.53	1.37%	\$ 1.66	per month	\$ 93.17	100.0%	3.05%	\$ 2.84	\$ 4.500	\$ 214.70	\$ 219.20	2.1%
5 x week	\$ 268.37	\$ 151.91	1.37%	\$ 2.08	per month	\$ 116.48	100.0%	3.05%	\$ 3.55	\$ 5.630	\$ 268.37	\$ 274.00	2.1%
6 x week	\$ 322.04	\$ 182.29	1.37%	\$ 2.50	per month	\$ 139.75	100.0%	3.05%	\$ 4.26	\$ 6.760	\$ 322.04	\$ 328.80	2.1%

CITY OF CANYON LAKE

EXHIBIT "C"

Schedule of Rates
(effective July 1, 2019)

2 Fully automated single family residential collection, fully mechanized recycling, composting, transfer and disposal:		
Monthly Rate: (includes Extraordinary Recycling Fee)	\$	24.07
3 Fully automated single family residential additional refuse, recycling or composting container:		
Monthly Rate Per Container:	\$	10.15
4 Single family residential additional bulky item pick up:		
Per Pick Up (two items per pick up):	\$	10.74
Residential Organic AD Service	\$	2.05
Additional Food Scrap Pail	\$	7.34
5 Commercial, industrial, and multi-family residential refuse monthly bin rates (one 3 cubic yard bin) with the following pick ups per week:		
1 x week	\$	131.64
2 x week	\$	262.10
3 x week	\$	392.57
4 x week	\$	523.00
5 x week	\$	653.49
6 x week	\$	783.94
6 Commercial, industrial, and multi-family residential recycle monthly bin rates (one 3 cubic yard bin) with the following pick ups per week:		
1 x week	\$	56.14
2 x week	\$	112.28
3 x week	\$	168.42
4 x week	\$	224.58
5 x week	\$	280.70
6 x week	\$	336.84
7 Temporary 3 cubic yard bin rate:	\$	100.21 per bin
8 Redeliver and reinstatement rate:	\$	45.86 per occurrence
9 40 cubic yard roll-off bin rate:	\$	240.65 + MRF/landfill fees
10 10 cubic yard roll-off/lowboy bin rate:	\$	240.65 + MRF/landfill fees

Residential New Account Set up	\$	26.20
Commercial New Account Set up	\$	52.42
Rolloff New Account Set up	\$	52.42

Organic AD Rates

Anaerobic Digester Rate Per Ton	\$	77.41
---------------------------------	----	-------

Commercial, industrial, and multi-family residential food monthly bin rates (one 2 cubic yard bin) with the following pick ups per week:

1 x week	\$	233.91
2 x week	\$	461.81
3 x week	\$	691.83
4 x week	\$	921.83
5 x week	\$	1,151.86
6 x week	\$	1,381.89

Commercial, industrial, and multi-family residential non-food monthly bin rates (one 2 cubic yard bin) with the following pick ups per week:

1 x week	\$	183.63
2 x week	\$	361.26
3 x week	\$	540.99
4 x week	\$	720.72
5 x week	\$	900.47
6 x week	\$	1,080.22

Commercial, industrial, and multi-family residential food monthly cart rate (one 64-gallon cart) with the following pick ups per week:

1 x week	\$	54.19
2 x week	\$	109.59
3 x week	\$	164.40
4 x week	\$	219.20
5 x week	\$	274.00
6 x week	\$	328.80

Databases, Tables & Calculators by Subject

SHARE ON:

Change Output Options: From: To: **GO**
 include graphs include annual averages

[More Formatting Options](#)

Data extracted on: April 16, 2019 (5:33:48 PM)

CPI-All Urban Consumers (Current Series)

Series Id: CUURS49ASA0L2
 Not Seasonally Adjusted
Series Title: All items less shelter in Los Angeles-Long Beach-Anaheim, CA, all urban consumers, not seasonally adjusted
Area: Los Angeles-Long Beach-Anaheim, CA
Item: All items less shelter
Base Period: 1982-84=100

Download: [.xlsx](#)

Year	Jan	Feb	Mar	Apr	May	Jun	Jul	Aug	Sep	Oct	Nov	Dec	Annual	HALF1	HALF2
2009	196.609	197.413	197.286	197.740	199.044	201.143	201.358	202.374	203.480	203.880	202.999	202.664	200.499	198.206	202.793
2010	203.971	203.802	205.285	205.774	206.399	205.431	205.740	205.834	205.164	206.379	205.234	206.460	205.456	205.110	205.802
2011	209.062	210.664	214.028	215.498	215.467	213.808	212.202	212.976	214.564	214.597	214.215	212.343	213.285	213.088	213.483
2012	214.742	215.904	218.816	218.468	218.457	216.740	216.127	218.077	219.094	221.751	218.360	215.928	217.705	217.188	218.223
2013	218.522	220.919	221.001	219.482	219.521	219.075	218.592	218.636	218.948	219.128	217.484	217.339	219.054	219.753	218.355
2014	218.614	219.973	221.974	221.692	222.926	222.942	222.330	221.841	221.494	220.815	218.208	216.134	220.745	221.353	220.137
2015	214.533	216.374	219.281	218.858	222.010	220.669	222.521	221.135	219.652	219.771	219.247	218.173	219.352	218.621	220.083
2016	220.019	219.387	219.558	220.292	221.281	221.134	220.438	219.575	219.676	220.640	218.881	218.445	219.944	220.279	219.609
2017	220.314	221.681	222.476	223.272	223.918	223.265	223.536	223.663	224.951	225.188	225.503	225.322	223.591	222.488	224.694
2018	227.716	229.387	229.885	230.208	230.818	229.915	230.487	230.417	231.225	233.375	231.868	230.095	230.450	229.655	231.245
2019	231.460	231.196	232.548												

12-Month Percent Change

Series Id: CUURS49ASA0L2
 Not Seasonally Adjusted
Series Title: All items less shelter in Los Angeles-Long Beach-Anaheim, CA, all urban consumers, not seasonally adjusted
Area: Los Angeles-Long Beach-Anaheim, CA
Item: All items less shelter
Base Period: 1982-84=100

Download: [.xlsx](#)

Year	Jan	Feb	Mar	Apr	May	Jun	Jul	Aug	Sep	Oct	Nov	Dec	Annual	HALF1	HALF2
2009	-1.5	-1.2	-2.7	-3.2	-3.8	-4.1	-4.3	-2.7	-1.5	-0.3	2.2	3.9	-1.7	-2.8	-0.5
2010	3.7	3.2	4.1	4.1	3.7	2.1	2.2	1.7	0.8	1.2	1.1	1.9	2.5	3.5	1.5
2011	2.5	3.4	4.3	4.7	4.4	4.1	3.1	3.5	4.6	4.0	4.4	2.8	3.8	3.9	3.7
2012	2.7	2.5	2.2	1.4	1.4	1.4	1.8	2.4	2.1	3.3	1.9	1.7	2.1	1.9	2.2
2013	1.8	2.3	1.0	0.5	0.5	1.1	1.1	0.3	-0.1	-1.2	-0.4	0.7	0.6	1.2	0.1
2014	0.0	-0.4	0.4	1.0	1.6	1.8	1.7	1.5	1.2	0.8	0.3	-0.6	0.8	0.7	0.8
2015	-1.9	-1.6	-1.2	-1.3	-0.4	-1.0	0.1	-0.3	-0.8	-0.5	0.5	0.9	-0.6	-1.2	0.0
2016	2.6	1.4	0.1	0.7	-0.3	0.2	-0.9	-0.7	0.0	0.4	-0.2	0.1	0.3	0.8	-0.2
2017	0.1	1.0	1.3	1.4	1.2	1.0	1.4	1.9	2.4	2.1	3.0	3.1	1.7	1.0	2.3
2018	3.4	3.5	3.3	3.1	3.1	3.0	3.1	3.0	2.8	3.6	2.8	2.1	3.1	3.2	2.9
2019	1.6	0.8	1.2												

Databases, Tables & Calculators by Subject

SHARE ON: [f](#) [t](#) [in](#)

Change Output Options: From: To: **GO**
 include graphs include annual averages

[More Formatting Options](#) **➔**

Data extracted on: April 16, 2019 (6:42:49 PM)

CPI-Urban Wage Earners and Clerical Workers (Current Series)

Series Id: CNURS49ASA0
 Not Seasonally Adjusted
Series Title: All items in Los Angeles-Long Beach-Anaheim, CA, urban wage earners and clerical workers, not seasonally adjusted
Area: Los Angeles-Long Beach-Anaheim, CA
Item: All items
Base Period: 1982-84=100

Download: [.xlsx](#)

Year	Jan	Feb	Mar	Apr	May	Jun	Jul	Aug	Sep	Oct	Nov	Dec	Annual	HALF1	HALF2
2009	212.454	213.234	213.013	213.405	214.446	216.145	216.128	216.628	217.302	217.474	216.618	216.233	215.257	213.783	216.730
2010	217.290	217.090	218.157	218.475	218.787	218.222	218.367	218.752	218.427	219.339	218.694	219.619	218.435	218.004	218.866
2011	221.540	222.814	225.770	227.051	226.842	225.461	224.277	224.665	226.096	226.116	225.786	224.444	225.072	224.913	225.231
2012	226.245	227.585	230.281	230.023	230.180	228.917	228.446	230.229	231.085	233.431	230.426	228.940	229.649	228.872	230.426
2013	230.651	232.983	233.200	232.030	232.387	232.378	232.190	232.245	232.817	232.735	231.598	231.594	232.234	232.271	232.197
2014	232.578	233.886	235.500	235.717	236.647	236.880	236.963	236.504	236.451	235.921	233.896	232.330	235.273	235.201	235.344
2015	231.063	232.975	235.991	235.697	238.816	237.792	239.889	238.755	237.324	237.472	237.190	236.787	236.646	235.389	237.903
2016	238.609	238.262	239.146	239.536	240.320	240.522	240.580	240.267	240.851	241.932	240.809	240.846	240.140	239.399	240.881
2017	242.735	244.254	244.932	245.417	246.153	245.900	246.681	247.260	248.550	249.234	249.680	249.854	246.721	244.899	248.543
2018	251.785	253.243	254.451	255.379	256.652	256.208	256.632	257.318	258.246	259.899	259.064	258.101	256.415	254.620	258.210
2019	259.182	259.734	261.278												

12-Month Percent Change

Series Id: CNURS49ASA0
 Not Seasonally Adjusted
Series Title: All items in Los Angeles-Long Beach-Anaheim, CA, urban wage earners and clerical workers, not seasonally adjusted
Area: Los Angeles-Long Beach-Anaheim, CA
Item: All items
Base Period: 1982-84=100

Download: [.xlsx](#)

Year	Jan	Feb	Mar	Apr	May	Jun	Jul	Aug	Sep	Oct	Nov	Dec	Annual	HALF1	HALF2
2009	-0.6	-0.5	-1.6	-2.1	-2.4	-2.8	-3.2	-2.1	-1.4	-0.6	1.2	2.5	-1.2	-1.7	-0.6
2010	2.3	1.8	2.4	2.4	2.0	1.0	1.0	1.0	0.5	0.9	1.0	1.6	1.5	2.0	1.0
2011	2.0	2.6	3.5	3.9	3.7	3.3	2.7	2.7	3.5	3.1	3.2	2.2	3.0	3.2	2.9
2012	2.1	2.1	2.0	1.3	1.5	1.5	1.9	2.5	2.2	3.2	2.1	2.0	2.0	1.8	2.3
2013	1.9	2.4	1.3	0.9	1.0	1.5	1.6	0.9	0.7	-0.3	0.5	1.2	1.1	1.5	0.8
2014	0.8	0.4	1.0	1.6	1.8	1.9	2.1	1.8	1.6	1.4	1.0	0.3	1.3	1.3	1.4
2015	-0.7	-0.4	0.2	0.0	0.9	0.4	1.2	1.0	0.4	0.7	1.4	1.9	0.6	0.1	1.1
2016	3.3	2.3	1.3	1.6	0.6	1.1	0.3	0.6	1.5	1.9	1.5	1.7	1.5	1.7	1.3
2017	1.7	2.5	2.4	2.5	2.4	2.2	2.5	2.9	3.2	3.0	3.7	3.7	2.7	2.3	3.2
2018	3.7	3.7	3.9	4.1	4.3	4.2	4.0	4.1	3.9	4.3	3.8	3.3	3.9	4.0	3.9
2019	2.9	2.6	2.7												

TOOLS
Areas at a Glance

CALCULATORS
Inflation

HELP
Help & Tutorials

INFO
What's New

RESOURCES
Inspector General (OIG)



Hans W. Kernkamp, General Manager-Chief Engineer

DATE: April 3, 2019
TO: Waste Haulers
FROM: Sandra Green – Assistant General Manager
Riverside County Department of Waste Resources
RE: Disposal Fee Increase – FY 2019/2020

The Riverside County Department of Waste Resources (Department) is responsible for assuring that there is, and will be in the future, sufficient and accessible landfill space to properly serve the population of the County in its disposal needs. To fulfill this mandate, the Department continually maintains and expands County landfill sites, and encourages, supports and develops recycling programs that minimize the dependence on landfill disposal facilities.

Due to sustained increases in labor expenses, capital improvement costs, regulatory compliance costs and closed site maintenance, an increase in disposal rates is essential to allow for continued and improved services. This letter serves as a notice that subject to approval by the Riverside County Board of Supervisors, landfill disposal rates will increase in FY 19/20 by the Consumer Price Index (CPI), which is 3.05% for calendar year 2018. If approved, the new rates will become effective for tonnage deliveries starting on July 1, 2019.

The Department is also proposing an increase to the current rate for processed green waste used as Alternative Daily Cover (ADC) from \$24.00 per ton to \$32.00 per ton. As you are aware, AB 1594 will eliminate the diversion benefit that currently exists and ADC placed in the landfill will constitute disposal beginning January 1, 2020. Our goal is to gradually increase the ADC rate to equal the disposal rate (currently \$39.31 per ton) between now and FY 20/21. While the use of ADC in the landfill system has been significantly reduced over the last several years due to the increased use of tarps to cover waste (14,000 tons in 2017, 10,000 tons in 2018), any additional revenue generated by the proposed increase will be allocated to the Department's ongoing advancement of diversion and organics processing within Riverside County. Processed green waste used as erosion control at the landfills will continue to be charged at the \$10 per ton rate for the foreseeable future, as it provides a beneficial use to the landfill system.

Thank you for your past cooperation and support. We appreciate your careful consideration and understanding of the matter.

SG:sg

cc: Keith Jones, LEA

**Riverside County Region
Historical Material Pricing Trend**

Commodity Value with CRV		2010	2011	2012	2013	2014	2015	2016	2017	2018	2019
Glass -Mixed		\$ (37.70)	\$ (34.20)	\$ (32.00)	\$ (32.00)	\$ (11.81)	\$ (11.81)	\$ (11.81)	\$ (16.32)	\$ (27.04)	\$ (26.10)
Aluminum Cans		\$ 4,492.50	\$ 4,766.71	\$ 4,535.75	\$ 4,474.48	\$ 4,667.48	\$ 4,342.69	\$ 4,258.67	\$ 4,416.49	\$ 4,502.39	\$ 4,130.00
Scrap Steel		\$ 170.75	\$ 240.84	\$ 208.51	\$ 179.43	\$ 162.93	\$ 84.95	\$ 63.92	\$ 114.16	\$ 134.71	\$ 119.43
Tin Cans		\$ 138.59	\$ 240.25	\$ 202.95	\$ 173.69	\$ 158.78	\$ 67.37	\$ 68.73	\$ 130.45	\$ 160.27	\$ 131.94
Cardboard		\$ 192.96	\$ 220.25	\$ 181.09	\$ 183.53	\$ 173.42	\$ 152.11	\$ 153.98	\$ 191.58	\$ 145.24	\$ 109.60
Commingled Materials		\$ 30.77	\$ 38.45	\$ 38.86	\$ 30.47	\$ 25.50	\$ 17.56	\$ 9.89	\$ 10.74	\$ 0.61	\$ 0.60
Mixed Paper		\$ 155.80	\$ 197.52	\$ 149.85	\$ 143.26	\$ 134.74	\$ 118.10	\$ 123.68	\$ 131.94	\$ 60.48	\$ 25.00
Newspaper		\$ 155.80	\$ 197.52	\$ 149.85	\$ 143.26	\$ 134.74	\$ 118.10	\$ 123.68	\$ 131.94	\$ 119.88	\$ 60.00
Plastic (HDPE) Color		\$ 456.90	\$ 555.97	\$ 563.44	\$ 509.68	\$ 626.97	\$ 520.51	\$ 424.32	\$ 426.00	\$ 426.00	\$ 442.00
Plastic (HDPE) Natural		\$ 633.88	\$ 736.66	\$ 709.13	\$ 721.71	\$ 905.48	\$ 680.17	\$ 614.17	\$ 593.59	\$ 729.01	\$ 524.20
Plastic (P.E.T.)		\$ 1,807.05	\$ 2,027.32	\$ 1,860.98	\$ 1,790.29	\$ 1,731.31	\$ 1,585.32	\$ 1,555.47	\$ 1,577.94	\$ 1,549.74	\$ 1,582.22
Plastic Mixed		\$ 154.70	\$ 203.10	\$ 174.32	\$ 156.61	\$ 252.91	\$ 153.13	\$ 109.08	\$ 90.37	\$ 55.73	\$ 55.00
RESIDUE		\$ (29.95)	\$ (30.30)	\$ (31.37)	\$ (32.05)	\$ (32.36)	\$ (32.90)	\$ (32.96)	\$ (33.50)	\$ (34.18)	\$ (34.83)
TOTAL											

Commodity Value per Ton with CRV		2010	2011	2012	2013	2014	2015	2016	2017	2018	2019
Glass -Mixed	5.43%	\$ (2.05)	\$ (1.86)	\$ (1.74)	\$ (1.74)	\$ (0.64)	\$ (0.64)	\$ (0.64)	\$ (0.89)	\$ (1.47)	\$ (1.42)
Aluminum Cans	0.79%	\$ 35.38	\$ 37.54	\$ 35.72	\$ 35.24	\$ 36.76	\$ 34.20	\$ 33.54	\$ 34.78	\$ 35.46	\$ 32.53
Scrap Steel	0.00%	\$ -	\$ -	\$ -	\$ -	\$ -	\$ -	\$ -	\$ -	\$ -	\$ -
Tin Cans	2.35%	\$ 3.25	\$ 5.64	\$ 4.76	\$ 4.08	\$ 3.73	\$ 1.58	\$ 1.61	\$ 3.06	\$ 3.76	\$ 3.10
Cardboard	28.56%	\$ 55.10	\$ 62.89	\$ 51.71	\$ 52.41	\$ 49.52	\$ 43.44	\$ 43.97	\$ 54.71	\$ 41.47	\$ 31.30
Commingled Mat	0.00%	\$ -	\$ -	\$ -	\$ -	\$ -	\$ -	\$ -	\$ -	\$ -	\$ -
Mixed Paper	7.16%	\$ 11.16	\$ 14.15	\$ 10.73	\$ 10.26	\$ 9.65	\$ 8.46	\$ 8.86	\$ 9.45	\$ 4.33	\$ 1.79
Newspaper	10.53%	\$ 16.41	\$ 20.80	\$ 15.78	\$ 15.09	\$ 14.19	\$ 12.44	\$ 13.02	\$ 13.90	\$ 12.62	\$ 6.32
Plastic (HDPE) Color	1.18%	\$ 5.41	\$ 6.59	\$ 6.68	\$ 6.04	\$ 7.43	\$ 6.17	\$ 5.03	\$ 5.05	\$ 5.05	\$ 5.24
Plastic (HDPE) Natural	1.18%	\$ 7.51	\$ 8.73	\$ 8.40	\$ 8.55	\$ 10.73	\$ 8.06	\$ 7.28	\$ 7.03	\$ 8.64	\$ 6.21
Plastic (P.E.T.)	1.49%	\$ 26.84	\$ 30.11	\$ 27.64	\$ 26.59	\$ 25.72	\$ 23.55	\$ 23.10	\$ 23.44	\$ 23.02	\$ 23.50
Plastic Mixed	4.20%	\$ 6.50	\$ 8.53	\$ 7.32	\$ 6.58	\$ 10.62	\$ 6.43	\$ 4.58	\$ 3.79	\$ 2.34	\$ 2.31
Residue	37.13%	\$ (11.12)	\$ (11.25)	\$ (11.65)	\$ (11.90)	\$ (12.01)	\$ (12.22)	\$ (12.24)	\$ (12.44)	\$ (12.69)	\$ (12.93)
Total Per Ton	100.00%	\$ 154.40	\$ 181.87	\$ 155.37	\$ 151.19	\$ 155.68	\$ 131.46	\$ 128.12	\$ 141.89	\$ 122.54	\$ 97.94
Tons Collected - Annual		28,813	28,962	28,639	28,648	30,122	31,241	34,048	37,027	35,552	35,552
Material Sales Total		\$ 4,448,670	\$ 5,267,403	\$ 4,449,613	\$ 4,331,351	\$ 4,689,519	\$ 4,107,046	\$ 4,362,163	\$ 5,253,713	\$ 4,356,362	\$ 3,481,925
Monthly Per Customer		\$ 3.22	\$ 3.81	\$ 3.22	\$ 3.13	\$ 3.39	\$ 2.97	\$ 3.15	\$ 3.80	\$ 3.15	\$ 2.52
8 Year Average Prior to the China Sword											\$ 3.33
2 Year Average Since the China Sword											\$ 2.83
Rate Increase Request - Monthly per Home											\$ 0.50

ATTACHMENT 3

CITY OF CANYON LAKE
NOTICE OF PUBLIC HEARING

MODIFICATION AND ADJUSTMENTS OF RATES OF SOLID WASTE SERVICES

IN ACCORDANCE WITH SECTION 6(A) OF ARTICLE XIII OF THE CALIFORNIA CONSTITUTION (PROPOSITION 218) AND GOVERNMENT CODE SECTIONS 53755 AND 53756 NOTICE IS HEREBY GIVEN THAT the City Council of the City of Canyon Lake will conduct a public hearing at its regularly scheduled meeting on August 7, 2019, at 6:30 p.m. or as soon thereafter as it may be heard. The meeting will take place in the City Council Chamber at City Hall, located at 31516 Railroad Canyon Road, Canyon Lake, CA 92587, on the question of a modification and adjustment of rates of solid waste services by CR&R Incorporated.

As provided for in the AGREEMENT BETWEEN THE CITY OF CANYON LAKE AND CR&R INCORPORATED, DBA CANYON LAKE ENVIRONMENTAL, FOR THE COLLECTION, TRANSPORTATION, RECYCLING, COMPOSTING, AND DISPOSAL OF SOLID WASTE, RECYCLABLES, COMPOSTABLES AND YARD WASTE AND TEMPORARY ROLL-OFF BINS/ROLL-OFF SERVICES, as amended (the "Franchise Agreement"), the "Schedule of Rates" shall be adjusted to reflect the annual change in certain consumer price indexes and adjustments to the Riverside County landfill or material recovery facility tipping fees. The "Schedule of Rates" shall be amended and approved by a Resolution of the Canyon Lake City Council. CR&R Incorporated is requesting the following modifications and/or adjustments commencing July 1, 2019:

- Annual (CPI) Rate Adjustment increase of 1.37%.
- Riverside County Landfill tipping fee increase of 3.05%.
- Extraordinary Recycling Rate Adjustment of \$0.54 cents per month for residential service.
- Commercial Overflow Fee of \$55.00.
- Rolloff Delivery Fee of \$80.00.
- Rolloff False Run Fee of \$80.00.
- Rolloff Relocation of Box Fee of \$89.00.

Government Code Section 53756 provides for refuse collection services to adopt a schedule of fees or charges for a property-related service for a period not to exceed five years. Please be advised that this serves as the notice of an annual consumer price index adjustment increase and Riverside County landfill or material recovery facility tipping fee increase for the years of 2019 – 2024.

Effective July 1, 2019 the rates shall be adjusted upward or downward to reflect changes in certain consumer price indexes and landfill or material recovery facility fees pursuant to the formula and terms set forth in the Franchise Agreement.

First, the landfill or material recovery facility pass through shall be determined on an annual basis by formula determining the percentage of the total rate which is the landfill or material recovery facility tipping fee cost. The consumer price index adjustment shall be taken only on the remaining percentage. The consumer price index adjustment may be made annually and such adjustment shall be effective as of the first day of July of each calendar year. The comparison shall be made for each March 1. The consumer price index adjustment shall be determined as follows: The percentage of the previous rate not attributable to landfill or material recovery facility costs shall be further broken down into the percentage for labor and for all other non-labor costs. The consumer price index adjustment for all costs other than labor shall be equal to the amount derived by multiplying (a) the previous rate by (b) the percentage increase or decrease

in the Consumer Price Index for all urban consumers in the Los Angeles-Long Beach-Anaheim Metropolitan Areas during the prior calendar year, excluding the housing component.

The consumer price index adjustment for labor costs shall be equal to the amount derived by multiplying the previous rate by the percentage increase or decrease in the Consumer Price Index for wage earners within the Los Angeles-Long Beach-Anaheim Metropolitan Areas during the prior calendar year.

The nonlabor and labor factors thus derived shall then be consolidated in proportion to the relative percentages represented by nonlabor and labor costs to yield the annual consumer price index adjustment factor. Where the price for a roll-off container does not include landfill or material recovery facility charges, any consumer price index increase, as set out above, shall be on 100% of the charge. Otherwise, the commercial percentages shall apply.

Examples of such calculations are set forth in the Franchise Agreement and are also shown in the schedule of proposed rates commencing July 1, 2019 which are attached hereto

If the tipping fee charged at the landfill or material recovery facility then in use is changed at any time during the term of the Franchise Agreement whatever reason including, but not limited to, new or increased taxes or regulatory fees, CR&R Incorporated shall be entitled to a corresponding and pro-rata adjustment in the rates, and said adjustment shall be effective at the start of the first full billing period after the tipping fee increase is implemented.

Effective July 1, 2020 and each July 1 thereafter, the "Schedule of Rates", including all ancillary fees and charges, as adjusted, shall be adjusted in accordance with the methodology set forth below:

Service Component. The Service Component comprises eighty percent (75%) of the rate. The Service Component will be adjusted by the percentage increase in the Consumer Price Index ("CPI"), All Urban Consumers, for the Riverside/San Bernardino/Ontario metropolitan area, All Urban Consumers, Index CUURS49CSA0, as published by the United States Department of Labor, Bureau of Labor Statistics, for the March to March period immediately preceding the effective date of the rate adjustment.

Disposal/Waste Processing Component. The Disposal/Waste Processing Component comprises twenty percent (25%) of the rate. The Disposal Waste Processing Component will be adjusted by the greater of:

- The percentage increase in the CPI for the January to December period immediately preceding the effective date of the rate adjustment; (OR)
- The percentage increase in the per ton tipping fee established by the Riverside County Waste Management Department for disposal of Solid Waste generated within Riverside County for the January to December period immediately preceding the effective date of the rate adjustment.

Adjustments to Ancillary or Other Fees. All Ancillary or Other Fees outlined in the rate schedule that do not have a disposal/waste processing component shall be adjusted on an annual basis each July 1st by applying 100% of the percentage increase in the Consumer Price Index (CPI), All Urban Consumers, for the Riverside/San Bernardino/Ontario metropolitan area, All Urban Consumers, Index CUURS49CSA0, as published by the United States Department of Labor, Bureau of Labor Statistics, for the March to March period immediately preceding the effective date of the rate adjustment.

Proposition 218

Record Owners, as defined under Proposition 218, and tenants may respond to the proposed fees in writing prior to or during the public hearing. Consistent with the provisions of Proposition 218 and Government Code Section 53755, this notice has been mailed to the record owners of the property at the addresses as they appear on the latest equalized assessment roll. If you object to the proposed fees as

described in this Notice you may file a written protest with the City at or before the time set for the public hearing. Protests can be mailed or personally delivered to:

City of Canyon Lake
Office of the City Clerk
31516 Railroad Canyon Road
Canyon Lake, CA 92587

A valid protest must include:

1. The name of the person submitting the protest and their interest in the property (e.g. owner or tenant), and
2. Identification of the property by either assessor's parcel number or street address, and
3. A statement of protest ("I/we protest" will suffice), and
4. The original signature of the protesting owner or tenant (photocopies will not be accepted).

Please note that pursuant to Government Code section 53755(b) only one written protest will be counted per parcel. Multiple protests returned for a single property will be disallowed and the City Clerk will only accept one protest per property.

The City Clerk will determine the validity of all protests submitted and exclude any invalid protests from the final tabulation. The City Clerk may confer with the City Attorney in determining the validity of written protests. As part of this process, the City Attorney may view contested or suspect protest forms. The City Clerk's decision shall be final and binding.

INQUIRIES: For any and all information relating to the proceedings, including relating to protest procedure, contact the Deputy City Clerk - (951) 244-8547. For all inquiries relating to the rate increase, method of calculation and proposed fees, contact CR&R Incorporated at (800) 755-8112.

/s/

Ana V. Sauseda
Deputy City Clerk
City of Canyon Lake

**City of Canyon Lake
City Council
Staff Report**

TO: Honorable Mayor and Members of the City Council

FROM: Chris Mann, City Manager

BY: Jim Morrissey, City Planner

DATE: August 7, 2019

SUBJECT: Adoption of Resolution No. 2019-30, Approving Variance No. 19-33 (Pitts Backyard Pool) located at 30211 Cove View Drive, Canyon Lake, CA 92587

cm

RECOMMENDATION:

Staff recommends that the City Council adopt Resolution No. 2019-30 approving Variance No. 19-33, to allow for the placement of a pool within approximately one foot from the rear property line and approximately four feet from the patio cover and existing residence, excluding the spa, located at 30211 Cove View Drive, based on the findings contained in Zoning Code Section 18.27 and Government Code Sec. 65906, subject to the findings as listed within the attached resolution. This project is not subject to further review under the California Environmental Quality Act because it will not result in a direct or reasonably foreseeable indirect physical change in the environment. 14 Cal. Code Regs. 15060(c)(2).

PROJECT DESCRIPTION:

Applicant, Mr. Pitts, proposes to place a built-in pool in the rear yard of an existing residence, within the required pool setback area of five feet from property line and the residence.

BACKGROUND:

Analysis

The applicant proposes to place a 13-foot-wide pool (including one-foot concrete edge around the pool) within a 17-foot rear yard area. The pool would be located within one foot of the rear property line and approximately four feet from the building. The applicant has a 13-foot-wide covered patio and separate storage rooms that extend beyond the habitable portion of the building, but due to its attachment to the building is considered part of the building for setback purposes. The Zoning Ordinance requires "Private swimming pools...shall be located not nearer than five (5) feet to any property line or dwelling." (Section 18.25) Staff has established the five-foot setback as being that

distance from the vertical patio supports, similar to measurements to exterior building walls and not the associated overhanging eaves.

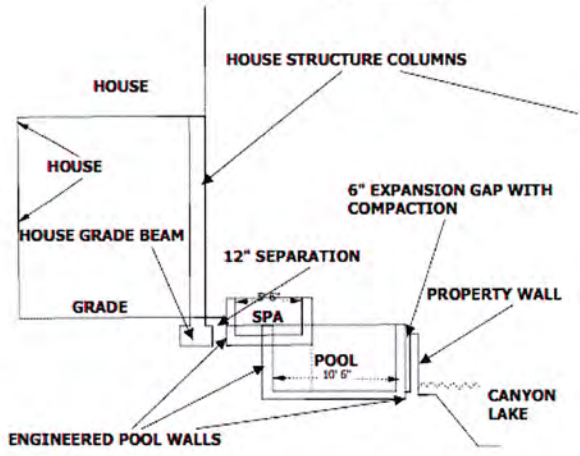
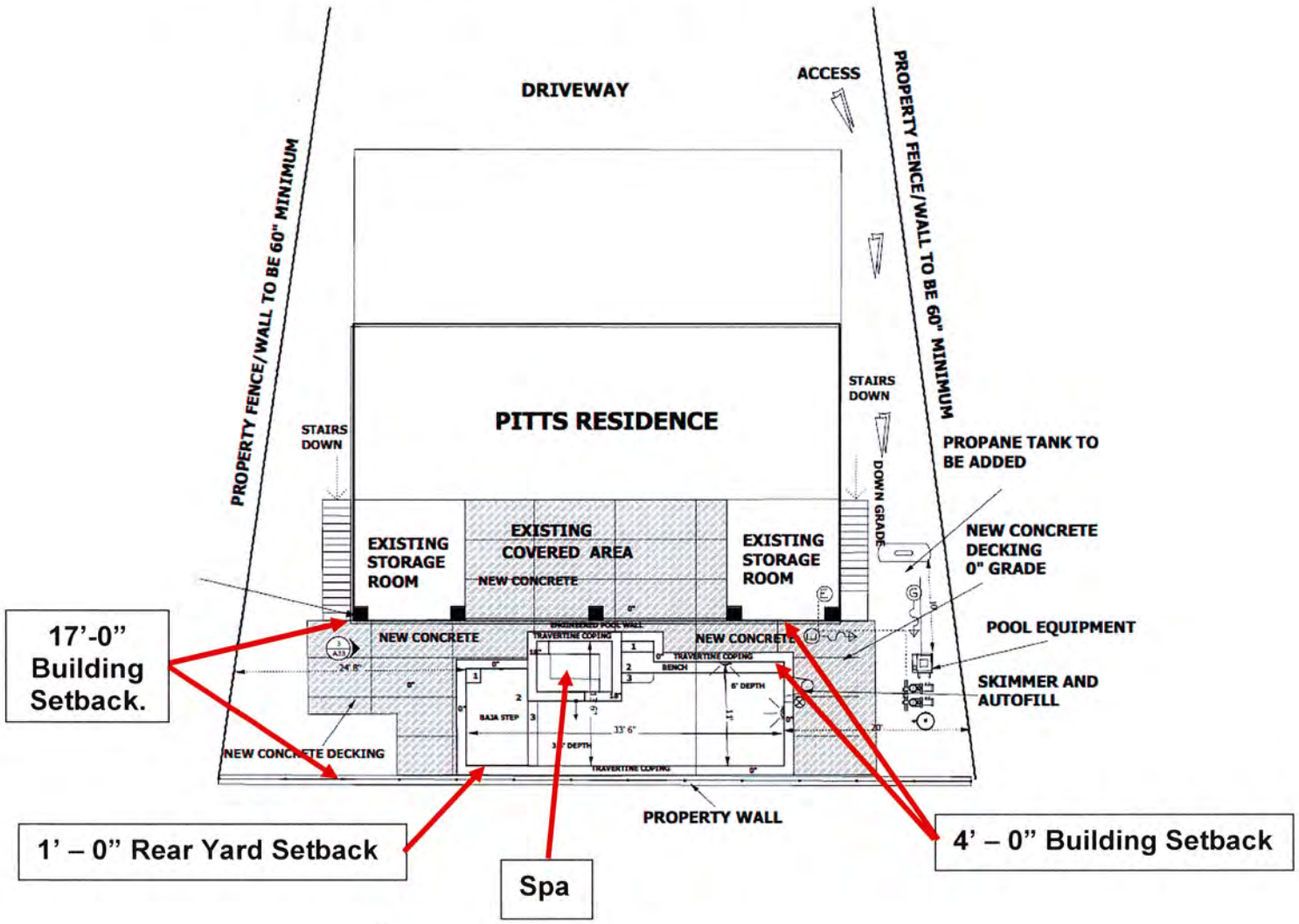

CROSS SECTION



Variations are typically evaluated based upon hardship, such as unusual property configuration or topography that preclude an ability to meet development requirements that are typically intended for rectangular and flat parcels. The subject property has a lot area similar to other lots in the area and does not have a unique circumstance related to

either its configuration or topography. The property is generally configured in a reasonable manner in compliance with standard subdivision practices. It's location on a street knuckle is not unique in that such a design typically occurs within a residential development. However, Canyon Lake does not have many street knuckles, but the few of those evaluated by Staff found the lots were relatively large. In this particular case, the subject parcel has a reduced lot depth when compared with other parcels in the area simply due to its location on a street knuckle. This is an important feature since all of the pools in the area are in the rear of the property.

The depth of the property is approximately 104 feet along both side yard property lines, while other lots along the same street or area with a pool have a greater depth. The depth along each property line for parcels identified with pools on the following exhibits are noted below. It should also be noted that most other lots along the lake edge in the area have a depth of 120 feet.

- Lot 1: 120'/112'
- Lot 2: 104'/111' (the adjoining lot)
- Lot 3: 120'/127'
- Lot 4: 120'/117'
- Subject Property: 104'/104'

The fact the Zoning Ordinance permits various improvements or uses does not ensure they can occur. In this instance, the development envelope (the development area within the front, rear and side yard setbacks, and building height) is extensively developed. Such an extensive use of the property may preclude the ability to install additional facilities, such as a pool, cabana, or other structures in the remaining yard space.

In this particular case the property owner's parcel is smaller in depth than other parcels in the area and is relatively unique, even though its depth meets Zoning Ordinance standards. However, the reduction in lot depth does constrain their ability to enjoy the rights available to others in the area under similar circumstances, which is one of the findings required by State law.



ASSESSOR MAP

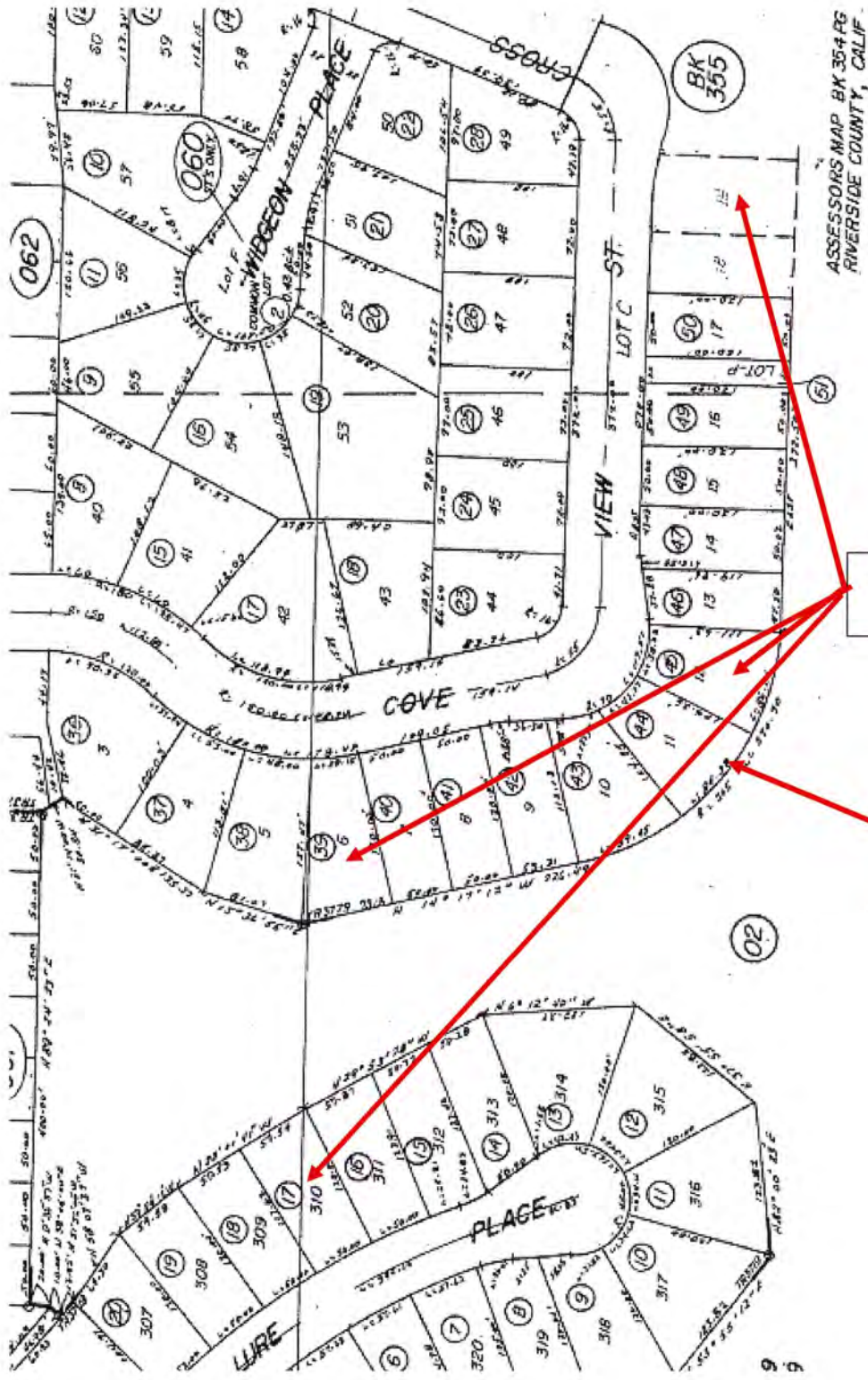

EXISTING SWIMMING POOLS

SUBJECT PROPERTY

FINDINGS OF APPROVAL

Below are the required findings for supporting Variance No. 19-33 are in accordance with Section 18.27 of the Canyon Lake Zoning Ordinance.

1. Variances from the terms of this ordinance may be granted when, because of special circumstances applicable to the parcel of property, including size, shape, topography, location or surroundings, the strict application of this ordinance deprives such property of privileges enjoyed by other property in the vicinity that is under the same zoning classification.

Response: *The lot depth of the subject property is notably less than properties in the surrounding area. Typically, lots around cul-de-sacs or knuckles are greater than lots along streets designed in a grid-like manner. The fact the lot may be larger in overall area than some lots due to its fan-like shape does not assist in the minimizing the depth, since structures are constructed in a rectangular shape. As such, the additional land provided along the side yards due to the widening of the lot cannot effectively replace a loss of lot depth and, thus, constrains the use of the property. This reduction minimizes the ability to utilize land to the extent available to other nearby properties. Permitting the reduced setbacks would allow the property owner the ability to utilize their land in a manner similar to others along the lake edge.*

2. A variance shall not be granted for a parcel of property which authorizes a use or activity that is not otherwise expressly authorized by the zone regulation governing the parcel of property, but shall be limited to modifications of property development standards, such as lot size, lot coverage, yards, and parking, and landscape requirements.

Response: *The variance is related to the size of the subject property and not a use or activity that is not otherwise expressly authorized by the zone regulation.*

Below are additional findings specified in the California Government Code, Section 65906.

3. Variances from the terms of the zoning ordinances shall be granted only when, because of special circumstances applicable to the property, including size, shape, topography, location or surroundings, the strict application of the zoning ordinance deprives such property of privileges enjoyed by other property in the vicinity under identical zoning classification.

Response: *The depth of the subject property is less than those of the surrounding properties that face the lake. Other nearby properties, including those with pools, have a lot depth of approximately 15 feet greater than the subject property. As such, the ability to utilize the property to the same extent as others is diminished.*

4. Any variance granted shall be subject to such conditions as will assure that the adjustment thereby authorized shall not constitute a grant of special privileges

inconsistent with the limitations upon other properties in the vicinity and zone in which such property is situated.

Response: *Other properties in the area have a greater lot depth than the subject property and are rectangular in configuration, thereby able to better utilize their property for development. The subject property is different in that the depth is not as great due to the configuration of the street knuckle which requires a greater width to ensure adequate vehicular movement, which reduces the potential size of the property.*

5. A variance shall not be granted for a parcel of property which authorizes a use or which is not otherwise expressly authorized by the zone regulation governing the parcel or property.

Response: *The variance is not related to a use or activity that is not otherwise expressly authorized by the zone regulation.*

6. The proposed development has been evaluated to determine compliance with the California Environmental Quality Act (CEQA) and represents the City's independent evaluation of the project.

Response: *The proposed variance would allow the construction of a swimming pool in the rear yard of an existing single-family residence. The pool would be required to meet all standard California Building Code and Engineering requirements typically employed for such construction. The land area has been disturbed as part of the original home construction and utilized by its current occupants. Construction of a pool would not affect the environment and would be exempt under the California Environmental Quality Act (CEQA).*

NOTICING AND ENVIRONMENTAL:

The required public noticing was published in the local newspaper, and hearing notices were mailed to property owners within a 300-foot radius of the project site. This project is not subject to further review under the California Environmental Quality Act because it will not result in a direct or reasonably foreseeable indirect physical change in the environment. 14 Cal. Code Regs. 15060(c)(2).

BUDGET (or FISCAL) IMPACT:

None

ATTACHMENTS:

1. Resolution 2019-30
2. Notice of Public Hearing

ATTACHMENT 1

RESOLUTION 2019-30

A RESOLUTION OF THE CITY COUNCIL OF THE CITY OF CANYON LAKE, CALIFORNIA APPROVING VARIANCE 19-35, TO ALLOW THE PLACEMENT OF A SWIMMING POOL WITHIN FIVE FEET OF THE REAR YARD PROPERTY LINE AND WITHIN FIVE FEET OF THE RESIDENCE, LOCATED ON COVE VIEW STREET, CANYON LAKE, CA 92587 (APN 354-062-044)

WHEREAS, The applicant, Dennis Pitts, has filed an application with the City of Canyon Lake for Variance 19-35 to allow a setback from the rear yard property line and main building that is less than the five feet required by the Zoning Ordinance, located at 30211 Cove View Street (Assessor's Parcel Number: 354-062-044) within the City of Canyon Lake, California, 92587; and

WHEREAS, notice of a public hearing of the City Council of the City of Canyon Lake to consider Applicant's application was given in accordance with applicable law; and

WHEREAS, the City Council has considered the staff report and all of the information, testimony, and evidence presented during the City Council hearing; and

WHEREAS, a Variance may be granted when, because of special circumstances applicable to a parcel of property, including size, shape, topography, location or surroundings, the strict application of this ordinance deprives such property of privileges enjoyed by other property in the vicinity that is under the same zoning classification; and

WHEREAS, this application is to approve a Variance to allow the swimming pool and attached spa to be located within approximately one foot of the rear yard property line and approximately four feet from the main building, excluding the attached spa, located on Cove View Street, Canyon Lake, CA 92587; and

WHEREAS, Canyon Lake's Zoning Ordinance Section 18.27, City Council approval is required for a variance from the adopted ordinances.

NOW, THEREFORE, THE CITY COUNCIL OF THE CITY OF CANYON LAKE RESOLVES AND ORDERS AS FOLLOWS:

SECTION 1. In accordance with Section 18.27 of the Canyon Lake Zoning Ordinance, based upon the staff report, public testimony, and record herein, the City Council makes the following findings regarding Variance 19-35:

1. Variances from the terms of this ordinance may be granted when, because of special circumstances applicable to the parcel of property, including size, shape, topography, location or surroundings, the strict application of this ordinance deprives such property of privileges enjoyed by other property in the vicinity that is under the same zoning classification.

Response: *The lot depth of the subject property is notably less than properties in the surrounding area. Typically, lots around cul-de-sacs or knuckles have greater depths than lots along streets designed in a grid-like manner. While the lot may be larger in area than the surrounding lots, due to its unique fan-like shape, the depth of the lot is actually less than the surrounding lots. As such, the additional land provided along the side yards due to the widening of the lot cannot effectively replace a loss of lot depth and, thus, constrains the use of the property. This reduction minimizes the ability to utilize land to the extent available to other nearby properties. Permitting the reduced setbacks would allow the property owner the ability to utilize their land in a manner similar to others along the lake edge.*

2. A variance shall not be granted for a parcel of property which authorizes a use or activity that is not otherwise expressly authorized by the zone regulation governing the parcel of property, but shall be limited to modifications of property development standards, such as lot size, lot coverage, yards, and parking, and landscape requirements.

Response: *The variance is related to the setbacks of the subject property and not a use or activity that is not otherwise expressly authorized by the zone regulation.*

3. Variances from the terms of the zoning ordinances shall be granted only when, because of special circumstances applicable to the property, including size, shape, topography, location or surroundings, the strict application of the zoning ordinance deprives such property of privileges enjoyed by other property in the vicinity under identical zoning classification.

Response: *The depth of the subject property is less than those of the surrounding properties that face the lake. Other nearby properties, including those with pools, have a lot depth of approximately 15 feet greater than the subject property. As such, the ability to utilize the property to the same extent as others is diminished.*

4. Any variance granted shall be subject to such conditions as will assure that the adjustment thereby authorized shall not constitute a grant of special privileges inconsistent with the limitations upon other properties in the vicinity and zone in which such property is situated.

Response: *Other properties in the area have a greater lot depth than the subject property and are rectangular in configuration, thereby able to better utilize their property for development. The subject property is different in that the depth is not as great due to the configuration of the street knuckle which requires a greater width to ensure adequate vehicular movement, which reduces the potential size of the property.*

5. A variance shall not be granted for a parcel of property which authorizes a use or which is not otherwise expressly authorized by the zone regulation governing the parcel or property.

Response: *The variance is not related to a use or activity that is not otherwise expressly authorized by the zone regulation.*

6. The proposed development has been evaluated to determine compliance with the California Environmental Quality Act (CEQA) and represents the City's independent evaluation of the project.

Response: *The proposed variance would allow the construction of a swimming pool in the rear yard of an existing single-family residence. The pool would be required to meet all standard California Building Code and Engineering requirements typically employed for such construction. The land area has been disturbed as part of the original home construction and utilized by its current occupants. Construction of a pool would not affect the environment and would be exempt under the California Environmental Quality Act (CEQA).*

SECTION 2. Pursuant to the above findings, the City Council of the City of Canyon Lake authorizes the findings and the environmental determination provided in this resolution and approves Variance 19-35 permitting a rear yard swimming pool to encroach within five feet of the rear yard property line and closer than five feet from the main building as shown on the Staff Report Exhibit on property at 30211 Cove View Street (Assessor's Parcel Number: 354-062-044).

PASSED, APPROVED AND ADOPTED this 7th day of August 2019.

Larry Green, Mayor

ATTEST:

Ana V. Sauseda, Deputy City Clerk

State of California
County of Riverside) ss
City of Canyon Lake)

I, Ana V. Sauseda, Deputy City Clerk of the City of Canyon Lake, California, DO HEREBY CERTIFY, that the foregoing is a true and correct copy of the Resolution No. 2019-30 adopted by the City Council of the City of Canyon Lake, California, at a regular meeting thereof, held on August 7, 2019, by the following vote:

AYES:

NOES:

ABSTAIN:

ABSENT:

Ana V. Sauseda, Deputy City Clerk

ATTACHMENT 2



NOTICE OF PUBLIC HEARING

Variance No. 19-35

Project Location: 30211 Cove View Drive, Canyon Lake, California

Notice is hereby given that the City Council of the City of Canyon Lake will conduct a **Public Hearing on Wednesday, August 7, 2019** during the course of the City Council meeting that begins at **6:30 p.m.**, at the Canyon Lake Municipal Building, Council Chamber, 31516 Railroad Canyon Road, Canyon Lake, CA 92587, to consider the placement of a pool within the rear yard of an existing residence approximately one foot from the rear property line and approximately four feet from the patio cover and existing residence, excluding the spa, which is less than the five feet separation required by the Zoning Ordinance. This project is not subject to further review under the California Environmental Quality Act because it will not result in a direct or reasonably foreseeable indirect physical change in the environment. 14 Cal. Code Regs. 15060(c)(2).

Mr. Dennis Pitts, the applicant, has filed an application requesting approval of Variance (VAR) No. 19-35 to allow the installation of the pool at an existing single-family residence, located at 30211 Cove View Drive, Canyon Lake, California.

Any person may appear and be heard in support or opposition to the proposal at the time of the hearing. Please address written responses to the City Clerk at the address below. Information on the above item is available for review at the Planning Division, at the address below.

If you challenge the above action in court, you may be limited to raising only those issues which you or someone else raised at the public hearing described in this notice, or in written correspondence delivered to the Council at, or prior to, the public hearing at the following address: Canyon Lake City Hall, 31516 Railroad Canyon Road, Canyon Lake, CA 92587 Monday through Thursday, 8 a.m. to 5 p.m. (951) 244-2955, fax: (951) 246-2022.

Jim Morrissey, City Planner, City of Canyon Lake

Publish Date: July 26, 2019