



CITY OF CANYON LAKE

City Hall

31516 Railroad Canyon Road
Canyon Lake, CA 92587

Website: www.cityofcanyonlake.org

Mayor Jordan Ehrenkranz
Mayor Pro Tem Kasey Castillo

Council Members:

Randy Bonner
Larry Greene
Jeremy Smith

City Manager Chris Mann
City Attorney Steven Graham
City Clerk Ana V. Sauseda, CMC

AGENDA

Regular Meeting of the Canyon Lake City Council
Wednesday, September 2, 2020

Closed Session 5:00 P.M. – City Hall Administration Office – 31526 Railroad Canyon Road, Suite 5

Open Session 6:30 P.M. – City Hall Council Chamber – 31516 Railroad Canyon Road

SPECIAL NOTICE – COVID-19 RELATED PROCEDURES IN EFFECT

Pursuant to Paragraph 3 of Executive Order N-29-20, executed by the Governor of California on March 17, 2020, as a response to mitigating the spread of Coronavirus (COVID-19), this regular meeting of the City Council of the City of Canyon Lake will allow Councilmembers to attend the City Council meeting telephonically from remote locations without requiring notice of or public access to those locations. The City Council Chamber will be closed to the public. Members of the public may observe the City Council meeting by selecting the Live Stream icon on the main page: www.cityofcanyonlake.org, the **City's Facebook page**, **Time Warner/Spectrum Channel 29**, or on FIOS/Frontier Channel 39.

In a further effort to allow for social distancing, members of the public may comment electronically by sending an email with their comment to PublicComment@cityofcanyonlake.com. The City Clerk will read these public comment submissions into the record during the "Public Comments" portion of the agenda.

If any member of the public has a disability and desires to request a modification or accommodation of the above procedures, please contact the City Clerk at least 24 hours prior to the meeting at 951-244-8547 or by email at asauseda@cityofcanyonlake.com.

CLOSED SESSION – 5:00 P.M.

CLOSED SESSION CALLED TO ORDER

ROLL CALL

PUBLIC COMMENT

LIMIT 3 MINUTES

Any person wishing to address the City Council on any matter within the jurisdiction of the City, whether or not it appears on this agenda, is asked to submit their comment electronically by sending an email to PublicComment@cityofcanyonlake.com. If you are commenting on an item on the Consent Calendar or on items not on the agenda, the City Clerk will read these public comment submissions into the record during the "Public Comments" portion of the agenda. Public comments submitted through email should (A) be no longer than 250 words; (B) include their name and agenda item number.

-
- A. CONFERENCE WITH LEGAL COUNSEL – EXISTING LITIGATION – Pursuant to paragraph (1) of subdivision (d) of Section 54956.9
Richard Beck v. City of Canyon Lake, Riverside Superior Court Case No.: RIC2003025
 - B. CONFERENCE WITH LEGAL COUNSEL – INITIATION OF LITIGATION – Pursuant to paragraph (4) of subdivision (d) of Section 54956.9 – 1 case
 - C. CONFERENCE WITH LEGAL COUNSEL - ANTICIPATED LITIGATION - Significant exposure to litigation pursuant to paragraph (2) of subdivision (d) of Section 54956.9 - 1 case
 - D. CONFERENCE WITH REAL PROPERTY NEGOTIATORS - Pursuant to Section 54956.8
Property: APN 349-290-008
Agency Negotiator: City Manager
Negotiating Parties: Jim Kipp
Under Negotiation: Price and Terms of Payment
-

OPEN SESSION - 6:30 P.M.

OPEN SESSION CALLED TO ORDER

INVOCATION Pastor Dave Dick

FLAG SALUTE

ROLL CALL

CLOSED SESSION REPORT

APPROVAL OF CITY COUNCIL AGENDA

CEREMONIAL MATTERS *Presentations, Awards, Proclamations*

- Presentation by City Clerk Ana Sauseda
- Proclamation by Mayor Ehrenkranz

COMMUNITY REPORTS

- Elsinore Valley Municipal Water District Update from Director Darcy Burke
- Canyon Lake Property Owners Association Update from President Chris Polland

PUBLIC SAFETY UPDATE

- ❖ Sheriff's Department
- ❖ Fire Department
- ❖ Code Enforcement

~~~~~

## PUBLIC COMMENT

Any person wishing to address the City Council on any matter within the jurisdiction of the City, whether or not it appears on this agenda, is asked to submit their comment electronically by sending an email to [PublicComment@cityofcanyonlake.com](mailto:PublicComment@cityofcanyonlake.com). If you are commenting on an item on the Consent Calendar or on items not on the agenda, the City Clerk will read these public comment submissions into the record during the "Public Comments" portion of the agenda. Public comments submitted through email should (A) be no longer than 250 words; (B) include their name and agenda item number. If you are commenting on a Business Item or Public Hearing, the City Clerk will read those public comment submissions into the record at the time that particular item is scheduled on the agenda.

~~~~~

CONSENT CALENDAR

All items listed on the Consent Calendar are considered to be routine matters, status reports or documents covering previous City Council action. The items listed on the Consent Calendar may be enacted in one motion. With the concurrence of the City Council, a Council Member may request that an item be removed for further discussion. Staff recommends approval of all items.

- (1) Waive Full Reading, Read all Ordinances by Title Only
- (2) Resolution - Adoption of Resolution No. 2020-35 & Resolution No. 2020-42, Approving Claims and Demands of the City
- (3) Minutes - Approval of City Council Minutes
 - August 5, 2020 – Canceled City Council Meeting
 - July 13, 2020 – Special City Council Meeting
 - July 8, 2020 – Regular City Council Meeting
 - March 25, 2020 - Special City Council Meeting
 - September 26, 2019 – Special City Council Meeting
- (4) Second Reading of Ordinance No. 200 - An Ordinance of the City Council of the City of Canyon Lake, California, Adding Chapter 5.25 to the Canyon Lake Municipal Code Regarding Short-Term Rentals
- (5) Resolution - Adoption of Resolution No. 2020-36, Authorizing a Budget Adjustment in the Amount of \$10,000 for FY 2020-21, for Participation in the WRCOG Fellowship Program
- (6) Resolution - Adoption of Resolution No. 2020-37, A Resolution of the City Council of the City of Canyon Lake, California, Authorizing a Budget Adjustment in the Amount of \$7,700 for FY 2020-21, for the Purchase of Protective Window Film at the Administration Office and Main Building
- (7) Resolution - Adoption of Resolution No. 2020-38, A Resolution of the City Council of the City of Canyon Lake, California, Authorizing a Budget Adjustment in the Amount of \$6,000 for FY 2020-21, for the Purchase of Furniture & Office Equipment at the New Office Space Located at 31526 Railroad Canyon Road, Suite 4
- (8) Resolution – Adoption of Resolution No. 2020-40, A Resolution of the City Council of the City of Canyon Lake, California, Authorizing a Budget Adjustment in the Amount of \$6,000 for FY 2020-21, for the Digitizing of Additional City Records

PULLED CONSENT CALENDAR ITEMS:

BUSINESS ITEMS

- (9) Resolution – Adoption of Resolution No. 2020-39, A Resolution of the City Council of the City of Canyon Lake, California, Indicating Compliance with the Annual Inspection of Certain Occupancies Pursuant to Section 13146.2 and 13146.3 of the California Health and Safety Code
- (10) Ordinance – Introduction and First Reading of Ordinance No. 201, An Ordinance of the City Council of the City of Canyon Lake, California, Adding Chapter 5.16 Regarding Peddling and Soliciting in the City of Canyon Lake
- (11) Resolution - Adoption of Resolution 2020-41, A Resolution of the City Council of the City of Canyon Lake, California, Authorizing the Reallocation of Previously Approved Community Development Block Grant Fund Balances for ADA Improvement Projects at New City Building of 31542 Railroad Canyon Road
- (12) Discussion – Discussion of the Status of City-Sponsored Events Scheduled in 2020
- (13) Update - Update on Canyon Lake Internship Program
- (14) Discussion - Discussion of Riverside County Sheriff's Department Citizen Volunteer Program
- (15) Designation of Voting Delegates – Designation of Voting Delegate and Alternates for League of California Cities Annual Conference – October 7th through 9th, 2020

CITY MANAGER COMMENTS

COMMITTEE AND COUNCIL REPORTS/COMMENTS

ANNOUNCEMENTS

The next regular meeting will be Wednesday, October 7, 2020 at 5:00 for Closed Session & 6:30 p.m. for Open Session

ADJOURNMENT

VISION STATEMENT

The vision of the City of Canyon Lake is to be a City that provides a quality of life that makes Canyon Lake the premier place to live in Southern California.

ATTENTION RESIDENTS:

During this period of social distancing, supporting documents, including staff reports, are available for review on the City's website at www.cityofcanyonlake.org once the agenda has been publicly posted. Any written materials relating to an item on this agenda submitted to the City Council after distribution of the agenda packet are available for public inspection electronically, by contacting the City Clerk's Office. It is the intention of the City of Canyon Lake to comply with the Americans with Disabilities Act (ADA) in all respects. If any member of the public has a disability and desires to request a modification or accommodation of the above procedures related to COVID-19, please contact the City Clerk at least 24 hours prior to the meeting at 951-244-8547 or by email at asauseda@cityofcanyonlake.com.

September 2, 2020 City Council Meeting

STATE OF CALIFORNIA }
COUNTY OF RIVERSIDE } SS. AFFIDAVIT OF POSTING
CITY OF CANYON LAKE }

I, Ana V. Sauseda, being duly sworn, depose and say that I am the duly appointed and qualified City Clerk of the City of Canyon Lake and that on August 28, 2020 before the hour of 5:00 p.m., I caused the above notice to be posted as required by Resolution 2019-42 of the City Council of the City of Canyon Lake.

Ana V. Sauseda, CMC
City Clerk



ITEM NO. 2

STAFF REPORT

TO: Honorable Mayor and Members of the City Council

FROM: Chris Mann, City Manager *CM*

BY: Kayla Lozano, Accountant

DATE: September 2, 2020

SUBJECT: Adoption of Resolution No. 2020-35, Allowing Certain Claims and Demands as Set Forth in Exhibit A

Recommendation

That the City Council adopt Resolution No. 2020-35, allowing certain claims and demands as set forth in Exhibit A.

Background

All claims and demands are reported and summarized for review and approval by the City Council on a routine basis at each City Council meeting. The attached claims represent the paid claims and demands since the City Council meeting of August 5, 2020.

Fiscal Impact

All claims and demands are paid from appropriated funds or authorized resources of the City and have been recorded in accordance with the City's policies.

Attachments

1. Resolution No. 2020-35
2. List of Demands

ATTACHMENT 1

RESOLUTION NO. 2020-35

A RESOLUTION OF THE CITY COUNCIL OF THE CITY OF CANYON LAKE, CALIFORNIA, ALLOWING CERTAIN CLAIMS AND DEMANDS AS SET FORTH IN EXHIBIT A

The City Council of the City of Canyon Lake does hereby resolve as follows:

Demands are approved as shown on the Demand\Warrant Register of September 2nd, in the amount of \$215,596.74 as follows:

Payroll Earnings (Gross)	\$ 67,055.43	(2nd Half of July & 1st Half of August)
Payroll Taxes - Employer	1,283.68	(2nd Half of July & 1st Half of August)
On-line Retirement	7,649.79	(2nd Half of July & 1st Half of August)
On-line Health	3,943.29	(For the Month of August)
Nationwide Deferred Comp.	341.01	(For the Month of July)
General	135,323.54	
TOTAL	<u>\$ 215,596.74</u>	

PASSED, APPROVED AND ADOPTED this 2nd day of September, 2020.

ATTEST:

Jordan Ehrenkranz
Mayor

Ana V. Sauseda, CMC
City Clerk

State of California
County of Riverside) ss
City of Canyon Lake)

I, Ana V. Sauseda, City Clerk of the City of Canyon Lake, California, DO HEREBY CERTIFY, that the foregoing is a true and correct copy of the Resolution No. 2020-35 adopted by the City Council of the City of Canyon Lake, California, at a regular meeting thereof, held on September 2, 2020, by the following vote:

AYES:
NOES:
ABSTAIN:
ABSENT:

Ana V. Sauseda, CMC
City Clerk

ATTACHMENT 2

Claims and Demands

City of Canyon Lake
 Check/Voucher Register - Council Report - Expenditures
 From 8/1/2020 Through 8/31/2020

Check Number	Matching Docum... Date	Vendor Name	Transaction Description	Check Amount	Fund Code	Fund Short Title
26030	6/30/2020	Interwest Consulting Group	Building & Safety Services for June 2020	25,161.27	10	GENERAL
Total 26030	6/30/2020			25,161.27		
26031	6/30/2020	Rogers, Anderson, Malody & Scott, LLP	Accounting Services for the month of June 2020	8,900.00	10	GENERAL
Total 26031	6/30/2020			8,900.00		
26032	6/30/2020	TRI LAKE CONSULTANTS, INC.	SB-1 Project & Expenditure Reporting June 2020	280.00	20	GAS TAX
Total 26032	6/30/2020			280.00		
26033	6/30/2020	TRI LAKE CONSULTANTS, INC.	General Engr. Svcs. - LLA 2020-002 Review June 2020	560.00	10	GENERAL
Total 26033	6/30/2020			560.00		
26034	8/6/2020	Abila	Additional User for Monthly Accounting Software, 7/29/20	50.00	10	GENERAL
26034	8/6/2020	Abila	Monthly Accounting Software Subscription, 8/5/2020	122.75	10	GENERAL
Total 26034	8/6/2020			172.75		
26035	8/6/2020	Air Force 1 Heating and Air, Inc.	Instl. of two New Air Conditioning Units for Rental, 7/21/20	17,500.00	60	ENTERPR... FUND
Total 26035	8/6/2020			17,500.00		
26036	8/6/2020	AMERICAN FORENSIC NURSES INC	Sheriff's Blood Draws, 7/15/2020	55.00	10	GENERAL
Total 26036	8/6/2020			55.00		

City of Canyon Lake
 Check/Voucher Register - Council Report - Expenditures
 From 8/1/2020 Through 8/31/2020

Check Number	Matching Docum... Date	Vendor Name	Transaction Description	Check Amount	Fund Code	Fund Short Title
26037	8/6/2020	AmeriGas	Propane for Fire Station, 7/22/2020	830.02	10	GENERAL
Total 26037	8/6/2020			830.02		
26038	8/6/2020	AMP GLOBAL LLC	Rent for Admin Bldg. for the month of September 2020	2,678.00	10	GENERAL
Total 26038	8/6/2020			2,678.00		
26039	8/6/2020	AMP GLOBAL LLC	Rent for 31526 Railroad Cyn. Suite #4 September 2020	400.00	10	GENERAL
Total 26039	8/6/2020			400.00		
26040	8/6/2020	Randall Bonner	Auto Allowance for the month of August - Bonner	100.00	10	GENERAL
Total 26040	8/6/2020			100.00		
26041	8/6/2020	California State Fire Protection	5lb. Extinguisher & Service Call for Admin Office, 7/21/2020	107.48	10	GENERAL
Total 26041	8/6/2020			107.48		
26042	8/6/2020	CANYON LAKE PEST CONTROL, Steven E. Young	City Hall Admin General Pest Qtrly, 7/16/2020	55.00	10	GENERAL
Total 26042	8/6/2020			55.00		
26043	8/6/2020	Cole Huber LLP	Attorney Services for Code Enforcement July 2020	784.50	10	GENERAL
26043	8/6/2020	Cole Huber LLP	Attorney Services for July 2020	5,000.00	10	GENERAL
26043	8/6/2020	Cole Huber LLP	Attorney Services July 2020 (Covid-19)	180.00	10	GENERAL

City of Canyon Lake
 Check/Voucher Register - Council Report - Expenditures
 From 8/1/2020 Through 8/31/2020

Check Number	Matching Docum... Date	Vendor Name	Transaction Description	Check Amount	Fund Code	Fund Short Title
Total 26043	8/6/2020			5,964.50		
26044	8/6/2020	Corelogic Information Solutions, INC.	Database for Code Enforcement Reports, July 2020	5.15	10	GENERAL
26044	8/6/2020	Corelogic Information Solutions, INC.	Database for Code Enforcement, July 2020	128.75	10	GENERAL
Total 26044	8/6/2020			133.90		
26045	8/6/2020	Jordan Ehrenkranz	Auto Allowance for the month of August - Ehrenkranz	100.00	10	GENERAL
Total 26045	8/6/2020			100.00		
26046	8/6/2020	Embroidery & More	City Logo Shirts Borja, Sauseda, Lozano, Day & Enriquez 7/28	195.03	10	GENERAL
Total 26046	8/6/2020			195.03		
26047	8/6/2020	FRIDAY FLYER	1/4 Page Ad for Candidate Nomination Period Opening, 7/10	245.00	10	GENERAL
26047	8/6/2020	FRIDAY FLYER	1/4 Page Ad for Virtual Town Hall Notice for EMS, 5/22/20	245.00	10	GENERAL
Total 26047	8/6/2020			490.00		
26048	8/6/2020	Jeremy Smith	Auto Allowance for the month of August - Smith	100.00	10	GENERAL
Total 26048	8/6/2020			100.00		
26049	8/6/2020	Joe's Hardware	Exchange Tank for Fire Station, 7/30/2020	22.51	10	GENERAL
26049	8/6/2020	Joe's Hardware	Keys and Screws/Bolts for Code Enforcement, 7/23/20	31.00	10	GENERAL

City of Canyon Lake
 Check/Voucher Register - Council Report - Expenditures
 From 8/1/2020 Through 8/31/2020

Check Number	Matching Docum... Date	Vendor Name	Transaction Description	Check Amount	Fund Code	Fund Short Title
Total 26049	8/6/2020			53.51		
26050	8/6/2020	Johnson Controls Security Solutions	Alarm Upgrade in Admin Office Final Invoice, 7/16/20	421.57	10	GENERAL
26050	8/6/2020	Johnson Controls Security Solutions	Security System for Admin July - September 2020	7.46	10	GENERAL
Total 26050	8/6/2020			429.03		
26051	8/6/2020	Kasey Castillo	Auto Allowance for the month of August - Castillo	100.00	10	GENERAL
Total 26051	8/6/2020			100.00		
26052	8/6/2020	Kansas City Life Group Benefits	Life Insurance for Employee's 7/15/20 to 8/14/20	125.74	10	GENERAL
Total 26052	8/6/2020			125.74		
26053	8/6/2020	Larry Greene	Auto Allowance for the month of August - Greene	100.00	10	GENERAL
Total 26053	8/6/2020			100.00		
26054	8/6/2020	Ruby Manzano	Reimbursement - Fuels for City Boats for 4th of July 2020	168.61	10	GENERAL
Total 26054	8/6/2020			168.61		
26055	8/6/2020	MR. WINDOW CLEANING	Window Cleaning Inside & Out City Hall (7/30/20)	75.00	10	GENERAL
Total 26055	8/6/2020			75.00		
26056	8/6/2020	Office & Ergonomic Solutions Inc.	New Desks and Filing Cabinets for New Admin Room, 7/8/20	9,696.45	10	GENERAL

City of Canyon Lake
 Check/Voucher Register - Council Report - Expenditures
 From 8/1/2020 Through 8/31/2020

Check Number	Matching Docum... Date	Vendor Name	Transaction Description	Check Amount	Fund Code	Fund Short Title
Total 26056	8/6/2020			9,696.45		
26057	8/6/2020	PZL, Inc.	Planning Services for July 2020	4,070.00	10	GENERAL
Total 26057	8/6/2020			4,070.00		
26058	8/6/2020	Regional Conservation Authority	MSHCP Fees Collected for July 2020	2,234.00	50	AGENCY
Total 26058	8/6/2020			2,234.00		
26059	8/6/2020	Riv Co Sheriff Dept Perris Station	Sheriff Extra Duty for 4th of July Weekend	4,560.76	10	GENERAL
Total 26059	8/6/2020			4,560.76		
26060	8/6/2020	STAPLES	Office Supplies (Election, Batteries, Keyboard, Binders)7/25	883.49	10	GENERAL
26060	8/6/2020	STAPLES	Office Supplies (Toner, Creamer, Binders, Sanitizer) 6/25/20	654.16	10	GENERAL
Total 26060	8/6/2020			1,537.65		
26061	8/6/2020	Syntech Group	Domain Name Migration for City Emails, July 2020	2,300.00	10	GENERAL
26061	8/6/2020	Syntech Group	IT Services for July 2020	1,750.00	10	GENERAL
Total 26061	8/6/2020			4,050.00		
26062	8/6/2020	Time Warner Cable	Digital Converter for City Hall, 7/22/20 to 8/21/20	5.25	10	GENERAL
Total 26062	8/6/2020			5.25		
26063	8/6/2020	Toshiba Financial Services	Monthly Copier Lease for Admin & City Hall, 7/10/2020	799.31	10	GENERAL

City of Canyon Lake
 Check/Voucher Register - Council Report - Expenditures
 From 8/1/2020 Through 8/31/2020

Check Number	Matching Docum... Date	Vendor Name	Transaction Description	Check Amount	Fund Code	Fund Short Title
Total 26063	8/6/2020			799.31		
26064	8/6/2020	Ur Wire Guy	Electrical Wiring of New Room - 31526 Railroad Cyn. Rd. 7/14	697.76	10	GENERAL
Total 26064	8/6/2020			697.76		
26065	8/10/2020	PV Maintenance Inc.	Covid-19 Enhancements & City Hall Police Office Maint 7/2020	1,861.67	10	GENERAL
Total 26065	8/10/2020			1,861.67		
26066	8/20/2020	Abila	Additional User for Monthly Accounting Software, 8/17/20	50.00	10	GENERAL
Total 26066	8/20/2020			50.00		
26067	8/20/2020	Aflac	Supplemental Insurance for August 2020	497.96	10	GENERAL
Total 26067	8/20/2020			497.96		
26068	8/20/2020	Center Against Sexual Assault	Domestic Violence Forensic Exam (Lake Elsinore), 8/1/20	800.00	10	GENERAL
26068	8/20/2020	Center Against Sexual Assault	Follow Up Exam (Lake Elsinore), 7/17/20	300.00	10	GENERAL
26068	8/20/2020	Center Against Sexual Assault	Sexual Assault Exam (Lake Elsinore), 7/16/20	1,200.00	10	GENERAL
Total 26068	8/20/2020			2,300.00		
26069	8/20/2020	Control Pump	Monthly Landscape Booster Station, July 2020	375.00	20	GAS TAX
Total 26069	8/20/2020			375.00		

City of Canyon Lake
 Check/Voucher Register - Council Report - Expenditures
 From 8/1/2020 Through 8/31/2020

Check Number	Matching Docum... Date	Vendor Name	Transaction Description	Check Amount	Fund Code	Fund Short Title
26070	8/20/2020	CR&R	Trash Services for Rental Bldg. August 2020	164.80	60	ENTERPR... FUND
Total 26070	8/20/2020			164.80		
26071	8/20/2020	CTAI Pacific Greenscape	Landscape Maintenance for Fire Station 60 August 2020	250.00	10	GENERAL
26071	8/20/2020	CTAI Pacific Greenscape	Landscape Maintenance for Median & Parkways August 2020	5,000.00	20	GAS TAX
Total 26071	8/20/2020			5,250.00		
26072	8/20/2020	DATA TICKET	Citation Processing, Code Enforcement & Hearing July 2020	680.00	10	GENERAL
26072	8/20/2020	DATA TICKET	Parking Citations, July 2020	112.10	10	GENERAL
Total 26072	8/20/2020			792.10		
26073	8/20/2020	DIRECTV	Satellite for Fire Station, 8/12/20 to 9/11/20	112.09	10	GENERAL
Total 26073	8/20/2020			112.09		
26074	8/20/2020	Frontier Communications	Internet for City Hall, 8/10/20 to 9/9/20	201.00	10	GENERAL
26074	8/20/2020	Frontier Communications	Phones for Fire Station, 8/13/20 to 9/12/20	381.27	10	GENERAL
Total 26074	8/20/2020			582.27		
26075	8/20/2020	NANCY GREENHALGH	Retiree Health Insurance for September 2020	188.03	10	GENERAL
Total 26075	8/20/2020			188.03		
26076	8/20/2020	Inland Urgent Care Wildomar	Drug Testing for Lozano & Ferrari, 8/3/20	120.00	10	GENERAL

City of Canyon Lake
 Check/Voucher Register - Council Report - Expenditures
 From 8/1/2020 Through 8/31/2020

Check Number	Matching Docum... Date	Vendor Name	Transaction Description	Check Amount	Fund Code	Fund Short Title
Total 26076	8/20/2020			120.00		
26077	8/20/2020	Joe's Hardware	32OZ Fuel for Fire Station, 8/13/20	7.77	10	GENERAL
26077	8/20/2020	Joe's Hardware	Antiseptic, Paint Brush, Paint Tray, etc. - Fire Station,8/7	38.62	10	GENERAL
26077	8/20/2020	Joe's Hardware	Bulbs for Fire Station, 8/18/20	16.36	10	GENERAL
26077	8/20/2020	Joe's Hardware	Sanddisk for Fire Station, 8/5/2020	10.23	10	GENERAL
26077	8/20/2020	Joe's Hardware	Office Supplies for Rental Bldg, 8/13/20	53.55	60	ENTERPR... FUND
Total 26077	8/20/2020			126.53		
26078	8/20/2020	Johnson Controls Security Solutions	Alarm Upgrade at City Hall, 7/17/20	782.05	10	GENERAL
Total 26078	8/20/2020			782.05		
26079	8/20/2020	Kansas City Life Group Benefits	Life Insurance for Employee's 8/15/20 to 9/14/20	125.74	10	GENERAL
26079	8/20/2020	Kansas City Life Group Benefits	Life Insurance for Employee's 9/15/20 to 10/14/20	125.74	10	GENERAL
Total 26079	8/20/2020			251.48		
26080	8/20/2020	PBK Golf Services	FY 20/21 Donation to the 2020 Golf Championship Tournament	1,000.00	10	GENERAL
Total 26080	8/20/2020			1,000.00		
26081	8/20/2020	Pitney Bowes Global Financial Services, LLC	Postage Machine Lease, 6/13/20 to 9/12/20	175.14	10	GENERAL
Total 26081	8/20/2020			175.14		
26082	8/20/2020	Regional Conservation Authority	MSHCP Fess Collected For August 2020	4,468.00	50	AGENCY

City of Canyon Lake
 Check/Voucher Register - Council Report - Expenditures
 From 8/1/2020 Through 8/31/2020

Check Number	Matching Docum... Date	Vendor Name	Transaction Description	Check Amount	Fund Code	Fund Short Title
Total 26082	8/20/2020			4,468.00		
26083	8/20/2020	JOHN REGUS	Library Lease for October 2020	1,106.86	10	GENERAL
Total 26083	8/20/2020			1,106.86		
26084	8/20/2020	Special District Risk Management Authority	Dental, Vision Ins.Ecclefield, Mann, Sauseda, Ferrari Sept20	363.23	10	GENERAL
Total 26084	8/20/2020			363.23		
26085	8/20/2020	STATE COMP. INS. FUND	Workers Comp Insurance for September 2020	971.33	10	GENERAL
Total 26085	8/20/2020			971.33		
26086	8/20/2020	Steve's Towing Inc.	Air Up Tires on City GMC Sierra, 7/20/20	70.00	10	GENERAL
Total 26086	8/20/2020			70.00		
26087	8/20/2020	Time Warner Cable	Internet for Fire Station, 8/10/20 to 9/9/20	104.98	10	GENERAL
Total 26087	8/20/2020			104.98		
26088	8/20/2020	U. S. Bank	Office Supplies, CCMF Dues, ICMA, Computers, Etc. 8/6/20	8,377.45	10	GENERAL
Total 26088	8/20/2020			8,377.45		
26089	8/20/2020	Verizon Wireless	Cell Phones, 7/4/20 to 8/3/20	226.12	10	GENERAL
26089	8/20/2020	Verizon Wireless	iPads, 7/4/20 to 8/3/20	167.10	10	GENERAL
Total 26089	8/20/2020			393.22		

City of Canyon Lake
 Check/Voucher Register - Council Report - Expenditures
 From 8/1/2020 Through 8/31/2020

Check Number	Matching Docum... Date	Vendor Name	Transaction Description	Check Amount	Fund Code	Fund Short Title
26090	6/30/2020	ANIMAL FRIENDS OF THE VALLEYS	Animal Control Services for June 2020	3,500.00	10	GENERAL
Total 26090	6/30/2020			3,500.00		
26091	6/30/2020	COUNTY OF RIVERSIDE-TLMA	SLF Costs for June 2020	3,141.92	10	GENERAL
Total 26091	6/30/2020			3,141.92		
EFT188		SOUTHERN CALIFORNIA EDISON	Electricity for Rental (A-D & STE. 1) 6/15/20 to 7/16/20	638.29	60	ENTERPR... FUND
Total EFT188				638.29		
EFT189		SOUTHERN CALIFORNIA EDISON	Electricity for City Hall 6/15/20 to 7/16/20	1,297.27	10	GENERAL
Total EFT189				1,297.27		
EFT190		SOUTHERN CALIFORNIA EDISON	Electricity for Traffic Signals 6/15/20 to 7/16/20	183.30	20	GAS TAX
Total EFT190				183.30		
EFT191		SOUTHERN CALIFORNIA EDISON	Electricity for Traffic Signals 6/19/20 to 7/22/20	7.90	20	GAS TAX
Total EFT191				7.90		
EFT192		SOUTHERN CALIFORNIA EDISON	Electricity for Pump Station 6/9/20 to 7/10/20	225.91	20	GAS TAX
Total EFT192				225.91		
EFT193		SOUTHERN CALIFORNIA EDISON	Electricity for Fire Station 6/15/20 to 7/16/20	785.78	20	GAS TAX

City of Canyon Lake
 Check/Voucher Register - Council Report - Expenditures
 From 8/1/2020 Through 8/31/2020

Check Number	Matching Docum... Date	Vendor Name	Transaction Description	Check Amount	Fund Code	Fund Short Title
Total EFT193				785.78		
EFT194		SOUTHERN CALIFORNIA EDISON	Electricity for Traffic Signals 6/22/20 to 7/23/20	51.13	20	GAS TAX
Total EFT194				51.13		
EFT195		SOUTHERN CALIFORNIA EDISON	Electricity for City Hall Admin 6/19/20 to 7/22/20	310.68	10	GENERAL
Total EFT195				310.68		
EFT196		SOUTHERN CALIFORNIA EDISON	Electricity for Traffic Signals 6/29/20 to 7/30/20	280.60	20	GAS TAX
Total EFT196				280.60		
EFT197		Sparkletts	Drinking Water for City Hall & Admin July 2020	143.95	10	GENERAL
Total EFT197				143.95		
EFT198		ELSINORE VALLEY MUNI WATER DIS	Water for Irrigation 6/28/20 to 7/28/20	940.51	20	GAS TAX
Total EFT198				940.51		
EFT199		ELSINORE VALLEY MUNI WATER DIS	Water for Fire Station 6/28/20 to 7/28/20	462.11	10	GENERAL
Total EFT199				462.11		
EFT200		ELSINORE VALLEY MUNI WATER DIS	Water for Rental (31542) 6/25/20 to 7/25/20	92.74	60	ENTERPR... FUND
Total EFT200				92.74		

City of Canyon Lake
 Check/Voucher Register - Council Report - Expenditures
 From 8/1/2020 Through 8/31/2020

Check Number	Matching Docum... Date	Vendor Name	Transaction Description	Check Amount	Fund Code	Fund Short Title
EFT201		ELSINORE VALLEY MUNI WATER DIS	Water for City Hall 6/25/20 to 7/25/20	84.53	10	GENERAL
Total EFT201				84.53		
EFT202		SOUTHERN CALIFORNIA EDISON	Electricity for Pump Station 7/10/20 to 8/10/20	206.71	20	GAS TAX
Total EFT202				206.71		
Report Total				135,323.54		

City of Canyon Lake
Invoices Selected for Payment - COUNCIL CHECK REPORT

Vendor ID	Invoice Description	Cash Required
ICG	Building & Safety Services for June 2020	25,161.27
RAMS	Accounting Services for the month of June 2020	8,900.00
TRI LAKE	SB-1 Project & Expenditure Reporting June 2020	280.00
	General Engr. Srvcs. - LLA 2020-002 Review June 2020	560.00
Report Total		34,901.27

City of Canyon Lake
Invoices Selected for Payment - COUNCIL CHECK REPORT

Vendor ID	Invoice Description	Cash Required
ABILA	Monthly Accounting Software Subscription, 8/5/2020	122.75
	Additional User for Monthly Accounting Software, 7/29/20	50.00
Air Force 1	Instl. of two New Air Conditioning Units for Rental, 7/21/20	17,500.00
AMERICAN FORENSIC	Sheriff's Blood Draws, 7/15/2020	55.00
AmeriGas	Propane for Fire Station, 7/22/2020	830.02
AMP	Rent for Admin Bldg. for the month of September 2020	2,678.00
	Rent for 31526 Railroad Cyn. Suite #4 September 2020	400.00
Bonner	Auto Allowance for the month of August - Bonner	100.00
California State Fire Protection	5lb. Extinguisher & Service Call for Admin Office, 7/21/2020	107.48
CL PEST	City Hall Admin General Pest Qtrly, 7/16/2020	55.00
Cole Huber	Attorney Services for July 2020	5,000.00
	Attorney Services for Code Enforcement July 2020	784.50
	Attorney Services July 2020 (Covid-19)	180.00
Corelogic	Database for Code Enforcement, July 2020	128.75
	Database for Code Enforcement Reports, July 2020	5.15
Ehrenkranz	Auto Allowance for the month of August - Ehrenkranz	100.00
Embroidery	City Logo Shirts Borja, Sauseda, Lozano, Day & Enriquez 7/28	195.03
FRIDAY FLYER	1/4 Page Ad for Virtual Town Hall Notice for EMS, 5/22/20	245.00
	1/4 Page Ad for Candidate Nomination Period Opening, 7/10	245.00
Jeremy Smith	Auto Allowance for the month of August - Smith	100.00
Joe's	Exchange Tank for Fire Station, 7/30/2020	22.51
	Keys and Screws/Bolts for Code Enforcement, 7/23/20	31.00
Johnson Controls	Security System for Admin July - September 2020	7.46
	Alarm Upgrade in Admin Office Final Invoice, 7/16/20	421.57
Kasey Castillo	Auto Allowance for the month of August - Castillo	100.00
KCL Group Benefits	Life Insurance for Employee's 7/15/20 to 8/14/20	125.74
Larry Greene	Auto Allowance for the month of August - Greene	100.00
Manzano	Reimbursement - Fuels for City Boats for 4th of July 2020	168.61
MR. WINDOW	Window Cleaning Inside & Out City Hall (7/30/20)	75.00
Office & Ergonomic	New Desks and Filing Cabinets for New Admin Room, 7/8/20	9,696.45
PZL, Inc.	Planning Services for July 2020	4,070.00

Date: 8/6/20

06:19:48 PM

09/02/2020 City Council Agenda

Page: 1

City of Canyon Lake
Invoices Selected for Payment - COUNCIL CHECK REPORT

Vendor ID	Invoice Description	Cash Required
RCA	MSHCP Fees Collected for July 2020	2,234.00
Riv Co Sheriff Dept	Sheriff Extra Duty for 4th of July Weekend	4,560.76
STAPLES	Office Supplies (Toner, Creamer, Binders, Sanitizer) 6/25/20	654.16
	Office Supplies (Election, Batteries, Keyboard, Binders)7/25	883.49
Syntech	Domain Name Migration for City Emails, July 2020	2,300.00
	IT Services for July 2020	1,750.00
Time Warner	Digital Converter for City Hall, 7/22/20 to 8/21/20	5.25
Toshiba	Monthly Copier Lease for Admin & City Hall, 7/10/2020	799.31
Ur Wire Guy	Electrical Wiring of New Room - 31526 Railroad Cyn. Rd. 7/14	697.76
Report Total		57,584.75

City of Canyon Lake
Invoices Selected for Payment - COUNCIL CHECK REPORT

Vendor ID	Invoice Description	Cash Required
ABILA	Additional User for Monthly Accounting Software, 8/17/20	50.00
Aflac	Supplemental Insurance for August 2020	497.96
CenterAgainst	Sexual Assault Exam (Lake Elsinore), 7/16/20	1,200.00
	Follow Up Exam (Lake Elsinore), 7/17/20	300.00
	Domestic Violence Forensic Exam (Lake Elsinore), 8/1/20	800.00
Control Pump	Monthly Landscape Booster Station, July 2020	375.00
CR&R	Trash Services for Rental Bldg. August 2020	164.80
CTAI	Landscape Maintenance for Fire Station 60 August 2020	250.00
	Landscape Maintenance for Median & Parkways August 2020	5,000.00
DATA TICKET	Parking Citations, July 2020	112.10
	Citation Processing, Code Enforcement & Hearing July 2020	680.00
DIRECTV	Satellite for Fire Station, 8/12/20 to 9/11/20	112.09
Frontier	Internet for City Hall, 8/10/20 to 9/9/20	201.00
	Phones for Fire Station, 8/13/20 to 9/12/20	381.27
GREENHALGH	Retiree Health Insurance for September 2020	188.03
Inland	Drug Testing for Lozano & Ferrari, 8/3/20	120.00
Joe's	Office Supplies for Rental Bldg, 8/13/20	53.55
	Bulbs for Fire Station, 8/18/20	16.36
	Antiseptic, Paint Brush, Paint Tray, etc. - Fire Station, 8/7	38.62
	32OZ Fuel for Fire Station, 8/13/20	7.77
	Sanddisk for Fire Station, 8/5/2020	10.23
Johnson Controls	Alarm Upgrade at City Hall, 7/17/20	782.05
KCL Group Benefits	Life Insurance for Employee's 8/15/20 to 9/14/20	125.74
	Life Insurance for Employee's 9/15/20 to 10/14/20	125.74
PBK Golf Services	FY 20/21 Donation to the 2020 Golf Championship Tournament	1,000.00
Pitney Bowes	Postage Machine Lease, 6/13/20 to 9/12/20	175.14
RCA	MSHCP Fess Collected For August 2020	4,468.00
REGUS	Library Lease for October 2020	1,106.86
SDRMA	Dental, Vision Ins.Ecclefield, Mann, Sauseda, Ferrari Sept20	363.23
STATE FUND	Workers Comp Insurance for September 2020	971.33
Steve's Towing	Air Up Tires on City GMC Sierra, 7/20/20	70.00
Time Warner	Internet for Fire Station, 8/10/20 to 9/9/20	104.98
US Bank	Office Supplies, CCMF Dues, ICMA, Computers, Etc. 8/6/20	8,377.45
VerizonW	iPads, 7/4/20 to 8/3/20	167.10
	Cell Phones, 7/4/20 to 8/3/20	226.12

Date: 8/20/20

05:55:01 PM

09/02/2020 City Council Agenda

Page: 1

City of Canyon Lake
Invoices Selected for Payment - COUNCIL CHECK REPORT

<u>Vendor ID</u>	<u>Invoice Description</u>	<u>Cash Required</u>
Report Total		28,622.52

City of Canyon Lake
Invoices Selected for Payment - COUNCIL CHECK REPORT

<u>Vendor ID</u>	<u>Invoice Description</u>	<u>Cash Required</u>
ANIMAL FRIENDS	Animal Control Services for June 2020	3,500.00
Riv Co TLMA	SLF Costs for June 2020	3,141.92
Report Total		<u>6,641.92</u>

City of Canyon Lake
Company (10756)

Check Date: 07/31/2020
Process: 2020073101
Period: 07/16/2020 to 07/31/2020

Labor Distribution

Department: (20)City Employees

Code	Earning	Hours	Amount	Deduction	Code	Amount	Code	Tax	Amount	Code	Tax	Amount	Taxable	Tax	Amount	Taxable	Amount
125CO	125 Cash		454.59	PTAXI Pre-Tax P.	CA	299.66	CA	California SI	4435.76	CA	CA Edu & T	183.04	0.00	0.00	0.00	0.00	0.00
Reg	Regular		4280.83	CASDI CA SDI - Err	CASDI	4735.42	CASUI	California SI	4735.42	CASUI	California SI	47.36	0.00	0.00	0.00	0.00	0.00
102	Emp Id			FITW Federal Incoi	FITW	4435.76	FED	Federal Incoi	4435.76	MED-R	Medicare - E	515.95	4735.42	68.66	68.66	4735.42	68.66
2280.83	Salary	9.50	0.00	MED Medicare	MED	4735.42	MED	Medicare	4735.42			68.66					
	Total Earnings	9.50	4735.42	Total Deductions		299.66		Total Employer Taxes				815.01					68.66
	Code	Earning	Hours	Amount	Code	Amount	Code	Tax	Amount	Code	Tax	Amount	Taxable	Tax	Amount	Taxable	Amount
Reg	Regular		45.00	970.20	CA	970.20	CA	California SI	970.20	CA	CA Edu & T	13.15	0.00	0.00	0.00	0.00	0.00
106	Emp Id			CASDI CA SDI - Err	CASDI	970.20	CASUI	California SI	970.20	CASUI	California SI	9.71	0.00	0.00	0.00	0.00	0.00
21.5600	Rate			FITW Federal Incoi	FITW	970.20	FED	Federal Incoi	970.20	MED-R	Medicare - E	47.44	970.20	14.07	14.07	970.20	14.07
	Total Earnings	45.00	970.20	Total Deductions		0.00		Total Employer Taxes				84.37					14.07
	Code	Earning	Hours	Amount	Code	Amount	Code	Tax	Amount	Code	Tax	Amount	Taxable	Tax	Amount	Taxable	Amount
Reg	Regular		45.00	769.50	CA	769.50	CA	California SI	711.79	CA	CA Edu & T	7.46	0.00	0.00	0.00	0.00	0.00
114	Emp Id			457B EE	457B	57.71	CA	California SI	711.79	CASDI	CA SDI - Err	7.69	769.50	0.00	0.00	0.00	0.00
17.1000	Rate			AflacP Aflac Post	AflacP	27.30	CASUI	California SI	769.50	FITW	Federal Incoi	21.60	711.79	11.16	11.16	769.50	11.16
	Total Earnings	45.00	769.50	Total Deductions		85.01		Total Employer Taxes				47.91					11.16
	Code	Earning	Hours	Amount	Code	Amount	Code	Tax	Amount	Code	Tax	Amount	Taxable	Tax	Amount	Taxable	Amount
Reg	Regular		45.00	186.93	PTXPE Pre-Tax P.	143.72	CA	California SI	2172.38	CA	CA Edu & T	73.61	0.00	0.00	0.00	0.00	0.00
115	Emp Id			2129.17	CASDI CA SDI - Err	23.16	CASUI	California SI	2316.10	CASUI	California SI	23.16	0.00	0.00	0.00	0.00	0.00
2129.17	Salary			FITW Federal Incoi	FITW	2172.38	FED	Federal Incoi	2172.38	MED-R	Medicare - E	190.46	2316.10	33.58	33.58	2316.10	33.58
	Total Earnings	45.00	769.50	Total Deductions		143.72		Total Employer Taxes				320.81					33.58
	Code	Earning	Hours	Amount	Code	Amount	Code	Tax	Amount	Code	Tax	Amount	Taxable	Tax	Amount	Taxable	Amount
Reg	Regular		0.00	166.99	PTXPE Pre-Tax P.	175.78	CA	California SI	2595.38	CA	CA Edu & T	116.42	2771.16	2.77	2.77	2771.16	2.77
117	Emp Id			2604.17	CASDI CA SDI - Err	27.71	CASUI	California SI	2771.16	CASUI	California SI	27.71	2771.16	149.64	149.64	2771.16	149.64
2604.17	Salary			FITW Federal Incoi	FITW	2595.38	FED	Federal Incoi	2595.38	MED-R	Medicare - E	281.90	2771.16	40.18	40.18	2771.16	40.18
	Total Earnings	0.00	2316.10	Total Deductions		175.78		Total Employer Taxes				466.21					192.59
	Code	Earning	Hours	Amount	Code	Amount	Code	Tax	Amount	Code	Tax	Amount	Taxable	Tax	Amount	Taxable	Amount
Reg	Regular		0.00	184.97	PTXPE Pre-Tax P.	464.06	CA	California SI	6670.91	CA	CA Edu & T	527.72	0.00	0.00	0.00	0.00	0.00
111	Emp Id			75.00	CASDI CA SDI - Err	7134.97	CASUI	California SI	7134.97	CASUI	California SI	71.35	0.00	0.00	0.00	0.00	0.00
6875.00	Salary			ELECT Reimburs	FITW	6670.91	FED	Federal Incoi	6670.91	MED-R	Medicare - E	1273.33	7134.97	103.46	103.46	7134.97	103.46
	Total Earnings	0.00	7134.97	Total Deductions		464.06		Total Employer Taxes				1975.86					103.46

City of Canyon Lake
Company (10756)

Check Date: 07/31/2020
Process: 2020073101
Period: 07/16/2020 to 07/31/2020

Labor Distribution

Code	Earning	Hours	Amount	Deduction	Code	Amount	Tax	Code	Amount	Tax	Code	Amount	Taxable	Tax	Amount	Taxable	Amount
125CO	125 Cash		527.74	457B EE	CA	66.00	California SI	3553.99	CA	86.05	CA	86.05	CA Edu & T	0.00	0.00	0.00	0.00
108	Reg Regular		3325.00	PTAXI Pre-Tax P	CASDI	232.75	CA SDI - Eir	3852.74	CASUI	38.53	CA	38.53	California SI	0.00	0.00	0.00	Gross 3852.74
	Salary	9.50	0.00		FITW	3553.99	Federal Incoi	3553.99	MED-R	286.02	MED-R	286.02	Medicare - E	3852.74	55.86	55.86	Tot Liab 3908.60
					MED	3852.74	Medicare	3852.74		55.86		55.86					Net Amt 3087.53
	Total Earnings	9.50	3852.74	Total Deductions		298.75	Total Employee Taxes			466.46	Total Employer Taxes				55.86		

Department: (20)City Employees Total

Code	Earning	Hours	Amount	Deduction	Code	Amount	Tax	Code	Amount	Tax	Code	Amount	Taxable	Tax	Amount	Taxable	Amount
7	125CO 125 Cash		1521.22	457B EE	CA	123.71	California SI	21110.41	CA	1007.45	CA	1007.45	CA Edu & T	2771.16	2.77	2.77	2.77
4	ELECT Reimburs		75.00	Aflac Post	CASDI	27.30	CA SDI - Eir	22550.09	CASUI	225.51	CA	225.51	California SI	2771.16	149.64	149.64	Gross 22550.09
3	Reg Regular	90.00	20953.87	PTAXI Pre-Tax P	FITW	532.41	Federal Incoi	21110.41	MED-R	2616.70	MED-R	2616.70	Medicare - E	22550.09	326.97	326.97	Tot Liab 23029.47
	Sick	9.50	0.00	PTXPE Pre-Tax P	MED	783.56	Medicare	22550.09	SS-R	326.97	SS-R	326.97	OASDI - Em	2771.16	0.00	0.00	Net Amt 16906.48
	Vac	9.50	0.00		SS	0.00	OASDI	2771.16		0.00		0.00					
	Total Earnings	109.00	22550.09	Total Deductions		1466.98	Total Employee Taxes			4176.63	Total Employer Taxes				479.38		

Department: (30)Special Enforcement Team

Code	Earning	Hours	Amount	Deduction	Code	Amount	Tax	Code	Amount	Tax	Code	Amount	Taxable	Tax	Amount	Taxable	Amount
Reg	Regular	85.50	2304.23	457B EE	CA	50.00	California SI	1970.94	CA	64.21	CA	64.21	CA Edu & T	0.00	0.00	0.00	0.00
				MEDI: Health Ins	CASDI	127.75	CA SDI - Eir	2176.48	CASUI	21.77	CA	21.77	California SI	0.00	0.00	0.00	Gross 2304.23
				PTXPE Pre-Tax P	FITW	155.54	Federal Incoi	1970.94	MED-R	160.55	MED-R	160.55	Medicare - E	2176.48	31.56	31.56	Tot Liab 2335.79
					MED	31.56	Medicare	2176.48		31.56		31.56					Net Amt 1692.85
	Total Earnings	85.50	2304.23	Total Deductions		333.29	Total Employee Taxes			278.09	Total Employer Taxes				31.56		

Code	Earning	Hours	Amount	Deduction	Code	Amount	Tax	Code	Amount	Tax	Code	Amount	Taxable	Tax	Amount	Taxable	Amount
125CO	125 Cash		477.29	PTAXI Pre-Tax P	CA	196.88	California SI	3092.91	CA	167.28	CA	167.28	CA Edu & T	0.00	0.00	0.00	0.00
101	Reg Regular		2812.50		CASDI	3289.79	CA SDI - Eir	3289.79	CASUI	32.89	CA	32.89	California SI	0.00	0.00	0.00	Gross 3289.79
					FITW	295.19	Federal Incoi	3092.91	MED-R	295.19	MED-R	295.19	Medicare - E	3289.79	47.70	47.70	Tot Liab 3337.49
					MED	47.70	Medicare	3289.79		47.70		47.70					Net Amt 2549.85
	Total Earnings	0.00	3289.79	Total Deductions		196.88	Total Employee Taxes			543.06	Total Employer Taxes				47.70		

Code	Earning	Hours	Amount	Deduction	Code	Amount	Tax	Code	Amount	Tax	Code	Amount	Taxable	Tax	Amount	Taxable	Amount
Reg	Regular	32.00	933.12		CA	12.33	California SI	933.12	CA	12.33	CA	12.33	CA Edu & T	0.00	0.00	0.00	0.00
					CASDI	9.33	CA SDI - Eir	933.12	CASUI	9.33	CA	9.33	California SI	0.00	0.00	0.00	Gross 933.12
					FITW	84.75	Federal Incoi	933.12	MED-R	84.75	MED-R	84.75	Medicare - E	933.12	13.53	13.53	Tot Liab 946.65
					MED	13.53	Medicare	933.12		13.53		13.53					Net Amt 813.18
	Total Earnings	32.00	933.12	Total Deductions		0.00	Total Employee Taxes			119.94	Total Employer Taxes				13.53		

Code	Earning	Hours	Amount	Deduction	Code	Amount	Tax	Code	Amount	Tax	Code	Amount	Taxable	Tax	Amount	Taxable	Amount
125CO	125 Cash		499.58	PTXPE Pre-Tax P	CA	161.77	California SI	2734.38	CA	65.63	CA	65.63	CA Edu & T	0.00	0.00	0.00	0.00
98	Comp Tin	38.00	1065.14		CASDI	28.96	CA SDI - Eir	2896.15	CASUI	28.96	CA	28.96	California SI	0.00	0.00	0.00	Gross 2896.15
	Reg Regular	38.00	1065.14		FITW	2734.38	Federal Incoi	2734.38	MED-R	252.17	MED-R	252.17	Medicare - E	2896.15	41.99	41.99	Tot Liab 2938.14
	Vac	9.50	266.29		MED	42.00	Medicare	2896.15		42.00		42.00					Net Amt 2345.62
	Total Earnings	85.50	2896.15	Total Deductions		161.77	Total Employee Taxes			388.76	Total Employer Taxes				41.99		

City of Canyon Lake
Company (10756)

Check Date: 07/31/2020 Page
Process: 2020073101 3
Period: 07/16/2020 to 07/31/2020

Labor Distribution

Code	Earning	Hours	Amount	Code	Deduction	Amount	Code	Tax	Amount	Code	Tax	Amount	Taxable	Amount	Taxable	Amount
Reg	Regular	57.00	1597.71	PTXPE	Pre-Tax P.	107.85	CA	California SI	1489.86	CAEIT	CA Edu & T	0.00	0.00	0.00	0.00	0.00
				CASD	CA SDI - Eir				1597.71	CASU	California SI	0.00	0.00	0.00	0.00	1597.71
				FITW	Federal Incoi				1489.86	MED-R	Medicare - E	23.17	1597.71	23.17	1597.71	1620.88
				MED	Medicare				1597.71							1313.70
Total Earnings			57.00	1597.71	Total Deductions	107.85	Total Employer Taxes	176.16	23.17	Total Employer Taxes	23.17					

Department: (30)Special Enforcement Team Total

Code	Earning	Hours	Amount	Code	Deduction	Amount	Code	Tax	Amount	Code	Tax	Amount	Taxable	Amount	Taxable	Amount
5	125CO 125 Cash		976.87	457B	457B EE:	50.00	CA	California SI	10221.21	CAEIT	CA Edu & T	0.00	0.00	0.00	0.00	0.00
3	Comp Tin	38.00	1065.14	MED	Health Ins	127.75	CASD	CA SDI - Eir	10893.25	CASU	California SI	0.00	0.00	0.00	0.00	11021.00
2	Regular	212.50	8712.70	PTAXI	Pre-Tax P.	196.88	FITW	Federal Incoi	10221.21	MED-R	Medicare - E	157.95	10893.25	157.95	10893.25	11178.95
	Vac	9.50	266.29	PTXPE	Pre-Tax P.	425.16	MED	Medicare	10893.25							8715.20
Total Earnings			11021.00	Total Deductions	799.79	Total Employer Taxes	1506.01	Total Employer Taxes	157.95							

Department: (50)Council Members

Code	Earning	Hours	Amount	Code	Deduction	Amount	Code	Tax	Amount	Code	Tax	Amount	Taxable	Amount	Taxable	Amount
Reg	Regular		300.00	CA	California SI		CA	California SI	300.00	CAEIT	CA Edu & T	0.30	300.00	0.30	300.00	300.00
				FITW	Federal Incoi		FITW	Federal Incoi	300.00	CASU	California SI	16.20	300.00	16.20	300.00	300.00
				MED	Medicare		MED	Medicare	300.00	MED-R	Medicare - E	4.36	300.00	4.36	300.00	300.00
Total Earnings			300.00	Total Deductions	0.00	Total Employer Taxes	4.35	Total Employer Taxes	20.86							
Reg	Regular		300.00	CA	California SI		CA	California SI	300.00	CAEIT	CA Edu & T	0.30	300.00	0.30	300.00	300.00
				FITW	Federal Incoi		FITW	Federal Incoi	300.00	CASU	California SI	16.20	300.00	16.20	300.00	300.00
				MED	Medicare		MED	Medicare	300.00	MED-R	Medicare - E	4.35	300.00	4.35	300.00	300.00
Total Earnings			300.00	Total Deductions	0.00	Total Employer Taxes	4.35	Total Employer Taxes	20.85							
Reg	Regular		300.00	CA	California SI		CA	California SI	300.00	CAEIT	CA Edu & T	0.30	300.00	0.30	300.00	300.00
				FITW	Federal Incoi		FITW	Federal Incoi	300.00	CASU	California SI	16.20	300.00	16.20	300.00	300.00
				MED	Medicare		MED	Medicare	300.00	MED-R	Medicare - E	4.35	300.00	4.35	300.00	300.00
Total Earnings			300.00	Total Deductions	0.00	Total Employer Taxes	4.35	Total Employer Taxes	20.85							
Reg	Regular		300.00	CA	California SI		CA	California SI	300.00	CAEIT	CA Edu & T	0.30	300.00	0.30	300.00	300.00
				FITW	Federal Incoi		FITW	Federal Incoi	300.00	CASU	California SI	16.20	300.00	16.20	300.00	300.00
				MED	Medicare		MED	Medicare	300.00	MED-R	Medicare - E	4.35	300.00	4.35	300.00	300.00
Total Earnings			300.00	Total Deductions	0.00	Total Employer Taxes	4.35	Total Employer Taxes	20.85							

Department: (20)City Employees

Code	Earning	Hours	Amount	Deduction	Code	Amount	Tax	Code	Amount	Tax	Code	Amount	Taxable	Tax	Code	Amount	Taxable	Amount
125CO	125 Cash		470.62	PTAXI Pre-Tax P.	CA	299.66	California SI	4451.79	184.45	CAETT CA Edu & T		0.00	0.00			0.00	0.00	
Reg	Regular		4280.83		CASDI CA SDI - Eir			4751.45	47.51	CASUI California SI		0.00	0.00			0.00	0.00	
Emp Id	102				FITW Federal Incoi			4451.79	519.48	MED-R Medicare - E		68.89	4751.45			68.89	4751.45	
Salary	4280.83				MED Medicare			4751.45	68.90									4820.34
					Total Deductions	299.66			820.34							68.89		3631.45

Code	Earning	Hours	Amount	Deduction	Code	Amount	Tax	Code	Amount	Tax	Code	Amount	Taxable	Tax	Code	Amount	Taxable	Amount
Reg	Regular	36.00	776.16		CA	California SI	883.96	883.96	11.25	CAETT CA Edu & T		0.00	0.00			0.00	0.00	
Sick	Sick	5.00	107.80		CASDI CA SDI - Eir			883.96	8.84	CASUI California SI		0.00	0.00			0.00	0.00	
Emp Id	106				FITW Federal Incoi			883.96	38.81	MED-R Medicare - E		12.82	883.96			12.82	883.96	
Rate	21.5600				MED Medicare			883.96	12.82									883.96
					Total Deductions	0.00			71.72							12.82		812.24

Code	Earning	Hours	Amount	Deduction	Code	Amount	Tax	Code	Amount	Tax	Code	Amount	Taxable	Tax	Code	Amount	Taxable	Amount
Reg	Regular	40.00	684.00	457B EE	CA	51.30	California SI	632.70	5.72	CAETT CA Edu & T		0.00	0.00			0.00	0.00	
Emp Id	114				AflacP, Aflac Post	13.65		684.00	6.84	CASUI California SI		0.00	0.00			0.00	0.00	
Rate	17.1000				FITW Federal Incoi			632.70	13.69	MED-R Medicare - E		9.92	684.00			9.92	684.00	
					MED Medicare			684.00	9.92									684.00
					Total Deductions	64.95			36.17							9.92		693.92

Code	Earning	Hours	Amount	Deduction	Code	Amount	Tax	Code	Amount	Tax	Code	Amount	Taxable	Tax	Code	Amount	Taxable	Amount
Reg	Regular	40.00	186.99	PTXPE Pre-Tax P.	CA	143.72	California SI	2172.38	73.61	CAETT CA Edu & T		0.00	0.00			0.00	0.00	
Emp Id	115				CASDI CA SDI - Eir			2316.10	23.16	CASUI California SI		0.00	0.00			0.00	0.00	
Salary	2129.17				FITW Federal Incoi			2172.38	190.46	MED-R Medicare - E		33.58	2316.10			33.58	2316.10	
					MED Medicare			2316.10	33.58									2316.10
					Total Deductions	143.72			320.81							33.58		2349.68

Code	Earning	Hours	Amount	Deduction	Code	Amount	Tax	Code	Amount	Tax	Code	Amount	Taxable	Tax	Code	Amount	Taxable	Amount
Reg	Regular	0.00	2604.17		CA	175.78	California SI	2593.38	116.42	CAETT CA Edu & T		1457.68	146			1457.68	146	
Emp Id	117				CASDI CA SDI - Eir			2771.16	27.71	CASUI California SI		78.71	2771.16			78.71	2771.16	
Salary	2604.17				FITW Federal Incoi			2593.38	281.90	MED-R Medicare - E		40.18	2771.16			40.18	2771.16	
					MED Medicare			2771.16	40.19	SS-R OASDI - Eir		0.00	2771.16			0.00	2771.16	
					SS OASDI			2771.16	0.00									2771.16
					Total Deductions	175.78			466.22							120.35		1851.57

Code	Earning	Hours	Amount	Deduction	Code	Amount	Tax	Code	Amount	Tax	Code	Amount	Taxable	Tax	Code	Amount	Taxable	Amount
Reg	Regular	0.00	182.99	PTXPE Pre-Tax P.	CA	464.06	California SI	6668.93	527.51	CAETT CA Edu & T		0.00	0.00			0.00	0.00	
Emp Id	111				CASDI CA SDI - Eir			7132.99	71.33	CASUI California SI		0.00	0.00			0.00	0.00	
Salary	6875.00				FITW Federal Incoi			6668.93	1272.86	MED-R Medicare - E		103.43	7132.99			103.43	7132.99	
					MED Medicare			7132.99	103.42									7132.99
					Total Deductions	464.06			1975.12							103.43		4693.81

City of Canyon Lake
Company (10756)

Check Date: 08/14/2020
Process: 2020081401
Period: 08/01/2020 to 08/15/2020

Labor Distribution

Code	Earning	Hours	Amount	Deduction	Code	Amount	Tax	Code	Amount	Tax	Code	Amount	Taxable	Tax	Code	Amount	Taxable	Amount
125CO	125 Cash		527.74	457B EE	CA	66.00	California SI	3553.99	CA ETT	CA Edu & T	CA ETT	86.05	0.00	CA ETT	CA Edu & T	CA ETT	0.00	0.00
108	Reg Regular		3325.00	PTAXI Pre-Tax P.	CASDI	232.75	CA SDI - Err	3852.74	CASUI	California SI	CASUI	38.52	0.00	CASUI	California SI	CASUI	0.00	0.00
3325.00	Salary			FITW Federal Incoi	FITW		Federal Incoi	3553.99	MED-R	Medicare - E	MED-R	286.02	3852.74	MED-R	Medicare - E	MED-R	55.86	3908.60
				MED Medicare	SS		Medicare	3852.74	OASDI	OASDI - Err	OASDI	55.87	2771.16	OASDI	OASDI - Err	OASDI	0.00	3087.53
				Total Deductions		298.75	Total Employee Taxes	466.46				466.46	Total Employer Taxes				55.86	

Department: (20)City Employees Total

Code	Earning	Hours	Amount	Deduction	Code	Amount	Tax	Code	Amount	Tax	Code	Amount	Taxable	Tax	Code	Amount	Taxable	Amount
7	Femaleles		1535.27	457B EE	CA	117.30	California SI	20959.13	CA ETT	CA Edu & T	CA ETT	1005.01	1457.68	CA ETT	CA Edu & T	CA ETT	1.46	
4	125CO 125 Cash		75.00	AflacP, Aflac Post	CASDI	13.65	CA SDI - Err	22392.40	CASUI	California SI	CASUI	223.91	1457.68	CASUI	California SI	CASUI	78.71	22392.40
3	ELECT Reimburs	76.00	20674.33	PTAXI Pre-Tax P.	FITW	532.41	Federal Incoi	20959.13	MED-R	Medicare - E	MED-R	2603.22	22392.40	MED-R	Medicare - E	MED-R	324.68	22797.25
	Reg Regular		107.80	PTXPE Pre-Tax P.	SS	783.56	Medicare	22392.40	SS-R	OASDI - Err	SS-R	324.70	2771.16	SS-R	OASDI - Err	SS-R	0.00	16788.64
	Sick Sick			OASDI			OASDI	2771.16				0.00						
				Total Deductions		1446.92	Total Employee Taxes	4156.84				4156.84	Total Employer Taxes				404.85	

Department: (30)Special Enforcement Team

Code	Earning	Hours	Amount	Deduction	Code	Amount	Tax	Code	Amount	Tax	Code	Amount	Taxable	Tax	Code	Amount	Taxable	Amount
	Regular	57.00	1536.15	457B EE	CA	50.00	California SI	1732.20	CA ETT	CA Edu & T	CA ETT	48.46	0.00	CA ETT	CA Edu & T	CA ETT	0.00	0.00
104	Vac Vacation	19.00	512.05	MEDI: Health Ins	CASDI	127.75	CA SDI - Err	1920.45	CASUI	California SI	CASUI	19.20	0.00	CASUI	California SI	CASUI	0.00	0.00
26.9500	Rate			PTXPE Pre-Tax P.	FITW	138.25	Federal Incoi	1732.20	MED-R	Medicare - E	MED-R	131.91	1920.45	MED-R	Medicare - E	MED-R	27.85	2048.20
				Total Deductions		316.00	Total Employee Taxes	227.41				227.41	Total Employer Taxes				27.85	

Code	Earning	Hours	Amount	Deduction	Code	Amount	Tax	Code	Amount	Tax	Code	Amount	Taxable	Tax	Code	Amount	Taxable	Amount
	Regular	76.00	2048.20	PTAXI Pre-Tax P.	CA	174.50	California SI	2795.59	CA ETT	CA Edu & T	CA ETT	136.86	0.00	CA ETT	CA Edu & T	CA ETT	0.00	0.00
	Rate				CASDI	29.70	CA SDI - Err	2970.09	CASUI	California SI	CASUI	29.70	0.00	CASUI	California SI	CASUI	0.00	0.00
				Total Deductions		174.50	Total Employee Taxes	469.14				469.14	Total Employer Taxes				43.07	

Code	Earning	Hours	Amount	Deduction	Code	Amount	Tax	Code	Amount	Tax	Code	Amount	Taxable	Tax	Code	Amount	Taxable	Amount
	Regular	21.00	612.36	PTXPE Pre-Tax P.	CA	143.79	California SI	612.36	CA ETT	CA Edu & T	CA ETT	0.00	0.00	CA ETT	CA Edu & T	CA ETT	0.00	0.00
	Rate				CASDI	499.58	CA SDI - Err	612.36	CASUI	California SI	CASUI	6.12	0.00	CASUI	California SI	CASUI	0.00	0.00
				Total Deductions		0.00	Total Employee Taxes	61.25				61.25	Total Employer Taxes				8.88	

Code	Earning	Hours	Amount	Deduction	Code	Amount	Tax	Code	Amount	Tax	Code	Amount	Taxable	Tax	Code	Amount	Taxable	Amount
	Regular	76.00	2029.86	PTXPE Pre-Tax P.	CA	143.79	California SI	2486.07	CA ETT	CA Edu & T	CA ETT	54.71	0.00	CA ETT	CA Edu & T	CA ETT	0.00	0.00
	Rate				CASDI	2130.28	CA SDI - Err	2629.86	CASUI	California SI	CASUI	26.30	0.00	CASUI	California SI	CASUI	0.00	0.00
				Total Deductions		143.79	Total Employee Taxes	341.51				341.51	Total Employer Taxes				38.13	

City of Canyon Lake
Company (10756)

Check Date: 08/14/2020
Process: 2020081401
Period: 08/01/2020 to 08/15/2020

Labor Distribution

Code	Earning	Hours	Amount	Deduction	Code	Tax	Code	Amount	Taxable	Code	Tax	Code	Amount	Taxable	Amount				
Reg	Regular	38.00	1065.14	PTXPE Pre-Tax P.	CA	California SI	89.87	1241.56	17.54	CAETT	CA Edu & T		0.00	0.00	0.00				
Sick	Sick	9.50	266.29		CASDI	CA SDI - Err		1331.43	13.32	CASUI	California SI		0.00	0.00	Gross				
					FITW	Federal Incoi		1241.56	78.76	MED-R	Medicare - E		1331.43	19.31	Tot Liab				
					MED	Medicare		1331.43	19.30						Net Amt				
Total Earnings													47.50	1331.43	Total Deductions	89.87	128.92	Total Employer Taxes	19.31

Department: (30)Special Enforcement Team Total

Code	Earning	Hours	Amount	Deduction	Code	Tax	Code	Amount	Taxable	Code	Tax	Code	Amount	Taxable	Amount				
3	125CO 125 Cash	268.00	7836.73	MEDI: Health Ins	CA	California SI	50.00	8867.78	257.57	CAETT	CA Edu & T		0.00	0.00	0.00				
2	Reg Regular	9.50	266.29	PTAXI Pre-Tax P.	CASDI	CA SDI - Err		9464.19	94.64	CASUI	California SI		0.00	0.00	Gross				
	Sick	19.00	512.05	PTXPE Pre-Tax P.	FITW	Federal Incoi		8867.78	738.80	MED-R	Medicare - E		9464.19	137.24	Tot Liab				
	Vac				MED	Medicare		9464.19	137.22						Net Amt				
Total Earnings													296.50	9591.94	Total Deductions	724.16	1228.23	Total Employer Taxes	137.24

Report Total

Code	Earning	Hours	Amount	Deduction	Code	Tax	Code	Amount	Taxable	Code	Tax	Code	Amount	Taxable	Amount				
7	125CO 125 Cash	344.00	28511.06	MEDI: Health Ins	CA	California SI	167.30	29826.91	1262.58	CAETT	CA Edu & T		1.46	1.46	31984.34				
5	ELECTI Reimburs	14.50	374.09	PTAXI Pre-Tax P.	CASDI	CA SDI - Err		31856.59	318.55	CASUI	California SI		461.92	461.92	Gross				
	Reg Regular	19.00	512.05	PTXPE Pre-Tax P.	FITW	Federal Incoi		29826.91	3342.02	MED-R	Medicare - E		2771.16	2771.16	Tot Liab				
	Sick				MED	Medicare		31856.59	461.92	SS-R	OASDI - Err		0.00	0.00	Net Amt				
	Vac				SS	OASDI		2771.16	0.00										
Total Earnings													377.50	31984.34	Total Deductions	2171.08	5385.07	Total Employer Taxes	542.09

Chris Mann
Chris Mann, City Manager

8-17-20
Date

Credit Card Review

U S BANK Statement dated 8/6/20

ITEM #	CREDITOR	DESCRIPTION	AMOUNT	ACCOUNT
1	Amazon	4 Year Office Equipment Protection Plan with Tech Support	\$ 89.97	10-550-8007
2	Amazon	3 HDMI 6 Feet Cable for New Office	\$ 32.28	10-550-8007
3	Amazon	Heavy Duty Door Stopper for Large Gaps Exterior/Interior Doors in Admin Office	\$ 14.00	10-550-8007
4	Amazon	3 Monitor's and 3 HDMI Cords for Admin Office	\$ 451.35	10-550-8007
5	Amazon	Adapter Arm/Mount Compatible with HP Pavilion Screen for Admin Office	\$ 60.32	10-550-8007
6	Microsoft	Credit for Monthly Fee - Overcharged Last Month	\$ (104.16)	10-310-6210
7	Microsoft	Emergency Preparedness Monthly Emails	\$ 44.00	10-425-6210
8	Microsoft	Microsoft 365 Monthly Fee	\$ 366.67	10-310-6210
9	Amazon Prime	Monthly Prime Membership Fee	\$ 14.00	10-310-6210
10	Arlo Technologies	Monthly Camera Service - City Hall	\$ 9.99	10-550-6610
11	Embroidery and More	Custom Mask w/Logo (Covid-19)	\$ 404.06	10-310-6210
12	Joe's Hardware	Supplies for New Office to Clean Window	\$ 7.31	10-550-8007
13	Arlo Technologies	Monthly Camera Service - City Hall Admin	\$ 14.99	10-550-6610
14	Embroidery and More	Two Shirt Left Chest Logo's for Mann	\$ 38.79	10-310-6210
15	Amazon	Multi-Port Desktop Hub for MacBook for Ferrari (Covid-19)	\$ 280.12	10-310-6210
16	Apple	Magic Keyboard for Ferrari (Covid-19)	\$ 160.55	10-310-6210
17	Apple	Magic Mouse for Ferrari (Covid-19)	\$ 106.67	10-310-6210
18	The Urban	Work Lunch - Mann, Sauseda, Lozano & Ferrari	\$ 73.15	10-310-6510
19	PayPal	California City Management Foundation Dues for FY 2020 - 2021	\$ 400.00	10-310-6510
20	Sports Stop & Pub	Work Lunch - Mann, Borja, Sauseda, Lozano & Ferrari	\$ 83.92	10-310-6510
21	Zoom	Monthly Subscription for Virtual Meetings	\$ 14.99	10-310-6210
22	Amazon	Office Supplies - Light Switch Covers for New Office	\$ 10.64	10-550-8007
23	BJ's Restaurant	Work Lunch - Mann, Borja, Sauseda, Lozano & Ferrari	\$ 103.00	10-310-6510
24	Apple	13-Inch Mac Book Pro Laptop for Ferrari (Covid-19)	\$ 2,157.91	10-310-6210
25	ICMA	2020 Effective Supervisory Practices Webinar Series Mann, Sauseda & Lozano	\$ 795.00	10-310-6510
26	ICMA	2020 Effective Supervisory Practices Webinar Series Book & Study Guide	\$ 430.11	10-310-6510
27	Canyon Lake Country Club	Work Lunch - Mann, Lozano & Ferrari	\$ 59.29	10-310-6510
28	DotGov Registration	Gov Domain Registration Annual Fee	\$ 400.00	10-310-6610
29	BJ's Restaurant	Lunch Meeting - Mann & Bonner	\$ 60.41	10-310-6510
30	4Imprint	USB Flash Drives for Election	\$ 194.29	10-320-6610
31	USPS	Certified Priority Mail - Election Binder to Ariel	\$ 54.80	10-320-6610
32	Staples	Office Supplies - Binders, etc.	\$ 55.36	10-320-6610
33	Five Guys	City Council Dinner	\$ 102.53	10-100-6225
34	Amazon	Election Materials Badge Lanyards	\$ 9.69	10-320-6610
35	Staples	Election Materials 2 Inch Book & Envelope	\$ 10.32	10-320-6610
36	Staples	Office Supplies - Stevia	\$ 17.23	10-310-6210
37	G/M Business Interiors	Name Plates for Lozano & Ferrari	\$ 100.01	10-550-8007
38	Target	Office Supplies - Soda's	\$ 52.50	10-310-6210
39	Amazon	3 Year Desktop Computer Protection Plan with Tech Support	\$ 57.99	10-550-8007
40	City Clerks Association	Membership Dues for Sauseda	\$ 130.00	10-320-6520
41	Amazon Prime	Monthly Membership Fee - Will be Refunded Next Month	\$ 14.13	10-310-6210
42	Tommy's Express	Car Wash for City Vehicles	\$ 102.95	10-520-6415
43	Amazon	Law Enforcement PC	\$ 840.29	10-410-6610
44	Amazon	HDMI Cable for Law Enforcement Room	\$ 25.58	10-410-6610
45	USPS	Certified Priority Mail Express to Secretary of State	\$ 30.45	10-310-6210

Late Fee \$ - 10-310-6965

\$ 8,377.45

Account Breakdown

City Council Dept. Expense	10-100-6220	
City Council Meeting Expense	10-100-6225	
Promotion and Advertising	10-100-6830	\$ 102.53
City Manager Office Expense	10-310-6210	
Conference/Meeting/Travel Expense	10-310-6510	\$ 3,627.06
City Manager Software	10-310-6530	\$ 1,931.73
City Manager Dept. Expense	10-310-6220	
City Manager Membership	10-310-6520	\$ 130.00
Professional/Specialized Services	10-310-6610	\$ 400.00
City Clerk Departmental Expense	10-320-6220	
City Clerk Conference/Meeting/Travel Expense	10-320-6510	
City Clerk Dues	10-320-6520	
Professional/Specialized Services	10-320-6610	\$ 324.46
City Clerk Training and Education	10-320-6710	
City Clerk Military Banner Program	10-320-6511	
Law Enforcement Specialized Services	10-410-6610	\$ 865.87
Fire & Medical Department Expense	10-420-6220	
Emergency Preparedness Office Supplies	10-425-6210	\$ 44.00
Emergency Preparedness Grant Expense	10-425-6215	
Code Enforcement Supplies	10-520-6210	
Vehicle Maintenance	10-520-6415	\$ 102.95
Code Enforcement Membership Dues	10-520-6520	
Code Enforcement Training	10-520-6710	
Building & Facilities Maintenance	10-550-6610	
Building & Facilities Maint. Capital Outlay	10-550-8000	\$ 24.98
Building & Facilities Maint. Furniture & Equip.	10-550-8007	\$ 823.87
Rental Office Expense	60-560-6210	
		\$ 8,377.45

Check Figure \$ -

*Copies for City Council
as directed by
the Finance Committee*

Home Profile Reporting Employment Information Enrollment and Payments My CalPERS

Manage Reports Billing and Payments Payroll Schedule Out-of-Class Validation Member Requests Health Reconciliation Retirement Appoint

Name: City of Canyon Lake CalPERS ID: 3813045770

Payment Request Acceptance

Your request for payment has been accepted

- To generate the employer payment report, please click the print button.
- If you need to contact us with questions regarding this payment, please have your Payment Confirmation Number for faster access.
- Your payment will reflect as paid in myCalPERS if your payroll has successfully posted. Once your payment is processed any credits will roll over to the same type of receivable in the next month, after your payroll has been processed.
- Your payment may take longer to post, depending upon your Financial Institution.

Payment Setup Total

Total Payment Amount: \$3,943.29

Payment Summary

Payment Confirmation Number	Payment Authorization Date	Receivable ID	Receivable Description	Payment Method	Payment Account Nickname	Selected Payment Amount
1001622188	08/03/2020	100000016113206	Health PA Billing - PERS	EFT - Debit	Citizens Business Bank -5402	\$3,943.29

[Contact Us](#) | [CalPERS Website](#) | [Privacy Policy](#) | [Conditions of Use](#) | [Accessibility](#) | © Copyright 2020 CalPERS

Build: v8.8 Baseline: 200611_083908_v8.8_Int.8947 UID: 318

Home > Reporting > Payroll Schedule > Payroll Schedule > City of Canyon Lake > 08/04/2020

Manage Reports | Payroll Schedule | Out-of-Class Validation | Member Requests | Health Reconciliation | Retirement Appointment

Name: City of Canyon Lake CalPERS ID: 3813045770

Pending Payments
Payment Status: Pending
Receivable Type: ▼

Payments
 To cancel a pending payment, select the Payment Authorization Date link.

Payment Authorization Date	Payment Posting Date	Vendor Number	Payment Amount	Payment Account Name	Payment Status	Receivable ID	Description
08/04/2020		1001624120	\$811.81	Citizens Business Bank -5402	Pending	100000016068462	Employer Contribution, Classic, 1684, CalPERS, 07/16/2020 - 07/31/2020
08/04/2020		1001624119	\$2,593.27	Citizens Business Bank -5402	Pending	100000016068496	Employer Contribution, PEPRA, 26189, CalPERS, 07/16/2020 - 07/31/2020

CJM

Home Profile Reporting Person Information Education Other Organizations

Manage Reports Billing and Payments Payroll Schedule Out-of-Class Validation Member Requests Health Reconciliation Retirement Appoint

Name: City of Canyon Lake CalPERS ID: 3813045770

Payment Request Acceptance

Your request for payment has been accepted

- **To generate the employer payment report, please click the print button.**
- If you need to contact us with questions regarding this payment, please have your Payment Confirmation Number for faster access.
- Your payment will reflect as paid in myCalPERS if your payroll has successfully posted. Once your payment is processed any credits will roll over to the same type of receivable in the next month, after your payroll has been processed.
- Your payment may take longer to post, depending upon your Financial Institution.

Payment Setup Total

Total Payment Amount: \$4,244.71

Payment Summary

Payment Confirmation Number	Payment Authorization Date	Receivable ID	Receivable Description	Payment Method	Payment Account Nickname	Selected Payment Amount
1001634177	08/19/2020	100000016105375	Employer Contribution, PEPR, 26189, CalPERS, 08/01/2020 - 08/15/2020	EFT - Debit	Citizens Business Bank -5402	\$2,479.06
1001634178	08/19/2020	100000016105336	Employer Contribution, Classic, 1684, CalPERS, 08/01/2020 - 08/15/2020	EFT - Debit	Citizens Business Bank -5402	\$1,765.65

[Contact Us](#) | [CalPERS Website](#) | [Privacy Policy](#) | [Conditions of Use](#) | [Accessibility](#) | © Copyright 2020 CalPERS

Build: v8.9 Baseline: 200806_081750_v8.9_Int.1468 UID: 318

CM

CITY OF CANYON LAKE
PLAN SPONSOR: 0035273

Acknowledgment

Your payment was successfully submitted. Provided it is in good order, it will process within contractual timeframes.

You can print this acknowledgment for your records.

Plan Name: **CITY OF CANYON LAKE 457 OBRA-PST**

Plan Number: **0035273002**

Payroll Center: **CITY OF CANYON LAKE OBRA**

Payroll Center Number: **001**

Payroll Received for Salary Reduction

Submission date: **08/05/2020**

Submission time: **11:23 AM**

Pay period end date: **07/31/2020**

Payment method: **Debit ACH**

Bank routing number: **122234149**

Bank account number: **245125402**

Contributions payment amount: **\$109.01**

Contributions count: **1**

Draft date: **08/06/2020**

CM

Nationwide Retirement Solutions and Nationwide Life Insurance Company (collectively "Nationwide") have endorsement relationships with the American Association of Actuaries, the International Association of Firefighters Financial Corporation, and the National Association of Police Organizations.

Nationwide may receive payments from mutual funds or their affiliates in connection with certain investment options. [Learn more about mutual funds.](#)

Retirement Specialists provide information for educational purposes only. This information is not meant to be used as investment advice. Retirement Specialists are Registered Representatives of Nationwide Investment Services Corporation, member FINRA.

CITY OF CANYON LAKE
PLAN SPONSOR: 0035273

Acknowledgment

Your payment was successfully submitted. Provided it is in good order, it will process within contractual timeframes.

You can print this acknowledgment for your records.

Plan Name: **CITY OF CANYON LAKE 457**

Plan Number: **0035273001**

Payroll Center: **CITY OF CANYON LAKE**

Payroll Center Number: **001**

Payroll Received for Salary Reduction

Submission date: **08/05/2020**

Submission time: **11:22 AM**

Pay period end date: **07/31/2020**

Payment method: **Debit ACH**

Bank routing number: **122234149**

Bank account number: **245125402**

Contributions payment amount: **\$232.00**

Contributions count: **2**

Draft date: **08/06/2020**

CM

Nationwide Retirement Solutions and Nationwide Life Insurance Company (collectively "Nationwide") have endorsement relationships with the National Association of Counties, the International Association of Fire Fighters Financial Cooperative, and the National Association of Police Organizations.

Nationwide may receive payments from mutual funds or their affiliates in connection with certain investment options. Learn more about mutual funds.

Retirement Specialists provide information for educational purposes only. This information is not meant to be used as investment advice. Retirement Specialists are Registered Representatives of Nationwide Investment Services Corporation, member FINRA.

Investment Reports

CITIZENSTRUST

PO Box 2549
Rancho Cucamonga, CA 91729-2549
Return Service Requested

RECEIVED

AUG 18 2020

BY: _____

00000041 MCBB1000080620126060 01 000000 41 004



CITY OF CANYON LAKE
31516 RAILROAD CANYON RD
CANYON LAKE CA 92587

STATEMENT FOR THE PERIOD FROM 07/01/2020 TO 07/31/2020
ACCOUNT 1035003119

THIS IS YOUR REPORT OF INVESTMENTS AND TRANSACTIONS FOR THE PERIOD. INCLUDED
IN THE REPORT ARE

- * PORTFOLIO: SUMMARY GRAPHICAL DISPLAY WITH MARKET VALUE & PERCENT
 - * ACTIVITY SUMMARY: MARKET VALUE WITH TRANSACTION SUMMARY
 - * PORTFOLIO STATEMENT: A LISTING OF COST AND MARKET VALUE OF ASSETS HELD IN THE PORTFOLIO
- COST BASIS APPLICABLE FOR CALCULATING CAPITAL GAINS AND LOSSES.
MARKET VALUE IS THE CURRENT VALUE OF EACH ASSET FOR MOST STOCKS AND BONDS.
MARKETS ARE THE CLOSING PRICES ON THE LAST TRADING DAY OF THE PERIOD.
- * TRANSACTION STATEMENT: A COMPLETE LISTING FOR THE PERIOD GROUPED BY TRANSACTION TYPE.
 - * DISCLOSURES: CITIZENS BUSINESS BANK MAY RECEIVE RESEARCH AND OTHER BENEFITS FROM BROKER DEALERS WHICH MAY BE CONSIDERED COMPENSATION TO US. UPON REQUEST WE WILL DISCLOSE DETAILS OF ANY COMPENSATION RECEIVED.
 - * TO TRUST BENEFICIARIES: UNDER SECTION 17200 OF CALIFORNIA PROBATE CODE, YOU MAY PETITION THE COURT TO OBTAIN A COURT REVIEW OF THE ACCOUNT AND THE ACTS OF THE TRUSTEE. CLAIMS AGAINST THE TRUSTEE FOR BREACH OF TRUST MUST BE MADE WITHIN THREE YEARS FROM THE DATE OF RECEIPT OF AN ACCOUNTING OR OTHER REPORT DISCLOSING FACTS GIVING RISE TO THE CLAIM.





Account Statement

Account Number: 1035003119
 July 01, 2020 To July 31, 2020

CITY OF CANYON LAKE
 31516 RAILROAD CANYON RD
 CANYON LAKE, CA 92587

Account Name:	CITY OF CANYON LAKE CITIZENS BUSINESS BANK
Account Number:	1035003119
Your Relationship Manager Is:	MIKE GARDNER
Phone:	909-483-4390

Investment Portfolio Summary

Market Value As Of	07/01/2020	07/31/2020	% Of Account
 CASH & CASH EQUIVALENTS	201,119.60	153,554.65	5.5%
 FIXED INCOME	2,415,086.15	2,467,955.35	88.8%
 MISCELLANEOUS	158,716.50	158,899.50	5.7%
Total	2,774,922.25	2,780,409.50	100.0%

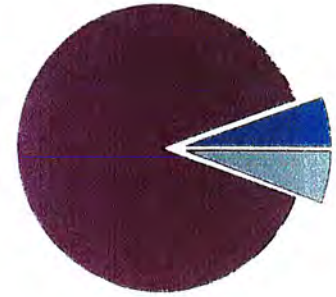

Activity Summary

	This Period	Year To Date	Realized Capital Gains / Losses	
			This Period	Year To Date
Beginning Market Value	2,774,922.25	2,740,120.38		
Income	7,859.38	30,328.02	Long Term	0.00
Asset Activity	54,969.00	515,523.45	Total Gains / Losses	0.00
Fees	455.33	3,214.09		1,223.31
Cash Management	47,564.95	488,409.52		
Change in Market Value	5,487.25	40,289.12		
Ending Market Value	2,780,409.50	2,780,409.50		

Account Statement

Account Number: 1035003119
July 01, 2020 To July 31, 2020

Portfolio Statement

Quantity	Description	Market Value	Cost Basis
Cash & Cash Equivalents			
Cash Equivalents			
Unclassified			
153,554.650	31607A703 FIDELITY GOVERNMENT PORTFOLIO	153,554.65	153,554.65
	Total Unclassified	153,554.65	153,554.65
Total	Cash Equivalents	153,554.65	153,554.65
Total	Cash & Cash Equivalents	153,554.65	153,554.65
Fixed Income			
Taxable			
100,000.000	05580ACZ5 BMW BANK BANK NORTH AMERICA DTD 09/30/15 MEDIUM-TERM CD 2.2% 09/30/2020	100,367.00	99,980.00
100,000.000	14042RAR2 CAPITAL ONE NA MEDIUM-TERM CD DTD 10/07/2015 2.2% 10/07/2020	100,409.00	99,615.00
100,000.000	24422ERE1 JOHN DEERE CAPITAL CORP SERIES MTN DTD 07/12/2011 3.9% 07/12/2021	103,488.00	102,099.11
100,000.000	29266NS32 ENERBANK USA DTD 10/16/2015 MEDIUM-TERM CD 1.75% 10/16/2020	100,351.00	100,000.00
125,000.000	3130AEWA4 FEDERAL HOME LOAN DTD 09/07/18 2.625% 10/01/2020	125,503.75	125,610.61
150,000.000	3130AJQR3 FEDERAL HOME LOAN BANK DTD 06/30/20 CALL .45% 06/30/2023-2020	150,013.50	150,000.00
100,000.000	3130AJRE1 FEDERAL HOME LOAN BANK DTD 6/24/2020 CALL .75% 06/24/2025-2020	100,032.00	100,000.00
105,000.000	3133EEG79 FEDERAL FARM CREDIT BANK DTD 05/07/2015 2.15% 09/07/2023	111,076.35	111,012.30
150,000.000	3133ELD76 FEDERAL FARM CREDIT BANK DTD 06/02/2020 CALL .34% 12/02/2022-2020	150,001.50	150,000.00
100,000.000	3133ELH56 FEDERAL FARM CREDIT BANK DTD 06/09/2020 CALL .27% 06/09/2022-2020	100,002.00	99,875.00
200,000.000	3133ELN75 FEDERAL FARM CREDIT BANK DTD 6/23/20 CALL .23% 12/23/2021-2020	200,004.00	199,900.00

Portfolio Statement (Continued)

Quantity	Description	Market Value	Cost Basis
Taxable			
100,000.000	3134GVY69 FREDDIE MAC DTD 6/30/2020 CALL .55% 06/30/2023-2020	100,012.00	100,000.00
100,000.000	3134GWBV7 FREDDIE MAC DTD 07/21/2020 CALL .8% 07/21/2025-2020	100,010.00	100,000.00
100,000.000	3134GWCZ7 FREDDIE MAC DTD 7/28/20 CALL .3% 10/28/2022-2021	100,026.00	99,985.00
100,000.000	3135G03Q4 FANNIE MAE DTD 04/23/2020 CALL 1.1% 04/23/2025-2020	100,096.00	100,000.00
205,000.000	3136G4A29 FANNIE MAE DTD 7/30/2020 CALL .55% 07/30/2024-2021	205,092.25	205,000.00
100,000.000	3136G4D83 FANNIE MAE DTD 7/29/2020 CALL .51% 07/29/2024-2021	99,973.00	99,984.00
200,000.000	69353REW4 PNC BANK NA DTD 04/29/16 CALL 2.15% 04/29/2021-2021	202,452.00	200,828.12
200,000.000	880591ER9 TENN VALLEY AUTHORITY DTD 09/29/14 2.875% 09/15/2024	219,046.00	209,944.60
Total	Taxable	2,467,955.35	2,453,833.74
Total	Fixed Income	2,467,955.35	2,453,833.74
Miscellaneous			
Corp Bond-sma			
Taxable Bonds			
150,000.000	24422ERT8 JOHN DEERE CAPITAL CORP DTD 06/26/12 2.8% 01/27/2023	158,899.50	158,469.00
Total	Taxable Bonds	158,899.50	158,469.00
Total	Corp Bond-sma	158,899.50	158,469.00
Miscellaneous Sundry Assets			
Documents			
1.000	DOC199647 INVESTMENT MANAGEMENT AGREEMENT CITY OF CANYON LAKE A/C# 1035003119	0.00	0.00
Total	Documents	0.00	0.00
Total	Miscellaneous Sundry Assets	0.00	0.00
Total	Miscellaneous	158,899.50	158,469.00
Grand Total Assets		2,780,409.50	2,765,857.39



Account Statement

Account Number: 1035003119

July 01, 2020 To July 31, 2020

Account Activity Summary

	Total Cash	Cost Basis Excluding Cash	Market Value Including Cash
Balances Beginning Of Period	0.00	2,759,486.19	2,787,225.61
Prior Accruals			12,303.36-
Unrealized Appreciation This Period			5,487.25
Current Accruals			7,757.60
Asset Activity	54,969.00-	54,969.00	54,969.00-
Cash Management	47,564.95	47,564.95-	47,564.95
Fees	455.33-	0.00	455.33-
Income	7,859.38	1,032.85-	7,859.38
Realized Gain/loss			0.00
Non Cash Asset Changes			
Balances End Of Period	0.00	2,765,857.39	2,788,167.10

Transaction Statement

Date	Quantity	Description	Transaction Type	Cash	Cost Basis
07/01/20		Beginning Balance		0.00	2,759,486.19
		Income			
		Interest			
		31607A703			
07/01/20		FIDELITY GOVERNMENT PORTFOLIO 3130AHUM3	INTEREST RCVD	38.45	
07/10/20		FEDERAL HOME LOAN BANK DTD 01/10/20 CALL 2% 01/10/2025-2020 24422ERE1	INTEREST RCVD	2,000.00	
07/13/20		JOHN DEERE CAPITAL CORP SERIES MTN DTD 07/12/2011 3.9% 07/12/2021 3133ELD76	INTEREST RCVD	1,950.00	
07/15/20		FEDERAL FARM CREDIT BANK DTD 06/02/2020 CALL .34% 12/02/2022-2020 29266NS32	ACCRUED INT	60.91-	
07/16/20		ENERBANK USA DTD 10/16/2015 MEDIUM-TERM CD 1.75% 10/16/2020 3134GU4S6	INTEREST RCVD	143.84	
07/21/20		FREDDIE MAC DTD 01/21/20 CALL 1.8% 04/21/2023-2020 3133ELWT7	INTEREST RCVD	900.00	
07/21/20		FEDERAL FARM CREDIT BANK DTD 4/21/2020 CALL 1.15% 10/21/2024-2020 24422ERT8	INTEREST RCVD	287.50	
07/27/20		JOHN DEERE CAPITAL CORP DTD 06/26/12 2.8% 01/27/2023 3133ELXV1	INTEREST RCVD	2,100.00	
07/28/20		FEDERAL FARM CREDIT BANK DTD 4/28/20 CALL 1.01% 04/28/2025-2020 3134GWCZ7	INTEREST RCVD	505.00	
07/30/20		FREDDIE MAC DTD 7/28/20 CALL .3% 10/28/2022-2021 3136G4D83	ACCRUED INT	1.67-	
07/31/20		FANNIE MAE DTD 7/29/2020 CALL .51% 07/29/2024-2021	ACCRUED INT	2.83-	
		Total Interest		7,859.38	0.00
		Total Income		7,859.38	0.00

Transaction Statement (Continued)

Date	Quantity	Description	Transaction Type	Cash	Cost Basis
Asset Activity					
Assets Purchased					
07/15/20	150,000.000	3133ELD76 FEDERAL FARM CREDIT BANK DTD 06/02/2020 CALL .34% 12/02/2022-2020	BUY	150,000.00-	150,000.00
07/21/20	100,000.000	3134GWBV7 FREDDIE MAC DTD 07/21/2020 CALL .8% 07/21/2025-2020	BUY	100,000.00-	100,000.00
07/30/20	205,000.000	3136G4A29 FANNIE MAE DTD 7/30/2020 CALL .55% 07/30/2024-2021	BUY	205,000.00-	205,000.00
07/30/20	100,000.000	3134GWCZ7 FREDDIE MAC DTD 7/28/20 CALL .3% 10/28/2022-2021	BUY	99,985.00-	99,985.00
07/31/20	100,000.000	3136G4D83 FANNIE MAE DTD 7/29/2020 CALL .51% 07/29/2024-2021	BUY	99,984.00-	99,984.00
Total Assets Purchased				654,969.00-	654,969.00
Assets Sold					
07/10/20	200,000.000-	3130AHUM3 FEDERAL HOME LOAN BANK DTD 01/10/20 CALL 2% 01/10/2025-2020	REDEEMED	200,000.00	200,000.00-
07/21/20	100,000.000-	3133ELWT7 FEDERAL FARM CREDIT BANK DTD 4/21/2020 CALL 1.15% 10/21/2024-2020	REDEEMED	100,000.00	100,000.00-
07/21/20	100,000.000-	3134GU4S6 FREDDIE MAC DTD 01/21/20 CALL 1.8% 04/21/2023-2020	REDEEMED	100,000.00	100,000.00-
07/28/20	200,000.000-	3133ELXV1 FEDERAL FARM CREDIT BANK DTD 4/28/20 CALL 1.01% 04/28/2025-2020	REDEEMED	200,000.00	200,000.00-
Total Assets Sold				600,000.00	600,000.00-
Total Asset Activity				54,969.00-	54,969.00
Fees					
07/27/20		MANAGEMENT FEES CITIZENS BUSINESS BANK FOR THE PERIOD ENDING 07/20/2020	DISBURSEMENT	455.33-	
Total Fees				455.33-	0.00
Cash Management					
07/31/20	47,564.950-	31607A703 NET CASH MANAGEMENT	NET CASH MGMT	47,564.95	47,564.95-
Total Cash Management				47,564.95	47,564.95-
Miscellaneous					
07/13/20		24422ERE1 AMORTIZATION ON 100,000 UNITS JOHN DEERE CAPITAL CORP SERIES MTN DTD 07/12/2011 3.9% 07/12/2021 EFFECTIVE 07/12/2020 TO ADJUST TAX LOT. AMORTIZATION = 1,032.85-	AMORTIZATION		1,032.85-
Total Miscellaneous				0.00	1,032.85-
07/31/20		Ending Balance		0.00	2,765,857.39

Account Number: 1035003119

July 01, 2020 To July 31, 2020

Market Perspectives

We hope that you and your family are all safe and healthy during these challenging times. The enclosed Q1 2020 Market Perspectives article is provided to assist in defining volatile market events over the last quarter and discuss the quarter ahead. Please be assured that dedicated team of professionals at CitizensTrust is monitoring the markets very closely, and if you have any questions or concerns we encourage you to reach out directly to your Relationship Manager.

Disclosure

CitizensTrust may receive research and other benefits from Brokers/Dealers which may be considered compensation. Upon request, we will disclose details of any compensation received. We have added an additional benchmark to your performance insert. Call for details.



ITEM NO. _____

STAFF REPORT

TO: Honorable Mayor and Members of the City Council

FROM: Chris Mann, City Manager

BY: Kayla Lozano, Accountant

DATE: August 5, 2020

SUBJECT: Adoption of Resolution No. 2020-42, Allowing Certain Claims and Demands as Set Forth in Exhibit A

Recommendation

That the City Council adopt Resolution No. 2020-42, allowing certain claims and demands as set forth in Exhibit A.

Background

All claims and demands are reported and summarized for review and approval by the City Council on a routine basis at each City Council meeting. The attached claims represent the paid claims and demands since the City Council meeting of July 8, 2020.

Fiscal Impact

All claims and demands are paid from appropriated funds or authorized resources of the City and have been recorded in accordance with the City's policies.

Attachments

1. Resolution No. 2020-42
2. List of Demands

ATTACHMENT 1

RESOLUTION NO. 2020-42

A RESOLUTION OF THE CITY COUNCIL OF THE CITY OF CANYON LAKE, CALIFORNIA, ALLOWING CERTAIN CLAIMS AND DEMANDS AS SET FORTH IN EXHIBIT A

The City Council of the City of Canyon Lake does hereby resolve as follows:

Demands are approved as shown on the Demand\Warrant Register of August 5th, in the amount of \$728,827.14 as follows:

Payroll Earnings (Gross)	\$ 65,004.55	(2nd Half of June & 1st Half of July)
Payroll Taxes - Employer	1,170.51	(2nd Half of June & 1st Half of July)
On-line Retirement	6,128.02	(2nd Half of June & 1st Half of July)
On-line Health	2,612.16	(For the Month of July)
Nationwide Deferred Comp.	340.47	(For the Month of June)
CalPERS Unfunded Accrued Liability	27,066.00	FY 2020/2021 - Classic
CalPERS Unfunded Accrued Liability	2,700.00	FY 2020/2021 - PEPRA
General	623,805.43	
TOTAL	<u>\$ 728,827.14</u>	

PASSED, APPROVED AND ADOPTED this 5th day of August, 2020.

ATTEST:

Jordan Ehrenkranz
Mayor

Ana V. Sauseda, CMC
City Clerk

State of California
County of Riverside) ss
City of Canyon Lake)

I, Ana V. Sauseda, City Clerk of the City of Canyon Lake, California, DO HEREBY CERTIFY, that the foregoing is a true and correct copy of the Resolution No. 2020-42 adopted by the City Council of the City of Canyon Lake, California, at a regular meeting thereof, held on August 5, 2020, by the following vote:

AYES:
NOES:
ABSTAIN:
ABSENT:

Ana V. Sauseda, CMC
City Clerk

ATTACHMENT 2

Claims and Demands

City of Canyon Lake
 Check/Voucher Register - Council Report - Expenditures
 From 7/1/2020 Through 7/31/2020

Check Number	Matching Docume... Date	Vendor Name	Transaction Description	Check Amount	Fund Code	Fund Short Title
25940	7/1/2020	AMP GLOBAL LLC	Rent for 31526 Railroad Cyn. Suite #4 July & August 2020	1,546.67	10	GENERAL
Total 25940	7/1/2020			1,546.67		
25941	6/30/2020	Fast Signs	Covid 19 Signage for City Hall & Installation, Final 6/3/20	704.22	10	GENERAL
Total 25941	6/30/2020			704.22		
25942	7/1/2020	Fast Signs	ADA Counter Sneeze Guards for City Hall, Final Invoice	809.19	10	GENERAL
25942	7/1/2020	Fast Signs	Area Temporarily Closed Coroplast for BLM Land, July 2020	604.78	10	GENERAL
Total 25942	7/1/2020			1,413.97		
25943	6/30/2020	AMERICAN FORENSIC NURSES INC	Sheriff's Blood Draws, 6/15/20	55.00	10	GENERAL
Total 25943	6/30/2020			55.00		
25944	6/30/2020	ANIMAL FRIENDS OF THE VALLEYS	Animal Control Services for Mar., Apr., & May 2020	10,500.00	10	GENERAL
Total 25944	6/30/2020			10,500.00		
25945	6/30/2020	CANYON LAKE PEST CONTROL, Steven E. Young	Monthly Pest Control for Fire Station, June 2020	40.00	10	GENERAL
25945	6/30/2020	CANYON LAKE PEST CONTROL, Steven E. Young	Quarterly Pest Control P.O. #09-010, 6/12/20	60.00	10	GENERAL
Total 25945	6/30/2020			100.00		

City of Canyon Lake
 Check/Voucher Register - Council Report - Expenditures
 From 7/1/2020 Through 7/31/2020

Check Number	Matching Docume... Date	Vendor Name	Transaction Description	Check Amount	Fund Code	Fund Short Title
25946	6/30/2020	Cole Huber LLP	Attorney Services for June 2020	5,000.00	10	GENERAL
25946	6/30/2020	Cole Huber LLP	Attorney Services for June 2020 (Covid 19)	300.00	10	GENERAL
Total 25946	6/30/2020			5,300.00		
25947	6/30/2020	Control Pump	Monthly Landscape Booster Station, June 2020	375.00	20	GAS TAX
Total 25947	6/30/2020			375.00		
25948	6/30/2020	Corelogic Information Solutions, INC.	Database for Code Enforcement Reports, June 2020	5.15	10	GENERAL
25948	6/30/2020	Corelogic Information Solutions, INC.	Database for Code Enforcement, June 2020	128.75	10	GENERAL
Total 25948	6/30/2020			133.90		
25949	6/30/2020	CTAI Pacific Greenscape	Monthly Landscape Maintenance for Fire Station June 2020	250.00	10	GENERAL
25949	6/30/2020	CTAI Pacific Greenscape	Monthly Landscapae Maint. for Median & Parkways for June 2020	5,000.00	20	GAS TAX
Total 25949	6/30/2020			5,250.00		
25950	6/30/2020	DATA TICKET	Citation Processing, Code Enforcement June 2020	304.00	10	GENERAL
Total 25950	6/30/2020			304.00		
25951	6/30/2020	Delgado Janitorial Services	Janitorial Service for the month of June 2020	944.50	10	GENERAL
Total 25951	6/30/2020			944.50		

City of Canyon Lake
 Check/Voucher Register - Council Report - Expenditures
 From 7/1/2020 Through 7/31/2020

Check Number	Matching Document Date	Vendor Name	Transaction Description	Check Amount	Fund Code	Fund Short Title
25952	6/30/2020	Emergency Services Consulting International	Feasibility Study monthly Progress Invoice, 6/30/20	19,112.00	10	GENERAL
Total 25952	6/30/2020			19,112.00		
25953	6/30/2020	Frontier Communications	Phones for Fire Station, 6/13/20 to 7/12/20	375.37	10	GENERAL
Total 25953	6/30/2020			375.37		
25954	6/30/2020	Santo John Giambra	Refund of Plot Plan deposit for 23476 Moccasin Circle,6/1/20	955.25	10	GENERAL
Total 25954	6/30/2020			955.25		
25955	6/30/2020	Interwest Consulting Group	Building & Safety Services for May 2020	28,117.87	10	GENERAL
Total 25955	6/30/2020			28,117.87		
25956	6/30/2020	Joe's Hardware	Outlet & GFCI Tester for Code Enforcement, 6/30/20	9.82	10	GENERAL
25956	6/30/2020	Joe's Hardware	Screws & Bolts for Code Enforcement, 6/30/20	1.22	10	GENERAL
Total 25956	6/30/2020			11.04		
25957	6/30/2020	Johnson Controls Security Solutions	New Alarm Upgrade at City Hall, 6/11/20	737.91	10	GENERAL
Total 25957	6/30/2020			737.91		
25958	6/30/2020	PZL, Inc.	Planning Services for June 2020	3,724.09	10	GENERAL
Total 25958	6/30/2020			3,724.09		

City of Canyon Lake
 Check/Voucher Register - Council Report - Expenditures
 From 7/1/2020 Through 7/31/2020

Check Number	Matching Docume... Date	Vendor Name	Transaction Description	Check Amount	Fund Code	Fund Short Title
25959	6/30/2020	Rogers, Anderson, Malody & Scott, LLP	Accounting Services for the month of May 2020	6,900.00	10	GENERAL
Total 25959	6/30/2020			6,900.00		
25960	6/30/2020	County Executive Office	SCFA Miscellaneous Admin Expenses 4th Qtr.	1,421.20	10	GENERAL
Total 25960	6/30/2020			1,421.20		
25961	6/30/2020	RIV. CO. SHERIFF'S DEPT., Acctg & Fin	Sheriff's Contract Law 4/23/20 to 5/20/20	129,639.00	10	GENERAL
Total 25961	6/30/2020			129,639.00		
25962	6/30/2020	Riv Co Sheriff Dept Perris Station	Sheriff's Dept. Extra Duty for Memorial Day 5/22 - 5/23/20	2,517.82	10	GENERAL
Total 25962	6/30/2020			2,517.82		
25963	6/30/2020	RIV COUNTY SHERIFF-Dept. Technical Svcs.	Communications Dispatch FY 19-20	10,088.00	10	GENERAL
Total 25963	6/30/2020			10,088.00		
25964	6/30/2020	State Controller's Office	State Controller's 2019 Offset Program - 7 Names Submitted	14.01	10	GENERAL
Total 25964	6/30/2020			14.01		
25965	6/30/2020	Syntech Group	IT Services for June 2020	1,530.00	10	GENERAL
25965	6/30/2020	Syntech Group	Migration to Cloud Project, 6/24/20	13,250.00	10	GENERAL
Total 25965	6/30/2020			14,780.00		

City of Canyon Lake
 Check/Voucher Register - Council Report - Expenditures
 From 7/1/2020 Through 7/31/2020

Check Number	Matching Docume... Date	Vendor Name	Transaction Description	Check Amount	Fund Code	Fund Short Title
25966	6/30/2020	Time Warner Cable	Internet for Fire Station, 6/10/20 to 7/9/20	104.98	10	GENERAL
Total 25966	6/30/2020			104.98		
25967	6/30/2020	Toshiba America Business Solutions	Color & Black/White Monthly Copy Costs 4/26/20 to 5/25/20	453.75	10	GENERAL
25967	6/30/2020	Toshiba America Business Solutions	Color & Black/White Monthly Copy Costs 5/26/20 to 6/25/20	704.95	10	GENERAL
Total 25967	6/30/2020			1,158.70		
25968	6/30/2020	TRI LAKE CONSULTANTS, INC.	General Engr. Srvc's - WRCOG Mtg's, Lot Line Adj, May 2020	700.00	10	GENERAL
Total 25968	6/30/2020			700.00		
25969	7/9/2020	Abila	Monthly Accounting Software Subscription 7/7/20	122.75	10	GENERAL
Total 25969	7/9/2020			122.75		
25970	7/9/2020	John Allen	Refund for overpayment of Rental Inspection Fees	29.50	10	GENERAL
Total 25970	7/9/2020			29.50		
25971	7/9/2020	AMP GLOBAL LLC	Rent for Admin Bldg. for the month of August 2020	2,678.00	10	GENERAL
Total 25971	7/9/2020			2,678.00		
25972	7/9/2020	Randall Bonner	Auto Allowance for the month of July - Bonner	100.00	10	GENERAL
Total 25972	7/9/2020			100.00		

City of Canyon Lake
 Check/Voucher Register - Council Report - Expenditures
 From 7/1/2020 Through 7/31/2020

Check Number	Matching Docume... Date	Vendor Name	Transaction Description	Check Amount	Fund Code	Fund Short Title
25973	7/9/2020	California State Fire Protection	Annual 5lb Extinguisher & Service Call for Rental Bldg, 7/6	113.50	60	ENTERPRI... FUND
Total 25973	7/9/2020			113.50		
25974	7/9/2020	Canyon Lake Investment Properties	Refund for overpayment of Rental Inspection Fees	10.00	10	GENERAL
Total 25974	7/9/2020			10.00		
25975	7/9/2020	Jordan Ehrenkranz	Auto Allowance for the month of July - Ehrenkranz	100.00	10	GENERAL
Total 25975	7/9/2020			100.00		
25976	7/9/2020	GovOffice	3 Year Website Hosting, 7/1/2020	4,325.00	10	GENERAL
Total 25976	7/9/2020			4,325.00		
25977	7/9/2020	Jeremy Smith	Auto Allowance for the month of July - Smith	100.00	10	GENERAL
Total 25977	7/9/2020			100.00		
25978	7/9/2020	Kasey Castillo	Auto Allowance for the month of July - Castillo	100.00	10	GENERAL
Total 25978	7/9/2020			100.00		
25979	7/9/2020	Larry Greene	Auto Allowance for the month of July - Greene	100.00	10	GENERAL
Total 25979	7/9/2020			100.00		
25980	7/9/2020	LESJWA	FY 20-21 Member Contributions	20,000.00	10	GENERAL

City of Canyon Lake
 Check/Voucher Register - Council Report - Expenditures
 From 7/1/2020 Through 7/31/2020

Check Number	Matching Docume... Date	Vendor Name	Transaction Description	Check Amount	Fund Code	Fund Short Title
Total 25980	7/9/2020			20,000.00		
25981	7/9/2020	Nate Volk	Video Broadcast Mtg. for 7/7/20	350.00	10	GENERAL
Total 25981	7/9/2020			350.00		
25982	7/9/2020	Public Entity Risk Management Authority	FY 20-21 Crime Coverage Program Insurance Premium	798.00	10	GENERAL
25982	7/9/2020	Public Entity Risk Management Authority	FY 20-21 Cyber Liability Coverage Program Insurance	776.00	10	GENERAL
25982	7/9/2020	Public Entity Risk Management Authority	FY 20-21 Deadly Weapon Response Program Insurance Premium	112.00	10	GENERAL
25982	7/9/2020	Public Entity Risk Management Authority	FY 20-21 Deposit Premium General Liability Program	38,784.00	10	GENERAL
25982	7/9/2020	Public Entity Risk Management Authority	FY 20-21 ERMA Deposit Premium	2,572.00	10	GENERAL
25982	7/9/2020	Public Entity Risk Management Authority	FY 20-21 Property Program Insurance Premium	4,073.00	10	GENERAL
Total 25982	7/9/2020			47,115.00		
25983	7/9/2020	Riverside County Auditor-Controller	LAFCO FY21 Fees & Admin Fees	620.96	10	GENERAL
Total 25983	7/9/2020			620.96		
25984	7/9/2020	Ana Sauseda	Reimb. for supplies purchased for July 8th CC Meeting	53.43	10	GENERAL
Total 25984	7/9/2020			53.43		
25985	7/9/2020	Southern California Association of Government	Due Assessment for FY 20-21	1,354.00	10	GENERAL
Total 25985	7/9/2020			1,354.00		

City of Canyon Lake
 Check/Voucher Register - Council Report - Expenditures
 From 7/1/2020 Through 7/31/2020

Check Number	Matching Docume... Date	Vendor Name	Transaction Description	Check Amount	Fund Code	Fund Short Title
25986	7/9/2020	Time Warner Cable	Digital Converter for City Hall, 6/22/20 to 7/21/20	5.25	10	GENERAL
Total 25986	7/9/2020			5.25		
25987	7/9/2020	Toshiba Financial Services	Monthly Copier Lease for Admin & City Hall, 7/10/20	799.31	10	GENERAL
Total 25987	7/9/2020			799.31		
25988	6/30/2020	Delgado Janitorial Services	Janitorial Service for the month of June 2020	941.50	10	GENERAL
Total 25988	6/30/2020			941.50		
25989	6/30/2020	Riverside County Clerk-Recorder	County Clerk Filing Fees for Lot Line Adjustment	114.00	10	GENERAL
Total 25989	6/30/2020			114.00		
25990	6/30/2020	American Legal Publishing	2020 S-11 Supplement Pages for City Clerk, 6/29/2020	3,114.05	10	GENERAL
Total 25990	6/30/2020			3,114.05		
25991	6/30/2020	BIO-TOX LABORATORIES	Sheriff's Dept. Blood Draw, 6/18/20	422.00	10	GENERAL
Total 25991	6/30/2020			422.00		
25992	6/30/2020	California Bulding Standards Commission	Permit Valuation April through June 2020	98.00	10	GENERAL
Total 25992	6/30/2020			98.00		
25993	6/30/2020	DATA TICKET	Parking Citations, June 2020	100.00	10	GENERAL
Total 25993	6/30/2020			100.00		

City of Canyon Lake
 Check/Voucher Register - Council Report - Expenditures
 From 7/1/2020 Through 7/31/2020

Check Number	Matching Docume... Date	Vendor Name	Transaction Description	Check Amount	Fund Code	Fund Short Title
25994	6/30/2020	DEPARTMENT OF CONSERVATION	Strong Motion Instrument & Seismic Hazard April - June 2020	237.68	10	GENERAL
Total 25994	6/30/2020			237.68		
25995	6/30/2020	Division of the State Architect	Disability & Education Fee Qtr. Ended 6/30/20	59.60	10	GENERAL
Total 25995	6/30/2020			59.60		
25996	6/30/2020	HINDERLITER, DE LLAMAS & ASSOC	Contract Services - Sales Tax Q4 2019	1,889.59	10	GENERAL
Total 25996	6/30/2020			1,889.59		
25997	6/30/2020	PV Maintenance Inc.	Street & Facility Maintenance (Install Signs) June 2020	2,069.56	20	GAS TAX
Total 25997	6/30/2020			2,069.56		
25998	6/30/2020	RIV. CO. SHERIFF'S DEPT., Acctg & Fin	Sheriff's Contract Law 5/21/20 to 6/30/20	194,797.75	10	GENERAL
Total 25998	6/30/2020			194,797.75		
25999	6/30/2020	Riv Co Sheriff Dept Perris Station	SART Exam for Sheriff's Department May 2020	1,200.00	10	GENERAL
Total 25999	6/30/2020			1,200.00		
26000	6/30/2020	U. S. Bank	Window Shade & Supplies for Admin, Covid-19 Supplies, 7/6/20	4,274.41	10	GENERAL
26000	6/30/2020	U. S. Bank	Window Shade & Supplies for Admin, Covid-19 Supplies, 7/6/20	238.76	27	MISC GRANT

City of Canyon Lake
 Check/Voucher Register - Council Report - Expenditures
 From 7/1/2020 Through 7/31/2020

Check Number	Matching Docume... Date	Vendor Name	Transaction Description	Check Amount	Fund Code	Fund Short Title
26000	6/30/2020	U. S. Bank	Window Shade & Supplies for Admin, Covid-19 Supplies, 7/6/20	122.34	60	ENTERPRI... FUND
Total 26000	6/30/2020			4,635.51		
26001	6/30/2020	Verizon Wireless	Cell Phones, 6/4/20 to 7/3/20	226.36	10	GENERAL
26001	6/30/2020	Verizon Wireless	iPads, 6/4/20 to 7/3/20	167.10	10	GENERAL
Total 26001	6/30/2020			393.46		
26002	7/23/2020	Aflac	Workers Comp Insurance for August 2020	497.96	10	GENERAL
Total 26002	7/23/2020			497.96		
26003	7/23/2020	Bill Blankenship	Economic Development Consulting July 2020	2,500.00	10	GENERAL
Total 26003	7/23/2020			2,500.00		
26004	7/23/2020	CANYON LAKE PEST CONTROL, Steven E. Young	Monthly Pest Control for Fire Station July 2020	40.00	10	GENERAL
Total 26004	7/23/2020			40.00		
26005	7/23/2020	Control Pump	Turned Pump Station Off & On due to Line Break, 7/12/20	740.00	20	GAS TAX
Total 26005	7/23/2020			740.00		
26006	7/23/2020	CR&R	Trash Services for Rental Bldg. July 2020	200.79	60	ENTERPRI... FUND
Total 26006	7/23/2020			200.79		

City of Canyon Lake
 Check/Voucher Register - Council Report - Expenditures
 From 7/1/2020 Through 7/31/2020

Check Number	Matching Docume... Date	Vendor Name	Transaction Description	Check Amount	Fund Code	Fund Short Title
26007	7/23/2020	CTAI Pacific Greenscape	Landscape Maintenance for Fire Station 60 July 2020	250.00	10	GENERAL
26007	7/23/2020	CTAI Pacific Greenscape	Landscape Maintenance for Medians & Parkways July 2020	5,000.00	20	GAS TAX
Total 26007	7/23/2020			5,250.00		
26008	7/23/2020	Delgado Janitorial Services	Janitorial Service for the month of July 2020	941.50	10	GENERAL
Total 26008	7/23/2020			941.50		
26009	7/23/2020	DIRECTV	Satellite for Fire Station, 7/12/20 to 8/11/20	112.09	10	GENERAL
Total 26009	7/23/2020			112.09		
26010	7/23/2020	FRIDAY FLYER	Ordinance No. 198 Changing Names Special Enf. to Code, 7/17	29.40	10	GENERAL
26010	7/23/2020	FRIDAY FLYER	Ordinance No. 200 Short Term Rentals, 7/17/20	29.40	10	GENERAL
26010	7/23/2020	FRIDAY FLYER	Urgency Ord. No. 199 Single Family Rental Inspections, 7/17	26.25	10	GENERAL
Total 26010	7/23/2020			85.05		
26011	7/23/2020	Frontier Communications	Internet for City Hall, 7/10/20 to 8/9/20	201.00	10	GENERAL
26011	7/23/2020	Frontier Communications	Phones for Fire Station, 7/13/20 to 8/12/20	388.88	10	GENERAL
Total 26011	7/23/2020			589.88		
26012	7/23/2020	NANCY GREENHALGH	Retiree Insurance for August 2020	188.03	10	GENERAL

City of Canyon Lake
 Check/Voucher Register - Council Report - Expenditures
 From 7/1/2020 Through 7/31/2020

Check Number	Matching Docume... Date	Vendor Name	Transaction Description	Check Amount	Fund Code	Fund Short Title
Total 26012	7/23/2020			188.03		
26013	7/23/2020	Joe's Hardware	Paint Sample for City Hall, 7/16/20	7.51	10	GENERAL
26013	7/23/2020	Joe's Hardware	Paint, Brush & Battery for City Hall & Chambers, 7/16/20	42.28	10	GENERAL
26013	7/23/2020	Joe's Hardware	Rope & Filters for Fire Station, 7/17/20	44.96	10	GENERAL
26013	7/23/2020	Joe's Hardware	Spackling Light & Screws/Bolts for Police Dept. Office, 7/15	9.19	10	GENERAL
Total 26013	7/23/2020			103.94		
26014	7/23/2020	Johnny Q Auto Detailing	City Boat Exterior/Interior Clean & Wax, 7/9/2020	350.00	10	GENERAL
Total 26014	7/23/2020			350.00		
26015	7/23/2020	Johnson Controls Security Solutions	Alarm Upgrade in Admin Office, 7/6/2020	409.99	10	GENERAL
Total 26015	7/23/2020			409.99		
26016	7/23/2020	KC Graphics	Fire Inspection Reports, 7/13/20	177.79	10	GENERAL
Total 26016	7/23/2020			177.79		
26017	7/23/2020	Les Schwab Tire Center	New Tires & Shock Repair on Jeep, 7/11/2020	1,406.47	10	GENERAL
Total 26017	7/23/2020			1,406.47		
26018	7/23/2020	LESJWA	FY 20-21 TMDL Member Contributions	37,787.00	10	GENERAL

City of Canyon Lake
 Check/Voucher Register - Council Report - Expenditures
 From 7/1/2020 Through 7/31/2020

Check Number	Matching Docume... Date	Vendor Name	Transaction Description	Check Amount	Fund Code	Fund Short Title
Total 26018	7/23/2020			37,787.00		
26019	7/23/2020	NorCal FPO	2019 California Fire Inspection Guide for Code Enf. 7/14/20	62.30	10	GENERAL
Total 26019	7/23/2020			62.30		
26020	7/23/2020	Purchase Power	Postage for 7/6/2020	400.00	10	GENERAL
Total 26020	7/23/2020			400.00		
26021	7/23/2020	Pitney Bowes, Inc.	Red Ink for Postage Machine, 7/20/20	87.00	10	GENERAL
Total 26021	7/23/2020			87.00		
26022	7/23/2020	JOHN REGUS	Library Lease for September 2020	1,106.86	10	GENERAL
Total 26022	7/23/2020			1,106.86		
26023	7/23/2020	RIV. CO. SHERIFF-S DEPT.	Riv Cal-ID FY 20-21 Member Agency Assessment	11,285.00	10	GENERAL
Total 26023	7/23/2020			11,285.00		
26024	7/23/2020	County Executive Office	SCFA Quarterly Sheltering Services for July - Sept. 2020	16,952.00	10	GENERAL
Total 26024	7/23/2020			16,952.00		
26025	7/23/2020	Special District Risk Management Authority	Dental/Vision Ins.Ecclefield. Mann, Sauseda, Ferrari Aug 20	363.23	10	GENERAL
Total 26025	7/23/2020			363.23		

City of Canyon Lake
 Check/Voucher Register - Council Report - Expenditures
 From 7/1/2020 Through 7/31/2020

Check Number	Matching Docume... Date	Vendor Name	Transaction Description	Check Amount	Fund Code	Fund Short Title
26026	7/23/2020	STATE COMP. INS. FUND	Workers Comp Insurance for August 2020	971.33	10	GENERAL
Total 26026	7/23/2020			971.33		
26027	7/23/2020	Time Warner Cable	Internet for Fire Station, 7/10/20 to 8/9/20	104.98	10	GENERAL
Total 26027	7/23/2020			104.98		
26028	7/23/2020	Trauma Intervention Program	Annual Trauma Intervention Program FY 2020-21	1,500.00	10	GENERAL
Total 26028	7/23/2020			1,500.00		
26029	7/23/2020	WRCOG	FY 20/21 WRCOG Member Dues, Invoice Date 7/1/2020	1,406.00	10	GENERAL
Total 26029	7/23/2020			1,406.00		
EFT174		SOUTHERN CALIFORNIA EDISON	Electricity for City Hall 5/14/20 to 6/15/20	839.17	10	GENERAL
Total EFT174				839.17		
EFT175		SOUTHERN CALIFORNIA EDISON	Electricity for Traffic Signals 5/14/20 to 6/15/20	184.82	20	GAS TAX
Total EFT175				184.82		
EFT176		SOUTHERN CALIFORNIA EDISON	Electricity for Traffic Signals 5/20/20 to 6/19/20	7.90	20	GAS TAX
Total EFT176				7.90		
EFT177		SOUTHERN CALIFORNIA EDISON	Electricity for Pump Station 5/8/20 to 6/9/20	199.37	20	GAS TAX

City of Canyon Lake
 Check/Voucher Register - Council Report - Expenditures
 From 7/1/2020 Through 7/31/2020

Check Number	Matching Docume... Date	Vendor Name	Transaction Description	Check Amount	Fund Code	Fund Short Title
Total EFT177				199.37		
EFT178		SOUTHERN CALIFORNIA EDISON	Electricity for Fire Station 5/14/20 to 6/15/20	479.65	10	GENERAL
Total EFT178				479.65		
EFT179		SOUTHERN CALIFORNIA EDISON	Electricity for Traffic Signals 5/21/20 to 6/22/20	50.61	20	GAS TAX
Total EFT179				50.61		
EFT180		SOUTHERN CALIFORNIA EDISON	Electricity for Admin Office 5/20/20 to 6/19/20	226.07	10	GENERAL
Total EFT180				226.07		
EFT181		SOUTHERN CALIFORNIA EDISON	Electricity for Rental 5/14/20 to 6/15/20	21.38	60	ENTERPRI... FUND
Total EFT181				21.38		
EFT182		Sparkletts	Drinking Water for City Hall & Admin Office June 2020	79.44	10	GENERAL
Total EFT182				79.44		
EFT183		SOUTHERN CALIFORNIA EDISON	Electricity for Traffic Signals 5/29/20 to 6/29/20	303.33	20	GAS TAX
Total EFT183				303.33		
EFT184		ELSINORE VALLEY MUNI WATER DIS	Water for Irrigation 5/29/20 to 6/28/20	1,006.37	20	GAS TAX
Total EFT184				1,006.37		

City of Canyon Lake
 Check/Voucher Register - Council Report - Expenditures
 From 7/1/2020 Through 7/31/2020

Check Number	Matching Docume... Date	Vendor Name	Transaction Description	Check Amount	Fund Code	Fund Short Title
EFT185		ELSINORE VALLEY MUNI WATER DIS	Water for City Hall 5/26/20 to 6/25/20	92.28	10	GENERAL
Total EFT185				92.28		
EFT186		ELSINORE VALLEY MUNI WATER DIS	Water for Fire Station 5/29/20 to 6/28/20	410.66	10	GENERAL
Total EFT186				410.66		
EFT187		ELSINORE VALLEY MUNI WATER DIS	Water for Rental Bldg 5/26/20 to 6/25/20	95.79	60	ENTERPRI... FUND
Total EFT187				95.79		
Report Total				624,746.93 - 941.50 <u>#623,805.43</u>		

City of Canyon Lake
Invoices Selected for Payment - COUNCIL CHECK REPORT

Vendor ID	Invoice Description	Cash Required
AMP	Rent for 31526 Railroad Cyn. Suite #4 July & August 2020	1,546.67
Report Total		<u>1,546.67</u>

City of Canyon Lake
Invoices Selected for Payment - COUNCIL CHECK REPORT

<u>Vendor ID</u>	<u>Invoice Description</u>	<u>Cash Required</u>
Fast Signs	Covid 19 Signage for City Hall & Installation, Final 6/3/20	704.22
Report Total		<u>704.22</u>

City of Canyon Lake
Invoices Selected for Payment - COUNCIL CHECK REPORT

Vendor ID	Invoice Description	Cash Required
Fast Signs	ADA Counter Sneeze Guards for City Hall, Final Invoice	809.19
	Area Temporarily Closed Coroplast for BLM Land, July 2020	604.78
Report Total		<u>1,413.97</u>

City of Canyon Lake
Invoices Selected for Payment - COUNCIL CHECK REPORT

Vendor ID	Invoice Description	Cash Required
AMERICAN FORENSIC	Sheriff's Blood Draws, 6/15/20	55.00
ANIMAL FRIENDS	Animal Control Services for Mar., Apr., & May 2020	10,500.00
CL PEST	Monthly Pest Control for Fire Station, June 2020	40.00
	Quarterly Pest Control P.O. #09-010, 6/12/20	60.00
Cole Huber	Attorney Services for June 2020	5,000.00
	Attorney Services for June 2020 (Covid 19)	300.00
Control Pump	Monthly Landscape Booster Station, June 2020	375.00
Corelogic	Database for Code Enforcement Reports, June 2020	5.15
	Database for Code Enforcement, June 2020	128.75
CTAI	Monthly Landscapae Maint. for Median & Parkways for June 2020	5,000.00
	Monthly Landscape Maintenance for Fire Station June 2020	250.00
DATA TICKET	Citation Processing, Code Enforcement June 2020	304.00
Delgado	Janitorial Service for the month of June 2020	941.50
Emergency Services Consulting Inter	Feasibility Study monthly Progress Invoice, 6/30/20	19,112.00
Frontier	Phones for Fire Station, 6/13/20 to 7/12/20	375.37
Giambra	Refund of Plot Plan deposit for 23476 Moccasin Circle,6/1/20	955.25
ICG	Building & Safety Services for May 2020	28,117.87
Joe's	Outlet & GFCI Tester for Code Enforcement, 6/30/20	9.82
	Screws & Bolts for Code Enforcement, 6/30/20	1.22
Johnson Controls	New Alarm Upgrade at City Hall, 6/11/20	737.91
PZL, Inc.	Planning Services for June 2020	3,724.09
RAMS	Accounting Services for the month of May 2020	6,900.00
riv Co Exec	SCFA Miscellaneous Admin Expenses 4th Qtr.	1,421.20
Riv Co Sheriff Acctg	Sheriff's Contract Law 4/23/20 to 5/20/20	129,639.00
Riv Co Sheriff Dept	Sheriff's Dept. Extra Duty for Memorial Day 5/22 - 5/23/20	2,517.82
Riv Co Sheriff DTS	Communications Dispatch FY 19-20	10,088.00
Sco	State Controller's 2019 Offset Program - 7 Names Submitted	14.01
Syntech	IT Services for June 2020	1,530.00
	Migration to Cloud Project, 6/24/20	13,250.00
Time Warner	Internet for Fire Station, 6/10/20 to 7/9/20	104.98
Toshiba Business Solutions, USA	Color & Black/White Monthly Copy Costs 4/26/20 to 5/25/20	453.75
	Color & Black/White Monthly Copy Costs 5/26/20 to 6/25/20	704.95
TRI LAKE	General Engr. Srvcs - WRCOG Mtg's, Lot Line Adj, May 2020	700.00
Report Total		243,316.64

Date: 7/9/20
04:21:46 PM

09/02/2020 City Council Agenda

Page: 1

City of Canyon Lake
Invoices Selected for Payment - COUNCIL CHECK REPORT

Vendor ID	Invoice Description	Cash Required
ABILA	Monthly Accounting Software Subscription 7/7/20	122.75
Allen	Refund for overpayment of Rental Inspection Fees	29.50
AMP	Rent for Admin Bldg. for the month of August 2020	2,678.00
Bonner	Auto Allowance for the month of July - Bonner	100.00
California State Fire Protection	Annual 5lb Extinguisher & Service Call for Rental Bldg, 7/6	113.50
CL Investment	Refund for overpayment of Rental Inspection Fees	10.00
Ehrenkranz	Auto Allowance for the month of July - Ehrenkranz	100.00
GOVOF	3 Year Website Hosting, 7/1/2020	4,325.00
Jeremy Smith	Auto Allowance for the month of July - Smith	100.00
Kasey Castillo	Auto Allowance for the month of July - Castillo	100.00
Larry Greene	Auto Allowance for the month of July - Greene	100.00
LESJWA	FY 20-21 Member Contributions	20,000.00
Nate Volk	Video Broadcast Mtg. for 7/7/20	350.00
PERMA	FY 20-21 Property Program Insurance Premium	4,073.00
	FY 20-21 Deadly Weapon Response Program Insurance Premium	112.00
	FY 20-21 ERMA Deposit Premium	2,572.00
	FY 20-21 Cyber Liability Coverage Program Insurance	776.00
	FY 20-21 Crime Coverage Program Insurance Premium	798.00
	FY 20-21 Deposit Premium General Liability Program	38,784.00
Riv Co Auditor	LAFCO FY21 Fees & Admin Fees	620.96
Sauseda	Reimb. for supplies purchased for July 8th CC Meeting	53.43
SCAG	Due Assessment for FY 20-21	1,354.00
Time Warner	Digital Converter for City Hall, 6/22/20 to 7/21/20	5.25
Toshiba	Monthly Copier Lease for Admin & City Hall, 7/10/20	799.31
Report Total		78,076.70

(M)

City of Canyon Lake
Invoices Selected for Payment - COUNCIL CHECK REPORT

Vendor ID	Invoice Description	Cash Required
Delgado	Janitorial Service for the month of June 2020	941.50
Riv Co Clerk-Recorder	County Clerk Filing Fees for Lot Line Adjustment	114.00
Report Total		<u>1,055.50</u>

City of Canyon Lake
Invoices Selected for Payment - COUNCIL CHECK REPORT

Vendor ID	Invoice Description	Cash Required
American Legal	2020 S-11 Supplement Pages for City Clerk, 6/29/2020	3,114.05
BIO-TOX	Sheriff's Dept. Blood Draw, 6/18/20	186.00
	Sheriff's Dept. Blood Draw, 6/18/20	236.00
CBSC	Permit Valuation April through June 2020	98.00
DATA TICKET	Parking Citations, June 2020	100.00
DEPT OF CONSER	Strong Motion Instrument & Seismic Hazard April - June 2020	237.68
DSA	Disability & Education Fee Qtr. Ended 6/30/20	59.60
HINDERLITER	Contract Services - Sales Tax Q4 2019	1,889.59
PVM	Street & Facility Maintenance (Install Signs) June 2020	2,069.56
Riv Co Sheriff Acctg	Sheriff's Contract Law 5/21/20 to 6/30/20	194,797.75
Riv Co Sheriff Dept	SART Exam for Sheriff's Department May 2020	1,200.00
US Bank	Window Shade & Supplies for Admin, Covid-19 Supplies, 7/6/20	238.76
	Window Shade & Supplies for Admin, Covid-19 Supplies, 7/6/20	4,274.41
	Window Shade & Supplies for Admin, Covid-19 Supplies, 7/6/20	122.34
VerizonW	Cell Phones, 6/4/20 to 7/3/20	226.36
	iPads, 6/4/20 to 7/3/20	167.10
Report Total		209,017.20

City of Canyon Lake
Invoices Selected for Payment - COUNCIL CHECK REPORT

Vendor ID	Invoice Description	Cash Required
Aflac	Workers Comp Insurance for August 2020	497.96
Bill Blankenship	Economic Development Consulting July 2020	2,500.00
CL PEST	Monthly Pest Control for Fire Station July 2020	40.00
Control Pump	Turned Pump Station Off & On due to Line Break, 7/12/20	740.00
CR&R	Trash Services for Rental Bldg. July 2020	200.79
CTAI	Landscape Maintenance for Medians & Parkways July 2020	5,000.00
	Landscape Maintenance for Fire Station 60 July 2020	250.00
Delgado	Janitorial Service for the month of July 2020	941.50
DIRECTV	Satellite for Fire Station, 7/12/20 to 8/11/20	112.09
FRIDAY FLYER	Ordinance No. 198 Changing Names Special Enf. to Code, 7/17	29.40
	Ordinance No. 200 Short Term Rentals, 7/17/20	29.40
	Urgency Ord. No. 199 Single Family Rental Inspections, 7/17	26.25
Frontier	Phones for Fire Station, 7/13/20 to 8/12/20	388.88
	Internet for City Hall, 7/10/20 to 8/9/20	201.00
GREENHALGH	Retiree Insurance for August 2020	188.03
Joe's	Spackling Light & Screws/Bolts for Police Dept. Office, 7/15	9.19
	Paint, Brush & Battery for City Hall & Chambers, 7/16/20	42.28
	Paint Sample for City Hall, 7/16/20	7.51
	Rope & Filters for Fire Station, 7/17/20	44.96
Johnny Q Auto Detailing	City Boat Exterior/Interior Clean & Wax, 7/9/2020	350.00
Johnson Controls	Alarm Upgrade in Admin Office, 7/6/2020	409.99
K Graphics	Fire Inspection Reports, 7/13/20	177.79
Les Schwab Tire Center	New Tires & Shock Repair on Jeep, 7/11/2020	1,406.47
LESJWA	FY 20-21 TMDL Member Contributions	37,787.00
NorCal FPO	2019 California Fire Inspection Guide for Code Enf. 7/14/20	62.30
Pitney Bowes - Purchase Power	Postage for 7/6/2020	400.00
Pitney Bowes, Inc.	Red Ink for Postage Machine, 7/20/20	87.00
REGUS	Library Lease for September 2020	1,106.86
Riv Co Cal-ID	Riv Cal-ID FY 20-21 Member Agency Assessment	11,285.00
riv Co Exec	SCFA Quarterly Sheltering Services for July - Sept. 2020	16,952.00
SDRMA	Dental/Vision Ins.Ecclefield, Mann, Sauseda, Ferrari Aug 20	363.23
STATE FUND	Workers Comp Insurance for August 2020	971.33
Time Warner	Internet for Fire Station, 7/10/20 to 8/9/20	104.98
TIP	Annual Trauma Intervention Program FY 2020-21	1,500.00

Date: 7/23/20

05:06:51 PM

09/02/2020 City Council Agenda

Page: 1

City of Canyon Lake
Invoices Selected for Payment - COUNCIL CHECK REPORT

Vendor ID	Invoice Description	Cash Required
WRCOG	FY 20/21 WRCOG Member Dues, Invoice Date 7/1/2020	1,406.00
Report Total		<u>85,619.19</u>

Labor Distribution

City of Canyon Lake
Company (10756)

Check Date: 06/30/2020
Process: 2020063001
Period: 06/16/2020 to 06/30/2020

Department: (20)City Employees

Code	Earning	Hours	Amount	Deduction	Code	Tax	Code	Tax	Amount	Code	Tax	Amount	Taxable	Tax	Amount	Taxable	Amount
125CO	125 Cash		492.43	PTAXI Pre-Tax P.	CA	California SI	CA	CA Edu & T	154.49	CAETT	CA Edu & T	0.00	0.00	0.00	0.00	0.00	0.00
Reg	Regular		3891.24		CASDI	CA SDI - Err	CASUI	California SI	43.84	CASUI	California SI	0.00	0.00	0.00	0.00	0.00	4383.67
102					FITW	Federal Inco	MED-R	Medicare - E	444.56	MED-R	Medicare - E	63.56	63.56	63.56	63.56	63.56	4383.67
Salary			3891.24		MED	Medicare			63.56								3404.83
Total Earnings										Total Deductions		Total Employer Taxes					
0.00										272.39		706.45		63.56			
Code	Earning	Hours	Amount	Deduction	Code	Tax	Code	Tax	Amount	Code	Tax	Amount	Taxable	Tax	Amount	Taxable	Amount
Reg	Regular	45.50	958.69		CA	California SI	CA	CA Edu & T	12.89	CAETT	CA Edu & T	0.00	0.00	0.00	0.00	0.00	0.00
106					CASDI	CA SDI - Err	CASUI	California SI	9.59	CASUI	California SI	0.00	0.00	0.00	0.00	0.00	0.00
Rate			21.0700		FITW	Federal Inco	MED-R	Medicare - E	46.29	MED-R	Medicare - E	13.90	13.90	13.90	13.90	13.90	958.69
Total Earnings										Total Deductions		Total Employer Taxes					
45.50										0.00		82.67		13.90			

Code	Earning	Hours	Amount	Deduction	Code	Tax	Code	Tax	Amount	Code	Tax	Amount	Taxable	Tax	Amount	Taxable	Amount
Reg	Regular	45.00	723.15	457B EE	CA	California SI	CA	CA Edu & T	6.52	CAETT	CA Edu & T	0.00	0.00	0.00	0.00	0.00	0.00
114					CASDI	CA SDI - Err	CASUI	California SI	7.23	CASUI	California SI	0.00	0.00	0.00	0.00	0.00	0.00
Rate			16.0700		FITW	Federal Inco	MED-R	Medicare - E	17.31	MED-R	Medicare - E	10.49	10.49	10.49	10.49	10.49	723.15
Total Earnings										Total Deductions		Total Employer Taxes					
45.00										54.24		41.55		10.49			

Code	Earning	Hours	Amount	Deduction	Code	Tax	Code	Tax	Amount	Code	Tax	Amount	Taxable	Tax	Amount	Taxable	Amount
Reg	Regular	45.00	186.93	PTXPE Pre-Tax P.	CA	California SI	CA	CA Edu & T	63.97	CAETT	CA Edu & T	0.00	0.00	0.00	0.00	0.00	0.00
115					CASDI	CA SDI - Err	CASUI	California SI	21.87	CASUI	California SI	0.00	0.00	0.00	0.00	0.00	0.00
Rate			2000.00		FITW	Federal Inco	MED-R	Medicare - E	176.00	MED-R	Medicare - E	31.71	31.71	31.71	31.71	31.71	2186.93
Total Earnings										Total Deductions		Total Employer Taxes					
45.00										135.00		293.55		31.71			

Code	Earning	Hours	Amount	Deduction	Code	Tax	Code	Tax	Amount	Code	Tax	Amount	Taxable	Tax	Amount	Taxable	Amount
ELECT	Reimburs		184.97	PTXPE Pre-Tax P.	CA	California SI	CA	CA Edu & T	527.72	CAETT	CA Edu & T	0.00	0.00	0.00	0.00	0.00	0.00
Reg	Regular		75.00		CASDI	CA SDI - Err	CASUI	California SI	71.35	CASUI	California SI	0.00	0.00	0.00	0.00	0.00	0.00
Salary			6875.00		FITW	Federal Inco	MED-R	Medicare - E	1273.33	MED-R	Medicare - E	103.46	103.46	103.46	103.46	103.46	7134.97
Total Earnings										Total Deductions		Total Employer Taxes					
0.00										464.06		1975.86		103.46			

Code	Earning	Hours	Amount	Deduction	Code	Tax	Code	Tax	Amount	Code	Tax	Amount	Taxable	Tax	Amount	Taxable	Amount
ADMV	Admin Le	17.50	527.74	457B EE	CA	California SI	CA	CA Edu & T	73.77	CAETT	CA Edu & T	0.00	0.00	0.00	0.00	0.00	0.00
Reg	Regular		3125.00	PTAXI Pre-Tax P.	CASDI	CA SDI - Err	CASUI	California SI	36.53	CASUI	California SI	0.00	0.00	0.00	0.00	0.00	0.00
Vac	Vacation	20.50	0.00		FITW	Federal Inco	MED-R	Medicare - E	263.70	MED-R	Medicare - E	52.96	52.96	52.96	52.96	52.96	3652.74
Total Earnings										Total Deductions		Total Employer Taxes					
38.00										284.75		426.96		52.96			

Department: (20)City Employees Total

Emp Code	Earning	Hours	Amount	Deduction	Code	Amount	Code	Tax	Code	Amount	Taxable	Tax	Code	Amount	Taxable	Amount	
6	Code																
3	125CO 125 Cash		1392.07	457B EE	457B	120.24	CA	California SI	CA	17829.71	839.36	CAEIT CA Edu & T		0.00	0.00	0.00	19040.15
3	ADMML Admin Le	17.50	0.00	PTAXI Pre-Tax P	PTAXI	491.14	CASDI CA SDI - Err	CASUI	19040.15	190.41	0.00	California SI		0.00	0.00	0.00	19316.23
	ELECT Reimburs		75.00	PTXPE Pre-Tax P	PTXPE	599.06	FITW Federal Inco	MED-R	17829.71	2221.19	276.08	Medicare - E		19040.15	276.08	0.00	14302.67
	Reg Regular	90.50	17573.08				MED	Medicare		19040.15	276.08						
	Vac Vacation	20.50	0.00														
	Total Earnings	128.50	19040.15	Total Deductions		1210.44	Total Employee Taxes			3527.04	Total Employer Taxes			276.08			

Department: (30)Special Enforcement Team

Emp Code	Earning	Hours	Amount	Deduction	Code	Amount	Code	Tax	Code	Amount	Taxable	Tax	Code	Amount	Taxable	Amount
	Reg Regular	85.50	2165.71	457B EE	457B	50.00	CA	California SI	CA	1841.77	55.69	CAEIT CA Edu & T		0.00	0.00	0.00
				MEDI: Health Ins	MEDI	127.75	CASDI CA SDI - Err	CASUI	2037.96	2037.96	0.00	California SI		0.00	0.00	0.00
				PTXPE Pre-Tax P	PTXPE	146.19	FITW Federal Inco	MED-R	1841.77	145.05	2037.96	Medicare - E		29.55	29.55	2165.71
							MED	Medicare		2037.96	29.55					2195.26
	Total Earnings	85.50	2165.71	Total Deductions		323.94	Total Employee Taxes			250.67	Total Employer Taxes			29.55		

Emp Code	Earning	Hours	Amount	Deduction	Code	Amount	Code	Tax	Code	Amount	Taxable	Tax	Code	Amount	Taxable	Amount
	125CO 125 Cash		477.29	PTAXI Pre-Tax P	PTAXI	184.52	CA	California SI	CA	2928.74	150.48	CAEIT CA Edu & T		0.00	0.00	0.00
	Comp Comp Tin	9.50	292.89				CASDI CA SDI - Err	CASUI	3113.26	31.13	0.00	California SI		0.00	0.00	0.00
	Reg Regular	57.00	1757.31				FITW Federal Inco	MED-R	2928.74	275.49	45.14	Medicare - E		3113.26	45.14	3113.26
	Vac Vacation	19.00	585.77				MED	Medicare		3113.26	45.15					3158.40
	Total Earnings	85.50	3113.26	Total Deductions		184.52	Total Employee Taxes			502.25	Total Employer Taxes			45.14		

Emp Code	Earning	Hours	Amount	Deduction	Code	Amount	Code	Tax	Code	Amount	Taxable	Tax	Code	Amount	Taxable	Amount
	Reg Regular	23.00	630.20				CA	California SI	CA	630.20	5.67	CAEIT CA Edu & T		0.00	0.00	0.00
							CASDI CA SDI - Err	CASUI	630.20	6.30	0.00	California SI		0.00	0.00	0.00
							FITW Federal Inco	MED-R	630.20	48.39	630.20	Medicare - E		630.20	9.14	630.20
							MED	Medicare		630.20	9.13					560.71
	Total Earnings	23.00	630.20	Total Deductions		0.00	Total Employee Taxes			69.49	Total Employer Taxes			9.14		

Emp Code	Earning	Hours	Amount	Deduction	Code	Amount	Code	Tax	Code	Amount	Taxable	Tax	Code	Amount	Taxable	Amount
	125CO 125 Cash		499.58	PTXPE Pre-Tax P	PTXPE	152.01	CA	California SI	CA	2599.64	59.71	CAEIT CA Edu & T		0.00	0.00	0.00
	Reg Regular	85.50	2252.07				CASDI CA SDI - Err	CASUI	2751.65	27.52	0.00	California SI		0.00	0.00	0.00
							FITW Federal Inco	MED-R	2599.64	236.00	39.90	Medicare - E		2751.65	39.90	2751.65
							MED	Medicare		2751.65	39.90					2791.55
	Total Earnings	85.50	2751.65	Total Deductions		152.01	Total Employee Taxes			363.13	Total Employer Taxes			39.90		

Emp Code	Earning	Hours	Amount	Deduction	Code	Amount	Code	Tax	Code	Amount	Taxable	Tax	Code	Amount	Taxable	Amount
	Reg Regular	24.00	632.16	PTXPE Pre-Tax P	PTXPE	42.67	CA	California SI	CA	589.49	0.00	CAEIT CA Edu & T		0.00	0.00	0.00
							CASDI CA SDI - Err	CASUI	632.16	6.32	0.00	California SI		0.00	0.00	0.00
							FITW Federal Inco	MED-R	589.49	7.28	632.16	Medicare - E		632.16	9.17	632.16
							MED	Medicare		632.16	9.16					566.73
	Total Earnings	24.00	632.16	Total Deductions		42.67	Total Employee Taxes			22.76	Total Employer Taxes			9.17		

Labor Distribution

City of Canyon Lake
Company (10756)

Check Date: 06/30/2020
Process: 2020063001
Period: 06/16/2020 to 06/30/2020

Department: (30)Special Enforcement Team Total

Emp No	Code	Earning	Hours	Amount	Code	Deduction	Amount	Code	Tax	Amount	Code	Tax	Amount	Taxable	Amount	Taxable	Amount
3	125CO	125 Cash		976.87	457B	457B EE	50.00	CA	California SI	8589.84	CAETT	CA Edu & T	271.55	0.00	0.00	0.00	0.00
2	Comp	Comp Tin	9.50	292.89	MEDI	Health Ins	127.75	CASDI	CA SDI - E	9165.23	CASUI	California SI	91.65	0.00	0.00	0.00	9292.98
	Reg	Regular	275.00	7437.45	PTAXI	Pre-Tax P.	184.52	FITW	Federal Inco	8589.84	MED-R	Medicare - E	712.21	9165.23	132.90	9165.23	9475.88
	Vac	Vacation	19.00	585.77	PTXPE	Pre-Tax P.	340.87	MED	Medicare	9165.23			132.89				7381.54
		Total Earnings	303.50	9792.98	Total Deductions		703.14	Total Employee Taxes		1208.30	Total Employer Taxes		132.90				

Department: (50)Council Members

Emp No	Code	Earning	Hours	Amount	Code	Deduction	Amount	Code	Tax	Amount	Code	Tax	Amount	Taxable	Amount	Taxable	Amount
78	Reg	Regular		300.00	CA	California SI		CAETT	CA Edu & T	300.00	CAETT	CA Edu & T	0.00	300.00	0.30	300.00	300.00
		Total Earnings	0.00	300.00	Total Deductions		0.00	Total Employee Taxes		4.35	Total Employer Taxes		20.85				

Emp No	Code	Earning	Hours	Amount	Code	Deduction	Amount	Code	Tax	Amount	Code	Tax	Amount	Taxable	Amount	Taxable	Amount
110	Reg	Regular		300.00	CA	California SI		CAETT	CA Edu & T	300.00	CAETT	CA Edu & T	0.00	300.00	0.30	300.00	300.00
		Total Earnings	0.00	300.00	Total Deductions		0.00	Total Employee Taxes		4.35	Total Employer Taxes		20.85				

Emp No	Code	Earning	Hours	Amount	Code	Deduction	Amount	Code	Tax	Amount	Code	Tax	Amount	Taxable	Amount	Taxable	Amount
62	Reg	Regular		300.00	FITW	Federal Inco		FITW	Federal Inco	300.00	CASUI	California SI	0.00	300.00	16.20	300.00	300.00
		Total Earnings	0.00	300.00	Total Deductions		0.00	Total Employee Taxes		4.35	Total Employer Taxes		20.85				

Emp No	Code	Earning	Hours	Amount	Code	Deduction	Amount	Code	Tax	Amount	Code	Tax	Amount	Taxable	Amount	Taxable	Amount
103	Reg	Regular		300.00	FITW	Federal Inco		FITW	Federal Inco	300.00	CASUI	California SI	0.00	300.00	16.20	300.00	300.00
		Total Earnings	0.00	300.00	Total Deductions		0.00	Total Employee Taxes		4.35	Total Employer Taxes		20.85				

Emp No	Code	Earning	Hours	Amount	Code	Deduction	Amount	Code	Tax	Amount	Code	Tax	Amount	Taxable	Amount	Taxable	Amount
109	Reg	Regular		300.00	CA	California SI		CAETT	CA Edu & T	300.00	CAETT	CA Edu & T	0.00	300.00	0.30	300.00	300.00
		Total Earnings	0.00	300.00	Total Deductions		0.00	Total Employee Taxes		4.35	Total Employer Taxes		20.85				

City of Canyon Lake
Company (10756)

Check Date: 06/30/2020
Process: 2020063001
Period: 06/16/2020 to 06/30/2020

Department: (50) Council Members Total

Employees	5	Code	Earning	Hours	Amount	Code	Deduction	Amount	Code	Tax	Amount	Code	Tax	Amount	Taxable	Tax	Amount	Taxable	Amount		
Female:	1	Reg	Regular		1500.00	CA	California SI		CA	California SI	1500.00	CAETT	CA, Edu & T	1500.00	1500.00		1500.00	1500.00	1.50		
Male:	4					FITW	Federal Incoi		FITW	Federal Incoi	1500.00	CASUI	California SI	1500.00	1500.00		1500.00	1500.00	81.00		
						MED	Medicare		MED	Medicare	1500.00	MED-R	Medicare - E	21.75	1500.00		1500.00	1500.00	21.75		
																				1500.00	
																					1604.25
																					1478.25
Total Earnings				0.00	1500.00	Total Deductions		0.00	Total Employee Taxes					21.75	Total Employer Taxes						104.25

Report Total

Employees	16	Code	Earning	Hours	Amount	Code	Deduction	Amount	Code	Tax	Amount	Code	Tax	Amount	Taxable	Tax	Amount	Taxable	Amount		
Female	7	125CO	125 Cash		2368.94	457B	457B EE:	170.24	CA	California SI	27919.55	CAETT	CA, Edu & T	1500.00	1500.00		1500.00	1500.00	1.50		
Male	9	ADML	Admin Le	17.50	0.00	MED1:	Health Ins	127.75	CASD1	CA SDI - En	28205.38	CASUI	California SI	1500.00	1500.00		1500.00	1500.00	81.00		
		Comp	Comp Tin	9.50	292.89	PTAXI	Pre-Tax P.	675.66	FITW	Federal Incoi	27919.55	MED-R	Medicare - E	29705.38	29705.38		29705.38	29705.38	430.73		
		ELECI	Reimburs		75.00	PTXPE	Pre-Tax P.	939.93	MED	Medicare	29705.38			430.72						430.73	
		Reg	Regular	365.50	26510.53																
		Vac	Vacation	39.50	585.77																
Total Earnings				432.00	29833.13	Total Deductions		1913.58	Total Employee Taxes					4757.09	Total Employer Taxes						513.23

Chris Mann, City Manager

7-7-20
Date

City of Canyon Lake
Company (10756)

Check Date: 07/15/2020
Process: 2020071501
Period: 07/01/2020 to 07/15/2020

Department: (1)Staff

Code	Earning	Hours	Amount	Deduction	Code	Amount	Tax	Taxable	Amount	Tax	Taxable	Amount
Reg	Regular	3.75	225.00									
107												Gross 225.00
60.0000												Tot Liab 225.00
												Net Amt 225.00
Total Earnings			3.75	225.00	Total Deductions	0.00	Total Employer Taxes	0.00	Total Employer Taxes	0.00	Total Employer Taxes	0.00

Department: (1)Staff Total

Emploees	1	Code	Earning	Hours	Amount	Deduction	Code	Amount	Tax	Taxable	Amount	Tax	Taxable	Amount
Female	1	Reg	Regular	3.75	225.00									
Male	0													
Total Earnings			3.75	225.00	Total Deductions	0.00	Total Employer Taxes	0.00	Total Employer Taxes	0.00	Total Employer Taxes	0.00	Total Employer Taxes	0.00

Department: (20)City Employees

Code	Earning	Hours	Amount	Deduction	Code	Amount	Tax	Taxable	Amount	Tax	Taxable	Amount		
125CO	125 Cash		492.43	PTAXF Pre-Tax P.	CA	California SI		4473.60	186.37	CAETT CA Edu & Ti	0.00	0.00		
102	Hol Holiday	9.50	0.00		CASDI	CA SDI - Err		4773.26	47.73	CASUI California SI	0.00	0.00		
4280.83	Reg Regular		4280.83		FITW	Federal Incoi		4473.60	524.28	MED-R Medicare - E	4773.26	69.22		
					MED	Medicare		4773.26	69.21			69.22		
Total Earnings			9.50	4773.26	Total Deductions	299.66	Total Employer Taxes	827.59	Total Employer Taxes	827.59	Total Employer Taxes	69.22	Total Employer Taxes	69.22

Code	Earning	Hours	Amount	Deduction	Code	Amount	Tax	Taxable	Amount	Tax	Taxable	Amount		
Reg	Regular	35.00	754.60		CA	California SI		754.60	8.40	CAETT CA Edu & Ti	0.00	0.00		
106					CASDI	CA SDI - Err		754.60	7.54	CASUI California SI	0.00	0.00		
21.5600					FITW	Federal Incoi		754.60	25.88	MED-R Medicare - E	754.60	10.94		
					MED	Medicare		754.60	10.94			10.94		
Total Earnings			35.00	754.60	Total Deductions	0.00	Total Employer Taxes	52.76	Total Employer Taxes	52.76	Total Employer Taxes	10.94	Total Employer Taxes	10.94

Code	Earning	Hours	Amount	Deduction	Code	Amount	Tax	Taxable	Amount	Tax	Taxable	Amount		
Reg	Regular	40.00	684.00	457B EE	CA	California SI		632.70	5.72	CAETT CA Edu & Ti	0.00	0.00		
114					CASDI	CA SDI - Err		684.00	6.84	CASUI California SI	0.00	0.00		
17.1000					FITW	Federal Incoi		632.70	13.69	MED-R Medicare - E	684.00	9.92		
					MED	Medicare		684.00	9.91			9.92		
Total Earnings			40.00	684.00	Total Deductions	51.30	Total Employer Taxes	36.16	Total Employer Taxes	36.16	Total Employer Taxes	9.92	Total Employer Taxes	9.92

Code	Earning	Hours	Amount	Deduction	Code	Amount	Tax	Taxable	Amount	Tax	Taxable	Amount		
125CO	125 Cash		186.93	PTXPE Pre-Tax P.	CA	California SI		2172.38	73.61	CAETT CA Edu & Ti	0.00	0.00		
115	Hol Holiday	9.50	0.00		CASDI	CA SDI - Err		2316.10	23.16	CASUI California SI	0.00	0.00		
2129.17	Reg Regular		2129.17		FITW	Federal Incoi		2172.38	190.46	MED-R Medicare - E	2316.10	33.58		
					MED	Medicare		2316.10	33.59			33.58		
Total Earnings			9.50	2316.10	Total Deductions	143.72	Total Employer Taxes	320.82	Total Employer Taxes	320.82	Total Employer Taxes	33.58	Total Employer Taxes	33.58

Labor Distribution

City of Canyon Lake

Company (10756)

Check Date: 07/15/2020
Process: 2020071501
Period: 07/01/2020 to 07/15/2020

09/02/2020 City Council

Code	Earning	Hours	Amount	Code	Deduction	Amount	Code	Tax	Amount	Taxable	Code	Tax	Amount	Taxable	Amount
125CO	125 Cash		166.99	PTXPE	Pre-Tax P.	175.78	CA	California SI	2595.38	2771.16	CA	Edu & T	2771.16	2771.16	2.77
117	Holiday	9.50	0.00				CASDI	CA SDI - Err	2771.16	2771.16	CASUI	California SI	2771.16	2771.16	149.64
2604.17	Regular		2604.17				FITW	Federal Inco	2595.38	2771.16	MED-R	Medicare - E	2771.16	2771.16	40.18
	Vac	9.50	0.00				MED	Medicare	2771.16	2771.16	SS-R	OASDI - Err	2771.16	2771.16	0.00
							SS	OASDI	2771.16	2771.16					0.00
Total Earnings			2771.16	Total Deductions			175.78	Total Employer Taxes			466.21	Total Employer Taxes			192.59

Code	Earning	Hours	Amount	Code	Deduction	Amount	Code	Tax	Amount	Taxable	Code	Tax	Amount	Taxable	Amount
125CO	125 Cash		184.97	PTXPE	Pre-Tax P.	464.06	CA	California SI	6670.91	6670.91	CA	Edu & T	0.00	0.00	0.00
111	ELECT Reimburs		75.00				CASDI	CA SDI - Err	7134.97	7134.97	CASUI	California SI	0.00	0.00	0.00
6875.00	Hol	9.50	0.00				FITW	Federal Inco	6670.91	6670.91	MED-R	Medicare - E	7134.97	7134.97	103.46
	Reg		6875.00				MED	Medicare	7134.97	7134.97					0.00
Total Earnings			7134.97	Total Deductions			464.06	Total Employer Taxes			1975.86	Total Employer Taxes			103.46

Code	Earning	Hours	Amount	Code	Deduction	Amount	Code	Tax	Amount	Taxable	Code	Tax	Amount	Taxable	Amount
125CO	125 Cash		527.74	457B	457B EE	66.00	CA	California SI	3553.99	3553.99	CA	Edu & T	0.00	0.00	0.00
108	Holiday	9.50	0.00	PTAXI	Pre-Tax P.	232.75	CASDI	CA SDI - Err	3852.74	3852.74	CASUI	California SI	0.00	0.00	0.00
3325.00	Reg		3325.00				FITW	Federal Inco	3553.99	3553.99	MED-R	Medicare - E	3852.74	3852.74	55.86
	Reg		3325.00				MED	Medicare	3852.74	3852.74					0.00
Total Earnings			3852.74	Total Deductions			298.75	Total Employer Taxes			466.47	Total Employer Taxes			55.86

Department: (20)City Employees Total

Code	Earning	Hours	Amount	Code	Deduction	Amount	Code	Tax	Amount	Taxable	Code	Tax	Amount	Taxable	Amount
7	Female		1559.06	457B	457B EE	117.30	CA	California SI	20853.56	20853.56	CA	Edu & T	2771.16	2771.16	2.77
4	Male		75.00	PTAXI	Pre-Tax P.	532.41	CASDI	CA SDI - Err	22286.83	22286.83	CASUI	California SI	2771.16	2771.16	149.64
	Hol	47.50	0.00				FITW	Federal Inco	20853.56	20853.56	MED-R	Medicare - E	22286.83	22286.83	323.16
	Reg	75.00	20652.77				MED	Medicare	22286.83	22286.83	SS-R	OASDI - Err	2771.16	2771.16	0.00
	Vac	9.50	0.00				SS	OASDI	2771.16	2771.16					0.00
Total Earnings			132.00	Total Deductions			1433.27	Total Employer Taxes			4145.87	Total Employer Taxes			475.57

Department: (30)Special Enforcement Team

Code	Earning	Hours	Amount	Code	Deduction	Amount	Code	Tax	Amount	Taxable	Code	Tax	Amount	Taxable	Amount
Comp	Comp Tin	9.50	256.02	457B	457B EE	50.00	CA	California SI	2132.63	2132.63	CA	Edu & T	0.00	0.00	0.00
104	Holiday	9.50	256.02	MEDI	Health Ins	127.75	CASDI	CA SDI - Err	2338.17	2338.17	CASUI	California SI	0.00	0.00	0.00
26.9500	OT	4.00	161.70	PTXPE	Pre-Tax P.	155.54	FITW	Federal Inco	2132.63	2132.63	MED-R	Medicare - E	2338.17	2338.17	33.90
	Reg	66.50	1792.18				MED	Medicare	2338.17	2338.17					0.00
Total Earnings			89.50	Total Deductions			333.29	Total Employer Taxes			312.95	Total Employer Taxes			33.90

Code	Earning	Hours	Amount	Code	Deduction	Amount	Code	Tax	Amount	Taxable	Code	Tax	Amount	Taxable	Amount
125CO	125 Cash		477.29	PTAXI	Pre-Tax P.	196.88	CA	California SI	3092.91	3092.91	CA	Edu & T	0.00	0.00	0.00
101	Holiday	9.50	0.00				CASDI	CA SDI - Err	3289.79	3289.79	CASUI	California SI	0.00	0.00	0.00
2812.50	Reg		2812.50				FITW	Federal Inco	3092.91	3092.91	MED-R	Medicare - E	3289.79	3289.79	47.70
	Sick	9.50	0.00				MED	Medicare	3289.79	3289.79					0.00
Total Earnings			19.00	Total Deductions			196.88	Total Employer Taxes			543.07	Total Employer Taxes			47.70

Labor Distribution

City of Canyon Lake
Company (10756)

Check Date: 07/15/2020
Process: 2020071501
Period: 07/01/2020 to 07/15/2020

09/02/2022 City Council

Code	Earning	Hours	Amount	Code	Deduction	Amount	Code	Tax	Amount	Code	Tax	Amount	Taxable	Amount	Taxable	Amount
DT	Double Ti	2.00	116.64	CA	California SI	2157.74	CA	CA ETT	77.91	CA Edu & Ti	0.00	0.00	0.00	0.00	0.00	0.00
113	OT	2.50	109.35	CASD	CA SDI - Err	2157.74	CASU	California SI	21.58	California SI	0.00	0.00	0.00	0.00	0.00	2157.74
29.1600	Reg	25.50	1931.75	FITW	Federal Inco	2157.74	MED-R	Medicare - E	264.45	Medicare - E	2157.74	31.29	2157.74	31.29	2157.74	2189.03
				MED	Medicare	2157.74			31.29							1762.51
	Total Earnings	30.00	2157.74		Total Deductions	0.00		Total Employer Taxes	395.23							31.29
Manzanillo, Rubi	125CO 125 Cash	499.58	161.77	CA	California SI	2902.57	CA	CA ETT	73.04	CA Edu & Ti	0.00	0.00	0.00	0.00	0.00	0.00
Emp Id	Comp Tin	854.92	3064.34	CASD	CA SDI - Err	3064.34	CASU	California SI	30.64	California SI	0.00	0.00	0.00	0.00	0.00	3064.34
Rate	Hol	266.29	2902.57	FITW	Federal Inco	2902.57	MED-R	Medicare - E	272.35	Medicare - E	3064.34	44.43	3064.34	44.43	3064.34	3064.34
28.0300	OT	168.18	1275.37	MED	Medicare	3064.34			44.43							3108.77
	Reg	45.50	1275.37		Total Deductions	161.77		Total Employer Taxes	420.46							44.43
	Total Earnings	89.50	3064.34		Total Deductions	161.77		Total Employer Taxes	420.46							44.43
Sun, Timothy L	Reg	60.00	1681.80	CA	California SI	1568.28	CA	CA ETT	32.04	CA Edu & Ti	0.00	0.00	0.00	0.00	0.00	0.00
Emp Id	Regular	60.00	1681.80	CASD	CA SDI - Err	1681.80	CASU	California SI	16.81	California SI	0.00	0.00	0.00	0.00	0.00	1681.80
Rate				FITW	Federal Inco	1568.28	MED-R	Medicare - E	117.96	Medicare - E	1681.80	24.39	1681.80	24.39	1681.80	1706.19
28.0300				MED	Medicare	1681.80			24.39							1377.08
	Total Earnings	60.00	1681.80		Total Deductions	113.52		Total Employer Taxes	191.20							24.39

Department: (30)Special Enforcement Team Total

Employees	Code	Earning	Hours	Amount	Code	Deduction	Amount	Code	Tax	Amount	Code	Tax	Amount	Taxable	Amount	Taxable	Amount
Female	5	125CO 125 Cash	976.87	457B	EE	50.00	CA	California SI	11854.13	CA ETT	CA Edu & Ti	425.97	0.00	0.00	0.00	0.00	0.00
Male	3	Comp Tin	1110.94	MED	Health Ins	127.75	CASD	CA SDI - Err	12531.84	CASU	California SI	125.31	0.00	0.00	0.00	0.00	12659.59
	2	Double Ti	116.64	PTAXI	Pre-Tax P.	196.88	FITW	Federal Inco	11854.13	MED-R	Medicare - E	1129.91	12531.84	181.71	12531.84	12841.30	9991.22
		Hol	28.50	PTXPE	Pre-Tax P.	430.83	MED	Medicare	12531.84			181.72					
		OT	439.23														
		Reg	9493.60														
		Sick	0.00														
		Total Earnings	288.00	12659.59	Total Deductions	805.46		Total Employer Taxes	1862.91								181.71

Report Total

Employees	Code	Earning	Hours	Amount	Code	Deduction	Amount	Code	Tax	Amount	Code	Tax	Amount	Taxable	Amount	Taxable	Amount
Female	13	125CO 125 Cash	2535.93	457B	EE	167.30	CA	California SI	32707.69	CA ETT	CA Edu & Ti	1430.26	2.77	2771.16	2771.16	2.77	2.77
Male	5	Comp Tin	1110.94	MED	Health Ins	127.75	CASD	CA SDI - Err	34818.67	CASU	California SI	348.17	149.64	34818.67	34818.67	149.64	35171.42
		Double Ti	116.64	PTAXI	Pre-Tax P.	729.29	FITW	Federal Inco	32707.69	MED-R	Medicare - E	3725.47	504.87	34818.67	504.87	504.87	35828.70
		ELECT Reimburs	75.00	PTXPE	Pre-Tax P.	1214.39	MED	Medicare	34818.67	SS-R	OASDI - Ein	504.88	0.00	2771.16	2771.16	0.00	26923.91
		Hol	522.31				SS	OASDI	2771.16			0.00					
		OT	439.23														
		Reg	30371.37														
		Sick	0.00														
		Vac	0.00														
		Total Earnings	423.75	35171.42	Total Deductions	2238.73		Total Employer Taxes	6008.78								657.28

Chris Mann, City Manager
Date

Credit Card Review

U S BANK Statement dated 7/6/20

ITEM #	CREDITOR	DESCRIPTION	AMOUNT	ACCOUNT
1	Amazon	Replacement Wheels for Podium	\$ 11.71	10-310-6210
2	Amazon Prime	Monthly Prime Membership Fee	\$ 14.00	10-310-6210
3	Two Brothers Locksmiths	Replace Lock for Electrical Room for Rental Bldg.	\$ 122.34	60-560-6210
4	Amazon	Replacement Wheels for Podium	\$ 11.71	10-310-6210
5	Ario Technologies	Monthly Camera Service - City Hall	\$ 9.99	10-550-6610
6	Amazon	3 Year Office Protection Plan for Wireless Nano Travel Router for Council Chambers (PEG)	\$ 4.99	27-100-6210
7	Amazon	Extension Cable & Nano Travel Router for Council Chambers (PEG)	\$ 82.95	27-100-6210
8	Amazon	1 Gallon Hand Sanitizer Gel (Covid-19)	\$ 40.94	10-310-6210
9	Amazon	1 Gallon Hand Sanitizer Gel (Qty:2) (Covid-19)	\$ 81.88	10-310-6210
10	Amazon	Hand Sanitizer Dispenser Station Kit (Covid-19)	\$ 280.14	10-310-6210
11	Amazon	Hand Sanitizer Dispenser Station Kit (Qty:2) (Covid-19)	\$ 560.28	10-310-6210
12	Amazon	Forehead Thermometer's (Qty:3) (Covid-19)	\$ 258.57	10-310-6210
13	Amazon	Wireless Handheld Microphone System & Base for Council Chambers (PEG)	\$ 150.82	27-100-6210
14	Joe's Hardware	Office Supplies for City Hall	\$ 42.00	10-310-6210
15	Lowe's	Office Supplies for Admin Office	\$ 131.30	10-310-6210
16	Amazon	Door Hardware & Door Sweep (Qty:4) for New Admin Office Room	\$ 53.60	10-310-6210
17	Amazon	Commercial Industrial Automatic Touchless Soap and Hand Sanitizer for City Hall (Covid-19)	\$ 605.53	10-310-6210
18	Roll-A-Shade	Window Shade for New Admin Office Room	\$ 549.53	10-550-8000
19	Amazon	1 Gallon Hand Sanitizer Gel (Qty:5) (Covid-19)	\$ 210.05	10-310-6210
20	Amazon	Door Hardware for New Admin Office Room	\$ 8.61	10-310-6210
21	Canyon Lake County Club	Lunch Mtg. for Economic Development Mann, Blankenship & Bush	\$ 51.90	10-310-6510
22	Amazon	Electronic Kettle for Admin Office	\$ 160.55	10-310-6210
23	Zoom	Monthly Subscription for Virtual Meetings	\$ 14.99	10-310-6210
24	Red Robin	Winter Wonderland Lunch Mann, Borja, Sauseda & Ferrari	\$ 68.93	10-310-6510
25	Sports Stop Pub & Grill	Lunch Mtg. for Property Management Mann & Blankenship	\$ 43.26	10-310-6510
26	Canyon Lake County Club	Lunch Mtg. for Economic Development Mann, Blankenship, Polland, Bush & Kazakoff	\$ 92.77	10-310-6510
27	Microsoft	Microsoft 365 Monthly Fee	\$ 340.00	10-310-6210
28	Microsoft	Emergency Preparedness Monthly Emails	\$ 44.00	10-425-6210
29	Red Robin	Staff Lunch	\$ 60.00	10-320-6510
30	Microsoft	Microsoft 365 Monthly Fee	\$ 387.50	10-310-6210
31	Tommy's Express	Car Wash for City Vehicles	\$ 102.95	10-520-6415
32	MCA Direct	Electronic Model Resolutions, Forms & Notices for City Clerk	\$ 37.72	10-320-6610
		Late Fee	\$ -	10-310-6965
			\$ 4,635.51	
		Account Breakdown		
	City Council Dept. Expense	10-100-6220		
	Council Meeting/Travel Expense	10-100-6510		
	Council Special Dept. Expense	10-100-6520		
	Promotion and Advertising	10-100-6830		
	City Council Misc. Grant Office Expense	27-100-6210	\$ 238.76	
	City Manager Office Expense	10-310-6210	\$ 3,213.36	
	Conference/Meeting/Travel Expense	10-310-6510	\$ 256.86	
	City Manager Software	10-310-6530		
	City Manager Dept. Expense	10-310-6220		
	City Manager Membership	10-310-6520		
	Professional/Specialized Services	10-310-6610		
	City Manager Replacement Boat	10-310-8003		
	City Manager Computer	10-310-8010		
	City Clerk Departmental Expense	10-320-6220		
	City Clerk Conference/Meeting/Travel Expense	10-320-6510	\$ 60.00	
	City Clerk Dues	10-320-6520		
	Professional/Specialized Services	10-320-6610	\$ 37.72	
	City Clerk Training and Education	10-320-6710		
	Planning Services	10-350-6616		
	General Plan Services	10-350-6619		
	Building Dept Expense	10-360-6220		
	City Clerk Military Banner Program	10-320-6511		
	Fire & Medical Department Expense	10-420-6220		
	Emergency Preparedness Office Supplies	10-425-6210	\$ 44.00	
	Emergency Preparedness Grant Expense	10-425-6215		
	Code Enforcement Supplies	10-520-6210		
	Special Enforcement Misc Expense	10-520-6220		
	Code Enforcement Vehicle Equipment	10-520-6410		
	Vehicle Maintenance	10-520-6415	\$ 102.95	
	Code Enforcement Membership Dues	10-520-6520		
	Code Enforcement Training	10-520-6710		
	Building & Facilities Maintenance	10-550-6610	\$ 9.99	
	Building & Facilities Maint. Capital Outlay	10-550-8000	\$ 549.53	
	Rental Office Expense	60-560-6210	\$ 122.34	
			\$ 4,635.51	
			Check Figure \$ -	

*Copies for City Council
as directed by
the Finance Committee*

027

Reporting Manage Reports Payroll Schedule Out-of-Class Validation Member Requests Health Reconciliation Retirement Appointr

Name: City of Canyon Lake CalPERS ID: 3813045770

Payment Confirmation

Your request for payment has been accepted

- To generate the employer payment report, please click the print button.
- If you need to contact us with questions regarding this payment, please have your Payment Confirmation Number for faster access.
- Your payment will reflect as paid in myCalPERS if your payroll has successfully posted. Once your payment is processed any credits will roll over to the same type of receivable in the next month, after your payroll has been processed.
- Your payment may take longer to post, depending upon your Financial Institution.

Payment Details

Total Payment Amount: \$2,612.16

Payment Summary

Payment Confirmation Number	Payment Acknowledgment Date	Receivable ID	Receivable Description	Payment Method	Payment Location	Payment Amount
1001601409	07/08/2020	100000016076478	Health PA Billing - PERS	EFT - Debit	Citizens Business Bank -5402	\$2,612.16

[Contact Us](#) | [CalPERS Website](#) | [Privacy Policy](#) | [Conditions of Use](#) | [Accessibility](#) | © Copyright 2020 CalPERS

Build: v8.8 Baseline: 200611_083908_v8.8_Int.8947 UID: 318

(M)

Reporting

Manage Reports | Payroll Schedule | Out-of-Class Validation | Member Requests | Health Reconciliation | Retirement Appoint

Name: City of Canyon Lake CalPERS ID: 3813045770

Payment Request Confirmation

Your request for payment has been accepted

- To generate the employer payment report, please click the print button.
- If you need to contact us with questions regarding this payment, please have your Payment Confirmation Number for faster access.
- Your payment will reflect as paid in myCalPERS if your payroll has successfully posted. Once your payment is processed any credits will roll over to the same type of receivable in the next month, after your payroll has been processed.
- Your payment may take longer to post, depending upon your Financial Institution.

Payment Summary

Total Payment Amount: \$3,522.58

Payment Summary

Payment Confirmation Number	Payment Authorization Date	Receivable ID	Receivable Description	Payment Method	Payment Account Name	Selected Payment Amount
1001601479	07/08/2020	100000016036224	Employer Contribution, PEPRA, 26189, CalPERS, 06/16/2020 - 06/30/2020	EFT - Debit	Citizens Business Bank -5402	\$1,912.59
1001601480	07/08/2020	100000016036185	Employer Contribution, Classic, 1684, CalPERS, 06/16/2020 - 06/30/2020	EFT - Debit	Citizens Business Bank -5402	\$1,609.99

[Contact Us](#) | [CalPERS Website](#) | [Privacy Policy](#) | [Conditions of Use](#) | [Accessibility](#) | © Copyright 2020 CalPERS

Build: v8.8 Baseline: 200611_083908_v8.8_Int.8947 UID: 318

CM

Reporting

Manage Reports Payroll Schedule Out-of-Class Validation Member Requests Health Reconciliation Retirement Appointr

Name: City of Canyon Lake

CalPERS ID: 3813045770

▼ Payment Status

Payment Status: Pending

Receivable Type:

▼ Display Generate Report

▼ Payment Authorization

To cancel a pending payment, select the Payment Authorization Date link.

Payment Authorization Date	Payment ID	Amount	Bank	Payment Status	Member ID	Description
07/22/2020	1001612940	\$2,605.44	Citizens Business Bank -5402	Pending	100000016068479	Employer Contribution, PEPR, 26189, CalPERS, 07/01/2020 - 07/15/2020

[Contact Us](#) | [CalPERS Website](#) | [Privacy Policy](#) | [Conditions of Use](#) | [Accessibility](#) | © Copyright 2020 CalPERS

Build: v8.8 Baseline: 200611_083908_v8.8_Int.8947 UID: 302

Home Profile Reporting Person Information Education Pension Outlook Other Organizations

Manage Reports Billing and Payments Payroll Schedule Out-of-Class Validation Member Requests Health Reconciliation Retirement Appointr

Name: City of Canyon Lake CalPERS ID: 3813045770

Payment Request Acceptance

Your request for payment has been accepted

- **To generate the employer payment report, please click the print button.**
- If you need to contact us with questions regarding this payment, please have your Payment Confirmation Number for faster access.
- Your payment will reflect as paid in myCalPERS if your payroll has successfully posted. Once your payment is processed any credits will roll over to the same type of receivable in the next month, after your payroll has been processed.
- Your payment may take longer to post, depending upon your Financial Institution.

Payment Setup Total

Total Payment Amount: \$27,066.00

Payment Summary

Payment Confirmation Number	Payment Authorization Date	Receivable ID	Receivable Description	Payment Method	Payment Account Nickname	Selected Payment Amount
1001608150	07/15/2020	100000016093633	Employer Contributions - Unfunded Accrued Liability, Classic, 1684, CalPERS, 2020/2021	EFT - Debit	Citizens Business Bank -5402	\$27,066.00

[Contact Us](#) | [CalPERS Website](#) | [Privacy Policy](#) | [Conditions of Use](#) | [Accessibility](#) | © Copyright 2020 CalPERS

CM

Build: v8.8 Baseline: 200611_083908_v8.8_Int.8947 UID: 318

Home Profile **Reporting** Person Information Education Pension Outlook Other Organizations

Manage Reports Billing and Payments Payroll Schedule Out-of-Class Validation Member Requests Health Reconciliation Retirement Appointr

Name: City of Canyon Lake **CalPERS ID:** 3813045770

Payment Request Acceptance

Your request for payment has been accepted

- **To generate the employer payment report, please click the print button.**
- If you need to contact us with questions regarding this payment, please have your Payment Confirmation Number for faster access.
- Your payment will reflect as paid in myCalPERS if your payroll has successfully posted. Once your payment is processed any credits will roll over to the same type of receivable in the next month, after your payroll has been processed.
- Your payment may take longer to post, depending upon your Financial Institution.

Payment Setup Total

Total Payment Amount: \$2,700.00

Payment Summary

Payment Confirmation Number	Payment Authorization Date	Receivable ID	Receivable Description	Payment Method	Payment Account Nickname	Selected Payment Amount
1001608148	07/15/2020	100000016093640	Employer Contributions - Unfunded Accrued Liability, PEPRA, 26189, CalPERS, 2020/2021	EFT - Debit	Citizens Business Bank -5402	\$2,700.00

[Contact Us](#) | [CalPERS Website](#) | [Privacy Policy](#) | [Conditions of Use](#) | [Accessibility](#) | © Copyright 2020 CalPERS

Build: v8.8 Baseline: 200611_083908_v8.8_Int.8947 **UID: 318**

cm

CITY OF CANYON LAKE
PLAN SPONSOR: 0035273

Acknowledgment

Your payment was successfully submitted. Provided it is in good order, it will process within contractual timeframes.

You can print this acknowledgment for your records.

Plan Name: **CITY OF CANYON LAKE 457 OBRA-PST**

Plan Number: **0035273002**

Payroll Center: **CITY OF CANYON LAKE OBRA**

Payroll Center Number: **001**

Payroll Received for Salary Reduction

Submission date: **07/09/2020**

Submission time: **08:24 PM**

Pay period end date: **06/30/2020**

Payment method: **Debit ACH**

Bank routing number: **122234149**

Bank account number: **245125402**

Contributions payment amount: **\$108.47**

Contributions count: **1**

Draft date: **07/13/2020**

CM

Nationwide Retirement Solutions and Nationwide Life Insurance Company (collectively "Nationwide") have endorsement relationships with the National Association of Counties, the International Association of Fire Fighters-Financial Corporation, and the National Association of Police Organizations.

Nationwide may receive payments from mutual funds or their affiliates in connection with certain investment options. [Learn more about these payments.](#)

Retirement Specialists provide information for educational purposes only. This information is not meant to be used as investment advice. Retirement Specialists are Registered Representatives of Nationwide Investment Services Corporation, member FINRA.

CITY OF CANYON LAKE
PLAN SPONSOR: 0035273

Acknowledgment

Your payment was successfully submitted. Provided it is in good order, it will process within contractual timeframes.

You can print this acknowledgment for your records.

Plan Name: **CITY OF CANYON LAKE 457**

Plan Number: **0035273001**

Payroll Center: **CITY OF CANYON LAKE**

Payroll Center Number: **001**

Payroll Received for Salary Reduction

Submission date: **07/09/2020**

Submission time: **08:22 PM**

Pay period end date: **06/30/2020**

Payment method: **Debit ACH**

Bank routing number: **122234149**

Bank account number: **245125402**

Contributions payment amount: **\$232.00**

Contributions count: **2**

Draft date: **07/13/2020**

(M)

Nationwide Retirement Solutions and Nationwide Life Insurance Company (collectively "Nationwide") have endorsement relationships with the National Association of Counties, the International Association of Fire Fighters Financial Corporation, and the National Association of Police Organizations.

Nationwide may receive payments from mutual funds or their affiliates in connection with certain investment options. Learn more about this at www.nationwidere.com.

Retirement Specialists provide information for educational purposes only. This information is not meant to be used as investment advice. Retirement Specialists are Registered Representatives of Nationwide Investment Services Corporation, member FINRA.

Investment Reports

CITIZENSTRUST

PO Box 2549
Rancho Cucamonga, CA 91729-2549
Return Service Requested

00000083 MCB1000070820879675 01 000000 54 005

RECEIVED
JUL 27 2020
BY 



CITY OF CANYON LAKE
31516 RAILROAD CANYON RD
CANYON LAKE CA 92587

STATEMENT FOR THE PERIOD FROM 06/01/2020 TO 06/30/2020
ACCOUNT 1035003119

THIS IS YOUR REPORT OF INVESTMENTS AND TRANSACTIONS FOR THE PERIOD. INCLUDED
IN THE REPORT ARE

- * PORTFOLIO: SUMMARY GRAPHICAL DISPLAY WITH MARKET VALUE & PERCENT
 - * ACTIVITY SUMMARY: MARKET VALUE WITH TRANSACTION SUMMARY
 - * PORTFOLIO STATEMENT: A LISTING OF COST AND MARKET VALUE OF ASSETS HELD IN THE PORTFOLIO
- COST BASIS APPLICABLE FOR CALCULATING CAPITAL GAINS AND LOSSES.
MARKET VALUE IS THE CURRENT VALUE OF EACH ASSET FOR MOST STOCKS AND BONDS.
MARKETS ARE THE CLOSING PRICES ON THE LAST TRADING DAY OF THE PERIOD.
- * TRANSACTION STATEMENT: A COMPLETE LISTING FOR THE PERIOD GROUPED BY TRANSACTION TYPE.
 - * DISCLOSURES: CITIZENS BUSINESS BANK MAY RECEIVE RESEARCH AND OTHER BENEFITS FROM BROKER DEALERS WHICH MAY BE CONSIDERED COMPENSATION TO US. UPON REQUEST WE WILL DISCLOSE DETAILS OF ANY COMPENSATION RECEIVED.
 - * TO TRUST BENEFICIARIES: UNDER SECTION 17200 OF CALIFORNIA PROBATE CODE, YOU MAY PETITION THE COURT TO OBTAIN A COURT REVIEW OF THE ACCOUNT AND THE ACTS OF THE TRUSTEE. CLAIMS AGAINST THE TRUSTEE FOR BREACH OF TRUST MUST BE MADE WITHIN THREE YEARS FROM THE DATE OF RECEIPT OF AN ACCOUNTING OR OTHER REPORT DISCLOSING FACTS GIVING RISE TO THE CLAIM.



CITIZENSTRUST™

PO Box 2549
 Rancho Cucamonga, CA 91729-2549
 Return Service Requested



Account Statement

Account Number: **1035003119**
 June 01, 2020 To June 30, 2020

CITY OF CANYON LAKE
 31516 RAILROAD CANYON RD
 CANYON LAKE, CA 92587

Account Name:	CITY OF CANYON LAKE CITIZENS BUSINESS BANK
Account Number:	1035003119
Your Relationship Manager Is:	MIKE GARDNER
Phone:	909-483-4390

Investment Portfolio Summary

Market Value As Of	06/01/2020	06/30/2020	% Of Account
 CASH & CASH EQUIVALENTS	293,412.80	201,119.60	7.2%
 FIXED INCOME	2,482,493.70	2,415,086.15	87.1%
 MISCELLANEOUS	0.00	158,716.50	5.7%
Total	2,775,906.50	2,774,922.25	100.0%

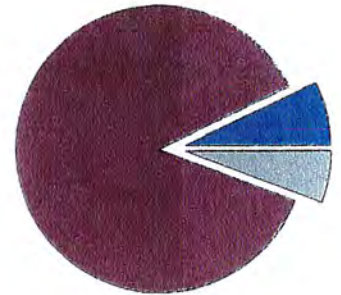

Activity Summary

	This Period	Year To Date	Realized Capital Gains / Losses	
			This Period	Year To Date
Beginning Market Value	2,775,906.50	2,740,120.38		
Income	1,756.36	22,468.64	Long Term	47.34-
Asset Activity	93,580.01-	460,554.45-	Total Gains / Losses	47.34-
Fees	469.55-	2,758.76-		1,223.31-
Cash Management	92,293.20	440,844.57		
Change In Market Value	984.25-	34,801.87		
Ending Market Value	2,774,922.25	2,774,922.25		



Account Statement

Account Number: 1035003119

June 01, 2020 To June 30, 2020

Performance Summary - Total Returns

	Market Value	1 Month	3 Months	1 Year	2 Years	3 Years	Since Inception 03/01/2010
TOTAL FUND	2,787,877	0.03	0.57	2.59	3.29	2.24	1.36
Return On Indexes Fixed GT (95% FX / 5% C)		0.19	0.98	5.15	5.07	3.30	2.09

Return Comparison

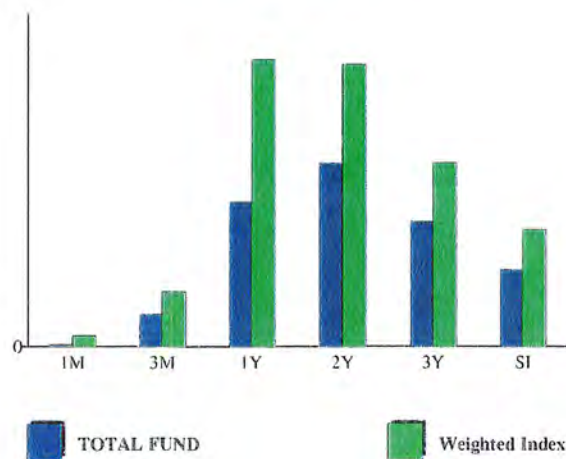

PAST RESULTS ARE NOT INDICATIVE OF FUTURE INVESTMENT RESULTS. FUND DATA IS ON A TRADE DATE BASIS. PERFORMANCE RESULTS ARE GROSS OF MANAGEMENT FEES. RETURNS FOR PERIODS LONGER THAN ONE YEAR ARE ANNUALIZED. MARKET VALUE DOES NOT INCLUDE ACCRUED INCOME.

Portfolio Statement

Quantity	Description	Market Value	Cost Basis
Cash & Cash Equivalents			
Cash Equivalents			
Unclassified			
201,119.600	31607A703 FIDELITY GOVERNMENT PORTFOLIO	201,119.60	201,119.60
	Total Unclassified	201,119.60	201,119.60
Total	Cash Equivalents	201,119.60	201,119.60
Total	Cash & Cash Equivalents	201,119.60	201,119.60
Fixed Income			
Taxable			
100,000.000	05580ACZ5 BMW BANK BANK NORTH AMERICA DTD 09/30/15 MEDIUM-TERM CD 2.2% 09/30/2020	100,543.00	99,980.00
100,000.000	14042RAR2 CAPITAL ONE NA MEDIUM-TERM CD DTD 10/07/2015 2.2% 10/07/2020	100,585.00	99,615.00
100,000.000	24422ERE1 JOHN DEERE CAPITAL CORP SERIES MTN DTD 07/12/2011 3.9% 07/12/2021	103,563.00	103,131.96
100,000.000	29266NS32 ENERBANK USA DTD 10/16/2015 MEDIUM-TERM CD 1.75% 10/16/2020	100,479.00	100,000.00
125,000.000	3130AEWA4 FEDERAL HOME LOAN DTD 09/07/18 2.625% 10/01/2020	125,765.00	125,610.61
200,000.000	3130AHUM3 FEDERAL HOME LOAN BANK DTD 01/10/20 CALL 2% 01/10/2025-2020	200,058.00	200,000.00
150,000.000	3130AJQR3 FEDERAL HOME LOAN BANK DTD 06/30/20 CALL .45% 06/30/2023-2020	149,889.00	150,000.00
100,000.000	3130AJRE1 FEDERAL HOME LOAN BANK DTD 6/24/2020 CALL .75% 06/24/2025-2020	99,900.00	100,000.00
105,000.000	3133EEG79 FEDERAL FARM CREDIT BANK DTD 05/07/2015 2.15% 09/07/2023	111,072.15	111,012.30
100,000.000	3133ELH56 FEDERAL FARM CREDIT BANK DTD 06/09/2020 CALL .27% 06/09/2022-2020	99,953.00	99,875.00
200,000.000	3133ELN75 FEDERAL FARM CREDIT BANK DTD 6/23/20 CALL .23% 12/23/2021-2020	199,870.00	199,900.00



Account Statement

Account Number: **1035003119**
 June 01, 2020 To June 30, 2020

Portfolio Statement (Continued)

Quantity	Description	Market Value	Cost Basis
Taxable			
100,000.000	3133ELWT7 FEDERAL FARM CREDIT BANK DTD 4/21/2020 CALL 1.15% 10/21/2024-2020	100,002.00	100,000.00
200,000.000	3133ELXV1 FEDERAL FARM CREDIT BANK DTD 4/28/20 CALL 1.01% 04/28/2025-2020	200,006.00	200,000.00
100,000.000	3134GU4S6 FREDDIE MAC DTD 01/21/20 CALL 1.8% 04/21/2023-2020	100,078.00	100,000.00
100,000.000	3134GVY69 FREDDIE MAC DTD 6/30/2020 CALL .55% 06/30/2023-2020	100,002.00	100,000.00
100,000.000	3135G03Q4 FANNIE MAE DTD 04/23/2020 CALL 1.1% 04/23/2025-2020	100,109.00	100,000.00
200,000.000	69353REW4 PNC BANK NA DTD 04/29/16 CALL 2.15% 04/29/2021-2021	202,620.00	200,828.12
200,000.000	880591ER9 TENN VALLEY AUTHORITY DTD 09/29/14 2.875% 09/15/2024	220,592.00	209,944.60
Total	Taxable	2,415,086.15	2,399,897.59
Total	Fixed Income	2,415,086.15	2,399,897.59
Miscellaneous			
Corp Bond-sma			
Taxable Bonds			
150,000.000	24422ERT8 JOHN DEERE CAPITAL CORP DTD 06/26/12 2.8% 01/27/2023	158,716.50	158,469.00
Total Taxable Bonds		158,716.50	158,469.00
Total	Corp Bond-sma	158,716.50	158,469.00
Miscellaneous Sundry Assets			
Documents			
1.000	DOC199647 INVESTMENT MANAGEMENT AGREEMENT CITY OF CANYON LAKE A/C# 1035003119	0.00	0.00
Total Documents		0.00	0.00
Total	Miscellaneous Sundry Assets	0.00	0.00
Total	Miscellaneous	158,716.50	158,469.00
Grand Total Assets		2,774,922.25	2,759,486.19

Account Activity Summary

	Total Cash	Cost Basis Excluding Cash	Market Value Including Cash
Balances Beginning Of Period	0.00	2,758,146.72	2,786,317.37
Prior Accruals			10,410.87-
Unrealized Depreciation This Period			936.91-
Current Accruals			12,303.36
Asset Activity	93,580.01-	93,532.67	93,580.01-
Cash Management	92,293.20	92,293.20-	92,293.20
Fees	469.55-	0.00	469.55-
Income	1,756.36	100.00	1,756.36
Realized Gain/loss			47.34-
Non Cash Asset Changes			
Balances End Of Period	0.00	2,759,486.19	2,787,225.61

Transaction Statement

Date	Quantity	Description	Transaction Type	Cash	Cost Basis
06/01/20		Beginning Balance		0.00	2,758,146.72
		Income			
		Interest			
06/01/20		31607A703 FIDELITY GOVERNMENT PORTFOLIO	INTEREST RCVD	28.59	
06/10/20		3130AJCS6 FEDERAL HOME LOAN BANK DTD	INTEREST RCVD	550.00	
		03/10/20 CALL 1.1% 03/10/2023-2020			
06/16/20		24422ERT8 JOHN DEERE CAPITAL CORP DTD	ACCRUED INT	1,621.67-	
		06/26/12 2.8% 01/27/2023			
06/16/20		29266NS32 ENERBANK USA DTD 10/16/2015	INTEREST RCVD	148.63	
		MEDIUM-TERM CD 1.75% 10/16/2020			
06/16/20		3130AHPM9 FEDERAL HOME LOAN BANK DTD	INTEREST RCVD	1,025.00	
		12/16/19 CALL 2.05% 12/16/2024-2020			
06/17/20		3133ELH56 FEDERAL FARM CREDIT BANK DTD	ACCRUED INT	6.00-	
		06/09/2020 CALL .27% 06/09/2022-2020			
06/19/20		3133ELTX2 FEDERAL FARM CREDIT BANK DTD	INTEREST RCVD	290.63	
		03/19/2020 CALL .93% 09/19/2022-2020			
06/22/20		3133EEG79 FEDERAL FARM CREDIT BANK DTD	ACCRUED INT	658.44-	
		05/07/2015 2.15% 09/07/2023			
06/23/20		3134GUZX1 FREDDIE MAC DTD 12/23/2019 CALL	INTEREST RCVD	1,035.00	
		2.07% 12/23/2024-2020			
06/25/20		3130AJF53 FEDERAL HOME LOAN BANK DTD	INTEREST RCVD	695.14	
		BCLASS 3/24/2020 CALL 1.375% 03/24/2025-2020			
06/25/20		31398R7H2 FANNIE MAE SERIES 2010-M4 CLASS	INTEREST RCVD	2.15	
		A3 DTD 07/01/10 3.819% 06/25/2020			



Account Statement

Account Number: 1035003119
June 01, 2020 To June 30, 2020

Transaction Statement (Continued)

Date	Quantity	Description	Transaction Type	Cash	Cost Basis
06/26/20		3130AJEN5 FEDERAL HOME LOAN BANK DTD 03/26/2020 CALL 1.1% 03/26/2024-2020	INTEREST RCVD	275.00	
06/29/20		3133ELN75 FEDERAL FARM CREDIT BANK DTD 6/23/20 CALL .23% 12/23/2021-2020	ACCRUED INT	7.67-	
Total Interest				1,756.36	0.00
Accretion					
06/19/20		3133ELTX2 FEDERAL FARM CREDIT BANK DTD 03/19/2020 CALL .93% 09/19/2022-2020	ACCRETION		100.00
Total Accretion				0.00	100.00
Total Income				1,756.36	100.00
Asset Activity					
Assets Purchased					
06/16/20	150,000.000	24422ERT8 JOHN DEERE CAPITAL CORP DTD 06/26/12 2.8% 01/27/2023	BUY	158,469.00-	158,469.00
06/17/20	100,000.000	3133ELH56 FEDERAL FARM CREDIT BANK DTD 06/09/2020 CALL .27% 06/09/2022-2020	BUY	99,875.00-	99,875.00
06/22/20	105,000.000	3133EEG79 FEDERAL FARM CREDIT BANK DTD 05/07/2015 2.15% 09/07/2023	BUY	111,012.30-	111,012.30
06/24/20	100,000.000	3130AJRE1 FEDERAL HOME LOAN BANK DTD 6/24/2020 CALL .75% 06/24/2025-2020	BUY	100,000.00-	100,000.00
06/29/20	200,000.000	3133ELN75 FEDERAL FARM CREDIT BANK DTD 6/23/20 CALL .23% 12/23/2021-2020	BUY	199,900.00-	199,900.00
06/30/20	100,000.000	3134GVY69 FREDDIE MAC DTD 6/30/2020 CALL .55% 06/30/2023-2020	BUY	100,000.00-	100,000.00
06/30/20	150,000.000	3130AJQR3 FEDERAL HOME LOAN BANK DTD 06/30/20 CALL .45% 06/30/2023-2020	BUY	150,000.00-	150,000.00
Total Assets Purchased				919,256.30-	919,256.30
Assets Sold					
06/16/20	100,000.000-	3130AHPM9 FEDERAL HOME LOAN BANK DTD 12/16/19 CALL 2.05% 12/16/2024-2020	REDEEMED	100,000.00	100,000.00-
06/23/20	100,000.000-	3134GUZX1 FREDDIE MAC DTD 12/23/2019 CALL 2.07% 12/23/2024-2020	REDEEMED	100,000.00	100,000.00-
06/25/20	200,000.000-	3130AJF53 FEDERAL HOME LOAN BANK DTD BCLASS 3/24/2020 CALL 1.375% 03/24/2025-2020	REDEEMED	200,000.00	200,000.00-

Transaction Statement (Continued)

Date	Quantity	Description	Transaction Type	Cash	Cost Basis
06/25/20	676.290-	31398R7H2 FANNIE MAE SERIES 2010-M4 CLASS A3 DTD 07/01/10 3.819% 06/25/2020	NOTE AND MTG PMT	676.29	723.63-
06/26/20	100,000.000-	3130AJEN5 FEDERAL HOME LOAN BANK DTD 03/26/2020 CALL 1.1% 03/26/2024-2020	REDEEMED	100,000.00	100,000.00-
Total Assets Sold				500,676.29	500,723.63-
Maturities					
06/10/20	200,000.000-	3130AJCS6 FEDERAL HOME LOAN BANK DTD 03/10/20 CALL 1.1% 03/10/2023-2020	MATURITY	200,000.00	200,000.00-
06/19/20	125,000.000-	3133ELTX2 FEDERAL FARM CREDIT BANK DTD 03/19/2020 CALL .93% 09/19/2022-2020	MATURITY	125,000.00	125,000.00-
Total Maturities				325,000.00	325,000.00-
Total Asset Activity				93,580.01-	93,532.67
Fees					
06/26/20		MANAGEMENT FEES CITIZENS BUSINESS BANK FOR THE PERIOD ENDING 06/20/2020	DISBURSEMENT	469.55-	
Total Fees				469.55-	0.00
Cash Management					
06/30/20	92,293.200-	31607A703 NET CASH MANAGEMENT	NET CASH MGMT	92,293.20	92,293.20-
Total Cash Management				92,293.20	92,293.20-
06/30/20		Ending Balance		0.00	2,759,486.19

Market Perspectives

We hope that you and your family are all safe and healthy during these challenging times. The enclosed Q1 2020 Market Perspectives article is provided to assist in defining volatile market events over the last quarter and discuss the quarter ahead. Please be assured that dedicated team of professionals at CitizensTrust is monitoring the markets very closely, and if you have any questions or concerns we encourage you to reach out directly to your Relationship Manager.



Account Statement

Page 8

Account Number: 1035003119

June 01, 2020 To June 30, 2020

Disclosure

CitizensTrust may receive research and other benefits from Brokers/Dealers which may be considered compensation. Upon request, we will disclose details of any compensation received. We have added an additional benchmark to your performance insert. Call for details.

Utility User Tax Revenue

MINUTES
REGULAR MEETING OF THE CANYON LAKE
CITY COUNCIL
Wednesday, August 5, 2020

City Council Chamber
31516 Railroad Canyon Road
Canyon Lake, CA 92587

**THE REGULAR MEETING OF THE CITY COUNCIL OF THE CITY OF CANYON LAKE
SCHEDULED FOR AUGUST 5, 2020, WAS CANCELLED.**

Respectfully Submitted,

Ana V. Sauseda, CMC
City Clerk

**MINUTES
SPECIAL MEETING OF THE
CANYON LAKE CITY COUNCIL
Monday, July 13, 2020**

SPECIAL NOTICE – COVID-19 RELATED PROCEDURES IN EFFECT

Pursuant to Paragraph 3 of Executive Order N-29-20, executed by the Governor of California on March 17, 2020, as a response to mitigating the spread of Coronavirus (COVID-19), this special meeting of the City Council of the City of Canyon Lake will allow Councilmembers to attend the City Council meeting telephonically from remote locations without requiring notice of or public access to those locations. The City Council Chamber will be closed to the public. Members of the public may observe the City Council meeting by visiting the **City's website at www.cityofcanyonlake.org** or on Time Warner/Spectrum Channel 29. To view from the website, select the Live Stream icon from the main page.

In a further effort to allow for social distancing, members of the public may comment electronically by sending an email with their comment to PublicComment@cityofcanyonlake.com. The City Clerk will read these public **comment submissions into the record during the "Public Comments" portion of the agenda, provided that such comments (A) are submitted and received no later than 1:00 P.M. on March 25, 2020; (B) are no longer than 250 words; (C) include their name and agenda item number (D) in accordance with Government Code Section 54956, relate only to the items listed on the agenda.**

If any member of the public has a disability and desires to request a modification or accommodation of the above procedures, please contact the City Clerk at least 24 hours prior to the meeting at 951-244-8547 or by email at asauseda@cityofcanyonlake.com.

**Open Session – 6:00 p.m.
City Hall Council Chamber
31516 Railroad Canyon Road
Canyon Lake, CA 92587**

CALL TO ORDER

Mayor Ehrenkranz called the meeting to order at 6:00 p.m.

FLAG SALUTE

Flag Salute was led by Administrative Services Manager Mike Borja.

ROLL CALL

Present: Councilmember Bonner, Mayor Pro Tem Castillo, Councilmember Greene, Councilmember Smith, and Mayor Ehrenkranz

** All members of the Council were present in the Council Chamber with the exception of Mayor Pro Tem Castillo who joined the meeting via telephone.

The following were also present in the room:

- Steven Graham, City Attorney

- Chris Mann, City Manager
- Ana V. Sauseda, City Clerk

The City Clerk confirmed that Mayor Pro Tem Castillo was able to hear her clearly.

APPROVAL OF THE CITY COUNCIL AGENDA

Motion and second by Councilmembers Greene/Smith to approve the agenda.

Motion carried 5-0, with Councilmember Bonner, Mayor Pro Tem Castillo, Councilmember Greene, Councilmember Smith, and Mayor Ehrenkranz voting aye.

PUBLIC COMMENT

There were no public comments.

BUSINESS ITEMS

- (1) Discussion – Presentation of Fire Department Feasibility Analysis conducted by Emergency Services Consulting International (ESCI)

City Manager Chris Mann gave a brief background on the item and introduced Emergency Services Consulting International (ESCI), who would be making the presentation. He explained that the meeting was intended to receive the report, understand it, and discuss it.

Discussion ensued.

City Manager Mann recommended that the Fire Ad Hoc committee meet to discuss the next steps.

There were no public comments.

ADJOURNMENT

The meeting was adjourned at 7:46 p.m.

Respectfully submitted,

Ana V. Sauseda, CMC
City Clerk

**MINUTES
REGULAR MEETING OF THE
CANYON LAKE CITY COUNCIL
Wednesday, July 8, 2020**

SPECIAL NOTICE – COVID-19 RELATED PROCEDURES IN EFFECT

Pursuant to Paragraph 3 of Executive Order N-29-20, executed by the Governor of California on March 17, 2020, as a response to mitigating the spread of Coronavirus (COVID-19), this regular meeting of the City Council of the City of Canyon Lake will allow Councilmembers to attend the City Council meeting telephonically from remote locations without requiring notice of or public access to those locations. The City Council Chamber will be closed to the public. Members of the public may observe the City Council meeting by selecting the Live Stream icon on the main page: www.cityofcanyonlake.org, the City's Facebook page, Time Warner/Spectrum Channel 29, or on FIOS/Frontier Channel 39.

In a further effort to allow for social distancing, members of the public may comment electronically by sending an email with their comment to PublicComment@cityofcanyonlake.com. The City Clerk will read these public comment submissions into the record during the "Public Comments" portion of the agenda.

If any member of the public has a disability and desires to request a modification or accommodation of the above procedures, please contact the City Clerk at least 24 hours prior to the meeting at 951-244-8547 or by email at asauseda@cityofcanyonlake.com.

**Closed Session – 5:00 p.m.
City Hall Administration Building
31526 Railroad Canyon Road, Suite 5
Canyon Lake, CA 92587**

CALL TO ORDER

Mayor Ehrenkranz called the meeting to order at 5:06 p.m.

CITY COUNCIL ROLL CALL

Present: Councilmember Bonner, Mayor Pro Tem Castillo, Councilmember Greene, Councilmember Smith, and Mayor Ehrenkranz

PUBLIC COMMENTS

There were no public comments.

CLOSED SESSION

- A. CONFERENCE WITH LEGAL COUNSEL - ANTICIPATED LITIGATION -
Significant exposure to litigation pursuant to paragraph (2) of subdivision (d) of
Section 54956.9 - 2 cases

B. CONFERENCE WITH LEGAL COUNSEL – INITIATION OF LITIGATION - Pursuant to paragraph (4) of subdivision (d) of Section 54956.9 – 1 case

C. CONFERENCE WITH REAL PROPERTY NEGOTIATORS - Pursuant to Section 54956.8

Property: APN 349-290-008

Agency Negotiator: City Manager

Negotiating Parties: Jim Kipp

Under Negotiation: Price and Terms of Payment

City Attorney Graham identified Closed Session Item A as being the EMS Subscription Program.

The City Council entered Closed Session at 5:07 p.m.

**Open Session – 6:30 p.m.
City Hall Council Chamber
31516 Railroad Canyon Road
Canyon Lake, CA 92587**

CALL OPEN SESSION TO ORDER

Mayor Ehrenkranz called the meeting to order at 6:35 p.m.

INVOCATION

Invocation was led by John Giardinelli.

FLAG SALUTE

Flag Salute was led by Councilmember Greene.

ROLL CALL

Present: Councilmember Bonner, Mayor Pro Tem Castillo, Councilmember Greene, Councilmember Smith, and Mayor Ehrenkranz

CLOSED SESSION REPORT

Attorney Steven Graham stated that there were no items to report out of closed session.

APPROVAL OF THE CITY COUNCIL AGENDA

Motion and second by Councilmembers Bonner/Greene to approve the agenda.

Motion carried 5-0, with Councilmember Bonner, Mayor Pro Tem Castillo, Councilmember Greene, Councilmember Smith, and Mayor Ehrenkranz voting aye.

CEREMONIAL MATTERS *Presentations, Awards, Proclamations*

- Presentation to the Riverside County Sheriff's Department Perris Station

Mayor Ehrenkranz presented the Proclamation to the Captain Lujan from the Lake Elsinore Station as representatives from the Perris Station were not present.

COMMUNITY REPORTS

- Elsinore Valley Municipal Water District Update

Director Darcy Burke joined the meeting via teleconference and gave an update on behalf of Elsinore Valley Municipal Water District.

- Canyon Lake Property Owners Association Update from President Chris Polland

Canyon Lake Property Owners Association President Chris Polland joined the meeting via teleconference and gave an update on behalf of the Property Owners Association.

PUBLIC SAFETY UPDATE

❖ Sheriff

Captain Michael Lujan announced that the Lake Elsinore Station assumed the public safety services as it related to law enforcement for the City of Canyon Lake effective July 1, 2020. He also introduced Lieutenant James Rayls who would be presenting the statistics going forward.

❖ Fire

Kirk Barnett, Division Chief, gave an update on the statistics and answered questions from the Council.

❖ Code Enforcement

Gina Dickson, Senior Code Enforcement Officer, gave a brief update and answered questions from the Council.

PUBLIC COMMENT

There were no comments

CONSENT CALENDAR

- (1) Waive Full Reading, Read all Ordinances by Title Only

- (2) Resolution - Adoption of Resolution No. 2020-32, Approving Claims and Demands of the City
- (3) Minutes - Approval of City Council Minutes
 - June 3, 2020 – Regular City Council Meeting
- (4) Second Reading of Ordinance No. 198 - An Ordinance of the City Council of the City of Canyon Lake, California, Changing the Name of Special Enforcement Department to Code Enforcement Department; Updating References Throughout the Canyon Lake Municipal Code; And Authorizing the City Manager to Make Changes to All City Documents Necessary to Reflect the Name Change
- (5) Resolution - Adoption of Resolution No. 2020-33, A Resolution of The City Council of The City of Canyon Lake, California, Authorizing Participation in the County of Riverside’s Urban County Program for Fiscal Years 2021-22, 2022-23, and 2023-24
- (6) Resolution - Adoption of Resolution No. 2020-34, A Resolution of The City Council of The City of Canyon Lake, California, Ratifying the Lease Agreement Between the City and AMP Global LLC for the Office Space Located at 31526 Railroad Canyon Road, Suite 4, and Authorizing a Budget Adjustment in the Amount of \$7,000 for FY 2020-21

Motion and second by Councilmembers Smith/Bonner to approve the Consent Calendar with the exception of Items 2 & 5.

Motion carried 5-0, with Councilmember Bonner, Mayor Pro Tem Castillo, Councilmember Greene, Councilmember Smith, and Mayor Ehrenkranz voting aye.

PULLED CONSENT CALENDAR ITEMS

- (2) Resolution - Adoption of Resolution No. 2020-32, Approving Claims and Demands of the City

Councilmember Greene had questions on Item 2.

- (5) Resolution - Adoption of Resolution No. 2020-33, A Resolution of The City Council of The City of Canyon Lake, California, Authorizing Participation in the County of Riverside’s Urban County Program for Fiscal Years 2021-22, 2022-23, and 2023-24

Councilmembers Greene & Smith had questions on Item 5.

Motion and second by Councilmembers Greene/Smith to approve Pulled Consent Calendar Items 2 & 5.

Motion carried 5-0, with Councilmember Bonner, Mayor Pro Tem Castillo, Councilmember Greene, Councilmember Smith, and Mayor Ehrenkranz voting aye.

BUSINESS ITEMS

- (7) Agreement – Award of Landscape and Irrigation Maintenance Agreement with CTAI Pacific Greenscape for Railroad Canyon Road

Presentation by Administrative Services Manager Mike Borja.

There were no public comments.

Motion and second by Councilmembers Greene/Smith to approve the agreement with the insertion of language in the paragraph regarding amendments, authorizing the City Manager to execute change orders not to exceed ten percent.

Motion carried 5-0, with Councilmember Bonner, Mayor Pro Tem Castillo, Councilmember Greene, Councilmember Smith, and Mayor Ehrenkranz voting aye.

- (8) Agreement - Adoption of Extended Agreement Between Animal Friends of the Valleys, Inc. and the City of Canyon Lake

Presentation by Management Analyst Tyler Ferrari.

There were no public comments.

Motion and second by Councilmembers Bonner/Smith to approve the agreement.

Motion carried 5-0, with Councilmember Bonner, Mayor Pro Tem Castillo, Councilmember Greene, Councilmember Smith, and Mayor Ehrenkranz voting aye.

- (9) Ordinance – Adoption of Urgency Ordinance No. 199, An Urgency Ordinance of The City Council of The City of Canyon Lake, California, Amending Section 5.22.070 of the Canyon Lake Municipal Code Regarding Single Family Residential Rental Inspections

Presentation by City Attorney Steven Graham.

There were no public comments.

Motion and second by Councilmembers Greene/Bonner to approve Urgency Ordinance No. 199 with the additional recommendations from the City Attorney, an Urgency Ordinance of The City Council of The City of Canyon Lake, California, Amending Section 5.22.070 of the Canyon Lake Municipal Code Regarding Single Family Residential Rental Inspections.

Motion carried 5-0, with Councilmember Bonner, Mayor Pro Tem Castillo, Councilmember Greene, Councilmember Smith, and Mayor Ehrenkranz voting aye.

- (10) Ordinance - Introduction and First Reading of Ordinance No. 200, An Ordinance of the City Council of the City of Canyon Lake, California, Adding Chapter 5.25 to the Canyon Lake Municipal Code Regarding Short-Term Rentals

Presentation by Senior Code Enforcement Officer Gina Dickson.

There were no public comments.

Councilmember Smith stepped away from the dais at 7:31 p.m. and returned at 7:33 p.m.

Motion and second by Councilmembers Bonner/Greene to approve the Introduction and First Reading of Ordinance No. 200, an Ordinance of the City Council of the City of Canyon Lake, California, Adding Chapter 5.25 to the Canyon Lake Municipal Code Regarding Short-Term Rentals.

Motion carried 5-0, with Councilmember Bonner, Mayor Pro Tem Castillo, Councilmember Greene, Councilmember Smith, and Mayor Ehrenkranz voting aye.

- (11) Discussion – Sign Ordinance Discussion

Presentation by City Clerk Ana Sauseda. Discussion ensued.

CITY MANAGER COMMENTS

City Manager Mann gave a few updates.

COMMITTEE AND COUNCIL REPORTS/COMMENTS

• COUNCILMEMBER BONNER

Councilmember Bonner reminded the public that construction on Railroad Canyon had begun and asked the public to drive safely. He announced that RCTC was dark in July. Lastly, he briefly discussed the upcoming roundtable meeting.

• MAYOR PRO TEM CASTILLO

Mayor Pro Tem Castillo thanked the City Manager for his responsiveness regarding the algae information from LESJWA. She thanked Management Analyst Tyler Ferrari on his responsiveness regarding temporary outdoor dining. She urged Canyon Lake residents to support the new pizza restaurant in the Town Center. Lastly, she thanked Law Enforcement for their efforts over the 4th of July weekend.

• COUNCILMEMBER GREENE

Councilmember Greene gave updates from the Regional Conservation Authority.

- **COUNCILMEMBER SMITH**

Councilmember Smith stated how impressed he was with the community over the 4th of July Weekend. He gave a few updates from the Riverside Transportation Authority. Lastly, he encouraged residents to try to enjoy the summer and to stay active.

- **MAYOR EHRENKRANZ**

Mayor Ehrenkranz gave an update from the Vector meeting he attended. He discussed the various zoom meetings he attended along with Mayors from other cities in Western Riverside County. He gave a brief recap from the Student of the Year Zoom Meeting he attended. He spoke about the 4th of July fireworks show and how pleased he was with the event. Lastly, he offered some inspirational words to close the meeting.

Councilmember Bonner asked that the meeting be adjourned in honor of Jim McGill who recently passed away.

ANNOUNCEMENTS

Mayor Ehrenkranz announced that the City Council would hold a special meeting on Monday, July 13, 2020 at 6:00 p.m. The next regular City Council meeting would be on August 5, 2020 at 5:00 p.m. for closed session and 6:30 p.m. for open session.

ADJOURNMENT

The meeting was adjourned at 8:31 p.m.

Respectfully submitted,

Ana V. Sauseda, CMC
City Clerk

**MINUTES
SPECIAL MEETING OF THE
CANYON LAKE CITY COUNCIL
Wednesday, March 25, 2020**

SPECIAL NOTICE – COVID-19 RELATED PROCEDURES IN EFFECT

Pursuant to Paragraph 3 of Executive Order N-29-20, executed by the Governor of California on March 17, 2020, as a response to mitigating the spread of Coronavirus (COVID-19), this special meeting of the City Council of the City of Canyon Lake will allow Councilmembers to attend the City Council meeting telephonically from remote locations without requiring notice of or public access to those locations. The City Council Chamber will be closed to the public. Members of the public may observe the City Council meeting by visiting the **City's website at www.cityofcanyonlake.org** or on Time Warner/Spectrum Channel 29. To view from the website, select the Live Stream icon from the main page.

In a further effort to allow for social distancing, members of the public may comment electronically by sending an email with their comment to PublicComment@cityofcanyonlake.com. The City Clerk will read these public **comment submissions into the record during the "Public Comments" portion of the agenda, provided that** such comments (A) are submitted and received no later than 1:00 P.M. on March 25, 2020; (B) are no longer than 250 words; (C) include their name and agenda item number (D) in accordance with Government Code Section 54956, relate only to the items listed on the agenda.

If any member of the public has a disability and desires to request a modification or accommodation of the above procedures, please contact the City Clerk at least 24 hours prior to the meeting at 951-244-8547 or by email at asauseda@cityofcanyonlake.com.

**Open Session – 2:00 p.m.
City Hall Council Chamber
31516 Railroad Canyon Road
Canyon Lake, CA 92587**

CALL TO ORDER

Mayor Ehrenkranz called the meeting to order at 6:33 p.m.

FLAG SALUTE

Flag Salute was led by Mayor Ehrenkranz.

ROLL CALL

Present: Councilmember Bonner, Mayor Pro Tem Castillo, Councilmember Smith, Councilmember Greene and Mayor Ehrenkranz

** All members of the Council were present via teleconference except for Mayor Ehrenkranz who was physically present in the Council Chamber.

The following were also present in the room:
Steven Graham, City Attorney

Chris Mann, City Manager
Ana V. Sauseda, City Clerk

The City Clerk confirmed that all members of the Council who joined via teleconference were able to hear her clearly. She also stated that all votes during the meeting were to be conducted by a roll call.

APPROVAL OF THE CITY COUNCIL AGENDA

Motion and second by Councilmembers Greene/Bonner to approve the agenda.

Motion carried 5-0, with Councilmember Bonner, Mayor Pro Tem Castillo, Councilmember Greene, Councilmember Smith, and Mayor Ehrenkranz voting aye.

PUBLIC COMMENT

City Clerk Sauseda read public comments from the following:

- Ruben Flores

BUSINESS ITEMS

- (1) Resolution – Adoption of Resolution 2020-08, Declaring the Existence of a Local Emergency Affecting the Public Health and Safety due to the Novel Coronavirus (Covid-19) Pandemic

Motion and second by Councilmembers Bonner/Greene to approve Resolution No. 2020-08.

Motion carried 5-0, with Councilmember Bonner, Mayor Pro Tem Castillo, Councilmember Greene, Councilmember Smith, and Mayor Ehrenkranz voting aye.

ANNOUNCEMENTS

City Manager discussed the City's efforts during the ongoing COVID-19 pandemic.

The next regular meeting will be Wednesday, April 1, 2020 at 5:00 p.m. for Open Session.

ADJOURNMENT

The meeting was adjourned at 2:17 p.m.

Respectfully submitted,

Ana V. Sauseda, CMC
City Clerk

**MINUTES
SPECIAL MEETING OF THE
CANYON LAKE CITY COUNCIL
Thursday, September 26, 2019
Closed Session – 5:30 p.m.
Open Session – 6:00 p.m.**

**City Hall Administration Office
31526 Railroad Canyon Road, Suite 5
Canyon Lake, CA 92587**

CALL TO ORDER

Mayor Pro Tem Castillo called the meeting to order at 5:30 p.m.

CITY COUNCIL ROLL CALL

Present: Councilmember Bonner, Mayor Pro Tem Castillo, Councilmember Smith, and Mayor Ehrenkranz

For the record, Mayor Ehrenkranz joined the Meeting via telephone from the Holiday Inn Express & Suites – 1410 Ocean St. Santa Cruz, CA 95060. His specific location within the hotel was in the conference room located in the lobby. Mayor Ehrenkranz stated that the phone number used to dial in was 951-712-7449.

Deputy City Clerk Ana Sauseda confirmed that she could hear Mayor Ehrenkranz clearly and presented the following questions to him:

“Please confirm that you can hear me clearly.”

Mayor Ehrenkranz responded yes.

“Please confirm that the agenda was posted 24 hours in advance at your location.”

Mayor Ehrenkranz stated that the agenda was posted 24 hours in advance, however, it was taken down by a third party. It was then reposted.

City Attorney Graham asked the Mayor if he had the agenda reposted as soon as he noticed it had been taken down.

Mayor Ehrenkranz responded yes.

City Attorney Graham asked the Deputy City Clerk if the agenda had been posted on the City’s website for the entire notice period.

She responded yes.

City Attorney Graham asked the Deputy City Clerk if the agenda had been posted in all its normal locations.

She responded yes.

“Mayor Please confirm that your location is ADA accessible.”

Mayor Ehrenkranz responded yes.

PUBLIC COMMENTS

There were no public comments.

CLOSED SESSION

- A. CONFERENCE WITH LEGAL COUNSEL - ANTICIPATED LITIGATION - Significant exposure to litigation pursuant to paragraph (2) of subdivision (d) of Section 54956.9 - 1 case

The City Council entered Closed Session at 5:32 p.m.

**City Council Chamber
31516 Railroad Canyon Road
Canyon Lake, CA 92587**

CALL TO ORDER

Mayor Pro Tem Castillo called the meeting to order at 6:08 p.m.

FLAG SALUTE

Flag Salute was led by Dale Welty.

CITY COUNCIL ROLL CALL

Present: Councilmember Bonner, Mayor Pro Tem Castillo, Councilmember Smith, and Mayor Ehrenkranz

For the record, Mayor Ehrenkranz joined the Meeting via telephone from the Holiday Inn Express & Suites – 1410 Ocean St. Santa Cruz, CA 95060. His specific location within the hotel was in the conference room located in the lobby. Mayor Ehrenkranz stated that the phone number used to dial in was 951-712-7449.

Deputy City Clerk Ana Sauseda confirmed that she could hear Mayor Ehrenkranz clearly and presented the following questions to him:

“Please confirm that you can hear me clearly.”

Mayor Ehrenkranz responded yes.

“Please confirm that the agenda was posted 24 hours in advance at your location.”

Mayor Ehrenkranz stated that the agenda was posted 24 hours in advance, however, it was taken down by a third party. It was then reposted.

City Attorney Graham asked the Mayor if he had the agenda reposted as soon as he noticed it had been taken down.

Mayor Ehrenkranz responded yes.

City Attorney Graham asked the Deputy City Clerk if the agenda had been posted on the City’s website for the entire notice period.

She responded yes.

City Attorney Graham asked the Deputy City Clerk if the agenda had been posted in all its normal locations.

She responded yes.

“Mayor Please confirm that your location is ADA accessible.”

Mayor Ehrenkranz responded yes.

Deputy City Clerk Sauseda reminded the Council that all votes for the Special Meeting would have to be conducted by a roll call vote.

CLOSED SESSION REPORT

City Attorney Graham stated that there were no items to report out of closed session.

APPROVAL OF CITY COUNCIL AGENDA

Motion and second by Councilmembers Smith/Bonner to approve the agenda.

Motion carried 4-0, with Councilmember Bonner, Mayor Pro Tem Castillo, Councilmember Smith, and Mayor Ehrenkranz voting aye.

PUBLIC COMMENTS

Deputy City Clerk Sauseda announced that there was one public comment card for Item 2 which would be heard at the time of that business item.

BUSINESS ITEMS

- (1) Agreement - Discussion and Possible Action on Cooperative Agreement with the County of Riverside for Fire Protection Services

City Manager Mann presented the item.

The following members of the public spoke:

- Travis Montgomery
- John Zaitz
- Jack Wamsley

Motion and second by Councilmembers Bonner/Smith to move forward with the recommendations presented by staff.

City Attorney Graham clarified that the recommendation was to send the letter to the county and hire a consultant that would lead the process of putting a fire department in place.

Motion carried 4-0, with Councilmembers Bonner, Mayor Pro Tem Castillo, Councilmember Smith, and Mayor Ehrenkranz voting aye.

- (2) Ordinance - Introduction and First Reading of Ordinance No. 187 – An Ordinance of the City Council of the City of Canyon Lake Establishing a Voluntary Emergency Medical Services Subscription Program

Attorney Graham presented the item.

Motion by Councilmember Bonner to solicit bids for an EMS subscription program fee study, award a contract and complete the study, and solicit bids from vendors needed to help run an EMS subscription program.

Motion failed due to a lack of a second.

Motion and second by Councilmembers Smith/Bonner to approve the Introduction and First Reading of Ordinance No. 187, An Ordinance of the City Council of the City of Canyon Lake Establishing a Voluntary Emergency Medical Services Subscription Program.

City Manager Mann confirmed that the motion does in fact give staff the authority to move forward with the fee study and soliciting vendors to work on the EMS subscription program.

The following members of the public spoke:

- Nancy Horton
- Travis Montgomery
- Dale Welty
- Jack Wamsley
- John Zaitz

Councilmember Bonner withdrew his second.

Mayor Pro Tem Castillo asked if there was a second for Councilmember Smith's motion.

Mayor Ehrenkranz asked for the motion to be restated.

Motion by Councilmember Smith to approve the Introduction and First Reading of Ordinance No. 187 as it stands along with the other two staff recommendations listed in the staff report.

Second by Mayor Ehrenkranz with the condition that staff hold off on the second reading of Ordinance No. 187 until the November City Council meeting.

Additional clarification on this item was provided by City Manager Mann.

Mayor Ehrenkranz withdrew his second with the condition of postponing the second reading.

Second by Mayor Ehrenkranz to approve the Introduction and First Reading of Ordinance No. 187 as is.

Motion and second by Councilmember Smith/ Mayor Ehrenkranz to approve the Introduction and First Reading of Ordinance No. 187, An Ordinance of the City Council of the City of Canyon Lake Establishing a Voluntary Emergency Medical Services Subscription Program.

Motion carried 3-1, with Mayor Pro Tem Castillo, Councilmember Smith, and Mayor Ehrenkranz voting aye and Councilmember Bonner voting no.

ANNOUNCEMENTS

City Manager Mann announced that as of 5:00 p.m. on September 26, 2019, the City received one application to fill the vacancy on the City Council. With only one application having been received, he recommended that the Council alter the previously proposed time frame for filling the vacancy and handle the appointment at the regularly scheduled City Council meeting on October 2, 2019. The Council was all in favor.

ADJOURNMENT

Mayor Pro Tem Castillo adjourned the meeting at 7:43 p.m.

Respectfully submitted,

Ana V. Sauseda, Deputy City Clerk

ORDINANCE NO. 200

AN ORDINANCE OF THE CITY COUNCIL OF THE CITY OF CANYON LAKE, CALIFORNIA, ADDING CHAPTER 5.25 TO THE CANYON LAKE MUNICIPAL CODE REGARDING SHORT-TERM RENTALS

WHEREAS, the City of Canyon Lake (“City”) has a compelling interest in protecting the public health, safety, and welfare of its citizens, residents, visitors and businesses, and in preserving the peace and quiet of the neighborhoods within the City; and

WHEREAS, the character of the City is residential, and the proliferation of short-term vacation rentals has the potential to undermine the small-town feel of the City with regard to a loss of housing stock; and

WHEREAS, the proliferation of short-term vacation rentals has the potential for negative impacts on the community associated with noise, parking and traffic impacts; and

WHEREAS, the City Council now desires to make certain changes to Title 5 (Business Regulations) of the Canyon Lake Municipal Code by adding Chapter 5.25 (Short Term Vacation Rentals) to establish a prohibition on short term vacation rentals within the City; and

NOW, THEREFORE, THE CITY COUNCIL OF THE CITY OF CANYON LAKE DOES ORDAIN AS FOLLOWS:

Section 1. The above recitals are true and correct and incorporated herein by this reference.

Section 2. The City Council finds:

A. Modified conditions warrant a revision to the City’s Business Regulations because the City wishes to prohibit short term vacation rentals to preserve the health, safety, and welfare of the City of Canyon Lake. The City has had the opportunity to study and develop the City’s laws, rules, procedures and fees related to short term vacation rentals and determines, that short term vacation rentals would have a negative impact on the community with regard to the removal of housing stock, noise, parking and traffic impacts on the community. This ordinance will promote clarity and a consistent application of the Municipal Code as it applies to a prohibition on short term vacation rentals.

B. A need for the proposed regulations exists because the Municipal Code does not currently contain any reference to short term vacation rentals. The purpose of the business regulations within the Municipal Code is to make business owners aware of regulations governing business. The City wishes to preserve the small-town feel of the City and ensure no negative impact on the community character or impacts associated with noise, parking and traffic. While because the City’s Zoning Code is permissive and does not currently permit short term vacation rentals, these businesses are already not permitted, nevertheless the City Council deems it necessary and proper to pass these business regulations prohibiting short term rentals in order to minimize any confusion or ambiguity in the application in the Municipal Code (including the Zoning Code).

C. These regulations are in the interest of public health, safety and general welfare of the community and are reasonably necessary to protect public health, safety, and welfare of the citizens of the City. The prohibition of short-term vacation rentals will ensure that housing stock is not made unavailable for long term rentals, and will ensure negative impacts from short term rentals, including noise, parking and traffic, will not undermine the small-town feel of the City.

Section 3. Based on the findings set forth in Section 2 above, Chapter 5.25 (Short Term Vacation Rentals) is added to Title 5 (Business Regulations) of the Canyon Lake Municipal Code, to read as follows:

“Chapter 5.25 SHORT-TERM VACATION RENTALS

5.25.010 Purpose

5.25.020 Definition

5.25.030 Short-Term Vacation Rentals Prohibited

5.25.040 Violation

5.25.010 Purpose.

The purpose of this Chapter is to prohibit the establishment and operation of short-term vacation rentals within the City of Canyon Lake.

5.25.020 Definition.

Short-Term Vacation Rental is defined “a dwelling unit or portion of a dwelling unit that is rented for dwelling, lodging, or sleeping purposes by the owner to another party for a period of thirty (30) or fewer consecutive days in exchange for any form of monetary or non-monetary consideration, such as, but not limited to, trade, fee, swap, or any other in-lieu of cash payments.”

5.25.030 Short-Term Vacation Rentals Prohibited.

The establishment and operation of a short-term vacation rental, as defined in Chapter 5.26.020 of this Chapter, is prohibited anywhere within the City of Canyon Lake. No permit or any other applicable license or entitlement for use, including, but not limited to, the issuance of a business license, shall be approved or issued for the establishment and operation of a short-term vacation rental within the city limits.

5.25.040 Violation.

A. Violations declared a public nuisance

Each and every violation of the provisions of this Chapter is hereby deemed unlawful and a public nuisance and may be summarily abated by the City Manager or designee. The City may recover any nuisance abatement costs and/or administrative fines relating to such violations in accordance with Government Code Sections 38773.1 and 38773.5.

B. Each violation a separate offense

Each and every violation of this Chapter shall constitute a separate violation and shall be subject to all remedies and enforcement measures authorized by this Code. Additionally, as a nuisance per se, any violation of this Chapter shall be subject to injunctive relief, any permit issued pursuant to this Chapter being deemed null and void, disgorgement and payment to the City for any monies unlawfully obtained, costs of abatement, costs of investigation, attorney fees, and any other relief or remedy available at law or in equity. The City may also pursue any and all remedies and actions available and applicable under state and local laws for any violations.

C. Criminal Penalties

Any person causing, permitting, aiding, abetting, suffering or concealing a violation of this Chapter shall be guilty of a misdemeanor, and may, in the discretion of the City Attorney, be prosecuted as a misdemeanor and upon conviction be subject to a fine not to exceed one thousand dollars (\$1,000) or imprisonment in the city or county jail for a period of not more than six (6) months, or by both such fine and imprisonment. The City Attorney, in his or her sound discretion, may prosecute a violation of this Chapter as an infraction, rather than a misdemeanor, or reduce or agree to the reduction of a previously filed misdemeanor to an infraction. Any person convicted of an infraction under this provisions of this Chapter shall be punished by a fine not exceeding one hundred dollars (\$100) for the first violation, a fine not exceeding two hundred dollars (\$200) for a second violation within one year, and a fine not exceeding five hundred dollars (\$500) for a third violation within one year. A fourth violation of this Chapter within one year shall be charged as a misdemeanor and may not be reduced to an infraction. Each day a violation is committed or permitted to continue shall constitute a separate offense.

D. Remedies cumulative and not exclusive

The remedies provided herein are not to be construed as exclusive remedies. The City is authorized to pursue any proceedings or remedies provided by law.

Section 4. This Ordinance is exempt from the California Environmental Quality Act (CEQA) under Section 15061(b)(3) of the CEQA Guidelines, which provides that CEQA only applies to projects that have the potential for causing a significant effect on the environment. Where, as here, it can be seen with certainty that there is no possibility that the activity in question may have a significant effect on the environment, the activity is not subject to CEQA. The addition to the Canyon Lake Municipal Code would only regulate the already prohibited business of short-term rentals and would not cause a significant effect on the environment.

Section 5. If any section, subsection, sentence, clause, or phrase of this ordinance is for any reason held to be invalid or unconstitutional by a decision of any court of any competent jurisdiction, such decision shall not affect the validity of the remaining portions of this ordinance. The City Council hereby declares that it would have passed this ordinance, and each and every section, subsection, sentence, clause and phrase thereof not declared invalid or unconstitutional without regard to whether any portion of the ordinance would be subsequently declared invalid or unconstitutional.

Section 6. The City Clerk shall certify to the passage and adoption of this Ordinance and shall publish as required by state law. This Ordinance shall take effect thirty (30) days after its adoption.

PASSED APPROVED AND ADOPTED this 2nd day of September, 2020.

Jordan Ehrenkranz, Mayor

ATTEST:

APPROVED AS TO FORM:

Ana V. Sauseda, CMC
City Clerk

Steven Graham
City Attorney



STAFF REPORT

TO: Honorable Mayor and Members of the City Council

FROM: Chris Mann, City Manager *CM*

BY: Tyler Ferrari, Management Analyst

DATE: September 2, 2020

SUBJECT: Adoption of Resolution No. 2020-36, Authorizing a Budget Adjustment in the Amount of \$10,000 for FY 2020-21, for Participation in the WRCOG Fellowship Program

Recommendation

That the City Council adopt Resolution No. 2020-36, authorizing a budget adjustment in the amount of \$10,000 to cover the City's share of the costs of a WRCOG Fellow to assist with essential City functions.

Background

The Western Riverside Council of Governments (WRCOG) offers a fellowship program every year to cities in Western Riverside County. The goal of the program is to allow current college students and recent graduates to earn work experience within local government, while also providing cities with additional staffing for essential projects. This staffing is provided at a lesser cost to the cities, with WRCOG footing half of the costs via funding from the PACE program. The total cost of the fellow is \$20,000.

In the past, WRCOG has funded the entirety of the fellow's salary, but due to a reduction in revenues generated by the PACE program they have moved to a cost-sharing model. Canyon Lake has benefited from the WRCOG Fellowship Program over the past two years. Fellows have assisted the City with a variety of projects and events. This year WRCOG has once again identified an individual that appears to be a good fit for Canyon Lake. The prospective fellow has been interviewed by WRCOG as well as City staff, and we believe they will be an asset to the City Hall Administration Office.

With the introduction of the City's new internship program, the addition of a fellow will provide for additional support for upcoming economic development, public outreach, and public safety items the City is prioritizing.

Fiscal Impact

Approval of this item will require an increase in the amount of \$10,000 to the City Manager's Department budget.

Attachments

1. Resolution No. 2020-36

ATTACHMENT 1

RESOLUTION NO. 2020-36

A RESOLUTION OF THE CITY COUNCIL OF THE CITY OF CANYON LAKE, CALIFORNIA, AUTHORIZING A BUDGET ADJUSTMENT IN THE AMOUNT OF \$10,000 FOR FY 2020-21, FOR PARTICIPATION IN THE WRCOG FELLOWSHIP PROGRAM

WHEREAS, the Western Riverside Council of Governments (WRCOG) is promoting a Fellowship Program, and providing fellows to cities to assist with essential projects; and

WHEREAS, in the past, WRCOG has provided the full cost of a fellow with revenues from the PACE program. Revenues from this program have decreased in past fiscal years, requiring a new funding formula for the fellowship program; and

WHEREAS, revenues generated from the PACE program have decreased, requiring a new funding formula for the Fellowship Program; and

WHEREAS, the City of Canyon Lake has benefitted from this program over the past two years, with the program providing fellows that have assisted the City with essential projects and events.

WHEREAS, the City sees the benefit of sharing the cost of the program with WRCOG by contributing \$10,000 in order to host a fellow for the 2020-2021 fiscal year.

NOW, THEREFORE, THE CITY COUNCIL OF THE CITY OF CANYON LAKE DOES RESOLVE AS FOLLOWS:

SECTION 1. The City Council authorizes General Fund expenditures in an amount not to exceed \$10,000 for the City of Canyon Lake’s participation in the WRCOG Fellowship Program.

SECTION 2. This Resolution takes effect immediately.

PASSED, APPROVED, AND ADOPTED on this 2nd day of September, 2020.

Jordan Ehrenkranz, Mayor

ATTEST:

Ana V. Sauseda, CMC
City Clerk



STAFF REPORT

TO: Honorable Mayor and Members of the City Council

FROM: Chris Mann, City Manager *CM*

BY: Mike A. Borja, Administrative Services Manager

DATE: September 2, 2020

SUBJECT: Adoption of Resolution No. 2020-37, Authorizing a Budget Adjustment in the Amount of \$7,700 for FY 2020-21, for the Purchase of Protective Window Film at the Administration Office and Main Building

Recommendation

That the City Council adopt Resolution 2020-37, authorizing a budget adjustment in the amount of \$7,700 for FY 2020-21, for the purchase of protective window film at the Administration Office and Main Building.

Background

Under the recent climate that all municipalities are finding themselves in due to the pandemic, many cities are turning to security measures that will ensure the safety of its public facilities and their employees. Windows at all public facilities leave a vulnerable point in our buildings for intruders to gain entry. Protective window film is used to enhance the safety of regular glass by strengthening it to help protect against break-ins, vandalism, accidents, terrorist attacks, and natural disasters.

Additional benefits to protective window film include reducing energy expenditures by blocking direct sunlight rays that cause buildings to heat up in the summer, while also maintaining warm air in during the colder winter months, overall reducing electricity costs. The protective film also provides a layer of protection against the negative effects of solar radiation by blocking ultraviolet light, which is damaging to people, furnishings, and equipment inside the buildings.

Fiscal Impact

Approval of this item will require a General Fund budget adjustment in the amount of \$7,700, which includes \$500 towards any unexpected expenses.

Attachments

1. Proposal from RC Window Films
2. Resolution No. 2020-37

ATTACHMENT 1

Proposal To: Mike Borja
9512462024
31516 Railroad Canyon Road
Canyon Lake, CA 92587

Proposal #432250
Date Jul 7, 2020

31516 Railroad Canyon Road, Canyon Lake, 92587

City Hall

9 items

Our Solution Solar and safety film with Dow 995 attachment

Window Tint: Solar Gard 8 mil Silver 20

Armorcoat's solar control safety films are a robust pairing of our Solar Control and "Clear Safety" films. These films provide a resilient layers of high-tensile polyester and aggressive adhesives for impact resistant security.

Key Safety Benefits

- Glass / Impact – Armorcoat provides exceptional blast and impact-resistant capabilities
- Flying Debris – Armorcoat reduces risks associated with broken glass and air-borne debris.
- Falling Glass Shards – Armorcoat holds broken glass shards in place, helping to avoid a major hazard for passersby.
- Post-incident Rescue and Cleanup – Armorcoat secures broken glass making the rescue and cleanup process safe and efficient.
- Solar Safety Film – Amorcoat film provides you protection against the negative effects of solar radiation.

Key Comfort Benefits

- Various light transmission ranging from 20-72
- High heat rejection results in improved indoor comfort
- UV blockers protect people and property from damaging UV rays

The US Government turns to Solar Gard for blast mitigation
Find out how Armorcoat is used to secure schools

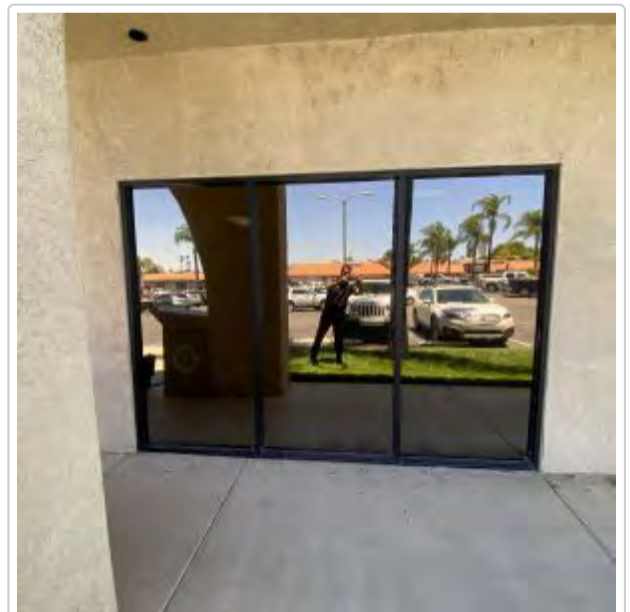
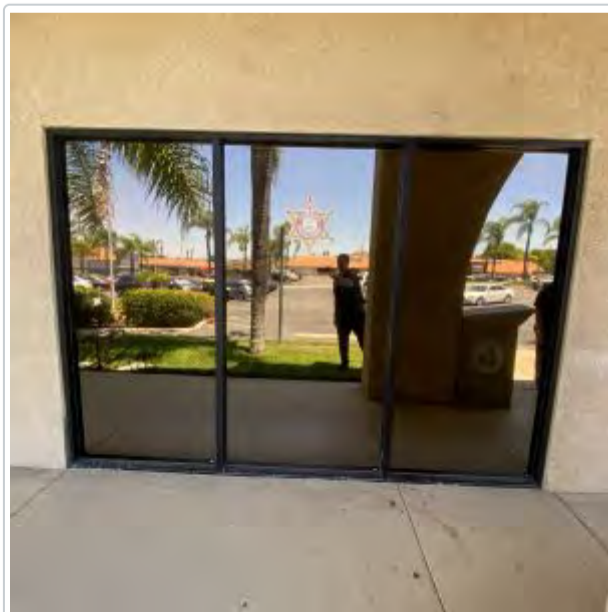
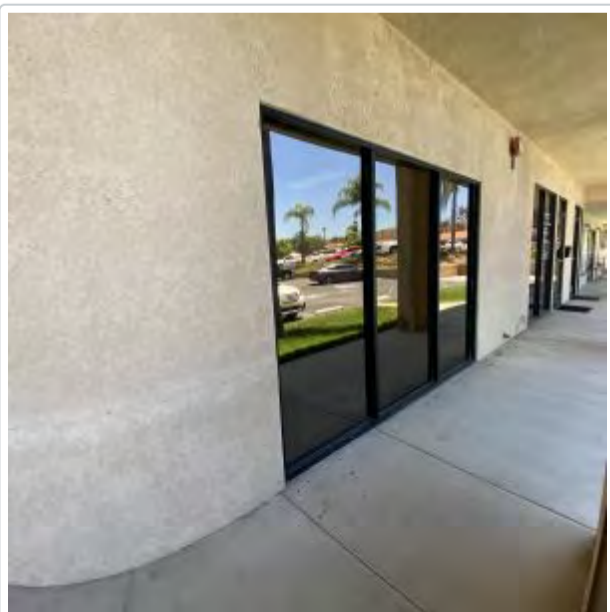
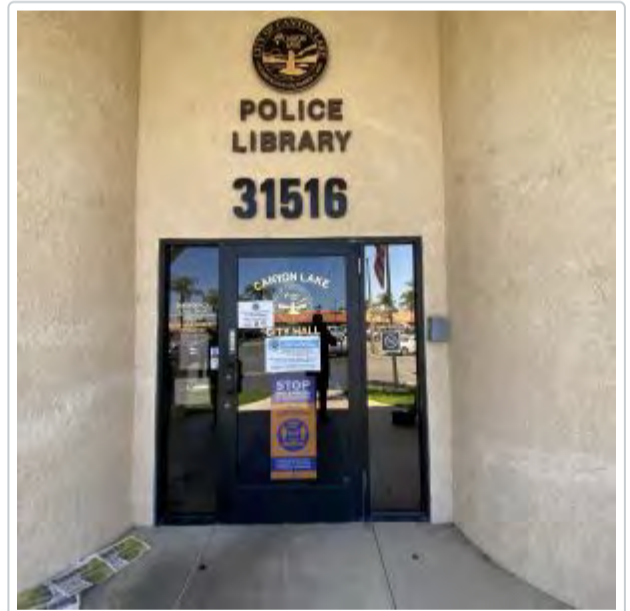
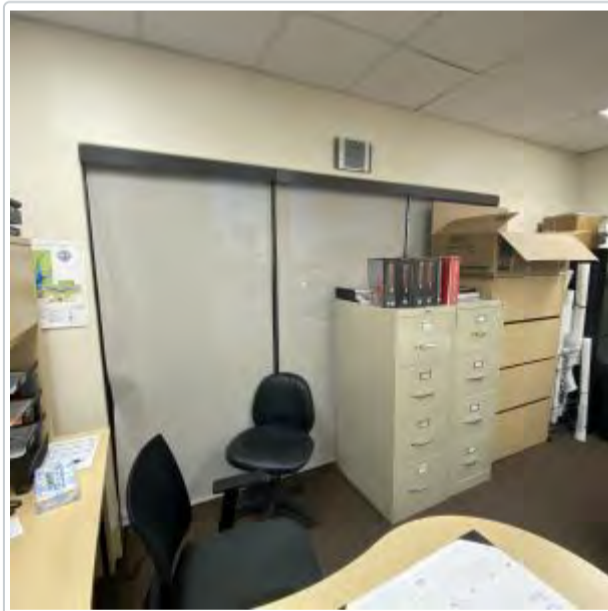
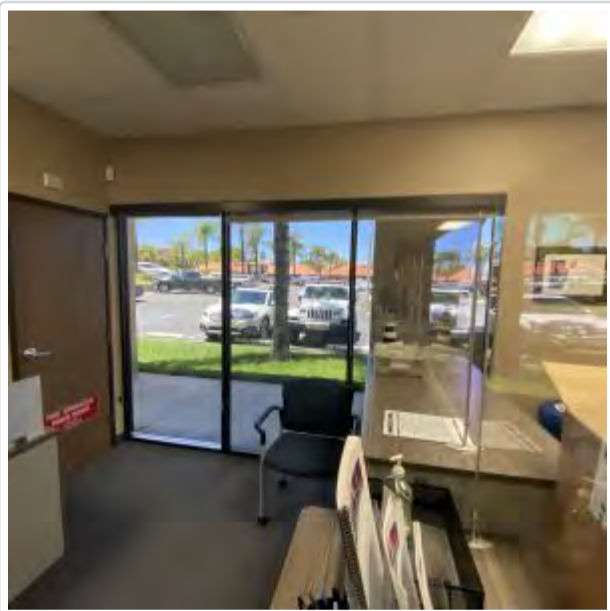

All CARD PAYMENTS will incur a 3.75% fee on the total amount due. Please note we "DO NOT" accept Discover/Amex.

PLEASE MOVE ALL WINDOW COVERING INCLUDING BLINDS, CURTAINS AND ANY FURNISHINGS OR OBJECTS THAT ARE WITHIN 3 FEET OF THE WINDOWS BEING INSTALLED.

The information contained in this message may be privileged and confidential and protected from disclosure. If the reader of this message is not the intended recipient, or an employee or agent responsible for delivering this message to the intended recipient, you are hereby notified that any dissemination, distribution or copying of this communication is strictly prohibited. If you have received this communication in error, please notify us immediately by replying to the message and deleting it from your computer.

TOTAL

\$ 2,821.00

Solar Gard Warranty

Panorama Warranty

Certificate of Liability Insurance

Residential Clients:

Full payment is required at project completion.

REMOVING BLINDS, CURTAINS OR FURNITURE IS AN ADDITIONAL COST.

THIS COST WILL APPEAR ON YOUR ORIGINAL PROPOSAL, IF YOU CHOOSE TO HAVE US MOVE CURTAINS, BLINDS, FURNISHINGS, OR OTHER OBJECTS.

IN SOME CASES, WE CAN MOVE FURNISHINGS, BLINDS OR CURTAINS FREE OF CHARGE WITH A SIGNED WAIVER ONLY.

DO NOT CLEAN THE FILM FOR 30 DAYS

All warranties are back by the manufacturers of our products. Films (as listed above, the "film(s)") against adhesive failure, bubbling, cracking/crazing, delamination, demetallization, peeling, or other manufacturer's defect; provided and on the condition that the films were properly sold and installed on an appropriate glass surface by RC Window films.

Powered By [TintWiz](#)

Proposal To: Mike Borja
 ☎ 9512462024
 📍 31526 Railroad Canyon Road
 Canyon Lake, CA 92587

Proposal #1409845371
Date Jul 7, 2020

📍 31526 Railroad Canyon Road, suite 5, Canyon Lake, 92587

Office 1	4 items
Main office	6 items
Conference Room	2 items
Lobby	6 items

Solution 1 Most Privacy - Office 1

Window Tint: Veloce Blend 5

Veloce’s multi-layer Dual Benefit Blend Technology (DBBT) features an exterior privacy layer and an interior layer with lower shine, for a better view. The light reflection creates a shiny exterior appearance.

- Maximum glare reduction and daytime privacy
- Maximum heat rejection
- Utilizes Veloce’s Dual Benefit Blend Technology (DBBT)
- Can help change the look of your exterior glass by creating a shiny appearance



~~\$ 539.00~~ **\$ 485.10**

Solution 2 Main office

Window Tint: Veloce Blend 20

Veloce’s multi-layer Dual Benefit Blend Technology (DBBT) features an exterior privacy layer and an interior layer with lower shine, for a better view. The light reflection creates a shiny exterior appearance.

- Maximum glare reduction and daytime privacy
- Maximum heat rejection
- Utilizes Veloce’s Dual Benefit Blend Technology (DBBT)
- Can help change the look of your exterior glass by creating a shiny appearance



~~\$ 1,026.67~~ **\$ 924.00**

Solution 3 Conference room

Window Tint: Veloce Blend 20

Veloce's multi-layer Dual Benefit Blend Technology (DBBT) features an exterior privacy layer and an interior layer with lower shine, for a better view. The light reflection creates a shiny exterior appearance.

- Maximum glare reduction and daytime privacy
- Maximum heat rejection
- Utilizes Veloce's Dual Benefit Blend Technology (DBBT)
- Can help change the look of your exterior glass by creating a shiny appearance

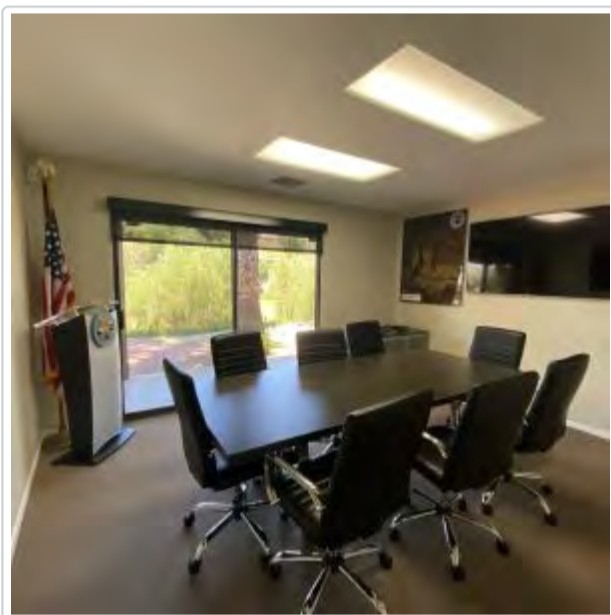

~~\$ 432.72~~ **\$ 389.45**

Solution 4 Lobby

Window Tint: Veloce Blend 20

Veloce's multi-layer Dual Benefit Blend Technology (DBBT) features an exterior privacy layer and an interior layer with lower shine, for a better view. The light reflection creates a shiny exterior appearance.

- Maximum glare reduction and daytime privacy
- Maximum heat rejection
- Utilizes Veloce's Dual Benefit Blend Technology (DBBT)
- Can help change the look of your exterior glass by creating a shiny appearance



\$ 535.33

Solution 5 Security application with attachment

Window Tint: Solar Gard 8 mil Silver 20

Armorcoat’s solar control safety films are a robust pairing of our Solar Control and “Clear Safety” films. These films provide a resilient layers of high-tensile polyester and aggressive adhesives for impact resistant security.

Key Safety Benefits

- Glass / Impact – Armorcoat provides exceptional blast and impact-resistant capabilities
 - Flying Debris – Armorcoat reduces risks associated with broken glass and air-borne debris.
 - Falling Glass Shards – Armorcoat holds broken glass shards in place, helping to avoid a major hazard for passersby.
 - Post-incident Rescue and Cleanup – Armorcoat secures broken glass making the rescue and cleanup process safe and efficient.
 - Solar Safety Film – Amorcoat film provides you protection against the negative effects of solar radiation.
- Key Comfort Benefits

- Various light transmission ranging from 20-72
 - High heat rejection results in improved indoor comfort
 - UV blockers protect people and property from damaging UV rays
- Additional Information

The US Government turns to Solar Gard for blast mitigation
 Find out how Armorcoat is used to secure schools

~~\$ 4,840.00~~ **\$ 4,356.00**

All CARD PAYMENTS will incur a 3.75% fee on the total amount due. Please note we “DO NOT” accept Discover/Amex.

PLEASE MOVE ALL WINDOW COVERING INCLUDING BLINDS, CURTAINS AND ANY FURNISHINGS OR OBJECTS THAT ARE WITHIN 3 FEET OF THE WINDOWS BEING INSTALLED.

The information contained in this message may be privileged and confidential and protected from disclosure. If the reader of this message is not the intended recipient, or an employee or agent responsible for delivering this message to the intended recipient, you are hereby notified that any dissemination, distribution or copying of this communication is strictly prohibited. If you have received this communication in error, please notify us immediately by replying to the message and deleting it from your computer.

Security application with attachment Solar Gard 8 mil Silver 20 **\$ 4,356.00**

TOTAL **\$ 4,356.00**

Solar Gard Warranty Panorama Warranty Certificate of Liability Insurance

Residential Clients:
 Full payment is required at project completion.

REMOVING BLINDS, CURTAINS OR FURNITURE IS AN ADDITIONAL COST.
 THIS COST WILL APPEAR ON YOUR ORIGINAL PROPOSAL, IF YOU CHOOSE TO HAVE US MOVE CURTAINS, BLINDS, FURNISHINGS, OR OTHER OBJECTS.

IN SOME CASES, WE CAN MOVE FURNISHINGS, BLINDS OR CURTAINS FREE OF CHARGE WITH A SIGNED WAIVER ONLY.

DO NOT CLEAN THE FILM FOR 30 DAYS

ATTACHMENT 2

RESOLUTION NO. 2020-37

A RESOLUTION OF THE CITY COUNCIL OF THE CITY OF CANYON LAKE, CALIFORNIA, AUTHORIZING A BUDGET ADJUSTMENT IN THE AMOUNT OF \$7,700 FOR FY 2020-21, FOR THE PURCHASE OF PROTECTIVE WINDOW FILM AT THE ADMINISTRATION OFFICE AND MAIN BUILDING

WHEREAS, many cities are implementing various security measures that will ensure the safety of its public facilities and their employees during and beyond the pandemic climate; and

WHEREAS, cities are enhancing the safety of public facilities by installing protective window film to strengthen them against break-ins, vandalism, accidents, terrorist attacks, and natural disasters; and

WHEREAS, the City of Canyon Lake desires to install the protective window film could also be of significant benefit to its facilities by reducing energy costs due to the reduction of sunlight and ultraviolet rays.

NOW, THEREFORE, THE CITY COUNCIL OF THE CITY OF CANYON LAKE DOES RESOLVE AS FOLLOWS:

SECTION 1. The City Council authorizes General Fund expenditures in an amount not to exceed \$7,700 for the City of Canyon Lake to purchase and install protective window film referenced above.

SECTION 2. The City Council authorizes the City Manager to take such actions and execute such purchase as may be necessary, including, but not limited to a budget adjustment in an amount not to exceed \$7,700 dollars, and the execution of any agreement with the participating vendor, if such agreements are approved as to form by the City Attorney.

SECTION 3. This Resolution takes effect immediately.

PASSED, APPROVED, AND ADOPTED on this 2nd day of September 2020.

Jordan Ehrenkranz, Mayor

ATTEST:

Ana V. Sauseda, CMC
City Clerk



STAFF REPORT

TO: Honorable Mayor and Members of the City Council

FROM: Chris Mann, City Manager *CM*

BY: Ana V. Sauseda, City Clerk

DATE: September 2, 2020

SUBJECT: Adoption of Resolution No. 2020-38, Authorizing a Budget Adjustment in the Amount of \$6,000 for FY 2020-21, for the Purchase of Furniture & Office Equipment at the New Office Space located at 31526 Railroad Canyon Road, Suite 4

Recommendation

That the City Council adopt Resolution 2020-38, authorizing a budget adjustment in the amount of \$6,000 for FY 2020-21, for the purchase of furniture & office equipment at the new office space located at 31526 Railroad Canyon Road, Suite 4.

Background

As the City has implemented a number of new programs over the past year, and as City operations continue to be updated and professionalized, a need for additional office space became apparent.

On June 23, 2020, the City Manager signed a lease agreement for approximately 168 square feet of additional office space located at 31526 Railroad Canyon Road, Suite 4. The additional space expanded the City's existing Administration Office as it is adjacent to and shares an interior door with Suite 5. The additional space is being utilized to provide offices for the City's Accountant/Human Resources Specialist & Management Analyst.

On July 8, 2020, at its regularly scheduled City Council Meeting, the City Council adopted Resolution No. 2020-34, ratifying the lease agreement signed by the City Manager on June 23, 2020.

In order for these new offices to be functional, it was necessary for the City to make an investment in furniture, equipment and supplies. In addition, the City will pay for other regular operating expenses including but not limited to insurance, HOA dues, electricity, water and trash. The total cost for furniture, equipment, and supplies is not expected to exceed \$6,000.

Fiscal Impact

Approval of this item will require a General Fund budget adjustment in the amount of \$6,000 in account # 10-550-8007. Additional operating expenses (insurance, HOA dues, electricity, water and trash), will be spread between fiscal years 2020-2021, 2021-2022, 2022-2023 and 2023-2024.

Attachments

1. Resolution No. 2020-38

ATTACHMENT 1

RESOLUTION NO. 2020-38

A RESOLUTION OF THE CITY COUNCIL OF THE CITY OF CANYON LAKE, CALIFORNIA, AUTHORIZING A BUDGET ADJUSTMENT IN THE AMOUNT OF \$6,000 FOR FY 2020-21, FOR THE PURCHASE OF FURNITURE & OFFICE EQUIPMENT AT THE NEW OFFICE SPACE LOCATED AT 31526 RAILROAD CANYON ROAD, SUITE 4

WHEREAS, the City has implemented a number of programs over the past year and has identified the need for additional space; and

WHEREAS, the City Manager signed a lease agreement for 31526 Railroad Canyon Road, Suite 4 on June 23, 2020; and

WHEREAS, staff purchased furniture & office equipment to ensure the new office space was functional; and

WHEREAS, the City will be required to pay for other regular operating expenses on an annual basis including but not limited to insurance, HOA dues, electricity, water, and trash.

NOW, THEREFORE, THE CITY COUNCIL OF THE CITY OF CANYON LAKE DOES RESOLVE AS FOLLOWS:

SECTION 1. The City Council authorizes a budget adjustment in General Fund Account # 10-550-8007 for FY 2020-21, in the amount of \$6,000.

SECTION 3. This Resolution takes effect immediately.

PASSED, APPROVED, AND ADOPTED this 2nd day of September, 2020.

Jordan Ehrenkranz, Mayor

ATTEST:

Ana V. Sauseda, CMC
City Clerk



STAFF REPORT

TO: Honorable Mayor and Members of the City Council

FROM: Chris Mann, City Manager *CM*

BY: Ana V. Sauseda, City Clerk

DATE: September 2, 2020

SUBJECT: Adoption of Resolution No. 2020-40, Authorizing a Budget Adjustment in the Amount of \$11,000 for FY 2020-21, for the digitizing of Additional City Records

Recommendation

That the City Council adopt Resolution 2020-40, authorizing a budget adjustment in the amount of \$11,000 for FY 2020-21 in Account #10-320-6610, for the digitizing of additional City records.

Background

On January 15, 2020, the City Council adopted goals for the 2020 Calendar year. One of the goals was to digitize City records. Over the last several months, staff has been working diligently to meet that goal.

The City contracted with ECS Imaging, Inc. who specializes in providing innovative turn-key document management solutions through the award winning Laserfiche system. Since the implementation of Laserfiche, ECS has assisted the City with the scanning of various documents due to the City's lack of equipment and resources. Most recently, the City has identified the Building & Safety Department as the most critically in need of scanning due to the accumulation of plans and permits since the City incorporated.

Staff initially anticipated spending \$5,500 in FY 2020-21 for the scanning of additional documents with the intent that additional scanning costs would be spread throughout future fiscal years. Since the adoption of the City's budget on June 3, 2020, staff has identified the need to scan the remainder of the Building & Safety documents to allow the destruction of paper records which would create much needed space in the department.

Fiscal Impact

Approval of this item will require a General Fund budget adjustment in the amount of \$11,000 in account # 10-320-6610.

Attachments

1. Resolution No. 2020-40

ATTACHMENT 1

RESOLUTION NO. 2020-40

A RESOLUTION OF THE CITY COUNCIL OF THE CITY OF CANYON LAKE, CALIFORNIA, AUTHORIZING A BUDGET ADJUSTMENT IN THE AMOUNT OF \$11,000 FOR FY 2020-21, FOR THE DIGITIZING OF ADDITIONAL CITY RECORDS

WHEREAS, the City Council identified digitizing City records as one of their goals for 2020; and

WHEREAS, the City contracted with ECS Imaging, Inc., to implement Laserfiche Solutions, a document management system which will serve as the City’s digital repository; and

WHEREAS, Since the implementation of Laserfiche, ECS has assisted the City in scanning documents due to the City’s lack of equipment and resources; and

WHEREAS, staff has identified the Building & Safety Department to be the most critically in need of scanning; and

WHEREAS, Documents from the Building & Safety Department have not been scanned since the City incorporated in 1990; and

WHEREAS, by allowing additional documents to be scanned, the City will gain much needed additional space in the Building & Safety Department by eliminating paper records.

NOW, THEREFORE, THE CITY COUNCIL OF THE CITY OF CANYON LAKE DOES RESOLVE AS FOLLOWS:

SECTION 1. The City Council authorizes a budget adjustment in General Fund Account # 10-320-6610 for FY 2020-21, in the amount of \$11,000.

SECTION 3. This Resolution takes effect immediately.

PASSED, APPROVED, AND ADOPTED this 2nd day of September, 2020.

Jordan Ehrenkranz, Mayor

ATTEST:

Ana V. Sauseda, CMC
City Clerk



STAFF REPORT

TO: Honorable Mayor and Members of the City Council

FROM: Chris Mann, City Manager *CM*

BY: Steve Swarthout, Deputy Fire Marshal

DATE: September 2, 2020

SUBJECT: Adoption of Resolution No. 2020-39, Acknowledging Receipt of a Report Made by the Fire Chief of the Riverside County Fire Department Regarding Compliance with the Annual Inspection of Certain Occupancies Pursuant to Sections 13146.2 and 13146.3 of the California Health and Safety Code

Recommendation

That the City Council adopt Resolution No. 2020-39, acknowledging receipt of a report made by the Fire Chief of the Riverside County Fire Department regarding compliance with the annual inspection of certain occupancies pursuant to sections 13146.2 and 13146.3 of the California Health and Safety Code.

Background

In 2018, California Health and Safety Code Section 13146.4 was added and became effective January 1, 2019. Section 13146.4 requires all fire departments, that provide fire protection services, to report annually to their administering authority on their compliance with Health and Safety Code Sections 13146.2 and 13146.3. Sections 13146.2 and 13146.3 require annual inspections of every building used as a public or private school, hotel, motel, lodging house, apartment house and certain residential care facilities for compliance with building standards.

Fiscal Impact

There is no fiscal impact from this new program.

Attachments

1. Resolution No. 2020-39
2. California Health and Safety Code Section 13146.2 to Section 13146.4
3. Senate Bill (SB) 1205 State Mandated Inspections for City of Canyon Lake

ATTACHMENT 1

RESOLUTION NO. 2020-39

A RESOLUTION OF THE CITY COUNCIL OF THE CITY OF CANYON LAKE, CALIFORNIA, ACKNOWLEDGING RECEIPT OF A REPORT MADE BY THE FIRE CHIEF OF THE RIVERSIDE COUNTY FIRE DEPARTMENT REGARDING COMPLIANCE WITH THE ANNUAL INSPECTION OF CERTAIN OCCUPANCIES PURSUANT TO SECTIONS 13146.2 and 13146.3 OF THE CALIFORNIA HEALTH AND SAFETY CODE

WHEREAS, California Health & Safety Code Section 13146.4 was added in 2018, and became effective on January 1, 2019; and

WHEREAS, California Health & Safety Code Section 13146.4 requires all fire departments, including the Riverside County Fire Department, that provide fire protection services to report annually to its administering authority on its compliance with Health & Safety Code sections 13146.2 and 13146.3; and

WHEREAS, California Health & Safety Code Section 13146.2 and 13146.3 requires all fire departments, including the Riverside County Fire Department, that provide fire protection services to perform annual inspections in every building used as a public or private school, hotel, motel, lodging house, apartment house, and certain residential care facilities for compliance with building standards, as provided; and

WHEREAS, the City Council of the City of Canyon Lake intends this Resolution to fulfill the requirements of the California Health & Safety Code 13146.4 regarding acknowledgment of the Riverside County Fire Department’s compliance with California Health and Safety Code Sections 13146.2 and 13146.3.

NOW, THEREFORE, THE CITY COUNCIL OF THE CITY OF CANYON LAKE DOES RESOLVE AS FOLLOWS:

SECTION 1. Educational Group E occupancies, for the purposes of this Resolution, are generally those public and private schools, used by more than six persons at any one time for educational purposes through the 12th grade. The Riverside County Fire Department completed 100% of the annual inspections of the identified Group E occupancies, buildings, structures and/or facilities in the City of Canyon Lake.

\\

\\

\\

SECTION 2. Residential Group R occupancies, for the purposes of this Resolution, are generally those occupancies containing sleeping units, and include hotels, motels, apartments (three units or more), etc. as well as other residential occupancies (including a number of residential care facilities). These residential care facilities have a number of different sub-classifications, and they may contain residents or clients that have a range of needs, including those related to custodial care, mobility impairments, cognitive disabilities, etc. The residents may also be non-ambulatory or bedridden. The Riverside County Fire Department completed 100% of the annual inspections of the identified Group R occupancies, buildings, structures and/or facilities in the City of Canyon Lake.

PASSED, APPROVED, AND ADOPTED this 2nd day of September, 2020.

Jordan Ehrenkranz, Mayor

ATTEST:

Ana V. Sauseda, CMC
City Clerk

ATTACHMENT 2

Senate Bill No. 1205

CHAPTER 854

An act to add Section 13146.4 to the Health and Safety Code, relating to fire protection.

[Approved by Governor September 27, 2018. Filed with Secretary of State September 27, 2018.]

LEGISLATIVE COUNSEL'S DIGEST

SB 1205, Hill. Fire protection services: inspections: compliance reporting.

Existing law requires the chief of any city or county fire department or district providing fire protection services and his or her authorized representatives to inspect every building used as a public or private school within his or her jurisdiction, for the purpose of enforcing specified building standards, not less than once each year, as provided. Existing law requires every city or county fire department or district providing fire protection services that is required to enforce specified building standards to annually inspect certain structures, including hotels, motels, lodging houses, and apartment houses, for compliance with building standards, as provided.

This bill would require every city or county fire department, city and county fire department, or district required to perform the above-described inspections to report annually to its administering authority, as defined, on the department's or district's compliance with the above-described inspection requirements, as provided. The bill would require the administering authority to acknowledge receipt of the report in a resolution or a similar formal document. To the extent this bill would expand the responsibility of a local agency, the bill would create a state-mandated local program.

The California Constitution requires the state to reimburse local agencies and school districts for certain costs mandated by the state. Statutory provisions establish procedures for making that reimbursement.

This bill would provide that, if the Commission on State Mandates determines that the bill contains costs mandated by the state, reimbursement for those costs shall be made pursuant to the statutory provisions noted above.

The people of the State of California do enact as follows:

SECTION 1. Section 13146.4 is added to the Health and Safety Code, to read:

13146.4. (a) Every city or county fire department, city and county fire department, or district required to perform an annual inspection pursuant

to Sections 13146.2 and 13146.3 shall report annually to its administering authority on its compliance with Sections 13146.2 and 13146.3.

(b) The report made pursuant to subdivision (a) shall occur when the administering authority discusses its annual budget, or at another time determined by the administering authority.

(c) The administering authority shall acknowledge receipt of the report made pursuant to subdivision (a) in a resolution or a similar formal document.

(d) For purposes of this section, “administering authority” means a city council, county board of supervisors, or district board, as the case may be.

SEC. 2. If the Commission on State Mandates determines that this act contains costs mandated by the state, reimbursement to local agencies and school districts for those costs shall be made pursuant to Part 7 (commencing with Section 17500) of Division 4 of Title 2 of the Government Code.

O

ATTACHMENT 3

Senate Bill (SB) 1205 State Mandated Inspections for City of Canyon Lake

State Mandated Inspections were performed at the following identified facility's

Inspection Type	Address
R-1 Hotels/Motels	Roadway Inn 31820 Railroad Canyon Rd.
R-2 Apartment/ Multi Family Complexes	TREASURE ISLAND HOMEOWNERS ASSOCIATION-Condos 22274–22106 Treasure Island Dr.
R-2 Apartment/ Multi Family Complexes	EASTPORT VILLAS CONDO OWNERS ASSOCIATION-Condos 24319 Canyon Lake Dr.
R-2 Apartment/ Multi Family Complexes	CANYON LAKE CONDO OWNERS ASSOCIATION -Condos 31864 Railroad Canyon Rd, # A-K
R-2 Apartment/ Multi Family Complexes	NORTH SHORE CONDO OWNERS ASSOCIATION- Condos 22570 Bass Pl #2 22570 Bass Pl, # 1-19
E Public or Private School	CANYON LAKE COMMUNITY CHURCH AND PRESCHOOL 30515 Railroad Canyon Road



STAFF REPORT

TO: Honorable Mayor and Members of the City Council

FROM: Chris Mann, City Manager *cm*

DATE: September 2, 2020

SUBJECT: Introduction and First Reading of Ordinance No. 201, An Ordinance of the City Council of the City of Canyon Lake, California, Adding Chapter 5.16 Regarding Peddling and Soliciting in the City of Canyon Lake

Recommendation

That the City Council approve the Introduction and First Reading of Ordinance No. 201 adding Chapter 5.16 regarding peddling and soliciting in the City of Canyon Lake.

Background

Members of the community have complained that persons and organizations have been visiting private residential properties in the City of Canyon Lake for the purpose of peddling and/or soliciting orders for the sale of goods, wares, merchandise or services, and many residents find such visits and the tactics used by such visitors to be bothersome and highly intrusive.

There have also been reports in other communities that these visitors sometimes use a variety of misrepresentations and other frauds when engaging in peddling and/or soliciting.

As many of the persons engaging in peddling and/or soliciting do not have local business locations, business registration licenses, and are not otherwise permitted by the City of Canyon Lake, it is difficult to locally resolve these issues.

This Ordinance would make it unlawful for any person to peddle or solicit to any residential property that has prominently placed a sign stating "No Peddling" or "No Soliciting" or a similar sign indicating that the residents do not want peddlers or solicitors at the property. These signs may be placed at any residential property, including any residence, dwelling, property owner's association, mobile home park, or apartment complex. The Ordinance also establishes that no peddling or soliciting may take place between the hours of eight p.m. and eight a.m. even in places where peddling or soliciting is permitted.

Staff recommends that the City Council find that the public safety, welfare and convenience necessitates the exercise of the police power of the City of Canyon Lake

through the enactment and enforcement of this ordinance for the purpose of protecting the privacy of residents and preventing aggressive, threatening, abusive and fraudulent practices by persons representing themselves as peddlers and solicitors.

Fiscal Impact

None

Attachments

1. Ordinance No. 201

ATTACHMENT 1

ORDINANCE NO. 201

AN ORDINANCE OF THE CITY COUNCIL OF THE CITY OF CANYON LAKE, CALIFORNIA, ADDING CHAPTER 5.16 REGARDING PEDDLING AND SOLICITING IN THE CITY OF CANYON LAKE

THE CITY COUNCIL OF THE CITY OF CANYON LAKE DOES ORDAIN AS FOLLOWS:

SECTION 1. CHAPTER 5.16

Chapter 5.16 is hereby added to the Canyon Lake Municipal Code to read as follows:

CHAPTER 5.16

- 5.16.010 Purpose.**
- 5.16.020 Definitions.**
- 5.16.030 “No Peddling” or “No Soliciting” signs.**
- 5.16.040 Provisions supplemental to business license regulation.**
- 5.16.050 Hours for peddling or soliciting.**
- 5.16.060 Violations.**

5.16.010 Purpose.

The Canyon Lake City Council finds that persons and organizations have been and are visiting private residential properties in the City of Canyon Lake for the purpose of peddling and/or soliciting orders for the sale of goods, wares, merchandise or services, and that many residents find such visits and the tactics used by such visitors to be bothersome and highly intrusive. The Canyon Lake City Council further finds that a variety of misrepresentations and other frauds are at times employed in such activities. The Canyon Lake City Council further finds that the public safety, welfare and convenience necessitates the exercise of the police power of the City of Canyon Lake through the enactment and enforcement of this Chapter for the purpose of protecting the privacy of residents and preventing aggressive, threatening, abusive and fraudulent practices by persons representing themselves as peddlers and solicitors.

5.16.020 Definitions.

(a) As used in this Chapter “peddling” includes the act of any person, traveling by foot, wagon, automotive vehicle, or any other type of conveyance, from place of residence to place of residence carrying, conveying, or transporting goods, wares, merchandise, meats, fish, vegetables, fruits, garden or truck farm products or provisions, offering and exposing the same for sale, or making sales and delivering articles to purchasers.

(b) As used in this Chapter “soliciting” includes the act of any person, traveling either by foot, wagon, automotive vehicle, or any other type of conveyance, from place of residence to place of residence taking or attempting to take orders for sale of goods, wares, and merchandise, personal property of any nature whatsoever for future delivery, or for services to be furnished or

performed in the future, whether or not such person has, carries, or exposes for sale a sample of the subject of such sale, or whether such person is collecting advance payment on such sale or not.

(c) Those persons peddling and/or soliciting on behalf of: (1) any institution or organization recognized by a tax board of the State of California and the Internal Revenue Service of the United States, which institution or organization is conducted wholly for the benefit of charitable, religious, political or nonprofit purposes and from which profit is not derived, either directly or indirectly, by any person, or (2) any governmental agency, shall be exempted from the requirements of this Chapter.

(d) The definition of peddling and soliciting above shall not include any person who sells food or merchandise from a pushcart, stand, display, pedal-driven cart, wagon, showcase, rack, or other nonmotorized conveyance, or from one's person, upon a public sidewalk or other pedestrian path.

5.16.030 “No Peddling” or “No Soliciting” signs.

(a) No person, who is exercising, practicing or engaging in any activity as described in Section 5.16.020(a) hereof, shall ring the bell of, or knock on the door of, or attempt to gain admittance to any place of residence, including but limited to any residence, dwelling, property owner’s association, mobile home park, or apartment complex whereon a sign bearing the words “No Peddling” or words of similar import, which indicate that peddlers are not wanted on the premises is painted, affixed or exposed to public view.

(b) No person, who is exercising, practicing or engaging in any activity as described in Section 5.16.020(b) hereof, shall ring the bell of, or knock on the door of, or attempt to gain admittance to any place of residence, including but limited to any residence, dwelling, property owner’s association, mobile home park, or apartment complex whereon a sign bearing the words “No Soliciting” or words of similar import, which indicate that solicitors are not wanted on the premises is painted, affixed or exposed to public view.

(c) No person, who is exercising, practicing or engaging in any activity as described in Sections 5.16.020(a) and 5.16.020(b), shall ring the bell of, or knock on the door of, or attempt to gain admittance to any place of residence, including but limited to any residence, dwelling, property owner’s association, mobile home park, or apartment complex whereon a sign bearing the words “No Peddling or Soliciting” or words of similar import, which indicate that peddlers or solicitors are not wanted on the premises is painted, affixed or exposed to public view.

(d) This section shall not apply to any peddler or solicitor who rings the bell of, or knocks on the door of any place of residence, including but limited to any residence, dwelling, property owner’s association, mobile home park, or apartment complex at the invitation of or with the consent of the owner, occupant, or some adult member of the household of any such place of residence.

5.16.040 Provisions supplemental to business license regulation.

The provisions of this Chapter are intended to augment and to be in addition to any other provision of the Canyon Lake Municipal Code, including but not limited to, Chapter 5.01 related to the Business License Registration Program.

5.16.050 Hours for peddling or soliciting.

No person shall practice or engage in peddling or soliciting as described in Sections 5.16.020(a) and 5.16.020(b) to any place of residence, including but limited to any residence, dwelling, property owner's association, mobile home park, or apartment complex, between the hours of eight p.m. and eight a.m. of any day, except upon the expressed invitation of or appointment with the owner, occupant, or some adult member of the household of any such place of residence.

5.16.060 Violations.

(a) Each and every violation of the provisions of this Chapter is hereby deemed unlawful and a public nuisance

(b) Each and every violation of this Chapter shall constitute a separate violation and shall be subject to all remedies and enforcement measures authorized by this Code. Additionally, as a nuisance per se, any violation of this Chapter shall be subject to injunctive relief, any permit issued pursuant to this Chapter being deemed null and void, disgorgement and payment to the City for any monies unlawfully obtained, costs of abatement, costs of investigation, attorney fees, and any other relief or remedy available at law or in equity. The City may also pursue any and all remedies and actions available and applicable under state and local laws for any violations.

(c) Any person causing, permitting, aiding, abetting, suffering or concealing a violation of this Chapter shall be guilty of a misdemeanor, and may, in the discretion of the City Attorney, be prosecuted as a misdemeanor and upon conviction be subject to a fine not to exceed one thousand dollars (\$1,000) or imprisonment in the city or county jail for a period of not more than six (6) months, or by both such fine and imprisonment. The City Attorney, in his or her sound discretion, may prosecute a violation of this Chapter as an infraction, rather than a misdemeanor, or reduce or agree to the reduction of a previously filed misdemeanor to an infraction. Any person convicted of an infraction under this provisions of this Chapter shall be punished by a fine not exceeding one hundred dollars (\$100) for the first violation, a fine not exceeding two hundred dollars (\$200) for a second violation within one year, and a fine not exceeding five hundred dollars (\$500) for a third violation within one year. A fourth violation of this Chapter within one year shall be charged as a misdemeanor and may not be reduced to an infraction. Each day a violation is committed or permitted to continue shall constitute a separate offense.

(d) The remedies provided herein are not to be construed as exclusive remedies. The City is authorized to pursue any proceedings or remedies provided by law.

SECTION 2. EFFECTIVE DATE

This ordinance shall become effective on the Thirty-First Day following passage by a majority of the City Council.

PASSED APPROVED AND ADOPTED this ____ day of _____, 2020.

Jordan Ehrenkranz, Mayor

ATTEST:

APPROVED AS TO FORM:

Ana V. Sauseda, CMC
City Clerk

Steven Graham
City Attorney



STAFF REPORT

TO: Honorable Mayor and Members of the City Council

FROM: Chris Mann, City Manager *CM*

BY: Mike Borja, Administrative Services Manager

DATE: September 2, 2020

SUBJECT: Adoption of Resolution 2020-41, a Resolution of the City Council of the City of Canyon Lake, California, Authorizing the Reallocation of Previously Approved Community Development Block Grant Fund Balances for ADA Improvement Projects at New City Building of 31542 Railroad Canyon Road

Recommendation

That the City Council adopt Resolution 2020-41, authorizing the reallocation of previously approved Community Development Block Grant (CDBG) fund balances for ADA improvement projects at the City's new building located at 31542 Railroad Canyon Rd.

Background

The City of Canyon Lake annually participates in the Community Development Block Grant Program (CDBG) through the Riverside County Economic Development Agency (EDA). Each year, the City is allocated grant funding that is used towards various low-income programs, including ADA accessibility projects, as previously approved by City Council.

At both the May 1, 2019 and October 2, 2019 City Council meetings, City Council approved CDBG allocations totaling \$43,634 towards ADA Accessibility Projects for City Hall. Because of the immediate need to address critical ADA issues that have been identified by Riverside County EDA at the City's new building, staff seeks Council authorization to reallocate previously approved CDBG allocations and allow City staff to resubmit a new application with Riverside County EDA to approve funding for the City's new building. Any remaining balance, along with future allocations, will be used for City Hall's ADA projects at that time.

Fiscal Impact

The City currently has a CDBG balance from Fiscal Year 16/17 & 17/18 in the amount of \$25,748, in addition to FY20/21 allocation of \$17,850. Total allocation of \$43,634 is to be used at the new building. Any remaining funds will be used for City Hall ADA projects.

Attachments

1. Resolution No. 2020-41
2. ADA Accessibility Report – 31542 Railroad Canyon Road

ATTACHMENT 1

RESOLUTION NO. 2020-41

A RESOLUTION OF THE CITY COUNCIL OF THE CITY OF CANYON LAKE, CALIFORNIA, AUTHORIZING THE REALLOCATION OF PREVIOUSLY APPROVED COMMUNITY DEVELOPMENT BLOCK GRANT FUNDS FOR ADA IMPROVEMENT PROJECTS AT NEW CITY BUILDING OF 31542 RAILROAD CANYON ROAD

WHEREAS, the City of Canyon Lake receives an annual allocation of Community Development Block Grant (CDBG) funds from the Riverside County Economic Development Agency (EDA); and

WHEREAS, on May 1, 2019 City Council authorized the reallocation of previous approved CDBG funds for the City's ADA Accessibility Project at Canyon Lake's City Hall; and

WHEREAS, on October 2, 2019 the City authorized the FY20/21 CDBG allocation for the City's ADA Accessibility Project at Canyon Lake's City Hall; and

WHEREAS, the City's ADA Accessibility Projects ensure that all people with disabilities have equality of opportunity, economic self-sufficiency, full participation in American life, and independent living.

NOW THEREFORE, THE CITY COUNCIL OF THE CITY OF CANYON LAKE DOES HEREBY RESOLVE AS FOLLOWS:

Section 1. The City's FY16/17 & 17/18 remaining CDBG balance of \$25,748 will be reallocated to the City's ADA Accessibility Project for the new building located at 31542 Railroad Canyon Road.

Section 2. The City's FY20/21 CDBG approval allocation of \$17,850 will be reallocated to the City's ADA Accessibility Project for the new building located at 31542 Railroad Canyon Road.

Section 3. That in the event the total CDBG allocation is more or less than anticipated, the City Manager is authorized and directed to increase or reduce the approximate amounts of funding based on the percentages set forth above.

Section 4. That the City Clerk is authorized to submit the required applications for funding for the approved project to Riverside County Economic Development Agency for further review.

Section 5. That the City Manager is authorized to execute documents, including supplemental agreements, with Riverside County, necessary to carry out the intent of this resolution.

Section 6. That the City Clerk shall certify to the passage and adoption of this resolution and enter it into the book of original resolutions.

PASSED, APPROVED, AND ADOPTED this 2nd day of September, 2020.

Jordan Ehrenkranz, Mayor

ATTEST:

Ana V. Sauseda, CMC
City Clerk

ATTACHMENT 2

Accessibility Inspection

31542 RAILROAD CANYON ROAD

CITY OF CANYON LAKE

ATTN: MIKE BORJA,
ADMINISTRATIVE SERVICES MANAGER
31516 RAILROAD CANYON RD,
CANYON LAKE, CA 92587



PREPARED BY:
INTERWEST CONSULTING GROUP
DAVE MARCUM
15140 TRANSISTOR LANE
HUNTINGTON BEACH, CA 92649



Accessibility inspection for 31542 Railroad Canyon Rd

Date of Inspection: 03/21/2020

Scope of work: Inspect 31542 Railroad Canyon Rd., a property recently purchased by the City of Canyon Lake, for compliance with current accessibility regulations in compliance with the State of California.

Area of Inspection: Walkway extending along exterior entrances to various units, exterior entrances and one unisex exterior restroom and interior tenant spaces of the building including the common restrooms (Men’s and woman’s).

City of Canyon Lake contact: Mike Borja

Inspector: Dave Marcum, CASP ICC



Table of Contents

Exterior sidewalk and landing adjacent to building entrances	3
Suite 1	6
New Hope Church conference room	6
Church Office	7
Suite 5	8
Men’s Restroom	9
Woman’s Restroom	10
Main Building Corridor	11
New Hope Sanctuary.....	12
Exterior Restroom	16
Nikki’s Hair Salon.....	18
Hope Learning Academy	19
 CODE KEY:	
A, B and C.....	23
D	24
E and F.....	25
G, H and I	26
J, K, L and M.....	28
N, O, P, Q, R and S	29
T	30

Exterior sidewalk and landings adjacent to building entrances.



Sidewalks and landings directly adjacent to the building and in front of building entrances appear generally level and slip resistant with no physical defects other than noted below.

Spalled concrete along the walk and under the archway which may constitute a barrier or present a tripping hazard.



Evidence of regular occurring standing water at door landings may create a slipping hazard and should be corrected. Rework of concrete surfaces may be required to allow water to drain away from the building entrances and toward the storm drain.

ADA 302.1 General. Floor and ground surfaces shall be stable, firm, and slip resistant and shall comply with 302

ADA 504.7 Wet Conditions. Stair treads and landings subject to wet conditions shall be designed to prevent the accumulation of water.

CBC 11B-405.10 Wet conditions. Landings subject to wet conditions shall be designed to prevent the accumulation of water.

CBC 11B-302.1 General. Floor and ground surfaces shall be stable, firm, and slip resistant and shall comply with Section 11B-302.





Suite one (1)

Threshold at suite entrance exceeds the allowable ½ inch change in elevation. **A**

Door opening pressure exceeds the allowable maximum of five (5) pounds. **B**

A tactile exit sign is required on the wall immediately adjacent to the door's strike side. **I**

Accessible point of sale counter spaces shall be a maximum of 34 inches in height and 36 inches wide with adequate roll under space if a forward approach is required. **C**



32-inch minimum clear doorway openings at interior doors are required. **R**

Lever handle hardware is required. **B**

Thumb screw locksets are not permitted. **B**

New Hope Church conference room

The conference room is accessed through an interior passage door from suite one or from a door along the main building entrance corridor.

The threshold between suite one and the conference room and the corridor to the conference room exceeds the allowable ½ inch height. **A**



Lever handle hardware is required. **B**

Thumb screw locksets are not permitted. **B**

Church Office (door access from main hallway)

Threshold at office entrance exceeds the allowable ½ inch change in level. **A**





The passageway and aisles are blocked by furniture and equipment and are not accessible. **E**

Lever handle hardware is required. **B**

Thumb screw locksets are not permitted. **B**

Suite Five (5)



A tactile exit sign is required on the suite-side wall immediately adjacent to the door strike side. **I**

Lever handle hardware is required. **B**

Thumb screw locksets are not permitted. **B**

The thresholds at the suite entrance, within suite and at the patio slider exceeds the allowable ½ inch change in level. **A**

The sliding glass door leading to the patio is inoperable and is not accessible.

A 10-inch kick plate is required at all doors within the accessible route. **Q**

Men's Restroom (Interior)

Flush valve shall be on the open side. **G**

A minimum of one- and one-half inch clearance from top of water closet tank to grab bar is required. **S**



Thumb screw locksets are not permitted at restroom doors. **B**

Woman's Restroom (Interior)



A minimum of one- and one-half inch clearance from top of water closet tank to grab bar is required. **S**



The bottom of mirror exceeds 40 inches. **P**

Thumb screw locksets are not permitted. **B**

Main Building Corridor



Door opening pressures exceeds the allowable maximum of five (5) pounds. (Main entrance) **B**

A tactile exit sign is required on the interior wall immediately adjacent to the right double door leaf. **I**

Thresholds exceed the maximum allowable ½ inch height. **A**

Door from Suite 9 to corridor is not accessible.

Threshold at interior double doors is over the allowable height of ½ inch. **A**

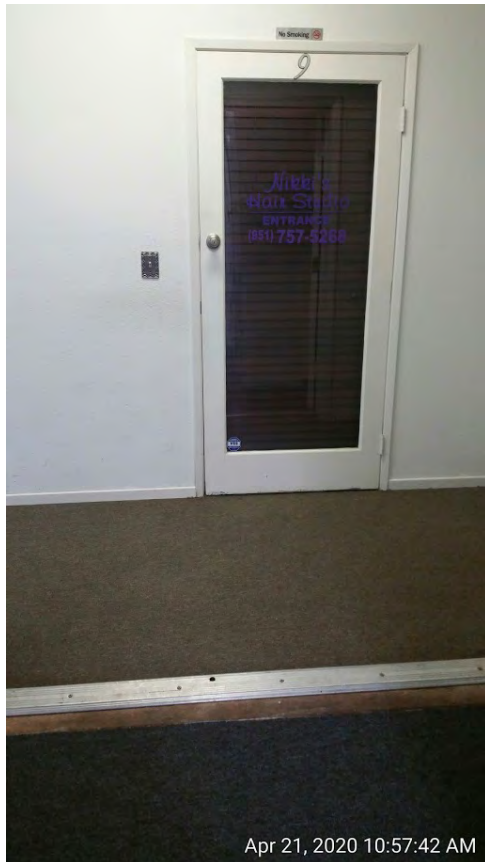

Church Sanctuary Area

Thresholds at exterior doors exceed the maximum allowable ½ inch height. **A**

Ramp to stage is not accessible. Lip at bottom of the ramp is not flush and there are no conforming handrails. **A, J**





Stage is not accessible.



Sound booth is not accessible.



Thermostat controls exceed allowable reach ranges. T



Aisle widths are too narrow at “back of house” area. **E**



Stairs from sanctuary to stage are not accessible. Contrasting stripe required at top of stairs and bottom tread and no handrail is in place. **N**

Exterior Restroom

Note: The exterior restroom is on the south side of the building.

Lever handle hardware is required. **B**

Thumb screw locksets are not permitted. **B**

Threshold at exterior door exceeds the maximum allowable ½ inch height. **A**

Accessible restroom sign exceeds the maximum allowable 60 inches to the center of the sign above the finish floor. **N**





Lavatory exceeds 34 inches in height to the top of the lavatory from the finish floor and is less than 18 inches from the wall to center line of lavatory. **L, O**

Bottom edge of mirror exceeds 40 inches above finish floor. **P**

Towel dispenser exceeds 40 inches to grab portion of the dispenser. **H**

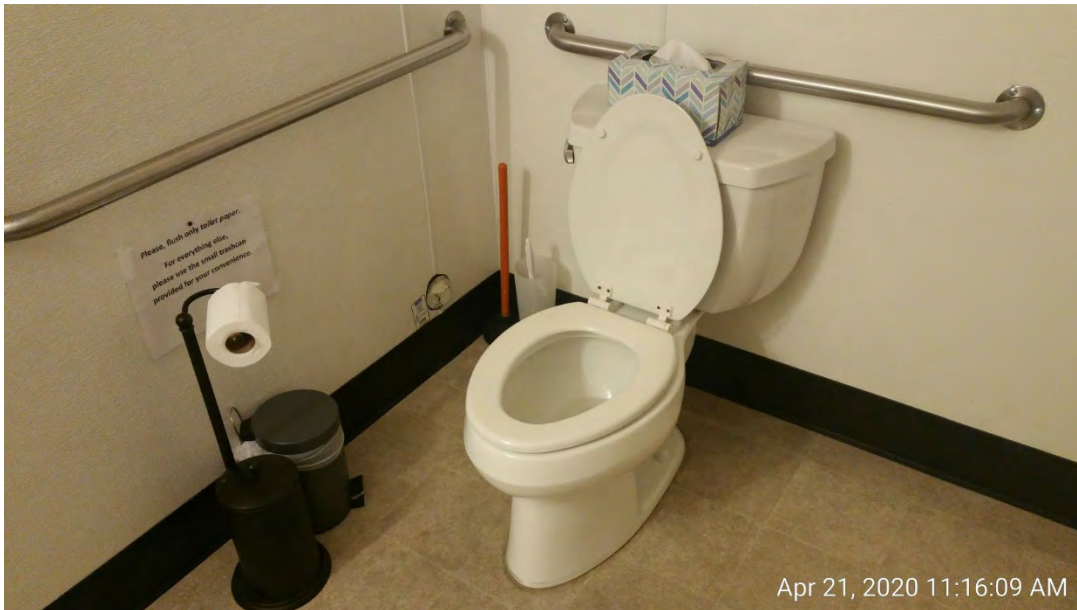

Grab bars at water closet appear to be installed incorrectly. **F**

Flush valve for water closet shall be on the open side of the room. **G**

Water closet shall be set 17-18 inches from the finish wall to the center line of the fixture. **K**

Nikki's Hair Salon



Threshold at suite entrance exceeds the allowable ½ inch change in level. **A**

Door opening pressure exceeds the allowable maximum of five (5) pounds. **B**

A tactile exit sign is required on the wall immediately adjacent to the door strike side. **I**

18-inch minimum strike side clearance at exit door is required. **D**

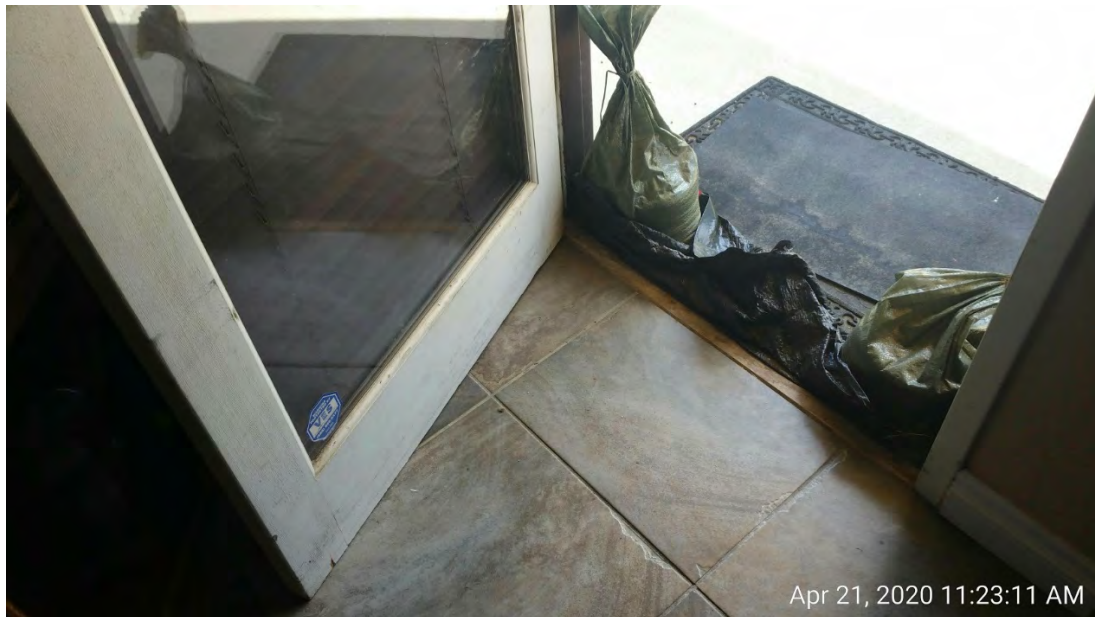

A smooth 10-inch minimum door kick is required. **Q**

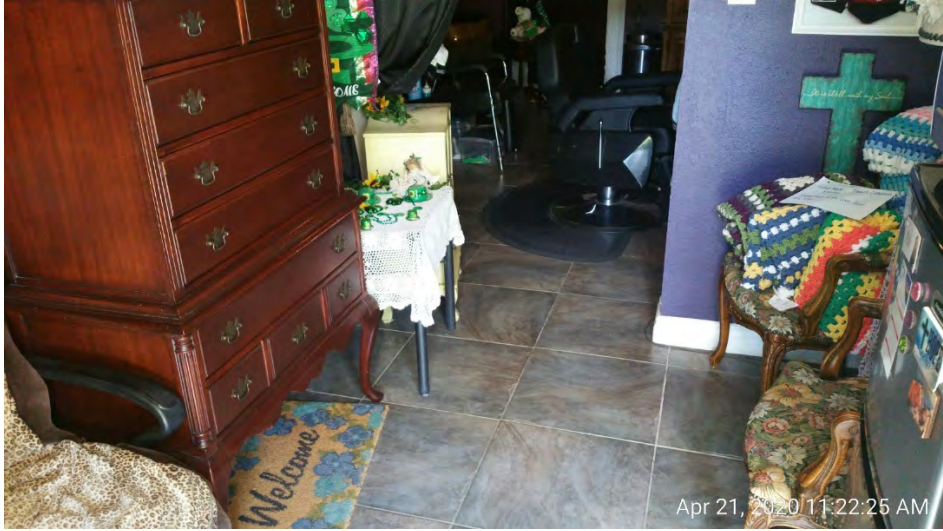

Passage ways within suite are restricted and not accessible. **E**

Hope Learning Academy



Lever handle door hardware required at all doors within the accessible route are required. No thumb screw type locksets are permitted. **B**

A ten (10) inch minimum, smooth surface (“kick”) at bottom of door is required. **Q**



Service counter is not accessible. **C**

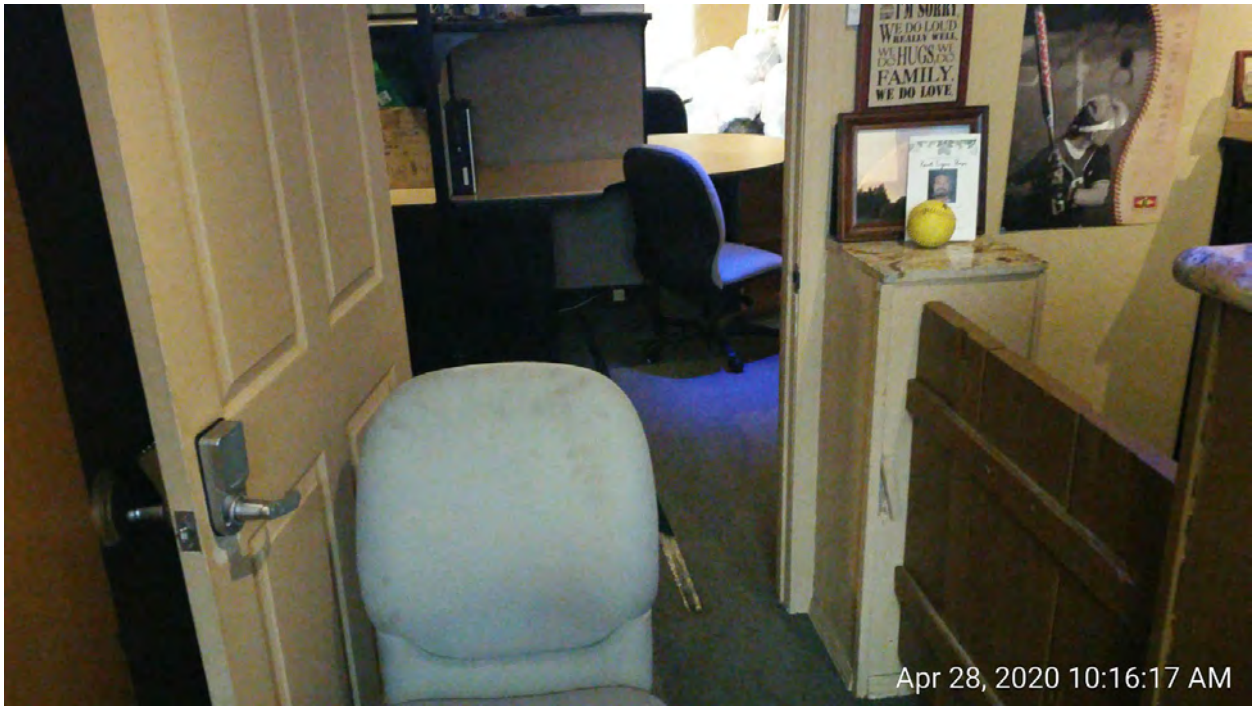

A minimum 18-inch strike side clearance on pull portion of doors is required. **D**

Door push/pull pressure may not exceed 5 pounds. **B**

Tactile "EXIT" and "EXIT ROUTE" signs are missing. **I**



Double doors leading to “multi-purpose” room:

Lever handle door hardware required. Thumb screw locksets are not permitted. **B**

Floor surface at threshold uneven and exceeds the ½ inch maximum elevation change. **A**



Tactile exit sign missing at multipurpose exit door. **I**



Thumb turn lock not accessible. **B**

CODE KEY

A.

ADA Level 303.1 General. Where changes in level are permitted in floor or ground surfaces, they shall comply with 303

303.2 Vertical. Changes in level of ¼ inch (6.4 mm) high maximum shall be permitted to be vertical.

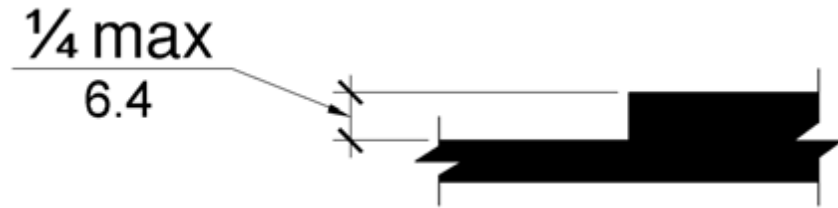

ADA 303.3 Beveled. Changes in level between ¼ inch (6.4 mm) high minimum and ½ inch (13 mm) high maximum shall be beveled with a slope not steeper than 1:2.

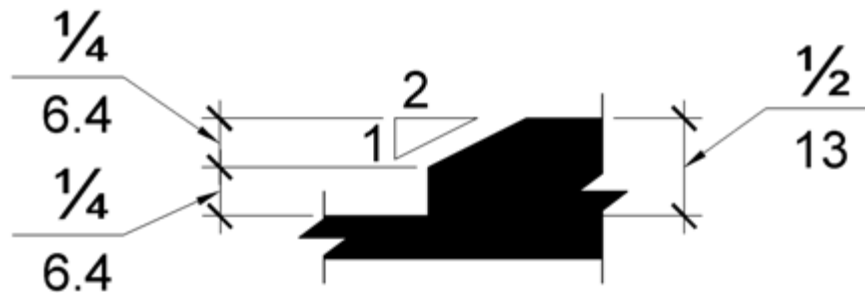

B.

CBC 11B-309.4 Operation. Operable parts shall be operable with one hand and shall not require tight grasping, pinching, or twisting of the wrist. The force required to activate operable parts shall be 5 pounds (22.2 N) maximum.

C.

CBC 11B-904.4 Sales and service counters. Sales counters and service counters shall comply with Section 11B-904.4.1 or 11B-904.4.2. The accessible portion of the counter top shall extend the same depth as the sales or service counter top.

11B-904.4.1 Parallel approach. A portion of the counter surface that is 36 inches (914 mm) long minimum and 34 inches (864 mm) high maximum above the finish floor shall be provided. A clear floor or ground space complying with Section 11B-305 shall be positioned for a parallel approach adjacent to the 36 inch (914 mm) minimum length of counter.

Exception: Where the provided counter surface is less than 36 inches (914 mm) long, the entire counter surface shall be 34 inches (864 mm) high maximum above the finish floor.

11B-904.4.2 Forward approach. A portion of the counter surface that is 36 inches (914 mm) long minimum and 34 inches (864 mm) high maximum shall be provided. Knee and toe space complying with

Section 11B-306 shall be provided under the counter. A clear floor or ground space complying with Section 11B-305 shall be positioned for a forward approach to the counter.

ADA 904.4.1 Parallel Approach. A portion of the counter surface that is 36 inches (915 mm) long minimum and 36 inches (915 mm) high maximum above the finish floor shall be provided. A clear floor or ground space complying with 305 shall be positioned for a parallel approach adjacent to the 36 inch (915 mm) minimum length of counter. **EXCEPTION:** Where the provided counter surface is less than 36 inches (915 mm) long, the entire counter surface shall be 36 inches (915 mm) high maximum above the finish floor.

904.4.2 Forward Approach. A portion of the counter surface that is 30 inches (760 mm) long minimum and 36 inches (915 mm) high maximum shall be provided. Knee and toe space complying with 306 shall be provided under the counter. A clear floor or ground space complying with 305 shall be positioned for a forward approach to the counter.

D.

CBC 11B-404.2.4 Maneuvering clearances. Minimum maneuvering clearances at doors and gates shall comply with Section 11B-404.2.4. Maneuvering clearances shall extend the full width of the doorway and the required latch side or hinge side clearance.

404.2.4.1 Swinging doors and gates. Swinging doors and gates shall have maneuvering clearances complying with Table 11B-404.2.4.1.

Table 11B-404.2.4.1 Maneuvering Clearances at Manual Swinging Doors and Gates Type of Use

Approach Direction	Door or Gate Side	Minimum Maneuvering Clearance	Minimum Maneuvering Clearance
		Perpendicular to Doorway	Parallel to Doorway (beyond latch side unless noted)
From front	Pull	60 inches (1524 mm)	18 inches (457 mm)⁵
From front	Push	48 inches (1219 mm)	0 inches (0 mm) ¹
From hinge side	Pull	60 inches (1524 mm)	36 inches (914 mm)
From hinge side	Push	44 inches (1118 mm) ²	22 inches (559 mm) ³
From latch side	Pull	60 inches (1524 mm)	24 inches (610 mm)
From latch side	Push	44 inches (1118 mm) ⁴	24 inches (610 mm)

1. Add 12 inches (305 mm) if closer and latch are provided.
2. Add 4 inches (102 mm) if closer and latch are provided.
3. Beyond hinge side.
4. Add 4 inches (102 mm) if closer is provided.
5. Add 6 inches (152 mm) at exterior side of exterior doors

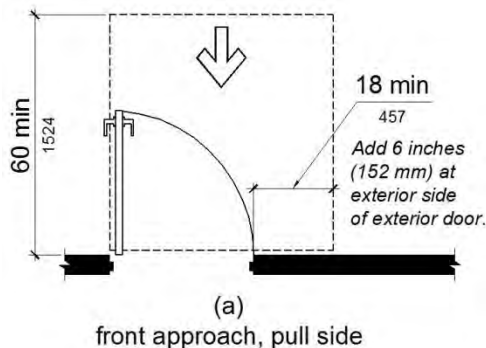

E.

ADA 403.5.1 Clear Width. Except as provided in 403.5.2 and 403.5.3, the clear width of walking surfaces shall be 36 inches (915 mm) minimum.

EXCEPTION: The clear width shall be permitted to be reduced to 32 inches (815 mm) minimum for a length of 24 inches (610 mm) maximum provided that reduced width segments are separated by segments that are 48 inches (1220 mm) long minimum and 36 inches (915 mm) wide minimum.

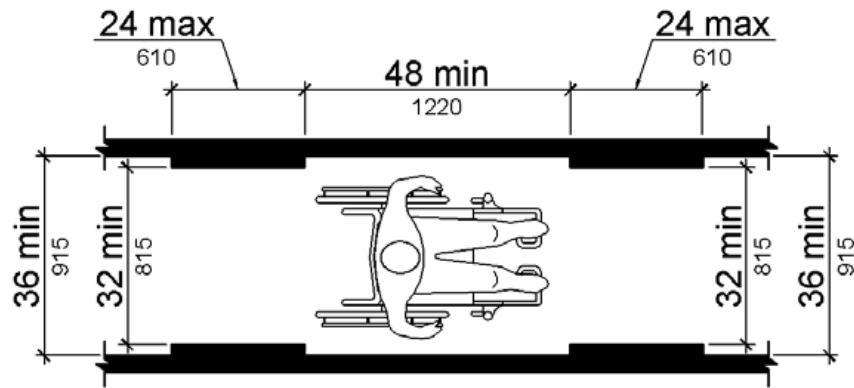
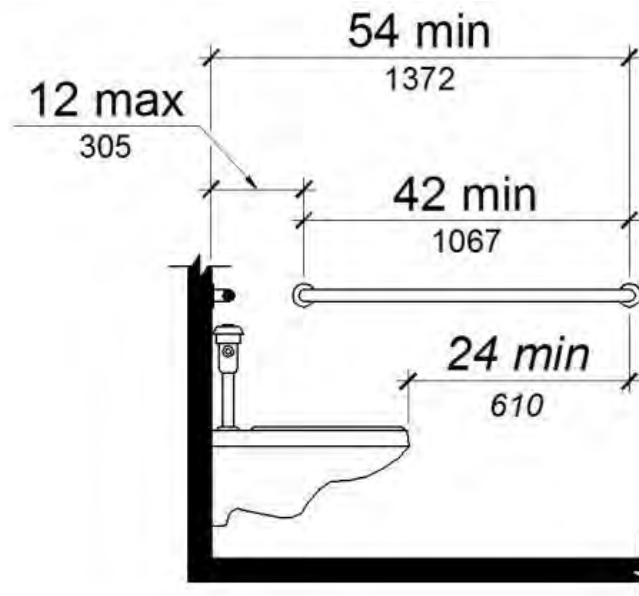

Figure 403.5.1 Clear Width of an Accessible Route

F.

CBC 11B-604.5.1 Side wall. The side wall grab bar shall be 42 inches (1067 mm) long minimum, located 12 inches (305 mm) maximum from the rear wall and extending 54 inches (1372 mm) minimum from the rear wall with the front end positioned 24 inches (610 mm) minimum in front of the water closet.



Side Wall Grab Bar at Water Closets

G.

CBC 11B-604.6 Flush controls. Flush controls shall be hand operated or automatic. Hand operated flush controls shall comply with *Section 11B-309 except they shall be located 44 inches (1118 mm) maximum above the floor.* Flush controls shall be located on the open side of the water closet except in ambulatory accessible compartments complying with *Section 11B-604.8.2.*

H.

11B-603.5 Accessories. *Where towel or sanitary napkin dispensers, waste receptacles, or other accessories are provided in toilet facilities, at least one of each type shall be located on an accessible route. All operable parts, including coin slots, shall be 40 inches (1016 mm) maximum above the finish floor.*

I.

CBC 1013.4 Raised character and braille exit signs. *Tactile exit signs shall be required at the following locations:*

- 1. Each grade-level exterior exit door that is required to comply with Section 1013.1, shall be identified by a tactile exit sign with the word, "EXIT"*
 - 2. Each exit door that is required to comply with Section 1013.1, and that leads directly to a grade-level exterior exit by means of a stairway or ramp shall be identified by a tactile exit sign with the following words as appropriate:
 - 2.1. "EXIT STAIR DOWN"*
 - 2.2. "EXIT RAMP DOWN"*
 - 2.3. "EXIT STAIR UP"*
 - 2.4. "EXIT RAMP UP"**
 - 3. Each exit door that is required to comply with Section 1013.1, and that leads directly to a grade-level exterior exit by means of an exit enclosure or an exit passageway shall be identified by a tactile exit sign with the words, "EXIT ROUTE".*
 - 4. Each exit access door from an interior room or area to a corridor or hallway that is required to comply with Section 1013.1, shall be identified by a tactile exit sign with the words "EXIT ROUTE".*
 - 5. Each exit door through a horizontal exit that is required to comply with Section 1013.1, shall be identified by a sign with the words, "TO EXIT".*
- Raised character and Braille exit signs shall comply with Chapter 11A, Section 1143A or Chapter 11B, Sections 11B-703.1, 11B-703.2, 11B-703.3 and 11B-703.5.*

CBC 11B-703.4.1 Height above finish floor or ground. Tactile characters on signs shall be located 48 inches (1219 mm) minimum above the finish floor or ground surface, measured from the baseline of the lowest *Braille cells* and 60 inches (1524 mm) maximum above the finish floor or ground surface, measured from the baseline of the highest *line of raised characters.*

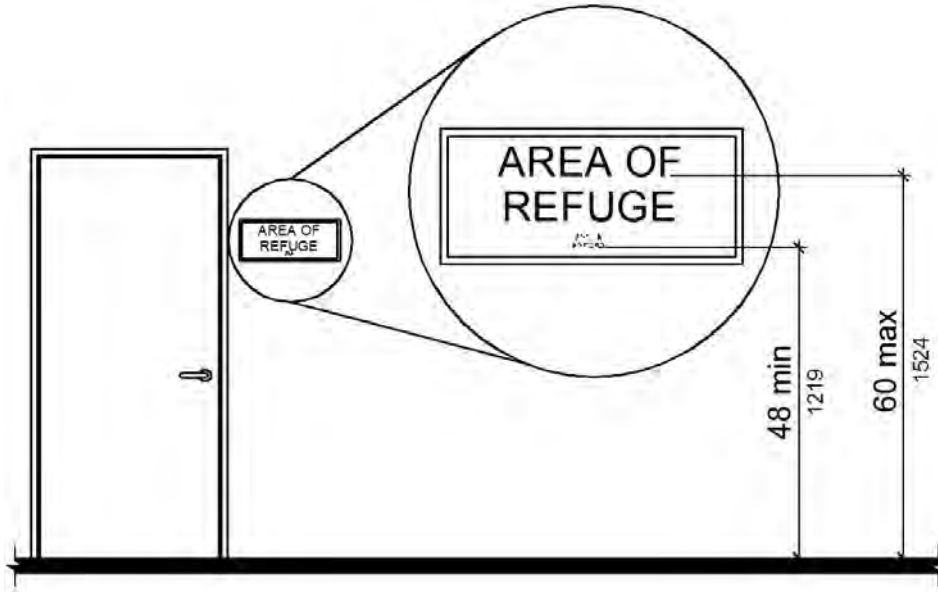

11B-703.4.2 Location. Where a tactile sign is provided at a door, the sign shall be located alongside the door at the latch side. Where a tactile sign is provided at double doors with one active leaf, the sign shall be located on the inactive leaf. Where a tactile sign is provided at double doors with two active leaves, the sign shall be located to the right of the right hand door. Where there is no wall space at the latch side of a single door or at the right side of double doors, signs shall be located on the nearest adjacent wall. Signs containing tactile characters shall be located so that a clear floor space of 18 inches (457 mm) minimum by 18 inches (457 mm) minimum, centered on the tactile characters, is provided beyond the arc of any door swing between the closed position and 45 degree open position. *Where provided, signs identifying permanent rooms and spaces shall be located at the entrance to, and outside of the room or space. Where provided, signs identifying exits shall be located at the exit door when approached in the direction of egress travel.*

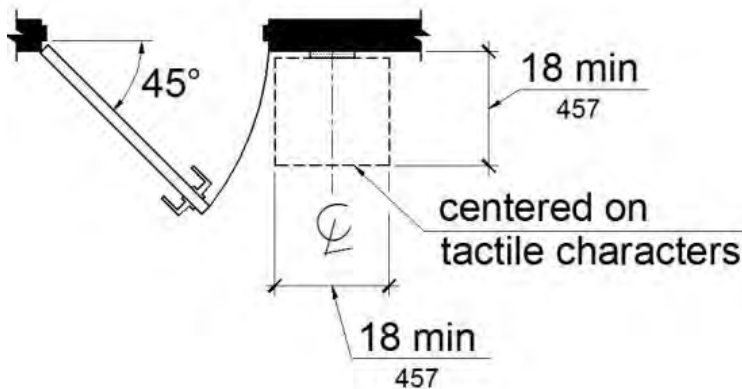

J.

11B-505.3 Continuity. Handrails shall be continuous within the full length of each stair flight or ramp run. Inside handrails on switchback or dogleg stairs and ramps shall be continuous between flights or runs.

11B-504.4.1 Contrasting stripe. Interior stairs shall have the upper approach and lower tread marked by a stripe providing clear visual contrast. Exterior stairs shall have the upper approach and all treads marked by a stripe providing clear visual contrast.

The stripe shall be a minimum of 2 inches (51 mm) wide to a maximum of 4 inches (102 mm) wide placed parallel to, and not more than 1 inch (25 mm) from, the nose of the step or upper approach. The stripe shall extend the full width of the step or upper approach and shall be of material that is at least as slip resistant as the other treads of the stair. A painted stripe shall be acceptable. Grooves shall not be used to satisfy this requirement.

K.

11B-604.2 Location. The water closet shall be positioned with a wall or partition to the rear and to one side. The centerline of the water closet shall be 17 inches (432 mm) minimum to 18 inches (457 mm) maximum from the side wall or partition, except that the water closet shall be 17 inches (432 mm) minimum and 19 inches (483 mm) maximum from the side wall or partition in the ambulatory accessible toilet compartment specified in Section 11B-604.8.2. Water closets shall be arranged for a left-hand or right-hand approach.

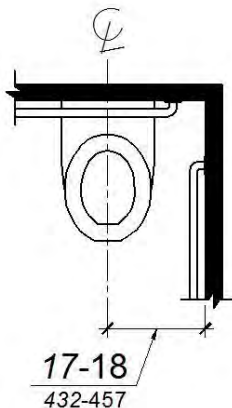

L.

11B-606.3 Height. Lavatories and sinks shall be installed with the front of the higher of the rim or counter surface 34 inches (864 mm) maximum above the finish floor or ground.

M.

11B-404.2.9 Door and gate opening force. The force for pushing or pulling open a door or gate shall be as follows: Exterior hinged doors: 5 pounds (22.2 N) maximum

N.

11B-703.7.2.6 Toilet and bathing facilities geometric symbols. Geometric symbols at entrances to toilet and bathing rooms shall be mounted at 58 inches (1473 mm) minimum and 60 inches (1524 mm) maximum above the finish floor or ground surface measured from the centerline of the symbol. Where a door is provided the symbol shall be mounted within 1 inch (25 mm) of the vertical centerline of the door. M.

O.

11B-606.6 Adjacent side wall or partition. Lavatories, when located adjacent to a side wall or partition, shall be a minimum of 18 inches (457 mm) to the centerline of the fixture.

P.

11B-603.3 Mirrors. Mirrors located above lavatories or countertops shall be installed with the bottom edge of the reflecting surface 40 inches (1016 mm) maximum above the finish floor or ground. Mirrors not located above lavatories or countertops shall be installed with the bottom edge of the reflecting surface 35 inches (889 mm) maximum above the finish floor or ground.

Q.

11B-404.2.10 Door and gate surfaces. Swinging door and gate surfaces within 10 inches (254 mm) of the finish floor or ground measured vertically shall have a smooth surface on the push side extending the full width of the door or gate. Parts creating horizontal or vertical joints in these surfaces shall be within 1/16 inch (1.6 mm) of the same plane as the other and be free of sharp or abrasive edges. Cavities created by added kick plates shall be capped.

R.

11B-404.2.3 Clear width. Door openings shall provide a clear width of 32 inches (813 mm) minimum. Clear openings of doorways with swinging doors shall be measured between the face of the door and the stop, with the door open 90 degrees. Openings more than 24 inches (610 mm) deep shall provide a clear opening of 36 inches (914 mm) minimum. There shall be no projections into the required clear opening width lower than 34 inches (864 mm) above the finish floor or ground. Projections into the clear opening width between 34 inches (864 mm) and 80 inches (2032 mm) above the finish floor or ground shall not exceed 4 inches (102 mm).

S.

11B-609.3 Spacing. The space between the wall and the grab bar shall be 1½ inches (38 mm). The space between the grab bar and projecting objects below and at the ends shall be 1½ inches (38 mm) minimum. The space between the grab bar and projecting objects above shall be 12 inches (305 mm) minimum.

T.

11B-308.3.2 Obstructed high reach. Where a clear floor or ground space allows a parallel approach to an element and the high side reach is over an obstruction, the height of the obstruction shall be 34 inches (864 mm) maximum and the depth of the obstruction shall be 24 inches (610 mm) maximum. The high side reach shall be 48 inches (1219 mm) maximum for a reach depth of 10 inches (254 mm) maximum. Where the reach depth exceeds 10 inches (254 mm), the high side reach shall be 46 inches (1168 mm) maximum for a reach depth of 24 inches (610 mm) maximum.



STAFF REPORT

TO: Honorable Mayor and Members of the City Council

FROM: Chris Mann, City Manager *CM*

BY: Ana V. Sauseda, City Clerk

DATE: September 2, 2020

SUBJECT: Discussion of the Status of City-Sponsored Events Scheduled in 2020

Recommendation

That the City Council approve amending the Veteran's Day event, canceling the State of the City/30th Anniversary Gala and the Winter Wonderland event, and redirecting a portion of the approved funding to improvements at Veterans Memorial Park.

Background

Due to the ongoing COVID-19 pandemic, we are seeing that many events throughout the state are being cancelled. The City Council has approved funding for three major events scheduled toward the end of this calendar year. The Veteran's Day event was scheduled for Wednesday, November 11, 2020, the State of the City/30th Anniversary Gala was scheduled for Tuesday, December 1, 2020 and the Winter Wonderland was scheduled for Saturday, December 5, 2020.

In light of ongoing high rates of COVID-19 infection in Riverside County, as well as State emergency orders prohibiting gatherings, staff recommends amending the Veteran's Day event in a way that allows the community to properly honor those who have served our Nation in the armed forces while at the same time discouraging large gatherings. Specifically, staff recommends proceeding with the plan developed by the Veteran's Day Committee, which involves a golf cart parade, the placing of flags on lawns and an enhanced flyover by the Warbirds, with no planned central gathering location.

Staff believes that it would not be possible to hold the State of the City/30th Anniversary Gala or the Winter Wonderland event without creating a large gathering of people. Therefore, staff recommends that these events be canceled for 2020 with the intention and hope that we will be able to proceed with them in 2021.

Staff further recommends that a portion of the funds approved for these canceled events be redirected to improvements in Veterans Memorial Park, to include upgraded lighting and electrical, a larger artificial tree more conducive to the Winter Wonderland event or other

events that may include a tree lighting ceremony, a cement foundation to support a larger tree, and an expanded area for the Veteran Brick Program.

The approved budget for the State of the City/30th Anniversary event is \$20,000, and the approved budget for the Winter Wonderland event is \$30,000. While it is not anticipated that the entire \$50,000 will be required for the contemplated improvements, staff requests that the Council give the City Manager discretion to reallocate these funds, not to exceed \$50,000, based on the proposals that are received.

Fiscal Impact

Likely minor reduction of expenditures in account 10-100-6830 of the General Fund.



STAFF REPORT

TO: Honorable Mayor and Members of the City Council

FROM: Chris Mann, City Manager

BY: Tyler Ferrari, Management Analyst

DATE: September 2, 2020

SUBJECT: Update on Canyon Lake Internship Program

Recommendation

Discussion only. No action required.

Background

At the January 15, 2020 City Council meeting, the Council adopted goals for the 2020 calendar year. One of the goals set by the Council was to establish an internship program at City Hall. Over the past few months, staff has been working to create a program that will benefit City operations while at the same time offering valuable experience and professional growth opportunities to those who participate as interns.

City staff is pleased to announce that the internship program has officially been launched, and the inaugural class of interns have been brought on-board. Three interns will serve primarily with the Administration Office, and one intern will serve primarily with Code Enforcement. Interns will be assisting City staff with a variety of projects, including an outreach program aimed at connecting more residents with the City's social media pages and CodeRED emergency notification system.

The interns have a curriculum that they will follow for the 10-12 weeks they are with the program, in addition to the daily tasks and assignments that City staff will provide for them. These tasks will range from purely administrative and organizational tasks, to assisting with research for city projects and potential new policies. Additionally, the interns will be asked to attend at least one council meeting, and one meeting of a regional agency of which the City is a member.

The City's hope for the interns is that they learn the fundamentals of local government operations while developing professional skills and proficiencies that will help them launch careers in public service.

Fiscal Impact

This is an unpaid internship program. However, there will be incidental costs associated with the program, such as business cards, email addresses, office supplies, etc. It is anticipated that these minor additional costs can be absorbed by the existing budget.



STAFF REPORT

TO: Honorable Mayor and Members of the City Council

FROM: Chris Mann, City Manager *CM*

BY: Tyler Ferrari, Management Analyst

DATE: September 2, 2020

SUBJECT: Discussion of Riverside County Sheriff's Department Citizen Volunteer Program

Recommendation

Discussion only. No action required.

Background

The City is currently working with the Riverside County Sheriff's Department, Lake Elsinore Station, to establish a Citizen Volunteer Program within the City of Canyon Lake. It is expected that volunteers will work in a myriad of assignments including within their own neighborhood, at a correctional facility, in patrol operations, clerical support, investigations, accounting, computer entry and many more. While volunteers will not carry a weapon or make arrests, they will act as essential "eyes and ears" in service to the community while working with City and Sheriff's Department staff.

This program is a cost effective way the City can enhance police presence within the community. Volunteers will assist Sheriff's Department personnel during special events (e.g. Fiesta Day, 4th of July, Veterans Day, etc.), when there are major traffic incidents, and during various emergency situations. Volunteers will also patrol the community, in addition to the sworn Sheriff's Deputies already on patrol. In addition, Canyon Lake residents aged 14-17 will have the opportunity to serve in the Explorer Program, which helps provide a path to a career in law enforcement.

The Citizen Volunteer Program has existed in other cities across the County long before the formation of a program in Canyon Lake, and it has proved successful for many neighboring cities. This volunteer program comes at no cost to the City, unless we were to choose to purchase vehicles, radios, and other equipment to be housed in Canyon Lake instead of at the Lake Elsinore Station, but that is not necessary to have a successful and robust program at this time.

City Staff has worked with the Lake Elsinore Station to create marketing for the program, and that marketing will be used to recruit volunteers to serve in Canyon Lake. These materials consist of designs posted to social media and a video that was filmed with current volunteers inside Canyon Lake.

Fiscal Impact

There is no fiscal impact at this time. In the future, the City may elect to purchase vehicles, radios and other equipment to be housed in Canyon Lake. Council approval will be sought prior to moving forward with any such expenditures.

Attachments

1. N/A



STAFF REPORT

TO: Honorable Mayor and Members of the City Council

FROM: Chris Mann, City Manager *CM*

BY: Ana V. Sauseda, City Clerk

DATE: September 2, 2020

SUBJECT: Designation of Voting Delegate and Alternates for League of California Cities Annual Conference – October 7th through 9th, 2020

Recommendation

That the City Council appoint a voting delegate and up to two alternates to the League of California Cities Annual Conference to be held virtually, October 7th through 9th, 2020, and direct City staff to complete and file the necessary paperwork.

Background

Consistent with the League of California Cities' bylaws, the City's voting delegate and up to two alternates must be designated by the City Council. The voting delegate and alternates must be registered to attend the conference.

Staff recommends that the Council discuss and appoint a voting delegate and one or two alternates to represent the City at the Business Meeting portion of the League of California Cities Annual Conference.

Fiscal Impact

Registration and expenses for attendance at the League of California Cities Annual Conference was included in the Fiscal Year 2020/2021 Budget.

Attachments

1. Letter from the League of California Cities Regarding Designation of Voting Delegates and Alternates

ATTACHMENT 1

Council Action Advised by August 31, 2020

June 30, 2020

TO: Mayors, City Managers and City Clerks

**RE: DESIGNATION OF VOTING DELEGATES AND ALTERNATES
League of California Cities Annual Conference & Expo – October 7 – 9, 2020**

The League's 2020 Annual Conference & Expo is scheduled for October 7 – 9. An important part of the Annual Conference is the Annual Business Meeting (during General Assembly) on Friday, October 9. At this meeting, the League membership considers and takes action on resolutions that establish League policy.

In order to vote at the Annual Business Meeting, your city council must designate a voting delegate. Your city may also appoint up to two alternate voting delegates, one of whom may vote in the event that the designated voting delegate is unable to serve in that capacity.

Please complete the attached Voting Delegate form and return it to the League's office no later than Wednesday, September 30. This will allow us time to establish voting delegate/alternate records prior to the conference.

Please note the following procedures are intended to ensure the integrity of the voting process at the Annual Business Meeting. These procedures assume that the conference will be held in-person at the Long Beach Convention Center as planned. Should COVID-19 conditions and restrictions prohibit the League from holding an in-person conference, new procedures will be provided.

- **Action by Council Required.** Consistent with League bylaws, a city's voting delegate and up to two alternates must be designated by the city council. When completing the attached Voting Delegate form, please attach either a copy of the council resolution that reflects the council action taken, or have your city clerk or mayor sign the form affirming that the names provided are those selected by the city council. Please note that designating the voting delegate and alternates **must** be done by city council action and cannot be accomplished by individual action of the mayor or city manager alone.
- **Conference Registration Required.** The voting delegate and alternates must be registered to attend the conference. They need not register for the entire conference; they may register for Friday only. Conference registration will open by the end of July at www.cacities.org. In order to cast a vote, at least one voter must be present at the Business Meeting and in possession of the voting delegate card. Voting delegates and alternates need to pick up their conference badges before signing in and picking up the voting delegate card at the Voting Delegate Desk. This will enable them to receive the



CITY: _____

**2020 ANNUAL CONFERENCE
VOTING DELEGATE/ALTERNATE FORM**

Please complete this form and return it to the League office by Wednesday, September 30, 2020. Forms not sent by this deadline may be submitted to the Voting Delegate Desk located in the Annual Conference Registration Area. Your city council may designate one voting delegate and up to two alternates.

In order to vote at the Annual Business Meeting (General Assembly), voting delegates and alternates must be designated by your city council. Please attach the council resolution as proof of designation. As an alternative, the Mayor or City Clerk may sign this form, affirming that the designation reflects the action taken by the council.

Please note: Voting delegates and alternates will be seated in a separate area at the Annual Business Meeting. Admission to this designated area will be limited to individuals (voting delegates and alternates) who are identified with a special sticker on their conference badge. This sticker can be obtained only at the Voting Delegate Desk.

1. VOTING DELEGATE

Name: _____

Title: _____

2. VOTING DELEGATE - ALTERNATE

Name: _____

Title: _____

3. VOTING DELEGATE - ALTERNATE

Name: _____

Title: _____

PLEASE ATTACH COUNCIL RESOLUTION DESIGNATING VOTING DELEGATE AND ALTERNATES.

OR

ATTEST: I affirm that the information provided reflects action by the city council to designate the voting delegate and alternate(s).

Name: _____

Email: _____

Mayor or City Clerk _____
(circle one) (signature)

Date: _____ Phone: _____

Please complete and return by Wednesday, September 30, 2020

League of California Cities
ATTN: Darla Yacub
1400 K Street, 4th Floor
Sacramento, CA 95814

FAX: (916) 658-8240
E-mail: dyacub@cacities.org
(916) 658-8254



Annual Conference Voting Procedures

1. **One City One Vote.** Each member city has a right to cast one vote on matters pertaining to League policy.
2. **Designating a City Voting Representative.** Prior to the Annual Conference, each city council may designate a voting delegate and up to two alternates; these individuals are identified on the Voting Delegate Form provided to the League Credentials Committee.
3. **Registering with the Credentials Committee.** The voting delegate, or alternates, may pick up the city's voting card at the Voting Delegate Desk in the conference registration area. Voting delegates and alternates must sign in at the Voting Delegate Desk. Here they will receive a special sticker on their name badge and thus be admitted to the voting area at the Business Meeting.
4. **Signing Initiated Resolution Petitions.** Only those individuals who are voting delegates (or alternates), and who have picked up their city's voting card by providing a signature to the Credentials Committee at the Voting Delegate Desk, may sign petitions to initiate a resolution.
5. **Voting.** To cast the city's vote, a city official must have in his or her possession the city's voting card and be registered with the Credentials Committee. The voting card may be transferred freely between the voting delegate and alternates, but may not be transferred to another city official who is neither a voting delegate or alternate.
6. **Voting Area at Business Meeting.** At the Business Meeting, individuals with a voting card will sit in a designated area. Admission will be limited to those individuals with a special sticker on their name badge identifying them as a voting delegate or alternate.
7. **Resolving Disputes.** In case of dispute, the Credentials Committee will determine the validity of signatures on petitioned resolutions and the right of a city official to vote at the Business Meeting.