

Preliminary Development Plan

Amendment

for

Mountain View Estates
Housing

Riggs Road and Pearl Drive

by:

The logo for KHovnanian Homes is displayed within a blue rectangular box. The text "KHovnanian" is in a large, white, serif font, with "Homes" in a smaller, white, serif font below it.

KHovnanian
Homes

Case No.: _____

Submitted: April 14, 2026

TABLE OF CONTENTS

I.	Introduction.....	1
II.	Proposed PDP Amendment.....	1
III.	Project Team.....	1
IV.	Conclusion	1

TABLE OF EXHIBITS

Exhibit No.	Description
1	Housing Elevations
2	Floor Plans

MOUNTAIN VIEW ESTATES – HOUSING

I. INTRODUCTION

Continuing its reputation of building high-quality, single-family communities, K. Hovnanian Homes (“K Hov”) is the proposed home builder for 8.08± gross (5.43± net) acres at the Riggs Road and Pearl Drive (the “Site”). The Site is known as “*Mountain View Estates.*” Mountain View Estates was rezoned for a 16 lot single-family community under DVR17-0034, which was approved in 2019 and the housing product was approved under PLH22-0039 in 2022 (the “2022 Approval”). K Hov proposes to development Mountain View Estates with its housing product and square footages. To achieve this, K Hov proposes a Preliminary Development Plan (Housing Product) amendment for the housing product included at *Exhibit 1* and floor plans at *Exhibit 2*.

II. PROPOSED PDP AMENDMENT

K Hov is proposing three, single-story floor plans, each with two distinct elevation styles that are in conformance with the 2022 Approval. The square footage of the homes range from 2,747 square feet to 4,074 square feet, and include upgraded features such as interior designer curated interiors, courtyards, expansive covered patios, three car garages, vaulted ceilings, grand foyers with high ceilings, and luxurious kitchen designs. The elevations, which are European and Farmhouse, offer a rich and elegant streetscape for the community. Each elevation style consists of proportionate massing, details, and roof lines that are true to style, an abundant use of brick veneer for texture and color, black window frames, sand finish stucco, and enhanced style specific garage doors and coach lights. *See Exhibit 3, Colors and Materials Palette.*

III. PROJECT TEAM

Home Builder:

K Hovnanian Homes
Attn: Chuck Chisholm
Mark Graminske
8800 East Raintree Drive, Suite 300
Scottsdale, AZ 85260

Zoning:

Ray Law Firm
Attn: Brennan Ray
2325 E. Camelback Road, Suite 400
Phoenix, AZ 85016

IV. CONCLUSION

K Hov’s housing product continues to build on its reputation of developing high-quality communities. Mountain View Estates will be no exception. We request your approval.

K Hovnanian Homes

PLAN 1 - GENEVA (#E2 7264)

PLAN 2 - FRANKFURT (#E2 7258)

PLAN 3 - LONDON (#E2 8754)



FARMHOUSE ELEVATIONS (FORM - WA)



FARMHOUSE ELEVATIONS (FORM - WA)



FARMHOUSE ELEVATIONS (FORM - WD)

**LONDON PLAN FORM LETTER SPECIFIC*



EUROPEAN ELEVATIONS (FORM - ZA)



EUROPEAN ELEVATIONS (FORM - ZA)



EUROPEAN ELEVATIONS (FORM - ZD)

**LONDON PLAN FORM LETTER SPECIFIC*

PLAN 1 - GENEVA (#E2 7264)

PLAN 2 - FRANKFURT (#E2 7258)

PLAN 3 - LONDON (#E2 8754)



FARMHOUSE ELEVATIONS (FORM - WA)



FARMHOUSE ELEVATIONS (FORM - WA)



FARMHOUSE ELEVATIONS (FORM - WD)
**LONDON PLAN FORM LETTER SPECIFIC*



EUROPEAN ELEVATIONS (FORM - ZA)



EUROPEAN ELEVATIONS (FORM - ZA)



EUROPEAN ELEVATIONS (FORM - ZD)
**LONDON PLAN FORM LETTER SPECIFIC*

PLAN 1 - GENEVA (#E2 7264)

PLAN 2 - FRANKFURT (#E2 7258)

PLAN 3 - LONDON (#E2 8754)



FARMHOUSE ELEVATIONS (FORM - WA)



FARMHOUSE ELEVATIONS (FORM - WA)



FARMHOUSE ELEVATIONS (FORM - WD)
**LONDON PLAN FORM LETTER SPECIFIC*



EUROPEAN ELEVATIONS (FORM - ZA)



EUROPEAN ELEVATIONS (FORM - ZA)



EUROPEAN ELEVATIONS (FORM - ZD)
**LONDON PLAN FORM LETTER SPECIFIC*

PLAN 1 - GENEVA (#E2 7264)

PLAN 2 - FRANKFURT (#E2 7258)

PLAN 3 - LONDON (#E2 8754)



FARMHOUSE ELEVATIONS (FORM - WA)



FARMHOUSE ELEVATIONS (FORM - WA)



FARMHOUSE ELEVATIONS (FORM - WD)
**LONDON PLAN FORM LETTER SPECIFIC*



EUROPEAN ELEVATIONS (FORM - ZA)



EUROPEAN ELEVATIONS (FORM - ZA)



EUROPEAN ELEVATIONS (FORM - ZD)
**LONDON PLAN FORM LETTER SPECIFIC*



GENEVA
PLAN 1 - #E2 7264
FORM WA - FARMHOUSE
2,747 SQ. FT. :: SINGLE-STORY

FRANKFURT
PLAN 2 - #E2 7258
FORM ZA - EUROPEAN
2,847 SQ. FT. :: SINGLE-STORY

LONDON
PLAN 3 - #E2 8754
FORM WD - EUROPEAN
4,074 SQ. FT. :: SINGLE-STORY

GENEVA
PLAN 1 - #E2 7264
FORM ZA - EUROPEAN
2,747 SQ. FT. :: SINGLE STORY

FRANKFURT
PLAN 2 - #E2 7258
FORM WA - FARMHOUSE
2,847 SQ. FT. :: SINGLE-STORY

STREET SCENE - FRONT
SCALE = NTS



GENEVA
PLAN 1 - #E2 7264
FORM WA - FARMHOUSE
2,747 SQ. FT. :: SINGLE-STORY

FRANKFURT
PLAN 2 - #E2 7258
FORM ZA - EUROPEAN
2,847 SQ. FT. :: SINGLE-STORY

LONDON
PLAN 3 - #E2 8754
FORM WD - EUROPEAN
4,074 SQ. FT. :: SINGLE-STORY

GENEVA
PLAN 1 - #E2 7264
FORM ZA - EUROPEAN
2,747 SQ. FT. :: SINGLE STORY

FRANKFURT
PLAN 2 - #E2 7258
FORM WA - FARMHOUSE
2,847 SQ. FT. :: SINGLE-STORY

STREET SCENE - REAR
SCALE = NTS

PLAN 1

LIV. SF: 2,747
 PLAN W x D: 50'-0" X 80'-0"
 PLAN #: E2 7264
 PLAN NAME: GENEVA
 FORM: WA - FARMHOUSE

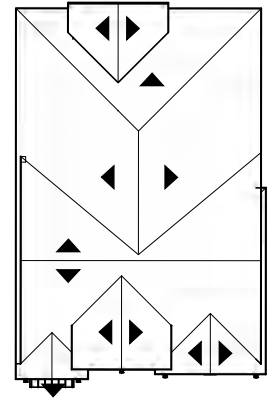

ROOF PLAN | 6:12 U.N.O.

STYLE LEGEND:

- 1 PROMINENT GABLES
- 2 CONCRETE 'FLAT' TILES
- 3 2" RAKES AND 12" EAVES
- 4 STANDING SEAM METAL ROOF
- 5 DECORATIVE BOARD & BATTEN
- 6 COACH LIGHTS
- 7 SAND FINISH STUCCO
- 8 2" RECESS AT GARAGE DOOR
- 9 COLOR SCHEME (PER PREVIOUSLY APPROVED COLOR MENU)
- 10 PLATE AT ENTRY - 14'-1" A.F.F.
- 11 PLATE HEIGHT - 10'-1" A.F.F.
- 12 WINDOW HEADER - 8'-0" A.F.F. & 10'-8" A.F.F.
- 13 8" X 24" DECORATIVE VENT WITH 3" BRICK TRIM



FORM WA - FARMHOUSE
 FRONT VIEW: N.T.S.

PLAN 1

LIV. SF: 2,747
 PLAN W x D: 50'-0" X 80'-0"
 PLAN #: E2 7264
 PLAN NAME: GENEVA
 FORM: WA - FARMHOUSE



REAR ELEVATION
 SCALE: 1/8" = 1'-0"

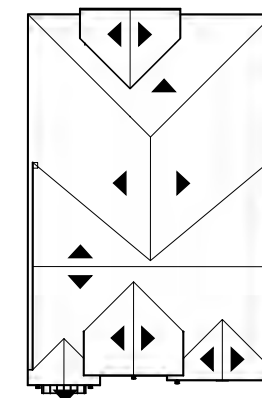

ROOF PLAN | 6:12 U.N.O.



FRONT ELEVATION
 SCALE: 1/8" = 1'-0"

STYLE LEGEND:

- 1 PROMINENT GABLES
- 2 CONCRETE 'FLAT' TILES
- 3 2" RAKES AND 12" EAVES
- 4 STANDING SEAM METAL ROOF
- 5 DECORATIVE BOARD & BATTEN
- 6 COACH LIGHTS
- 7 SAND FINISH STUCCO
- 8 2" RECESS AT GARAGE DOOR
- 9 COLOR SCHEME (PER PREVIOUSLY APPROVED COLOR MENU)
- 10 PLATE AT ENTRY - 14'-1" A.F.F.
- 11 PLATE HEIGHT - 10'-1" A.F.F.
- 12 WINDOW HEADER - 8'-0" A.F.F. & 10'-8" A.F.F.
- 13 8" X 24" DECORATIVE VENT WITH 3" BRICK TRIM



PLAN 1

LIV. SF: 2,747
 PLAN W x D: 50'-0" X 80'-0"
 PLAN #: E2 7264
 PLAN NAME: GENEVA
 FORM: WA - FARMHOUSE



RIGHT ELEVATION
 SCALE: 1/8" = 1'-0"

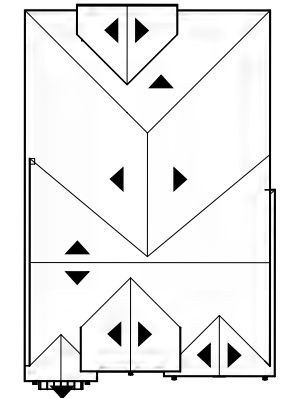

ROOF PLAN | 6:12 U.N.O.



LEFT ELEVATION
 SCALE: 1/8" = 1'-0"

STYLE LEGEND:

- 1 PROMINENT GABLES
- 2 CONCRETE 'FLAT' TILES
- 3 2" RAKES AND 12" EAVES
- 4 STANDING SEAM METAL ROOF
- 5 DECORATIVE BOARD & BATTEN
- 6 COACH LIGHTS
- 7 SAND FINISH STUCCO
- 8 2" RECESS AT GARAGE DOOR
- 9 COLOR SCHEME (PER PREVIOUSLY APPROVED COLOR MENU)
- 10 PLATE AT ENTRY - 14'-1" A.F.F.
- 11 PLATE HEIGHT - 10'-1" A.F.F.
- 12 WINDOW HEADER - 8'-0" A.F.F. & 10'-8" A.F.F.
- 13 8" X 24" DECORATIVE VENT WITH 3" BRICK TRIM



PLAN 1

LIV. SF: 2,747
 PLAN W x D: 50'-0" X 79'-0"
 PLAN #: E2 7264
 PLAN NAME: GENEVA
 FORM: ZA - EUROPEAN

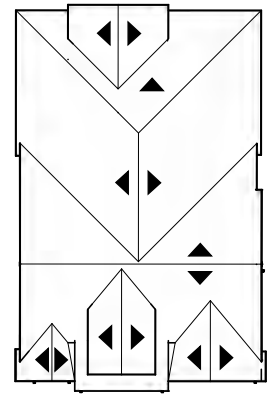

ROOF PLAN | 6:12 U.N.O.

STYLE LEGEND:

- 1 PROMINENT GABLES
- 2 CONCRETE 'FLAT' TILES
- 3 0" RAKES AND 12" EAVES
- 4 8" X 24" DECORATIVE VENT WITH 3" BRICK TRIM
- 5 DECORATIVE BRICK VENEER
- 6 COACH LIGHTS
- 7 SAND FINISH STUCCO
- 8 24" RECESS AT GARAGE DOOR
- 9 COLOR SCHEME (PER PREVIOUSLY APPROVED COLOR MENU)
- 10 PLATE AT ENTRY - 14'-1" A.F.F.
- 11 PLATE HEIGHT - 10'-1" A.F.F.
- 12 WINDOW HEADER - 8'-0" A.F.F. & 10'-8" A.F.F.



FORM ZA - EUROPEAN
 FRONT VIEW: N.T.S.

PLAN 1

LIV. SF: 2,747
 PLAN W x D: 50'-0" X 79'-0"
 PLAN #: E2 7264
 PLAN NAME: GENEVA
 FORM: ZA - EUROPEAN



REAR ELEVATION
 SCALE: 1/8" = 1'-0"

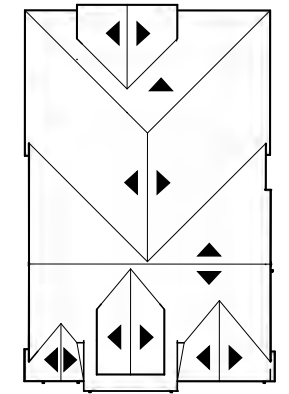

ROOF PLAN | 6:12 U.N.O.



FRONT ELEVATION
 SCALE: 1/8" = 1'-0"

STYLE LEGEND:

- 1 PROMINENT GABLES
- 2 CONCRETE 'FLAT' TILES
- 3 0" RAKES AND 12" EAVES
- 4 8" X 24" DECORATIVE VENT WITH 3" BRICK TRIM
- 5 DECORATIVE BRICK VENEER
- 6 COACH LIGHTS
- 7 SAND FINISH STUCCO
- 8 24" RECESS AT GARAGE DOOR
- 9 COLOR SCHEME (PER PREVIOUSLY APPROVED COLOR MENU)
- 10 PLATE AT ENTRY - 14'-1" A.F.F.
- 11 PLATE HEIGHT - 10'-1" A.F.F.
- 12 WINDOW HEADER - 8'-0" A.F.F. & 10'-8" A.F.F.

PLAN 1

LIV. SF: 2,747
 PLAN W x D: 50'-0" X 79'-0"
 PLAN #: E2 7264
 PLAN NAME: GENEVA
 FORM: ZA - EUROPEAN



RIGHT ELEVATION
 SCALE: 1/8" = 1'-0"

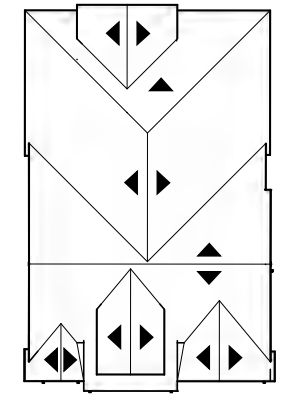

ROOF PLAN | 6:12 U.N.O.



LEFT ELEVATION
 SCALE: 1/8" = 1'-0"

STYLE LEGEND:

- 1 PROMINENT GABLES
- 2 CONCRETE 'FLAT' TILES
- 3 0" RAKES AND 12" EAVES
- 4 8" X 24" DECORATIVE VENT WITH 3" BRICK TRIM
- 5 DECORATIVE BRICK VENEER
- 6 COACH LIGHTS
- 7 SAND FINISH STUCCO
- 8 24" RECESS AT GARAGE DOOR
- 9 COLOR SCHEME (PER PREVIOUSLY APPROVED COLOR MENU)
- 10 PLATE AT ENTRY - 14'-1" A.F.F.
- 11 PLATE HEIGHT - 10'-1" A.F.F.
- 12 WINDOW HEADER - 8'-0" A.F.F. & 10'-8" A.F.F.

PLAN 1 (OPTIONS)

LIV. SF: 2,747
PLAN W x D: VARIES
PLAN #: E2 7264
PLAN NAME: GENEVA
FORM: ALL FORMS
OPT. 12080 SGD



FORM ZA - EUROPEAN

OPT. REAR ELEVATION
SCALE: 3/32" = 1'-0"



FORM WA - FARMHOUSE

OPT. REAR ELEVATION
SCALE: 3/32" = 1'-0"

PLAN 2

LIV. SF: 2,847
 PLAN W x D: 50'-0" X 84'-0"
 PLAN #: E2 7258
 PLAN NAME: FRANKFURT
 FORM: WA - FARMHOUSE

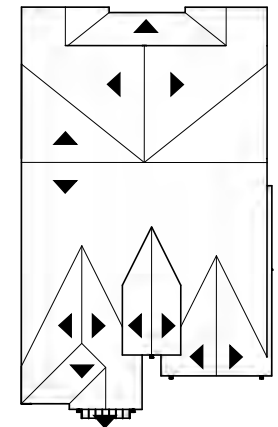

ROOF PLAN | 6:12 U.N.O.

STYLE LEGEND:

- 1 PROMINENT GABLES
- 2 CONCRETE 'FLAT' TILES
- 3 2" RAKES AND 12" EAVES
- 4 STANDING SEAM METAL ROOF
- 5 DECORATIVE BOARD & BATTEN
- 6 COACH LIGHTS
- 7 SAND FINISH STUCCO
- 8 2" RECESS AT GARAGE DOOR
- 9 COLOR SCHEME (PER PREVIOUSLY APPROVED COLOR MENU)
- 10 PLATE AT ENTRY - 14'-1" A.F.F.
- 11 PLATE HEIGHT - 10'-1" A.F.F.
- 12 WINDOW HEADER - 8'-0" A.F.F. & 10'-8" A.F.F.
- 13 8" X 24" DECORATIVE VENT WITH 3" BRICK TRIM



FORM WA - FARMHOUSE
 FRONT VIEW: N.T.S.

PLAN 2

LIV. SF: 2,847
 PLAN W x D: 50'-0" X 84'-0"
 PLAN #: E2 7258
 PLAN NAME: FRANKFURT
 FORM: WA - FARMHOUSE



REAR ELEVATION
 SCALE: 1/8" = 1'-0"

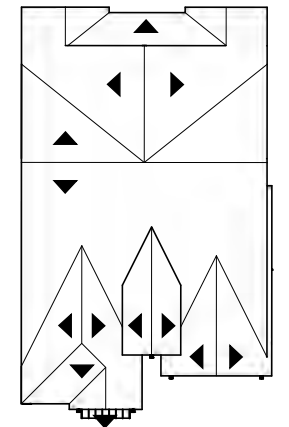

ROOF PLAN | 6:12 U.N.O.



FRONT ELEVATION
 SCALE: 1/8" = 1'-0"

STYLE LEGEND:

- 1 PROMINENT GABLES
- 2 CONCRETE 'FLAT' TILES
- 3 2" RAKES AND 12" EAVES
- 4 STANDING SEAM METAL ROOF
- 5 DECORATIVE BOARD & BATTEN
- 6 COACH LIGHTS
- 7 SAND FINISH STUCCO
- 8 2" RECESS AT GARAGE DOOR
- 9 COLOR SCHEME (PER PREVIOUSLY APPROVED COLOR MENU)
- 10 PLATE AT ENTRY - 14'-1" A.F.F.
- 11 PLATE HEIGHT - 10'-1" A.F.F.
- 12 WINDOW HEADER - 8'-0" A.F.F. & 10'-8" A.F.F.
- 13 8" X 24" DECORATIVE VENT WITH 3" BRICK TRIM

PLAN 2

LIV. SF: 2,847
 PLAN W x D: 50'-0" X 84'-0"
 PLAN #: E2 7258
 PLAN NAME: FRANKFURT
 FORM: WA - FARMHOUSE



RIGHT ELEVATION
 SCALE: 1/8" = 1'-0"

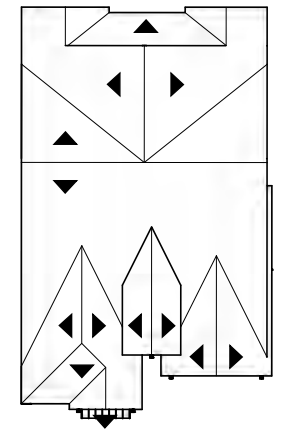

ROOF PLAN | 6:12 U.N.O.



LEFT ELEVATION
 SCALE: 1/8" = 1'-0"

STYLE LEGEND:

- 1 PROMINENT GABLES
- 2 CONCRETE 'FLAT' TILES
- 3 2" RAKES AND 12" EAVES
- 4 STANDING SEAM METAL ROOF
- 5 DECORATIVE BOARD & BATTEN
- 6 COACH LIGHTS
- 7 SAND FINISH STUCCO
- 8 2" RECESS AT GARAGE DOOR
- 9 COLOR SCHEME (PER PREVIOUSLY APPROVED COLOR MENU)
- 10 PLATE AT ENTRY - 14'-1" A.F.F.
- 11 PLATE HEIGHT - 10'-1" A.F.F.
- 12 WINDOW HEADER - 8'-0" A.F.F. & 10'-8" A.F.F.
- 13 8" X 24" DECORATIVE VENT WITH 3" BRICK TRIM



PLAN 2

LIV. SF: 2,847
 PLAN W x D: 50'-0" X 83'-0"
 PLAN #: E2 7258
 PLAN NAME: FRANKFURT
 FORM: ZA - EUROPEAN

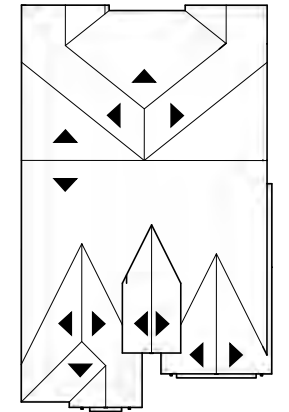

ROOF PLAN | 6:12 U.N.O.

STYLE LEGEND:

- 1 PROMINENT GABLES
- 2 CONCRETE 'FLAT' TILES
- 3 0" RAKES AND 12" EAVES
- 4 8" X 24" DECORATIVE VENT WITH 3" BRICK TRIM
- 5 DECORATIVE BRICK VENEER
- 6 COACH LIGHTS
- 7 SAND FINISH STUCCO
- 8 14" RECESS AT GARAGE DOOR
- 9 COLOR SCHEME (PER PREVIOUSLY APPROVED COLOR MENU)
- 10 PLATE AT ENTRY - 14'-1" A.F.F.
- 11 PLATE HEIGHT - 10'-1" A.F.F.
- 12 WINDOW HEADER - 8'-0" A.F.F. & 10'-8" A.F.F.



FORM ZA - EUROPEAN
 FRONT VIEW: N.T.S.

PLAN 2

LIV. SF: 2,847
 PLAN W x D: 50'-0" X 83'-0"
 PLAN #: E2 7258
 PLAN NAME: FRANKFURT
 FORM: ZA - EUROPEAN



REAR ELEVATION
 SCALE: 1/8" = 1'-0"

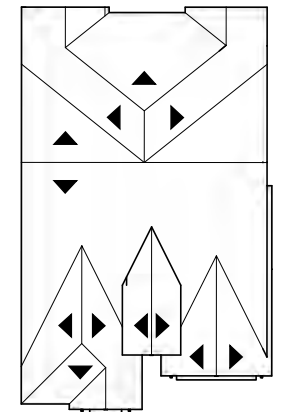

ROOF PLAN | 6:12 U.N.O.

STYLE LEGEND:

- 1 PROMINENT GABLES
- 2 CONCRETE 'FLAT' TILES
- 3 0" RAKES AND 12" EAVES
- 4 8" X 24" DECORATIVE VENT WITH 3" BRICK TRIM
- 5 DECORATIVE BRICK VENEER
- 6 COACH LIGHTS
- 7 SAND FINISH STUCCO
- 8 14" RECESS AT GARAGE DOOR
- 9 COLOR SCHEME (PER PREVIOUSLY APPROVED COLOR MENU)
- 10 PLATE AT ENTRY - 14'-1" A.F.F.
- 11 PLATE HEIGHT - 10'-1" A.F.F.
- 12 WINDOW HEADER - 8'-0" A.F.F. & 10'-8" A.F.F.



FRONT ELEVATION
 SCALE: 1/8" = 1'-0"

PLAN 2

LIV. SF: 2,847
 PLAN W x D: 50'-0" X 83'-0"
 PLAN #: E2 7258
 PLAN NAME: FRANKFURT
 FORM: ZA - EUROPEAN



RIGHT ELEVATION
 SCALE: 1/8" = 1'-0"

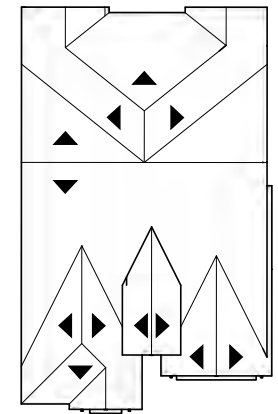

ROOF PLAN | 6:12 U.N.O.



LEFT ELEVATION
 SCALE: 1/8" = 1'-0"

STYLE LEGEND:

- 1 PROMINENT GABLES
- 2 CONCRETE 'FLAT' TILES
- 3 0" RAKES AND 12" EAVES
- 4 8" X 24" DECORATIVE VENT WITH 3" BRICK TRIM
- 5 DECORATIVE BRICK VENEER
- 6 COACH LIGHTS
- 7 SAND FINISH STUCCO
- 8 14" RECESS AT GARAGE DOOR
- 9 COLOR SCHEME (PER PREVIOUSLY APPROVED COLOR MENU)
- 10 PLATE AT ENTRY - 14'-1" A.F.F.
- 11 PLATE HEIGHT - 10'-1" A.F.F.
- 12 WINDOW HEADER - 8'-0" A.F.F. & 10'-8" A.F.F.

PLAN 2 (OPTIONS)

LIV. SF: 2,847
PLAN W x D: VARIES
PLAN #: E2 7258
PLAN NAME: FRANKFURT
FORM: ALL FORMS
OPT. 12080 SGD



FORM ZA - EUROPEAN

OPT. REAR ELEVATION
SCALE: 3/32" = 1'-0"



FORM WA - FARMHOUSE

OPT. REAR ELEVATION
SCALE: 3/32" = 1'-0"

PLAN 3

LIV. SF: 4,074
 PLAN W x D: 69'-4" X 88'-4"
 PLAN #: E2 8754
 PLAN NAME: LONDON
 FORM: WD - FARMHOUSE

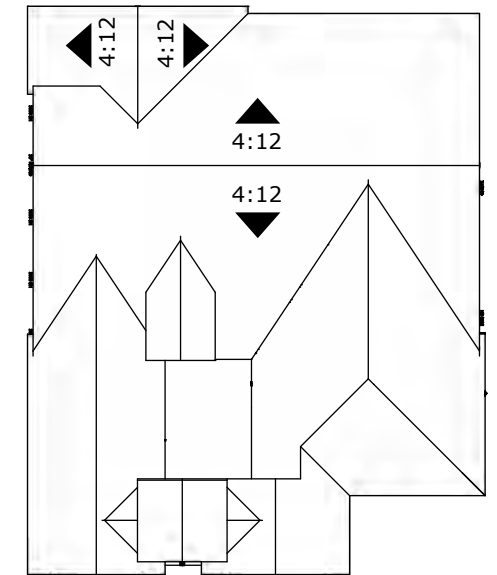

ROOF PLAN | 6:12 U.N.O.

STYLE LEGEND:

- 1 PROMINENT GABLES
- 2 CONCRETE 'FLAT' TILES
- 3 2" RAKES AND 12" EAVES
- 4 8" X 24" DECORATIVE VENT WITH 3" BRICK TRIM
- 5 DECORATIVE BRICK VENEER
- 6 SAND FINISH STUCCO
- 7 COACH LIGHTS
- 8 2" RECESS AT WINDOWS SIDES AND REARS
- 9 14" RECESS AT GARAGE DOOR
- 10 COLOR SCHEME (PER PREVIOUSLY APPROVED COLOR MENU)
- 11 PLATE AT ENTRY - 17'-1" A.F.F.
- 12 PLATE HEIGHT - 10'-1" A.F.F.
- 13 WINDOW HEADER - 8'-0" A.F.F. & 10'-8" A.F.F.



FORM WD - FARMHOUSE
 FRONT VIEW: N.T.S.

PLAN 3

LIV. SF: 4,074
 PLAN W x D: 69'-4" X 88'-4"
 PLAN #: E2 8754
 PLAN NAME: LONDON
 FORM: WD - FARMHOUSE



REAR ELEVATION
 SCALE: 1/8" = 1'-0"

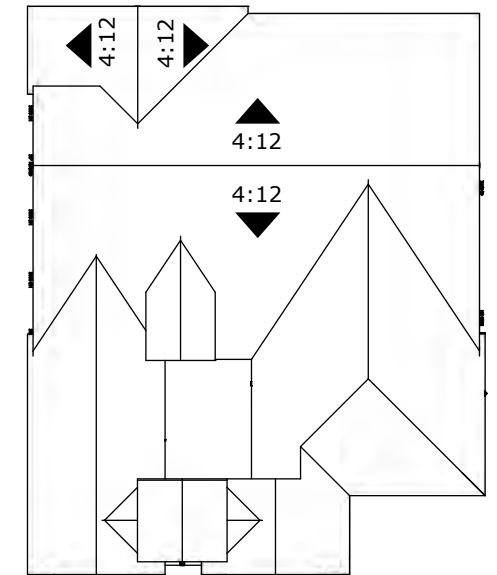

ROOF PLAN | 6:12 U.N.O.

STYLE LEGEND:

- 1 PROMINENT GABLES
- 2 CONCRETE 'FLAT' TILES
- 3 2" RAKES AND 12" EAVES
- 4 8" X 24" DECORATIVE VENT WITH 3" BRICK TRIM
- 5 DECORATIVE BRICK VENEER
- 6 SAND FINISH STUCCO
- 7 COACH LIGHTS
- 8 2" RECESS AT WINDOWS SIDES AND REARS
- 9 14" RECESS AT GARAGE DOOR
- 10 COLOR SCHEME (PER PREVIOUSLY APPROVED COLOR MENU)
- 11 PLATE AT ENTRY - 17'-1" A.F.F.
- 12 PLATE HEIGHT - 10'-1" A.F.F.
- 13 WINDOW HEADER - 8'-0" A.F.F. & 10'-8" A.F.F.



T.O. RIDGE
 20'-6"
 11
 12
 13

FRONT ELEVATION
 SCALE: 1/8" = 1'-0"



PLAN 3

LIV. SF: 4,074
 PLAN W x D: 69'-4" X 88'-4"
 PLAN #: E2 8754
 PLAN NAME: LONDON
 FORM: WD - FARMHOUSE



RIGHT ELEVATION
 SCALE: 1/8" = 1'-0"

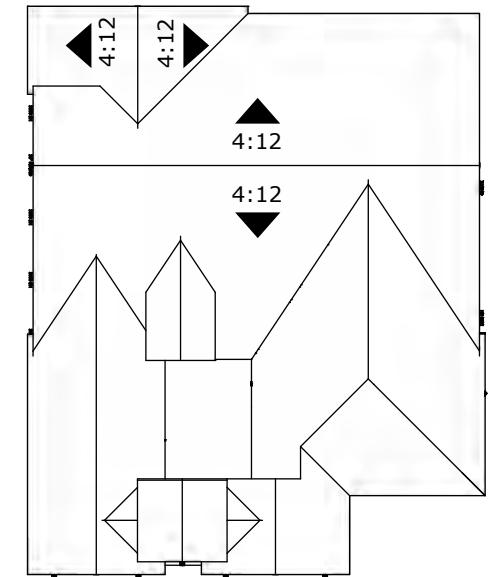

ROOF PLAN | 6:12 U.N.O.



LEFT ELEVATION
 SCALE: 1/8" = 1'-0"

STYLE LEGEND:

- 1 PROMINENT GABLES
- 2 CONCRETE 'FLAT' TILES
- 3 2" RAKES AND 12" EAVES
- 4 8" X 24" DECORATIVE VENT WITH 3" BRICK TRIM
- 5 DECORATIVE BRICK VENEER
- 6 SAND FINISH STUCCO
- 7 COACH LIGHTS
- 8 2" RECESS AT WINDOWS SIDES AND REARS
- 9 14" RECESS AT GARAGE DOOR
- 10 COLOR SCHEME (PER PREVIOUSLY APPROVED COLOR MENU)
- 11 PLATE AT ENTRY - 17'-1" A.F.F.
- 12 PLATE HEIGHT - 10'-1" A.F.F.
- 13 WINDOW HEADER - 8'-0" A.F.F. & 10'-8" A.F.F.



PLAN 3 (COURTYARD)

LIV. SF: 4,074
 PLAN W x D: 69'-4" X 88'-4"
 PLAN #: E2 8754
 PLAN NAME: LONDON
 FORM: WD - FARMHOUSE



RIGHT ELEVATION
 SCALE: 1/8" = 1'-0"



FRONT ELEVATION
 SCALE: 1/8" = 1'-0"

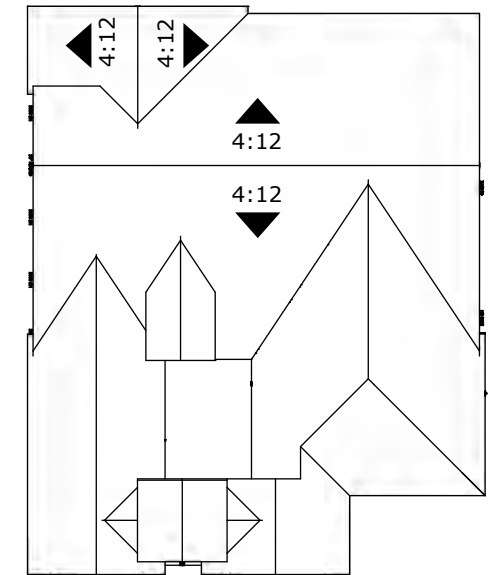

ROOF PLAN | 6:12 U.N.O.

STYLE LEGEND:

- 1 PROMINENT GABLES
- 2 CONCRETE 'FLAT' TILES
- 3 2" RAKES AND 12" EAVES
- 4 8" X 24" DECORATIVE VENT WITH 3" BRICK TRIM
- 5 DECORATIVE BRICK VENEER
- 6 SAND FINISH STUCCO
- 7 COACH LIGHTS
- 8 2" RECESS AT WINDOWS SIDES AND REARS
- 9 14" RECESS AT GARAGE DOOR
- 10 COLOR SCHEME (PER PREVIOUSLY APPROVED COLOR MENU)
- 11 PLATE AT ENTRY - 17'-1" A.F.F.
- 12 PLATE HEIGHT - 10'-1" A.F.F.
- 13 WINDOW HEADER - 8'-0" A.F.F. & 10'-8" A.F.F.



LEFT ELEVATION
 SCALE: 1/8" = 1'-0"

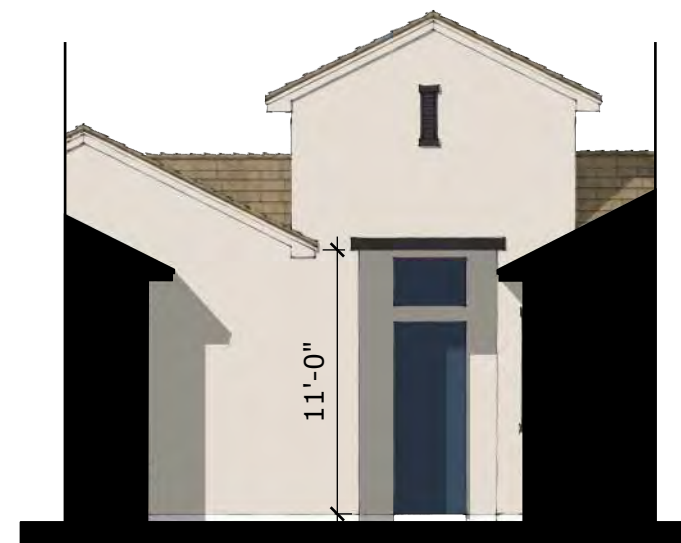

REAR ELEVATION
 SCALE: 1/8" = 1'-0"

PLAN 3

LIV. SF: 4,074
 PLAN W x D: 69'-4" X 88'-4"
 PLAN #: E2 8754
 PLAN NAME: LONDON
 FORM: ZD - EUROPEAN

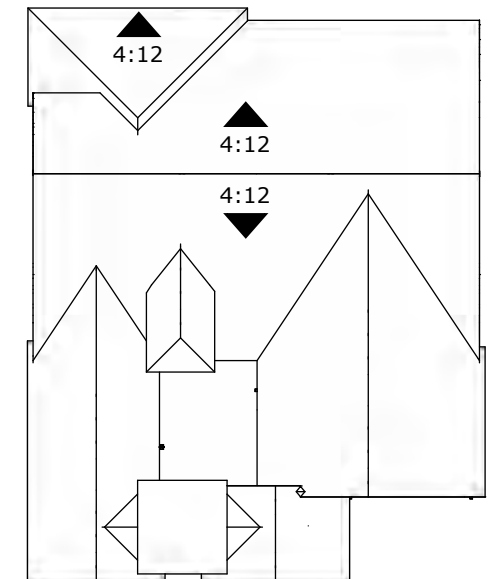

ROOF PLAN | 6:12 U.N.O.

STYLE LEGEND:

- 1 PROMINENT GABLES
- 2 CONCRETE 'FLAT' TILES
- 3 0" RAKES AND 12" EAVES
- 4 8" X 24" DECORATIVE VENT WITH 3" BRICK TRIM
- 5 DECORATIVE BRICK VENEER
- 6 SAND FINISH STUCCO
- 7 COACH LIGHTS
- 8 2" RECESS AT WINDOWS SIDES AND REARS
- 9 14" RECESS AT GARAGE DOOR
- 10 COLOR SCHEME (PER PREVIOUSLY APPROVED COLOR MENU)
- 11 PLATE AT ENTRY - 17'-1" A.F.F.
- 12 PLATE HEIGHT - 10'-1" A.F.F.
- 13 WINDOW HEADER - 8'-0" A.F.F. & 10'-8" A.F.F.



FORM ZD - EUROPEAN
 FRONT VIEW: N.T.S.

PLAN 3

LIV. SF: 4,074
 PLAN W x D: 69'-4" X 88'-4"
 PLAN #: E2 8754
 PLAN NAME: LONDON
 FORM: ZD - EUROPEAN



REAR ELEVATION
 SCALE: 1/8" = 1'-0"

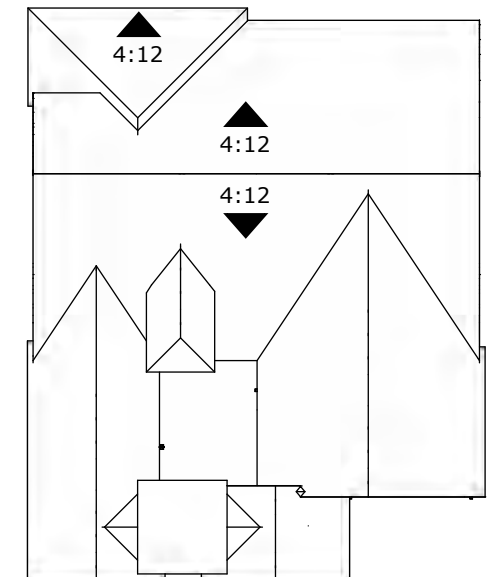

ROOF PLAN | 6:12 U.N.O.

STYLE LEGEND:

- 1 PROMINENT GABLES
- 2 CONCRETE 'FLAT' TILES
- 3 0" RAKES AND 12" EAVES
- 4 8" X 24" DECORATIVE VENT WITH 3" BRICK TRIM
- 5 DECORATIVE BRICK VENEER
- 6 SAND FINISH STUCCO
- 7 COACH LIGHTS
- 8 2" RECESS AT WINDOWS SIDES AND REARS
- 9 14" RECESS AT GARAGE DOOR
- 10 COLOR SCHEME (PER PREVIOUSLY APPROVED COLOR MENU)
- 11 PLATE AT ENTRY - 15'-6" A.F.F.
- 12 PLATE HEIGHT - 10'-1" A.F.F.
- 13 WINDOW HEADER - 8'-0" A.F.F. & 10'-8" A.F.F.



FRONT ELEVATION
 SCALE: 1/8" = 1'-0"



PLAN 3

LIV. SF: 4,074
 PLAN W x D: 69'-4" X 88'-4"
 PLAN #: E2 8754
 PLAN NAME: LONDON
 FORM: ZD - EUROPEAN



RIGHT ELEVATION
 SCALE: 1/8" = 1'-0"

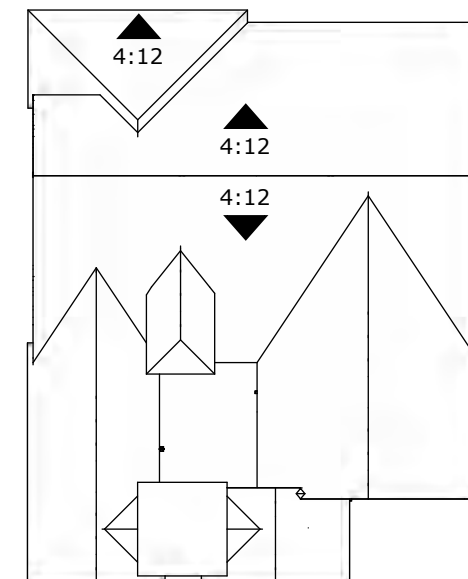

ROOF PLAN | 6:12 U.N.O.



LEFT ELEVATION
 SCALE: 1/8" = 1'-0"

STYLE LEGEND:

- 1 PROMINENT GABLES
- 2 CONCRETE 'FLAT' TILES
- 3 0" RAKES AND 12" EAVES
- 4 8" X 24" DECORATIVE VENT WITH 3" BRICK TRIM
- 5 DECORATIVE BRICK VENEER
- 6 SAND FINISH STUCCO
- 7 COACH LIGHTS
- 8 2" RECESS AT WINDOWS SIDES AND REARS
- 9 14" RECESS AT GARAGE DOOR
- 10 COLOR SCHEME (PER PREVIOUSLY APPROVED COLOR MENU)
- 11 PLATE AT ENTRY - 17'-1" A.F.F.
- 12 PLATE HEIGHT - 10'-1" A.F.F.
- 13 WINDOW HEADER - 8'-0" A.F.F. & 10'-8" A.F.F.



PLAN 3 (COURTYARD)

LIV. SF: 4,074
 PLAN W x D: 69'-4" X 88'-4"
 PLAN #: E2 8754
 PLAN NAME: LONDON
 FORM: ZD - EUROPEAN



RIGHT ELEVATION
 SCALE: 1/8" = 1'-0"



FRONT ELEVATION
 SCALE: 1/8" = 1'-0"

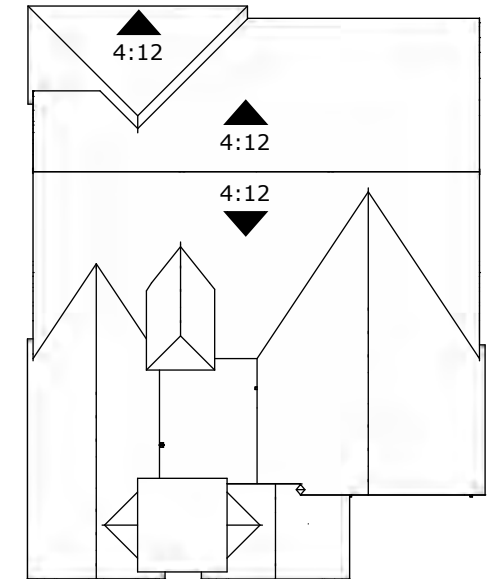

ROOF PLAN | 6:12 U.N.O.

STYLE LEGEND:

- 1 PROMINENT GABLES
- 2 CONCRETE 'FLAT' TILES
- 3 0" RAKES AND 12" EAVES
- 4 8" X 24" DECORATIVE VENT WITH 3" BRICK TRIM
- 5 DECORATIVE BRICK VENEER
- 6 SAND FINISH STUCCO
- 7 COACH LIGHTS
- 8 2" RECESS AT WINDOWS SIDES AND REARS
- 9 14" RECESS AT GARAGE DOOR
- 10 COLOR SCHEME (PER PREVIOUSLY APPROVED COLOR MENU)
- 11 PLATE AT ENTRY - 17'-1" A.F.F.
- 12 PLATE HEIGHT - 10'-1" A.F.F.
- 13 WINDOW HEADER - 8'-0" A.F.F. & 10'-8" A.F.F.



LEFT ELEVATION
 SCALE: 1/8" = 1'-0"



REAR ELEVATION
 SCALE: 1/8" = 1'-0"

PLAN 3 (OPTIONS)

LIV. SF: 4,074

PLAN W x D: 69'-4" X 88'-4"

PLAN #: E2 8754

PLAN NAME: LONDON

FORM: ALL FORMS

OPT. 9080 SGD AT STUDY



RIGHT ELEVATION - FARMHOUSE
SCALE: 1/8" = 1'-0"



RIGHT ELEVATION - CONTEMPORARY
SCALE: 1/8" = 1'-0"

PLAN 1

LIV. SF: 2,747
PLAN W x D: 79'-0" x 50'-0"
PLAN #: 7264
SCALE: 1/8" = 1'-0"
PLAN NAME: Geneva

VITAL STATS

BEDROOM	5
BATH	3.5
CAR	3
CEILING	10'
WINDOW HDR	8'

STATUS | NTL PORTFOLIO PLAN

AREA S.F. BREAKDOWN

MAX. LIVABLE (A):	2,747
(A) 1ST FLR LIVABLE:	2,747
(B) GARAGE:	
3 CAR TANDEM:	605
(C) COVERED PORCH:	
ELEVATION WA:	47
ELEVATION ZA:	117
(D) ARCH PROJECTIONS:	
ELEVATION WA:	78
ELEVATION ZA:	68
(E) COVERED PATIO:	301
MAX FOOTPRINT	3,838

TYP LOT SIZE | 65'x130' (8,450 SF)
LOT COVERAGE ALLOW | 50.0%
LOT COVERAGE | 3,838 / 8,450 = 45.4%
TYP LOT SIZE | 87'x150' (13,050 SF)
LOT COVERAGE ALLOW | 50.0%
LOT COVERAGE | 3,838 / 13,050 = 29.4%

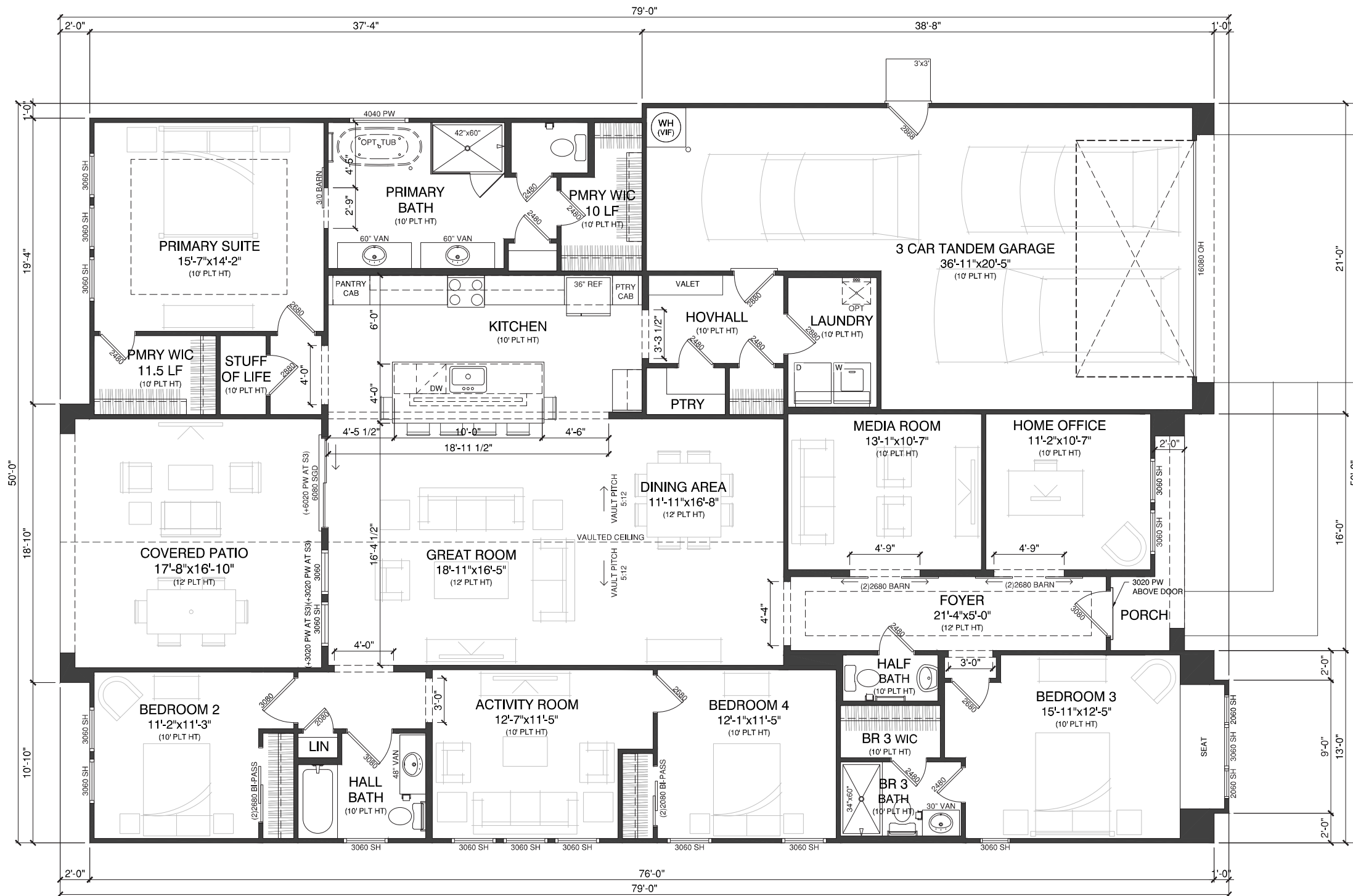
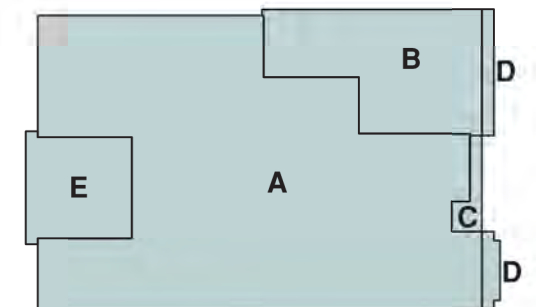

FIRST FLOOR PLAN
 WA - FARMHOUSE

PLAN 1

LIV. SF: 2,747
PLAN W x D: 80'-0" x 50'-0"
PLAN #: 7264
SCALE: 1/8" = 1'-0"
PLAN NAME: Geneva

VITAL STATS

BEDROOM	5
BATH	3.5
CAR	3
CEILING	10'
WINDOW HDR	8'

STATUS | NTL PORTFOLIO PLAN

AREA S.F. BREAKDOWN

MAX. LIVABLE (A):	2,747
(A) 1ST FLR LIVABLE:	2,747
(B) GARAGE:	
3 CAR TANDEM:	605
(C) COVERED PORCH:	
ELEVATION WA:	47
ELEVATION ZA:	117
(D) ARCH PROJECTIONS:	
ELEVATION WA:	78
ELEVATION ZA:	68
(E) COVERED PATIO:	301
MAX FOOTPRINT	3,838

TYP LOT SIZE | 65'x130' (8,450 SF)
LOT COVERAGE ALLOW | 50.0%
LOT COVERAGE | 3,838 / 8,450 = 45.4%
TYP LOT SIZE | 87'x150' (13,050 SF)
LOT COVERAGE ALLOW | 50.0%
LOT COVERAGE | 3,838 / 13,050 = 29.4%

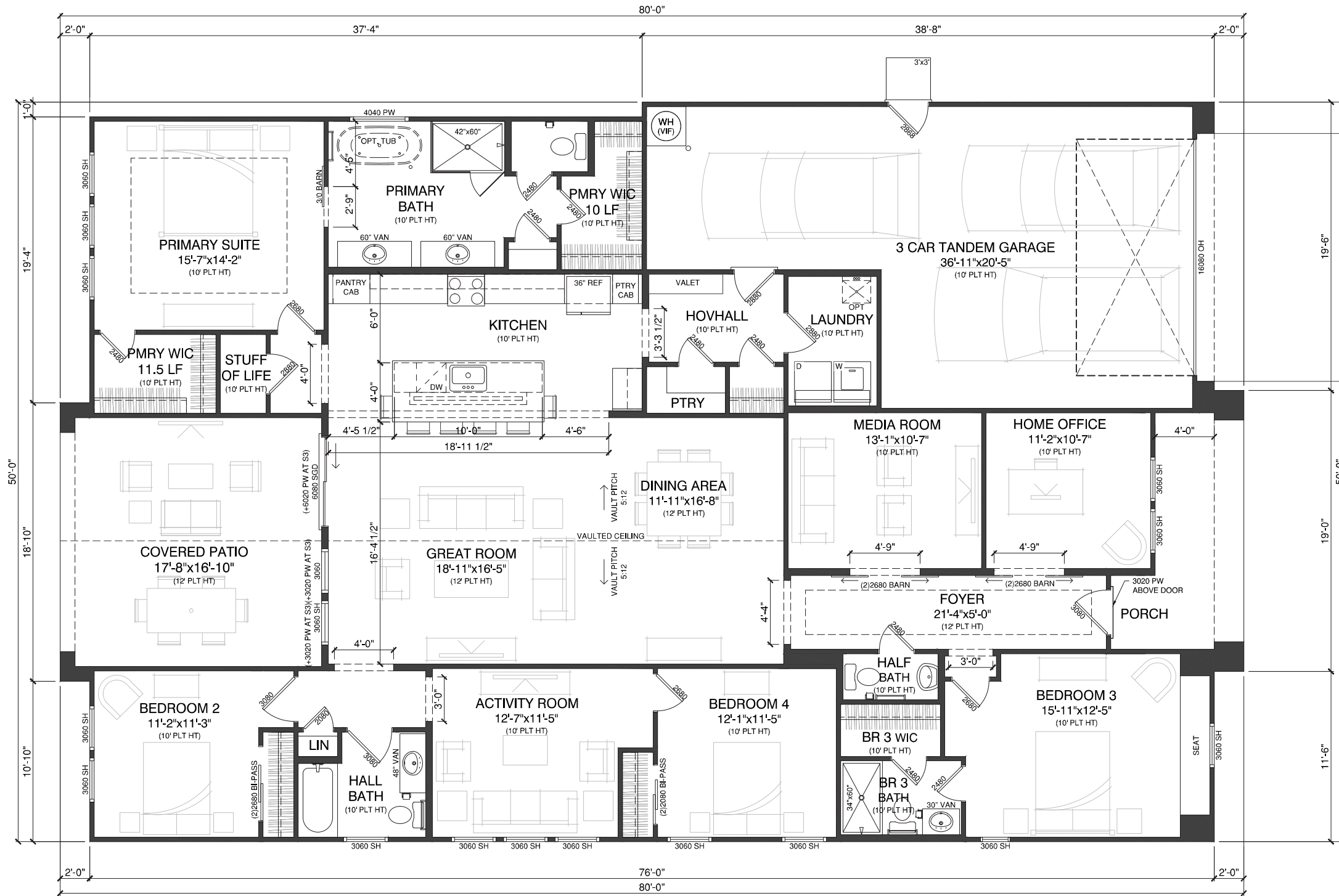
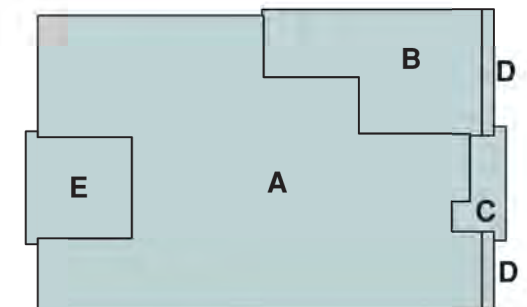

FIRST FLOOR PLAN
 ZA - EUROPEAN

PLAN 1

LIV. SF: **2,747**
 PLAN W x D: **79'-0" x 50'-0"**
 PLAN #: 7264
 SCALE: 1/8" = 1'-0"
 PLAN NAME: **Geneva**

VITAL STATS
 BEDROOM 5
 BATH 3.5
 CAR 3
 CEILING 10'
 WINDOW HDR 8'

STATUS | NTL PORTFOLIO PLAN

AREA S.F. BREAKDOWN
MAX. LIVABLE (A): 2,747
 (A) 1ST FLR LIVABLE: 2,747
 (B) GARAGE:
 3 CAR TANDEM: 605
 (C) COVERED PORCH:
 ELEVATION WA: 47
 ELEVATION ZA: 117
 (D) ARCH PROJECTIONS:
 ELEVATION WA: 78
 ELEVATION ZA: 68
 (E) COVERED PATIO: 301
MAX FOOTPRINT 3,838

TYP LOT SIZE | 65'x130' (8,450 SF)
LOT COVERAGE ALLOW | 50.0%
LOT COVERAGE | 3,838 / 8,450 = 45.4%
TYP LOT SIZE | 87'x150' (13,050 SF)
LOT COVERAGE ALLOW | 50.0%
LOT COVERAGE | 3,838 / 13,050 = 29.4%

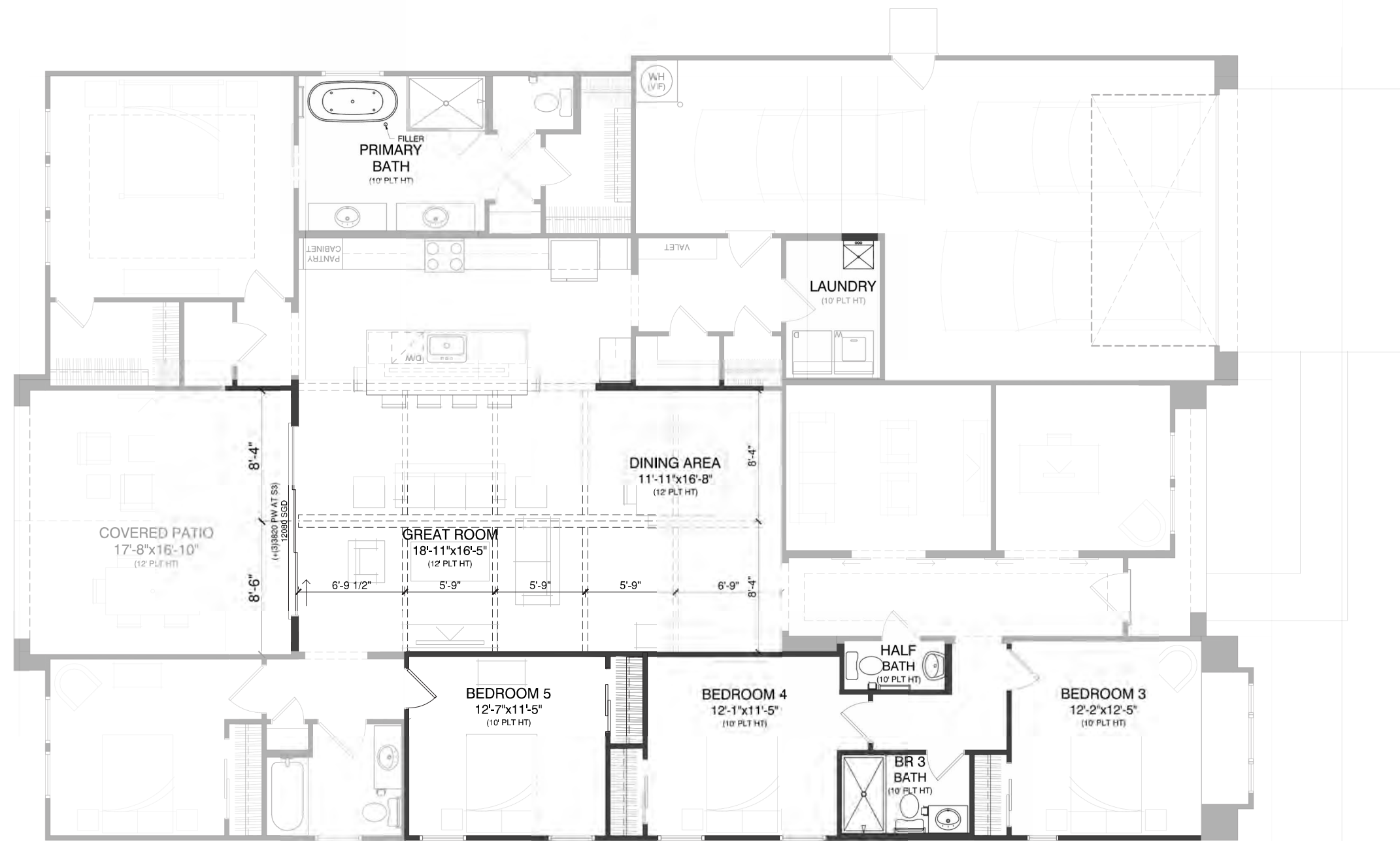

- OPTION :: CEILING BEAMS AT KITCHEN, GREAT ROOM, AND DINING AREA
- OPTION :: 12080 SGD AT GREAT ROOM
- OPTION :: FREESTANDING-TUB AT PRIMARY BATH
- OPTION :: LAUNDRY TUB AT LAUNDRY CENTER
- OPTION :: BEDROOM 5 ILO ACTIVITY ROOM

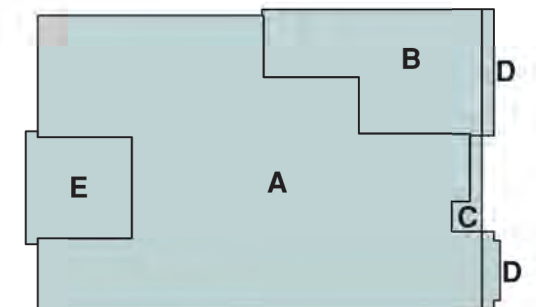

FIRST FLOOR PLAN
 WA - FARMHOUSE

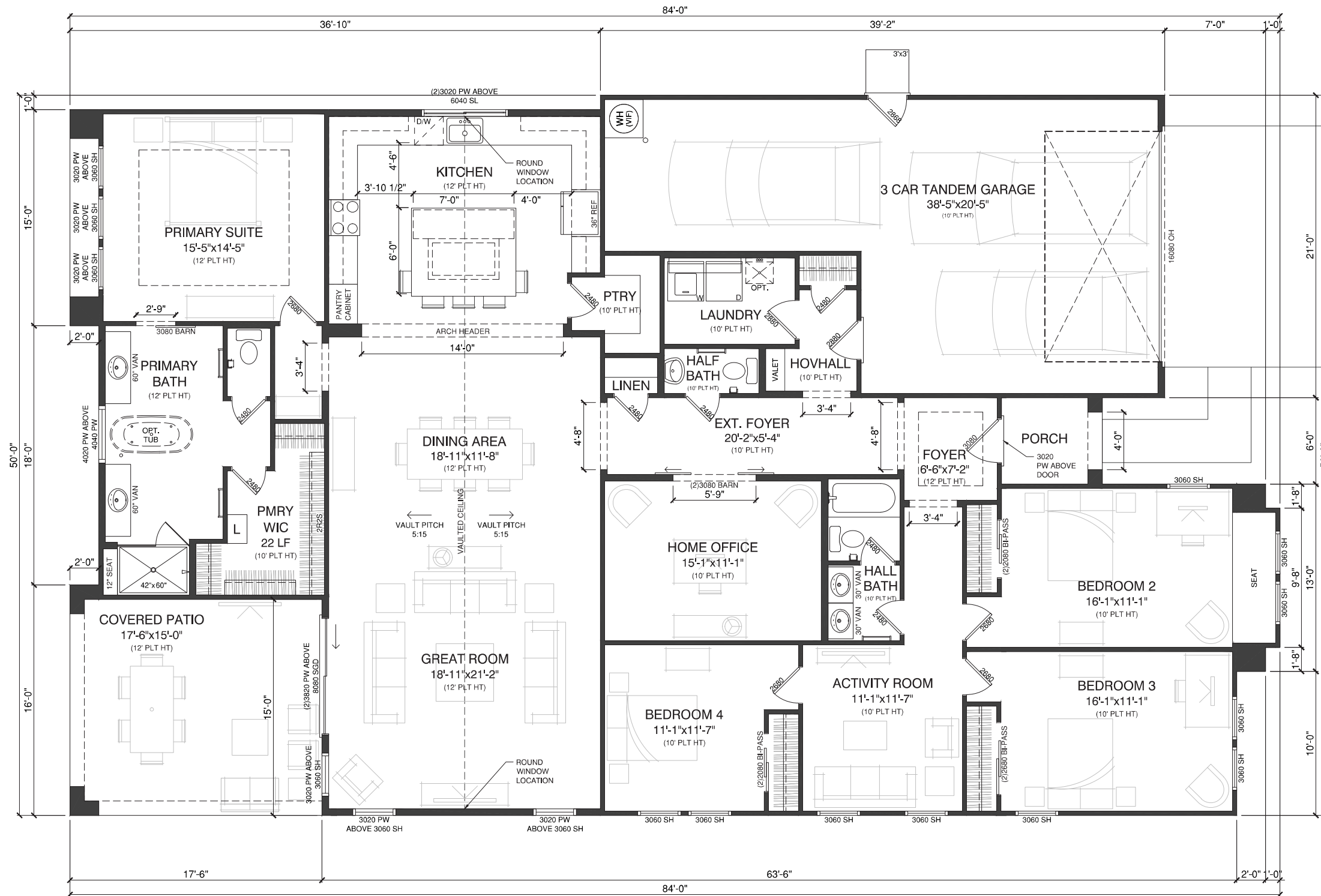

PLAN 2

LIV. SF: 2,847
PLAN W x D: 84'-0" x 50'-0"
PLAN #: 7258
SCALE: 1/8" = 1'-0"
PLAN NAME: Frankfurt

VITAL STATS

BEDROOM 4
 BATH 2.5
 CAR 3
 CEILING 10'
 WINDOW HDR 8'

STATUS | NTL PORTFOLIO PLAN

AREA S.F. BREAKDOWN

MAX. LIVABLE (A): 2,847
 (A) 1ST FLR LIVABLE: 2,732
 +5' LIVABLE: 115
 (B) GARAGE: 633
 3 CAR GARAGE: 594
 +1' EXTENSION: 39
 (C) COVERED PORCH: 42
 ELEVATION WA: 42
 ELEVATION ZA: 42
 (D) ARCH PROJECTIONS: 65
 ELEVATION WA: 55
 ELEVATION ZA: 55
 (E) COVERED PATIO: 265
 PATIO: 233
 +2' EXTENSION: 32

MAX FOOTPRINT 3,852

TYP LOT SIZE | 65'x130' (8,450 SF)
LOT COVERAGE ALLOW | 50.0%
LOT COVERAGE | 3,852 / 8,450 = 45.5%
TYP LOT SIZE | 87'x150' (13,050 SF)
LOT COVERAGE ALLOW | 50.0%
LOT COVERAGE | 3,852 / 13,050 = 29.5%

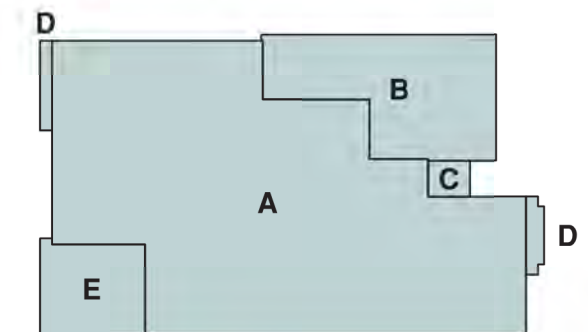

FIRST FLOOR PLAN
 WA - FARMHOUSE

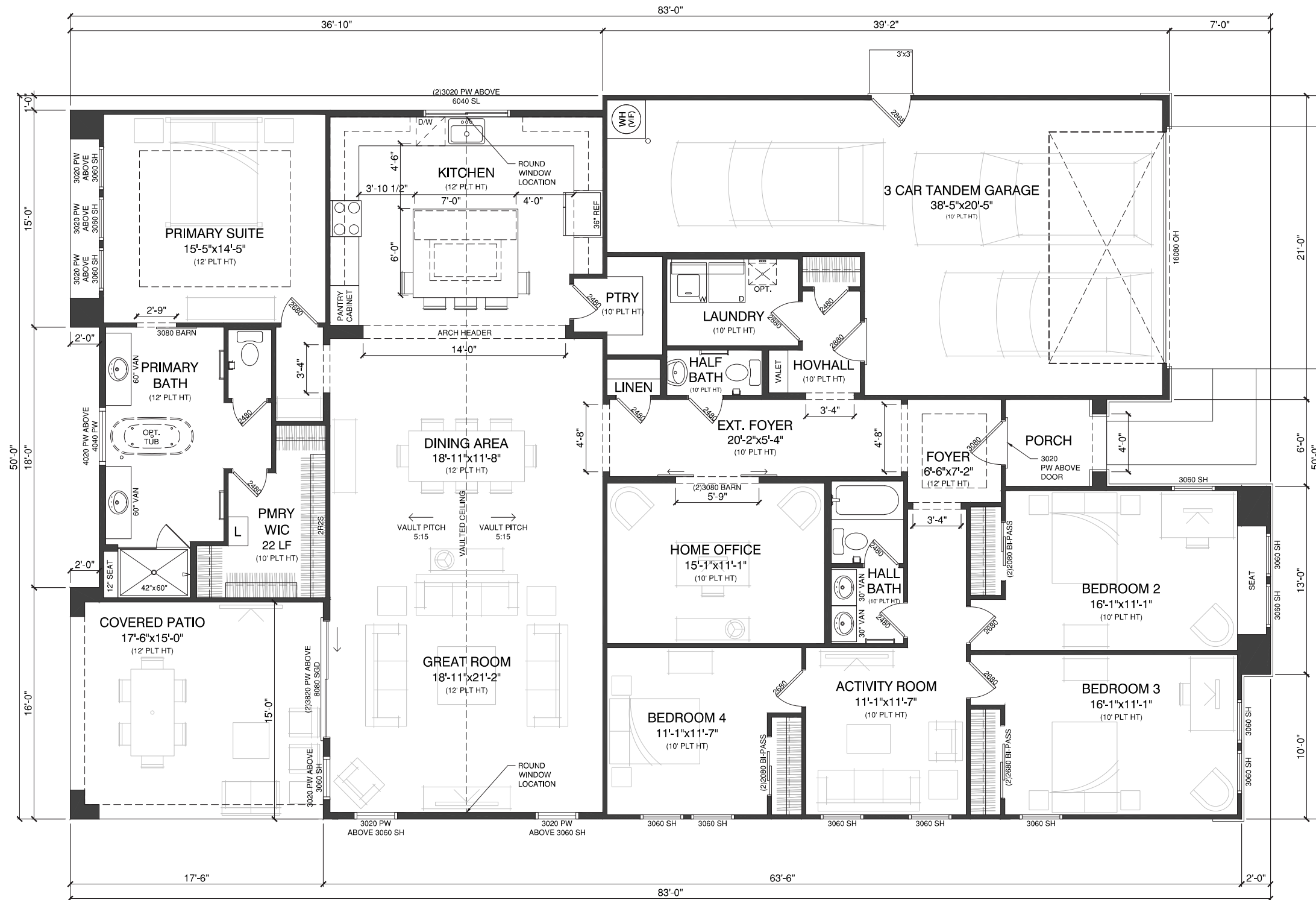

PLAN 2

LIV. SF: 2,847
PLAN W x D: 83'-0" x 50'-0"
PLAN #: 7258
SCALE: 1/8" = 1'-0"
PLAN NAME: Frankfurt

VITAL STATS

BEDROOM 4
 BATH 2.5
 CAR 3
 CEILING 10'
 WINDOW HDR 8'

STATUS | NTL PORTFOLIO PLAN

AREA S.F. BREAKDOWN

MAX. LIVABLE (A): 2,847
 (A) 1ST FLR LIVABLE: 2,732
 +5' LIVABLE: 115
 (B) GARAGE: 633
 3 CAR GARAGE: 594
 +1' EXTENSION: 39
 (C) COVERED PORCH: 42
 ELEVATION WA: 42
 ELEVATION ZA: 42
 (D) ARCH PROJECTIONS: 65
 ELEVATION WA: 55
 ELEVATION ZA: 55
 (E) COVERED PATIO: 265
 PATIO: 233
 +2' EXTENSION: 32

MAX FOOTPRINT 3,852

TYP LOT SIZE | 65'x130' (8,450 SF)
LOT COVERAGE ALLOW | 50.0%
LOT COVERAGE | 3,852 / 8,450 = 45.5%
TYP LOT SIZE | 87'x150' (13,050 SF)
LOT COVERAGE ALLOW | 50.0%
LOT COVERAGE | 3,852 / 13,050 = 29.5%

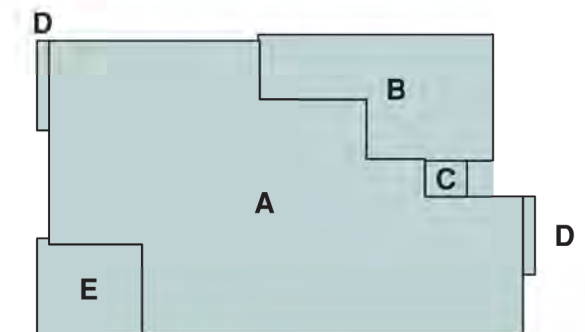

FIRST FLOOR PLAN
 ZA - EUROPEAN

PLAN 2

LIV. SF: 2,847
PLAN W x D: 92'-0" x 50'-0"
PLAN #: 7258
SCALE: 1/8" = 1'-0"
PLAN NAME: Frankfurt

VITAL STATS

BEDROOM 4
 BATH 2.5
 CAR 3
 CEILING 10'
 WINDOW HDR 8'

STATUS | NTL PORTFOLIO PLAN

AREA S.F. BREAKDOWN

MAX. LIVABLE (A): 2,847
 (A) 1ST FLR LIVABLE: 2,732
 +5' LIVABLE: 115
 (B) GARAGE: 633
 3 CAR GARAGE: 594
 +1' EXTENSION: 39
 (C) COVERED PORCH: 42
 ELEVATION WA: 42
 ELEVATION ZA: 42
 (D) ARCH PROJECTIONS: 65
 ELEVATION WA: 55
 ELEVATION ZA: 55
 (E) COVERED PATIO: 265
 PATIO: 233
 +2' EXTENSION: 32

MAX FOOTPRINT 3,852

TYP LOT SIZE | 65'x130' (8,450 SF)
LOT COVERAGE ALLOW | 50.0%
LOT COVERAGE | 3,852 /8,450 = 45.5%
TYP LOT SIZE | 87'x150' (13,050 SF)
LOT COVERAGE ALLOW | 50.0%
LOT COVERAGE | 3,852 /13,050 = 29.5%

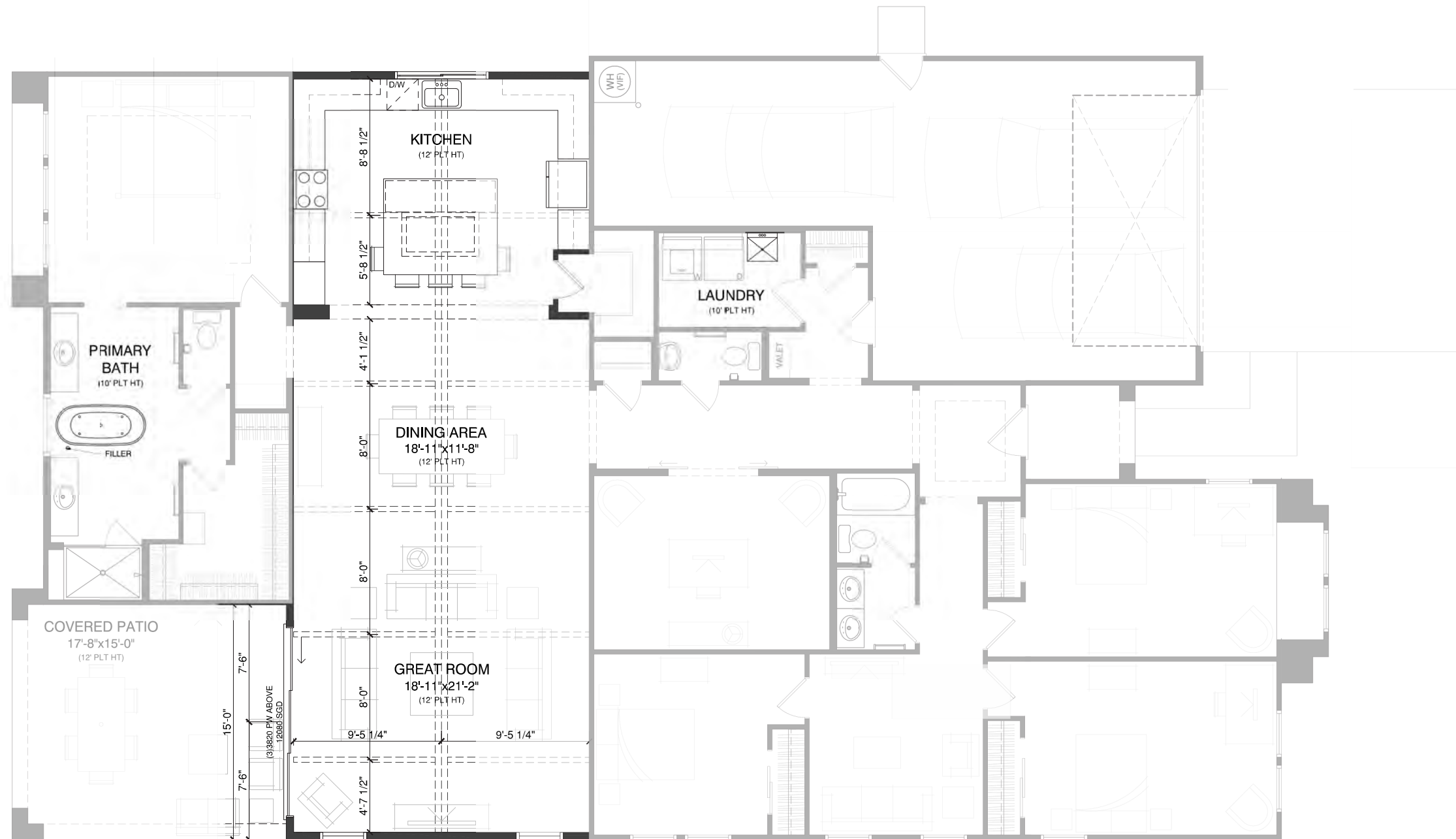
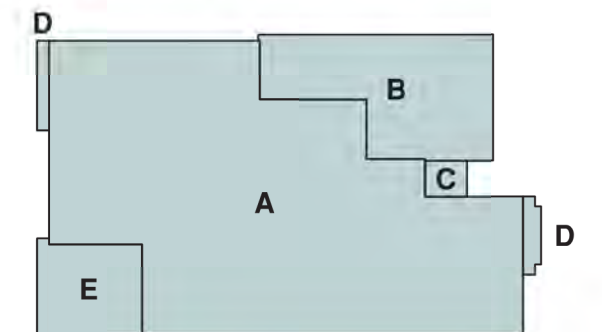

OPTION :: CEILING BEAMS AT KITCHEN, GREAT ROOM, AND DINING AREA
OPTION :: 12080 SGD AT GREAT ROOM
OPTION :: FREESTANDING-TUB AT PRIMARY BATH
OPTION :: LAUNDRY TUB AT LAUNDRY CENTER

FIRST FLOOR PLAN
 WA - FARMHOUSE

PLAN 3

LIV. SF: **4,074**
 PLAN W x D: **88'-4" x 69'-4"**
 PLAN #: 8754
 SCALE: 1/8" = 1'-0"
 PLAN NAME: **London (2x6)**

VITAL STATS
 BEDROOM 4
 BATH 4.5
 CAR 3
 CEILING 10'
 WINDOW HDR 8'

STATUS | NTL PORTFOLIO PLAN

AREA S.F. BREAKDOWN
MAX. LIVABLE (A): 4,074
 (A) 1ST FLR LIVABLE: 4,074
 (B) GARAGE: 905
 2 CAR GARAGE: 449
 1 CAR SPLIT GARAGE: 258
 (C) COVERED PORCH: 124
 ELEVATION WD: 124
 ELEVATION ZD: 124
 (D) ARCH PROJECTIONS: 102
 ELEVATION VD: 102
 ELEVATION WD: 102
 (E) COVERED PATIO: 450
 (F) COURTYARD: 301
MAX FOOTPRINT 5,757

TYP LOT SIZE | 87'x150' (13,050 SF)
LOT COVERAGE ALLOW | 50.0%
LOT COVERAGE | 5,757 / 13,050 = 44.1%

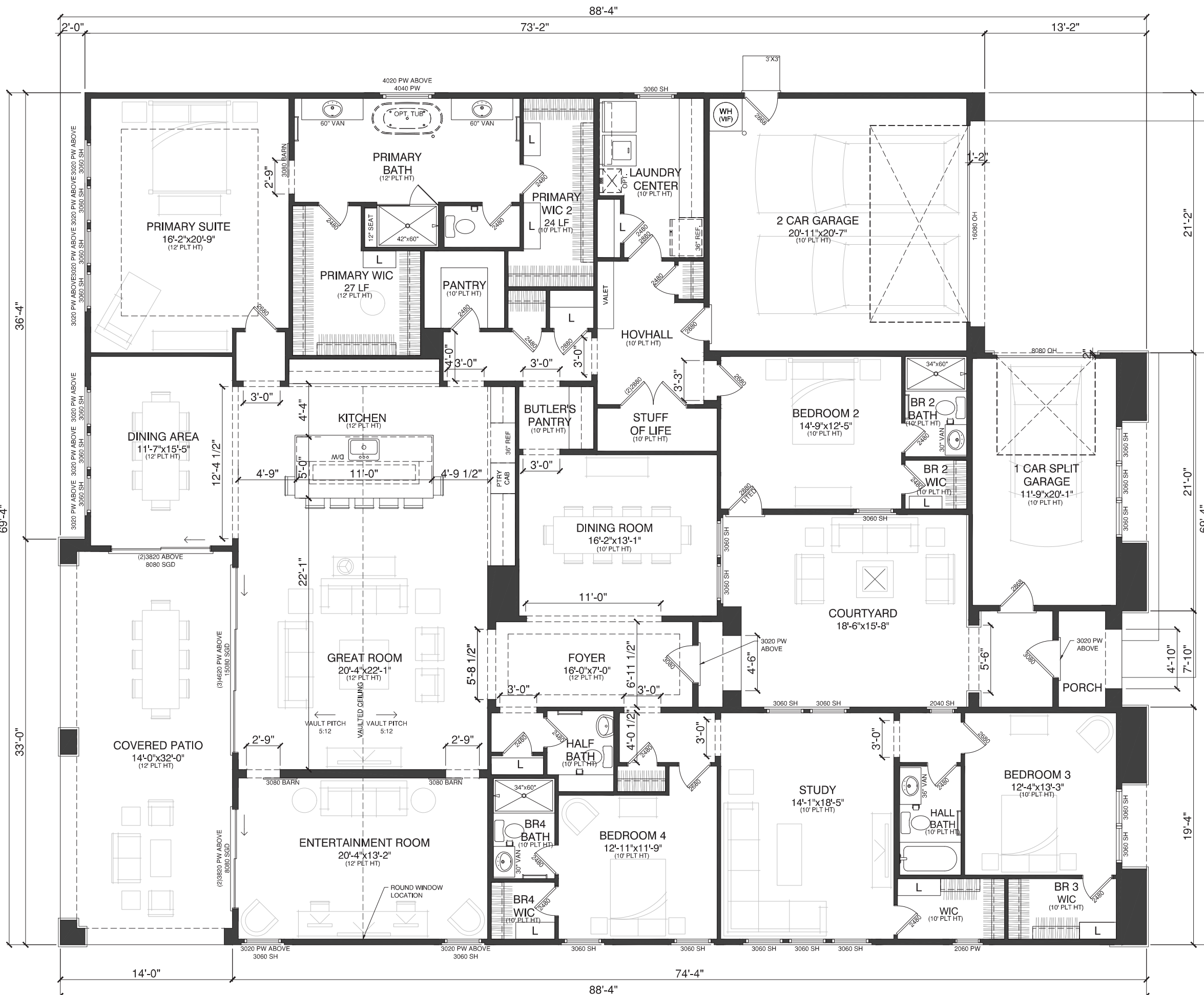
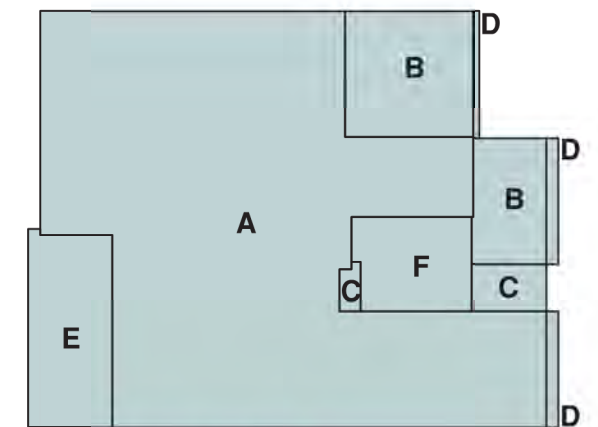

PLAN 3

LIV. SF: **4,074**
 PLAN W x D: **88'-4" x 69'-4"**
 PLAN #: 8754
 SCALE: 1/8" = 1'-0"
 PLAN NAME: **London (2x6)**

VITAL STATS
 BEDROOM 4
 BATH 4.5
 CAR 3
 CEILING 10'
 WINDOW HDR 8'

STATUS | NTL PORTFOLIO PLAN

AREA S.F. BREAKDOWN

MAX. LIVABLE (A):	4,074
(A) 1ST FLR LIVABLE:	4,074
(B) GARAGE:	905
2 CAR GARAGE:	449
1 CAR SPLIT GARAGE:	258
(C) COVERED PORCH:	
ELEVATION WD:	124
ELEVATION ZD:	124
(D) ARCH PROJECTIONS:	
ELEVATION VD:	102
ELEVATION WD:	102
(E) COVERED PATIO:	450
(F) COURTYARD:	301
MAX FOOTPRINT	5,757

TYP LOT SIZE | 87'x150' (13,050 SF)
LOT COVERAGE ALLOW | 50.0%
LOT COVERAGE | 5,757 / 13,050 = 44.1%

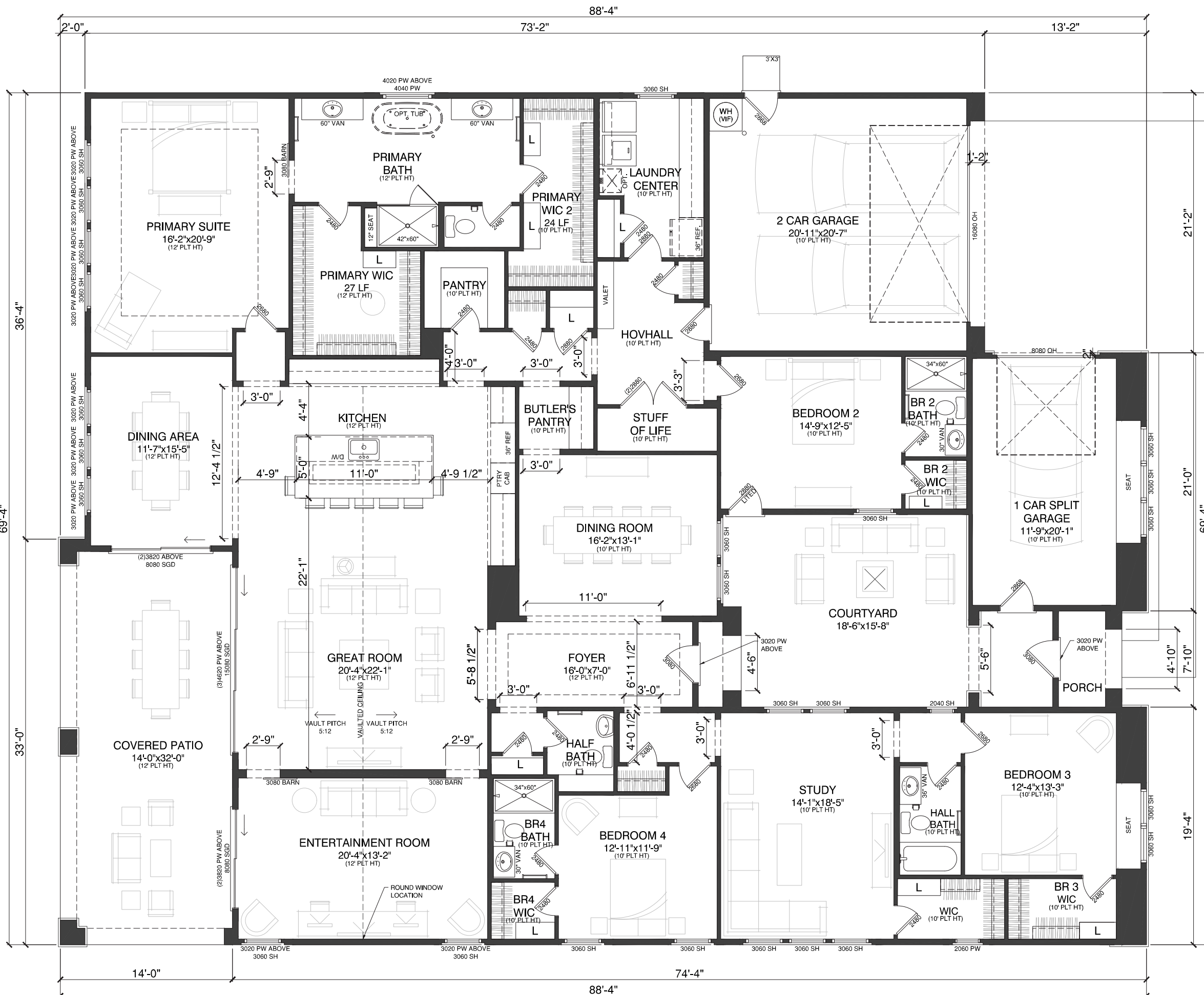
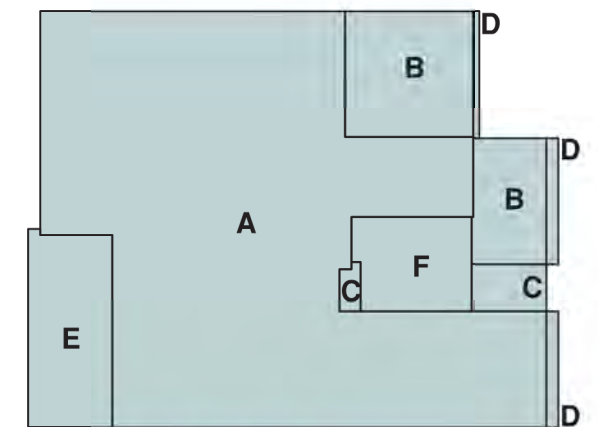

PLAN 3

LIV. SF: **4,074**
 PLAN W x D: **88'-4" x 69'-4"**
 PLAN #: 8754
 SCALE: 1/8" = 1'-0"
 PLAN NAME: **London (2x6)**

VITAL STATS

BEDROOM 4
 BATH 4.5
 CAR 3
 CEILING 10'
 WINDOW HDR 8'

STATUS | NTL PORTFOLIO PLAN

AREA S.F. BREAKDOWN

MAX. LIVABLE (A): 4,074
 (A) 1ST FLR LIVABLE: 4,074
 (B) GARAGE: 905
 2 CAR GARAGE: 449
 1 CAR SPLIT GARAGE: 258
 (C) COVERED PORCH:
 ELEVATION WD: 124
 ELEVATION ZD: 124
 (D) ARCH PROJECTIONS:
 ELEVATION VD: 102
 ELEVATION WD: 102
 (E) COVERED PATIO: 450
 (F) COURTYARD: 301

MAX FOOTPRINT 5,757

TYP LOT SIZE | 87'x150' (13,050 SF)
LOT COVERAGE ALLOW | 50.0%
LOT COVERAGE | 5,757 /13,050 = 44.1%

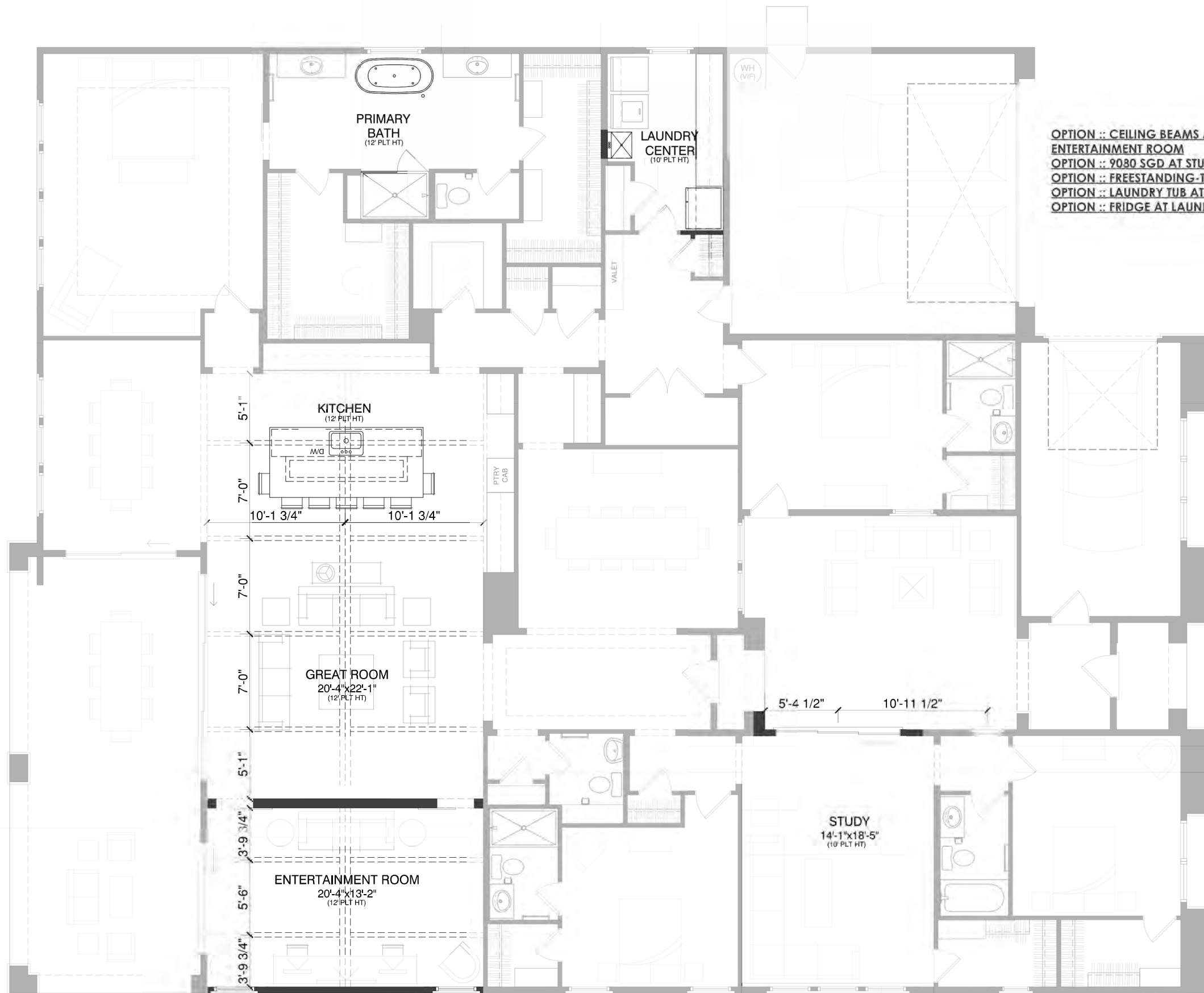
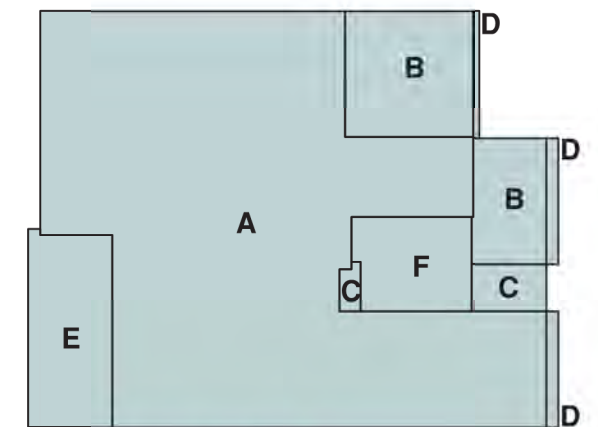

PLAN 3

LIV. SF: **4,074**
 PLAN W x D: **88'-4" x 69'-4"**
 PLAN #: 8754
 SCALE: 1/8" = 1'-0"
 PLAN NAME: **London (2x6)**

VITAL STATS

BEDROOM 4
 BATH 4.5
 CAR 3
 CEILING 10'
 WINDOW HDR 8'

STATUS | NTL PORTFOLIO PLAN

AREA S.F. BREAKDOWN

MAX. LIVABLE (A): 4,074
 (A) 1ST FLR LIVABLE: 4,074
 (B) GARAGE: 905
 2 CAR GARAGE: 449
 1 CAR SPLIT GARAGE: 258
 (C) COVERED PORCH:
 ELEVATION WD: 124
 ELEVATION ZD: 124
 (D) ARCH PROJECTIONS:
 ELEVATION VD: 102
 ELEVATION WD: 102
 (E) COVERED PATIO: 450
 (F) COURTYARD: 301

MAX FOOTPRINT 5,757

TYP LOT SIZE | 87'x150' (13,050 SF)
LOT COVERAGE ALLOW | 50.0%
LOT COVERAGE | 5,757 /13,050 = 44.1%

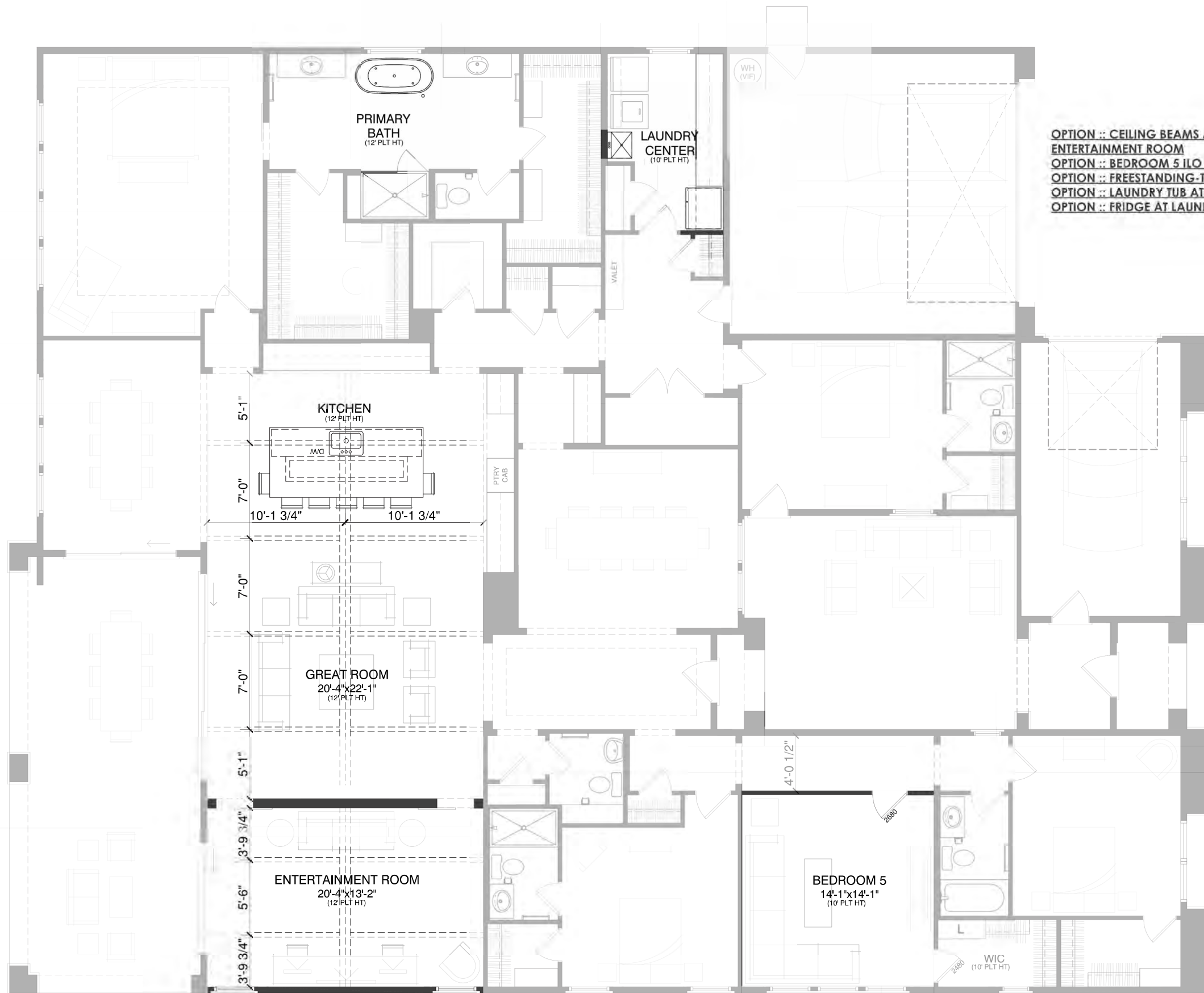
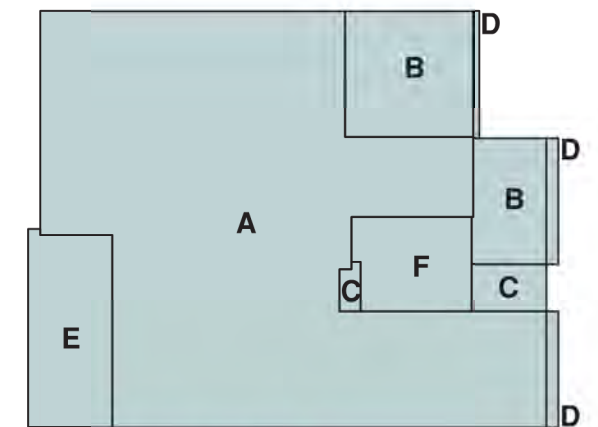

OPTION :: CEILING BEAMS AT KITCHEN, GREAT ROOM, AND ENTERTAINMENT ROOM
OPTION :: BEDROOM 5 ILO STUDY
OPTION :: FREESTANDING-TUB AT PRIMARY BATH
OPTION :: LAUNDRY TUB AT LAUNDRY CENTER
OPTION :: FRIDGE AT LAUNDRY CENTER



**Vistara
Chandler ,AZ**

WIP Date: 10/2/2025
DR Approval Date:

Rev 1: 1/31/2026
Rev 2: 2/16/2026
Rev 3: 3/16/2026

		Body		Siding		Trim	Fascia	Gar Door	Entry	Shutters	Pavers	Roof Tile	Veneer	
		LRV	LRV	LRV	LRV	LRV	LRV	LRV	LRV	LRV	LRV	LRV	LRV	
FORM Z - European	STLXXXX	9500	6073 Perfect Greige	42	NA	0	6071 Popular Gray	6071 Popular Gray	7008 Alabaster	7062 Rock Bottom	NA	Belgard_Catalina Grana_Victorian Blend	Flat_5687_Brown Grey Range	Eldorado Stone_LoreioBrick_Farola
	STLXXXX	9501	7636 Origami White	76	NA	0	7636 Origami White	7069 Iron Ore	7069 Iron Ore	6214 Underseas	NA	Belgard_Catalina Grana_Victorian Blend	Flat_5602_Concord Blend	Eldorado Stone_LoreioBrick_Farola
	STLXXXX	9502	7004 Snowbound	0	NA	0	7067 Cityscape	7067 Cityscape	7069 Iron Ore	7069 Iron Ore	NA	Belgard_Catalina Grana_Rio	Flat_5503_Sierra Madre	Eldorado Stone_LoreioBrick_Talavera
	STLXXXX	9503	7650 Ellie Gray	40	NA	0	8917 Shell White	8917 Shell White	7069 Iron Ore	7602 Indigo Batik	NA	Belgard_Catalina Grana_Sonoran Gray	Flat_5699_Charcoal Range	Eldorado Stone_LoreioBrick_Lilia
FORM W - Farmhouse	STLXXXX	9600	7042 Shoji White	74	7048 Urbane Bronze	8	7048 Urbane Bronze	7048 Urbane Bronze	6990 Caviar	6990 Caviar	6990 Caviar	Belgard_Catalina Grana_Victorian Blend	Flat_4520_Weathered Terracotta Flashed	Cultured Stone_Handmade_Moroccan Sands
	STLXXXX	9601	7064 Passive	60	7068 Grizzle Gray	0	7068 Grizzle Gray	7069 Iron Ore	7069 Iron Ore	7069 Iron Ore	7069 Iron Ore	Belgard_Catalina Grana_Rio	Flat_49503_Sierra Madre	Cultured Stone_Handmade_Carbon
	STLXXXX	9602	7030 Anew Gray	47	7069 Iron Ore	6	7032 Warm Stone	7069 Iron Ore	7069 Iron Ore	7069 Iron Ore	7069 Iron Ore	Belgard_Catalina Grana_Victorian Blend	Flat_5687_Brown Grey Range	Cultured Stone_Handmade_Titanium
	STLXXXX	9603	7004 Snowbound	0	6988 Bohemian Black	0	7018 Dovetail	6988 Bohemian Black	6988 Bohemian Black	6988 Bohemian Black	6988 Bohemian Black	Belgard_Catalina Grana_Rio	Flat_49503_Sierra Madre	Cultured Stone_Handmade_Canvas

**Vistara
Chandler ,AZ**





































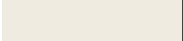

















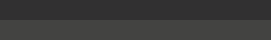
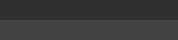











WIP Date:
10/2/2025

DR Approval Date:

Rev 1:
1/31/2026

Rev 2:
2/18/2026

Rev 3:
3/16/2026

	Body	Siding	Trim	Fascia	Gar Door	Entry	Shutters	Pavers	Roof Tile	Veneer
9500										
9501										
9502										
9503										
9600										
9601										
9602										
9603										

Z - European

Color Scheme 9500

Vistara

Body 6073 Perfect Greige 42

Entry 7062 Rock Bottom

Gar Door 7008 Alabaster

Fascia 6071 Popular Gray

Trim 6071 Popular Gray



Z - European

Color Scheme 9501

Vistara

Body 7636 Origami White 76

Entry 6214 Underseas

Gar Door 7069 Iron Ore

Fascia 7069 Iron Ore

Trim 7636 Origami White

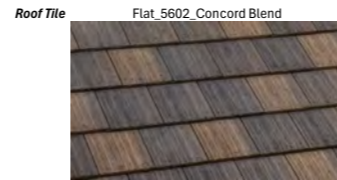

Z - European

Color Scheme 9502

Vistara

Body 7004 Snowbound 0

Entry 7069 Iron Ore

Gar Door 7069 Iron Ore

Fascia 7067 Cityscape

Trim 7067 Cityscape

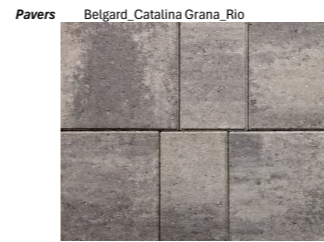

Z - European

Color Scheme 9503

Vistara

Body 7650 Ellie Gray 40

Entry 7602 Indigo Batik

Gar Door 7069 Iron Ore

Fascia 8917 Shell White

Trim 8917 Shell White

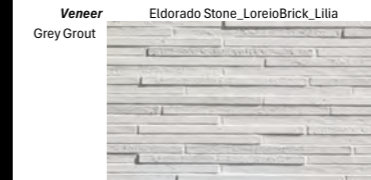

W - Farmhouse

Color Scheme 9600

Vistara

Body 7042 Shoji White 74

Entry 6990 Caviar

Gar Door 6990 Caviar

Fascia 7048 Urbane Bronze

Trim 7048 Urbane Bronze

Siding 7048 Urbane Bronze
or 2nd_Body

Shutters 6990 Caviar

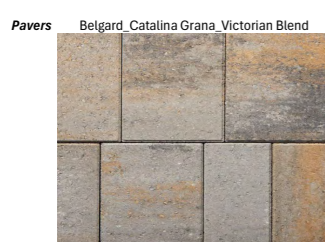

W - Farmhouse

Color Scheme 9601

Vistara

Body 7064 Passive 60

Entry 7069 Iron Ore

Gar Door 7069 Iron Ore

Fascia 7069 Iron Ore

Trim 7068 Grizzle Gray

Siding 7068 Grizzle Gray
or 2nd_Body

Shutters 7069 Iron Ore

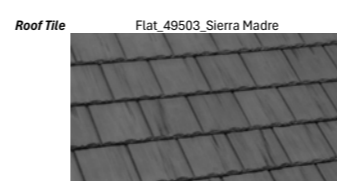

W - Farmhouse

Color Scheme 9602

Vistara

Body 7030 Anew Gray 47

Entry 7069 Iron Ore

Gar Door 7069 Iron Ore

Fascia 7069 Iron Ore

Trim 7032 Warm Stone

Siding 7069 Iron Ore
or 2nd_Body

Shutters 7069 Iron Ore

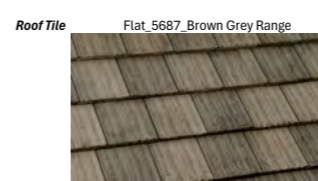
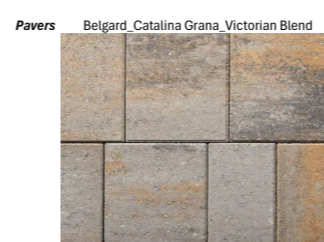

W - Farmhouse

Color Scheme 9603

Vistara

Body 7004 Snowbound

Entry 6988 Bohemian Black

Gar Door 6988 Bohemian Black

Fascia 6988 Bohemian Black

Trim 7018 Dovetail

Siding 6988 Bohemian Black
or 2nd_Body

Shutters 6988 Bohemian Black

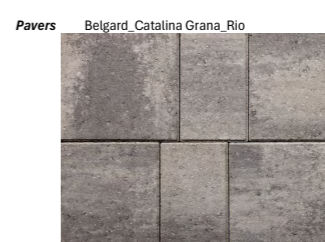

Z - European

Color Scheme 9500

Vistara

Body 6073 Perfect Greige 42

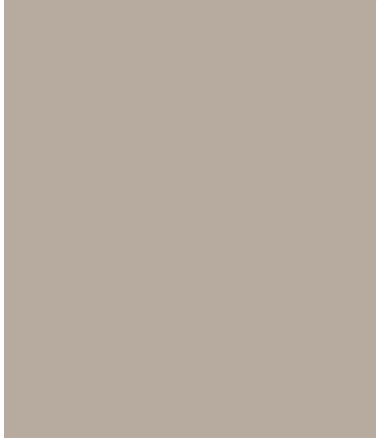

Entry 7062 Rock Bottom



Gar Door 7008 Alabaster

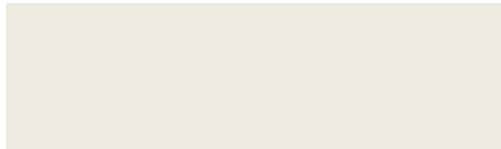

Fascia 6071 Popular Gray

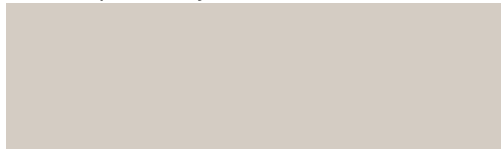

Trim 6071 Popular Gray

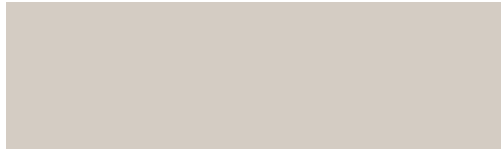

Pavers Belgard_Catalina Grana_Victorian Blend



Veneer Eldorado Stone_LoreioBrick_Farola



Roof Tile Flat_5687_Brown Grey Range



Z - European

Color Scheme **9501**

Vistara

Body 7636 Origami White 76

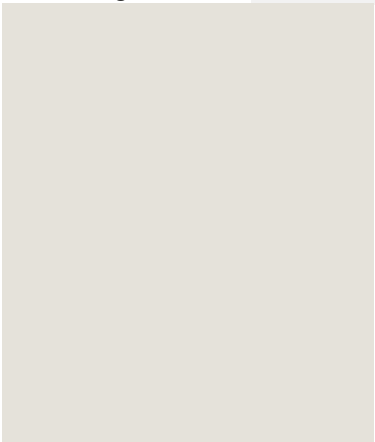

Entry 6214 Underseas



Gar Door 7069 Iron Ore



Fascia 7069 Iron Ore



Trim 7636 Origami White



Pavers Belgard_Catalina Grana_Victorian Blend



Veneer Eldorado Stone_LoreioBrick_Farola



Roof Tile Flat_5602_Concord Blend



Z - European

Color Scheme **9502**

Vistara

Body 7004 Snowbound 0

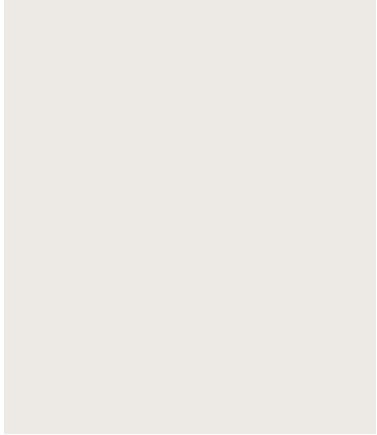

Entry 7069 Iron Ore

Gar Door 7069 Iron Ore

Fascia 7067 Cityscape

Trim 7067 Cityscape

Pavers Belgard_Catalina Grana_Rio



Veneer Eldorado Stone_LoreioBrick_Talavera



Roof Tile Flat_5503_Sierra Madre



Z - European

Color Scheme **9503**

Vistara

Body 7650 Ellie Gray 40

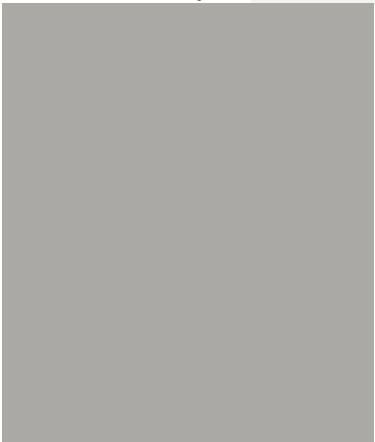

Entry 7602 Indigo Batik



Gar Door 7069 Iron Ore



Fascia 8917 Shell White



Trim 8917 Shell White

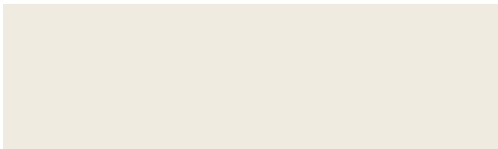

Pavers Belgard_Catalina Grana_Sonoran Gray



Veneer Eldorado Stone_LoreioBrick_Lilia



Roof Tile Flat_5699_Charcoal Range



W - Farmhouse

Color Scheme 9600

Vistara

Body 7042 Shoji White 74

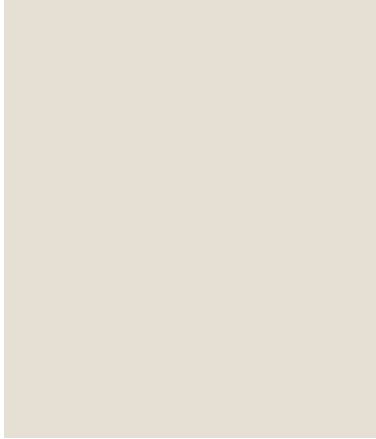

Entry 6990 Caviar

Gar Door 6990 Caviar

Fascia 7048 Urbane Bronze

Siding or 2nd_Body 7048 Urbane Bronze

Trim 7048 Urbane Bronze

Shutters 6990 Caviar

Pavers Belgard_Catalina Grana_Victorian Blend

Veneer Cultured Stone_Handmade_Moroccan Sands

Roof Tile Flat_4520_Weathered Terracotta Flashed

W - Farmhouse

Color Scheme **9601**

Vistara

Body 7064 Passive 60

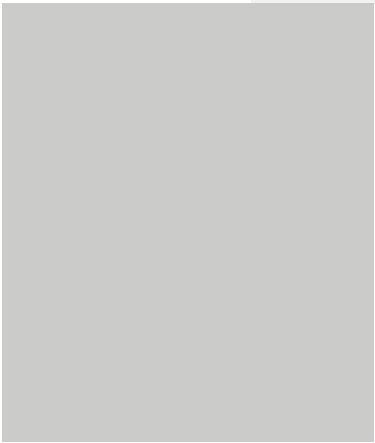

Entry 7069 Iron Ore



Gar Door 7069 Iron Ore



Fascia 7069 Iron Ore



Siding 7068 Grizzle Gray
or 2nd_Body



Trim 7068 Grizzle Gray



Pavers Belgard_Catalina Grana_Rio



Shutters 7069 Iron Ore



Veneer Cultured Stone_Handmade_Carbon



Roof Tile Flat_49503_Sierra Madre

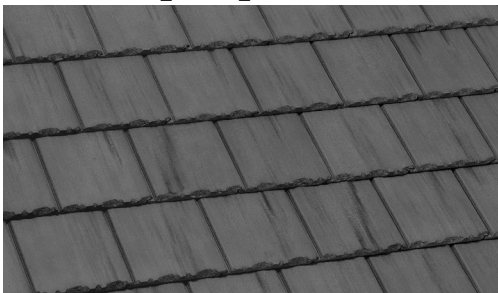

W - Farmhouse

Color Scheme **9602**

Vistara

Body 7030 Anew Gray 47

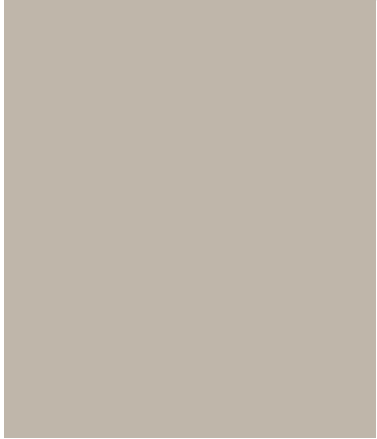

Entry 7069 Iron Ore



Gar Door 7069 Iron Ore



Fascia 7069 Iron Ore



Trim 7032 Warm Stone



Siding 7069 Iron Ore



Shutters 7069 Iron Ore



Pavers Belgard_Catalina Grana_Victorian Blend



Veneer Cultured Stone_Handmade_Titanium



Roof Tile Flat_5687_Brown Grey Range



W - Farmhouse

Color Scheme 9603

Vistara

Body 7004 Snowbound 0

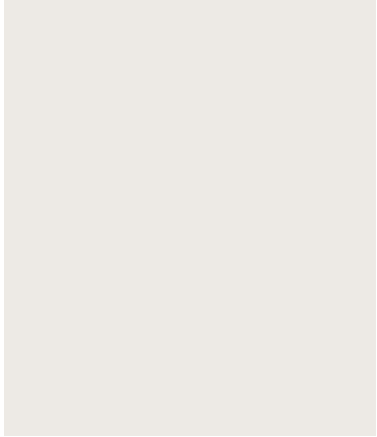

Entry 6988 Bohemian Black

Gar Door 6988 Bohemian Black

Fascia 6988 Bohemian Black

Siding 6988 Bohemian Black
or 2nd_Body

Trim 7018 Dovetail

Pavers Belgard_Catalina Grana_Rio

Shutters 6988 Bohemian Black

Veneer Cultured Stone_Handmade_Canvas

Roof Tile Flat_49503_Sierra Madre