



CITY COUNCIL MEETING

520 Jackson Avenue

August 1, 2023 – 6:30 pm

AGENDA

CALL TO ORDER

ROLL CALL

READING AGENDA – ADDITIONS/DELETIONS

AUTHORIZATION TO PARTICIPATE IN MEETING VIA REMOTE ACCESS

CONSENT AGENDA – ITEMS DESIGNATED BY (*)

Illinois local governments may adopt by a single roll call vote ordinances, resolutions, motions and orders. Any Council Member or the Mayor may request that any item proposed not be included in that vote but considered separately.

APPROVAL OF MINUTES:

- 1) ***MINUTES:** Regular City Council Meeting for July 18, 2023.

AUDITING CLAIMS:

- 2) ***PAYROLL:** Regular Pay Period ending July 15, 2023.
- 3) ***BILLS PAYABLE:** August 4, 2023.

ACTION ITEMS:

- 4) ***PROCLAMATION:** Recognizing September 10-16, 2023, as Chamber of Commerce Week.
- 5) ***RESOLUTION:** Authorizing Street Closure of the south 200 Feet of the Alley to the east of Ike's for Back to School Events on August 12, 19, and 26, 2023.
- 6) ***RESOLUTION:** Authorizing Street Closures on the Square for the Magic & Music Event for the Uptowner/Cellar on August 12, 2023.
- 7) **RESOLUTION:** Approving Change Order No. 8 for Wastewater Treatment Plant Nutrient Removal Project.
- 8) **RESOLUTION:** Approving Bid for New Ambulance through Houston Galveston Area Council Purchasing Group.
- 9) **ORDINANCE:** Amending Title 3-3-12: Number of Licenses.

PUBLIC PRESENTATIONS, PETITIONS & COMMUNICATIONS:

This portion of the City Council meeting is reserved for anyone wishing to address Council. The Illinois Open Meetings Act (5 ILCS 120/1) mandates NO action shall be taken on matters not listed on this agenda, but Council may direct staff to address the topic or refer the matter for action on a subsequent agenda. Please provide City Clerk with name & address; speak into microphone; limit presentation to 3 minutes; and avoid repetitious comments. Thank you.

EXECUTIVE SESSION:

ADJOURNMENT

City Council Regular Meeting

1)

Meeting Date: 08/01/2023

Submitted By: Deborah Muller, City Clerk

TITLE:

***MINUTES:** Regular City Council Meeting for July 18, 2023.

STAFF RECOMMENDATION:

Approve.

Attachments

CC Minutes: 07/18/2023.

City of Charleston
Regular City Council Meeting
MINUTES
July 18, 2023

State of Illinois
County of Coles
City of Charleston } ss.

The Council of the City of Charleston, Coles County, Illinois, met for the regular session at 6:30 p.m. on Tuesday, July 18, 2023, at 520 Jackson Avenue, Charleston, Illinois, with Mayor *Pro Tem* Dennis Malak presiding. Mayor *Pro Tem* Malak called the meeting to order at 6:31 p.m. The Mayor *Pro Tem* directed the City Clerk to call the roll and the following were physically present and answered affirmatively to the call of his or her name: Councilmen Jeff Lahr and Tim Newell; and Mayor *Pro Tem* Dennis Malak. Other City Officers physically present were: Deputy City Manager/City Planner Steve Pamperin; Deputy City Manager/Comptroller Heather Kuykendall; City Clerk Deborah Muller; City Attorney Rachael Cunningham; Public Works Director Curt Buescher; Fire Chief Steve Bennett; and Police Chief Heath Thornton.

Mayor *Pro Tem* Malak welcomed everyone and then led the audience in the Pledge of Allegiance.

Mayor *Pro Tem* Malak then introduced and thoroughly reviewed the **CONSENT AGENDA**, which consisted of the following items: **1) MINUTES**—Regular and Executive City Council Meetings for July 5, 2023; **2) PAYROLL**—Regular Pay Period ending on July 1, 2023; **3) BILLS PAYABLE**—July 21, 2023; **4) COMPTROLLER’S REPORT**—June 2023; **5) RAFFLE LICENSE**—Mattoon FFA Alumni on August 1, 2023, at 7:00 p.m. during the Tractor Pull at the Coles County Fairgrounds to raise funds for the Mattoon FFA Chapter; **6) PROCLAMATION**—Recognizing the Week of August 6, 2023, through August 12, 2023, as National Farmers Market Week; **7) RESOLUTION**—Authorizing the Release of Closed Session Meeting Minutes; and **8) RESOLUTION**—Authorizing the Destruction of Audio or Video Recordings of Closed Session Meetings.

A **motion** was made by Council Member Lahr and seconded by Council Member Newell that the Consent Agenda be approved as presented. Mayor *Pro Tem* Malak directed the City Clerk to call the roll and the following voted Yea: Council Members Lahr, Newell, and Mayor *Pro Tem* Malak. Mayor *Pro Tem* Malak declared the motion carried by a vote of 3 Yeas, Nays—0.

ITEM 9: RESOLUTION: A **motion** was made by Council Member Newell and seconded by Council Member Lahr that the Resolution approving a Street Closure of the Alley adjacent to Ike’s at 459 Lincoln Avenue for Class Reunions taking place on July 15, July 21, July 22, and July 29, 2023, be approved, and the layover period waived.

Mayor *Pro Tem* Malak directed the City Clerk to call the roll and the following voted Yea: Council Members Lahr, Newell, and Mayor *Pro Tem* Malak. Mayor *Pro Tem* Malak declared the motion carried by a vote of 3 Yeas, Nays—0.

Mayor *Pro Tem* Malak said that this concluded the Agenda items. He then opened the floor to any public comments, communications, petitions, and presentations.

No comments were forthcoming.

The Mayor *Pro Tem* asked City Attorney Rachael Cunningham if she had any comments. She did not.

Mayor *Pro Tem* Malak asked DCMs Pamperin and Kuykendall if they had any comments; they did not.

The Mayor *Pro Tem* asked if there were any comments from Council. There were not.

Mayor *Pro Tem* Malak having confirmed that neither he nor City Clerk Muller had received any communications via telephone or email, said that he would entertain a motion to adjourn.

A motion was made by Council Member Lahr and seconded by Council Member Newell to adjourn.

Mayor *Pro Tem* Malak directed the City Clerk to call the roll and the following voted Yea: Council Members Lahr, Newell, and Mayor *Pro Tem* Malak. Mayor *Pro Tem* Malak declared the motion carried by a vote of 3 Yeas, Nays—0.

Adjournment: 6:34 p.m.

Minutes approved this 1st Day of August 2023.

Dennis Malak, Mayor *Pro Tem*

ATTEST:

Deborah Muller, City Clerk

City Council Regular Meeting

2)

Meeting Date: 08/01/2023

Submitted For: Heather Kuykendall, Comptroller

Submitted By: Deborah Muller, City Clerk

TITLE:

***PAYROLL:** Regular Pay Period ending July 15, 2023.

STAFF RECOMMENDATION:

Approve.

Attachments

Payroll: 07/15/2023.

Pay Period Ending:

7/15/2023

| | | |
|----------|------------------------------------|----------------------|
| 1 | GENERAL FUND | |
| | A. General Administration | 77,937.33 |
| | B. Building and Development | 26,972.89 |
| | C. Tourism | 3,781.29 |
| | D. Parks & Maintenance | 35,463.57 |
| | E. Police | 236,789.57 |
| | F. Fire | 231,612.89 |
| | G. Street | 41,667.84 |
| | H. City Garage | 4,317.85 |
| | I. Contingencies | - |
| | TOTAL GENERAL FUND: | \$ 658,543.23 |
| 2 | PLAYGROUND & RECREATION | 49,436.19 |
| 3 | LIBRARY | 9,359.67 |
| 4 | WATER AND SEWER FUND | |
| | A. Water Billing Department | 21,326.43 |
| | B. Utility Department | 55,348.94 |
| | C. Water Treatment Plant | 40,373.53 |
| | D. Waste Water Treatment Plant | 23,899.39 |
| | E. City Garage | 7,203.33 |
| | TOTAL WATER AND SEWER FUND: | \$ 148,151.62 |
| 5 | MOTOR FUEL TAX | 3,332.92 |
| 6 | EMPLOYEE BENEFITS | 5,542.29 |
| | TOTAL GROSS PAYROLL | \$ 874,365.92 |

City Council Regular Meeting

3)

Meeting Date: 08/01/2023

Submitted For: Heather Kuykendall, Comptroller

Submitted By: Deborah Muller, City Clerk

TITLE:

***BILLS PAYABLE:** August 4, 2023.

STAFF RECOMMENDATION:

Approve.

Attachments

Bills Payable: 08/04/2023.



Accounts Payable Invoice Report - Council

08/01/2023

Invoice Due Date Range 07/22/23 - 08/04/23

Report By Vendor - Invoice

| Invoice Number | Invoice Description | Status | Held Reason | Invoice Date | Due Date | G/L Date | Received Date | Payment Date | Invoice Net Amount |
|---|---|--------|-------------|-----------------|------------|---|---------------------|-----------------------------------|------------------------|
| Vendor 1033 - ACE HARDWARE 651 - NIEMANN FOODS, INC. | | | | | | | | | |
| 463085/6 | Concession building materials/ENG | Open | | 07/13/2023 | 08/04/2023 | 07/13/2023 | | | 153.65 |
| <i>P.O. Number</i> | <i>Item Description</i> | | | <i>Quantity</i> | <i>U/M</i> | <i>Amount/Unit</i> | <i>Total Amount</i> | <i>Vendor Catalog Part Number</i> | <i>Contract Number</i> |
| | Capital Improvement projects - Concession building materials/ENG | | | 1.0000 | EA | 153.6500 | 153.65 | | |
| | <i>G/L Account</i> | | | | | <i>Project</i> | | <i>Amount</i> | |
| | 11-4095-4106 (General Fund-Engineering Department-Capital improvement projects) | | | | | PW 20 26 020 (Community Drive Concession Building) | | 153.65 | |
| | | | | Invoice Items | | 1 | | | |
| 463102/6 | Maintenance building materials/ENG | Open | | 07/13/2023 | 08/04/2023 | 07/13/2023 | | | 12.63 |
| <i>P.O. Number</i> | <i>Item Description</i> | | | <i>Quantity</i> | <i>U/M</i> | <i>Amount/Unit</i> | <i>Total Amount</i> | <i>Vendor Catalog Part Number</i> | <i>Contract Number</i> |
| | Capital Improvement projects - Maintenance building materials/ENG | | | 1.0000 | EA | 12.6300 | 12.63 | | |
| | <i>G/L Account</i> | | | | | <i>Project</i> | | <i>Amount</i> | |
| | 11-4095-4106 (General Fund-Engineering Department-Capital improvement projects) | | | | | PW 20 26 019 (Community Drive Maintenance Building) | | 12.63 | |
| | | | | Invoice Items | | 1 | | | |
| 463238/6 | Maintenance building materials/ENG | Open | | 07/17/2023 | 08/04/2023 | 07/17/2023 | | | 21.61 |
| <i>P.O. Number</i> | <i>Item Description</i> | | | <i>Quantity</i> | <i>U/M</i> | <i>Amount/Unit</i> | <i>Total Amount</i> | <i>Vendor Catalog Part Number</i> | <i>Contract Number</i> |
| | Capital Improvement projects - Maintenance building materials/ENG | | | 1.0000 | EA | 21.6100 | 21.61 | | |
| | <i>G/L Account</i> | | | | | <i>Project</i> | | <i>Amount</i> | |
| | 11-4095-4106 (General Fund-Engineering Department-Capital improvement projects) | | | | | PW 20 26 019 (Community Drive Maintenance Building) | | 21.61 | |
| | | | | Invoice Items | | 1 | | | |
| 458936/6 | Pliers/UTILITY | Open | | 04/20/2023 | 08/04/2023 | 04/20/2023 | | | 11.99 |
| <i>P.O. Number</i> | <i>Item Description</i> | | | <i>Quantity</i> | <i>U/M</i> | <i>Amount/Unit</i> | <i>Total Amount</i> | <i>Vendor Catalog Part Number</i> | <i>Contract Number</i> |
| | 1/4 page full color ad/tourism - Pliers/UTILITY | | | 1.0000 | EA | 11.9900 | 11.99 | | |
| | <i>G/L Account</i> | | | | | <i>Project</i> | | <i>Amount</i> | |
| | 61-4610-2801 (Water and Sewer Fund-Utility Department-Hand tools) | | | | | | | 11.99 | |
| | | | | Invoice Items | | 1 | | | |
| 460691/6 | Duct Tape/UTILITY | Open | | 05/25/2023 | 08/04/2023 | 05/25/2023 | | | 12.99 |
| <i>P.O. Number</i> | <i>Item Description</i> | | | <i>Quantity</i> | <i>U/M</i> | <i>Amount/Unit</i> | <i>Total Amount</i> | <i>Vendor Catalog Part Number</i> | <i>Contract Number</i> |
| | 1/4 page full color ad/tourism - Duct Tape/UTILITY | | | 1.0000 | EA | 12.9900 | 12.99 | | |
| | <i>G/L Account</i> | | | | | <i>Project</i> | | <i>Amount</i> | |
| | 61-4610-2699 (Water and Sewer Fund-Utility Department-Other building materials) | | | | | | | 12.99 | |
| | | | | Invoice Items | | 1 | | | |



Accounts Payable Invoice Report - Council

08/01/2023

Invoice Due Date Range 07/22/23 - 08/04/23

Report By Vendor - Invoice

| Invoice Number | Invoice Description | Status | Held Reason | Invoice Date | Due Date | G/L Date | Received Date | Payment Date | Invoice Net Amount |
|--------------------|---|--------|-----------------|---------------|---|---------------------|-----------------------------------|------------------------|--------------------|
| 462941/6 | Plugs/STREET | Open | | 07/10/2023 | 08/04/2023 | 07/10/2023 | | | 20.97 |
| <i>P.O. Number</i> | <i>Item Description</i> | | <i>Quantity</i> | <i>U/M</i> | <i>Amount/Unit</i> | <i>Total Amount</i> | <i>Vendor Catalog Part Number</i> | <i>Contract Number</i> | |
| | 1/4 page full color ad/tourism - Plugs/STREET | | 1.0000 | EA | 20.9700 | 20.97 | | | |
| | <i>G/L Account</i> | | | | <i>Project</i> | | <i>Amount</i> | | |
| | 11-4310-2401 (General Fund-Street Department-Vehicle parts & supplies) | | | | 6315 (2014 Case Loader backhoe NDC586315) | | 20.97 | | |
| | | | | Invoice Items | 1 | | | | |
| 461281/6 | Plants - MAINT | Open | | 06/07/2023 | 08/04/2023 | 06/07/2023 | | | 333.90 |
| <i>P.O. Number</i> | <i>Item Description</i> | | <i>Quantity</i> | <i>U/M</i> | <i>Amount/Unit</i> | <i>Total Amount</i> | <i>Vendor Catalog Part Number</i> | <i>Contract Number</i> | |
| | Park maintenance materials - Plants - MAINT | | 1.0000 | EA | 333.9000 | 333.90 | | | |
| | <i>G/L Account</i> | | | | <i>Project</i> | | <i>Amount</i> | | |
| | 11-4194-2513 (General Fund-Parks & Maintenance Department-Park maintenance materials) | | | | | | 333.90 | | |
| | | | | Invoice Items | 1 | | | | |
| 463241/6 | Gauges - MAINT | Open | | 07/17/2023 | 08/04/2023 | 07/17/2023 | | | 18.99 |
| <i>P.O. Number</i> | <i>Item Description</i> | | <i>Quantity</i> | <i>U/M</i> | <i>Amount/Unit</i> | <i>Total Amount</i> | <i>Vendor Catalog Part Number</i> | <i>Contract Number</i> | |
| | Park maintenance materials - Gauges - MAINT | | 1.0000 | EA | 18.9900 | 18.99 | | | |
| | <i>G/L Account</i> | | | | <i>Project</i> | | <i>Amount</i> | | |
| | 11-4194-2513 (General Fund-Parks & Maintenance Department-Park maintenance materials) | | | | | | 18.99 | | |
| | | | | Invoice Items | 1 | | | | |
| 463667/6 | Paint - MAINT | Open | | 07/24/2023 | 08/04/2023 | 07/24/2023 | | | 31.99 |
| <i>P.O. Number</i> | <i>Item Description</i> | | <i>Quantity</i> | <i>U/M</i> | <i>Amount/Unit</i> | <i>Total Amount</i> | <i>Vendor Catalog Part Number</i> | <i>Contract Number</i> | |
| | Park maintenance materials - Paint - MAINT | | 1.0000 | EA | 31.9900 | 31.99 | | | |
| | <i>G/L Account</i> | | | | <i>Project</i> | | <i>Amount</i> | | |
| | 11-4194-2513 (General Fund-Parks & Maintenance Department-Park maintenance materials) | | | | | | 31.99 | | |
| | | | | Invoice Items | 1 | | | | |
| 463749/6 | Cleaners and gloves - MAINT | Open | | 07/25/2023 | 08/04/2023 | 07/25/2023 | | | 59.83 |
| <i>P.O. Number</i> | <i>Item Description</i> | | <i>Quantity</i> | <i>U/M</i> | <i>Amount/Unit</i> | <i>Total Amount</i> | <i>Vendor Catalog Part Number</i> | <i>Contract Number</i> | |
| | Janitorial & cleaning supplies - Cleaners and gloves - MAINT | | 1.0000 | EA | 59.8300 | 59.83 | | | |
| | <i>G/L Account</i> | | | | <i>Project</i> | | <i>Amount</i> | | |
| | 11-4194-2301 (General Fund-Parks & Maintenance Department-Janitorial & cleaning supplies) | | | | | | 59.83 | | |
| | | | | Invoice Items | 1 | | | | |



Accounts Payable Invoice Report - Council

08/01/2023

Invoice Due Date Range 07/22/23 - 08/04/23

Report By Vendor - Invoice

| Invoice Number | Invoice Description | Status | Held Reason | Invoice Date | Due Date | G/L Date | Received Date | Payment Date | Invoice Net Amount |
|--------------------|--|--------|-----------------|---------------|----------------------------|---------------------|-----------------------------------|------------------------|--------------------|
| 463551/6 | anchors for pictures/FD | Open | | 07/21/2023 | 07/26/2023 | 07/21/2023 | | | 22.99 |
| <i>P.O. Number</i> | <i>Item Description</i> | | <i>Quantity</i> | <i>U/M</i> | <i>Amount/Unit</i> | <i>Total Amount</i> | <i>Vendor Catalog Part Number</i> | <i>Contract Number</i> | |
| | Other building materials - anchors for pictures/FD | | 1.0000 | EA | 22.9900 | 22.99 | | | |
| | <i>G/L Account</i> | | | | <i>Project</i> | | | <i>Amount</i> | |
| | 11-4221-2699 (General Fund-Fire Department-Other building materials) | | | | | | | 22.99 | |
| | | | | Invoice Items | 1 | | | | |
| 463098/6 | WP Misc Supplies - Pipe, Fittings, etc | Open | | 07/13/2023 | 08/04/2023 | 07/13/2023 | | | 11.98 |
| <i>P.O. Number</i> | <i>Item Description</i> | | <i>Quantity</i> | <i>U/M</i> | <i>Amount/Unit</i> | <i>Total Amount</i> | <i>Vendor Catalog Part Number</i> | <i>Contract Number</i> | |
| | Pipe and fittings for chem feed changes to existing plant/wtp - WP Misc Supplies - Pipe, Fittings, etc | | 1.0000 | EA | 11.9800 | 11.98 | | | |
| | <i>G/L Account</i> | | | | <i>Project</i> | | | <i>Amount</i> | |
| | 61-4611-2310 (Water and Sewer Fund-Water Treatment Plant-Other maintenance supplies) | | | | | | | 11.98 | |
| | | | | Invoice Items | 1 | | | | |
| 463180/6 | WP Hand Tools | Open | | 07/14/2023 | 08/04/2023 | 07/14/2023 | | | 31.98 |
| <i>P.O. Number</i> | <i>Item Description</i> | | <i>Quantity</i> | <i>U/M</i> | <i>Amount/Unit</i> | <i>Total Amount</i> | <i>Vendor Catalog Part Number</i> | <i>Contract Number</i> | |
| | Hand tools / WTP - WP Hand Tools | | 1.0000 | EA | 31.9800 | 31.98 | | | |
| | <i>G/L Account</i> | | | | <i>Project</i> | | | <i>Amount</i> | |
| | 61-4611-2801 (Water and Sewer Fund-Water Treatment Plant-Hand tools) | | | | | | | 31.98 | |
| | | | | Invoice Items | 1 | | | | |
| 463169/6 | WW Misc. Supplies | Open | | 07/14/2023 | 08/04/2023 | 07/14/2023 | | | 7.18 |
| <i>P.O. Number</i> | <i>Item Description</i> | | <i>Quantity</i> | <i>U/M</i> | <i>Amount/Unit</i> | <i>Total Amount</i> | <i>Vendor Catalog Part Number</i> | <i>Contract Number</i> | |
| | Other repair & maintenance - WW Misc. Supplies | | 1.0000 | EA | 7.1800 | 7.18 | | | |
| | <i>G/L Account</i> | | | | <i>Project</i> | | | <i>Amount</i> | |
| | 61-4621-2310 (Water and Sewer Fund-Waste Water Treatment Plant-Other maintenance supplies) | | | | 0000 (0000 - Misc. Equip.) | | | 7.18 | |
| | | | | Invoice Items | 1 | | | | |
| 463178/6 | WW Misc. Supplies | Open | | 07/14/2023 | 08/04/2023 | 07/14/2023 | | | 29.23 |
| <i>P.O. Number</i> | <i>Item Description</i> | | <i>Quantity</i> | <i>U/M</i> | <i>Amount/Unit</i> | <i>Total Amount</i> | <i>Vendor Catalog Part Number</i> | <i>Contract Number</i> | |
| | Other repair & maintenance - WW Misc. Supplies | | 1.0000 | EA | 29.2300 | 29.23 | | | |
| | <i>G/L Account</i> | | | | <i>Project</i> | | | <i>Amount</i> | |
| | 61-4621-2310 (Water and Sewer Fund-Waste Water Treatment Plant-Other maintenance supplies) | | | | 0000 (0000 - Misc. Equip.) | | | 29.23 | |
| | | | | Invoice Items | 1 | | | | |



Accounts Payable Invoice Report - Council

08/01/2023

Invoice Due Date Range 07/22/23 - 08/04/23

Report By Vendor - Invoice

| Invoice Number | Invoice Description | Status | Held Reason | Invoice Date | Due Date | G/L Date | Received Date | Payment Date | Invoice Net Amount |
|--------------------|---|--------|-----------------|----------------------------|--------------------|---------------------|-----------------------------------|------------------------|--------------------|
| 463253/6 | WW Misc. Supplies | Open | | 07/17/2023 | 08/04/2023 | 07/17/2023 | | | 74.22 |
| <i>P.O. Number</i> | <i>Item Description</i> | | <i>Quantity</i> | <i>U/M</i> | <i>Amount/Unit</i> | <i>Total Amount</i> | <i>Vendor Catalog Part Number</i> | <i>Contract Number</i> | |
| | Other repair & maintenance - WW Misc. Supplies | | 1.0000 | EA | 74.2200 | 74.22 | | | |
| | <i>G/L Account</i> | | | <i>Project</i> | | <i>Amount</i> | | | |
| | 61-4621-2310 (Water and Sewer Fund-Waste Water Treatment Plant- Other maintenance supplies) | | | 0000 (0000 - Misc. Equip.) | | 74.22 | | | |
| | | | | Invoice Items | 1 | | | | |
| 463336/6 | WW Misc. Supplies | Open | | 07/18/2023 | 08/04/2023 | 07/18/2023 | | | 21.78 |
| <i>P.O. Number</i> | <i>Item Description</i> | | <i>Quantity</i> | <i>U/M</i> | <i>Amount/Unit</i> | <i>Total Amount</i> | <i>Vendor Catalog Part Number</i> | <i>Contract Number</i> | |
| | Other repair & maintenance - WW Misc. Supplies | | 1.0000 | EA | 21.7800 | 21.78 | | | |
| | <i>G/L Account</i> | | | <i>Project</i> | | <i>Amount</i> | | | |
| | 61-4621-2310 (Water and Sewer Fund-Waste Water Treatment Plant- Other maintenance supplies) | | | 0000 (0000 - Misc. Equip.) | | 21.78 | | | |
| | | | | Invoice Items | 1 | | | | |
| 463373/6 | WW Misc. Supplies | Open | | 07/19/2023 | 08/04/2023 | 07/19/2023 | | | 72.98 |
| <i>P.O. Number</i> | <i>Item Description</i> | | <i>Quantity</i> | <i>U/M</i> | <i>Amount/Unit</i> | <i>Total Amount</i> | <i>Vendor Catalog Part Number</i> | <i>Contract Number</i> | |
| | Other repair & maintenance - WW Misc. Supplies | | 1.0000 | EA | 72.9800 | 72.98 | | | |
| | <i>G/L Account</i> | | | <i>Project</i> | | <i>Amount</i> | | | |
| | 61-4621-2310 (Water and Sewer Fund-Waste Water Treatment Plant- Other maintenance supplies) | | | 0000 (0000 - Misc. Equip.) | | 72.98 | | | |
| | | | | Invoice Items | 1 | | | | |
| 463523/6 | WW Misc. Supplies | Open | | 07/21/2023 | 08/04/2023 | 07/21/2023 | | | 78.15 |
| <i>P.O. Number</i> | <i>Item Description</i> | | <i>Quantity</i> | <i>U/M</i> | <i>Amount/Unit</i> | <i>Total Amount</i> | <i>Vendor Catalog Part Number</i> | <i>Contract Number</i> | |
| | Other repair & maintenance - WW Misc. Supplies | | 1.0000 | EA | 78.1500 | 78.15 | | | |
| | <i>G/L Account</i> | | | <i>Project</i> | | <i>Amount</i> | | | |
| | 61-4621-2310 (Water and Sewer Fund-Waste Water Treatment Plant- Other maintenance supplies) | | | 0000 (0000 - Misc. Equip.) | | 78.15 | | | |
| | | | | Invoice Items | 1 | | | | |
| 463561/6 | WW Misc. Supplies | Open | | 07/21/2023 | 08/04/2023 | 07/21/2023 | | | 7.59 |
| <i>P.O. Number</i> | <i>Item Description</i> | | <i>Quantity</i> | <i>U/M</i> | <i>Amount/Unit</i> | <i>Total Amount</i> | <i>Vendor Catalog Part Number</i> | <i>Contract Number</i> | |
| | Other repair & maintenance - WW Misc. Supplies | | 1.0000 | EA | 7.5900 | 7.59 | | | |
| | <i>G/L Account</i> | | | <i>Project</i> | | <i>Amount</i> | | | |
| | 61-4621-2310 (Water and Sewer Fund-Waste Water Treatment Plant- Other maintenance supplies) | | | 0000 (0000 - Misc. Equip.) | | 7.59 | | | |
| | | | | Invoice Items | 1 | | | | |

Vendor **1033 - ACE HARDWARE 651 - NIEMANN FOODS, INC.** Totals

Invoices

20

\$1,036.63



Accounts Payable Invoice Report - Council

08/01/2023

Invoice Due Date Range 07/22/23 - 08/04/23

Report By Vendor - Invoice

| Invoice Number | Invoice Description | Status | Held Reason | Invoice Date | Due Date | G/L Date | Received Date | Payment Date | Invoice Net Amount |
|---|---|--------|-----------------|---------------|--------------------|--------------------------------------|-----------------------------------|------------------------|--------------------|
| Vendor 1038 - AFLAC - AMERICAN FAMILY LIFE ASSURANCE CO | | | | | | | | | |
| 528202 | July 2023 Premium / EBHR | Open | | 07/12/2023 | 08/04/2023 | 07/12/2023 | | | 2,225.84 |
| <i>P.O. Number</i> | <i>Item Description</i> | | <i>Quantity</i> | <i>U/M</i> | <i>Amount/Unit</i> | <i>Total Amount</i> | <i>Vendor Catalog Part Number</i> | <i>Contract Number</i> | |
| | Aflac Deductions Withheld - July 2023 Premium / EBHR | | 1.0000 | EA | 2,225.8400 | 2,225.84 | | | |
| | <i>G/L Account</i> | | | | <i>Project</i> | | | <i>Amount</i> | |
| | 11-2033 (General Fund-Other voluntary deductions) | | | | | | | 2,225.84 | |
| | | | | Invoice Items | 1 | | | | |
| Vendor 1038 - AFLAC - AMERICAN FAMILY LIFE ASSURANCE CO Totals | | | | | | | Invoices | 1 | \$2,225.84 |
| Vendor 3146 - ALBIN ANIMAL HOSPITAL | | | | | | | | | |
| 07/18/2023 | Exam for Bolt/PD | Open | | 07/18/2023 | 08/04/2023 | 07/18/2023 | | | 260.95 |
| <i>P.O. Number</i> | <i>Item Description</i> | | <i>Quantity</i> | <i>U/M</i> | <i>Amount/Unit</i> | <i>Total Amount</i> | <i>Vendor Catalog Part Number</i> | <i>Contract Number</i> | |
| | K-9 supplies & expenses / PD - Exam for Bolt/PD | | 1.0000 | EA | 260.9500 | 260.95 | | | |
| | <i>G/L Account</i> | | | | <i>Project</i> | | | <i>Amount</i> | |
| | 11-4210-2120 (General Fund-Police Department-K-9 Expenses) | | | | | | | 260.95 | |
| | | | | Invoice Items | 1 | | | | |
| Vendor 3146 - ALBIN ANIMAL HOSPITAL Totals | | | | | | | Invoices | 1 | \$260.95 |
| Vendor 1029 - ALTORFER INC | | | | | | | | | |
| PC010172608 | 4-1 Hydraulic Coupler/STREET | Open | | 07/07/2023 | 08/04/2023 | 07/07/2023 | | | 342.01 |
| <i>P.O. Number</i> | <i>Item Description</i> | | <i>Quantity</i> | <i>U/M</i> | <i>Amount/Unit</i> | <i>Total Amount</i> | <i>Vendor Catalog Part Number</i> | <i>Contract Number</i> | |
| | 1/4 page full color ad/tourism - 4-1 Hydraulic Coupler/STREET | | 1.0000 | EA | 342.0100 | 342.01 | | | |
| | <i>G/L Account</i> | | | | <i>Project</i> | | | <i>Amount</i> | |
| | 11-4310-3508 (General Fund-Street Department-Repair of operating equipment) | | | | | 0848 (Caterpillar 924H Wheel loader) | | 342.01 | |
| | | | | Invoice Items | 1 | | | | |
| Vendor 1029 - ALTORFER INC Totals | | | | | | | Invoices | 2 | \$378.46 |
| Vendor 2331 - AMAZON CAPITAL SERVICES, INC | | | | | | | | | |



Accounts Payable Invoice Report - Council

08/01/2023

Invoice Due Date Range 07/22/23 - 08/04/23

Report By Vendor - Invoice

| Invoice Number | Invoice Description | Status | Held Reason | Invoice Date | Due Date | G/L Date | Received Date | Payment Date | Invoice Net Amount |
|--|--|--------|-------------|-----------------|------------|--------------------------|---------------------|-----------------------------------|------------------------|
| 7952230 | Breakroom supplies/ADMIN | Open | | 07/20/2023 | 08/04/2023 | 07/20/2023 | | | 95.53 |
| <i>P.O. Number</i> | <i>Item Description</i> | | | <i>Quantity</i> | <i>U/M</i> | <i>Amount/Unit</i> | <i>Total Amount</i> | <i>Vendor Catalog Part Number</i> | <i>Contract Number</i> |
| | Office Supplies / ADMIN - Breakroom supplies/ADMIN | | | 1.0000 | EA | 95.5300 | 95.53 | | |
| | <i>G/L Account</i> | | | | | <i>Project</i> | | <i>Amount</i> | |
| | 11-4001-2001 (General Fund-Administration & Boards- Manager-Office supplies) | | | | | | | 95.53 | |
| | | | | Invoice Items | | 1 | | | |
| 1929875 | Wrist bands for Day Camp - REC | Open | | 07/21/2023 | 08/04/2023 | 07/21/2023 | | | 24.98 |
| <i>P.O. Number</i> | <i>Item Description</i> | | | <i>Quantity</i> | <i>U/M</i> | <i>Amount/Unit</i> | <i>Total Amount</i> | <i>Vendor Catalog Part Number</i> | <i>Contract Number</i> |
| | Other Supplies / REC - Wrist bands for Day Camp - REC | | | 1.0000 | EA | 24.9800 | 24.98 | | |
| | <i>G/L Account</i> | | | | | <i>Project</i> | | <i>Amount</i> | |
| | 22-4510-2119 (Playground & Recreation Fund-Recreation Programs- Other supplies) | | | | | REC 1004 3120 (Day Camp) | | 24.98 | |
| | | | | Invoice Items | | 1 | | | |
| 5898640 | Wrist bands for Day Camp - REC | Open | | 07/21/2023 | 08/04/2023 | 07/21/2023 | | | 22.98 |
| <i>P.O. Number</i> | <i>Item Description</i> | | | <i>Quantity</i> | <i>U/M</i> | <i>Amount/Unit</i> | <i>Total Amount</i> | <i>Vendor Catalog Part Number</i> | <i>Contract Number</i> |
| | Other supplies - Wrist bands for Day Camp - REC | | | 1.0000 | EA | 22.9800 | 22.98 | | |
| | <i>G/L Account</i> | | | | | <i>Project</i> | | <i>Amount</i> | |
| | 22-4510-2119 (Playground & Recreation Fund-Recreation Programs- Other supplies) | | | | | REC 1004 3120 (Day Camp) | | 22.98 | |
| | | | | Invoice Items | | 1 | | | |
| 1QXV-7YD7-WJRR | Wristbands for Day Camp - REC | Open | | 07/23/2023 | 08/04/2023 | 07/23/2023 | | | 47.96 |
| <i>P.O. Number</i> | <i>Item Description</i> | | | <i>Quantity</i> | <i>U/M</i> | <i>Amount/Unit</i> | <i>Total Amount</i> | <i>Vendor Catalog Part Number</i> | <i>Contract Number</i> |
| | Other Supplies / REC - Wristbands for Day Camp - REC | | | 1.0000 | EA | 47.9600 | 47.96 | | |
| | <i>G/L Account</i> | | | | | <i>Project</i> | | <i>Amount</i> | |
| | 22-4510-2119 (Playground & Recreation Fund-Recreation Programs- Other supplies) | | | | | REC 1004 3120 (Day Camp) | | 47.96 | |
| | | | | Invoice Items | | 1 | | | |
| Vendor 2331 - AMAZON CAPITAL SERVICES, INC Totals | | | | | | | Invoices | 4 | \$191.45 |
| Vendor 3248 - AMEREN ILLINOIS | | | | | | | | | |
| 1735007511 06/23 | 1200 W Madison Ave/WWTP | Open | | 06/30/2023 | 08/04/2023 | 06/30/2023 | | | 63.72 |
| <i>P.O. Number</i> | <i>Item Description</i> | | | <i>Quantity</i> | <i>U/M</i> | <i>Amount/Unit</i> | <i>Total Amount</i> | <i>Vendor Catalog Part Number</i> | <i>Contract Number</i> |
| | Electricity & gas | | | 1.0000 | EA | 63.7200 | 63.72 | | |
| | <i>G/L Account</i> | | | | | <i>Project</i> | | <i>Amount</i> | |
| | 61-4621-3403 (Water and Sewer Fund-Waste Water Treatment Plant- Electricity & gas) | | | | | | | 63.72 | |
| | | | | Invoice Items | | 1 | | | |



Accounts Payable Invoice Report - Council

08/01/2023

Invoice Due Date Range 07/22/23 - 08/04/23

Report By Vendor - Invoice

| Invoice Number | Invoice Description | Status | Held Reason | Invoice Date | Due Date | G/L Date | Received Date | Payment Date | Invoice Net Amount |
|--------------------|--|--------|-----------------|---------------|----------------------------------|---------------------|-----------------------------------|------------------------|--------------------|
| 1809067021 07/23 | 9th Route 16 TFLT/MFT | Open | | 07/17/2023 | 08/04/2023 | 07/17/2023 | | | 93.83 |
| <i>P.O. Number</i> | <i>Item Description</i> | | <i>Quantity</i> | <i>U/M</i> | <i>Amount/Unit</i> | <i>Total Amount</i> | <i>Vendor Catalog Part Number</i> | <i>Contract Number</i> | |
| | Street lights electricity | | 1.0000 | EA | 93.8300 | 93.83 | | | |
| | <i>G/L Account</i> | | | | <i>Project</i> | | | <i>Amount</i> | |
| | 25-4312-3405 (Motor Fuel Tax Fund-Motor Fuel Tax Department-Street lights electricity) | | | | MFT LIGHTS (MFT street lighting) | | | 93.83 | |
| | | | | Invoice Items | 1 | | | | |
| 2271032061 07/23 | 4th Route 16 TFLT/MFT | Open | | 07/17/2023 | 08/04/2023 | 07/17/2023 | | | 89.47 |
| <i>P.O. Number</i> | <i>Item Description</i> | | <i>Quantity</i> | <i>U/M</i> | <i>Amount/Unit</i> | <i>Total Amount</i> | <i>Vendor Catalog Part Number</i> | <i>Contract Number</i> | |
| | Street lights electricity | | 1.0000 | EA | 89.4700 | 89.47 | | | |
| | <i>G/L Account</i> | | | | <i>Project</i> | | | <i>Amount</i> | |
| | 25-4312-3405 (Motor Fuel Tax Fund-Motor Fuel Tax Department-Street lights electricity) | | | | MFT LIGHTS (MFT street lighting) | | | 89.47 | |
| | | | | Invoice Items | 1 | | | | |
| 2803068086 07/23 | E St Route 16 TFLT/MFT | Open | | 07/17/2023 | 08/04/2023 | 07/17/2023 | | | 75.54 |
| <i>P.O. Number</i> | <i>Item Description</i> | | <i>Quantity</i> | <i>U/M</i> | <i>Amount/Unit</i> | <i>Total Amount</i> | <i>Vendor Catalog Part Number</i> | <i>Contract Number</i> | |
| | Street lights electricity | | 1.0000 | EA | 75.5400 | 75.54 | | | |
| | <i>G/L Account</i> | | | | <i>Project</i> | | | <i>Amount</i> | |
| | 25-4312-3405 (Motor Fuel Tax Fund-Motor Fuel Tax Department-Street lights electricity) | | | | MFT LIGHTS (MFT street lighting) | | | 75.54 | |
| | | | | Invoice Items | 1 | | | | |
| 4651056018 07/23 | Douglas Route 16/MFT | Open | | 07/17/2023 | 08/04/2023 | 07/17/2023 | | | 72.22 |
| <i>P.O. Number</i> | <i>Item Description</i> | | <i>Quantity</i> | <i>U/M</i> | <i>Amount/Unit</i> | <i>Total Amount</i> | <i>Vendor Catalog Part Number</i> | <i>Contract Number</i> | |
| | Street lights electricity | | 1.0000 | EA | 72.2200 | 72.22 | | | |
| | <i>G/L Account</i> | | | | <i>Project</i> | | | <i>Amount</i> | |
| | 25-4312-3405 (Motor Fuel Tax Fund-Motor Fuel Tax Department-Street lights electricity) | | | | MFT LIGHTS (MFT street lighting) | | | 72.22 | |
| | | | | Invoice Items | 1 | | | | |
| 6625147011 07/23 | IL Route 16 & 18th/MFT | Open | | 07/17/2023 | 08/04/2023 | 07/17/2023 | | | 68.75 |
| <i>P.O. Number</i> | <i>Item Description</i> | | <i>Quantity</i> | <i>U/M</i> | <i>Amount/Unit</i> | <i>Total Amount</i> | <i>Vendor Catalog Part Number</i> | <i>Contract Number</i> | |
| | Street lights electricity | | 1.0000 | EA | 68.7500 | 68.75 | | | |
| | <i>G/L Account</i> | | | | <i>Project</i> | | | <i>Amount</i> | |
| | 25-4312-3405 (Motor Fuel Tax Fund-Motor Fuel Tax Department-Street lights electricity) | | | | MFT LIGHTS (MFT street lighting) | | | 68.75 | |
| | | | | Invoice Items | 1 | | | | |
| 6639027017 07/23 | 6th Route 16 TFLT/MFT | Open | | 07/17/2023 | 08/04/2023 | 07/17/2023 | | | 73.97 |
| <i>P.O. Number</i> | <i>Item Description</i> | | <i>Quantity</i> | <i>U/M</i> | <i>Amount/Unit</i> | <i>Total Amount</i> | <i>Vendor Catalog Part Number</i> | <i>Contract Number</i> | |
| | Street lights electricity | | 1.0000 | EA | 73.9700 | 73.97 | | | |
| | <i>G/L Account</i> | | | | <i>Project</i> | | | <i>Amount</i> | |



Accounts Payable Invoice Report - Council

08/01/2023

Invoice Due Date Range 07/22/23 - 08/04/23

Report By Vendor - Invoice

| Invoice Number | Invoice Description | Status | Held Reason | Invoice Date | Due Date | G/L Date | Received Date | Payment Date | Invoice Net Amount |
|--|--|--------|-------------|-----------------|------------|----------------------------------|---------------------|-----------------------------------|------------------------|
| 6639027017 07/23 | 6th Route 16 TFLT/MFT | Open | | 07/17/2023 | 08/04/2023 | 07/17/2023 | | | 73.97 |
| <i>P.O. Number</i> | <i>Item Description</i> | | | <i>Quantity</i> | <i>U/M</i> | <i>Amount/Unit</i> | <i>Total Amount</i> | <i>Vendor Catalog Part Number</i> | <i>Contract Number</i> |
| | 25-4312-3405 (Motor Fuel Tax Fund-Motor Fuel Tax Department-Street lights electricity) | | | | | | | | 73.97 |
| | | | | Invoice Items | | 1 | | | |
| 0109143034 07/23 | W Lincoln Ave Division/MFT | Open | | 07/19/2023 | 08/04/2023 | 07/19/2023 | | | 90.64 |
| <i>P.O. Number</i> | <i>Item Description</i> | | | <i>Quantity</i> | <i>U/M</i> | <i>Amount/Unit</i> | <i>Total Amount</i> | <i>Vendor Catalog Part Number</i> | <i>Contract Number</i> |
| | Street lights electricity | | | 1.0000 | EA | 90.6400 | 90.64 | | |
| | <i>G/L Account</i> | | | | | <i>Project</i> | | <i>Amount</i> | |
| | 25-4312-3405 (Motor Fuel Tax Fund-Motor Fuel Tax Department-Street lights electricity) | | | | | MFT LIGHTS (MFT street lighting) | | 90.64 | |
| | | | | Invoice Items | | 1 | | | |
| 2689143015 07/23 | 71 N LOXA RD | Open | | 07/20/2023 | 08/04/2023 | 07/20/2023 | | | 85.11 |
| <i>P.O. Number</i> | <i>Item Description</i> | | | <i>Quantity</i> | <i>U/M</i> | <i>Amount/Unit</i> | <i>Total Amount</i> | <i>Vendor Catalog Part Number</i> | <i>Contract Number</i> |
| | Electricity & gas | | | 1.0000 | EA | 85.1100 | 85.11 | | |
| | <i>G/L Account</i> | | | | | <i>Project</i> | | <i>Amount</i> | |
| | 11-4194-3403 (General Fund-Parks & Maintenance Department-Electricity & gas) | | | | | PK 1018 (LOXA RESTAREA) | | 85.11 | |
| | | | | Invoice Items | | 1 | | | |
| Vendor 3248 - AMEREN ILLINOIS Totals | | | | | Invoices | 9 | | | \$713.25 |
| Vendor 2716 - BANK OF AMERICA Commercial Card | | | | | | | | | |
| AIKMAN 6/8/23 | Field trip for Day Camp - REC / bh | Open | | 06/08/2023 | 08/04/2023 | 06/08/2023 | | | 1,512.00 |
| <i>P.O. Number</i> | <i>Item Description</i> | | | <i>Quantity</i> | <i>U/M</i> | <i>Amount/Unit</i> | <i>Total Amount</i> | <i>Vendor Catalog Part Number</i> | <i>Contract Number</i> |
| | Other Contractual Service - REC - Field trip for Day Camp - REC / bh | | | 1.0000 | EA | 1,512.0000 | 1,512.00 | | |
| | <i>G/L Account</i> | | | | | <i>Project</i> | | <i>Amount</i> | |
| | 22-4510-3999 (Playground & Recreation Fund-Recreation Programs-Other contractual services) | | | | | REC 1004 3120 (Day Camp) | | 1,512.00 | |
| | | | | Invoice Items | | 1 | | | |
| FSP*NC 06/08 | NCTRC annual fee for Director - REC / dr | Open | | 06/08/2023 | 08/04/2023 | 06/08/2023 | | | 80.00 |
| <i>P.O. Number</i> | <i>Item Description</i> | | | <i>Quantity</i> | <i>U/M</i> | <i>Amount/Unit</i> | <i>Total Amount</i> | <i>Vendor Catalog Part Number</i> | <i>Contract Number</i> |
| | Professional membership - NCTRC annual fee for Director - REC / dr | | | 1.0000 | EA | 80.0000 | 80.00 | | |
| | <i>G/L Account</i> | | | | | <i>Project</i> | | <i>Amount</i> | |
| | 22-4510-3704 (Playground & Recreation Fund-Recreation Programs-Professional memberships) | | | | | | | 80.00 | |
| | | | | Invoice Items | | 1 | | | |



Accounts Payable Invoice Report - Council

08/01/2023

Invoice Due Date Range 07/22/23 - 08/04/23

Report By Vendor - Invoice

| Invoice Number | Invoice Description | Status | Held Reason | Invoice Date | Due Date | G/L Date | Received Date | Payment Date | Invoice Net Amount |
|--------------------|---|--------|-------------|-----------------|------------|-----------------------------------|---------------------|-----------------------------------|------------------------|
| ACE 06/09 | Day Camp veggies for garden - REC / dr | Open | | 06/09/2023 | 08/04/2023 | 06/09/2023 | | | 23.98 |
| <i>P.O. Number</i> | <i>Item Description</i> | | | <i>Quantity</i> | <i>U/M</i> | <i>Amount/Unit</i> | <i>Total Amount</i> | <i>Vendor Catalog Part Number</i> | <i>Contract Number</i> |
| | Other Supplies / REC - Day Camp veggies for garden - REC / dr | | | 1.0000 | EA | 23.9800 | 23.98 | | |
| | <i>G/L Account</i> | | | | | <i>Project</i> | | <i>Amount</i> | |
| | 22-4510-2119 (Playground & Recreation Fund-Recreation Programs- Other supplies) | | | | | REC 1004 3120 (Day Camp) | | 23.98 | |
| | | | | Invoice Items | | 1 | | | |
| Staples 06/09 | Pencil organizer and paper cutter - TOUR / lh | Open | | 06/09/2023 | 08/04/2023 | 06/09/2023 | | | 56.78 |
| <i>P.O. Number</i> | <i>Item Description</i> | | | <i>Quantity</i> | <i>U/M</i> | <i>Amount/Unit</i> | <i>Total Amount</i> | <i>Vendor Catalog Part Number</i> | <i>Contract Number</i> |
| | Office Supplies - Pencil organizer and paper cutter - TOUR / lh | | | 1.0000 | EA | 56.7800 | 56.78 | | |
| | <i>G/L Account</i> | | | | | <i>Project</i> | | <i>Amount</i> | |
| | 11-4099-2001 (General Fund-Tourism-Office supplies) | | | | | | | 56.78 | |
| | | | | Invoice Items | | 1 | | | |
| My Music 06/13 | Music folders - REC / lh | Open | | 06/13/2023 | 08/04/2023 | 06/13/2023 | | | 602.56 |
| <i>P.O. Number</i> | <i>Item Description</i> | | | <i>Quantity</i> | <i>U/M</i> | <i>Amount/Unit</i> | <i>Total Amount</i> | <i>Vendor Catalog Part Number</i> | <i>Contract Number</i> |
| | Affiliate expense- reimbursed - Music folders - REC / lh | | | 1.0000 | EA | 602.5600 | 602.56 | | |
| | <i>G/L Account</i> | | | | | <i>Project</i> | | <i>Amount</i> | |
| | 22-4510-3997 (Playground & Recreation Fund-Recreation Programs- Affiliate expenses) | | | | | REC 1010 6080 (Community Band) | | 602.56 | |
| | | | | Invoice Items | | 1 | | | |
| DTree 06/14 | Supplies for Day Camp - REC / dr | Open | | 06/14/2023 | 08/04/2023 | 06/14/2023 | | | 5.00 |
| <i>P.O. Number</i> | <i>Item Description</i> | | | <i>Quantity</i> | <i>U/M</i> | <i>Amount/Unit</i> | <i>Total Amount</i> | <i>Vendor Catalog Part Number</i> | <i>Contract Number</i> |
| | Other Supplies / REC - Supplies for Day Camp - REC / dr | | | 1.0000 | EA | 5.0000 | 5.00 | | |
| | <i>G/L Account</i> | | | | | <i>Project</i> | | <i>Amount</i> | |
| | 22-4510-2119 (Playground & Recreation Fund-Recreation Programs- Other supplies) | | | | | REC 1004 3120 (Day Camp) | | 5.00 | |
| | | | | Invoice Items | | 1 | | | |
| IL DNR 06/14 | Grant application fee - REC / dr | Open | | 06/14/2023 | 08/04/2023 | 06/14/2023 | | | 306.75 |
| <i>P.O. Number</i> | <i>Item Description</i> | | | <i>Quantity</i> | <i>U/M</i> | <i>Amount/Unit</i> | <i>Total Amount</i> | <i>Vendor Catalog Part Number</i> | <i>Contract Number</i> |
| | Community Development Projects - Grant application fee - REC / dr | | | 1.0000 | EA | 306.7500 | 306.75 | | |
| | <i>G/L Account</i> | | | | | <i>Project</i> | | <i>Amount</i> | |
| | 11-4640-4103 (General Fund-Building & Development Services- Community Development Projects) | | | | | COMMUNITY (Community Development) | | 306.75 | |
| | | | | Invoice Items | | 1 | | | |



Accounts Payable Invoice Report - Council

08/01/2023

Invoice Due Date Range 07/22/23 - 08/04/23

Report By Vendor - Invoice

| Invoice Number | Invoice Description | Status | Held Reason | Invoice Date | Due Date | G/L Date | Received Date | Payment Date | Invoice Net Amount |
|--------------------|--|--------|-------------|-----------------|------------|----------------------------------|---------------------|-----------------------------------|------------------------|
| WHENTO 06/14 | When to Work app for Scheduling - REC / dr | Open | | 06/14/2023 | 08/04/2023 | 06/14/2023 | | | 220.00 |
| <i>P.O. Number</i> | <i>Item Description</i> | | | <i>Quantity</i> | <i>U/M</i> | <i>Amount/Unit</i> | <i>Total Amount</i> | <i>Vendor Catalog Part Number</i> | <i>Contract Number</i> |
| | Other Contractual Service - REC - When to Work app for Scheduling - REC / dr | | | 1.0000 | EA | 220.0000 | 220.00 | | |
| | <i>G/L Account</i> | | | | | <i>Project</i> | | <i>Amount</i> | |
| | 22-4510-3999 (Playground & Recreation Fund-Recreation Programs-Other contractual services) | | | | | REC 1004 3000 (Afterschool Club) | | 110.00 | |
| | 22-4510-3999 (Playground & Recreation Fund-Recreation Programs-Other contractual services) | | | | | REC 1004 3120 (Day Camp) | | 110.00 | |
| | <i>Invoice Items</i> | | | | | 1 | | | |
| TST Lincoln 6/15 | Gift card for Community Band incentive - REC / lh | Open | | 06/15/2023 | 08/04/2023 | 06/15/2023 | | | 25.00 |
| <i>P.O. Number</i> | <i>Item Description</i> | | | <i>Quantity</i> | <i>U/M</i> | <i>Amount/Unit</i> | <i>Total Amount</i> | <i>Vendor Catalog Part Number</i> | <i>Contract Number</i> |
| | Affiliate expense- reimbursed - Gift card for Community Band incentive - REC / lh | | | 1.0000 | EA | 25.0000 | 25.00 | | |
| | <i>G/L Account</i> | | | | | <i>Project</i> | | <i>Amount</i> | |
| | 22-4510-3997 (Playground & Recreation Fund-Recreation Programs-Affiliate expenses) | | | | | REC 1010 6080 (Community Band) | | 25.00 | |
| | <i>Invoice Items</i> | | | | | 1 | | | |
| UBER 06/17 | Hannah used the wrong card & paid us back cash - REC / hd | Open | | 06/17/2023 | 08/04/2023 | 06/17/2023 | | | 7.90 |
| <i>P.O. Number</i> | <i>Item Description</i> | | | <i>Quantity</i> | <i>U/M</i> | <i>Amount/Unit</i> | <i>Total Amount</i> | <i>Vendor Catalog Part Number</i> | <i>Contract Number</i> |
| | Affiliate expense- reimbursed - Hannah used the wrong card & paid us back cash - REC / hd | | | 1.0000 | EA | 7.9000 | 7.90 | | |
| | <i>G/L Account</i> | | | | | <i>Project</i> | | <i>Amount</i> | |
| | 22-4510-3997 (Playground & Recreation Fund-Recreation Programs-Affiliate expenses) | | | | | | | 7.90 | |
| | <i>Invoice Items</i> | | | | | 1 | | | |
| UBER TRIP 06/17 | Hannah used the wrong card & paid us back cash - REC / hd | Open | | 06/17/2023 | 08/04/2023 | 06/17/2023 | | | 3.00 |
| <i>P.O. Number</i> | <i>Item Description</i> | | | <i>Quantity</i> | <i>U/M</i> | <i>Amount/Unit</i> | <i>Total Amount</i> | <i>Vendor Catalog Part Number</i> | <i>Contract Number</i> |
| | Affiliate expense- reimbursed - Hannah used the wrong card & paid us back cash - REC / hd | | | 1.0000 | EA | 3.0000 | 3.00 | | |
| | <i>G/L Account</i> | | | | | <i>Project</i> | | <i>Amount</i> | |
| | 22-4510-3997 (Playground & Recreation Fund-Recreation Programs-Affiliate expenses) | | | | | | | 3.00 | |
| | <i>Invoice Items</i> | | | | | 1 | | | |



Accounts Payable Invoice Report - Council

08/01/2023

Invoice Due Date Range 07/22/23 - 08/04/23

Report By Vendor - Invoice

| Invoice Number | Invoice Description | Status | Held Reason | Invoice Date | Due Date | G/L Date | Received Date | Payment Date | Invoice Net Amount |
|--------------------|--|--------|-------------|-----------------|------------|--------------------------------|---------------------|-----------------------------------|------------------------|
| Elevate 06/19 | Field trip for Day Camp - REC / bh | Open | | 06/19/2023 | 08/04/2023 | 06/19/2023 | | | 630.00 |
| <i>P.O. Number</i> | <i>Item Description</i> | | | <i>Quantity</i> | <i>U/M</i> | <i>Amount/Unit</i> | <i>Total Amount</i> | <i>Vendor Catalog Part Number</i> | <i>Contract Number</i> |
| | Other contractual services - Field trip for Day Camp - REC / bh | | | 1.0000 | EA | 630.0000 | 630.00 | | |
| | <i>G/L Account</i> | | | | | <i>Project</i> | | <i>Amount</i> | |
| | 22-4510-3999 (Playground & Recreation Fund-Recreation Programs- Other contractual services) | | | | | REC 1004 3120 (Day Camp) | | 630.00 | |
| | | | | Invoice Items | | 1 | | | |
| CountyM 06/21 | Party supplies for end of the year EIFC party - REC / bh | Open | | 06/21/2023 | 08/04/2023 | 06/28/2023 | | | 113.66 |
| <i>P.O. Number</i> | <i>Item Description</i> | | | <i>Quantity</i> | <i>U/M</i> | <i>Amount/Unit</i> | <i>Total Amount</i> | <i>Vendor Catalog Part Number</i> | <i>Contract Number</i> |
| | Affiliate expense- reimbursed - Party supplies for end of the year EIFC party - REC / bh | | | 1.0000 | EA | 113.6600 | 113.66 | | |
| | <i>G/L Account</i> | | | | | <i>Project</i> | | <i>Amount</i> | |
| | 22-4510-3997 (Playground & Recreation Fund-Recreation Programs- Affiliate expenses) | | | | | REC 1002 1460 (Soccer, Travel) | | 113.66 | |
| | | | | Invoice Items | | 1 | | | |
| LCaesars 06/21 | Pizza for end of the year EIFC party - REC / bh | Open | | 06/21/2023 | 08/04/2023 | 06/21/2023 | | | 59.92 |
| <i>P.O. Number</i> | <i>Item Description</i> | | | <i>Quantity</i> | <i>U/M</i> | <i>Amount/Unit</i> | <i>Total Amount</i> | <i>Vendor Catalog Part Number</i> | <i>Contract Number</i> |
| | Affiliate expense- reimbursed - Pizza for end of the year EIFC party - REC / bh | | | 1.0000 | EA | 59.9200 | 59.92 | | |
| | <i>G/L Account</i> | | | | | <i>Project</i> | | <i>Amount</i> | |
| | 22-4510-3997 (Playground & Recreation Fund-Recreation Programs- Affiliate expenses) | | | | | REC 1002 1460 (Soccer, Travel) | | 59.92 | |
| | | | | Invoice Items | | 1 | | | |
| CKE Dirty's 6/22 | Gift card for Community Band incentive for rehearsals - REC / lh | Open | | 06/22/2023 | 08/04/2023 | 06/22/2023 | | | 25.00 |
| <i>P.O. Number</i> | <i>Item Description</i> | | | <i>Quantity</i> | <i>U/M</i> | <i>Amount/Unit</i> | <i>Total Amount</i> | <i>Vendor Catalog Part Number</i> | <i>Contract Number</i> |
| | Affiliate expense- reimbursed - Gift card for Community Band incentive for rehearsals - REC / lh | | | 1.0000 | EA | 25.0000 | 25.00 | | |
| | <i>G/L Account</i> | | | | | <i>Project</i> | | <i>Amount</i> | |
| | 22-4510-3997 (Playground & Recreation Fund-Recreation Programs- Affiliate expenses) | | | | | REC 1010 6080 (Community Band) | | 25.00 | |
| | | | | Invoice Items | | 1 | | | |



Accounts Payable Invoice Report - Council

08/01/2023

Invoice Due Date Range 07/22/23 - 08/04/23

Report By Vendor - Invoice

| Invoice Number | Invoice Description | Status | Held Reason | Invoice Date | Due Date | G/L Date | Received Date | Payment Date | Invoice Net Amount |
|--------------------|--|--------|---------------|-----------------|------------|--------------------------------|---------------------|-----------------------------------|------------------------|
| Dairy Q 6/22 | Dilly Bars for Community Band - REC / lh | Open | | 06/22/2023 | 08/04/2023 | 06/22/2023 | | | 41.96 |
| <i>P.O. Number</i> | <i>Item Description</i> | | | <i>Quantity</i> | <i>U/M</i> | <i>Amount/Unit</i> | <i>Total Amount</i> | <i>Vendor Catalog Part Number</i> | <i>Contract Number</i> |
| | Affiliate expense- reimbursed - Dilly Bars for Community Band - REC / lh | | | 1.0000 | EA | 41.9600 | 41.96 | | |
| | <i>G/L Account</i> | | | | | <i>Project</i> | | <i>Amount</i> | |
| | 22-4510-3997 (Playground & Recreation Fund-Recreation Programs-Affiliate expenses) | | | | | REC 1010 6080 (Community Band) | | 41.96 | |
| | | | Invoice Items | | | 1 | | | |
| ILPark 06/23 | IAPD class - REC / dr | Open | | 06/23/2023 | 08/04/2023 | 06/23/2023 | | | 6.00 |
| <i>P.O. Number</i> | <i>Item Description</i> | | | <i>Quantity</i> | <i>U/M</i> | <i>Amount/Unit</i> | <i>Total Amount</i> | <i>Vendor Catalog Part Number</i> | <i>Contract Number</i> |
| | Education & training expense - IAPD class - REC / dr | | | 1.0000 | EA | 6.0000 | 6.00 | | |
| | <i>G/L Account</i> | | | | | <i>Project</i> | | <i>Amount</i> | |
| | 22-4510-3706 (Playground & Recreation Fund-Recreation Programs-Education & training expense) | | | | | | | 6.00 | |
| | | | Invoice Items | | | 1 | | | |
| 4IMPRINT 06/28 | Polo's for band members - REC / lh | Open | | 06/28/2023 | 08/04/2023 | 06/28/2023 | | | 223.66 |
| <i>P.O. Number</i> | <i>Item Description</i> | | | <i>Quantity</i> | <i>U/M</i> | <i>Amount/Unit</i> | <i>Total Amount</i> | <i>Vendor Catalog Part Number</i> | <i>Contract Number</i> |
| | Affiliate expense- reimbursed - Polo's for band members - REC / lh | | | 1.0000 | EA | 223.6600 | 223.66 | | |
| | <i>G/L Account</i> | | | | | <i>Project</i> | | <i>Amount</i> | |
| | 22-4510-3997 (Playground & Recreation Fund-Recreation Programs-Affiliate expenses) | | | | | REC 1010 6080 (Community Band) | | 223.66 | |
| | | | Invoice Items | | | 1 | | | |
| AMC 06/29 | Field trip for Day Camp - REC / dr | Open | | 06/29/2023 | 08/04/2023 | 06/29/2023 | | | 556.40 |
| <i>P.O. Number</i> | <i>Item Description</i> | | | <i>Quantity</i> | <i>U/M</i> | <i>Amount/Unit</i> | <i>Total Amount</i> | <i>Vendor Catalog Part Number</i> | <i>Contract Number</i> |
| | Other Supplies / REC - Field trip for Day Camp - REC / dr | | | 1.0000 | EA | 556.4000 | 556.40 | | |
| | <i>G/L Account</i> | | | | | <i>Project</i> | | <i>Amount</i> | |
| | 22-4510-2119 (Playground & Recreation Fund-Recreation Programs-Other supplies) | | | | | REC 1004 3120 (Day Camp) | | 556.40 | |
| | | | Invoice Items | | | 1 | | | |
| DairyQ 06/29 | Dilly Bars for Community Band - REC / lh | Open | | 06/29/2023 | 08/04/2023 | 06/29/2023 | | | 52.45 |
| <i>P.O. Number</i> | <i>Item Description</i> | | | <i>Quantity</i> | <i>U/M</i> | <i>Amount/Unit</i> | <i>Total Amount</i> | <i>Vendor Catalog Part Number</i> | <i>Contract Number</i> |
| | Affiliate expense- reimbursed - Dilly Bars for Community Band - REC / lh | | | 1.0000 | EA | 52.4500 | 52.45 | | |
| | <i>G/L Account</i> | | | | | <i>Project</i> | | <i>Amount</i> | |
| | 22-4510-3997 (Playground & Recreation Fund-Recreation Programs-Affiliate expenses) | | | | | REC 1010 6080 (Community Band) | | 52.45 | |
| | | | Invoice Items | | | 1 | | | |



Accounts Payable Invoice Report - Council

08/01/2023

Invoice Due Date Range 07/22/23 - 08/04/23

Report By Vendor - Invoice

| Invoice Number | Invoice Description | Status | Held Reason | Invoice Date | Due Date | G/L Date | Received Date | Payment Date | Invoice Net Amount |
|--------------------|--|--------|-------------|-----------------|------------|--------------------------------|---------------------|-----------------------------------|------------------------|
| Amaz 07/03 | Supplies for JFL parade - REC / bh | Open | | 07/03/2023 | 08/04/2023 | 07/03/2023 | | | 217.83 |
| <i>P.O. Number</i> | <i>Item Description</i> | | | <i>Quantity</i> | <i>U/M</i> | <i>Amount/Unit</i> | <i>Total Amount</i> | <i>Vendor Catalog Part Number</i> | <i>Contract Number</i> |
| | Affiliate expense- reimbursed - Supplies for JFL parade - REC / bh | | | 1.0000 | EA | 217.8300 | 217.83 | | |
| | <i>G/L Account</i> | | | | | <i>Project</i> | | <i>Amount</i> | |
| | 22-4510-3997 (Playground & Recreation Fund-Recreation Programs-Affiliate expenses) | | | | | REC 1002 1900 (JFL) | | 217.83 | |
| | | | | Invoice Items | | 1 | | | |
| AMZN 07/03/23 | Supplies for JFL - REC / bh | Open | | 07/03/2023 | 08/04/2023 | 07/03/2023 | | | 139.86 |
| <i>P.O. Number</i> | <i>Item Description</i> | | | <i>Quantity</i> | <i>U/M</i> | <i>Amount/Unit</i> | <i>Total Amount</i> | <i>Vendor Catalog Part Number</i> | <i>Contract Number</i> |
| | Affiliate expense- reimbursed - Supplies for JFL - REC / bh | | | 1.0000 | EA | 139.8600 | 139.86 | | |
| | <i>G/L Account</i> | | | | | <i>Project</i> | | <i>Amount</i> | |
| | 22-4510-3997 (Playground & Recreation Fund-Recreation Programs-Affiliate expenses) | | | | | REC 1002 1900 (JFL) | | 139.86 | |
| | | | | Invoice Items | | 1 | | | |
| Bloomz 07/05 | Bloomz app yearly fee for Day Camp - REC / dr | Open | | 07/05/2023 | 08/04/2023 | 07/05/2023 | | | 125.00 |
| <i>P.O. Number</i> | <i>Item Description</i> | | | <i>Quantity</i> | <i>U/M</i> | <i>Amount/Unit</i> | <i>Total Amount</i> | <i>Vendor Catalog Part Number</i> | <i>Contract Number</i> |
| | Other Contractual Service - REC - Bloomz app yearly fee for Day Camp - REC | | | 1.0000 | EA | 125.0000 | 125.00 | | |
| | <i>G/L Account</i> | | | | | <i>Project</i> | | <i>Amount</i> | |
| | 22-4510-3999 (Playground & Recreation Fund-Recreation Programs-Other contractual services) | | | | | REC 1004 3120 (Day Camp) | | 125.00 | |
| | | | | Invoice Items | | 1 | | | |
| CHARMEATS 07/08 | Gift card truck driver (parade),band member rehearsals - REC / lh | Open | | 07/05/2023 | 08/04/2023 | 07/05/2023 | | | 77.99 |
| <i>P.O. Number</i> | <i>Item Description</i> | | | <i>Quantity</i> | <i>U/M</i> | <i>Amount/Unit</i> | <i>Total Amount</i> | <i>Vendor Catalog Part Number</i> | <i>Contract Number</i> |
| | Affiliate expense- reimbursed - Gift card truck driver(parade),band member rehearsals - REC / lh | | | 1.0000 | EA | 77.9900 | 77.99 | | |
| | <i>G/L Account</i> | | | | | <i>Project</i> | | <i>Amount</i> | |
| | 22-4510-3997 (Playground & Recreation Fund-Recreation Programs-Affiliate expenses) | | | | | REC 1010 6080 (Community Band) | | 77.99 | |
| | | | | Invoice Items | | 1 | | | |



Accounts Payable Invoice Report - Council

08/01/2023

Invoice Due Date Range 07/22/23 - 08/04/23

Report By Vendor - Invoice

| Invoice Number | Invoice Description | Status | Held Reason | Invoice Date | Due Date | G/L Date | Received Date | Payment Date | Invoice Net Amount |
|--------------------|--|--------|---------------|-----------------|------------|--------------------------------|---------------------|-----------------------------------|------------------------|
| CHARRURAL 07/05 | Bottled water for band members - REC / lh | Open | | 07/05/2023 | 08/04/2023 | 07/05/2023 | | | 11.56 |
| <i>P.O. Number</i> | <i>Item Description</i> | | | <i>Quantity</i> | <i>U/M</i> | <i>Amount/Unit</i> | <i>Total Amount</i> | <i>Vendor Catalog Part Number</i> | <i>Contract Number</i> |
| | Affiliate expense- reimbursed - Bottled water for band members - REC / lh | | | 1.0000 | EA | 11.5600 | 11.56 | | |
| | <i>G/L Account</i> | | | | | <i>Project</i> | | <i>Amount</i> | |
| | 22-4510-3997 (Playground & Recreation Fund-Recreation Programs-Affiliate expenses) | | | | | REC 1010 6080 (Community Band) | | 11.56 | |
| | | | Invoice Items | | | 1 | | | |
| WB's 07/06 | Gift card for Community Band incentive for rehearsals - REC / lh | Open | | 07/06/2023 | 08/04/2023 | 07/06/2023 | | | 25.00 |
| <i>P.O. Number</i> | <i>Item Description</i> | | | <i>Quantity</i> | <i>U/M</i> | <i>Amount/Unit</i> | <i>Total Amount</i> | <i>Vendor Catalog Part Number</i> | <i>Contract Number</i> |
| | Affiliate expense- reimbursed - Gift card for Community Band incentive for rehearsals - REC / lh | | | 1.0000 | EA | 25.0000 | 25.00 | | |
| | <i>G/L Account</i> | | | | | <i>Project</i> | | <i>Amount</i> | |
| | 22-4510-3997 (Playground & Recreation Fund-Recreation Programs-Affiliate expenses) | | | | | REC 1010 6080 (Community Band) | | 25.00 | |
| | | | Invoice Items | | | 1 | | | |
| Dairy Q 06/22 | Ice cream for field trip - REC / hd | Open | | 07/24/2023 | 08/04/2023 | 07/24/2023 | | | 156.22 |
| <i>P.O. Number</i> | <i>Item Description</i> | | | <i>Quantity</i> | <i>U/M</i> | <i>Amount/Unit</i> | <i>Total Amount</i> | <i>Vendor Catalog Part Number</i> | <i>Contract Number</i> |
| | Other Supplies / REC - Ice cream for field trip - REC / hd | | | 1.0000 | EA | 156.2200 | 156.22 | | |
| | <i>G/L Account</i> | | | | | <i>Project</i> | | <i>Amount</i> | |
| | 22-4510-2119 (Playground & Recreation Fund-Recreation Programs-Other supplies) | | | | | REC 1004 3120 (Day Camp) | | 156.22 | |
| | | | Invoice Items | | | 1 | | | |
| Grammar 6/16 | Grammarly subscription for Director - REC / dr | Open | | 07/24/2023 | 08/04/2023 | 07/24/2023 | | | 72.00 |
| <i>P.O. Number</i> | <i>Item Description</i> | | | <i>Quantity</i> | <i>U/M</i> | <i>Amount/Unit</i> | <i>Total Amount</i> | <i>Vendor Catalog Part Number</i> | <i>Contract Number</i> |
| | Office Supplies - REC - Grammarly subscription for Director - REC / dr | | | 1.0000 | EA | 72.0000 | 72.00 | | |
| | <i>G/L Account</i> | | | | | <i>Project</i> | | <i>Amount</i> | |
| | 22-4510-2001 (Playground & Recreation Fund-Recreation Programs-Office supplies) | | | | | | | 72.00 | |
| | | | Invoice Items | | | 1 | | | |
| WM SUP 06/16 | Snacks for Movie night - REC / dr | Open | | 07/24/2023 | 08/04/2023 | 07/24/2023 | | | 42.68 |
| <i>P.O. Number</i> | <i>Item Description</i> | | | <i>Quantity</i> | <i>U/M</i> | <i>Amount/Unit</i> | <i>Total Amount</i> | <i>Vendor Catalog Part Number</i> | <i>Contract Number</i> |
| | Other Supplies / REC - Snacks for Movie night - REC / dr | | | 1.0000 | EA | 42.6800 | 42.68 | | |
| | <i>G/L Account</i> | | | | | <i>Project</i> | | <i>Amount</i> | |
| | | | | | | | | | |



Accounts Payable Invoice Report - Council

08/01/2023

Invoice Due Date Range 07/22/23 - 08/04/23

Report By Vendor - Invoice

| Invoice Number | Invoice Description | Status | Held Reason | Invoice Date | Due Date | G/L Date | Received Date | Payment Date | Invoice Net Amount |
|---|--|--------|-------------|-----------------|------------|------------------------------------|---------------------|-----------------------------------|------------------------|
| WM SUP 06/16 | Snacks for Movie night - REC / dr | Open | | 07/24/2023 | 08/04/2023 | 07/24/2023 | | | 42.68 |
| <i>P.O. Number</i> | <i>Item Description</i> | | | <i>Quantity</i> | <i>U/M</i> | <i>Amount/Unit</i> | <i>Total Amount</i> | <i>Vendor Catalog Part Number</i> | <i>Contract Number</i> |
| | 22-4510-2119 (Playground & Recreation Fund-Recreation Programs- Other supplies) | | | | | REC 1008 5060 (Family Movie Night) | | 42.68 | |
| | | | | Invoice Items | | 1 | | | |
| Vendor 2716 - BANK OF AMERICA Commercial Card Totals | | | | | | | Invoices | 29 | \$5,420.16 |
| Vendor 1075 - BATTERY SPECIALISTS | | | | | | | | | |
| 312102 | WW Misc. Supplies | Open | | 07/12/2023 | 08/04/2023 | 07/12/2023 | | | 38.95 |
| <i>P.O. Number</i> | <i>Item Description</i> | | | <i>Quantity</i> | <i>U/M</i> | <i>Amount/Unit</i> | <i>Total Amount</i> | <i>Vendor Catalog Part Number</i> | <i>Contract Number</i> |
| | Other repair & maintenance - WW Misc. Supplies | | | 1.0000 | EA | 38.9500 | 38.95 | | |
| | <i>G/L Account</i> | | | | | <i>Project</i> | | <i>Amount</i> | |
| | 61-4621-2310 (Water and Sewer Fund-Waste Water Treatment Plant- Other maintenance supplies) | | | | | 0000 (0000 - Misc. Equip.) | | 38.95 | |
| | | | | Invoice Items | | 1 | | | |
| Vendor 1075 - BATTERY SPECIALISTS Totals | | | | | | | Invoices | 1 | \$38.95 |
| Vendor 3653 - BERNS, CLANCY AND ASSOCIATES | | | | | | | | | |
| invoice 14 | Eng on EIU Water Tower/ WTP | Open | | 07/19/2023 | 08/04/2023 | 07/19/2023 | | | 5,806.55 |
| <i>P.O. Number</i> | <i>Item Description</i> | | | <i>Quantity</i> | <i>U/M</i> | <i>Amount/Unit</i> | <i>Total Amount</i> | <i>Vendor Catalog Part Number</i> | <i>Contract Number</i> |
| | Architect & Engineering Services - Eng on EIU Water Tower/ WTP | | | 1.0000 | EA | 5,806.5500 | 5,806.55 | | |
| | <i>G/L Account</i> | | | | | <i>Project</i> | | <i>Amount</i> | |
| | 61-4611-3103 (Water and Sewer Fund-Water Treatment Plant-Architect & engineering services) | | | | | PW 21 63 (EIU Water Tower) | | 5,806.55 | |
| | | | | Invoice Items | | 1 | | | |
| Vendor 3653 - BERNS, CLANCY AND ASSOCIATES Totals | | | | | | | Invoices | 1 | \$5,806.55 |
| Vendor 1089 - BIRKEY'S | | | | | | | | | |
| P48108 | Pin for Hydraulic Thumb/UTILITY | Open | | 06/28/2023 | 08/04/2023 | 06/28/2023 | | | 595.71 |
| <i>P.O. Number</i> | <i>Item Description</i> | | | <i>Quantity</i> | <i>U/M</i> | <i>Amount/Unit</i> | <i>Total Amount</i> | <i>Vendor Catalog Part Number</i> | <i>Contract Number</i> |
| | 1/4 page full color ad/tourism - Pin for Hydraulic Thumb/UTILITY | | | 1.0000 | EA | 595.7100 | 595.71 | | |
| | <i>G/L Account</i> | | | | | <i>Project</i> | | <i>Amount</i> | |
| | 61-4610-3508 (Water and Sewer Fund-Utility Department-Repair of operating equipment) | | | | | 1433 (Excavator - Case CX80C) | | 595.71 | |
| | | | | Invoice Items | | 1 | | | |



Accounts Payable Invoice Report - Council

08/01/2023

Invoice Due Date Range 07/22/23 - 08/04/23

Report By Vendor - Invoice

| Invoice Number | Invoice Description | Status | Held Reason | Invoice Date | Due Date | G/L Date | Received Date | Payment Date | Invoice Net Amount |
|--------------------------------------|--|--------|-----------------|---|--------------------|---------------------|-----------------------------------|------------------------|--------------------|
| P48168 | Belt, Tran/STREET | Open | | 06/30/2023 | 08/04/2023 | 06/30/2023 | | | 80.00 |
| <i>P.O. Number</i> | <i>Item Description</i> | | <i>Quantity</i> | <i>U/M</i> | <i>Amount/Unit</i> | <i>Total Amount</i> | <i>Vendor Catalog Part Number</i> | <i>Contract Number</i> | |
| | 1/4 page full color ad/tourism - Belt, Tran/STREET | | 1.0000 | EA | 80.0000 | 80.00 | | | |
| | <i>G/L Account</i> | | | <i>Project</i> | <i>Amount</i> | | | | |
| | 11-4310-3508 (General Fund-Street Department-Repair of operating equipment) | | | 5095 (2020 CASE 590SN Backhoe) | 80.00 | | | | |
| | <i>Invoice Items</i> | | | 1 | | | | | |
| P48454 | Hydraulic Tube-Hose/UTILITY | Open | | 07/13/2023 | 08/04/2023 | 07/13/2023 | | | 185.25 |
| <i>P.O. Number</i> | <i>Item Description</i> | | <i>Quantity</i> | <i>U/M</i> | <i>Amount/Unit</i> | <i>Total Amount</i> | <i>Vendor Catalog Part Number</i> | <i>Contract Number</i> | |
| | 1/4 page full color ad/tourism - Hydraulic Tube-Hose/UTILITY | | 1.0000 | EA | 185.2500 | 185.25 | | | |
| | <i>G/L Account</i> | | | <i>Project</i> | <i>Amount</i> | | | | |
| | 61-4610-3508 (Water and Sewer Fund-Utility Department-Repair of operating equipment) | | | 5133 (5133 - 2014 Case 590 SN Loader backhoe) | 185.25 | | | | |
| | <i>Invoice Items</i> | | | 1 | | | | | |
| P48039 | Power washer, hose, valve and discharge - MAINT | Open | | 06/26/2023 | 08/04/2023 | 06/26/2023 | | | 792.41 |
| <i>P.O. Number</i> | <i>Item Description</i> | | <i>Quantity</i> | <i>U/M</i> | <i>Amount/Unit</i> | <i>Total Amount</i> | <i>Vendor Catalog Part Number</i> | <i>Contract Number</i> | |
| | Vehicle parts & supplies / MAINT - Power washer, hose, valve and discharge - MAINT | | 1.0000 | EA | 792.4100 | 792.41 | | | |
| | <i>G/L Account</i> | | | <i>Project</i> | <i>Amount</i> | | | | |
| | 11-4194-2401 (General Fund-Parks & Maintenance Department-Vehicle parts & supplies) | | | 0000 (0000 - Misc. Equip.) | 792.41 | | | | |
| | <i>Invoice Items</i> | | | 1 | | | | | |
| P48433 | Pump for washer - MAINT | Open | | 07/13/2023 | 08/04/2023 | 07/13/2023 | | | 555.00 |
| <i>P.O. Number</i> | <i>Item Description</i> | | <i>Quantity</i> | <i>U/M</i> | <i>Amount/Unit</i> | <i>Total Amount</i> | <i>Vendor Catalog Part Number</i> | <i>Contract Number</i> | |
| | Vehicle parts & supplies / MAINT - Pump for washer - MAINT | | 1.0000 | EA | 555.0000 | 555.00 | | | |
| | <i>G/L Account</i> | | | <i>Project</i> | <i>Amount</i> | | | | |
| | 11-4194-2401 (General Fund-Parks & Maintenance Department-Vehicle parts & supplies) | | | 0000 (0000 - Misc. Equip.) | 555.00 | | | | |
| | <i>Invoice Items</i> | | | 1 | | | | | |
| Vendor 1089 - BIRKEY'S Totals | | | | | Invoices | 5 | | | \$2,208.37 |
| Vendor 4680 - INC BLOOMZ | | | | | | | | | |
| 4669 | Bloomz parent app - REC | Open | | 07/06/2023 | 08/04/2023 | 07/06/2023 | | | 1,248.75 |
| <i>P.O. Number</i> | <i>Item Description</i> | | <i>Quantity</i> | <i>U/M</i> | <i>Amount/Unit</i> | <i>Total Amount</i> | <i>Vendor Catalog Part Number</i> | <i>Contract Number</i> | |
| | Other Contractual Service - REC - Bloomz parent app - REC | | 1.0000 | EA | 1,248.7500 | 1,248.75 | | | |
| | <i>G/L Account</i> | | | <i>Project</i> | <i>Amount</i> | | | | |



Accounts Payable Invoice Report - Council

08/01/2023

Invoice Due Date Range 07/22/23 - 08/04/23

Report By Vendor - Invoice

| Invoice Number | Invoice Description | Status | Held Reason | Invoice Date | Due Date | G/L Date | Received Date | Payment Date | Invoice Net Amount |
|---|---|--------|-----------------|--------------|----------------------------|---------------------|-----------------------------------|------------------------|--------------------|
| 4669 | Bloomz parent app - REC | Open | | 07/06/2023 | 08/04/2023 | 07/06/2023 | | | 1,248.75 |
| <i>P.O. Number</i> | <i>Item Description</i> | | <i>Quantity</i> | <i>U/M</i> | <i>Amount/Unit</i> | <i>Total Amount</i> | <i>Vendor Catalog Part Number</i> | <i>Contract Number</i> | |
| | 22-4510-3999 (Playground & Recreation Fund-Recreation Programs- Other contractual services) | | | | REC 1004 3120 (Day Camp) | | | 1,248.75 | |
| | | | Invoice Items | 1 | | | | | |
| Vendor 4680 - INC BLOOMZ Totals | | | | | | | | | \$1,248.75 |
| Vendor 4449 - BLUE CROSS BLUE SHIELD OF ILLINOIS - DENTAL | | | | | | | | | |
| 7/17/23 | August 2023 Premium / EBHR | Open | | 07/17/2023 | 08/04/2023 | 07/17/2023 | | | 6,675.58 |
| <i>P.O. Number</i> | <i>Item Description</i> | | <i>Quantity</i> | <i>U/M</i> | <i>Amount/Unit</i> | <i>Total Amount</i> | <i>Vendor Catalog Part Number</i> | <i>Contract Number</i> | |
| | Dental insurance employee voluntary deduction / EB - August 2023 Premium / EBHR | | 1.0000 | EA | 6,675.5800 | 6,675.58 | | | |
| | <i>G/L Account</i> | | | | <i>Project</i> | | | <i>Amount</i> | |
| | 11-2033 (General Fund-Other voluntary deductions) | | | | | | | 6,675.58 | |
| | | | Invoice Items | 1 | | | | | |
| Vendor 4449 - BLUE CROSS BLUE SHIELD OF ILLINOIS - DENTAL Totals | | | | | | | | | \$6,675.58 |
| Vendor 2947 - BPC - BENEFIT PLANNING CONSULTANTS | | | | | | | | | |
| BPC100312075 | Flex & COBRA August 2023 / EBHR | Open | | 07/13/2023 | 08/04/2023 | 07/13/2023 | | | 216.20 |
| <i>P.O. Number</i> | <i>Item Description</i> | | <i>Quantity</i> | <i>U/M</i> | <i>Amount/Unit</i> | <i>Total Amount</i> | <i>Vendor Catalog Part Number</i> | <i>Contract Number</i> | |
| | Other consulting services - Flex & COBRA August 2023 / EBHR | | 1.0000 | EA | 216.2000 | 216.20 | | | |
| | <i>G/L Account</i> | | | | <i>Project</i> | | | <i>Amount</i> | |
| | 11-4700-3106 (General Fund-Human Resources-Other consulting services) | | | | | | | 216.20 | |
| | | | Invoice Items | 1 | | | | | |
| Vendor 2947 - BPC - BENEFIT PLANNING CONSULTANTS Totals | | | | | | | | | \$216.20 |
| Vendor 1130 - CDW GOVERNMENT INC | | | | | | | | | |
| KN07442 | FHD display/IS | Open | | 07/03/2023 | 08/04/2023 | 07/03/2023 | | | 527.31 |
| <i>P.O. Number</i> | <i>Item Description</i> | | <i>Quantity</i> | <i>U/M</i> | <i>Amount/Unit</i> | <i>Total Amount</i> | <i>Vendor Catalog Part Number</i> | <i>Contract Number</i> | |
| | Office furniture and equipment - FHD display/IS | | 1.0000 | EA | 527.3100 | 527.31 | | | |
| | <i>G/L Account</i> | | | | <i>Project</i> | | | <i>Amount</i> | |
| | 11-4060-4499 (General Fund-Information Services-Office furniture & equipment) | | | | 0000 (0000 - Misc. Equip.) | | | 527.31 | |
| | | | Invoice Items | 1 | | | | | |
| Vendor 1130 - CDW GOVERNMENT INC Totals | | | | | | | | | \$527.31 |
| Vendor 4478 - CHAMPAIGN SIGNAL AND LIGHTING COMPANY INC | | | | | | | | | |



Accounts Payable Invoice Report - Council

08/01/2023

Invoice Due Date Range 07/22/23 - 08/04/23

Report By Vendor - Invoice

| Invoice Number | Invoice Description | Status | Held Reason | Invoice Date | Due Date | G/L Date | Received Date | Payment Date | Invoice Net Amount |
|---|---|--------|-------------|-----------------|------------|----------------------------|---------------------|-----------------------------------|------------------------|
| 2340-001.72 | Rt. 16 & 9th Street Damage to Pedestrian Post/MOTOR FUEL TAX | Open | | 07/06/2023 | 08/04/2023 | 07/06/2023 | | | 4,350.90 |
| <i>P.O. Number</i> | <i>Item Description</i> | | | <i>Quantity</i> | <i>U/M</i> | <i>Amount/Unit</i> | <i>Total Amount</i> | <i>Vendor Catalog Part Number</i> | <i>Contract Number</i> |
| | 1/4 page full color ad/tourism - Rt. 16 & 9th Street Damage to Pedestrian Post/MOTOR FUEL TAX | | | 1.0000 | EA | 4,350.9000 | 4,350.90 | | |
| | <i>G/L Account</i> | | | | | <i>Project</i> | | <i>Amount</i> | |
| | 25-4312-2305 (Motor Fuel Tax Fund-Motor Fuel Tax Department-Traffic signal maintenance) | | | | | PW 23 05 (MFT Commodities) | | 4,350.90 | |
| | Invoice Items | | | 1 | | | | | |
| Vendor 4478 - CHAMPAIGN SIGNAL AND LIGHTING COMPANY INC Totals | | | | | | | Invoices | 1 | \$4,350.90 |
| Vendor 1155 - CHARLESTON STONE CO 3876 | CA6 for Shop (170.42 Tons)/MOTOR FUEL TAX | Open | | 06/30/2023 | 08/04/2023 | 06/30/2023 | | | 2,897.14 |
| <i>P.O. Number</i> | <i>Item Description</i> | | | <i>Quantity</i> | <i>U/M</i> | <i>Amount/Unit</i> | <i>Total Amount</i> | <i>Vendor Catalog Part Number</i> | <i>Contract Number</i> |
| | 1/4 page full color ad/tourism - CA6 for Shop (170.42 Tons)/MOTOR FUEL TAX | | | 1.0000 | EA | 2,897.1400 | 2,897.14 | | |
| | <i>G/L Account</i> | | | | | <i>Project</i> | | <i>Amount</i> | |
| | 25-4312-2503 (Motor Fuel Tax Fund-Motor Fuel Tax Department-Rock & sand) | | | | | PW 23 05 (MFT Commodities) | | 2,897.14 | |
| | Invoice Items | | | 1 | | | | | |
| Vendor 1155 - CHARLESTON STONE CO Totals | | | | | | | Invoices | 1 | \$2,897.14 |
| Vendor 4477 - CINTAS 4160990373 | Black mats/PD | Open | | 07/10/2023 | 08/04/2023 | 07/10/2023 | | | 15.16 |
| <i>P.O. Number</i> | <i>Item Description</i> | | | <i>Quantity</i> | <i>U/M</i> | <i>Amount/Unit</i> | <i>Total Amount</i> | <i>Vendor Catalog Part Number</i> | <i>Contract Number</i> |
| | Repair of buildings and facilities - Black mats/PD | | | 1.0000 | EA | 15.1600 | 15.16 | | |
| | <i>G/L Account</i> | | | | | <i>Project</i> | | <i>Amount</i> | |
| | 11-4210-3510 (General Fund-Police Department-Repair of buildings & facilities) | | | | | | | 15.16 | |
| | Invoice Items | | | 1 | | | | | |
| 4161677549 | Black mats/PD | Open | | 07/17/2023 | 08/04/2023 | 07/17/2023 | | | 15.16 |
| <i>P.O. Number</i> | <i>Item Description</i> | | | <i>Quantity</i> | <i>U/M</i> | <i>Amount/Unit</i> | <i>Total Amount</i> | <i>Vendor Catalog Part Number</i> | <i>Contract Number</i> |
| | Repair of buildings and facilities - Black mats/PD | | | 1.0000 | EA | 15.1600 | 15.16 | | |
| | <i>G/L Account</i> | | | | | <i>Project</i> | | <i>Amount</i> | |
| | 11-4210-3510 (General Fund-Police Department-Repair of buildings & facilities) | | | | | | | 15.16 | |
| | Invoice Items | | | 1 | | | | | |



Accounts Payable Invoice Report - Council

08/01/2023

Invoice Due Date Range 07/22/23 - 08/04/23

Report By Vendor - Invoice

| Invoice Number | Invoice Description | Status | Held Reason | Invoice Date | Due Date | G/L Date | Received Date | Payment Date | Invoice Net Amount |
|--------------------|--|--------|-----------------|---------------|--------------------|---------------------|-----------------------------------|------------------------|--------------------|
| 4162370550 | Black mats/PD | Open | | 07/24/2023 | 08/04/2023 | 07/24/2023 | | | 15.16 |
| <i>P.O. Number</i> | <i>Item Description</i> | | <i>Quantity</i> | <i>U/M</i> | <i>Amount/Unit</i> | <i>Total Amount</i> | <i>Vendor Catalog Part Number</i> | <i>Contract Number</i> | |
| | Repair of buildings and facilities - Black mats/PD | | 1.0000 | EA | 15.1600 | 15.16 | | | |
| | <i>G/L Account</i> | | | | <i>Project</i> | | | <i>Amount</i> | |
| | 11-4210-3510 (General Fund-Police Department-Repair of buildings & facilities) | | | | | | | 15.16 | |
| | | | | Invoice Items | 1 | | | | |
| 4160033756 | Uniforms/STREET | Open | | 06/29/2023 | 08/04/2023 | 06/29/2023 | | | 28.36 |
| <i>P.O. Number</i> | <i>Item Description</i> | | <i>Quantity</i> | <i>U/M</i> | <i>Amount/Unit</i> | <i>Total Amount</i> | <i>Vendor Catalog Part Number</i> | <i>Contract Number</i> | |
| | 1/4 page full color ad/tourism - Uniforms/STREET | | 1.0000 | EA | 28.3600 | 28.36 | | | |
| | <i>G/L Account</i> | | | | <i>Project</i> | | | <i>Amount</i> | |
| | 11-4310-2701 (General Fund-Street Department-Uniforms) | | | | | | | 28.36 | |
| | | | | Invoice Items | 1 | | | | |
| 4160033877 | Uniforms/UTILITY | Open | | 06/29/2023 | 08/04/2023 | 06/29/2023 | | | 132.47 |
| <i>P.O. Number</i> | <i>Item Description</i> | | <i>Quantity</i> | <i>U/M</i> | <i>Amount/Unit</i> | <i>Total Amount</i> | <i>Vendor Catalog Part Number</i> | <i>Contract Number</i> | |
| | 1/4 page full color ad/tourism - Uniforms/UTILITY | | 1.0000 | EA | 132.4700 | 132.47 | | | |
| | <i>G/L Account</i> | | | | <i>Project</i> | | | <i>Amount</i> | |
| | 61-4610-2701 (Water and Sewer Fund-Utility Department-Uniforms) | | | | | | | 132.47 | |
| | | | | Invoice Items | 1 | | | | |
| 4160033894 | Uniforms/STREET | Open | | 06/29/2023 | 08/04/2023 | 06/29/2023 | | | 139.02 |
| <i>P.O. Number</i> | <i>Item Description</i> | | <i>Quantity</i> | <i>U/M</i> | <i>Amount/Unit</i> | <i>Total Amount</i> | <i>Vendor Catalog Part Number</i> | <i>Contract Number</i> | |
| | 1/4 page full color ad/tourism - Uniforms/STREET | | 1.0000 | EA | 139.0200 | 139.02 | | | |
| | <i>G/L Account</i> | | | | <i>Project</i> | | | <i>Amount</i> | |
| | 11-4310-2701 (General Fund-Street Department-Uniforms) | | | | | | | 139.02 | |
| | | | | Invoice Items | 1 | | | | |
| 4160837407 | Uniforms/STREET | Open | | 07/07/2023 | 08/04/2023 | 07/07/2023 | | | 35.24 |
| <i>P.O. Number</i> | <i>Item Description</i> | | <i>Quantity</i> | <i>U/M</i> | <i>Amount/Unit</i> | <i>Total Amount</i> | <i>Vendor Catalog Part Number</i> | <i>Contract Number</i> | |
| | 1/4 page full color ad/tourism - Uniforms/STREET | | 1.0000 | EA | 35.2400 | 35.24 | | | |
| | <i>G/L Account</i> | | | | <i>Project</i> | | | <i>Amount</i> | |
| | 11-4310-2701 (General Fund-Street Department-Uniforms) | | | | | | | 35.24 | |
| | | | | Invoice Items | 1 | | | | |



Accounts Payable Invoice Report - Council

08/01/2023

Invoice Due Date Range 07/22/23 - 08/04/23

Report By Vendor - Invoice

| Invoice Number | Invoice Description | Status | Held Reason | Invoice Date | Due Date | G/L Date | Received Date | Payment Date | Invoice Net Amount |
|--------------------|---|--------|-----------------|--------------|--------------------|---------------------|-----------------------------------|------------------------|--------------------|
| 4160837450 | Uniforms/STREET | Open | | 07/07/2023 | 08/04/2023 | 07/07/2023 | | | 139.02 |
| <i>P.O. Number</i> | <i>Item Description</i> | | <i>Quantity</i> | <i>U/M</i> | <i>Amount/Unit</i> | <i>Total Amount</i> | <i>Vendor Catalog Part Number</i> | <i>Contract Number</i> | |
| | 1/4 page full color ad/tourism - Uniforms/STREET | | 1.0000 | EA | 139.0200 | 139.02 | | | |
| | <i>G/L Account</i> | | | | <i>Project</i> | | | <i>Amount</i> | |
| | 11-4310-2701 (General Fund-Street Department-Uniforms) | | | | | | | 139.02 | |
| | <i>Invoice Items</i> | | | | 1 | | | | |
| 4160837561 | Uniforms/UTILITY | Open | | 07/07/2023 | 08/04/2023 | 07/07/2023 | | | 174.94 |
| <i>P.O. Number</i> | <i>Item Description</i> | | <i>Quantity</i> | <i>U/M</i> | <i>Amount/Unit</i> | <i>Total Amount</i> | <i>Vendor Catalog Part Number</i> | <i>Contract Number</i> | |
| | 1/4 page full color ad/tourism - Uniforms/UTILITY | | 1.0000 | EA | 174.9400 | 174.94 | | | |
| | <i>G/L Account</i> | | | | <i>Project</i> | | | <i>Amount</i> | |
| | 61-4610-2701 (Water and Sewer Fund-Utility Department-Uniforms) | | | | | | | 174.94 | |
| | <i>Invoice Items</i> | | | | 1 | | | | |
| 4161427986 | Uniforms/STREET | Open | | 07/13/2023 | 08/04/2023 | 07/13/2023 | | | 28.36 |
| <i>P.O. Number</i> | <i>Item Description</i> | | <i>Quantity</i> | <i>U/M</i> | <i>Amount/Unit</i> | <i>Total Amount</i> | <i>Vendor Catalog Part Number</i> | <i>Contract Number</i> | |
| | 1/4 page full color ad/tourism - Uniforms/STREET | | 1.0000 | EA | 28.3600 | 28.36 | | | |
| | <i>G/L Account</i> | | | | <i>Project</i> | | | <i>Amount</i> | |
| | 11-4310-2701 (General Fund-Street Department-Uniforms) | | | | | | | 28.36 | |
| | <i>Invoice Items</i> | | | | 1 | | | | |
| 4161428135 | Uniforms/STREET | Open | | 07/13/2023 | 08/04/2023 | 07/13/2023 | | | 139.02 |
| <i>P.O. Number</i> | <i>Item Description</i> | | <i>Quantity</i> | <i>U/M</i> | <i>Amount/Unit</i> | <i>Total Amount</i> | <i>Vendor Catalog Part Number</i> | <i>Contract Number</i> | |
| | 1/4 page full color ad/tourism - Uniforms/STREET | | 1.0000 | EA | 139.0200 | 139.02 | | | |
| | <i>G/L Account</i> | | | | <i>Project</i> | | | <i>Amount</i> | |
| | 11-4310-2701 (General Fund-Street Department-Uniforms) | | | | | | | 139.02 | |
| | <i>Invoice Items</i> | | | | 1 | | | | |
| 4161428193 | Uniforms/UTILITY | Open | | 07/13/2023 | 08/04/2023 | 07/13/2023 | | | 132.47 |
| <i>P.O. Number</i> | <i>Item Description</i> | | <i>Quantity</i> | <i>U/M</i> | <i>Amount/Unit</i> | <i>Total Amount</i> | <i>Vendor Catalog Part Number</i> | <i>Contract Number</i> | |
| | 1/4 page full color ad/tourism - Uniforms/UTILITY | | 1.0000 | EA | 132.4700 | 132.47 | | | |
| | <i>G/L Account</i> | | | | <i>Project</i> | | | <i>Amount</i> | |
| | 61-4610-2701 (Water and Sewer Fund-Utility Department-Uniforms) | | | | | | | 132.47 | |
| | <i>Invoice Items</i> | | | | 1 | | | | |
| 4162126092 | Uniforms/STREET | Open | | 07/20/2023 | 08/04/2023 | 07/20/2023 | | | 35.24 |
| <i>P.O. Number</i> | <i>Item Description</i> | | <i>Quantity</i> | <i>U/M</i> | <i>Amount/Unit</i> | <i>Total Amount</i> | <i>Vendor Catalog Part Number</i> | <i>Contract Number</i> | |
| | 1/4 page full color ad/tourism - Uniforms/STREET | | 1.0000 | EA | 35.2400 | 35.24 | | | |
| | <i>G/L Account</i> | | | | <i>Project</i> | | | <i>Amount</i> | |
| | | | | | | | | | |



Accounts Payable Invoice Report - Council

08/01/2023

Invoice Due Date Range 07/22/23 - 08/04/23

Report By Vendor - Invoice

| Invoice Number | Invoice Description | Status | Held Reason | Invoice Date | Due Date | G/L Date | Received Date | Payment Date | Invoice Net Amount |
|--------------------|---|--------|-----------------|--------------|--------------------|---------------------|-----------------------------------|------------------------|--------------------|
| 4162126092 | Uniforms/STREET | Open | | 07/20/2023 | 08/04/2023 | 07/20/2023 | | | 35.24 |
| <i>P.O. Number</i> | <i>Item Description</i> | | <i>Quantity</i> | <i>U/M</i> | <i>Amount/Unit</i> | <i>Total Amount</i> | <i>Vendor Catalog Part Number</i> | <i>Contract Number</i> | |
| | 11-4310-2701 (General Fund-Street Department-Uniforms) | | | | | | | 35.24 | |
| | | | Invoice Items | 1 | | | | | |
| 4162126140 | Uniforms/STREET | Open | | 07/20/2023 | 08/04/2023 | 07/20/2023 | | | 139.02 |
| <i>P.O. Number</i> | <i>Item Description</i> | | <i>Quantity</i> | <i>U/M</i> | <i>Amount/Unit</i> | <i>Total Amount</i> | <i>Vendor Catalog Part Number</i> | <i>Contract Number</i> | |
| | 1/4 page full color ad/tourism - Uniforms/STREET | | 1.0000 | EA | 139.0200 | 139.02 | | | |
| | <i>G/L Account</i> | | | | <i>Project</i> | | | <i>Amount</i> | |
| | 11-4310-2701 (General Fund-Street Department-Uniforms) | | | | | | | 139.02 | |
| | | | Invoice Items | 1 | | | | | |
| 4162126215 | Uniforms/UTILITY | Open | | 07/20/2023 | 08/04/2023 | 07/20/2023 | | | 171.62 |
| <i>P.O. Number</i> | <i>Item Description</i> | | <i>Quantity</i> | <i>U/M</i> | <i>Amount/Unit</i> | <i>Total Amount</i> | <i>Vendor Catalog Part Number</i> | <i>Contract Number</i> | |
| | 1/4 page full color ad/tourism - Uniforms/UTILITY | | 1.0000 | EA | 171.6200 | 171.62 | | | |
| | <i>G/L Account</i> | | | | <i>Project</i> | | | <i>Amount</i> | |
| | 61-4610-2701 (Water and Sewer Fund-Utility Department-Uniforms) | | | | | | | 171.62 | |
| | | | Invoice Items | 1 | | | | | |
| 4160033731 | Uniforms - MAINT | Open | | 06/29/2023 | 08/04/2023 | 06/29/2023 | | | 22.90 |
| <i>P.O. Number</i> | <i>Item Description</i> | | <i>Quantity</i> | <i>U/M</i> | <i>Amount/Unit</i> | <i>Total Amount</i> | <i>Vendor Catalog Part Number</i> | <i>Contract Number</i> | |
| | Uniforms / MAINT - Uniforms - MAINT | | 1.0000 | EA | 22.9000 | 22.90 | | | |
| | <i>G/L Account</i> | | | | <i>Project</i> | | | <i>Amount</i> | |
| | 11-4194-2701 (General Fund-Parks & Maintenance Department-Uniforms) | | | | | | | 22.90 | |
| | | | Invoice Items | 1 | | | | | |
| 4160837453 | Uniforms - MAINT | Open | | 07/07/2023 | 08/04/2023 | 07/07/2023 | | | 22.90 |
| <i>P.O. Number</i> | <i>Item Description</i> | | <i>Quantity</i> | <i>U/M</i> | <i>Amount/Unit</i> | <i>Total Amount</i> | <i>Vendor Catalog Part Number</i> | <i>Contract Number</i> | |
| | Uniforms / MAINT - Uniforms - MAINT | | 1.0000 | EA | 22.9000 | 22.90 | | | |
| | <i>G/L Account</i> | | | | <i>Project</i> | | | <i>Amount</i> | |
| | 11-4194-2701 (General Fund-Parks & Maintenance Department-Uniforms) | | | | | | | 22.90 | |
| | | | Invoice Items | 1 | | | | | |
| 4161427967 | Uniforms - MAINT | Open | | 07/13/2023 | 08/04/2023 | 07/13/2023 | | | 22.90 |
| <i>P.O. Number</i> | <i>Item Description</i> | | <i>Quantity</i> | <i>U/M</i> | <i>Amount/Unit</i> | <i>Total Amount</i> | <i>Vendor Catalog Part Number</i> | <i>Contract Number</i> | |
| | Uniforms / MAINT - Uniforms - MAINT | | 1.0000 | EA | 22.9000 | 22.90 | | | |
| | <i>G/L Account</i> | | | | <i>Project</i> | | | <i>Amount</i> | |
| | 11-4194-2701 (General Fund-Parks & Maintenance Department-Uniforms) | | | | | | | 22.90 | |
| | | | Invoice Items | 1 | | | | | |



Accounts Payable Invoice Report - Council

08/01/2023

Invoice Due Date Range 07/22/23 - 08/04/23

Report By Vendor - Invoice

| Invoice Number | Invoice Description | Status | Held Reason | Invoice Date | Due Date | G/L Date | Received Date | Payment Date | Invoice Net Amount |
|--|--|--------|-----------------|---------------|--------------------|---------------------|-----------------------------------|------------------------|--------------------|
| 4162126029 | Uniforms - MAINT | Open | | 07/20/2023 | 08/04/2023 | 07/20/2023 | | | 22.90 |
| <i>P.O. Number</i> | <i>Item Description</i> | | <i>Quantity</i> | <i>U/M</i> | <i>Amount/Unit</i> | <i>Total Amount</i> | <i>Vendor Catalog Part Number</i> | <i>Contract Number</i> | |
| | Uniforms / MAINT - Uniforms - MAINT | | 1.0000 | EA | 22.9000 | 22.90 | | | |
| | <i>G/L Account</i> | | | | <i>Project</i> | | | <i>Amount</i> | |
| | 11-4194-2701 (General Fund-Parks & Maintenance Department-Uniforms) | | | | | | | 22.90 | |
| | | | | Invoice Items | 1 | | | | |
| 4161677557 | WP Uniforms | Open | | 07/17/2023 | 08/04/2023 | 07/17/2023 | | | 94.52 |
| <i>P.O. Number</i> | <i>Item Description</i> | | <i>Quantity</i> | <i>U/M</i> | <i>Amount/Unit</i> | <i>Total Amount</i> | <i>Vendor Catalog Part Number</i> | <i>Contract Number</i> | |
| | Uniforms / WTP - WP Uniforms | | 1.0000 | EA | 94.5200 | 94.52 | | | |
| | <i>G/L Account</i> | | | | <i>Project</i> | | | <i>Amount</i> | |
| | 61-4611-2701 (Water and Sewer Fund-Water Treatment Plant-Uniforms) | | | | | | | 94.52 | |
| | | | | Invoice Items | 1 | | | | |
| 4162370469 | WP Uniforms | Open | | 07/24/2023 | 08/04/2023 | 07/24/2023 | | | 94.52 |
| <i>P.O. Number</i> | <i>Item Description</i> | | <i>Quantity</i> | <i>U/M</i> | <i>Amount/Unit</i> | <i>Total Amount</i> | <i>Vendor Catalog Part Number</i> | <i>Contract Number</i> | |
| | Uniforms / WTP - WP Uniforms | | 1.0000 | EA | 94.5200 | 94.52 | | | |
| | <i>G/L Account</i> | | | | <i>Project</i> | | | <i>Amount</i> | |
| | 61-4611-2701 (Water and Sewer Fund-Water Treatment Plant-Uniforms) | | | | | | | 94.52 | |
| | | | | Invoice Items | 1 | | | | |
| 4161427831 | Uniforms WWTP | Open | | 07/13/2023 | 08/04/2023 | 07/13/2023 | | | 66.48 |
| <i>P.O. Number</i> | <i>Item Description</i> | | <i>Quantity</i> | <i>U/M</i> | <i>Amount/Unit</i> | <i>Total Amount</i> | <i>Vendor Catalog Part Number</i> | <i>Contract Number</i> | |
| | Uniforms / WWTP - Uniforms WWTP | | 1.0000 | EA | 66.4800 | 66.48 | | | |
| | <i>G/L Account</i> | | | | <i>Project</i> | | | <i>Amount</i> | |
| | 61-4621-2701 (Water and Sewer Fund-Waste Water Treatment Plant-Uniforms) | | | | | | | 66.48 | |
| | | | | Invoice Items | 1 | | | | |
| 4162125996 | Uniforms WWTP | Open | | 07/20/2023 | 08/04/2023 | 07/20/2023 | | | 25.63 |
| <i>P.O. Number</i> | <i>Item Description</i> | | <i>Quantity</i> | <i>U/M</i> | <i>Amount/Unit</i> | <i>Total Amount</i> | <i>Vendor Catalog Part Number</i> | <i>Contract Number</i> | |
| | Uniforms / WWTP - Uniforms WWTP | | 1.0000 | EA | 25.6300 | 25.63 | | | |
| | <i>G/L Account</i> | | | | <i>Project</i> | | | <i>Amount</i> | |
| | 61-4621-2701 (Water and Sewer Fund-Waste Water Treatment Plant-Uniforms) | | | | | | | 25.63 | |
| | | | | Invoice Items | 1 | | | | |
| Vendor 4477 - CINTAS Totals | | | | | Invoices | 23 | | | \$1,713.01 |
| Vendor 1170 - CITY OF CHARLESTON/W&S DEPT | 2801 McKinley Ave- House/WTP | Open | | 07/14/2023 | 08/04/2023 | 07/14/2023 | | | 17.58 |
| <i>P.O. Number</i> | <i>Item Description</i> | | <i>Quantity</i> | <i>U/M</i> | <i>Amount/Unit</i> | <i>Total Amount</i> | <i>Vendor Catalog Part Number</i> | <i>Contract Number</i> | |
| | Water service | | 1.0000 | EA | 17.5800 | 17.58 | | | |
| | <i>G/L Account</i> | | | | <i>Project</i> | | | <i>Amount</i> | |



Accounts Payable Invoice Report - Council

08/01/2023

Invoice Due Date Range 07/22/23 - 08/04/23

Report By Vendor - Invoice

| Invoice Number | Invoice Description | Status | Held Reason | Invoice Date | Due Date | G/L Date | Received Date | Payment Date | Invoice Net Amount |
|--------------------|--|--------|-----------------|--------------|---------------------------------|---------------------|-----------------------------------|------------------------|--------------------|
| 1030140002 07/23 | 2801 McKinley Ave- House/WTP | Open | | 07/14/2023 | 08/04/2023 | 07/14/2023 | | | 17.58 |
| <i>P.O. Number</i> | <i>Item Description</i> | | <i>Quantity</i> | <i>U/M</i> | <i>Amount/Unit</i> | <i>Total Amount</i> | <i>Vendor Catalog Part Number</i> | <i>Contract Number</i> | |
| | 61-4611-3407 (Water and Sewer Fund-Water Treatment Plant-Water) | | | | | | | 17.58 | |
| | | | Invoice Items | | 1 | | | | |
| 1031590033 07/23 | 1600 A Woodlawn - Sister city pavilion/MAINT | Open | | 07/14/2023 | 08/04/2023 | 07/14/2023 | | | 17.58 |
| <i>P.O. Number</i> | <i>Item Description</i> | | <i>Quantity</i> | <i>U/M</i> | <i>Amount/Unit</i> | <i>Total Amount</i> | <i>Vendor Catalog Part Number</i> | <i>Contract Number</i> | |
| | Water service | | 1.0000 | EA | 17.5800 | 17.58 | | | |
| | <i>G/L Account</i> | | | | <i>Project</i> | | | <i>Amount</i> | |
| | 11-4194-3407 (General Fund-Parks & Maintenance Department-Water) | | | | PK 1011 (SISTER CITY PARK) | | | 17.58 | |
| | | | Invoice Items | | 1 | | | | |
| 1031600032 07/23 | 1600 Woodlawn - Sister City Pavilion | Open | | 07/14/2023 | 08/04/2023 | 07/14/2023 | | | 17.58 |
| <i>P.O. Number</i> | <i>Item Description</i> | | <i>Quantity</i> | <i>U/M</i> | <i>Amount/Unit</i> | <i>Total Amount</i> | <i>Vendor Catalog Part Number</i> | <i>Contract Number</i> | |
| | Water | | 1.0000 | EA | 17.5800 | 17.58 | | | |
| | <i>G/L Account</i> | | | | <i>Project</i> | | | <i>Amount</i> | |
| | 11-4194-3407 (General Fund-Parks & Maintenance Department-Water) | | | | PK 1011 (SISTER CITY PARK) | | | 17.58 | |
| | | | Invoice Items | | 1 | | | | |
| 1031640001 07/23 | 2901 Community Drive | Open | | 07/14/2023 | 08/04/2023 | 07/14/2023 | | | 17.58 |
| <i>P.O. Number</i> | <i>Item Description</i> | | <i>Quantity</i> | <i>U/M</i> | <i>Amount/Unit</i> | <i>Total Amount</i> | <i>Vendor Catalog Part Number</i> | <i>Contract Number</i> | |
| | Water service | | 1.0000 | EA | 17.5800 | 17.58 | | | |
| | <i>G/L Account</i> | | | | <i>Project</i> | | | <i>Amount</i> | |
| | 11-4194-3407 (General Fund-Parks & Maintenance Department-Water) | | | | PK 1012 (LINDER SPORTS COMPLEX) | | | 17.58 | |
| | | | Invoice Items | | 1 | | | | |
| 1091015002 07/23 | 17801 Lake Charleston Pavilion/MAINT | Open | | 07/14/2023 | 08/04/2023 | 07/14/2023 | | | 53.79 |
| <i>P.O. Number</i> | <i>Item Description</i> | | <i>Quantity</i> | <i>U/M</i> | <i>Amount/Unit</i> | <i>Total Amount</i> | <i>Vendor Catalog Part Number</i> | <i>Contract Number</i> | |
| | Water service | | 1.0000 | EA | 53.7900 | 53.79 | | | |
| | <i>G/L Account</i> | | | | <i>Project</i> | | | <i>Amount</i> | |
| | 11-4194-3407 (General Fund-Parks & Maintenance Department-Water) | | | | PK 1014 (LAKE CHARLESTON) | | | 53.79 | |
| | | | Invoice Items | | 1 | | | | |
| 1031630001 07/23 | 2901 Irrigation Community Dr | Open | | 07/19/2023 | 08/04/2023 | 07/19/2023 | | | 2,102.86 |
| <i>P.O. Number</i> | <i>Item Description</i> | | <i>Quantity</i> | <i>U/M</i> | <i>Amount/Unit</i> | <i>Total Amount</i> | <i>Vendor Catalog Part Number</i> | <i>Contract Number</i> | |
| | Water service | | 1.0000 | EA | 2,102.8600 | 2,102.86 | | | |
| | <i>G/L Account</i> | | | | <i>Project</i> | | | <i>Amount</i> | |
| | 11-4194-3407 (General Fund-Parks & Maintenance Department-Water) | | | | PK 1012 (LINDER SPORTS COMPLEX) | | | 2,102.86 | |
| | | | Invoice Items | | 1 | | | | |



Accounts Payable Invoice Report - Council

08/01/2023

Invoice Due Date Range 07/22/23 - 08/04/23

Report By Vendor - Invoice

| Invoice Number | Invoice Description | Status | Held Reason | Invoice Date | Due Date | G/L Date | Received Date | Payment Date | Invoice Net Amount |
|---|---|--------|-------------|---------------------------|------------|--------------------|---------------------|-----------------------------------|------------------------------|
| 1090915019 07/23 | 6050 Rt130 Woodyard/MAINT | Open | | 07/19/2023 | 08/04/2023 | 07/19/2023 | | | 15.82 |
| <i>P.O. Number</i> | <i>Item Description</i> | | | <i>Quantity</i> | <i>U/M</i> | <i>Amount/Unit</i> | <i>Total Amount</i> | <i>Vendor Catalog Part Number</i> | <i>Contract Number</i> |
| | Water service | | | 1.0000 | EA | 15.8200 | 15.82 | | |
| | <i>G/L Account</i> | | | <i>Project</i> | | | <i>Amount</i> | | |
| | 11-4194-3407 (General Fund-Parks & Maintenance Department-Water) | | | PK 1013 (WOODYARD PARK) | | | 15.82 | | |
| | | | | <i>Invoice Items</i> | | | 1 | | |
| Vendor 1170 - CITY OF CHARLESTON/W&S DEPT Totals | | | | | | | | | Invoices 9 <u>\$2,276.19</u> |
| Vendor 3675 - COBAN TECHNOLOGIES, INC. | | | | | | | | | |
| 53072 | Uniform - molle dock/PD | Open | | 07/19/2023 | 08/04/2023 | 07/19/2023 | | | 99.00 |
| <i>P.O. Number</i> | <i>Item Description</i> | | | <i>Quantity</i> | <i>U/M</i> | <i>Amount/Unit</i> | <i>Total Amount</i> | <i>Vendor Catalog Part Number</i> | <i>Contract Number</i> |
| | Uniforms / PD - Uniform - molle dock/PD | | | 1.0000 | EA | 99.0000 | 99.00 | | |
| | <i>G/L Account</i> | | | <i>Project</i> | | | <i>Amount</i> | | |
| | 11-4210-2701 (General Fund-Police Department-Uniforms) | | | PK 1014 (LAKE CHARLESTON) | | | 99.00 | | |
| | | | | <i>Invoice Items</i> | | | 1 | | |
| Vendor 3675 - COBAN TECHNOLOGIES, INC. Totals | | | | | | | | | Invoices 1 <u>\$99.00</u> |
| Vendor 2937 - COLES COUNTY COUNCIL ON AGING | | | | | | | | | |
| 08/01/2023 | Monthly payment/ADMIN | Open | | 08/01/2023 | 08/04/2023 | 08/01/2023 | | | 2,150.00 |
| <i>P.O. Number</i> | <i>Item Description</i> | | | <i>Quantity</i> | <i>U/M</i> | <i>Amount/Unit</i> | <i>Total Amount</i> | <i>Vendor Catalog Part Number</i> | <i>Contract Number</i> |
| | Other contractual services - Monthly payment/ADMIN | | | 1.0000 | EA | 2,150.0000 | 2,150.00 | | |
| | <i>G/L Account</i> | | | <i>Project</i> | | | <i>Amount</i> | | |
| | 11-4001-3999 (General Fund-Administration & Boards- Manager-Other contractual services) | | | | | | 2,150.00 | | |
| | | | | <i>Invoice Items</i> | | | 1 | | |
| Vendor 2937 - COLES COUNTY COUNCIL ON AGING Totals | | | | | | | | | Invoices 1 <u>\$2,150.00</u> |
| Vendor 1193 - COLES COUNTY EMERGENCY COMMUNICATIONS | | | | | | | | | |



Accounts Payable Invoice Report - Council

08/01/2023

Invoice Due Date Range 07/22/23 - 08/04/23

Report By Vendor - Invoice

| Invoice Number | Invoice Description | Status | Held Reason | Invoice Date | Due Date | G/L Date | Received Date | Payment Date | Invoice Net Amount |
|---|--|--------|-----------------|----------------|--------------------|---------------------|-----------------------------------|------------------------|-------------------------------|
| 08/01/2023 FD | Monthly dispatch service/FD | Open | | 08/01/2023 | 08/04/2023 | 08/01/2023 | | | 2,320.72 |
| <i>P.O. Number</i> | <i>Item Description</i> | | <i>Quantity</i> | <i>U/M</i> | <i>Amount/Unit</i> | <i>Total Amount</i> | <i>Vendor Catalog Part Number</i> | <i>Contract Number</i> | |
| | Other business services - Monthly dispatch service/FD | | 1.0000 | EA | 2,320.7200 | 2,320.72 | | | |
| | <i>G/L Account</i> | | | <i>Project</i> | | | | <i>Amount</i> | |
| | 11-4221-3199 (General Fund-Fire Department-Business services) | | | | | | | 2,320.72 | |
| | Invoice Items | | | 1 | | | | | |
| Vendor 1193 - COLES COUNTY EMERGENCY COMMUNICATIONS Totals | | | | | | | | | Invoices 2 <u>\$15,337.17</u> |
| 08/01/2023 PD | Monthly dispatch service/PD | Open | | 08/01/2023 | 08/04/2023 | 08/01/2023 | | | 13,016.45 |
| <i>P.O. Number</i> | <i>Item Description</i> | | <i>Quantity</i> | <i>U/M</i> | <i>Amount/Unit</i> | <i>Total Amount</i> | <i>Vendor Catalog Part Number</i> | <i>Contract Number</i> | |
| | Other business services - Monthly dispatch service/PD | | 1.0000 | EA | 13,016.4500 | 13,016.45 | | | |
| | <i>G/L Account</i> | | | <i>Project</i> | | | | <i>Amount</i> | |
| | 11-4210-3199 (General Fund-Police Department-Business services) | | | | | | | 13,016.45 | |
| | Invoice Items | | | 1 | | | | | |
| Vendor 1187 - COLES COUNTY REGIONAL PLANNING Totals | | | | | | | | | Invoices 1 <u>\$87.50</u> |
| 7581 | June TA expenses - B&D | Open | | 07/14/2023 | 08/04/2023 | 07/14/2023 | | | 87.50 |
| <i>P.O. Number</i> | <i>Item Description</i> | | <i>Quantity</i> | <i>U/M</i> | <i>Amount/Unit</i> | <i>Total Amount</i> | <i>Vendor Catalog Part Number</i> | <i>Contract Number</i> | |
| | Other contractual services - June TA expenses - B&D | | 1.0000 | EA | 87.5000 | 87.50 | | | |
| | <i>G/L Account</i> | | | <i>Project</i> | | | | <i>Amount</i> | |
| | 11-4640-3999 (General Fund-Building & Development Services-Other contractual services) | | | | | | | 87.50 | |
| | Invoice Items | | | 1 | | | | | |
| Vendor 1187 - COLES COUNTY REGIONAL PLANNING Totals | | | | | | | | | Invoices 1 <u>\$87.50</u> |
| 6269 | Pledge - unrestricted/B&D | Open | | 07/01/2023 | 08/04/2023 | 07/01/2023 | | | 12,500.00 |
| <i>P.O. Number</i> | <i>Item Description</i> | | <i>Quantity</i> | <i>U/M</i> | <i>Amount/Unit</i> | <i>Total Amount</i> | <i>Vendor Catalog Part Number</i> | <i>Contract Number</i> | |
| | Other contractual services - Pledge - unrestricted/B&D | | 1.0000 | EA | 12,500.0000 | 12,500.00 | | | |
| | <i>G/L Account</i> | | | <i>Project</i> | | | | <i>Amount</i> | |
| | 11-4640-3999 (General Fund-Building & Development Services-Other contractual services) | | | | | | | 12,500.00 | |
| | Invoice Items | | | 1 | | | | | |
| Vendor 1203 - COLES TOGETHER Totals | | | | | | | | | Invoices 1 <u>\$12,500.00</u> |

Vendor **1204 - COLES-MOULTRIE ELECTRIC COOP**



Accounts Payable Invoice Report - Council

08/01/2023

Invoice Due Date Range 07/22/23 - 08/04/23

Report By Vendor - Invoice

| Invoice Number | Invoice Description | Status | Held Reason | Invoice Date | Due Date | G/L Date | Received Date | Payment Date | Invoice Net Amount |
|--------------------|--|--------|-----------------|---------------|--------------------|---------------------|-----------------------------------|------------------------|--------------------|
| 1440400 06/23 | RR1 Charleston/WTP | Open | | 06/30/2023 | 08/04/2023 | 06/30/2023 | | | 23.50 |
| <i>P.O. Number</i> | <i>Item Description</i> | | <i>Quantity</i> | <i>U/M</i> | <i>Amount/Unit</i> | <i>Total Amount</i> | <i>Vendor Catalog Part Number</i> | <i>Contract Number</i> | |
| | Electricity & gas | | 1.0000 | EA | 23.5000 | 23.50 | | | |
| | <i>G/L Account</i> | | | | <i>Project</i> | | | <i>Amount</i> | |
| | 61-4611-3403 (Water and Sewer Fund-Water Treatment Plant-Electricity & gas) | | | | | | | 23.50 | |
| | | | | Invoice Items | 1 | | | | |
| 1484000 06/23 | RR 3-R3-8 Traffic signal/MFT | Open | | 06/30/2023 | 08/04/2023 | 06/30/2023 | | | 55.23 |
| <i>P.O. Number</i> | <i>Item Description</i> | | <i>Quantity</i> | <i>U/M</i> | <i>Amount/Unit</i> | <i>Total Amount</i> | <i>Vendor Catalog Part Number</i> | <i>Contract Number</i> | |
| | Street lights electricity | | 1.0000 | EA | 55.2300 | 55.23 | | | |
| | <i>G/L Account</i> | | | | <i>Project</i> | | | <i>Amount</i> | |
| | 25-4312-3405 (Motor Fuel Tax Fund-Motor Fuel Tax Department-Street lights electricity) | | | | | | | 55.23 | |
| | | | | Invoice Items | 1 | | | | |
| 1569500 06/23 | 11547 Old State Rd lift/WWTP | Open | | 06/30/2023 | 08/04/2023 | 06/30/2023 | | | 167.67 |
| <i>P.O. Number</i> | <i>Item Description</i> | | <i>Quantity</i> | <i>U/M</i> | <i>Amount/Unit</i> | <i>Total Amount</i> | <i>Vendor Catalog Part Number</i> | <i>Contract Number</i> | |
| | Electricity & gas | | 1.0000 | EA | 167.6700 | 167.67 | | | |
| | <i>G/L Account</i> | | | | <i>Project</i> | | | <i>Amount</i> | |
| | 61-4621-3403 (Water and Sewer Fund-Waste Water Treatment Plant-Electricity & gas) | | | | | | | 167.67 | |
| | | | | Invoice Items | 1 | | | | |
| 2039100 06/23 | 6050 Rt130 Woodyard/MAINT | Open | | 06/30/2023 | 08/04/2023 | 06/30/2023 | | | 34.00 |
| <i>P.O. Number</i> | <i>Item Description</i> | | <i>Quantity</i> | <i>U/M</i> | <i>Amount/Unit</i> | <i>Total Amount</i> | <i>Vendor Catalog Part Number</i> | <i>Contract Number</i> | |
| | Electricity & gas | | 1.0000 | EA | 34.0000 | 34.00 | | | |
| | <i>G/L Account</i> | | | | <i>Project</i> | | | <i>Amount</i> | |
| | 11-4194-3403 (General Fund-Parks & Maintenance Department-Electricity & gas) | | | | | | | 34.00 | |
| | | | | Invoice Items | 1 | | | | |
| 2086900 06/23 | NECO electric - MAINT | Open | | 06/30/2023 | 08/04/2023 | 06/30/2023 | | | 245.70 |
| <i>P.O. Number</i> | <i>Item Description</i> | | <i>Quantity</i> | <i>U/M</i> | <i>Amount/Unit</i> | <i>Total Amount</i> | <i>Vendor Catalog Part Number</i> | <i>Contract Number</i> | |
| | Electricity & gas | | 1.0000 | EA | 245.7000 | 245.70 | | | |
| | <i>G/L Account</i> | | | | <i>Project</i> | | | <i>Amount</i> | |
| | 11-4194-3403 (General Fund-Parks & Maintenance Department-Electricity & gas) | | | | | | | 245.70 | |
| | | | | Invoice Items | 1 | | | | |
| 2107500 06/23 | Fishing pier & pavilion/MAINT | Open | | 06/30/2023 | 08/04/2023 | 06/30/2023 | | | 40.47 |
| <i>P.O. Number</i> | <i>Item Description</i> | | <i>Quantity</i> | <i>U/M</i> | <i>Amount/Unit</i> | <i>Total Amount</i> | <i>Vendor Catalog Part Number</i> | <i>Contract Number</i> | |
| | Electric & Gas service | | 1.0000 | EA | 40.4700 | 40.47 | | | |
| | <i>G/L Account</i> | | | | <i>Project</i> | | | <i>Amount</i> | |
| | | | | | | | | | |



Accounts Payable Invoice Report - Council

08/01/2023

Invoice Due Date Range 07/22/23 - 08/04/23

Report By Vendor - Invoice

| Invoice Number | Invoice Description | Status | Held Reason | Invoice Date | Due Date | G/L Date | Received Date | Payment Date | Invoice Net Amount |
|--------------------|---|--------|-----------------|--------------|--------------------|----------------------------------|-----------------------------------|------------------------|--------------------|
| 2107500 06/23 | Fishing pier & pavilion/MAINT | Open | | 06/30/2023 | 08/04/2023 | 06/30/2023 | | | 40.47 |
| <i>P.O. Number</i> | <i>Item Description</i> | | <i>Quantity</i> | <i>U/M</i> | <i>Amount/Unit</i> | <i>Total Amount</i> | <i>Vendor Catalog Part Number</i> | <i>Contract Number</i> | |
| | 11-4194-3403 (General Fund-Parks & Maintenance Department- Electricity & gas) | | | | | PK 1014 (LAKE CHARLESTON) | | 40.47 | |
| | | | Invoice Items | | 1 | | | | |
| 2224000 06/23 | Lake bathrooms/MAINT | Open | | 06/30/2023 | 08/04/2023 | 06/30/2023 | | | 51.65 |
| <i>P.O. Number</i> | <i>Item Description</i> | | <i>Quantity</i> | <i>U/M</i> | <i>Amount/Unit</i> | <i>Total Amount</i> | <i>Vendor Catalog Part Number</i> | <i>Contract Number</i> | |
| | Electric & Gas service | | 1.0000 | EA | 51.6500 | 51.65 | | | |
| | <i>G/L Account</i> | | | | | <i>Project</i> | | <i>Amount</i> | |
| | 11-4194-3403 (General Fund-Parks & Maintenance Department- Electricity & gas) | | | | | PK 1014 (LAKE CHARLESTON) | | 51.65 | |
| | | | Invoice Items | | 1 | | | | |
| 2225300 06/23 | Rt 16 & Loxa Rd lights/MFT | Open | | 06/30/2023 | 08/04/2023 | 06/30/2023 | | | 103.57 |
| <i>P.O. Number</i> | <i>Item Description</i> | | <i>Quantity</i> | <i>U/M</i> | <i>Amount/Unit</i> | <i>Total Amount</i> | <i>Vendor Catalog Part Number</i> | <i>Contract Number</i> | |
| | Street lights electricity | | 1.0000 | EA | 103.5700 | 103.57 | | | |
| | <i>G/L Account</i> | | | | | <i>Project</i> | | <i>Amount</i> | |
| | 25-4312-3405 (Motor Fuel Tax Fund-Motor Fuel Tax Department-Street lights electricity) | | | | | MFT LIGHTS (MFT street lighting) | | 103.57 | |
| | | | Invoice Items | | 1 | | | | |
| 2247700 06/23 | LIT Pavilion/MAINT | Open | | 06/30/2023 | 08/04/2023 | 06/30/2023 | | | 65.08 |
| <i>P.O. Number</i> | <i>Item Description</i> | | <i>Quantity</i> | <i>U/M</i> | <i>Amount/Unit</i> | <i>Total Amount</i> | <i>Vendor Catalog Part Number</i> | <i>Contract Number</i> | |
| | Electric & Gas service | | 1.0000 | EA | 65.0800 | 65.08 | | | |
| | <i>G/L Account</i> | | | | | <i>Project</i> | | <i>Amount</i> | |
| | 11-4194-3403 (General Fund-Parks & Maintenance Department- Electricity & gas) | | | | | PK 1014 (LAKE CHARLESTON) | | 65.08 | |
| | | | Invoice Items | | 1 | | | | |
| 2294500 06/23 | 2901 Community Drive | Open | | 06/30/2023 | 08/04/2023 | 06/30/2023 | | | 664.00 |
| <i>P.O. Number</i> | <i>Item Description</i> | | <i>Quantity</i> | <i>U/M</i> | <i>Amount/Unit</i> | <i>Total Amount</i> | <i>Vendor Catalog Part Number</i> | <i>Contract Number</i> | |
| | Electricity & gas | | 1.0000 | EA | 664.0000 | 664.00 | | | |
| | <i>G/L Account</i> | | | | | <i>Project</i> | | <i>Amount</i> | |
| | 11-4194-3403 (General Fund-Parks & Maintenance Department- Electricity & gas) | | | | | PK 1012 (LINDER SPORTS COMPLEX) | | 664.00 | |
| | | | Invoice Items | | 1 | | | | |
| 363200 06/23 | Security lights/MFT | Open | | 06/30/2023 | 08/04/2023 | 06/30/2023 | | | 1,119.27 |
| <i>P.O. Number</i> | <i>Item Description</i> | | <i>Quantity</i> | <i>U/M</i> | <i>Amount/Unit</i> | <i>Total Amount</i> | <i>Vendor Catalog Part Number</i> | <i>Contract Number</i> | |
| | Street lights electricity | | 1.0000 | EA | 1,119.2700 | 1,119.27 | | | |
| | <i>G/L Account</i> | | | | | <i>Project</i> | | <i>Amount</i> | |
| | 25-4312-3405 (Motor Fuel Tax Fund-Motor Fuel Tax Department-Street lights electricity) | | | | | MFT LIGHTS (MFT street lighting) | | 1,119.27 | |
| | | | Invoice Items | | 1 | | | | |



Accounts Payable Invoice Report - Council

08/01/2023

Invoice Due Date Range 07/22/23 - 08/04/23

Report By Vendor - Invoice

| Invoice Number | Invoice Description | Status | Held Reason | Invoice Date | Due Date | G/L Date | Received Date | Payment Date | Invoice Net Amount |
|--|---|--------|-------------|-----------------|------------|-------------------------------|---------------------|-----------------------------------|------------------------|
| 660400 06/23 | 2400 Cambridge- Heritage Wood/MAINT | Open | | 06/30/2023 | 08/04/2023 | 06/30/2023 | | | 35.81 |
| <i>P.O. Number</i> | <i>Item Description</i> | | | <i>Quantity</i> | <i>U/M</i> | <i>Amount/Unit</i> | <i>Total Amount</i> | <i>Vendor Catalog Part Number</i> | <i>Contract Number</i> |
| | Electricity & gas | | | 1.0000 | EA | 35.8100 | 35.81 | | |
| | <i>G/L Account</i> | | | | | <i>Project</i> | | <i>Amount</i> | |
| | 11-4194-3403 (General Fund-Parks & Maintenance Department-Electricity & gas) | | | | | PK 1009 (HERITAGE WOODS PARK) | | 35.81 | |
| | | | | Invoice Items | | 1 | | | |
| 719500 06/23 | Tornado siren/MAINT | Open | | 06/30/2023 | 08/04/2023 | 06/30/2023 | | | 88.33 |
| <i>P.O. Number</i> | <i>Item Description</i> | | | <i>Quantity</i> | <i>U/M</i> | <i>Amount/Unit</i> | <i>Total Amount</i> | <i>Vendor Catalog Part Number</i> | <i>Contract Number</i> |
| | Electric & Gas service | | | 1.0000 | EA | 88.3300 | 88.33 | | |
| | <i>G/L Account</i> | | | | | <i>Project</i> | | <i>Amount</i> | |
| | 11-4194-3403 (General Fund-Parks & Maintenance Department-Electricity & gas) | | | | | | | 88.33 | |
| | | | | Invoice Items | | 1 | | | |
| 808600 06/23 | River pump house/WTP | Open | | 06/30/2023 | 08/04/2023 | 06/30/2023 | | | 673.52 |
| <i>P.O. Number</i> | <i>Item Description</i> | | | <i>Quantity</i> | <i>U/M</i> | <i>Amount/Unit</i> | <i>Total Amount</i> | <i>Vendor Catalog Part Number</i> | <i>Contract Number</i> |
| | Electricity & gas | | | 1.0000 | EA | 673.5200 | 673.52 | | |
| | <i>G/L Account</i> | | | | | <i>Project</i> | | <i>Amount</i> | |
| | 61-4611-3403 (Water and Sewer Fund-Water Treatment Plant-Electricity & gas) | | | | | | | 673.52 | |
| | | | | Invoice Items | | 1 | | | |
| 997600 06/23 | Sister City Pavilion/MAINT | Open | | 06/30/2023 | 08/04/2023 | 06/30/2023 | | | 44.88 |
| <i>P.O. Number</i> | <i>Item Description</i> | | | <i>Quantity</i> | <i>U/M</i> | <i>Amount/Unit</i> | <i>Total Amount</i> | <i>Vendor Catalog Part Number</i> | <i>Contract Number</i> |
| | Electric & Gas service | | | 1.0000 | EA | 44.8800 | 44.88 | | |
| | <i>G/L Account</i> | | | | | <i>Project</i> | | <i>Amount</i> | |
| | 11-4194-3403 (General Fund-Parks & Maintenance Department-Electricity & gas) | | | | | PK 1011 (SISTER CITY PARK) | | 44.88 | |
| | | | | Invoice Items | | 1 | | | |
| Vendor 1204 - COLES-MOULTRIE ELECTRIC COOP Totals | | | | | | | Invoices | 15 | \$3,412.68 |
| Vendor 1205 - COMMERCIAL ELECTRIC INC | | | | | | | | | |
| 20440601 | WP Equipment Expense - River Pumps | Open | | 07/14/2023 | 08/04/2023 | 07/14/2023 | | | 444.00 |
| <i>P.O. Number</i> | <i>Item Description</i> | | | <i>Quantity</i> | <i>U/M</i> | <i>Amount/Unit</i> | <i>Total Amount</i> | <i>Vendor Catalog Part Number</i> | <i>Contract Number</i> |
| | Electric repair - WP Equipment Expense - River Pumps | | | 1.0000 | EA | 444.0000 | 444.00 | | |
| | <i>G/L Account</i> | | | | | <i>Project</i> | | <i>Amount</i> | |
| | 61-4611-3508 (Water and Sewer Fund-Water Treatment Plant-Repair of operating equipment) | | | | | 0000 (0000 - Misc. Equip.) | | 444.00 | |
| | | | | Invoice Items | | 1 | | | |



Accounts Payable Invoice Report - Council

08/01/2023

Invoice Due Date Range 07/22/23 - 08/04/23

Report By Vendor - Invoice

| Invoice Number | Invoice Description | Status | Held Reason | Invoice Date | Due Date | G/L Date | Received Date | Payment Date | Invoice Net Amount |
|---|--|--------|-----------------|---------------|---------------------------|---------------------|-----------------------------------|------------------------|---------------------|
| 20440101 | WW Equipment Expense - Generator | Open | | 07/14/2023 | 08/04/2023 | 07/14/2023 | | | 231.00 |
| <i>P.O. Number</i> | <i>Item Description</i> | | <i>Quantity</i> | <i>U/M</i> | <i>Amount/Unit</i> | <i>Total Amount</i> | <i>Vendor Catalog Part Number</i> | <i>Contract Number</i> | |
| | Misc. services - WW Equipment Expense - Generator | | 1.0000 | EA | 231.0000 | 231.00 | | | |
| | <i>G/L Account</i> | | | | <i>Project</i> | | <i>Amount</i> | | |
| | 61-4621-3508 (Water and Sewer Fund-Waste Water Treatment Plant- Repair of operating equipment) | | | | PW 20 107 (WWTP Electric) | | 231.00 | | |
| | | | | Invoice Items | 1 | | | | |
| Vendor 1205 - COMMERCIAL ELECTRIC INC Totals | | | | | | | | | Invoices 2 \$675.00 |
| Vendor 1213 - CONSOLIDATED COMMUNICATIONS - CCI | | | | | | | | | |
| 2173458425 07/23 | Monthly internet and telephone allocation | Open | | 07/11/2023 | 08/04/2023 | 07/11/2023 | | | 177.42 |
| <i>P.O. Number</i> | <i>Item Description</i> | | <i>Quantity</i> | <i>U/M</i> | <i>Amount/Unit</i> | <i>Total Amount</i> | <i>Vendor Catalog Part Number</i> | <i>Contract Number</i> | |
| | Telephone Service - Monthly internet and telephone allocation | | 1.0000 | EA | 177.4200 | 177.42 | | | |
| | <i>G/L Account</i> | | | | <i>Project</i> | | <i>Amount</i> | | |
| | 11-4001-3401 (General Fund-Administration & Boards- Manager- Telephone expense) | | | | | | 54.55 | | |
| | 11-4004-3401 (General Fund-Comptroller's Office-Telephone expense) | | | | | | 33.89 | | |
| | 11-4194-3401 (General Fund-Parks & Maintenance Department- Telephone expense) | | | | | | 88.98 | | |
| | | | | Invoice Items | 1 | | | | |
| Vendor 1213 - CONSOLIDATED COMMUNICATIONS - CCI Totals | | | | | | | | | Invoices 1 \$177.42 |
| Vendor 1224 - COUNTY OFFICE PRODUCTS INC | | | | | | | | | |
| 0238488-001 | Report covers for council packets/CLERK | Open | | 07/18/2023 | 08/04/2023 | 07/18/2023 | | | 33.36 |
| <i>P.O. Number</i> | <i>Item Description</i> | | <i>Quantity</i> | <i>U/M</i> | <i>Amount/Unit</i> | <i>Total Amount</i> | <i>Vendor Catalog Part Number</i> | <i>Contract Number</i> | |
| | Office supplies / CLERK - Report covers for council packets/CLERK | | 1.0000 | EA | 33.3600 | 33.36 | | | |
| | <i>G/L Account</i> | | | | <i>Project</i> | | <i>Amount</i> | | |
| | 11-4002-2001 (General Fund-City Clerk-Office supplies) | | | | | | 33.36 | | |
| | | | | Invoice Items | 1 | | | | |
| 0238277-001 | Calculator (Bretta)/WATER DEPARTMENT | Open | | 07/11/2023 | 08/04/2023 | 07/11/2023 | | | 170.18 |
| <i>P.O. Number</i> | <i>Item Description</i> | | <i>Quantity</i> | <i>U/M</i> | <i>Amount/Unit</i> | <i>Total Amount</i> | <i>Vendor Catalog Part Number</i> | <i>Contract Number</i> | |
| | 1/4 page full color ad/tourism - Calculator (Bretta)/WATER DEPARTMENT | | 1.0000 | EA | 170.1800 | 170.18 | | | |
| | <i>G/L Account</i> | | | | <i>Project</i> | | <i>Amount</i> | | |
| | 61-4630-2001 (Water and Sewer Fund-Water Department-Office supplies) | | | | | | 170.18 | | |
| | | | | Invoice Items | 1 | | | | |



Accounts Payable Invoice Report - Council

08/01/2023

Invoice Due Date Range 07/22/23 - 08/04/23

Report By Vendor - Invoice

| Invoice Number | Invoice Description | Status | Held Reason | Invoice Date | Due Date | G/L Date | Received Date | Payment Date | Invoice Net Amount |
|---|---|--------|-----------------|---------------|--------------------|---------------------|-----------------------------------|------------------------|--------------------|
| 0238471-001 | Paper-Trashcan-Rolls/WATER DEPARTMENT | Open | | 07/18/2023 | 08/04/2023 | 07/18/2023 | | | 147.56 |
| <i>P.O. Number</i> | <i>Item Description</i> | | <i>Quantity</i> | <i>U/M</i> | <i>Amount/Unit</i> | <i>Total Amount</i> | <i>Vendor Catalog Part Number</i> | <i>Contract Number</i> | |
| | 1/4 page full color ad/tourism - Paper-Trashcan-Rolls/WATER DEPARTMENT | | 1.0000 | EA | 147.5600 | 147.56 | | | |
| | <i>G/L Account</i> | | | | <i>Project</i> | | | <i>Amount</i> | |
| | 61-4630-2001 (Water and Sewer Fund-Water Department-Office supplies) | | | | | | | 147.56 | |
| | | | | Invoice Items | 1 | | | | |
| 0238709-001 | Calculator/WATER DEPARTMENT | Open | | 07/25/2023 | 08/04/2023 | 07/25/2023 | | | 170.18 |
| <i>P.O. Number</i> | <i>Item Description</i> | | <i>Quantity</i> | <i>U/M</i> | <i>Amount/Unit</i> | <i>Total Amount</i> | <i>Vendor Catalog Part Number</i> | <i>Contract Number</i> | |
| | 1/4 page full color ad/tourism - Calculator/WATER DEPARTMENT | | 1.0000 | EA | 170.1800 | 170.18 | | | |
| | <i>G/L Account</i> | | | | <i>Project</i> | | | <i>Amount</i> | |
| | 61-4630-2001 (Water and Sewer Fund-Water Department-Office supplies) | | | | | | | 170.18 | |
| | | | | Invoice Items | 1 | | | | |
| 0238679-001 | File folders - REC | Open | | 07/24/2023 | 08/04/2023 | 07/24/2023 | | | 15.89 |
| <i>P.O. Number</i> | <i>Item Description</i> | | <i>Quantity</i> | <i>U/M</i> | <i>Amount/Unit</i> | <i>Total Amount</i> | <i>Vendor Catalog Part Number</i> | <i>Contract Number</i> | |
| | Office Supplies - REC - File folders - REC | | 1.0000 | EA | 15.8900 | 15.89 | | | |
| | <i>G/L Account</i> | | | | <i>Project</i> | | | <i>Amount</i> | |
| | 22-4510-2001 (Playground & Recreation Fund-Recreation Programs-Office supplies) | | | | | | | 15.89 | |
| | | | | Invoice Items | 1 | | | | |
| 0238375-001 | misc office supplies/FD | Open | | 07/13/2023 | 07/26/2023 | 07/13/2023 | | | 12.59 |
| <i>P.O. Number</i> | <i>Item Description</i> | | <i>Quantity</i> | <i>U/M</i> | <i>Amount/Unit</i> | <i>Total Amount</i> | <i>Vendor Catalog Part Number</i> | <i>Contract Number</i> | |
| | Office supplies / FD - misc office supplies/FD | | 1.0000 | EA | 12.5900 | 12.59 | | | |
| | <i>G/L Account</i> | | | | <i>Project</i> | | | <i>Amount</i> | |
| | 11-4221-2001 (General Fund-Fire Department-Office supplies) | | | | | | | 12.59 | |
| | | | | Invoice Items | 1 | | | | |
| Vendor 1224 - COUNTY OFFICE PRODUCTS INC Totals | | | | | | | Invoices | 6 | \$549.76 |
| Vendor 4626 - CROSSROADS CONTRACTOR SUPPLY CORP | | | | | | | | | |
| 18643 | Milwaukee Tool Kit for Sewer Crew/UTILITY | Open | | 07/17/2023 | 08/04/2023 | 07/17/2023 | | | 1,128.00 |
| <i>P.O. Number</i> | <i>Item Description</i> | | <i>Quantity</i> | <i>U/M</i> | <i>Amount/Unit</i> | <i>Total Amount</i> | <i>Vendor Catalog Part Number</i> | <i>Contract Number</i> | |
| | 1/4 page full color ad/tourism - Milwaukee Tool Kit for Sewer Crew/UTILITY | | 1.0000 | EA | 1,128.0000 | 1,128.00 | | | |
| | <i>G/L Account</i> | | | | <i>Project</i> | | | <i>Amount</i> | |
| | 61-4610-2801 (Water and Sewer Fund-Utility Department-Hand tools) | | | | | | | 1,128.00 | |
| | | | | Invoice Items | 1 | | | | |
| Vendor 4626 - CROSSROADS CONTRACTOR SUPPLY CORP Totals | | | | | | | Invoices | 1 | \$1,128.00 |



Accounts Payable Invoice Report - Council

08/01/2023

Invoice Due Date Range 07/22/23 - 08/04/23

Report By Vendor - Invoice

| Invoice Number | Invoice Description | Status | Held Reason | Invoice Date | Due Date | G/L Date | Received Date | Payment Date | Invoice Net Amount |
|--|---|--------|-------------|-----------------|------------|--|---------------------|-----------------------------------|------------------------|
| Vendor 3391 - D & M ELECTRICAL | | | | | | | | | |
| 9727 | WP Equipment Expense - CAT Generator | Open | | 07/17/2023 | 08/04/2023 | 07/17/2023 | | | 900.33 |
| <i>P.O. Number</i> | <i>Item Description</i> | | | <i>Quantity</i> | <i>U/M</i> | <i>Amount/Unit</i> | <i>Total Amount</i> | <i>Vendor Catalog Part Number</i> | <i>Contract Number</i> |
| | Maintenance on generator/dced - WP Equipment Expense - CAT Generator | | | 1.0000 | EA | 900.3300 | 900.33 | | |
| | <i>G/L Account</i> | | | | | <i>Project</i> | | <i>Amount</i> | |
| | 61-4611-3508 (Water and Sewer Fund-Water Treatment Plant-Repair of operating equipment) | | | | | 0000 (0000 - Misc. Equip.) | | 900.33 | |
| | | | | Invoice Items | | 1 | | | |
| i1015 | WW Equipment Expense - Generator | Open | | 07/21/2023 | 08/04/2023 | 07/21/2023 | | | 900.34 |
| <i>P.O. Number</i> | <i>Item Description</i> | | | <i>Quantity</i> | <i>U/M</i> | <i>Amount/Unit</i> | <i>Total Amount</i> | <i>Vendor Catalog Part Number</i> | <i>Contract Number</i> |
| | Misc. services - WW Equipment Expense - Generator | | | 1.0000 | EA | 900.3400 | 900.34 | | |
| | <i>G/L Account</i> | | | | | <i>Project</i> | | <i>Amount</i> | |
| | 61-4621-3508 (Water and Sewer Fund-Waste Water Treatment Plant-Repair of operating equipment) | | | | | 0000 (0000 - Misc. Equip.) | | 900.34 | |
| | | | | Invoice Items | | 1 | | | |
| Vendor 3391 - D & M ELECTRICAL Totals | | | | | | | Invoices | 2 | \$1,800.67 |
| Vendor 1241 - DAN PILSON AUTO CENTER OF MATTOON | | | | | | | | | |
| 537805 | Cannister/PD | Open | | 07/12/2023 | 08/04/2023 | 07/12/2023 | | | 148.75 |
| <i>P.O. Number</i> | <i>Item Description</i> | | | <i>Quantity</i> | <i>U/M</i> | <i>Amount/Unit</i> | <i>Total Amount</i> | <i>Vendor Catalog Part Number</i> | <i>Contract Number</i> |
| | Vehicle parts and supplies - Cannister/PD | | | 1.0000 | EA | 148.7500 | 148.75 | | |
| | <i>G/L Account</i> | | | | | <i>Project</i> | | <i>Amount</i> | |
| | 11-4210-2401 (General Fund-Police Department-Vehicle parts & supplies) | | | | | 4431 (2018 Ford Explorer) | | 148.75 | |
| | | | | Invoice Items | | 1 | | | |
| 537229 | Shifter Coble Repair/UTILITY | Open | | 05/17/2023 | 08/04/2023 | 05/17/2023 | | | 187.89 |
| <i>P.O. Number</i> | <i>Item Description</i> | | | <i>Quantity</i> | <i>U/M</i> | <i>Amount/Unit</i> | <i>Total Amount</i> | <i>Vendor Catalog Part Number</i> | <i>Contract Number</i> |
| | 1/4 page full color ad/tourism - Shifter Coble Repair/UTILITY | | | 1.0000 | EA | 187.8900 | 187.89 | | |
| | <i>G/L Account</i> | | | | | <i>Project</i> | | <i>Amount</i> | |
| | 61-4610-2401 (Water and Sewer Fund-Utility Department-Vehicle parts & supplies) | | | | | 5850 (5850 - 2004 Ford 1 Ton F350 Truck #42) | | 187.89 | |
| | | | | Invoice Items | | 1 | | | |
| 537870 | spark plug/FD | Open | | 07/17/2023 | 07/26/2023 | 07/17/2023 | | | 113.04 |
| <i>P.O. Number</i> | <i>Item Description</i> | | | <i>Quantity</i> | <i>U/M</i> | <i>Amount/Unit</i> | <i>Total Amount</i> | <i>Vendor Catalog Part Number</i> | <i>Contract Number</i> |
| | Vehicle parts and supplies - spark plug/FD | | | 1.0000 | EA | 113.0400 | 113.04 | | |
| | <i>G/L Account</i> | | | | | <i>Project</i> | | <i>Amount</i> | |



Accounts Payable Invoice Report - Council

08/01/2023

Invoice Due Date Range 07/22/23 - 08/04/23

Report By Vendor - Invoice

| Invoice Number | Invoice Description | Status | Held Reason | Invoice Date | Due Date | G/L Date | Received Date | Payment Date | Invoice Net Amount |
|---|--|--------|----------------------|--------------|--|---------------------|-----------------------------------|------------------------|-----------------------|
| 537870 | spark plug/FD | Open | | 07/17/2023 | 07/26/2023 | 07/17/2023 | | | 113.04 |
| <i>P.O. Number</i> | <i>Item Description</i> | | <i>Quantity</i> | <i>U/M</i> | <i>Amount/Unit</i> | <i>Total Amount</i> | <i>Vendor Catalog Part Number</i> | <i>Contract Number</i> | |
| | 11-4221-2401 (General Fund-Fire Department-Vehicle parts & supplies) | | | 8921 | (8921 - 2006 Ford Expedition) | | | 113.04 | |
| | | | <i>Invoice Items</i> | | 1 | | | | |
| Vendor 1241 - DAN PILSON AUTO CENTER OF MATTOON Totals | | | | | | | | | Invoices 3 \$449.68 |
| Vendor 4673 - DAVE ROEPKE PAINTING INC. | | | | | | | | | |
| 1563 | Doors and lower concrete @ Linder - MAINT | Open | | 07/21/2023 | 08/04/2023 | 07/21/2023 | | | 3,400.00 |
| <i>P.O. Number</i> | <i>Item Description</i> | | <i>Quantity</i> | <i>U/M</i> | <i>Amount/Unit</i> | <i>Total Amount</i> | <i>Vendor Catalog Part Number</i> | <i>Contract Number</i> | |
| | Capital Improvement projects - Doors and lower concrete @ Linder - MAINT | | 1.0000 | EA | 3,400.0000 | 3,400.00 | | | |
| | <i>G/L Account</i> | | | | <i>Project</i> | | | <i>Amount</i> | |
| | 11-4095-4106 (General Fund-Engineering Department-Capital improvement projects) | | | | PW 20 26 020 (Community Drive Concession Building) | | | 3,400.00 | |
| | | | <i>Invoice Items</i> | | 1 | | | | |
| Vendor 4673 - DAVE ROEPKE PAINTING INC. Totals | | | | | | | | | Invoices 1 \$3,400.00 |
| Vendor 4462 - DEARBORN LIFE INSURANCE COMPANY | | | | | | | | | |
| 7/7/23 | August 2023 Premium / EBHR | Open | | 07/07/2023 | 08/04/2023 | 07/07/2023 | | | 5,719.30 |
| <i>P.O. Number</i> | <i>Item Description</i> | | <i>Quantity</i> | <i>U/M</i> | <i>Amount/Unit</i> | <i>Total Amount</i> | <i>Vendor Catalog Part Number</i> | <i>Contract Number</i> | |
| | Employee Insurance Premiums - August 2023 Premium / EBHR | | 1.0000 | EA | 5,719.3000 | 5,719.30 | | | |
| | <i>G/L Account</i> | | | | <i>Project</i> | | | <i>Amount</i> | |
| | 11-2038 (General Fund-Other payroll withholdings) | | | | | | | 5,719.30 | |
| | | | <i>Invoice Items</i> | | 1 | | | | |
| Vendor 4462 - DEARBORN LIFE INSURANCE COMPANY Totals | | | | | | | | | Invoices 1 \$5,719.30 |
| Vendor 2184 - DONOHUE & ASSOCIATES INC | | | | | | | | | |
| 12251-58 | WW Nutrient Removal Capital Improvement Planning | Open | | 07/14/2023 | 08/04/2023 | 07/14/2023 | | | 1,287.50 |
| <i>P.O. Number</i> | <i>Item Description</i> | | <i>Quantity</i> | <i>U/M</i> | <i>Amount/Unit</i> | <i>Total Amount</i> | <i>Vendor Catalog Part Number</i> | <i>Contract Number</i> | |
| | Capital Improvement projects - WW Nutrient Removal Capital Improvement Planning | | 1.0000 | EA | 1,287.5000 | 1,287.50 | | | |
| | <i>G/L Account</i> | | | | <i>Project</i> | | | <i>Amount</i> | |
| | 61-4621-4106 (Water and Sewer Fund-Waste Water Treatment Plant-Capital improvement projects) | | | | PW 18 18 (Nutrient Removal at WWTP) | | | 1,287.50 | |
| | | | <i>Invoice Items</i> | | 1 | | | | |
| Vendor 2184 - DONOHUE & ASSOCIATES INC Totals | | | | | | | | | Invoices 1 \$1,287.50 |
| Vendor 3176 - Douglas Hart- Nature Center | | | | | | | | | |



Accounts Payable Invoice Report - Council

08/01/2023

Invoice Due Date Range 07/22/23 - 08/04/23

Report By Vendor - Invoice

| Invoice Number | Invoice Description | Status | Held Reason | Invoice Date | Due Date | G/L Date | Received Date | Payment Date | Invoice Net Amount |
|--|--|--------|-------------|-----------------|------------|---|---------------------|-----------------------------------|------------------------|
| HART 07/20 | Field trip for Day Camp - REC / bh | Open | | 07/20/2023 | 08/04/2023 | 07/20/2023 | | | 159.00 |
| <i>P.O. Number</i> | <i>Item Description</i> | | | <i>Quantity</i> | <i>U/M</i> | <i>Amount/Unit</i> | <i>Total Amount</i> | <i>Vendor Catalog Part Number</i> | <i>Contract Number</i> |
| | Other Contractual Service - REC - Field trip for Day Camp - REC / bh | | EA | 1.0000 | | 159.0000 | 159.00 | | |
| | <i>G/L Account</i> | | | | | <i>Project</i> | | <i>Amount</i> | |
| | 22-4510-3999 (Playground & Recreation Fund-Recreation Programs-Other contractual services) | | | | | REC 1004 3120 (Day Camp) | | 159.00 | |
| | <i>Invoice Items</i> | | | | | 1 | | | |
| Vendor 3176 - Douglas Hart- Nature Center | | | | | Totals | | Invoices | 1 | \$159.00 |
| Vendor 1287 - EASTERN ELECTRIC SUPPLY CO | | | | | | | | | |
| 372188 | Credit of returned wire from invoice 371594/ENG | Open | | 07/21/2023 | 08/04/2023 | 07/21/2023 | | | (651.88) |
| <i>P.O. Number</i> | <i>Item Description</i> | | | <i>Quantity</i> | <i>U/M</i> | <i>Amount/Unit</i> | <i>Total Amount</i> | <i>Vendor Catalog Part Number</i> | <i>Contract Number</i> |
| | Capital Improvement projects - Credit of returned wire from invoice 371594/ENG | | EA | 1.0000 | | (651.8800) | (651.88) | | |
| | <i>G/L Account</i> | | | | | <i>Project</i> | | <i>Amount</i> | |
| | 11-4095-4106 (General Fund-Engineering Department-Capital improvement projects) | | | | | PW 20 26 011 (Street / Parking Lot Fixture and Poles) | | (651.88) | |
| | <i>Invoice Items</i> | | | | | 1 | | | |
| E058097 | Lamp - MAINT | Open | | 07/07/2023 | 08/04/2023 | 07/07/2023 | | | 34.95 |
| <i>P.O. Number</i> | <i>Item Description</i> | | | <i>Quantity</i> | <i>U/M</i> | <i>Amount/Unit</i> | <i>Total Amount</i> | <i>Vendor Catalog Part Number</i> | <i>Contract Number</i> |
| | Park maintenance materials - Lamp - MAINT | | EA | 1.0000 | | 34.9500 | 34.95 | | |
| | <i>G/L Account</i> | | | | | <i>Project</i> | | <i>Amount</i> | |
| | 11-4194-2513 (General Fund-Parks & Maintenance Department-Park maintenance materials) | | | | | | | 34.95 | |
| | <i>Invoice Items</i> | | | | | 1 | | | |
| E058098 | Electrical box - MAINT | Open | | 07/07/2023 | 08/04/2023 | 07/07/2023 | | | 2.51 |
| <i>P.O. Number</i> | <i>Item Description</i> | | | <i>Quantity</i> | <i>U/M</i> | <i>Amount/Unit</i> | <i>Total Amount</i> | <i>Vendor Catalog Part Number</i> | <i>Contract Number</i> |
| | Park maintenance materials - Electrical box - MAINT | | EA | 1.0000 | | 2.5100 | 2.51 | | |
| | <i>G/L Account</i> | | | | | <i>Project</i> | | <i>Amount</i> | |
| | 11-4194-2513 (General Fund-Parks & Maintenance Department-Park maintenance materials) | | | | | | | 2.51 | |
| | <i>Invoice Items</i> | | | | | 1 | | | |
| E058192 | Photocontrol - MAINT | Open | | 07/20/2023 | 08/04/2023 | 07/20/2023 | | | 14.95 |
| <i>P.O. Number</i> | <i>Item Description</i> | | | <i>Quantity</i> | <i>U/M</i> | <i>Amount/Unit</i> | <i>Total Amount</i> | <i>Vendor Catalog Part Number</i> | <i>Contract Number</i> |
| | Park maintenance materials - Photocontrol - MAINT | | EA | 1.0000 | | 14.9500 | 14.95 | | |
| | <i>G/L Account</i> | | | | | <i>Project</i> | | <i>Amount</i> | |
| | | | | | | | | | |



Accounts Payable Invoice Report - Council

08/01/2023

Invoice Due Date Range 07/22/23 - 08/04/23

Report By Vendor - Invoice

| Invoice Number | Invoice Description | Status | Held Reason | Invoice Date | Due Date | G/L Date | Received Date | Payment Date | Invoice Net Amount |
|--------------------|---|--------|-----------------|--------------|--------------------|---------------------|-----------------------------------|------------------------|--------------------|
| E058192 | Photocontrol - MAINT | Open | | 07/20/2023 | 08/04/2023 | 07/20/2023 | | | 14.95 |
| <i>P.O. Number</i> | <i>Item Description</i> | | <i>Quantity</i> | <i>U/M</i> | <i>Amount/Unit</i> | <i>Total Amount</i> | <i>Vendor Catalog Part Number</i> | <i>Contract Number</i> | |
| | 11-4194-2513 (General Fund-Parks & Maintenance Department-Park maintenance materials) | | | | | | | 14.95 | |
| | | | Invoice Items | 1 | | | | | |

Vendor **1287 - EASTERN ELECTRIC SUPPLY CO** Totals Invoices 4 (\$599.47)

Vendor **4262 - LUKE EDWARDS**

| | | | | | | | | | |
|--------------------|--|------|-----------------|------------|--------------------|---------------------|-----------------------------------|------------------------|-------|
| 07/20/2023 | Continuing education - plumbing license - Luke | Open | | 07/20/2023 | 08/04/2023 | 07/20/2023 | | | 50.00 |
| <i>P.O. Number</i> | <i>Item Description</i> | | <i>Quantity</i> | <i>U/M</i> | <i>Amount/Unit</i> | <i>Total Amount</i> | <i>Vendor Catalog Part Number</i> | <i>Contract Number</i> | |
| | Education & training expense - Continuing education - plumbing license - Luke | | 1.0000 | EA | 50.0000 | 50.00 | | | |
| | <i>G/L Account</i> | | | | <i>Project</i> | | | <i>Amount</i> | |
| | 11-4640-3706 (General Fund-Building & Development Services-Education & training expense) | | | | | | | 50.00 | |
| | | | Invoice Items | 1 | | | | | |

Vendor **4262 - LUKE EDWARDS** Totals Invoices 1 \$50.00

Vendor **3643 - EUBANK ENTERPRISE**

| | | | | | | | | | |
|--------------------|--|------|-----------------|------------|----------------------------|---------------------|-----------------------------------|------------------------|--------|
| 7710 | WW Lift Station - Lake Vaults | Open | | 07/24/2023 | 08/04/2023 | 07/24/2023 | | | 170.00 |
| <i>P.O. Number</i> | <i>Item Description</i> | | <i>Quantity</i> | <i>U/M</i> | <i>Amount/Unit</i> | <i>Total Amount</i> | <i>Vendor Catalog Part Number</i> | <i>Contract Number</i> | |
| | Lift station repair / WWTP - WW Lift Station - Lake Vaults | | 1.0000 | EA | 170.0000 | 170.00 | | | |
| | <i>G/L Account</i> | | | | <i>Project</i> | | | <i>Amount</i> | |
| | 61-4621-2512 (Water and Sewer Fund-Waste Water Treatment Plant-Lift station maintenance) | | | | 0000 (0000 - Misc. Equip.) | | | 170.00 | |
| | | | Invoice Items | 1 | | | | | |

Vendor **3643 - EUBANK ENTERPRISE** Totals Invoices 1 \$170.00

Vendor **3953 - EXCEL ECOCLEAN**

| | | | | | | | | | |
|--------------------|---|------|-----------------|------------|--------------------|---------------------|-----------------------------------|------------------------|----------|
| 21259146 | Carpet cleaning - MAINT | Open | | 06/10/2023 | 08/04/2023 | 06/10/2023 | | | 2,786.00 |
| <i>P.O. Number</i> | <i>Item Description</i> | | <i>Quantity</i> | <i>U/M</i> | <i>Amount/Unit</i> | <i>Total Amount</i> | <i>Vendor Catalog Part Number</i> | <i>Contract Number</i> | |
| | Repair of buildings and facilities - Carpet cleaning - MAINT | | 1.0000 | EA | 2,786.0000 | 2,786.00 | | | |
| | <i>G/L Account</i> | | | | <i>Project</i> | | | <i>Amount</i> | |
| | 11-4194-3510 (General Fund-Parks & Maintenance Department-Repair of buildings & facilities) | | | | | | | 2,786.00 | |
| | | | Invoice Items | 1 | | | | | |

Vendor **3953 - EXCEL ECOCLEAN** Totals Invoices 1 \$2,786.00

Vendor **1328 - FASTENAL COMPANY**



Accounts Payable Invoice Report - Council

08/01/2023

Invoice Due Date Range 07/22/23 - 08/04/23

Report By Vendor - Invoice

| Invoice Number | Invoice Description | Status | Held Reason | Invoice Date | Due Date | G/L Date | Received Date | Payment Date | Invoice Net Amount |
|---|---|--------|-----------------|--------------|------------------------------|---------------------|-----------------------------------|------------------------|--------------------|
| ILMAT164422 | Misc Nuts & Bolts for Shop/GARAGE/MECHANIC | Open | | 07/06/2023 | 08/04/2023 | 07/06/2023 | | | 72.97 |
| <i>P.O. Number</i> | <i>Item Description</i> | | <i>Quantity</i> | <i>U/M</i> | <i>Amount/Unit</i> | <i>Total Amount</i> | <i>Vendor Catalog Part Number</i> | <i>Contract Number</i> | |
| | 1/4 page full color ad/tourism - Misc Nuts & Bolts for Shop/GARAGE/MECHANIC | | 1.0000 | EA | 72.9700 | 72.97 | | | |
| | <i>G/L Account</i> | | | | <i>Project</i> | | | <i>Amount</i> | |
| | 11-4311-2401 (General Fund-City Garage-Vehicle parts & supplies) | | | | 0000 (0000 - Misc. Equip.) | | | 72.97 | |
| | <i>Invoice Items</i> | | | | 1 | | | | |
| Vendor 1328 - FASTENAL COMPANY Totals | | | | | | | Invoices | 1 | \$72.97 |
| Vendor 1330 - FEDEX | | | | | | | | | |
| 8-184-59512 | Delivery of PD supplies | Open | | 07/06/2023 | 08/04/2023 | 07/06/2023 | | | 21.89 |
| <i>P.O. Number</i> | <i>Item Description</i> | | <i>Quantity</i> | <i>U/M</i> | <i>Amount/Unit</i> | <i>Total Amount</i> | <i>Vendor Catalog Part Number</i> | <i>Contract Number</i> | |
| | Other supplies - Delivery of PD supplies | | 1.0000 | EA | 21.8900 | 21.89 | | | |
| | <i>G/L Account</i> | | | | <i>Project</i> | | | <i>Amount</i> | |
| | 11-4210-2119 (General Fund-Police Department-Other supplies) | | | | | | | 21.89 | |
| | <i>Invoice Items</i> | | | | 1 | | | | |
| Vendor 1330 - FEDEX Totals | | | | | | | Invoices | 1 | \$21.89 |
| Vendor 3989 - FIRE APPARATUS INDEPENDENT REPAIR | | | | | | | | | |
| 2265 | Annual fire pump service test/FD | Open | | 07/21/2023 | 07/26/2023 | 07/21/2023 | | | 700.00 |
| <i>P.O. Number</i> | <i>Item Description</i> | | <i>Quantity</i> | <i>U/M</i> | <i>Amount/Unit</i> | <i>Total Amount</i> | <i>Vendor Catalog Part Number</i> | <i>Contract Number</i> | |
| | Repair of operating equipment - Annual fire pump service test/FD | | 1.0000 | EA | 700.0000 | 700.00 | | | |
| | <i>G/L Account</i> | | | | <i>Project</i> | | | <i>Amount</i> | |
| | 11-4221-3508 (General Fund-Fire Department-Repair of operating equipment) | | | | 0000 (0000 - Misc. Equip.) | | | 700.00 | |
| | <i>Invoice Items</i> | | | | 1 | | | | |
| Vendor 3989 - FIRE APPARATUS INDEPENDENT REPAIR Totals | | | | | | | Invoices | 1 | \$700.00 |
| Vendor 4606 - FORT HARRISON TRUCK TIRE CENTER | | | | | | | | | |
| 152987 | Tires for #118/STREET | Open | | 05/01/2023 | 08/04/2023 | 05/01/2023 | | | 1,050.66 |
| <i>P.O. Number</i> | <i>Item Description</i> | | <i>Quantity</i> | <i>U/M</i> | <i>Amount/Unit</i> | <i>Total Amount</i> | <i>Vendor Catalog Part Number</i> | <i>Contract Number</i> | |
| | 1/4 page full color ad/tourism - Tires for #118/STREET | | 1.0000 | EA | 1,050.6600 | 1,050.66 | | | |
| | <i>G/L Account</i> | | | | <i>Project</i> | | | <i>Amount</i> | |
| | 11-4310-3503 (General Fund-Street Department-Repair of vehicles) | | | | 0790 (2014 Ford F-5920 4 WD) | | | 1,050.66 | |
| | <i>Invoice Items</i> | | | | 1 | | | | |
| Vendor 4606 - FORT HARRISON TRUCK TIRE CENTER Totals | | | | | | | Invoices | 1 | \$1,050.66 |

Vendor **1361 - GALLS, LLC**



Accounts Payable Invoice Report - Council

08/01/2023

Invoice Due Date Range 07/22/23 - 08/04/23

Report By Vendor - Invoice

| Invoice Number | Invoice Description | Status | Held Reason | Invoice Date | Due Date | G/L Date | Received Date | Payment Date | Invoice Net Amount |
|--|--|--------|-----------------|---------------|----------------------------|---------------------|-----------------------------------|------------------------|---------------------|
| 024923939 | Holster - Kraft/PD | Open | | 06/28/2023 | 08/04/2023 | 06/28/2023 | | | 65.90 |
| <i>P.O. Number</i> | <i>Item Description</i> | | <i>Quantity</i> | <i>U/M</i> | <i>Amount/Unit</i> | <i>Total Amount</i> | <i>Vendor Catalog Part Number</i> | <i>Contract Number</i> | |
| | Uniforms / PD - Holster - Kraft/PD | | 1.0000 | EA | 65.9000 | 65.90 | | | |
| | <i>G/L Account</i> | | | | <i>Project</i> | | | <i>Amount</i> | |
| | 11-4210-2701 (General Fund-Police Department-Uniforms) | | | | | | | 65.90 | |
| | | | | Invoice Items | 1 | | | | |
| Vendor 1361 - GALLS, LLC Totals | | | | | | | | | Invoices 1 \$65.90 |
| Vendor 2754 - GOEDECKE COMPANY | | | | | | | | | |
| 867827 | 10' Magnesium Strike Off/UTILITY | Open | | 06/26/2023 | 08/04/2023 | 06/26/2023 | | | 165.00 |
| <i>P.O. Number</i> | <i>Item Description</i> | | <i>Quantity</i> | <i>U/M</i> | <i>Amount/Unit</i> | <i>Total Amount</i> | <i>Vendor Catalog Part Number</i> | <i>Contract Number</i> | |
| | 1/4 page full color ad/tourism - 10' Magnesium Strike Off/UTILITY | | 1.0000 | EA | 165.0000 | 165.00 | | | |
| | <i>G/L Account</i> | | | | <i>Project</i> | | | <i>Amount</i> | |
| | 61-4610-2801 (Water and Sewer Fund-Utility Department-Hand tools) | | | | | | | 165.00 | |
| | | | | Invoice Items | 1 | | | | |
| Vendor 2754 - GOEDECKE COMPANY Totals | | | | | | | | | Invoices 1 \$165.00 |
| Vendor 1874 - GRAINGER | | | | | | | | | |
| 9763544195 | WW Misc. Supplies | Open | | 07/07/2023 | 08/04/2023 | 07/07/2023 | | | 180.19 |
| <i>P.O. Number</i> | <i>Item Description</i> | | <i>Quantity</i> | <i>U/M</i> | <i>Amount/Unit</i> | <i>Total Amount</i> | <i>Vendor Catalog Part Number</i> | <i>Contract Number</i> | |
| | Other repair & maintenance - WW Misc. Supplies | | 1.0000 | EA | 180.1900 | 180.19 | | | |
| | <i>G/L Account</i> | | | | <i>Project</i> | | | <i>Amount</i> | |
| | 61-4621-2310 (Water and Sewer Fund-Waste Water Treatment Plant-Other maintenance supplies) | | | | 0000 (0000 - Misc. Equip.) | | | 180.19 | |
| | | | | Invoice Items | 1 | | | | |
| Vendor 1874 - GRAINGER Totals | | | | | | | | | Invoices 1 \$180.19 |
| 9766491022 | WW Misc. Supplies | Open | | 07/11/2023 | 08/04/2023 | 07/11/2023 | | | 68.28 |
| <i>P.O. Number</i> | <i>Item Description</i> | | <i>Quantity</i> | <i>U/M</i> | <i>Amount/Unit</i> | <i>Total Amount</i> | <i>Vendor Catalog Part Number</i> | <i>Contract Number</i> | |
| | Other repair & maintenance - WW Misc. Supplies | | 1.0000 | EA | 68.2800 | 68.28 | | | |
| | <i>G/L Account</i> | | | | <i>Project</i> | | | <i>Amount</i> | |
| | 61-4621-2310 (Water and Sewer Fund-Waste Water Treatment Plant-Other maintenance supplies) | | | | 0000 (0000 - Misc. Equip.) | | | 68.28 | |
| | | | | Invoice Items | 1 | | | | |
| Vendor 9766491022 Totals | | | | | | | | | Invoices 1 \$68.28 |
| 9768868342 | WW Misc. Supplies | Open | | 07/13/2023 | 08/04/2023 | 07/13/2023 | | | 45.00 |
| <i>P.O. Number</i> | <i>Item Description</i> | | <i>Quantity</i> | <i>U/M</i> | <i>Amount/Unit</i> | <i>Total Amount</i> | <i>Vendor Catalog Part Number</i> | <i>Contract Number</i> | |
| | Other repair & maintenance - WW Misc. Supplies | | 1.0000 | EA | 45.0000 | 45.00 | | | |
| | <i>G/L Account</i> | | | | <i>Project</i> | | | <i>Amount</i> | |
| Vendor 9768868342 Totals | | | | | | | | | Invoices 1 \$45.00 |



Accounts Payable Invoice Report - Council

08/01/2023

Invoice Due Date Range 07/22/23 - 08/04/23

Report By Vendor - Invoice

| Invoice Number | Invoice Description | Status | Held Reason | Invoice Date | Due Date | G/L Date | Received Date | Payment Date | Invoice Net Amount |
|--------------------|--|--------|-----------------|---------------|----------------------------|---------------------|-----------------------------------|------------------------|--------------------|
| 9768868342 | WW Misc. Supplies | Open | | 07/13/2023 | 08/04/2023 | 07/13/2023 | | | 45.00 |
| <i>P.O. Number</i> | <i>Item Description</i> | | <i>Quantity</i> | <i>U/M</i> | <i>Amount/Unit</i> | <i>Total Amount</i> | <i>Vendor Catalog Part Number</i> | <i>Contract Number</i> | |
| | 61-4621-2310 (Water and Sewer Fund-Waste Water Treatment Plant- Other maintenance supplies) | | | | 0000 (0000 - Misc. Equip.) | | | 45.00 | |
| | | | | Invoice Items | 1 | | | | |

Vendor **1874 - GRAINGER** Totals Invoices 3 \$293.47

Vendor **1955 - HOME DEPOT CREDIT SERVICES**

| | | | | | | | | | |
|--------------------|---|------|-----------------|---------------|----------------------------|---------------------|-----------------------------------|------------------------|--------|
| 01813 | K9 Vito - Kennel/PD | Open | | 07/14/2023 | 08/04/2023 | 07/14/2023 | | | 224.63 |
| <i>P.O. Number</i> | <i>Item Description</i> | | <i>Quantity</i> | <i>U/M</i> | <i>Amount/Unit</i> | <i>Total Amount</i> | <i>Vendor Catalog Part Number</i> | <i>Contract Number</i> | |
| | Other capital expense - K9 Vito - Kennel/PD | | 1.0000 | EA | 224.6300 | 224.63 | | | |
| | <i>G/L Account</i> | | | | <i>Project</i> | | | <i>Amount</i> | |
| | 11-4210-4604 (General Fund-Police Department-Other capital expense) | | | | 0000 (0000 - Misc. Equip.) | | | 224.63 | |
| | | | | Invoice Items | 1 | | | | |

| | | | | | | | | | |
|--------------------|--|------|-----------------|---------------|--------------------|---------------------|-----------------------------------|------------------------|-------|
| 07132023 | WW Safety Supplies | Open | | 07/13/2023 | 08/04/2023 | 07/13/2023 | | | 41.97 |
| <i>P.O. Number</i> | <i>Item Description</i> | | <i>Quantity</i> | <i>U/M</i> | <i>Amount/Unit</i> | <i>Total Amount</i> | <i>Vendor Catalog Part Number</i> | <i>Contract Number</i> | |
| | Safety gear & clothing - WW Safety Supplies | | 1.0000 | EA | 41.9700 | 41.97 | | | |
| | <i>G/L Account</i> | | | | <i>Project</i> | | | <i>Amount</i> | |
| | 61-4621-2704 (Water and Sewer Fund-Waste Water Treatment Plant- Safety gear & clothing) | | | | | | | 41.97 | |
| | | | | Invoice Items | 1 | | | | |

| | | | | | | | | | |
|--------------------|--|------|-----------------|---------------|----------------------------|---------------------|-----------------------------------|------------------------|--------|
| 071323 | WW Misc. Supplies | Open | | 07/13/2023 | 08/04/2023 | 07/13/2023 | | | 129.30 |
| <i>P.O. Number</i> | <i>Item Description</i> | | <i>Quantity</i> | <i>U/M</i> | <i>Amount/Unit</i> | <i>Total Amount</i> | <i>Vendor Catalog Part Number</i> | <i>Contract Number</i> | |
| | Other repair & maintenance - WW Misc. Supplies | | 1.0000 | EA | 129.3000 | 129.30 | | | |
| | <i>G/L Account</i> | | | | <i>Project</i> | | | <i>Amount</i> | |
| | 61-4621-2310 (Water and Sewer Fund-Waste Water Treatment Plant- Other maintenance supplies) | | | | 0000 (0000 - Misc. Equip.) | | | 129.30 | |
| | | | | Invoice Items | 1 | | | | |

Vendor **1955 - HOME DEPOT CREDIT SERVICES** Totals Invoices 3 \$395.90

Vendor **4681 - BAKESHOP HOW I ROLL**

| | | | | | | | | | |
|--------------------|--|------|-----------------|---------------|--------------------|---------------------|-----------------------------------|------------------------|--------|
| ROLL 07/20 | Refreshments for Historic Preservation event - TOUR | Open | | 07/20/2023 | 08/04/2023 | 07/20/2023 | | | 120.00 |
| <i>P.O. Number</i> | <i>Item Description</i> | | <i>Quantity</i> | <i>U/M</i> | <i>Amount/Unit</i> | <i>Total Amount</i> | <i>Vendor Catalog Part Number</i> | <i>Contract Number</i> | |
| | Public relations - Refreshments for Historic Preservation event - TOUR | | 1.0000 | EA | 120.0000 | 120.00 | | | |
| | <i>G/L Account</i> | | | | <i>Project</i> | | | <i>Amount</i> | |
| | 11-4099-3009 (General Fund-Tourism-Public relations) | | | | | | | 120.00 | |
| | | | | Invoice Items | 1 | | | | |



Accounts Payable Invoice Report - Council

08/01/2023

Invoice Due Date Range 07/22/23 - 08/04/23

Report By Vendor - Invoice

| Invoice Number | Invoice Description | Status | Held Reason | Invoice Date | Due Date | G/L Date | Received Date | Payment Date | Invoice Net Amount |
|--|--|--------|---|--------------|--|---------------------|-----------------------------------|------------------------|--------------------|
| | | | Vendor 4681 - BAKESHOP HOW I ROLL Totals | | | | Invoices | 1 | \$120.00 |
| Vendor 4452 - BRIAN E HUSTON | | | | | | | | | |
| 60 | Installation of exterior lighting on 2023 Dodge Durango/PD | Open | | 07/07/2023 | 08/04/2023 | 07/07/2023 | | | 1,562.50 |
| <i>P.O. Number</i> | <i>Item Description</i> | | <i>Quantity</i> | <i>U/M</i> | <i>Amount/Unit</i> | <i>Total Amount</i> | <i>Vendor Catalog Part Number</i> | <i>Contract Number</i> | |
| | Vehicle & service equipment - Installation of exterior lighting on 2023 Dodge Durango/PD | | 1.0000 | EA | 1,562.5000 | 1,562.50 | | | |
| | <i>G/L Account</i> | | | | <i>Project</i> | | | <i>Amount</i> | |
| | 11-4210-4299 (General Fund-Police Department-Vehicles & service equipment) | | | | 7769 (2023 Dodge Durango) | | | 1,562.50 | |
| | | | Invoice Items | | 1 | | | | |
| | | | Vendor 4452 - BRIAN E HUSTON Totals | | | | Invoices | 1 | \$1,562.50 |
| Vendor 3693 - ILLINOIS TOLLWAY | | | | | | | | | |
| G129000005383 | Tollway fee - CLERK | Open | | 04/27/2023 | 08/04/2023 | 04/27/2023 | | | 9.50 |
| <i>P.O. Number</i> | <i>Item Description</i> | | <i>Quantity</i> | <i>U/M</i> | <i>Amount/Unit</i> | <i>Total Amount</i> | <i>Vendor Catalog Part Number</i> | <i>Contract Number</i> | |
| | Travel expense / lodging, fuel, meals - Tollway fee - CLERK | | 1.0000 | EA | 9.5000 | 9.50 | | | |
| | <i>G/L Account</i> | | | | <i>Project</i> | | | <i>Amount</i> | |
| | 11-4002-3707 (General Fund-City Clerk-Travel expenses) | | | | | | | 9.50 | |
| | | | Invoice Items | | 1 | | | | |
| | | | Vendor 3693 - ILLINOIS TOLLWAY Totals | | | | Invoices | 1 | \$9.50 |
| Vendor 4583 - ILMO PRODUCTS COMPANY | | | | | | | | | |
| 01395571 | Torch Fuel/W/S GARAGE | Open | | 06/30/2023 | 08/04/2023 | 06/30/2023 | | | 56.40 |
| <i>P.O. Number</i> | <i>Item Description</i> | | <i>Quantity</i> | <i>U/M</i> | <i>Amount/Unit</i> | <i>Total Amount</i> | <i>Vendor Catalog Part Number</i> | <i>Contract Number</i> | |
| | 1/4 page full color ad/tourism - Torch Fuel/W/S GARAGE | | 1.0000 | EA | 56.4000 | 56.40 | | | |
| | <i>G/L Account</i> | | | | <i>Project</i> | | | <i>Amount</i> | |
| | 61-4611-2201 (Water and Sewer Fund-Water Treatment Plant-Fuel & oil) | | | | | | | 56.40 | |
| | | | Invoice Items | | 1 | | | | |
| | | | Vendor 4583 - ILMO PRODUCTS COMPANY Totals | | | | Invoices | 1 | \$56.40 |
| Vendor 3355 - JOHN DEERE FINANCIAL | | | | | | | | | |
| 60143 | Concession building materials/ENG | Open | | 07/12/2023 | 08/04/2023 | 07/12/2023 | | | 8.97 |
| <i>P.O. Number</i> | <i>Item Description</i> | | <i>Quantity</i> | <i>U/M</i> | <i>Amount/Unit</i> | <i>Total Amount</i> | <i>Vendor Catalog Part Number</i> | <i>Contract Number</i> | |
| | Capital Improvement projects - Concession building materials/ENG | | 1.0000 | EA | 8.9700 | 8.97 | | | |
| | <i>G/L Account</i> | | | | <i>Project</i> | | | <i>Amount</i> | |
| | 11-4095-4106 (General Fund-Engineering Department-Capital improvement projects) | | | | PW 20 26 020 (Community Drive Concession Building) | | | 8.97 | |
| | | | Invoice Items | | 1 | | | | |



Accounts Payable Invoice Report - Council

08/01/2023

Invoice Due Date Range 07/22/23 - 08/04/23

Report By Vendor - Invoice

| Invoice Number | Invoice Description | Status | Held Reason | Invoice Date | Due Date | G/L Date | Received Date | Payment Date | Invoice Net Amount |
|--------------------|---|--------|-----------------|---------------|---|---------------------|-----------------------------------|------------------------|--------------------|
| 92345 | Concession building materials/ENG | Open | | 07/12/2023 | 08/04/2023 | 07/12/2023 | | | 32.96 |
| <i>P.O. Number</i> | <i>Item Description</i> | | <i>Quantity</i> | <i>U/M</i> | <i>Amount/Unit</i> | <i>Total Amount</i> | <i>Vendor Catalog Part Number</i> | <i>Contract Number</i> | |
| | Capital Improvement projects - Concession building materials/ENG | | 1.0000 | EA | 32.9600 | 32.96 | | | |
| | <i>G/L Account</i> | | | | <i>Project</i> | | <i>Amount</i> | | |
| | 11-4095-4106 (General Fund-Engineering Department-Capital improvement projects) | | | | PW 20 26 020 (Community Drive Concession Building) | | 32.96 | | |
| | | | | Invoice Items | 1 | | | | |
| 90178 | Concession building materials/ENG | Open | | 07/14/2023 | 08/04/2023 | 07/14/2023 | | | 2.79 |
| <i>P.O. Number</i> | <i>Item Description</i> | | <i>Quantity</i> | <i>U/M</i> | <i>Amount/Unit</i> | <i>Total Amount</i> | <i>Vendor Catalog Part Number</i> | <i>Contract Number</i> | |
| | Capital Improvement projects - Concession building materials/ENG | | 1.0000 | EA | 2.7900 | 2.79 | | | |
| | <i>G/L Account</i> | | | | <i>Project</i> | | <i>Amount</i> | | |
| | 11-4095-4106 (General Fund-Engineering Department-Capital improvement projects) | | | | PW 20 26 020 (Community Drive Concession Building) | | 2.79 | | |
| | | | | Invoice Items | 1 | | | | |
| 90222 | Maintenance building materials/ENG | Open | | 07/14/2023 | 08/04/2023 | 07/14/2023 | | | 18.98 |
| <i>P.O. Number</i> | <i>Item Description</i> | | <i>Quantity</i> | <i>U/M</i> | <i>Amount/Unit</i> | <i>Total Amount</i> | <i>Vendor Catalog Part Number</i> | <i>Contract Number</i> | |
| | Capital Improvement projects - Maintenance building materials/ENG | | 1.0000 | EA | 18.9800 | 18.98 | | | |
| | <i>G/L Account</i> | | | | <i>Project</i> | | <i>Amount</i> | | |
| | 11-4095-4106 (General Fund-Engineering Department-Capital improvement projects) | | | | PW 20 26 019 (Community Drive Maintenance Building) | | 18.98 | | |
| | | | | Invoice Items | 1 | | | | |
| 137384 | Concession building materials/ENG | Open | | 07/18/2023 | 08/04/2023 | 07/18/2023 | | | 105.43 |
| <i>P.O. Number</i> | <i>Item Description</i> | | <i>Quantity</i> | <i>U/M</i> | <i>Amount/Unit</i> | <i>Total Amount</i> | <i>Vendor Catalog Part Number</i> | <i>Contract Number</i> | |
| | Capital Improvement projects - Concession building materials/ENG | | 1.0000 | EA | 105.4300 | 105.43 | | | |
| | <i>G/L Account</i> | | | | <i>Project</i> | | <i>Amount</i> | | |
| | 11-4095-4106 (General Fund-Engineering Department-Capital improvement projects) | | | | PW 20 26 020 (Community Drive Concession Building) | | 105.43 | | |
| | | | | Invoice Items | 1 | | | | |



Accounts Payable Invoice Report - Council

08/01/2023

Invoice Due Date Range 07/22/23 - 08/04/23

Report By Vendor - Invoice

| Invoice Number | Invoice Description | Status | Held Reason | Invoice Date | Due Date | G/L Date | Received Date | Payment Date | Invoice Net Amount |
|--------------------|---|--------|-----------------|---------------|--|---------------------|-----------------------------------|------------------------|--------------------|
| 137641 | Concession building materials/ENG | Open | | 07/19/2023 | 08/04/2023 | 07/19/2023 | | | 8.49 |
| <i>P.O. Number</i> | <i>Item Description</i> | | <i>Quantity</i> | <i>U/M</i> | <i>Amount/Unit</i> | <i>Total Amount</i> | <i>Vendor Catalog Part Number</i> | <i>Contract Number</i> | |
| | Capital Improvement projects - Concession building materials/ENG | | 1.0000 | EA | 8.4900 | 8.49 | | | |
| | <i>G/L Account</i> | | | | <i>Project</i> | | | <i>Amount</i> | |
| | 11-4095-4106 (General Fund-Engineering Department-Capital improvement projects) | | | | PW 20 26 020 (Community Drive Concession Building) | | | 8.49 | |
| | | | | Invoice Items | 1 | | | | |
| 73501 | Batteries & Gloves/UTILITY | Open | | 04/25/2023 | 08/04/2023 | 04/25/2023 | | | 22.48 |
| <i>P.O. Number</i> | <i>Item Description</i> | | <i>Quantity</i> | <i>U/M</i> | <i>Amount/Unit</i> | <i>Total Amount</i> | <i>Vendor Catalog Part Number</i> | <i>Contract Number</i> | |
| | 1/4 page full color ad/tourism - Batteries & Gloves/UTILITY | | 1.0000 | EA | 22.4800 | 22.48 | | | |
| | <i>G/L Account</i> | | | | <i>Project</i> | | | <i>Amount</i> | |
| | 61-4610-2704 (Water and Sewer Fund-Utility Department-Safety gear & clothing) | | | | | | | 22.48 | |
| | | | | Invoice Items | 1 | | | | |
| 75084 | Misc Bolts/UTILITY | Open | | 05/03/2023 | 08/04/2023 | 05/03/2023 | | | 2.62 |
| <i>P.O. Number</i> | <i>Item Description</i> | | <i>Quantity</i> | <i>U/M</i> | <i>Amount/Unit</i> | <i>Total Amount</i> | <i>Vendor Catalog Part Number</i> | <i>Contract Number</i> | |
| | 1/4 page full color ad/tourism - Misc Bolts/UTILITY | | 1.0000 | EA | 2.6200 | 2.62 | | | |
| | <i>G/L Account</i> | | | | <i>Project</i> | | | <i>Amount</i> | |
| | 61-4610-2699 (Water and Sewer Fund-Utility Department-Other building materials) | | | | | | | 2.62 | |
| | | | | Invoice Items | 1 | | | | |
| 102595 | Gloves/STREET | Open | | 05/04/2023 | 08/04/2023 | 05/04/2023 | | | 10.99 |
| <i>P.O. Number</i> | <i>Item Description</i> | | <i>Quantity</i> | <i>U/M</i> | <i>Amount/Unit</i> | <i>Total Amount</i> | <i>Vendor Catalog Part Number</i> | <i>Contract Number</i> | |
| | 1/4 page full color ad/tourism - Gloves/STREET | | 1.0000 | EA | 10.9900 | 10.99 | | | |
| | <i>G/L Account</i> | | | | <i>Project</i> | | | <i>Amount</i> | |
| | 11-4310-2704 (General Fund-Street Department-Safety gear & clothing) | | | | | | | 10.99 | |
| | | | | Invoice Items | 1 | | | | |
| 75326 | Pliers/STREET | Open | | 05/04/2023 | 08/04/2023 | 05/04/2023 | | | 9.99 |
| <i>P.O. Number</i> | <i>Item Description</i> | | <i>Quantity</i> | <i>U/M</i> | <i>Amount/Unit</i> | <i>Total Amount</i> | <i>Vendor Catalog Part Number</i> | <i>Contract Number</i> | |
| | 1/4 page full color ad/tourism - Pliers/STREET | | 1.0000 | EA | 9.9900 | 9.99 | | | |
| | <i>G/L Account</i> | | | | <i>Project</i> | | | <i>Amount</i> | |
| | 11-4310-2801 (General Fund-Street Department-Hand tools) | | | | | | | 9.99 | |
| | | | | Invoice Items | 1 | | | | |



Accounts Payable Invoice Report - Council

08/01/2023

Invoice Due Date Range 07/22/23 - 08/04/23

Report By Vendor - Invoice

| Invoice Number | Invoice Description | Status | Held Reason | Invoice Date | Due Date | G/L Date | Received Date | Payment Date | Invoice Net Amount |
|--------------------|---|--------|-----------------|---------------|--------------------|---------------------|-----------------------------------|------------------------|--------------------|
| 50946 | Batteries for Laser/UTILITY | Open | | 05/05/2023 | 08/04/2023 | 05/05/2023 | | | 14.99 |
| <i>P.O. Number</i> | <i>Item Description</i> | | <i>Quantity</i> | <i>U/M</i> | <i>Amount/Unit</i> | <i>Total Amount</i> | <i>Vendor Catalog Part Number</i> | <i>Contract Number</i> | |
| | 1/4 page full color ad/tourism - Batteries for Laser/UTILITY | | 1.0000 | EA | 14.9900 | 14.99 | | | |
| | <i>G/L Account</i> | | | | <i>Project</i> | | | <i>Amount</i> | |
| | 61-4610-2001 (Water and Sewer Fund-Utility Department-Office supplies) | | | | | | | 14.99 | |
| | | | | Invoice Items | 1 | | | | |
| 126003 | Drill Bits/STREET | Open | | 05/08/2023 | 08/04/2023 | 05/08/2023 | | | 39.98 |
| <i>P.O. Number</i> | <i>Item Description</i> | | <i>Quantity</i> | <i>U/M</i> | <i>Amount/Unit</i> | <i>Total Amount</i> | <i>Vendor Catalog Part Number</i> | <i>Contract Number</i> | |
| | 1/4 page full color ad/tourism - Drill Bits/STREET | | 1.0000 | EA | 39.9800 | 39.98 | | | |
| | <i>G/L Account</i> | | | | <i>Project</i> | | | <i>Amount</i> | |
| | 11-4310-2801 (General Fund-Street Department-Hand tools) | | | | | | | 39.98 | |
| | | | | Invoice Items | 1 | | | | |
| 80124 | Sawzall Blades/UTILITY | Open | | 05/24/2023 | 08/04/2023 | 05/24/2023 | | | 46.97 |
| <i>P.O. Number</i> | <i>Item Description</i> | | <i>Quantity</i> | <i>U/M</i> | <i>Amount/Unit</i> | <i>Total Amount</i> | <i>Vendor Catalog Part Number</i> | <i>Contract Number</i> | |
| | 1/4 page full color ad/tourism - Sawzall Blades/UTILITY | | 1.0000 | EA | 46.9700 | 46.97 | | | |
| | <i>G/L Account</i> | | | | <i>Project</i> | | | <i>Amount</i> | |
| | 61-4610-2801 (Water and Sewer Fund-Utility Department-Hand tools) | | | | | | | 46.97 | |
| | | | | Invoice Items | 1 | | | | |
| 55709 | Utility Knife/STREET | Open | | 06/08/2023 | 08/04/2023 | 06/08/2023 | | | 37.95 |
| <i>P.O. Number</i> | <i>Item Description</i> | | <i>Quantity</i> | <i>U/M</i> | <i>Amount/Unit</i> | <i>Total Amount</i> | <i>Vendor Catalog Part Number</i> | <i>Contract Number</i> | |
| | 1/4 page full color ad/tourism - Utility Knife/STREET | | 1.0000 | EA | 37.9500 | 37.95 | | | |
| | <i>G/L Account</i> | | | | <i>Project</i> | | | <i>Amount</i> | |
| | 11-4310-2801 (General Fund-Street Department-Hand tools) | | | | | | | 37.95 | |
| | | | | Invoice Items | 1 | | | | |
| 109552 | Pail Poly 1 Qt./UTILITY | Open | | 06/15/2023 | 08/04/2023 | 06/15/2023 | | | 1.29 |
| <i>P.O. Number</i> | <i>Item Description</i> | | <i>Quantity</i> | <i>U/M</i> | <i>Amount/Unit</i> | <i>Total Amount</i> | <i>Vendor Catalog Part Number</i> | <i>Contract Number</i> | |
| | 1/4 page full color ad/tourism - Pail Poly 1 Qt./UTILITY | | 1.0000 | EA | 1.2900 | 1.29 | | | |
| | <i>G/L Account</i> | | | | <i>Project</i> | | | <i>Amount</i> | |
| | 61-4610-2699 (Water and Sewer Fund-Utility Department-Other building materials) | | | | | | | 1.29 | |
| | | | | Invoice Items | 1 | | | | |



Accounts Payable Invoice Report - Council

08/01/2023

Invoice Due Date Range 07/22/23 - 08/04/23

Report By Vendor - Invoice

| Invoice Number | Invoice Description | Status | Held Reason | Invoice Date | Due Date | G/L Date | Received Date | Payment Date | Invoice Net Amount |
|--------------------|---|--------|-----------------|---------------|----------------------------|---------------------|-----------------------------------|------------------------|--------------------|
| 58345 | Kerosene Can/W/S GARAGE | Open | | 06/26/2023 | 08/04/2023 | 06/26/2023 | | | 16.99 |
| <i>P.O. Number</i> | <i>Item Description</i> | | <i>Quantity</i> | <i>U/M</i> | <i>Amount/Unit</i> | <i>Total Amount</i> | <i>Vendor Catalog Part Number</i> | <i>Contract Number</i> | |
| | 1/4 page full color ad/tourism - Kerosene Can/W/S GARAGE | | 1.0000 | EA | 16.9900 | 16.99 | | | |
| | <i>G/L Account</i> | | | | <i>Project</i> | | | <i>Amount</i> | |
| | 61-4311-2401 (Water and Sewer Fund-City Garage-Vehicle parts & supplies) | | | | 0000 (0000 - Misc. Equip.) | | | 16.99 | |
| | | | | Invoice Items | 1 | | | | |
| 111387 | Chain Saw Bar Oil/STREET | Open | | 06/27/2023 | 08/04/2023 | 06/27/2023 | | | 16.99 |
| <i>P.O. Number</i> | <i>Item Description</i> | | <i>Quantity</i> | <i>U/M</i> | <i>Amount/Unit</i> | <i>Total Amount</i> | <i>Vendor Catalog Part Number</i> | <i>Contract Number</i> | |
| | 1/4 page full color ad/tourism - Chain Saw Bar Oil/STREET | | 1.0000 | EA | 16.9900 | 16.99 | | | |
| | <i>G/L Account</i> | | | | <i>Project</i> | | | <i>Amount</i> | |
| | 11-4310-2201 (General Fund-Street Department-Fuel & oil) | | | | | | | 16.99 | |
| | | | | Invoice Items | 1 | | | | |
| 58667 | Breakroom Supplies/UTILITY | Open | | 06/29/2023 | 08/04/2023 | 06/29/2023 | | | 9.98 |
| <i>P.O. Number</i> | <i>Item Description</i> | | <i>Quantity</i> | <i>U/M</i> | <i>Amount/Unit</i> | <i>Total Amount</i> | <i>Vendor Catalog Part Number</i> | <i>Contract Number</i> | |
| | 1/4 page full color ad/tourism - Breakroom Supplies/UTILITY | | 1.0000 | EA | 9.9800 | 9.98 | | | |
| | <i>G/L Account</i> | | | | <i>Project</i> | | | <i>Amount</i> | |
| | 61-4610-2001 (Water and Sewer Fund-Utility Department-Office supplies) | | | | | | | 9.98 | |
| | | | | Invoice Items | 1 | | | | |
| 58669 | Heat Shrink Tubing/UTILITY | Open | | 06/29/2023 | 08/04/2023 | 06/29/2023 | | | 4.38 |
| <i>P.O. Number</i> | <i>Item Description</i> | | <i>Quantity</i> | <i>U/M</i> | <i>Amount/Unit</i> | <i>Total Amount</i> | <i>Vendor Catalog Part Number</i> | <i>Contract Number</i> | |
| | 1/4 page full color ad/tourism - Heat Shrink Tubing/UTILITY | | 1.0000 | EA | 4.3800 | 4.38 | | | |
| | <i>G/L Account</i> | | | | <i>Project</i> | | | <i>Amount</i> | |
| | 61-4610-2699 (Water and Sewer Fund-Utility Department-Other building materials) | | | | | | | 4.38 | |
| | | | | Invoice Items | 1 | | | | |
| 87393 | Chain Saw Bar Oil/UTILITY | Open | | 06/29/2023 | 08/04/2023 | 06/29/2023 | | | 16.99 |
| <i>P.O. Number</i> | <i>Item Description</i> | | <i>Quantity</i> | <i>U/M</i> | <i>Amount/Unit</i> | <i>Total Amount</i> | <i>Vendor Catalog Part Number</i> | <i>Contract Number</i> | |
| | 1/4 page full color ad/tourism - Chain Saw Bar Oil/UTILITY | | 1.0000 | EA | 16.9900 | 16.99 | | | |
| | <i>G/L Account</i> | | | | <i>Project</i> | | | <i>Amount</i> | |
| | 61-4610-2201 (Water and Sewer Fund-Utility Department-Fuel & oil) | | | | | | | 16.99 | |
| | | | | Invoice Items | 1 | | | | |



Accounts Payable Invoice Report - Council

08/01/2023

Invoice Due Date Range 07/22/23 - 08/04/23

Report By Vendor - Invoice

| Invoice Number | Invoice Description | Status | Held Reason | Invoice Date | Due Date | G/L Date | Received Date | Payment Date | Invoice Net Amount |
|--------------------|---|--------|-----------------|---------------|--------------------|---------------------|-----------------------------------|------------------------|--------------------|
| 134639 | Round-Up/STREET | Open | | 06/30/2023 | 08/04/2023 | 06/30/2023 | | | 72.97 |
| <i>P.O. Number</i> | <i>Item Description</i> | | <i>Quantity</i> | <i>U/M</i> | <i>Amount/Unit</i> | <i>Total Amount</i> | <i>Vendor Catalog Part Number</i> | <i>Contract Number</i> | |
| | 1/4 page full color ad/tourism - Round-Up/STREET | | 1.0000 | EA | 72.9700 | 72.97 | | | |
| | <i>G/L Account</i> | | | | <i>Project</i> | | | <i>Amount</i> | |
| | 11-4310-2108 (General Fund-Street Department-Agricultural supplies) | | | | 1 | | | 72.97 | |
| | | | | Invoice Items | | | | | |
| 135361 | Chain/STREET | Open | | 07/03/2023 | 08/04/2023 | 07/03/2023 | | | 24.99 |
| <i>P.O. Number</i> | <i>Item Description</i> | | <i>Quantity</i> | <i>U/M</i> | <i>Amount/Unit</i> | <i>Total Amount</i> | <i>Vendor Catalog Part Number</i> | <i>Contract Number</i> | |
| | 1/4 page full color ad/tourism - Chain/STREET | | 1.0000 | EA | 24.9900 | 24.99 | | | |
| | <i>G/L Account</i> | | | | <i>Project</i> | | | <i>Amount</i> | |
| | 11-4310-2801 (General Fund-Street Department-Hand tools) | | | | 1 | | | 24.99 | |
| | | | | Invoice Items | | | | | |
| 59411 | Spray Paint/UTILITY | Open | | 07/06/2023 | 08/04/2023 | 07/06/2023 | | | 20.97 |
| <i>P.O. Number</i> | <i>Item Description</i> | | <i>Quantity</i> | <i>U/M</i> | <i>Amount/Unit</i> | <i>Total Amount</i> | <i>Vendor Catalog Part Number</i> | <i>Contract Number</i> | |
| | 1/4 page full color ad/tourism - Spray Paint/UTILITY | | 1.0000 | EA | 20.9700 | 20.97 | | | |
| | <i>G/L Account</i> | | | | <i>Project</i> | | | <i>Amount</i> | |
| | 61-4610-2699 (Water and Sewer Fund-Utility Department-Other building materials) | | | | 1 | | | 20.97 | |
| | | | | Invoice Items | | | | | |
| 89439 | Chain/UTILITY | Open | | 07/10/2023 | 08/04/2023 | 07/10/2023 | | | 22.00 |
| <i>P.O. Number</i> | <i>Item Description</i> | | <i>Quantity</i> | <i>U/M</i> | <i>Amount/Unit</i> | <i>Total Amount</i> | <i>Vendor Catalog Part Number</i> | <i>Contract Number</i> | |
| | 1/4 page full color ad/tourism - Chain/UTILITY | | 1.0000 | EA | 22.0000 | 22.00 | | | |
| | <i>G/L Account</i> | | | | <i>Project</i> | | | <i>Amount</i> | |
| | 61-4610-2699 (Water and Sewer Fund-Utility Department-Other building materials) | | | | 1 | | | 22.00 | |
| | | | | Invoice Items | | | | | |
| 92192 | Chain Loop/UTILITY | Open | | 07/10/2023 | 08/04/2023 | 07/10/2023 | | | 25.00 |
| <i>P.O. Number</i> | <i>Item Description</i> | | <i>Quantity</i> | <i>U/M</i> | <i>Amount/Unit</i> | <i>Total Amount</i> | <i>Vendor Catalog Part Number</i> | <i>Contract Number</i> | |
| | 1/4 page full color ad/tourism - Chain Loop/UTILITY | | 1.0000 | EA | 25.0000 | 25.00 | | | |
| | <i>G/L Account</i> | | | | <i>Project</i> | | | <i>Amount</i> | |
| | 61-4610-2801 (Water and Sewer Fund-Utility Department-Hand tools) | | | | 1 | | | 25.00 | |
| | | | | Invoice Items | | | | | |
| 59940 | Chain (Return)/UTILITY | Open | | 07/11/2023 | 08/04/2023 | 07/11/2023 | | | (25.00) |
| <i>P.O. Number</i> | <i>Item Description</i> | | <i>Quantity</i> | <i>U/M</i> | <i>Amount/Unit</i> | <i>Total Amount</i> | <i>Vendor Catalog Part Number</i> | <i>Contract Number</i> | |
| | 1/4 page full color ad/tourism - Chain (Return)/UTILITY | | 1.0000 | EA | (25.0000) | (25.00) | | | |
| | <i>G/L Account</i> | | | | <i>Project</i> | | | <i>Amount</i> | |
| | | | | Invoice Items | | | | | |



Accounts Payable Invoice Report - Council

08/01/2023

Invoice Due Date Range 07/22/23 - 08/04/23

Report By Vendor - Invoice

| Invoice Number | Invoice Description | Status | Held Reason | Invoice Date | Due Date | G/L Date | Received Date | Payment Date | Invoice Net Amount |
|--------------------|---|--------|-----------------|--------------|---|---------------------|-----------------------------------|------------------------|--------------------|
| 59940 | Chain (Return)/UTILITY | Open | | 07/11/2023 | 08/04/2023 | 07/11/2023 | | | (25.00) |
| <i>P.O. Number</i> | <i>Item Description</i> | | <i>Quantity</i> | <i>U/M</i> | <i>Amount/Unit</i> | <i>Total Amount</i> | <i>Vendor Catalog Part Number</i> | <i>Contract Number</i> | |
| | 61-4610-2801 (Water and Sewer Fund-Utility Department-Hand tools) | | | | | | | (25.00) | |
| | | | Invoice Items | 1 | | | | | |
| 59987 | Chain G70 w/ Tow Hooks/UTILITY | Open | | 07/11/2023 | 08/04/2023 | 07/11/2023 | | | 79.99 |
| <i>P.O. Number</i> | <i>Item Description</i> | | <i>Quantity</i> | <i>U/M</i> | <i>Amount/Unit</i> | <i>Total Amount</i> | <i>Vendor Catalog Part Number</i> | <i>Contract Number</i> | |
| | 1/4 page full color ad/tourism - Chain G70 w/ Tow Hooks/UTILITY | | 1.0000 | EA | 79.9900 | 79.99 | | | |
| | <i>G/L Account</i> | | | | <i>Project</i> | | | <i>Amount</i> | |
| | 61-4610-2401 (Water and Sewer Fund-Utility Department-Vehicle parts & supplies) | | | | 4700 (4700 - 2012 Int'l Dump Truck - Automatic) | | | 79.99 | |
| | | | Invoice Items | 1 | | | | | |
| 92440 | Hose for Fuel Cell/UTILITY | Open | | 07/12/2023 | 08/04/2023 | 07/12/2023 | | | 46.99 |
| <i>P.O. Number</i> | <i>Item Description</i> | | <i>Quantity</i> | <i>U/M</i> | <i>Amount/Unit</i> | <i>Total Amount</i> | <i>Vendor Catalog Part Number</i> | <i>Contract Number</i> | |
| | 1/4 page full color ad/tourism - Hose for Fuel Cell/UTILITY | | 1.0000 | EA | 46.9900 | 46.99 | | | |
| | <i>G/L Account</i> | | | | <i>Project</i> | | | <i>Amount</i> | |
| | 61-4610-2401 (Water and Sewer Fund-Utility Department-Vehicle parts & supplies) | | | | 0050 (2014 Ford F250) | | | 46.99 | |
| | | | Invoice Items | 1 | | | | | |
| 89963 | Shovels & Rakes/UTILITY | Open | | 07/13/2023 | 08/04/2023 | 07/13/2023 | | | 57.96 |
| <i>P.O. Number</i> | <i>Item Description</i> | | <i>Quantity</i> | <i>U/M</i> | <i>Amount/Unit</i> | <i>Total Amount</i> | <i>Vendor Catalog Part Number</i> | <i>Contract Number</i> | |
| | 1/4 page full color ad/tourism - Shovels & Rakes/UTILITY | | 1.0000 | EA | 57.9600 | 57.96 | | | |
| | <i>G/L Account</i> | | | | <i>Project</i> | | | <i>Amount</i> | |
| | 61-4610-2801 (Water and Sewer Fund-Utility Department-Hand tools) | | | | | | | 57.96 | |
| | | | Invoice Items | 1 | | | | | |
| 114189 | Duct Tape/UTILITY | Open | | 07/18/2023 | 08/04/2023 | 07/18/2023 | | | 11.18 |
| <i>P.O. Number</i> | <i>Item Description</i> | | <i>Quantity</i> | <i>U/M</i> | <i>Amount/Unit</i> | <i>Total Amount</i> | <i>Vendor Catalog Part Number</i> | <i>Contract Number</i> | |
| | 1/4 page full color ad/tourism - Duct Tape/UTILITY | | 1.0000 | EA | 11.1800 | 11.18 | | | |
| | <i>G/L Account</i> | | | | <i>Project</i> | | | <i>Amount</i> | |
| | 61-4610-2699 (Water and Sewer Fund-Utility Department-Other building materials) | | | | | | | 11.18 | |
| | | | Invoice Items | 1 | | | | | |



Accounts Payable Invoice Report - Council

08/01/2023

Invoice Due Date Range 07/22/23 - 08/04/23

Report By Vendor - Invoice

| Invoice Number | Invoice Description | Status | Held Reason | Invoice Date | Due Date | G/L Date | Received Date | Payment Date | Invoice Net Amount |
|--------------------|---|--------|-----------------|----------------|--------------------|---------------------|-----------------------------------|------------------------|--------------------|
| 60825 | Galv. Threaded Pipe/UTILITY | Open | | 07/19/2023 | 08/04/2023 | 07/19/2023 | | | 20.47 |
| <i>P.O. Number</i> | <i>Item Description</i> | | <i>Quantity</i> | <i>U/M</i> | <i>Amount/Unit</i> | <i>Total Amount</i> | <i>Vendor Catalog Part Number</i> | <i>Contract Number</i> | |
| | 1/4 page full color ad/tourism - Galv. Threaded Pipe/UTILITY | | 1.0000 | EA | 20.4700 | 20.47 | | | |
| | <i>G/L Account</i> | | | <i>Project</i> | | | | <i>Amount</i> | |
| | 61-4610-2699 (Water and Sewer Fund-Utility Department-Other building materials) | | | | | | | 20.47 | |
| | | | | Invoice Items | 1 | | | | |
| 136686 | Blades - MAINT | Open | | 07/13/2023 | 08/04/2023 | 07/13/2023 | | | 38.00 |
| <i>P.O. Number</i> | <i>Item Description</i> | | <i>Quantity</i> | <i>U/M</i> | <i>Amount/Unit</i> | <i>Total Amount</i> | <i>Vendor Catalog Part Number</i> | <i>Contract Number</i> | |
| | Park maintenance materials - Blades - MAINT | | 1.0000 | EA | 38.0000 | 38.00 | | | |
| | <i>G/L Account</i> | | | <i>Project</i> | | | | <i>Amount</i> | |
| | 11-4194-2513 (General Fund-Parks & Maintenance Department-Park maintenance materials) | | | | | | | 38.00 | |
| | | | | Invoice Items | 1 | | | | |
| 90221 | Landscape tools and blades - MAINT | Open | | 07/14/2023 | 08/04/2023 | 07/14/2023 | | | 55.96 |
| <i>P.O. Number</i> | <i>Item Description</i> | | <i>Quantity</i> | <i>U/M</i> | <i>Amount/Unit</i> | <i>Total Amount</i> | <i>Vendor Catalog Part Number</i> | <i>Contract Number</i> | |
| | Park maintenance materials - Landscape tools and blades - MAINT | | 1.0000 | EA | 55.9600 | 55.96 | | | |
| | <i>G/L Account</i> | | | <i>Project</i> | | | | <i>Amount</i> | |
| | 11-4194-2513 (General Fund-Parks & Maintenance Department-Park maintenance materials) | | | | | | | 55.96 | |
| | | | | Invoice Items | 1 | | | | |
| 137346 | Batteries - MAINT | Open | | 07/17/2023 | 08/04/2023 | 07/17/2023 | | | 14.99 |
| <i>P.O. Number</i> | <i>Item Description</i> | | <i>Quantity</i> | <i>U/M</i> | <i>Amount/Unit</i> | <i>Total Amount</i> | <i>Vendor Catalog Part Number</i> | <i>Contract Number</i> | |
| | Park maintenance materials - Batteries - MAINT | | 1.0000 | EA | 14.9900 | 14.99 | | | |
| | <i>G/L Account</i> | | | <i>Project</i> | | | | <i>Amount</i> | |
| | 11-4194-2513 (General Fund-Parks & Maintenance Department-Park maintenance materials) | | | | | | | 14.99 | |
| | | | | Invoice Items | 1 | | | | |
| 91913 | Gloves and grabber - MAINT | Open | | 07/25/2023 | 08/04/2023 | 07/25/2023 | | | 39.96 |
| <i>P.O. Number</i> | <i>Item Description</i> | | <i>Quantity</i> | <i>U/M</i> | <i>Amount/Unit</i> | <i>Total Amount</i> | <i>Vendor Catalog Part Number</i> | <i>Contract Number</i> | |
| | Park maintenance materials - Gloves and grabber - MAINT | | 1.0000 | EA | 39.9600 | 39.96 | | | |
| | <i>G/L Account</i> | | | <i>Project</i> | | | | <i>Amount</i> | |
| | 11-4194-2513 (General Fund-Parks & Maintenance Department-Park maintenance materials) | | | | | | | 39.96 | |
| | | | | Invoice Items | 1 | | | | |



Accounts Payable Invoice Report - Council

08/01/2023

Invoice Due Date Range 07/22/23 - 08/04/23

Report By Vendor - Invoice

| Invoice Number | Invoice Description | Status | Held Reason | Invoice Date | Due Date | G/L Date | Received Date | Payment Date | Invoice Net Amount |
|--------------------|--|--------|-----------------|---------------|----------------------------|---------------------|-----------------------------------|------------------------|--------------------|
| 137444 | WP Misc Supplies - Misc | Open | | 07/18/2023 | 08/04/2023 | 07/18/2023 | | | 48.98 |
| <i>P.O. Number</i> | <i>Item Description</i> | | <i>Quantity</i> | <i>U/M</i> | <i>Amount/Unit</i> | <i>Total Amount</i> | <i>Vendor Catalog Part Number</i> | <i>Contract Number</i> | |
| | Misc parts - WP Misc Supplies - Misc | | 1.0000 | EA | 48.9800 | 48.98 | | | |
| | <i>G/L Account</i> | | | | <i>Project</i> | | | <i>Amount</i> | |
| | 61-4611-2310 (Water and Sewer Fund-Water Treatment Plant-Other maintenance supplies) | | | | | | | 48.98 | |
| | | | | Invoice Items | 1 | | | | |
| 60726 | WP Misc Supplies - Pipe, Fittings, etc | Open | | 07/18/2023 | 08/04/2023 | 07/18/2023 | | | 15.78 |
| <i>P.O. Number</i> | <i>Item Description</i> | | <i>Quantity</i> | <i>U/M</i> | <i>Amount/Unit</i> | <i>Total Amount</i> | <i>Vendor Catalog Part Number</i> | <i>Contract Number</i> | |
| | Pipe and fittings for chem feed changes to existing plant/wtp - WP Misc Supplies - Pipe, Fittings, etc | | 1.0000 | EA | 15.7800 | 15.78 | | | |
| | <i>G/L Account</i> | | | | <i>Project</i> | | | <i>Amount</i> | |
| | 61-4611-2310 (Water and Sewer Fund-Water Treatment Plant-Other maintenance supplies) | | | | | | | 15.78 | |
| | | | | Invoice Items | 1 | | | | |
| 60820 | WP Misc Supplies - Misc | Open | | 07/19/2023 | 08/04/2023 | 07/19/2023 | | | 68.95 |
| <i>P.O. Number</i> | <i>Item Description</i> | | <i>Quantity</i> | <i>U/M</i> | <i>Amount/Unit</i> | <i>Total Amount</i> | <i>Vendor Catalog Part Number</i> | <i>Contract Number</i> | |
| | Misc. supplies / WTP - WP Misc Supplies - Misc | | 1.0000 | EA | 68.9500 | 68.95 | | | |
| | <i>G/L Account</i> | | | | <i>Project</i> | | | <i>Amount</i> | |
| | 61-4611-2310 (Water and Sewer Fund-Water Treatment Plant-Other maintenance supplies) | | | | | | | 68.95 | |
| | | | | Invoice Items | 1 | | | | |
| 90196 | WW Misc. Supplies | Open | | 07/14/2023 | 08/04/2023 | 07/14/2023 | | | 155.95 |
| <i>P.O. Number</i> | <i>Item Description</i> | | <i>Quantity</i> | <i>U/M</i> | <i>Amount/Unit</i> | <i>Total Amount</i> | <i>Vendor Catalog Part Number</i> | <i>Contract Number</i> | |
| | Other repair & maintenance - WW Misc. Supplies | | 1.0000 | EA | 155.9500 | 155.95 | | | |
| | <i>G/L Account</i> | | | | <i>Project</i> | | | <i>Amount</i> | |
| | 61-4621-2310 (Water and Sewer Fund-Waste Water Treatment Plant-Other maintenance supplies) | | | | 0000 (0000 - Misc. Equip.) | | | 155.95 | |
| | | | | Invoice Items | 1 | | | | |
| 137686 | WW Misc. Supplies | Open | | 07/19/2023 | 08/04/2023 | 07/19/2023 | | | 109.99 |
| <i>P.O. Number</i> | <i>Item Description</i> | | <i>Quantity</i> | <i>U/M</i> | <i>Amount/Unit</i> | <i>Total Amount</i> | <i>Vendor Catalog Part Number</i> | <i>Contract Number</i> | |
| | Other repair & maintenance - WW Misc. Supplies | | 1.0000 | EA | 109.9900 | 109.99 | | | |
| | <i>G/L Account</i> | | | | <i>Project</i> | | | <i>Amount</i> | |
| | 61-4621-2310 (Water and Sewer Fund-Waste Water Treatment Plant-Other maintenance supplies) | | | | 0000 (0000 - Misc. Equip.) | | | 109.99 | |
| | | | | Invoice Items | 1 | | | | |

Vendor **3355 - JOHN DEERE FINANCIAL** Totals Invoices 40 \$1,336.29



Accounts Payable Invoice Report - Council

08/01/2023

Invoice Due Date Range 07/22/23 - 08/04/23

Report By Vendor - Invoice

| Invoice Number | Invoice Description | Status | Held Reason | Invoice Date | Due Date | G/L Date | Received Date | Payment Date | Invoice Net Amount |
|--|---|--------|-----------------|---------------|--|---------------------|-----------------------------------|------------------------|--------------------|
| Vendor 1512 - KIRCHNER BUILDING CENTER | | | | | | | | | |
| 398289 | Lumber crayon/ENG | Open | | 07/17/2023 | 08/04/2023 | 07/17/2023 | | | .94 |
| <i>P.O. Number</i> | <i>Item Description</i> | | <i>Quantity</i> | <i>U/M</i> | <i>Amount/Unit</i> | <i>Total Amount</i> | <i>Vendor Catalog Part Number</i> | <i>Contract Number</i> | |
| | Capital Improvement projects - Lumber crayon/ENG | | 1.0000 | EA | .9400 | .94 | | | |
| | <i>G/L Account</i> | | | | <i>Project</i> | | <i>Amount</i> | | |
| | 11-4095-4106 (General Fund-Engineering Department-Capital improvement projects) | | | | PW 20 26 020 (Community Drive Concession Building) | | .94 | | |
| | | | | Invoice Items | 1 | | | | |
| Vendor 1512 - KIRCHNER BUILDING CENTER Totals | | | | | | Invoices | 4 | | \$431.76 |
| Vendor 4456 - LEGACY GRAPHICS INC | | | | | | | | | |
| 35178 | Staff shirts for Day Camp - REC | Open | | 07/21/2023 | 08/04/2023 | 07/21/2023 | | | 330.12 |
| <i>P.O. Number</i> | <i>Item Description</i> | | <i>Quantity</i> | <i>U/M</i> | <i>Amount/Unit</i> | <i>Total Amount</i> | <i>Vendor Catalog Part Number</i> | <i>Contract Number</i> | |
| | Uniforms / REC - Staff shirts for Day Camp - REC | | 1.0000 | EA | 330.1200 | 330.12 | | | |
| | <i>G/L Account</i> | | | | <i>Project</i> | | <i>Amount</i> | | |
| | | | | | | | | | |



Accounts Payable Invoice Report - Council

08/01/2023

Invoice Due Date Range 07/22/23 - 08/04/23

Report By Vendor - Invoice

| Invoice Number | Invoice Description | Status | Held Reason | Invoice Date | Due Date | G/L Date | Received Date | Payment Date | Invoice Net Amount |
|---|---|--------|-----------------|--------------|--------------------------|---------------------|-----------------------------------|------------------------|--------------------|
| 35178 | Staff shirts for Day Camp - REC | Open | | 07/21/2023 | 08/04/2023 | 07/21/2023 | | | 330.12 |
| <i>P.O. Number</i> | <i>Item Description</i> | | <i>Quantity</i> | <i>U/M</i> | <i>Amount/Unit</i> | <i>Total Amount</i> | <i>Vendor Catalog Part Number</i> | <i>Contract Number</i> | |
| | 22-4510-2701 (Playground & Recreation Fund-Recreation Programs-Uniforms) | | | | REC 1004 3120 (Day Camp) | | | 330.12 | |
| | | | Invoice Items | 1 | | | | | |
| Vendor 4456 - LEGACY GRAPHICS INC Totals | | | | | | | Invoices | 1 | \$330.12 |
| Vendor 3609 - LEGALSHIELD | | | | | | | | | |
| 7/15/23 | July 2023 Premium / EBHR | Open | | 07/15/2023 | 08/04/2023 | 07/15/2023 | | | 754.00 |
| <i>P.O. Number</i> | <i>Item Description</i> | | <i>Quantity</i> | <i>U/M</i> | <i>Amount/Unit</i> | <i>Total Amount</i> | <i>Vendor Catalog Part Number</i> | <i>Contract Number</i> | |
| | Legalshield - voluntary legal insurance/ EBHR - July 2023 Premium / EBHR | | 1.0000 | EA | 754.0000 | 754.00 | | | |
| | <i>G/L Account</i> | | | | <i>Project</i> | | | <i>Amount</i> | |
| | 11-2033 (General Fund-Other voluntary deductions) | | | | | | | 754.00 | |
| | | | Invoice Items | 1 | | | | | |
| Vendor 3609 - LEGALSHIELD Totals | | | | | | | Invoices | 1 | \$754.00 |
| Vendor 1542 - LORENZ WHOLESALE CO | | | | | | | | | |
| 606793 | Supplies - MAINT | Open | | 07/19/2023 | 08/04/2023 | 07/19/2023 | | | 1,217.10 |
| <i>P.O. Number</i> | <i>Item Description</i> | | <i>Quantity</i> | <i>U/M</i> | <i>Amount/Unit</i> | <i>Total Amount</i> | <i>Vendor Catalog Part Number</i> | <i>Contract Number</i> | |
| | Janitorial & cleaning supplies - Supplies - MAINT | | 1.0000 | EA | 1,217.1000 | 1,217.10 | | | |
| | <i>G/L Account</i> | | | | <i>Project</i> | | | <i>Amount</i> | |
| | 11-4194-2301 (General Fund-Parks & Maintenance Department-Janitorial & cleaning supplies) | | | | | | | 1,217.10 | |
| | | | Invoice Items | 1 | | | | | |
| Vendor 1542 - LORENZ WHOLESALE CO Totals | | | | | | | Invoices | 1 | \$1,217.10 |
| 606812 | Can lid - MAINT | Open | | 07/19/2023 | 08/04/2023 | 07/19/2023 | | | 148.76 |
| <i>P.O. Number</i> | <i>Item Description</i> | | <i>Quantity</i> | <i>U/M</i> | <i>Amount/Unit</i> | <i>Total Amount</i> | <i>Vendor Catalog Part Number</i> | <i>Contract Number</i> | |
| | Janitorial & cleaning supplies - Can lid - MAINT | | 1.0000 | EA | 148.7600 | 148.76 | | | |
| | <i>G/L Account</i> | | | | <i>Project</i> | | | <i>Amount</i> | |
| | 11-4194-2301 (General Fund-Parks & Maintenance Department-Janitorial & cleaning supplies) | | | | | | | 148.76 | |
| | | | Invoice Items | 1 | | | | | |
| Vendor 606812 Totals | | | | | | | Invoices | 1 | \$148.76 |
| 606718 | Trash bags for Pool - POOL | Open | | 07/19/2023 | 08/04/2023 | 07/19/2023 | | | 46.38 |
| <i>P.O. Number</i> | <i>Item Description</i> | | <i>Quantity</i> | <i>U/M</i> | <i>Amount/Unit</i> | <i>Total Amount</i> | <i>Vendor Catalog Part Number</i> | <i>Contract Number</i> | |
| | Janitorial & cleaning supplies - Trash bags for Pool - POOL | | 1.0000 | EA | 46.3800 | 46.38 | | | |
| | <i>G/L Account</i> | | | | <i>Project</i> | | | <i>Amount</i> | |
| | 22-4520-2301 (Playground & Recreation Fund-Pool-Janitorial & cleaning supplies) | | | | | | | 46.38 | |
| | | | Invoice Items | 1 | | | | | |
| Vendor 606718 Totals | | | | | | | Invoices | 1 | \$46.38 |



Accounts Payable Invoice Report - Council

08/01/2023

Invoice Due Date Range 07/22/23 - 08/04/23

Report By Vendor - Invoice

| Invoice Number | Invoice Description | Status | Held Reason | Invoice Date | Due Date | G/L Date | Received Date | Payment Date | Invoice Net Amount |
|---|--|--------|-------------|---|------------|---------------------------------|---------------------|-----------------------------------|------------------------|
| 606876 | Toilet paper for the Pool - POOL | Open | | 07/20/2023 | 08/04/2023 | 07/20/2023 | | | 157.70 |
| <i>P.O. Number</i> | <i>Item Description</i> | | | <i>Quantity</i> | <i>U/M</i> | <i>Amount/Unit</i> | <i>Total Amount</i> | <i>Vendor Catalog Part Number</i> | <i>Contract Number</i> |
| | Janitorial & cleaning supplies - Toilet paper for the Pool - POOL | | | 1.0000 | EA | 157.7000 | 157.70 | | |
| | <i>G/L Account</i> | | | | | <i>Project</i> | | <i>Amount</i> | |
| | 22-4520-2301 (Playground & Recreation Fund-Pool-Janitorial & cleaning supplies) | | | | | | | 157.70 | |
| | | | | Invoice Items | | 1 | | | |
| | | | | Vendor 1542 - LORENZ WHOLESALE CO Totals | | | Invoices | 4 | \$1,569.94 |
| 00083293 | WP Safety Equip - Steel Toe Boots | Open | | 07/24/2023 | 08/04/2023 | 07/24/2023 | | | 135.15 |
| <i>P.O. Number</i> | <i>Item Description</i> | | | <i>Quantity</i> | <i>U/M</i> | <i>Amount/Unit</i> | <i>Total Amount</i> | <i>Vendor Catalog Part Number</i> | <i>Contract Number</i> |
| | Boots - WP Safety Equip - Steel Toe Boots | | | 1.0000 | EA | 135.1500 | 135.15 | | |
| | <i>G/L Account</i> | | | | | <i>Project</i> | | <i>Amount</i> | |
| | 61-4611-2704 (Water and Sewer Fund-Water Treatment Plant-Safety gear & clothing) | | | | | | | 135.15 | |
| | | | | Invoice Items | | 1 | | | |
| | | | | Vendor 1550 - MACK MOORE SHOE STORE Totals | | | Invoices | 1 | \$135.15 |
| 0028059671 | WP Chemicals - LOX | Open | | 07/07/2023 | 08/04/2023 | 07/07/2023 | | | 2,506.06 |
| <i>P.O. Number</i> | <i>Item Description</i> | | | <i>Quantity</i> | <i>U/M</i> | <i>Amount/Unit</i> | <i>Total Amount</i> | <i>Vendor Catalog Part Number</i> | <i>Contract Number</i> |
| | Chemicals / WTP - WP Chemicals - LOX | | | 1.0000 | EA | 2,506.0600 | 2,506.06 | | |
| | <i>G/L Account</i> | | | | | <i>Project</i> | | <i>Amount</i> | |
| | 61-4611-2109 (Water and Sewer Fund-Water Treatment Plant-Chemicals) | | | | | | | 2,506.06 | |
| | | | | Invoice Items | | 1 | | | |
| | | | | Vendor 4125 - MATHESON TRI-GAS, INC Totals | | | Invoices | 1 | \$2,506.06 |
| 07/12/2023 | Retorque wheels/PD | Open | | 07/12/2023 | 08/04/2023 | 07/12/2023 | | | 788.05 |
| <i>P.O. Number</i> | <i>Item Description</i> | | | <i>Quantity</i> | <i>U/M</i> | <i>Amount/Unit</i> | <i>Total Amount</i> | <i>Vendor Catalog Part Number</i> | <i>Contract Number</i> |
| | Vehicle parts and supplies - Retorque wheels/PD | | | 1.0000 | EA | 788.0500 | 788.05 | | |
| | <i>G/L Account</i> | | | | | <i>Project</i> | | <i>Amount</i> | |
| | 11-4210-2401 (General Fund-Police Department-Vehicle parts & supplies) | | | | | 9035 (2022 Ford Explorer Squad) | | 788.05 | |
| | | | | Invoice Items | | 1 | | | |
| | | | | Vendor 4598 - Mel's Quality Tire Totals | | | Invoices | 1 | \$788.05 |
| Vendor 1576 - MID-ILLINOIS CONCRETE, INC | | | | | | | | | |



Accounts Payable Invoice Report - Council

08/01/2023

Invoice Due Date Range 07/22/23 - 08/04/23

Report By Vendor - Invoice

| Invoice Number | Invoice Description | Status | Held Reason | Invoice Date | Due Date | G/L Date | Received Date | Payment Date | Invoice Net Amount |
|--------------------|--|--------|-------------|-----------------|------------|---|---------------------|-----------------------------------|------------------------|
| 263889 | Concrete for Rec drive Tie ins/ENG | Open | | 06/28/2023 | 08/04/2023 | 06/28/2023 | | | 1,991.26 |
| <i>P.O. Number</i> | <i>Item Description</i> | | | <i>Quantity</i> | <i>U/M</i> | <i>Amount/Unit</i> | <i>Total Amount</i> | <i>Vendor Catalog Part Number</i> | <i>Contract Number</i> |
| | Capital Improvement projects - Concrete for Rec drive Tie ins/ENG | | | 1.0000 | EA | 1,991.2600 | 1,991.26 | | |
| | <i>G/L Account</i> | | | | | <i>Project</i> | | <i>Amount</i> | |
| | 11-4095-4106 (General Fund-Engineering Department-Capital improvement projects) | | | | | PW 20 26 023 (Recreation Drive) | | 1,991.26 | |
| | | | | Invoice Items | | 1 | | | |
| 263890 | Concrete for scoreboards/ENG | Open | | 06/28/2023 | 08/04/2023 | 06/28/2023 | | | 464.63 |
| <i>P.O. Number</i> | <i>Item Description</i> | | | <i>Quantity</i> | <i>U/M</i> | <i>Amount/Unit</i> | <i>Total Amount</i> | <i>Vendor Catalog Part Number</i> | <i>Contract Number</i> |
| | Capital Improvement projects - Concrete for scoreboards/ENG | | | 1.0000 | EA | 464.6300 | 464.63 | | |
| | <i>G/L Account</i> | | | | | <i>Project</i> | | <i>Amount</i> | |
| | 11-4095-4106 (General Fund-Engineering Department-Capital improvement projects) | | | | | PW 20 26 022 (Field Nets at End of Fields, Fence along South End) | | 464.63 | |
| | | | | Invoice Items | | 1 | | | |
| 264177 | Rec drive multi-use path tie in/ENG | Open | | 06/30/2023 | 08/04/2023 | 06/30/2023 | | | 5,442.77 |
| <i>P.O. Number</i> | <i>Item Description</i> | | | <i>Quantity</i> | <i>U/M</i> | <i>Amount/Unit</i> | <i>Total Amount</i> | <i>Vendor Catalog Part Number</i> | <i>Contract Number</i> |
| | Capital Improvement projects - Rec drive multi-use path tie in/ENG | | | 1.0000 | EA | 5,442.7700 | 5,442.77 | | |
| | <i>G/L Account</i> | | | | | <i>Project</i> | | <i>Amount</i> | |
| | 11-4095-4106 (General Fund-Engineering Department-Capital improvement projects) | | | | | PW 20 26 023 (Recreation Drive) | | 5,442.77 | |
| | | | | Invoice Items | | 1 | | | |
| 264176 | Concrete for Hand Rails over TBC/MOTOR FUEL TAX | Open | | 06/30/2023 | 08/04/2023 | 06/30/2023 | | | 199.13 |
| <i>P.O. Number</i> | <i>Item Description</i> | | | <i>Quantity</i> | <i>U/M</i> | <i>Amount/Unit</i> | <i>Total Amount</i> | <i>Vendor Catalog Part Number</i> | <i>Contract Number</i> |
| | 1/4 page full color ad/tourism - Concrete for Hand Rails over TBC/MOTOR FUEL TAX | | | 1.0000 | EA | 199.1300 | 199.13 | | |
| | <i>G/L Account</i> | | | | | <i>Project</i> | | <i>Amount</i> | |
| | 25-4312-2501 (Motor Fuel Tax Fund-Motor Fuel Tax Department-Concrete) | | | | | PW 23 05 (MFT Commodities) | | 199.13 | |
| | | | | Invoice Items | | 1 | | | |

Vendor **1576 - MID-ILLINOIS CONCRETE, INC** Totals Invoices 4 **\$8,097.79**

Vendor **1584 - MIDWEST METER INC**



Accounts Payable Invoice Report - Council

08/01/2023

Invoice Due Date Range 07/22/23 - 08/04/23

Report By Vendor - Invoice

| Invoice Number | Invoice Description | Status | Held Reason | Invoice Date | Due Date | G/L Date | Received Date | Payment Date | Invoice Net Amount |
|--------------------|---|--------|-------------|-----------------|------------|----------------------------|---------------------|-----------------------------------|------------------------|
| 0157355-IN | 12" Pipe Drainage and storm sewer maintenance/MFT | Open | | 07/11/2023 | 08/04/2023 | 07/11/2023 | | | 15,936.00 |
| <i>P.O. Number</i> | <i>Item Description</i> | | | <i>Quantity</i> | <i>U/M</i> | <i>Amount/Unit</i> | <i>Total Amount</i> | <i>Vendor Catalog Part Number</i> | <i>Contract Number</i> |
| | Sewer repair materials - 12" Pipe Drainage and storm sewer maintenance/MFT | | | 1.0000 | EA | 15,936.0000 | 15,936.00 | | |
| | <i>G/L Account</i> | | | | | <i>Project</i> | | <i>Amount</i> | |
| | 25-4312-2505 (Motor Fuel Tax Fund-Motor Fuel Tax Department-Sewer repair materials) | | | | | PW 23 05 (MFT Commodities) | | 15,936.00 | |
| | | | | Invoice Items | | 1 | | | |
| 0157052-IN | 15"SDR35 Pipe/UTILITY | Open | | 06/28/2023 | 08/04/2023 | 06/28/2023 | | | 1,010.52 |
| <i>P.O. Number</i> | <i>Item Description</i> | | | <i>Quantity</i> | <i>U/M</i> | <i>Amount/Unit</i> | <i>Total Amount</i> | <i>Vendor Catalog Part Number</i> | <i>Contract Number</i> |
| | 1/4 page full color ad/tourism - 15"SDR35 Pipe/UTILITY | | | 1.0000 | EA | 1,010.5200 | 1,010.52 | | |
| | <i>G/L Account</i> | | | | | <i>Project</i> | | <i>Amount</i> | |
| | 61-4610-2505 (Water and Sewer Fund-Utility Department-Sewer repair materials) | | | | | | | 1,010.52 | |
| | | | | Invoice Items | | 1 | | | |
| 0157053-IN | 1" Corp Stop/UTILITY | Open | | 06/28/2023 | 08/04/2023 | 06/28/2023 | | | 180.00 |
| <i>P.O. Number</i> | <i>Item Description</i> | | | <i>Quantity</i> | <i>U/M</i> | <i>Amount/Unit</i> | <i>Total Amount</i> | <i>Vendor Catalog Part Number</i> | <i>Contract Number</i> |
| | 1/4 page full color ad/tourism - 1" Corp Stop/UTILITY | | | 1.0000 | EA | 180.0000 | 180.00 | | |
| | <i>G/L Account</i> | | | | | <i>Project</i> | | <i>Amount</i> | |
| | 61-4610-2510 (Water and Sewer Fund-Utility Department-Watermain materials) | | | | | | | 180.00 | |
| | | | | Invoice Items | | 1 | | | |
| 0157075-IN | 3/4" Top Shut-Off's & 1" Curb Stops/UTILITY | Open | | 06/29/2023 | 08/04/2023 | 06/29/2023 | | | 1,238.00 |
| <i>P.O. Number</i> | <i>Item Description</i> | | | <i>Quantity</i> | <i>U/M</i> | <i>Amount/Unit</i> | <i>Total Amount</i> | <i>Vendor Catalog Part Number</i> | <i>Contract Number</i> |
| | 1/4 page full color ad/tourism - 3/4" Top Shut-Off's & 1" Curb Stops/UTILITY | | | 1.0000 | EA | 1,238.0000 | 1,238.00 | | |
| | <i>G/L Account</i> | | | | | <i>Project</i> | | <i>Amount</i> | |
| | 61-4610-2510 (Water and Sewer Fund-Utility Department-Watermain materials) | | | | | | | 1,238.00 | |
| | | | | Invoice Items | | 1 | | | |
| 0157221-IN | 3/4" Meter Setter/UTILITY | Open | | 07/06/2023 | 08/04/2023 | 07/06/2023 | | | 992.00 |
| <i>P.O. Number</i> | <i>Item Description</i> | | | <i>Quantity</i> | <i>U/M</i> | <i>Amount/Unit</i> | <i>Total Amount</i> | <i>Vendor Catalog Part Number</i> | <i>Contract Number</i> |
| | 1/4 page full color ad/tourism - 3/4" Meter Setter/UTILITY | | | 1.0000 | EA | 992.0000 | 992.00 | | |
| | <i>G/L Account</i> | | | | | <i>Project</i> | | <i>Amount</i> | |
| | 61-4610-2510 (Water and Sewer Fund-Utility Department-Watermain materials) | | | | | | | 992.00 | |
| | | | | Invoice Items | | 1 | | | |



Accounts Payable Invoice Report - Council

08/01/2023

Invoice Due Date Range 07/22/23 - 08/04/23

Report By Vendor - Invoice

| Invoice Number | Invoice Description | Status | Held Reason | Invoice Date | Due Date | G/L Date | Received Date | Payment Date | Invoice Net Amount |
|---|--|--------|-----------------|---------------|-----------------------------|---------------------|-----------------------------------|------------------------|--------------------|
| 0157222-IN | 3/4" Top Shut Off/UTILITY | Open | | 07/06/2023 | 08/04/2023 | 07/06/2023 | | | 594.00 |
| <i>P.O. Number</i> | <i>Item Description</i> | | <i>Quantity</i> | <i>U/M</i> | <i>Amount/Unit</i> | <i>Total Amount</i> | <i>Vendor Catalog Part Number</i> | <i>Contract Number</i> | |
| | 1/4 page full color ad/tourism - 3/4" Top Shut Off/UTILITY | | 1.0000 | EA | 594.0000 | 594.00 | | | |
| | <i>G/L Account</i> | | | | <i>Project</i> | | | <i>Amount</i> | |
| | 61-4610-2510 (Water and Sewer Fund-Utility Department-Watermain materials) | | | | | | | 594.00 | |
| | | | | Invoice Items | 1 | | | | |
| Vendor 1584 - MIDWEST METER INC Totals | | | | | | | | | \$21,177.52 |
| | | | | | | | Invoices | 7 | |
| 0157223-IN | 1" Model 70 Bases & Transmitters (3)/UTILITY | Open | | 07/06/2023 | 08/04/2023 | 07/06/2023 | | | 1,227.00 |
| <i>P.O. Number</i> | <i>Item Description</i> | | <i>Quantity</i> | <i>U/M</i> | <i>Amount/Unit</i> | <i>Total Amount</i> | <i>Vendor Catalog Part Number</i> | <i>Contract Number</i> | |
| | 1/4 page full color ad/tourism - 1" Model 70 Bases & Transmitters (3)/UTILITY | | 1.0000 | EA | 1,227.0000 | 1,227.00 | | | |
| | <i>G/L Account</i> | | | | <i>Project</i> | | | <i>Amount</i> | |
| | 61-4610-4609 (Water and Sewer Fund-Utility Department-Meters, pipes & parts) | | | | 0000 (0000 - Misc. Equip.) | | | 1,227.00 | |
| | | | | Invoice Items | 1 | | | | |
| Vendor 1591 - MISSISSIPPI LIME CO Totals | | | | | | | | | \$8,749.04 |
| | | | | | | | Invoices | 1 | |
| 53072 | New Stihl MS271 Chainsaw for storm debris cleanup/STREET | Open | | 06/30/2023 | 08/04/2023 | 06/30/2023 | | | 522.88 |
| <i>P.O. Number</i> | <i>Item Description</i> | | <i>Quantity</i> | <i>U/M</i> | <i>Amount/Unit</i> | <i>Total Amount</i> | <i>Vendor Catalog Part Number</i> | <i>Contract Number</i> | |
| | Operating Equipment - New Stihl MS271 Chainsaw for storm debris cleanup/STREET | | 1.0000 | EA | 522.8800 | 522.88 | | | |
| | <i>G/L Account</i> | | | | <i>Project</i> | | | <i>Amount</i> | |
| | 11-4310-4399 (General Fund-Street Department-Operating equipment) | | | | 3193 (Stihl MS271 Chainsaw) | | | 522.88 | |
| | | | | Invoice Items | 1 | | | | |



Accounts Payable Invoice Report - Council

08/01/2023

Invoice Due Date Range 07/22/23 - 08/04/23

Report By Vendor - Invoice

| Invoice Number | Invoice Description | Status | Held Reason | Invoice Date | Due Date | G/L Date | Received Date | Payment Date | Invoice Net Amount |
|--|---|--------|-----------------|---------------|----------------------------|---------------------|-----------------------------------|------------------------|--------------------|
| 53076 | Handle Brake for MS361 Chainsaw/STREET | Open | | 06/30/2023 | 08/04/2023 | 06/30/2023 | | | 31.35 |
| <i>P.O. Number</i> | <i>Item Description</i> | | <i>Quantity</i> | <i>U/M</i> | <i>Amount/Unit</i> | <i>Total Amount</i> | <i>Vendor Catalog Part Number</i> | <i>Contract Number</i> | |
| | 1/4 page full color ad/tourism - Handle Brake for MS361 Chainsaw/STREET | | 1.0000 | EA | 31.3500 | 31.35 | | | |
| | <i>G/L Account</i> | | | | <i>Project</i> | | | <i>Amount</i> | |
| | 11-4310-2401 (General Fund-Street Department-Vehicle parts & supplies) | | | | 0000 (0000 - Misc. Equip.) | | | 31.35 | |
| | | | | Invoice Items | 1 | | | | |
| 53141 | Bar Oil for Chainsaw/STREET | Open | | 07/10/2023 | 08/04/2023 | 07/10/2023 | | | 49.99 |
| <i>P.O. Number</i> | <i>Item Description</i> | | <i>Quantity</i> | <i>U/M</i> | <i>Amount/Unit</i> | <i>Total Amount</i> | <i>Vendor Catalog Part Number</i> | <i>Contract Number</i> | |
| | 1/4 page full color ad/tourism - Bar Oil for Chainsaw/STREET | | 1.0000 | EA | 49.9900 | 49.99 | | | |
| | <i>G/L Account</i> | | | | <i>Project</i> | | | <i>Amount</i> | |
| | 11-4310-2201 (General Fund-Street Department-Fuel & oil) | | | | | | | 49.99 | |
| | | | | Invoice Items | 1 | | | | |
| 53192 | Pole Saw New Chain/STREET | Open | | 07/17/2023 | 08/04/2023 | 07/17/2023 | | | 35.85 |
| <i>P.O. Number</i> | <i>Item Description</i> | | <i>Quantity</i> | <i>U/M</i> | <i>Amount/Unit</i> | <i>Total Amount</i> | <i>Vendor Catalog Part Number</i> | <i>Contract Number</i> | |
| | 1/4 page full color ad/tourism - Pole Saw New Chain/STREET | | 1.0000 | EA | 35.8500 | 35.85 | | | |
| | <i>G/L Account</i> | | | | <i>Project</i> | | | <i>Amount</i> | |
| | 11-4310-2401 (General Fund-Street Department-Vehicle parts & supplies) | | | | 0000 (0000 - Misc. Equip.) | | | 35.85 | |
| | | | | Invoice Items | 1 | | | | |
| Vendor 1592 - MLB OUTDOOR PRODUCTS Totals | | | | | | | Invoices | 4 | \$640.07 |
| Vendor 2490 - MUNICIPAL EMERGENCY SERVICE - MES-ILLINOIS | | | | | | | | | |
| IN1905012 | annual scuba & mash testing/FD | Open | | 07/17/2023 | 07/26/2023 | 07/17/2023 | | | 3,233.26 |
| <i>P.O. Number</i> | <i>Item Description</i> | | <i>Quantity</i> | <i>U/M</i> | <i>Amount/Unit</i> | <i>Total Amount</i> | <i>Vendor Catalog Part Number</i> | <i>Contract Number</i> | |
| | Repair of operating equipment - annual scuba & mash testing/FD | | 1.0000 | EA | 3,233.2600 | 3,233.26 | | | |
| | <i>G/L Account</i> | | | | <i>Project</i> | | | <i>Amount</i> | |
| | 11-4221-3508 (General Fund-Fire Department-Repair of operating equipment) | | | | 0000 (0000 - Misc. Equip.) | | | 3,233.26 | |
| | | | | Invoice Items | 1 | | | | |
| Vendor 2490 - MUNICIPAL EMERGENCY SERVICE - MES-ILLINOIS Totals | | | | | | | Invoices | 1 | \$3,233.26 |
| Vendor 2439 - MUNICIPAL EQUIPMENT CO. | | | | | | | | | |



Accounts Payable Invoice Report - Council

08/01/2023

Invoice Due Date Range 07/22/23 - 08/04/23

Report By Vendor - Invoice

| Invoice Number | Invoice Description | Status | Held Reason | Invoice Date | Due Date | G/L Date | Received Date | Payment Date | Invoice Net Amount |
|---|--|--------|-----------------|---------------|--|---------------------|-----------------------------------|------------------------|--------------------|
| INV0025114 | WP Equipment Expense - Chemical Feed Pumps | Open | | 07/21/2023 | 08/04/2023 | 07/21/2023 | | | 522.00 |
| <i>P.O. Number</i> | <i>Item Description</i> | | <i>Quantity</i> | <i>U/M</i> | <i>Amount/Unit</i> | <i>Total Amount</i> | <i>Vendor Catalog Part Number</i> | <i>Contract Number</i> | |
| | Pump repairs - parts and supplies - WP Equipment Expense - Chemical Feed Pumps | | 1.0000 | EA | 522.0000 | 522.00 | | | |
| | <i>G/L Account</i> | | | | <i>Project</i> | | | <i>Amount</i> | |
| | 61-4611-2310 (Water and Sewer Fund-Water Treatment Plant-Other maintenance supplies) | | | | | | | 522.00 | |
| | | | | Invoice Items | 1 | | | | |
| INV0025115 | WP Equipment Expense - Chemical Feed Pumps | Open | | 07/21/2023 | 08/04/2023 | 07/21/2023 | | | 261.00 |
| <i>P.O. Number</i> | <i>Item Description</i> | | <i>Quantity</i> | <i>U/M</i> | <i>Amount/Unit</i> | <i>Total Amount</i> | <i>Vendor Catalog Part Number</i> | <i>Contract Number</i> | |
| | Pump repairs - parts and supplies - WP Equipment Expense - Chemical Feed Pumps | | 1.0000 | EA | 261.0000 | 261.00 | | | |
| | <i>G/L Account</i> | | | | <i>Project</i> | | | <i>Amount</i> | |
| | 61-4611-2310 (Water and Sewer Fund-Water Treatment Plant-Other maintenance supplies) | | | | | | | 261.00 | |
| | | | | Invoice Items | 1 | | | | |
| Vendor 2439 - MUNICIPAL EQUIPMENT CO. Totals | | | | | Invoices | 2 | | | \$783.00 |
| Vendor 3092 - NAPA - MCKAY AUTO PARTS | | | | | | | | | |
| 124720 | Oil filter/B&D | Open | | 06/29/2023 | 08/04/2023 | 06/29/2023 | | | 5.33 |
| <i>P.O. Number</i> | <i>Item Description</i> | | <i>Quantity</i> | <i>U/M</i> | <i>Amount/Unit</i> | <i>Total Amount</i> | <i>Vendor Catalog Part Number</i> | <i>Contract Number</i> | |
| | Vehicle parts and supplies - Oil filter/B&D | | 1.0000 | EA | 5.3300 | 5.33 | | | |
| | <i>G/L Account</i> | | | | <i>Project</i> | | | <i>Amount</i> | |
| | 11-4640-2401 (General Fund-Building & Development Services-Vehicle parts & supplies) | | | | 1290 (2021 Ford Ranger 4x4) | | | 5.33 | |
| | | | | Invoice Items | 1 | | | | |
| 124586 | Adapter (7)/STREET | Open | | 06/27/2023 | 08/04/2023 | 06/27/2023 | | | 27.58 |
| <i>P.O. Number</i> | <i>Item Description</i> | | <i>Quantity</i> | <i>U/M</i> | <i>Amount/Unit</i> | <i>Total Amount</i> | <i>Vendor Catalog Part Number</i> | <i>Contract Number</i> | |
| | 1/4 page full color ad/tourism - Adapter (7)/STREET | | 1.0000 | EA | 27.5800 | 27.58 | | | |
| | <i>G/L Account</i> | | | | <i>Project</i> | | | <i>Amount</i> | |
| | 11-4310-2401 (General Fund-Street Department-Vehicle parts & supplies) | | | | 1815 (2023 Intl HV507 Dump Truck #130) | | | 27.58 | |
| | | | | Invoice Items | 1 | | | | |
| 124657 | Air Filters (2)/UTILITY | Open | | 06/28/2023 | 08/04/2023 | 06/28/2023 | | | 55.87 |
| <i>P.O. Number</i> | <i>Item Description</i> | | <i>Quantity</i> | <i>U/M</i> | <i>Amount/Unit</i> | <i>Total Amount</i> | <i>Vendor Catalog Part Number</i> | <i>Contract Number</i> | |
| | 1/4 page full color ad/tourism - Air Filters (2)/UTILITY | | 1.0000 | EA | 55.8700 | 55.87 | | | |
| | <i>G/L Account</i> | | | | <i>Project</i> | | | <i>Amount</i> | |
| | | | | | | | | | |



Accounts Payable Invoice Report - Council

08/01/2023

Invoice Due Date Range 07/22/23 - 08/04/23

Report By Vendor - Invoice

| Invoice Number | Invoice Description | Status | Held Reason | Invoice Date | Due Date | G/L Date | Received Date | Payment Date | Invoice Net Amount |
|--------------------|---|--------|-----------------|--------------|--------------------------------------|---------------------|-----------------------------------|------------------------|--------------------|
| 124657 | Air Filters (2)/UTILITY | Open | | 06/28/2023 | 08/04/2023 | 06/28/2023 | | | 55.87 |
| <i>P.O. Number</i> | <i>Item Description</i> | | <i>Quantity</i> | <i>U/M</i> | <i>Amount/Unit</i> | <i>Total Amount</i> | <i>Vendor Catalog Part Number</i> | <i>Contract Number</i> | |
| | 61-4610-2401 (Water and Sewer Fund-Utility Department-Vehicle parts & supplies) | | | | 6053 (2017 Case TV380 loader) | | | 55.87 | |
| | | | Invoice Items | | 1 | | | | |
| 124710 | Non Chlor Compliant/W/S GARAGE | Open | | 06/29/2023 | 08/04/2023 | 06/29/2023 | | | 14.82 |
| <i>P.O. Number</i> | <i>Item Description</i> | | <i>Quantity</i> | <i>U/M</i> | <i>Amount/Unit</i> | <i>Total Amount</i> | <i>Vendor Catalog Part Number</i> | <i>Contract Number</i> | |
| | 1/4 page full color ad/tourism - Non Chlor Compliant/W/S GARAGE | | 1.0000 | EA | 14.8200 | 14.82 | | | |
| | <i>G/L Account</i> | | | | <i>Project</i> | | | <i>Amount</i> | |
| | 61-4311-2401 (Water and Sewer Fund-City Garage-Vehicle parts & supplies) | | | | 0000 (0000 - Misc. Equip.) | | | 14.82 | |
| | | | Invoice Items | | 1 | | | | |
| 124750 | Hyd Hose Fittings/STREET | Open | | 06/30/2023 | 08/04/2023 | 06/30/2023 | | | 56.56 |
| <i>P.O. Number</i> | <i>Item Description</i> | | <i>Quantity</i> | <i>U/M</i> | <i>Amount/Unit</i> | <i>Total Amount</i> | <i>Vendor Catalog Part Number</i> | <i>Contract Number</i> | |
| | 1/4 page full color ad/tourism - Hyd Hose Fittings/STREET | | 1.0000 | EA | 56.5600 | 56.56 | | | |
| | <i>G/L Account</i> | | | | <i>Project</i> | | | <i>Amount</i> | |
| | 11-4310-3508 (General Fund-Street Department-Repair of operating equipment) | | | | 5095 (2020 CASE 590SN Backhoe) | | | 56.56 | |
| | | | Invoice Items | | 1 | | | | |
| 124751 | Brake Cleaner/W/S GARAGE | Open | | 06/30/2023 | 08/04/2023 | 06/30/2023 | | | 59.28 |
| <i>P.O. Number</i> | <i>Item Description</i> | | <i>Quantity</i> | <i>U/M</i> | <i>Amount/Unit</i> | <i>Total Amount</i> | <i>Vendor Catalog Part Number</i> | <i>Contract Number</i> | |
| | 1/4 page full color ad/tourism - Brake Cleaner/W/S GARAGE | | 1.0000 | EA | 59.2800 | 59.28 | | | |
| | <i>G/L Account</i> | | | | <i>Project</i> | | | <i>Amount</i> | |
| | 61-4311-2401 (Water and Sewer Fund-City Garage-Vehicle parts & supplies) | | | | 0000 (0000 - Misc. Equip.) | | | 59.28 | |
| | | | Invoice Items | | 1 | | | | |
| 124915 | Hyd Hose Fittings/STREET | Open | | 07/06/2023 | 08/04/2023 | 07/06/2023 | | | 100.44 |
| <i>P.O. Number</i> | <i>Item Description</i> | | <i>Quantity</i> | <i>U/M</i> | <i>Amount/Unit</i> | <i>Total Amount</i> | <i>Vendor Catalog Part Number</i> | <i>Contract Number</i> | |
| | 1/4 page full color ad/tourism - Hyd Hose Fittings/STREET | | 1.0000 | EA | 100.4400 | 100.44 | | | |
| | <i>G/L Account</i> | | | | <i>Project</i> | | | <i>Amount</i> | |
| | 11-4310-3508 (General Fund-Street Department-Repair of operating equipment) | | | | 0848 (Caterpillar 924H Wheel loader) | | | 100.44 | |
| | | | Invoice Items | | 1 | | | | |



Accounts Payable Invoice Report - Council

08/01/2023

Invoice Due Date Range 07/22/23 - 08/04/23

Report By Vendor - Invoice

| Invoice Number | Invoice Description | Status | Held Reason | Invoice Date | Due Date | G/L Date | Received Date | Payment Date | Invoice Net Amount |
|--------------------|--|--------|-------------|-----------------|------------|----------------------------|---------------------|-----------------------------------|------------------------|
| 125025 | Exhaust Fluid (2)/STREET | Open | | 07/10/2023 | 08/04/2023 | 07/10/2023 | | | 25.22 |
| <i>P.O. Number</i> | <i>Item Description</i> | | | <i>Quantity</i> | <i>U/M</i> | <i>Amount/Unit</i> | <i>Total Amount</i> | <i>Vendor Catalog Part Number</i> | <i>Contract Number</i> |
| | 1/4 page full color ad/tourism - Exhaust Fluid (2)/STREET | | | 1.0000 | EA | 25.2200 | 25.22 | | |
| | <i>G/L Account</i> | | | | | <i>Project</i> | | <i>Amount</i> | |
| | 11-4310-2201 (General Fund-Street Department-Fuel & oil) | | | | | | | 25.22 | |
| | <i>Invoice Items</i> | | | | | 1 | | | |
| 125027 | 2.5 Def (2)/UTILITY | Open | | 07/10/2023 | 08/04/2023 | 07/10/2023 | | | 25.22 |
| <i>P.O. Number</i> | <i>Item Description</i> | | | <i>Quantity</i> | <i>U/M</i> | <i>Amount/Unit</i> | <i>Total Amount</i> | <i>Vendor Catalog Part Number</i> | <i>Contract Number</i> |
| | 1/4 page full color ad/tourism - 2.5 Def (2)/UTILITY | | | 1.0000 | EA | 25.2200 | 25.22 | | |
| | <i>G/L Account</i> | | | | | <i>Project</i> | | <i>Amount</i> | |
| | 61-4610-2201 (Water and Sewer Fund-Utility Department-Fuel & oil) | | | | | | | 25.22 | |
| | <i>Invoice Items</i> | | | | | 1 | | | |
| 125029 | Washer Fluid (6)/W/S GARAGE | Open | | 07/10/2023 | 08/04/2023 | 07/10/2023 | | | 16.74 |
| <i>P.O. Number</i> | <i>Item Description</i> | | | <i>Quantity</i> | <i>U/M</i> | <i>Amount/Unit</i> | <i>Total Amount</i> | <i>Vendor Catalog Part Number</i> | <i>Contract Number</i> |
| | 1/4 page full color ad/tourism - Washer Fluid (6)/W/S GARAGE | | | 1.0000 | EA | 16.7400 | 16.74 | | |
| | <i>G/L Account</i> | | | | | <i>Project</i> | | <i>Amount</i> | |
| | 61-4311-2401 (Water and Sewer Fund-City Garage-Vehicle parts & supplies) | | | | | 0000 (0000 - Misc. Equip.) | | 16.74 | |
| | <i>Invoice Items</i> | | | | | 1 | | | |
| 125047 | Adapters/W/S GARAGE | Open | | 07/10/2023 | 08/04/2023 | 07/10/2023 | | | 1.96 |
| <i>P.O. Number</i> | <i>Item Description</i> | | | <i>Quantity</i> | <i>U/M</i> | <i>Amount/Unit</i> | <i>Total Amount</i> | <i>Vendor Catalog Part Number</i> | <i>Contract Number</i> |
| | 1/4 page full color ad/tourism - Adapters/W/S GARAGE | | | 1.0000 | EA | 1.9600 | 1.96 | | |
| | <i>G/L Account</i> | | | | | <i>Project</i> | | <i>Amount</i> | |
| | 61-4311-2401 (Water and Sewer Fund-City Garage-Vehicle parts & supplies) | | | | | 0000 (0000 - Misc. Equip.) | | 1.96 | |
| | <i>Invoice Items</i> | | | | | 1 | | | |
| 125123 | Oil for Services/STREET | Open | | 07/12/2023 | 08/04/2023 | 07/12/2023 | | | 302.88 |
| <i>P.O. Number</i> | <i>Item Description</i> | | | <i>Quantity</i> | <i>U/M</i> | <i>Amount/Unit</i> | <i>Total Amount</i> | <i>Vendor Catalog Part Number</i> | <i>Contract Number</i> |
| | 1/4 page full color ad/tourism - Oil for Services/STREET | | | 1.0000 | EA | 302.8800 | 302.88 | | |
| | <i>G/L Account</i> | | | | | <i>Project</i> | | <i>Amount</i> | |
| | 11-4310-2201 (General Fund-Street Department-Fuel & oil) | | | | | | | 302.88 | |
| | <i>Invoice Items</i> | | | | | 1 | | | |



Accounts Payable Invoice Report - Council

08/01/2023

Invoice Due Date Range 07/22/23 - 08/04/23

Report By Vendor - Invoice

| Invoice Number | Invoice Description | Status | Held Reason | Invoice Date | Due Date | G/L Date | Received Date | Payment Date | Invoice Net Amount |
|--------------------|---|--------|---------------|-----------------|------------|----------------------------|---------------------|-----------------------------------|------------------------|
| 125216 | Tire Rep Needle-Strips-Probe/W/S GARAGE | Open | | 07/14/2023 | 08/04/2023 | 07/14/2023 | | | 13.47 |
| <i>P.O. Number</i> | <i>Item Description</i> | | | <i>Quantity</i> | <i>U/M</i> | <i>Amount/Unit</i> | <i>Total Amount</i> | <i>Vendor Catalog Part Number</i> | <i>Contract Number</i> |
| | 1/4 page full color ad/tourism - Tire Rep Needle-Strips-Probe/W/S GARAGE | | | 1.0000 | EA | 13.4700 | 13.47 | | |
| | <i>G/L Account</i> | | | | | <i>Project</i> | | <i>Amount</i> | |
| | 61-4311-2401 (Water and Sewer Fund-City Garage-Vehicle parts & supplies) | | | | | 0000 (0000 - Misc. Equip.) | | 13.47 | |
| | | | Invoice Items | | | 1 | | | |
| 125221 | Quality Htr Hose/W/S GARAGE | Open | | 07/14/2023 | 08/04/2023 | 07/14/2023 | | | 3.02 |
| <i>P.O. Number</i> | <i>Item Description</i> | | | <i>Quantity</i> | <i>U/M</i> | <i>Amount/Unit</i> | <i>Total Amount</i> | <i>Vendor Catalog Part Number</i> | <i>Contract Number</i> |
| | 1/4 page full color ad/tourism - Quality Htr Hose/W/S GARAGE | | | 1.0000 | EA | 3.0200 | 3.02 | | |
| | <i>G/L Account</i> | | | | | <i>Project</i> | | <i>Amount</i> | |
| | 61-4311-2401 (Water and Sewer Fund-City Garage-Vehicle parts & supplies) | | | | | 0000 (0000 - Misc. Equip.) | | 3.02 | |
| | | | Invoice Items | | | 1 | | | |
| 125275 | Tire Rep Rad Strings (50)/W/S GARAGE | Open | | 07/17/2023 | 08/04/2023 | 07/17/2023 | | | 14.50 |
| <i>P.O. Number</i> | <i>Item Description</i> | | | <i>Quantity</i> | <i>U/M</i> | <i>Amount/Unit</i> | <i>Total Amount</i> | <i>Vendor Catalog Part Number</i> | <i>Contract Number</i> |
| | 1/4 page full color ad/tourism - Tire Rep Rad Strings (50)/W/S GARAGE | | | 1.0000 | EA | 14.5000 | 14.50 | | |
| | <i>G/L Account</i> | | | | | <i>Project</i> | | <i>Amount</i> | |
| | 61-4311-2401 (Water and Sewer Fund-City Garage-Vehicle parts & supplies) | | | | | 0000 (0000 - Misc. Equip.) | | 14.50 | |
| | | | Invoice Items | | | 1 | | | |
| 124737 | Couplers - MAINT | Open | | 06/29/2023 | 08/04/2023 | 06/29/2023 | | | 11.48 |
| <i>P.O. Number</i> | <i>Item Description</i> | | | <i>Quantity</i> | <i>U/M</i> | <i>Amount/Unit</i> | <i>Total Amount</i> | <i>Vendor Catalog Part Number</i> | <i>Contract Number</i> |
| | Vehicle parts & supplies / MAINT - Couplers - MAINT | | | 1.0000 | EA | 11.4800 | 11.48 | | |
| | <i>G/L Account</i> | | | | | <i>Project</i> | | <i>Amount</i> | |
| | 11-4194-2401 (General Fund-Parks & Maintenance Department-Vehicle parts & supplies) | | | | | 0000 (0000 - Misc. Equip.) | | 11.48 | |
| | | | Invoice Items | | | 1 | | | |
| 124890 | Returned coupler - MAINT | Open | | 07/05/2023 | 08/04/2023 | 07/05/2023 | | | (22.99) |
| <i>P.O. Number</i> | <i>Item Description</i> | | | <i>Quantity</i> | <i>U/M</i> | <i>Amount/Unit</i> | <i>Total Amount</i> | <i>Vendor Catalog Part Number</i> | <i>Contract Number</i> |
| | Vehicle parts & supplies / MAINT - Returned coupler - MAINT | | | 1.0000 | EA | (22.9900) | (22.99) | | |
| | <i>G/L Account</i> | | | | | <i>Project</i> | | <i>Amount</i> | |
| | 11-4194-2401 (General Fund-Parks & Maintenance Department-Vehicle parts & supplies) | | | | | 0000 (0000 - Misc. Equip.) | | (22.99) | |
| | | | Invoice Items | | | 1 | | | |



Accounts Payable Invoice Report - Council

08/01/2023

Invoice Due Date Range 07/22/23 - 08/04/23

Report By Vendor - Invoice

| Invoice Number | Invoice Description | Status | Held Reason | Invoice Date | Due Date | G/L Date | Received Date | Payment Date | Invoice Net Amount |
|--------------------|--|--------|-----------------|----------------------|--|---------------------|-----------------------------------|------------------------|--------------------|
| 124936 | fuel filter/FD | Open | | 07/06/2023 | 07/26/2023 | 07/06/2023 | | | 80.06 |
| <i>P.O. Number</i> | <i>Item Description</i> | | <i>Quantity</i> | <i>U/M</i> | <i>Amount/Unit</i> | <i>Total Amount</i> | <i>Vendor Catalog Part Number</i> | <i>Contract Number</i> | |
| | Vehicle parts and supplies - fuel filter/FD | | 1.0000 | EA | 80.0600 | 80.06 | | | |
| | <i>G/L Account</i> | | | | <i>Project</i> | | | <i>Amount</i> | |
| | 11-4221-2401 (General Fund-Fire Department-Vehicle parts & supplies) | | | | 3483 (3483 2016 AEV TramaHawk TypeIII Ambulance) | | | 80.06 | |
| | | | | <i>Invoice Items</i> | 1 | | | | |
| 125176 | Oil filter/FD | Open | | 07/13/2023 | 07/26/2023 | 07/13/2023 | | | 18.44 |
| <i>P.O. Number</i> | <i>Item Description</i> | | <i>Quantity</i> | <i>U/M</i> | <i>Amount/Unit</i> | <i>Total Amount</i> | <i>Vendor Catalog Part Number</i> | <i>Contract Number</i> | |
| | Vehicle parts and supplies - Oil filter/FD | | 1.0000 | EA | 18.4400 | 18.44 | | | |
| | <i>G/L Account</i> | | | | <i>Project</i> | | | <i>Amount</i> | |
| | 11-4221-2401 (General Fund-Fire Department-Vehicle parts & supplies) | | | | 1069 (2022 AEV Type 1 Ambulance - F550) | | | 18.44 | |
| | | | | <i>Invoice Items</i> | 1 | | | | |
| 125276 | fuel filter/FD | Open | | 07/17/2023 | 07/26/2023 | 07/17/2023 | | | 9.34 |
| <i>P.O. Number</i> | <i>Item Description</i> | | <i>Quantity</i> | <i>U/M</i> | <i>Amount/Unit</i> | <i>Total Amount</i> | <i>Vendor Catalog Part Number</i> | <i>Contract Number</i> | |
| | Vehicle parts and supplies - fuel filter/FD | | 1.0000 | EA | 9.3400 | 9.34 | | | |
| | <i>G/L Account</i> | | | | <i>Project</i> | | | <i>Amount</i> | |
| | 11-4221-2401 (General Fund-Fire Department-Vehicle parts & supplies) | | | | 8921 (8921 - 2006 Ford Expedition) | | | 9.34 | |
| | | | | <i>Invoice Items</i> | 1 | | | | |
| 125278 | 4 Def fluid/FD | Open | | 07/17/2023 | 07/26/2023 | 07/17/2023 | | | 50.44 |
| <i>P.O. Number</i> | <i>Item Description</i> | | <i>Quantity</i> | <i>U/M</i> | <i>Amount/Unit</i> | <i>Total Amount</i> | <i>Vendor Catalog Part Number</i> | <i>Contract Number</i> | |
| | Vehicle parts and supplies - 4 Def fluid/FD | | 1.0000 | EA | 50.4400 | 50.44 | | | |
| | <i>G/L Account</i> | | | | <i>Project</i> | | | <i>Amount</i> | |
| | 11-4221-2401 (General Fund-Fire Department-Vehicle parts & supplies) | | | | 0000 (0000 - Misc. Equip.) | | | 50.44 | |
| | | | | <i>Invoice Items</i> | 1 | | | | |
| 125323 | Air filter/FD | Open | | 07/18/2023 | 07/26/2023 | 07/18/2023 | | | 10.09 |
| <i>P.O. Number</i> | <i>Item Description</i> | | <i>Quantity</i> | <i>U/M</i> | <i>Amount/Unit</i> | <i>Total Amount</i> | <i>Vendor Catalog Part Number</i> | <i>Contract Number</i> | |
| | Vehicle parts and supplies - Air filter/FD | | 1.0000 | EA | 10.0900 | 10.09 | | | |
| | <i>G/L Account</i> | | | | <i>Project</i> | | | <i>Amount</i> | |
| | 11-4221-2401 (General Fund-Fire Department-Vehicle parts & supplies) | | | | 8921 (8921 - 2006 Ford Expedition) | | | 10.09 | |
| | | | | <i>Invoice Items</i> | 1 | | | | |
| 125385 | fuel pump assembly/FD | Open | | 07/19/2023 | 07/26/2023 | 07/19/2023 | | | 187.46 |
| <i>P.O. Number</i> | <i>Item Description</i> | | <i>Quantity</i> | <i>U/M</i> | <i>Amount/Unit</i> | <i>Total Amount</i> | <i>Vendor Catalog Part Number</i> | <i>Contract Number</i> | |
| | Vehicle parts and supplies - fuel pump assembly/FD | | 1.0000 | EA | 187.4600 | 187.46 | | | |
| | <i>G/L Account</i> | | | | <i>Project</i> | | | <i>Amount</i> | |
| | 11-4221-2401 (General Fund-Fire Department-Vehicle parts & supplies) | | | | 8921 (8921 - 2006 Ford Expedition) | | | 187.46 | |
| | | | | <i>Invoice Items</i> | 1 | | | | |



Accounts Payable Invoice Report - Council

08/01/2023

Invoice Due Date Range 07/22/23 - 08/04/23

Report By Vendor - Invoice

| Invoice Number | Invoice Description | Status | Held Reason | Invoice Date | Due Date | G/L Date | Received Date | Payment Date | Invoice Net Amount |
|---|--|--------|-----------------|--------------|------------------------------------|---------------------|-----------------------------------|------------------------|--------------------|
| 125387 | fuelpdrmod/FD | Open | | 07/19/2023 | 07/26/2023 | 07/19/2023 | | | 99.75 |
| <i>P.O. Number</i> | <i>Item Description</i> | | <i>Quantity</i> | <i>U/M</i> | <i>Amount/Unit</i> | <i>Total Amount</i> | <i>Vendor Catalog Part Number</i> | <i>Contract Number</i> | |
| | Vehicle parts and supplies - fuelpdrmod/FD | | 1.0000 | EA | 99.7500 | 99.75 | | | |
| | <i>G/L Account</i> | | | | <i>Project</i> | | | <i>Amount</i> | |
| | 11-4221-2401 (General Fund-Fire Department-Vehicle parts & supplies) | | | | 8921 (8921 - 2006 Ford Expedition) | | | 99.75 | |
| | <i>Invoice Items</i> | | | | 1 | | | | |
| 125397 | invoice #125385 warranty credit/FD | Open | | 07/19/2023 | 07/26/2023 | 07/19/2023 | | | (187.46) |
| <i>P.O. Number</i> | <i>Item Description</i> | | <i>Quantity</i> | <i>U/M</i> | <i>Amount/Unit</i> | <i>Total Amount</i> | <i>Vendor Catalog Part Number</i> | <i>Contract Number</i> | |
| | Vehicle parts and supplies - invoice #125385 warranty credit/FD | | 1.0000 | EA | (187.4600) | (187.46) | | | |
| | <i>G/L Account</i> | | | | <i>Project</i> | | | <i>Amount</i> | |
| | 11-4221-2401 (General Fund-Fire Department-Vehicle parts & supplies) | | | | 8921 (8921 - 2006 Ford Expedition) | | | (187.46) | |
| | <i>Invoice Items</i> | | | | 1 | | | | |
| 125419 | fuel module/FD | Open | | 07/20/2023 | 07/26/2023 | 07/20/2023 | | | 289.99 |
| <i>P.O. Number</i> | <i>Item Description</i> | | <i>Quantity</i> | <i>U/M</i> | <i>Amount/Unit</i> | <i>Total Amount</i> | <i>Vendor Catalog Part Number</i> | <i>Contract Number</i> | |
| | Vehicle parts and supplies - fuel module/FD | | 1.0000 | EA | 289.9900 | 289.99 | | | |
| | <i>G/L Account</i> | | | | <i>Project</i> | | | <i>Amount</i> | |
| | 11-4221-2401 (General Fund-Fire Department-Vehicle parts & supplies) | | | | 8921 (8921 - 2006 Ford Expedition) | | | 289.99 | |
| | <i>Invoice Items</i> | | | | 1 | | | | |
| 125453 | invoice#125387 credit/FD | Open | | 07/20/2023 | 07/26/2023 | 07/20/2023 | | | (11.61) |
| <i>P.O. Number</i> | <i>Item Description</i> | | <i>Quantity</i> | <i>U/M</i> | <i>Amount/Unit</i> | <i>Total Amount</i> | <i>Vendor Catalog Part Number</i> | <i>Contract Number</i> | |
| | Vehicle parts and supplies - invoice#125387 credit/FD | | 1.0000 | EA | (11.6100) | (11.61) | | | |
| | <i>G/L Account</i> | | | | <i>Project</i> | | | <i>Amount</i> | |
| | 11-4221-2401 (General Fund-Fire Department-Vehicle parts & supplies) | | | | 8921 (8921 - 2006 Ford Expedition) | | | (11.61) | |
| | <i>Invoice Items</i> | | | | 1 | | | | |
| 125457 | on invoice #125453/FD | Open | | 07/20/2023 | 07/26/2023 | 07/20/2023 | | | (33.53) |
| <i>P.O. Number</i> | <i>Item Description</i> | | <i>Quantity</i> | <i>U/M</i> | <i>Amount/Unit</i> | <i>Total Amount</i> | <i>Vendor Catalog Part Number</i> | <i>Contract Number</i> | |
| | Vehicle parts and supplies - on invoice #125453/FD | | 1.0000 | EA | (33.5300) | (33.53) | | | |
| | <i>G/L Account</i> | | | | <i>Project</i> | | | <i>Amount</i> | |
| | 11-4221-2401 (General Fund-Fire Department-Vehicle parts & supplies) | | | | 8921 (8921 - 2006 Ford Expedition) | | | (33.53) | |
| | <i>Invoice Items</i> | | | | 1 | | | | |
| Vendor 3092 - NAPA - MCKAY AUTO PARTS Totals | | | | | Invoices | 28 | | | \$1,224.35 |

Vendor **2551 - NCPERS - 0216 - IL IMRF**



Accounts Payable Invoice Report - Council

08/01/2023

Invoice Due Date Range 07/22/23 - 08/04/23

Report By Vendor - Invoice

| Invoice Number | Invoice Description | Status | Held Reason | Invoice Date | Due Date | G/L Date | Received Date | Payment Date | Invoice Net Amount |
|--|---|--------|-----------------|----------------------------|--------------------|---------------------|-----------------------------------|------------------------|---------------------|
| 0216082023 | August 2023 Premium / EBHR | Open | | 07/01/2023 | 08/04/2023 | 07/01/2023 | | | 160.00 |
| <i>P.O. Number</i> | <i>Item Description</i> | | <i>Quantity</i> | <i>U/M</i> | <i>Amount/Unit</i> | <i>Total Amount</i> | <i>Vendor Catalog Part Number</i> | <i>Contract Number</i> | |
| | Life insurance employee deductions / EB - August 2023 Premium / EBHR | | 1.0000 | EA | 160.0000 | 160.00 | | | |
| | <i>G/L Account</i> | | | <i>Project</i> | | | <i>Amount</i> | | |
| | 11-2033 (General Fund-Other voluntary deductions) | | | | | | 160.00 | | |
| | <i>Invoice Items</i> | | | 1 | | | | | |
| Vendor 2551 - NCPERS - 0216 - IL IMRF Totals | | | | | | | | | Invoices 1 \$160.00 |
| Vendor 1625 - NEAL TIRE & AUTO SERVICE | | | | | | | | | |
| 1040178890 | Trailer tire - MAINT | Open | | 07/11/2023 | 08/04/2023 | 07/11/2023 | | | 94.07 |
| <i>P.O. Number</i> | <i>Item Description</i> | | <i>Quantity</i> | <i>U/M</i> | <i>Amount/Unit</i> | <i>Total Amount</i> | <i>Vendor Catalog Part Number</i> | <i>Contract Number</i> | |
| | Vehicle parts & supplies / MAINT - Trailer tire - MAINT | | 1.0000 | EA | 94.0700 | 94.07 | | | |
| | <i>G/L Account</i> | | | <i>Project</i> | | | <i>Amount</i> | | |
| | 11-4194-2401 (General Fund-Parks & Maintenance Department-Vehicle parts & supplies) | | | 0000 (0000 - Misc. Equip.) | | | 94.07 | | |
| | <i>Invoice Items</i> | | | 1 | | | | | |
| Vendor 1625 - NEAL TIRE & AUTO SERVICE Totals | | | | | | | | | Invoices 1 \$94.07 |
| Vendor 1660 - PAAP PRINTING | | | | | | | | | |
| 42073 | Tow sheets, bail bond forms/PD | Open | | 07/19/2023 | 08/04/2023 | 07/19/2023 | | | 295.00 |
| <i>P.O. Number</i> | <i>Item Description</i> | | <i>Quantity</i> | <i>U/M</i> | <i>Amount/Unit</i> | <i>Total Amount</i> | <i>Vendor Catalog Part Number</i> | <i>Contract Number</i> | |
| | Printed forms - Tow sheets, bail bond forms/PD | | 1.0000 | EA | 295.0000 | 295.00 | | | |
| | <i>G/L Account</i> | | | <i>Project</i> | | | <i>Amount</i> | | |
| | 11-4210-2004 (General Fund-Police Department-Printed forms) | | | | | | 295.00 | | |
| | <i>Invoice Items</i> | | | 1 | | | | | |
| Vendor 1660 - PAAP PRINTING Totals | | | | | | | | | Invoices 2 \$416.00 |
| Vendor 3156 - PENHALL COMPANY | | | | | | | | | |



Accounts Payable Invoice Report - Council

08/01/2023

Invoice Due Date Range 07/22/23 - 08/04/23

Report By Vendor - Invoice

| Invoice Number | Invoice Description | Status | Held Reason | Invoice Date | Due Date | G/L Date | Received Date | Payment Date | Invoice Net Amount |
|--|--|--------|-------------|---------------|---------------------------------------|-----------------------------------|------------------------|--------------|-----------------------|
| 161056 | Full depth concrete sawing/MFT | Open | | 06/30/2023 | 08/04/2023 | 06/30/2023 | | | 7,150.00 |
| <i>P.O. Number</i> | <i>Item Description</i> | | | | <i>Total Amount</i> | <i>Vendor Catalog Part Number</i> | <i>Contract Number</i> | | |
| | Concrete - Full depth concrete sawing/MFT | | | 1.0000 | EA | 7,150.0000 | | | |
| | <i>G/L Account</i> | | | | <i>Project</i> | | <i>Amount</i> | | |
| | 25-4312-2501 (Motor Fuel Tax Fund-Motor Fuel Tax Department-Concrete) | | | | PW 23 55 (Full Depth Concrete Sawing) | | 7,150.00 | | |
| | | | | Invoice Items | 1 | | | | |
| Vendor 3156 - PENHALL COMPANY Totals | | | | | | | | | Invoices 2 \$8,272.00 |
| 04/30/2023 | Ambulance return addresses/FD | Open | | 04/30/2023 | 08/04/2023 | 04/30/2023 | | | 8.88 |
| <i>P.O. Number</i> | <i>Item Description</i> | | | | <i>Total Amount</i> | <i>Vendor Catalog Part Number</i> | <i>Contract Number</i> | | |
| | Office supplies / FD - Ambulance return addresses/FD | | | 1.0000 | EA | 8.8800 | | | |
| | <i>G/L Account</i> | | | | <i>Project</i> | | <i>Amount</i> | | |
| | 11-4221-2001 (General Fund-Fire Department-Office supplies) | | | | | | 8.88 | | |
| | | | | Invoice Items | 1 | | | | |
| Vendor 2540 - PETTY CASH - WATER DEPT. Totals | | | | | | | | | Invoices 2 \$17.02 |
| 06/30/2023 | Ambulance return addresses/FD | Open | | 06/30/2023 | 08/04/2023 | 06/30/2023 | | | 8.14 |
| <i>P.O. Number</i> | <i>Item Description</i> | | | | <i>Total Amount</i> | <i>Vendor Catalog Part Number</i> | <i>Contract Number</i> | | |
| | Office supplies / FD - Ambulance return addresses/FD | | | 1.0000 | EA | 8.1400 | | | |
| | <i>G/L Account</i> | | | | <i>Project</i> | | <i>Amount</i> | | |
| | 11-4221-2001 (General Fund-Fire Department-Office supplies) | | | | | | 8.14 | | |
| | | | | Invoice Items | 1 | | | | |
| Vendor 2540 - PETTY CASH - WATER DEPT. Totals | | | | | | | | | Invoices 2 \$17.02 |
| 117984 | Water pump replacement and etc vehicle maintenance/PD | Open | | 05/11/2023 | 08/04/2023 | 05/11/2023 | | | 575.41 |
| <i>P.O. Number</i> | <i>Item Description</i> | | | | <i>Total Amount</i> | <i>Vendor Catalog Part Number</i> | <i>Contract Number</i> | | |
| | Vehicle parts and supplies - Water pump replacement and etc vehicle maintenance/PD | | | 1.0000 | EA | 575.4100 | | | |
| | <i>G/L Account</i> | | | | <i>Project</i> | | <i>Amount</i> | | |
| | | | | | | | | | |



Accounts Payable Invoice Report - Council

08/01/2023

Invoice Due Date Range 07/22/23 - 08/04/23

Report By Vendor - Invoice

| Invoice Number | Invoice Description | Status | Held Reason | Invoice Date | Due Date | G/L Date | Received Date | Payment Date | Invoice Net Amount |
|---|---|--------|-------------|-----------------|------------|--------------------------------------|---------------------|-----------------------------------|------------------------|
| 117984 | Water pump replacement and etc vehicle maintenance/PD | Open | | 05/11/2023 | 08/04/2023 | 05/11/2023 | | | 575.41 |
| <i>P.O. Number</i> | <i>Item Description</i> | | | <i>Quantity</i> | <i>U/M</i> | <i>Amount/Unit</i> | <i>Total Amount</i> | <i>Vendor Catalog Part Number</i> | <i>Contract Number</i> |
| | 11-4210-2401 (General Fund-Police Department-Vehicle parts & supplies) | | | 2613 | | (2020 Ford Explorer (actually 2614)) | | 575.41 | |
| | | | | Invoice Items | | | 1 | | |
| 118796 | Rear camera maintenance/PD | Open | | 06/27/2023 | 08/04/2023 | 06/27/2023 | | | 346.93 |
| <i>P.O. Number</i> | <i>Item Description</i> | | | <i>Quantity</i> | <i>U/M</i> | <i>Amount/Unit</i> | <i>Total Amount</i> | <i>Vendor Catalog Part Number</i> | <i>Contract Number</i> |
| | Vehicle parts and supplies - Rear camera maintenance/PD | | | 1.0000 | EA | 346.9300 | 346.93 | | |
| | <i>G/L Account</i> | | | | | <i>Project</i> | | <i>Amount</i> | |
| | 11-4210-2401 (General Fund-Police Department-Vehicle parts & supplies) | | | | | 4146 (2020 Ford Explorer) | | 346.93 | |
| | | | | Invoice Items | | | 1 | | |
| 118453 | Replacement of front shaft, axle, and etc vehicle maint/PD | Open | | 07/13/2023 | 08/04/2023 | 07/13/2023 | | | 2,604.33 |
| <i>P.O. Number</i> | <i>Item Description</i> | | | <i>Quantity</i> | <i>U/M</i> | <i>Amount/Unit</i> | <i>Total Amount</i> | <i>Vendor Catalog Part Number</i> | <i>Contract Number</i> |
| | Vehicle parts and supplies - Replacement of front shaft, axle, and etc vehicle maint/PD | | | 1.0000 | EA | 2,604.3300 | 2,604.33 | | |
| | <i>G/L Account</i> | | | | | <i>Project</i> | | <i>Amount</i> | |
| | 11-4210-2401 (General Fund-Police Department-Vehicle parts & supplies) | | | | | 4144 (2020 Ford Explorer) | | 2,604.33 | |
| | | | | Invoice Items | | | 1 | | |
| Vendor 2729 - PILSON AUTO CENTER OF CHARLESTON INC | | | | Totals | | | Invoices | 3 | \$3,526.67 |
| Vendor 1681 - POSTMASTER | | | | | | | | | |
| 08/01/2023 | Monthly postage - permit #7/WATER | Open | | 08/01/2023 | 08/04/2023 | 08/01/2023 | | | 2,100.00 |
| <i>P.O. Number</i> | <i>Item Description</i> | | | <i>Quantity</i> | <i>U/M</i> | <i>Amount/Unit</i> | <i>Total Amount</i> | <i>Vendor Catalog Part Number</i> | <i>Contract Number</i> |
| | Postage expense - Monthly postage - permit #7/WATER | | | 1.0000 | EA | 2,100.0000 | 2,100.00 | | |
| | <i>G/L Account</i> | | | | | <i>Project</i> | | <i>Amount</i> | |
| | 61-4630-3901 (Water and Sewer Fund-Water Department-Postage expense) | | | | | | | 2,100.00 | |
| | | | | Invoice Items | | | 1 | | |
| Vendor 1681 - POSTMASTER | | | | Totals | | | Invoices | 1 | \$2,100.00 |
| Vendor 1719 - RAY O'HERRON CO, INC | | | | | | | | | |



Accounts Payable Invoice Report - Council

08/01/2023

Invoice Due Date Range 07/22/23 - 08/04/23

Report By Vendor - Invoice

| Invoice Number | Invoice Description | Status | Held Reason | Invoice Date | Due Date | G/L Date | Received Date | Payment Date | Invoice Net Amount |
|--------------------|--|--------|----------------------|--------------|----------------------------|---------------------|-----------------------------------|------------------------|--------------------|
| 2253534 | Chevron uniform/PD | Open | | 02/21/2023 | 08/04/2023 | 02/21/2023 | | | 43.49 |
| <i>P.O. Number</i> | <i>Item Description</i> | | <i>Quantity</i> | <i>U/M</i> | <i>Amount/Unit</i> | <i>Total Amount</i> | <i>Vendor Catalog Part Number</i> | <i>Contract Number</i> | |
| | Uniforms / PD - Chevron uniform/PD | | 1.0000 | EA | 43.4900 | 43.49 | | | |
| | <i>G/L Account</i> | | | | <i>Project</i> | | <i>Amount</i> | | |
| | 11-4210-2701 (General Fund-Police Department-Uniforms) | | | | | | 43.49 | | |
| | | | <i>Invoice Items</i> | | 1 | | | | |
| 2267434 | Equipment for new dodge durangos/PD | Open | | 04/28/2023 | 08/04/2023 | 04/28/2023 | | | 872.00 |
| <i>P.O. Number</i> | <i>Item Description</i> | | <i>Quantity</i> | <i>U/M</i> | <i>Amount/Unit</i> | <i>Total Amount</i> | <i>Vendor Catalog Part Number</i> | <i>Contract Number</i> | |
| | Vehicle & service equipment - Equipment for new dodge durangos/PD | | 1.0000 | EA | 872.0000 | 872.00 | | | |
| | <i>G/L Account</i> | | | | <i>Project</i> | | <i>Amount</i> | | |
| | 11-4210-4299 (General Fund-Police Department-Vehicles & service equipment) | | | | 0000 (0000 - Misc. Equip.) | | 872.00 | | |
| | | | <i>Invoice Items</i> | | 1 | | | | |
| CR3140385 | Credit for duplicate payment - uniform Kraft/PD | Open | | 04/30/2023 | 08/04/2023 | 04/30/2023 | | | (81.98) |
| <i>P.O. Number</i> | <i>Item Description</i> | | <i>Quantity</i> | <i>U/M</i> | <i>Amount/Unit</i> | <i>Total Amount</i> | <i>Vendor Catalog Part Number</i> | <i>Contract Number</i> | |
| | Uniforms / PD - Credit for duplicate payment - uniform Kraft/PD | | 1.0000 | EA | (81.9800) | (81.98) | | | |
| | <i>G/L Account</i> | | | | <i>Project</i> | | <i>Amount</i> | | |
| | 11-4210-2701 (General Fund-Police Department-Uniforms) | | | | | | (81.98) | | |
| | | | <i>Invoice Items</i> | | 1 | | | | |
| 2269855 | Equipment for new dodge durangos/PD | Open | | 05/09/2023 | 08/04/2023 | 05/09/2023 | | | 182.00 |
| <i>P.O. Number</i> | <i>Item Description</i> | | <i>Quantity</i> | <i>U/M</i> | <i>Amount/Unit</i> | <i>Total Amount</i> | <i>Vendor Catalog Part Number</i> | <i>Contract Number</i> | |
| | Vehicle & service equipment - Equipment for new dodge durangos/PD | | 1.0000 | EA | 182.0000 | 182.00 | | | |
| | <i>G/L Account</i> | | | | <i>Project</i> | | <i>Amount</i> | | |
| | 11-4210-4299 (General Fund-Police Department-Vehicles & service equipment) | | | | 0000 (0000 - Misc. Equip.) | | 182.00 | | |
| | | | <i>Invoice Items</i> | | 1 | | | | |
| 2269978 | Uniforms/PD | Open | | 05/09/2023 | 08/04/2023 | 05/09/2023 | | | 408.81 |
| <i>P.O. Number</i> | <i>Item Description</i> | | <i>Quantity</i> | <i>U/M</i> | <i>Amount/Unit</i> | <i>Total Amount</i> | <i>Vendor Catalog Part Number</i> | <i>Contract Number</i> | |
| | Uniforms / PD - Uniforms/PD | | 1.0000 | EA | 408.8100 | 408.81 | | | |
| | <i>G/L Account</i> | | | | <i>Project</i> | | <i>Amount</i> | | |
| | 11-4210-2701 (General Fund-Police Department-Uniforms) | | | | | | 408.81 | | |
| | | | <i>Invoice Items</i> | | 1 | | | | |



Accounts Payable Invoice Report - Council

08/01/2023

Invoice Due Date Range 07/22/23 - 08/04/23

Report By Vendor - Invoice

| Invoice Number | Invoice Description | Status | Held Reason | Invoice Date | Due Date | G/L Date | Received Date | Payment Date | Invoice Net Amount |
|---|--|--------|-------------|-----------------|------------|--|---------------------|-----------------------------------|------------------------|
| 2276095 | Equipment for new dodge durangos/PD | Open | | 06/08/2023 | 08/04/2023 | 06/08/2023 | | | 2,591.66 |
| <i>P.O. Number</i> | <i>Item Description</i> | | | <i>Quantity</i> | <i>U/M</i> | <i>Amount/Unit</i> | <i>Total Amount</i> | <i>Vendor Catalog Part Number</i> | <i>Contract Number</i> |
| | Vehicle & service equipment - Equipment for new dodge durangos/PD | | | 1.0000 | EA | 2,591.6600 | 2,591.66 | | |
| | <i>G/L Account</i> | | | | | <i>Project</i> | | <i>Amount</i> | |
| | 11-4210-4299 (General Fund-Police Department-Vehicles & service equipment) | | | | | 0000 (0000 - Misc. Equip.) | | 2,591.66 | |
| | Invoice Items | | | | | 1 | | | |
| 2283185 | Ammo - PD | Open | | 07/18/2023 | 08/04/2023 | 07/18/2023 | | | 616.00 |
| <i>P.O. Number</i> | <i>Item Description</i> | | | <i>Quantity</i> | <i>U/M</i> | <i>Amount/Unit</i> | <i>Total Amount</i> | <i>Vendor Catalog Part Number</i> | <i>Contract Number</i> |
| | Ammunition & Supplies - Ammo - PD | | | 1.0000 | EA | 616.0000 | 616.00 | | |
| | <i>G/L Account</i> | | | | | <i>Project</i> | | <i>Amount</i> | |
| | 11-4210-2110 (General Fund-Police Department-Ammunition & supplies) | | | | | | | 616.00 | |
| | Invoice Items | | | | | 1 | | | |
| 2283850 | OC Spray/PD | Open | | 07/21/2023 | 08/04/2023 | 07/21/2023 | | | 172.49 |
| <i>P.O. Number</i> | <i>Item Description</i> | | | <i>Quantity</i> | <i>U/M</i> | <i>Amount/Unit</i> | <i>Total Amount</i> | <i>Vendor Catalog Part Number</i> | <i>Contract Number</i> |
| | Other supplies - OC Spray/PD | | | 1.0000 | EA | 172.4900 | 172.49 | | |
| | <i>G/L Account</i> | | | | | <i>Project</i> | | <i>Amount</i> | |
| | 11-4210-2107 (General Fund-Police Department-Operating Supplies) | | | | | | | 172.49 | |
| | Invoice Items | | | | | 1 | | | |
| Vendor 1719 - RAY O'HERRON CO, INC Totals | | | | | | | Invoices | 8 | \$4,804.47 |
| Vendor 4597 - RUSH TRUCK CENTER - EFFINGHAM | | | | | | | | | |
| 3033241437 | Drain Vlv w/Htr/UTILITY | Open | | 07/11/2023 | 08/04/2023 | 07/11/2023 | | | 520.00 |
| <i>P.O. Number</i> | <i>Item Description</i> | | | <i>Quantity</i> | <i>U/M</i> | <i>Amount/Unit</i> | <i>Total Amount</i> | <i>Vendor Catalog Part Number</i> | <i>Contract Number</i> |
| | 1/4 page full color ad/tourism - Drain Vlv w/Htr/UTILITY | | | 1.0000 | EA | 520.0000 | 520.00 | | |
| | <i>G/L Account</i> | | | | | <i>Project</i> | | <i>Amount</i> | |
| | 61-4610-3508 (Water and Sewer Fund-Utility Department-Repair of operating equipment) | | | | | 9211 (92112021 Dump Truck) | | 520.00 | |
| | Invoice Items | | | | | 1 | | | |
| 3033314408 | Kit, Filter/STREET | Open | | 07/14/2023 | 08/04/2023 | 07/14/2023 | | | 125.00 |
| <i>P.O. Number</i> | <i>Item Description</i> | | | <i>Quantity</i> | <i>U/M</i> | <i>Amount/Unit</i> | <i>Total Amount</i> | <i>Vendor Catalog Part Number</i> | <i>Contract Number</i> |
| | 1/4 page full color ad/tourism - Kit, Filter/STREET | | | 1.0000 | EA | 125.0000 | 125.00 | | |
| | <i>G/L Account</i> | | | | | <i>Project</i> | | <i>Amount</i> | |
| | 11-4310-2401 (General Fund-Street Department-Vehicle parts & supplies) | | | | | 1815 (2023 Intl HV507 Dump Truck #130) | | 125.00 | |
| | Invoice Items | | | | | 1 | | | |
| Vendor 4597 - RUSH TRUCK CENTER - EFFINGHAM Totals | | | | | | | Invoices | 2 | \$645.00 |



Accounts Payable Invoice Report - Council

08/01/2023

Invoice Due Date Range 07/22/23 - 08/04/23

Report By Vendor - Invoice

| Invoice Number | Invoice Description | Status | Held Reason | Invoice Date | Due Date | G/L Date | Received Date | Payment Date | Invoice Net Amount |
|---|--|--------|-----------------|---------------|--------------------|---------------------|-----------------------------------|------------------------|--------------------|
| Vendor 1748 - SARAH BUSH LINCOLN HLTH CNTR | | | | | | | | | |
| 7/12/23 | Travis Campbell Injury / EBHR | Open | | 07/12/2023 | 08/04/2023 | 07/12/2023 | | | 287.00 |
| <i>P.O. Number</i> | <i>Item Description</i> | | <i>Quantity</i> | <i>U/M</i> | <i>Amount/Unit</i> | <i>Total Amount</i> | <i>Vendor Catalog Part Number</i> | <i>Contract Number</i> | |
| | Work comp deductibles - Travis Campbell Injury / EBHR | | 1.0000 | EA | 287.0000 | 287.00 | | | |
| | <i>G/L Account</i> | | | | <i>Project</i> | | | <i>Amount</i> | |
| | 11-4910-3311 (General Fund-Premiums, Judgments & Claims-Deductible Payments-Work Comp) | | | | | | | 287.00 | |
| | | | | Invoice Items | 1 | | | | |
| Vendor 1748 - SARAH BUSH LINCOLN HLTH CNTR Totals | | | | | | | | | \$434.00 |
| | | | | | | | Invoices | 2 | |
| Vendor 2902 - SCHAEFFER MANUFACTURING COMPANY | | | | | | | | | |
| RER2754 | Synforce Grease/UTILITY | Open | | 06/26/2023 | 08/04/2023 | 06/26/2023 | | | 667.80 |
| <i>P.O. Number</i> | <i>Item Description</i> | | <i>Quantity</i> | <i>U/M</i> | <i>Amount/Unit</i> | <i>Total Amount</i> | <i>Vendor Catalog Part Number</i> | <i>Contract Number</i> | |
| | 1/4 page full color ad/tourism - Synforce Grease/UTILITY | | 1.0000 | EA | 667.8000 | 667.80 | | | |
| | <i>G/L Account</i> | | | | <i>Project</i> | | | <i>Amount</i> | |
| | 61-4610-2201 (Water and Sewer Fund-Utility Department-Fuel & oil) | | | | | | | 667.80 | |
| | | | | Invoice Items | 1 | | | | |
| Vendor 2902 - SCHAEFFER MANUFACTURING COMPANY Totals | | | | | | | | | \$667.80 |
| | | | | | | | Invoices | 1 | |
| Vendor 4639 - SCHWENKE, CHAD | | | | | | | | | |
| 07/20/2023 | Clothing reimbursement/PD | Open | | 07/20/2023 | 08/04/2023 | 07/20/2023 | | | 139.05 |
| <i>P.O. Number</i> | <i>Item Description</i> | | <i>Quantity</i> | <i>U/M</i> | <i>Amount/Unit</i> | <i>Total Amount</i> | <i>Vendor Catalog Part Number</i> | <i>Contract Number</i> | |
| | Uniforms / PD - Clothing reimbursement/PD | | 1.0000 | EA | 139.0500 | 139.05 | | | |
| | <i>G/L Account</i> | | | | <i>Project</i> | | | <i>Amount</i> | |
| | 11-4210-2701 (General Fund-Police Department-Uniforms) | | | | | | | 139.05 | |
| | | | | Invoice Items | 1 | | | | |
| Vendor 4639 - SCHWENKE, CHAD Totals | | | | | | | | | \$139.05 |
| | | | | | | | Invoices | 1 | |

Vendor **1768 - SHERWIN-WILLIAMS**



Accounts Payable Invoice Report - Council

08/01/2023

Invoice Due Date Range 07/22/23 - 08/04/23

Report By Vendor - Invoice

| Invoice Number | Invoice Description | Status | Held Reason | Invoice Date | Due Date | G/L Date | Received Date | Payment Date | Invoice Net Amount |
|---|---|--------|-----------------|---------------|---|---------------------|-----------------------------------|------------------------|------------------------|
| 820869 | Paint - MAINT | Open | | 06/23/2023 | 08/04/2023 | 06/23/2023 | | | 556.69 |
| <i>P.O. Number</i> | <i>Item Description</i> | | <i>Quantity</i> | <i>U/M</i> | <i>Amount/Unit</i> | <i>Total Amount</i> | <i>Vendor Catalog Part Number</i> | <i>Contract Number</i> | |
| | Park maintenance materials - Paint - MAINT | | 1.0000 | EA | 556.6900 | 556.69 | | | |
| | <i>G/L Account</i> | | | | <i>Project</i> | | <i>Amount</i> | | |
| | 11-4194-2513 (General Fund-Parks & Maintenance Department-Park maintenance materials) | | | | | | 556.69 | | |
| | | | | Invoice Items | 1 | | | | |
| Vendor 1768 - SHERWIN-WILLIAMS Totals | | | | | | | | | Invoices 1 \$556.69 |
| Vendor 1771 - SIGN APPEAL | | | | | | | | | |
| 133345 | Prime and paint scoreboard structures - REC | Open | | 06/29/2023 | 08/04/2023 | 06/29/2023 | | | 4,648.00 |
| <i>P.O. Number</i> | <i>Item Description</i> | | <i>Quantity</i> | <i>U/M</i> | <i>Amount/Unit</i> | <i>Total Amount</i> | <i>Vendor Catalog Part Number</i> | <i>Contract Number</i> | |
| | Capital Improvement projects - Prime and paint scoreboard structures - REC | | 1.0000 | EA | 4,648.0000 | 4,648.00 | | | |
| | <i>G/L Account</i> | | | | <i>Project</i> | | <i>Amount</i> | | |
| | 11-4095-4106 (General Fund-Engineering Department-Capital improvement projects) | | | | PW 20 26 022 (Field Nets at End of Fields, Fence along South End) | | 4,648.00 | | |
| | | | | Invoice Items | 1 | | | | |
| Vendor 1771 - SIGN APPEAL Totals | | | | | | | | | Invoices 2 \$27,982.24 |
| Vendor 4014 - SIMPSON'S HEATING & AIR, INC. | | | | | | | | | |
| 1700 | Air at the Museum - REC | Open | | 06/13/2023 | 08/04/2023 | 06/13/2023 | | | 9,736.00 |
| <i>P.O. Number</i> | <i>Item Description</i> | | <i>Quantity</i> | <i>U/M</i> | <i>Amount/Unit</i> | <i>Total Amount</i> | <i>Vendor Catalog Part Number</i> | <i>Contract Number</i> | |
| | Building & Improvements - Air at the Museum - REC | | 1.0000 | EA | 9,736.0000 | 9,736.00 | | | |
| | <i>G/L Account</i> | | | | <i>Project</i> | | <i>Amount</i> | | |
| | 11-4194-4199 (General Fund-Parks & Maintenance Department-Building & improvements) | | | | 0000 (0000 - Misc. Equip.) | | 9,736.00 | | |
| | | | | Invoice Items | 1 | | | | |
| Vendor 4014 - SIMPSON'S HEATING & AIR, INC. Totals | | | | | | | | | Invoices 1 \$9,736.00 |
| Vendor 3448 - SOUTH CENTRAL FS, INC. | | | | | | | | | |



Accounts Payable Invoice Report - Council

08/01/2023

Invoice Due Date Range 07/22/23 - 08/04/23

Report By Vendor - Invoice

| Invoice Number | Invoice Description | Status | Held Reason | Invoice Date | Due Date | G/L Date | Received Date | Payment Date | Invoice Net Amount |
|--------------------|--|--------|-----------------|--------------|--------------------|---------------------|-----------------------------------|------------------------|--------------------|
| 06/30/2023 | Monthly fuel allocation | Open | | 06/30/2023 | 08/04/2023 | 06/30/2023 | | | 29,585.23 |
| <i>P.O. Number</i> | <i>Item Description</i> | | <i>Quantity</i> | <i>U/M</i> | <i>Amount/Unit</i> | <i>Total Amount</i> | <i>Vendor Catalog Part Number</i> | <i>Contract Number</i> | |
| | Fuel & Oil - Monthly fuel allocation | | 1.0000 | EA | 29,585.2300 | 29,585.23 | | | |
| | <i>G/L Account</i> | | | | <i>Project</i> | | | <i>Amount</i> | |
| | 11-4095-2201 (General Fund-Engineering Department-Fuel & oil) | | | | | | | 551.71 | |
| | 11-4194-2201 (General Fund-Parks & Maintenance Department-Fuel & oil) | | | | | | | 2,250.58 | |
| | 11-4210-2201 (General Fund-Police Department-Fuel & oil) | | | | | | | 8,092.32 | |
| | 11-4221-2201 (General Fund-Fire Department-Fuel & oil) | | | | | | | 3,721.60 | |
| | 11-4310-2201 (General Fund-Street Department-Fuel & oil) | | | | | | | 3,406.08 | |
| | 11-4311-2201 (General Fund-City Garage-Fuel & oil) | | | | | | | 2,812.20 | |
| | 11-4640-2201 (General Fund-Building & Development Services-Fuel & oil) | | | | | | | 709.82 | |
| | 61-4610-2201 (Water and Sewer Fund-Utility Department-Fuel & oil) | | | | | | | 4,482.46 | |
| | 61-4611-2201 (Water and Sewer Fund-Water Treatment Plant-Fuel & oil) | | | | | | | 292.68 | |
| | 61-4621-2201 (Water and Sewer Fund-Waste Water Treatment Plant-Fuel & oil) | | | | | | | 284.27 | |
| | 11-4001-2201 (General Fund-Administration & Boards- Manager-Fuel & oil) | | | | | | | 98.66 | |
| | 61-4311-2201 (Water and Sewer Fund-City Garage-Fuel & oil) | | | | | | | 2,718.01 | |
| | 22-4510-2201 (Playground & Recreation Fund-Recreation Programs-Fuel & oil) | | | | | | | 164.84 | |
| | Invoice Items | | | | 1 | | | | |

Vendor **3448 - SOUTH CENTRAL FS, INC.** Totals Invoices 1 \$29,585.23

| Invoice Number | Invoice Description | Status | Held Reason | Invoice Date | Due Date | G/L Date | Received Date | Payment Date | Invoice Net Amount |
|--------------------|---|--------|-----------------|--------------|--------------------|---------------------|-----------------------------------|------------------------|--------------------|
| 16822914 | Monthly natural gas allocation | Open | | 06/30/2023 | 08/04/2023 | 06/30/2023 | | | 28.83 |
| <i>P.O. Number</i> | <i>Item Description</i> | | <i>Quantity</i> | <i>U/M</i> | <i>Amount/Unit</i> | <i>Total Amount</i> | <i>Vendor Catalog Part Number</i> | <i>Contract Number</i> | |
| | Electricity & gas - Monthly natural gas allocation | | 1.0000 | EA | 28.8300 | 28.83 | | | |
| | <i>G/L Account</i> | | | | <i>Project</i> | | | <i>Amount</i> | |
| | 11-4194-3403 (General Fund-Parks & Maintenance Department-Electricity & gas) | | | | | | | 1.82 | |
| | 11-4210-3403 (General Fund-Police Department-Electricity & gas) | | | | | | | 13.87 | |
| | 11-4221-3403 (General Fund-Fire Department-Electricity & gas) | | | | | | | 8.65 | |
| | 11-4311-3403 (General Fund-City Garage-Electricity & gas) | | | | | | | 2.08 | |
| | 61-4621-3403 (Water and Sewer Fund-Waste Water Treatment Plant-Electricity & gas) | | | | | | | .34 | |
| | 61-4311-3403 (Water and Sewer Fund-City Garage-Electricity & gas) | | | | | | | 2.07 | |
| | Invoice Items | | | | 1 | | | | |

Vendor **4481 - SYMMETRY ENERGY SOLUTIONS LLC** Totals Invoices 1 \$28.83

Vendor **3646 - TEKLAB INC**



Accounts Payable Invoice Report - Council

08/01/2023

Invoice Due Date Range 07/22/23 - 08/04/23
Report By Vendor - Invoice

| Invoice Number | Invoice Description | Status | Held Reason | Invoice Date | Due Date | G/L Date | Received Date | Payment Date | Invoice Net Amount |
|---|--|--------|-------------|-----------------|------------|--------------------|---------------------|-----------------------------------|------------------------|
| 292022 | WP Lab Expense - Outside Testing | Open | | 07/18/2023 | 08/04/2023 | 07/18/2023 | | | 479.90 |
| <i>P.O. Number</i> | <i>Item Description</i> | | | <i>Quantity</i> | <i>U/M</i> | <i>Amount/Unit</i> | <i>Total Amount</i> | <i>Vendor Catalog Part Number</i> | <i>Contract Number</i> |
| | sludge testing fees/wwtp - WP Lab Expense - Outside Testing | | | 1.0000 | EA | 479.9000 | 479.90 | | |
| | <i>G/L Account</i> | | | | | <i>Project</i> | | <i>Amount</i> | |
| | 61-4611-3106 (Water and Sewer Fund-Water Treatment Plant-Other consulting services) | | | | | | | 479.90 | |
| | | | | Invoice Items | | 1 | | | |
| Vendor 3646 - TEKLAB INC Totals | | | | | | | | | Invoices 1 \$479.90 |
| Vendor 4679 - UNIFIED HEALTH SERVICES | | | | | | | | | |
| A006242989 | Ella Keefer Injury / EBHR | Open | | 07/14/2023 | 08/04/2023 | 07/14/2023 | | | 215.00 |
| <i>P.O. Number</i> | <i>Item Description</i> | | | <i>Quantity</i> | <i>U/M</i> | <i>Amount/Unit</i> | <i>Total Amount</i> | <i>Vendor Catalog Part Number</i> | <i>Contract Number</i> |
| | Work comp deductibles - Ella Keefer Injury / EBHR | | | 1.0000 | EA | 215.0000 | 215.00 | | |
| | <i>G/L Account</i> | | | | | <i>Project</i> | | <i>Amount</i> | |
| | 11-4910-3311 (General Fund-Premiums, Judgments & Claims-Deductible Payments-Work Comp) | | | | | | | 215.00 | |
| | | | | Invoice Items | | 1 | | | |
| Vendor 4679 - UNIFIED HEALTH SERVICES Totals | | | | | | | | | Invoices 1 \$215.00 |
| Vendor 1851 - UNITED PARCEL SERVICE | | | | | | | | | |
| 000029Y964273 | WP Lab Expense - Freight | Open | | 07/08/2023 | 08/04/2023 | 07/08/2023 | | | 17.03 |
| <i>P.O. Number</i> | <i>Item Description</i> | | | <i>Quantity</i> | <i>U/M</i> | <i>Amount/Unit</i> | <i>Total Amount</i> | <i>Vendor Catalog Part Number</i> | <i>Contract Number</i> |
| | Freight - WP Lab Expense - Freight | | | 1.0000 | EA | 17.0300 | 17.03 | | |
| | <i>G/L Account</i> | | | | | <i>Project</i> | | <i>Amount</i> | |
| | 61-4611-3106 (Water and Sewer Fund-Water Treatment Plant-Other consulting services) | | | | | | | 17.03 | |
| | | | | Invoice Items | | 1 | | | |
| Vendor 1851 - UNITED PARCEL SERVICE Totals | | | | | | | | | Invoices 1 \$17.03 |
| 000029Y964283b | WP Lab Expense - Freight | Open | | 07/15/2023 | 08/04/2023 | 07/15/2023 | | | 32.70 |
| <i>P.O. Number</i> | <i>Item Description</i> | | | <i>Quantity</i> | <i>U/M</i> | <i>Amount/Unit</i> | <i>Total Amount</i> | <i>Vendor Catalog Part Number</i> | <i>Contract Number</i> |
| | Freight - WP Lab Expense - Freight | | | 1.0000 | EA | 32.7000 | 32.70 | | |
| | <i>G/L Account</i> | | | | | <i>Project</i> | | <i>Amount</i> | |
| | 61-4611-3106 (Water and Sewer Fund-Water Treatment Plant-Other consulting services) | | | | | | | 32.70 | |
| | | | | Invoice Items | | 1 | | | |
| Vendor 1851 - UNITED PARCEL SERVICE Totals | | | | | | | | | Invoices 1 \$32.70 |
| 000029Y964293b | WP Lab Expense - Freight | Open | | 07/22/2023 | 08/04/2023 | 07/22/2023 | | | 16.35 |
| <i>P.O. Number</i> | <i>Item Description</i> | | | <i>Quantity</i> | <i>U/M</i> | <i>Amount/Unit</i> | <i>Total Amount</i> | <i>Vendor Catalog Part Number</i> | <i>Contract Number</i> |
| | Freight - WP Lab Expense - Freight | | | 1.0000 | EA | 16.3500 | 16.35 | | |
| | <i>G/L Account</i> | | | | | <i>Project</i> | | <i>Amount</i> | |
| | | | | | | | | | |



Accounts Payable Invoice Report - Council

08/01/2023

Invoice Due Date Range 07/22/23 - 08/04/23

Report By Vendor - Invoice

| Invoice Number | Invoice Description | Status | Held Reason | Invoice Date | Due Date | G/L Date | Received Date | Payment Date | Invoice Net Amount |
|---|---|--------|-----------------|--------------|--------------------|---------------------|-----------------------------------|------------------------|--------------------|
| 000029Y964293b | WP Lab Expense - Freight | Open | | 07/22/2023 | 08/04/2023 | 07/22/2023 | | | 16.35 |
| <i>P.O. Number</i> | <i>Item Description</i> | | <i>Quantity</i> | <i>U/M</i> | <i>Amount/Unit</i> | <i>Total Amount</i> | <i>Vendor Catalog Part Number</i> | <i>Contract Number</i> | |
| | 61-4611-3106 (Water and Sewer Fund-Water Treatment Plant-Other consulting services) | | | | | | | 16.35 | |
| | | | Invoice Items | 1 | | | | | |
| Vendor 1851 - UNITED PARCEL SERVICE Totals | | | | | | Invoices | 3 | | \$66.08 |
| Vendor 1860 - USA BLUE BOOK | | | | | | | | | |
| INV00056643 | WP Lab Supplies - Chemicals, Reagents, etc | Open | | 06/27/2023 | 08/04/2023 | 06/27/2023 | | | 417.58 |
| <i>P.O. Number</i> | <i>Item Description</i> | | <i>Quantity</i> | <i>U/M</i> | <i>Amount/Unit</i> | <i>Total Amount</i> | <i>Vendor Catalog Part Number</i> | <i>Contract Number</i> | |
| | Lab supplies / WTP - WP Lab Supplies - Chemicals, Reagents, etc | | 1.0000 | EA | 417.5800 | 417.58 | | | |
| | <i>G/L Account</i> | | | | <i>Project</i> | | | <i>Amount</i> | |
| | 61-4611-2105 (Water and Sewer Fund-Water Treatment Plant-Laboratory supplies) | | | | | | | 417.58 | |
| | | | Invoice Items | 1 | | | | | |
| Vendor 1860 - USA BLUE BOOK Totals | | | | | | Invoices | 2 | | \$510.60 |
| Vendor 1868 - VERIZON WIRELESS | | | | | | | | | |
| 9939717615 | Monthly cell phone usage | Open | | 07/15/2023 | 08/04/2023 | 07/15/2023 | | | 2,408.90 |
| <i>P.O. Number</i> | <i>Item Description</i> | | <i>Quantity</i> | <i>U/M</i> | <i>Amount/Unit</i> | <i>Total Amount</i> | <i>Vendor Catalog Part Number</i> | <i>Contract Number</i> | |
| | Cell phone service - Monthly cell phone usage | | 1.0000 | EA | 2,408.9000 | 2,408.90 | | | |
| | <i>G/L Account</i> | | | | <i>Project</i> | | | <i>Amount</i> | |
| | 11-4001-3402 (General Fund-Administration & Boards- Manager-Cell phone expense) | | | | | | | 47.00 | |
| | 11-4095-3402 (General Fund-Engineering Department-Cell phone expense) | | | | | | | 94.00 | |
| | 11-4194-3402 (General Fund-Parks & Maintenance Department-Cell phone expense) | | | | | | | 47.00 | |
| | 11-4210-3402 (General Fund-Police Department-Cell phone expense) | | | | | | | 529.58 | |
| | 11-4221-3402 (General Fund-Fire Department-Cell phone expense) | | | | | | | 842.28 | |
| | 11-4640-3402 (General Fund-Building & Development Services-Cell phone expense) | | | | | | | 339.70 | |



Accounts Payable Invoice Report - Council

08/01/2023

Invoice Due Date Range 07/22/23 - 08/04/23

Report By Vendor - Invoice

| Invoice Number | Invoice Description | Status | Held Reason | Invoice Date | Due Date | G/L Date | Received Date | Payment Date | Invoice Net Amount | | |
|--|--|--------|-----------------|--------------|-------------------------|---------------------|-----------------------------------|------------------------|--------------------|---|------------|
| 9939717615 | Monthly cell phone usage | Open | | 07/15/2023 | 08/04/2023 | 07/15/2023 | | | 2,408.90 | | |
| <i>P.O. Number</i> | <i>Item Description</i> | | <i>Quantity</i> | <i>U/M</i> | <i>Amount/Unit</i> | <i>Total Amount</i> | <i>Vendor Catalog Part Number</i> | <i>Contract Number</i> | | | |
| | 61-4610-3402 (Water and Sewer Fund-Utility Department-Cell phone expense) | | | | | | | 132.01 | | | |
| | 61-4611-3402 (Water and Sewer Fund-Water Treatment Plant-Cell phone expense) | | | | | | | 67.59 | | | |
| | 61-4621-3402 (Water and Sewer Fund-Waste Water Treatment Plant-Cell phone expense) | | | | | | | 42.00 | | | |
| | 22-4510-3401 (Playground & Recreation Fund-Recreation Programs-Telephone expense) | | | | | | | 42.00 | | | |
| | 22-4510-3401 (Playground & Recreation Fund-Recreation Programs-Telephone expense) | | | REC 1004 | 3000 (Afterschool Club) | | | 84.00 | | | |
| | 11-4004-3402 (General Fund-Comptroller's Office-Cell phone expense) | | | | | | | 61.73 | | | |
| | 61-4630-3402 (Water and Sewer Fund-Water Department-Cell phone expense) | | | | | | | 38.01 | | | |
| | 22-4520-3402 (Playground & Recreation Fund-Pool-Cell phone expense) | | | | | | | 42.00 | | | |
| | Invoice Items | | | 1 | | | | | | | |
| Vendor 1868 - VERIZON WIRELESS Totals | | | | | | | | | Invoices | 1 | \$2,408.90 |

| Vendor 2179 - VSP - VISION SERVICE PLAN (IL) | | | | | | | | | | | |
|--|--|--------|-----------------|--------------|--------------------|---------------------|-----------------------------------|------------------------|--------------------|---|----------|
| Invoice Number | Invoice Description | Status | Held Reason | Invoice Date | Due Date | G/L Date | Received Date | Payment Date | Invoice Net Amount | | |
| Aug 2023 | August 2023 Premium / EBHR | Open | | 07/17/2023 | 08/04/2023 | 07/17/2023 | | | 792.38 | | |
| <i>P.O. Number</i> | <i>Item Description</i> | | <i>Quantity</i> | <i>U/M</i> | <i>Amount/Unit</i> | <i>Total Amount</i> | <i>Vendor Catalog Part Number</i> | <i>Contract Number</i> | | | |
| | Vision employee deductions / EB - August 2023 Premium / EBHR | | 1.0000 | EA | 792.3800 | 792.38 | | | | | |
| | <i>G/L Account</i> | | | | | | <i>Project</i> | <i>Amount</i> | | | |
| | 11-2033 (General Fund-Other voluntary deductions) | | | | | | | 792.38 | | | |
| | Invoice Items | | | 1 | | | | | | | |
| Vendor 2179 - VSP - VISION SERVICE PLAN (IL) Totals | | | | | | | | | Invoices | 2 | \$907.79 |

Vendor **1877 - WALMART**



Accounts Payable Invoice Report - Council

08/01/2023

Invoice Due Date Range 07/22/23 - 08/04/23

Report By Vendor - Invoice

| Invoice Number | Invoice Description | Status | Held Reason | Invoice Date | Due Date | G/L Date | Received Date | Payment Date | Invoice Net Amount |
|--------------------|--|--------|---------------|-----------------|------------|--------------------|---|-----------------------------------|------------------------|
| 025650 | Cookout supplies for workers on the job/ENG | Open | | 07/13/2023 | 08/04/2023 | 07/13/2023 | | | 216.60 |
| <i>P.O. Number</i> | <i>Item Description</i> | | | <i>Quantity</i> | <i>U/M</i> | <i>Amount/Unit</i> | <i>Total Amount</i> | <i>Vendor Catalog Part Number</i> | <i>Contract Number</i> |
| | Capital Improvement projects - Cookout supplies for workers on the job/ENG | | | 1.0000 | EA | 216.6000 | 216.60 | | |
| | <i>G/L Account</i> | | | | | | <i>Project</i> | | <i>Amount</i> |
| | 11-4095-4106 (General Fund-Engineering Department-Capital improvement projects) | | | | | | PW 20 26 019 (Community Drive Maintenance Building) | | 216.60 |
| | | | Invoice Items | | | | 1 | | |
| 8969 | Shop Supplies for Project Completion Cookout/STREET | Open | | 06/28/2023 | 08/04/2023 | 06/28/2023 | | | 247.25 |
| <i>P.O. Number</i> | <i>Item Description</i> | | | <i>Quantity</i> | <i>U/M</i> | <i>Amount/Unit</i> | <i>Total Amount</i> | <i>Vendor Catalog Part Number</i> | <i>Contract Number</i> |
| | Other maintenance supplies - Shop Supplies for Project Completion Cookout/STREET | | | 1.0000 | EA | 247.2500 | 247.25 | | |
| | <i>G/L Account</i> | | | | | | <i>Project</i> | | <i>Amount</i> |
| | 11-4310-2310 (General Fund-Street Department-Other maintenance supplies) | | | | | | | | 247.25 |
| | | | Invoice Items | | | | 1 | | |
| 01313 | Ice for Coolers/UTILITY | Open | | 07/06/2023 | 08/04/2023 | 07/06/2023 | | | 131.60 |
| <i>P.O. Number</i> | <i>Item Description</i> | | | <i>Quantity</i> | <i>U/M</i> | <i>Amount/Unit</i> | <i>Total Amount</i> | <i>Vendor Catalog Part Number</i> | <i>Contract Number</i> |
| | 1/4 page full color ad/tourism - Ice for Coolers/UTILITY | | | 1.0000 | EA | 131.6000 | 131.60 | | |
| | <i>G/L Account</i> | | | | | | <i>Project</i> | | <i>Amount</i> |
| | 61-4610-2704 (Water and Sewer Fund-Utility Department-Safety gear & clothing) | | | | | | | | 131.60 |
| | | | Invoice Items | | | | 1 | | |
| 02087 | Yearly Planner & Pens/UTILITY | Open | | 07/24/2023 | 08/04/2023 | 07/24/2023 | | | 32.40 |
| <i>P.O. Number</i> | <i>Item Description</i> | | | <i>Quantity</i> | <i>U/M</i> | <i>Amount/Unit</i> | <i>Total Amount</i> | <i>Vendor Catalog Part Number</i> | <i>Contract Number</i> |
| | 1/4 page full color ad/tourism - Yearly Planner & Pens/UTILITY | | | 1.0000 | EA | 32.4000 | 32.40 | | |
| | <i>G/L Account</i> | | | | | | <i>Project</i> | | <i>Amount</i> |
| | 61-4610-2001 (Water and Sewer Fund-Utility Department-Office supplies) | | | | | | | | 32.40 |
| | | | Invoice Items | | | | 1 | | |
| 04587 | Sunscreen for Day Camp - REC | Open | | 07/24/2023 | 08/04/2023 | 07/24/2023 | | | 59.84 |
| <i>P.O. Number</i> | <i>Item Description</i> | | | <i>Quantity</i> | <i>U/M</i> | <i>Amount/Unit</i> | <i>Total Amount</i> | <i>Vendor Catalog Part Number</i> | <i>Contract Number</i> |
| | Other Supplies / REC - Sunscreen for Day Camp - REC | | | 1.0000 | EA | 59.8400 | 59.84 | | |
| | <i>G/L Account</i> | | | | | | <i>Project</i> | | <i>Amount</i> |
| | 22-4510-2119 (Playground & Recreation Fund-Recreation Programs-Other supplies) | | | | | | REC 1004 3120 (Day Camp) | | 59.84 |
| | | | Invoice Items | | | | 1 | | |



Accounts Payable Invoice Report - Council

08/01/2023

Invoice Due Date Range 07/22/23 - 08/04/23

Report By Vendor - Invoice

| Invoice Number | Invoice Description | Status | Held Reason | Invoice Date | Due Date | G/L Date | Received Date | Payment Date | Invoice Net Amount |
|---|---|--------|-----------------|---------------|--------------------|---------------------|-----------------------------------|------------------------|--------------------|
| 964781 | WP Misc Supplies - Misc | Open | | 07/24/2023 | 08/04/2023 | 07/24/2023 | | | 14.84 |
| <i>P.O. Number</i> | <i>Item Description</i> | | <i>Quantity</i> | <i>U/M</i> | <i>Amount/Unit</i> | <i>Total Amount</i> | <i>Vendor Catalog Part Number</i> | <i>Contract Number</i> | |
| | Ice / MAINT - WP Misc Supplies - Misc | | 1.0000 | EA | 14.8400 | 14.84 | | | |
| | <i>G/L Account</i> | | | | <i>Project</i> | | | <i>Amount</i> | |
| | 61-4611-2001 (Water and Sewer Fund-Water Treatment Plant-Office supplies) | | | | | | | 14.84 | |
| | | | | Invoice Items | 1 | | | | |
| 463113 | WP Office Supplies - paper, pens, etc | Open | | 07/25/2023 | 08/04/2023 | 07/25/2023 | | | 126.98 |
| <i>P.O. Number</i> | <i>Item Description</i> | | <i>Quantity</i> | <i>U/M</i> | <i>Amount/Unit</i> | <i>Total Amount</i> | <i>Vendor Catalog Part Number</i> | <i>Contract Number</i> | |
| | Office Supplies - WP Office Supplies - paper, pens, etc | | 1.0000 | EA | 126.9800 | 126.98 | | | |
| | <i>G/L Account</i> | | | | <i>Project</i> | | | <i>Amount</i> | |
| | 61-4611-2001 (Water and Sewer Fund-Water Treatment Plant-Office supplies) | | | | | | | 126.98 | |
| | | | | Invoice Items | 1 | | | | |
| Vendor 1877 - WALMART Totals | | | | | Invoices | 7 | | | \$829.51 |
| Vendor 2946 - WATER SOLUTIONS UNLIMITED, INC. | | | | | | | | | |
| 115184 | HYD chlor for the Pool - POOL | Open | | 07/20/2023 | 08/04/2023 | 07/20/2023 | | | 713.85 |
| <i>P.O. Number</i> | <i>Item Description</i> | | <i>Quantity</i> | <i>U/M</i> | <i>Amount/Unit</i> | <i>Total Amount</i> | <i>Vendor Catalog Part Number</i> | <i>Contract Number</i> | |
| | Chemicals - Pool / REC - HYD chlor for the Pool - POOL | | 1.0000 | EA | 713.8500 | 713.85 | | | |
| | <i>G/L Account</i> | | | | <i>Project</i> | | | <i>Amount</i> | |
| | 22-4520-2109 (Playground & Recreation Fund-Pool-Chemicals) | | | | | | | 713.85 | |
| | | | | Invoice Items | 1 | | | | |
| 114782 | WP Chemicals - Bleach | Open | | 06/30/2023 | 08/04/2023 | 06/30/2023 | | | 3,631.00 |
| <i>P.O. Number</i> | <i>Item Description</i> | | <i>Quantity</i> | <i>U/M</i> | <i>Amount/Unit</i> | <i>Total Amount</i> | <i>Vendor Catalog Part Number</i> | <i>Contract Number</i> | |
| | Chemicals / WTP - WP Chemicals - Bleach | | 1.0000 | EA | 3,631.0000 | 3,631.00 | | | |
| | <i>G/L Account</i> | | | | <i>Project</i> | | | <i>Amount</i> | |
| | 61-4611-2109 (Water and Sewer Fund-Water Treatment Plant-Chemicals) | | | | | | | 3,631.00 | |
| | | | | Invoice Items | 1 | | | | |
| Vendor 2946 - WATER SOLUTIONS UNLIMITED, INC. Totals | | | | | Invoices | 2 | | | \$4,344.85 |
| Vendor 3964 - WATTS COPY SYSTEM INC - DALLAS, TX | | | | | | | | | |
| 34362490 | Copy service/PD | Open | | 06/29/2023 | 08/04/2023 | 06/29/2023 | | | 109.43 |
| <i>P.O. Number</i> | <i>Item Description</i> | | <i>Quantity</i> | <i>U/M</i> | <i>Amount/Unit</i> | <i>Total Amount</i> | <i>Vendor Catalog Part Number</i> | <i>Contract Number</i> | |
| | Repair of office equipment - Copy service/PD | | 1.0000 | EA | 109.4300 | 109.43 | | | |
| | <i>G/L Account</i> | | | | <i>Project</i> | | | <i>Amount</i> | |
| | | | | | | | | | |



Accounts Payable Invoice Report - Council

08/01/2023

Invoice Due Date Range 07/22/23 - 08/04/23

Report By Vendor - Invoice

| Invoice Number | Invoice Description | Status | Held Reason | Invoice Date | Due Date | G/L Date | Received Date | Payment Date | Invoice Net Amount |
|--|---|--------|-----------------|--------------|--------------------------|---------------------|-----------------------------------|------------------------|--------------------|
| 34362490 | Copy service/PD | Open | | 06/29/2023 | 08/04/2023 | 06/29/2023 | | | 109.43 |
| <i>P.O. Number</i> | <i>Item Description</i> | | <i>Quantity</i> | <i>U/M</i> | <i>Amount/Unit</i> | <i>Total Amount</i> | <i>Vendor Catalog Part Number</i> | <i>Contract Number</i> | |
| | 11-4210-3507 (General Fund-Police Department-Repair of office equipment) | | | | | | | 109.43 | |
| | | | Invoice Items | 1 | | | | | |
| Vendor 3964 - WATTS COPY SYSTEM INC - DALLAS, TX Totals | | | | | | | Invoices | 1 | \$109.43 |
| Vendor ELLA KEEFER | | | | | | | | | |
| KEEFER 07/12 | Food for Day Camp - REC | Open | | 07/24/2023 | 08/04/2023 | 07/24/2023 | | | 19.07 |
| <i>P.O. Number</i> | <i>Item Description</i> | | <i>Quantity</i> | <i>U/M</i> | <i>Amount/Unit</i> | <i>Total Amount</i> | <i>Vendor Catalog Part Number</i> | <i>Contract Number</i> | |
| | Other Supplies / REC - Food for Day Camp - REC | | 1.0000 | EA | 19.0700 | 19.07 | | | |
| | <i>G/L Account</i> | | | | <i>Project</i> | | | <i>Amount</i> | |
| | 22-4510-2119 (Playground & Recreation Fund-Recreation Programs- Other supplies) | | | | REC 1004 3120 (Day Camp) | | | 19.07 | |
| | | | Invoice Items | 1 | | | | | |
| Vendor ELLA KEEFER Totals | | | | | | | Invoices | 1 | \$19.07 |
| Vendor MIKAYLA LANE | | | | | | | | | |
| LANE 07/14 | Reimbursement for Day Camp supplies - REC | Open | | 07/24/2023 | 08/04/2023 | 07/24/2023 | | | 24.60 |
| <i>P.O. Number</i> | <i>Item Description</i> | | <i>Quantity</i> | <i>U/M</i> | <i>Amount/Unit</i> | <i>Total Amount</i> | <i>Vendor Catalog Part Number</i> | <i>Contract Number</i> | |
| | Other Supplies / REC - Reimbursement for Day Camp supplies - REC | | 1.0000 | EA | 24.6000 | 24.60 | | | |
| | <i>G/L Account</i> | | | | <i>Project</i> | | | <i>Amount</i> | |
| | 22-4510-2119 (Playground & Recreation Fund-Recreation Programs- Other supplies) | | | | REC 1004 3120 (Day Camp) | | | 24.60 | |
| | | | Invoice Items | 1 | | | | | |
| Vendor MIKAYLA LANE Totals | | | | | | | Invoices | 1 | \$24.60 |
| Vendor LIBERTY WATSON | | | | | | | | | |
| WATSON 07/11 | Day camp snacks and supplies - REC | Open | | 07/24/2023 | 08/04/2023 | 07/24/2023 | | | 25.76 |
| <i>P.O. Number</i> | <i>Item Description</i> | | <i>Quantity</i> | <i>U/M</i> | <i>Amount/Unit</i> | <i>Total Amount</i> | <i>Vendor Catalog Part Number</i> | <i>Contract Number</i> | |
| | Other supplies - Day camp snacks and supplies - REC | | 1.0000 | EA | 25.7600 | 25.76 | | | |
| | <i>G/L Account</i> | | | | <i>Project</i> | | | <i>Amount</i> | |
| | 22-4510-2119 (Playground & Recreation Fund-Recreation Programs- Other supplies) | | | | REC 1004 3120 (Day Camp) | | | 25.76 | |
| | | | Invoice Items | 1 | | | | | |
| Vendor LIBERTY WATSON Totals | | | | | | | Invoices | 1 | \$25.76 |



Accounts Payable Invoice Report - Council

08/01/2023

Invoice Due Date Range 07/22/23 - 08/04/23

Report By Vendor - Invoice

Grand Totals

Invoices

329

\$244,902.05

City Council Regular Meeting

4)

Meeting Date: 08/01/2023

Submitted By: Deborah Muller, City Clerk

TITLE:

***PROCLAMATION:** Recognizing September 10-16, 2023, as Chamber of Commerce Week.

STAFF RECOMMENDATION:

Approve.

Attachments

Proclamation: Recognizing September 10-16, 2023, as Chamber of Commerce Week.

Proclamation

WHEREAS, the Charleston Area Chamber of Commerce works with businesses, merchants and industry to advance the civic, economic, industrial, professional and cultural life of the City of Charleston; and

WHEREAS, chambers of commerce have contributed to the civic and economic life of Illinois for 185 years since the founding of the Galena Chamber of Commerce in 1838; and

WHEREAS, this year marks the 104th Anniversary of the founding of the Illinois Chamber of Commerce, the State's leading broad-based business organization; and

WHEREAS, the Chamber of Commerce and its members provide citizens with a strong business environment that increases employment, retail trade and commerce, and industrial growth in order to make the City of Charleston a better place to live; and

WHEREAS, the Chamber of Commerce encourages the growth of existing industries, services, and commercial firms and encourages new firms and individuals to locate in the City of Charleston; and

WHEREAS, the State of Illinois is home to International Chambers of Commerce, the Great Lakes Regional Office of the U.S. Chamber of Commerce, the Illinois Chamber of Commerce and more than 400 local chambers of commerce; and

WHEREAS, this year marks the 108th Anniversary of the Illinois Association of Chamber of Commerce Executives, a career development organization for chamber of commerce professionals;

NOW, THEREFORE, I, Brandon Combs, Mayor of the City of Charleston, do proclaim the week of September 10-16, 2023, as **CHAMBER OF COMMERCE WEEK** in the City of Charleston, and call its significance to the citizens of the City of Charleston.

In Witness Whereof, I have set my hand and caused the seal of the City of Charleston to be affixed.

DATED this ____ day of _____, 2023.

Mayor

ATTEST:

City Clerk

City Council Regular Meeting

5)

Meeting Date: 08/01/2023

Submitted For: Heath Thornton, Police Chief

Submitted By: Deborah Muller, City Clerk

TITLE:

***RESOLUTION:** Authorizing Street Closure of the south 200 Feet of the Alley to the east of Ike's for Back to School Events on August 12, 19, and 26, 2023.

STAFF RECOMMENDATION:

Approve.

Attachments

Street Closure for Back to School events in the Alley east of Ike's.

RES: Street Closure for Back to School Events in the Alley east of Ike's.

CITY OF CHARLESTON
STREET CLOSURE REQUEST

Name/Organization: Ube's
Contact Person: Tammy Bell
Address: 459 Lincoln Ave
Telephone: Home: _____ Business: _____ Cell: 217-549-7241

Function/Reason for Closure: Back to school

Closure Location(s) / Route:

Alley

Attach Map of Route for Parade or Race.

Submission Date: 7/26/23
Requested Closure Date(s): Aug 12, Aug 19, Aug 26
Requested Closure Time(s): 11 AM - 8 p.m

**NOTE: STREET CLOSURE REQUESTS MUST BE APPROVED BY CITY COUNCIL.
REQUESTS MUST BE SUBMITTED AT LEAST THREE (3) WEEKS PRIOR TO
DATE OF EVENT.**

R E S O L U T I O N

2023 – R – 77

RESOLUTION RELATING TO OUTDOOR BAND EVENTS **AUTHORIZING TEMPORARY STREET CLOSURE**

WHEREAS, BS of Charleston, Inc. d/b/a Ike's would like to temporarily close the following street or alley:

The Alley adjacent to Ike's at 459 Lincoln Avenue

for facilitation of Class Reunions to be held from 9:00 a.m. to 10:00 p.m. on July 15, July 22, and July 29, 2023; and from 5:00 p.m. to 12:00 a.m. (Midnight) on Friday, July 21, 2023.

NOW THEREFORE BE IT RESOLVED by the City Council of the City of Charleston, Coles County, Illinois, that the following alley: The Alley adjacent to Ike's at 459 Lincoln Avenue, shall be temporarily closed to traffic from 9:00 a.m. to 10:00 p.m. on July 15, July 22, and July 29, 2023; and from 5:00 p.m. to 12:00 a.m. (Midnight) on Friday, July 21, 2023.

BE IT FURTHER RESOLVED by the City Council of the City of Charleston that the Charleston Police Department be and is hereby authorized and directed to erect and place appropriate barricades and signage necessary to effectuate the intention of this Resolution.

INTRODUCED to Council this ____ day of _____ 2023.

PASSED by Council this ____ day of _____ 2023.

APPROVED this ____ day of _____ 2023.

| | <u>AYE</u> | <u>NAY</u> | <u>ABSTAIN</u> | <u>ABSENT</u> |
|----------------------|------------|------------|----------------|---------------|
| Mayor: | | | | |
| <i>Brandon Combs</i> | | | | X |
| City Council: | | | | |
| <i>Matthew Hutti</i> | | | | X |
| <i>Jeff Lahr</i> | X | | | |
| <i>Dennis Malak</i> | X | | | |
| <i>Tim Newell</i> | X | | | |

Dennis Malak, Mayor Pro Tem

ATTEST:

Deborah Muller, City Clerk

City Council Regular Meeting

6)

Meeting Date: 08/01/2023

Submitted For: Heath Thornton, Police Chief

Submitted By: Deborah Muller, City Clerk

TITLE:

***RESOLUTION:** Authorizing Street Closures on the Square for the Magic & Music Event for the Uptowner/Cellar on August 12, 2023.

STAFF RECOMMENDATION:

Approve.

Attachments

RES: Street Closure for Magic & Music Event for the Uptowner/Cellar.

RESOLUTION

2023 – R – _____

RESOLUTION RELATING TO OUTDOOR BAND— MAGIC & MUSIC EVENT AUTHORIZING TEMPORARY STREET CLOSURE

WHEREAS, MAC Enterprise d/b/a Uptowner / Cellar would like to temporarily close, in addition to **7th Street—from Monroe Avenue north to Madison Avenue**, the following streets:

**6th Street—between Monroe Avenue & Jackson Avenue, and
Monroe Avenue—between 6th Street and 7th Street;**

for the facilitation of an Outdoor Band—Magic & Music Event to be held from 7:00 o'clock a.m. until 11:00 o'clock p.m. on Saturday, August 12, 2023.

NOW THEREFORE BE IT RESOLVED by the City Council of the City of Charleston, Coles County, Illinois, that the following streets: 7th Street—from Monroe Avenue north to Madison Avenue, 6th Street—between Monroe Avenue & Jackson Avenue and Monroe Avenue—between 6th Street & 7th Street shall be temporarily closed to traffic on August 12, 2023; from the hours of 7:00 a.m. until 11:00 p.m.

BE IT FURTHER RESOLVED by the City Council of the City of Charleston that the Charleston Police Department be and is hereby authorized and directed to erect and place appropriate barricades and signage necessary to effectuate the intention of this Resolution.

INTRODUCED to Council this ____ day of _____ 2023.

PASSED by Council this _____ day of _____ 2023.

APPROVED this _____ day of _____ 2023.

| | AYE | NAY | ABSTAIN | ABSENT |
|----------------------|-----|-----|---------|--------|
| Mayor: | | | | |
| <i>Brandon Combs</i> | | | | |
| | | | | |
| City Council: | | | | |
| <i>Matthew Hutti</i> | | | | |
| <i>Jeff Lahr</i> | | | | |
| <i>Dennis Malak</i> | | | | |
| <i>Tim Newell</i> | | | | |

Brandon Combs, Mayor

ATTEST:

Deborah Muller, City Clerk

City Council Regular Meeting

7)

Meeting Date: 08/01/2023

Submitted For: Curt Buescher, Public Works Director

Submitted By: Deborah Muller, City Clerk

TITLE:

RESOLUTION: Approving Change Order No. 8 for Wastewater Treatment Plant Nutrient Removal Project.

STAFF RECOMMENDATION:

Waive layover period and approve.

Attachments

RES: Approving CO #8 for WWTP Nutrient Removal Project.

Change Order #8 for WWTP Nutrient Removal Project.

RESOLUTION

2023 – R – _____

RESOLUTION TO APPROVE CHANGE ORDER #8 FOR WASTEWATER TREATMENT PLANT NUTRIENT REMOVAL PROJECT

WHEREAS, Title 1-11-5 D of the Charleston City Code stipulates that “Any change order in excess of ten thousand dollars (\$10,000.00) must be approved by the council;” and

WHEREAS, a request for Change Order #8 includes \$70,618 of added expense for necessary work as detailed in the change order; and

WHEREAS, the total increase in the project cost included in Change Order #8 of \$70,618 has been determined to be necessary by the consulting engineers, the plant Superintendent, and the Director of Public Works;

THEREFORE BE IT HEREBY RESOLVED by the City Council of the City of Charleston that Change Order #8 for the WWTP Nutrient Removal Project in the amount of \$70,618 be approved.

INTRODUCED this _____ day of _____ 2023.

PASSED this _____ day of _____ 2023.

APPROVED this _____ day of _____ 2023.

| | Aye | Nay | Abstain | Absent |
|----------------------|-----|-----|---------|--------|
| Mayor: | | | | |
| <i>Brandon Combs</i> | | | | |
| City Council: | | | | |
| <i>Matthew Hutti</i> | | | | |
| <i>Jeff Lahr</i> | | | | |
| <i>Dennis Malak</i> | | | | |
| <i>Tim Newell</i> | | | | |

Mayor

ATTEST:

City Clerk



**WILLIAMS
BROTHERS**
CONSTRUCTION, INC

Engineer's
Format

Contractor's / Subcontractor's Proposal Breakdown Summary

Date: 07/15/23

RFP

#008

GENERAL CONTRACTOR P.O. Box 1366 / Peoria, IL 61654 / Phone (309) 688-0416 / Fax (309) 688-0891

Engineer: Donohue and Associates

OWNER: City of Charleston

On Site Representation: The Upchurch Group

PROJECT: Charleston WWTP Improvements

WBCI: Job #549

I DESCRIPTION OF CHANGE:

RFP #008 - Relocate Electrical Equipment Storage Room to Main Level

II SUMMARY OF DETAILED BREAKDOWN

| | Additions | Deletions | Net Total |
|---------------------------------------|--------------------------------|---------------|------------|
| A. MATERIAL | \$3,621.00 | \$0.00 | \$3,621.00 |
| B. LABOR | \$2,611.68 | \$0.00 | \$2,611.68 |
| C. EQUIPMENT / OTHER | \$2,090.00 | \$0.00 | \$2,090.00 |
| D. NET TOTAL | | (A+B+C) | \$8,322.68 |
| E. OVERHEAD AND PROFIT | (Line D x 15%) - (Deletion 5%) | | \$1,248.40 |
| F. TOTAL WORK PERFORMED BY CONTRACTOR | | (Lines D + E) | \$9,571.08 |

III CONTRACTOR'S MARK-UP ON WORK OF SUBCONTRACTORS

Detailed Breakdowns and summaries from each contractor must be attached.

| SUBCONTRACTOR: Firm Name | CONTRACT WORK: Description | PROPOSAL |
|--|----------------------------|-------------|
| 1. Merz | HVAC | \$696.56 |
| 2. Otto Baum | Masonry | \$2,282.66 |
| 3. Commercial Electric | Electrical | \$53,377.70 |
| 4. | | |
| 5. | | |
| 6. | | |
| G. SUBTOTAL of all work performed by contractor's subcontractors | | \$56,356.92 |
| H. CONTRACTOR'S MARK-UP on work of subcontractors | (Line G x 5%) | \$2,817.85 |
| I. TOTAL WORK PERFORMED BY SUBCONTRACTOR | (Lines G + H) | \$59,174.77 |

| | | |
|-----------------------------|---------------------|-------------|
| J. PROPOSAL | (Lines F+I) | \$68,745.85 |
| K. SUPPLEMENTAL COSTS | | |
| 1. SAFETY | (1% of LABOR) | \$26.12 |
| 2. EXPENDABLE TOOLS | (2.5% of LABOR) | \$65.29 |
| L. BONDS | (0.60% of PROPOSAL) | \$412.48 |
| M. OTHER REQUIRED INSURANCE | (1.99% of PROPOSAL) | \$1,368.04 |

IV TOTAL PROPOSAL

| | |
|---|-----------------|
| N. TOTAL PROPOSAL for subject RFP increase (decrease) in contract amount | \$70,618 |
| O. The work for this RFP will require an extension of time of <u>0</u> Calendar Days. | |
| P. All costs are valid for 10 days. | |

CONTRACTOR

(SIGNATURE).....

Ryan Lynch

Title: Project Manager

Date: 07/15/23



509 SOUTH WILLOW
PO BOX 1305
EFFINGHAM, ILLINOIS 62401-1305

Heating
and
Air Conditioning

509 S. Willow St.
P.O. Box 1305
Effingham, IL 62401-1305
Phone 217-342-2323
Fax 217-347-5302

PROPOSAL

PROPOSAL SUBMITTED TO:

**WILLIAMS BROTHER CONSTRUCTION
ATTN RYAN LYNCH**

DESCRIPTION OF JOB:

**CHARLESTON WATER TREATMENT
HVAC
RFP 30**

PHONE: () -
EMAIL:

PAGE: 1 OF 1
DATE: MAY 15TH 2023

SPECIFICATIONS AND ESTIMATES FOR

WE ARE PLEASED TO QUOTE THE FOLLOWING FOR YOUR CONSIDERATION

RELOCATE ACCU-1, AND ACCU-2 TO THE LOWER LEVEL

| | |
|---|-----------|
| 2 - 3/8" X 5/8" X 50' LINESETS (\$ 211.52 X 2)..... | \$ 423.03 |
| 25' - 14/4 SO CORD..... (\$ 1.485 X 25') | \$ 37.13 |
| 2 HOURS LABOR(2 X \$ 72.77 / HOUR) | \$ 145.54 |

| | | |
|----------------------------|-------------------|------------------|
| | TOTAL COST | \$ 605.70 |
| OVERHEAD AND PROFIT | ADD 15% | \$ 90.86 |

TOTAL HVAC CHANGE FOR RFP #30 \$ 696.56

We hereby propose to furnish labor and materials complete in accordance with the above specifications for the sum of

ABOVE

With payment to be made as follows:

NET 30

Note: We may withdraw this proposal if not accepted in 30 days.

The law requires that the contractor shall submit a sworn statement of persons furnishing materials and labor before any payments are required to be made to the contractor.

Any alternations or deviation from above specifications involving extra cost will become an extra charge. All agreements are contingent upon strikes, accidents or delays beyond our control. Owner is to carry fire, tornado and other necessary insurance.

In the event of default, including but not limited to the failure of the undersigned to pay all or any part of that amount due under this agreement, the undersigned shall pay and be responsible for all cost of collection, court cost, and attorney fees incurred by Merz Heating & Air Conditioning, Inc. in the enforcement of the terms and conditions of this agreement.

AUTHORIZED SIGNATURE

ACCEPTANCE OF PROPOSAL

The above prices, specifications, terms, and conditions stated above are hereby accepted by the undersigned. Merz Heating and Air Conditioning, Inc. is authorized to do the work as specified above, payment will be made by the undersigned as specified above, and the undersigned agrees to pay a late payment charge of 2% for each 30 day interval during which the account remains delinquent.

DATE ACCEPTED _____

SIGNATURE _____



CAPITOL GROUP, INC. - Champaign
 3101 RESEARCH ROAD
 CHAMPAIGN, IL 61822
 217-351-1050
 Fax 217-351-1051

Quotation

| | |
|--|--------------|
| EXPIRATION DATE | QUOTE NUMBER |
| 06/29/2023 | S2335136 |
| CAPITOL GROUP, INC. - Champaign 3101 RESEARCH ROAD CHAMPAIGN, IL 61822 217-351-1050 Fax 217-351-1051 | |
| PAGE NO. | |
| 1 of 1 | |

QUOTE TO:

SHIP TO:

MERZ HEATING & AIR CONDI
 PO BOX 1305
 509 W WILLOW
 EFFINGHAM, IL 62401

MERZ HEATING & AIR CONDI
 PO BOX 1305
 509 W WILLOW
 EFFINGHAM, IL 62401

| CUSTOMER NUMBER | CUSTOMER PO NUMBER | JOB / RELEASE # | QUOTED TO | SALESPERSON |
|-----------------|--|------------------|--|-------------------|
| 5365 | CHARLESTON WTP | | KURT | Tony Gascoigne |
| WRITER | SHIP VIA | TERMS | SHIP DATE | FREIGHT ALLOWED |
| Ken Bensyl | | NET END OF MONTH | 05/15/2023 | No |
| ORDER QTY | DESCRIPTION | | UNIT PRICE | EXT PRICE |
| 3ea <u>2</u> | 3/8" X 5/8" X 50' 1/2" BLACK TEAR RESISTANT INSULATION LINESET 610K0500L 061008500B | | 211.516/ea <u>X 2</u> \$ <u>423.03</u> | 634.55 |

Note: Unless specifically stated otherwise upon this quote, the standard TERMS & CONDITIONS will be applicable as stated and found upon our Company website: www.capitolgroupinc.com All returns subject to a restock charge.

| | |
|-------------|-------------------|
| Subtotal | 634.55 |
| S&H Charges | 0.00 |
| Amount Due | 634.55 |



1815 Sagamore Pkwy
Lafayette, IN 47904

INVOICE

| INVOICE DATE | INVOICE NUMBER | CUSTOMER # |
|--------------|----------------|-------------|
| 02/09/23 | S112389457.001 | 75433 |
| DUE DATE | TOTAL DUE | AMOUNT PAID |
| 03/11/23 | 742.54 | |

PLEASE REMIT PAYMENT TO:

KIRBY RISK CORPORATION
27561 Network Place
CHICAGO IL 60673-1275

SHIP TO:

MERZ HEATING & AIR CONDITIONING INC
509 S WILLOW
EFFINGHAM IL 62401

MERZ HEATING & AIR CONDITIONING INC
PO BOX 1305
EFFINGHAM IL 62401-1305

DETACH UPPER PORTION AND RETURN WITH YOUR PAYMENT

| CUSTOMER NUMBER | | CUSTOMER PO NUMBER | | RELEASE NUMBER | | TERMS | | |
|-----------------|----------|--|--|----------------|-------------------------|--------------|--------------|-----------|
| 75433 | | 56940 | | | | NET 30 DAYS | | |
| SALESPERSON | | SHIP VIA | | ORDERED BY | | SALES OFFICE | PHONE NUMBER | SHIP DATE |
| WALTER ROBISON | | PK PICK-UP | | eric | | EFFINGHAM | 217-347-2733 | 02/09/23 |
| ORDER QTY | SHIP QTY | DESCRIPTION | | | ITEM PRICE | UNIT | EXT AMOUNT | CASH DISC |
| 500ft | 500ft | CORD SOOW-14/4-BLA-500FT FLEXCORD 14/4 SOOW 90C BK IND 500R 55810205 | | | 1485.07 | 1000ft | 742.54 | |
| | | | | | 25' X \$1.485 = \$37.13 | | | |
| | | | | | COPY | | | |
| ACCT# | | _____ | | | | | | |
| Vendor | | 9526 | | | | | | |

Billing Questions: Billing_request@kirbyrisk.com (765) 446-3054

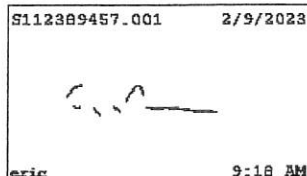

Invoice is due by 03/11/23.

| | |
|-------------------|----------------|
| Invoice Number | S112389457.001 |
| Subtotal | 742.54 |
| S&H Charges | 0.00 |
| Sales Tax | 0.00 |
| AMOUNT DUE | 742.54 |



DATE: May 3, 2023
PROJECT: Charleston WWTP
WORK CATEGORY: New Masonry
BASIS OF BID: RFI 30 Response
COR 1

TO: Williams Brothers Construction
Ryan Lynch
(309) 643-3129
ryanl@wbci.us

SUBMITTED BY: Aaron Moser
DIRECT: (309) 284-1760
CELL: (217) 202-3545
E-MAIL: aaronmoser@ottobaum.com

We hereby propose to perform & complete the work defined herein for the stated sum(s) as follows:

BASE BID SCOPE INCLUDES:

- Added CMU for wall dimension change per RFI 030 response
- Added dowels into concrete floor for new CMU wall per S385 to match vertical reinforcing

| | | | | |
|-------------------------|-----------|---------|---|-------------------|
| Mason Foreman | 4 hours @ | \$95.12 | = | \$380.48 |
| Mason Journeyman | 4 hours @ | \$77.95 | = | \$311.80 |
| Laborer | 4 hours @ | \$76.91 | = | \$307.64 |
| Equipment and Materials | | | = | \$985.00 |
| Overhead & Profit @ 15% | | | = | \$297.74 |
| Total | | | | \$2,282.66 |

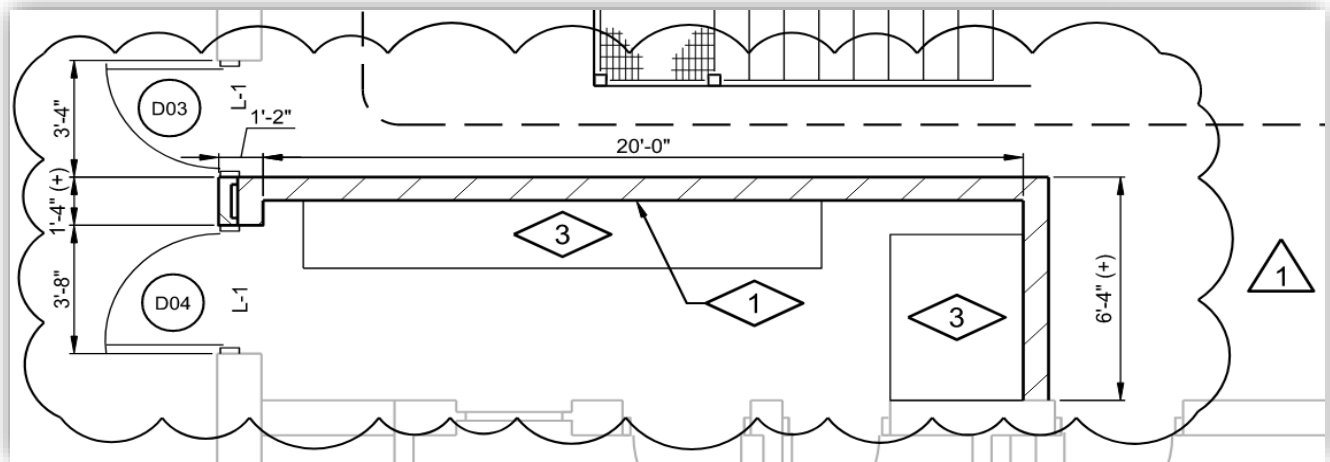
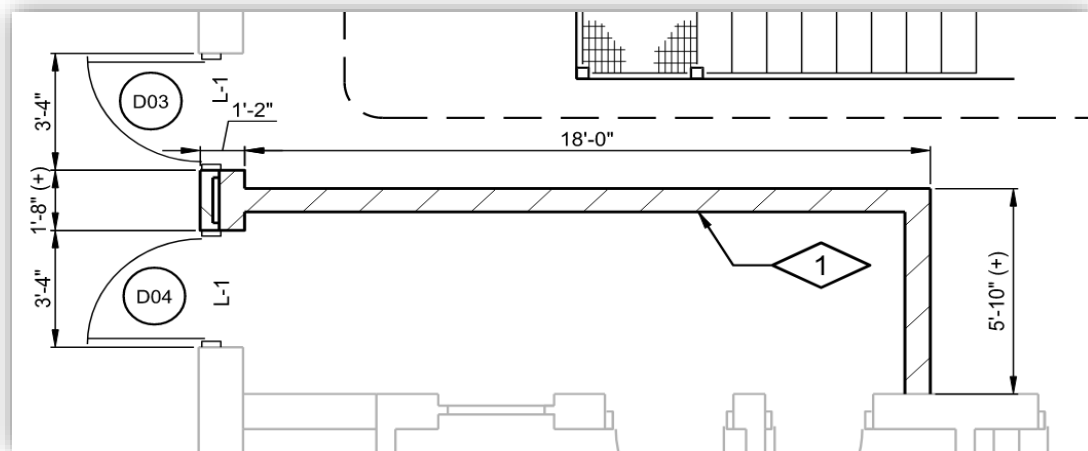

PLAN NOTES:

1. 8" CMU WALL REINFORCED WITH #5@48" W/ MATCH DOWELS, SEE (S451) & (S385). TOP OF WALL SHALL EXTEND TO THE CEILING AND HAVE A CONTINUOUS BOND BEAM REINFORCED WITH 2-#5 BARS, SEE (S400)



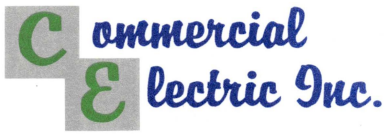

Commercial Electric, Inc.
720 S 17th St
Mattoon, Illinois 61938
Phone: +12172350616

Project: 10-0733 - Williams - CWWTP Improvements
1200 W Madison Ave
Charleston, Illinois 61920

Prime Contract Potential Change Order #004: RFI-030 Relocate Electrical Room

| | | | |
|-------------------------------|--|-------------------------------------|---|
| TO: | | FROM: | |
| PCO NUMBER/REVISION: | 004 / 2 | CONTRACT: | 10-0733 - Williams - CWWTP Improvements |
| REQUEST RECEIVED FROM: | Jacob Lee (Williams Brothers Construction, Inc.) | CREATED BY: | Sarah Otto (Commercial Electric, Inc.) |
| STATUS: | Pending - In Review | CREATED DATE: | 5/8/2023 |
| REFERENCE: | | PRIME CONTRACT CHANGE ORDER: | None |
| FIELD CHANGE: | No | | |
| LOCATION: | | ACCOUNTING METHOD: | Amount Based |
| SCHEDULE IMPACT: | | PAID IN FULL: | No |
| | | TOTAL AMOUNT: | \$53,377.70 |

POTENTIAL CHANGE ORDER TITLE: RFI-030 Relocate Electrical Room

CHANGE REASON: No Change Reason

POTENTIAL CHANGE ORDER DESCRIPTION: (The Contract Is Changed As Follows)

Scope of Work:

Provide labor and material for electrical work associate with RFI-030.
Saw cut of floor to be provided by WBCI.

| # | Cost Code | Description | Type | Amount |
|---|-----------------------|----------------------------------|---------------------|-------------|
| 1 | 1-099 - MISCELLANEOUS | RFI-030 Relocate Electrical Room | Material | \$53,377.70 |
| | | | Subtotal: | \$53,377.70 |
| | | | Grand Total: | \$53,377.70 |

SIGNATURE

DATE

SIGNATURE

DATE

SIGNATURE

DATE

BID SUMMARY

| | |
|----------------|--|
| Job: 5699 | CHARLESTON WASTEWATER TREATMENT PLANT IMPROVEMENTS |
| Estimate: 5699 | CHARLESTON WASTEWATER TREATMENT Date: 5/8/23 |

| Num | Description | Ref Amount | Rate | Amount | Subtotal | <Amount> |
|-----|------------------------|------------|------|-----------|-----------------|----------|
| 1 | MATERIAL TOTAL: | 28,379.41 | 1.00 | 28,379.41 | | |
| 2 | PREFAB MATERIAL TOTAL: | 0.00 | 1.00 | 0.00 | | |
| 3 | SUBTOTAL | | | | 28379.41 | |

***MAJOR QUOTATIONS**

4 **FIXTURE QUOTE:**

| | | |
|--|------|------|
| | 1.00 | 0.00 |
|--|------|------|

6 **SWITCHGEAR QUOTES:**

| | | |
|--|------|------|
| | 1.00 | 0.00 |
|--|------|------|

8 **FIRE ALARM**

| | | |
|--|------|------|
| | 1.00 | 0.00 |
|--|------|------|

10 **GENERATOR**

| | | |
|--|------|------|
| | 1.00 | 0.00 |
|--|------|------|

12 **NURSE CALL**

| | | |
|--|------|------|
| | 1.00 | 0.00 |
|--|------|------|

14 **CABLE TRAY**

| | | |
|--|------|------|
| | 1.00 | 0.00 |
|--|------|------|

16 **FLOOR BOXES**

| | | |
|--|------|------|
| | 1.00 | 0.00 |
|--|------|------|

18 **MISC.**

| | | |
|--|------|------|
| | 1.00 | 0.00 |
|--|------|------|

| | | |
|--------------------|--|-------------|
| 20 SUBTOTAL | | 0.00 |
|--------------------|--|-------------|

***DIRECT JOB EXP:**

| | | |
|-----------------------|-----------|------|
| 55 P/R TAX % - DIRECT | 18,035.99 | 0.00 |
|-----------------------|-----------|------|

| | | |
|-------------------------|------|------|
| 56 P/R TAX % - INDIRECT | 0.00 | 0.00 |
|-------------------------|------|------|

| | | |
|-------------------------|------|------|
| 57 P/R TAX % - NON-PROD | 0.00 | 0.00 |
|-------------------------|------|------|

| | | |
|----------------------|--|--|
| 58 SPECIAL INSURANCE | | |
|----------------------|--|--|

| | | |
|---------------------|------|------|
| 59 EQUIPMENT RENTAL | 1.00 | 0.00 |
|---------------------|------|------|

| | | |
|---------------------|------|--|
| 60 TOOLS EXPENDABLE | 0.00 | |
|---------------------|------|--|

| | | |
|----------------|--|--|
| 61 INSPECT FEE | | |
|----------------|--|--|

| | | |
|----------------|--|--|
| 62 JOB TRAILER | | |
|----------------|--|--|

| | | |
|--------------|--|--|
| 63 TELEPHONE | | |
|--------------|--|--|

| | | |
|------------------------|--|--|
| 64 DRAWING/ENGINEERING | | |
|------------------------|--|--|

| | | |
|--------------------|--|--|
| 65 TRAVEL EXPENSES | | |
|--------------------|--|--|

| | | |
|---------------|--|--|
| 66 TEMP POWER | | |
|---------------|--|--|

| | | |
|------------|--|--|
| 67 PARKING | | |
|------------|--|--|

| | | |
|--------------------|--|-------------|
| 67 SUBTOTAL | | 0.00 |
|--------------------|--|-------------|

BID SUMMARY

| | | | | |
|---------------------------|---------------------------|-----------|-------|-----------------|
| *SUB CONTRACTS: | | | | |
| 68 | | | 1.00 | 0.00 |
| 74 | SUBTOTAL | | | 0.00 |
| ***** | | | | |
| 75 | JOB SUBTOTAL | | | 46415.39 |
| ***** | | | | |
| *MARKUPS/OVERHEAD: | | | | |
| 76 | FLAT MARKUP % | 46,415.39 | 15.00 | 6,962.31 |
| 77 | - OR - | | | |
| 78 | MATERIAL | 28,379.41 | | 0.00 |
| 79 | MAJOR QUOTATIONS | 0.00 | | 0.00 |
| 80 | SALES TAX \$ | 0.00 | | 0.00 |
| 81 | DIRECT LABOR | 18,035.99 | | 0.00 |
| 82 | INDIRECT LABOR | 0.00 | | 0.00 |
| 83 | NON-PRODUCTIVE LABOR | 0.00 | | 0.00 |
| 84 | DIRECT JOB EXPENSES | 0.00 | | 0.00 |
| 85 | SUB CONTRACTS | 0.00 | | 0.00 |
| 86 | JOB TOTAL | | | 53377.70 |
| ***** | | | | |
| 87 | PROFIT | 53,377.70 | | 0.00 |
| 88 | JOB TOTAL + PROFIT | 0.00 | 1.00 | 53377.70 |
| 89 | >BOND | | | |
| 90 | >PERMIT | | | 0.00 |
| 91 | >COST PER SQ FT | 53,377.70 | 1.00 | 53,377.70 |
| 92 | ***** | | | |
| 93 | ***** | | | |
| 94 | BID TOTAL | | | 53377.70 |

Job: 5699 CHARLESTON WASTEWATER TREATMENT PLANT IMPROVEMENTS
 Estimate: 5699 CHARLESTON WASTEWATER TREATMENT PLANT IMPROVEMENTS
 Summary: 10 PCO-004 RELOCATE ELECTRICAL ROOM

Date: 5/8/23

| # | Item # | Size | Description | Qty | UOM | Material | | | Labor | | |
|---|--------|--------|------------------------------------|-----|------|-----------|------|----------------|---------|------|--------------|
| | | | | | | Unit | Adj | Ext | Unit | Adj | Ext |
| PCO-004 RELOCATE ELECTRICAL ROOM | | | | | | | | | | | |
| CHANGE ORDER 004: PCO-004 - PCO-004-ELCTRICAL ROOM RELOCATE SLUDGE TRANS | | | | | | | | | | | |
| Category 000: (None) | | | | | | | | | | | |
| ## | 16614 | 300 | TRANSFORMER ON GRADE | 1 | EACH | Quote | | 0.00 | -4.0000 | 1.00 | -4.00 |
| 1 | 77 | | MCC-004 20"X92" AUX GUTTER | 1 | | 1200.0000 | 1.00 | 1200.00 | 8.0000 | 1.00 | 8.00 |
| Subtotals for Category 000: (None) | | | | | | | | 1200.00 | | | 4.00 |
| Category 003: CONDUIT | | | | | | | | | | | |
| 2 | 3422 | 3/4" | GRC | 78 | FEET | 3.0680 | | 239.30 | 0.0600 | 1.00 | 4.68 |
| 3 | 3427 | 2 1/2" | GRC | 82 | FEET | 19.1348 | | 1569.05 | 0.1500 | 1.00 | 12.30 |
| 4 | 3428 | 3" | GRC | 165 | FEET | 21.7036 | | 3581.09 | 0.2000 | 1.00 | 33.00 |
| 5 | 3430 | 4" | GRC | 120 | FEET | 30.0790 | | 3609.48 | 0.3000 | 1.00 | 36.00 |
| Subtotals for Category 003: CONDUIT | | | | | | | | 8998.93 | | | 85.98 |
| Category 004: ELBOWS | | | | | | | | | | | |
| 6 | 4422 | 3/4" | GRC FIELD BENDS | 6 | EACH | Skip | 1.00 | 0.00 | 0.2660 | 1.00 | 1.60 |
| 7 | 4427 | 2 1/2" | GRC FIELD BENDS | 4 | EACH | Skip | 1.00 | 0.00 | 0.9000 | 1.00 | 3.60 |
| 8 | 4428 | 3" | GRC FIELD BENDS | 4 | EACH | Skip | 1.00 | 0.00 | 1.1000 | 1.00 | 4.40 |
| Subtotals for Category 004: ELBOWS | | | | | | | | 0.00 | | | 9.60 |
| Category 005: FITTINGS | | | | | | | | | | | |
| 9 | 5860 | 3/4" | CUT/THREAD-LABOR | 5 | EACH | Skip | 1.00 | 0.00 | 0.1800 | 1.00 | 0.90 |
| 10 | 5865 | 2 1/2" | CUT/THREAD-LABOR | 4 | EACH | Skip | 1.00 | 0.00 | 0.8000 | 1.00 | 3.20 |
| 11 | 5866 | 3" | CUT/THREAD-LABOR | 20 | EACH | Skip | 1.00 | 0.00 | 0.9600 | 1.00 | 19.20 |
| 12 | 5869 | 4" | CUT/THREAD-LABOR | 6 | EACH | Skip | 1.00 | 0.00 | 1.2500 | 1.00 | 7.50 |
| Subtotals for Category 005: FITTINGS | | | | | | | | 0.00 | | | 30.80 |
| Category 007: HANGERS/STRAPS & MISC HARDWARE | | | | | | | | | | | |
| 13 | 7002 | 3/4" | GRC 1 HOLE STRAP | 10 | EACH | 0.1371 | | 1.37 | 0.0300 | 1.00 | 0.30 |
| 14 | 7149 | 3/4" | MALLABLE CLAMP BACK | 10 | EACH | 1.3500 | | 13.50 | 0.0100 | 1.00 | 0.10 |
| 15 | 7187 | | 2-1/2" HOLE DRILL & PATCH CONCRETE | 2 | EACH | 2.5000 | | 5.00 | 1.7500 | 1.00 | 3.50 |
| 16 | 7190 | | 4" HOLE DRILL & PATCH CONCRETE | 3 | EACH | 4.0000 | | 12.00 | 2.2500 | 1.00 | 6.75 |
| 17 | 7201 | | 3" HOLE DRILL & PATCH MASONRY | 4 | EACH | 3.0000 | | 12.00 | 2.2500 | 1.00 | 9.00 |
| 18 | 7292 | 1/4-20 | TAMPIN | 10 | EACH | 0.6354 | | 6.35 | 0.0300 | 1.00 | 0.30 |
| 19 | 7304 | 1/4-20 | 1 MACHINE SCREW | 10 | EACH | 0.0454 | | 0.45 | 0.0010 | 1.00 | 0.01 |

| | | | | | | | | | | | |
|---|-------|--------|------------------------------|-----|------|---------|------|-----------------|--------|------|---------------|
| 20 | 7423 | 3/4" | S.S.STRUT STRAPS | 7 | EACH | 2.8000 | | 19.60 | 0.0300 | 1.00 | 0.21 |
| 21 | 7428 | 2 1/2" | S.S.STRUT STRAPS | 14 | EACH | 7.6100 | | 106.54 | 0.0550 | 1.00 | 0.77 |
| 22 | 7429 | 3" | S.S.STRUT STRAPS | 20 | EACH | 7.6100 | | 152.20 | 0.0550 | 1.00 | 1.10 |
| 23 | 7431 | 4" | S.S.STRUT STRAPS | 18 | EACH | 10.1700 | | 183.06 | 0.0600 | 1.00 | 1.08 |
| Subtotals for Category 007: HANGERS/STRAPS & MISC HARDWARE | | | | | | | | 512.08 | | | 23.12 |
| Category 011: WIRE | | | | | | | | | | | |
| 24 | 11131 | 14 | THHN STR CU | 682 | FEET | 0.1350 | | 92.07 | 0.0060 | 1.00 | 4.09 |
| 25 | 11143 | 4/0 | THHN STR CU | 400 | FEET | 5.4623 | | 2184.92 | 0.0290 | 1.00 | 11.60 |
| 26 | 11148 | 500 | THHN STR CU | 660 | FEET | 12.7752 | | 8431.63 | 0.0440 | 1.00 | 29.04 |
| 27 | 11164 | 1. | XHHW STR CU | 199 | FEET | 2.4727 | | 492.07 | 0.0200 | 1.00 | 3.98 |
| 28 | 11171 | 350 | XHHW STR CU | 595 | FEET | 9.5876 | | 5704.62 | 0.0380 | 1.00 | 22.61 |
| 29 | 11281 | 14 | THHN CU GREEN | 160 | FEET | 0.1350 | | 21.60 | 0.0050 | 1.00 | 0.80 |
| 30 | 11285 | 6. | THHN CU GREEN | 100 | FEET | 0.8510 | | 85.10 | 0.0110 | 1.00 | 1.10 |
| 31 | 11291 | 3/0 | THHN CU GREEN | 150 | FEET | 4.3759 | | 656.39 | 0.0260 | 1.00 | 3.90 |
| 32 | 11583 | 3/0 | WIRE TERM-LABOR ONLY | 0 | EACH | Skip | 1.00 | 0.00 | 0.2000 | 1.00 | 0.00 |
| 33 | 11589 | 500 | WIRE TERM-LABOR ONLY | 0 | EACH | Skip | 1.00 | 0.00 | 0.5300 | 1.00 | 0.00 |
| Subtotals for Category 011: WIRE | | | | | | | | 17668.40 | | | 77.12 |
| Category 060: INSTRUMENTATION-CONTROL WIRING | | | | | | | | | | | |
| 34 | 36 | | VENDER FURNISHED CABLE (VFC) | 38 | | FBO | 1.00 | 0.00 | 0.0200 | 1.00 | 0.76 |
| Subtotals for Category 060: INSTRUMENTATION-CONTROL WIRING | | | | | | | | 0.00 | | | 0.76 |
| Subtotals for CHANGE ORDER 004: PCO-004 - PCO-004-ELCTRICAL ROOM RELOCATE SLUDGE TRANS | | | | | | | | 28379.41 | | | 231.38 |
| Grand Totals for PCO-004 RELOCATE ELECTRICAL ROOM | | | | | | | | 28379.41 | | | 231.38 |

| Description | Material | Labor |
|---|-----------------|---------------|
| PCO-004 RELOCATE ELECTRICAL ROOM | | |
| CHANGE ORDER 004: PCO-004 - PCO-004-ELCTRICAL ROOM RELOCATE SLUDGE TRANS | | |
| Category 000: (None) | 1200.00 | 4.00 |
| Category 003: CONDUIT | 8998.93 | 85.98 |
| Category 004: ELBOWS | 0.00 | 9.60 |
| Category 005: FITTINGS | 0.00 | 30.80 |
| Category 007: HANGERS/STRAPS & MISC HARDWARE | 512.08 | 23.12 |
| Category 011: WIRE | 17668.40 | 77.12 |
| Category 060: INSTRUMENTATION-CONTROL WIRING | 0.00 | 0.76 |
| Subtotals for CHANGE ORDER 004: PCO-004 - PCO-004-ELCTRICAL ROOM | 28379.41 | 231.38 |
| Grand Totals for PCO-004 RELOCATE ELECTRICAL ROOM | 28379.41 | 231.38 |



S&S BUILDERS HARDWARE CO.

917 W. Pioneer Parkway, Peoria, IL 61615 ■ P.O. Box 3678, Peoria, IL 61612-3678

Phone 309/692-0828 Fax 309/693-0873

June 12, 2023

Williams Brothers Construction Inc
Attn: Ryan

RE: Charleston WWTP – RFP 8 – door change

Furnish new door/frame/hardware 520.D04 at 3-4 x 7-0 door opening

- (1) HM frame – welded, galvanized
- (1) HM door – flush, insulated, galvanized
- (1) Hardware set 08

Total \$3,395

Regards, Jeff Johnson

REQUEST FOR INFORMATION

Request No. **030**

Date: 04-12-2023

Contractor: Williams Bothers Construction Inc.

Specification Section / Drawing No.: 520-EN-2

Project: City of Charleston

Contract: WWTP Improvements

This is a request for information on the following

Transformer 520-XFMR-1 has an approximate weight of 4,100lbs and a load per square foot of 340 pounds. The maximum load per square foot in Storage Room 201 is 100lbs. We will exceed the maximum load by roughly 240 pounds per square foot if the transformer is installed at its drawn location. Commercial Electric suggest relocating the transformer to a different location. Please see attached photos and drawing 520-EN-2 for reference.

PLC-103A in Storage Room 201 will require a 48"x48" opening in the North CMU wall in order to safely lift the PLC into the storage room. Please see the attached drawing and pictures for reference. Commercial Electric suggests relocating the PLC into a new location with the transformer.

Prepared By: Ryan Lynch

Date Response Needed: As Soon as Possible

Response:

See attached drawings for relocating electrical equipment to the main level.

Prepared By: **Greg Garnes**

Date: **4/25/2023**

Response Returned to Contractor On:

cc: Owner: _____

Resident Project Representative: _____

Donohue & Associates, Inc.
Project No. 13756

REQUEST FOR INFORMATION
RFI

| TAG NAME | DESCRIPTION | DETAIL | WIRING | DESTINATION | COMMENTS |
|-----------|---------------------------|--------|---------|-------------|-------------|
| PLC-103A | SLUDGE PLC A | N180 | (1) CE | PLC-103 | |
| 520-TCP-1 | TEMPERATURE CONTROL PANEL | N170 | (6) #14 | PLC-103A | |
| 520-SPD-1 | MCC-4 SPD | MFR | (2) #14 | PLC-103A | |
| 520-SPD-2 | LIGHTING PANEL SPD | MFR | (2) #14 | PLC-103A | |
| MCC-4 | MCC-4 | MFR | (1) CE | PLC-103A | POWER METER |

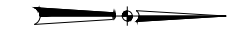

GENERAL NOTES:

1. CONTRACTOR TO FIELD VERIFY EXISTING CONDITIONS, DIMENSIONS, AND ELEVATIONS PRIOR TO CONSTRUCTION AND/OR FABRICATION.
2. CONTRACTOR TO REFER TO SPACE ENVIRONMENT AND HAZARDOUS RATING SCHEDULE PER 001-ENV-1 FOR HAZARDOUS RATINGS AND MATERIAL.

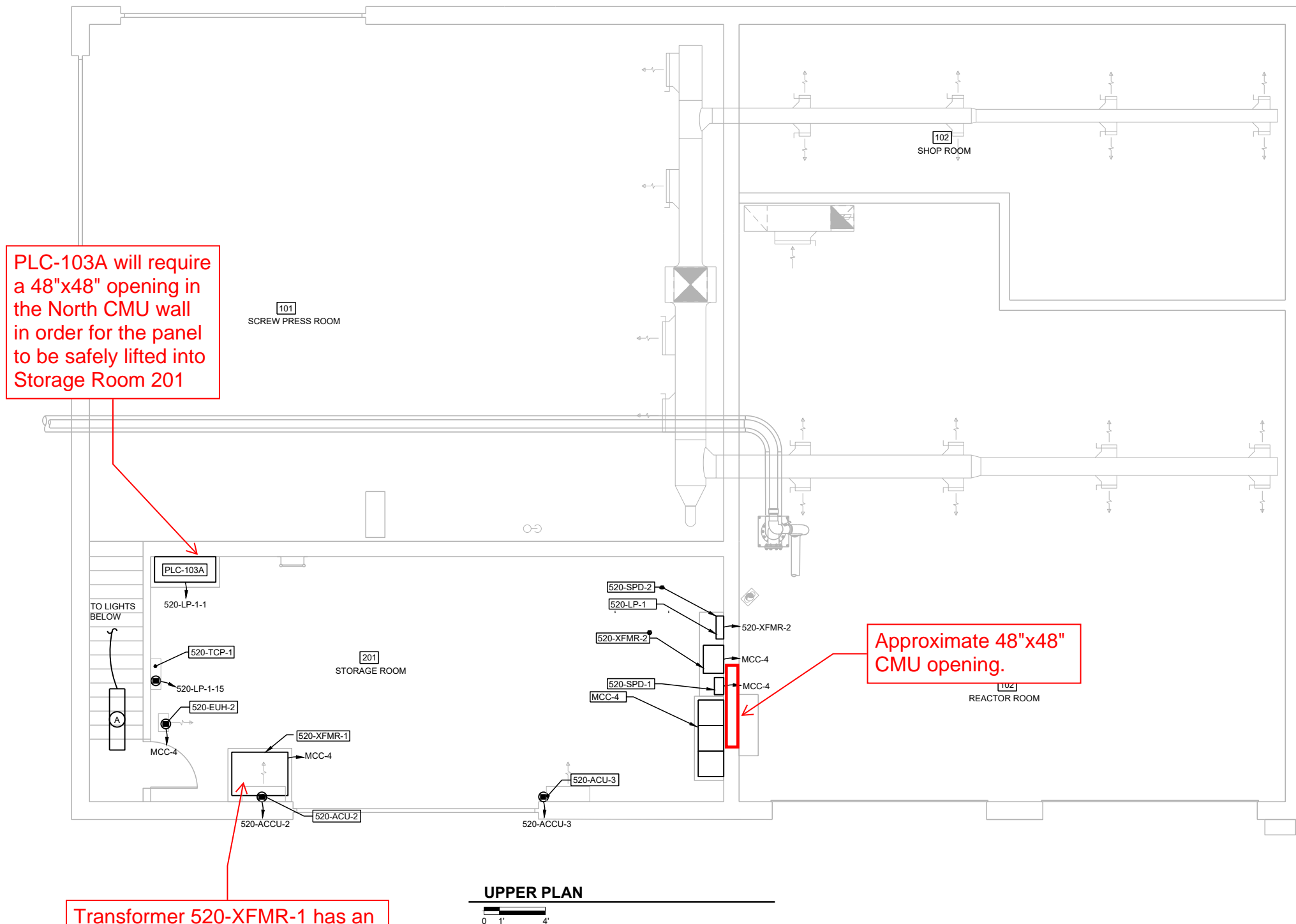

PLC-103A will require a 48"x48" opening in the North CMU wall in order for the panel to be safely lifted into Storage Room 201

Approximate 48"x48" CMU opening.

Transformer 520-XFMR-1 has an approximate weight of 4100lbs. The maximum safe load applied to floor is 100 pounds/square foot. The transformer will exceed this by roughly 250 pounds/square foot.

UPPER PLAN
0 1' 4'

| Revision Number | Revision Description | Checked By | Drawn By | Date |
|-----------------|----------------------|------------|----------|------|
| | | | | |
| | | | | |
| | | | | |
| | | | | |
| | | | | |
| | | | | |
| | | | | |
| | | | | |
| | | | | |
| | | | | |

| | |
|--------------|-------------|
| Designed By | FGM/AHB |
| Drawn By | FGM/AHB |
| Checked By | JAB |
| Approved By | JAB |
| Filename | 520ENP1.DWG |
| Project No. | 13756 |
| Project Date | JULY 2021 |

**CITY OF CHARLESTON
WASTEWATER TREATMENT PLANT IMPROVEMENTS
CHARLESTON, ILLINOIS
SLUDGE HANDLING BUILDING PLAN**

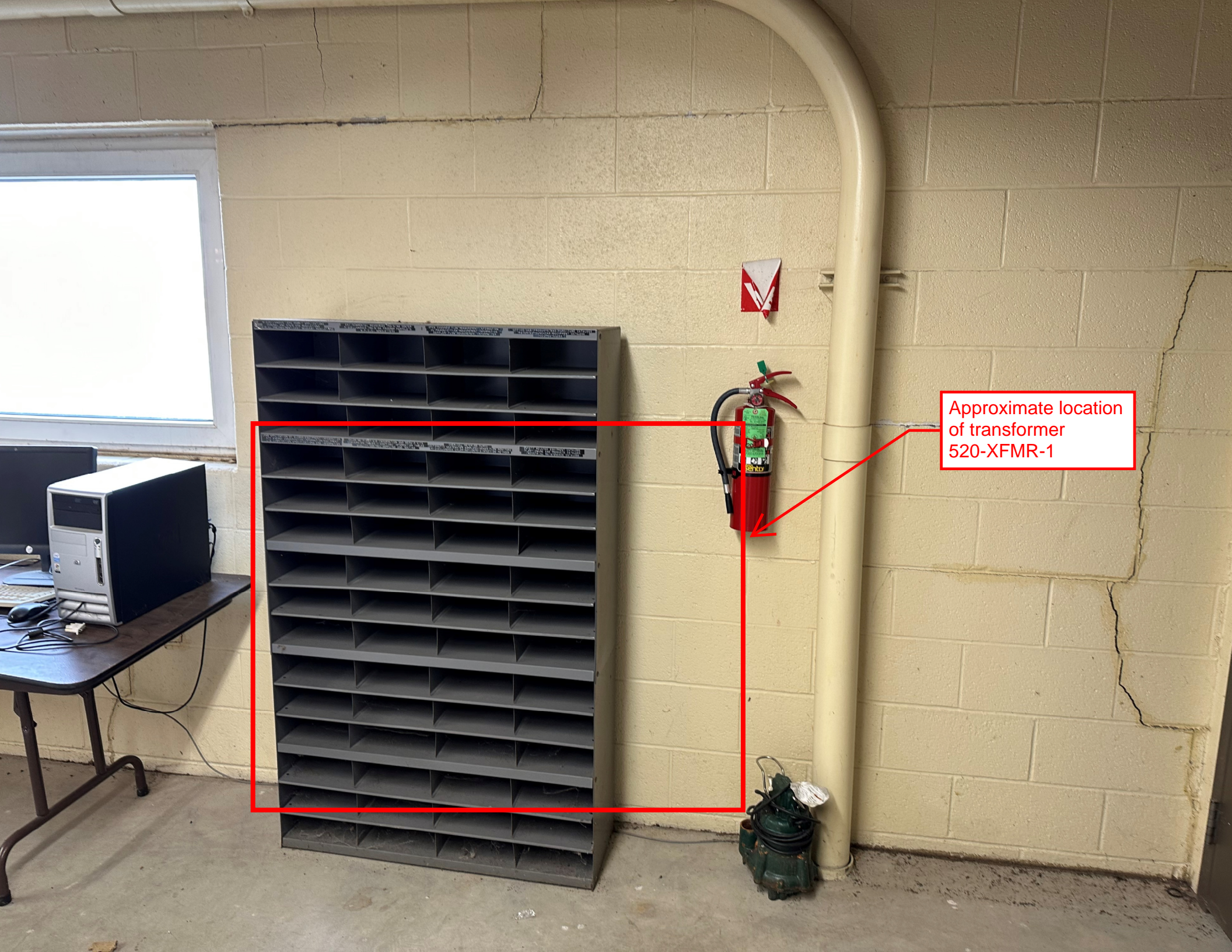

Approximate location
of transformer
520-XFMR-1

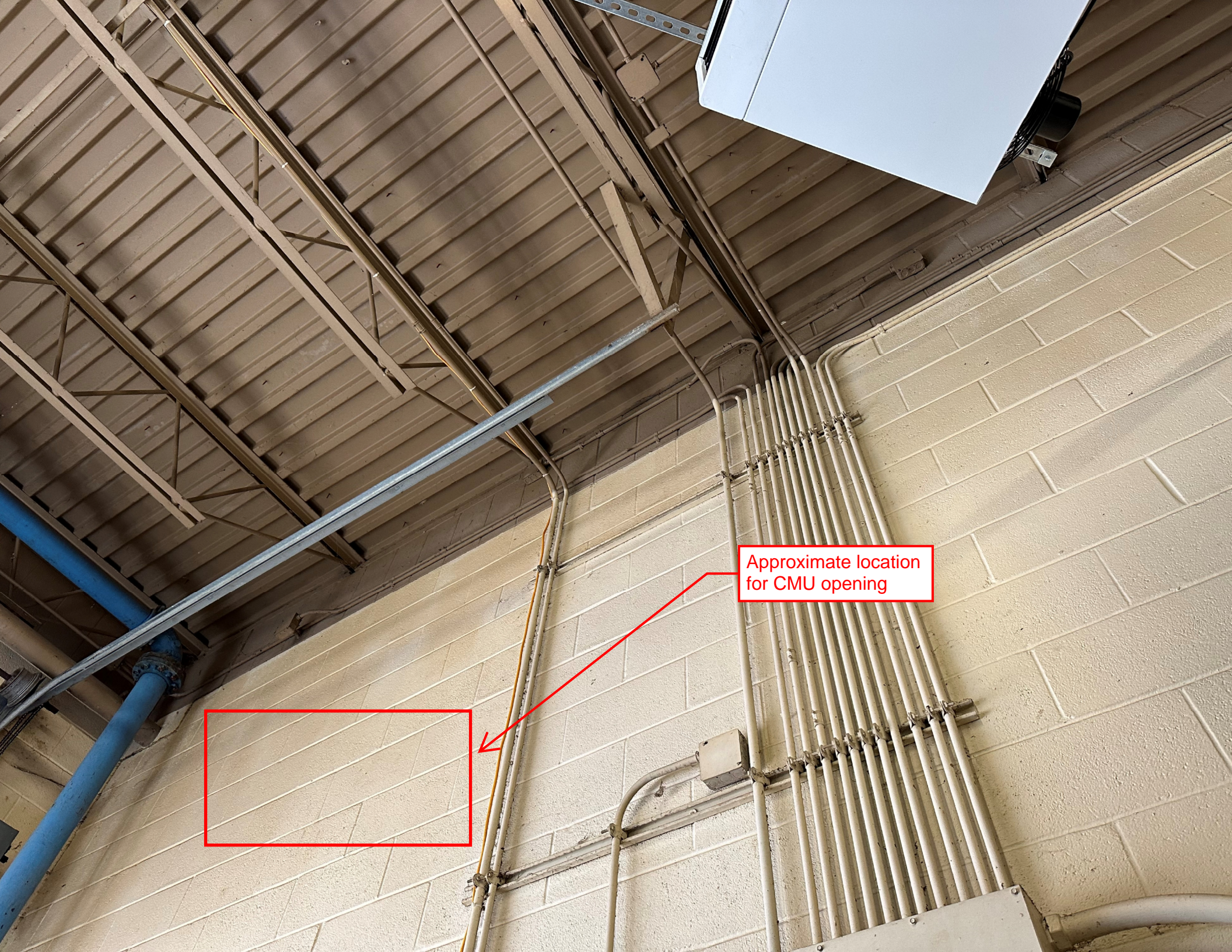

Approximate location
for CMU opening



THE MAXIMUM SAFE LOAD
THAT MAY BE APPLIED TO
THE FLOOR IN THIS ROOM IS
100 POUNDS/SQUARE FOOT.

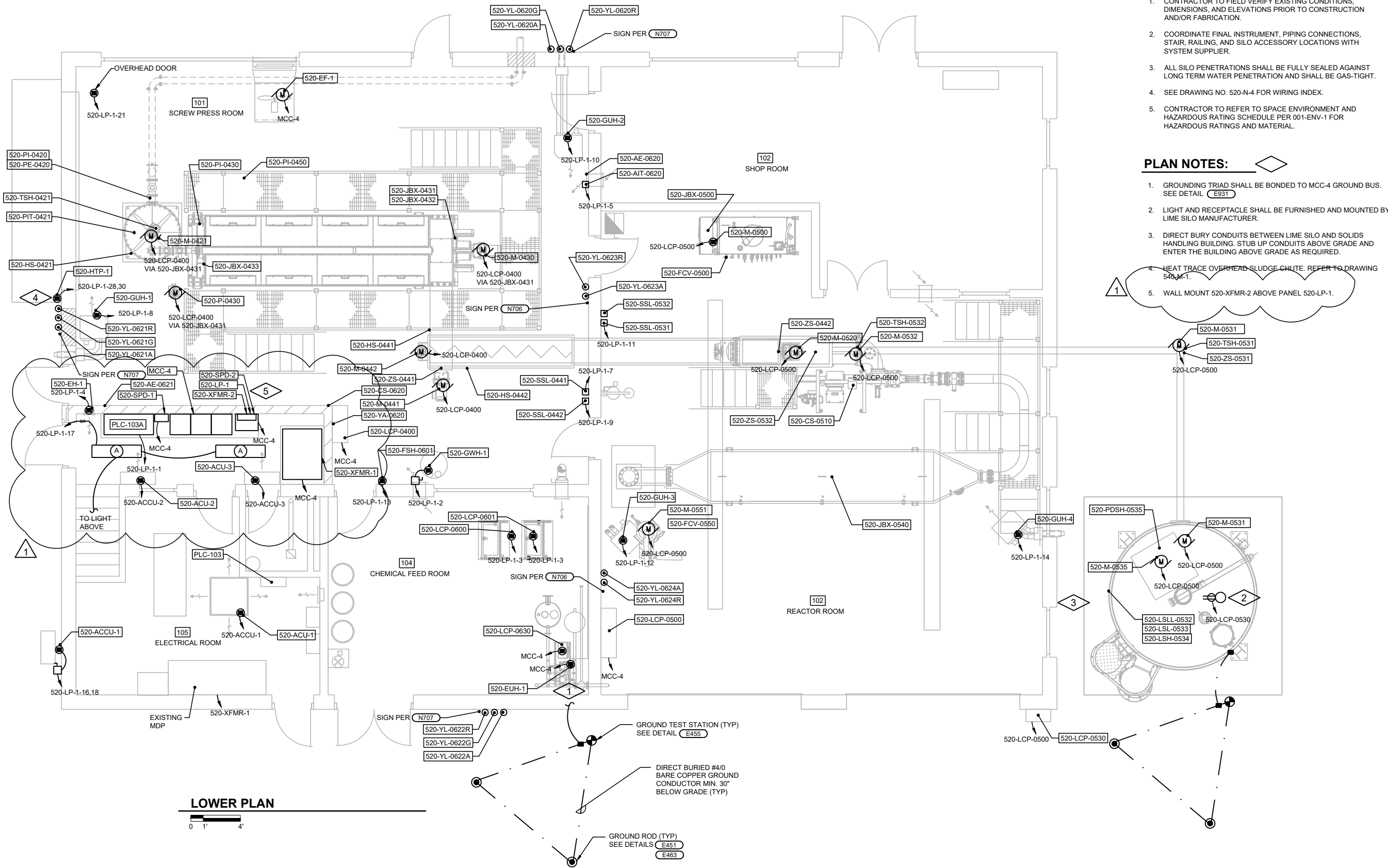
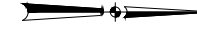

GENERAL NOTES:

1. CONTRACTOR TO FIELD VERIFY EXISTING CONDITIONS, DIMENSIONS, AND ELEVATIONS PRIOR TO CONSTRUCTION AND/OR FABRICATION.
2. COORDINATE FINAL INSTRUMENT, PIPING CONNECTIONS, STAIR, RAILING, AND SILO ACCESSORY LOCATIONS WITH SYSTEM SUPPLIER.
3. ALL SILO PENETRATIONS SHALL BE FULLY SEALED AGAINST LONG TERM WATER PENETRATION AND SHALL BE GAS-TIGHT.
4. SEE DRAWING NO. 520-N-4 FOR WIRING INDEX.
5. CONTRACTOR TO REFER TO SPACE ENVIRONMENT AND HAZARDOUS RATING SCHEDULE PER 001-ENV-1 FOR HAZARDOUS RATINGS AND MATERIAL.

PLAN NOTES:

1. GROUNDING TRIAD SHALL BE BONDED TO MCC-4 GROUND BUS. SEE DETAIL E931
2. LIGHT AND RECEPTACLE SHALL BE FURNISHED AND MOUNTED BY LIME SILO MANUFACTURER.
3. DIRECT BURY CONDUITS BETWEEN LIME SILO AND SOLIDS HANDLING BUILDING. STUB UP CONDUITS ABOVE GRADE AND ENTER THE BUILDING ABOVE GRADE AS REQUIRED.
4. HEAT TRACE OVERHEAD SLUDGE CHUTE. REFER TO DRAWING 540-N-1.
5. WALL MOUNT 520-XFMR-2 ABOVE PANEL 520-LP-1.

| Revision Number | Description |
|-----------------|-------------|
| | |
| | |
| | |
| | |
| | |
| | |
| | |

| | |
|--------------|------------|
| Designed By | FGM/AHB |
| Drawn By | FGM/AHB |
| Checked By | JAB |
| Approved By | JAB |
| Filename | 520EN1.DWG |
| Project No. | 13756 |
| Project Date | JULY 2021 |

CITY OF CHARLESTON
WASTEWATER TREATMENT PLANT IMPROVEMENTS
CHARLESTON, ILLINOIS
SLUDGE HANDLING BUILDING PLAN

| | |
|-------------|----------|
| | |
| Sheet No. | 92 |
| Drawing No. | 520-EN-1 |

| TAG NAME | DESCRIPTION | DETAIL | WIRING | DESTINATION | COMMENTS |
|-----------|---------------------------|--------|---------|-------------|-------------|
| PLC-103A | SLUDGE PLC A | N180 | (1) CE | PLC-103 | |
| 520-TCP-1 | TEMPERATURE CONTROL PANEL | N170 | (6) #14 | PLC-103A | |
| 520-SPD-1 | MCC-4 SPD | MFR | (2) #14 | PLC-103A | |
| 520-SPD-2 | LIGHTING PANEL SPD | MFR | (2) #14 | PLC-103A | |
| MCC-4 | MCC-4 | MFR | (1) CE | PLC-103A | POWER METER |



GENERAL NOTES:

- CONTRACTOR TO FIELD VERIFY EXISTING CONDITIONS, DIMENSIONS, AND ELEVATIONS PRIOR TO CONSTRUCTION AND/OR FABRICATION.
- CONTRACTOR TO REFER TO SPACE ENVIRONMENT AND HAZARDOUS RATING SCHEDULE PER 001-ENV-1 FOR HAZARDOUS RATINGS AND MATERIAL.

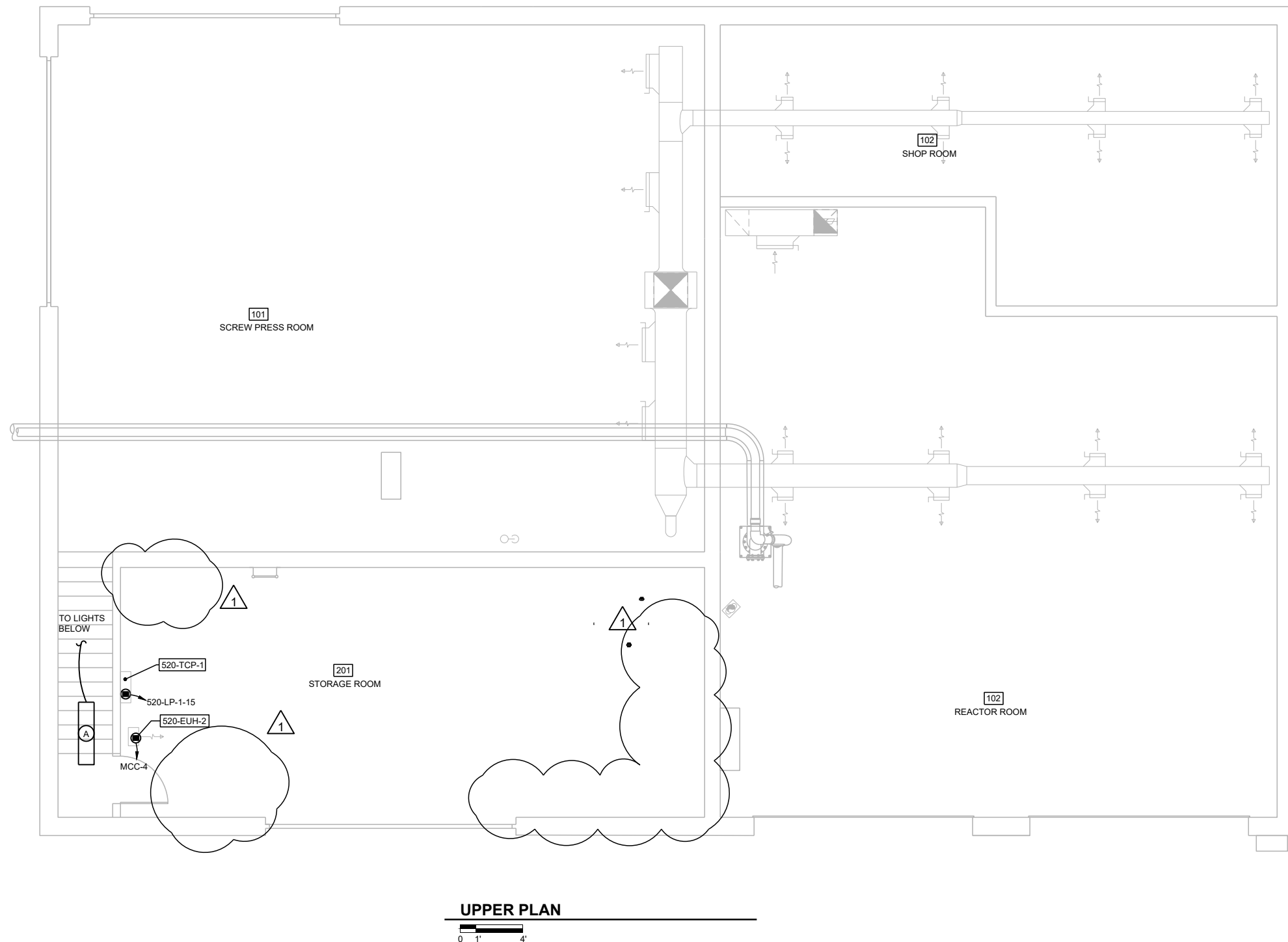

UPPER PLAN
 0 1' 4'

| Revision Number | Description | Drawn By | Checked By | Date |
|-----------------|-------------|----------|------------|------|
| | | | | |
| | | | | |
| | | | | |

| | |
|--------------|-------------|
| Designed By | FGM/AHB |
| Drawn By | FGM/AHB |
| Checked By | JAB |
| Approved By | JAB |
| Filename | 520ENP1.DWG |
| Project No. | 13756 |
| Project Date | JULY 2021 |

CITY OF CHARLESTON
WASTEWATER TREATMENT PLANT IMPROVEMENTS
CHARLESTON, ILLINOIS
SLUDGE HANDLING BUILDING PLAN



Sheet No. 93
 Drawing No.

520-EN-2

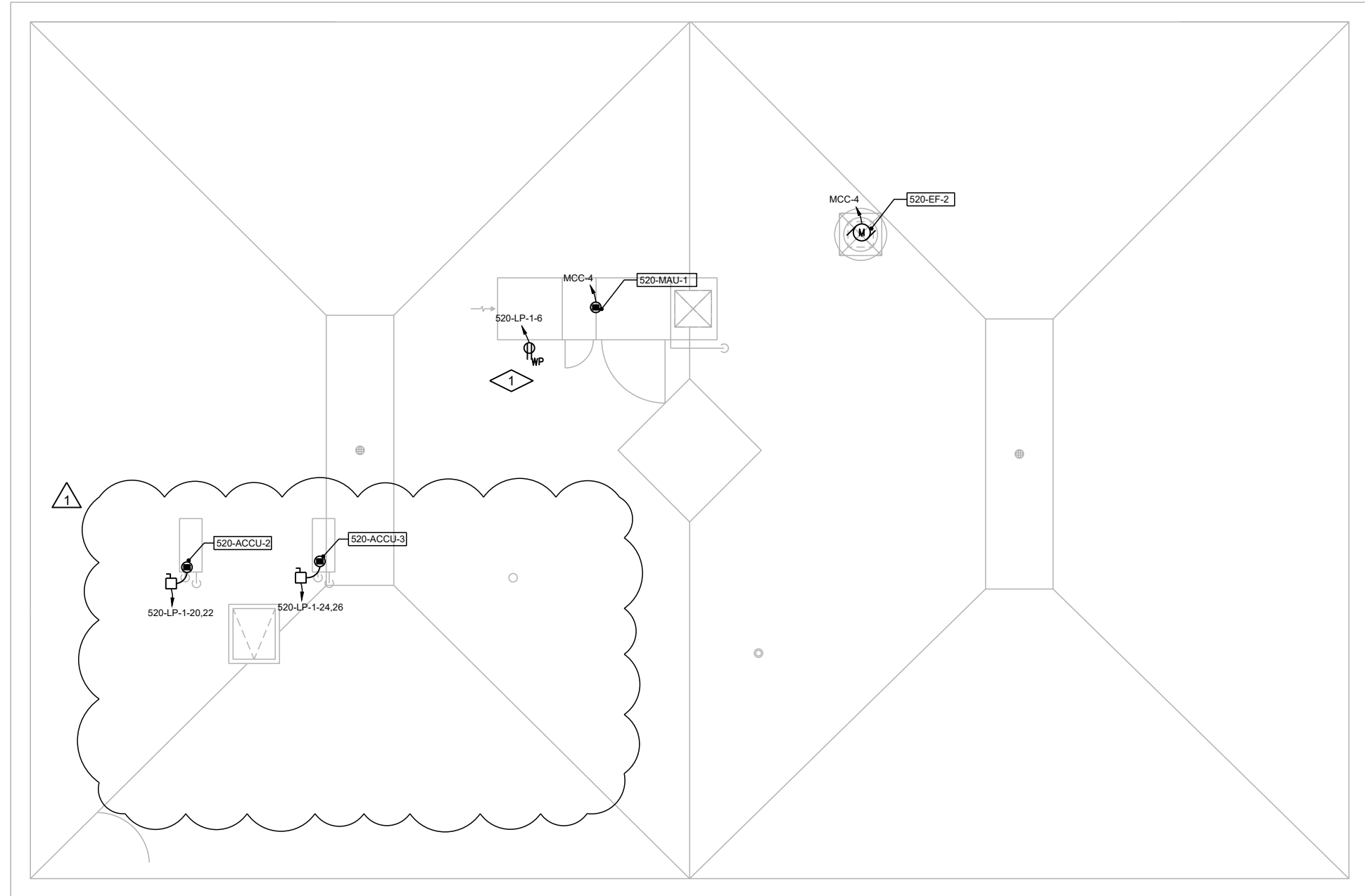
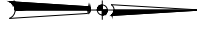

GENERAL NOTES:

1. CONTRACTOR TO FIELD VERIFY EXISTING CONDITIONS, DIMENSIONS, AND ELEVATIONS PRIOR TO CONSTRUCTION AND/OR FABRICATION.
2. CONTRACTOR TO REFER TO SPACE ENVIRONMENT AND HAZARDOUS RATING SCHEDULE PER 001-ENV-1 FOR HAZARDOUS RATINGS AND MATERIAL.

PLAN NOTES:

1. INSTALL STRUT MOUNTED RECEPTACLE ADJACENT TO MAKEUP AIR UNIT.

ROOF PLAN



| Revision Number | Revision Description | Drawn By | Checked By | Date |
|-----------------|----------------------|----------|------------|------|
| | | | | |
| | | | | |
| | | | | |
| | | | | |
| | | | | |
| | | | | |
| | | | | |
| | | | | |
| | | | | |
| | | | | |

| | |
|--------------|-------------|
| Designed By | FGM/AHB |
| Drawn By | FGM/AHB |
| Checked By | JAB |
| Approved By | JAB |
| Filename | 520ENP1.DWG |
| Project No. | 13756 |
| Project Date | JULY 2021 |

CITY OF CHARLESTON
WASTEWATER TREATMENT PLANT IMPROVEMENTS
CHARLESTON, ILLINOIS
SLUDGE HANDLING BUILDING
PLAN



Sheet No. 94
Drawing No.

520-EN-3

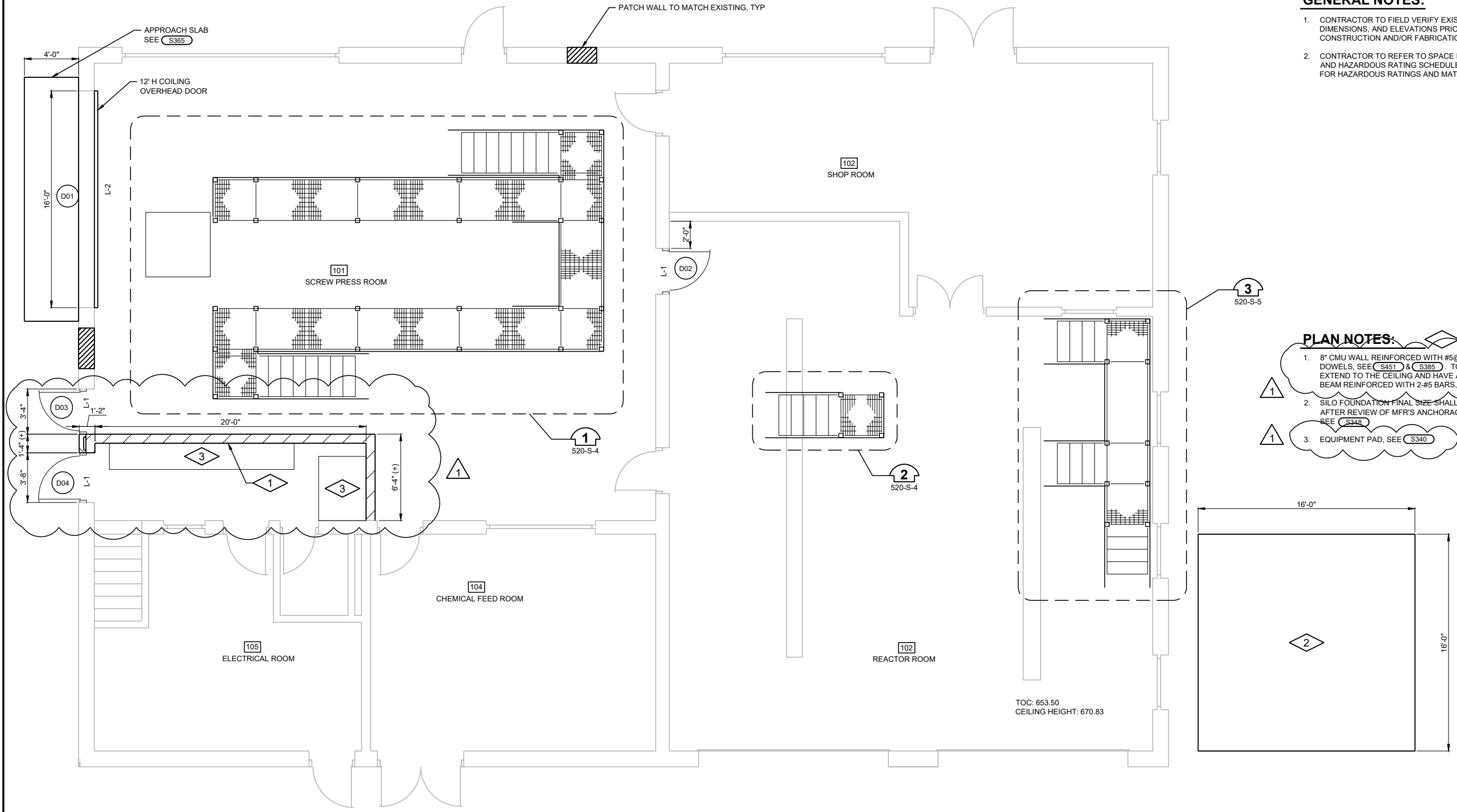
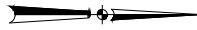

GENERAL NOTES:

1. CONTRACTOR TO FIELD VERIFY EXISTING CONDITIONS, DIMENSIONS, AND ELEVATIONS PRIOR TO CONSTRUCTION AND/OR FABRICATION.
2. CONTRACTOR TO REFER TO SPACE ENVIRONMENT AND HAZARDOUS RATING SCHEDULE PER 001-ENV-1 FOR HAZARDOUS RATINGS AND MATERIAL.

PLAN NOTES:

1. 8" CMU WALL REINFORCED WITH #5@48" W/ MATCH DOWELS, SEE (S451) & (S385). TOP OF WALL SHALL EXTEND TO THE CEILING AND HAVE A CONTINUOUS BOND BEAM REINFORCED WITH 2-#5 BARS, SEE (S400)
2. SILO FOUNDATION FINAL SIZE SHALL BE CONFIRMED AFTER REVIEW OF MFR'S ANCHORAGE REQUIREMENTS. SEE (S348)
3. EQUIPMENT PAD, SEE (S340)

LOWER PLAN

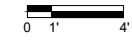

| Revision Number | Revision Description | Date |
|-----------------|----------------------|------------|
| 1 | RFI 30 | 04/XX/2023 |

| | |
|--------------|------------|
| Designed By | CEE |
| Drawn By | CEE |
| Checked By | CEE |
| Approved By | CLS |
| Filename | 520SP1.DWG |
| Project No. | 13756 |
| Project Date | JULY 2021 |

CITY OF CHARLESTON
WASTEWATER TREATMENT PLANT IMPROVEMENTS
CHARELSTON, ILLINOIS
SLUDGE HANDLING BUILDING
PLAN



Sheet No. 80
Drawing No.

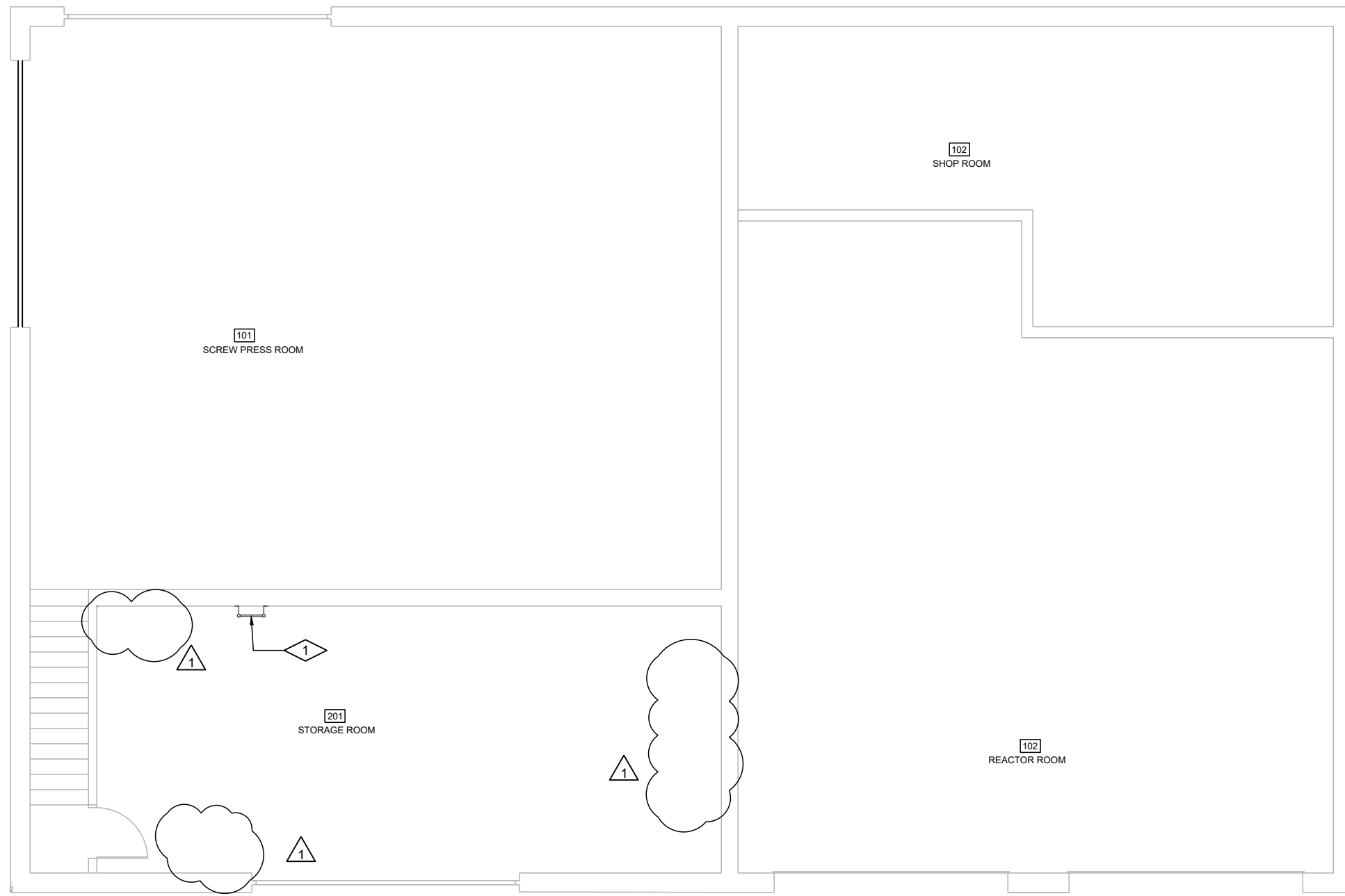

- GENERAL NOTES:**
1. CONTRACTOR TO FIELD VERIFY EXISTING CONDITIONS, DIMENSIONS, AND ELEVATIONS PRIOR TO CONSTRUCTION AND/OR FABRICATION.
 2. CONTRACTOR TO REFER TO SPACE ENVIRONMENT AND HAZARDOUS RATING SCHEDULE PER 001-ENV-1 FOR HAZARDOUS RATINGS AND MATERIAL.

- PLAN NOTES:**
1. LOCATED ALUMINUM LADDER WITH RETRACTABLE SAFETY POST BETWEEN EXISTING JOISTS AND CENTER ROOF HATCH ABOVE, SEE **SS26**

| Revision Number | Revision Description | Drawn By | Checked By | Date |
|-----------------|----------------------|----------|------------|------------|
| 1 | RF 130 | CEE | CEE | 04/XX/2023 |
| | | | | |
| | | | | |
| | | | | |
| | | | | |
| | | | | |
| | | | | |
| | | | | |
| | | | | |
| | | | | |
| | | | | |
| | | | | |
| | | | | |
| | | | | |

| | |
|--------------|------------|
| Designed By | CEE |
| Drawn By | CEE |
| Checked By | CLS |
| Approved By | CLS |
| Filename | 520SP1.DWG |
| Project No. | 13756 |
| Project Date | JULY 2021 |

**CITY OF CHARLESTON
WASTEWATER TREATMENT PLANT IMPROVEMENTS
CHARELSTON, ILLINOIS
SLUDGE HANDLING BUILDING
PLAN**



Sheet No. 81
Drawing No.

520-S-2

UPPER PLAN

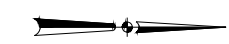
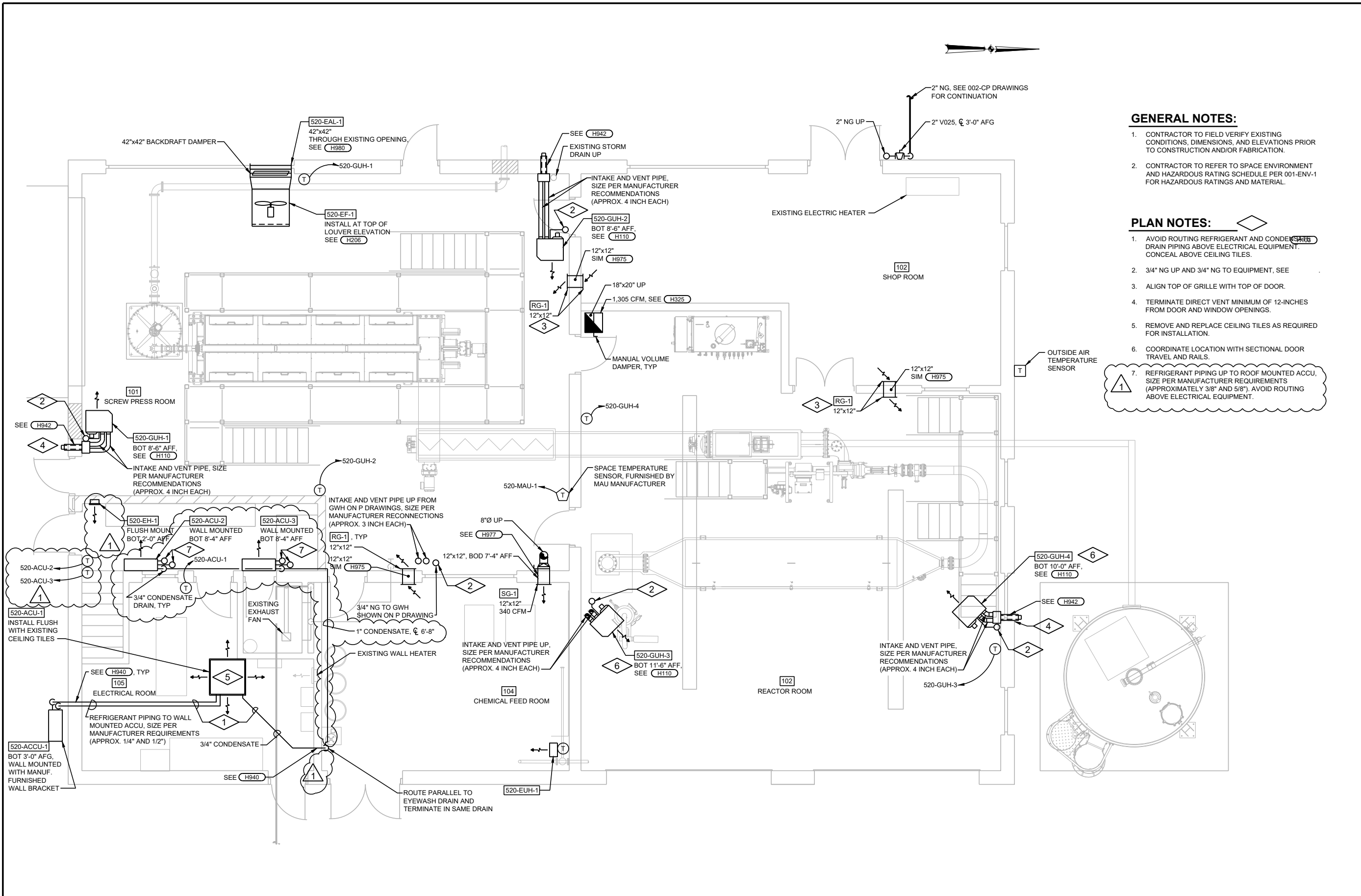

GENERAL NOTES:

1. CONTRACTOR TO FIELD VERIFY EXISTING CONDITIONS, DIMENSIONS, AND ELEVATIONS PRIOR TO CONSTRUCTION AND/OR FABRICATION.
2. CONTRACTOR TO REFER TO SPACE ENVIRONMENT AND HAZARDOUS RATING SCHEDULE PER 001-ENV-1 FOR HAZARDOUS RATINGS AND MATERIAL.

PLAN NOTES:

1. AVOID ROUTING REFRIGERANT AND CONDENSATE DRAIN PIPING ABOVE ELECTRICAL EQUIPMENT. CONCEAL ABOVE CEILING TILES.
2. 3/4" NG UP AND 3/4" NG TO EQUIPMENT, SEE [REDACTED]
3. ALIGN TOP OF GRILLE WITH TOP OF DOOR.
4. TERMINATE DIRECT VENT MINIMUM OF 12-INCHES FROM DOOR AND WINDOW OPENINGS.
5. REMOVE AND REPLACE CEILING TILES AS REQUIRED FOR INSTALLATION.
6. COORDINATE LOCATION WITH SECTIONAL DOOR TRAVEL AND RAILS.
7. REFRIGERANT PIPING UP TO ROOF MOUNTED ACCU. SIZE PER MANUFACTURER REQUIREMENTS (APPROXIMATELY 3/8" AND 5/8"). AVOID ROUTING ABOVE ELECTRICAL EQUIPMENT.

LOWER PLAN
 0 1' 4'

| | |
|----------------------|------------|
| Date | 05/01/2023 |
| Checked By | PML |
| Drawn By | PML |
| Revision Description | |
| Revision Number | RFI 30 |
| Revision Number | 1 |
| Designed By | PML |
| Drawn By | PML |
| Checked By | JLW |
| Approved By | JLW |
| Filename | 520HP1.DWG |
| Project No. | 13756 |
| Project Date | JULY 2021 |

**CITY OF CHARLESTON
 WASTEWATER TREATMENT PLANT IMPROVEMENTS
 CHARELSTON, ILLINOIS
 SLUDGE HANDLING BUILDING
 PLAN**

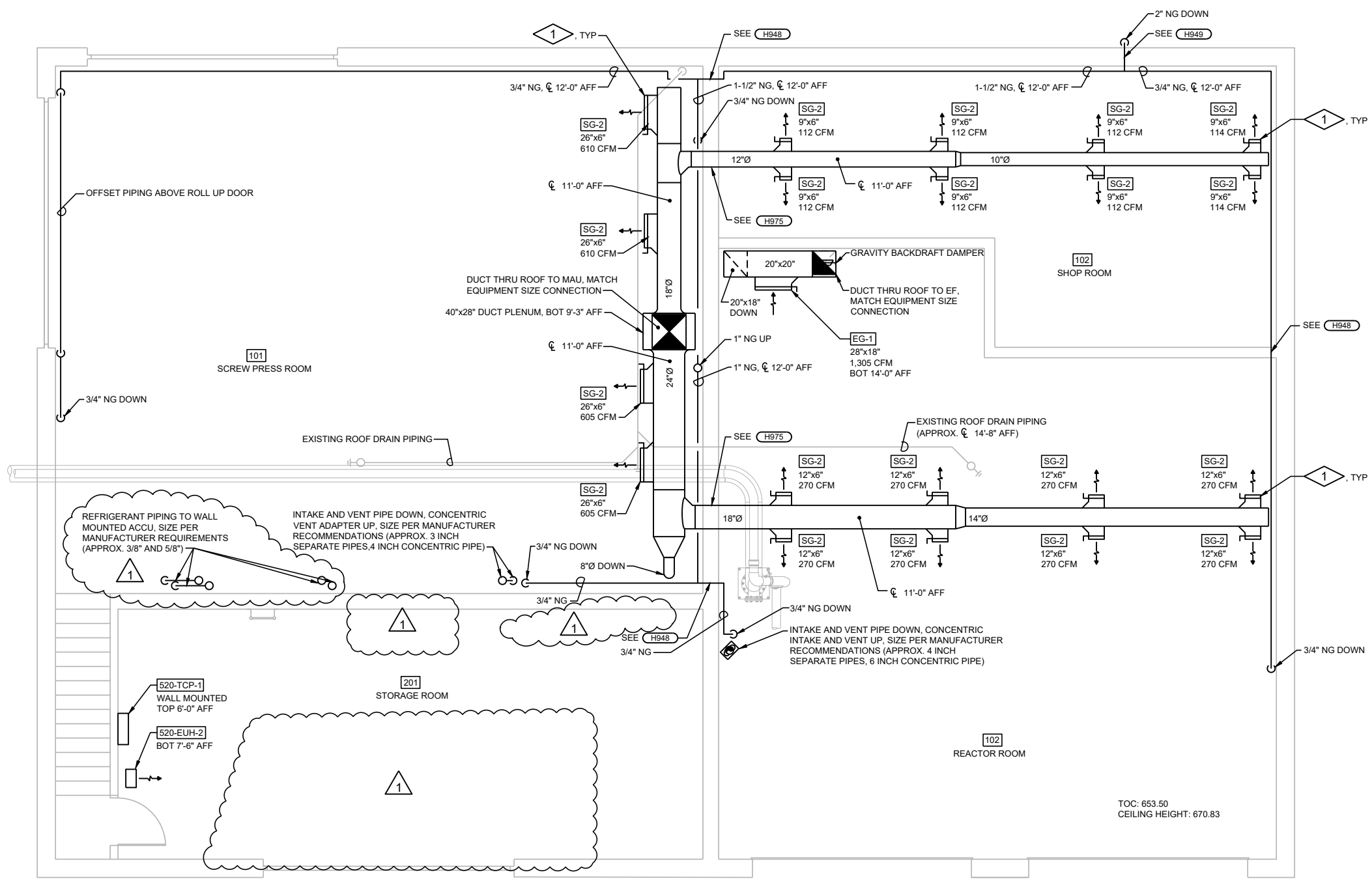

- GENERAL NOTES:**
- CONTRACTOR TO FIELD VERIFY EXISTING CONDITIONS, DIMENSIONS, AND ELEVATIONS PRIOR TO CONSTRUCTION AND/OR FABRICATION.
 - ALL GRILLES ON ROUND DUCTWORK INSTALLED AT 45-DEGREE ANGLE DOWN FROM HORIZONTAL.
 - CONTRACTOR TO REFER TO SPACE ENVIRONMENT AND HAZARDOUS RATING SCHEDULE PER 001-ENV-1 FOR HAZARDOUS RATINGS AND MATERIAL.

- PLAN NOTES:**
- GRILLE INSTALLED AT 45-DEGREE ANGLE DOWN FROM HORIZONTAL.

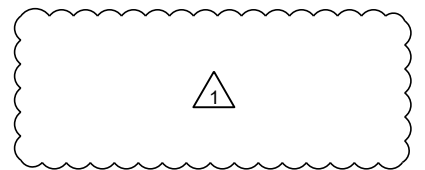

| Revision Number | Revision Description | Checked By | Date |
|-----------------|----------------------|------------|------------|
| 1 | RFI 30 | PML | 05/01/2023 |

| | |
|--------------|------------|
| Designed By | PML |
| Drawn By | PML |
| Checked By | JLW |
| Approved By | JLW |
| Filename | 520HP1.DWG |
| Project No. | 13756 |
| Project Date | JULY 2021 |

CITY OF CHARLESTON
WASTEWATER TREATMENT PLANT IMPROVEMENTS
CHARLESTON, ILLINOIS
SLUDGE HANDLING BUILDING PLAN

DONOHUE

Sheet No. 90
Drawing No. 520-H-2

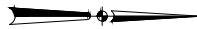

GENERAL NOTES:

1. CONTRACTOR TO FIELD VERIFY EXISTING CONDITIONS, DIMENSIONS, AND ELEVATIONS PRIOR TO CONSTRUCTION AND/OR FABRICATION.
2. CONTRACTOR TO REFER TO SPACE ENVIRONMENT AND HAZARDOUS RATING SCHEDULE PER 001-ENV-1 FOR HAZARDOUS RATINGS AND MATERIAL.

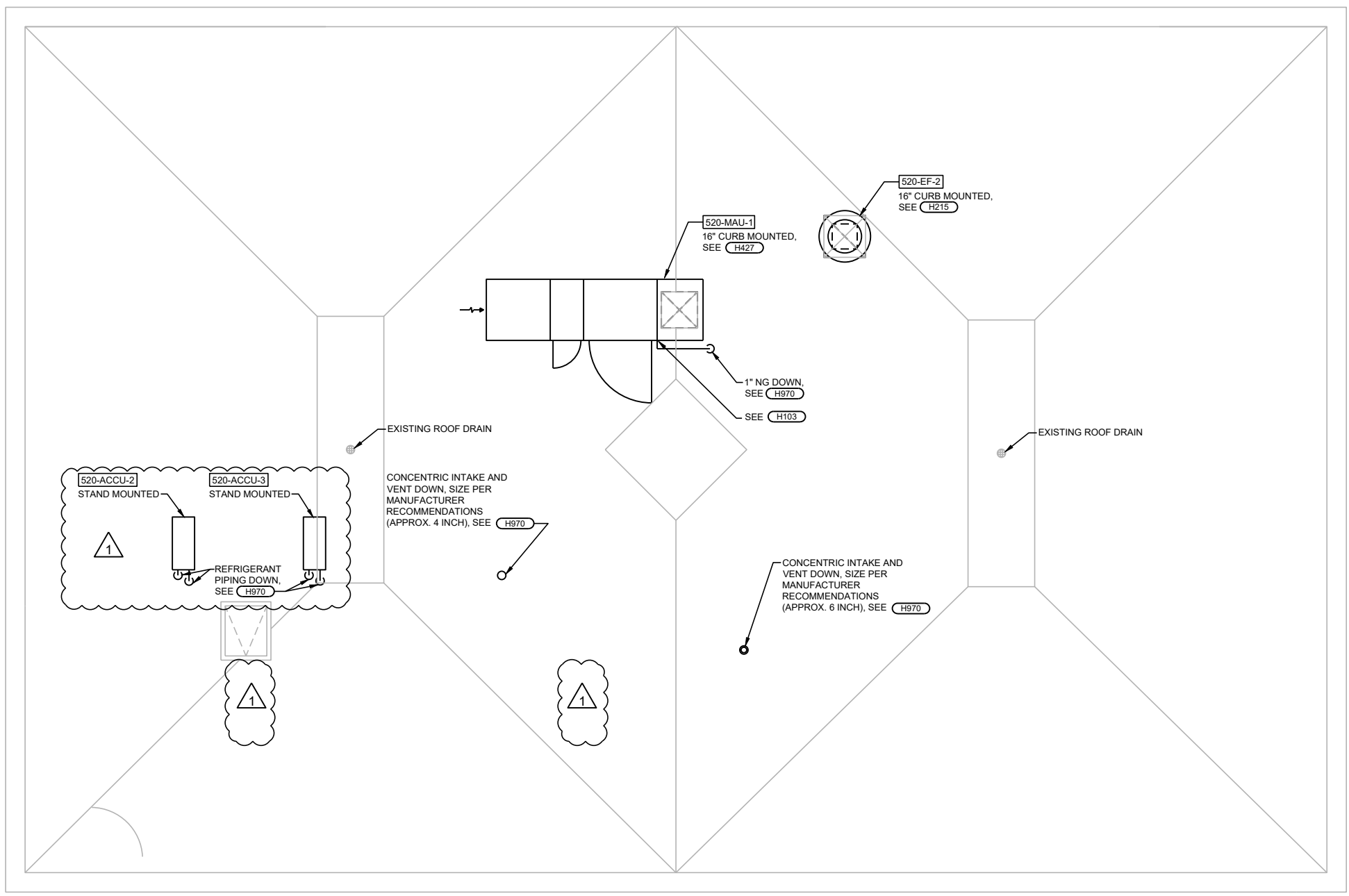

ROOF PLAN
 0 1' 4'

| Revision Number | Revision Description | Drawn By | Checked By | Date |
|-----------------|----------------------|----------|------------|------------|
| 1 | RFI 30 | PML | PML | 05/01/2023 |

Designed By: PML

Drawn By: PML

Checked By: JLW

Approved By: JLW

Filename: 520HP1.DWG

Project No.: 13756

Project Date: JULY 2021

**CITY OF CHARLESTON
 WASTEWATER TREATMENT PLANT IMPROVEMENTS
 CHARELSTON, ILLINOIS
 SLUDGE HANDLING BUILDING
 PLAN**



Sheet No. 91

Drawing No.

520-H-3

| DOOR SCHEDULE | | | | | | | | | | | | S602 |
|---------------|----------|--------|--------|-----------------|--------|---------|--------|----------|-------|---------|--------|---|
| STRUC. NO. | DOOR NO. | DOOR * | | | | | | | FRAME | | | REMARKS |
| | | TYPE | LINTEL | SIZE | | MATT'L. | FINISH | H.W. SET | TYPE | MATT'L. | FINISH | |
| | | | | WIDTH X HEIGHT | THK | | | | | | | |
| 210 | D01 | 1 | - | 3'-8"X7'-2" | 1-3/4" | GHM | COAT | 8 | 1 | GHM | COAT | |
| | D02 | 1 | - | (2) 3'-0"X7'-0" | 1-3/4" | GHM | COAT | 9 | 2 | GHM | COAT | |
| 220 | D01 | 1 | - | 3'-0"X7'-0" | 1-3/4" | GHM | COAT | 5 | 1 | GHM | COAT | |
| 520 | D01 | 2 | - | 16'-0"X12'-0" | 1-3/4" | GHM | - | - | 1 | STL | - | OVERHEAD COILING DOOR VERIFY EXISTING OPENING SIZE |
| | D02 | 1 | - | 3'-0"X7'-0" | 1-3/4" | GHM | COAT | 2 | 1 | GHM | COAT | |
| | D03 | 1 | - | 3'-0"X7'-0" | 1-3/4" | GHM | COAT | 5 | 1 | GHM | COAT | |
| | D04 | 1 | - | 3'-4"X7'-0" | 1-3/4" | GHM | COAT | 8 | 1 | GHM | COAT | |

KEY
 AL = ALUMINUM
 GHM = GALVANIZED HOLLOW METAL
 EXST = EXISTING

FRP = FIBERGLASS REINFORCED PLASTIC
 PNT = PAINT
 * ALL DOORS ARE TO BE INSULATED

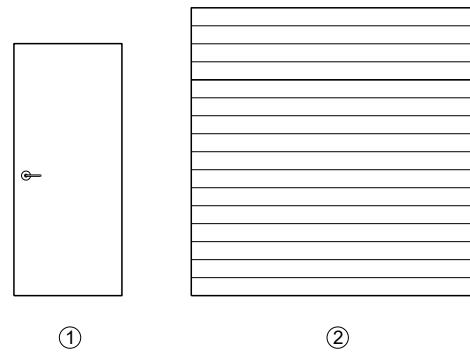

DOOR TYPE = (X)

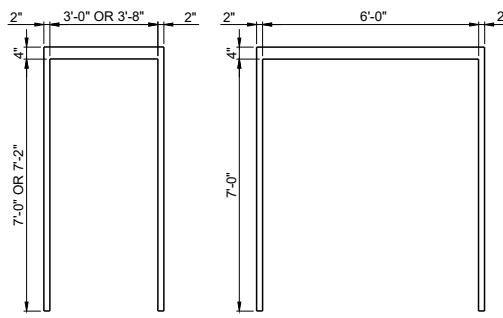

FRAME TYPE = (X)

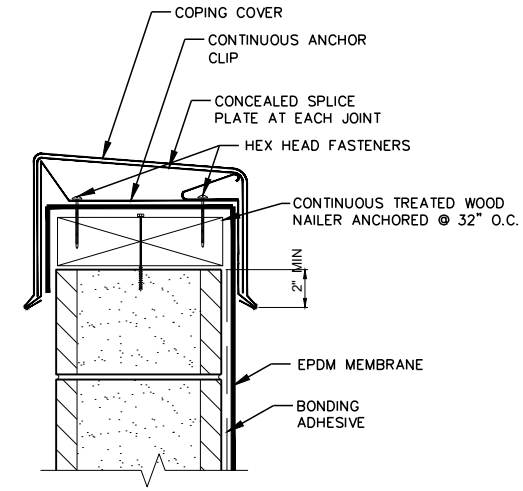

METAL COPING DETAIL S700
 NTS

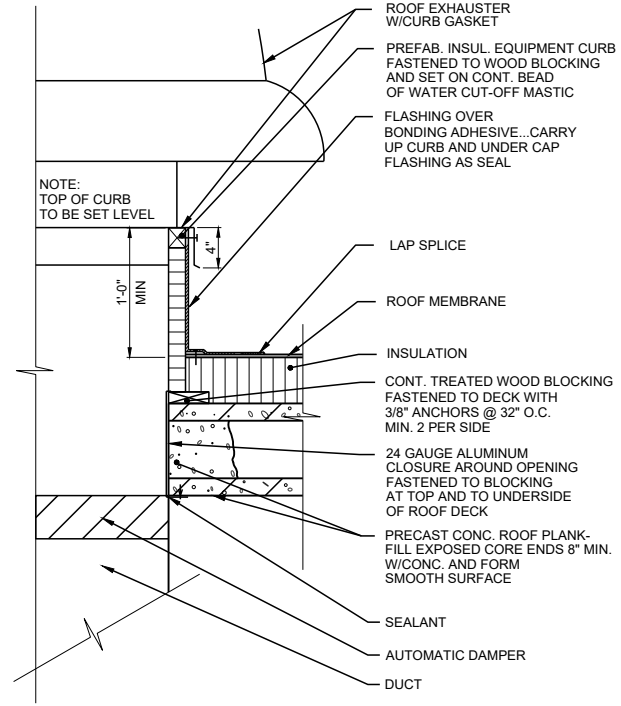

ROOF EXHAUSTER CURB DETAIL S774
 NTS

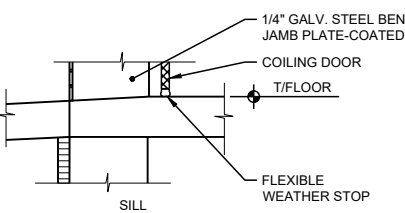
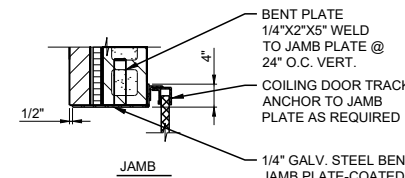
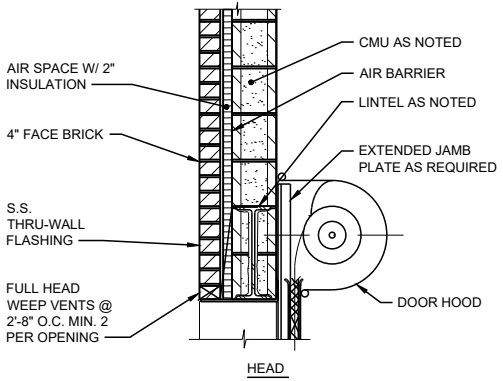

COILING DOOR S801
 NTS

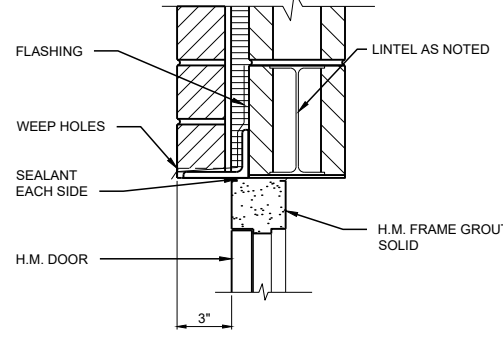

EXTERIOR H.M. FRAME DOOR HEAD S823
 NTS

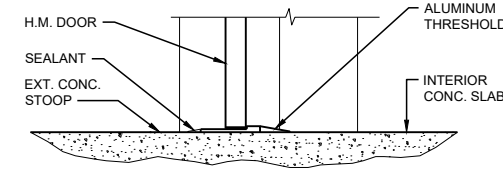

EXTERIOR H.M. FRAME DOOR SILL S825
 NTS

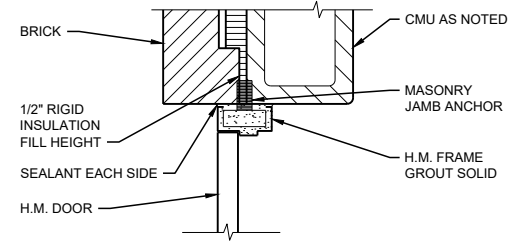

EXTERIOR H.M. FRAME DOOR JAMB S824
 NTS

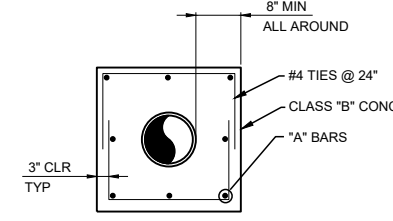

PIPE ENCASEMENT DETAIL S900
 NTS

| PIPE SIZE | "A" BARS |
|---------------------|----------|
| 4" AND SMALLER PIPE | 4-#4 |
| 5" TO 12" PIPE | 8-#4 |
| 14" TO 36" PIPE | 8-#5 |
| 42" AND LARGER PIPE | 12-#5 |

NOTE:
 EXTEND HORIZONTAL REINF. A MINIMUM OF 12" INTO STRUCTURE.

| Revision Number | Revision Description | Drawn By | Checked By | Date |
|-----------------|----------------------|----------|------------|------------|
| 1 | RFI 30 | CEE | CEE | 04/XX/2023 |

| | |
|--------------|------------|
| Designed By | CEE |
| Drawn By | CEE |
| Checked By | CLS |
| Approved By | CLS |
| Filename | 999SD1.DWG |
| Project No. | 13756 |
| Project Date | JULY 2021 |

CITY OF CHARLESTON
 WASTEWATER TREATMENT PLANT IMPROVEMENTS
 CHARELSTON, ILLINOIS
 STANDARD DETAILS
 STRUCTURAL



Sheet No. 103
 Drawing No.

City Council Regular Meeting

8)

Meeting Date: 08/01/2023

Submitted For: Steve Bennett, Fire Chief

Submitted By: Deborah Muller, City Clerk

TITLE:

RESOLUTION: Approving Bid for New Ambulance through Houston Galveston Area Council Purchasing Group.

STAFF RECOMMENDATION:

Waive layover period and approve.

Attachments

RES: Approving Purchase of Ambulance through HGAC Purchasing Group.

HGAC Purchasing Group Contract.

RESOLUTION

2023 – R – _____

RESOLUTION APPROVING BID FOR AMBULANCE

WHEREAS, the City of Charleston has a Capitol Fleet plan; and

WHEREAS, according to the Fire Department Fleet Plan, the 2016 Chevy AEV ambulance is due be replaced in the FY 25/26 Budget Year; and

WHEREAS, due to the current vehicle industry climate, there will be significant cost increases and delay in delivery; and

WHEREAS, it would be in the City's best interest to make an intent to purchase now, in order to shield us from further price increases; and

WHEREAS, Illinois State Statute 5 ILCS 220/2-3 provides that local units of government may enter into agreements with any other public agency within the United States; and

WHEREAS, the City of Charleston is a member of the Houston Galveston Area Council Purchasing Group; and

WHEREAS, the Houston Galveston Area Council Purchasing Group solicits for competitive bids for equipment and services; and

WHEREAS, American Response Vehicles has submitted a competitive bid for a 2023 or newer Ford F550 Type I Ambulance; and

WHEREAS, the funding will be budgeted for in the Fiscal year 25/26 Budget; and

WHEREAS, purchase of a new ambulance is consistent with the Fire Department Fleet Plan;

NOW, THEREFORE, BE IT HEREBY RESOLVED by the City Council of the City of Charleston that the bid is accepted and shall be awarded to American Response Vehicles for the amount of \$293,582.

INTRODUCED to Council this _____ day of _____ 2023.

PASSED by Council this _____ day of _____ 2023

APPROVED by the Mayor this _____ day of _____ 2023.

| | Aye | Nay | Abstain | Absent |
|----------------------|-----|-----|---------|--------|
| Mayor: | | | | |
| <i>Brandon Combs</i> | | | | |
| | | | | |
| City Council: | | | | |
| <i>Dennis Malak</i> | | | | |
| <i>Matthew Hutti</i> | | | | |
| <i>Jeff Lahr</i> | | | | |
| <i>Tim Newell</i> | | | | |

Mayor

ATTEST:

City Clerk



CONTRACT PRICING WORKSHEET
For MOTOR VEHICLES Only

Contract No.: AEV-AM10-20

Date Prepared: 26-Jul

This Worksheet is prepared by Contractor and given to End User. If a PO is issued, both documents MUST be faxed to H-GAC @ 713-993-4548. Therefore please type or print legibly.

| | | | |
|-----------------|------------------------------------|--------------|----------------------------|
| Buying Agency: | City of Charleston Fire Department | Contractor: | American Response Vehicles |
| Contact Person: | Steve Bennett | Prepared By: | Grant Godwin |
| Phone: | 217-345-8441 | Phone: | 573-443-8881 |
| Fax: | 217-345-8443 | Fax: | 573-815-0051 |
| Email: | bennett.steve@co.coles.il.us | Email: | grant@arvambulance.com |

| | | | |
|---------------|----------|--------------|-----------------------------------|
| Product Code: | AM20AA04 | Description: | TYPE I, FORD F550 TRAUMAHAWK 172" |
|---------------|----------|--------------|-----------------------------------|

| | |
|---|--------|
| A. Product Item Base Unit Price Per Contractor's H-GAC Contract: | 187104 |
|---|--------|

B. Published Options - Itemize below - Attach additional sheet(s) if necessary - Include Option Code in description if applicable.
(Note: Published Options are options which were submitted and priced in Contractor's bid.)

| Description | Cost | Description | Cost |
|---|------|-------------|-------|
| See Attached Sheets | | | |
| | | | |
| | | | |
| | | | |
| | | | |
| | | | |
| | | | |
| | | | |
| | | | |
| | | | |
| | | | |
| | | | |
| | | | |
| Subtotal From Additional Sheet(s): | | | 41271 |
| Subtotal B: | | | 41271 |

C. Unpublished Options - Itemize below / attach additional sheet(s) if necessary.
(Note: Unpublished options are items which were not submitted and priced in Contractor's bid.)

| Description | Cost | Description | Cost |
|---|------|-------------|-------|
| See Attached Sheets | | | |
| | | | |
| | | | |
| Subtotal From Additional Sheet(s): | | | 28639 |
| Subtotal C: | | | 28639 |

| | | |
|--|---|-----|
| Check: Total cost of Unpublished Options (C) cannot exceed 25% of the total of the Base Unit Price plus Published Options (A+B). | For this transaction the percentage is: | 13% |
|--|---|-----|

D. Total Cost Before Any Applicable Trade-In / Other Allowances / Discounts (A+B+C)

| | | | | | | |
|-------------------|---|--------------------------|--------|---|-------------|--------|
| Quantity Ordered: | 1 | X Subtotal of A + B + C: | 257014 | = | Subtotal D: | 257014 |
|-------------------|---|--------------------------|--------|---|-------------|--------|

E. H-GAC Order Processing Charge (Amount Per Current Policy)

| | |
|-------------|------|
| Subtotal E: | 1000 |
|-------------|------|

F. Trade-Ins / Special Discounts / Other Allowances / Freight / Installation / Miscellaneous Charges

| Description | Cost | Description | Cost |
|---------------------|-------|-------------|-------|
| See Attached Sheets | 35568 | | |
| | | | |
| | | | |
| Subtotal F: | | | 35568 |

| | | | |
|-----------------------|--------------------|---|--------|
| Delivery Date: | 720-900 ARO | G. Total Purchase Price (D+E+F): | 293582 |
|-----------------------|--------------------|---|--------|

| Part No | Published Options | Qty | Each | Extended |
|------------|--|-----|------|----------|
| 01-00-0001 | Chassis Upgrade: Ford Chassis to 4x4 | 1 | 3565 | 3565 |
| 02-00-3000 | *****WIDE AISLE UNIT - 50 3/4" Wide ILOS***** | 1 | 197 | 197 |
| 02-B0-CC1B | Compartment Ventilation - M-1A Pancake Fan & 1-Column of Louvers | 1 | 64 | 64 |
| 02-B1-M1BB | M-1a Compt (LF Upper): 72 HR, 17.56" H x 22.125" W x 19.5" D | 1 | 523 | 523 |
| 02-B2-1096 | Body, Mod: Type 1 LWB, 172" x 95" x 72" Interior HR - 6" Body Drop F | 1 | 450 | 450 |
| 02-BC-0502 | Walk through, Cab Height, T1 Light Truck 2017 + Ford | 1 | 806 | 806 |
| 02-BD-0120 | Body Drop: 6" Both Sides, Ahead of Rear Wheels | 1 | 197 | 197 |
| 02-W1-WW06 | Wheel well Closeout: Interior, Rounded Speedliner Dark Gray | 1 | 254 | 254 |
| 04-AS-0200 | Fuel over Fill protection plate: Diamond plate | 1 | 40 | 40 |
| 04-AS-0420 | DEF over fill protection plate: Diamond plate | 1 | 40 | 40 |
| 04-EA-1460 | Running Boards: DP F-Series Modular - 2 Door 2017+ | 1 | 340 | 340 |
| 04-HA-1310 | ARCTIC WEDGE Condenser Cover: Install on Front Body over Condenser | 1 | 1466 | 1466 |
| 04-TS-1016 | Tool plate on uni-strut, .125 Smooth Aluminum/DA sanded in compartment | 3 | 88 | 264 |
| 04-TS-11B0 | Shelf, Adjustable, Ext: .125 Aluminum, 2" Upward Lips | 1 | 142 | 142 |
| 04-TS-HOOK | Hooks, Equipment, (1 Pair) FW-559, Installed | 1 | 80 | 80 |
| 04-TS-STR3 | Strap: 2" Webb, w/ Chrome Metal Seatbelt buckle w footman loops IATS | 3 | 20 | 60 |
| 05-EL-2420 | Stop/Tail, Whelen M6 Series, LED, Pair | 1 | 252 | 252 |
| 05-EL-2426 | Turn, Whelen M6 Series, LED, Pair | 1 | 224 | 224 |
| 05-EL-2432 | Back up, Whelen M6 Series, LED, Pair | 1 | 326 | 326 |
| 05-EL-252B | Red/White LED POB Light, Each | 10 | 47 | 470 |
| 05-EL-35A6 | Side Marker Lts: (2) Whelen M6 LED Red Running/Turn, ILOS | 1 | 326 | 326 |
| 05-EL-40N1 | Light, Compt, LED, M-1 (LF): Intertek Model No ZY-156-LEDC, ILOS | 1 | 15 | 15 |
| 05-EL-40N3 | Light, Compt, LED, M-3 (LR): Intertek Model No ZY-156-LEDC, ILOS | 1 | 15 | 15 |
| 05-EL-40N5 | Light, Compt, LED, M-5 (RR): Intertek Model No ZY-156-LEDC, ILOS | 1 | 15 | 15 |
| 05-EL-40NB | Light, Compt, LED, M-1A (LF Upper): Intertek Model No ZY-156-LEDC, ILOS | 1 | 15 | 15 |
| 05-EL-45L4 | Left Scene Lights: (2) LED-M9, Chrome Flange Whelen | 1 | 760 | 760 |
| 05-EL-45T4 | Right Scene Lights: (2) LED-M9, Chrome flange Whelen | 1 | 760 | 760 |
| 05-EL-46R4 | Rear Load Lights: (2) LED-M9, Chrome flange Whelen | 1 | 760 | 760 |
| 05-EL-4951 | Light, Compartment: Kinequip #108818C 8", Strip Light, M-2, ILOS | 1 | 17 | 17 |
| 05-EL-4956 | Light, Compartment: Kinequip #108818C 8", Strip Light, M-7, ILOS | 4 | 45 | 180 |
| 05-EL-4965 | Light, Compartment: LED, Intertek #ZY-156-LEDC, Additional, Each | 1 | 47 | 47 |
| 05-EL-4966 | Light, Compartment: Kinequip #108818C 8", Strip Light, Additional, Each | 2 | 45 | 90 |
| 05-FS-1212 | Opt A Programmable Lights Split Color - Color 1 Flashes Opposite Color 2 | 5 | 20 | 100 |
| 05-HB-1310 | Condenser, 12V: Pro -Air Dual Fan, FRKG 126 Front of Body over Cab | 1 | 662 | 662 |
| 05-IL-09SZ | ILOS Lt, Step Well: 3" Kin#4302S LED stainless steel surface mount housing | 1 | 25 | 25 |
| 05-IL-12ML | Cab Ovhd Lights: Pair, Kinequip 440912WB, Red/White LED | 1 | 135 | 135 |
| 05-IL-2035 | Pre-wire, (1), For Customer Installed Rechargeable Flashlight, | 1 | 49 | 49 |
| 05-PH-LT19 | Lights: (2) Whelen 5TIR6, (1) RED & (1) BLUE LED W/ Clear Lens ILOS | 1 | 54 | 54 |
| 05-PM-LQ06 | LED M6 Amber - Each | 1 | 162 | 162 |
| 05-PM-LRC3 | Light, Whelen LED M7 Red/Blue LED/Clear Lens - Programmable | 2 | 169 | 338 |
| 05-PM-LRK1 | Light: Whelen M9, LED, WHITE LED/CLEAR Lens, Programmable ea ilos | 1 | 295 | 295 |
| 05-PM-LRM1 | Light: Whelen M9, LED, Split RED/BLUE LED/CLEAR Lens, Programmable ILOS | 8 | 336 | 2688 |
| 05-PM-LT04 | Light: Whelen M9, LED, RED LED/CLEAR Lens, Non-Programmable IATS | 2 | 280 | 560 |
| 05-PM-LT26 | Light: Whelen M9, LED, Split RED/BLUE LED/CLEAR Lens, Programmable IATS | 4 | 390 | 1560 |
| 06-00-0043 | Secure Idle System Ford Super Duty 2020+ Installed | 1 | 331 | 331 |
| 06-AL-4802 | Hand Held Spot Light: Eagle Eye, Rubber Housing, Hard Wired to console | 1 | 135 | 135 |
| 06-EC-03A3 | Radio Power No 3: 30A, Pos and Neg, 10 awg Wires | 1 | 34 | 34 |
| 06-EC-03CK | (1) Buss Bar 150 Amp,Dual Bus Plus 20 Stud 5 Gang 1/4" | 1 | 76 | 76 |
| 06-EC-050A | Door Locks, Tied into OEM System Type 1 Ford | 1 | 259 | 259 |
| 06-EC-05M1 | Electric Door Lock: (M-1) Left Front Compartment | 1 | 109 | 109 |
| 06-EC-05M2 | Electric Door Lock: (M-2) Left Middle Compartment | 1 | 109 | 109 |
| 06-EC-05M4 | Electric Door Lock: (M-3) Left Rear Compartment | 1 | 109 | 109 |
| 06-EC-05M6 | Electric Door Lock: Rear Access Doors | 1 | 109 | 109 |
| 06-EC-05M7 | Electric Door Lock: (M-5) Right Rear Compartment | 1 | 109 | 109 |
| 06-EC-05N0 | Electric Door Lock: Curbside Access Door | 1 | 109 | 109 |
| 06-EC-05N1 | Electric Door Lock: (M-7) Right Front Compt | 1 | 109 | 109 |
| 06-EC-08A0 | Battery Switch & Auto-Shut-down (Circuit): 5 Minute ILOS driver seat base | 1 | 243 | 243 |
| 06-EC-1000 | Timer, Spring Wound, Constant Hot, Check out, 60 Minute | 1 | 100 | 100 |
| 06-EC-2800 | Door Unlock Switch, Momentary, Exterior, hidden | 1 | 46 | 46 |

| | | | | |
|------------|--|---|------|------|
| 06-EC-31FW | Patient Area Bullet Camera: Voyager VCCYL37 | 1 | 276 | 276 |
| 06-EC-CBZ2 | Circuit Board, 12V: Multiplex LX1 F3/4/550 ILOS | 1 | 6468 | 6468 |
| 06-EL-1800 | Add Activation: Rearward Left and Right scene lights. come on w/ Reverse | 1 | 46 | 46 |
| 06-EL-2497 | Brake Light Override: Wire into rear warning lights above LX-1 elec syst. | 1 | 17 | 17 |
| 06-IG-0310 | Inverter : Vanner 20-1050 CUL-DC - Full Mod | 1 | 1359 | 1359 |
| 06-RR-0700 | (2) Speakers: Stereo, patient compartment, in center pad | 1 | 68 | 68 |
| 06-RR-1710 | Antenna Base w/ Coaxial Cable: KE794 #1 | 1 | 47 | 47 |
| 06-RR-1712 | Antenna Base w/ Coaxial Cable: KE794 #2 | 1 | 47 | 47 |
| 06-RR-1714 | Antenna Base w/ Coaxial Cable: KE794 #3 | 1 | 47 | 47 |
| 06-SO-0500 | Shore Line Inlet: 20A Super Auto Eject, ILOS | 1 | 349 | 349 |
| 06-SO-10TT | Inpower Timer: VCM-05-01SF, Installed | 1 | 68 | 68 |
| 06-SO-1103 | 12V Outlet, No 3: Power Point - Wire thru Med Isolator | 1 | 49 | 49 |
| 06-SO-1127 | Hard Wired 12V Circuit, For Customer/Dealer Supplied Component | 1 | 29 | 29 |
| 06-SO-1161 | 12V Outlet, DUAL USB Fast 4.8A,. 2.4 A per slot Round IATS EACH | 1 | 83 | 83 |
| 06-SO-13M1 | 125 VAC W Dual USB & Power Light Outlet, No 1: 20A, Hospital Grade, White ILOS | 1 | 64 | 64 |
| 06-SO-13M2 | 125 VAC W Dual USB & Power Light Outlet, No 2: 20A, Hospital Grade, White ILOS | 1 | 64 | 64 |
| 06-SO-1403 | 125 VAC Outlet, No 3: 15A, Hospital Grade, IVORY | 1 | 90 | 90 |
| 06-SO-1404 | 125 VAC Outlet, No 4: 15A, Hospital Grade, IVORY | 1 | 90 | 90 |
| 06-SO-1405 | 125 VAC Outlet, No 5: 15A, Hospital Grade, IVORY | 1 | 90 | 90 |
| 06-SS-11A3 | Siren: Carson, SA441M, Mforce - Mech, 200watt, ILOS F | 1 | 594 | 594 |
| 06-SS-DF00 | Siren Speakers: Federal # ES100-ESMFT-EF, Ford F-350/450/550 2017 ILOS | 1 | 72 | 72 |
| 07-01-SEK2 | Att Seat:EVS, 1882P4B 6 Deg Child Safety Seat Gunmetal ,Per4Max Black | 1 | 653 | 653 |
| 07-BK-0002 | Bulkhead Cabinet Above Talk Thru: Installed IATS, See Drawing | 1 | 324 | 324 |
| 07-CA-0300 | CURBSIDE UPPER: Over S/B, Mods | 1 | 439 | 439 |
| 07-CA-0400 | CURBSIDE REAR: Rear of S/B, Mods | 1 | 439 | 439 |
| 07-CA-04A9 | Cabinet, (2) Glove Storage, over Rear Entry Doors | 1 | 366 | 366 |
| 07-CA-04AB | Cabinet, (4) Glove Storage, 45° Section of RF ALS cabinet, IATS | 1 | 490 | 490 |
| 07-CU-K107 | Cabinet K1 & K2: (2) Openings with flush center divider | 2 | 85 | 170 |
| 07-DR-M052 | EZ- Reach Double doors ALS 1/2 LOS | 3 | 119 | 357 |
| 07-HW-SO11 | Round Pull Latch: Non-locking - Chrome Finish | 9 | 30 | 270 |
| 07-HW-SO12 | Round Pull Latch: Locking - Chrome Finish | 3 | 33 | 99 |
| 07-RR-020F | Add-on Console: Type 1 | 1 | 191 | 191 |
| 07-RR-02A0 | Drink Holder: (2) In Add-on Console, Big Gulp Size | 2 | 22 | 44 |
| 07-RR-02F0 | Note Book Slot: Single - Full width by 6" wide | 1 | 55 | 55 |
| 07-RR-02F3 | Double removable Lexan Divider(s) | 1 | 31 | 31 |
| 07-RR-2354 | Glove Storage: (3) Glove Box Storage Across Rear of add on console | 1 | 67 | 67 |
| 07-SB-1022 | Bio-waste/Sharps No 1: (1) Tilt-out Door (Wall cabinet) | 1 | 286 | 286 |
| 07-SB-1101 | Bio-waste/Sharps No 1: Roll-out DRAWER | 1 | 398 | 398 |
| 07-SE-0901 | BASE: Swivel base for EVS Child Seat Option Handle on RIGHT std | 1 | 171 | 171 |
| 07-TC-C641 | Cabinet Over CPR: Over 24" wide Side seat | 1 | 277 | 277 |
| 07-WC-SS02 | Side Seat: 24" - Single Position - Under Lid Storage w/Latch | 1 | 202 | 202 |
| 08-00-FL27 | Flooring: Lonplate - #164 Gunmetal (Gray) | 1 | 301 | 301 |
| 08-CR-1001 | 12v power for cot mount provided up through floor | 1 | 44 | 44 |
| 08-MH-0319 | Grab Handle, CS Entry: (1) 3-pt "L" Shaped 90, Gray Antimicrobial New 5-12-16 | 1 | 126 | 126 |
| 08-MH-03E9 | Grab Handles, Rear Access: (2) 3-pt "L" Shaped 90, Gray Antimicrobial New 5-12 | 1 | 249 | 249 |
| 08-OS-0403 | Oxygen Outlet No 3: Amico Console - Ohmeda/Ohio Diamond Style | 1 | 159 | 159 |
| 08-OS-0404 | Oxygen Outlet No 4: Amico Console - Ohmeda/Ohio Diamond Style | 1 | 159 | 159 |
| 08-OS-0904 | Port Cyl Rack No 1: Zico QR-D-2 - D or Jumbo D - No Strap Req | 1 | 333 | 333 |
| 08-OS-13Y0 | Rack No 1: Cylinder Adjustable W QR-MV & Zico Pull Straps compliant ilos | 1 | 155 | 155 |
| 08-OS-13Y2 | Rack No 2: cylinder Adjustable W QR-MV & Zico Pull Straps compliant | 1 | 344 | 344 |
| 08-OS-1400 | Electric Oxygen, 12V solenoid valve w/ manual by-pass | 2 | 128 | 256 |
| 08-OS-1755 | Transducer, Additional, LX-1 system | 1 | 396 | 396 |
| 09-00-001D | Soft Touch Trim Kit: Installed (Per Cabinet) - ILOS | 1 | 75 | 75 |
| 09-FE-05SS | Fire Extinguisher, 5 pound, Kidde ABC Installed, ILOS | 1 | 17 | 17 |
| 09-FE-05ST | Fire Extinguisher, 5 pound, Installed, IATS | 1 | 68 | 68 |
| 09-FM-1093 | Dri-Dek Compt Floors and shelves, Black | 1 | 358 | 358 |
| 09-FM-11F0 | Dri-Dek EDGES: Black, Beveled frontal edges | 1 | 51 | 51 |
| 09-MH-0801 | IV Hook No 1: CPI Rubber IV 2008-1(Recessed Mount), ILOS | 1 | 106 | 106 |
| 09-MH-0802 | IV Hook No 2: CPI Rubber IV 2008-1(Recessed Mount), ILOS | 1 | 106 | 106 |
| 09-MH-08A3 | IV Hook No 3: Hook 07 w/ Velcro bag stabilizer - IATS | 1 | 23 | 23 |

| | | | | |
|------------|--|---|-----|-----|
| 09-MH-08A3 | IV Hook No 3: Hook 07 w/ Velcro bag stabilizer - IATS | 1 | 23 | 23 |
| 09-MH-2706 | Grab Rail, C/S wall, curve out over C/S Entry, Yellow Antimicrobial | 1 | 128 | 128 |
| 09-MH-2AS2 | Streetside Non-Recess Grab Rail, 1.25 Dia..... x 72", 3 point, Yellow | 1 | 160 | 160 |
| 09-WI-0601 | UPPER Window: CS Access, Fold Out Glass, std tint ILOS | 1 | 82 | 82 |
| 10-RR-0600 | Volume Control, Stereo: in A/A, For Rear speakers | 1 | 28 | 28 |
| 11-MC-1100 | Clock, Aviation Style, 6" Round, 24 Hour, Battery Powered | 1 | 90 | 90 |
| 12-B0-0004 | Painted Part- Painted Special color to match Body | 1 | 67 | 67 |
| 12-PT-03B0 | Box Roof Oxford White (YZ) ILO Over All, wraps down to Bottom of drip rail | 1 | 562 | 562 |
| 13-RF-STAR | Decals: Install 32" Star of Life on Mod Roof | 1 | 24 | 24 |
| 25-PH-LT84 | LED Lights: Programmable, Single Light | 6 | 10 | 60 |

41271

| Unpublished Options | Qty | Each | Extended |
|---|-----|------|----------|
| Change Ford F-Series Chassis Year Model from 2020 to 2021 | 1 | 910 | 910 |
| Change Ford F-Series Chassis Year Model from 2021 to 2022 | 1 | 725 | 725 |
| 2022 Ford F-Series Chassis Surcharge #1 | 1 | 1595 | 1595 |
| 2022 Ford F-Series Chassis Surcharge #2 | 1 | 1250 | 1250 |
| 2022 Ford F-Series Chassis Surcharge #3 | 1 | 1115 | 1115 |
| Change Ford F-Series Chassis Year Model from 2022 to 2024 | 1 | 4355 | 4355 |
| Change Gas Engine to Diesel Engine | 1 | 8500 | 8500 |
| Increase Box size to 176x95x74 | 1 | 800 | 800 |
| M5 Dividers and Shelves | 1 | 255 | 255 |
| Vanner Lifesine 1100 Pure Sine Wave Inverter | 1 | 1625 | 1625 |
| Walk Through Door: Sliding, Into Pocket on Bulkhead | 1 | 564 | 564 |
| Paint and Graphics | 1 | 5860 | 5860 |
| Liquid Spring Surcharge | 1 | 1085 | 1085 |
| | | | 28639 |

| F. Trade-Ins / Special Discounts / Allowances / Freight / Installation / Misc. | Qty | Each | Extended |
|--|-----|--------|----------|
| Delivery | 1 | 1750 | 1750 |
| Final Inspection Trip for (1) Member to the Factory | 1 | 2200 | 2200 |
| AEV/REV Product Item Base & Published Option Price Increase - 11/1/2022 (4%) | 1 | 9135 | 9135 |
| AEV/REV Product Item Base & Published Option Price Increase - 2/1/2022 (9%) | 1 | 20553 | 20553 |
| AEV/REV Product Item Base & Published Option Price Increase - 6/6/2022 (7%) | 1 | 15986 | 15986 |
| AEV/REV Product Item Base & Published Option Price Increase - 10/6/2022 (7%) | 1 | 15986 | 15986 |
| Trade-In | 1 | -8000 | -8000 |
| ARV Discounts | 1 | -22042 | -22042 |
| | | | 35568 |

City Council Regular Meeting

9)

Meeting Date: 08/01/2023

Submitted For: Rachael Cunningham, City Attorney

Submitted By: Deborah Muller, City Clerk

TITLE:

ORDINANCE: Amending Title 3-3-12: Number of Licenses.

STAFF RECOMMENDATION:

Waive layover period and approve.

Attachments

ORD: Amending Title 3-3-12: Number of Licenses.

CITY OF CHARLESTON

ORDINANCE

2023-O-____

**AN ORDINANCE AMENDING THE CITY CODE OF ORDINANCES
CONCERNING TITLE III: BUSINESS AND LICENSE REGULATIONS:
CHAPTER 3: ALCOHOLIC BEVERAGES:
SECTION 12: NUMBER OF LICENSES**

ADOPTED BY THE MAYOR AND CITY COUNCIL
OF THE CITY OF CHARLESTON, COLES COUNTY, ILLINOIS
THIS 1ST DAY OF AUGUST 2023

PUBLISHED IN PAMPHLET FORM BY AUTHORITY OF THE MAYOR
AND CITY COUNCIL OF THE CITY OF CHARLESTON, COLES COUNTY, ILLINOIS
AS PROVIDED BY LAW THIS ____ DAY OF AUGUST 2023

ORDINANCE

2023 – O – _____

**AN ORDINANCE AMENDING THE CITY CODE OF ORDINANCES
CONCERNING TITLE III: BUSINESS AND LICENSE REGULATIONS:
CHAPTER 3: ALCOHOLIC BEVERAGES:
SECTION 12: NUMBER OF LICENSES**

WHEREAS, the City of Charleston (“City”) is a municipal corporation organized and existing under the Illinois Municipal Code, 65 ILCS 5/1-1-1 et seq.; and

WHEREAS, the City has established a comprehensive set of regulations concerning the regulation and licensure of those businesses selling alcoholic beverages within the City in Title III, Chapter 3 of the City Code, as amended (“Code”); and

WHEREAS, the corporate authorities of the City have determined that it would be in the best interests of the City and its residents to amend certain provisions of Title III, Chapter 3 of the City’s Code.

NOW, THEREFORE, BE IT ORDAINED BY THE MAYOR AND CITY COUNCIL OF THE CITY OF CHARLESTON, COLES COUNTY, ILLINOIS, AS FOLLOWS:

SECTION ONE: RECITALS. The foregoing recitals shall be and are hereby incorporated into and made a part of this Ordinance as if fully set forth in the Sections 12.

SECTION TWO: AMENDMENT TO TITLE III, CHAPTER 3, SECTION 12

The following amendments are hereby made to Title III, Chapter 3, Section 12 of the City Code of Ordinances. Additions are indicated by underlined text; deletions are indicated by text with strikethrough.

3-3-12: NUMBER OF LICENSES:

The total number of licenses issued and in force at any one time in any one year shall not exceed the following:

| | |
|---------|-----|
| Class A | 5 |
| Class B | 4 |
| Class C | 19 |
| Class D | N/A |
| Class E | 8 |

| | |
|---------|------------|
| Class G | 1 |
| Class H | 1 |
| Class I | 1 |
| Class M | 3 <u>4</u> |

SECTION THREE. If any section, subsection, sentence, clause, phrase or portion of this Ordinance is for any reason held invalid or unconstitutional by any court of competent jurisdiction, such portion shall be deemed a separate, distinct, and independent provision and such holding shall not affect the validity of the remaining portions hereof.

SECTION FOUR: All prior Ordinances and Resolutions in conflict or inconsistent herewith are hereby expressly repealed only to the extent of such conflict or inconsistency.

SECTION FIVE: This Ordinance shall be in full force and effect upon passage, approval and publication in pamphlet form as provided by law.

APPROVED and ADOPTED by the Mayor and City Council of the City of Charleston this ____ day of _____, 2023 pursuant to roll call vote as follows:

INTRODUCED this ____ day of _____, 2023.

PASSED this ____ day of _____, 2023.

APPROVED this ____ day of _____, 2023.

| | Aye | Nay | Abstain | Absent |
|----------------------|-----|-----|---------|--------|
| Mayor: | | | | |
| Brandon Combs | | | | |
| City Council: | | | | |
| Matthew Hutti | | | | |
| Jeff Lahr | | | | |
| Dennis Malak | | | | |
| Tim Newell | | | | |

Mayor

ATTEST:

City Clerk