

Woody Mountain Apartments

2922 South Alvan Clark Boulevard, Flagstaff Arizona 86001
05/03/2023
#22065

CONTENTS

COVER	0.0
PROJECT INFORMATION	1.0
SITE PLAN	2.0
DETACHED GARAGES	2.1
TRASH ENCLOSURE & PERGOLA	2.2
FLOOR PLANS - CLUB-HOUSE (BUILDING A)	3.0
FLOOR PLANS - 24 UNIT (BUILDING B) - LEVEL 1	3.01
FLOOR PLANS - 24 UNIT (BUILDING B) - LEVEL 2	3.02
FLOOR PLANS - 24 UNIT (BUILDING B) - LEVEL 3	3.03
FLOOR PLANS - 24 UNIT (BUILDING C) - LEVEL 1	3.04
FLOOR PLANS - 24 UNIT (BUILDING C) - LEVEL 2	3.05
FLOOR PLANS - 24 UNIT (BUILDING C) - LEVEL 3	3.06
FLOOR PLANS - 36 UNIT (BUILDING D) - LEVEL 1	3.07
FLOOR PLANS - 36 UNIT (BUILDING D) - LEVEL 2	3.08
FLOOR PLANS - 36 UNIT (BUILDING D) - LEVEL 3	3.09
FLOOR PLANS - 65 UNIT (BUILDING E) - LEVEL -1 (EAST)	3.10
FLOOR PLANS - 65 UNIT (BUILDING E) - LEVEL -1 (WEST)	3.11
FLOOR PLANS - 65 UNIT (BUILDING E) - LEVEL 1 (EAST)	3.12
FLOOR PLANS - 65 UNIT (BUILDING E) - LEVEL 1 (WEST)	3.13
FLOOR PLANS - 65 UNIT (BUILDING E) - LEVEL 2 (EAST)	3.14
FLOOR PLANS - 65 UNIT (BUILDING E) - LEVEL 2 (WEST)	3.15
FLOOR PLANS - 65 UNIT (BUILDING E) - LEVEL 3 (EAST)	3.16
FLOOR PLANS - 65 UNIT (BUILDING E) - LEVEL 3 (WEST)	3.17
BUILDING SECTION AND WINDOW DETAILS	4.0
BUILDING PERSPECTIVES	5.0
BUILDING PERSPECTIVES	5.1
EXTERIOR ELEVATIONS - CLUBHOUSE (BLDG A) & SIGNAGE DETAILS	6.0
EXTERIOR ELEVATIONS - 24 UNIT (BUILDING B)	6.1
EXTERIOR ELEVATIONS - 24 UNIT (BUILDING C)	6.2
EXTERIOR ELEVATIONS - 36 UNIT (BUILDING D)	6.3
EXTERIOR ELEVATIONS - 65 UNIT (BUILDING E)	6.4
EXTERIOR ELEVATIONS - 65 UNIT (BUILDING E)	6.5



PROJECT TEAM

DEVELOPMENT

Roers Companies
Two Carlson Parkway, #400
Plymouth, MN 55447
(651) 395-0684

ARCHITECT

Kaas Wilson Architects
1301 American Blvd E, Suite 100
Bloomington, MN 55425
(612) 879-6000

CIVIL ENGINEER & LANDSCAPE ARCHITECT

WLB Group
500 North Beaver St.
Flagstaff, AZ 86001
(928) 779-1500



1 Vicinity Map
1" = 100'-0"

SITE METRICS

PARCEL
PARCEL ID 112-01-156
BLOCK 1 OF TIMBER SKY

ADDRESS 2922 S. ALVAN CLARK BLVD
FLAGSTAFF, AZ 86001

SITE AREA:
GROSS AREA ±11.62 ACRES (±506,167 SF)
NET AREA ±10.84 ACRES (±472,190 SF)

ZONING:
EXISTING ZONING HR (HIGH-DENSITY RESIDENTIAL)
PROPOSED HR (HIGH-DENSITY RESIDENTIAL)

HEIGHT:
ALLOWED: 60 FEET
PROVIDED: VARIES (SEE ELEVATION)

LOT COVERAGE:
REQUIRED: 50%
50% x 506,167 SF = 253,084 SF
PROVIDED: 101,604 SF / 459,964 SF = 22.09%

DENSITY
MAXIMUM ALLOWED: 22 D.U. / GROSS ACRE
PROVIDED GROSS: ±20.93 ACRES

CONSTRUCTION TYPE:
PROPOSED: TYPE V-A

OCCUPANCY TYPE:
BUILDING A (Group A-3)
BUILDING B-E (Group R-2)

FIRE SPRINKLER:
BUILDING A (13)
BUILDING B-D (13R)
BUILDING E (13)

PARKING:
REQUIRED PARKING (AFFORDABLE HOUSING):
1 BEDROOM / 1 BATH (15 D.U. x 1.0 P.S./D.U.) = 15 P.S.
2 BEDROOM / 2 BATH (113 D.U. x 1.5 P.S./D.U.) = 169.5 P.S.
3 BEDROOM / 3 BATH (93 D.U. x 1.5 P.S./D.U.) = 139.5 P.S.
GUEST - 2 & 3 BEDROOM (0.25 x 206 D.U.) = 51.5 P.S.
TOTAL REQUIRED: 377 P.S.

PROVIDED PARKING:
SURFACE PARKING 290 P.S.
UNDERGROUND GARAGE PARKING 64 P.S.
DETACHED GARAGE PARKING 19 P.S.
MOTORCYCLE PARKING 3 P.S.
ACCESSIBLE SURFACE PARKING 27 P.S. (1 in Detached Garage)
ACCESSIBLE GARAGE PARKING 3 P.S.
TOTAL PROVIDED: 377 P.S.

ACCESSIBILITY REQUIREMENTS:
TOTAL PARKING IN FACILITY 377 P.S.
REQUIRED MIN. ACCESSIBLE SPACES (1106.1) 9 P.S.
PROVIDED ACCESSIBLE SPACES 30 P.S.

GENERAL PARKING DIMENSIONS:
PARKING SPACE 9' x 18'
ACCESSIBLE SPACE 11' x 18'
AISLE WIDTH 24'
8 P.S. MAX PER 1 LANDSCAPE ISLAND

BUILDING SETBACKS

	REQUIRED	PROVIDED
FRONT (ALVAN CLARK WAY)	15'	16'
SIDE (ROUTE 66)	5'	16'(BUILDING)
SIDE (SOUTH PROPERTY LINE)	5'	108'(CLUBHOUSE)
REAR (EAST PROPERTY LINE)	15'	16'

BICYCLE PARKING REQUIREMENTS:
PROPOSED: 5% X 377 P.S. = 19 BIKE STALLS
5 PADS OF 3 BIKE STALLS 19 TOTAL
1 PAD OF 4 BIKE STALLS

22065 - Building Gross SF						
Building Type	Building Information	Level -1 Gross SF	Level 1 Gross SF	Level 2 Gross SF	Level 3 Gross SF	Gross Area per Bldg
Building A	Clubhouse	-	2,916 sf	-	-	2,916 sf
Building B	Dwelling Units: 24	-	8,925 sf	8,925 sf	8,925 sf	26,775 sf
Building C1	Dwelling Units: 24	-	8,925 sf	8,925 sf	8,925 sf	26,775 sf
Building C2	Dwelling Units: 24	-	8,925 sf	8,925 sf	8,925 sf	26,775 sf
Building C3	Dwelling Units: 24	-	8,925 sf	8,925 sf	8,925 sf	26,775 sf
Building C4	Dwelling Units: 24	-	8,925 sf	8,925 sf	8,925 sf	26,775 sf
Building D	Dwelling Units: 36	-	13,690 sf	13,690 sf	13,690 sf	41,070 sf
Building E	Dwelling Units: 65	23,182 sf	23,182 sf	23,182 sf	23,182 sf	92,728 sf
Garage A	Enclosed Parking: 5 stalls	-	1,323 sf	-	-	1,323 sf
Garage B	Enclosed Parking: 7 stalls	-	1,719 sf	-	-	1,719 sf
Garage C	Enclosed Parking: 7 stalls	-	2,100 sf	-	-	2,100 sf
Grand Totals						275,731 sf

UNIT MIX - GROSS AREA

Name	Count	Unit Gross Area		%
		Main Floor	Total Area	
Building B, C2, C4				
Unit 2-0	11	902 ft ²	9,922 ft ²	7%
Unit 2-0 Type A	1	902 ft ²	902 ft ²	1%
Unit 4-0	12	1,153 ft ²	13,838 ft ²	8%
	24		24,662 ft ²	16%

Building C1, C3				
Unit 2-0	12	902 ft ²	10,824 ft ²	8%
Unit 4-0	11	1,153 ft ²	12,685 ft ²	7%
Unit 4-0 Type A	1	1,153 ft ²	1,153 ft ²	1%
	24		24,662 ft ²	16%

Building D				
Unit 2-0	10	902 ft ²	9,020 ft ²	7%
Unit 2-0 Type A	2	902 ft ²	1,804 ft ²	1%
Unit 2-3	3	936 ft ²	2,808 ft ²	2%
Unit 4-0	13	1,153 ft ²	14,991 ft ²	9%
Unit 4-0 Type A	2	1,153 ft ²	2,306 ft ²	1%
Unit 4-1	3	1,161 ft ²	3,483 ft ²	2%
Unit 4-3	3	1,153 ft ²	3,459 ft ²	2%
	36		37,872 ft ²	24%

Building E				
Unit 1-0	8	716 ft ²	5,729 ft ²	5%
Unit 1-0 Type A	1	716 ft ²	716 ft ²	1%
Unit 1-0E	3	699 ft ²	2,096 ft ²	2%
Unit 1-1	3	719 ft ²	2,156 ft ²	2%
Unit 2-2	24	883 ft ²	21,196 ft ²	16%
Unit 2-2 Type A	2	883 ft ²	1,766 ft ²	1%
Unit 2-2B	12	883 ft ²	10,598 ft ²	8%
Unit 4-2	11	1,228 ft ²	13,508 ft ²	7%
Unit 4-2 Type A	1	1,228 ft ²	1,228 ft ²	1%
	65		58,994 ft ²	44%
Grand total	221		146,190 ft ²	100%

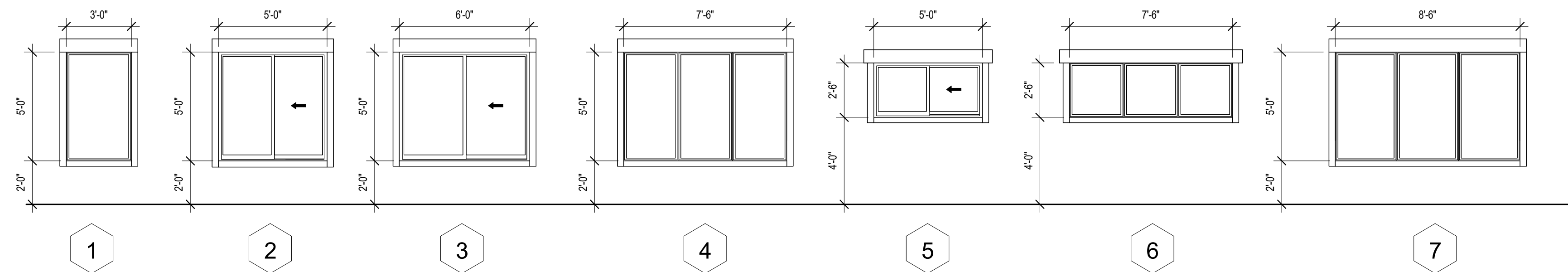

Window Elevations
1/4" = 1'-0"



COLORED SITE PLAN PALETTE

ASPHALT	
SIDEWALK 1	
PATIO	
GRASS 1	
GRASS 2	
BUILDING	
GARAGE	
RETAINING WALL	
TRASH ENCLOSURE	
BIKE RACK	
DOG RUN	
PARK/PLAYGROUND	
EV = EV READY STALLS	

1 Arch Site Plan (For City Submission)
1" = 40'-0"

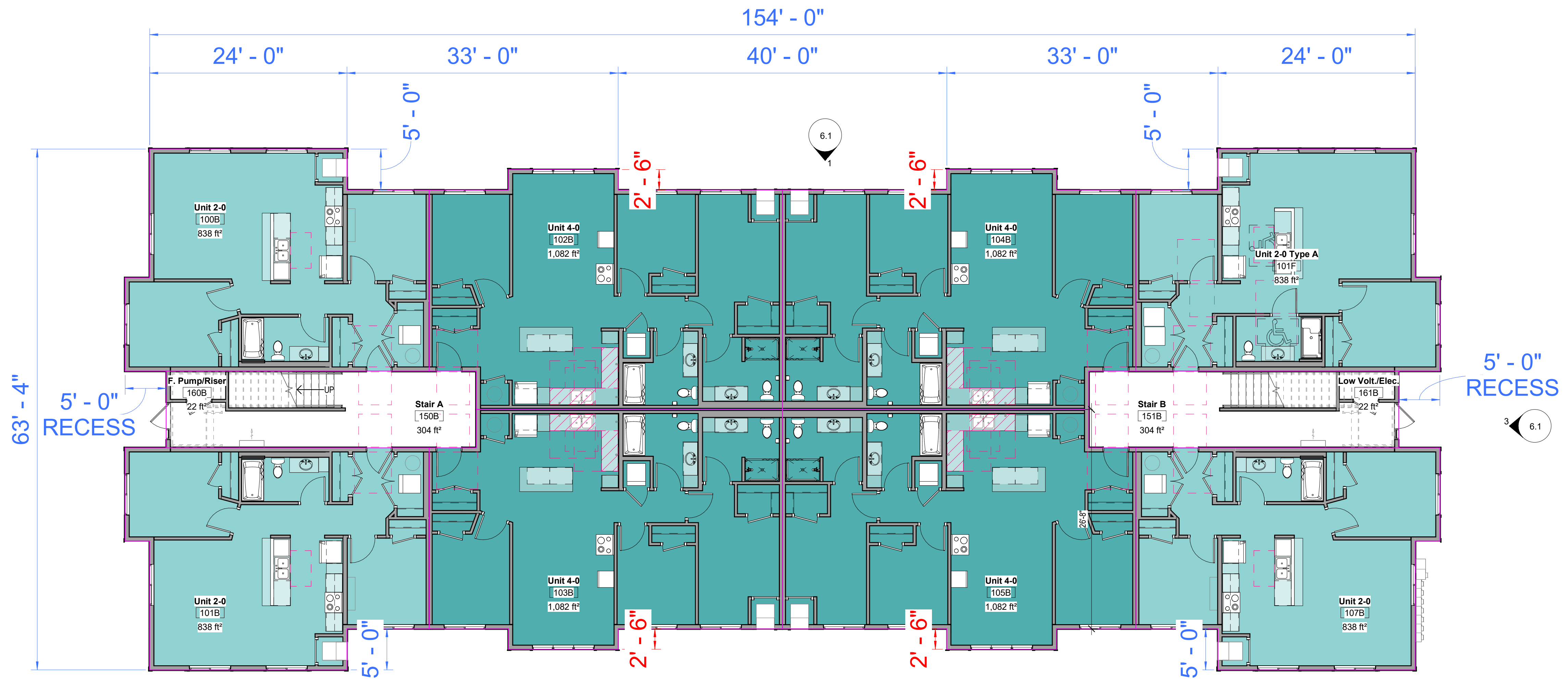

RED DIMENSIONS: VARIANCE REQUEST PER 10-50.20.030(B)(2)

1 (B,C2,C4) Level 1
1/8" = 1'-0"

2

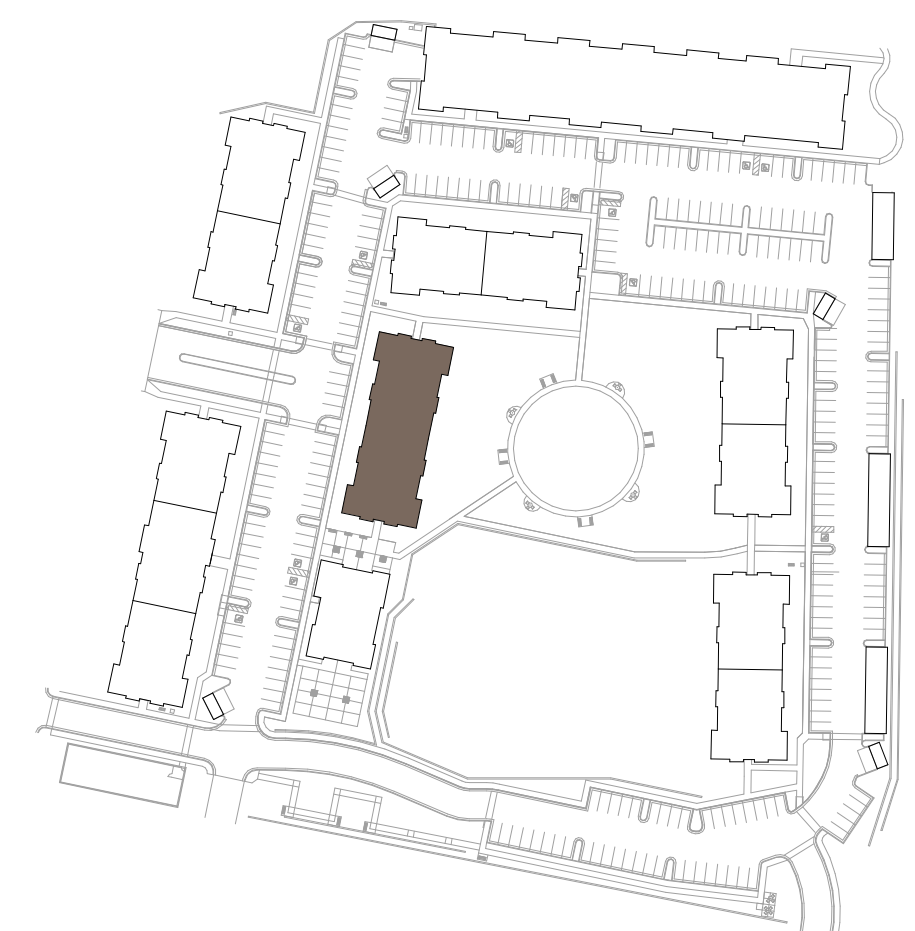

SD - KEY PLAN -BLDG B
1" = 160'-0"

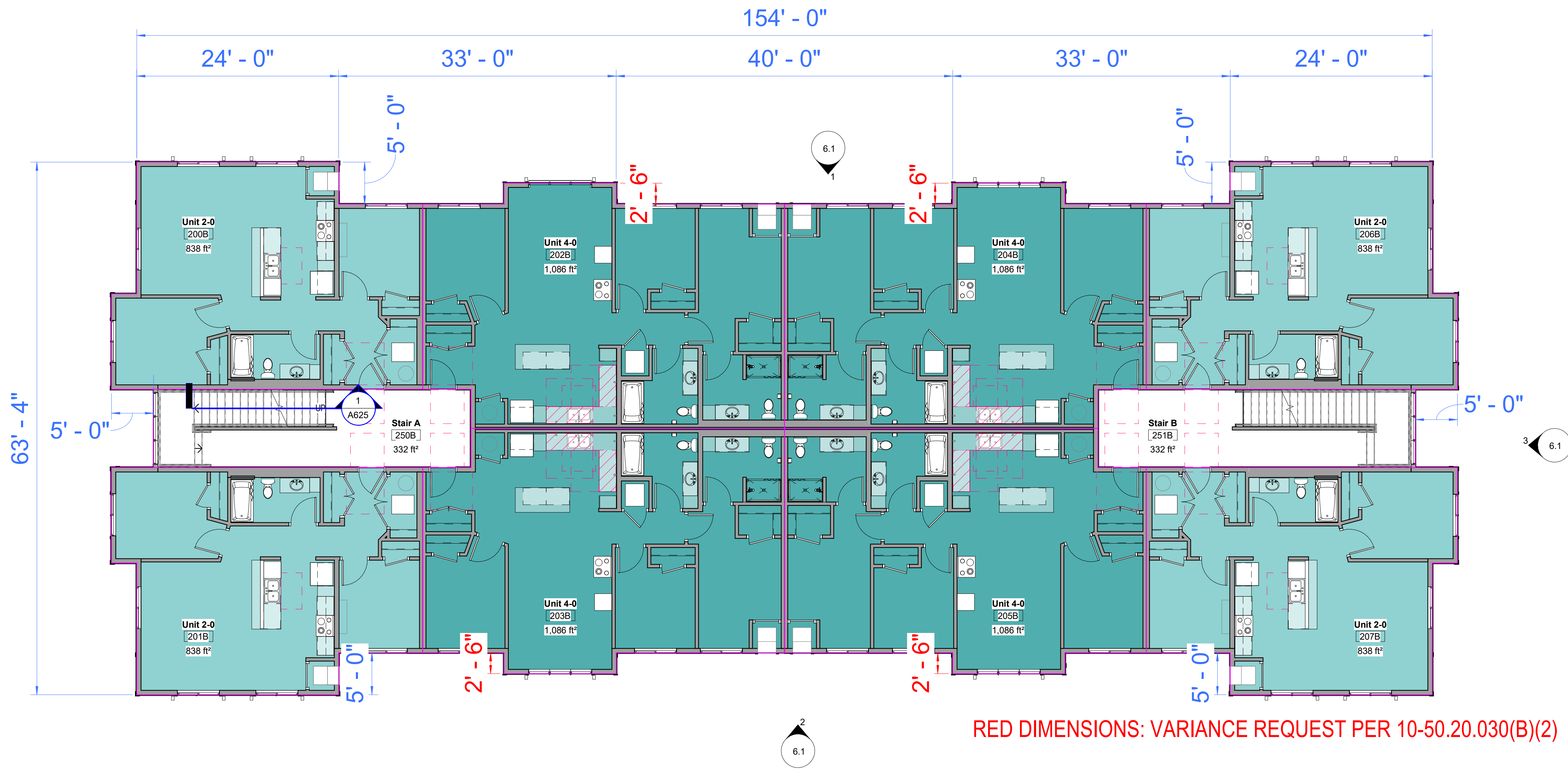

1 (B,C2,C4) Level 2
1/8" = 1'-0"

2

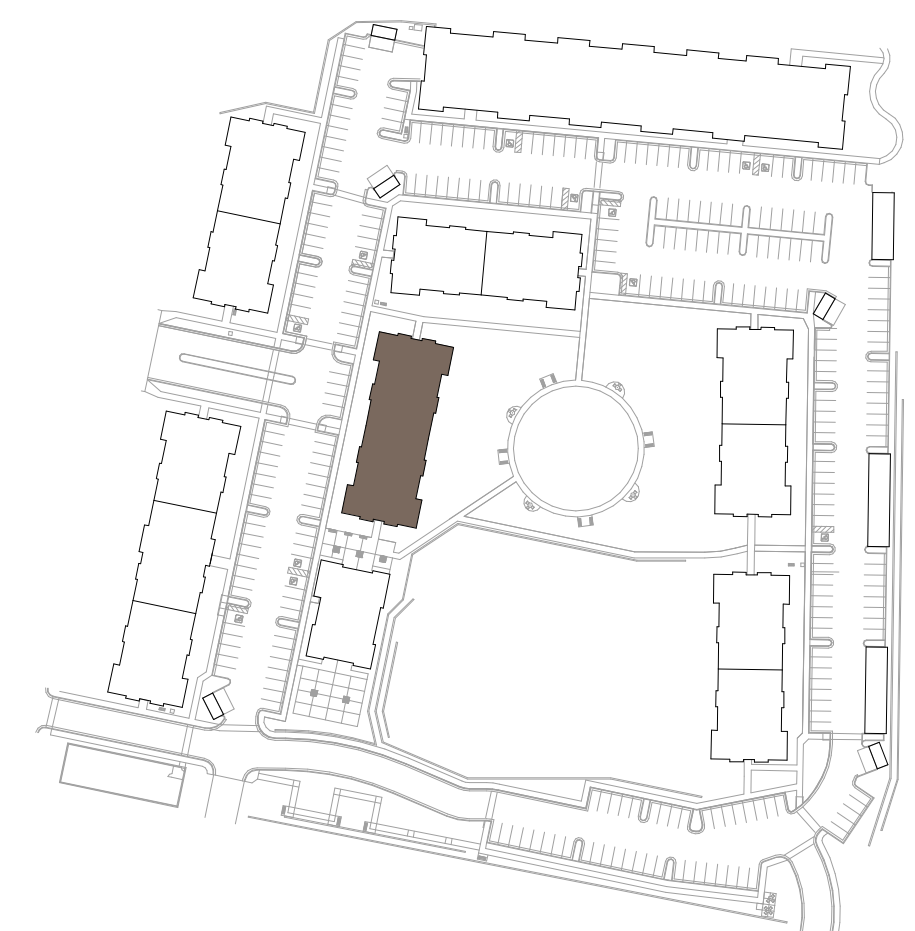

SD - KEY PLAN - BLDG B
1" = 160'-0"

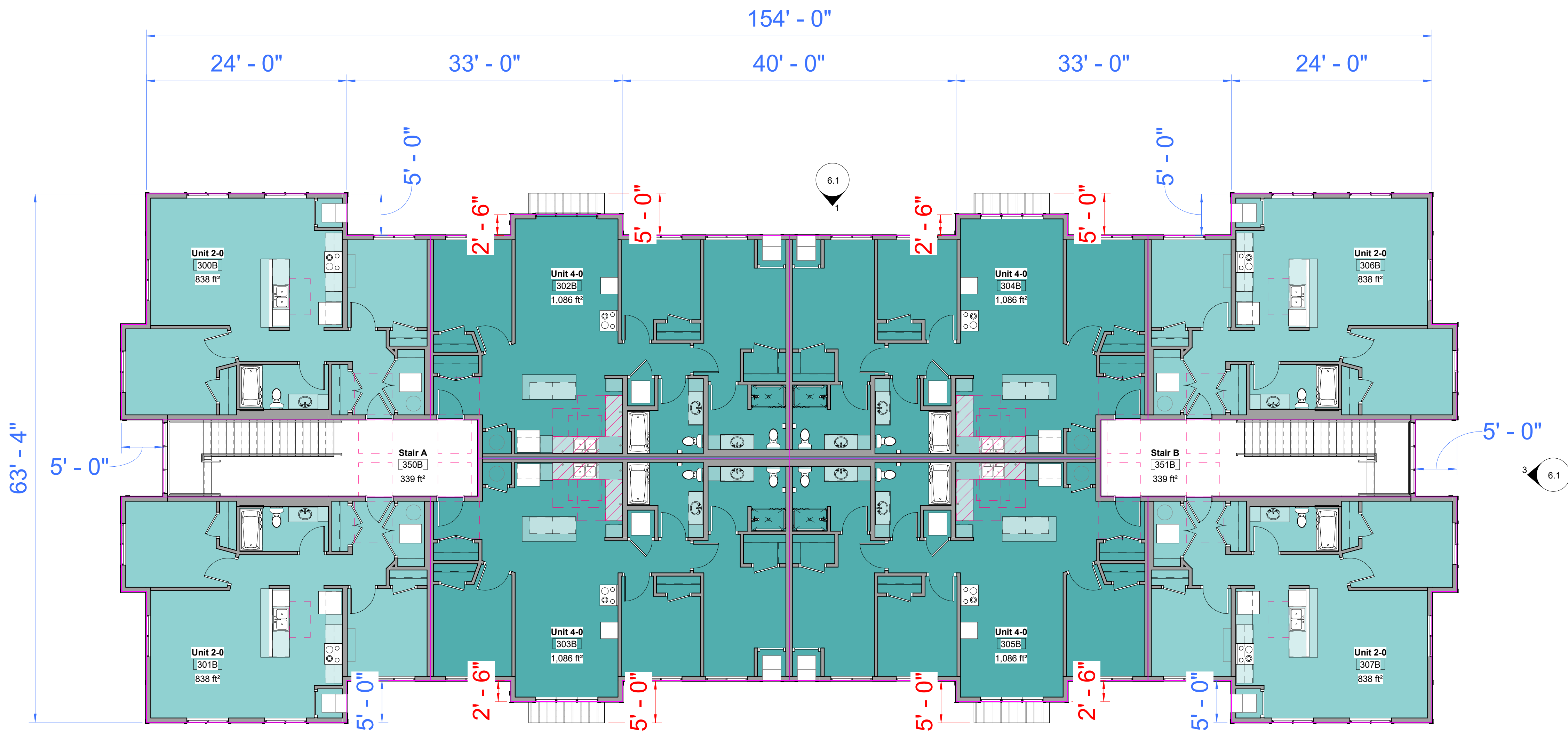

RED DIMENSIONS: VARIANCE REQUEST PER 10-50.20.030(B)(2)

1 (B, C2, C4) Level 3
1/8" = 1'-0"

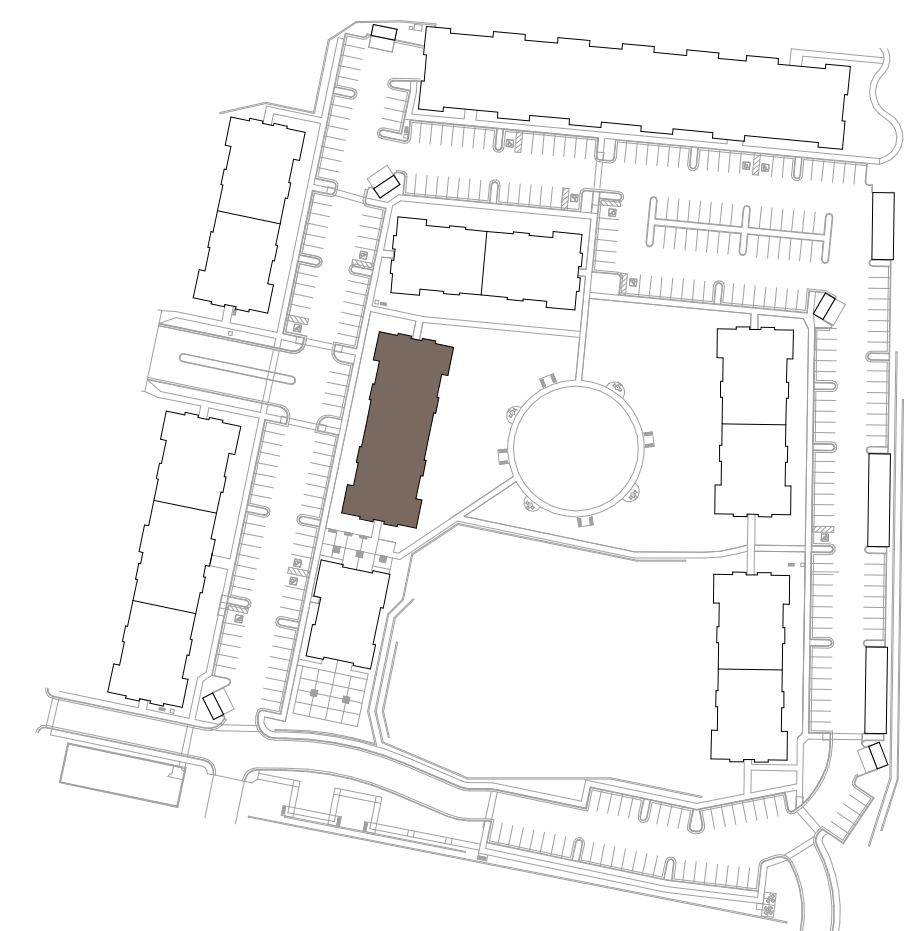

SD - KEY PLAN - BLDG B
1" = 160'-0"

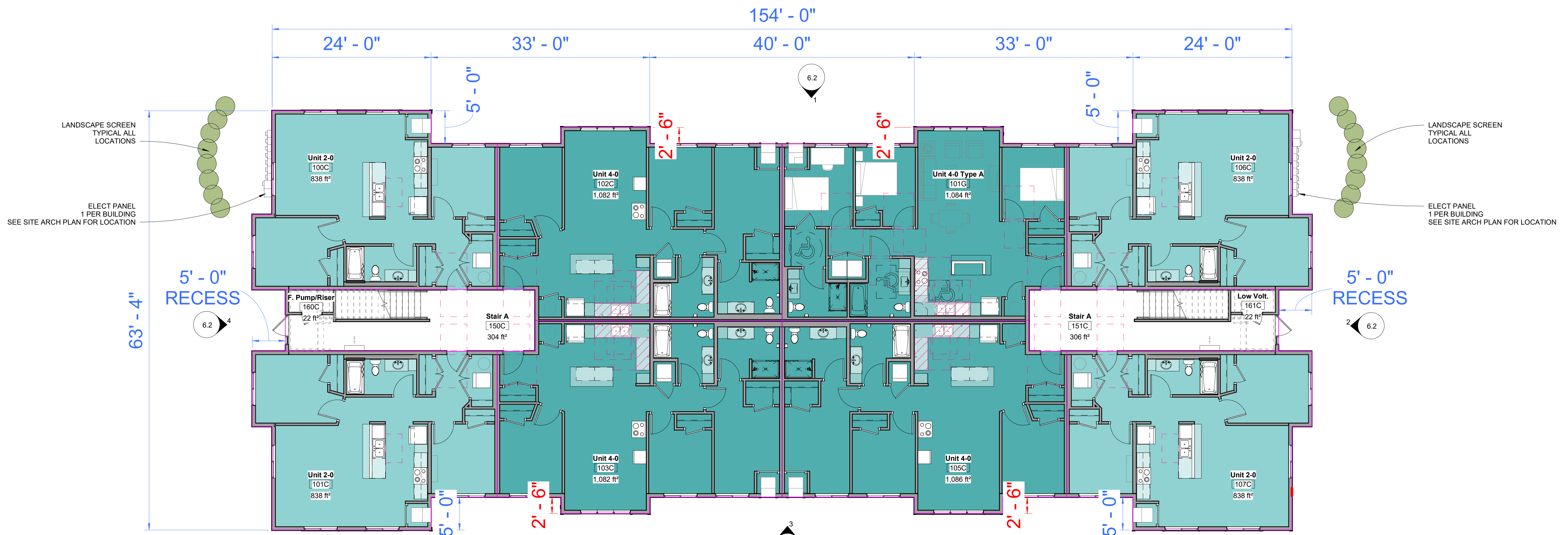

RED DIMENSIONS: VARIANCE REQUEST PER 10-50.20.030(B)(2)

① (C1,C3) - Level 1
1/8" = 1'-0"

Ⓩ Varies, See Site Plan

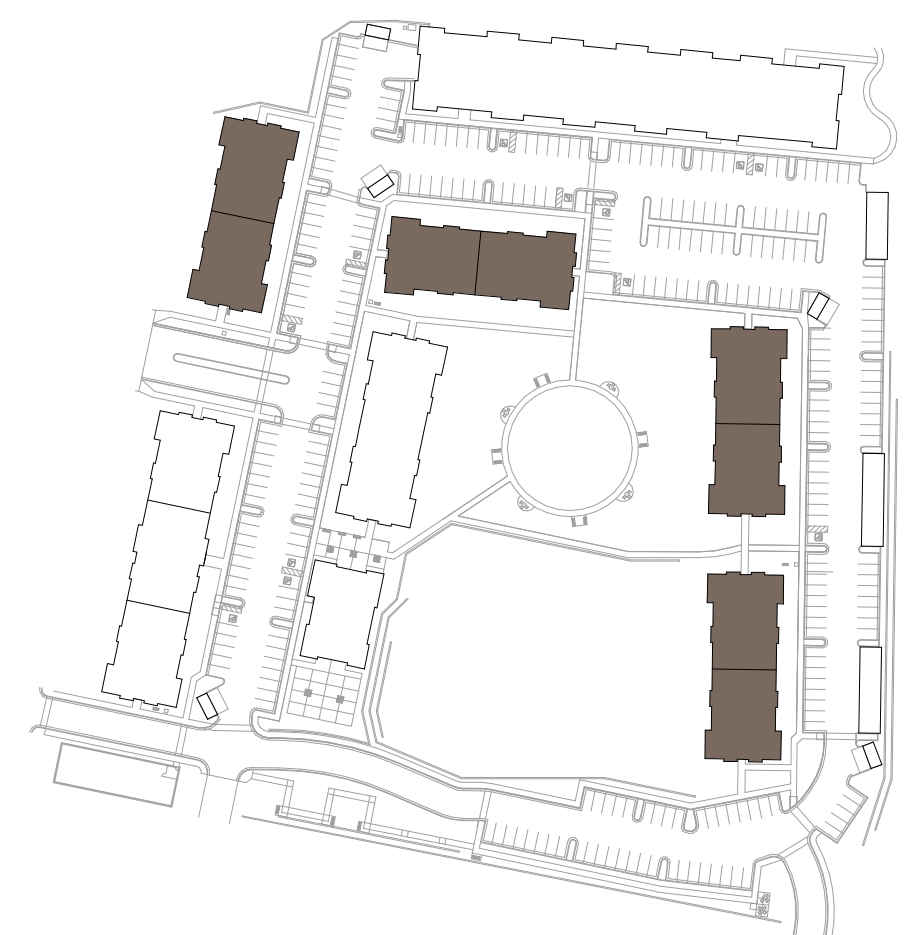

SD - KEY PLAN - BLDG C1,
C2, C3, C4
1" = 160'-0"

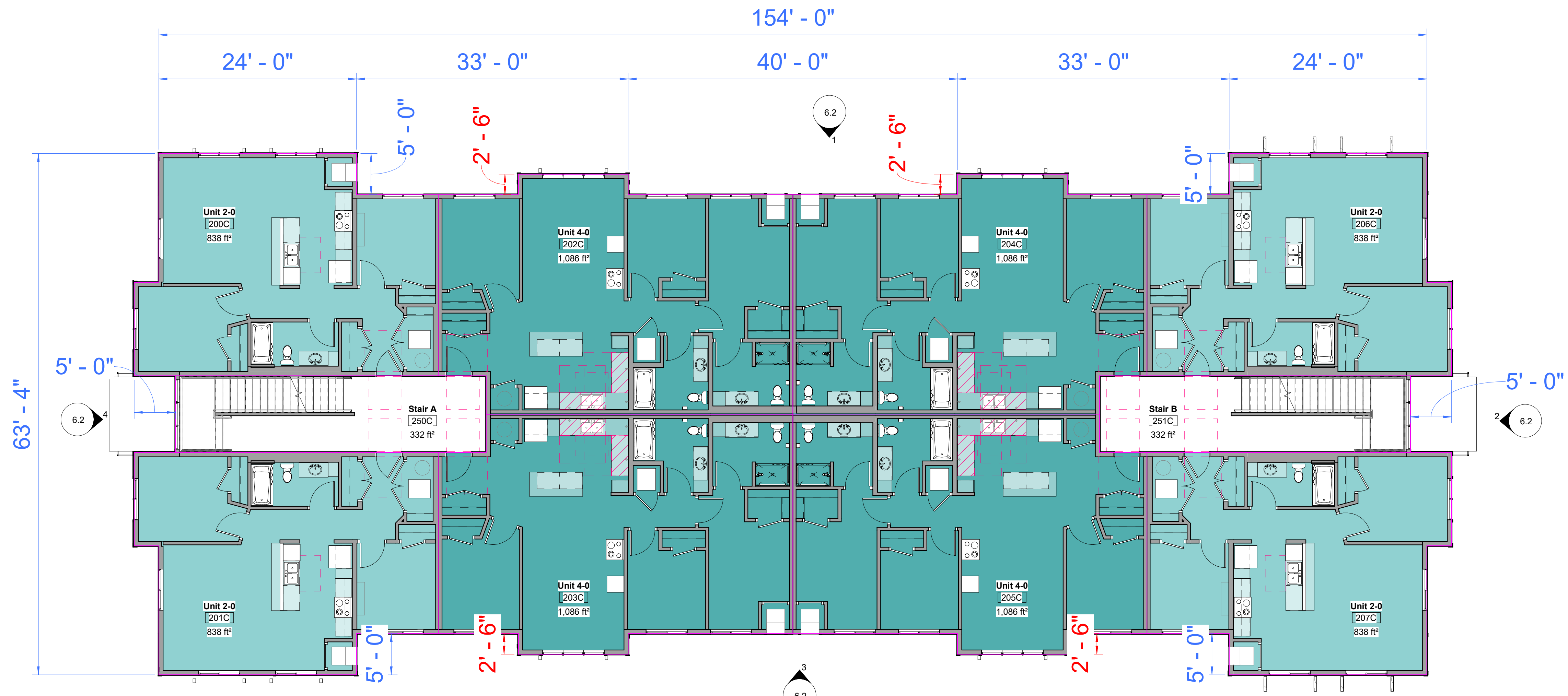

RED DIMENSIONS: VARIANCE REQUEST PER 10-50.20.030(B)(2)

① (C1,C3) - Level 2
1/8" = 1'-0"

Ⓩ
VARIES, SEE
SITE PLAN



SD - KEY PLAN -BLDG C1,
C2, C3, C4
1" = 160'-0"

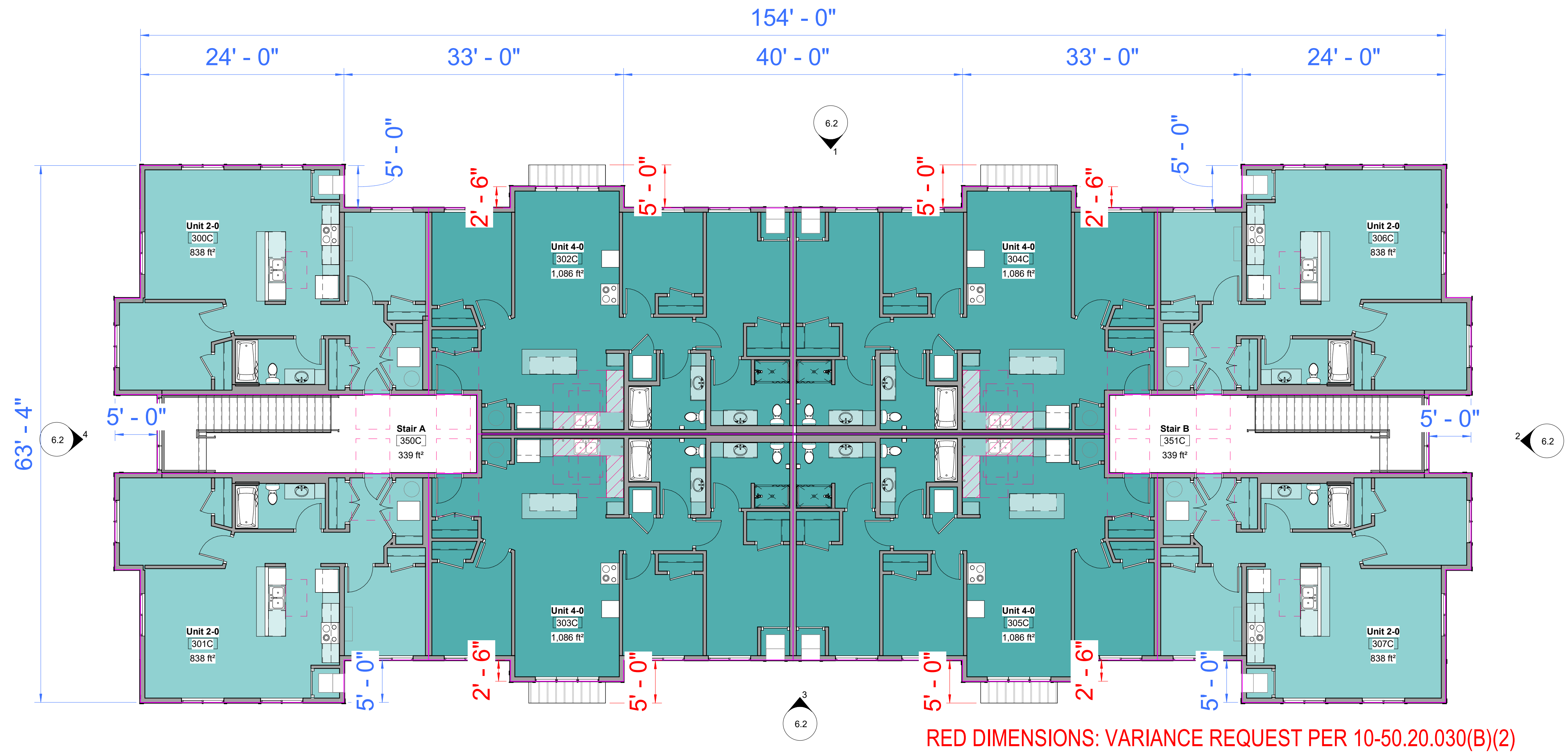

① (C1,C3) - Level 3
1/8" = 1'-0"

Ⓩ
VARIES, SEE
SITE PLAN



SD - KEY PLAN -BLDG C1,
C2, C3, C4
1" = 160'-0"

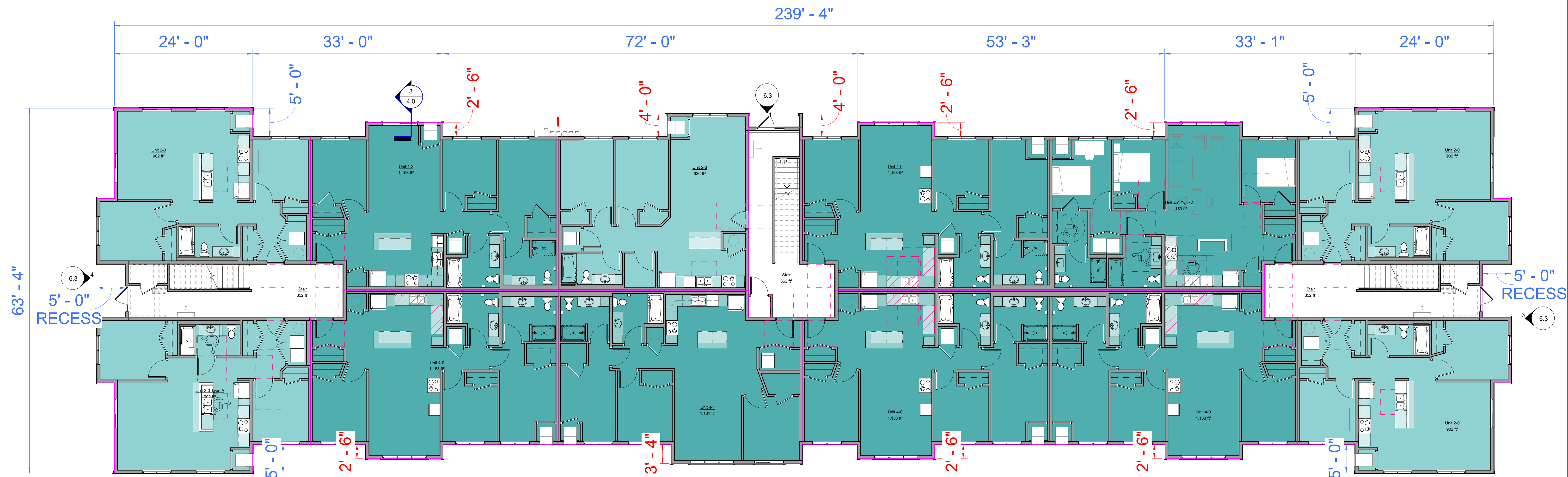

① (D) - Level 1
1/8" = 1'-0"

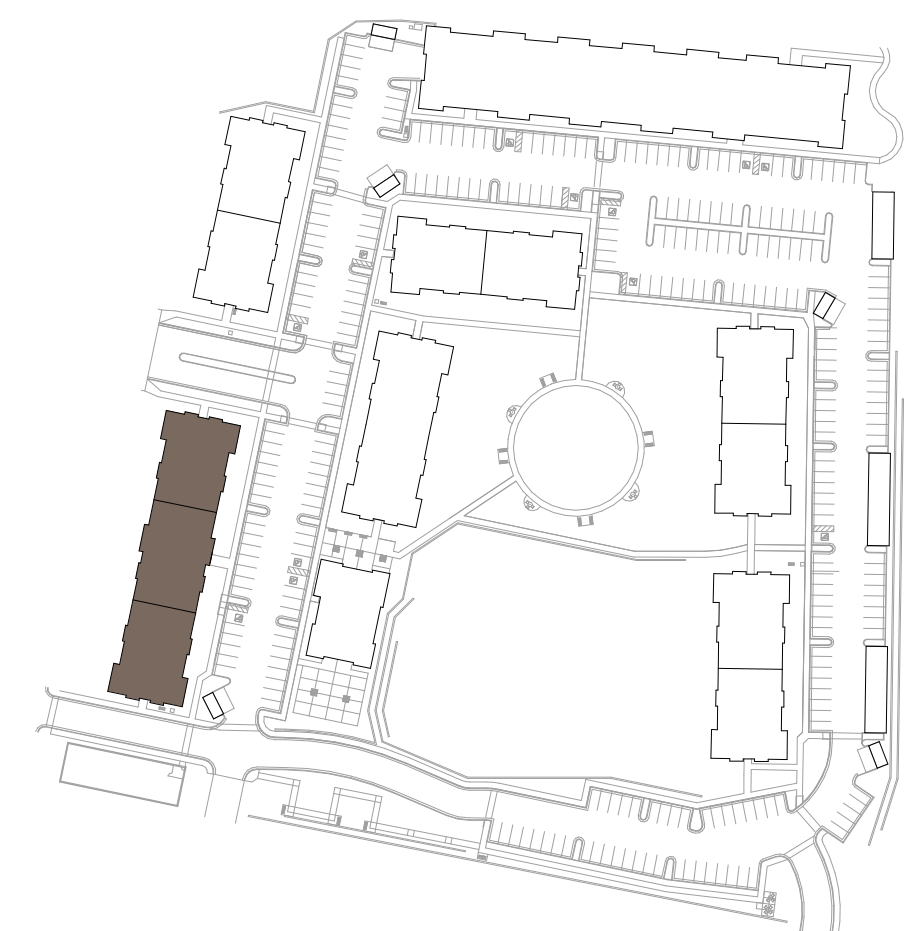
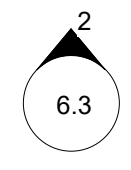

SD - KEY PLAN - BLDG D
1" = 160'-0"

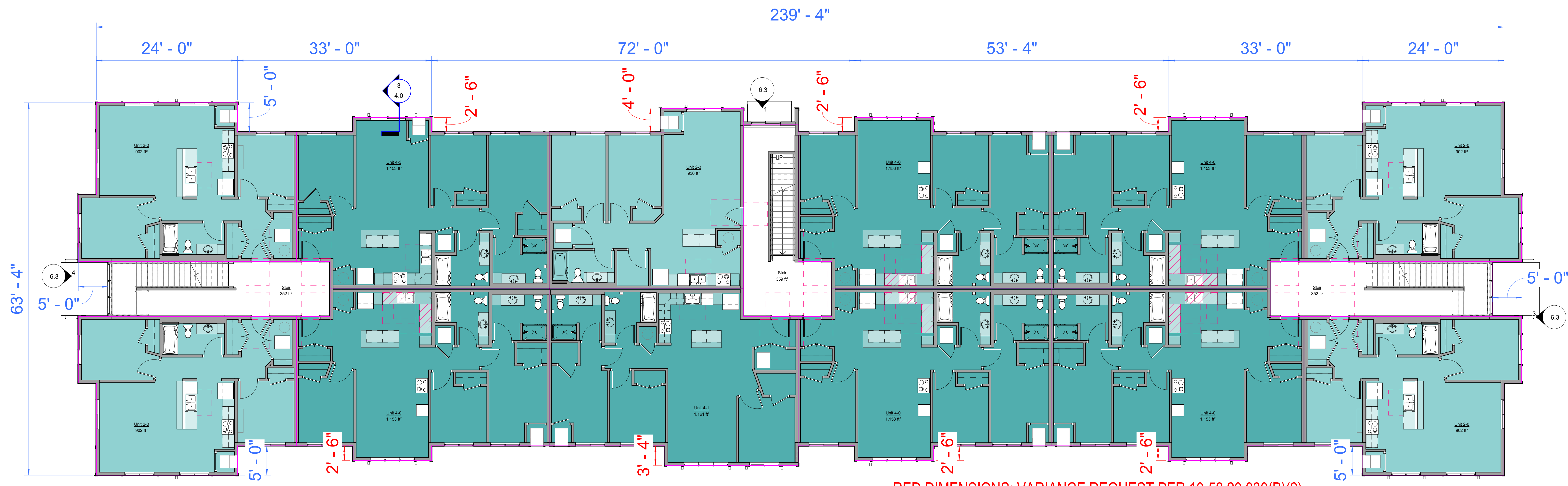

① (D) - Level 2
1/8" = 1'-0"

RED DIMENSIONS: VARIANCE REQUEST PER 10-50.20.030(B)(2)

②

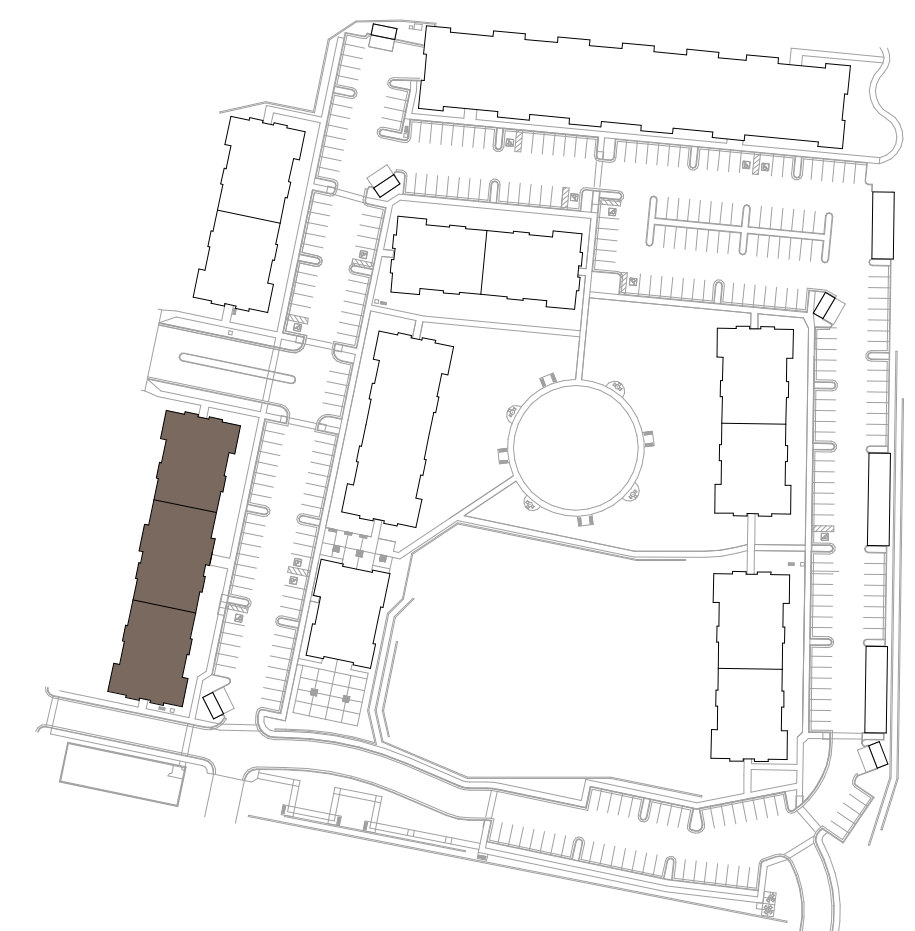

SD - KEY PLAN - BLDG D
1" = 160'-0"

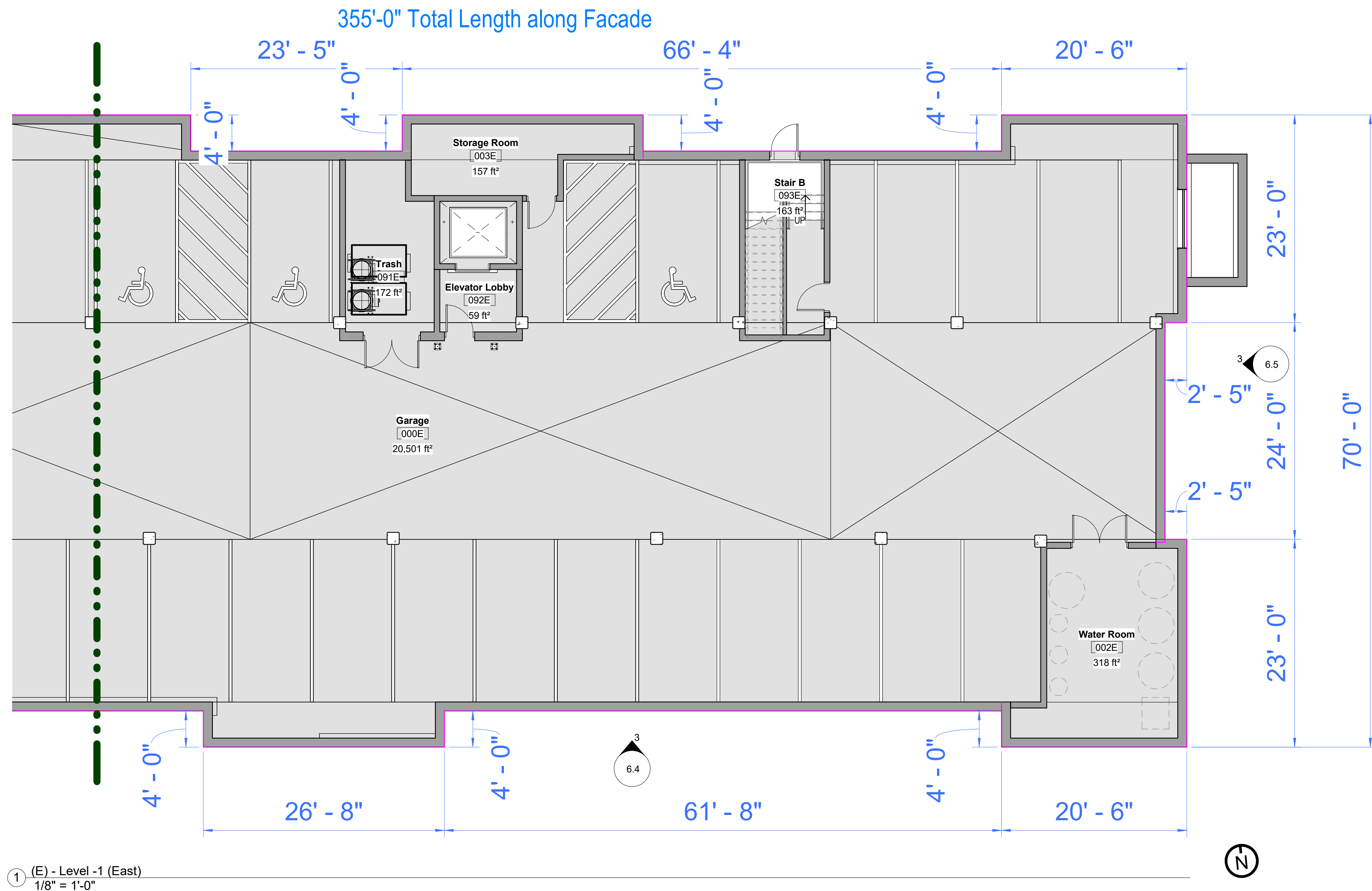

① (E) - Level -1 (East)
1/8" = 1'-0"

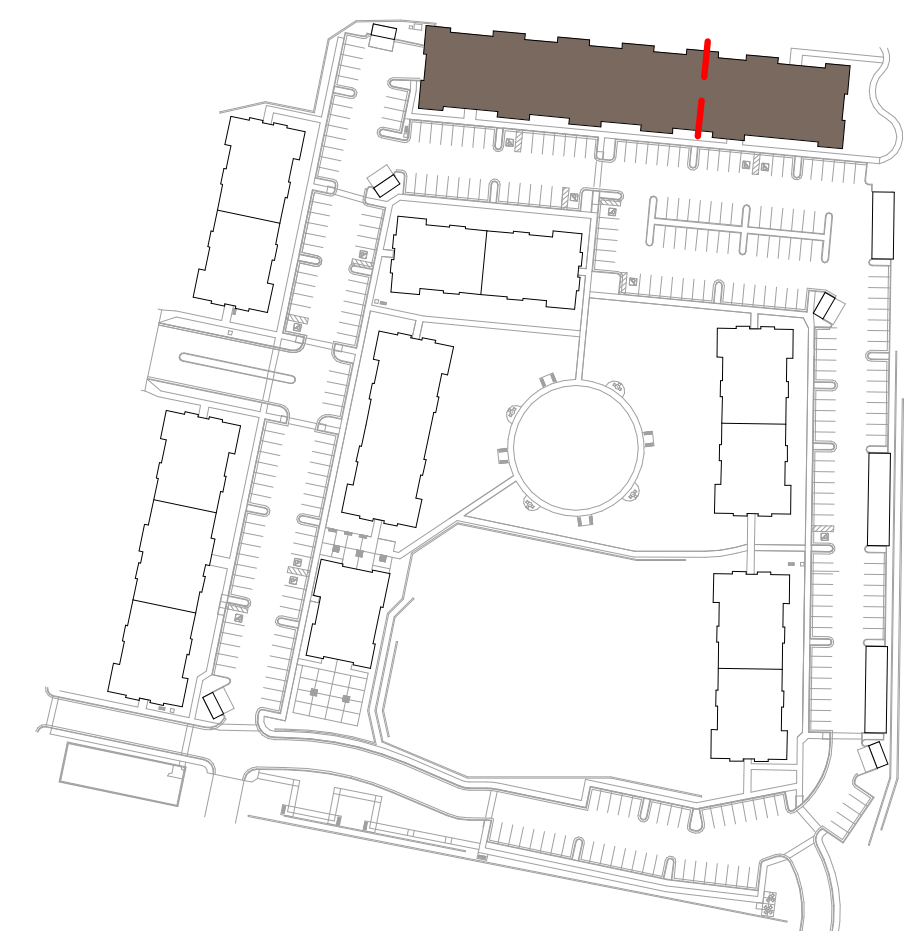

SD - KEY PLAN - BLDG E
1" = 160'-0"

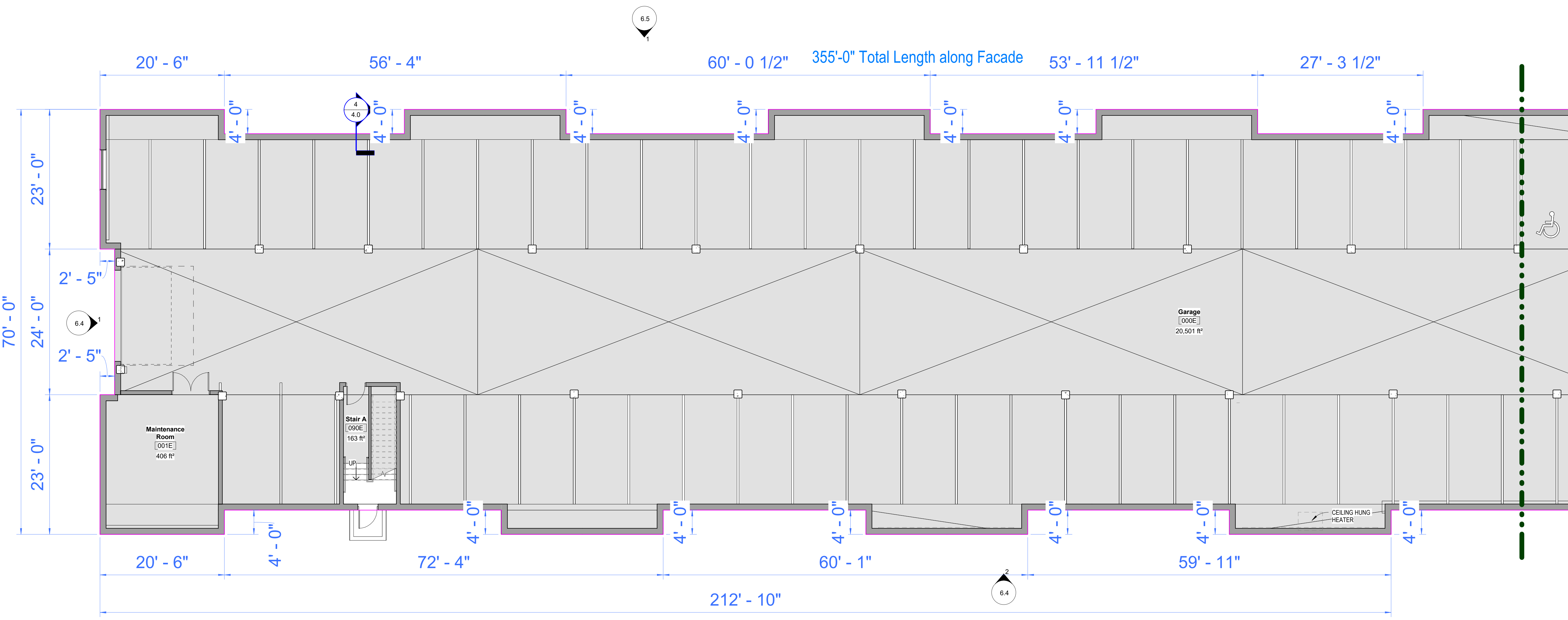

1 (E) - Level -1 (West)
1/8" = 1'-0"

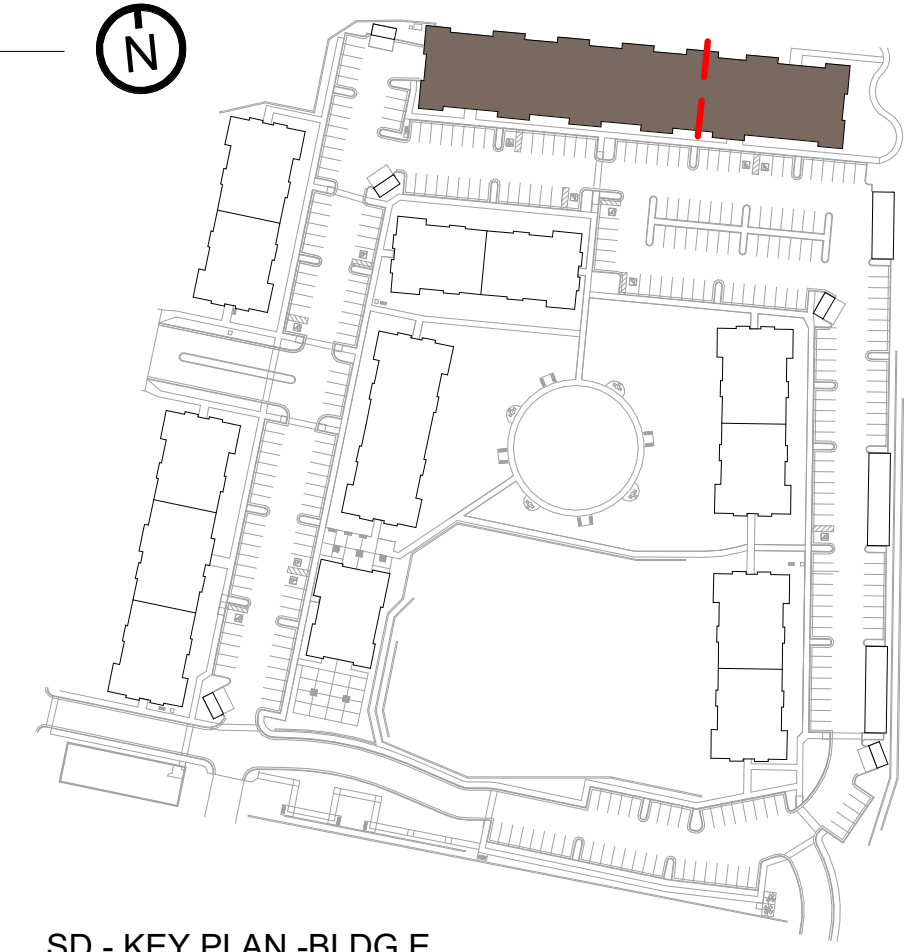

SD - KEY PLAN - BLDG E
1" = 160'-0"



RED DIMENSIONS: VARIANCE REQUEST PER 10-50.20.030(B)(2)

① (E) - Level 1 (East)
1/8" = 1'-0"

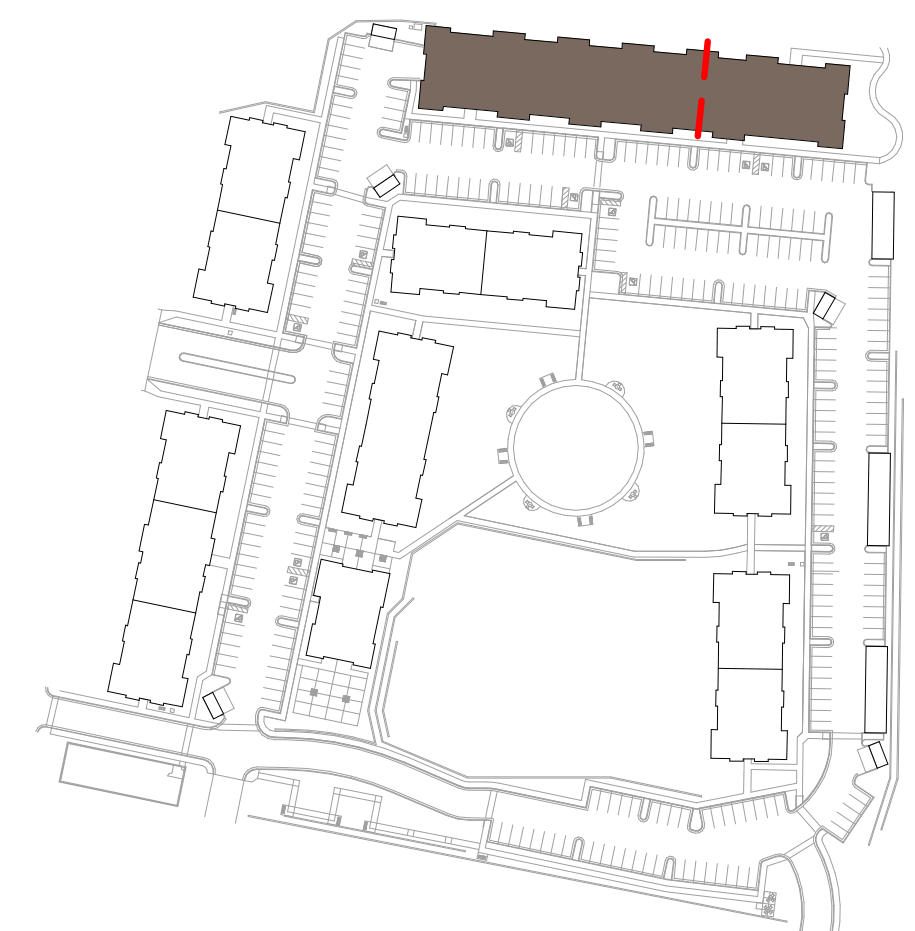

SD - KEY PLAN - BLDG E
1" = 160'-0"

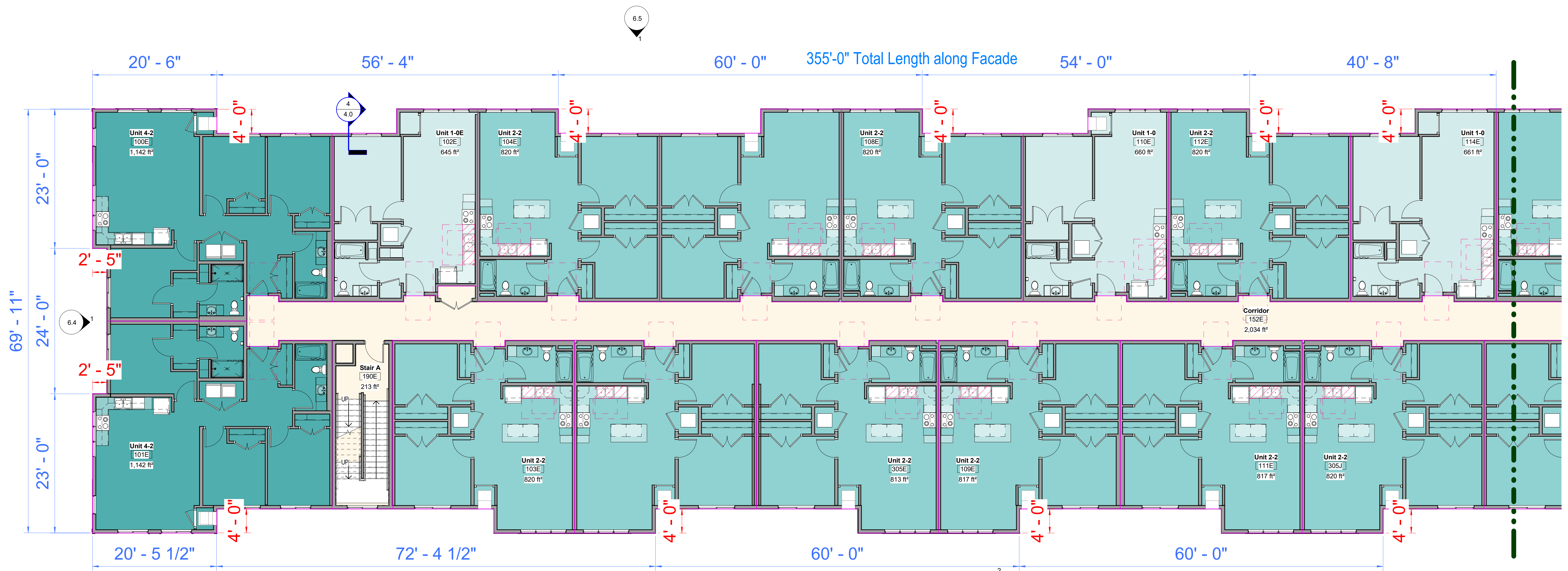

RED DIMENSIONS: VARIANCE REQUEST PER 10-50.20.030(B)(2)

① (E) - Level 1 (West)
1/8" = 1'-0"

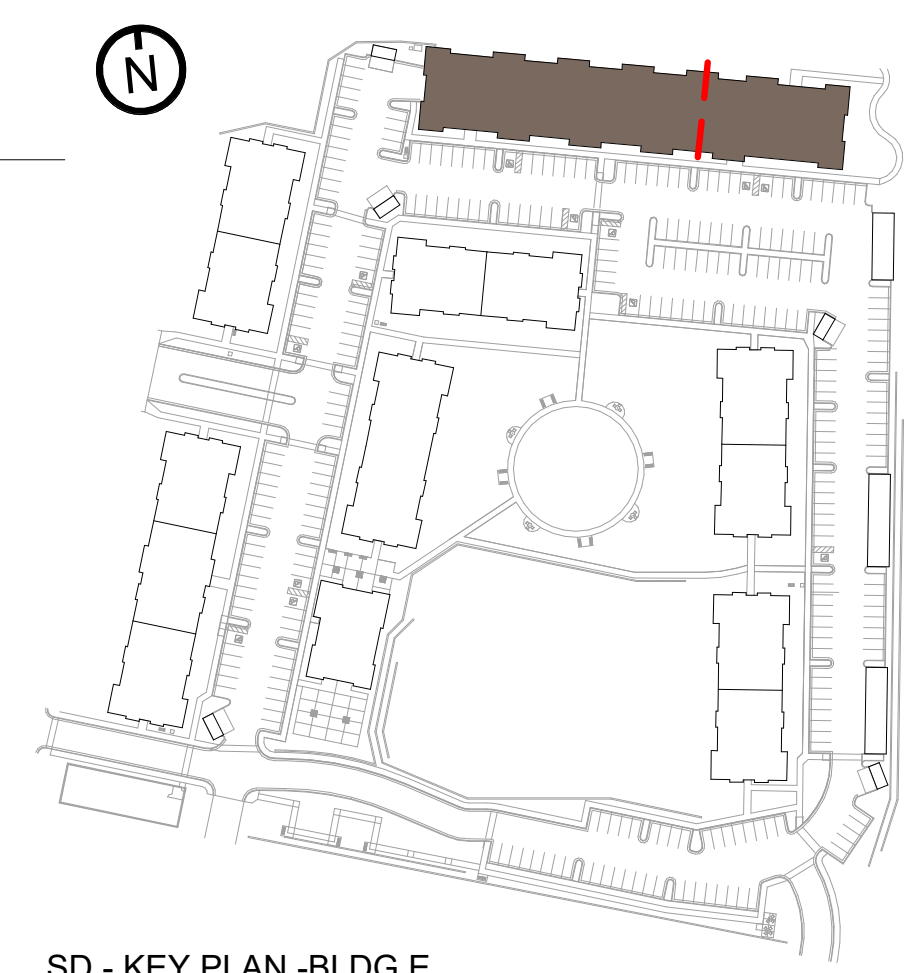

SD - KEY PLAN - BLDG E
1" = 160'-0"

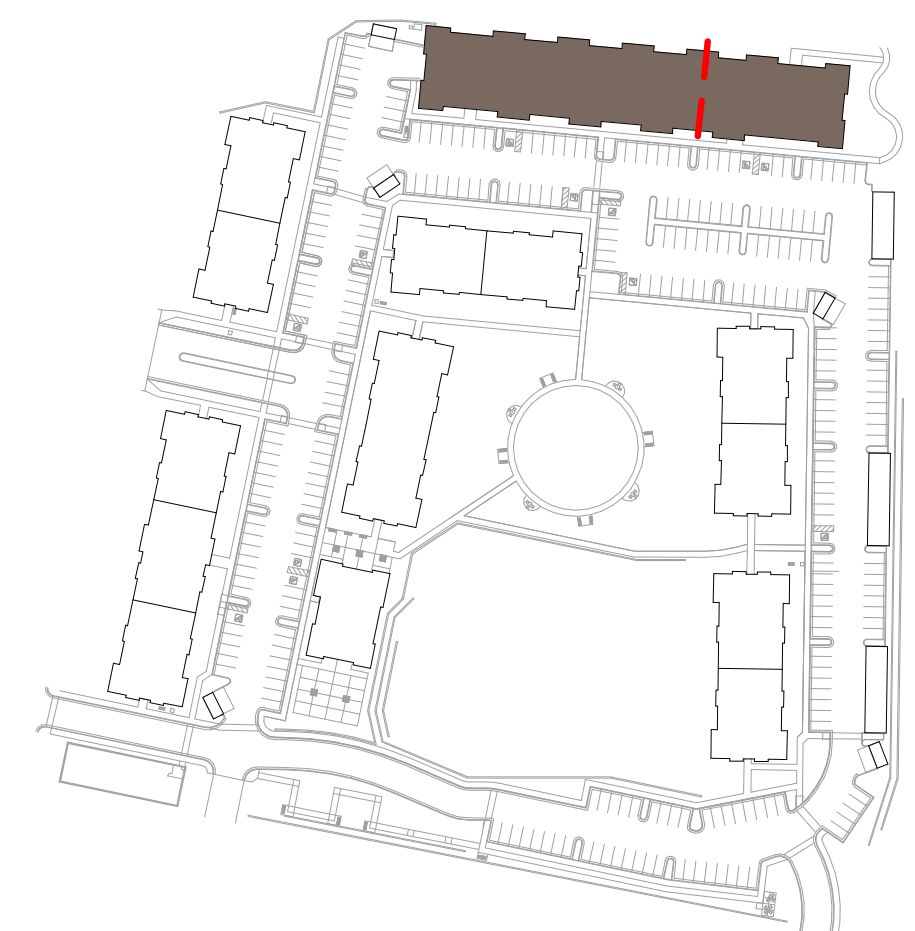
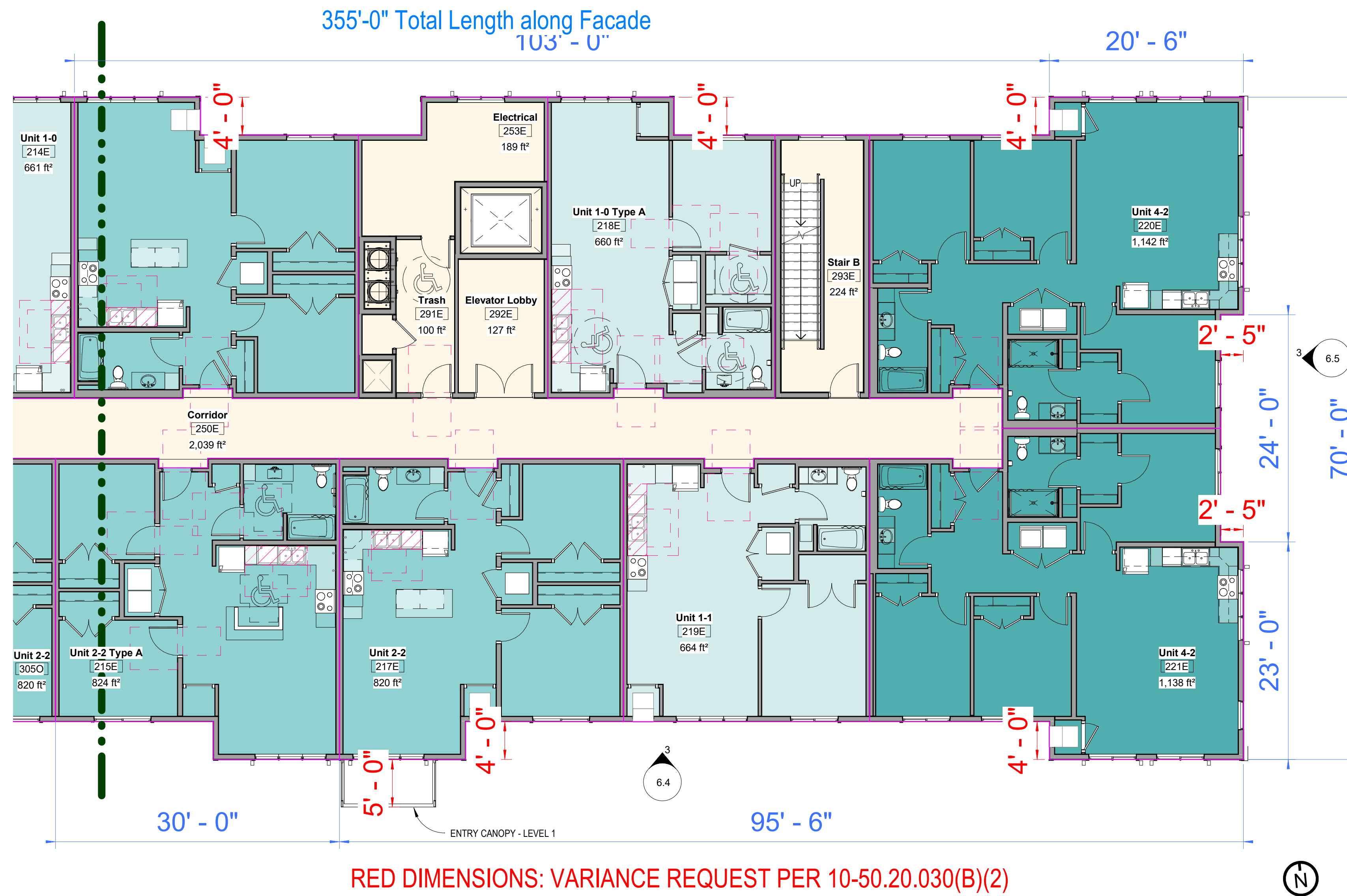

SD - KEY PLAN - BLDG E
1" = 160'-0"

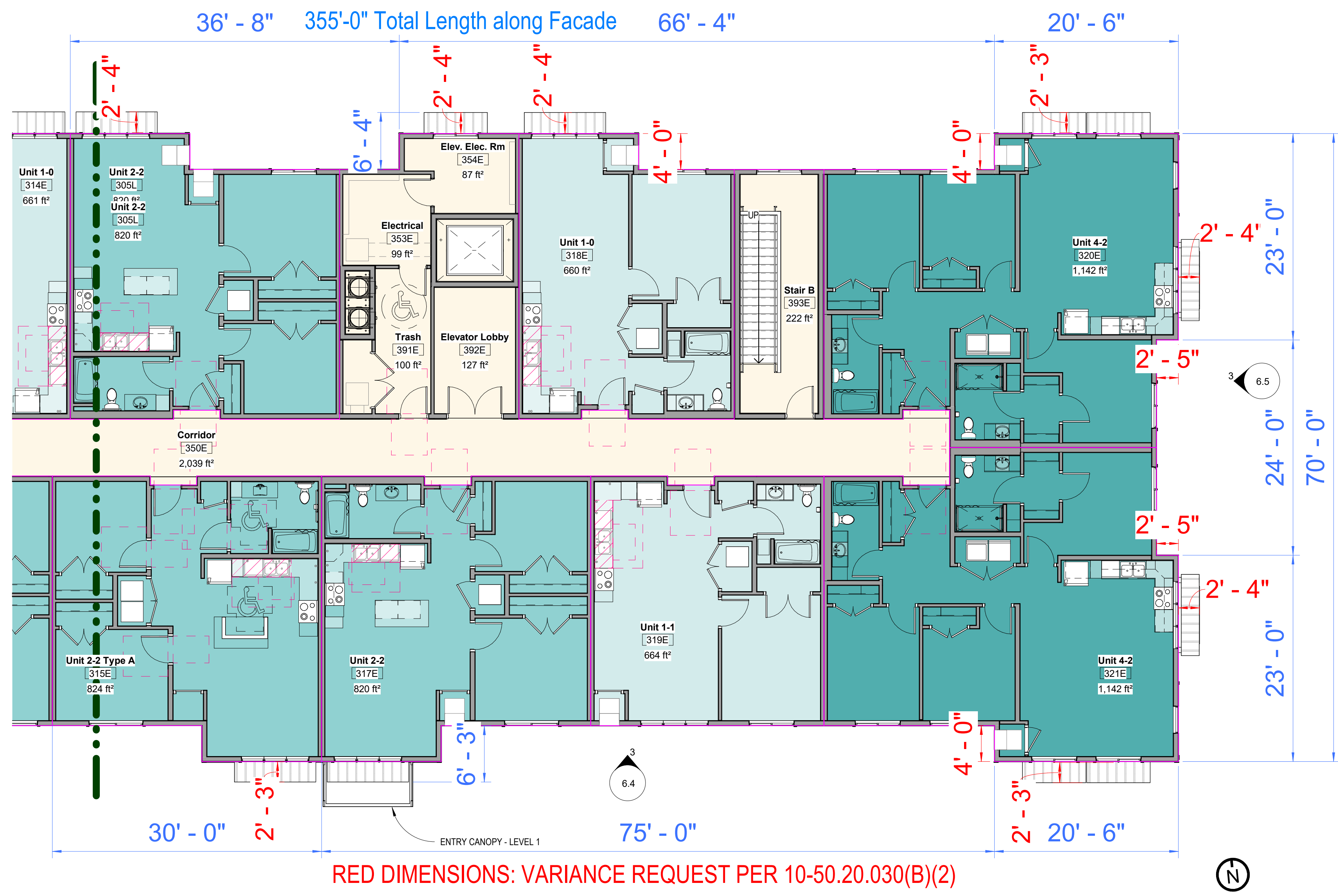

① (E) - Level 3 (East)
1/8" = 1'-0"

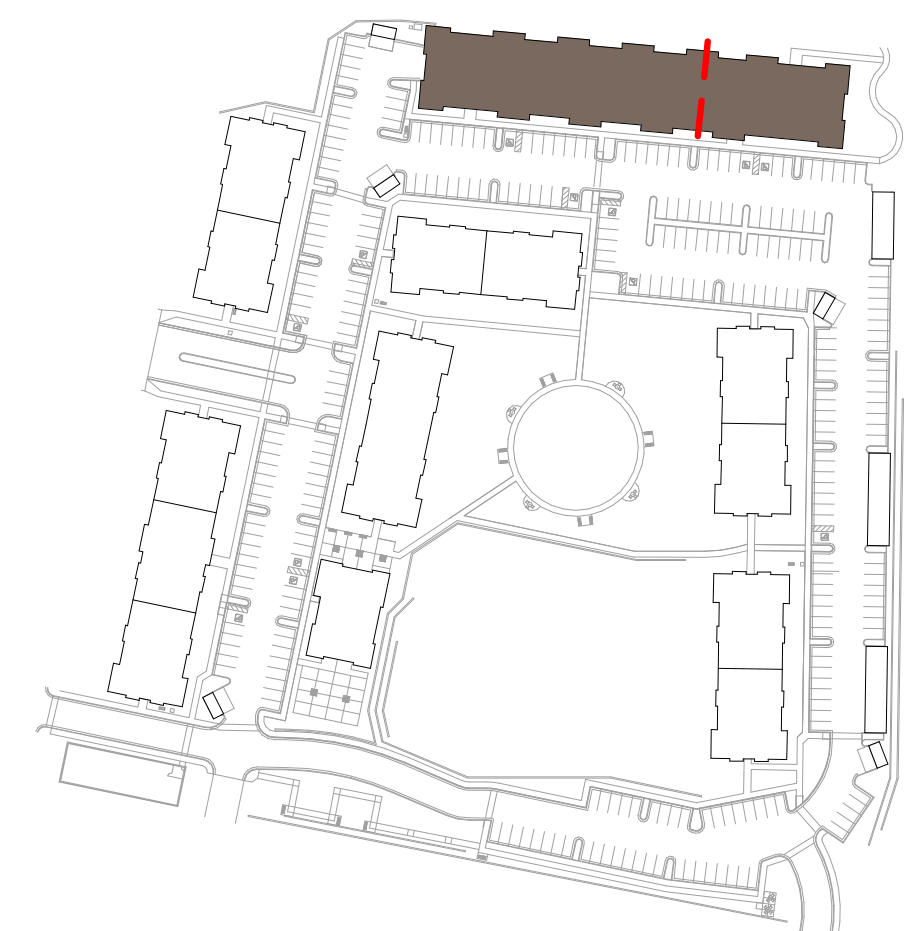

SD - KEY PLAN - BLDG E
1" = 160'-0"

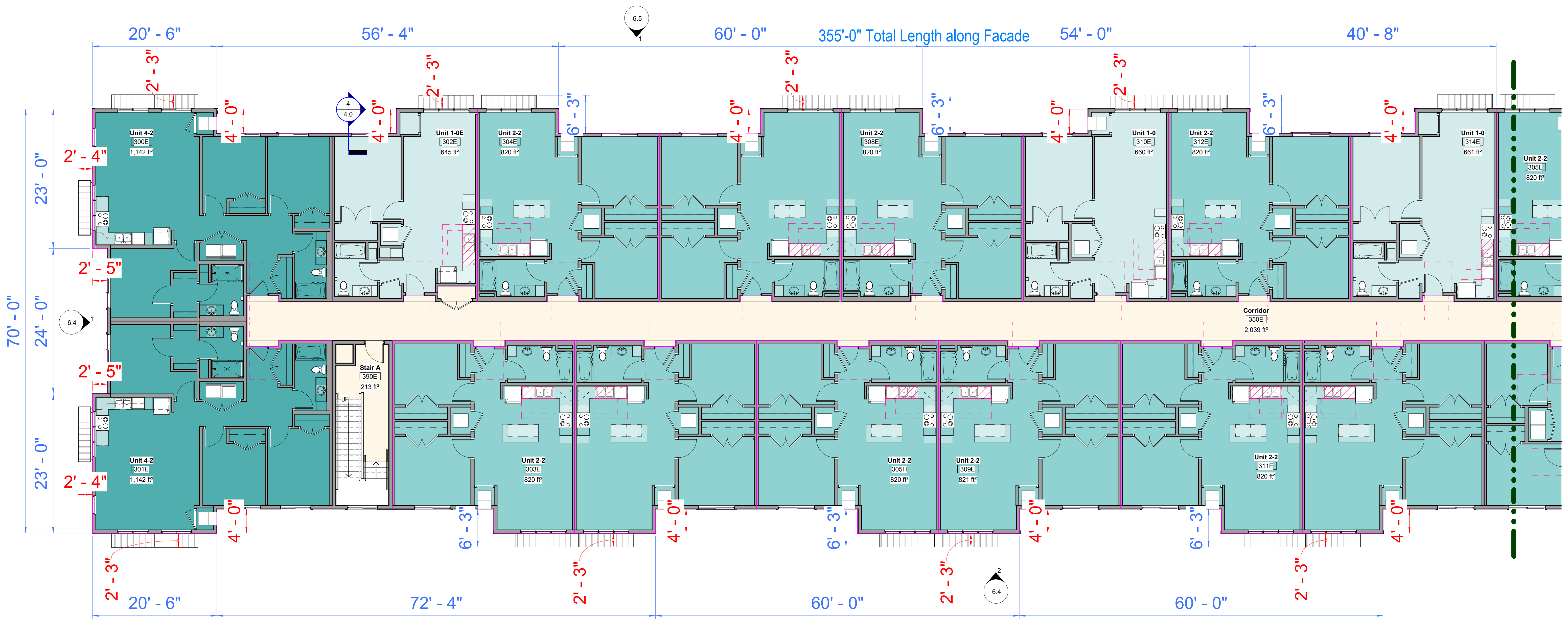

RED DIMENSIONS: VARIANCE REQUEST PER 10-50.20.030(B)(2)

① (E) - Level 3 (West)
1/8" = 1'-0"

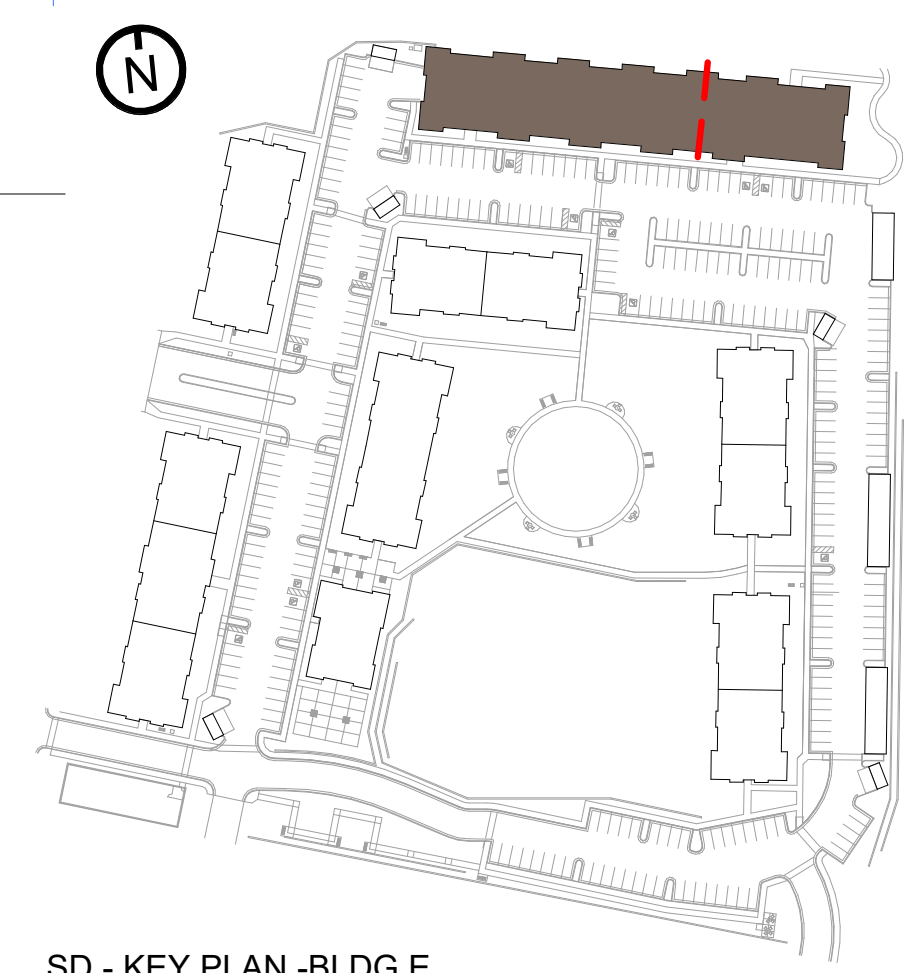

SD - KEY PLAN - BLDG E
1" = 160'-0"

EXTERIOR MATERIALS

Material Mark	Description
7.1a	CFB Lap Siding: LP Smartside Color: Tundra Gray LRV: 18.17 (11" Exposure)
7.1b	CFB Lap Siding: LP Smartside Color: Tundra Gray LRV: 18.17 (5" Exposure)
7.6	CFB Trim: LP Smartside Color: Timberland Suede LRV: 21.37
8.0	Asphalt Shingles: Certainteed Landmark Series Color: Driftwood



1 Garage A - Front Side
1/8" = 1'-0"



2 Stepped Garage B - Front Side
1/8" = 1'-0"



3 Stepped Garage C - Front Side
1/8" = 1'-0"

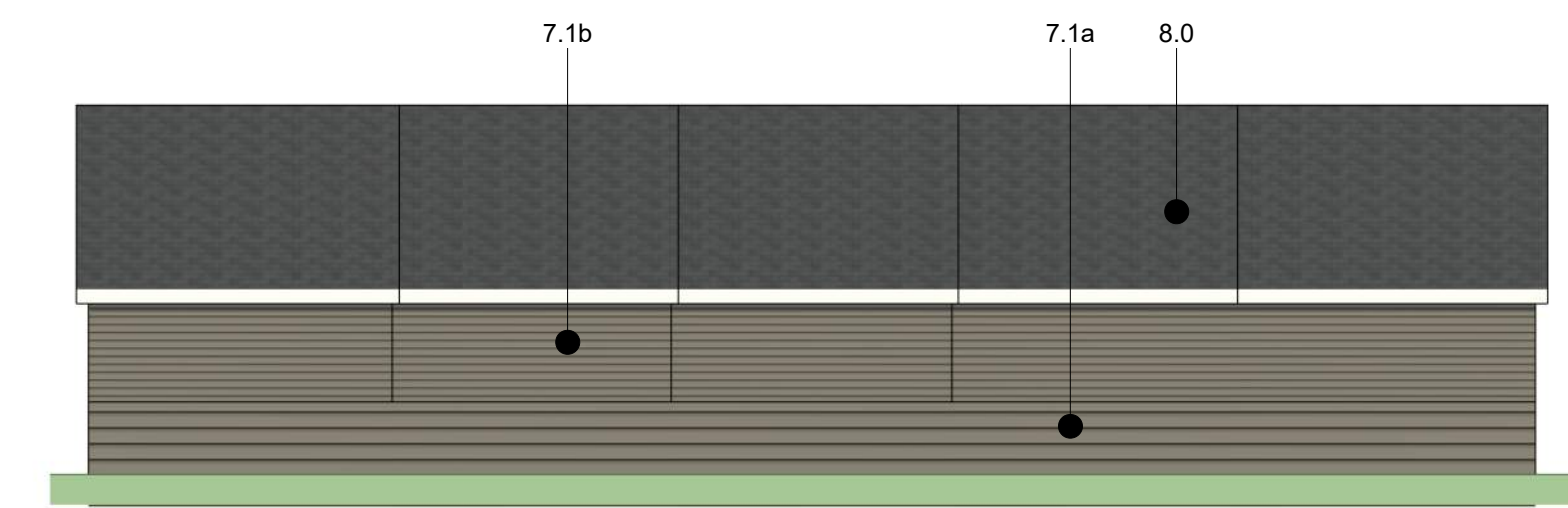

4 Garage A - Back Side
1/8" = 1'-0"

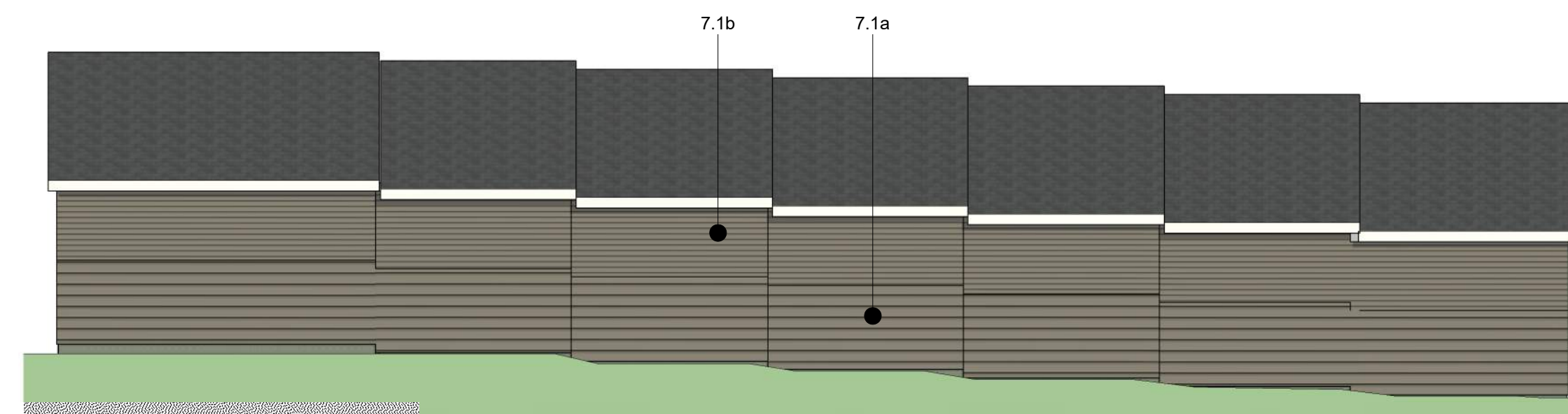

5 Stepped Garage B - Back Side
1/8" = 1'-0"

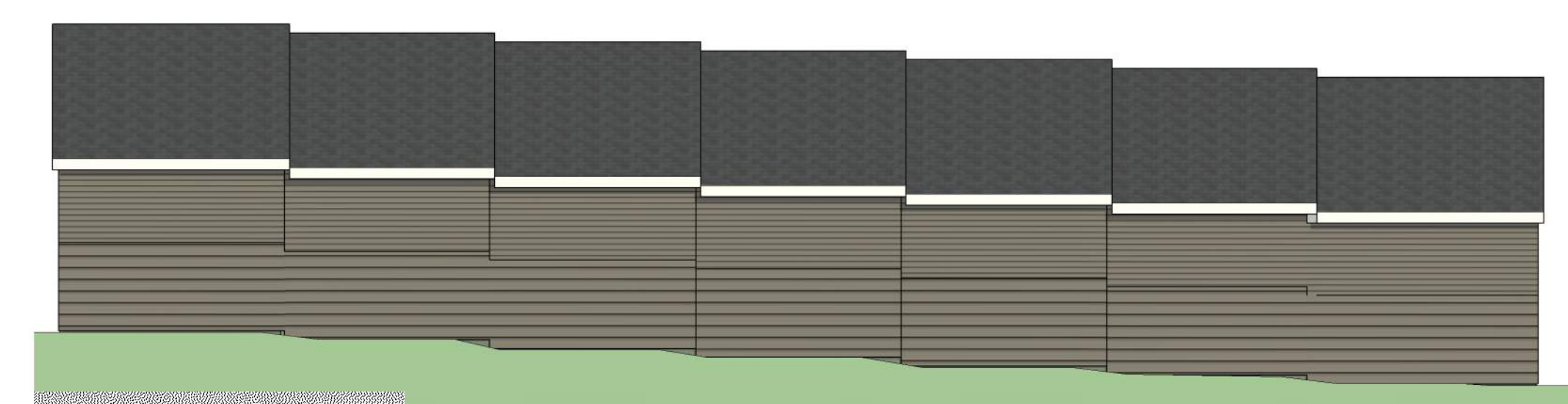

6 Stepped Garage C - Back Side
1/8" = 1'-0"

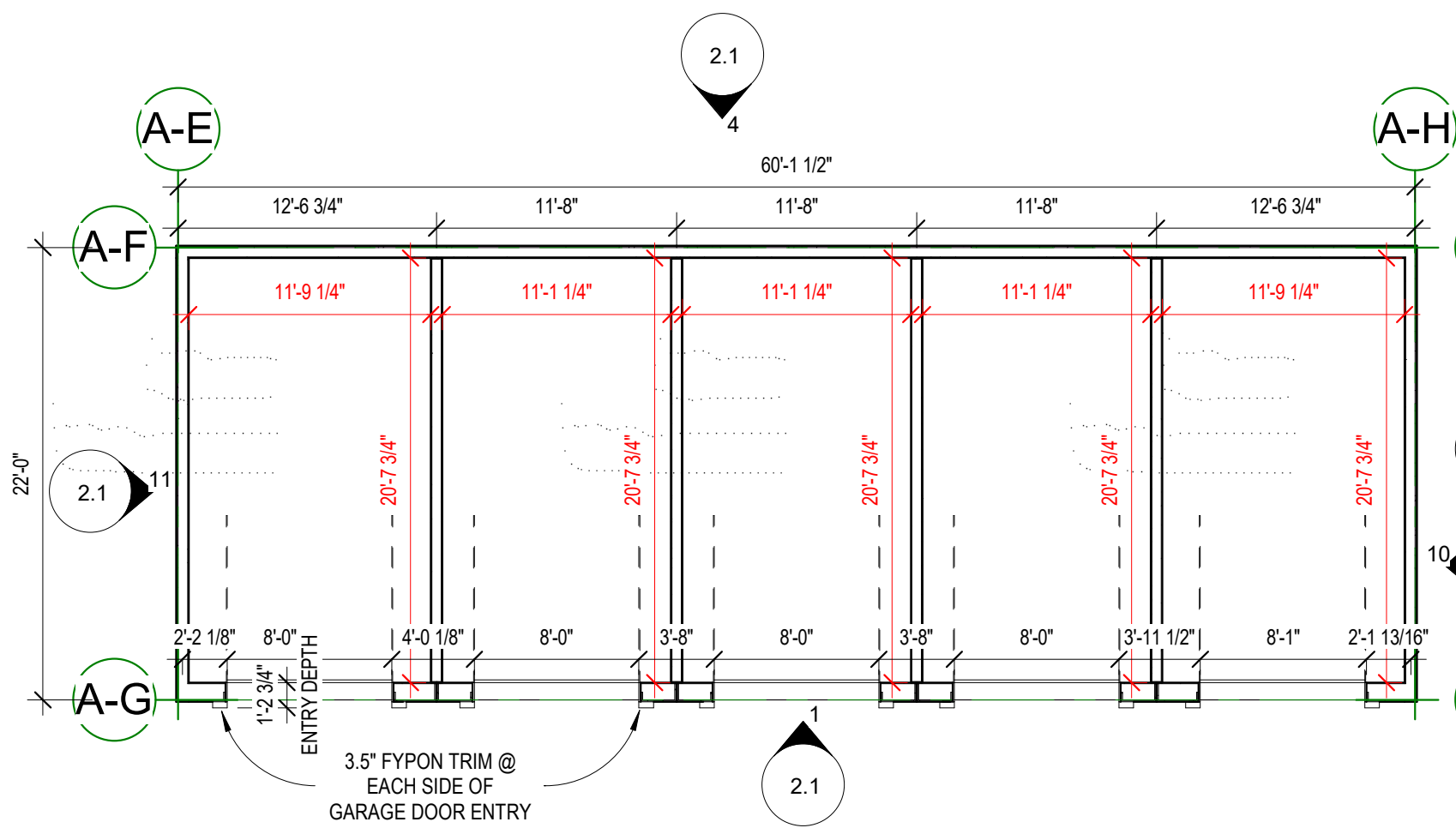

7 Garage A
1/8" = 1'-0"

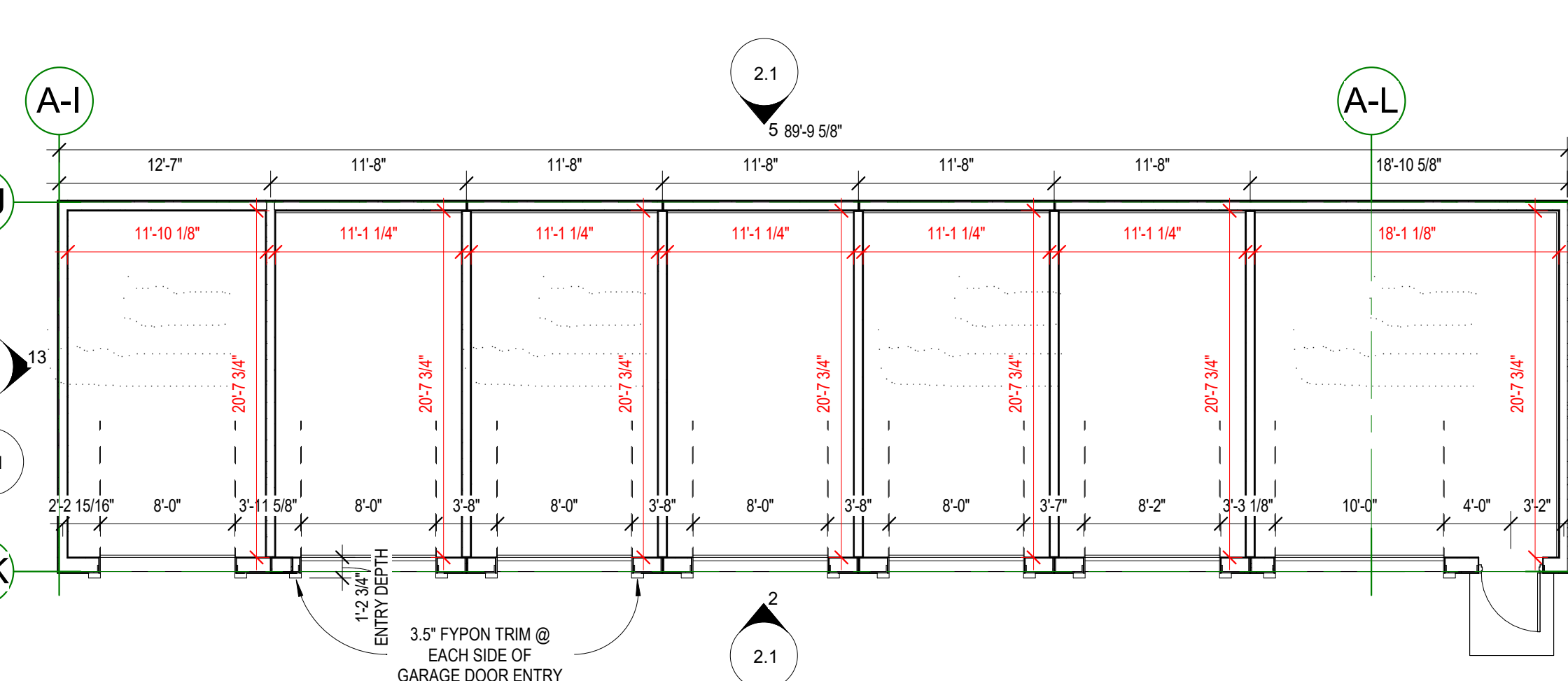

8 Garage B
1/8" = 1'-0"

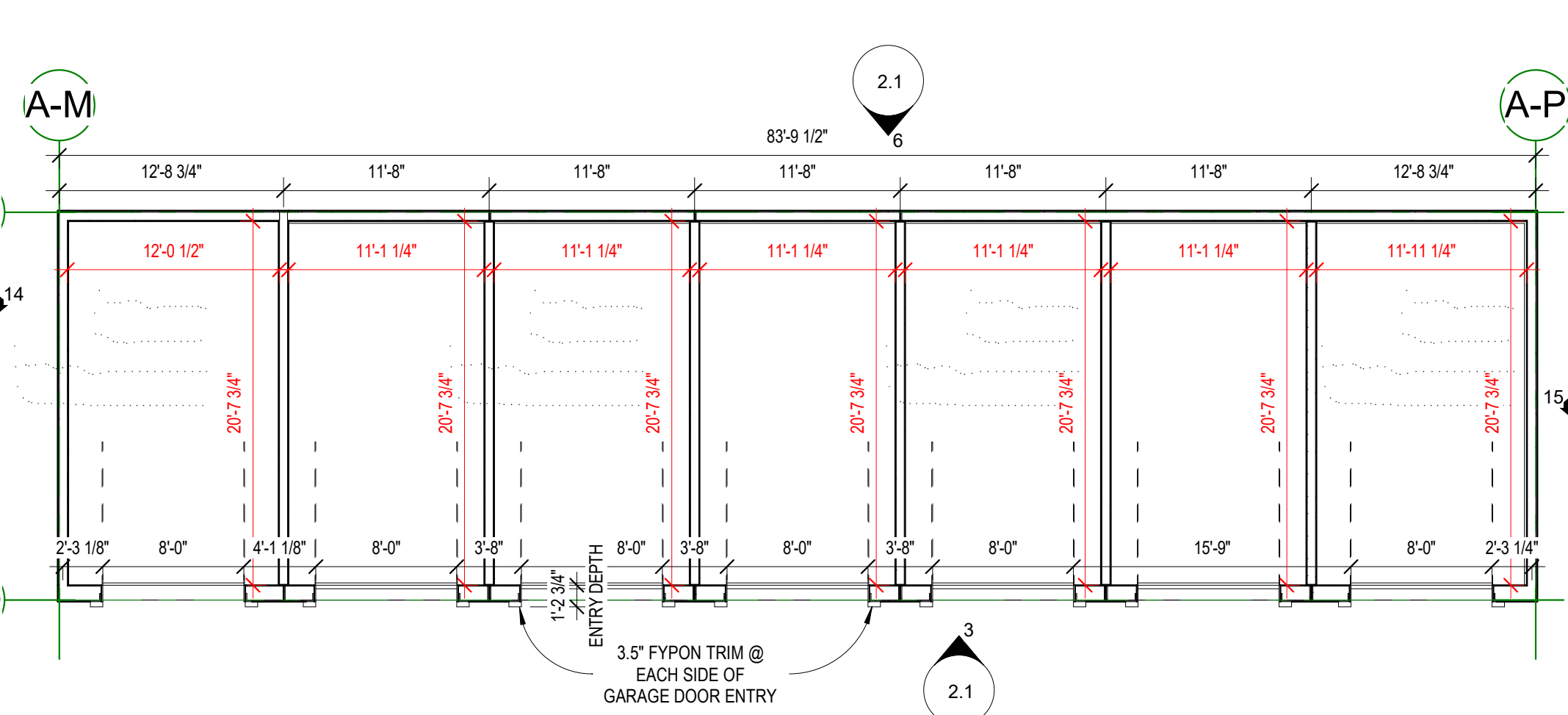

9 Garage C
1/8" = 1'-0"

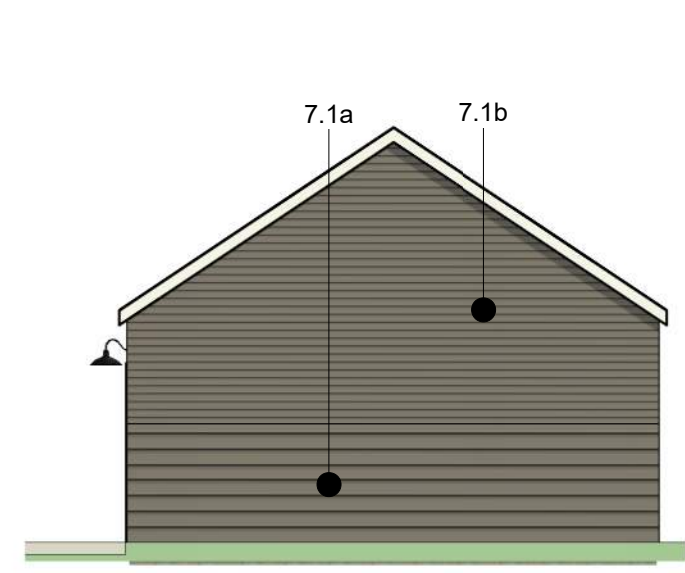

10 Garage A - South Facade
1/8" = 1'-0"

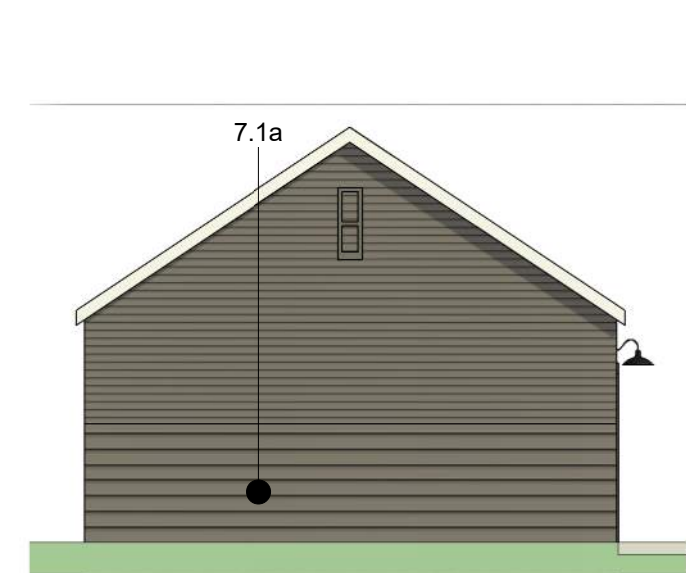

11 Garage A - North Facade
1/8" = 1'-0"

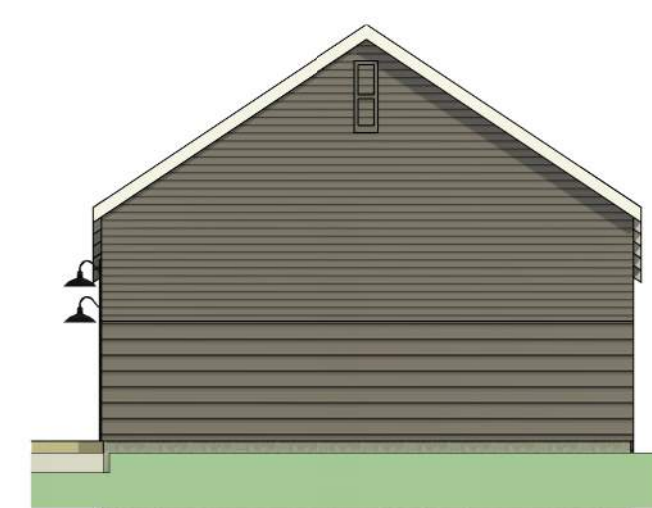

12 Stepped Garage B - South Facade
1/8" = 1'-0"

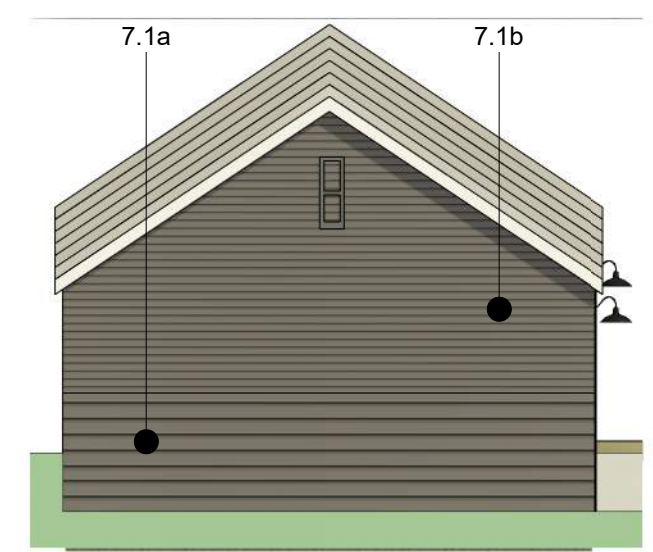

13 Stepped Garage B - North Facade
1/8" = 1'-0"

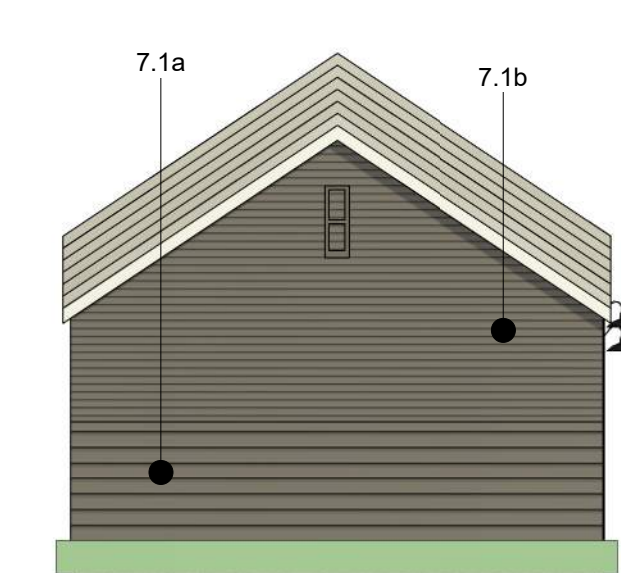

14 Stepped Garage C - North Facade
1/8" = 1'-0"

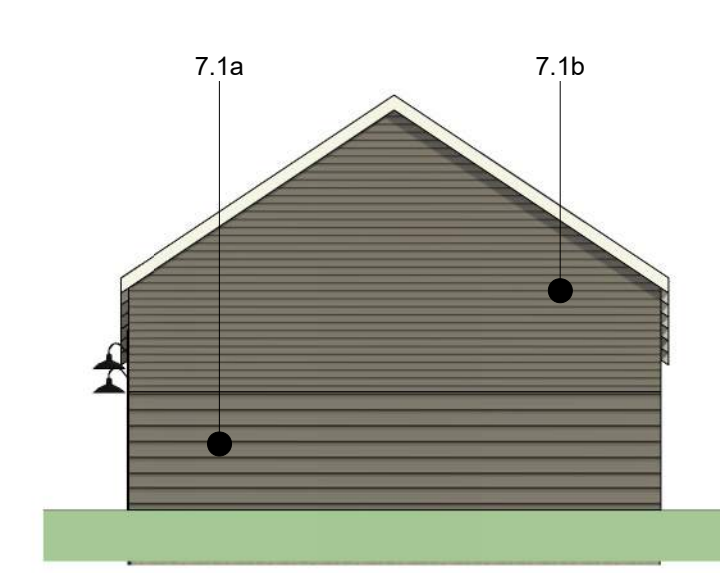

15 Stepped Garage C - South Facade
1/8" = 1'-0"

SEE 6.4 - EXTERIOR ELEVATION - 65 UNIT (BUILDING E) FOR PICTURE OF WINDOW APPLICATION

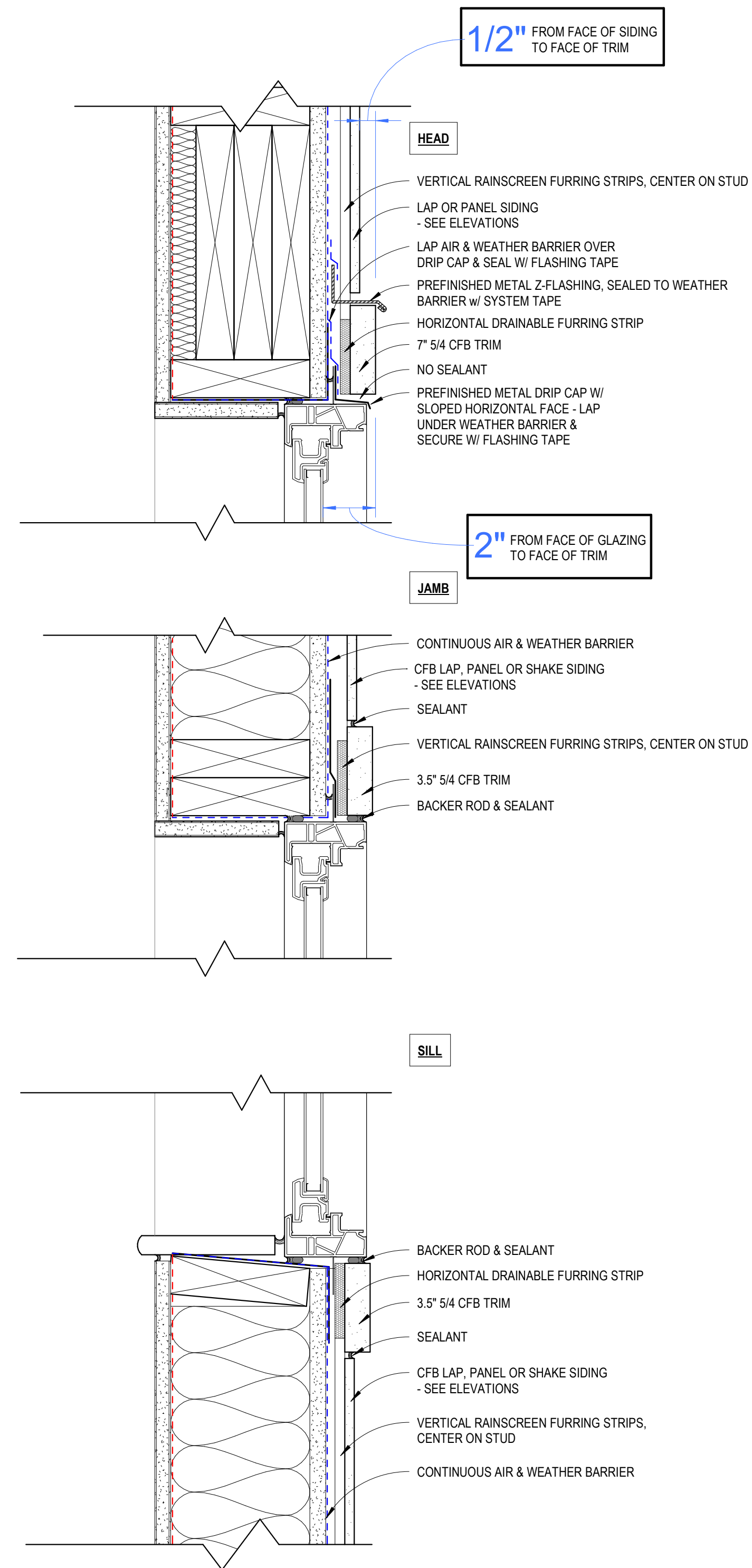

② Vinyl Window @ CFB Siding - Head/Jamb/Sill
3" = 1'-0"

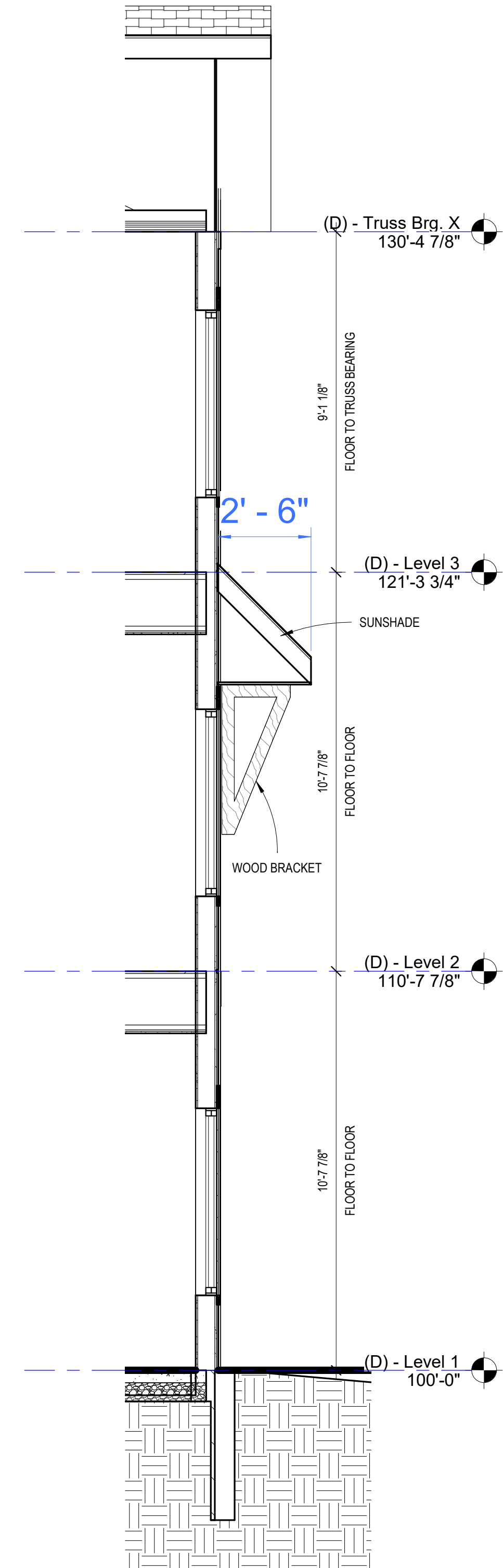

③ Typical Section w/ Awning
3/8" = 1'-0"

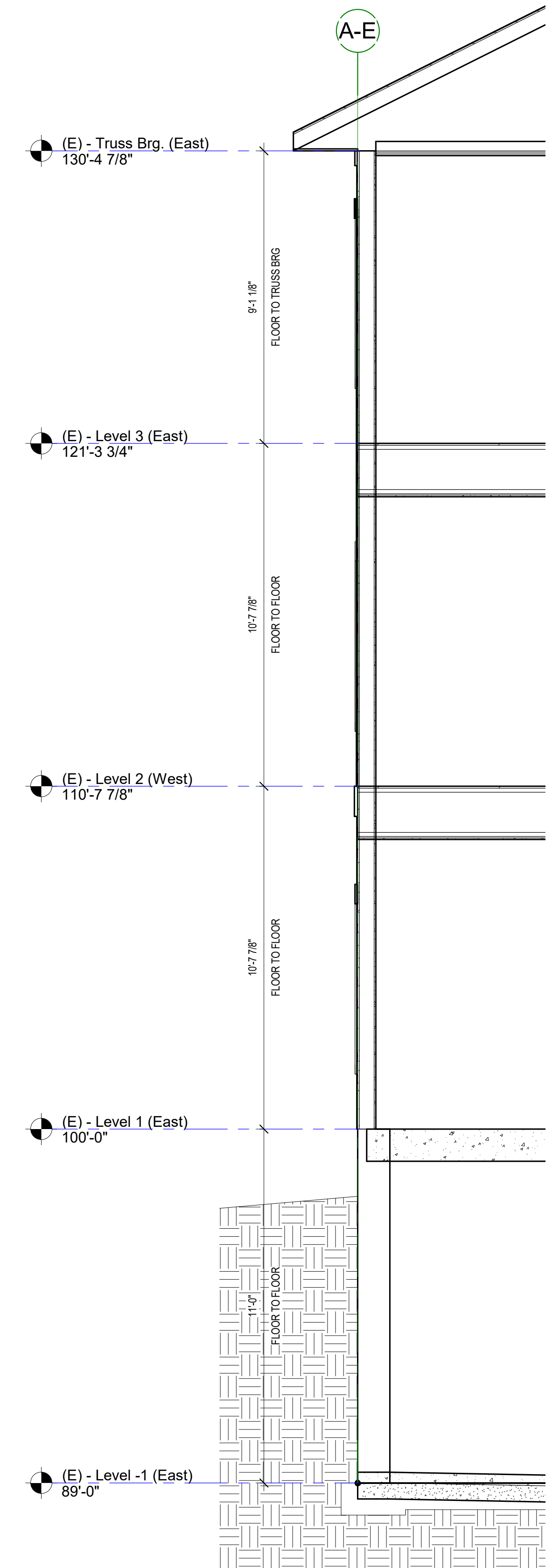

④ Typical Section - Building E
3/8" = 1'-0"

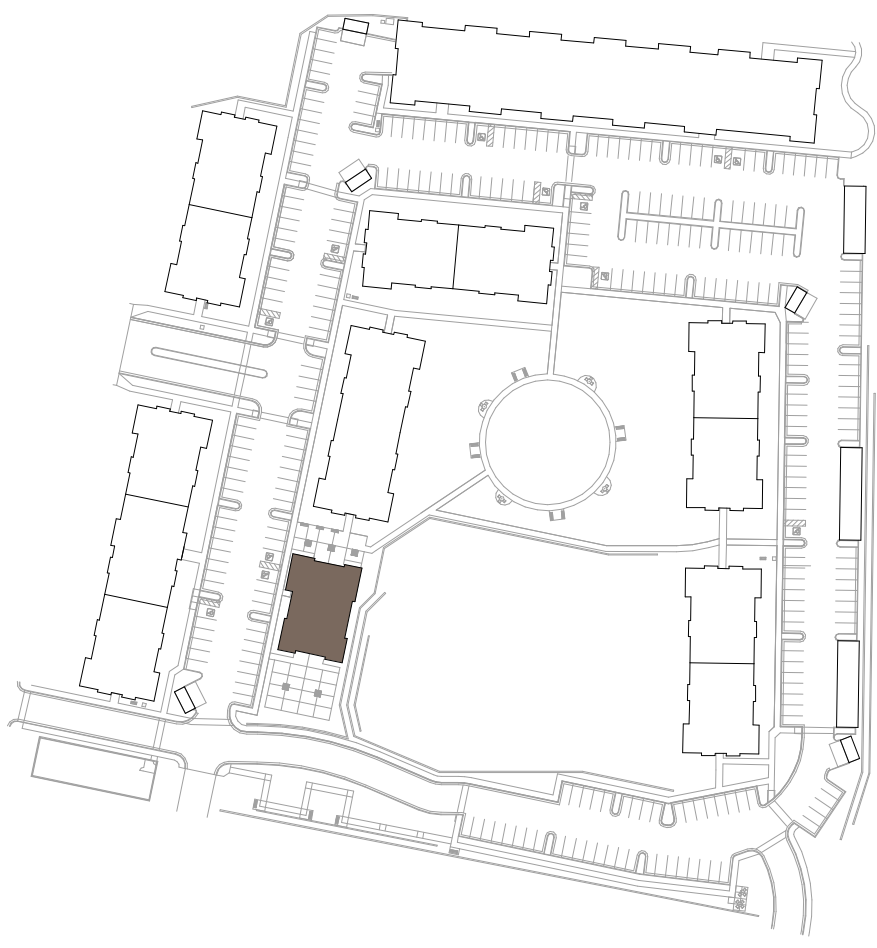

SD - KEY PLAN -BLDG A / GARAGES / TRASH ENCL.
1" = 160'-0"



CLUBHOUSE



BLDG C1, C2, C3, C4



BLDG B

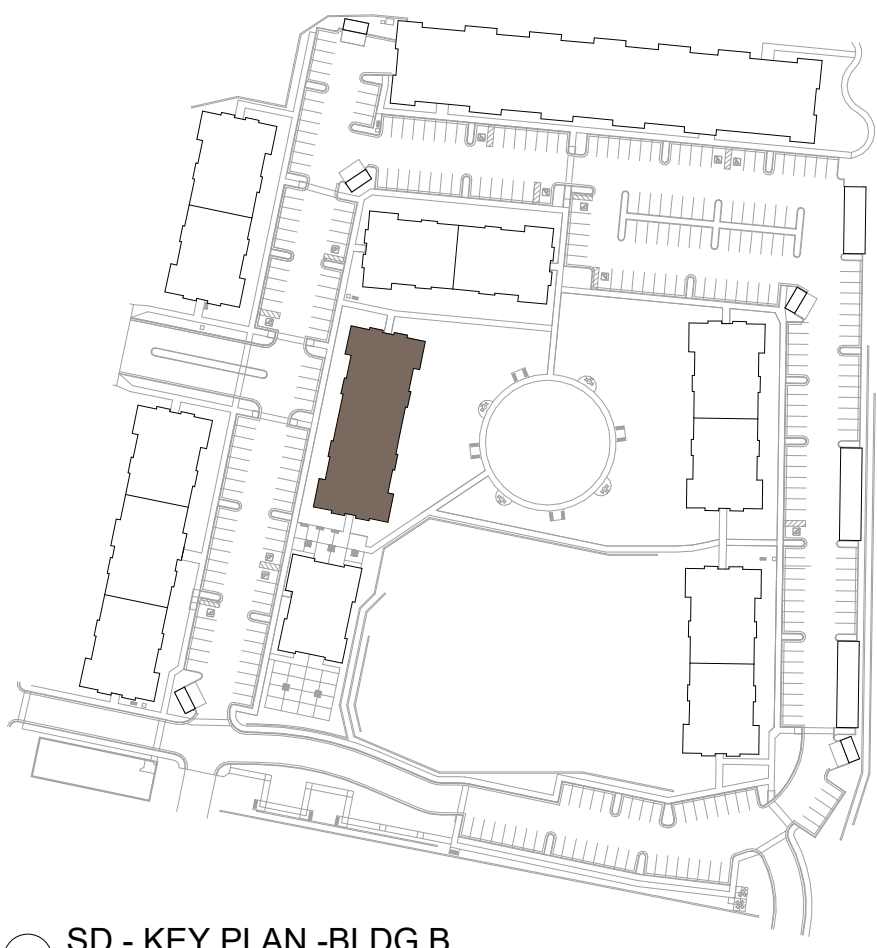

SD - KEY PLAN -BLDG B
1" = 160'-0"

BLDG C1, C2, C3, C4

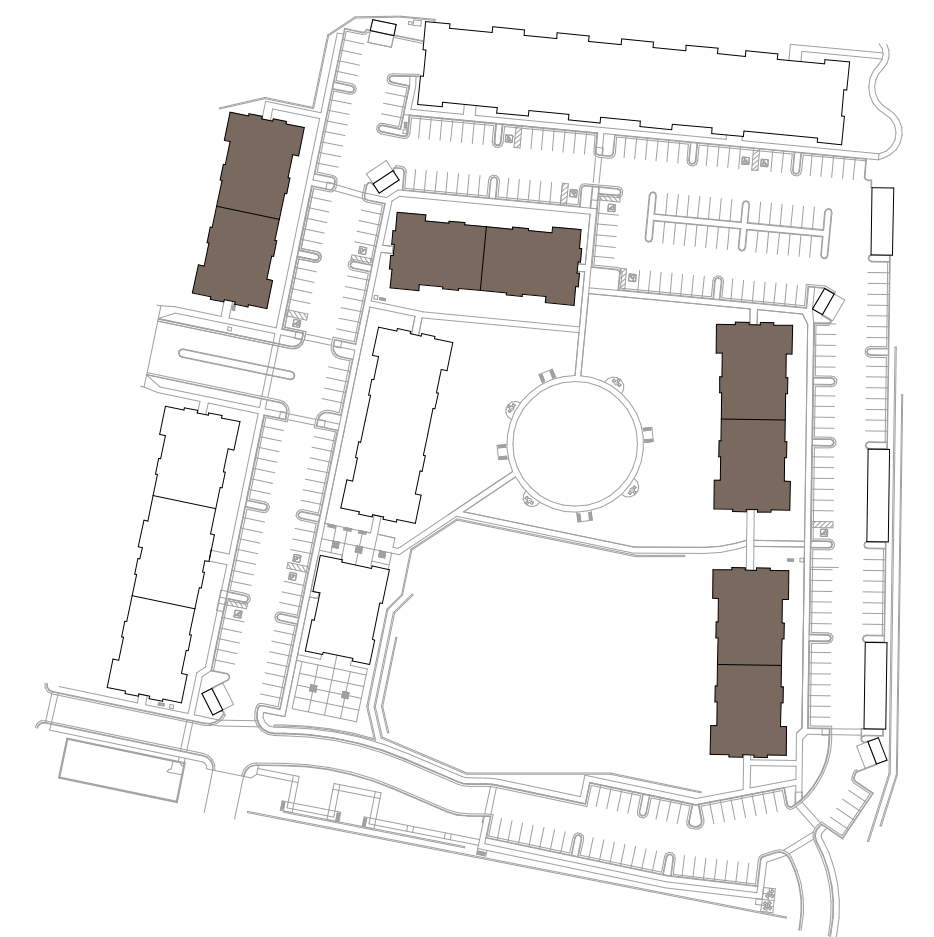

SD - KEY PLAN -BLDG C1, C2, C3, C4
1" = 160'-0"

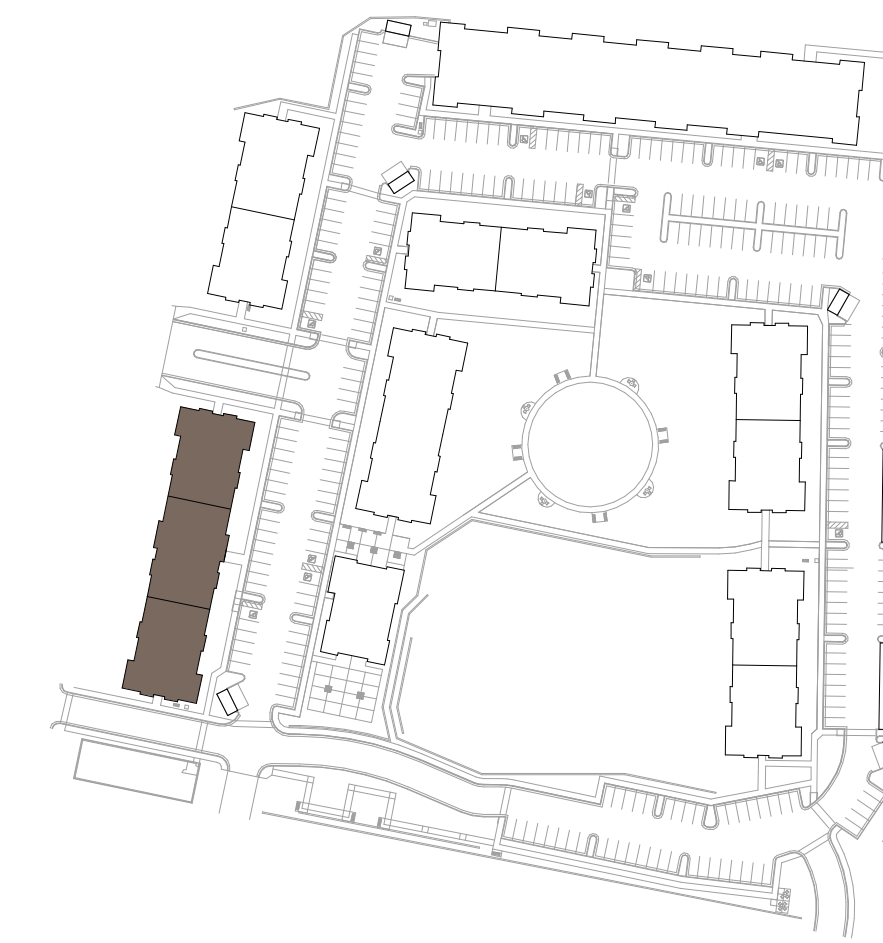

SD - KEY PLAN -BLDG D
1" = 160'-0"

BLDG D

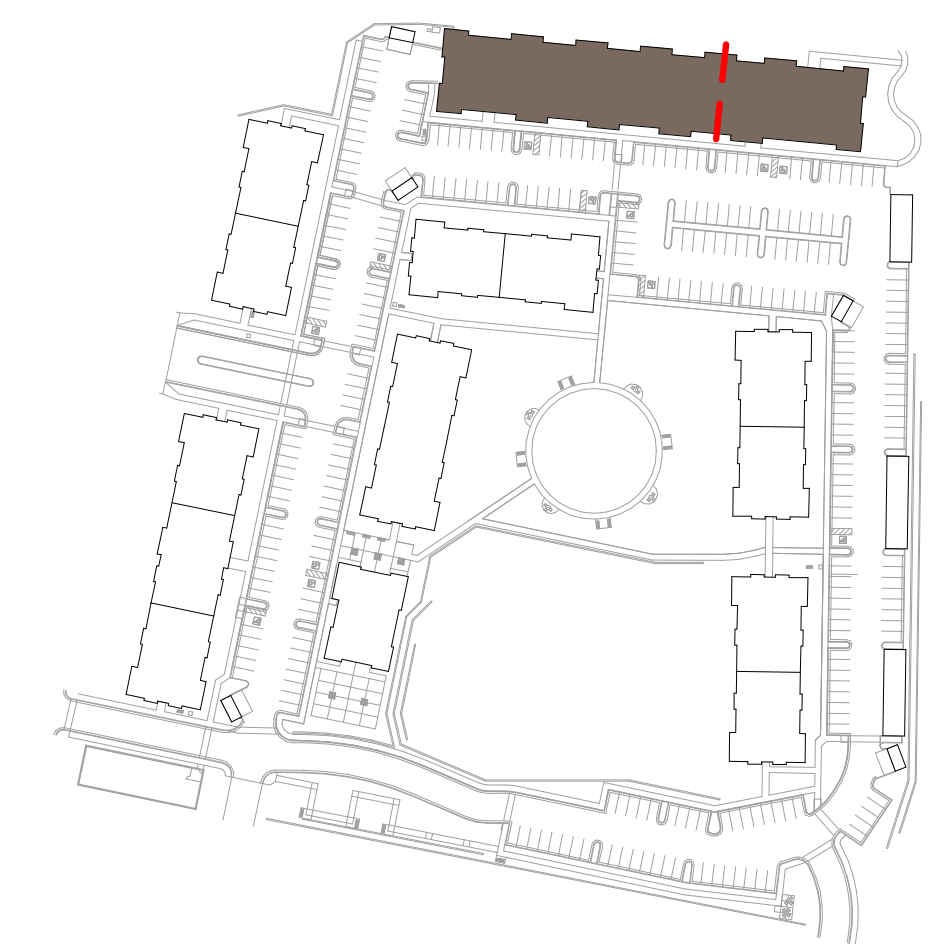

SD - KEY PLAN -BLDG E
1" = 160'-0"

BLDG E



1 SD - (B) Plan West
3/32" = 1'-0"

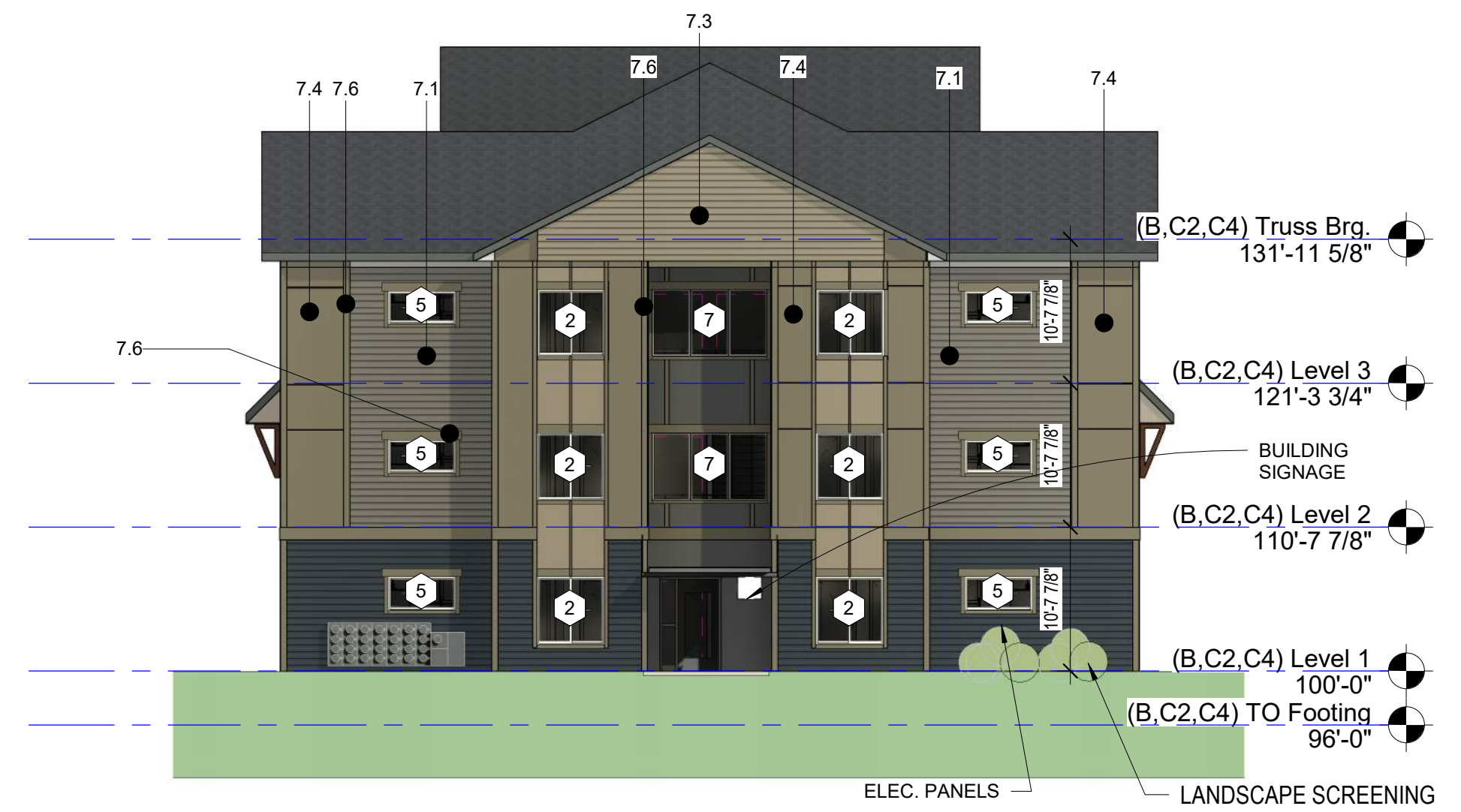

3 SD - (B) Plan North1
3/32" = 1'-0"



2 SD - (B) Plan East
3/32" = 1'-0"

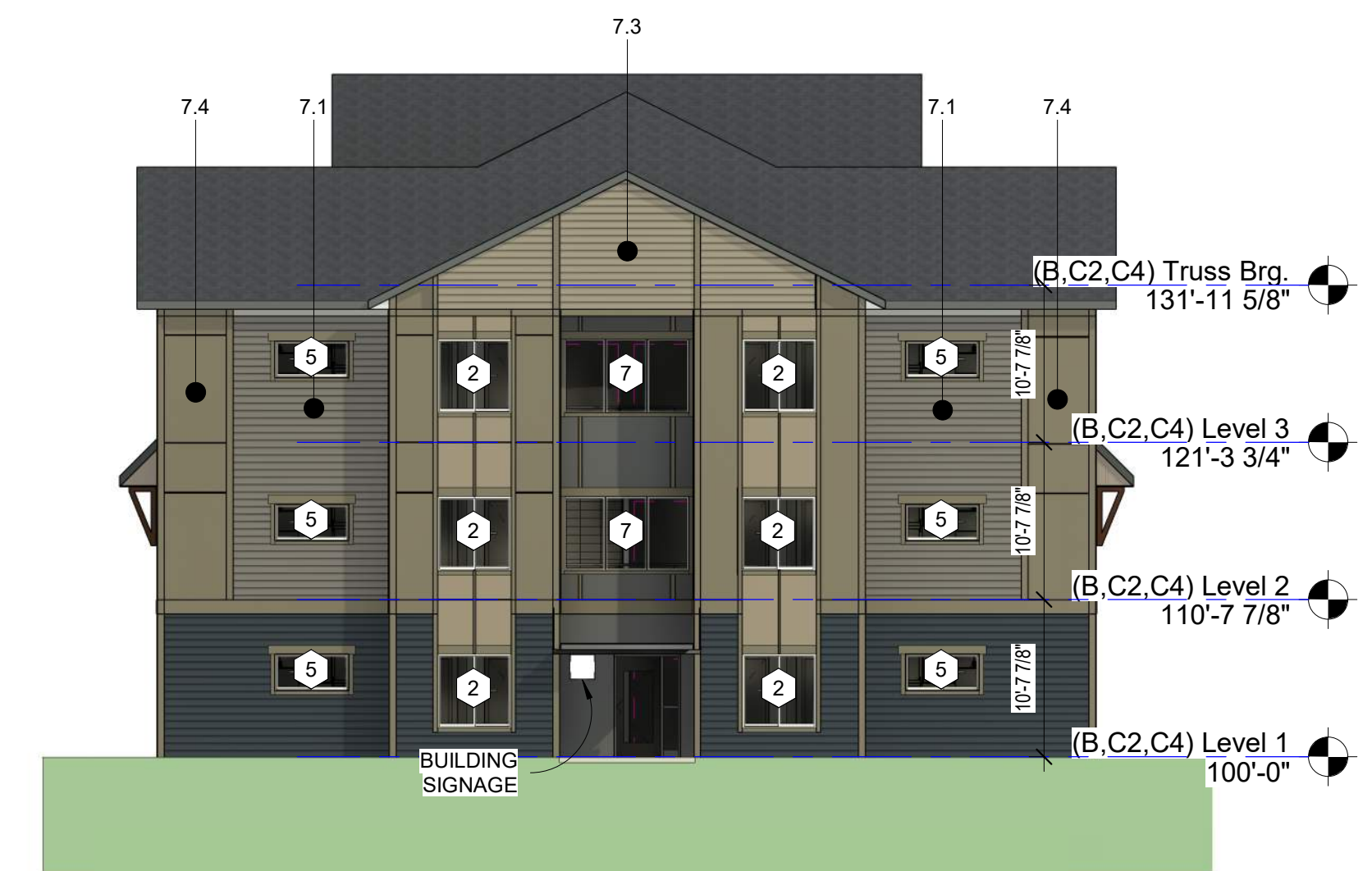

4 SD - (B) Plan South1
3/32" = 1'-0"



EXTERIOR MATERIALS

Material Mark	Description
4.0	CIP Foundation - Color: Stained Light Tan Formliner: Limestone-Texture
6.0	Wood Brackets
7.0	CFB Lap Siding: LP Smartside Color: Midnight Shadow LRV: New Color - No LRV Yet
7.1	CFB Lap Siding: LP Smartside Color: Tundra Gray LRV: 18.17
7.2	CFB Lap Siding: LP Smartside Color: Terra Brown LRV: 29.61
7.3	CFB Lap Siding: LP Smartside Color: Quarry Gray LRV: 47.20
7.4	CFB Panel Siding: LP Smartside Color: Timberland Suede LRV: 21.37
7.5	CFB Panel Siding: LP Smartside Color: Terra Brown LRV: 29.61
7.6	CFB Trim: LP Smartside Color: Timberland Suede LRV: 21.37
7.8	CFB Trim: LP Smartside Color: Quarry Gray LRV: 47.20
7.9	CFB 1x2 Batten Trim: LP Smartside Color: Terra Brown LRV: 29.61
8.0	Asphalt Shingles: Certaineed Landmark Series Color: Driftwood
8.1	Awning Canopies - Asphalt Roof Shingles to Match 8.0
23.0	HVAC Louver

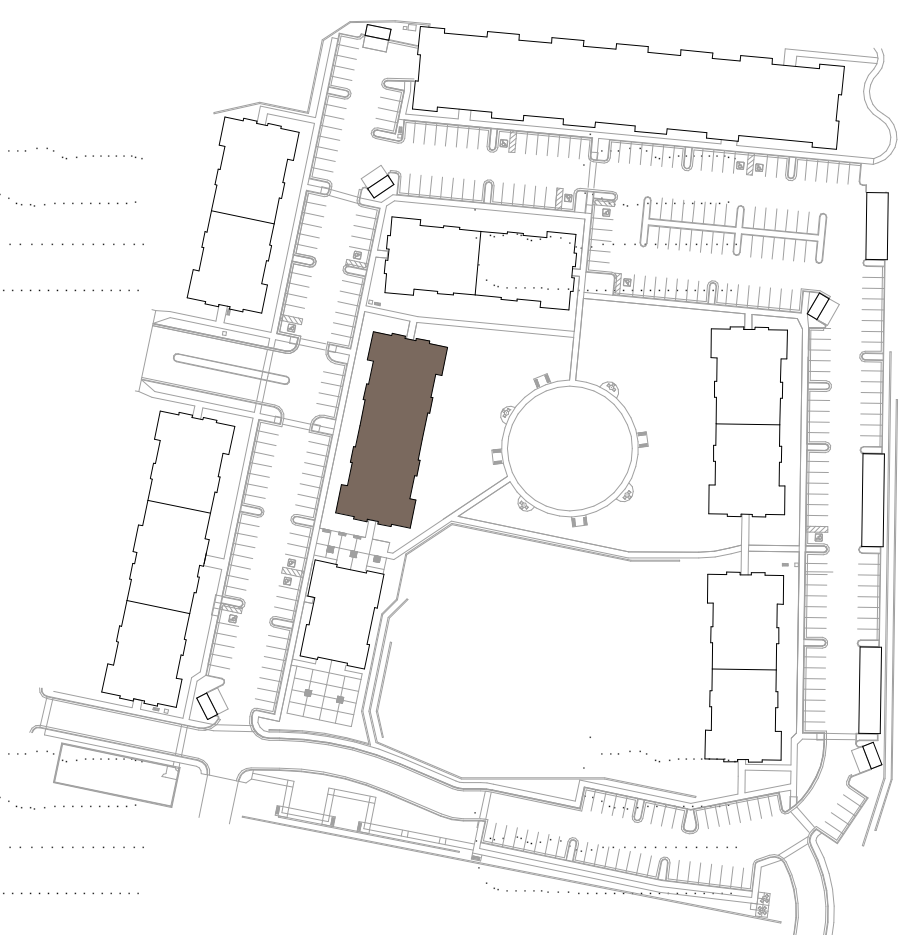

SD - KEY PLAN -BLDG B
1" = 160'-0"

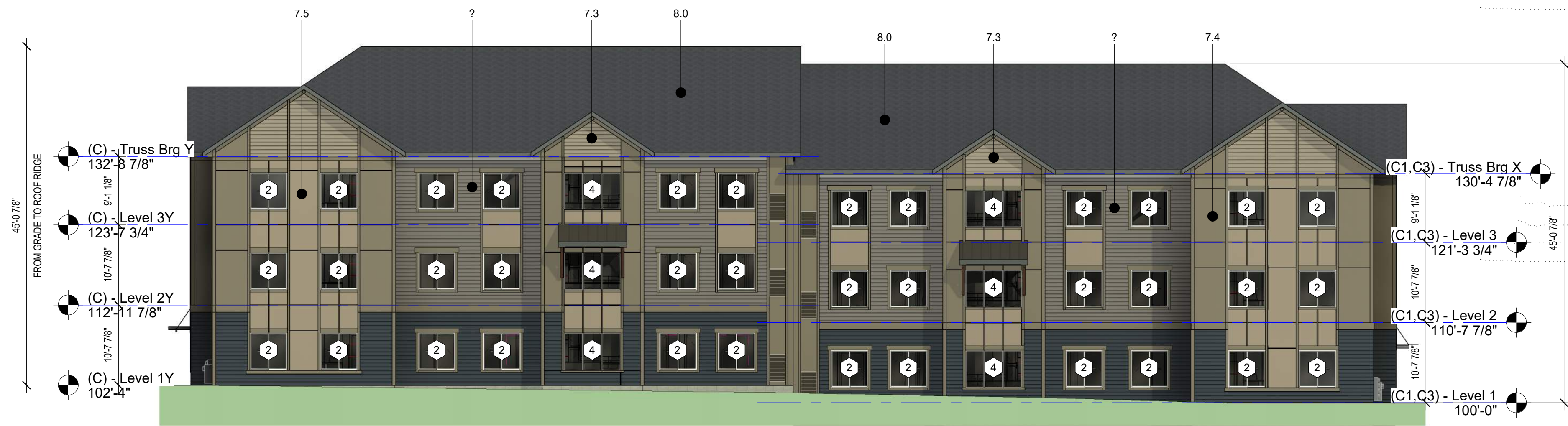

1 SD - (C) Plan North
3/32" = 1'-0"

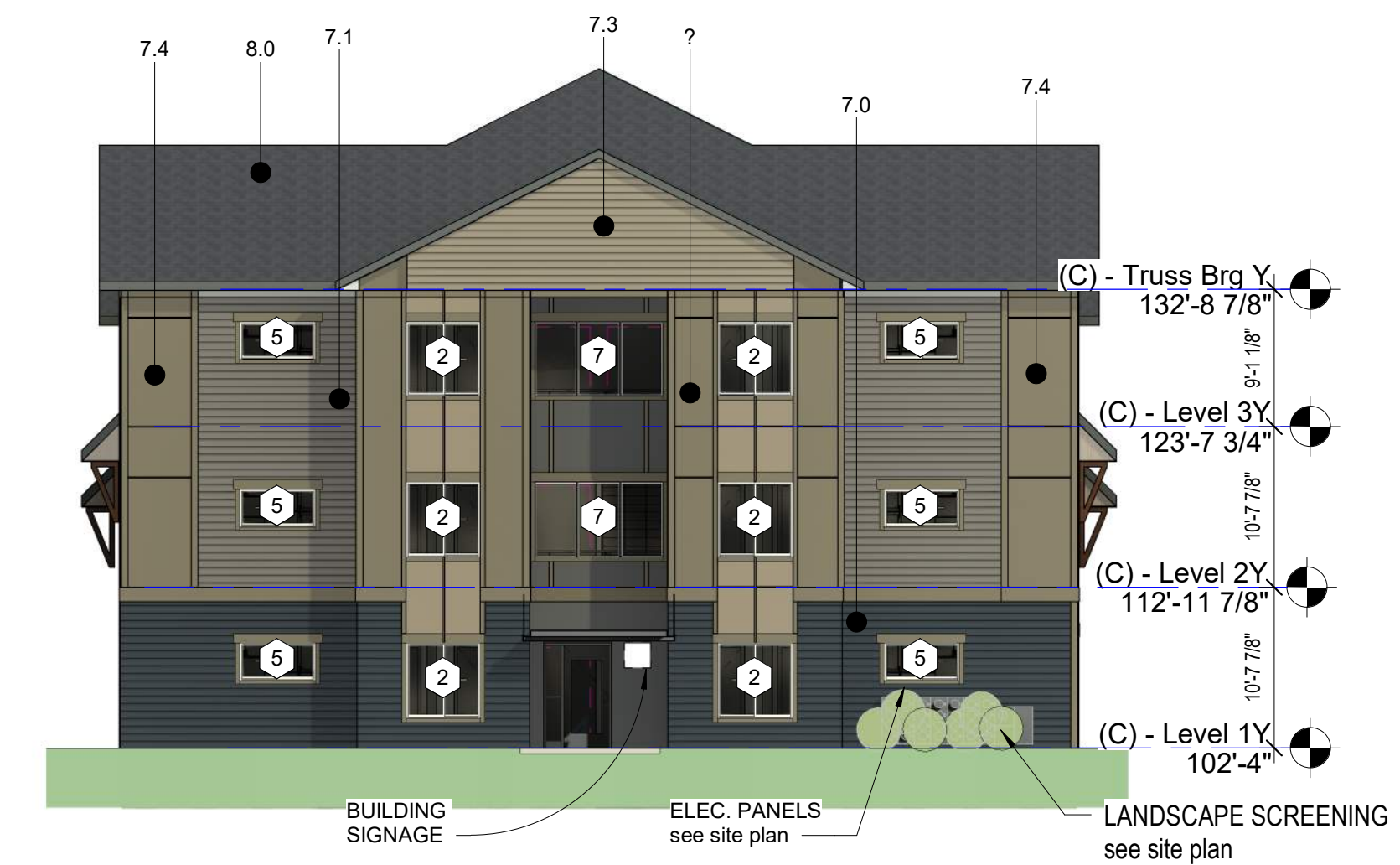

2 SD - (C) - Plan East
3/32" = 1'-0"

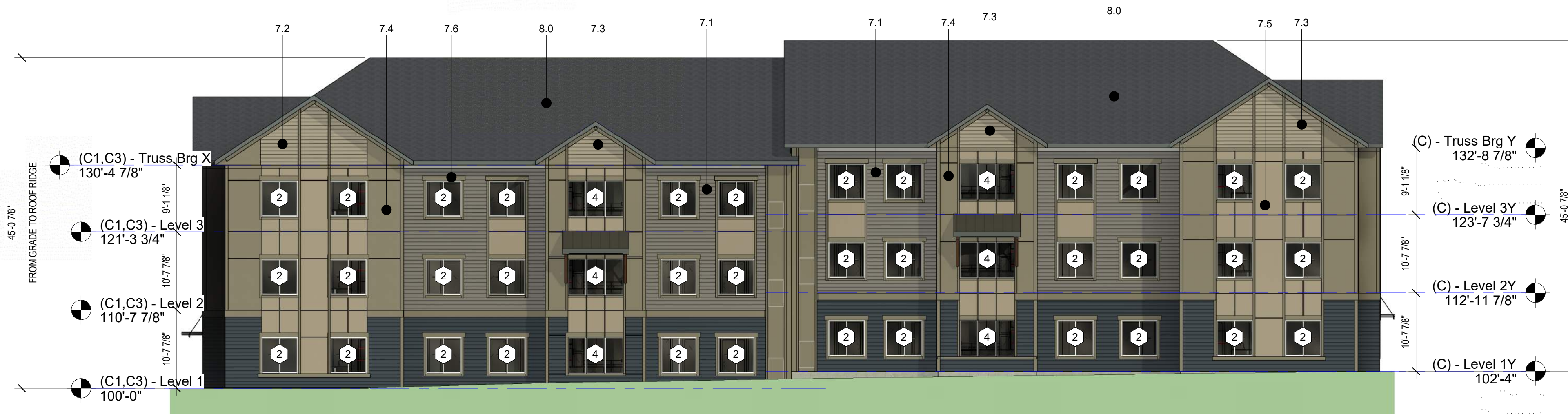

3 SD - (C) Plan South
3/32" = 1'-0"



4 SD - (C) Plan West
3/32" = 1'-0"



EXTERIOR MATERIALS

Material Mark	Description
4.0	CIP Foundation Color: Stained Light Tan Formliner: Limestone Texture
6.0	Wood Brackets
7.0	CFB Lap Siding: LP Smartside Color: Midnight Shadow LRV: New Color - No LRV Yet
7.1	CFB Lap Siding: LP Smartside Color: Tundra Gray LRV: 18.17
7.2	CFB Lap Siding: LP Smartside Color: Terra Brown LRV: 29.61
7.3	CFB Lap Siding: LP Smartside Color: Quarry Gray LRV: 47.20
7.4	CFB Panel Siding: LP Smartside Color: Timberland Suede LRV: 21.37
7.5	CFB Panel Siding: LP Smartside Color: Terra Brown LRV: 29.61
7.6	CFB Trim: LP Smartside Color: Timberland Suede LRV: 21.37
7.8	CFB Trim: LP Smartside Color: Quarry Gray LRV: 47.20
7.9	CFB 1x2 Batten Trim: LP Smartside Color: Terra Brown LRV: 29.61
8.0	Asphalt Shingles: Certainteed Landmark Series Color: Driftwood
8.1	Awning Canopies - Asphalt Roof Shingles to Match 8.0
23.0	HVAC Louver

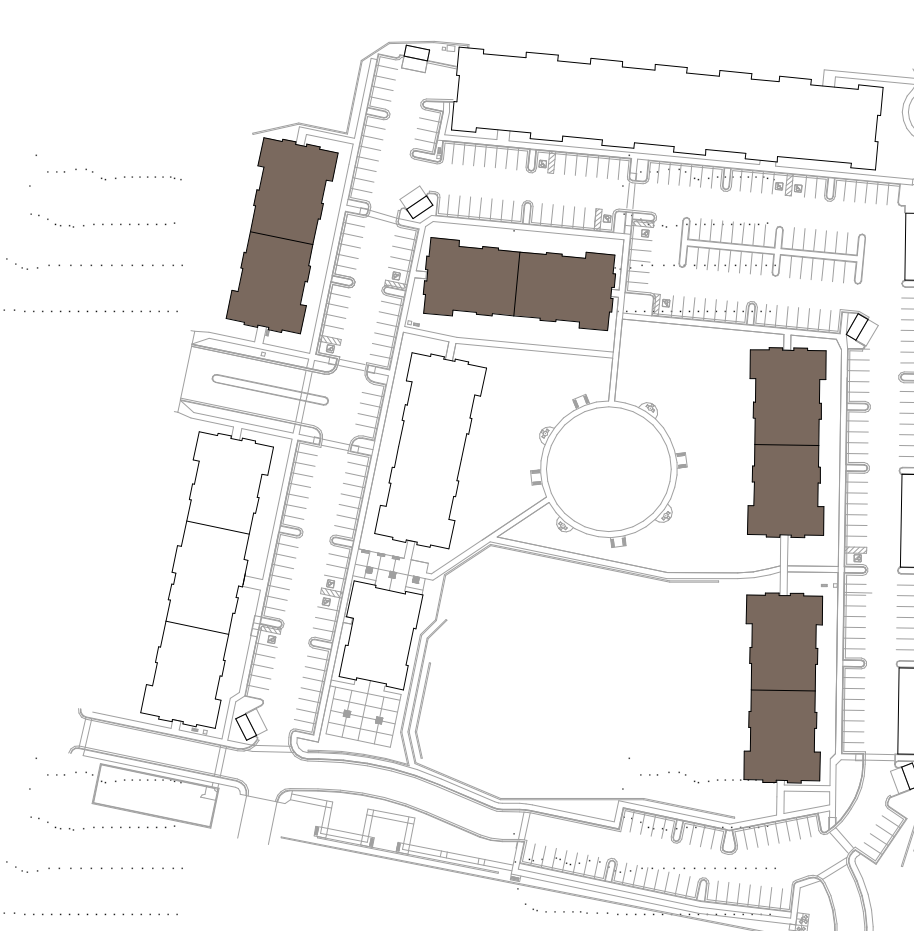

SD - KEY PLAN -BLDG C1,
C2, C3, C4
1" = 160'-0"

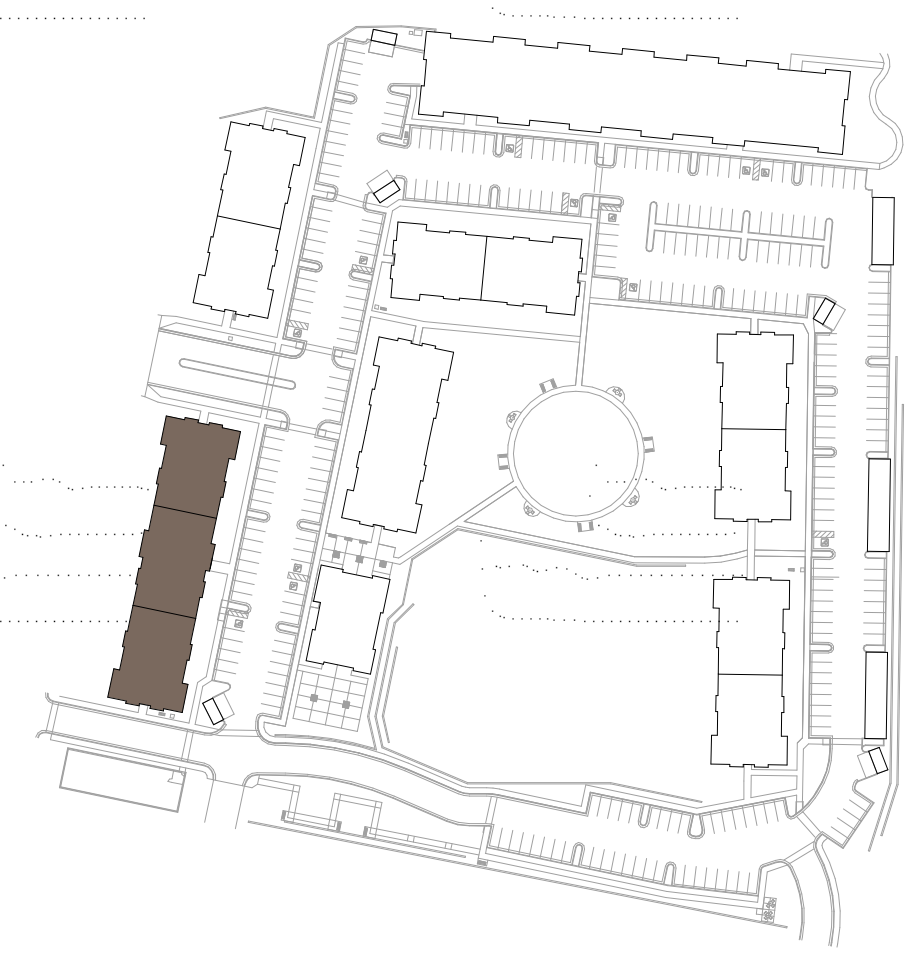

SD - KEY PLAN - BLDG D
1" = 160'-0"

1 SD - (D) Plan North
3/32" = 1'-0"

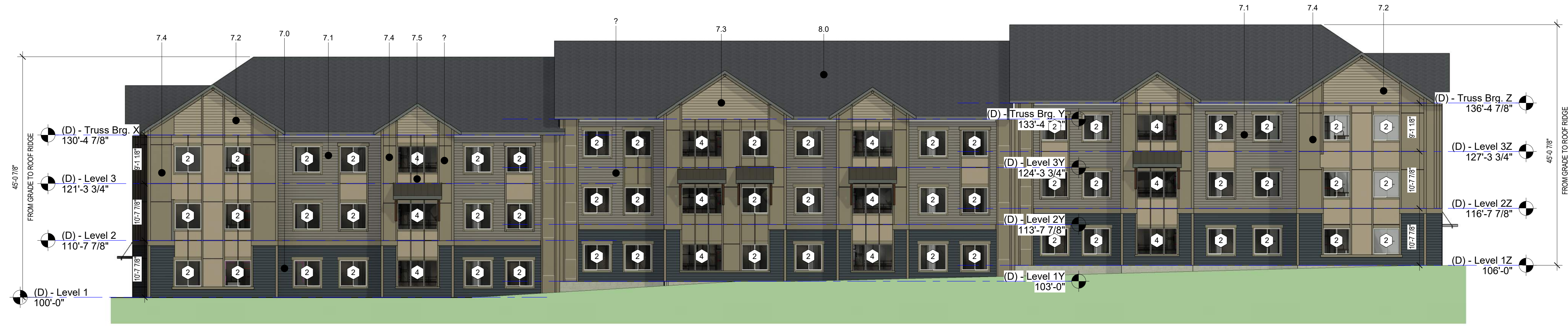

2 SD - (D) Plan South
3/32" = 1'-0"

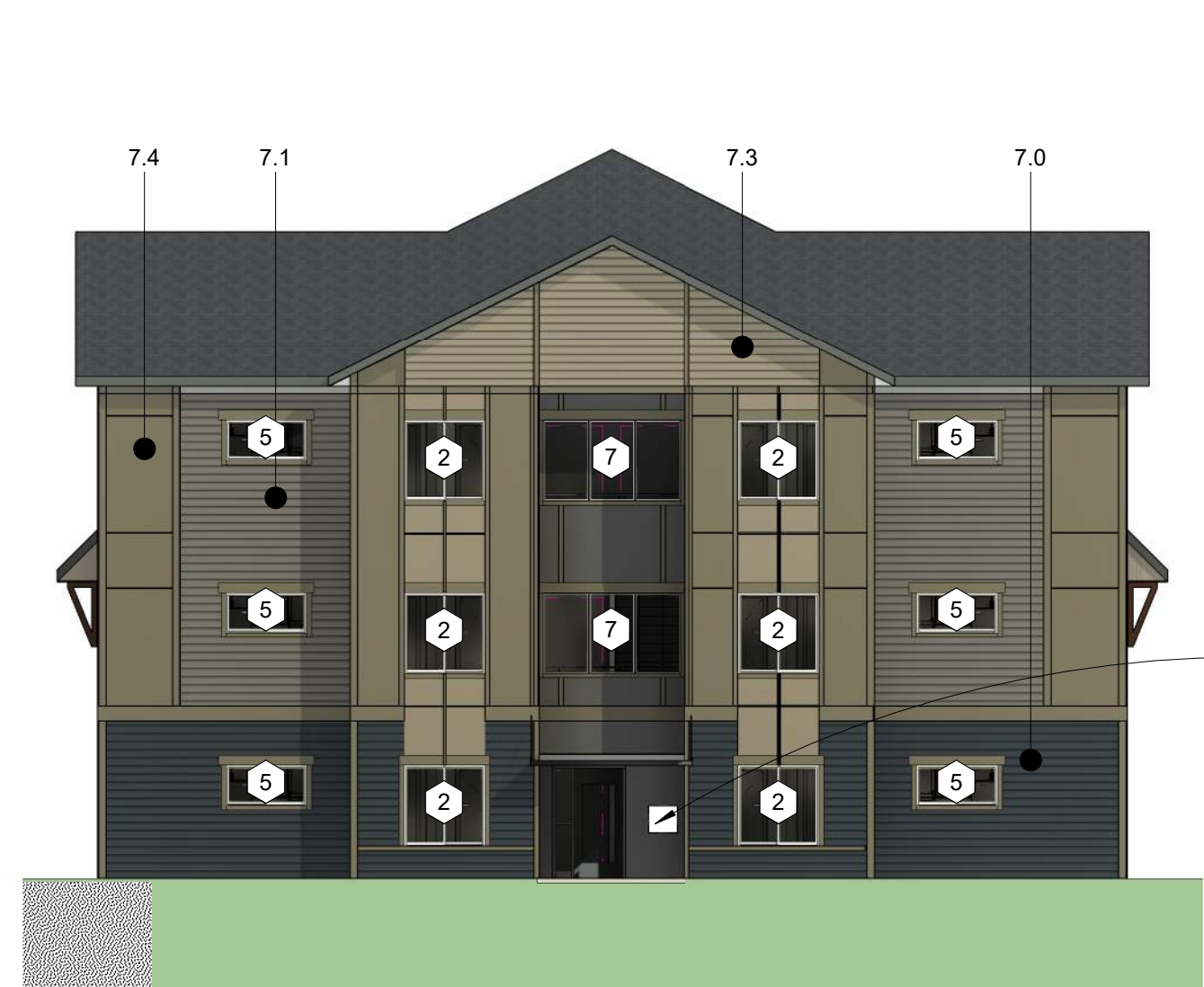

3 SD - (D) Plan East
3/32" = 1'-0"

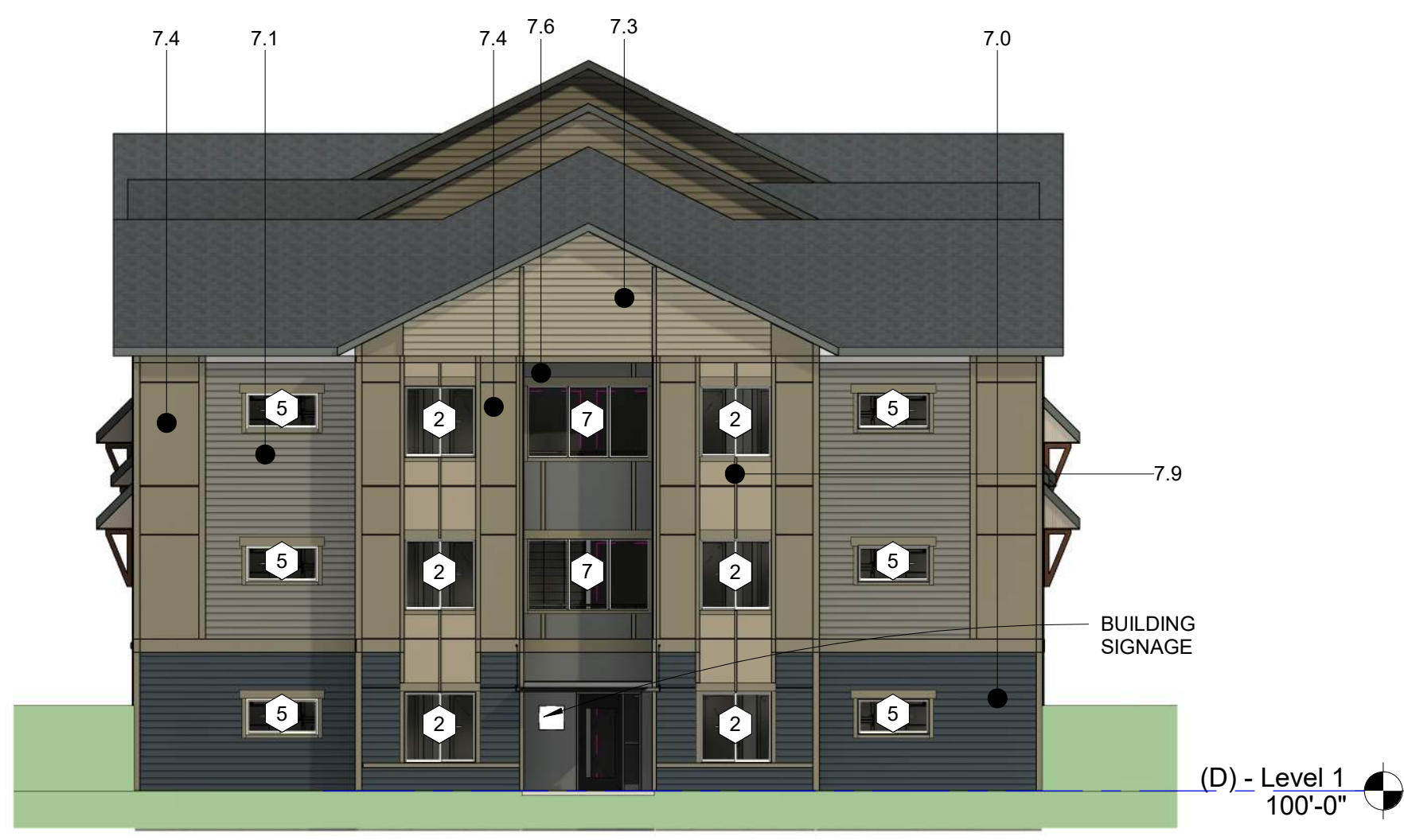

4 SD - (D) Plan West
3/32" = 1'-0"





② Building E - South (West)
3/32" = 1'-0"



③ Building E - South (East)
3/32" = 1'-0"

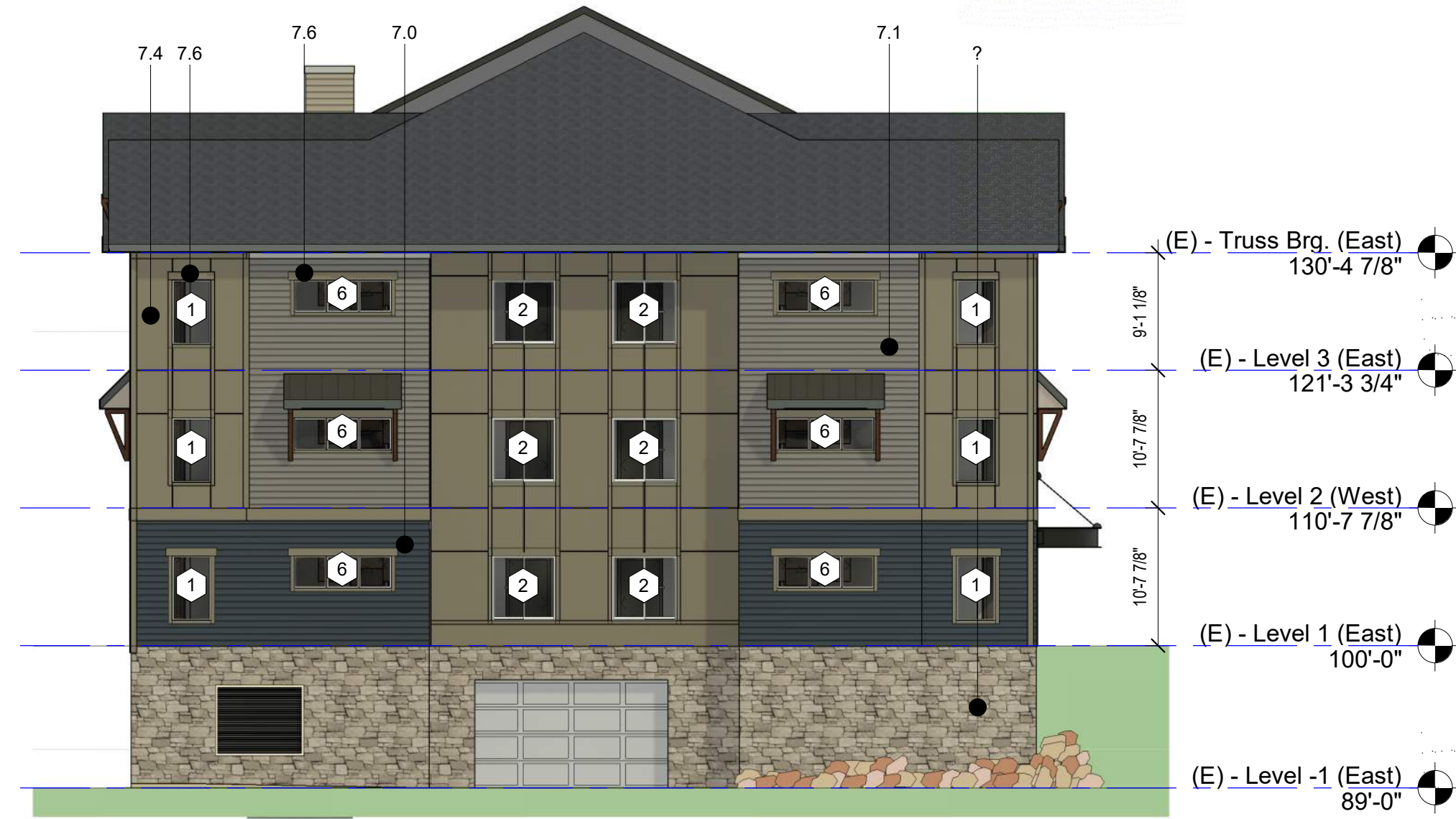

① Building E - West
3/32" = 1'-0"



EXTERIOR MATERIALS

Material Mark	Description
4.0	CIP Foundation Color: Stained Light Tan Formliner: Limestone Texture
6.0	Wood Brackets
7.0	CFB Lap Siding: LP Smartside Color: Midnight Shadow LRV: New Color - No LRV Yet
7.1	CFB Lap Siding: LP Smartside Color: Tundra Gray LRV: 18.17
7.2	CFB Lap Siding: LP Smartside Color: Terra Brown LRV: 29.61
7.3	CFB Lap Siding: LP Smartside Color: Quarry Gray LRV: 47.20
7.4	CFB Panel Siding: LP Smartside Color: Timberland Suede LRV: 21.37
7.5	CFB Panel Siding: LP Smartside Color: Terra Brown LRV: 29.61
7.6	CFB Trim: LP Smartside Color: Timberland Suede LRV: 21.37
7.8	CFB Trim: LP Smartside Color: Quarry Gray LRV: 47.20
7.9	CFB 1x2 Batten Trim: LP Smartside Color: Terra Brown LRV: 29.61
8.0	Asphalt Shingles: Certainteed Landmark Series Color: Driftwood
8.1	Awning Canopies - Asphalt Roof Shingles to Match 8.0
23.0	HVAC Louver

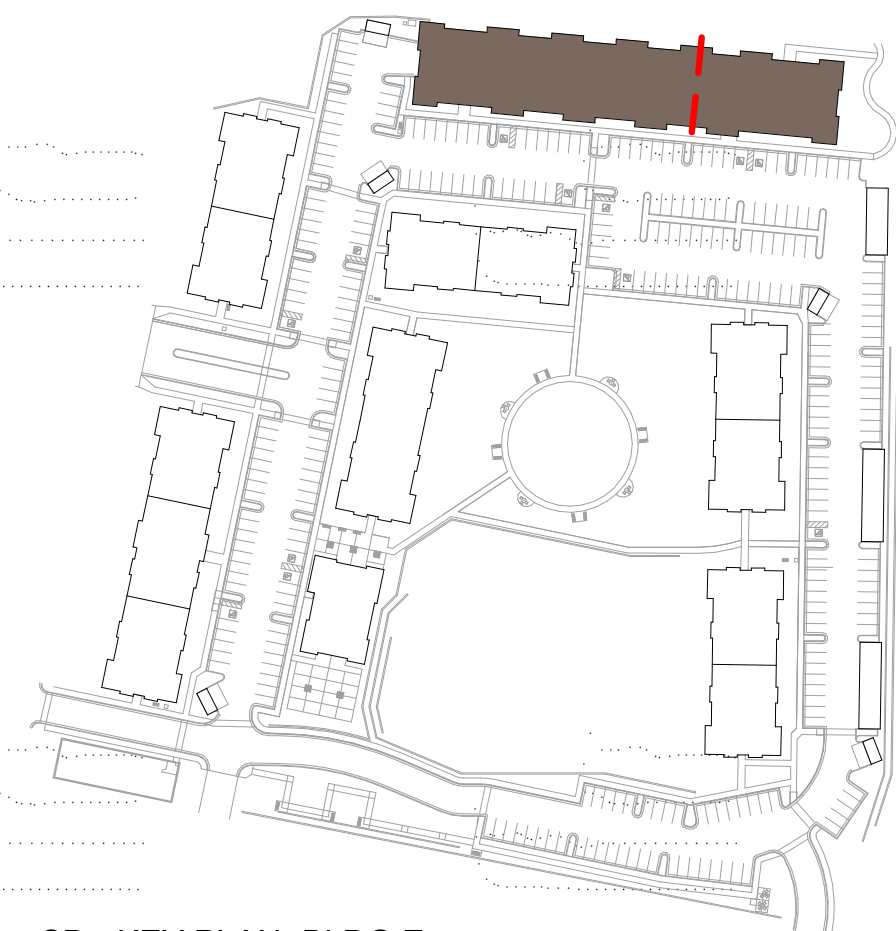

SD - KEY PLAN - BLDG E
1" = 160'-0"



① Building E - North (West)
3/32" = 1'-0"



② Building E - North (East)
3/32" = 1'-0"



③ Building E - East
3/32" = 1'-0"



EXTERIOR MATERIALS

Material Mark	Description
4.0	CIP Foundation Color: Stained Light Tan Formliner: Limestone Texture
6.0	Wood Brackets
7.0	CFB Lap Siding: LP Smartside Color: Midnight Shadow LRV: New Color - No LRV Yet
7.1	CFB Lap Siding: LP Smartside Color: Tundra Gray LRV: 18.17
7.2	CFB Lap Siding: LP Smartside Color: Terra Brown LRV: 29.61
7.3	CFB Lap Siding: LP Smartside Color: Quarry Gray LRV: 47.20
7.4	CFB Panel Siding: LP Smartside Color: Timberland Suede LRV: 21.37
7.5	CFB Panel Siding: LP Smartside Color: Terra Brown LRV: 29.61
7.6	CFB Trim: LP Smartside Color: Timberland Suede LRV: 21.37
7.8	CFB Trim: LP Smartside Color: Quarry Gray LRV: 47.20
7.9	CFB 1x2 Batten Trim: LP Smartside Color: Terra Brown LRV: 29.61
8.0	Asphalt Shingles: Certaineed Landmark Series Color: Driftwood
8.1	Awning Canopies - Asphalt Roof Shingles to Match 8.0
23.0	HVAC Louver