

## COOPERATIVE PURCHASE CONTRACT

Contract No. 2024-165

This Cooperative Purchase Contract is made and entered into this \_\_\_\_\_ day of \_\_\_\_\_, 20\_\_\_\_ by and between the City of Flagstaff, Arizona, a political subdivision of the State of Arizona ("City") and Morning Dew Landscaping, Inc., an Arizona C Corporation ("Contractor").

### RECITALS:

- A. Contractor is a fully authorized vendor of landscaping and maintenance services;
- B. The Coconino County Flood Control District of Arizona, Procurement Department, Public Sector conducted a competitive and open procurement process through Request for Qualifications Solicitation No. 2023-105 that resulted in Contract No. 2023-105 with Contractor ("Agency Contract"); and
- C. The City has authority to enter into a cooperative purchase contract with Contractor utilizing the Agency Contract.

### AGREEMENT:

NOW THEREFORE, in consideration for the mutual promises contained herein, the Parties agree as follows:

1. Materials and or Services Purchased: Contractor shall provide to the City the materials and or services, as specified in the Scope of Work attached as Exhibit A, and in accordance with the Agency Contract. A general description of materials and/or services being purchased is:

#### **CLOE MURDOCH NEIGHBORHOOD PARK**

2. Specific Requirements of City: Contractor shall comply with all specific purchase and delivery requirements and/or options of City, as specified in the Scope of Work attached as Exhibit A and incorporated by reference.
3. Compensation: The City will pay Contractor for satisfactory performance of the Contract in an amount not to exceed **THREE HUNDRED FORTY-FOUR THOUSAND ONE HUNDRED SIXTY-NINE DOLLARS AND ZERO CENTS (\$344,169.00)**, including fees and taxes, made in accordance with the price list and terms set forth in the Agency Contract. Any price adjustment must be approved by mutual written consent of the parties through a formal amendment. The City Manager or his/her designee (the Purchasing Director) may approve an amendment if the total amount of the Contract as amended is less than \$100,000; otherwise, City Council approval is required.
4. Terms and Conditions of Agency Contract Apply: All provisions of the Agency Contract documents attached as Exhibit B, including any amendments, are incorporated in and shall apply to this Contract as though fully set forth herein. Contractor is responsible for promptly notifying City in writing of any changes to the Agency Contract, including, specifically changes in price for materials and/or services.

5. Grant Provisions: Contractor shall meet the requirements of the U.S. Department of Housing and Urban Development, Community Development Block Grant, B22-MC-04-0510, CFDA Number 14.218, attached as Exhibit C.
6. Certificates of Insurance: All insurance provisions of the Agency Contract shall apply, including any requirement to name the City as an additional insured. Prior to commencing performance under this Contract, Contractor shall furnish City with a copy of the current Certificate of Insurance required by the Agency Contract.
7. Term: This Cooperative Purchase Contract shall commence upon execution by the Parties and shall continue until expiration or termination of the underlying Agency Contract, unless sooner terminated by City in writing.
8. Renewal: This Cooperative Purchase Contract shall be automatically renewed if the underlying Agency Contract is renewed, for the same renewal period, unless City provides advance written notice to Contractor of its intention to non-renew.
9. Notice: Any formal notice required under the Contract shall be in writing and sent by certified mail and email as follows:

To the City:

Amy Hagin  
City of Flagstaff  
211 W. Aspen Ave.  
Flagstaff, AZ 86001  
[ahagin@flagstaffaz.gov](mailto:ahagin@flagstaffaz.gov)  
Phone: 928-213-2164

With a copy to:

Emily Markel  
City of Flagstaff  
211 W. Aspen Ave.  
Flagstaff, AZ 86001  
[emarkel@flagstaffaz.gov](mailto:emarkel@flagstaffaz.gov)  
Phone: 928-213-2276

To Contractor:

Chris Lloyd  
Morning Dew Landscaping, Inc.  
2684 E. Huntington Dr.  
Flagstaff, AZ 86004  
[chris@morningdewlandscaping.com](mailto:chris@morningdewlandscaping.com)  
Phone: 928-606-4988

With a copy to:

Kristine Pavlick  
City of Flagstaff  
211 W. Aspen Ave.  
Flagstaff, AZ 86001  
[Kristine.Pavlik@flagstaffaz.gov](mailto:Kristine.Pavlik@flagstaffaz.gov)

9. Authority: Each Party warrants that it has authority to enter into the Contract and perform its obligations hereunder, and that it has taken all actions necessary to enter into the Contract.

MORNING DEW LANDSCAPING, INC.:

By: \_\_\_\_\_

Title: \_\_\_\_\_

CITY OF FLAGSTAFF

By: \_\_\_\_\_

Title: \_\_\_\_\_

ATTEST:

\_\_\_\_\_  
City Clerk

APPROVED AS TO FORM:

\_\_\_\_\_  
City Attorney's Office

Notice to Proceed issued: \_\_\_\_\_, 20\_\_.

# Cleo Murdoch Neighborhood Park

201 E Brannen Ave

## Project Performance Outline

---

### Cleo Murdoch Neighborhood Park

The new park includes the existing “pocket park” landscaping west of the Murdoch Center building, the mega chess board and land north of the Murdoch and land east of the Murdoch. Access and accessibility work is included at a later phase in areas south and around the Murdoch to interface development requirements and for runoff control. The Murdoch Center is leased by the Southside Community Association and utilized as a publicly accessible community center. The Murdoch lease from the city includes the building, a parking strip adjacent to a north-south alley and “pollinator garden” and a triangular paved area south of the Murdoch building.



### Park Area

The area to be developed as a neighborhood park is separated from the Murdoch lease is shown in green below. Full development of the park will be completed in phased construction.

## Phase 1 Improvements

Phase 1 construction limits are generally described as including the west pocket park and limited by the cross-connecting walkway and stub wall. With the exception of the chain-link fence fabric & post removal and site grubbing. Contracted work is limited to the cross-connecting east-west concrete (and walk & stub-wall) and improvements to the north of this concrete connecting sidewalk.

## Park Improvements & Features

Many features shown below are included and shown below but are not limited to this graphic. See the specifications for additional information and details.

### Park Improvement - Cleo Murdoch Neighborhood Park

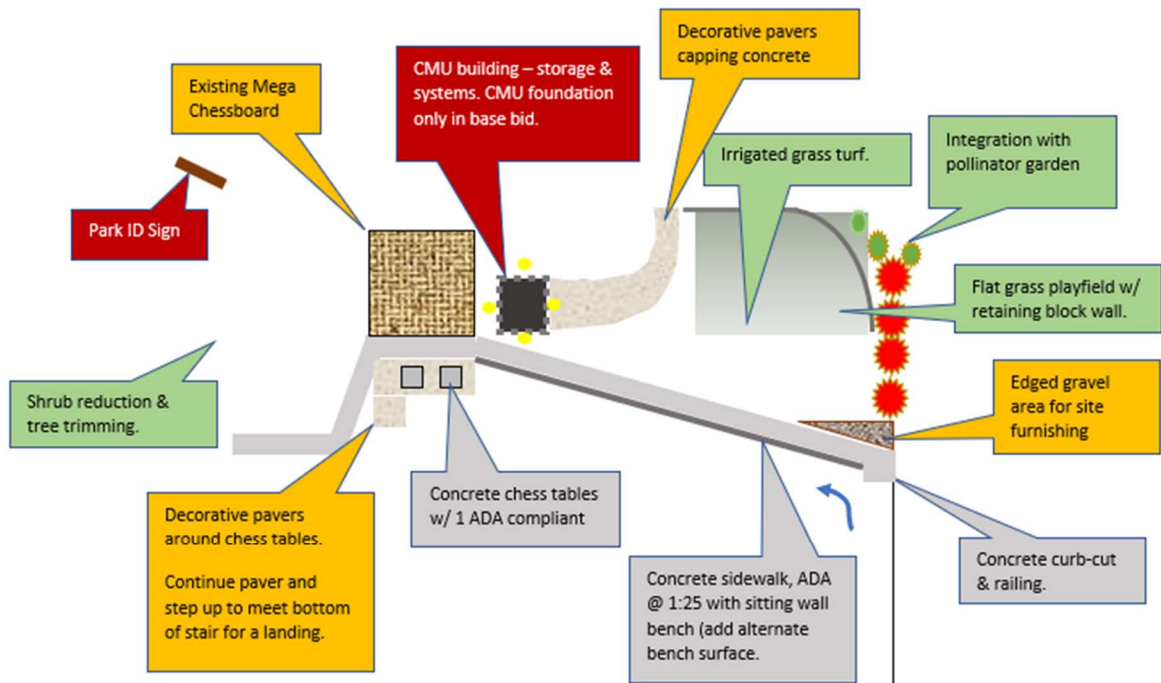

Cleo Murdoch Neighborhood Park – Graphic Concept Plan

**NOTE: Only Park Features and Improvements Shown**

**NOTE: Davis-Bacon Wage Requirements:** All contracted work is subject to Davis-Bacon Wage requirement, reporting and inspections and interviews.

**Permits:** Permits will be required for various contracted work items. This includes but is not limited to hook up to potable water, electrical and general work as a minor improvement permit to be purchased by the contractor. The foundation for the small CMU building (building to be completed in a later phase) does not require a building permit and only a minor improvement permit along with other CMU and concrete flatwork. Contact the Project Manager/Architect for additional information and assistance. Bollard lighting replacement for the pocket park has been awarded separately and includes a “Dark Sky” lighting permit.

## **Mobilization & Early Preparation Work Specification**

**Post Site & Flag:** Around site post temporary signage and flag tape to close off the site. Signage to read “No trespassing, area closed for park construction – City of Flagstaff” Small text “Questions Contact Mark Reavis, Neighborhood Planner-Project Manager [Mark.Reavis@Flagstaffaz.gov](mailto:Mark.Reavis@Flagstaffaz.gov) (928) 213-2633. Note: Please contact Flagstaff Police at non-emergency number (928) 774-1414 when area (particularly pocket park) is occupied.

**Wood platform:** Dispose of the wood framed platform at the NW corner of the Murdoch Center.

**Chain-link Fence and Posts:** The contractor can determine the best time to remove the fence fabric and posts. Early removal appears to be a preference. Remove all chain-link fabric at the site and all fence posts west, north, east and south. Note: Salvage the east parking permit (5) signs for the Murdoch Center at the east parking strip and mount to new temporary “pound-in” fence posts.

**Parkway:** The area between the sidewalk and street is non-irrigated grass and is to remain as is but can be utilized for posting the park closure.

**Pocket Park trimming and Removal:** Additional tree trimming, and shrub & root removal can take place early prior to the start of construction.

## **Site Electrical – Trenching & Conduit:**

The electrical is to come from an existing APS pole with drop-down protection and trenched over to new small CMU storage/systems building’s **footing**. Install new 200-amp meter base, disconnect and panel on an “H” frame that can later be integrated and secured to the completed CMU building. Power to come from the east alley APS pole (L374620). See additional specification to follow.

## Murdoch Center Sanitary Sewer

Please note the location of the sanitary sewer of the Murdoch Center building that starts at the south face of the Murdoch, heads east and then north connecting to Brannen Ave. A PVC clean-out appears NE of the building. Locate the clean-out and avoid damage to the sewer as excavation work takes place. Install a box and cover at the clean-out location now at the new grade surface for continued access.

---

## Landscape Section Outline:

- Existing landscape maintenance and removal @ pocket park.
- Site & Soil Preparation
  - Mega Chess Board protection and perimeter interface.
  - Excavation, Fill & Grading
  - Retaining wall blocks
  - Soil prep & Topsoil
- Irrigation
  - Grass turf area
  - NE trees, pollinator garden
  - Rough-in for later phase irrigation.
  - Technical Specifications
- Stormwater collection and retention routes.
- Grass turf (sod) specifications
- Surface Treatments
- Concrete Pavers
- Related Work & Installations
  - Site Furnishings- planning for
  - Site Soil Retention & Flatwork
  - Curbs and walkways
- CMU Building foundation & Services
  - CMU Storage/Utility system building
  - Electrical Service
  - Site furnishings specifications
  - Signage
  - Custom Bike Rack "CLEO"
- Cross connecting walkway w/ stub wall bench (see drawing w/ details)
- Site Electrical
  - Feed from east pole underground
  - Future Lighting rough-in locations
- Meter Base & Panel (APS) "H" temporary frame

- CMU storage/Utility systems building (see drawing)
  - Footings & Rough-ins (**this contract**).
  - Later Phase CMU building (3 types of blocks – Chess piece look “Rook”)
    - Roof structure, scupper, interior space
    - Doors and elevations requirements
    - Lighting, security, hose bib
- Contour Survey (3 drawings) by Engineering Firm

**NOTE:** *All work is generally described and is to be “performed” by the contractor following best practices in a workman-like manner. Not all details and exact measurements have been provided. Contact the Project manager with any questions or requirements.*

**Mark A. Reavis, AICP, NCARB**

Heritage Preservation Officer/Neighborhood Planner  
Planning & Development Services, 211 W. Aspen Av.  
Community Development, Flagstaff AZ 86001

**Phone/message: (928) 213-2633**

[Mark.Reavis@flagstaffaz.gov](mailto:Mark.Reavis@flagstaffaz.gov) [www.flagstaffaz.gov](http://www.flagstaffaz.gov)

## **Cleo Murdoch Neighborhood Park**

**201 E Brannen Ave**

### **LANDSCAPE SECTION**

#### **Performance Specifications**

#### **Introduction:**

The City of Flagstaff has allocated a portion of its Federal Community Development Block Grant (CDBG) Funding for improvements surrounding the Murdoch Community Center (203 E Brannen Ave) managed by the Southside Community Association. The City of Flagstaff has pulled out portions of the property surrounding the Murdoch from the Murdoch lease for the development of a small neighborhood park to be managed and maintained by City of Flagstaff Parks (PROSE) the park now has an independent address which is 201 E Brannen Ave. These areas are on the east side of the Murdoch, north and to the west that includes the current landscaped area “pocket park” that filled in a right-of-way. The west landscape/hard-scape area project intends to improve visibility of the area and clear away hidden areas of landscaping west of Murdoch Center adjacent to Butler Ave.

**Phased Project Graphics:** This document includes various graphic plans that were provided to communicate concepts to the public, staff and interested organizations and individuals. The contractor shall rely on the written requirements vs. representation shown on the graphic plans. The graphic can be used to assist in preparing a bid.

**Performance Specifications:**

This is a limited scope project that has written performance specification that describe the work. The contractor is expected to perform work professionally meeting the intent of the written descriptions, graphics, and plans.

**NOTE: The project is subject to Davis Bacon wage confirmation. Please provide documentation regarding compliance or exemptions.**

---

## Existing Landscape & New Landscaping

### Tree Trimming & Shrub Sculpting & Removal-

#### New Plant list and locations

**Chain link Fence:** The chain-link fence surrounding the yard west, north, east and south of the Murdoch Center Building is to have it fabric and posts removed, contractor to determine best time to remove.

**Juniper Shrubs:**

The spreading junipers in the west “pocket park” have become overgrown and problematic.

- Remove all junipers in the areas of the pocket park.
- South Butler Ave Sidewalk Shrubbery – The hedge like row of shrubs along the sidewalk are to be extensively thinned and separated as individual plants. Separation is to provide visual openings into the park. Remove all junipers in this area and any other shrubs that will provide visual separation.

**Shrub Trunks & Roots Removal (junipers):** Cut flush all remove juniper and shrub location to eliminate all above ground remains of junipers previously cut out and those called out above to be removed.

Previously within a 5–7-foot perimeter of the west Murdoch wall have been cut back to trunks. The removal was at the NW corner of the building and along the entire west wall and to the exiting chain-link fence. Cut trunks flush for previously removed Junipers. Contact project manager/architect for question regarding any required detaining.

**NOTE: Underground Electrical!** The bollard lighting is fed from a light pole APS # L374625 w/ lock on box on the light pole. Bollard lights are being replaced with new improved bollard lights in a separate contract. Landscape contractor is not required to do any excavation within the pocket park.

#### **Pine Tree Limb Removal:**

The 3 existing pine trees shall have their bottom limbs removed for an improved visual clearance up to approximately 12 feet in height. Removal shall be appropriate to maintain a desired visual appearance of each tree. Dispose of removed branches properly and remove from the site. NOTE: Consult with project manager/architect regarding any detailing of work.

#### **Deciduous Tree Pruning:**

**Pocket Park Trees:** The area west of the Murdoch building and west of the existing chain-link fence has 7 deciduous trees to receive some additional trimming. Trees were trimmed in the spring. Some final sculpting by the contractor is required to judiciously prune the branches that extend over the existing concrete walkways that limit a clear pathway. Pruning is to take place to improve visibility of area. Contact Project Manager with questions on the extent of pruning for specific trees and locations.

**Central Tree:** The 8<sup>th</sup> tree surrounded by walkways is the future potential site of a 3-D art piece, the tree may be incorporated with the art or may possibly be removed, the contractor is to do no work on this central tree.

**West chain-link Trees:** The tall tree (unknown species) just within the chain-link fence area is to have lower growth trimmed but the trees are to remain. The 2 large flowering crabs at the Brannen St sidewalk have dead branches. Cut out dead and sculp tree to improve balance.

#### **Shrub Pruning:**

Shrubs within the west area are to be trimmed of any dead overgrowth. Trim and provide clearance at existing concrete walks. Sculpt shrubs of extended branches and twigs to improve visual appearance. All junipers are removed, remaining shrubs need sculpting. The remaining plants need extensive work to reduce height and spread. The large shrub at the corner of WC Riles and Brannen between the street and sidewalk is an example of this. NOTE: Contact Project Manager/Architect for extent of shrub detailing.

#### **Park Plants**

Additional plantings are planned for installation at the Cleo Murdoch Neighborhood Park. These are planned for later phases of the park. The location for additional planting are primarily on the backside of the walkway/stub wall and will be completed at later phases in the project. The only new plantings are the trees at the NE corner of the site and interface with the pollinator garden and provided irrigation.

In a later phase the list is for preferred tree and plant material for various locations called out within the park. The listed plants may be impacted with availability by area growers. Appropriate alternatives can be provided in lieu of those called out with the approval of the Project Manager. Preference for alternative is for area producers in planting zones per USDA recommendations.

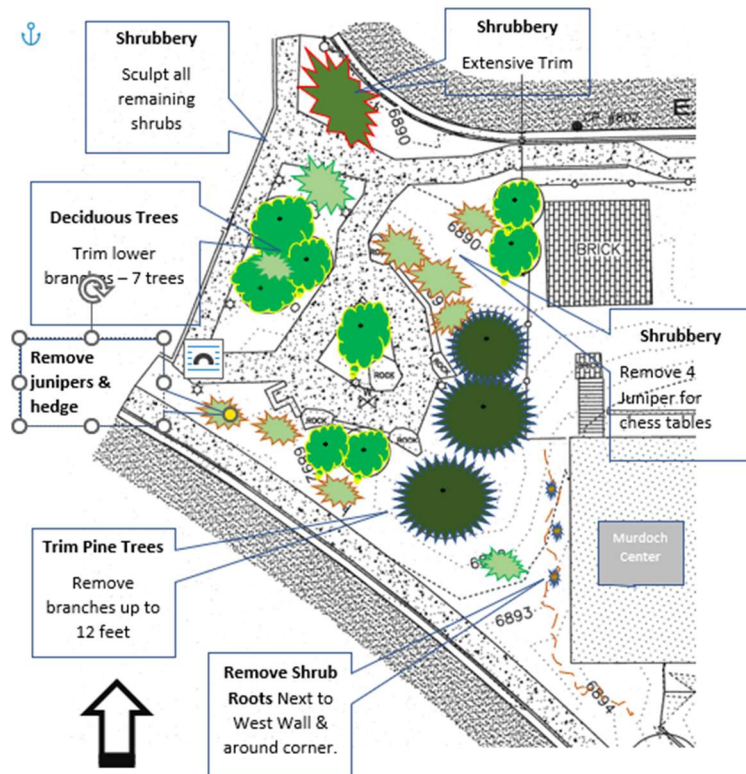

## Trees:

**Tree Decorative Boarder:** (4 decorative trees at the NE area of park at the pollinator garden and parking interface) **4 Freeman Maple** (evenly spaced in planting strip) Bright red foliage in fall.

**Irrigation:** Water to irrigate the trees and the pollinator garden is to be provided. Drip irrigation emitter for the trees and hook up to an installed drip irrigation system for the pollinator garden.

**Rough-in for future irrigation (back side of stub-wall walkway):** The plan below shows some future later phase planting on the backside (south side) of the sub-wall bench. Provide conduit for water and valve controls.



## SITE & SOIL PREPERATION – Cleo Murdoch Neighborhood Park

**General:** The entire park site except for the west right-of-way “pocket park” is to be stripped of its current grass surface and thin layer of topsoil. Grubbing of the entire area is required to limit weeds and as a primary means to remove cheatgrass. This work includes but is not limited to the areas around the mega chessboard and areas north and east of the Murdoch. The curved concrete former driveway is to remain and capped with concrete pavers. The thin areas adjacent to the Murdoch’s north and east walls elevated with concrete retaining wall block are to remain. NOTE: final surface treatments are defined in other sections of this document; Irrigation, planting, surfacing.

### Mega Chessboard:

The mega chess board pavers shall be protected during the execution of specified work. Care shall be taken when work takes place adjacent to the pavers and provisions made to stabilize edge provisions that interface with the pavers for the concrete walkway specified.

### Excavation, fill & Grading:

Manipulation of existing contours is primarily for building up a flat play area in the NW corner of the site (approx. 20’ X 30’) and requirements of an ADA accessible concrete path & stud-wall (less than 1:20 crossing (called out as 1:25)) connecting portions of the park. Installation of irrigation system and required electrical and future additional site lighting. Grading is to transition smoothly to meet with adjacent perimeter elevations and new work. Site drainage from the Murdoch asphalt parking area will be intercepted by the specified walkway/stub-wall. Additional drainage controls will be constructed to pick up runoff conditions from the paved areas south of the Murdoch Center Building in a later phase of the project. NOTE: The Murdoch’s sewer system was rerouted through the park (south from restrooms, then east, then north to Brannen Ave) when Butler Ave was widened. Locate stub-up clean out and modify pipe placing in an accessible flush mount ground box.

### Retaining wall block installation:

Locking retaining wall blocks (Equal to block-lite) are to be installed to support new filled area at the NE corner of the park for the flat play field 20’ X 30’ building up approximately 2 & ½ feet above the north

sidewalk with soil for a level field. NOTE: From base course to capping stone the wall shall not exceed 40". Blocks installed per manufactures requirements. Installation parallels Brannen Ave sidewalk and curves south (curve as allowed per blocks used) and runs south uphill terminating into the slope.

**Subsoil Preparation:** With the completion of irrigation and electrical (lighting rough-in & valves) site concrete work and block walls rough grade for contours of the site as required to accommodate final topsoil and sod or other treatment. Till the site to a depth of 2 -3 inches to loosen. Amend subsoil for a pH between 6.0 and 7.0. NOTE: Subsoil preparation is in all areas of the park including areas north and east of the Murdoch building in areas for sod as well as tree planting.

**Topsoil:**

Topsoil work completed in spring as weather and sod availability allows. The contractor shall furnish all topsoil, labor, material, and equipment required to complete the work in accordance with the performance specifications, graphics, and drawings. The topsoil shall be a loamy sand, clay loam, loam, silt loam, sandy clay loam and other soil deemed acceptable by the sod provider and CMNP Project Manager/Architect and Parks (PROSE) representative. Topsoil shall be in close range of a 6.5 pH and free of growth inhibiting minerals. Topsoil depth shall be evenly spread to a minimum depth of 3" with most coverage at 4". NOTE: Topsoil is to be placed over all prepared subsoil including tree planting area.

**Sod Turf Grass:** See specification for CMNP Grass Sod

---

## Cross connecting ADA compliant concrete walkway & stub wall with Bench – East to West connection with pocket park.

- Provide a transitional walkway connecting the existing west concrete walks in the pocket park to the mega chessboard area and extending east to the parking area adjacent to the alley (see site plan below). Start at widest point between existing 2 rocks and narrow to 5-foot width routing between conifer trees to area adjacent to mega chessboard. From chessboard SE corner to parking walkway slope is 1: 25 for a 90-foot run with a 3.5 rise. Modify contours to meet slope requirements. The walk shall have no cross-slope for the 90' run.

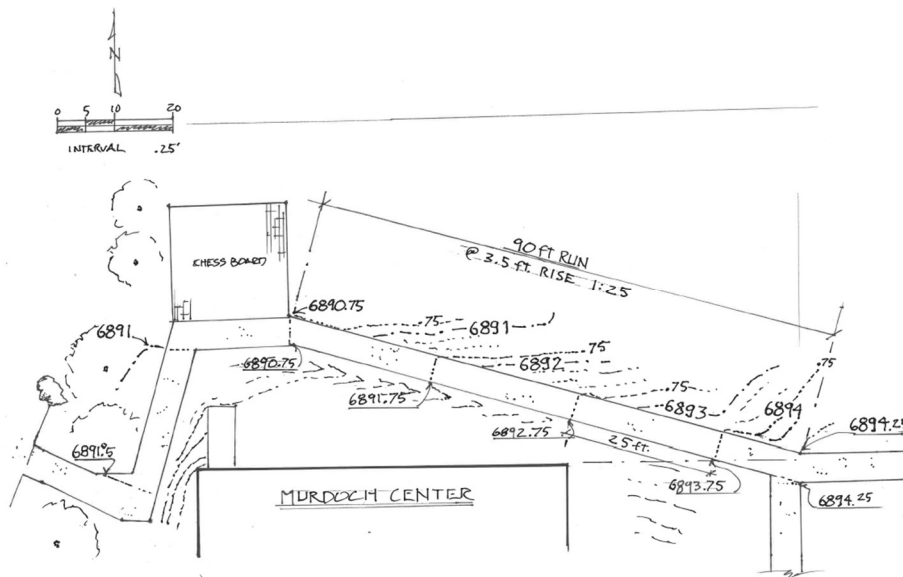

- In no case of the length of the walkway shall any segment have a slope that exceeds 1:48 cross-slope for remaining portions of walk.
- Provide a 5-foot-wide (4" thick) concrete walk that follows the south edge of the mega chess board (see site plan) then connects to the west (see 90' walk & wall to the east). Install 2 concrete Chess tables (one Handicap accessible) and fill in on the south side of the new walk (see landscaping) with decorative concrete pavers at the width of the mega chess board. Additional pavers around mega chessboard in later phases (also see CMU storage building).
- To the east the 90-foot length of 5-foot sidewalk at a 1:25 slope is to include a stub-wall (poured concrete or CMU) and bench surface (**as add alternate**). Provide the 5-foot-wide concrete walkway with integrated stub-wall/retaining-wall capped with seating surface (**seating surface as add alternate**). Walk transects the site connecting the mega chess board walk segment to the parking areas running west to east. Angle new sidewalk/stub wall to gain access to upper level of the site to the east parking. Walk is designed at 1:25 slope but in no case exceed 1:20 slope and shall have no cross slope. In no case shall a 1:48 cross-slope be exceeded with the intent to provide general ADA access to many of the park improvements. NOTE: (Cross slope not required for most of run and shall not exceed 1:48 max cross slope).

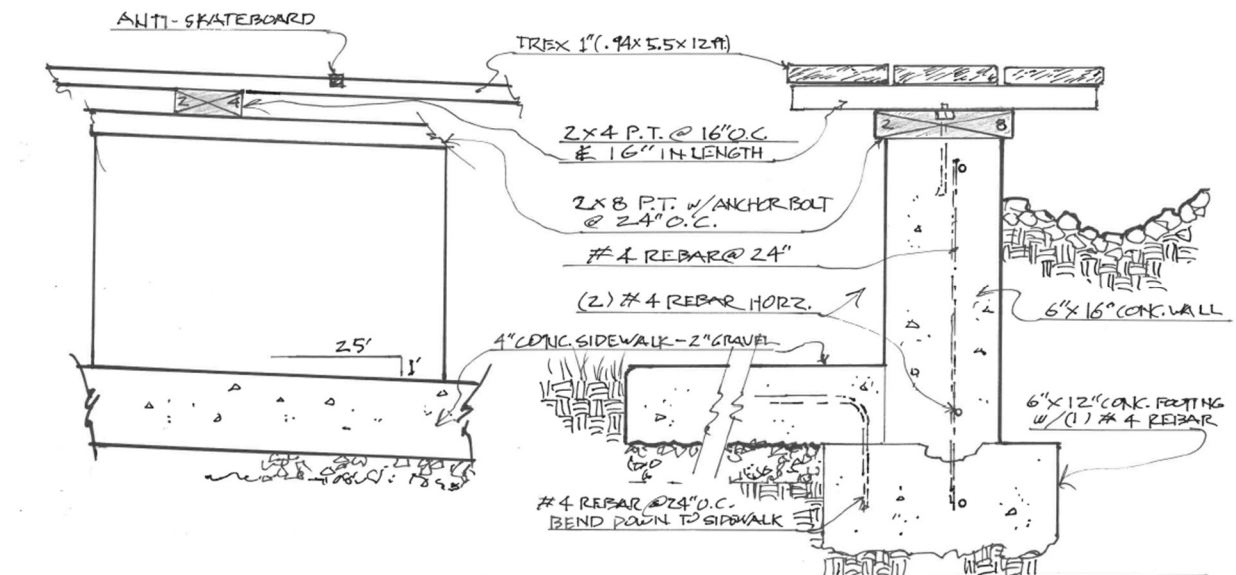

- See drawings above for wall/walk section, details and notes.
- Form and pour 6"x 12" footing with (1) # 4 rebar horizontal continuous and vertical #4 @ 24" o.c. (see drawings). Provide rough key-way in footing for wall (see drawings). In addition to the vertical install a bent #4 rebar into footing to be integrated into the walk walk at 24" o.c. (see drawing).
- Bent-down #4 rebar for walk connection is in place. Form and pour 5-foot-wide concrete walk 4" thick on compacted 2" gravel base (see drawing).

- Form up short concrete stub wall (16" high) to be integrated with horizontal walk slab to form a short retaining wall (6" min thick). Finished assembly of bench surface to a little under the height of 16" above walk surface. (see plans for dimensions noted, details and reinforcing). Wall is not to be stepped but continually sloped at 1:25. **NOTE:** Contractor may replace formed and poured concrete with CMU, see below.

## Stub-wall bench CMU alternative.

- The contractor may replace the formed concrete stub-wall with CMU. Utilize the split face texture block specified for the CMU storage/utility building equal to Block-lite # 8816 S1S. Texture face on sidewalk side. Grout CMU solid. CMU may be 6" or 8" wide at contractor's discretion, other dimensions, and details to remain the same. NOTE: CMUs to be placed on sloped footing (1:25 slope) with CMU vertical joints are allowed at an angle and not plumb.
- Grout CMU solid with required reinforcing. If add alternate is awarded the anchor bolts may be installed when grouted or added later and drilled and epoxied.

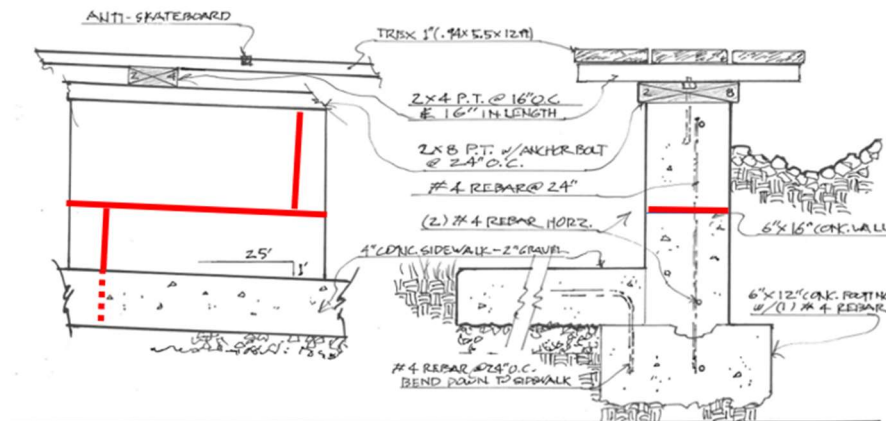

### Add Alternate #1 Bench Construction

- Pour wall and insert anchor bolts @ 24" o.c. (for anchorage of 2x8 pressure treated board) or drill and epoxy later.
- Cap wall with lengths of pressure treated 2 x 8 lumber secured with previously placed anchor bolts a concrete top.
- Install pressure treated 2 x 4s (16 inches in length) at 90 degrees to 2 x 8 to receive decking material. Space 2 x 4s at a maximum of 16" o.c. or per decking requirements.
- Install and finish seating with "Trex" or equal decking to complete and continuous sitting wall bench surface with 3 continuous and staggered decking for a finished seating surface at approx. 16.5" in width. See plans for details and specific notations.
- Area south, on backside of stub retaining/seating wall forms an area for plants and trees. Stub wall also serves to control on site drainage and retention, provide a small swale behind the stub-wall. Area behind wall to also receive future site lighting. NOTE: Site plan for additional future installation.

# East Termination of Cross-connection walk w/ ADA curb cut access.

The 90-foot sloped walk/stub-wall is to finish approximately 5-feet short of the asphalt parking to allow for the future connection to a future phase sidewalk heading up-hill to the south. The contractor is to install a short segment ADA curb-cut integrating with the 5-foot-wide concrete walk. Protect the north edge of the improvement with an ADA compliant railing with lower <4" edge protection integrated. Future (later phase) curb and sidewalk will not extend further to the north downhill. Parking surface is to be improved later to improve ADA compliance and may retain curb cut or extend sidewalk into ADA parking area (shown is some graphics) that will be determined in later phases.

### 406 Curb Ramps

**406.1 General.** Curb ramps on accessible routes shall comply with 406, 405.2 through 405.5, and 405.10.

**406.2 Counter Slope.** Counter slopes of adjoining gutters and road surfaces immediately adjacent to the curb ramp shall not be steeper than 1:20. The adjacent surfaces at transitions at curb ramps to walks, gutters, and streets shall be at the same level.

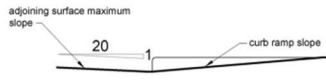

Figure 406.2  
Counter Slope of Surfaces Adjacent to Curb Ramps

**406.3 Sides of Curb Ramps.** Where provided, curb ramp flares shall not be steeper than 1:10.

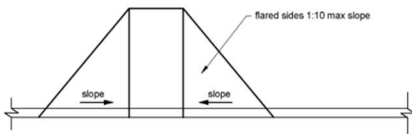
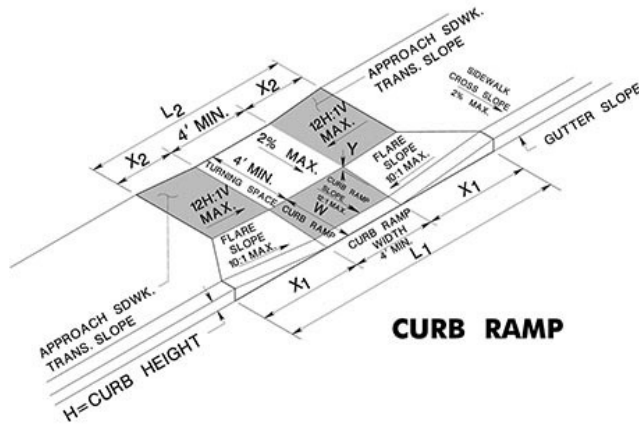

Figure 406.3  
Sides of Curb Ramps

**406.4 Landings.** Landings shall be provided at the tops of curb ramps. The landing clear length shall be 36 inches (915 mm) minimum. The landing clear width shall be at least as wide as the curb ramp, excluding flared sides, leading to the landing.

**EXCEPTION:** In alterations, where there is no landing at the top of curb ramps, curb ramp flares shall be provided and shall not be steeper than 1:12.



**CURB RAMP**

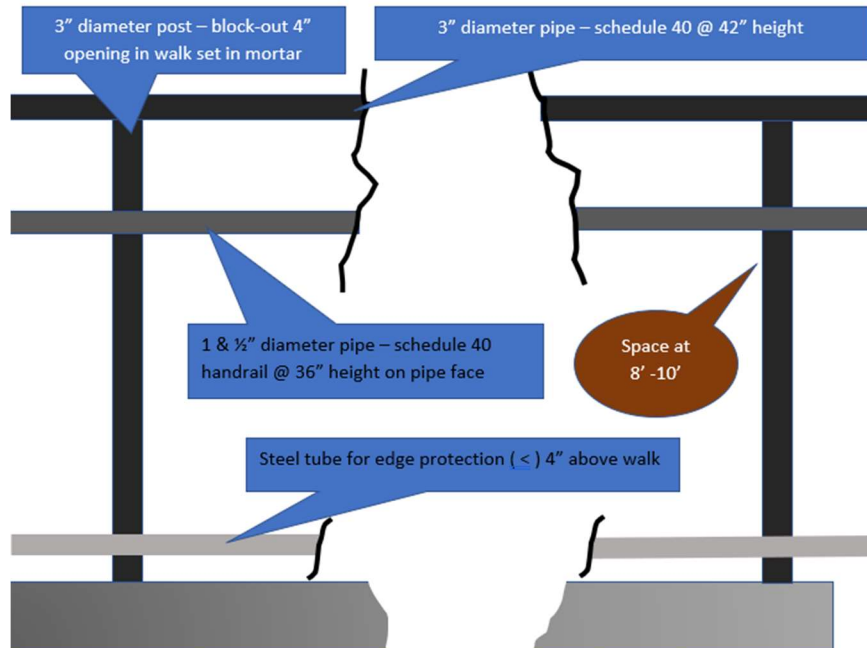

## IRRIGATION SYSTEMS – Cleo Murdoch Neighborhood Park

This section applies to the design and installation of underground irrigation systems for landscaped areas that includes irrigated turf areas and planting beds for trees and future irrigation.

The installation for sprinklers for irrigated turf areas with pop-up heads. Irrigation for Trees with water emitters and drip irrigation in indicated areas.

**NOTE:** The work does not include the reactivation of the west irrigation system in the right-of-way “pocket park” to provide supplemental irrigation to established plantings. Potable water for irrigation is provided from Brannen Ave at the “hot box” location just east of the 2 large flowering crab trees. PROSE (parks) has recently performed work on the hot box to ready it for irrigation hook up. Flagstaff calls out preference to be given for the use of reclaim water irrigation systems, reclaimed water is not available at the Cleo Murdoch Park Site.

**NOTE Pollinator Garden:** Provide all necessary items to hook up a previously installed drip irrigation system for the NE Pollinator Garden including but not limited to a ground box for pressure reduction, shutoff and winter shut down.

General guidance is provided by the following specification and indicated Standards. The contractor is responsible for the design of the irrigation system, its installation and warrantee for a period of one-year after acceptance of the project. Provide a drawing to scale of the installed irrigation system.

**NOTE: Maricopa Association of Governments (MAG) Standards** can be referenced and utilized where required to meet those requirements of a fully operational irrigation system.

**NOTE: Irrigation system shall utilize “Drawings” City of Flagstaff Chapter 13-23 and Sections 19-01-020 thru 19-02-037 for standardized installations.**

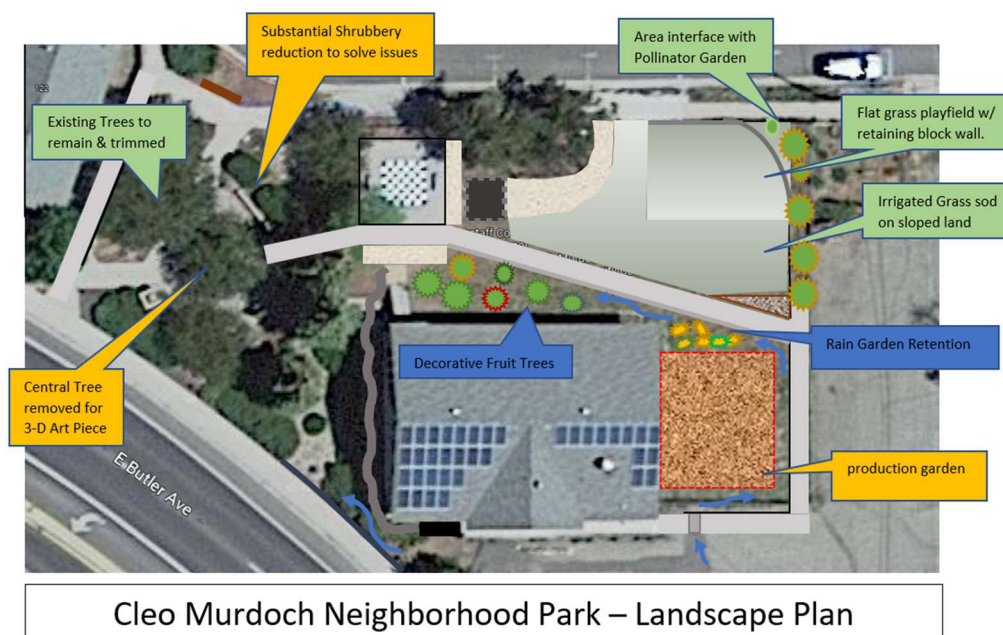

**Conceptual Graphic – See planting schedule for number & location of plants.**



**Conceptual Graphic – Field verify areas for landscape with completion of excavation and concrete work completion. NOTE:** *The irrigation system design is conceived with the intent of water conservation. Site runoff is being redirected back onto the park site and roof runoff being considered along with site orientation. The irrigation of the turf area is specifically having irrigation designed to minimize large sprinkler heads that cause overspray and waste. Area sprinkler coverage is to be specific to turf orientation and slope. 4 zoned areas are specified.*

**Scope of Work - Design, provide, install, and test the following irrigation systems.**

- Pop-up sprinkler irrigation system for the Turf-sod areas. A minimum of 4 zones required. **Recommendation:** *Divide the irrigated sod areas into 4 quadrants to address slope and orientation. NE (flat playfield) 600 sf, SE sloped 600 sf, SW Sloped triangular 300 sf, NW steep slope 300 sf (areas approximate).*
- Emitters for existing trees and new at interface with pollinator garden and parking strip.
- Irrigation system hook-up to previously installed pollinator garden.
- Rough-in for future supplemental irrigation for roof runoff and for rain garden runoff area south of back side of stub-wall bench.

**Technical Specifications – City of Flagstaff Requirement. NOTE: The following are adjustments to the Technical Specifications while still utilizing the included Flagstaff Requirements. Adjust requirements for now preferred control, electric irrigation controllers and flow sensor.**

**Landscape Section (& related work).**

**Control** - Adjust irrigation specs in Table 13-19-004-01 as follows as we no longer utilize the Rainbird MaxiCom control system and associated components.

**Electric Irrigation Controllers** – remove components listed and replace with the WeatherTRAK ET Pro3 controller.

This is our new standard smart irrigation controller that incorporates all listed features into one controller.

**Flow Sensor** – Replace listed with WeatherTRAK Flow HD sensor.

---

#### **13-19-001-0001 General Design Criteria**

A. Sprinkler irrigation system installation shall be in accordance with MAG Specification 440 unless modified by City of Flagstaff Engineering Standards. Wherever available, preference is given for the use of reclaim water irrigation systems.

1. Irrigation system static pressure range shall not vary by more than ten percent (10%) and shall be designed to provide for a maximum pressure of eighty-five (85) psi.
2. Design irrigation system lateral piping to limit pressure drops to less than twenty percent (20%) of the average sprinkler operation pressure.
3. Install sprinkler heads and nozzle types of the same manufacturer and pressure rating within the same irrigation zone.
4. Zone the irrigation system according to plant water requirements, targeting plants with similar water requirements. Zone trees, shrubs, planting beds, turf and hydroseed areas separately.
5. Integrate existing and new irrigation systems to insure a homogeneous system with balanced coverage. When there is an alteration to an existing irrigation system, test existing mainline, control valves, lateral lines, sprinklers, drip lines and wiring prior to alteration. Perform mainline static and working pressure tests, lateral line working pressure, GPM and coverage tests and circuit continuity testing for control wiring.
6. Design all sprinkler layouts for head-to-head coverage.
7. Provide matched precipitation rates for sprinklers within the same irrigation zone.
8. Contingent upon soil texture and slope, precipitation rates shall not exceed infiltration rates.

9. Design mainline flow based upon the largest zone GPM plus a single quick coupler at twenty (20) GPM.
10. Design piping with a horizontal layout on slopes. Do not design with elevation changes that exceed the capacity of sprinkler check valves. Compensating emitters shall be required on slopes.
11. Irrigation system as-built plans shall be provided to the Parks and Recreation Division. Preference is for as-built plans to be submitted on compact disc (CD). Provision of as-built plans is a condition of project acceptance.
12. The backflow prevention device shall be tested by a certified tester prior to project acceptance.
13. The contractor shall be responsible for providing and installing all necessary signage for reclaimed water systems. Reclaim work shall comply with Title 18, Chapter 9, Articles 6 and 7 of the Arizona Administrative Code. (Ord. 2017-22, Rep&ReEn, 07/05/2017)

### **13-19-001-0002 General System Criteria**

- A. A manual shutoff ball valve is required to isolate the irrigation system from the water supply main.
- B. Provide a quick coupler valve at a maximum distance of two hundred (200) feet throughout the project. Locate quick coupler valves to minimize the necessity of water hoses crossing walkways, driveways, and roads.
- C. Sprinkler swing assemblies shall be one (1) piece and shall not exceed twenty-four (24) inches.
- D. Provide two (2) spare control wires to all remote mainline legs. A spare common wire shall be installed through the entire project. A spare hot wire is required to be run to every valve.
- E. The ProMax remote controller shall be hard wired into each irrigation controller in accordance with the manufacturer's written instructions.
- F. Provide a three (3) foot loop of irrigation wiring at each valve box.
- G. All irrigation wiring shall be contained in adequately sized conduit.
- H. Locate valve boxes, valves and quick coupler valves at a minimum of thirty-six (36) inches from hardscape edges.
- I. All backflow prevention devices shall be contained in an insulated hot box.
- J. Isolation ball valves are required before all electric control valves.
- K. A quick coupler is required immediately following the backflow prevention device.
- L. A filter is required immediately prior to the backflow prevention device.
- M. Strainers are required a minimum of every two hundreds (200) linear feet in the main irrigation line.
- N. A surge protection device and quick disconnect box shall be placed before the irrigation controller.

- O. A twenty (20) amp breaker is required in the backflow prevention device hot box (for heat tape use).
  - P. Provide a tee, with a plug facing up, after the water meter and before the backflow prevention device.
  - Q. Provide a ball valve on the main water line after the curb stop and before the tee with plug. Ball valve and plug shall be contained within the same irrigation box.
  - R. Emitters shall come off of PVC line and not drip tubing.
  - S. A manual drain valve shall be placed at the end of the irrigation water main line and at the end of each system line.
  - T. Telescoping unions (slip fix) shall be placed after the electric control valves.
  - U. Sleeves are required below sidewalks, driveways, trails, retaining walls, and/or other similar features, and shall extend ten (10) inches past the structures. Sleeves shall be set a minimum of twenty-four (24) inches deep.
  - V. All drip tubing shall be installed at a minimum of three (3) inches deep.
  - W. The main irrigation line and the irrigation wires shall share the same trench. The trench shall be a minimum of twenty-four (24) inches deep.
  - X. The trench for lateral irrigation lines shall be a minimum of eighteen (18) inches deep.
  - Y. Trenches shall not be backfilled until all required inspections and tests are performed.
  - Z. All PVC irrigation lines shall be bedded, shaded, and backfilled to four (4) inches above the top of pipe with clean native or fine granular import material, free of clods, stone, or other deleterious material, one-half (1/2) inch in diameter or larger. Backfill above the initial backfilling, as described above, shall be clean native or fine granular import material, free of clods, stone, or other deleterious material, one and one-half (1-1/2) inch in diameter or larger. In turf areas, the one-half (1/2) inch maximum size of clods, stone or other deleterious material shall apply for all backfill.
  - AA. Pipe backfilling shall be in six (6) inch maximum lifts, mechanically compacted, to a dry density equal to adjacent undisturbed soils in landscaped areas. Compaction beneath pavements and other hardscape shall be as specified on the plans and/or in the applicable specifications.
  - BB. Backfill shall conform to the line and elevation of adjacent grades with no surface irregularities.
  - CC. If settlement occurs, the Contractor shall make all necessary adjustments and repairs to pipes, valves, heads, lawns, plantings and other construction at no cost to the owner.
  - DD. Irrigation marking tape is required to be installed over the irrigation water main at a nominal depth of twelve (12) inches. (Ord. 2017-22, Rep&ReEn, 07/05/2017)
-

**NOTE: The contractor is to provide an irrigation plan for the park project per the following: 13-19-002-0001 Irrigation Plans**

Minimum plan requirements include a schematic utility connection detail, irrigation legend, piping diagrams, pipe diameter and design calculations. (Ord. 2017-22, Rep&ReEn, 07/05/2017)

The Schematic plan is to be reviewed and approved by the CMNP Project Manager/Architect and a representative of Parks (PROSE).

---

**13-19-003-0001 System Flushing and Testing**

- A. MAG Section 440.10, Flushing and Testing, shall apply.
  - B. An operational test of the irrigation system in the presence of the City of Flagstaff authorized representative is required. The coverage test shall be performed after sprinkler heads have been installed and shall demonstrate that each section or unit in the irrigation system is balanced to provide uniform head to head coverage of the service area.
  - C. Irrigation systems shall be warranted against defects in materials and workmanship for one (1) year from date of acceptance. (Ord. 2017-22, Rep&ReEn, 07/05/2017)
- 

**NOTE:** The specification below provides general guidance and is specific to larger areas such as large park turf areas. Contractor is to adjust the specification as required for a design that minimizes overspray and water usage with appropriate sprinkler head selection.

**13-19-004-0001 Supplemental Products, Materials, and Equipment**

- A. Provide supplemental inventory of the following items to the City:
  - 1. For each size of unit installed, provide one (1) additional quick coupling valve, quick coupling valve operating key and quick coupling valve hose swivel.
  - 2. Provide one (1) additional controller key pad for each type of irrigation controller installed.
  - 3. Provide one (1) additional controller programming/access key per project for the solar irrigation controller.
  - 4. Provide one (1) ProMax remote controller and adapter cord with plug at each end.
  - 5. Provide an additional ten percent (10%) of the installed quantity of sprinkler heads, emitters and irrigation control valves. (Ord. 2017-22, Rep&ReEn, 07/05/2017)

**13-19-004-0002 Products, Materials and Equipment**

All products are indicative of the quality anticipated for the work and "or equal" is applicable with prior City of Flagstaff approval:

**Table 13-19-004-01**

**Backflow Prevention Device**

**Febco 825 YA**

<b>Backflow Enclosure</b>	<b>Lock Box or Hot Box</b>
	<b>Shall be an insulated box. Cage is not acceptable.</b>
<b>Pressure Regulator</b>	<b>Watts or Febco</b>
<b>Quick Coupling Valves</b>	<b>Rainbird 44 LRC, 44K (1") valve key and hose swivel</b>
	<b>Rainbird 7, 1 piece body, 7K (1-1/2") valve key and hose swivel</b>
<b>Control Valves</b>	<b>Weathermatic 11000 Series</b>
<b>Irrigation Valve Boxes</b>	<b>Carson No. 1 and No. 2, Model 1220</b>
	<b>Reclaim shall be purple. Potable shall be green.</b>
<b>Strainers</b>	<b>Watts or Febco</b>
<b>Drip System Pressure Regulator</b>	<b>Watts or Febco</b>
<b>Drip System Emitters</b>	<b>Quadra Bubbler</b>
	<b>Octa Bubbler System</b>
	<b>Bowsmith ML 200 Multi-emitter</b>
	<b>Bowsmith SL 206 Single Emitter</b>
<b>Electric Irrigation Controllers</b>	<b>Rainbird MaxiCom Central Control System</b>
	<b>- ProMax remote control required</b>
	<b>Rainsafe Control System - preassembled with controller unit, master valve flow sensor</b>
	<b>Rainbird ESP-SAT Series Controller (when required)</b>
<b>Spray Heads</b>	<b>Hunter: I-40/PGP/I-25 Stainless Steel Riser/PS Series 2" and 6"</b>
	<b>Toro: Series 300 or 570 or 640 or Super 600 or V-1550</b>
	<b>Rainbird: 1800 Series – 6", 8" and 12"</b>

<b>Piping</b>	<p>PVC pipes and fittings shall be schedule 40</p> <p>PVC Cement: medium bodied, primer required</p> <p>Copper tubing shall be K copper</p> <p>Poly drip tubing: allowed only after emitters</p>
<b>Manual Valves</b>	<p>Shall be resilient seated ball valve</p>
<b>Master Valves – required on main line of irrigation system</b>	<p>Less than 2": Griswold Master Valve - a pressure reducing valve is required</p> <p>2" or larger: Singer Model No. 106-PR-SC24V</p>
<b>Flow Sensor</b>	<p>Compatible with MaxiCom System. Required on main line of irrigation system.</p>

(Ord. 2017-22, Rep&ReEn, 07/05/2017)

---

## Cleo Murdoch Neighborhood Park Grass Sod Specification

**Grass Sod Specification:** Grass Sod (AKA Turf) shall be grown in a similar area climate of Arizona (such as Chino Valley or Colorado Plateau) to assure success. Grass Sod to be a “cool weather grass” with a seed mix of Kentucky Blue Grass and Rye and other selected grasses. Seed to be certified seed weed free mix, with color retention and disease resistance. Grass mix blend with drought & heat tolerant capabilities and recovery. Texture of fine leaf blade and dark green color. Cultivated sod and seed blend is for high traffic in a small park play area meeting recommend performance of National Turf Grass Evaluation Program (NTEP). Mowing Height of ½” to 4” allowance. Grass areas will be irrigated with head-to-head coverage but will be impacted by seasonal changes. Contractor shall confirm sod grass seed mix, maturity, and harvested thickness with CMNP Project Manager and Flagstaff Parks (PROSE) representative prior to harvesting.

**Preparation:** Irrigation will be fully tested and dialed in for head-to-head coverage. Base soil will be level to accommodate a minimum topsoil depth of 3-4”. Organics containing topsoil meeting sod providers recommendation with a PH of 6.5 is to be provided. Sprinkler height and sod thickness is all considered with final sod installation. Smooth out final topsoil and dampen topsoil prior to sod installation. **Note: the final grade of the turf top shall be flush with north edge of the new east-west sidewalk (with grass blades extending above) to provide no drop-off at the edge for ADA edge protection requirements. Soil is to be brought up flush for the west portion of the sidewalk after the mega chessboard.**

**Harvesting:** Grass sod shall be cut with a full  $\frac{3}{4}$ " heavy soil covering no more than 24 hours prior to planting and be maintained in a moist condition from the time of harvest until planted. Contractor to ensure laying of sod within the 24-hour time-period.

**Installation:** Reject and discard any sod with dried out edges. Lay sod over moisten topsoil. Sod shall be installed with tight abutting seams and no gaps. Limit walking on prepared topsoil. Use a weighted sod roller over installed sod to engage new sod with prepared topsoil. Water installation and continue to water per best established requirements to support root growth for a period of 1 month, watering more than the later established watering schedule. Water per current climate conditions but do not overwater. Tape off perimeter of turf with plastic safety tape and temporary posts. Install signage indicating "area closed" to promote root growth. Limit walking on turf as much as possible for the 1-month period.

**Acceptance:** Initial acceptance (or rejection) of installation will be made by CMNP Manager/Architect and Parks (PROSE) representative @ substantial completion, the contractor will be responsible for all watering, maintenance, and corrective actions. Sod installation with established roots will be evaluated at final completion. The contractor shall warrantee the sod installation for a period of 90 days. Throughout the 90 period upon initial acceptance the contractor will provide the watering. Contractor shall work with PROSE representative during the 90 days to assist in the future management of the required watering schedule per contractor recommended requirements. Contractor is to meet with PROSE representative upon watering hand-off providing information on past watering times in zones and any recommendations specific to the site.

---

## **Cleo Murdoch Neighborhood Park – Surface Treatments.**

**Treatments:** Surface treatments are used to cap subsoil excavation of the site. Each treatment is for a specific site requirement. The first phase of work will only include the grass turf area and concrete pavers and a small gravel surface area at the east end of the sidewalk. Future treatments are shown in the graphic but not included in this phase.

**Grass Field:** The use of grass is limited and allocated to one area of the site.

**Gravel:** Edged gravel is used for a small triangular area at the east edge of the site proposed for future site furnishing improvements.

**Concrete Pavers:** Decorative concrete pavers contracting from the mega chessboard perimeter are placed on compacted soil and gravel base or set into a bituminous coating on the existing concrete. *NOTE: See specifications below.*



## Concrete Pavers:

Concrete pavers shall be equal to “Block-Lite” pavers, style “Holland Stone”, color Sonoran Blend set in Basket weave. Follow manufactures recommendations. The intent with the basket weave is that cutting of pavers is **not** required when capping the existing concrete for a crenulated rough edge.

**Installation associated with Mega Chessboard:** The area adjacent to the east and west side of the mega chess board is to be completed in a later phase. The new concrete walkway is to have additional surfacing of decorative concrete pavers to accommodate concrete chess tables. The area is at the new concrete walkways south edge and is linked to the Murdoch’s north exist stair, stepping up pavers as required to meet up with bottom stair landing. The main area that matches the width of the mega chess board is to be ADA compliant accessible paver surface. The pavers are to be standard sand-set per manufactures requirements. NOTE: one Roll-up ADA chess table (and one standard) at the south edge of the new concrete walkway that is accessible form the mega chessboard. The ADA chess table is to be ordered with one extra seat (3 total).

Excavate 8", add ¾" minus rock and compact in lifts. Standard paver is 2-3/8" plan for final elevation matching existing. Provide solid edging at perimeter of installation. This installation is for improved ADA compliance accessibility with no cross slope intended and not to exceed 1:40. Install sand bed and screed, install pavers and hammer set, sweep sand (polymeric) to set. Mechanically compact over pavers covered with sand and compact. Let set, clean off excess.

**Installation over existing concrete drive:** Install pavers on top of prepared existing concrete driveway area on the site to enhance surface appearance. Level cracks and height variations. Coat concrete drive with coating of asphalt (foundation waterproofing) as a preparation for the concrete. Set pavers in a ¾" leveled bed of sand mixed with a bituminous binder to adhere the pavers to the prepared concrete. Installation is then similar to standard sand bed installation for typical installations. Fill between pavers with polymeric jointing sand. At the interface of the sidewalk install a triangular braced folded plate 3" rise with a 12" run and extension or tabs to mount. Though the concrete is curved the intent is to not cut pavers and simply stagger the edge. Bring soil and sod up to the pavers that are set on the prepared concrete. Consider proper drainage.

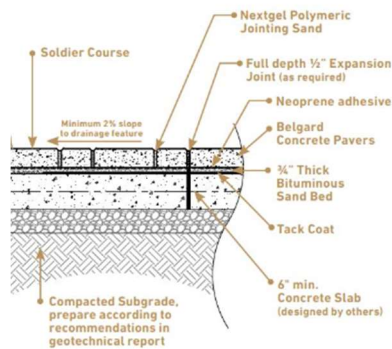

**Alternative:** Contractor may choose to remove the concrete and install pavers with standard base preparation and sand bed per manufacture's requirements. Area surfaced with pavers to match up with concrete removed. Delete the triangular transition.

This area is provided with a custom bike rack (CLEO) and signage. (see site furnishings) place at north edge of new paver to be viewed between the 2 large flowing crab trees.

---

**Related Work & Installations:** Note the requirements of other work called out in other specification (Architectural), graphics, and drawings.

**Site Furnishings: Signage, posts, lighting, railings, benches, trash receptacles, etc.:**

Site furnishing shall be planned for with provisions for installations made prior to other work being performed. Care shall be taken so as not to damage systems and other installed work.

# Site Soil Retention & Flatwork:

**Concrete blocks:** Retaining wall concrete blocks are utilized in several area of the site to build-up areas for surfaces and to control run off.

**Cast Concrete wall/sidewalk/bench:** A concrete wall (capped w/ bench) and sidewalk bisects the site to connect portions of the site. The construction is integral to how the site is intended to perform.

**Concrete walk:** The completion of concrete walkways that includes a stub-wall/bench is a significant aspect of the park project. The landscape contractor shall review other sections of the specifications for integration of their required landscape work.

## Planting Details:

**DECOMPOSED GRANITE**

2" MIN. DECOMPOSED GRANITE FINISH GRADE TO BE RAKED SMOOTH. PROVIDE FINAL APPLICATION OF WEED CONTROL UPON FINAL RAKING.

FINE GRADED SUBGRADE. APPLY PRE-EMERGENT HERBICIDE AS PER MANUFACTURER'S RECOMMENDATIONS. (SURFLAN or EQUAL APPROVED BY COF).

ALL GROUND COVERS TO BE PLANTED ON CENTER (SEE PLANT LEGEND) IN A TRIANGULAR PATTERN. X=O.C. DIMENSION AS NOTED ON PLAN. Y=0.86 OF DIMENSION "X".

MULCH SOIL TO A DEPTH OF 2" 1" IN DIAMETER. KEEP MULCH 2" AWAY FROM PLANT BASE.

BACKFILL WITH NATIVE SOIL. APPLY SLOW-RELEASE FERTILIZER TO SURFACE AWAY FROM TRUNK PER MANUFACTURER'S SPECIFICATIONS.

**GROUNDCOVERS**

PREPARE SOIL PER SEPCIFICATIONS AND ROTOTILL TO A DEPTH OF 6" PRIOR TO ANY SPRINKLER WORK.

**SHRUB PLANTING**

FORM TEMPORARY IRRIGATION BORDER JUST OUTSIDE OF ROOT BALL. USE WATER TO SETTLE BACKFILL. DO NOT PACK BACKFILL.

SET TOP OF ROOT BALL AT SOIL SURFACE.

BACKFILL WITH NATIVE SOIL (NO ROCKS GREATER THAN 1") APPLY SLOW-RELEASE FERTILIZER TO SURFACE AWAY FROM TRUNK PER MANUFACTURER'S SPECIFICATIONS.

PLANTING HOLE SHALL BE 2-2 1/2 TIMES DIAMETER OF ROOT BALL AND NO DEEPER THAN HEIGHT OF ROOT BALL. SCARIFY SIDES AND BOTTOM OF PLANTING HOLE.

SCARIFY SIDES OF ROOT BALL PRIOR TO PLANTING.

**TREE PLANTING AND STAKING**

PRUNE TREE AT TIME OF STAKE REMOVAL.

(2) 2" DIAMETER x 10' LONG LODGEPOLE PINE TREE STAKES. BURY 3" IN GROUND AND CUT OFF STAKE 12" ABOVE TIE WIRE. STAKES SHALL REMAIN IN PLACE FOR 2 YEARS UNLESS REMOVAL IS APPROVED BY MAINTENANCE DIRECTOR.

SET TOP OF ROOT BALL AT SOIL SURFACE.

TWO STRAND -12 GA. GALV. WIRE WITH NYLON MESH STRAP WITH END OF WIRE TWISTED AROUND POLE. TIES SHALL BE 2 OPPOSING LOOPS, NOT TO BE A SINGLE LOOP.

FORM TEMPORARY IRRIGATION BORDER JUST OUTSIDE OF ROOT BALL. USE WATER TO SETTLE BACKFILL. DO NOT PACK BACKFILL.

BACKFILL WITH NATIVE SOIL (NO ROCKS GREATER THAN 1") APPLY SLOW-RELEASE FERTILIZER TO SURFACE AWAY FROM TRUNK PER MANUFACTURER'S SPECIFICATIONS.

PLANTING HOLE SHALL BE 3 TIMES DIAMETER OF ROOT BALL AND NO DEEPER THAN HEIGHT OF ROOT BALL. SCARIFY SIDES AND BOTTOM OF PLANTING HOLE.

SCARIFY SIDES OF ROOT BALL PRIOR TO PLANTING.

**NOTES:**

- SUFFICIENT CLEARANCE SHALL BE MAINTAINED BETWEEN SHRUBS AND UTILITY FACILITIES SO AS TO NOT HINDER USE OF THESE FACILITIES.
- PLANT PIT BASINS WITHIN SLOPED PLANTING AREAS SHALL BE CONSTRUCTED WITH A MAX. 2:1 SLOPE. PROVIDE SMOOTH TRANSITION TO SURROUNDING FINISH GRADE.
- SEE DETAIL 18-04-050 FOR CONIFER TREE PLANTING.

NTS

 <p>City of Flagstaff</p> <p>ENGINEERING DETAIL</p>	<b>LANDSCAPE DETAILS</b>		
	DETAIL NO. <b>18-03-050</b>	REVISION DATE: 11/22/16	<b>1</b> <b>1</b>

## Building & Services

**CMU storage & systems Building:** A small cement block (CMU) building is being constructed to be the central point of all systems and controls for the park. Review this building design and requirements for integration with landscaping requirements. **Only the foundation and rough-ins are included in the initial phase.**

**Electrical Service – Pocket Park:** Overhead electrical lines to a west light pole supply power to the west bollard lights and will remain. Replacement lights are being completed in a separated contract.

## Cleo Murdoch Neighborhood Park – Site Furnishings.

**Park Chess Tables:** Provide and install 2 precast concrete chess tables (with chess board) manufactured by UPC Park Site Furnishings. 2 tables to be installed in new decorative pavers on the south side of the new concrete walk. One (1) table in standard seat configuration and one table (ADA) ordered with an extra seat at 90 degrees for HC roll-up on concrete paver surfaced area (3 seats total for ADA table). Contractor to confirm that seats are separate from table, if not provide an alternative additional seat.

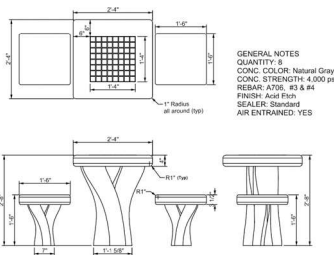

<https://upcparks.com/site-furnishings/>

Provide one (1) Dog Waste Stations at the north curb-cut entry point to park.



**Dog Waste Depot 12316 World Trade Drive San Diego, CA 92128 800-678-1612**

## Signage:

**Park Rules:** Provide and install 5 park rule posts at entry points to the park. Parks (PROSE) is providing the signage with the park rules. Contact PROSE representative for post locations and post requirements that allow mounting of rule signage.

**Park Monument Sign:** Provide a 2-foot x 8-foot park monument sign. Sign made of rusting Core-Ten (aka core-10) steel plate. Indicated below the text in black indicates cutouts of the steel with stencil text. The general location of the sign is at the corner of Brannen Ave and WC Riles St, confirm location with Project Manager/Architect and Parks (PROSE) to confirm location. Install with break-away posts set in concrete.

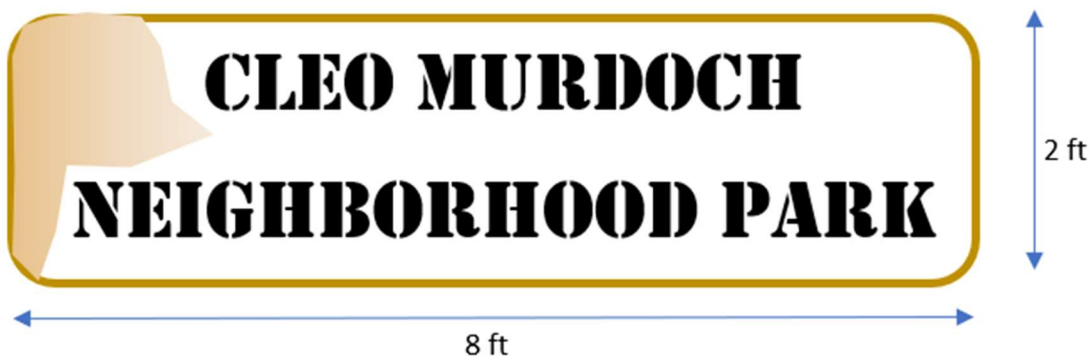

## Custom Bike Rack:

The Contractor is to have fabricated and installed a custom bike rack for the park. Bicycle Rack to be an adapted block letter graphic reading "CLEO" per the namesake of the Park "Cleo Murdoch". The 4 letters are fabricated of 1 & ½" nominal outer dimension schedule 40 steel tubing. The tubing outlines the block letter for enclosed areas to secure the bike lock. Block lettering is set out with a grid of 6" with (4) 6" grids high and bottom grid 6" wide and 8" high for a total height of 32". "C & O" are 30" in width and "L & E" at 24" with 6" between each letter. Link all letters with a continuous tub and provide 12" long extensions for embedding into concrete for inground mounting. Assembled letters to be power-coated purple. *See Flagstaff Municipal Code Appendix 1.4 Bicycle Parking Space Design Requirements, "C" Alternative Bicycle Designs for additional information and requirements. See Drawing:*

Location is generally at the north edge of the concrete paver area with access in from the central curb cut. Contact Project Manager/Architect for exact placement.

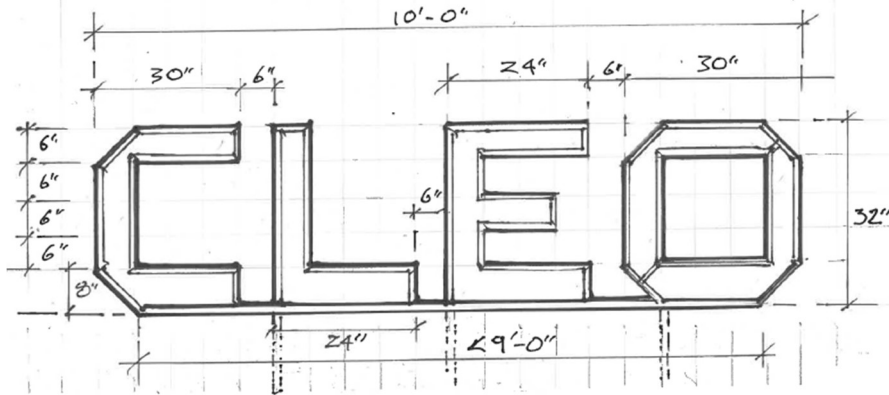

**Bike Rack Sign:** Provide one sign (9 X12) or similar standard available size (aluminum sign panel) and post calling out custom bike rack. To read “Lock your bike up with Cleo” include bicycle graphic.

## Site Electrical:

The electrical is to come from an existing APS pole with drop-down protection and trenched over to new small CMU storage/systems building’s **footing**. Install new 200-amp meter base, disconnect and panel on an “H” frame that can later be integrated and secured to the completed CMU building. Power to come from the east alley APS pole (L374620).

## Meter Base & Electrical Panel:

The project will have small electrical loads though the preference is to have a 200-amp panel. Contractor to confirm loads and discuss requirements with APS. Below is an excerpt of APS preapproved panels. Contact APS for additional information. Place “H” frame for electrical on the south side of the CMU foundation, noting that a roof scupper is on the north and there is a door on the west and east. Contact project architect for detailing of later integration with CMU building.

### ARIZONA PUBLIC SERVICE COMPANY

#### PRE-APPROVED EQUIPMENT LIST

#### RESIDENTIAL ALL-IN-ONE METER PANELS

#### (THAT WILL ACCEPT LOAD CONTROL CT'S IN THE NON-SEALED AREA)

All new panel installations and upgrades will require customer/contractor to install an all-in-one denoted on this list, with main disconnect(s) that meet current AIC requirements (per APS ESRM). APS does not allow the use of the flush mount panel design with an overhead panel. Overhead riser is not allowed to be enclosed or covered in a wall. All Equipment listed shall be installed per the manufacturers installation instructions. It is intended as an informational tool regarding what equipment will accept load controller CT's in the non-sealed, customer portion of the service equipment. Equipment not listed does not imply CT location in sealed utility area is permitted. Equipment shall have CT's located in the customer's side of the equipment. In all cases, APS Service Requirements and EUSERC Manufacturing Requirements shall apply. For specific questions regarding the service equipment, please contact the Manufacturer's Representative listed.

APS does not allow the use of the flush mount design with an OH panel. The affected catalog numbers are marked with an asterisk (\*). This note applies to all residential panels on this approved list

MANUFACTURER	REPRESENTATIVE	AMPS	CATALOG NUMBER	UG/OH
CIRCLE AW	Apex Electric Sales	400	U4042230MC/22K	UG
	Rick Kostewa	400	U4042MC (Meter/Main)	UG
	480-940-1010			
EATON (Formerly Cutler Hammer)	James Hayes	100	MBE1428B100BS or F*	UG
	480-449-4277	100	MBE1224B100BTS or F*	UG
		100	MBE1224B100TS	OH

## Lighting rough-in & Electrical

**Concept:** The lighting for the park is conceived to significantly improve visibility with the park with multiple fixtures and configurations yet implemented in a later phase. In the west pocket park area, the low bollard lights are being replaced with improved bollard lights under a separate contract. Lighting is designed to improve safety as well as enhance the appearance of the park and its neighborhood use. **Rough-in:** Provide rough-ins for lighting, irrigation, and irrigation controls with routing in appropriately sized PVC conduit.

**“Hot box” (irrigation water to site) power for heat-tape:** Contractor to provide an underground circuit to the existing hot box. Provide a GFIC weatherproof duplex outlet within box for heat-tape. Contractor to install heat-tape on existing exposed plumbing and wrap with thin fiberglass tape.



## Concrete Block Storage/Utility Building (castle (“Rook”) chess piece)

*The CMU Storage/Utility building is to be the central point for the parks systems (irrigation controls and electrical service location), storage for maintenance equipment and the large chess pieces for the mega chessboard. The building is to be semi-reminiscent of a “Rook” aka “Castle” chess piece with a crenelated top and detailing related to the mega chess board.*

**NOTE: For this portion of contracted landscape work the contractor is to provide only the initial CMU foundation and rough-ins. The entire building specification is included to assist the contractor with related requirements.**

- 10'-8" X 10'-8" CMU building footprint (See site plan for general location). The building is to line up with the existing former concrete driveway to the east. Cut concrete as required for installation of building. For a final floor height of 2-3" above mega chessboard (and new pavers) surface height for West Elevation door, excavate to required depth. Footings are (2) stacked 8" X 16" perimeter CMU blocks as footings (1 # 4 rebar horz each grout solid), compact gravel fill @ 2" lifts. **NOTE: Modify foundation to be (3) stacked CMUs and deletion of the Concrete Slab with compacted gravel brought up flush with the intended floor level.** Plan for and stub in protecting PVC conduit for electrical runs to lighting and irrigation control valves and all other requirements. **NOTE: Delete thickened slab as follows.** Cap CMU footings with a 4" reinforced slab (4" x 4 Welded Wire Fabric reinforcing) and 8" thickened edge (w/ #4 rebar horz). Pour per building plan set over compacted gravel base.

**NOTE: Provide all rough-ins and provisions for plumbing, irrigation, electrical, and controls required for future completion of the building.**

---

- Plumbing: The building shall also be equipped with water and a keyed hose bib on the exterior. Recommendation is on the west elevation (consult with project manager for alternate location if site conditions dictate).
- Provide a 10'-8" x 10'-8" Cement Masonry Unit (CMU) storage/utility building on the site. Building is approximately 12 feet in height with a crenelated top resembling a “Castle” (Rook) chess piece. Option #1 is the preferred CMU Spacing for Fluted CMU and solid 1-5/8" caps. Three CMU block (8" X 16") types are called out that have various surface treatments. 1) Smooth face with vertical score (standard gray) for body, 2) Split face for banding detail (Burlap if in-stock available or gray), 3) 2" fluted for base and cap (gray) with fluted design extending 9". Basic units are provided (shown below) with the contractor providing all other accessory block in the category for corners, bond-beams and required accessories.
- Building to be provided with a (2) 2'-6 x 6'-8 hollow metal doors & masonry frames with security keyed (mechanical code locks) provisions. One door on west elevation for mega chess piece access storage and one for access to larger area of the building for park systems on east elevation. The west elevation is to include a glazed window (Plexi-glass) for the mounting of the security monitor (showing monitoring/recording is taking place). Provide signage on building indicating surveillance.

- Building is for mounting of the park's electrical service (underground feed, meter base, disconnect, grounding), video monitoring, irrigation controls to the irrigation system valves. Building to also contain electrical power distribution to the park's lighting components and exterior and interior lighting of the building (motion activation) and power receptacles (interior and exterior). Building to have integrated shielded lighting on each face (see lighting). Provide storage shelving for chess pieces (west) and shelving east as required. *NOTE: see architectural plans for construction detailing, notes, and for more specific requirements.*
  - Irrigation control board supports zone control valves for sprinklers and drip irrigation. PVC conduit for electric lines to control valves.
  - Electrical service (from eastern pole trenched across site) meter and distribution panel is located at new CMU building. Electrical power from building to "pocket park picking up existing lighting location. Underground routing to feed to existing and new lighting.
  - Building will contain video monitoring and recording device. 8 channels min with 8 cameras with night vision capabilities. One camera per building elevation (X 4); two additional focused on west pocket park, and one per door pointing at the door from the interior. The west wall of the CMU building will have a protected plexi-glass window for placing a video monitor screen visible from the exterior. Provide an additional monitor in the interior of the east portion of the building.
- East Area – Additional Items: Contractor is to provide 2 complete project manuals, indicating all items w/ installation instruction & warranties, etc, utilized in the park. Provide 3 additional light fixtures (pole mount type) and 1 additional wall mount fixture. Provide 2 each of each type of sprinkler head utilized. Provide as-built notes on project changes and sketches of underground electrical runs. Provide a diagram of sprinkler layout.

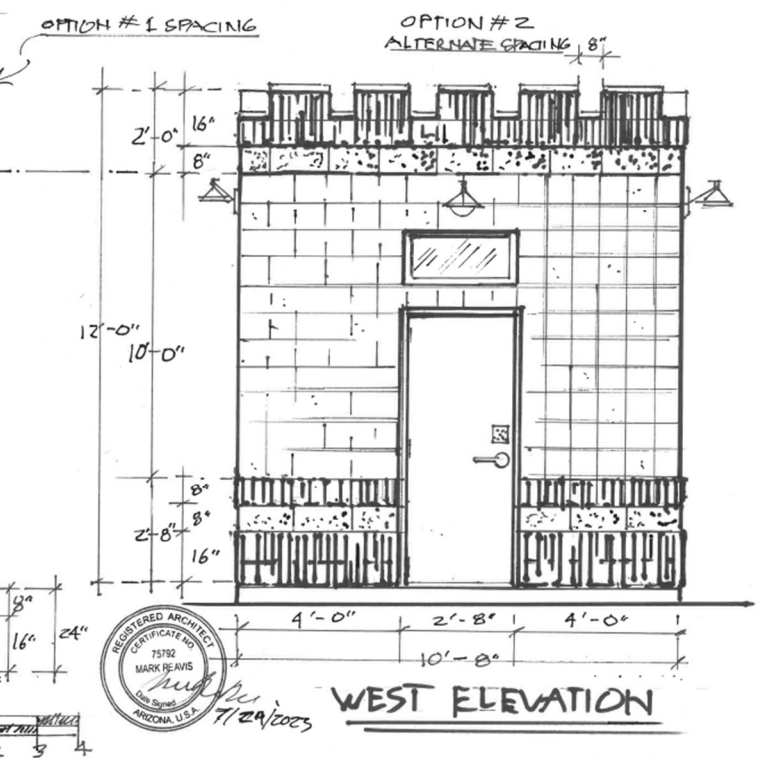
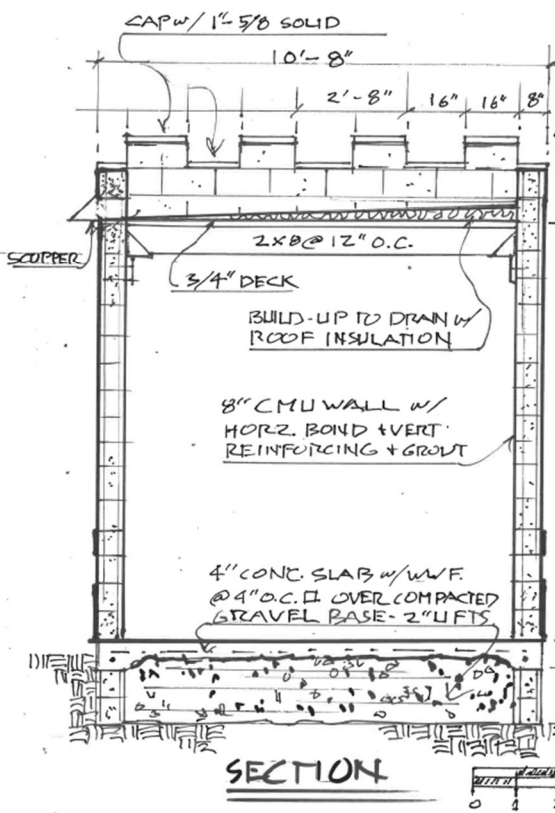
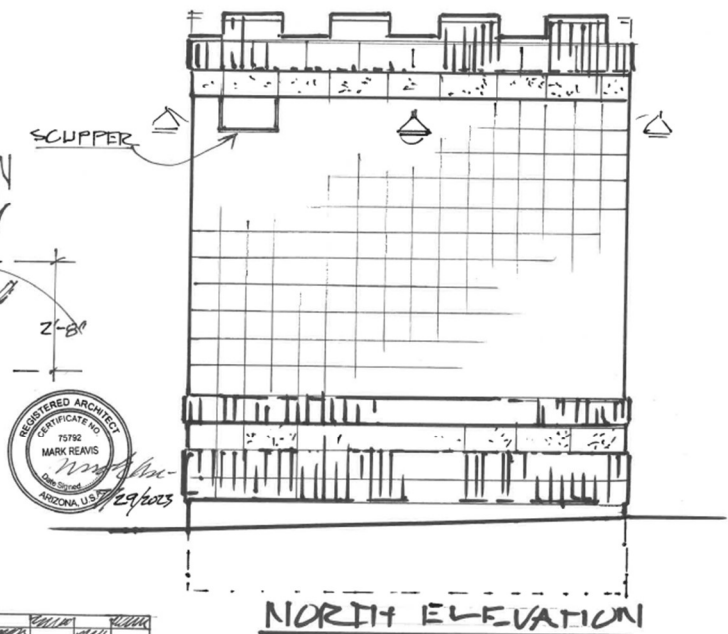
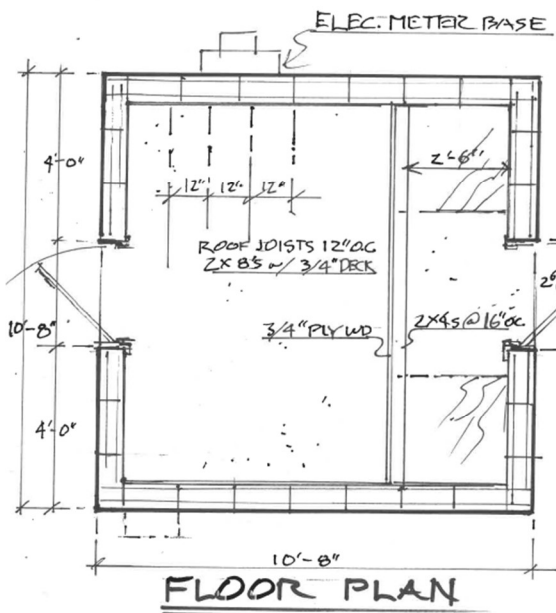

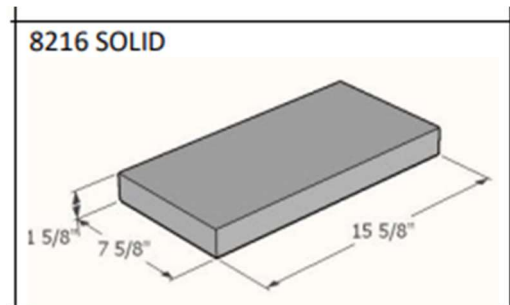
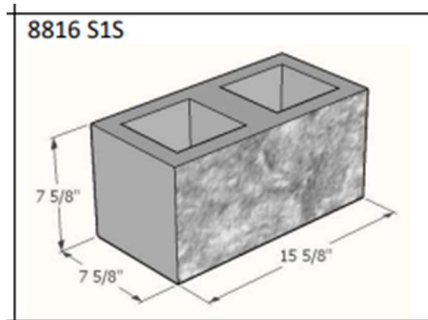
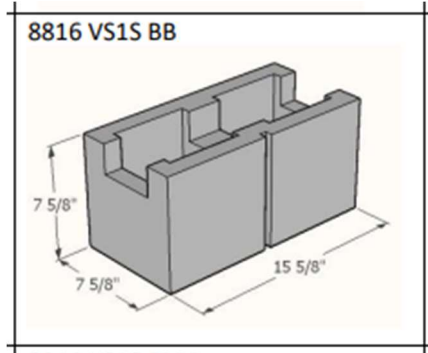

**NOTE:** All work is generally described and is to be “performed” by the contractor following best practices in a workman-like manner. Not all details and exact measurements have been provided. Contact the Project manager with any questions or requirements.

**Mark A. Reavis, AICP, NCARB**

Heritage Preservation Officer/Neighborhood Planner  
Planning & Development Services, 211 W. Aspen Av.  
Community Development, Flagstaff AZ 86001

Phone/message: (928) 213-2633

[Mark.Reavis@flagstaffaz.gov](mailto:Mark.Reavis@flagstaffaz.gov) [www|flagstaffaz.gov](http://www.flagstaffaz.gov)





# Bid Form

## Cleo Murdoch Neighborhood Park

All work as discussed with Amy Hagin shall be executed professionally by a qualified contractor for a total Price of: \$ 344,169 .00  
Cost includes P&P bond.

In writing: Three Hundred Forty Four Thousand One Hundred Sixty Nine .00

Add Alternate #1 Carpentry for Stub-wall bench wall cap \$ Included .00

In writing: Included in base bid .00

Return via email or hand deliver to Front Counter Community Development, City Hall 211 W Aspen Ave, Flagstaff AZ - Bid price submitted to remain confidential until bid award.

Work is estimated to commence on July /      / ~~2023~~ 2024 CL Initial

Project Performance Specifications understood. CL Initial

Contractor Insured by: Selective Insurance Company of America Initial

Davis Bacon Wage Documentations Available Yes Initial

Contactor's Firm Name Morning Dew Landscaping, Inc.

Contactor's Legal Representative *sign* \_\_\_\_\_

*Print* Chris Lloyd

Contractor's License Number KB2 - 276527/CR-21 153463

***Project Manager/ Architect Mark Reavis, AZ # 75792***

**Mark A. Reavis, AICP, NCARB**

Heritage Preservation Officer/Neighborhood Planner  
Planning & Development Services, 211 W. Aspen Av.  
Community Development, Flagstaff AZ 86001

Phone/message: (928) 213-2633

[Mark.Reavis@flagstaffaz.gov](mailto:Mark.Reavis@flagstaffaz.gov) [www.flagstaff.az.gov](http://www.flagstaff.az.gov)

EXHIBIT B - AGENCY CONTRACT

**JOB ORDER CONTRACT**

**Between**

**Coconino County Flood Control District**

**and**

**Morning Dew Landscaping, Inc.**

**Effective From: June 6, 2023 To: June 30, 2028**

**[AWARDED PURSUANT TO REQUEST FOR QUALIFICATIONS RFQ 2023-105]**

TABLE OF CONTENTS

ARTICLE NO.

ARTICLE 1 - DEFINITIONS ..... 1  
ARTICLE 2 - CONTRACTOR’S SERVICES AND RESPONSIBILITIES ..... 3  
ARTICLE 3 - CONTRACT TIME AND JOB ORDER TIME..... 18  
ARTICLE 4 - COMPENSATION ..... 24  
ARTICLE 5 - PROCEDURE FOR PAYMENT ..... 28  
ARTICLE 6 - CLAIMS AND DISPUTES ..... 31  
ARTICLE 7 - SUSPENSION AND TERMINATION..... 33  
ARTICLE 8 - INSURANCE ..... 35  
ARTICLE 9 - INDEMNITY ..... 38  
ARTICLE 10 – PERFORMANCE AND PAYMENT BONDS..... 39  
ARTICLE 11 - ADDITIONAL PROVISIONS..... 40

- EXHIBIT A: FEDERALLY FUNDED PROJECT REQUIREMENTS
- EXHIBIT B: JOC TASK MATRIX
- EXHIBIT C: PERFORMANCE BOND
- EXHIBIT D: PAYMENT BOND

## JOB ORDER CONTRACT

THIS JOB ORDER CONTRACT is entered into and made effective June 6, 2023 (the "Effective Date") by and between the Coconino County Flood Control District, a political subdivision of the State of Arizona (the "District") and MORNING DEW LANDSCAPING, INC., an Arizona corporation with offices at 2684 E. Huntington Drive Flagstaff, Arizona 86004 (the "Contractor").

### RECITALS

A. The District intends to contract to construct a number of Projects that will be constructed as Job Orders.

B. The Contractor has represented to the District the ability to provide or procure construction and design services and based on this representation the District engages the Contractor for these services.

### AGREEMENT

NOW THEREFORE, for and in consideration of the introduction and recitals above, which are incorporated herein by reference, the mutual covenants and considerations hereinafter contained, and other good and valuable consideration, the receipt and sufficiency of which are hereby acknowledged, it is agreed by and between the District and the Contractor as follows:

### ARTICLE 1 - DEFINITIONS

1.1 "Construction Documents" means the plans, technical specifications and any approved Shop Drawings related to the Work.

1.2 "Contract" means this agreement including its attachments and all Job Orders that may be issued hereunder, and any modifications to this agreement, its attachments and its Job Orders.

1.3 "Contract Amendment" means a written modification to this Contract, executed by the District and the Contractor.

1.4 "Contract Documents" means the following items and documents in descending order of precedence executed by the District and the Contractor: (i) Job Orders, including any amendments thereto; (ii) Contract Amendments; (iii) this Contract, including all exhibits and attachments; (iv) the Request for Qualifications issued in conjunction with this Contract; (v) the Contractor's Proposal in response to the Request for Qualifications; and (vi) the Contractor Statement of Qualifications.

1.5 "Contract Services" means the services required of the Contractor by the Contract Documents.

1.6 “Contract Time” means the time set forth in Section 4 subject to Contract Amendments approved in accordance with this Contract.

1.7 “Contractor’s Representative” means the Contractor’s duly authorized representative specifically authorized to act for the Contractor by executing the Contract and any modifications thereto. The Contractor’s duties include administration of the Contract on behalf of the Contractor and performance of the Work.

1.8 “Cost of the Work” means the direct costs necessarily incurred by the Contractor in the proper performance of the Work. The Cost of the Work shall include direct labor costs, subcontract costs, costs of materials and equipment incorporated in the completed construction, costs of other materials and equipment, temporary facilities, permit and license fees, materials testing, and related items. The Cost of the Work shall not include the Contractor’s construction fee, general conditions costs, and taxes.

1.9 “Critical Path” means the time set forth in the Schedule (as described in Section 4.2) that represents the minimum time necessary to complete the sequence of dependent tasks in a Job Order.

1.10 “Day(s)” means calendar day(s) unless otherwise specifically noted in the Contract Documents.

1.11 “Differing Site Conditions” means concealed or latent physical conditions or subsurface conditions at the Site that: (i) materially differ from the conditions indicated in the Job Order; or (ii) are of an unusual nature, differing materially from the conditions ordinarily encountered and generally recognized as inherent in the Work.

1.12 “District’s Authorized Representative” means the firm or person or their properly authorized delegates designated by the District to oversee the Work.

1.13 “Engineer” means the architectural or engineering firm, if any, designated by the District to prepare plans and specifications for the Work and perform other design or submittal services as required by the District. If an Engineer is not designated, the Engineer’s duties will be performed by the person or entity designated by the District’s Authorized Representative.

1.14 “Final Acceptance” means the completion of a Job Order as prescribed in Section 3.7 below.

1.15 “Job Order” means a specific written agreement between the District and the Contractor for specified Work to be performed under this Contract, including a scope of Work, the Job Order Price, the Job Order Time and any special conditions that may apply. The Job Order includes the Construction Documents and any applicable special provisions included therein.

1.16 “Job Order Payment Request” means the District form used by the Contractor to request progress payments for Job Orders in accordance with Section 6 below.

1.17 "Job Order Price" means the sum of: (i) the maximum cost of the Work for a Job Order; (ii) the Contractor's construction fee; (iii) the general conditions fee; (iv) taxes, bonds, insurances costs; (v) and contingency as proposed and approved.

1.18 "Job Order Time" means the time set forth in a Job Order specifying when the Contractor will perform the Work from the Job Order Notice-to-Proceed to Substantial Completion.

1.19 "Legal Requirements" means all applicable federal, state and local laws, codes, ordinances, rules, regulations, orders and decrees of any government or quasigovernmental entity having jurisdiction over a Site or any Work, including, but not limited to: (i) requirements of the respective "Authority Having Jurisdiction" (Coconino County, the District or the City of Flagstaff or other jurisdiction depending on location and permitting); (ii) Coconino County's Engineering Design & Construction Criteria and Construction Standards; (iii) ADOT Standards and Specifications, current edition(s); (iv) MAG Standards and Specifications, current editions/revisions; and (v) Manual of Uniform Traffic Control Devices (MUTCD), current edition.

1.20 "Project" means the Work as carried out at a particular Site pursuant to a Job Order.

1.21 "Purchase Order" means the written documentation from the District confirming the scope of Work and agreed-upon compensation for a Job Order.

1.22 "Shop Drawings" mean drawings, diagrams, schedules and other data specially prepared for the Work by the Contractor or a Subcontractor, manufacturer, supplier or distributor to illustrate some portion of the Work.

1.23 "Site" means the land or premises upon which the Work pursuant to a Job Order is to be performed.

1.24 "Subcontract" as used herein means any Contract, including purchase orders (other than one involving an employer-employee relationship) entered into by the Contractor calling for equipment, supplies or services required for Contract performance, including any modifications thereto.

1.25 "Subcontractor" or "Subconsultant" means any person or entity retained by the Contractor as an independent contractor to perform a portion of the Work and shall include materialmen and suppliers.

1.26 "Substantial Completion" means the Work has been completed in accordance with the Contract Documents to the extent that the District can use or occupy the entire Project, or the designated portion of the Project for the use intended without any outstanding, concurrent construction at the Site, except as may be required to complete or correct punch list items.

1.27 "Work" means any or all of the services that are set forth in any Job Order and all labor, services, incidental expenses and material necessary or incidental thereto.

## ARTICLE 2 - CONTRACTOR'S SERVICES AND RESPONSIBILITIES

## 2.1 General Provisions.

A. General Information. This is a fixed unit price, indefinite quantity type Contract for the performance of a broad range of construction, repair and maintenance work on an as-needed basis as may be required by the District. The specific work requirements will be identified in Job Orders to be issued by the District. Contract Services will include, but are not limited to the following:

- Provide preconstruction services
- Serve as the general contractor during construction
- Coordinate and manage subcontractors during construction
- Coordinate with franchise utilities
- Attend public meetings and provide notifications (when required)
- Arrange for procurement of materials and equipment
- Schedule and manage Site operations
- Use a collaborative process
- Provide quality controls
- Bond and insure the construction of certain projects based on cost or risk
- Comply with all federal, state and local permitting requirements
- Maintain a safe work site for all project participants
- Provide commissioning
- Prepare and turn over record drawings (when required)
- Provide operations and maintenance manuals (when required)
- Provide repairs to existing District infrastructure and District assets

B. General Scope of Work. The District requires general contracting (flood control) construction services for minor and major construction projects, maintenance, renovations, repairs, additions, demolition, re-constructions and alteration services to District facilities, roadways, and District infrastructure. The Contractor will be required to furnish all materials, equipment and personnel necessary to manage and accomplish each project.

(1) All work performed by the Contractor shall meet all applicable state and local codes and the Contractor shall be required to obtain all required permits and inspections.

(2) Job Orders will include, but are not limited to tasks such as construction and repair of on-forest watershed restoration measures, construction and repair work in support of Forest Restoration, construction and repair of flood water detention & retention facilities, floodwater conveyance channels, box and other forms of culverts/crossings, storm drain systems and inlets, bridges, catch basins, rock riprap, gabion baskets, excavation, drainages, and associated roadway grading, surfacing, placement of aggregate base, millings, asphalt pavement, roadway striping, concrete work, tree removal, traffic control, and utility relocations.

(3) Job Order proposals shall include, unless waived by the District, a completed "JOC Task Matrix" in the form attached as Exhibit B hereto and incorporated herein by reference.

C. Work Authorization. Any Work required under this Contract shall be authorized by issuance of formal, written Job Orders, as follows:

(1) As the need exists (as determined by the District) for performance under the terms of this Contract, the District will notify the Contractor of an existing requirement.

(2) Upon the receipt of this notification, the Contractor shall respond within two working days, or as otherwise agreed, by: (a) visiting the proposed Site in the company of the District; or (b) establishing contact with the District to further define the scope of the requirement.

(3) After mutual agreement on the scope of the Work, the Contractor shall then prepare a proposal for accomplishment of the task unless the Contractor, in its sole discretion, elects not to undertake the Work. If the Work is declined, the Contractor will so notify the District in a timely manner.

(4) The Contractor's proposal shall be submitted within 10 Days unless otherwise agreed.

(5) Upon receipt of the Contractor's proposal, the District will review the proposal for completeness and will reach agreement with the Contractor on pricing, schedule, and all other terms, prior to issuance of a Job Order.

(6) In the event the District does not issue a Job Order after receipt of the Contractor's proposal, the District is not obligated to reimburse the Contractor for any costs incurred in the preparation of the proposal.

D. Scheduling of Work.

(1) For each Job Order, the District will issue a Notice to Proceed. The first day of performance under a Job Order shall be the effective date specified in the Notice to Proceed. Any preliminary work started or material ordered or purchased before receipt of the Notice to Proceed shall be at the risk and expense of the Contractor. The Contractor shall diligently prosecute the Work to completion within the Job Order Time. The period of performance includes allowance for mobilization, holidays, weekend days, normal inclement weather, and cleanup. Therefore, claims for delay based on these elements will not be allowed.

(2) Placement of materials and equipment on the Site shall be made with a minimum of interference to neighboring property and the District's operations and personnel.

(3) The Contractor shall take all precautions to ensure that no damage will result from its operations to private or public property. All damages shall be repaired or replaced by the Contractor at no cost to the District.

(4) The Contractor shall be responsible for providing all necessary traffic control, such as street blockages, traffic cones, flagmen, etc., as required for each Job Order. Proposed traffic control methods shall be submitted to the District for approval.

E. Quality Assurance/Quality Control Program. The Contractor shall submit, for the District approval, a quality assurance/quality control plan within 15 calendar days after issuance of the initial Job Order. This plan should address all aspects of quality control including responsibility for surveillance of work, documentation, trend analysis, corrective action and interface with the District's inspectors.

F. Shop Drawings. The Contractor's duties under the Contract include the preparation of Shop Drawings or sketches necessary to permit orderly construction of the District's design plans. The Contractor agrees to provide detailed design drawings and plans if requested by the District.

G. Commencement of the Work. Performance of the Work shall be undertaken only upon execution of a Job Order by both parties and delivery of a Purchase Order and Notice to Proceed by the District. In response to Job Orders that may be mutually agreed upon and issued periodically by the District, the Contractor shall, in accordance with the Contract Documents, except as may be specified elsewhere in the Contract Documents, furnish all necessary labor, materials, tools, supplies, equipment, transportation, supervision, management, and perform all operations necessary and required for survey, design and construction services related to the Work, which will be defined and further described as to specific project requirements in each Job Order. The Work shall be performed in accordance with the requirements set forth in each Job Order.

H. Quality Standards. The Work shall be performed in a good, workmanlike and substantial manner and to the satisfaction of the District and under the direction and supervision of the District's Authorized Representative, or the District's properly authorized agents within the care and skill of a qualified contractor in Flagstaff, Arizona.

I. Hours of Work.

(1) Standard hours of work will be from 7:00 AM to 4:00 PM, Monday through Friday, unless alternate standard hours are agreed to and adopted; all hours worked on Saturdays, Sundays and holidays will be considered nonstandard hours.

(2) Non-standard hours worked by the Contractor to regain schedule or for the Contractor's convenience shall not be entitled to additional compensation.

J. Minor Design by Contractor. Minor design services may be required for some Job Orders. For those Job Orders that may require design services, the Contractor shall seek the services of an Arizona registered design professional to prepare plans for permitting.

(1) The selected design professional shall maintain at least \$1,000,000 Professional Liability Coverage.

(2) All documents prepared by the selected design professional are subject to review by the District. Review by the District does not relieve any design professional from the professional liability associated with the documents they have prepared.

K. Contractor Supervisor. The Contractor's Representative shall be reasonably available to the District and shall have the necessary expertise and experience required to supervise

the Contract Services. A Contractor's Representative will be assigned for each Job Order. The Contractor's Representative shall communicate regularly with the District and shall be vested with the authority to act on behalf of the Contractor.

L. Federally Funded Project Requirements. For Projects designated by the District as being funded, in whole or in part, by federal funding, the Contractor shall adhere to the Federally Funded Project Requirements set forth in Exhibit A attached hereto and incorporated herein by reference.

M. No Guarantee of Job Orders. This Contract embodies the agreement of the District and the Contractor to terms and conditions that will govern any Work described under a Job Order that may be issued by the District and agreed to by the Contractor. Nothing herein shall be construed as requiring the District to issue any Job Order, nor requiring the Contractor to accept same, it being the intent that both parties must mutually agree to any specific Work before a Job Order may be issued.

2.2 Subcontractor Selection Plan. The Contractor must prepare and submit a Subcontractor selection plan with its response to the District's request for a Job Order.

A. Qualifications-Based Selection Required. The Subcontractor selection plan must provide a process to select Subcontractors based on qualifications alone or on a combination of qualifications and price and shall not select subcontractors based on price alone.

B. No Deviation from Approved Plan. The approved Subcontractor selection plan must be adhered to for the duration of the Contract. Deviation from or changes to the approved plan must be submitted to and approved by the District.

C. District Right to Object. The District reserves the right to reject the Contractor's selection of Subcontractors on individual projects. Failure to include the subcontractor list in the price proposal submitted for each Job Order shall be cause for rejection of the proposal as non-responsive.

2.3 Government Approvals and Permits.

A. Permit Responsibility. Unless otherwise provided in a Job Order, the Contractor shall obtain or assist the District in obtaining all necessary permits, approvals and licenses required for the prosecution of the Work from any government or quasi-government entity having jurisdiction over the Project. **The Contractor is specifically reminded of the need to obtain the necessary environmental permits or file the necessary environmental notices.**

B. Copies of Permits. Copies of these permits and notices must be provided to the District's Authorized Representative prior to starting the permitted activity. This provision does not constitute an assumption by the District of an obligation of any kind for violation of said permit or notice requirements.

C. Temporary Utilities. The Contractor is responsible for the cost of water meter(s), water and sewer taps, fire lines and taps, and all water bills on the project meters until

Final Acceptance of the Project. Arrangements for construction water are the Contractor's responsibility.

## 2.4 Pre-Construction Conference.

A. Timing of Conference. After execution of a Job Order by the District and the Contractor, but prior to issuance of a Purchase Order and prior to issuance of a Notice to Proceed and the commencement of any Work pursuant to such Job Order, a pre-construction conference will be scheduled.

B. Purpose of Conference. The purpose of this conference is to establish a working relationship between the Contractor, utility firms, and other interested entities. The agenda will include: critical elements of the Work and Schedule; submittal schedule; access to Site and protocol for admission; hours of construction operation, if different from the standard hours set forth in this Contract; designation of a staging area; specific quality requirements for equipment and material; requirements for catalog cuts, technical data, samples, Shop Drawings and incidental design; the presence of hazardous materials; coordination with the involved utility firms regarding temporary services and shutoffs; safety issues/concerns and procedures; date on which price proposal is due; cost breakdown of major lump sum items; payment application and processing; level of record drawings required; and emergency telephone numbers for all representatives involved in the course of construction.

C. Mandatory Attendance. The Contractor shall ensure attendance by the Contractor's Representative, the job superintendent, and the Contractor's safety officer.

D. Notice to Proceed Established. The Job Order Notice to Proceed date will be established.

## 2.5 Control of Work.

A. Supervision; Inspection. Unless otherwise provided in the Job Order to be the responsibility of the District or a separate contractor, the Contractor shall provide through itself or Subcontractors the necessary supervision, labor, inspection, testing, start-up, material, equipment, machinery, temporary utilities and other temporary facilities necessary to permit the Contractor to complete the Work according to the requirements in this Contract and the Job Order.

B. Requisite Skill. The Contractor shall perform all construction activities efficiently and with the requisite expertise, skill and competence to satisfy the requirements of the Job Order. The Contractor shall at all times exercise complete and exclusive control over the means, methods, sequences and techniques of construction.

C. On-Site Supervision. The Contractor's superintendent, or suitable designee, shall be present at the Site at all times that construction activities are taking place.

(1) All elements of the Work, such as concrete work, pipe work, etc., shall be under the direct supervision of the Contractor's foreman or designated representative on the Site who shall have the authority to take actions required to properly carry out that particular element of the Work.

(2) In the event of noncompliance of this subsection, the District may require the Contractor to stop or suspend the Work, in whole or in part, until the required supervision is provided.

D. Manufacturer Approval. Where the Job Order requires that a particular product be installed and/or applied by an applicator approved by the manufacturer, it is the Contractor's responsibility to ensure the Subcontractor employed for such work is approved by the manufacturer.

E. Materials Measurements. Before ordering materials or doing work, the Contractor and each Subcontractor shall verify measurements at the Site and shall be responsible for the correctness of such measurements. No extra charge or compensation will be allowed because of differences between actual dimensions and the dimensions indicated on the drawings; differences shall be submitted to the District for resolution before proceeding with the Work.

F. Field Measurements. The Contractor shall take field measurements and verify field conditions and shall carefully compare such field measurements and conditions and other information known to the Contractor with the Job Order before commencing activities. Errors, inconsistencies or omissions discovered shall be reported to the District at once.

G. Construction Grades; Lines; Benchmarks. The Contractor shall establish and maintain all building and construction grades, lines, levels, and benchmarks, and shall be responsible for accuracy and protection of same. This work shall be performed or supervised by a licensed civil engineer or surveyor.

H. Unsuitable Personnel. Any person employed by the Contractor or any Subcontractor who, in the opinion of the District, does not perform work in a proper, skillful and safe manner or is intemperate or disorderly shall, at the written request of the District, be removed from the Project by the Contractor or Subcontractor employing such person, and shall not be employed again in any portion of Project without the written approval of the District. The Contractor or Subcontractor shall defend and hold the District harmless from damages or claims which may occur in the enforcement of this section.

I. Responsibility for Subcontractors. The Contractor assumes responsibility to the District for the proper performance of the work of Subcontractors and any acts and omissions in connection with such performance. Nothing in the Contract Documents is intended or deemed to create any legal or contractual relationship between the District and any Subcontractor, including but not limited to any third-party beneficiary rights.

J. Coordination. The Contractor shall coordinate the activities of all Subcontractors. If the District performs other work on the Project or at the Site with separate contractors under the District's control, the Contractor agrees to reasonably cooperate and coordinate its activities with those of such separate contractors so that the Project can be completed in an orderly and coordinated manner without unreasonable disruption.

## 2.6 Control of Work Site.

A. Debris; Construction Waste. Throughout all phases of construction, including suspension of the Work, the Contractor shall keep the Site reasonably free from debris, trash and construction wastes to permit the Contractor to perform its construction services efficiently, safely and without interfering with the use of adjacent land areas. Upon Substantial Completion of the Work, or a portion of the Work, the Contractor shall remove all debris, trash, construction wastes, materials, equipment, machinery and tools arising from the Work or applicable portions thereof to permit the District to occupy the Project or a portion of the Project for its intended use.

B. Dust Control. The Contractor shall take whatever steps, procedures or means to prevent any dust nuisance due to construction operations. The dust control measures shall be maintained at all times to the satisfaction of the District and in accordance with the requirements of any governmental entity having jurisdiction over air quality of the Project.

C. Site Storage. Only materials and equipment which are to be used directly in the Work shall be brought to and stored on the Site by the Contractor. When equipment is no longer required for the Work, it shall be removed promptly from the Site. Protection of construction materials and equipment stored at the Site from weather, theft, damage and all other adversity is solely the responsibility of the Contractor.

D. Sanitary Facilities. During construction, the Contractor shall supply the Site with a minimum of one portable chemical toilet, or more as necessary or directed by the District for larger projects.

## 2.7 Specifications and Drawings.

A. Copy on Site; Order of Priority. The Contractor shall keep on the Work Site a copy of the drawings and/or specifications and shall at all times give the District's Authorized Representative access thereto. Anything mentioned in the specifications and not shown on the drawings, or shown on the drawings and not mentioned in the specifications, shall be of like effect as if shown or mentioned in both. In case of differences between drawings and specifications, the drawings shall govern. In case of discrepancy either in the figures, in the drawings, or in the specifications, the matter shall be promptly submitted to the District's Authorized Representative, who shall promptly submit them to the District Engineer for a determination in writing. Any adjustment by the Contractor without such a determination shall be at its own risk and expense.

B. Term Usage. Wherever in the specifications or upon the drawings the words "directed," "required," "ordered," "designated," "prescribed," or words of like import are used, it shall be understood that the "direction," "requirement," "order," "designation," or "prescription," of the District or the District's Authorized Representative is intended and similarly the words "approved," "acceptable," "satisfactory," or words of like import shall mean "approved by," or "acceptable to," or "satisfactory to" the District or the District's Authorized Representative, unless otherwise expressly stated. Where "as shown," "as indicated," "as detailed," or words of similar import are used, it shall be understood that the reference is made to the drawings accompanying

the Contract unless stated otherwise. The word “provided” as used herein shall be understood to mean “provide complete in place,” that is “furnished and installed.”

C. Omissions. Omissions from the drawings or specifications or the mis-description of details of work which are manifestly necessary to carry out the intent of the drawings and specifications, or which are customarily performed, shall not relieve the Contractor from performing such omitted or mis-described details of the Work but they shall be performed as if fully and correctly set forth and described in the drawings and specifications.

D. Contractor Obligation to Inspect. The Contractor shall check all District-furnished drawings immediately upon receipt and shall promptly notify the District’s Authorized Representative of any discrepancies. Figures marked on drawings shall be followed in preference to scale measurements. Large scale drawings shall govern small scale drawings. The Contractor shall compare all drawings and verify the figures before laying out the Work and will be responsible for any errors which might have been avoided thereby.

E. Ownership of Documents. All drawings (to include as-built drawings), sketches, designs, design data, specifications, note books, technical and scientific data provided to the Contractor or developed by the Contractor pursuant to the Contract and all photographs, negatives, reports, findings, recommendations, data and memoranda of every description relating thereto, as well as all copies of the foregoing relating to the Work or any part thereof, shall be the property of the District and may be used by the District without any claim by the Contractor for additional compensation, unless such material developed by the Contractor does not result in an issued Job Order. In such cases, the Contractor will receive reasonable reimbursement for the development of such materials before the District uses them in any manner whatsoever. In addition, the District agrees to hold the Contractor harmless to the extent permitted by law from any legal liability arising out of the District’s use of such materials.

## 2.8 Shop Drawings, Product Data and Samples.

A. Shop Drawing Approval. The Contractor shall coordinate all Shop Drawings, and review them for accuracy, completeness, and compliance with Contract requirements and shall indicate its approval thereon as evidence of such coordination and review. Shop drawings submitted to the District’s Authorized Representative without evidence of the Contractor’s approval may be returned for resubmission. The District will indicate its approval or disapproval of the Shop Drawings and if not approved as submitted shall indicate the District’s reasons therefore. Any work done before such approval shall be at the Contractor’s risk. Approval by the District shall not relieve the Contractor from responsibility for any errors or omissions in such drawings, nor from responsibility for complying with the requirements of the Contract and the applicable Job Order, except with respect to variations described and approved in accordance with Subsection 2.8(B) below.

B. Variations. If Shop Drawings show variations from the Job Order requirements, the Contractor shall describe such variations in writing, separate from the drawings, at the time of submission. If the District approves any such variation, the District shall issue an appropriate Job Order modification, including any necessary adjustments related to the variation. If the variation is minor and does not involve a change in price or in time of performance, a

modification need not be issued.

C. Not Contract Documents. Shop Drawings, product data, samples and similar submittals are not Contract Documents. The purpose of their submittal is to demonstrate for those portions of the Work for which submittals are required the way the Contractor proposes to conform to the information given and the design concept expressed in the Job Order.

D. Timely Review. The Contractor shall review, approve, verify, and submit to the District copies of each Shop Drawing, product data, samples, and similar submittal required by the Job Order in accordance with the approved schedule as to cause no delay in the Work or in the activities of the District or of separate contractors. Submittals made by the Contractor that are not required by the Job Order may be returned without action.

E. No Work Prior to Approval. The Contractor shall perform no portion of the Work requiring submittal and review of Shop Drawings, product data, samples, or similar submittals until the respective submittal has been approved by the District. Such Work shall be in accordance with approved submittals.

F. Contractor Representations. By approving, verifying and submitting Shop Drawings, product data, samples and similar submittals, the Contractor represents that the Contractor has determined and verified materials, field measurements and field construction criteria related thereto, or will do so, and has checked and coordinated the information contained within such submittals with the requirements of the Work and of the Job Order.

G. Contractor Responsible. The Contractor shall not be relieved of responsibility for deviations from requirements of the Job Order by the District's approval of Shop Drawings, product data, samples or similar submittals unless the Contractor has specifically informed the District in writing of such deviation at the time of submittal and the District has given written approval to the specific deviation. The Contractor shall not be relieved of responsibility for errors or omissions in Shop Drawings, product data, samples, or similar submittals by the District's approval thereof.

H. Highlighting Revisions. The Contractor shall direct specific attention, in writing or on resubmitted Shop Drawings, product data, samples, or similar submittals, to revisions other than those requested by the District on previous submittals.

I. Information-Only Submittals. Informational submittals upon which the District is not expected to take responsive action must be so identified in the submittal.

J. Reliance on Professional Certification. When professional certification of performance criteria of materials, systems or equipment is required by the Job Order, the District shall be entitled to rely upon the accuracy and completeness of such calculations and certifications.

## 2.9 Quality Control, Testing and Inspection.

A. New Materials. All materials used in the Work shall be new and unused, unless otherwise noted, and shall meet all quality requirements of the Job Order.

B. Materials Subject to Inspection. All construction materials to be used on the Work or incorporated into the Work, equipment, plant, tools, appliances or methods to be used in the Work may be subject to the inspection and approval or rejection of the District.

C. Sampling. The procedures and methods used to sample and test material will be determined by the District. Unless otherwise specified, samples and tests shall be made in accordance with the standard methods of AASHTO or ASTM.

D. Independent Testing. The District will select a pre-qualified District or Independent Testing Laboratory and will pay for initial District acceptance testing.

(1) When the first and subsequent tests indicate noncompliance with the Job Order, the cost associated with that noncompliance, including subsequent tests, will be paid for by the Contractor.

(2) When the first and subsequent tests indicate noncompliance with the Job Order, all retesting shall be performed by the same testing agency.

E. Contractor Cooperation. The Contractor will cooperate with the selected testing laboratory and all others responsible for testing and inspecting the Work and shall provide them access to the Work at all times.

F. Material Approval at Source. At the option of the District, materials may be approved at the source of supply before delivery is started.

G. Compliance Testing. Code compliance testing and inspections required by codes or ordinances, or by a plan approval authority, and which are made by a legally constituted authority, shall be the responsibility of and shall be paid by the Contractor, unless otherwise provided in the Job Order.

H. Contractor's Sole Expense. The Contractor's convenience and quality control testing and inspections shall be the sole responsibility of the Contractor and paid by the Contractor.

#### 2.10 Project Record Documents.

A. Required Documentation. At the pre-construction conference described above, the District's Authorized Representative will describe the required documentation for the record documents for each Job Order.

(1) During the construction period, the Contractor shall maintain at the jobsite a set of prints of the Construction Documents for record document purposes. The Contractor will mark these drawings to indicate the actual installation where the installation varies appreciably from the original Construction Documents. The Contractor shall give particular attention to information on concealed elements that would be difficult to identify or measure and record later. Items to be marked may include but are not limited to:

- Dimensional changes to the Construction Documents.

- Revisions to details shown on the Construction Documents.
- Depths of foundations below first floor.
- Locations and depths of underground utilities.
- Revisions to routing of piping and conduits.
- Revisions to electrical circuitry.
- Actual equipment locations.
- Duct size and routing.
- Locations of concealed internal utilities.
- Changes made by change order.
- Details not on the original Construction Documents.

(2) The Contractor shall mark completely and accurately record document prints of Construction Documents. Where Shop Drawings are marked, show cross-references on the related other Construction Documents.

(3) The Contractor shall mark Project record drawing sets with red erasable colored pencil.

(4) The Contractor shall note RFI Numbers, ASI Numbers and change order numbers, etc., as required to identify the source of the change to the Construction Documents.

(5) The Contractor shall, at the time of Substantial Completion, submit record document prints and Shop Drawings to the District or the District's Authorized Representative for review and comment.

B. Corrections. Immediately upon receipt of the reviewed record documents from the District, the Contractor shall correct any deficiencies and/or omissions to the drawings and prepare the following for submission to the District:

(1) A complete set of electronic record documents prepared in AutoCAD format compatible with the District's CADD technology. If original Construction Documents were prepared by a separate design professional, the District shall ensure the design professional provides files of the original Construction Documents to the Contractor for the use of preparing these final record documents or the Contractor may contract with the design professional to revise and update the electronic drawing files. Each drawing shall be clearly identified as an "As-Built Document."

(2) If requested by the District, a complete set of reproducible mylars from the final AutoCAD drawings and five edge-bound blue-line or black-line sets reproduced from these mylars.

(3) The original copy of the record documents (redline mark-ups).

## 2.11 Project Safety.

A. Scope of Safety Responsibilities. The Contractor recognizes the importance of performing the Work in a safe manner so as to prevent damage, injury or loss to (1) all individuals at the Site, whether working or visiting, (2) the Work, including materials and equipment incorporated into the Work or stored on-Site or off-Site, and (3) all other property at the Site or adjacent thereto. During the construction process, the Contractor shall comply with all applicable federal, state and county, and District health and safety laws and regulations including, but not limited to all applicable “OSHA Standards for the Construction Industry” shall be followed, including, but not limited to, 29 CFR Part 1926, Subpart P – Excavations. All construction equipment and materials shall be safely fenced off from public access during the entirety of the project. Knowing and following OSHA Safety Standards is the Contractor’s responsibility. The District may stop construction on a project until safety concerns have been corrected.

B. Responsibility for Safety Programs. The Contractor assumes responsibility for implementing and monitoring all safety precautions and programs related to the performance of the Work.

C. Safety Representative. The Contractor shall, prior to commencing construction, designate a safety representative with the necessary qualifications and experience to supervise the implementation and monitoring of all safety precautions and programs related to the Work. Unless otherwise required by the Contract Documents, the Contractor’s safety representative shall be an individual stationed at the Site who may have responsibilities on the Project in addition to safety.

D. Inspections; Safety Meetings. The Contractor’s safety representative shall make routine daily inspections of the Site and shall hold weekly safety meetings with the Contractor’s personnel, Subcontractors and others as applicable.

E. Compliance with Legal Requirements. The Contractor and Subcontractors shall comply with all Legal Requirements relating to safety, as well as any District-specific safety requirements set forth in the Contract Documents; provided that such District-specific requirements do not violate any applicable Legal Requirement.

F. Reporting Obligation. The Contractor will immediately report in writing any safety-related injury, loss, damage or accident arising from the Work to the District’s Authorized Representative and, to the extent mandated by Legal Requirements, to all government or quasi-government authorities having jurisdiction over safety-related matters involving the Project or the Work.

G. Subcontractor Safety Requirements. The Contractor’s responsibility for safety under this Section 2.11 is not intended in any way to relieve Subcontractors of their own contractual and legal obligations and responsibility for (1) complying with all Legal Requirements, including those related to health and safety matters, and (2) taking all necessary measures to implement and monitor all safety precautions and programs to guard against injury, losses, damages or accidents resulting from their performance of the Work.

2.12 Warranty.

A. Only New Materials and Equipment. The Contractor warrants to the District that the construction, including all materials and equipment furnished as part of the construction, shall be new, unless otherwise specified in the Contract Documents, of good quality, in conformance with the Contract Documents and free of defects in materials and workmanship.

B. Alterations or Damage by Others. The Contractor's warranty obligation excludes defects caused by abuse, alterations, or failure to maintain the Work by persons other than the Contractor or anyone for whose acts the Contractor may be liable.

C. Duration of Construction Warranty. The Contractor's warranty obligation shall be for one year from the Final Acceptance date.

D. No Limitation on Other Warranties. Nothing in this warranty is intended to limit any manufacturer's warranty that provides the District with greater warranty rights than set forth in this Section 2.12 or the Contract Documents. The Contractor will provide the District with all manufacturers' warranties upon Substantial Completion.

2.13 Correction of Defective Work.

A. Contractor Responsible. The Contractor shall be responsible for the completeness and accuracy of its reviews, reports, supporting data, and other work prepared or compiled as required by this Contract and shall correct its work, at the Contractor's sole expense. The fact that the District has accepted, approved or pays for the Contractor's work shall in no way relieve the Contractor of any of its responsibilities.

B. Contractor Corrections. The Contractor agrees to correct any Work that is found to not be in conformance with the Contract Documents, including that part of the Work subject to Section 2.12 above, within a period of one year from the date of Substantial Completion of the Work or any portion of the Work, or within such longer period to the extent required by the Contract Documents. A progress payment, or partial or entire use or occupancy of the Project by the District shall not constitute acceptance of the Work not in accordance with the Contract Documents.

C. Time for Corrections; District Self-Help. During the Job Order Time, the Contractor shall take meaningful steps to commence correction of such nonconforming Work as notified by the District. This includes the correction, removal or replacement of the nonconforming Work and any damage caused to other parts of the Work affected by the nonconforming Work. If the Contractor fails to commence the necessary steps during the Job Order Time, the District, in addition to any other remedies provided under the Contract Documents, may provide the Contractor with written notice that the District will commence correction of such nonconforming Work with its own forces.

D. Time for Correction of Warranty Work; District Self-Help The Contractor shall take meaningful steps to commence correction of nonconforming Work subject to Section 2.12 above, within seven days of receipt of written notice from the District. This includes the correction, removal or replacement of the nonconforming Work and any damage caused to other

parts of the Work affected by the nonconforming Work. If the Contractor fails to commence the necessary steps within such seven-day period, the District, in addition to any other remedies provided under the Contract Documents, may provide the Contractor with written notice that the District will commence correction of such nonconforming Work with its own forces.

E. Costs of District Self-Help to be Paid by Contractor. If the District performs corrective Work as described above, the Contractor shall be responsible for all reasonable costs incurred by the District in performing such correction.

F. Emergency Work. For Nonconforming Work that creates an emergency requiring an immediate response, the Contractor will respond and initiate corrections within 24 hours.

G. Warranty Not Limitations Period. The one-year period referenced in Subsection 2.12(B) above applies only to the Contractor's obligation to correct nonconforming Work and is not intended to constitute a period of limitations for any other rights or remedies the District may have regarding the Contractor's other obligations under the Contract Documents.

2.14 Fair Treatment to Workers. The Contractor shall keep fully informed of all Federal and State laws, County and District ordinances, regulations, codes and all orders and decrees of bodies or tribunals having any jurisdiction or authority that in any way affect the conduct of the Work. The Contractor shall at all times observe and comply with all such laws, ordinances, regulations, codes, orders and decrees; this includes, but is not limited to laws and regulations ensuring fair and equal treatment for all employees and against unfair employment practices, including OSHA and the Fair Labor Standards Act (FLSA). The Contractor shall defend and indemnify the District and its representatives against any claim or liability arising from or based on the violation of such, whether by the Contractor or its employees.

### ARTICLE 3 - CONTRACT TIME AND JOB ORDER TIME

3.1 Contract Time. The Contract Time shall be five years from the Effective Date. A Contract Amendment will be processed for any extension. This Contract will remain in full force and effect during the performance of any Job Order.

#### 3.2 Job Order Time.

A. Documentation. Each Job Order will include the Work "Schedule" (as defined below) with the Job Order Time and a calculated Substantial Completion date.

B. Schedule. The Contractor will submit for approval with the Job Order a "Schedule" showing the sequence in which the Contractor proposes to perform the Work, and the dates on which the Contractor contemplates starting and completing the significant elements of the Work (including acquiring materials, plant and equipment). The Schedule may be a formal computerized schedule or a progress chart in a bar chart format of suitable scale to indicate appropriately the percentage of the Work scheduled for completion by any given date during the period. In either case the basic information should be the same and the Schedule chart must contain as a minimum:

- (1) A list of the different types of work activities or work elements.
- (2) The logical dependencies (ties) to indicate what Work shall be accomplished before other Work can begin.
- (3) Proposed start and complete dates or time frames for each work activity or work element.
- (4) The “weighting” or relative worth each work activity or work element is of the total project either as a percent or dollar amount. If the Contractor fails to submit a Schedule with the Job Order, the District may withhold issuance of a Notice to Proceed until the Contractor submits the required Schedule.

C. Adherence to Schedule. The Contractor shall prosecute the Work so that the portion of the Work completed at any point in time shall be not less than as required by the Schedule. The Contractor shall submit a progress report every 30 days, or as directed by the District’s Authorized Representative, and upon doing so shall immediately deliver a current Schedule to the District’s Authorized Representative. If the Contractor falls behind the approved Schedule, the Contractor shall take steps necessary to improve its progress, including those that may be reasonably required by the District’s Authorized Representative. If the delay is an Inexcusable Delay (as defined below), the Contractor shall prepare a recovery schedule for the District’s review and approval, showing how the Contractor will compensate for the delays and achieve Substantial Completion by the date shown on the Schedule. If the Contractor is unable to demonstrate how it will overcome Inexcusable Delays, the District may order the Contractor to employ such extraordinary measures as are necessary to bring the Work into conformity with the date of Substantial Completion set forth therein, the costs of which shall be included as part of the Cost of the Work. If the delay is an Excusable Delay (as defined below), the District shall either (1) authorize an equitable extension in the Schedule to account for such delay, and equitably adjust the Job Order Price on account of such delay, or (2) request that the Contractor prepare a recovery schedule showing how (if possible) the Contractor can achieve Substantial Completion by the date shown on the Schedule, and equitably adjust the applicable Job Order Price in accordance with the change order provisions of this Contract related to any extraordinary activities required of the Contractor on account of such recovery schedule.

D. Emergency Work. The Contractor will give top priority to any emergency work the District may have and will allocate all resources necessary to accomplish such work in accordance with the District’s Schedule requirements. To the extent the Contractor incurs additional cost, expense or schedule delay in performing the District’s emergency work, the District will equitably adjust the Contract.

E. District Requirements. Failure of the Contractor to comply with the requirements of the District or the District’s Authorized Representative under this article shall be grounds for a determination by the District that the Contractor is not prosecuting the Work with sufficient diligence to ensure completion within the time specified in the Job Order. Upon making this determination, the District may terminate the Contractor’s right to proceed with the Work, or any separable part of it, in accordance with this Contract.

F. Progress Completion. The District and the Contractor agree the time limits stated in the Job Order, as the same may be amended and updated by the parties, are of the essence of this Contract.

G. Commencement of the Work. The Work shall commence on the Notice to Proceed date of the applicable Job Order, and shall proceed in general accordance with the Schedule for the Work set forth therein. Each Job Order shall establish a separate Notice to Proceed date, Substantial Completion date, and Job Order Time.

H. Critical Path Activities. To the extent the Contractor completes activities on the Critical Path earlier than scheduled, the savings in time on account thereof shall belong solely to the Contractor.

### 3.3 Extensions of Job Order Time.

A. Limitation on Extensions. An extension in the scheduled Substantial Completion date for a Job Order will only be granted in the event of Excusable Delays affecting Work activities on the Critical Path. The Contractor shall be entitled to general condition costs and extra costs related to the Excusable Delay for idle labor, equipment inefficiency, and lost productivity of the performance of the Work; however, the Contractor must submit evidence reasonably satisfactory to the District substantiating such costs. Such adjustment to the Job Order Price and Substantial Completion date shall be issued in an amendment to the applicable Job Order.

B. Excusable Delay. To the extent any of the following events results in an actual delay in the Work affecting activities on the Critical Path, such shall constitute an "Excusable Delay" (to the extent not set forth below, a delay will be considered an "Inexcusable Delay"):

(1) Delays resulting from Force Majeure events: The term "Force Majeure" means an occurrence that is beyond the control of the party affected and occurs without its fault or negligence. Without limiting the foregoing, Force Majeure includes acts of God, acts of the public enemy, war, riots, strikes, mobilization, labor disputes, civil disorders, fire, floods, lockouts, injunctions, intervention, acts or failures or refusals to act by government authority, and other similar occurrences beyond the control of the party declaring Force Majeure which such party is unable to prevent by exercising reasonable diligence. The Force Majeure shall be deemed to commence when the party declaring Force Majeure notifies the other party, in accordance with Subsection 4.3(C), of the existence of the Force Majeure and shall be deemed to continue as long as the results or effects of the Force Majeure prevent the party from resuming performance in accordance with this Contract and the applicable Job Order. Force Majeure shall not include (1) late delivery of equipment or materials caused by congestion at a manufacturer's plant or elsewhere, an oversold condition of the market, inefficiencies, or similar occurrences, or (2) late performance by a Subcontractor unless the delay arises out of a Force Majeure occurrence in accordance with this Subsection 4.3(B)(1). Any delay or failure in performance by either party hereto shall not constitute default hereunder or give rise to any claim for damages or loss of anticipated profits if, and to the extent that such delay or failure is caused by Force Majeure. The delayed party shall cause such delay to cease as soon as practicable and shall notify the other party in writing. The time of Substantial Completion or Final Completion shall be extended by written

amendment for a period of time equal to the time that the results or effects of such delay prevent the delayed party from performing in accordance with this Contract and the applicable Job Order.

(2) Differing, unusual, or concealed Site conditions that could not reasonably have been anticipated by the Contractor in preparing the Schedule, including, without limitation, archaeological finds and unusual soil conditions (including rock or other geological conditions), underground foundations, abandoned or not properly identified utility lines, and water conditions.

(3) Delays resulting from the existence or discovery of hazardous materials on the Site not brought to the Site by or on behalf of the Contractor.

(4) Delays resulting from changes in Legal Requirements occurring after the date of execution of this Contract.

(5) Delays occurring due to the acts or omissions of the District and those within the control of the District.

(6) Delays occurring due to the acts or omissions of a utility, so long as the Contractor has coordinated with the utility causing the delay, and the delay occurs despite reasonable steps taken by the Contractor to avoid the delay.

(7) Delays resulting from weather conditions that make it unreasonable to perform the Work in accordance with the Schedule.

C. Requirements for Extension. To obtain an extension of time due to an Excusable Delay, the Contractor must comply with the following requirements: the Contractor shall notify the District of the Excusable Delay as soon as practicable, but in no event more than seven Days after the Contractor becomes aware of the occurrence of the Excusable Delay. Such notice shall describe the Excusable Delay and shall state the approximate number of Days the Contractor expects to be delayed. After the cessation of the Excusable Delay, the Contractor shall notify the District of the number of Days the Contractor believes that its activities were in fact delayed by the Excusable Delay. In the event that the delay arises as a result of a change order request by the District, the request for an extension of time contained in the resulting change order proposal or amendment to this Contract, as applicable, shall be deemed sufficient for purposes of this Subsection.

D. Determination of Delay. Within 10 Days after cessation of an event giving rise to either an Excusable Delay or Inexcusable Delay, the parties will use good faith efforts to agree on the extent to which the Work has been delayed and whether the delay is an Excusable Delay or an Inexcusable Delay. In the absence of agreement between the parties as to the then-current status of Excusable Delays and Inexcusable Delays, the Contractor shall request the District prepare a determination of the number and character of the delay days. The District will provide the Contractor with written notice of the District's determination of the number of Days of Excusable Delay and/or Inexcusable Delay within 10 Days after receipt by the District of the Contractor's written request for such determination. The Contractor shall not, however, deem an issuance by the District of such a determination to be a concurrence with any matters set forth in

the Contractor's request. The Contractor may invoke the dispute resolution procedures set forth below with respect to such determination.

3.4 Concurrent Delays. To the extent the Contractor may be entitled to an extension of time due to an Excusable Delay, but the performance of the Work would have been suspended, delayed, or interrupted by the fault or neglect of the Contractor or by an Inexcusable Delay, the Contractor shall not be entitled to any additional costs for the period of such concurrency.

3.5 Weather Delays. The Contractor shall include and clearly identify an appropriate number of Days of weather-related delays within the Schedule for the Work for the applicable Job Order. If the Contractor experiences additional weather-related delays beyond the number of Days set forth in the Schedule for the applicable Job Order, the Contractor shall be entitled to commensurate extension of time and reimbursement of costs associated with such delay; provided such requests for extensions of time are submitted and approved according to the process set forth in Subsection 4.3(C) above. If the Contractor fails to include an appropriate number of Days of weather-related delays within the applicable Job Order for any portion of the Project, the Contractor shall not be eligible for any extension of time or reimbursement of costs related to otherwise Excusable Delays relating to weather for the applicable Job Order.

3.6 Substantial Completion.

A. Notification. The Contractor shall notify the District when it believes the Work, or to the extent permitted in the Contract Documents, a portion of the Work, is substantially complete. When the District determines the Work to be substantially complete, the District will issue a certificate of Substantial Completion with a list of items to be completed or corrected prior to final payment for the Job Order. The Contractor shall proceed promptly to complete and correct items on the list.

B. Punch List. Prior to notifying the District as set forth above, the Contractor shall inspect the Work and prepare and submit to the District a comprehensive list of items to be completed or corrected (a "Punch List"). The Contractor shall proceed promptly to complete and correct items on the Punch List. Failure to include an item on such list does not alter the responsibility of the Contractor to complete all Work in accordance with the Contract Documents. The District may supplement the Punch List following its inspection of the Work.

C. Inspection. Within five days of the District's receipt of the Contractor's notice, the District and the Contractor will jointly inspect such Work to verify that it is substantially complete in accordance with the requirements of the Contract Documents.

D. Certificate of Substantial Completion. If such Work is substantially complete, the District shall prepare and issue a certificate of Substantial Completion that will set forth (1) the date of Substantial Completion of the Work or portion thereof, (2) the remaining items of the Work that have to be completed within 30 calendar days before Final Acceptance, (3) provisions (to the extent not already provided in the Contract Documents) establishing the District's and the Contractor's responsibility for the Project's security, maintenance, utilities and insurance pending Final Acceptance and (4) an acknowledgment that warranties commence to run

on the date of Substantial Completion, except as may otherwise be noted in the certificate of Substantial Completion.

E. Partial Use or Occupancy. The District, at its option, may use a portion of the Work which has been determined to be substantially complete; provided, however, that (1) a certificate of Substantial Completion has been issued for the portion of the Work addressing the items set forth in Subsection 3.6(B) above, (2) the Contractor and the District have obtained the consent of their sureties and insurers, and to the extent applicable, the appropriate government authorities having jurisdiction over the Project, and (3) the District and the Contractor agree that the District's use or occupancy will not interfere with the Contractor's completion of the remaining Work.

3.7 Final Acceptance. Upon receipt of written notice that the Work or identified portions of the Work is ready for final inspection and acceptance, the District and the Contractor will jointly inspect to verify that the remaining items of the Work have been completed as set forth in Subsection 4.6(B). The District will issue a Final Acceptance letter for the Job Order.

3.8 Liquidated Damages.

A. Generally. The Contractor and the District acknowledge that in the event that the Contractor fails to achieve Substantial Completion or Final Acceptance of the Project by the dates established therefore in the applicable Job Order, as adjusted, the District will incur substantial damages and the extent of such damages shall be incapable of accurate measurement. Nonetheless, the parties acknowledge that on the date of this Contract, the amount of liquidated damages set forth below represents a good faith estimate as to the actual potential damages that the District would incur as a result of late Substantial Completion or Final Acceptance of the Project. Such liquidated damages shall be the sole and exclusive remedy of the District for late completion of the Project, and the District hereby waives all other remedies available at law or in equity with respect to losses resulting from late completion. The amount of the liquidated damages calculated hereunder does not include any penalty.

B. When Imposed. If the Contractor fails to achieve Substantial Completion of that portion of the Work applicable to a particular Job Order on or before the Substantial Completion date set forth in the applicable Job Order, as adjusted, for any reason other than Excusable Delays, the Contractor shall pay to the District liquidated damages in the amount per Day set forth below for each Day Substantial Completion is delayed beyond the Substantial Completion date set forth in the applicable Job Order.

(1) If the Contractor fails to achieve Final Acceptance of that portion of the Work applicable to a particular Job Order on or before the Final Acceptance date, as adjusted, for any reason other than Excusable Delays, the Contractor shall pay to the District liquidated damages in the amount per Day as set forth below for each Day Final Acceptance is delayed beyond the Final Acceptance date established according to the applicable Job Order.

(2) In no case may the amount of liquidated damages due under this Subsection 3.8(B) for any single Day of delay exceed the highest amount, as determined according

to the schedule below, that would be charged for any single Inexcusable Delay existing on such Day.

(3) Payment of liquidated damages is to be made contemporaneously with any required payment to the Contractor, and such payments may be offset against each other.

C. Amount. The following will be the liquidated damages for each Job Order unless a specific amount has been determined in the Job Order.

<b>Schedule of Liquidated Damages</b>			
Job Order Price		Liquidated Damages Per Day	
From More Than:	To and Including:	Calendar Day or Fixed Date:	Working Day:
\$0	\$100,000	\$350	\$500
100,000	500,000	490	700
500,000	1,000,000	840	1,200
1,000,000	2,000,000	910	1,300

D. District Right to Waive. The District may waive all or any portion of the liquidated damage assessment after the date the Work is substantially completed and is: (1) in condition for safe and convenient use by the travelling public; or (2) available for next-stage construction without restriction.

E. No Accrual During Authorized Suspension. No liquidated damages will accrue during periods of time when the District has authorized, in writing, suspension of the Work.

F. No Waiver. Permitting the Contractor to continue and finish the Work or any part of it after the time fixed for its completion shall not in any way operate as a waiver on the part of the District of any of its rights under this Contract. Neither by the act of taking over the Work nor by annulment of this Contract or any Job Order related hereto shall the District forfeit the right to recover liquidated damages from the Contractor or its Sureties.

#### ARTICLE 4 - COMPENSATION

4.1 Generally. A separate Purchase Order will be issued for each Job Order before the commencement of any work by the Contractor. The compensation to be paid to the Contractor for services performed pursuant to this Contract shall be based upon Purchase Orders prepared for each Job Order, each of which will establish the Job Order Price for the applicable Project.

#### 4.2 Job Order Price.

A. Maximum Per Job Order. The District intends that each Job Order performed under this Contract will not exceed [\$2,000,000.]

(1) Each Job Order Price is subject to adjustments made in accordance with this Article 4.

(2) Unless otherwise provided in the Contract Documents, each Job Order price is deemed to include all sales, use, consumer and other taxes that are legally enacted when negotiations concluded, whether or not yet effective or merely scheduled to go into effect.

(3) The Contractor guarantees to bring each Job Order within the Job Order Price or the Contractor alone will be required to pay the difference between the actual cost and the Job Order Price.

B. Price Based on Scope. The scope of Work will vary with each Job Order. At the beginning of each Job Order, a scope conference will be scheduled to define design and construction services required of the Contractor. The Job Order and related documents will be given to the Contractor. The Contractor will be asked to provide a proposal with Job Order Price and schedule indicating the Job Order Time for the proposed Job Order based on the scope meeting and the provided documents. The price proposal for a specific scope of Work shall include a complete list of quantities and prices of parts and materials to be utilized, total labor cost to be broken down by trade, hours for each trade, hourly cost per trade, total dollar cost and completion date. The project price proposal shall be all-inclusive with any cost overruns to be absorbed by the Contractor unless change orders are pre-approved by the District. The District will review the submitted proposal. The District and the Contractor shall negotiate in good faith and as expeditiously as possible an agreed upon Job Order Price and the Job Order Time. Upon reaching concurrence, the parties shall execute the Job Order reflecting the terms agreed upon.

C. Contractor Warranty Regarding Price Proposal. By executing a price proposal, the Contractor represents that it has visited the project site(s) and familiarized itself with the local conditions under which the Work is to be performed. The District does not undertake to represent or warrant the Site or local conditions.

D. Multiple Proposals. The District has the right to request Job Order proposals from more than one firm for competitive purposes. Pricing will be determined by Open Book Pricing consisting of firm subcontractor price quotes that are shared with and approved by the District.

4.3 Mark up for Changes. If the Job Order Price requires an adjustment due to changes in the Work, the cost of such changes is determined subject to Section 6. The markups that shall be allowed on such changes shall be no greater than the markups delineated in the Job Order proposal.

4.4 Differing Site Conditions.

A. Price and Time Adjustments. If the Contractor encounters a Differing Site Condition, the Contractor will be entitled to an adjustment in the Job Order Price and/or Job Order Times to the extent the Contractor's cost and/or time of performance are adversely impacted by the Differing Site Condition.

B. Notice to District. Upon encountering a Differing Site Condition, the Contractor shall provide prompt written notice to the District of such condition, which notice shall not be later than seven days after such condition has been encountered. The Contractor shall, to the extent reasonably possible, provide such notice before the Differing Site Condition has been substantially disturbed or altered.

4.5 Errors, Discrepancies and Omissions.

A. Contractor Request for Clarification. If the Contractor observes errors, discrepancies or omissions in the Contract Documents, he shall promptly notify the District and request clarification.

B. Contractor Bears Risk. If the Contractor proceeds with the Work affected by such errors, discrepancies or omissions, without receiving such clarifications, he does so at his own risk. Adjustments involving such circumstances made by the Contractor prior to clarification by the District shall be at the Contractor's risk.

4.6 District Requested Change in a Job Order.

A. The District reserves the right to make, at any time during the progress of a Job Order, such alterations as may be found necessary or desirable.

B. Such alterations and changes shall not invalidate this Contract or the Job Order nor release the surety and the Contractor agrees to perform the Job Order as altered, the same as if it has been a part of the original Contract Documents.

C. The District will request a proposal for a change in a Job Order from the Contractor, and an adjustment in the Job Order Price and/or Job Order Times shall be made based on a mutually agreed upon cost and time.

4.7 Legal Requirements. The Job Order Price and/or Job Order Times shall be adjusted to compensate the Contractor for the effects of any changes in the Legal Requirements enacted after the date of the Job Order affecting the performance of the Work, or the date of the Job Order Price. Such effects may include, without limitation, revisions required to be made to the Construction Documents because of changes in Legal Requirements.

4.8 Job Order Amendments.

A. Negotiation of Amendments. The District and the Contractor shall negotiate in good faith and as expeditiously as possible the appropriate adjustments to a Job Order. Upon reaching an agreement, the parties shall prepare and execute an appropriate Job Order Amendments reflecting the terms of the changes.

B. Contract Documents Govern. All changes to a Job Order authorized by change orders shall be performed under the conditions of the Contract Documents.

#### 4.9 Minor Changes in a Job Order.

A. By District. The District has authority to order minor changes to a Job Order that do not materially and adversely affect the Work, including the design, quality, performance and workmanship required by the Contract Documents. Such changes shall be implemented by written order and shall be binding on the District and the Contractor. The Contractor shall carry out such written orders promptly.

B. By Contractor. The Contractor may make minor changes to a Job Order; provided, however, that the Contractor shall promptly inform the District, in writing, of any such changes and record such changes, if appropriate, on the Project Record Documents maintained by the Contractor.

C. No Price or Time Adjustments. Minor changes to a Job Order will not involve an adjustment in the Job Order Price and/or Job Order Time.

#### 4.10 Job Order Price Adjustments.

A. Acceptable Methods. The increase or decrease in Job Order Price resulting from a change in the Work shall be determined by one or more of the following methods:

(1) Unit prices set forth in the Job Order or as subsequently agreed to between the parties.

(2) A mutually accepted lump sum, properly itemized and supported by sufficient substantiating data to permit evaluation by the District.

(3) Costs, fees and any other markups set forth in Section 5.2.

B. Inability to Agree on Method. If an increase or decrease cannot be agreed to as set forth in items (1) through (3) above and the District issues a change order, the cost of the change of the Work shall be determined by the reasonable expense and savings in the performance of the Work resulting from the change, including a reasonable overhead and profit, as may be set forth in the Job Order. The Contractor shall maintain a documented, itemized accounting evidencing the expenses and savings associated with such changes.

C. Equitable Adjustment of Unit Prices. If unit prices are set forth in the Contract Documents or are subsequently agreed to by the parties, but application of such unit prices will cause substantial inequity to the District or the Contractor because of differences in the character or quantity of such unit items as originally contemplated, such unit prices shall be equitably adjusted.

D. Dispute Resolution. If the District and the Contractor disagree upon whether the Contractor is entitled to be paid for any services required by the District, or if there are any other disagreements over the scope of a Job Order or proposed changes to a Job Order, the District and the Contractor shall resolve the disagreement pursuant to Article 6 hereof.

(1) As part of the negotiation process, the Contractor shall furnish the District with a good faith estimate of the costs to perform the disputed services in accordance with the District's interpretations.

(2) If the parties are unable to agree and the District expects the Contractor to perform the services in accordance with the District's interpretations, the Contractor shall proceed to perform the disputed services, conditioned upon the District issuing a written order to the Contractor (i) directing the Contractor to proceed and (ii) specifying the District's interpretation of the services that are to be performed.

4.11 Emergencies. In any emergency affecting the safety of persons and/or property, the Contractor shall act, at its discretion, to prevent threatened damage, injury or loss. Any change in the Job Order Price and/or Job Order Time resulting from emergency work under this Section 4.11 shall be determined as provided in Article 4.

## ARTICLE 5 - PROCEDURE FOR PAYMENT

### 5.1 Job Order Payment Request.

A. Schedule of Values. At the pre-construction conference prescribed above, the Contractor shall submit for the District's review and approval a schedule of values. The schedule of values will include values for all items comprising the Job Order Price and will serve as the basis for monthly progress payments made to the Contractor throughout the Work.

B. Progress of the Work. The Contractor shall invoices as Job Order Pay Requests for progress payments at the end of each calendar month. Invoices shall be submitted to the District's Business Manager who will be issuing the Purchase Order and submitting invoices for payment. Such invoice shall include a detailed breakdown of all charges and shall be based on completion of tasks. At least five working days prior to the date established for a progress payment, the Contractor shall meet with the District's Authorized Representative to review the progress of the Work as it will be reflected on the Job Order Payment Request.

C. Contractor Representation. The Job Order Payment Request shall constitute the Contractor's representation that the Work has been performed consistent with the Contract Documents, has progressed to the point indicated in the Job Order Payment Request, and that title to all Work will pass to the District free and clear of all claims, liens, encumbrances, and security interests upon the incorporation of the Work.

### 5.2 Partial Payments.

A. When Allowed. Partial payment will be made for Job Orders with Job Order Time greater than 90 Days and may be made if Job Order Time is less than 90 Days.

B. Submittal Date. The Contractor shall submit a Job Order Payment Request to the District on the monthly anniversary of the Job Order Notice to Proceed beginning with the first month after the Job Order Notice to Proceed.

C. Incorporation of Equipment and Materials. The Job Order Payment Request may include payment for equipment and materials not yet incorporated into the Work if construction progress is in reasonable conformance with the approved Schedule.

(1) For equipment and material suitably stored at the Site, the equipment and materials shall be protected by suitable insurance and the District shall receive the equipment and materials free and clear of all liens and encumbrances.

(2) No material or equipment may be stored off the Site without the District's prior, written approval. The material and equipment must be stored within Coconino County and be accessible for the District's inspection, and title to such materials and equipment must protect the District's interest and shall include applicable insurance, bonding, storage and transportation to the Site.

(3) All bonds and insurance required for stored materials shall name the District as the loss payee to the extent of its interest in the stored materials.

### 5.3 Payment of Job Order.

A. Timing of Payment. The District shall make payment in accordance with A.R.S. § 34-609, as amended. Payment will be made no later than 14 calendar days after the Job Order Payment Request is certified and approved, but in each case less the total of payments previously made, and less amounts properly withheld under Section 5.5 below. The Contractor shall be paid 95% of the earned sum when payment is due, with not more than 5% being retained to ensure faithful performance of the Agreement. All amounts withheld may be included in the final payment.

B. Withholding Amounts. The District shall pay the Contractor all amounts properly due. If the District determines that the Contractor is not entitled to all or part of a Job Order Payment Request, it will notify the Contractor in writing within seven days after the date the Job Order Payment Request is received by the District. The notice shall indicate the specific amounts the District intends to withhold, the reasons and contractual basis for the withholding, and the specific measures the Contractor must take to rectify the District's concerns. The Contractor and the District will attempt to resolve the District's concerns. If the parties cannot resolve such concerns, the Contractor may pursue its rights under the Contract Documents.

### 5.4 Final Payment.

A. Conditions. After receipt of a final Job Order Payment Request, the District shall make final payment as prescribed in this Section 5.4, provided that the Contractor has completed all of the Work in conformance with the Contract Documents and a Final Acceptance Letter has been issued by the District.

B. Submittal Requirements. At the time of submission of its final Job Order Payment Request, the Contractor shall provide the following information:

(1) An affidavit that there are no claims, obligations or liens outstanding or unsatisfied for labor, services, material, equipment, taxes or other items performed, furnished or incurred for or in connection with the Work which will in any way affect the District's interests.

(2) A general release executed by the Contractor waiving, upon receipt of final payment by the Contractor, all claims, except those claims previously made in writing to the District and remaining unsettled at the time of final payment.

#### 5.5 Payments to Subcontractors or Supplier.

A. Timing of Payments. The Contractor shall pay its Subcontractors or suppliers within seven calendar days of receipt of each progress payment from the District. The Contractor shall pay for the amount of the Work performed or materials supplied by each Subcontractor or supplier as accepted and approved by the District with each progress payment. No contract between the Contractor and its Subcontractors and suppliers may materially alter the rights of any Subcontractor or supplier to receive prompt payment as provided herein.

B. District Actions. If the Contractor fails to make payments in accordance with these provisions, the Contractor agrees the District may take any one or more of the following actions:

(1) Hold the Contractor in default under this Contract.

(2) Withhold future payments until proper payment has been made to Subcontractors or suppliers in accordance with these provisions.

(3) Reject all future offers to perform work for the District from the Contractor for a period not to exceed one year from Substantial Completion date of the Work contemplated by this Contract.

C. Disputes with Subcontractor. If the Contractor's payment to a Subcontractor or supplier is in dispute, the Contractor and Subcontractor or supplier agree to submit the dispute to any of one of the following dispute resolution processes within 14 calendar days from the date any party gives notice to the other: (1) binding arbitration; (2) a form of alternative dispute resolution (ADR) agreeable to all parties; or (3) a District-facilitated mediation. When a disputed claim is resolved through ADR or otherwise, the Contractor and Subcontractor or suppliers agree to implement the resolution within seven calendar days from the resolution date.

D. No Waiver. Should the District fail or delay in exercising or enforcing any right, power, privilege, or remedy under this Section, such failure or delay shall not be deemed a waiver, release, or modification of the requirements of this Section or of any of the terms or provisions thereof.

E. Required Contract Provisions. The Contractor shall include these prompt payment provisions in every subcontract, including procurement of materials and leases of equipment for this Contract.

5.6 Record Keeping and Finance Controls.

A. Time Period Covered. Records of the Contractor's direct personnel payroll, reimbursable expenses pertaining to each Job Order and records of accounts between the District and the Contractor shall be kept on a generally recognized accounting basis and shall be available for three years after completion of the Project.

B. Audit Rights. The District, the District's Authorized Representative, and/or the appropriate federal agency, reserve the right to audit the Contractor's records to verify the accuracy and appropriateness of all pricing data, including data used to negotiate Contract Documents and any Job Order.

C. Right to Reduce Job Order Price. In addition to any other remedies available at law or equity, the District reserves the right to decrease Job Order Price and/or payments made on this Contract if, upon audit of the Contractor's records, the audit discloses the Contractor has provided false, misleading, or inaccurate cost and pricing data.

D. Inclusion in Other Agreements. The Contractor shall include a similar provision in all of its agreements with Subconsultants and Subcontractors providing services under the Contract Documents to ensure the District, the District's Authorized Representative, and/or the appropriate federal agency, has access to the Subconsultants' and Subcontractors' records to verify the accuracy of cost and pricing data.

E. Reduction for Failure to Include. In addition to any other remedies available at law or equity, the District reserves the right to decrease Job Order Price and/or payments made on this Contract if the above provision is not included in Subconsultant's and Subcontractor's contracts, and one or more Subconsultants and/or Subcontractors do not allow the District to audit their records to verify the accuracy and appropriateness of pricing data.

ARTICLE 6 - CLAIMS AND DISPUTES

6.1 Requests for Contract Adjustments and Relief. If either the Contractor or the District believes that it is entitled to relief against the other for any event arising out of or related to Contract Services other than requests for extensions of Job Order Time as described above, such party shall provide written notice to the other party of the basis for its claim for relief. Such notice shall, if possible, be made prior to incurring any cost or expense and in accordance with any specific notice requirements contained in applicable sections of the Contract. In the absence of any specific notice requirement set forth in a Job Order, written notice shall be given within a reasonable time, not to exceed 21 days, after the occurrence giving rise to the claim for relief or after the claiming party reasonably should have recognized the event or condition giving rise to the request, whichever is later. Such notice shall include sufficient information to advise the other party of the circumstances giving rise to the claim for relief, the specific contractual adjustment or relief requested and the basis of such request.

6.2 Dispute Avoidance and Resolution. The parties are fully committed to working with each other and agree to communicate regularly with each other at all times so as to avoid or minimize disputes or disagreements. If disputes or disagreements do arise, the Contractor and the District each commit to resolving such disputes or disagreements in an amicable, professional and

expeditious manner so as to avoid unnecessary losses, delays and disruptions to the Work. The Contractor and the District will first attempt to resolve disputes or disagreements at the field level through discussions between the Contractor's Representative and the District's Authorized Representative. If a dispute or disagreement cannot be resolved through the Contractor's Representative and the District's Authorized Representative, the Contractor's Senior Representative and the District's Senior Representative (each as defined below), upon the request of either party, shall meet as soon as conveniently possible, but in no case later than 30 days after such a request is made, to attempt to resolve such dispute or disagreement. Prior to any meetings between the Senior Representatives, the parties will exchange relevant information that will assist the parties in resolving their dispute or disagreement.

6.3 Duty to Continue Performance. Unless provided to the contrary in the Contract Documents, the Contractor shall continue to perform the Work and the District shall continue to satisfy its payment obligations to the Contractor, pending the final resolution of any dispute or disagreement between the Contractor and the District.

6.4 Representatives of the Parties.

A. District's Representatives.

(1) The District designates the individual listed below as the "District's Senior Representative," which individual has the authority and responsibility for avoiding and resolving disputes as set forth above:

Lucinda Andreani  
Flood Control District Administrator  
5600 E. Commerce Ave. Flagstaff, AZ 86004  
(928) 679-7166

(2) The District will designate an individual for each Job Order as the District's Authorized Representative. This person will manage the Job Order.

B. Contractor's Representatives.

(1) The Contractor designates the individual listed below as the "Contractor's Senior Representative," which individual has the authority and responsibility for avoiding and resolving disputes as set forth above:

Name: Chris Lloyd  
Title: Owner  
Address: 2684 E. Huntington Drive Flagstaff, AZ 86004  
Telephone #: (928) 779-3125

(2) The Contractor will designate an individual for each Job Order as the Contractor's Representative.

## ARTICLE 7 - SUSPENSION AND TERMINATION

7.1 District's Rights to Suspend Contract Services. The District may, at its discretion and without cause, order the Contractor in writing to stop and suspend the Work on a Job Order. Such suspension shall not exceed 180 consecutive Days. The Contractor may seek an adjustment of the Job Order Price and/or Job Order Time if its cost or time to perform the Contract Services has been adversely impacted by any suspension or stoppage of the Work by the District. If the District suspends the Work on any Job Order for 181 consecutive Days or more, such suspension shall be deemed a termination for convenience.

7.2 Termination for Convenience. Upon receipt of written notice to the Contractor, the District may, at its discretion and without cause, elect to terminate this Contract or any Job Order.

A. Contractor Duties. Upon receipt of written notice of termination of this Contract or any Job Order, the Contractor shall proceed with the following obligations:

- (1) Stop the Work as specified in the notice.
- (2) Place no further subcontracts or orders.
- (3) Terminate all subcontracts to the extent they relate to the Work terminated.
- (4) Assign to the District all rights, title and interest of the Contractor under the subcontracts terminated, in which case the District shall have the right, but not the obligation, to settle or to pay any termination settlement proposal arising out of those terminations.
- (5) Take any action that may be necessary for the protection and preservation of the property related to the Job Order that is in the possession of the Contractor and which the District has or may acquire an interest.

B. Termination Inventory. The Contractor shall submit complete termination inventory schedules no later than 120 Days from the date of the notice of termination.

C. District Payments. The District shall pay the Contractor the following:

- (1) The direct value of its completed Work and materials supplied as of the date of termination.
- (2) The reasonable costs and expenses attributable to such termination.
- (3) The Contractor's profit and overhead on completed Work only; the Contractor shall not be entitled to anticipated profit or anticipated overhead for uncompleted Work. If it appears the Contractor would have sustained a loss on the entire Contract Services had they been completed, the Contractor shall not be allowed profit and the District shall reduce the settlement to reflect the indicated rate of loss.

D. Contractor Records Retention Period. The Contractor shall maintain all records and documents for three years after final settlement. These records shall be maintained and subject to auditing as prescribed above.

7.3 District's Right to Perform and Terminate for Cause.

A. For Contractor's Failure to Maintain Site. If the District provides the Contractor with a written order to provide adequate maintenance of traffic, adequate cleanup, adequate dust control or to correct deficiencies or damage resulting from abnormal weather conditions, and the Contractor fails to comply in a time frame specified, the District may have work accomplished by other sources at the Contractor's expense.

B. For Contractor's Persistent Failures. If the Contractor persistently fails to (1) provide a sufficient number of skilled workers, (2) supply the materials required by the Contract Documents, (3) comply with applicable Legal Requirements, (4) timely pay, without cause, Subconsultants and/or Subcontractors, (5) execute the Contract Services with promptness and diligence to ensure that a Job Order is completed by the Job Order Time, as such times may be adjusted, or (6) perform material obligations under the Contract Documents, then the District, in addition to any other rights and remedies provided in the Contract Documents or by law, shall have the rights set forth below.

C. District Notice. Upon the occurrence of an event set forth in Subsection 7.3(B) above, the District may provide written notice to the Contractor that it intends to terminate the Contract unless the problem cited is cured, or commenced to be cured, within seven days of the Contractor's receipt of such notice.

(1) If the Contractor fails to cure, or reasonably commence to cure, such problem, then the District may give a second written notice to the Contractor of its intent to terminate within an additional seven-day period.

(2) If the Contractor, within such second seven-day period, fails to cure, or reasonably commence to cure, such problem, then the District may declare the Contract terminated for default by providing written notice to the Contractor of such declaration.

D. District Possession of Materials and Equipment. Upon declaring the Contract terminated pursuant to Subsection 7.3(C)(2) above, the District may, for all Job Orders, enter upon the premises and take possession, for the purpose of completing the Work, of all materials, equipment, tools, appliances and other items thereon, which have been purchased or provided for the performance of the Work, all of which the Contractor hereby transfers, assigns and sets over to the District for such purpose, and to employ any person or persons to complete the Work and provide all of the required labor, services, materials, equipment and other items.

E. Payments to Contractor. In the event of such termination, the Contractor shall not be entitled to receive any further payments under the Contract Documents until the Work on all Job Orders shall be finally completed in accordance with the Contract Documents. At such time, the Contractor will only be entitled to be paid for the Work performed and accepted by the District prior to its default.

F. Payments to District. If the District's cost and expense of completing the Work exceeds the unpaid balance of a Job Order Price or Job Order Prices, then the Contractor shall be obligated to pay the difference to the District. Such costs and expense shall include not only the cost of completing the Work, but also losses, damages, costs and expense, including attorneys' fees and expenses, incurred by the District in connection with the procurement and defense of claims arising from the Contractor's default.

G. Conversion to Termination for Convenience. If the District terminates this Contract for cause and the determination is determined to have without legal right, the termination for cause shall be deemed to have been a termination for convenience in accordance with the provisions of Section 7.2.

## ARTICLE 8 - INSURANCE

### 8.1 General.

A. Rating. Without limiting any obligations or liabilities of the Contractor, the Contractor shall purchase and maintain, at its own expense, hereinafter stipulated minimum insurance with insurance companies authorized to do business in the State of Arizona pursuant to A.R.S. § 20-206, as amended, with an AM Best, Inc. rating of "A-" or above with policies and forms satisfactory to the District. Failure to maintain insurance as specified herein may result in termination of this Contract at the District's option.

B. Coverage Adequacy. By requiring insurance herein, the District does not represent that coverage and limits will be adequate to protect the Contractor. The District reserves the right to review any and all of the insurance policies and/or endorsements cited in this Contract but has no obligation to do so. Failure to demand such evidence of full compliance with the insurance requirements set forth in this Contract or failure to identify any insurance deficiency shall not relieve the Contractor from, nor be construed or deemed a waiver of, its obligation to maintain the required insurance at all times during the performance of this Contract.

C. Additionally Insured. All insurance coverage, except Workers' Compensation insurance and Professional Liability insurance, if applicable, shall name, to the fullest extent permitted by law for claims arising out of the performance of this Contract, the District, its agents, representatives, officers, directors, officials, and employees as Additional Named Insured as specified under the respective coverage sections of this Contract.

D. Coverage Period. All insurance required herein shall be maintained in full force and effect until all work or services required to be performed under the terms of this Contract are satisfactorily performed, completed, and formally accepted by the District, unless specified otherwise in this Contract.

E. Primary Insurance. The Contractor's insurance shall be primary insurance with respect to performance of this Contract and in the protection of the District as an Additional Insured.

F. Claims Made Extension. In the event any insurance policies required by this Contract are written on a "claims made" basis, coverage shall extend, either by keeping

coverage in force or purchasing an extended reporting option, for three years past completion and Final Acceptance of the services. Such continuing coverage shall be evidenced by submission of annual Certificates of Insurance and necessary endorsements citing applicable coverage is in force and contains the provisions as required herein for the three-year period.

G. Waiver of Subrogation. All policies, excluding Professional Liability but including Workers' Compensation insurance, shall contain a waiver of rights of recovery (subrogation) against the District, its agents, representatives, officials, officers, and employees for any claims arising out of the Work or services of the Contractor. The Contractor shall arrange to have such subrogation waivers incorporated into each policy via formal written endorsement thereto.

H. Deductibles; Self-Insured Retentions. The policies set forth in these requirements may provide coverage that contains deductibles or self-insured retention amounts. Such deductibles or self-insured retention shall not be applicable with respect to the policy limits provided to the District. The Contractor shall be solely responsible for any such deductible or self-insured retention amount.

I. Subcontractor Insurance. If any work under this Contract is subcontracted in any way, the Contractor shall execute written agreements with its Subcontractors containing the indemnification provisions set forth below and insurance requirements set forth herein protecting the District and the Contractor. The Contractor shall be responsible for executing any agreements with its Subcontractors and obtaining certificates of insurance verifying the insurance requirements.

J. Evidence of Insurance. Prior to commencing any work or services under this Contract, the Contractor will provide the District with suitable evidence of insurance in the form of certificates of insurance and a copy of the declaration page(s) of the insurance policies as required by this Contract, issued by the Contractor's insurance insurer(s) as evidence that policies are placed with acceptable insurers as specified herein and provide the required coverages, conditions, and limits of coverage specified in this Contract, and that such coverage and provisions are in full force and effect. Confidential information such as the policy premium may be redacted from the declaration page(s) of each insurance policy, provided that such redactions do not alter any of the information required by this Contract. The District shall reasonably rely upon the certificates of insurance and declaration page(s) of the insurance policies as evidence of coverage but such acceptance and reliance shall not waive or alter in any way the insurance requirements or obligations of this Contract. If any of the policies required by this Contract expire during the life of this Contract, it shall be the Contractor's responsibility to forward renewal certificates and declaration page(s) to the District 30 Days prior to the expiration date. All certificates of insurance and declarations required by this Contract shall be identified by referencing this Contract. A \$25.00 administrative fee shall be assessed for all certificates or declarations received without a reference to this Contract. Additionally, certificates of insurance and declaration page(s) of the insurance policies submitted without referencing this Contract will be subject to rejection and may be returned or discarded. Certificates of insurance and declaration page(s) shall specifically include the following provisions:

(1) The District, its agents, representatives, officers, directors, officials, and employees are Additional Insureds as follows:

(a) Commercial General Liability – Under Insurance Services Office, Inc., (“ISO”) Form CG 20 10 03 97 or equivalent.

(b) Auto Liability – Under ISO Form CA 20 48 or equivalent.

(c) Excess Liability – Follow Form to underlying insurance.

(2) The Contractor’s insurance shall be primary insurance with respect to performance of this Contract.

(3) All policies, except for Professional Liability, including Workers’ Compensation, waive rights of recovery (subrogation) against the District, its agents, representatives, officers, officials, and employees for any claims arising out of work or services performed by the Contractor under this Contract.

(4) ACORD certificate of insurance form 25 (2014/01) is preferred. If ACORD certificate of insurance form 25 (2001/08) is used, the phrases in the cancellation provision “endeavor to” and “but failure to mail such notice shall impose no obligation or liability of any kind upon the company, its agents or representatives” shall be deleted. Certificate forms other than ACORD form shall have similar restrictive language deleted.

K. Endorsements. The Contractor shall provide the District with the necessary endorsements to ensure the District is provided the insurance coverage set forth in this Section.

## 8.2 Required Insurance Coverage.

A. Commercial General Liability. The Contractor shall maintain “occurrence” form Commercial General Liability insurance with an unimpaired limit of not less than \$1,000,000 for each occurrence, \$2,000,000 Products and Completed Operations Annual Aggregate and a \$2,000,000 General Aggregate Limit. The policy shall cover liability arising from premises, operations, independent contractors, products-completed operations, personal injury, and advertising injury. Coverage under the policy will be at least as broad as ISO policy form CG 00 010 93 or equivalent thereof, including but not limited to, separation of insured’s clause. To the fullest extent allowed by law, for claims arising out of the performance of this Contract, the District, its agents, representatives, officers, officials, and employees shall be cited as an Additional Insured under ISO, Commercial General Liability Additional Insured Endorsement form CG 20 10 03 97, or equivalent, which shall read “Who is an Insured (Section II) is amended to include as an insured the person or organization shown in the Schedule, but only with respect to liability arising out of “your work” for that insured by or for you.” If any Excess insurance is utilized to fulfill the requirements of this Subsection, such Excess insurance shall be “follow form” equal or broader in coverage scope than underlying insurance.

B. Business Automobile Liability. The Contractor shall maintain Business Automobile Liability insurance with a limit of \$1,000,000 each occurrence on the Contractor’s owned, hired, and non-owned vehicles assigned to or used in the performance of the Contractor’s

work or services under this Contract. Coverage will be at least as broad as ISO coverage code “1” “any auto” policy form CA 00 01 12 93 or equivalent thereof. To the fullest extent allowed by law, for claims arising out of the performance of this Contract, the District, its agents, representatives, officers, directors, officials, and employees shall be cited as an Additional Insured under ISO Business Auto policy Designated Insured Endorsement form CA 20 48 or equivalent. If any Excess insurance is utilized to fulfill the requirements of this Subsection, such Excess insurance shall be “follow form” equal or broader in coverage scope than underlying insurance.

C. Professional Liability Insurance. If this Contract is the subject of any professional services or work, or if the Contractor engages in any professional services or work in any way related to performing the Work under this Contract, the Contractor shall maintain Professional Liability insurance covering negligent errors and omissions arising out of the Contract Services performed by the Contractor, or anyone employed by the Contractor, or anyone for whose negligent acts, mistakes, errors, and omissions the Contractor is legally liable, with an unimpaired liability insurance limit of \$2,000,000 each claim and \$2,000,000 annual aggregate.

D. Worker’s Compensation. The Contractor shall maintain Workers’ Compensation insurance to cover obligations imposed by federal and state statutes having jurisdiction over the Contractor’s employees engaged in the performance of work or services under this Contract and shall also maintain Employers Liability Insurance of not less than \$500,000 for each accident, \$500,000 disease for each employee and \$1,000,000 disease policy limit.

E. Project Replacement Insurance. Unless expressly waived by the District in a written amendment to this Contract, the Contractor shall be responsible for purchasing and maintaining insurance to protect the Project from perils of physical loss. The insurance shall provide for the full cost of replacement for the entire Project at the time of any loss. The insurance shall include as named insureds the District, the Contractor, and the Contractor’s Subcontractors, and shall insure against loss from the perils of fire and all-risk coverage for physical loss or damage due to theft, vandalism, collapse, malicious mischief, transit, flood, earthquake, and testing, and resulting loss arising from defective design, negligent workmanship, or defective material. The Contractor shall increase the coverage limits as necessary to reflect changes in the estimated replacement cost.

8.3 Cancellation and Expiration Notice. The Contractor shall provide at least 30 Days’ prior written notice to the District before insurance required herein expires, is canceled, or is materially changed.

## ARTICLE 9 - INDEMNITY

9.1 Contractor Indemnity. To the fullest extent permitted by law, the Contractor shall indemnify and hold harmless the District and each council member, officer, employee, or agent thereof (the District and any such person being herein called an “Indemnified Party”), for, from, and against any and all losses, claims, damages, liabilities, costs, and expenses (including, but not limited to, reasonable attorneys’ fees, court costs, and the costs of appellate proceedings) to which any such Indemnified Party may become subject, under any theory of liability whatsoever (“Claims”) to the extent that such Claims (or actions in respect thereof) are caused by the negligent acts, recklessness, or intentional misconduct of the Contractor, its officers, employees, agents, or

any tier of subcontractor in connection with the Contractor's work or services in the performance of this Contract. The amount and type of insurance coverage requirements set forth below will in no way be construed as limiting the scope of the indemnity in this Section.

9.2 Other Employee Claims. If an employee of the Contractor, Subconsultants, Subcontractors, anyone employed directly or indirectly by any of them or anyone for whose acts any of them may be liable has a claim against the District, its officers, directors, employees, or agents, the Contractor's indemnity obligation set forth in Section 9.1 above shall extend to such claims and the amount of such indemnity shall not be limited by any limitation on the amount of insurance coverage required herein.

9.3 Intellectual Property Claims. The Contractor shall pay all royalties and license fees associated with its performance of services herewith. The Contractor shall defend suits or claims for infringement of patent rights and shall hold the District harmless from loss on account thereof, but shall not be responsible for such defense or loss when a particular design, process or product of a particular manufacturer or manufacturers is required by the Contract Documents. However, if the Contractor has reason to believe that the required design, process or product is an infringement of a patent, the Contractor shall be responsible for such loss unless such information is promptly furnished to the applicable design professional.

## ARTICLE 10 – PERFORMANCE AND PAYMENT BONDS

10.1 Performance Bond. This Agreement is subject to the provisions of A.R.S. § 34-610 *et seq.* After the District and the Contractor have agreed to a Job Order, but prior to commencing the Contract Services attributable to such Job Order, the Contractor shall furnish the District with an irrevocable security binding the Contractor to provide faithful performance of this Agreement in the amount of 100% of the percentage of the Job Order Price attributable to the construction, payable to the District, and shall not include the cost of any design services, preconstruction services, finance services, maintenance services, operations services, or any other related services. Performance security shall be in the form of a performance bond, certified check, or cashier's check. If the Contractor fails to execute the security document as required, the Contractor may be found in material default of this Contract, permitting the District to terminate this Contract for cause as set forth in Article 7 above. In case of default, the District reserves all rights. All performance bonds shall be executed on the form attached hereto as Exhibit C and incorporated herein by reference, duly executed by the Contractor as principal and having as surety thereon a surety company approved by the District and holding a Certificate of Authority issued by the Arizona Department of Insurance to transact surety business in the State of Arizona. Individual sureties are unacceptable. All insurers and sureties shall have at the time of submission of the proposal an A.M. Best's Key Rating Guide of "A-" or better as currently listed in the most recent Best Key Guide, published by the A.M. Best Company.

10.2 Payment Bond. This Agreement is subject to the provisions of A.R.S. § 34-610 *et seq.* After the District and the Contractor have agreed to a Job Order, but prior to commencing the Contract Services attributable to such Job Order, the Contractor shall furnish the District with an irrevocable security for the protection of all claimants supplying labor or materials to the Contractor or any Subcontractor in the prosecution of the construction and not for the protection of persons providing any design services, preconstruction services, finance services, maintenance

services, operations services, or other services related to the Contract. Payment security shall be in the amount of 100% of the applicable Job Order attributable to construction and be payable to the District. Payment security shall be in the form of a payment bond, certified check, or cashier's check. If the Contractor fails to execute the security document as required, the Contractor may be found in material default of this Contract, permitting the District to terminate this Contract for cause as set forth in Article 7 above. All payment bonds shall be executed on the form attached hereto as Exhibit D and incorporated herein by reference, duly executed by the Contractor as principal and having as surety thereon a surety company approved by the District and holding a Certificate of Authority issued by the Arizona Department of Insurance to transact surety business in the State of Arizona. Individual sureties are unacceptable. All insurers and sureties shall have at the time of submission of the proposal an A.M. Best's Key Rating Guide of "A-" or better as currently listed in the most recent Best Key Guide, published by the A.M. Best Company.

#### ARTICLE 11 - ADDITIONAL PROVISIONS

11.1 Confidential Information. The Contractor shall not disclose or permit the disclosure of any confidential information except to its agents, employees, and Subcontractors who need such confidential information in order to properly perform their duties relative to this Contract.

11.2 Assignment; Transfer. The District and the Contractor each bind themselves, their successors, assigns, and legal representatives to the terms of this Contract. Neither the District nor the Contractor shall assign or transfer its interest in this Contract without the written consent of the other, except that the Contractor may assign accounts receivable to a commercial bank for securing loans without approval of the District. Nothing contained in this Section shall prevent the Contractor from employing such consultants, associates, or Subcontractors as the Contractor may deem appropriate to assist in performance of the Contract Services hereunder.

11.3 Entire Agreement. This Contract represents the entire and integrated agreement between the District and the Contractor and supersedes all prior negotiations, representations, or agreements, either written or oral. This Contract may be amended only by written instrument signed by both the District and the Contractor. Nothing contained in this Contract is intended to benefit any third party. Subcontractors, if any, and the Project designers are not intended third-party beneficiaries of this Contract.

11.4 Severability. If any provision of this Contract is held as a matter of law to be unenforceable by a court of competent jurisdiction, the remainder of this Contract shall be enforceable without such provision.

11.5 Internal References. References made in the singular shall include the plural and to one gender shall include all genders.

11.6 Notices. Other than notices to the parties' respective Senior Representatives for dispute resolution purposes as set forth above, any notice or other communication required or permitted to be given under this Contract shall be in writing and shall be deemed to have been duly given if (A) delivered to the party at the address set forth below, (B) deposited in the U.S. Mail,

registered or certified, return receipt requested, to the address set forth below, or (C) given to a recognized and reputable overnight delivery service, to the address set forth below:

If to the District: Coconino County Flood Control District  
5600 E. Commerce Ave.  
Flagstaff, AZ 86004  
Attn: Lucinda Andreani

With a copy to: Gust Rosenfeld P.L.C.  
One East Washington Street, Suite 1600  
Phoenix, AZ 85004  
Attn: Andrew McGuire

If to the Contractor: Morning Dew Landscaping, Inc.  
2684 E. Huntington Drive  
Flagstaff, AZ 86004  
Attn: Chris Lloyd

or at such other address, and to the attention of such other person or officer, as any party may designate in writing by notice duly given pursuant to this Section. Notices shall be deemed received (A) when delivered to the party, (B) three business days after being placed in the U.S. Mail, properly addressed, with sufficient postage, or (C) the following business day after being given to a recognized overnight delivery service, with the person giving the notice paying all required charges and instructing the delivery service to deliver on the following business day. If a copy of a notice is also given to a party's counsel or other recipient, the provisions above governing the date on which a notice is deemed to have been received by a party shall mean and refer to the date on which the party, and not its counsel or other recipient to which a copy of the notice may be sent, is deemed to have received the notice.

11.7 Governing Law; Venue. This Contract shall be governed by the laws of the State of Arizona and venue shall be in Coconino County.

11.8 No Waiver. The failure of either party to insist, in any one or more instances, on the performance of any of the terms, covenants, or conditions of this Contract, or to exercise any of its rights, shall not be construed as a waiver or relinquishment of such term, covenant, condition, or right with respect to further performance.

11.9 Headings. The headings given to any of the provisions of this Contract are for ease of reference only and shall not be relied upon or cited for any other purpose.

11.10 Asbestos-Free Materials. The Project is to be constructed by the Contractor with asbestos-free materials. A written, notarized statement on company letterhead shall be submitted to the District by the Contractor with the final payment request certifying that the Contractor has incorporated no asbestos material into the Project. Final payment shall be withheld until such statement is submitted. The Contractor shall agree that if materials containing asbestos are subsequently discovered at any future time to have been included in the construction done by the Contractor or any of its Subcontractors or agents and were not specified in the design or required

by the Contract Documents, the Contractor shall be liable for all costs related to the abatement of such asbestos and damages or claims against the District notwithstanding any statute of limitations or other legal bar to any claim by the District.

11.11 Conflict of Interest Cancellation. This Contract may be cancelled by the District pursuant to A.R.S. § 38-511.

11.12 Endangered Wood Species. The Contractor shall ensure that products containing endangered wood species shall not be utilized in the construction of the Project unless exempted pursuant to A.R.S. § 34-201(J), as amended.

11.13 Employment Verification Records. The Contractor's and its Subcontractor's books, records, correspondence, accounting procedures, and practices, and any other supporting evidence relating to this Contract, including the papers of any of the Contractor's and its Subcontractors' employees who perform any work or Services pursuant to this Contract to ensure that the Contractor and its Subcontractors are complying with the warranty under Subsection 10.14 below (all the foregoing hereinafter referred to as "Records"), shall be open to inspection and subject to audit and/or reproduction during normal working hours by the District, to the extent necessary to adequately permit (A) evaluation and verification of any invoices, payments or claims based on the Contractor's and its Subcontractors' actual costs (including direct and indirect costs and overhead allocations) incurred, or units expended directly in the performance of the Work under this Contract, and (B) evaluation of the Contractor's and its Subcontractors' compliance with the Arizona employer sanctions laws referenced in Subsection 10.14 below. To the extent necessary for the District to audit Records as set forth in this Subsection, the Contractor and its Subcontractors hereby waive any rights to keep such Records confidential. For the purpose of evaluating or verifying such actual or claimed costs or units expended, the District shall have access to said Records, even if located at its Subcontractors' facilities, from the effective date of this Contract for the duration of the Work and until three years after the date of final payment by the District to the Contractor pursuant to this Contract. The Contractor and its Subcontractors shall provide the District with adequate and appropriate workspace so that the District can conduct audits in compliance with the provisions of this Subsection. The District shall give the Contractor or its Subcontractors reasonable advance notice of intended audits. The Contractor shall require its Subcontractors to comply with the provisions of this Subsection by insertion of the requirements hereof in any subcontract pursuant to this Contract.

11.14 E-Verify. To the extent applicable under A.R.S. § 41-4401, the Contractor and its Subcontractors warrant compliance with all federal immigration laws and regulations that relate to their employees and compliance with the E-verify requirements under A.R.S. § 23-214(A). The Contractor's or its Subcontractor's failure to comply with such warranty shall be deemed a material breach of this Contract and may result in the termination of this Contract by the District.

11.15 No Boycott of Israel. The Contractor certifies that it is not currently engaged in, and agrees for the duration of this Contract that it will not engage in, a "boycott" of Israel, as that term is defined in A.R.S. § 35-393.

11.16 Independent Contractor Status. The Contractor is and will be an independent contractor and whatever measure of control the District exercises over the Work or deliverable

pursuant to the Contract will be as to the results of the Work only. No provision in this Contract will give or be construed to give the District the right to direct the Contractor as to the details of accomplishing the Work or deliverable. These results will comply with all applicable laws and ordinances.

A. Acts and Omissions of Individuals. The Contractor will be solely responsible for the acts and omissions of its officers, agents, servants, and employees. As an independent contractor, the Contractor is responsible for the payment of all applicable income and employment taxes and for providing all workers' compensation insurance required by law.

B. Not District Employees. The Contractor will operate as an independent entity and none of the employees of the Contractor will be considered employees of the District. The Contractor's employees are not eligible for District group health insurance or other benefits.

C. Contractor Health Insurance. The Independent Contractor will be solely responsible for offering health insurance to its employees as required by the Affordable Care Act, and for any penalties charged to it by the Internal Revenue Service for noncompliance with the Affordable Care Act.

D. Control of Process of the Work. In performance of services within this contract, the Contractor shall determine its necessary hours of work; provided such hours must be within the standard work hours set forth in this Contract. The Contractor shall provide whatever tools; equipment, vehicles, and supplies the Contractor may determine to be necessary in performance of services hereunder. The Contractor may establish offices in such locations within or outside Arizona, as the Contractor may determine to be necessary for the performance of services hereunder, and shall be responsible for all expenses of operation of said office, including expenses incurred in hiring employees and assistants to the Contractor.

E. No Authority to Represent District. The Independent Contractor has no authority to enter into contracts or agreements on behalf of the District. This Contract does not create a partnership between the parties.

11.17 Annual Appropriations. The District is obligated only to pay its obligations set forth in this Contract as may lawfully be made from funds appropriated and budgeted for that purpose during the District's then-current fiscal year. The District's obligations under this Contract are current expenses subject to the "budget law" and the unfettered legislative discretion of the District concerning budgeted purposes and appropriation of funds. Should the District elect not to appropriate and budget funds to pay its Contract obligations, this Contract and any related Job Orders shall be deemed terminated at the end of the then-current fiscal year term for which such funds were appropriated and budgeted for such purpose and the District shall be relieved of any subsequent obligation under this Contract. The parties agree that the District has no obligation or duty of good faith to budget or appropriate the payment of the District's obligations set forth in this Contract in any budget in any fiscal year other than the fiscal year in which this Contract is executed and delivered. The District shall be the sole judge and authority in determining the availability of funds for its obligations under this Contract. The District shall keep the Contractor informed as to the availability of funds for this Contract. The obligation of the District to make any payment pursuant to this Contract is not a general obligation or indebtedness of the District.

The Contractor hereby waives any and all rights to bring any claim against the District from or relating in any way to the District's termination of this Contract pursuant to this Section.

11.18 No Forced Labor of Ethnic Uyghurs. To the extent applicable under A.R.S. § 35-394, the Contractor warrants and certifies that it does not currently, and agrees for the duration of this Contract that it will not use the forced labor, any goods or services produced by the forced labor, or any contractors, subcontractors, or suppliers that use the forced labor or any goods or services produced by the forced labor of ethnic Uyghurs in the People's Republic of China. If the Contractor becomes aware that it is not in compliance with this paragraph, the Contractor shall notify the District of the noncompliance within five business days of becoming aware of it. If the Contractor fails to provide a written certification that the Contractor has remedied the noncompliance within 180 days after that, this Contract shall terminate unless the termination date of this Contract occurs before the end of the remedy, in which case this Contract terminates on the Contract termination date.

[Signatures on following page.]

IN WITNESS WHEREOF, the parties hereto have executed this Contract as of the date first set forth above.

**“Coconino County”**

COCONINO COUNTY FLOOD CONTROL  
DISTRICT,  
An Arizona political subdivision

By:   
Patrice Horstman, Chair, Flood Control District  
Board of Directors

ATTEST:

  
Clerk of the Board

APPROVED AS TO FORM:

  
Gust Rosenfeld P.L.C., District Attorneys

**“Contractor”**

MORNING DEW LANDSCAPING, INC.,  
a(n) Arizona Corporation

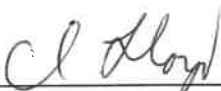
By:   
\_\_\_\_\_

Name: Chris Lloyd

Title: Owner

EXHIBIT A  
TO  
JOB ORDER CONTRACT  
BETWEEN  
COCONINO COUNTY FLOOD CONTROL DISTRICT  
AND  
MORNING DEW LANDSCAPING, INC.

[Federally Funded Project Requirements]

See following pages.

## Federally Funded Project Requirements

### Cancelation or termination for breach

A contractor who violates or breaches a contract may have the contract terminated for cause. IC will be paid for services provided but may be ineligible for future contracts. Contracts may also be terminated by the County for convenience.

### Equal Employment Opportunity:

During the performance of this contract, the contractor agrees as follows:

(1) The contractor will not discriminate against any employee or applicant for employment because of race, color, religion, sex, sexual orientation, gender identity, or national origin. The contractor will take affirmative action to ensure that applicants are employed, and that employees are treated during employment, without regard to their race, color, religion, sex, sexual orientation, gender identity, or national origin. Such action shall include, but not be limited to the following:

Employment, upgrading, demotion, or transfer, recruitment or recruitment advertising; layoff or termination; rates of pay or other forms of compensation; and selection for training, including apprenticeship. The contractor agrees to post in conspicuous places, available to employees and applicants for employment, notices to be provided by the contracting officer setting forth the provisions of this nondiscrimination clause.

(2) The contractor will, in all solicitations or advertisements for employees placed by or on behalf of the contractor, state that all qualified applicants will receive consideration for employment without regard to race, color, religion, sex, sexual orientation, gender identity, or national origin.

(3) The contractor will not discharge or in any other manner discriminate against any employee or applicant for employment because such employee or applicant has inquired about, discussed, or disclosed the compensation of the employee or applicant or another employee or applicant. This provision shall not apply to instances in which an employee who has access to the compensation information of other employees or applicants as a part of such employee's essential job functions discloses the compensation of such other employees or applicants to individuals who do not otherwise have access to such information, unless such disclosure is in response to a formal complaint or charge, in furtherance of an investigation, proceeding, hearing, or action, including an investigation conducted by the employer, or is consistent with the contractor's legal duty to furnish information.

(4) The contractor will send to each labor union or representative of workers with which it has a collective bargaining agreement or other contract or understanding, a notice to be provided by the agency contracting officer, advising the labor union or workers' representative of the contractor's commitments under section 202 of Executive Order

11246 of September 24, 1965, and shall post copies of the notice in conspicuous places available to employees and applicants for employment.

(5) The contractor will comply with all provisions of Executive Order 11246 of September 24, 1965, and of the rules, regulations, and relevant orders of the Secretary of Labor.

(6) The contractor will furnish all information and reports required by Executive Order 11246 of September 24, 1965, and by the rules, regulations, and orders of the Secretary of Labor, or pursuant thereto, and will permit access to his books, records, and accounts by the contracting agency and the Secretary of Labor for purposes of investigation to ascertain compliance with such rules, regulations, and orders.

(7) In the event of the contractor's non-compliance with the nondiscrimination clauses of this contract or with any of such rules, regulations, or orders, this contract may be canceled, terminated or suspended in whole or in part and the contractor may be declared ineligible for further Government contracts in accordance with procedures authorized in Executive Order 11246 of September 24, 1965, and such other sanctions may be imposed and remedies invoked as provided in Executive Order 11246 of September 24, 1965, or by rule, regulation, or order of the Secretary of Labor, or as otherwise provided by law.

(8) The contractor will include the portion of the sentence immediately preceding paragraph (1) and the provisions of paragraphs (1) through (8) in every subcontract or purchase order unless exempted by rules, regulations, or orders of the Secretary of Labor issued pursuant to section 204 of Executive Order 11246 of September 24, 1965, so that such provisions will be binding upon each subcontractor or vendor. The contractor will take such action with respect to any subcontract or purchase order as may be directed by the Secretary of Labor as a means of enforcing such provisions including sanctions for noncompliance:

Provided, however, that in the event the contractor becomes involved in, or is threatened with, litigation with a subcontractor or vendor as a result of such direction, the contractor may request the United States to enter into such litigation to protect the interests of the United States.

The applicant further agrees that it will be bound by the above equal opportunity clause with respect to its own employment practices when it participates in federally assisted construction work: *Provided*, That if the applicant so participating is a State or local government, the above equal opportunity clause is not applicable to any agency, instrumentality or subdivision of such government which does not participate in work on or under the contract.

The applicant agrees that it will assist and cooperate actively with the administering agency and the Secretary of Labor in obtaining the compliance of contractors and subcontractors with the equal opportunity clause and the rules, regulations, and relevant

orders of the Secretary of Labor, that it will furnish the administering agency and the Secretary of Labor such information as they may require for the supervision of such compliance, and that it will otherwise assist the administering agency in the discharge of the agency's primary responsibility for securing compliance.

The applicant further agrees that it will refrain from entering into any contract or contract modification subject to Executive Order 11246 of September 24, 1965, with a contractor debarred from, or who has not demonstrated eligibility for, Government contracts and federally assisted construction contracts pursuant to the Executive Order and will carry out such sanctions and penalties for violation of the equal opportunity clause as may be imposed upon contractors and subcontractors by the administering agency or the Secretary of Labor pursuant to Part II, Subpart D of the Executive Order. In addition, the applicant agrees that if it fails or refuses to comply with these undertakings, the administering agency may take any or all of the following actions: Cancel, terminate, or suspend in whole or in part this grant (contract, loan, insurance, guarantee); refrain from extending any further assistance to the applicant under the program with respect to which the failure or refund occurred until satisfactory assurance of future compliance has been received from such applicant; and refer the case to the Department of Justice for appropriate legal proceedings.

*Subcontracts.* Each nonexempt prime contractor or subcontractor shall include the above equal opportunity clause in each of its nonexempt subcontracts.

#### Davis Bacon Act

Davis-Bacon Act, as amended (40 U.S.C. 3141-3148). When required by Federal program legislation, all prime construction contracts in excess of \$2,000 awarded by non-Federal entities must include a provision for compliance with the Davis-Bacon Act (40 U.S.C. 3141-3144, and 3146-3148) as supplemented by Department of Labor regulations (29 CFR Part 5, "Labor Standards Provisions Applicable to Contracts Covering Federally Financed and Assisted Construction"). In accordance with the statute, contractors must be required to pay wages to laborers and mechanics at a rate not less than the prevailing wages specified in a wage determination made by the Secretary of Labor. In addition, contractors must be required to pay wages not less than once a week. The non-Federal entity must place a copy of the current prevailing wage determination issued by the Department of Labor in each solicitation. The decision to award a contract or subcontract must be conditioned upon the acceptance of the wage determination. The non-Federal entity must report all suspected or reported violations to the Federal awarding agency. The contracts must also include a provision for compliance with the Copeland "Anti-Kickback" Act (40 U.S.C. 3145), as supplemented by Department of Labor regulations (29 CFR Part 3, "Contractors and Subcontractors on Public Building or Public Work Financed in Whole or in Part by Loans or Grants from the United States"). The Act provides that each contractor or sub recipient must be prohibited from inducing, by any means, any person employed in the construction, completion, or repair of public work, to give up any part of the

compensation to which he or she is otherwise entitled. The non-Federal entity must report all suspected or reported violations to the Federal awarding agency.

*If applicable* pursuant to the conditions of a federal funding award:

- a. All transactions regarding this contract shall be done in compliance with the Davis-Bacon Act (40 U.S.C. 3141- 3144, and 3146-3148) and the requirements of 29 C.F.R. pt. 5 as may be applicable. The contractor shall comply with 40 U.S.C. 3141-3144, and 3146-3148 and the requirements of 29 C.F.R. pt. 5 as applicable.
- b. Contractors are required to pay wages to laborers and mechanics at a rate not less than the prevailing wages specified in a wage determination made by the Secretary of Labor.
- c. Additionally, contractors are required to pay wages not less than once a week.

Compliance with the Copeland Anti-Kickback Act:

- a. Contractor. The contractor shall comply with 18 U.S.C. §874, 40 U.S.C. §3145, and the requirements of 29 C.F.R. pt.3 as may be applicable, which are incorporated by reference into this contract.
- b. Subcontracts. The contractor or subcontractor shall insert in any subcontracts the clause above and such other clauses as FEMA may by appropriate instructions require, and also a clause requiring the subcontractor to include these clauses in any lower tier subcontracts. The prime contractor shall be responsible for the compliance by any subcontractor or lower tier subcontractor with all of these contract clauses.
- c. Breach. A breach of the contract clauses above may be grounds for termination of the contract and for debarment as a contractor and subcontractor as provided in 29 C.F.R §5.12.

Compliance with the Contract Work Hours and Safety Standards Act.

(1) Overtime requirements. No contractor or subcontractor contracting for any part of the contract work which may require or involve the employment of laborers or mechanics shall require or permit any such laborer or mechanic in any workweek in which he or she is employed on such work to work in excess of forty hours in such workweek unless such laborer or mechanic receives compensation at a rate not less than one and one-half times the basic rate of pay for all hours worked in excess of forty hours in such workweek.

(2) Violation; liability for unpaid wages; liquidated damages. In the event of any violation of the clause set forth in paragraph (b)(1) of this section the contractor and any subcontractor responsible therefor shall be liable for the unpaid wages. In addition, such contractor and subcontractor shall be liable to the United States (in the

case of work done under contract for the District of Columbia or a territory, to such District or to such territory), for liquidated damages. Such liquidated damages shall be computed with respect to each individual laborer or mechanic, including watchmen and guards, employed in violation of the clause set forth in paragraph (b)(1) of this section, in the sum of \$27 for each calendar day on which such individual was required or permitted to work in excess of the standard workweek of forty hours without payment of the overtime wages required by the clause set forth in paragraph (b)(1) of this section.

- (3) Withholding for unpaid wages and liquidated damages. The (write in the name of the Federal agency or the loan or grant recipient) shall upon its own action or upon written request of an authorized representative of the Department of Labor withhold or cause to be withheld, from any moneys payable on account of work performed by the contractor or subcontractor under any such contract or any other Federal contract with the same prime contractor, or any other federally-assisted contract subject to the Contract Work Hours and Safety Standards Act, which is held by the same prime contractor, such sums as may be determined to be necessary to satisfy any liabilities of such contractor or subcontractor for unpaid wages and liquidated damages as provided in the clause set forth in paragraph (b)(2) of this section. (4) Subcontracts. The contractor or subcontractor shall insert in any subcontracts the clauses set forth in paragraph (b)(1) through (4) of this section and also a clause requiring the subcontractors to include these clauses in any lower tier subcontracts. The prime contractor shall be responsible for compliance by any subcontractor or lower tier subcontractor with the clauses set forth in paragraphs (b)(1) through (4) of this section.

#### Clean Air Act

1. The contractor agrees to comply with all applicable standards, orders or regulations issued pursuant to the Clean Air Act, as amended, 42 U.S.C. § 7401 et seq.
2. The contractor agrees to report each violation to the Coconino County Flood Control District and understands and agrees that Coconino County Flood Control District will, in turn, report each violation as required to assure notification to the Federal Emergency Management Agency, and the appropriate Environmental Protection Agency Regional Office.
3. The contractor agrees to include these requirements in each subcontract exceeding \$150,000 financed in whole or in part with Federal assistance provided by FEMA.

#### Federal Water Pollution Control Act

1. The contractor agrees to comply with all applicable standards, orders, or regulations issued pursuant to the Federal Water Pollution Control Act, as amended, 33 U.S.C. 1251 et seq.
2. The contractor agrees to report each violation to the Coconino County Flood Control District and understands and agrees that the Coconino County Flood Control District

will, in turn, report each violation as required to assure notification to the Federal Emergency Management Agency, and the appropriate Environmental Protection Agency Regional Office.

3. The contractor agrees to include these requirements in each subcontract exceeding \$150,000 financed in whole or in part with Federal assistance provided by FEMA.

#### Suspension and Debarment

(1) This contract is a covered transaction for purposes of 2 C.F.R. pt. 180 and 2 C.F.R. pt. 3000. As such, the contractor is required to verify that none of the contractor's principals (defined at 2 C.F.R. § 180.995) or its affiliates (defined at 2 C.F.R. § 180.905) are excluded (defined at 2 C.F.R. § 180.940) or disqualified (defined at 2 C.F.R. § 180.935).

(2) The contractor must comply with 2 C.F.R. pt. 180, subpart C and 2 C.F.R. pt. 3000, subpart C, and must include a requirement to comply with these regulations in any lower tier covered transaction it enters into.

(3) This certification is a material representation of fact relied upon by Coconino County Flood Control District. If it is later determined that the contractor did not comply with 2 C.F.R. pt. 180, subpart C and 2 C.F.R. pt. 3000, subpart C, in addition to remedies available to Coconino County Flood Control District, the Federal Government may pursue available remedies, including but not limited to suspension and/or debarment.

(4) The bidder or proposer agrees to comply with the requirements of 2 C.F.R. pt. 180, subpart C and 2 C.F.R. pt. 3000, subpart C while this offer is valid and throughout the period of any contract that may arise from this offer. The bidder or proposer further agrees to include a provision requiring such compliance in its lower tier covered transactions.

#### Procurement of Recovered Materials

i. In the performance of this contract, the Contractor shall make maximum use of products containing recovered materials that are EPA-designated items unless the product cannot be acquired –

- a. Competitively within a timeframe providing for compliance with the contract performance schedule;
- b. Meeting contract performance requirements; or
- c. At a reasonable price.

ii. Information about this requirement, along with the list of EPA designated items, is available at EPA's Comprehensive Procurement Guidelines web site, <https://www.epa.gov/smm/comprehensive-procurement-guideline-cpg-program>.

iii. The Contractor also agrees to comply with all other applicable requirements of Section 6002 of the Solid Waste Disposal Act.

#### Access to Records

- (1) The Contractor agrees to provide Coconino County Flood Control District, the FEMA Administrator, the Comptroller General of the United States, or any of their authorized representatives access to any books, documents, papers, and records of the Contractor which are directly pertinent to this contract for the purposes of making audits, examinations, excerpts, and transcriptions.
- (2) The Contractor agrees to permit any of the foregoing parties to reproduce by any means whatsoever or to copy excerpts and transcriptions as reasonably needed.
- (3) The Contractor agrees to provide the FEMA Administrator or his authorized representatives access to construction or other work sites pertaining to the work being completed under the contract.
- (4) In compliance with the Disaster Recovery Act of 2018, Coconino County Flood Control District and the Contractor acknowledge and agree that no language in this contract is intended to prohibit audits or internal reviews by the FEMA Administrator or the Comptroller General of the United States.

#### DHS Seal, Logo and Flags

The contractor shall not use the DHS seal(s), logos, crests, or reproductions of flags or likenesses of DHS agency officials without specific FEMA pre-approval.

#### Compliance with Federal Law, Regulations, and Executive Orders

This is an acknowledgement that FEMA financial assistance will be used to fund all or a portion of the contract. The contractor will comply with all applicable Federal law, regulations, executive orders, FEMA policies, procedures, and directives.

#### No Obligation by Federal Government

The Federal Government is not a party to this contract and is not subject to any obligations or liabilities to the non-Federal entity, contractor, or any other party pertaining to any matter resulting from the contract.

#### Program Fraud and False or Fraudulent Statements or Related Acts

The Contractor acknowledges that 31 U.S.C. Chap. 38 (Administrative Remedies for False Claims and Statements) applies to the Contractor's actions pertaining to this contract.

#### Byrd Anti-Lobbying Amendment, 31 U.S.C. § 1352 (as amended)

Contractors who apply or bid for an award of \$100,000 or more shall file the required certification. Each tier certifies to the tier above that it will not and has not used Federal appropriated funds to pay any person or organization for influencing or attempting to influence an officer or employee of any agency, a Member of Congress, officer or employee of Congress, or an employee of a Member of Congress in connection with obtaining any Federal contract, grant, or any other award covered by 31 U.S.C. § 1352. Each tier shall also disclose any lobbying with non-Federal funds that takes place in connection with obtaining any Federal award. Such disclosures are forwarded from tier to tier up to the recipient who in turn will forward the certification(s) to the awarding agency.

If applicable, contractors must sign and submit the following certification:

Certification for Contracts, Grants, Loans, and Cooperative Agreements

The undersigned certifies, to the best of his or her knowledge and belief, that:

1. No Federal appropriated funds have been paid or will be paid, by or on behalf of the undersigned, to any person for influencing or attempting to influence an officer or employee of an agency, a Member of Congress, an officer or employee of Congress, or an employee of a Member of Congress in connection with the awarding of any Federal contract, the making of any Federal grant, the making of any Federal loan, the entering into of any cooperative agreement, and the extension, continuation, renewal, amendment, or modification of any Federal contract, grant, loan, or cooperative agreement.
2. If any funds other than Federal appropriated funds have been paid or will be paid to any person for influencing or attempting to influence an officer or employee of any agency, a Member of Congress, an officer or employee of Congress, or an employee of a Member of Congress in connection with this Federal contract, grant, loan, or cooperative agreement, the undersigned shall complete and submit Standard Form-LLL, "Disclosure Form to Report Lobbying," in accordance with its instructions.
3. The undersigned shall require that the language of this certification be included in the award documents for all subawards at all tiers (including subcontracts, subgrants, and contracts under grants, loans, and cooperative agreements) and that all subrecipients shall certify and disclose accordingly.

This certification is a material representation of fact upon which reliance was placed when this transaction was made or entered into. Submission of this certification is a prerequisite for making or entering into this transaction imposed by section 1352, title 31, U.S. Code. Any person who fails to file the required certification shall be subject to a civil penalty of not less than \$10,000 and not more than \$100,000 for each such failure.

The Contractor, \_\_\_\_\_, certifies or affirms the truthfulness and accuracy of each statement of its certification and disclosure, if any. In addition, the Contractor understands

and agrees that the provisions of 31 U.S.C. Chap. 38, Administrative Remedies for False Claims and Statements, apply to this certification and disclosure, if any.

*Cl Lloyd*

\_\_\_\_\_  
Signature of Contractor's Authorized Official

*Chris Lloyd, President*  
\_\_\_\_\_  
Name and Title of Contractor's Authorized Official

*8/7/2003*  
\_\_\_\_\_  
Date

EXHIBIT B  
TO  
JOB ORDER CONTRACT  
BETWEEN  
COCONINO COUNTY FLOOD CONTROL DISTRICT  
AND  
MORNING DEW LANDSCAPING, INC.

[JOC Task Matrix]

See following pages.

February 14, 2023

Mr. Scott Richardson  
Coconino County Purchasing Department  
219 E. Cherry Ave.  
Flagstaff, AZ 86001

**Re: SOQ for RFQ 2023-105**

Dear Mr. Richardson,

Enclosed is our proposal for *Job Order Contracting (JOC): General Contracting Construction Services for the Coconino County Flood District*.

As early as 1997, Morning Dew has been providing landscaping installation services. Since obtaining our Arizona General Contractor's license in 2012, we have completed numerous residential and commercial construction projects for Coconino County, the City of Flagstaff, the Federal Government, and private property owners. Many of these projects have included the design, installation, repair, and maintenance of water control features. Morning Dew also brings experience as a current JOC provider to the County, having recently provided clean up work to assist with the County's flood mitigation measures. We are highly experienced in operating under around-the-clock, 24-7 emergency conditions—this has proven invaluable for our snow plow and post-flood clean up operations.

With our emphasis on people, both customers and employees, we have been able to attract and retain highly skilled talent with specialized knowledge. Our landscape architecture department has years of experience in planning and implementing landscape restoration measures and have proven especially effective in collaborating with our construction personnel. We look forward to continuing to serve the needs of the County by successfully fulfilling the requirements of this JOC.

Sincerely,

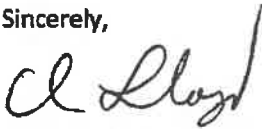

Chris Lloyd, Owner of Morning Dew Landscaping, Inc.  
[Chris@morningdewlandscaping.com](mailto:Chris@morningdewlandscaping.com)



2684 E. Huntington Drive  
Flagstaff, AZ 86004  
928-779-3125 | [www.morningdewlandscaping.com](http://www.morningdewlandscaping.com)  
ROC #276527 (KB-2 Dual Residential and Small Commercial)  
ROC #153463 (CR-21 Hardscaping and Irrigation Systems)



2684 E. Huntington Drive  
 Flagstaff, AZ 86004  
 Office: 928-779-3125  
 Fax: 928-779-9253  
 info@morningdewlandscaping.com  
 http://www.morningdewlandscaping.com/  
 ROC #276527 (KB-2 Dual Residential and Small Commercial)  
 ROC #153463 (CR-21 Hardscaping and Irrigation Systems)

**Prepared for:** Coconino County RFQ 2023-105 JOC –  
 General Contracting Construction Services for the County Flood Control District  
**Submittal deadline:** February 15, 2023, 2:00 PM Arizona Time

TABLE OF CONTENTS

Cover letter ..... 1

5.0 Statement of Qualifications (SOQ) Evaluation Criteria.....2

    5.1 Firm and Subcontractor General Information.....2

    5.2 Experience and Qualifications of the Firm .....4

    5.3 Experience of Key Personnel Expected to be Assigned to this Project .....9

    5.4 Approach to Performing the Required Services.....14

    5.6 Past Performance on County Projects .....16

Appendix A – Subcontractors ..... A-1

Appendix B – Resumes and Certifications ..... B-1

Appendix C – Bondability Letter ..... C-1

Appendix D – Job Order Process..... D-1

Appendix E – Construction Change Directive Form, Look Ahead Schedule, Job Hazard Analysis Form .....E-1

Appendix F – JOC Task Matrix.....F-1

Appendix G – Compliance with Immigration and Anti-terrorism Laws, Non-Collusion Affidavit ..... G-1

Appendix H – Addenda ..... H-1

SERVICES	SELF- Performed	SUB-Contract
• Open Channel conveyance ditches	Yes	
• Gabion Baskets	Yes	
• Rock Riprap	Yes	
• Detention Ponds	Yes	
<b>Forest restorations</b>		
• Construction of Fans		Yes
• Rock Chutes		Yes
• Log rundown		Yes
• Rock cluster		Yes
• Tree Removal	Yes	
• Clear and Grubb	Yes	
• Gabion Basket	Yes	
• Trash rack for headwalls		Yes
• Archeological Monitoring		
<b>Bridge Construction / Reconstruction</b>		
• New Bridge Construction		
• Existing Bridge Repair		
o Bridge deck		
▪ Replacement		
▪ Surface Treatments and repair		
o Abutments and Diaphragms		
o Approach Slabs		Yes
o CIP guard rail		Yes
o Footing and Scour Repair		
• Box Culverts precast and CIP		
<b>Roadway Support Infrastructure</b>		
• Stripe		Yes
• Signage	Yes	
• Installation of New Guard rail and repair and Damaged Guardrail		Yes
• Cattle guards	Yes	
• Seeding	Yes	
• Installation of Landscaping	Yes	
<b>Utilities</b>		
• Waterline Adjustment		Yes
• Water Valve Replacement and Installation		Yes
• Dry Utility Installation and replacement		Yes
• Sewer/Wastewater Construction & Repair		Yes

## APPENDIX F – JOC TASK MATRIX

SERVICES	SELF- Performed	SUB-Contract
<b>Grading</b>		
• Mass Excavation		Yes
• Geogrid Installation		
○ Slope Stabilization	Yes	
○ Drainage Channel Reinforcement		Yes
• Placement of Aggregate base	Yes	
• Soil Stabilization of subgrade		
○ Lime Treated		Yes
○ Cement Treated		Yes
○ Geogrid		Yes
○ SWPPP / NOI / NOT	Yes	
<b>Asphalt Pavement</b>		
• Preservation		
○ Chip Seal		Yes
○ Crack Filling		Yes
○ Fog Seal		Yes
○ Cape Seal		Yes
○ Slurry Seal		Yes
○ Rubber Chip Seal		Yes
○ Micro Seal		Yes
○ Micro Seal with fiberglass		Yes
• Rehabilitation		
○ Asphalt Milling and micro surfacing		Yes
○ Hot Mix Asphalt overlay 2"		Yes
○ Hot Mix Asphalt overlay 2" with geogrid underlayment		Yes
○ Fiber Reinforced Hot Mix Asphalt		
• Reconstruction		
○ Hot Mix Asphalt full depth		Yes
○ Cold Mix Asphalt		Yes
○ RAP Asphalt		Yes
<b>Drainage Systems</b>		
• Installing Culverts and Catch Basins		Yes
• Storm Sewer 36" to 60"		
○ Manhole		Yes
○ Head wall		Yes

<b>SERVICES</b>	<b>SELF- Performed</b>	<b>SUB-Contract</b>
• Street Light		Yes
• Traffic Signals and Control Devices		Yes
<b>Emergency Services</b>		
• Snow plow services	Yes	
• Snow removal	Yes	
• Set Jersey Barriers for flood diversion	Yes	
• Sand bags manufacture and deployment	Yes	
• Temporary Drainage Structures	Yes	
<b>Specialty Services</b>		
• Rock Crushing		Yes
• Blasting		Yes
• Roadway Striping		Yes

EXHIBIT C  
TO  
JOB ORDER CONTRACT  
BETWEEN  
COCONINO COUNTY FLOOD CONTROL DISTRICT  
AND  
MORNING DEW LANDSCAPING, INC.

[Performance Bond]

See following page.

PERFORMANCE BOND

KNOW ALL PERSONS BY THESE PRESENTS:

THAT, \_\_\_\_\_ (hereinafter called Principal), as Principal, and \_\_\_\_\_, a corporation organized and existing under the laws of the State of \_\_\_\_\_, with its principal office at \_\_\_\_\_ (hereinafter called the Surety), as Surety, are held and firmly bound unto the Coconino County Flood Control District (hereinafter called the Obligee) in the amount of \_\_\_\_\_ (Dollars) (\$ \_\_\_\_\_), for the payment whereof, the said Principal and Surety bind themselves, and their heirs, administrators, executors, successors and assigns, jointly and severally, firmly by these presents.

WHEREAS, the Principal has entered into a certain written Contract with the Obligee, dated the \_\_\_\_\_ day of \_\_\_\_\_ 20\_\_\_\_, for the material, service or construction described as \_\_\_\_\_ is hereby referred to and made a part hereof as fully and to the same extent as if copied at length herein.

NOW, THEREFORE, THE CONDITION OF THIS OBLIGATION IS SUCH, that if the Principal faithfully performs and fulfills all of the undertakings, covenants, terms, conditions and agreements of the Contract during the original term of the Contract and any extension of the Contract, with or without notice to the Surety, and during the life of any guaranty required under the Contract, and also performs and fulfills all of the undertakings, covenants, terms, conditions and agreements of all duly authorized modifications of the Contract that may hereafter be made, notice of which modifications to the surety being hereby waived, the above obligation is void. Otherwise it remains in full force and effect.

PROVIDED, however, that this bond is executed pursuant to the provisions of Title 34, Chapter 6, Article 1, Arizona Revised Statutes, and all liabilities on this bond shall be determined in accordance with the provisions of Title 34, Chapter 6, Article 1, Arizona Revised Statutes, to the extent as if it were copied at length in this agreement.

The prevailing party in a suit on this bond shall recover as part of the judgment reasonable attorney fees that may be fixed by a judge of the Court.

Witness our hands this \_\_\_\_\_ day of \_\_\_\_\_ 20\_\_\_\_.

\_\_\_\_\_  
Principal Seal

By: \_\_\_\_\_

\_\_\_\_\_  
Surety Seal

By: \_\_\_\_\_

\_\_\_\_\_  
Agency of Record

EXHIBIT D  
TO  
JOB ORDER CONTRACT  
BETWEEN  
COCONINO COUNTY FLOOD CONTROL DISTRICT  
AND  
MORNING DEW LANDSCAPING, INC.

[Payment Bond]

See following page.

PAYMENT BOND

KNOW ALL PERSONS BY THESE PRESENTS:

THAT, \_\_\_\_\_ (hereinafter called Principal), as Principal, and \_\_\_\_\_, a corporation organized and existing under the laws of the State of \_\_\_\_\_, with its principal office at \_\_\_\_\_ (hereinafter called the Surety), as Surety, are held and firmly bound unto the Coconino County Flood Control District (hereinafter called the Obligee) in the amount of \_\_\_\_\_ (Dollars) (\$ \_\_\_\_\_), for the payment whereof, the said Principal and Surety bind themselves, and their heirs, administrators, executors, successors and assigns, jointly and severally, firmly by these presents.

WHEREAS, the Principal has entered into a certain written Contract with the Obligee, dated the \_\_\_\_\_ day of \_\_\_\_\_ 20\_\_\_\_, for the material, service or construction described as \_\_\_\_\_ which Contract is hereby referred to and made a part hereof as fully and to the same extent as if copied at length herein.

NOW, THEREFORE, THE CONDITION OF THIS OBLIGATION IS SUCH, that if the Principal promptly pays all monies due to all persons supplying labor or materials to the Principal or the Principal's Subcontractors in the prosecution of the Work provided for in the Contract, this obligation is void. Otherwise it remains in full force and effect.

PROVIDED, however, that this bond is executed pursuant to the provisions of Title 34, Chapter 6, Article 1, Arizona Revised Statutes, and all liabilities on this bond shall be determined in accordance with the provisions, conditions and limitations of Title 34, Chapter 6, Article 1, Arizona Revised Statutes, to the same extent as if they were copied at length in this agreement.

The prevailing party in a suit on this bond shall recover as a part of the judgment reasonable attorney fees that may be fixed by a judge of the Court.

Witness our hands this \_\_\_\_\_ day of \_\_\_\_\_, 20\_\_\_\_.

\_\_\_\_\_  
Principal Seal

By: \_\_\_\_\_

\_\_\_\_\_  
Surety Seal

By: \_\_\_\_\_

\_\_\_\_\_  
Agency of Record



EXHIBIT C - GRANT PROVISIONS

City of Flagstaff CDBG Grant Provisions



## GRANT PROVISIONS

<b>Funding Contractor:</b>	<b>U.S. Department of Housing and Urban Development</b>
<b>Grant Project Title:</b>	<b>Community Development Block</b>
<b>Grant Program Year:</b>	<b>2022</b>
<b>Grant Agreement Number:</b>	<b>B22-MC-04-0510</b>
<b>CFDA Number:</b>	<b>14.218</b>

*Note: This document is to be used as a guide for contractors and subcontractors working on Community Development Block Grant projects in the City of Flagstaff. It is not verified to be all inclusive and the contractor is fully responsible for complying with all federal regulations applicable to the CDBG program.*

## **FEDERAL - GRANT PROVISIONS**

The Contractor and its Subcontractor shall comply with the following grant provisions:

### **Applicable Laws**

Compliance with all applicable Federal, State, and Local laws and regulations.

### **Awards to debarred and suspended parties**

The City will not make any award or permit any award (subgrant or contract) at any tier to any party which is debarred or suspended or is otherwise excluded from or ineligible for participation in Federal assistance programs under Executive Orders 12549 and 12689, "Debarment and Suspension."

### **Contracting with Small and Minority firms, Women's Business Enterprise and Labor Surplus Area Firms**

The Contractor will take all necessary affirmative steps to assure that minority firms, women's business enterprises, and labor surplus area firms are used when possible.

Affirmative steps shall include:

- i) Placing qualified small and minority businesses and women's business enterprises on solicitation lists;
- ii) Assuring that small and minority businesses, and women's business enterprises are solicited whenever they are potential sources;
- iii) Dividing total requirements, when economically feasible, into smaller tasks or quantities to permit maximum participation by small and minority business, and women's business enterprises;
- iv) Establishing delivery schedules, where the requirement permits, which encourage participation by small and minority business, and women's business enterprises;
- v) Using the services and assistance of the Small Business Administration, and the Minority Business Development Agency of the Department of Commerce.

### **Equal Employment Opportunity**

Compliance with Executive Order 11246 of September 24, 1965, entitled "Equal Employment Opportunity," as amended by Executive Order 11375 of October 13, 1967, and as supplemented in Department of Labor regulations (41 CFR chapter 60).

(All construction contracts awarded in excess of \$10,000 by grantees and their contractors or subgrantees)

### **Clean Water and Air Act**

Compliance with all applicable standards, orders, or requirements issued under section 306 of the Clean Air Act (42 U.S.C. 1857(h)), section 508 of the Clean Water Act (33 U.S.C. 1368), Executive Order 11738, and Environmental Protection Agency regulations (40 CFR part 15).

(Contracts, subcontracts, and subgrants of amounts in excess of \$100,000)

### **Energy Policy and Conservation Act**

Mandatory standards and policies relating to energy efficiency which are contained in the state energy conservation plan issued in compliance with the Energy Policy and Conservation Act (Pub. L. 94-163, 89 Stat. 871).

### **Resource Conservation and Recovery Act**

Compliance with the Resource Conservation and Recovery Act (RCRA) requires federal agencies to assess the impact that debris, debris removal, hazardous wastes, and hazardous waste clean-up projects will have on air and water quality and take actions to prevent degradation. RCRA gives EPA the authority to control hazardous waste from the "cradle-to-grave" to facilities that generate hazardous materials and sets forth a framework for the management of non-hazardous waste (42 USC, 6901).

### **Conflicts of Interest**

The City (grantee) and Contractor (subgrantees) will maintain a written code of standards of conduct governing the performance of their employees engaged in the award and administration of contracts. No employee, officer or agent of the grantee or subgrantee shall participate in selection, or in the award or administration of a contract supported by Federal funds if a conflict of interest, real or apparent, would be involved.

Such a conflict would arise when:

- i) The employee, officer, or agent,
- ii) Any member of his immediate family,
- iii) His or her partner, or
- iv) An organization which employs, or is about to employ, any of the above, has a financial or other interest in the firm selected for award.

The grantee's or subgrantee's officers, employees or agents will neither solicit nor accept gratuities, favors or anything of monetary value from contractors, potential contractors, or parties to sub agreements. Grantee and subgrantees may set minimum rules where the financial interest is not substantial, or the gift is an unsolicited item of nominal intrinsic value. To the extent permitted by State or local law or regulations, such standards or conduct will provide for penalties, sanctions, or other disciplinary actions for violations of such standards by the grantee's and subgrantee's officers, employees, or agents, or by contractors or their agents. The awarding agency may in regulation provide additional prohibitions relative to real, apparent, or potential conflicts of interest.

### **Copyrights**

Reports, maps, or other documents produced in whole or in part are works for hire and shall not be the subject of any application for copyright by or on behalf of the Contractor or its Subcontractor.

The Contractor shall advise the City or its designee at the time of delivery of any copyrighted or copyrightable work furnished under this Agreement, or any adversely held copyrighted or copyrightable material incorporated in any such work and of any invasion of the right of privacy therein contained.

### **Patent Fees and Royalties**

Contractor shall pay all license fees and royalties and assume all costs incident to the use in the performance of the Work or the incorporation in the Work of any invention, design, process, product, or device that is the subject of patent rights or copyrights held by others. If a particular invention, design, process, product, or device is specified in the Contract Documents for use in Funding Agency Contracting Provisions for Construction Projects the performance of the Work and if, to the actual knowledge of Owner or Engineer, its use is subject to patent rights or copyrights calling for the payment of any license fee or royalty to others, the existence of such rights shall be disclosed by the Owner in the Contract Documents.

### **Responsible Contractors**

The City will make awards only to responsible contractors possessing the ability to perform successfully under the terms and conditions of the proposed procurement. Consideration will be given to such matters as contractor integrity, compliance with public policy, record of past performance, and financial and technical resources.

### **Access and Retention of Records**

Access by the grantee, the subgrantee, the Federal grantor agency, the Comptroller General of the United States, or any of their duly authorized representatives to any books, documents, papers, and records of the contractor which are directly pertinent to that specific contract for the purpose of making audit, examination, excerpts, and transcriptions.

Retention of all required records for three years after grantees or subgrantees make final payments and all other pending matters are closed.

### **Additional Contract Requirements**

1. Compliance with Executive Order 11246 - During the performance of this Contract, the Contractor agrees as follows:
  - a. The Contractor will not discriminate against any employee or applicant because of race, creed, color, age, sex, handicap or national origin. The Contractor will take affirmative action to ensure that applicants are employed and that employees are treated during employment without regard to their race, religion, color, sex, sexual orientation, age, handicap or national origin. Such action shall include, but not be limited to, the following: Employment, upgrading, demotion or transfer; recruitment advertising, layoff or termination, rates of pay or other forms of compensation, and selection for training, including apprenticeship. The Contractor agrees to post in conspicuous places, available to employees and applicants for employment, notices to be provided setting forth the provisions of this non-discriminating clause.
  - b. The Contractor will, in all solicitations or advertisements for employees place by or on behalf of the Contractor, state that all qualified applicants will receive consideration for employment without regard to race, religion, color, sex, age, handicap or national origin.
  - c. The Contractor will send to each labor union or representative of workers with which he has a collective bargaining agreement or other contract or

understanding, a notice advising the said labor union or worker's representatives of commitments under this section and shall post copies of the notice in conspicuous places available to employees and applicants for employment.

- d. The Contractor will not discriminate against any employee or applicant for employment because he or she is a disabled veteran or a veteran of the Vietnam Era in regard to any position for which the employee or applicant for employment is qualified. The Contractor agrees to take affirmative action to employ, advance in employment, and otherwise treat qualified disabled veterans and veterans of the Vietnam Era without discrimination based upon their disability or veteran status in all employment practices such as the following: employment upgrading, demotion or transfer, recruitment, advertising, layoff or termination, rates of pay or other forms of compensation, and selection for training, including apprenticeship.
  - e. The Contractor will comply with all provisions of Executive Order 11246 of September 24, 1965, and of the rules, regulations and relevant orders of the Secretary of Labor. No segregated facilities will be maintained as required by Title VI of Civil Rights Acts of 1964.
  - f. The Contractor will furnish all information and reports required by Executive Order 11246 of September 24, 1965, and by rules, regulations and orders of the Secretary of Labor, or pursuant thereto, and will permit access to his book, records, timecards, and accounts by the administering agency and the Secretary of Labor for the purposes of investigation to ascertain compliance with such rules, regulations and orders.
  - g. In the event of the Contractor's non-compliance with the non-discriminatory clauses of this Contract or with any of the said rules, regulations or orders, this Contract may be canceled, terminated, or suspended in whole or in part and the Contractor may be declared ineligible for further grantee contracts or federally assisted construction contracts in accordance with procedures authorized in Executive Order 11236 of September 24, 1965, and such other sanctions may be imposed and remedies invoked as provided in Executive Order 11246 of September 24, 1965, or by rule, regulations or order, of the Secretary of Labor, or as otherwise provided by law.
  - h. The Contractor will include the portion of the sentence immediately preceding paragraph (1) and the provisions of paragraphs (1) through (8) in every subcontract or purchase order unless exempted by rules, regulations or orders of the Secretary of Labor issued pursuant to Section 204 of Executive Order 11246 of September 24, 1965, so that such provisions will be binding upon each subcontractor or vendor. The Contractor will take such action with respect to any subcontract or purchase order as the administering agency may direct as a means of enforcing such provisions, including sanctions for noncompliance. Provided, however, that in the event a contractor becomes involved in, or is threatened with, litigation with a subcontractor or vendor as a result of such direction by the administering agency, the Contractor may request the United States to enter into such litigation to protect the interests of the United States.
2. Audit, Inspection, and Retention of Records - The Contractor shall permit the Owner, the City of Pascagoula, the U.S. Department of Housing and Urban Development, the U.S. Department of Labor, the Comptroller General of the United States, or any of their duly authorized representatives, to inspect and audit any books, documents, papers, and records of the Contractor which are directly pertinent to the Contractor's performance

under this Contract until the expiration of three (3) years after the Owner makes final payment under this Contract and all other pending matters are closed. Failure of the Contractor to produce or have available these records may result in debarment.

3. Energy Efficiency - The Contractor shall comply with the mandatory standards and policies relating to energy efficiency which are contained in the state energy conservation plan issued in compliance with the Energy Policy and Conservation Act (Pub. L. 94-163, 89 Stat. 871).
4. Violation or Breach of Contract - If any party violates or breaches any term of this Contract, such violation or breach shall be deemed to constitute a default, and the other parties have the right to seek such administrative, contractual or legal remedies as may be suitable to the violation or breach; and, in addition, if any party, by reason of any default, fails within fifteen (15) days after notice thereof by another party to comply with the conditions of the Contract, the party having provided such notice may terminate this Contract.
5. Termination for Default or Convenience
  - a. The Owner may terminate this Contract, in whole or in part, at any time by written notice to the Contractor. The Contractor shall be paid its costs, including Contract closeout costs and profit on work performed up to the time of termination. The Contractor shall promptly submit its termination claim to be paid to the Contractor. If the Contractor has any property in its possession belonging to the Owner, the Contractor will account for the same, and dispose of it in the manner the Owner directs. The parties agree that the Owner shall not be liable for the cost of the Contractor doing business, his overhead, or salaries if this Contract is terminated.
  - b. If the Contractor fails to perform in the manner called for in this Contract, or if the Contractor fails to comply with any other provisions of this Contract, the Owner may terminate this Contract for default. Termination shall be effected by serving a "Notice of Termination" on the Contractor setting forth the manner in which the Contractor is in default. The Contractor will only be paid the Contract price for services performed in accordance with the manner of performance set forth in this Contract.
  - c. In the event of a strike, fire, flood, or events which are not the fault of the Contractor, or events that make it impossible or impractical for the Contractor to complete said work on schedule, the Owner, after establishing a new performance schedule, may allow the Contractor to continue work, or may treat the said events as a termination for convenience.
6. Subcontracts
  - a. The Contractor shall not subcontract any work to be performed under this Contract to parties listed on the General Services Administration's List of Parties Excluded from Federal Procurement or Nonprocurement Programs in accordance with E.O.s 12549 and 12689, "Debarment and Suspension." This list contains the names of parties debarred, suspended, or otherwise excluded by agencies, and contractors declared ineligible under statutory or regulatory authority other than E.O. 12549.
  - b. The provisions enumerated herein (including Exhibits) shall be applied to and physically be made a part of any and all subcontracts entered into by the Contractor for the performance of any part of the work of this Contract. The

Contractor shall notify the Owner and the City of Pascagoula Community and Economic Development Department in writing prior to executing such subcontracts so that a pre-construction conference may be scheduled with the subcontractor and Owner to review applicable contract provisions.

7. Section 3 Clause (Applicable if Contract amount exceeds \$100,000)

- a. The work to be performed under this Contract is subject to the requirements of Section 3 of the Housing and Urban Development Act of 1968, as amended, 12 U.S.C. 1701u (Section 3). The purpose of Section 3 is to ensure that employment and other economic opportunities generated by HUD assistance or HUD-assisted projects covered by Section 3, shall, to the greatest extent feasible, be directed to low- and very low-income persons, particularly persons who are recipients of HUD assistance for housing.
- b. The parties to this contract agree to comply with HUD's regulations in 24 CFR part 135, which implement Section 3. As evidenced by their execution of this contract, the parties to this contract certify that they are under no contractual or other impediment that would prevent them from complying with the 24 CFR part 135 regulations.
- c. The Contractor agrees to send to each labor organization or representative of workers with which the Contractor has a collective bargaining agreement or other understanding, if any, a notice advising the labor organization or workers' representative of the Contractor's commitments under this Section 3 clause, and will post copies of the notice in conspicuous places at the work site where both employees and applicants for training and employment positions can see the notice. The notice shall describe the Section 3 preference, shall set forth minimum number and job titles subject to hire, availability of apprenticeship and training positions, the qualifications for each; and the name and location of the person(s) taking applications for each of the positions; and the anticipated date the work shall begin.
- d. The Contractor agrees to include this Section 3 clause in every subcontract subject to compliance with regulations in 24 CFR part 135, and agrees to take appropriate action, as provided in an applicable provision of the subcontract in this Section 3 clause, upon a finding that the subcontractor is in violation of the regulations in 24 CFR part 135. The Contractor will not subcontract with any subcontractor where the Contractor has notice or knowledge that the subcontractor has been found in violation of the regulations in 24 CFR part 135.
- e. The Contractor will certify that any vacant employment positions, including training positions, that are filled (1) after the Contractor is selected but before the contract is executed, and (2) with persons other than those to whom the regulations of 24 CFR part 135 require employment opportunities to be directed, were not filled to circumvent the Contractor's obligations under 24 CFR part 135.
- f. Noncompliance with HUD's regulations in 24 CFR part 135 may result in sanctions, termination of this contract for default, and debarment or suspension from future HUD assisted contracts.
- g. With respect to work performed in connection with Section 3 covered Indian housing assistance, Section 7(b) of the Indian Self-Determination and Education Assistance Act (25 U.S.C. 450e) also applies to the work to be performed under this contract. Section 7(b) requires that to the greatest extent feasible (i)

preference and opportunities for training and employment shall be given to Indians, and (ii) preference in the award of contracts and subcontracts shall be given to Indian organizations and Indian-owned Economic Enterprises. Parties to this contract that are subject to the provisions of Section 3 and Section 7(b) agree to comply with Section 3 to the maximum extent feasible, but not in derogation of compliance with Section 7(b).

8. Environmental Protection (Applicable if Contract amount exceeds \$100,000) - The Contractor shall comply with the applicable standards, orders, or requirements issued under section 306 of the Clean Air Act (42 U.S.C. 1857(h)), section 508 of the Clean Water Act (33 U.S.C. 1368), Executive Order 11738, and Environmental Protection Agency regulations (40 CFR part 15).

## **CODE OF FEDERAL REGULATION (CFR) - Title 2: Grants and Agreements**

### **PART 200—UNIFORM ADMINISTRATIVE REQUIREMENTS, COST PRINCIPLES, AND AUDIT REQUIREMENTS FOR FEDERAL AWARDS**

---

#### **Appendix II to Part 200—Contract Provisions for Non-Federal Entity Contracts Under Federal Awards**

In addition to other provisions required by the Federal agency or non-Federal entity, all contracts made by the non-Federal entity under the Federal award must contain provisions covering the following, as applicable:

- (A) Contracts for more than the simplified acquisition threshold currently set at \$150,000, which is the inflation adjusted amount determined by the Civilian Agency Acquisition Council and the Defense Acquisition Regulations Council (Councils) as authorized by 41 U.S.C. 1908, must address administrative, contractual, or legal remedies in instances where contractors violate or breach contract terms, and provide for such sanctions and penalties as appropriate.
- (B) All contracts in excess of \$10,000 must address termination for cause and for convenience by the non-Federal entity including the manner by which it will be effected and the basis for settlement.
- (C) Equal Employment Opportunity. Except as otherwise provided under 41 CFR Part 60, all contracts that meet the definition of “federally assisted construction contract” in 41 CFR Part 60-1.3 must include the equal opportunity clause provided under 41 CFR 60-1.4(b), in accordance with Executive Order 11246, “Equal Employment Opportunity” (30 FR 12319, 12935, 3 CFR Part, 1964- 1965 Comp., p. 339), as amended by Executive Order 11375, “Amending Executive Order 11246 Relating to Equal Employment Opportunity,” and implementing regulations at 41 CFR part 60, “Office of Federal Contract Compliance Programs, Equal Employment Opportunity, Department of Labor.”
- (D) Davis-Bacon Act, as amended (40 U.S.C. 3141-3148). When required by Federal program legislation, all prime construction contracts in excess of \$2,000 awarded by non-Federal entities must include a provision for compliance with the Davis-

Bacon Act (40 U.S.C. 3141-3144, and 3146-3148) as supplemented by Department of Labor regulations (29 CFR Part 5, "Labor Standards Provisions Applicable to Contracts Covering Federally Financed and Assisted Construction"). In accordance with the statute, contractors must be required to pay wages to laborers and mechanics at a rate not less than the prevailing wages specified in a wage determination made by the Secretary of Labor. In addition, contractors must be required to pay wages not less than once a week. The non-Federal entity must place a copy of the current prevailing wage determination issued by the Department of Labor in each solicitation. The decision to award a contract or subcontract must be conditioned upon the acceptance of the wage determination. The non-Federal entity must report all suspected or reported violations to the Federal awarding agency. The contracts must also include a provision for compliance with the Copeland "Anti-Kickback" Act (40 U.S.C. 3145), as supplemented by Department of Labor regulations (29 CFR Part 3, "Contractors and Subcontractors on Public Building or Public Work Financed in Whole or in Part by Loans or Grants from the United States"). The Act provides that each contractor or subrecipient must be prohibited from inducing, by any means, any person employed in the construction, completion, or repair of public work, to give up any part of the compensation to which he or she is otherwise entitled. The non-Federal entity must report all suspected or reported violations to the Federal awarding agency.

- (E) Contract Work Hours and Safety Standards Act (40 U.S.C. 3701-3708). Where applicable, all contracts awarded by the non-Federal entity in excess of \$100,000 that involve the employment of mechanics or laborers must include a provision for compliance with 40 U.S.C. 3702 and 3704, as supplemented by Department of Labor regulations (29 CFR Part 5). Under 40 U.S.C. 3702 of the Act, each contractor must be required to compute the wages of every mechanic and laborer on the basis of a standard work week of 40 hours. Work in excess of the standard work week is permissible provided that the worker is compensated at a rate of not less than one and a half times the basic rate of pay for all hours worked in excess of 40 hours in the work week. The requirements of 40 U.S.C. 3704 are applicable to construction work and provide that no laborer or mechanic must be required to work in surroundings or under working conditions which are unsanitary, hazardous or dangerous. These requirements do not apply to the purchases of supplies or materials or articles ordinarily available on the open market, or contracts for transportation or transmission of intelligence.
- (F) Rights to Inventions Made Under a Contract or Agreement. If the Federal award meets the definition of "funding agreement" under 37 CFR §401.2 (a) and the recipient or subrecipient wishes to enter into a contract with a small business firm or nonprofit organization regarding the substitution of parties, assignment or performance of experimental, developmental, or research work under that "funding agreement," the recipient or subrecipient must comply with the requirements of 37 CFR Part 401, "Rights to Inventions Made by Nonprofit Organizations and Small Business Firms Under Government Grants, Contracts and Cooperative Agreements," and any implementing regulations issued by the awarding agency.
- (G) Clean Air Act (42 U.S.C. 7401-7671q.) and the Federal Water Pollution Control Act (33 U.S.C. 1251-1387), as amended—Contracts and subgrants of amounts in excess of

\$150,000 must contain a provision that requires the non-Federal award to agree to comply with all applicable standards, orders or regulations issued pursuant to the Clean Air Act (42 U.S.C. 7401-7671q) and the Federal Water Pollution Control Act as amended (33 U.S.C. 1251-1387). Violations must be reported to the Federal awarding agency and the Regional Office of the Environmental Protection Agency (EPA).

- (H) Debarment and Suspension (Executive Orders 12549 and 12689)—A contract award (see 2 CFR 180.220) must not be made to parties listed on the governmentwide exclusions in the System for Award Management (SAM), in accordance with the OMB guidelines at 2 CFR 180 that implement Executive Orders 12549 (3 CFR part 1986 Comp., p. 189) and 12689 (3 CFR part 1989 Comp., p. 235), “Debarment and Suspension.” SAM Exclusions contains the names of parties debarred, suspended, or otherwise excluded by agencies, as well as parties declared ineligible under statutory or regulatory authority other than Executive Order 12549.
- (I) Byrd Anti-Lobbying Amendment (31 U.S.C. 1352)—Contractors that apply or bid for an award exceeding \$100,000 must file the required certification. Each tier certifies to the tier above that it will not and has not used Federal appropriated funds to pay any person or organization for influencing or attempting to influence an officer or employee of any agency, a member of Congress, officer or employee of Congress, or an employee of a member of Congress in connection with obtaining any Federal contract, grant or any other award covered by 31 U.S.C. 1352. Each tier must also disclose any lobbying with non-Federal funds that takes place in connection with obtaining any Federal award. Such disclosures are forwarded from tier to tier up to the non-Federal award.
- (J) See §200.322 Procurement of recovered materials.

[78 FR 78608, Dec. 26, 2013, as amended at 79 FR 75888, Dec. 19, 2014]

## **CODE OF FEDERAL REGULATION (CFR) - Title 29: Labor**

### **PART 200— CONTRACT PROVISIONS FOR NON-FEDERAL ENTITY CONTRACTS UNDER FEDERAL AWARDS**

---

#### **Appendix II to Part 200— Part 5 — Labor standards provisions applicable to contracts covering federally financed and assisted construction (also labor standards provisions applicable to non-construction contracts subject to the contract work hours and safety standards act)**

##### **§ 5.5 Contract provisions and related matters.**

(a) The Agency head shall cause or require the contracting officer to insert in full in any contract in excess of \$2,000 which is entered into for the actual construction, alteration and/or repair, including painting and decorating, of a public building or public work, or building or work financed in whole or in part from Federal funds or in accordance with guarantees of a Federal agency or financed from funds obtained by pledge of any contract of a Federal agency to make a loan, grant or annual contribution (except where

a different meaning is expressly indicated), and which is subject to the labor standards provisions of any of the acts listed in §5.1, the following clauses (or any modifications thereof to meet the particular needs of the agency, Provided, That such modifications are first approved by the Department of Labor):

(1) Minimum wages. (i) All laborers and mechanics employed or working upon the site of the work (or under the United States Housing Act of 1937 or under the Housing Act of 1949 in the construction or development of the project), will be paid unconditionally and not less often than once a week, and without subsequent deduction or rebate on any account (except such payroll deductions as are permitted by regulations issued by the Secretary of Labor under the Copeland Act (29 CFR part 3)), the full amount of wages and bona fide fringe benefits (or cash equivalents thereof) due at time of payment computed at rates not less than those contained in the wage determination of the Secretary of Labor which is attached hereto and made a part hereof, regardless of any contractual relationship which may be alleged to exist between the contractor and such laborers and mechanics.

Contributions made or costs reasonably anticipated for bona fide fringe benefits under section 1(b)(2) of the Davis-Bacon Act on behalf of laborers or mechanics are considered wages paid to such laborers or mechanics, subject to the provisions of paragraph (a)(1)(iv) of this section; also, regular contributions made or costs incurred for more than a weekly period (but not less often than quarterly) under plans, funds, or programs which cover the particular weekly period, are deemed to be constructively made or incurred during such weekly period. Such laborers and mechanics shall be paid the appropriate wage rate and fringe benefits on the wage determination for the classification of work actually performed, without regard to skill, except as provided in §5.5(a)(4). Laborers or mechanics performing work in more than one classification may be compensated at the rate specified for each classification for the time actually worked therein: Provided, That the employer's payroll records accurately set forth the time spent in each classification in which work is performed. The wage determination (including any additional classification and wage rates conformed under paragraph (a)(1)(ii) of this section) and the Davis-Bacon poster (WH-1321) shall be posted at all times by the contractor and its subcontractors at the site of the work in a prominent and accessible place where it can be easily seen by the workers.

(ii)(A) The contracting officer shall require that any class of laborers or mechanics, including helpers, which is not listed in the wage determination, and which is to be employed under the contract shall be classified in conformance with the wage determination.

The contracting officer shall approve an additional classification and wage rate and fringe benefits therefore only when the following criteria have been met:

- (1) The work to be performed by the classification requested is not performed by a classification in the wage determination; and
- (2) The classification is utilized in the area by the construction industry; and
- (3) The proposed wage rate, including any bona fide fringe benefits, bears a reasonable relationship to the wage rates contained in the wage determination.

(B) If the contractor and the laborers and mechanics to be employed in the classification (if known), or their representatives, and the contracting officer agree on the classification and wage rate (including the amount designated for fringe benefits where appropriate), a report of the action taken shall be sent by the contracting officer to the Administrator of the Wage and Hour Division, Employment Standards Administration, U.S. Department of Labor, Washington, DC 20210. The Administrator, or an authorized representative, will approve, modify, or disapprove every additional classification action within 30 days of receipt and so advise the contracting officer or will notify the contracting officer within the 30-day period that additional time is necessary.

(C) In the event the contractor, the laborers or mechanics to be employed in the classification or their representatives, and the contracting officer do not agree on the proposed classification and wage rate (including the amount designated for fringe benefits, where appropriate), the contracting officer shall refer the questions, including the views of all interested parties and the recommendation of the contracting officer, to the Administrator for determination. The Administrator, or an authorized representative, will issue a determination within 30 days of receipt and so advise the contracting officer or will notify the contracting officer within the 30-day period that additional time is necessary.

(D) The wage rate (including fringe benefits where appropriate) determined pursuant to paragraphs (a)(1)(ii) (B) or (C) of this section, shall be paid to all workers performing work in the classification under this contract from the first day on which work is performed in the classification.

(iii) Whenever the minimum wage rate prescribed in the contract for a class of laborers or mechanics includes a fringe benefit which is not expressed as an hourly rate, the contractor shall either pay the benefit as stated in the wage determination or shall pay another bona fide fringe benefit or an hourly cash equivalent thereof.

(iv) If the contractor does not make payments to a trustee or other third person, the contractor may consider as part of the wages of any laborer or mechanic the amount of any costs reasonably anticipated in providing bona fide fringe benefits under a plan or program, Provided, That the Secretary of Labor has found, upon the written request of the contractor, that the applicable standards of the Davis- Bacon Act have been met. The Secretary of Labor may require the contractor to set aside in a separate account assets for the meeting of obligations under the plan or program.

(2) Withholding. The (write in name of Federal Agency or the loan or grant recipient) shall upon its own action or upon written request of an authorized representative of the Department of Labor withhold or cause to be withheld from the contractor under this contract or any other Federal contract with the same prime contractor, or any other federally-assisted contract subject to Davis-Bacon prevailing wage requirements, which is held by the same prime contractor, so much of the accrued payments or advances as may be considered necessary to pay laborers and mechanics, including apprentices, trainees, and helpers, employed by the contractor or any subcontractor the full amount of wages required by the contract. In the event of failure to pay any laborer or mechanic, including any apprentice, trainee, or helper, employed or working on the site of the work (or under the United States Housing Act of 1937 or under the Housing Act of

1949 in the construction or development of the project), all or part of the wages required by the contract, the (Agency) may, after written notice to the contractor, sponsor, applicant, or owner, take such action as may be necessary to cause the suspension of any further payment, advance, or guarantee of funds until such violations have ceased.

(3) Payrolls and basic records. (i) Payrolls and basic records relating thereto shall be maintained by the contractor during the course of the work and preserved for a period of three years thereafter for all laborers and mechanics working at the site of the work (or under the United States Housing Act of 1937, or under the Housing Act of 1949, in the construction or development of the project). Such records shall contain the name, address, and social security number of each such worker, his or her correct classification, hourly rates of wages paid (including rates of contributions or costs anticipated for bona fide fringe benefits or cash equivalents thereof of the types described in section 1(b)(2)(B) of the Davis-Bacon Act), daily and weekly number of hours worked, deductions made and actual wages paid. Whenever the Secretary of Labor has found under 29 CFR 5.5(a)(1)(iv) that the wages of any laborer or mechanic include the amount of any costs reasonably anticipated in providing benefits under a plan or program described in section 1(b)(2)(B) of the Davis-Bacon Act, the contractor shall maintain records which show that the commitment to provide such benefits is enforceable, that the plan or program is financially responsible, and that the plan or program has been communicated in writing to the laborers or mechanics affected, and records which show the costs anticipated or the actual cost incurred in providing such benefits. Contractors employing apprentices or trainees under approved programs shall maintain written evidence of the registration of apprenticeship programs and certification of trainee programs, the registration of the apprentices and trainees, and the ratios and wage rates prescribed in the applicable programs.

(ii) (A) The contractor shall submit weekly for each week in which any contract work is performed a copy of all payrolls to the (write in name of appropriate federal agency) if the agency is a party to the contract, but if the agency is not such a party, the contractor will submit the payrolls to the applicant, sponsor, or owner, as the case may be, for transmission to the (write in name of agency). The payrolls submitted shall set out accurately and completely all of the information required to be maintained under 29 CFR 5.5(a)(3)(i), except that full social security numbers and home addresses shall not be included on weekly transmittals. Instead the payrolls shall only need to include an individually identifying number for each employee ( e.g. , the last four digits of the employee's social security number). The required weekly payroll information may be submitted in any form desired. Optional Form WH-347 is available for this purpose from the Wage and Hour Division Web site at <http://www.dol.gov/esa/whd/forms/wh347instr.htm> or its successor site.

The prime contractor is responsible for the submission of copies of payrolls by all subcontractors. Contractors and subcontractors shall maintain the full social security number and current address of each covered worker, and shall provide them upon request to the (write in name of appropriate federal agency) if the agency is a party to the contract, but if the agency is not such a party, the contractor will submit them to the applicant, sponsor, or owner, as the case may be, for transmission to the (write in name of agency), the contractor, or the Wage and Hour Division of the Department of Labor

for purposes of an investigation or audit of compliance with prevailing wage requirements. It is not a violation of this section for a prime contractor to require a subcontractor to provide addresses and social security numbers to the prime contractor for its own records, without weekly submission to the sponsoring government agency (or the applicant, sponsor, or owner).

(B) Each payroll submitted shall be accompanied by a —Statement of Compliance, signed by the contractor or subcontractor or his or her agent who pays or supervises the payment of the persons employed under the contract and shall certify the following:

(1) That the payroll for the payroll period contains the information required to be provided under §5.5 (a)(3)(ii) of Regulations, 29 CFR part 5, the appropriate information is being maintained under §5.5 (a)(3)(i) of Regulations, 29 CFR part 5, and that such information is correct and complete;

(2) That each laborer or mechanic (including each helper, apprentice, and trainee) employed on the contract during the payroll period has been paid the full weekly wages earned, without rebate, either directly or indirectly, and that no deductions have been made either directly or indirectly from the full wages earned, other than permissible deductions as set forth in Regulations, 29 CFR part 3;

(3) That each laborer or mechanic has been paid not less than the applicable wage rates and fringe benefits or cash equivalents for the classification of work performed, as specified in the applicable wage determination incorporated into the contract.

(C) The weekly submission of a properly executed certification set forth on the reverse side of Optional Form WH–347 shall satisfy the requirement for submission of the —Statement of Compliance required by paragraph (a)(3)(ii)(B) of this section.

(D) The falsification of any of the above certifications may subject the contractor or subcontractor to civil or criminal prosecution under section 1001 of title 18 and section 231 of title 31 of the United States Code.

(iii) The contractor or subcontractor shall make the records required under paragraph (a)(3)(i) of this section available for inspection, copying, or transcription by authorized representatives of the (write the name of the agency) or the Department of Labor, and shall permit such representatives to interview employees during working hours on the job. If the contractor or subcontractor fails to submit the required records or to make them available, the Federal agency may, after written notice to the contractor, sponsor, applicant, or owner, take such action as may be necessary to cause the suspension of any further payment, advance, or guarantee of funds. Furthermore, failure to submit the required records upon request or to make such records available may be grounds for debarment action pursuant to 29 CFR 5.12.

(4) Apprentices and trainees —

(i) Apprentices. Apprentices will be permitted to work at less than the predetermined rate for the work they performed when they are employed pursuant to and individually registered in a bona fide apprenticeship program registered with the U.S. Department of Labor, Employment and Training Administration, Office of Apprenticeship Training, Employer and Labor Services, or with a State Apprenticeship Agency recognized by the

Office, or if a person is employed in his or her first 90 days of probationary employment as an apprentice in such an apprenticeship program, who is not individually registered in the program, but who has been certified by the Office of Apprenticeship Training, Employer and Labor Services or a State Apprenticeship Agency (where appropriate) to be eligible for probationary employment as an apprentice. The allowable ratio of apprentices to journeymen on the job site in any craft classification shall not be greater than the ratio permitted to the contractor as to the entire work force under the registered program. Any worker listed on a payroll at an apprentice wage rate, who is not registered or otherwise employed as stated above, shall be paid not less than the applicable wage rate on the wage determination for the classification of work actually performed. In addition, any apprentice performing work on the job site in excess of the ratio permitted under the registered program shall be paid not less than the applicable wage rate on the wage determination for the work actually performed. Where a contractor is performing construction on a project in a locality other than that in which its program is registered, the ratios and wage rates (expressed in percentages of the journeyman's hourly rate) specified in the contractor's or subcontractor's registered program shall be observed. Every apprentice must be paid at not less than the rate specified in the registered program for the apprentice's level of progress, expressed as a percentage of the journeymen hourly rate specified in the applicable wage determination. Apprentices shall be paid fringe benefits in accordance with the provisions of the apprenticeship program. If the apprenticeship program does not specify fringe benefits, apprentices must be paid the full amount of fringe benefits listed on the wage determination for the applicable classification. If the Administrator determines that a different practice prevails for the applicable apprentice classification, fringes shall be paid in accordance with that determination. In the event the Office of Apprenticeship Training, Employer and Labor Services, or a State Apprenticeship Agency recognized by the Office, withdraws approval of an apprenticeship program, the contractor will no longer be permitted to utilize apprentices at less than the applicable predetermined rate for the work performed until an acceptable program is approved.

(ii) Trainees. Except as provided in 29 CFR 5.16, trainees will not be permitted to work at less than the predetermined rate for the work performed unless they are employed pursuant to and individually registered in a program which has received prior approval, evidenced by formal certification by the U.S. Department of Labor, Employment and Training Administration. The ratio of trainees to journeymen on the job site shall not be greater than permitted under the plan approved by the Employment and Training Administration. Every trainee must be paid at not less than the rate specified in the approved program for the trainee's level of progress, expressed as a percentage of the journeyman hourly rate specified in the applicable wage determination. Trainees shall be paid fringe benefits in accordance with the provisions of the trainee program. If the trainee program does not mention fringe benefits, trainees shall be paid the full amount of fringe benefits listed on the wage determination unless the Administrator of the Wage and Hour Division determines that there is an apprenticeship program associated with the corresponding journeyman wage rate on the wage determination which provides for less than full fringe benefits for apprentices.

Any employee listed on the payroll at a trainee rate who is not registered and participating in a training plan approved by the Employment and Training Administration shall be paid not less

than the applicable wage rate on the wage determination for the classification of work actually performed. In addition, any trainee performing work on the job site in excess of the ratio permitted under the registered program shall be paid not less than the applicable wage rate on the wage determination for the work actually performed. In the event the Employment and Training Administration withdraws approval of a training program, the contractor will no longer be permitted to utilize trainees at less than the applicable predetermined rate for the work performed until an acceptable program is approved.

(5) Equal employment opportunity. The utilization of apprentices, trainees and journeymen under this part shall be in conformity with the equal employment opportunity requirements of Executive Order 11246, as amended, and 29 CFR part 30.

(6) Compliance with Copeland Act requirements. The contractor shall comply with the requirements of 29 CFR part 3, which are incorporated by reference in this contract.

(7) Subcontracts. The contractor or subcontractor shall insert in any subcontracts the clauses contained in 29 CFR 5.5(a)(1) through (10) and such other clauses as the (write in the name of the Federal agency) may by appropriate instructions require, and also a clause requiring the subcontractors to include these clauses in any lower tier subcontracts. The prime contractor shall be responsible for the compliance by any subcontractor or lower tier subcontractor with all the contract clauses in 29 CFR 5.5.

(8) Contract termination: debarment. A breach of the contract clauses in 29 CFR 5.5 may be grounds for termination of the contract, and for debarment as a contractor and a subcontractor as provided in 29 CFR 5.12.

(9) Compliance with Davis-Bacon and Related Act requirements. All rulings and interpretations of the Davis-Bacon and Related Acts contained in 29 CFR parts 1, 3, and 5 are herein incorporated by reference in this contract.

(10) Disputes concerning labor standards. Disputes arising out of the labor standards provisions of this contract shall not be subject to the general disputes clause of this contract. Such disputes shall be resolved in accordance with the procedures of the Department of Labor set forth in 29 CFR parts 5, 6, and 7. Disputes within the meaning of this clause include disputes between the contractor (or any of its subcontractors) and the contracting agency, the U.S. Department of Labor, or the employees or their representatives.

(11) Certification of eligibility. (i) By entering into this contract, the contractor certifies that neither it (nor he or she) nor any person or firm who has an interest in the contractor's firm is a person or firm ineligible to be awarded Government contracts by virtue of section 3(a) of the Davis-Bacon Act or 29 CFR 5.12(a)(1).

(ii) No part of this contract shall be subcontracted to any person or firm ineligible for award of a Government contract by virtue of section 3(a) of the Davis-Bacon Act or 29 CFR 5.12(a)(1).

(iii) The penalty for making false statements is prescribed in the U.S. Criminal Code, 18 U.S.C. 1001.

(b) Contract Work Hours and Safety Standards Act. The Agency Head shall cause or require the contracting officer to insert the following clauses set forth in paragraphs (b)(1), (2), (3), and (4) of this section in full in any contract in an amount in excess of \$100,000 and subject to the overtime provisions of the Contract Work Hours and Safety Standards Act. These clauses shall be inserted in addition to the clauses required by §5.5(a) or 4.6 of part 4 of this title. As used in this paragraph, the terms laborers and mechanics include watchmen and guards.

(1) Overtime requirements. No contractor or subcontractor contracting for any part of the contract work which may require or involve the employment of laborers or mechanics shall require or permit any such laborer or mechanic in any workweek in which he or she is employed on such work to work in excess of forty hours in such workweek unless such laborer or mechanic receives compensation at a rate not less than one and one-half times the basic rate of pay for all hours worked in excess of forty hours in such workweek.

(2) Violation; liability for unpaid wages; liquidated damages. In the event of any violation of the clause set forth in paragraph (b)(1) of this section the contractor and any subcontractor responsible therefor shall be liable for the unpaid wages. In addition, such contractor and subcontractor shall be liable to the United States (in the case of work done under contract for the District of Columbia or a territory, to such District or to such territory), for liquidated damages. Such liquidated damages shall be computed with respect to each individual laborer or mechanic, including watchmen and guards, employed in violation of the clause set forth in paragraph (b)(1) of this section, in the sum of \$10 for each calendar day on which such individual was required or permitted to work in excess of the standard workweek of forty hours without payment of the overtime wages required by the clause set forth in paragraph (b)(1) of this section.

(3) Withholding for unpaid wages and liquidated damages. The (write in the name of the Federal agency or the loan or grant recipient) shall upon its own action or upon written request of an authorized representative of the Department of Labor withhold or cause to be withheld, from any moneys payable on account of work performed by the contractor or subcontractor under any such contract or any other Federal contract with the same prime contractor, or any other federally-assisted contract subject to the Contract Work Hours and Safety Standards Act, which is held by the same prime contractor, such sums as may be determined to be necessary to satisfy any liabilities of such contractor or subcontractor for unpaid wages and liquidated damages as provided in the clause set forth in paragraph (b)(2) of this section.

(4) Subcontracts. The contractor or subcontractor shall insert in any subcontracts the clauses set forth in paragraph (b)(1) through (4) of this section and also a clause requiring the subcontractors to include these clauses in any lower tier subcontracts. The prime contractor shall be responsible for compliance by any subcontractor or lower tier subcontractor with the clauses set forth in paragraphs (b)(1) through (4) of this section.

(c) In addition to the clauses contained in paragraph (b), in any contract subject only to the Contract Work Hours and Safety Standards Act and not to any of the other statutes cited in §5.1, the Agency Head shall cause or require the contracting officer to insert a

clause requiring that the contractor or subcontractor shall maintain payrolls and basic payroll records during the course of the work and shall preserve them for a period of three years from the completion of the contract for all laborers and mechanics, including guards and watchmen, working on the contract. Such records shall contain the name and address of each such employee, social security number, correct classifications, hourly rates of wages paid, daily and weekly number of hours worked, deductions made, and actual wages paid. Further, the Agency Head shall cause or require the contracting officer to insert in any such contract a clause providing that the records to be maintained under this paragraph shall be made available by the contractor or subcontractor for inspection, copying, or transcription by authorized representatives of the (write the name of agency) and the Department of Labor, and the contractor or subcontractor will permit such representatives to interview employees during working hours on the job.

The information collection, recordkeeping, and reporting requirements contained in the following paragraphs of this section were approved by the Office of Management and Budget:

Paragraph	OMB Control Number
(a)(1)(ii)(B)	1215-0140
(a)(1)(ii)(C)	1215-0140
(a)(1)(iv)	1215-0140
(a)(3)(i)	1215-0140
	1215-0017
(a)(3)(ii)(A)	1215-0149
(c)	1215-0140
	1215-0017

[48 FR 19540, Apr. 29, 1983, as amended at 51 FR 12265, Apr. 9, 1986; 55 FR 50150, Dec. 4, 1990; 57 FR 28776, June 26, 1992; 58 FR 58955, Nov. 5, 1993; 61 FR 40716, Aug. 5, 1996; 65 FR 69693, Nov. 20, 2000; 73 FR 77511, Dec. 19, 2008]

**Effective Date Note:** At 58 FR 58955, Nov. 5, 1993, §5.5 was amended by suspending paragraph (a)(1)(ii) indefinitely.

### SECTION 3 CONTRACT REQUIREMENTS [24 CFR 75]

***(24 CFR 75 is applicable to HUD-funded projects awarded ON or AFTER to November 30, 2020)***

Insertion in all contracts and sub-contracts funded with Community Development Block Grant (CDBG) dollars when the CDBG Award to the Grantee is greater than \$200,000 and the CDBG Project includes Construction and/or Demolition Activities\*\*:

- A. Section 3 of the Housing and Urban Development Act of 1968: The work to be performed under this contract is subject to the requirements of Section 3 of the Housing and Urban Development Act of 1968, as amended, 12 U.S.C. 1701u (Section 3). The purpose of Section 3 is to ensure that employment and other economic opportunities generated by the U.S. Department of Housing and Urban Development (HUD) assistance or HUD-assisted projects covered by Section 3, shall, to the greatest extent feasible, be directed to low- and very low-income persons, particularly persons who are recipients of HUD assistance for housing.
- B. Contractor Certification of Compliance: The parties to this contract agree to comply with HUD's regulations in 24 CFR 75, which implement Section 3. As evidenced by their execution of this contract, the parties to this contract certify that they are under no contractual or other impediment that would prevent them from complying with the 24 CFR 75 regulations.
- C. Contract Language Requirement: The contractor agrees to include this Section 3 Contract Requirements clause in every sub-contract subject to compliance with regulations in 24 CFR 75, and agrees to take appropriate action, as provided in an applicable provision of the sub-contractor in this Section 3 Contract Requirements clause, upon a finding that the sub-contractor is in violation of the regulations in 24 CFR 75. The contractor will not sub-contract with any subcontractor where the contractor has notice or knowledge that the sub-contractor has been found in violation of the regulations in 24 CFR 75.
- D. Contracting Requirements: To the greatest extent feasible, and consistent with existing Federal, state, and local laws and regulations, the CDBG Grantee and contractors and sub-contractors for the CDBG project shall ensure contracts and sub-contracts for work awarded in connection with the project are awarded to business concerns that provide economic opportunities to Section 3 Workers; and where feasible in the following order of priority: (1) Section 3 Business concerns that provide economic opportunities to Section 3 Workers residing within the metropolitan area (or nonmetropolitan county) in which the HUD funded assistance is provided/in which the HUD funded/CDBG project is occurring; and (2) YouthBuild programs.
- E. Employment and Training Requirements: To the greatest extent feasible, and consistent with existing Federal, state, and local laws and regulations, the CDBG Grantee and contractors and sub-contractors for the CDBG project shall ensure employment and training opportunities generated in connection with the project are filled by Section 3 Workers; and where feasible, in the following order of priority: (1) low- and very low-income persons residing within the metropolitan area (or nonmetropolitan county) in which the CDBG assistance is expended (i.e., in which the CDBG project is occurring); and (2) participants in YouthBuild programs.

F. Section 3 Definitions [24 CFR 75]: Definitions for Section 3 terms per 24 CFR 75 are as follows:

- a. **Section 3 Worker:** An employee who currently fits (if hired more than five (5) years before starting work on the CDBG project), or fit at the time of hire (if hired within five (5) years of starting work on the CDBG project), at least one (1) of the following categories:
  - i. is employed by a Section 3 Business concern; or
  - ii. is a low- or very low-income resident (i.e., a local person living within the Section 3 service area as defined in 24 CFR 75.5, with an individual annualized income at the time of hire (if hired within five (5) years of starting work on the CDBG project), or currently as of date of starting work on the project (if hired more than five (5) years before starting work on the CDBG project) that was/is at or below the lowincome (80%) threshold established by HUD for a Family of 1 for the county in which the person lives) [Note: The HUD income threshold must be from the HUD Income Limits for the CDBG program that are in effect at the time of hire (if hired within five (5) years of starting work on the CDBG project), or currently in effect as of the date the worker started work on the CDBG project (if hired more than five (5) years prior to starting work on the CDBG project). The HUD Income Limits are updated annually, typically in March or April.]; or
  - iii. is a YouthBuild participant.
- b. **Targeted Section 3 Worker:** An employee who is employed by a Section 3 Business concern; or who currently fits (or when hired fit) at least one (1) of the following categories as documented within the past five (5) years:
  - i. lives/lived within the Section 3 service area or the neighborhood of the CDBG project as defined in 24 CFR 75.5; or
  - ii. is a YouthBuild participant.
- c. **Section 3 Business concern:** A business that fits at least one (1) of the following categories:
  - i. 51% or more owned by low- or very low-income persons; or
  - ii. 75% or more of the labor hours are performed by low- or very low-income persons; or
  - iii. 51% or more owned by current residents of public housing or Section 8-assisted housing.
- d. **Section 3 Service Area:** An area within one (1) mile of the CDBG project's location (i.e., street address); or an area within a circle centered around the CDBG project site that encompasses 5,000 people [if less than 5,000 people live within a one (1) mile radius of the CDBG project site].

G. Reporting Labor Hours: CDBG Grantee and contractors and sub-contractors for the CDBG project shall report all worker (see exception on next page)\* labor hours on the project as follows:

- a. the total number of labor hours worked;
- b. the total number of labor hours worked by Section 3 Workers; and

- c. the total number of labor hours worked by Targeted Section 3 Workers.

The labor hours reported shall include the total number of labor hours worked on the financially assisted project by workers employed by the CDBG Grantee, and employed by their contractors and sub-contractors, during the reporting period specified by HUD and the State CDBG Program. The labor hours reported may be based on the employer's good faith assessment of the labor hours of a full-time or part-time employee informed by the employer's Page 2 Form v.2021-12-13 existing salary or time and attendance based payroll systems, unless the project or activity is otherwise subject to requirements specifying time and attendance reporting.

[Note: Construction contractors required to maintain certified payroll records to meet federal labor standards requirements shall report actual work hours as reported on the certified payroll records.]

\*Exception for positions that require an advanced degree or professional certification: Reporting of hours for positions requiring an advanced degree or professional certification is not required, but the hours may be reported to demonstrate Section 3 "best efforts". The CDBG Grantee, contractors and sub-contractors may report the labor hours by Section 3 Workers and Targeted Section 3 Workers without including labor hours from employees in positions requiring an advanced degree or professional certification in the total number of labor hours worked, but if the contract covers both work requiring an advanced degree or professional certification and other work, the labor hours for the other work under the contract that are not from employees in positions requiring an advanced degree or professional certification must still be reported.

- H. Section 3 Benchmarks: The HUD Section 3 Final Rule (24 CFR 75) establishes "safe harbor" benchmarks that are quantitative benchmarks and prioritized qualitative efforts that funding recipients must complete to assist low- and very low-income persons with employment and training opportunities:
  - a. 25% or more of all labor hours worked must be worked by Section 3 Workers; and
  - b. 5% or more of all labor hours worked must be worked by Targeted Section 3 Workers.

If the "safe harbor" benchmarks are not met over the course of the project, then the CDBG Grantee and contractors and sub-contractors for the CDBG project shall provide evidence of completing qualitative efforts to assist low and very low-income persons with employment and training opportunities. Supporting documentation of these completed efforts must also be maintained in the CDBG Grantee's and contractors' CDBG project files, to be made available upon request for monitoring purposes.

- I. Demonstrating Best Efforts: When the Section 3 benchmarks are not met, the CDBG Grantee and contractors and sub-contractors for the CDBG project shall demonstrate and report qualitative efforts made in an attempt to meet the benchmarks, which may include but are not limited to the following:
  - a. Engage in outreach efforts to generate job applicants who are Targeted Section 3 Workers.

- b. Provide training or apprenticeship opportunities.
  - c. Provide technical assistance to help Section 3 Workers compete for jobs (e.g., resume assistance, coaching).
  - d. Provide or connect Section 3 Workers with assistance in seeking employment including: drafting resumes, preparing for interviews, and finding job opportunities connecting residents to job placement services.
  - e. Hold one or more job fairs.
  - f. Provide or refer Section 3 Workers to services supporting work readiness and retention (e.g., work readiness activities, interview clothing, test fees, transportation, child care).
  - g. Provide assistance to Section 3 Workers to apply for/or attend community college, a four-year educational institution, or vocational/technical training.
  - h. Assist Section 3 Workers to obtain financial literacy training and/or coaching.
  - i. Engage in outreach efforts to identify and secure bids from Section 3 Business concerns.
  - j. Provide technical assistance to help Section 3 Business concerns understand and bid on contracts.
  - k. Divide contracts into smaller jobs to facilitate participation by Section 3 Business concerns.
  - l. Provide bonding assistance, guaranties, or other efforts to support viable bids from Section 3 Business concerns.
  - m. Promote use of business registries designed to create opportunities for disadvantaged and small businesses.
  - n. Conduct outreach, engagement, or referrals with the state one-stop system as defined in Section 121(e)(2) of the Workforce Innovation and Opportunity Act.
- J. Recordkeeping & Reporting: The CDBG Grantee and contractors and sub-contractors for the CDBG project shall maintain all records demonstrating compliance with 24 CFR 75, including contracting information and documents, worker income certifications (for Section 3 Worker status determinations), and worker labor hours on CDBG project; and provide data and reporting documents as requested and required by the State CDBG Program and/or HUD. Grantee and contractor records may be monitored for compliance by the State CDBG Program and/or HUD.
- K. Non-Compliance: Non-compliance with HUD's regulations in 24 CFR 75 may result in sanctions, termination of this contract for default, and debarment or suspension from future HUD assisted contracts.
- L. Indian Housing Assistance Project Specifications: With respect to work performed in connection with Section 3 covered Indian housing assistance, Section 7(b) of the Indian Self-Determination and Education Assistance Act (25 U.S.C. 450e) also applies to the work to be performed under this contract. Section 7(b) requires that to the greatest extent feasible:
- i. preference and opportunities for training and employment shall be given to Indians; and
  - ii. preference in the award of contracts and sub-contracts shall be given to Indian organizations and Indian-Owned Economic Enterprises.
- Parties to this contract that are subject to the provisions of Section 3 and Section 7(b) agree to comply with Section 3 to the maximum extent feasible, but not in derogation of compliance with section 7(b).

\*\*This language is required to be included in contracts and sub-contracts for a HUD funded project that are funded in whole or in part with the federal dollars, and the CDBG/HUD Funded Award to the Grantee is greater than \$200,000 and awarded 11/30/2020 or later, and the CDBG/HUD Funded Project includes construction (including building/structural rehabilitation) and/or demolition activities. CDBG projects awarded on or after 11/30/2020, for which the CDBG/HUD funded Award is less than \$200,000 and/or for which Planning, Public Services, or Financial Assistance (e.g., loans for economic development) are the only activities, with no construction and no demolition in the project scope of work, are not subject to these Section 3 requirements and reporting.

Insertion of this Section 3 Clause is strongly recommended to be included in ALL contracts and sub-contracts for a HUD funded project that is subject to Section 3 requirements, regardless of the funding source for the specific contract, to help avoid issues with compliance and reporting later in the project cycle if the funding source changes. **All subcontractors of a prime contractor that is funded in whole or in part with CDBG/HUD funding are subject to the same Section 3 requirements as the prime contractor.**

**BUILD AMERICA, BUY AMERICA (BABA) ACT REQUIREMENTS  
COMMUNITY DEVELOPMENT BLOCK GRANT (CDBG)  
FOR CONSTRUCTION CONTRACTORS AND SUBCONTRACTORS**

**BACKGROUND INFORMATION**

The Build America, Buy America (BABA) Act, 41 USC § 8301 note, was enacted in the Infrastructure Investment and Jobs Act on November 15, 2021. The BABA Act specifies that products purchased in connection with infrastructure projects funded by Federal financial assistance (FFA) programs must be produced in the United States (U.S.). According to the BABA Act, “none of the funds made available for a Federal Financial Assistance program for infrastructure, including each deficient program, may be obligated for a project unless all of the iron, steel, manufactured products, and construction materials used in the project are produced in the United States.” This requirement is known as the “**Buy America Preference (BAP)**” (or “domestic procurement requirement”). The purpose of BABA is to stimulate private sector investments in American manufacturing, bolster critical American supply chains, and support the creation of jobs so that America’s workers and firms can complete and lead globally. Additional information is provided on the [HUD BABA website](https://www.hudexchange.info/programs/baba/) at: <https://www.hudexchange.info/programs/baba/>

**REQUIREMENTS**

The prime contractor and all subcontractors (all tiers) must comply with the requirements of the BABA Act, 41 USC 8301 note, and all applicable rules and notices, as may be amended, as applicable to the Community Development Block Grant (CDBG) infrastructure project. Pursuant to the U.S. Department of Housing and Urban Development’s (HUD’s) [CPD-2023-12](#) notice, “*Public Interest Phased Implementation Waiver for FY2022 and 2023 of Build America, Buy America Provisions as Applied to Recipients of HUD Federal Financial Assistance*” (88 FR 17001), any funds obligated by HUD on or after the applicable BAP

implementation dates listed in [88 FR 17001](#) are subject to BABA requirements, unless excepted by a waiver.

**The contractor (whether a prime contractor or subcontractor – any tier) must:**

- **ensure compliance with the BAP requirement** for all products and materials covered under BABA that are purchased for a CDBG infrastructure project, unless the project or item qualifies for a waiver or exemption; and
- **maintain records that verify compliance with the BAP** for all products and materials covered under BABA and provide them to the CDBG Grantee/unit of general local government (UGLG), State of Wisconsin Department of Administration (DOA) – Division of Energy, Housing and Community Resources (DEHCR), HUD, and/or other regulating entities upon request; and
- **receive the required approvals for any project-specific waiver request prior to purchasing** any product or material not produced in the U.S. that is covered under BABA and not eligible for a general waiver or other exemption.

General waivers and project-specific waiver categories are specified in [88 FR 17001](#).

In accordance with HUD's phased implementation plan for BABA for the CDBG program,\* iron and steel, manufactured products, and production materials purchased for infrastructure project awarded by DEHCR to a CDBG Grantee/UGLG on or after the dates listed below must be produced in the U.S. unless a waiver or exemption applies:

<u>Category:</u>	<u>CDBG Projects Subject to BABA:*</u>
Iron and steel products	Grant Awarded on or after 1/1/2023
Construction materials specifically listed in <a href="#">88 FR 17001</a>	Grant Awarded on or after 1/1/2024
Construction materials <i>not</i> specifically listed in <a href="#">88 FR 17001</a>	Grant Awarded on or after 1/1/2025
Manufactured products	Grant Awarded on or after 1/1/2025

An article, material, or supply is not to be classified into more than one category and must be made based on the status of the article, material, or supply upon arrival to the work site for use in an infrastructure project. Articles, materials, or supplies must meet the BAP for only the single category in which they are classified and, in some cases, may not fall under any of the categories listed above.

## **DEFINITIONS**

Key terms that have relevance to the interpretation and implementation of the BAP for CDBG are defined in the BABA statute and may be found in HUD Notice [CPD-2023-12](#), [2 CFR 184](#), and [OMB M-24-02](#) guidance.

## **BABA PROJECT-SPECIFIC WAIVER REQUEST PROCESS**

Waivers are explained in HUD Notice [CPD-2023-12](#) and [OMB M-24-02](#) and are required by the Infrastructure, Investments and Jobs Act (IIJA) sections 70901 through 70952 for exceptions not otherwise exempt to the BAP.

A contractor seeking a project-specific waiver must demonstrate the criteria for one or more of

the project-specific waiver categories are met. Contractors are to consult with and submit waiver requests to the Grantee/UGLG.

The contractor must submit the waiver request documentation to the CDBG Grantee/UGLG, and the CDBG Grantee/UGLG must verify that it is complete and submit it to DEHCR. DEHCR will review the documentation and if it is confirmed to be complete and in compliance, will submit the required waiver request information and additional documentation to the appropriate HUD representative for further review and processing. A waiver must be approved by DEHCR, HUD, and the [Made in America Office](#) (MIAO) prior to an entity proceeding with using any construction items subject to the BAP for the CDBG project that are not produced in the U.S.

*[Note: The waiver request review process includes a public notice requirement and the issuance of a decision by HUD and the MIAO may require six (6) weeks or more.]*

*\*Other Federal funding agencies may have different phase-in plans with different phase-in dates.*

*\*\*If the project is funded with multiple Federal funding sources, to avoid duplicative waiver requests, the Grantee/UGLG and DEHCR are to coordinate with the "Cognizant Agency" (i.e., the entity contributing the greatest amount of Federal funds to the project) to process the waiver request and submit it for approval by the Federal agency and MIAO. The Cognizant Agency is responsible for consulting with the other Federal agencies, publicizing the proposed joint waiver, and submitting the proposed joint waiver for review to the MIAO*

**Applicability**

The Project or Program to which the construction work covered by this contract pertains is being assisted by the United States of America and the following Federal Labor Standards Provisions are included in this Contract pursuant to the provisions applicable to such Federal assistance.

**A. 1. (i) Minimum Wages.** All laborers and mechanics employed or working upon the site of the work, will be paid unconditionally and not less often than once a week, and without subsequent deduction or rebate on any account (except such payroll deductions as are permitted by regulations issued by the Secretary of Labor under the Copeland Act (29 CFR Part 3), the full amount of wages and bona fide fringe benefits (or cash equivalents thereof) due at time of payment computed at rates not less than those contained in the wage determination of the Secretary of Labor which is attached hereto and made a part hereof, regardless of any contractual relationship which may be alleged to exist between the contractor and such laborers and mechanics. Contributions made or costs reasonably anticipated for bona fide fringe benefits under Section 1(b)(2) of the Davis-Bacon Act on behalf of laborers or mechanics are considered wages paid to such laborers or mechanics, subject to the provisions of 29 CFR 5.5(a)(1)(iv); also, regular contributions made or costs incurred for more than a weekly period (but not less often than quarterly) under plans, funds, or programs, which cover the particular weekly period, are deemed to be constructively made or incurred during such weekly period.

Such laborers and mechanics shall be paid the appropriate wage rate and fringe benefits on the wage determination for the classification of work actually performed, without regard to skill, except as provided in 29 CFR 5.5(a)(4). Laborers or mechanics performing work in more than one classification may be compensated at the rate specified for each classification for the time actually worked therein: Provided, That the employer's payroll records accurately set forth the time spent in each classification in which work is performed. The wage determination (including any additional classification and wage rates conformed under 29 CFR 5.5(a)(1)(ii) and the Davis-Bacon poster (WH-1321) shall be posted at all times by the contractor and its subcontractors at the site of the work in a prominent and accessible, place where it can be easily seen by the workers.

**(ii) (a)** Any class of laborers or mechanics which is not listed in the wage determination and which is to be employed under the contract shall be classified in conformance with the wage determination. HUD shall approve an additional classification and wage rate and fringe benefits therefor only when the following criteria have been met:

**(1)** The work to be performed by the classification requested is not performed by a classification in the wage determination; and

**(2)** The classification is utilized in the area by the construction industry; and

**(3)** The proposed wage rate, including any bona fide fringe benefits, bears a reasonable relationship to the wage rates contained in the wage determination.

**(b)** If the contractor and the laborers and mechanics to be employed in the classification (if known), or their representatives, and HUD or its designee agree on the classification and wage rate (including the amount designated for fringe benefits where appropriate), a report of the action taken shall be sent by HUD or its designee to the Administrator of the Wage and Hour Division, Employment Standards Administration, U. S. Department of Labor, Washington, D. C. 20210. The Administrator, or an authorized representative, will approve, modify, or disapprove every additional classification action within 30 days of receipt and so advise HUD or its designee or will notify HUD or its designee within the 30-day period that additional time is necessary. (Approved by the Office of Management and Budget under OMB control number 1215-0140.)

**(c)** In the event the contractor, the laborers or mechanics to be employed in the classification or their representatives, and HUD or its designee do not agree on the proposed classification and wage rate (including the amount designated for fringe benefits, where appropriate), HUD or its designee shall refer the questions, including the views of all interested parties and the recommendation of HUD or its designee, to the Administrator for determination. The Administrator, or an authorized representative, will issue a determination within 30 days of receipt and so advise HUD or its designee or will notify HUD or its designee within the 30-day period that additional time is necessary. (Approved by the Office of Management and Budget under OMB Control Number 1215-0140.)

**(d)** The wage rate (including fringe benefits where appropriate) determined pursuant to subparagraphs (1)(ii)(b) or (c) of this paragraph, shall be paid to all workers performing work in the classification under this contract from the first day on which work is performed in the classification.

**(iii)** Whenever the minimum wage rate prescribed in the contract for a class of laborers or mechanics includes a fringe benefit which is not expressed as an hourly rate, the contractor shall either pay the benefit as stated in the wage determination or shall pay another bona fide fringe benefit or an hourly cash equivalent thereof.

**(iv)** If the contractor does not make payments to a trustee or other third person, the contractor may consider as part

## Applicability

The Project or Program to which the construction work covered by this contract pertains is being assisted by the United States of America and the following Federal Labor Standards Provisions are included in this Contract pursuant to the provisions applicable to such Federal assistance.

**A. 1. (i) Minimum Wages.** All laborers and mechanics employed or working upon the site of the work, will be paid unconditionally and not less often than once a week, and without subsequent deduction or rebate on any account (except such payroll deductions as are permitted by regulations issued by the Secretary of Labor under the Copeland Act (29 CFR Part 3), the full amount of wages and bona fide fringe benefits (or cash equivalents thereof) due at time of payment computed at rates not less than those contained in the wage determination of the Secretary of Labor which is attached hereto and made a part hereof, regardless of any contractual relationship which may be alleged to exist between the contractor and such laborers and mechanics. Contributions made or costs reasonably anticipated for bona fide fringe benefits under Section 1(b)(2) of the Davis-Bacon Act on behalf of laborers or mechanics are considered wages paid to such laborers or mechanics, subject to the provisions of 29 CFR 5.5(a)(1)(iv); also, regular contributions made or costs incurred for more than a weekly period (but not less often than quarterly) under plans, funds, or programs, which cover the particular weekly period, are deemed to be constructively made or incurred during such weekly period.

Such laborers and mechanics shall be paid the appropriate wage rate and fringe benefits on the wage determination for the classification of work actually performed, without regard to skill, except as provided in 29 CFR 5.5(a)(4). Laborers or mechanics performing work in more than one classification may be compensated at the rate specified for each classification for the time actually worked therein: Provided, That the employer's payroll records accurately set forth the time spent in each classification in which work is performed. The wage determination (including any additional classification and wage rates conformed under 29 CFR 5.5(a)(1)(ii) and the Davis-Bacon poster (WH-1321) shall be posted at all times by the contractor and its subcontractors at the site of the work in a prominent and accessible, place where it can be easily seen by the workers.

**(ii) (a)** Any class of laborers or mechanics which is not listed in the wage determination and which is to be employed under the contract shall be classified in conformance with the wage determination. HUD shall approve an additional classification and wage rate and fringe benefits therefor only when the following criteria have been met:

**(1)** The work to be performed by the classification requested is not performed by a classification in the wage determination; and

**(2)** The classification is utilized in the area by the construction industry; and

**(3)** The proposed wage rate, including any bona fide fringe benefits, bears a reasonable relationship to the wage rates contained in the wage determination.

**(b)** If the contractor and the laborers and mechanics to be employed in the classification (if known), or their representatives, and HUD or its designee agree on the classification and wage rate (including the amount designated for fringe benefits where appropriate), a report of the action taken shall be sent by HUD or its designee to the Administrator of the Wage and Hour Division, Employment Standards Administration, U. S. Department of Labor, Washington, D. C. 20210. The Administrator, or an authorized representative, will approve, modify, or disapprove every additional classification action within 30 days of receipt and so advise HUD or its designee or will notify HUD or its designee within the 30-day period that additional time is necessary. (Approved by the Office of Management and Budget under OMB control number 1215-0140.)

**(c)** In the event the contractor, the laborers or mechanics to be employed in the classification or their representatives, and HUD or its designee do not agree on the proposed classification and wage rate (including the amount designated for fringe benefits, where appropriate), HUD or its designee shall refer the questions, including the views of all interested parties and the recommendation of HUD or its designee, to the Administrator for determination. The Administrator, or an authorized representative, will issue a determination within 30 days of receipt and so advise HUD or its designee or will notify HUD or its designee within the 30-day period that additional time is necessary. (Approved by the Office of Management and Budget under OMB Control Number 1215-0140.)

**(d)** The wage rate (including fringe benefits where appropriate) determined pursuant to subparagraphs (1)(ii)(b) or (c) of this paragraph, shall be paid to all workers performing work in the classification under this contract from the first day on which work is performed in the classification.

**(iii)** Whenever the minimum wage rate prescribed in the contract for a class of laborers or mechanics includes a fringe benefit which is not expressed as an hourly rate, the contractor shall either pay the benefit as stated in the wage determination or shall pay another bona fide fringe benefit or an hourly cash equivalent thereof.

**(iv)** If the contractor does not make payments to a trustee or other third person, the contractor may consider as part

of the wages of any laborer or mechanic the amount of any costs reasonably anticipated in providing bona fide fringe benefits under a plan or program, Provided, That the Secretary of Labor has found, upon the written request of the contractor, that the applicable standards of the Davis-Bacon Act have been met. The Secretary of Labor may require the contractor to set aside in a separate account assets for the meeting of obligations under the plan or program. (Approved by the Office of Management and Budget under OMB Control Number 1215- 0140.)

**2. Withholding.** HUD or its designee shall upon its own action or upon written request of an authorized representative of the Department of Labor withhold or cause to be withheld from the contractor under this contract or any other Federal contract with the same prime contractor, or any other Federally-assisted contract subject to Davis-Bacon prevailing wage requirements, which is held by the same prime contractor so much of the accrued payments or advances as may be considered necessary to pay laborers and mechanics, including apprentices, trainees and helpers, employed by the contractor or any subcontractor the full amount of wages required by the contract. In the event of failure to pay any laborer or mechanic, including any apprentice, trainee or helper, employed or working on the site of the work, all or part of the wages required by the contract, HUD or its designee may, after written notice to the contractor, sponsor, applicant, or owner, take such action as may be necessary to cause the suspension of any further payment, advance, or guarantee of funds until such violations have ceased. HUD or its designee may, after written notice to the contractor, disburse such amounts withheld for and on account of the contractor or subcontractor to the respective employees to whom they are due. The Comptroller General shall make such disbursements in the case of direct Davis-Bacon Act contracts.

**3. (i) Payrolls and basic records.** Payrolls and basic records relating thereto shall be maintained by the contractor during the course of the work preserved for a period of three years thereafter for all laborers and mechanics working at the site of the work. Such records shall contain the name, address, and social security number of each such worker, his or her correct classification, hourly rates of wages paid (including rates of contributions or costs anticipated for bona fide fringe benefits or cash equivalents thereof of the types described in Section I(b)(2)(B) of the Davis-bacon Act), daily and weekly number of hours worked, deductions made and actual wages paid. Whenever the Secretary of Labor has found under 29 CFR 5. 5 (a)(1)(iv) that the wages of any laborer or mechanic include the amount of any costs reasonably anticipated in providing benefits under a plan or program described in Section I (b)(2)(B) of the Davis- Bacon Act, the contractor shall maintain records which show that the commitment to provide such benefits is enforceable, that the plan or program is financially responsible, and that the plan or program has been

communicated in writing to the laborers or mechanics affected, and records which show the costs anticipated or the actual cost incurred in providing such benefits. Contractors employing apprentices or trainees under approved programs shall maintain written evidence of the registration of apprenticeship programs and certification of trainee programs, the registration of the apprentices and trainees, and the ratios and wage rates prescribed in the applicable programs. (Approved by the Office of Management and Budget under OMB Control Numbers 1215 -0140 and 1215-0017.)

**(ii) (a)** The contractor shall submit weekly for each week in which any contract work is performed a copy of all payrolls to HUD or its designee if the agency is a party to the contract, but if the agency is not such a party, the contractor will submit the payrolls to the applicant sponsor, or owner, as the case may be, for transmission to HUD or its designee. The payrolls submitted shall set out accurately and completely all of the information required to be maintained under 29 CFR 5. 5( a)( 3)(i) except that full social security numbers and home addresses shall not be included on weekly transmissions. Instead the payrolls shall only need to include an individually identifying number for each employee (e. g., the last four digits of the employee' s social security number). The required weekly payroll information may be submitted in any form desired. Optional Form WH-347 is available for this purpose from the Wage and Hour Division Web site at <http://www.dol.gov/esa/whd/forms/wh347instr.htm> or its successor site. The prime contractor is responsible for the submission of copies of payrolls by all subcontractors. Contractors and subcontractors shall maintain the full social security number and current address of each covered worker, and shall provide them upon request to HUD or its designee if the agency is a party to the contract, but if the agency is not such a party, the contractor will submit the payrolls to the applicant sponsor, or owner, as the case may be, for transmission to HUD or its designee, the contractor, or the Wage and Hour Division of the Department of Labor for purposes of an investigation or audit of compliance with prevailing wage requirements. It is not a violation of this subparagraph for a prime contractor to require a subcontractor to provide addresses and social security numbers to the prime contractor for its own records, without weekly submission to HUD or its designee. (Approved by the Office of Management and Budget under OMB Control Number 1215-0149.)

**(b)** Each payroll submitted shall be accompanied by a "Statement of Compliance," signed by the contractor or subcontractor or his or her agent who pays or supervises the payment of the persons employed under the contract and shall certify the following:

**(1)** That the payroll for the payroll period contains the information required to be provided under 29 CFR 5. 5 (a)(3)(ii), the appropriate information is being maintained under 29 CFR 5. 5( a)(3)(i), and that such information is correct and complete;

(2) That each laborer or mechanic (including each helper, apprentice, and trainee) employed on the contract during the payroll period has been paid the full weekly wages earned, without rebate, either directly or indirectly, and that no deductions have been made either directly or indirectly from the full wages earned, other than permissible deductions as set forth in 29 CFR Part 3;

(3) That each laborer or mechanic has been paid not less than the applicable wage rates and fringe benefits or cash equivalents for the classification of work performed, as specified in the applicable wage determination incorporated into the contract.

(c) The weekly submission of a properly executed certification set forth on the reverse side of Optional Form WH-347 shall satisfy the requirement for submission of the "Statement of Compliance" required by subparagraph A. 3.(ii)(b).

(d) The falsification of any of the above certifications may subject the contractor or subcontractor to civil or criminal prosecution under Section 1001 of Title 18 and Section 231 of Title 31 of the United States Code.

(iii) The contractor or subcontractor shall make the records required under subparagraph A. 3.(i) available for inspection, copying, or transcription by authorized representatives of HUD or its designee or the Department of Labor, and shall permit such representatives to interview employees during working hours on the job. If the contractor or subcontractor fails to submit the required records or to make them available, HUD or its designee may, after written notice to the contractor, sponsor, applicant or owner, take such action as may be necessary to cause the suspension of any further payment, advance, or guarantee of funds. Furthermore, failure to submit the required records upon request or to make such records available may be grounds for debarment action pursuant to 29 CFR 5.12.

#### 4. Apprentices and Trainees.

(i) **Apprentices.** Apprentices will be permitted to work at less than the predetermined rate for the work they performed when they are employed pursuant to and individually registered in a bona fide apprenticeship program registered with the U. S. Department of Labor, Employment and Training Administration, Office of Apprenticeship Training, Employer and Labor Services, or with a State Apprenticeship Agency recognized by the Office, or if a person is employed in his or her first 90 days of probationary employment as an apprentice in such an apprenticeship program, who is not individually registered in the program, but who has been certified by the Office of Apprenticeship Training, Employer and Labor Services or a State Apprenticeship Agency (where appropriate) to be eligible for probationary employment as an apprentice. The allowable ratio of apprentices to journeymen on the job site in any craft classification shall not be greater than the ratio permitted to the contractor as to the entire work force under the registered program. Any worker listed on a payroll at an apprentice wage rate, who

is not registered or otherwise employed as stated above, shall be paid not less than the applicable wage rate on the wage determination for the classification of work actually performed. In addition, any apprentice performing work on the job site in excess of the ratio permitted under the registered program shall be paid not less than the applicable wage rate on the wage determination for the work actually performed. Where a contractor is performing construction on a project in a locality other than that in which its program is registered, the ratios and wage rates (expressed in percentages of the journeyman's hourly rate) specified in the contractor's or subcontractor's registered program shall be observed. Every apprentice must be paid at not less than the rate specified in the registered program for the apprentice's level of progress, expressed as a percentage of the journeymen hourly rate specified in the applicable wage determination. Apprentices shall be paid fringe benefits in accordance with the provisions of the apprenticeship program. If the apprenticeship program does not specify fringe benefits, apprentices must be paid the full amount of fringe benefits listed on the wage determination for the applicable classification. If the Administrator determines that a different practice prevails for the applicable apprentice classification, fringes shall be paid in accordance with that determination. In the event the Office of Apprenticeship Training, Employer and Labor Services, or a State Apprenticeship Agency recognized by the Office, withdraws approval of an apprenticeship program, the contractor will no longer be permitted to utilize apprentices at less than the applicable predetermined rate for the work performed until an acceptable program is approved.

(ii) **Trainees.** Except as provided in 29 CFR 5.16, trainees will not be permitted to work at less than the predetermined rate for the work performed unless they are employed pursuant to and individually registered in a program which has received prior approval, evidenced by formal certification by the U. S. Department of Labor, Employment and Training Administration. The ratio of trainees to journeymen on the job site shall not be greater than permitted under the plan approved by the Employment and Training Administration. Every trainee must be paid at not less than the rate specified in the approved program for the trainee's level of progress, expressed as a percentage of the journeyman hourly rate specified in the applicable wage determination. Trainees shall be paid fringe benefits in accordance with the provisions of the trainee program. If the trainee program does not mention fringe benefits, trainees shall be paid the full amount of fringe benefits listed on the wage determination unless the Administrator of the Wage and Hour Division determines that there is an apprenticeship program associated with the corresponding journeyman wage rate on the wage determination which provides for less than full fringe benefits for apprentices. Any employee listed on the payroll at a trainee rate who is not registered and participating in a training plan approved by

form HUD-4010 (06/2009)

the Employment and Training Administration shall be paid not less than the applicable wage rate on the wage determination for the work actually performed. In addition, any trainee performing work on the job site in excess of the ratio permitted under the registered program shall be paid not less than the applicable wage rate on the wage determination for the work actually performed. In the event the Employment and Training Administration withdraws approval of a training program, the contractor will no longer be permitted to utilize trainees at less than the applicable predetermined rate for the work performed until an acceptable program is approved.

**(iii) Equal employment opportunity.** The utilization of apprentices, trainees and journeymen under 29 CFR Part 5 shall be in conformity with the equal employment opportunity requirements of Executive Order 11246, as amended, and 29 CFR Part 30.

**5. Compliance with Copeland Act requirements.** The contractor shall comply with the requirements of 29 CFR Part 3 which are incorporated by reference in this contract

**6. Subcontracts.** The contractor or subcontractor will insert in any subcontracts the clauses contained in subparagraphs 1 through 11 in this paragraph A and such other clauses as HUD or its designee may by appropriate instructions require, and a copy of the applicable prevailing wage decision, and also a clause requiring the subcontractors to include these clauses in any lower tier subcontracts. The prime contractor shall be responsible for the compliance by any subcontractor or lower tier subcontractor with all the contract clauses in this paragraph.

**7. Contract termination; debarment.** A breach of the contract clauses in 29 CFR 5.5 may be grounds for termination of the contract and for debarment as a contractor and a subcontractor as provided in 29 CFR 5.12.

**8. Compliance with Davis-Bacon and Related Act Requirements.** All rulings and interpretations of the Davis-Bacon and Related Acts contained in 29 CFR Parts 1, 3, and 5 are herein incorporated by reference in this contract

**9. Disputes concerning labor standards.** Disputes arising out of the labor standards provisions of this contract shall not be subject to the general disputes clause of this contract. Such disputes shall be resolved in accordance with the procedures of the Department of Labor set forth in 29 CFR Parts 5, 6, and 7. Disputes within the meaning of this clause include disputes between the contractor (or any of its subcontractors) and HUD or its designee, the U. S. Department of Labor, or the employees or their representatives.

**10. (i) Certification of Eligibility.** By entering into this contract the contractor certifies that neither it (nor he or she) nor any person or firm who has an interest in the contractor's firm is a person or firm ineligible to be awarded Government contracts by virtue of Section 3 (a) of the Davis-Bacon Act or 29 CFR 5.12 (a)(1) or to be

awarded HUD contracts or participate in HUD programs pursuant to 24 CFR Part 24.

**(ii)** No part of this contract shall be subcontracted to any person or firm ineligible for award of a Government contract by virtue of Section 3 (a) of the Davis-Bacon Act or 29 CFR 5.12 (a)(1) or to be awarded HUD contracts or participate in HUD programs pursuant to 24 CFR Part 24 .

**(iii)** The penalty for making false statements is prescribed in the U. S. Criminal Code, 18 U. S. C. 1001. Additionally, U. S. Criminal Code, Section 1010, Title 18, U.S.C., "Federal Housing Administration transactions", provides in part: "Whoever, for the purpose of . . . influencing in any way the action of such Administration . . . makes, utters or publishes any statement knowing the same to be false . . .

shall be fined not more than \$5,000 or imprisoned not more than two years, or both."

**11. Complaints, Proceedings, or Testimony by Employees.** No laborer or mechanic to whom the wage, salary, or other labor standards provisions of this Contract are applicable shall be discharged or in any other manner discriminated against by the Contractor or any subcontractor because such employee has filed any complaint or instituted or caused to be instituted any proceeding or has testified or is about to testify in any proceeding under or relating to the labor standards applicable under this Contract to his employer.

**B. Contract Work Hours and Safety Standards Act.** The provisions of this paragraph B are applicable where the amount of the prime contract exceeds \$100,000. As used in this paragraph, the terms "laborers" and "mechanics" include watchmen and guards.

**(1) Overtime requirements.** No contractor or subcontractor contracting for any part of the contract work which may require or involve the employment of laborers or mechanics shall require or permit any such laborer or mechanic in any workweek in which the individual is employed on such work to work in excess of 40 hours in such workweek unless such laborer or mechanic receives compensation at a rate not less than one and one-half times the basic rate of pay for all hours worked in excess of 40 hours in such workweek.

**(2) Violation; Liability for unpaid wages; Liquidated damages.** In the event of any violation of the clause set forth in subparagraph (1) of this paragraph, the contractor and any subcontractor responsible therefor shall be liable for the unpaid wages. In addition, such contractor and subcontractor shall be liable to the United States (in the case of work done under contract for the District of Columbia or a territory, to such District or to such territory), for liquidated damages. Such liquidated damages shall be computed with respect to each individual laborer or mechanic, including watchmen and guards, employed in violation of the clause set forth in subparagraph (1) of this paragraph, in the sum of \$10 for each calendar day on which such individual was required or permitted to work in excess of the standard workweek of 40 hours without payment of the overtime wages required by the clause set forth in subparagraph (1) of this paragraph.

---

**(3) Withholding for unpaid wages and liquidated damages.** HUD or its designee shall upon its own action or upon written request of an authorized representative of the Department of Labor withhold or cause to be withheld, from any moneys payable on account of work performed by the contractor or subcontractor under any such contract or any other Federal contract with the same prime contract, or any other Federally- assisted contract subject to the Contract Work Hours and Safety Standards Act which is held by the same prime contractor such sums as may be determined to be necessary to satisfy any liabilities of such contractor or subcontractor for unpaid wages and liquidated damages as provided in the clause set forth in subparagraph (2) of this paragraph.

**(4) Subcontracts.** The contractor or subcontractor shall insert in any subcontracts the clauses set forth in subparagraph (1) through (4) of this paragraph and also a clause requiring the subcontractors to include these clauses in any lower tier subcontracts. The prime contractor shall be responsible for compliance by any subcontractor or lower tier subcontractor with the clauses set forth in subparagraphs (1) through (4) of this paragraph.

**C. Health and Safety.** The provisions of this paragraph C are applicable where the amount of the prime contract exceeds \$100,000.

**(1)** No laborer or mechanic shall be required to work in surroundings or under working conditions which are unsanitary, hazardous, or dangerous to his health and safety as determined under construction safety and health standards promulgated by the Secretary of Labor by regulation.

**(2)** The Contractor shall comply with all regulations issued by the Secretary of Labor pursuant to Title 29 Part 1926 and failure to comply may result in imposition of sanctions pursuant to the Contract Work Hours and Safety Standards Act, (Public Law 91- 54, 83 Stat 96). 40 USC 3701 et seq.

**(3)** The contractor shall include the provisions of this paragraph in every subcontract so that such provisions will be binding on each subcontractor. The contractor shall take such action with respect to any subcontractor as the Secretary of Housing and Urban Development or the Secretary of Labor shall direct as a means of enforcing such provisions.

## Davis Bacon Wage Determination

### EXAMPLE ONLY

**Rate at the time of the bid is what is used and is only updated 10 days prior to the bid due date.**

**General Decision Number: AZ20240012 03/22/2024**

**Superseded General Decision Number: AZ20230012**

**State: Arizona**

**Construction Type: Residential**

**Counties: Coconino and Yavapai Counties in Arizona.**

EXCLUDING NAVAJO INDIAN RESERVATION

RESIDENTIAL CONSTRUCTION PROJECTS (consisting of single family homes and apartments up to and including 4 stories).

Note: Contracts subject to the Davis-Bacon Act are generally required to pay at least the applicable minimum wage rate required under Executive Order 14026 or Executive Order 13658.

Please note that these Executive Orders apply to covered contracts entered into by the federal government that are subject to the Davis-Bacon Act itself, but do not apply to contracts subject only to the Davis-Bacon Related Acts, including those set forth at 29 CFR 5.1(a)(1)

---

If the contract is entered  into on or after January 30,  2022, or the contract is  renewed or extended (e.g., an  option is exercised) on or  after January 30, 2022:             	. Executive Order 14026    generally applies to the    contract.    . The contractor must pay    all covered workers at    least \$17.20 per hour (or    the applicable wage rate    listed on this wage    determination, if it is    higher) for all hours    spent performing on the    contract in 2024.
If the contract was awarded on  or between January 1, 2015 and  January 29, 2022, and the  contract is not renewed or  extended on or after January  30, 2022:         	. Executive Order 13658    generally applies to the    contract.    . The contractor must pay all    covered workers at least    \$12.90 per hour (or the    applicable wage rate listed    on this wage determination,    if it is higher) for all    hours spent performing on    that contract in 2024.

The applicable Executive Order minimum wage rate will be adjusted annually. If this contract is covered by one of the Executive Orders and a classification considered necessary for performance of work on the contract does not appear on this wage determination, the contractor must still submit a conformance request.

Additional information on contractor requirements and worker protections under the Executive Orders is available at <http://www.dol.gov/whd/govcontracts>.

**Modification Number    Publication Date**

<b>0</b>	<b>01/05/2024</b>
<b>1</b>	<b>01/19/2024</b>
<b>2</b>	<b>03/22/2024</b>

-----

BRAZ0003-007 07/01/2023

	Rates	Fringes
BRICKLAYER.....	\$ 32.74	9.52

**ZONE PAY:**

(Radius miles from the intersection of Central Ave. and Washington St., Phoenix, AZ)

- Zone A: 0-60 miles- Base Rate
- Zone B: 61-75 miles- Base Rate plus \$2.00 per hour
- Zone C: 75-100 miles- Base Rate plus \$3.00 per hour
- Zone D: 101-200 miles- Base Rate plus \$3.50 per hour
- Zone E: Over 200 miles- Base Rate plus \$6.50 per hour

-----

ELEC0518-002 01/01/2018

	Rates	Fringes
ELECTRICIAN.....	\$ 17.50	7.57

-----

ENGI0428-005 06/01/2022

	Rates	Fringes
POWER EQUIPMENT OPERATOR (Grader/Blade).....	\$ 34.49	12.57

-----  
IRON0075-008 10/01/2023

	Rates	Fringes
IRONWORKER, STRUCTURAL.....	\$ 32.00	18.91

-----  
\* PLAS0394-006 01/01/2024

	Rates	Fringes
CEMENT MASON/CONCRETE FINISHER...	\$ 28.78	9.17

-----  
\* SUAZ2011-005 07/28/2011

	Rates	Fringes
CARPENTER, Excludes Drywall Hanging.....	\$ 18.16	0.00
FORM WORKER.....	\$ 14.37 **	0.00
HVAC MECHANIC (Installation of HVAC Duct).....	\$ 14.13 **	0.00
LABORER: Common or General.....	\$ 10.20 **	0.00
LABORER: Mason Tender - Brick...	\$ 12.77 **	0.00
LABORER: Mason Tender - Cement/Concrete/Stone.....	\$ 11.00 **	0.00

LABORER: Pipelayer.....	\$ 13.00 **	0.00
OPERATOR: Backhoe.....	\$ 18.29	0.00
OPERATOR: Excavator.....	\$ 24.67	0.00
OPERATOR: Forklift.....	\$ 16.00 **	0.00
OPERATOR: Loader (Front End)....	\$ 15.00 **	0.00
OPERATOR: Paver (Asphalt, Aggregate, and Concrete).....	\$ 20.75	0.00
OPERATOR: Roller .....	\$ 16.24 **	1.42
OPERATOR: Scraper.....	\$ 19.20	1.52
OPERATOR: Tractor .....	\$ 20.98	0.00
PAINTER: Brush, Roller and Spray .....	\$ 13.31 **	0.00
PLUMBER.....	\$ 20.14	4.08
ROOFER.....	\$ 13.67 **	0.00
TRUCK DRIVER: Dump Truck.....	\$ 17.02 **	0.00
TRUCK DRIVER: Water Truck.....	\$ 14.50 **	0.00

-----  
WELDERS - Receive rate prescribed for craft performing operation to which welding is incidental.

\*\* Workers in this classification may be entitled to a higher minimum wage under Executive Order 14026 (\$17.20) or 13658 (\$12.90). Please see the Note at the top of the wage determination for more information. Please also note that the minimum wage requirements of Executive Order 14026 are not currently being enforced as to any contract or subcontract to which the states of Texas, Louisiana, or Mississippi, including their agencies, are a party.

Note: Executive Order (EO) 13706, Establishing Paid Sick Leave for Federal Contractors applies to all contracts subject to the Davis-Bacon Act for which the contract is awarded (and any solicitation was issued) on or after January 1, 2017. If this contract is covered by the EO, the contractor must provide employees with 1 hour of paid sick leave for every 30 hours they work, up to 56 hours of paid sick leave each year.

Employees must be permitted to use paid sick leave for their own illness, injury or other health-related needs, including preventive care; to assist a family member (or person who is like family to the employee) who is ill, injured, or has other health-related needs, including preventive care; or for reasons resulting from, or to assist a family member (or person who is like family to the employee) who is a victim of, domestic violence, sexual assault, or stalking. Additional information on contractor requirements and worker protections under the EO is available at: <https://www.dol.gov/agencies/whd/government-contracts>.

Unlisted classifications needed for work not included within the scope of the classifications listed may be added after award only as provided in the labor standards contract clauses (29CFR 5.5 (a) (1) (iii)).

-----

The body of each wage determination lists the classification and wage rates that have been found to be prevailing for the cited type(s) of construction in the area covered by the wage determination. The classifications are listed in alphabetical order of ""identifiers"" that indicate whether the particular rate is a union rate (current union negotiated rate for local), a survey rate (weighted average rate) or a union average rate (weighted union average rate).

#### Union Rate Identifiers

A four letter classification abbreviation identifier enclosed in dotted lines beginning with characters other than ""SU"" or ""UAVG"" denotes that the union classification and rate were prevailing for that classification in the survey.

Example:

PLUM0198-005 07/01/2014.

PLUM is an abbreviation identifier of the union which prevailed in the survey for this classification, which in this example would be Plumbers.

0198 indicates the local union number or district council number where applicable, i.e., Plumbers Local 0198.

The next number, 005 in the example, is an internal number used in processing the wage determination. 07/01/2014 is the effective date of the most current negotiated rate, which in this example is July 1, 2014.

Union prevailing wage rates are updated to reflect all rate changes in the collective bargaining agreement (CBA) governing this classification and rate.

## Survey Rate Identifiers

Classifications listed under the "SU" identifier indicate that no one rate prevailed for this classification in the survey and the published rate is derived by computing a weighted average rate based on all the rates reported in the survey for that classification. As this weighted average rate includes all rates reported in the survey, it may include both union and non-union rates.

Example:

SULA2012-007 5/13/2014.

SU indicates the rates are survey rates based on a weighted average calculation of rates and are not majority rates. LA indicates the State of Louisiana. 2012 is the year of survey on which these classifications and rates are based. The next number, 007 in the example, is an internal number used in producing the wage determination. 5/13/2014 indicates the survey completion date for the classifications and rates under that identifier.

Survey wage rates are not updated and remain in effect until a new survey is conducted.

## Union Average Rate Identifiers

Classification(s) listed under the UAVG identifier indicate that no single majority rate prevailed for those classifications; however, 100% of the data reported for the classifications was union data.

EXAMPLE:

UAVG-OH-0010 08/29/2014.

UAVG indicates that the rate is a weighted union average rate. OH indicates the state.

The next number, 0010 in the example, is an internal number used in producing the wage determination. 08/29/2014 indicates the survey completion date for the classifications and rates under that identifier.

A UAVG rate will be updated once a year, usually in January of each year, to reflect a weighted average of the current negotiated/CBA rate of the union locals from which the rate is based.

-----

## WAGE DETERMINATION APPEALS PROCESS

1.) Has there been an initial decision in the matter? This can be:

- \* an existing published wage determination
- \* a survey underlying a wage determination
- \* a Wage and Hour Division letter setting forth a position on a wage determination matter
- \* a conformance (additional classification and rate) ruling

On survey related matters, initial contact, including requests for summaries of surveys, should be with the Wage and Hour National Office because National Office has responsibility for the Davis-Bacon survey program. If the response from this initial contact is not satisfactory, then the process described in 2.) and 3.) should be followed.

With regard to any other matter not yet ripe for the formal process described here, initial contact should be with the Branch of Construction Wage Determinations.

Write to:

Branch of Construction Wage Determinations  
Wage and Hour Division  
U.S. Department of Labor  
200 Constitution Avenue, N.W.  
Washington, DC 20210

2.) If the answer to the question in 1.) is yes, then an interested party (those affected by the action) can request review and reconsideration from the Wage and Hour Administrator (See 29 CFR Part 1.8 and 29 CFR Part 7).

Write to:

Wage and Hour Administrator  
U.S. Department of Labor  
200 Constitution Avenue, N.W.  
Washington, DC 20210

The request should be accompanied by a full statement of the interested party's position and by any information (wage payment data, project description, area practice material, etc.) that the requestor considers relevant to the issue.

3.) If the decision of the Administrator is not favorable, an interested party may appeal directly to the Administrative Review Board (formerly the Wage Appeals Board).

Write to:

Administrative Review Board  
U.S. Department of Labor  
200 Constitution Avenue, N.W.  
Washington, DC 20210

4.) All decisions by the Administrative Review Board are final.

=====

END OF GENERAL DECISION"

## Agreement Form

**Subcontractor Information:**

---

---

---

---

**Agency Information:**

---

---

---

---

I, the below signed subcontractor, have read and agree to all items in the Grant Provisions for Community Development Block Grant Construction Contracts.

Please Sign Below:

**Subcontractor Signature:** \_\_\_\_\_

**Date:** \_\_\_\_\_

**Agency Signature:** \_\_\_\_\_

**Date:** \_\_\_\_\_

## Reporting and Misc. Documents

## Fact Sheet #66: The Davis-Bacon and Related Acts (DBRA)

This fact sheet provides general information concerning DBRA.

### Coverage

DBRA requires payment of prevailing wages on federally funded or assisted construction projects.

The [Davis-Bacon Act](#) applies to each federal government or District of Columbia contract in excess of \$2,000 for the construction, alteration, or repair (including painting and decorating) of [public buildings or public works](#). Many federal laws that authorize federal assistance for construction through grants, loans, loan guarantees, and insurance are Davis-Bacon “related Acts.” The “related Acts” include provisions that require Davis-Bacon labor standards apply to most federally assisted construction. Examples of “related Acts” include the Federal-Aid Highway Acts, the Housing and Community Development Act of 1974, and the Federal Water Pollution Control Act.

### Basic Provisions/Requirements

Contractors and subcontractors must pay [laborers and mechanics employed](#) directly upon the [site of the work](#) at least the locally prevailing wages (including fringe benefits), listed in the Davis-Bacon wage determination in the contract, for the work performed. [Davis-Bacon labor standards clauses](#) must be included in covered contracts.

The Davis-Bacon “prevailing wage” is the combination of the basic hourly rate and any fringe benefits listed in a Davis-Bacon wage determination. The contractor’s obligation to pay at least the prevailing wage listed in the contract wage determination can be met by paying each laborer and mechanic the applicable prevailing wage entirely as cash wages or by a combination of cash wages and employer-provided bona fide fringe benefits. Prevailing wages, including fringe benefits, must be paid on all hours worked on the site of the work.

Apprentices or trainees may be employed at less than the rates listed in the contract wage determination only when they are in an apprenticeship program registered with the Department of Labor or with a state apprenticeship agency recognized by the Department.

Contractors and subcontractors are required to pay covered workers weekly and submit weekly certified payroll records to the contracting agency. They are also required to post the applicable Davis-Bacon wage determination with the [Davis-Bacon poster \(WH-1321\)](#) on the job site in a prominent and accessible place where they can be easily seen by the workers.

### Davis-Bacon Wage Determinations

Davis-Bacon wage determinations are published on the Wage Determinations On Line ([WDOL website](#)) for contracting agencies to incorporate them into covered contracts. The “prevailing wages” are determined based on wages paid to various classes of laborers and mechanics employed on specific types of construction projects in an area. Guidance on determining the type of construction is provided in All Agency Memoranda [Nos. 130](#) and [131](#).

## Penalties/Sanctions and Appeals

Contract payments may be withheld in sufficient amounts to satisfy liabilities for underpayment of wages and for liquidated damages for overtime violations under the Contract Work Hours and Safety Standards Act (CWHSSA). In addition, violations of the Davis-Bacon contract clauses may be grounds for contract termination, contractor liability for any resulting costs to the government and debarment from future contracts for a period up to three years.

Contractors and subcontractors may challenge determinations of violations and debarment before an Administrative Law Judge (ALJ). Interested parties may appeal ALJ decisions to the Department's Administrative Review Board. Final Board determinations on violations and debarment may be appealed to and are enforceable through the federal courts.

## Typical Problems

(1) Misclassification of laborers and mechanics. (2) Failure to pay full prevailing wage, including fringe benefits, for all hours worked (including overtime hours). (3) Inadequate recordkeeping, such as not counting all hours worked or not recording hours worked by an individual in two or more classifications during a day. (4) Failure of to maintain a copy of bona fide apprenticeship program and individual registration documents for apprentices. (5) Failure to submit certified payrolls weekly. (6) Failure to post the Davis-Bacon poster and applicable wage determination.

## Relation to State, Local, and Other Federal Laws

The [Copeland "Anti-Kickback" Act](#) prohibits contractors from in any way inducing an employee to give up any part of the compensation to which he or she is entitled under his or her contract of employment, and requires contractors to submit a weekly statement of the wages paid to each employee performing DBRA covered work.

Contractors on projects subject to DBRA labor standards may also be subject to additional prevailing wage and overtime pay requirements under State (and local) laws. Also, overtime work pay requirements under CWHSSA) and the [Fair Labor Standards Act](#) may apply.

Under [Reorganization Plan No. 14 of 1950](#), (5 U.S.C.A. Appendix), the federal contracting or assistance-administering agencies have day-to-day responsibility for administration and enforcement of the Davis-Bacon labor standards provisions and, in order to promote consistent and effective enforcement, the Department of Labor has regulatory and oversight authority, including the authority to investigate compliance.

## Where to Obtain Additional Information

For additional information, visit our Wage and Hour Division Website: <http://www.wagehour.dol.gov> and/or call our toll-free information and helpline, available 8 a.m. to 5 p.m. in your time zone, 1-866-4USWAGE (1-866-487-9243).

This publication is for general information and is not to be considered in the same light as official statements of position contained in the regulations.

**U.S. Department of Labor**  
Frances Perkins Building  
200 Constitution Avenue, NW  
Washington, DC 20210

**1-866-4-USWAGE**  
TTY: 1-866-487-9243  
[Contact Us](#)

# EMPLOYEE RIGHTS UNDER THE DAVIS-BACON ACT

## FOR LABORERS AND MECHANICS EMPLOYED ON FEDERAL OR FEDERALLY ASSISTED CONSTRUCTION PROJECTS

THE UNITED STATES DEPARTMENT OF LABOR WAGE AND HOUR DIVISION

### PREVAILING WAGES

You must be paid not less than the wage rate listed in the Davis-Bacon Wage Decision posted with this Notice for the work you perform.

### OVERTIME

You must be paid not less than one and one-half times your basic rate of pay for all hours worked over 40 in a work week. There are few exceptions.

### ENFORCEMENT

Contract payments can be withheld to ensure workers receive wages and overtime pay due, and liquidated damages may apply if overtime pay requirements are not met. Davis-Bacon contract clauses allow contract termination and debarment of contractors from future federal contracts for up to three years. A contractor who falsifies certified payroll records or induces wage kickbacks may be subject to civil or criminal prosecution, fines and/or imprisonment.

### APPRENTICES

Apprentice rates apply only to apprentices properly registered under approved Federal or State apprenticeship programs.

### PROPER PAY

If you do not receive proper pay, or require further information on the applicable wages, contact the Contracting Officer listed below:

or contact the U.S. Department of Labor's Wage and Hour Division.



For additional information:

**1-866-4-USWAGE**  
(1-866-487-9243) TTY: 1-877-889-5627



**WWW.WAGEHOUR.DOL.GOV**

# Equal Employment Opportunity is

# THE LAW

## Private Employers, State and Local Governments, Educational Institutions, Employment Agencies and Labor Organizations

Applicants to and employees of most private employers, state and local governments, educational institutions, employment agencies and labor organizations are protected under Federal law from discrimination on the following bases:

### **RACE, COLOR, RELIGION, SEX, NATIONAL ORIGIN**

Title VII of the Civil Rights Act of 1964, as amended, protects applicants and employees from discrimination in hiring, promotion, discharge, pay, fringe benefits, job training, classification, referral, and other aspects of employment, on the basis of race, color, religion, sex (including pregnancy), or national origin. Religious discrimination includes failing to reasonably accommodate an employee's religious practices where the accommodation does not impose undue hardship.

### **DISABILITY**

Title I and Title V of the Americans with Disabilities Act of 1990, as amended, protect qualified individuals from discrimination on the basis of disability in hiring, promotion, discharge, pay, fringe benefits, job training, classification, referral, and other aspects of employment. Disability discrimination includes not making reasonable accommodation to the known physical or mental limitations of an otherwise qualified individual with a disability who is an applicant or employee, barring undue hardship.

### **AGE**

The Age Discrimination in Employment Act of 1967, as amended, protects applicants and employees 40 years of age or older from discrimination based on age in hiring, promotion, discharge, pay, fringe benefits, job training, classification, referral, and other aspects of employment.

### **SEX (WAGES)**

In addition to sex discrimination prohibited by Title VII of the Civil Rights Act, as amended, the Equal Pay Act of 1963, as amended, prohibits sex discrimination in the payment of wages to women and men performing substantially equal work, in jobs that require equal skill, effort, and responsibility, under similar working conditions, in the same establishment.

### **GENETICS**

Title II of the Genetic Information Nondiscrimination Act of 2008 protects applicants and employees from discrimination based on genetic information in hiring, promotion, discharge, pay, fringe benefits, job training, classification, referral, and other aspects of employment. GINA also restricts employers' acquisition of genetic information and strictly limits disclosure of genetic information. Genetic information includes information about genetic tests of applicants, employees, or their family members; the manifestation of diseases or disorders in family members (family medical history); and requests for or receipt of genetic services by applicants, employees, or their family members.

### **RETALIATION**

All of these Federal laws prohibit covered entities from retaliating against a person who files a charge of discrimination, participates in a discrimination proceeding, or otherwise opposes an unlawful employment practice.

### **WHAT TO DO IF YOU BELIEVE DISCRIMINATION HAS OCCURRED**

There are strict time limits for filing charges of employment discrimination. To preserve the ability of EEOC to act on your behalf and to protect your right to file a private lawsuit, should you ultimately need to, you should contact EEOC promptly when discrimination is suspected:

The U.S. Equal Employment Opportunity Commission (EEOC), 1-800-669-4000 (toll-free) or 1-800-669-6820 (toll-free TTY number for individuals with hearing impairments). EEOC field office information is available at [www.eeoc.gov](http://www.eeoc.gov) or in most telephone directories in the U.S. Government or Federal Government section. Additional information about EEOC, including information about charge filing, is available at [www.eeoc.gov](http://www.eeoc.gov).

---

## Employers Holding Federal Contracts or Subcontracts

Applicants to and employees of companies with a Federal government contract or subcontract are protected under Federal law from discrimination on the following bases:

### **RACE, COLOR, RELIGION, SEX, NATIONAL ORIGIN**

Executive Order 11246, as amended, prohibits job discrimination on the basis of race, color, religion, sex or national origin, and requires affirmative action to ensure equality of opportunity in all aspects of employment.

### **INDIVIDUALS WITH DISABILITIES**

Section 503 of the Rehabilitation Act of 1973, as amended, protects qualified individuals from discrimination on the basis of disability in hiring, promotion, discharge, pay, fringe benefits, job training, classification, referral, and other aspects of employment. Disability discrimination includes not making reasonable accommodation to the known physical or mental limitations of an otherwise qualified individual with a disability who is an applicant or employee, barring undue hardship. Section 503 also requires that Federal contractors take affirmative action to employ and advance in employment qualified individuals with disabilities at all levels of employment, including the executive level.

### **DISABLED, RECENTLY SEPARATED, OTHER PROTECTED, AND ARMED FORCES SERVICE MEDAL VETERANS**

The Vietnam Era Veterans' Readjustment Assistance Act of 1974, as amended, 38 U.S.C. 4212, prohibits job discrimination and requires affirmative action to employ and advance in employment disabled veterans, recently separated veterans (within

three years of discharge or release from active duty), other protected veterans (veterans who served during a war or in a campaign or expedition for which a campaign badge has been authorized), and Armed Forces service medal veterans (veterans who, while on active duty, participated in a U.S. military operation for which an Armed Forces service medal was awarded).

### **RETALIATION**

Retaliation is prohibited against a person who files a complaint of discrimination, participates in an OFCCP proceeding, or otherwise opposes discrimination under these Federal laws.

Any person who believes a contractor has violated its nondiscrimination or affirmative action obligations under the authorities above should contact immediately:

The Office of Federal Contract Compliance Programs (OFCCP), U.S. Department of Labor, 200 Constitution Avenue, N.W., Washington, D.C. 20210, 1-800-397-6251 (toll-free) or (202) 693-1337 (TTY). OFCCP may also be contacted by e-mail at [OFCCP-Public@dol.gov](mailto:OFCCP-Public@dol.gov), or by calling an OFCCP regional or district office, listed in most telephone directories under U.S. Government, Department of Labor.

---

## Programs or Activities Receiving Federal Financial Assistance

### **RACE, COLOR, NATIONAL ORIGIN, SEX**

In addition to the protections of Title VII of the Civil Rights Act of 1964, as amended, Title VI of the Civil Rights Act of 1964, as amended, prohibits discrimination on the basis of race, color or national origin in programs or activities receiving Federal financial assistance. Employment discrimination is covered by Title VI if the primary objective of the financial assistance is provision of employment, or where employment discrimination causes or may cause discrimination in providing services under such programs. Title IX of the Education Amendments of 1972 prohibits employment discrimination on the basis of sex in educational programs or activities which receive Federal financial assistance.

### **INDIVIDUALS WITH DISABILITIES**

Section 504 of the Rehabilitation Act of 1973, as amended, prohibits employment discrimination on the basis of disability in any program or activity which receives Federal financial assistance. Discrimination is prohibited in all aspects of employment against persons with disabilities who, with or without reasonable accommodation, can perform the essential functions of the job.

If you believe you have been discriminated against in a program of any institution which receives Federal financial assistance, you should immediately contact the Federal agency providing such assistance.

**PAYROLL**  
**(For Contractor's Optional Use; See Instructions at [www.dol.gov/whd/forms/wh347instr.htm](http://www.dol.gov/whd/forms/wh347instr.htm))**



*Persons are not required to respond to the collection of information unless it displays a currently valid OMB control number.*

Rev. Dec. 2008

NAME OF CONTRACTOR  OR SUBCONTRACTOR  ADDRESS OMB No.: 1235-0008  
Expires: 02/28/2018

PAYROLL NO.	FOR WEEK ENDING	PROJECT AND LOCATION	PROJECT OR CONTRACT NO.															
(1) NAME AND INDIVIDUAL IDENTIFYING NUMBER (e.g., LAST FOUR DIGITS OF SOCIAL SECURITY NUMBER) OF WORKER	(2) NO. OF WITHHOLDING EXEMPTIONS	(3) WORK CLASSIFICATION	(4) DAY AND DATE							(5) TOTAL HOURS	(6) RATE OF PAY	(7) GROSS AMOUNT EARNED	(8) DEDUCTIONS				(9) NET WAGES PAID FOR WEEK	
			OT	OR	S									FICA	WITH-HOLDING TAX	OTHER		TOTAL DEDUCTIONS
			O															
			S															
			O															
			S															
			O															
			S															
			O															
			S															
			O															
			S															

While completion of Form WH-347 is optional, it is mandatory for covered contractors and subcontractors performing work on Federally financed or assisted construction contracts to respond to the information collection contained in 29 C.F.R. §§ 3.3, 5.5(a). The Copeland Act (40 U.S.C. § 3145) contractors and subcontractors performing work on Federally financed or assisted construction contracts to "furnish weekly a statement with respect to the wages paid each employee during the preceding week." U.S. Department of Labor (DOL) regulations at 29 C.F.R. § 5.5(a)(3)(ii) require contractors to submit weekly a copy of all payrolls to the Federal agency contracting for or financing the construction project, accompanied by a signed "Statement of Compliance" indicating that the payrolls are correct and complete and that each laborer or mechanic has been paid not less than the proper Davis-Bacon prevailing wage rate for the work performed. DOL and federal contracting agencies receiving this information review the information to determine that employees have received legally required wages and fringe benefits.

**Public Burden Statement** We estimate that it will take an average of 55 minutes to complete this collection, including time for reviewing instructions, searching existing data sources, gathering and maintaining the data needed, and completing and reviewing the collection of information. If you have any comments regarding these estimates or any other aspect of this collection, including suggestions for reducing this burden, send them to the Administrator, Wage and Hour Division, U.S. Department of Labor, Room S3502, 200 Constitution Avenue, N.W.



**Wage/Fringe Benefit Certification**

(To be completed by contractor/subcontractors prior to contract award.)

GRANTEE: \_\_\_\_\_

GRANT: \_\_\_\_\_

PROJECT: \_\_\_\_\_

This is to certify that plans to use the following classifications of workers on the above referenced project:

From Applicable Wage Decision				Base Wage to be paid by Contractor	Fringe Benefits to be provided by Contractor		Total Package to be paid by Contractor
Classification	Base Wage	Fringe Benefits	Total Package		Benefit	Hourly Amount	
	Due	Due	Due				
I		111		I			
I		f		L		L .. .	L J
I							
L							.....
I	1	1		I			L
I							
I		1	L	L		L .. .	....
L	.....	,11		L		I	
I				L			

Certified by: L. \_\_\_\_\_ Title: \_\_\_\_\_ Date: \_\_\_\_\_

(Must be certified by Owner or Chief Financial Officer)

# Wage and Hour Division (WHD)

## Instructions For Completing Payroll Form, WH-347

[WH-347](#) (PDF)

OMB Control No. 1235-0008, Expires 02/28/2018.

**General:** Form WH-347 has been made available for the convenience of contractors and subcontractors required by their Federal or Federally-aided construction-type contracts and subcontracts to submit weekly payrolls. Properly filled out, this form will satisfy the requirements of Regulations, Parts 3 and 5 (29 C.F.R., Subtitle A), as to payrolls submitted in connection with contracts subject to the Davis-Bacon and related Acts.

While completion of Form WH-347 is optional, it is mandatory for covered contractors and subcontractors performing work on Federally financed or assisted construction contracts to respond to the information collection contained in 29 C.F.R. §§ 3.3, 5.5(a). The Copeland Act (40 U.S.C. § 3145) requires contractors and subcontractors performing work on Federally financed or assisted construction contracts to "furnish weekly a statement with respect to the wages paid each employee during the preceding week." U.S. Department of Labor (DOL) Regulations at 29 C.F.R. § 5.5(a)(3)(ii) require contractors to submit weekly a copy of all payrolls to the Federal agency contracting for or financing the construction project, accompanied by a signed "Statement of Compliance" indicating that the payrolls are correct and complete and that each laborer or mechanic has been paid not less than the proper Davis-Bacon prevailing wage rate for the work performed. DOL and federal contracting agencies receiving this information review the information to determine that employees have received legally required wages and fringe benefits.

Under the Davis-Bacon and related Acts, the contractor is required to pay not less than prevailing wage, including fringe benefits, as predetermined by the Department of Labor. The contractor's obligation to pay fringe benefits may be met either by payment of the fringe benefits to bona fide benefit plans, funds or programs or by making payments to the covered workers (laborers and mechanics) as cash in lieu of fringe benefits.

This payroll provides for the contractor to show on the face of the payroll all monies to each worker, whether as basic rates or as cash in lieu of fringe benefits, and provides for the contractor's representation in the statement of compliance on the payroll (as shown on page 2) that he/she is paying for fringe benefits required by the contract and not paid as cash in lieu of fringe benefits. Detailed instructions concerning the preparation of the payroll follow:

**Contractor or Subcontractor:** Fill in your firm's name and check appropriate box.

**Address:** Fill in your firm's address.

**Payroll No.:** Beginning with the number "1", list the payroll number for the submission.

**For Week Ending:** List the workweek ending date.

**Project and Location:** Self-explanatory.

**Project or Contract No.:** Self-explanatory.

**Column 1 - Name and Individual Identifying Number of Worker:** Enter each worker's full name and an individual identifying number (e.g., last four digits of worker's social security number) on each weekly payroll submitted.

**Column 2 - No. of Withholding Exemptions:** This column is merely inserted for the employer's convenience and is not a requirement of Regulations, Part 3 and 5.

**Column 3 - Work Classifications:** List classification descriptive of work actually performed by each laborer or mechanic. Consult classification and minimum wage schedule set forth in contract specifications. If additional classifications are deemed necessary, see Contracting Officer or Agency representative. An individual may be shown as having worked in more than one classification provided an accurate breakdown of hours worked in each classification is maintained and shown on the submitted payroll by use of separate entries.

**Column 4 - Hours worked:** List the day and date and straight time and overtime hours worked in the applicable boxes. On all contracts subject to the Contract Work Hours Standard Act, enter hours worked in excess of 40 hours a week as "overtime".

**Column 5 - Total:** Self-explanatory

**Column 6 - Rate of Pay (Including Fringe Benefits):** In the "straight time" box for each worker, list the actual hourly rate paid for straight time worked, plus cash paid in lieu of fringe benefits paid. When recording the straight time hourly rate, any cash paid in lieu of fringe benefits may be shown separately from the basic rate. For example, "\$12.25/.40" would reflect a \$12.25 base hourly rate plus \$0.40 for fringe benefits. This is of assistance in correctly computing overtime. See "Fringe Benefits" below. When overtime is worked, show the overtime hourly rate paid plus any cash in lieu of fringe benefits paid in the "overtime" box for each worker; otherwise, you may skip this box. See "Fringe Benefits" below. Payment of not less than time and one-half the basic or regular rate paid is required for overtime under the Contract Work Hours Standard Act of 1962 if the prime contract exceeds \$100,000. In addition to paying no less than the predetermined rate for the classification which an individual works, the contractor must pay amounts predetermined as fringe benefits in the wage decision made part of the contract to approved fringe benefit plans, funds or programs or shall pay as cash in lieu of fringe benefits. See "FRINGE BENEFITS" below.

**Column 7 - Gross Amount Earned:** Enter gross amount earned on this project. If part of a worker's weekly wage was earned on projects other than the project described on this payroll, enter in column 7 first the amount earned on the Federal or Federally assisted project and then the gross amount earned during the week on all projects, thus "\$163.00/\$420.00" would reflect the earnings of a worker who earned \$163.00 on a Federally assisted construction project during a week in which \$420.00 was earned on all work.

**Column 8 - Deductions:** Five columns are provided for showing deductions made. If more than five deduction are involved, use the first four columns and show the balance deductions under "Other" column; show actual total under "Total Deductions" column; and in the attachment to the payroll describe the deduction(s) contained in the "Other" column. All deductions must be in accordance with the provisions of the Copeland Act Regulations, 29 C.F.R., Part 3. If an individual worked on other jobs in addition to this project, show actual deductions from his/her weekly gross wage, and indicate that deductions are based on his gross wages.

**Column 9 - Net Wages Paid for Week:** Self-explanatory.

**Totals** - Space has been left at the bottom of the columns so that totals may be shown if the contractor so desires.

**Statement Required by Regulations, Parts 3 and 5:** While the "statement of compliance" need not be notarized, the statement (on page 2 of the payroll form) is subject to the penalties provided by 18 U.S.C. § 1001, namely, a fine, possible imprisonment of not more than 5 years, or both. Accordingly, the party signing this statement should have knowledge of the facts represented as true.

**Items 1 and 2:** Space has been provided between items (1) and (2) of the statement for describing any deductions made. If all deductions made are adequately described in the "Deductions" column above, state "*See Deductions column in this payroll.*" *See "FRINGE BENEFITS"* below for instructions concerning filling out paragraph 4 of the statement.

**Item 4 FRINGE BENEFITS - Contractors who pay all required fringe benefits:** If paying all fringe benefits to approved plans, funds, or programs in amounts not less than were determined in the applicable wage decision of the Secretary of Labor, show the basic cash hourly rate and overtime rate paid to each worker on the face of the payroll and check paragraph 4(a) of the statement on page 2 of the WH-347 payroll form to indicate the payment. Note any exceptions in section 4(c).

**Contractors who pay no fringe benefits:** If not paying all fringe benefits to approved plans, funds, or programs in amounts of at least those that were determined in the applicable wage decision of the Secretary of Labor, pay any remaining fringe benefit amount to each laborer and mechanic and insert in the "straight time" of the "Rate of Pay" column of the payroll an amount not less than the predetermined rate for each classification plus the amount of fringe benefits determined for each classification in the application wage decision. Inasmuch as it is not necessary to pay time and a half on cash paid in lieu of fringe benefits, the overtime rate shall be not less than the sum of the basic predetermined rate, plus the half time premium on basic or regular rate, plus the required cash in lieu of fringe benefits at the straight time rate. In addition, check paragraph 4(b) of the statement on page 2 the payroll form to indicate the payment of fringe benefits in cash directly to the workers. Note any exceptions in section 4(c).

## Use of Section 4(c), Exceptions

Any contractor who is making payment to approved plans, funds, or programs in amounts less than the wage determination requires is obliged to pay the deficiency directly to the covered worker as cash in lieu of fringe benefits. Enter any exceptions to section 4(a) or 4(b) in section 4(c). Enter in the Exception column the craft, and enter in the Explanation column the hourly amount paid each worker as cash in lieu of fringe benefits and the hourly amount paid to plans, funds, or programs as fringe benefits. The contractor must pay an amount not less than the predetermined rate plus cash in lieu of fringe benefits as shown in section 4(c) to each such individual for all hours worked (unless otherwise provided by applicable wage determination) on the Federal or Federally assisted project. Enter the rate paid and amount of cash paid in lieu of fringe benefits per hour in column 6 on the payroll. See paragraph on "Contractors who pay no fringe benefits" for computation of overtime rate.

---

**Public Burden Statement:** We estimate that it will take an average of 55 minutes to complete this collection of information, including time for reviewing instructions, searching existing data sources, gathering and maintaining the data needed, and completing and reviewing the collection of information. If you have any comments regarding these estimates or any other aspect of this collection of information, including suggestions for reducing this burden, send them to the Administrator, Wage and Hour Division, ESA, U.S. Department of Labor, Room S3502, 200 Constitution Avenue, N.W., Washington, D.C. 20210.

**Note:** In order to view, fill out, and print PDF forms, you need Adobe® Acrobat® Reader® version 5 or later, which you may download for free at [www.adobe.com/products/acrobat/readstep2.html](http://www.adobe.com/products/acrobat/readstep2.html). To save the completed forms on your workstation, you need to use the "Save As" method to save the file.

For example, move your mouse cursor over the PDF link and click on your "RIGHT" mouse button. This will cause a menu to be displayed, from which you will select the proper save option -- depending upon which browser you are using:

For Microsoft IE users, select "Save Target As"

For Netscape Navigator users, select "Save Link As"

Once you've selected the proper save option for your browser, and have saved the file to a location you specified, go to your program menu and start the Adobe Acrobat® Reader. Once open, locate the PDF file you saved and open it directly in Acrobat®.

# CITY OF FLAGSTAFF – Labor Standards Interview

## DEPARTMENT OF LABOR

### **Title 29: Labor**

#### **PART 5—LABOR STANDARDS PROVISIONS APPLICABLE TO CONTRACTS COVERING FEDERALLY FINANCED AND ASSISTED CONSTRUCTION (ALSO LABOR STANDARDS PROVISIONS APPLICABLE TO NONCONSTRUCTION CONTRACTS SUBJECT TO THE CONTRACT WORK HOURS AND SAFETY STANDARDS ACT)**

##### **§ 5.5 Contract provisions and related matters.**

(iii) The contractor or subcontractor shall make the records required under paragraph (a)(3)(i) of this section available for inspection, copying, or transcription by authorized representatives of the (write the name of the agency) or the Department of Labor, and shall permit such representatives to interview employees during working hours on the job. If the contractor or subcontractor fails to submit the required records or to make them available, the Federal agency may, after written notice to the contractor, sponsor, applicant, or owner, take such action as may be necessary to cause the suspension of any further payment, advance, or guarantee of funds. Furthermore, failure to submit the required records upon request or to make such records available may be grounds for debarment action pursuant to 29 CFR 5.12.

## GENERAL INFORMATION

Davis-Bacon requires labor interviews to ensure compliance. **SF 1445 – Labor Standards Interview** is the form used by the Department of Labor.

Interviews should be conducted in the following manner:

- **INTERVIEWER.** City is required to use a consulting engineer or the city staff unaffiliated with the contractors and on site regularly to conduct interviews.
- **NUMBER OF INTERVIEWS.** The task will consist of doing a “representative sample” of interviews using the attached form. Interview a sufficient number of employees or former employees, who represent all classifications, to develop information regarding the method and amount of payments, deductions, hours worked, and the type of work performed
- **TIMING.** The federal guidance states that interviews should be done on, at minimum, two different occasions. One should be within the first two weeks after actual construction begins and payrolls are submitted. The second round should occur closer to substantial completion, while workers are still on site. Additional interviews should be done when issues or discrepancies arise and should be targeted at the contractor in question.
- **PURPOSE OF INTERVIEWS.** The purpose of the interview is to uncover discrepancies between the work actually being done by construction workers and the job titles/wages being reported on the certified payrolls. Each interview should probably only take about 10 minutes and is to be done confidentially to protect the workers. Interviews should then be compared to payrolls to identify inconsistencies, if any.
- **RECORDS.** At the end of the project, interview forms should be kept with the grant project file in the City of Flagstaff, Management Services-Grants Office for a period of no less than 5 years. The interview forms have identifying employee information that should be kept confidential from contractors generally, but the project folders should be available for inspection by the Department of Labor upon request.

## LABOR STANDARDS INTERVIEW

CONTRACT NUMBER			EMPLOYEE INFORMATION		
NAME OF PRIME CONTRACTOR			LAST NAME		FIRST NAME
			STREET ADDRESS		
NAME OF EMPLOYER			CITY		
			STATE	ZIP CODE	
SUPERVISOR'S NAME			WORK CLASSIFICATION		
LAST NAME		FIRST NAME	MI	WAGE RATE	

ACTION	CHECK BELOW	
	YES	NO
Do you work over 8 hours per day?		
Do you work over 40 hours per week?		
Are you paid at least time and a half for overtime hours?		
Are you receiving any cash payments for fringe benefits required by the posted wage determination decision?		

WHAT DEDUCTIONS OTHER THAN TAXES AND SOCIAL SECURITY ARE MADE FROM YOUR PAY?

HOW MANY HOURS DID YOU WORK ON YOUR LAST WORK DAY BEFORE THIS INTERVIEW?	TOOLS YOU USE	
DATE OF LAST WORK DAY BEFORE INTERVIEW (YYMMDD)		
DATE YOU BEGAN WORK ON THIS PROJECT (YYMMDD)		

THE ABOVE IS CORRECT TO THE BEST OF MY KNOWLEDGE

EMPLOYEE'S SIGNATURE			DATE (YYMMDD)
INTERVIEWER	SIGNATURE	TYPED OR PRINTED NAME	DATE (YYMMDD)

### INTERVIEWER'S COMMENTS

WORK EMPLOYEE WAS DOING WHEN INTERVIEWED	ACTION <i>(If explanation is needed, use comments section)</i>	YES	NO
	IS EMPLOYEE PROPERLY CLASSIFIED AND PAID?		
	ARE WAGE RATES AND POSTERS DISPLAYED?		

### FOR USE BY PAYROLL CHECKER

IS ABOVE INFORMATION IN AGREEMENT WITH PAYROLL DATA?

YES       NO

COMMENTS

CHECKER			
LAST NAME	FIRST NAME	MI	JOB TITLE
SIGNATURE			DATE (YYMMDD)

## Minority and Women's Business Enterprise (MBE/WBE) Information Form

This form must be completed by all vendors involved in construction projects (general contractors, subcontractors and those providing professional services), funded with CDBG funding.

Return completed form(s) to: City of Flagstaff Housing Section

Business name: \_\_\_\_\_

Business full address: \_\_\_\_\_

Phone: \_\_\_\_\_ Email: \_\_\_\_\_ Cell: \_\_\_\_\_

Owner's name: \_\_\_\_\_

Owner's full address: \_\_\_\_\_

Taxpayer's EIN: \_\_\_\_\_

Project Name: \_\_\_\_\_ Amount of Contract \$ \_\_\_\_\_

Scope of Work :  
\_\_\_\_\_

Category (select the category which applies to the applicant)

\_\_\_(A) Professional Services \_\_\_(B) General Contractor \_\_\_(C) Sub-Contractor

\_\_\_(D) Other (please describe) \_\_\_\_\_

Business Description: \_\_\_\_\_

Check all that apply:  Minority-owned  Women-owned  Neither

*Definition of a minority or women- owned business: A minority or women-owned business is one that is 51% or more owned, operated and controlled on a daily basis by a minority or female.*

Racial/Ethnic Code Number from table below: \_\_\_\_\_

#1 – White Americans #2 – Black Americans #3 – Native Americans #4 – Hispanic Americans

#5 – Asian Pacific Americans #6 – Hasidic Jews #7 – Alaskan Native

Form Completed by (Print Name): \_\_\_\_\_

Title: \_\_\_\_\_

Signature: \_\_\_\_\_ Date: \_\_\_\_\_



This report is to be completed by grantees, developers, sponsors, builders, agencies, and/or project owners for reporting contract and subcontract activities of \$10,000 or more under the following programs: Community Development Block Grants (entitlement and small cities); Urban Development Action Grants; Housing Development Grants; Multifamily Insured and Noninsured; Public and Indian Housing Authorities; and contracts entered into by recipients of CDBG rehabilitation assistance.

Contracts/subcontracts of less than \$10,000 need be reported only if such contracts represent a significant portion of your total contracting activity. Include only contracts executed during this reporting period.

This form has been modified to capture Section 3 contract data in columns 7g and 7i. Section 3 requires that the employment and other economic opportunities generated by HUD financial assistance for housing and community development programs shall, to the greatest extent feasible, be directed toward low- and very low-income persons, particularly those who are recipients of government assistance for housing. Recipients using this form to report Section 3 contract data must also use Part I of form HUD-60002 to report employment and training opportunities data. Form HUD-2516 is to be

completed for public and Indian housing and most community development programs. Form HUD-60002 is to be completed by all other HUD programs including State administered community development programs covered under Section 3. A Section 3 Contractor/subcontractor is a business concern that provides economic opportunities to low and very Low-income residents of the metropolitan area (or nonmetropolitan county), including a business concern that is 51 person or more owned by low-income residents;

or provides subcontracting or business development opportunities to businesses owned by low or low-income residents. Low and very low-income residents; include participants in Youthbuild programs established under Subtitle D of Title IV of the Cranston-Gonzalez National Affordable Housing Act.

The terms "low-income persons" and "very low-income persons" have the same meanings given the terms in section 3(b)(2) of the United States Housing Act of 1937. Low-income persons mean families (including single persons) whose incomes do not exceed 80 per centum of the median income for the area, as determined by the Secretary, with adjustments for smaller and larger families, except that the Secretary may establish income ceilings higher or lower than 80 per centum of the median for the area on the basis of the Secretary's findings that such variations are necessary because of prevailing levels of construction

costs or unusually high or low-income families. Very low-income families (including single persons) whose incomes do not exceed 50 per centum of the median family income for the area, as determined by the Secretary with adjustments for smaller and larger families, except that the secretary may establish income ceilings higher or lower than 50 per centum of the median for the area on the basis of the Secretary's findings that such variations are necessary because of unusually high or low family incomes.

Submit two (2) copies of this report to your local HUD Office within ten (10) days after the end of the reporting period you checked in item 4 on the front. Complete item 7h. Only once for each contractor/subcontractor on each semi-annual report.

Enter the prime contractor's ID in item 7f. for all contracts and subcontracts. Include only contracts expected during this reporting period. PHAs/IHAs are to report all contracts/subcontracts.

---

### Community Development Programs

**1. Grantee:** Enter the name of the unit of government submitting this report.

**3. Contact Person:** Enter name and phone of person responsible for maintaining and submitting contract/subcontract data.

**7a. Grant Number:** Enter the HUD Community Development Block Grant Identification Number (with dashes). For example: B-32-MC-25-0034. For Entitlement Programs and Small City multi-year comprehensive programs, enter the latest approved grant number.

**7b. Amount of Contract/Subcontract:** Enter the dollar amount rounded to the nearest dollar. If subcontractor ID number is provided in 7f, the dollar figure would be for the subcontract only and not for the prime contract.

**7c. Type of Trade:** Enter the numeric codes which best indicates the contractor's/subcontractor's service. If subcontractor ID number is provided in 7f., the type of trade code would be for the subcontractor only and not for the prime contractor.

The "other" category includes supply, professional services and all other activities except

construction and education/training activities.

**7d. Business Racial/Ethnic/Gender Code:** Enter the numeric code which indicates the racial/ethnic/gender character of the owner(s) and controller(s) of 51% of the business.

When 51% or more is not owned and controlled by any single racial/ethnic/gender category, enter the code which seems most appropriate. If the subcontractor ID number is provided, the code would apply to the subcontractor and not to the prime contractor.

**7e. Woman Owned Business:** Enter Yes or No.

**7f. Contractor Identification (ID) Number:** Enter the Employer (IRS) Number of the Prime Contractor as the unique identifier for prime recipient of HUD funds. Note that the Employer (IRS) Number must be provided for each contract/subcontract awarded.

---

### Multifamily Housing Programs

**1. Grantee/Project Owner:** Enter the name of the unit of government, agency or mortgagor entity submitting this report.

**3. Contact Person:** Same as item 3 under CPD Programs.

**4. Reporting Period:** Check only one period.

**5. Program Code:** Enter the appropriate program code.

**7a. Grant/Project Number:** Enter the HUD Project Number or Housing Development Grant or number assigned.

**7b. Amount of Contract/Subcontract:** Same as item 7b. under CPD Programs.

**7c. Type of Trade:** Same as item 7c. under CPD Programs.

**7d. Business Racial/Ethnic/Gender Code:** Same as item 7d. under CPD Programs.

**7e. Woman Owned Business:** Enter Yes or No.

**7f. Contractor Identification (ID) Number:** Same as item 7f. under CPD Programs.

---

### Public Housing and Indian Housing Programs

PHAs/IHAs are to report all contracts/subcontracts. Include only contracts executed during this reporting period.

**1. Project Owner:** Enter the name of the unit of government, agency or mortgagor entity submitting this report. Check box as appropriate.

**3. Contact Person:** Same as item 3 under CPD Programs.

**4. Reporting Period:** Check only one period.

**5. Program Code:** Enter the appropriate program code.

**7a. Grant/Project Number:** Enter the HUD Project Number or Housing Development Grant or number assigned.

**7b. Amount of Contract/Subcontract:** Same as item 7b. under CPD Programs.

**7c. Type of Trade:** Same as item 7c. under CPD Programs.

**7d. Business Racial/Ethnic/Gender Code:** Same as item 7d. under CPD Programs.

**7e. Woman Owned Business:** Enter Yes or No.

**7g. Section 3 Contractor:** Enter Yes or No.

**7g. Section 3 Contractor:** Enter Yes or No.

**7f. Contractor Identification (ID) Number:** Same as item 7f. under CPD Programs.

**7h. Subcontractor Identification (ID) Number:** Enter the Employer (IRS) Number of the subcontractor as the unique identifier for each subcontract awarded from HUD funds. When the subcontractor ID Number is provided, the respective Prime Contractor ID Number must also be provided.

**7i. Section 3 Contractor:** Enter Yes or No.

**7j. Contractor/Subcontractor Name and Address:** Enter this information for each firm receiving contract/subcontract activity only one time on each report for each firm.

**7h. Subcontractor Identification (ID) Number:** Same as item 7h. under CPD Programs.

**7i. Section 3 Contractor:** Enter Yes or No.

**7j. Contractor/Subcontractor Name and Address:** Same as item 7j. under CPD Programs.

**7g. Section 3 Contractor:** Enter Yes or No.

**7h. Subcontractor Identification (ID) Number:** Same as item 7h. under CPD Programs.

**7i. Section 3 Contractor:** Enter Yes or No.

**7j. Contractor/Subcontractor Name and Address:** Same as item 7j. under CPD Programs.

<b>Section 3 Housing and Community Development Employer Certification Form</b>	<b>U.S. Department of Housing and Urban Development Office of Field Policy and Management</b>	<b>HUD FORM 4736A</b> OMB Approval Number 2501-0041 (Exp. 04/30/2025)
--	---	---

*(In compliance with Section 3 of the HUD Act of 1968 and 24 CFR Part 75)*

Public reporting for this collection of information is estimated to average 0.5 hours per response, including the time for reviewing instructions, searching existing data sources, gathering, and maintaining the data needed, and completing and reviewing the collection of information.

Section 3 of the Housing and Urban Development Act of 1968, as amended by the Housing and Community Development Act of 1992 (Section 3), and 12 U.S.C. § 1701u ensure that employment and other economic opportunities generated by Federal financial assistance for housing and community development programs are, to the greatest extent feasible, directed toward low- and very low-income persons, particularly those who receive government assistance for housing. The regulations are found at 24 CFR Part 75. This collection of information is required in order to ensure that a worker can be certified as an eligible Section 3 worker as outlined in 24 C.F.R. § 75.31. The information will be used by the Department to ensure compliance with Section 3 of the HUD Act of 1968 employer certification requirements listed in 24 CFR § 75.31, to assess the results of the Department's efforts to meet the statutory objectives of Section 3, to prepare reports to Congress, and by recipients to ensure they are complying with their recordkeeping requirements found in the regulation, and as a self-monitoring tool.

Send comments regarding this burden estimate or any other aspect of this collection of information, including suggestions to reduce this burden, to Anna P. Guido, Reports Management Officer, QDAM, Department of Housing and Urban Development, 451 7th Street, SW, Room 4176, Washington, DC 20410-5000. When providing comments, please refer to OMB Approval No. 2501-0041. HUD may not conduct and sponsor, and a person is not required to respond to, a collection of information unless the collection displays a valid control number. No assurances of confidentiality are provided for this information collection.

The purpose of this form is to comply with Section 3 of the HUD Act of 1968 employer certification requirements listed in 24 CFR § 75.31. To qualify as a Section 3 worker, the United States legal resident's annual income must not exceed the HUD income limits for the year before the worker was hired, or the individual's current income annualized on a full-time basis for the year must be below the HUD income limit. Additionally, an individual can qualify as a Section 3 worker and Targeted Section 3 worker, if an employee of a Section 3 Business Concern. To qualify as a Targeted Section 3 worker, an employer can confirm that the employee lives within the service area or neighborhood of the project.

Please provide the following information about the business/employer:

Name of Business: \_\_\_\_\_

Street Address \_\_\_\_\_ City \_\_\_\_\_ State \_\_\_\_\_ Zip \_\_\_\_\_

Phone #: \_\_\_\_\_ Email: \_\_\_\_\_

---

Please Provide the following information about the worker/employee:

Printed Name of Worker: \_\_\_\_\_

Street Address (Not a PO Box)                      Apt#                      City                      State                      Zip

Phone #: \_\_\_\_\_ Email: \_\_\_\_\_

---

Please indicate which of the following is true for the worker listed above: (Select all that apply)

<input type="checkbox"/> Worker's income from your employment is below the income limit based on a calculation of what the worker's wage rate would translate to if annualized on a full-time basis*	Income limit \$50,900.00
<input type="checkbox"/> Worker is employed by a Section 3 Business Concern (Select if your business qualifies as a Section 3 Business Concern)	
<input type="checkbox"/> Worker's residence is within the service area or neighborhood of the project	

\*Currently or at the time of hire if hired within the past 5 years.

---

I/We, the undersigned, certify under penalty of perjury that the information provided above is true and correct and certifies that the worker identified above meets the definition of a Section 3 worker. **WARNING:** Anyone who knowingly submits a false claim or makes a false statement is subject to criminal and/or civil penalties, including confinement for up to 5 years, fines, and civil and administrative penalties. (18 U.S.C. §§ 287, 1001, 1010, 1012; 31 U.S.C. §3729, 3802)

\_\_\_\_\_  
Signature

\_\_\_\_\_  
Date

"General Decision Number: AZ20240043 01/19/2024

Superseded General Decision Number: AZ20230043

State: Arizona

Construction Type: Building

Counties: Coconino, Mohave and Yavapai Counties in Arizona.

BUILDING CONSTRUCTION PROJECTS (does not include single family homes or apartments up to and including 4 stories).

Note: Contracts subject to the Davis-Bacon Act are generally required to pay at least the applicable minimum wage rate required under Executive Order 14026 or Executive Order 13658. Please note that these Executive Orders apply to covered contracts entered into by the federal government that are subject to the Davis-Bacon Act itself, but do not apply to contracts subject only to the Davis-Bacon Related Acts, including those set forth at 29 CFR 5.1(a)(1).

If the contract is entered into on or after January 30, 2022, or the contract is renewed or extended (e.g., an option is exercised) on or after January 30, 2022:	<ul style="list-style-type: none"> <li>◆ Executive Order 14026 generally applies to the contract.</li> <li>◆ The contractor must pay all covered workers at least \$17.20 per hour (or the applicable wage rate listed on this wage determination, if it is higher) for all hours spent performing on the contract in 2024.</li> </ul>
If the contract was awarded on or between January 1, 2015 and January 29, 2022, and the contract is not renewed or extended on or after January 30, 2022:	<ul style="list-style-type: none"> <li>◆ Executive Order 13658 generally applies to the contract.</li> <li>◆ The contractor must pay all covered workers at least \$12.90 per hour (or the applicable wage rate listed on this wage determination, if it is higher) for all hours performing on that contract in 2024.</li> </ul>

The applicable Executive Order minimum wage rate will be adjusted annually. If this contract is covered by one of the Executive Orders and a classification considered necessary for performance of work on the contract does not appear on this wage determination, the contractor must still submit a conformance request.

Additional information on contractor requirements and worker protections under the Executive Orders is available at <http://www.dol.gov/whd/govcontracts>.

Modification Number	Publication Date
0	01/05/2024
1	01/19/2024

BRAZ0003-001 07/01/2023

	Rates	Fringes
BRICKLAYER.....	\$ 32.74	9.52
-----		

CARP1912-001 07/01/2023

	Rates	Fringes
CARPENTER.....	\$ 33.55	14.17

ELEC0640-002 01/01/2023

	Rates	Fringes
ELECTRICIAN.....	\$ 33.10	13.58

ENGI0428-017 06/01/2023

	Rates	Fringes
POWER EQUIPMENT OPERATOR		
Bulldozer.....	\$ 31.69	13.52
Crane.....	\$ 36.04	13.52
Loader.....	\$ 34.96	13.52

\* IRON0075-012 10/01/2023

	Rates	Fringes
IRONWORKER.....	\$ 32.00	18.91

PLUM0469-010 07/01/2023

	Rates	Fringes
PIPEFITTER.....	\$ 45.65	18.00
PLUMBER.....	\$ 45.65	18.00

SHEE0359-001 07/01/2022

	Rates	Fringes
SHEET METAL WORKER.....	\$ 40.82	19.04

\* SUAZ2019-006 06/12/2023

	Rates	Fringes
CEMENT MASON/CONCRETE FINISHER...	\$ 22.00	0.00
LABORER: Common or General.....	\$ 16.00 **	0.00
LABORER: Mason Tender - Cement/Concrete.....	\$ 18.90	0.00
LABORER: Pipelayer.....	\$ 16.77 **	1.05
OPERATOR: Backhoe/Excavator/Trackhoe.....	\$ 24.97	5.41
OPERATOR: Roller.....	\$ 23.62	6.44
PAINTER.....	\$ 16.48 **	0.00
TILE SETTER.....	\$ 21.50	0.00

WELDERS - Receive rate prescribed for craft performing operation to which welding is incidental.

\*\* Workers in this classification may be entitled to a higher minimum wage under Executive Order 14026 (\$17.20) or 13658 (\$12.90). Please see the Note at the top of the wage determination for more information. Please also note that the

minimum wage requirements of Executive Order 14026 are not currently being enforced as to any contract or subcontract to which the states of Texas, Louisiana, or Mississippi, including their agencies, are a party.

Note: Executive Order (EO) 13706, Establishing Paid Sick Leave for Federal Contractors applies to all contracts subject to the Davis-Bacon Act for which the contract is awarded (and any solicitation was issued) on or after January 1, 2017. If this contract is covered by the EO, the contractor must provide employees with 1 hour of paid sick leave for every 30 hours they work, up to 56 hours of paid sick leave each year. Employees must be permitted to use paid sick leave for their own illness, injury or other health-related needs, including preventive care; to assist a family member (or person who is like family to the employee) who is ill, injured, or has other health-related needs, including preventive care; or for reasons resulting from, or to assist a family member (or person who is like family to the employee) who is a victim of, domestic violence, sexual assault, or stalking. Additional information on contractor requirements and worker protections under the EO is available at <https://www.dol.gov/agencies/whd/government-contracts>.

Unlisted classifications needed for work not included within the scope of the classifications listed may be added after award only as provided in the labor standards contract clauses (29CFR 5.5 (a) (1) (iii)).

-----

The body of each wage determination lists the classification and wage rates that have been found to be prevailing for the cited type(s) of construction in the area covered by the wage determination. The classifications are listed in alphabetical order of ""identifiers"" that indicate whether the particular rate is a union rate (current union negotiated rate for local), a survey rate (weighted average rate) or a union average rate (weighted union average rate).

#### Union Rate Identifiers

A four letter classification abbreviation identifier enclosed in dotted lines beginning with characters other than ""SU"" or ""UAVG"" denotes that the union classification and rate were prevailing for that classification in the survey. Example: PLUM0198-005 07/01/2014. PLUM is an abbreviation identifier of the union which prevailed in the survey for this classification, which in this example would be Plumbers. 0198 indicates the local union number or district council number where applicable, i.e., Plumbers Local 0198. The next number, 005 in the example, is an internal number used in processing the wage determination. 07/01/2014 is the effective date of the most current negotiated rate, which in this example is July 1, 2014.

Union prevailing wage rates are updated to reflect all rate changes in the collective bargaining agreement (CBA) governing this classification and rate.

#### Survey Rate Identifiers

Classifications listed under the ""SU"" identifier indicate that no one rate prevailed for this classification in the survey and the published rate is derived by computing a weighted average rate based on all the rates reported in the survey for that classification. As this weighted average rate includes all rates reported in the survey, it may include both union and non-union rates. Example: SULA2012-007 5/13/2014. SU indicates the rates are survey rates based on a weighted average

calculation of rates and are not majority rates. LA indicates the State of Louisiana. 2012 is the year of survey on which these classifications and rates are based. The next number, 007 in the example, is an internal number used in producing the wage determination. 5/13/2014 indicates the survey completion date for the classifications and rates under that identifier.

Survey wage rates are not updated and remain in effect until a new survey is conducted.

#### Union Average Rate Identifiers

Classification(s) listed under the UAVG identifier indicate that no single majority rate prevailed for those classifications; however, 100% of the data reported for the classifications was union data. EXAMPLE: UAVG-OH-0010 08/29/2014. UAVG indicates that the rate is a weighted union average rate. OH indicates the state. The next number, 0010 in the example, is an internal number used in producing the wage determination. 08/29/2014 indicates the survey completion date for the classifications and rates under that identifier.

A UAVG rate will be updated once a year, usually in January of each year, to reflect a weighted average of the current negotiated/CBA rate of the union locals from which the rate is based.

---

#### WAGE DETERMINATION APPEALS PROCESS

1.) Has there been an initial decision in the matter? This can be:

- \* an existing published wage determination
- \* a survey underlying a wage determination
- \* a Wage and Hour Division letter setting forth a position on a wage determination matter
- \* a conformance (additional classification and rate) ruling

On survey related matters, initial contact, including requests for summaries of surveys, should be with the Wage and Hour National Office because National Office has responsibility for the Davis-Bacon survey program. If the response from this initial contact is not satisfactory, then the process described in 2.) and 3.) should be followed.

With regard to any other matter not yet ripe for the formal process described here, initial contact should be with the Branch of Construction Wage Determinations. Write to:

Branch of Construction Wage Determinations  
Wage and Hour Division  
U.S. Department of Labor  
200 Constitution Avenue, N.W.  
Washington, DC 20210

2.) If the answer to the question in 1.) is yes, then an interested party (those affected by the action) can request review and reconsideration from the Wage and Hour Administrator (See 29 CFR Part 1.8 and 29 CFR Part 7). Write to:

Wage and Hour Administrator  
U.S. Department of Labor  
200 Constitution Avenue, N.W.  
Washington, DC 20210

The request should be accompanied by a full statement of the interested party's position and by any information (wage payment data, project description, area practice material,

etc.) that the requestor considers relevant to the issue.

3.) If the decision of the Administrator is not favorable, an interested party may appeal directly to the Administrative Review Board (formerly the Wage Appeals Board). Write to:

Administrative Review Board  
U.S. Department of Labor  
200 Constitution Avenue, N.W.  
Washington, DC 20210

4.) All decisions by the Administrative Review Board are final.

=====

END OF GENERAL DECISION"