



PLANT LEGEND

TREES	SPECIFICATION	QTY
<i>Pinus ponderosa</i> Ponderosa Pine	6' Height	133
<i>Pinus nigra</i> Austrian Pine	6' Height	12
<i>Populus tremuloides</i> Quaking Aspen	3" Caliper	42
<i>Platanus wrightii</i> Arizona Sycamore	3" Caliper	49
<i>Malus "Spring Snow"</i> Spring Snow Crabapple	3.0" Caliper	44
<i>Fraxinus pennsylvanica</i> Green Ash	3" Caliper	51
<i>Gledetsia triacanthos inermis</i> Thornless Honeylocust	4" Caliper	8
<i>Acer x freemanii</i> Freeman Maple	3" Caliper	18
<i>Prunus virginiana "Shubert"</i> Canada Red Chokecherry	3" Caliper	33
SHRUBS	SIZE	QTY
<i>Berberis thunbergii "atropurpurea"</i> Rosy Glow Barberry	5 Gallon	24
<i>Potentilla fruticosa "Gold Drop"</i> Gold Drop Potentilla	5 Gallon	55
<i>Spiraea japonica "Little Princess"</i> Little Princess Spiraea	5 Gallon	115
<i>Juniperus sabina "Arcadia"</i> Arcadia Juniper	5 Gallon	177
<i>Mahonia AZ. Compacta</i> Oregon Grape	5 Gallon	326
<i>Prunus v. melanocarpa</i> Common Chokecherry	5 Gallon	94
<i>Syringa patula "Miss Kim"</i> Miss Kim Lilac	5 Gallon	32
<i>Stringa meyeri palibin</i> Dwarf Korean Lilac	5 Gallon	164
<i>Rhus glabra</i> Staghorn Sumac	5 Gallon	66
<i>Cornus stolonifera</i> Red Osier Dogwood	5 Gallon	81
<i>Prunus cistena</i> Purple Sandcherry	5 Gallon	86
<i>Chaenomeles japonica</i> Flowering Quince	5 Gallon	180
GROUNDCOVERS	SIZE	QTY
<i>Juniperus horizontalis</i> Creeping Juniper	1 Gallon	74
<i>Mahonia repens</i> Creeping Mahonia	1 Gallon	56
<i>Taenidium chamaedrys</i> Gemander	1 Gallon	33
<i>Verbena macdougalii</i> New Mexican Vervain	1 Gallon	188
<i>Festuca arizonica</i> Arizona Fescue	SEED	8,400 S.F.
LANDSCAPE MATERIALS		
(Contractor to submit sample for approval)		
Shredded Mulch	3" Depth	

LANDSCAPE CALCULATIONS

STREET BUFFER:
(PER TABLE 10-50.60.050.B)
LENGTH = 2,090'
(1) TREE PER 25' = 84 TREES
(1) SHRUBS PER TREE = 168 SHRUBS
(2) GROUNDCOVERS PER TREE = 168 GROUNDCOVERS

PERIPHERAL BUFFER:
LENGTH = 910'
(1) TREE PER 25' = 37 TREES
(2) SHRUBS PER TREE = 74 SHRUBS
(2) GROUNDCOVERS PER TREE = 74 GROUNDCOVERS

BUILDING FOUNDATION:
(PER TABLE 10-50.60.040.B.1)
LENGTH = 5,270'
(1) TREE PER 25' = 210 TREES
(2) SHRUBS PER TREE = 420 SHRUBS
(2) GROUNDCOVERS PER TREE = 420 GROUNDCOVERS

PARKING AREA:
(PER TABLE 10-50.60.040.C.)
SPACES = 141
30 S.F. / SPACE = 4,230 S.F. (REQUIRED)
4,356 S.F. (PROVIDED)

SPACES = 141
(2) TREES PER 8 SPACES = 36 TREES
(2) SHRUBS PER TREE = 72 SHRUBS
(2) GROUNDCOVERS PER TREE = 72 GROUNDCOVERS

SUMMARY:

TOTAL TREES = 367
TOTAL SHRUBS = 734
TOTAL GROUNDCOVERS = 734

TREE SPACING USED = 25' - 30'
SHRUB SPACING USED = 5' - 6'
GROUNDCOVER SPACING USED = 5' - 6'

PER SECTION 10-50.60.050:
6" OR GREATER TREES TO REMAIN = 25
RETAINED POINTS = 260

PERIPHERAL BUFFER TREES TO BE WAIVED = 2
BUILDING FOUNDATION TREES TO BE WAIVED = 4
STREET BUFFER TREES TO BE WAIVED = 2

TOTAL NEW TREES = 359
TOTAL SHRUBS = 718
TOTAL GROUNDCOVERS = 718

SYMBOL LEGEND:

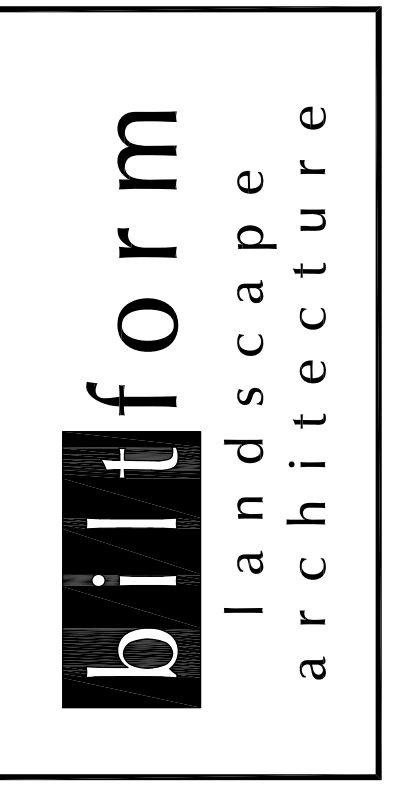
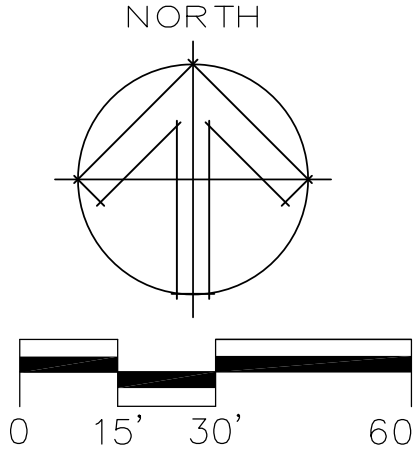
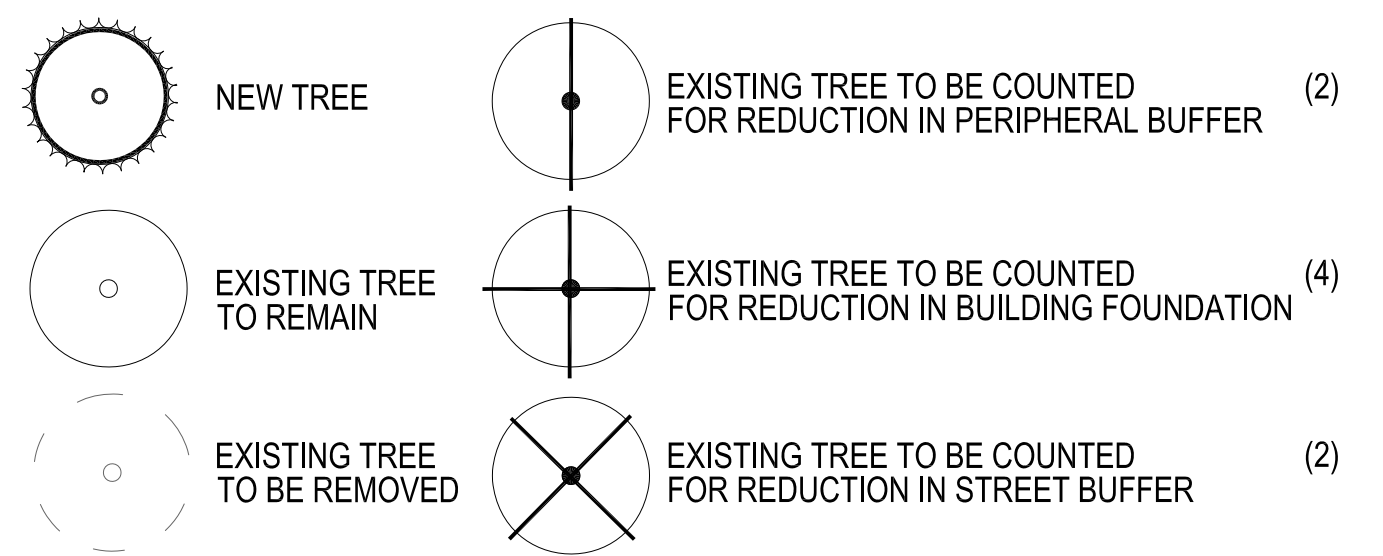

biltform landscape architecture group, inc.
11460 North Cave Creek Rd. suite 6
Phoenix, Arizona 85020
Phone 602.285.9200 Fax 602.285.9229
email: dave@biltform.com



LAKE MARY HOUSING
Single Family & Apartment Residences
FLAGSTAFF, ARIZONA

ATLANTIC DEVELOPMENT & INVESTMENTS LLC.
15957 N. 81ST ST., SUITE 101, SCOTTSDALE AZ. 85260
PHONE: 480-256-0506

PROJECT NAME: LAKE MARY HOUSING
PROJECT OWNER: ATLANTIC DEVELOPMENT & INVESTMENTS LLC.

REVISIONS:

1	City Comments 9/20/22
2	City Comments 10/28/22
3	City Comments 12/7/22
4	
5	

JOB NO: 21-028L
DATE: June 17, 2022
SCALE: 1" = 30'-0"
SHEET NO:



PLANT LEGEND

TREES	SPECIFICATION	QTY
<i>Pinus ponderosa</i>	6' Height	133
<i>Pinus nigra</i>	6' Height	12
<i>Populus tremuloides</i>	3" Caliper	42
<i>Platanus wrightii</i>	3" Caliper	49
<i>Malus "Spring Snow"</i>	3.0" Caliper	44
<i>Fraxinus pennsylvanica</i>	3" Caliper	51
<i>Gleditsia triacanthos inermis</i>	4" Caliper	8
<i>Acer x freemanii</i>	3" Caliper	18
<i>Prunus virginiana "Shubert"</i>	3" Caliper	33
SHRUBS	SIZE	QTY
<i>Berberis thunbergii "atropurpurea"</i>	5 Gallon	24
<i>Potentilla fruticosa "Gold Drop"</i>	5 Gallon	55
<i>Spiraea japonica "Little Princess"</i>	5 Gallon	115
<i>Juniperus sabina "Arcadia"</i>	5 Gallon	177
<i>Mahonia AZ. Compacta</i>	5 Gallon	326
<i>Prunus v. melanocarpa</i>	5 Gallon	94
<i>Syringa patula "Miss Kim"</i>	5 Gallon	32
<i>Stringa meyeri pallbin</i>	5 Gallon	164
<i>Rhus glabra</i>	5 Gallon	66
<i>Cornus stolonifera</i>	5 Gallon	81
<i>Prunus cistena</i>	5 Gallon	86
<i>Chaenomeles japonica</i>	5 Gallon	180
GROUNDCOVERS	SIZE	QTY
<i>Juniperus horizontalis</i>	1 Gallon	74
<i>Mahonia repens</i>	1 Gallon	56
<i>Teucrium chamaedrys</i>	1 Gallon	33
<i>Verbena macdougalii</i>	1 Gallon	188
<i>Festuca arizonica</i>	SEED	8,400 S.F.
LANDSCAPE MATERIALS	(Contractor to submit sample for approval)	
Shredded Mulch	3" Depth	

LANDSCAPE CALCULATIONS

STREET BUFFER:
 (PER TABLE 10-50.60.050.B)
 LENGTH = 2,090'
 (1) TREE PER 25' = 84 TREES
 (2) SHRUBS PER TREE = 168 SHRUBS
 (2) GROUNDCOVERS PER TREE = 168 GROUNDCOVERS

PERIPHERAL BUFFER:
 LENGTH = 910'
 (1) TREE PER 25' = 37 TREES
 (2) SHRUBS PER TREE = 74 SHRUBS
 (2) GROUNDCOVERS PER TREE = 74 GROUNDCOVERS

BUILDING FOUNDATION:
 (PER TABLE 10-50.60.040.B.1)
 LENGTH = 5,270'
 (1) TREE PER 25' = 210 TREES
 (2) SHRUBS PER TREE = 420 SHRUBS
 (2) GROUNDCOVERS PER TREE = 420 GROUNDCOVERS

PARKING AREA:
 (PER TABLE 10-50.60.040.C.)
 SPACES = 141
 30 S.F. / SPACE = 4,230 S.F. (REQUIRED)
 4,356 S.F. (PROVIDED)

SPACES = 141
 (2) TREES PER 8 SPACES = 36 TREES
 (2) SHRUBS PER TREE = 72 SHRUBS
 (2) GROUNDCOVERS PER TREE = 72 GROUNDCOVERS

SUMMARY:

TOTAL TREES = 367
 TOTAL SHRUBS = 734
 TOTAL GROUNDCOVERS = 734

TREE SPACING USED = 25' - 30'
 SHRUB SPACING USED = 5' - 6'
 GROUNDCOVER SPACING USED = 5' - 6'

PER SECTION 10-50.60.050:
 6" OR GREATER TREES TO REMAIN = 25
 RETAINED POINTS = 260

PERIPHERAL BUFFER TREES TO BE WAIVED = 2
 BUILDING FOUNDATION TREES TO BE WAIVED = 4
 STREET BUFFER TREES TO BE WAIVED = 2

TOTAL NEW TREES = 359
 TOTAL SHRUBS = 718
 TOTAL GROUNDCOVERS = 718

SYMBOL LEGEND:

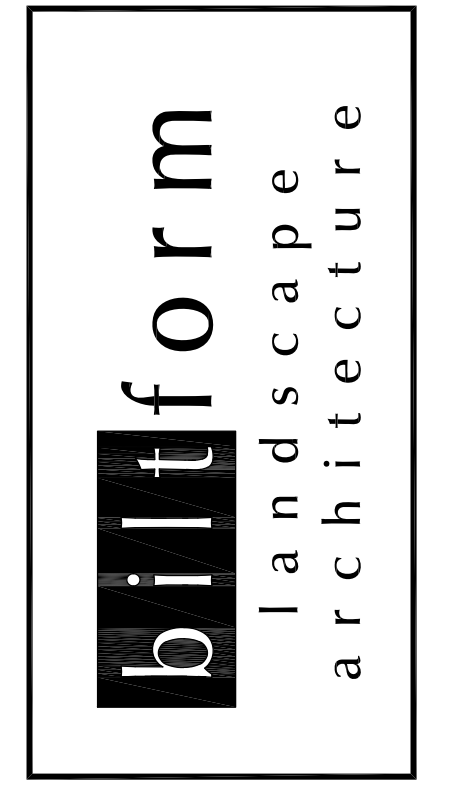
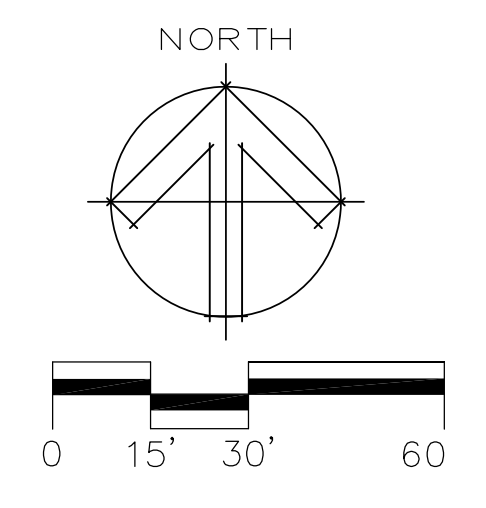
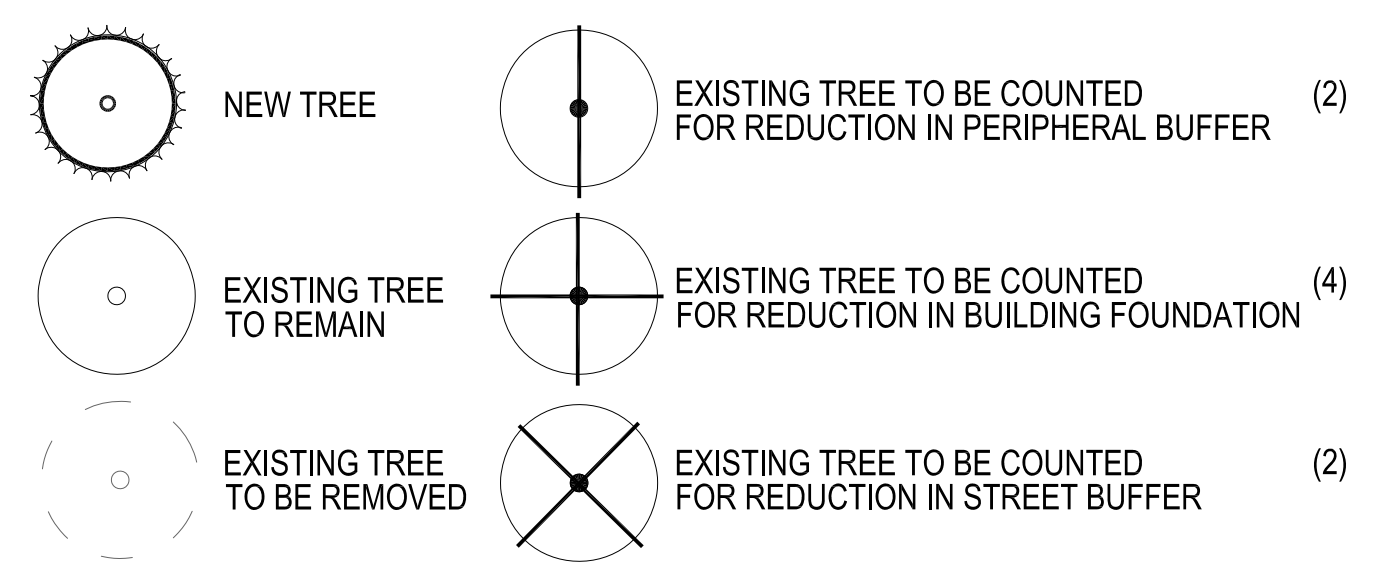

biltform landscape architecture group, inc.
 11460 North Cave Creek Rd., suite 6
 phoenix, arizona 85020
 Phone 602.285.9200 Fax 602.285.9229
 email: dave@biltform.com



LAKE MARY HOUSING
 Single Family & Apartment Residences

ATLANTIC DEVELOPMENT & INVESTMENTS LLC.
 15957 N. 81ST ST., SUITE 101, SCOTTSDALE AZ. 85260
 PHONE: 480-266-0506

REVISIONS:

1	City Comments 9/20/22
2	City Comments 10/28/22
3	City Comments 12/7/22
4	
5	

JOB NO: 21-028L
 DATE: June 17, 2022
 SCALE: 1" = 30'-0"
 SHEET NO:

L 2.4

LANDSCAPE PLAN



PLANT LEGEND

TREES	SPECIFICATION	QTY
<i>Pinus ponderosa</i> Ponderosa Pine	6' Height	133
<i>Pinus nigra</i> Austrian Pine	6' Height	12
<i>Populus tremuloides</i> Quaking Aspen	3" Caliper	42
<i>Platanus wrightii</i> Arizona Sycamore	3" Caliper	49
<i>Malus "Spring Snow"</i> Spring Snow Crabapple	3.0" Caliper	44
<i>Fraxinus pennsylvanica</i> Green Ash	3" Caliper	51
<i>Gleditsia triacanthos inermis</i> Thornless Honeylocust	4" Caliper	8
<i>Acer x freemanii</i> Freeman Maple	3" Caliper	18
<i>Prunus virginiana "Shubert"</i> Canada Red Chokecherry	3" Caliper	33
SHRUBS	SIZE	QTY
<i>Berberis thunbergii "atropurpurea"</i> Rosy Glow Barberry	5 Gallon	24
<i>Potentilla fruticosa "Gold Drop"</i> Gold Drop Potentilla	5 Gallon	55
<i>Spiraea japonica "Little Princess"</i> Little Princess Spirea	5 Gallon	115
<i>Juniperus sabina "Arcadia"</i> Arcadia Juniper	5 Gallon	177
<i>Mahonia AZ. Compacta</i> Oregon Grape	5 Gallon	326
<i>Prunus v. melanocarpa</i> Common Chokecherry	5 Gallon	94
<i>Syringa patula "Miss Kim"</i> Miss Kim Lilac	5 Gallon	32
<i>Stringa meyeri palibin</i> Dwarf Korean Lilac	5 Gallon	164
<i>Rhus glabra</i> Staghorn Sumac	5 Gallon	66
<i>Cornus stolonifera</i> Red Osier Dogwood	5 Gallon	81
<i>Prunus cistena</i> Purple Sandcherry	5 Gallon	86
<i>Chaenomeles japonica</i> Flowering Quince	5 Gallon	180
GROUNDCOVERS	SIZE	QTY
<i>Juniperus horizontalis</i> Creeping Juniper	1 Gallon	74
<i>Mahonia repens</i> Creeping Mahonia	1 Gallon	56
<i>Teucrium chamaedrys</i> Germanier	1 Gallon	33
<i>Verbena macdougalii</i> New Mexican Vervain	1 Gallon	188
<i>Festuca arizonica</i> Arizona Fescue	SEED	8,400 S.F.
LANDSCAPE MATERIALS		
(Contractor to submit sample for approval)		
Shredded Mulch	3" Depth	

LANDSCAPE CALCULATIONS

STREET BUFFER:
(PER TABLE 10-50.60.050.B)
LENGTH = 2,090'
(1) TREE PER 25' = 84 TREES
(2) SHRUBS PER TREE = 168 SHRUBS
(2) GROUNDCOVERS PER TREE = 168 GROUNDCOVERS

PERIPHERAL BUFFER:
LENGTH = 910'
(1) TREE PER 25' = 37 TREES
(2) SHRUBS PER TREE = 74 SHRUBS
(2) GROUNDCOVERS PER TREE = 74 GROUNDCOVERS

BUILDING FOUNDATION:
(PER TABLE 10-50.60.040.B.1)
LENGTH = 5,270'
(1) TREE PER 25' = 210 TREES
(2) SHRUBS PER TREE = 420 SHRUBS
(2) GROUNDCOVERS PER TREE = 420 GROUNDCOVERS

PARKING AREA:
(PER TABLE 10-50.60.040.C.)
SPACES = 141
30 S.F. / SPACE = 4,230 S.F. (REQUIRED)
4,356 S.F. (PROVIDED)

SPACES = 141
(2) TREES PER 8 SPACES = 36 TREES
(2) SHRUBS PER TREE = 72 SHRUBS
(2) GROUNDCOVERS PER TREE = 72 GROUNDCOVERS

SUMMARY:

TOTAL TREES = 367
TOTAL SHRUBS = 734
TOTAL GROUNDCOVERS = 734

TREE SPACING USED = 25' - 30'
SHRUB SPACING USED = 5' - 6'
GROUNDCOVER SPACING USED = 5' - 6'

PER SECTION 10-50.60.050:
6" OR GREATER TREES TO REMAIN = 25
RETAINED POINTS = 260

PERIPHERAL BUFFER TREES TO BE WAIVED = 2
BUILDING FOUNDATION TREES TO BE WAIVED = 4
STREET BUFFER TREES TO BE WAIVED = 2

TOTAL NEW TREES = 359
TOTAL SHRUBS = 718
TOTAL GROUNDCOVERS = 718

SYMBOL LEGEND:

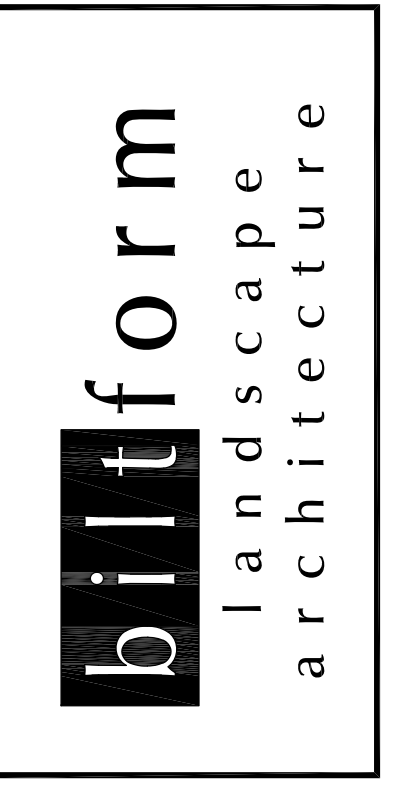
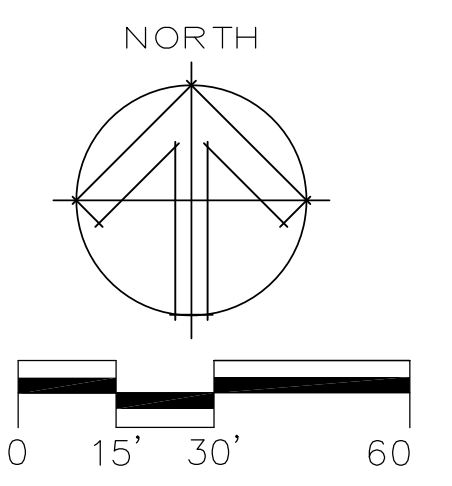
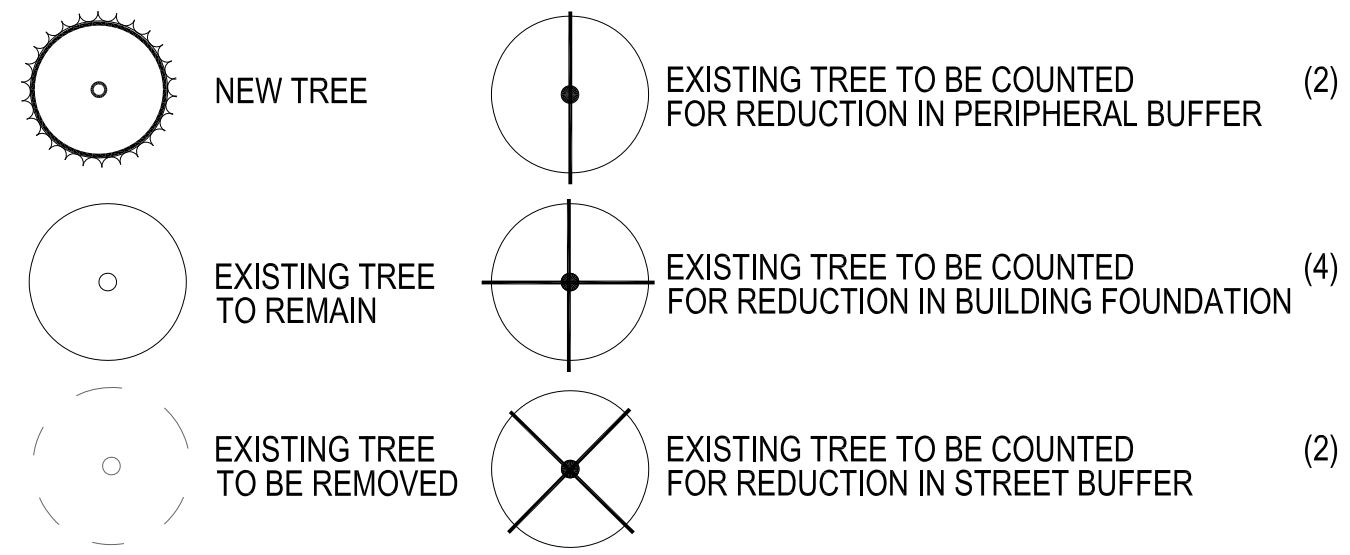

biltform landscape architecture group, inc.
11460 North Cave Creek Rd, suite 6
phoenix, arizona 85020
Phone 602.285.9200 Fax 602.285.9229
email: dave@biltform.com



LAKE MARY HOUSING
Single Family & Apartment Residences

ATLANTIC DEVELOPMENT & INVESTMENTS LLC.
15957 N. 81ST ST., SUITE 101, SCOTTSDALE AZ. 85260
PHONE: 480-266-0506

PROJECT NAME: FLAGSTAFF, ARIZONA

REVISIONS:

1	City Comments 9/20/22
2	City Comments 10/28/22
3	City Comments 12/7/22
4	
5	

JOB NO: 21-028L
DATE: June 17, 2022
SCALE: 1" = 30'-0"
SHEET NO:

L 3.4

LANDSCAPE PLAN

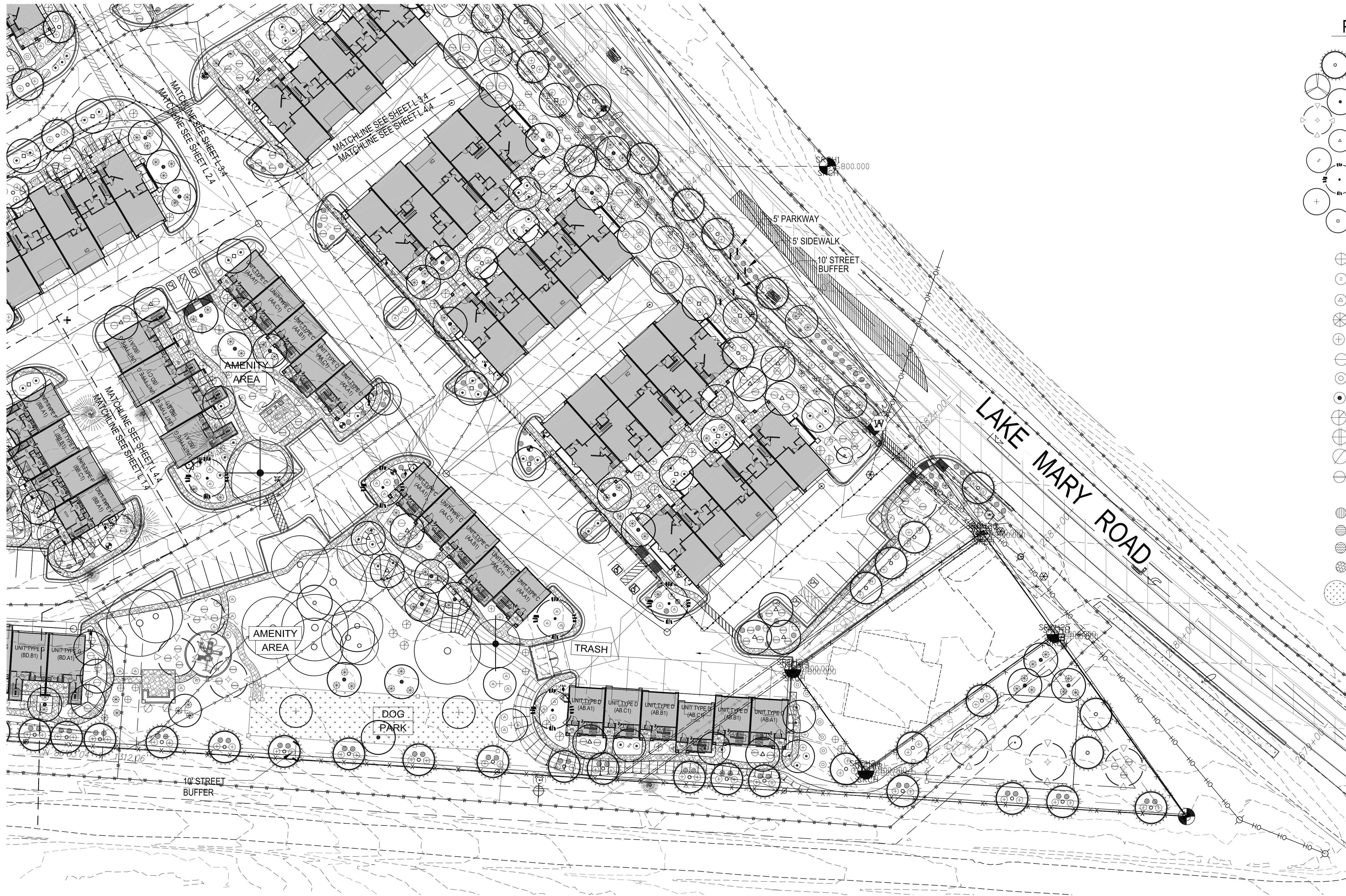

PLANT LEGEND

TREES	SPECIFICATION	QTY
<i>Pinus ponderosa</i> Ponderosa Pine	6' Height	133
<i>Pinus nigra</i> Austrian Pine	6' Height	12
<i>Populus tremuloides</i> Quaking Aspen	3" Caliper	42
<i>Platanus wrightii</i> Arizona Sycamore	3" Caliper	49
<i>Malus "Spring Snow"</i> Spring Snow Crabapple	3.0" Caliper	44
<i>Fraxinus pennsylvanica</i> Green Ash	3" Caliper	51
<i>Gleditsia triacanthos inermis</i> Thornless Honeylocust	4" Caliper	8
<i>Acer x freemanii</i> Freeman Maple	3" Caliper	18
<i>Prunus virginiana "Shubert"</i> Canada Red Chokecherry	3" Caliper	33
SHRUBS	SIZE	QTY
<i>Berberis thunbergii "atropurpurea"</i> Rosy Glow Barberry	5 Gallon	24
<i>Potentilla fruticosa "Gold Drop"</i> Gold Drop Potentilla	5 Gallon	55
<i>Spiraea japonica "Little Princess"</i> Little Princess Spirea	5 Gallon	115
<i>Juniperus sabina "Arcadia"</i> Arcadia Juniper	5 Gallon	177
<i>Mahonia AZ. Compacta</i> Oregon Grape	5 Gallon	326
<i>Prunus v. melanocarpa</i> Common Chokecherry	5 Gallon	94
<i>Syringa patula "Miss Kim"</i> Miss Kim Lilac	5 Gallon	32
<i>Stringa meyeri palibin</i> Dwarf Korean Lilac	5 Gallon	164
<i>Rhus glabra</i> Staghorn Sumac	5 Gallon	66
<i>Cornus stolonifera</i> Red Osier Dogwood	5 Gallon	81
<i>Prunus cistena</i> Purple Sandcherry	5 Gallon	86
<i>Chaenomeles japonica</i> Flowering Quince	5 Gallon	180
GROUNDCOVERS	SIZE	QTY
<i>Juniperus horizontalis</i> Creeping Juniper	1 Gallon	74
<i>Mahonia repens</i> Creeping Mahonia	1 Gallon	56
<i>Teucrium chamaedrys</i> Germander	1 Gallon	33
<i>Verbena macdougallii</i> New Mexican Vervain	1 Gallon	188
<i>Festuca arizonica</i> Arizona Fescue	SEED	8,400 S.F.
LANDSCAPE MATERIALS	(Contractor to submit sample for approval)	
Shredded Mulch	3" Depth	

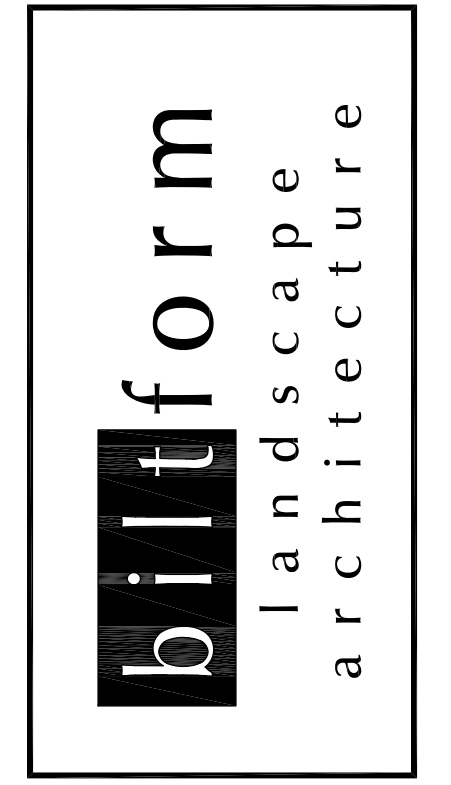

biltform landscape architecture group, inc.
11460 North Cave Creek Rd, suite 6
phoenix, arizona 85020
Phone 602.285.9200 Fax 602.285.9229
email: dave@biltform.com



LAKE MARY HOUSING
Single Family & Apartment Residences
ATLANTIC DEVELOPMENT & INVESTMENTS LLC.
15957 N. 81ST ST., SUITE 101, SCOTTSDALE AZ. 85260
PHONE: 480-256-0506

REVISIONS:

1	City Comments 9/20/22
2	City Comments 10/28/22
3	City Comments 12/7/22
4	
5	

JOB NO: 21-028L
DATE: June 17, 2022
SCALE: 1" = 30'-0"
SHEET NO:

L 4.4

LANDSCAPE CALCULATIONS

<p>STREET BUFFER: (PER TABLE 10-50.60.050.B) LENGTH = 2,090' (1) TREE PER 25' = 84 TREES (2) SHRUBS PER TREE = 168 SHRUBS (2) GROUNDCOVERS PER TREE = 168 GROUNDCOVERS</p> <p>PERIPHERAL BUFFER: LENGTH = 910' (1) TREE PER 25' = 37 TREES (2) SHRUBS PER TREE = 74 SHRUBS (2) GROUNDCOVERS PER TREE = 74 GROUNDCOVERS</p>	<p>BUILDING FOUNDATION: (PER TABLE 10-50.60.040.B.1) LENGTH = 5,270' (1) TREE PER 25' = 210 TREES (2) SHRUBS PER TREE = 420 SHRUBS (2) GROUNDCOVERS PER TREE = 420 GROUNDCOVERS</p> <p>PARKING AREA: (PER TABLE 10-50.60.040.C.) SPACES = 141 30 S.F./SPACE = 4,230 S.F. (REQUIRED) 4,356 S.F. (PROVIDED)</p> <p>SPACES = 141 (2) TREES PER 8 SPACES = 36 TREES (2) SHRUBS PER TREE = 72 SHRUBS (2) GROUNDCOVERS PER TREE = 72 GROUNDCOVERS</p>
--	---

SUMMARY:

TOTAL TREES = 367
TOTAL SHRUBS = 734
TOTAL GROUNDCOVERS = 734

TREE SPACING USED = 25' - 30'
SHRUB SPACING USED = 5' - 6'
GROUNDCOVER SPACING USED = 5' - 6'

PER SECTION 10-50.60.050:
6" OR GREATER TREES TO REMAIN = 25
RETAINED POINTS = 260

PERIPHERAL BUFFER TREES TO BE WAIVED = 2
BUILDING FOUNDATION TREES TO BE WAIVED = 4
STREET BUFFER TREES TO BE WAIVED = 2

TOTAL NEW TREES = 359
TOTAL SHRUBS = 718
TOTAL GROUNDCOVERS = 718

SYMBOL LEGEND:

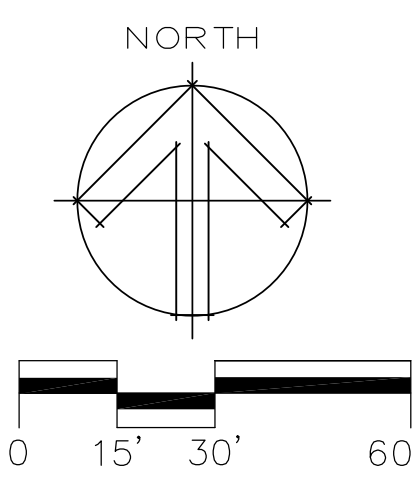
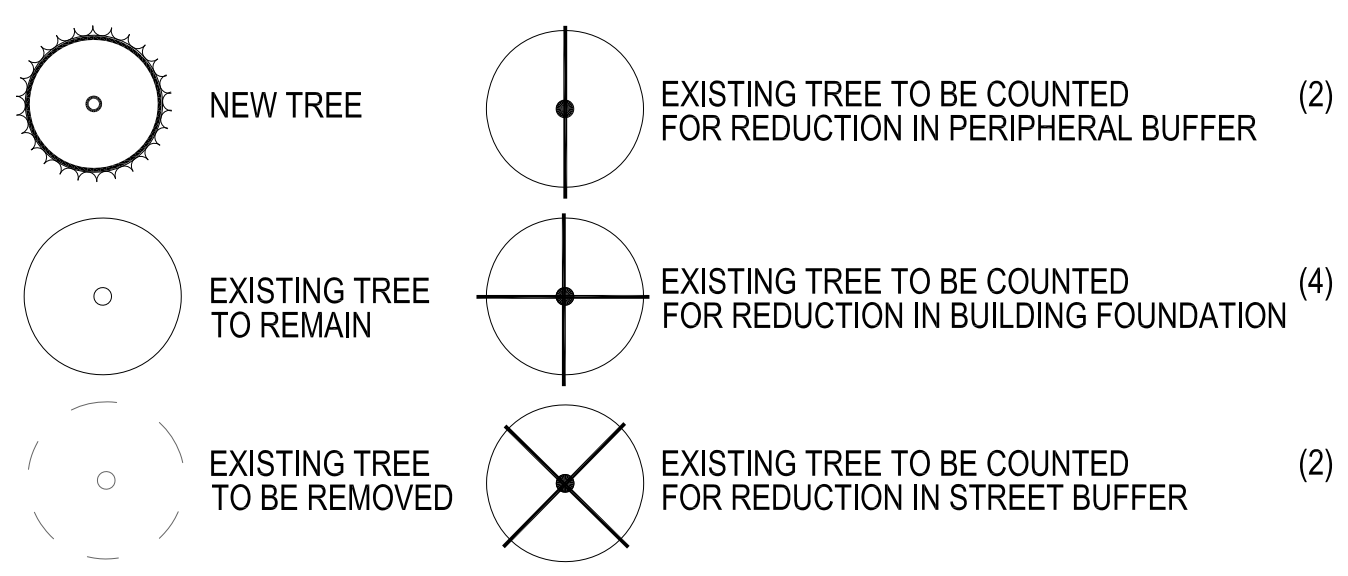

LANDSCAPE PLAN



IRRIGATION LEGEND

EQUIPMENT

<ul style="list-style-type: none"> ⊠ C.O.G. ▲ RAINBIRD ▼ FEBCO ◆ RAINBIRD ⊕ NIBCO ⊙ RAINBIRD ⊖ RAINBIRD ⊗ RAINBIRD ⊘ RAINBIRD 	<ul style="list-style-type: none"> PER CODE ESP-LXME 825YA-BV 33DR/33K T-180 PEB SERIES FS 200 B PE5B 	<ul style="list-style-type: none"> 2" WATER METER ELECTRIC CONTROLLER W/FLOW SMART MODULE 2" BACKFLOW PREVENTER W/ ENCLOSURE QUICK COUPLER BALL VALVE TURF ELECTRIC VALVE FLOW SENSOR 4" MASTER VALVE
--	---	---

HEADS

MFG.	BODY TYPE	NOZZLE	DESCRIPTION	GPM	PSI
⊙	RAINBIRD UNI-SPRAY	6" VAN	TURF SPRAY	.60	30
○	RAINBIRD UNI-SPRAY	15" VAN	TURF SPRAY	1.86	30
⊙	RAINBIRD UNI-SPRAY	15" VAN	TURF SPRAY	3.72	30
▽	RAINBIRD 5000-SERIES	MRP-25	TURF ROTOR	1.73	35
▼	RAINBIRD 5000-SERIES	MRP-25 (F)	TURF ROTOR	3.34	35

DRIP EQUIPMENT

<ul style="list-style-type: none"> ■ RAINBIRD SENINGER HYDRO RAIN SPEARS SPEARS BOWSMITH 	<ul style="list-style-type: none"> XCZ-100PRB-LC PR-25MP3/4F X 3/4F 420-3/4 (150 MESH) PVC 90 ST. EL. W/THREADED CAP PVC 90 ST. EL. W/ CAP SL & ML 200 SERIES 	<ul style="list-style-type: none"> INLINE CONTROL ZONE KIT PRESSURE REGULATOR "Y" STRAINER PVC DRIP FLUSH END CAP PVC DRIP END CAP SINGLE & MULTI-PORT EMITTERS
--	---	---

PROVIDE (2) ML-220 EMITTERS PER TREE EQUALLY SPACED AND (1) SL-210 EMITTER PER SHRUB OR GROUND COVER OR (1) ML-210 PER 6 PLANTS WITH A MAXIMUM DISTRIBUTION LINE LENGTH OF 5'.

ANNUAL BEDS TO BE ON A SEPARATE VALVE, USE POP UP MICRO SPRAYS.

PIPE SCHEDULE

1/2"	0-5	G.P.M.
3/4"	6-10	G.P.M.
1"	11-18	G.P.M.
1-1/4"	19-27	G.P.M.
1-1/2"	28-36	G.P.M.
2"	37-57	G.P.M.
2-1/2"	58-80	G.P.M.
3"	81-120	G.P.M.

PIPE LEGEND

---	CLASS 200 PVC (LATERALS)
---	SCH. 40 PVC (MAIN LINE)
---	SCH. 40 PVC (SLEEVES)

CONTROLLER(S)

IRRIGATION CONTROLLER(S) TO BE WALL MOUNTED IN POOL EQUIPMENT ROOM(S). COORDINATE POWER REQUIREMENTS WITH GENERAL CONTRACTOR

SCHEDULE

CONTROLLER : RAINBIRD ESP-LXME: 36 STATION
 PROGRAM "A": (1-7) TURF
 PROGRAM "A": (1-26) DRIP



biltform landscape architecture group, inc.
 11460 North Cave Creek Rd, suite 6
 phoenix, arizona 85020
 Phone 602.285.9200 Fax 602.285.9229
 email: dave@biltform.com



LAKE MARY HOUSING
 Single Family & Apartment Residences
 FLAGSTAFF, ARIZONA

ATLANTIC DEVELOPMENT & INVESTMENTS LLC.
 15957 N. 81ST ST., SUITE 101, SCOTTSDALE AZ. 85260
 PHONE: 480-256-0506

PROJECT NAME:
 PROJECT OWNER:

REVISIONS:

1	City Comments 9/20/22
2	City Comments 10/28/22
3	City Comments 12/7/22
4	
5	

JOB NO: 21-028L
 DATE: June 17, 2022
 SCALE: 1" = 30'-0"
 SHEET NO:

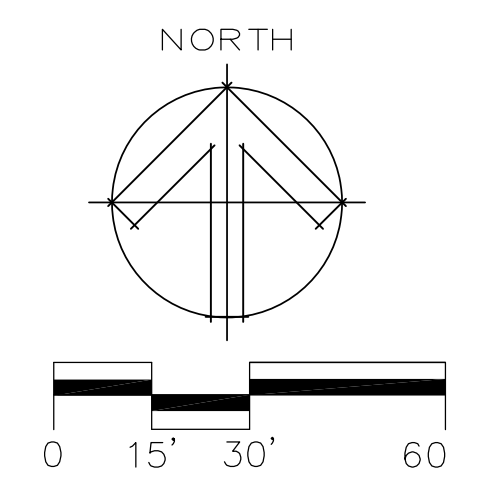

11.4

IRRIGATION PLAN



IRRIGATION LEGEND

EQUIPMENT

SYMBOL	DESCRIPTION	PER CODE	2" WATER METER
□	C.O.G.		
○	RAINBIRD ESP-LXME		ELECTRIC CONTROLLER W/FLOW SMART MODULE
●	FEBCO 825YA-BV		2" BACKFLOW PREVENTER W/ ENCLOSURE
▼	RAINBIRD 33DRC/33K		QUICK COUPLER
+	NIBCO T-180		BALL VALVE
⊕	RAINBIRD PEB SERIES		TURF ELECTRIC VALVE
○	RAINBIRD FS 200 B		FLOW SENSOR
⊗	RAINBIRD PESB		4" MASTER VALVE

HEADS

MFG.	BODY TYPE	NOZZLE	DESCRIPTION	GPM	PSI
○	RAINBIRD UNI-SPRAY	6" VAN	TURF SPRAY	.60	30
○	RAINBIRD UNI-SPRAY	15" VAN	TURF SPRAY	1.86	30
○	RAINBIRD UNI-SPRAY	15" VAN	TURF SPRAY	3.72	30
▽	RAINBIRD 5000-SERIES	MRP-25	TURF ROTOR	1.73	35
▽	RAINBIRD 5000-SERIES	MRP-25 (F)	TURF ROTOR	3.34	35

DRIP EQUIPMENT

■	RAINBIRD XCZ-100PRB-LC	INLINE CONTROL ZONE KIT
○	SENNINGER PR-25MF3/4F X 3/4"	PRESSURE REGULATOR
○	HYDRO RAIN 420-3/4 (150 MESH)	"Y" STRAINER
—	SPEARS PVC 90 ST. EL. W/THREADED CAP	PVC DRIP FLUSH END CAP
—	SPEARS PVC 90 ST. EL. W/ CAP	PVC DRIP END CAP
—	BOWSMITH SL & ML 200 SERIES	SINGLE & MULTI-PORT EMITTERS

PROVIDE (2) ML-220 EMITTERS PER TREE EQUALLY SPACED AND (1) SL-210 EMITTER PER SHRUB OR GROUND COVER OR (1) ML-210 PER 6 PLANTS WITH A MAXIMUM DISTRIBUTION LINE LENGTH OF 5'.
ANNUAL BEDS TO BE ON A SEPARATE VALVE. USE POP UP MICRO SPRAYS.

PIPE SCHEDULE

1/2"	0-5	G.P.M.
3/4"	6-10	G.P.M.
1"	11-18	G.P.M.
1-1/4"	19-27	G.P.M.
1-1/2"	28-36	G.P.M.
2"	37-57	G.P.M.
2-1/2"	58-80	G.P.M.
3"	81-120	G.P.M.

PIPE LEGEND

---	CLASS 200 PVC (LATERALS)
---	SCH. 40 PVC (MAIN LINE)
---	SCH. 40 PVC (SLEEVES)

CONTROLLER(S)

IRRIGATION CONTROLLER(S) TO BE WALL MOUNTED IN POOL EQUIPMENT ROOM(S), COORDINATE POWER REQUIREMENTS WITH GENERAL CONTRACTOR

SCHEDULE

CONTROLLER : RAINBIRD ESP-LXME: 36 STATION
PROGRAM "A": (1- 7) TURF
PROGRAM "A": (1- 26) DRIP

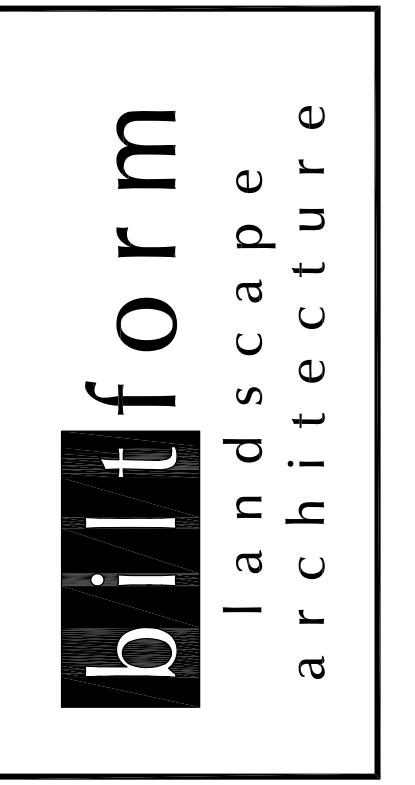

biltform landscape architecture group, inc.
11460 North Cave Creek Rd, suite 6
phoenix, arizona 85020
Phone 602.285.9200 Fax 602.285.9229
email: dave@biltform.com



LAKE MARY HOUSING
Single Family & Apartment Residences
FLAGSTAFF, ARIZONA

ATLANTIC DEVELOPMENT & INVESTMENTS LLC.
15957 N. 81ST ST., SUITE 101, SCOTTSDALE AZ. 85260
PHONE: 480-266-0506

REVISIONS:

1	City Comments 9/20/22
2	City Comments 10/28/22
3	City Comments 12/7/22
4	
5	

JOB NO: 21-028L
DATE: June 17, 2022
SCALE: 1" = 30'-0"
SHEET NO:

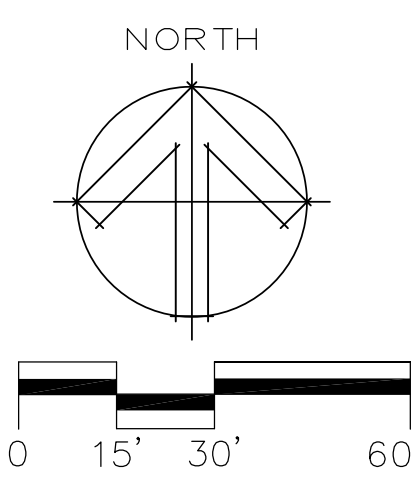

12.4

IRRIGATION PLAN



IRRIGATION LEGEND

EQUIPMENT

□	C.O.G.	PER CODE	2" WATER METER
▲	RAINBIRD	ESP-LXME	ELECTRIC CONTROLLER W/FLOW SMART MODULE
▼	FEBCO	825YA-BV	2" BACKFLOW PREVENTER W/ ENCLOSURE
◆	RAINBIRD	33DR/33K	QUICK COUPLER
+	NIBCO	T-180	BALL VALVE
⊕	RAINBIRD	PEB SERIES	TURF ELECTRIC VALVE
○	RAINBIRD	FS 200 B	FLOW SENSOR
⊗	RAINBIRD	PESB	4" MASTER VALVE

HEADS

MFG.	BODY TYPE	NOZZLE	DESCRIPTION	GPM	PSI
⊕	RAINBIRD	UNI-SPRAY	6"VAN	TURF SPRAY	.60 30
○	RAINBIRD	UNI-SPRAY	15" VAN	TURF SPRAY	1.86 30
⊙	RAINBIRD	UNI-SPRAY	15"VAN	TURF SPRAY	3.72 30
▽	RAINBIRD	5000- SERIES	MRP-25	TURF ROTOR	1.73 35
▼	RAINBIRD	5000- SERIES	MRP-25 (F)	TURF ROTOR	3.34 35

DRIP EQUIPMENT

■	RAINBIRD	XCZ-100PRB-LC	INLINE CONTROL ZONE KIT
■	SENNINGER	PR-25MF3/4F X 3/4F	PRESSURE REGULATOR
—	HYDRO RAIN	420-3/4 (150 MESH)	"Y" STRAINER
—	SPEARS	PVC 90 ST. EL. W/THREADED CAP	PVC DRIP FLUSH END CAP
—	SPEARS	PVC 90 ST. EL. W/ CAP	PVC DRIP END CAP
—	BOWSMITH	SL & ML 200 SERIES	SINGLE & MULTI-PORT EMITTERS

PROVIDE (2) ML-220 EMITTERS PER TREE EQUALLY SPACED AND (1) SL-210 EMITTER PER SHRUB OR GROUNDCOVER OR (1) ML-210 PER 6 PLANTS WITH A MAXIMUM DISTRIBUTION LINE LENGTH OF 5'.

ANNUAL BEDS TO BE ON A SEPARATE VALVE. USE POP UP MICRO SPRAYS.

PIPE SCHEDULE

1/2"	0-5	G.P.M.
3/4"	6-10	G.P.M.
1"	11-18	G.P.M.
1-1/4"	19-27	G.P.M.
1-1/2"	28-36	G.P.M.
2"	37-57	G.P.M.
2-1/2"	58-80	G.P.M.
3"	81-120	G.P.M.

PIPE LEGEND

---	CLASS 200 PVC (LATERALS)
---	SCH. 40 PVC (MAIN LINE)
---	SCH. 40 PVC (SLEEVES)

CONTROLLER(S)

IRRIGATION CONTROLLER(S) TO BE WALL MOUNTED IN POOL EQUIPMENT ROOM(S). COORDINATE POWER REQUIREMENTS WITH GENERAL CONTRACTOR

SCHEDULE

CONTROLLER : RAINBIRD ESP-LXME: 36 STATION
 PROGRAM "A": (1- 7) TURF
 PROGRAM "A": (1- 26) DRIP

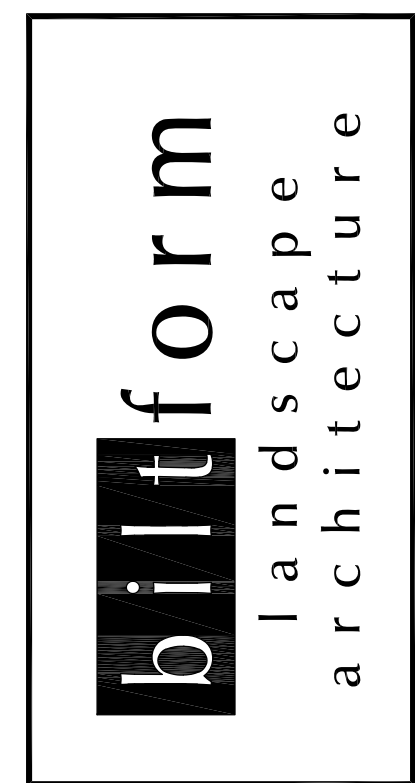

biltform landscape architecture group, inc.

11460 North Cave Creek Rd, suite 6
 phoenix, arizona 85020
 Phone 602.285.9200 Fax 602.285.9229
 email: dave@biltform.com



LAKE MARY HOUSING
 Single Family & Apartment Residences
 FLAGSTAFF, ARIZONA

ATLANTIC DEVELOPMENT & INVESTMENTS LLC.
 15957 N. 81ST ST., SUITE 101, SCOTTSDALE AZ. 85260
 PHONE: 480-266-0506

REVISIONS:

1	City Comments 9/20/22
2	City Comments 10/28/22
3	City Comments 12/7/22
4	
5	

JOB NO: 21-028L
 DATE: June 17, 2022
 SCALE: 1" = 30'-0"
 SHEET NO:

134

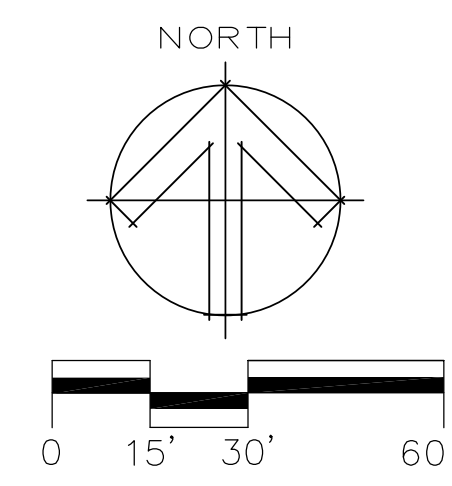

IRRIGATION PLAN

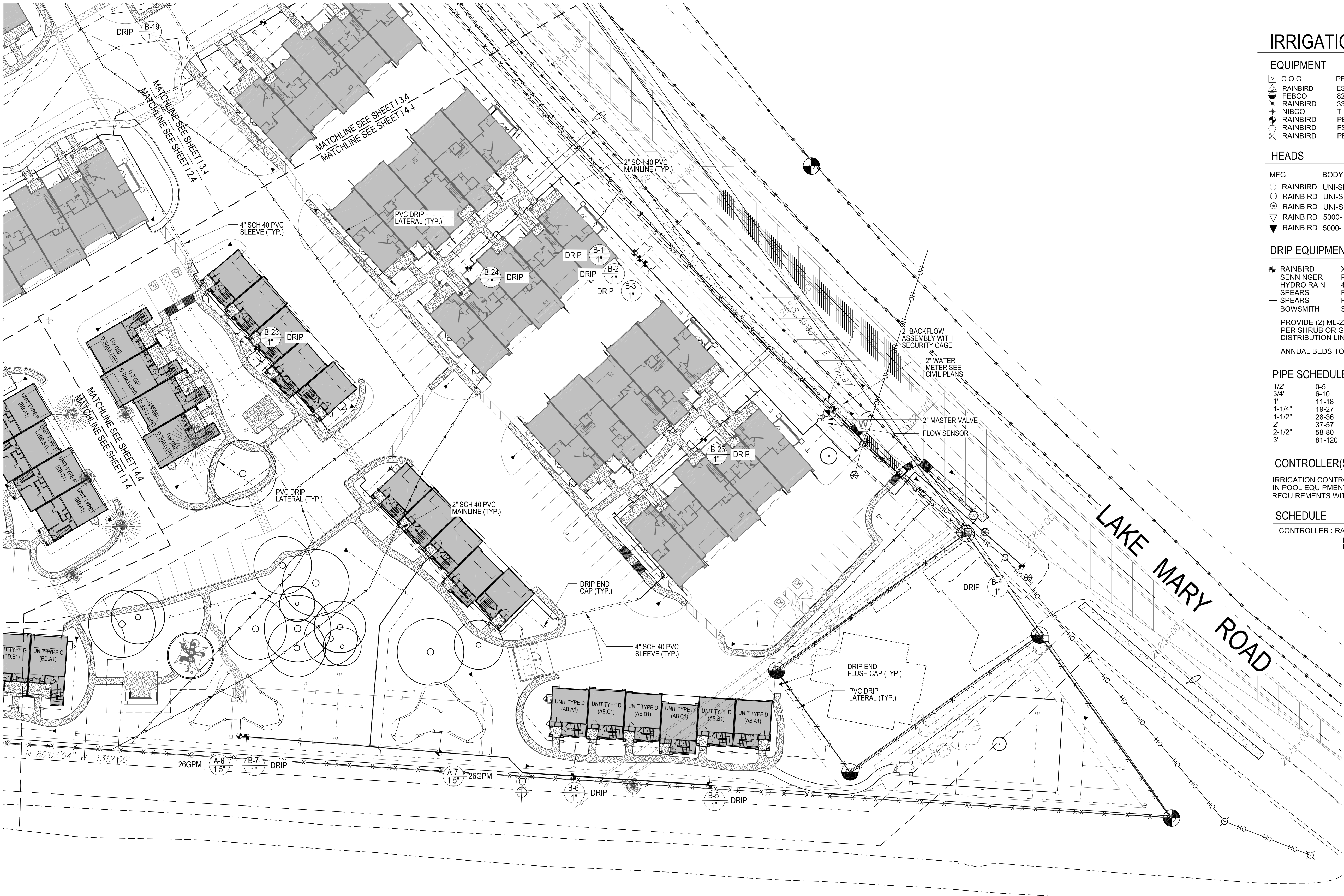

IRRIGATION LEGEND

EQUIPMENT		
□	C.O.G.	2" WATER METER
○	RAINBIRD ESP-LXME	ELECTRIC CONTROLLER W/FLOW SMART MODULE
●	FEBCO 825YA-BV	2" BACKFLOW PREVENTER W/ ENCLOSURE
▲	RAINBIRD 33DR/33K	QUICK COUPLER
+	NIBCO T-180	BALL VALVE
●	RAINBIRD FEB SERIES	TURF ELECTRIC VALVE
○	RAINBIRD FS 200 B	FLOW SENSOR
○	RAINBIRD PESB	4" MASTER VALVE

HEADS					
MFG.	BODY TYPE	NOZZLE	DESCRIPTION	GPM	PSI
○	RAINBIRD UNI-SPRAY	6"VAN	TURF SPRAY	.60	30
○	RAINBIRD UNI-SPRAY	15"VAN	TURF SPRAY	1.86	30
○	RAINBIRD UNI-SPRAY	15"VAN	TURF SPRAY	3.72	30
○	RAINBIRD 5000-SERIES	MRP-25	TURF ROTOR	1.73	35
▽	RAINBIRD 5000-SERIES	MRP-25 (F)	TURF ROTOR	3.34	35

DRIP EQUIPMENT		
■	RAINBIRD XCZ-100PRB-LC	INLINE CONTROL ZONE KIT
■	SENNINGER PR-25MF3/4F X 3/4F	PRESSURE REGULATOR
■	HYDRO RAIN 420-3/4 (150 MESH)	"Y" STRAINER
—	SPEARS PVC 90 ST. EL. W/THREADED CAP	PVC DRIP FLUSH END CAP
—	SPEARS PVC 90 ST. EL. W/ CAP	PVC DRIP END CAP
—	BOWSMITH SL & ML 200 SERIES	SINGLE & MULTI-PORT EMITTERS

PROVIDE (2) ML-220 EMITTERS PER TREE EQUALLY SPACED AND (1) SL-210 EMITTER PER SHRUB OR GROUNDCOVER OR (1) ML-210 PER 6 PLANTS WITH A MAXIMUM DISTRIBUTION LINE LENGTH OF 5'.
ANNUAL BEDS TO BE ON A SEPARATE VALVE. USE POP UP MICRO SPRAYS.

PIPE SCHEDULE		PIPE LEGEND	
1/2"	0-5 G.P.M.	---	CLASS 200 PVC (LATERALS)
3/4"	6-10 G.P.M.	---	SCH. 40 PVC (MAIN LINE)
1"	11-18 G.P.M.	---	SCH. 40 PVC (SLEEVES)
1-1/4"	19-27 G.P.M.		
1-1/2"	28-36 G.P.M.		
2"	37-57 G.P.M.		
2-1/2"	58-80 G.P.M.		
3"	81-120 G.P.M.		

CONTROLLER(S)
IRRIGATION CONTROLLER(S) TO BE WALL MOUNTED IN POOL EQUIPMENT ROOM(S). COORDINATE POWER REQUIREMENTS WITH GENERAL CONTRACTOR

SCHEDULE
CONTROLLER : RAINBIRD ESP-LXME: 36 STATION
PROGRAM "A": (1-7) TURF
PROGRAM "A": (1-26) DRIP

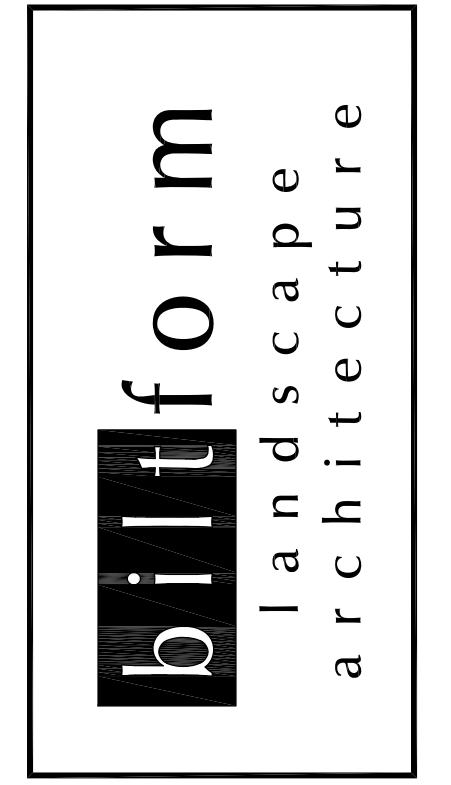

biltform landscape architecture group, inc.
11460 North Cave Creek Rd, suite 6
phoenix, arizona 85020
Phone 602.285.9200 Fax 602.285.9229
email: dave@biltform.com

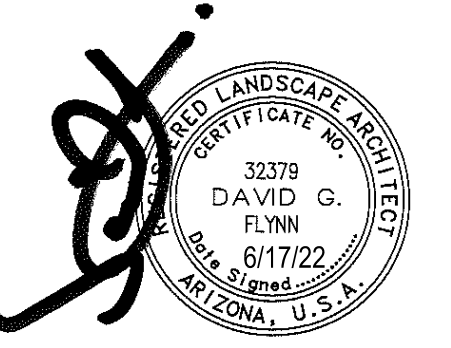

LAKE MARY HOUSING
Single Family & Apartment Residences
ATLANTIC DEVELOPMENT & INVESTMENTS LLC.
15957 N. 81ST ST., SUITE 101, SCOTTSDALE AZ. 85260
PHONE: 480-256-0506

REVISIONS:

1	City Comments 9/20/22
2	City Comments 10/28/22
3	City Comments 12/7/22
4	
5	

JOB NO: 21-028L
DATE: June 17, 2022
SCALE: 1" = 30'-0"
SHEET NO:

