

JOB ORDER CONSTRUCTION CONTRACT
#2025-121
(Under Job Order Services Master Contract #2020-100)

City of Flagstaff, Arizona
and
KEAR Civil Corporation

This Job Order Construction Contract (“Contract”) is made and entered into this 10 day of January, 2025, ~~2024~~, by and between the City of Flagstaff, a political subdivision of the state of Arizona (“Owner”), and KEAR Civil Corporation, an Arizona corporation (“Contractor”), with offices at 3100 N. Caden Ct. Contractor, Flagstaff, AZ 86004 (“Contractor”). Owner and Contractor may be referred to each individually as a “Party” and collectively as the “Parties.”

RECITALS

- A. Owner desires to obtain Job Order Contracting (“JOC”) for **Water/Wastewater General Construction** services (“Services”); and
- B. Contractor has available and offers to provide personnel and materials necessary to accomplish the work and complete the Project as described in the Scope of Work within the required time in accordance with the calendar days included in this Contract.

NOW, THEREFORE, the Owner and Contractor agree as follows:

1. Scope of Work. Contractor shall furnish any and all labor, materials, equipment, transportation, utilities, services, and facilities for the **Water Pump Station Meter Replacement KEAR #2025-121** (“Project”). The Project scope is specific to the attached Special Provisions (“Exhibit A”). Contractor shall construct the Project for the Owner in a good, workmanlike and substantial manner and to the satisfaction of the Owner through its engineers and under the direction and supervision of the City Engineer or his properly authorized agents (“Engineer”), including but not limited to project managers and project engineers. Contractor’s work shall be strictly pursuant to and in conformity with the Contract.

1.1 A Pre-Construction Conference will be held with the successful Contractor after the Notice of Award is issued. The date and time of the Conference will be agreed upon between Contractor and the Engineer at a location identified by the Owner. The purpose of the Conference is to outline specific construction items and procedures that the Owner feels require special attention on the part of Contractor. Contractor may also present any variations in procedures to improve the workability of the Project, reduce the cost, or reduce inconvenience to the public. Contractor shall submit a written proposal at this Conference outlining intended plans for pavement replacement, maintaining continuous access to residences and businesses along the construction site, and traffic control.

2. Contract; Ownership of Work. Contractor shall furnish and deliver all of the materials and perform all of the work in accordance with this Contract; Construction Plans (“Plans”); Special Provisions; the City of Flagstaff Engineering Design and Construction Standards and

Specifications; the latest version of the Maricopa Association of Governments (“MAG”) Specifications for Public Works Construction and City Revisions of MAG Standard Specifications for Public Works Construction (“Exhibit B”); and any Arizona Department of Transportation (“ADOT”) Standards that may be referenced on the Plans or in the specifications, incorporated in this Contract by reference, plans, and associated documents. All provisions of the Invitation for Construction Bids, Performance Bond, Payment Bond, Certificates of Insurance, Addenda, Change Orders, and Field Orders, if any, are hereby incorporated into this Contract. All materials, work, specifications, and plans shall be the property of the Owner.

The following exhibits are incorporated by reference and are expressly made a part of this Contract:

- 2.1 Specifications (Scope & Cost Estimation) Exhibit A
- 2.2 Revisions of MAG Standard Specifications for Public Works Construction Exhibit B (“Flagstaff Addendum to MAG”)

3. Payments. In consideration of the faithful performance of the work described in this Contract, the Owner shall pay an amount not to exceed the Total Contract Amount of **six hundred forty-six thousand nine hundred sixty-three dollars and eighty-nine cents (\$646,963.89)** to Contractor for work and materials provided in accordance with the Specifications (Scope & Cost Estimation), which amount includes all federal, state, and local taxes, as applicable. This amount shall be payable through monthly progress payments, subject to the following conditions:

3.1 Contractor shall promptly submit to the Owner all proper invoices necessary for the determination of the prices of labor and materials;

3.2 The Engineer shall have the right to finally determine the amount due to Contractor;

3.3 Monthly progress payments shall be made by the Owner, on or before fourteen (14) calendar days after the receipt by the Owner of an approved estimate of the work completed;

3.4 Contractor agrees that title to materials incorporated in the work, and stored at the site, shall vest with the Owner upon receipt of the corresponding progress payment;

3.5 The remainder of the Contract price, after deducting all such monthly payments and any retention, shall be paid within sixty (60) days after final acceptance of completed work by the Owner. The release of retention or alternate surety shall be made following the Owner’s receipt and acceptance of: Contractor’s Affidavit Regarding Settlement of Claims, Affidavit of Payment, Consent of Surety for Final Payment, and Unconditional Full and Final lien waivers from all subcontractors and suppliers who have filed an Arizona Preliminary Twenty Day Lien Notice in accordance with A.R.S. §§ 33-992.01 and 33-992.02.

4. Time of Completion. Contractor agrees to complete all work as described in this Contract within **three hundred sixty (360) calendar days** from the date of the Owner’s Notice to Proceed, free of all liens, claims, and demands of any kind for materials, equipment, supplies, services, labor, taxes, and damages to property or persons, in the manner and under the conditions specified within the time or times specified in this Contract.

5. Performance of Work. All work covered by this Contract shall be done in accordance with the latest and best accepted practices of the trades involved. Contractor shall use only skilled craftsmen experienced in their respective trades to prepare the materials and to perform the work.

6. Acceptance of Work; Non-Waiver. No failure of the Owner during the progress of the work to discover or reject materials or work not in accordance with this Contract shall be deemed an acceptance of, or a waiver of, defects in work or materials. No payment shall be construed to be an acceptance of work or materials which are not strictly in accordance with the Contract.

7. Delay of Work. Any delay in the performance of this Contract due to strikes, lockouts, fires, or other unavoidable casualties beyond the control of Contractor and not caused by any wrongful act or negligence of Contractor shall entitle Contractor to an extension of time equal to the delay so caused. Contractor shall notify the Owner in writing specifying such cause within twenty-four (24) hours after its occurrence. In the event such delay is caused by strikes, lockouts, or inability to obtain workmen for any other cause, the Owner shall have the right but shall not be obligated to complete the work on the same basis as is provided for in this Contract.

8. Failure to Complete Project in Timely Manner. If Contractor fails or refuses to execute this Contract within the time specified within this Contract, or such additional time as may be allowed, the proceeds of Contractor's performance guaranty shall become subject to deposit into the Treasury of the municipality as monies available to compensate the Owner for damages as provided by A.R.S. § 34-201 for the delay in the performance of work under this Contract, and the necessity of accepting a higher or less desirable bid from such failure or refusal to perform this Contract as required. If Contractor has submitted a certified check or cashier's check as a performance guaranty, the check shall be returned after the completion of this Contract.

9. Labor Demonstration. It is understood that the work covered by this Contract is for the Owner's business purposes and that any unfavorable publicity or demonstrations in connection with the work will have a negative effect upon the Owner. If Contractor's actions in performance of the Contract result in any public demonstration on behalf of the laborers or organized labor in the vicinity of the Owner's premises, whether such demonstration is in the form of picketing, posting of placards or signs, violence, threats of violence, or in any other form, which in the Owner's judgment might convey to the public the impression that the Owner or the Contractor or any subcontractor is unfair to laborers or to organized labor, the Owner shall have the right to terminate this Contract immediately, unless the Contractor shall have caused such demonstration to be discontinued within two (2) days after request of the Owner to do so. In the event any such demonstration is attended by violence, the Owner may fix lesser time within which a discontinuance shall be accomplished. In the event of Contract termination, Contractor agrees to remove from the Premises within twenty-four (24) hours of termination all machinery, tools, and equipment belonging to it or to its subcontractors. All obligations or liabilities of the Owner to Contractor shall be discharged by such termination, except the obligation to pay to Contractor a portion of the Contract price representing the value based upon the Contract prices of labor and materials incorporated in the work as established by the Owner, less the aggregate of all previous payments, but subject to all of the conditions pertaining to payments generally.

10. Material Storage. During the progress of the work, Contractor shall arrange for office facilities and for the orderly storage of materials and equipment. Contractor shall erect any

temporary structures required for the work at his or her own expense. Contractor shall at all times keep the premises reasonably free from debris and in a condition which will not increase fire hazards. Upon completion of the work, Contractor shall remove all temporary buildings and facilities and all equipment, surplus materials, and supplies belonging to Contractor. Contractor shall leave the Premises in good order, clean, and ready to use by the Owner. The establishment of any temporary construction yard, material storage area, or staging area to be located within City of Flagstaff limits and outside the public right-of-way or Project limits generally requires a Temporary Use Permit. (See Exhibit B, Section 107.2.1.).

11. Maintenance During Winter Suspension of Work.

11.1 A “Winter Shutdown” is the period of time typically including December through March during which no work will be performed by any person or entity (including but not limited to Contractor) on the Project and Contractor shall shutdown, properly insulate, and shelter the Project in a safe and workmanlike manner pursuant to local, state, and federal laws. Although December through March is typically the time frame, the Owner reserves the right to initiate and terminate a Winter Shutdown at the Owner’s sole discretion in the event of adverse weather conditions. A Winter Shutdown may be declared by the Owner despite delays, *for any reason*, on the Project. The Owner retains the right to declare a Winter Shutdown. If work has been suspended due to winter weather, Contractor shall be responsible for maintenance and protection of the improvements and of partially completed portions of the work until final acceptance of the Project. Winter Shutdown shall be by field order, change order, or original contract. If repairs and/or maintenance are needed during the Winter Shutdown, Contractor is required to perform the repairs and/or maintenance within twenty-four (24) hours of notification from the Owner. If the needed repairs and/or maintenance are not addressed within the time frame, the Owner will accomplish the work and deduct the cost from monies due or that become due to Contractor.

11.2 The Owner shall provide snow removal operations on active traffic lanes only during the Winter Shutdown. All other snow removal and maintenance operations shall be the responsibility of Contractor during the Winter Shutdown. All costs associated with snow removal and proper disposal shall be considered incidental to the work including repair of temporary surface improvements due to normal wear and snow removal operations during the Winter Shutdown.

12. Assignment. Contractor shall not assign this Contract, in whole or in part, without the prior written consent of the Owner, and no delegation of any duty of Contractor shall be made without prior written consent of the Owner. The Owner shall not unreasonably withhold consent to such assignment. Contractor agrees that any assignment agreement between Contractor and the assignee shall include and subject to the assignee all obligations, terms, and conditions of this Contract and that Contractor shall also remain liable under all obligations, terms, and conditions of this Contract.

13. Notices. Any notices or demands required to be given, pursuant to the terms of this Contract, may be given to the other Party in writing, delivered in person, sent by facsimile transmission, emailed, deposited in the United States mail, postage prepaid, or deposited with any commercial air courier or express service at the addresses set forth below, or to such other address as the Parties may substitute by written notice, given in the manner prescribed in this paragraph. However, notices of termination, notices of default, and any notice regarding

warranties shall be sent via registered or certified mail, return receipt requested, at the address set forth below **and** to legal counsel for the Party to whom the notice is being given.

If to Owner:

Emily Markel
Purchasing Manager
City of Flagstaff
211 West Aspen Avenue
Flagstaff, AZ 86001
emarkel@flagstaffaz.gov

If to Contractor:

Mike Fossett
President
KEAR Civil Corp.
3100 N. Caden Ct.
Flagstaff, AZ 86004
Mike.Fossett@kearcorp.com

With a Copy to:

Brian Huntzinger
Water Production Manager
City of Flagstaff
4500 Lake Mary Rd
Flagstaff, AZ 86001
BHuntzinger@flagstaffaz.gov

14. Contract Violations. In the event that any of the provisions of this Contract are violated by Contractor or by any of Contractor’s subcontractors, the Owner may serve written notice upon Contractor and the Surety of its intention to terminate such Contract (“Notice to Terminate”). The Contract shall terminate within five (5) days of the date Contractor receives the Notice to Terminate, unless the violation ceases and Contractor makes arrangements for correction satisfactory to the Owner. In the event of any such termination, the Owner shall immediately serve notice of the termination upon the Surety by registered mail, return receipt requested. The Surety shall have the right to take over and perform the Contract. If the Surety does not commence performance within ten (10) days from the date of receipt of the Owner’s notice of termination, the Owner may complete the work at the expense of Contractor, and Contractor and his or her Surety shall be liable to the Owner for any excess cost incurred by the Owner to complete the work. If the Owner completes the work, the Owner may take possession of and utilize such materials, appliances, and plants as may be on the worksite site and necessary for completion of the work.

15. Termination for Convenience. The Owner may terminate this Contract at any time for any reason by giving at least **thirty (30) days** written notice to Contractor. If termination occurs under this Section, Contractor shall be paid fair market value for work completed by Contractor as of the date of termination. The Parties agree that fair market value shall be determined based on Contractor’s Specifications (Scope & Cost Estimation), less any work not yet completed by Contractor as of the date the written notice of termination is given to Contractor.

16. Contractor’s Liability and Indemnification. To the fullest extent permitted by law, Contractor shall indemnify, save, and hold harmless the City of Flagstaff and its officers, officials, agents, and employees (“Indemnitee”) from and against liabilities, damages, losses, and costs, including reasonable attorneys’ fees, but only to the extent caused by the recklessness or intentional wrongful conduct of Contractor, subcontractor, or design professional, or other persons employed or used by Contractor, subcontractor, or design professional in the performance of the Contract. The amount and type of insurance coverage requirements set forth in

this Contract (Exhibit B, Section 103.6) will in no way be construed as limiting the scope of the indemnity in this paragraph.

17. Non-Appropriation. In the event that no funds or insufficient funds are appropriated and budgeted in any fiscal period of the Owner to meet the Owner's obligations under this Contract, the Owner will notify Contractor in writing of such occurrence, and this Contract will terminate on the earlier of the last day of the fiscal period for which sufficient appropriation was made or whenever the funds appropriated for payment under this Contract are exhausted. No payments shall be made or due to the other Party under this Contract beyond these amounts appropriated and budgeted by the Owner to fund the Owner's obligations under this Contract.

18. Amendment of Contract. This Contract may not be modified or altered except through a formal written amendment or a written change order, approved by the Owner's Change Order Committee, signed by duly authorized representatives of the parties, which directs Owner or Contractor, to make alterations to the original Contract.

19. Subcontracts. Contractor shall not enter into any subcontract, or issue any purchase order for the completed work, or any substantial part of the work, unless in each instance, prior written approval shall have been given by the Owner. Contractor shall be fully responsible to the Owner for acts and omissions of Contractor's subcontractors and all persons either directly or indirectly employed by them.

20. Cancellation for Conflict of Interest. This Contract is subject to the cancellation provisions of A.R.S. § 38-511.

21. Compliance with All Laws. Contractor shall comply with all applicable laws, statutes, ordinances, regulations, and governmental requirements in the performance of this Contract.

22. Employment of Aliens. Contractor shall comply with A.R.S. § 34-301, which provides that a person who is not a citizen or ward of the United States shall not be employed upon or in connection with any state, county, or municipal public works project.

24. Contractor's Warranty. Contractor warrants that it complies with all Federal Immigration laws and regulations that relate to its employees and complies with A.R.S. § 23-214.A, Verification of Employment Eligibility. Contractor shall not employ aliens in accordance with A.R.S. § 34-301, Employment of Aliens on Public Works Prohibited. Contractor acknowledges that pursuant to A.R.S. § 41-4401, Government Procurement; E-Verify Requirement; Definitions, a breach of this warranty is a material breach of this Contract subject to penalties up to and including termination of this Contract, and that the Owner retains the legal right to inspect the papers of any employee who works on the Contract to ensure compliance with this warranty.

25. Jurisdiction and Venue. This Contract shall be administered and interpreted under the laws of the State of Arizona. Contractor hereby submits itself to the original jurisdiction of those courts located within Coconino County, Arizona.

26. Attorneys' Fees. If suit or action is initiated in connection with any controversy arising out of this Contract, the prevailing party shall be entitled to recover in addition to costs such sum as the

court may adjudge reasonable as attorney fees, or in event of appeal as allowed by the appellate court.

27. Time is of the Essence. Contractor acknowledges that the completion of the Contract by the dates specified is critical to the Owner, time being of the essence of this Contract.

28. No Third-Party Beneficiaries. The Parties acknowledge and agree that the terms, provisions, conditions, and obligations of this Contract are for the sole benefit of, and may be enforceable solely by, the Parties to this Contract, and none of the terms, provisions, conditions, and obligations of this Contract are for the benefit of, or may be enforced by, any person or entity not a party to this Contract.

29. Headings. The article and section headings contained herein are for convenience in reference and are not intended to define or limit the scope of any provision of this Contract.

30. Severability. If any part of this Contract is determined by a court to be in conflict with any statute or constitution or to be unlawful for any reason, the Parties intend that the remaining provisions of this Contract shall remain in full force and effect unless the stricken provision leaves the remaining Contract unenforceable.

31. Records. The Owner and its employees, agents, and authorized representatives shall have the right at all reasonable times and during all business hours to inspect and examine Contractor's records related to this Contract. Contractor shall retain all records related to this Contract for a period consistent with the City of Flagstaff's records retention policy. This record retention requirement shall remain in effect following termination of the Contract.

32. Force Majeure.

32.1 There may be events that occur during the term of this Contract that are beyond the control of both the Owner and Contractor, including events of war, floods, labor, disputes, earthquakes, epidemics, pandemics, adverse weather conditions not reasonably anticipated, forest fires, and other acts of God ("Events"). These Events may result in a temporary delay of contractual deliverables, or the permanent inability to provide the contractual deliverables that are the subject of this Contract.

32.2 There shall be no claims arising from a temporary delay of contractual deliverables, or the permanent inability to provide the contractual deliverables caused by the Events, and the Owner shall not pay additional costs incurred by Contractor as a result of such Events.

32.3 The Parties shall act in good faith to extend the Contract completion date without any penalty to Contractor and the extension will be in an amount of time equal to any temporary delay. This provision of the Contract supersedes all other terms regarding temporary delay, permanent shut down, or increased costs.

33. No Boycott of Israel. Pursuant to A.R.S. §§ 35-393 and 35-393.01, if a Party has over ten (10) employees and the Contract is worth at least one-hundred thousand dollars and no cents (\$100,000.00), the Party shall certify that it is not currently engaged in, and agrees, for the duration of the Contract, will not engage in a boycott of Israel.

34. Modification to Contract. This Contract shall not be modified within the first year after Contract award where: (a) an amendment may result in a competitive advantage that was not made available to other proposers/bidders; or (b) requests for changes may delay commencement of performance.

35. Forced Labor of Ethnic Uyghurs. If Contractor engages in for-profit activity and has ten (10) or more employees, pursuant to A.R.S. §35-394, the Contractor certifies that it does not currently, and agrees for the duration of the contract that it will not, use: 1) the forced labor of ethnic Uyghurs in the People’s Republic of China; 2) any goods or services produced by the forced labor of ethnic Uyghurs in the People’s Republic of China; and 3) any contractors, subcontractors, or suppliers that use the forced labor or any goods or services produced by the forced labor of ethnic Uyghurs in the People’s Republic of China. If Contractor becomes aware during the term of the Contract that Contractor is not in compliance with the written certification, Contractor shall notify the Owner within five (5) business days after becoming aware of the noncompliance. If Contractor does not provide the Owner with a written certification that Contractor has remedied the noncompliance within 180 days after notifying the Owner of the noncompliance, this Contract terminates, except that if the contract termination date occurs before the end of the remedy period the Contract terminates on the Contract termination date.

36. Authority. Each Party warrants that it has authority to enter into the Contract and perform its obligations hereunder, and that it has taken all actions necessary to enter into the Contract.

(REMAINDER OF PAGE INTENTIONALLY BLANK)

IN WITNESS WHEREOF, the Owner and Contractor, by their duly authorized representatives, have executed this Contract as of the date written above.

(Please sign in blue ink. Submit original signatures – photocopies not accepted)

Owner, City of Flagstaff

KEAR Civil Corporation

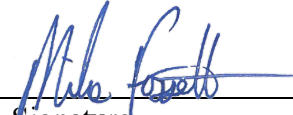

Greg Clifton signed on 1/9/2025 9:46:19 AM

Signature

Greg Clifton, City Manager

Mike Fossett

Attest:

Printed Name

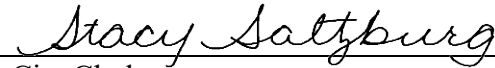

President

Stacy Saltzburg signed on 1/10/2025 3:46:01 PM

Title

Approved as to form:

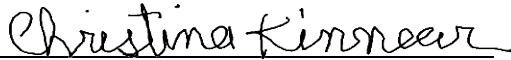

City Attorney
Christina Kinnear signed on 12/30/2024 9:04:37 AM

Last Updated November 13, 2023

in accordance with the provisions of said Title and Chapter, to the extent as if it were copied at length in this Contract.

The prevailing party in a suit on this bond shall recover as part of the judgment reasonable attorney fees that may be fixed by a judge of the court.

Witness our hands this 10th day of December 20 24 .

KEAR Civil Corporation

Principal (Seal)

By: Mike Fossett, President



Hartford Fire Insurance Company

Surety (Seal)

By: Jessika Gulliver, Attorney-in-Fact



USI Insurance Services LLC

Agency of Record

2375 E. Camelback Road #250, Phoenix, AZ 85016

Agency Address



**CITY OF FLAGSTAFF, ARIZONA
PAYMENT BOND**

PROJECT NAME: Water Pump Station Meter Replacement Bond No. 59BCSJA2410
PROJECT NUMBER: #2025-121

STATUTORY PAYMENT BOND PURSUANT TO TITLE 34
CHAPTER 2, ARTICLE 2, OF THE ARIZONA REVISED STATUTES
(Penalty of this Bond must be 100% of the Contract Amount)

KNOW ALL MEN BY THESE PRESENTS:

That, KEAR Civil Corporation

(Hereinafter called the Principal), as Principal, and, Hartford Fire Insurance Company

_____ , a corporation organized and existing under the laws of the State of CT , with its principal office in the City of Hartford, CT ("Surety"), as Surety, are held and firmly bound unto the City of Flagstaff, Arizona ("Obligee"), in the amount of Six Hundred Forty Six Thousand Nine Hundred Sixty Three Dollars and 89/100 Dollars (\$646,963.89) for the payment whereof, the said Principal and Surety bind themselves, and their heirs, administrators, executors, successors and assigns, jointly and severally, firmly by these presents.

WHEREAS, the Principal has entered into a certain written Contract with the Obligee, dated this 12th day of December, 2024, to the City of Flagstaff, which Contract is hereby referred to and made a part hereof as fully and to the same extent as if copied at length herein.

Now, therefore, the condition of this obligation is such, that if the principal promptly pays all monies due to all persons supplying labor or materials to the principal or the principal's subcontractors in the prosecution of the work provided for in the contract, this obligation is void. Otherwise it remains in full force and effect.

Provided, however, that this bond is executed pursuant to the provisions of Title 34, Chapter 2, Article 2, Arizona Revised Statutes, and all liabilities on this bond shall be determined in accordance with the provisions, conditions and limitations of said Title and Chapter, to the same extent as if it were copied at length in this Contract.

The prevailing party in a suit on this bond shall recover as a part of the judgment reasonable attorney fees that may be fixed by a judge of the court.

Witness our hands this 10th day of December 2024.

KEAR Civil Corporation

Hartford Fire Insurance Company

Principal (Seal)

Surety (Seal)

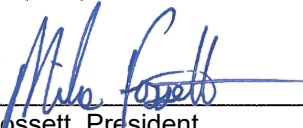
By: 
Mike Fossett, President

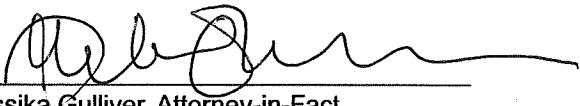
By: 
Jessika Gulliver, Attorney-in-Fact

USI Insurance Services LLC

2375 E.Camelback Road #250, Phoenix, AZ 85016

Agency of Record

Agency Address

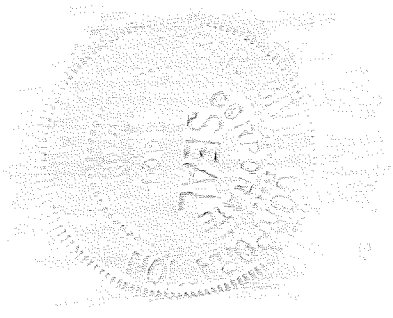

POWER OF ATTORNEY

Direct Inquiries/Claims to:

THE HARTFORD
 BOND, T-11
 One Hartford Plaza
 Hartford, Connecticut 06155
Bond.Claims@thehartford.com
 call: 888-266-3488 or fax: 860-757-5835

KNOW ALL PERSONS BY THESE PRESENTS THAT:

Agency Name: USI INSURANCE SERVICES LLC
 Agency Code: 59-305706

- Hartford Fire Insurance Company**, a corporation duly organized under the laws of the State of Connecticut
- Hartford Casualty Insurance Company**, a corporation duly organized under the laws of the State of Indiana
- Hartford Accident and Indemnity Company**, a corporation duly organized under the laws of the State of Connecticut
- Hartford Underwriters Insurance Company**, a corporation duly organized under the laws of the State of Connecticut
- Twin City Fire Insurance Company**, a corporation duly organized under the laws of the State of Indiana
- Hartford Insurance Company of Illinois**, a corporation duly organized under the laws of the State of Illinois
- Hartford Insurance Company of the Midwest**, a corporation duly organized under the laws of the State of Indiana
- Hartford Insurance Company of the Southeast**, a corporation duly organized under the laws of the State of Florida

having their home office in Hartford, Connecticut, (hereinafter collectively referred to as the "Companies") do hereby make, constitute and appoint, **up to the amount of Unlimited :**

Jorge L. Mendez, Jessika Gulliver, Kischa Rushing

of PHOENIX, Arizona

their true and lawful Attorney(s)-in-Fact, each in their separate capacity if more than one is named above, to sign its name as surety(ies) only as delineated above by , and to execute, seal and acknowledge any and all bonds, undertakings, contracts and other written instruments in the nature thereof, on behalf of the Companies in their business of guaranteeing the fidelity of persons, guaranteeing the performance of contracts and executing or guaranteeing bonds and undertakings required or permitted in any actions or proceedings allowed by law.

In Witness Whereof, and as authorized by a Resolution of the Board of Directors of the Companies on May 23, 2016 the Companies have caused these presents to be signed by its Assistant Vice President and its corporate seals to be hereto affixed, duly attested by its Assistant Secretary. Further, pursuant to Resolution of the Board of Directors of the Companies, the Companies hereby unambiguously affirm that they are and will be bound by any mechanically applied signatures applied to this Power of Attorney.



Shelby Wiggins

Shelby Wiggins, Assistant Secretary

Joelle L. LaPierre

Joelle L. LaPierre, Assistant Vice President

STATE OF FLORIDA

COUNTY OF SEMINOLE

ss. Lake Mary

On this 20th day of May, 2021, before me personally came Joelle LaPierre, to me known, who being by me duly sworn, did depose and say: that (s)he resides in Seminole County, State of Florida; that (s)he is the Assistant Vice President of the Companies, the corporations described in and which executed the above instrument; that (s)he knows the seals of the said corporations; that the seals affixed to the said instrument are such corporate seals; that they were so affixed by authority of the Boards of Directors of said corporations and that (s)he signed his/her name thereto by like authority.



Jessica Ciccone

Jessica Ciccone
 My Commission HH 122280
 Expires June 20, 2025

I, the undersigned, Assistant Vice President of the Companies, DO HEREBY CERTIFY that the above and foregoing is a true and correct copy of the Power of Attorney executed by said Companies, which is still in full force effective as of December 10, 2024.

Signed and sealed in Lake Mary, Florida.



Keith D. Dozois

Keith D. Dozois, Assistant Vice President

EXHIBIT A - SPECIFICATIONS

Finish Water Pump Station Meter Replacement

LAKE MARY WATER TREATMENT PLANT

Flagstaff, Arizona

KEAR CIVIL CORPORATION

Prepared & Submitted By:

KEAR Civil Corporation
22555 N. 20th Ave
Phoenix, AZ 85027

www.kearcorp.com

TN Lic 65481





Aug 20, 2024

City of Flagstaff
2323 N. Walgreens Street Suite 01
Flagstaff, AZ 86004
Attn: Brian Huntzinger

Subject: Proposal for Lake Mary Finish Water Pump Station Meter Replacement
Reference: JOC- Flagstaff Lake Mary Water Treatment Plant/ Drawing 9111G-10

Dear Brian Huntzinger,

We are pleased to submit our proposal for the necessary work on the Lake Mary Finish Water Pump Station Meter Replacement. This letter outlines the scope of work and provides a detailed quote for the project.

The project scope includes the following key activities:

- 1) The removal of the existing yard piping finished water pump station, and existing valve and meter, as indicated on drawing D-01.
- 2) Hauling and disposing of the removed materials off-site and excavating for the installation of a new vault.
- 3) Preparation of the surface and installation of a new vault, ductile pipe and pipe support, 7200 series ENVIROMAG flow meter, and related components and back filling to finish as shown in drawing M-02.
- 4) Asphalt repairs and landscaping to restore the area following the installation.
- 5) Functional testing of the new flow meter, as well as training for operational staff on its use included.
- 6) Electrical work, including new conduit runs, and pulling and connecting data and power lines as shown in drawing TM-01.

During the execution of the project, KEAR's supervision team will oversee all operations, ensuring that the process runs smoothly and providing regular progress reports estimated duration 30 days to complete.

Enclosed is a detailed quote for the work outlined above. We are confident that our proposal offers a comprehensive solution to restore the functionality, integrity, and appearance of the Lake Mary Finish Water Pump Station, ensuring its long-term performance.

We look forward to the opportunity to collaborate on this important project and are eager to apply our expertise to ensure its successful completion. Kindly let us know your decision at your earliest convenience so we can schedule the work and proceed accordingly.

Project Manager
Best regards,

Sincerely,
KEAR Civil Corporation

James Orsillo
Project Manager

A handwritten signature in blue ink that reads "James Orsillo".



City of Flagstaff Job Order Cost Proposal

Contractor Name	KEAR Civil Corporation		
Contract Type:	JOC	City Project No.:	
Job Order No.:		Contractor Job #	N/A
City Project Mgr.	Brain Huntzinger	Prepared By:	James Orsillo
Fee Type:		Revision#	0
Location	Lake Mary WTP		
Job Title	Lake Mary Finish Water Pump Station Meter Replacement		
Description of Work to be Performed (supporting information attached):	<p>The project involves the removal of the existing yard piping, finished water pump station, and valve and meter as per drawing D-01. After hauling and disposing of the removed materials, excavation will be done to install a new vault. The surface will be prepped for the installation of the new vault, ductile pipe, pipe support, and a 7200 series electromagnetic flow meter, followed by backfilling as indicated in drawing M-02. Asphalt repairs and landscaping will be completed to restore the area. The scope also includes functional testing of the new flow meter and providing training for operational staff. Electrical work will involve new conduit runs and connecting data and power lines as per drawing TM-01.</p>		

SECTION A: LABOR (inclusive of burden)				
Position	Unit	Quantity	Labor Cost	
			Each	Total
Project Manager	Hours	176.00	\$ 118.67	\$ 20,885.82
Project Engineer	Hours	176.00	\$ 63.23	\$ 11,127.60
Project Superintendent	Hours	176.00	\$ 106.35	\$ 18,717.33
Pipelayer	Hours	156.00	\$ 46.73	\$ 7,289.65
Operator	Hours	144.00	\$ 44.25	\$ 6,371.75
Apprentice / Laborer	Hours	196.00	\$ 41.11	\$ 8,058.09
Per Diem	Hours	120.00	\$ 173.57	\$ 20,828.00
Per Diem	Hours	36.00	\$ 218.00	\$ 7,848.00
	Hours	-	-	
			Section "A" Sub-Total	\$ 101,126.24

SECTION B: EQUIPMENT (supporting information attached, i.e. EquipmentWatch.com)

Item	Unit	Quantity	Labor Cost	
			Each	Total
Backhoe - CAT 426 Backhoe .37CY	Hours	140.00	\$ 44.19	\$ 6,186.00
JD 710 Backhoe .37CY	Hours	4.00	\$ 123.50	\$ 494.00
12" Plate Compactor	Hours	20	\$ 160.45	\$ 3,209.00
Reach Forklift	Hours	140	\$ 48.51	\$ 6,792.00
Pick Up Truck - Light Duty	Hours	528	\$ 13.81	\$ 7,292.00
Boom Truck	LP	1.00	\$ 4,800.00	\$ 4,800.00
Small Tools & Supplies (Consumables)	LP	1	\$ 5,000.00	\$ 5,000.00
Temp Fence	LP	1	\$ 3,000.00	\$ 3,000.00
MOB / DMOB	LP	1	\$ 1,500.00	\$ 1,500.00
		-	-	
Section "B" Sub-Total				\$38,273.00

SECTION C: Material (Please attach supporting information)

Item	Unit	Quantity	Material	
			Each	Total
KROHNE - ENVIROMAG 2000	EA	1.00	\$ 21,025.00	\$ 21,025.00
Ductile Pipe and Fittings	LP	1.00	\$ 135,083.26	\$ 135,083.26
Valves	LP	1.00	\$ 32,165.15	\$ 32,165.15
Pre Cast Vault	EA	1	\$ 32,165.15	\$ 32,165.15
Pipe Support and Cast	EA	3.00	\$ 1,962.00	\$ 5,886.00
Civil Material Misc Material & Tools	EA	1.00	\$ 45,686.24	\$ 45,686.24
Mechaincal Misc Materal & Tools	EA	1.00	\$ 81,132.61	\$ 81,132.61
		-	-	
Section "C" Sub-Total				\$ 353,143.41

SECTION D: SUBCONTRACTORS & CONSULTANTS (Please attach supporting information)

Company	Description of wok	Total
Asphalt	Cut and repair street	\$ 15,000.00
Landscape	Restore surroundings	\$ 2,000.00
Elcetrical Contractor	Run condit and Connect power and data	\$ 10,000.00
Mateial Testing	Compaction	\$ 4,000.00
Potholing	Potholing	\$ 5,600.00
Survey	Survey	\$ 6,000.00
Section "D" Sub-Total		\$ 42,600.00

OVERHEAD:	5.50%	(% to be taken from matrix)
-----------	-------	-----------------------------

PROFIT:	8.75%	(% to be taken from matrix)
---------	-------	-----------------------------

Subtotal General Contractor Costs (A+C):	\$454,269.65
--	--------------

O&P (% of A+C):	\$64,733.43
-----------------	-------------

Subtotal General Contractor Costs (B):	\$38,273.00
--	-------------

Total General Contractor Costs including O&P:	\$557,276.08
---	--------------

Subtotal Subcontractor Costs (D)	\$42,600.00
----------------------------------	-------------

Subcontractor Profit (5% of D)	\$2,130.00
--------------------------------	------------

Total Subcontractor Costs including O&P:	\$44,730.00
--	-------------

TOTAL GC and Subcontractor Costs including O&P:	\$602,006.08
---	--------------

Bond Costs @ 1.5%	\$9,030.09
-------------------	------------

Sales Tax (65% of 9.181%)	\$35,927.72
---------------------------	-------------

Subtotal Job Cost:	\$646,963.89
--------------------	--------------

Owner's Contingencies	\$0.00
-----------------------	--------

Owner must provide prior approval (in writing) before the use of any Contingency Funds

TOTAL JOB COST:	\$646,963.89
-----------------	--------------

Submitted By

Date

James Orsillo

10/15/20024

Flow Meter Spec



ENVIROMAG 2000 Technical Datasheet

Electromagnetic Flow Sensor

- Engineered and manufactured for the North American water and wastewater industry
- NSF Approved for potable water
- Proven and unsurpassed lifetime performance
- Long-term reliability and durability
- Available IP68 rating
- Available for direct burial installation



Solution for the water & wastewater Industry

The ENVIROMAG 2000 magmeter is the optimum solution for North American water and wastewater measurement applications. It's design and performance makes it the choice for flow measurement throughout the process.



1. Flanged design
2. PP. Polyurethane and Hard Rubber liner
3. 3/8" to 80" diameter
4. ANSI or AWWA flanges

Highlights

- Short inlet and outlet runs
- Unaffected by contamination, solids, fibers, slurries
- No maintenance
- Wet calibrated - includes calibration report
- Suitable for potable, chlorinated, fluorinated water, etc.
- Continuous self diagnostics
- NSF approved
- Available "virtual reference" eliminates grounding rings

Applications

- Wastewater processes
- Desalination processes
- Irrigation networks
- Clean water processes
- Water distribution
- Cooling stations - district heating

OPTIFLUX converters: All converters fit to all sensors



IFC 300 High-performance solution



IFC 010 Economical solution

Temperature Range

Temperature range [°C]	Process [°C]		Ambient [°C]	
	min.	max.	min.	max.

Hardrubber

Separate flow sensor (OPTIFLUX 2000 F)	-5	80	-40	65
Compact with IFC 300 (OPTIFLUX 2300 C)	-5	80	-40	65
Compact with IFC 010 (OPTIFLUX 2010 C)	-5	80	-25	60

* Hard Rubber available for sizes DN25 - 2000

Polyurethane

Separate flow sensor (OPTIFLUX 2000 F)	-5	69	-40	65
Compact with IFC 300 (OPTIFLUX 2300 C)	-5	69	-40	65
Compact with IFC 010 (OPTIFLUX 2010 C)	-5	69	-25	60

* Polyurethane available for DN 50-1000

Polypropylene

Separate flow sensor (OPTIFLUX 2000 F)	-5	90	-40	65
Compact with IFC 300 (OPTIFLUX 2300 C)	-5	90	-40	65
Compact with IFC 010 (OPTIFLUX 2010 C)	-5	90	-25	60

* Polypropylene available for DN 10-15

Temperature range [°F]	Process [°F]		Ambient [°F]	
	min.	max.	min.	max.

Hardrubber

Separate flow sensor (OPTIFLUX 2000 F)	23	176	-40	149
Compact with IFC 300 (OPTIFLUX 2300 C)	23	176	-40	149
Compact with IFC 010 (OPTIFLUX 2010 C)	23	176	-13	140

* Hard Rubber available for sizes 1" - 80"

Polyurethane

Separate flow sensor (OPTIFLUX 2000 F)	23	156	-40	149
Compact with IFC 300 (OPTIFLUX 2300 C)	23	156	-40	149
Compact with IFC 010 (OPTIFLUX 2010 C)	23	156	-13	140

* Polyurethane available for sizes 2" - 40"

Polypropylene

Separate flow sensor (OPTIFLUX 2000 F)	23	194	-40	149
Compact with IFC 300 (OPTIFLUX 2300 C)	23	194	-40	149
Compact with IFC 010 (OPTIFLUX 2010 C)	23	194	-13	140

* Polypropylene available for ASME 3/8" - 1/2"

Vacuum Load

Liner	Diameter [mm]	Minimum operating pressure absolute in mbar (abs) at process temperature			
		20°C	40°C	60°C	80°C
Polypropylene	DN 10 - 15	250	250	400	400
Hardrubber	DN 25 - 300	250	250	400	400
and	DN 350 - 1000	500	500	600	600
Polyurethane	DN 1200 - 2000	600	600	750	750

Liner	Diameter [inch]	Minimum operating pressure absolute in psia at process temperature			
		68°F	104°F	140°F	176°F
Polypropylene	3/8" - 1/2"	3.6	3.6	5.8	5.8
Hardrubber	1"-12"	3.6	3.6	5.8	5.8
and	14" - 40"	7.3	7.3	8.7	8.7
Polyurethane	48" -80"	8.7	8.7	10.9	10.9

ENVIROMAG 2000

Dimensions and Weights

Refer to diagrams on page 7

Nominal size [inch-mm]	Flange Type/ Rating	Dimensions [mm]						Dimensions [inch]						Approximate weight	
					T						T			[kg]	[lb]
		L ¹	H	W	box	010	300	L ¹	H	W	box	010	300		
3/8" - 10	ANSI 150	150	179	89	257	285	339	5.9	7.1	3.5	10.1	11.2	13.3	7	16.0
1/2" - 15	ANSI 150	150	179	89	257	285	339	5.9	7.1	3.5	10.1	11.2	13.3	7	16.0
1" - 25	ANSI 150	150	179	108	257	285	339	5.9	7.1	4.3	10.1	11.2	13.3	8	18.0
1½" -40	ANSI 150	150	203	127	281	309	363	5.9	8.0	5.0	11.1	12.2	14.3	10	22.0
2" -50	ANSI 150	200	191	152	269	297	351	7.9	7.5	6.0	10.6	11.7	13.8	13	29.0
3" - 80	ANSI 150	200	210	191	288	316	370	7.9	8.3	7.5	11.3	12.4	14.6	17	37.0
4" - 100	ANSI 150	250	256	229	334	362	416	9.8	10.1	9.0	13.2	14.3	16.4	23	51.0
5" - 125	ANSI 150	250	280	254	358	386	440	9.8	11.0	10.0	14.1	15.2	17.3	27	60.0
6" - 150	ANSI 150	300	304	279	382	410	464	11.8	12.0	11.0	15.0	16.1	18.3	34	75.0
8" - 200	ANSI 150	350	355	343	433	461	515	13.8	14.0	13.5	17.0	18.1	20.3	50	110.0
10" - 250	ANSI 150	400	433	406	511	539	593	15.8	17.1	16.0	20.1	21.2	23.3	73	160.0
12" - 300	ANSI 150	500	499	483	577	605	659	19.7	19.7	19.0	22.7	23.8	25.9	100	220.0
14" - 350	ANSI 150	500	552	533	630	658	712	19.7	21.7	21.0	24.8	25.9	28.0	114	250.0
16" - 400	ANSI 150	600	608	597	686	714	768	23.6	23.9	23.5	27.0	28.1	30.2	155	340.0
18" - 450	ANSI 150	600	672	635	750	778	832	23.6	26.5	25.0	29.5	30.6	32.8	170	375.0
20" - 500	AWWA Cl. D	600	739	699	817	845	899	23.6	29.1	27.5	32.2	33.3	35.4	191	420.0
24" - 600	AWWA Cl. D	600	852	813	930	958	1012	23.6	33.5	32.0	36.6	37.7	39.8	250	550.0
28" - 700	AWWA Cl. D	700	918	927	996	1024	1078	27.6	36.1	36.5	39.2	40.3	42.4	320	704.0
30" - 750	AWWA Cl. D	800	974	984	1052	1080	1134	31.5	38.3	38.8	41.4	42.5	44.6	358	787.6
32" - 800	AWWA Cl. D	800	1038	1060	1116	1144	1198	31.5	40.9	41.8	43.9	45.0	47.2	395	869.0
36" - 900	AWWA Cl. D	900	1144	1168	1222	1250	1304	35.4	45.0	46.0	48.1	49.2	51.3	450	990.0
40" - 1000	AWWA Cl. D	1000	1258	1289	1336	1364	1418	39.4	49.5	50.8	52.6	53.7	55.8	665	1463.0
42" - 1050	AWWA Cl. D	1300	1313	1350	1391	Not Applicable	1473	51.2	51.7	53.1	54.8	Not Applicable	58.0	683	1502.6
48" - 1200	AWWA Cl. D	1300	1483	1511	1561	Not Applicable	1643	51.2	58.4	59.5	61.5	Not Applicable	64.7	970	2134.0
54" - 1350	AWWA Cl. D	1600	1635	1682	1713	Not Applicable	1795	63.0	64.4	66.2	67.4	Not Applicable	70.7	TBA	TBA
60" - 1500	AWWA Cl. D	1700	1782	1860	1860	Not Applicable	1942	66.9	70.2	73.2	73.2	Not Applicable	76.5	TBA	TBA
70" - 1750	AWWA Cl. D	1800	2139	2197	2217	Not Applicable	2299	70.9	84.2	86.5	87.3	Not Applicable	90.5	TBA	TBA

Nominal size [inch-mm]	Flange Type/ Rating	Dimensions [mm]						Dimensions [inch]						Approximate weight	
					T						T			[kg]	[lb]
		L ¹	H	W	box	010	300	L ¹	H	W	box	010	300		
1" - 25	ANSI 300	150	145	124	223	251	305	5.9	5.7	4.9	8.8	9.9	12.0	8	18.0
1½" -40	ANSI 300	200	169	156	247	275	329	7.9	6.7	6.1	9.7	10.8	13.0	9	20.0
2" -50	ANSI 300	250	186	165	264	292	346	9.8	7.3	6.5	10.4	11.5	13.6	13	29.0
3" - 80	ANSI 300	250	214	210	292	320	374	9.8	8.4	8.3	11.5	12.6	14.7	17	37.0
4" - 100	ANSI 300	300	275	254	353	381	435	11.8	10.8	10.0	13.9	15.0	17.1	23	51.0
6" - 150	ANSI 300	350	316	318	394	422	476	13.8	12.4	12.5	15.5	16.6	18.7	36	79.0
8" - 200	ANSI 300	400	382	381	460	488	542	15.8	15.0	15.0	18.1	19.2	21.3	71	157.0
10" - 250	ANSI 300	500	448	445	526	554	608	19.7	17.6	17.5	20.7	21.8	23.9	112	247.0
12" - 300	ANSI 300	600	519	521	597	625	679	23.6	20.4	20.5	23.5	24.6	26.7	170	375.0
14" - 350	ANSI 300	700	595	584	673	701	755	27.6	23.4	23.0	26.5	27.6	29.7	215	474.0
16" - 400	ANSI 300	800	646	648	724	752	806	31.5	25.4	25.5	28.5	29.6	31.7	290	639.0
18" - 450	ANSI 300	800	709	711	787	815	869	31.5	27.9	28.0	31.0	32.1	34.2	359	789.0
20" - 500	ANSI 300	800	777	775	855	883	937	31.5	30.6	30.5	33.7	34.8	36.9	426	937.0
24" - 600	ANSI 300	800	903	914	981	1009	1063	31.5	35.5	36.0	38.6	39.7	41.8	611	1345.0

Notes:

¹ If flowmeter is supplied with separate grounding rings, the totals fitting length "L" is computed as follows: "L" + 2 x 3 mm (1/8") + 2 x gasket thickness

Frontview ENVIROMAG 2000F

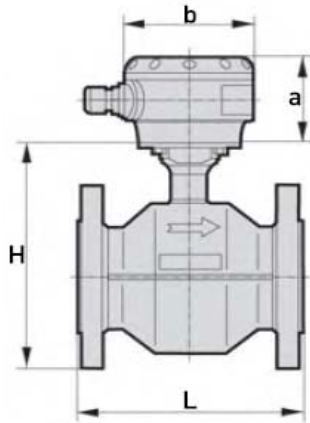

a = 77 mm / 3,1"
b = 111 mm / 4,4"

Sideview ENVIROMAG 2000F

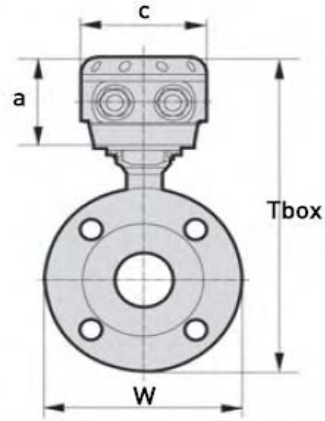

a = 77 mm / 3,1"
c = 106 mm / 4,2"

Frontview ENVIROMAG 2010C

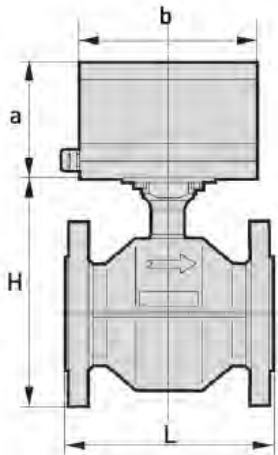

a = 105 mm / 4,2"
b = 160 mm / 6,3"

Sideview ENVIROMAG 2010C

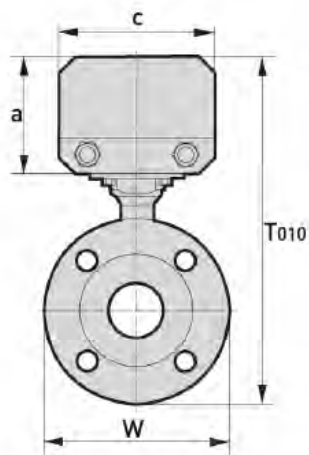

a = 105 mm / 4,2"
c = 140mm / 5,5"

Frontview ENVIROMAG 2300C

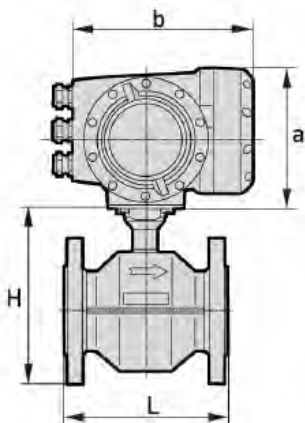

a = 155 mm / 6,1"
b = 202 mm / 7,8"

Sideview ENVIROMAG 2300C

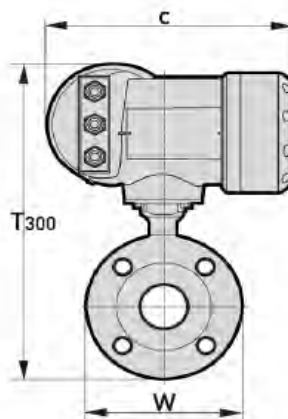

c = 260 mm / 10,2"

KROHNE Product Overview

- Electromagnetic flowmeters
- Variable area flowmeters
- Mass flowmeters
- Ultrasonic flowmeters
- Vortex flowmeters
- Flow controllers
- Level measuring instruments
- Pressure gauges
- Temperature measuring instruments
- Water solutions & analysis
- Oil and gas turnkey solutions

KROHNE, Inc.
7 Dearborn Road
Peabody, MA, 01960 (USA)
1-800-FLOWING (978 535-6060)
www.krohne.com/northamerica
info@krohne.com



EXHIBIT B



**CITY OF FLAGSTAFF
AMENDMENTS
to
MAG STANDARD SPECIFICATIONS
FOR PUBLIC WORKS CONSTRUCTION
(General Provisions)**

The
MAG UNIFORM STANDARD SPECIFICATIONS
for
PUBLIC WORKS CONSTRUCTION
is hereby amended to include the following:

PART 100 - GENERAL CONDITIONS

SECTION 102 - BIDDING REQUIREMENTS AND CONDITIONS

102.1 ELIGIBILITY AND PREFERENCE:
(revise to include the following)

If requested by the City, a Bidder shall furnish satisfactory evidence of the Bidder's competency to perform the proposed work. Such evidence of competency, unless otherwise specified, shall consist of statements covering the Bidder's experience on similar work, a list of equipment that would be available for the work and a list of key personnel that would be available.

In addition, if requested, a Bidder shall furnish the City of Flagstaff with satisfactory evidence of the Bidder's financial responsibility. Such evidence of financial responsibility, unless otherwise specified, shall consist of a confidential statement or report of the Bidder's financial resources and liabilities as of the last calendar year or the contractor's last fiscal year. Such statements or reports shall be certified by a public accountant. At the time of submitting such financial statements or reports, the Bidder shall further certify whether the Bidder's financial responsibility is approximately the same as stated or reported by the public accountant. If the Bidder's financial responsibility has changed, the Bidder shall qualify the public accountant's statement or report to reflect the Bidder's true financial condition at the time such qualified statement or report is submitted to the City of Flagstaff.

The Bidder shall submit such "evidence of competency" and "evidence of financial responsibility" to the City of Flagstaff no later than five (5) working days after receipt of a written request by the City of Flagstaff.

Each bidder, contractor and subcontractor shall possess and maintain the appropriate contractor's license for the work included in this contract. The appropriate license shall be as required by the Arizona State Registrar of Contractors and as required by Arizona Revised Statutes Chapter 10, Title 32.

102.2 CONTENTS OF PROPOSAL PAMPHLET:

(revise to include the following)

The Plans, Specifications and other Documents designated in the Contract Documents shall be considered a part of the Contract whether attached or not.

The City of Flagstaff reserves the right to refuse to issue a proposal form or accept a proposal form from a prospective Bidder if they are in default for any of the following reasons:

- (A) Failure to comply with any prequalification regulations of the City of Flagstaff, if such regulations are cited or otherwise included in the Proposal as a requirement for bidding;
- (B) Failure to pay or satisfactorily settle all bills due for labor and materials on former contracts in force (with the City of Flagstaff) at the time the City of Flagstaff issues the Proposal to a prospective Bidder;
- (C) Contractor, as a company owner, has defaulted under previous contract(s) with the City of Flagstaff in the prior five calendar years;
- (D) Record of unsatisfactory work on previous contract(s) with the City of Flagstaff in the prior five calendar years.

102.2 CONTENTS OF PROPOSAL PAMPHLET:

(third paragraph, revise last sentence to read as follows)

The work embraced herein shall be done in accordance with the requirements of:

City of Flagstaff Amendments to MAG Standard Specifications for Public Works Construction (General Provisions).

City of Flagstaff (City) Engineering Standards (Current Version and adopted revisions).

Maricopa Association of Governments (MAG), *Uniform Standard Specifications for Public Works Construction*, Current Version (MAG Specifications).

MAG Standard Details for Public Works Construction, Current Version and adopted revisions (MAG Details).

Arizona Department of Transportation (ADOT) Standard Specifications for Road and Bridge Construction, Current Version and adopted revisions.

In the case of conflict, the following order of precedence shall govern:

1. Special Provisions
2. Construction Plans and Addenda
3. General Provisions and MAG Revisions
4. City of Flagstaff Standards and Specifications
5. MAG Standards and Specifications
6. ADOT Standards and Specifications
7. FHWA Manual of Uniform Traffic Control Devices

102.4 EXAMINATION OF PLANS, SPECIAL PROVISIONS AND SITE OF WORK:

(revise to include the following)

Before submitting a bid, each bidder shall examine the site and obtain information that pertains to the physical conditions of the site that may affect the cost, progress or performance of the work. Any restrictions or difficulties relating to the completion of the work shall be considered in accordance with the terms and conditions of the contract documents.

102.7 IRREGULAR PROPOSALS:

(revise to include the following)

The City of Flagstaff reserves the right to reject any irregular Proposal and the right to waive technicalities for acceptance of Proposals, if such waiver is in the best interest of the City of Flagstaff and conforms to local laws and ordinances pertaining to the letting of construction contracts.

Proposals shall be considered irregular for the following additional reasons:

- (A) If the Proposal contains unit prices that are obviously unbalanced.
- (B) If the Proposal is not accompanied by the proposal guaranty specified by the City.

102.12 DISQUALIFICATION OF BIDDERS:

(revise to include the following)

A Bidder shall also be considered disqualified if the Bidder is considered in default for any reason specified in Subsection 102.2 as amended by this MAG Amendment.

102.13 SUCCESSFUL BIDDERS:

(revise paragraph to read as follows)

The City of Flagstaff shall provide six (6) sets of plans and Contract Documents at no cost. A direct expense fee shall be charged for any additional copies.

SECTION 103 - AWARD AND EXECUTION OF CONTRACT

103.6 CONTRACTOR'S INSURANCE:

103.6.1 GENERAL:

(revise subsection to read as follows)

The Contractor and its Subcontractors, at Contractor's and Subcontractors' own expense, shall purchase and maintain the herein stipulated minimum insurance with companies duly licensed, possessing a current A.M. Best, Inc. Rating of A-, 7, or approved by the City. The insurance company shall be licensed in the State of Arizona. Policies and forms shall be satisfactory to the City.

All insurance required herein shall be maintained in full force and effect until all work and/or services required to be performed, under the terms of the Contract, are satisfactorily completed and formally accepted. At the sole discretion of the City, failure to do so may constitute a material breach of this Contract.

The Contractor's insurance shall be primary insurance as respects the City. Any insurance or self-insurance maintained by the City shall not contribute to it.

Contractor shall not fail to comply with the claim reporting provisions of the insurance policies or cause a breach of any insurance policy warranty that would affect coverage afforded under insurance policies to protect the City.

The insurance policies (except Worker's Compensation) shall contain a waiver of transfer of rights of recovery (subrogation) against the City, its agents, representatives, directors, officers, and employees for any claims arising out of the Contractor's acts, errors, mistakes, omissions, work or service.

The insurance policies may provide coverage, which contains deductibles or self-insured retentions. Such deductible and/or self-insured retentions shall not be applicable with respect to the coverage provided to the City under such policies. The Contractor shall be solely responsible for the deductible and/or self-insured retentions, and the City, at its option, may require the Contractor to secure payment of such deductibles or self-insured retentions by a Surety Bond or an irrevocable and unconditional letter of credit.

The City reserves the right to request and to receive, within 10 working days, certified copies of any or all of the herein required insurance policies and/or endorsements. The City shall not be obligated, however, to review same or to advise Contractor of any deficiencies in such policies and endorsements, and such receipt shall not relieve Contractor from, or be deemed a waiver of the City's right to insist on, strict fulfillment of Contractor's obligations under this Contract.

Except for Worker's Compensation, the insurance policies, required by this Contract shall name the City, its agents, representatives, officers, directors, officials and employees as additional insureds.

Required Coverage

A. COMMERCIAL GENERAL LIABILITY

The Contractor shall maintain Commercial General Liability insurance with a limit of not less than \$1,000,000 for each occurrence with a \$2,000,000 Products/Completed Operations Aggregate and a \$2,000,000 General Aggregate Limit. The Policy shall include coverage for bodily injury, broad form property damage, personal injury, products and completed operations and blanket contractual coverage. Coverage will be at least as broad as Insurance Service Office, Inc. Policy Form CG 00011093 or any replacements thereof. The coverage shall not exclude X, C, U.

Such policy shall contain a severability of interest provision and shall not contain a sunset provision or commutation clause, nor any provision, which would serve to limit third party action over claims. The Commercial General Liability additional insured endorsement shall be at least as broad as the Insurance Service Office, Inc. Additional Insured, Form B, CG 20101185, and shall include coverage for Contractor's operations and products and completed operations.

B. OWNERS AND CONTRACTOR'S PROTECTIVE LIABILITY

The Contractor shall purchase and maintain, at all times during prosecution of the work, services or operations under this Contract, an Owner's and Contractor's Protective Liability insurance policy for bodily injury and property damage, including death, which may arise in the prosecution of the Work or Contractor's operations under this Contract. Coverage shall be on an occurrence basis with a limit not less than \$1,000,000 per occurrence, and the policy shall be issued by the same insurance company that issues the Contractor's Commercial General Liability insurance.

C. AUTOMOBILE LIABILITY

Contractor shall maintain Commercial/Business Automobile Liability insurance with a combined single limit for bodily injury and property damage of not less than \$1,000,000 each occurrence with respect to the Contractor's any auto, all owned autos, scheduled autos, hired autos, non-owned autos assigned to or used in performance of the Contractor's work. Coverage will be at least as broad as coverage code 1, "any auto", (Insurance Service Office, Inc. Policy CA 00011293, or any replacements thereof). Such insurance shall include coverage for loading and off-loading hazards. If hazardous substances, materials or wastes are to be transported, MCS 90 endorsement shall be included and \$5,000,000 per accident limits for bodily injury and property damage shall apply.

D. WORKER'S COMPENSATION

The Contractor shall carry Worker's Compensation insurance to cover obligations imposed by federal and state statutes having jurisdiction of Consultant's employees engaged in the performance of the work or services; and Employer's Liability insurance of not less than \$100,000 for each accident, \$100,000 disease for each employee, and \$500,000 disease policy limit.

In case any work is subcontracted, the Contractor will require the Subcontractor to provide Worker's Compensation and Employer's Liability to at least the same extent as required of the Contractor.

E. BUILDER'S RISK (PROPERTY) INSURANCE (AS REQUIRED)

When the project includes construction of a new building, an addition to an existing building, modifications to an existing building, or as otherwise may be required by the contracting agency, the Contractor shall purchase and maintain, on a replacement cost basis, Builder's Risk insurance in the amount of the initial Contract Amount as well as subsequent modifications thereto for the entire work at the site. At a minimum, the policy limits of such insurance shall be equal in face amount to the full Contract Amount. Such Builder's Risk insurance shall be maintained until final payment has been made or until no person or entity other than the City has an insurable interest in the property required to be covered, whichever is earlier. This insurance shall include interests of the City, the Contractor, and all Subcontractors and Sub-Subcontractors in the work during the life of the Contract and course of construction, and shall continue until the work is completed and accepted by the City. For new construction projects, the Contractor agrees to assume full responsibility for loss or damage to the work being performed and to the buildings under construction. For renovation construction projects, the Contractor agrees to assume responsibility for loss or damage to the work being performed at least up to the full Contract Amount, unless otherwise required by the Contract Documents or amendments thereto.

Builder's Risk insurance shall be on an all-risk policy form and shall cover false work and temporary buildings. Builder's Risk insurance shall insure against risk of direct physical loss or damage from external causes including debris removal, demolition occasioned by enforcement of any applicable legal requirements and shall cover reasonable compensation for Architect's service and expenses required as a result of such insured loss and other "soft costs" as required by the Contract.

Builder's Risk insurance must provide coverage from the time any covered property becomes Contractor's control and/or responsibility, and continue without interruption during construction or renovation or installation, including any time during which the covered property is being

transported to the construction installation site, and while on the construction or installation site awaiting installation. The policy will provide coverage while the covered premises or any part thereof is occupied. Builder's Risk insurance shall be primary and not contributory.

If the Contract requires testing of equipment or other similar operations, at the option of the City, the Contractor will be responsible for providing property insurance for these exposures under a Boiler Machinery insurance policy.

Required coverage may be modified by an amendment to the Contract Documents.

CERTIFICATES OF INSURANCE

Prior to commencing work or services under this Contract, Contractor shall furnish the City with Certificates of Insurance, or formal endorsements as required by the Contract, issued by Contractor's insurer(s), as evidence that policies providing the required coverage, conditions and limits required by this Contract are in full force and effect.

In the event any insurance policies required by this contract are written on a "claims made" basis, coverage shall extend for two years past completion and acceptance of the Contractor's work or services and as evidenced by annual Certificates of Insurance.

If a policy does expire during the life of the Contract, a renewal certificate must be sent to the City fifteen (15) days prior to the expiration date.

All Certificates of Insurance shall be identified with bid/project number and project name. A \$25.00 administrative fee will be assessed for all certificates received without the appropriate bid serial number and title.

CANCELLATION AND EXPIRATION NOTICE

Insurance required herein shall not expire, be canceled, or materially changed without thirty (30) days written notice to the City.

SECTION 104 - SCOPE OF WORK

104.1.3 WATER SUPPLY: (revise to include the following)

Potable water may not be used for major construction activity, such as dust control, soil compaction, or street cleaning. Reclaimed water is available at the Wildcat Hill Wastewater Treatment plant on East Highway 66 and at the south end of Babbitt Drive at the Rio De Flag Water Reclamation Plant. Additional reclaimed water bulk loading sites are located in other areas of the city. The contractor should obtain current locations from the Water Services Department. **Current rates for the**

reclaimed water shall apply. The Contractor is responsible for the cost of construction water and it is considered incidental to the cost of the contract.

Prior to loading, hauling and applying reclaimed water, the Contractor shall be required to obtain the necessary no fee permit at the Wildcat Hill Wastewater Treatment Plant or from the Rio De Flag plant and shall be responsible for complying with all permit and ADEQ requirements regarding the use of reclaimed water.

104.1.4 SPECIAL ACCESS REQUIREMENTS:
(revise to include the following)

The Contractor shall maintain access to all side streets, access roads, driveways, alleys, parking lots and to adjacent properties during their hours of operation. The Contractor shall coordinate with residents and ensure access to all driveways be provided during all non-working hours. Where a property has more than one driveway, no more than one access will be restricted or closed at one time. Should it be necessary to close access to private property, driveways or alley entrances, the closure must be for as short a time as possible and be restored at the end of the work shift. If primary business access cannot be restored, the Contractor shall provide an alternate access, which will be coordinated with the business and pre-approved by the Owner prior to any restrictions being implemented.

104.1.5 SANITATION PICKUP:

When construction activity interferes with pickup, the contractor shall provide for sanitation and recycling vehicle access to the affected properties or relocate the containers where access is acceptable.

104.1.6 EMERGENCY ACCESS:

Street closure information shall be submitted to the City's Project Representative who will forward the information to the Fire Department and Police Department. All notices shall be submitted at least 72 hours in advance of the closures.

104.1.7 POSTAL SERVICE ACCESS:

The contractor shall be responsible for maintaining access for Postal Service within the project area at all times.

104.1.8 SCHOOL BUS ACCESS:

The contractor shall be responsible for maintaining access for bus access within the project area.

104.2 ALTERATION OF THE WORK:

104.2.3 DUE TO EXTRA WORK:
(revise to include the following)

When Allowance and/or Contingency items are provided for in the contract, the funds are encumbered for use at the discretion of the Project Manager. The funds are to cover unanticipated costs to complete items of work not included in the Contract Documents or may be applied to any work deemed necessary by the Owner. Work would include, but not limited to, unanticipated conditions, scope changes, addressing errors or omissions, and/or construction changes that are warranted for project completion consistent with the purpose of the work.

The amount of the allowance item is determined by the City and is not subject to individual bid pricing. The allowance is not part of the bidding process and per the City of Flagstaff Procurement Manual, will be added to the contract amount, if approved by the City Council.

The allowance item provides an estimated funding to cover unforeseen changes that may be encountered and corresponding extra work needed to complete the contract. Any work which is to be paid out of this allowance shall be authorized in writing and approved by Field Order prior to proceeding with the work. Extra work shall be paid for in the following order of precedence: 1.) by extension of unit bid prices, 2.) by negotiated price or 3.) by a time and materials basis in accordance with MAG Section 109.5.

It shall be understood that the amount for this item in the proposal is an estimate only and no guarantee is given that the full amount or any portion thereof will be utilized. It shall not be utilized without first obtaining an approved Field Order signed by the Contractor and the Project Manager.

105.2.1 RECORD DRAWING PREPARATION AND COORDINATION
(revise to include new subsection as follows)

Record drawing preparation shall be the obligation of the Contractor whose purpose is to accurately record and depict the as-built conditions. During the construction phase and prior to backfilling or covering of improvements, the Contractor shall have the work surveyed and recorded for record drawing preparation.

The Contractor shall maintain a redline working copy of the project plans which shall include changes made in construction of the project. The redline copy of the plans shall be updated weekly.

105.2.2 RECORD DRAWING (As-Built Plans)

(revise to include new subsection as follows)

The Contractor shall retain an Arizona licensed civil engineer to record as-built information per Arizona Revised Statute § 32-152. Water and sewer record drawing certification shall comply with ADEQ R18-5-508 (drinking water) and ADEQ R18-9-E301 (sewage collection) requirements for as-built drawings. Unless otherwise noted, the City will complete and submit the Engineer's Certificate of Completion to ADEQ.

Prior to the City's final approval and acceptance of public improvements (sanitary sewer, water, storm sewer, streets) record drawings (as-built plans) must be submitted to the City for review and acceptance per Engineering Standard Specifications.

A redline submittal shall be a .pdf and/or two sets of blue or black line paper sets, copied from the originally approved plan set. Redline submittal will be reviewed by the City and returned with applicable comments. Comments are to be addressed and resubmitted for the City's final approval. A reference checklist is available from the Office of the City Engineer.

Upon City and ADEQ (when applicable) review and approval of the submittal, an electronic .pdf of the plans shall be submitted to the City as a permanent record. All record drawing plan sets shall contain a statement by a licensed professional engineer, currently registered to practice in Arizona, certifying that the drawings are per the as-built condition. The record set requires the seal and signature of the registrant per Arizona Revised Statutes § 32-152. All survey data given by the record drawings shall be performed by a land surveyor who is currently registered in the State of Arizona. Plans must show seal and signature of registrant.

Payment shall be lump sum for all work required to develop the necessary documents, including but not limited to coordination, field inspection, survey, drafting, printing and engineer's seal. The fee shall include as-built information for all record changes within the project area.

SECTION 105 - CONTROL OF WORK

105.8 CONSTRUCTION STAKES, LINES AND GRADES:

(revise entire subsection to read as follows)

The Contractor shall be responsible for all required construction staking, including preconstruction staking for relocation of existing utilities. All construction staking is to be done under the direct supervision of a Registered Land Surveyor or Civil Engineer. All costs associated with this work are to be included in the amount bid for the items of work to which it is incidental or appurtenant. No separate payment will be made for construction staking.

105.10 INSPECTION OF THE WORK

(revise to include the following)

The Contractor is responsible for Quality Control of the work. The City will perform Quality Assurance; frequency of testing will be determined by the City. The Contractor shall be responsible for coordinating and scheduling all inspections of the work and shall confirm that the required inspections and material testing are completed and accepted prior to proceeding with additional work. The Contractor is required to perform the work to a confidence level that the City's Quality Assurance will validate that the work meets specification(s).

105.11 REMOVAL OF UNACCEPTABLE AND UNAUTHORIZED WORK:

(revise to include the following)

Any work and/or materials condemned by the Project Manager as inferior or not in compliance with the Contract, Specifications and Plans shall be immediately removed by the Contractor. Materials and/or work so condemned shall be removed and promptly replaced and executed in accordance with the Contract, Specifications and Plans without any expense to the Owner. The Contractor shall bear the expense of making good on all work of other contractors destroyed or damaged by such removal and replacement.

105.12 MAINTENANCE DURING CONSTRUCTION:

(revise to include the following)

The Contractor is responsible to provide adequate drainage for the construction area at all times. Damage to any portion of the work caused by the Contractor's failure to provide adequate drainage of the construction area shall be repaired at the Contractor's expense. A contract time extension will not be granted for any additional time required to make such repairs.

The Contractor shall control open excavations and stockpiling in a manner to prevent water from running into excavations. Obstructions of surface drainage shall be avoided and means shall be provided whereby storm water and wastewater can flow uninterrupted in existing or established pipes, flow courses, other surface drains, temporary drains or channels.

Material for backfill or for protection of excavations within public roads or easements shall be placed and shaped to cause the least possible interference to public travel. In no event shall any flows be allowed to enter private property.

105.16 MAINTENANCE DURING WINTER SUSPENSION OF WORK

(revise to include new subsection as follows)

The City retains the right to declare a winter shutdown, *for any reason*, on the Project including but not limited to adverse weather conditions. A winter shutdown period is typically December through March during which no work will be performed on the Project.

The Contractor shall shutdown, properly insulate and shelter the Project in a safe and workmanlike manner pursuant to local, state and federal laws.

If work has been suspended due to winter weather, the Contractor shall be responsible for maintenance and protection of the improvements and of partially completed portions of the work until final acceptance of the project. Winter suspension shall be by field order, change order or original contract. If repairs and/or maintenance are needed during the suspension, the Contractor is required to perform the repairs and/or maintenance within twenty-four (24) hours of notification from the City. If the needed repairs and/or maintenance are not addressed within the timeframe, the City will accomplish the work and deduct the cost from monies due or become due to the Contractor.

The City shall provide snow removal operations on active traffic lanes only. All other snow removal and maintenance operations shall be the responsibility of the Contractor. All cost associated with snow removal and proper disposal shall be considered incidental to the work including the repair of temporary surface improvements due to normal wear and snow removal operations during the Winter Shutdown.

SECTION 107 - LEGAL REGULATIONS AND RESPONSIBILITY TO THE PUBLIC

107.1 LAWS TO BE OBSERVED: (revise to include the following)

(G) TAX EXEMPTION: Certain material, machinery and equipment to be installed in this project is exempt from sales tax or use tax as allowed in Arizona Revised Statutes Section 42-5061, 42-5009 and Section 42-5159 and by the Administrative Rules and Regulations of the Arizona Department of Revenue; ACC R15-5-608, R15-5-120 and R15-5-2314.

The City wishes to rely upon the expertise of the contractor in the purchase of items that qualify for the tax exemption. With respect to purchase of the qualifying items, the Contractor is authorized to act as an agent for the City. This agency agreement is strictly limited to the purchase of the qualifying items to be used in the construction of the project and will not otherwise affect or alter the respective rights, responsibilities and remedies of the parties as specified under this contract. The contractor shall furnish the City a list of suppliers and the material, machinery and equipment

to be furnished by each. The City will then issue the materials and equipment exemption certificate to each supplier pursuant to A.R.S. §42-5009 (A) (2). The contractor's applicable unit bid prices for items qualifying for this tax exemption should not include sales or use tax. The materials, machinery and equipment that are a part of this project and to which the exemption applies are listed below:

1. Pipes, valves and appurtenances four (4) inches in diameter or larger used to transport potable water,
2. Any additional material, machinery or equipment identified in the Special Provisions.

107.2.1 TEMPORARY USE PERMITS:
(revise to include new subsection as follows)

A Temporary Use Permit (and Above Ground Fuel Storage Permit if applicable) is required prior to the establishment of any temporary construction yard, material storage area or staging area located within City limits and outside the public right-of-way or project limits. The Contractor is responsible for obtaining the necessary Temporary Use Permit from the agency with jurisdictional authority.

The time required to process the Temporary Use Permit is approximately twelve (12) calendar days. The Contractor shall submit the necessary permit application no later than ten (10) calendar days following the Notice of Award. Any delays experienced by the Contractor in acquiring the Temporary Use Permit shall not necessarily be grounds for delaying the project Notice to Proceed.

107.2.2 DISPOSAL OF WASTE AND SURPLUS MATERIAL:
(revise to include the following)

All disposal costs, regardless of disposal site, shall be included in the bid unit price for the related item of work and no direct payment will be made for disposal of waste or surplus materials. This right of disposal does not apply to any substance or items that are regarded as toxic and/or hazardous by the City, the State of Arizona or the United States Government.

Alternate disposal sites may be proposed by the Contractor but are subject to all applicable local ordinances and codes. In addition to the property owner's written authorization, all disposal sites within the city limits are subject to review and approval by the Temporary Use Permit process. The disposal of material at alternate disposal sites will not be allowed without written authorization of the owner, approval of the appropriate jurisdictional authority, and the issuance of all necessary permits.

107.2.3 ABOVE GROUND FUEL STORAGE PERMIT:

(revise to include new subsection as follows)

If required, Above Ground Fuel Storage Permits may be obtained from the City of Flagstaff Fire Department, located at 211 West Aspen Avenue, Flagstaff, AZ. The Contractor is responsible for obtaining the permit.

107.5 SAFETY, HEALTH, AND SANITATION PROVISIONS:

107.5.4 HANDLING, REMOVAL AND DISPOSAL OF SURPLUS MATERIAL AND ASBESTOS CONTAINING MATERIALS (ACM)

(revise to include new subsection as follows)

The Contractor is responsible for handling, removal and disposal of all soil material generated by the project as described in the General Provisions.

The City requires compliance with Environmental Protection Agency (EPA), Arizona Department of Environmental Quality (ADEQ) and Occupational Safety and Health Administration (OSHA) asbestos regulations for all City projects.

Utility pipes constructed of materials other than metal or polyvinyl chloride (PVC) require testing prior to any disturbance of the pipes to determine if regulated levels of asbestos are present in the pipe material. Suspect pipe materials requiring testing typically include vitrified clay and cement pipe (transite). Asbestos testing is not required for metal pipes.

City Public Works/Sustainability & Environmental Management staff are available to collect samples and submit the samples for analyses. The City of Flagstaff will provide testing free of charge. If the pipe does not contain regulated levels of asbestos, the contractor may disturb and remove the piping. If utility piping contains regulated levels of asbestos, an asbestos abatement contractor must perform any disturbance/removal of the pipe materials. This is required to ensure workers are not exposed to any asbestos fibers.

Work may require the proper handling, removal and disposal of regulated asbestos piping and materials generated by cutting or breaking the pipe to remove it from the ground. If asbestos containing materials (ACM) removal is necessary on the project, the City of Flagstaff requirements for handling, removal and disposal are as follows:

- If an infrastructure or building material that is not either wood, glass or metal is encountered during the project and has not yet been either assumed or positively identified to be ACM then the material(s) must be sampled in accordance with regulations generated by the EPA Asbestos Hazard and Emergency Response Act (AHERA) 40 CFR 763 as well as OSHA 29 CFR 1910.1101, by a certified AHERA Building Inspector and sent to a National Voluntary Laboratory Accreditation Program (NVLAP) certified laboratory for analysis.

- Once materials of concern are assumed or properly identified to be ACM then material removal is required according to OSHA 29 CFR 1910-1926.1101 by a certified asbestos abatement worker, and NOT a general contractor (GC). However, if the GC holds the appropriate asbestos certifications (AHERA Asbestos Operations and Maintenance), which the City would need to verify is current, then the GC could perform the asbestos abatement.

The City requires the General Contractor arrange for abatement of assumed and/or identified ACM by a certified asbestos abatement contractor and to arrange area and/or clearance air monitoring by a third party certified asbestos consultant. If applicable to the project, copies of abatement activities and air monitoring shall be provided to City of Flagstaff Environmental Management staff.

In the event of large disturbances to ACM, compliance with the National Emission Standards for Hazardous Air Pollutants (NESHAP) 40 CFR 61, Subpart M shall be followed. Notification would be required the Arizona Department of Environmental Quality 10 working days in advance of the start of a large project. This notification is not typically required for utility pipe work, but could be required for a very large project involving numerous saw cuts of utility pipes. <http://www.azdeq.gov/enviro/air/asbestos/>

If ACM removal is necessary on the project, the City of Flagstaff requirements for ACM disposal at the City's Cinder Lake Landfill are as follows:

Only non-friable asbestos waste is accepted for disposal at Cinder Lake Landfill. PRIOR to disposal of non-friable ACM, obtain the necessary forms, which are:

- Non-Friable Asbestos Waste Acceptance Application and accompanying instructions
- Non-Friable Asbestos Waste Shipment Record (WSR)

The Asbestos Waste Acceptance Application is available at the City of Flagstaff's website or by contacting the City of Flagstaff Environmental Management staff. A Waste Shipment Record is required to accompany each load of non-friable asbestos waste taken to the Cinder Lake Landfill.

Assure the non-friable ACM is properly handled and wrapped. Non-friable ACM must be thoroughly wetted using amended water PRIOR to being wrapped in 6-millimeter poly and be tightly sealed with duct tape. If the material is heavy (such as transite pipe), has sharp edges, or may easily puncture the poly wrap, a double layer of poly will be necessary. The Cinder Lake Landfill scale house attendant will inspect the load to ensure it is properly wrapped. Containers holding non-friable ACM shall be carefully unloaded and placed in a designated location. Dumping using a hydraulically lifted bed of a truck is not permitted (dump truck), as the poly wrap may be torn open.

If using a large bin for disposal, attach a copy of the Waste Shipment Record to the disposal bin. If not using a City of Flagstaff disposal bin, make sure the delivery driver takes a copy of the SIGNED Non-Friable Asbestos Waste Acceptance Application and the Waste Shipment Record to the Cinder Lakes Landfill with the waste delivery.

If using a City of Flagstaff disposal bin call City Environmental Services at (928) 774-0668 to schedule a pick-up for the disposal bin. Please be sure to provide the driver with the SIGNED Non-Friable Asbestos Waste Acceptance Application and the Waste Shipment Record and be sure to clarify if you would like the disposal bin emptied and removed, or emptied and returned to the work site. When disposal is completed, the Landfill Manager will sign the Waste Shipment Record and landfill staff will provide or mail a copy of the Waste Shipment Record.

Cutting of utility pipes generates Regulated Asbestos Containing Material (RACM). RACM requires disposal at the Joseph City Landfill or at other landfills located in southern Arizona.

All work relating to the removal and disposal of unknown and unanticipated hazardous materials as described above shall be paid per MAG 109.4.3.

107.8 107 USE OF EXPLOSIVES:

(first paragraph, revise second sentence to read as follows)

The Contractor shall submit a blasting plan for approval and obtain a Blasting Permit from the City of Flagstaff Fire Department, located at 211 W. Aspen Avenue, Flagstaff, Arizona.

(revise to include the following)

The Contractor shall submit a copy of the approved blasting plan to the Project Manager. The plan shall include as a minimum; safety layout, drilling pattern, size and depth of bore, weight and type of charge, delay sequence, contractor's anticipated peak particle velocity at the right-of-way line or nearest structure, and the proposed seismograph locations.

A record of each blast shall be kept and all records including seismograph reports shall be available for inspection. Each record shall provide as a minimum; location, date and time of blast, name of person in charge, number of holes burdened, spacing, diameter and depth of holes, boring logs to determine top of rock, type and total amount of explosives used, direction and distance to nearest building, type of detonators and delay periods used, and exact locations of seismographs.

When blasting operations are to be conducted within 200 feet of a water line, sewer line or other underground utility, the Contractor shall take additional precautionary measures. The Contractor shall also coordinate with Franchise Utilities prior to blasting operations. The Contractor shall notify the owner of the facility a minimum of two weeks in advance that such blasting operations are

intended. At their discretion, the Owner may perform pre-blast, post-blast pressure tests or other inspection of the facility. If any damage occurs because of blasting operations, the Contractor shall be responsible for the restoration of the facility to pre-blast conditions.

107.9 PROTECTION AND RESTORATION OF PROPERTY AND LANDSCAPE:
(revise to include the following)

The Contractor is responsible for replacing and/or restoring the site, landscaping and owner's improvements associated with the project to the pre-existing condition using in-kind materials. All cost shall be included in the bid as incidental to the work, unless otherwise specified in the bid schedule or plans.

Within easements, the Contractor is responsible for removing existing improvements and salvaging items (not identified for removal) for relocation after the public improvements are completed. Close coordination between the Contractor and property owners and/or residents is required.

107.11 CONTRACTOR'S RESPONSIBILITY FOR UTILITY PROPERTY AND SERVICES:
(revise to include the following)

All power poles, pedestals, guy wires and underground facilities shall be removed and/or relocated by the respective owners of the facilities. The contractor is responsible for the notification and coordination with the utility companies to ensure that this work is accomplished in a manner consistent with the construction schedule. Payment for Franchise Utility coordination and location is incidental to the cost of the work.

The Contractor shall perform utility potholes and identify potential conflicts prior to trenching. The utility pothole information and identification of potential conflicts shall be provided to the Project Manager at least two weeks prior to performing trenching or pipeline construction.

SECTION 108 - COMMENCEMENT, PROSECUTION AND PROGRESS

108.1 NOTICE TO PROCEED:
(revise to include the following)

Time is of the essence in submitting the initial and revised construction schedule and traffic control plan. Each is a requirement that precedes the Contractor's right and the City's obligation to proceed with the agreement.

The Notice to Proceed shall be issued for a start date no later than twenty-seven (27) calendar days following receipt of the Notice of Award. The Contractor shall be required to submit a construction schedule and traffic control plan in accordance with the Contract Documents and the following:

The Contractor shall within seven (7) calendar days of receiving the Notice of Award, submit a construction schedule and traffic control plan to the Project Manager. The Project Manager shall promptly review the construction schedule and traffic control plan and either approve them, or provide a written list of the items that will require revision. The Contractor shall submit the revised construction schedule and traffic control plan within five (5) calendar days of receiving the Project Manager's list of required revisions. The corrected construction schedule and traffic control plan submittal shall address all comments from the Project Manager's list of required revisions.

108.3 CORRESPONDENCE TO THE CONTRACTOR:
(revise to include the following)

In addition to written communication to the Project Manager, the Contractor shall provide and maintain a contact located within ten miles of the job site at all times throughout the duration of the Contract. The designated contact shall be accessible by telephone at all times to respond to agency requirements and emergencies. The local location and phone number(s) shall be provided to the Project Manager prior to issuance of the Notice to Proceed. Any changes of the location or phone number(s) shall be reported immediately to the Project Manager.

If a response is needed, the Contractor is required to respond and perform the repairs and/or maintenance within two (2) hours of notification from the City. If the needed repairs and/or maintenance are not addressed within the timeframe, the City will accomplish the work and deduct the cost from monies due or become due to the Contractor.

108.4 CONTRACTOR'S CONSTRUCTION SCHEDULE:
(revise to include the following)

The Contractor's schedule shall include, as a minimum, the following:

- Identification of project tasks with assigned dates and durations, which reflect anticipated sequencing of construction activities on scheduled working days;
- All anticipated subcontractors that will be used during the course of the work;
- The anticipated number of crews to expedite the progress and ensure prompt completion of the work;

Definition of a crew;

- personnel (*e.g. operator, laborer*)
- equipment (*e.g. Cat 325 Excavator, 950 Loader*)
- workdays anticipated or scheduled per week (*e.g. Monday through Friday*)
- work hours anticipated or scheduled per day (*e.g. 7:00 am to 3:30 pm*)

- Anticipated adverse weather days for weather dependent activities, weekends and holidays.
- Specific long lead times for delivery of equipment and materials;
- Critical path project schedules may be required as provided for by the Special Provisions or Project Addenda.

108.5 LIMITATION OF OPERATIONS:
(third paragraph, revise to read as follows)

Except in emergencies endangering life or property, written permission shall be obtained from the City prior to performing any work on weekends, legal holidays or after regular work hours (hereinafter defined as 7:00 a.m. to 5:00 p.m. - Monday through Friday). Work on Saturdays will be permitted with prior approval by the City’s Engineering Inspection Supervisor. 72 hours advance notice will be required. Work on Sundays and legal City Holidays will not be permitted except in emergencies or as approved by the owner. Inspection and testing will not be provided on Sundays or City legal holidays without prior approval from the Project Manager (72-hour advance notice) and full compensation by the Contractor for any necessary personnel, equipment and services.

Overtime compensation for City personnel shall be as follows:

- Construction Supervisor @ \$ 43.00/hour
- Inspector II @ \$ 35.00/hour
- Inspector I @ \$30.00/hour
- Lab Tech I @ \$ 25.00/hour
- Vehicle @ \$1.80/hour

108.7 DETERMINATION AND EXTENSION OF CONTRACT TIME:
(revise to include the following)

The contract time, including final clean-up of the project site and storage areas, may be extended because of weather conditions that cannot be reasonably anticipated. The number of actual days that the scheduled work is impacted by adverse weather shall be recorded weekly during the construction period.

The Contractor will be entitled to a contract time extension if the actual adverse weather days experienced during the work exceed the anticipated adverse weather days shown. The following is the monthly schedule of adverse weather days that shall be anticipated by the Contractor in scheduling the work:

TABLE 108.7 MONTHLY CALENDAR DAYS for ANTICIPATED ADVERSE WEATHER

<i>MONTH</i>	<i>JANUARY</i>	<i>FEBRUARY</i>	<i>MARCH</i>	<i>APRIL</i>	<i>MAY</i>	<i>JUNE</i>
Monthly Calendar Days for Anticipated Adverse Weather	7 Days	7 Days	8 Days	6 Days	4 Days	3 Days
Average Monthly Precipitation	1.98"	1.96"	2.05"	1.34"	0.68"	0.51"
<i>MONTH</i>	<i>JULY</i>	<i>AUGUST</i>	<i>SEPTEMBER</i>	<i>OCTOBER</i>	<i>NOVEMBER</i>	<i>DECEMBER</i>
Monthly Calendar Days for Anticipated Adverse Weather	12 Days	11 Days	7 Days	5 Days	5 Days	6 Days
Average Monthly Precipitation	2.78"	2.68"	1.82"	1.52"	1.49"	1.90"

The above schedule of anticipated adverse weather days establishes the base line for the project's monthly weather impacts based on historical records, as recorded by the National Weather Service at Pulliam Airport, for precipitation in excess of 0.01 of an inch per calendar day.

The number of actual days that scheduled work is impacted by adverse weather as defined above shall be recorded weekly during the contract period. It is the Contractor's responsibility to request in writing any adverse weather delays experienced during the prior week no later than the normally scheduled weekly project meeting. Any adverse weather day requests that are not received, as stated above, shall neither be considered nor approved. Once the number of approved actual adverse weather days exceeds the number of anticipated adverse weather days in the schedule above, the Contractor is entitled to a contract time extension.

Actual adverse weather days must also prevent work for fifty (50) percent or more of the Contractor's work day and delay scheduled work critical to the timely completion of the project. The City will convert any delays meeting the above requirements to calendar days and extend the contract period as necessary. No additional compensation will be allowed for direct and indirect overhead expenses associated with any such contract time extensions. The Contractor's schedule must include the above anticipated adverse weather delays for all weather dependent activities and shall show all weekends and holidays.

108.8 GUARANTEE AND WARRANTY PROVISIONS:
(revise to include the following)

If requested by the City, the Contractor shall return to the project site eleven months after acceptance of the project and visually inspect, in the presence of the Owner's Representative, all accessible construction items and appurtenances. All defective materials and/or workmanship shall be satisfactorily repaired or replaced at the sole expense of the Contractor.

All costs for the 11-month inspection and repair shall be borne by the Contractor and in figuring his or her bid, the Contractor shall include an appropriate amount for such inspection and possible required repair, and no additional payment will be allowed.

108.10 FORFEITURE AND DEFAULT OF CONTRACT:
(revise to include new section)

Due to Failure to Prosecute the Work

If the Contractor fails to prosecute the work in accordance with the contract, including requirements of the progress schedule, the City may correct these deficiencies after three days after providing written notice to the Contractor. The cost of these remedies shall be charged against the Contractor. A change order may be issued to make the necessary changes in the contract and to make an appropriate reduction in the contract price. Such a change order shall not require the signature or approval of the Contractor. The remedy shall not prejudice the City's use of any other remedy, which the City may be entitled to use.

108.12 AUTHORIZED SIGNATURES:
(revise to include new section)

The Contractor shall provide a notarized list of all authorized signatures for project related documents. Only those individuals listed by the Contractor on the project Authorized Signature form shall be authorized to sign the contract, contract change orders, time extensions, bonds, securities, pay requests, certifications or other documents that affect the execution of the Contract.

108.13 SUBSTANTIAL COMPLETION:
(revise to include new section)

The project is substantially complete within the contract time and liquidated damages will no longer be assessed when the following have occurred:

(A) All contract items of work have been substantially completed and pedestrian and vehicular traffic can move unimpeded through the project;

(B) The only work left for completion is incidental, causes no disruption to pedestrian and vehicular traffic, and does not affect the safety and convenience of the public;

The decision whether the project is substantially complete is within the sole discretion of the Project Manager. At that time, a *Substantial Completion* letter will be issued by the City to the Contractor.

The remaining incidental work shall be completed within 15 calendar days from the issuance of the *Substantial Completion* letter. Failure to prosecute the remaining work within this time-period will result in the resumption of time charges and the application of liquidated damages from the date scheduled for final acceptance and start of warranty.

The start of the project warranty period will be established in the *Notice of Final Acceptance* and does not begin with substantial completion.

The Contractor is responsible for correction and repair of any project deficiencies until the end of the warranty period established in the *Notice of Final Acceptance* at which time the City will accept the improvements for operation and maintenance.

108.14 SUSPENSION and TERMINATION:
(revise to include new section)

CITY'S RIGHT TO STOP WORK

The City may, at its discretion and without cause, order the Contractor in writing to stop and suspend the Work. Such suspension shall not exceed one hundred and eighty (180) consecutive days.

The Contractor may seek an adjustment of the Contract Price and/or Contract Time if its cost or time to perform the Work has been adversely impacted by any suspension or stoppage of Work by the City.

TERMINATION FOR CONVENIENCE

Upon receipt of written notice to the Contractor, the City may, at its discretion and without cause, elect to terminate this Agreement. In such event, the City shall pay the Contractor only the direct value of its completed Work and materials supplied as of the date of termination. The Contractor shall be entitled to profit and overhead on completed Work only but shall not be entitled to anticipated profit or anticipated overhead.

If the City suspends the Work for one hundred eighty-one (181) consecutive days or more, such suspension shall be deemed a termination for convenience.

Upon such termination, the Contractor shall proceed with the following obligations.

1. Stop Work as specified in the notice.
2. Place no further subcontracts or orders.
3. Terminate all subcontracts to the extent they relate to the work terminated. The Contractor shall ensure that all subcontracts contain this same termination for convenience provision.
4. At the City's sole discretion and if requested in writing by the City, assign to the City all right, title and interest of the Contractor under the subcontracts subject to termination.
5. Take any action that may be necessary for the protection and preservation of the property related to this Agreement that is in the possession of the Contractor and in which the City has or may acquire an interest.

6. The Contractor shall submit complete termination inventory schedules no later than one hundred twenty (120) days from the date of the notice of termination.

The City shall pay the Contractor the following:

1. The direct value of its completed Work and materials supplied as of the date of termination.
2. The reasonable and direct, actual costs and expenses attributable to such termination. Reasonable costs and expenses shall not include, among other things, anticipated profit, anticipated overhead, or costs arising from the Contractor's failure to perform as required under this Agreement.
3. The Contractor shall be entitled to profit and overhead on completed Work only but shall not be entitled to anticipated profit or anticipated overhead. If it is determined that the Contractor would have sustained a loss on the entire Work had they been completed, the Contractor shall not be allowed profit and the City shall reduce the settlement to reflect the indicated rate of loss.

The Contractor shall maintain all records and documents for three (3) years after final settlement. These records shall be maintained and subject to auditing as prescribed in Section 7.7.

THE CITY'S RIGHT TO PERFORM AND TERMINATE FOR CAUSE

If the City provides the Contractor with a written order to provide adequate maintenance of traffic, adequate cleanup, adequate dust control or to correct deficiencies or damage resulting from abnormal weather conditions and the Contractor fails to comply in a time frame specified, the City may have work accomplished by other sources at Contractor's sole expense.

If the Contractor persistently fails to

1. provide a sufficient number of skilled workers,
2. supply the materials required by the Contract Documents,
3. comply with applicable Legal Requirements,
4. timely pay, without cause, sub-consultants and/or subcontractors,
5. prosecute the Work with promptness and diligence to ensure that the Work is completed by the Contract Time, as such times may be adjusted, or
6. perform material obligations under the Contract Documents, then the City, in addition to any other rights and remedies provided in the Contract Documents or by law, shall have the rights set forth below.

Upon the occurrence of an event set forth above, the City may provide written notice to the Contractor that it intends to terminate this Agreement unless the problem cited is cured, or commenced to be cured, within seven (7) days of the Contractor's receipt of such notice.

If the Contractor fails to cure, or reasonably commence to cure, such problem, then the City may give a second written notice to the Contractor of its intent to terminate within an additional seven (7) day period.

If the Contractor, within such second seven (7) day period, fails to cure, or reasonably commence to cure, such problem, then the City may declare this Agreement terminated for default by providing written notice to the Contractor of such declaration.

Upon declaring this Agreement terminated and for the purpose of completing the Work, the City may enter upon the premises and take possession of all materials, equipment, scaffolds, tools, appliances and other items thereon, which have been purchased or provided for the performance of the Work. The Contractor hereby transfers, assigns and conveys all items, which have been purchased or provided for the performance of the Work to the City for such purpose and to employ any person or persons to complete the Work and provide all of the required labor, services, materials, equipment and other items.

In the event of such termination, the Contractor shall not be entitled to receive any further payments under the Contract Documents until the Work shall be finally completed in accordance with the Contract Documents. At such time, the Contractor shall be entitled to be paid only for Work performed and accepted by the City prior to its default.

If the City's cost and expense of completing the Work exceeds the unpaid balance of the Contract Price, then the Contractor shall be obligated to pay the difference to the City. Such costs and expenses shall include not only the cost of completing the Work, but also losses, damages, costs and expense, including attorneys' fees and expenses, incurred by the City in connection with the re-procurement and defense of claims arising from the Contractor's default.

If the City improperly terminates the Agreement for cause, the termination for cause shall be converted to a termination for convenience in accordance with the provisions of 108.14

SECTION 109 - MEASUREMENTS AND PAYMENTS

109.1 MEASUREMENT OF QUANTITIES: (revise to include the following)

It is the responsibility of the Contractor to conform to the Contract Documents, including plans, typical sections and specifications including but not be limited to dimensions, materials, application rates and densities. The Contractor shall take all actions necessary to ensure that the work conforms to the contract documents. The Contractor shall cooperate fully with the Project Manager or Project Manager's representative to correct any known nonconformity to the contract documents.

109.1 MEASUREMENT OF QUANTITIES:
(delete the second paragraph)

Unless otherwise specified, longitudinal and surface (plane) measurements will be made in a horizontal plane.

PART 200 - EARTHWORK

SECTION 201 - CLEARING AND GRUBBING

201.3 CONSTRUCTION METHODS:
(revise to include the following)

The Contractor shall make every effort possible to avoid damaging existing trees. In the event that any trees suffer limb damage, the Contractor shall cut branches to the nearest branch crotch or to the branch collar at the trunk.

No separate payment will be made for trimming trees. The cost shall be considered incidental to the work.

SECTION 205 – ROADWAY EXCAVATION

205.1 DESCRIPTION
(revise to include the following)

The bid schedule unit cost for excavation, backfill and embankment work shall include the cost of rock excavation, handling rock or disposing of rock and no separate measurement or payment shall be made. Rock shall be defined as any highly cemented or hard material that may require additional efforts for removal, handling or disposal.

205.2 UNSUITABLE MATERIAL:
(third paragraph, revise to read as follows)

Should unsuitable material be encountered at subgrade elevation in cut areas or at existing grade in fill areas, the unsuitable material shall be removed and replaced with suitable fill material in accordance with MAG Section 210 and MAG Section 211.

Determination of unsuitable material and the limits and depths of required removal and replacement shall be at the sole discretion of the Project Manager. In no case shall any unsuitable material be removed without prior written consent of the Project Manager.

Measurement and payment for removal and replacement of unsuitable material will be by the cubic yard as shown in the proposal. Payment shall be compensation in full for the work complete and in-place including any borrow, permits, pit royalties, all excavation, hauling, placing, compacting, conditioning, watering and proper disposal, together with all appurtenant costs.

205.3 MEASUREMENT

(revise to include the following)

Earthwork is incidental to the roadway construction and no additional payment will be made for roadway excavation. The Contractor shall be responsible for estimating and accounting for earthwork import and haul off. It is recommended that the Contractor review the report on geotechnical investigation and sampling results.

PART 300 -- STREETS AND RELATED WORK

SECTION 301 - SUB-GRADE PREPARATION

301.1 DESCRIPTION:

(revise to include the following)

The untreated base or prepared subgrade shall be test rolled in the presence of the Project Manager prior to the placement of asphalt paving materials. The equipment used to perform the test roll shall be approved by the Project Manager. The Contractor shall be responsible for scheduling this test roll with the Inspector during regularly scheduled work. All costs associated with the test roll shall be considered incidental to and included in the cost of sub-grade preparation.

SECTION 336 - PAVEMENT MATCHING AND SURFACING REPLACEMENT

336.1 DESCRIPTION:

(first paragraph, revise to include the following)

The exact points of pavement matching shall be determined in the field by the Project Manager.

336.2 MATERIALS AND CONSTRUCTION METHODS:

336.2.1 PAVEMENT WIDENING OR EXTENSIONS:

(first paragraph, revise second sentence to read as follows)

The minimum depth of cut shall be four (4) inches or Depth/4, whichever is greater.

PART 400 -- RIGHT-OF-WAY AND TRAFFIC CONTROL

SECTION 401 - TRAFFIC CONTROL

401.5 GENERAL TRAFFIC REGULATIONS:

(revise to include the following)

Within seven (7) calendar days following receipt of the Notice of Award and in accordance with Section 108.1 of these General Provisions, the Contractor shall submit to the Project Manager a traffic control plan that shows the control of traffic in accordance with Part VI of the FHWA Manual on Uniform Traffic Control Devices for all phases of the work. The plan should include nights, weekends, shut down periods and an approximate schedule of street closures and detours.

The Traffic Control Plan is to detail the Contractor's proposal for routing traffic and pedestrians around the areas of construction. The Plan shall be coordinated with the proposed construction schedule and show how the locations of the various traffic and pedestrian control devices will change as construction progresses. The Plan shall allow for complete detours around the work areas.

Private and commercial driveways shall not be closed for any period exceeding eight hours during any twenty-four-hour period. The affected resident and the City shall be notified 48 hours in advance of any closure. Convenient access to driveways, houses and buildings along the line of work shall be maintained and temporary crossings or alternate access shall be provided and maintained in good condition, except during that period mentioned above. **Business access shall be maintained at all times by at least one driveway.**

(eleventh paragraph, revise to read as follows)

The Contractor will reinstall all permanent traffic control devices as required by the approved construction plans and specifications.

(twelfth paragraph, delete the last sentence)

Delete - The Traffic Engineering Department will reinstall all traffic signs.

401.7 PAYMENT:

(revise paragraph to read as follows)

Payment for all work and materials required to prepare a traffic control plan and provide traffic control during construction shall be made at the lump sum price shown on the Bid Schedule. Full compensation for any required traffic control devices, flaggers, uniformed off-duty law enforcement

officers, pilot cars and drivers shall be included in the lump sum contract price and no additional payment shall be allowed. Progress payments shall be made based on the Contractor's estimate for percent complete as approved by the Owner.

SECTION 425 TOPSOIL

425.2 MATERIALS: (revise to read as follows)

Overburden topsoil shall be salvaged and reused when possible. All topsoil, whether overburden or imported, shall be free of roots, heavy clay, clods, noxious weed seeds, coarse sand, large rocks, sticks, brush, litter and other deleterious material and meet the requirements of MAG Section 795. The Project Manager's approval of the proposed topsoil shall be obtained before delivery to the project.

425.4 MEASUREMENT: (revise paragraph to read as follows)

Topsoil shall be measured lump sum, complete and in place unless indicated otherwise by the bid schedule.

425.5 PAYMENT: (revise to read as follows)

Topsoil will be paid for in accordance with the contracted price for furnishing and placing topsoil, as described and specified. Progress payment shall be made based on the Contractor's estimate for percent complete as approved by the Owner.

SECTION 430 – LANDSCAPING AND PLANTING (revise to include section as follows)

430.3 LAWN AREAS

430.3.1 Preparation of In Place Soil (delete the second paragraph and revise to read as follows)

After clearing, grubbing and initial cultivation has been completed, a slow release chemical fertilizer shall be mechanically spread over the turfgrass area at an average rate of 1 pound of actual nitrogen per 1000 square feet. After spreading, the fertilizer shall be cultivated into the top four inches of soil using suitable equipment. The resulting soil shall be in a friable condition suitable for planting. (Actual nitrogen is determined by using the nitrogen ratio number x weight of the bag/100).

430.3.2 Seeding

(delete the first and second paragraph revise to read as follows)

The rate of seeding shall be three pounds of seed per 1000 square feet using the following seed mixture;

Poa pratensis	Kentucky Bluegrass (mix of three varieties)	70%
Lolium perenne	Perennial Rye Grass	10%
Festuca rubra	Creeping Red Fescue	20%

Alternative species may be acceptable but are subject to prior approval from the City Project Manager or duly authorized representative.

SECTION 431 – EROSION CONTROL

(revise to include new section as follows)

431.1 DESCRIPTION

Erosion control applies to improvements within the city and as part of the erosion control section of a Storm Water Pollution Prevention Plan (SWPPP). Materials, means and methods for erosion control and stabilization, Best Management Practices (BMPs), Erosion Control Plans (ECPs) and SWPPPs are described in the City of Flagstaff Stormwater Design Manual.

The Contractor shall stabilize all disturbed areas within the project site and as shown on the plans. Work shall be performed according to the provisions of this Section and shall include but not be limited to the furnishing, hauling, placement and application of erosion control materials.

The Contractor is responsible for complying with the requirements of the National Pollutant Discharge Elimination System (NPDES) permit program. This generally includes submittal of a Notice of Intent to the Arizona Department of Environmental Quality (ADEQ) and Notice of Termination to ADEQ for the project. Preparation and implementation of a Storm Water Pollution Prevention Plan (SWPPP) for the site is required per ADEQ and City of Flagstaff standards.

The cost for complying with the NPDES permit and the SWPPP, including the erosion control devices, shall be included in the NPDES & SWPPP Requirements portion of the Contractor’s bid. It is recommended that contractors see the ADEQ Smart NOI (Notice of Intent) program website (<http://az.gov/webapp/noi/main.do>) for information and processes.

Progress payment shall be made based on the Contractor’s estimate for percent complete as approved by the Owner.

432.1 NATIVE SEEDING

All areas to be seeded that are accessible to machinery shall be tilled to a minimum depth of four (4) inches. Areas inaccessible to machinery shall be hand tilled and prepared to a minimum depth of two (2) inches. Cut slopes of 2:1 or steeper do not require tilling. Cultivation on sloping terrain shall run perpendicular to the direction to the slope. If weeds or herbaceous plant material interferes with proper seedbed preparation, the contractor shall remove them from the seedbed.

Contractor shall remove and dispose of all debris and other objectionable material that may interfere with seeding operations.

The area to be seeded shall be relatively smooth and all surface irregularities (e.g. rills, tire marks) shall be filled and firmed to conform to the desired cross sections. The seedbed shall be rolled both before and after the seeding operation with a minimum of one pass of a cultipacker or drag harrow.

Seed shall be sown when conditions will promote germination and growth. Normal non-irrigated permanent native seed application dates are between April 1 and June 15, between August 15 and September 20 and after the first frost (recurring overnight temperature of 28 degrees F) until snowfall. Seeding work shall be performed only after planting and other work affecting ground surface is complete.

To assist in establishment of the permanent seed mix, a nurse crop shall be used for this work. Preapproved nurse crop seed shall be one of the following, incorporated with the specified permanent seed mix;

Annual ryegrass	<i>(Lolium multiflorum)</i>	30 lbs/acre
Oats	<i>(Avena sativa)</i>	60 lbs/acre
Regreen©	<i>(Triticum aestivum x Elytrigia elongata)</i>	30 lbs/acre

Alternative species may be acceptable but are subject to prior approval from the City Project Manager or duly authorized representative.

When cut or fill slopes are greater than six (6) feet in height and steeper than 3H:1V, the seeded area shall be covered with American Excelsior Company straw/coconut blanket or an approved equal. Installation shall be per the manufacturer’s written directions.

440.10. (D) SEQUENCING
(add the following section)

The irrigation system shall be installed, inspected, approved and operable prior to the installation of plant materials, landscape fabric and ground plane treatments (*decomposed granite, landscape rock, mulch, etc.*)

PART 600 - WATER AND SEWER

SECTION 601 - TRENCH EXCAVATION, BACKFILLING AND COMPACTION

601.2 EXCAVATION:

601.2.1 GENERAL:

(revise to include the following)

All excavation, including trench excavation, shall be performed in any substance and material encountered. The cost is considered incidental to and is to be included in the price for the bid item to be constructed or installed. No special payment shall be made for trench excavation other than rock excavation as specified under Trench Rock Excavation.

Trench Rock Excavation

Trench rock is defined as consolidated igneous, metamorphic and/or sedimentary material in the original bed and/or in well-defined ledges that cannot be removed by a mechanical method and therefore requires pneumatic hammering, drilling or blasting for removal. Example of mechanical methods include hand tools, trenching machine, backhoe, ≥ 195 horsepower hydraulic excavator with ripping teeth or equivalent.

Boulders and pieces of rock having a volume of more than 27 cubic feet (1 cubic yard) shall be considered rock.

For projects where trench rock excavation is anticipated, the estimated contingent quantity is shown in the proposal under the applicable bid item. The contingency quantity is an estimate only and no guaranty is given that any portion will be utilized. Trench rock excavation will be paid for separately at the unit price bid per cubic yard for Trench Rock Excavation.

Measurement of Trench Rock Excavation shall be per cubic yard in place. This volume of rock will be measured by the City representative, using the maximum trench width allowed in accordance with MAG Table 601-1, the lineal footage of actual rock excavation required and the actual depth of rock as determined by inspection of the trench after rock excavation and before backfilling.

SECTION 611 – WATER, SEWER AND STORM DRAIN TESTING

611.2 DISINFECTING WATER MAINS:

611.2.13 Fire Flow Testing:

(revise to include the following new section)

All water lines that have new fire hydrants shall require a fire flow test per CoF Engineering Standard 13-09-006-0006.1.

Fire flow testing shall be performed by a certified tester. Results shall be sealed by an Arizona Professional Engineer.

The City Water Services Section requires a 72-hour notice via e-mail to schedule hydrant operation and testing observation. A digital copy of the test results shall be submitted to the City Project Manager.

SECTION 631 WATER TAPS AND METER SERVICE CONNECTIONS

(revise to add the following)

631.3 INSTALLATION:

New water service lines shall be installed to replace the existing water service lines. Construction includes replacement of all water services to COF Engineering Standards, including the service saddle at the main, corporation stop, pipe and curb stop to the meter and adjust the customers' service to the new outlet meter coupling elevation. The lines shall be extended to the new polymer meter box location and a new meter box shall be installed and shall connect to the existing meter. If the existing meter is not at the City's standard depth; the contractor shall adjust the elevation of the meter. In cases where the meter box moves, the contractor shall salvage the existing meter and shift it to the proposed location. At each of these locations the contractor is required to connect the existing water services on the private side of the meter. The Contractor shall coordinate with each homeowner where private construction is required to verify the water line rerouting and to restore landscaping to its original condition.

The City will provide the contractor with Temporary Rights of Entry for the water service connection, replacement/adjustment of water meter boxes and associated work. If the contractor needs to go outside the Temporary Right of Entry limits they will have to provide the City with written permission from the property owner prior to conducting the work.

A residential plumber's license will be required for all work that is done on the private service side of the meter.

City of Flagstaff utility tapping fees are the responsibility of the contractor. The contractor shall perform all work and coordinate payment directly with the City Water Services Department. All costs for utility tap work and fees shall be included in the line item for installation of the new service, including but not limited to all labor and materials for complete installation. Repair associated within any abandoned or new tap shall be included in the contract bid item.

SECTION 710 - ASPHALT CONCRETE

710.1 **GENERAL:**
(revise to include the following)

The asphaltic concrete designation shall be 3/4 inch, except as required by the project plans or Special Provisions.

End of Document