

PERIMETER

SURVEYING & MAPPING
 Prepared by: Jeff S. Hodapp, P.S.M.
 Certificate of Authorization No. LB7264
 949A Clint Moore Road
 Boca Raton, Florida 33487
 Tel: (561) 241-9988
 Fax: (561) 241-5182

CARRIAGE POINTE ESTATES

A PORTION OF SECTION 30, TOWNSHIP 35 SOUTH, RANGE 40, EAST
 CITY OF FT. PIERCE, ST. LUCIE COUNTY, FLORIDA.
 JUNE, 2014

SEE SHEET 6

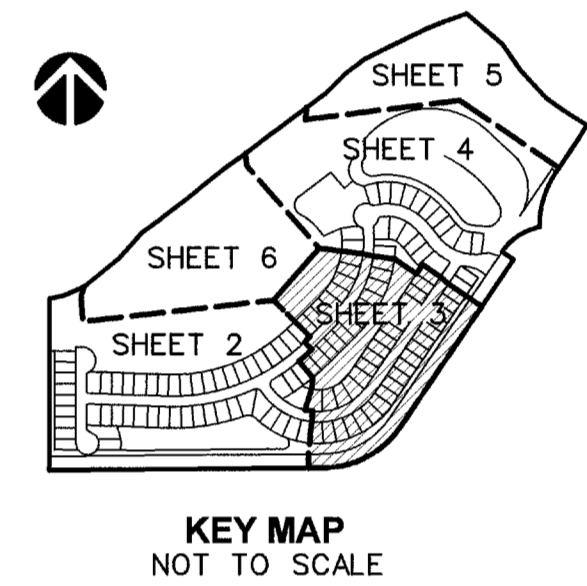
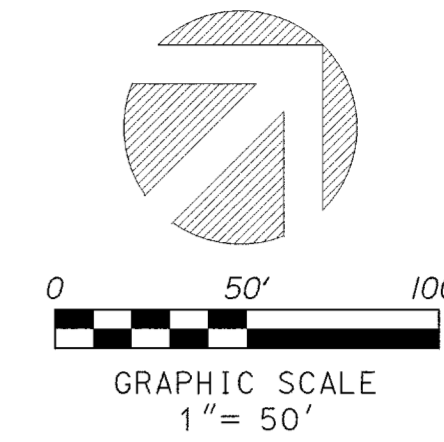

SEE SHEET 2

SEE SHEET 4

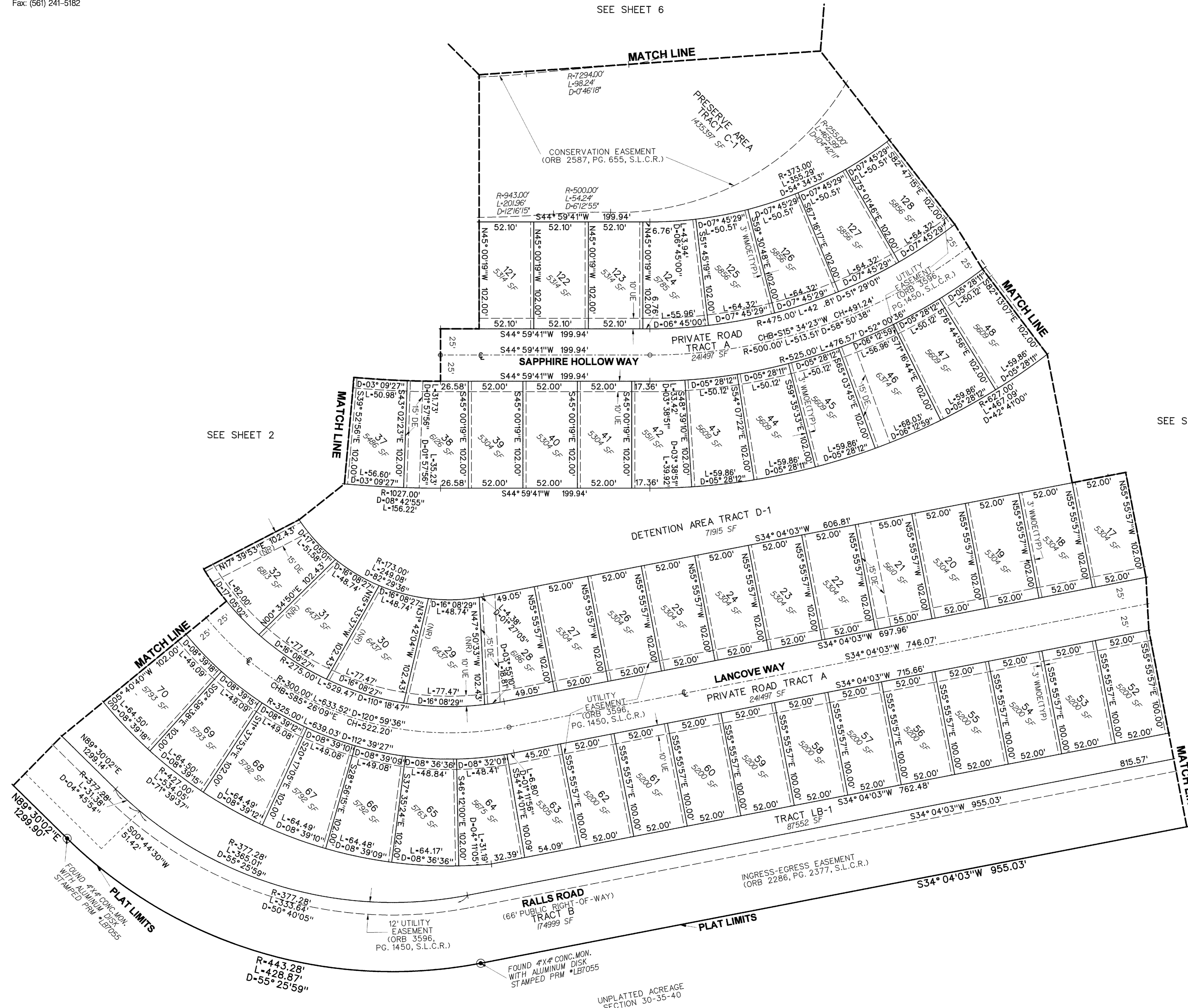

- LEGEND:**
- o : P.C.P. STAMPED •LB7264
 - ⊕ : CENTERLINE
- ABBREVIATIONS:**
- AC. : ACRES
 - CHORD : CHORD
 - CHB : CHORD BEARING
 - CONC. : CONCRETE
 - COR. : CORNER
 - D : DELTA (CENTRAL ANGLE)
 - D.E. : DRAINAGE EASEMENT
 - L : ARC LENGTH
 - L.B. : LICENSED BUSINESS
 - L.E. : LANDSCAPE EASEMENT
 - L.M.E. : LAKE MAINTENANCE EASEMENT
 - L.S. : LICENSED SURVEYOR
 - L.S.E. : LIFT STATION EASEMENT
 - MON. : MONUMENT
 - NAVD : NORTH AMERICAN VERTICAL DATUM
 - NGVD : NATIONAL GEODETIC VERTICAL DATUM
 - O.R.B. : OFFICIAL RECORDS BOOK
 - (NR) : NON-RADIAL
 - P.A.E. : PEDESTRIAN ACCESS EASEMENT
 - P.B. : PLAT BOOK
 - PG. : PAGE
 - P.C.P. : PERMANENT CONTROL POINT
 - P.O.B. : POINT OF BEGINNING
 - P.O.C. : POINT OF COMMENCEMENT
 - P.R.M. : PERMANENT REFERENCE MONUMENT
 - P.S.M. : PROFESSIONAL SURVEYOR & MAPPER
 - R : RADIUS
 - R/W : RIGHT-OF-WAY
 - SEC. : SECTION
 - SF : SQUARE FEET
 - S.L.C.R. : ST. LUCIE COUNTY RECORDS
 - (TYP) : TYPICAL
 - U.E. : UTILITY EASEMENT
 - WMOE : WATER, MAINTENANCE & OVERHANG EASEMENT