

CITY OF FORT PIERCE

CITY COMMISSION AGENDA

Regular Meeting - Monday, December 21, 2015 - 6:30 p.m.

City Hall - City Commission Chambers, 100 North U.S. #1, Fort Pierce, Florida

Beginning at 6:15, please join us for a special performance by the St. Lucie County Boy's and Girls Club

1. **CALL TO ORDER**
2. **OPENING PRAYER** - Father Yves Geffrard, Notre Dame Catholic Mission
3. **PLEDGE OF ALLEGIANCE**
4. **ROLL CALL**
5. **APPROVAL OF MINUTES**
 - a. Approval of minutes from the December 7, 2015 regular meeting.
6. **PROCLAMATIONS**
7. **LETTERS TO COMMISSION**
 - a. Letter of appreciation from Robert. P. Greene recognizing the appointment of Officer Al Garcia as their neighborhood sentry and commending his professional demeanor, positive attitude and the positive role model he creates.
 - b. Letter of appreciation from Pam Gillette, Main Street Fort Pierce to the Mayor and Commissioners, City Manager, Police Chief and Public Works for their support of the 27th Annual Sights and Sounds on Second Festival and Parade.
8. **COMMENTS FROM THE PUBLIC ON AGENDA ITEMS NOT REQUIRING PUBLIC HEARINGS**

Any person who wishes to comment on an agenda item which is not under Public Hearings on the Agenda may be heard at this time and must sign up to speak in advance. Please limit your comments to three (3) minutes or less, as directed by the Mayor, as this section of the Agenda is limited to thirty minutes. The City Commission will not be able to take any official actions under Comments from the Public. Speakers will address the Mayor, Commissioners, and the Public with respect. Inappropriate language will not be tolerated.

9. **CONSENT AGENDA**

- a. Request to waive interest, penalties, and administrative fees in the amount of \$134,840.00 for code enforcement lien against 2020 S 3rd Street, Ft. Pierce, FL, Parcel ID 2415-801-0024-000-3, previously owned by Rachel Nazario, 2020 S 3rd Street, Ft. Pierce, FL 34950 and currently owned by Cariann D. Martin, 374 NE Genessee Avenue, Port St. Lucie, FL 34983 \$21,510.58.
- b. Approval of Subordination of Utility Interest Agreements between the State of Florida, Department of Transportation and the City of Fort Pierce, Florida for the use and benefit of Fort Pierce Utilities Authority, as for the Midway Road widening project.
- c. Approve staff recommendation to award Request for Proposal #2016-003 - Banking Services to Harbor Community Bank.
- d. Approval of Settlement Agreement in K & K II, Inc. v City of Fort Pierce (Case #562013CA002183 BC) in the amount of \$87,500.00.
- e. Approval of Employment Agreement with Nicholas C. Mimms, City Manager.
- f. Approval of blanket purchase orders for FY 2016 for the Police Department in the total budgeted amount of \$288,131.00.
- h. Approve the purchase by the police department of three (3) Segways with two accessory packages in the total amount not to exceed \$35,886.90 .
- i. Approval of the sale of fourteen (14) mixed performance mortgage loans to Harbor Community Bank in the amount of \$729,300.00.
- j. Approval to provide a net \$50 holiday bonus to each employee.

10. **PUBLIC HEARINGS**

- a. Ordinance No. 15- 057 voluntarily annexing property located on Oleander Avenue just north of Kanner Drive (parcel number 2427-601-0010-000-5). SECOND READING
- b. Review and approval of an application for a Waiver of Distance, submitted by Property Owners, Bamboo Palms LLC, Applicant, Fraternal Order of Eagles Aerie #3582 to establish an 11C alcoholic beverage license for their Non-profit club at 1717 S. US Highway 1, Fort Pierce, FL. The property is zoned General Commercial (C-3), (Parcel ID 2415-311-0004-000-3).

- c. Ordinance No. 15-058 - Amending Code Section 13-73 (c) to allow the Retirement Board to select their own attorney with the approval of the City Commission. FIRST READING

11. **MISCELLANEOUS REPORTS & REQUESTS**

- a. Monthly Financial Report for the Month Ending November 30, 2015

12. **CITY COMMISSION**

- a. Consideration of Application for Appointment to Communitywide Council, submitted by Mr. John Kevin Griffin.
- b. Request for Reimbursement of Legal Fees and Costs in the amount of \$8,875.07 associated with the defense of complaints filed with the Commission on Ethics against Robert Schwerer which were dismissed.
- c. Request for Reimbursement of Legal Fees and Costs in the amount of \$3,015.00 associated with the defense of complaints filed with the Commission on Ethics against Thomas Perona which were dismissed.
- d. Request for Reimbursement of Legal Fees and Costs in the amount of \$2,325.00 associated with the defense of a complaint filed with the Commission on Ethics against Edward Becht which has been dismissed.

13. **COMMENTS FROM THE PUBLIC**

Any person who wishes to comment on any subject may be heard at this time and must sign up to speak in advance. Please limit your comments to three (3) minutes or less, as directed by the Mayor, as this section of the Agenda is limited to thirty minutes. The City Commission will not be able to take any official actions under Comments from the Public. Speakers will address the Mayor, Commissioners, and the Public with respect. Inappropriate language will not be tolerated.

14. **COMMENTS FROM THE CITY MANAGER**

- a. City Manager's Departmental Activity Report

15. **COMMENTS FROM THE COMMISSION**

16. **ADJOURNMENT**

Pursuant to Section 286.0105, Florida Statutes, the City hereby advises you that if you or another person decide to appeal any decision made by the City Commission with respect to any matter considered at its meeting or hearing, that you or said person will need a record of the proceedings, and that for such purpose, affected persons may need to insure that a verbatim record of the proceedings is made, which record includes the testimony and evidence upon which the appeal is to be based. This notice does not constitute consent by the City for the introduction or admission into evidence of otherwise inadmissible or irrelevant evidence, nor does it authorize challenges or appeals not otherwise allowed by law.

In accordance with the Americans with Disabilities Act and Section 286.26, Florida Statutes, persons with disabilities needing special accommodation to participate in this meeting should contact the City Clerk's Office at (772) 467-3052 at least 48 hours prior to the meeting.

City Commission Regular Meeting

Agenda Item # 5. a.

Meeting Date: 12/21/2015

Re:

SUBJECT:

Approval of minutes from the December 7, 2015 regular meeting.

Attachments

12.07.2015 Minutes

Form Review

Form Started By: Linda Cox

Started On: 12/16/2015 03:56 PM

Final Approval Date: 12/16/2015

MINUTES OF A REGULAR MEETING OF THE CITY COMMISSION OF THE CITY OF FORT PIERCE, FLORIDA, HELD IN THE CITY HALL COMMISSION CHAMBERS, 100 NORTH U.S. #1, FORT PIERCE, FLORIDA, AT 6:30 P.M. ON MONDAY, DECEMBER 7, 2015.

1. **CALL TO ORDER** - Mayor Hudson called the meeting to order at 6:30 p.m.
2. **OPENING PRAYER** - Reverend Eldrew Baldwin of First Bethel Missionary Baptist Church offered the opening prayer.
3. **PLEDGE OF ALLEGIANCE**
4. **ROLL CALL**

Present: Mayor Linda Hudson; Commissioner Edward Becht; Commissioner Thomas Perona; Commissioner Reginald Sessions

Absent: Commissioner Rufus Alexander

Staff Present: City Clerk Linda Cox
Interim City Manager Nicholas Mimms
City Attorney Robert Schwerer

Commissioner Rufus Alexander arrived at 6:34 p.m.

5. **APPROVAL OF MINUTES**

- a. Approval of Minutes from the November 16, 2015 Out of the Sunshine meeting and the November 16, 2015 Regular Meeting.

Motion was made by Commissioner Thomas Perona, seconded by Commissioner Edward Becht to approve the Minutes from the November 16, 2015 Out of the Sunshine meeting and the November 16, 2015 Regular Meeting.

AYE: Commissioner Edward Becht, Commissioner Thomas Perona, Commissioner Reginald Sessions, Mayor Linda Hudson

Passed

6. **PROCLAMATIONS** - There were no proclamations.
7. **LETTERS TO COMMISSION** - The following letter will be kept on file in the City Clerk's office.
 - a. Commendation Letter for Kim West and Mechelle Arbuzow, from Mr. Jerry Curci, Fairview Terrace Mobile Home Park

8. **COMMENTS FROM THE PUBLIC ON AGENDA ITEMS NOT REQUIRING PUBLIC HEARINGS**

London Reeves - Item 12D

9. **CONSENT AGENDA**

- a. Request to reduce code enforcement fines in the amount of \$108,530.00 against 2014 Delaware Avenue (PID 2409-313-0014-000/3) which was previously owned by Pierina Montano, 15751 SW 139th Street, Miami, FL 33196 and currently owned by Simon P. Castor, 207 Dixieland Drive, Ft. Pierce, FL 34982 to \$1,512.01.
- b. Request to reduce code enforcement fines in the amount of \$2030.00 against 3204 Ohio Avenue (PID 2417-505-0021-000/9) owned by Systec LLC, 1175 NW 17th Avenue, Delray Beach, FL 33445 and occupied by Charles Pitt, 5303 Palmetto Avenue, Ft. Pierce, FL 34982 to \$750.00 payable in 60 days.
- c. Approval of contract award to Playcore Wisconsin DBA Game Time, Longwood, Florida, in the amount of \$25,000 to purchase playground equipment for Maravilla Park.
- d. Approve Site Plan extension for Sunrise Heights Senior Housing Center located at 707 North 7th Street until December 16, 2017.
- e. Approval of Professional Services Agreement with Colin Baenziger & Associates for the purpose of selecting and hiring a professional in-house City Attorney for the City of Fort Pierce for an amount not to exceed \$24,750.
- f. Approval to award RFP No. 2015-051 for Realtor Services to the highest ranked respondent.

Mayor Hudson pulled items **9e** and **9f**.

Motion was made by Commissioner Thomas Perona, seconded by Commissioner Rufus Alexander to approve items **9a, 9b, 9c, 9d**.

AYE: Commissioner Rufus Alexander, Commissioner Edward Becht, Commissioner Thomas Perona, Commissioner Reginald Sessions, Mayor Linda Hudson

Passed

As to item **9e**, Mayor Hudson wanted to discuss if the applicant will be required to live within the City's limits within a certain time frame and if the option for the county reception should be removed. The consensus was that the reception will be removed and that the residency details will be ironed out during consultation with Colin Baezinger & Associates.

Motion was made by Commissioner Thomas Perona, seconded by Commissioner Edward Becht to approve item **9e**.

AYE: Commissioner Rufus Alexander, Commissioner Edward Becht, Commissioner Thomas Perona, Commissioner Reginald Sessions, Mayor Linda Hudson

Passed

As to item **9f**, Mayor Hudson questioned why we would give the highest points possible to an applicant that did not provide a complete proposal.

Tony Barnes, Director of Administrative Services, stated that in order to re-rank the applicants, the RFP will need to be sent out for bid again. The process will take 30 days.

Nicholas Mimms, Interim City Manager, stated that based on the CRA comments and the fact that the current hot properties are zoned commercial, this will be sent out for re-bid.

Commission discussion included the ranking procedure being reviewed, updating the criterion

that commercial experience is desired, splitting the bid up to differentiate between commercial and residential properties, and the possibility to allow the selected firm take care of properties for the CRA as well as the entire City.

Motion was made by Commissioner Rufus Alexander, seconded by Commissioner Reginald Sessions to deny item **9f**, send for re-bid and update the criterion to include commercial experience.

AYE: Commissioner Rufus Alexander, Commissioner Edward Becht, Commissioner Thomas Perona, Commissioner Reginald Sessions, Mayor Linda Hudson

Passed

10. PUBLIC HEARINGS

- a. Approve with conditions a Conditional Use application to allow Harbor Community Bank to operate administrative offices within an I1, Light Industrial Zone, at 600 Edwards Road, Fort Pierce, FL.

Clarissa Davis, Planner, gave a brief presentation and was available for questions.

Mayor Hudson opened the public hearing.

Michael Brown Jr, EVP Harbor Community, appeared and was available for questions. They have agreed to comply with all conditions.

Mayor Hudson closed the public hearing.

Commissioner Perona stated that he would like to have the applicant request that the county designate the sidewalk funds are used in the City of Fort Pierce.

Motion was made by Commissioner Edward Becht, seconded by Commissioner Thomas Perona to approve the conditional use application with conditions:

1. Applicant to provide sidewalk along Edwards Road right-of-way. Applicant may submit "payment in lieu of" to St. Lucie County.
2. Applicant to install required shrubs.
3. Applicant to provide three additional parking spaces or "payment in lieu of" to the City.
4. Applicant to suggest that the county use the "payment in lieu of" sidewalk funds within the City of Fort Pierce.

AYE: Commissioner Rufus Alexander, Commissioner Edward Becht, Commissioner Thomas Perona, Commissioner Reginald Sessions, Mayor Linda Hudson

Passed

- b. Approval with conditions an application for Conditional Use, submitted by Property Owners; Orange Blossom Investment, LLC, and applicant; St. James Christian Academy to expand the operation of a private school located at 4300 Okeechobee Road, Fort Pierce, FL. The property is zoned C-3, General Commercial (Parcel ID 2418-431-0001-000-0).

Vennis Gilmore, Planning Analyst, gave a brief presentation and was available for questions.

Mayor Hudson opened the public hearing.

Don Bergman, applicant representative, addressed the landscaping question.

Seeing no one else, Mayor Hudson closed the public hearing.

Motion was made by Commissioner Edward Becht, seconded by Commissioner Thomas Perona to approve the conditional use application with staff conditions.

AYE: Commissioner Rufus Alexander, Commissioner Edward Becht, Commissioner Thomas Perona, Commissioner Reginald Sessions, Mayor Linda Hudson

Passed

- c. Ordinance No. 15-049 - Comprehensive Plan Text Amendment to eliminate the 40% total floor area minimum requirement for residential uses, reduce the required number of uses from three (3) to two (2) and modify the open and green space requirements.

Staff recommends that this be postponed until the January 4, 2016 City Commission meeting.

Motion was made by Commissioner Thomas Perona, seconded by Commissioner Reginald Sessions to postpone item **10c** to January 4, 2016.

AYE: Commissioner Rufus Alexander, Commissioner Edward Becht, Commissioner Thomas Perona, Commissioner Reginald Sessions, Mayor Linda Hudson

Passed

- d. Ordinance No. 15-056 amending section 5-267 "Permit Fee Schedule". SECOND READING -

Staff recommends that this be postponed until the January 4, 2016 City Commission meeting.

Motion was made by Commissioner Rufus Alexander, seconded by Commissioner Reginald Sessions to postpone item **10d** to January 4, 2016.

AYE: Commissioner Rufus Alexander, Commissioner Edward Becht, Commissioner Thomas Perona, Commissioner Reginald Sessions, Mayor Linda Hudson

Passed

- e. Ordinance No. 15- 057 voluntarily annexing property located on Oleander Avenue just north of Kanner Drive (parcel number 2427-601-0010-000-5). FIRST READING

Clarissa Davis, Planner, gave a brief presentation and was available for questions.

Mayor Hudson opened the public hearing.

Richard LaVenture, applicant representative, appeared and was available for questions.

Seeing no one else, Mayor Hudson closed the public hearing.

Motion was made by Commissioner Edward Becht, seconded by Commissioner Rufus Alexander to approve item **10e**.

AYE: Commissioner Rufus Alexander, Commissioner Edward Becht, Commissioner Thomas Perona, Commissioner Reginald Sessions, Mayor Linda Hudson

Passed

11. MISCELLANEOUS REPORTS & REQUESTS

- a. Greenway & Trails Update by St. Lucie County Environmental Resource Team

Charles Barrowclough, St. Lucie County Environmental Land Coordinator, appeared and provided an update on the initiative, current challenges, and long range plans of the Greenways & Trails Master Plan. The coordination of land acquisition, easements, and funding to complete the connection preserves via public greenways and trails has been ongoing for 14 years. The Greenways & Trails initiative implements pedestrian, bicycle, and equestrian greenways and trails throughout St. Lucie County to connect natural resources, parks, and neighborhoods.

- b. Monthly Financial Report for the Month Ending October 31, 2015

Johnna Morris, Finance Director, presented the Monthly Financial Report for the Month Ending October 31, 2015. Total available resources are 4,481,025, minus reserves, the unrestricted resources are \$629,205.

12. CITY COMMISSION

- a. Resolution 15-R34 Appointing Gwendolyn Taylor to the Communitywide Council.

Motion was made by Commissioner Rufus Alexander, seconded by Commissioner Edward Becht to approve item **12a**.

AYE: Commissioner Rufus Alexander, Commissioner Edward Becht, Commissioner Thomas Perona, Commissioner Reginald Sessions, Mayor Linda Hudson

Passed

- b. Resolution 15-R35 Appointing Frank Creyaufmiller to the Planning Board as an alternate.

Motion was made by Commissioner Thomas Perona, seconded by Commissioner Edward Becht to approve item **12b**.

AYE: Commissioner Rufus Alexander, Commissioner Edward Becht, Commissioner Thomas Perona, Commissioner Reginald Sessions, Mayor Linda Hudson

Passed

- c. Resolution 15-R36 re-appointing JoAnn Parrish to the Housing Authority Board.

Motion was made by Commissioner Edward Becht, seconded by Commissioner Thomas Perona to approve item **12c**.

AYE: Commissioner Rufus Alexander, Commissioner Edward Becht, Commissioner Thomas Perona, Commissioner Reginald Sessions, Mayor Linda Hudson

Passed

- d. Discussion and consideration of the appointment of Nicholas Mimms as City Manager.

Commissioner Perona stated that he is an advocate for a nationwide search because of the past success. It does not mean that he feels Mr. Mimms is not a good candidate.

Motion was made by Commissioner Edward Becht, seconded by Commissioner Rufus Alexander to appoint Nicholas Mimms as the City Manager, using the previous City Manager contract as a baseline, and to include salary and severance details.

AYE: Commissioner Rufus Alexander, Commissioner Edward Becht, Commissioner Thomas Perona, Commissioner Reginald Sessions, Mayor Linda Hudson

Passed

- e. Discussion on city policy regarding the advertising of job descriptions at the request of Commissioner Becht.

Commissioner Becht stated that he believes the City has a problem with the hiring and firing process. He requested that Mr. Mimms come back within 30 days to address the concern.

Mr. Mimms stated that he will come back with a report within 30 days, as well as solutions to improve upon the hiring and termination process. It will be best to discuss at a Conference Agenda meeting.

13. COMMENTS FROM THE PUBLIC

Rick Reed
Reverend Shaw

14. COMMENTS FROM THE CITY MANAGER

- a. Interim City Manager's Departmental Activity Report

Nick Mimms, City Manager, reported that the Sights and Sounds parade was a tremendous success; Main Street and Kiwanis Club should be commended. Main Street Fort Pierce has been designated Florida Main Street of the Month. Fort Pierce's Main Street was named #1 in the country. The negative stigma about Fort Pierce is being surpassed. The ED Team delivered the Update to the Chamber and it was successful and we received lots of positive feedback. Veterans' Park storm water improvements have commenced, it will help with the protection of the Indian River Lagoon. The December 14, 2015 Conference Agenda topics were outlined.

15. COMMENTS FROM THE COMMISSION

Commissioner Alexander apologized for missing the parade. He will not be in attendance at the upcoming Commission meeting.

Commissioner Perona stated that he looks forward to working with Mr. Mimms. He would like to work towards a solution on the boats that are being moored in the waterways. He recently attended a Violence Connection workshop for animals that was very interesting and he would like to have this type of education available to all.

Commissioner Sessions congratulated Mr. Mimms and stated that he believes that he is ready to handle the issues of unemployment, poverty and crime within the City.

Commissioner Becht also congratulated Mr. Mimms and looks forward to working with him. The parade was diverse and well attended, noticing that there were many children enjoying the festivities. He encouraged citizens to shop local. The private sector businesses are making an investment in Fort Pierce, highlighting Harbor Federal relocation, and the St. James school expansion. He encouraged citizens to shop local to keep small businesses open.

Mayor Hudson stated that she was looking forward to working with Mr. Mimms. The Boat Parade is scheduled for December 12 and Santa will be coming downtown on the train on Saturday afternoon, December 12, 2015.

16. ADJOURNMENT

There being no further business, Mayor Hudson declared the meeting adjourned at 8:41 p.m.

ATTEST:

CITY CLERK

MAYOR COMMISSIONER

City Commission Regular Meeting

Agenda Item # 7. a.

Meeting Date: 12/21/2015

Re:

SUBJECT:

Letter of appreciation from Robert. P. Greene recognizing the appointment of Officer Al Garcia as their neighborhood sentry and commending his professional demeanor, positive attitude and the positive role model he creates.

Attachments

Officer Garcia

Form Review

Form Started By: Linda Cox

Started On: 12/16/2015 01:04 PM

Final Approval Date: 12/16/2015

December 7, 2015

Office of the Mayor
City Hall
100 North US 1
Fort Pierce, FL 34950

RECEIVED
TIME _____
DEC 15 2015
CITY OF FT. PIERCE
CITY MANAGER'S OFFICE

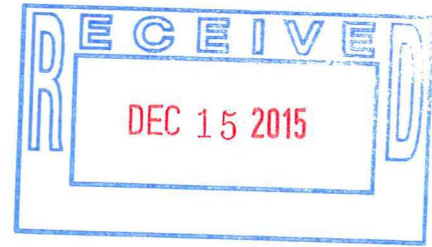

Dear Mayor Hudson:

My wife and I reside in Thumb Point on Hutchinson Island in the City of Fort Pierce. The Fort Pierce Police Department recently appointed **Officer Al Garcia** as sentry to our neighborhood. I would like to make a few comments regarding his presence.

Officer Al Garcia epitomizes what a member of a local police force should be; he routinely goes out of his way to introduce himself and converse with those he meets. His overall demeanor, both professional and personable raises the bar and sets the standard for what a local community expects, wants, and needs.

He does not hesitate to answer questions, offer suggestions and convey his willingness to assist if needed. **Officer Al Garcia's** overall attitude is positive, helpful and assuring, thus giving us confidence that the Fort Pierce Police Department holds the needs of its citizens as a top priority.

I would like to offer a personal 'thank you' to both you and to **Chief Diane Hobley-Burney** for making it possible for our small neighborhood to feel as if the clock turned back to another time when police officers received the respect they deserve for the oftentimes-thankless duties they must frequently preform. **Officer Al Garcia** is a positive role model for all of us.

Thank you for your time, but too often, well-intended citizens pick up the telephone, write a letter, text, or email to complain. I wanted to bring something positive to your attention.

Sincerely,

Robert P. Greene
602 Malabar Ave.
Fort Pierce, FL 34949

Cc: Chief Diane Hobley-Burney, FPPD

City Commission Regular Meeting

Agenda Item # 7. b.

Meeting Date: 12/21/2015

Re: Main Street Thanks

SUBJECT:

Letter of appreciation from Pam Gillette, Main Street Fort Pierce to the Mayor and Commissioners, City Manager, Police Chief and Public Works for their support of the 27th Annual Sights and Sounds on Second Festival and Parade.

Attachments

Main Street

Form Review

Form Started By: Linda Cox

Started On: 12/16/2015 01:08 PM

Final Approval Date: 12/16/2015



----- Forwarded by Nicholas Mimms/cfp on 12/16/2015 11:36 AM -----

From: "Pam Gillette" <pamgillette@mainstreetfortpierce.org>
To: "Pam Gillette" <pamgillette@mainstreetfortpierce.org>
Date: 12/16/2015 10:42 AM
Subject: Thank You <Watchdog: Virus checked>

Wednesday, December 16, 2015

City of Fort Pierce
P.O. Box 1480
Fort Pierce, FL 34954

Mayor Hudson, Nick Mimms, Police Chief Hobley- Burney, Mike Reals, and City Commissioners,

Main Street Fort Pierce and the Board of Directors would like to thank you for your support of the 27th Annual Sights and Sounds on Second Festival and Parade, "A Christmas to Remember". With over 80 entries and 1900 participants; this year was one of the best parades in our history. Attached are 2 photos taken by John Culverhouse showing the wonderful attendance to the parade this year.

Main Street Fort Pierce greatly appreciates the City of Fort Pierce support of the Sights and Sounds on Second Festival and Parade. We commend The Fort Pierce Police Department, the Public Works Department, and the Kiwanis Club for their hard work and dedication to the festival and parade. We could not put on this successful event year after year without their support.

Main Street is very proud of our partnership with the City of Fort Pierce. Throughout the past 27 years, the City of Fort Pierce has been there to assist us with many of our events and to help us bring people back to our beautiful City. We thank you again and we look forward to next year.

Main Street Fort Pierce would like to wish you and your staff a very happy and safe holiday season!

Sincerely,

Pamela L. Gillette

Pam Gillette
Marketing and Events
Main Street Fort Pierce

City Commission Regular Meeting

Agenda Item # 9. a.

Meeting Date: 12/21/2015

Re: Lien Reduction - Case 11-1440 - 2020 S 3rd Street

Submitted For: Peggy Arraiz, Code Compliance Manager, Code Enforcement

SUBJECT:

Request to waive interest, penalties, and administrative fees in the amount of \$134,840.00 for code enforcement lien against 2020 S 3rd Street, Ft. Pierce, FL, Parcel ID 2415-801-0024-000-3, previously owned by Rachel Nazario, 2020 S 3rd Street, Ft. Pierce, FL 34950 and currently owned by Cariann D. Martin, 374 NE Genessee Avenue, Port St. Lucie, FL 34983 \$21,510.58.

SUMMARY:

BACKGROUND: Cariann Martin purchased the house in August of this year through a tax deed sale. Excess funds from the tax sale was received by the City on October 27, 2015 in the amount of \$21,510.58. On receipt of the check we notified the new owners of the payment and the lien. Over the next 10 days the new property owners complied all violations.

RECOMMENDATION:

The Code Enforcement Board heard the request on November 18 and recommends the City Commission accept the offer and reduce the lien to \$21,510.58.

ALTERNATIVES:

- 1. Deny the request.
- 2. Make alternative recommendations.

RESPONSIBLE STAFF:

Colleen Greer, Executive Secretary.

COORDINATED WITH:

Margaret Arraiz, Code Compliance Manager.

Fiscal Impact

Budgeted Y/N: 2016

Fiscal Year:

Account:

Amount: 21,510.58

OTHER INFORMATION:

\$21,510.58 to the general fund.

Attachments

Request page 2

Tax Card

Breakdown

Minutes

Form Review

Inbox

City Manager

Form Started By: Collen Greer

Final Approval Date: 12/16/2015

Reviewed By

Nick Mimms

Date

12/16/2015 04:30 PM

Started On: 11/19/2015 01:48 PM



CITY OF FORT PIERCE

DIVISIONS OF CODE ENFORCEMENT & ANIMAL CONTROL

Margaret M. Arraiz, Code Compliance Manager

REQUEST FOR A REDUCTION OR RESCINDMENT OF CODE ENFORCEMENT FINES / LIENS

Date:	10/30/15		
Property address:	2020 S. 3rd St. Fort Pierce, FL 34950		
Owner(s) of record:	Cariann D. Martin		
Mailing address:	374 NE Genesee ave, Port St. Lucie, FL 34983		
Property tax ID #:	2415-801-0024-000-3		
Original purchase date:	AUG 3rd / 15	Original purchase price:	28,720.
Other Information:	<input type="checkbox"/> Inherited Property	<input checked="" type="checkbox"/> Purchased at Tax Sale	<input type="checkbox"/> Adjoining Property Owner
Property is used for:	<input checked="" type="checkbox"/> Single Family	<input type="checkbox"/> Multi-family	<input type="checkbox"/> Commercial <input type="checkbox"/> Industrial <input type="checkbox"/> Vacant Lot
Name of person requesting reduction:	Cariann D. Martin	Relationship to owner(s):	Self.
Telephone #:	(772) 672-0594	Mobile phone #:	(same)
E-mail:	CarrieJones062	Preferred contact method:	e mail.
What are owner(s) intentions for property:	Rental - rent out		
Amount of Fine:	\$134,840.00	Date Fine Initiated:	12/06/11
Are there current code violations?	<input checked="" type="checkbox"/> No	<input type="checkbox"/> Yes	Explain: (please attached notice)
Is a lien filed against the property?	<input type="checkbox"/> No	<input checked="" type="checkbox"/> Yes	If yes, what is the lien amount? \$134,840.
Is property listed for sale?	<input checked="" type="checkbox"/> No	<input type="checkbox"/> Yes	If yes, what is listing price?
Is property under contract for sale?	<input checked="" type="checkbox"/> No	<input type="checkbox"/> Yes	If yes, what is the sale price?

AMOUNT OF FINE / LIEN \$ 134,840.⁰⁰

DOLLAR AMOUNT REQUESTING TO BE WAIVED \$ 134,730.⁰⁰

DOLLAR AMOUNT I AGREE TO PAY \$ 110.⁰⁰

If the city waives any fees, interest, penalties, fine or lien amount, the undersigned does hereby agree to pay the remainder within sixty (60) days from the date of the Board, Magistrate or Commission's decision unless an alternate time frame is specified in the motion.

(Signature of Owner or Representative)

Cariann D Martin
(Printed Name)

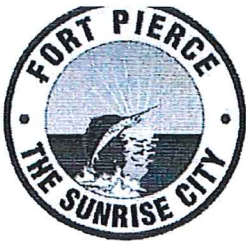

CITY OF FORT PIERCE

DIVISIONS OF CODE ENFORCEMENT & ANIMAL CONTROL

Margaret M. Arraiz, Code Compliance Manager

REQUEST FOR REDUCTION OF PENALTY

By completing this form, you are making statements under oath. Failure to be truthful is a violation of Fort Pierce City Code and Florida Statutes pertaining to perjury, which is a felony punishable by up to fifteen (15) years imprisonment.

INSTRUCTIONS:

1. Please fill in blanks completely.
2. Be specific when writing your statement. Use additional pages if necessary.
3. If you are claiming medical or financial hardship, attach supporting documentation (i.e. doctor's statement or proof of income).
4. Complete either the application for Waiver of Penalties (lot clearing / demolition) or Request for Reduction / Rescindment (code enforcement fines).
5. For lot clearing or demolition liens, contact Kathy D'Arton in the Finance Department (772-467-3076) for cost / fees breakdown.
6. For code enforcement liens (those imposed by a Special Magistrate or Code Enforcement Board), contact Colleen Greer (772-467-3149) for cost / fees breakdown.
7. If you do not have access to a Notary of the Public, one will be provided to you by the Department at no charge. All forms must be signed in the presence of the Notary to be valid.
8. Return this form, the application and any other pertinent documentation to the Code Enforcement Department.
9. Requests for Reduction / Rescindment of code enforcement liens must be heard before either the Code Enforcement Board or Special Magistrate prior to being heard before the City Commission.

Property Address: 2020 S. 3rd St. Fort Pierce, FL 34950.
Property Owner: Carriann D. Martin
Mailing Address: 374 NE Genesee Ave. PSL FL 34983
Telephone #: _____ Cell Phone #: (772) 672-0594
E-Mail Address: CarrieJones06@gmail.com

Is the property in compliance? yes If no, please explain _____



CITY OF FORT PIERCE

DIVISIONS OF CODE ENFORCEMENT & ANIMAL CONTROL

Margaret M. Arraiz, Code Compliance Manager

The property is now in great shape, curb appeal - great, spent weeks of sweat, and \$ to bring it back, for a nice family,

I, Cariann D. Martin, do hereby submit this Petition in request for a

reduction in the total amount of the penalty imposed and in support offer the following statement:

I bought the house on AUG, 3rd, 2015. I was not aware it had been empty for so many years. The yard was about 3-4 ft high, around whole property, I called city and told them, I just bought it and would immediately cut, trim the yard to be in compliance. It was so weeded through the fence, it took myself and friends + family to get it to look good. My family and I cleaned it, inside and out to improve not only this property but properties around it. I am requesting I pay only what I accrued from time I bought it, unit it was in compliance, approx. 10 days.

Date: _____

10/30/15

Signed: Cariann D. Martin

Print Name: Cariann D. Martin

STATE OF FLORIDA

COUNTY OF ST. LUCIE

PERSONALLY APPEARED before me, the undersigned authority Cariann D Martin

who acknowledged before me that the information contained herein is true and correct. He / She is not

personally known to me and has produced FLDL - M635104715191

as identification.

SWORN TO AND SUBSCRIBED before me this 5 day of November, 2015.

Property Identification

Site Address: 2020 S 3rd ST Parcel ID: 2415-801-0024- Account #: 25387 Sec/Town/Range:
 000-3
 Map ID: 24/15S Zoning: R2 Use Type: 0100 15/35S/40E
 Jurisdiction: Fort Pierce

Ownership

Cariann D Martin
 265 Bermuda Beach DR
 Fort Pierce, FL 34949-1527

Legal Description

INDIAN HILLS ESTATES BLK 3 LOT 4 (OR 3775-1977)

Current Values

Just/Market: \$28,900 Assessed: \$28,900 Year
 Exemptions: \$0 Taxable: \$28,900

Historical Values 3-year

Year	Just/Market	Assessed	Exemptions	Taxable
2015	\$28,900	\$28,900	\$0	\$28,900
2014	\$29,800	\$29,800	\$0	\$29,800
2013	\$29,400	\$29,400	\$0	\$29,400

Sale History

Date	Book/Page	Sale Code	Deed	Grantor	Price
08-03-2015	3775 / 1977	0111	TD	Nazario Rachel	\$30,000
05-18-2015	3749 / 0008	0111	TD	Punto Azul Investments LLC	\$0
05-18-2015	3747 / 1255	0111	TD	Nazario Rachel	\$30,100

Primary Building Information

Finished Area of this building: 1,055 SF
 Gross Area of this building: 1,367 SF

Exterior Data

View:	Roof Cover: Dim Shingle	Roof Structure: Gable	Building Type: HD+
Year Built: 1955	Frame:	Grade: D+	Effective Year: 1965
Primary Wall: CB Stucco	Story Height: 1 Story	No. Units: 1	Secondary Wall:

Interior Data

Bedrooms: 2	A/C %: 100%	Electric: MAXIMUM	Primary Int Wall:
Full Baths: 1	Heated %: 100%	Heat Type: FredHotAir	Avg Hgt/Floor: 0
Half Baths: 0	Sprinkled %: 0%	Heat Fuel: ELEC	Primary Floors: Carpet

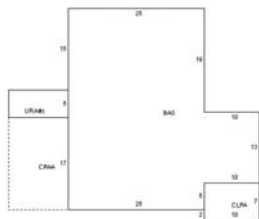

Total Areas

Finished/Under Air (SF):	1,055
Gross Area (SF):	1,367
Land Size (acres):	0.17
Land Size (SF):	7,500
Total Building Count:	1

Special Features and Yard Items

Type	Qty	Units	Year Blt
UTILITY AVG	1	80	1999
CHAINLINK 4'	1	144	2004

This information is believed to be correct at this time but it is subject to change and is not warranted.
 © Copyright 2015 Saint Lucie County Property Appraiser. All rights reserved.

MEMORANDUM

TO: The Honorable Mayor and Members of the City Commission

THROUGH: Mr. Nick Mimms, Interim City Manager

FROM: Colleen Greer, Executive Secretary to Code Enforcement

SUBJECT: CODE ENFORCEMENT LIEN REDUCTION
2020 S 3rd Street, Ft. Pierce, FL

DATE: December 21, 2015

The following is a breakdown of the above property:

	Costs (General Fund)	Interest & Penalties	Administrative Fees
CASE # 11-1440	\$134,800.00	\$0.00	\$40.00
TOTAL	\$134,800.00	\$0.00	\$40.00

CAN BE WAIVED (ALL COSTS)

\$134,840.00

MINUTES OF A REGULAR MEETING OF THE CODE ENFORCEMENT BOARD OF THE CITY OF FORT PIERCE, FLORIDA, HELD IN THE CITY HALL COMMISSION CHAMBERS, 100 NORTH U.S. #1, FORT PIERCE, FLORIDA, AT 9:00 A.M. ON WEDNESDAY, NOVEMBER 18, 2015.

1. CALL TO ORDER:
9:10 AM

2. PLEDGE OF ALLEGIANCE

3. ROLL CALL

Present: Al Bernetti; Geraldine Murphy; Chairwoman Mary Padrick Minton; Vice Chair Roderick Waller; Terry Wolters; Lara Amyx; Alternate Jim Flynn

Absent: John George

Staff Present: Margaret Arraiz, Code Compliance Manager
Colleen Greer, Secretary to the Code Enforcement Board
Terry Denmark, Code Enforcement Officer
Isaac Saucedo, Code Enforcement Officer
Shaun Coss, Building Dept Investigator (BDI)
James Walker, Asst. City Attorney

Attendees: Officer McWilliams - Sgt of Arms

4. ADMINISTRATIVE BUSINESS

A. CONSIDERATION OF ABSENCES: Lara Amyx was absent from the Sept. 9 meeting.

Ms. Amyx stated that she did not notify Staff that she wouldn't be at the September 9. She stated that an emergency had come up at work that she had to take care of and did not call in. Mr. Walker stated that the Board should defer excusing her absence until the next meeting.

Staff stated that Mr. George had called in first thing that morning. He said he wasn't feeling very good so he wouldn't be there today.

Motion was made by Al Bernetti, seconded by Geraldine Murphy to defer Lara Amyx absence until the next meeting.

AYE: Alternate Jim Flynn, Al Bernetti, Geraldine Murphy, Lara Amyx, Terry Wolters, Chairwoman Mary Padrick Minton, Vice Chair Roderick Waller

Passed

Motion was made by Lara Amyx, seconded by Geraldine Murphy to excuse Mr. George's absence.

AYE: Alternate Jim Flynn, Al Bernetti, Geraldine Murphy, Lara Amyx, Terry Wolters, Chairwoman Mary Padrick Minton, Vice Chair Roderick Waller

Passed

B. APPROVAL OF MINUTES

Chairwoman Minton said there was an error in the minutes. In Section 6.1 of the lien reduction motion the part about recommending to the City Commission to approve the reduction is missing.

Motion was made by Al Bernetti, seconded by Geraldine Murphy to approve the minutes of September 9 providing the changes are made.

AYE: Alternate Jim Flynn, Al Bernetti, Geraldine Murphy, Lara Amyx, Terry Wolters, Chairwoman Mary Padrick Minton, Vice Chair Roderick Waller

Passed

C. CERTIFICATION OF ALTERNATE MEMBER VOTING STATUS:

Chairwoman Minton welcomed Mr. Flynn to the Board. As the alternate, he was invited to sit in for Mr. George. He is also qualified to make comments and vote on the different cases being presented.

D. ADMINISTRATION OF OATH TO DEPARTMENTAL WITNESSES:

Margaret Arraiz, Isaac Saucedo, Terry Denton, and Shaun Coss were sworn in.

E. IDENTIFICATION OF CASES IN COMPLIANCE

1.	14-2155	2905 Dunbar Street	Simonson, Franca & Robert	Isaac Saucedo
----	---------	--------------------	---------------------------	---------------

Case Initiated:	October 23, 2014	Type of Presentation:	Regular - COMPLIED
-----------------	------------------	-----------------------	---------------------------

OWNER: Robert & Franca Simonson 1273 NW 11th Street Boynton Beach, FL 33426	OCCUPIED BY:
--	--------------

Section(s): 5-368 Property Maintenance

2.	15-0681	107 S 18th Street	Dantilus, Jean R	Shaun Coss
----	---------	-------------------	------------------	------------

Case Initiated:	May 6, 2015	Type of Presentation:	Regular - COMPLIED
-----------------	-------------	-----------------------	---------------------------

OWNER: Jean R Dantilus 555 NW Twylite Terrace Port St. Lucie, FL 34983	OCCUPIED BY:
---	--------------

Section(s): 5-1.105.1 Permit Required

3.	15-1011	1206 Avenue D	Joseph, Marie M	Shaun Coss
----	---------	---------------	-----------------	------------

Case Initiated:	June 30, 2015	Type of Presentation:	Regular - CONTINUED
-----------------	---------------	-----------------------	----------------------------

OWNER: Marie M Joseph 301 N 19th Street Ft. Pierce, FL 34950	OCCUPIED BY:
---	--------------

Section(s): 5-1.105.1 Permit Required

4.	15-1473	4603 - 4611 S US Hwy 1	Easy Livin' RV PK White City	Shaun Coss
----	---------	------------------------	------------------------------	------------

Case Initiated:	September 2, 2015	Type of Presentation:	Regular - COMPLIED
-----------------	-------------------	-----------------------	---------------------------

OWNER: Easy Livin' RV PK White City 4611 S US Highway 1 Ft. Pierce, FL 34982	OCCUPIED BY: Advance Auto Sales 4603 S US Highway 1 Ft. Pierce, FL 34982
---	---

OCCUPIED BY: Window Tinting or current occupant 4603 S US Highway 1 Ft. Pierce, FL 34982

Section(s): 5-1.105.1 Permit Required

5.

15-1537	913 N 18th Street	Brown, Marcus L	Isaac Saucedo
---------	-------------------	-----------------	---------------

Case Initiated:	September 10, 2015	Type of Presentation:	Regular - CONTINUED
-----------------	--------------------	-----------------------	-------------------------------

OWNER: Marcus L Brown 913 N 18th Street Fort Pierce, FL 34950	OCCUPIED BY:
--	--------------

Section(s): 22-187 (13) Landscape Maintenance

5. PUBLIC HEARINGS - VIOLATION CASES

2.

15-0671	4531 - 4611 S US Hwy 1	Easy Livin' RV PK White City	Shaun Coss
---------	------------------------	------------------------------	------------

Case Initiated:	April 30, 2015	Type of Presentation:	Regular
-----------------	----------------	-----------------------	---------

OWNER: Easy Livin' RV PK White City 4611 S US Highway 1 Ft. Pierce, FL 34982	OCCUPIED BY:
---	--------------

Section(s): 5-1.105.1 Permit Required

Margaret Arraiz asked Mr. Waller to recuse himself from the vote as he is the contractor for this case. Mr. Waller stepped aside as the motion was being read and voted on.

Motion was made by Lara Amyx, seconded by Terry Wolters that the Board finds a violation does exist and the violators that are not present are deemed to have admitted guilt. It was further moved that they be given the number of days recommended by the Code Enforcement Officer on the case summary sheet to come into compliance or they would be fined the amount also shown on the summary sheet.

AYE: Alternate Jim Flynn, Al Bernetti, Geraldine Murphy, Lara Amyx, Terry Wolters, Chairwoman Mary Padrick Minton

Other: Vice Chair Roderick Waller (RECUSE)

Passed

4.

15-0811	1302 N 16th Street	Bell Sr., David	Terry Denmark
---------	--------------------	-----------------	---------------

Case Initiated:	May 29, 2015	Type of Presentation:	Regular
-----------------	--------------	-----------------------	---------

OWNER: David Bell Sr. 1304 N. 16th St. Ft. Pierce, FL 34950	OCCUPIED BY:
--	--------------

Section(s): 16-46, 16-47, 16-48 (1) (3) Nuisance as an Object.

Chairwoman Minton asked if 15 days was enough time to comply for these violations and Code Compliance Manager Arraiz said it was. It sounded like a lot but really wasn't.

Motion was made by Al Bernetti, seconded by Alternate Jim Flynn that the Board finds a violation does exist and the violators that are not present are deemed to have admitted guilt. It was further moved that they be given the number of days recommended by the Code Enforcement Officer on the case summary sheet to come into compliance or they would be fined the amount also shown on the summary sheet.

AYE: Alternate Jim Flynn, Al Bernetti, Geraldine Murphy, Lara Amyx, Terry Wolters, Chairwoman Mary Padrick Minton, Vice Chair Roderick Waller

Passed

5.

15-0819	917, 919, 921 Avenue J	Ormit & Gal Omer	Shaun Coss
---------	---------------------------	------------------	------------

Case Initiated:	June 1, 2015	Type of Presentation:	Regular
-----------------	--------------	-----------------------	---------

OWNER: Ormit & Gal Omer PO BOX 600086 N Miami Beach, FL 33160	OCCUPIED BY:
--	--------------

Section(s): 5-1.105.1 Permit Required

Motion was made by Al Bernetti, seconded by Alternate Jim Flynn that the Board finds a violation does exist and the violators that are not present are deemed to have admitted guilt. It was further moved that they be given the number of days recommended by the Code Enforcement Officer on the case summary sheet to come into compliance or they would be fined the amount also shown on the summary sheet.

AYE: Alternate Jim Flynn, Al Bernetti, Geraldine Murphy, Lara Amyx, Terry Wolters, Chairwoman Mary Padrick Minton, Vice Chair Roderick Waller

Passed

6.

15-0846	1905 Okeechobee Road B	Herbert Rochester Holdings LLC	Shaun Coss
---------	---------------------------	-----------------------------------	------------

Case Initiated:	June 7, 2015	Type of Presentation:	Regular
-----------------	--------------	-----------------------	---------

OWNER: Herbert Rochester Holdings LLC 5514 Palmetto Drive Ft. Pierce, FL 34982	OCCUPIED BY:
---	--------------

Section(s): 5-1.105.1 Permit Required

BDI Shaun Coss read the facts of the case and presented photos which were marked as Exhibit 1. He stated that the violator was not contesting the charges and they were working on getting the permit.

Mr. Sam Wolkowsky, Property Manager for Rochester Holdings LLC was sworn in for testimony. He agreed with the violations and said he thought he could get them corrected within 60 days.

Mr. Bernetti asked if a survey was done and Mr. Walker stated that only came into effect if the violator requested an extension.

Motion was made by Al Bernetti, seconded by Lara Amyx that a violation does exist and that Herbert Rochester Holdings LLC has committed or is responsible for the violations. The violator has 60 days in which to apply for the permit and comply with the conditions of the permit. In the event the violations are not cured or complied within the time period given, a fine of \$100.00 per day will be assessed for each day the violation continues past the date set for compliance. The violator has 30 days in which to appeal their decision in the Circuit Court of St. Lucie County.

AYE: Alternate Jim Flynn, Al Bernetti, Geraldine Murphy, Lara Amyx, Terry Wolters, Chairwoman Mary Padrick Minton, Vice Chair Roderick Waller

Passed

8.

15-1158	1230 Avenue B	Delva, Wilnor	Terry Denmark
---------	---------------	---------------	---------------

Case Initiated:	July 21, 2015	Type of Presentation:	Regular - STIPULATION
-----------------	---------------	-----------------------	---------------------------------

OWNER: Wlnor Delva Marie P Louis 1230 Avenue B Ft. Pierce, FL 34950	OCCUPIED BY:
---	--------------

Section(s): 16-46, 16-47, 16-48 (1)(5) Outside Storage
Section(s): 16-46, 16-47, 16-48 (11) Outside Storage-Indoor Furniture
Section(s): 16-46, 16-48 Hanging Clothes on Fence

9.

15-1414	912 N 13th Street	Hubbard, Georgina M (Est)	Isaac Saucedo
---------	-------------------	------------------------------	---------------

Case Initiated:	August 25, 2015	Type of Presentation:	Regular
-----------------	-----------------	-----------------------	---------

OWNER: Georgia M Hubbard (Est) 912 N 13th Street Fort Pierce, FI 34950	OCCUPIED BY:
---	--------------

Section(s): 5-369 Vacant Buildings

Motion was made by Al Bernetti, seconded by Alternate Jim Flynn that the Board finds a violation does exist and the violators that are not present are deemed to have admitted guilt. It was further moved that they be given the number of days recommended by the Code Enforcement Officer on the case summary sheet to come into compliance or they would be fined the amount also shown on the summary sheet.

AYE: Alternate Jim Flynn, Al Bernetti, Geraldine Murphy, Lara Amyx, Terry Wolters, Chairwoman Mary Padrick Minton, Vice Chair Roderick Waller

Passed

6. **PUBLIC HEARINGS - MASSEY HEARINGS (FINE REDUCTIONS)**

7. **PUBLIC HEARINGS - LIEN REDUCTION REQUESTS**

0.	11-1440	2020 S 3rd Street	Nazario, Rachel	Peggy Arraiz
	Case Initiated:	September 15, 2011	Type of Presentation:	Lien Reduction
	PREVIOUS OWNER: Rachel Nazario 2020 S 3rd Street Ft. Pierce, FL 34950		CURRENT OWNER: Cariann D. Martin 374 NE Genesee Avenue Port St. Lucie, FL 34983	

Section(s): 22-187 (13) Landscape Maintenance.

Margaret Arraiz read the facts of the case and went over the 7 Criteria of Rule 17 of the Rules of Procedure. Staff received a notice of tax deed sale and that there was excess funds. After sending in the required documents, the City has received the money. Staff notified the new owners of the excess funds and informed them that there was a lien on the property. On November 10th Staff received the Request of Lien Reduction from Cariann Martin, the new owner.

Motion was made by Lara Amyx, seconded by Terry Wolters based on the 7 Criteria of Rule 17 to recommend to the City Commission that they approve reducing the code enforcement lien in the amount of \$134,840.00 assessed against Rachel Nazario to \$21,510.58.

AYE: Alternate Jim Flynn, Al Bernetti, Geraldine Murphy, Lara Amyx, Terry Wolters, Chairwoman Mary Padrick Minton, Vice Chair Roderick Waller

Passed

8. **PUBLIC HEARINGS - REQUEST FOR EXTENSION OF TIME**

1.	14-2512	637 N 2nd Street	Trujillo, Dio	Shaun Coss
	Case Initiated:	December 30, 2014	Type of Presentation:	Extension of Time
	OWNER: Mr. Dio Trujillo Seaway Complex Inc. 8213 Butler Greenwood Drive West Palm Beach, FL 33411		OCCUPIED BY:	

Section(s): 5-1.105.1 Permit Required.

BDI Shaun Coss read the facts of the case. Mr. Waller was asked to recuse himself as he is the contractor on this job. He was reminded by Mr. Walker to fill out the required form(s) that are in the City Clerk's office. Mr. Waller was then sworn in for testimony. Mr. Coss stated that the permit is ready to pick up and it does address all of the violations. Margaret Arraiz advised him that after the permit is picked up, if they have a valid inspection made within 6 months, it will keep the permit active.

Mr. Waller stated that the plumber has been out of town and they are waiting for his signature. He was asked when the plumber will return and he said he was expected by Friday, no later than Monday. They were requesting additional time to come into compliance.

Motion was made by Al Bernetti, seconded by Terry Wolters that the request for an extension of time within which to comply with the requirements of the Code Enforcement Board's Order Determining Violation be granted and extend the time for 30 days from today's date. If not complied within that time a fine there will be imposed of \$100.00 per day.

AYE: Alternate Jim Flynn, Al Bernetti, Geraldine Murphy, Lara Amyx, Terry Wolters, Chairwoman Mary Padrick Minton

Other: Vice Chair Roderick Waller (RECUSE)

Passed

9. NEW BUSINESS

A. Election of Officers for 2016

Motion was made by Al Bernetti, seconded by Lara Amyx to nominate Misty Minton to continue as Chairwoman for the upcoming year.

AYE: Alternate Jim Flynn, Al Bernetti, Geraldine Murphy, Lara Amyx, Terry Wolters, Chairwoman Mary Padrick Minton, Vice Chair Roderick Waller

Passed

Motion was made by Al Bernetti, seconded by Lara Amyx to nominate Rod Waller as Vice Chair for the upcoming year.

AYE: Alternate Jim Flynn, Al Bernetti, Geraldine Murphy, Lara Amyx, Terry Wolters, Chairwoman Mary Padrick Minton, Vice Chair Roderick Waller

Passed

10. PUBLIC COMMENT

11. COMMENTS FROM STAFF

A. **Discussion of items presented to the City Manager at the request of the Code Board:**

Peggy Arraiz stated that she had taken the Board's request for changes, specifically their fence concerns, to the City Manager and he has asked that each member submit their concerns in writing.

13. ADJOURNMENT:

Meeting adjourned 9:55 AM.

Respectfully submitted:

Colleen Greer

Secretary for the Code Enforcement Board

City Commission Regular Meeting

Agenda Item # 9. b.

Meeting Date: 12/21/2015

Re: Subordination Agreements - FPUA

SUBJECT:

Approval of Subordination of Utility Interest Agreements between the State of Florida, Department of Transportation and the City of Fort Pierce, Florida for the use and benefit of Fort Pierce Utilities Authority, as for the Midway Road widening project.

SUMMARY:

The Florida Department of Transportation is requiring the attached subordination of utility interest documents be executed in association with the upcoming FDOT Midway Road Widening Project. The agreements were approved by the Fort Pierce Utilities Authority on December 15, 2015.

RECOMMENDATION:

Authorize the Mayor to sign the subordination agreements to FDOT.

ALTERNATIVES:

n/a

RESPONSIBLE STAFF:

Linda W. Cox, City Clerk

COORDINATED WITH:

Rob Schwerer, City Attorney
Clay Lindstrom, FPUA

Fiscal Impact

Budgeted Y/N:

Fiscal Year:

Account:

Amount:

OTHER INFORMATION:

TBD

Attachments

Subordination Agreements

Form Review

Inbox

City Manager

Form Started By: Linda Cox

Reviewed By

Nick Mimms

Date

12/16/2015 04:30 PM

Started On: 11/23/2015 09:42 AM

Final Approval Date: 12/16/2015



Director of Financial Services
"Committed to Quality"

MEMORANDUM

TO: Fort Pierce City Commission

FROM: Nina B. Hurtubise, CPA 
FPUA Director of Financial Services

THROUGH: Clayton W. Lindstrom, P.E. 
FPUA Director of Utilities

DATE: December 16, 2015

SUBJECT: **City Commission Consent Agenda Request for December 21, 2015 Meeting Subordination of City Utility Interests – Parcel Nos. 109-3R, 110-3R, 111-3R, 143-2R, 145-2R, 153-2R, 154-2R, 822-2R, 824-2R**

I am forwarding for consideration and approval by the City Commission during the December 21, 2015 City Commission meeting the above Subordination of Utility Interest documents associated with the upcoming FDOT Midway Road Widening Project.

Please return all three copies of each of the nine Subordination documents to me for execution by the FDOT. If you have any questions or are in need of additional information, please contact me.

cc: City Manager
City Clerk

23-UTL.01-06/93

This instrument prepared	Parcel No.	109.3R
under the direction of:	Item/Segment No.	2314402
Dawn Raduano, Esq. _____	Section:	94530-2510
Legal Description prepared by:	Managing District:	04
Jeff Smith, P.S.M. (09-05-13) _____	C.R. No.	712
Document prepared by:	County:	St. Lucie
Grace K. Abel (09-08-15) _____		

Department of Transportation
Right of Way Production Services
3400 W. Commercial Boulevard
Ft. Lauderdale, Florida 33309

SUBORDINATION OF UTILITY INTERESTS

THIS AGREEMENT, entered into this _____ day of _____, 201____, by and between the STATE OF FLORIDA DEPARTMENT OF TRANSPORTATION, hereinafter called "FDOT", and CITY OF FORT PIERCE, FLORIDA for the use and benefit of FORT PIERCE UTILITIES AUTHORITY, hereinafter called "Utility".

W I T N E S S E T H:

WHEREAS, the Utility presently has an interest in certain lands that have been determined necessary for highway purposes; and

WHEREAS, the proposed use of these lands for highway purposes will require subordination of the interest claimed in such lands by Utility to the FDOT; and

WHEREAS, the FDOT is willing to pay to have the Utility's facilities relocated if necessary to prevent conflict between the facilities so that the benefits of each may be retained.

NOW, THEREFORE, in consideration of the mutual covenants and promises of the parties hereto, Utility and FDOT agree as follows:

Utility hereby subordinates to the interest of FDOT, its successors, or assigns, any and all of its interest in the lands as follows, viz:

Parcel No. 109

Item/Segment No. 2314402
Section: 94530-2510

A portion of UNIT 1, RENAISSANCE COMMONS, A CONDOMINIUM per Declaration of Condominium, as recorded in Official Records Book 2899,

(Continue on the next page)

Page 2434, being of the Public Records of St. Lucie County, Florida, lying in Section 4, Township 36 South, Range 40 East, St. Lucie County, Florida, being more particularly described as follows:

Commence at the west one-quarter (W. 1/4) corner of said Section 4; thence South 00°12'54" East, a distance of 0.82 feet along the west line of the southwest one-quarter (S.W. 1/4) of said Section 4 to a point on the Baseline of Survey of County Road 712 (Midway Road) as shown on the Florida Department of Transportation Right of Way Map for Item/Segment No. 2314402, Section 94530-2510; thence North 89°51'59" East, a distance of 3.90 feet along said Baseline of Survey; thence North 89°44'43" East, a distance of 83.93 feet continuing along said Baseline of Survey; thence North 00°15'17" West, a distance of 40.00 feet along a line at a right angle to the last described course to the north existing right of way line of said County Road 712 (Midway Road) and the POINT OF BEGINNING; thence North 43°39'56" West, a distance of 69.59 feet along said north existing right of way line to the east existing right of way line of County Road 615 (S. 25th Street/Hawley Road) as shown on the Florida Department of Transportation Right of Way Map for Item/Segment No. 2314402, Section 94530-2510; thence along said east existing right of way line for the next three (3) courses: (1) North 00°14'50" West, a distance of 91.15 feet; thence (2) North 07°19'26" East, a distance of 77.94 feet; thence (3) North 01°12'21" West, a distance of 23.32 feet; thence North 89°44'43" East, a distance of 5.49 feet; thence South 13°03'39" East, a distance of 32.85 feet; thence South 02°12'54" East, a distance of 102.60 feet; thence South 11°16'51" West, a distance of 25.71 feet; thence South 02°12'54" East, a distance of 22.49 feet; thence South 46°10'27" East, a distance of 42.00 feet; thence North 89°51'59" East, a distance of 143.44 feet; thence South 00°14'50" East, a distance of 30.51 feet to a point on the north existing right of way line of said County Road 712 (Midway Road); thence South 89°44'43" West, a distance of 147.60 feet along said north existing right of way line to the POINT OF BEGINNING.

Containing 9,427 square feet, more or less.

RECORDED

INSTRUMENT	DATE	FROM	TO	O.R.B. & PAGE
Easement	06/03/92	3D Development & Leasing, Inc.	City of Fort Pierce, Florida for the use and benefit of the Fort Pierce Utilities Authority	0795/0729

PROVIDED that the Utility has the following rights:

1. The Utility shall have the right to construct, operate, maintain, improve, add to, upgrade, remove, and relocate facilities on, within, and upon the lands described herein in accordance with the FDOT's current minimum standards for such facilities as required by the FDOT, Utility Accommodation Manual in effect at the time the agreement is executed. Any new construction or relocation of facilities within the lands will be subject to prior approval by the FDOT. Should the FDOT fail to approve any new construction or relocation of facilities by the Utility or require the Utility to alter, adjust, or relocate its facilities located within said lands, the FDOT hereby agrees to pay the cost of such alteration, adjustment, or relocation, including, but not limited to the cost of acquiring appropriate easements.
2. Notwithstanding any provisions set forth herein, the terms of the utility permits shall supersede any contrary provisions, with the exception herein with reimbursement rights.
3. The Utility shall have a reasonable right to enter upon the lands described herein for the purposes outlined in Paragraph 1 above, including the right to trim such trees, brush, and growth which might endanger or interfere with such facilities, provided that such rights do not interfere with the operation and safety of the FDOT's facilities.
4. The Utility agrees to repair any damage to FDOT facilities and be responsible to the FDOT against any loss or damage resulting from the Utility exercising its rights outlined in Paragraphs 1 and 3 above; however the Utility does not waive its sovereign immunity.

IN WITNESS WHEREOF, the FDOT hereto has executed this agreement on the day and year first above written.

Signed, sealed and delivered
in the presence of witnesses:

STATE OF FLORIDA DEPARTMENT
OF TRANSPORTATION

Print Name: _____

By: _____
Print Name: GERRY O'REILLY
Title: District Secretary
for District IV

Print Name: _____

Attorney approved as to form:

Name: DAWN RADUANO

STATE OF FLORIDA
COUNTY OF BROWARD

The foregoing instrument was acknowledged before me this _____
day of _____, 201____, by GERRY O'REILLY, District
Secretary for District IV, who is personally known to me or who has
produced _____ as identification.

Print Name: _____
Notary Public in and for the
County and State last aforesaid.
My Commission Expires: _____
Serial No., if any: _____

IN WITNESS WHEREOF, the Utility has caused these presents to be executed in its name, and its Corporate Seal to be hereunto affixed, by its proper officers thereunto duly authorized, the day and year first above written.

ATTEST: *Daniel M. DeIulio*
Daniel M. DeIulio
Secretary

CITY OF FORT PIERCE, a municipal corporation, for the use and benefit of FORT PIERCE UTILITIES AUTHORITY

By: *Michael A. Perri, Jr.*
Michael A. Perri, Jr., Chairman

Approved as to Form and Correctness:

By: *[Signature]*
Fort Pierce Utilities Authority
Attorney

STATE OF FLORIDA
COUNTY OF ST. LUCIE

The foregoing instrument was acknowledged before me this 15 day of December, 2015, by Michael A. Perri, Jr., Chairman of Fort Pierce Utilities Authority, who is personally known to me.



Florinda Kay Mazzarella
Florinda Kay Mazzarella
Notary Public in and for the
County and State last aforesaid

Linda Hudson, Mayor-Commissioner

ATTEST:

Linda W. Cox, City Clerk
(City Seal)

Approved as to Form and Correctness:

Robert V. Schwerer, City Attorney

23-UTL.01-06/93

This instrument prepared	Parcel No.	110.3R
under the direction of:	Item/Segment No.	2314402
Dawn Raduano, Esq. _____	Section:	94530-2510
Legal Description prepared by:	Managing District:	04
Jeff Smith, P.S.M. (09-05-13) _____	C.R. No.	712
Document prepared by:	County:	St. Lucie
Grace K. Abel (09-08-15) _____		

Department of Transportation
Right of Way Production Services
3400 W. Commercial Boulevard
Ft. Lauderdale, Florida 33309

SUBORDINATION OF UTILITY INTERESTS

THIS AGREEMENT, entered into this _____ day of _____, 201____, by and between the STATE OF FLORIDA DEPARTMENT OF TRANSPORTATION, hereinafter called "FDOT", and CITY OF FORT PIERCE, FLORIDA for the use and benefit of FORT PIERCE UTILITIES AUTHORITY, hereinafter called "Utility".

W I T N E S S E T H:

WHEREAS, the Utility presently has an interest in certain lands that have been determined necessary for highway purposes; and

WHEREAS, the proposed use of these lands for highway purposes will require subordination of the interest claimed in such lands by Utility to the FDOT; and

WHEREAS, the FDOT is willing to pay to have the Utility's facilities relocated if necessary to prevent conflict between the facilities so that the benefits of each may be retained.

NOW, THEREFORE, in consideration of the mutual covenants and promises of the parties hereto, Utility and FDOT agree as follows:

Utility hereby subordinates to the interest of FDOT, its successors, or assigns, any and all of its interest in the lands as follows, viz:

Parcel No. 110	Item/Segment No. 2314402
	Section: 94530-2510

A portion of RENAISSANCE COMMONS, A CONDOMINIUM per Declaration of Condominium, as recorded in Official Records Book 2899, Page 2434,

(Continue on the next page)

being of the Public Records of St. Lucie County, Florida, lying in Section 4, Township 36 South, Range 40 East, St. Lucie County, Florida, being more particularly described as follows:

Commence at the west one-quarter (W. 1/4) corner of said Section 4; thence South 00°12'54" East, a distance of 0.82 feet along the west line of the southwest one-quarter (S.W. 1/4) of said Section 4 to a point on the Baseline of Survey of County Road 712 (Midway Road) as shown on the Florida Department of Transportation Right of Way Map for Item/Segment No. 2314402, Section 94530-2510; thence North 89°51'59" East, a distance of 3.90 feet along said Baseline of Survey; thence North 89°44'43" East, a distance of 383.11 feet continuing along said Baseline of Survey; thence North 00°15'17" West, a distance of 40.00 feet along a line at a right angle to the last described course to the north existing right of way line of said County Road 712 (Midway Road) and the POINT OF BEGINNING; thence South 89°44'43" West, a distance of 151.58 feet along said north existing right of way line; thence North 00°14'50" West, a distance of 30.51 feet; thence North 89°51'59" East, a distance 151.58 feet; thence South 00°14'50" East, a distance of 30.19 feet to a point on said north existing right of way line of County Road 712 (Midway Road) and the POINT OF BEGINNING.

Containing 4,601 square feet, more or less.

AND

A portion of RENAISSANCE COMMONS, a Condominium per Declaration of Condominium, as recorded in Official Records Book 2899, Page 2434, being of the Public Records of St. Lucie County, Florida, lying in Section 4, Township 36 South, Range 40 East, St. Lucie County, Florida, being more particularly described as follows:

Commence at the west one-quarter (W. 1/4) corner of said Section 4; thence North 00°14'50" West, a distance of 307.51 feet along the west line of the northwest one-quarter (N.W. 1/4) of said Section 4; thence North 89°45'10" East, a distance of 49.44 feet along a line at a right angle to the last described course to the POINT OF BEGINNING, being on the east existing right of way line of County Road 615 (S. 25th Street/Hawley Road) as shown on said Florida Department of Transportation Right of Way Map for Item/Segment No. 2314402, Section 94530-2510; thence along said east existing right of way line of said County Road 615 for the next (2) two courses, North 11°49'44" West, a distance of 47.04 feet; thence North 00°14'50" West, a distance of 189.13 feet; thence South 03°12'54" East, a distance of 32.61 feet; thence South 02°26'20" East, 202.78 feet to a point on said east existing right of way line; thence South 13°03'39" East, a distance of 26.71 feet; thence South 89°44'43" West, a distance of 5.49 feet to a point on said east existing right of way line; thence North 01°12'21" West, a distance of 26.05 feet along said east existing right of way line to the POINT OF BEGINNING.

Containing 1,009 square feet, more or less.

All together containing 5,610 square feet, more or less.

RECORDED

INSTRUMENT	DATE	FROM	TO	O.R.B. & PAGE
Easement	06/03/92	3D Development & Leasing, Inc.	City of Fort Pierce, Florida for the use and benefit of the Fort Pierce Utilities Authority	0795/0729

PROVIDED that the Utility has the following rights:

1. The Utility shall have the right to construct, operate, maintain, improve, add to, upgrade, remove, and relocate facilities on, within, and upon the lands described herein in accordance with the FDOT's current minimum standards for such facilities as required by the FDOT, Utility Accommodation Manual in effect at the time the agreement is executed. Any new construction or relocation of facilities within the lands will be subject to prior approval by the FDOT. Should the FDOT fail to approve any new construction or relocation of facilities by the Utility or require the Utility to alter, adjust, or relocate its facilities located within said lands, the FDOT hereby agrees to pay the cost of such alteration, adjustment, or relocation, including, but not limited to the cost of acquiring appropriate easements.
2. Notwithstanding any provisions set forth herein, the terms of the utility permits shall supersede any contrary provisions, with the exception herein with reimbursement rights.
3. The Utility shall have a reasonable right to enter upon the lands described herein for the purposes outlined in Paragraph 1 above, including the right to trim such trees, brush, and growth which might endanger or interfere with such facilities, provided that such rights do not interfere with the operation and safety of the FDOT's facilities.
4. The Utility agrees to repair any damage to FDOT facilities and be responsible to the FDOT against any loss or damage resulting from the Utility exercising its rights outlined in Paragraphs 1 and 3 above; however the Utility does not waive its sovereign immunity.

IN WITNESS WHEREOF, the FDOT hereto has executed this agreement on the day and year first above written.

Signed, sealed and delivered
in the presence of witnesses:

STATE OF FLORIDA DEPARTMENT
OF TRANSPORTATION

Print Name: _____

By: _____
Print Name: GERRY O'REILLY
Title: District Secretary
for District IV

Print Name: _____

Attorney approved as to form:

Name: DAWN RADUANO

STATE OF FLORIDA

COUNTY OF BROWARD

The foregoing instrument was acknowledged before me this _____
day of _____, 201____, by GERRY O'REILLY, District
Secretary for District IV, who is personally known to me or who has
produced _____ as identification.

Print Name: _____
Notary Public in and for the
County and State last aforesaid.
My Commission Expires: _____
Serial No., if any: _____

IN WITNESS WHEREOF, the Utility has caused these presents to be executed in its name, and its Corporate Seal to be hereunto affixed, by its proper officers thereunto duly authorized, the day and year first above written.

ATTEST: *Daniel M. DeIulio*
Daniel M. DeIulio
Secretary

CITY OF FORT PIERCE, a municipal corporation, for the use and benefit of FORT PIERCE UTILITIES AUTHORITY

By: *Michael A. Perri, Jr.*
Michael A. Perri, Jr., Chairman

Approved as to Form and Correctness:

By: *[Signature]*
Fort Pierce Utilities Authority
Attorney

STATE OF FLORIDA
COUNTY OF ST. LUCIE

The foregoing instrument was acknowledged before me this 15 day of December, 2015, by Michael A. Perri, Jr., Chairman of Fort Pierce Utilities Authority, who is personally known to me.



Florinda Kay Mazzarella
Florinda Kay Mazzarella
Notary Public in and for the
County and State last aforesaid

Linda Hudson, Mayor-Commissioner

ATTEST:

Linda W. Cox, City Clerk
(City Seal)

Approved as to Form and Correctness:

Robert V. Schwerer, City Attorney

23-UTL.01-06/93

This instrument prepared	Parcel No.	111.3R
under the direction of:	Item/Segment No.	2314402
Dawn Raduano, Esq. _____	Section:	94530-2510
Legal Description prepared by:	Managing District:	04
Jeff Smith, P.S.M. (09-05-13)	C.R. No.	712
Document prepared by:	County:	St. Lucie
Grace K. Abel (09-08-15)		

Department of Transportation
Right of Way Production Services
3400 W. Commercial Boulevard
Ft. Lauderdale, Florida 33309

SUBORDINATION OF UTILITY INTERESTS

THIS AGREEMENT, entered into this _____ day of _____, 201____, by and between the STATE OF FLORIDA DEPARTMENT OF TRANSPORTATION, hereinafter called "FDOT", and CITY OF FORT PIERCE, FLORIDA for the use and benefit of FORT PIERCE UTILITIES AUTHORITY, hereinafter called "Utility".

W I T N E S S E T H:

WHEREAS, the Utility presently has an interest in certain lands that have been determined necessary for highway purposes; and

WHEREAS, the proposed use of these lands for highway purposes will require subordination of the interest claimed in such lands by Utility to the FDOT; and

WHEREAS, the FDOT is willing to pay to have the Utility's facilities relocated if necessary to prevent conflict between the facilities so that the benefits of each may be retained.

NOW, THEREFORE, in consideration of the mutual covenants and promises of the parties hereto, Utility and FDOT agree as follows:

Utility hereby subordinates to the interest of FDOT, its successors, or assigns, any and all of its interest in the lands as follows, viz:

Parcel No. 111

Item/Segment No. 2314402
Section: 94530-2510

A portion of Lot 61, WHITE CITY SUBDIVISION OF SECTIONS 3, 4, 5, 8, 9, AND 10, TOWNSHIP 36 S, RANGE 40 E, according to the plat thereof, as

(Continue on the next page)

Signed, sealed and delivered
in the presence of witnesses:

STATE OF FLORIDA DEPARTMENT
OF TRANSPORTATION

Print Name: _____

By: _____
Print Name: GERRY O'REILLY
Title: District Secretary
for District IV

Print Name: _____

Attorney approved as to form:

Name: DAWN RADUANO

STATE OF FLORIDA

COUNTY OF BROWARD

The foregoing instrument was acknowledged before me this _____
day of _____, 201____, by GERRY O'REILLY, District
Secretary for District IV, who is personally known to me or who has
produced _____ as identification.

Print Name: _____
Notary Public in and for the
County and State last aforesaid.
My Commission Expires: _____
Serial No., if any: _____

IN WITNESS WHEREOF, the Utility has caused these presents to be executed in its name, and its Corporate Seal to be hereunto affixed, by its proper officers thereunto duly authorized, the day and year first above written.

ATTEST: Daniel M. DeIulio
Daniel M. DeIulio
Secretary

CITY OF FORT PIERCE, a municipal corporation, for the use and benefit of FORT PIERCE UTILITIES AUTHORITY

By: Michael A. Perri, Jr.
Michael A. Perri, Jr., Chairman

Approved as to Form and Correctness:

By: [Signature]
Fort Pierce Utilities Authority
Attorney

STATE OF FLORIDA
COUNTY OF ST. LUCIE

The foregoing instrument was acknowledged before me this 15 day of December, 2015, by Michael A. Perri, Jr., Chairman of Fort Pierce Utilities Authority, who is personally known to me.



Florinda Kay Mazzarella
Florinda Kay Mazzarella
Notary Public in and for the
County and State last aforesaid

Linda Hudson, Mayor-Commissioner

ATTEST:

Linda W. Cox, City Clerk
(City Seal)

Approved as to Form and Correctness:

Robert V. Schwerer, City Attorney

23-UTL.01-06/93

This instrument prepared
under the direction of:
Dawn Raduano, Esq. _____
Legal Description prepared by:
Jeff Smith, P.S.M. (09-05-13)
Document prepared by:
Grace K. Abel (09-08-15)
Department of Transportation
Right of Way Production Services
3400 W. Commercial Boulevard
Ft. Lauderdale, Florida 33309

Parcel No. 143.2R
Item/Segment No. 2314402
Section: 94530-2510
Managing District: 04
C.R. No. 712
County: St. Lucie

SUBORDINATION OF UTILITY INTERESTS

THIS AGREEMENT, entered into this _____ day of _____,
201____, by and between the STATE OF FLORIDA DEPARTMENT OF
TRANSPORTATION, hereinafter called "FDOT", and CITY OF FORT PIERCE,
FLORIDA for the use and benefit of FORT PIERCE UTILITIES AUTHORITY,
hereinafter called "Utility".

W I T N E S S E T H:

WHEREAS, the Utility presently has an interest in certain lands
that have been determined necessary for highway purposes; and

WHEREAS, the proposed use of these lands for highway purposes
will require subordination of the interest claimed in such lands by
Utility to the FDOT; and

WHEREAS, the FDOT is willing to pay to have the Utility's
facilities relocated if necessary to prevent conflict between the
facilities so that the benefits of each may be retained.

NOW, THEREFORE, in consideration of the mutual covenants and
promises of the parties hereto, Utility and FDOT agree as follows:

Utility hereby subordinates to the interest of FDOT, its
successors, or assigns, any and all of its interest in the lands as
follows, viz: .

Parcel No. 143

Item/Segment No. 2314402
Section: 94530-2510

A portion of Section 3, Township 36 South, Range 40 East, St. Lucie
County, Florida, being more particularly described as follows:

(Continue on the next page)

Commence at a found pk nail with disk stamped "R.W. HERR PLS 4907" marking the west one-quarter (W. 1/4) corner of said Section 3; thence North 00°11'02" West, 88.16 feet along the west line of the Northwest one-quarter (N.W. 1/4) of said Section 3 to the north existing right of way line of County Road 712 (Midway Road) and the east existing right of way line of County Road 605 (Oleander Avenue) as shown on the Florida Department of Transportation Right of Way Map for Item/Segment No. 2314402, Section 94530-2510 and the POINT OF BEGINNING; thence North 00°11'02" West, 16.82 feet continuing along said west line of the northwest one-quarter (N.W. 1/4) of Section 3 and said east existing right of way line of County Road 605 (Oleander Avenue); thence South 43°54'49" East, 9.86 feet; thence South 89°42'45" East, 434.44 feet; thence South 00°13'20" East, 9.75 feet to said north existing right of way line of County Road 712 (Midway Road); thence North 89°42'45" West, 441.26 feet along said north existing right of way line to the POINT OF BEGINNING.

Containing 4,326 square feet, more or less.

RECORDED

INSTRUMENT	DATE	FROM	TO	O.R.B. & PAGE
Easement	09/27/84	White City United Methodist Church, Inc.	City of Fort Pierce, Florida for the use and benefit of the Fort Pierce Utilities Authority	448/1201
Easement	03/29/88	White City United Methodist Church, Inc.	City of Fort Pierce, Florida for the use and benefit of the Fort Pierce Utilities Authority	600/1582
Easement	09/27/84	White City United Methodist Church, Inc.	City of Fort Pierce, Florida for the use and benefit of the Fort Pierce Utilities Authority	635/235

PROVIDED that the Utility has the following rights:

1. The Utility shall have the right to construct, operate, maintain, improve, add to, upgrade, remove, and relocate facilities on, within, and upon the lands described herein in accordance with the FDOT's current minimum standards for such facilities as required by the FDOT, Utility Accommodation Manual in effect at the time the agreement is executed. Any new construction or relocation of facilities within the lands will be subject to

Signed, sealed and delivered
in the presence of witnesses:

STATE OF FLORIDA DEPARTMENT
OF TRANSPORTATION

Print Name: _____

By: _____
Print Name: GERRY O'REILLY
Title: District Secretary
for District IV

Print Name: _____

Attorney approved as to form:

Name: DAWN RADUANO

STATE OF FLORIDA

COUNTY OF BROWARD

The foregoing instrument was acknowledged before me this _____
day of _____, 201____, by GERRY O'REILLY, District
Secretary for District IV, who is personally known to me or who has
produced _____ as identification.

Print Name: _____
Notary Public in and for the
County and State last aforesaid.
My Commission Expires: _____
Serial No., if any: _____

IN WITNESS WHEREOF, the Utility has caused these presents to be executed in its name, and its Corporate Seal to be hereunto affixed, by its proper officers thereunto duly authorized, the day and year first above written.

ATTEST: *Daniel M. DeIulio*
Daniel M. DeIulio
Secretary

CITY OF FORT PIERCE, a municipal corporation, for the use and benefit of FORT PIERCE UTILITIES AUTHORITY

By: *Michael A. Perri, Jr.*
Michael A. Perri, Jr., Chairman

Approved as to Form and Correctness:

By: *ARK*
Fort Pierce Utilities Authority
Attorney

STATE OF FLORIDA
COUNTY OF ST. LUCIE

The foregoing instrument was acknowledged before me this 15 day of December, 2015, by Michael A. Perri, Jr., Chairman of Fort Pierce Utilities Authority, who is personally known to me.



Florinda Kay Mazzarella
Florinda Kay Mazzarella
Notary Public in and for the
County and State last aforesaid

Linda Hudson, Mayor-Commissioner

ATTEST:

Linda W. Cox, City Clerk
(City Seal)

Approved as to Form and Correctness:

Robert V. Schwerer, City Attorney

23-UTL.01-06/93

This instrument prepared under the direction of:	Parcel No.	145.2R
Dawn Raduano, Esq. _____	Item/Segment No.	2314402
Legal Description prepared by:	Section:	94530-2510
Jeff Smith, P.S.M. (09-05-13)	Managing District:	04
Document prepared by:	C.R. No.	712
Grace K. Abel (09-08-15) _____	County:	St. Lucie

Department of Transportation
Right of Way Production Services
3400 W. Commercial Boulevard
Ft. Lauderdale, Florida 33309

SUBORDINATION OF UTILITY INTERESTS

THIS AGREEMENT, entered into this _____ day of _____, 201____, by and between the STATE OF FLORIDA DEPARTMENT OF TRANSPORTATION, hereinafter called "FDOT", and CITY OF FORT PIERCE, FLORIDA for the use and benefit of FORT PIERCE UTILITIES AUTHORITY, hereinafter called "Utility".

W I T N E S S E T H:

WHEREAS, the Utility presently has an interest in certain lands that have been determined necessary for highway purposes; and

WHEREAS, the proposed use of these lands for highway purposes will require subordination of the interest claimed in such lands by Utility to the FDOT; and

WHEREAS, the FDOT is willing to pay to have the Utility's facilities relocated if necessary to prevent conflict between the facilities so that the benefits of each may be retained.

NOW, THEREFORE, in consideration of the mutual covenants and promises of the parties hereto, Utility and FDOT agree as follows:

Utility hereby subordinates to the interest of FDOT, its successors, or assigns, any and all of its interest in the lands as follows, viz:

Parcel No. 145

Item/Segment No. 2314402
Section: 94530-2510

A portion of Lot 23, WHITE CITY SUBDIVISION OF SECTIONS 3, 4, 5, 8, 9, AND 10, TOWNSHIP 36 S, RANGE 40 E, according to the plat thereof, as

(Continue on the next page)

recorded in Plat Book 1, Page 23, of the Public Records of St. Lucie County, Florida, lying in Section 3, Township 36 South, Range 40 East, St. Lucie County, Florida, being more particularly described as follows:

Commence at a found pk nail with disk stamped "R.W. HERR PLS 4907" marking the west one-quarter (W. 1/4) corner of said Section 3; thence North 00°11'02" West, 48.16 feet along the west line of the northwest one-quarter (N.W. 1/4) of said Section 3 to the Baseline of Survey of County Road 712 (Midway Road) as shown on the Florida Department of Transportation Right of Way Map for Item/Segment No. 2314402, Section 94530-2510; thence South 89°42'45" East, 649.64 feet along said Baseline of Survey; thence North 00°17'15" East, 40.00 feet along a line at a right angle to the last described course to the north existing right of way line of said County Road 712 (Midway Road) and the POINT OF BEGINNING; thence North 00°13'20" West, 9.75 feet; thence South 89°42'45" East, 420.94 feet; thence North 89°00'38" East, 197.82 feet; thence North 00°17'15" East, 615.84 feet; thence South 89°42'45" East, 40.00 feet; thence South 00°17'15" West, 630.00 feet to said north existing right of way line of County Road 712 (Midway Road); thence North 89°42'45" West, 658.62 feet along said north existing right of way line to the POINT OF BEGINNING.

Containing 0.727 acres, more or less.

RECORDED

INSTRUMENT	DATE	FROM	TO	O.R.B. & PAGE
Easement	09/05/84	Tony Backiel and Frieda Backiel	City of Fort Pierce, Florida for the use and benefit of the Fort Pierce Utilities Authority	448/1203
Easement	06/26/89	Land America Investment Fund I, Ltd., a Florida limited partnership	City of Fort Pierce, Florida for the use and benefit of the Fort Pierce Utilities Authority	644/2919

PROVIDED that the Utility has the following rights:

1. The Utility shall have the right to construct, operate, maintain, improve, add to, upgrade, remove, and relocate facilities on, within, and upon the lands described herein in accordance with the FDOT's current minimum standards for such facilities as required by the FDOT, Utility Accommodation Manual in effect at the time the agreement is executed. Any new construction or relocation of facilities within the lands will be subject to prior approval by the FDOT. Should the FDOT fail to approve any new construction or relocation of facilities by the Utility or require the Utility to alter, adjust, or relocate its facilities located within said lands, the FDOT hereby agrees to pay the cost of such alteration, adjustment, or relocation, including, but not limited to the cost of acquiring appropriate easements.
2. Notwithstanding any provisions set forth herein, the terms of the utility permits shall supersede any contrary provisions, with the exception herein with reimbursement rights.
3. The Utility shall have a reasonable right to enter upon the lands described herein for the purposes outlined in Paragraph 1 above, including the right to trim such trees, brush, and growth which might endanger or interfere with such facilities, provided that such rights do not interfere with the operation and safety of the FDOT's facilities.
4. The Utility agrees to repair any damage to FDOT facilities and be responsible to the FDOT against any loss or damage resulting from the Utility exercising its rights outlined in Paragraphs 1 and 3 above; however the Utility does not waive its sovereign immunity.

IN WITNESS WHEREOF, the FDOT hereto has executed this agreement on the day and year first above written.

Signed, sealed and delivered
in the presence of witnesses:

STATE OF FLORIDA DEPARTMENT
OF TRANSPORTATION

Print Name: _____

By: _____
Print Name: GERRY O'REILLY
Title: District Secretary
for District IV

Print Name: _____

Attorney approved as to form:

Name: DAWN RADUANO

STATE OF FLORIDA

COUNTY OF BROWARD

The foregoing instrument was acknowledged before me this _____
day of _____, 201____, by GERRY O'REILLY, District
Secretary for District IV, who is personally known to me or who has
produced _____ as identification.

Print Name: _____
Notary Public in and for the
County and State last aforesaid.
My Commission Expires: _____
Serial No., if any: _____

IN WITNESS WHEREOF, the Utility has caused these presents to be executed in its name, and its Corporate Seal to be hereunto affixed, by its proper officers thereunto duly authorized, the day and year first above written.

ATTEST: *D.M. Delulio*
Daniel M. Delulio
Secretary

CITY OF FORT PIERCE, a municipal corporation, for the use and benefit of FORT PIERCE UTILITIES AUTHORITY
By: *Michael A. Perri, Jr.*
Michael A. Perri, Jr., Chairman

Approved as to Form and Correctness:

By: *ANN*
Fort Pierce Utilities Authority
Attorney

STATE OF FLORIDA
COUNTY OF ST. LUCIE

The foregoing instrument was acknowledged before me this 15 day of December, 2015, by Michael A. Perri, Jr., Chairman of Fort Pierce Utilities Authority, who is personally known to me.

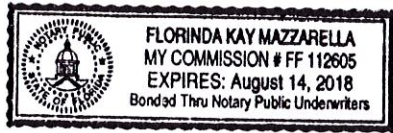

Florinda Kay Mazzarella
Florinda Kay Mazzarella
Notary Public in and for the
County and State last aforesaid

Linda Hudson, Mayor-Commissioner

ATTEST:

Linda W. Cox, City Clerk
(City Seal)

Approved as to Form and Correctness:

Robert V. Schwerer, City Attorney

23-UTL.01-06/93

This instrument prepared under the direction of:	Parcel No.	153.2R
Dawn Raduano, Esq. _____	Item/Segment No.	2314402
Legal Description prepared by:	Section:	94530-2510
Jeff Smith, P.S.M. (09-05-13) _____	Managing District:	04
Document prepared by:	C.R. No.	712
Grace K. Abel (09-08-15) _____	County:	St. Lucie

Department of Transportation
Right of Way Production Services
3400 W. Commercial Boulevard
Ft. Lauderdale, Florida 33309

SUBORDINATION OF UTILITY INTERESTS

THIS AGREEMENT, entered into this _____ day of _____, 201____, by and between the STATE OF FLORIDA DEPARTMENT OF TRANSPORTATION, hereinafter called "FDOT", and CITY OF FORT PIERCE, FLORIDA for the use and benefit of FORT PIERCE UTILITIES AUTHORITY, hereinafter called "Utility".

W I T N E S S E T H:

WHEREAS, the Utility presently has an interest in certain lands that have been determined necessary for highway purposes; and

WHEREAS, the proposed use of these lands for highway purposes will require subordination of the interest claimed in such lands by Utility to the FDOT; and

WHEREAS, the FDOT is willing to pay to have the Utility's facilities relocated if necessary to prevent conflict between the facilities so that the benefits of each may be retained.

NOW, THEREFORE, in consideration of the mutual covenants and promises of the parties hereto, Utility and FDOT agree as follows:

Utility hereby subordinates to the interest of FDOT, its successors, or assigns, any and all of its interest in the lands as follows, viz:

Parcel No. 153

Item/Segment No. 2314402
Section: 94530-2510

A portion of Section 3, Township 36 South, Range 40 East, St. Lucie County, Florida, being more particularly described as follows:

(Continue on the next page)

Commence at a found pk nail with disk stamped "R.W. HERR PLS 4907" marking the west one-quarter (W. 1/4) corner of said Section 3; thence North 00°11'02" West, 48.16 feet along the west line of the northwest one-quarter (N.W. 1/4) of said Section 3 to the Baseline of Survey of County Road 712 (Midway Road) as shown on the Florida Department of Transportation Right of Way Map for Item/Segment No. 2314402, Section 94530-2510; thence South 89°42'45" East, 1,308.27 feet along said Baseline of Survey; thence North 00°17'15" East, 40.00 feet along a line at a right angle to the last described course to the north existing right of way line of said County Road 712 (Midway Road) and the POINT OF BEGINNING; thence North 00°17'15" East, 15.05 feet; thence North 89°00'38" East, 25.24 feet; thence South 89°40'58" East, 219.89 feet; thence South 00°17'15" West, 15.50 feet to said north existing right of way line of County Road 712 (Midway Road); thence North 89°42'45" West, 245.13 feet along said north existing right of way line to the POINT OF BEGINNING.

Containing 3,807 square feet, more or less.

RECORDED

INSTRUMENT	DATE	FROM	TO	O.R.B. & PAGE
Easement	08/29/84	Josephine Bass	City of Fort Pierce, Florida for the use and benefit of the Fort Pierce Utilities Authority	448/1204

PROVIDED that the Utility has the following rights:

1. The Utility shall have the right to construct, operate, maintain, improve, add to, upgrade, remove, and relocate facilities on, within, and upon the lands described herein in accordance with the FDOT's current minimum standards for such facilities as required by the FDOT, Utility Accommodation Manual in effect at the time the agreement is executed. Any new construction or relocation of facilities within the lands will be subject to prior approval by the FDOT. Should the FDOT fail to approve any new construction or relocation of facilities by the Utility or require the Utility to alter, adjust, or relocate its facilities located within said lands, the FDOT hereby agrees to pay the cost of such alteration, adjustment, or relocation, including, but not limited to the cost of acquiring appropriate easements.
2. Notwithstanding any provisions set forth herein, the terms of the utility permits shall supersede any contrary provisions, with the exception herein with reimbursement rights.

3. The Utility shall have a reasonable right to enter upon the lands described herein for the purposes outlined in Paragraph 1 above, including the right to trim such trees, brush, and growth which might endanger or interfere with such facilities, provided that such rights do not interfere with the operation and safety of the FDOT's facilities.
4. The Utility agrees to repair any damage to FDOT facilities and be responsible to the FDOT against any loss or damage resulting from the Utility exercising its rights outlined in Paragraphs 1 and 3 above; however the Utility does not waive its sovereign immunity.

IN WITNESS WHEREOF, the FDOT hereto has executed this agreement on the day and year first above written.

Signed, sealed and delivered
in the presence of witnesses:

STATE OF FLORIDA DEPARTMENT
OF TRANSPORTATION

Print Name: _____

By: _____
Print Name: GERRY O'REILLY
Title: District Secretary
for District IV

Print Name: _____

Attorney approved as to form:

Name: DAWN RADUANO

STATE OF FLORIDA

COUNTY OF BROWARD

The foregoing instrument was acknowledged before me this _____ day of _____, 201____, by GERRY O'REILLY, District Secretary for District IV, who is personally known to me or who has produced _____ as identification.

Print Name: _____
Notary Public in and for the
County and State last aforesaid.
My Commission Expires: _____
Serial No., if any: _____

IN WITNESS WHEREOF, the Utility has caused these presents to be executed in its name, and its Corporate Seal to be hereunto affixed, by its proper officers thereunto duly authorized, the day and year first above written.

ATTEST: D.M. DeL.
Daniel M. DeIulio
Secretary

CITY OF FORT PIERCE, a municipal corporation, for the use and benefit of FORT PIERCE UTILITIES AUTHORITY

By: Michael A. Perri, Jr.
Michael A. Perri, Jr., Chairman

Approved as to Form and Correctness:

By: R. N. Kelt
Fort Pierce Utilities Authority
Attorney

STATE OF FLORIDA
COUNTY OF ST. LUCIE

The foregoing instrument was acknowledged before me this 15 day of December, 2015, by Michael A. Perri, Jr., Chairman of Fort Pierce Utilities Authority, who is personally known to me.



Florinda Kay Mazzarella
Florinda Kay Mazzarella
Notary Public in and for the
County and State last aforesaid

Linda Hudson; Mayor-Commissioner

ATTEST:

Linda W. Cox, City Clerk
(City Seal)

Approved as to Form and Correctness:

Robert V. Schwerer, City Attorney

23-UTL.01-06/93-Modified by D4/DR

This instrument prepared
under the direction of:
Dawn Raduano, Esq. _____
Legal Description prepared by:
Jeff Smith, P.S.M. (09-05-13)
Document prepared by:
Grace K. Abel (09-08-15)
Department of Transportation
Right of Way Production Services
3400 W. Commercial Boulevard
Ft. Lauderdale, Florida 33309

Parcel No. 154.2R
Item/Segment No. 2314402
Section: 94530-2510
Managing District: 04
C.R. No. 712
County: St. Lucie

SUBORDINATION OF UTILITY INTERESTS

THIS AGREEMENT, entered into this _____ day of _____,
201____, by and between the STATE OF FLORIDA DEPARTMENT OF
TRANSPORTATION, hereinafter called "FDOT", and CITY OF FORT PIERCE,
FLORIDA for the use and benefit of FORT PIERCE UTILITIES AUTHORITY,
hereinafter called "Utility".

W I T N E S S E T H:

WHEREAS, the Utility presently has an interest in certain lands
that have been determined necessary for highway purposes; and

WHEREAS, the proposed use of these lands for highway purposes
will require subordination of the interest claimed in such lands by
Utility to the FDOT; and

WHEREAS, the FDOT is willing to pay to have the Utility's
facilities relocated if necessary to prevent conflict between the
facilities so that the benefits of each may be retained.

NOW, THEREFORE, in consideration of the mutual covenants and
promises of the parties hereto, Utility and FDOT agree as follows:

Utility hereby subordinates to the interest of FDOT, its
successors, or assigns, any and all of its interest in the lands as
follows, viz:

Parcel No. 154

Item/Segment No. 2314402
Section: 94530-2510

A portion of Section 3, Township 36 South, Range 40 East, St. Lucie
County, Florida, being more particularly described as follows:

(Continue on the next page)

Commence at a found pk nail with disk stamped "R.W. HERR PLS 4907" marking the west one-quarter (W. 1/4) corner of said Section 3; thence North 00°11'02" West, 48.16 feet along the west line of the northwest one-quarter (N.W. 1/4) of said Section 3 to a point on the Baseline of Survey of County Road 712 (Midway Road) as shown on the Florida Department of Transportation Right of Way Map for Item/Segment No. 2314402, Section 94530-2510; thence South 89°42'45" East, 1,553.39 feet along said Baseline of Survey; thence North 00°17'15" East, 40.00 feet along a line at a right angle to the last described course to the north existing right of way line of said County Road 712 (Midway Road) and the POINT OF BEGINNING; thence North 00°17'15" East, 15.50 feet; thence South 89°40'58" East, 85.00 feet; thence South 00°17'15" West, 15.45 feet to said north existing right of way line of County Road 712 (Midway Road); thence North 89°42'45" West, 85.00 feet along said north existing right of way line to the POINT OF BEGINNING.

Containing 1,315 square feet, more or less.

RECORDED

INSTRUMENT	DATE	FROM	TO	O.R.B. & PAGE
Easement	11/02/84	Ellis Reed Turley and E. Irene Farmer, Guardian of Rosetta Gilmore	City of Fort Pierce, Florida for the use and benefit of the Fort Pierce Utilities Authority	448/1199

PROVIDED that the Utility has the following rights:

1. The Utility shall have the right to construct, operate, maintain, improve, add to, upgrade, remove, and relocate facilities on, within, and upon the lands described herein in accordance with the FDOT's current minimum standards for such facilities as required by the FDOT, Utility Accommodation Manual in effect at the time the agreement is executed. Any new construction or relocation of facilities within the lands will be subject to prior approval by the FDOT. Should the FDOT fail to approve any new construction or relocation of facilities by the Utility or require the Utility to alter, adjust, or relocate its facilities located within said lands, the FDOT hereby agrees to pay the cost of such alteration, adjustment, or relocation, including, but not limited to the cost of acquiring appropriate easements.
2. Notwithstanding any provisions set forth herein, the terms of the utility permits shall supersede any contrary provisions, with the exception herein with reimbursement rights.

3. The Utility shall have a reasonable right to enter upon the lands described herein for the purposes outlined in Paragraph 1 above, including the right to trim such trees, brush, and growth which might endanger or interfere with such facilities, provided that such rights do not interfere with the operation and safety of the FDOT's facilities.
4. The Utility agrees to repair any damage to FDOT facilities and be responsible to the FDOT against any loss or damage resulting from the Utility exercising its rights outlined in Paragraphs 1 and 3 above; however the Utility does not waive its sovereign immunity.

IN WITNESS WHEREOF, the FDOT hereto has executed this agreement on the day and year first above written.

Signed, sealed and delivered
in the presence of witnesses:

STATE OF FLORIDA DEPARTMENT
OF TRANSPORTATION

Print Name: _____

By: _____
Print Name: GERRY O'REILLY
Title: District Secretary
for District IV

Print Name: _____

Attorney approved as to form:

Name: DAWN RADUANO

STATE OF FLORIDA

COUNTY OF BROWARD

The foregoing instrument was acknowledged before me this _____ day of _____, 201____, by GERRY O'REILLY, District Secretary for District IV, who is personally known to me or who has produced _____ as identification.

Print Name: _____
Notary Public in and for the
County and State last aforesaid.
My Commission Expires: _____
Serial No., if any: _____

IN WITNESS WHEREOF, the Utility has caused these presents to be executed in its name, and its Corporate Seal to be hereunto affixed, by its proper officers thereunto duly authorized, the day and year first above written.

ATTEST: *Daniel M. DeJulio*
Daniel M. DeJulio
Secretary

CITY OF FORT PIERCE, a municipal corporation, for the use and benefit of FORT PIERCE UTILITIES AUTHORITY

By: *Michael A. Perri, Jr.*
Michael A. Perri, Jr., Chairman

Approved as to Form and Correctness:

By: *Anna A.*
Fort Pierce Utilities Authority
Attorney

STATE OF FLORIDA
COUNTY OF ST. LUCIE

The foregoing instrument was acknowledged before me this 15 day of December, 2015, by Michael A. Perri, Jr., Chairman of Fort Pierce Utilities Authority, who is personally known to me.

Florinda Kay Mazzarella
Florinda Kay Mazzarella
Notary Public in and for the
County and State last aforesaid

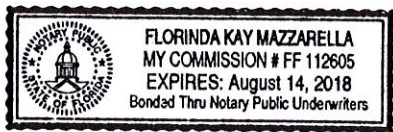

Linda Hudson, Mayor-Commissioner

ATTEST:

Linda W. Cox, City Clerk
(City Seal)

Approved as to Form and Correctness:

Robert V. Schwerer, City Attorney

23-UTL.01-06/93-Modified by D4/DR

This instrument prepared	Parcel No.	822.2R
under the direction of:	Item/Segment No.	2314402
Dawn Raduano, Esq.	Section:	94530-2510
Legal Description prepared by:	Managing District:	04
<u>Louis Cefolia, P.S.M. (08-19-14)</u>	C.R. No.	712
Document prepared by:	County:	St. Lucie
<u>Grace K. Abel (09-08-15)</u>		
Department of Transportation		
Right of Way Production Services		
3400 W. Commercial Boulevard		
Ft. Lauderdale, Florida 33309		

SUBORDINATION OF UTILITY INTERESTS

THIS AGREEMENT, entered into this _____ day of _____, 201____, by and between the STATE OF FLORIDA DEPARTMENT OF TRANSPORTATION, hereinafter called "FDOT", and CITY OF FORT PIERCE, FLORIDA for the use and benefit of FORT PIERCE UTILITIES AUTHORITY, hereinafter called "Utility".

W I T N E S S E T H:

WHEREAS, the Utility presently has an interest in certain lands that have been determined necessary for highway purposes; and

WHEREAS, the proposed use of these lands for highway purposes will require subordination of the interest claimed in such lands by Utility to the FDOT; and

WHEREAS, the FDOT is willing to pay to have the Utility's facilities relocated if necessary to prevent conflict between the facilities so that the benefits of each may be retained.

NOW, THEREFORE, in consideration of the mutual covenants and promises of the parties hereto, Utility and FDOT agree as follows:

Utility hereby subordinates to the interest of FDOT, its successors, or assigns, any and all of its interest in the lands as follows, viz:

Parcel No. 822

Item/Segment No. 2314402
Section: 94530-2510

A portion of Section 3, Township 36 South, Range 40 East, St. Lucie County, Florida, being more particularly described as follows:

(Continue on the next page)

Commence at a pk nail with disk stamped "R.W. HERR PLS 4907", found marking the West One-Quarter (W. 1/4) Corner of said Section 3; thence North 00°11'02" West along the West line of the Northwest One-Quarter (N.W. 1/4) of said Section 3, a distance of 88.16 feet to the Northerly Existing Right of Way line of County Road 712 (Midway Road) and the Easterly Existing Right of Way line of County Road 605 (Oleander Avenue) as shown on the Florida Department of Transportation Right of Way Map for Item/Segment No. 2314402, Section 94530-2510; thence South 89°42'45" East along said Northerly Existing Right of Way line, a distance of 441.26 feet; thence North 00°13'20" West, a distance of 9.75 feet to the POINT OF BEGINNING; thence continuing North 00°13'20" West, a distance of 5.00 feet; thence North 89°42'45" West, a distance of 439.26 feet; thence South 43°54'49" East, a distance of 6.97 feet; thence South 89°42'45" East, a distance of 434.44 feet to the POINT OF BEGINNING.

Containing 2,184 square feet, more or less.

RECORDED

INSTRUMENT	DATE	FROM	TO	O.R.B. & PAGE
Easement	09/27/84	White City United Methodist Church, Inc.	City of Fort Pierce, Florida for the use and benefit of the Fort Pierce Utilities Authority	448/1201
Easement	03/29/88	White City United Methodist Church, Inc.	City of Fort Pierce, Florida for the use and benefit of the Fort Pierce Utilities Authority	600/1582
Easement	09/27/84	White City United Methodist Church, Inc.	City of Fort Pierce, Florida for the use and benefit of the Fort Pierce Utilities Authority	635/235

PROVIDED that the Utility has the following rights:

1. The Utility shall have the right to construct, operate, maintain, improve, add to, upgrade, remove, and relocate facilities on, within, and upon the lands described herein in accordance with the FDOT's current minimum standards for such facilities as required by the FDOT, Utility Accommodation Manual in effect at the time the agreement is executed. Any new construction or

relocation of facilities within the lands will be subject to prior approval by the FDOT. Should the FDOT fail to approve any new construction or relocation of facilities by the Utility or require the Utility to alter, adjust, or relocate its facilities located within said lands, the FDOT hereby agrees to pay the cost of such alteration, adjustment, or relocation, including, but not limited to the cost of acquiring appropriate easements.

2. Notwithstanding any provisions set forth herein, the terms of the utility permits shall supersede any contrary provisions, with the exception herein with reimbursement rights.
3. The Utility shall have a reasonable right to enter upon the lands described herein for the purposes outlined in Paragraph 1 above, including the right to trim such trees, brush, and growth which might endanger or interfere with such facilities, provided that such rights do not interfere with the operation and safety of the FDOT's facilities.
4. The Utility agrees to repair any damage to FDOT facilities and be responsible to the FDOT against any loss or damage resulting from the Utility exercising its rights outlined in Paragraphs 1 and 3 above; however the Utility does not waive its sovereign immunity.

IN WITNESS WHEREOF, the FDOT hereto has executed this agreement on the day and year first above written.

Signed, sealed and delivered
in the presence of witnesses:

STATE OF FLORIDA DEPARTMENT
OF TRANSPORTATION

Print Name: _____

By: _____
Print Name: GERRY O'REILLY
Title: District Secretary
for District IV

Print Name: _____

Attorney approved as to form:

Name: DAWN RADUANO

STATE OF FLORIDA

COUNTY OF BROWARD

The foregoing instrument was acknowledged before me this _____
day of _____, 201____, by GERRY O'REILLY, District
Secretary for District IV, who is personally known to me or who has
produced _____ as identification.

Print Name: _____
Notary Public in and for the
County and State last aforesaid.
My Commission Expires: _____
Serial No., if any: _____

IN WITNESS WHEREOF, the Utility has caused these presents to be executed in its name, and its Corporate Seal to be hereunto affixed, by its proper officers thereunto duly authorized, the day and year first above written.

ATTEST: D. M. DeLi.
Daniel M. DeIulio
Secretary

CITY OF FORT PIERCE, a municipal corporation, for the use and benefit of FORT PIERCE UTILITIES AUTHORITY

By: Michael A. Perri, Jr.
Michael A. Perri, Jr., Chairman

Approved as to Form and Correctness:

By: [Signature]
Fort Pierce Utilities Authority
Attorney

STATE OF FLORIDA
COUNTY OF ST. LUCIE

The foregoing instrument was acknowledged before me this 15 day of December, 2015, by Michael A. Perri, Jr., Chairman of Fort Pierce Utilities Authority, who is personally known to me.



Florinda Kay Mazzarella
Florinda Kay Mazzarella
Notary Public in and for the
County and State last aforesaid

Linda Hudson, Mayor-Commissioner

ATTEST:

Linda W. Cox, City Clerk
(City Seal)

Approved as to Form and Correctness:

Robert V. Schwerer, City Attorney

23-UTL.01-06/93-Modified by D4/DR

This instrument prepared
under the direction of:
Dawn Raduano, Esq. _____
Legal Description prepared by:
Louis Cefolia, P.S.M. (08-19-14)
Document prepared by:
Grace K. Abel (09-08-15)
Department of Transportation
Right of Way Production Services
3400 W. Commercial Boulevard
Ft. Lauderdale, Florida 33309

Parcel No. 824.2R
Item/Segment No. 2314402
Section: 94530-2510
Managing District: 04
C.R. No. 712
County: St. Lucie

SUBORDINATION OF UTILITY INTERESTS

THIS AGREEMENT, entered into this _____ day of _____,
201____, by and between the STATE OF FLORIDA DEPARTMENT OF
TRANSPORTATION, hereinafter called "FDOT", and CITY OF FORT PIERCE,
FLORIDA for the use and benefit of FORT PIERCE UTILITIES AUTHORITY,
hereinafter called "Utility".

W I T N E S S E T H:

WHEREAS, the Utility presently has an interest in certain lands
that have been determined necessary for highway purposes; and

WHEREAS, the proposed use of these lands for highway purposes
will require subordination of the interest claimed in such lands by
Utility to the FDOT; and

WHEREAS, the FDOT is willing to pay to have the Utility's
facilities relocated if necessary to prevent conflict between the
facilities so that the benefits of each may be retained.

NOW, THEREFORE, in consideration of the mutual covenants and
promises of the parties hereto, Utility and FDOT agree as follows:

Utility hereby subordinates to the interest of FDOT, its
successors, or assigns, any and all of its interest in the lands as
follows, viz:

Parcel No. 824

Item/Segment No. 2314402
Section: 94530-2510

A portion of Lot 23, WHITE CITY SUBDIVISION OF SECTIONS 3, 4, 5, 8, 9,
AND 10, TOWNSHIP 36 S, RANGE 40 E, according to the plat thereof, as

(Continue on the next page)

1. The Utility shall have the right to construct, operate, maintain, improve, add to, upgrade, remove, and relocate facilities on, within, and upon the lands described herein in accordance with the FDOT's current minimum standards for such facilities as required by the FDOT, Utility Accommodation Manual in effect at the time the agreement is executed. Any new construction or relocation of facilities within the lands will be subject to prior approval by the FDOT. Should the FDOT fail to approve any new construction or relocation of facilities by the Utility or require the Utility to alter, adjust, or relocate its facilities located within said lands, the FDOT hereby agrees to pay the cost of such alteration, adjustment, or relocation, including, but not limited to the cost of acquiring appropriate easements.
2. Notwithstanding any provisions set forth herein, the terms of the utility permits shall supersede any contrary provisions, with the exception herein with reimbursement rights.
3. The Utility shall have a reasonable right to enter upon the lands described herein for the purposes outlined in Paragraph 1 above, including the right to trim such trees, brush, and growth which might endanger or interfere with such facilities, provided that such rights do not interfere with the operation and safety of the FDOT's facilities.
4. The Utility agrees to repair any damage to FDOT facilities and be responsible to the FDOT against any loss or damage resulting from the Utility exercising its rights outlined in Paragraphs 1 and 3 above; however the Utility does not waive its sovereign immunity.

IN WITNESS WHEREOF, the FDOT hereto has executed this agreement on the day and year first above written.

Signed, sealed and delivered
in the presence of witnesses:

STATE OF FLORIDA DEPARTMENT
OF TRANSPORTATION

Print Name: _____

By: _____
Print Name: GERRY O'REILLY
Title: District Secretary
for District IV

Print Name: _____

Attorney approved as to form:

Name: DAWN RADUANO

STATE OF FLORIDA

COUNTY OF BROWARD

The foregoing instrument was acknowledged before me this _____
day of _____, 201____, by GERRY O'REILLY, District
Secretary for District IV, who is personally known to me or who has
produced _____ as identification.

Print Name: _____
Notary Public in and for the
County and State last aforesaid.
My Commission Expires: _____
Serial No., if any: _____

IN WITNESS WHEREOF, the Utility has caused these presents to be executed in its name, and its Corporate Seal to be hereunto affixed, by its proper officers thereunto duly authorized, the day and year first above written.

ATTEST: Daniel M. DeIulio
Daniel M. DeIulio
Secretary

CITY OF FORT PIERCE, a municipal corporation, for the use and benefit of FORT PIERCE UTILITIES AUTHORITY

By: Michael A. Perri, Jr.
Michael A. Perri, Jr., Chairman

Approved as to Form and Correctness:

By: an [signature]
Fort Pierce Utilities Authority
Attorney

STATE OF FLORIDA
COUNTY OF ST. LUCIE

The foregoing instrument was acknowledged before me this 15 day of December, 2015, by Michael A. Perri, Jr., Chairman of Fort Pierce Utilities Authority, who is personally known to me.



Florinda Kay Mazzarella
Florinda Kay Mazzarella
Notary Public in and for the
County and State last aforesaid

Linda Hudson, Mayor-Commissioner

ATTEST:

Linda W. Cox, City Clerk
(City Seal)

Approved as to Form and Correctness:

Robert V. Schwerer, City Attorney

City Commission Regular Meeting

Agenda Item # 9. c.

Meeting Date: 12/21/2015

Re: Banking Services

Submitted For: Johnna Morris, Finance Director, Finance Department

SUBJECT:

Approve staff recommendation to award Request for Proposal #2016-003 - Banking Services to Harbor Community Bank.

SUMMARY:

The City's Finance Department solicited proposals for banking services from several financial institutions; there were three responses. Of the three responses Harbor Community proposed to offer the services at the best overall cost to the City.

RECOMMENDATION:

Award the banking services proposal to Harbor Community Bank.

ALTERNATIVES:

Contract with another bank who can provide the service needs of the City at additional cost.

RESPONSIBLE STAFF:

Director of Finance

COORDINATED WITH:

Accountant, Banking/Accounts Receivable Clerk, Golf Course Manager and Marina Accounting Clerk.

Fiscal Impact

Budgeted Y/N: N

Fiscal Year: 2016

Account:

Amount:

OTHER INFORMATION:

None

Attachments

Memo re: Banking Services

Scoring Sheet

Evaluation Sheet

Form Review

Inbox

Reviewed By

Date

City Manager Jennifer Robinson

Purchasing Tony Barnes

City Manager Nick Mimms

Form Started By: Johnna Morris

Final Approval Date: 12/16/2015

12/14/2015 10:04 AM

12/14/2015 10:45 AM

12/16/2015 04:30 PM

Started On: 12/11/2015 09:30 AM



Interoffice Memorandum REVISED

From The Office Of The

Director of Finance

TIME _____
DEC 11 2015
CITY OF FORT PIERCE
CITY MANAGER'S OFFICE

TO: Mayor & Commissioners
FROM: Johnna Morris, Director of Finance
THRU: Nick Mimms, City Manager
RE: **Banking Services**
DATE: December 11, 2015

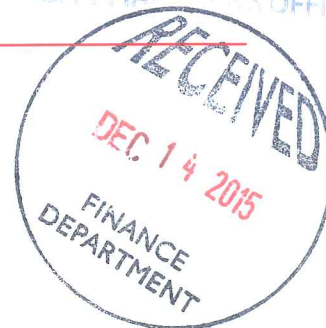

The City, through Request for Proposal #2016-003, solicited proposals for banking services from qualified financial institutions. Three proposals were received and evaluated by the City's Accountant, Banking/Accounts Receivable Clerk, Golf Course Manager, Marina Accounting Clerk and myself. As a result of our evaluation, we are recommending the banking services contract be awarded to Harbor Community Bank.

Harbor Community Bank has offered to provide the services we requested in the proposal at no cost (\$0) or required compensating balance, the best of all submitted proposals. The interest rate will be the federal funds target rate. They have experience servicing local governments and are heavily involved in community services.

The contract period shall begin February 1, 2016 and terminate February 28, 2019, with an option to renew the contract for two (2) additional one-year periods by mutual agreement of both parties.

We believe the strength of their proposal demonstrates their determination and willingness to provide cost effective service for the City.

RFP #2016-003 Banking Services Evaluation Sheet

	Harbour Community Bank	Seacoast National Bank	TD Bank
Ability to provide the type & quality of services requested Total Possible 50pts	47	50	33
Investment Earnings Rate Total Possible 100pts	86	100	55
Required Compensating Balance Total Possible 50pts	50	37	37
Cost of Banking Services Total Possible 50pts	50	36	29
Transaction Closing Time Total Possible 25pts	25	20	20
New Financial Services available in excess of requirements Total Possible 25pts	19	19	19
Prior experience servicing local governments Total Possible 50pts	49	47	45
Community Involvement Total Possible 25pts	25	25	25
Locality Total Possible 100pts	100	100	75
Total Possible 500 Points	451	434	338

Services	Seacoast National Bank			Harbor Community Bank			TD Bank			
	Volume	Unit Price	Total Monthly Price	Volume	Unit Price	Total Monthly Price	Volume	Unit Price	Total Monthly Price	
DEMAND DEPOSIT RELATED SERVICES										
Account Maintenance	9	\$ 7.50	\$ 67.50	9	\$ -	\$ -	9	\$ 10.00	\$ 90.00	
Regular Deposit Ticket	62	\$ 0.175	\$ 10.85	62	\$ -	\$ -	62	\$ 0.90	\$ 55.80	
Paid Items		\$ -	\$ -		\$ -	\$ -		\$ 0.10	\$ -	
FICO Insurance Charge	\$ -	151	\$ 0.11	\$ 16.61	151	\$ -	\$ -	151	\$ -	\$ -
Account Analysis Statements Mailed		\$ -	\$ -		\$ -	\$ -		\$ 4.00	\$ -	
Deposit Items -On US (N)	48	\$ 0.055	\$ 2.64	48	\$ -	\$ -	48	\$ 0.08	\$ 3.84	
Deposit Items -Local City(N)	6	\$ 0.055	\$ 0.33	6	\$ -	\$ -	6	\$ 0.08	\$ 0.48	
Deposit Items -Local RCPC(N)	101	\$ 0.055	\$ 5.56	101	\$ -	\$ -	101	\$ 0.08	\$ 8.08	
Deposit Items -Other Fed City(N)	38	\$ 0.055	\$ 2.09	38	\$ -	\$ -	38	\$ 0.08	\$ 3.04	
Deposit Items -Other Fed RCPC(N)	68	\$ 0.055	\$ 3.74	68	\$ -	\$ -	68	\$ 0.08	\$ 5.44	
Deposit Items -Other Fed Premium(N)		\$ 0.055	\$ -		\$ -	\$ -		\$ 0.08	\$ -	
Deposit Items -Other Fed Select (N)	716	\$ 0.055	\$ 39.38	716	\$ -	\$ -	716	\$ 0.08	\$ 57.28	
Print Image Statement Maintenance	6	\$ -	\$ -	6	\$ -	\$ -	6	\$ -	\$ -	
Returns	1	\$ 4.00	\$ 4.00	1	\$ -	\$ -	1	\$ 12.00	\$ 12.00	
Cash Verification Fee (\$10.00 Units)		\$ -	\$ -		\$ -	\$ -		\$ -	\$ -	
Working Cash Investment Service		\$ -	\$ -		\$ -	\$ -		\$ -	\$ -	
REMOTE DEPOSIT RELATED SERVICES										
Image Deposit Items	\$ 0.055	487	\$ -	\$ -	487	\$ -	\$ -	487	\$ 0.08	\$ 38.96
NCC CRC Maintenance	\$ 50.00	1	\$ 15.000	\$ 15.00	1	\$ -	\$ -	1	\$ 110.00	\$ 110.00
NCC CRC Captured Item		487	\$ -	\$ -	487	\$ -	\$ -	487	\$ 0.04	\$ 19.48
MONEY ROOM SERVICES										
Cash Vault Faxed Receipts		3	\$ -	\$ -	3	\$ -	\$ -	3	\$ -	\$ -
ACCOUNT RECONCILEMENT SERVICES										
Partial Recon Monthly Maintenance	\$ 25.00	N/A	\$ 8.33	\$ -	3	\$ -	\$ -	N/A	\$ 40.00	
Account Reconciliation Raid Recon			\$ -	\$ -			\$ -	\$ -	\$ -	
Output Transmission/Item	\$ 0.075	714	\$ -	\$ -	714	\$ -	\$ -		\$ -	
Image Maintenance		14	\$ -	\$ -	14	\$ -	\$ -	14	\$ -	
Image Output CD	\$ 10.00	3	\$ 3.33	\$ 9.99	3	\$ -	\$ -			
<i>CD-ROM Per Additional Account</i>										
Web Disbursement Stop Payments & Cancels	\$ 16.00	5	\$ -	\$ -	5	\$ -	\$ -	5	\$ 10.00	\$ 50.00
Web Disbursement Check Inquiry		20	\$ -	\$ -	20	\$ -	\$ -	20	\$ -	\$ -
Web Image Viewed		20	\$ -	\$ -	20	\$ -	\$ -	9	\$ -	\$ -
<i>*ARP File Transmission (Capped at \$175)</i>								4	\$ 17.50	\$ 70.00
<i>*ARP Items Paid</i>								714	\$ 0.09	\$ 64.26
<i>**CD-ROM Maintenance</i>								3	\$ 30.00	\$ 90.00
<i>**CD-rom Per Additional Account</i>								11	\$ 5.00	\$ 55.00
<i>*CD ROM Image Per Item</i>								714	\$ 0.03	\$ 21.42

Services	Seacoast National Bank			Harbor Community Bank			TD Bank			
	Volume	Unit Price	Total Monthly Price	Volume	Unit Price	Total Monthly Price	Volume	Unit Price	Total Monthly Price	
AUTOMATED CLEARING HOUSE										
Debits Received	76	\$ 0.10	\$ 7.60	76	\$ -	\$ -	76	\$ 0.15	\$ 11.40	
Credits Received	310	\$ 0.10	\$ 31.00	310	\$ -	\$ -	310	\$ 0.15	\$ 46.50	
NCC ACH Origination-Return Items	\$ 3.00	1	\$ 4.00	\$ 4.00	1	\$ -	\$ -	1	\$ 5.50	\$ 5.50
NCC ACH Origination-Notification of Change	\$ 1.50	6	\$ -	\$ -	6	\$ -	\$ -	6	\$ 4.00	\$ 24.00
NOC via Electronic Delivery	\$ 15.00		\$ -	\$ -		\$ -	\$ -		\$ -	\$ -
ACH Origination-Web-Accounts Transfers	\$ 0.10	60	\$ 0.11	\$ 6.60	60	\$ -	\$ -	60	\$ 0.50	\$ 30.00
ACH Origination-Web-Credits/Debit Items	\$ 0.10	1085	\$ 0.11	\$ 119.35	1085	\$ -	\$ -	1085	\$ 0.06	\$ 65.10
NCC ACH Orig-Web Maintenance	\$ 20.00	1	\$ 5.00	\$ 5.00		\$ -	\$ -	1	\$ -	\$ -
WIRE TRANSFER SERVICES										
Electronic Advice		10	\$ -	\$ -	10	\$ -	\$ -	10	\$ 1.00	\$ 10.00
Incoming Wire Transfer		5	\$ 7.50	\$ 37.50	5	\$ -	\$ -	5	\$ 4.50	\$ 22.50
incoming Book Transfer		5	\$ -	\$ -	5	\$ -	\$ -	5	\$ 4.50	\$ 22.50
Voice Domestic Non-Repetitive	\$ 12.50		\$ 11.00	\$ -		\$ -	\$ -		\$ 37.35	\$ -
Web Outgoing Domestic		7	\$ 11.00	\$ 77.00	7	\$ -	\$ -	7	\$ 8.00	\$ 56.00
Information Services										
Previous Day Account		15	\$ -	\$ -	15	\$ -	\$ -	15	\$ -	\$ -
Incoming DX Account-High Speed		2	\$ -	\$ -	2	\$ -	\$ -	2	\$ -	\$ -
Previous Day Detail Balance-6 months storage		1649	\$ -	\$ -	1649	\$ -	\$ -	*164	\$ -	\$ -
Current Day Detail Balance		1287	\$ -	\$ -	1287	\$ -	\$ -	*128	\$ -	\$ -
Info Reporting Monthly	\$ 50.00	1	\$ 15.00	\$ 15.00	1	\$ -	\$ -	1	\$ 90.00	\$ 90.00
Previous Day Transaction-6 Months		1672	\$ -	\$ -	1672	\$ -	\$ -	*167	\$ -	\$ -
Current Day Transaction		1290	\$ -	\$ -	1290	\$ -	\$ -	*129	\$ -	\$ -
ACH Special Report		26	\$ -	\$ -	26	\$ -	\$ -	26	\$ -	\$ -
Previous Day Reporting Image			\$ -	\$ -		\$ -	\$ -		\$ -	\$ -
Event Notification-Per Event			\$ -	\$ -		\$ -	\$ -		\$ -	\$ -
Disbursements Monthly Maintenance		1	\$ -	\$ -	1	\$ -	\$ -	1	\$ -	\$ -
Funds Transfer Monthly Maintenance	\$ 5.00	1	\$ -	\$ -	1	\$ -	\$ -	1	\$ -	\$ -
Account Transfer Monthly Maintenance				\$ -	1	\$ -	\$ -		\$ -	\$ -
TD eTreasury records > 250								993	\$ 0.11	\$ 109.23
TD eTreasury Balance Reporting Accounts > 2								12	\$ 6.00	\$ 72.00
TD eTreasury Security Tokens								2	\$ 8.00	\$ 16.00
PINACLE Account Transfer			\$ -	\$ -		\$ -	\$ -		\$ -	\$ -
PINACLE Deposit-on-Site Monthly Maintenance			\$ -	\$ -		\$ -	\$ -		\$ -	\$ -
NCC ACH Origination-Web-Maintenance	\$ -	1	\$ 20.00	\$ 20.00		\$ -	\$ -	1	\$ -	\$ -
Estimated Monthly Fees			\$	500.74		\$	-		\$	1,335.81
Compensating Balance in Lieu of Fees		N/A	\$	6,793,586.25	N/A	\$	-		\$	2,840,589.00
Compensating Balance Changes		N/A	\$	-	N/A	\$	-	N/A		
Line of Credit		Interest Only Monthly w/principal due on demand. Floating, Bank Qualified Tax Exempt 1.4% w/Floor of 1.3%-based on Wall Street Journal Prime + variable determined by Bank, Maintain Primary Account for life of loan			Interest Only Monthly w/principal due on demand with term to coincide with that of the related depositor contract. WSP +.0% adjusting daily. Fees 0.25%; thereafter, 0.25% annually.			Financing options available. RFP is too broad for Bank to respond with specific credit proposal at this time.		

Services	Seacoast National Bank			Harbor Community Bank			TD Bank		
	Volume	Unit Price	Total Monthly Price	Volume	Unit Price	Total Monthly Price	Volume	Unit Price	Total Monthly Price
Banking Supplies	Minimal or NO Cost to City/Negotiable			Provided at NO Cost to City			Provided at Cost to City; maybe offset by applying to analysis statement		
Compatible with Klik2Gov	Yes			Yes			Yes		
Investment Earnings Credit Rate	Repo accounts will receive Federal Reserve's Federal Open Market Committee (FOMC), .60% at time of RFP, and other accounts will receive Earnings Credit of .30% Currently all account are Repo with the exception of 2 that do not earn credit. Based on a beginning balance of \$22,000,000 REPO interest earnings would be \$11,000			Federal Reserve's Federal Open Market Committee (FOMC) Current 52 week range is .25% -.25% unchanged. Based on a beginning balance of \$22,000,000 earning would be \$4,583.33			Average balance Less 3% for estimated float, 10% for required reserve, Earnings credit allowance .55% and fees for service is the Excess Investable Balance. Interest Calculation: Rate for Tier I < 1,000,0001 is.20% Tier II > \$1,000,000 Rate .30% Based on a beginning balance of \$22,000,000 ECR would be \$4,073.72		
Credit Card for CM, CPD and FD	Yes, Through First National Bank of Omaha			Yes, Through TIB Bank			Yes, TD Corporate Cards		
Community Involvement	Yes			Yes			Yes		
Account Analysis Statement by 5th of Month	No, available on the 10th			No, available on the 10th/Online			No, available by the 15th/Online - Paper can also be mailed at a small fee		
Liaison	Yes			Yes			Yes		
Deposit Deadline	4pm-Same day			Mon - Thursday 5pm-Same day, Friday 6pm-same day			4pm-Same Day		
Direct Deposit Disbursement	4pm-1 Day Prior			5pm-1 Day Prior			5pm-2 Days Prior		
Repurchase Agreement	Zero Balance Sweep Daily, Fixed Weekly Rate based on 13 week T-Bill rate, Less than \$1 million = T-Bill rate Greater than \$1 million, but Less than \$2.499 million = T-Bill rate + 20 basis pts. Greater than \$2.5 million =T-Bill rate + 30 basis pts.			HBC does not offer this product, however, Internal sweep are available between accounts			Is Not Offering Outside Repurchase Agreement, but does have an Internal sweep available		
Prior Experience Serrvicing Local Government	Yes			Yes			Yes		
Collateral	Yes			Yes-Through Government Advantage Interest Checking Account or a Public Fund Now Account			Yes		
Continuity of Service	Yes			Yes			Yes		
Overdraft/Protection	Yes-Notified Immediately, No Charge			Yes-Notified Immediately, No Charge			Yes- Charged \$35 per Item, Notified Immediately		
Return Item Processing	Yes			Yes			Yes		
Safe Keeping	Yes			No			Yes		
Statement Processing by 3rd of Month	Yes- CD ROM & File in TIFF Format			Yes-Online			Yes - CD Rom & Online		
Stop Payments	Yes			Yes			Yes		
ACH & Wire Transfers	Yes			Yes			Yes		
Advices Daily	Yes - Email			Yes - Fax or Electronic Transmission			Yes- Onile; Fax and Mail Service additional charge		

Services	Seacoast National Bank			Harbor Community Bank			TD Bank		
	Volume	Unit Price	Total Monthly Price	Volume	Unit Price	Total Monthly Price	Volume	Unit Price	Total Monthly Price
Credit Card Processing	First Data Platform, Compatible with Verifone Systems, IC Verify & Click to Gov thru PayFlow Pro Rates: Visa, MC & Disc - Inerchange Rate + .30% + .05, Monthly Fee Waived & PCI Compliance Fee of \$94.75 Amex & - 2.89% + .15 Transaction Fee, Monthly Minimum - \$25 No charge for supplies			Through their partner, Vanitiv, Cost plus .32% basis points + \$.03, Minumum processing fee \$25.00 Monthly access \$15, Amex Transaction fee \$.15, Batch header fee \$.25, PCI - \$99 annually Account maintenance \$5.00, Regulation Comp \$5.00 Member fee \$5, 950 Authoriization - \$.05 AVS fee per transaction, Watts - \$.05 per transaction, Business Advantage - \$4.95 Would need to purchase or lease new equipment			First Data Platform, \$500 Termination Fee, Compatible with Verifone Systems, IC Verify & not Click to Gov Rates: Visa, MC & Disc - Inerchange Rate + 11% , .05 Transaction Fee & TD Fee - .20% Amex - .08 Transaction Fee + \$.50 Monthly Fee eMerchantview - \$12.00 24 month contract w/termination fee equal to \$5.00 month and \$15.00 activation fee for remaining months of contract		
Deposit Errors	Yes - Notified Immediately, less than \$10 written off			Yes			Yes - Notified Immediately if adjustment of \$100 (+ or -), all other by mail		
Employee Benefit Package	Yes			Yes			Yes		
New Accounts	Yes			Yes			Yes		
Stale Checks	Yes-Thru Postive Pay			Yes-Thru Postive Pay			Yes- Thru Postive Pay		
Transfer Between Accounts	Yes			Yes			Yes		
Other Investments	Yes			Yes			Yes		
Additional Services	Full & Partial Reconcilaition, Deposit Slips accepted w/adding tape, Online Service			Full & Partial Reconcilaition, Deposit Slips accepted w/adding tape, Online Service			Full & Partial Reconcilaition, Deposit Slips accepted w/adding tape, Online Service, 3 months of Service Charges Waived, 1st Order of Supplies Free		

City Manager
Finance Department
City Manager
Form Started By: Linda Cox
Final Approval Date: 12/16/2015

Jennifer Robinson
Johnna Morris
Nick Mimms

12/15/2015 04:48 PM
12/16/2015 09:44 AM
12/16/2015 04:30 PM
Started On: 12/09/2015 12:23 PM

THIS MEMORANDUM IS A COMMUNICATION FROM COUNSEL TO AGENTS AND REPRESENTATIVES OF THE CITY OF FORT PIERCE IN AN ATTORNEY/CLIENT RELATIONSHIP AND IS THEREFORE CONFIDENTIAL AND IS FURTHER PROTECTED BY FLORIDA STATUTE SECTION 119.07 AS IT CONTAINS WORK PRODUCT OF THE ATTORNEY PREPARED IN ANTICIPATION OF, OR IN CONNECTION WITH, POTENTIAL OR PENDING ADVERSARIAL ADMINISTRATIVE PROCEEDINGS AND/OR CIVIL LITIGATION.

CITY OF FORT PIERCE - OFFICE OF THE CITY ATTORNEY

MEMORANDUM

TO: Fort Pierce Mayor and Commissioners (*via email*)

FROM: Robert V. Schwerer, City Attorney

SUBJECT: K & K II, Inc. v City of Fort Pierce

DATE: December 10, 2015

Please be advised we have reached a settlement with K & K II, Inc. on their claim against the City of Fort Pierce relating to the Sunrise Theatre "free ticket" covenant. Attached is a copy of the Settlement Agreement already signed by K & K. The agreement requires Commission approval and is being submitted to you with such recommendation.

Please let me know if you have any questions concerning the attached.

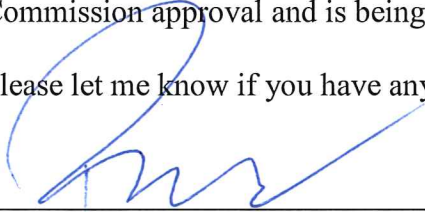

Robert V. Schwerer, Esq.
City Attorney

/mlp

Attachments

cc: Nicholas Mimms, City Manager (*via email*)
John Wilkes, Executive Director, Sunrise Theatre (*via email*)
William J. Cornwell, Esquire (*via email*)

SETTLEMENT AGREEMENT

THIS SETTLEMENT AGREEMENT ("Agreement") is made this 7th day of December, 2015, by and among K & K II, INC ("K&K") and the CITY OF FORT PIERCE, FLORIDA ("City"), K&K and City are sometimes hereinafter collectively referred to as the "Parties" and each is sometimes hereinafter referred to individually as a "Party".

RECITALS

WHEREAS, on or about July 12, 2013, K&K filed a lawsuit styled *K&K II, Inc. v. City of Fort Pierce*, Case No. 56 2013 CA 002183 (BC) in the Circuit Court of the Nineteenth Judicial Circuit in and for Saint Lucie County, Florida against the City alleging claims for: (1) breach of contract; (2) specific performance; (3) inverse condemnation; and (4) declaratory judgment (the "Lawsuit" or the "Complaint").

WHEREAS, on or about November 25, 2013, the City filed its Amended Answer and Amended Affirmative Defenses to K&K's Complaint disputing the claims asserted by K&K.

WHEREAS, the Lawsuit is currently scheduled for trial on January 19, 2016.

WHEREAS, the Parties would like to resolve such disputes between them, all as more specifically set forth below;

NOW, THEREFORE, in consideration of the premises and mutual agreements herein contained and other good and valuable consideration, the receipt and sufficiency of which is hereby acknowledged, the Parties hereto hereby mutually covenant and agree as follows:

1. **Recitals.** The foregoing recitals are true and correct and by this reference are hereby incorporated into this Agreement.

2. **Settlement Subject to Approval of City Commission:** This Settlement Agreement is contingent on the approval of this Settlement Agreement by the City of Fort Pierce City Commission.

3. **Payment by City:** The City will pay K&K within thirty (30) days of approval of the Settlement Agreement by the City Commission the sum of Eighty Seven Thousand Five Hundred (\$87,500) Dollars. Payment shall be made to K&K's counsel The Koblegard Law Firm Trust Account.

4. **Ticket Purchase Rights:** K&K will have the same rights that preferred members of the theater have to elect to purchase at face value up to 6 tickets located at Row K, Seats 101-106. Tickets acquisition is subject to all rules applicable and any changes in the preferred ticket holder program that the City adopts in the future applicable to advance ticket purchases for the preferred member program.

5. **Mutual Releases to be Executed:** Within five (5) business days of receipt of payment K&K shall execute a Release in favor of the City in the form attached hereto as Exhibit

"A" and the City shall execute a Release in favor of K&K in the form attached hereto as Exhibit "B".

6. **Joint Stipulation for Dismissal with Prejudice:** Within five (5) business days of each party's receipt of the releases required in paragraph 5 above, the parties counsel shall execute a Joint Stipulation for Dismissal With Prejudice with each party to bear their own attorneys' fees and costs in the form attached hereto as Exhibit "C".

7. **No Admission.** It is acknowledged, understood and agreed among the Parties that this Agreement represents a settlement and compromise of heavily disputed claims reached as a business decision and shall not constitute or be construed as an admission of liability or guilt by any of the Parties. If this Agreement is not fully and finally consummated, then no statements contained in this Agreement shall be used for any purpose against any of the Parties to this Agreement in any subsequent proceeding.

8. **Consultation with Counsel.** Each of the Parties to this Agreement represents that they have fully reviewed this Agreement with their respective attorneys and understand the legal effect of this Agreement and Mutual Release provided for herein, and each of the Parties represents that having understood the legal effects of this Agreement, each of the Parties has freely and voluntarily consented to and authorized this Agreement.

9. **Termination Instrument to be Executed.** Within five (5) business days of receipt of payment K&K shall execute an instrument, in a form acceptable to the City, to be recorded by the City in the public records of Saint Lucie County terminating and forever extinguishing Section 6.01 ("Theater Tickets") of the Declaration of Covenants, Conditions, Restrictions and Easements pertaining to the Sunrise Theatre Building recorded in the Public Records of St. Lucie County, Florida and that deed dated the 30th day of June, 2000 and recorded at OR Book 1311, Page 1556 of the Public Records of St. Lucie County, Florida.

10. **Miscellaneous.**

(a) **Attorneys' Fees.** Each Party will bear its own attorneys' fees and court costs in connection with the preparation, negotiation and execution of this Agreement.

(b) **Entire Agreement.** This Agreement constitutes the entire agreement between the Parties hereto with respect to the subject matter hereof. It supersedes all prior negotiations, letters and understandings relating to the subject matter hereof.

(c) **Choice of Law.** This Agreement shall be interpreted, construed and enforced in accordance with the laws of the State of Florida, without regard to its choice of law provisions.

(d) **Effect of Waiver.** The failure of any Party at any time or times to require performance of any provision of this Agreement will not in any manner affect the right to enforce the same. The waiver by any Party of any breach of any provision of this Agreement will not be construed to be a waiver by any such Party of any succeeding breach of that provision or a waiver by such Party of any breach of any other provision.

with a copy to:

Rupert N. Koblegard, III, Esq.
The Koblegard Law Firm
200 S. Indian River Drive, Suite 201
Fort Pierce, FL 34950
koblegardlaw@aol.com

unless the address is changed by the party by like notice given to the other parties. Notice shall be in writing and shall be deemed received: (i) if mailed by certified mail, return receipt requested, postage prepaid and properly addressed to the address above, then three (3) business days after deposit of same in a regularly maintained U.S. Mail receptacle; or (ii) if mailed by Federal Express, UPS or other nationally recognized overnight courier service, overnight delivery, then one (1) business day after deposit of same in a regularly maintained receptacle of such overnight courier; or (iii) if hand delivered, then upon hand delivery thereof to the address indicated on or prior to 5:00 p.m., EST, on a business day with a signed receipt of delivery obtained from the person to whom delivery was made. Any notice hand delivered after 5:00 p.m., EST, shall be deemed delivered on the following business day. Notwithstanding the foregoing, notice, consents, waivers or other communications referred to in this Agreement may be sent by facsimile, e-mail, or other method of delivery, but shall be deemed to have been delivered only when the sending party has confirmed (by reply e-mail or some other form of written confirmation from the receiving party) that the notice has been received by the other party.

IN WITNESS WHEREOF, the Parties have caused this Agreement to be duly executed as of the date first above written.

Signed, Sealed and Delivered
In the Presence of:

BEN L. BRYAN, JR.
as President of K&K II, Inc.,
a Florida corporation

NICHOLAS MIMMS
as Interim City Manager of the City of Fort
Pierce, a Florida municipal corporation

THE KOBLEGARD LAW FIRM
Counsel for Plaintiff
200 S. Indian River Drive
Suite 201
Fort Pierce, FL 34950
772-461-7772; Fax: 772-461-0226
koblegardlaw@aol.com
koblegardlaw2@aol.com

WEISS, HANDLER & CORNWELL, P.A.
Counsel for Defendant
One Boca Place
2255 Glades Road, Suite 218-A
Boca Raton, FL 33431
561-997-9995; Fax: 561-997-5280
wjc@whcfla.com
dkf@whcfla.com
filings@whcfla.com

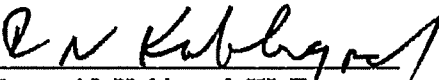
By: 
Rupert N. Koblegard, III, Esq.
Florida Bar No. 108382

By: _____
WILLIAM J. CORNWELL, ESQ.
Florida Bar No. 782017
DAVID K. FRIEDMAN, ESQ.
Florida Bar No. 307378

and

MATTHEW KOBLEGARD, ESQ.
Florida Bar No. 056137
37 Binnacle Hill
Oakland, CA 94618
352-262-4269
matthewkoblegard@gmail.com

and

ROBERT V. SCHWERER, ESQ.
Florida Bar No. 320315
schwererlaw@aol.com
christinefamularo@city-ftpierce.com
maryperegrin@city-ftpierce.com
HAYSKAR, WALKER, SCHWERER,
DUNDAS & MCCAIN, P.A.
Co-Counsel for Defendant
Post Office Box 1480
Fort Pierce, FL 34954-1480
772-467-3000; Fax: 772-466-5492

EXHIBIT "A"

RELEASE

KNOW ALL MEN BY THESE PRESENTS:

That K & K II, INC., a Florida corporation, its respective administrators, successors, assigns, related entities, employees, agents, principals, attorneys, officers, directors, and representatives, ("First Party"), for and in consideration of the sum of EIGHTY SEVEN THOUSAND FIVE HUNDRED and no/100 (\$87,500.00) DOLLARS, the sufficiency whereof is hereby acknowledged, do hereby release, acquit, and forever discharge the CITY OF FORT PIERCE, FLORIDA, a Florida municipal corporation, its respective administrators, successors, assigns, related entities, employees, agents, principals, attorneys, officers, directors, and representatives, ("Second Party"), from any and all claims, actions, causes of action, suits, sums of money, covenants, contracts, controversies, agreements, promises, damages or demands, economic, noneconomic, compensatory, in whatever name or nature, in tort, in contract or by statute, which the said First Party ever had, now have, or which any personal representative, successor, heir or assign of said First Party, hereafter can, shall or may have, against the Second Party for, upon, or by reason of any matter, cause or thing which has arisen, arises from, or which may hereafter arise out of the allegations in the case of K & K II, INC., Plaintiff, v. CITY OF FORT PIERCE, FLORIDA, Defendant, Case No: 562013CA002183 (BC), Circuit Court, St. Lucie County, Florida, together with all claims or causes of action arising from or related to Section 6.01 of the Declaration of Covenants, Conditions, Restrictions and Easements pertaining to the Sunrise Theatre Building recorded in the Public Records of St. Lucie County, Florida and that deed dated the 30th day of June, 2000 and recorded at OR Book 1311, Page 1556 of the Public Records of St. Lucie County, Florida.

This release covers and encompasses all claimable elements of damage and injuries under Florida law, known and unknown, including, but not limited to attorneys' fees, costs, and interest, that may be claimed in the above set forth lawsuit. Further, the First Party hereby agrees to indemnify, to save, defend, and hold harmless the Second Party from and of any and all claims, subrogated interests, or liens of any third parties, and any and all other subrogated interests or liens, regardless of their source, including any all mechanic's, materialman's, or laborer's liens.

ALL PARTIES TO THIS RELEASE ARE TO BEAR THEIR OWN RESPECTNE
ATTORNEY'S FEES AND COSTS.

The First Party hereby acknowledge that they understand and accept all of the terms and conditions herein and that this is a settlement of the herein mentioned claims without an admission of liability therefore on the part of any party to this release.

IN WITNESS WHEREOF, we have hereunto set our hand and seal this 7th of December,

2015.

Signed, sealed and delivered in presence of:

Leah M. Hubbard
Print name: Leah M. Hubbard

Ben L. Bryan, Jr.
Benjamin L. Bryan, Jr., President
K & K, II, a Florida corporation

Amy Shevlin
Print name: AMY SHEVLIN

STATE OF FLORIDA
COUNTY OF ST. LUCIE

I HEREBY CERTIFY that on this day, before me, an officer duly authorized in the State aforesaid and in the County aforesaid to take acknowledgments, personally appeared Benjamin L. Bryan, Jr. for K & K, II, Inc., to me known to be the person described in, who took an oath, who read and executed the foregoing instrument, and who acknowledged before me that he is authorized to execute, and did execute the same.

WITNESS my hand and official seal in the County and State last aforesaid this 7th day of December, 2015.

Leah M. Hubbard
Notary Signature-State of Florida at Large



EXHIBIT "B"

RELEASE

KNOW ALL MEN BY THESE PRESENTS:

That CITY OF FORT PIERCE, FLORIDA, a Florida municipal corporation, its respective administrators, successors, assigns, related entities, employees, agents, principals, attorneys, officers, directors, and representatives, ("First Party"), for and in consideration of the sum of TEN and no/100 (\$10.00) DOLLARS, the sufficiency whereof is hereby acknowledged, do hereby release, acquit, and forever discharge K & K II, INC., a Florida corporation, its respective administrators, successors, assigns, related entities, employees, agents, principals, attorneys, officers, directors, and representatives, ("Second Party"), from any and all claims, actions, causes of action, suits, sums of money, covenants, contracts, controversies, agreements, promises, damages or demands, economic, noneconomic, compensatory, in whatever name or nature, in tort, in contract or by statute, which the said First Party ever had, now have, or which any personal representative, successor, heir or assign of said First Party, hereafter can, shall or may have, against the Second Party for, upon, or by reason of any matter, cause or thing which has arisen, arises from, or which may hereafter arise out of the allegations in the case of K & K II, INC., Plaintiff, v. CITY OF FORT PIERCE, FLORIDA, Defendant, Case No: 562013CA002183 (BC), Circuit Court, St. Lucie County, Florida, together with all claims or causes of action arising from or related to Section 6.01 of the Declaration of Covenants, Conditions, Restrictions and Easements pertaining to the Sunrise Theatre Building recorded in the Public Records of St. Lucie County, Florida and that deed dated the 30th day of June, 2000 and recorded at OR Book 1311, Page 1556 of the Public Records of St. Lucie County, Florida.

This release covers and encompasses all claimable elements of damage and injuries under Florida law, known and unknown, including, but not limited to attorneys' fees, costs, and interest, that may be claimed in the above set forth lawsuit. Further, the First Party hereby agrees to indemnify, to save, defend, and hold harmless the Second Party from and of any and all claims, subrogated interests, or liens of any third parties, and any and all other subrogated interests or liens, regardless of their source, including any all mechanic's, materialman's, or laborer's liens.

**ALL PARTIES TO THIS RELEASE ARE TO BEAR THEIR OWN RESPECTNE
ATTORNEY'S FEES AND COSTS.**

The First Party hereby acknowledge that they understand and accept all of the terms and conditions herein and that this is a settlement of the herein mentioned claims without an admission of liability therefore on the part of any party to this release.

IN WITNESS WHEREOF, we have hereunto set our hand and seal this ____ of _____,
2015.

Signed, sealed and delivered in presence of:

Print name: _____

Print name: _____

STATE OF FLORIDA
COUNTY OF ST. LUCIE

I HEREBY CERTIFY that on this day, before me, an officer duly authorized in the State aforesaid and in the County aforesaid to take acknowledgments, personally appeared _____, to me known to be the person described in, who took an oath, who read and executed the foregoing instrument, and who acknowledged before me that he is authorized to execute, and did execute the same.

WITNESS my hand and official seal in the County and State last aforesaid this ____ day of _____, 2015.

Notary Signature-State of Florida at Large

EXHIBIT "C"

IN THE CIRCUIT COURT OF THE NINETEENTH JUDICIAL CIRCUIT
IN AND FOR SAINT LUCIE COUNTY, FLORIDA

K & K II, INC., a Florida corporation,

Plaintiff,

v.

CASE NO.: 56 2013 CA 002183 (BC)

CITY OF FORT PIERCE, FLORIDA, a Florida
municipal corporation,

JUDGE: WILLIAM L. ROBY

Defendant.

JOINT STIPULATION FOR DISMISSAL WITH PREJUDICE

IT IS HEREBY stipulated and agreed by and between the parties that this case has been settled and may be dismissed with prejudice, with each party to bear its own attorneys' fees and costs.

Dated: 12/7/15

THE KOBLEGARD LAW FIRM
Counsel for Plaintiff
200 S. Indian River Drive
Suite 201
Fort Pierce, FL 34950
772-461-7772; Fax: 772-461-0226
koblegardlaw@aol.com
koblegardlaw2@aol.com

By:

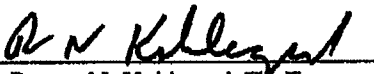
Rupert N. Koblegard, II, Esq.
Florida Bar No. 108382

Dated: _____

WEISS, HANDLER & CORNWELL, P.A.
Counsel for Defendant
One Boca Place
2255 Glades Road, Suite 218-A
Boca Raton, FL 33431
561-997-9995; Fax: 561-997-5280
wjc@whcfla.com
dkf@whcfla.com
filings@whcfla.com

By: _____

WILLIAM J. CORNWELL, ESQ.
Florida Bar No. 782017
DAVID K. FRIEDMAN, ESQ.
Florida Bar No. 307378

and

MATTHEW KOBLEGARD, ESQ.
Florida Bar No. 056137
37 Binnacle Hill
Oakland, CA 94618
352-262-4269
matthewkoblegard@gmail.com

and

ROBERT V. SCHWERER, ESQ.
Florida Bar No. 320315
schwererlaw@aol.com
christinefumularo@city-ftpierce.com
maryperegrin@city-ftpierce.com
HAYSKAR, WALKER, SCHWERER, DUNDAS &
MCCAIN, P.A.
Co-Counsel for Defendant
Post Office Box 1480
Fort Pierce, FL 34954-1480
772-467-3000; Fax: 772-466-5492

CERTIFICATE OF SERVICE

I HEREBY CERTIFY that a true copy of the foregoing has been furnished, via e-service, to: Rupert N. Koblegard, III, Esq., The Koblegard Law Firm, 200 S. Indian River Drive, Suite 201, Fort Pierce, FL 34950, koblegardlaw@aol.com; koblegardlaw2@aol.com; and to: Matthew D. Koblegard, Esq., Wright, Ponsoldt & Lozeau, LLP, 10002 S.E. Monterey Commons Blvd., Suite 100, Stuart, FL 34996; mkoblegard@wpltrnlattorneys.com; matthewkoblegard@gmail.com; this ____ day of December, 2015.

WEISS, HANDLER & CORNWELL, P.A.
Counsel for Defendant
One Boca Place
2255 Glades Road, Suite 218-A
Boca Raton, FL 33431
561-997-9995; Fax: 561-997-5280

By: _____
WILLIAM J. CORNWELL, ESQ.
Florida Bar No. 782017
wjc@weissandhandlerpa.com
DAVID K. FRIEDMAN, ESQ.
Florida Bar No. 307378
wjc@weissandhandlerpa.com
dkf@weissandhandlerpa.com
filings@weissandhandlerpa.com

and

ROBERT V. SCHWERER, ESQ.
Florida Bar No. 320315
schwererlaw@aol.com
cfamularo@city-ftpierce.com
mperegrin@city-ftpierce.com
HAYSKAR, WALKER, SCHWERER, DUNDAS &
MCCAIN, P.A.
Co-Counsel for Defendant
Post Office Box 1480
Fort Pierce, FL 34954-1480
(772) 467-3000; Fax (772)466-5492

City Commission Regular Meeting

Agenda Item # 9. e.

Meeting Date: 12/21/2015

Re: Nicholas C. Mimms, Employment Agreement

Submitted For: Nick Mimms, Interim City Manager, City Manager

SUBJECT:

Approval of Employment Agreement with Nicholas C. Mimms, City Manager.

SUMMARY:

The City Commission appointed Mr. Mimms as the City Manager at the December 7, 2015. Attached is the proposed employment agreement for approval.

RECOMMENDATION:

Approve agreement.

ALTERNATIVES:

Approve agreement with modifications.

RESPONSIBLE STAFF:

Robert Schwerer, City Attorney

COORDINATED WITH:

Nicholas C. Mimms, City Manager

Fiscal Impact

Budgeted Y/N:

Fiscal Year:

Account:

Amount:

OTHER INFORMATION:

TBD

Attachments

City Manager's Employment Agreement

Form Review

Inbox

City Manager

Form Started By: Jennifer Robinson

Final Approval Date: 12/17/2015

Reviewed By

Nick Mimms

Date

12/17/2015 02:15 PM

Started On: 12/08/2015 12:20 PM

CITY OF FORT PIERCE - OFFICE OF THE CITY ATTORNEY

MEMORANDUM

TO: Nicholas Mimms, City Manager
FROM: Robert V. Schwerer, City Attorney
SUBJECT: City Manager Employment Agreement
DATE: December 18, 2015

RECEIVED
TIME _____
DEC 18 2015
CITY OF FT. PIERCE
CITY MANAGER'S OFFICE

Attached is the original of the City Manager Employment Agreement approved as to form and correctness by this office. The agreement is anticipated to be approved by the City Commission at their December 21 meeting. Please have the same executed by the Mayor and return a copy to me for my records.

Please let me know if you have any questions.

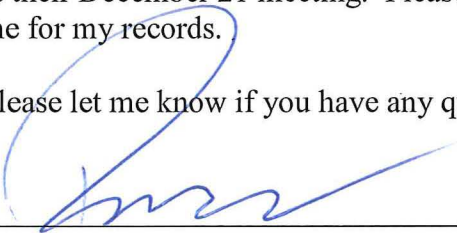

Robert V. Schwerer, Esq.
City Attorney

/mlp
Attachment

CITY OF FORT PIERCE, FLORIDA

**NICHOLAS MIMMS
CITY MANAGER**

EMPLOYMENT AGREEMENT

THIS EMPLOYMENT AGREEMENT made and entered into effective December 7, 2015, by and between the **CITY OF FORT PIERCE, FLORIDA**, a municipal corporation, hereafter referred as to "**CITY**" and **NICHOLAS MIMMS**, hereafter referred to as "**MIMMS**".

WHEREAS, CITY desires to secure the services of **MIMMS** as City Manager for a minimum of three (3) years from the Effective Date of this agreement and **MIMMS** desires to accept such position; and

WHEREAS, CITY and **MIMMS** intend by this Agreement to provide certain benefits and establish certain conditions of employment to which **MIMMS** has agreed.

NOW, THEREFORE, in consideration of the material advantages occurring to the parties and the mutual covenants contained herein, **CITY** and **MIMMS** agree with each other as follows:

1. Employment.

MIMMS will render full time professional services to **CITY** in the capacity of City Manager of the **CITY** for the initial term of three (3) years, commencing December 7, 2015 (the "Effective Date"), through December 6, 2018. In the event written notice of termination or notice of non-renewal of this Agreement is not given by either party to the other party ninety (90) days prior to the expiration of the term as hereinabove provided, this Agreement shall automatically renew and continue thereafter on a year-to-year basis.

MIMMS shall devote all of his time, attention, knowledge and skill, solely and exclusively to the business and interest of the City of Fort Pierce, and the public which it serves. **MIMMS** will at all times faithfully, industriously, and diligently perform to the best of his ability all duties that may be required of him by virtue of his position as City Manager, including the performance of all duties set forth in the City Charter, Ordinances,

Resolutions and other City policies, and to perform other legally permissible and proper duties and functions to the reasonable satisfaction of the City Commission. In performing such duties, **MIMMS** further agrees to be subject to the ICMA Code of Ethics, and to otherwise devote full time and attention to his work as City Manager. Nothing herein shall prohibit **MIMMS** from maintaining membership in or participating in private social or civic endeavors that do not interfere or detract from his performance of the terms of this Agreement. In the event **MIMMS** makes formal application for full-time employment elsewhere while serving as City Manager, he shall be required to provide written notice to the City Commission simultaneously with such application or submittal.

2. Compensation.

In consideration for these services as City Manager, **CITY** agrees to pay **MIMMS** an annual base salary of ONE-HUNDRED FORTY THOUSAND DOLLARS (\$140,000.00) per annum, payable in bi-weekly installments, or such higher figure as may be negotiated after a mandatory six-month evaluation of **MIMMS'** performance by the City Commission. Base annual salary adjustments, including cost of living increases, for each subsequent year during the term of this Agreement shall be negotiated between the parties on an annual basis.

The **CITY** agrees that it will not, at any time during the term of this Agreement, reduce **MIMMS'** base salary or other financial benefits in a greater percentage than an applicable across the board reduction for all employees of the **CITY**.

3. Performance Evaluations.

The City Commission shall, upon the expiration of six (6) months of the Effective Date of this Agreement, and on an annual basis thereafter, evaluate **MIMMS'** performance as City Manager. These performance evaluations shall occur during the calendar month of June of each year, and the matter of the performance evaluation shall be agendaed by the City Manager, to be discussed by the City Commission, at the first City Manager

Conference Agenda in June of each year of this Agreement. These performance reviews shall consider continuing management objectives and responsibilities as well as achievement of key specific objectives as mutually agreed upon by City Commission and **MIMMS**.

Should it be determined that **MIMMS** was successful in his overall performance, and if the Commission, in its sole discretion, determines that the fiscal condition of the **CITY** is sufficient, the City Commission will consider **MIMMS'** compensation and benefits, and endeavor to maintain them at a level commensurate with his peers in the city management profession in similarly situated Florida cities and the rate of general inflation in the economy.

4. Benefits.

In addition to annual compensation specified above, the **CITY** agrees to provide **MIMMS** with the following benefits:

(a) **MIMMS** shall be entitled to receive the same vacation, sick leave, and holiday time as defined in the City of Fort Pierce Personnel Rules and Regulations, including provisions governing accrual and payment thereof on termination of employment.

(b) Paid attendance at the ICMA annual conference at a rate agreed upon by the City Commission and **MIMMS**.

(c) Lease or car allowance at \$350.00 per month, or such other rate agreed upon by the City Commission.

(d) Membership dues to professional associations and societies and to such service organizations and clubs of which **MIMMS** is a member, subject to the approval of the City Commission.

(e) Comprehensive health and major medical insurance equal to that which is provided to other City employees.

(f) Retirement benefits as currently provided to **MIMMS** as a City employee

5. **Termination.**

At all times during the term of this Agreement, **MIMMS** shall be deemed an employee-at-will, and may be terminated at any time, with or without cause. For purposes of this Agreement, termination shall occur upon the happening of any of the following events:

(a) A majority vote of the entire City Commission at a duly authorized public meeting, with or without cause, at the sole discretion of the City Commission.

(b) If the **CITY**, its citizens, or legislature amends any provision of the Charter or Code substantially changing the form of government directly pertaining to the role, powers, duties, authority and responsibilities of **MIMMS** as City Manager, **MIMMS** shall have the right to declare that such amendments constitute termination; or

(c) If **MIMMS** resigns following a formal offer to accept resignation made by the majority of the entire City Commission at a duly authorized public meeting.

6. **Severance.**

Except as provided in this Agreement, severance will be paid to **MIMMS** when employment is terminated as defined in Paragraph 6 above. Upon termination, all rights, duties and obligations of both parties shall cease except that the **CITY** shall continue to pay **MIMMS** his then annual base salary for One Hundred Twenty (120) consecutive days thereafter, and the **CITY** shall also maintain **MIMMS'** life insurance and major medical insurance coverage paid up and in effect during such period. **MIMMS** shall also be compensated for all accrued sick leave and vacation time payable upon termination of employment as provided in the Personnel Rules and Regulations. During any time severance is being paid, **MIMMS** shall not be required to perform any duties for the City or come to the City.

The severance provisions set forth herein shall not apply and the City shall not be

obligated to pay the One Hundred Twenty (120) days severance in the event **MIMMS** is terminated for cause. "Cause" shall be defined as either conviction of any felony or any misdemeanor involving moral turpitude, commission of any act of fraud involving or affecting the City, willful failure to perform the duties of City Manager, or material breach by **MIMMS** of any duties or obligations under this Agreement and failure to cure such failure or breach after receipt of reasonable written notice, then, in that event, CITY shall have no obligation to pay the aggregate severance sum designated in this paragraph.

7. **Attendance at Meetings.**

The **CITY** agrees to permit **MIMMS** to be absent from the **CITY** during working days to attend professional meetings and to attend to such outside professional duties in the city management field as have been mutually agreed upon between him and the City Commission. Attendance at such approved meetings and accomplishment of approved professional duties shall be fully compensated service time and shall not be considered vacation time. The **CITY** shall reimburse **MIMMS** for all reasonable expenses incurred by him incident to attendance at approved professional meetings; provided, however, that such reimbursement is appropriate and within the limits of the City's budget.

8. **Best Efforts of Employee.**

MIMMS agrees that he will at all times faithfully, industriously and to the best of his ability, experience and talents, perform all the duties which may be required of and from him pursuant to the express and implicit terms hereof, to the reasonable satisfaction of **CITY**. **MIMMS** further agrees that he will continue his education and training so that he will keep up with or exceed education requirements of his position. Such duties shall be rendered at Fort Pierce, St. Lucie County, Florida, and at such other places as **CITY** shall in good faith require, or as the interest, needs or opportunity of **CITY** shall require.

9. **Disability.**

If **MIMMS** is permanently disabled or is otherwise unable to perform his duties because of sickness, accident, injury, mental incapacity or health for a period of either eight (8) successive weeks beyond any accrued sick leave, or for twenty (20) working days over a sixty (60) working day period, **CITY** shall have the option to terminate this Agreement, subject to the severance pay requirements of Paragraph 6. However, **MIMMS** shall be compensated for any accrued sick leave, vacation, holidays, and other accrued benefits.

10. **Residency.**

MIMMS shall, at all times, maintain permanent residency within the City of Fort Pierce, Florida, during his term as City Manager.

11. **Employee At-Will.**

MIMMS is an employee-at-will and works at the pleasure of the **CITY** who may, at any time and without showing cause, terminate this Employment Agreement.

12. **Liability Claims.**

The **CITY** shall defend and save harmless **MIMMS**, but only to the limits of sovereign immunity, against any tort, professional liability claim or demand or other legal claim or action, whether groundless or otherwise, arising out of an alleged act or omission occurring in or arising out of the good faith performance of **MIMMS'** duties as City Manager of the City of Fort Pierce. However, this covenant shall not apply to acts outside the scope of **MIMMS'** employment or services or for claims for punitive damages. The **CITY** will have the authority to compromise and settle any such claim or suit within the scope of **MIMMS'** employment and pay the amount of any settlement or judgment rendered thereon. To the maximum extent permitted by law, the **CITY** and **MIMMS** shall rely upon the doctrine of sovereign immunity and the provisions of Section 768.28, Florida Statutes, or other applicable law.

13. **Voluntary Resignation.**

In the event **MIMMS** voluntarily resigns his position with the **CITY**, **MIMMS** shall provide a minimum ninety (90) days written notice unless the parties agree otherwise. Unless such resignation follows a formal offer to accept resignation made by the majority of the entire City Commission as specified in Paragraph 5(c) above, **MIMMS** shall not be entitled to nor shall the **CITY** be liable to pay severance if **MIMMS** resigns.

14. **General Provisions.**

The following general provisions shall govern this Agreement:

(a) This Agreement shall be governed in accordance with the laws of the State of Florida.

(b) Jurisdiction over any dispute arising under this Agreement, and the venue thereof, shall lie in the Circuit Court of the Nineteenth Judicial Circuit, in and for St. Lucie County, Florida.

(c) This Agreement shall become effective immediately upon execution, and supersedes and replaces any prior written employment agreement.

(d) This Agreement constitutes the entire agreement and understanding between the parties and contains all of the agreements between them with respect to the subject matter hereof, and supersedes any and all other agreements or contracts, either oral or written, between the parties with respect to the subject matter hereof.

(e) The parties by mutual written agreement may amend any provision of this Agreement during the life of the agreement by document approved and signed with the same formalities as this Agreement. Such amendments will be incorporated and made a part of this Agreement.

(f) The invalidity or partial invalidity of any portion of this Agreement will not affect the validity of any other provision. In the event that any provision of this Agreement

is held to be invalid, the remaining provisions shall be deemed to be in full force and effect as if they have been executed by both parties subsequent to the expungement or judicial modification of the invalid provision.

(g) This Agreement shall be binding upon and inure to the benefit of the **CITY** and the City Commission, its successors and assigns, and shall be binding upon **MIMMS**, his administrators, executors, legatees, heirs, and assigns.

IN WITNESS WHEREOF, the parties have hereunto set their hands and seals on the day and year first above written.

CITY OF FORT PIERCE, FLORIDA

By: _____
Linda Hudson, Mayor

ATTEST:

Linda Cox, City Clerk

EMPLOYEE:

Nicholas Mimms

Approved as to Form and Correctness
for Use by the City of Fort Pierce:



Robert V. Schwerer, Esq.
City Attorney

City Commission Regular Meeting

Agenda Item # 9. f.

Meeting Date: 12/21/2015

Re: Blanket/Annual Purchase Order Approvals

Submitted For: Diane Hobley-Burney, Chief of Police, Police Department

SUBJECT:

Approval of blanket purchase orders for FY 2016 for the Police Department in the total budgeted amount of \$288,131.00.

SUMMARY:

All of the Police Department Bureaus will purchase equipment, services and materials from the vendors with the best price and products to meet the Police Department's specific needs.

RECOMMENDATION:

Staff recommends approval of the request.

ALTERNATIVES:

The alternative would be to issue individual purchase orders and/or paperless requisitions for every purchase which would be very time consuming and will lead to inefficiencies.

RESPONSIBLE STAFF:

Deputy Chief Amandro
Deputy Chief Norris
Lt. Chris Bender
Stephanie Smith

COORDINATED WITH:

Lt. Chris Bender
Stephanie Smith, Fiscal Manager

Fiscal Impact

Budgeted Y/N: Y
Fiscal Year: 2016
Account: 001.3000.521.0000
Amount: \$288,131

FISCAL IMPACT:

There are various account codes. All items are budgeted in the Grant and Police Department's FY2016 budget. See the attached list of vendors and account codes.

Attachments

FY16 BPO/Annual PO Vendors and Accounts

Form Review

Inbox

Purchasing

Finance Department

City Manager

Form Started By: Christopher Bender

Final Approval Date: 12/16/2015

Reviewed By

Tony Barnes

Johnna Morris

Nick Mimms

Date

12/11/2015 04:31 PM

12/14/2015 02:02 PM

12/16/2015 04:30 PM

Started On: 12/09/2015 12:58 PM

FY2016 Police Department Budget

Support Services – 001.3002.521.

3510 – Indian River Crime Laboratory - Fort Pierce, FL	\$130,912
• Crime Laboratory Support – Bid # 4946 - Single Source	
4110 – Verizon Wireless – Dallas, TX	\$77,000
• Cellular Services –FL State Contract/SUNCOM DMS1011-008C	
4680 - EMCI, Wireless – Fort Pierce, FL	\$10,000
• Fleet Motorola Radio Maintenance and Repairs - Single Source	
5250 – Day Dreams Uniforms – Port St. Lucie, FL	\$15,000
• Police Uniforms – Single Source	
5250 – Dana Safety Supply – Greensboro, NC	\$11,000
• Tactical Uniforms – Demandstar #20150023mh	
5251 – Florida Bullet, Inc. – Clearwater, FL	\$34,219
• Ammunition – Sole Source	
5251 – DGG Taser & Tactical Company – Jacksonville, FL	\$10,000
• Safariland Leather gear – FL State Contract- Defense Products 46000000-15-1	

City Commission Regular Meeting

Agenda Item # 9. h.

Meeting Date: 12/21/2015

Re: Request to Purchase 3 Segways

Submitted For: Diane Hobley-Burney, Chief of Police, Police Department

SUBJECT:

Approve the purchase by the police department of three (3) Segways with two accessory packages in the total amount not to exceed \$35,886.90 .

SUMMARY:

The Police Department requests the approval to purchase three (2- x2 Patrollers, 1- SE3 Patroller) Segway personal transporters. In addition, we would like to purchase two accessory packages for the two x2 Patrollers. These Segways will be used to patrol the downtown area, festivals, parades, parking garages, and other venues, where practical.

RECOMMENDATION:

Staff recommends the purchase of the Segways.

ALTERNATIVES:

There are no alternatives as Segways can only be purchased from the manufacturer.

RESPONSIBLE STAFF:

Lt. Chris Bender

COORDINATED WITH:

Lt. Chris Bender

Fiscal Impact

Budgeted Y/N: Y
Fiscal Year: 2016
Account: 001.6000.513.6440
Amount: \$35,886.90

FISCAL IMPACT:

Left blank per Deputy Chief Amandro.

Attachments

Capital Improvement Memo
Segway Quote
Segway Sole Source
Accessory Quote
Accessory Sole Source

Form Review

Inbox

Purchasing

Finance Department

City Manager

Form Started By: Christopher Bender

Final Approval Date: 12/16/2015

Reviewed By

Tony Barnes

Johnna Morris

Nick Mimms

Date

12/16/2015 09:15 AM

12/16/2015 09:47 AM

12/16/2015 04:30 PM

Started On: 11/24/2015 10:09 AM



Diane Hobley-Burney, Chief of Police

To: Diane Hobley-Burney, Chief of Police
 From: Frank J. Amandro, Deputy Chief
 Date: July 1, 2015
 Subject: FY 2016 Budget: Capital Improvements for the Police Department

I completed the review of the Capital Improvement needs for the police department in preparation for the FY 2016 Budget. As you are aware, the police department has not had a capital improvement budget since FY 2008. As such, some of our critical infrastructure has not been replaced; namely, computer equipment (laptops, desktops, surveillance/undercover electronics) and vehicles.

Our number one priority is our fleet and computers are our second priority. Since 2007, the police department has purchased a total of ten (10) new vehicles, two (2) Ford Fusions, three (3) Chevy Impalas, and five (5) Ford Taurus. We have purchased these vehicles either by insurance replacement, trading in several vehicles for one good vehicle or with unexpended monies from our Operating Budget but not through our Capital Improvement Budget. The police department's Vehicle Take Home program has enabled us to maximize the life cycle of our Fleet; however, even a Vehicle Take Home program has its limitations. Replacing our aging fleet has become a critical issue. Therefore, I am recommending the following to be included in the police department's Capital Improvements:

Vehicles:

13	Ford Interceptor Sedan (27,955) <i>* vehicle and fully equipped police packaged vehicle</i>	\$	363,415.00
2	Ford Interceptors Utility (34,337) <i>* vehicle and minimal emergency equipment package</i>	\$	68,674.00
1	Ford Transit Van Crime Scene (25,000) <i>* vehicle only</i>	\$	25,000.00
15	Undercover Vehicles (returned lease vehicles) (15,000) <i>*vehicle and minimal emergency equipment package</i>	\$	225,000.00
<i>Subtotal:</i>		\$	682,089.00

Laptops:			
15	Patrol and Investigation Divisions	(\$1,900)	\$ 28,500.00
	<i>Subtotal:</i>		\$ 28,500.00
Other Equipment:			
2	Police Segways	(\$10,000)	\$ 20,000.00
	* <i>Downtown</i>		
2	4 X 4 Vehicles	(\$10,000)	\$ 20,000.00
	* <i>Beach Patrol, side-by-side style</i>		
	<i>Subtotal:</i>		<u>\$ 40,000.00</u>
Grand Total:			\$ 750,589.00

The Ford Interceptor Sedan and Utility vehicles along with the Ford Transit Van are priced from the Florida Sheriff's Association & Florida Association of Counties Bid Award Announcement, Contract # 14-22-0904, which is effective October 1, 2014 through September 30, 2015. This contracted is extended to any and all units of local government and political subdivisions including municipalities and/or police agencies.

Segway Inc.

Quote is valid for 30 days

Patroller_Sales_Agreement







The Customer identified below ("Customer") submits this Segway Inc. Sales Agreement to Segway Inc., a Delaware corporation of 14 Technology Drive, Bedford, NH 03110 USA ("Segway Inc."). This Sales Agreement is valid only if the Segway® Personal Transporters, Patrollers, Accessories, and Services - Terms and Conditions of Sale are attached hereto. Customer hereby offers and agrees to purchase from Segway Inc. the products and services described below on the terms stated in this Sales Agreement and the Terms and Conditions of Sale attached below. If Segway Inc. accepts this offer, an agreement shall exist between Customer and Segway Inc. on the terms stated herein. Please fax the Sales Agreement and signed Terms and Conditions of Sale to 1-603-222-6001.

Salesperson	Gerry White
E-mail	Gerald.white@segway.com
Phone	949-910-5928
Fax	603-222-6001

Customer Name	Fort Pierce Police Department
Contact Name	Christopher Bender
Contact Title	Lt
Contact e-mail	cbender@fppd.org
Contact Phone	(772) 467-6944
Submitted Date	23-Nov-15
Requested Ship Date	Ship within 30 days
Bill to Address	920 South U.S. Highway #1 Fort Pierce, Florida 34954
Ship to Address	same
Quote #	1642-112315
Dealer of Record	SEGWAY OF SEGWAY FLORIDA
Payment Method	PO / Wire Transfer / Credit Card / Check

Quote Summary		
Patrollers	\$	28,997.00
Patroller Shipping	\$	790.00
Parts & Accessories	\$	-
Accessory Shipping	\$	-
Tax	\$	-
Order Total	\$	29,787.00

STEP 1 - Select Models

Segway PT i2 Patroller Models				Shield Color	Quantity	Price	Total
23444-00002	i2 SE Patroller		i2 Patroller Model Includes: Upper and Lower Shields, Patroller Bag, Reflective Labels, Word Labels (specify below), Front Bumper, Lights, Comfort Mats, LED Taillight, Lower Cargo Frames, Mounting Hardware, InfoKey Wrist Strap	WHITE		\$ -	\$ -
23444-00002	i2 SE Patroller			YELLOW		\$ -	\$ -
Segway PT x2 Patroller Models					Quantity	Price	Total
23580-00002	x2 SE Patroller		x2 Patroller Model Includes: Upper and Lower Shields, Patroller Bag, Reflective Labels, Word Labels (specify below), Front Bumper, Lights, Comfort Mats, LED Taillight, Mounting Hardware, InfoKey Wrist Strap	WHITE	2	\$7,999.00	\$ 15,998.00
23580-00002	x2 SE Patroller			YELLOW		\$7,999.00	\$ -
Segway PT x2T Patroller Models					Quantity	Price	Total
23580-00004	x2T SE Patroller		x2T Patroller Model Includes: Upper and Lower Shields, Patroller Bag, Reflective Labels, Word Labels (specify below), Front Bumper, Lights, Comfort Mats, LED Taillight, Mounting Hardware, InfoKey Wrist Strap, Turf Tires	WHITE		\$ -	\$ -
23580-00004	x2T SE Patroller			YELLOW		\$ -	\$ -
Segway SE-3 Patroller Models					Quantity	Price	Total
23879-00001	SE-3 Patroller (Police)			POLICE (Red/Blue)	1	\$ 12,999.00	\$ 12,999.00
23879-00002	SE-3 Patroller (Security)			SECURITY (Amber/Amber)		\$ 12,999.00	\$ -

STEP 2 - Select Lights (PT models only. Not needed for SE-3 Patrollers)

Integrated Flashing Light Kits (Select One per Patroller Model Ordered)			Quantity	
22200-00001	RED/BLUE		2	NO CHARGE
22200-00002	AMBER/WHITE			NO CHARGE
21707-00006	RED/RED			NO CHARGE
21707-00007	BLUE/BLUE			NO CHARGE

STEP 3 - Select Language Labels (PT models only. Not needed for SE-3 Patrollers)

Individual language Sticker Kits (Select One per Patroller Model Ordered)			Quantity	
22272-00001	Police - English/French		2	NO CHARGE
22272-00002	Police - Spanish			NO CHARGE
22272-00003	Police - Italian			NO CHARGE
22272-00004	Police - German			NO CHARGE
22272-00005	Security - English			NO CHARGE

Comments or Special Instructions

Volume discounts start at 6 units for i2 and x2 models.
i2 and x2 orders shipped to local dealer for assembly and test prior to delivery.

Parts and Accessories

Category	Subcategory	Part #	Name	Price	Order Qty	Line Total
Accessory	Patroller Replace. Kit	22200-00001	Patroller Light System, Red/Blue	\$423.00		\$ -
Accessory	Patroller Replace. Kit	22200-00002	Patroller Light System, Amber/White	\$423.00		\$ -
Accessory	Patroller Replace. Kit	21707-00006	Patroller Light System, Red/Red	\$423.00		\$ -
Accessory	Patroller Replace. Kit	21707-00007	Patroller Light System, Blue/Blue	\$423.00		\$ -
Accessory	Patroller Replace. Kit	22201-00001	Patroller Bag Replacement Kit	\$194.00		\$ -
Accessory	Patroller Replace. Kit	22199-00001	Patroller Bumper and Bracket Replacement Kit	\$109.00		\$ -
Accessory	Patroller Replace. Kit	22202-00001	Upper and Lower Shield Replacement Kit, White	\$242.00		\$ -
Accessory	Patroller Replace. Kit	22202-00002	Upper and Lower Shield Replacement Kit, Yellow	\$242.00		\$ -
Accessory	Patroller Replace. Kit	22517-00001	Upper Shield Replacement Kit, White	\$99.00		\$ -
Accessory	Patroller Replace. Kit	22517-00002	Upper Shield Replacement Kit, Yellow	\$99.00		\$ -

Accessory	Patroller Replace. Kit	22228-00001	Label Replacement Kit (3), Police, English/French	\$121.00	\$ -
Accessory	Patroller Replace. Kit	22228-00004	Label Replacement Kit (3), Police, Spanish	\$121.00	\$ -
Accessory	Patroller Replace. Kit	22228-00005	Label Replacement Kit (3), Police, Italian	\$121.00	\$ -
Accessory	Patroller Replace. Kit	22228-00006	Label Replacement Kit (3), Police, German	\$121.00	\$ -
Accessory	Patroller Replace. Kit	22228-00003	Label Replacement Kit (3), Security, English	\$121.00	\$ -
Accessory	Patroller Replace. Kit	22461-00001	Wristband Kit, InfoKey, Segway Branded, Black (10 pack)	\$181.00	\$ -
Accessory	Patroller Replace. Kit	21710-00001	Reflective Decal, Lower Shield, Left Side, White	\$20.00	\$ -
Accessory	Patroller Replace. Kit	21710-00002	Reflective Decal, Lower Shield, Right Side, White	\$20.00	\$ -
Accessory	Patroller Replace. Kit	21711-00001	Reflective Decal, Upper Shield, White	\$17.00	\$ -
Accessory	Patroller Replace. Kit	21710-00003	Reflective Decal, Lower Shield, Left Side, Yellow	\$20.00	\$ -
Accessory	Patroller Replace. Kit	21710-00004	Reflective Decal, Lower Shield, Right Side, Yellow	\$20.00	\$ -
Accessory	Patroller Replace. Kit	21711-00002	Reflective Decal, Upper Shield, Yellow	\$17.00	\$ -
Accessory	Patroller Replace. Kit	23639-00001	Kit, Patroller Handlebar & Clamp	\$57.00	\$ -
Accessory	Cargo	22237-00001	Patroller Accessory Bar Kit	\$85.00	\$ -
Accessory	Cargo	20412-00001	i2 Lower Cargo Frame Kit (2)	\$175.00	\$ -
Accessory	Cargo	20413-00001	Universal Cargo Plate Kit (2)	\$175.00	\$ -
Accessory	Cargo	20419-00001	Segway Hard Side Case & Structure (2)	\$325.00	\$ -
Accessory	Cargo	21649-00001	Single Side Cargo Kit	\$343.00	\$ -
Accessory	Cargo	22334-00001	Universal Cargo Plate Kit Fastener Kit (incl. 8)	\$11.00	\$ -
Accessory	SE Cargo	24167-00001	Cargo Rack	\$259.00	\$ -
Accessory	SE Cargo	24168-00001	Quick Release Universal Case Mount	\$185.00	\$ -
Accessory	SE Cargo	24169-00001	Waterproof Cargo Case Set	\$579.00	\$ -
Accessory	SE Cargo	24170-00001	Open Top Storage Bin Set	\$135.00	\$ -
Accessory	InfoKey	22027-00001	Segway InfoKey Protector Kit - 10 Pack	\$164.00	\$ -
Accessory	InfoKey	21523-00001	Segway InfoKey Protector Kit (1)	\$16.00	\$ -
Accessory	InfoKey	22295-00001	Segway InfoKey Holder with Zipper and Belt Clip - 10 Pack	\$164.00	\$ -
Accessory	InfoKey	20717-00001	Segway InfoKey Holder with Zipper and Belt Clip (1)	\$16.00	\$ -
Accessory	Light	22327-00001	Light Kit, LED, 200L AA Chrome	\$164.00	\$ -
Accessory	Light	22327-00002	Light Kit, LED, 200L AA Black	\$164.00	\$ -
Accessory	Mat	20659-00001	Comfort Mat (2)	\$120.00	\$ -
Accessory	Misc	20417-00001	Segway Ramp Kit	\$325.00	\$ -
Accessory	Parking Stand	22309-00003	Segway Modular Parking Stand Kit - i2 SE	\$66.00	\$ -
Accessory	Parking Stand	22309-00004	Segway Modular Parking Stand Kit - x2 SE	\$66.00	\$ -
Part	Battery	20878-00001	Lithium ion Battery Kit (1)	\$943.00	\$ -
Part	Battery	24380-00001	Lithium ion Battery Module Kit, SE-3 Patroller (1)	\$3,145.00	\$ -
Accessory	Charging	23322-00001	Off-Board Charger, PT	\$919.00	\$ -
Accessory	Charging	24518-00001	Off-Board Charger, SE-3	\$919.00	\$ -
Part	Charging	17298-00001	French/German/Italian Power Cord	\$20.00	\$ -
Part	Charging	16965-00001	Power Cord Kit	\$22.00	\$ -
Part	Fender	20945-00001	i2 Fender Kit (1)	\$44.00	\$ -
Part	Fender	20959-00001	x2 Fender Frame Kit (Left) (1)	\$95.00	\$ -
Part	Fender	20960-00001	x2 Fender Frame Kit (Right) (1)	\$95.00	\$ -
Part	Fender	20961-00001	x2 Fender Kit (Left) (1)	\$55.00	\$ -
Part	Fender	20962-00001	x2 Fender Kit (Right) (1)	\$55.00	\$ -
Part	Handlebar	20955-00001	i2 / x2 Handlebar w/ Grips Kit (1)	\$57.00	\$ -
Part	InfoKey	21064-00001	InfoKey Kit, Programmed (1)	\$236.00	\$ -
Part	Shipping Box	20907-00001	i2 Box Kit	\$57.00	\$ -
Part	Shipping Box	21449-00001	x2 Box Kit	\$69.00	\$ -
Part	Tire/Wheel	22214-00001	i2 Wheel Cap Kit - Quantity 10	\$125.00	\$ -
Part	Tire/Wheel	20942-00001	i2 Wheel Kit (1)	\$153.00	\$ -
Part	Tire/Wheel	23684-00001	New x2 Tire & Wheel Kit with Hubcap (1)	\$295.00	\$ -
Part	Tire/Wheel	23909-00001	Replacement x2 Hubcap	\$20.00	\$ -
Part	Tire/Wheel	21162-00001	x2 Turf Tire / Wheel & Spacer Kit (1)	\$295.00	\$ -
Part	Tire/Wheel	20963-00001	x2 Wheel Hub Adapter (1)	\$142.00	\$ -
Part	Tire/Wheel	20965-00001	x2 Wheel Trim Kit (1)	\$83.00	\$ -
Part	Trim	20944-00001	i2 / x2 Gearbox Cover Kit (1)	\$30.00	\$ -
Service	Warranty	17218-00005	1-Year Warranty Extension, PT	\$595.00	\$ -
Service	Warranty	17218-00007	2-Year Warranty Extension, PT	\$895.00	\$ -

Customer Signature: _____

Date: _____

SEGWAY® PERSONAL TRANSPORTERS, PATROLLERS, ACCESSORIES, AND SERVICES - TERMS AND CONDITIONS OF SALE

This Segway® Personal Transporters, Patrollers, Accessories, and Services – Terms and Conditions of Sale applies to the sales of Segway® Personal Transporter models i2 SE Patroller, x2 SE Patroller (collectively referred to herein as “Segway PT”) and SE-3 Patroller, to the sales of accessories, and to the sales of services provided by Segway Inc. Hereinafter, the Segway Products, and Segway accessories may be referred to as (“Product or Products”) and the services shall be referred to as (“Services”).

Risk of Injury; Product Orientation and Training. Customer (“Customer”) understands that use of the Segway Products involves risk of injury. Customer understands that, before attempting to use any Segway Product, Customer should read the Segway “User Manual” delivered with the Product and watch the “Safety Video” available at www.segway.com/support/manuals-guides.php or www.segwaysafety.com and Customer should, at a minimum, complete Segway Product Orientation (see below). The instructions and warnings set forth in the “Safety Video” and in the “User Manual” apply to each of the Segway Products listed above. Customer understands that complying with the instructions and warnings contained in the “Safety Video” and “User Manual” and completing Product Orientation reduces the risk of injury, but does not eliminate the risk. Product Orientation consists of introducing the Customer to the Segway Product’s features and operation and assisting Customer with Customer’s first ride. Product Orientation is included in the purchase price of the Segway Product and is performed by a Segway Inc. representative, authorized dealer, or other person acting with authority from Segway Inc. To schedule Product Orientation, Customer should contact Customer Operations at 1-866-4SEGWAY or by email to customeroperation@segway.com. Upon receipt of Customer’s request Segway Inc. will arrange for Customer’s Product Orientation at an authorized dealer’s retail location or other reasonable location as determined by Segway Inc. Customer may be required to assemble the Segway Product and charge the Segway Product battery packs (in accordance with the instructions delivered with the Segway Product) before Segway Product Orientation and may be required to make the Segway Product available to the Segway Inc. representative, an authorized dealer, or other person acting with authority from Segway Inc. for Product Orientation. Segway Inc. recommends that Customer complete Segway Product Orientation.

Shipping; Title; Risk of Loss. Unless Customer has selected “Customer Pickup”, Segway Inc. shall arrange to ship Products to Customer by the method stated on the Sales Agreement to which these Terms and Conditions are attached. Customer shall pay Segway Inc.’s charges for shipping and handling as stated on the Sales Agreement. Title to Products and risk of loss or damage to Products passes from Segway Inc. to Customer upon Segway Inc. transferring possession of the Products to the carrier (or to Customer) at Segway Inc.’s facility for shipment to Customer. Unless Segway Inc. and Customer agree upon a separate delivery schedule, Segway Inc. will ship Products within forty five (45) days after this Sales Agreement is accepted.

Payment. Customer shall pay Segway Inc. for Products, shipping and handling charges, and applicable sales taxes before shipment and shall pay for Services before the Services are rendered unless otherwise agreed in writing by Customer and Segway Inc. Customer shall pay by wire transfer to be delivered to Segway Inc. before shipment unless otherwise agreed in writing by Customer and Segway Inc. If Customer fails to make payment when due to Segway Inc., Customer shall also pay to Segway Inc. interest on the unpaid amount from the date due until the date paid at the rate of one and one-half per cent per month (or, if less, the highest rate allowed by law), and Customer shall reimburse Segway Inc. for all costs of collection including reasonable attorney’s fees.

Non-delivery. If, for any reason, Segway Inc. is unable to deliver Products or Services to Customer as provided in this Agreement, Segway Inc. shall, upon Customer’s written request, refund to Customer any portion of the price which Customer may have paid to Segway Inc. for the undelivered Products and/or Services, and each of Segway Inc. and Customer shall be Discharged from any further obligation relating to the undelivered Products and/or Services. Customer shall have no other remedy against Segway Inc. for such undelivered Products and/or Services.

Limited Warranty for Products. THE STANDARD LIMITED WARRANTY APPLICABLE TO SEGWAY INC. PRODUCTS IS THE “SEGWAY® PERSONAL TRANSPORTER LIMITED WARRANTY” or “SEGWAY SE-3 PATROLLER LIMITED WARRANTY” (copy available at <http://www.segway.com/support/warranty.php> or Segway Inc. will send a copy to Customer on request). **SEGWAY INC. MAKES NO OTHER EXPRESS OR IMPLIED WARRANTY. SEGWAY INC. DOES NOT WARRANT SERVICES. SEGWAY INC. EXPRESSLY DISCLAIMS ANY IMPLIED WARRANTY OF MERCHANTABILITY OR FITNESS FOR ANY PARTICULAR PURPOSE.**

Returns. Segway Inc. will only accept return of unused and undamaged Product that is returned in the original packaging. Customer must follow this return procedure. Within ten days after receipt of the Product, Customer must contact Segway Customer Operations at 866-4SEGWAY and request a Return Material Authorization (RMA) number. Customer must return the Product to Segway Inc. in an unused, undamaged condition and in the original packaging. Customer is responsible for the cost of shipping the Product back to Segway Inc. (at the address specified when the RMA was issued) and Customer bears the risk of loss during shipment. The Product must be delivered back to Segway Inc. not later than ten days after the RMA is issued. Customer, as a condition of returning the Product, must pay Segway Inc. a re-stocking fee equal to 10% of the purchase price for the returned Product. Payment of this fee is due at the time Customer obtains the RMA, subject to actual return of the Product in accordance with the terms of this procedure. Upon receipt of the returned Product, Segway Inc. shall inspect the returned Product to confirm that it is unused and undamaged and in the original packaging. Upon such confirmation, and provided the Customer has followed the procedure set forth in this section, Segway Inc. shall credit Customer for the purchase price less the 10% restocking fee. If Customer returns Product that is used, damaged, not in the original packaging, or otherwise not in accord with this procedure, then Segway Inc. shall not issue any credit to Customer and Customer shall pay all costs for return shipment of the Product to Customer.

Not a Medical Device. Segway Products have not been designed, tested, or approved for use as a medical device. The rider must be able to step on and off the Product, which requires physical abilities similar to climbing and descending stairs without assistance and without using a handrail. When using the Segway PT models identified above, the rider’s weight and all payload must not exceed 260 pounds (117 kg). When using an SE-3 Patroller, the rider’s weight and all payload must not exceed 350 lbs (159kg). For all Segway Products, the rider must weigh at least 100 pounds (45 kg).

Disputes. Any controversy or claim arising out of or relating to this Agreement or the breach thereof, or in any other way relating to Segway Inc.’s Products or Services, shall be brought in the Hillsborough County Superior Court in the State of New Hampshire, USA or, if it has or can acquire jurisdiction, in the United States District Court for the District of New Hampshire, USA and Customer consents to the jurisdiction of such courts (and of the appropriate appellate courts) in any such action or proceeding and waives any objection to venue laid therein.

State Laws. Use of Segway Products on public roads or sidewalks is regulated by many states and municipalities (and prohibited by some). Segway Inc. has advised Customer to consult local and state authorities to identify and become familiar with all current laws and regulations. (Many of these laws use the term “Electric Personal Assistive Device” or “Personal Motorized Mobility Device”, which are generally defined so as to include Segway PTs.) In addition to other requirements, these laws and regulations may specify minimum ages for Segway PT riders on public roads and/or sidewalks and may mandate protective gear for riders. If Customer is purchasing i2 SE Patroller, x2 SE Patroller or SE-3 Patroller Products, Customer warrants and represents that Customer is a public safety entity authorized to purchase public safety products under current laws and regulations.

Entire Agreement; Governing Law. By signing below and upon Segway Inc.’s acceptance, Customer agrees that the Sales Agreement attached and these Terms and Conditions (collectively this “Agreement”) set forth the entire agreement between Segway Inc. and Customer. Segway Inc. has made no representation or warranty regarding Segway Inc. Products or Services other than as stated in this Agreement. Any terms or conditions that may be stated on Customer’s purchase order (or other document previously or hereafter issued by Customer to Segway Inc.) are not part of the agreement between Segway Inc. and Customer. The only terms and conditions of the sales of Products and Services by Segway Inc. to Customer are those stated on the Sales Agreement and in these Terms and Conditions as accepted by Segway Inc. This Agreement supersedes any contrary terms and conditions provided in or on Customer’s purchase order (or other document previously or hereafter issued by Customer to Segway Inc.) This Agreement may only be amended by a document signed by authorized representatives of Segway Inc. and Customer. If any provision of this Agreement shall be held to be void, unlawful or unenforceable, such provision shall be deemed stricken from this Agreement, but the remaining provisions of this Agreement shall continue in full force and effect, modified only as necessary to accomplish, as nearly as possible, the purposes of the stricken provision. New Hampshire, USA law governs this Agreement without regard to conflicts of law principles. The UN Convention on Contracts for the International Sale of Goods does not apply to this Agreement. This Agreement is made in the English language. A signature received electronically or by fax is as valid as an original signature.

Date: _____

Customer Signature: _____



RE; Segway Sole Source

November 17, 2015

To Whom It May Concern,

Segway Inc. is the only manufacturer and sole source provider of the Segway Transporter (PT) i2 Patroller, x2 Patroller, SE3 Patroller, and the Patroller Upgrade Kit package. All the Patroller models and upgrade kit are sold only as a direct transaction between Segway Inc. and end customers, unless specifically authorized by Segway Inc.

Our Authorized Public Safety dealers act as representatives on our behalf. They provide product demonstrations, training, and other services to customers. They are not permitted to participate in a bid or formally quote the Patroller models or Patroller upgrade kit unless specifically authorized by Segway Inc. Any Quote for a Segway Patroller or Patroller upgrade kit that is not issued from Segway Inc. is not valid.

When executing a purchase, please issue the purchase order to:

Segway Inc.
14Technology Drive
Bedford, New Hampshire

Sincerely,

A handwritten signature in black ink, appearing to read "Gerald White", with a large, stylized flourish at the end.

Gerald White
Director of Patroller Sales
949-910-5928
Gerald.white@segway.com

Segway of Central Florida
 430 N Alexander Street
 Mount Dora, FL 32757

(352)383-9900
 dave@segwayofcentralflorida.com
 http://www.segwayofcentralflorida.com



Quote

Date	Quote #
11/23/2015	779.1395
Exp. Date	
	12/23/2015

Address
Lt Christopher Bender Fort Pierce Police Department 920 South U.S. Highway #1 FL USA

Ship Via	Sales Rep
SOCF Truck	dgh

Item Description	Quantity	Unit Price	Amount
• StreetSmart Light Bars (pair): Police - Front White LED Headlight, Rear Flashing Red LED Tail Light, Front/Rear/Side Whelen Warning Lights, Hi Capacity Lithium Rechargeable Battery, Charging Unit (requires mounting on lower cargo frames), Remote Control System, Soft Side Cargo Bags, Patroller Bag Upgrade Kit - Siren w/ Adjustable Volume, High Capacity 12-Volt Rechargeable Lithium Battery, Whelen Wide Angle LED Headlight, Wiring Harness (includes dealer installation)	2	2,900.00	5,800.00
• SEGautostand - Rear Operated, Automatic Retracting Heavy Duty Segway Parking Stand - x2 Model	2	149.95	299.90
Total			\$6,099.90

"Changing Your World, One Segway at a Time"

"Segway equipment and accessories are not sold for export outside of the USA"

Accepted By _____

Accepted Date _____



StreetSmart®

Sole Source Provider

StreetSmart® is a “sole source provider” for our full range of manufactured StreetSmart Components for the Segway PT. Included is the StreetSmart LifeLine® (EMS unit), StreetSmart® Police, StreetSmart® Security, and the StreetSmart® Hazmat.

Sole Source Procurement Defined

Sole source procurement is any contract for a particular acquisition, which by the contract specifications needed by the requestor or by the clear and specific restrictions imposed by a funds provider, restricts the contract to one bidder or to one brand name.

Supplier – This type of sole source asserts that one and only one, supplier is capable of delivering the goods or service needed, and that the supplier is peculiarly capable in the entire market place to do so.

Brand name – This type of sole source asserts that one and only one, brand of goods or service is capable of addressing the need, and that the brand is peculiarly capable in the entire market place to do so.

For purchasing any StreetSmart component, StreetSmart® is a “sole source provider” for the following reasons:

- StreetSmart® is the inventor and manufacturer of the StreetSmart® Component Packages
- StreetSmart® Component Packages are not available from any other source
- The technical specifications of each StreetSmart® Component Package uses either patented or patent-pending add-on designed systems

The StreetSmart® Package includes:

- StreetSmart® Integrated Front Bag with department specific HD flashing light, HD wide angle white driving light, and siren with volume control
- StreetSmart® Light Bars with integrated emergency warning lighting system in department specific colors, front white driving light and rear red flashing tail lights.
- StreetSmart® custom designed Med Bags for the StreetSmart LifeLine® unit.



StreetSmart® Corporate Office
136 S. Main Street
Spanish Fork, Utah
84660

www.streetsmartsegway.com

801-794-2184

DUNS# 17422363

City Commission Regular Meeting

Agenda Item # 9. i.

Meeting Date: 12/21/2015

Re: RFP No. 2015-054 Sale of Mixed Performance Mortgage Loans

Submitted For: Johnna Morris, Finance Director, Finance Department

SUBJECT:

Approval of the sale of fourteen (14) mixed performance mortgage loans to Harbor Community Bank in the amount of \$729,300.00.

SUMMARY:

The City of Fort Pierce requested bids from qualified financial institutions for the sale of its portfolio through RFP No. 2015-054, Sale of Mixed Performance Mortgage Loans. The portfolio consists of fourteen (14) mixed performance mortgage loans, which are all first mortgage loans secured by residential collateral.

The mortgage loans totaled \$1,722,000 when originally issued with a remaining balance of \$1,571,404.81 at the time that the RFP was issued. Harbor Community Bank submitted a bid proposal in the amount of \$729,300 for the purchase of all 14 loans. This equates to 46.4% of the current loan balance.

RECOMMENDATION:

Staff recommends approval and acceptance of Harbor Community Bank's proposal in the amount of \$729,300.00.

ALTERNATIVES:

Staff will proceed as directed by the City Commission.

RESPONSIBLE STAFF:

Johnna Morris, Director of Finance

COORDINATED WITH:

Nicholas C. Mimms, City Manager
Purchasing Department

Fiscal Impact

Budgeted Y/N: N

Fiscal Year: 2016

Account:

Amount: \$729,300.00

FISCAL IMPACT:

Revenue received will be re-invested into the SHIP Program.

Attachments

Sale of Mixed Performance Mortgage Loans Worksheet
Letter from F. Fee including Bid from Harbor Community Bank

Form Review

Inbox	Reviewed By	Date
Finance Department	Johnna Morris	12/14/2015 04:12 PM
Purchasing	Tony Barnes	12/15/2015 04:19 PM
Finance Department	Jennifer Robinson	12/15/2015 04:28 PM
City Manager	Nick Mimms	12/16/2015 04:31 PM
Form Started By: Jennifer Robinson		Started On: 12/14/2015 02:58 PM
Final Approval Date: 12/16/2015		

**First Mortgages Loan Information for Sale
as of 8-5-15**

Property #	Owner	Original Loan Date	Original Loan Amount	Interest Rate	Current Loan Balance	Market Value (Current)*	Assessed Value (Current)*	Maturity Date	Monthly Principal Payment	Days Delinquent
1	[REDACTED]	5/21/2009	\$ 105,000.00	2.00%	\$ 106,929.79	\$ 82,500.00	\$ 82,500.00	6/15/2045 **	\$ 225.31	0
2	[REDACTED]	5/26/2009	115,000.00	2.00%	101,266.69	94,200.00	93,482.00	6/15/2045 **	212.53	0
3	[REDACTED]	5/27/2009	115,000.00	2.00%	118,207.61	93,900.00	93,177.00	6/15/2045 **	248.94	0
4	[REDACTED]	5/20/2009	\$ 110,000.00	2.00%	\$ 101,728.41	\$ 86,700.00	\$ 86,700.00	7/20/2039	\$ 241.98	90+ days
5	[REDACTED]	5/21/2009	120,000.00	2.00%	100,799.81	97,300.00	96,527.00	7/21/2039	274.34	0-29 days
6	[REDACTED]	5/22/2009	105,000.00	2.00%	86,527.25	82,400.00	82,400.00	7/22/2039	240.45	0
7	[REDACTED]	5/20/2009	\$ 110,000.00	2.00%	\$ 92,646.69	\$ 94,400.00	\$ 93,583.00	7/20/2039	\$ 251.91	0

First Mortgages Loan Information for Sale
as of 8-5-15

Property #	Owner	Original Loan Date	Original Loan Amount	Interest Rate	Current Loan Balance	Market Value (Current)*	Assessed Value (Current)*	Maturity Date	Monthly Principal Payment	Days Delinquent
8	[REDACTED]	5/21/2009	112,000.00	2.00%	94,723.73	92,800.00	92,162.00	7/21/2039	255.67	0
9	[REDACTED]	5/20/2009	115,000.00	2.00%	97,021.02	97,900.00	97,136.00	7/20/2039	212.53	0
10	[REDACTED]	5/20/2009	\$ 110,000.00	2.00%	\$ 117,817.61	\$ 86,600.00	\$ 86,600.00	7/20/1939	\$ 227.58	90+ days
11	[REDACTED]	5/20/2009	110,000.00	2.00%	95,335.93	94,300.00	93,482.00	7/20/1939	249.26	90+ days
12	[REDACTED]	5/20/2009	112,000.00	2.00%	94,490.17	92,600.00	91,959.00	7/20/1939	256.49	0
13	[REDACTED]	8/21/2008	133,000.00	1.00%	106,577.49	60,500.00	55,948.00	9/21/2038	338.99	0
14	[REDACTED]	8/21/2008	250,000.00	1.00%	257,332.61	129,800.00	128,702.00	9/21/2038	601.47	90+ days
Grand Total			\$ 1,722,000.00		\$ 1,571,404.81	\$ 1,285,900.00	\$ 1,274,358.00			

* As appraised
by property
appraiser

** Loan
Modified
07/2015

FEE, DeROSS & FEE, P.L.

ATTORNEYS AT LAW

SINCE 1905

FRANK H. FEE, III
FRANK H. FEE, IV
JOSEPH J. DeROSS, JR., P.A.

426 AVENUE A
FORT PIERCE, FLORIDA 34950

FRED FEE (1888-1939)
FRANK FEE (1913-1983)

TELEPHONE
(772) 461-5020

POPPELL HOUSE
A Designated Historic Property

TELECOPIER
(772) 468-8461

Writer's Email
ffee@feederossfee.com

October 14, 2015

Procurement Department
City of Fort Pierce
100 North U S. Highway 1
Fort Pierce, FL 34950

Re: Bid/Sale of Mixed Performance Loans
Bid. No. 2015-054

Ladies and Gentlemen:

I am business counsel to Harbor Community Bank. As such, I am pleased to enclose the bid response form and other documents required to formally bid on the above, whole loans. The bid amount of my client is \$729,300.00.

The bid of Harbor Community Bank is subject to the following conditions or contingencies:

1. The bid is extended on an "all or nothing" basis, i.e., the bid is for all loans and does not consider a piecemeal sale.
2. Satisfactory review of the credit files and documents for adequacy and enforceability.

My client is a knowledgeable mortgage lender, and is positioned to close on its bid and to receive transfer of the loans for its own administration within a short time of the acceptance of its bid. As counsel, we will seek to expedite completion of the accepted bid.

Respectfully,



Frank H. Fee, III

FHF:cs
Enclosure



BID RESPONSE FORM



Bid Item	SALE OF MIXED PERFORMANCE MORTGAG LOANS		
Bid Number	2015-053	Due Date & Time	OCTOBER 15, 2015, 3:00 PM

The offerer agrees to furnish the following items or services to the City of Fort Pierce at the place specified, in accordance with specifications herein at the prices quoted below:

LOAN NUMBER	TOTAL	
1	\$ 54,600	
2	\$ 51,600	
3	\$ 55,700	
4	\$ 47,500	
5	\$ 56,500	
6	\$ 48,900	
7	\$ 51,900	
8	\$ 52,900	
9	\$ 50,200	
10	\$ 48,600	
11	\$ 47,500	
12	\$ 52,900	
13	\$ 37,500	
14	\$ 73,000	TOTAL \$729,300

Do you have a local Branch? Yes No. If yes how many? 9

Please list the address of a local branch: 200 S. INDIAN RIVER DR., FORT PIERCE 34950

Typed Name J. HAL ROBERTS, JR.

Title PRESIDENT, COO

Signature  Date 10/14/15

Address 200 S. INDIAN RIVER DRIVE, SUITE 200

City, State, Zip Code FORT PIERCE, FL 34950

Email Address HALROBERTS@HARBORCB.COM

Telephone # 772-409-2272 Fax # 772-489-9560

Harbor Community Bank
 City of Ft. Pierce loan bid list
 October 15, 2015

Property #	Owner	Address	Original Loan Date	Original Loan Amount	Interest Rate	Current Balance	Assumed Appraisal Amount	Tax Assessed Fair Value	Days Delinquent	Taxes 2014	Loan Balance	5.375% Interest Rate Discount	Credit Discount	8% YTM Risk Premium	Appraisal Adj. 50% minimum	Total Discount	Bid Amount (Rounded)	Bid % of Current Balance	IRR with full performance
1	[REDACTED]	308 N 13th Street	05/21/2009	105,000	2.00%	106,930	95,000	82,500		1,020 Paid	106,930	(35,700)	(11,930)	(4,700)	-	(52,330)	54,600	51.1%	8.00%
2	[REDACTED]	118 N 12th Street	05/26/2009	115,000	2.00%	101,267	95,000	94,200		1,289 Paid	101,267	(33,800)	(6,267)	(9,600)		(49,667)	51,600	51.0%	8.01%
3	[REDACTED]	104 N 13th Street	05/27/2009	115,000	2.00%	118,208	95,000	93,900		1,281 Paid	118,208	(39,300)	(23,208)	-		(62,508)	55,700	47.1%	8.88%
4	[REDACTED]	105 N 12th Street	05/20/2009	110,000	2.00%	101,728	95,000	86,700	90+ days	1,123 Paid	101,728	(32,000)	(6,728)	(17,100)	1,600	(54,228)	47,500	46.7%	9.99%
5	[REDACTED]	120 N 13th Street	05/21/2009	120,000	2.00%	100,800	110,000	97,300		1,364 Paid	100,800	(32,000)	(2,016)	(10,300)		(44,316)	56,500	56.1%	8.00%
6	[REDACTED]	110 N 12th Street	05/22/2009	105,000	2.00%	86,527	95,000	82,400		1,018 Paid	86,527	(24,900)	(1,731)	(11,000)		(37,631)	48,900	56.5%	7.99%
7	[REDACTED]	111 N 12th Street	05/20/2009	110,000	2.00%	92,647	95,000	94,400		1,292 Paid	92,647	(27,000)	(1,853)	(11,900)		(40,753)	51,900	56.0%	8.00%
8	[REDACTED]	109 N 12th Street	05/21/2009	112,000	2.00%	94,724	95,000	92,800		1,257 Paid	94,724	(27,800)	(1,894)	(12,100)		(41,794)	52,900	55.8%	8.00%
9	[REDACTED]	114 N 13th Street	05/20/2009	115,000	2.00%	97,021	95,000	97,900		1,366 Paid	97,021	(31,700)	(2,021)	(13,100)		(46,821)	50,200	51.7%	8.01%
10	[REDACTED]	117 N 12th Street	05/20/2009	110,000	2.00%	117,818	95,000	86,600	90+ days	1,121 Paid	117,818	(41,000)	(22,818)	(5,400)		(69,218)	48,600	41.3%	10.00%
11	[REDACTED]	113 N 12th Street	05/20/2009	110,000	2.00%	95,336	95,000	94,300	90+ days	1,289 Paid	95,336	(28,400)	(336)	(21,800)	2,700	(47,836)	47,500	49.8%	10.00%
12	[REDACTED]	118 N 13th Street	05/20/2009	112,000	2.00%	94,490	95,000	92,600		1,252 Paid	94,490	(27,600)	(1,890)	(12,100)		(41,590)	52,900	56.0%	8.01%
13	[REDACTED]	153-A Phosson Lane	08/21/2008	133,000	1.00%	106,577	75,000	60,500		683 Paid	106,577	(38,400)	(31,577)	-	900	(69,077)	37,500	35.2%	13.40%
14	[REDACTED]	[REDACTED]	08/21/2008	250,000	1.00%	257,333	146,000	129,800	90+ days	2,175 Paid	257,333	(110,000)	(111,333)	-	37,000	(184,333)	73,000	28.4%	27.19%
Total											1,571,405	(529,600)	(225,601)	(129,100)	42,200	(842,101)	729,300	46.4%	

City Commission Regular Meeting

Agenda Item # 9. j.

Meeting Date: 12/21/2015

Re: Holiday Bonus Pay

Submitted For: Johnna Morris, Finance Director, Finance Department

SUBJECT:

Approval to provide a net \$50 holiday bonus to each employee.

SUMMARY:

As a token of appreciation for the employees' service and hard work during the past year, it is recommended that each employee be given a \$50 holiday bonus.

RECOMMENDATION:

Staff recommends approval.

ALTERNATIVES:

Staff will provide as directed by the Commission.

RESPONSIBLE STAFF:

Finance Director

COORDINATED WITH:

City Manager

Fiscal Impact

Budgeted Y/N: No

Fiscal Year: 2016

Account:

Amount: \$17,820.00

OTHER INFORMATION:

\$17,820.00; funds to be provided from excess revenue from Purchasing Card Rebate.

Form Review

Inbox

Finance Department

City Manager

Form Started By: Queen Thompkins

Final Approval Date: 12/16/2015

Reviewed By

Johnna Morris

Nick Mimms

Date

12/14/2015 02:00 PM

12/16/2015 04:31 PM

Started On: 12/14/2015 01:24 PM

City Commission Regular Meeting

Agenda Item # 10. a.

Meeting Date: 12/21/2015

Re: Voluntary Annexation - Oleander Avenue

SUBJECT:

Ordinance No. 15- 057 voluntarily annexing property located on Oleander Avenue just north of Kanner Drive (parcel number 2427-601-0010-000-5). SECOND READING

SUMMARY:

The property is 1.07 acres and has the St. Lucie County zoning designation of RM-11, Residential, Multiple-Family with a RH, Residential High future land use. Staff is proposing to grant the property a R-5, High Density Residential zoning and RH, High Density flu once annexed into City limits.

RECOMMENDATION:

Approval.

ALTERNATIVES:

Approval with conditions.

RESPONSIBLE STAFF:

Clarissa Davis, Planner

COORDINATED WITH:

Rebecca Grohall, AICP, Planning Manager

Fiscal Impact

Budgeted Y/N:

Fiscal Year:

Account:

Amount:

OTHER INFORMATION:

With a millage rate of 6.5786%, the taxable revenue for the property located on Oleander Avenue is estimated at \$2460.

Attachments

Staff Report

Application

Warranty Deed

Survey

Ordinance 15-057

Form Review

Inbox

City Manager

Form Started By: Clarissa Davis

Final Approval Date: 12/08/2015

Reviewed By

Nick Mimms

Date

12/02/2015 04:46 PM

Started On: 11/25/2015 10:25 AM



CITY OF FORT PIERCE

PLANNING DEPARTMENT

REBECCA GROHALL, AICP, PLANNING MANAGER
COMPREHENSIVE PLANNING ♦ DEVELOPMENT REVIEW
HISTORIC PRESERVATION ♦ URBAN DESIGN ♦ URBAN FORESTRY ♦ ZONING

TO: The Honorable Mayor and Members of the City Commission

THROUGH: Rebecca Grohall, AICP, Planning Manager

FROM: Clarissa Davis, Planner

RE: **Voluntary Annexation – Oleander Avenue**

DATE: November 25th, 2015

STAFF REPORT

The applicant is requesting approval of the voluntary annexation application for a property located on Oleander Avenue south of Edwards Road. The property is 1.07 acres and has the St. Lucie County zoning designation of RM-11, Residential, Multiple-Family with a RH, Residential High future land use. The RM-11 zoning district allows for a maximum of 11 units per acre while the RH future land use designation allows 15 units per acre. When the City facilitates annexation applications, a comparable zoning and future land use is assigned to the property. Though the RM-11 designation is more comparable with the City's R4, Medium Density Residential zoning district, staff believes that the R5, High Density zoning district will be a more appropriate match with the High Residential future land use.

It has been confirmed that the property is located within an unincorporated part of St. Lucie County (SLC) and that the parcel is contiguous to the municipal boundary.

Comprehensive Plan

Consistent with Objective 1.11 and Policies, 1.11.5 and 1.11.6 of the City Comprehensive Plan, the City shall evaluate proposed annexations within the urban service boundary based upon the following criteria:

1. The ability of the City to provide public services at a level equal to or better than that available from the current service providers;
2. The ability of the City to provide public services at the City's adopted levels of service;
3. Whether the annexation would eliminate an unincorporated island or could be expanded to eliminate an unincorporated island; and
4. Whether the annexation would eliminate an irregularity or irregularities in the City's boundaries, thereby improving service delivery.

Pursuant to the Future Land Use Element of the Comprehensive Plan, annexations are reviewed for fiscal impacts, the effect upon adopted level of service standards for public facilities and the elimination of the municipal boundary irregularities to improve service delivery. With a millage rate of 6.5786%, the taxable revenue for the property located on Oleander Avenue is estimated at \$2460.

Planning Board Recommendation

At their November 10th meeting, the Planning Board recommended approval of the application.

Staff Recommendation

Staff recommends that the City Commission hold a public hearing and approve the first reading of ordinance 15-057.

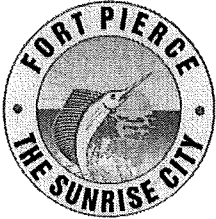

CITY OF FORT PIERCE

PLANNING DEPARTMENT

COMPREHENSIVE PLANNING ◊ DEVELOPMENT REVIEW
HISTORIC PRESERVATION ◊ URBAN DESIGN ◊ URBAN FORESTRY ◊ ZONING

APPLICATION FOR ANNEXATION

Annexation applications will require the adoption of an ordinance which will require a public meeting before the Planning Board and two public hearings before the City Commission.

Application submission shall include the following:

- **TRC (*Initial Submission):** One (1) original and (8) paper copies of the application and support documents and provide one (1) electronic copy of the application packet as described below.
- **Planning Board:** One (1) original and (16) paper copies of the application and support documents and provide one (1) electronic copy of the application packet as described below.
- **City Commission:** One (1) original and (11) paper copies of the application and support documents and provide one (1) electronic copy of the application packet as described below.

In addition to a complete application, packets shall include:

- Warranty Deed
- Current Survey (completed within the last 12 months)

1. Address: TBD Oleander Avenue, (Lot 54) Maravilla Gardens, Ft. Pierce

2. Legal description of real property for which annexation is being requested:
Beginning at the Northwest corner of Lot 154 Maravilla Gardens, Unit 3, Plat Book 6, Page 62, Public Records of St. Lucie County, Florida; Run east 300 feet; thence turn and run south 156 feet; thence turn and run west 300 feet; thence turn and run north 156 feet to the Point of Beginning.

Property Tax ID: 2427-601-0010-000-5

3. Size of described property: 1.07 Ac.

4. Project description: Oleander Avenue Apartments

5. Current St. Lucie County Future Land Use Designation: 0000

6. Current St. Lucie County Zoning: RM-1

7. Is this a Historic property? No

8. Appraised value: \$37,500.00

9. Name of Owner(s): Charles Bean/Brian Bean

Signature of Owner(s): *[Handwritten Signatures]*

Mailing Address: 5900 Silver Oak Drive

City Fort Pierce State FL Zip 34982

Phone Charles - 772-370-0578 Fax _____

10. Name of Representative: Laventure & Zeiss Engineering, Inc.

Signature of representative: _____

Mailing Address: 774 W. Midway Road

City) Fort Pierce State FL Zip 34982

Phone 772-398-1520 Fax 772-398-1521

E-mail: Gatorrr@msn.com

OFFICE USE:

DATE RECEIVED: _____ Signed: _____

File Number: _____ Check No: _____ Receipt No: _____

TRC Review: _____ Planning Board Review: _____ City Commission: _____

Ordinance No: _____ Date Approved: _____

RETURN TO:
UNIVERSAL LAND TITLE, INC.
COUNTHOUSE BOX 40

Prepared by and return to:
Universal Land Title, Inc.
Nancy Perella
1908 SE Port St. Lucie Blvd.
Port St. Lucie, FL 34952
2427-601-0010-000-5
File Number: 20767-07

(Space Above This Line For Recording Data)

COPY

Warranty Deed

married adult

This Warranty Deed made this 20th day of December, 2005, between Michael Hofstee whose post office address is 2017 S 10th St., Fort Pierce, FL 34950, grantor, and Charles Bean and Brian Bean, as *Single* adult, whose post office address is *5700 Silver Oak Dr, Fort Pierce, FL 34982*, grantee:

(Whenever used herein the terms "grantor" and "grantee" include all the parties to this instrument and the heirs, legal representatives, and assigns of individuals, and the successors and assigns of corporations, trusts and trustees)

Witnesseth, that said grantor, for and in consideration of the sum of TEN AND NO/100 DOLLARS (\$10.00) and other good and valuable considerations to said grantor in hand paid by said grantee, the receipt whereof is hereby acknowledged, has granted, bargained, and sold to the said grantee, and grantee's heirs and assigns forever, the following described land, situate, lying and being in the St. Lucie County, Florida, to-wit:

Beginning at the Northwest corner of Lot 154, MARAVILLA GARDENS, UNIT THREE, according to the Plat thereof, as recorded in Plat Book 6, Page 62, public records of St. Lucie County, Florida; run East 300 feet; thence turn and run South 156 feet; thence turn and run West 300 feet; thence turn and run North 156 feet to the Point of Beginning.

Parcel Identification Number: 2427-601-0010-000-5

Grantor herein expressly warrants this is not his homestead nor is it contiguous to his homestead, and is, in fact, vacant unimproved land

Together with all the tenements, hereditaments and appurtenances thereto belonging or in anywise appertaining.

To Have and to Hold, the same in fee simple forever.

And the grantor hereby covenants with said grantee that the grantor is lawfully seized of said land in fee simple; that the grantor has good right and lawful authority to sell and convey said land; that the grantor hereby fully warrants the title to said land and will defend the same against the lawful claims of all persons whomsoever; and that said land is free of all encumbrances, except taxes accruing subsequent to December 31, 2005, restrictions, reservations, covenants and easements of record, if any.

In Witness Whereof, grantor has hereunto set grantor's hand and seal the day and year first above written.

Signed, sealed and delivered in our presence:

Nancy Perella
Witness Name: Nancy Perella

Michael Hofstee
Michael Hofstee

Jill Anderson
Witness Name: Jill Anderson

State of Florida
County of St. Lucie

The foregoing instrument was acknowledged before me this 20th day of Dec, 2005, by Michael Hofstee, she () is personally known to me or () has produced Photo ID as identification.

[Signature]
Notary Public

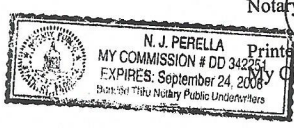

Printed Name: _____
Commission Expires: _____

CERTIFIED TO:
CHARLES BEAN AND BRIAN BEAN

DESCRIPTION

A PARCEL OF LAND LYING WITHIN LOT 154, MARAVILLA GARDENS UNIT 3, ACCORDING TO THE PLAT THEREOF, AS RECORDED IN PLAT BOOK 6, PAGE 62 OF THE PUBLIC RECORDS OF ST. LUCIE COUNTY, FLORIDA, BEING MORE PARTICULARLY DESCRIBED AS FOLLOWS:
BEGIN AT THE NORTHWEST CORNER OF LOT 154, MARAVILLA GARDENS UNIT 3; THENCE RUN EAST 300 FEET; THENCE RUN SOUTH 156 FEET; THENCE RUN WEST 300 FEET; THENCE RUN NORTH 156 FEET TO THE POINT OF BEGINNING. SAID LAND CONTAINS 1.07 ACRES, MORE OR LESS.

SURVEY NOTES

1. THIS SURVEY IS NOT VALID WITHOUT A SIGNATURE AND ORIGINAL EMBOSSED SEAL OF A FLORIDA PROFESSIONAL LAND SURVEYOR.
2. DESCRIPTION PROVIDED BY CLIENT AND/OR THEIR AGENT.
3. THE LAST DATE OF FIELD WORK WAS AUGUST 17, 2015.
4. UNDERGROUND IMPROVEMENTS AND FOUNDATIONS WERE NOT LOCATED AS PART OF THIS SURVEY.
5. BEARINGS SHOWN HEREON ARE BASED ON THE EAST R/W LINE OF OLEANDER AVENUE, BEARING N00°09'17"E, AS MENTIONED. ALL BEARINGS ARE RELATIVE HERETO.
6. ADDITIONS OR DELETIONS TO SURVEY MAPS OR REPORTS BY OTHER THAN THE SIGNING PARTY OR PARTIES IS PROHIBITED WITHOUT WRITTEN CONSENT OF THE SIGNING PARTY OR PARTIES.
7. LANDS SHOWN HEREON WERE NOT ABSTRACTED FOR EASEMENTS, SETBACKS, RESERVATIONS AND RIGHT-OF-WAYS APPEARING IN THE PUBLIC RECORDS.
8. PROPERTY LIES IN FLOOD ZONE "X", PER MAP 12111CO187.J, DATED 2-16-12.
9. PROPERTY IS CURRENTLY VACANT.

OLEANDER AVENUE
(75' R/W)

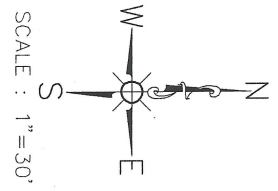

LEGEND

- Δ = CURVE CENTRAL ANGLE
- R = CURVE RADIUS
- L = CURVE LENGTH
- (C) = CALCULATED
- (P) = PLAT
- (D) = DEED
- ORB = OFFICIAL RECORD BOOK
- POB = POINT OF BEGINNING
- POC = POINT OF COMMENCEMENT
- IR = # 5 IRON ROD
- EL = ELEVATION
- IRC = # 5 IRON ROD & CAP
- MIN = MINIMUM
- FTE = FINISH FLOOR ELEVATION
- CM = CONCRETE MONUMENT
- P.L.S. = PROFESSIONAL LAND SURVEYOR
- LB = LICENSED BUSINESS
- PB = PLAT BOOK
- IP = 1/2" IRON PIPE
- N = NAIL AND DISK
- P/W = EXISTING AT-LET HANDBOLE
- ⊙ = EXISTING FIRE ALARM
- ⊙ = EXISTING IRIGATION WELL
- ⊙ = SET #4x8x10 UTILITY EASEMENT
- ⊙ = SET #4x8x10 UTILITY EASEMENT
- ⊙ = CABLE TELEVISION BOX
- ⊙ = LAMP POST
- ⊙ = WATER METER
- ⊙ = A&P FESTIVAL
- ⊙ = WOOD POWER POLE
- ⊙ = CONCRETE POWER POLE
- ⊙ = GUY WIRE
- ⊙ = CONCRETE FENCE
- ⊙ = CHAIN LINK FENCE
- ⊙ = TOP OF BANK
- ⊙ = OVERHEAD UTILITY
- ⊙ = PERMANENT CONTROL POINT
- ⊙ = BACKFLOW PREVENTER

BOUNDARY SURVEY

PREPARED FOR
CHARLES & BRIAN BEAN

BY: RICHARD C. LAVENTURE, FLORIDA P.L.S. #5209 DATE: _____

REVISIONS

NO.	DATE	DESCRIPTION

TASK	BY	DATE
FIELD <td>MMH</td> <td>8/17/15</td>	MMH	8/17/15
CALCS. <td>RCL</td> <td>8/17/15</td>	RCL	8/17/15
DRAWN <td>MMH</td> <td>9/24/15</td>	MMH	9/24/15
CHECKED <td>RCL</td> <td>9/24/15</td>	RCL	9/24/15
FILE REF. <td>FIELD BK./P.O.</td> <td>15-2809</td>	FIELD BK./P.O.	15-2809



LAVENTURE & ASSOCIATES, INC.
PROFESSIONAL SURVEYING AND MAPPING
CIVIL ENGINEERING CONSULTANTS
7724 W. ANDRVA ROAD, SUITE 34082
FORT LAUDERDALE, FLORIDA 33408
(772) 398-6430 PHONE (772) 398-6426 FAX

DATE: 9-24-15
HORIZ. SCALE: 1"=30'
VERT. SCALE: N/A
JOB No. 15-2809
SHEET 1 OF 1

ORDINANCE NO. 15-057

AN ORDINANCE EXTENDING THE TERRITORIAL LIMITS OF THE CITY OF FORT PIERCE, FLORIDA, TO INCLUDE PROPERTY GENERALLY LOCATED AT **EAST OF OLEANDER AVENUE (2427-601-0010-000-5) NORTH OF KANNER DRIVE** SHOWN ON EXHIBIT A; DIRECTING THE ST. LUCIE COUNTY PROPERTY APPRAISER TO ASSESS SAID PROPERTY AND PLACE IT ON THE CITY TAX ROLLS AS OF JANUARY 1, 2016; DIRECTING THE ST. LUCIE COUNTY TAX COLLECTOR TO COLLECT TAXES ON THE HEREIN DESCRIBED PROPERTY; CERTIFYING PUBLICATION OF THIS ORDINANCE; ESTABLISHING THE ZONING DESIGNATION; ESTABLISHING THE LAND USE DESIGNATION; REPEALING ALL ORDINANCES OR PARTS OF ORDINANCES IN CONFLICT HERewith; AND PROVIDING FOR THE EFFECTIVE DATE HEREOF.

WHEREAS, Part I, Chapter 171, Florida Statutes, set forth a procedure for Municipal Annexation;

WHEREAS, in Chapter 171.044 F.S., the owner or owners of real property in an unincorporated area of a county which is contiguous to a municipality and reasonably compact may petition the governing body of said municipality that said property be annexed to the municipality, and;

WHEREAS, the owner or owners have signed an agreement with the Fort Pierce Utility Authorities for the provision of water service and/or sewer service outside the City limits of the City of Fort Pierce, and have agreed to be voluntarily annexed into the City of Fort Pierce and;

NOW, THEREFORE BE IT ORDAINED BY THE CITY COMMISSION OF THE CITY OF FORT PIERCE, FLORIDA:

SECTION 1. The territorial limits of the City of Fort Pierce, Florida, be and they are hereby extended to annex the following described lands:

Oleander Avenue; Parcel ID: 2427-601-0010-000-5
Legal Description: MARAVILLA GARDENS S/D-UNIT THREE- BEG AT NW COR OF LOT 154, TH RUN E 300 FT, S 156 FT, TH W 300 FT, TH N 156 FT TO POB (MAP24/27N) (1.07 AC) (OR 2454-1322)

SECTION 2. That the St. Lucie County Property Appraiser and the St. Lucie County Tax Collector are directed to place upon and add to the assessment roll, and to collect taxes on the land above described and in Exhibit A as of January 1, 2016 and subsequent years, and to enter the same at such valuation that it will bear an equal and just proportion of taxes as of that date and subsequent years.

SECTION 3. That upon this ordinance becoming effective, the land herein described on Exhibit A and annexed to the territorial limits of the City of Fort Pierce shall be zoned R-5, High Density Residential, and assigned a future land use designation RH, High Density Residential.

SECTION 4. All ordinances or parts thereof that may be determined to be in conflict herewith are hereby repealed.

SECTION 5. This Ordinance shall be and become effective immediately upon final passage.

APPROVED AS TO FORM
AND CORRECTNESS:

Robert V. Schwerer, Esq.
City Attorney

STATE OF FLORIDA)
ST. LUCIE COUNTY) ^{SS}

WE, THE UNDERSIGNED, Mayor Commissioner and the City Clerk of the City of Fort Pierce, Florida, do hereby certify that the foregoing and above Ordinance No. 15-057 was duly advertised in accordance with Section 171.044(2) of the Florida Statutes in the St. Lucie News Tribune on _____, and on _____; copy of said Ordinance was made available at the office of the City Clerk to the public upon request; said ordinance was duly introduced, read by title only, and passed on first reading by the City Commission of the City of Fort Pierce, Florida on _____; and was duly introduced, read by title only and passed on second and final reading on December 21st, 2015, by the City Commission of the City of Fort Pierce, Florida.

IN WITNESS HEREWITH, we hereunto set our hands and affix the Official Seal of the City of Fort Pierce, Florida, this the 21st of December, 2015.

Mayor Commissioner

Linda W. Cox, City Clerk

(CITY SEAL)

Exhibit A to Ordinance 15-057

Parcel ID and Legal Description of Parcel Included in Annexation

1. Parcel ID: 2427-601-0010-000-5

Legal Description: MARAVILLA GARDENS S/D-UNIT THREE- BEG AT NW COR OF LOT 154, TH RUN E 300 FT, S 156 FT, TH W 300 FT, TH N 156 FT TO POB (MAP24/27N) (1.07 AC) (OR 2454-1322)

Exhibit B to Ordinance 15-057

Maps

Proposed Annexation Area

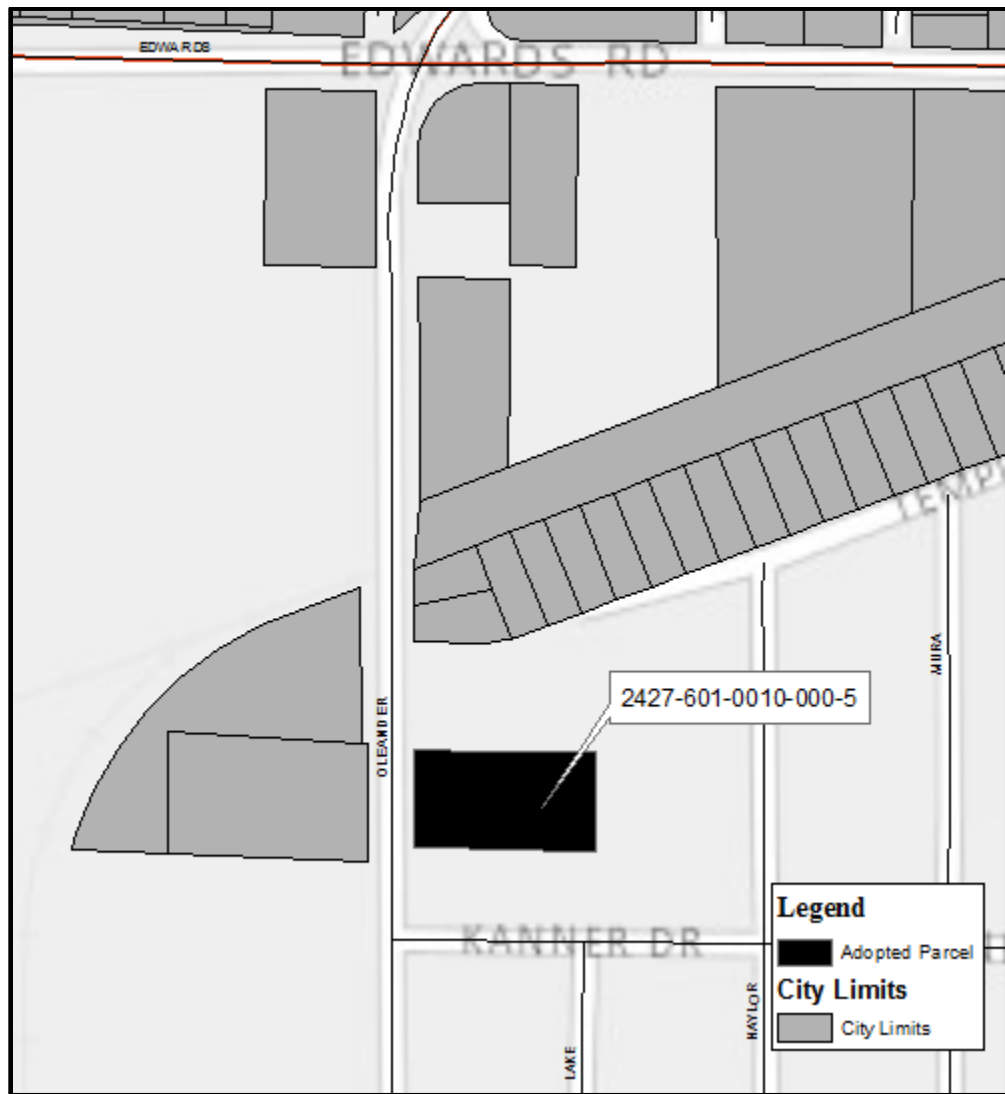

*The selected parcel is currently zoned RM-11, Residential, Multiple-Family - 11 with a FLU of RH, High Density Residential. Once annexed, these parcels will have a City zoning of R-5, High Density Residential and have a FLU of RH, High Density Residential.

City Commission Regular Meeting**Agenda Item # 10. b.****Meeting Date:** 12/21/2015**Re:** Application for Waiver of Distance - Fraternal Order of Eagles**Submitted For:** Rebecca Grohall, Planning & Zoning Manager, Planning & Zoning**SUBJECT:**

Review and approval of an application for a Waiver of Distance, submitted by Property Owners, Bamboo Palms LLC, Applicant, Fraternal Order of Eagles Aerie #3582 to establish an 11C alcoholic beverage license for their Non-profit club at 1717 S. US Highway 1, Fort Pierce, FL. The property is zoned General Commercial (C-3), (Parcel ID 2415-311-0004-000-3).

SUMMARY:

- The Fraternal Order of Eagles Aerie #3582 is seeking to relocate their non-profit club from the Denmark Building at 510 S US Highway 1, to the Royal Palms Shoppes Plaza located at 1717 S. US Highway 1.
- The Eagles hold an 11C alcohol license to provide their non-profit clubs the capacity for consumption of alcohol on premises, by the drink, for members and members' guests only.
- The applicant is requesting the Waiver of Distance based upon the presence of two (2) other licensed establishments that are located within 1,600 feet of the proposed site.
- The Property Owners and Applicants are proposing minor site and landscape improvements to the plaza for the new tenant.
- A total of 31 notifications of the proposed Conditional Use were mailed to the owners of property located within 500 feet of the subject property. As of December 11, 2015, 0 responses have been received. An update will be provided to the City Commission at the public hearing.
- The Planning Board, at their December 8th, 2015 meeting, voted unanimously to recommend approval of the request with the recommended conditions presented by Staff.

RECOMMENDATION:

Approval with the following conditions:

- 1) The applicant provides a site lighting assessment, and upgrade the lighting if necessary, to ensure the site lighting meets the minimum average of three (3) footcandles, as required by City Code, prior to release of the alcohol license;
- 2) The applicant integrates two (2) additional handicap parking spaces within the parking area, to meet the requirements of City Code Section 22-60 – Off-street Parking, as presented; and
- 3) The applicant completes the proposed landscape improvement plan to provide a vegetative screening along the vehicular use area abutting US Highway 1, as presented.

ALTERNATIVES:

- Approval with alternative conditions
- Denial

RESPONSIBLE STAFF:

Kori Benton, Senior Planner

COORDINATED WITH:

Technical Review Committee

Fiscal Impact

Budgeted Y/N:

Fiscal Year:

Account:

Amount:

OTHER INFORMATION:

A fiscal impact is not presented by this request.

Attachments

Staff Report

Site Aerial

Application

Floor Plan

Site & Landscape Improvement Plans

Form Review

Inbox

City Manager

Form Started By: Kori Benton

Final Approval Date: 12/16/2015

Reviewed By

Nick Mimms

Date

12/16/2015 04:30 PM

Started On: 12/11/2015 09:18 AM



CITY OF FORT PIERCE

PLANNING DEPARTMENT

REBECCA GROHALL, AICP, PLANNING MANAGER
COMPREHENSIVE PLANNING ♦ DEVELOPMENT REVIEW
HISTORIC PRESERVATION ♦ URBAN DESIGN ♦ URBAN FORESTRY ♦ ZONING

TO: Nicholas Mimms, PE, City Manager

THROUGH: Rebecca Grohall, AICP, Planning Manager

FROM: Kori Benton, Senior Planner

RE: Application for Waiver of Distance - 11C Alcoholic Beverage License
Fraternal Order of Eagles Aerie #3582
1717 S. US Highway 1

DATE: December 11, 2015

STAFF REPORT

Applicant/Organization Name: Fraternal Order of Eagles Aerie #3582
Walter M. Griffith
510 S US Highway 1
Fort Pierce, Florida 34950

Property Owner: Bamboo Palms LLC
Anne S Freeman, Esq.
300 Turner St
Clearwater, FL 33756

Requested Action: Approval of a Waiver of Distance for an alcoholic beverage license

Type of License: 11C - Club: Beer, wine and liquor. Issued to non-profit clubs for consumption by the drink for members and members' guests only. No package sales allowed. Unless otherwise noted, must be in continuous active existence and operation for a period of two years in the county where it exists.

Name of Establishment: Fraternal Order of Eagles Aerie #3582

Site Location: 1717 S. US Highway 1

Parcel ID: 2415-311-0004-000-3

Current Zoning: C-3, General Commercial Zone

Surrounding Zoning

North	East	South	West
C-3	C-3	C-3	C-3

Staff Analysis:

The Fraternal Order of Eagles Aerie #3582 is seeking to relocate their non-profit club from the Denmark Building at 510 S US Highway 1, to the Royal Palms Shoppes Plaza located at 1717 S. US Highway 1. The Eagles hold an 11C alcohol license to provide their non-profit clubs the capacity for consumption of alcohol on premises, by the drink, for members and members' guests only. Section 3-7 of the City Code restricts the sale or distribution of alcoholic beverages for consumption on the premises where the establishment is located within 1600 feet of a church, school or other licensed establishment; unless a Waiver of Distance is granted.

The applicant is requesting the waiver based upon the presence of two (2) other licensed establishments that are located within 1,600 feet of the proposed site. Therefore, in accordance with Section 3-9 of the City Code, the applicant is requesting a waiver of the minimum required distance of 1,600 feet between the applicant's proposed establishment and the other established uses.

As specified by Section 3-11 of the City Code, a waiver of distance shall be granted only if it does not adversely affect community health, safety or general welfare and that the following are considered:

- a. The actual location and distance of the proposed establishment with respect to other places of business licensed to sell intoxicating beverages, whether on or off the premises, as well as churches and schools;

The proposed establishment is located approximately 1,100 feet from Pueblo Viejo Restaurant and approximately 1,300 feet from China Star. There is not a heavy concentration of alcoholic beverage establishments within the vicinity of this proposed location.

- b. The type and size of the establishment, including any bar floor space and seating capacity, and whether, in view of such type or size, the proposed establishment is likely to create a public nuisance or traffic impediment by drawing crowds or persons milling about outside the building;

The proposed establishment is a non-profit, philanthropic organization occupying a gross floor area of approximately 1,800 square feet and seating for approximately 30 members and guests. The subject parcel is approximately .77 acres in size. Given the type and size of the proposed establishment, staff finds that it is not likely to create a public nuisance or traffic impediment by drawing crowds or persons milling about outside the building. No package sale of alcohol is permitted with this license.

- c. Whether adequate parking and landscaping for the facility are provided so as to meet the requirements set forth in sections 22-59 through 22-61;

The subject suite is located within an established commercial plaza, containing a variety of retail and service related tenants. Per Section 22-60(a)(4) of the City Code, if several uses occupy a single parcel, the total requirements for off-street parking and loading shall be the sum of the uses, calculated separately. However, per Section 22-60(a)(5) of the City Code, owners of two (2) or more uses, structures or parcels of land may agree to utilize jointly the same parking and loading spaces when the hours of operation do not overlap. The property

owner has provided a statement indicating that the hours of operation of the other tenants and the proposed establishment will not overlap and therefore the parking will be shared amongst the different tenants.

Additionally, per Sections 3-14(2) and 22-60(g)(1)d. of the City Code, off-street parking for an establishment that serves beer, wine and liquor for on-premise consumption shall be provided with a minimum of three (3) foot-candles of site lighting. A site lighting plan is being commissioned to accompany the request to ensure the site will meet the minimum Code requirements.

The site landscaping will be augmented by the installation of a vegetative hedge along US Highway 1, within 30 days, in order to screen the site parking area.

- d. Whether the facility is physically separated or well buffered from all adjacent residentially zoned areas;

The proposed establishment is entirely surrounded by commercial property.

- e. Whether traffic generated by patrons or pickup/delivery vehicles will pass through low or moderate density residentially zoned neighborhoods;

The proposed establishment's vehicular access is from South US Highway 1 and should not generate any additional traffic by patrons or pickup/delivery vehicles in low or moderate density, residentially zoned neighborhoods.

- f. Whether, if the facility is located within sixteen hundred (1,600) feet of a church or school, it will generate traffic which may adversely affect the safety of persons attending such church or school.

Given the proposed establishment's size, its location proximate to South US Highway 1 and that it is located within the City's urban core, staff finds that the establishment is not likely to adversely affect the safety of persons attending a nearby church or school.

Technical Review Committee:

All affected City Departments have reviewed the proposed Waiver of Distance and have provided conditional approval based on compliance with requirements of the City Code. The comments generated from the technical review, and responses by the applicant are provided for review.

Property Owner Response Summary:

A total of 31 notifications of the proposed Conditional Use were mailed to the owners of property located within 500 feet of the subject property. As of December 11, 2015, 0 responses have been received. An update will be provided to the City Commission at the public hearing.

Planning Board Recommendation:

The Planning Board, at their December 8th, 2015 meeting, voted unanimously to recommend approval of the request with the recommended conditions presented by Staff.

Staff Recommendation:

The requested Waiver of Distance is consistent with City Code, the Comprehensive Plan, and does not adversely affect the public health, safety, convenience and general welfare; Staff recommends the City Commission approve the requested Waiver of Distance for an 11C Alcoholic Beverage License for the proposed establishment, with the following conditions:

- 1) The applicant provides a site lighting assessment, and upgrade the lighting if necessary, to ensure the site lighting meets the minimum average of three (3) footcandles, as required by City Code, prior to release of the alcohol license;
- 2) The applicant integrates two (2) additional handicap parking spaces within the parking area, to meet the requirements of City Code Section 22-60 – Off-street Parking, as presented; and
- 3) The applicant completes the proposed landscape improvement plan to provide a vegetative screening along the vehicular use area abutting US Highway 1, as presented.

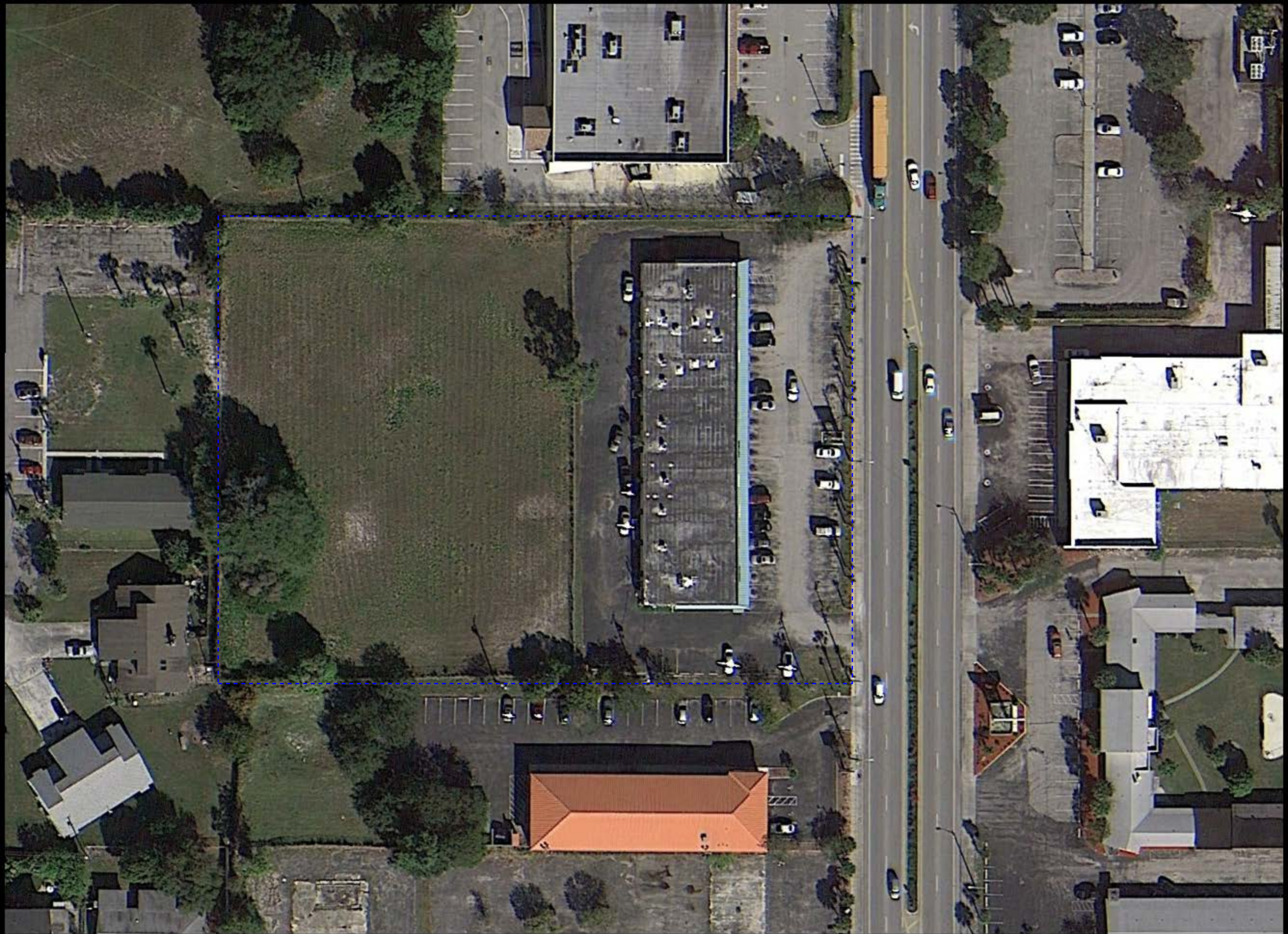

1717 S US Highway 1

Site Aerial

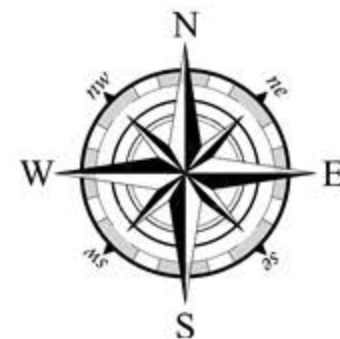



CITY OF FORT PIERCE

PLANNING DEPARTMENT

REBECCA GROHALL, AICP, DIRECTOR
COMPREHENSIVE PLANNING ♦ DEVELOPMENT REVIEW
HISTORIC PRESERVATION ♦ URBAN DESIGN ♦ URBAN FORESTRY ♦ ZONING

WAIVER OF DISTANCE

Property address or Location 1717 S. US Hwy 1, FT. Pierce, FL. 34950, 10[#]
Parcel ID #(s) 2415-311-0004-000-03
Project description _____

BAMBOO PALMS, LLC
Property Owner(s)
1717 S. US Hwy 1
Street Address
FT. PIERCE FL 34950
City State Zip
772-468-7355
Phone Number

Email Address

ROBERT CAMERON
Applicant/Representative, Title, Company
820 S. 15th ST,
Street Address
FT. PIERCE FL 34950
City State Zip
772-461-1941
Phone Number
ROBERTRSC@ATT.NET
Email Address

Property Owner(s) Acknowledgements: - This application will not be considered complete without the signature of all property owners of record, which shall serve as an acknowledgement of the submission of this application. The property owner's signature below shall also authorize the Applicant (if other than the property owner) and/or Representative to act in his/her behalf for the purposes of seeking approval for the application described herein.

William C. Koford
Property Owner(s) Signature(s)

STATE OF FLORIDA -- COUNTY
The foregoing instrument was acknowledged before me this 29 day of October, 2015, by
William Koford who is personally known to me or has produced
FL DL Exp. 11/22 as identification.

Shari L. Brown
Signature of Notary

(seal)
SHARI L. BROWN
NOTARY PUBLIC
STATE OF FLORIDA
Comm# FF161137
Expires 9/18/2018

INTAKE MEETINGS ARE REQUIRED FOR ALL SUBMITTALS. CALL (772) 467-3000 x729

TO BE COMPLETED BY STAFF

Zoning	Future Land Use	Total Acres	Historic District	Historic Designation	
				Contributing	Individual
				Non-Contributing	None

Pre-Application Meeting Date _____ Fees _____ Control # _____ B. Permit # _____
Intake Planner _____
Planner Assigned _____
Approved By _____ Date _____
Comments _____

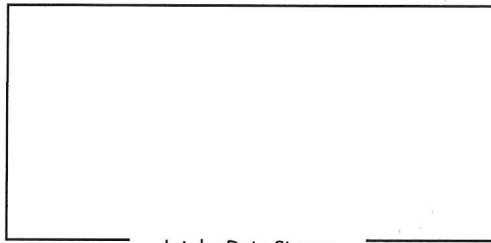
Intake Date Stamp

WAIVER OF DISTANCE

Submit one (1) original & seven (7) hard copies and one (1) CD of the following. Additional copies will be required of subsequent submittals.

- As-built site drawing, to scale, including the building, front door, parking area, traffic ingress and egress, sidewalks, landscaping and exterior lighting
- Sketch of the building's interior layout including square footage of the following: kitchen, bar area, seating arrangement, and restrooms
- Complete, notarized

Application Type:

- 1 APS/2APS: Beer Only / Package Sales or On-Premises Consumption
- 1 COP/2COP: Beer and Wine/Package Sales or On-Premises Consumption
- 3 APS: Beer, Wine & Liquor/Package Sales Only
- 4 COP: Beer, Wine & Liquor/On-Premises Consumption

Business Information:

- New Business
- Transfer from: 510 S. US Hwy 1 address #3, FT. Pierce, FL 34950 Open since: 4-4-12 year

Building Size _____ Maximum Occupancy _____ Total Seating _____ Parking Spaces _____

Hours of Operation:

Monday	Tuesday	Wednesday	Thursday	Friday	Saturday	Sunday
to	to	to	to	to	to	to
10 10	10 10	10 10	10 10	10 10	10 10	11 8

Application Outlook

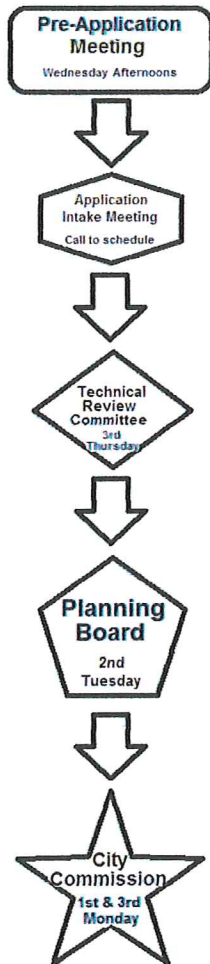

Minimum requirements for on-premises consumption.

(1) An applicant holding a "Beer and Wine—Consume on Premises and Package Sales" license must be engaged in conducting a bona fide restaurant establishment, for which such waiver is sought, and to qualify as a bona fide restaurant the restaurant must:

- (a) Have tables capable of seating not fewer than twenty (20) persons simultaneously, for the purpose of serving meals;
- (b) Must dispense sales of beer and wine only to persons patronizing the establishment for the main purpose of ordering and consuming food;
- (c) Have permanent kitchen facilities with a commercial stove, refrigerator and oven located within the premises in which meals are regularly prepared for service to patrons of the establishment.

(2) An applicant holding a "Beer, Wine and Liquor—Consume on Premises and Package Sales" license must demonstrate that any parking area provided for is illuminated by not less than three (3) footcandles per square foot of parking lot area.

Engle 3582

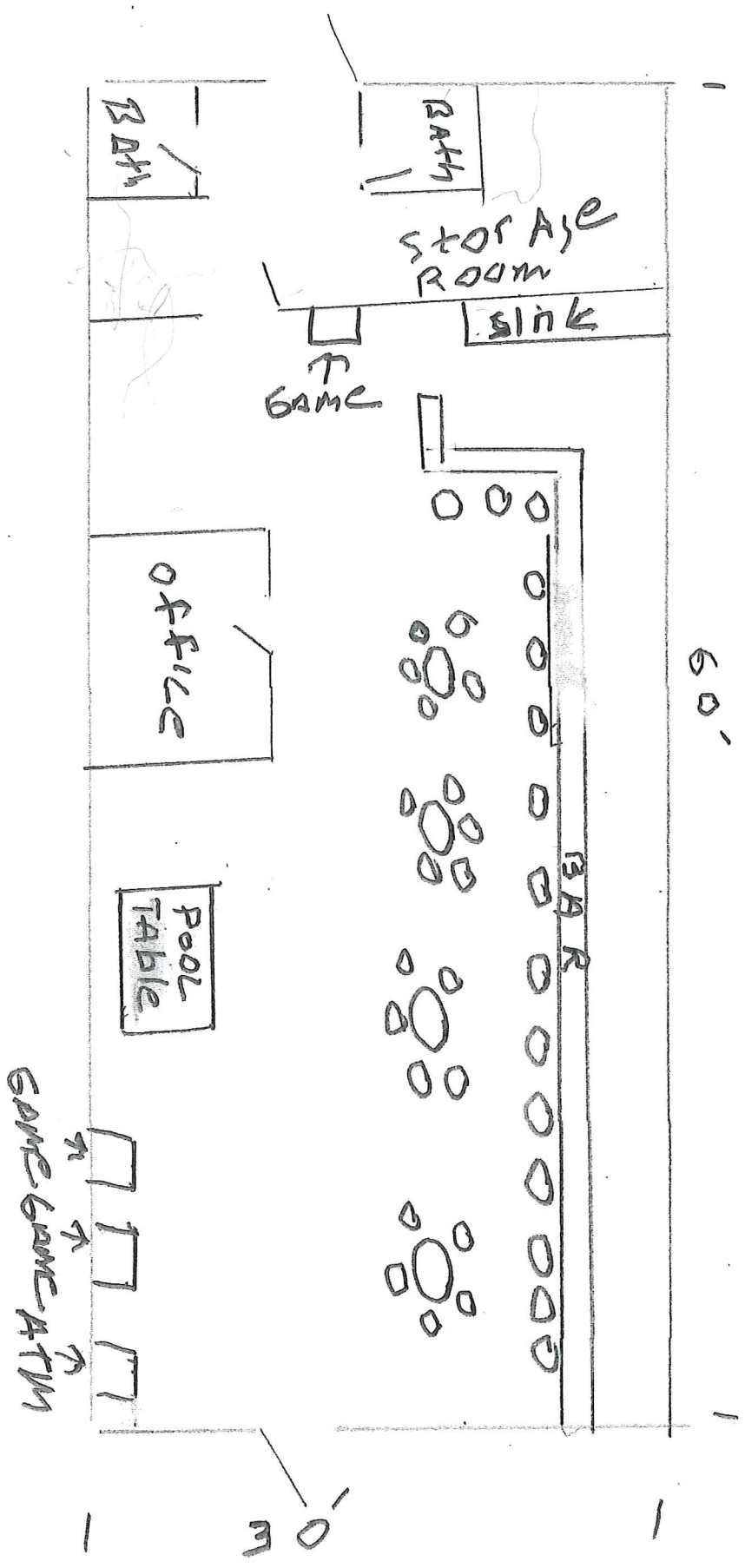

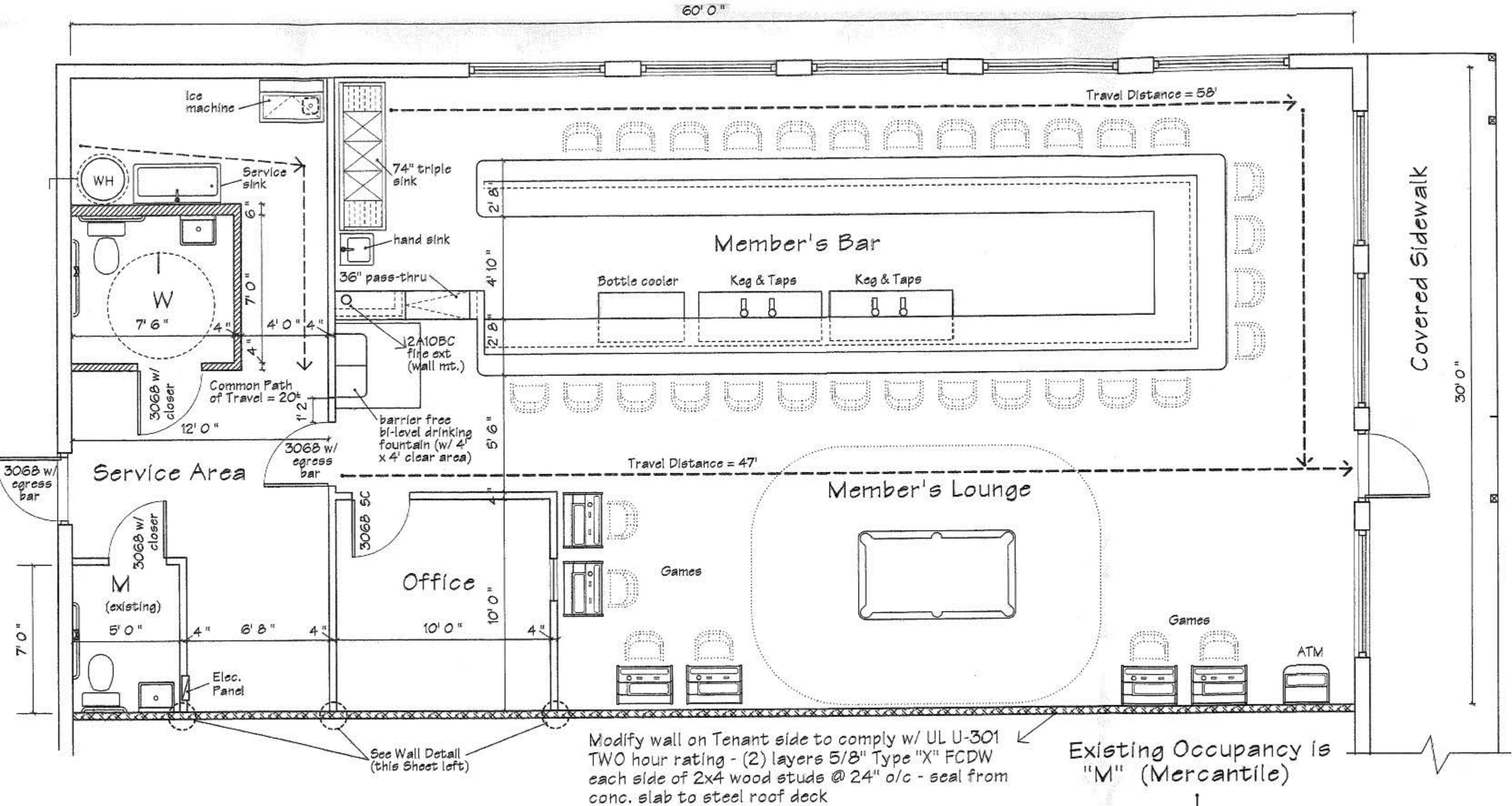

Renovation Floor Plan

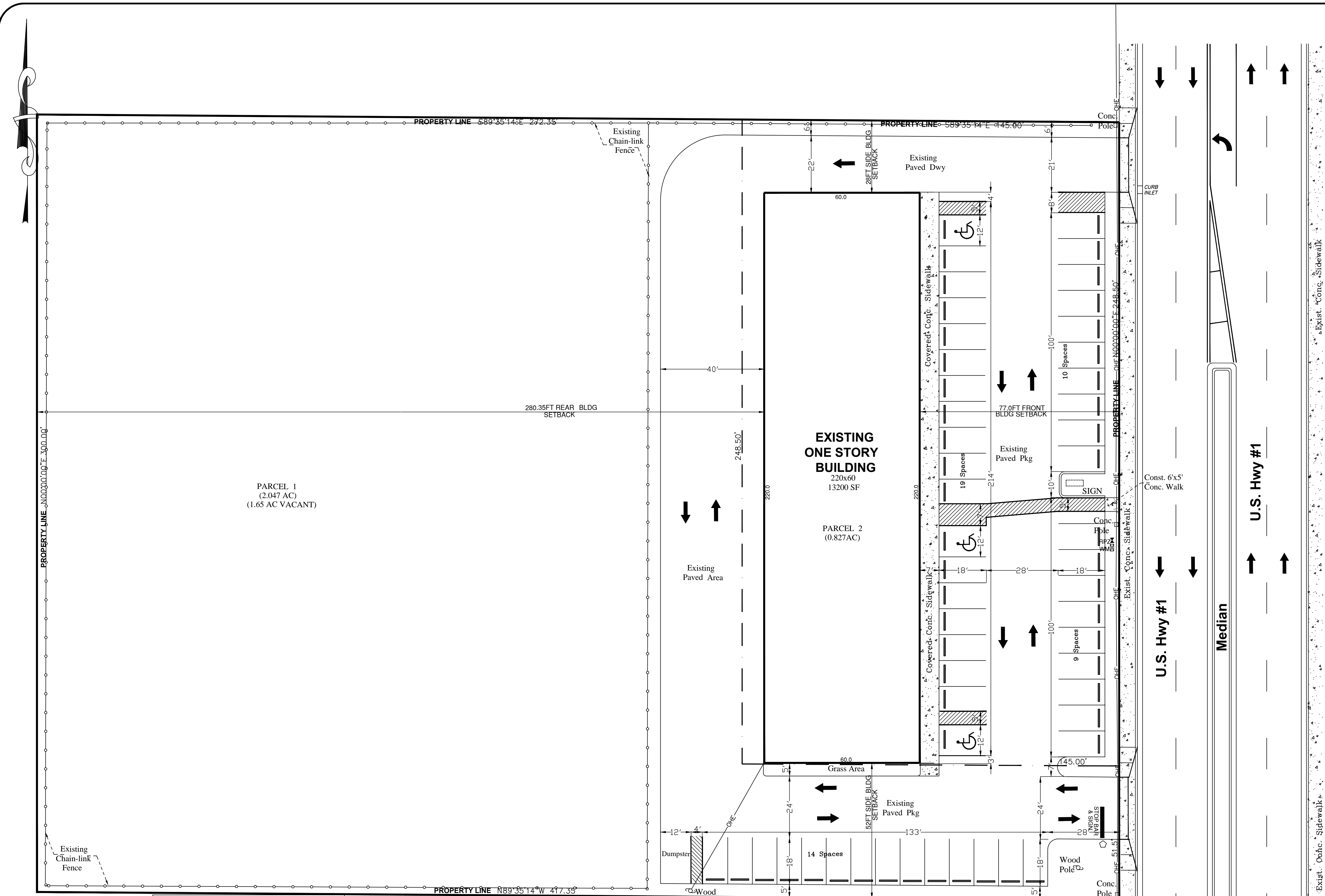

GENERAL NOTES
 PROJECT NAME: ROYAL PALM SHOPS
 LOCATION: 1717 S. US Hwy#1, FORT PIERCE, FL
 OWNER: BAMBOO PALMS LLC, 300 Turner St. Clearwater, FL 33756
 CURRENT ZONING: C-3
 FUTURE LAND USE: C-3
 CURRENT USE: OCCUPIED
 LEGAL DESCRIPTION: PARCEL 1 BEING THE EAST 417.35 FEET OF THE SOUTH 300 FEET OF THE NORTH 680 FEET ON THAT PART OF THE NORTHEAST 1/4 OF SECTION 15, TOWNSHIP 35 SOUTH, RANGE 40 EAST LYING WEST OF US HIGHWAY #1 RIGHT OF WAY. LESS AND EXCEPTION THE NORTH 248.5 FEET OF THE EAST 145 FEET THEREOF, OF THE PUBLIC RECORDS OF ST. LUCIE COUNTY, FLORIDA.
 PARCEL 2 NORTH 248.5 FT OF THE EAST 145 FT OF THE EAST 417.35 FT OF THE SOUTH 300 FT OF THE NORTH 680 FT OF THE NORTHEAST 1/4 OF THE SOUTHWEST 1/4 OF SECTION 15, TOWNSHIP 35 SOUTH, RANGE 40 EAST LYING WEST OF US #1 RIGHT OF WAY. OF THE PUBLIC RECORDS OF ST. LUCIE COUNTY, FLORIDA.
 PIN: 241531100040106 / 241531100040003
 BUILDING HEIGHT: 30.0 FEET
 NUMBER OF STORIES: ONE
UTILITIES
 ELECTRICAL: FPUA
 WATER & SEWER: FPUA FOR WATER AND WASTEWATER
 TELEPHONE: ATT
 SOLID WASTE: FORT PIERCE SOLID WASTE
NOTE: ALL UTILITIES SHALL BE INSTALLED UNDERGROUND

AREA TABULATION

SITE COVERAGE	SF	ACREAGE	% OF SITE
EXIST. BLDG	13200	0.3030	10.54
EXIST. COVERED SIDEWALK	1540	0.0354	1.23
EXIST. PAVED AREA	32245	0.7402	25.75
TOTAL IMPERVIOUS	46985	1.0786	37.52
GREEN AREA / OPEN SPACE	78220	1.7957	62.48
TOTAL	125205	2.8743	100.00

PARKING CALCULATIONS
 PARKING SPACES REQUIRED : 13200SF X 1SPACE/300SF = 44 SPACES
 TOTAL 44 SPACES
 PARKING PROVIDED : 49 REGULAR & 3 H.C. TOTAL 52 SPACES

BUILDING SETBACKS
 FRONT : 77.00 FT
 REAR : 280.35 FT
 LEFT SIDE : 52.00 FT
 RIGHT SIDE : 28.00 FT

PROPERTY LIES IN F.I.R.M. ZONE X AS SHOWN ON PANEL 12111C-0179 DATED 3/16/2012
DRAINAGE STATEMENT: PROPOSED STORMWATER DRAINAGE SYSTEM WILL COMPLY WITH CITY OF PIERCE CH 17&22
SOLID WASTE STATEMENT: CURB SIDE PICK UP WILL BE PROVIDED
HAZARDOUS WASTE: ANY & ALL HAZARDOUS OR TOXIC MATERIALS GENERATED OR USED OR STORED ON SITE SHALL BE DISPOSED OF IN ACCORDANCE WITH ALL LOCAL, STATE AND FEDERAL REGULATIONS

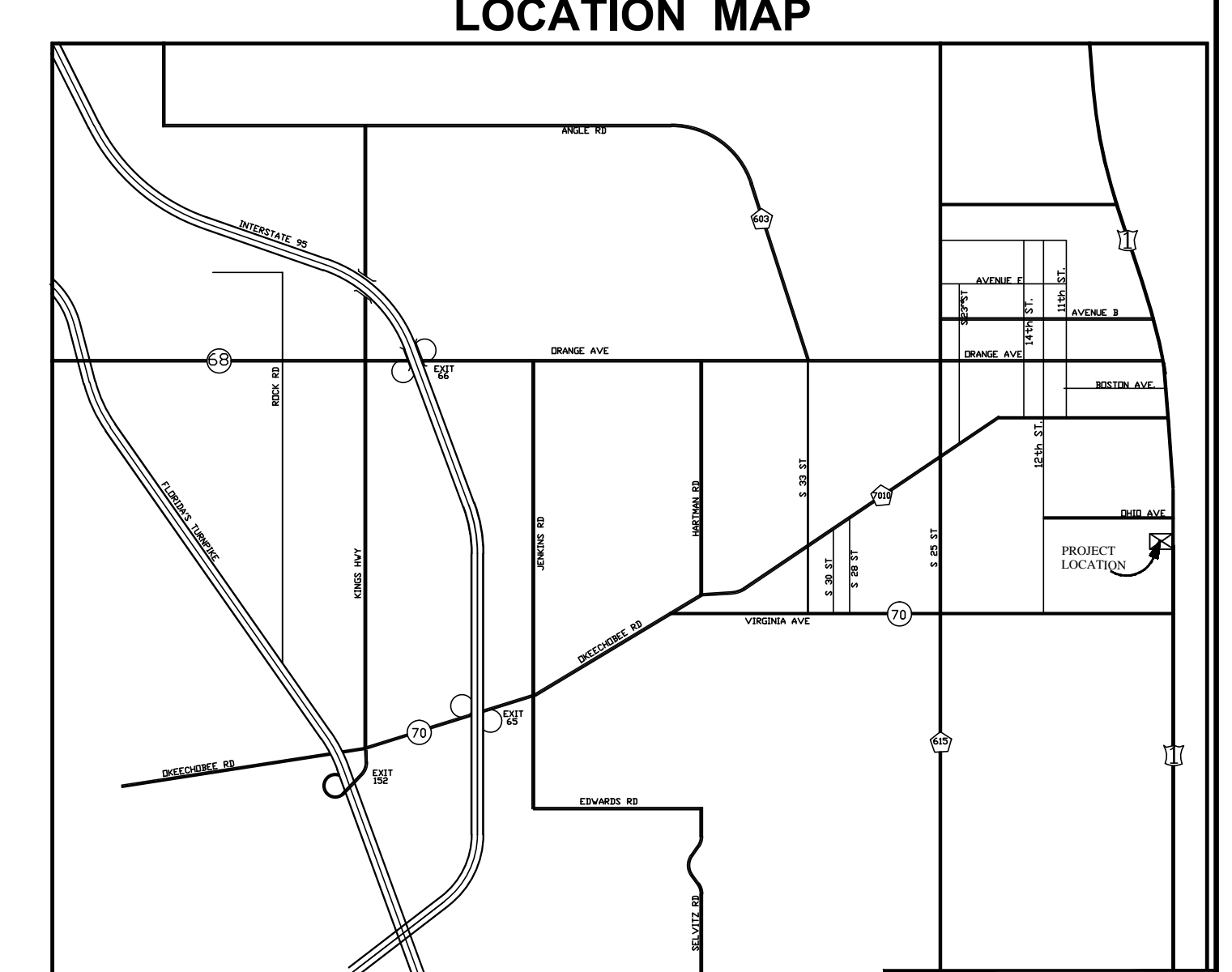

NOTE: Proposed Sidewalks & Ramps Must Comply W/ADA Standards

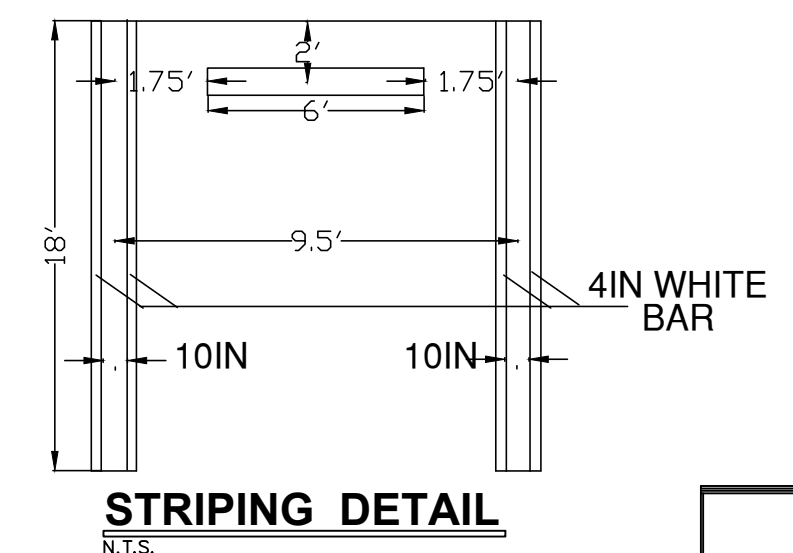
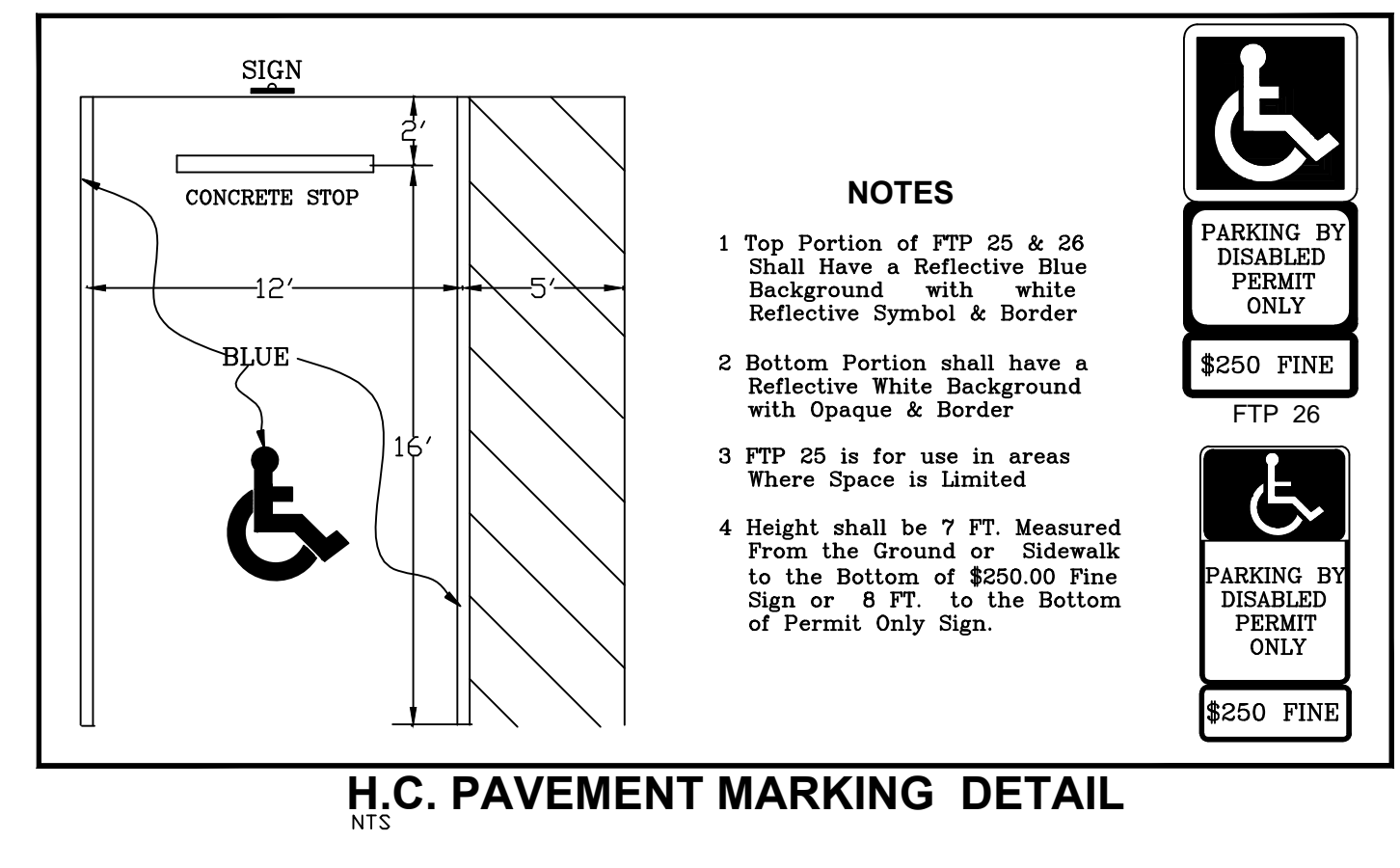
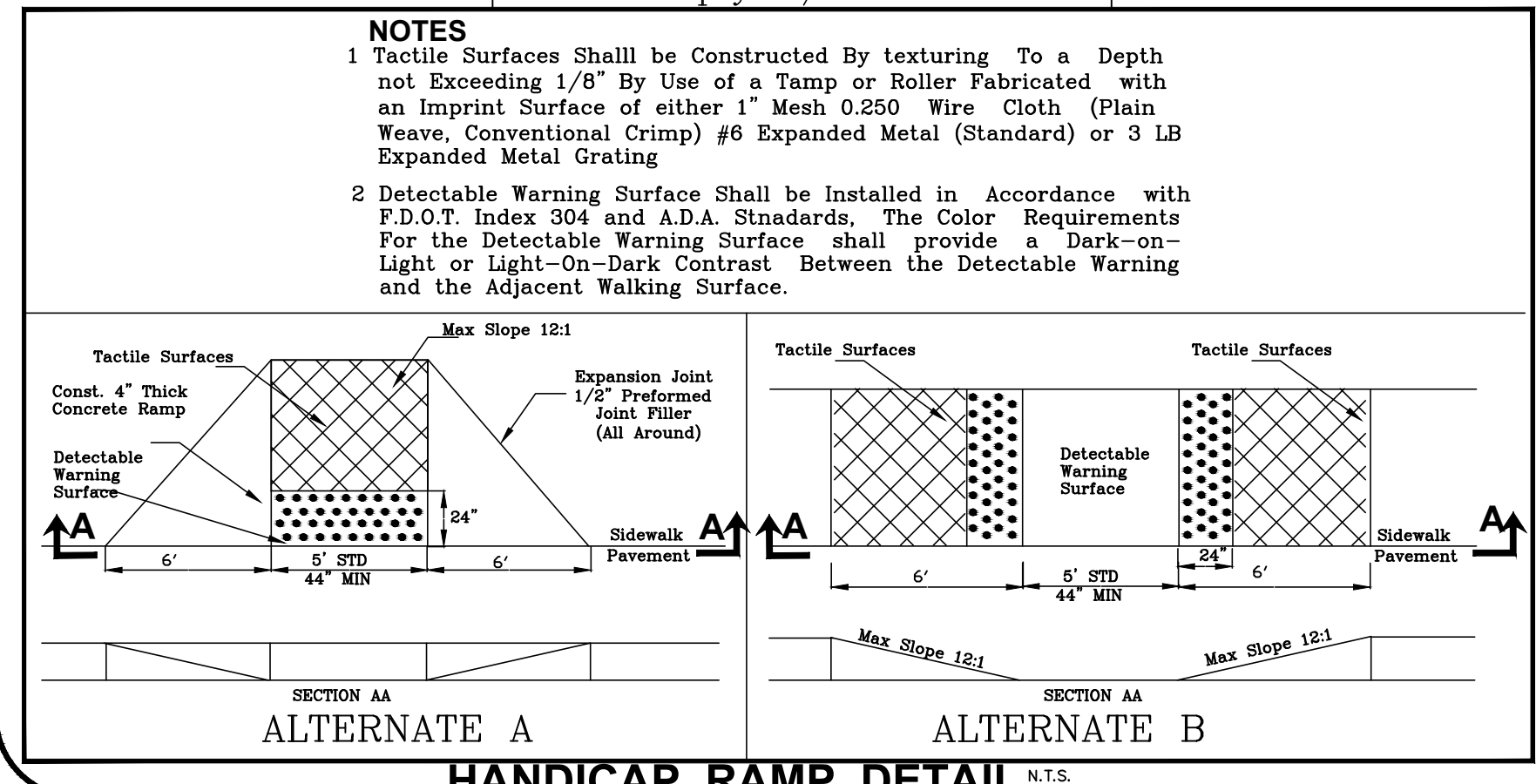

48 HOURS BEFORE DIGGING
 CALL TOLL-FREE
 1-800-432-4770
 SUNSHINE STATE ONE CALL
 OF FLORIDA, INC
 UNDERGROUND UTILITIES NOTIFICATION CENTER

ABRAHAM CHABAB, Inc.
 FL. BOARD OF PROF. ENG. AUTH. #26790
 5428 NW EDGEWATER AVE
 PORT ST. LUCIE FL 34983
 Email agchabab@msn.com
 772 878-5079/475-6630
 Fax 772 785-8291

ROYAL PALM SHOPS

SITE PLAN

DESIGNED BY	AC	REVISIONS	DATE
DRAWN BY	AC		
DATE	Nov. 21/2015		
SHEET	1 OF 1		

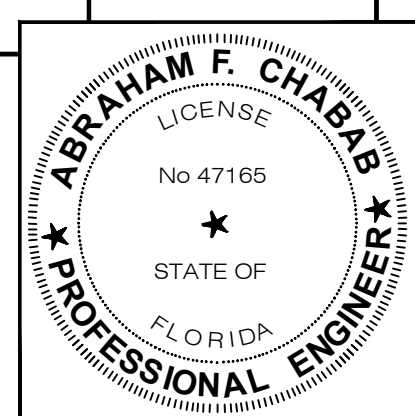

SCALE 1" = 20'

City Commission Regular Meeting

Agenda Item # 10. c.

Meeting Date: 12/21/2015

Re: Ordinance No. 15-058

Submitted For: Johnna Morris, Finance Director, Finance Department

SUBJECT:

Ordinance No. 15-058 - Amending Code Section 13-73 (c) to allow the Retirement Board to select their own attorney with the approval of the City Commission. FIRST READING

SUMMARY:

The amendment of Code Section 13-73 (c) allows the Retirement Board to choose it's own attorney with approval by the City Commission.

RECOMMENDATION:

Adopt Ordinance No. 15-058, amending Code Section 13-73 (c)

ALTERNATIVES:

Deny the amendment of the Code

RESPONSIBLE STAFF:

Finance Director

COORDINATED WITH:

Assistant City Attorney, Jim Walker, Stan Fidge, Retirement Board Vice Chair, and City Clerk for Advertising.

Fiscal Impact

Budgeted Y/N: N

Fiscal Year:

Account:

Amount:

OTHER INFORMATION:

Fiscal impact is not currently known.

Attachments

15-058

Vice Chair Memo

Retirement Board Minutes-Discussion on Legal Counsel

Form Review

Inbox
City Manager

Reviewed By
Nick Mimms

Date
12/16/2015 04:31 PM

Form Started By: Johnna Morris
Final Approval Date: 12/16/2015

Started On: 12/15/2015 08:22 AM

ORDINANCE NO. 15-058

AN ORDINANCE AMENDING THE CODE OF ORDINANCES OF THE CITY OF FORT PIERCE, FLORIDA; **AMENDING CODE SECTION 13-73(c); PROVIDING THAT RETIREMENT BOARD MAY BE REPRESENTED BY ATTORNEY OF ITS OWN CHOOSING UPON APPROVAL BY THE CITY COMMISSION**; REPEALING ORDINANCES OR PARTS THEREOF IN CONFLICT; PROVIDING FOR AN EFFECTIVE DATE.

BE IT ORDAINED BY THE CITY COMMISSION OF THE CITY OF FORT PIERCE, FLORIDA, AS FOLLOWS:

SECTION 1. Section 13-73 is hereby amended so that the same shall read hereinafter as follows:

Sec.13-73. - Officers; actuary; contracts.

- (a) The retirement board, at its first meeting in October, shall designate from its own number a chairperson and vice chairperson.
- (b) The director of finance of the city shall be treasurer and secretary of the retirement system and the custodian of its assets.
- (c) The city attorney or such other counsel as the Board may choose, upon approval by the City Commission, shall be legal advisor to the retirement board.
- (d) The retirement board shall designate an actuary who shall be technical advisor to the board and who shall perform such other duties as the retirement board shall from time to time designate.
- (e) The retirement board is authorized and empowered to employ such professional and other services as are required for the proper administration of the retirement system. Such services shall be employed on a contractual or fee basis and persons performing such services shall not be considered employees of the city. Compensation for such services shall be fixed by the retirement board, subject to approval by the city commission.

SECTION 2. All Ordinances or parts of Ordinances in conflict herewith are and the same shall be repealed and shall be of no further force or effect whatsoever.

SECTION 3. This Ordinance is and the same shall become effective immediately upon final adoption hereof.

APPROVED AS TO FORM
AND CORRECTNESS:

ROBERT V. SCHWERER, ESQ.
CITY ATTORNEY

STATE OF FLORIDA

ST. LUCIE COUNTY

WE, THE UNDERSIGNED, Mayor Commissioner and the City Clerk of the City of Fort Pierce, Florida, do hereby certify that the foregoing and above Ordinance No. 15-058 was duly advertised by title only in the St. Lucie News Tribune on December 11, 2015; a copy of said ordinance was made available at the office of the City Clerk to the public upon request; said ordinance was duly introduced, read by title only, and passed on first reading by the City Commission of the City of Fort Pierce, Florida, on December 21, 2015; and was duly introduced, read by title only, and passed on second and final reading on January 4, 2016 by the City Commission of the City of Fort Pierce, Florida.

In witness herewith, we hereunto set our hands and affix the Official Seal of the City of Fort Pierce, Florida, this the 4th day of January, 2016.

LINDA HUDSON, MAYOR COMMISSIONER

LINDA W. COX, CITY CLERK

(CITY SEAL)



CITY OF FORT PIERCE RETIREMENT AND BENEFIT SYSTEM

CITY OF FORT PIERCE
OFFICE OF DIRECTOR OF FINANCE
P.O. BOX 1480
FORT PIERCE, FL 34954
(772) 467-3000 ~ Fax (772) 489-2594

To: Honorable Mayor and City Commissioners

From: Stanley Fidge, Vice Chairman 

RE: Ordinance No. 15-058 Amending Code Sections 13-73(c); Providing That Retirement Board May Be Represented By Attorney of its Own Choosing Upon Approval by the City Commission

Date: November 23, 2015

This memorandum serves to enclose an ordinance setting out the amendment to Chapter 13, of the City's Code of Ordinances.

The Retirement Board has requested that the City Commission consider for formal adoption Ordinance No. 15-058, amending Section 13-73(c) of the Code. As it is currently written, the City Attorney, or his/her designee shall serve as legal advisor to the retirement board; this amendment will allow for legal representation of the board's own choosing, with approval by the City Commission.

In light of the changes in the City's legal department, the board desires to retain Attorney Jim Walker as its legal counsel. Atty. Walker has served as legal counsel to the board for several years, and has done an outstanding job safeguarding its long-term integrity. He has a plethora of knowledge, as it relates to pension law, as well as institutional knowledge of the City's retirement plan.

The retirement board is authorized and empowered to employ professionals and other services as are required for the proper administration of the retirement system. Such services shall be employed on a contractual or fee basis and shall be fixed by the retirement board, subject to your approval.

ITEM NO.8 ~ NEW BUSINESS – DISCUSSION OF FUTURE LEGAL REPRESENTATION

Comm. Perona said comments were made at the last Board meeting concerning future representation. He asked Mr. Walker what was the position of the Board as far as choosing its own representation.

Mr. Walker said it would require an amendment of the code. He said before he came on the Board, the code required that the counsel for the Board be the City Attorney. He said when he came on board; the Board adopted a rule amendment providing that it was to be represented by either the City Attorney or the City Attorney's designee. It was considered that was compatible with the code provision since the City Attorney and his designator are centrally alter egos of each other. Mr. Walker said since the code does require that the Board be represented by the City Attorney, and since the Commission is currently dispose to go in-house, that would require an amendment of the code. In the event the Board determines that it wishes to recommend to the Commission a change to that provision, he does have a proposed draft of an amendment to the code that the Board being in a position to consider.

Comm. Perona said the position of Board Attorney has gotten to be one that has to have an immense amount of experience and at least a network to be able to know where to go get the answer. He said that Mr. Walker has proven his knowledge and has kept the Board navigating through these mind fields lately. Comm. Persona said he is very impressed with this type of service the Board has gotten. He said from his standpoint, he would like to continue this and if it's the Board's direction he is willing to speak to the Commission concerning the Board adopting this proposal.

Mr. Nieves said due to the fact that we already have a standing code and in the event we hire a different attorney, which would soon come, would that still be standing? He said if that is the rule now; the City Attorney, whether it being he or she, decide to remove Mr. Walker, that would put the Board in harm's way in the event the City Attorney decides to remove him because of that code.

Mr. Walker said that is the rule that says that; not the Ordinance. The Ordinance says that it must be the City Attorney. He said it would also require a rules change as well. Since the immediate focus is one the Code of Ordinances, Mr. Walker said this is what he is immediately focused on.

Mr. Nieves said the Mr. Walker that this is for his protection and the protection of the Board as well.

Mr. Walker said he appreciated that. He said the proposed amendment would provide that the Board would be represented by the City Attorney or such other counsel as the Board might choose upon approval of the City Commission. Ultimately it is the City Commission that would obtain the last word.

Comm. Perona said Mr. Walker attends all of the updated conferences and stays in line with Mr. Lynn. He said this type of dynamic is proven to be the strong asset for this Board. Comm.

Perona said when you have good service; and he feels comfortable in doing what the Board is doing; a lot has been done in the last two years; a lot of changes have been made, even to the Board's portfolio; it is very important that the Board enter into these things with the legal guidance of someone savvy of the issues that are in front of the Board. Comm. Perona said he would like to keep this. He said he doesn't know where the future of our legal services for the City of Fort Pierce is going to take us so he would like for some things to remain the same as much as it possibly can. Comm. Perona said getting ahead of it now before the Board chooses an in-house attorney will probably be the key to the Board's success. Comm. Perona asked what would the Board have to do to adopt this.

Ms. Johnna Morris asked Mr. Walker if they would have to do a RFP. She asked if the Board can just say that Mr. Walker is the Board's choice.

Mr. Walker said he believe the answer to Ms. Morris's question is yes. He would need to verify it.

Comm. Perona said there are other Boards that choose their counsel accordingly. He said he knows that Civil Service Appeals has done this in the past. Comm. Perona said we are talking about a very defined and specific type of legal representation and that expertise is something this Board should be able to identify and retain accordingly.

Ms. Hurtubise said the Board really can't control what the City Commission does; they can certainly recommend approval of this Ordinance but it is up to the City Commission to decide. She said assuming the City does indeed bring in an in-house City Attorney; that City Attorney is going to be really busy. She would be much happier having someone with the expertise of Mr. Walker representing the Board instead of someone coming in. Ms. Hurtubise said Mr. Walker services the Board well and she doesn't know if the Board would receive the proper attention from another attorney that has other priorities.

Mr. Keith Stephens asked Mr. Walker how many years he has been representing this Board.

Mr. Walker said he has been representing the Board for 18 years.

Mr. Stephens said he has been on the Board a little over a year and the experience Mr. Walker has with this Board puts a lot of value in him.

Comm. Perona said the only thing he has to be cautious of is, let's not put Mr. Walker in that position right now. He said let's talk about 15 to 20 years from now. How would this Ordinance stand up to the benefit of the community? Comm. Perona said he is sure Mr. Walker is going to tell him that the Commission at any given time could change that Ordinance to go back to whatever they determine is the right path for them at that moment.

Mr. Walker said the Commission is the boss.

Comm. Perona said anything that the Board does now, the Board's recommendations can be undone if Mr. Walker steps down or retire. He asked if he could get a motion from the Board to make the recommendation to the Commission to adopt accordingly. **A motion was made by Mr. Nieves and seconded by Mr. Fidge to forward the draft with the recommendation to the Commission. All those in favor of the motion signified by saying aye. There was no opposition and the motion was carried unanimously.**

Mr. Walker said it is understood that there be a motion to draft of the Ordinance with a recommendation to the Commission. He personally thanked the Board for the support and confidence reflected in this vote.

Comm. Perona said hopefully they can insulate this group and make sure that no matter what happens citywide, the Board is doing their job and doing it effectively. He said not only what the Board does here with the oversight of Mr. Walker, the Board's money managers, and the advisors accordingly, the Board is working in the right format.

City Commission Regular Meeting

Agenda Item # 11. a.

Meeting Date: 12/21/2015

Re: Monthly financial Report for Month Ending November 30, 2015

Submitted For: Johnna Morris, Finance Director, Finance Department

SUBJECT:

Monthly Financial Report for the Month Ending November 30, 2015

SUMMARY:

The Finance Director prepares and presents to the City Commission and Citizens a monthly report on the financial status of the different funds of the City. The financial report for the month ending October 31, 2015, encompasses General, Marina, Solid Waste, Golf Course, Sunrise Theatre, Building & Code, and Fort Pierce Redevelopment Agency Funds.

RECOMMENDATION:

The Finance Department welcomes any suggestions and/or changes to the format.

ALTERNATIVES:

The report can be enhanced or changed.

RESPONSIBLE STAFF:

Finance Director

COORDINATED WITH:

Finance Department & City Manager

Fiscal Impact

Budgeted Y/N: Y

Fiscal Year: 2016

Account:

Amount:

OTHER INFORMATION:

Monthly Report on budgeted Revenue and Expenditures

Attachments

November 2015 Monthly Report

Form Review

Inbox

Finance Department
City Manager

Reviewed By

Johnna Morris
Nick Mimms

Date

12/14/2015 02:01 PM
12/16/2015 04:30 PM
Started On: 12/09/2015 12:10 PM

Form Started By: Queen Thompkins
Final Approval Date: 12/16/2015

City of Fort Pierce
Monthly Financial Report
For the Month Ending November 30, 2015
(17% Year Lapse)

General Fund				
Revenue	Budget		FYTD	%
Beginning Available Resources		\$	4,245,533	
Revenue:				
Taxes	\$ 18,943,496	\$	3,526,769	18.62%
Licenses & Permits	348,000		260,377	74.82%
Intergovernmental	2,994,000		478,363	15.98%
Charges for Services	201,600		38,728	19.21%
Fines & Forfeitures	167,500		31,975	19.09%
Miscellaneous Revenue	1,821,952		184,737	10.14%
Interfund Transfers	2,882,437		0	0.00%
Contribution from Enterprise	7,170,772		0	0.00%
Capital Projects Loan	1,400,000		1,400,000	100.00%
Appropriated Fund Balance	550,000		0	0.00%
Restricted Revenue	(626,494)		0	0.00%
Total Revenue	\$ 35,853,263	\$	5,920,950	16.51%

Expenditures:	Budget		FYTD	%
City Commission	\$ 208,361	\$	31,792	15.26%
City Manager	606,019		87,326	14.41%
City Attorney	605,108		28,148	4.65%
City Clerk	284,796		39,305	13.80%
Administrative Services	590,176		88,197	14.94%
Finance	736,272		91,608	12.44%
MIS	994,642		129,606	13.03%
Planning	451,837		55,696	12.33%
Code Enforcement	880,723		245,088	27.83%
Police	12,864,723		1,591,425	12.37%
Public Works/Director	93,729		21,229	22.65%
Public Works/Fleet Maint.	492,552		62,680	12.73%
Public Works/Facilities Maint.	879,181		138,810	15.79%
Public Works/Parks & Grounds	1,908,734		225,829	11.83%
Public Works/Streets	1,704,576		205,186	12.04%
Engineering	1,099,251		111,909	10.18%
Riverwalk	150,397		22,292	14.82%
Administrative	11,302,186		481,959	4.26%
Total Expenditures	\$ 35,853,263	\$	3,658,085	10.20%

Net Resources	\$ 2,262,864
Total Available Resources	\$ 6,508,397
Less:	
10% Budget Reserve	(3,585,326)
Reserve	(626,494)
Unrestricted Resources	\$ 2,296,577

Special Revenue Funds

FPRA	Budget	FYTD	%
Beginning Available Resources		\$ 69,040	
Revenue:			
Taxes	4,445,548	0	0.00%
Licenses & Permits	0	0	0.00%
Intergovernmental	75,000	10,142	13.52%
Miscellaneous Revenue	160,500	20,397	12.71%
Transfers	1,676,422	0	0.00%
Total Revenue	6,357,470	30,539	0.48%
Expenses:			
Operating	323,500	48,255	14.92%
Capital Outlay	0	0	0.00%
Other Programs & Projects	20,000	2,160	10.80%
Transfers	6,013,970	0	0.00%
Total Expenses	6,357,470	50,415	0.79%
Net Resources		(19,876)	
Unrestricted Resources	\$	49,164	

CDBG	Budget	FYTD	%
Beginning Available Resources		\$ 724,363	
Revenue:			
Intergovernmental Revenue	1,360,105	8,400	0.62%
Misc. Revenue	0	0	0.00%
Transfers	0	0	0.00%
Total Revenue	1,360,105	8,400	0.62%
Expenses:			
Administrative	180,902	25,765	14.24%
Rehabilitation Department	50,000	346	0.69%
Capital Outlay	0	0	0.00%
Economic Development	265,318	4,182	1.58%
Public Service	70,000	11,402	16.29%
Unencumbered	71,377	0	0.00%
Roll Over Expenditures	722,508	0	0.00%
Total Expenses	1,360,105	41,695	3.07%
Net Resources		(33,295)	
Unrestricted Resources	\$	691,068	

Grant Administration	Budget	FYTD	%
Beginning Available Resources		\$ 200,710	
Revenue:			
Program Income	50,000	8,458	16.92%
Misc. Revenue	193,250	4,748	2.46%
Interfund Transfers	0	0	0.00%
Total Revenue	243,250	13,206	5.43%
Expenses:			
Personnel Services	0	0	0.00%
Operating	243,250	618	0.25%
Transfers	0	0	0.00%
Total Expenses	243,250	618	0.25%
Net Resources		12,588	
Unrestricted Resources	\$	213,297	

SHIP	Budget	FYTD	%
Beginning Available Resources		\$ 62,431	
Revenue:			
SHIP	204,112	64,017	31.36%
Program Income	0	0	0.00%
Misc. Revenue	0	14,836	0.00%
Carry Over Funding	44,506	0	0.00%
Total Revenue	248,618	78,853	31.72%
Expenses:			
Operating	20,411	95	0.47%
Grants/Programs & Projects	228,207	492	0.22%
Total Expenses	248,618	587	0.24%
Net Resources		78,265	
Unrestricted Resources	\$	140,696	

Enterprise Funds

Marina	Budget	YTD	%
Beginning Available Resources			
	\$	291,581	
Revenue:			
Grants	470,000	0	0.00%
Charges for Services	1,539,348	187,182	12.16%
Misc. Revenue	1,526,800	205,210	13.44%
Debt Proceeds	0	0	0.00%
Approp Retained Earnings	27,122	0	0.00%
Total Revenue	3,563,270	392,392	11.01%
Expenses:			
Personnel Services	351,859	54,822	15.58%
Operating	2,714,454	362,368	13.35%
Capital	498,000	13,310	2.67%
Debt Service	451,114	5,423	1.20%
Non Operating	305,626	0	0.00%
Total Expenses	4,321,053	435,924	10.09%
Plus Depreciation		126,297	
Net Resources		82,766	
Unrestricted Resources Available	\$	374,347	

Golf Course	Budget	YTD	%
Beginning Available Resources			
	\$	(24,053)	
Revenue:			
Charges for Services	1,327,500	153,027	11.53%
Misc. Revenue	130,750	17,055	13.04%
Approp Retained Earnings	0	0	0.00%
Total Revenue	1,458,250	170,083	11.66%
Expenses:			
Personnel Services	633,868	90,666	14.30%
Operating	925,055	124,111	13.42%
Capital	7,000	0	0.00%
Non Operating	32,641	25	0.08%
Total Expenses	1,598,564	214,801	13.44%
Plus Depreciation		23,386	
Net Resources		(21,333)	
Unrestricted Resources Available	\$	(45,386)	

Building	Budget	YTD	%
Beginning Available Resources			
	\$	329,834	
Revenue:			
Licenses & Permits	1,180,000	249,002	21.10%
Charges for Services	37,000	3,096	8.37%
Fine & Forfeits	3,000	400	13.33%
Misc. Revenue	24,000	4,436	18.48%
Transfers	0	0	0.00%
Approp Retained Earnings	(14,679)	0	0.00%
Total Revenue	1,229,321	256,934	20.90%
Expenses:			
Personnel Services	716,730	108,849	15.19%
Operating	444,766	49,172	11.06%
Capital	70,000	0	0.00%
Non Operating	0	0	0.00%
Total Expenses	1,231,496	158,021	12.83%
Plus Depreciation		452	
Net Resources		99,366	
Unrestricted Resources Available	\$	429,200	

Solid Waste	Budget	YTD	%
Beginning Available Resources			
	\$	52,854	
Revenue:			
Charges for Services	6,107,000	1,070,769	17.53%
Misc. Revenue	4,000	2,475	61.87%
Approp Retained Earnings	191,280	0	0.00%
Total Revenue	6,302,280	1,073,244	17.03%
Expenses:			
Personnel Services	2,017,627	282,986	14.03%
Operating	3,084,653	558,292	18.10%
Capital	350,000	51,087	14.60%
Non Operating	1,200,000	0	0.00%
Total Expenses	6,652,280	892,364	13.41%
Plus Depreciation		54,508	
Net Resources		235,387	
Unrestricted Resources Available	\$	288,241	

Sunrise Theatre	Budget	YTD	%
Beginning Available Resources			
	\$	(51,292)	
Revenue:			
Grants	0	17,235	0.00%
Charges for Services	3,125,000	1,465,825	46.91%
Misc. Revenue	297,600	27,723	9.32%
Transfers	450,000	0	0.00%
Total Revenue	3,872,600	1,510,783	39.01%
Expenses:			
Personnel Services	586,481	69,489	11.85%
Operating	3,823,297	517,821	13.54%
Capital	1,000	0	0.00%
Non Operating	0	0	0.00%
Total Expenses	4,410,778	587,310	13.32%
Plus Depreciation		89,687	
Net Resources		1,013,160	
Unrestricted Resources Available	\$	961,869	

City Commission Regular Meeting

Agenda Item # 12. a.

Meeting Date: 12/21/2015

Re: Consideration of Application for Appointment for Communitywide Council

Submitted For: Libby Woodruff, Grant Writer, Urban Redevelopment

SUBJECT:

Consideration of Application for Appointment to Communitywide Council, submitted by Mr. John Kevin Griffin.

SUMMARY:

Application for Appointment to serve on the Communitywide Council was recently received from Mr. John Kevin Griffin, residence 1913 York Court.

RECOMMENDATION:

Approve appointment of Mr. John Kevin Griffin to serve on the Communitywide Council.

ALTERNATIVES:

Do not approve Mr. Griffin's appointment to the Communitywide Council.

RESPONSIBLE STAFF:

Libby Woodruff, Interim Urban Redevelopment Manager

COORDINATED WITH:

Nicholas C. Mimms, City Manager

Fiscal Impact

Budgeted Y/N: N

Fiscal Year: N/A

Account: N/A

Amount: \$0

OTHER INFORMATION:

There is no fiscal impact with this Agenda Item.

Attachments

Griffin - CWC Application

Form Review

Inbox

City Manager

Form Started By: Libby Woodruff

Final Approval Date: 12/16/2015

Reviewed By

Nick Mimms

Date

12/16/2015 04:30 PM

Started On: 12/01/2015 12:03 PM



CITY OF FORT PIERCE

100 NORTH US HWY 1
FORT PIERCE, FLORIDA 34950
(772) 467-3000 FAX (772) 467-3841

APPLICATION FOR APPOINTMENT/REAPPOINTMENT

Communitywide Council

Name of Board or Boards for which you are applying: _____

Name: John Kevin Griffin	Phone: 772 489 7776
Home Address: 1913 York Ct	How long at this address? 2 yrs
Are you a citizen of the United States? <input checked="" type="checkbox"/> Yes <input type="checkbox"/> No	Ten years in city
Occupation: Lawyer	
Do you own a business that operates within the City of Fort Pierce? <input checked="" type="checkbox"/> Yes <input type="checkbox"/> No If yes, list the address and nature of said business: 1913 York Ct, civil law practice	
Do you now or in the future plan to do business with the City of Fort Pierce? <input checked="" type="checkbox"/> Yes <input type="checkbox"/> No If yes, in what capacity? commissioner	
Are you employed by a business that is located within the City of Fort Pierce? <input checked="" type="checkbox"/> Yes <input type="checkbox"/> No If yes, state the business and location: 1913 York Ct	
Do you have special training or knowledge in the area of: Architecture: <input type="checkbox"/> Yes <input type="checkbox"/> No Engineering: <input checked="" type="checkbox"/> Yes <input type="checkbox"/> No Real Estate Brokering: <input checked="" type="checkbox"/> Yes <input type="checkbox"/> No Contracting: <input checked="" type="checkbox"/> Yes <input type="checkbox"/> No Land Development: <input checked="" type="checkbox"/> Yes <input type="checkbox"/> No Other: Describe your education, background, training and knowledge in the above area(s): civil litigation Memphis BA, DePaul University College of Law JD, Practice of law 25 years.	
Are you currently a member of a Commission-appointed board/committee? <input type="checkbox"/> Yes <input checked="" type="checkbox"/> No If yes, please specify:	
Have you ever been convicted of a crime? <input type="checkbox"/> Yes <input checked="" type="checkbox"/> No If yes, what was the nature of the crime(s) you were convicted of:	
Referred by: Chris Dzdovsky	Email Address: kevin@griffin123.com
Date: 11/30/2015	Applicant's Signature /s/JohnKevinGriffin electronic signature

APPLICATIONS EXPIRE 6 MONTHS FROM THE DATE OF SUBMISSION. PLEASE REAPPLY AS OFTEN AS DESIRED.

Please return form to: City Clerk's Office – 100 North US Hwy 1, Fort Pierce, Florida 34950

fax (772) 468-3841 or via email at lcox@city-ftpierce.com

City Commission Regular Meeting

Agenda Item # 12. b.

Meeting Date: 12/21/2015

Re: Request for Reimbursement of Attorney Fees

Submitted For: Tony Barnes, Director of Administrative Services, Purchasing

SUBJECT:

Request for Reimbursement of Legal Fees and Costs in the amount of \$8,875.07 associated with the defense of complaints filed with the Commission on Ethics against Robert Schwerer which were dismissed.

SUMMARY:

Complaint 14-033 and Complaint 14-075 were filed. A probable cause hearing was heard before the Ethics Commission on September 11, 2015. This request has been reviewed by an external independent attorney and deemed to be acceptable based on federal, state and local laws. Both complaints were dismissed.

RECOMMENDATION:

Reimburse the Attorney Fees and Cost associated with the defense of Complaints 14-033 and 14-075 to Robert V. Schwerer in the amount of \$8,875.07.

ALTERNATIVES:

None

RESPONSIBLE STAFF:

Tony Barnes, Director of Administrative Services

COORDINATED WITH:

Nick Mimms, City Manager

Fiscal Impact

Budgeted Y/N: N
Fiscal Year: 2016
Account: 001-1400-514-3123
Amount: \$8,875.07

OTHER INFORMATION:

As per Director of Finance

Attachments

Schwerer
City Manager Memo

Form Review

Inbox

City Manager
Purchasing (Originator)
Finance Department
Purchasing (Originator)
Finance Department
City Manager
Form Started By: Tony Barnes
Final Approval Date: 12/17/2015

Reviewed By

Jennifer Robinson
Tony Barnes
Tony Barnes
Tony Barnes
Jennifer Robinson
Nick Mimms

Date

12/17/2015 10:15 AM
12/17/2015 11:42 AM
12/17/2015 12:26 PM
12/17/2015 12:29 PM
12/17/2015 02:07 PM
12/17/2015 02:14 PM
Started On: 12/16/2015 05:13 PM

MESSER CAPARELLO
Attorneys At Law
Strategically Positioned in Florida's Capital

Mark Herron
Also Admitted in Georgia
Email: mherron@lawfla.com

November 18, 2015

Nicholas "Nick" Mimms
Interim City Manager
City of Ft. Pierce
100 North U.S. Highway 1
Ft. Pierce, FL 34950

RECEIVED
TIME _____
NOV 20 2015
CITY OF FT. PIERCE
CITY MANAGER'S OFFICE

RECEIVED
NOV 23 2015
CITY OF FORT PIERCE
PURCHASING DEPT.

RE: *In re Robert V. Schwerer, Complaint No. 14-033 & 14-075 (Ethics Commission)*

Dear Mr. Mimms:

The purpose of this correspondence is to request, on behalf of Robert V. Schwerer, the City Attorney of the City of Ft. Pierce, that he be reimbursed for the payment of attorney's fees and costs associated with the successful defense of the above-referenced complaints filed with the Commission on Ethics.

Both case law and Attorney General's opinions authorize payment or reimbursement of legal fees in connection with the successful defense of a complaint filed with the Ethics Commission when the public official was performing official duties while serving a public purpose.

Briefly, the complaints filed against Mr. Schwerer can be summarized as follows:

- **Complaint 14-033** filed by T. Michael Abinanti alleged that Mr. Schwerer "represented the City and/or its Redevelopment Agency in efforts to redevelop property, and that the Respondent used his public position to gain an advantage for his law firm in negotiations with its landlord, an entity owning property, or connected to owners of property, involved in the redevelopment efforts."
- **Complaint 14-075** filed by Rick Reed alleged that the Mr. Schwerer "provided publicly funded legal representation to a City Commissioner in connection with a lawsuit against the Commissioner which alleged a defamatory act committed during a time when the Commissioner held no public position and which named the Commissioner individually as the sole defendant."

Both of these complaints were found to be legally sufficient to warrant investigation and, following investigation by the Commission on Ethics and a probable cause hearing before

Nicholas "Nick" Mimms

November 18, 2015

Page 2 of 2

the Commission on September 11, 2015. A copy of the Public Report dismissing both complaints is included with this letter. Underlying the Commission's finding of "no probable cause" is a determination that Mr. Schwerer was performing official duties while serving a public purpose in connection with his actions that were the subject of the complaints.

Our firm has billed Mr. Schwerer **\$8,875.07** in connection with the defense of this matter. The services of Mark Herron and J. Brennan Donnelly have been billed at the hourly rate of \$300 per hour. Copies of billing statements regarding these fees and costs included with this letter as well.

Thank you for your attention to this request. If you have additional questions or concerns, or need any additional information, with respect to this request, please let me know.

Sincerely,

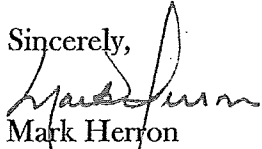
Mark Herron

cc: Robert V. Schwerer, Esquire



INTEROFFICE MEMORANDUM
FROM THE OFFICE OF THE
CITY MANAGER

TO : The Honorable Mayor and Members of the City Commission

FROM : Nicholas C. Mimms, P.E., City Manager

A handwritten signature in blue ink, appearing to read "N. Mimms", is written over the "FROM" line.

RE : **Reimbursement of Attorney's Fees – Report**

DATE : December 21, 2015

Attached is a report from Richard V. Neill, Jr. with regard to the requests from Commissioners Becht and Perona and City Attorney Robert V. Schwerer for the reimbursement of attorney's fees related to ethics complaints that were dismissed. The report is attached for your information.

If you have any questions or need additional information, please contact me.

NCM:jdr

c: Linda Cox, City Clerk
Robert V. Schwerer, City Attorney

LAW OFFICES
NEILL, GRIFFIN, TIERNEY, NEILL & MARQUIS

CHARTERED

311 SOUTH SECOND STREET

SUITE 200

FORT PIERCE, FLORIDA 34950

RICHARD V. NEILL[□]
J. STEPHEN TIERNEY, III
RICHARD V. NEILL, JR.[†][°]
RENÉE MARQUIS-ABRAMS^{*}

^{*}BOARD CERTIFIED WILLS, TRUSTS & ESTATES LAWYER
[°]CERTIFIED CIRCUIT CIVIL/COUNTY COURT MEDIATOR
[†]BOARD CERTIFIED CIVIL TRIAL LAWYER
[□]OF COUNSEL

December 18, 2015

MAILING ADDRESS:
POST OFFICE BOX 1270
FORT PIERCE, FL 34954
TELEPHONE (772) 464-8200
FAX (772) 464-2566

HAND DELIVERY

Mr. Nicholas Mimms, P.E.
City Manager
City of Fort Pierce
Post Office Box 1480
Fort Pierce, Florida 34954

RECEIVED
TIME _____
DEC 21 2015
CITY OF FT. PIERCE
CITY MANAGER'S OFFICE

Dear Mr. Mimms:

You have asked that I review the issue of reimbursing attorneys' fees incurred by Commissioners Becht and Perona, and by City Attorney Schwerer (collectively "the officials"), in relation to ethics complaints which have been dismissed.

You provided the November 18, 2015, letters and enclosures received from their attorney, Mark Herron. I've reviewed that correspondence, including the public reports determining no probable cause on each of the complaints.

I have also reviewed additional documents provided by the officials, including copies of complaints, the Advocate's Recommendation on Mr. Becht's case, and Mr. Schwerer's response to the Advocate's Recommendation on his case.

My understanding is that the City of Fort Pierce does not have any written policy or code provision directly addressing reimbursement of such attorney's fees; and, while there is a State statute providing for defense of civil actions against public officials, there is not one directly addressing reimbursement of expenses incurred in responding to an ethics complaint.

The Courts in Florida have, however, clearly recognized that officials have the right to reimbursement, independent of any statute, for expense incurred in successfully defending claims of malfeasance in office.

Mr. Nick Mimms
City Manager
December 18, 2015
Page 2

As stated by the Attorney General's Office:

Florida courts have recognized a common law right of public officials to legal representation at public expense to defend themselves against litigation arising from the performance of their official duties while serving a public purpose. The purpose of this rule is to avoid the "chilling effect" that a denial of representation might have on a public official in performing his duties properly and diligently. Such an obligation arises independent of statute, ordinance or charter and "is not subject to the discretion of the keepers of [the] City coffers".

Ops. Att'y Gen. Fla. 98-12.

This is a right which has been extended to successful defense of ethics complaints. See, Maloy v. Board of County Commissioners of Leon County, 946 So.2d 1260 (Fla. 1st DCA), rev. den., 962 So.2d 337 (Fla. 2007); Ellison v. Reid, 397 So.2d 352 (Fla. 1st DCA 1981); and Ops. Att'y Gen. Fla. 90-74 (1990).

So, if the City Commission concludes on the facts presented that the officials incurred the expense in successfully defending themselves against ethic's complaints arising from the performance of their official duties while serving a public purpose, the officials are entitled to reimbursement of that cost.

The Courts do recognize that a public purpose is served by defending an unfounded complaint or action, because, "the public has an overriding interest in ensuring the effective and efficient functioning of its governing body", Thorner v. City of Fort Walton Beach, 568 So.2d 914, 917 (Fla. 1990), and, "[i]f a public officer is charged with misconduct while performing his official duties and while serving a public purpose, the public has a primary interest in such a controversy and should pay the reasonable and necessary legal fees incurred by the public officer in successfully defending against unfounded allegations of official misconduct". Ellison, supra, at 354.

Under the circumstances as I understand them, and based on the decisions of Florida's appellate courts, I recommend reimbursement of the expenses as requested.

Mr. Nick Mimms
City Manager
December 18, 2015
Page 3

Finally, I'm enclosing our statement for services on this matter and thank you for asking me to review this issue for the City.

Sincerely,

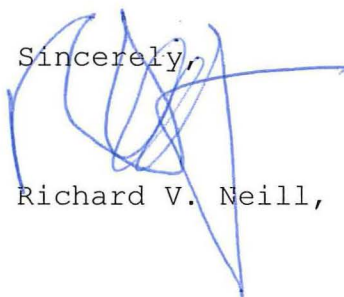

Richard V. Neill, Jr.

RVNjr/hg
Enclosure

cc: Tony Barnes, Purchasing Director (w/encl.) (hand delivery)

City Commission Regular Meeting

Agenda Item # 12. c.

Meeting Date: 12/21/2015

Re: Request for Reimbursement of Attorney Fees

Submitted For: Tony Barnes, Director of Administrative Services, Purchasing

SUBJECT:

Request for Reimbursement of Legal Fees and Costs in the amount of \$3,015.00 associated with the defense of complaints filed with the Commission on Ethics against Thomas Perona which were dismissed.

SUMMARY:

Complaints 14-041 and 14-123 . A probable cause hearing was heard before the Ethics Commission on September 11, 2015. This request has been reviewed by an external independent attorney and deemed to be acceptable based on federal, state and local laws. Both Complaints were dismissed.

RECOMMENDATION:

Reimburse the Attorney Fees and Cost associated with the defense of Complaints 14-041 and 14-123 to Thomas K. Perona in the amount of \$3,015.00.

ALTERNATIVES:

None

RESPONSIBLE STAFF:

Tony Barnes, Director of Administrative Services

COORDINATED WITH:

Nick Mimms, City Manager

Fiscal Impact

Budgeted Y/N: N
Fiscal Year: 2016
Account: 001-1400-514-3123
Amount: \$3,015.00

OTHER INFORMATION:

As per Director of Finance

Attachments

Perona
City Manager Memo

Form Review

Inbox

City Manager

Purchasing (Originator)

Finance Department

Purchasing (Originator)

Finance Department

City Manager

Form Started By: Tony Barnes

Final Approval Date: 12/17/2015

Reviewed By

Jennifer Robinson

Tony Barnes

Tony Barnes

Tony Barnes

Jennifer Robinson

Nick Mimms

Date

12/17/2015 10:16 AM

12/17/2015 12:03 PM

12/17/2015 12:25 PM

12/17/2015 12:30 PM

12/17/2015 02:07 PM

12/17/2015 02:14 PM

Started On: 12/16/2015 05:36 PM

MESSER CAPARELLO
Attorneys At Law
Strategically Positioned in Florida's Capital

Mark Herron
Also Admitted in Georgia
Email: mherron@lawfla.com

November 18, 2015

Nicholas "Nick" Mimms
Interim City Manager
City of Ft. Pierce
100 North U.S. Highway 1
Ft. Pierce, FL 34950

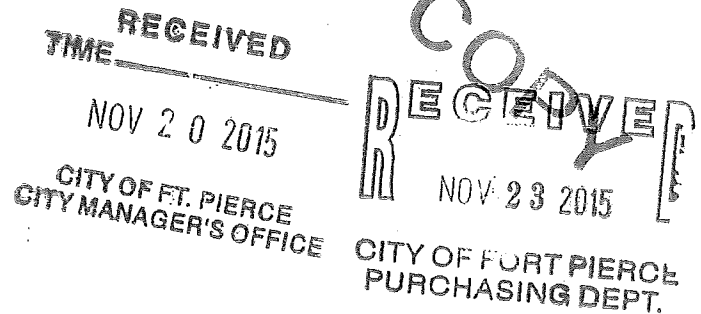

RE: *In re Thomas K. Perona, Complaint No. 14-041 and 14-123 (Ethics Commission)*

Dear Mr. Mimms:

The purpose of this correspondence is to request, on behalf of Thomas K. Perona, a member of the City of Ft. Pierce City Commission, that he be reimbursed for the payment of attorney's fees and costs associated with the successful defense of the above-referenced complaints filed with the Commission on Ethics.

Both case law and Attorney General's opinions authorize payment or reimbursement of legal fees in connection with the successful defense of a complaint filed with the Ethics Commission when the public official was performing official duties while serving a public purpose.

Briefly, the complaints filed against Mr. Perona can be summarized as follows:

- **Complaint 14-041:** This complaint was filed by Rick Reed and alleged, among other things, that Mr. Perona accepted publicly funded legal representation by the City Attorney in connection with a lawsuit against the Mr. Perona which alleged a defamatory act committed during a time when the Mr. Perona held no public position and which named the Mr. Perona individually as the sole defendant. The complaint also alleges that the Respondent voted on measures related to the lawsuit referenced above in paragraph 3 during open City Commission meetings on July 1, 2013, and July 15, 2013, and that he participated in "shade" meetings on September 23, 2013, and December 16, 2013, during which the Commission discussed or voted on confidential settlement/mediation issues related to the lawsuit.
- **Complaint 14-123:** This complaint was filed by Rick Reed and alleged, among other things, that Mr. Perona, as a candidate for reelection to the City Commission, publicly referred to the City Clerk and the City Marketing Manager as "my team

Nicholas "Nick" Mimms
November 18, 2015
Page 2 of 2

from City Hall" and that he directed them to work on his campaign while "on the clock" as City employees and to use City resources for the campaign.

Both of these complaints were found to be legally sufficient to warrant investigation and, following investigation by the Commission on Ethics and a probable cause hearing before the Commission on September 11, 2015. A copy of the Public Report dismissing both complaints is included with this letter. Underlying the Commission's finding of "no probable cause" is a determination that Mr. Perona was performing official duties while serving a public purpose in connection with his actions that were the subject of the complaints.

Our firm has billed Mr. Perona \$3,015.00 in connection with the defense of this matter. The services of Mark Herron and J. Brennan Donnelly have been billed at the hourly rate of \$300 per hour. Copies of billing statements regarding these fees and costs included with this letter as well.

Thank you for your attention to this request. If you have additional questions or concerns, or need any additional information, with respect to this request, please let me know.

Sincerely,



Mark Herron

cc: Thomas K. Perona, City Commissioner



INTEROFFICE MEMORANDUM
FROM THE OFFICE OF THE
CITY MANAGER

TO : The Honorable Mayor and Members of the City Commission

FROM : Nicholas C. Mimms, P.E., City Manager

A handwritten signature in blue ink, appearing to read "N. Mimms", is written over the name of the City Manager.

RE : **Reimbursement of Attorney's Fees – Report**

DATE : December 21, 2015

Attached is a report from Richard V. Neill, Jr. with regard to the requests from Commissioners Becht and Perona and City Attorney Robert V. Schwerer for the reimbursement of attorney's fees related to ethics complaints that were dismissed. The report is attached for your information.

If you have any questions or need additional information, please contact me.

NCM:jdr

c: Linda Cox, City Clerk
Robert V. Schwerer, City Attorney

LAW OFFICES
NEILL, GRIFFIN, TIERNEY, NEILL & MARQUIS

CHARTERED

311 SOUTH SECOND STREET

SUITE 200

FORT PIERCE, FLORIDA 34950

RICHARD V. NEILL[□]
J. STEPHEN TIERNEY, III
RICHARD V. NEILL, JR.[†][°]
RENÉE MARQUIS-ABRAMS*

*BOARD CERTIFIED WILLS, TRUSTS & ESTATES LAWYER
°CERTIFIED CIRCUIT CIVIL/COUNTY COURT MEDIATOR
†BOARD CERTIFIED CIVIL TRIAL LAWYER
□OF COUNSEL

December 18, 2015

MAILING ADDRESS:
POST OFFICE BOX 1270
FORT PIERCE, FL 34954
TELEPHONE (772) 464-8200
FAX (772) 464-2566

HAND DELIVERY

Mr. Nicholas Mimms, P.E.
City Manager
City of Fort Pierce
Post Office Box 1480
Fort Pierce, Florida 34954

RECEIVED
TIME _____
DEC 21 2015
CITY OF FT. PIERCE
CITY MANAGER'S OFFICE

Dear Mr. Mimms:

You have asked that I review the issue of reimbursing attorneys' fees incurred by Commissioners Becht and Perona, and by City Attorney Schwerer (collectively "the officials"), in relation to ethics complaints which have been dismissed.

You provided the November 18, 2015, letters and enclosures received from their attorney, Mark Herron. I've reviewed that correspondence, including the public reports determining no probable cause on each of the complaints.

I have also reviewed additional documents provided by the officials, including copies of complaints, the Advocate's Recommendation on Mr. Becht's case, and Mr. Schwerer's response to the Advocate's Recommendation on his case.

My understanding is that the City of Fort Pierce does not have any written policy or code provision directly addressing reimbursement of such attorney's fees; and, while there is a State statute providing for defense of civil actions against public officials, there is not one directly addressing reimbursement of expenses incurred in responding to an ethics complaint.

The Courts in Florida have, however, clearly recognized that officials have the right to reimbursement, independent of any statute, for expense incurred in successfully defending claims of malfeasance in office.

Mr. Nick Mimms
City Manager
December 18, 2015
Page 2

As stated by the Attorney General's Office:

Florida courts have recognized a common law right of public officials to legal representation at public expense to defend themselves against litigation arising from the performance of their official duties while serving a public purpose. The purpose of this rule is to avoid the "chilling effect" that a denial of representation might have on a public official in performing his duties properly and diligently. Such an obligation arises independent of statute, ordinance or charter and "is not subject to the discretion of the keepers of [the] City coffers".

Ops. Att'y Gen. Fla. 98-12.

This is a right which has been extended to successful defense of ethics complaints. See, Maloy v. Board of County Commissioners of Leon County, 946 So.2d 1260 (Fla. 1st DCA), rev. den., 962 So.2d 337 (Fla. 2007); Ellison v. Reid, 397 So.2d 352 (Fla. 1st DCA 1981); and Ops. Att'y Gen. Fla. 90-74 (1990).

So, if the City Commission concludes on the facts presented that the officials incurred the expense in successfully defending themselves against ethic's complaints arising from the performance of their official duties while serving a public purpose, the officials are entitled to reimbursement of that cost.

The Courts do recognize that a public purpose is served by defending an unfounded complaint or action, because, "the public has an overriding interest in ensuring the effective and efficient functioning of its governing body", Thornber v. City of Fort Walton Beach, 568 So.2d 914, 917 (Fla. 1990), and, "[i]f a public officer is charged with misconduct while performing his official duties and while serving a public purpose, the public has a primary interest in such a controversy and should pay the reasonable and necessary legal fees incurred by the public officer in successfully defending against unfounded allegations of official misconduct". Ellison, supra, at 354.

Under the circumstances as I understand them, and based on the decisions of Florida's appellate courts, I recommend reimbursement of the expenses as requested.

Mr. Nick Mimms
City Manager
December 18, 2015
Page 3

Finally, I'm enclosing our statement for services on this matter and thank you for asking me to review this issue for the City.

Sincerely,

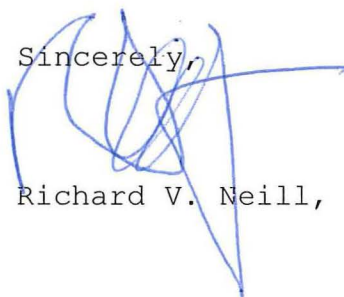

Richard V. Neill, Jr.

RVNjr/hg
Enclosure

cc: Tony Barnes, Purchasing Director (w/encl.) (hand delivery)

City Commission Regular Meeting

Agenda Item # 12. d.

Meeting Date: 12/21/2015

Re: Request for Reimbursement of Attorney Fees

Submitted For: Tony Barnes, Director of Administrative Services, Purchasing

SUBJECT:

Request for Reimbursement of Legal Fees and Costs in the amount of \$2,325.00 associated with the defense of a complaint filed with the Commission on Ethics against Edward Becht which has been dismissed.

SUMMARY:

Complaint 14-040. A probable cause hearing was heard before the Ethics Commission on October 23, 2015. This request has been reviewed by an external independent attorney and deemed to be acceptable based upon federal, state and local laws. The complaint was dismissed.

RECOMMENDATION:

Reimburse the Attorney Fees and Cost associated with the defense of Complaint 14-040 to Edward Becht in the amount of \$2,325.00.

ALTERNATIVES:

None

RESPONSIBLE STAFF:

Tony Barnes, Director of Administrative Services

COORDINATED WITH:

Nick Mimms, City Manager

Fiscal Impact

Budgeted Y/N: N
Fiscal Year: 2016
Account: 001-1400-514-3123
Amount: \$2,325.00

OTHER INFORMATION:

As per Director of Finance

Attachments

Becht
City Manager Memo

Form Review

Inbox

City Manager
Purchasing (Originator)
Finance Department
City Manager
Form Started By: Tony Barnes
Final Approval Date: 12/17/2015

Reviewed By

Jennifer Robinson
Tony Barnes
Jennifer Robinson
Nick Mimms

Date

12/17/2015 10:16 AM
12/17/2015 12:31 PM
12/17/2015 02:08 PM
12/17/2015 02:14 PM
Started On: 12/16/2015 07:10 PM

MESSER CAPARELLO
Attorneys At Law
Strategically Positioned in Florida's Capital

Mark Herron
Also Admitted in Georgia
Email: mherron@lawfla.com

December 1, 2015

Nicholas "Nick" Mimms
Interim City Manager
City of Ft. Pierce
100 North U.S. Highway 1
Ft. Pierce, FL 34950

RE: *In re Edward Becht, Complaint No. 14-040 (Ethics Commission)*

Dear Mr. Mimms:

The purpose of this correspondence is to request, on behalf of Edward Becht, a member of the City of Ft. Pierce City Commission, that he be reimbursed for the payment of attorney's fees and costs associated with the successful defense of the above-referenced complaint filed with the Commission on Ethics.

Both case law and Attorney General's opinions authorize payment or reimbursement of legal fees in connection with the successful defense of a complaint filed with the Ethics Commission when the public official was performing official duties while serving a public purpose.

Briefly, the complaint filed against Mr. Becht can be summarized as follows: The complaint was filed by Rick Reed and alleged, among other things, that Mr. Becht voted on measures related Ft. Pierce Redevelopment Agency owned property adjacent to property owned by a company owned by Mr. Becht without filing a memorandum of voting conflict; that Mr. Becht asked the City Attorney to provide him with information about a possible City investigation of an individual who was adverse to a client of Mr. Becht's law firm; and that Mr. Becht had a voting conflict concerning measures related to the development of property and the abandonment of a City right-of-way adjacent to real property which either he or a company owned by Mr. Becht owned.

This complaint was found to be legally sufficient to warrant investigation and, following investigation by the Commission on Ethics and a probable cause hearing before the Commission on October 23, 2015. A copy of the Public Report dismissing both complaints is included with this letter. Underlying the Commission's finding of "no probable cause" is a determination that Mr. Becht was performing official duties while

Nicholas "Nick" Mimms
December 1, 2015
Page 2 of 2

-serving a public purpose in connection with his actions that were the subject of the complaints.

Our firm has billed Mr. Becht **\$2,325.00** in connection with the defense of this matter. The services of Mark Herron and J. Brennan Donnelly have been billed at the hourly rate of \$300 per hour. Copies of billing statements regarding these fees and costs included with this letter as well.

Thank you for your attention to this request. If you have additional questions or concerns, or need any additional information, with respect to this request, please let me know.

Sincerely,

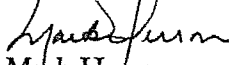

Mark Herron

cc: Edward Becht, City Commissioner



INTEROFFICE MEMORANDUM
FROM THE OFFICE OF THE
CITY MANAGER

TO : The Honorable Mayor and Members of the City Commission

FROM : Nicholas C. Mimms, P.E., City Manager

A handwritten signature in blue ink, appearing to read "N. Mimms", is written over the printed name of the City Manager.

RE : **Reimbursement of Attorney's Fees – Report**

DATE : December 21, 2015

Attached is a report from Richard V. Neill, Jr. with regard to the requests from Commissioners Becht and Perona and City Attorney Robert V. Schwerer for the reimbursement of attorney's fees related to ethics complaints that were dismissed. The report is attached for your information.

If you have any questions or need additional information, please contact me.

NCM:jdr

c: Linda Cox, City Clerk
Robert V. Schwerer, City Attorney

LAW OFFICES
NEILL, GRIFFIN, TIERNEY, NEILL & MARQUIS

CHARTERED

311 SOUTH SECOND STREET

SUITE 200

FORT PIERCE, FLORIDA 34950

RICHARD V. NEILL[□]
J. STEPHEN TIERNEY, III
RICHARD V. NEILL, JR.[†][°]
RENÉE MARQUIS-ABRAMS^{*}

^{*}BOARD CERTIFIED WILLS, TRUSTS & ESTATES LAWYER
[°]CERTIFIED CIRCUIT CIVIL/COUNTY COURT MEDIATOR
[†]BOARD CERTIFIED CIVIL TRIAL LAWYER
[□]OF COUNSEL

December 18, 2015

MAILING ADDRESS:
POST OFFICE BOX 1270
FORT PIERCE, FL 34954
TELEPHONE (772) 464-8200
FAX (772) 464-2566

HAND DELIVERY

Mr. Nicholas Mimms, P.E.
City Manager
City of Fort Pierce
Post Office Box 1480
Fort Pierce, Florida 34954

RECEIVED
TIME _____
DEC 21 2015
CITY OF FT. PIERCE
CITY MANAGER'S OFFICE

Dear Mr. Mimms:

You have asked that I review the issue of reimbursing attorneys' fees incurred by Commissioners Becht and Perona, and by City Attorney Schwerer (collectively "the officials"), in relation to ethics complaints which have been dismissed.

You provided the November 18, 2015, letters and enclosures received from their attorney, Mark Herron. I've reviewed that correspondence, including the public reports determining no probable cause on each of the complaints.

I have also reviewed additional documents provided by the officials, including copies of complaints, the Advocate's Recommendation on Mr. Becht's case, and Mr. Schwerer's response to the Advocate's Recommendation on his case.

My understanding is that the City of Fort Pierce does not have any written policy or code provision directly addressing reimbursement of such attorney's fees; and, while there is a State statute providing for defense of civil actions against public officials, there is not one directly addressing reimbursement of expenses incurred in responding to an ethics complaint.

The Courts in Florida have, however, clearly recognized that officials have the right to reimbursement, independent of any statute, for expense incurred in successfully defending claims of malfeasance in office.

Mr. Nick Mimms
City Manager
December 18, 2015
Page 2

As stated by the Attorney General's Office:

Florida courts have recognized a common law right of public officials to legal representation at public expense to defend themselves against litigation arising from the performance of their official duties while serving a public purpose. The purpose of this rule is to avoid the "chilling effect" that a denial of representation might have on a public official in performing his duties properly and diligently. Such an obligation arises independent of statute, ordinance or charter and "is not subject to the discretion of the keepers of [the] City coffers".

Ops. Att'y Gen. Fla. 98-12.

This is a right which has been extended to successful defense of ethics complaints. See, Maloy v. Board of County Commissioners of Leon County, 946 So.2d 1260 (Fla. 1st DCA), rev. den., 962 So.2d 337 (Fla. 2007); Ellison v. Reid, 397 So.2d 352 (Fla. 1st DCA 1981); and Ops. Att'y Gen. Fla. 90-74 (1990).

So, if the City Commission concludes on the facts presented that the officials incurred the expense in successfully defending themselves against ethic's complaints arising from the performance of their official duties while serving a public purpose, the officials are entitled to reimbursement of that cost.

The Courts do recognize that a public purpose is served by defending an unfounded complaint or action, because, "the public has an overriding interest in ensuring the effective and efficient functioning of its governing body", Thorner v. City of Fort Walton Beach, 568 So.2d 914, 917 (Fla. 1990), and, "[i]f a public officer is charged with misconduct while performing his official duties and while serving a public purpose, the public has a primary interest in such a controversy and should pay the reasonable and necessary legal fees incurred by the public officer in successfully defending against unfounded allegations of official misconduct". Ellison, supra, at 354.

Under the circumstances as I understand them, and based on the decisions of Florida's appellate courts, I recommend reimbursement of the expenses as requested.

Mr. Nick Mimms
City Manager
December 18, 2015
Page 3

Finally, I'm enclosing our statement for services on this matter and thank you for asking me to review this issue for the City.

Sincerely,

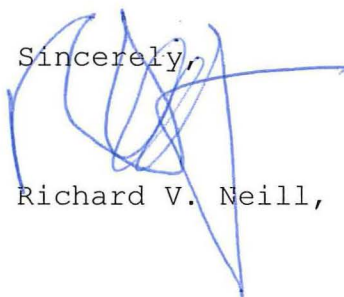

Richard V. Neill, Jr.

RVNjr/hg
Enclosure

cc: Tony Barnes, Purchasing Director (w/encl.) (hand delivery)

City Commission Regular Meeting

Agenda Item # 14. a.

Meeting Date: 12/21/2015

Re: City Manager's Departmental Activity Report

Submitted For: Nick Mimms, Interim City Manager, City Manager

SUBJECT:

City Manager's Departmental Activity Report

Attachments

City Manager's Departmental Activity Report

Form Review

Form Started By: Jennifer Robinson

Started On: 09/21/2015 03:57 PM

Final Approval Date: 09/22/2015



INTEROFFICE MEMORANDUM

FROM THE OFFICE OF THE
CITY MANAGER

TO: The Honorable Mayor and Members of the City Commission
FROM: Nicholas C. Mimms, City Manager
RE: Departmental Activity Report
DATE: December 16, 2015

A handwritten signature in blue ink, appearing to read "N. Mimms".

The information that follows is intended to keep the Commission abreast of the on-going activities, issues, programs and services within the City.

City Manager's Office

- The City Manager and City Clerk met to discuss the updating of action items for City Commission meetings.
- The City Manager and City Attorney met with Commissioner Perona to discuss the agenda for the December 7, 2015 City Commission meeting.
- The City Manager and Finance Director met with the Sunrise Theatre Director regarding positions at the theatre.
- The City Manager met with a downtown business owner regarding his concerns.
- The City Manager met with Commissioner Becht to discuss various City issues.
- The City Manager met with Colin Baenziger regarding the search for a City Attorney.
- The City Manager held a Conference Agenda meeting on December 14, 2015.
- The City Manager attended the FPUA Board meeting on December 15, 2015.

City Clerk's Office

- **Business Tax Receipts –**
New: 10 Renewals: 110 Transfers: 3
- **Vendor Permits Issued –**
New: 0 Renewals: 1
- **Contractor Licensing –**
New: 14 New (Board): 2 Renewals: 14
- **Public Records Requests (not including Building Department) –**
New Requests: 2
- **Animal Registrations –**
New/Renewals/Impound Fees: 7
- **Enterprise Zone Applications –**
Sales Tax Refund Applications: 1
- **Vehicle Tags/ Title Applications – 0**
- **Agenda Preparation and Meeting Minutes –**
 1. Treasure Coast Council of Local Governments – 12/2/2015
 2. Fort Pierce City Commission Meeting – 12/7/2015
- **Special Projects –**
 1. Launched Task Tracker system in Agenda Quick to assign, track and report Action Items of the Mayor and City Commission
 2. Coordinating with MIS to begin scanning for permanent retention and search-ability all BTR applications
 3. Deputy City Clerks calling all businesses with unrenewed BTRs to collect outstanding tax payments
 4. Final mailing of invoices for BTR renewals
 5. Working with Code Enforcement to verify closed businesses not renewing their BTRs
 6. Working with Destiny Software to utilize the Term Tracker system to integrate all Board and Committee members' names and terms on the City website.
- **Meetings/Special Events Attended**
 1. 12/1/2015 Deputy City Clerk attended Highwaymen Heritage Trail Project Meeting
 2. 12/2/2015 City Clerk participated with Economic Development Team to give Fort Pierce Update to Chamber of Commerce
 3. 12/2/2015 Deputy City Clerk attended Treasure Coast Council of Local Government's Holiday Meeting
 4. 12/3/2015 City Clerk's office hosted and attended the Florida Association of Business Tax Officials Holiday Meeting
 5. 12/3/2015 Deputy City Clerk attended Mingle and Jingle Open House Event
 6. 12/3/2015 Deputy City Clerk attended Chamber Business After Hours
 7. 12/5/2015 City Clerk attended Learn to Read Feast for Literacy Event
 8. 12/6/2015 City Clerk participated in Sights and Sounds Christmas Parade
 9. 12/6/2015 Deputy City Clerk attended Sights and Sounds Christmas Parade
 10. 12/7/2015 City Clerk attended PIO Training at Fort Pierce Police Department
 11. 12/10/2015 Deputy City Clerk attended LPMS Board Meeting

Administrative Services Department

- **Procurement –**
 1. Completed and distributed Contract for Bid No: 2015-045 Veterans Memorial Park Stormwater Improvement.
 2. Purchase Orders and day to day operations of the Purchasing Division.
 3. Processing and / or completion of Awards to vendors contractors approved by Commission.
 4. Meetings:
 - a) Director of Administrative Services met with City Manager, and Consultant regarding Hiring of City Attorney.
 - b) Director of Administrative Services and Human Resource attended the Civil Service Appeals Board Meeting.
 - c) Director of Administrative Services met with Public Works Manager and Lisa's Kayaks regarding RFP No: 2015-052 Non- Motorized Watercraft and Bicycle Rental.
 - d) Purchasing Manager, Director of Finance, Accountant and Evaluation team met regarding RFP No: 2016-003 Banking Services.

- **Human Resources –**
 1. Orientated New HR Manager on current HR Processes and issues
 2. New Hire P.A. Processing, and New Hire Orientation
 3. Distributed monthly Reports to each department such as Accrual Register, Time Sheets and payroll registers to all Departments.
 4. Verified car and clothing allowance along with payroll report.
 5. Processed employee evaluation forms.
 6. Complete Verification of Employment/Loss of Income forms.
 7. Create and process retirement package for employee.
 8. Complete Family Medical Leave package for employees.

- **Risk Management –**
 1. Conference Call with Florida Blue to finalize Heath Fair.
 2. Processed day to day Risk Management Duties.
 3. Accident Investigation and Injury Reviews.
 4. Audited, Closed, and Processed WC Claims.
 5. Processed Insurance Subrogation.
 6. Consulted with the City Carrier Regarding Liability Claims

Code Enforcement Division

- **Hearing –**
 1. Special Magistrate Blandino
 - a) 11 regular hearings
 - b) 1 request for extension of time

- **Code Enforcement –**
 1. Issued 4 written warnings
 2. Issued 0 citations
 3. Initiated 56 new cases
 - 36 general violations
 - 16 lot clearing violations
 - 4 nuisance abatement violations
 4. Conducted 231 follow-up inspections
 5. Closed 46 cases

- **Animal Control –**
 1. County Court – Judge Cliff Barnes
 - a) COFP v. Granados
 - Rabies required (2 counts) – guilty of 1 count / 1 count dismissed by judge.
 - Registration required (2 counts) – guilty of 1 count / 1 count dismissed by judge.
 2. Daily Animal Control activities.

- **Revenue –**
 1. Conducted 39 title / lien searches.

- **Miscellaneous –**
 1. Code Enforcement and Animal Control staff attended the seminar in Port St Lucie about Animal Violence and how it relates to physical violence.
 2. Code Enforcement staff attended a seminar in Port St Lucie on Active Shooters.
 3. Animal Control Officers attended a webinar on Animal Cruelty.
 4. Code Compliance Manager and ACO Gasparre met with a potential buyer of a residence on Delaware Ave to determine the feasibility of maintaining a dog breeding and grooming business at this location.
 5. Code Compliance Manager met with Assistant City Attorney Walker and new Code Board member Jim Flynn for a training session.
 6. Daily code enforcement and animal control activities.

MIS Department

- Processing of SunGard – Public Sector biannual updates of the AS400 and SunGard HTE applications and backups.
- MIS senior staff is working with Swagit and Prosound to order and install equipment which is in progress to acquire tightrope hardware and software for 2nd floor conference room, audio/visual, and broadcasting equipment.
- Working with the City Manager, Chief of Police, & Public Works Manager regarding enhancements of City Hall Security.
- Working with Chief of Police on adding Police Department website services to the City's main website.
- Working with Marina on wireless meters and configuring the NuCore application which reads the water and electric usage.
- Working with SunGard – Public Sector to implement Click-2-Gov Employee Self Service Portal and Applicant Tracking. SunGard is scheduled to provide training
- Working with Selectron Technologies, Inc. to migrate to the Interactive Voice Response (IVR) system with hosted services for the Building Department.
- Working to continue to upgrade cell phones with Text Guard application.
- Working with Diebold on upgrading hardware and software for Security System for City Hall.
- Working with Group Business Software on Transitioning Sunrise Theatre emails. Assessment for transition completed. Waiting for quote from vendor for approval to transition email system.
- Converting all sites to City Hall with a true WAN with River Walk, Marina, Indian Hills/Police Department and Public Works completed. Work has started on Sunrise Theatre.
- Searching for options for Commissioners to be able to engage in audio or video conferencing when not physically able to attend meetings.
- Upgrading out of lease copiers for several departments.
- Working on new switches, servers, racks and Intune software citywide.
- Exploring cloud based options for different applications.
- Working on a WorkOptiFlow pilot program with Indian Hills Department.
- Major problems with email due to virus attacks to our system (on-going).
- Servers and computer equipment for Sunrise Theatre are being processed for distribution.
- Software integrations citywide (on-going).
- Working with AT&T and State of Florida on the fiber optic installation preparation for Public Works/Solid Waste (ongoing).
- Updating MIS documentation and procedural policies (on-going).
- Received twenty-nine (29) new work orders and completed ninety-three (93) work orders for the period ending December 11, 2015.

Planning Department

- **Administrative/Meetings –**
 1. All Staff members conducted ‘Planner of the Day’ duties on a rotating basis
 2. Walk-ins/Call-ins
 3. Planning Board Meeting
 4. Pre-application meeting - Adult Daycare - 2400 Rhode Island.

- **Development Review –**
 1. Conditional Use - Adult Day Care Center - 2400 Rhode Island
 2. Baker Residence - Conditional Use with New Construction - 1709 Surfside Drive – Planning Board Approval
 3. Fraternal Order of Eagles - Waiver of Distance - 1717 US Highway 1 – Planning Board Approval
 4. Causeway Cove - Site Plan & Conditional Use - 601 Seaway Drive - Applicant Meeting
 5. Mount Bethel Baptist Church - Major Amendment to Site Plan - S 25th Street – Technical Review Committee Review
 6. O'Reilly Autoparts - Site Plan - S 25th Street - Technical Review Committee Re-Review
 7. Conditional Use with New Construction - Indian River Villas - 401 S Indian River Drive
 8. Final Plat - Inlet Palms - 1502 Seaway Drive
 9. Zoning Atlas Amendment / PD, Development Plan - Indian River Commerce - 401 S Indian River Drive
 10. Conditional Use - Harbor Community Bank - 600 Edwards Road
 11. ROW Abandonment - Indian River Villas/Commerce - 401 S Indian River Dr.
 12. Zoning Atlas Amendment / PD, Development Plan / Preliminary Plat - Village at Midway - 9850 Midway Road
 13. Conditional Use with New Construction - RG Towers 2551 Jenkins Road
 14. Site Plan & Design Review - Cumberland Farms - 2009 S 35th Street
 15. Conditional Use - The Haven Detox - 4707 Oleander Avenue
 16. Conditional Use - Water's Edge Detox - 912 Avenue I

- **Comprehensive Planning, Long Range Planning –**
 1. Voluntary Annexation - Oleander Avenue

- **Historic Preservation –**
 1. 201 S 2nd Street – Wall Sign - Administrative Certificate of Appropriateness issued
 2. 100 N 2nd Street – Wall Sign - Administrative Certificate of Appropriateness issued
 3. 709 Easter Avenue – Roof, Shutters, Door - Administrative Certificate of Appropriateness issued
 4. 308 Avenue A – Roof – Administrative Certificate of Appropriateness issued
 5. 647 N 2nd Avenue – Siding Replacement – Administrative Certificate of Appropriateness pending
 6. 436 N 9th Street – Demolition - Historic Preservation Board Staff Report
 7. 302 S 2nd Street - Sign - Historic Preservation Board Staff Report
 8. Avenue D – Memorial Wall and Landscaping - Historic Preservation Board Staff Report

- **Economic Development –**
 1. Chamber of Commerce - ED Team Presentation

Engineering Department

- **Development Reviews** – Intake of thirteen (13) Building Permit, Site Plan, or Certificate of Occupancy reviews.
- **Traffic Control** – City continues maintenance of all signals. We continue system software upgrades for traffic controllers, video detection cameras and CENTRACs system controller.
- **City Marina Reconstruction – Phase II – Docks** – FEMA is working to wrap up the closeout of the 2004 projects.
- **City Marina Dinghy Dock Construction** – Once we have the executed BIG grant contracts we will proceed with the project advertisement. RFP anticipated advertisement in January and construction start anticipated March 2016. We have received the executed FIND documents for incorporation into the RFP documents.
- **S. 21st Street / Havana Ave. Sidewalk Project** – A final inspection has been conducted and a final punch list was provided to the contractor.
- **Indian Hills Recreation Area - Stormwater Improvements** – Work continues on the pedestrian bridges with pile driving and sub-structure construction. Hauling material to St. Lucie County Land Fill Operations has been completed. Connecting path from Phase I to Phase 2 is under construction. Reimbursement in the amount of \$1,340,000 submitted to FDEP.
- **Veterans Memorial Park Phase II Stormwater Improvements** – Construction of the stormwater improvements is underway. Contractor has commenced with the lake excavation. A meeting with Senator Joe Negron's staff and Rep. Larry Lee was held on 12-8-15 to discuss funding options for the non-stormwater related items.
- **Melody Lane Fishing Pier** – Construction underway. Completion date currently scheduled for December 23, 2015.
- **H.D. King Power Plant Clean-up** – Cardno has begun design work on the seawall replacement along Moore's Creek. Final design build costs will be provided within the next 30 days.
- **Lincoln Park Neighborhood Improvements** – Construction complete. A preliminary walk-thru was conducted on 11-24-15 and a punch list of items has been generated. Contractor is currently addressing the outstanding issues.
- **13th Street and 17th Street Reconstruction** – The design professional is working on phasing the existing plans so we can proceed with advertisement of bids. The project limits along 13th Street will begin at a point 360 LF south of Avenue D, north a distance of 1,160 LF to a point 60 LF north of Avenue E. 17th Street work will extend From Orange Avenue to Avenue D.

Police Department

- **Staffing** – The police department has eight (8) vacancies as of this report: five (5) sworn officer positions and three (3) civilian positions (Senior Accounting Clerks, Records Supervisor, and Crime Scene Investigator).
- **Front Porch Roll Call** – Shift Commanders and Supervisors continue to concentrate their Front Porch Roll Calls in recent crime areas and throughout Downtown, the City Marina, and River Walk Center. They are also conducting Roll Calls at our shopping centers for this holiday shopping season.
- **Parking Problems** – The Parking Committee is moving forward with the recommendations and direction from the City Commission at the November 18th Commission Meeting.
- **Homeless Initiative** – Nothing new to report: the Salvation Army is still pursuing the building at 707 N. 7th Street, the old Head Start building as a temporary shelter. We are working with Pastor Hazel Hoylman, Image of Christ to expand her shelter services to assist the police department with providing an alternative to arrest.
- **The First Step** – The attendance by the neighborhood children and community leaders has steadily grown since the first event. There will be a special Christmas First Step Event at the December 22nd gathering at the park (N. 31st Street and Avenue G), 4:30 PM.
- **Updates** –
 1. December 5th, Breakfast with Santa, Fort Pierce Police Explorer Post # 477. We are pleased to report that the 1st Annual Breakfast with Santa was a wonderful event. It was well attended, raising several hundred dollars for our Explorer Post. We are already looking at plans to enhance next year.
 2. December 6th, the Sights and Sounds Parade and Festival. We are pleased to report that this year's event was a huge success. One of, if not, the largest crowd to attend the parade and the longest parade in memory (70+ floats/entries).
 3. December 12th, Toy Train, 1:30 PM. 2nd Street and Orange Avenue
 4. December 12th, the Boat Parade, 6:00 PM, City Marina
 5. December 13th, Fort Pierce Police PAL Toy Run, 10:00 AM, Victory Motorcycle
 6. December 18th, Santa Cop. This year will be delivering toys and dinner to approximately 100 families in Fort Pierce.
 7. December 22nd, Shop with a Cop, Wal-Mart, 10:30 AM. We are pleased to report that we have expanded this year's event with the additional funding from the Boys and Girls Club. We will be able to provide gift cards to another 34 children, allowing us to bring Christmas to a grand total of 84 children.

Urban Redevelopment Department**• Grants Administrator –**

1. Continued Coordination of:
 - a) Highwaymen Heritage Trail ribbon cutting and festivities
 - b) Hurston Trail (website creation; rehab for trail markers)
 - c) Remaining 2014-2015 commercial facade grant funded projects
 - d) Remaining 2014-2015 public service grant funded projects
 - e) Fort Pierce Authentic Tours program
 - f) Melody Lane Public Fishing Pier grant award management
 - g) Lincoln Park Mural Project
 - h) January 14 Job Fair
 - i) Highwaymen Trail website
2. Created
 - a) Meeting Advertisements for creation of 5-Year Consolidated Plan and Analysis of Impediments of Fair Housing Report
 - b) Grant Application to FDOT/Keep America Beautiful for Keep Fort Pierce Beautiful program
 - c) Mid-Term Grant Report to Allegany Franciscan Ministries for Public Service Agency grants they provided for Lincoln Park Supportive Service providers
 - d) Board Recruitment Letters for FPAT
 - e) Program for Melody Lane Public Fishing Pier Ribbon Cutting
 - f) Program for Highwaymen Heritage Trail Ribbon Cutting
 - g) Designed and placed order for brass plaque engraved with Livingston Roberts name and info to affix to Highwaymen Obelisk
 - h) Press Release announcing new Zora Neale Hurston Dust Tracks Heritage Trail website going live
 - i) Press Release and Poster for January 14 Job Fair
 - j) Updated and preparations to release 2015-2016 Public Service Agency grant opportunity
3. Meetings:
 - a) Ironside Press - Vero Beach - Creation of Highwaymen Heritage Trail Invitation
 - b) St. Lucie County Chamber Update Presentation at Pelican Yacht Club
 - c) Career Source Research Coast - January 14 Job Fair
 - d) Fort Pierce Authentic Tours Advisory Board

• Program Analyst –

1. FEMA
 - a) Marina Project
 - Waiting on final site inspections for two project worksheets to close out Marina
 - Close out versions of PW 9399 & 438 have been written and approved by the State and forwarded to FEMA for their approval.
 - b) Windows Expansion Project
 - All close out information submitted and accepted by State.
 - Awaiting concurrence from FEMA for final close out letter
 - Preparing power point presentation of funds expended and window installations
2. SHIP
 - a) Working on 2015-2016 applicants
 - b) Received second SHIP disbursement

Finance Department

- Met with Asst. City Attorney and employee's attorney on retirement issue
- Retirement Board Meeting
- Met with evaluation team on banking services RFP
- Met with Grant Writer on year end CDBG matters
- Met with Interim City Manager and Sunrise Theatre Director
- Met with API on transparency portal launch
- Preparing funds for year-end audit
- Oversee Day to Day Operations.

Building Division

- Single Family Home, New Construction - 2721 Oak Alley Drive: Building Permit Application Received
- Single Family Home, New Construction - 2726 Oak Alley Drive: Building Permit Application Received
- Single Family Home, New Construction - 4427 Belle Grove Drive: Building Permit Application Received
- Park Renovation, Veteran's Memorial Park - 600 North Indian River Drive: Building Permit Application Received
- New Construction, Mt. Bethel Baptist Church - 4150 South 25th Street: Building Permit Application Received
- **Building Department Investigator –**
 - a) 8 cases seen before the Special Magistrate
 - b) 6 in violation
 - c) 1 continued until next meeting
 - d) 1 in compliance
 - e) 0 Contractor Complaints brought before the Board
 - f) 1 Unlicensed Contractor brought before the Board
 - g) 0 Appeals presented to CBAA

Public Works Department

- **Energy Efficiency & Conservation** – This project is completed.
- **Dan McCarty Track Resurfacing** – Resurfacing of the walking track and LED light replacement is set to begin soon. The ILA has been approved and this project will begin shortly.
- **Old Fort Park** – The mounds stabilization project is completed. Members of the Lion’s Club, Planning and Public Works Department worked together to accomplish this tasks. Stability netting was placed on the mound and approximately 6 inches of soil was spread over the mound before 600 native dune daisies were planted.
- **Multi-Family Single Stream Recycling** –The PWD is excited to implement our Multi-family Single Stream Recycling Program. Our goal is to initiate a rollout of this service during the first quarter of 2016. Our order of Multi-family carts has been placed and we should see them by the end of the year.
- **River Walk Center** – Phase II of the storm water construction has begun at Veteran’s Park.

Marina

- Oversee daily operations for City Marina and Fisherman's Wharf Marina.

Golf Course

- Met with Director of Administrative Services to discuss the Superintendent position.
- Met with maintenance staff to go over assignments in absence of Superintendent.
- Met with Assistant Golf Professionals to access what assignments they could take over for maintenance staff short-term.
- Day-to-day operations.

River Walk Center

Park Permits	150.00
Programming	873.14
River Walk Center	918.65
Garden Center	235.00
Special Events	1300.00
Maravilla Center	100.00
Historic City Hall	480.00
Youth Activity	0
Total	\$4,056.79

Sunrise Theatre

- Over the past weeks, the following performances and activities were presented in the Sunrise & Black Box Theatre: Fort Pierce Jazz and Blues Society and the Sunrise Theatre co-presented Tuesday Night Jazz Jam evenings on December 1 & 8; Comedy Corner Improv on Saturday, November 28; 104.7 The Flame held Working Women's Wednesday on December 2; ST On The Verge Concert Series presented Danielle Nicole on December 5 at 8pm; Lawnwood Medical Center & Heart Institute Board of Directors held their Holiday Reception on December 10. Performances on the Sunrise Theatre main stage included: Billy Gibbons & The BFG's on November 28; A Christmas Carol rehearsal on December 3 & performance on December 5; Howie Mandel on December 4; Brian Wilson on December 6; Neil Sedaka on December 9; St. Lucie Ballet – The Nutcracker rehearsal on December 10, 10:30am School Time performance December 11 and evening performances on December 11 & 12.
- Assistance continues with future rental events and co-presentations with various community groups including, but not limited to: St. Lucie County Agape Center's I've Lived, The Life of Zora Neale Hurston, January 2; St. Andrew's Academy Christmas Program on December 17; Chris MacDonald's Memories of Elvis on January 15.
- Contracts for artists and attractions are being received and executed for the coming season.
- Research on artists, teleconferences with agents discussing artist fees, tour routing and availability for the 2015/16 season, along with offers, artist confirmations, and contract negotiations are ongoing on a daily basis.
- Information from all departments is collected on a daily basis for the monthly report on the activities of the Sunrise Theatre, which was requested by the City Manager's office, to be delivered on a monthly basis. This report includes the schedule of in-house shows, rentals, attendance, revenue, and expenditures (tech, marketing, etc.).
- Marketing and show sponsorship packages are being put together to solicit for next season. Foundation grant opportunities continue to be researched and grant applications continue to be written and submitted.
- Budget projections and adjustments for this and next year's fiscal year continue to be reviewed and implemented.