

# PLANNED DEVELOPMENT FOR INLET PALMS

SECTION 01, TOWNSHIP 35 S, RANGE 40 E  
CITY OF FT. PIERCE, FLORIDA

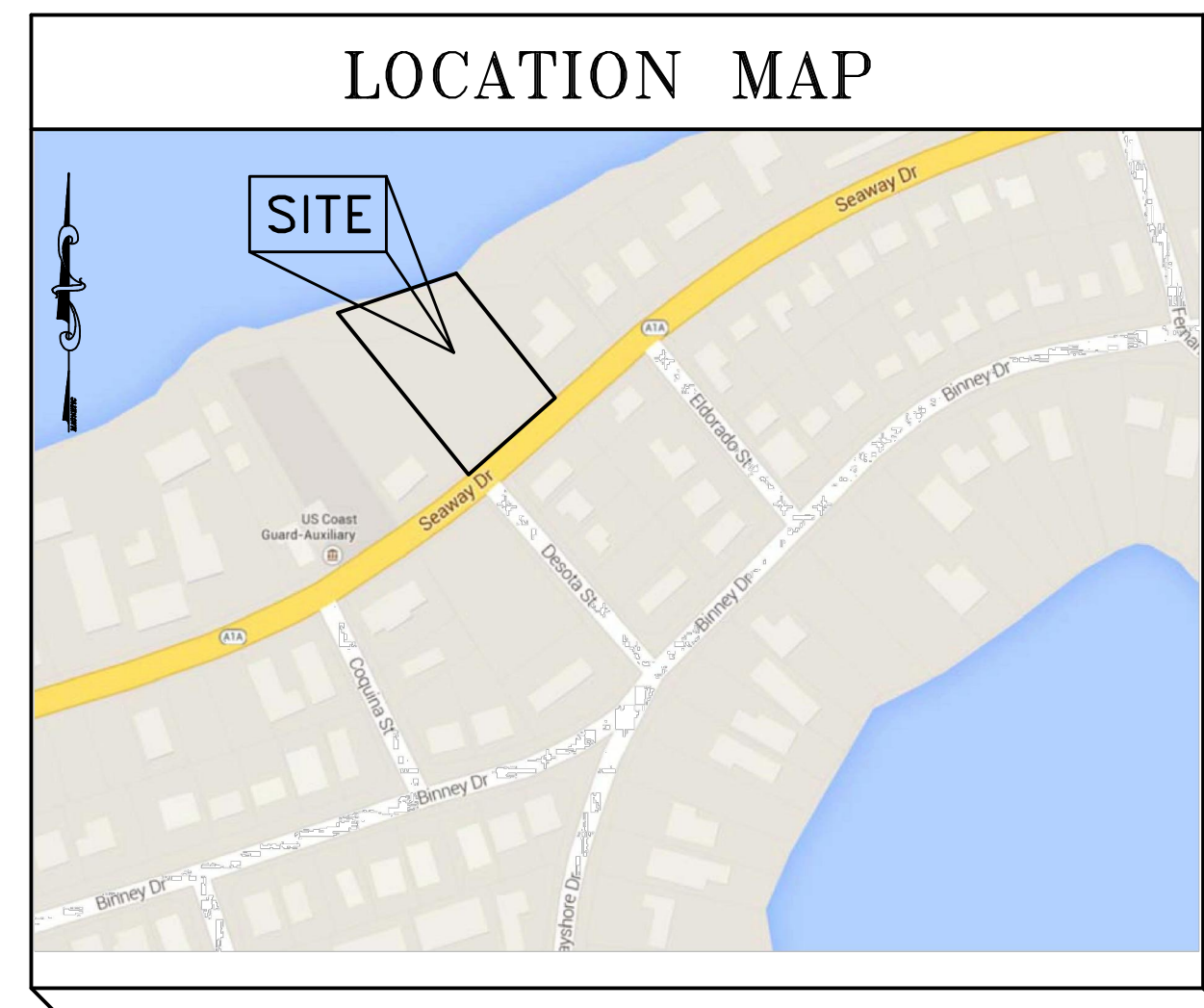

**LEGAL DESCRIPTION**  
LOTS 16, 17 AND 18, BLOCK 16, REVISED MAP OF FT. PIERCE BEACH, ACCORDING TO THE PLAT THEREOF, AS RECORDED IN PLAT BOOK 8, PAGE 29, OF THE PUBLIC RECORDS OF ST. LUCIE COUNTY, FLORIDA.

DRAWING INDEX	
SHEET	DESCRIPTION
1	COVER SHEET
2	EXISTING CONDITIONS AND POLLUTION PREVENTION
3	POLLUTION PREVENTION DETAILS
4	SOIL BORINGS
5	PRELIMINARY PLAT
6	SITE PLAN
7	PAVING, GRADING AND DRAINAGE PLAN
8	UTILITY PLAN
9	LANDSCAPE PLAN
10	CROSS SECTIONS
11-13	MISCELLANEOUS DETAILS
14	AERIAL
ATTACHED	SURVEY

SITE DATA			
<b>OWNER</b>	BELMONT AVE PROPERTY, LLC 2777 N. CIRCLE DRIVE PALATKA, FL 32909-0000		
<b>DEVELOPER</b>	FOGLIA CUSTOM HOMES 1555 INDIAN RIVER BLVD, UNIT B141 VERO BEACH, FL 32960		
<b>ENGINEER</b>	SCHULKE, BITTLE & STODDARD, L.L.C. JUDAH B. BITTLE, P.E. 57368 1717 INDIAN RIVER BLVD, SUITE 201 VERO BEACH, FL 32960 (772) 770-9622		
<b>SURVEYOR</b>	MERIDIAN LAND SURVEYORS CHARLES BLANCHARD, PSM #5755 1717 INDIAN RIVER BLVD., SUITE 201 VERO BEACH, FL 32960 PH: (772) 794-1213		
<b>EXISTING USE</b>	UNDEVELOPED (PREVIOUSLY A HOTEL)		
<b>PROPOSED USE</b>	SEVEN (7) MULTI-FAMILY UNITS		
<b>PROJECT LOCATION</b>	NORTH SIDE OF SEAWAY DRIVE AT DESOTO STREET		
<b>SITE ADDRESS</b>	1502 SEAWAY DRIVE, FT. PIERCE, FL		
<b>PARCEL I.D. NUMBER</b>	2401-501-0279-000-1 AND 2401-501-0279-010-4		
<b>CURRENT LAND USE</b>	HR (HUTCHINSON ISLAND RESIDENTIAL)		
<b>CURRENT ZONING</b>	R-4A (HUTCHINSON ISLAND MEDIUM DENSITY RESIDENTIAL)		
<b>PROPOSED ZONING</b>	PD (PLANNED DEVELOPMENT)		
<b>DEVELOPMENT PARAMETERS:</b>	<b>EXISTING</b>	<b>PROPOSED PD ZONING</b>	<b>PROPOSED DEVELOPMENT</b>
<b>MIN. OVERALL LOT WIDTH</b>	200'	175'	178.8'
<b>MIN. INTERIOR LOT SIZE</b>	1,500 SF	1,500 SF	2,949 SF
<b>MAX. INTERIOR LOT WIDTH</b>	24'	25'	24.7'
<b>MIN. INTERIOR LOT DEPTH</b>	90'	65'	67.9'
<b>MIN. YARD SETBACKS:</b>			
FRONT (SOUTH)	10'	10'	10.0'
SIDE (WEST)	10'	10'	15.0'
SIDE (EAST)	10'	10'	10.0'
REAR (NORTH)	15'	15'	15.0'
DISTANCE BETWEEN BLDGS.	20'	5'	7.0'
<b>MAX. LOT COVERAGE BY BLDGS</b>	45%	45%	27.6%
<b>MIN. OPEN SPACE</b>	25%	25%	28.7%
<b>MAX. IMPERVIOUS AREA</b>	75%	75%	71.3%
<b>MAXIMUM DENSITY</b>	8 UNITS/ACRE	8.5 UNITS/ACRE	8.45 UNITS/ACRE
<b>A/C/ PAD SETBACK</b>	10'	4'	4'
<b>MAX. BLDG. HEIGHT</b>	45'	*SEE BELOW	*SEE BELOW
* UNITS 1 AND 3 - 43'-3 1/4" ABOVE VE 7' NAVD UNITS 2 AND 4 - 47'-4" ABOVE VE 7' NAVD UNITS 5 AND 6 - 43'-3 1/4" ABOVE VE 7' NAVD UNITS 7 - 43'-8 3/4" ABOVE DATUM 6' NAVD			
<b>AREA CALCULATIONS:</b>	<b>PROPOSED</b>		
<b>SITE AREA:</b>	36,055 SF	0.828 AC	100.0%
<b>DEVELOPABLE AREA:</b>	25,695 SF	0.590 AC	71.3%
<b>IMPERVIOUS AREA:</b>	9,938 SF	0.228 AC	27.6%
<b>BUILDING AREA:</b>	10,912 SF	0.251 AC	30.3%
<b>DRIVEWAY/CONCRETE/PORCH AREA:</b>	4,845 SF	0.111 AC	13.4%
<b>POOL/PATIO/WALKWAY AREA:</b>	10,360 SF	0.238 AC	28.7%
<b>PERVIOUS AREA:</b>	10,360 SF	0.238 AC	28.7%
<b>GREEN SPACE:</b>			
<b>NATIVE VEGETATION/PRESERVATION:</b> N/A. NO PRESERVATION REQUIRED, NO NATIVE HABITAT IS EXISTING			
<b>PARKING CALCULATIONS:</b> REQUIRED: 2 SPACE PER UNIT 7 UNITS X 2 SPACES/UNIT = 14 SPACES PROVIDED: 14 INTERIOR DRIVEWAY PARKING SPACES			
<b>AVERAGE DAILY TRIPS:</b> PROPOSED USE: PER ITE 9TH EDITION TRIP GENERATION MANUAL, LAND USE 230 7 MULTI-FAMILY UNITS X 7.78 TRIPS/UNIT = 55 TRIPS			
<b>CONSTRUCTION SCHEDULE:</b> DATE OF COMMENCEMENT: 8/15 DATE OF COMPLETION: 1/16			
<b>GENERAL NOTES</b>			
1. PROPOSED PUBLIC WATER SUPPLY - FT. PIERCE UTILITY AUTHORITY			
2. PROPOSED PUBLIC SEWER - FT. PIERCE UTILITY AUTHORITY			
3. GARBAGE IS HANDLED WITH CANS STORED IN THE UNITS. NO DUMPSTER PROPOSED.			
4. THE PARCEL OF LAND SHOWN HEREON APPEARS TO BE IN FLOOD ZONE AE-6, AE-7, C & VE-8 PER FLOOD INSURANCE RATE MAP #2111C0183 J, DATED FEBRUARY 16TH, 2012.			
5. ALL CONSTRUCTION ON SITE TO BE DONE PER ALL CITY OF FT. PIERCE STANDARDS AND SPECIFICATIONS.			
6. ALL UTILITY CONSTRUCTION ON SITE TO BE DONE PER F.P.U.A. UTILITY STANDARDS AND SPECIFICATIONS, LATEST EDITION.			
7. ALL SIGNS AND PAVEMENT MARKINGS SHALL BE IN ACCORDANCE WITH THE LATEST VERSIONS OF THE M.U.T.C.D., FLORIDA DEPARTMENT OF TRANSPORTATION DESIGN STANDARDS, AND CITY OF FT. PIERCE TYPICAL PAVEMENT MARKINGS AND SIGNING DETAILS. IN ADDITION, ALL PAVEMENT MARKINGS WITHIN THE RIGHT-OF-WAY SHALL BE INSTALLED IN THERMO-PLASTIC.			
8. EXISTING DRIVES AND/OR INTERSECTIONS SHOWN ARE WITHIN THE 300' RADIUS REQUIRED FROM THE PROPOSED SITE.			
9. THE EXISTING SPEED LIMIT FOR SEAWAY DRIVE IS 35 M.P.H.			
10. ALL PROPOSED TRAFFIC CONTROL DEVICES SHOWN ON SITE TO BE PER THE MANUAL ON UNIFORM TRAFFIC CONTROL DEVICES.			
11. THE SITE LIGHTING (SOURCE OF ILLUMINATION) CANNOT BE VISIBLE FROM THE SITE.			
12. ANY NUISANCE/EXOTIC PLANTS IN THE DEVELOPED AREA WILL BE REMOVED.			
13. AT INTERSECTIONS, WALLS, FENCES, PLANTS OR SIGHT OBSTRUCTIONS OF ANY KIND OVER 18' IN HEIGHT ARE PROHIBITED WITHIN THE SITE DISTANCE TRIANGLE AS REQUIRED BY FDOT INDEX 546, 2014 EDITION.			
14. ANY DISTURBED AREAS ON SITE OR IN THE COUNTY RIGHT-OF-WAY TO BE SODED.			
15. RUN-OFF FROM ROOF TO BE DIRECTED TO STORMWATER SYSTEM.			
16. ALL LIGHTS MUST MEET THE FOLLOWING CRITERIA: - ALL POLES MUST BE BLACK OR BRONZE - ALL LIGHTS MUST BE DIRECTED DOWNWARD, WITH A 90 DEG. CUT-OFF - LIGHTS MUST NOT CAUSE GLARE ONTO ADJACENT R/W OR PROPERTIES.			
17. ALL STOP SIGNS (R1-1) SHALL BE 30"			
18. NO DEWATERING BETWEEN 8 PM AND 6 AM WITHOUT CITY OF FT PIERCE APPROVAL.			
19. AN ENTRANCE GATE IS PROPOSED FOR THIS SITE.			
20. CITY OF FT. PIERCE OR FOOT MAY HAVE UNDERGROUND CONDUIT FOR TRAFFIC SIGNAL INTERCONNECTIONS IN THIS AREA AS WELL AS OTHER TRAFFIC SIGNAL EQUIPMENT. IT SHALL BE THE CONTRACTORS RESPONSIBILITY TO CONTACT SUNSHINE STATE ONE CALL SYSTEM AT 1-800-452-4270 FOR LOCATIONS OF THIS EQUIPMENT AT LEAST 72 HOURS PRIOR TO ANY CONSTRUCTION.			
21. ALL SOLID, NON-BREAKAWAY OBJECTS (GATE POSTS/COLUMNS, BOLLARDS, STREET LIGHT POLES, ETC.) ALONGSIDE INTERIOR STREETS AND DRIVING AISLES SHALL BE LOCATED OUTSIDE THE CLEAR ZONE. FOR STREETS AND DRIVING AISLES WITH A DESIGN SPEED OF 25 MPH OR LESS, THE MINIMUM CLEAR ZONE IS 2.5 FEET FROM THE FACE OF THE CURB (TYPE 'D' OR 'F'), OR 6 FEET FROM THE EDGE OF THE TRAVEL LANE. THIS APPLIES TO PUBLIC AND PRIVATE PROPERTY.			
22. THE BEARING BASE FOR THIS SURVEY IS A GRID BEARING OF 548°30'43"W ALONG THE NORTH R/W LINE OF SEAWAY DRIVE AND BASED ON FOUND MONUMENTATION.			
23. THE ELEVATIONS SHOWN HEREON ARE BASED ON THE NORTH AMERICAN VERTICAL DATUM (NAVD) OF 1988. THE BENCHMARK IS COS MONUMENT G 231 1965, ELEVATION 4.47' NAVD. SECONDARY BENCHMARK IS AS SHOWN HEREON. THE CONVERSION TO NAVD29 IS BY ADDING 1.489 FT.			
24. ALL CROSS WALKS SHALL HAVE TRUNCATED DOME WARNING SURFACE SYMBOL ON THE SIDEWALK ADJACENT TO THE PAVED DRIVEWAY PER FDOT INDEX NO. 304.			
25. ANY ABANDONED FLOW WELLS FOUND ON SITE SHALL BE PLUGGED PURSUANT TO D.O.H. AND SPWMD REGULATIONS.			
26. ALL PAVEMENT MARKINGS IN THE RIGHT-OF-WAY SHALL BE 90 MIL., EXTRUDED TYPE, ALKO BASE THERMOPLASTIC.			
27. ALL HANDICAPPED PARKING SPACES SHALL BE PROPERLY SIGNED AND STRIPED IN ACCORDANCE WITH THE FDOT STANDARD INDEX 17346, 2014 EDITION.			
28. ALL STOP SIGNS SHALL BE HIGH INTENSITY RETRO-REFLECTIVITY			
29. ALL UTILITIES MUST BE PLACED UNDERGROUND.			
30. THE CONTRACTOR SHALL FIELD LOCATE ALL EXISTING UTILITY LINES AND STRUCTURES PRIOR TO CONSTRUCTION.			
31. PROPANE TANKS TO BE UNDERGROUND.			

## SCHULKE, BITTLE & STODDARD, L.L.C.

CIVIL & STRUCTURAL ENGINEERING • LAND PLANNING • ENVIRONMENTAL PERMITTING

CERTIFICATION OF AUTHORIZATION NO.: 00008668

1717 INDIAN RIVER BLVD., SUITE 201 VERO BEACH, FLORIDA 32960  
TEL 772 / 770-9622 FAX 772 / 770-9496 EMAIL info@sbsengineers.com

ENGINEER CERTIFICATION:

DATE:  
 □ JOSEPH W. SCHULKE, P.E. REG. No 47048  
 □ JUDAH B. BITTLE, P.E. REG. No 57368  
 □ WILLIAM P. STODDARD, Ph.D., P.E. REG. No 57605

**EROSION CONTROL NOTES**

1. SEDIMENT BASINS AND TRAPS, PERIMETER DIKES, SEDIMENT BARRIERS AND OTHER MEASURES INTENDED TO TRAP SEDIMENT SHALL BE CONSTRUCTED AS A FIRST STEP IN ANY LAND DISTURBING ACTIVITY AND SHALL BE MADE FUNCTIONAL BEFORE UP-SLOPE LAND DISTURBANCE TAKES PLACE.
2. ALL SEDIMENT CONTROL MEASURES ARE TO BE ADJUSTED TO MEET FIELD CONDITIONS AT THE TIME OF CONSTRUCTION AND BE CONSTRUCTED PRIOR TO ANY GRADING OR DISTURBANCE OF EXISTING SURFACE MATERIAL ON BALANCE SITE. PERIMETER SEDIMENT BARRIERS SHALL BE CONSTRUCTED TO PREVENT SEDIMENT OR TRASH FROM FLOWING OR FLOATING ON TO ADJACENT PROPERTIES.
3. PERMANENT OR TEMPORARY SOIL STABILIZATION SHALL BE APPLIED TO DENUDED AREAS WITHIN SEVEN (7) DAYS AFTER FINAL GRADE IS REACHED ON ANY PORTION OF THE SITE. TEMPORARY SOIL STABILIZATION SHALL BE APPLIED WITHIN SEVEN (7) DAYS TO DENUDED AREAS THAT MAY NOT BE AT FINAL GRADE BUT WILL REMAIN UNDISTURBED FOR LONGER THAN 30 DAYS. PERMANENT STABILIZATION SHALL BE APPLIED TO AREAS THAT ARE TO BE LEFT UNDISTURBED FOR MORE THAN ONE YEAR.
4. DURING CONSTRUCTION OF THE PROJECT, SOIL STOCKPILES SHALL BE STABILIZED, COVERED OR CONTAINED WITH SEDIMENT TRAPPING MEASURES. THE CONTRACTOR IS RESPONSIBLE FOR THE TEMPORARY PROTECTION AND PERMANENT STABILIZATION OF ALL SOIL STOCKPILES ON SITE AS WELL AS SOIL INTENTIONALLY TRANSPORTED FROM THE PROJECT SITE.
5. A PERMANENT VEGETATIVE COVER SHALL BE ESTABLISHED ON DENUDED AREAS NOT OTHERWISE PERMANENTLY STABILIZED. AFTER ANY SIGNIFICANT RAINFALL, (2" OR GREATER) SEDIMENT CONTROL STRUCTURES WILL BE INSPECTED FOR INTEGRITY. ANY DAMAGED DEVICES SHALL BE CORRECTED IMMEDIATELY.
6. CONCENTRATED RUNOFF SHALL NOT FLOW DOWN CUT OR FILL SLOPES UNLESS CONTAINED WITH AN ADEQUATE TEMPORARY OR PERMANENT CHANNEL, FLUME, SLOPE DRAIN STRUCTURE OR APPROVED CONTROL.
7. SEDIMENT WILL BE PREVENTED FROM ENTERING ANY STORM WATER SYSTEM, DITCH OR CHANNEL. ALL STORM WATER INLETS THAT ARE MADE OPERABLE DURING CONSTRUCTION SHALL BE PROTECTED SO THAT SEDIMENT-LADEN WATER CANNOT ENTER THE CONVEYANCE SYSTEM WITHOUT FIRST BEING FILTERED OR OTHERWISE TREATED TO REMOVE SEDIMENT.
8. WHEN WORK IN A LIVE WATERCOURSE IS PERFORMED, PRECAUTIONS SHALL BE TAKEN TO MINIMIZE ENCROACHMENT, CONTROL SEDIMENT TRANSPORT AND STABILIZE THE WORK AREA TO THE GREATEST EXTENT POSSIBLE DURING CONSTRUCTION.
9. PERIODIC INSPECTION AND MAINTENANCE OF ALL SEDIMENT CONTROL STRUCTURES MUST BE PROVIDED TO ENSURE INTENDED PURPOSE IS ACCOMPLISHED. THE DEVELOPER, OWNER AND/OR CONTRACTOR SHALL BE CONTINUALLY RESPONSIBLE FOR ALL SEDIMENT CONTROLS. SEDIMENT CONTROL MEASURES SHALL BE IN WORKING CONDITION AT THE END OF EACH WORKING DAY.
10. WHERE CONSTRUCTION VEHICLE ACCESS ROUTES INTERSECT PAVED PUBLIC ROADS, PROVISIONS SHALL BE MADE TO MINIMIZE THE TRANSPORT OF SEDIMENT BY TRACKING ONTO THE PAVED SURFACE. WHERE SEDIMENT IS TRANSPORTED ONTO A PUBLIC ROAD SURFACE, THE ROAD SHALL BE CLEANED THOROUGHLY AT THE END OF EACH DAY. SEDIMENT SHALL BE REMOVED FROM THE ROADS BY SHOVELING OR SWEEPING AND TRANSPORTED TO A SEDIMENT DISPOSAL AREA. STREET WASHING SHALL BE ALLOWED ONLY AFTER SEDIMENT IS REMOVED IN THIS MANNER. THIS PROVISION SHALL APPLY TO INDIVIDUAL LOTS AS WELL AS TO LARGER LAND DISTURBING ACTIVITIES.
11. ALL TEMPORARY EROSION AND SEDIMENT CONTROL MEASURES SHALL BE REMOVED WITHIN 30 DAYS AFTER FINAL SITE STABILIZATION OR AFTER THE TEMPORARY AREAS ARE NO LONGER NEEDED.
12. PROPERTIES AND WATERWAYS DOWNSTREAM FROM CONSTRUCTION SITES SHALL BE PROTECTED FROM SEDIMENT DEPOSITION AND EROSION.
13. EROSION CONTROL DESIGN AND CONSTRUCTION SHALL FOLLOW THE REQUIREMENTS IN INDEX NUMBERS 101, 102 AND 103 OF F.O.T. ROADWAY AND TRAFFIC DESIGN STANDARDS, IN ADDITION TO THESE PLANS.
14. CONTRACTOR IS RESPONSIBLE FOR ALL SURFACE WATER DISCHARGES, RAINFALL RUN-OFF OR DEWATERING ACTIVITIES.
15. CONTRACTOR MUST INCORPORATE ALL BMP'S NECESSARY TO MEET OR EXCEED STATE WATER QUALITY REQUIREMENTS.
16. POLLUTION PREVENTION PLAN IS A MINIMUM GUIDELINE ONLY. ADDITIONAL BMP'S MAY BE NECESSARY AT CONTRACTOR'S EXPENSE. NO. TO BE POSTED ON SITE.
17. NO TURBID DISCHARGE. TURBIDITY READINGS ARE REQUIRED ONCE A WEEK AND MUST BE REPORTED TO THE PROJECT ENGINEER.
18. DEWATERING ACTIVITIES:
  - A. DISCHARGE MUST NOT EXCEED STATE WATER QUALITY STANDARDS.
  - B. CONTRACTOR MUST HAVE OR OBTAIN A TRANSFERABLE SURFID CONSUMPTIVE USE PERMIT KNOWN AS A "NOTICED GENERAL PERMIT FOR SHORT TERM CONSTRUCTION DE-WATERING" UNLESS DEWATERING ACTIVITIES WILL RESULT IN LESS THAN 300,000 GPD FOR 30 DAYS OR LESS.
  - C. NO HYDRAULIC PUMPS MAY BE USED FOR DEWATERING UNLESS APPROVED BY THE WATER MANAGEMENT DISTRICT FOR THAT AREA. DEWATERING EXISTING STORMWATER COLLECTION AREAS (POND/LAKES) MAY BE EXEMPT FROM THIS CONDITION. CONTRACTOR TO CONFIRM WITH SURFID.
  - D. NO TURBID DISCHARGE. TURBIDITY READINGS ARE REQUIRED ONCE A WEEK AND MUST BE REPORTED TO THE PROJECT ENGINEER AND TO CITY OF FT. PIERCE.
19. SEE ADDITIONAL DETAILS, SPECIFICATIONS AND REQUIREMENTS OF SHEET 4. 11-13.

**STORMWATER POLLUTION PREVENTION PLAN**

A SITE PLAN MUST BE DEVELOPED AND MUST CONTAIN, AT A MINIMUM, THE FOLLOWING INFORMATION:

1. DRAINAGE PATTERNS - SEE SURVEY AND DRAINAGE PLAN SHEET 3 & 7.
2. APPROXIMATE SLOPES AFTER MAJOR GRADING ACTIVITIES - SEE SHEET 7.
3. AREAS OF SOIL DISTURBANCE - SEE SHEETS 2, AND THIS SHEET.
4. OUTLINE ALL AREAS THAT ARE NOT TO BE DISTURBED - N/A.
5. LOCATION OF ALL MAJOR STRUCTURAL AND NON-STRUCTURAL CONTROLS, THIS SHEET.
6. THE LOCATION OF EXPECTED STABILIZATION PRACTICES, THIS SHEET.
7. NO WETLANDS AND SURFACE WATERS.
8. LOCATIONS WHERE STORMWATER MAY DISCHARGE TO A SURFACE WATER OR MSA. SEE SHEET 7.

DESCRIBE THE NATURE OF THE CONSTRUCTION ACTIVITY:  
DEMOLITION, LAND CLEARING, EARTHWORK, PAVING AND UTILITY WORK FOR BUILDINGS, PARKING AND SITE IMPROVEMENTS

DESCRIBE THE INTENDED SEQUENCE OF MAJOR SOIL DISTURBING ACTIVITIES:

1. SITE PREPARATION AND STABILIZE CONSTRUCTION ENTRANCE.
2. INSTALL SILT FENCE AROUND PERIMETER OF SITE. INSTALL TURBIDITY BARRIERS AT ALL OUTFALL LOCATIONS. CLEAR LAND AND CONSTRUCT BERM AND TEMPORARY SWALES AS SHOWN ON PLANS. BERM SHALL BE CONSTRUCTED USING INITIAL IMPORTED FILL MATERIAL. THE BERM AND SWALE SHALL BE SEEDED.

TOTAL AREA OF THE SITE: 0.828 ACRES  
TOTAL AREA OF THE SITE TO BE DISTURBED: 0.828 ACRES

EXISTING DATA DESCRIBING THE SOIL OR QUALITY OF ANY STORMWATER DISCHARGE:  
SEE SOIL BORINGS BY SHEETS 2. NO DISCHARGE FROM DISTURBED AREAS IS ANTICIPATED.

DRAINAGE AREA SIZE FOR EACH DISCHARGE POINT:  
ENTRANCE: 0.028 ACRES

LATITUDE AND LONGITUDE OF THE SITE:  
LATITUDE = N 27° 28' 11.9"  
LONGITUDE = W 80° 17' 53.9"

BEST MANAGEMENT PRACTICES (BMP'S) AND MEASURES THAT WILL BE IMPLEMENTED AT THE CONSTRUCTION SITE AND TIME FRAMES IN WHICH THE CONTROLS WILL BE IMPLEMENTED:  
THE CONTRACTOR WILL USE HAY BALES, SILT FENCE, FILTER BARRIERS, AND OTHER BMP'S. THE TIME FRAMES FOR CLEARING, EARTHWORK, AND ANTICIPATED BMP'S ARE:

1. INSTALL SILT FENCE AT PERIMETER OF SITE AND SILT BARRIERS AT DOWNSTREAM DITCHES/SWALES.
2. CLEAR/GRUB AREA NECESSARY FOR TEMPORARY GRAVEL DRIVEWAY AND ADJACENT SWALE.
3. CONSTRUCT TEMPORARY GRAVEL DRIVEWAY WITH SWALE, AND GRADE/SOD SWALE AT ENTRANCE.
4. CLEAR BALANCE OF SITE.
5. CONSTRUCT 12" RC AND MITERED END SECTIONS.
6. IMPORT FILL MATERIAL.
7. MAINTAIN DOWNSTREAM SILT BARRIERS AND PERIMETER SILT FENCE, DURING CONSTRUCTION.
8. INCORPORATE ADDITIONAL BMP'S WHEN NEEDED DURING THE COURSE OF CONSTRUCTION.
9. POLY/WOODPILE SILT FENCE/ FILTER SOCKS AND INLETS ARE INSTALLED.
10. PROVIDE STOCKPILE PROTECTION, CONCRETE/ STUCCO WASH AREAS, AND OTHER BMP'S WHEN NECESSARY TO CONTAIN PROPOSED WORK.

TEMPORARY AND PERMANENT STABILIZATION PRACTICES:  
TEMP: HAY BALE/SILT FENCES/FLOATING TURBIDITY BARRIERS PER PLAN. FILTER FABRIC SHALL BE PLACED UNDER THE ROCK GRAVEL DRIVEWAY, AT ALL SWALE OUTFALLS, AND RETENTION POND OUTFALLS.  
PERM: SEEDED/MULCHED/SOD. CONTROLLED GRADING AND DRAINAGE TO DETENTION BASINS.  
STABILIZE ALL DE-NUDED AREAS IF LEFT UNDISTURBED FOR MORE THAN 7 DAYS - USE RYE GRASS PER MANUFACTURER'S APPLICATION RATES, AND MULCHED WITH STRAW AT 4000 LB PER ACRE.

STRUCTURAL CONTROLS TO BE IMPLEMENTED TO DIVERT STORMWATER FLOW FROM RECEIVING WATERS:  
TEMP: GRAVEL ENTRANCE ROAD, GRADED TO DRAIN TO A TEMPORARY SEDIMENT SWALE OR RETENTION AREA.  
TEMP: DRAINS TO RETENTION PONDS.  
TEMP: BERMS AT PROJECT PERIMETER - PER PLAN.  
INLETS/OUTLETS WILL BE PROTECTED WITH FILTER FABRIC AND PROPERLY INSTALLED HAY BALES.  
SILT FENCE SHALL BE PLACED AROUND THE ENTIRE PERIMETER OF DISTURBED AREAS.  
A DOUBLE ROW OF SILT FENCE WILL BE PROVIDED AROUND ALL STOCK PILE AREAS.

PERMANENT STORMWATER MANAGEMENT CONTROLS SUCH AS, DETENTION OR RETENTION SYSTEMS OR VEGETATED SWALES.  
WET DETENTION SYSTEMS INCORPORATED AS PERMANENT BMP FOR WATER QUALITY CONTROL.

DESCRIBE IN DETAIL CONTROLS FOR THE FOLLOWING POTENTIAL POLLUTANTS:  
**WASTE DISPOSAL**  
ON SITE WASTE WILL BE CONTAINERIZED. CONTRACTOR IS RESPONSIBLE FOR RECYCLING ALL WASTE MATERIALS, WITH A MINIMUM REQUIREMENT OF 75%.  
CONCRETE/ STUCCO WASH AREA SHALL BE PROVIDED.  
STOCKPILE AREAS SHALL BE PROTECTED WITH SILT FENCE AND STABILIZED/ SEEDED IF LEFT UNATTENDED FOR MORE THAN 7 DAYS.

OFFSITE VEHICLE TRACKING:  
PROVIDE HARD SURFACE AT TEMP. DRIVEWAY (ROCK/GRAVEL DRIVEWAY).  
REGULAR MAINTENANCE OF ADJACENT ROAD RIGHT OF WAY, INCLUDING STREET SWEEPING, & RUT REPAIR IN NON-PAVED AREAS.  
APPLICATION RATES OF ALL FERTILIZERS, HERBICIDES AND PESTICIDES:  
-NONE PROPOSED.

STORAGE, APPLICATION, GENERATION AND MIGRATION OF ALL TOXIC SUBSTANCES:  
-NONE PROPOSED.

DESCRIPTION OF THE MAINTENANCE PLAN FOR ALL STRUCTURAL AND NON-STRUCTURAL CONTROLS.  
CONTRACTOR SHALL HAVE SWPPP COMPONENTS INSPECTED BY A FDEP CERTIFIED INSPECTOR AND MAINTAIN ALL CONTROLS DAILY, AND HAVE WEEKLY SWPPP INSPECTION REPORTS PREPARED, AND WITHIN 24 HOURS OF THE END OF ANY RAINFALL EVENT THAT IS 1/2" OR GREATER. ENGINEER SHALL INSPECT PERIODICALLY.

**PLAN PREPARATION:**

1. THIS PLAN ORIGINALLY PREPARED BY THE OWNER'S ENGINEER. THIS PLAN WILL BE MADE AVAILABLE TO CONTRACTOR TO EDIT, CHANGE, MODIFY, AS IT DEEMS NECESSARY FOR COMPLIANCE WITH FDEP REGULATIONS, PERMIT CONDITIONS, AND AS REQUIRED FOR CONTRACTOR TO SIGN THE CERTIFICATION BELONGING TO THE FOLLOWING CERTIFICATION SHALL BE SIGNED BY THE ENTITY (CONTRACTOR) RESPONSIBLE FOR SWPPP PLAN IMPLEMENTATION:
2. "I CERTIFY UNDER PENALTY OF LAW THAT THIS DOCUMENT AND ALL ATTACHMENTS WERE PREPARED UNDER MY DIRECTION OR SUPERVISION IN ACCORDANCE WITH A SYSTEM DESIGNED TO ASSURE THAT QUALIFIED PERSONNEL, PROPERLY GATHERED AND EVALUATED THE INFORMATION SUBMITTED, BASED ON MY INQUIRY OF THE PERSON OR PERSONS WHO MANAGE THE SYSTEM, OR THOSE PERSONS DIRECTLY RESPONSIBLE FOR GATHERING THE INFORMATION, THE INFORMATION SUBMITTED IS, TO THE BEST OF MY KNOWLEDGE AND BELIEF TRUE, ACCURATE, AND COMPLETE. I AM AWARE THAT THERE ARE SIGNIFICANT PENALTIES FOR SUBMITTING FALSE INFORMATION, INCLUDING THE POSSIBILITY OF FINE AND IMPRISONMENT FOR KNOWING VIOLATIONS."

BY: \_\_\_\_\_ DATE: \_\_\_\_\_  
SIGNATURE \_\_\_\_\_

**ARCHAEOLOGICAL:**  
IF PREHISTORIC OR HISTORIC ARTIFACTS, SUCH AS POTTERY OR CERAMICS, STONE TOOLS, OR METAL IMPLEMENTS, OR ANY OTHER PHYSICAL REMAINS THAT COULD BE ASSOCIATED WITH THE NATIVE AMERICAN CULTURES, OR EARLY COLONIAL OR AMERICAN SETTLEMENT ARE ENCOUNTERED AT ANY TIME WITHIN THE PROJECT SITE AREA, THE PERMITTED PROJECT SHOULD CEASE ALL ACTIVITIES INVOLVING SUBSURFACE DISTURBANCE IN THE IMMEDIATE VICINITY OF SUCH DISCOVERIES. THE PERMITEE, OR OTHER DESIGNEE, SHOULD CONTACT THE FLORIDA DEPARTMENT OF STATE, DIVISION OF HISTORICAL RESOURCES, REVIEW AND COMPLIANCE SECTION AT (850) 245-6333 OR (800) 847-7278, AS WELL AS THE APPROPRIATE PERMITTING AGENCY OFFICE. PROJECT ACTIVITIES SHOULD NOT RESUME WITHOUT VERBAL AND/OR WRITTEN AUTHORIZATION FROM THE DIVISION OF HISTORICAL RESOURCES. IN THE EVENT THAT UNMARKED HUMAN REMAINS ARE ENCOUNTERED DURING PERMITTED ACTIVITIES, ALL WORK SHALL STOP IMMEDIATELY AND THE PROPER AUTHORITIES NOTIFIED IN ACCORDANCE WITH SECTION 97.05, FLORIDA STATUTES.

**EROSION AND SEDIMENTATION CONTROL:**

- A. THE LAND DISTURBING ACTIVITY SHALL CONFORM TO EXISTING TOPOGRAPHY AND SOIL TYPE SO AS TO CREATE THE LOWEST PRACTICAL EROSION POTENTIAL.
- B. LAND DISTURBING ACTIVITIES SHALL BE CONDUCTED IN A MANNER MINIMIZING EROSION.
- C. THE DISTURBED AREA AND THE DURATION OF EXPOSURE TO EROSION ELEMENTS SHALL BE KEPT TO A PRACTICABLE MINIMUM.
- D. EROSION CONTROL MUST BE STRICTLY MAINTAINED DURING CUT AND FILL OPERATIONS.
- E. DISTURBED SOIL SHALL BE STABILIZED AS QUICKLY AS PRACTICABLE.
- F. WHENEVER FEASIBLE, NATURAL VEGETATION OR MULCHING SHALL BE EMPLOYED TO PROTECT EXPOSED CRITICAL AREAS DURING DEVELOPMENT.
- G. TEMPORARY VEGETATION OR MULCHING SHALL BE EMPLOYED TO PROTECT EXPOSED CRITICAL AREAS DURING DEVELOPMENT.
- H. PERMANENT VEGETATION AND STRUCTURAL EROSION CONTROL MEASURES SHALL BE INSTALLED AS SOON AS PRACTICABLE.
- I. ADEQUATE PROVISIONS MUST BE PROVIDED TO MINIMIZE DAMAGE FROM SURFACE WATER TO THE CUT FACE OF EXCAVATION OR THE SLOPING SURFACE OF FILLS.
- J. TO THE EXTENT NECESSARY, SEDIMENT IN RUNOFF WATER MUST BE TRAPPED BY THE USE OF DEBRIS BASINS, SEDIMENT BASINS, SILT TRAPS OR SIMILAR MEASURES UNTIL THE DISTURBED AREA IS STABILIZED.
- K. CUTS AND FILLS MUST BE CONSTRUCTED IN SUCH A MANNER THAT EROSION AND RUNOFF FROM THE SITE DOES NOT ENDANGER ADJOINING PROPERTY.
- L. FILLS MAY NOT ENROACH UPON NATURAL WATERCOURSES OR CONSTRUCTED CHANNELS IN A MANNER SO AS TO ADVERSELY AFFECT OTHER PROPERTY OWNERS WITHOUT ADEQUATE PROVISIONS FOR AN EQUIVALENT ALTERNATE SYSTEM WITH A POSITIVE OUTFALL.
- M. ALL R.O.W.'S, WATERWAYS, STREETS AND SIDEWALKS SHALL BE BUFFERED BY A TYPICAL 50' FOOT WIDE STRIP OF GRASS OR OTHER SUITABLE MEANS.
- N. GRADING EQUIPMENT MUST CROSS FLOWING STREAMS BY MEANS OF BRIDGES OR CULVERTS EXCEPT WHEN SUCH METHODS NOT FEASIBLE AND PROVIDED IN ANY CASE, THAT SUCH CROSSINGS ARE KEPT TO A MINIMUM AND SEDIMENTATION CONTROL DEVICES ARE PROVIDED.

**STORMWATER POLLUTION PREVENTION PLAN**

A SITE PLAN MUST BE DEVELOPED AND MUST CONTAIN, AT A MINIMUM, THE FOLLOWING INFORMATION:

1. DRAINAGE PATTERNS - SEE SURVEY AND DRAINAGE PLAN SHEET 3 & 7.
2. APPROXIMATE SLOPES AFTER MAJOR GRADING ACTIVITIES - SEE SHEET 7.
3. AREAS OF SOIL DISTURBANCE - SEE SHEETS 2, AND THIS SHEET.
4. OUTLINE ALL AREAS THAT ARE NOT TO BE DISTURBED - N/A.
5. LOCATION OF ALL MAJOR STRUCTURAL AND NON-STRUCTURAL CONTROLS, THIS SHEET.
6. THE LOCATION OF EXPECTED STABILIZATION PRACTICES, THIS SHEET.
7. NO WETLANDS AND SURFACE WATERS.
8. LOCATIONS WHERE STORMWATER MAY DISCHARGE TO A SURFACE WATER OR MSA. SEE SHEET 7.

DESCRIBE THE NATURE OF THE CONSTRUCTION ACTIVITY:  
DEMOLITION, LAND CLEARING, EARTHWORK, PAVING AND UTILITY WORK FOR BUILDINGS, PARKING AND SITE IMPROVEMENTS

DESCRIBE THE INTENDED SEQUENCE OF MAJOR SOIL DISTURBING ACTIVITIES:

1. SITE PREPARATION AND STABILIZE CONSTRUCTION ENTRANCE.
2. INSTALL SILT FENCE AROUND PERIMETER OF SITE. INSTALL TURBIDITY BARRIERS AT ALL OUTFALL LOCATIONS. CLEAR LAND AND CONSTRUCT BERM AND TEMPORARY SWALES AS SHOWN ON PLANS. BERM SHALL BE CONSTRUCTED USING INITIAL IMPORTED FILL MATERIAL. THE BERM AND SWALE SHALL BE SEEDED.

TOTAL AREA OF THE SITE: 0.828 ACRES  
TOTAL AREA OF THE SITE TO BE DISTURBED: 0.828 ACRES

EXISTING DATA DESCRIBING THE SOIL OR QUALITY OF ANY STORMWATER DISCHARGE:  
SEE SOIL BORINGS BY SHEETS 2. NO DISCHARGE FROM DISTURBED AREAS IS ANTICIPATED.

DRAINAGE AREA SIZE FOR EACH DISCHARGE POINT:  
ENTRANCE: 0.028 ACRES

LATITUDE AND LONGITUDE OF THE SITE:  
LATITUDE = N 27° 28' 11.9"  
LONGITUDE = W 80° 17' 53.9"

BEST MANAGEMENT PRACTICES (BMP'S) AND MEASURES THAT WILL BE IMPLEMENTED AT THE CONSTRUCTION SITE AND TIME FRAMES IN WHICH THE CONTROLS WILL BE IMPLEMENTED:  
THE CONTRACTOR WILL USE HAY BALES, SILT FENCE, FILTER BARRIERS, AND OTHER BMP'S. THE TIME FRAMES FOR CLEARING, EARTHWORK, AND ANTICIPATED BMP'S ARE:

1. INSTALL SILT FENCE AT PERIMETER OF SITE AND SILT BARRIERS AT DOWNSTREAM DITCHES/SWALES.
2. CLEAR/GRUB AREA NECESSARY FOR TEMPORARY GRAVEL DRIVEWAY AND ADJACENT SWALE.
3. CONSTRUCT TEMPORARY GRAVEL DRIVEWAY WITH SWALE, AND GRADE/SOD SWALE AT ENTRANCE.
4. CLEAR BALANCE OF SITE.
5. CONSTRUCT 12" RC AND MITERED END SECTIONS.
6. IMPORT FILL MATERIAL.
7. MAINTAIN DOWNSTREAM SILT BARRIERS AND PERIMETER SILT FENCE, DURING CONSTRUCTION.
8. INCORPORATE ADDITIONAL BMP'S WHEN NEEDED DURING THE COURSE OF CONSTRUCTION.
9. POLY/WOODPILE SILT FENCE/ FILTER SOCKS AND INLETS ARE INSTALLED.
10. PROVIDE STOCKPILE PROTECTION, CONCRETE/ STUCCO WASH AREAS, AND OTHER BMP'S WHEN NECESSARY TO CONTAIN PROPOSED WORK.

TEMPORARY AND PERMANENT STABILIZATION PRACTICES:  
TEMP: HAY BALE/SILT FENCES/FLOATING TURBIDITY BARRIERS PER PLAN. FILTER FABRIC SHALL BE PLACED UNDER THE ROCK GRAVEL DRIVEWAY, AT ALL SWALE OUTFALLS, AND RETENTION POND OUTFALLS.  
PERM: SEEDED/MULCHED/SOD. CONTROLLED GRADING AND DRAINAGE TO DETENTION BASINS.  
STABILIZE ALL DE-NUDED AREAS IF LEFT UNDISTURBED FOR MORE THAN 7 DAYS - USE RYE GRASS PER MANUFACTURER'S APPLICATION RATES, AND MULCHED WITH STRAW AT 4000 LB PER ACRE.

STRUCTURAL CONTROLS TO BE IMPLEMENTED TO DIVERT STORMWATER FLOW FROM RECEIVING WATERS:  
TEMP: GRAVEL ENTRANCE ROAD, GRADED TO DRAIN TO A TEMPORARY SEDIMENT SWALE OR RETENTION AREA.  
TEMP: DRAINS TO RETENTION PONDS.  
TEMP: BERMS AT PROJECT PERIMETER - PER PLAN.  
INLETS/OUTLETS WILL BE PROTECTED WITH FILTER FABRIC AND PROPERLY INSTALLED HAY BALES.  
SILT FENCE SHALL BE PLACED AROUND THE ENTIRE PERIMETER OF DISTURBED AREAS.  
A DOUBLE ROW OF SILT FENCE WILL BE PROVIDED AROUND ALL STOCK PILE AREAS.

PERMANENT STORMWATER MANAGEMENT CONTROLS SUCH AS, DETENTION OR RETENTION SYSTEMS OR VEGETATED SWALES.  
WET DETENTION SYSTEMS INCORPORATED AS PERMANENT BMP FOR WATER QUALITY CONTROL.

DESCRIBE IN DETAIL CONTROLS FOR THE FOLLOWING POTENTIAL POLLUTANTS:  
**WASTE DISPOSAL**  
ON SITE WASTE WILL BE CONTAINERIZED. CONTRACTOR IS RESPONSIBLE FOR RECYCLING ALL WASTE MATERIALS, WITH A MINIMUM REQUIREMENT OF 75%.  
CONCRETE/ STUCCO WASH AREA SHALL BE PROVIDED.  
STOCKPILE AREAS SHALL BE PROTECTED WITH SILT FENCE AND STABILIZED/ SEEDED IF LEFT UNATTENDED FOR MORE THAN 7 DAYS.

OFFSITE VEHICLE TRACKING:  
PROVIDE HARD SURFACE AT TEMP. DRIVEWAY (ROCK/GRAVEL DRIVEWAY).  
REGULAR MAINTENANCE OF ADJACENT ROAD RIGHT OF WAY, INCLUDING STREET SWEEPING, & RUT REPAIR IN NON-PAVED AREAS.  
APPLICATION RATES OF ALL FERTILIZERS, HERBICIDES AND PESTICIDES:  
-NONE PROPOSED.

STORAGE, APPLICATION, GENERATION AND MIGRATION OF ALL TOXIC SUBSTANCES:  
-NONE PROPOSED.

DESCRIPTION OF THE MAINTENANCE PLAN FOR ALL STRUCTURAL AND NON-STRUCTURAL CONTROLS.  
CONTRACTOR SHALL HAVE SWPPP COMPONENTS INSPECTED BY A FDEP CERTIFIED INSPECTOR AND MAINTAIN ALL CONTROLS DAILY, AND HAVE WEEKLY SWPPP INSPECTION REPORTS PREPARED, AND WITHIN 24 HOURS OF THE END OF ANY RAINFALL EVENT THAT IS 1/2" OR GREATER. ENGINEER SHALL INSPECT PERIODICALLY.

**NOTES:**

1. THIS PLAN (SHEETS 4 AND 5), COPY OF FDEP NOI (STATE OF FLORIDA GENERIC PERMIT FOR STORMWATER DISCHARGE FROM LARGE AND SMALL CONSTRUCTION ACTIVITIES) AND ALL REQUIRED INSPECTION REPORTS, TESTS, AND ALL OTHER DOCUMENTATION SHALL BE KEPT AT THE PROJECT SITE.
2. THE FOLLOWING CERTIFICATION SHALL BE COMPLETED BY ALL CONTRACTORS/SUB-CONTRACTORS RESPONSIBLE FOR ANY PORTION OF THE IMPLEMENTATION OF THE S.W.P.P.P.:

CERTIFICATION:  
"I CERTIFY UNDER THE PENALTY OF LAW THAT I UNDERSTAND AND SHALL COMPLY WITH THE TERMS AND CONDITIONS OF THE STATE OF FLORIDA PERMIT FOR STORMWATER DISCHARGE FROM LARGE AND SMALL CONSTRUCTION ACTIVITIES AND THIS STORMWATER POLLUTION PREVENTION PLAN PREPARED THEREUNDER."

SWPPP DESCRIPTION OF WORK/ RESPONSIBILITY	NAME TITLE	CONTRACTOR OR SUB CONTRACTOR (NAME, ADDRESS, PHONE)	NAME/SIGNATURE TO CERTIFICATION	DATE

PLS	PROFESSIONAL LAND SURVEYOR	(P)	PLAT
PSM	PROFESSIONAL SURVEYOR & MAPPER	(C)	CALCULATED
LB	LAND SURVEYING BUSINESS	NAVD	NORTH AMERICAN VERTICAL DATUM
Q	CENTERLINE	425.3'	TYPICAL ELEVATION
R	RADIUS	AC	AIR CONDITIONER
L	LENGTH	CONC.	CONCRETE
Δ	DELTA ANGLE	F.F.	FINISH FLOOR
EP	EDGE OF PAVEMENT	BSB	BUILDING SETBACK LINE
BC	BACK OF CURB	EL-ELEV.	ELEVATION
B.M.	BENCHMARK	RW	RIGHT OF WAY
POC	POINT OF COMMENCEMENT	AB	AS-BUILT
POB	POINT OF BEGINNING	PK	PARKER-KALON
o	(PCP) PERMANENT CONTROL POINT		
PCP	PERMANENT CONTROL POINT		
BI	(PRM) PERMANENT REFERENCE MONUMENT		
PRM	PERMANENT REFERENCE MONUMENT		
O	(IP) IRON PIPE		
IP	IRON PIPE		
●	(IRC) IRON ROD & CAP		
IRC	IRON ROD & CAP		
□	(CM) CONCRETE MONUMENT		
CM	CONCRETE MONUMENT		
FD	FOUND		
(M)	MEASURED		

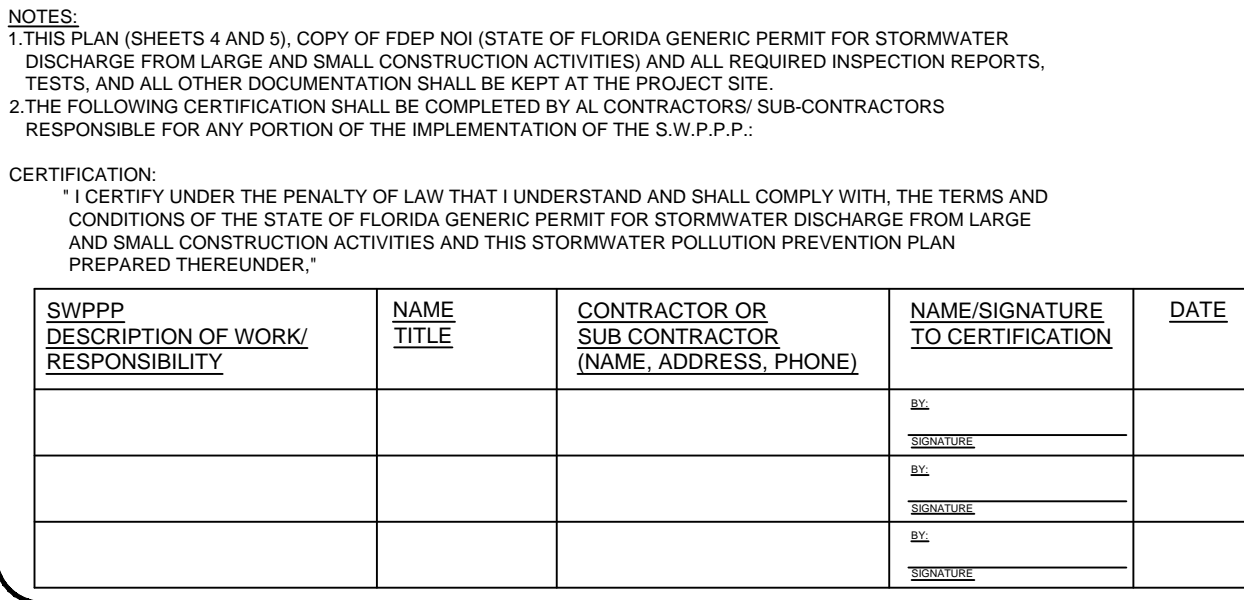
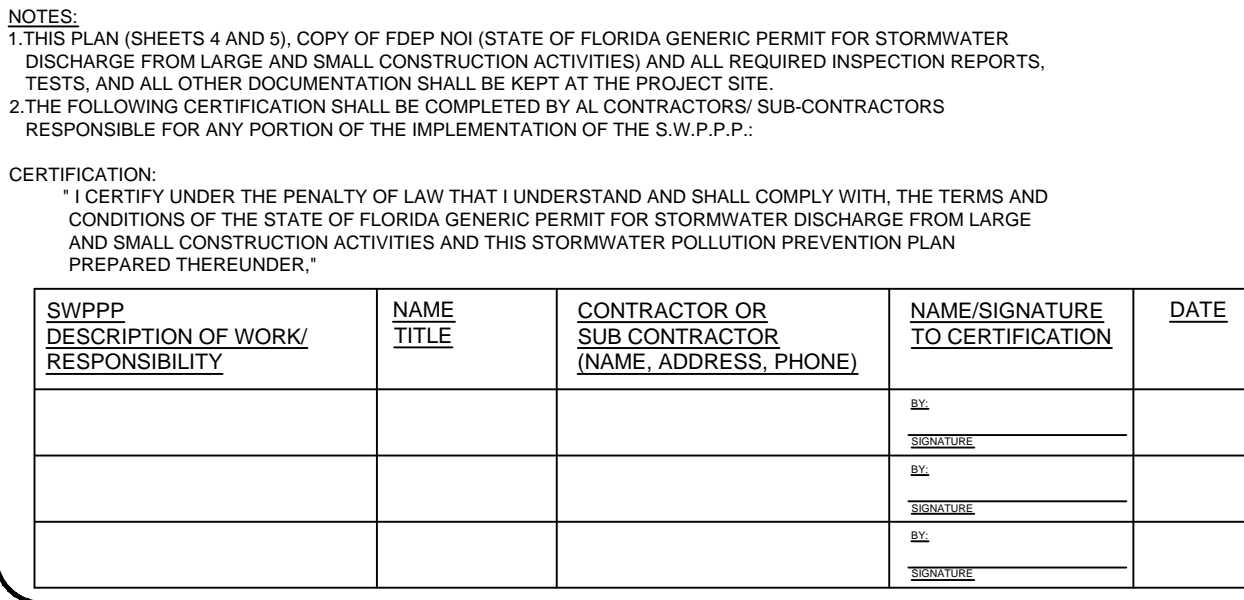
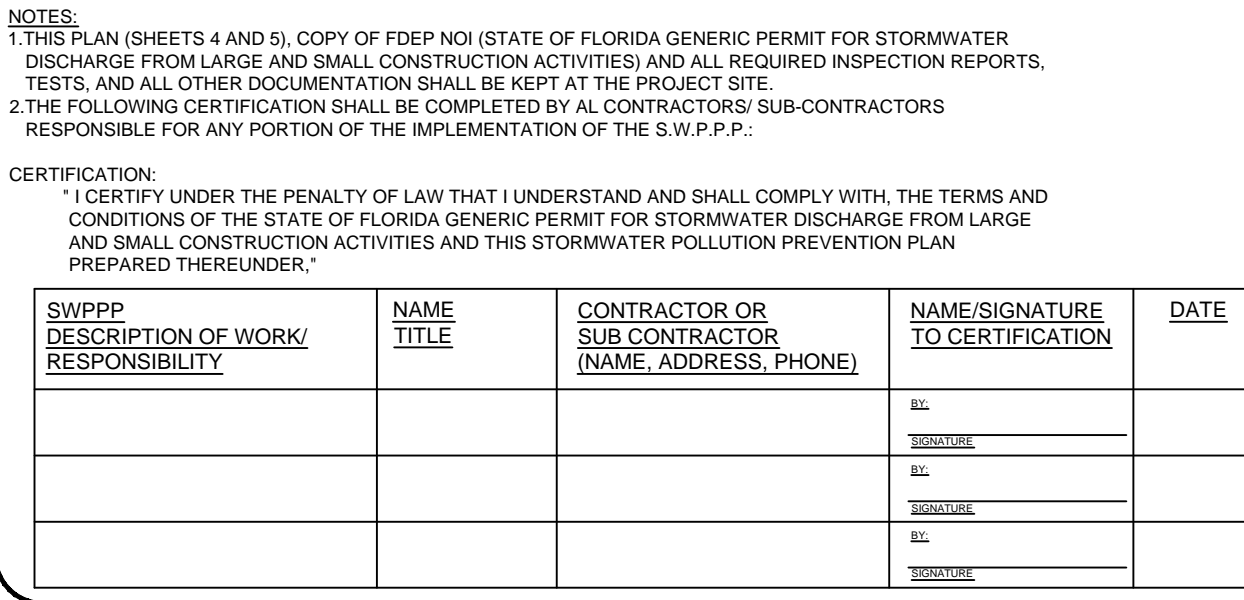
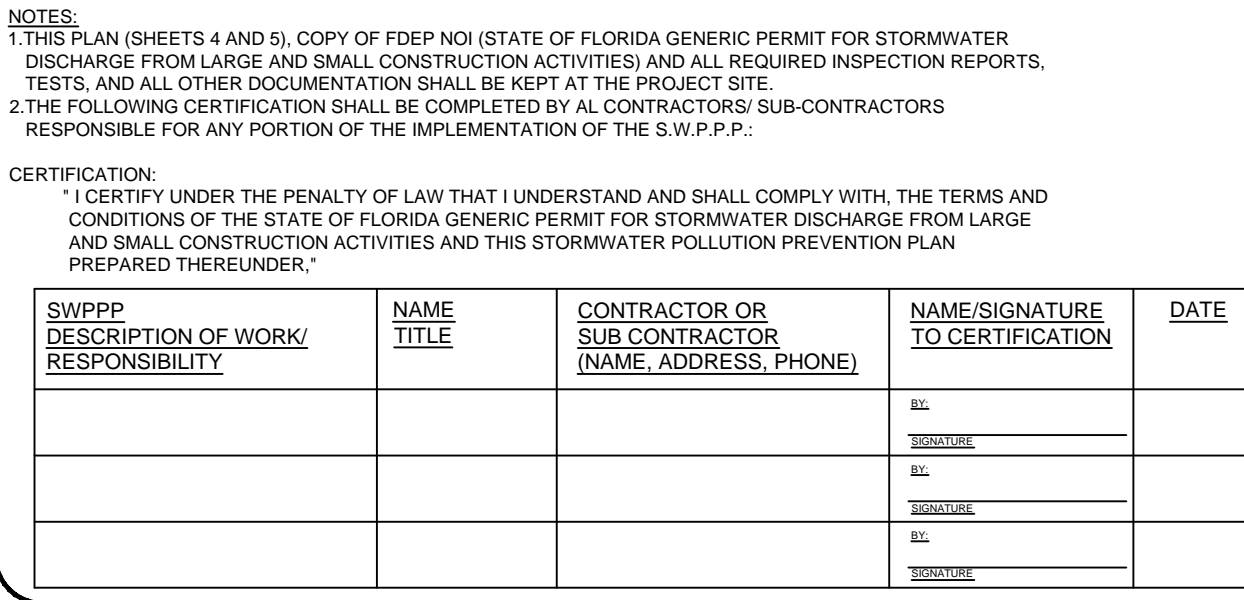
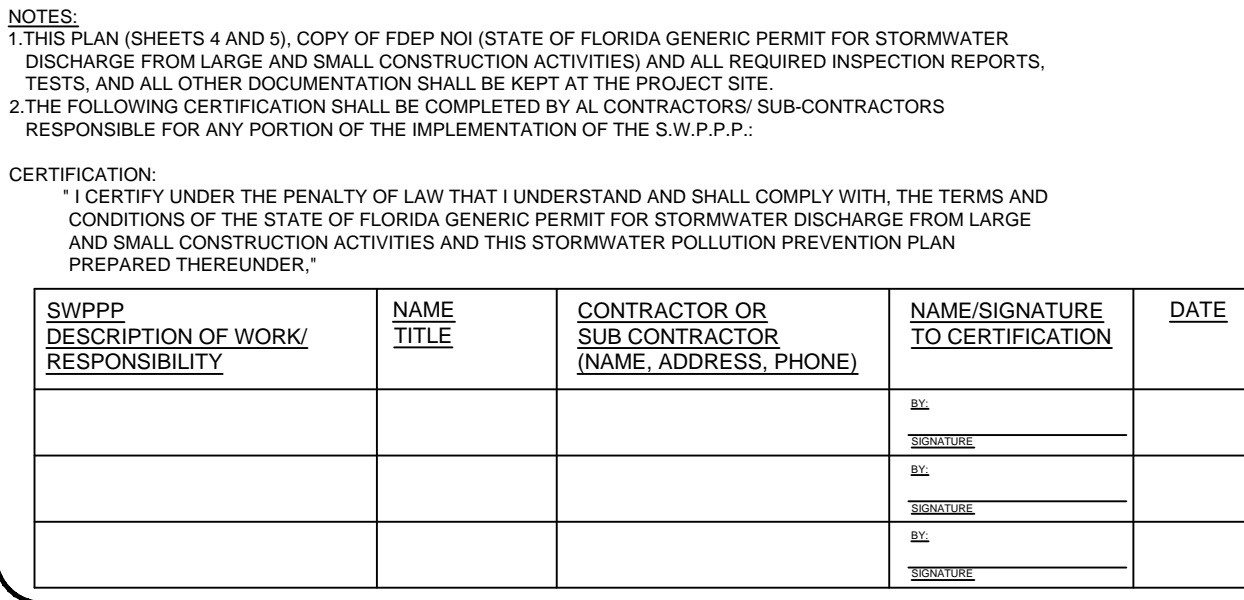
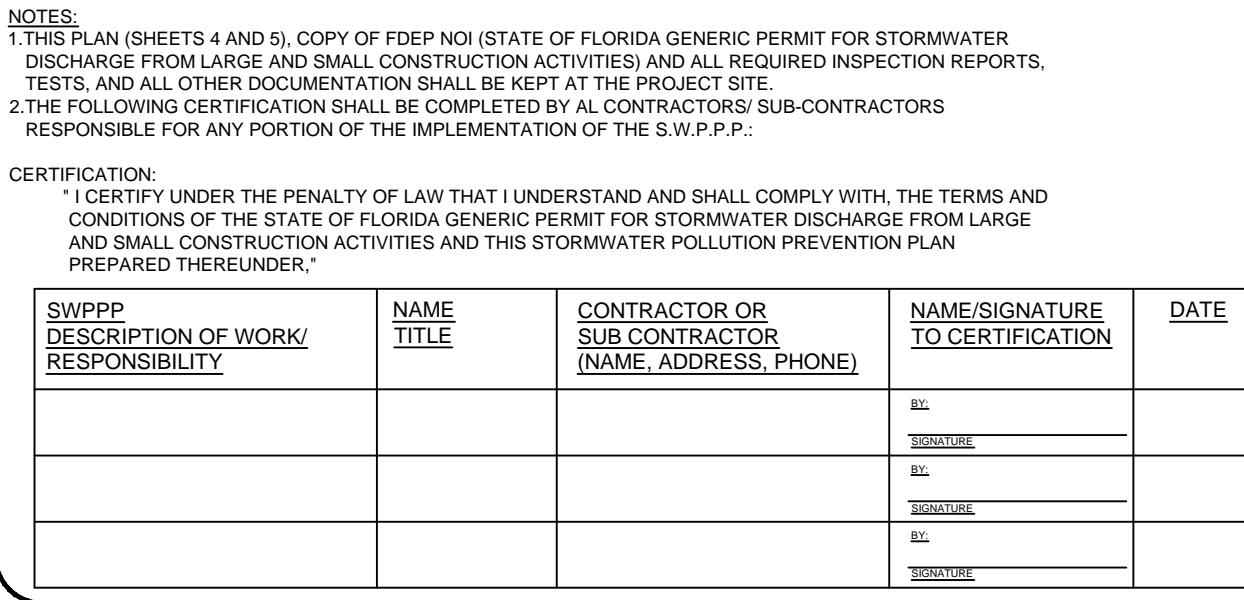
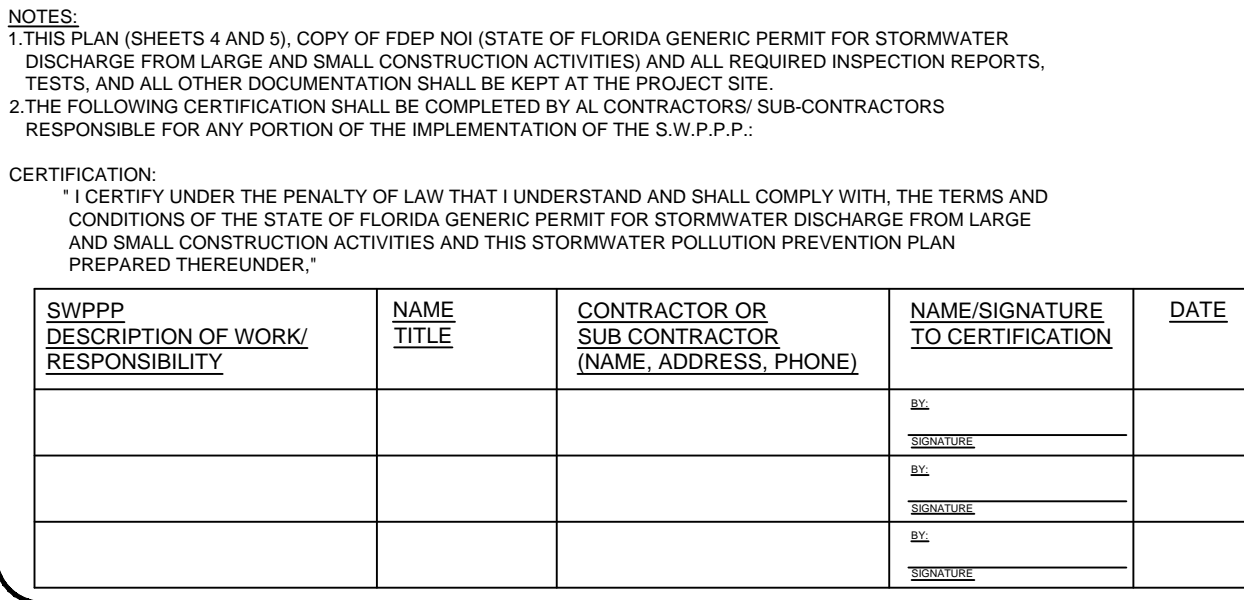
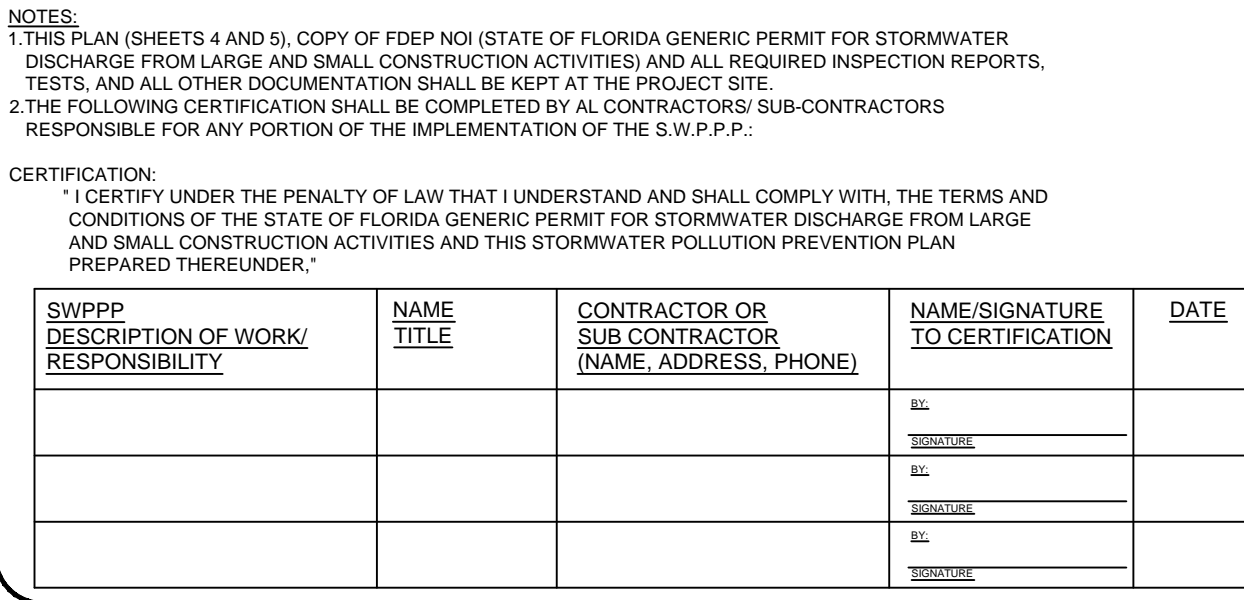
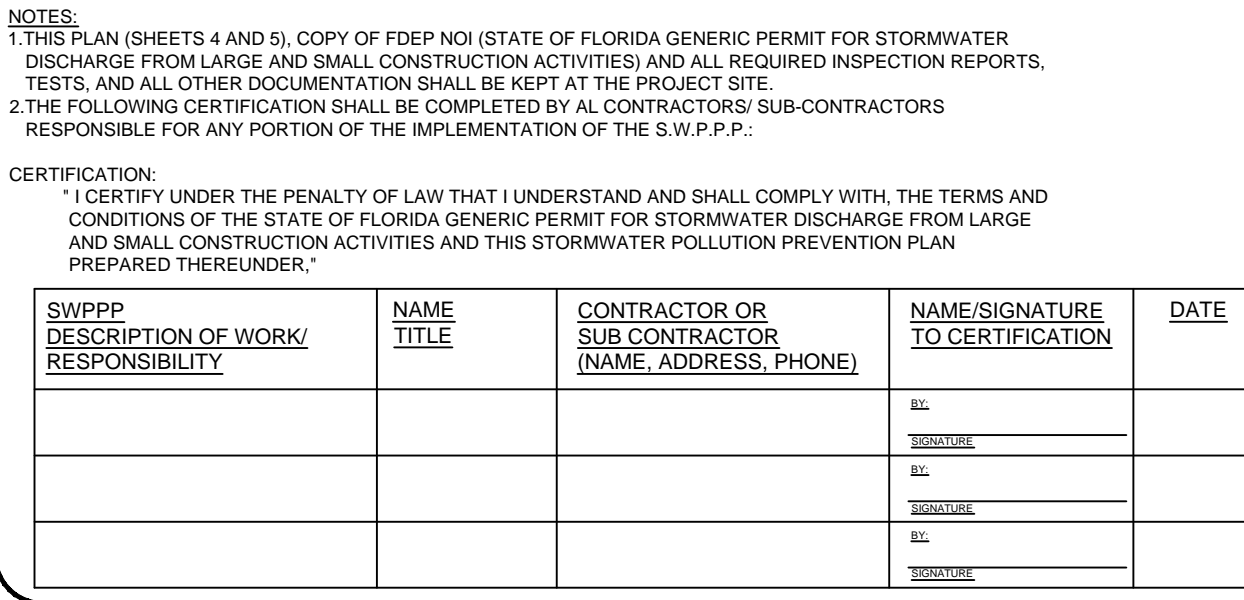
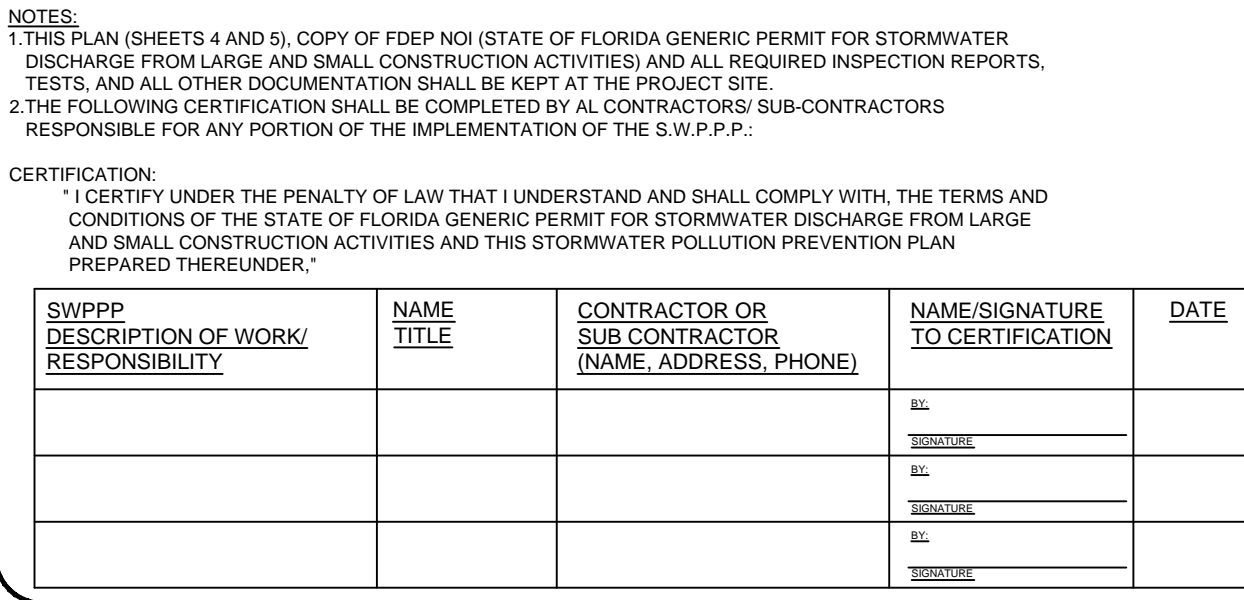
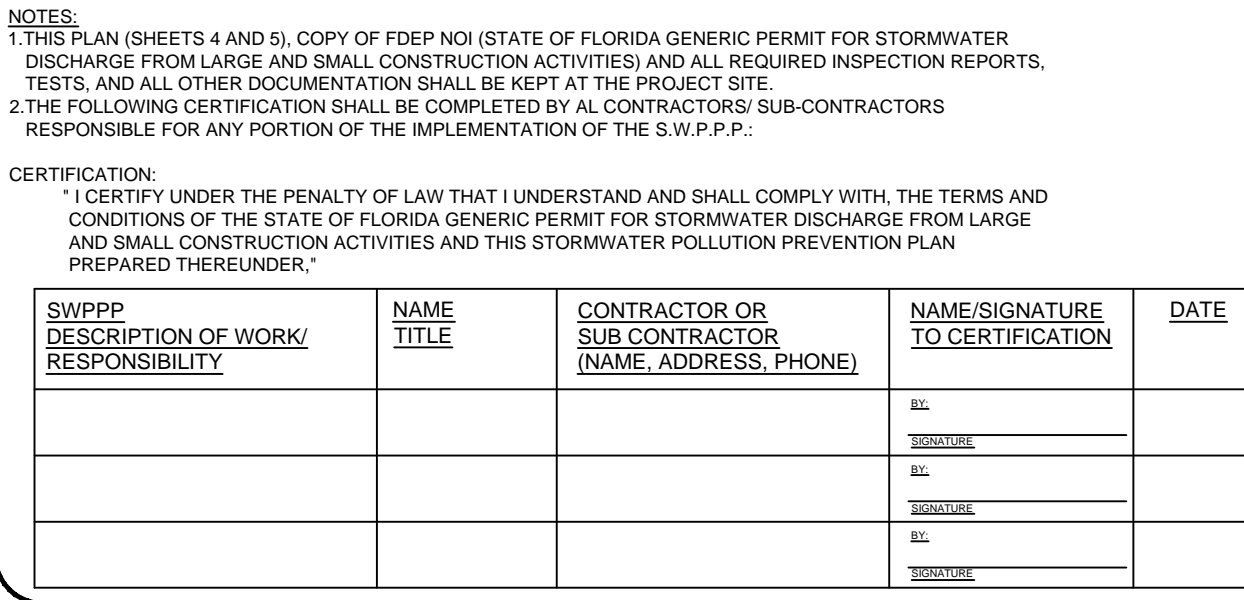
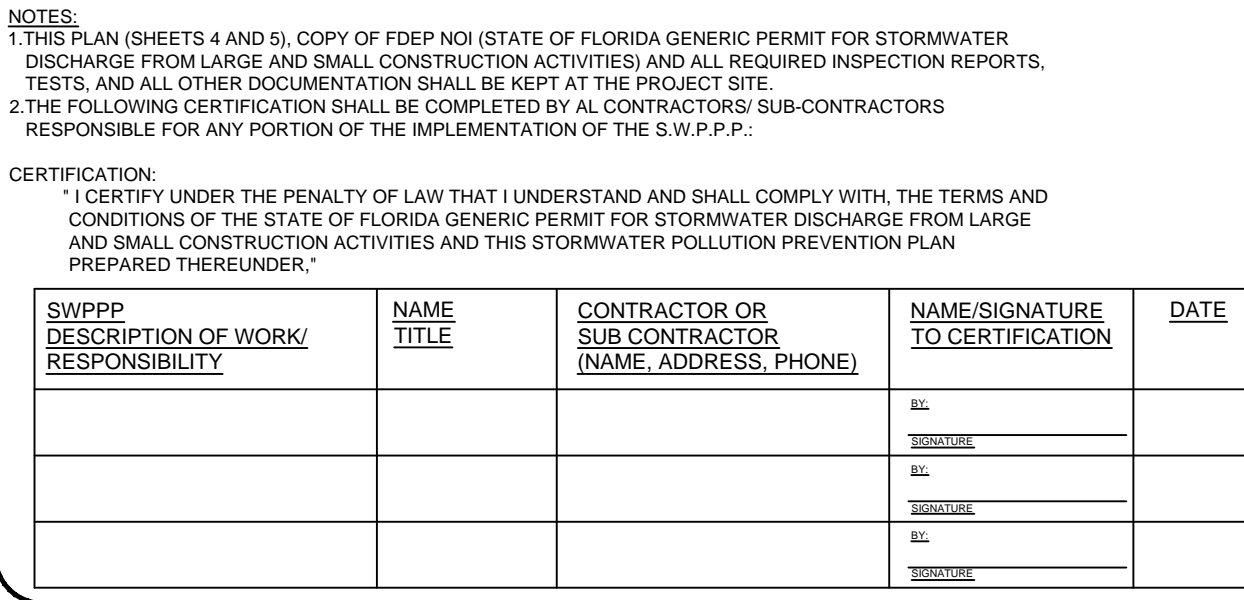
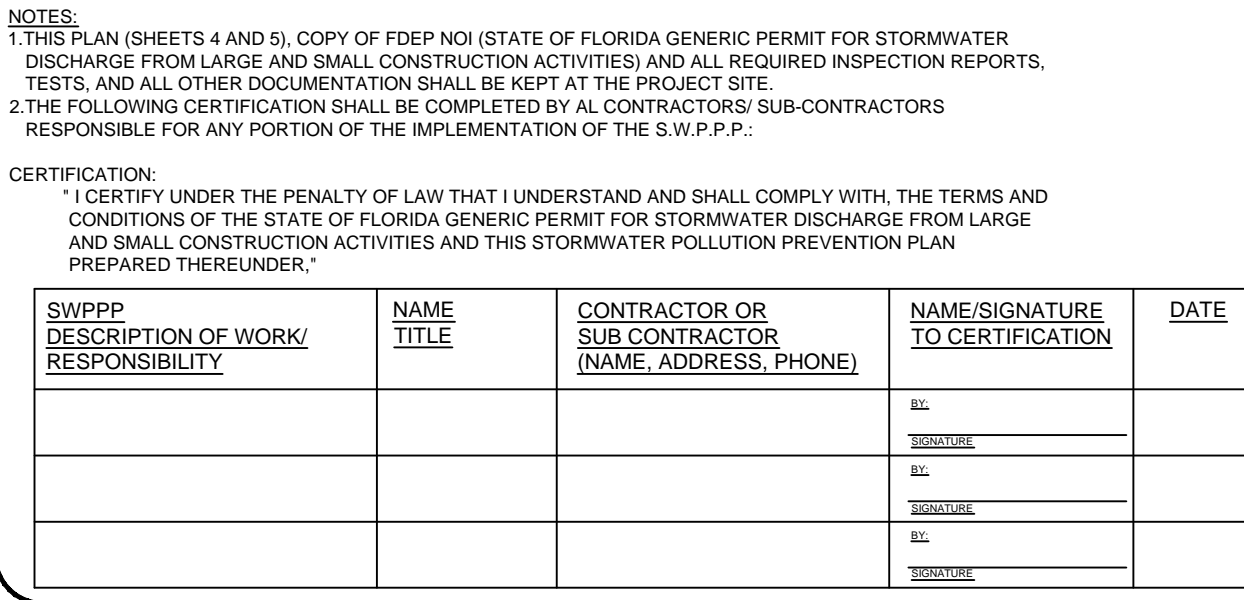
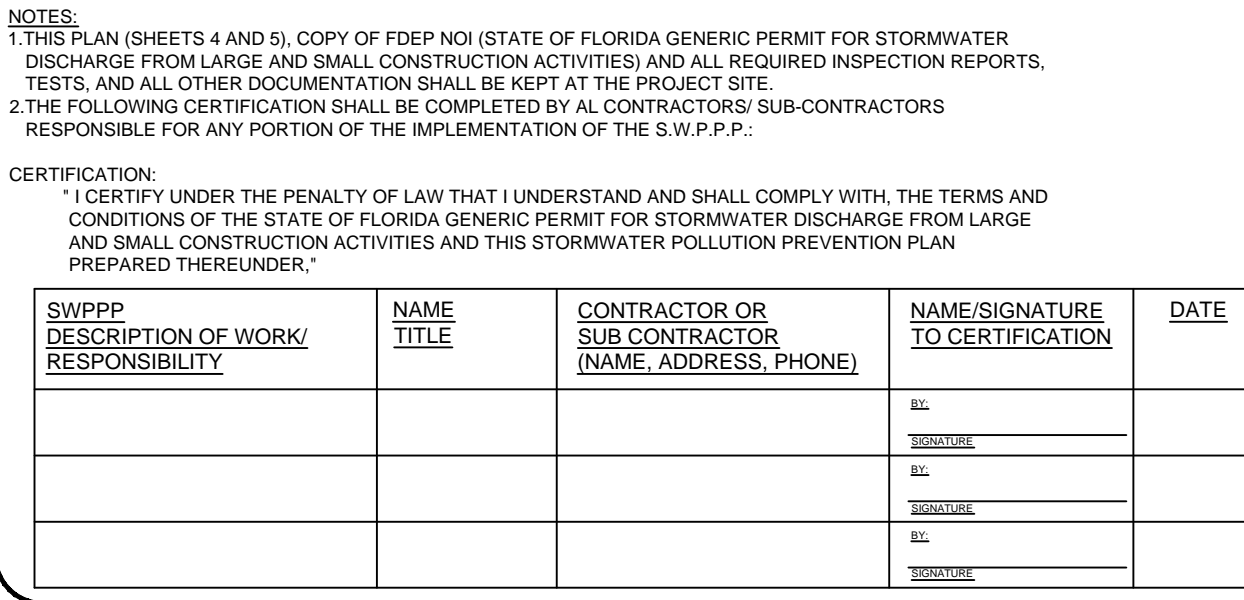
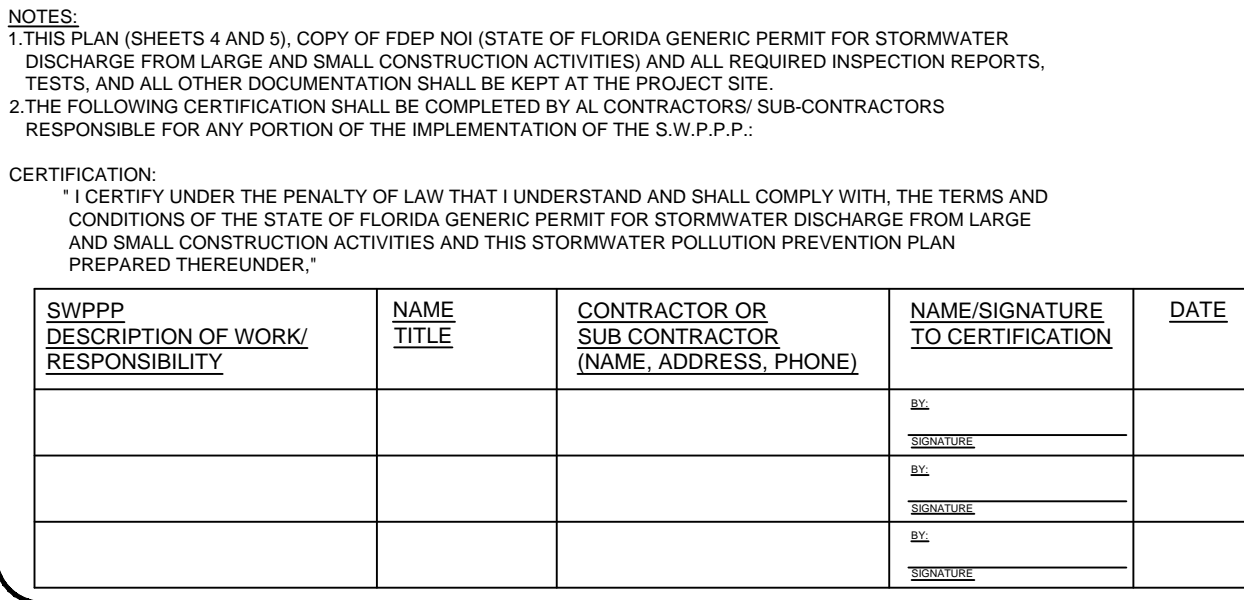
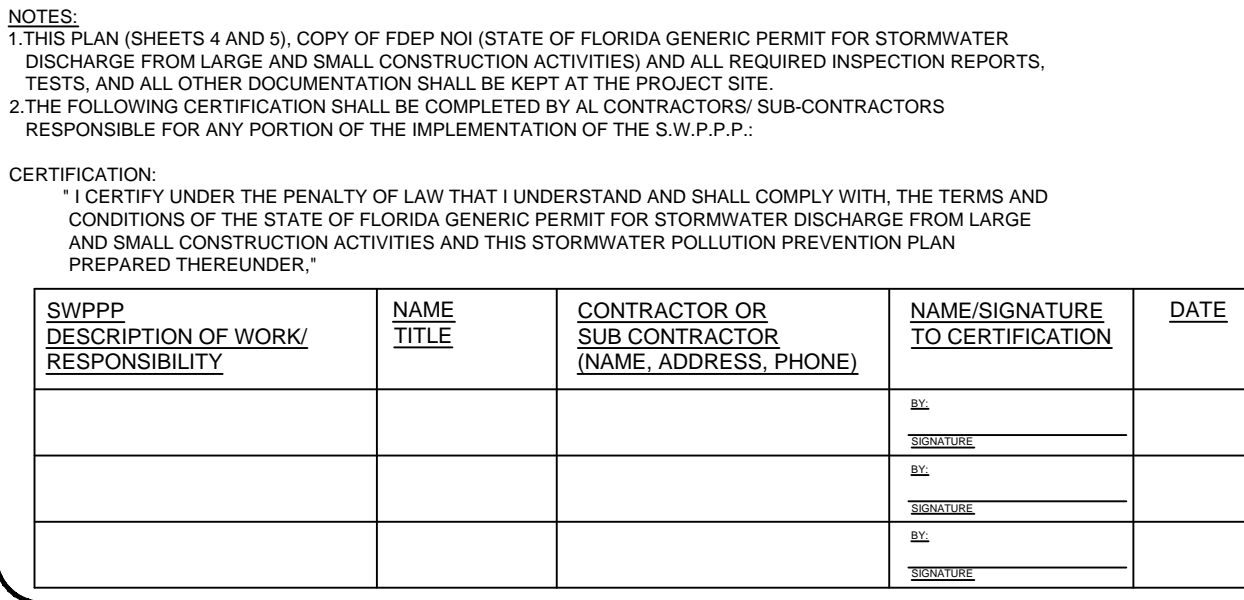
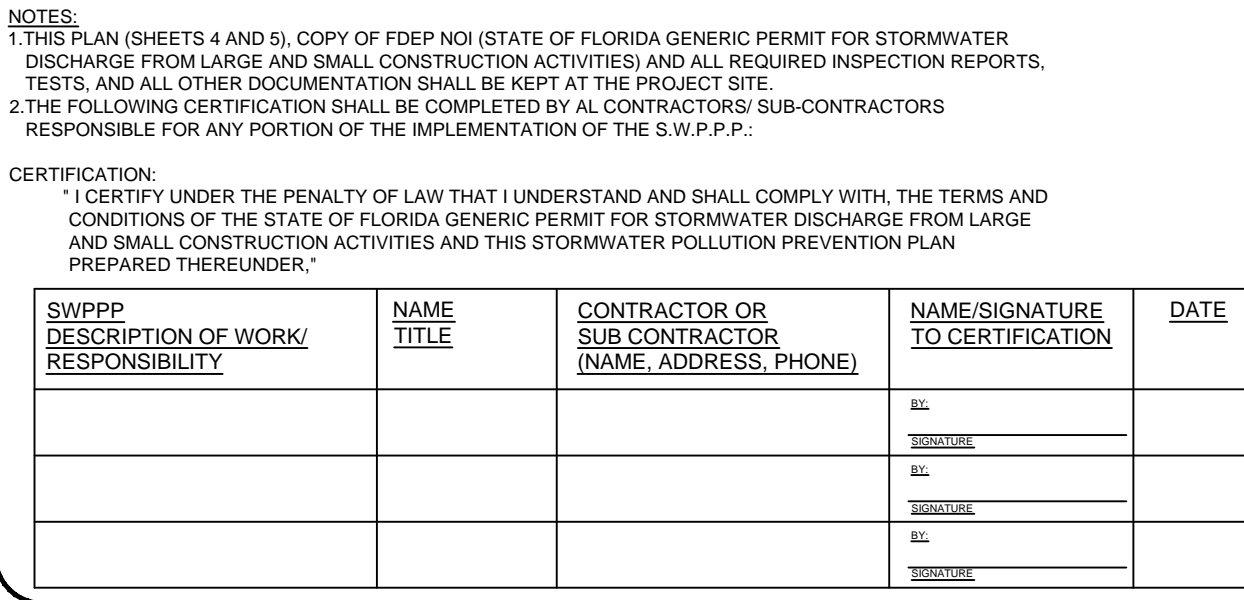
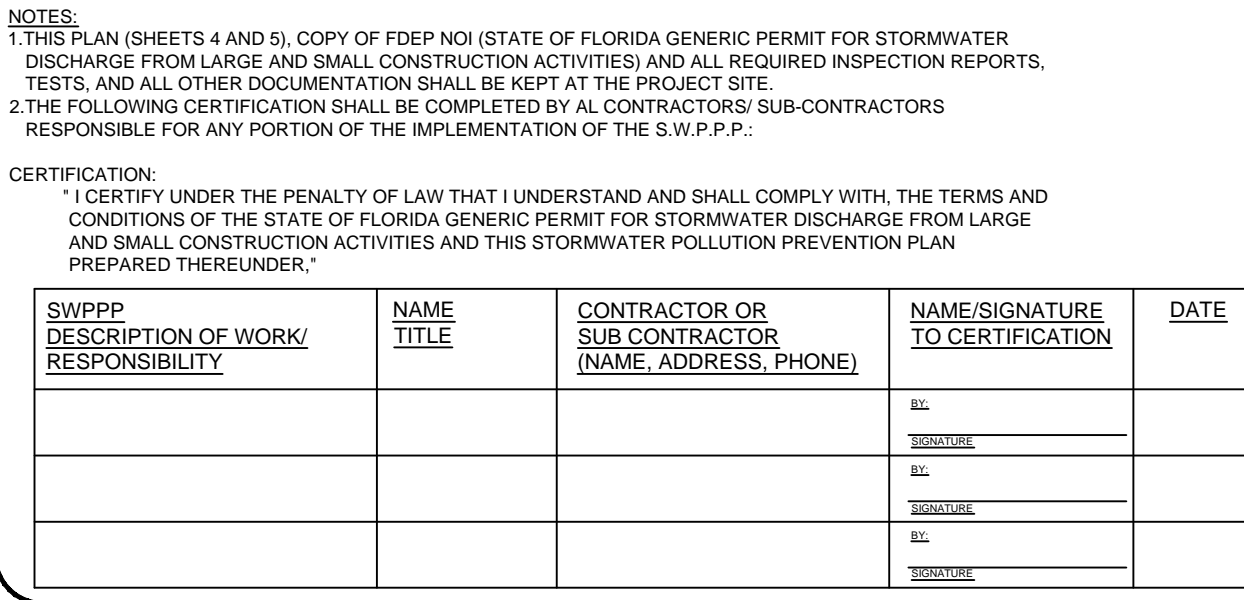
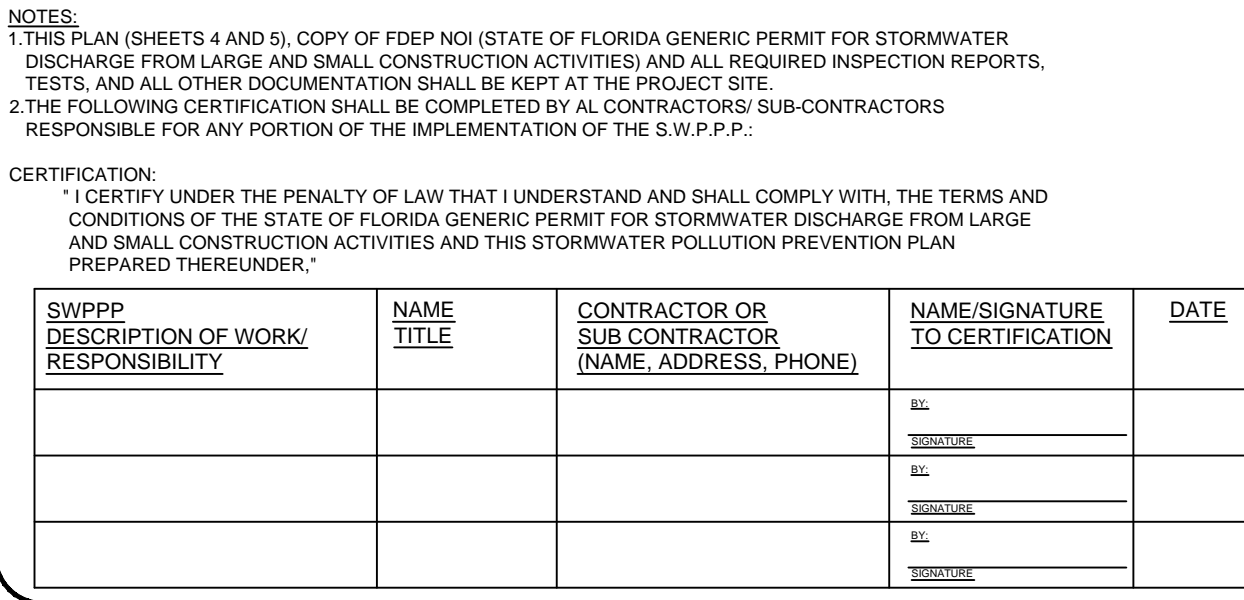
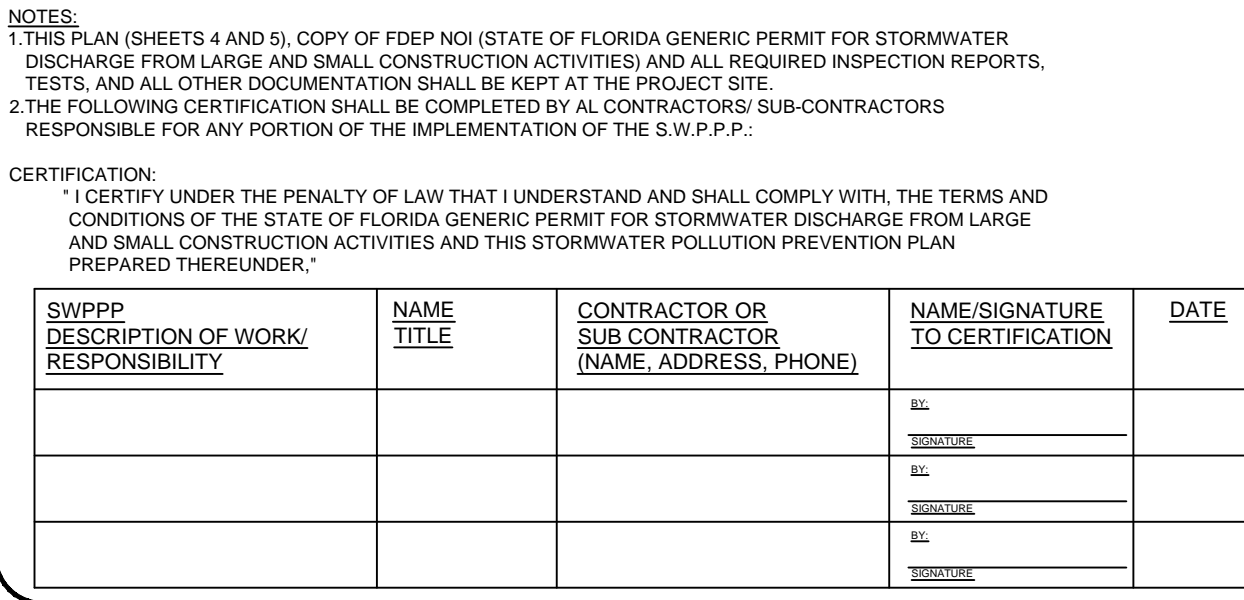
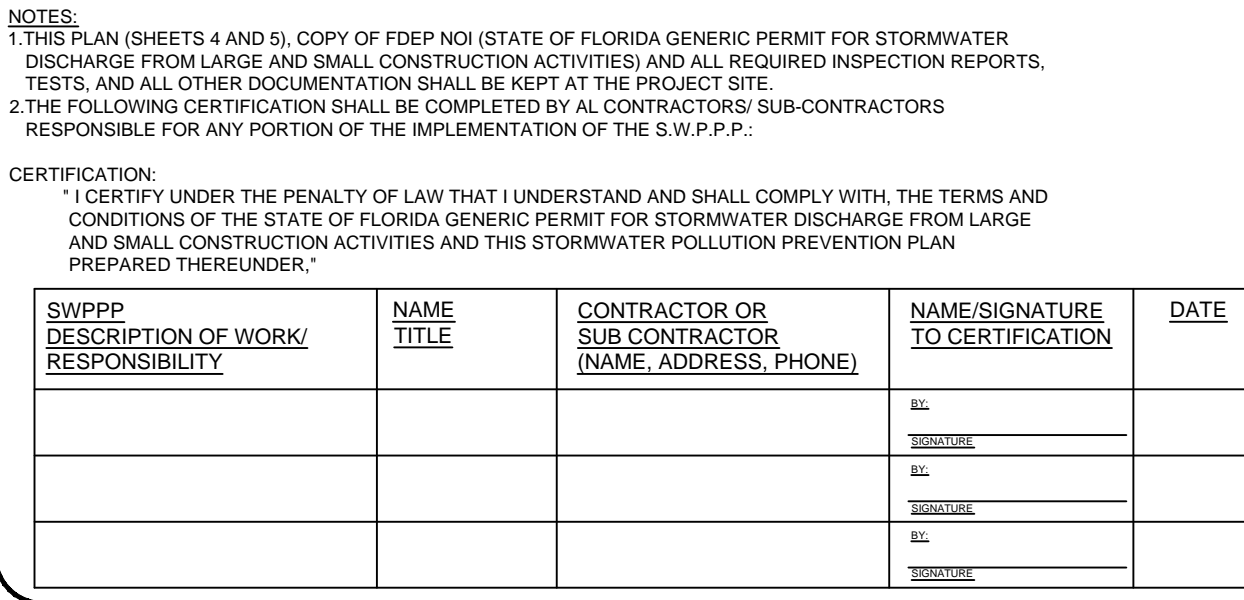
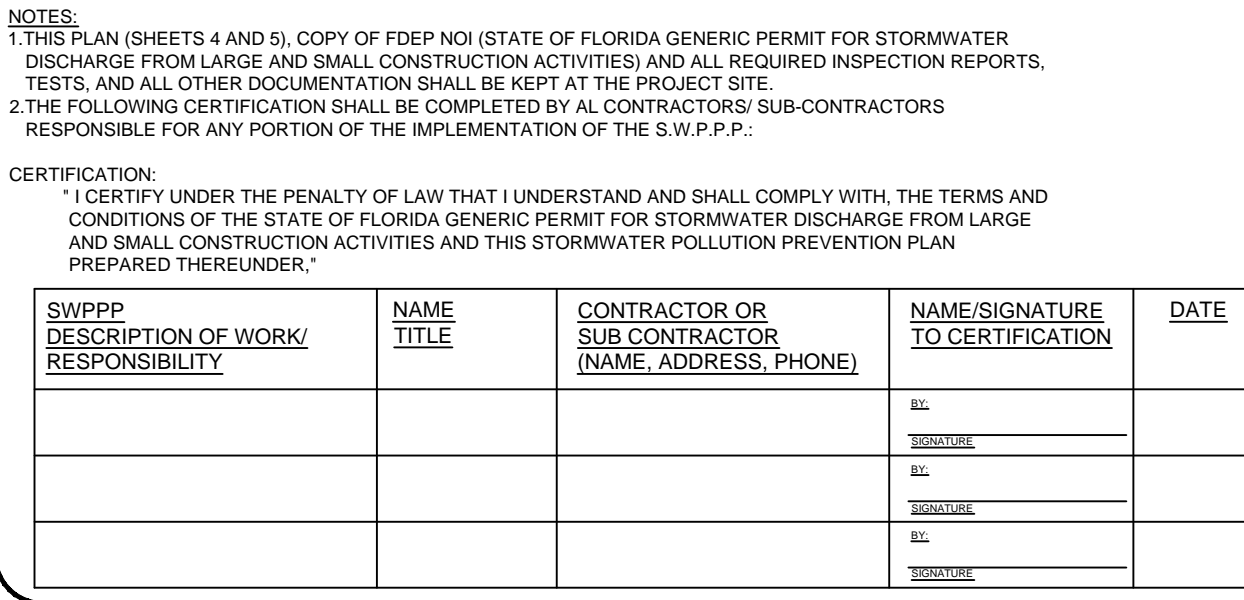
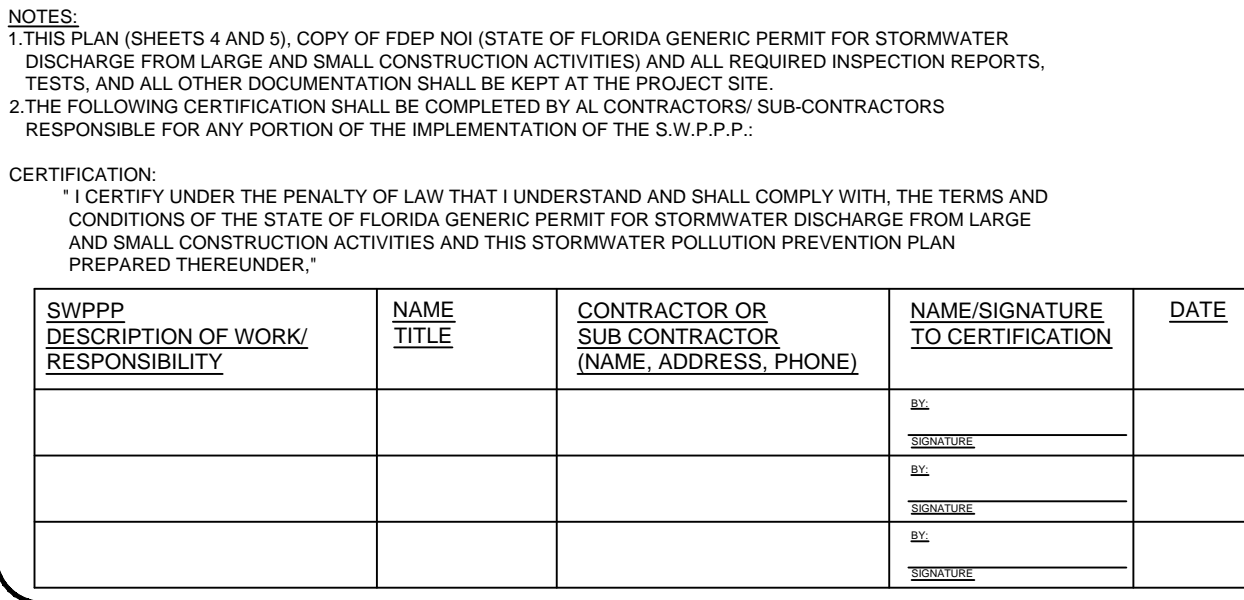
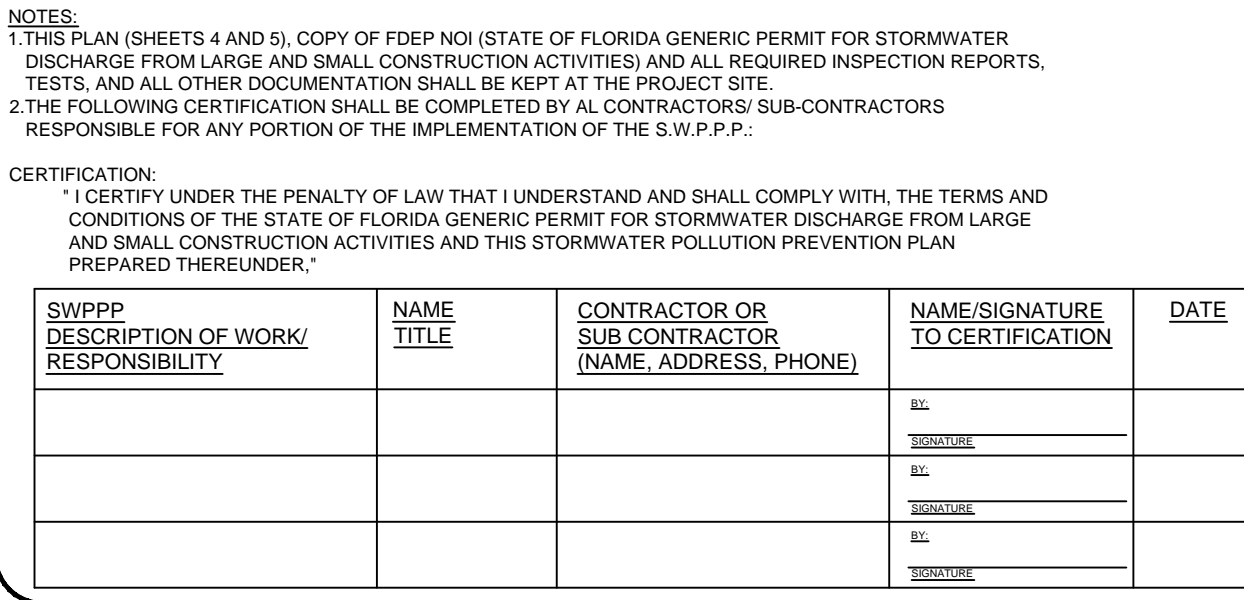
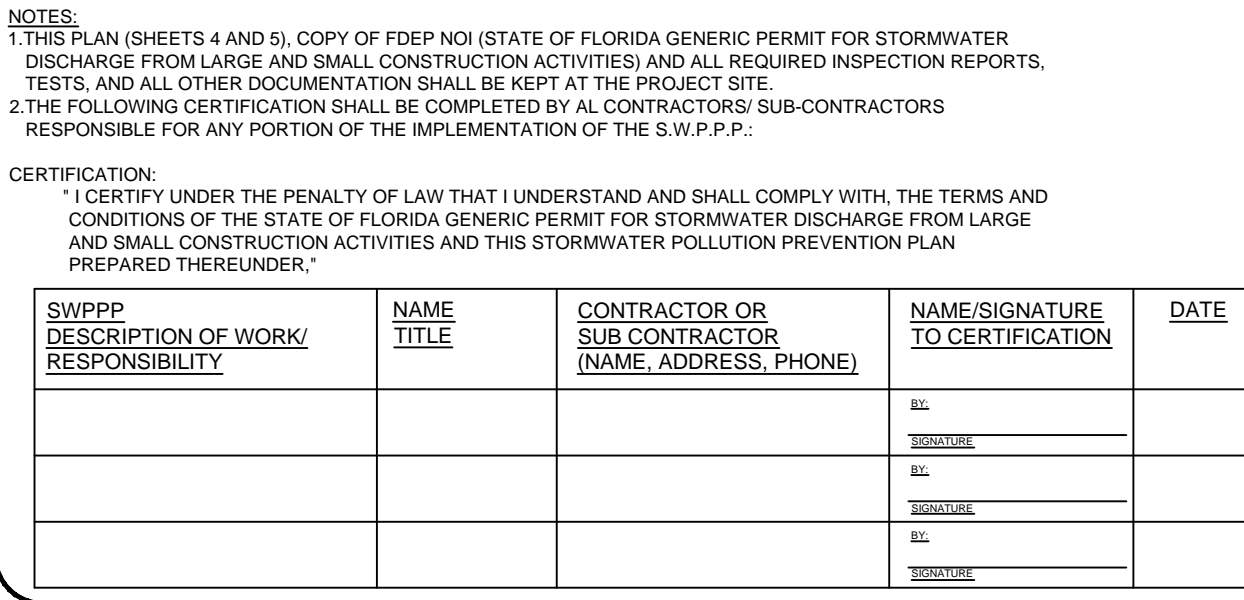
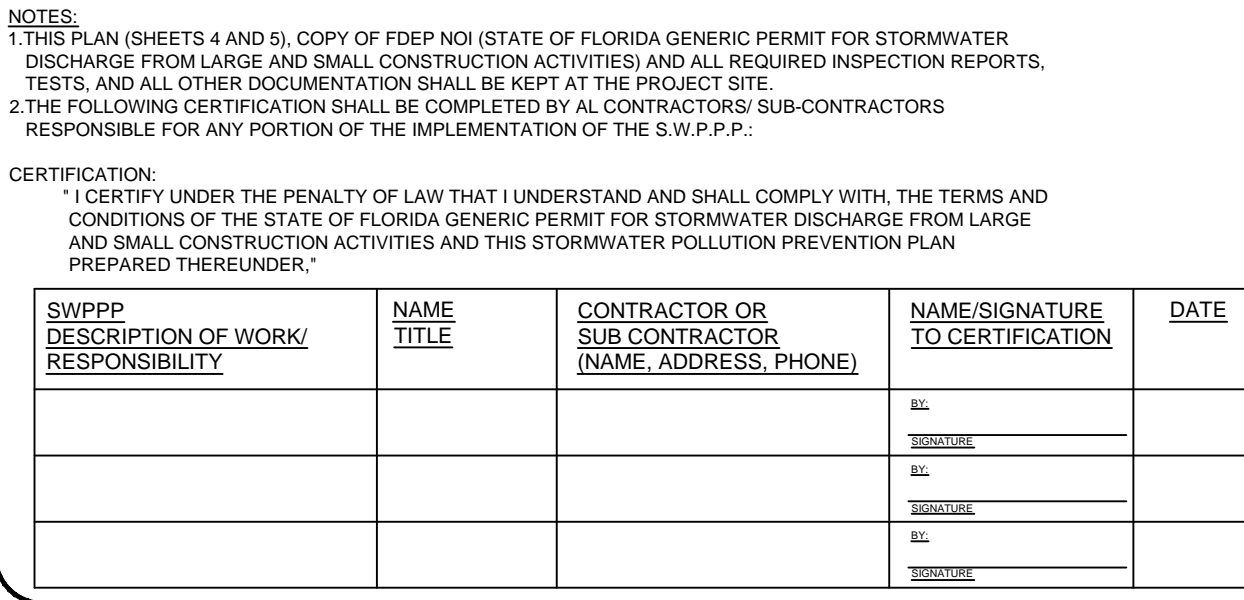
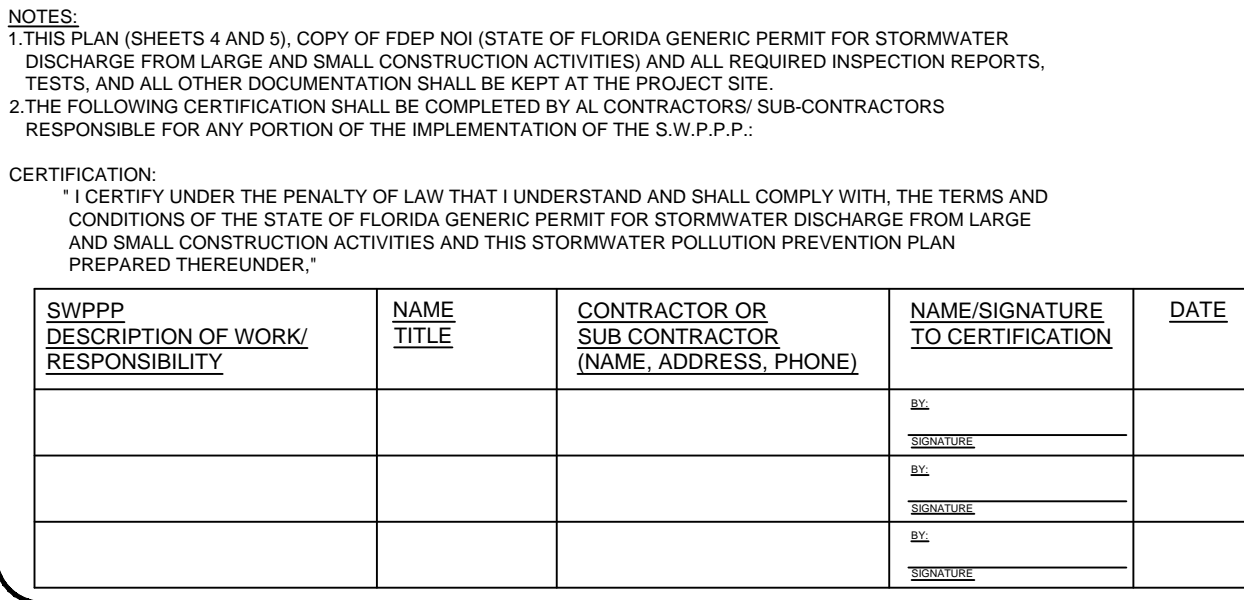
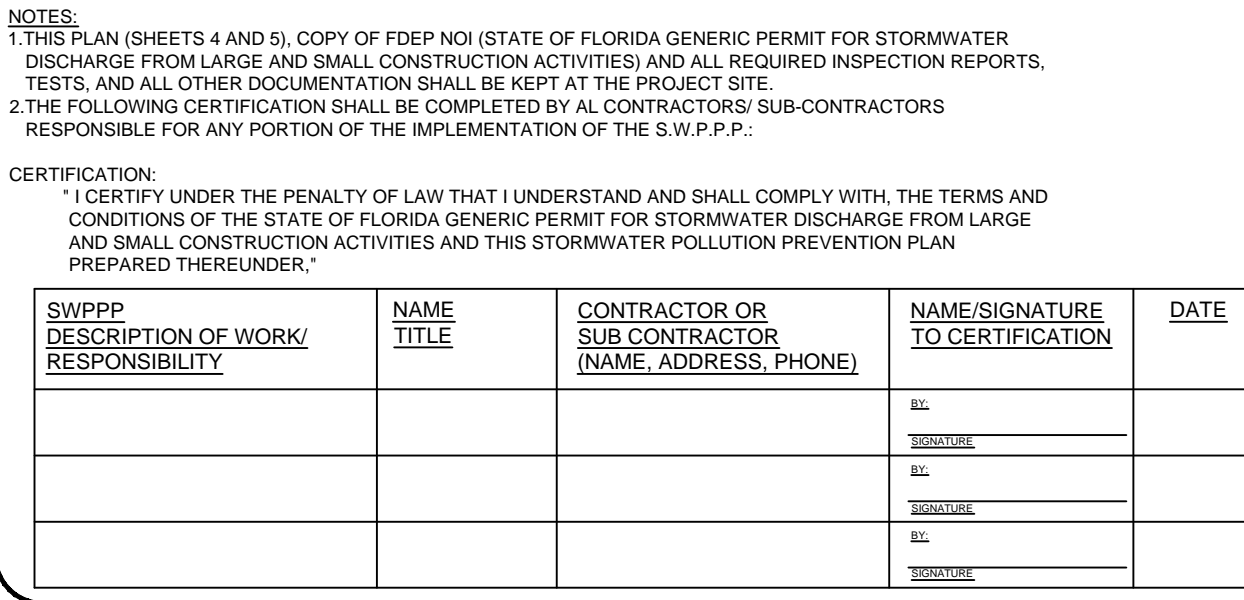
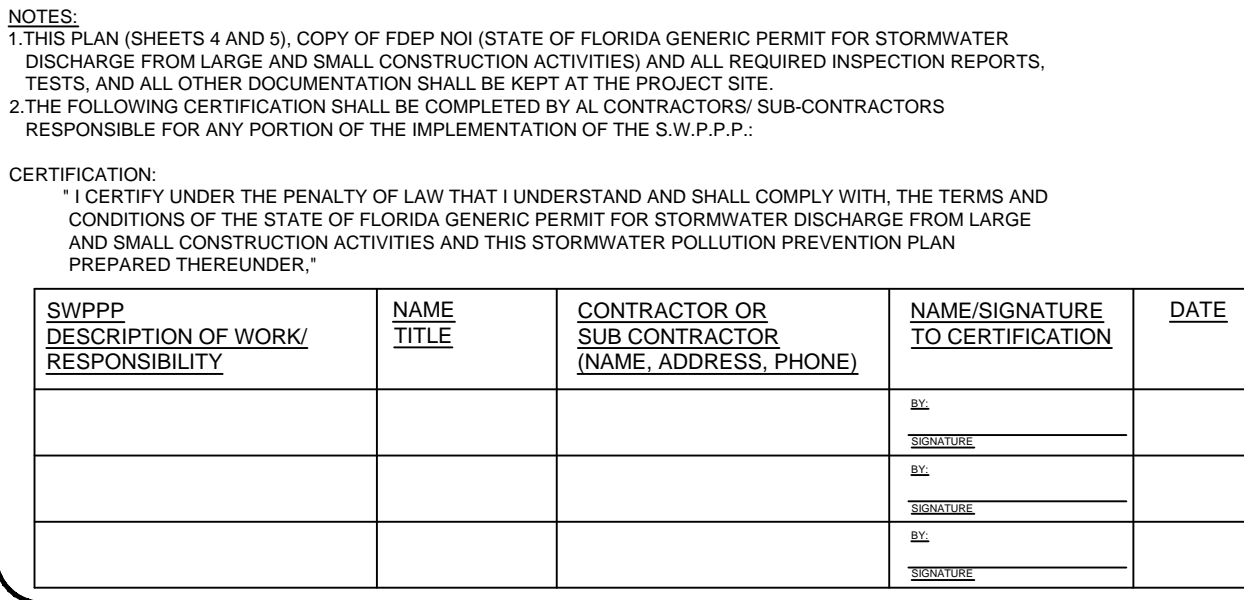
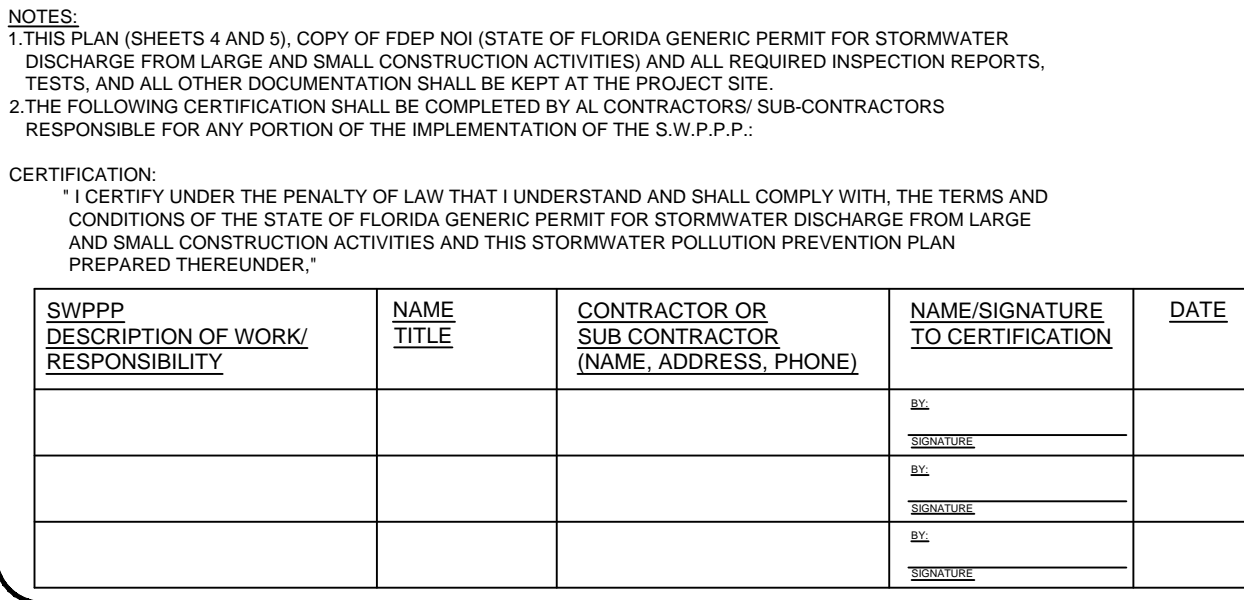
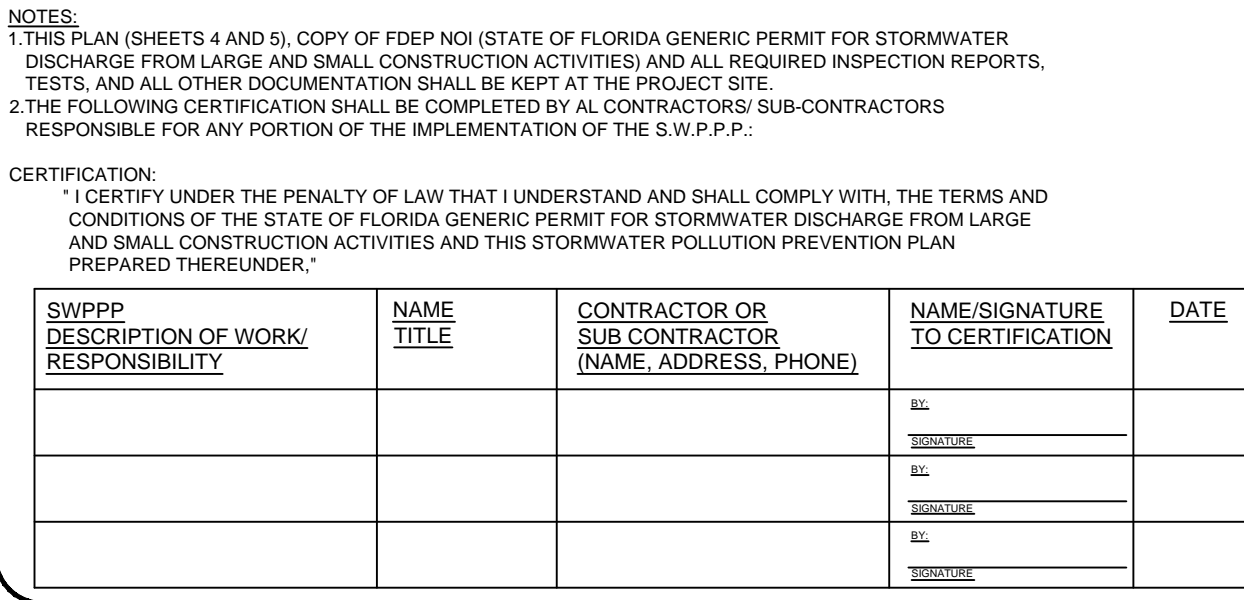
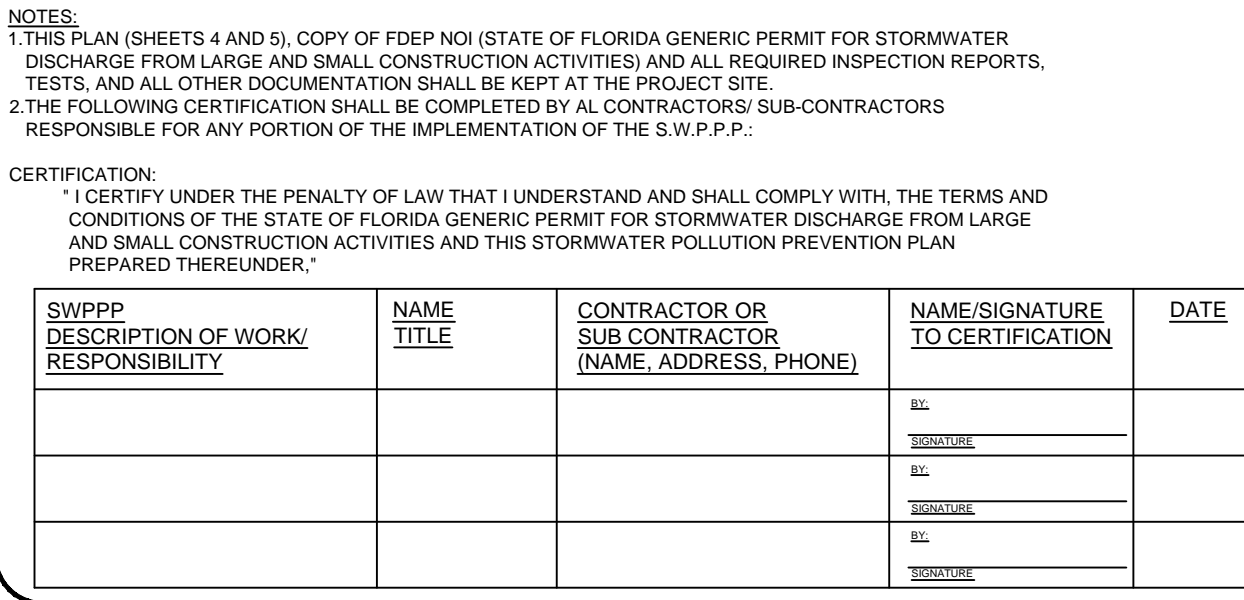
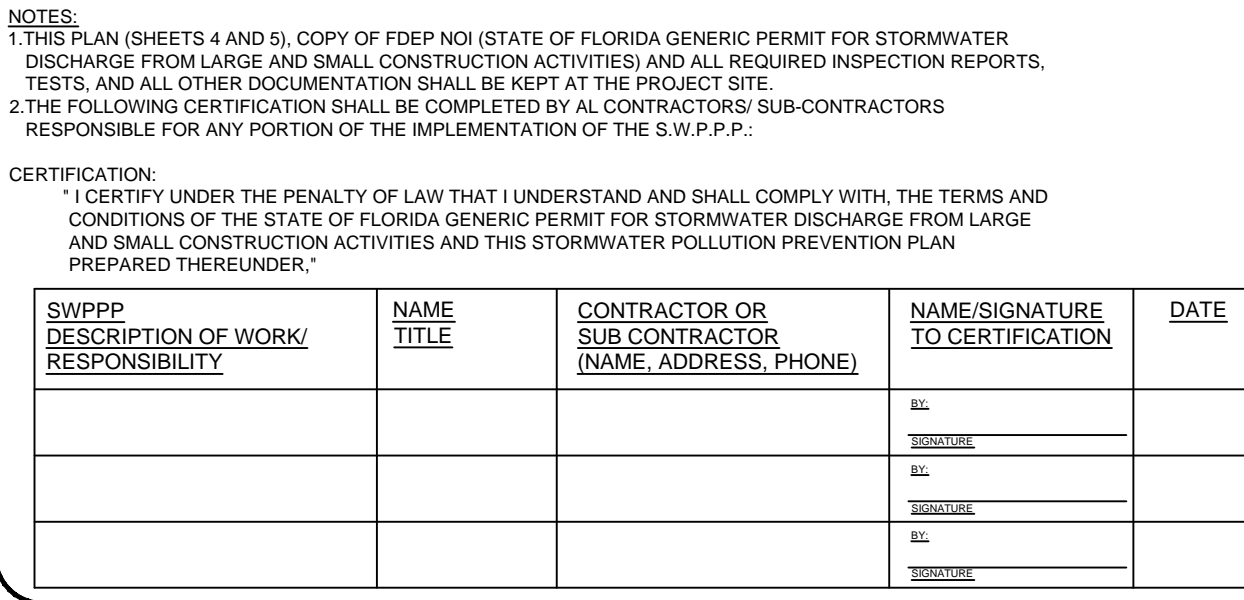
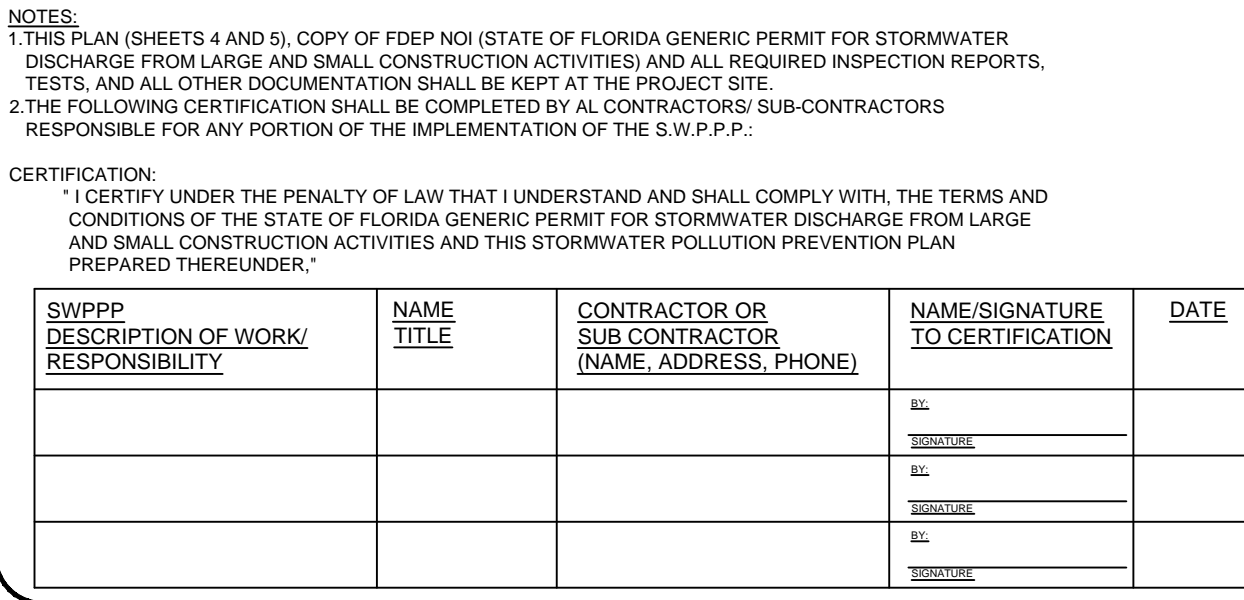
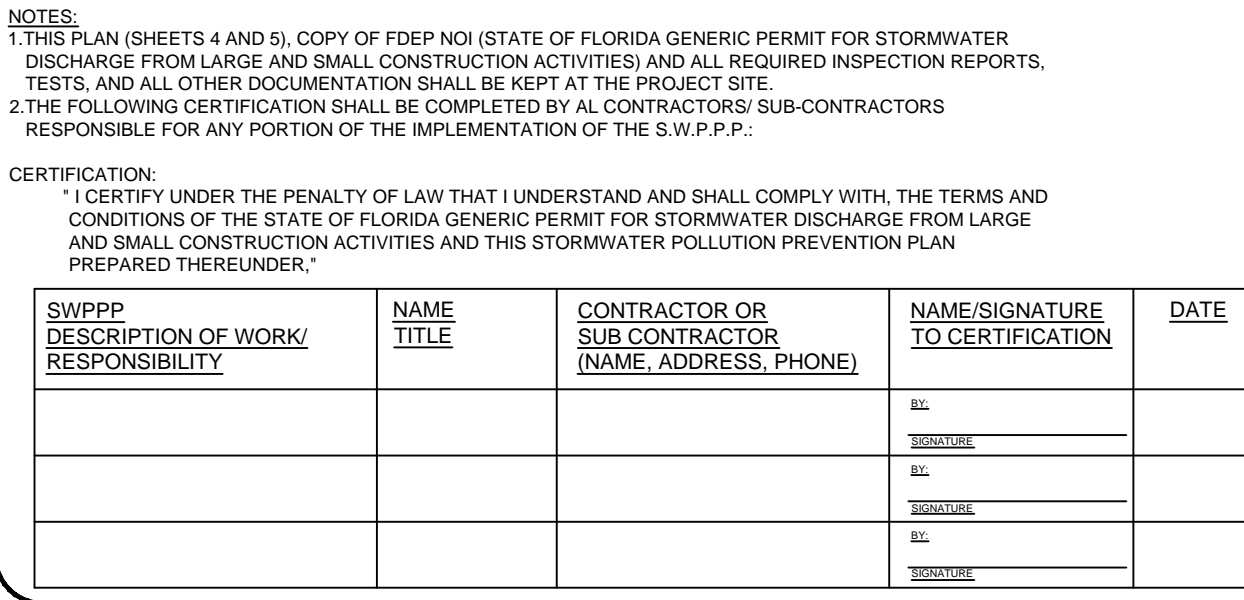
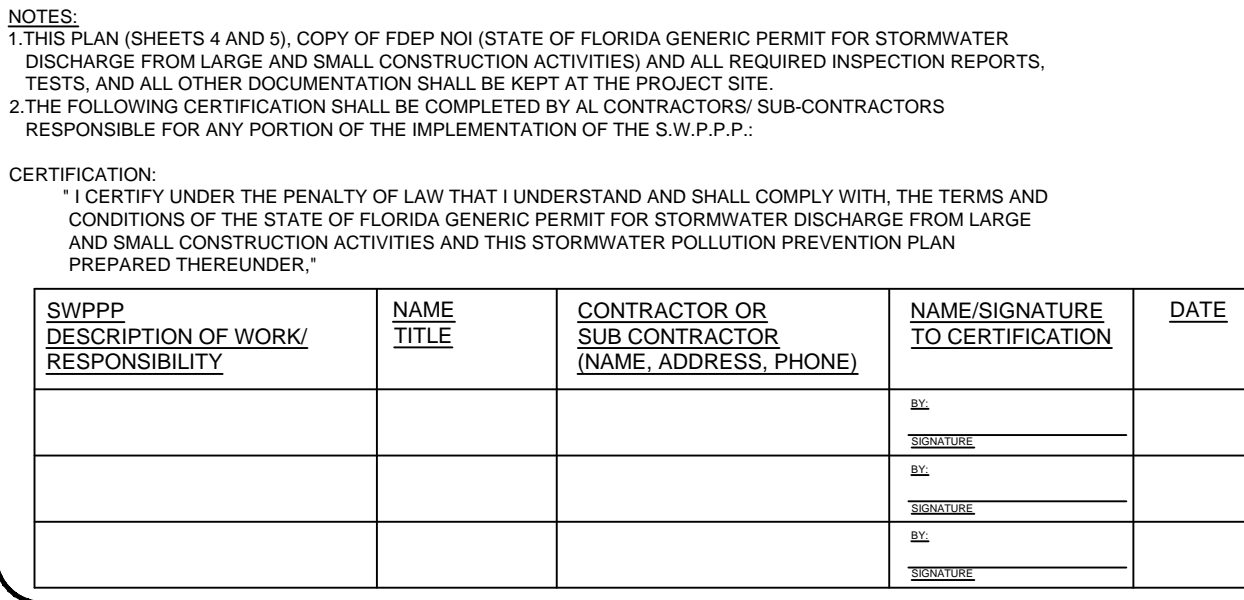
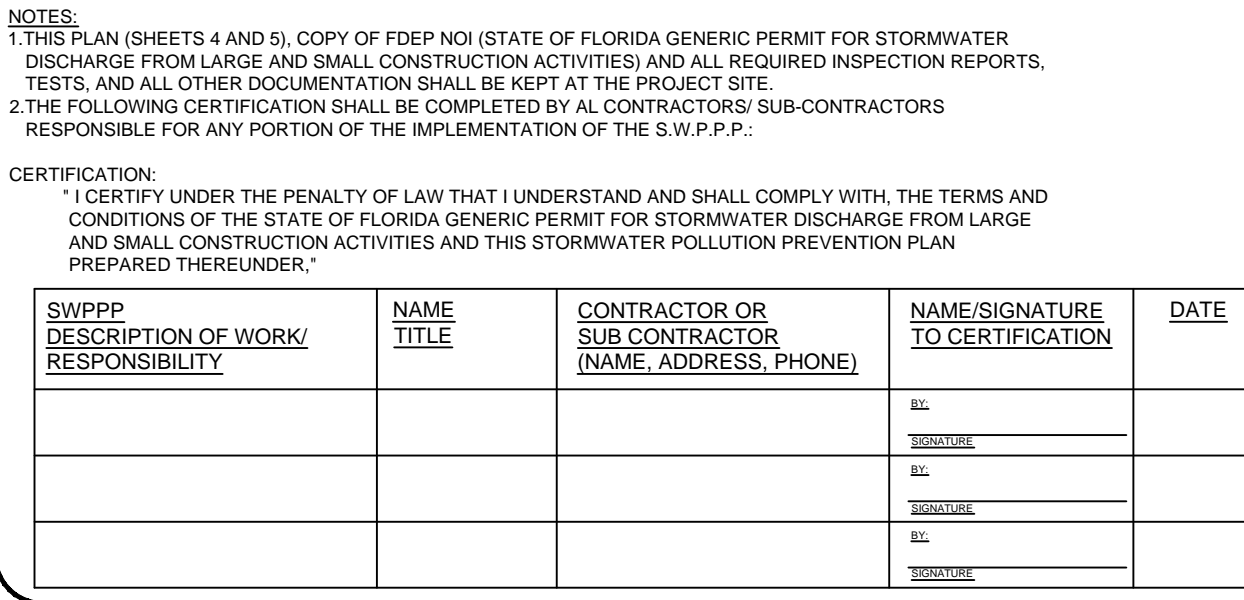
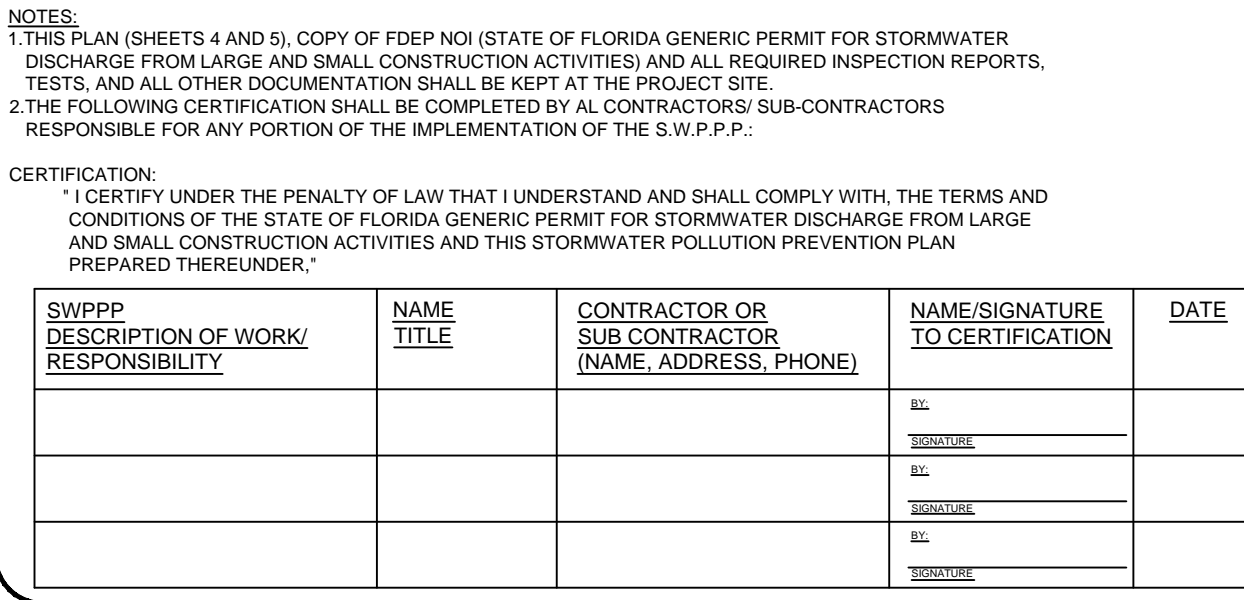

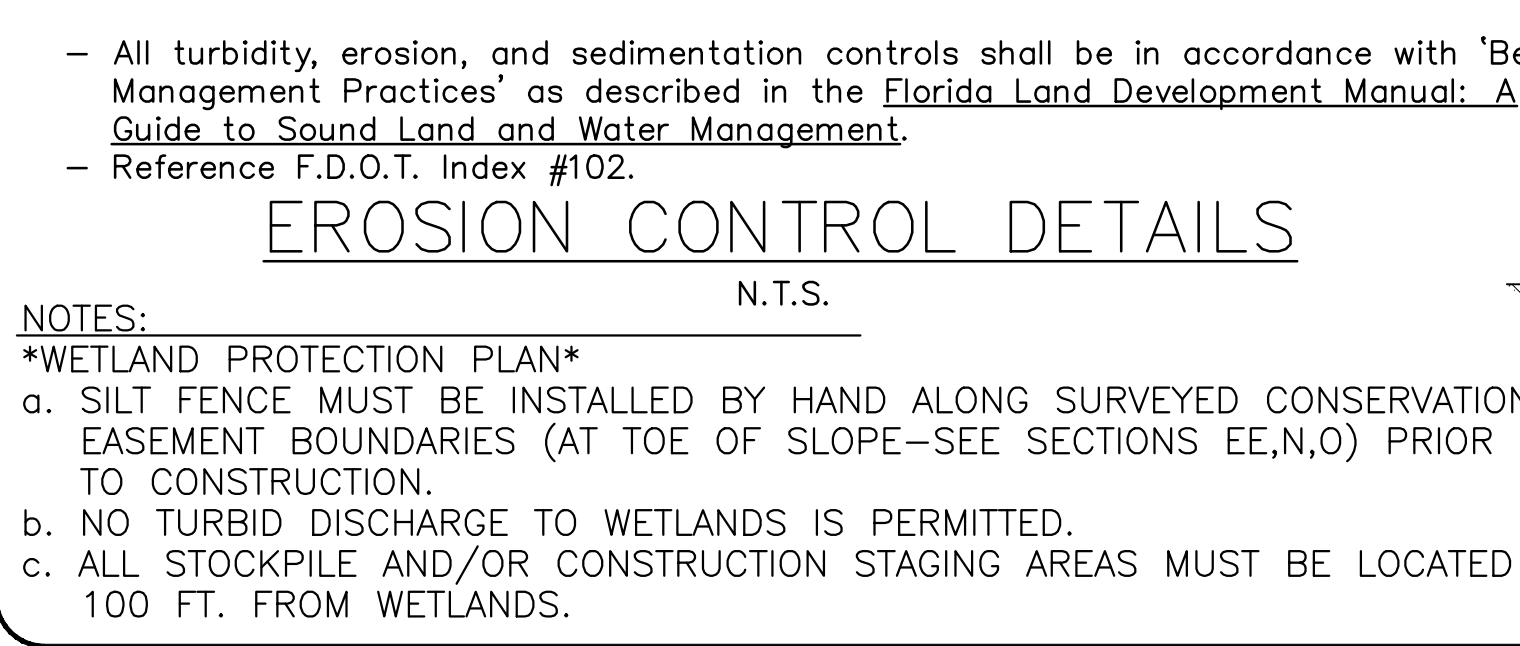
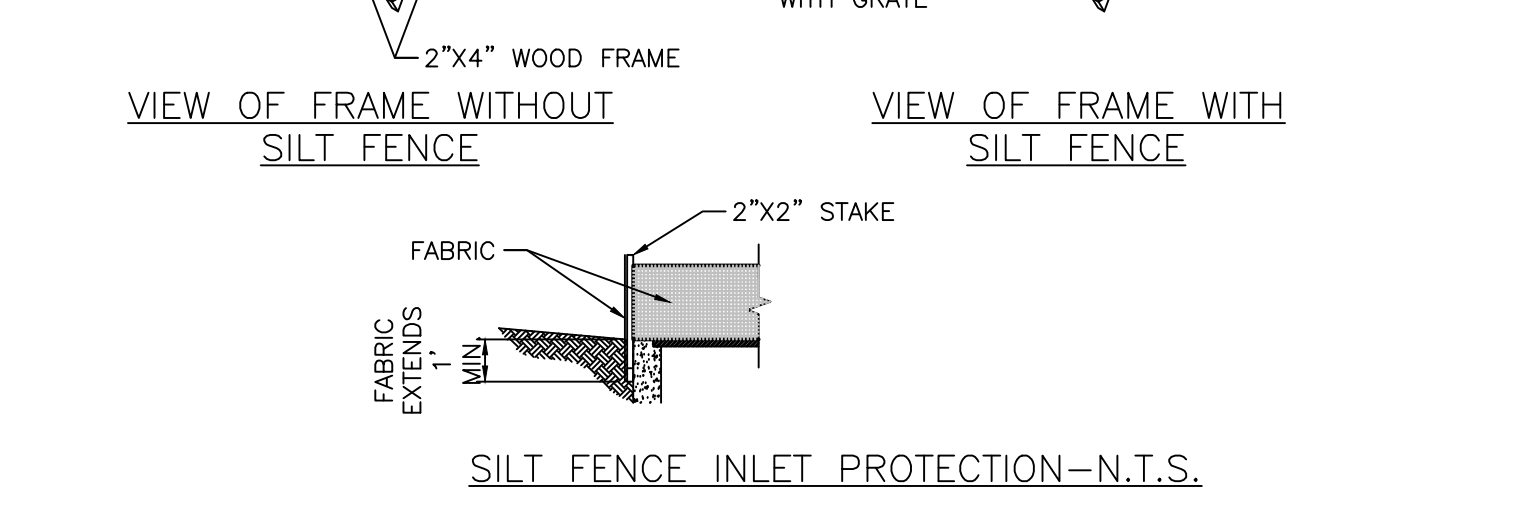
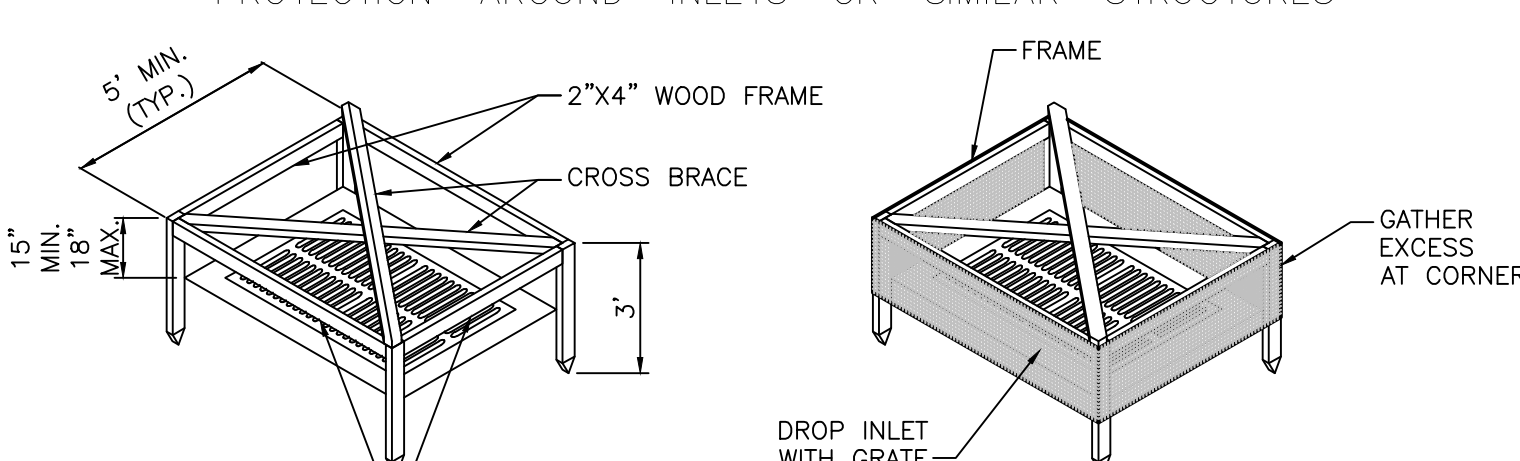
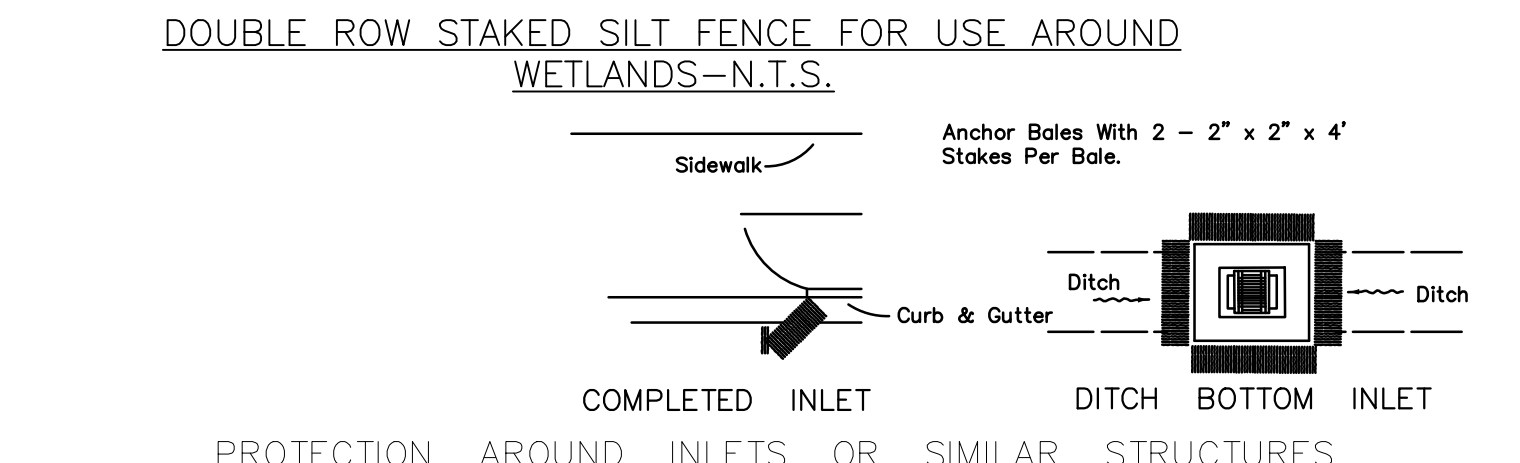
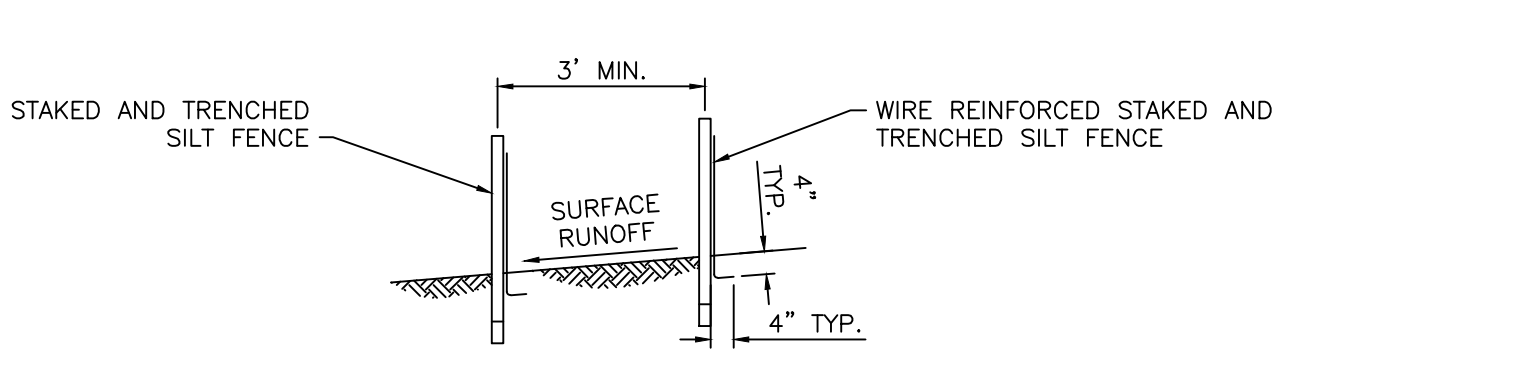
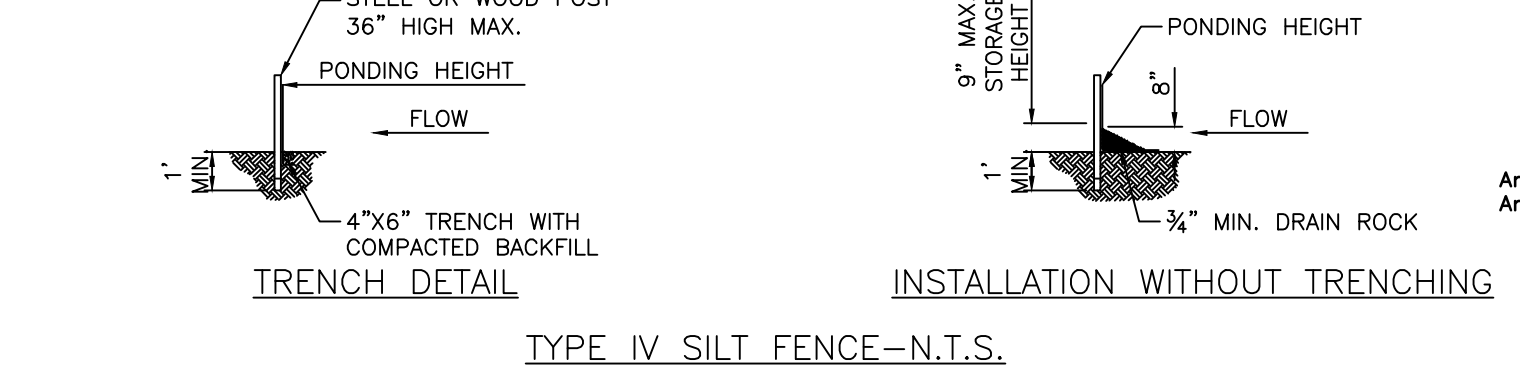
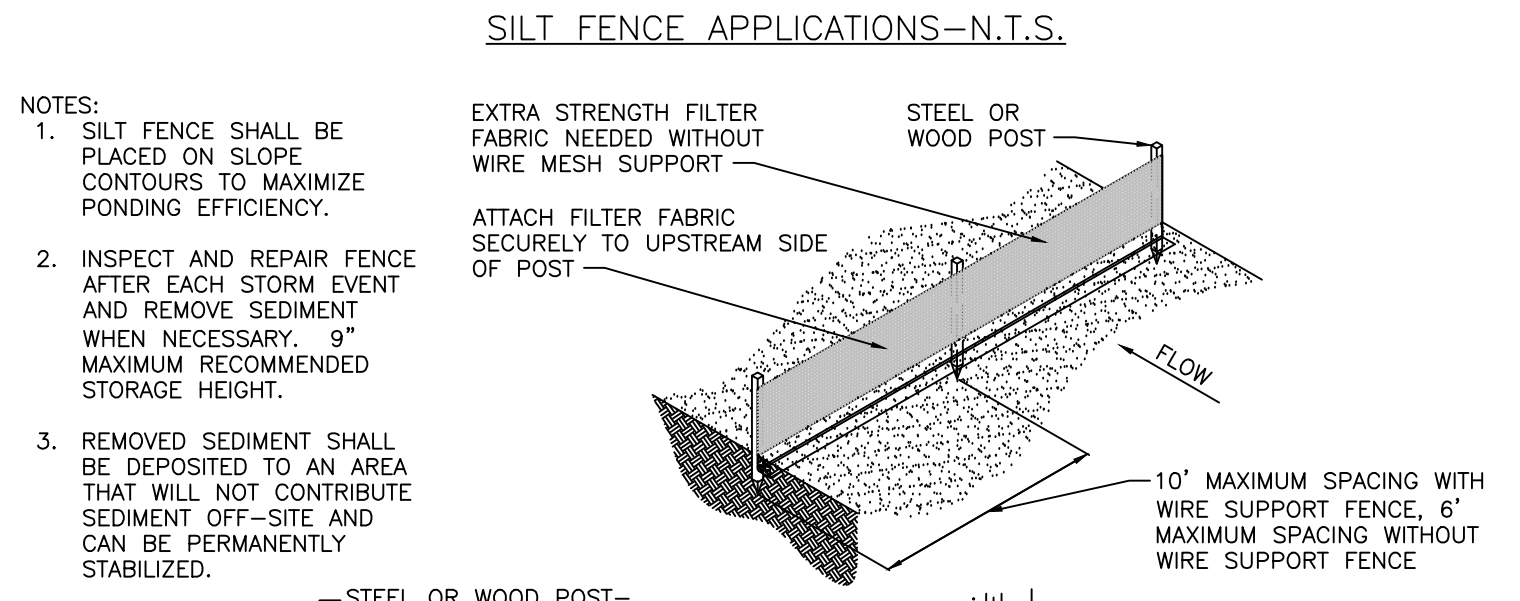
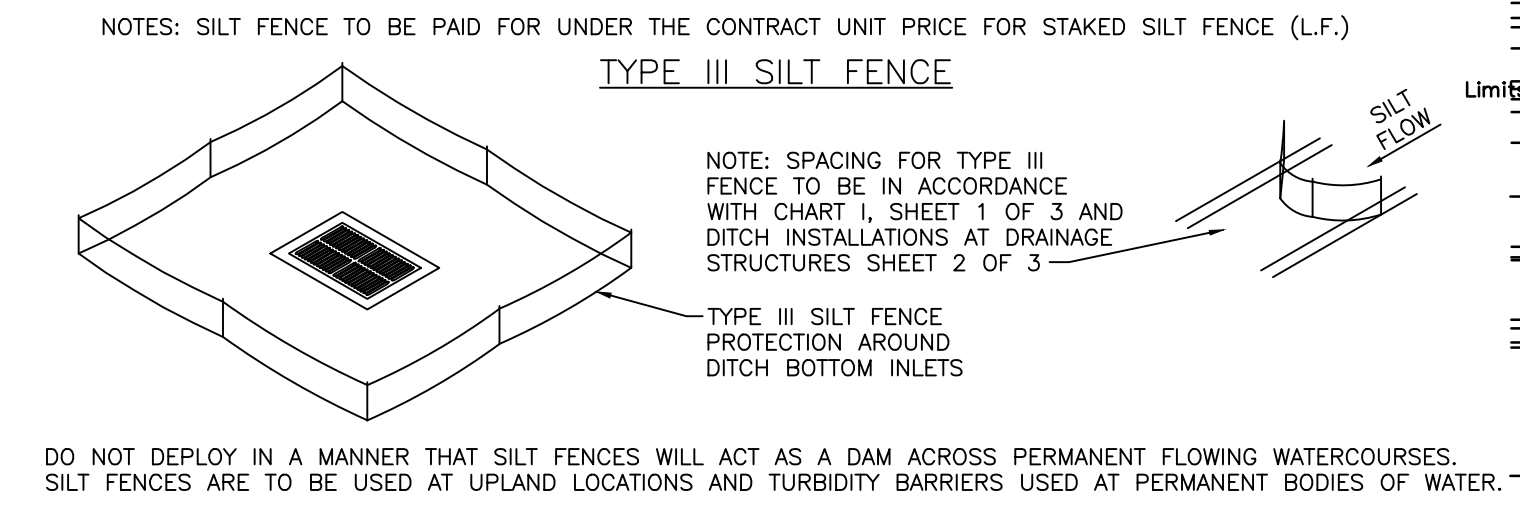
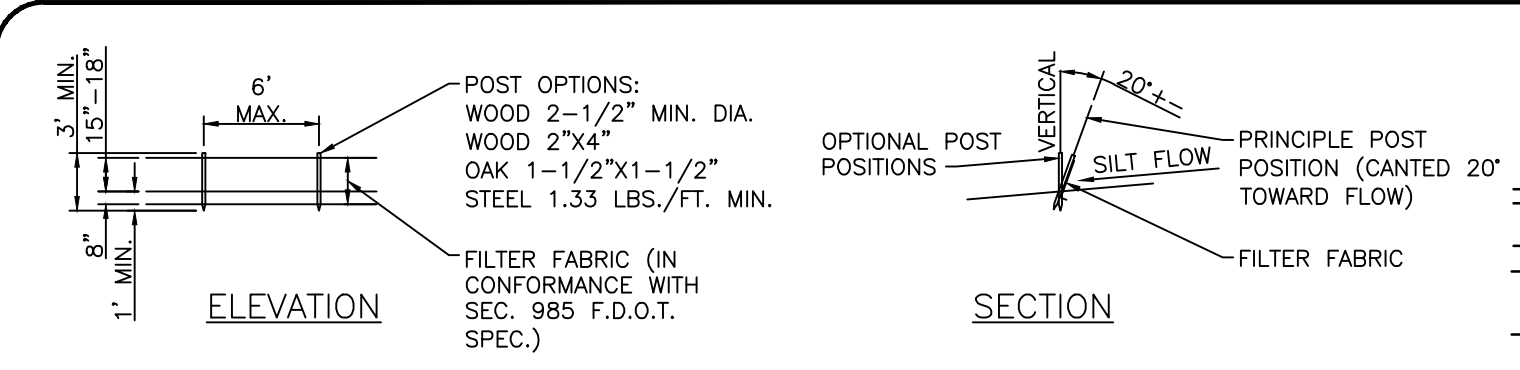

**NOTES:**  
 \*WETLAND PROTECTION PLAN\*  
 a. SILT FENCE MUST BE INSTALLED BY HAND ALONG SURVEYED CONSERVATION EASEMENT BOUNDARIES (AT TOE OF SLOPE-SEE SECTIONS EE,N,O) PRIOR TO CONSTRUCTION.  
 b. NO TURBID DISCHARGE TO WETLANDS IS PERMITTED.  
 c. ALL STOCKPILE AND/OR CONSTRUCTION STAGING AREAS MUST BE LOCATED 100 FT. FROM WETLANDS.

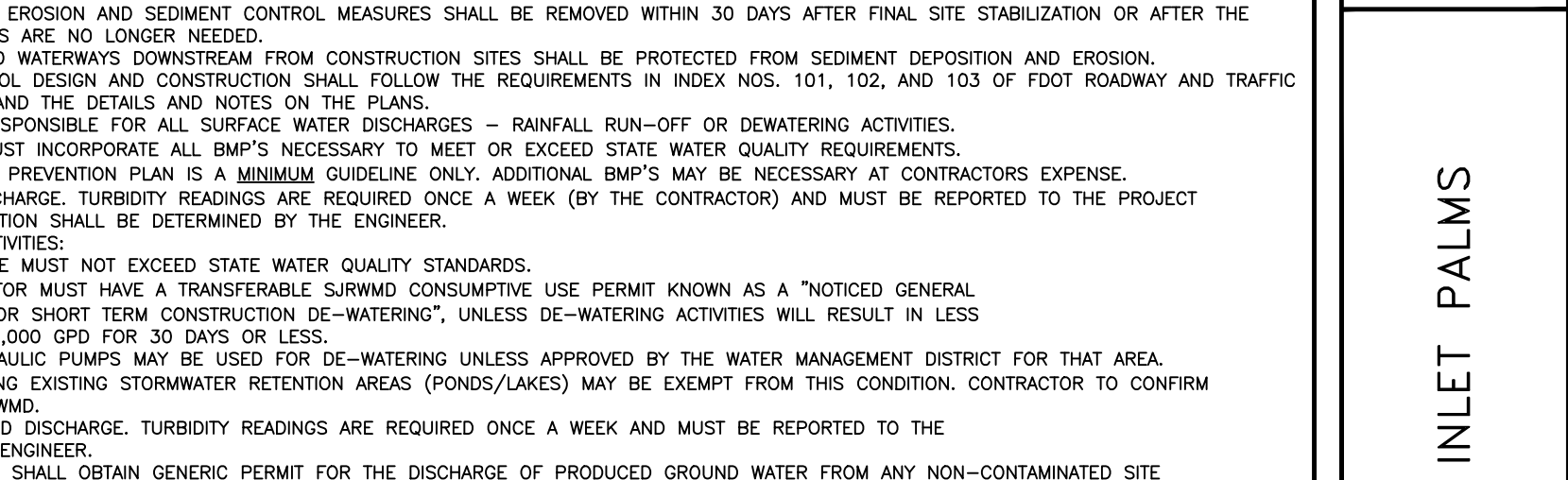
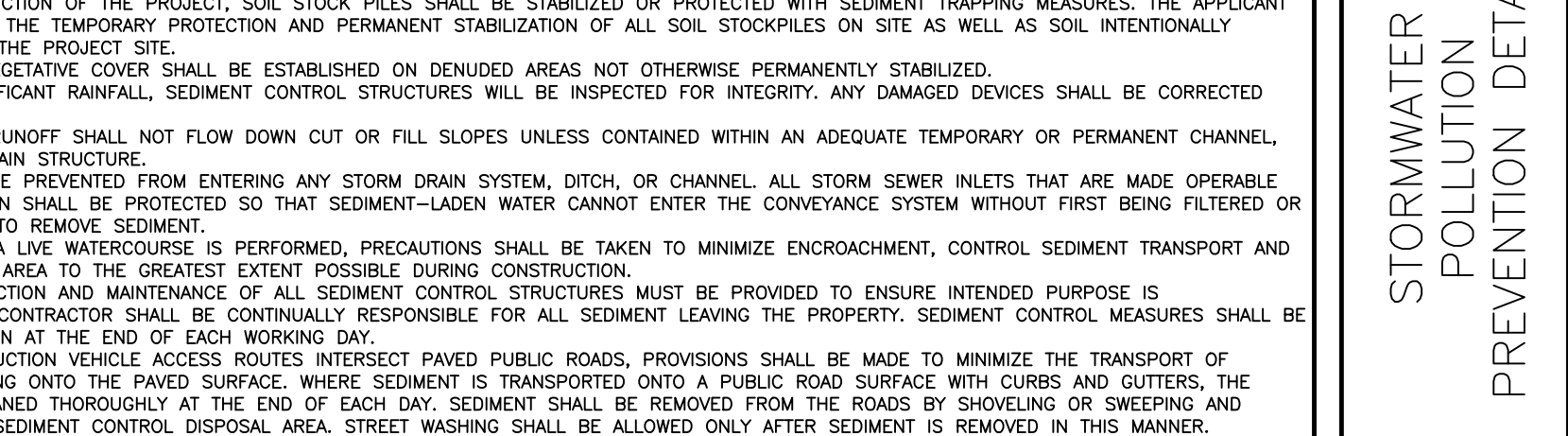
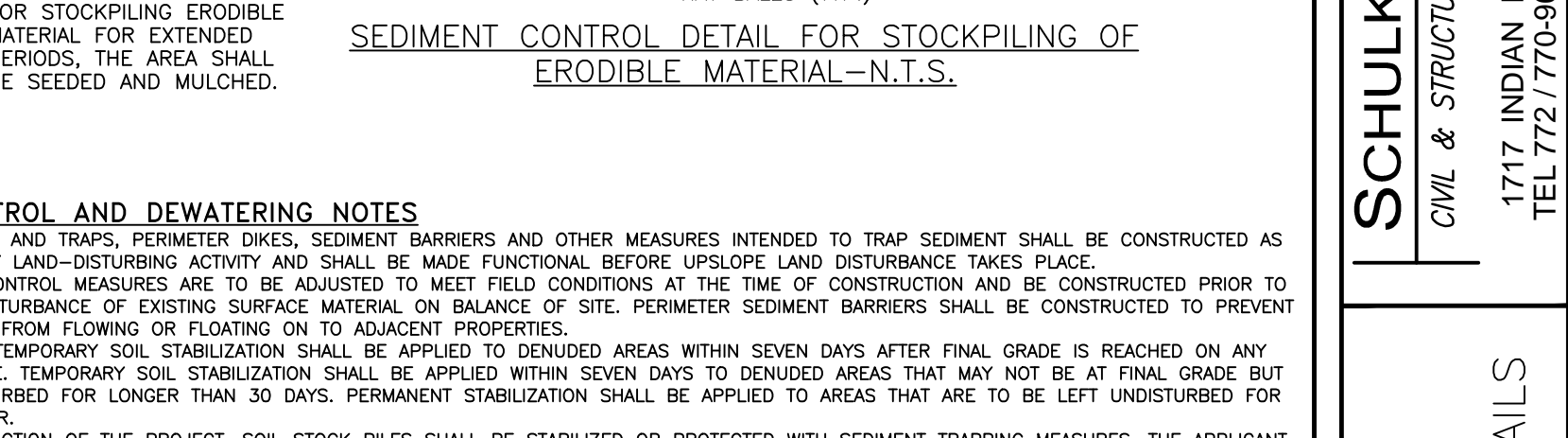
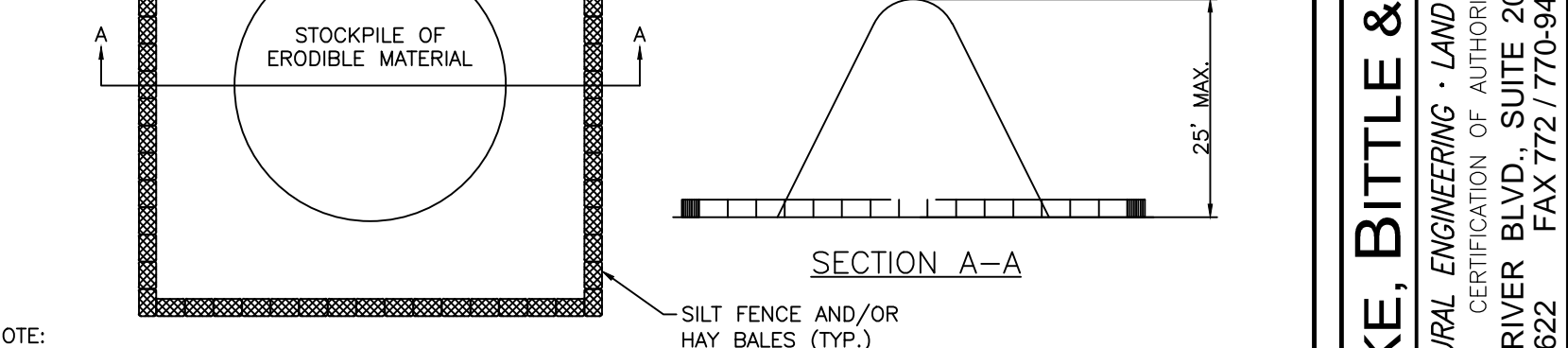
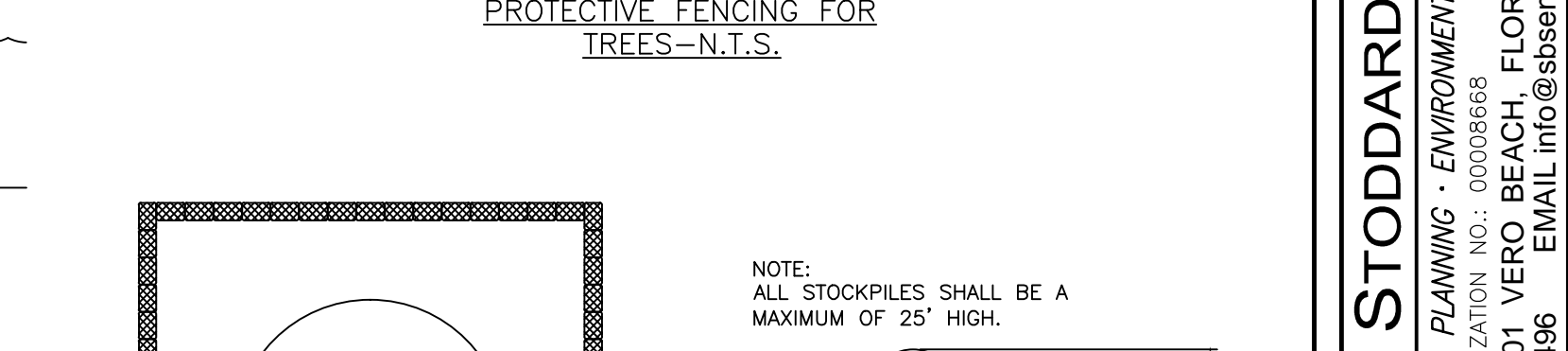
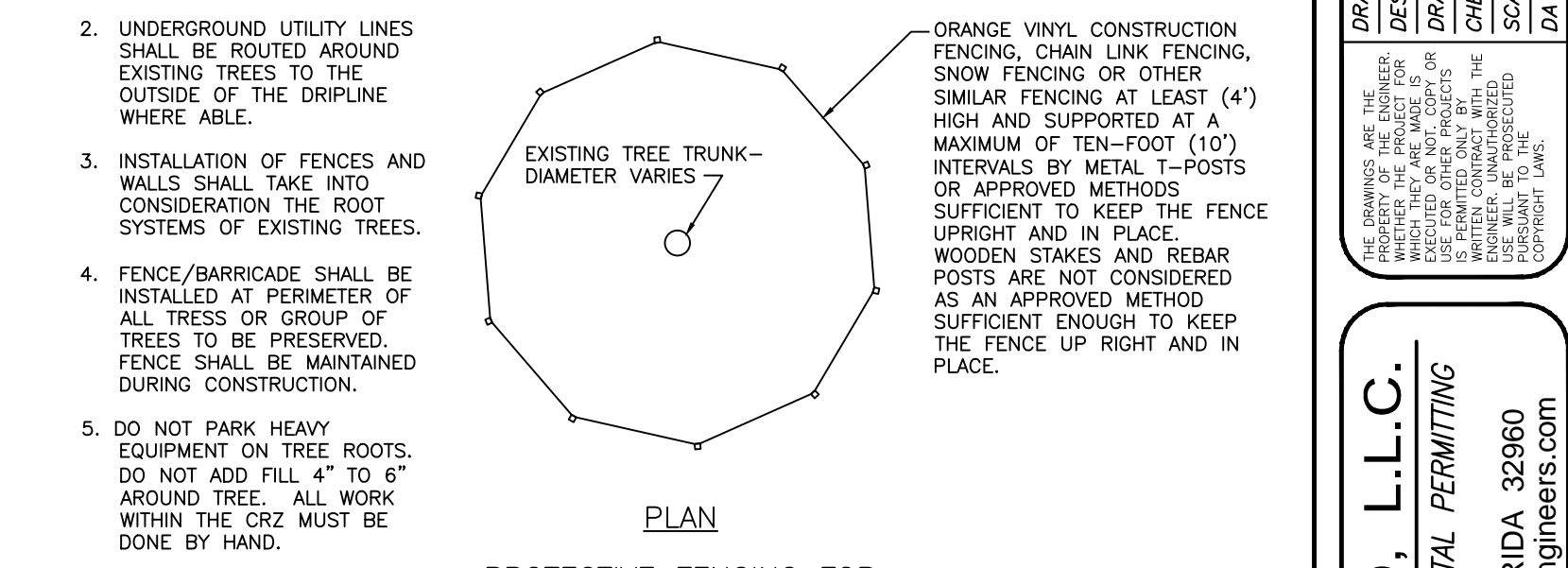
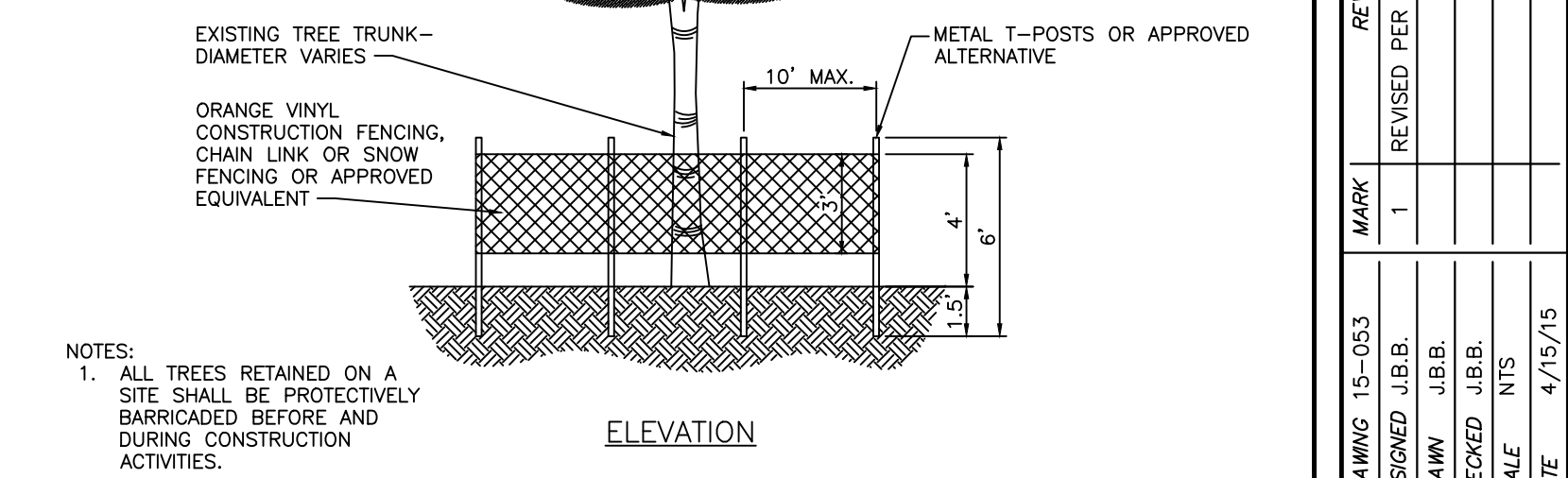
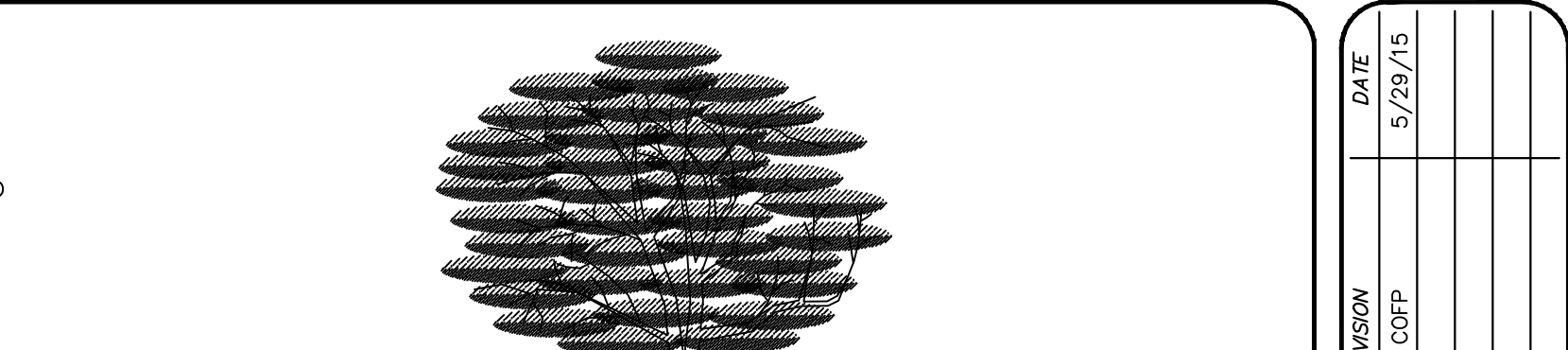
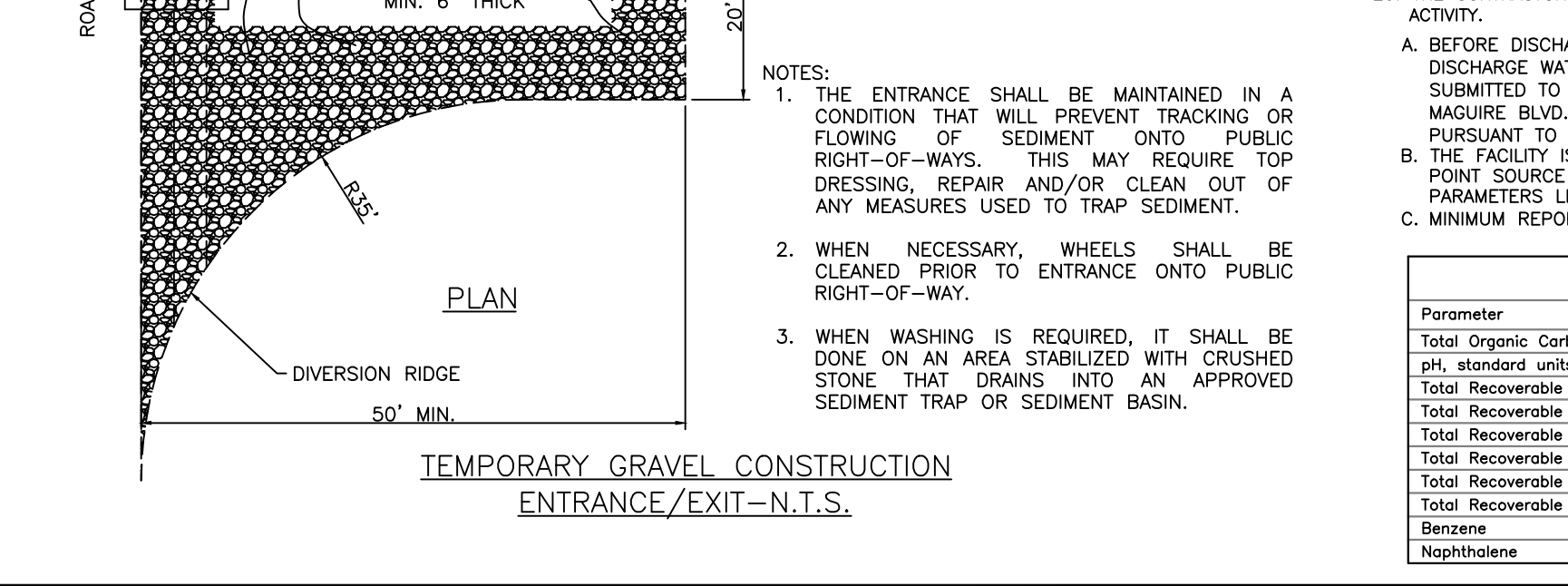
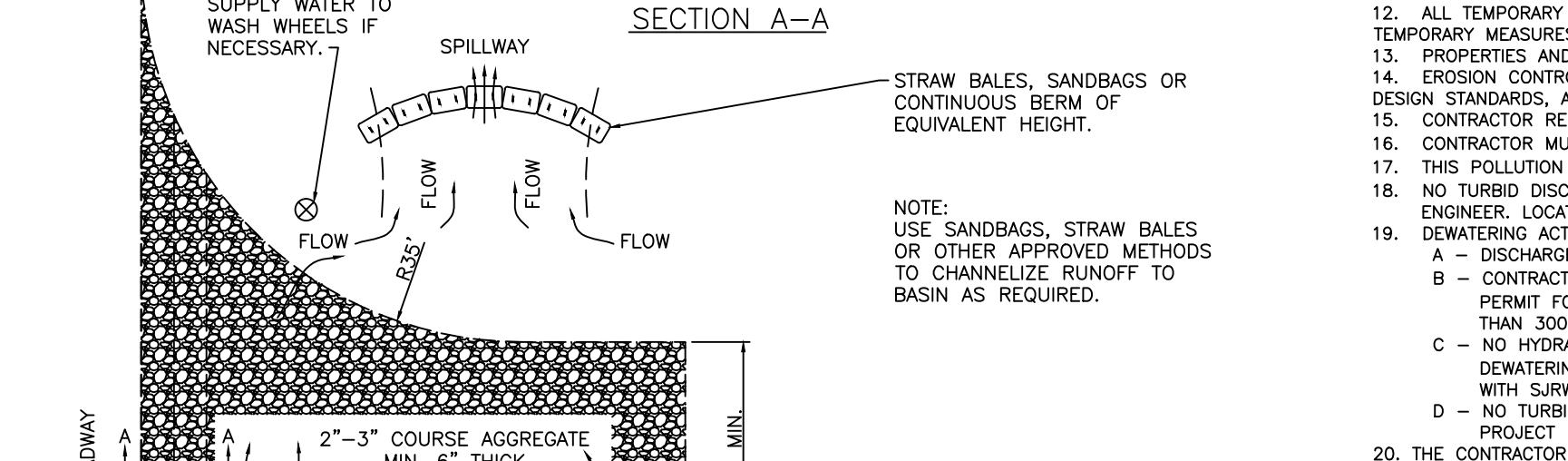
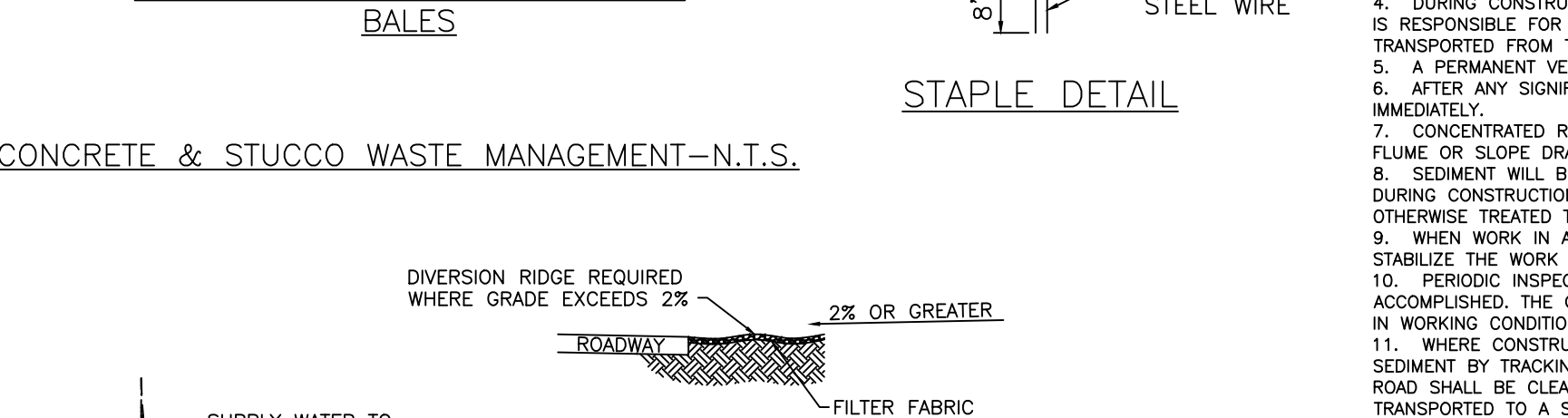
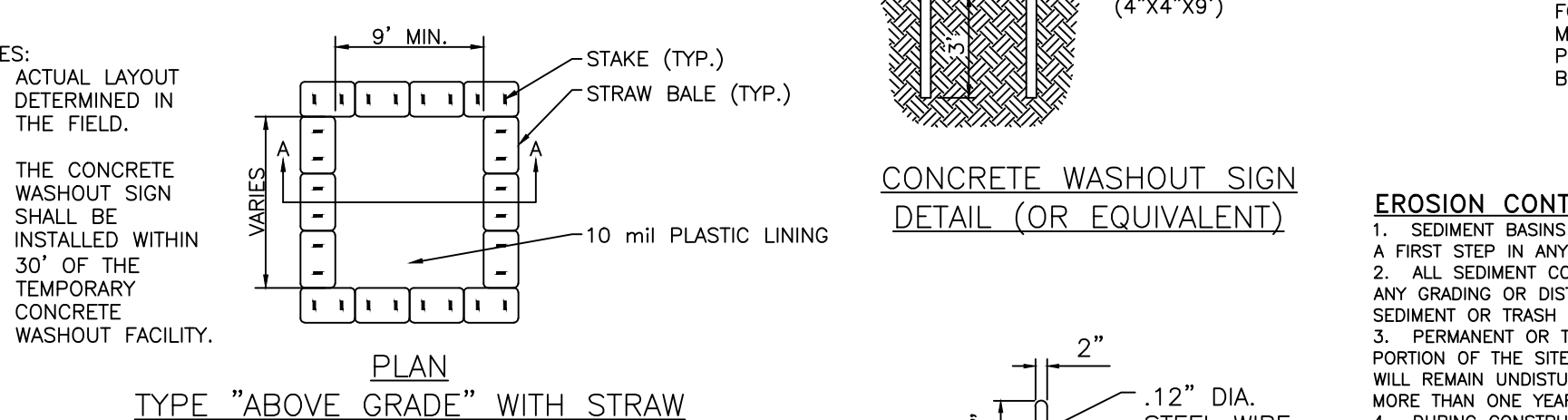
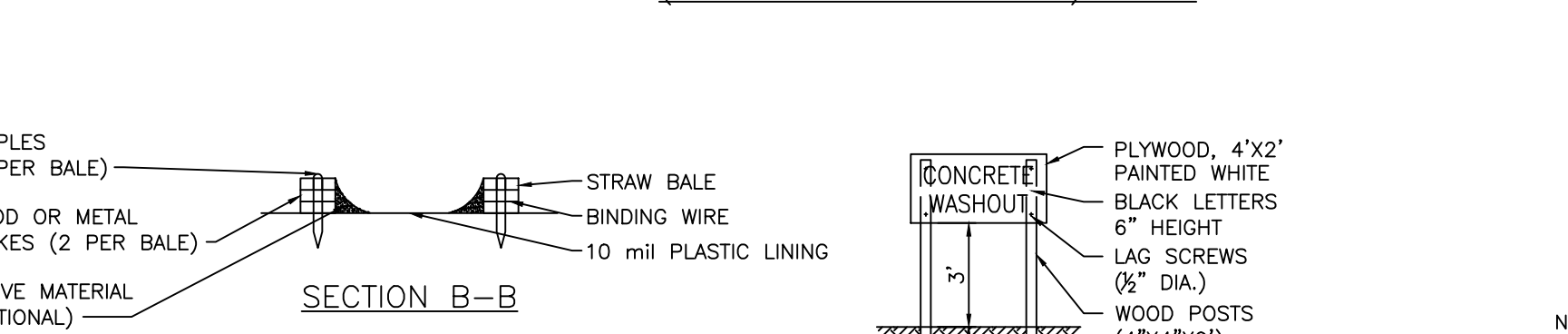
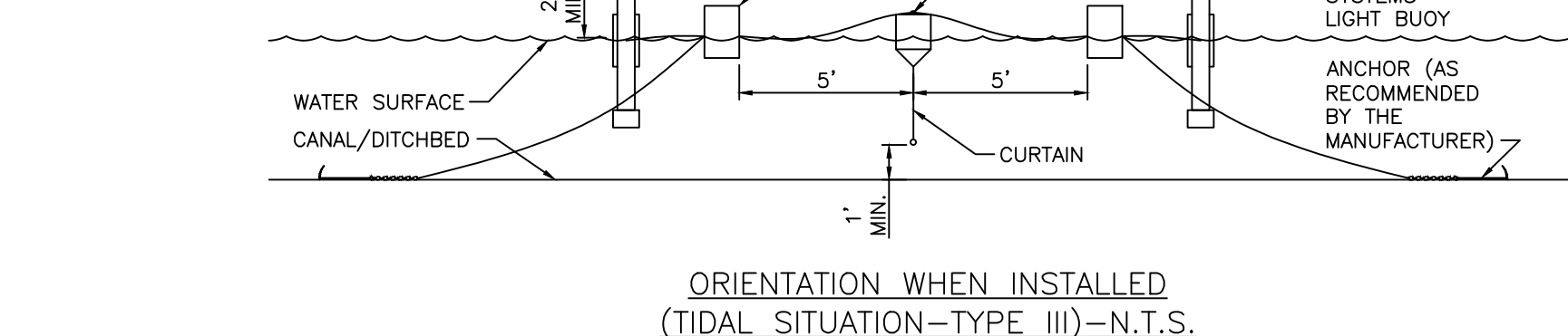
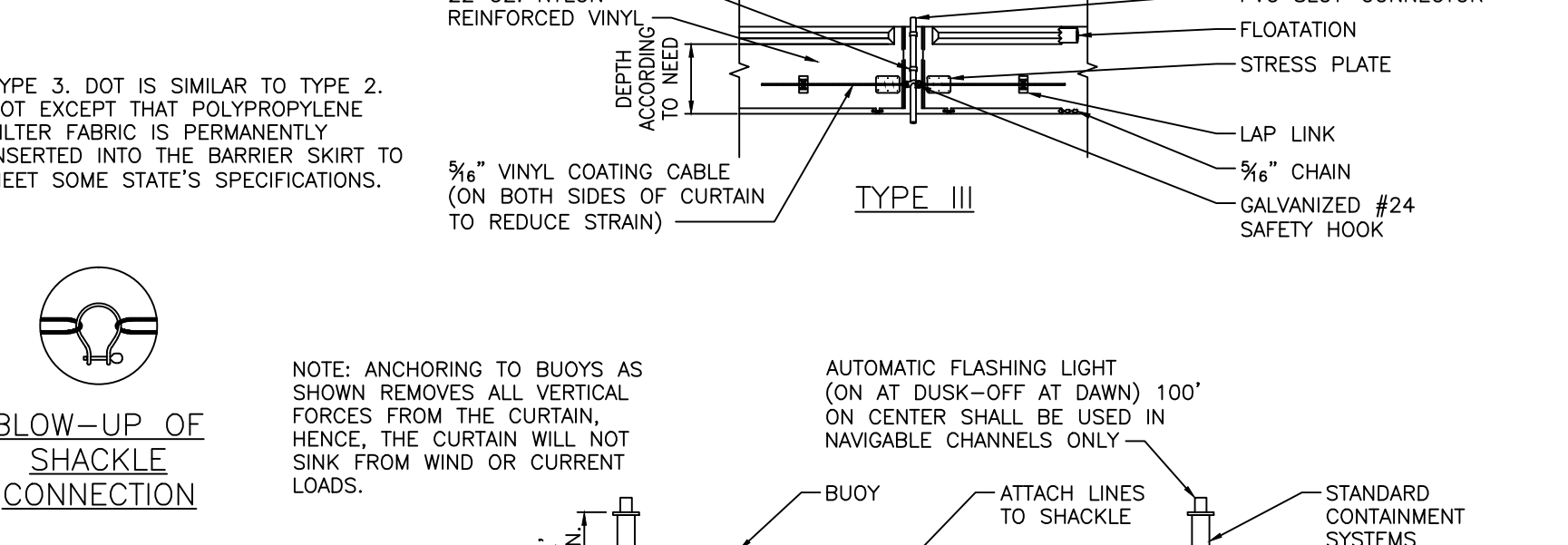
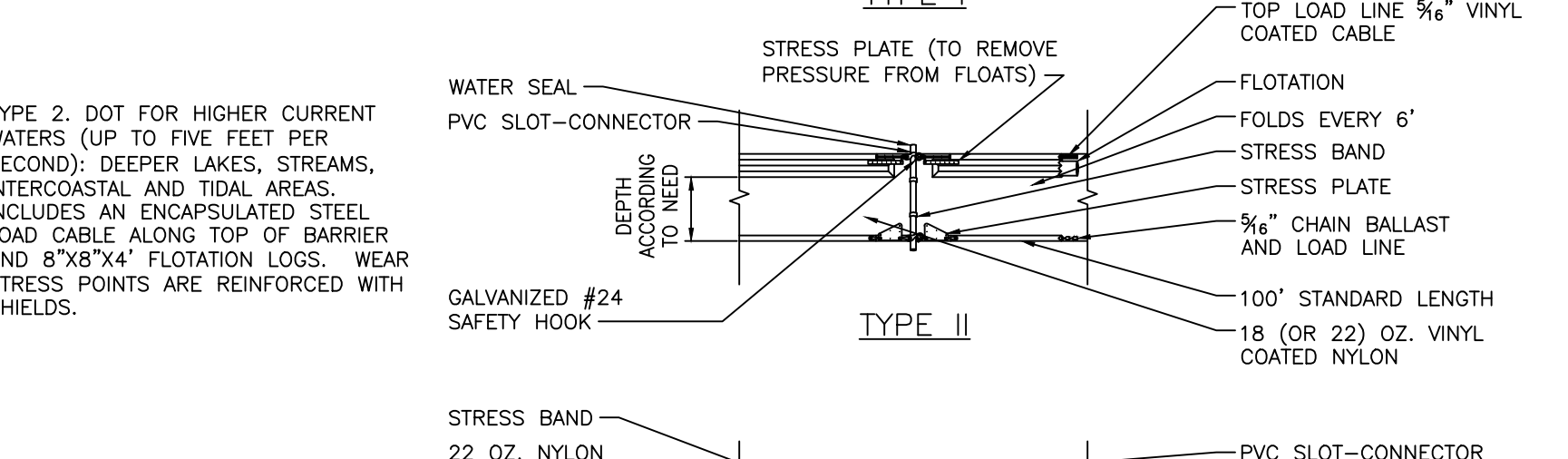
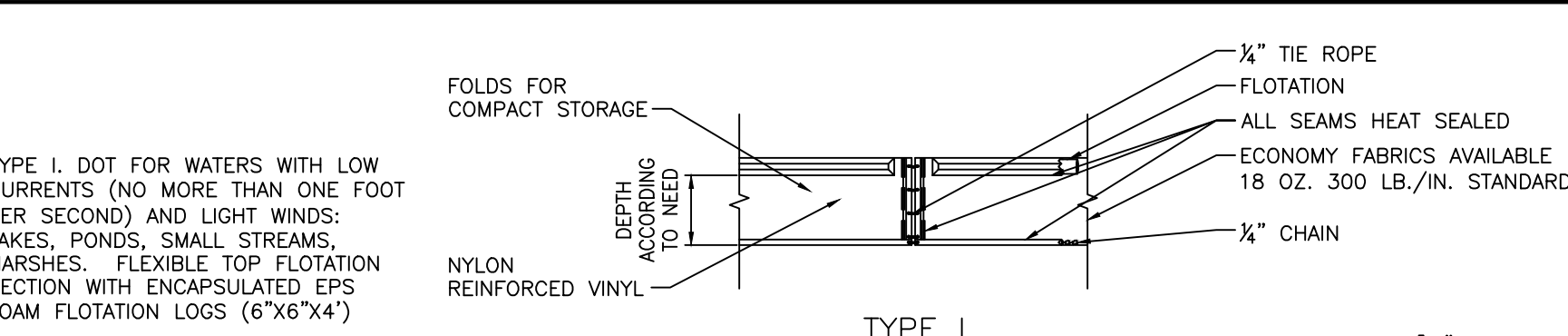
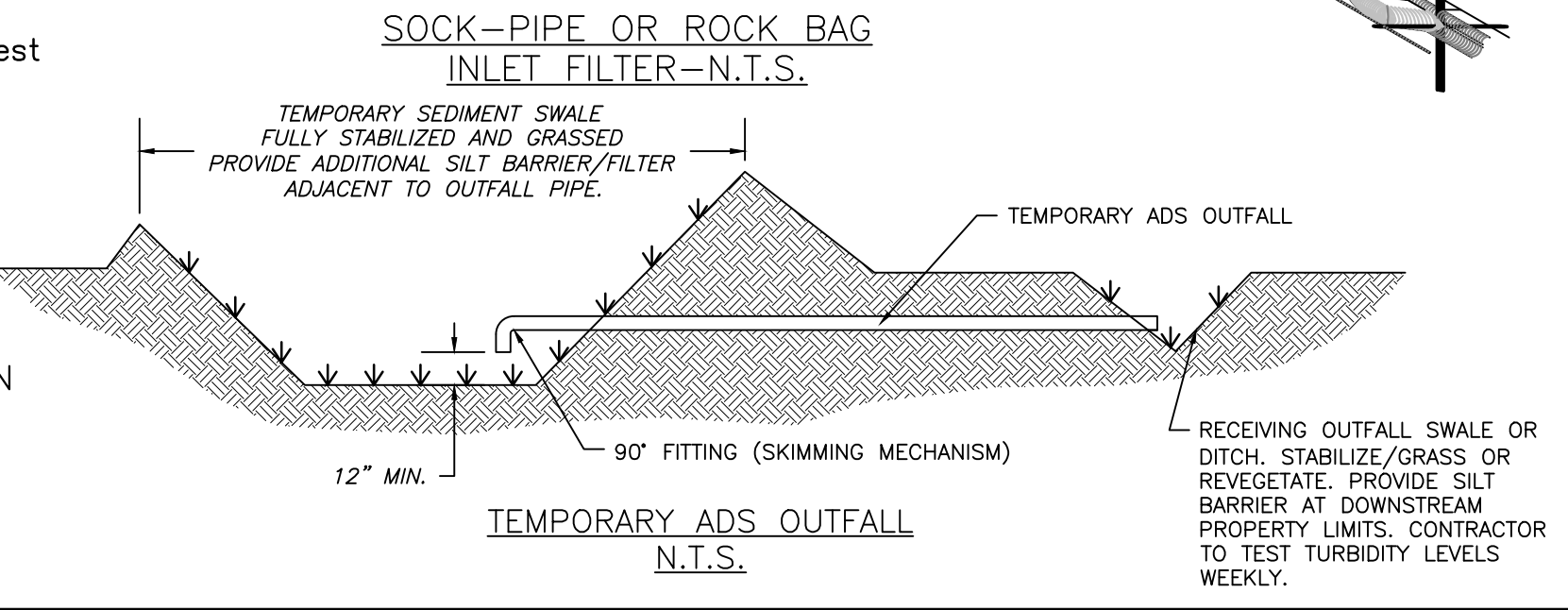
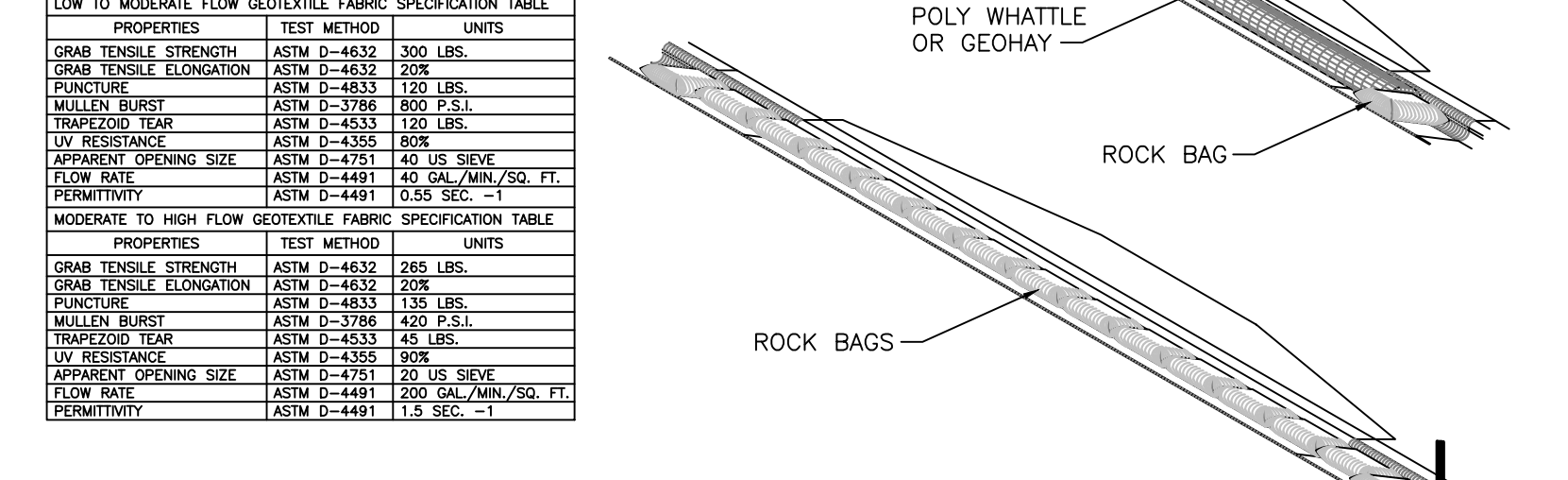
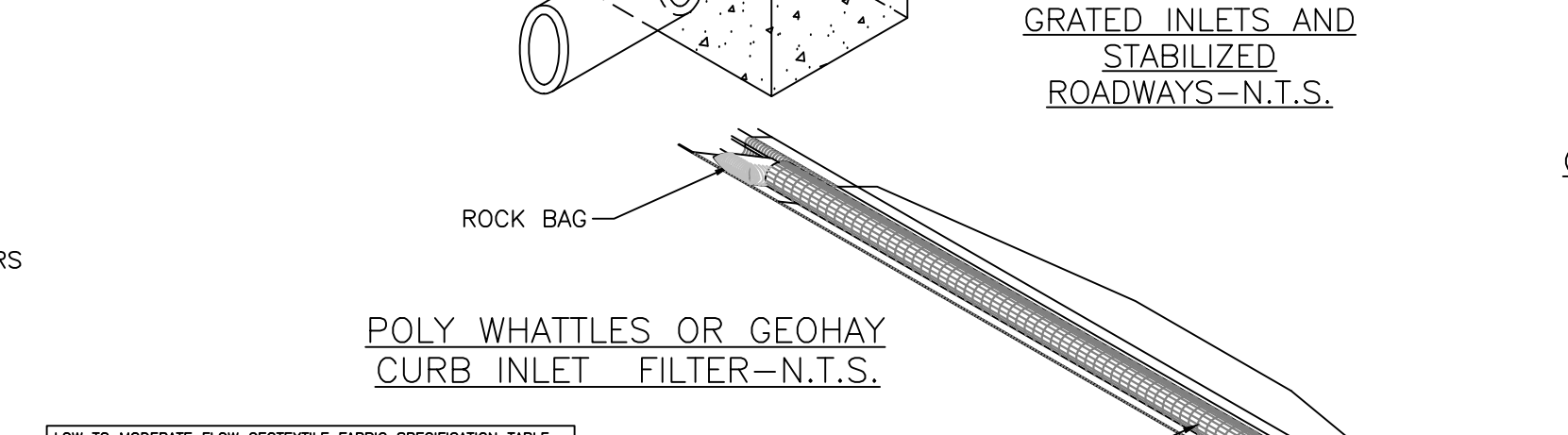
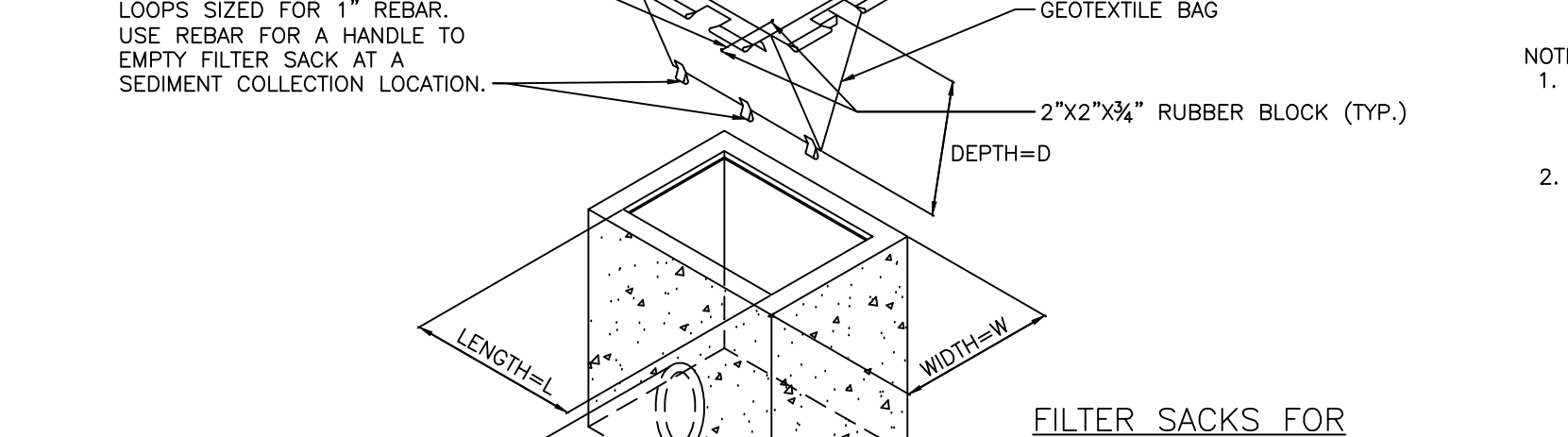
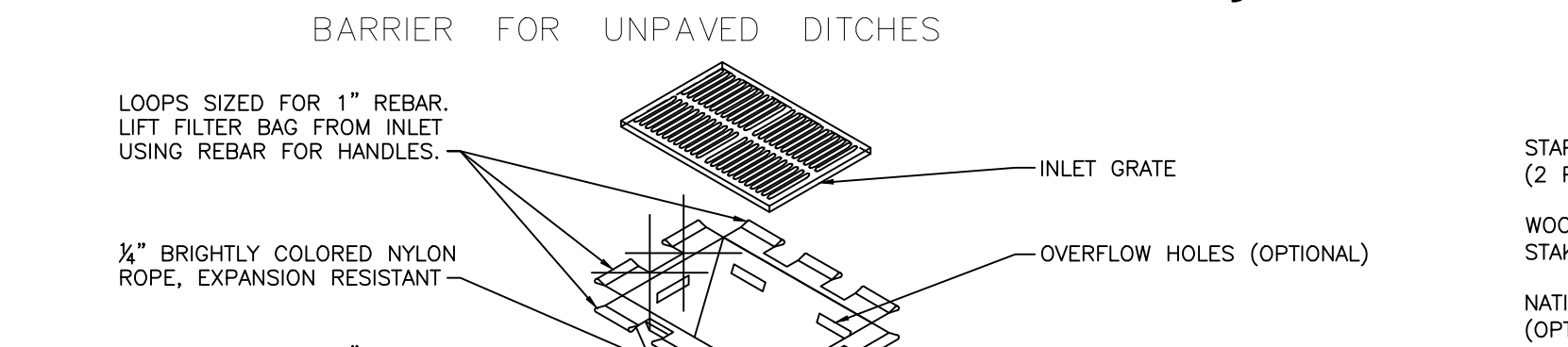
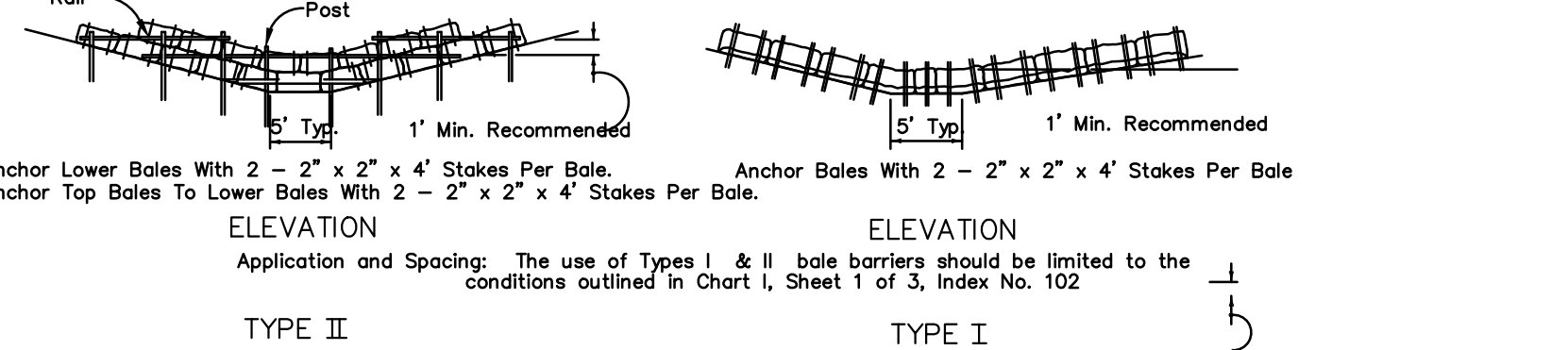
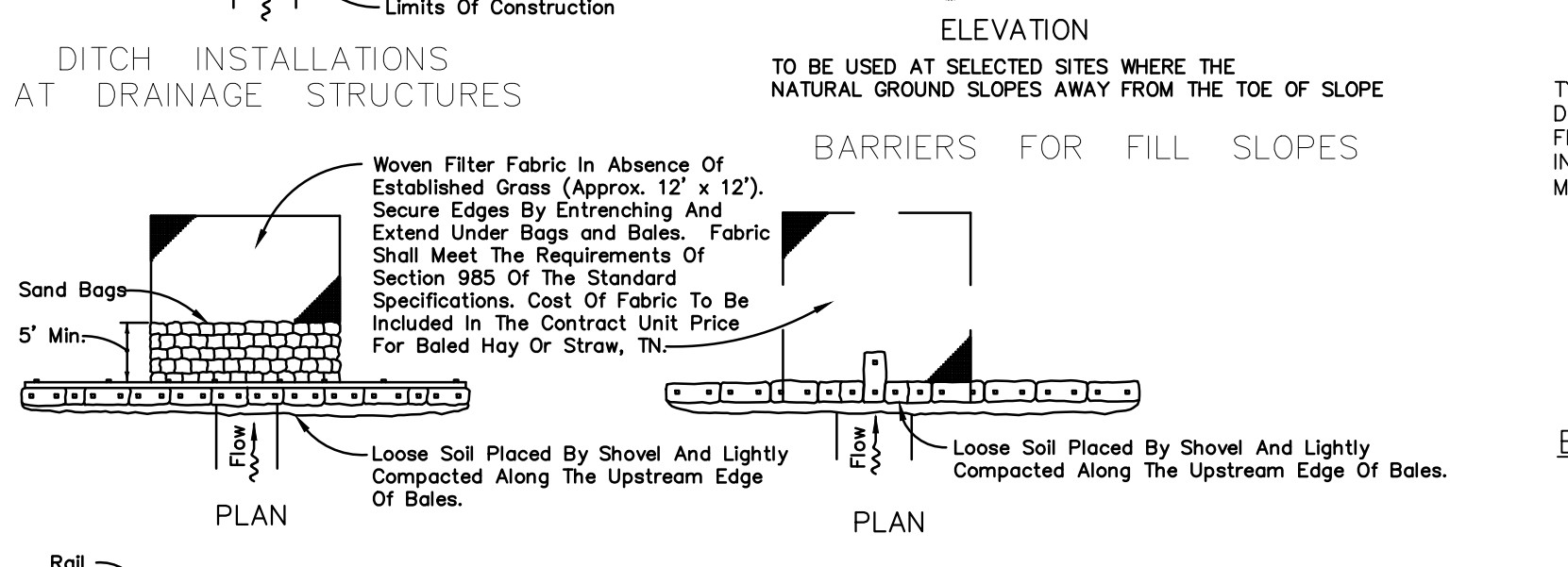
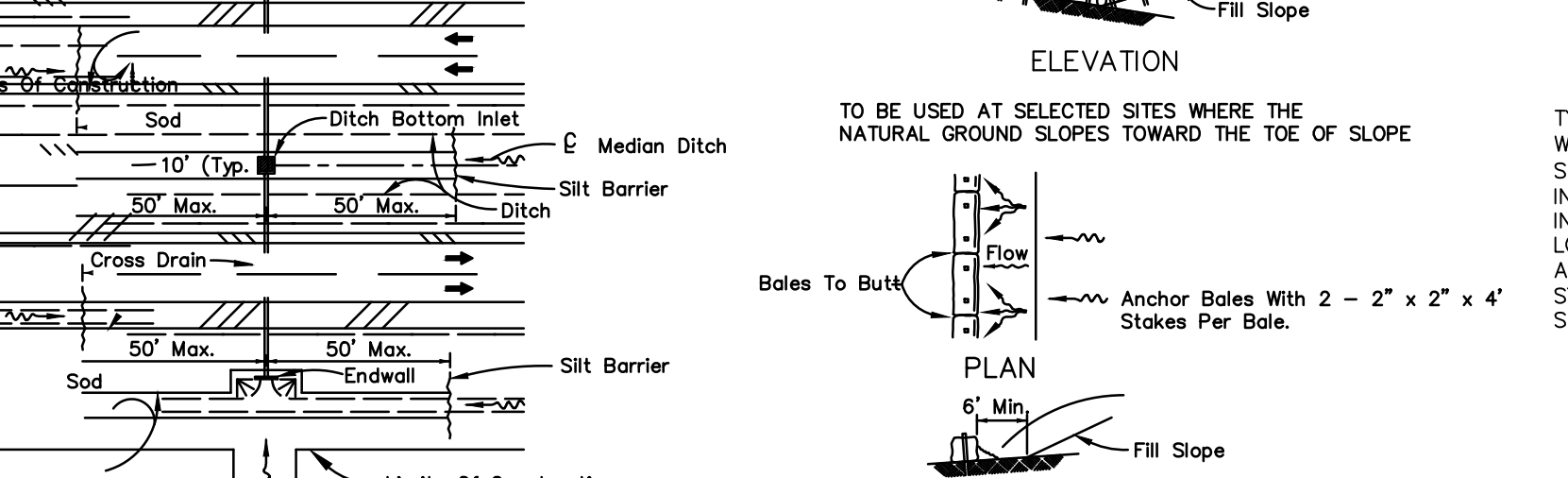
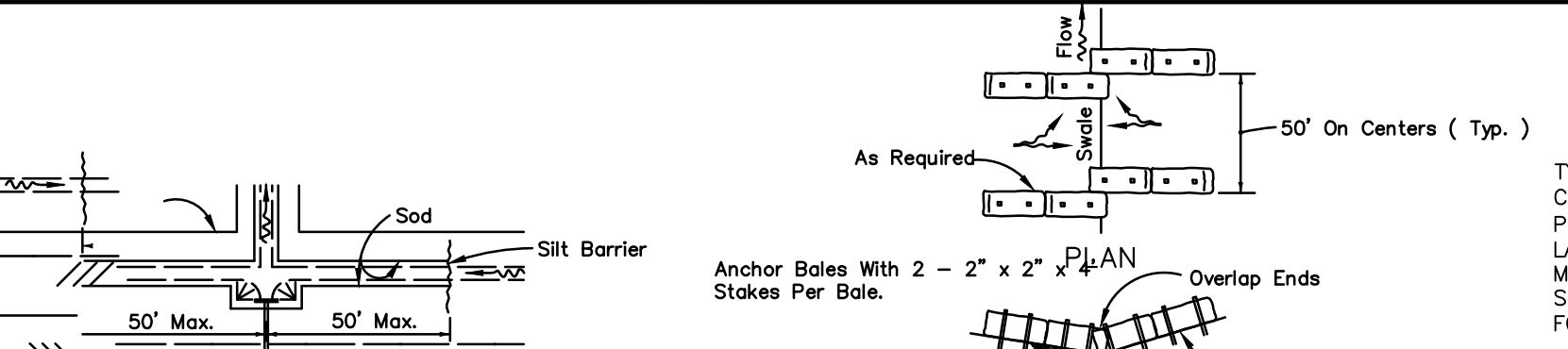

Parameter	Fresh Waters	Coastal Waters
Total Organic Carbon (TOC)	110.0 mg/L	110.0 mg/L
pH, standard units	6.0-8.5	6.5-8.5
Total Recoverable Mercury	0.012 µg/L	0.025 µg/L
Total Recoverable Cadmium	9.3 µg/L	9.3 µg/L
Total Recoverable Copper	2.9 mg/L	2.9 mg/L
Total Recoverable Lead	0.03 mg/L	5.6 mg/L
Total Recoverable Zinc	86.0 µg/L	86.0 µg/L
Total Recoverable Chromium (Hex.)	11.0 µg/L	1.0 µg/L
Benzene	1.0 µg/L	1.0 µg/L
Naphthalene	100.0 µg/L	100.0 µg/L

**SCHULKE, BITTLE & STODDARD, L.L.C.**  
 CIVIL & STRUCTURAL ENGINEERING - LAND PLANNING - ENVIRONMENTAL PERMITTING  
 1717 INDIAN RIVER BLVD., SUITE 201 VERO BEACH, FLORIDA 32960  
 TEL 772 / 770-9622 FAX 772 / 770-9496 EMAIL info@sbsengineers.com

**STORMWATER POLLUTION PREVENTION DETAILS**

**INLET PALMS**

**ENGINEER CERTIFICATION**  
 JOSEPH W. SCHULKE  
 FL REG. NO. 47948  
 JOHN B. BITTLE  
 FL REG. NO. 57396  
 WILLIAM P. STODDARD  
 FL REG. NO. 57605

DATE: SHEET 3 PROJECT NO. 15-053

**KSM**  
**KELLER, SCHLEICHER & MacWILLIAM ENGINEERING AND TESTING, INC.**  
 MARTIN (772) 337-7750 P.O. BOX 78-1377 SEBASTIAN, FL 32976-1377 SEBASTIAN (772) 338-0112  
 PALM BEACH (561) 845-7445 P.O. BOX 78-1377 SEBASTIAN, FL 32976-1377 MELBOURNE (321) 788-8488  
 PALM BEACH (561) 845-7445 P.O. BOX 78-1377 SEBASTIAN, FL 32976-1377 ST. LUCCIE (772) 228-8600  
 C.A. 5693 E-Mail: KSM@KSMENGINEERING.NET  
 April 21, 2015

Joseph Foglia  
 Foglia Construction  
 622 Beachland Blvd.  
 Vero Beach, FL 32963

Re: The Inlet Palms  
 1502 Seaway Drive  
 Fort Pierce, Florida  
 KSM Project #: 150917-b

Dear Mr. Foglia:

As requested, KSM Engineering & Testing has performed a subsurface investigation at the above referenced site. The data gathered during the investigation, together with our geotechnical related opinions, are included in this report.

**A. Site Description:**

The site is located on the Fort Pierce Inlet at 1502 Seaway Drive, Fort Pierce, Florida. At the time of drilling, the waterfront site was cleared and fairly flat with no major vegetation.

**B. Project Description:**

It is our understanding that seven (7) townhomes are planned for the site. Although our office was not provided with detailed structural loads, for our geotechnical analyses, we have assumed the maximum wall loading for the 3-story structures will be about 7,000 pounds per linear foot along the wall foundation and less than 150 kips for any individual column loads.

Site grading for the new structure will include approximately several feet of structural fill to reach the desired grades.

Ronald G. Keller, P.E.: 37293 / SI Lic. No. 860 / Julie E. Keller, P.E.: 68366

**KSM**  
**KELLER, SCHLEICHER & MacWILLIAM ENGINEERING AND TESTING, INC.**  
 MARTIN (772) 337-7750 P.O. BOX 78-1377 SEBASTIAN, FL 32976-1377 SEBASTIAN (772) 338-0112  
 PALM BEACH (561) 845-7445 P.O. BOX 78-1377 SEBASTIAN, FL 32976-1377 MELBOURNE (321) 788-8488  
 PALM BEACH (561) 845-7445 P.O. BOX 78-1377 SEBASTIAN, FL 32976-1377 ST. LUCCIE (772) 228-8600  
 C.A. 5693 E-Mail: KSM@KSMENGINEERING.NET  
 April 21, 2015

**C. The scope of our study consisted of the following:**

1. Performed Standard Penetration Test Borings in the proposed construction area to estimate the subsurface relative density.
2. Measured the groundwater level at each boring.
3. Evaluated the existing soil conditions in relation to the proposed construction and provided recommendations for site preparation and foundation design.
4. Prepared this report to document our findings.

**D. Site Investigation:**

The site investigation program consisted of performing a total of six (6) Standard Penetration Test borings in the proposed construction area. The borings were terminated at depths of 40 to 60 feet below existing grade. The locations of the borings are shown on the attached boring location plan.

The SPT borings were completed in accordance with procedures described in ASTM D-1586. A standard 1.5 inch I.D., 2 inch O.D. split-spoon sampler is driven into the soil by successive blows of a 140 pound hammer freely falling 30 inches. The number of blows required to drive the sampler 1 foot, after seating 6 in., is designated the Penetration Resistance, or "N" value. At regular intervals the sampler is extracted from the ground and opened to allow visual examination and classification of the retained soil sample. Also, the groundwater table was allowed to stabilize and the depth of the groundwater elevation recorded from existing grade.

The records of the soils encountered, the penetration resistances and groundwater level are shown on the attached logs.

Ronald G. Keller, P.E.: 37293 / SI Lic. No. 860 / Julie E. Keller, P.E.: 68366

**KSM**  
**KELLER, SCHLEICHER & MacWILLIAM ENGINEERING AND TESTING, INC.**  
 MARTIN (772) 337-7750 P.O. BOX 78-1377 SEBASTIAN, FL 32976-1377 SEBASTIAN (772) 338-0112  
 PALM BEACH (561) 845-7445 P.O. BOX 78-1377 SEBASTIAN, FL 32976-1377 MELBOURNE (321) 788-8488  
 PALM BEACH (561) 845-7445 P.O. BOX 78-1377 SEBASTIAN, FL 32976-1377 ST. LUCCIE (772) 228-8600  
 C.A. 5693 E-Mail: KSM@KSMENGINEERING.NET  
 April 21, 2015

**E. Engineering Evaluation and Conclusions:**

Based on the information obtained from this site investigation we are pleased to offer the following evaluation:

The boring logs indicate there are soft soil layers located on the site including organic material. The soft and organic layers were encountered about 4 feet to 8 feet below grade. Another soft layer of gray clay and sand was found in two (2) of the soils borings at a depth of approximately 13 feet below existing grade. This layer is approximately 2 to 4 feet thick.

In order for a shallow foundation to perform satisfactorily, it must be able to support the structural loads with an acceptable factor of safety against excessive settlements, both total and differential. Due to the settlement potential of the soft/organic soil layers found on the site, we do not recommend supporting the proposed structures on conventional shallow footings. The anticipated settlement, in our opinion, would be too excessive and beyond the general accepted safe limits for the structure.

In order to avoid any damaging structural distress due to settlements, and based on past experience of other projects that had similar underlying subsurface conditions, we recommend the installation of a concrete pile supported foundation system. The concrete piles will carry the structural loads below the weak soil layers. We recommend using auger cast-in-place piles. Although we have not been furnished with estimated structural loads, we assume that the following capacities will be sufficient to support the intended loading.

Pile Diameter (Inches)	Pile Capacity (Kips)	Pile Depth (Feet)	Allowable Uplift (Kips)	Lateral Load (Kips)
14	36	25	20	5
14	45	30	28	5
14	75	37	40	5

All Piles should be installed and inspected in accordance to the recommendation published by the Auger Cast-In-Place File Committee of the Deep Foundation Institute.

Ronald G. Keller, P.E.: 37293 / SI Lic. No. 860 / Julie E. Keller, P.E.: 68366

**KSM**  
**KELLER, SCHLEICHER & MacWILLIAM ENGINEERING AND TESTING, INC.**  
 MARTIN (772) 337-7750 P.O. BOX 78-1377 SEBASTIAN, FL 32976-1377 SEBASTIAN (772) 338-0112  
 PALM BEACH (561) 845-7445 P.O. BOX 78-1377 SEBASTIAN, FL 32976-1377 MELBOURNE (321) 788-8488  
 PALM BEACH (561) 845-7445 P.O. BOX 78-1377 SEBASTIAN, FL 32976-1377 ST. LUCCIE (772) 228-8600  
 C.A. 5693 E-Mail: KSM@KSMENGINEERING.NET  
 April 21, 2015

**F. Site Preparation:**

The proposed building area, plus a minimum margin of five feet beyond the proposed building limits shall be stripped and grubbed of surface debris, including vegetation, roots and organic matter and profiled. Sufficient passes should be made during compaction operations to produce a density no less than 90 percent of its modified dry Proctor value to a depth of two feet.

After the exposed surface has been profiled, the building and pavement areas may be filled to the desired grades. The fill material shall consist of clean granular sand containing less than 10% material passing the U.S. Standard No. 200 mesh sieve. Place structural fill in loose lifts of 12 inches in thickness and compact each lift to at least 95 percent of its modified dry Proctor value.

We recommend field density tests and on-site inspection be performed at appropriate times during the earth work operations in order to verify that the site preparations have been properly constructed.

**G. Swimming Pools:**

The pool shell and pool deck can also be supported on a pile foundation system.

An alternative would be to over-excavate the pool site completely removing the soft organic material from 4 feet to 8 feet and replace it with 3/4 stones. Compact the 3/4" stone with a "jumping jack" compactor in 12 inch lifts so the subgrade below the pool is firm and stable. Call for an inspection to verify that the site has been properly prepared prior to placing the pool shell reinforcing.

Backfill material behind the pool shell shall consist of clean granular sand with less than 10 percent "fines" passing the U.S. No. 200 sieve. Place backfill material in loose lifts of 12 inches in thickness and compact each lift to no less than 95 percent of its modified dry Proctor value (ASTM D 1557).

Ronald G. Keller, P.E.: 37293 / SI Lic. No. 860 / Julie E. Keller, P.E.: 68366

**KSM**  
**KELLER, SCHLEICHER & MacWILLIAM ENGINEERING AND TESTING, INC.**  
 MARTIN (772) 337-7750 P.O. BOX 78-1377 SEBASTIAN, FL 32976-1377 SEBASTIAN (772) 338-0112  
 PALM BEACH (561) 845-7445 P.O. BOX 78-1377 SEBASTIAN, FL 32976-1377 MELBOURNE (321) 788-8488  
 PALM BEACH (561) 845-7445 P.O. BOX 78-1377 SEBASTIAN, FL 32976-1377 ST. LUCCIE (772) 228-8600  
 C.A. 5693 E-Mail: KSM@KSMENGINEERING.NET  
 April 21, 2015

**H. Closure:**

This report has been prepared in accordance with generally accepted soil and foundation engineering practices based on the results of the test borings and the assumed loading conditions. This report does not reflect any variations which may occur between the borings. If variations appear evident during the course of construction, it would be necessary to re-evaluate the recommendations of this project.

We are pleased to be of assistance to you on this phase of your project. When we may be of assistance to you or should you have any questions, please feel free to call.



Email To: rsk007@aol.com; wstoddard@sbsengineers.com

Ronald G. Keller, P.E.: 37293 / SI Lic. No. 860 / Julie E. Keller, P.E.: 68366

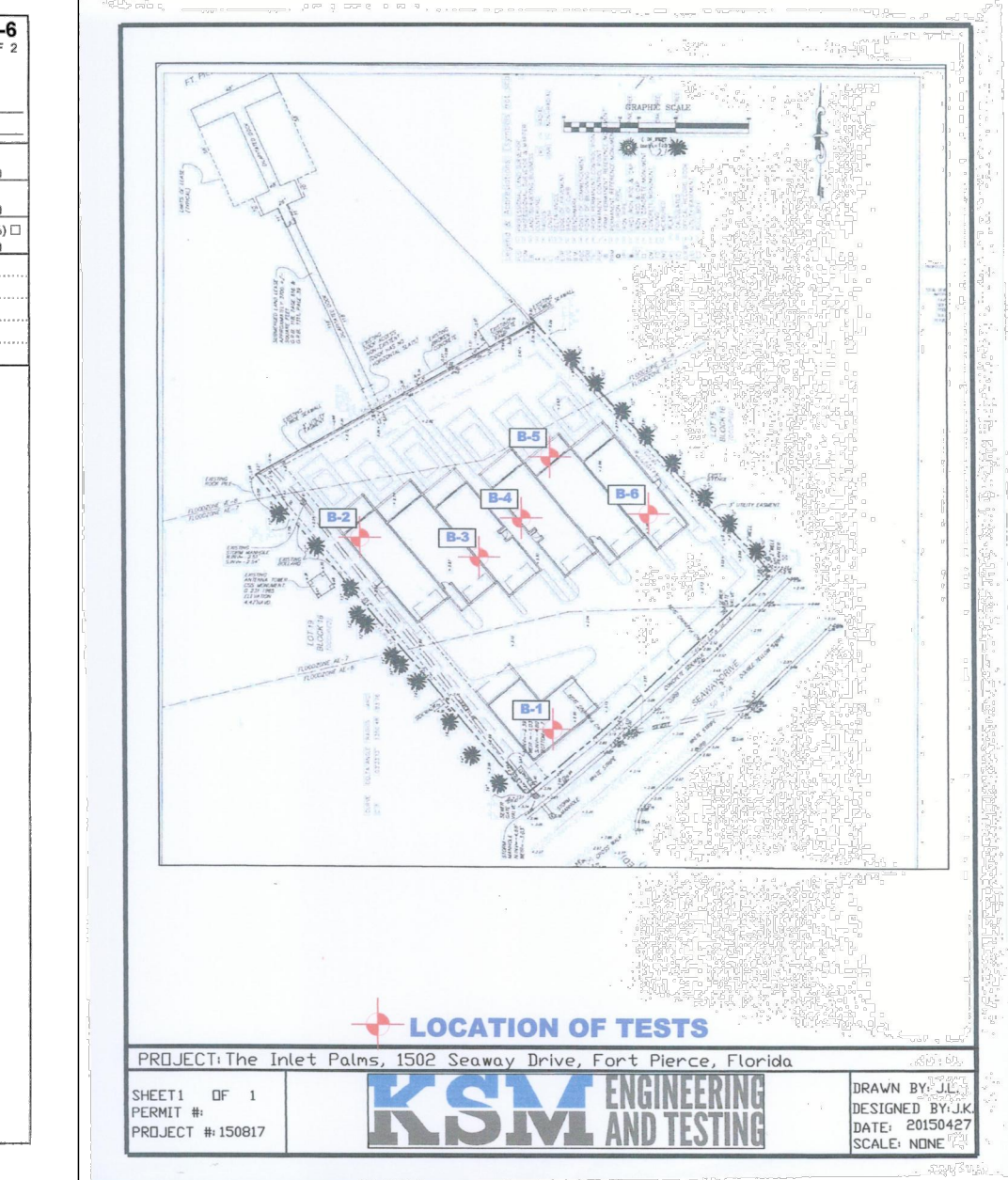
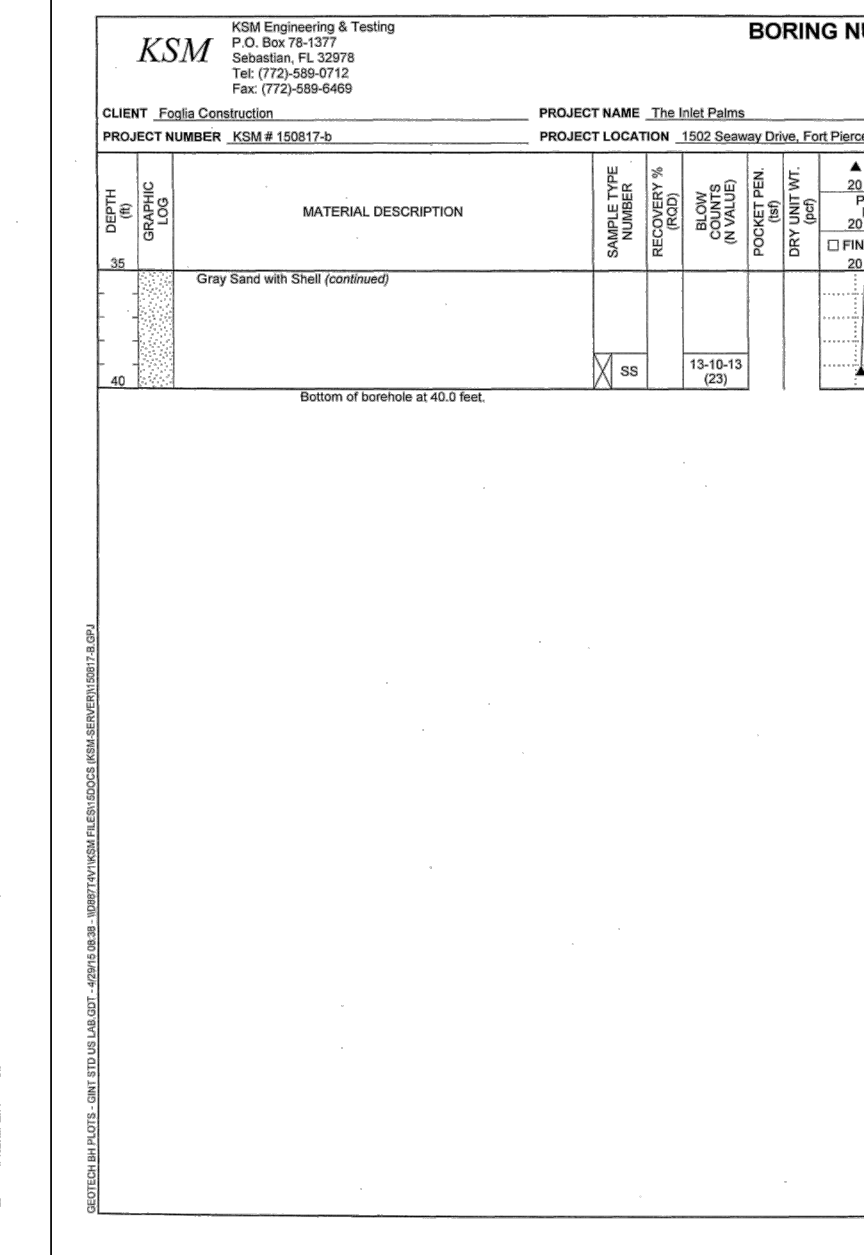
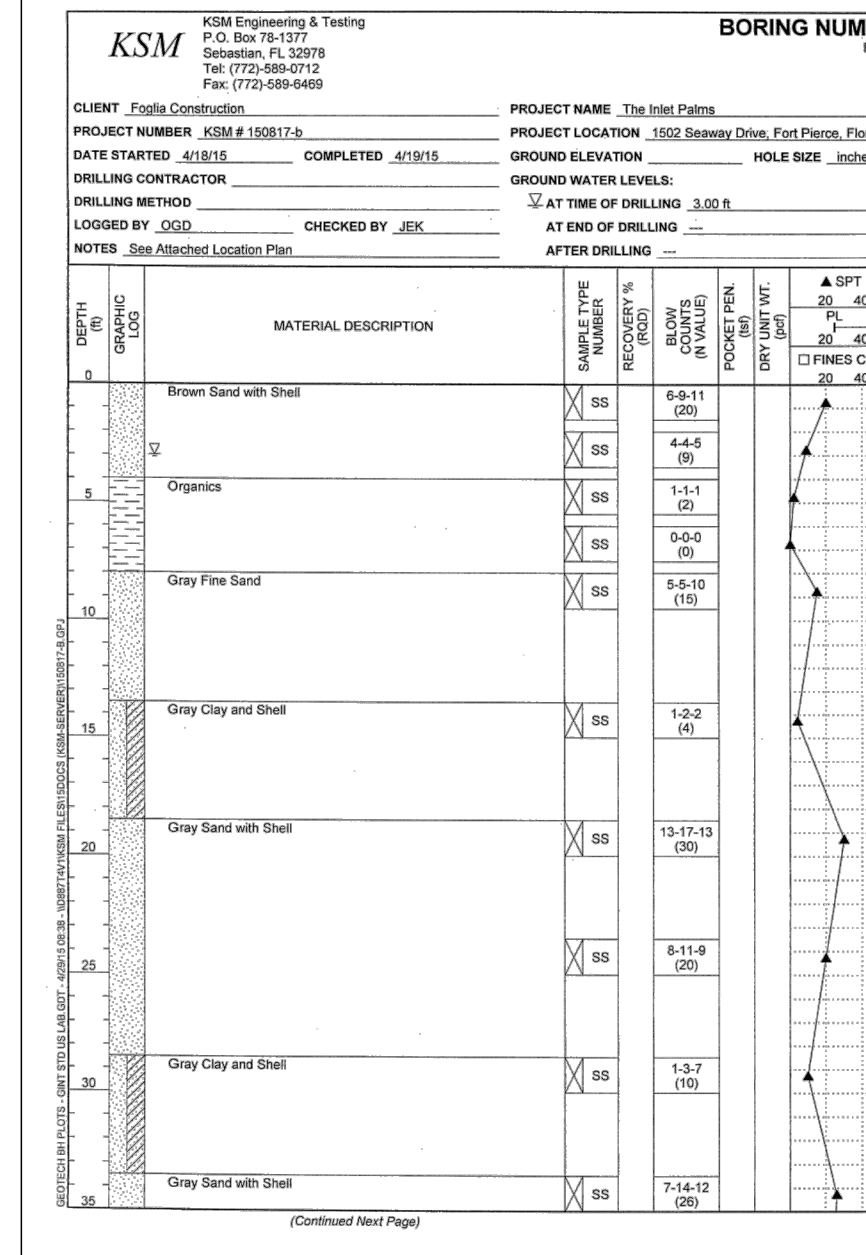
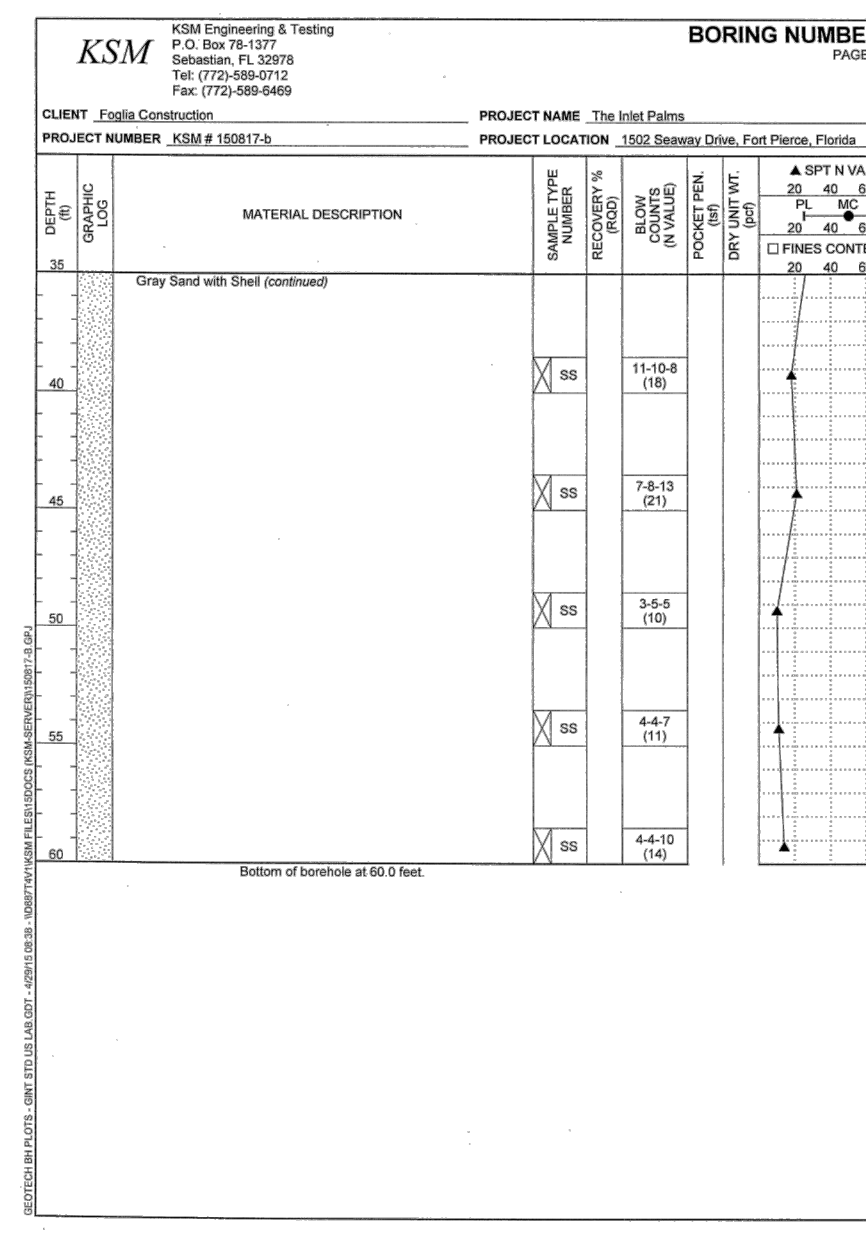
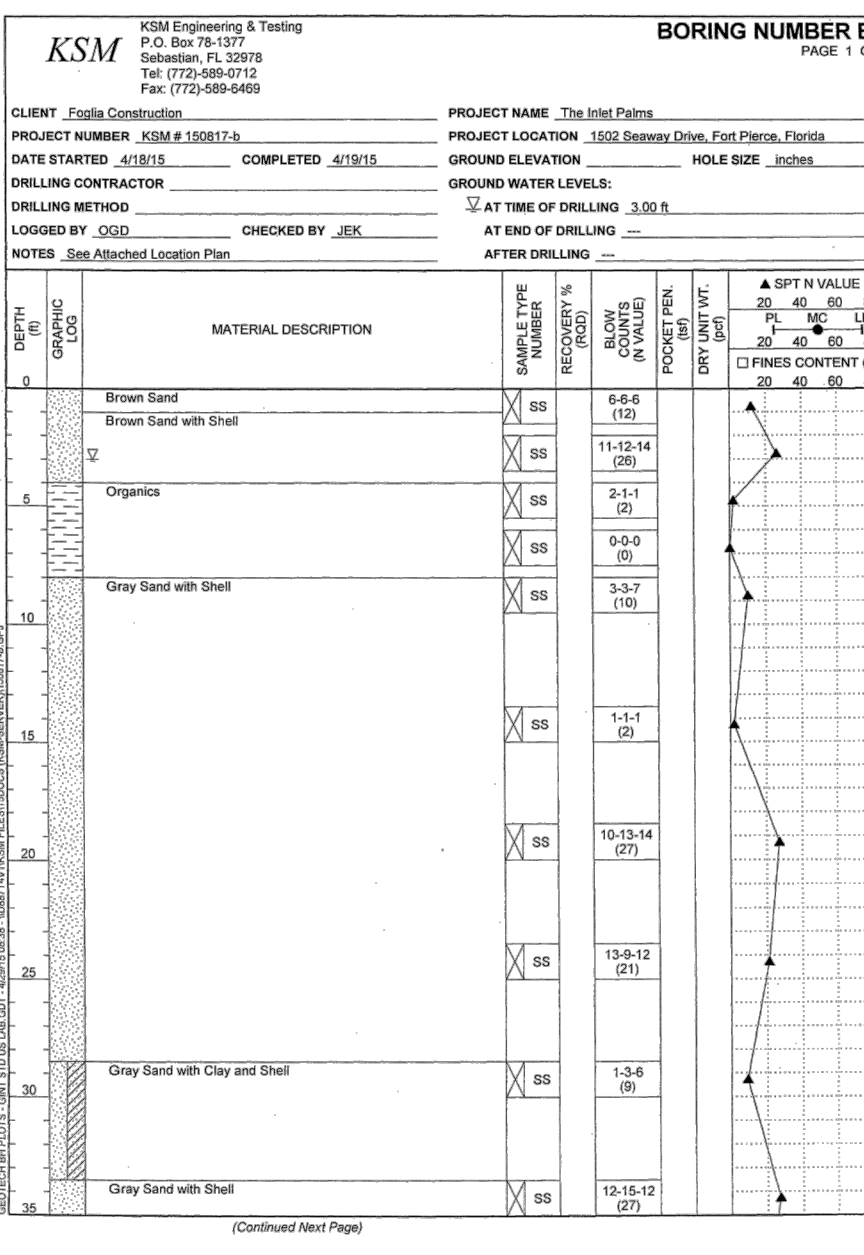
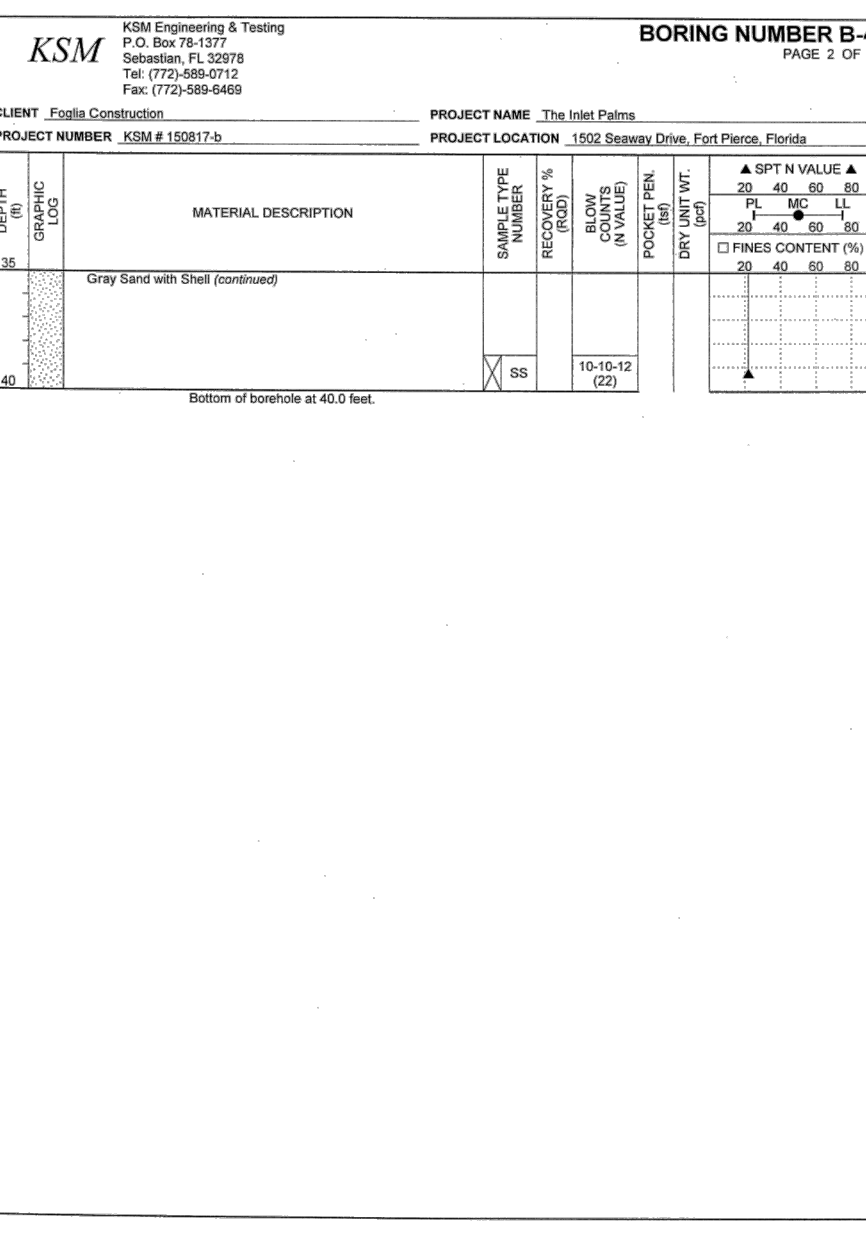
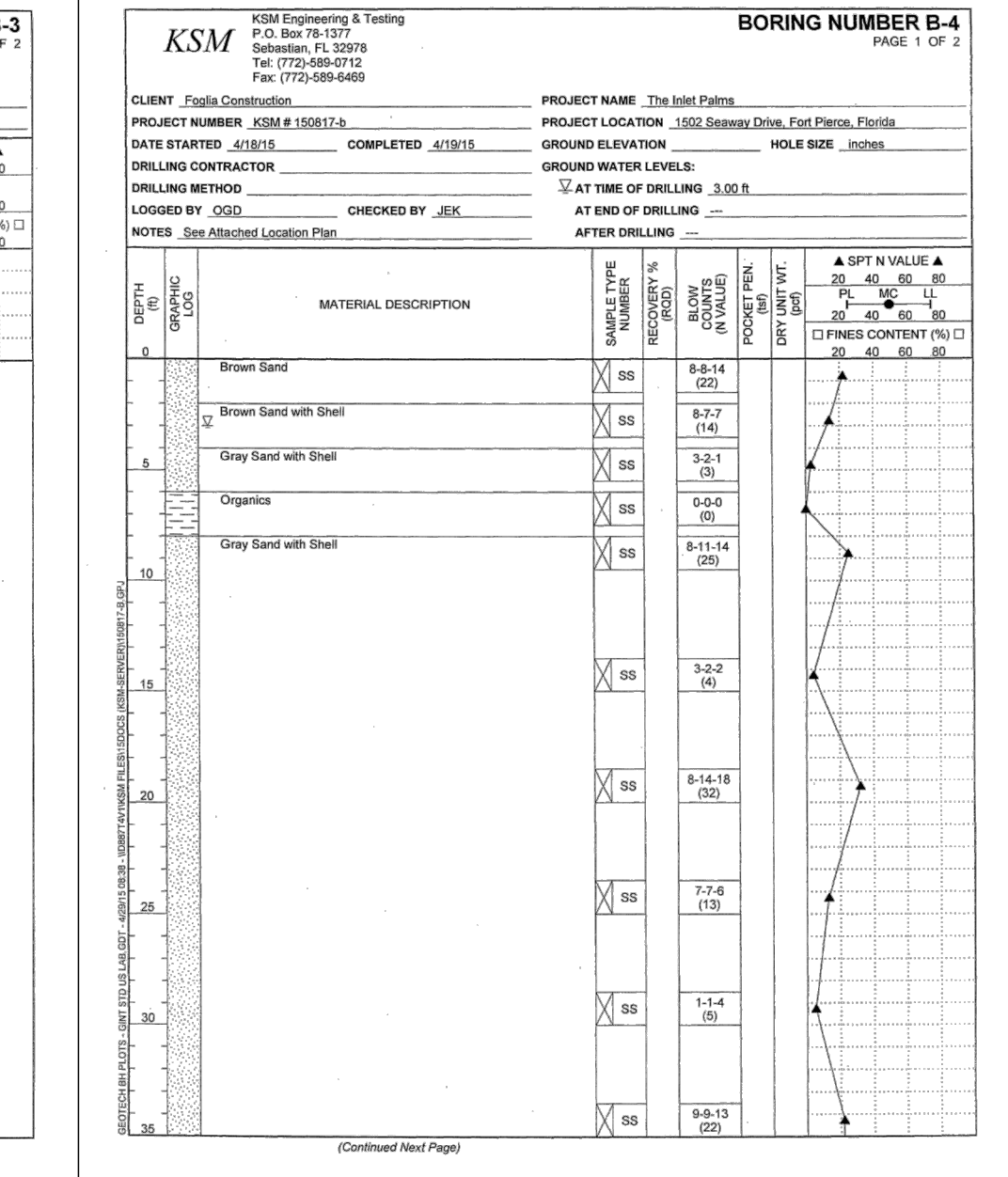
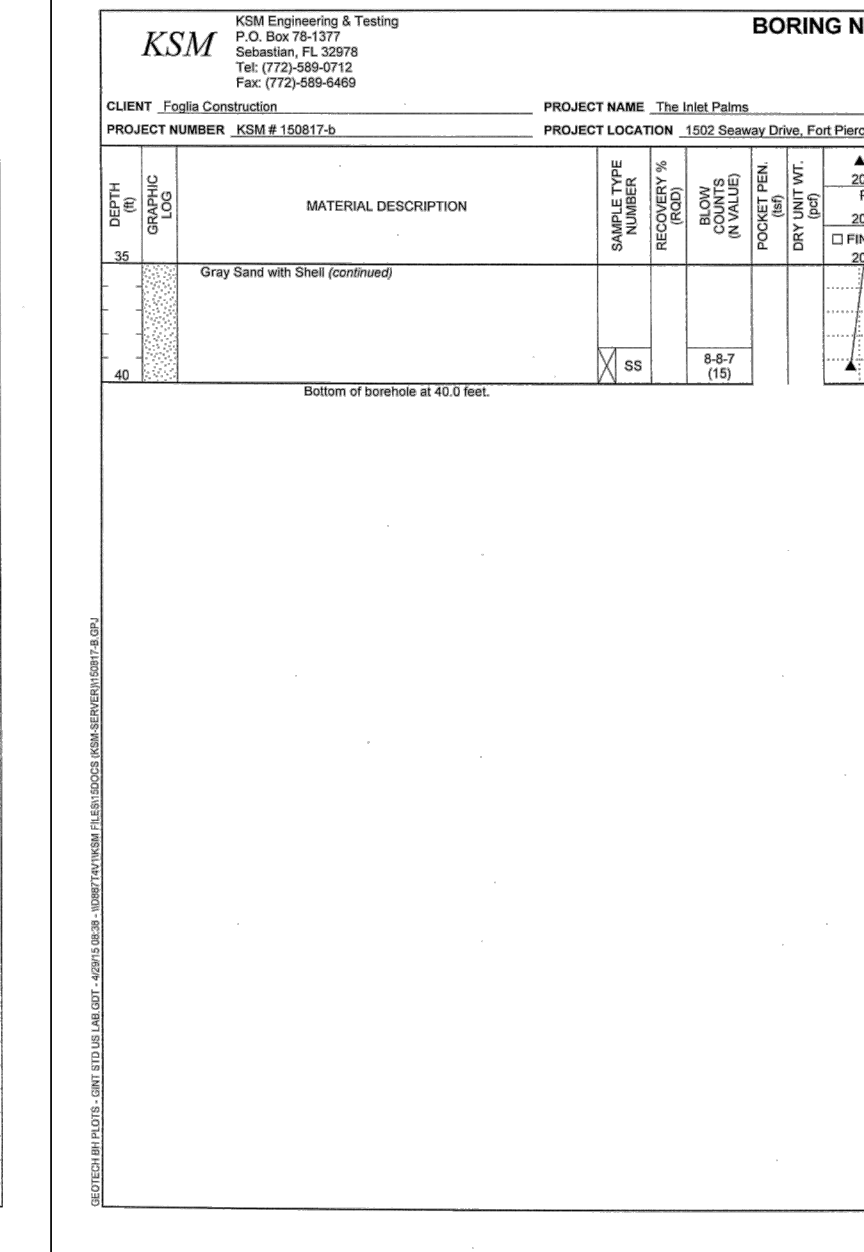
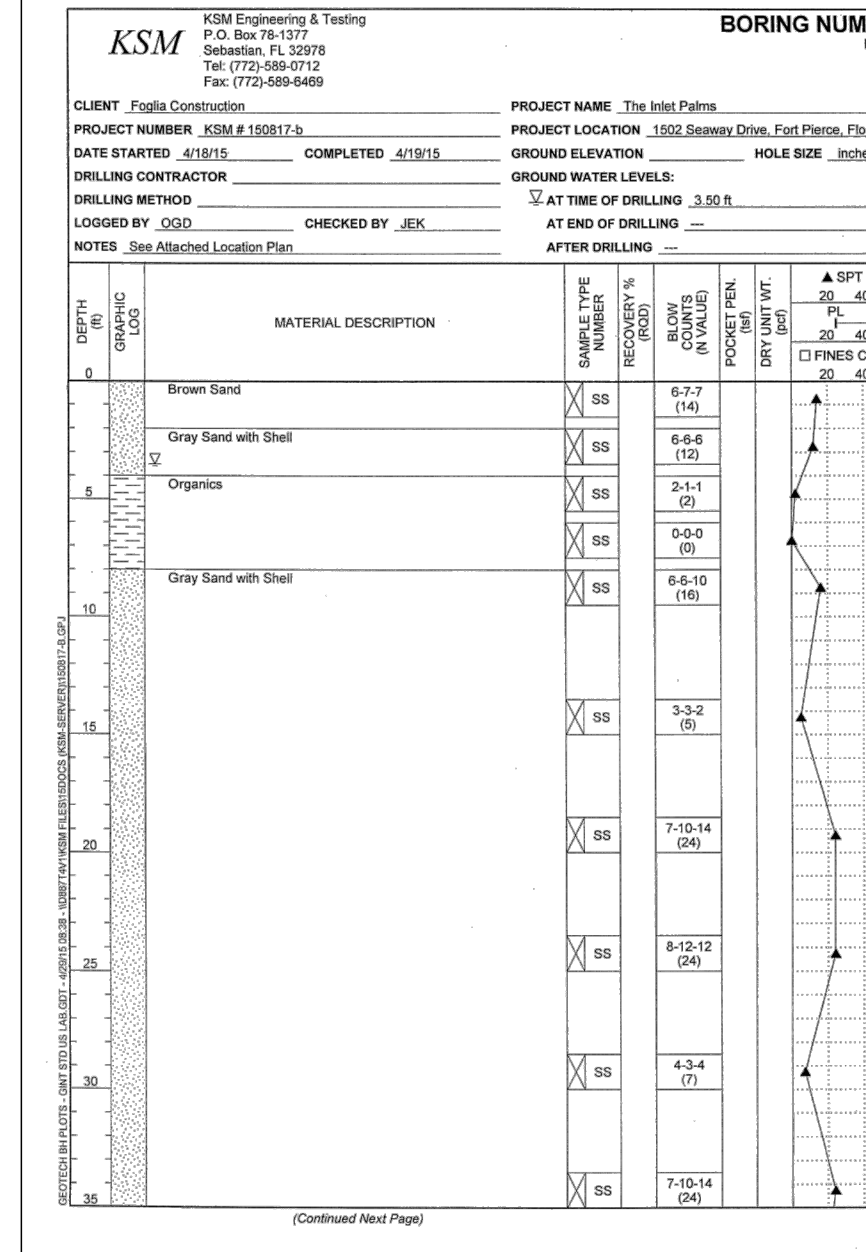
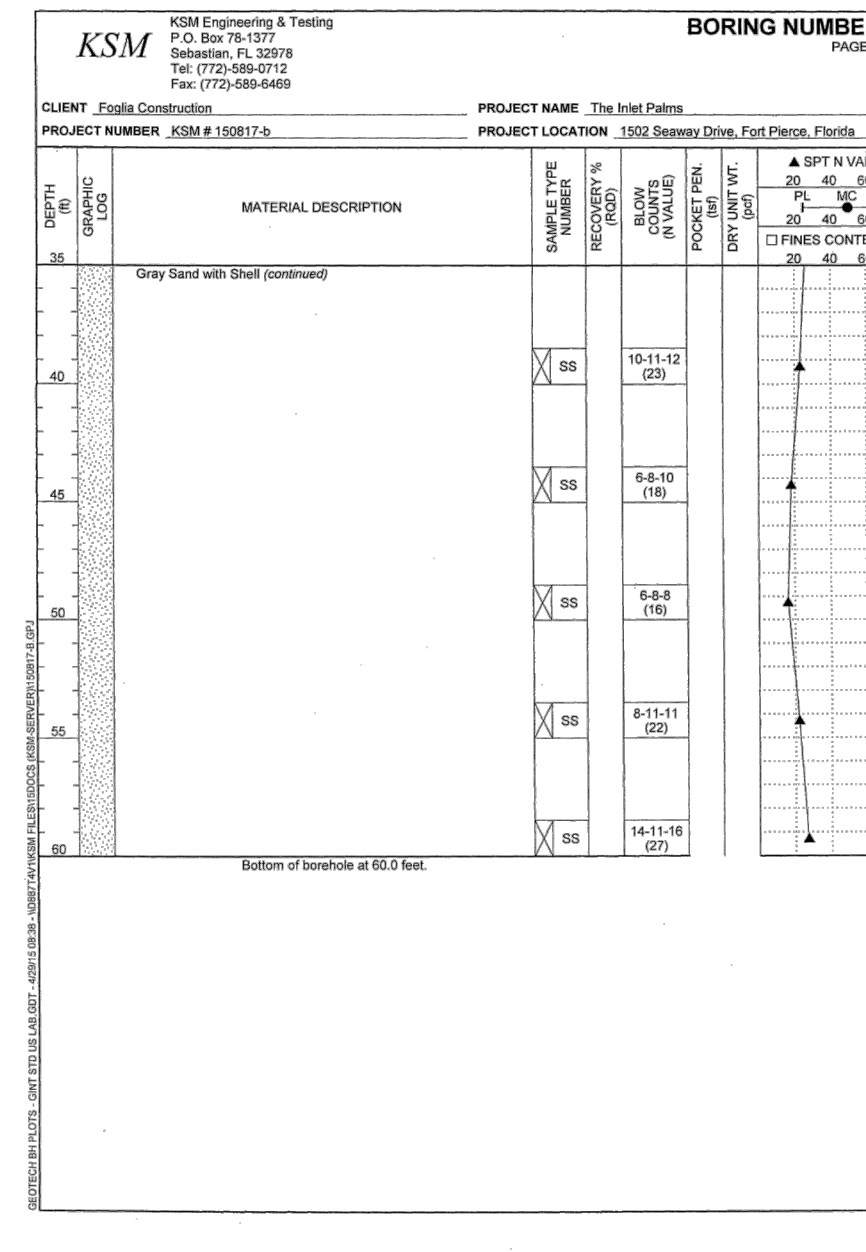
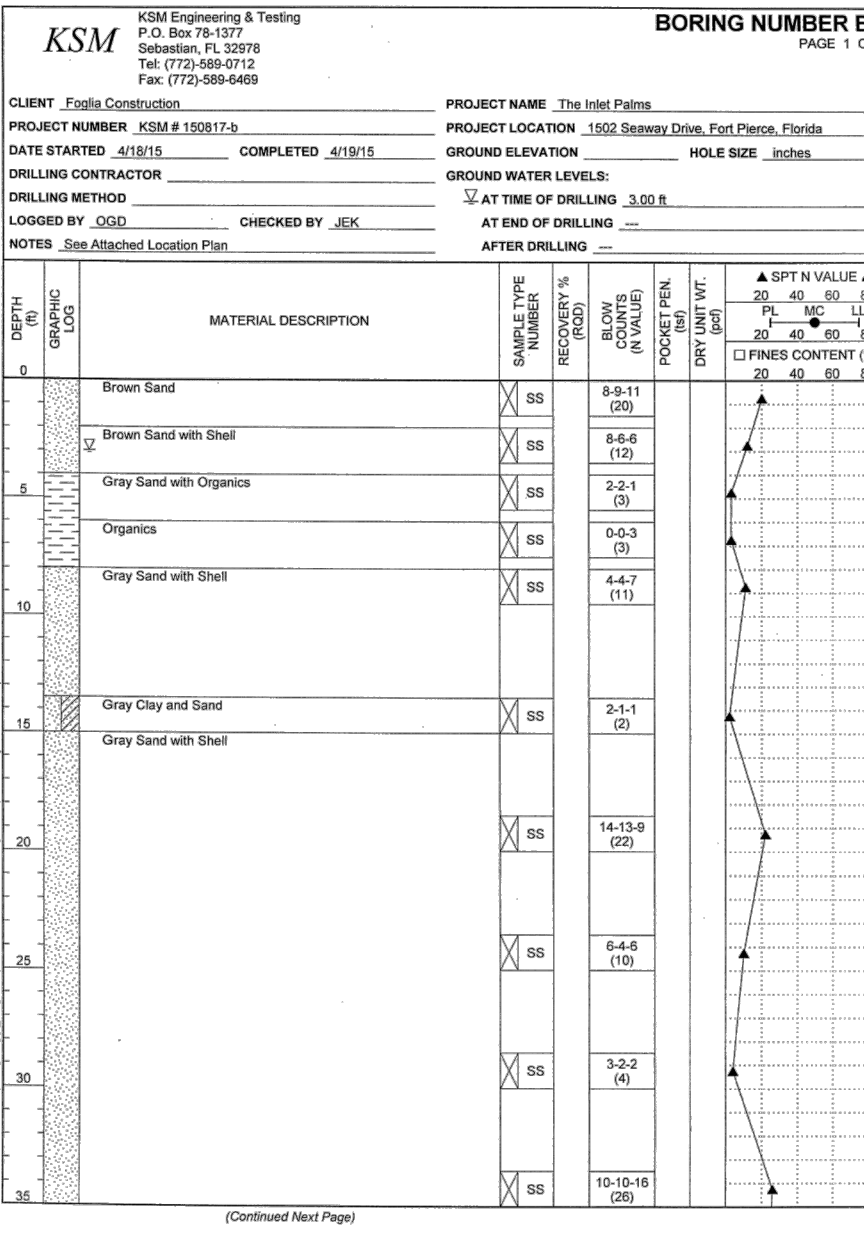
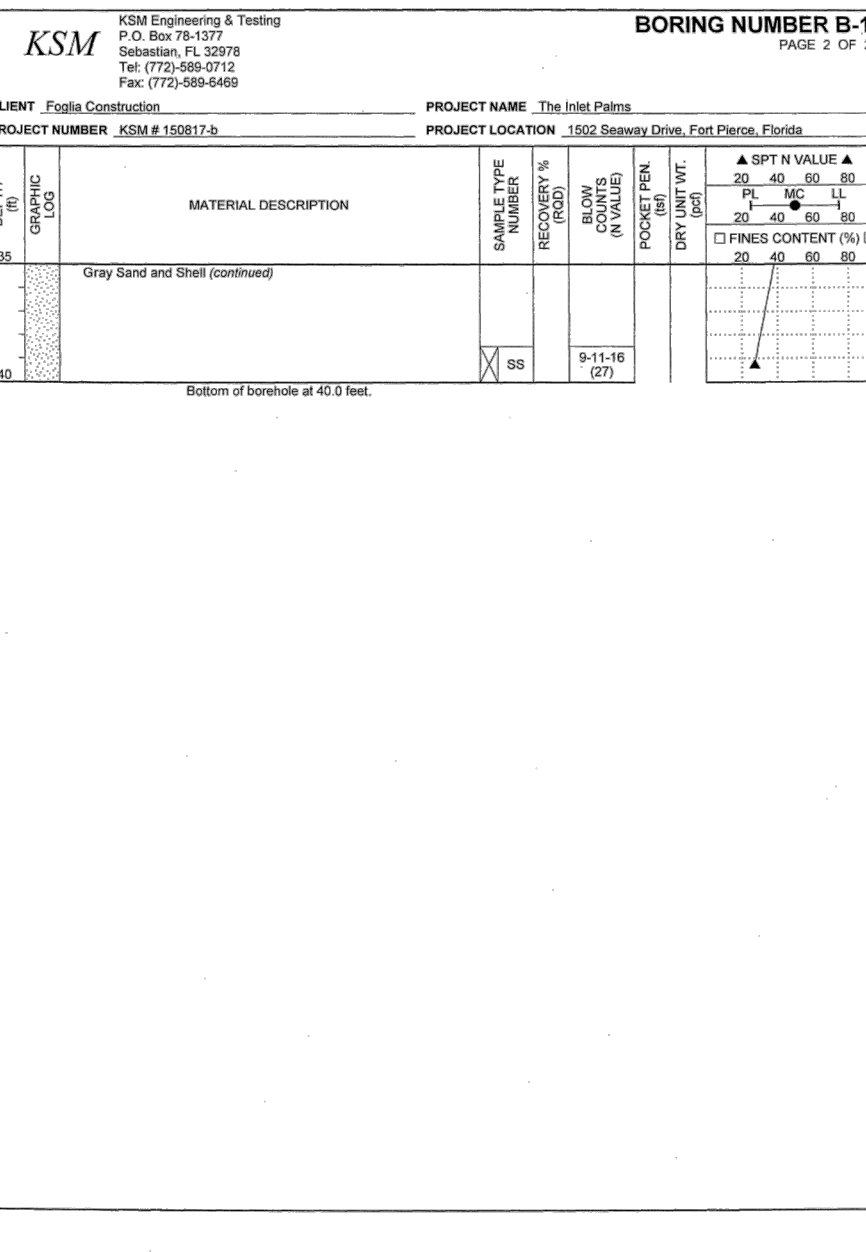
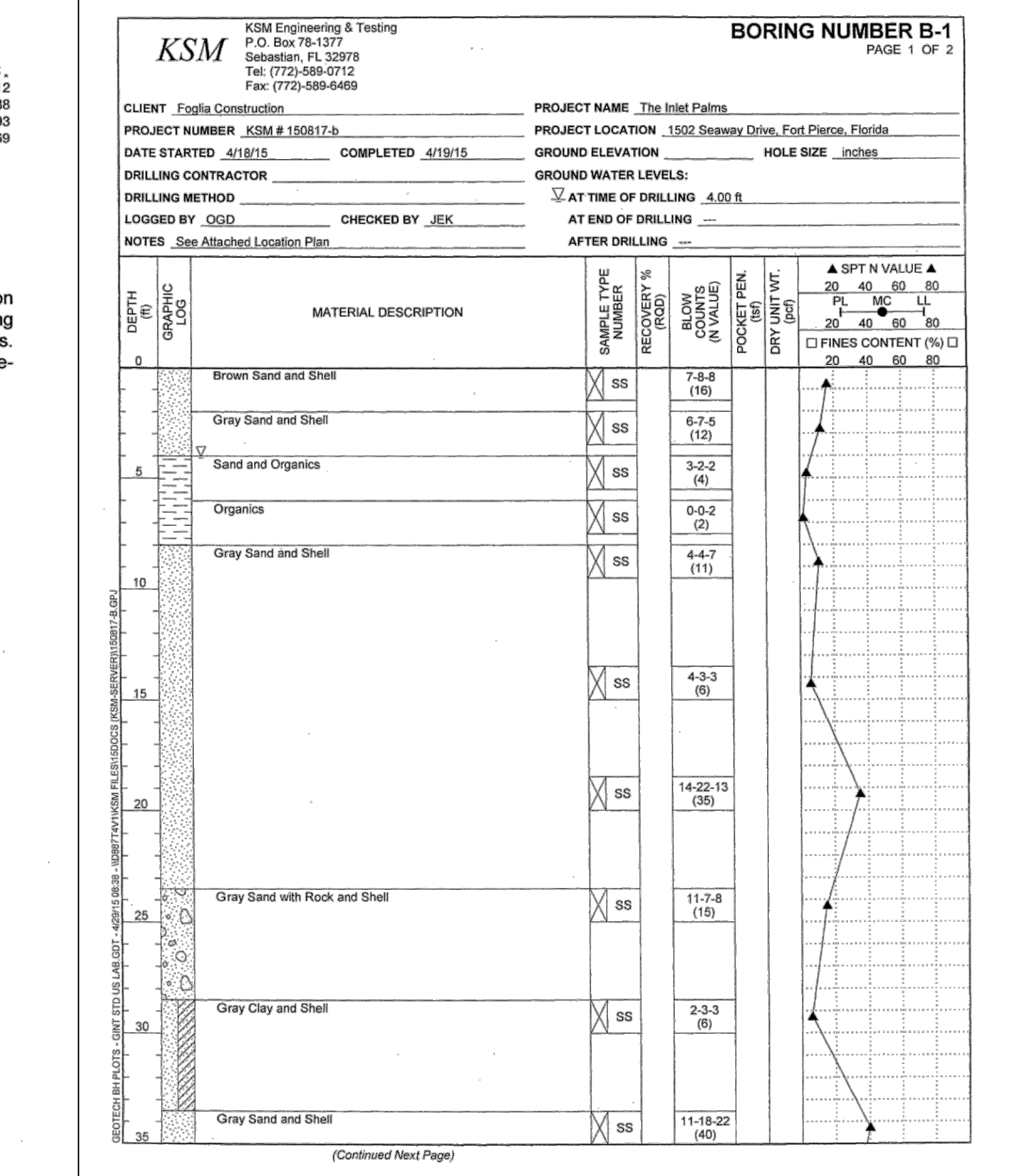

LOCATION OF TESTS  
 PROJECT: The Inlet Palms, 1502 Seaway Drive, Fort Pierce, Florida  
 SHEET: 1 OF 1  
 DRAWN BY: JEL  
 DESIGNED BY: JEL  
 DATE: 04/21/15  
 SCALE: NONE

DATE	REVISION
5/29/15 <td>1</td>	1

**SCHULKE, BITTLE & STODDARD, L.L.C.**  
 CIVIL & STRUCTURAL ENGINEERING • LAND PLANNING • ENVIRONMENTAL PERMITTING  
 CERTIFICATION OF AUTHORIZATION NO. 0000858  
 1717 INDIAN RIVER BLVD., SUITE 201 VERO BEACH, FLORIDA 32960  
 TEL 772 770-9622 FAX 772 770-9496 EMAIL info@sbsengineers.com

**SOIL BORINGS**  
**INLET PALMS**

ENGINEER CERTIFICATION  
 I, JOSEPH W. SCHULKE, FL. REG. NO. 47048  
 I, JOAH B. BITTLE, FL. REG. NO. 57396  
 I, WILLIAM P. STODDARD, FL. REG. NO. 57605

DATE: SHEET 4 PROJECT NO. 15-053

# INLET PALMS PLANNED DEVELOPMENT PRELIMINARY PLAT SECTION 01, TOWNSHIP 35 S, RANGE 40 E - CITY OF FT PIERCE, FLORIDA

## LEGEND

	EXISTING SANITARY SEWERLINE		PROPOSED SANITARY SEWERLINE
	EXISTING DRAINAGE PIPE		PROPOSED DRAINAGE PIPE
	EXISTING WATER MAIN		PROPOSED WATER MAIN
	FILTER FENCE/SEDIMENT BARRIER		EXISTING WOOD FENCE
	PROPOSED FENCE		PROPOSED SPOT ELEVATION AT EOP/SIDEWALK
	PROPOSED GRADE / CONTOUR		PROPOSED DRAINAGE FLOW DIRECTION
	PROPOSED EOP RADIUS 1,000 GAL UNDERGROUND PROPAANE TANK		24" ADS YARD DRAIN
	STORMTECH DRAIN		CONCRETE STORMTECH WALL
	TRENCH DRAIN		STREET LIGHT
	MODIFIED TYPE 'C' INLET		JUNCTION MANHOLE
	DRAINAGE STRUCTURE LABEL		FIRE HYDRANT
	PROPOSED SIGN		SEWER MANHOLE

### Legend & Abbreviations: (symbols not scaleable for size)

PLS - PROFESSIONAL LAND SURVEYOR	PL - PLAT	23.5 - PROPOSED GRADE
PSM - PROFESSIONAL SURVEYOR & MAPPER	CALC - CALCULATED	NAVD - NORTH AMERICAN VERTICAL DATUM
LB - LAND SURVEYING BUSINESS	NAVJ - NAVIGATION	22.5 - TYPICAL ELEVATION
C - CENTERLINE	TRC - TRAFFIC CONTROL BOX	AW - AIR CONDITIONER
R - RADIUS	GW - GUY WIRE	CONC - CONCRETE
L - LENGTH	WUP - WOOD UTILITY POLE	F.F. - FINISH FLOOR
Δ - DELTA ANGLE	TS - TELEPHONE SERVICE	BSB - BUILDING SETBACK LINE
EP - EDGE OF PAVEMENT	CB - CABLE TV BOX	EL/ELEV. - ELEVATION
B/C - BACK OF CURB	EB - ELECTRIC BOX	AB - AS-BUILT
B.M. - BENCHMARK	WELL - WELL	PIK - PARKER-KALON
POC - POINT OF COMMENCEMENT	HYDRANT - HYDRANT	
POB - POINT OF BEGINNING	GATE VALVE - GATE VALVE	
PCP - (PCP) PERMANENT CONTROL POINT	IRRIGATION VALVE - IRRIGATION VALVE	
PC - PERMANENT CONTROL POINT	WATER METER - WATER METER	
PRM - (PRM) PERMANENT REFERENCE MONUMENT	SANITARY MANHOLE - SANITARY MANHOLE	
PRM - PERMANENT REFERENCE MONUMENT	SANITARY SERVICE - SANITARY SERVICE	
(PI) IRON PIPE	SEPTIC TANK - SEPTIC TANK	
IP - IRON PIPE	DRAINAGE MANHOLE - DRAINAGE MANHOLE	
(IRC) IRON ROD & CAP	CURB INLET - CURB INLET	
IRC - IRON ROD & CAP	SURFACE INLET - SURFACE INLET	
(CM) CONCRETE MONUMENT	MITERED END SECTION - MITERED END SECTION	
CM - CONCRETE MONUMENT	CONCEPTUAL DRAINAGE - CONCEPTUAL DRAINAGE	
FD - FOUND	STREET SIGN - STREET SIGN	
(M) - MEASURED		

### NOTES

- ALL DISTURBED AREAS IN THE RIGHT-OF-WAY SHALL BE SODED. SEED AND MULCH IS NOT ACCEPTABLE.
- ANY DAMAGE TO THE EXISTING INFRASTRUCTURE, INCLUDING SIDEWALKS, BY THE CONTRACTOR MUST BE REPLACED PRIOR TO FINAL INSPECTION. SIDEWALK PATCHING IS NOT ACCEPTABLE.
- CURB RAMPS MUST MEET THE REQUIREMENTS OF FDOT STANDARD INDEX 304.
- ALL STRIPING WITHIN THE RIGHT-OF-WAY SHALL BE THERMOPLASTIC.
- THE CONTRACTOR SHALL BE RESPONSIBLE FOR ANY DAMAGE TO THE EXISTING PUBLIC ROADWAY, CURBS, GUTTERS, SIDEWALKS, DRAINAGE SYSTEMS AND UTILITIES AS A DIRECT RESULT OF NEW CONSTRUCTION. ROAD IMPROVEMENTS SUCH AS BUT NOT LIMITED TO RESURFACING MAY BE REQUIRED.
- THE SITE DRAINAGE AND CONSTRUCTION IMPROVEMENTS SHALL NOT ADVERSELY IMPACT ADJOINING PROPERTIES AND/OR ROADWAYS.
- IT SHALL BE THE CONTRACTOR'S RESPONSIBILITY TO CONTACT SUNSHINE STATE ONE CALL SYSTEM AT 1-800-432-4770 FOR LOCATIONS OF THIS EQUIPMENT AT LEAST 72 HOURS PRIOR TO ANY CONSTRUCTION.
- ANY CONFLICTS WITH THE PLANS AND EXISTING UTILITIES, DRAINAGE, ETC TO BE REPORTED TO ENGINEER FOR RESOLUTION OF ISSUES.
- CONTRACTOR TO FIELD VERIFY ALL REPORTED INVERTS AND UTILITIES AND REPORT TO ENGINEER.
- PROPAANE TANKS TO BE UNDERGROUND.

OWNER: BELMONT AVE PROPERTY, LLC  
2277 N. CIRCLE DRIVE  
PALATINE, IL 60067-0000

DEVELOPER: FOOLIA CUSTOM HOMES  
1555 INDIAN RIVER BLVD, UNIT B141  
VERO BEACH, FL 32960

ENGINEER: SCHULKE, BITTLE & STODDARD, L.L.C.  
JODAH B. BITTLE, P.E. 57396  
1717 INDIAN RIVER BLVD, SUITE 201  
VERO BEACH, FL 32960  
(772) 770-9622

SURVEYOR: MERIDIAN LAND SURVEYORS  
CHARLES BLANCHARD, PSM #5755  
1717 INDIAN RIVER BLVD, SUITE 201  
VERO BEACH, FL 32960  
PH. (772) 770-1213

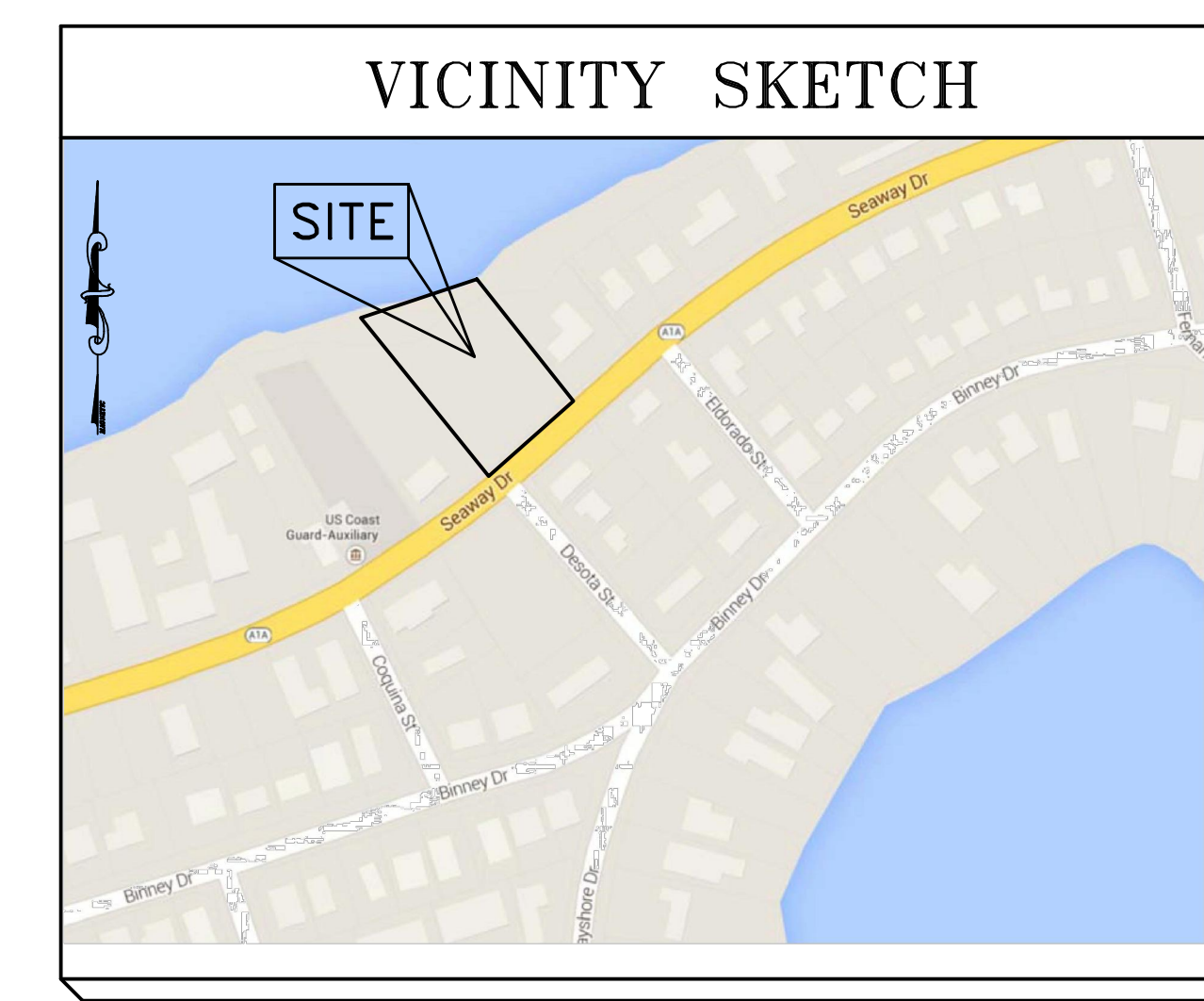

### HATCH LEGEND

	COMMON AREA TRACT 'B'
	ACCESS TRACT 'A'
	ACCESS EASEMENT OVER LOTS 1 TO 6

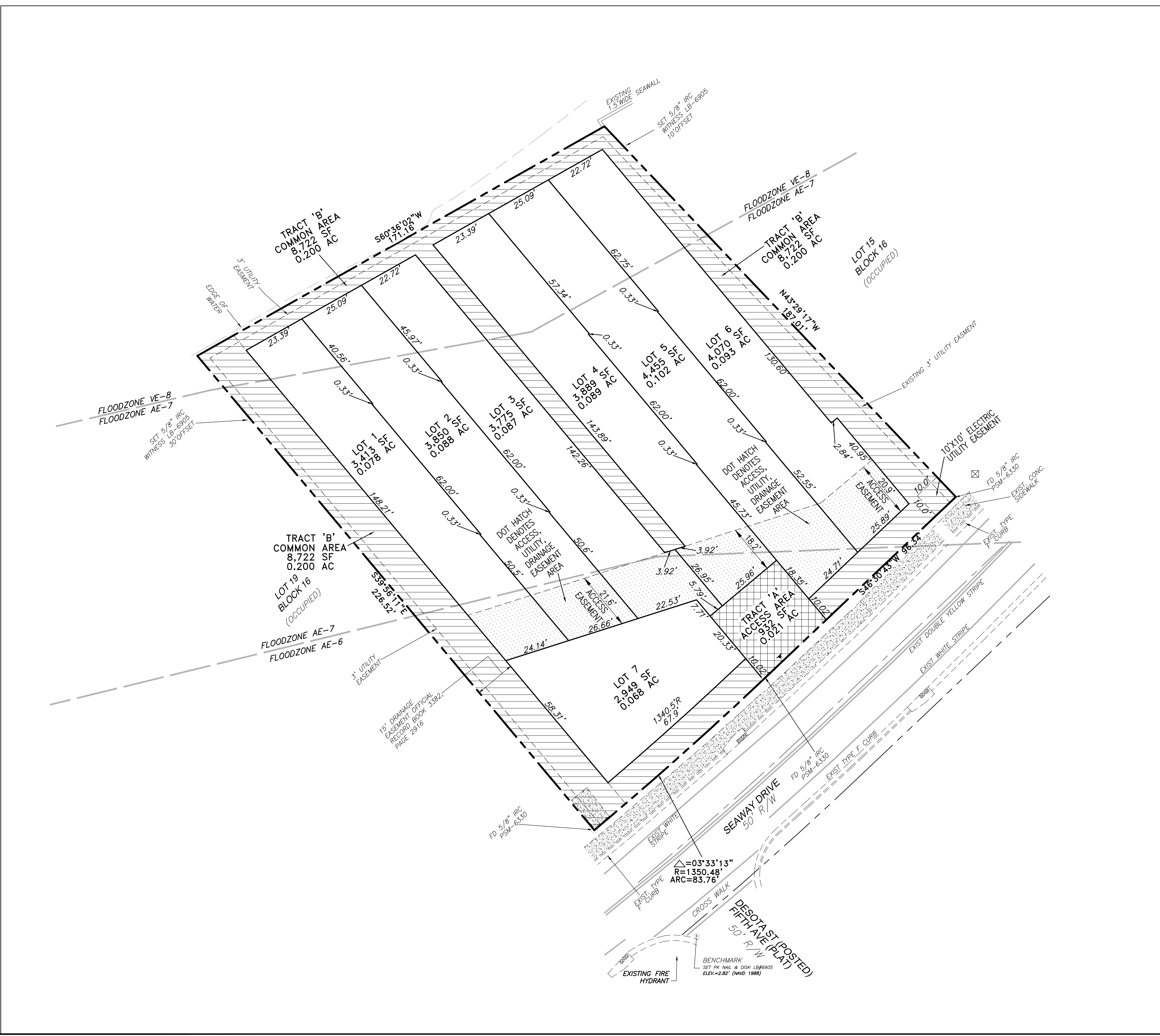
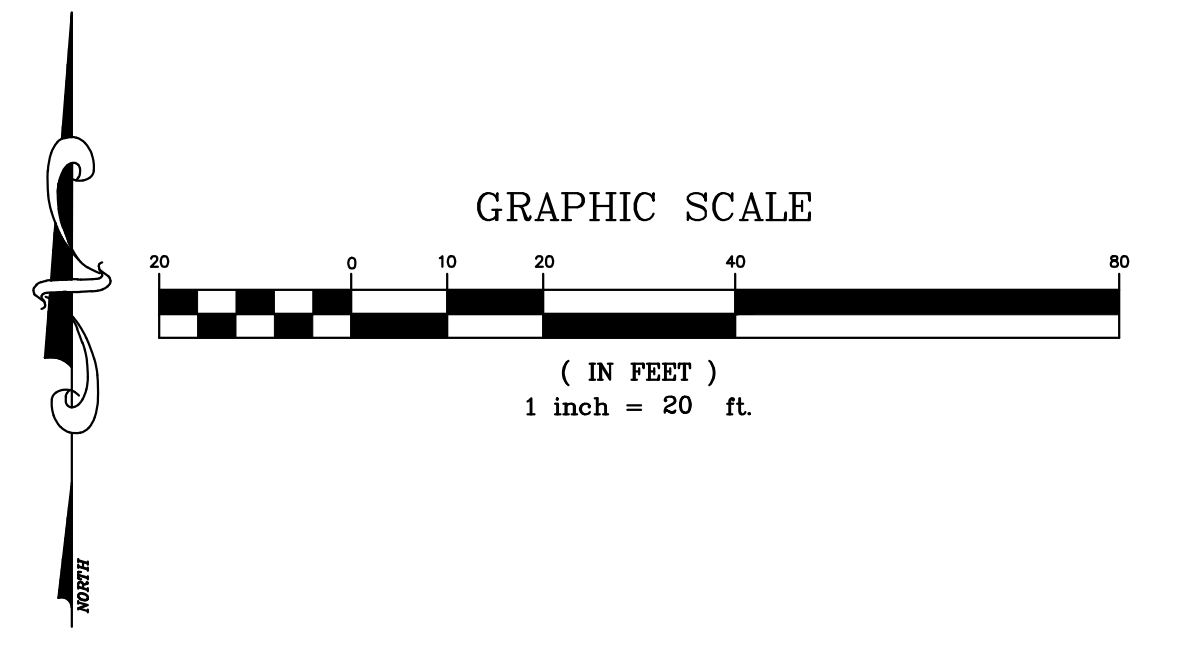

DRAWING NO.	15-053	DESIGNED	J.B.B.	CHECKED	J.B.B.	SCALE	1:20	DATE	4/15/2015
DATE	5/29/15	REVISION	PEER COFF	MARK	1	REVISION	PEER COFF	MARK	1

SCHULKE, BITTLE & STODDARD, L.L.C.  
 CIVIL & STRUCTURAL ENGINEERING - LAND PLANNING - ENVIRONMENTAL PERMITTING  
 CERTIFICATION OF AUTHORIZATION NO.: 00008668  
 1717 INDIAN RIVER BLVD., SUITE 201 VERO BEACH, FLORIDA 32960  
 TEL 772 / 770-9622 EMAIL info@sbsengineers.com

PRELIMINARY PLAT  
 INLET PALMS

ENGINEER CERTIFICATION	DATE:
<input type="checkbox"/> JOSEPH W. SCHULKE FL. REG. NO. 47048 <input type="checkbox"/> JODAH B. BITTLE FL. REG. NO. 57396 <input type="checkbox"/> WILLIAM P. STODDARD FL. REG. NO. 57605	SHEET 5 PROJECT NO. 15-053

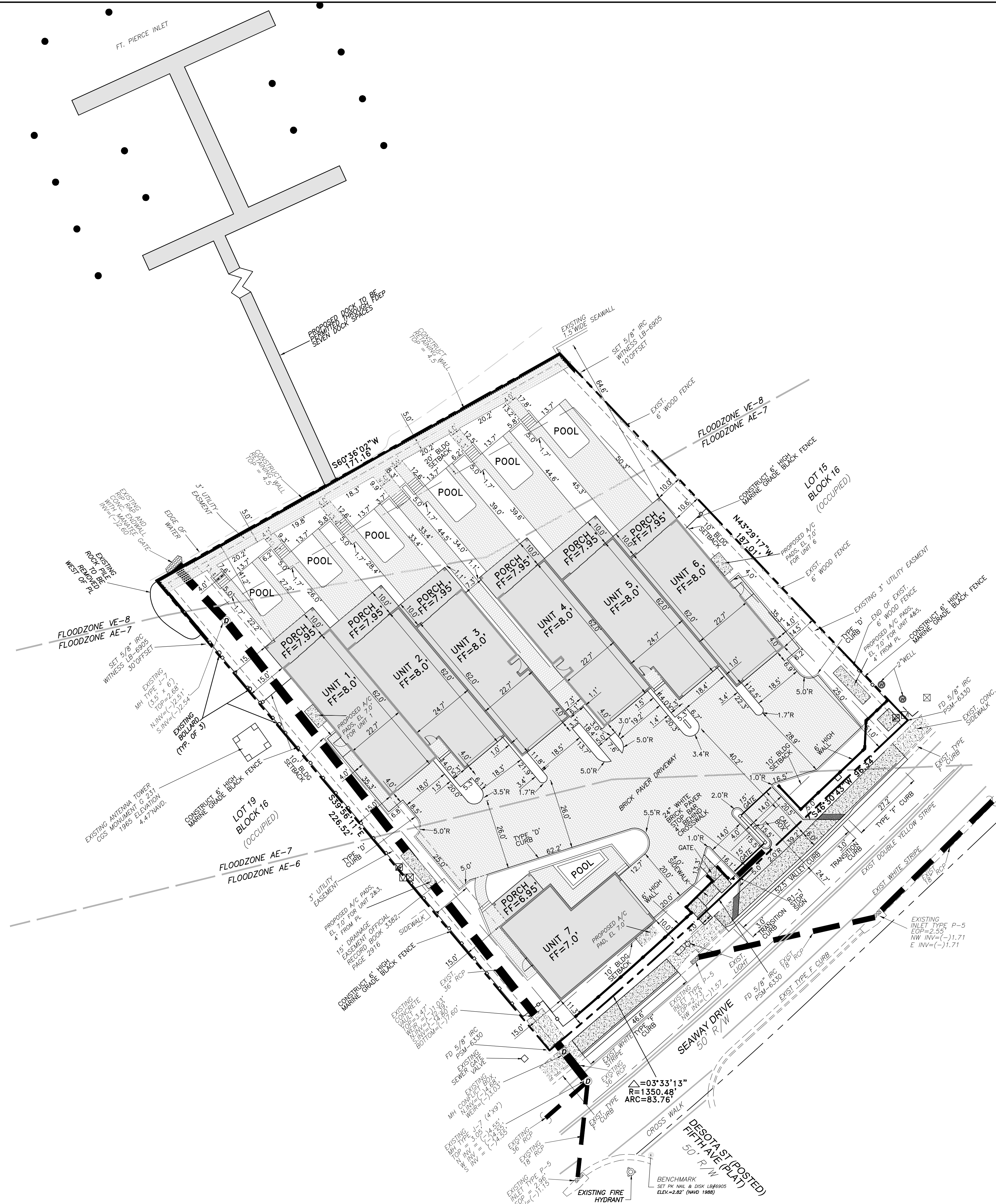

# LEGEND

--- EX SAN --- EX SAN	EXISTING SANITARY SEWERLINE	9.0'R	PROPOSED EOP RADIUS
--- SAN --- SAN	PROPOSED SANITARY SEWERLINE	1,000 GAL UNDERGROUND	PROPRANE TANK
--- EX DRAIN --- EX DRAIN	EXISTING DRAINAGE PIPE	24" ADS YARD DRAIN	STORMTECH DRAIN
--- DRAIN --- DRAIN	PROPOSED DRAINAGE PIPE	PROPOSED WALL	TRENCH DRAIN
--- EX WM --- EX WM	EXISTING WATER MAIN	☆	STREET LIGHT
--- WATER --- WATER	PROPOSED WATER MAIN	⊠	MODIFIED TYPE 'C' INLET
--- FILTER --- FILTER	FILTER FENCE/SEDIMENT BARRIER	⊠	JUNCTION MANHOLE
--- EX WOOD --- EX WOOD	EXISTING WOOD FENCE	⊠	DRAINAGE STRUCTURE LABEL
--- FENCE --- FENCE	PROPOSED FENCE	⊠	FIRE HYDRANT
24.45	PROPOSED SPOT ELEVATION AT EOP/SIDEWALK	⊠	PROPOSED SIGN
25.0	PROPOSED GRADE / CONTOUR	⊠	SEWER MANHOLE
--- FLOW --- FLOW	PROPOSED DRAINAGE FLOW DIRECTION		

**Legend & Abbreviations: (symbols not scaleable for size)**

PLS	PROFESSIONAL LAND SURVEYOR	(P)	PLAT	PROPOSED GRADE	
PSM	PROFESSIONAL SURVEYOR & MAPPER	(C)	CALCULATED	NAVDO	NORTH AMERICAN VERTICAL DATUM
LB	LAND SURVEYING BUSINESS	⊠	TRAFFIC CONTROL BOX	25.5	TYPICAL ELEVATION
C	CENTERLINE	⊠	GUY WIRE	A/C	AIR CONDITIONER
R	RADIUS	⊠	WOOD UTILITY POLE	CONC.	CONCRETE
L	LENGTH	⊠	TELEPHONE SERVICE	FF	FINISH FLOOR
Δ	DELTA ANGLE	⊠	CABLE TV BOX	BSB	BUILDING SETBACK LINE
E/P	EDGE OF PAVEMENT	⊠	ELECTRIC BOX	EL/ELEV.	ELEVATION
B/C	BACK OF CURB	⊠	LIGHT POST	R/W	RIGHT OF WAY
B.M.	BENCHMARK	⊠	HYDRANT	AS-BUILT	AS-BUILT
POC	POINT OF COMMENCEMENT	⊠	GATE VALVE	PK	PARKER-KALON
POB	POINT OF BEGINNING	⊠	IRRIGATION VALVE		
PCP	PERMANENT CONTROL POINT	⊠	WATER METER		
PRM	PERMANENT REFERENCE MONUMENT	⊠	SANITARY MANHOLE		
IP	IRON PIPE	⊠	SANITARY SERVICE		
(M)	MEASURED	⊠	SEPTIC TANK		
(R)	IRON ROD & CAP	⊠	DRAINAGE MANHOLE		
(CM)	CONCRETE MONUMENT	⊠	CURB INLET		
(FD)	FOUND	⊠	SURFACE INLET		
(M)	MEASURED	⊠	MITERED END SECTION		
		⊠	CONCEPTUAL DRAINAGE		
		⊠	STREET SIGN		

## NOTES

1. ALL DISTURBED AREAS IN THE RIGHT-OF-WAY SHALL BE SODED. SEED AND MULCH IS NOT ACCEPTABLE.
2. ANY DAMAGE TO THE EXISTING INFRASTRUCTURE, INCLUDING SIDEWALKS, BY THE CONTRACTOR MUST BE REPLACED PRIOR TO FINAL INSPECTION. SIDEWALK PATCHING IS NOT ACCEPTABLE.
3. CURB RAMP MUST MEET THE REQUIREMENTS OF FOOT STANDARD INDEX 304.
4. ALL STRIPING WITHIN THE RIGHT-OF-WAY SHALL BE THERMOPLASTIC.
5. THE CONTRACTOR SHALL BE RESPONSIBLE FOR ANY DAMAGE TO THE EXISTING PUBLIC ROADWAY, CURBS, GUTTERS, SIDEWALKS, DRAINAGE SYSTEMS AND UTILITIES AS A DIRECT RESULT OF NEW CONSTRUCTION. ROAD IMPROVEMENTS SUCH AS BUT NOT LIMITED TO RESURFACING MAYBE REQUIRED.
6. THE SITE DRAINAGE AND CONSTRUCTION IMPROVEMENTS SHALL NOT ADVERSELY IMPACT ADJOINING PROPERTIES AND/OR ROADWAYS.
7. IT SHALL BE THE CONTRACTORS RESPONSIBILITY TO CONTACT SUNSHINE STATE ONE CALL SYSTEM AT 1-800-432-4770 FOR LOCATIONS OF THIS EQUIPMENT AT LEAST 72 HOURS PRIOR TO ANY CONSTRUCTION.
8. ANY CONFLICTS WITH THE PLANS AND EXISTING UTILITIES, DRAINAGE, ETC TO BE REPORTED TO ENGINEER FOR RESOLUTION OF ISSUES.
9. CONTRACTOR TO FIELD VERIFY ALL REPORTED INVERTS AND UTILITIES AND REPORT TO ENGINEER.
10. PROPANE TANKS TO BE UNDERGROUND.

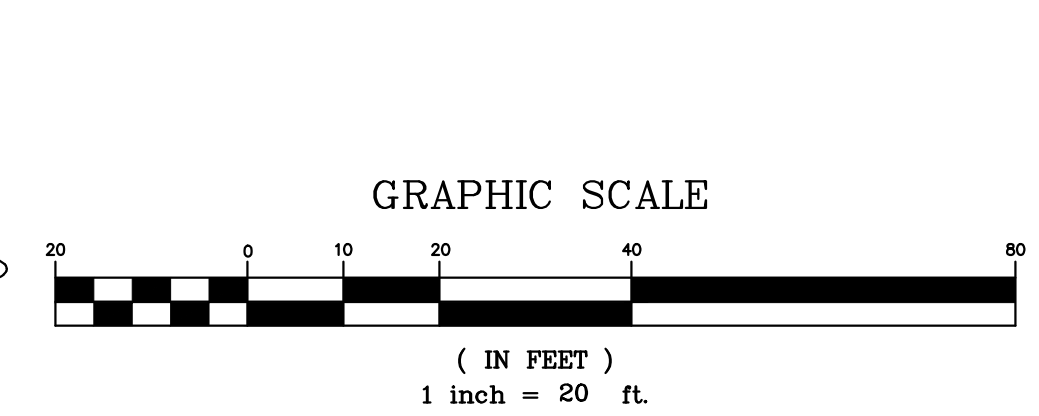

## HATCH LEGEND

⊠	PROPOSED BRICK PAVERS
⊠	EXISTING CONCRETE TO REMAIN
⊠	PROPOSED CONCRETE
⊠	PROPOSED BUILDING FOOTPRINT

DATE	5/29/15
REVISION	
MARK	
DESIGNED	J.S.B.
DRAWN	J.S.B.
CHECKED	J.S.B.
SCALE	1:20
DATE	4/15/2015

**SCHULKE, BITTLE & STODDARD, L.L.C.**  
 CIVIL & STRUCTURAL ENGINEERING - LAND PLANNING - ENVIRONMENTAL PERMITTING  
 CERTIFICATION OF AUTHORIZATION NO.: 00008888  
 1717 INDIAN RIVER BLVD., SUITE 201 VERO BEACH, FLORIDA 32960  
 TEL 772 / 770-9622 FAX 772 / 770-9496 EMAIL info@sbsengineers.com

SITE PLAN

INLET PALMS

ENGINEER CERTIFICATION  
 JOSEPH W. SCHULKE  
 FL. REG. NO. 47048  
 JUDAH B. BITTLE  
 FL. REG. NO. 57396  
 WILLIAM P. STODDARD  
 FL. REG. NO. 57068

DATE: SHEET 6  
 PROJECT NO. 15-053

# LEGEND

--- EX SAN --- EX SAN ---	EXISTING SANITARY SEWERLINE	9.0'R	PROPOSED EOP RADIUS
--- SAN --- SAN ---	PROPOSED SANITARY SEWERLINE	PROPRANE	1000 GAL UNDERGROUND PROPRANE TANK
--- EX DRAIN --- EX DRAIN ---	EXISTING DRAINAGE PIPE	24"	24" ADS YARD DRAIN
--- DRAIN --- DRAIN ---	PROPOSED DRAINAGE PIPE	STORMTECH	STORMTECH DRAIN
--- EX WM --- EX WM ---	EXISTING WATER MAIN	---	PROPOSED WALL
--- WM --- WM ---	PROPOSED WATER MAIN	---	TRENCH DRAIN
---	FILTER FENCE/SEDIMENT BARRIER	---	STREET LIGHT
---	EXISTING WOOD FENCE	---	MODIFIED TYPE 'C' INLET
---	PROPOSED FENCE	---	JUNCTION MANHOLE
24.45	PROPOSED SPOT ELEVATION AT EOP/SIDEWALK	DS-1	DRAINAGE STRUCTURE LABEL
25.0	PROPOSED GRADE / CONTOUR	---	FIRE HYDRANT
---	PROPOSED DRAINAGE FLOW DIRECTION	---	PROPOSED SIGN
---	---	---	SEWER MANHOLE

Legend & Abbreviations: (symbols not scaleable for size)

- PLS - PROFESSIONAL LAND SURVEYOR
- PSM - PROFESSIONAL SURVEYOR & MAPPER
- LB - LAND SURVEYING BUSINESS
- CL - CENTERLINE
- R - RADIUS
- L - LENGTH
- Δ - DELTA ANGLE
- E/P - EDGE OF PAVEMENT
- B.M. - BENCHMARK
- POC - POINT OF COMMENCEMENT
- POB - POINT OF BEGINNING
- PCP - PERMANENT CONTROL POINT
- PRM - PERMANENT REFERENCE MONUMENT
- (P) - IRON PIPE
- (IRC) - IRON ROD & CAP
- (ICM) - CONCRETE MONUMENT
- CM - CONCRETE MONUMENT
- FD - FOUND
- (M) - MEASURED
- (P) - PLAT
- (C) - CALCULATED
- TRAFFIC CONTROL BOX
- GLY WIRE
- WOOD UTILITY POLE
- TELEPHONE SERVICE
- CABLE TV BOX
- ELECTRIC BOX
- LIGHT POST
- WELL
- HYDRANT
- GATE VALVE
- IRRIGATION VALVE
- WATER METER
- SANITARY MANHOLE
- SEPTIC TANK
- DRAINAGE MANHOLE
- CURB INLET
- MITERED END SECTION
- CONCEPTUAL DRAINAGE
- STREET SIGN
- PROPOSED GRADE
- NAV D - NORTH AMERICAN VERTICAL DATUM
- ± - TYPICAL ELEVATION
- A/C - AIR CONDITIONER
- CONC - CONCRETE
- FF - FINISH FLOOR
- BSB - BUILDING SETBACK LINE
- EL.ELEV - ELEVATION
- R/W - RIGHT OF WAY
- AB - AS-BUILT
- PK - PARKER-KALON

## NOTES

- ALL DISTURBED AREAS IN THE RIGHT-OF-WAY SHALL BE SODED. SED AND MULCH IS NOT ACCEPTABLE.
- ANY DAMAGE TO THE EXISTING INFRASTRUCTURE, INCLUDING SIDEWALKS, BY THE CONTRACTOR MUST BE REPLACED PRIOR TO FINAL INSPECTION. SIDEWALK PATCHING IS NOT ACCEPTABLE.
- CURB RAMPS MUST MEET THE REQUIREMENTS OF FDOT STANDARD INDEX 304.
- ALL STRIPING WITHIN THE RIGHT-OF-WAY SHALL BE THERMOPLASTIC.
- THE CONTRACTOR SHALL BE RESPONSIBLE FOR ANY DAMAGE TO THE EXISTING PUBLIC ROADWAY, CURBS, GUTTERS, SIDEWALKS, DRAINAGE SYSTEMS AND UTILITIES AS A DIRECT RESULT OF NEW CONSTRUCTION. ROAD IMPROVEMENTS SUCH AS BUT NOT LIMITED TO RESURFACING MAYBE REQUIRED.
- THE SITE DRAINAGE AND CONSTRUCTION IMPROVEMENTS SHALL NOT ADVERSELY IMPACT ADJOINING PROPERTIES AND/OR ROADWAYS.
- IT SHALL BE THE CONTRACTOR'S RESPONSIBILITY TO CONTACT SUNSHINE STATE ONE CALL SYSTEM AT 1-800-432-4770 FOR LOCATIONS OF THIS EQUIPMENT AT LEAST 72 HOURS PRIOR TO ANY CONSTRUCTION.
- ANY CONFLICTS WITH THE PLANS AND EXISTING UTILITIES, DRAINAGE, ETC TO BE REPORTED TO ENGINEER FOR RESOLUTION OF ISSUES.
- CONTRACTOR TO FIELD VERIFY ALL REPORTED INVERTS AND UTILITIES AND REPORT TO ENGINEER.
- PROPANE TANKS TO BE UNDERGROUND.

## GRAPHIC SCALE

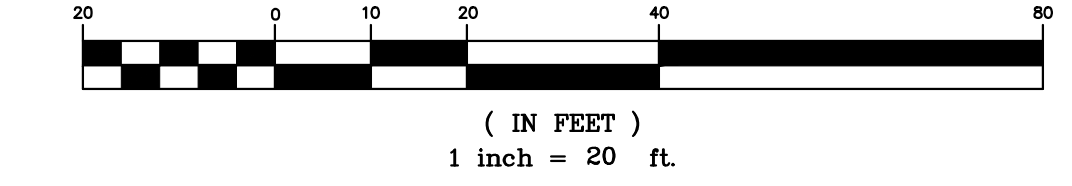

## HATCH LEGEND

- PROPOSED BRICK PAVERS
- EXISTING CONCRETE TO REMAIN
- PROPOSED CONCRETE
- PROPOSED BUILDING FOOTPRINT

## DRAINAGE OUTFALL STATEMENT

THE PROJECT WILL HAVE TWO OUTFALL POINTS, THE FIRST BASIN IS THE SOUTH PORTION OF THE SITE THAT WILL FLOW INTO THE SEAWAY DRIVE DRAINAGE SYSTEM. THE SECOND BASIN IS THE NORTH PORTION OF THE SITE THAT WILL DISCHARGE INTO THE EXISTING PIPE ALONG THE WEST PROPERTY LINE.

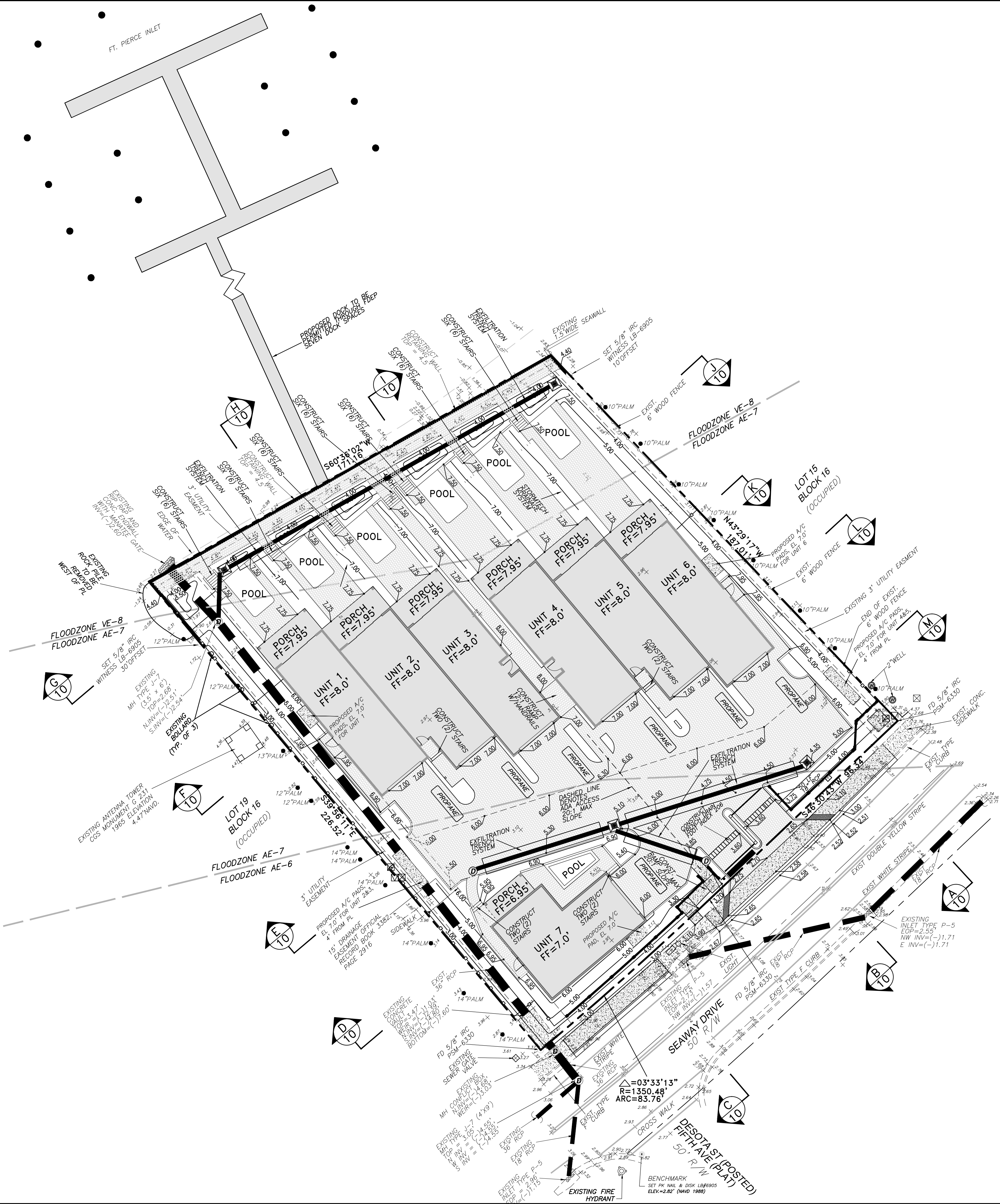

DATE	5/23/15
REASON	REVISED PER CDP
MARK	1
DRAWING J.B.B.	J.B.B.
DRAWN	J.B.B.
CHECKED	J.B.B.
SCALE	1:20
DATE	4/15/2015

**SCHULKE, BITTLE & STODDARD, L.L.C.**  
 CIVIL & STRUCTURAL ENGINEERING - LAND PLANNING - ENVIRONMENTAL PERMITTING  
 1717 INDIAN RIVER BLVD., SUITE 201 VERO BEACH, FLORIDA 32960  
 TEL 772 / 770-9622 FAX 772 / 770-9496 EMAIL info@sbsengineers.com

**PAVING, GRADING & DRAINAGE PLAN**

**INLET PALMS**

ENGINEER CERTIFICATION  
 JOSEPH W. SCHULKE  
 FL. REG. NO. 47048  
 KIM B. BITTLE  
 FL. REG. NO. 57396  
 WILLIAM P. STODDARD  
 FL. REG. NO. 57665

DATE:	SHEET
	7
	PROJECT NO.
	15-053

# LEGEND

--- EX SAN ---	EXISTING SANITARY SEWERLINE	9.0'R	PROPOSED EOP RADIUS
--- SAN ---	PROPOSED SANITARY SEWERLINE	PROPRANE	1,000 GAL UNDERGROUND PROPRANE TANK
--- EX WM ---	EXISTING WATER MAIN	24"	24" ADS YARD DRAIN
--- WAT ---	PROPOSED WATER MAIN	STORMTECH	STORMTECH DRAIN
--- EX WM ---	EXISTING WOOD FENCE	TRENCH	TRENCH DRAIN
--- WAT ---	PROPOSED WATER MAIN	☆	STREET LIGHT
---	FILTER FENCE/SEDIMENT BARRIER	⊞	MODIFIED TYPE 'C' INLET
---	EXISTING WOOD FENCE	⊞	JUNCTION MANHOLE
---	PROPOSED FENCE	⊞	DRAINAGE STRUCTURE LABEL
---	PROPOSED SPOT ELEVATION AT EOP/SIDEWALK	⊞	FIRE HYDRANT
---	PROPOSED GRADE / CONTOUR	⊞	PROPOSED SIGN
---	PROPOSED DRAINAGE FLOW DIRECTION	⊞	SEWER MANHOLE

Legend & Abbreviations: (symbols not scaleable for size)

NOTES

- PLS - PROFESSIONAL LAND SURVEYOR
- PSM - PROFESSIONAL SURVEYOR & MAPPER
- LB - LAND SURVEYING BUSINESS
- CL - CENTERLINE
- R - RADIUS
- L - LENGTH
- Δ - DELTA ANGLE
- EP - EDGE OF PAVEMENT
- B/C - BACK OF CURB
- B.M. - BENCHMARK
- POC - POINT OF COMMENCEMENT
- POB - POINT OF BEGINNING
- PCP - PERMANENT CONTROL POINT
- PCP - PERMANENT CONTROL POINT
- PRM - PERMANENT REFERENCE MONUMENT
- IRM - IRON ROD & CAP
- IP - IRON PIPE
- IRC - IRON ROD & CAP
- CM - CONCRETE MONUMENT
- FD - FOUND
- (M) - MEASURED
- (P) - PLAT
- (C) - CALCULATED
- TR - TRAFFIC CONTROL BOX
- GL - GLY WIRE
- WUP - WOOD UTILITY POLE
- TEL - TELEPHONE SERVICE
- CAB - CABLE T.V. BOX
- ELB - ELECTRIC BOX
- LPT - LIGHT POST
- WELL - WELL
- HYD - HYDRANT
- IRV - IRRIGATION VALVE
- WM - WATER METER
- SM - SANITARY MANHOLE
- SS - SEPTIC TANK
- SM - SANITARY SERVICE
- DM - DRAINAGE MANHOLE
- CI - CURB INLET
- SI - SURFACE INLET
- MS - MITERED END SECTION
- CS - CONCEPTUAL DRAINAGE
- ST - STREET SIGN
- PG - PROPOSED GRADE
- NAV D - NORTH AMERICAN VERTICAL DATUM
- ±2.5' - TYPICAL ELEVATION
- AC - AIR CONDITIONER
- CONC - CONCRETE
- F.F. - FINISH FLOOR
- BSB - BUILDING SETBACK LINE
- EL - ELEVATION
- RW - RIGHT OF WAY
- AB - AS-BUILT
- PK - PARKER-KALON

1. ALL DISTURBED AREAS IN THE RIGHT-OF-WAY SHALL BE SOODED, SEED AND MULCH IS NOT ACCEPTABLE.
2. ANY DAMAGE TO THE EXISTING INFRASTRUCTURE, INCLUDING SIDEWALKS, BY THE CONTRACTOR MUST BE REPLACED PRIOR TO FINAL INSPECTION. SIDEWALK PATCHING IS NOT ACCEPTABLE.
3. CURB RAMPS MUST MEET THE REQUIREMENTS OF FDOT STANDARD INDEX 304.
4. ALL STRIPING WITHIN THE RIGHT-OF-WAY SHALL BE THERMOPLASTIC.
5. THE CONTRACTOR SHALL BE RESPONSIBLE FOR ANY DAMAGE TO THE EXISTING PUBLIC ROADWAY, CURBS, GUTTERS, SIDEWALKS, DRAINAGE SYSTEMS AND UTILITIES AS A DIRECT RESULT OF NEW CONSTRUCTION. ROAD IMPROVEMENTS SUCH AS BUT NOT LIMITED TO RESURFACING MAYBE REQUIRED.
6. THE SITE DRAINAGE AND CONSTRUCTION IMPROVEMENTS SHALL NOT ADVERSELY IMPACT ADJOINING PROPERTIES AND/OR ROADWAYS.
7. IT SHALL BE THE CONTRACTORS RESPONSIBILITY TO CONTACT SUNGRIE STATE CALL SYSTEM AT 1-800-332-4770 FOR LOCATIONS OF THIS EQUIPMENT AT LEAST 72 HOURS PRIOR TO ANY CONSTRUCTION.
8. ANY CONFLICTS WITH THE PLANS AND EXISTING UTILITIES, DRAINAGE, ETC TO BE REPORTED TO ENGINEER FOR RESOLUTION OF ISSUES.
9. CONTRACTOR TO FIELD VERIFY ALL REPORTED INVERTS AND UTILITIES AND REPORT TO ENGINEER.
10. PROPANE TANKS TO BE UNDERGROUND.

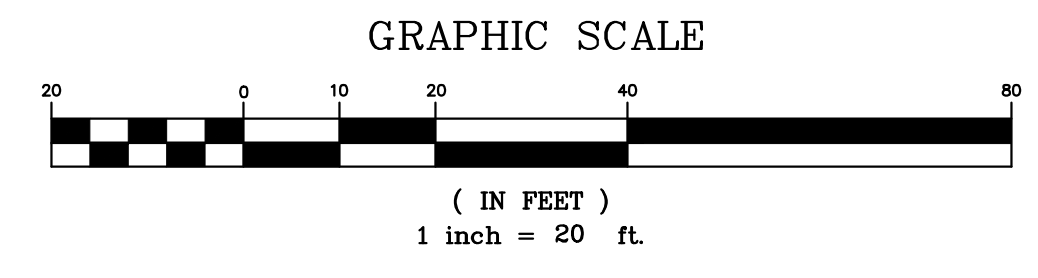

## HATCH LEGEND

- PROPOSED BRICK PAVERS
- EXISTING CONCRETE TO REMAIN
- PROPOSED CONCRETE
- PROPOSED BUILDING FOOTPRINT

1. SUBMITTALS
  - A. PRODUCT DATA AND SHOP DRAWINGS
    1. FOR ALL SITE WORK CONSTRUCTION, THE CONTRACTOR SHALL SUBMIT PRODUCT DATA IN THE FORM OF MANUFACTURERS CUT SHEETS AND CATALOG DATA FOR ALL PRODUCTS, MATERIAL AND EQUIPMENT CLEARLY INDICATING THE SPECIFIC PART OR PRODUCT CATALOG NUMBER(S) FOR APPROVAL.
    2. THE CONTRACTOR SHALL SUBMIT SHOP DRAWINGS FOR ALL PRODUCTS, MATERIALS AND EQUIPMENT REQUIRED TO BE FABRICATED, OR WHEN STANDARD PUBLISHED PRODUCT DATA IS NOT SUITABLE FOR USE.
    3. SUBMIT 6 COPIES OF REQUESTED INFORMATION, NEATLY BOUND AND INDEXED PER CATEGORY FOR THE FOLLOWING:
      - A. UTILITIES
        - ALL PIPE, FITTINGS, VALVES, OTHER MISCELLANEOUS APPURTENANCES, CONTROLS, PUMP STATION EQUIPMENT, COMPONENTS AND STRUCTURES, AND ALL OTHER UTILITY SYSTEM PRODUCTS, MATERIALS AND COMPONENTS AND SIMILAR CONTROLS.
      - B. DRAINAGE
        - ALL PIPE, FITTINGS, AND COMPONENTS THEREOF, STRUCTURES, FRAMES, GRATES, LIDS, GASKETS, FASTENERS, COUPLINGS AND SIMILAR, AND ALL OTHER DRAINAGE SYSTEM PRODUCTS, MATERIALS, AND COMPONENTS AND SIMILAR CONTROLS.
      - C. PAVING AND GRADING
        - FOOT CERTIFICATIONS AND LAB ANALYSIS/RESULTS FOR PAVEMENT, BASE, SUBGRADE, AND FILL MATERIALS, INCLUDING EVIDENCE (CERTIFICATIONS) THAT THE MATERIALS PROPOSED TO BE USED MEET OR EXCEED FDOT SPECIFICATIONS AND THE CONTRACT DOCUMENTS.
      - D. SIGNING AND PAVEMENT MARKING
        - SIGN AND PAVEMENT MARKING PRODUCTS AND MATERIALS, AND EVIDENCE THAT THE PRODUCTS AND MATERIALS PROPOSED TO BE USED MEET OR EXCEED REQUIREMENTS SPECIFIED IN THE CONTRACT DOCUMENTS, LOCAL ENGINEERING DEPARTMENT, MUTCO AND FDOT SPECIFICATIONS.
      - E. IRRIGATION
        - ALL PIPE, FITTINGS, VALVES, OTHER MISCELLANEOUS APPURTENANCES, CONTROLS, PUMP STATION EQUIPMENT, COMPONENTS AND STRUCTURES, AND ALL OTHER UTILITY SYSTEM PRODUCTS, MATERIALS AND COMPONENTS AND SIMILAR CONTROLS, WELLS, AND/OR OTHER IRRIGATION SOURCES. THE CONTRACTOR SHALL SUBMIT AN IRRIGATION COORDINATION DRAWING, INDICATING CONTRACTOR'S PROPOSED LOCATION OF MAIN LINES, SECONDARY LINES, HEAD LOCATIONS, WELL, PUMP, CONTROL PANEL, SENSORS, CONTROL VALVE AND VALVE LOCATIONS. THIS DRAWING SHALL SHOW ANY ADJUSTMENTS OR CHANGES THE CONTRACTOR PROPOSES. THE DRAWINGS SHALL INDICATE ALL PROPOSED SUBSTITUTIONS OF SIZE, MATERIAL, AND/OR MANUFACTURER.
    4. ALLOW TWO WEEKS FOR THE ENGINEER TO COMPLETE REVIEW OF PRODUCT DATA AND SHOP DRAWINGS. ENGINEER WILL NOT BE RESPONSIBLE FOR PROJECT DELAYS RELATED TO DELIVERY AND TRANSMISSION OF THE DOCUMENTS ONCE INFORMATION HAS LEFT ENGINEER'S OFFICE. ITEMS REQUIRING A LONG LEAD TIME SHOULD BE SUBMITTED AS SOON AS POSSIBLE.
    5. THE CONTRACTOR SHALL PROVIDE A STAMP INDICATING ITS REVIEW AND APPROVAL, INITIALED OR SIGNED, CERTIFYING TO REVIEW OF SUBMITTALS, FIELD MEASUREMENTS AND FIELD CONSTRUCTION CRITERIA, AND COORDINATION OF THE INFORMATION WITH THE SUBMITTAL, WITH REQUIREMENTS OF THE WORK AND OF CONTRACT DOCUMENTS, INCLUDING PLANS AND SPECIFICATIONS OF OTHER DESIGN PROFESSIONALS (I.E., ARCHITECT, MECHANICAL, ELECTRICAL, AND STRUCTURAL ENGINEERS).
  - B. TESTING
    1. WATER, PRESSURE (MAIN AND TAPS), BACTERIOLOGICAL, BACKFLOW DENSITIES, BACKFLOW PREVENTOR TESTS AND CERTIFICATION, AND AS PER PROJECT SPECIFICATIONS, LOCAL UTILITIES DEPARTMENT, AND FDEP REQUIREMENTS.
    2. SEWER, EXFIL, TV, AND BACKFLOW PREVENTOR TESTS, PRESSURE TEST (MANS AND TAPS) LIFT STATION START-UP, ALL PER PROJECT SPECIFICATIONS, COVB AND FDEP REQUIREMENTS.
    3. DRAINAGE, EXFIL, LAMPING (FIELD), AND BACKFILL DENSITIES PER PROJECT SPECIFICATIONS AND LOCAL ENGINEERING REQUIREMENTS.
    4. EARTHWORK & PAVING, DENSITIES, LBR'S AND FBV'S AS PER PROJECT SPECIFICATIONS AND LOCAL ENGINEERING REQUIREMENTS.
    5. SUBMIT ALL TEST RESULTS FOR ENGINEERING REVIEW WITHIN 3 DAYS OF TESTING. FAILURE TO PROVIDE TEST RESULTS, OR PROVIDING FAILING TEST RESULTS WILL BE GROUNDS FOR DELAY AND/OR REJECTION OF PAY REQUEST APPLICATIONS.
  - C. AS-BUILTS
    1. GRADING: LOCATION AND ELEVATION OF ALL: CONCRETE AND PAVEMENT (VEHICLE USE AND PEDESTRIAN USE IMPROVEMENTS) AT HILLO POINTS, EDGE OF PAVEMENT, AND CENTERLINE AT 50' ON CENTER AND AT CHANGE OF DIRECTION, GRADE BREAKS, PROPERTY LINES (CROSS SECTIONS 50' ON CENTER), TOP OF BANK AND T.O.E. OF SLOPE AND/OR CENTERLINE OF SWALES AND RETENTION AREAS; CROSS SECTIONS 50' ON CENTER ON STORMWATER LAKES FROM TOP TO BOTTOM, MECHANICAL PADS AND FINISHED FLOOR ELEVATIONS; DETAILED LOCATION AND TOPOGRAPHY OF DRIVEWAY TURNOUTS.
    2. WATER AND SEWER FORCE MAINS: LOCATION, TOP ELEVATION AND STATE PLANE COORDINATES AT ALL FITTINGS, VALVES, CHANGES OF DIRECTION AND AT 100' ON CENTER.
    3. GRAVITY SEWER:
      - SEWER STRUCTURES: DIAMETER OR SIZE, AND LOCATION AND ELEVATION OF STRUCTURES, TOP, BOTTOMS, AND SEWER INVERTS.
      - MANS AND LATERALS: LOCATION AND INVERT ELEVATIONS AT CONNECTIONS, FITTINGS, AND TERMINATION.
      - LIFT STATIONS: HORIZONTAL LAYOUT AND LOCATION OF ALL EQUIPMENT, PANELS, VALVES, WET WELL, VALVES, LOCATION OF CONDUIT RUNS AND WATER SERVICE/HOSE BIBB, LOCATION AND INVERT ELEVATIONS OF GRAVITY AND FORCE MAINS TO AND FROM LIFT STATION; WET WELL DIAMETER, TOP AND BOTTOM ELEVATION; TYPE, DISCHARGE DIAMETER, MANUFACTURER AND MODEL #.
      - 4. DRAINAGE: ALL STRUCTURES DIAMETER OR SIZE, LOCATION, AND ELEVATION OF TOP, BOTTOM, AND INVERT ELEVATIONS, ALL PIPES, DIAMETER, TYPE/MATERIAL, LOCATION AND INVERT ELEVATION AT CONNECTIONS, FITTINGS, AND TERMINATION POINTS.
      - 5. IRRIGATION: ALL LINES, SYSTEM EQUIPMENT COMPONENTS, MATERIALS INCLUDING PIPES, VALVES, FITTINGS, SPRINKLER HEADS, AND MISCELLANEOUS APPURTENANCES.
  - D. OPERATION AND MAINTENANCE MANUALS
    1. CONTRACTOR SHALL PROVIDE THE OWNER WITH OPERATION AND MAINTENANCE MANUALS FOR ALL OPERABLE EQUIPMENT (PUMP STATIONS AND CONTROLS, AUTOMATIC CONTROL VALVES, AND OTHER AUTOMATED EQUIPMENT; CONTROL PANELS, ETC).
    2. OPERATION AND MAINTENANCE MANUALS SHALL BE SUBMITTED AS A PRE-REQUISITE TO THE PROJECT BEING DEEMED SUBSTANTIALLY COMPLETE.
  - E. WARRANTY
    1. THE CONTRACTOR SHALL PROVIDE ALL WARRANTIES, CERTIFICATIONS, GUARANTIES, AND WARRANTY BONDS AS SPECIFIED IN THE CONTRACT DOCUMENTS AND PERMIT CONDITIONS INCLUDING:
      - UTILITY MAINTENANCE BOND - FOR ALL PUBLIC WATER AND SEWER UTILITIES INFRASTRUCTURE - (25% OF CONTRACT VALUE)
      - ENGINEERING MAINTENANCE BOND - FOR ALL PAVING, GRADING, AND DRAINAGE IMPROVEMENTS AND INFRASTRUCTURE (25% OF CONTRACT VALUE)
    2. OWNER TRAINING
      - THE CONTRACTOR SHALL INCLUDE 2 HOURS OF OWNER TRAINING (FOR EACH WATER, SEWER, DRAINAGE, AND IRRIGATION SYSTEMS) OF EQUIPMENT AND TIME FOR ONE FOLLOW-UP VISIT AND ADJUSTMENTS OF EQUIPMENT 60 DAYS AFTER END USER HAD OPERATIONAL TIME WITH THE EQUIPMENT.

DATE	5/29/15
REVISION	
MARK	1
DRAWING	J.B.B.
DESIGNED	J.B.B.
CHECKED	J.B.B.
SCALE	1:20
DATE	4/15/15

**SCHULKE, BITTLE & STODDARD, L.L.C.**  
 CIVIL & STRUCTURAL ENGINEERING - LAND PLANNING - ENVIRONMENTAL PERMITTING  
 CERTIFICATION OF AUTHORIZATION NO.: 00008668  
 1717 INDIAN RIVER BLVD., SUITE 201 VERO BEACH, FLORIDA, 32960  
 TEL 772 770-9622 FAX 772 770-9496 EMAIL info@sbsengineers.com

UTILITIES PLAN

INLET PALMS

ENGINEER CERTIFICATION  
 JOSEPH M. SCHULKE  
 FL. REG. NO. 47048  
 ADAM B. BITTLE  
 FL. REG. NO. 57396  
 WILLIAM P. STODDARD  
 FL. REG. NO. 57605

DATE:	SHEET
	8
	PROJECT NO.
	15-053

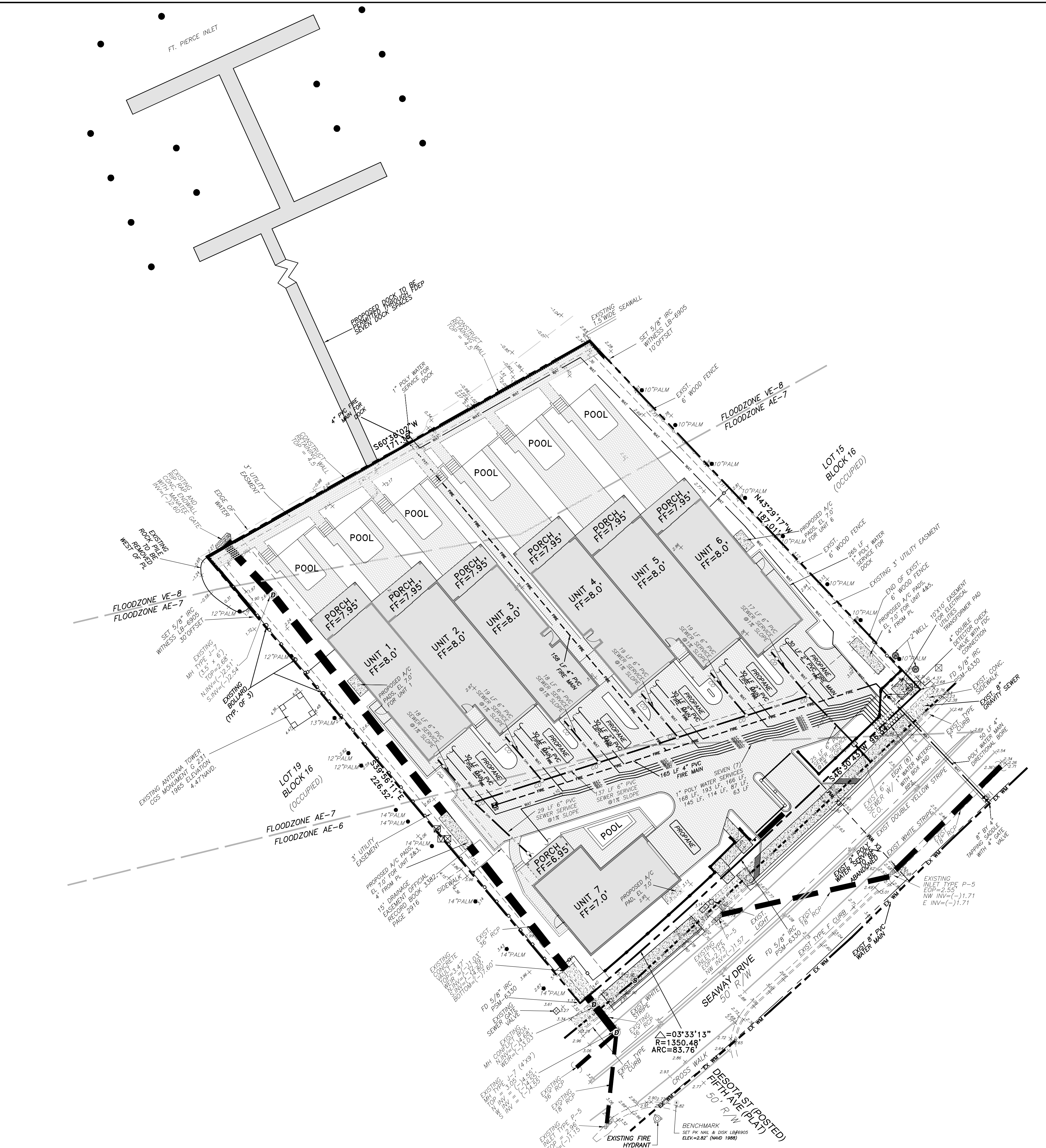



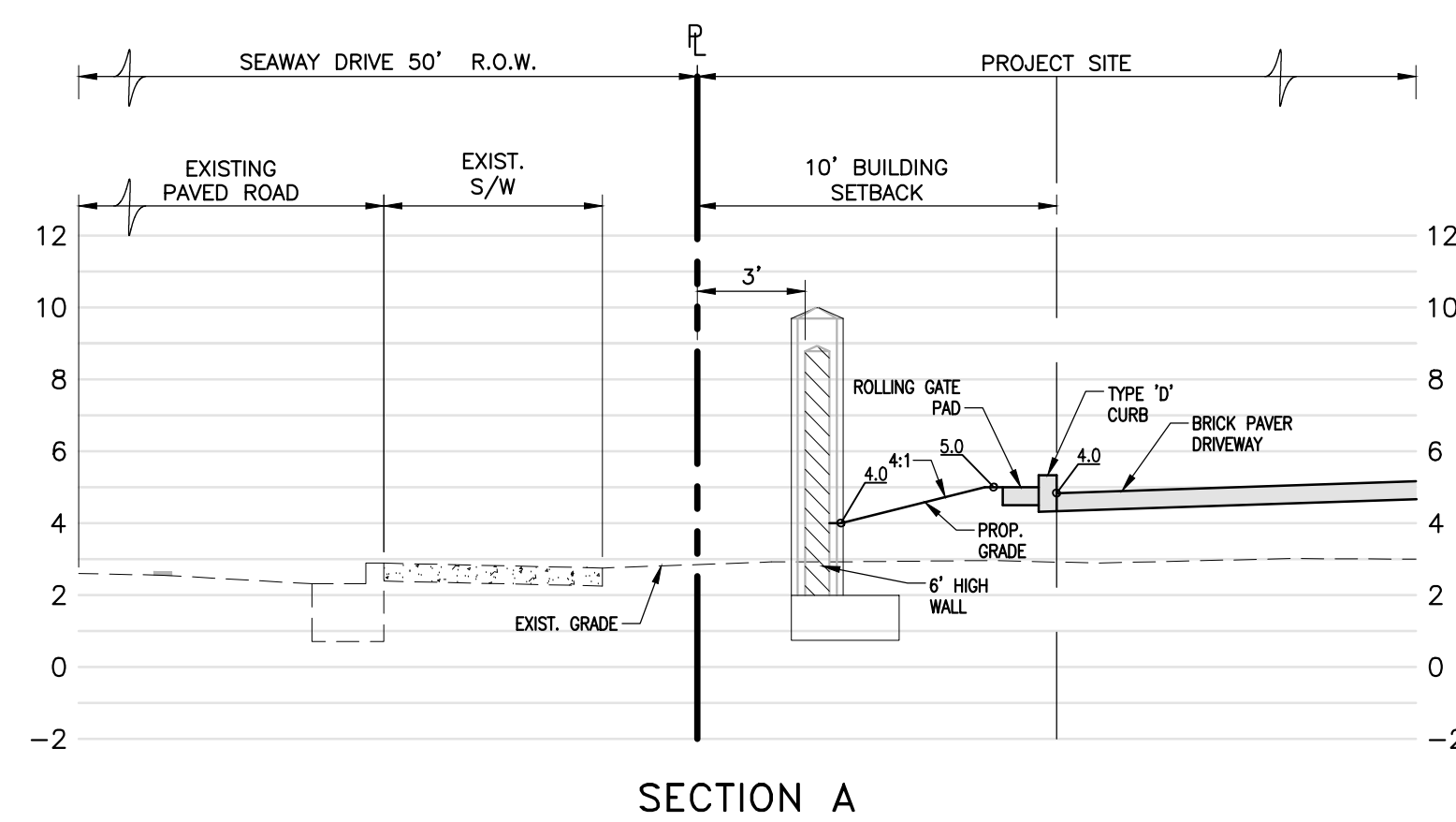

SECTION A

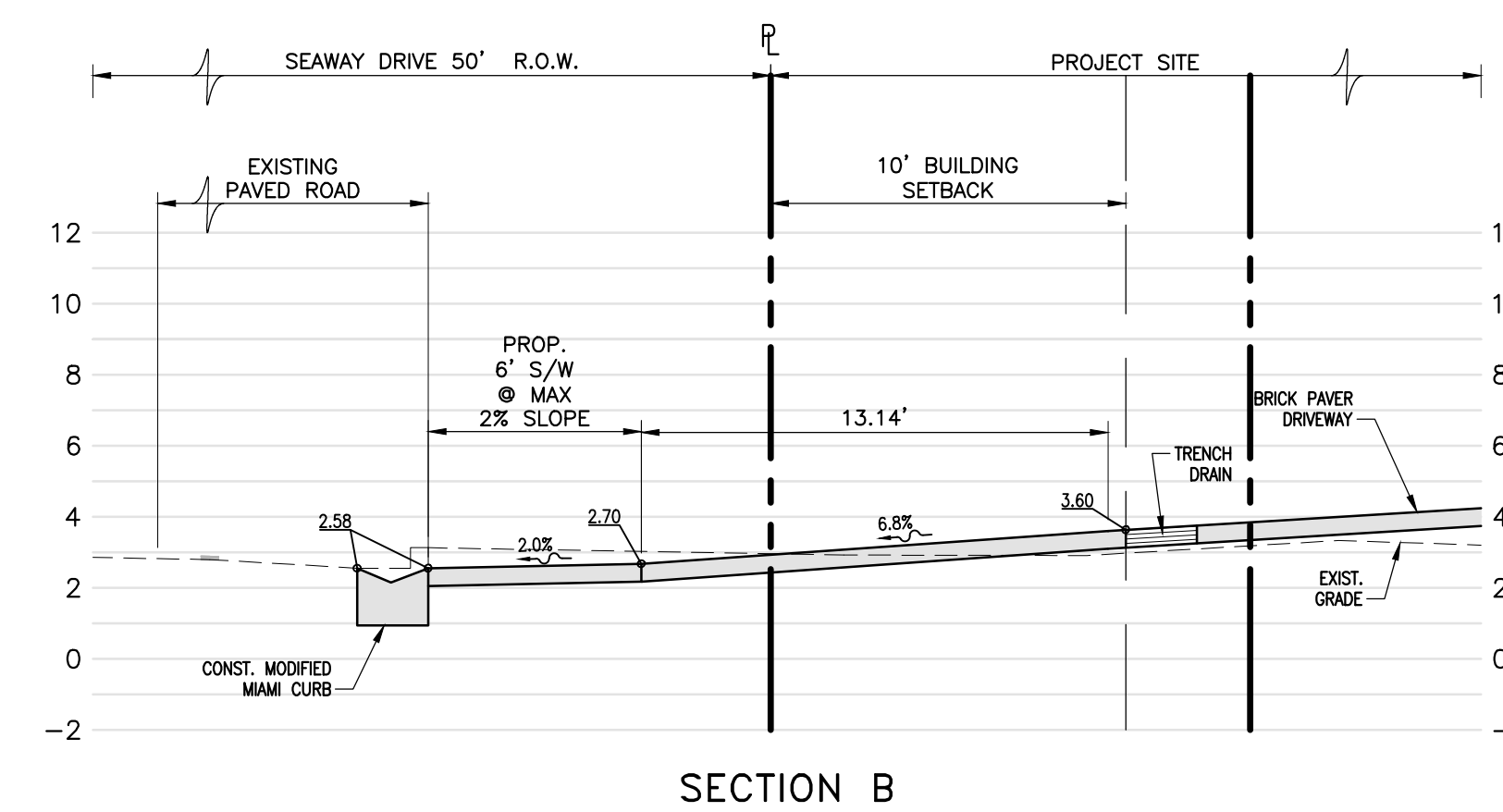

SECTION B

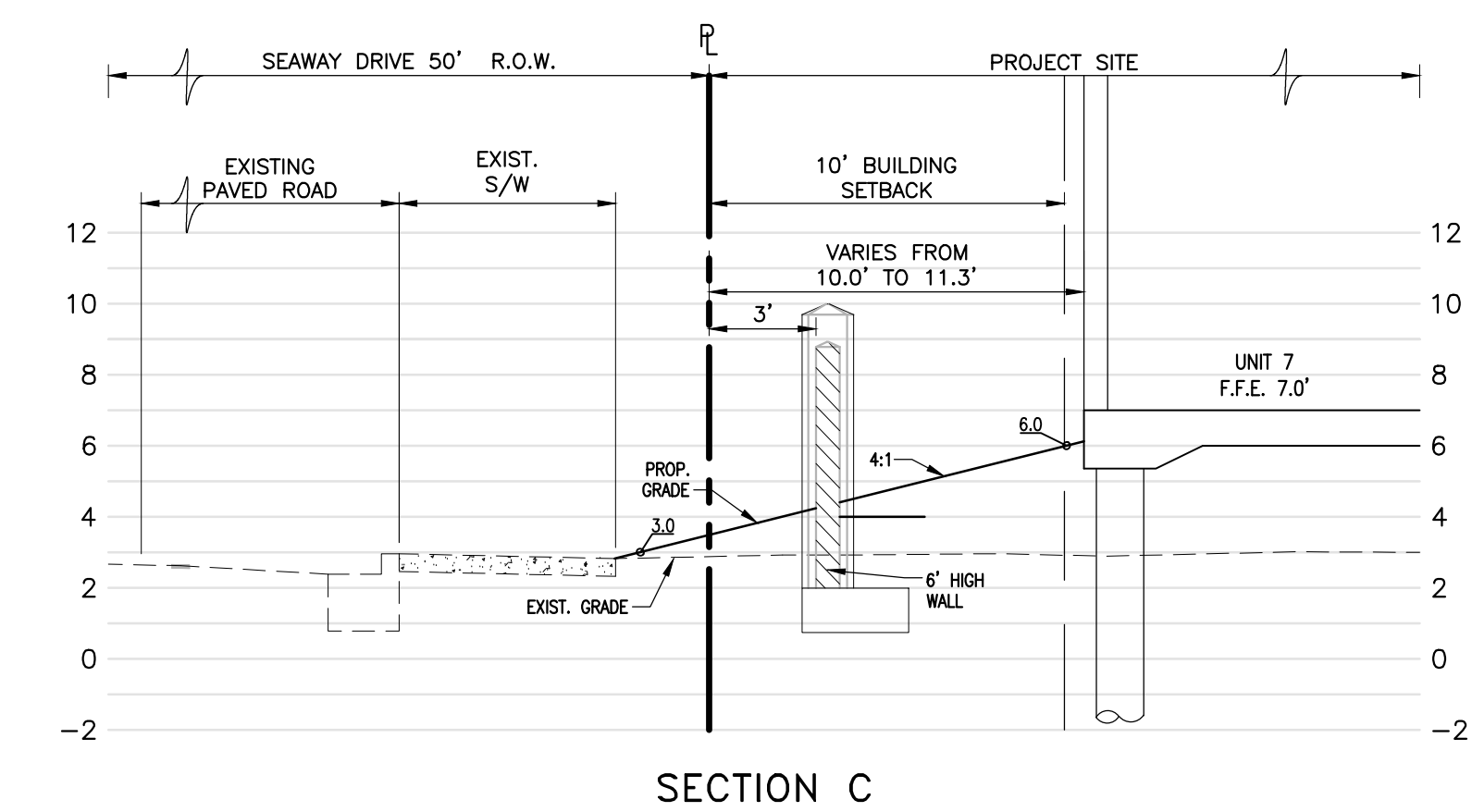

SECTION C

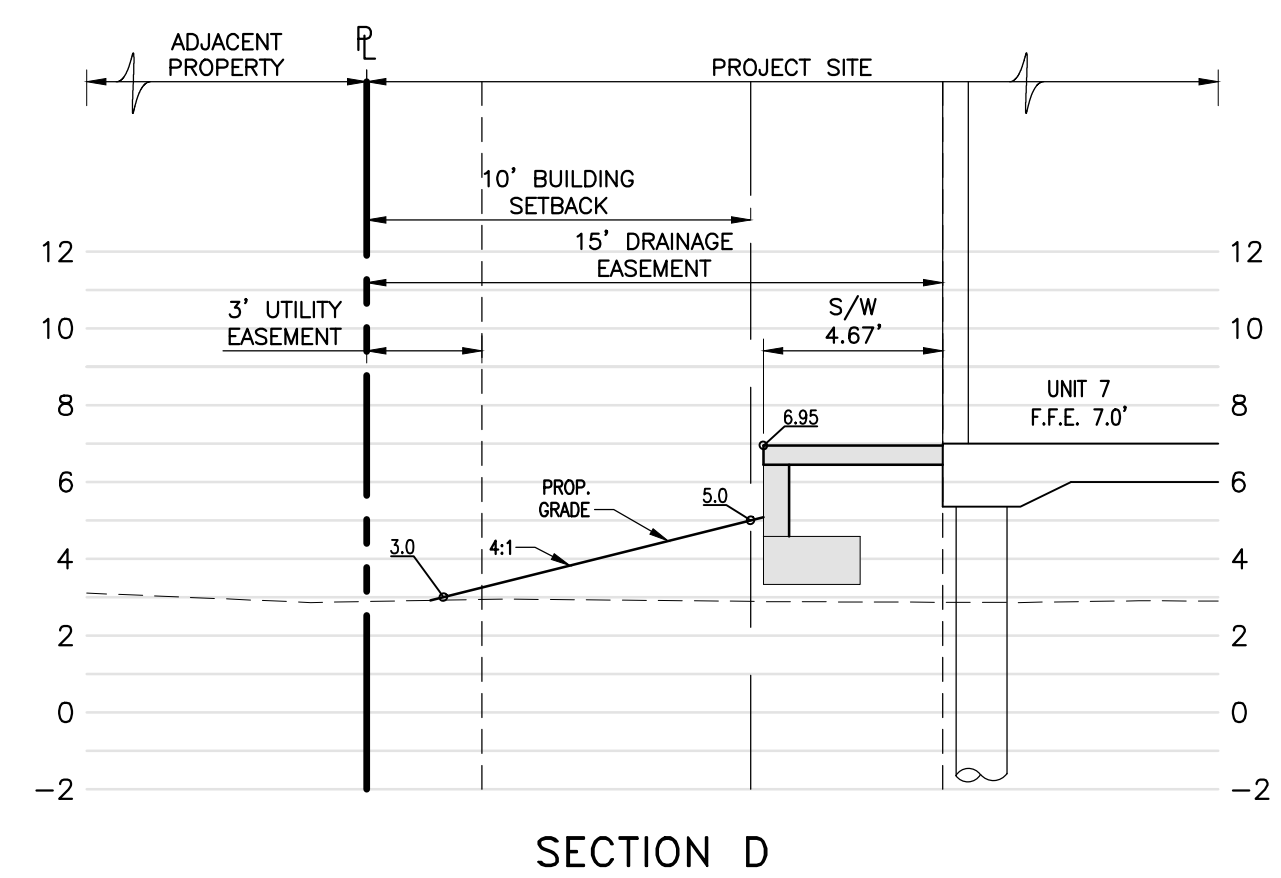

SECTION D

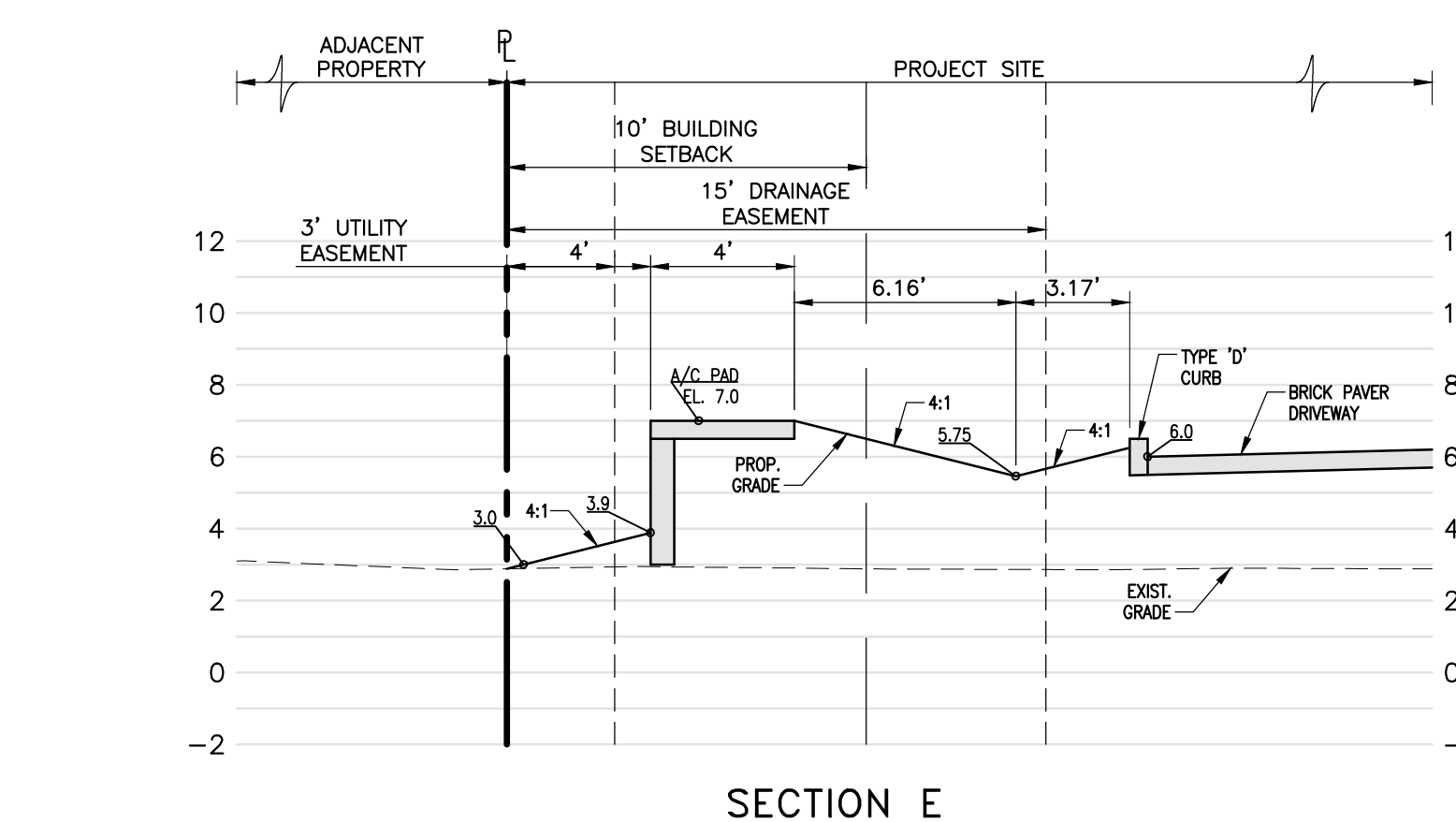

SECTION E

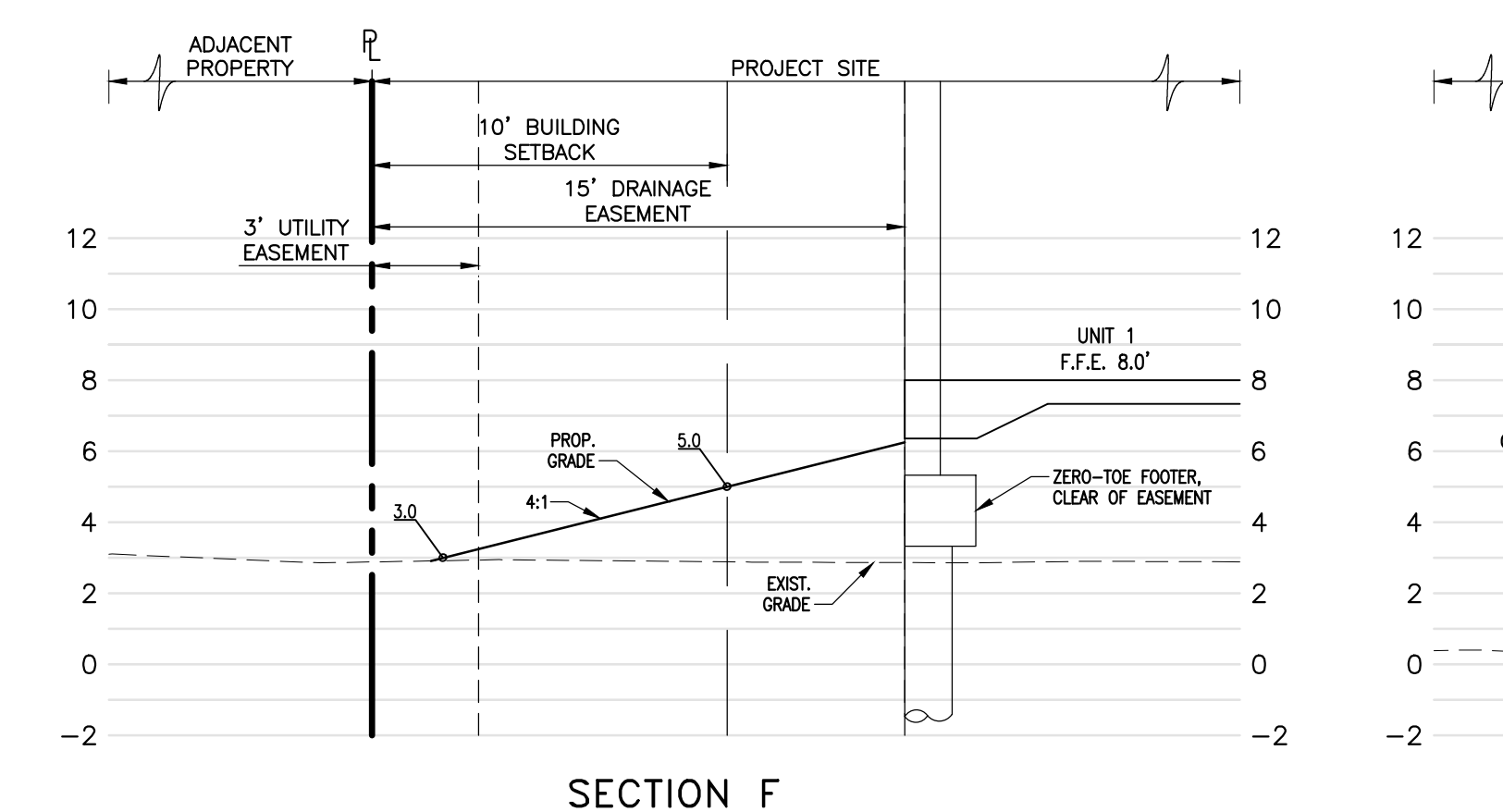

SECTION F

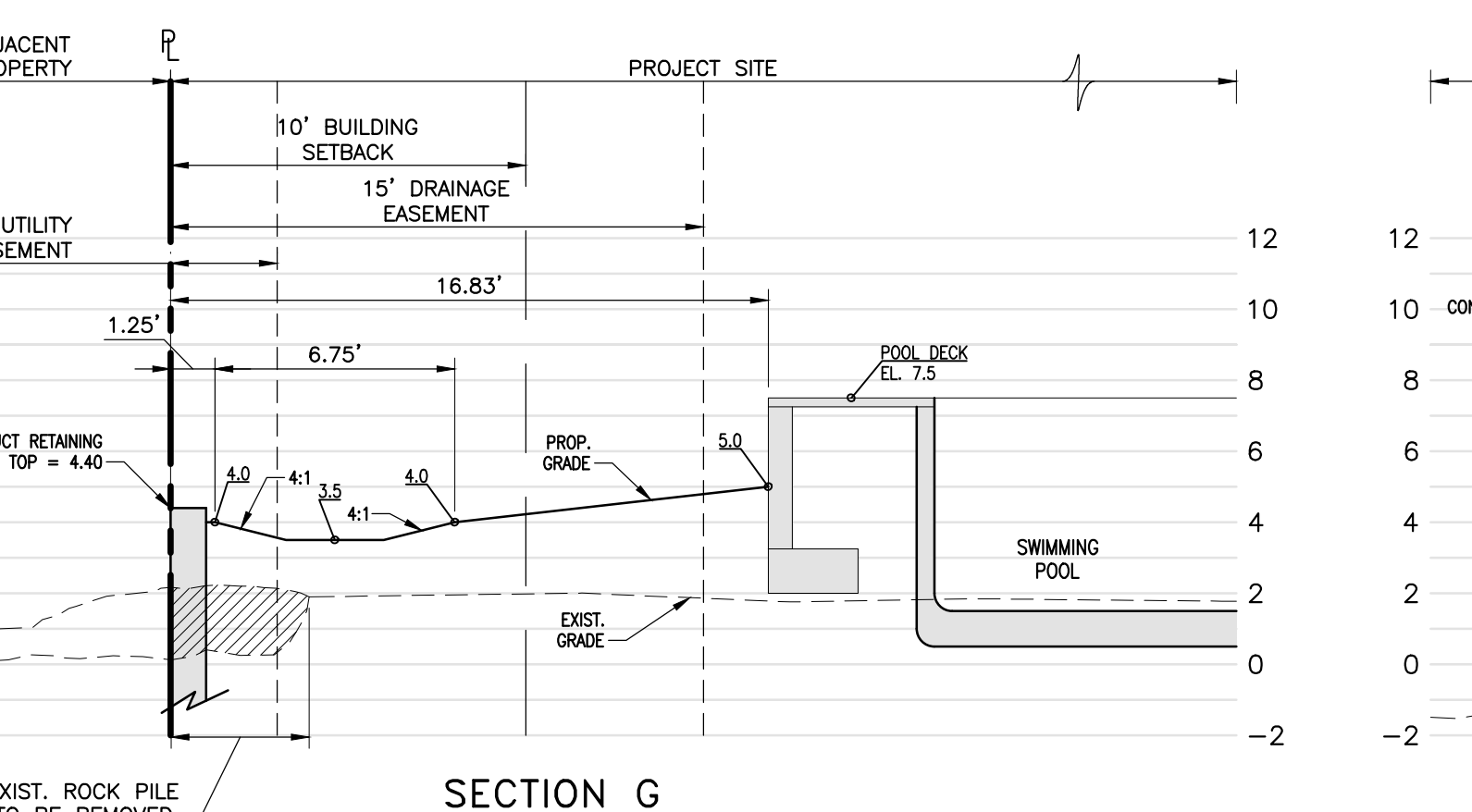

SECTION G

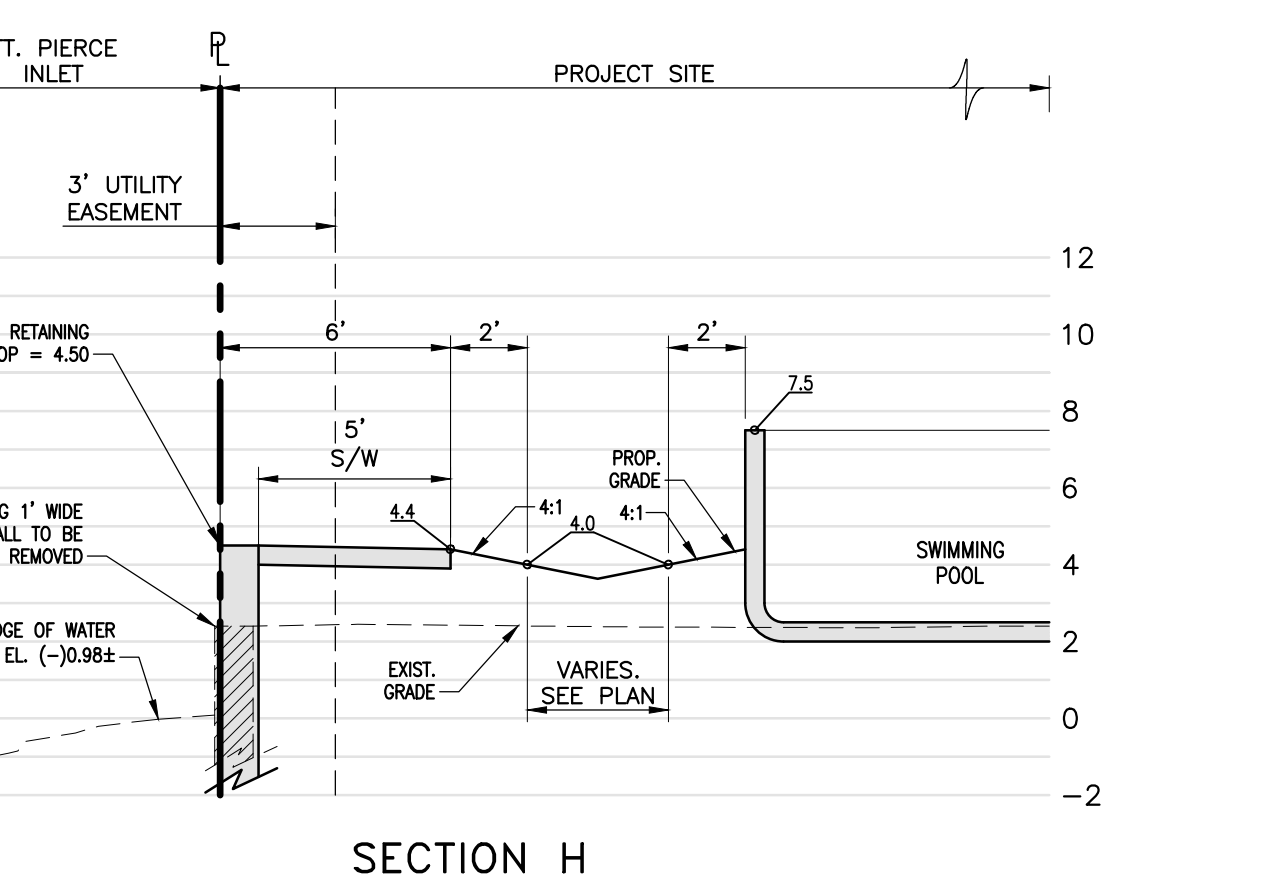

SECTION H

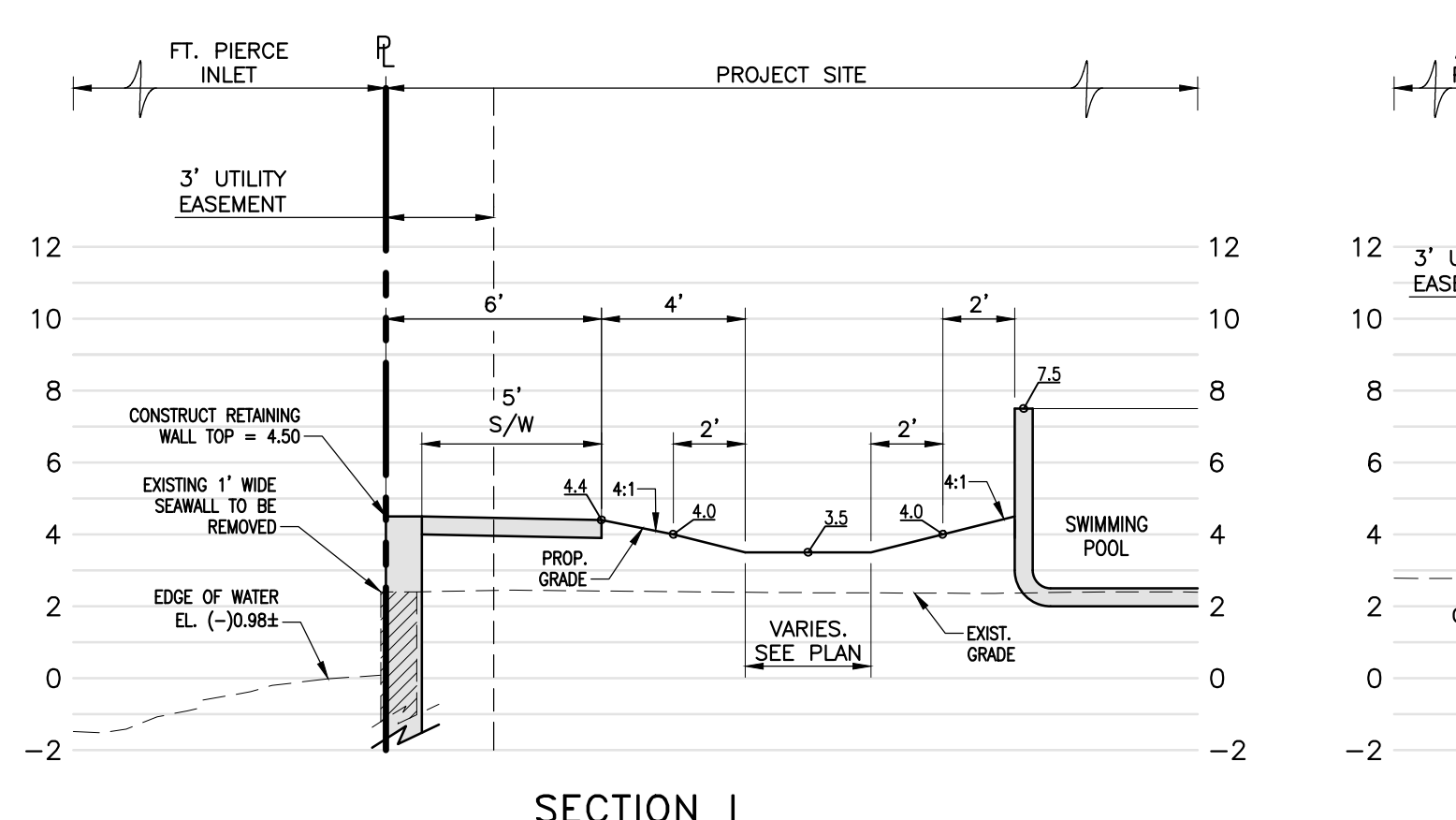

SECTION I

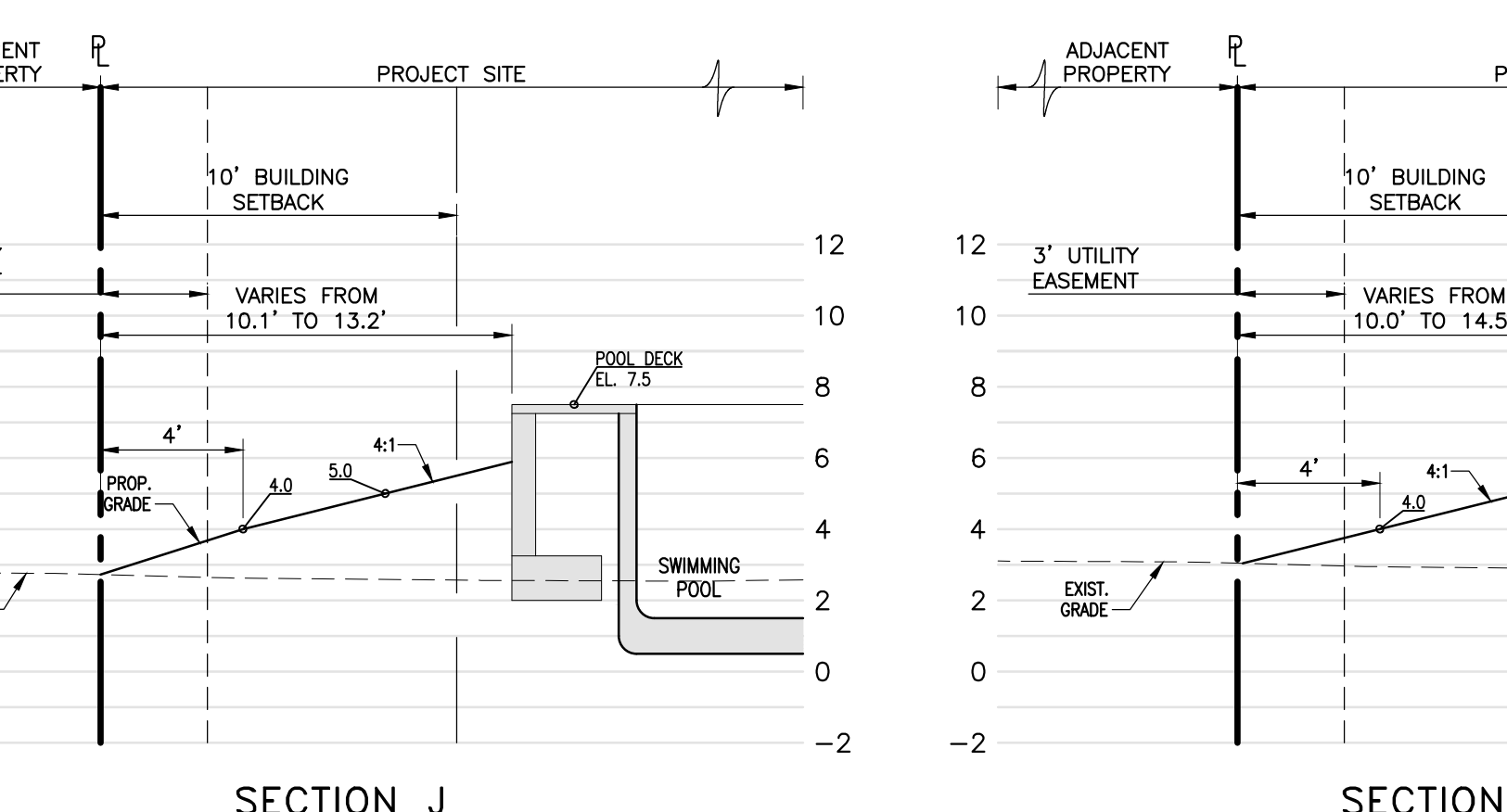

SECTION J

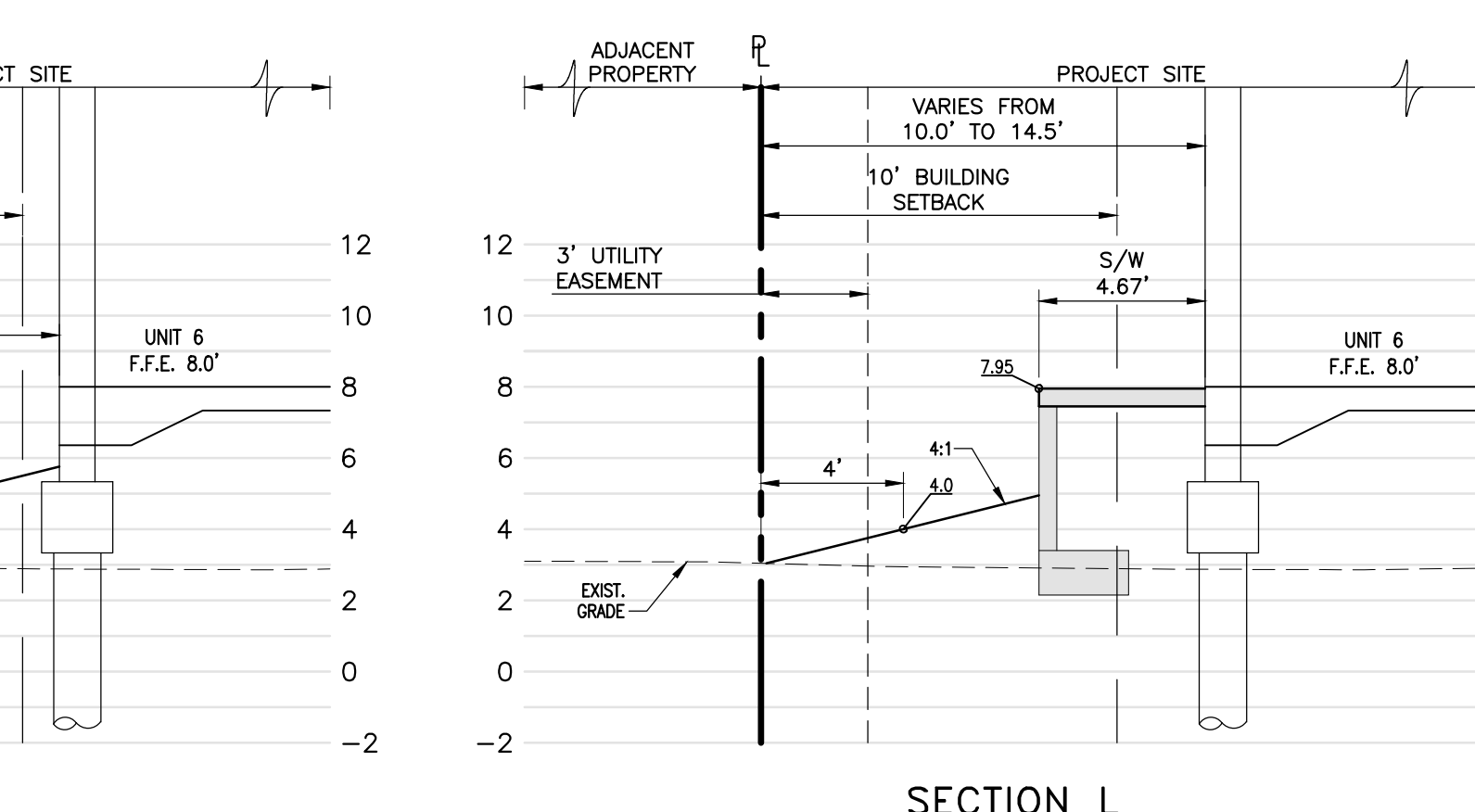

SECTION K

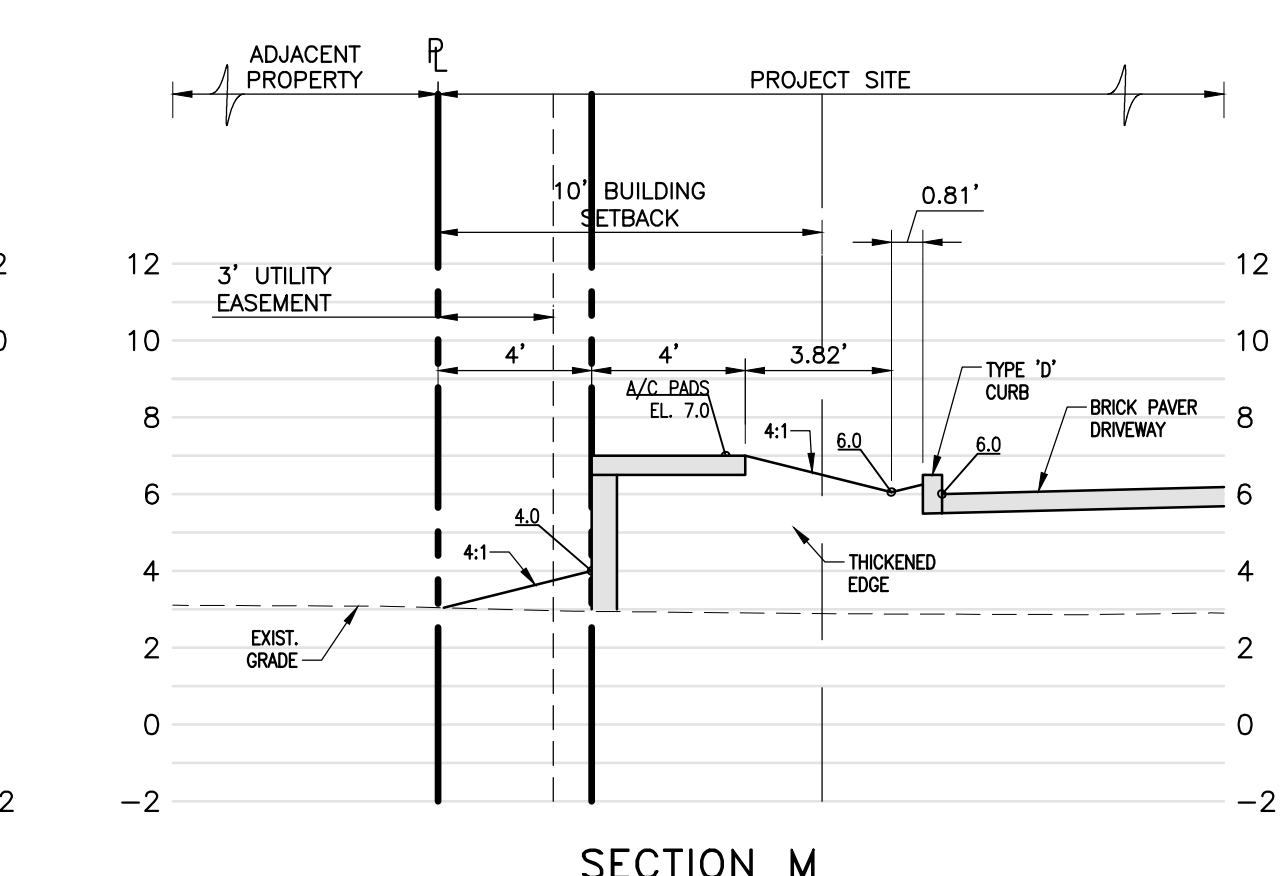

SECTION L



SECTION M

DATE	5/25/15
REVISION	
MARK	
DESIGNED	J.S.B.
DRAWN	J.S.B.
CHECKED	J.S.B.
SCALE	1"=5'
DATE	4/15/15

**SCHULKE, BITTLE & STODDARD, L.L.C.**  
 CIVIL & STRUCTURAL ENGINEERING - LAND PLANNING - ENVIRONMENTAL PERMITTING  
 1140 7th COURT, SUITE F VERO BEACH, FLORIDA 32980  
 TEL: 772 / 770-9622 FAX: 772 / 770-9496 EMAIL: sbseng@gate.net

CROSS SECTIONS  
 INLET PALMS

ENGINEER CERTIFICATION	
<input type="checkbox"/> JOSEPH W. SCHULKE	FL. REG. NO. 47046
<input type="checkbox"/> JOAHN B. BITTLE	FL. REG. NO. 57396
<input type="checkbox"/> WILLIAM P. STODDARD	FL. REG. NO. 57665
DATE:	
SHEET	10
PROJECT NO.	15-053



### FORT PIERCE UTILITIES AUTHORITY WATER DISTRIBUTION NOTES

1. ALL CONSTRUCTION MATERIAL, INSTALLATION AND TESTING SHALL CONFORM TO THE STANDARD SPECIFICATIONS OF THE FORT PIERCE UTILITIES AUTHORITY.
2. WATER MAINS SHALL BE POLYVINE CHLORIDE (PVC) SHALL CONFORM TO ANNA C-900 OR C-905, PRESSURE CLASS 150, OR (110) WATER MAINS WHEN SPECIFIED AS POLYETHYLENE (PE) SHALL CONFORM TO ANNA C-901 OR C-904, STANDARD CODE DESIGNATION PE200 PIPE CLASS 200 DIMENSION RATIO (DR) 11 FOR DIRECT BURIAL, (DR) 11 FOR DIRECTIONAL BORING, AND (DR) 9 FOR 2 INCH AND SMALLER PIPELINES.
3. WATER MAIN, WHEN SPECIFIED AS DUCTILE IRON PIPE, SHALL CONFORM TO ANNA/CANADA C151/A21.51 AND SHALL BE PRESSURE CLASS 250 (MINIMUM).
4. POLYVINE CHLORIDE WATER MAIN SHALL BE BLUE IN COLOR OR WHITE IN COLOR WITH BLUE STRIPES. USE OF IDENTIFICATION TAPE ATTACHED TO THE TOP OF THE PIPE MAY BE USED IN LIEU OF MARKING ON THE PIPE. ALSO DP PIPE SHALL REQUIRE THE USE OF IDENTIFICATION TAPE AND THIN WIRE.
5. FITTINGS SHALL BE DUCTILE IRON CONFORMING TO ANNA/CANADA C110/A21.10, CLASS 250 MM, CHEMIST LEAD AND FACTORY COATED.
6. GATE VALVES SHALL BE SMALLER RESISTANT SEAT, KENNEDY KEN-30K, AMERICAN OR APPROVED EQUAL, VALVES SHALL CONFORM TO ANNA C-500.
7. WATER LINES SHALL BE BACKFILLED AND COMPACTED IN ACCORDANCE WITH FPLUA DESIGN AND CONSTRUCTION STANDARDS. THE CONTRACTOR SHALL SUBMIT COMPACTED DENSITY TESTS AS REQUIRED BY FPLUA ENGINEERS AND THE CITY, COUNTY, FOOT, IN CASES WHERE PAVED AREAS FALL WITHIN THE JURISDICTION OF LOCAL GOVERNMENT AGENCIES, THE COMPACTED REQUIREMENTS SHALL NOT BE LESS THAN THE MINIMUM REQUIRED BY THE APPROPRIATE RESPONSIBLE AGENCY.
8. NO FIELD CHANGES OR DEVIATIONS FROM THE DESIGN SHALL BE MADE WITHOUT PRIOR APPROVAL OF THE FPLUA ENGINEER AND CITY/COUNTY/FOOT ENGINEER.
9. THE CONTRACTOR SHALL NOTIFY FPLUA ENGINEERING AND CITY/COUNTY/FOOT ENGINEERING 48 HOURS PRIOR TO COMMENCING CONSTRUCTION.
10. A PRE-CONSTRUCTION CONFERENCE BETWEEN THE ENGINEER, THE CONTRACTOR, FPLUA AND CITY/COUNTY/FOOT ENGINEER SHALL BE MANDATORY PRIOR TO COMMENCEMENT OF CONSTRUCTION.
11. TRAFFIC CONTROL, BARRIAGES, ETC. SHALL BE IN ACCORDANCE WITH THE FLORIDA DEPARTMENT OF TRANSPORTATION STANDARDS AND APPROVED BY THE CITY ENGINEER.
12. UNPAVED AREAS SHALL BE 36 INCHES EXPOSED AS APPROVED BY THE UTILITIES ENGINEER AND CITY/COUNTY/FOOT ENGINEER. PIPES WITH COVER LESS THAN 30 INCHES SHALL BE CONSTRUCTED OF DUCTILE IRON OR IN PVC CASING.
13. RESTORED AREAS SHALL BE RESTORED IN CONFORMANCE WITH THE APPLICABLE GOVERNING AGENCY REQUIREMENTS.
14. EXISTING UTILITIES AND DRAINAGE SHALL BE FIELD VERIFIED PRIOR TO CONSTRUCTION AND PROTECTED BY THE CONTRACTOR.
15. WATER MAINS SHALL BE TESTED AND DISINFECTED IN ACCORDANCE WITH THE APPLICABLE FLORIDA DEPARTMENT OF ENVIRONMENTAL PROTECTION AND ANNA C-651 FOR DISINFECTION.

WATER DISTRIBUTION	G-1
NOTES	
DESIGNED BY: [Signature]	DESIGNED BY: [Signature]
DRAWN BY: [Signature]	DRAWN BY: [Signature]
CHECKED BY: [Signature]	CHECKED BY: [Signature]
SCALE: N.T.S.	SCALE: N.T.S.
DATE: [Date]	DATE: [Date]

### FORT PIERCE UTILITIES AUTHORITY WASTEWATER CONSTRUCTION NOTES

1. ALL CONSTRUCTION MATERIAL, INSTALLATION AND TESTING SHALL CONFORM TO THE STANDARD SPECIFICATIONS OF THE FORT PIERCE UTILITIES AUTHORITY.
2. GRAFFTY SEWER MAIN SHALL BE POLYVINE CHLORIDE (PVC) SHALL CONFORM TO ANNA C-900 OR C-905, PRESSURE CLASS 150, OR (110) GRAFFTY SEWER MAIN SHALL HAVE LOCATOR TAPE WITH "SEWER" MARKED ON TAPE AND SHALL CONFORM TO ANNA C-500A.
3. THE MANHOLE BASE SHALL BE SET ON A FIRM DRY AND STABLE OR COMPACTED BASE FOUNDATION. IF NECESSARY, THE CONTRACTOR SHALL UTILIZE ROCK TO PROVIDE A FIRM AND SUITABLE MANHOLE BASE FOUNDATION.
4. WASTEWATER LINES SHALL BE BACKFILLED AND COMPACTED IN ACCORDANCE WITH FPLUA DESIGN AND CONSTRUCTION STANDARDS. THE CONTRACTOR SHALL SUBMIT COMPACTED DENSITY TESTS AS REQUIRED BY FPLUA ENGINEERS AND THE CITY, COUNTY, FOOT, IN CASES WHERE PAVED AREAS FALL WITHIN THE JURISDICTION OF LOCAL GOVERNMENT AGENCIES, THE COMPACTED REQUIREMENTS SHALL NOT BE LESS THAN THE MINIMUM REQUIRED BY THE APPROPRIATE RESPONSIBLE AGENCY.
5. A 1% MINIMUM SLOPE SHALL BE MAINTAINED ON ALL SANITARY SERVICE LATERALS.
6. THE CONTRACTOR SHALL FURNISH RECORD DRAWING INFORMATION TO THE ENGINEER CONSISTING OF PIPE SIZES, LOCATION OF SERVICE LATERALS, SPACED TO BE SERVICES, LOCATION OF INFORMATION NECESSARY TO LOCATE TRENCHES UNDER THIS PROJECT.
7. MANHOLE 5X FEET AND PREFERABLY 10-FOOT HORIZONTAL DISTANCE BETWEEN SERVICE LATERALS AND SEWER MAINS AS A MINIMUM.
8. WASTEWATER FORCE MAINS, WASTEWATER COLLECTION LINES, AND STORM SEWERS SHOULD CROSS UNDER WATER MAINS UNLESS OTHERWISE SPECIFIED. A MINIMUM VERTICAL DISTANCE OF 12 INCHES BETWEEN THE INVERT OF THE UPPER PIPE AND THE CROWN OF THE LOWER PIPE SHALL BE MAINTAINED UNLESS OTHERWISE SPECIFIED. WHERE THE MINIMUM SEPARATION CANNOT BE MAINTAINED, THE CROSSING SHALL BE ARRANGED SO THAT THE SEWER PIPE JOINTS AND WATER MAIN PIPE JOINTS ARE EQUIDISTANT FROM THE POINT OF CROSSING. THE WATER MAIN SHALL BE CONSTRUCTED OF DUCTILE IRON PIPE (DIP) CENTERED ON THE CROSSING. DIP IS NOT REQUIRED FOR STORM SEWERS. SUFFICIENT LENGTH OF DIP MUST BE USED TO PROVIDE A MINIMUM SEPARATION OF 10 FEET BETWEEN TWO JOINTS. ALL JOINTS ON THE WATER MAIN WITHIN 30 FEET OF THE CROSSING MUST BE MECHANICALLY RESTRAINED.
9. ALL CROSSINGS SHALL BE ARRANGED SO THAT THE SEWER PIPE JOINTS AND WATER MAIN PIPE JOINTS ARE EQUIDISTANT FROM THE POINT OF CROSSING (PIPES CENTERED ON THE CROSSING). AT SUCH CROSSINGS PIPES SHALL BE ARRANGED SO THAT ALL WATER MAIN JOINTS ARE AT LEAST THREE FEET FROM ALL JOINTS ON THE SEWER PIPE. THE MINIMUM HORIZONTAL SEPARATION DISTANCE BETWEEN WATER MAINS AND GRAFFTY-TYPE SANITARY SEWERS SHALL BE REDUCED TO 3 FEET WHERE THE BOTTOM OF THE WATER MAIN IS AT LEAST SIX INCHES ABOVE THE TOP OF THE SEWER.
10. WHERE IT IS NOT POSSIBLE TO MAINTAIN A 10-FOOT HORIZONTAL SEPARATION, THE WATER MAIN MUST BE Laid IN A SEPARATE TRENCH OR ON A UNDISTURBED EARTH SHAFT LOCATED ON ONE SIDE OF THE SEWER OR TOP OF THE SEWER. AN ELEVATION THAT THE BOTTOM OF THE WATER MAIN IS AT LEAST 8 INCHES ABOVE THE TOP OF THE SEWER.
11. IN CASES WHERE IT IS NOT POSSIBLE TO MAINTAIN A 10-FOOT HORIZONTAL SEPARATION, THE WATER MAIN SHALL BE CONSTRUCTED OF DIP AND THE SEWER OR FORCE MAIN SHALL BE CONSTRUCTED OF DIP (EXCEPT STORM SEWERS) WITH A MINIMUM VERTICAL DISTANCE OF 6 INCHES. THE WATER MAIN SHOULD ALWAYS BE ABOVE THE SEWER. JOINTS ON THE WATER MAIN SHALL BE LOCATED AS FAR APART AS POSSIBLE FROM JOINTS ON THE SEWER OR FORCE MAIN (CROSSING JOINTS).
12. EACH SERVICE LATERAL WILL BE MARKED WITH A LOCATOR SHALL AS MANUFACTURED BY 3M CORPORATION OR APPROVED EQUAL, AS REQUIRED. PROTECTIVE MEASURES AGAINST CORROSION SHALL BE USED AS DETERMINED BY THE DESIGN ENGINEER.
13. ALL MANHOLES SHALL HAVE SEWER RAIN GUARDS INSTALLED AS REQUIRED BY FPLUA ENGINEER.
14. THE CONTRACTOR SHALL COMPLY WITH THE FLORIDA TRENCH SAFETY ACT REGULATIONS.

WASTEWATER CONSTRUCTION NOTES	G-2
CONSTRUCTION NOTES	
DESIGNED BY: [Signature]	DESIGNED BY: [Signature]
DRAWN BY: [Signature]	DRAWN BY: [Signature]
CHECKED BY: [Signature]	CHECKED BY: [Signature]
SCALE: N.T.S.	SCALE: N.T.S.
DATE: [Date]	DATE: [Date]

### STANDARD SEPARATION STATEMENT FOR WATER / SEWER CONFLICTS

1. SANITARY SERVICE, FORCE MAINS, AND STORM SEWERS SHOULD CROSS UNDER WATER MAINS UNLESS OTHERWISE SPECIFIED. A MINIMUM VERTICAL DISTANCE OF 12 INCHES BETWEEN THE INVERT OF THE UPPER PIPE AND THE CROWN OF THE LOWER PIPE SHALL BE MAINTAINED UNLESS OTHERWISE SPECIFIED. WHERE THE MINIMUM SEPARATION CANNOT BE MAINTAINED, THE CROSSING SHALL BE ARRANGED SO THAT THE SEWER PIPE JOINTS AND WATER MAIN PIPE JOINTS ARE EQUIDISTANT FROM THE POINT OF CROSSING. THE WATER MAIN SHALL BE CONSTRUCTED OF DUCTILE IRON PIPE (DIP) CENTERED ON THE CROSSING. DIP IS NOT REQUIRED FOR STORM SEWERS. SUFFICIENT LENGTH OF DIP MUST BE USED TO PROVIDE A MINIMUM SEPARATION OF 10 FEET BETWEEN TWO JOINTS. ALL JOINTS ON THE WATER MAIN WITHIN 30 FEET OF THE CROSSING MUST BE MECHANICALLY RESTRAINED.
2. A MINIMUM 5-FOOT HORIZONTAL SEPARATION SHALL BE MAINTAINED BETWEEN ALL TYPE OF STORM SEWER AND WATER MAIN IN PARALLEL INSTALLATIONS UNLESS OTHERWISE SPECIFIED.
3. A MINIMUM 10-FOOT HORIZONTAL SEPARATION SHALL BE MAINTAINED BETWEEN "TONGUE SERVICE TREATMENT AND DISPOSAL SYSTEM" AND WATER MAIN IN PARALLEL INSTALLATIONS UNLESS OTHERWISE SPECIFIED.
4. A MINIMUM 8-FOOT, AND PREFERABLY 10-FOOT HORIZONTAL SEPARATION SHALL BE MAINTAINED BETWEEN GRAFFTY TYPE SANITARY SEWER, WASTEWATER FORCE MAIN, OR PIPELINE CONVEYING RECLAIMED WATER AND WATER MAIN IN PARALLEL INSTALLATIONS UNLESS OTHERWISE SPECIFIED. THE MINIMUM HORIZONTAL SEPARATION DISTANCE BETWEEN WATER MAINS AND GRAFFTY-TYPE SANITARY SEWERS SHALL BE REDUCED TO 3 FEET WHERE THE BOTTOM OF THE WATER MAIN IS AT LEAST SIX INCHES ABOVE THE TOP OF THE SEWER.
5. IN CASES WHERE IT IS NOT POSSIBLE TO MAINTAIN A 10-FOOT HORIZONTAL SEPARATION, THE WATER MAIN MUST BE Laid IN A SEPARATE TRENCH OR ON A UNDISTURBED EARTH SHAFT LOCATED ON ONE SIDE OF THE SEWER OR TOP OF THE SEWER. AN ELEVATION THAT THE BOTTOM OF THE WATER MAIN IS AT LEAST 8 INCHES ABOVE THE TOP OF THE SEWER.
6. WHERE IT IS NOT POSSIBLE TO MAINTAIN A VERTICAL DISTANCE OF 6 INCHES IN PARALLEL INSTALLATIONS, THE WATER MAIN SHALL BE CONSTRUCTED OF DIP AND THE SEWER OR FORCE MAIN SHALL BE CONSTRUCTED OF DIP (EXCEPT STORM SEWERS) WITH A MINIMUM VERTICAL DISTANCE OF 6 INCHES. THE WATER MAIN SHOULD ALWAYS BE ABOVE THE SEWER. JOINTS ON THE WATER MAIN SHALL BE LOCATED AS FAR APART AS POSSIBLE FROM JOINTS ON THE SEWER OR FORCE MAIN (CROSSING JOINTS).
7. ALL DIP SHALL BE PRESSURE CLASS 250 MIN. ADEQUATE PROTECTIVE MEASURES AGAINST CORROSION SHALL BE USED AS DETERMINED BY THE DESIGN ENGINEER.

STANDARD SEPARATION STATEMENT FOR WATER/SEWER CONFLICT	G-3
WATER/SEWER CONFLICT	
DESIGNED BY: [Signature]	DESIGNED BY: [Signature]
DRAWN BY: [Signature]	DRAWN BY: [Signature]
CHECKED BY: [Signature]	CHECKED BY: [Signature]
SCALE: N.T.S.	SCALE: N.T.S.
DATE: [Date]	DATE: [Date]

### TYPICAL TRENCH DETAIL

**NOTES:**

- 1) THE CONTRACTOR SHALL COMPLY WITH REQUIREMENTS OF THE FLORIDA TRENCH SAFETY ACT.
- 2) INITIAL BACKFILL SHALL BE HAND PLACED TO 12" ABOVE THE PIPE. BACKFILL SHALL BE MECHANICALLY TAMPED TO A MINIMUM OF 100% OF MAX DENSITY AS DETERMINED BY ASTM METHOD T-99.

TYPICAL TRENCH DETAILS	M-1
DESIGNED BY: [Signature]	DESIGNED BY: [Signature]
DRAWN BY: [Signature]	DRAWN BY: [Signature]
CHECKED BY: [Signature]	CHECKED BY: [Signature]
SCALE: N.T.S.	SCALE: N.T.S.
DATE: [Date]	DATE: [Date]

### BACKFILLING REQUIREMENTS

**NOTES:**

- 1) IN CERTAIN SOIL CONDITIONS A FOUNDATION MAY BE REQUIRED.
- 2) BEDDING IS REQUIRED PRIMARILY TO BRING THE TRENCH BOTTOM UP TO GRADE. BEDDING MATERIALS SHALL PROVIDE A UNIFORM AND ADEQUATE LONGITUDINAL SUPPORT UNDER THE PIPE.
- 3) MANHOUSING MATERIAL SHALL BE HAND PLACED TO THE SPRINGLINE OF THE PIPE. ADEQUATE SOIL SUPPORT.
- 4) INITIAL BACKFILL MATERIAL SHALL BE HAND PLACED TO 12" ABOVE THE TOP OF PIPE. THE SOIL SHALL BE COMPACTED TO 100% MAX DENSITY (ASTM D-1557).
- 5) BACKFILL SHALL BE COMPACTED TO 100% OF MAX DENSITY AS PER ASTM D-1557 TO A POINT 30" BELOW PROPOSED PROFILE GRADE OR EXISTING GRADE. THE FINAL 30" OF BACKFILL SHALL BE COMPACTED TO 95% OF MAX DENSITY AS PER ASTM D-1557.
- 6) DENSITY TEST SHALL BE PERFORMED AT AREAS DETERMINED BY THE UTILITIES ENGINEER OR PROPERTY AGENCY REPRESENTATIVE, AT THE CONTRACTOR'S EXPENSE.
- 7) CONTRACTOR TO COMPLY WITH ALL FEDERAL, STATE AND LOCAL TRENCH SAFETY REGULATIONS.

BACKFILLING REQUIREMENTS	M-2
DESIGNED BY: [Signature]	DESIGNED BY: [Signature]
DRAWN BY: [Signature]	DRAWN BY: [Signature]
CHECKED BY: [Signature]	CHECKED BY: [Signature]
SCALE: N.T.S.	SCALE: N.T.S.
DATE: [Date]	DATE: [Date]

### UTILITY CROSSING DETAIL

**NOTES:**

1. BLUE REFLECTIVE PAVEMENT MARKER FRIMS FOR WATER MAINS AND GREEN FRIMS FOR WASTEWATER MAINS.
2. FOR WATER AND WASTEWATER MAINS INSTALLED IN PAVED AREAS, ELIMINATE CONCRETE PAD AND ENCASE THE MAGNETIC WIRE IN 1/2" PVC INSIDE THE VALVE BOX SIX INCHES BELOW GRADE.
3. DIP MAY BE USED AS RISERS ONLY IF A VALVE BOX IS NOT MANUFACTURED FOR THAT DIRECTION. NO TWO RISERS SHALL BE USED IN ANY CIRCUMSTANCES.

UTILITY CROSSING DETAIL	M-5
DESIGNED BY: [Signature]	DESIGNED BY: [Signature]
DRAWN BY: [Signature]	DRAWN BY: [Signature]
CHECKED BY: [Signature]	CHECKED BY: [Signature]
SCALE: N.T.S.	SCALE: N.T.S.
DATE: [Date]	DATE: [Date]

### TYPICAL GATE VALVE & WEIGHTED VALVE BOX DETAIL

**NOTES:**

1. BLUE REFLECTIVE PAVEMENT MARKER FRIMS FOR WATER MAINS AND GREEN FRIMS FOR WASTEWATER MAINS.
2. FOR WATER AND WASTEWATER MAINS INSTALLED IN PAVED AREAS, ELIMINATE CONCRETE PAD AND ENCASE THE MAGNETIC WIRE IN 1/2" PVC INSIDE THE VALVE BOX SIX INCHES BELOW GRADE.
3. DIP MAY BE USED AS RISERS ONLY IF A VALVE BOX IS NOT MANUFACTURED FOR THAT DIRECTION. NO TWO RISERS SHALL BE USED IN ANY CIRCUMSTANCES.

TYPICAL GATE VALVE & WEIGHTED VALVE BOX DETAIL	M-6
DESIGNED BY: [Signature]	DESIGNED BY: [Signature]
DRAWN BY: [Signature]	DRAWN BY: [Signature]
CHECKED BY: [Signature]	CHECKED BY: [Signature]
SCALE: N.T.S.	SCALE: N.T.S.
DATE: [Date]	DATE: [Date]

### JACK & BORE DETAIL

**NOTES:**

- 1) CASING INSULATORS SHALL BE MADE WITH SPECIAL RUNNER HEIGHTS SO AS NOT TO INTERFERE WITH PIPE JOINTS.
- 2) ALL CARRIER PIPES MUST HAVE MECHANICALLY RESTRAINED JOINTS.
- 3) INSULATOR SPACING SHALL BE AS REQUIRED BY THE MANUFACTURER, HOWEVER, NO LESS THAN THREE (3) CASING INSULATORS SHALL BE INSTALLED PER LENGTH OF PIPE.
- 4) CASING LENGTH SHALL EXTEND A MINIMUM OF 6 FEET BEYOND THE EDGE OF PAVEMENT OR CURBING.

JACK & BORE DETAIL	M-7
DESIGNED BY: [Signature]	DESIGNED BY: [Signature]
DRAWN BY: [Signature]	DRAWN BY: [Signature]
CHECKED BY: [Signature]	CHECKED BY: [Signature]
SCALE: N.T.S.	SCALE: N.T.S.
DATE: [Date]	DATE: [Date]

### TRACE WIRE DETAIL

**NOTES:**

- 1) TRACE WIRE IS REQUIRED ON ALL PIPE AS NOTED BY UTILITIES ENGINEER AND SHOWN IN STANDARD DETAILS.
- 2) INCLUDE ALL COST OF MATERIALS AND LABOR IN PRICE OF TRACE WIRE.
- 3) CONTRACTOR IS RESPONSIBLE FOR CONTINUITY OF ALL TRACE WIRE.

TRACE WIRE DETAIL	M-11
DESIGNED BY: [Signature]	DESIGNED BY: [Signature]
DRAWN BY: [Signature]	DRAWN BY: [Signature]
CHECKED BY: [Signature]	CHECKED BY: [Signature]
SCALE: N.T.S.	SCALE: N.T.S.
DATE: [Date]	DATE: [Date]

### TYPICAL DRIVEWAY RESTORATION

**NOTES:**

- 1) ALL DRIVEWAYS SHALL BE REPLACED WITH MATERIAL OF THE SAME TYPE AND COMPOSITION AS THE MATERIAL REMOVED TO THE LIMITS OF THE EXISTING DRIVEWAY.
- 2) ALL CONCRETE DRIVEWAYS SHALL BE 8" THICK, 6" x 6" 10/10 GAUGE WIRE MESH, CLASS 1 5000 PSI CONCRETE. THE SUB-GRADE FOR THE CONCRETE SHALL BE 6" SAND OR OTHER APPROVED MATERIAL COMPACTED TO 95% MAXIMUM DENSITY.
- 3) ALL ASPHALT DRIVEWAYS SHALL BE 1" TYPE 1-1 AND 4" COMPACTED LIME/SUBSOIL BASE.
- 4) SAW-CUT AND REMOVE ALL EXISTING DRIVEWAYS TO LIMITS AND REPLACE TO SAME GRADE AND LINES AS ORIGINAL. CONCRETE DRIVEWAYS SHOULD BE REPAIRED TO THE NEAREST EXISTING JOINT.
- 5) 30% MINIMUM OUTSIDE OF EDGE OF REPLACED DRIVEWAY AND ALL DISTURBED AREAS.
- 6) ROCK/SHELL AND DIRT DRIVEWAYS SHALL BE COMPACTED TO 95% MAXIMUM DENSITY PER ASTM D-1557. ROCK/SHELL DEPTH SHALL BE SIX INCHES. COMPACTED DEPTH.
- 7) CONTRACTOR SHALL REPLACE ALL DRIVEWAYS IN KIND, IN ACCORDANCE WITH THIS DETAIL. THE SPECIFICATIONS ON THE ST. LUCIE COUNTY STANDARDS, WHICHEVER IS THE MOST STRINGENT.
- 8) NEW DRIVEWAYS SHALL BE SLOPED IN A MANNER THAT WILL NOT ALLOW POONDING OF STORM WATER.
- 9) CONTRACTOR SHALL REMOVE ALL REMOVED MATERIAL IN A SUITABLE FASHION IN ACCORDANCE WITH ALL CITY, COUNTY AND STATE REGULATIONS.
- 10) FOR ASPHALT DRIVEWAYS, THE BASE SHALL EXTEND SIX INCHES BEYOND THE ASPHALT COURSE.
- 11) ALL REPLACEMENT DRIVEWAYS SHALL BE CONSTRUCTED WITH A FOOTING PARALLEL TO THE ROADWAY. FOOTING SHALL BE A MINIMUM 8" DEEP AND 8" WIDE FOR THE ENTIRE LENGTH OF THE DRIVEWAY FRONTAGE.
- 12) ALL ASPHALT DRIVEWAYS SHALL BE OVERLAPPED WITHIN THE LIMITS OF THE ROAD-OF-WAY.

TYPICAL DRIVEWAY RESTORATION	R-1
DESIGNED BY: [Signature]	DESIGNED BY: [Signature]
DRAWN BY: [Signature]	DRAWN BY: [Signature]
CHECKED BY: [Signature]	CHECKED BY: [Signature]
SCALE: N.T.S.	SCALE: N.T.S.
DATE: [Date]	DATE: [Date]

### PAVEMENT RESTORATION (COUNTY)

**NOTES:**

1. MINIMUM RESTORATION FOR CONSTRUCTION SHALL BE 12" MINIMUM DEPTH.
2. MINIMUM RESTORATION FOR MAINTENANCE SHALL BE 6" MINIMUM DEPTH.
3. MINIMUM RESTORATION FOR REPAIR SHALL BE 4" MINIMUM DEPTH.
4. MINIMUM RESTORATION FOR PATCH SHALL BE 4" MINIMUM DEPTH.
5. MINIMUM RESTORATION FOR PATCH SHALL BE 4" MINIMUM DEPTH.
6. MINIMUM RESTORATION FOR PATCH SHALL BE 4" MINIMUM DEPTH.
7. MINIMUM RESTORATION FOR PATCH SHALL BE 4" MINIMUM DEPTH.
8. MINIMUM RESTORATION FOR PATCH SHALL BE 4" MINIMUM DEPTH.
9. MINIMUM RESTORATION FOR PATCH SHALL BE 4" MINIMUM DEPTH.
10. MINIMUM RESTORATION FOR PATCH SHALL BE 4" MINIMUM DEPTH.

PAVEMENT RESTORATION (COUNTY)	R-2
DESIGNED BY: [Signature]	DESIGNED BY: [Signature]
DRAWN BY: [Signature]	DRAWN BY: [Signature]
CHECKED BY: [Signature]	CHECKED BY: [Signature]
SCALE: N.T.S.	SCALE: N.T.S.
DATE: [Date]	DATE: [Date]

### PAVEMENT RESTORATION DETAIL WITH TRENCH

**NOTES:**

1. INITIAL BACKFILL SHALL BE PLACED TO 12" ABOVE THE PIPE IN 6" LIFTS. BACKFILL SHALL BE MECHANICALLY TAMPED TO A MINIMUM OF 95% OF MAXIMUM DENSITY AS DETERMINED BY ASTM METHOD T-99. UNDERMOST 12" BE COMPACTED TO 95% OF T-99.
2. LIME/ROCK OR CRUSHED COOLUNA COMPACTED TO 95% OF MAXIMUM DENSITY AS DETERMINED BY ASTM METHOD T-160.

PAVEMENT RESTORATION DETAIL WITH TRENCH	R-3
DESIGNED BY: [Signature]	DESIGNED BY: [Signature]
DRAWN BY: [Signature]	DRAWN BY: [Signature]
CHECKED BY: [Signature]	CHECKED BY: [Signature]
SCALE: N.T.S.	SCALE: N.T.S.
DATE: [Date]	DATE: [Date]

### FLEXIBLE PAVEMENT

**NOTES:**

1. MINIMUM RESTORATION FOR CONSTRUCTION SHALL BE 12" MINIMUM DEPTH.
2. MINIMUM RESTORATION FOR MAINTENANCE SHALL BE 6" MINIMUM DEPTH.
3. MINIMUM RESTORATION FOR REPAIR SHALL BE 4" MINIMUM DEPTH.
4. MINIMUM RESTORATION FOR PATCH SHALL BE 4" MINIMUM DEPTH.
5. MINIMUM RESTORATION FOR PATCH SHALL BE 4" MINIMUM DEPTH.
6. MINIMUM RESTORATION FOR PATCH SHALL BE 4" MINIMUM DEPTH.
7. MINIMUM RESTORATION FOR PATCH SHALL BE 4" MINIMUM DEPTH.
8. MINIMUM RESTORATION FOR PATCH SHALL BE 4" MINIMUM DEPTH.
9. MINIMUM RESTORATION FOR PATCH SHALL BE 4" MINIMUM DEPTH.
10. MINIMUM RESTORATION FOR PATCH SHALL BE 4" MINIMUM DEPTH.

FLEXIBLE PAVEMENT	R-4
DESIGNED BY: [Signature]	DESIGNED BY: [Signature]
DRAWN BY: [Signature]	DRAWN BY: [Signature]
CHECKED BY: [Signature]	CHECKED BY: [Signature]
SCALE: N.T.S.	SCALE: N.T.S.
DATE: [Date]	DATE: [Date]

### GENERAL POLICY

WHERE COST JUSTIFIED AND OPERATIONALLY FEASIBLE, IT IS THE GENERAL POLICY OF THE F.P.U.A. TO PROVIDE WATER, ELECTRIC, SEWER AND GAS SERVICE FROM THE STREET SIDE OF A PIECE OF PROPERTY. DRAINAGE OR FACTORY DRAINAGE OR FACTORY DRAINAGE SUPPLY SOURCE FACILITIES, REAR OR SIDE LOT LINE SUPPLY MAY BE AUTHORIZED, BUT ONLY WITH PRIOR APPROVAL FROM THE F.P.U.A.

**NOTES:**

- 1) HORIZONTAL SEPARATION OF WATER AND WASTEWATER SERVICES SHOULD BE A MINIMUM OF SIX FEET AND PREFERABLY 10 FEET.
- 2) THE WASTEWATER LATERAL SHALL BE LOCATED WITHIN RIGHT-OF-WAY AND TERMINATE AT THE PROPERTY LINE.
- 3) THE F.P.U.A. SHALL BE RESPONSIBLE FOR THE MAINTENANCE AND REPAIR OF THE WASTEWATER LATERAL WITHIN THE EASEMENT OR RIGHT-OF-WAY, UP TO THE POINT OF CONNECTION.

WASTEWATER SERVICE PLACEMENT POLICY	S-1
DESIGNED BY: [Signature]	DESIGNED BY: [Signature]
DRAWN BY: [Signature]	DRAWN BY: [Signature]
CHECKED BY: [Signature]	CHECKED BY: [Signature]
SCALE: N.T.S.	SCALE: N.T.S.
DATE: [Date]	DATE: [Date]

### SERVICE CONNECTION

**NOTES:**

- 1) SHALL TYPE WASTEWATER LOCATOR BY 3M CORP. OR APPROVED EQUAL.
- 2) MINIMUM SLOPE OF 1/8" PER FOOT, USE GREATER SLOPE WHERE POSSIBLE.
- 3) SERVICE LATERAL SHALL TERMINATE WITH A CLEANOUT.
- 4) INSTALL CLEANOUT AT THE PROPERTY LINE. REFER TO DETAIL S-1 FOR SPECIFIC PROPERTY LAYOUT.

SERVICE CONNECTION	S-2
DESIGNED BY: [Signature]	DESIGNED BY: [Signature]
DRAWN BY: [Signature]	DRAWN BY: [Signature]
CHECKED BY: [Signature]	CHECKED BY: [Signature]
SCALE: N.T.S.	SCALE: N.T.S.
DATE: [Date]	DATE: [Date]

DRAWING NO. 15-053	REVISION	DATE
DESIGNED BY: [Signature]	REVISION PER CORP	5/29/15
DRAWN BY: [Signature]	MARK	
CHECKED BY: [Signature]	1	
SCALE: N.T.S.	MARK	
DATE: [Date]	1	

**SCHULKE, BITTLE & STODDARD, L.L.C.**  
 CIVIL & STRUCTURAL ENGINEERING - LAND PLANNING - ENVIRONMENTAL PERMITTING  
 CERTIFICATION NO.: 00008668  
 1717 INDIAN RIVER BLVD., SUITE 201 VERO BEACH, FLORIDA 32980  
 TEL 772/770-9622 FAX 772/770-9496 EMAIL: info@sbsengineers.com

MISCELLANEOUS DETAILS & SPECIFICATIONS

INLET PALMS

ENGINEER CERTIFICATION	DATE:
<input type="checkbox"/> JOSEPH W. SCHULKE FL. REG. NO. 47048 <input type="checkbox"/> JOAHN B. BITTLE FL. REG. NO. 57390 <input type="checkbox"/> WILLIAM P. STODDARD FL. REG. NO. 57605	SHEET 12
PROJECT NO. 15-053	

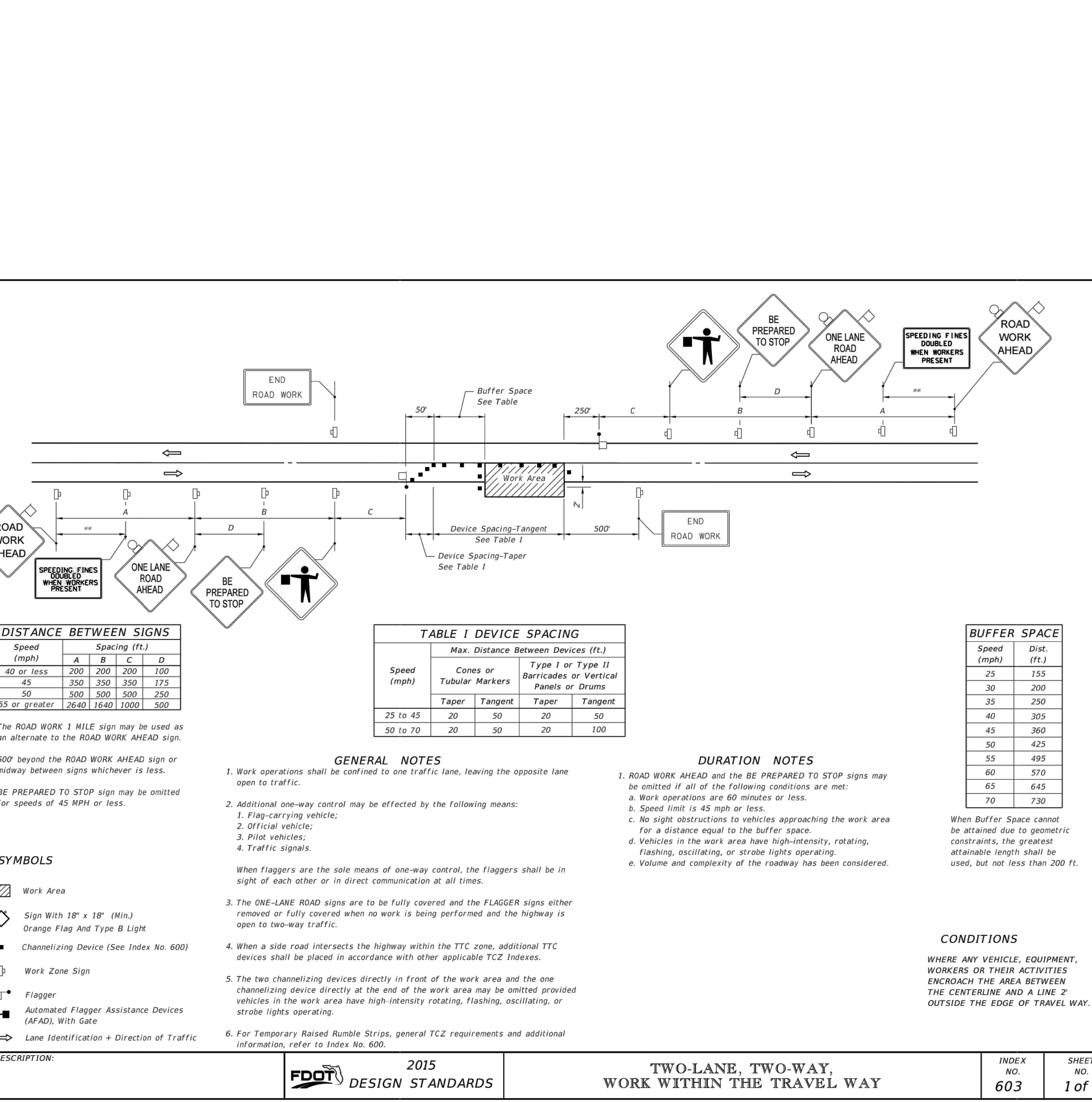
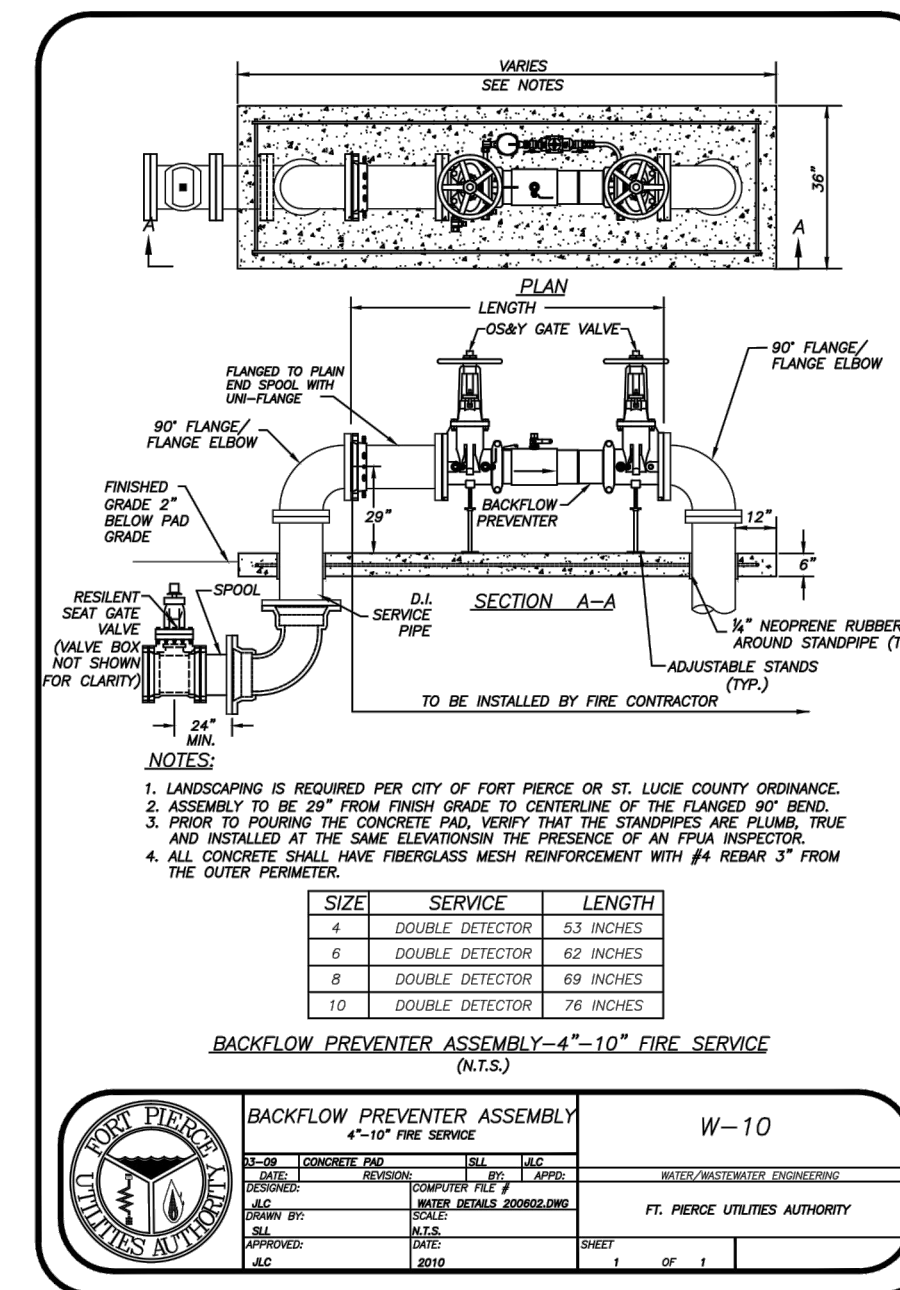
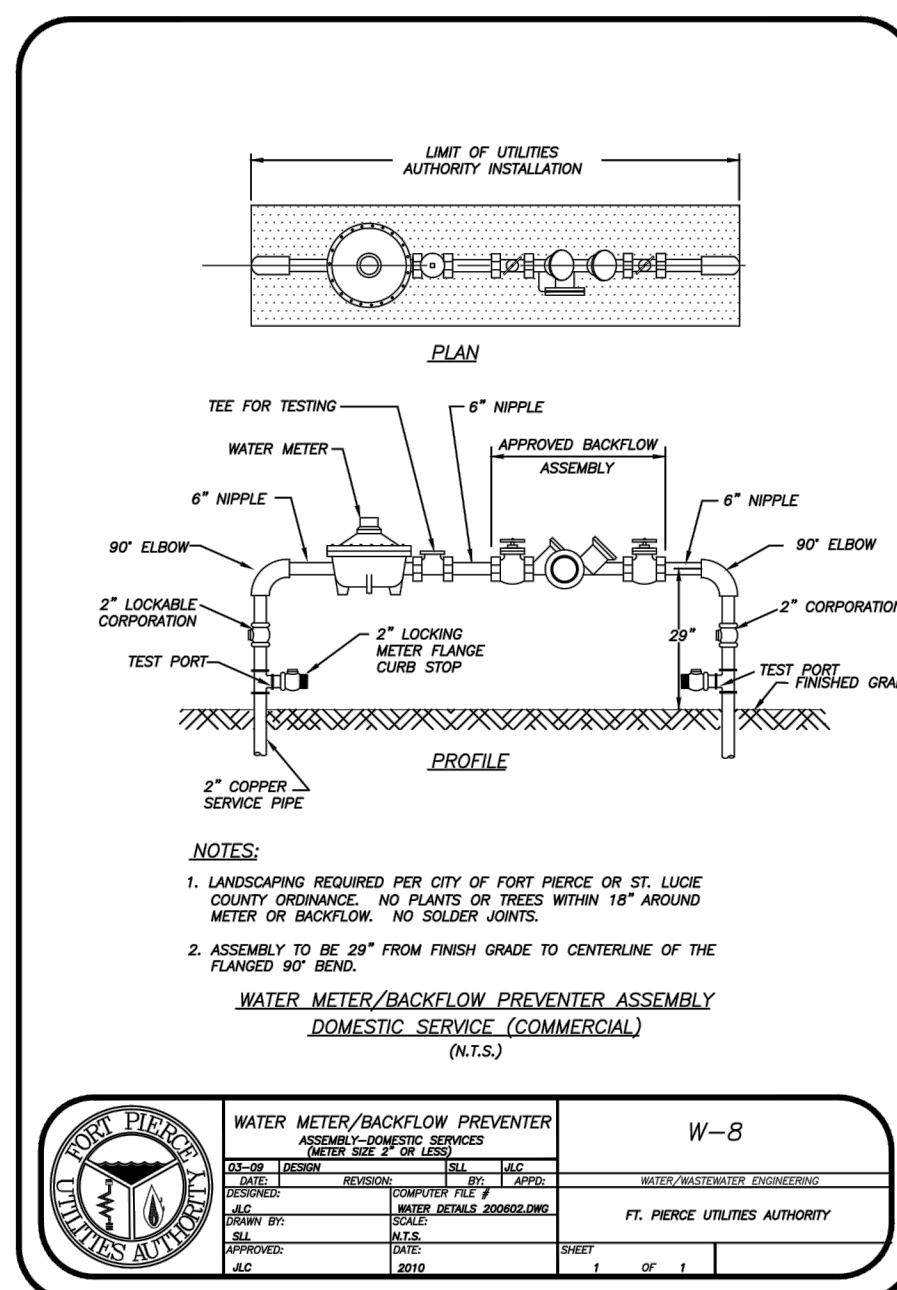
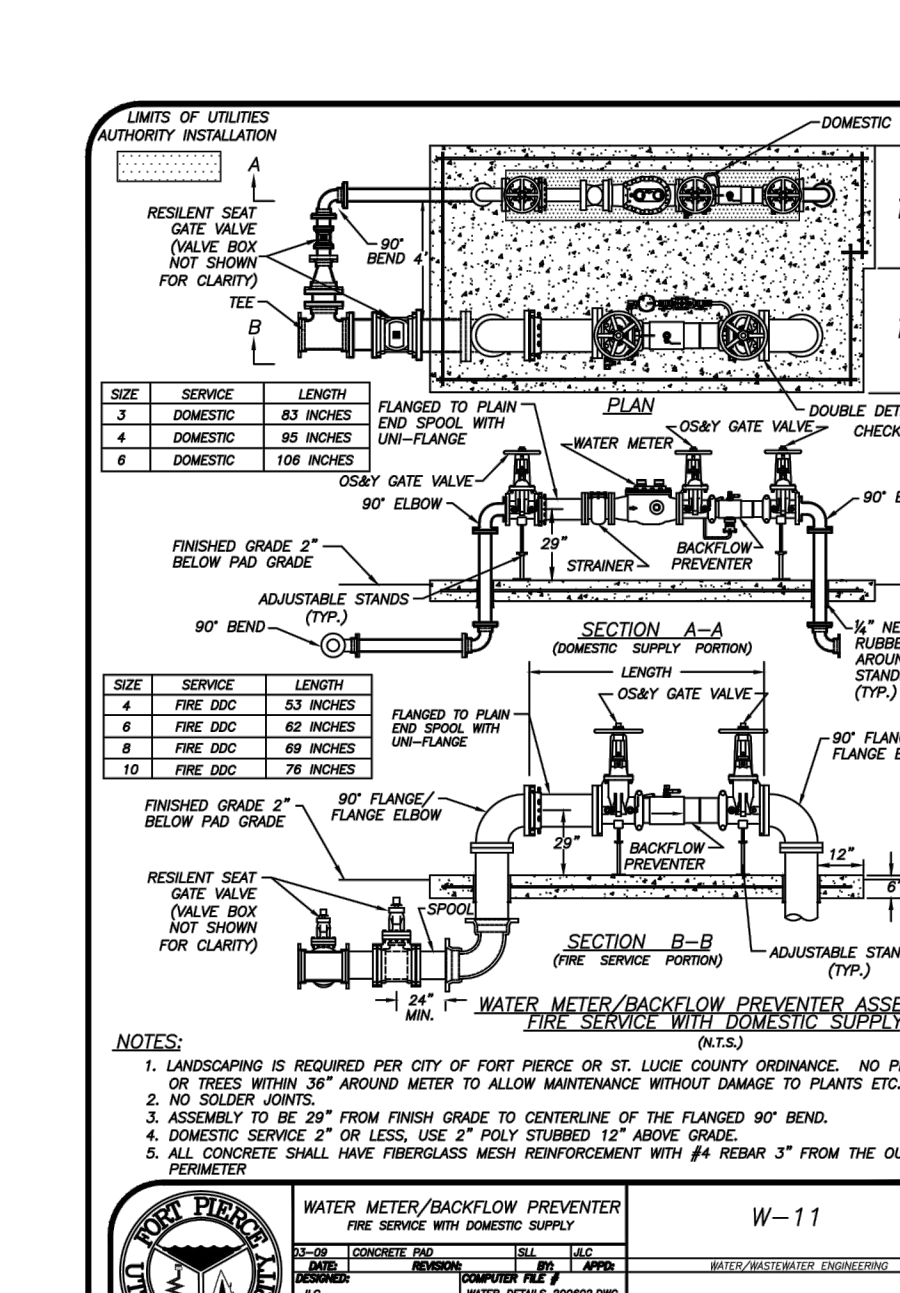
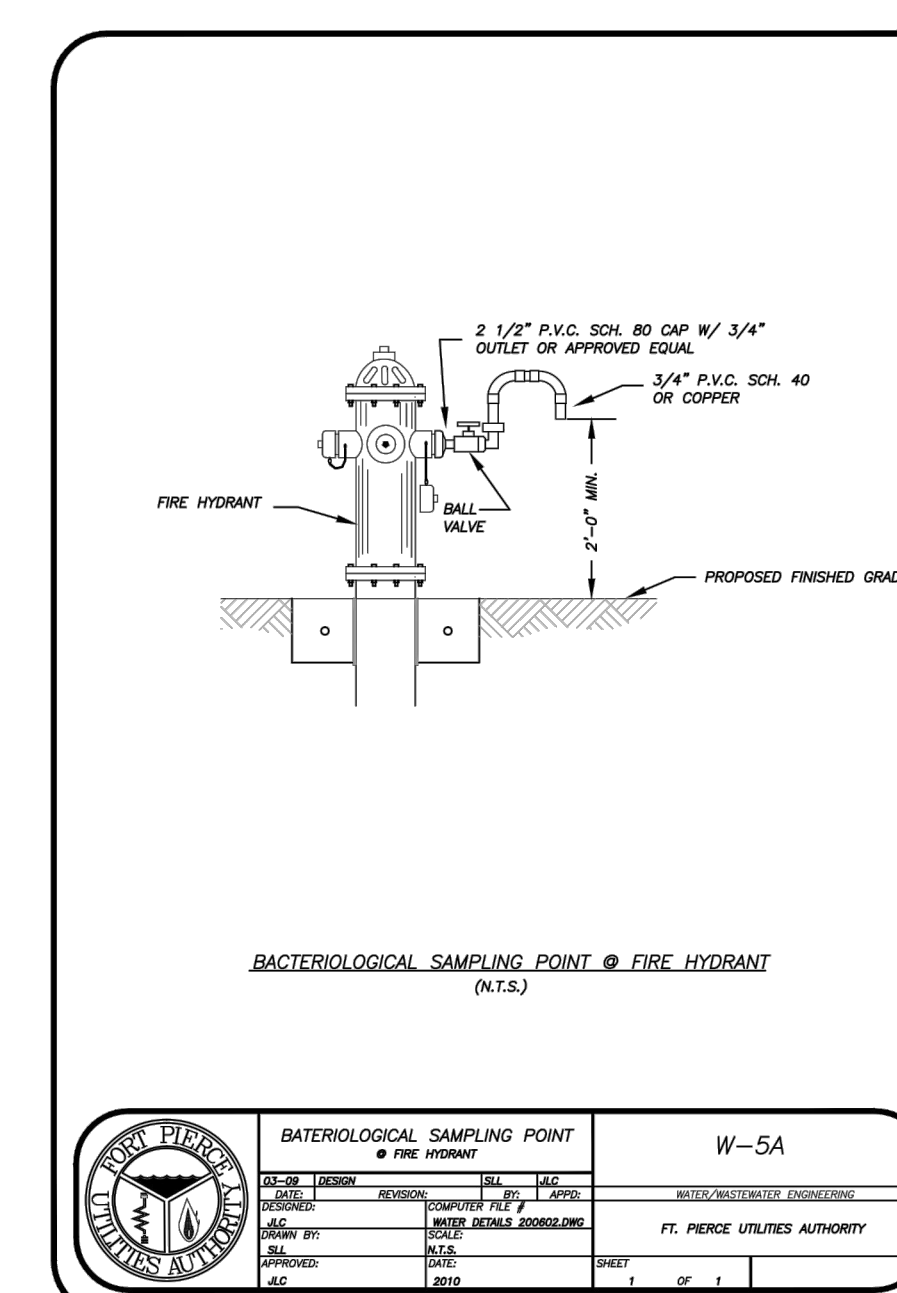
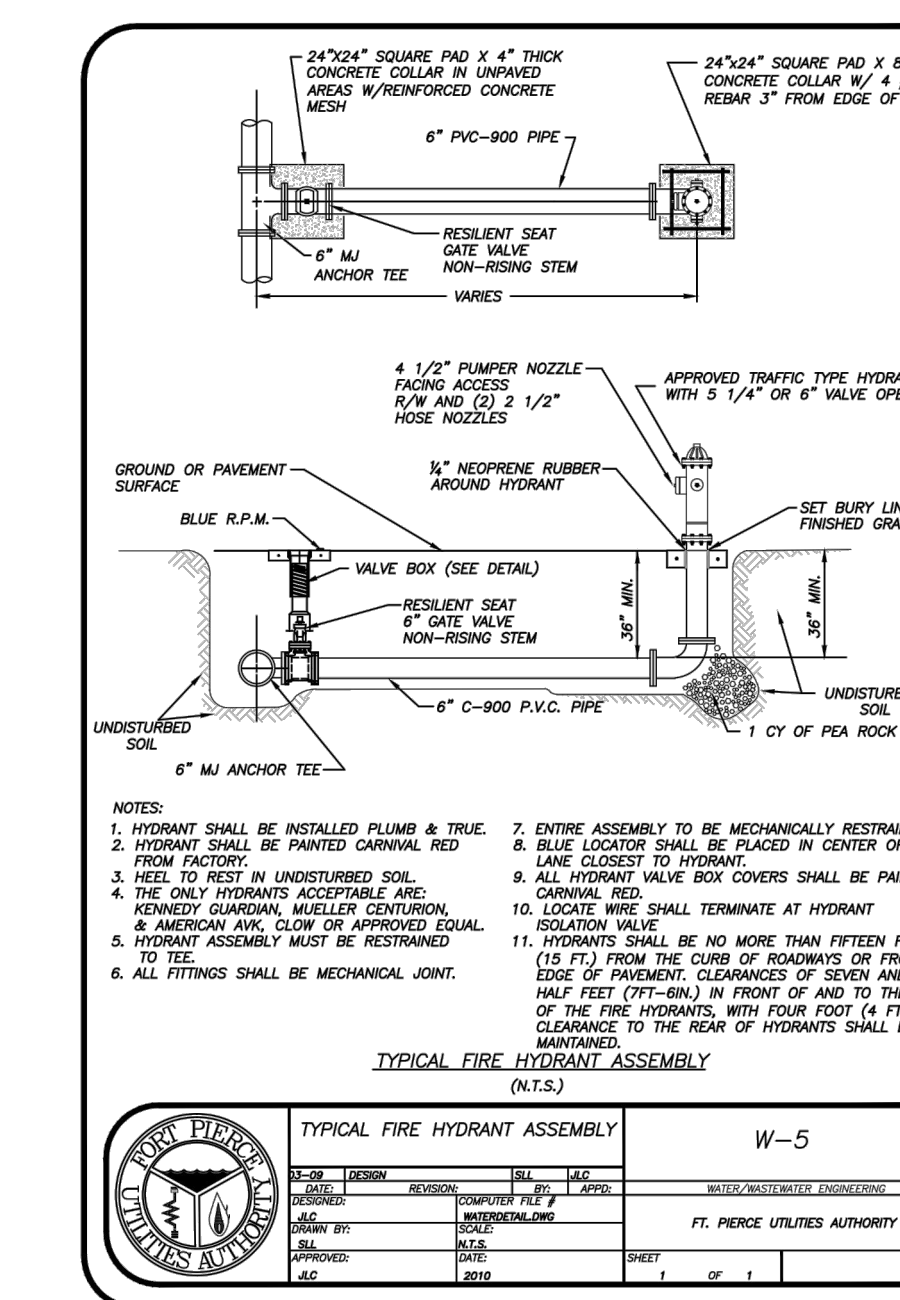
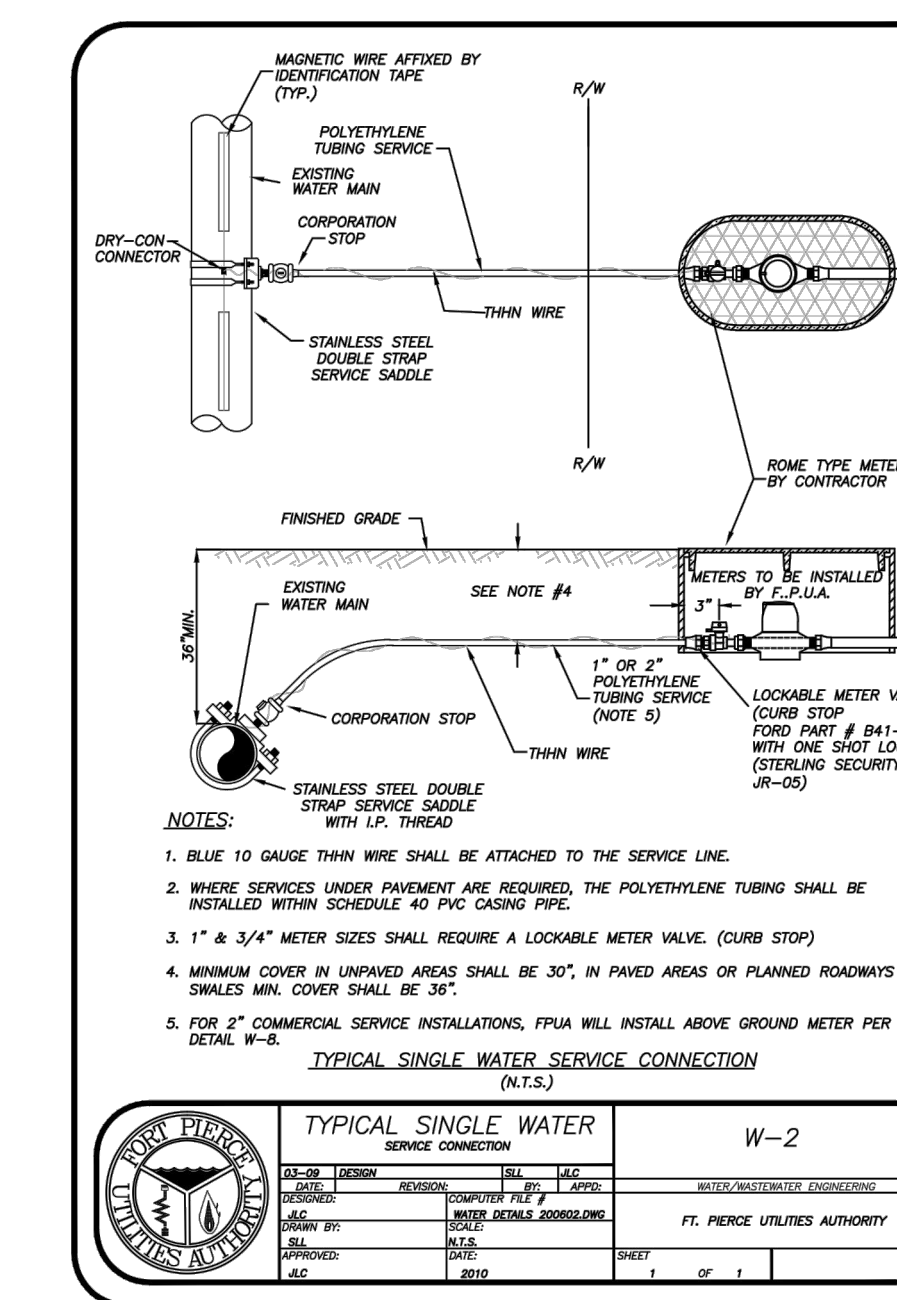
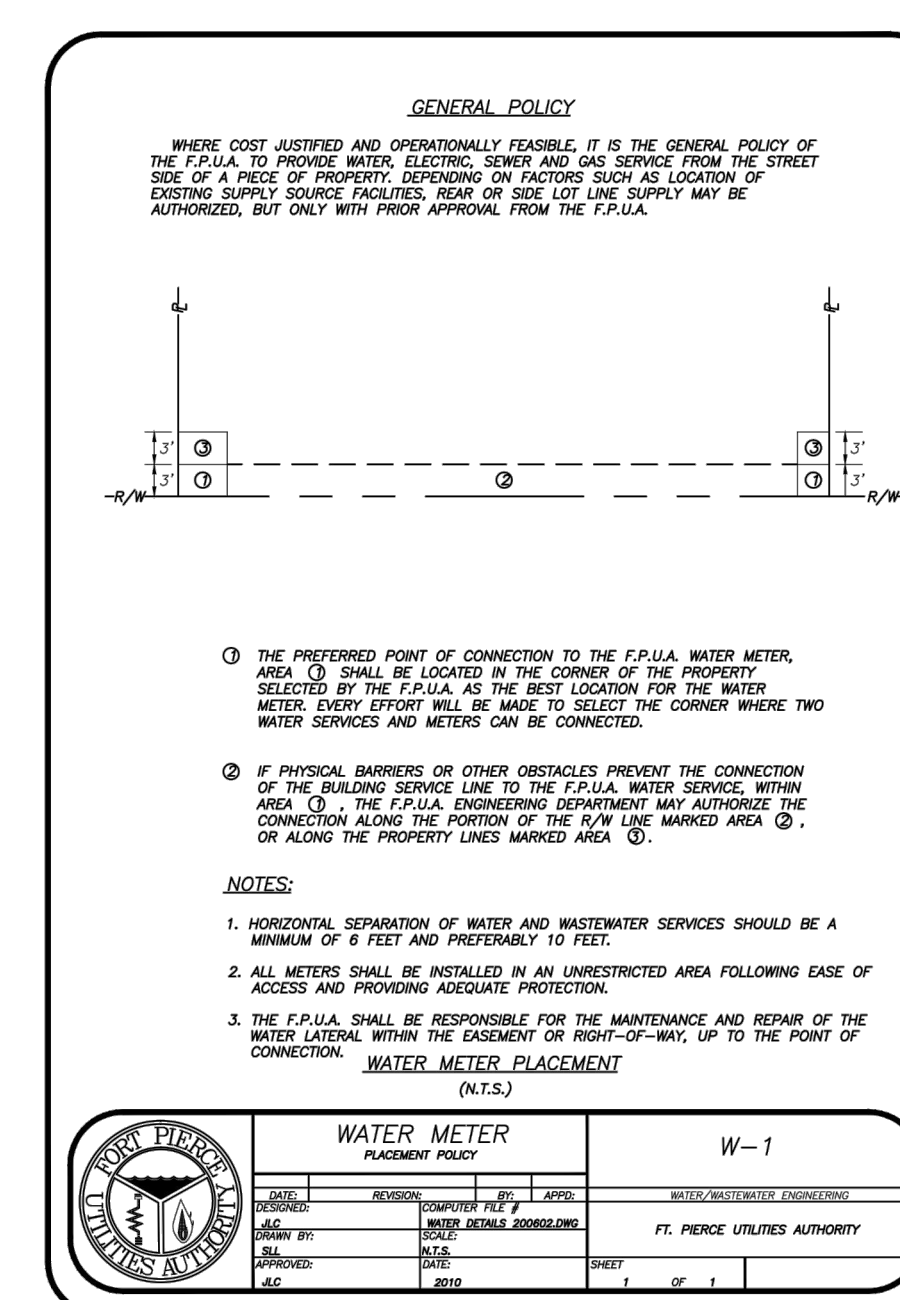
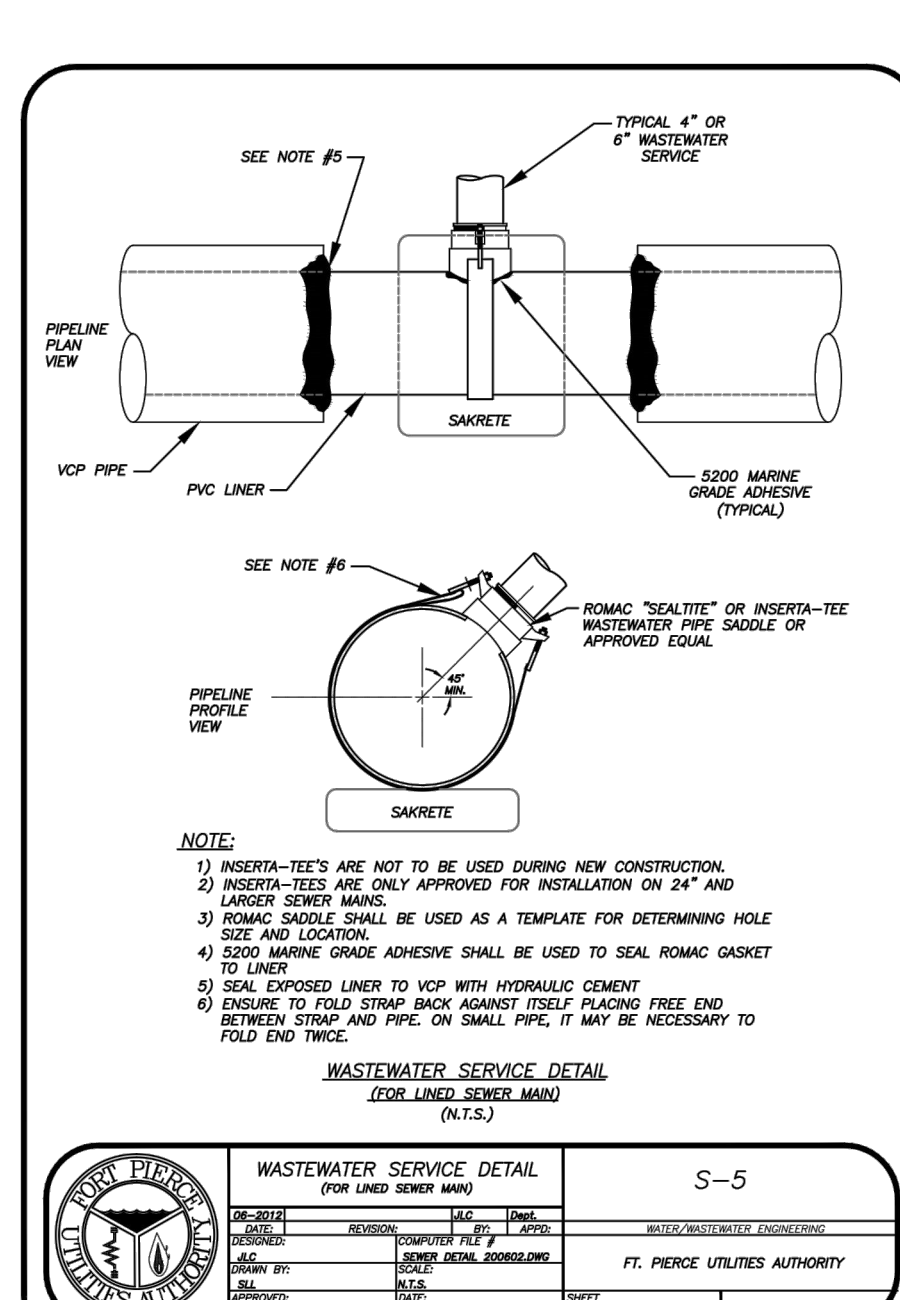
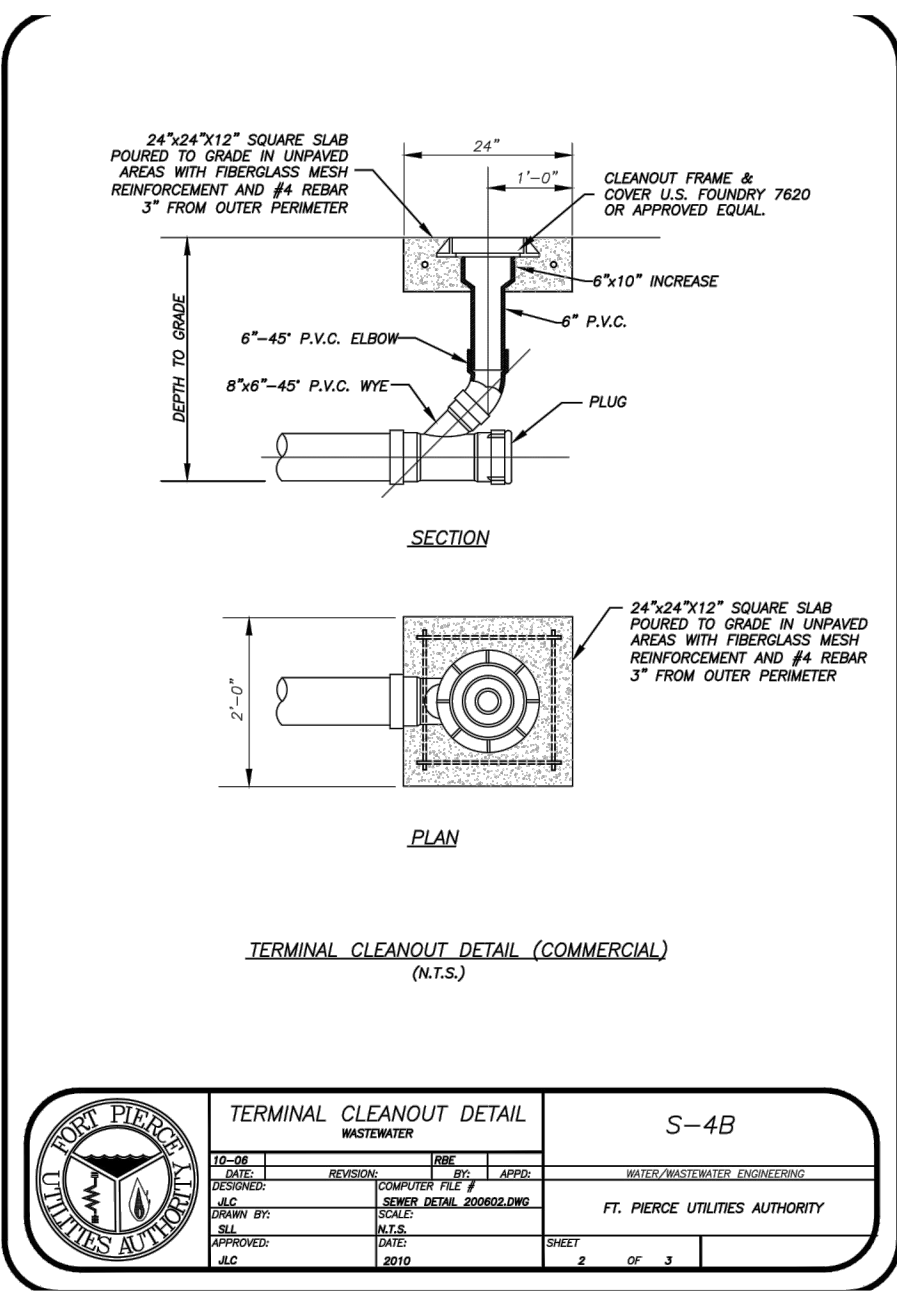

DATE: 5/29/15  
 REVISION: 1  
 MARK: 1

DESIGNED BY: J.E.B.  
 DRAWN BY: J.S.B.  
 CHECKED BY: J.S.B.  
 SCALE: N.T.S.  
 DATE: 4/15/15

**SCHULKE, BITTLE & STODDARD, L.L.C.**  
 CIVIL & STRUCTURAL ENGINEERING - LAND PLANNING - ENVIRONMENTAL PERMITTING  
 CERTIFICATION OF AUTHORIZATION NO.: 00080866  
 1717 INDIAN RIVER BLVD., SUITE 201, VERO BEACH, FLORIDA, 32960  
 TEL: 772-770-9622 EMAIL: info@sbsengineers.com

MISCELLANEOUS DETAILS & SPECIFICATIONS

INLET PALMS

ENGINEER CERTIFICATION  
 [ ] JOSEPH W. SCHULKE  
 FL REG. NO. 47048  
 [ ] JOHANN B. BITTLE  
 FL REG. NO. 57396  
 [ ] WILLIAM P. STODDARD  
 FL REG. NO. 57605

DATE: SHEET 13  
 PROJECT NO. 15-053



THE DRAWINGS ARE THE PROPERTY OF SCHULKE, BITTLE & STODDARD, L.L.C. AND ARE NOT TO BE REPRODUCED OR TRANSMITTED IN ANY FORM OR BY ANY MEANS, ELECTRONIC OR MECHANICAL, INCLUDING PHOTOCOPYING, RECORDING, OR BY ANY INFORMATION STORAGE AND RETRIEVAL SYSTEM, WITHOUT THE WRITTEN CONSENT OF SCHULKE, BITTLE & STODDARD, L.L.C. ALL RIGHTS ARE RESERVED.

MARK	REVISION	DATE
1	REVISED PER CORP	5/29/15

**SCHULKE, BITTLE & STODDARD, L.L.C.**  
 CIVIL & STRUCTURAL ENGINEERING • LAND PLANNING • ENVIRONMENTAL PERMITTING  
 CERTIFICATION OF AUTHORIZATION NO.: 00008668  
 1717 INDIAN RIVER BLVD., SUITE 201 VERO BEACH, FLORIDA 32960  
 TEL 772 / 770-9622 FAX 772 / 770-9496 EMAIL info@sbsengineers.com

AERIAL

INLET PALMS

ENGINEER CERTIFICATION  
 JOSEPH W. SCHULKE  
 FL. REG. NO. 47048  
 ADAM B. BITTLE  
 FL. REG. NO. 57396  
 WILLIAM P. STODDARD  
 FL. REG. NO. 57865

DATE: \_\_\_\_\_  
 SHEET  
 14  
 PROJECT NO.  
 15-053

Report of Survey:

- \* TYPE OF SURVEY: BOUNDARY & TOPOGRAPHIC
- \* THIS SURVEY PERFORMED BY:  
MERIDIAN LAND SURVEYORS  
1717 INDIAN RIVER BLVD. SUITE 101  
VERO BEACH, FLORIDA 32968
- \* PROFESSIONAL SURVEYOR & MAPPER IN RESPONSIBLE CHARGE:  
CHARLES H. BLANCHARD P.S.M. #5755
- \* THE EXPECTED USE OF THE LAND, AS CLASSIFIED IN THE FLORIDA STANDARDS OF PRACTICE (6J-17, FAC) IS COMMERCIAL /HIGH RISK. THE MINIMUM RELATIVE ACCURACY FOR THIS TYPE OF BOUNDARY SURVEY IS 1 FOOT IN 10,000. THE MEASUREMENT AND CALCULATION OF A CLOSED GEOMETRIC FIGURE WAS FOUND TO BE IN EXCESS OF THIS ACCURACY REQUIREMENT.
- \* THIS SURVEY MEETS ALL APPLICABLE REQUIREMENTS OF THE FLORIDA STANDARDS OF PRACTICE AS CONTAINED IN 6J-17, FLORIDA ADMINISTRATIVE CODE.
- \* ELEVATIONS AND DIMENSIONS SHOWN HEREON ARE MEASURED IN FEET AND DECIMAL PARTS THEREOF.
- \* THE LAST DATE OF FIELD WORK WAS: 03/30/15
- \* BUILDING SETBACK LINES, IF SHOWN ARE BASED ON THE BEST AVAILABLE INFORMATION, BUT ARE NOT CERTIFIED TO. THE SETBACKS MUST BE VERIFIED PRIOR TO DESIGN OR CONSTRUCTION.
- \* THE BEARING BASE FOR THIS SURVEY IS A GRID BEARING OF S46°30'43"W, ALONG THE NORTH R/W LINE OF SEAWAY DRIVE AND BASED ON FOUND MONUMENTATION.
- \* THIS SURVEY DOES NOT CERTIFY TO THE EXISTENCE OR LOCATION OF ANY UNDERGROUND IMPROVEMENTS: UTILITIES, FOUNDATIONS, OR ENCROACHMENTS, EXCEPT AS SHOWN.
- \* NO INSTRUMENTS OF RECORD REGARDING EASEMENTS, RIGHT-OF-WAYS, OR OWNERSHIP WERE SUPPLIED TO THIS SURVEYOR, EXCEPT AS SHOWN.
- \* NO TITLE OPINION OR GUARANTEE IS EXPRESSED OR IMPLIED.
- \* UNLESS A COMPARISON IS SHOWN, PLAT VALUES AND MEASURED VALUES ARE THE SAME.
- \* LEGAL DESCRIPTION IS AS PROVIDED BY THE CLIENT.
- \* UNLESS OTHERWISE INDICATED, FOUND MONUMENTATION, IS UNIDENTIFIED.
- \* THE PARCEL OF LAND SHOWN HEREON APPEARS TO BE IN FLOOD ZONE AE-6, AE-7, C & VE-8 PER FLOOD INSURANCE RATE MAP #12111C0183 J, DATED FEBRUARY 16TH, 2012.
- \* THE ELEVATIONS SHOWN HEREON ARE BASED ON THE NORTH AMERICAN VERTICAL DATUM (NAVD) OF 1988. THE BENCHMARK IS CGS MONUMENT G 231 1965, ELEVATION 4.47' NAVD. SECONDARY BENCHMARK IS AS SHOWN HEREON.

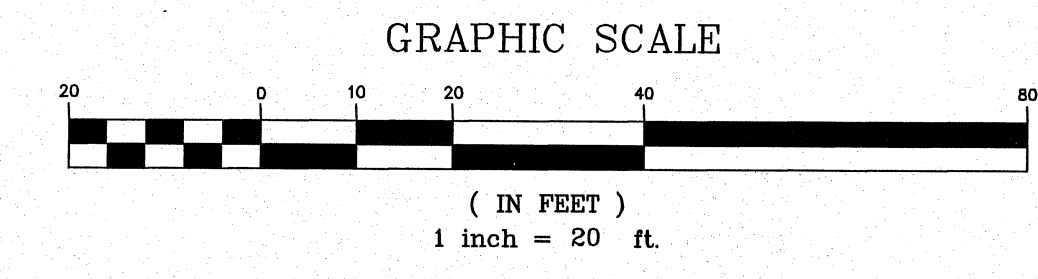
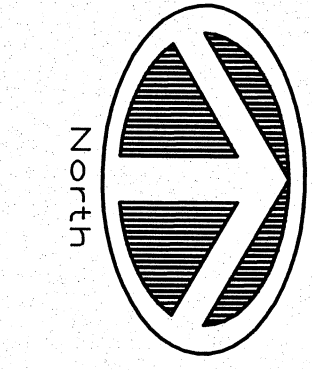

CURVE	DELTA ANGLE	RADIUS	ARC
C 1	03°33'13"	1350.48'	83.76'

Legend & Abbreviations: (symbols not scaleable for size)

- PLS - PROFESSIONAL LAND SURVEYOR
- PSM - PROFESSIONAL SURVEYOR & MAPPER
- LB - LAND SURVEYING BUSINESS
- C - CENTERLINE
- R - RADIUS
- L - LENGTH
- Δ - DELTA ANGLE
- E/P - EDGE OF PAVEMENT
- B/C - BACK OF CURB
- B.M. - BENCHMARK
- POC - POINT OF COMMENCEMENT
- POB - POINT OF BEGINNING
- PCP - PERMANENT CONTROL POINT
- PRM - PERMANENT REFERENCE MONUMENT
- IP - IRON PIPE
- IRC - IRON ROD & CAP
- CM - CONCRETE MONUMENT
- FD - FOUND
- (M) - MEASURED
- (C) - CALCULATED
- GUY WIRE
- WOOD UTILITY POLE
- TELEPHONE SERVICE
- CABLE T.V. BOX
- ELECTRIC BOX
- LIGHT POST
- WELL
- HYDRANT
- GATE VALVE
- IRRIGATION VALVE
- WATER METER
- SANITARY MANHOLE
- SANITARY SERVICE
- SEPTIC TANK
- DRAINAGE MANHOLE
- CURB INLET
- SURFACE INLET
- MITERED END SECTION
- CONCEPTUAL DRAINAGE
- STREET SIGN
- PROPOSED GRADE
- NAVD - NORTH AMERICAN VERTICAL DATUM
- TYPICAL ELEVATION
- A/C - AIR CONDITIONER
- CONC. - CONCRETE
- F.F. - FINISH FLOOR
- BSB - BUILDING SETBACK LINE
- EL./ELEV. - ELEVATION
- R/W - RIGHT OF WAY
- AB - AS-BUILT
- P/K - PARKER-KALON

Legend & Abbreviations: (symbols not scaleable for size)

- PLS - PROFESSIONAL LAND SURVEYOR
- PSM - PROFESSIONAL SURVEYOR & MAPPER
- LB - LAND SURVEYING BUSINESS
- C - CENTERLINE (R) - RADIAL (NR) - NON-RADIAL
- R - RADIUS
- L - LENGTH
- Δ - DELTA ANGLE
- E/P - EDGE OF PAVEMENT
- B/C - BACK OF CURB
- B.M. - BENCHMARK
- POC - POINT OF COMMENCEMENT
- POB - POINT OF BEGINNING
- PCP - PERMANENT CONTROL POINT
- PRM - PERMANENT REFERENCE MONUMENT
- IP - IRON PIPE
- IRC - IRON ROD & CAP
- CM - CONCRETE MONUMENT
- FD - FOUND
- (M) - MEASURED
- (P) - PLAT
- (C) - CALCULATED
- O.R.B. - OFFICAL RECORD BOOK
- UE - UTILITY EASEMENT
- PULL BOX
- GUY WIRE
- WOOD UTILITY POLE
- TELEPHONE SERVICE
- CABLE T.V. BOX
- ELECTRIC BOX
- LIGHT POST
- WELL
- HYDRANT
- GATE VALVE
- IRRIGATION VALVE
- WATER METER
- SANITARY MANHOLE
- SANITARY SERVICE
- SEPTIC TANK
- DRAINAGE MANHOLE
- CURB INLET
- SURFACE INLET
- MITERED END SECTION
- CONCEPTUAL DRAINAGE
- STREET SIGN
- PROPOSED GRADE
- NAVD - NORTH AMERICAN VERTICAL DATUM
- TYPICAL ELEVATION
- A/C - AIR CONDITIONER
- CONC. - CONCRETE
- F.F. - FINISH FLOOR
- BSB - BUILDING SETBACK LINE
- EL./ELEV. - ELEVATION
- R/W - RIGHT OF WAY
- AB - AS-BUILT
- P/K - PARKER-KALON

LEGAL DESCRIPTION:  
LOTS 16, 17 AND 18, BLOCK 16, REVISED MAP OF FT. PIERCE BEACH, ACCORDING TO THE PLAT THEREOF, AS RECORDED IN PLAT BOOK 8, PAGE 29, OF THE PUBLIC RECORDS OF ST. LUCIE COUNTY, FLORIDA.

NOTE:  
THIS SURVEY IS BASED ON A MAP OF SURVEY BY ALEXANDER J. PIAZZA PSM, INC. LB #7280, DATED 09-21-05, PROJECT NUMBER 05-0543.

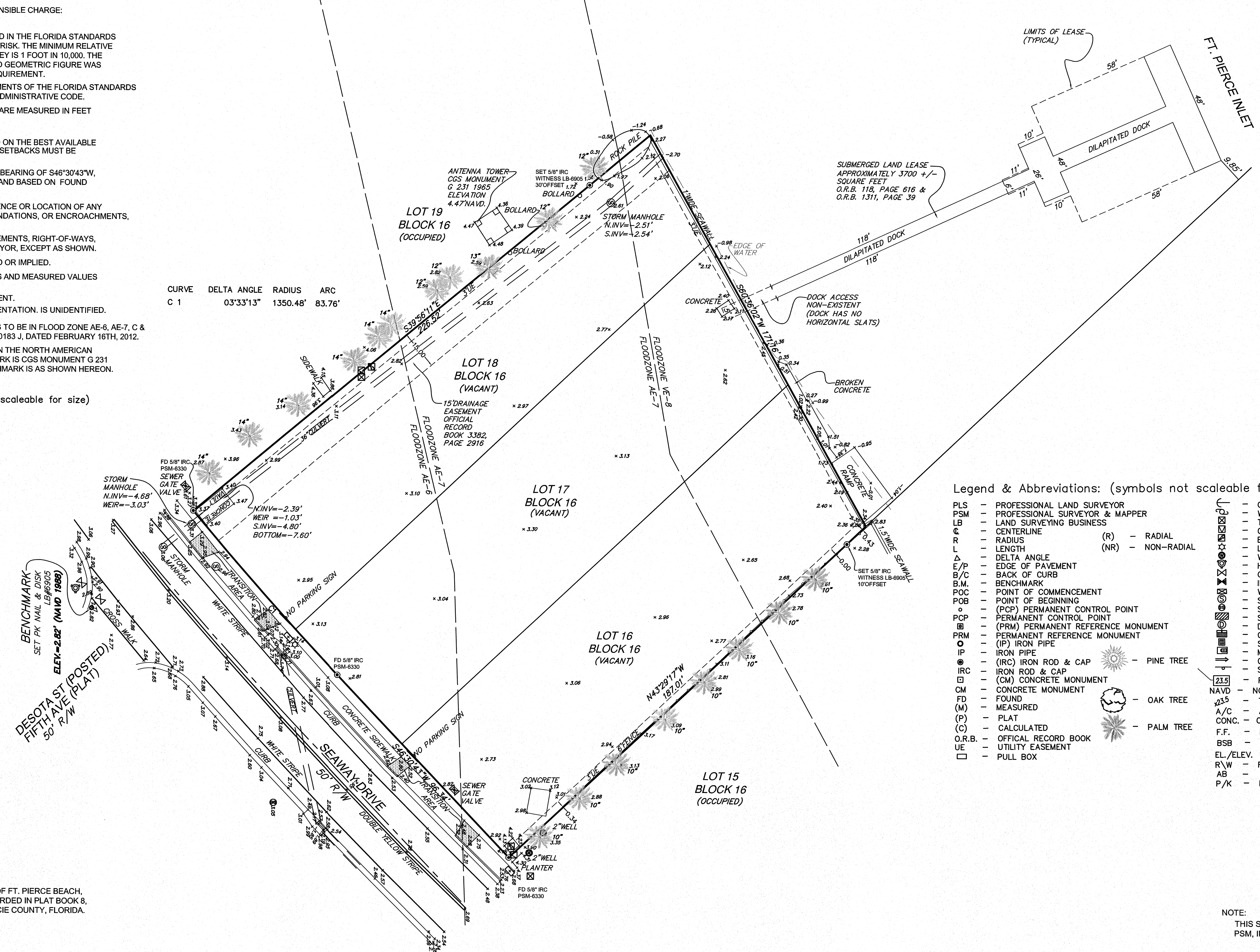

**MERIDIAN**  
LAND SURVEYORS  
1717 INDIAN RIVER BLVD, SUITE 201  
VERO BEACH, FL. 32960 LB#6905  
PHONE: 772-794-1213, FAX: 772-794-1096  
E-MAIL: LB6905@BELLSOUTH.NET

TYPE: BOUNDARY & TOPOGRAPHIC	REVISIONS
PROJECT# 15-024	
DATE: 3/23/15 F.B.214 PGE.27	
DRAWN BY: C.H.B.	2. 5-29-15 REVISE TYPO'S CHB
CHECKED BY: S.P.T.	1. 4-21-15 ADD DRAINAGE EASEMENT CHB
SCALE: 1:20 SHEET: 1 OF 1	NO. DATE DESCRIPTION BY

PLAT OF SURVEY FOR:  
**FOGLIA CONSTRUCTION**

THIS SURVEY IS NOT VALID WITHOUT THE SIGNATURE AND THE ORIGINAL RAISED SEAL OF THE FLORIDA LICENSED SURVEYOR AND MAPPER NAMED BELOW.

*Charles H. Blanchard*  
CHARLES H. BLANCHARD P.S.M. #5755

WATERFRONT TOWN HOMES  
**INLET PALMS**

1502 SEAWAY DRIVE  
FORT PIERCE, FLORIDA

SPA - 04/30/2015  
SPA COMMENTS - 05/28/2015



ARCHITECT:

**Atelier d'Architecture**

By Jeff L. Ray, Inc.  
912 22nd Place  
Vero Beach, Florida 32960

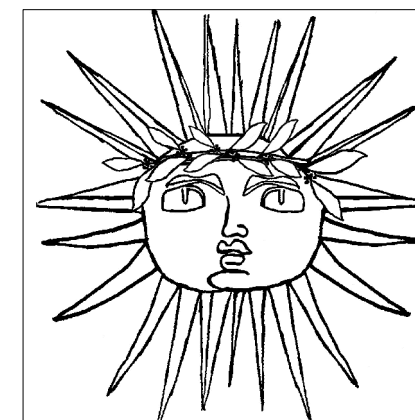

(772) 770-9094 ph/fax  
(772) 766-1611 cell

Reg. No.: AA26002550 Lic. No.: AR94893	Dwn: J.L.R. Chd: J.L.R. Sheet No:	Dwg. File: Project No.: 1507
Date Signed:	<b>A0.10</b>	
<small>Copyright © 2015, Atelier d'Architecture By Jeff L. Ray, Inc.</small>		

Project:

WATERFRONT TOWN HOMES:  
**INLET  
PALMS**  
FORT PIERCE, FLORIDA

Key Plan:

Issues:

No.	Date	Description
1.	04/30/2015	SPA
2.	05/28/2015	SPA COMMENTS



SOUTH ELEVATION BUILDINGS - 1 & 2

SCALE: 1/8" = 1'-0"



NORTH ELEVATION BUILDINGS - 1 & 2

SCALE: 1/8" = 1'-0"

ARCHITECT:

**Atelier d'Architecture**  
By Jeff L. Ray, Inc.  
912 22nd Place  
Vero Beach, Florida 32960

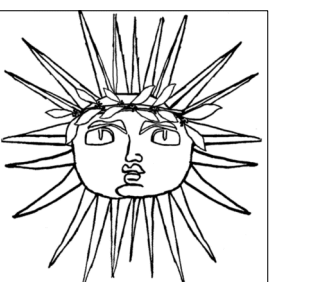

(772) 770-9094 ph/fax  
(772) 766-1611 cell

SEAL:

Drawing Title:

ELEVATIONS

Reference North

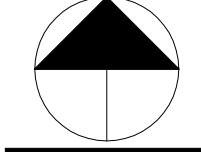

Dwn:	Dwg. File:
J.L.R.	.
Chd:	Project No.:
.	.
Sheet No.:	.

Reg. No.: AA26002550  
Lic. No.: AR34623

**A3.10**

Date Signed:

Copyright © 2015, Atelier d'Architecture By Jeff L. Ray, Inc.

Project:

WATERFRONT TOWN HOMES:  
**INLET  
PALMS**  
FORT PIERCE, FLORIDA

Key Plan:

Issues:

No.:	Date:	Description:
1.	04/30/2015	SPA
2.	05/28/2015	SPA COMMENTS



WEST ELEVATION BUILDING - 1

SCALE: 1/8" = 1'-0"

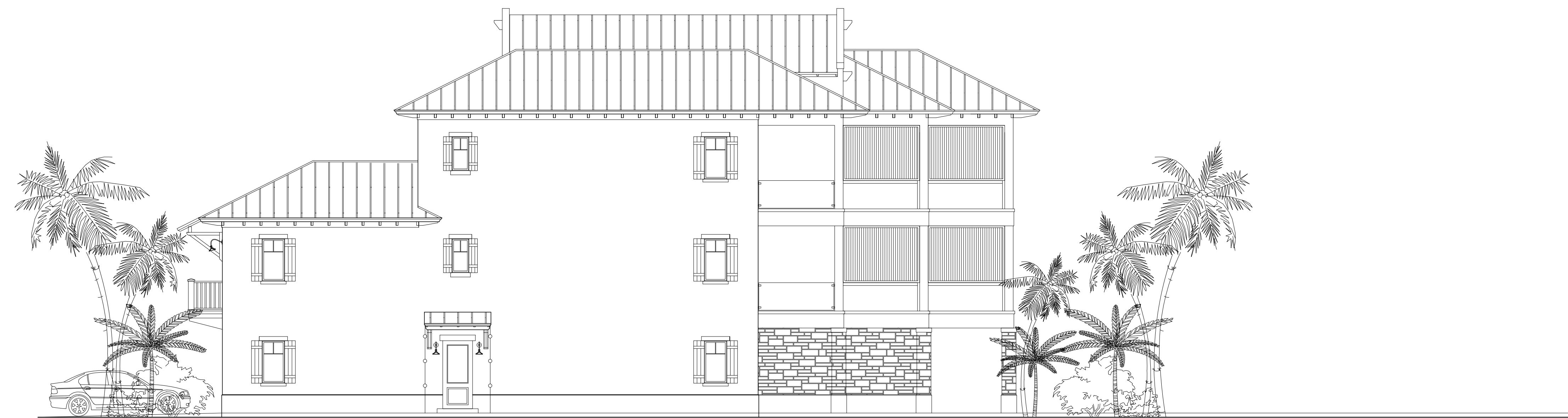

EAST ELEVATION BUILDING - 1

SCALE: 1/8" = 1'-0"

ARCHITECT:

**Atelier d'Architecture**  
By Jeff L. Ray, Inc.  
912 22nd Place  
Vero Beach, Florida 32960

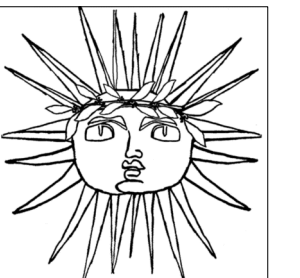

(772) 770-9094 ph/fax  
(772) 766-1611 cell

SEAL:

Drawing Title:

ELEVATIONS

Reference North

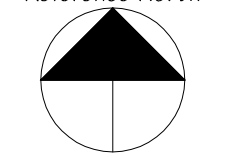

Dwn:	Dwg. File:
J.L.R.	.
Chd:	Project No.:
.	.
Sheet No.:	.

Reg. No.: A26002550  
Lic. No.: AR34623

Date Signed:

**A3.11**

Copyright © 2015, Atelier d'Architecture By Jeff L. Ray, Inc.



WEST ELEVATION BUILDING - 2

SCALE: 1/8" = 1'-0"

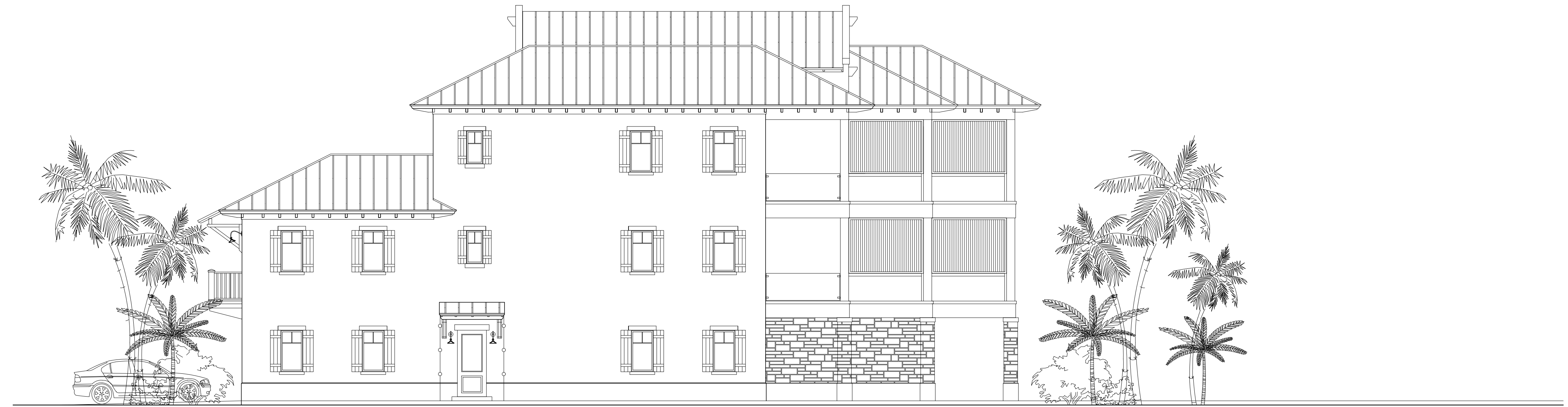

EAST ELEVATION BUILDING - 2

SCALE: 1/8" = 1'-0"

Project:

WATERFRONT TOWN HOMES:  
**INLET  
 PALMS**  
 FORT PIERCE, FLORIDA

Key Plan:

Issues:

No.:	Date:	Description:
1.	04/30/2015	SPA
2.	05/28/2015	SPA COMMENTS

ARCHITECT:

**Atelier d'Architecture**  
 By Jeff L. Ray, Inc.  
 912 22nd Place  
 Vero Beach, Florida 32960

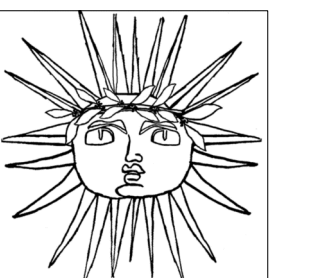

(772) 770-9094 ph/fax  
 (772) 766-1611 cell

SEAL:

Drawing Title:

ELEVATIONS

Reference North

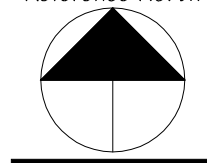

Dwn:	Dwg. File:
J.L.R.	.
Chd:	Project No.:
.	.
Sheet No.:	.

Reg. No.: AA26002550  
 Lic. No.: AR34623

**A3.12**

Date Signed:



SOUTH ELEVATION BUILDING - 3

SCALE: 1/8" = 1'-0"



NORTH ELEVATION BUILDING - 3

SCALE: 1/8" = 1'-0"



EAST ELEVATION BUILDING - 3

SCALE: 1/8" = 1'-0"



WEST ELEVATION BUILDING - 3

SCALE: 1/8" = 1'-0"

Project:

WATERFRONT TOWN HOMES:  
**INLET  
 PALMS**  
 1502 SEAWAY DRIVE  
 FORT PIERCE, FLORIDA

Key Plan:

Issues:

No.:	Date:	Description:
1.	04/30/2015	SPA
2.	05/28/2015	SPA COMMENTS

ARCHITECT:

**Atelier d'Architecture**  
 By Jeff L. Ray, Inc.  
 912 22nd Place  
 Vero Beach, Florida 32960

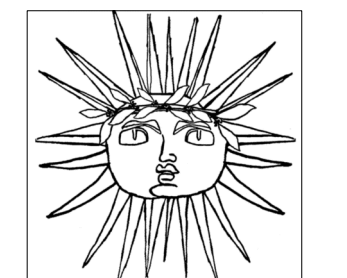

(772) 770-9094 ph/fax  
 (772) 766-1611 cell

SEAL:

Drawing Title:

ELEVATIONS

Reference North

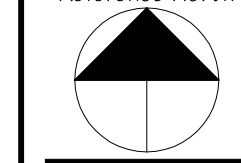

Dwn: J.L.R.  
 Cnd: Project No.:  
 Sheet No.:

Reg. No.: A26002550  
 Lic. No.: AR34623

**A3.13**

Date Signed: