

Table of Contents

Strategic Planning for the City of Fort Pierce

1

Fort Pierce Vision 2032

3

City of Fort Pierce Plan 2017 – 2022

9

City of Fort Pierce Action Agenda 2017

34

DRY [UPDATED: 2/28/17]

This report and all related materials are copyrighted. This report may be duplicated for distribution to appropriate parties as needed. No unauthorized duplication is allowed, including for use in training within your organization or for consulting purposes outside your organization. All requests for duplication must be submitted in writing.

STRATEGIC PLANNING FOR THE CITY OF FORT PIERCE

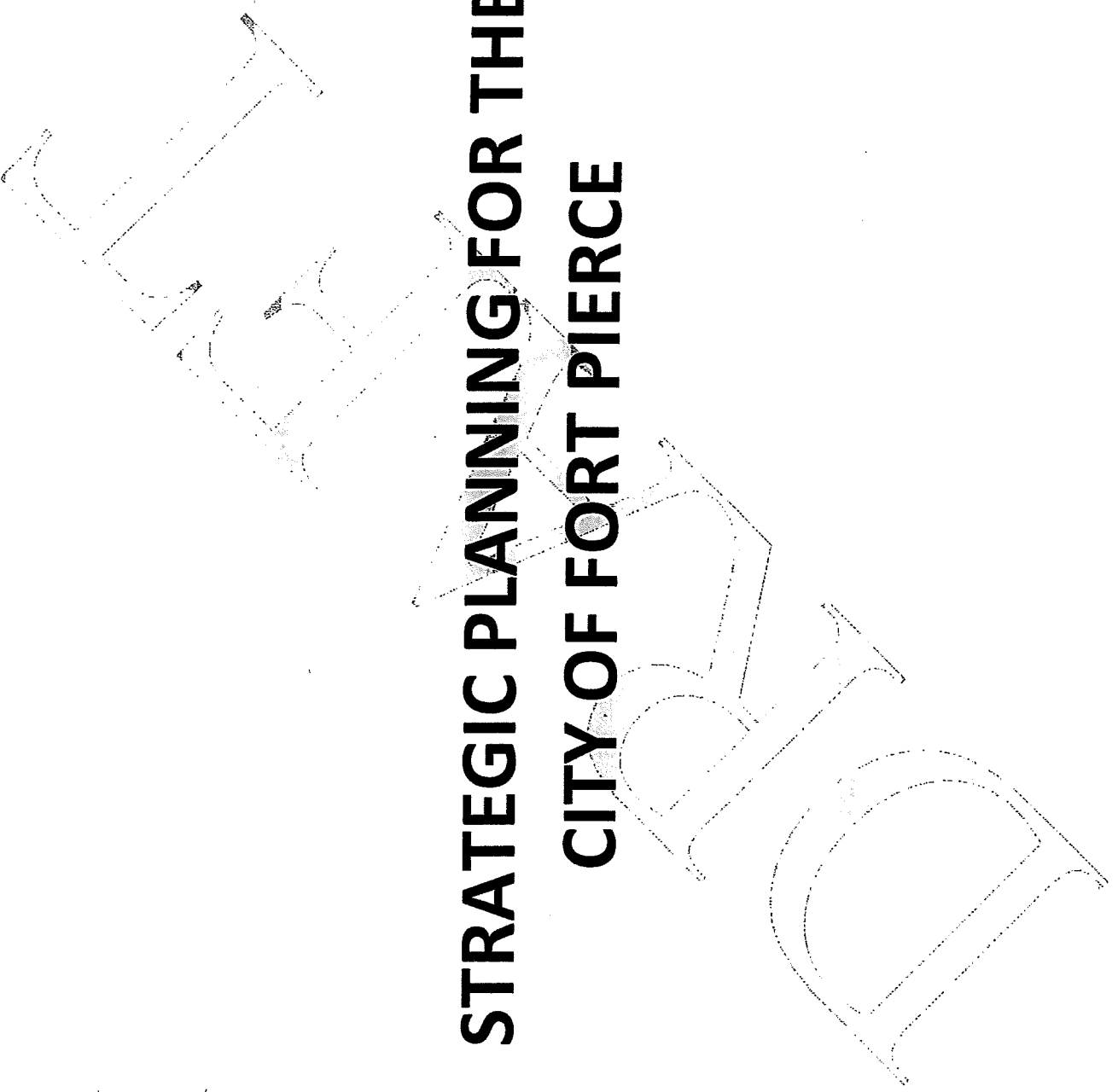

Strategic Planning Model for the City of Fort Pierce

Value-based principles that describe the preferred future in 15 years

VISION

Destination
"You Have Arrived"

Strategic goals that focus outcome-based objectives and potential actions for 5 years

PLAN

Map
"The Right Route"

Focus for one year – a work program: policy agenda for Mayor and Commission, management agenda for staff, major projects

EXECUTION

Itinerary
"The Right Direction"

Principles that define the responsibility of city government and frame the primary services – core service businesses

MISSION

Vehicle
"The Right Bus"

Personal values that define performance standards and expectations for employees

CORE BELIEFS

Fuel
"The Right People"

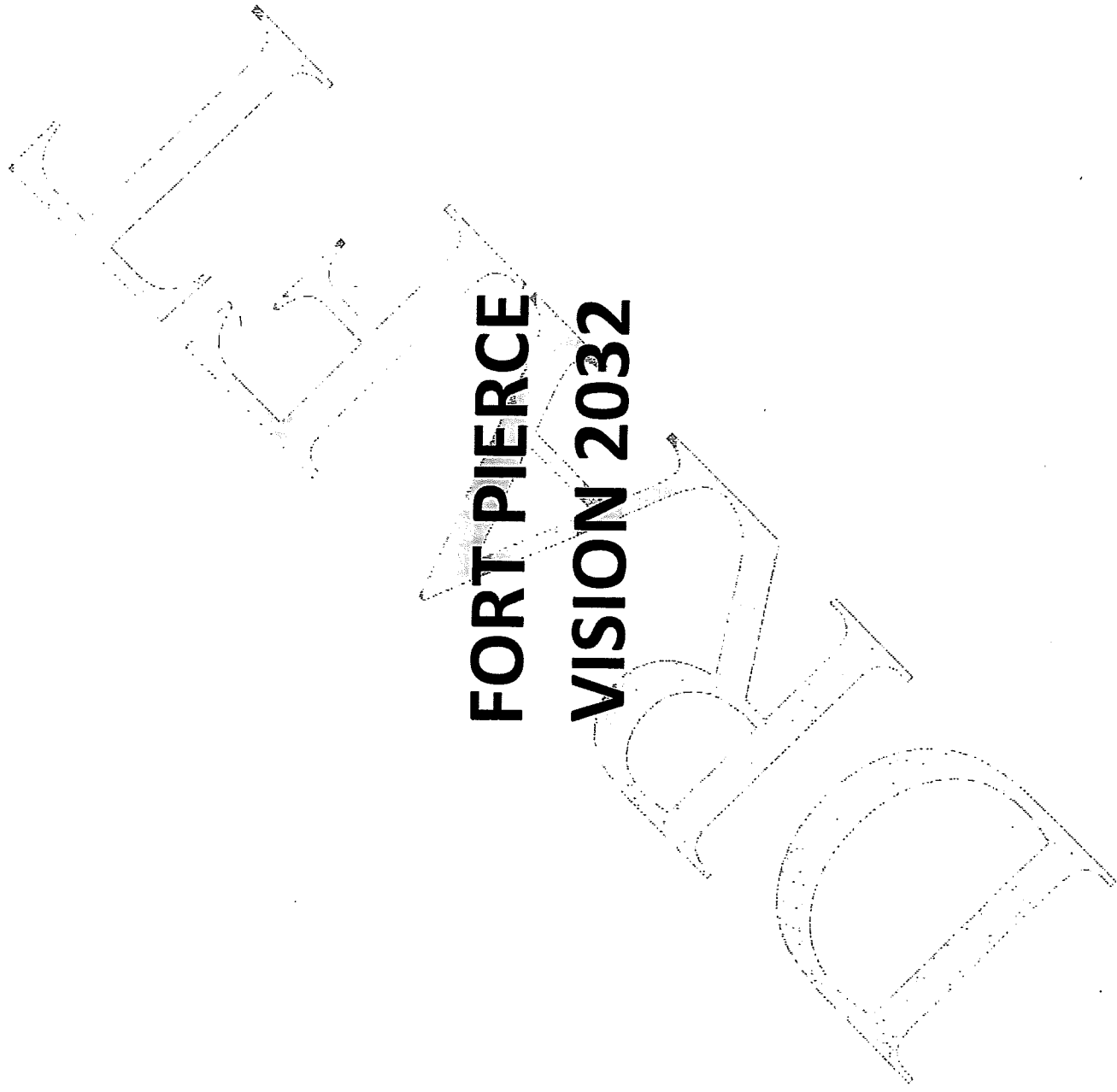

FORT PIERCE VISION 2032

Fort Pierce Vision 2032

Fort Pierce 2032 is a Unique Coastal Florida City

Our WATERFRONTS, ⁽¹⁾

STRONG LOCAL ECONOMY, ⁽²⁾

HISTORY, ARTS AND CULTURE, ⁽³⁾

CHOICE OF DESIRABLE NEIGHBORHOODS, ⁽⁴⁾

OPPORTUNITIES FOR FUN, ⁽⁵⁾

COMMUNITY UNITY AND PRIDE ⁽⁶⁾

WHAT MAKES US UNIQUE

Fort Pierce Vision 2032

PRINCIPLE 1

WATERFRONTS

► Means

1. Public access to the water for use and enjoyment
2. World-class beaches
3. Water quality in the Indian River Lagoon
4. High quality boutique hotel (5)
5. Operational mixed-use port
6. Marinas for residents and visiting boaters
7. Preservation of views and vista of the water
8. Fishing tournaments attracting fishermen from all over the world
9. Wastewater treatment plant relocated

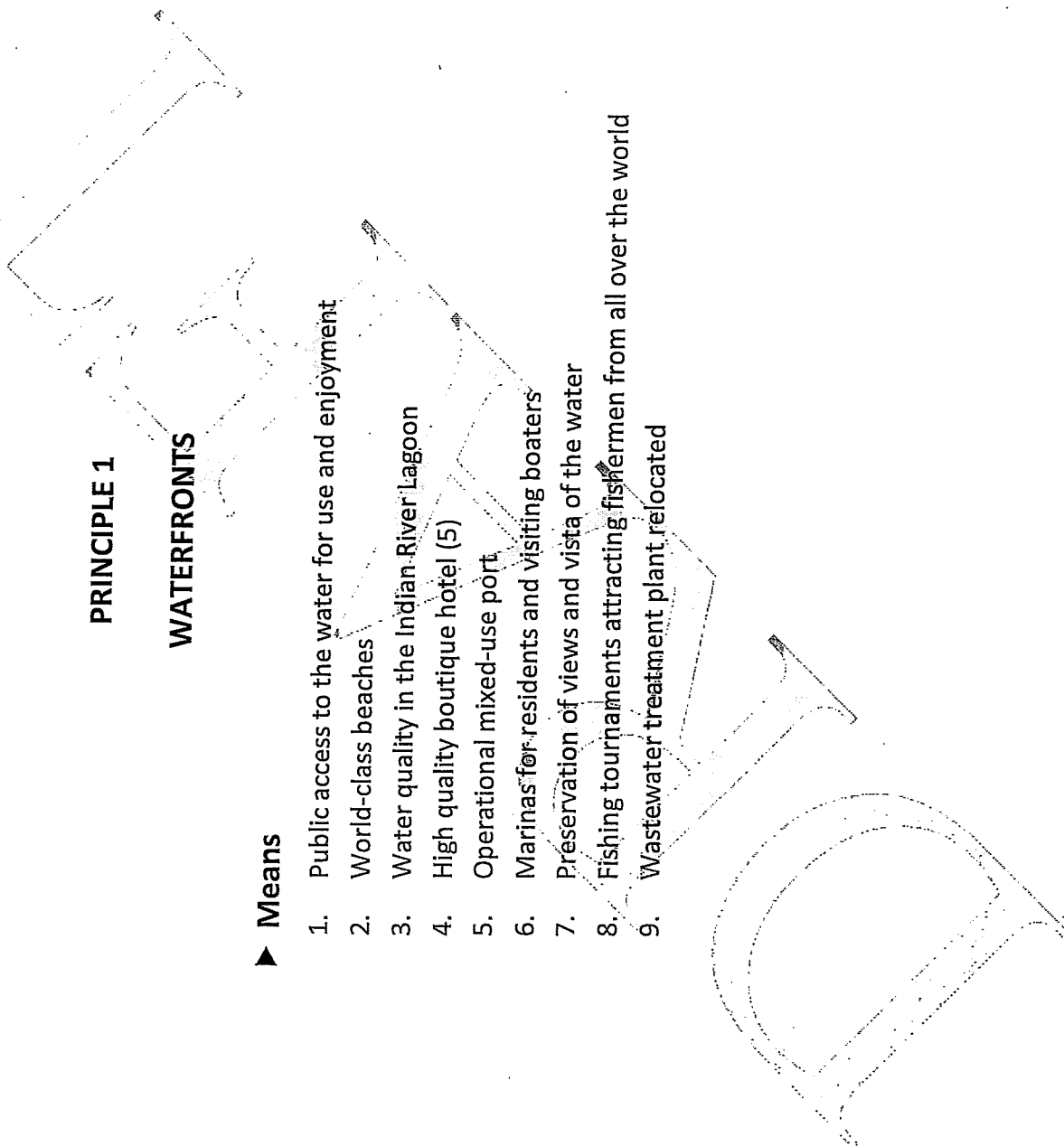

PRINCIPLE 2

STRONG LOCAL ECONOMY

► Means

1. Economy based upon tourism, education, research, and marine-related businesses
2. Visitors having a choice of a variety of high quality hotels throughout the City, including a conference center
3. Diverse reasons for tourist to visit: history; arts and culture; water-based activities- boating, fishing, kayaking, parasailing; and eco-tourism
4. Quality higher education with Indian River State College, Florida Atlantic University Harbor Branch, Oceanographic Institute, University of Florida Research Center, and Bethune Cookman University
5. International airport surrounded by commercial and industrial businesses
6. Active port with commercial shipping, mega yacht manufacturing and maintenance, hotel, and passenger cruises
7. Business friendly City government: people, regulations, and processes
8. Sport tournaments coming and returning to Fort Pierce
9. Light specialty/manufacturing businesses located here
10. Workforce and "trade" development programs in public schools and Indian River State College

PRINCIPLE 3

HISTORY, ARTS AND CULTURE

► Means

1. Art galleries and museums showcasing the community's art and history
2. Celebrating the achievements of famous City residents like A. E. Backus, Zora Neale Hurston, The Highwaymen Artists, etc.
3. Historic Sunrise Theatre providing diverse and multi-cultural programs and performances for all ages
4. Art in public spaces
5. Art incorporated in private developments
6. Community performing venues for jazz, blues and other music
7. Common sense, flexible Building Codes to preserve historic homes and buildings that are structurally sound, and facilitate removal of old, unsound structures

PRINCIPLE 4

CHOICE OF DESIRABLE NEIGHBORHOODS

► Means

1. Sense of personal safety and security at home and in the neighborhood – living without fear
2. Well-maintained housing stock
3. High percentage of home ownership in every neighborhood
4. Quality rental housing that is inspected and meets Building Code requirements
5. Homes retaining their property values
6. Variety of neighborhoods: historic, beachfront, urban, semi-rural
7. Well-maintained streets, utilities, drainage system, curbs and sidewalks
8. Effective multi-modal public transportation for residents moving from home to desired destinations in a timely manner
9. Public green spaces in every neighborhood

PRINCIPLE 5

OPPORTUNITIES FOR FUN

► Means

1. Recreational activities and programs for all generations
2. Easy access to water based activities: boating, fishing, beaches, kayaking, canoeing, parasailing, etc.
3. Performing and cultural arts with diverse and multi-cultural programs and performances for all
4. Indoor recreational facility with rooms, and a variety of venues
5. Organized sports for youth, adults and seniors: recreation and tournaments
6. Quality public golf course with a clubhouse containing community rooms and banquet facilities
7. Aquatic facility(ies) and pools for residents to enjoy
8. Opportunities for biking, hiking, walking and running
9. Variety of specialty parks responsive to community needs

PRINCIPLE 6

COMMUNITY UNITY AND PRIDE

► Means

1. Respect, tolerance and appreciating different cultures
2. Strong community events and festivals with high level of participation
3. Television and social media promoting positive accomplishments and community successes
4. Individuals and community organizations working for community benefit
5. Recognizing the accomplishment of youth in partnership with St. Lucie County schools
6. Business owners, property owners, institutions and residents taking responsibility for their property
7. Multi-cultural festival celebrating the diverse cultures in the community
8. All residents working together on common community goals and solving problems
9. Residents taking pride in saying "I am from Fort Pierce"

CITY OF FORT PIERCE PLAN for 2017

City of Fort Pierce Goals 2022

FINANCIALLY SOUND CITY PROVIDING EXCELLENT SERVICES

SAFER AND MORE BEAUTIFUL CITY

VIBRANT DOWNTOWN AND NEIGHBORHOODS

COMMUNITY UNITY AND PRIDE

GREAT PLACE TO LIVE, LEARN, WORK, AND PLAY

ALIVE WATERFRONTS

GOAL 1

FINANCIALLY SOUND CITY PROVIDING EXCELLENT SERVICES

OBJECTIVES

1. Maintain top quality City workforce dedicated to serving the Fort Pierce community
2. Have excellent City services delivered in the most cost effective manner
3. Partner with others to expand resources in order to support City services
4. Reduce dependence on Ad Valorem Tax receipts
5. Develop and fund for City capital/equipment replacement
6. Maintain financial reserves consistent with the City policies

MEANS TO RESIDENTS

1. Value for your taxes and fees
2. Customer friendly City services
3. Easy access to City information and services
4. City Commission acting as responsible fiscal stewards
5. Reliable City services that are responsive to residents' needs

SHORT TERM CHALLENGES AND OPPORTUNITIES

1. Aging City infrastructure and facilities requiring significant maintenance and replacement
2. Deferred capital and equipment investment now requiring significant funding
3. Outdated information technology needing significant investment
4. **Rising costs of healthcare, pensions, materials and energy**
5. Increasing demands for City services
6. Actions by Federal and State governments: impacting revenues, unfunded mandates and regulations, fewer grants and earmarked projects

4.

LONG TERM CHALLENGES AND OPPORTUNITIES

Retaining a quality City workforce

3. City staffing and the capacity to provide services
4. Optimizing revenues and resources from enterprise funds, including the Fort Pierce Utilities Authority
4. Willingness to raise taxes and fees

2.

DRAFT

POLICY ACTIONS 2017

PRIORITY

1. Police Compensation
2. Charter/City Code Review
3. Police Training and Equipment
4. Boards/Committees *Revision*

Solid Waste Fee

5. *Stormwater Management Utility*
Capital Outlaying Plan and Annual Funding
6. City Employee Compensation and Benefits
7. Golf Course Comprehensive Evaluation

Wastewater Services Regionalization Expansion

MANAGEMENT ACTIONS 2017

PRIORITY

1. Financial Policies Comprehensive Review
2. City Electronic Communications Policy
3. Television Channel Effectiveness Plan
4. Sunrise Theater: Succession Plan
5. Civil Service Appeal Process
7. Citywide Record Retention, Storage and Destruction Program Development
8. Vendor Ordinance: Revision

9. City Owned Property

MANAGEMENT IN PROGRESS 2017

1. City Marketing Plan and Actions: Expansion
2. Multi-Family Single Stream Recycling Program
3. Comprehensive Employee Wellness Policy and Program

Police Labor Contracts

4. Information and Data Base Management and Security
6. Paperless Purchase Order system
7. Click-2-Gov
 - Business Tax Receipts
 - Contractor Competency Cards

8. Citywide Payment Card Policy (Online)

9. Police Promotion Examinations
 - a) Lieutenant
 - b) Sergeant
10. Police Mentorship Program: Development
11. Wide Area Network (WAN)/Local Area Network (LAN) Infrastructure Maintenance and Upgrade
12. Police Minority Recruitment Program/Advancement: Revision
13. *Courageous Kid Program*
14. Key Performance Indicators: Development

MANAGEMENT IN PROGRESS 2017 (Continued)

- 15. Purchasing Policy (Limits): Direction
- 16. Website: "Bid Awards"
"Purchasing Procedures"

- 17. Solid Waste Division Efficiency Study
Projectdox: Building Department

19. Dockwa: City Marina

20. See-Click-Fix: City

21. RcTrac Cloud: IHGC Funding

22. Electronic Applicant Tracking System

23. Golf Course Advisory Committee: Development

24. Paperless Payroll Process: Electronic Stubs and Forms

25. New Software for Retirement System

26. Pavement Condition Survey: Report

27. Sungard One Solution Animal Control Module

28. Code Officers: Certified Parking Enforcement, Officers Trained

29. T2 Parking Enforcement Software for Mobile Parking Enforcement

MANAGEMENT IN PROGRESS 2017 (Continued)

- 30. Opti View Training
- 31. Online Searchable Portal: Development
- 32. Certified Municipal Clerk Designation

MAJOR PROJECTS 2017

1. Police Athletic League (PAL) Park Restrooms
2. Restrooms
 - a) Downtown (2)
 - b) Powell Park (1)
 - c) Rotary
 - d) Fenn
3. City Parking Garage: Ceiling
4. City Hall: Seal/Paint
5. Powell Park: Outside Basketball Courts
6. Pinewood Recreation Facility Improvements
7. Chamber and Conference Room: Upgrade
8. Call Center Operations: Upgrade
9. Facilities Access Control and Security Upgrade
10. Golf Course Improvements
 - a) Bunkers
 - b) Cart Paths

MAJOR PROJECTS 2017 (Continued)

11. 13th Street Reconstruction (South of Avenue "D" to Avenue "E")
12. Drainage Improvement Projects
 - a) Bayshore Drive/Sunset Isle Road
 - b) Rio - Vista Drive
 - c) Francis Avenue
13. 7th Street Roadway Reconstruction (Wendell Road to 19th Street)
14. 17th Street Reconstruction: Funding (Orange Avenue to Avenue "D")

ON THE HORIZON 2018 - 2022 (Continued)

5. Information Technology: Upgrades
 - Direction
 - Funding
6. Recreation Department
 - Evaluation Report
 - Direction
7. City Services and Staffing
 - Evaluation Report
 - Direction

ON THE HORIZON 2018 - 2022

1. Impact Fees: Updated
2. St. Lucie County Strategy
 - Issues
 - Direction
 - City Actions
3. "One Stop" Shop for Development/Permitting
4. Vehicle and Equipment Replacement
 - Maintenance Evaluation
 - Plan
 - Funding

8. Enterprise GIS System

ON THE HORIZON 2018 – 2022

(Continued)

- 9** New Alternative Revenue Study
 - Report with Options
 - Direction
- 10** Comprehensive Analysis of Fee Schedules
 - Market Analysis/Report
 - Direction
- 11** Debt Reduction Policy and Plan
- 12** Special Assessment: Evaluation
- 13.** Ethics Policy: Direction
- 14** Enterprise Funds: Evaluation
- 15.** Nutrient Removal: Georgia Avenue Outfall Grant/Matching Funds

Goal 2 SAFER AND MORE BEAUTIFUL CITY

OBJECTIVES

1. More attractive corridors, including Orange Avenue
2. Demolish or reuse abandoned buildings and homes
3. Develop a reputation as a "safe community"
4. Increase property owners taking responsibility for complying with City Code of Ordinances
5. Reduce the visual blight in the City
6. Upgrade or replace older housing stock
7. Reduce crime rate
8. Build new homes on vacant lots

MEANS TO RESIDENTS

1. Protection of property values
2. More attractive community
3. Owners and tenants taking care of their buildings and homes
4. Greater compliance with City Code of Ordinances

SHORT TERM CHALLENGES AND OPPORTUNITIES

1. Reputation and appearance of Fort Pierce, particularly Orange Avenue
2. Funding for code compliance, law enforcement and public works
3. Continuing to have residents sharing information with the Police Department
4. Reinforcing trust in the Police Department
5. Lack of police staffing for community policing
6. Improving the entire City with a unified vision

LONG TERM CHALLENGES AND OPPORTUNITIES

1. Responding proactively to gangs and drugs
2. Lack of incentives and consequences for violations of codes
3. Youth recreation and job opportunities
4. City Commission support and follow through for their decisions: direction and actions
5. Expanding neighborhood watch and community programs to increase residents investments in safety and their neighborhood
5. Irresponsible property owners who avoid complying with the City Code of Ordinances
6. Inconsistent application of the Code of Ordinances
7. High percentage of rental housing

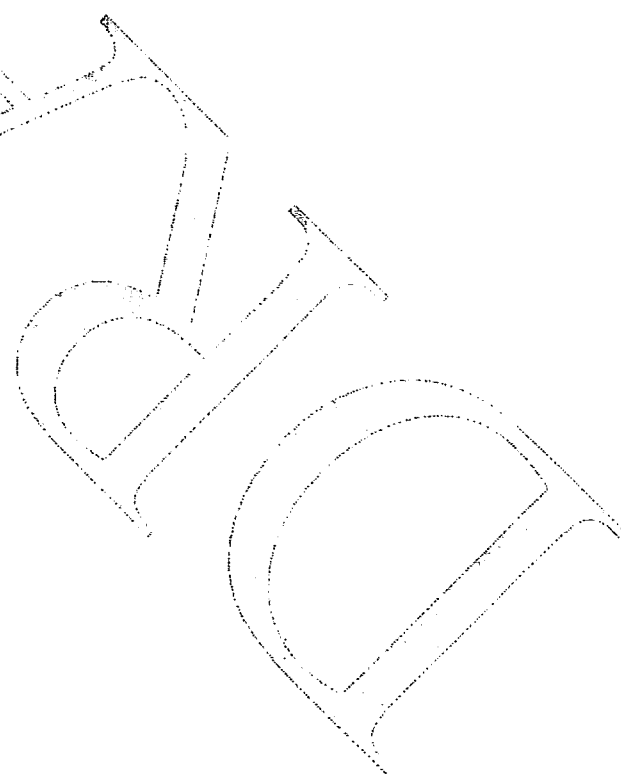

POLICY ACTIONS 2017

PRIORITY

1. Lincoln Park Corridor Revitalization Initiative
2. Sign Ordinance: Revision
3. Entrances/Beach/Gateways Beautification Plan
4. Homeless Strategy and Actions
5. Clean Community Initiative (CCI)

MANAGEMENT ACTIONS 2017

PRIORITY

1. Gangs Action Plan: Update
2. DOJ Community Oriented Policing Assessment Report

MANAGEMENT IN PROGRESS 2017

1. Police Training
 - a) Scenario Based
 - b) Cultural Sensitivity/Diversity and De-Escalation
 - c) Active Shooter
2. Police Body Worn Cameras
3. Police Re-Accreditation (FLA - PAC)
4. Milo Training Simulator
5. Crime Prevention Truck
6. Police Citizens Review Board: Development
7. Police Youth Advisory Committee: Development

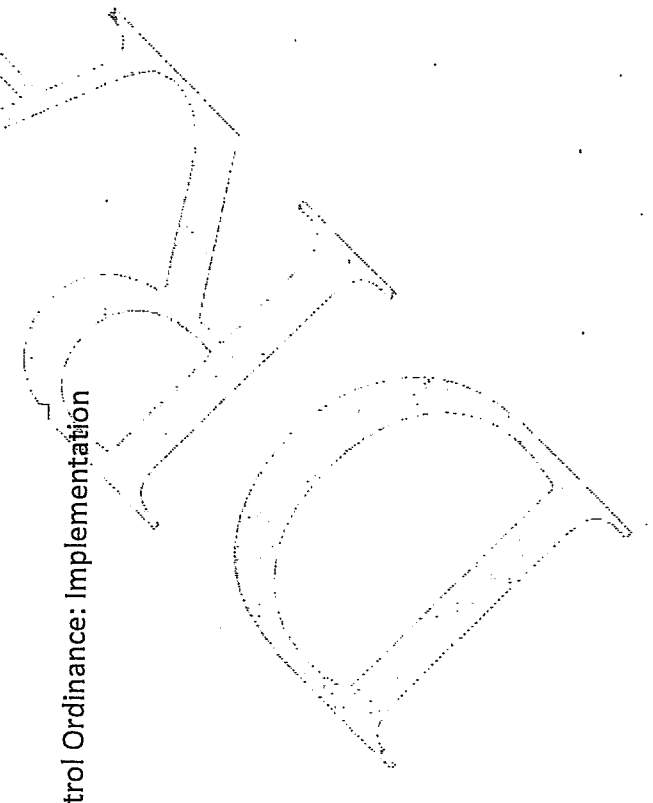

ON THE HORIZON 2018 – 2022

1. Youth Program: Enhancement
 - Pop Warner Football/Cheerleading (2018)
 - Flag Football
2. Neighborhood Watch/Citizen Patrol: Expansion
3. Old Fort Park Project: Sidewalk Connectivity
4. Arts and Cultural Master Plan: Adoption
5. Arts in Public Spaces Policy: Direction
6. Historic Code: Revision

Goal 3 COMMUNITY UNITY AND PRIDE

OBJECTIVES

1. Develop a reputation as an inclusive community with everyone feeling welcome and part of the community
2. Residents working together for what is best overall for the Fort Pierce community
3. Community, businesses and City government sharing and working together on a common vision and goals
4. City government providing leadership to create community partnerships to expand community resources

MEANS TO RESIDENTS

1. Feeling welcome in the City of Fort Pierce
2. Opportunities to contribute to the community
3. People working together for community benefit
4. Community benefit over personal benefit or gain
5. Individuals with different cultures or backgrounds are respected

SHORT TERM CHALLENGES AND OPPORTUNITIES

1. Diverse population of Fort Pierce
2. Developing future community leaders and City employees
3. Opportunities for job opportunities
4. Developing common goals and vision for Fort Pierce that become the community's rallying point
5. Expanding community wide youth programs to develop community pride
6. Commissioner districts and representation

LONG TERM CHALLENGES AND OPPORTUNITIES

1. Capturing Fort Pierce "alumni"
2. Looking to the whole community
3. Residents and businesses believing that the City is responsible for everything and solving all problems
4. Personal biases and prejudices
5. Expanding and enhancing current community events
6. Overcoming the split between different neighborhoods
7. Past history of a racially/socio – economic divided community
8. Mobility and transportation options for residents

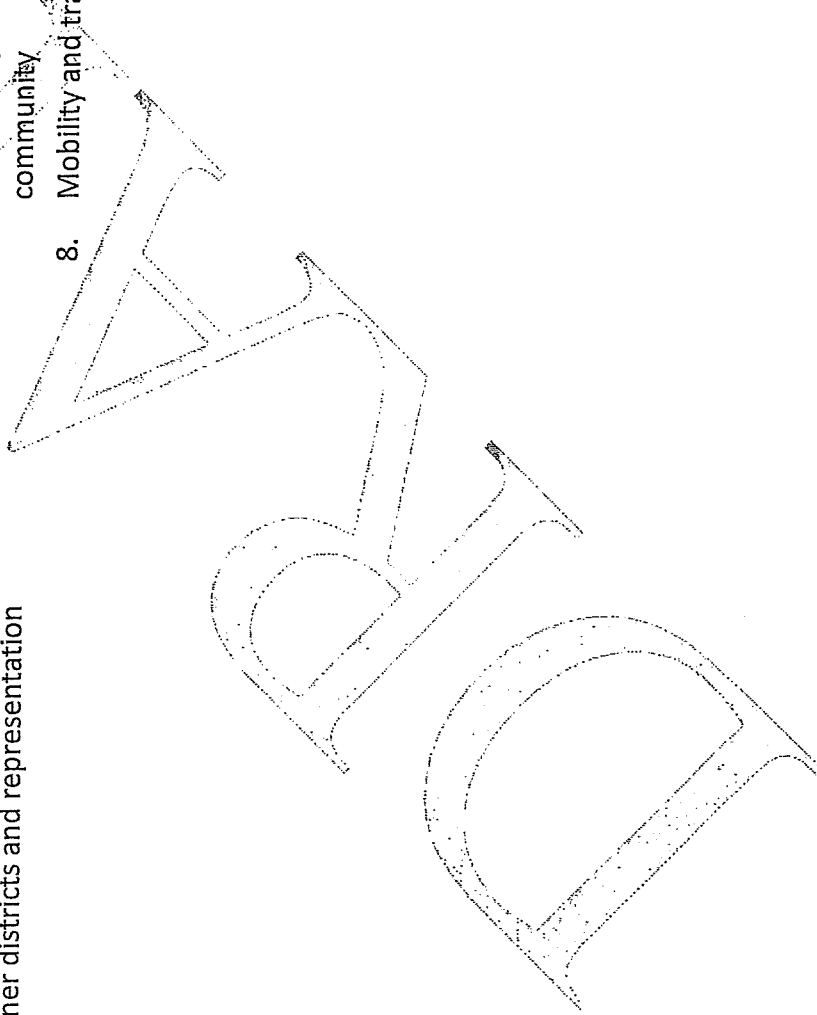

POLICY ACTIONS 2017

1. Community Unity Strategy and Action Plan
2. School Enhancement Strategy

MANAGEMENT IN PROGRESS 2017

1. The Highwayman Heritage Trail Arts and Culture
2. Zora Neale Hurston ~~Trail~~ Festival Day

MANAGEMENT ACTIONS 2017

1. Youth Council: Report with Recommendations
2. Restoring the Village Program

PRIORITY

ON THE HORIZON 2018 – 2022

1. Marketing Program for Arts, Culture and Museums
2. Backus Museum Expansion
3. Moore's Creek Multi Cultural Festival: Foods and Arts Celebration

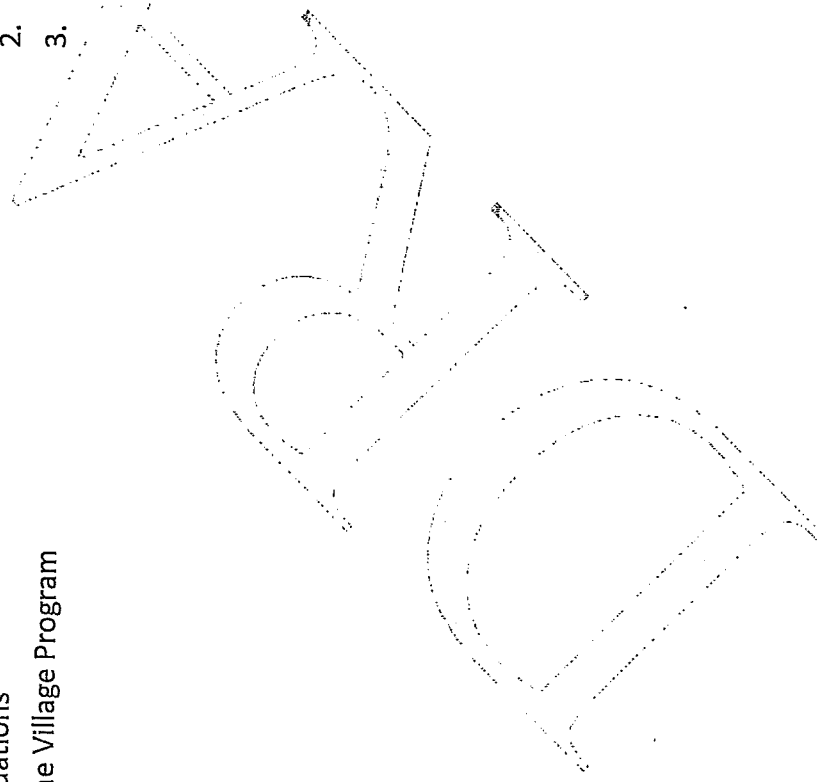

Goal 4 VIBRANT DOWNTOWN AND NEIGHBORHOODS

OBJECTIVES

1. More people living in downtown area and surrounding neighborhoods
2. Increase the number of fine dining restaurants, entertainment venues, and trendy eating establishments
3. Redevelop historic neighborhoods while preserving their unique character
4. Increase the ease to park and walk
5. More niche small retail businesses with hours and merchandise for residents and guests
6. Preserve open space in downtown area
7. Enhance relationship with the Downtown Business Association

MEANS TO RESIDENTS

1. Protection of property values
2. Honoring and celebrating the historical roots of Fort Pierce
3. Expanded housing choices
4. More reasons to go to the downtown area
5. Easy access and convenient parking to a pedestrian friendly area

SHORT TERM CHALLENGES AND OPPORTUNITIES

1. Preserving and enhancing pedestrian friendly connectivity within downtown Fort Pierce
2. Increasing multi-modal transportation to and from downtown
3. Working with the property owners, businesses and residents
4. Preserving the view of waterfront
5. Deteriorating structures needing demolition or rehabilitation
6. Balancing the needs of the residential and needs of commercial properties

LONG TERM CHALLENGES AND OPPORTUNITIES

1. Continuing the momentum in the downtown area and the surrounding neighborhoods
2. Attracting developers and residents to downtown Fort Pierce
3. Defining the City's role and incentives
4. U.S. Highway 1 traffic as a barrier to downtown connectivity
5. Expanding Court buildings and visits/clientele
6. Reduced sponsorship funding from the City for Sunrise Theater

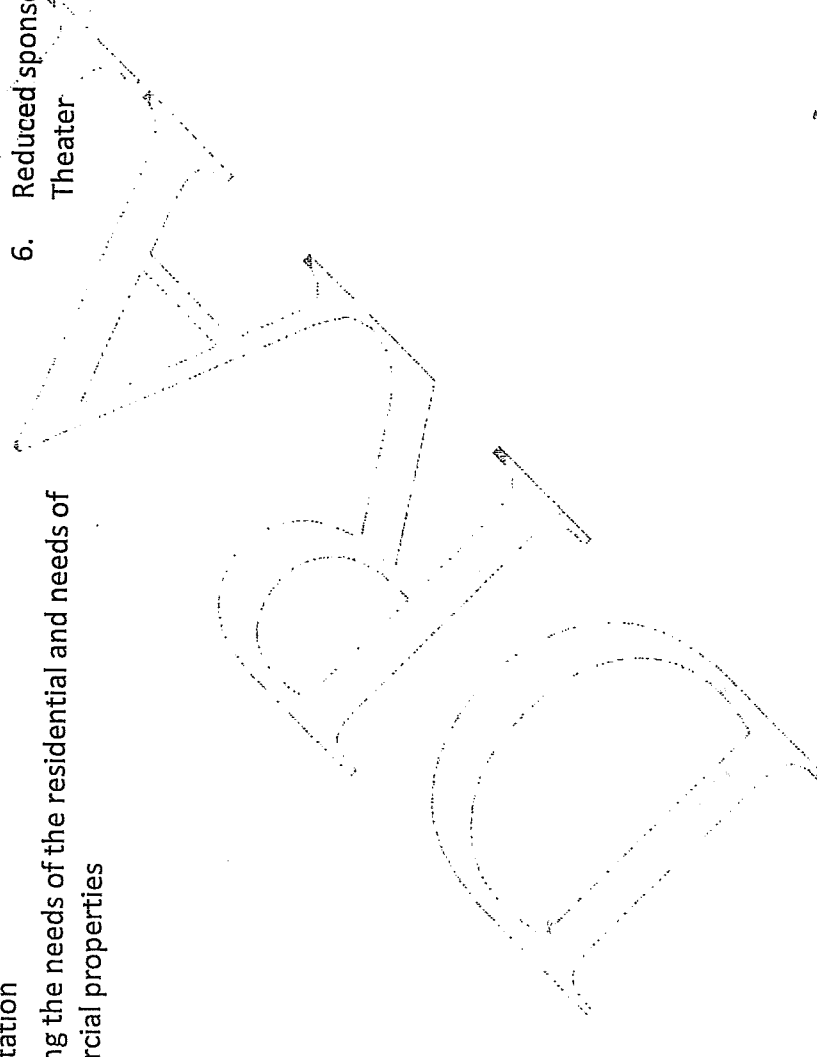

POLICY ACTION 2017

PRIORITY

1. Downtown Development: Hotel, Retail Expansion
2. Incentive for Buildings/Homes Rehabilitation/Use
3. Downtown Height Requirement

4. Peacock Arts District Incentives

MANAGEMENT IN PROGRESS 2017

1. Sunrise Theater New Corporate Partnerships

MAJOR PROJECTS 2017

1. Sunrise Theater Improvements

- Chiller
- Ticketing

ON THE HORIZON 2018 – 2022

2. Sunrise Theater Upgrade Projects

- Direction
- Funding

3. Downtown Study: Update

4. Public Assets: Brick Paver Sidewalks Clean Up and Maintenance Funding

5. MSTU: Evaluation, Direction

Goal 5 GREAT PLACE TO LIVE, LEARN, WORK, AND PLAY

OBJECTIVES

1. Upgrade the existing housing stock to meet the City's Building Codes and regulations
2. Attract new businesses to Fort Pierce that are consistent with our vision
3. More job opportunities for residents, and a lower unemployment rate
4. Retain and support the growth of local businesses
5. Improve and expand City parks and recreational facilities
6. Expand transportation connectivity
7. Enhance quality of schools and educational programs for lifelong learning

MEANS TO RESIDENTS

1. More reasons to live in Fort Pierce
2. Job opportunities near home resulting in more leisure time
3. Choices for your leisure time
4. Housing options with choice of type, location, and price
5. Support for family oriented activities

SHORT TERM CHALLENGES AND OPPORTUNITIES

1. Developing an image as a "business friendly" community and City
2. Property owners taking responsibility for maintaining their buildings or homes
3. City's aging infrastructure and facilities
4. Attracting the appropriate new businesses to Fort Pierce
5. Consistency with County decisions for areas to be annexed
6. Defining the City's role in recreation and cultural programming and activities

LONG TERM CHALLENGES AND OPPORTUNITIES

1. Squaring-off City boundaries
2. Funding and performance accountability for economic development activities
3. Expanding entertainment opportunities
4. Variable quality of the older housing stock

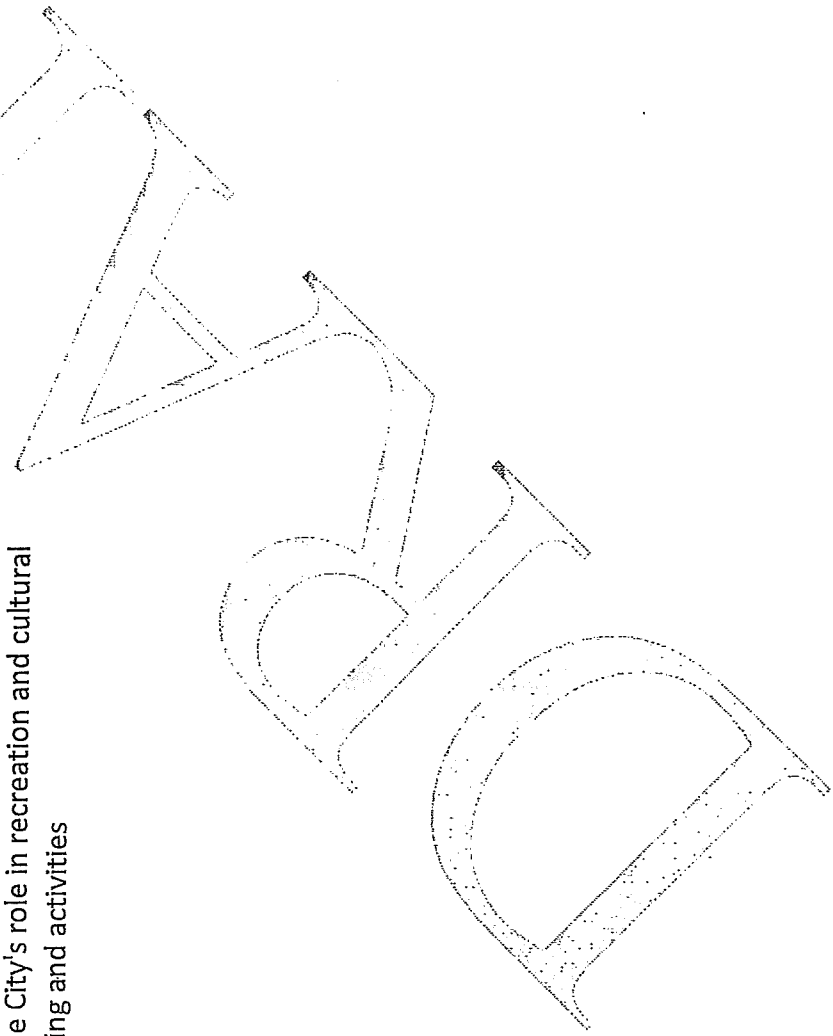

POLICY ACTIONS 2017

PRIORITY

1. Street *Resurfacing*
2. Annexations Direction
3. Commercial Air Service at Airport
4. Major Hotel Attraction Strategy
5. Orange Avenue Corridor Revitalization Plan
6. CRA Plan: Update

2. *Harbor Pointe Development Policy*

MANAGEMENT ACTIONS 2017

PRIORITY

1. EAR/Comprehensive Plan
2. Ohio Avenue and U.S. 1 Signalization Upgrade

3. *Economic Development, Next Steps*

MANAGEMENT IN PROGRESS 2017

1. Business Retention and Expansion (BRE)
2. Federal Emergency/Management Association (FEMA) Regulation for Flood Insurance: Public Education
3. Small Business Growth: SCORE Workshops
4. Community Rating System (CRS) Audit

MAJOR PROJECTS 2017

1. Percy Peek Gymnasium: Floor Resurfacing and Classrooms
2. North 2nd Street Road Improvements
4. Savannah Recreation Trail Connectivity to Indian Hills Trail
5. Jaycee Park Connectivity Improvements
6. MLK Dreamland Park
7. Murals Program (2)

ON THE HORIZON 2018 - 2022

1. Short Term Rentals: Direction
2. Citrus Bridge Overpass
 - Direction
 - Funding

ON THE HORIZON 2018 – 2022 (Continued)

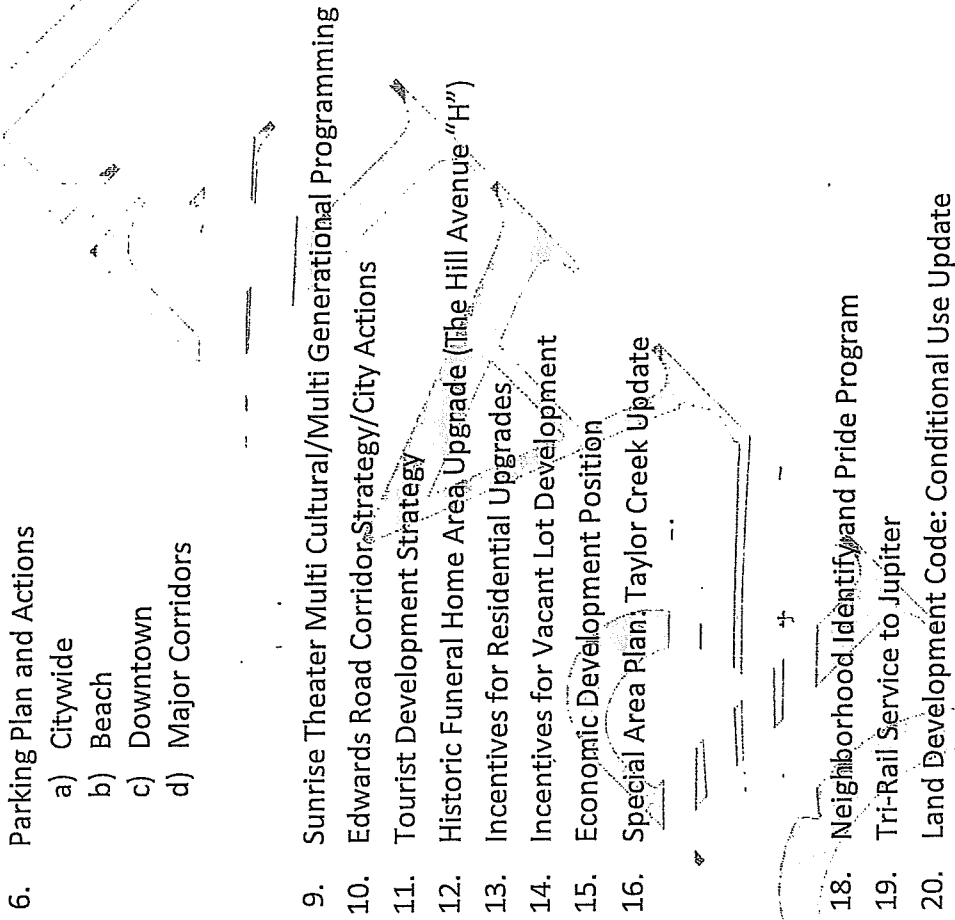
- 
6. Parking Plan and Actions
 - a) Citywide
 - b) Beach
 - c) Downtown
 - d) Major Corridors

 9. Sunrise Theater Multi Cultural/Multi Generational Programming
 10. Edwards Road Corridor Strategy/City Actions
 11. Tourist Development Strategy
 12. Historic Funeral Home Area Upgrade (The Hill Avenue "H")
 13. Incentives for Residential Upgrades
 14. Incentives for Vacant Lot Development
 15. Economic Development Position
 16. Special Area Plan, Taylor Creek Update

 18. Neighborhood Identify and Pride Program
 19. Tri-Rail Service to Jupiter
 20. Land Development Code: Conditional Use Update

Goal 6

ALIVE WATERFRONTS

OBJECTIVES

1. Relocate the Wastewater Treatment Plant and replace it with housing or a hotel
2. Preserve the quality of water
3. Host national and international fishing tournaments
4. Expand the reputation as a great destination for eco-tourism
5. Have a commercially/Sustainable Port of Fort Pierce
6. Increase public access and use of the waterways
7. Maintain beaches and waterfront

MEANS TO RESIDENTS

1. Opportunities to enjoy the water
2. Variety of recreational choices
3. Waterfront as a strong component of the local economy with business and job opportunities
4. Protection of property values
5. Housing opportunities with the ability to walk to the waterfront

SHORT TERM CHALLENGES AND OPPORTUNITIES

1. Funding for projects
2. Marketing waterfront assets
3. Tapping the development of the Port of Fort Pierce
4. Working with other governments to achieve desired outcomes
5. Aging, deteriorated boat ramps
6. Creating a world-class tourist destination for residents and visitors
7. FEMA and flood regulations/guidelines

LONG TERM CHALLENGES AND OPPORTUNITIES

1. Maintaining and expanding public access to water
2. Attracting appropriate businesses to locate on or near the water
3. Tapping the full potential of Fort Pierce's water assets
4. Increasing investments from St. Lucie County, City of Port St. Lucie
5. Supporting the developing of a water taxi
6. Job skills for Port development and businesses

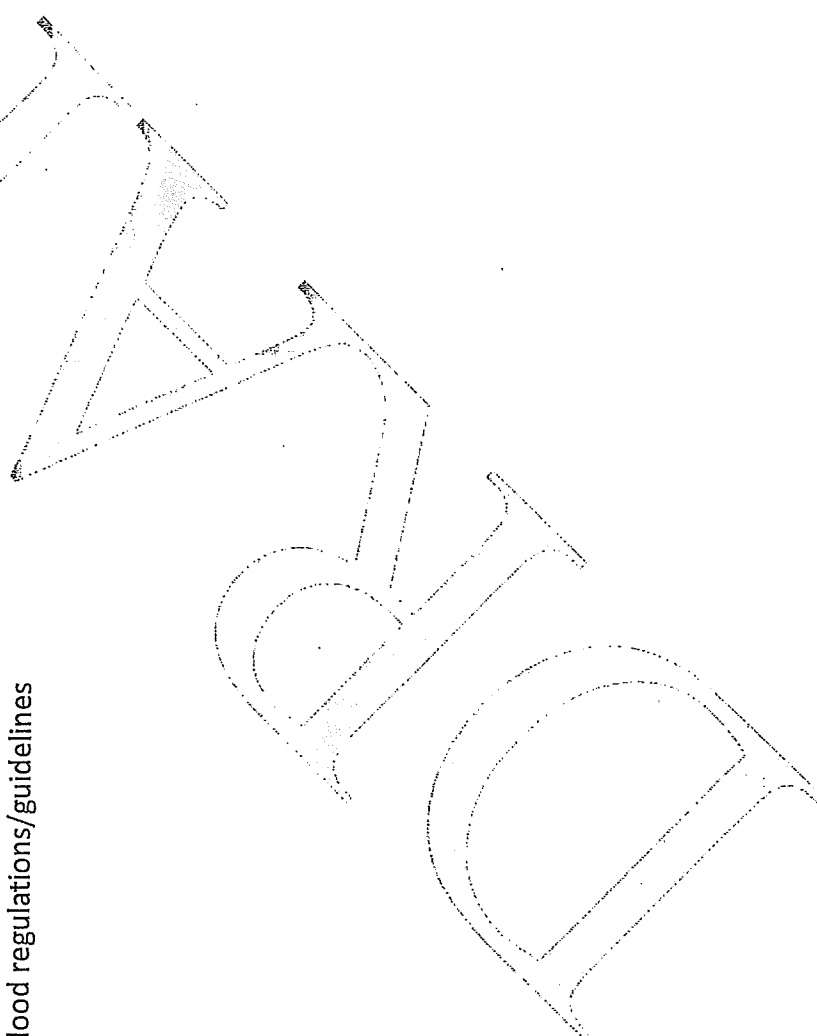

POLICY ACTIONS 2017

1. Fisherman's Wharf/Seawall
2. Restaurant Lease
4. Dredging Marina Access Channel
5. Port of Fort Pierce Strategy

PRIORITY

1. Wastewater Treatment Plant Relocation
2. Boat Ramp Use/Regulation
3. Shuffleboard Court Relocation
4. Boat Ramps Update
5. Marina/Waterway Dredging: Direction
6. Public Access to Waterfront: LDC Changes
7. Transit Link: Downtown/Community and Beach
8. Indian River Terminal Purchase
9. Porpoise Park Development

MANAGEMENT IN PROGRESS 2017

1. City Marina Online Reservation System

MAJOR PROJECTS 2017

1. Public Day/"Dingy" Dock
2. Moore's Creek Boat Ramp Area Repairs (Joint Project with St. Lucie County)
3. Moore's Creek Seawall Replacement
4. Dredging Maintenance Projects (Short Term)
5. Fisherman's Wharf Boat Ramp: Rebuild

ON THE HORIZON 2018 – 2022

1. Wastewater Treatment Plant Relocation
2. Boat Ramp Use/Regulation
3. Shuffleboard Court Relocation
4. Boat Ramps Update
5. Marina/Waterway Dredging: Direction
6. Public Access to Waterfront: LDC Changes
7. Transit Link: Downtown/Community and Beach
8. Indian River Terminal Purchase
9. Porpoise Park Development

CITY OF FORT PIERCE ACTION AGENDA 2017

City of Fort Pierce Policy Agenda 2017

TOP PRIORITY

HIGH PRIORITY

City of Fort Pierce Management Agenda 2017

TOP PRIORITY

HIGH PRIORITY

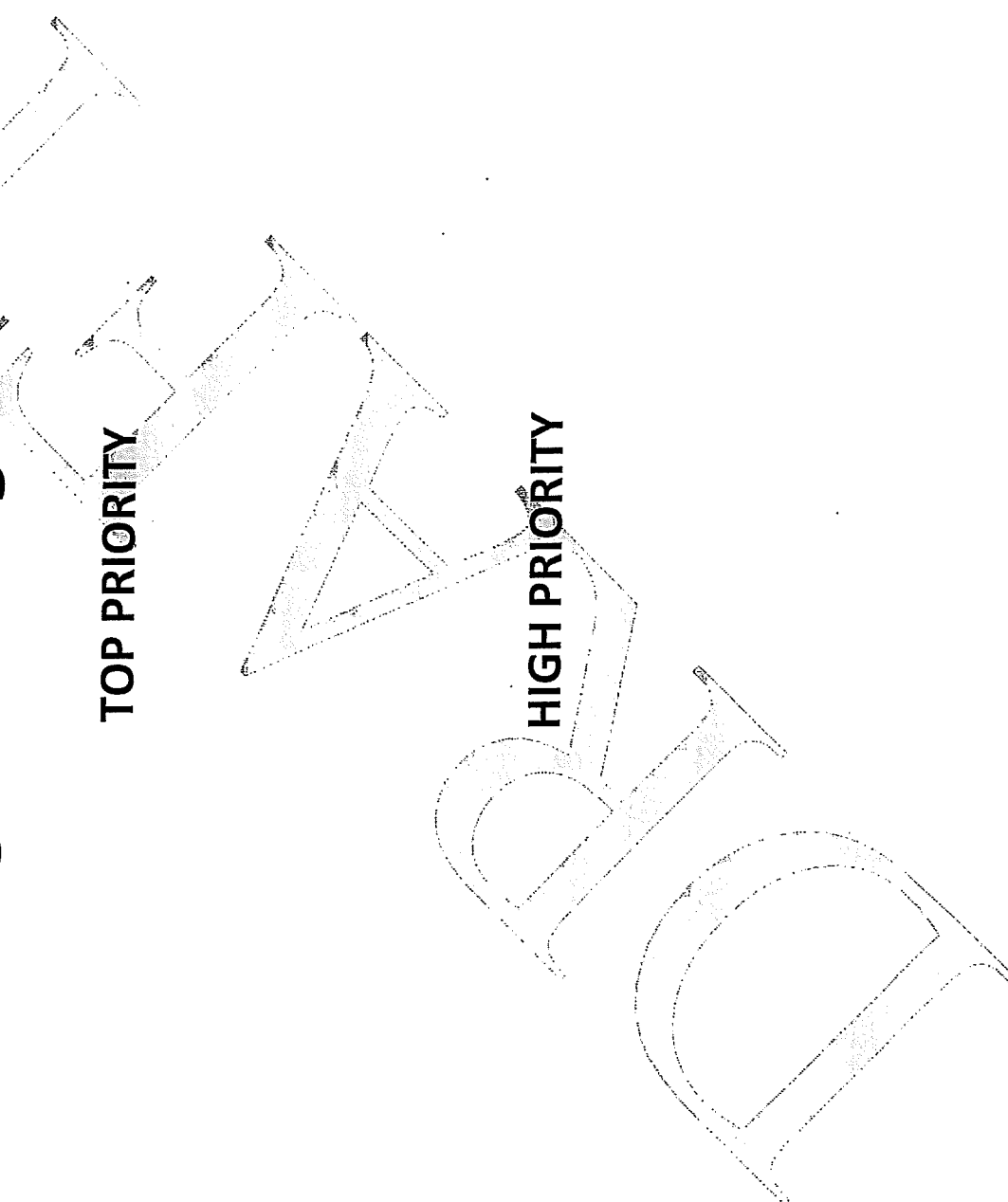

City of Fort Pierce Management in Progress 2017

City Marketing Plan and Actions: Expansion

Multi-Family Single Stream Recycling Program

Comprehensive Employee Wellness Policy and Program

Sexual Harassment/LGBT Policy

Drug Policy

Police Labor Contracts

Information and Data Base Management and Security

Paperless Purchase Order system

Click-Z-Gov: Business Tax Receipts, Contractor Competency Cards

Enterprise GIS System

Citywide Payment Card Policy (Online)

Police Promotion Examinations: Lieutenant, Sergeant

Police Mentorship Program: Development

Wide Area Network (WAN)/Local Area Network (LAN) Infrastructure Maintenance and Upgrade

Police Minority Recruitment Program/Advancement: Revision

Non Smoking Facility and Outside Policy

Key Performance Indicators: Development

Purchasing Policy (Limits): Direction

Website: "Bid Awards": "Purchasing Procedures"

Contract and Insurance Management Module System

Solid Waste Division Efficiency Study

Projectdix: Building Department

Click-Z-Gov 3: Building, City Clerk

Dockwa: City Marina

See Click Fix: City

RacTrac Cloud: IHGC Funding

Electronic Applicant Tracking System

Golf Course Advisory Committee: Development

Paperless Payroll Process: Electronic Stubs and Forms

New Software for Retirement System

Fiscal Policies: Update

Pavement Condition Survey: Report

Sungard One Solution Animal Control Module

Code Officers: Certified Parking Enforcement, Officers Trained

T2 Parking Enforcement Software for Mobile Parking Enforcement

Public Records Training

Opti View Training

Online Searchable Portal: Development

Certified Municipal Clerk Designation

Proactive Legal Nuisance Abatement

Police Training: Scenario Based, Cultural Sensitivity/Diversity and De-Escalation, Active Shooter

Police Body Worn Cameras

Police Re-Accreditation (FLA – PAC)

Milo Training Simulator

Crime Prevention Truck

Police Citizens Review Board: Development

Police Youth Advisory Committee: Development

The Highwayman Heritage Trail Arts and Culture

Zora Neale Hurston Trial Festival Day

Sunrise Theater New Corporate Partnerships

Business Retention and Expansion (BRE)

River Walk Center Recreation Program Expansion

Percy Peek Gymnasium Recreation Program Expansion

Federal Emergency/Management Association (FEMA) Regulation for Flood Insurance: Public Education

Small Business Growth: SCORE Workshops

Community Rating System (CRS) Audit

City Marina Online Reservation System

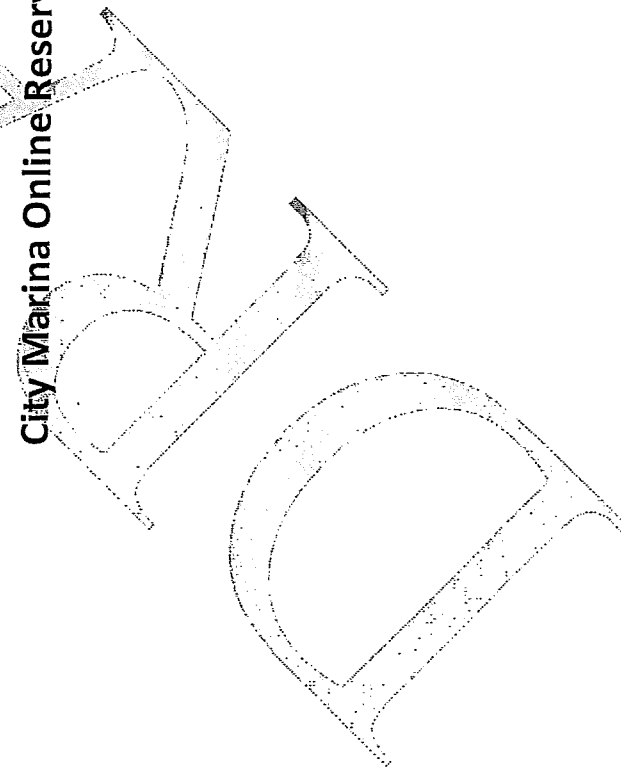

City of Fort Pierce

Major Projects 2017

Police Athletic League (PAL) Park Restrooms

Restrooms: Downtown (2), Powell Park (1), Rotary, Fenn

City Parking Garage: Ceiling

City Hall: Seal/Paint

Powell Park: Outside Basketball Courts

Pinewood Recreation Facility Improvements

Chamber and Conference Room: Upgrade

Call Center Operations: Upgrade

Facilities Access Control and Security Upgrade

Golf Course Improvements: Bunkers, Cart Paths

13th Street Reconstruction (South of Avenue "D" to Avenue "E")

Drainage Improvement Projects: Bayshore Drive/Sunset Isle Road, Rio – Vista Drive
Francis Avenue

- 7th Street Roadway Reconstruction (Wendell Road to 19th Street)**
- 17th Street Reconstruction: Funding (Orange Avenue to Avenue "D")**
 - Sunrise Theater Improvement Chiller, Roof, Ticketing**
 - Peercy Peek Gymnasium: Floor Resurfacing and Classrooms**
 - North 2nd Street Road Improvements**
 - Fenn Park Restrooms**
- Savannah Recreation Trail Connectivity to Indian Hills Trail**
- Jaycee Park Connectivity Improvements**
- MLK Dreamland Park**
- Murals Program (2)**
- Public Day/"Dingy" Dock**
- More's Creek Boat Ramp Area Repairs (Joint Project with St. Lucie County)**
 - Moore's Creek Seawall Replacement**
 - Dredging Maintenance Projects (Short Term)**
 - Fisherman's Wharf Boat Ramp: Rebuild**

