



COA# 17-38



Bldg. Permit # _____

Certificate of Appropriateness Application

Building & Site Information

Address of the Site: 1313 Delaware Ave
 Parcel ID #: 2409-431-0003-000-6
 Type of Designation: Contributing Non-contributing Site within the _____ Historic District
 Individually Designated Site, City Commission Resolution No. _____

Property Owner/ Applicant Information

Property Owner(s)
 Name(s): Mazola Barnes
 Mailing Address: 1313 Delaware Ave
 Phone Number(s): _____ Email: _____

Applicant
 Name(s): Andros Roofing + Construction LLC
 Mailing Address: 2706 Atlantic Ave.
 Phone Number(s): (772) 475-4517 Email: Androsconstruction@gmail.com

Representative
 Name(s): _____
 Mailing Address: _____
 Phone Number(s): _____ Email: _____

Property Owner(s) Acknowledgements:- This application will not be considered complete without the signature of all property owners of record, which shall serve as an acknowledgement of the submission of this application. The property owner's signature below shall also authorize the Applicant (if other than the property owner) and/or Representative to act in his/her behalf for the purposes of seeking approval for the application described herein. The undersigned consents to inspection and photographing of the subject property by the Historic Preservation staff for purposes of consideration of this Application and/or presentation to the Historic Preservation Board.

X I/We, Mazola Barnes as Owner(s) of the subject property do hereby authorize the filing of this application on my/our behalf.

X Mazola Barnes
 Signature of Owner

6/19/2017
 Date

Description of Requested Work

Please indicate the type of work requested:

- | | | | |
|--|---|-------------------------------------|--|
| <input type="checkbox"/> Fence | <input type="checkbox"/> Shed | <input type="checkbox"/> Door(s) | <input checked="" type="checkbox"/> Roof |
| <input type="checkbox"/> Window(s) | <input type="checkbox"/> Signage | <input type="checkbox"/> Shutter(s) | <input type="checkbox"/> Porch |
| <input checked="" type="checkbox"/> Rehabilitation | <input type="checkbox"/> New Construction | <input type="checkbox"/> Demolition | <input type="checkbox"/> Relocation |

Site Improvements (describe) _____

Other (describe) _____

Please provide a detailed description of the proposed work to be performed: Remove the existing asphalt shingle roof and replace with 5r crimp mill finished metal roof. (Up to half of the main roof, east side only removed and replaced)

Have other alterations been made to the site within the last 12 months? No Yes, _____

Will the proposed work require a Zoning Variance? No Yes, Code Section(s): _____

Application Requirements

- \$10.00 Application fee
- Site Plan with dimensions.
- Architectural Drawings:
 - Drawings should show all current and proposed floor plans and elevations, fences, walls, and any other landscape features.
 - Drawings should indicate materials to be used.
- Photos - One (1) color photograph of the main façade of the site and photographs of any areas affected by the proposed project.
- Material(s) specifications and/or sample(s)
- Color samples.
- Demolition - Plans for what will be taking the demolished structure's place should be submitted.







PROFILE DRAWINGS

DETAIL A 26 GA. COASTAL 5V-CRIMP ROOF PANEL

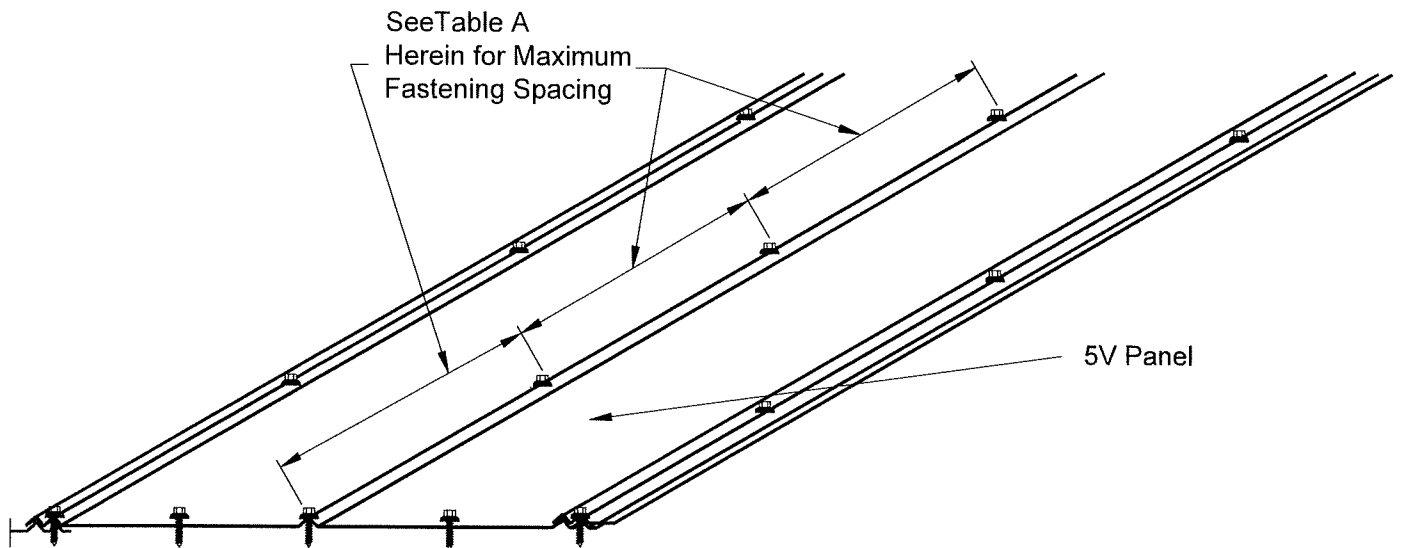
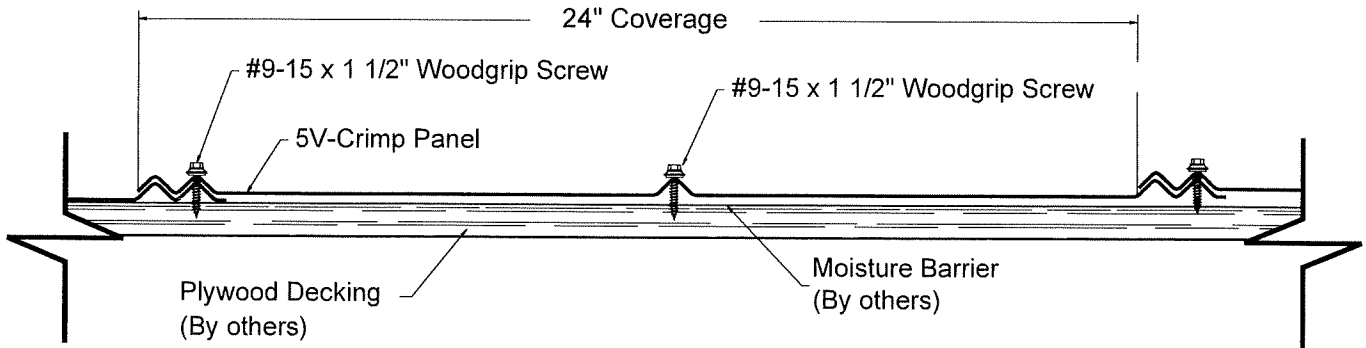

END OF THIS ACCEPTANCE



NOA No.: 14-0520.02
Expiration Date: 08/21/19
Approval Date: 08/21/14
Page 5 of 5