

Michelle Franklin, CFA -- Saint Lucie County Property Appraiser -- All rights reserved.

### Property Identification

Site Address: 704 BEACH CT  
 Sec/Town/Range: 10/35S/40E  
 Map ID: 24/10S  
 Zoning: R1

Parcel ID: 2410-709-0142-000-8  
 Account #: 23726  
 Use Type: 0100  
 Jurisdiction: Fort Pierce

### Ownership

Michelle King  
 520 NE 70th ST  
 Miami, FL 33138

### Legal Description

OAKLAND PARK BLK 16 S 1/2 OF LOT3 AND ALL OF LOT 6 (MAP 24/10F) (OR 3379-2117; 3972-2111)

### Current Values

Just/Market Value: \$65,000  
 Assessed Value: \$49,830  
 Exemptions: \$0  
 Taxable Value: \$49,830

Taxes for this parcel: SLC Tax Collector's Office

Download TRIM for this parcel: [Download PDF](#)



### Total Areas

Finished/Under Air (SF): 1,112  
 Gross Area (SF): 1,743  
 Land Size (acres): 0.22  
 Land Size (SF): 9,750

### Sale History

Date	Book/Page	Sale Code	Deed	Grantor	Price
Nov 5, 2015	3972 / 2111	0111	QC	Brandhorst Charles	\$0
Apr 11, 2012	3379 / 2117	0001	WD	Dent,Robert C	\$60,000
Jan 3, 2012	3356 / 2802	0119	PR	Dent,Robert C	\$0
Dec 1, 2011	3343 / 1757	0111	TR	Dent (EST),M Irene	\$100
Mar 1, 1995	0945 / 0266	XX01	WD	Albert W Dent	\$100
Apr 1, 1976	0251 / 1018	XX00	CV		\$28,000

### Building Information (1 of 1)

Finished Area: 1,112 SF

Gross Total Area: 1,743 SF

#### Exterior Data

View:	Roof Cover: Mtl Shingles	Roof Structure: Hip
Building Type: HC-	Year Built: 1940	Frame:
Grade: C-	Effective Year: 1975	Primary Wall: Wood/Sheath
Story Height: 1 Story	No. Units: 1	Secondary Wall:

#### Interior Data

Bedrooms: 2	Electric: MAXIMUM	Primary Int Wall:
Full Baths: 2	Heat Type: FredHotAir	Avg Hgt/Floor: 0
Half Baths: 0	Heat Fuel: ELEC	Primary Floors: Hardwood
A/C %: 100%	Heated %: 100%	Sprinkled %: 0%

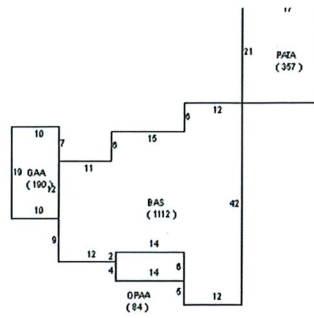

**Sketch Area Legend**

Sub Area	Description	Area	Fin. Area	Perimeter
BAS	BASE AREA	1112	1112	164
GAA	Garage Attached Average	190	0	58
OPAA	Open Porch Attached Average	84	0	40
PATA	Patio Average (Plain Slab)	357	0	76

**Special Features and Yard Items**

Type	Qty	Units	Year Blt
POOL DK-AVG	1	357	1977

**Current Year Values**

Current Values Breakdown		Current Year Exemption Value Breakdown				
	Amount	Tax Year	Grant Year	Code	Description	Amount
Building:	\$52,600					
Land:	\$12,400					
Just/Market:	\$65,000					
Ag Credit:	\$0					
Save Our Homes or 10% Cap:	\$15,170					
Assessed:	\$49,830					
Exemption(s):	\$0					
Taxable:	\$49,830					

**Current Year Special Assessment Breakdown**

Start Year	AssessCode	Units	Description	Amount
1999	0041	1	Fort Pierce Stormwater Charge	\$54.00

This does not necessarily represent the total Special Assessments that could be charged against this property. The total amount charged for special assessments is reflected on the most current tax statement and information is available with the SLC Tax Collector's Office.

**Historical Values**

Year	Just/Market	Assessed	Exemptions	Taxable
2017	\$65,000	\$49,830	\$0	\$49,830
2016	\$45,300	\$45,300	\$0	\$45,300
2015	\$46,200	\$46,200	\$0	\$46,200

**Permits**

Number	Issue Date	Description	Amount	Fee
--------	------------	-------------	--------	-----

Notice: This does not necessarily represent all the permits for this property.  
Click the following link to check for additional permit data in Fort Pierce

This information is believed to be correct at this time but it is subject to change and is not warranted.  
© Copyright 2017 Saint Lucie County Property Appraiser. All rights reserved.