



MEMORANDUM
from the
PURCHASING DIVISION

TO: Mike Reals, Director of Finance

THROUGH: Gelencia Carter, Purchasing Manager *[Signature]*

FROM: Georgia Montgomery, Purchasing Specialist *[Signature]*

SUBJECT: Bid No. 2018-011 ~ Fuel Tank Removal and Installation

DATE: March 29, 2018

Attached are the tabulation sheet and a copy of each bid submitted for the above referenced bid. The file is available for review in the Purchasing Division.

The invitation was sent to 443 vendors. Seven (7) vendors requested specifications with four (4) responding (57.14 %) plus 0 “No Bid” (57.14 % total response).

Please respond to the Purchasing Division for recommendation of award.

Expiration date is May 27, 2018. Commission approval must be completed by this date.

/gm

Attachment

cc: J.T. McDermott, Facility Maintenance Manager
File



CITY OF FORT PIERCE TABULATION OF BIDS

"Offers from the vendors listed herein are the only offers received timely as of the above opening date and time. All other offers submitted in response to this solicitation, if any, are hereby rejected as late."

RFP ON:	FUEL TANK REMOVAL AND INSTALLATION
RFP NUMBER:	2018-011
OPEN / DUE DATE:	3/29/18 @ 3:00 PM
RECOMMENDED AWARD:	Pending

RESPONSE
4 of 7 = 57.14 %
0 "No Bids"
Total =57.14 %

VENDOR	BID BOND	TOTAL BID AMOUNT
ATC Group Services , LLC Tampa, FL	10%	\$160,000.00
Gulfstream Petroleum Services Inc. Miami, FL	10%	\$164,495.00
R.C. Development Group Ponte Vedra, FL	10%	\$200,917.00
Guardian Fueling Technologies, LLC Jacksonville, FL	10%	\$205,155.00

PLEASE NOTE:

- COMMISSION MEETINGS ARE HELD THE FIRST AND THIRD MONDAY OF EVERY MONTH. CALL THE PURCHASING DEPARTMENT WEDNESDAY PRIOR TO THE MEETINGS FOR RECOMMENDATION OF AWARD.

COPY



10236 Fisher Avenue
Suite A
Tampa, FL 33619
Telephone 813-681-4067
Fax 813-689-0974
www.atcgroupservices.com

March 27, 2018

Ms. Gelencia Carter, Purchasing Manager
City of Fort Pierce
P.O. Box 1480
Fort Pierce, FL 34954

RE: RFP No. 2018-011
FUEL TANK REMOVAL AND INSTALLATION

Dear Ms. Carter:

ATC Group Services, LLC (ATC) is pleased to provide you with this cost proposal for the removal and installation of two (2)-12000 gallon fuel storage tanks, at the Public Works facility located at 52 Savannah Road, Fort Pierce, Florida. We are State Licensed Storage Tank Contractors and have completed several similar projects in the Tampa Bay area and other parts of the State for over 10+ years. We are also Licensed Engineers in the State of Florida and provide both engineering as well as construction services which very few storage tank installers provide. ATC Personnel have visited the site and reviewed the scope of work to be completed. Our scope includes cleaning and disposal of the two (2) existing fuel tanks at a metal recycling facility with a waste manifest provided for your records. We propose to install two (2) -12,000 gallons Cylindrical Double Wall Fireguard UL-2085 fuel tanks (8.5 ft. Dia X 9.5 ft. Tall X 33 ft. long) manufactured by Highland Tank Manufacturing Company, on the existing slab. A brochure of the Fireguard Tank is included for your reference. All existing tank accessories will be transferred to the new tank, including the existing Veeder Root ATG, level probe, and STP. The new tanks will be equipped with a 3 inch Remote Fill Port bolted and piped to the tank including a 3 inch overfill prevention valve with quick connect, dust cap and drop tube assembly. Following installation, the fuel tanks will be started up for use.

We acknowledge the receipt of Addendum 1 & 2, and Bid Bond is enclosed.

We look forward to assisting you on this important project. Please call me at (813) 267-7660 or Branch Manager Scott Patterson at (813) 713-4898, if you have any questions on this proposal.

Sincerely,
ATC Group Services, LLC.

A handwritten signature in cursive script that reads 'K. Senapati'.

Kiron Senapati, P.E.
Senior Engineer/ Project Manager

AIA[®] Document A310[™] – 2010

Bid Bond

CONTRACTOR:

(Name, legal status and address)

ATC GROUP SERVICES, LLC
10236 Fisher Avenue, Suite A
Tampa, FL 33619

SURETY:

(Name, legal status and principal place of business)

FIDELITY AND DEPOSIT COMPANY OF MARYLAND
1299 Zurich Way, 5th Floor
Schaumburg, IL 60196-1056

This document has important legal consequences. Consultation with an attorney is encouraged with respect to its completion or modification.

Any singular reference to Contractor, Surety, Owner or other party shall be considered plural where applicable.

OWNER:

(Name, legal status and address)

CITY OF FORT PIERCE

Purchasing Division, 100 North U.S. #1, Room 101, Fort Pierce, FL 34950

BOND AMOUNT: Ten percent of amount bid.
(10% of Amount Bid)

PROJECT:

(Name, location or address, and Project number, if any)

Fuel Tank Removal & Installation
Bid No: 2018-011

Project Number, if any:

The Contractor and Surety are bound to the Owner in the amount set forth above, for the payment of which the Contractor and Surety bind themselves, their heirs, executors, administrators, successors and assigns, jointly and severally, as provided herein. The conditions of this Bond are such that if the Owner accepts the bid of the Contractor within the time specified in the bid documents, or within such time period as may be agreed to by the Owner and Contractor, and the Contractor either (1) enters into a contract with the Owner in accordance with the terms of such bid, and gives such bond or bonds as may be specified in the bidding or Contract Documents, with a surety admitted in the jurisdiction of the Project and otherwise acceptable to the Owner, for the faithful performance of such Contract and for the prompt payment of labor and material furnished in the prosecution thereof; or (2) pays to the Owner the difference, not to exceed the amount of this Bond, between the amount specified in said bid and such larger amount for which the Owner may in good faith contract with another party to perform the work covered by said bid, then this obligation shall be null and void, otherwise to remain in full force and effect. The Surety hereby waives any notice of an agreement between the Owner and Contractor to extend the time in which the Owner may accept the bid. Waiver of notice by the Surety shall not apply to any extension exceeding sixty (60) days in the aggregate beyond the time for acceptance of bids specified in the bid documents, and the Owner and Contractor shall obtain the Surety's consent for an extension beyond sixty (60) days.

If this Bond is issued in connection with a subcontractor's bid to a Contractor, the term Contractor in this Bond shall be deemed to be Subcontractor and the term Owner shall be deemed to be Contractor.

When this Bond has been furnished to comply with a statutory or other legal requirement in the location of the Project, any provision in this Bond conflicting with said statutory or legal requirement shall be deemed deleted herefrom and provisions conforming to such statutory or other legal requirement shall be deemed incorporated herein. When so furnished, the intent is that this Bond shall be construed as a statutory bond and not as a common law bond.

Signed and sealed this 21st day of March, 2018

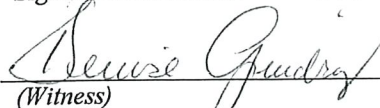
(Witness)

ATC GROUP SERVICES, LLC

(Principal)

(Title)

FIDELITY AND DEPOSIT COMPANY OF MARYLAND

(Surety)

(Title)

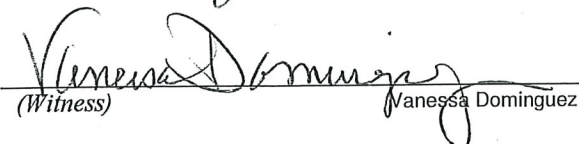
(Witness) Vanessa Dominguez

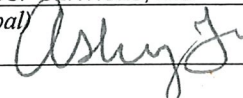

(Seal)

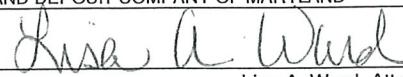

(Seal)

Lisa A. Ward, Attorney in Fact

**ZURICH AMERICAN INSURANCE COMPANY
COLONIAL AMERICAN CASUALTY AND SURETY COMPANY
FIDELITY AND DEPOSIT COMPANY OF MARYLAND
POWER OF ATTORNEY**

KNOW ALL MEN BY THESE PRESENTS: That the ZURICH AMERICAN INSURANCE COMPANY, a corporation of the State of New York, the COLONIAL AMERICAN CASUALTY AND SURETY COMPANY, a corporation of the State of Maryland, and the FIDELITY AND DEPOSIT COMPANY OF MARYLAND a corporation of the State of Maryland (herein collectively called the "Companies"), by **DAVID MCVICKER, Vice President**, in pursuance of authority granted by Article V, Section 8, of the By-Laws of said Companies, which are set forth on the reverse side hereof and are hereby certified to be in full force and effect on the date hereof, do hereby nominate, constitute, and appoint **Melissa L. FORTIER, Vanessa DOMINGUEZ, Michael J. HERROD, Wendy W. STUCKEY, Lupe TYLER, Lisa A. WARD and Donna L. WILLIAMS**, all of Houston, Texas, **EACH** its true and lawful agent and Attorney-in-Fact, to make, execute, seal and deliver, for, and on its behalf as surety, and as its act and deed: **any and all bonds and undertakings, EXCEPT bonds on behalf of Independent Executors, Community Survivors and Community Guardians**. and the execution of such bonds or undertakings in pursuance of these presents, shall be as binding upon said Companies, as fully and amply, to all intents and purposes, as if they had been duly executed and acknowledged by the regularly elected officers of the ZURICH AMERICAN INSURANCE COMPANY at its office in New York, New York., the regularly elected officers of the COLONIAL AMERICAN CASUALTY AND SURETY COMPANY at its office in Owings Mills, Maryland., and the regularly elected officers of the FIDELITY AND DEPOSIT COMPANY OF MARYLAND at its office in Owings Mills, Maryland., in their own proper persons.

The said Vice President does hereby certify that the extract set forth on the reverse side hereof is a true copy of Article V, Section 8, of the By-Laws of said Companies, and is now in force.

IN WITNESS WHEREOF, the said Vice-President has hereunto subscribed his/her names and affixed the Corporate Seals of the said **ZURICH AMERICAN INSURANCE COMPANY, COLONIAL AMERICAN CASUALTY AND SURETY COMPANY, and FIDELITY AND DEPOSIT COMPANY OF MARYLAND**, this 22nd day of May, A.D. 2017.

ATTEST:

**ZURICH AMERICAN INSURANCE COMPANY
COLONIAL AMERICAN CASUALTY AND SURETY COMPANY
FIDELITY AND DEPOSIT COMPANY OF MARYLAND**



Dawn E. Brown

By: _____
*Assistant Secretary
Dawn E. Brown*

David McVicker

*Vice President
David McVicker*

State of Maryland
County of Baltimore

On this 22nd day of May, A.D. 2017, before the subscriber, a Notary Public of the State of Maryland, duly commissioned and qualified, **DAVID MCVICKER, Vice President, and DAWN E. BROWN, Assistant Secretary**, of the Companies, to me personally known to be the individuals and officers described in and who executed the preceding instrument, and acknowledged the execution of same, and being by me duly sworn, depose and saith, that he/she is the said officer of the Company aforesaid, and that the seals affixed to the preceding instrument are the Corporate Seals of said Companies, and that the said Corporate Seals and the signature as such officer were duly affixed and subscribed to the said instrument by the authority and direction of the said Corporations.

IN TESTIMONY WHEREOF, I have hereunto set my hand and affixed my Official Seal the day and year first above written.

Constance A. Dunn

Constance A. Dunn, Notary Public
My Commission Expires: July 9, 2019



<p>DELIVER TO: City of Fort Pierce Purchasing Division, Room 101 100 North U.S. #1 Fort Pierce, FL 34950</p> <p>MAIL TO: City of Fort Pierce Purchasing Division, Room 101 P.O. Box 1480 Fort Pierce, FL 34954-1480</p>	<p>INVITATION TO BID</p> <p>and</p> <p>BIDDER ACKNOWLEDGMENT</p>
<p>Contact: Gelencia Carter, (772) 467-3748</p>	<p>Bid No: 2018-011</p>
<p>Mandatory Pre-Bid Conference : N/A</p>	<p>Bid Title: FUEL TANK REMOVAL & INSTALLATION</p>
<p>Mandatory Pre-Bid Conference Location: N/A</p>	<p>Opening Location: City of Ft. Pierce Purchasing Division, Room 101 100 North U.S. #1 Ft. Pierce, Florida 34950</p>
<p>Bid Due Date & Time: 3:00 PM, WEDNESDAY, MARCH 28, 2018</p>	<p>If you need any reasonable accommodation for any type of disability in order to participate in this procurement, please contact this department as soon as possible.</p>
<p>Bidder Name: ATC GROUP SERVICES LLC</p> <p>-----</p> <p>Mailing Address: 10236 FISHER AVE, SUITE A</p> <p>-----</p> <p>TAMPA, FL 33619</p> <p>-----</p>	<p><i>I hereby certify that this bid is made without prior understanding, agreement, or connection with any corporation, firm, or person submitting a bid for the same materials, supplies or equipment, and is in all respects fair and without collusion or fraud. I agree to abide by all conditions of this bid and certify that I am authorized to sign this bid for the bidder.</i></p> <p style="text-align: center;"> X _____ Authorized Signature (Manual)</p>
<p>City, State, Zip Code:</p>	<p>Typed or Printed Name: SCOTT PATTERSON, P.G.</p>
<p>Type of Entity (Circle One): <input checked="" type="checkbox"/> Corporation <input type="checkbox"/> Partnership <input type="checkbox"/> Proprietorship</p>	<p>Title: BRANCH MANAGER</p>
<p>Incorporated in the State of: DE Year: 1993</p>	<p>Delivery in <u>120</u> days, ARO</p>
<p>Phone Number: 813-681-4067</p>	<p>Payment Terms: Net 30 Days</p>
<p>Fax Number: 813-689-7660</p>	<p>FEIN or SS Number: 46-0399408</p>
<p>E-Mail Address: Scott.Patterson@atcassociates.com</p>	<p>Local Business: <u> </u> Y <u>X</u> N MWBE: <u> </u> Y <u>X</u> N</p>
<p>Bid Security is attached, when required, in the amount of \$ <u>10% OF BID AMOUNT</u> F.O.B. DESTINATION</p>	<p>If returning as a "No Bid" state reason:</p>
<p>THIS PAGE MUST BE COMPLETED AND RETURNED WITH YOUR BID</p>	



COMPANY PROFILE

Complete the following form and submit with your Bid response:

1. Company Name: ATC GROUP SERVICES LLC

2. Address: 10236 FISHER AVE SUITE A, TAMPA, FL 33619

3. Contact Name: KIRON SENAPATI, P.E.

Contact Numbers

4. Telephone No.: 813-681-4067

Cell No.: 813-267-7660

Fax No.: 813-689-0974

5. Company is a certified Minority Business Enterprise as defined in Florida Statute 287.09431
 Yes No

6. Length of time Firm has been in business under same name: 35+

7. Is your organization currently pre-qualified with any governmental agency? If so, please
list: FLORIDA DEPARTMENT OF ENVIRONMENTAL PROTECTION

8. Give brief Resume including, but not limited to: name, location, job assignments, experience, qualifications, certifications, etc. (RESUME ATTACHED)

KIRON SENAPATI, P.E. - PROJECT MANAGER
JAMES SHARP - CONSTRUCTION MANAGER



THE SUNRISE CITY

FORT PIERCE

PURCHASING
DEPARTMENT

Florida

DRUG~FREE WORKPLACE FORM

The undersigned vendor in accordance with Florida Statute 287.087 hereby certified that

ATC GROUP SERVICES LLC

does:

(Name of Business)

1. Publish a statement notifying employees that the unlawful manufacture, distribution, dispensing, possession, or use of a controlled substance is prohibited in the workplace and specifying the actions that will be taken against employees for violations of such prohibition.
2. Inform employees about the dangers of drug abuse in the workplace, the business's policy of maintaining a drug-free workplace, any available drug counseling, rehabilitation, and employee assistance programs, and the penalties that may be imposed upon employees for drug abuse violations.
3. Give each employee engaged in providing the commodities or contractual services that are proposed a copy of the statement specified in subsection (1).
4. In the statement specified in subsection (1), notify the employees that, as a condition of working on the commodities or contractual services that are under bid, the employee will abide by the terms of the statement and will notify the employer of any conviction of, or plea of guilty or nolo contendere to, any violation of Chapter 893 or of any controlled substance law of the United States or any state, for a violation occurring in the workplace no later than five (5) days after such conviction.
5. Impose a sanction on, or require the satisfactory participation in a drug abuse assistance or rehabilitation program if such is available in the employee's community, by any employee who is so convicted.
6. Make a good faith effort to continue to maintain a drug-free workplace through implementation of this section.

As the person authorized to sign the statement, I certify that this firm complies fully with the above requirements.

Bidder's Signature

3/27/18

Date



THE SUNRISE CITY

FORT PIERCE

PURCHASING
DEPARTMENT

Florida

1 of 3

100 North U.S.1, P.O. Box 1480
Fort Pierce, Florida, 34954-1480

Phone: 772-467-3748
Fax: 772-467-3848

REFERENCE CHECK FORM

(Please print or type)

Bid Number: 2018-011	Title: FUEL TANK REMOVAL & INSTALLATION
Proposer/Respondent Name: ATC GROUP SERVICES LLC	(KIRON SENAPATI - PROJECT MANAGER)
Reference Company Name: THE VILLAGES UTILITIES DEPT.	(INSTALLATION OF 2000 GALLON FUEL TANK)
Telephone #: 352-674-1920	Fax #:
Contact Name: WAYNE KORNEGAY, DIRECTOR	Email: WAYNE.KORNEGAY@DISTRICTGOV.ORG

Reference Instructions: Submit a minimum of two (2) References – Fill out top portion only. The City will send form to the referenced company for completion after the City's receipt of form in Bid.

The above company submitted a proposal to provide Fuel Tank services to the City of Fort Pierce. He/she listed you as a reference. Please complete the questions below and fax back to (772)467-3848.

- When did this company work for you? From: _____ To: _____
- How would you describe the Contractor:

Quality of Work: _____

Dependability: _____

Integrity of owner and employees: _____

What areas could he/she improve upon? _____

Would you contract with this Contractor again? Yes No Maybe

- On a scale of 1 to 5, how would you rate his/her work in general? 1 2 3 4 5

- Add any information/comments that might help us evaluate their ability to perform for us?

2 of 3



THE SUNRISE CITY
FORT PIERCE
PURCHASING
DEPARTMENT
Florida

100 North U.S.1, P.O. Box 1480
Fort Pierce, Florida, 34954-1480

Phone: 772-467-3748
Fax: 772-467-3848

REFERENCE CHECK FORM
(Please print or type)

Bid Number: <u>2018-011</u>	Title: <u>FUEL TANK REMOVAL & INSTALLATION</u>
Proposer/Respondent Name: <u>ATC GROUP SERVICES LLC (KIRON SENAPATI - PROJECT MANAGER)</u>	
Reference Company Name: <u>HILLSBOROUGH COUNTY - MULTIPLE FIRE STATION FUEL TANK INSTALLATION</u>	
Telephone #: <u>813-307-1038</u>	Fax #: _____
Contact Name: <u>MANSOUR YAZDI</u>	Email: <u>YAZDIM@HILLSBOROUGHCOUNTY.ORG</u>

Reference Instructions: Submit a minimum of two (2) References – Fill out top portion only. The City will send form to the referenced company for completion after the City’s receipt of form in Bid.

The above company submitted a proposal to provide Fuel Tank services to the City of Fort Pierce. He/she listed you as a reference. Please complete the questions below and fax back to (772)467-3848.

- When did this company work for you? From: _____ To: _____
- How would you describe the Contractor:

Quality of Work: _____

Dependability: _____

Integrity of owner and employees: _____

What areas could he/she improve upon? _____

Would you contract with this Contractor again? Yes No Maybe

- On a scale of 1 to 5, how would you rate his/her work in general? 1 2 3 4 5

- Add any information/comments that might help us evaluate their ability to perform for us?



THE SUNRISE CITY
FORT PIERCE
 PURCHASING
 DEPARTMENT

Florida

3 of 3

100 North U.S.1, P.O. Box 1480
 Fort Pierce, Florida, 34954-1480

Phone: 772-467-3748
 Fax: 772-467-3848

REFERENCE CHECK FORM
 (Please print or type)

Bid Number: 2018-011	Title: FUEL TANK REMOVAL & INSTALLATION
Proposer/Respondent Name: ATC GROUP SERVICES LLC (KIRON SENAPATI - PROJECT MANAGER)	
Reference Company Name: SOLID WASTE AUTHORITY PALM BEACH COUNTY (12,000 GALLON AST INSTALLED)	
Telephone #: 561-640-4000 XTN 4602	Fax #:
Contact Name: KEN HAERTIG, PROJECT MANAGER	Email: KHAERTIG@SWA.ORG

Reference Instructions: Submit a minimum of two (2) References – Fill out top portion only. The City will send form to the referenced company for completion after the City’s receipt of form in Bid.

The above company submitted a proposal to provide Fuel Tank services to the City of Fort Pierce. He/she listed you as a reference. Please complete the questions below and fax back to (772)467-3848.

- When did this company work for you? From: _____ To: _____
- How would you describe the Contractor:

Quality of Work: _____

Dependability: _____

Integrity of owner and employees: _____

What areas could he/she improve upon? _____

Would you contract with this Contractor again? Yes No Maybe

- On a scale of 1 to 5, how would you rate his/her work in general? 1 2 3 4 5

- Add any information/comments that might help us evaluate their ability to perform for us?



NOT APPLICABLE

Certification Statement Local Vendor Preference

I certify that my company meets all of the following qualifications to be eligible for the local vendor preference:

- 1) That my company has a fixed, staffed office or distribution point located in and having a street address within St. Lucie, Indian River, Martin or Okeechobee County for at least one year prior to the issuance of the request for competitive bids or request for proposals by St. Lucie County; and
- 2) That my company holds any business or contractor license required by St. Lucie County and/or can document payment of business license taxes in St. Lucie County;
- 3) That my company is principal offeror who is single offeror; a business which is the prime contractor and not a subcontractor; or a partner or joint venturer submitting an offer in conjunction with other businesses.
- 4) Attached is a copy of a business or contractor license and/or business tax receipt for St. Lucie County, Indian River, Martin or Okeechobee Counties to verify that I have been in business at least one year prior to the issuance of the Request for Bid or Proposal.

Company Name: _____

Address: _____

Business or Contractor License Number: _____

Phone Number: _____ Fax Number: _____

Owner's Name: _____

Signature: _____

Sworn to before me this _____ day of _____, 201_____

Notary Public for the State of _____ My Commission Expires _____

Notary Public Signature _____ Printed Name _____

FOR PRUCHASING OFFICE ONLY ~ DO NOT COMPLETE BELOW

To be verified and completed by an authorized representative from the City of Fort Pierce Purchasing Department:

Vendor Certified by: _____ Date: _____
(Authorized Signature)

To be approved as a local bidder and receive bid preference on an eligible local project, this certification and a copy of your local business or contractor license must be submitted with your bonafide Bid/RFP package.

Request for Taxpayer Identification Number and Certification

Give Form to the
 requester. Do not
 send to the IRS.

Print or type See Specific Instructions on page 2.	1 Name (as shown on your income tax return). Name is required on this line; do not leave this line blank. ATC Group Services LLC		
	2 Business name/disregarded entity name, if different from above ATC Group Services LLC		
	3 Check appropriate box for federal tax classification; check only one of the following seven boxes: <input type="checkbox"/> Individual/sole proprietor or single-member LLC <input checked="" type="checkbox"/> Limited liability company. Enter the tax classification (C=C corporation, S=S corporation, P=partnership) ▶ P <small>Note. For a single-member LLC that is disregarded, do not check LLC; check the appropriate box in the line above for the tax classification of the single-member owner.</small> <input type="checkbox"/> Other (see instructions) ▶		4 Exemptions (codes apply only to certain entities, not individuals; see instructions on page 3): Exempt payee code (if any) _____ Exemption from FATCA reporting code (if any) _____ <small>(Applies to accounts maintained outside the U.S.)</small>
	5 Address (number, street, and apt. or suite no.) Dept # 2630 - PO Box 11407		Requester's name and address (optional)
	6 City, state, and ZIP code Birmingham, AL 35246-2630		
	7 List account number(s) here (optional)		

Part I Taxpayer Identification Number (TIN)

Enter your TIN in the appropriate box. The TIN provided must match the name given on line 1 to avoid backup withholding. For individuals, this is generally your social security number (SSN). However, for a resident alien, sole proprietor, or disregarded entity, see the Part I instructions on page 3. For other entities, it is your employer identification number (EIN). If you do not have a number, see *How to get a TIN* on page 3.

Social security number

			-			-				
--	--	--	---	--	--	---	--	--	--	--

or

Employer identification number

4	6	-	0	3	9	9	4	0	8
---	---	---	---	---	---	---	---	---	---

Note. If the account is in more than one name, see the instructions for line 1 and the chart on page 4 for guidelines on whose number to enter.

Part II Certification

Under penalties of perjury, I certify that:

- The number shown on this form is my correct taxpayer identification number (or I am waiting for a number to be issued to me); and
- I am not subject to backup withholding because: (a) I am exempt from backup withholding, or (b) I have not been notified by the Internal Revenue Service (IRS) that I am subject to backup withholding as a result of a failure to report all interest or dividends, or (c) the IRS has notified me that I am no longer subject to backup withholding; and
- I am a U.S. citizen or other U.S. person (defined below); and
- The FATCA code(s) entered on this form (if any) indicating that I am exempt from FATCA reporting is correct.

Certification instructions. You must cross out item 2 above if you have been notified by the IRS that you are currently subject to backup withholding because you have failed to report all interest and dividends on your tax return. For real estate transactions, item 2 does not apply. For mortgage interest paid, acquisition or abandonment of secured property, cancellation of debt, contributions to an individual retirement arrangement (IRA), and generally, payments other than interest and dividends, you are not required to sign the certification, but you must provide your correct TIN. See the instructions on page 3.

Sign Here Signature of U.S. person ▶ *Stephanie Jenkins* Date ▶ *1/20/16*

General Instructions

Section references are to the Internal Revenue Code unless otherwise noted.

Future developments. Information about developments affecting Form W-9 (such as legislation enacted after we release it) is at www.irs.gov/irv9.

Purpose of Form

An individual or entity (Form W-9 requester) who is required to file an information return with the IRS must obtain your correct taxpayer identification number (TIN) which may be your social security number (SSN), individual taxpayer identification number (ITIN), adoption taxpayer identification number (ATIN), or employer identification number (EIN), to report on an information return the amount paid to you, or other amount reportable on an information return. Examples of information returns include, but are not limited to, the following:

- Form 1099-INT (interest earned or paid)
- Form 1099-DIV (dividends, including those from stocks or mutual funds)
- Form 1099-MISC (various types of income, prizes, awards, or gross proceeds)
- Form 1099-B (stock or mutual fund sales and certain other transactions by brokers)
- Form 1099-S (proceeds from real estate transactions)
- Form 1099-K (merchant card and third party network transactions)

- Form 1098 (home mortgage interest), 1098-E (student loan interest), 1098-T (tuition)
- Form 1099-C (canceled debt)
- Form 1099-A (acquisition or abandonment of secured property)

Use Form W-9 only if you are a U.S. person (including a resident alien), to provide your correct TIN.

If you do not return Form W-9 to the requester with a TIN, you might be subject to backup withholding. See What is backup withholding? on page 2.

By signing the filled-out form, you:

- Certify that the TIN you are giving is correct (or you are waiting for a number to be issued),
- Certify that the TIN you are giving is correct (or you are waiting for a number to be issued),
- Claim exemption from backup withholding if you are a U.S. exempt payee. If applicable, you are also certifying that as a U.S. person, your allocable share of any partnership income from a U.S. trade or business is not subject to the withholding tax on foreign partners' share of effectively connected income, and
- Certify that FATCA code(s) entered on this form (if any) indicating that you are exempt from the FATCA reporting, is correct. See *What is FATCA reporting?* on page 2 for further information.



BID RESPONSE FORM



Bid Item	FUEL TANK REMOVAL & INSTALLATION		
Bid Number	2018-011	Due Date & Time	3:00PM, WEDNESDAY, MARCH 28, 2018

The offerer agrees to furnish the following items or services to the City of Fort Pierce at the place specified, in accordance with specifications herein at the prices quoted below:

Description	Lump Sum Total
Furnish and Install two (2) 12,000 Gallon Tanks as specified under the scope of work	\$ 160,000.00

Fuel Tank Make	Fuel Tank Model
HIGHLAND TANK MANUFACTURING COMPANY	FG-12000 UL-2085

The Bidder hereby acknowledges receipt of the following addenda:

ADDENDUM NO.	ADDENDUM DATE
1	MARCH 20, 2018
2	MARCH 21, 2018

Vendor: ATC GROUP SERVICES LLC

Address: 10236 FISHER AVE, SUITE A

City, State, Zip Code: TAMPA, FL 33619

Email Address: KIRON.SENAPATI@ATCGS.COM

Typed Name & Title: KIRON SENAPATI, P.E./ SENIOR ENGINEER/ PROJECT MANAGER

Signature: *K Senapati* Date: 3-27-18

Telephone No.: 813-267-7660 Fax No.: 813-689-0974

(*Please include Remit to address if different than address stated above)

Remit To:

Check block below for applicable minority indicator:

- Asian Indian
 Black
 Asian Pacific
 Hispanic
 Native American
 Small Business
 Women Owned
 Small Disadvantage Business

2017 - 2018 TROURGH COUNTY BUSINESS TAX RECEIPT
OCC. CODE
280.052006 CONSULTANT

EXPIRES SEPTEMBER 30, 2018

36865
RENEWAL

28 Employees	Receipt Fee	150.00
	Hazardous Waste Surcharge	0.00
	Law Library Fee	0.00

BUSINESS ATC GROUP SERVICES LLC
5602 THOMPSON CENTER CT
TAMPA, FL 33634

2017 - 2018

ATC GROUP SERVICES LLC
NAME 221 RUE DE JEAN
MAILING SUITE 300
ADDRESS LAFAYETTE, LA 70508

Paid 16-616-003475
07/21/2017 150.00

BUSINESS TAX RECEIPT

HAS HEREBY PAID A PRIVILEGE TAX TO ENGAGE
IN BUSINESS, PROFESSION, OR OCCUPATION SPECIFIED HEREON

DOUG BELDEN, TAX COLLECTOR
813-635-5200
THIS BECOMES A TAX RECEIPT WHEN VALIDATED.



CERTIFICATE OF LIABILITY INSURANCE

DATE(MM/DD/YYYY)
11/16/2017

THIS CERTIFICATE IS ISSUED AS A MATTER OF INFORMATION ONLY AND CONFERS NO RIGHTS UPON THE CERTIFICATE HOLDER. THIS CERTIFICATE DOES NOT AFFIRMATIVELY OR NEGATIVELY AMEND, EXTEND OR ALTER THE COVERAGE AFFORDED BY THE POLICIES BELOW. THIS CERTIFICATE OF INSURANCE DOES NOT CONSTITUTE A CONTRACT BETWEEN THE ISSUING INSURER(S), AUTHORIZED REPRESENTATIVE OR PRODUCER, AND THE CERTIFICATE HOLDER.

IMPORTANT: If the certificate holder is an ADDITIONAL INSURED, the policy(ies) must have ADDITIONAL INSURED provisions or be endorsed. If SUBROGATION IS WAIVED, subject to the terms and conditions of the policy, certain policies may require an endorsement. A statement on this certificate does not confer rights to the certificate holder in lieu of such endorsement(s).

PRODUCER Aon Risk Services Southwest, Inc. Houston TX Office 5555 San Felipe Suite 1500 Houston TX 77056 USA	CONTACT NAME: PHONE (A/C. No. Ext): (866) 283-7122 FAX (A/C. No.): (800) 363-0105		
	E-MAIL ADDRESS:		
INSURER(S) AFFORDING COVERAGE		NAIC #	
INSURED ATC Group Services LLC 221 Rue De Jean Suite 300 Lafayette LA 70508-3283 USA	INSURER A: Steadfast Insurance Company		26387
	INSURER B: Zurich American Ins Co		16535
	INSURER C:		
	INSURER D:		
	INSURER E:		
	INSURER F:		

COVERAGES **CERTIFICATE NUMBER: 570069242000** **REVISION NUMBER:**

THIS IS TO CERTIFY THAT THE POLICIES OF INSURANCE LISTED BELOW HAVE BEEN ISSUED TO THE INSURED NAMED ABOVE FOR THE POLICY PERIOD INDICATED. NOTWITHSTANDING ANY REQUIREMENT, TERM OR CONDITION OF ANY CONTRACT OR OTHER DOCUMENT WITH RESPECT TO WHICH THIS CERTIFICATE MAY BE ISSUED OR MAY PERTAIN, THE INSURANCE AFFORDED BY THE POLICIES DESCRIBED HEREIN IS SUBJECT TO ALL THE TERMS, EXCLUSIONS AND CONDITIONS OF SUCH POLICIES. LIMITS SHOWN MAY HAVE BEEN REDUCED BY PAID CLAIMS. **Limits shown are as requested**

INSR LTR	TYPE OF INSURANCE	ADDL INSD	SUBR WVD	POLICY NUMBER	POLICY EFF (MM/DD/YYYY)	POLICY EXP (MM/DD/YYYY)	LIMITS	
A	<input checked="" type="checkbox"/> COMMERCIAL GENERAL LIABILITY <input type="checkbox"/> CLAIMS-MADE <input checked="" type="checkbox"/> OCCUR GEN'L AGGREGATE LIMIT APPLIES PER: <input type="checkbox"/> POLICY <input checked="" type="checkbox"/> PRO-JECT <input checked="" type="checkbox"/> LOC OTHER:			GPL021708502	11/13/2017	11/13/2018	EACH OCCURRENCE	\$1,000,000
							DAMAGE TO RENTED PREMISES (Ea occurrence)	\$100,000
							MED EXP (Any one person)	\$5,000
							PERSONAL & ADV INJURY	\$1,000,000
							GENERAL AGGREGATE	\$2,000,000
							PRODUCTS - COMP/OP AGG	\$2,000,000
B	<input checked="" type="checkbox"/> AUTOMOBILE LIABILITY <input checked="" type="checkbox"/> ANY AUTO <input type="checkbox"/> OWNED AUTOS ONLY <input type="checkbox"/> SCHEDULED AUTOS <input checked="" type="checkbox"/> HIRED AUTOS ONLY <input checked="" type="checkbox"/> NON-OWNED AUTOS ONLY			BAP 0217109-02	11/13/2017	11/13/2018	COMBINED SINGLE LIMIT (Ea accident)	\$1,000,000
							BODILY INJURY (Per person)	
							BODILY INJURY (Per accident)	
							PROPERTY DAMAGE (Per accident)	
	<input type="checkbox"/> UMBRELLA LIAB <input type="checkbox"/> OCCUR <input type="checkbox"/> EXCESS LIAB <input type="checkbox"/> CLAIMS-MADE <input type="checkbox"/> DED <input type="checkbox"/> RETENTION						EACH OCCURRENCE	
							AGGREGATE	
B	<input checked="" type="checkbox"/> WORKERS COMPENSATION AND EMPLOYERS' LIABILITY ANY PROPRIETOR / PARTNER / EXECUTIVE OFFICER/MEMBER EXCLUDED? (Mandatory in NH) If yes, describe under DESCRIPTION OF OPERATIONS below			WC021711102	11/13/2017	11/13/2018	<input checked="" type="checkbox"/> PER STATUTE <input type="checkbox"/> OTH-ER	
							E.L. EACH ACCIDENT	\$1,000,000
							E.L. DISEASE-EA EMPLOYEE	\$1,000,000
							E.L. DISEASE-POLICY LIMIT	\$1,000,000
A	Env Contr Pol			GPL021708502	11/13/2017	11/13/2018	Policy Aggregate	\$1,000,000
							Each Incident	\$1,000,000

DESCRIPTION OF OPERATIONS / LOCATIONS / VEHICLES (ACORD 101, Additional Remarks Schedule, may be attached if more space is required)

RE: Client Services Agreement.
 Evidence of Insurance.
 Contractual Liability is included under the General Liability policy.

CERTIFICATE HOLDER

CANCELLATION

<p style="text-align: center;">FOR PROPOSAL PURPOSES ONLY</p> <p>ATC Group Services LLC 221 Rue De Jean, Suite 300 Lafayette LA 70508-3283 USA</p>	<p>SHOULD ANY OF THE ABOVE DESCRIBED POLICIES BE CANCELLED BEFORE THE EXPIRATION DATE THEREOF, NOTICE WILL BE DELIVERED IN ACCORDANCE WITH THE POLICY PROVISIONS.</p> <p>AUTHORIZED REPRESENTATIVE</p> <p style="text-align: center;"><i>Aon Risk Services Southwest Inc.</i></p>
---	---

©1988-2015 ACORD CORPORATION. All rights reserved.



ADDITIONAL REMARKS SCHEDULE

AGENCY Aon Risk Services Southwest, Inc.		NAMED INSURED ATC Group Services LLC	
POLICY NUMBER See Certificate Number: 570069242000			
CARRIER See Certificate Number: 570069242000	NAIC CODE	EFFECTIVE DATE:	

ADDITIONAL REMARKS

THIS ADDITIONAL REMARKS FORM IS A SCHEDULE TO ACORD FORM,
FORM NUMBER: ACORD 25 FORM TITLE: Certificate of Liability Insurance

INSURER(S) AFFORDING COVERAGE	NAIC #
INSURER	
INSURER	
INSURER	
INSURER	

ADDITIONAL POLICIES If a policy below does not include limit information, refer to the corresponding policy on the ACORD certificate form for policy limits.

INSR LTR	TYPE OF INSURANCE	ADDL INSD	SUBR WVD	POLICY NUMBER	POLICY EFFECTIVE DATE (MM/DD/YYYY)	POLICY EXPIRATION DATE (MM/DD/YYYY)	LIMITS	
	OTHER							
A	E&O-PL-Primary			GPL021708502 CLAIMS MADE	11/13/2017	11/13/2018	Policy Aggregate	\$1,000,000
							Each Incident	\$1,000,000



ATC Group Services LLC (ATC) is a full service consulting and environmental construction firm with demonstrated experience performing petroleum storage facility design and construction services in Florida. Our professional and field staff have been involved in the performance of these services for over 20 years. Over the past 10 years, the storage tank construction staff has installed over 50 petroleum fuel storage facilities for various private, municipal, and federal clients. Our Mission at ATC is to differentiate ourselves in the marketplace as committed to performing **Quality Work** on all assignments, completing engagements **On Time**, and **Within Budget**. Our Client and Team Driven Focus is at the core of ATC's local and national reputation.

Over the past 35 years, ATC has become one of the leading national providers of environmental and engineering support services nationwide. We are a full service firm specializing in geotechnical and construction material testing, hazardous materials management, industrial hygiene, safety and compliance, environmental remediation, storage tank construction, and health & safety training. We are now considered one of the top diversified engineering consulting firms in the United States.

Our local office in Tampa, Florida was established in 1997, and provides petroleum storage tank design and construction services including site selection and design, equipment specification and selection, site preparation, site construction, maintenance and testing, and decommissioning services. We also provide a full suite of services related to environmental investigation and remediation, indoor air quality and industrial hygiene, and building material sciences.

Our staff, residing locally in Tampa, possess the necessary qualifications and experience required to support the Hillsborough County Sheriff's Office facility project. Our licenses and certifications include the following:

<u>Type of License or Certification</u>	<u>License / Certification Number</u>
Authorization to Conduct Business	M1600000408
Engineering Certificate of Authorization	CA7783
Certified General Contractor	CGC1522696
Pollutant Storage System Specialty Contractor	PCC056779

ATC follows procedures, methodology, and standards developed by the American Petroleum Institute (API), Petroleum Equipment Institute (PEI), National Fire Protection Act (NFPA), the United States Environmental Protection Agency (US EPA), and the Florida Department of Environmental Protection (FDEP). Our professional and technical staff have also received training and certification from many of these organizations.

We have prepared this response to RFP 7-18 to closely follow the solicitation request document. We hope that the presentation of our qualifications, experience, and understanding of the Sheriff Department's needs are evidence of how our firm can provide tremendous value to the Department and the residents of Hillsborough County.



**STATE OF FLORIDA
DEPARTMENT OF BUSINESS AND PROFESSIONAL REGULATION**

**CONSTRUCTION INDUSTRY LICENSING BOARD
2601 BLAIR STONE ROAD
TALLAHASSEE FL 32399-0783**

(850) 487-1395

SENAPATI, KIRON
ATC GROUP SERVICES LLC
9510 NORCHESTER CIR
TAMPA FL 33647

Congratulations! With this license you become one of the nearly one million Floridians licensed by the Department of Business and Professional Regulation. Our professionals and businesses range from architects to yacht brokers, from boxers to barbeque restaurants, and they keep Florida's economy strong.

Every day we work to improve the way we do business in order to serve you better. For information about our services, please log onto www.myfloridalicense.com. There you can find more information about our divisions and the regulations that impact you, subscribe to department newsletters and learn more about the Department's initiatives.

Our mission at the Department is: License Efficiently, Regulate Fairly. We constantly strive to serve you better so that you can serve your customers. Thank you for doing business in Florida, and congratulations on your new license!



**STATE OF FLORIDA
DEPARTMENT OF BUSINESS AND
PROFESSIONAL REGULATION**

CGC1522696 ISSUED: 08/29/2017

**CERTIFIED GENERAL CONTRACTOR
SENAPATI, KIRON
ATC GROUP SERVICES LLC**

IS CERTIFIED under the provisions of Ch.489 FS.
Expiration date : AUG 31, 2018 L1708290003083

DETACH HERE

RICK SCOTT, GOVERNOR

JONATHAN ZACHEM, SECRETARY

**STATE OF FLORIDA
DEPARTMENT OF BUSINESS AND PROFESSIONAL REGULATION
CONSTRUCTION INDUSTRY LICENSING BOARD**

LICENSE NUMBER	
CGC1522696	



The GENERAL CONTRACTOR
Named below IS CERTIFIED
Under the provisions of Chapter 489 FS.
Expiration date: AUG 31, 2018

SENAPATI, KIRON
ATC GROUP SERVICES LLC
9510 NORCHESTER CIR
TAMPA FL 33647





**STATE OF FLORIDA
DEPARTMENT OF BUSINESS AND PROFESSIONAL REGULATION**

**CONSTRUCTION INDUSTRY LICENSING BOARD
2601 BLAIR STONE ROAD
TALLAHASSEE FL 32399-0783**

(850) 487-1395

SENAPATI, KIRON
ATC GROUP SERVICES LLC
9510 NORCHESTER CIR
TAMPA FL 33647

Congratulations! With this license you become one of the nearly one million Floridians licensed by the Department of Business and Professional Regulation. Our professionals and businesses range from architects to yacht brokers, from boxers to barbeque restaurants, and they keep Florida's economy strong.

Every day we work to improve the way we do business in order to serve you better. For information about our services, please log onto www.myfloridalicense.com. There you can find more information about our divisions and the regulations that impact you, subscribe to department newsletters and learn more about the Department's initiatives.

Our mission at the Department is: License Efficiently, Regulate Fairly. We constantly strive to serve you better so that you can serve your customers. Thank you for doing business in Florida, and congratulations on your new license!



**STATE OF FLORIDA
DEPARTMENT OF BUSINESS AND
PROFESSIONAL REGULATION**

PCC056779 ISSUED: 08/23/2017

CERT POLLUTANT STORAGE SYS CONTR
SENAPATI, KIRON
ATC GROUP SERVICES LLC

IS CERTIFIED under the provisions of Ch.489 FS.
Expiration date : AUG 31, 2018 L1708230002324

DETACH HERE

RICK SCOTT, GOVERNOR

JONATHAN ZACHEM, SECRETARY

**STATE OF FLORIDA
DEPARTMENT OF BUSINESS AND PROFESSIONAL REGULATION
CONSTRUCTION INDUSTRY LICENSING BOARD**

LICENSE NUMBER	
PCC056779	



The POLLUTANT STORAGE SYSTEMS CONTRACTOR
Named below IS CERTIFIED
Under the provisions of Chapter 489 FS.
Expiration date: AUG 31, 2018

SENAPATI, KIRON
ATC GROUP SERVICES LLC
9510 NORCHESTER CIR
TAMPA FL 33647





Kiron Senapati, PE

Senior Engineer/Project Manager

Branch Location

- Tampa, FL

Education

- M.S., Chemical Engineering
University of Alabama, 1981

Professional Registrations/ Certifications

- Professional Engineer, Florida
- Professional Engineer,
Alabama
- Professional Engineer,
Georgia
- Florida Certified General
Contractor
- Florida Pollutant Storage
Systems Contractor

Specialized Training

- OSHA 40-Hour HAZWOPER
and Current 8-Hour Refresher
- Photovoltaic Systems Design
- Geothermal Heat Pump
Design

Professional Affiliations

- American Institute of
Chemical Engineers, Senior
Member
- Association of Energy
Engineers

ATC Start Date

- March 2013

Publications

- Remedial Options for Treating
Arsenic in Groundwater,
Remediation Conference,
Orlando, FL 2004
- Arsenic Treatment Unit,
Reliable Technology for
Arsenic Safe Water,
International Workshop for
Arsenic Removal
Technologies, United Nations
University, Osaka, Japan, 2001
- Applications of Ozone for
Removal of Chlorinated
Organic Contaminants from
Groundwater, Remediation
Conference, Orlando, FL 2000

Mr. Senapati is an innovative engineering professional with over 24 years of process engineering and industrial construction experience in a variety of industries. His background ranges from engineering of manufacturing facilities to design and development of innovative products for the water and wastewater treatment industry. He has varied experience in equipment design, construction, business development, and supervision of engineering staff and has designed, implemented, and managed several water and wastewater treatment projects throughout the US and overseas.

Areas of Expertise

- Storage tank system design and installation
- Water and wastewater treatment design and installation
- Sustainability programs
- Pollution prevention programs
- Alternative energy programs and engineering

In addition to the above, Mr. Senapati's engineering talents include contract document development, plans review, permitting, and construction oversight, which make him a highly effective project manager. He has extensive experience in managing large multidisciplinary projects. Being trained as an engineer and certified as a general contractor, he can provide valuable vision for constructability of an engineering design. He has supervised project teams from start to completion for multiple projects, starting with proposal preparation, pilot testing, detail design/specification, installation, and start-up. Following is a summary of some of the projects he has successfully implemented at various locations throughout the United States and overseas.

Project Experience

Transportation

Fuel Tank Installation, Lee County Port Authority – Fort Myers, FL

Project Manager - Design and install two (2) – 6,000-gallon double wall fuel storage tanks for the vehicle maintenance facility located at the Southwest Florida International Airport. One (1) - 6,000-gallon Fireguard Tank with remote fill box was installed for diesel fuel storage and, one (1) – 6,000-gallon Fireguard Tank with remote fill box and vapor recovery was installed for gasoline storage. The existing fuel dispensers were brought into compliance by providing containment boxes and tied to the existing Megatrex Fuel Management System.

Telecom and Utilities

Electric Operations Building Generator, New Smyrna Beach Utilities – New Smyrna Beach, FL

Project Manager - Removed an existing gas feed generator and replaced it with a client supplied new 100 KW diesel backup generator, at their main Electric Operations Building. A 500-gallon double wall "Convault" diesel fuel storage tank was procured and installed to supply diesel fuel to the new generator. The work scope also included installation of a new 600A, NEMA1, 120/208V, 3-Pole Auto Transfer Switch.

Project Experience

Water/Wastewater

Wastewater Pre-Treatment/Recycle Treatment System, Chromalloy Castings – Tampa, FL

Project Manager - The wastewater treatment system was designed and installed for the Air Craft Engine Parts Manufacturer includes treatment to meet the POTW discharge limits by removing heavy metals and pH adjustment prior to discharge. The treatment system utilized Ceramic Membrane Filtration (CMF) and Reverse Osmosis, for removal of suspended and colloidal solids. The rejected solids are dewatered using a filter press and disposed as a non-hazardous waste.

Refining and Chemicals

Zinc Impacted Soil Remediation, American Radionics Company – Palm Coast, FL

Project Manager - The subject site was impacted with zinc dust produced during manufacturing of capacitors. Performed site assessment of soil and groundwater and determined that only the top soil was impacted with zinc above regulatory cleanup standards. The Florida Department of Environmental Protection (FDEP) had offered two options to the site owner; (a) institutional controls to minimize the potential for human exposure to zinc (b) remediate the site to residential Soil Cleanup Target Limits (SCTLs) for zinc. The site owner decided to implement site remediation. A Remedial Action Plan was prepared and following approval by the FDEP, the site was remediated to residential SCTL for zinc.

Government

Fuel Tank Upgrade, Solid Waste Authority – West Palm Beach, FL

Project Manager - Remove an existing 10,000-gallon single wall diesel fuel tank and replace it with a new 12,000-gallon double wall "Fireguard" diesel fuel storage tank for the West Central County Transfer Station, located in Royal Palm Beach, Florida. The 12,000-gallon double wall "Fireguard" diesel fuel storage tank was installed with a tank mounted fuel dispenser. The new tank was installed adjacent to the existing fuel tank such that fuel service to the facility could be continued during the installation of the new tank to minimize downtime. A complete fuel management system consisting of Veeder Root Model TMS2000 along with OPW K-800 Hybrid Fuel Controller with Key Reader for fueling their fleet vehicles was installed for the new fuel storage tank.

Hillsborough County Fire Rescue, Multiple Fire Stations – Tampa, FL

Project Manager - Installed above ground Fireguard Diesel Fuel Tanks at six (6) different Fire Stations located throughout Hillsborough County for their fleet fueling operations. The tanks included tank mounted fuel dispensers, Veeder Root TLS 450 tank management systems and fuel management systems consisting of Fuel Master Model TMS3500 along with key reader and remote readout for fueling fleet vehicles.

Leachate Storage Tank, Pasco County Solid Waste Transfer Station – Dade City, FL

Project Manager - The 15,000-gallon underground double wall leachate tank was installed with a programmable loading station for pumping out the leachate stored in the tank. The tank was equipped with a grinder pump to pump a pre-set volume of leachate into a tanker truck for offsite disposal. The tank was also equipped with a LEL sensor and alarm to monitor methane.

Fire Protection Tank, Hillsborough County Sheriff's Training Facility – Lithia, FL

Project Manager - The 30,000-gallon above ground fire protection tank was installed along with an onsite production well to provide water for fire protection and training purposes. The original design had specified an onsite built storage tank, but due to on site constraints, and operation of the training facility, the client accepted our offer to install a factory built storage tank to minimize impact on the training operations.

Presentations

- Industrial Wastewater Treatment Technologies, Florida Industrial Pre-Treatment Association Conference, Daytona Beach, FL 2009
- Arsenic Removal from Drinking Water Using Iron-Based Adsorbents, AWWA Conference, San Diego, CA 2007



Jim Sharp
Construction Project Manager

Branch Location

- Tampa, FL

Professional Registrations/ Certifications

- Certified Environmental Compliance Manager (CECM), Columbia Southern University, 2004
- UST Removal, Arkansas Department Pollution Control and Ecology, License No. 751
- Monitoring Well Installation, Arkansas Water Well Commission, Cert. No. 2403
- UST Installation, Nebraska State Fire Marshal, License No. 2571
- UST Removal, International Fire Code Institute (IFCI) Cert. No. 82987
- UST Installation and Retrofitting, International Fire Code Institute, (IFCI) Cert. No. 85450
- Tank Testing, International Fire Code Institute (IFCI) Cert. No. 1036177-27
- Volumetric Tank Testing Certification, Horner Creative Products, MI
- Well Drilling and Pump Installation, Missouri Department of Natural Resources,
- UST Closure, Louisiana Department of Environment, Cert. No. C-0494
- Steel and Fiberglass Tank Installation (Xerxes, Highland, Modern, Convault, etc.)
- Fiberglass and Geoflex Piping Installation (OPW, Ameron, Smith, APT, etc.)
- Veeder-Root, EBW, and Pnuemercator Tank Monitoring Systems Installation, Programming, Startup.
- Class "A" Commercial Driver's License, Florida

Mr. Sharp has 24 years providing environmental construction and management services to public and private clients throughout the U.S. Having served as a Director of Operations, Construction Manager, and Project Manager for numerous companies, Mr. Sharp oversees all construction tasks including remedial systems installation, AST and UST installations, removals, upgrades, site demolition and restoration, hazardous and non-hazardous waste mitigation, HAZMAT response, industrial services, and OSHA and field training of personnel. He has experience in fuel systems design and installation of fleet and retail fueling services for both UST and AST applications. He is knowledgeable of applicable OSHA, ASTM, STI, NFPA and API regulations. He has successfully established construction and estimating departments for three separate entities, and has expanded the capabilities and endeavors of others.

Areas of Expertise

- Personnel Management
- Project Management
- Construction Management
- Federal Project Management
- Fuel Systems Design
- Basic Electronics
- Automated Controls – Design, Construction, Installations
- Remedial Systems Troubleshooting, Design, Installations
- Industrial Mechanical Processes
- Construction Technologies
- Training Program Administrator
- HAZMAT Response/Command
- Confined Space Supervisor/Instructor

Project Experience

UST and AST Services

- **U.S. Postal Service, Fleet Fuel System Upgrades.** Removal and closure of USTs and installation of ASTs at six postal facilities in Alabama and Florida. \$650,000.
- **U.S. Coast Guard, Miami, Florida.** Closure of USTs and installation of AST with day tank and generator fuel supply system. \$250,000.
- **Hillsborough County Sheriff's Correctional Facilities.** Performed UST upgrades of piping, dispensers, sumps and monitoring systems at three facilities in Hillsborough County.
- **Fuel System Upgrades, Mac Dill AFB, Tampa, Florida.** Project Manager for upgrading fuel systems at seven high security locations while keeping fuel stations active. Revenues were approximately \$350,000.
- **Pinellas County Fuel System Upgrades.** Construction Manager responsible for installing upgrade tanks and dispensers at Sheriff's and police offices in Pinellas County. \$420,000.
- **Florida Department of Transportation.** Design and installation of 40,000-gallon AST Fleet fueling system. \$480,000.

Specialized Training

- OSHA 40-Hour HAZWOPER and Current 8-Hour Refresher
- Hazardous Waste Operations Trainer, New Environment, Inc., Ohio
- Aquatic Environments: Marine Reef Ecosystems. 1985-1992
- First Aid and CPR Training, 1985, Biennial Refresher
- Confined Space Supervisor and Instructor
- Hazardous Response Supervisor (1998 – 2003)
- Superfund Manager and Supervisor

Professional Affiliations

- U.S. Air Force
- U.S. Marine Corp
- Society of American Military Engineers (SAME)

ATC Start Date

- May 2009

Project Experience

UST and AST Services continued

- **Citrus County Emergency Operations Center.** Installation of emergency generator fuel system, integral alarm, communications, and automatic fuel circulation and filtration system. \$400,000.
- **Citrus County Schools Storage Tank Upgrades.** Removal and closure of existing UST systems and subsequent installation of AST fleet fueling systems for bus maintenance facilities at three locations within county. \$450,000.

Industrial Services

- **Facility Closure, Coronet Industries, Plant City, Florida.** Site supervisor of facility storage vessel cleaning and decommissioning with the characterization, handling, and disposal of approximately 200,000-gallons of assorted hazardous wastes. Revenues were approximately \$600,000.
- **A Plus Fireplace and Granite, New Port Richey, Florida.** Design and installation of a water recovery and reclamation system for a granite and marble materials manufacturer. \$145,000.
- **Stormwater Collection and Treatment System, Orlando, Florida.** Installation of containment area for commercial bulk oil services company. Above grade oil water separator with multiple submersible pump catch basins and automated control panel.

Environmental Services

- **Superfund Site Corbin, Kentucky.** Closure of bulk oil facility and barrel recycling center. Design and installation of active insitu and exsitu bio-remediation system for treatment of approximately 22,000 cubic yards of contaminated soils. \$2.5M.
- **St. Louis International Airport Expansion, St. Louis, MO.** Closure of deicing facility storage tanks and mitigation of 9500 cubic yards of contaminated soils. \$550,000.
- **Superfund Site Lakeland, Florida.** Site Supervisor and Safety Officer for the mitigation of pesticide laden soils at a former processing facility. Full level B and C excavation, geotextile, and restoration. \$550,000.
- **Superfund Site Tampa, Florida.** Project Manager and Site Supervisor for removal of hazardous impacted soils and treatment of groundwater at an active pesticide processing facility. \$1.5M.
- **Numerous Soil and Groundwater Remediation Systems Installations, Florida.** AS and VES system installations throughout Florida. One bio-regeneration and augmentation system and two TCE recovery and remediation systems.

Construction Services

- **Project Manager, Youth Center Facility, Camp LeJeune, North Carolina.** Federal Project for the construction of a new recreation center for youth activities and classes that included a full size basketball gymnasium. \$2.5 M.
- **Project Manager, Airport Terminal Renovation, New River Air Station, North Carolina.** Federal project for the renovation of the existing airport terminal. Upgrades to HVAC, boiler, fire, electrical, and remodel. Included change order for addition of VIP lounge. \$700,000.
- **Hanger Renovation, Camp LeJeune, North Carolina.** Federal project for the complete renovation of existing 1940s era hanger facility. Included interior and exterior demolition and renovation, lead and asbestos abatement. \$2.5 M.
- **Rehabilitation Center Renovation and Upgrade, Kinston, North Carolina.** State funded project for the installation of fire protection systems, firewalls, and asbestos abatement. \$650,000.



Woodberry Pump Station Hillsborough County, FL

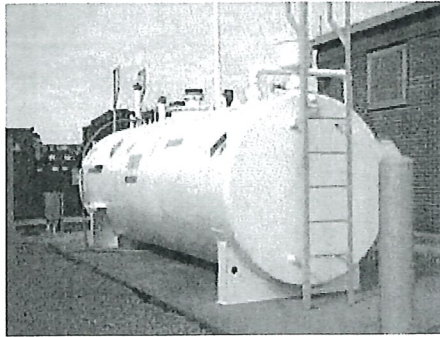

PROJECT HIGHLIGHTS:

- > Fuel tank removal and replacement
- > Installation of steel piping
- > Installation of TMS 2000 monitoring system
- > Installation of 100 gallon Day Tank for generator
- > Installation of automatic fuel polishing system

CLIENT:

- > Hillsborough County Public Utilities Department
Kelly Kiner, Project Manager
Public Utilities Department
Utility Operations Division
Engineering Services Group
925 East Twiggs Street
Tampa, FL 33601
813.272.5977, ext. 43343
kinerk@hillsboroughcounty.org

PROJECT VALUE:

- > \$290,000

COMPLETION DATE:

- > January 2014

Environmental Compliance Services, Inc., (ECS) was selected by Hillsborough County Public Utilities Department remove an existing 2,200 gallon underground fuel storage tank for their Master Pump Station, Critical Generator and replace it with a double wall 3,000 gallon Aboveground Fuel Storage Tank, located in Tampa, Florida. (FIREGUARGD UL- 2085 TANK)

The work scope included providing a temporary trailer mounted fuel tank with temporary fuel lines to the critical use generator during the construction of the new AST. A complete tank level detection and real time monitoring system to monitor level, tank leak detection, and volume of fuel in the tank was installed inside the generator room. The scope included installation of 100 gallon Day Tank to provide fuel from the AST to the generator. Additionally, an automatic fuel polishing system was installed to remove water and bacterial growth and other particulate matter from the fuel stored in the AST on a preset weekly schedule.

The project was completed within budget in record time to the satisfaction of the Client. Based on the project performance, the Hillsborough County Project Manager has retained ECS to relocate another generator fuel tank including new piping at their Vandyke Waste Water Treatment Plant, Odessa, Florida.



WHERE BUSINESS AND THE ENVIRONMENT CONVERGE

> CONNECTICUT > FLORIDA > MASSACHUSETTS > NEW HAMPSHIRE > NORTH CAROLINA > OHIO > VERMONT >

www.ecsconsult.com

Removal/Replacement of Fuel Tank West Central County Transfer Station Royal Palm Beach, FL

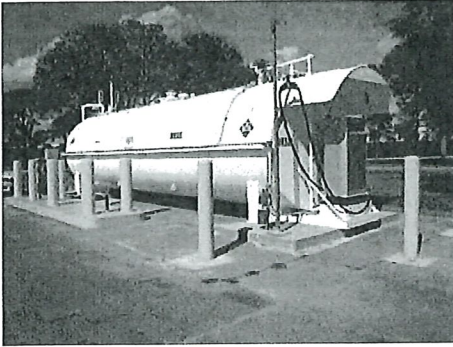

PROJECT HIGHLIGHTS:

- > Removal of 10,000 gallon fuel tank and concrete containment
- > Installation of 12,000 gallon AST
- > Installation of fuel management system with remote readout
- > Replacement of electrical panel
- > Maintenance of temporary power

CLIENT:

- > Solid Waste Authority of Palm Beach County
Kenneth Haertig, Project Manager
7501 North Jog Road
West Palm Beach, FL 33412
561.640.4000, ext. 4602
khaertig@swa.org

PROJECT VALUE:

- > \$220,000

Environmental Compliance Services, Inc. (ECS) was selected by the Solid Waste Authority of Palm Beach County, Florida to remove an existing 10,000 gallon single wall diesel fuel tank and replace it with a new 12,000 gallon double wall "Fireguard" diesel fuel storage tank for their West Central County Transfer Station, located in Royal Palm Beach, Florida.

The 12,000 gallon double wall "Fireguard" diesel fuel storage tank was installed with a tank mounted fuel dispenser. The new tank was installed adjacent to the existing fuel tank such that fuel service to the facility could be continued during the installation of the new tank to minimize downtime. The switch over to the new fuel tank was accomplished within couple weeks of shutdown of the existing fuel tank. A complete fuel management system consisting of Veeder Root Model TMS2000 along with OPW K-800 Hybrid Fuel Controller with Key Reader for fueling their fleet vehicles was installed for the new fuel storage tank. The work scope also included replacement of the existing electric panel "MDP" which was damaged, with a new 600 A, 480VAC, 4W panel. Temporary power was maintained during the replacement of the MDP panel and the shutdown was done during off hours on a weekend, without interrupting operation of the Transfer Station.

The project was completed to the satisfaction of the Client. The Client Project Manger stated, **"We like your attention to detail and quality of work and look forward to working with you on another fuel system project provided you win competitively."**

AST Installation Hillsborough County Fire Station No. 7 Valrico, FL



PROJECT HIGHLIGHTS:

- > Installation of 2,000 gallon AST
- > Installation of fuel management system
- > Installation of tank monitoring system

CLIENT:

- > CRS Building Corporation
Joe Viverito, Project Manager
100 Second Ave. South, Suite 301-S
St. Petersburg, FL 33701
727.895.7500
jviverito@crsbuildingcorp.com
- > Hillsborough County Fire Rescue
Tim Donahue, CPE, Facilities Mgr.
Hillsborough County BOCC
813.272.6600
donahuet@hillsboroughcounty.org

PROJECT VALUE:

- > \$68,000

Environmental Compliance Services, Inc. (ECS) was selected by General Contractor CRS Building Corporation to install a 2,000 gallon Fireguard double wall above ground fuel storage tank to dispense fuel to the fire vehicles.

The 2,000 gallon double wall Fireguard diesel fuel storage tank was installed with a tank mounted fuel dispenser. A complete fuel management system consisting of Fuel Master Model TMS3500 along with Key Reader and remote readout for fueling fire vehicles was installed for the new fuel storage tank.

The project was completed to the satisfaction of the Hillsborough County Fire Rescue. Subsequently, CRS Building Corporation has retained ECS to install similar fueling systems at three additional new fire stations: No. 25 in Plant City, No. 16 in Riverview, and No. 4 in Seffner, Hillsborough County, Florida.

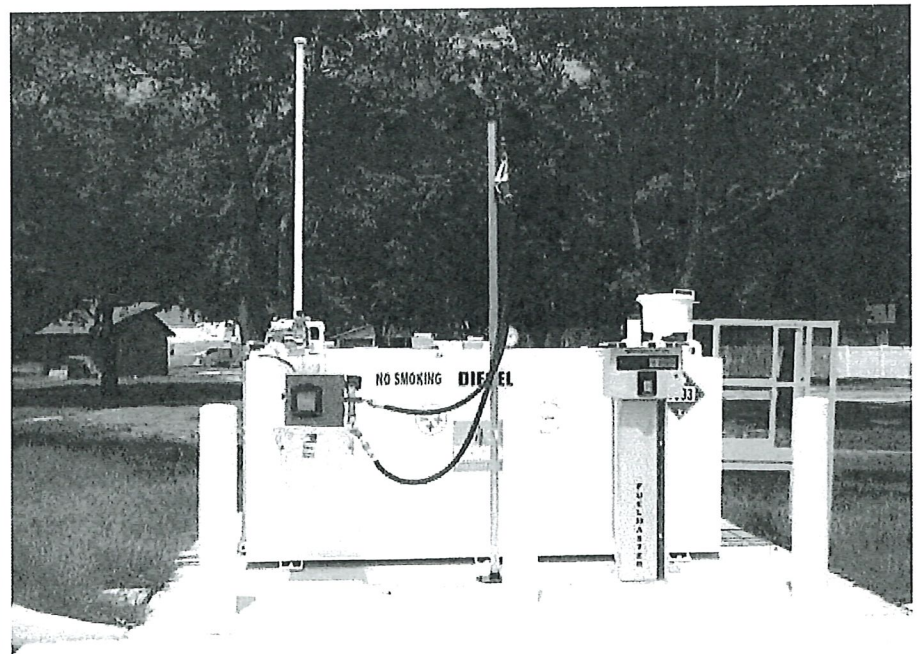

Fireguard® Thermally Protected Steel Storage Tanks

HT-1105

Cylindrical & Rectangular Aboveground Double-wall Tanks



Highland Tank®

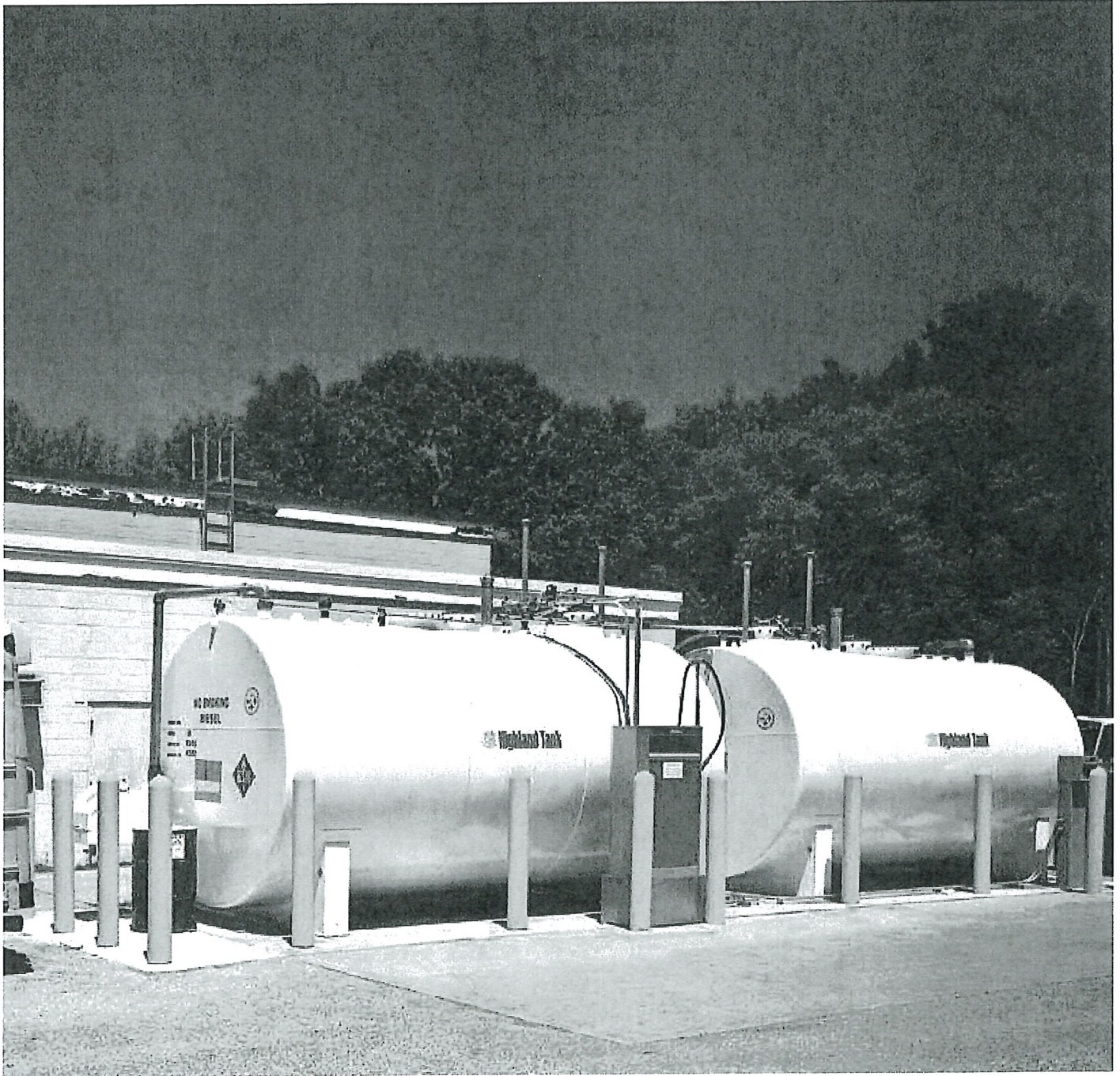

Unmatched Quality & Service



Fireguard® tanks are thermally protected, double-wall steel cylindrical or rectangular aboveground tanks. Fireguard® is an alternative for the safe storage of motor fuels and other flammable and combustible liquids aboveground. They are used where a fire-protected tank is needed because of setback limitations or regulatory requirements. These tanks are UL labeled and meet or exceed the requirements of UL-2085 including:

- Two-Hour Full Scale Pool Fire Test
- Hose Stream Test
- Ballistics/Projectile Test
- Vehicle Impact Test
- Interstitial Communication Test

Blast Effect Analysis proved Fireguard® resists, with limited damage to the primary steel tank, the effects of a 50 lb man-portable explosive device, a 500 lb vehicle-borne improvised explosive device, and a 10 psig vapor cloud explosion.

Fireguard® tanks are approved and labeled for service with the addition of heads and a 15 ton the inner tank.

Fireguard® Features

Each tank is constructed with a minimum 3" interstice around the inner tank. The interstice is completely filled with a lightweight, monolithic material. This high efficiency insulation protects the inner tank in the unlikely event of a fire or extreme heat. It is porous to allow fluid migration through the interstice to the monitoring point.

Unlike concrete encased tanks, Fireguard® tanks' steel outer wall protects the insulation, eliminating the problem of cracking and spalling concrete. Because of its unique construction, each tank is pressure-testable in the factory and at the jobsite. With Fireguard®, there is no question of compliance with fire codes; the tank is shipped with factory-installed emergency vents on both the primary and the secondary containment tanks for protection if exposed to fire or excessive pressure.

Fireguard® Advantages

- Carries UL-2085 listing as Insulated Secondary Containment for Flammable Liquids
- Lightweight – insulation 75% lighter than concrete – costing less to ship and install
- Reduces tank setback and separation distance requirements by up to 50%
- Fireguard's® secondary containment can be tightness-tested on-site
- Steel outer wall protects insulation
- Available in rectangular or cylindrical design
- Wide range of tank capacities: 300-60,000 gallons
- Subject to strict, three-tier independent third-party quality assurance program
- STI® standard 30-year limited warranty

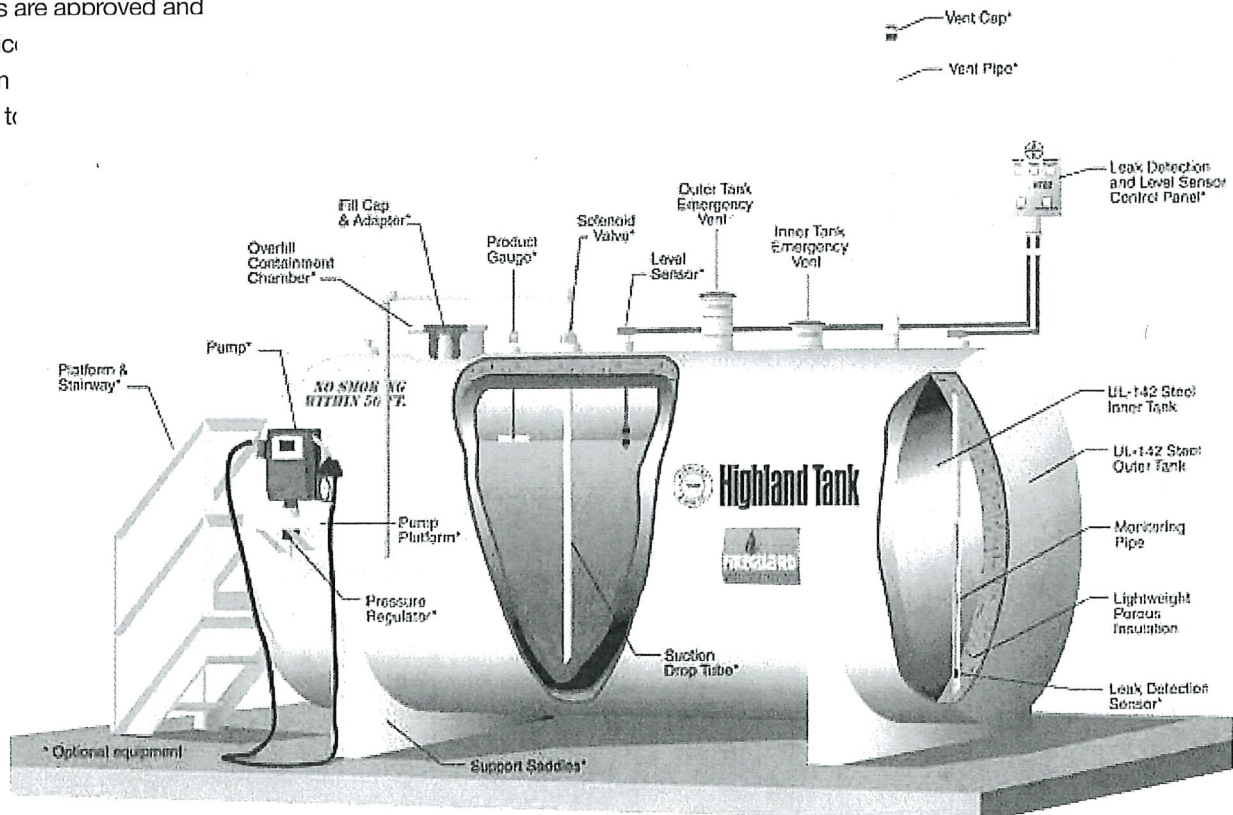

Fireguard® Design Options

Diesel or Biodiesel Blend -

Top-fill and top-mounted pump suction system. This configuration is popular in many small diesel or biodiesel vehicle fueling applications.

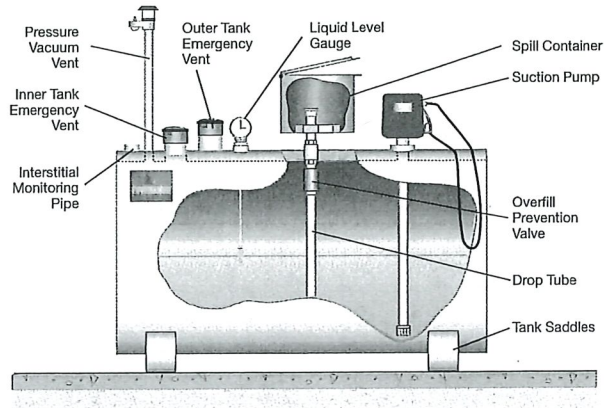

Boiler or Emergency Diesel-Electric Generator - Suction system with top-fill supply and return lines. This is a typical Fireguard® layout for fuel oil applications or supplying stationary combustion engines used for auxiliary power and emergency generators at first responder or mission critical facilities.

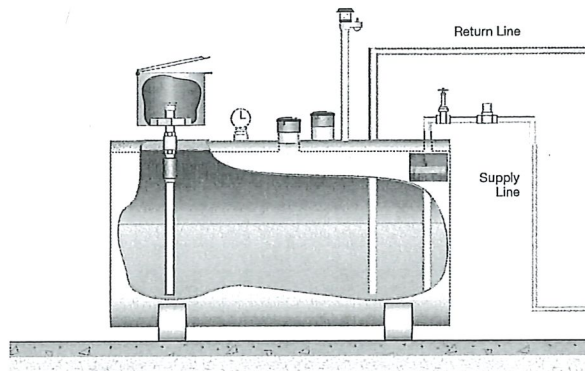

Gasoline or E85 Ethanol -

Suction system with remote fill and pump. This arrangement is common at many fleet vehicle maintenance facilities for diesel, biodiesel, gasoline or E85 fuel ethanol dispensing.

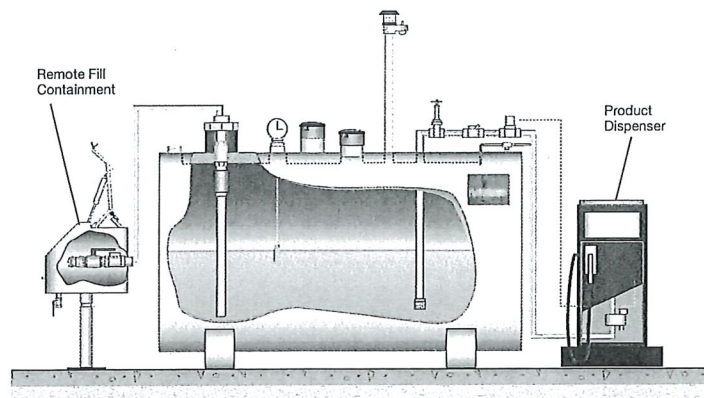

Aviation Refueling - Fireguard® Tank as part of a modular system with pump and filtration module. This arrangement would include an additional module(s) for direct-to-plane, truck load or remote dispensing. A specific application at a military or commercial installation would dictate engineered fueling systems.

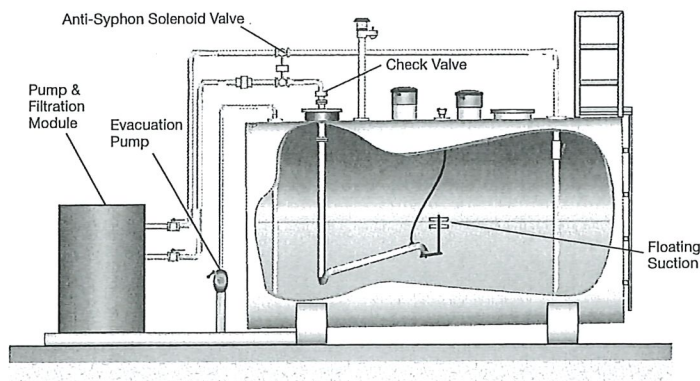

Fireguard® Sizing Chart

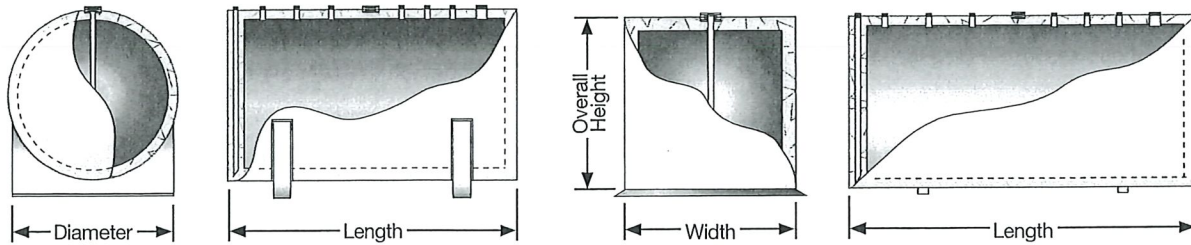

Cylindrical

Volume (Gallons)	Inner Tank		Outer Tank		
	Diameter	Length	Diameter	Overall Height	Length
300	3'-2"	5'-0"	4'-2"	5'-0"	6'-0"
500	4'-0"	5'-5"	4'-6"	5'-4"	6'-0"
1,000	4'-0"	10'-9"	4'-6"	5'-4"	11'-4"
1,000	5'-4"	6'-0"	5'-10"	6'-8"	6'-7"
2,000	5'-4"	12'-0"	5'-10"	6'-8"	12'-7"
3,000	5'-4"	18'-0"	5'-10"	6'-8"	18'-7"
4,000	5'-4"	24'-0"	5'-10"	6'-8"	24'-7"
4,000	8'-0"	10'-8"	8'-6"	9'-4"	11'-3"
5,000	8'-0"	13'-4"	8'-6"	9'-4"	13'-11"
6,000	8'-0"	16'-0"	8'-6"	9'-4"	16'-7"
8,000	8'-0"	21'-4"	8'-6"	9'-4"	21'-11"
10,000	8'-0"	26'-8"	8'-6"	9'-4"	27'-3"
12,000	8'-0"	32'-0"	8'-6"	9'-4"	32'-7"
15,000	10'-0"	25'-6"	10'-6"	11'-4"	27'-1"
20,000	10'-0"	34'-0"	10'-6"	11'-4"	34'-7"
25,000	10'-0"	42'-7"	10'-6"	11'-4"	43'-2"
30,000	10'-0"	51'-2"	10'-6"	11'-4"	51'-9"
40,000	11'-6"	51'-6"	12'-0"	13'-0"	52'-1"
50,000	12'-0"	59'-2"	12'-6"	13'-6"	59'-8"
60,000	13'-0"	60'-6"	13'-6"	14'-6"	61'-0"

Rectangular

Volume (Gallons)	Width	Height	Length	Width	Overall Height	Length
500	3'-0"	3'-0"	7'-6"	4'-0"	4'-6"	8'-6"
1,000	4'-8"	3'-0"	9'-8"	5'-2"	4'-1"	10'-3"
2,000	6'-4"	4'-0"	10'-8"	6'-10"	5'-1"	11'-4"
3,000	5'-5"	5'-5"	13'-8"	5'-11"	6'-5"	14'-3"
4,000	5'-5"	5'-5"	18'-2"	5'-11"	6'-5"	18'-9"
5,000	5'-5"	5'-5"	22'-9"	5'-11"	6'-5"	23'-4"
6,000	10'-10"	5'-5"	13'-8"	11'-4"	6'-5"	14'-3"
6,000	5'-5"	5'-5"	27'-4"	5'-11"	6'-5"	27'-11"
8,000	10'-10"	5'-5"	18'-2"	11'-4"	6'-5"	18'-9"
10,000	10'-10"	5'-5"	22'-10"	11'-4"	6'-5"	23'-5"
12,000	10'-10"	5'-5"	27'-4"	11'-4"	6'-5"	27'-11"



Please visit us at www.highlandtank.com

One Highland Road
Stoystown, PA 15563
P: 814-893-5701
F: 814-893-6126

4535 Elizabethtown Road
Manheim, PA 17545
P: 717-664-0600
F: 717-664-0617

958 19th Street
Watervliet, NY 12189
P: 518-273-0801
F: 518-273-1365

2700 Patterson Street
Greensboro, NC 27407
P: 336-218-0801
F: 336-218-1292

2225 Chestnut Street
Lebanon, PA 17042
P: 717-664-0602
F: 717-664-0631

1510 Stoystown Road
Friedens, PA 15541
P: 814-443-6800
F: 814-444-8662

NOTE: ALL RIGHTS RESERVED. THIS DRAWING MUST NOT BE REPRODUCED IN ANY FORM WITHOUT THE WRITTEN PERMISSION OF HIGHLAND TANK®. HIGHLAND TANK® SHALL BE RESPONSIBLE ONLY FOR ITEMS INDICATED ON THIS FABRICATION DRAWING UNLESS OTHERWISE NOTED. CUSTOMER IS RESPONSIBLE FOR VERIFYING CORRECTNESS OF SIZE AND LOCATION OF FITTINGS, ACCESSORIES, AND COATINGS SHOWN ON THIS DRAWING. TOUCH UP OF FINISHED PAINT IS REQUIRED BY INSTALLATION CONTRACTOR. TOUCH UP PAINT SHIPPED WITH TANK.

SHIP LOOSE
 (2) 8" FLANGED EMERGENCY VENTS
 INSTALLED
 (1) HIGH-LINK LEVEL MODULE MODEL# LS_XEXD 99" LONG & BUSHING.

SHIPPING LUGS AS NEEDED

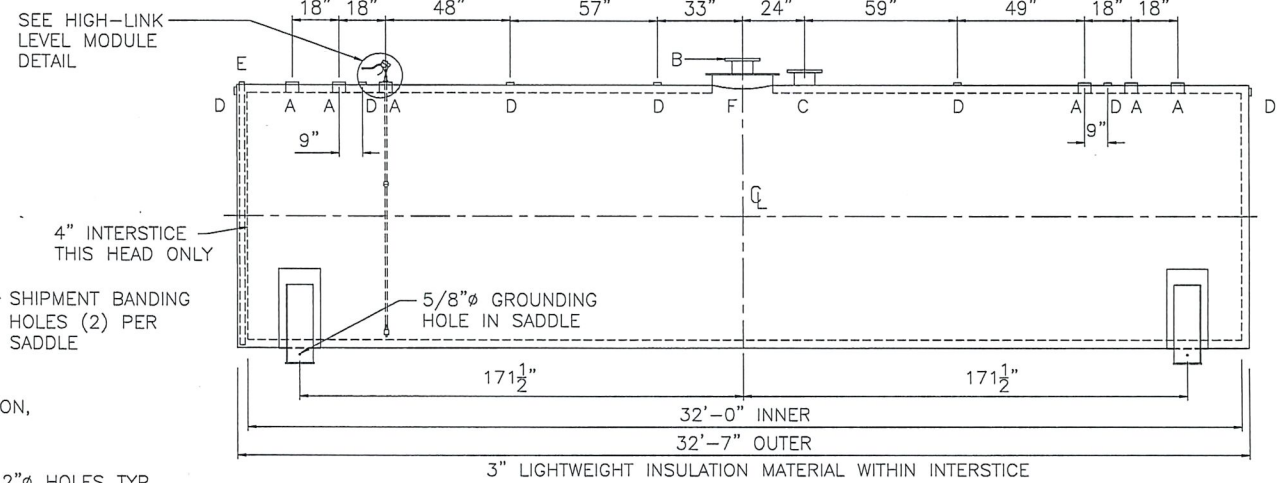
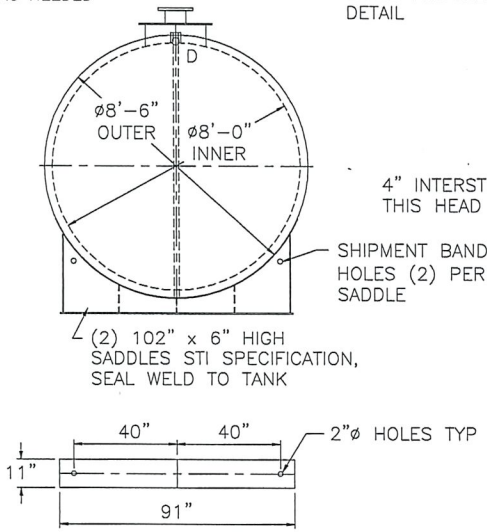

FOR PROPOSAL PURPOSES ONLY

DESIGN DATA	
CAPACITY:	12,000 GALLONS
TYPE:	FIREGUARD® CYLINDRICAL
FIREGUARD® IS A TRADEMARK OF THE STEEL TANK INSTITUTE	
NO. REQ.	--
OPERATING PRESSURE	ATMOSPHERIC
SPECIFIC GRAVITY	= 1.0
TANK MATERIAL	MILD CARBON STEEL
THICKNESS - INNER - HEADS	5/16" SHELL-1/4"
THICKNESS - OUTER - HEADS	5/16" SHELL-1/4" MIN. GAUGE OR THICKNESS (PER U.L. 2085)
CONSTRUCTION - INNER	LAP WELD OUTSIDE ONLY
CONSTRUCTION - OUTER	LAP WELD OUTSIDE ONLY
TANK TEST	PER UL 2085
INT. FINISH	NONE
EXT. FINISH	SP-6 BLAST, FINISH PAINT WHITE
LABEL	UL 2085 AND FIREGUARD® PER sti

LEGEND	
A	4" FEMALE FG COUPLING
B	8" FFSO 150# FLANGE - PRIMARY EMERGENCY VENT USE ONLY
C	8" FFSO 150# FLANGE THROUGH OUTER SHELL ONLY, MARK WITH SPECIAL WARNING LABEL INTERSTITIAL EMERGENCY VENT USE ONLY
D	2" FITTING THROUGH OUTER SHELL ONLY WITH CAST IRON PLUG- MFG USE ONLY
E	2" MONITOR PIPE WITH MALE NPT END
F	24" x 1/4" PLATE TIGHT BOLT MANWAY WITH 1/8" THICK NEO-CORK GASKET AND "B" IN COVER ON CL
G	

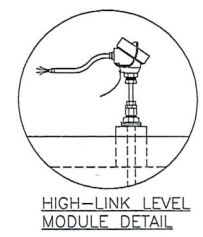

NOTES: STRIKER PLATES ARE NOT SUPPLIED ON FIREGUARDS® UNLESS SPECIFIED

<h1>Highland Tank</h1>	
<small>UNLESS NOTED, TOLERANCES ARE +/- 1"</small>	
<h2>12,000 GAL 96" Ø CYL. FIREGUARD®</h2>	
<small>PATENT: 5,695,089 PATENT: 5,809,650</small>	
CUSTOMER:	
PROJECT:	
QUOTE NO:	CHK'D BY:
SCALE: 1/4" = 12"	DATE:
DWG. BY:	DWG. NO:
<h3>12000FGCYL96</h3>	