

Administrative Certificates of Appropriateness

Attached are Certificates of Appropriateness issued administratively in June 2020.
Part VI

- COA #20-46, 721 Avenue D – Install new garage door
- COA #20-47, 1108 Avenue D – Install new roof
- COA #20-48, 102 N 2nd Street – Paint exterior walls
- COA #20-49, 504 N 15th Street – Install new roof



CERTIFICATE OF APPROPRIATENESS
 TO ALTER A DESIGNATED HISTORIC SITE

COA#20-46 HISTORIC PRESERVATION BOARD APPROVAL ADMINISTRATIVE APPROVAL

Site address: 721 Avenue D

Contributing Non-Contributing Individually Designated

SITE ALTERATIONS:

Request	Conditions	Applicable Standards
Remove and replace garage doors. New doors will be white. Please see attached.	Building trim including windows and doors trim shall be painted white.	Secretary of the Interior's Standards for Rehabilitation of Historic Properties, Standard 9.

APPROVED:

Board Approval

Administrative Approval

 Suzanne Boardman, Chair Date
 Historic Preservation Board

 _____ 06/22/20
 Maria Lewicka, AICP Date
 Historic Preservation Planner

This alteration meets the Secretary of the Interior's Standards for the Treatment of Historic Properties and the City of Fort Pierce Code of Ordinances.

Should you have any further questions or concerns, contact Maria Lewicka, Historic Preservation Planner, at (772) 467-3738 or via e-mail at mlewicka@cityoffortpierce.com.

Thank you for your efforts to preserve and redevelop historic Fort Pierce through your participation in the Certificate of Appropriateness Application process. Staff looks forward to working with you in the future to preserve and rehabilitate our historic neighborhoods and structures.

Provided to:	Name/Address	Via
Owner	SLC Fort Pierce Fire District 5160 NW Milner Dr Port St Lucie, FL 34983	E-Mail doormasterpermits2@gmail.com

RECEIVED

JUN 22 2020

COA# 20-46

Bldg. Permit # _____



CITY OF FORT PIERCE

CITY OF FORT PIERCE
PLANNING & ZONING

PLANNING DEPARTMENT

COMPREHENSIVE PLANNING ◊ DEVELOPMENT REVIEW
HISTORIC PRESERVATION ◊ URBAN DESIGN ◊ URBAN FORESTRY ◊ ZONING

Certificate of Appropriateness Application

Building & Site Information

Address of the Site: 721 Avenue D

Parcel ID #: 2410.601.0176.000.4

Type of Designation: Contributing Non-contributing Site within the _____ Historic District

Individually Designated Site, City Commission Resolution No. _____

Property Owner/ Applicant Information

Property Owner(s)
Name(s): SLC Fort Pierce Fire Dist

Mailing Address: 5160 NW Milner Dr. Port St. Lucie

Phone Number(s): _____ Email: _____

Applicant
Name(s): _____

Mailing Address: _____

Phone Number(s): _____ Email: _____

Representative
Name(s): _____

Mailing Address: _____

Phone Number(s): _____ Email: _____

Property Owner(s) Acknowledgements:- This application will not be considered complete without the signature of all property owners of record, which shall serve as an acknowledgement of the submission of this application. The property owner's signature below shall also authorize the Applicant (if other than the property owner) and/or Representative to act in his/her behalf for the purposes of seeking approval for the application described herein. The undersigned consents to inspection and photographing of the subject property by the Historic Preservation staff for purposes of consideration of this Application and/or presentation to the Historic Preservation Board.

I / We, Jennifer Chambers, SLC FD Dep. Chief as Owner(s) of the subject property do hereby authorize the filing of this application on my/our behalf.

[Signature]
Signature of Owner

6/4/2020
Date

621-3332

Description of Requested Work

Please indicate the type of work requested:

- Fence
- Shed
- Door(s)
- Roof
- Window(s)
- Signage
- Shutter(s)
- Porch

- Rehabilitation
- New Construction
- Demolition
- Relocation

- Site Improvements (describe) Replace garage door size for size
- Other (describe) _____

Please provide a detailed description of the proposed work to be performed: _____
Replace garage door size for size

Have other alterations been made to the site within the last 12 months? No Yes, _____

Will the proposed work require a Zoning Variance? No Yes, Code Section(s): _____

Application Requirements

- \$10.00 Application fee
- Site Plan with dimensions.
- Architectural Drawings:
 - Drawings should show all current and proposed floor plans and elevations, fences, walls, and any other landscape features.
 - Drawings should indicate materials to be used.
- Photos - One (1) color photograph of the main façade of the site and photographs of any areas affected by the proposed project.
- Material(s) specifications and/or sample(s)
- Color samples.
- Demolition – Plans for what will be taking the demolished structure’s place should be submitted.



Mr. Tarik Dalak
Overhead Door of America
3802 N. Cocoa Blvd
Cocoa, FL 32926

RE: Wind Pressures for Overhead Door for St. Lucie County Fire #15

LPM Technical Services Inc. (LPMTS) was tasked by Overhead Door of America to provide wind pressures for the above referenced facility located at 721 Avenue D, Fort Pierce, FL 34950. The following information was provided via as-built (legacy) plans and Overhead Door of America:

1. Building Length = 80.00 feet
2. Building Width = 47.33 feet
3. Roof Type = Hipped
4. Soffit overhang = 4.17 feet (all around)
5. Ridge Hipped Length = 32.67 feet
6. Ridge Height = 26 feet (assumed)
7. Eave Height = 18 feet (assumed)
8. Door Dimensions = 14 feet (H) x 14 feet (W)

The following wind load parameters were used to calculate the wind:

1. Ultimate Windspeed = 171 MPH (3-sec gust)
2. Risk Category = IV (essential facility – Fire Station)
3. Exposure = C
4. Building Enclosure = Enclosed

The wind pressures for components and cladding were calculated in accordance with ASCE 7-10 Allowable Strength Design (ASD). The following table summarizes the wind pressures.

Components and Cladding Wind Pressures (ASD) (Do No Factor Down)				
Effective Area SQ FT (*)	Zone 4 (+) (psf)	Zone 4 (-) (psf)	Zone 5 (+) (psf)	Zone 5 (-) (psf)
65	39.3	-43.0	39.3	-49.0

(*) Effective Area = Door Span x Door Span/3 Width of Zone 5 (End Zones), A = 4.733 ft use 4'-9"

The information provided is assumed to be accurate about the building. Any incorrect information makes this letter void and until such time that corrected information is provided can be reassessed.

Feel free to contact us with any questions.

Sincerely,

Lutfi Mized, PE
President/Senior Structural Engineer

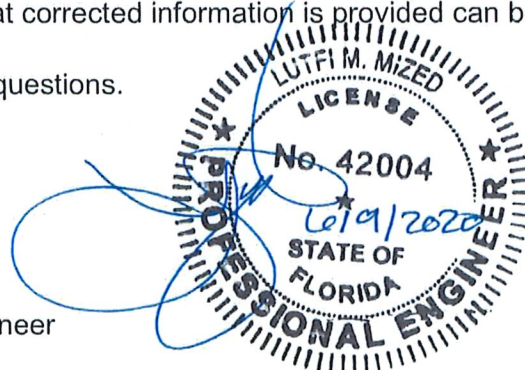

CLOPAY COMMERCIAL – MODELS 524, 524V, 524S

industrial series

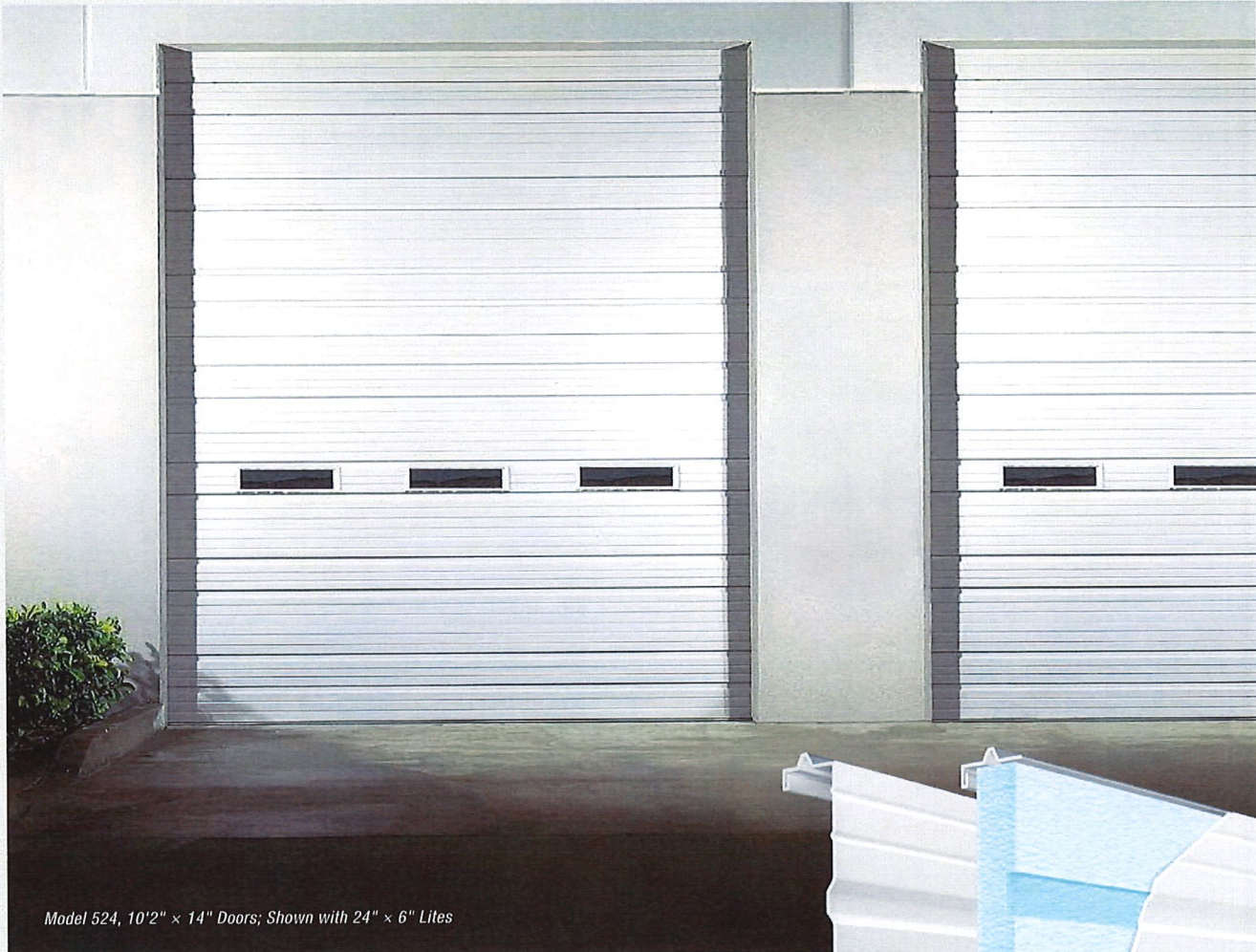

Model 524, 10'2" x 14" Doors; Shown with 24" x 6" Lites

RIBBED STEEL DOORS

Available non-insulated (524) or insulated (524V/524S) with polystyrene insulation conformed to panel. Ideal for commercial and industrial building applications.

- Polystyrene insulation available on 524V and 524S.
- 3-stage paint process delivers a virtually maintenance-free finish.
- Tog-L-Loc® advanced design, eliminates the need for antiquated welds and rivet construction, improving rust and leak prevention.
- Injection-molded lite frames with integral weatherseal are durable and seal against the elements. Multiple glass options available providing visibility or privacy.



Panels are pre-painted inside and out to inhibit rust. Hot-dipped, galvanized steel is painted with primer and given a tough oven-baked polyester top coat to provide the most rust-resistant steel door available. Ten-year warranty against rust-through.

clopaycommercial.com

EXTERIOR SKIN PATTERN

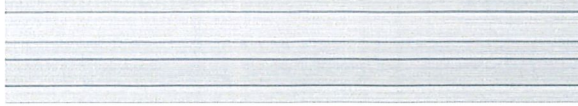

Deep Ribbed

COLOR OPTIONS

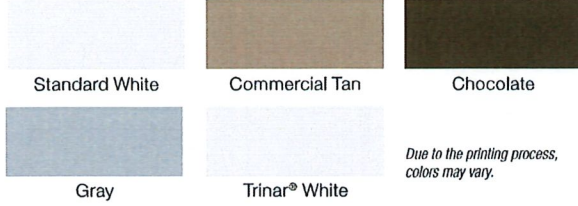

Standard White

Commercial Tan

Chocolate

Gray

Trinar® White

Due to the printing process, colors may vary.

CUSTOM PAINT OPTION



Color Blast® finish offers more than 1,500 Sherwin-Williams® color options to complement your building design. This durable two-part paint system has been thoroughly tested and is backed by a five-year warranty.

Due to solar reflective formulation to meet greater than a 38 LRV, some colors may not be available.

FEATURES

STANDARD HARDWARE

- TPE astragal in aluminum retainer
- Commercial 10-ball steel rollers (nylon tires available)
- Steel step plate and lift handle
- Galvanized steel end stiles
- Inside slide lock for increased security
- 2" track
- 10,000 cycle springs
- Galvanized aircraft cable with minimum 7:1 safety factor
- Variety of track configurations to meet building specifications

MATERIALS AND CONSTRUCTION

Panel Thickness	2"
Insulation	1-3/8" polystyrene (Available on Models 524V and 524S)
R-value	6.6* (Available on Models 524V and 524S)
Joining System	Tog-L-Loc®
Exterior Steel	24 gauge (.58 mm)
Interior Cover	Vinyl backing (Available on Model 524V) Painted steel back cover (Available on Model 524S)
Exterior Steel Emboss	Stucco
Max Width	26'2"
Max Height	24'
Exterior Colors	Standard White, Commercial Tan, Chocolate, Gray and Trinar® White. Also available in Color Blast® finish
Interior Color	Standard White
Limited Warranties	10-year paint 5-year Color Blast® finish 1-year materials and workmanship

*Calculated door section R-value is in accordance with DASMA TDS-163.

For special sizes, applications and options, consult Commercial Information Assistance (CIA) at 1-800-526-4301.

ADDITIONAL OPTIONS

WINDOW OPTIONS



24" x 6"

24" x 12"



Full-View

Glazing options for 524 include DSB, plexiglass and wire glass. Double pane insulated windows are available for Models 524V and 524S. Prepainted full-view section with White or Chocolate finish available with DSB glass, plexiglass, wire glass or insulated glass.

HEAVY-DUTY HARDWARE (where not standard)

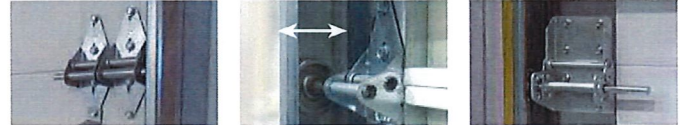

Double-end hinge

3" Track

High performance hardware features 10 gauge end hinges, heavy-duty top bracket and 3" sealed roller with 5/8" stem.

MULLIONS



Carry-away, roll-away or swing-up mullions are available on select sizes.

EXHAUST PORT



Can be cut into any type of sectional door. Available in select sizes.



WindCode® design pressure (DP) up to 14 PSF depending on size. Models tested 50% greater than DP.



Upgrade your standard door with industrial-grade components.

HIGH CYCLE SPRINGS



25,000, 50,000 or 100,000 cycle springs available.

DISTRIBUTED BY:



For more information on these and other Clopay products, call 1-800-526-4301 or visit clopaycommercial.com



©2020 Clopay Corporation. All rights reserved.



CMDC-0524-02_REV0520



CERTIFICATE OF APPROPRIATENESS
 TO ALTER A DESIGNATED HISTORIC SITE

COA#20-47

BP #20-00001926

HISTORIC PRESERVATION BOARD APPROVAL

ADMINISTRATIVE APPROVAL

Site address: 1108 Avenue D

Contributing

Non-Contributing

Individually Designated

SITE ALTERATIONS:

Request	Conditions	Applicable Standards
Removed and replace shingle roof (Glacier White). Please see attached.		Secretary of the Interior's Standards for Rehabilitation of Historic Properties, Standard 9.

APPROVED:

Board Approval

Administrative Approval

 Suzanne Boardman, Chair
 Historic Preservation Board

 Date

 Maria Lewicka, AICP
 Historic Preservation Planner

 06/26/20
 Date

This alteration meets the Secretary of the Interior's Standards for the Treatment of Historic Properties and the City of Fort Pierce Code of Ordinances.

Should you have any further questions or concerns, contact Maria Lewicka, Historic Preservation Planner, at (772) 467-3738 or via e-mail at mlewicka@cityoffortpierce.com.

Thank you for your efforts to preserve and redevelop historic Fort Pierce through your participation in the Certificate of Appropriateness Application process. Staff looks forward to working with you in the future to preserve and rehabilitate our historic neighborhoods and structures.

Provided to:	Name/Address	Via
Owner	Joseph Mercer 1108 Avenue D Fort Pierce, FL 34950	E-Mail
Applicant	Shoreline Roofing 1973 SW Glendale Street PSL, FL 34987	E-Mail shorelineroofing@yahoo.com



Bldg. Permit # _____

COA# 20-47

Certificate of Appropriateness Application

Building & Site Information

Address of the Site: 1108 Ave D
 Parcel ID #: 2409-501-0100-000-0
 Type of Designation: Contributing Non-contributing Site within the LP Historic District
 Individually Designated Site, City Commission Resolution No. _____

Property Owner / Applicant Information

Property Owner(s) Name(s): Joseph Mercer
 Mailing Address: 1108 Ave D
 Phone Number(s): 772-227-8290 Email: _____

Applicant Name(s): Shoreline Roofing
 Mailing Address: 1973 Sw Glendale St. Port St. Lucie Fl 34987
 Phone Number(s): 772-260-9565 Email: shorelineroofing@yahoo

Representative Name(s): _____
 Mailing Address: _____
 Phone Number(s): _____ Email: _____

Property Owner(s) Acknowledgements:- This application will not be considered complete without the signature of all property owners of record, which shall serve as an acknowledgement of the submission of this application. The property owner's signature below shall also authorize the Applicant (if other than the property owner) and/or Representative to act in his/her behalf for the purposes of seeking approval for the application described herein. The undersigned consents to inspection and photographing of the subject property by the Historic Preservation staff for purposes of consideration of this Application and/or presentation to the Historic Preservation Board.

I / We, Joseph Mercer as Owner(s) of the subject property do hereby authorize the filing of this application on my/our behalf.

[Signature]
Signature of Owner

6/26/2020
Date

Description of Requested Work

Please indicate the type of work requested:

- | | | | |
|---|---|-------------------------------------|--|
| <input type="checkbox"/> Fence | <input type="checkbox"/> Shed | <input type="checkbox"/> Door(s) | <input checked="" type="checkbox"/> Roof |
| <input type="checkbox"/> Window(s) | <input type="checkbox"/> Signage | <input type="checkbox"/> Shutter(s) | <input type="checkbox"/> Porch |
| <hr/> | | | |
| <input type="checkbox"/> Rehabilitation | <input type="checkbox"/> New Construction | <input type="checkbox"/> Demolition | <input type="checkbox"/> Relocation |

Site Improvements (describe) _____

Other (describe) _____

Please provide a detailed description of the proposed work to be performed: _____

tear off shingles put back shingles color is Glacier White

Have other alterations been made to the site within the last 12 months? No Yes, _____

Will the proposed work require a Zoning Variance? No Yes, Code Section(s): _____

Application Requirements

- \$10.00 Application fee
- Site Plan with dimensions.
- Architectural Drawings:
 - Drawings should show all current and proposed floor plans and elevations, fences, walls, and any other landscape features.
 - Drawings should indicate materials to be used.
- Photos - One (1) color photograph of the main façade of the site and photographs of any areas affected by the proposed project.
- Material(s) specifications and/or sample(s)
- Color samples.
- Demolition - Plans for what will be taking the demolished structure's place should be submitted.



1000

PRIVATE PROPERTY

Recycling Center

1000







CERTIFICATE OF APPROPRIATENESS
TO ALTER A DESIGNATED HISTORIC SITE

COA#20-48

HISTORIC PRESERVATION BOARD APPROVAL

ADMINISTRATIVE APPROVAL

Site address: 102 N 2nd Street

Contributing

Non-Contributing

Individually Designated

SITE ALTERATIONS:

Request	Conditions	Applicable Standards
Paint part of the building occupied by Dunkin Donuts. Main façade color – Arctic Cotton Pilasters color – Cool Slate See attached drawings.		Secretary of the Interior's Standards for Rehabilitation of Historic Properties, Standard 9.

APPROVED:

Board Approval

Administrative Approval

Suzanne Boardman, Chair
Historic Preservation Board

Date



Maria Lewicka, AICP
Historic Preservation Planner

06/26/20
Date

This alteration meets the Secretary of the Interior's Standards for the Treatment of Historic Properties and the City of Fort Pierce Code of Ordinances.

Should you have any further questions or concerns, contact Maria Lewicka, Historic Preservation Planner, at (772) 467-3738 or via e-mail at mlewicka@cityoffortpierce.com.

Thank you for your efforts to preserve and redevelop historic Fort Pierce through your participation in the Certificate of Appropriateness Application process. Staff looks forward to working with you in the future to preserve and rehabilitate our historic neighborhoods and structures.

Provided to:	Name/Address	Via
Owner	RFMD Investments LLC. PO BOX 650991 Vero Beach, FL 32965	E-Mail pattyatRFMD@aol.com
Representative	Gus Sofikitis	E-Mail Greek_nutt@yahoo.com



Bldg. Permit # _____

COA# 10-48

Certificate of Appropriateness Application

Building & Site Information

Address of the Site: 102 N 2nd St Fort Pierce

Parcel ID #: 2410.503.0069.000.0

Type of Designation: Contributing Non-contributing Site within the _____ Historic District

Individually Designated Site, City Commission Resolution No. _____

Property Owner/ Applicant Information

Property Owner(s) Name(s): RFMD Investments LLC

Mailing Address: PO BOX 650991 Vero Beach Fl. 32965

Phone Number(s): 772-577-4145 Email: pattyatRFMD@aol.com

Applicant

Name(s): _____

Mailing Address: _____

Phone Number(s): _____ Email: _____

Representative

Name(s): Gus Sofikitis

Mailing Address: _____

Phone Number(s): 772-201-6087 Email: Greek_nutt@yahoo.com

Property Owner(s) Acknowledgements:- This application will not be considered complete without the signature of all property owners of record, which shall serve as an acknowledgement of the submission of this application. The property owner's signature below shall also authorize the Applicant (if other than the property owner) and/or Representative to act in his/her behalf for the purposes of seeking approval for the application described herein. The undersigned consents to inspection and photographing of the subject property by the Historic Preservation staff for purposes of consideration of this Application and/or presentation to the Historic Preservation Board.

I / We, RFMD Investments LLC as Owner(s) of the subject property do hereby authorize the filing of this application on my/our behalf.

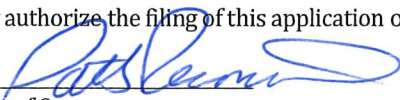
Signature of Owner

6/26/20
Date

Description of Requested Work

Please indicate the type of work requested:

- | | | | |
|---|---|-------------------------------------|-------------------------------------|
| <input type="checkbox"/> Fence | <input type="checkbox"/> Shed | <input type="checkbox"/> Door(s) | <input type="checkbox"/> Roof |
| <input type="checkbox"/> Window(s) | <input type="checkbox"/> Signage | <input type="checkbox"/> Shutter(s) | <input type="checkbox"/> Porch |
| <hr/> | | | |
| <input type="checkbox"/> Rehabilitation | <input type="checkbox"/> New Construction | <input type="checkbox"/> Demolition | <input type="checkbox"/> Relocation |

Site Improvements (describe) _____

Other (describe) Paint _____

Please provide a detailed description of the proposed work to be performed: _____

102 N 2nd St will be painted with a light gray paint color

Have other alterations been made to the site within the last 12 months? No Yes, _____

Will the proposed work require a Zoning Variance? No Yes, Code Section(s): _____

Application Requirements

- \$10.00 Application fee
- Site Plan with dimensions.
- Architectural Drawings:
 - Drawings should show all current and proposed floor plans and elevations, fences, walls, and any other landscape features.
 - Drawings should indicate materials to be used.
- Photos - One (1) color photograph of the main façade of the site and photographs of any areas affected by the proposed project.
- Material(s) specifications and/or sample(s)
- Color samples.
- Demolition - Plans for what will be taking the demolished structure's place should be submitted.

From: pattyatrfmd
Sent: Friday, June 26, 2020 3:03 PM
To: Maria Lewicka
Subject: RE: 102 N 2nd St.

SECURITY WARNING: This email originated outside of the City of Fort Pierce systems. Please use caution when clicking links or opening attachments. For questions or concerns please contact IT immediately. .

Apologize the pic didn't attach.

Patty Reconco

Sent via the Samsung Galaxy S8, an AT&T 5G Evolution capable smartphone

----- Original message -----

From: pattyatrfmd <pattyatrfmd@aol.com>
Date: 6/26/20 3:01 PM (GMT-05:00)
To: Maria Lewicka <mlewicka@cityoffortpierce.com>
Subject: 102 N 2nd St.

Hi Maria

Thanks for your patience.
Please see the pic attached. Vertical lines will be the darker gray (cool slate). The lighter gray (artic cotton) will be for the inner area.

Patty Reconco

Sent via the Samsung Galaxy S8, an AT&T 5G Evolution capable smartphone



Arctic Cotton
PPG1002-2

Cool Slate
PPG1002-3

EXISTING ELEVATIONS



JOB TITLE DUNKIN DONUTS 116 n 2nd St

NOTE: ALL ARTWORK & COLORS MUST BE SIGNED OFF BEFORE ANY WORK IS TO BEGIN
IF EXACT COLORS ARE REQUIRED OR MORE DETAILS PLEASE NOTE. CUSTOMER IS
RESPONSIBLE FOR ANY CHANGES ONCE WORK BEGINS.

- APPROVED
- APPROVED W/ CHANGES
- NOT APPROVED
- RESUBMIT W/ CHANGES



4444 S.E. COMMERCE AVE.
STUART, FL. 34997
772.220.7768
flamingosigns@aol.com

This drawing, rendering & specs are the exclusive property of Flamingo Signs. And may not be shown to any person or corporation outside the clients organization. Nor are they to be reproduced in any way, shape or form without the expressed written consent





CERTIFICATE OF APPROPRIATENESS
 TO ALTER A DESIGNATED HISTORIC SITE

COA#20-49
 BP #20-00001937

HISTORIC PRESERVATION BOARD APPROVAL

ADMINISTRATIVE APPROVAL

Site address: 504 N 15th Street

Contributing

Non-Contributing

Individually Designated

SITE ALTERATIONS:

Request	Conditions	Applicable Standards
Removed and replace shingle roof. Please see attached.		Secretary of the Interior's Standards for Rehabilitation of Historic Properties, Standard 9.

APPROVED:

Board Approval

Administrative Approval

 Suzanne Boardman, Chair
 Historic Preservation Board

 Date

 Maria Lewicka, AICP
 Historic Preservation Planner

06/29/20

 Date

This alteration meets the Secretary of the Interior's Standards for the Treatment of Historic Properties and the City of Fort Pierce Code of Ordinances.

Should you have any further questions or concerns, contact Maria Lewicka, Historic Preservation Planner, at (772) 467-3738 or via e-mail at mlewicka@cityoffortpierce.com.

Thank you for your efforts to preserve and redevelop historic Fort Pierce through your participation in the Certificate of Appropriateness Application process. Staff looks forward to working with you in the future to preserve and rehabilitate our historic neighborhoods and structures.

Provided to:	Name/Address	Via
Owner	Ewald A Knolle 4694 SW 45 th Avenue Fort Lauderdale, FL 33313	E-Mail whitechocolate754@gmail.com
Applicant	Andros Roofing & Construction, LLC 2706 Atlantic Avenue Fort Pierce, FL 34947	E-Mail androsconstruction@gmail.com



20-49

COA# 20-1937

Bldg. Permit # _____

Certificate of Appropriateness Application

Building & Site Information

Address of the Site: 504 N 15TH ST

Parcel ID #: 2409 503 0027 000 0

Type of Designation: Contributing Non-contributing Site within the _____ Historic District
 Individually Designated Site, City Commission Resolution No. _____

Property Owner / Applicant Information

Property Owner(s) Name(s): EWALD A KNOLLE

Mailing Address: 4694 SW 45TH AV, FT. LAUDERDALE, FL 33314

Phone Number(s): _____ Email: WHITTECHOCOLATE754@GMAIL.COM

Applicant Name(s): ANDROS ROOFING & CONSTRUCTION, LLC

Mailing Address: 2706 ATLANTIC AV, FORT PIERCE, FL 34947

Phone Number(s): 772-475-4915 Email: ANDROS.CONSTRUCTION@GMAIL.COM

Representative Name(s): N/A

Mailing Address: _____

Phone Number(s): _____ Email: _____

Property Owner(s) Acknowledgements:- This application will not be considered complete without the signature of all property owners of record, which shall serve as an acknowledgement of the submission of this application. The property owner's signature below shall also authorize the Applicant (if other than the property owner) and/or Representative to act in his/her behalf for the purposes of seeking approval for the application described herein. The undersigned consents to inspection and photographing of the subject property by the Historic Preservation staff for purposes of consideration of this Application and/or presentation to the Historic Preservation Board.

I / We, Ewald Andrew Knolle as Owner(s) of the subject property do hereby authorize the filing of this application on my/our behalf.

[Signature]
Signature of Owner

6/27/20
Date

RECEIVED

JUN 29 2020

CITY OF FORT PIERCE
PLANNING & ZONING

Description of Requested Work

Please indicate the type of work requested:

- Fence
 - Shed
 - Door(s)
 - Roof
 - Window(s)
 - Signage
 - Shutter(s)
 - Porch
-
- Rehabilitation
 - New Construction
 - Demolition
 - Relocation

Site Improvements (describe) Re-Roof Removal & Replacement Total

Other (describe) _____

Please provide a detailed description of the proposed work to be performed: TOTAL REMOVAL AND REPLACEMENT OF THE ROOF SYSTEM WITH ARCHITECTURAL SHINGLES.

Have other alterations been made to the site within the last 12 months? No Yes, _____

Will the proposed work require a Zoning Variance? No Yes, Code Section(s): _____

Application Requirements

- \$10.00 Application fee
 - Site Plan with dimensions.
 - Architectural Drawings:
 - Drawings should show all current and proposed floor plans and elevations, fences, walls, and any other landscape features.
 - Drawings should indicate materials to be used.
 - Photos - One (1) color photograph of the main façade of the site and photographs of any areas affected by the proposed project.
 - Material(s) specifications and/or sample(s)
 - Color samples.
-
- Demolition – Plans for what will be taking the demolished structure’s place should be submitted.

current type of shingles on the roof, Three Tab Shingles.



intended to install Architectural Shingles.



DETAIL A

HERITAGE, HERITAGE WOODGATE, AND HERITAGE PREMIUM

All dimensions are in inches.

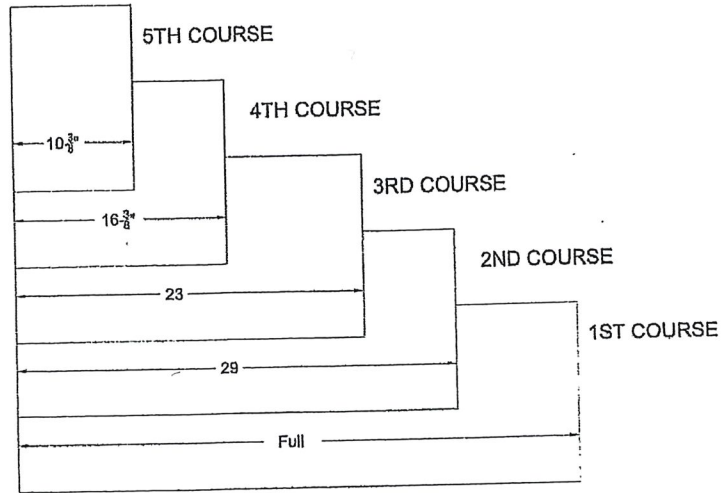

DETAIL B

HERITAGE SHINGLE FIG. 1 FASTENING PATTERN

All dimensions are in inches

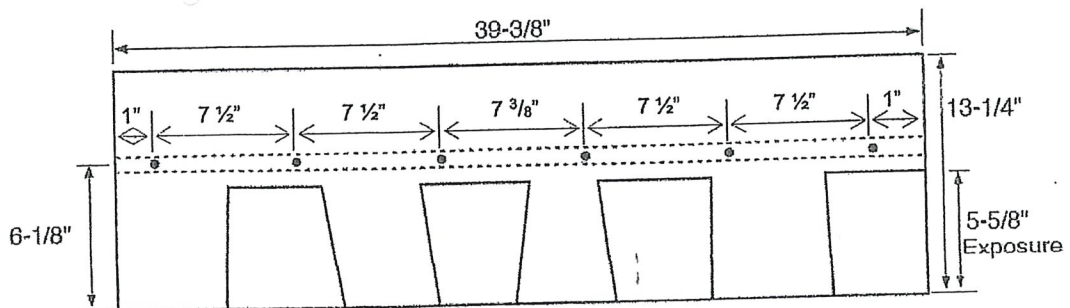

NOA No.: 15-0709.19
Expiration Date: 12/01/20
Approval Date: 11/12/15
Page 4 of 6



