

DELIVER TO:

City of Fort Pierce, Purchasing Division
Room 101
100 North U.S. #1
Fort Pierce, FL 34950

MAIL TO:

City of Fort Pierce Purchasing Division,
Room 101
P.O. Box 1480
Fort Pierce, FL 34954-1480

CITY OF FORT PIERCE



City of Fort Pierce

APR 23 2021

Engineering Dept.

**INVITATION TO BID
and
BIDDER ACKNOWLEDGMENT**

Bid Writer: Gelencia Carter, 772-467-3102

Bid No: 2021-024(REBID)

Mandatory Site-Visit:

N/A

Bid Title: SOUTH 5TH STREET ROADWAY
IMPROVEMENTS (BOSTON AVENUE TO
DELAWARE AVENUE)

Mandatory Site-Visit Location:

N/A

Bid Opening Location:

Purchasing Division Conference Room, Room 101
100 North U.S. #1, 1st Floor
Ft. Pierce, Florida 34950

Bid Due Date & Time:

3:00 PM, THURSDAY, APRIL 22, 2021

If you need any reasonable accommodation for any type of disability in order to participate in this procurement, please contact this department as soon as possible.

Bidder Name:

DICKERSON FLORIDA, INC.

I hereby certify that this bid is made without prior understanding, agreement, or connection with any corporation, firm, or person submitting a bid for the same materials, supplies or equipment, and is in all respects fair and without collusion or fraud. I agree to abide by all conditions of this bid and certify that I am authorized to sign this bid for the bidder.

Mailing Address:

P.O. BOX 910

X

Authorized Signature (Manual)

City, State, Zip Code:

FT. PIERCE, FL 34954

Typed or Printed Name:

RICHARD J. FORLIFER

Type of Entity (Select one):

Corporation

Partnership

Proprietorship

Title: VICE PRESIDENT

Incorporated in the State of: FLORIDA **Year:** 1982

Delivery in 150 **days, After Receipt Order**

Phone Number: (772) 429-4444

Payment Terms: Net 30 Days

Fax Number: (772) 429-4445

FEIN or SS Number: 56-1327509

E-Mail Address: rickf@dfifl.com

Local Business: Y N **MWBE:** Y N

Bid Security is attached, when required, in the amount of \$ 10% of amount bid

F.O.B. DESTINATION

If returning as a "No Bid" state reason:

THIS PAGE MUST BE COMPLETED AND RETURNED WITH YOUR BID

**Request for Taxpayer
Identification Number and Certification**

Give form to the
requester. Do not
send to the IRS.

Name (as shown on your income tax return)
Dickerson Florida, Inc.

Business name, if different from above

Check appropriate box: Individual/Sole proprietor Corporation Partnership
 Limited liability company. Enter the tax classification (D=disregarded entity, C=corporation, P=partnership) ▶ ..C... Exempt payee
 Other (see instructions) ▶

Address (number, street, and apt. or suite no.)
P.O. Box 910

City, state, and ZIP code
Ft. Pierce, FL 34954-0910

List account number(s) here (optional)

Requester's name and address (optional)

Part I Taxpayer Identification Number (TIN)

Enter your TIN in the appropriate box. The TIN provided must match the name given on Line 1 to avoid backup withholding. For individuals, this is your social security number (SSN). However, for a resident alien, sole proprietor, or disregarded entity, see the Part I instructions on page 3. For other entities, it is your employer identification number (EIN). If you do not have a number, see *How to get a TIN* on page 3.

Note. If the account is in more than one name, see the chart on page 4 for guidelines on whose number to enter.

| |
|---|
| Social security number |
| or |
| Employer identification number 56 : 1327509 |

Part II Certification

Under penalties of perjury, I certify that:

- The number shown on this form is my correct taxpayer identification number (or I am waiting for a number to be issued to me), and
- I am not subject to backup withholding because: (a) I am exempt from backup withholding, or (b) I have not been notified by the Internal Revenue Service (IRS) that I am subject to backup withholding as a result of a failure to report all interest or dividends, or (c) the IRS has notified me that I am no longer subject to backup withholding, and
- I am a U.S. citizen or other U.S. person (defined below).

Certification instructions. You must cross out item 2 above if you have been notified by the IRS that you are currently subject to backup withholding because you have failed to report all interest and dividends on your tax return. For real estate transactions, item 2 does not apply. For mortgage interest paid, acquisition or abandonment of secured property, cancellation of debt, contributions to an individual retirement arrangement (IRA), and generally, payments other than interest and dividends, you are not required to sign the Certification, but you must provide your correct TIN. See the instructions on page 4.

Sign Here Signature of U.S. person ▶  Date ▶ **4/22/21**

General Instructions
Section references are to the Internal Revenue Code unless otherwise noted.

Purpose of Form
A person who is required to file an information return with the IRS must obtain your correct taxpayer identification number (TIN) to report, for example, income paid to you, real estate transactions, mortgage interest you paid, acquisition or abandonment of secured property, cancellation of debt, or contributions you made to an IRA.

Use Form W-9 only if you are a U.S. person (including a resident alien), to provide your correct TIN to the person requesting it (the requester) and, when applicable, to:

- Certify that the TIN you are giving is correct (or you are waiting for a number to be issued),
- Certify that you are not subject to backup withholding, or
- Claim exemption from backup withholding if you are a U.S. exempt payee. If applicable, you are also certifying that as a U.S. person, your allocable share of any partnership income from a U.S. trade or business is not subject to the withholding tax on foreign partners' share of effectively connected income.

Note. If a requester gives you a form other than Form W-9 to request your TIN, you must use the requester's form if it is substantially similar to this Form W-9.

Definition of a U.S. person. For federal tax purposes, you are considered a U.S. person if you are:

- An individual who is a U.S. citizen or U.S. resident alien,
- A partnership, corporation, company, or association created or organized in the United States or under the laws of the United States,
- An estate (other than a foreign estate), or
- A domestic trust (as defined in Regulations section 301.7701-7).

Special rules for partnerships. Partnerships that conduct a trade or business in the United States are generally required to pay a withholding tax on any foreign partners' share of income from such business. Further, in certain cases where a Form W-9 has not been received, a partnership is required to presume that a partner is a foreign person, and pay the withholding tax. Therefore, if you are a U.S. person that is a partner in a partnership conducting a trade or business in the United States, provide Form W-9 to the partnership to establish your U.S. status and avoid withholding on your share of partnership income.

The person who gives Form W-9 to the partnership for purposes of establishing its U.S. status and avoiding withholding on its allocable share of net income from the partnership conducting a trade or business in the United States is in the following cases:

- The U.S. owner of a disregarded entity and not the entity,

CITY OF FORT PIERCE BIDDER'S CHECKLIST

This checklist is provided to assist each Bidder in the preparation of their bid response. Included in this checklist are important requirements, which is the responsibility of each Bidder to submit with their response in order to make their response fully compliant. This checklist is only a guideline, it is the responsibility of each Bidder to read and comply with the Invitation to Bid in its entirety.

Check "Yes" or "No" to each of the following:

| | YES | NO |
|---|--------------|---------------|
| Is Invitation to Bid cover page (page 1) completed, signed and attached? | <u> X </u> | <u> </u> |
| Is Bid Response Form completed, signed and attached? | <u> X </u> | <u> </u> |
| W-9 Form completed, signed and attached? | <u> X </u> | <u> </u> |
| All prices have been reviewed for mathematical accuracy, all price corrections initialed, and all price extensions and totals thoroughly checked. | <u> X </u> | <u> </u> |
| Include proof of proper licensing as stated in bid documents. | <u> X </u> | <u> </u> |
| Include proof of proper insurance as stated in bid documents. | <u> X </u> | <u> </u> |
| Bid envelope is marked accordingly. | <u> X </u> | <u> </u> |
| Is Drug-Free Work Place form signed and enclosed? | <u> X </u> | <u> </u> |
| Are two (2) complete bid packages included (one original and one electronic copy (PDF) on a USB Flash Drive) | <u> X </u> | <u> </u> |
| Is each Bid Addendum (when issued) signed and included? | <u> X </u> | <u> </u> |

PLEASE SIGN AND RETURN WITH BID  _____

BID NO. 2021-018 (REBID)
SOUTH 5TH STREET
(BOSTON AVENUE TO DELAWARE AVENUE)
22-Apr-21

| ITEM NO. | DESCRIPTION | UNITS | QUANTITY | UNIT PRICE | AMOUNT |
|-------------|--|-------|----------|---------------|---------------|
| 101-1 | MOBILIZATION/BOND/GENERAL CONDITIONS | LS | 1 | \$ 100,000.00 | \$ 100,000.00 |
| 101-2A | MATERIAL TESTING | LS | 1 | \$ 10,000.00 | \$ 10,000.00 |
| 102-1 | MAINTENANCE OF TRAFFIC | LS | 1 | \$ 80,000.00 | \$ 80,000.00 |
| 104-2 | PREVENTION, CONTROL & ABATEMENT OF EROSION & WATER POLLUTION | LS | 1 | \$ 2,000.00 | \$ 2,000.00 |
| 108-1 | CONSTRUCITON LAYOUT/RECORD DRAWINGS | LS | 1 | \$ 10,000.00 | \$ 10,000.00 |
| 110-1-1 | CLEARING & GRUBBING/PAVEMENT MILLING | LS | 1 | \$ 70,000.00 | \$ 70,000.00 |
| 160-4 | 12" STABILATION, TYPE "B" | SY | 2,527 | \$ 8.00 | \$ 20,216.00 |
| 285-706 | CEMENTED COQUINA LBR 100 (8") | SY | 2,494 | \$ 12.00 | \$ 29,928.00 |
| 334-1-13A | SUPERRAVE ASPHALTIC CONCRETE (SP 9.5) (TRAFFIC C) (1") | TN | 134 | \$ 180.00 | \$ 24,120.00 |
| 334-1-13B | SUPERPAVE ASPHALTIC CONCRETE (SP 12.5) (TRAFFIC C) (1.5") | TN | 200 | \$ 140.00 | \$ 28,000.00 |
| 425-1-201 | INLETS (CURB TYPE 9) (<10) | EA | 5 | \$ 4,500.00 | \$ 22,500.00 |
| 425-2 | 4' MANHOLE (STORM) | EA | 2 | \$ 4,500.00 | \$ 9,000.00 |
| 425-2 | 6' MANHOLE (STORM) | EA | 2 | \$ 4,500.00 | \$ 9,000.00 |
| 430-175-115 | CONCRETE PIPE CULVERT (15" RCP) | LF | 219 | \$ 150.00 | \$ 32,850.00 |
| 520-1-10 | CONCRETE CURB & GUTTER (TYPE F) | LF | 1,200 | \$ 20.00 | \$ 24,000.00 |
| 522-1 | CONCRETE SIDEWALK, 4" THICK, FIBERMESH | SY | 1,100 | \$ 50.00 | \$ 55,000.00 |
| 522-2 | CONCRETE SIDEWALK/DRIVEWAY, 6" THICK, FIBERMESH | SY | 113 | \$ 55.00 | \$ 6,215.00 |
| 570-1-2 | PERFORMANCE TURF (SOD) (BAHIA) | SY | 2,570 | \$ 2.00 | \$ 5,140.00 |
| CR1 | BRICK PAVER CROSSWALKS COMPLETE WITH & 8" HEADER CURB AND CONCRETE BASE | SY | 125 | \$ 230.00 | \$ 28,750.00 |
| 527-2 | ADA CURB RAMP W/DETECTABLE WARNING COMPLETE (CONCRETE BRICK PAVERS - BRICK RED COLOR) | EA | 7 | \$ 1,500.00 | \$ 10,500.00 |
| 700-20-11 | SINGLE POST STOP/STREET SIGN (FURNISH & INSTALL) (LESS THAN 12 SF) | EA | 4 | \$ 3,300.00 | \$ 13,200.00 |
| 711 | THERMOPLASTIC PAVEMENT STRIPING PER PLAN | LS | 1 | \$ 4,701.00 | \$ 4,701.00 |
| L1 | 3' x 7' TREE PIT WITH BRICK PAVER SOLDIER COURSE | EA | 18 | \$ 700.00 | \$ 12,600.00 |
| L2 | LIVISTONIA PALM(10' CT, 20' OA) COMPLETE WITH MULCH | EA | 4 | \$ 1,000.00 | \$ 4,000.00 |
| L3 | PINK CREPE MYRTLE (14' HT, 4" CAL) COMPLETE WITH MULCH | EA | 6 | \$ 750.00 | \$ 4,500.00 |
| L4 | WHITE CREPE MYRTLE (14' HT, 4" CAL) COMPLETE WITH MULCH | EA | 6 | \$ 750.00 | \$ 4,500.00 |
| L5 | LAVENDAR CREPE MYRTLE (14' HT, 4" CAL) COMPLETE WITH MULCH | EA | 6 | \$ 750.00 | \$ 4,500.00 |
| IQ | IRRIGATION SYSTEM COMPLETE WITH BATTERY OPERATED CONTROLLER, RPZ BACKFLOW PREVENTER, AND METER | EA | 1 | \$ 8,000.00 | \$ 8,000.00 |

BID NO. 2021-018 (REBID)
SOUTH 5TH STREET
(BOSTON AVENUE TO DELAWARE AVENUE)
 22-Apr-21

| | | | | | |
|--|---|----|-------|--------------|----------------------|
| C | 4" PVC CONDUIT INSTALLATION (LABOR ONLY) | LF | 3,500 | \$ 4.00 | \$ 14,000.00 |
| SL1 | STREETLIGHTING LOAD CENTER COMPLETE | EA | 1 | \$ 10,000.00 | \$ 10,000.00 |
| SL2 | ELECTRICAL BUILDING PERMIT AND STREETLIGHTING SYSTEM CONNECTION | EA | 1 | \$ 5,000.00 | \$ 5,000.00 |
| SL3 | STREETLIGHTS W/ FOUNDATION | EA | 12 | \$ 8,200.00 | \$ 98,400.00 |
| SL4 | STREETLIGHT CONDUIT (3/4") | LF | 960 | \$ 8.00 | \$ 7,680.00 |
| Subtotal Roadway, Drainage, Signing, Striping, Irrigation, Landscaping & Streetlighting Bid | | | | | \$ 768,300.00 |
| Add 10% Construction Contingency for potential field change orders | | | | | \$ 76,830.00 |
| TOTAL FINAL BID | | | | | \$ 845,130.00 |

OPTION FOR SUBMITTING THIS FORM

The Bid Response Form is available in Excel Format. To access the form, open Excel Attachment from the website, perform "file save as" and save spreadsheet to your computer. Fill in pricing, preferably electronically. Include the Bid Response Form, in excel format (not pdf), on a USB drive with the rest of your submittal documents.

PROPOSAL TO
THE CITY OF FORT PIERCE

FOR

**SOUTH 5TH STREET ROADWAY IMPROVEMENTS
(BOSTON AVENUE TO DELAWARE AVENUE)**

NAME OF BIDDER: DICKERSON FLORIDA, INC.

MAILING ADDRESS: P.O. BOX 910 FT. PIERCE, FL 34954

STREET ADDRESS: 3122 N. 25TH ST., FT. PIERCE, FL 34946 (Zip Code)

PHONE NUMBER: (772) 429-4444

To the: City of Fort Pierce

Pursuant to and in compliance with your notice inviting sealed proposals (Call for Bids), Instructions to Bidders, and the other documents relating thereto, the undersigned bidder, having familiarized himself with the terms of the Contract Documents, local conditions affecting the performance of the contract, and the cost of the Work at the place where the Work is to be done, hereby proposes and agrees to perform within the time stipulated in the Contract, including all of its component parts and everything required to be performed, and to provide and furnish any and all utility and transportation services necessary to perform the contract and complete in a workmanlike manner, all of the Work required in connection with the construction of said Work, all in strict conformity with the plans and/or details, specifications and other related Contract Documents included herein.

The undersigned Bidder acknowledges receipt of the following Addenda, which have been considered in preparation of this Bid:

| | | | |
|--------------|----------------------|-----------|-------------|
| No. <u>1</u> | Dated <u>4/2/21</u> | No. _____ | Dated _____ |
| No. <u>2</u> | Dated <u>4/7/21</u> | No. _____ | Dated _____ |
| No. <u>3</u> | Dated <u>4/13/21</u> | No. _____ | Dated _____ |

The undersigned Bidder agrees that the Work shall be completed within 180 calendar days according to the schedule and the Notice to Proceed set forth in these Documents.

The undersigned Bidder further agrees to pay liquidated damages as described herein and engineering and field inspection expenses, due to overtime work and avoidable delays, which shall be in addition to such other amounts for actual delay damages.

Bidder has stated all prices in numerals in accordance with Section 11.2 of the Instruction to Bidders in the blank space(s) provided for that purpose. Bidder has completed all portions of the Bid to avoid disqualification.

April 2, 2021



CITY OF FORT PIERCE

SOUTH 5TH STREET ROADWAY IMPROVEMENTS
(BOSTON AVENUE TO DELAWARE AVENUE)

BID NO. 2021-024(REBID)

ADDENDUM NO. 1

The purpose of this addendum is to respond to questions submitted by potential bidders for clarification of the proposal specifications:

- 1. All storm manhole covers shall bear the City of Fort Pierce logo, refer to attached US Foundry detail.**

All other conditions of this bid remain the same.

Please acknowledge receipt of this addendum and include it with your submittal.

Signature:  _____

Manual

Signature: Richard J. Forlifer, Vice President _____

Typed or Printed

Company Name: Dickerson Florida, Inc. _____

Address: 3122 N. 25th St., Ft. Pierce, FL 34946 _____

Date: April 22, 2021 _____

THE INFORMATION CONTAINED IN THIS DRAWING IS THE SOLE PROPERTY OF U.S. FOUNDRY & MFG CORP. ANY REPRODUCTION IN PART OR AS A WHOLE WITHOUT THE WRITTEN PERMISSION OF U.S. FOUNDRY & MFG CORP. IS PROHIBITED. U.S. FOUNDRY & MFG CORP. RESERVES THE RIGHT TO MAKE MODIFICATIONS TO DESIGN WITHOUT PRIOR NOTICE. DRAWING IS UNCONTROLLED WHEN PRINTED UNLESS OTHERWISE NOTED. SCALE: AS SHOWN. DIMENSIONS ARE IN INCHES UNLESS OTHERWISE SPECIFIED. U.S. FOUNDRY & MFG CORP. 8351 NW 93RD STREET, MEADLEY, FL 33166-2025. PHONE: 1-800-432-9709. FAX: 305-887-9429. WWW.USFOUNDRY.COM. AN EAGLE MANUFACTURING COMPANY. © 2020 U.S. FOUNDRY & MFG MANUFACTURING COMPANY.

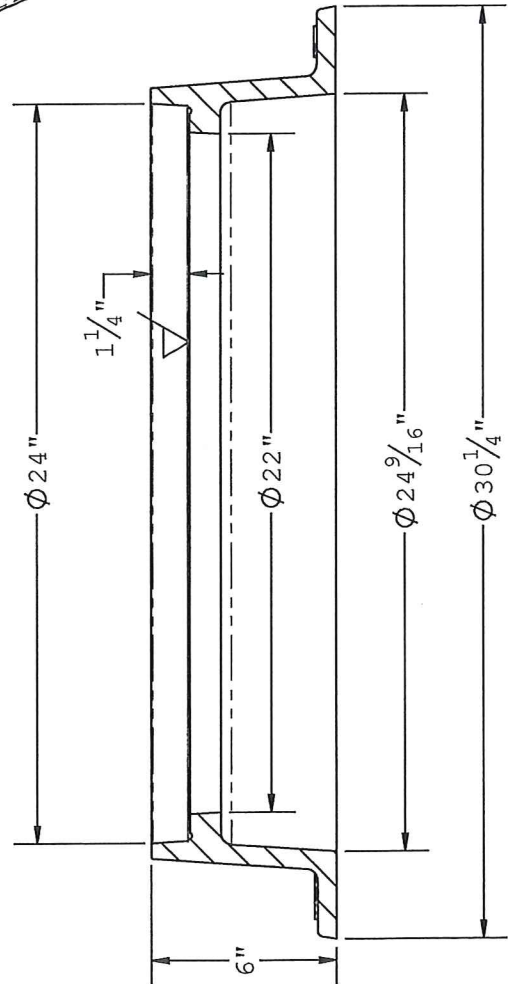
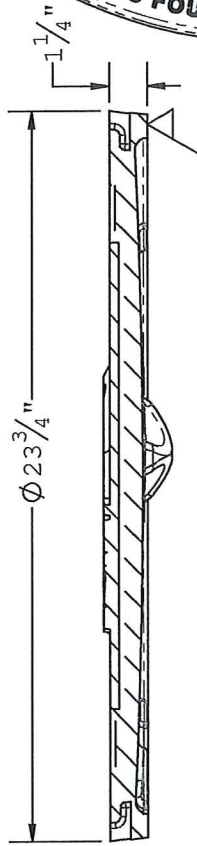
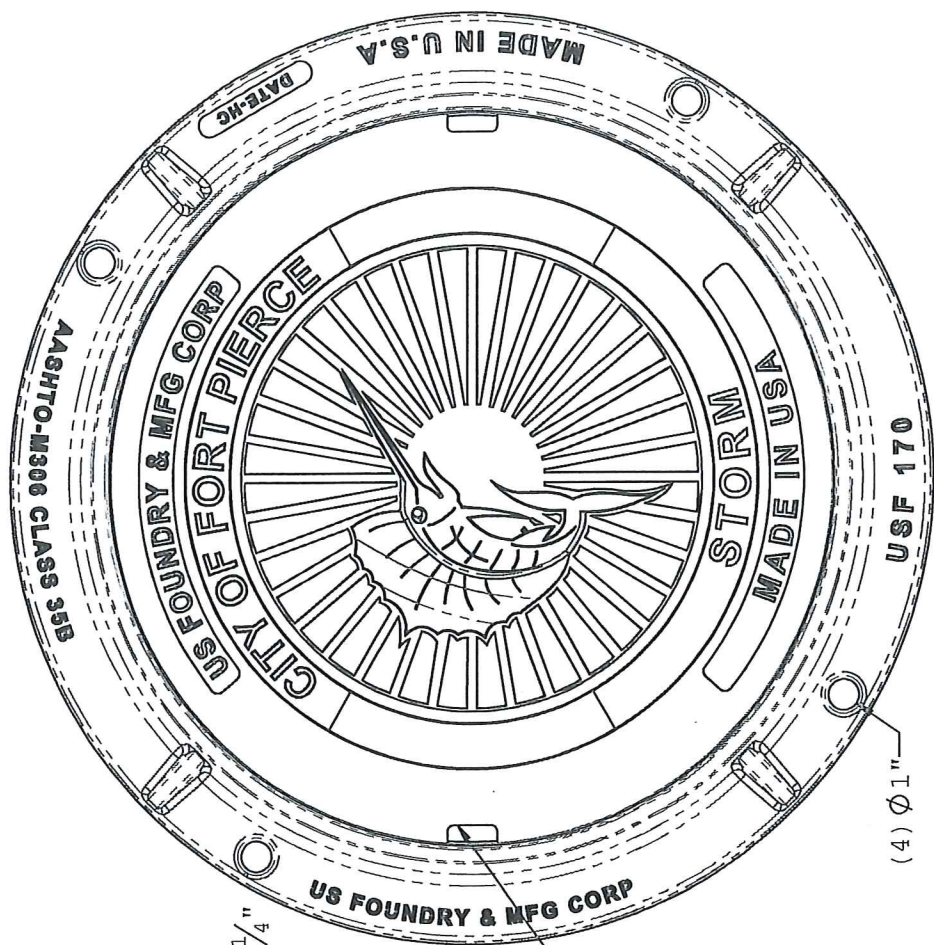

PROPOSAL FOR APPROVAL

8351 NW 93rd Street
 Meadley, FL 33166-2025
 Ph: 1-800-432-9709
 Fax: 305-887-9429
 www.usfoundry.com
 AN EAGLE MANUFACTURING COMPANY © 2020 All Rights Reserved



| | | | |
|-------------------------|----------|-----------|----------------------|
| USF 170 Ring & ME Cover | | MATERIAL: | |
| ITEM | BAAN # | Ring | Gray Cast Iron |
| Cover | 8021468 | | ASTM-A48 Class 35B |
| Assembly | | | LOAD CLASSIFICATION: |
| REV B | REV DATE | REV BY | REV DATE |
| | | IF | 3/16/2020 |
| | | DRAWN BY | QUOTE # |
| | | | IF |

THIS DRAWING MUST BE SIGNED, AND ACCOMPANY PURCHASE ORDER FOR THE PRODUCTS DEPICTED

For a complete product offering please visit us at www.usfoundry.com

April 7, 2021



CITY OF FORT PIERCE

SOUTH 5TH STREET ROADWAY IMPROVEMENTS
(BOSTON AVENUE TO DELAWARE AVENUE)

BID NO. 2021-024 (REBID)

ADDENDUM NO. 2

The purpose of this addendum is to respond to a question submitted by potential bidders for clarification of the proposal specifications:

1. **QUESTION:** Your bid documents state the license requirement is a General Contractor's license. Would a St. Lucie County Certificate of Competency and/or an FDOT prequalification be acceptable in lieu of a GC license?

ANSWER: A Florida General Contractor's license is required.

All other conditions of this bid remain the same.

Please acknowledge receipt of this addendum and include it with your submittal.

Signature:  Manual

Signature: Richard J. Forlifer, Vice President Typed or Printed

Company Name: Dickerson Florida, Inc.

Address: 3122 N. 25th St., Ft. Pierce, FL 34946

Date: April 22, 2021

April 13, 2021



CITY OF FORT PIERCE

SOUTH 5TH STREET ROADWAY IMPROVEMENTS
(BOSTON AVENUE TO DELAWARE AVENUE)

BID NO. 2021-024 (REBID)

ADDENDUM NO. 3

The purpose of this addendum is to respond to questions submitted by potential bidders for clarification of the proposal specifications:

1. **QUESTION:** Please confirm if whether or not a pre-bid meeting will take place? If so, is it Mandatory? when/when? Also, please confirm if whether or not a Bid bond is required? If so, what amount?

ANSWER: No pre-bid meeting will be held. A 10% bid bond is required.

2. **QUESTION:** We do see a Bid bond form was provided, however, on DemandStar.com it states "None"

ANSWER: The "None" was stated in error. Which has now been corrected with Demandstar.

All other conditions of this bid remain the same.

Please acknowledge receipt of this addendum and include it with your submittal.

Signature:  _____

Signature: _____ Manual
Richard J. Forlifer, Vice President

Company Name: _____ Typed or Printed
Dickerson Florida, Inc.

Address: _____
3122 N. 25th Street, Fort Pierce, FL 34946

Date: _____
April 22, 2021

The undersigned, as Bidder, declares that the Bid is made in good faith; that this proposal is made without collusion with any person, firm, or corporation; and he proposes and agrees, if the proposal is accepted, that he will execute a contract with the City in the form set forth in the Contract Documents; that he will furnish the Contract Security Insurance Certificates; that he is aware that failure to properly comply with the requirements set out in the INSTRUCTIONS TO BIDDERS and elsewhere in the Contract Documents may result in a finding that the Bidder is non-responsive and a forfeiture of the Bid Security.

The undersigned Bidder agrees to furnish the required bonds and insurance and to enter into a contract within 10 days after receipt of Notice of Award and further agrees to complete the Work within the time period specified in the Notices to Proceed for each individual project.

The undersigned declares that he has had prior experiences in the type of Work required and has the necessary finances, personnel, working organization, and equipment available to execute the proposed Work.

Bids shall only be considered from those Bidders who have obtained these Contract Documents directly from the City either electronically or from Demand Star.

LIST OF MAJOR SUBCONTRACTORS

1. If awarded a contract as a result of this Bid, the major subcontractors used in the prosecution of the Work will be those listed below, and
2. The following list includes all subcontractors who will perform Work, and
3. The Bidder represents that the subcontractors listed below are financially responsible and are qualified to do the Work required, and
4. 60% of Work must be done by the General Contractor's entity.

If no major subcontractors are to be used, so state on this form.

| <u>Work to be Done</u> | <u>Name of Subcontractor</u> | <u>Address</u> |
|------------------------|------------------------------|--|
| Pipe | Johnson-Davis, Inc. | 604 Hillbrath Dr. Lantana, FL |
| Asphalt Paving | Ranger Construction Indus. | 4510 Glades Cut-Off Rd. Ft. Pierce, FL |
| Mosley & Son | Concrete | 1400 SE Monterey Rd. Stuart, FL |
| Lighting | Carr Construction | 2968 Hwy 710 E. Okeechobee, FL |
| Brick Pavers | Precise Paving | 1243 45th St. WPB, FL |
| Landscape/Sod | Nature's Keeper | 302 S. Brocksmith Rd. Ft. Pierce, FL |
| | | |
| | | |
| | | |
| | | |
| | | |

Notice to Proceed shall be issued by the City with the specified Work to be completed as described in Section 8 of the General Conditions, within the number of days stated when each Project Contract Time begins to run as specified in the Notice to Proceed.

Work shall be completed, ready for final payment in accordance with Section 8 and 9 of the General Conditions.

Time is of the essence of this Contract and Contractor recognizes that the City will suffer financial loss if the Work, or portions authorized, is not completed within the number of days stated above. Accordingly, Contractor agrees to pay City the liquidated damages stated in the Agreement for each day after the time specified above that the Work is not complete in accordance with Sections 8 and 9 of the General Conditions and with the Agreement.

These liquidated damages are cumulative and additive and represent a reasonable estimate of City's expenses for extended delays. Furthermore, Contractor agrees to pay City expenses for inspection, engineering services, and administrative costs associated with such delay.

In addition to these amounts, there may be additional other amounts for delay damages incurred by City as a result of delays by Contractor. These actual delay damages will include, but not be limited to, delay damage settlements or awards, penalties, and professional fees incurred in connection with such settlements, awards, or penalties and fines imposed by regulatory agencies, contract damages, and loss of use.

ACCOMPANYING THIS PROPOSAL IS BIDDER'S BOND

(Insert the word(s) "cashier's check," "bidder's bond," "certified check," or other security as provided by law, as the case may be), in an amount equal to at least 10% of the total amount of the bid, payable to the CITY OF FORT PIERCE the undersigned deposits above-named security as a proposal guarantee and agrees that it shall be forfeited to the City as liquidated damages in case this proposal is accepted by the City and the undersigned fails to execute a contract with the City as specified in the Contract Documents, accompanied by the required payment and faithful performance bonds, with sureties satisfactory to the City, and accompanied by the required certificates of insurance coverage and endorsements. Should the City be required to engage the services of an attorney in connection with the enforcement of this bid, bidder promises to pay City reasonable attorneys' fees and costs (including attorneys' fees and costs on appeals), incurred with or without suit.

The Work shall be performed under a State of Florida Contractor's License. Contract shall not be awarded unless proof of valid license(s) is provided, and license shall be appropriate for the nature of the Work.

The Bidder certifies that the following documents are included in the Bid and are complete:

1. Bid form, list of Addenda received, and authorized signatures.

BID FORMS

2. Bid Bond with Power of Attorney attached.
3. Affidavit of Non-Collusion.
4. Trench Safety Act Form.

The Bidder further certifies that he will submit within ten (10) days of notification of the Apparent Successful Bidder:

1. List of Major Subcontractors
2. Payment Bond
3. Performance Bond
4. Agreement
5. Certificates of Insurance

NOTE: If bidder is a corporation, the legal name of the corporation shall be set forth below, together with signature(s) of the officer or officers authorized to sign contracts on behalf of the corporation and corporate seal; if bidder is a partnership, the true name of the firm shall be set forth below with the signature(s) of the partner or partners authorized to sign contracts in behalf of the partnership; and if the bidder is an individual, his signature shall be placed below.

Bidder: Dickerson Florida, Inc.
(Type or Print)

By:  _____

Name: Richard J Forlifer

Title: Vice President

Dated: 4/22/2021, 2021

(Corporate Seal)

Attest
If Corporation

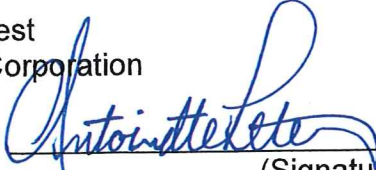
By:  _____
(Signature)

Name: Antoinette Peterson

Title: Secretary _____

Witnesses: Cindy Heath
(Signature)

(If partnership
Or individual) _____
(Signature)

Contractor's License (State, Number, Expiration Date, Type of License)

Florida Certified General Contractor CGC 060797 expires 8/31/22

END OF SECTION

BID BOND

KNOW ALL MEN BY THESE PRESENTS, that we, Dickerson Florida, Inc.
, as Principal, and
Travelers Casualty and Surety Company of America, as Surety,
are held and firmly bound unto the City of Fort Pierce, hereinafter called the City, in the
penal sum of ten percent (10%)
of the amount bid----- Dollars (\$-----), lawful money
of the United States, for the payment of which sum well and truly to be made, we bind
ourselves, our heirs, executors, administrators, and successors, jointly and severally,
firmly by these presents. The Bid Bond amount shall be ten (10) percent of the Base Bid
amount as entered on the Bid Form.

The condition of this obligation is such that whereas the principal has submitted the
accompanying bid dated April 22, 2021, for the South 5th Street Roadway
Improvements (Boston Avenue to Delaware Avenue), Fort Pierce, Florida

NOW, THEREFORE, if the Principal shall not withdraw said bid within the period of time
set forth in the Contract Documents, and shall within ten (10) calendar days after receipt
of the Notice of Award enter into a written contract with the City in accordance with the
bid as accepted, and if the Principal shall give the required bonds with good and sufficient
sureties for the faithful performance and proper fulfillment of such contract and for the
protection of subcontractors, laborers and material men, and if the Principal has provided
the required evidence of insurance as set forth in the Contract Documents and complied
with the Florida Department of Environmental Protection certifications and requirements,
and all other contract provisions, or in the event of withdrawal of said bid within the
periods specified, or the failure to enter into said contract, or failure to comply with FDEP
requirements, or otherwise, if the Principal shall within sixty (60) days after request by
the City to pay to the City the difference between the amount specified in said bid and
the amount for which the City may procure the required work, if the latter amount be in
excess of the former, then the above obligation shall be void and of no effect, otherwise
to remain in full force and effect.

It is further agreed that if the City is required to utilize legal counsel to recover on this
bond, it may also recover its costs relating thereto, including a reasonable amount for
attorneys' fees and costs, including attorneys' fees and costs in appellate proceedings.

IN WITNESS WHEREOF, the above parties have executed this instrument under their several seals this 22nd day of April, 2021, the name and corporate seal of each corporate party being hereto affixed, and these presents duly signed by its undersigned representative pursuant to authority of its governing body.

WITNESSES
(if individual
or partnership)

PRINCIPAL

Dickerson Florida, Inc.

By: Richard J. Forlifer

(Signature)

Name: _____

Title: Vice President

ATTEST (if corporation)

By: _____

(Signature)

Name: Antoinette Peterson

Title: Secretary

(Corporate Seal)

SURETY

Travelers Casualty and Surety Company of America

By: _____

(Signature)

Name: Karen K. Beard

Title: Attorney-in-Fact and Florida Licensed Agent

(Surety Seal)

EXHIBIT "D"
SECTION 002

Attach a certified copy of Power of Attorney appointing individual Attorney-in-Fact for execution of Bid Bond on behalf of Surety.

Any Claims under this bond may be addressed to:

Name of Surety Travelers Casualty and Surety Company of America

Mailing Address One Tower Square

Street Address Hartford, Connecticut 06183

Name and Mailing and Street Surety Agency LLC

Address of Agent or 552-B New Haw Creek Rd

Representative in Florida Asheville, NC 28805

(if different than above) _____

Telephone Number of Surety 919-474-4803

and Agent or Representative 828-236-1000

in Florida _____

END OF SECTION



**Travelers Casualty and Surety Company of America
Travelers Casualty and Surety Company
St. Paul Fire and Marine Insurance Company**

POWER OF ATTORNEY

KNOW ALL MEN BY THESE PRESENTS: That Travelers Casualty and Surety Company of America, Travelers Casualty and Surety Company, and St. Paul Fire and Marine Insurance Company are corporations duly organized under the laws of the State of Connecticut (herein collectively called the "Companies"), and that the Companies do hereby make, constitute and appoint **Karen K. Beard** of **ASHEVILLE North Carolina**, their true and lawful Attorney-in-Fact to sign, execute, seal and acknowledge any and all bonds, recognizances, conditional undertakings and other writings obligatory in the nature thereof on behalf of the Companies in their business of guaranteeing the fidelity of persons, guaranteeing the performance of contracts and executing or guaranteeing bonds and undertakings required or permitted in any actions or proceedings allowed by law.

IN WITNESS WHEREOF, the Companies have caused this instrument to be signed, and their corporate seals to be hereto affixed, this 3rd day of February, 2017.



State of Connecticut

City of Hartford ss.

By:
Robert L. Raney, Senior Vice President

On this the 3rd day of February, 2017, before me personally appeared **Robert L. Raney**, who acknowledged himself to be the Senior Vice President of Travelers Casualty and Surety Company of America, Travelers Casualty and Surety Company, and St. Paul Fire and Marine Insurance Company, and that he, as such, being authorized so to do, executed the foregoing instrument for the purposes therein contained by signing on behalf of the corporations by himself as a duly authorized officer.

In Witness Whereof, I hereunto set my hand and official seal.

My Commission expires the 30th day of June, 2021



Marie C. Tetreault, Notary Public

This Power of Attorney is granted under and by the authority of the following resolutions adopted by the Boards of Directors of Travelers Casualty and Surety Company of America, Travelers Casualty and Surety Company, and St. Paul Fire and Marine Insurance Company, which resolutions are now in full force and effect, reading as follows:

RESOLVED, that the Chairman, the President, any Vice Chairman, any Executive Vice President, any Senior Vice President, any Vice President, any Second Vice President, the Treasurer, any Assistant Treasurer, the Corporate Secretary or any Assistant Secretary may appoint Attorneys-in-Fact and Agents to act for and on behalf of the Company and may give such appointee such authority as his or her certificate of authority may prescribe to sign with the Company's name and seal with the Company's seal bonds, recognizances, contracts of indemnity, and other writings obligatory in the nature of a bond, recognizance, or conditional undertaking, and any of said officers or the Board of Directors at any time may remove any such appointee and revoke the power given him or her; and it is

FURTHER RESOLVED, that the Chairman, the President, any Vice Chairman, any Executive Vice President, any Senior Vice President or any Vice President may delegate all or any part of the foregoing authority to one or more officers or employees of this Company, provided that each such delegation is in writing and a copy thereof is filed in the office of the Secretary; and it is

FURTHER RESOLVED, that any bond, recognizance, contract of indemnity, or writing obligatory in the nature of a bond, recognizance, or conditional undertaking shall be valid and binding upon the Company when (a) signed by the President, any Vice Chairman, any Executive Vice President, any Senior Vice President or any Vice President, any Second Vice President, the Treasurer, any Assistant Treasurer, the Corporate Secretary or any Assistant Secretary and duly attested and sealed with the Company's seal by a Secretary or Assistant Secretary; or (b) duly executed (under seal, if required) by one or more Attorneys-in-Fact and Agents pursuant to the power prescribed in his or her certificate or their certificates of authority or by one or more Company officers pursuant to a written delegation of authority; and it is

FURTHER RESOLVED, that the signature of each of the following officers: President, any Executive Vice President, any Senior Vice President, any Vice President, any Assistant Vice President, any Secretary, any Assistant Secretary, and the seal of the Company may be affixed by facsimile to any Power of Attorney or to any certificate relating thereto appointing Resident Vice Presidents, Resident Assistant Secretaries or Attorneys-in-Fact for purposes only of executing and attesting bonds and undertakings and other writings obligatory in the nature thereof, and any such Power of Attorney or certificate bearing such facsimile signature or facsimile seal shall be valid and binding upon the Company and any such power so executed and certified by such facsimile signature and facsimile seal shall be valid and binding on the Company in the future with respect to any bond or understanding to which it is attached.

I, **Kevin E. Hughes**, the undersigned, Assistant Secretary of Travelers Casualty and Surety Company of America, Travelers Casualty and Surety Company, and St. Paul Fire and Marine Insurance Company, do hereby certify that the above and foregoing is a true and correct copy of the Power of Attorney executed by said Companies, which remains in full force and effect.

Dated this 22nd day of April, 2021



Kevin E. Hughes, Assistant Secretary

**To verify the authenticity of this Power of Attorney, please call us at 1-800-421-3880.
Please refer to the above-named Attorney-in-Fact and the details of the bond to which the power is attached.**



CERTIFICATE OF LIABILITY INSURANCE

DATE (MM/DD/YYYY)
04/14/2021

THIS CERTIFICATE IS ISSUED AS A MATTER OF INFORMATION ONLY AND CONFERS NO RIGHTS UPON THE CERTIFICATE HOLDER. THIS CERTIFICATE DOES NOT AFFIRMATIVELY OR NEGATIVELY AMEND, EXTEND OR ALTER THE COVERAGE AFFORDED BY THE POLICIES BELOW. THIS CERTIFICATE OF INSURANCE DOES NOT CONSTITUTE A CONTRACT BETWEEN THE ISSUING INSURER(S), AUTHORIZED REPRESENTATIVE OR PRODUCER, AND THE CERTIFICATE HOLDER.

IMPORTANT: If the certificate holder is an ADDITIONAL INSURED, the policy(ies) must be endorsed. If SUBROGATION IS WAIVED, subject to the terms and conditions of the policy, certain policies may require an endorsement. A statement on this certificate does not confer rights to the certificate holder in lieu of such endorsement(s).

| | | | |
|--|---|-----------------------------------|-----------------------------|
| PRODUCER SURETY AGENCY, LLC 552-B NEW HAW CREEK ROAD ASHEVILLE, NC 28805 828-236-1000 FAX 828-236-1001 | CONTACT NAME KAREN BEARD | PHONE (A/C No, Ext): 828-236-1000 | FAX (A/C, No): 828-236-1001 |
| | E-MAIL ADDRESS: KAREN110@BELLSOUTH.NET | | |
| INSURED DICKERSON FLORIDA, INC. P. O. BOX 910 FT. PIERCE, FL 34954-0910 | INSURER(S) AFFORDING COVERAGE | | NAIC # |
| | INSURER A: ZURICH AMERICAN INSURANCE COMPANY | | |
| | INSURER B: AMERICAN GUARANTEE & LIABILITY INS CO | | |
| | INSURER C: | | |
| | INSURER D: | | |
| | INSURER E: | | |

COVERAGES CERTIFICATE NUMBER: 101018 REVISION NUMBER:

THIS IS TO CERTIFY THAT THE POLICIES OF INSURANCE LISTED BELOW HAVE BEEN ISSUED TO THE INSURED NAMED ABOVE FOR THE POLICY PERIOD INDICATED. NOTWITHSTANDING ANY REQUIREMENT, TERM OR CONDITION OF ANY CONTRACT OR OTHER DOCUMENT WITH RESPECT TO WHICH THIS CERTIFICATE MAY BE ISSUED OR MAY PERTAIN, THE INSURANCE AFFORDED BY THE POLICIES DESCRIBED HEREIN IS SUBJECT TO ALL THE TERMS, EXCLUSIONS AND CONDITIONS OF SUCH POLICIES. LIMITS SHOWN SHOWN MAY HAVE BEEN REDUCED BY PAID CLAIMS.

| INSR LTR | TYPE OF INSURANCE | ADDL INSR | SUBR WVD | POLICY NUMBER | POLICY EFF (MM/DD/YYYY) | POLICY EXP (MM/DD/YYYY) | LIMITS |
|----------|--|-----------|----------|---------------|-------------------------|-------------------------|---|
| A | GENERAL LIABILITY <input checked="" type="checkbox"/> COMMERCIAL GENERAL LIABILITY <input type="checkbox"/> CLAIMS-MADE <input checked="" type="checkbox"/> OCCUR GEN'L AGGREGATE LIMIT APPLIES PER: <input type="checkbox"/> POLICY <input checked="" type="checkbox"/> PROJECT <input type="checkbox"/> LOC | X | | GLO5761374 | 07/01/2020 | 07/01/2021 | EACH OCCURRENCE \$ 1,000,000 DAMAGE TO RENTED PREMISES (Ea occurrence) \$ 300,000 MED EXP (Any one person) \$ EXCLUDED PERSONAL & ADV INJURY \$ 1,000,000 GENERAL AGGREGATE \$ 2,000,000 PRODUCTS - COMP/OP AGG \$ 2,000,000 |
| A | AUTOMOBILE LIABILITY <input checked="" type="checkbox"/> ANY AUTO ALL OWNED AUTOS <input checked="" type="checkbox"/> HIRED AUTOS <input type="checkbox"/> SCHEDULED AUTOS <input checked="" type="checkbox"/> NON-OWNED AUTOS | | | BAP5761373 | 07/01/2020 | 07/01/2021 | COMBINED SINGLE LIMIT (Ea accident) \$ 1,000,000 BODILY INJURY (Per person) \$ BODILY INJURY (Per accident) \$ PROPERTY DAMAGE (Per accident) \$ |
| B | UMBRELLA LIAB <input checked="" type="checkbox"/> OCCUR EXCESS LIAB <input type="checkbox"/> CLAIMS-MADE DED RETENTION \$ | | | AUC9266387 | 07/01/2020 | 07/01/2021 | EACH OCCURRENCE \$ 3,000,000 AGGREGATE \$ 3,000,000 |
| A | WORKERS COMPENSATION AND EMPLOYERS' LIABILITY Y/N ANY PROPRIETOR/PARTNER/EXECUTIVE OFFICER/MEMBER EXCLUDED? <input type="checkbox"/> N/A (Mandatory in NH) If yes, describe under DESCRIPTION OF OPERATIONS below | | X | WC5761375 | 07/01/2020 | 07/01/2021 | <input checked="" type="checkbox"/> WC STATUTORY LIMITS OTH-ER E.L. EACH ACCIDENT \$ 1,000,000 E.L. DISEASE - EA EMPLOYEE \$ 1,000,000 E.L. DISEASE - POLICY LIMIT \$ 1,000,000 |

DESCRIPTION OF OPERATIONS / LOCATIONS / VEHICLES (Attach ACORD 101, Additional Remarks Schedule, if more space is required)

RE: BID NO. 2021-024, SOUTH 5TH STREET IMPROVEMENTS (BOSTON AVENUE TO DELAWARE AVENUE)

CITY OF FORT PIERCE AND THE CITY'S BOARD MEMBERS, OFFICIALS, OFFICERS, AGENTS AND EMPLOYEES ARE ADDITIONAL INSURED FOR GENERAL LIABILITY AS INDICATED IN THE INCLUDED ENDORSEMENT CG D2 46 08 05 "BLANKET ADDITIONAL INSURED" ONLY FOR THE WORK PERFORMED BY THE INSURED

SHOULD ANY OF THE ABOVE DESCRIBED POLICIES BE CANCELLED BEFORE THE EXPIRATION DATE THEREOF, THE ISSUING

| | |
|---|---|
| CITY OF FORT PIERCE ATTN: PURCHASING DIVISION 100 NORTH U.S. HIGHWAY 1 FORT PIERCE, FL 34950 | CANCELLATION |
| | SHOULD ANY OF THE ABOVE DESCRIBED POLICIES BE CANCELLED BEFORE THE EXPIRATION DATE THEREOF, NOTICE WILL BE DELIVERED IN ACCORDANCE WITH THE POLICY PROVISIONS. AUTHORIZED REPRESENTATIVE <i>Karen Beard</i> |

© 1988-2010 ACORD CORPORATION. All rights reserved.



ZURICH

Additional Insured – Automatic – Owners, Lessees Or Contractors

| Policy No. | Eff. Date of Pol. | Exp. Date of Pol. | Eff. Date of End. | Producer No. | Add'l. Prem. | Return Prem. |
|------------|-------------------|-------------------|-------------------|--------------|--------------|--------------|
| GL05761374 | 07/01/2020 | 07/01/2021 | 07/01/2020 | | | |

THIS ENDORSEMENT CHANGES THE POLICY. PLEASE READ IT CAREFULLY.

Named Insured: Dickerson Florida, Inc.
Address (including ZIP Code):

This endorsement modifies insurance provided under the:
Commercial General Liability Coverage Part

A. Section II – Who Is An Insured is amended to include as an additional insured any person or organization whom you are required to add as an additional insured on this policy under a written contract or written agreement. Such person or organization is an additional insured only with respect to liability for "bodily injury", "property damage" or "personal and advertising injury" caused, in whole or in part, by:

1. Your acts or omissions; or
2. The acts or omissions of those acting on your behalf.

in the performance of your ongoing operations or "your work" as included in the "products-completed operations hazard", which is the subject of the written contract or written agreement.

However, the insurance afforded to such additional insured:

1. Only applies to the extent permitted by law; and
2. Will not be broader than that which you are required by the written contract or written agreement to provide for such additional insured.

B. With respect to the insurance afforded to these additional insureds, the following additional exclusion applies:

This insurance does not apply to:

"Bodily injury", "property damage" or "personal and advertising injury" arising out of the rendering of, or failure to render, any professional architectural, engineering or surveying services including:

- a. The preparing, approving or failing to prepare or approve maps, shop drawings, opinions, reports, surveys, field orders, change orders or drawings and specifications; or
- b. Supervisory, inspection, architectural or engineering activities.

This exclusion applies even if the claims against any insured allege negligence or other wrongdoing in the supervision, hiring, employment, training or monitoring of others by that insured, if the "occurrence" which caused the "bodily injury" or "property damage", or the offense which caused the "personal and advertising injury", involved the rendering of or the failure to render any professional architectural, engineering or surveying services.

C. The following is added to Paragraph 2. Duties In The Event Of Occurrence, Offense, Claim Or Suit of Section IV -- **Commercial General Liability Conditions:**

The additional insured must see to it that:

1. We are notified as soon as practicable of an "occurrence" or offense that may result in a claim;
2. We receive written notice of a claim or "suit" as soon as practicable; and
3. A request for defense and indemnity of the claim or "suit" will promptly be brought against any policy issued by another insurer under which the additional insured may be an insured in any capacity. This provision does not apply to insurance on which the additional insured is a Named Insured if the written contract or written agreement requires that this coverage be primary and non-contributory.

D. For the purposes of the coverage provided by this endorsement:

1. The following is added to the Other Insurance Condition of Section IV -- **Commercial General Liability Conditions:**

Primary and Noncontributory Insurance

This insurance is primary to and will not seek contribution from any other insurance available to an additional insured provided that:

- a. The additional insured is a Named Insured under such other insurance; and
- b. You are required by written contract or written agreement that this insurance be primary and not seek contribution from any other insurance available to the additional insured.

2. The following paragraph is added to Paragraph 4.b. of the Other Insurance Condition of Section IV -- **Commercial General Liability Conditions:**

This insurance is excess over:

Any of the other insurance, whether primary, excess, contingent or on any other basis, available to an additional insured, in which the additional insured on our policy is also covered as an additional insured on another policy providing coverage for the same "occurrence", offense, claim or "suit". This provision does not apply to any policy in which the additional insured is a Named Insured on such other policy and where our policy is required by a written contract or written agreement to provide coverage to the additional insured on a primary and non-contributory basis.

E. This endorsement does not apply to an additional insured which has been added to this policy by an endorsement showing the additional insured in a Schedule of additional insureds, and which endorsement applies specifically to that identified additional insured.

F. With respect to the insurance afforded to the additional insureds under this endorsement, the following is added to Section III -- **Limits Of Insurance:**

The most we will pay on behalf of the additional insured is the amount of insurance:

1. Required by the written contract or written agreement referenced in Paragraph A. of this endorsement; or
 2. Available under the applicable Limits of Insurance shown in the Declarations,
- whichever is less.

This endorsement shall not increase the applicable Limits of Insurance shown in the Declarations.

All other terms and conditions of this policy remain unchanged.

EARLIER NOTICE OF NON-RENEWAL OR CHANGE IN COVERAGE

| Policy No. | Eff. Date of Pol. | Exp. Date of Pol. | Eff. Date of End. | Producer | Add'l. Prem | Return Prem. |
|------------|-------------------|-------------------|-------------------|----------|-------------|--------------|
| GLO5761374 | 07/01/2020 | 07/01/2021 | 07/01/2020 | | \$ | \$ |

This endorsement modifies the insurance provided under the following:

COMMERCIAL GENERAL LIABILITY COVERAGE FORM
 BUSINESS AUTOMOBILE COVERAGE FORM

SCHEDULE

| Name | Address | Project Name/Number/Description |
|------|---------|---------------------------------|
|------|---------|---------------------------------|

Number or Day's Notice 90

(If no entry appears above, information required to complete this Schedule will be shown in the Declarations as applicable to this endorsement.)

- A. For any statutorily permitted reason other than nonpayment of premium, the number of days required for notice of non-renewal, as provided in the Policy Conditions, as amended by an applicable state endorsement, or as provided by an applicable state's change in coverage regulation is increased to the number of days shown in the Schedule above.
- B. We will not provide notice of non-renewal and/or change in coverage to the first Named Insured or any person or organization shown in the Schedule, if:
 - 1. You have purchased insurance elsewhere;
 - 2. You have obtained replacement coverage or have agreed in writing to obtain replacement coverage;
 - 3. You have requested or agreed to non-renewal; or,
 - 4. We, or another company within the same insurance group have offered to issue a renewal.

EARLIER NOTICE OF NON-RENEWAL OR CHANGE IN COVERAGE

| Policy No. | Eff. Date of Pol. | Exp. Date of Pol. | Eff. Date of End. | Producer | Add'l. Prem | Return Prem. |
|------------|-------------------|-------------------|-------------------|----------|-------------|--------------|
| BAP5761373 | 07/01/2020 | 07/01/2021 | 07/01/2020 | | \$ | \$ |

This endorsement modifies the insurance provided under the following:

COMMERCIAL GENERAL LIABILITY COVERAGE FORM
BUSINESS AUTOMOBILE COVERAGE FORM

SCHEDULE

| Name | Address | Project Name/Number/Description |
|------|---------|---------------------------------|
|------|---------|---------------------------------|

Number or Day's Notice 90

(If no entry appears above, information required to complete this Schedule will be shown in the Declarations as applicable to this endorsement.)

- A. For any statutorily permitted reason other than nonpayment of premium, the number of days required for notice of non-renewal, as provided in the Policy Conditions, as amended by an applicable state endorsement, or as provided by an applicable state's change in coverage regulation is increased to the number of days shown in the Schedule above.
- B. We will not provide notice of non-renewal and/or change in coverage to the first Named Insured or any person or organization shown in the Schedule, if:
 - 1. You have purchased insurance elsewhere;
 - 2. You have obtained replacement coverage or have agreed in writing to obtain replacement coverage;
 - 3. You have requested or agreed to non-renewal; or,
 - 4. We, or another company within the same insurance group have offered to issue a renewal.

WAIVER OF OUR RIGHT TO RECOVER FROM OTHERS ENDORSEMENT

We have the right to recover our payments from anyone liable for an injury covered by this policy. We will not enforce our right against the person or organization named in the Schedule. (This agreement applies only to the extent that you perform work under a written contract that requires you to obtain this agreement from us.)

This agreement shall not operate directly or indirectly to benefit anyone not named in the Schedule.

Schedule

ALL PERSONS AND/OR ORGANIZATIONS THAT ARE REQUIRED BY WRITTEN CONTRACT OR AGREEMENT WITH THE INSURED, EXECUTED PRIOR TO THE ACCIDENT OR LOSS, THAT WAIVER OF SUBROGATION BE PROVIDED UNDER THIS POLICY FOR WORK PERFORMED BY YOU FOR THAT PERSON AND/OR ORGANIZATION OR SCHEDULED AND PREMIUM CHARGE.

This endorsement changes the policy to which it is attached and is effective on the date issued unless otherwise stated.

(The information below is required only when this endorsement is issued subsequent to preparation of the policy.)

Endorsement Effective 07-01-2020 Policy No. WC5761375 Endorsement No.

Insured Dickerson Florida, Inc.

Premium \$

Insurance Company Zurich American Insurance Company

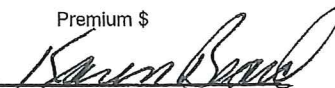
Countersigned By 

CERTIFICATE OF OWNER'S ATTORNEY

PROJECT: _____

I, the undersigned, _____
(Name of Attorney)

the duly authorized and acting legal representative of _____

_____, do hereby certify as follows:
(Owner)

I have examined the attached contract(s) and surety bonds and the manner of execution thereof, and I am of the opinion that each of the aforesaid agreements has been duly executed by the proper parties thereto acting through their duly authorized representatives; that said representatives have full power and authority to execute said agreements on behalf of the respective parties named thereon; and that the foregoing agreements constitute valid and legally binding obligations upon the parties executing the same in accordance with terms, conditions, and provisions thereof.

Attorney

Date

END OF SECTION

BIDDER'S QUESTIONNAIRE

All questions must be answered and the data given must be clear and comprehensive. This statement must be notarized. If necessary, questions may be answered on separate attached sheets. The Bidder may submit any additional information he desires. Qualifications Questionnaire must be submitted with the Proposal.

1. Name of Bidder. Dickerson Florida, Inc.
2. Permanent Main Office address. 3122 N. 25th St., Ft. Pierce, FL 34946
3. When organized? March 1982
4. If a corporation, where incorporated? Florida
5. How many years have you been engaged in construction under this present firm or trade name? 38
6. Contracts on hand: (Schedule of these, showing gross amount of each contract and the appropriate anticipated dates of completion.) Please see attached status of contracts
7. General character of work performed by you. heavy civil contracting
8. Have you ever failed to complete any work awarded to you? If so, where and why?
no
9. Have you ever defaulted on a contract? If so, where and why?
no
10. List the more important contracts recently completed by you, stating approximate gross costs of each and the month and year completed. Include the name and telephone number of contact in company for which you provided work.
Please see attached list of recently completed projects
11. List your major equipment available for this contract. Please see attached equipment list
12. Experience in general construction work similar in scope to this project. (If additional space is needed or required, it may be attached to this sheet.)
Please see attached list of completed projects
13. Background and experience of the principal members of your company, including the officers. Please see attached company overview
14. Give bank reference. Please see attached bank reference
15. You will furnish a detailed financial statement and, upon request, any other information that may be required by the City of Fort Pierce. will provide upon award
16. The Undersigned hereby authorizes and requests any person, firm, or corporation to furnish any information requested by the City of Fort Pierce in the County of St. Lucie in verification of the recitals comprising this Bidder's Qualifications Questionnaire.

Dated at Ft. Pierce, FL this 22nd day of April, 2021.

EXHIBIT "D"
SECTION 010

Contractor:

Dickerson Florida, Inc.

By [Signature]

Richard J. Forlifer, Vice President
(Name & Title)

County of St. Lucie
State of Florida

Richard J. Forlifer, being duly sworn, deposes and says that he is Vice President of Dickerson Florida, Inc., and that the answers to the foregoing questions and all statements contained therein are true and correct.

Subscribed and sworn to before me this 22nd day of April, 2021.

[Signature]
Notary Public

My Commission Expires:

05/06/2023

(Seal)



Cynthia Clark Cheatham
NOTARY PUBLIC
STATE OF FLORIDA
Comm# GG331046
Expires 5/6/2023

END OF SECTION

NON-COLLUSION AFFIDAVIT

STATE OF Florida

COUNTY OF St. Lucie

Richard J. Forlifer, being first duly sworn, deposes
and says:

That he/she is Vice President of Dickerson Florida, Inc.
(a partner or officer of the firm of, etc.)

the party making the foregoing proposal or bid, that such proposal or bid is genuine and not collusive or sham; that said bidder has not colluded, conspired, connived or agreed directly or indirectly with any bidder or person, to put in a sham bid or to refrain from bidding, and has not in any manner, directly or indirectly sought by agreement or collusion, or communication or conference with any person, to fix the bid price of affiant or of any other bidder, or to fix any overhead, profit or cost element of said bid price, or of that of any other bidder, or to secure any advantage against the City of Fort Pierce, of the County of St. Lucie, or any person interested in the proposed contract; and that all statements in said proposal or bid are true.

Dickerson Florida, Inc.
(Firm Name)

By: [Signature]

Title: Vice President

Subscribed and sworn to before me this 22nd

day of April, 2021

[Signature]
Notary Public

My Commission expires: (Seal)

05/06/2023



Cynthia Clark Cheatham
NOTARY PUBLIC
STATE OF FLORIDA
Comm# GG331046
Expires 5/6/2023

END OF SECTION

PUBLIC ENTITY AFFIDAVIT
SWORN STATEMENT UNDER SECTION 287.133(3)(a),
FLORIDA STATUTES, ON PUBLIC ENTITY CRIMES

THIS FORM MUST BE SIGNED IN THE PRESENCE OF A NOTARY PUBLIC OR OTHER OFFICER AUTHORIZED TO ADMINISTER OATHS.

1. This sworn statement is submitted with Bid No. 2021-024 for City of Ft. Pierce.
2. This sworn statement is submitted by Dickerson Florida, Inc.
(name of entity submitting sworn statement)
whose business address is 3122 N. 25th St., Ft. Pierce, FL 34946
and (if applicable) its Federal Employer Identification Number (FEIN) is 56-1327509
(If the entity has no FEIN, include the Social Security Number of the individual signing this sworn statement: _____.)
3. My name is Richard J. Forlifer my relationship to the entity
(please print name of individual signing)
named above is Vice President.
4. I understand that a "public entity crime" as defined in Paragraph 287.133(1)(g), Florida Statutes, means a violation of any state or federal law by a person with respect to and directly related to the transaction of business with any public entity or with an agency or political subdivision of any other state or with the United States, including, but not limited to, any bid or contract for goods or services to be provided to any public entity or an agency or political subdivision of any other state or of the United States and involving antitrust, fraud, theft, bribery, collusion, racketeering, conspiracy, or material misrepresentation.
5. I understand that "convicted" or "conviction" as defined in Paragraph 287.133(1)(b), Florida Statutes, means a finding of guilt or a conviction of a public entity crime, with or without an adjudication of guilt, in any federal or state trial court of record relating to charges brought by indictment or information after July 1, 1989, as a result of a jury verdict, nonjury trial, or entry of a plea of guilty or nolo contendere.
6. I understand that an "affiliate" as defined in paragraph 287.133(1)(a), Florida Statutes, means:
 1. A predecessor or successor of a person convicted of a public entity crime: or
 2. An entity under the control of any natural person who is active in the management of the entity and who has been convicted of a public entity crime. The term "affiliate" includes those officers, directors, executives, partners, shareholders, employees, members, and agents who are active in the management of an affiliate. The ownership by one person of shares constituting a controlling interest in another person, or a pooling of equipment or income among persons when not for fair market value under an arm's length agreement, shall be a prima facie case that one person controls another person. A person who knowingly enters into a joint venture with a person

EXHIBIT "D"
SECTION 012

who has been convicted of a public entity crime in Florida during the preceding 36 months shall be considered an affiliate.

7. I understand that a "person" as defined in Paragraph 287.133(1)(e), Florida Statutes, means any natural person or entity organized under the laws of any state or of the United States with the legal power to enter into a binding contract and which bids or applies to bid on contracts for the provision of goods or services let by a public entity, or which otherwise transacts or applies to transact business with a public entity. The term "person" includes those officers, directors, executives, partners, shareholders, employees, members, and agents who are active in management of an entity.
8. Based on information and belief, the statement which I have marked below is true in relation to the entity submitting this sworn statement.
(Please indicate which statement applies.)

Neither the entity submitting this sworn statement, nor any officers, directors, executives, partners, shareholders, employees, members, or agents who are active in management of the entity, nor any affiliate of the entity have been charged with and convicted of a public entity crime subsequent to July 1, 1989.

The entity submitting this sworn statement, or one or more of the officers, directors, executives, partners, shareholders, employees, members, or agents who are active in management of the entity, or an affiliate of the entity has been charged with and convicted of a public entity crime subsequent to July 1, 1989, AND **(Please indicate which additional statement applies.)**

There has been a proceeding concerning the conviction before a hearing officer of the State of Florida, Division of Administrative Hearings. The final order entered by the hearing officer did not place the person or affiliate on the convicted vendor list.
(Please attach a copy of the final order.)

The person or affiliate was placed on the convicted vendor list. There has been a subsequent proceeding before a hearing officer of the State of Florida, Division of Administrative Hearings. The final order entered by the hearing officer determined that it was in the public interest to remove the person or affiliate from the convicted vendor list. **(Please attach a copy of the final order.)**

The person or affiliate has not been placed on the convicted vendor list.
(Please describe any action taken by or pending with the Department of General Services.)

Signature: _____



EXHIBIT "D"
SECTION 012

Date: April 22, 2021

STATE OF Florida

COUNTY OF St. Lucie

PERSONALLY APPEARED BEFORE ME, the undersigned authority,

Richard J. Forlifer who, after first being sworn by me, affixed his/her signature in (name of individual signing) the space provided above on this 22nd day of April, 2021.

NOTARY PUBLIC SEAL:



Cynthia Clark Cheatham
NOTARY PUBLIC
STATE OF FLORIDA
Comm# GG331046
Expires 5/6/2023

My commission expires: 05/06/2023

END OF SECTION

CERTIFICATION OF NON-SEGREGATED FACILITIES

The Bidder certifies that he does not maintain or provide for his employees any segregated facilities at any of his establishments, and that he does not permit his employees to perform their services at any location, under his control where segregated facilities are maintained. The Bidder certifies further that he will not maintain or provide for his employees any segregated facilities at any of his establishments, and that he will not permit his employees to perform their services at any location under his control where segregated facilities are maintained. The Bidder agrees that a breach of this certification will be a violation of the Equal Opportunity clause in any contract resulting from acceptance of this Bid. As used in this certification, the term "segregated facilities" means any waiting rooms, work areas, restrooms and washrooms, restaurants, and other eating areas, time clocks, locker rooms, and other storage or dressing areas, parking lots, drinking fountains, recreation or entertainment areas, transportation, and housing facilities provided for employees which are segregated on the basis of race, color, religion, or national origin, because of habit, local custom, or otherwise. The Bidder agrees that (except where he has obtained identical certification from proposed subcontractors for specific time periods) he will obtain identical certifications from proposed subcontractors, exempt from the provisions of the Equal Opportunity clause, and that he will retain such certification in his files.

NOTE: The penalty for making false statements in offers is prescribed in 18 U.S.C. 1001.

DATE: April 22, 2021

Official Address
(Including Zip Code):

3122 N. 25th Street
Ft. Pierce, FL 34946

By: 
Vice President
(Title)

END OF SECTION

TRENCH SAFETY ACT COMPLIANCE STATEMENT

BID NO. 2021-024(REBID)

Instructions:

Chapter 90-96 of the Laws of Florida requires all contractors engaged by the City of Fort Pierce to comply with Occupational Safety and Health Administration Standard 29 C.F.R. s. 1926.650 Subpart P. All prospective contractors are required to sign the compliance statement and provide compliance cost information where indicated below. The costs for complying with the Trench Safety Act must be incorporated into this project's base bid.

Certify this form in the presence of a notary public or other officer authorized to administer oaths.

Certification:

1. I understand that Chapter 90-96 of the Laws of Florida (The Trench Safety Act) requires me to comply with OSHA Standard 29 C.F.R. s. 1926.650 Subpart P. I will comply with The Trench Safety Act and I will design and provide trench safety systems at all trench excavations in excess of five feet in depth for this project.

2. The estimated cost imposed by compliance with The Trench Safety Act will be:

five thousand Dollars
\$5,000.00 (Written)
(Figures)

3. The amount listed above has been included within the Base Bid.

Certified: Dickerson Florida, Inc.
(Company-Contractor)
By: [Signature]
(President's Signature)
Larry T. Dale
(President's Typed or Printed Name)

Notarization:

Sworn to and subscribed before me in St. Lucie County, Florida on the 22nd day of April, 2021.

Notary Public: [Signature] (affix seal)

My Commission Expires: 05/06/2023

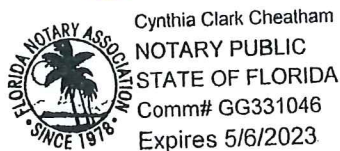

END OF SECTION

DRUG-FREE WORK PLACE FORM

The undersigned vendor in accordance with Florida Statute 287.087 hereby certifies that

Dickerson Florida, Inc.

does:

(Name of Business)

1. Publish a statement notifying employees that the unlawful manufacture, distribution, dispensing, possession, or use of a controlled substance is prohibited in the workplace and specifying the actions that will be taken against employees for violations of such prohibition.
2. Inform employees about the dangers of drug abuse in the workplace, the business's policy of maintaining a drug-free workplace, any available drug counseling, rehabilitation, and employee assistance programs, and the penalties that may be imposed upon employees for drug abuse violations.
3. Give each employee engaged in providing the commodities or contractual services that are proposed a copy of the statement specified in subsection (1).
4. In the statement specified in subsection (1), notify the employees that, as a condition of working on the commodities or contractual services that are under bid, the employee will abide by the terms of the statement and will notify the employer of any conviction of, or plea of guilty or nolo contendere to, any violation of Chapter 893 or of any controlled substance law of the United States or any state, for a violation occurring in the workplace no later than five (5) days after such conviction.
5. Impose a sanction on or require the satisfactory participation in a drug abuse assistance or rehabilitation program if such is available in the employee's community, by any employee who is so convicted.
6. Make a good faith effort to continue to maintain a drug-free workplace thorough implementation of this section.

As the person authorized to sign the statement, I certify that this firm complies fully with the above requirements.



Proposer's Signature

April 22, 2021

Date

END OF SECTION

CONTRACTOR VERIFICATION FORM
FORT PIERCE, FLORIDA
SEALED BID NO. 2021-024(REBID)

**PROJECT TITLE: SOUTH 5TH STREET ROADWAY IMPROVEMENTS
(BOSTON AVENUE TO DELAWARE AVENUE)**

THE FOLLOWING IS TO COMPLETED BY PRIME BIDDER:

Name of Firm Dickerson Florida, Inc.

Corporate Title: Vice President

Address: 3122 N. 25th St.

Ft. Pierce, FL 34946

By: Richard J. Forlifer (Print name) Vice President (Print title)

(Authorized Signature)

Telephone: (772) 429-4444

Fax: (772) 429-4445

State License # CGC060797 (ATTACH COPY)

County License # Business Tax Receipt 1428-602-0028-000/7 (ATTACH COPY)

City License: (ATTACH PROOF OF REGISTRATION WITH THE CITY)

Type of License: Certified General Contractor

Unlimited yes (yes/no)

If "NO", Limited to what trade? _____

END OF SECTION

Ron DeSantis, Governor



Halsey Beshears, Secretary



STATE OF FLORIDA
DEPARTMENT OF BUSINESS AND PROFESSIONAL REGULATION

CONSTRUCTION INDUSTRY LICENSING BOARD

THE GENERAL CONTRACTOR HEREIN IS CERTIFIED UNDER THE
PROVISIONS OF CHAPTER 489, FLORIDA STATUTES



DALE, LARRY THOMAS

DICKERSON FLORIDA INC
3122 N 25 STREET
FT PIERCE FL 34946

LICENSE NUMBER: CGC060797

EXPIRATION DATE: AUGUST 31, 2022

Always verify licenses online at MyFloridaLicense.com



Do not alter this document in any form.

This is your license. It is unlawful for anyone other than the licensee to use this document.

City of Fort Pierce, Florida
100 N. US Highway 1
Fort Pierce, FL 34950
(772) 467-3065

City of Fort Pierce, Florida
Certificate of Competency

GENERAL CONTRACTOR (CERTIFIED)

Control #0036856 License # 21-00017955

Amount Paid: \$25.00 Issued: July 21, 2020

Comp Card Expires: September 30, 2021
State License Expires: CGC060797 08/31/22
Worker's Comp Expires: WC5761375 07/01/21
Liability Ins. Expires: GLO5761374 07/01/21

DICKERSON FLORIDA INC.
DALE, LARRY T.
PO BOX 910
FT PIERCE FL 34954

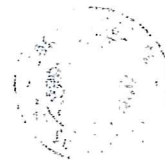

CITY OF FORT PIERCE
*** CUSTOMER RECEIPT ***

Batch ID: ATRUMBLE 7/21/20 01 Receipt no: 22008

| Customer | Location | Type | SvcCd | Description | Amount |
|----------|----------|------|-------|---------------------|---------|
| 2020 | 17955 | DT | | CONTRACTOR-RENEWALS | \$25.00 |

DICKERSON FLORIDA INC.
LICENSE ADDRESS
FT PIERCE, FL 34950

Tender detail
SQ SQUARE TRANS \$25.00
Total tendered: \$25.00
Total payment: \$25.00

Trans date: 7/21/20 Time: 12:50:55

THANK YOU!

200067

DICKERSON FLORIDA INC.
PO BOX 910

FT PIERCE FL 34954

Dickerson Florida, Inc. - References

Greg Vandetta, MPM, PMP

Duke Energy – Carolinas West
Project Manager I – Transmission
(980) 373-1220 Office
Gregory.Vandetta@Duke-Energy.com

Martin County

Don Donaldson, Deputy County Administrator
2401 SE Monterey Road
Stuart, FL 34996
772-288-5503

Florida Department of Transportation

Dan Hiden, P.E. Treasure Coast Operations
3601 Oleander Ave.
Ft. Pierce, FL 34982
(772) 429-4885

St. Lucie County

Kim Graham, P.E.
County Engineer
2300 Virginia Ave.
Ft. Pierce, FL 34982
(772) 462-1712

Kennedy Contractors, Inc.

Daniel Kennedy, P.E.
901 Northpoint Parkway
Suite 200
West Palm Beach, FL 33407
Dan.kennedy@kennedycompanies.com
334-444-2555 Cell

Consor Engineers, LLC

Kelly Cowger, P.E.
3549 SW Corporate Pkwy.
Palm City, FL 34990
772-473-6103
kcowger@consoreng.com

E-VERIFY
FORT PIERCE, FLORIDA

**PROJECT TITLE: SOUTH 5TH STREET ROADWAY
IMPROVEMENTS(BOSTON AVENUE TO
DELAWARE AVENUE)**

Bid No.: 2021-024(REBID)

Project Description: South 5th Street Improvements (Boston Avenue
to Delaware Avenue)

Vendor/Consultant acknowledges and agrees to the following:

1. Vendor/Consultant shall utilize the U.S. Department of Homeland Security's E-Verify system to verify the employment eligibility of all new employees hired by the Vendor/Consultant during the term of the contract; and
2. shall expressly require any subcontractors performing work or providing services pursuant to this contract to likewise utilize the U.S. Department of Homeland Security's E-Verify system to verify the employment eligibility of all new employees hired by the subcontractor during the contract term.

Company/Firm: Dickerson Florida, Inc.

Authorized Signature:  _____

Title: Vice President

Date: April 22, 2021

END OF SECTION

City of Fort Pierce
5th Street Improvements
Bid Due: April 22, 2021

DICKERSON FLORIDA, INC.

EQUIPMENT LIST

1. CAT 336 EXCAVATOR
2. CAT ROLLER
3. CAT 12M MOTORGRADER
4. CAT 938 LOADER
5. CAT 320 ARTICULATING EXCAVATOR
6. CAT 277 SKID STEER
7. FORD BROOM TRACTOR

| PROJECT | Completion Date | Owner | Contact |
|---|------------------------------------|---|--|
| US1 DITCH RESTORATION Restoration of lateral drainage ditches along US-1 (Indian River County) | Complete June-16 | FDOT Contract Amt \$1,156,044 | Josh Baker joshua.baker@dot.state.fl.us (772) 519-8517 |
| FELLSMERE EMERGENCY SPILLWAY 2800 LF emergency spillway along the levee forming the northern border of the Fellsmere Water Mgmt Area allowing water to spill over from the FWMA into the C-54 Canal | Complete June-16 | SIRWMD Contract Amt \$1,491,118 | Ralph Brown rbrown@sjrwmd.com (321) 863-0063 |
| CR 880-20 MI BEND clearing, excavation, embankment and rip-rap slope stabilization | Complete PH I September-16 | Palm Beach County Contract Amt \$862,893 | Steve O'Neil sonel@pbcgov.org (561) 684-4180 |
| CR 880-20 MI BEND clearing, excavation, embankment and rip-rap slope stabilization | Complete PH III September-17 | Palm Beach County Contract Amt \$784,655 | Steve O'Neil sonel@pbcgov.org (561) 684-4180 |
| CR 880-20 MI BEND clearing, excavation, embankment and rip-rap slope stabilization achieved incentive bonus for early completion | Complete PH IV October-18 | Palm Beach County Contract Amt \$647,527 | Steve O'Neil sonel@pbcgov.org (561) 684-4180 |
| VALKARIA AIRPORT RUNWAY 14-32 REHAB | Complete August-18 | Brevard County Contract Amt \$3,596,278 | Steve Borowski steve.borowski@brevardfl.gov |

| PROJECT | Completion Date | Owner | Contact |
|--|-------------------------|--|---|
| MIDWAY ROAD widening excavation, embankment, drainage, concrete, guardrail, signing, pavement markings, signalization, utilities, landscaping & irrigation | Complete June-17 | St. Lucie County Contract Amt \$15,797,303 | Kim Graham, P.E. grahamk@stlucieco.org County Engineer (772) 462-1707 |
| INDRIO ROAD Description: reconstruction of an existing 2-lane roadway as a 4-lane divided urban roadway, connector ramp, intersection improvements, widening, milling, resurfacing, drainage, signing and pavement markings, lighting and bridge replacement | Complete February-19 | FDOT Contract Amt \$23,489,241 | Kelly Cowger, P.E. kcowfer@consoreng.com (772) 473-6103 |
| FPL Miami Quarry Substation Sitework for new substation on 27 acres included construction of access road, removal and disposal of 13,000 truckloads of unsuitable material, hauled in 500,000 tons of embankment, daily onsite environmental monitoring | Complete Mar-19 | DFI as sub to Kennedy Contractors, Owner - FPL Contract Amt \$13,025,915 | Daniel Kennedy, P.E. dan.kennedy@kennedycompanies.com (561) 434-1300 |
| Treasure Coast Int'l Airport Crossfield Taxiway G clearing, excavation, embankment, drainage, paving, taxiway striping, seeding and sod, fence and gates, electrical and lighting | Complete Sep-17 | St. Lucie County Contract Amt \$3,101,567 | Kevin McCauley, P.E. kevin.mccauley@atkinsglobal.com |
| 66th Avenue Roadway Improvements (SR 60 to North of 49th St.) Description: Widening and reconstruction of the roadway to a 4-lane divided roadway including curb and gutter and sidewalks. The existing bridges at (5) intersecting side streets will be removed and replaced. The side streets on the east and west of the intersection approaches will be widened and reconstructed to a three lane roadway section. Also included is storm water drainage improvement, pavement markings, traffic signals and landscape improvements. | Complete June-17 | Indian River County (Owner) Contract Amount: \$20,773, 389 | Rich Szpyrka rszpyrka@iregov.com (772) 226-1221 |
| KINGS HWY & INDRIO RD INTERSECTION IMPROVEMENTS Kings Hwy expanded to 4-lane divided hwy with bicycle lanes and pedestrian facilities. Indrio Rd improvements included dual thru lanes, bicycle lanes and pedestrian facilities. | Complete Dec-19 | St. Lucie County Contract Amt \$17,812,206 | Kim Graham, P.E. grahamk@stlucieco.org County Engineer (772) 462-1707 |

| PROJECT | Completion Date | Owner | Contact |
|--|------------------------|-------------------------------------|---|
| SEBASTIAN AIRPORT TAXIWAY C | Complete January-20 | CITY OF SEBASTIAN \$2,192,481.00 | SCOTT BAKER 772-228-7013 sbaker@cityofsebastian.org |
| INDIAN RIVER SERVICE CENTER - FPL DFI as sub to KAST CONSTRUCTION | Complete April-21 | FPL \$6,376,277.00 | JIM LENT (561) 689-2910 jlent@kastbuild.com |
| FPL GLENDALE-EMERSON | Complete Dec-20 | FPL \$2,556,125 | RAY GARCIA 561-904-3628 Raymond.Garcia@fpl.com |
| AVON PARK AIRPORT REALIGN AND EXTEND TAXIWAY F | COMPLETE Jul-20 | CITY OF AVON PARK \$1,265,218.00 | DANIELLE PHILLIPS 863-452-4409 Interim Airport Mgr d.phillips@avonpark.cc |
| BELLE GLADE SIDEWALKS | COMPLETE Mar-21 | FDOT \$1,840,414.00 | IDO SHIMONY, P.E. 954-579-4892 Eisman & Russo, Inc. ishimony@eismanrusso.com |
| FELLSMERE-GLENDALE | COMPLETE Mar-21 | FPL \$1,511,000.00 | RAY GARCIA 561-904-3628 Raymond.Garcia@fpl.com |



Dickerson Florida, Inc. (DFI) is a subsidiary of Dickerson Group, Inc. (DGI) established in 1947 in Monroe, North Carolina. Dickerson Florida, Inc. has conducted business in Florida since February 1957. We have been incorporated in the State of Florida since March 1982.

Street Address: 3122 North 25th Street, Fort Pierce, FL 34946 No mail receptacle available.
Mailing Address: PO Box 910, Fort Pierce, FL 34954-0910
Phone Number: (772) 429-4444 Fax Number (772) 429-4445
Accounts Payable Contact: Donna Zales, extension 4467 accountspayable@dfifl.com

The officers of the Dickerson Group, Inc and Dickerson Florida, Inc. are prohibited from personally guaranteeing payment on behalf of the corporation.

Larry T. Dale President
Dale J. McTaggart Vice President

Federal ID: 56-1327509 DFI DUNS: 14-481-4100 DGI DUNS: 00-699-7068

Centerstate Bank
2400 SE Monterey Road, Stuart, FL 34996 (772)408-5940
Contact: Tammy Roncaglione, Sr. V.P (772)408-5941 Fax
Contact: Sherry Batchelor- sbatchelor@centerstatebank.com (772)408-5948

Credit References:

Palmdale Oil Company, 1900 Skees Rd, West Palm Beach, FL 33411 (561)229-0362
Contact: Kim Gaylord, Credit Manager - kim@palmdaleoil.com (561)784-0700 Fax

Stewart Materials, 2075 Jupiter Park Dr., Ste 1100, Jupiter, FL 33458 (561)972-4517
Contact: Amanda Stewart – amanda@stewartmaterials.com (772)465-9524 Fax

Kelly Tractor, P.O. Box 210057, Miami, FL 33121 (305) 592-5360
Contact: Ana Blanco, Credit Manager – Ana_Blanco@kellytractor.com (305) 463-6089 Fax

Lake Point Restoration, 12012 South Shore, #107, Wellington, FL 33411 (561)249-3728
Contact: Bonnie Owen, Credit Mgr. bowen@lakepointrestoration.com (561)841-6086 Fax

Jules & Associates, Inc., 515 S. Figueroa St., Ste 1900, Los Angeles, CA 90071 (213) 362-5600 x.206
Contact: Ken Beltran (213) 367-5610

All purchases must be authorized with a purchase order number, signatures must be legible, if not, require name to be printed.



DICKERSON FLORIDA, INC.

BUILT ON SAFETY

COMPANY INTRODUCTION

Dickerson Florida, Inc. was incorporated in 1982 as a wholly owned subsidiary of the Dickerson Group in Monroe, NC. Prior to this, Dickerson Florida, Inc. operated as Dickerson, Inc., a division of the Dickerson Group, which was an outgrowth of a 1936 partnership which progressed to incorporation in 1947, and has operated in Palm Beach County and the Treasure Coast from the same location in Martin County since 1958 until moving to a new office building in St. Lucie County, Florida.

- Dickerson Florida, Inc. "Dickerson" is a General Contractor in **Florida, North Carolina, South Carolina** and **Georgia** and is prequalified by the Florida Department of Transportation for contract work in excess of \$417 million.
- Dickerson performs a wide variety of civil construction services for Federal and State agencies, municipalities, counties, airports, private developers, commercial developments, and retail operations.

Dickerson has operated in numerous capacities including major highway development, bridge construction, mining, as well as development construction for many well-known communities along the southeast coast.

Dickerson provides field staff with extensive experience and training with many employees possessing ATSSA worksite traffic safety, OSHA certifications, NPDES Storm water inspection, and basic first aid training.

CORE VALUES

- *Safety* – Dickerson is committed to a safe and effective work place, tailored to a company culture of best safety management practices and zero tolerance; providing our clients and partners the work environment for a successful project.
- *Partnership* – Our core belief of partnering, interdependence, continuing team concept and empowerment of the project team is key to our long term working relationships.

- *Quality* – Dickerson maintains a reputation among all its partners and clients for the highest and best practices of quality consistent with a successful on time delivery process.

Our management, experience, skill, diversification and equipment combine to provide our clients the maximum project advantage.

DFI has an EMR of 1.0 and employs a "Safety Incentive Program" that rewards employees for their conscientious efforts to work safely.



DICKERSON FLORIDA, INC.
BUILT ON SAFETY

KEY STAFF

Larry Dale **President**

Mr. Dale's experience in all areas of civil site and roadway construction serves Dickerson well from a project's beginning to final completion. His open communication with the project management team keeps him informed and updated on a regular basis. He is actively involved in a project from start to finish and successfully leads the team to complete on time and within budget.

Mr. Dale has successfully overseen several energy sector projects including the first Independent Spent Fuel Storage Installation project for FPL in Florida. His professionalism and expertise is respected within the industry. He encourages an attitude of excellence and that reflects in the projects undertaken by Dickerson.

Richard J. Forlifer **Vice President/Chief Estimator**

Mr. Forlifer's extensive estimating experience combined with his project management skills allows him to analyze each project during the bidding process to offer a comprehensive proposal with the best opportunity for a successful outcome. His careful and thorough approach to each bid and his familiarity with all aspects of civil construction are a true benefit to the Dickerson team.

Ray Sheltra **Vice President/General Superintendent**

Mr. Sheltra brings years of experience as a business owner as well as extensive project management experience to the Dickerson Florida team. He oversees all projects under contract, communicating directly with management concerning equipment requirements, personnel and scheduling needs to assure each job has the resources necessary to provide a quality project upon completion.

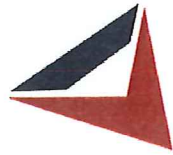

DICKERSON FLORIDA, INC.

BUILT ON SAFETY

Michael Bryant
Vice President/Senior Project Manager

Mr. Bryant's management experience at diversified facilities has given him a unique perspective which made him a valuable addition to the Dickerson team. His familiarity with the various procedures at nuclear facilities with an emphasis on safety affords Dickerson a high level of confidence as he currently manages a substation project in North Carolina and recently completed a nuclear site project in Crystal River, Florida and another substation project in Miami.

Dale McTaggart
Vice President/Treasurer/Controller

Mr. McTaggart has extensive accounting experience including cash flow management, managing road construction project revenue and cost; asphalt plant and quarry production, inventory, fixed assets, balance sheet accounts, audits, etc. with a background in accounting management and company organization. In addition, he offers exceptional communication, motivational and supervisory skills. His exemplary supervisory style combined with his dedication to the company has enabled him to seamlessly advance into upper management.

John Pluswick
Project Manager

Extensive project management experience and effective communication and problem solving skills allows Mr. Pluswick to confidently coordinate between coworkers, clients, government agencies, salespeople, subcontractors, inspectors and engineers. His background in commercial, residential, and public projects, his strong grading and earthwork balancing skills along with his abilities in storm drain, culvert and pre-cast structure design allows him to effectively manage a wide variety of projects.



DICKERSON FLORIDA, INC.

BUILT ON SAFETY

Marvin Madrigal
Estimator/Project Manager

Mr. Madrigal has over 25 years of experience in the construction estimating field. His ability to move from estimator to Project Manager highlights his leadership and organizational qualities. In addition to estimating, his recent accomplishments include assisting with project management on the FPL-Miami Quarry Substation project and providing oversight on our Lake Wales Airport project, Polk County.

Jeff Ehrhard
Project Manager

Jeff Ehrhard serves as project manager on various Dickerson jobsites. He has a comprehensive safety background with strong knowledge of OSHA, MSHA and DOT safety regulations, as well as experience with stormwater/pollution regulations, regulatory interface and defense. He continues to provide support to our Safety and Risk Management Department.