

<b>DELIVER TO:</b> City of Fort Pierce, Purchasing Division Room 101 100 North U.S. #1 Fort Pierce, FL 34950  <b>MAIL TO:</b> City of Fort Pierce Purchasing Division, Room 101 P.O. Box 1480 Fort Pierce, FL 34954-1480	<p style="text-align: center;"><b>CITY OF FORT PIERCE</b></p>  <p style="text-align: center;"><b>INVITATION TO BID and BIDDER ACKNOWLEDGMENT</b></p>
Bid Writer: Latonya Hubbard, 772-467-3102	Bid No: 2021-023
Mandatory Site-Visit: <p style="text-align: center;">N/A</p>	Bid Title: DISPOSITION OF SURPLUS PROPERTIES
Mandatory Site-Visit Location: <p style="text-align: center;">N/A</p>	Bid Opening Location: City of Ft. Pierce Purchasing Division Room 101 100 North U.S. #1, 1st Floor Ft. Pierce, Florida 34950
Bid Due Date & Time: <p style="text-align: center;">3:00 PM, THURSDAY, APRIL 15, 2021</p>	If you need any reasonable accommodation for any type of disability in order to participate in this procurement, please contact this department as soon as possible.
Bidder Name: <p style="text-align: center;">Progression Properties LLC</p> <hr/> Mailing Address: <p style="text-align: center;">2415 Lake Ibis Lane sw</p> <hr/> <hr/> <hr/>	<i>I hereby certify that this bid is made without prior understanding, agreement, or connection with any corporation, firm, or person submitting a bid for the same materials, supplies or equipment, and is in all respects fair and without collusion or fraud. I agree to abide by all conditions of this bid and certify that I am authorized to sign this bid for the bidder.</i>   X _____ Authorized Signature (Manual)
City, State, Zip Code: Vero Beach, Florida 32962	Typed or Printed Name: Pamela E. Carithers
Type of Entity (Select one): Corporation _____ Partnership _____ Proprietorship <u>  X  </u>	Title: <p style="text-align: center;">Managing Partner</p>
Incorporated in the State of: Nevada Year: 2016	Delivery in _____ days, ARO
Phone Number: 407-257-1678	Payment Terms: Net 30 Days
Fax Number: 772-257-6908	FEIN or SS Number: 81-4752136
E-Mail Address:	Local Business: <u>  X  </u> <u>  Y  </u> <u>  N  </u> MWBE: <u>  Y  </u> <u>  N  </u>
Bid Security is attached, when required, in the amount of \$ <u>          NOT APPLICABLE          </u> <p style="text-align: center;">F.O.B. DESTINATION</p>	If returning as a "No Bid" state reason:
<b>THIS PAGE MUST BE COMPLETED AND RETURNED WITH YOUR BID</b>	



City of Fort Pierce
OFFER TO PURCHASE/BID RESPONSE FORM
DISPOSITION OF SURPLUS PROPERTIES
Bid No. 2021-023

Date: April 14, 2021

I/we propose to purchase property located at: (Check the property proposing to purchase. If proposing to purchase multiple properties, complete a separate Offer to Purchase/Bid Response Form for each).

- X 321 N. 13th Street, A/B
X 1409 Avenue J
X 2002 Avenue M
X Dundas Court - Parcel ID# 2403-711-0001-000-3
X Dundas Court - Parcel ID# 2410-604-0156-000-7

PROPOSED SUBMITTED BY:

Legal Name (s): Progression Properties LLC
Address: 2415 Lake Ibis Lane sw Vero Beach, Florida 32962
Day-time Phone Number: 407-257-1678 Mobile Number: 407-257-1678
Email: progressionpropertiesllc@gmail.com

INTENDED USE

I/we propose to use the property for:

X Residential Commercial Both Commercial & Residential

If residential or combination; will the residential unit be your primary residence? Yes X No

If not above, what do you intend to develop the property for: Rental X Resale Other

If other, please explain

IMPROVEMENTS

In consideration for the City of Fort Pierce transferring the property, I/we propose to make the following improvements. (Provide a detailed description of the project outlining intended use of the property with a description of rehabilitation, renovation, modifications, or new construction):

The proposed use of the land is for new construction of a single-family home, 3 bedroom, 2 bath, one car garage with two parking spaces. The building will be of concrete block structure. Landscape will be consistent with the City's proposed vision of redevelopment of the area. It is our goal to provide access to entry level homes that are workable and affordable to the community while maintaining the historical integrity of the area.

(Attach pages as needed)

Total value of all proposed improvements to the property: \$ 114,000.00

**BID AMOUNT**

I/we offer to pay the City of Fort Pierce \$ 4,600.00 for the property.

**REQUIRED INFORMATION**

To be considered complete, the following documentation/information must be submitted. Please indicated if the information is included with this submittal. Only complete proposals will be considered.

- Yes  No **Large, clear detailed drawings** of the front, side and rear elevations for new construction. For rehab projects, large, clear, detailed photographs of the front, side and rear elevations with changes indicated.
- Yes  No **Cost Estimate** improvements by a knowledgeable & experienced third-party professional, e.g. an engineer, architect or experienced contractor. Complex projects should be broken down by cost centers.
- Yes  No **Proof of financial ability** to complete the project. Proof may be letter of credit, loan commitment, or proof on cash on hand, or some other form as approved by the City. Grants or special financing must be listed but cannot be counted as proof as financial ability unless a copy of the award notice or other acceptable guarantee is provided.
- Yes  No **Description of landscape improvements:** plan drawings may be necessary.
- Yes  No **Proof of financial ability** to complete the project. Proof may be letter of credit, loan commitment, or proof on cash on hand, or some other form as approved by the City. Grants or special financing must be listed but cannot be counted as proof as financial ability unless a copy of the award notice or other acceptable guarantee is provided.
- Yes  No **Project timeline**

**PROOF OF FINANCIAL ABILITY**

Proof of financial ability to complete the project in an amount matching the estimated costs. The Bidder shall include proof may be letter of credit, loan commitment, or proof on cash on hand, or some other form as approved by the City.

**BIDDER'S ACKNOWLEDGEMENT**

The Bidder understands that information contained in this Bid Form is to be relied upon by the City of Fort Pierce in awarding the specified Bid, and such information is warranted by the Bidder to be true. Bidder understands that the City/Agency has the right to verify the information submitted and to seek any additional information relating to the Bidder's qualifications. The discovery of any misstatement, which, in the sole opinion of the City/Agency, materially affects the Bidder's qualifications to perform, shall cause the rejection of the Bid, and if after the award, to cancel the sale of agreement. The Bidder acknowledges that the deed will include a clause stating that the property reverts to the City of Fort Pierce if substantial compliance with the provisions of the proposal is not met according to an agreed upon timeline.

  
Bidder of Authorized Representative

Pamela E. Carithers  
Typed Name  
April 14, 2021  
Date



## Progression Properties, LLC

*Progressive Real Estate Development Co.*  
2415 Lake Ibis Lane sw, Vero Beach, FL 32962  
*Phone:* 407-257-1678; *Fax:* 772-257-6908  
*Email:* [progressionpropertiesllc@gmail.com](mailto:progressionpropertiesllc@gmail.com)  
[www.progressionproperties.net](http://www.progressionproperties.net)



4/15/2021

City of Fort Pierce  
100 N. US Highway 1  
Fort Pierce, Florida 34950

Dear Selection Committee,

I am pleased to present this proposal for the purchase of the property located at Dundas Court Parcel ID #2410-604-0156-000-7, Fort Pierce, Florida. I am very familiar with the location of this property and the intimately knowledgeable of the City's proposed revitalization plans for the Lincoln Park community. I believe the proposed development plans presented in this offer for purchase further the mission of the City's revitalization vision for Lincoln Park and addresses the need of the community for affordable housing.

I am a veteran woman owned minority business since 2016. I am uniquely in tune with the cultural and heritage of Lincoln Park and view the development and workable housing infill through the lens of the community. The current entry-level housing market is in need of single-family homes that will complement the existing infrastructure, in line with future growth and development for the surrounding area while increasing property values.

The current trend in building materials and supplies has increased on average some 35% since the onset of the pandemic. This price cycle will run its course as production of materials resumes and transportation of these materials began to meet demand as the nation moves to acceptable standards of normal commerce. By the end of the year, supply will catch up with the market and costs will return to normal pricing. This will be timely for our project as permits will be obtained and land clearing will take place.

Our team is excited about the opportunity to build homes for working families to make memories and support the local economy at the same time.

I look forward to presenting our vision to your committee.

Sincerely,

A handwritten signature in blue ink, appearing to read "P. Carithers", is written over the typed name and title.

Pamela Carithers  
Managing Partner

### ***Intended Use of Property***

The intended use of the subject property is to construct a single family 3 bedroom 2 bath one car garage with two parking spaces. The proposed construction will be consistent with the existing Oaks at Moore's Creek subdivision homes. It is our goal to provide access to entry level homes that are workable and affordable to the community while maintaining the historical integrity of the area. This intended use of the property will improve the availability of affordable housing and home ownership. The intended use will create equity in the neighborhood and support various uses associated with the neighboring redevelopment plan of the City of Fort Pierce.

### ***Minority Participation and Outreach Plan***

Progression Properties is a Woman Owned Minority Business Enterprise located in Vero Beach, Florida. Our policy is to make a concerted effort to contract with minority and women owned businesses in Fort Pierce and St. Lucie County. The local projects have been contracted with the same General Contractor, which is a minority; the Electrical, Plumbing, A/C subcontractors are all minorities; and the crews consists of members of the minority group. This team is the same team that moves from one house to the next for all local projects. This model ensures a consistent, professional work product and contributes to the local economy. Our outreach program is to continue to contract with minority vendors in the Fort Pierce and St. Lucie County area in every phase of the project. This approach bridges the generational investment in the local workforce and levels the playing field in the contracts awarded to minority/women owned business enterprises (M/WBE).

### ***Proposed Commitment Date***

The proposed commencing date is within six months after the sale of the property to develop a full set of plans and apply for permits. Upon approval of permits, we will break ground and commence to land clearing and building the single-family home. **Anticipated project completion 18-24 months.**

### ***Value of Improvements:***

Total cost of construction is \$114,000.00. This figure is based on contractor grade materials and supplies and estimated at labor for a rate of \$95.00 per square foot for a 1,200 square foot single-family home. Landscape improvements will be living trees, and shrubs planted for the purpose of enhancing the aesthetic value of the property. ***See attachment A.***

### ***Proof of Financial Ability***

Bader's Financial Center, 359 Lanternback Island Drive, Satellite Beach, FL has provided a proof of funds by an approval letter. ***See attached as attachment B.***

## **Summary of Experience:**

### ***Developer***

Progression Properties LLC, is a real estate investment firm specializing in the acquisition of properties both residential and commercial at a discount since 2016. Pamela Carithers, managing partner, holds an MBA in Marketing and a B.S. in Computer Information Systems. She has more than 25 years of corporate; architectural, engineering and construction; nonprofit and real estate investing experience.

Progression Properties portfolio of properties includes six active properties and two more currently under contract. Of the six properties, one has been renovated/updated; two currently being renovated; one is being prepared for permits; the other two are scheduled for renovation by summer. Progression Properties owns four properties in Fort Pierce, one multi-family and three single family residences. The property in Boynton Beach will be sold upon completion of renovations. The two properties currently under contract are single family residences and will be renovated/updated by the conclusion of the summer and held for rental properties. *See Attachment C.*

### ***Contractor***

Andros Construction and Andros Roofing a certified City of Fort Pierce contractor, is a general contractor and roofing contractor with more than 18 years of experience in the construction. Andros Construction specializes in commercial and residential roofing and foundations. The company started in 2000. And while they perform all types of building structural projects, they specialize in both roofing and foundations, projects requiring all phases of low-slope roofing, architectural sheet metal, and specialized steep slope applications. They offer help, education and advise to their customers when their customers are making decisions about material and specification choices.

We have 18 years of experience in the roofing industry and 18 years experience in foundation work. They have a team of hard-working professionals who bring skill and "attention to detail," to every project. In 2018, they opened up our larger office on Frist Blvd in Fort Pierce to meet the rising demand for qualified roofers in this area. Their sales have increased each year in business, and have completed projects of all sizes.

Andros construction has established a reputation as one of St. Lucie County's leading roofing contractors. We strive to consistently deliver high-end results at an affordable price. Our customers trust us to protect their families and investments with quality craftsmanship, and courteous, reliable service. A copy of the license and liability insurance is included as *Attachment D.*

# ATTACHMENTS

**ATTACHMENT A  
VALUE OF IMPROVEMENTS/COSTS**

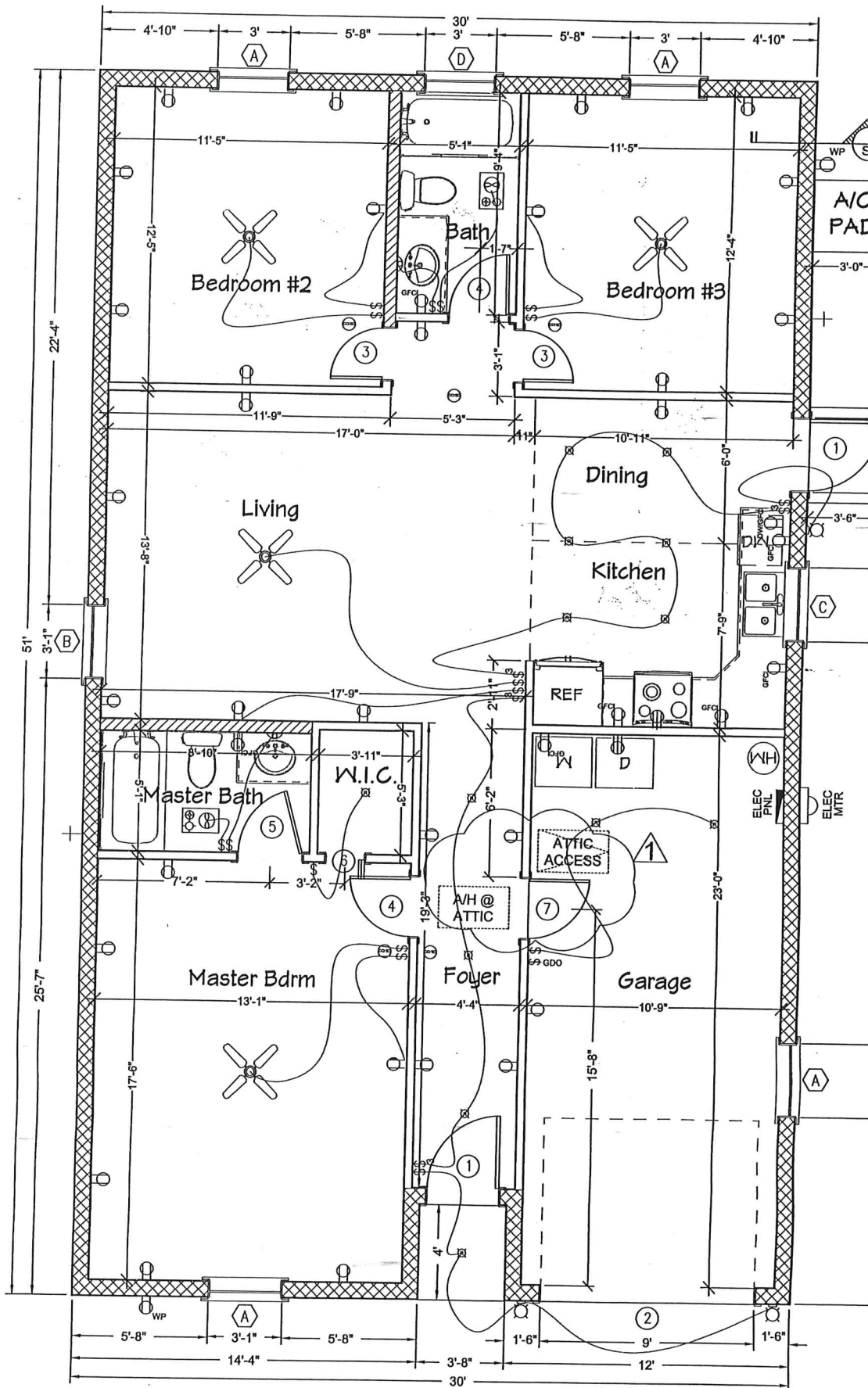











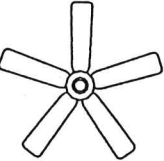





# FLOOR PLAN

SCALE: 1/4" = 1'-0"

-  EXTERIOR 8" CMU WALLS
-  INTERIOR 6" FRAME WALLS
-  INTERIOR 4" FRAME WALLS

NOTE: AIR HANDLER MUST HAVE A SECONDARY D WITH AN AUTOMATIC SHUTOFF FOR OVERF

### ELECTRICAL LEGEND

	CEILING FAN W/LIGHT FIXTURE		ELECTRICAL PANEL
	CEILING MOUNTED RECESSED LIGHT		ELECTRICAL METER
	WALL MOUNTED SCONCE		HOSE BIB
	CEILING MOUNTED EXHAUST FAN/LIGHT COMBO		WIRE INDICATION
	LIGHT SWITCH		110 V. RECEPTACLE
	3-WAY LIGHT SWITCH		SWITCHED RECEPTACLE
	GARAGE DOOR OPENER SWITCH		GROUND FAULT INTERRUPTER RECEPTACLE
			WEATHER PROOF/GFI RECEPTACLE
			COMBO CARBON MONOXIDE /SMOKE DETECTOR

1.5 IN MIN SIZE CONDUIT  
2/0 CU UNDERGROUND COND  
4 CU NEUTRAL (MIN)

GROUNDING ELECTRODE SHALL COMPLY

CONDUCTOR:

5/8" X 10' CU. CL

GROUND TO WATER PIPE

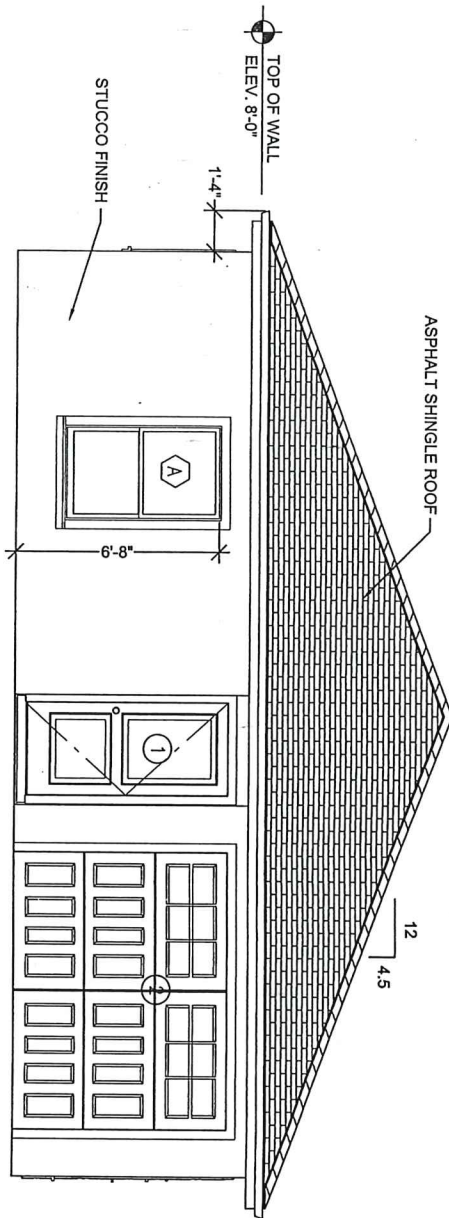

**FRONT ELEVATION**

SCALE: 1/4" = 1'-0"

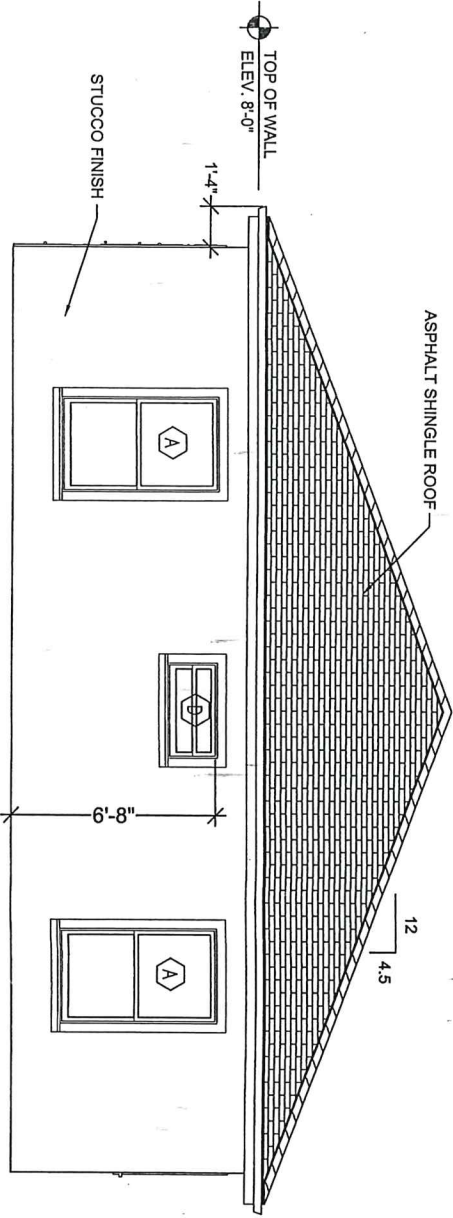

**REAR ELEVATION**

SCALE: 1/4" = 1'-0"

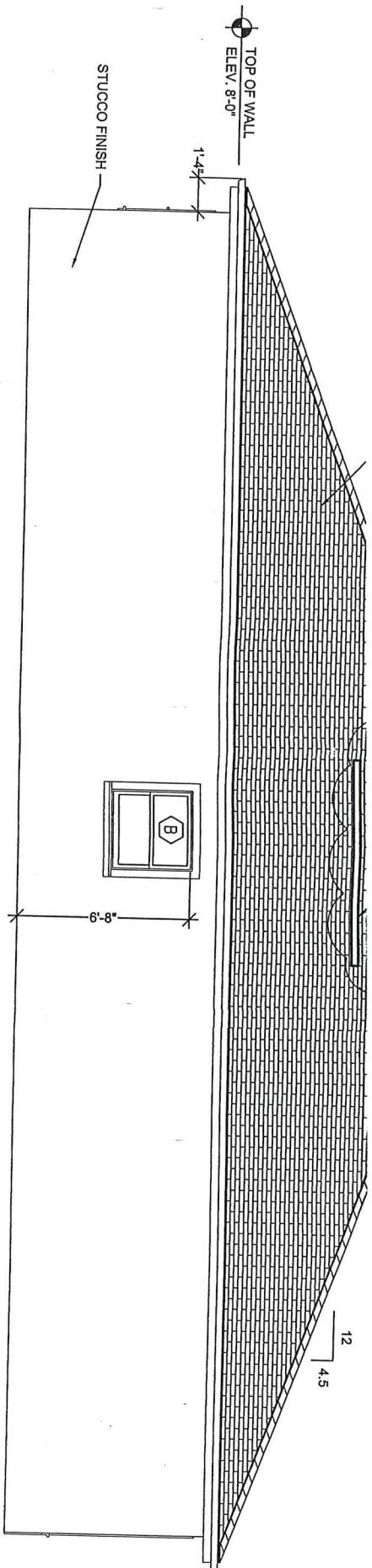

LEFT SIDE ELEVATION

SCALE: 1/4" = 1'-0"

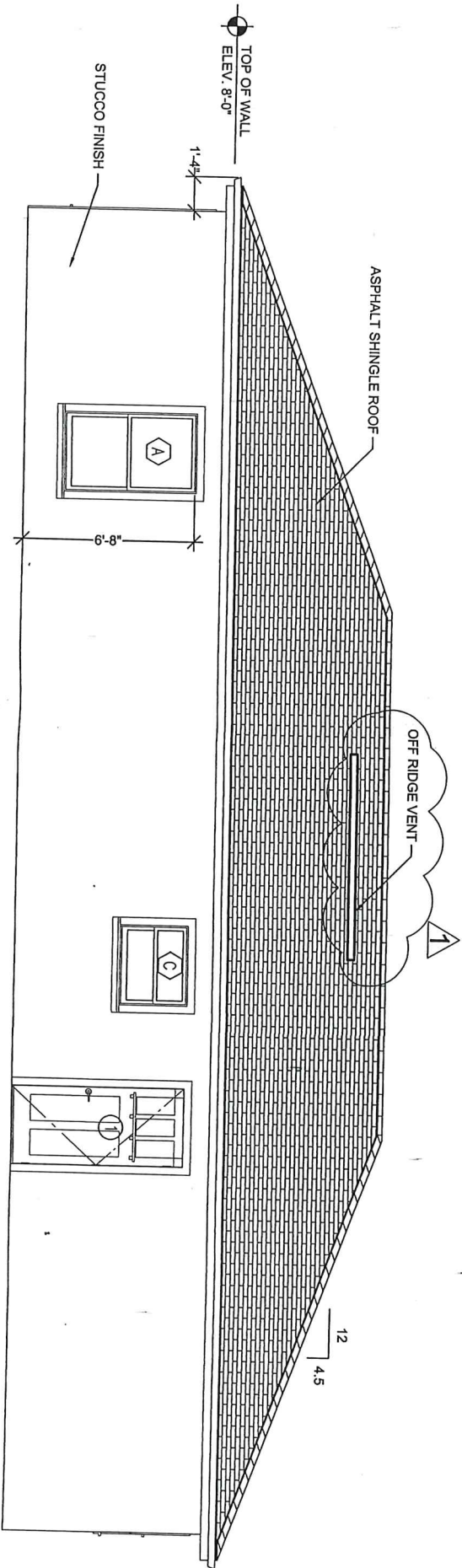

RIGHT SIDE ELEVATION

SCALE: 1/4" = 1'-0"

**ATTACHMENT B  
PROOF OF FINANCIAL ABILITY**

---

---

## BADER'S FINANCIAL CENTER INC.

359 Lanternback Island Drive, Satellite Beach, Fl. 32937  
305-310-1018 baderfinancial@gmail.com

April 15<sup>th</sup> 2021

Buyer: The Dundas Court Land Trust, Common Wealth Trust Services,  
LLC, Andrea Hosch, Esq. as Trustee and Progression Properties, Beneficiary  
(Andrea Hosch, Esq. (407) 755-1010, 122 E. Lake Avenue, Longwood FL 32750)

Subject: \$ 4,200.00 and The Purchase of:

Property: Dundas Court, Fort Pierce, Fl. 34950

Legal description: Parcel ID # 2410-604-0156-000-7 Legal Description: BEN J HOGG'S ADDN BLK J  
LOT 5 – LESS W 40 FT – (MAP 24/10D) (OR 2990-2394)

Seller: Fort Pierce Redevelopment Agency 100 N. US Highway 1, Ft. Pierce, Fl. 34950

To Whom It May Concern: (City of Fort Pierce – 100 N. US Hwy 1, Ft. Pierce, Fl.31950,

This is to confirm the above borrower has been pre-qualified and approved by our Private Lending Company for a First Mortgage in an amount sufficient to purchase the above mentioned property.

This letter is issued on their behalf after a thorough analyses of their credit, income, savings and the required cash to close.

We have also received all documents as requested and in a timely manner.

Please feel free to call me if you have any questions whatsoever.

Yours truly,

*Omer S. Bader* (Signature on file as of 4/15/2021)

President NMLS 393590

Bader's Financial Center Inc.

prequael 13<sup>th</sup> St.docx

**ATTACHMENT C**  
**PHOTOS OF PAST PROJECTS (PROGRESSION PROPERTIES)**

1908 Avenue G, Fort Pierce, FL

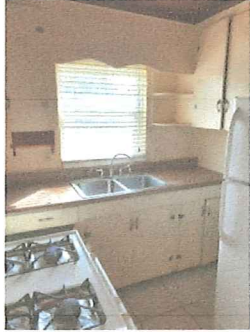

1902 N. 16<sup>th</sup> Street, Fort Pierce, FL

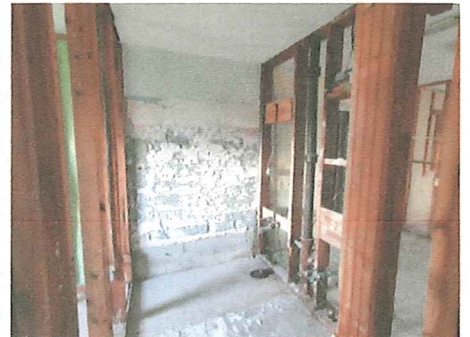

615 Chelsea Drive, Jackson, MS



**ATTACHMENT D  
CONTRACTORS LICENSE & INSURANCE**

**Licensee Details**

**Licensee Information**

Name: **CONSTANT, LLOYD MITCHELL (Primary Name)**  
**ANDROS ROOFING\*CONSTRUCTION LLC (DBA Name)**

Main Address: **2706 ATLANTIC AVE**  
**FORT PIERCE Florida 34947**

County: **ST. LUCIE**

License Mailing: **2706 ATLANTIC AV**  
**FORT PIERCE FL 34947**

County: **ST. LUCIE**

LicenseLocation:

**License Information**

License Type: **Certified General Contractor**

Rank: **Cert General**

License Number: **CGC1516095**

Status: **Current,Active**

Licensure Date: **09/08/2008**

Expires: **08/31/2022**

**Special Qualifications**      **Qualification Effective**  
**Construction Business**      **09/08/2008**

**Alternate Names**

**[View Related License Information](#)**

**[View License Complaint](#)**

.....  
**[2601 Blair Stone Road, Tallahassee FL 32399](#)** :: Email: **[Customer Contact Center](#)** :: Customer Contact Center: 850.487.1395

The State of Florida is an AA/EEO employer. **[Copyright 2007-2010 State of Florida, Privacy Statement](#)**

Under Florida law, email addresses are public records. If you do not want your email address released in response to a public-records request, do not send electronic mail to this entity. Instead, contact the office by phone or by traditional mail. If you have any questions, please contact 850.487.1395. \*Pursuant to Section 455.275(1), Florida Statutes, effective October 1, 2012, licensees licensed under Chapter 455, F.S. must provide the Department with an email address if they have one. The emails provided may be used for official communication with the licensee. However email addresses are public record. If you do not wish to supply a personal address, please provide the Department with an email address which can be made available to the public.

**Licensee Details**

**Licensee Information**

Name: **CONSTANT, LLOYD MITCHELL (Primary Name)**  
**ANDROS ROOFING\*CONSTRUCTION LLC (DBA Name)**

Main Address: **2706 ATLANTIC AVE**  
**FORT PIERCE Florida 34947**

County: **ST. LUCIE**

License Mailing:

LicenseLocation:

**License Information**

License Type: **Certified Roofing Contractor**

Rank: **Cert Roofing**

License Number: **CCC1327225**

Status: **Current,Active**

Licensure Date: **03/28/2006**

Expires: **08/31/2022**

**Special Qualifications**      **Qualification Effective**  
**Construction Business**      **03/28/2006**

**Alternate Names**

[View Related License Information](#)

[View License Complaint](#)

.....  
**2601 Blair Stone Road, Tallahassee FL 32399** :: Email: [Customer Contact Center](#) :: Customer Contact Center: 850.487.1395

The State of Florida is an AA/EEO employer. [Copyright 2007-2010 State of Florida. Privacy Statement](#)

Under Florida law, email addresses are public records. If you do not want your email address released in response to a public-records request, do not send electronic mail to this entity. Instead, contact the office by phone or by traditional mail. If you have any questions, please contact 850.487.1395.  
 \*Pursuant to Section 455.275(1), Florida Statutes, effective October 1, 2012, licensees licensed under Chapter 455, F.S. must provide the Department with an email address if they have one. The emails provided may be used for official communication with the licensee. However email addresses are public record. If you do not wish to supply a personal address, please provide the Department with an email address which can be made available to the public.

**Licensee Details**

This is a business tracking record only.  
[Click here for information on how to verify that this business is properly licensed.](#)

**Licensee Information**

Name: **ANDROS ROOFING\*CONSTRUCTION LLC (Primary Name)**  
Main Address: **2706 ATLANTIC AVE  
FORT PIERCE Florida 34947**  
County: **ST. LUCIE**  
License Mailing:  
LicenseLocation:

**License Information**

License Type: **Construction Business Information**  
Rank: **Business Info**  
License Number:  
Status: **Current**  
Licensure Date: **03/28/2006**  
Expires:

**Special Qualifications**      **Qualification Effective**

**Alternate Names**

[View Related License Information](#)

[View License Complaint](#)

\*\*\*\*\*  
[2601 Blair Stone Road, Tallahassee FL 32399](#) :: Email: [Customer Contact Center](#) :: Customer Contact Center: 850.487.1395

The State of Florida is an AA/EEO employer. [Copyright 2007-2010 State of Florida, Privacy Statement](#)

Under Florida law, email addresses are public records. If you do not want your email address released in response to a public-records request, do not send electronic mail to this entity. Instead, contact the office by phone or by traditional mail. If you have any questions, please contact 850.487.1395.  
\*Pursuant to Section 455.275(1), Florida Statutes, effective October 1, 2012, licensees licensed under Chapter 455, F.S. must provide the Department with an email address if they have one. The emails provided may be used for official communication with the licensee. However email addresses are public record. If you do not wish to supply a personal address, please provide the Department with an email address which can be made available to the public.



# CERTIFICATE OF LIABILITY INSURANCE

DATE (MM/DD/YYYY)  
12/17/2020

THIS CERTIFICATE IS ISSUED AS A MATTER OF INFORMATION ONLY AND CONFERS NO RIGHTS UPON THE CERTIFICATE HOLDER. THIS CERTIFICATE DOES NOT AFFIRMATIVELY OR NEGATIVELY AMEND, EXTEND OR ALTER THE COVERAGE AFFORDED BY THE POLICIES BELOW. THIS CERTIFICATE OF INSURANCE DOES NOT CONSTITUTE A CONTRACT BETWEEN THE ISSUING INSURER(S), AUTHORIZED REPRESENTATIVE OR PRODUCER, AND THE CERTIFICATE HOLDER.

**IMPORTANT:** If the certificate holder is an ADDITIONAL INSURED, the policy(ies) must have ADDITIONAL INSURED provisions or be endorsed. If SUBROGATION IS WAIVED, subject to the terms and conditions of the policy, certain policies may require an endorsement. A statement on this certificate does not confer rights to the certificate holder in lieu of such endorsement(s).

<b>PRODUCER</b> <b>IMPACT INSURANCE SERVICES LLC</b> 18064 SW 33 Court Miramar, FL 33029		<b>CONTACT NAME:</b> PAULETTE BROWN <b>PHONE (A/C, No, Ext):</b> (954)885-3884 <b>FAX (A/C, No):</b> (954)885-3885 <b>E-MAIL ADDRESS:</b> impactserv@msn.com	
<b>INSURED</b> <b>ANDROS ROOFING CONSTRUCTION LLC</b> 2706 ATLANTIC AVENUE FORT PIERCE, FL 34947		<b>INSURER(S) AFFORDING COVERAGE</b> <b>NAIC #</b>	
		<b>INSURER A:</b> NAUTILUS INSURANCE COMPANY	
		<b>INSURER B:</b>	
		<b>INSURER C:</b>	
		<b>INSURER D:</b>	
		<b>INSURER E:</b>	
		<b>INSURER F:</b>	

**COVERAGES**      **CERTIFICATE NUMBER:**      **REVISION NUMBER:**

THIS IS TO CERTIFY THAT THE POLICIES OF INSURANCE LISTED BELOW HAVE BEEN ISSUED TO THE INSURED NAMED ABOVE FOR THE POLICY PERIOD INDICATED. NOTWITHSTANDING ANY REQUIREMENT, TERM OR CONDITION OF ANY CONTRACT OR OTHER DOCUMENT WITH RESPECT TO WHICH THIS CERTIFICATE MAY BE ISSUED OR MAY PERTAIN, THE INSURANCE AFFORDED BY THE POLICIES DESCRIBED HEREIN IS SUBJECT TO ALL THE TERMS, EXCLUSIONS AND CONDITIONS OF SUCH POLICIES. LIMITS SHOWN MAY HAVE BEEN REDUCED BY PAID CLAIMS.

INSR LTR	TYPE OF INSURANCE	ADDL SUBR INSD WVD	POLICY NUMBER	POLICY EFF (MM/DD/YYYY)	POLICY EXP (MM/DD/YYYY)	LIMITS	
A	<input checked="" type="checkbox"/> COMMERCIAL GENERAL LIABILITY		NN1181292	10/10/2020	10/10/2021	EACH OCCURRENCE \$ <b>1,000,000</b>	
	<input type="checkbox"/> CLAIMS-MADE <input checked="" type="checkbox"/> OCCUR					DAMAGE TO RENTED PREMISES (Ea occurrence) \$ <b>100,000</b>	
	GEN'L AGGREGATE LIMIT APPLIES PER:						MED EXP (Any one person) \$ <b>5,000</b>
	<input checked="" type="checkbox"/> POLICY <input type="checkbox"/> PRO-JECT <input type="checkbox"/> LOC					PERSONAL & ADV INJURY \$ <b>1,000,000</b>	
	OTHER:					GENERAL AGGREGATE \$ <b>2,000,000</b>	
						PRODUCTS - COM/OP AGG \$ <b>2,000,000</b>	
	<b>AUTOMOBILE LIABILITY</b>					COMBINED SINGLE LIMIT (Ea accident) \$	
	<input type="checkbox"/> ANY AUTO					BODILY INJURY (Per person) \$	
	<input type="checkbox"/> OWNED AUTOS ONLY	<input type="checkbox"/> SCHEDULED AUTOS				BODILY INJURY (Per accident) \$	
	<input type="checkbox"/> HIRED AUTOS ONLY	<input type="checkbox"/> NON-OWNED AUTOS ONLY				PROPERTY DAMAGE (Per accident) \$	
						\$	
	<b>UMBRELLA LIAB</b>	<input type="checkbox"/> OCCUR				EACH OCCURRENCE \$	
	<b>EXCESS LIAB</b>	<input type="checkbox"/> CLAIMS-MADE				AGGREGATE \$	
	DED	RETENTION \$				\$	
	<b>WORKERS COMPENSATION AND EMPLOYERS' LIABILITY</b>					PER STATUTE      OTH-ER	
	ANY PROPRIETOR/PARTNER/EXECUTIVE OFFICER/MEMBER EXCLUDED? (Mandatory in NH)	<input type="checkbox"/> Y/N	N/A			E.L. EACH ACCIDENT \$	
	If yes, describe under DESCRIPTION OF OPERATIONS below					E.L. DISEASE - EA EMPLOYEE \$	
						E.L. DISEASE - POLICY LIMIT \$	

**DESCRIPTION OF OPERATIONS / LOCATIONS / VEHICLES (ACORD 101, Additional Remarks Schedule, may be attached if more space is required)**

**GENERAL CONTRACTOR - ROOFING CONSTRUCTION**

<b>CERTIFICATE HOLDER</b> CITY OF PORT ST LUCIE BUILDING DEPT 121 SW PORT ST LUCIE BLVD. BUILDING B PORT ST LUCIE, FL 34984	<b>CANCELLATION</b> SHOULD ANY OF THE ABOVE DESCRIBED POLICIES BE CANCELLED BEFORE THE EXPIRATION DATE THEREOF, NOTICE WILL BE DELIVERED IN ACCORDANCE WITH THE POLICY PROVISIONS. AUTHORIZED REPRESENTATIVE 
--	---

**ATTACHMENT E  
PROJECT SCHEDULE/TIMELINE**

**ATTACHMENT F**  
**ADDITIONAL INFORMATION**