

STATE OF FLORIDA DEPARTMENT OF TRANSPORTATION
COMMUNITY AESTHETIC FEATURE AGREEMENT

State Road/Local Road _____ Section No. _____ CAFA No. _____

This Community Aesthetic Feature Agreement (“Agreement”) is entered into this _____ day of _____, between the State of Florida, Department of Transportation (“Department”) and The Fort Pierce Redevelopment Agency (“Agency”). The Department and the Agency are sometimes referred to in this Agreement as a “Party” and collectively as the “Parties.”

RECITALS

- A. The Agency has requested permission from the Department to install a [**CHOOSE ONE:** Public Art, Local Identification Marker] community aesthetic feature on that certain right-of-way owned by the Department which is located on State Road/Local Road Varies, see Exhibit "A" at MP _____ in St. Lucie County, Florida (“Project”).
- B. The Department agrees that transportation facilities enhanced by community aesthetic features can benefit the public, result in positive economic development, and increase tourism both locally and throughout Florida.
- C. The Parties agree to the installation and maintenance of the Project, subject to the terms and conditions in this Agreement.

AGREEMENT

1. TERM. The term of this Agreement shall commence upon full execution of this Agreement (“Effective Date”) and continue through 2025, which is determined as the lifespan of the Project, unless terminated at an earlier date as provided in this Agreement. If the Agency does not complete the installation of the Project within 1 year (365) days of the Effective Date of this Agreement, the Department may immediately terminate this Agreement. This Agreement may only be renewed for a term no longer than the original term of this Agreement upon a writing executed by both Parties to this Agreement.

2. PROJECT DESCRIPTION. The Project is a [**CHOOSE ONE:** Public Art, Local Identification Marker], as more fully described in the plans in Exhibit “A”, attached and incorporated in this Agreement.

3. FUNDING OF THE PROJECT. The Agency has agreed by resolution to approve the Project and to fund all costs for the design, installation, and maintenance of the Project, and such resolution is attached and incorporated in this Agreement as Exhibit “D”. The Department shall not be responsible for any costs associated with the Project. All improvements funded, constructed, and installed by the Agency shall remain the Agency’s property. However, this permissive use of the Department’s right-of-way where the Project is located does not vest any property right, title, or interest in or to the Agency for the Department’s right-of-way.

4. DESIGN AND CONSTRUCTION STANDARDS AND REQUIRED APPROVALS.

- a. The Agency is responsible for the design, construction, and maintenance of the Project in accordance with all applicable federal, state and local statutes, rules and regulations, including the Department standards and specifications. A professional engineer, registered in Florida, shall provide the certification that all design and construction for the Project meets the minimum construction standards established by the Department and applicable Florida Building Code construction standards. The Agency shall submit all plans or related construction documents, cost estimates, project schedule, and applicable third party agreements to the Department for review and approval prior to installation of the Project. The Agency is responsible for the preparation of all design plans for the Project, suitable for reproduction on 11 inch by 17 inch sheets, together with a complete set of specifications covering all construction requirements for the Project. A copy of the design plans shall be provided to the Department’s District Design Engineer, located at 3400 West Commercial Blvd., Fort Lauderdale, FL 33309.
The Department will review the plans for conformance to the Department’s requirements and feasibility. The Department review shall not be considered an adoption of the plans nor a substitution for the engineer’s responsibility for the plans. By review of the plans, the Department signifies only that such plans and improvements satisfies the Department’s requirements, and the Department expressly

disclaims all other representations and warranties in connection with the plans, including, but not limited to the integrity, suitability, or fitness for the intended purpose or whether the improvements are constructed in accordance with the plans. The Department's review of the plans does not relieve the Agency, its consultants or contractors of any professional or other liability for the plans. All changes required by the Department shall be made by the Agency and final corrected plans shall be provided to the Department within thirty (30) days.

- b. The Agency shall be responsible for locating all existing utilities, both aerial and underground, and for ensuring that all utility locations be accurately documented on the construction plans. All utility conflicts shall be fully resolved directly with the applicable utility. Section 337.403, Florida Statutes, shall determine whether the utility bears the costs of utility work. The Agency shall bear the costs of utility work not required to be borne by the utility by Section 337.403, Florida Statutes.
- c. The Agency shall be responsible for monitoring construction operations and the maintenance of traffic ("MOT") throughout the course of the Project in accordance with the latest edition of FDOT Standard Specifications, Section 102. The Agency is responsible for the development of a MOT plan and making any changes to that plan as necessary. The MOT plan shall be in accordance with the latest version of FDOT Design Standards, Index 600 series. Any MOT plan developed by the Agency that deviates from FDOT Design Standards must be signed and sealed by a professional engineer. MOT plans will require approval by the Department prior to implementation.
- d. The Agency is responsible for obtaining all permits that may be required by any federal, state, or local agency.
- e. Prior to commencing the Project, the Agency shall request a Notice to Proceed from the Department's Construction Project Manager, _____, at (____) ____ - ____ or from an appointed designee.
- f. The Agency is authorized, subject to the conditions in this Agreement, to enter Department's right-of-way to install the Project (see attached Exhibit "B" Special Provisions). The Parties agree that this Agreement creates a permissive use only. Neither the granting of permission to use Department's right-of-way nor the placing of facilities upon Department's right-of-way shall operate to create or vest any property right in or to the Agency. The Agency shall not acquire any right, title, interest, or estate in the Department's right-of-way, of any nature or kind whatsoever, by virtue of the execution, operation, effect, or performance of this Agreement including, but not limited to, the Agency's use, occupancy or possession of the Department's right-of-way.
- g. The Department shall have the right, but not the obligation, to perform independent assurance testing during the course of construction and throughout the maintenance term of the Project. If the Department determines that a condition exists which threatens the public's safety, the Department may, at its discretion, cause the Project to cease and/or immediately have any potential hazards removed from its right-of-way at the sole cost, expense, and effort of the Agency. Should the Agency fail to remove the safety hazard within thirty (30) days, the Department may remove the safety hazard at the Agency's sole cost, expense, and effort.
- h. The Agency shall be responsible to ensure that construction of the Project is performed in accordance with the approved construction documents, and that it will meet all applicable federal, state, and local standards and that the work is performed in accord with the Terms and Conditions contained in Exhibit "C".
- i. The Agency shall notify the Department a minimum of forty eight (48) hours before beginning the Project within the Department's right-of-way. The Agency shall notify the Department should installation be suspended for more than five (5) working days.
- j. Upon completion of the Project, the Agency shall notify the Department in writing of the completion of the installation of the Project. For all design work that originally required certification by a Professional Engineer, the notification shall contain a Responsible Professional's Certification of Compliance, signed and sealed by the responsible professional for the project, the form of which is attached to this

Agreement as Exhibit "E". The certification shall state that work has been completed in compliance with the Project construction plans and specifications. If any deviations are found from the approved plans, the certification shall include a list of all deviations along with an explanation that justifies the reason to accept each deviation. The Agency and its contractors shall remove their presence, including, but not limited to, all of the Agency or its contractor's/ subcontractor's/ consultant's/ subconsultant's property, machinery, and equipment from the Department's right-of-way and shall restore those portions of the Department's right-of-way disturbed or otherwise altered by the Project to substantially the same condition that existed immediately prior to the commencement of the Project, at Agency's sole cost and expense.

- k. If the Department determines that the Project is not completed in accordance with the provisions of this Agreement, the Department shall deliver written notification to the Agency. The Agency shall have thirty (30) days from the date of receipt of the Department's written notice to complete the Project and provide the Department with written notice of the same ("Notice of Completion"). If the Agency fails to timely deliver the Notice of Completion, or if it is determined that the Project is not properly completed after receipt of the Notice of Completion, the Department may: 1) provide the Agency with written authorization granting additional time as the Department deems appropriate to correct the deficiency(ies); or 2) correct the deficiency(ies) at the Agency's sole cost and expense, without Department liability to the Agency for any resulting loss or damage to property, including but not limited to machinery and equipment. If the Department elects to correct the deficiency(ies), the Department shall provide the Agency with an invoice for the costs incurred by the Department and the Agency shall pay the invoice within thirty (30) days of the date of the invoice.

- l. Upon completion of the Project, the Agency shall be responsible for the perpetual maintenance of the Project, including all costs. The maintenance schedule shall include initial defect, instantaneous damage and deterioration components. The initial defect maintenance inspection should be conducted, and any required repairs performed during the construction phase. The instantaneous damage maintenance inspection should be conducted sixty (60) to ninety (90) days after placement and is intended to identify short term damage that does not develop over longer time periods. The deterioration maintenance inspection shall be conducted on regular, longer term intervals and is intended to identify defects and damages that occur by naturally occurring chemical, physical or biological actions, repeated actions such as those causing fatigues, normal or severe environmental influences, abuse or damage due to other causes. Deterioration maintenance shall include, but is not limited to, the following services:

Inspection of signage and sign base every 6 months.

- m. The Agency shall, within thirty (30) days after expiration or termination of this Agreement, remove the Project and restore the right-of-way to its original condition prior to the Project. The Agency shall secure its obligation to remove the Project and restore the right-of-way by providing a removal and restoration deposit, letter of credit, or performance bond in the amount of \$ _____. The removal and restoration deposit, letter of credit, or bond shall be maintained by the Agency at all times during the term of this Agreement and evidence of the deposit, letter of credit, or bond shall be submitted to the Department on an annual basis. A waiver of the deposit, letter of credit, or bond requirement is permitted with approval from the District Maintenance Engineer for those installations with estimated restoration/removal costs less than or equal to \$2000.00.

District Maintenance Engineer, _____ Date: _____.

- n. The Department reserves its right to cause the Agency to relocate or remove the Project, in the Department's sole discretion, and at the Agency's sole cost.

5. INDEMNITY AND INSURANCE.

- a. The Agency agrees to include the following indemnification in all contracts with contractors, subcontractors, consultants, and subconsultants, who perform work in connection with this Agreement:

"The contractor/ subcontractor/ consultant/ subconsultant shall indemnify, defend, save and hold harmless the State of Florida, Department of Transportation and all of its officers, agents or employees from all suits, actions, claims, demands, liability of any nature whatsoever arising out of, because of, or due to any negligent act or occurrence of omission or commission of the contractor/ subcontractor/ consultant/ subconsultant, its officers, agents or employees."

- b. The Agency shall carry or cause its contractor/ subcontractor/ consultant/ subconsultant to carry and keep in force during the period of this Agreement a general liability insurance policy or policies with a company or companies authorized to do business in Florida, affording public liability insurance with combined bodily injury limits of at least \$1,000,000 per person and \$5,000,000 each occurrence, and property damage insurance of at least \$100,000 each occurrence, for the services to be rendered in accordance with this Agreement. Additionally, the Agency or its contractor/ subcontractor/ consultant/subconsultant shall cause the Department to be an additional insured party on the policy or policies, and shall provide the Department with certificates documenting that the required insurance coverage is in place and effective. In addition to any other forms of insurance or bonds required under the terms of the Agreement, when it includes construction within the limits of a railroad right-of-way, the Agency must provide or cause its contractor to obtain the appropriate rail permits and provide insurance coverage in accordance with Section 7-13 of the Department's current Standard Specifications for Road and Bridge Construction, as amended.
- c. The Agency shall also carry or cause its contractor/ subcontractor/ consultant/ subconsultant to carry and keep in force Worker's Compensation insurance as required by the State of Florida under the Worker's Compensation Law.

6. NOTICES. All notices pertaining to this Agreement are in effect upon receipt by either Party, shall be in writing, and shall be transmitted either by personal hand delivery; United States Post Office, return receipt requested; or, overnight express mail delivery. E-mail and facsimile may be used if the notice is also transmitted by one of the preceding forms of delivery. The addresses set forth below for the respective parties shall be the places where notices shall be sent, unless prior written notice of change of address is given.

STATE OF FLORIDA, DEPARTMENT OF TRANSPORTATION
DISTRICT _____ PROGRAM MANAGER

Phone: _____
Fax: _____

Fort Pierce _____ COUNTY [OR CITY], FLORIDA
Fort Pierce Redevelopment Agency
Nick Mimms, P.E.
100 North US Highway 1, Fort Pierce FL 24950
Phone: 772-465-4170
Fax: _____

7. TERMINATION OF AGREEMENT. The Department may terminate this Agreement upon no less than thirty (30) days notice in writing delivered by certified mail, return receipt requested, or in person with proof of delivery. The Agency waives any equitable claims or defenses in connection with termination of the Agreement by the Department pursuant to this Paragraph 7.

8. LEGAL REQUIREMENTS.

- a. This Agreement is executed and entered into in the State of Florida and will be construed, performed, and enforced in all respects in strict conformity with local, state, and federal laws, rules, and regulations. Any and all litigation arising under this Agreement shall be brought in a state court of appropriate jurisdiction in Leon County, Florida, applying Florida law.
- b. If any term or provision of the Agreement is found to be illegal or unenforceable, the remainder of the Agreement will remain in full force and effect and such term or provision will be deemed stricken.
- c. The Agency shall allow public access to all documents, papers, letters, or other material subject to the provisions of Chapter 119, Florida Statutes, and made or received by the Agency in conjunction with this Agreement. Failure by the Agency to grant such public access shall be grounds for immediate unilateral cancellation of this Agreement by the Department.
- d. The Agency and the Department agree that the Agency, its employees, contractors, subcontractors, consultants, and subconsultants are not agents of the Department as a result of this Agreement.
- e. The Agency shall not cause any liens or encumbrances to attach to any portion of the Department's right-of-way.

9. PUBLIC ENTITY CRIME. The Agency affirms that it is aware of the provisions of Section 287.133(2)(a), Florida Statutes. A person or affiliate who has been placed on the convicted vendor list following a conviction for a public entity crime may not submit a bid on a contract to provide any goods or services to a public entity, may not submit a bid on a contract with a public entity for the construction or repair of a public building or public work, may not submit bids on leases of real property to a public entity, may not be awarded or perform work as a contractor, supplier, subcontractor, or consultant under a contract with any public entity, and may not transact business with any public entity in excess of the threshold amount provided in Section 287.017, Florida Statutes, for CATEGORY TWO for a period of thirty six (36) months from the date of being placed on the convicted vendor list. The Agency agrees that it shall not violate Section 287.133(2)(a), Florida Statutes, and further acknowledges and agrees that any conviction during the term of this Agreement may result in the termination of this Agreement.

10. UNAUTHORIZED ALIENS. The Department will consider the employment of unauthorized aliens, by any contractor or subcontractor, as described by Section 274A(e) of the Immigration and Nationalization Act, cause for termination of this Agreement.

11. NON-DISCRIMINATION. The Agency will not discriminate against any employee employed in the performance of this Agreement, or against any applicant for employment because of age, ethnicity, race, religious belief, disability, national origin, or sex. The Agency shall provide a harassment-free workplace, with any allegation of harassment given priority attention and action by management. The Agency shall insert similar provisions in all contracts and subcontracts for services by this Agreement.

12. DISCRIMINATORY VENDOR LIST. The Agency affirms that it is aware of the provisions of Section 287.134(2)(a), Florida Statutes. An entity or affiliate who has been placed on the discriminatory vendor list may not submit a bid on a contract to provide any goods or services to a public entity, may not submit a bid on a contract with a public entity for the construction or repair of a public building or public work, may not submit bids on leases of real property to a public entity, may not be awarded or perform work as a contractor, supplier, subcontractor, or consultant under a contract with any public entity, and may not transact business with any public entity. The Agency further agrees

that it shall not violate Section 287.134(2)(a), Florida Statutes, and acknowledges and agrees that placement on the list during the term of this Agreement may result in the termination of this Agreement.

13. **ATTORNEY FEES.** Each Party shall bear its own attorney's fees and costs.

14. **TRAVEL.** There shall be no reimbursement for travel expenses under this Agreement.

15. **PRESERVATION OF REMEDIES.** No delay or omission to exercise any right, power, or remedy accruing to either Party upon breach or default by either Party under this Agreement, will impair any such right, power or remedy of either party; nor will such delay or omission be construed as a waiver of any breach or default or any similar breach or default.

16. **MODIFICATION.** This Agreement may not be modified unless done so in a writing executed by both Parties to this Agreement.

17. **NON-ASSIGNMENT.** The Agency may not assign, sublicense, or otherwise transfer its rights, duties, or obligations under this Agreement without the prior written consent of the Department. Any assignment, sublicense, or transfer occurring without the required prior written approval of the Department will be null and void. The Department will at all times be entitled to assign or transfer its rights, duties, or obligations under this Agreement to another governmental agency in the State of Florida, upon giving prior written notice to the Agency. In the event that the Department approves transfer of the Agency's obligations, the Agency remains responsible for all work performed and all expenses incurred in connection with this Agreement.

18. **BINDING AGREEMENT.** This Agreement is binding upon and inures to the benefit of the Parties and their respective successors and assigns. Nothing in this Agreement is intended to confer any rights, privileges, benefits, obligations, or remedies upon any other person or entity except as expressly provided for in this Agreement.

19. **INTERPRETATION.** No term or provision of this Agreement shall be interpreted for or against any party because that party or that party's legal representative drafted the provision.

20. **ENTIRE AGREEMENT.** This Agreement, together with the attached exhibits and documents made a part by reference, embodies the entire agreement of the Parties. There are no provisions, terms, conditions, or obligations other than those contained in this Agreement. This Agreement supersedes all previous communication, representation, or agreement, either verbal or written, between the Parties. No amendment will be effective unless reduced to writing and signed by an authorized officer of the Agency and the authorized officer of the Department or his/her delegate.

21. **DUPLICATE ORIGINALS.** This Agreement may be executed in duplicate originals.

The remainder of this page is intentionally left blank.

Section No. _____ CAFA No. _____

AGENCY

FORT PIERCE REDEVELOPMENT AGENCY

By: _____

Print Name: Linda Hudson

Title: Chair

As approved by the Council, Board, or

Commission on: _____

Attest: _____

Legal Review:

City or County Attorney

DEPARTMENT

State of Florida, Department of Transportation

By: _____

Print Name: _____

Title: _____

Date: _____

Legal Review:

Section No. _____ CAFA No. _____

EXHIBIT "A"

PROJECT DESCRIPTION

I. SCOPE OF SERVICES

The project involves the design, construction, installation and maintenance of 6 Gateway signs at designated locations on FDOT rights-of-way within Fort Pierce. The signs will serve as welcoming features and visually distinguish the entrances to the city.

The locations are:

- Location 2: SR 70/Okeechobee Rd. MP 21.413 (FDOT R/W)
- Location 3: SR5/US1 MP 14.888 (FDOT R/W)
- Location 5: SR5/US1 MP 8.137 (FDOT R/W)
- Location 6: SR A1A/South Ocean Dr. MP 12.931 (FDOT R/W)
- Location 7: SR 68/Orange Ave. MP 18.1 (FDOT R/W)
- Location 8: SR 615/N. 25th St. MP 3.6 (FDOT R/W)

II. PROJECT PLANS

The Agency is authorized to install the Project in accordance with the attached plans prepared by Don Bell Signs, Inc, P.E./R.L.A./Architect and dated 4/30/2024. Any revisions to these plans must be approved by the Department in writing.

A.2

GATEWAY MONUMENT W/ FDOT BREAKAWAY

Scope of Work:

Don Bell Signs to fabricate & install:
 -(6) D/F intern-illum. Gateway signs
 as specified

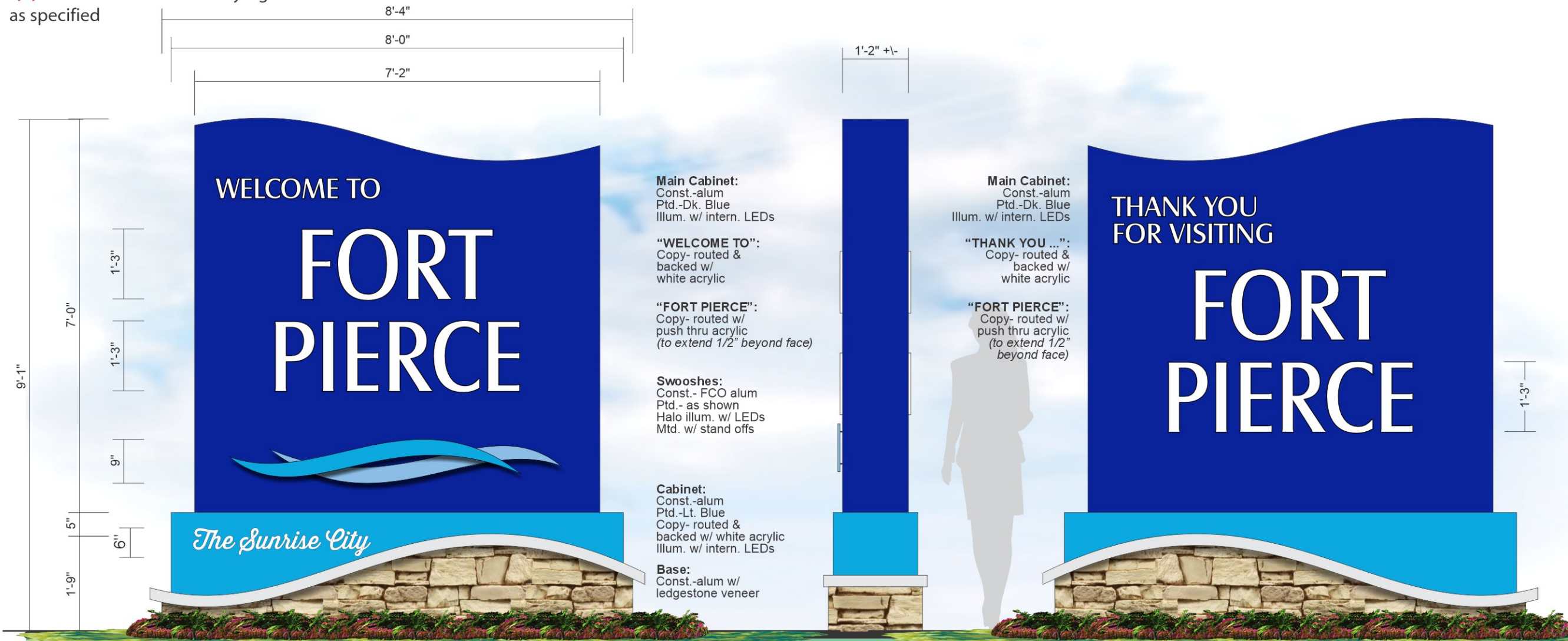

Elevation of Intern. Illum. D/F Monument

COLOR SCHEDULE

Dk Blue PMS Dark Blue	Lt Blue PMS 632	PMS 631

Note: The color on your computer screen or printer output may vary. Please consult the specifications in this drawing and proper color guide for accurate color depiction.

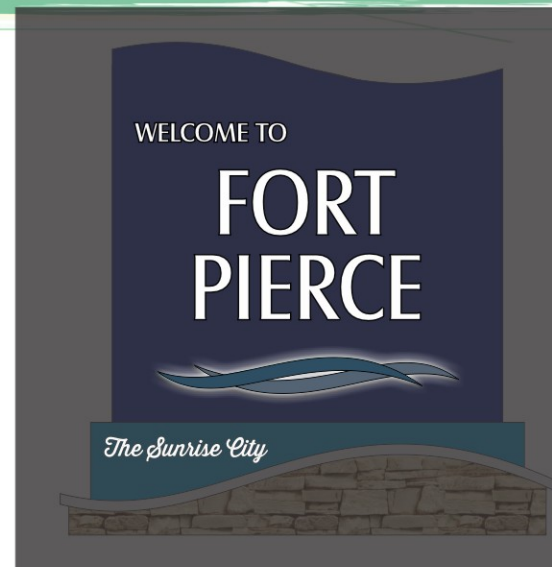

Simulated nightview: NTS

LANDSCAPING BY OTHERS

All signage to be installed in compliance with National Electrical Code - NEC 2017

All signage to be constructed and installed according to ETL standards.

Electrical Requirements () 20 AMP Circuit(s) @ 120v

PRIMARY ELECTRIC BY OTHERS



DESIGN #: 2100575 R12
 DATE: 04-30-24
 DRAWN BY: Andrew

Revisions / Date / Initials

R11-ADDED GATEWAY INSTALL LOCATIONS & FDOT REQUIREMENTS
R12-ADJUSTED AS PER CITY/PERMITTING NOTES

ETL Acct. #115459
 UL 48 Listed Signage
 All Sign Components shall be UL listed and Recognized in the SAM Manual
 All Wiring shall be at least 90' C rated

ACCOUNT #115459 120 Volt 277 Volt

SHEET 1

CITY OF FT. PIERCE
 South 25th St & North of Winding Creek Lane

SALES REP: Frank B, Gary B
 SCALE: As Noted
 PROGRAM: CorelDRAW

Note: Primary power & signage lighting control by others. The primary power must be located within 5' of applicable signs installation location.

All penetrations to have bushings
PRIMARY ELECTRIC BY OTHERS

This design (except registered or existing trademarks) is the property of DON BELL SIGNS LLC and shall not be reproduced or copied in whole or in part without the written permission of the above named owner.

DON BELL SIGNS LLC

365 OAK PLACE
 PORT ORANGE, FL 32127
 386-788-8084
 800-824-0080



City of Ft. Pierce
City Signs

DESIGN #: 2100575 R12
DATE: 04-30-24
DRAWN BY: Andrew

Revisions / Date / Initials
R11-ADDED GATEWAY INSTALL LOCATIONS & FDOT REQUIREMENTS
R12-ADJUSTED AS PER CITY/PERMITTING NOTES

ETL Acct. #115459
UL 48 Listed Signage
All Sign Components shall be UL listed and Recognized in the SAM Manual
All Wiring shall be at least 90° C rated

ACCOUNT #115459
 120 Volt
 277 Volt

SHEET 2

CITY OF FT. PIERCE
South 25th St & North of Winding Creek Lane

SALES REP: Frank B, Gary B
SCALE: As Noted
FILE NAME:
PROGRAM: CorelDRAW
CUSTOMER APPROVAL: DATE:

Note: Primary power & signage lighting control by others. The primary power must be located within 5' of applicable signs installation location.

**All penetrations to have bushings
PRIMARY ELECTRIC BY OTHERS**

This design (except registered or existing trademarks) is the property of DON BELL SIGNS LLC and shall not be reproduced or copied in whole or in part without the written permission of the above named owner.



365 OAK PLACE
PORT ORANGE, FL 32127
386-788-8084
800-824-0080

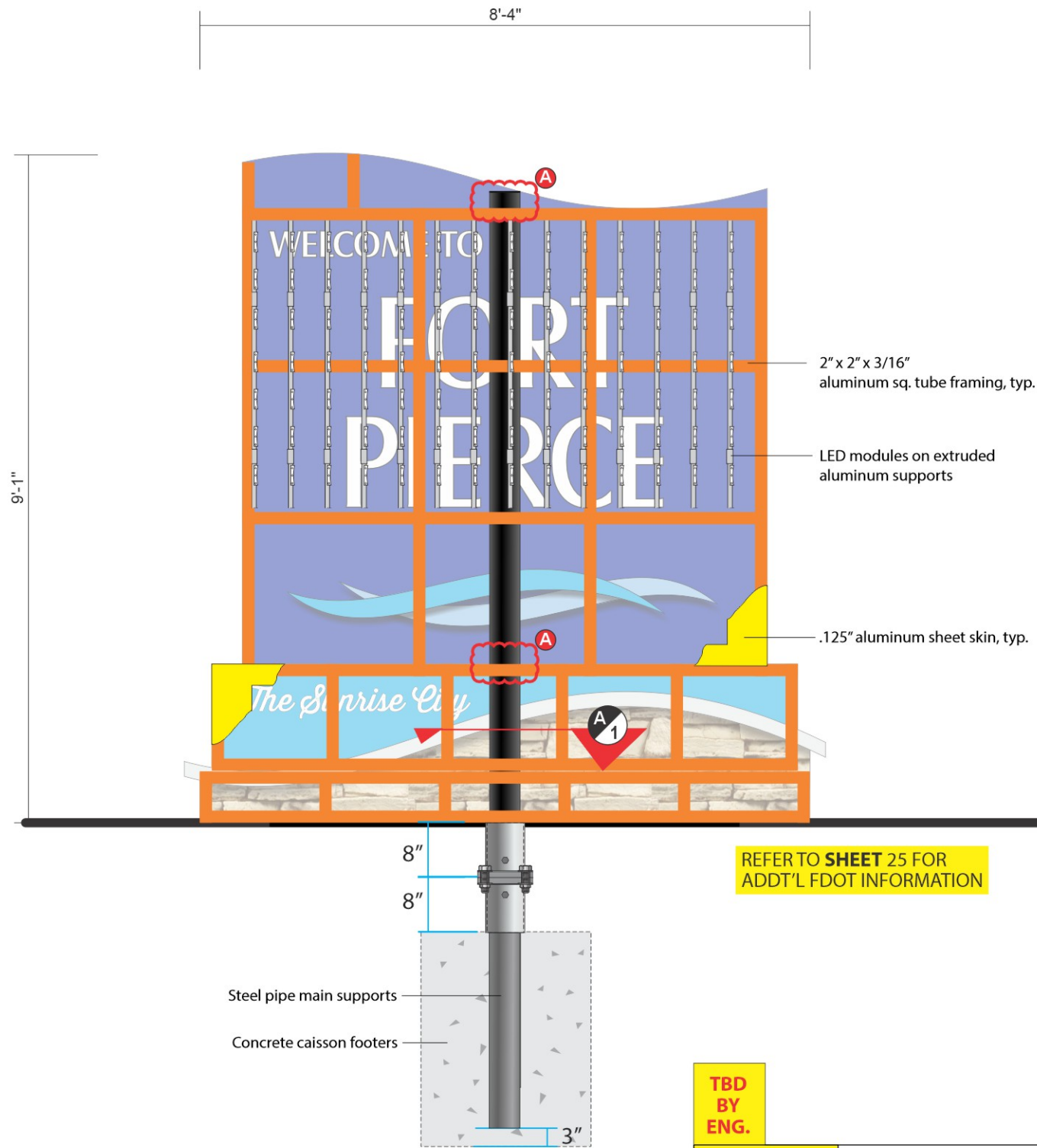

REFER TO SHEET 25 FOR ADDT'L FDOT INFORMATION

TBD BY ENG.

Column (Post) Size		SLIP BASE DETAILS												
Outside Dia.	Wall Thickness	Sleeve I.D. (Max.)	Sleeve Height 'H'	Weld 'W'	Base Plate			Base Bolt		Base Plate Torque	Hole Size 'D'	SHIM		
					'L'	'T'	'R'	Size	Length			ft.-lbs	in.-lbs	L
4"	1/4"	4 1/16"	6"	1/4"	8"	3/4"	1 1/32"	5/8"	3"	29	345	1 1/16"	1 3/8"	1 1/16"
4 1/2"	1/4"	4 9/16"	6"	1/4"	8"	7/8"	1 1/32"	5/8"	3 1/4"	29	345	1 1/16"	1 3/8"	1 1/16"
5"	1/4"	5 1/16"	7"	1/4"	8"	7/8"	1 1/32"	5/8"	3 1/4"	29	345	1 1/16"	1 3/8"	1 1/16"
6"	1/4"	6 1/16"	8"	1/4"	9"	1"	1 3/32"	3/4"	3 1/2"	46	554	1 3/16"	1 3/4"	1 3/16"
8"	1/4"	8 1/16"	10"	1/4"	11"	1"	1 5/32"	7/8"	3 3/4"	53	640	1 5/16"	2 3/8"	1 1/16"

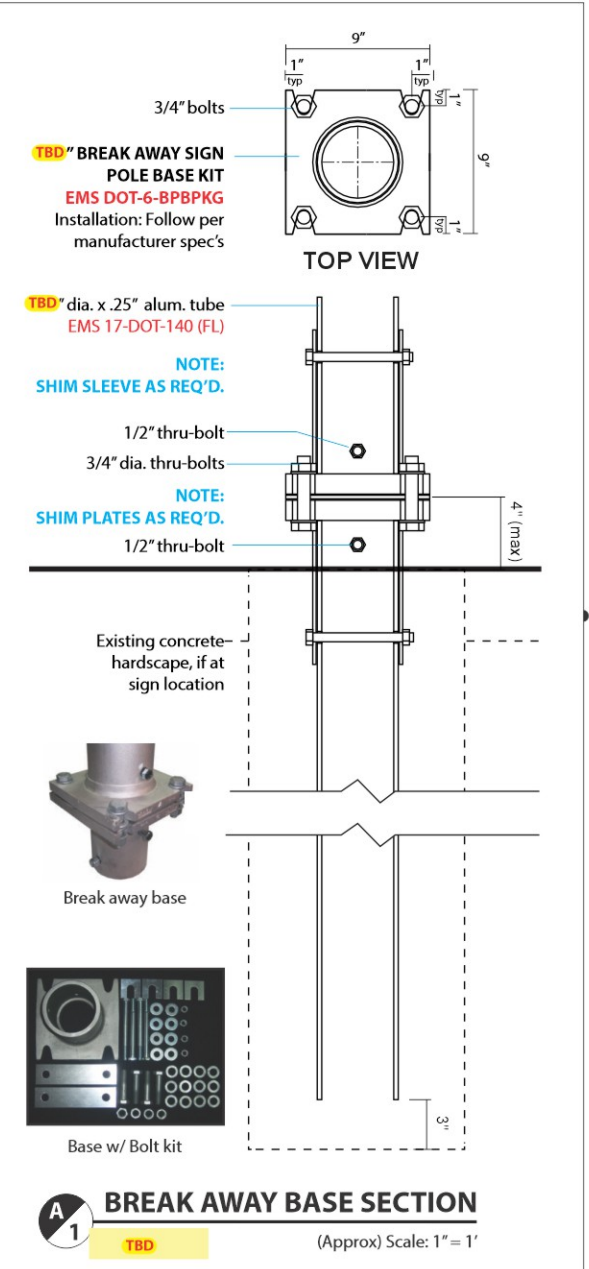
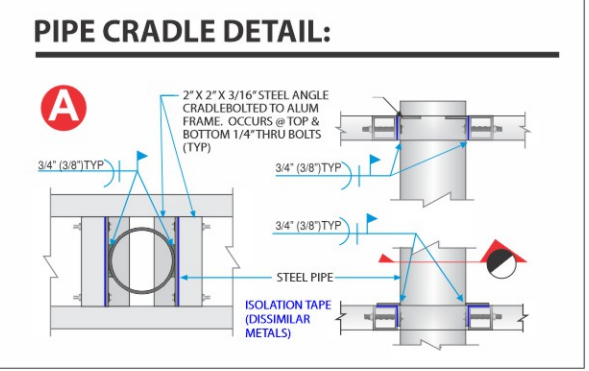

A1 BREAK AWAY BASE SECTION
TBD (Approx) Scale: 1" = 1'

GATEWAY MONUMENT -INSTALL LOCATION

LOCATION 2

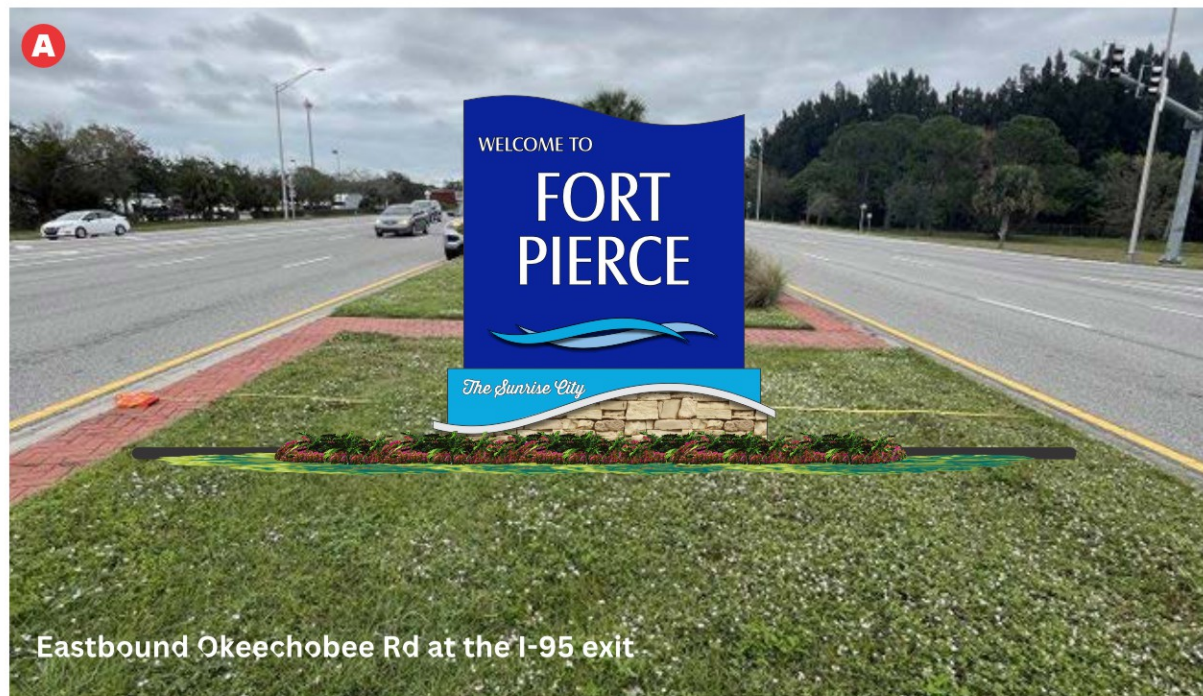

Sign Type	Location	Median Width	Design Speed
	State Road 70 (Okeechobee rd) at the I-195 Exit	23 FT	45 mph

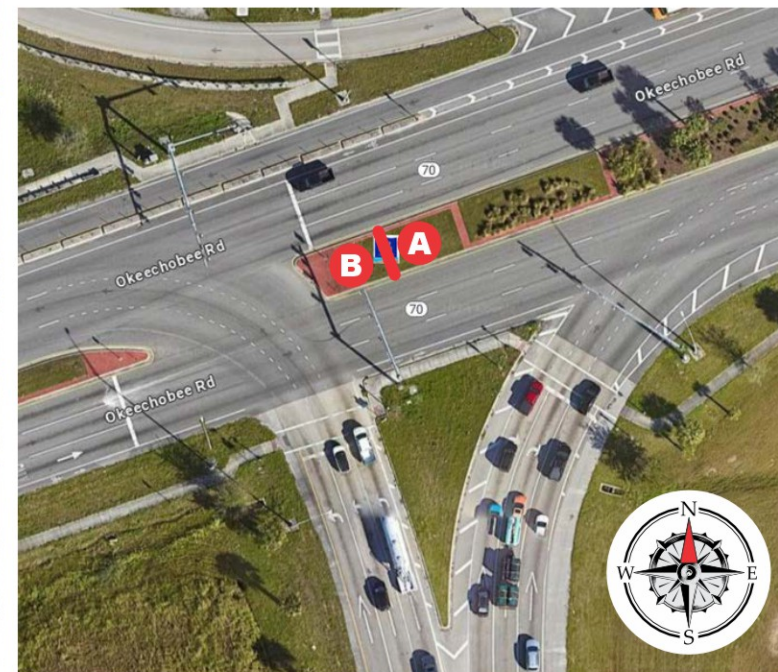

DESIGN #: **2100575 R12**
 DATE: **04-30-24**
 DRAWN BY: *Andrew*

Revisions / Date / Initials

R11-ADDED GATEWAY INSTALL LOCATIONS & FDOT REQUIREMENTS
 R12-ADJUSTED AS PER CITY/PERMITTING NOTES

ETL Acct. #115459
 UL 48 Listed Signage
 All Sign Components shall be UL listed and Recognized in the SAM Manual
 All Wiring shall be at least 90' C rated

ACCOUNT #115459 120 Volt
 277 Volt

SHEET 3

ACCOUNT: City of Ft. Pierce

STREET: XXXX
 CITY: XXXX STATE: FL
 SALES REP: Frank B, Gary B
 SCALE: As Noted
 FILE NAME:
 PROGRAM: CorelDRAW
 FONTS USED:
 CUSTOMER APPROVAL: DATE:

Note: Primary power & signage lighting control by others. The primary power must be located within 5' of applicable signs installation location.

All penetrations to have bushings
PRIMARY ELECTRIC BY OTHERS

This design (except registered or existing trademarks) is the property of DON BELL SIGNS LLC and shall not be reproduced or copied in whole or in part without the written permission of the above named owner.



365 OAK PLACE
 PORT ORANGE, FL 32127
 386-788-8084
 800-824-0080

NOTES:
 -4' measurement is measured from the face of the curb to the sign base and is a minimum required setback
 -Landscaping by others

GATEWAY MONUMENT -INSTALL LOCATION

LOCATION 3

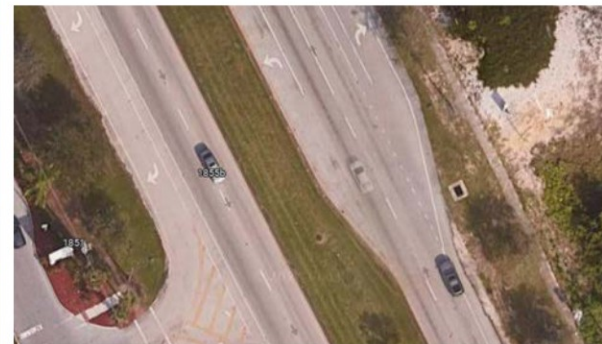
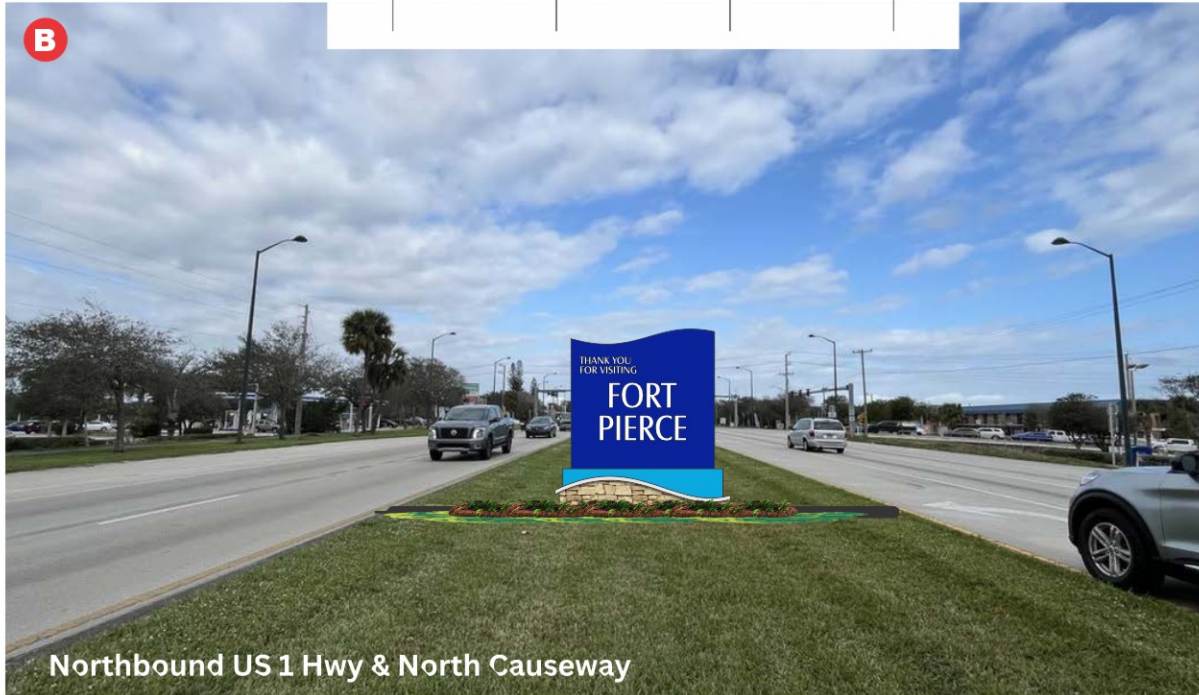

Sign Type	Location	Median Width	Design Speed
	State Road 5 (US Hwy 1) South of N. Causeway bridge	24 FT	45 mph



DESIGN #: 2100575 R12
 DATE: 04-30-24
 DRAWN BY: Andrew

Revisions / Date / Initials
 R11-ADDED GATEWAY INSTALL LOCATIONS & FDOT REQUIREMENTS
 R12-ADJUSTED AS PER CITY/PERMITTING NOTES

ETL Acct. #115459
 UL 48 Listed Signage
 All Sign Components shall be UL listed and Recognized in the SAM Manual
 All Wiring shall be at least 90' C rated

ACCOUNT #115459 120 Volt
 277 Volt

SHEET 4

ACCOUNT City of Ft. Pierce

US Hwy 1 & North Causeway

SALES REP: Frank B, Gary B

SCALE: As Noted

FILE NAME:

PROGRAM: CorelDRAW

FONTS USED:

CUSTOMER APPROVAL: DATE:

Note: Primary power & signage lighting control by others. The primary power must be located within 5' of applicable signs installation location.

All penetrations to have bushings

PRIMARY ELECTRIC BY OTHERS

This design (except registered or existing trademarks) is the property of DON BELL SIGNS LLC and shall not be reproduced or copied in whole or in part without the written permission of the above named owner.



365 OAK PLACE
 PORT ORANGE, FL 32127
 386-788-8084
 800-824-0080

NOTES:

-4' measurement is measured from the face of the curb to the sign base and is a minimum required setback

-Landscaping by others

GATEWAY MONUMENT -INSTALL LOCATION

LOCATION 5



Sign Type	Location	Median Width	Design Speed
	State Road 5 (US Highway 1) East of Midway Rd	22 FT	45 mph



City of Ft. Pierce
City Signs

DESIGN #: 2100575 R12

DATE: 04-30-24

DRAWN BY: Andrew

Revisions / Date / Initials

R11-ADDED GATEWAY INSTALL LOCATIONS & FDOT REQUIREMENTS

R12-ADJUSTED AS PER CITY/PERMITTING NOTES

ETL Acct. #115459
UL 48 Listed Signage
All Sign Components shall be UL listed and Recognized in the SAM Manual
All Wiring shall be at least 90' C rated

ACCOUNT #115459 120 Volt
 277 Volt

SHEET 5

CITY OF FT. PIERCE

US Hwy 1 East of Midway Rd

SALES REP: Frank B, Gary B

SCALE: As Noted

FILE NAME:

PROGRAM: CorelDRAW

FONTS USED:

CUSTOMER APPROVAL:

DATE:

Note: Primary power & signage lighting control by others. The primary power must be located within 5' of applicable signs installation location.

All penetrations to have bushings

PRIMARY ELECTRIC BY OTHERS

This design (except registered or existing trademarks) is the property of DON BELL SIGNS LLC and shall not be reproduced or copied in whole or in part without the written permission of the above named owner.



365 OAK PLACE
PORT ORANGE, FL 32127
386-788-8084
800-824-0080

NOTES:

-4' measurement is measured from the face of the curb to the sign base and is a minimum required setback

-Landscaping by others

GATEWAY MONUMENT -INSTALL LOCATION

LOCATION 6



Sign Type	Location	Median Width	Design Speed
	State Road A1A (S. Ocean Drive) South of Blue Heron Blvd	31 FT	35 mph



DESIGN #: 2100575 R12
 DATE: 04-30-24
 DRAWN BY: Andrew

Revisions / Date / Initials
 R11-ADDED GATEWAY INSTALL LOCATIONS & FDOT REQUIREMENTS
 R12-ADJUSTED AS PER CITY/PERMITTING NOTES

ETL Acct. #115459
 UL 48 Listed Signage
 All Sign Components shall be UL listed and Recognized in the SAM Manual
 All Wiring shall be at least 90' C rated

ACCOUNT #115459 120 Volt
 277 Volt

SHEET 6

ACCOUNT City of Ft. Pierce

South Ocean Drive (South of Pie Hole)

SALES REP: Frank B, Gary B

SCALE: As Noted

FILE NAME:

PROGRAM: CorelDRAW

CUSTOMER APPROVAL: DATE:

Note: Primary power & signage lighting control by others. The primary power must be located within 5' of applicable signs installation location.

All penetrations to have bushings

PRIMARY ELECTRIC BY OTHERS

This design (except registered or existing trademarks) is the property of DON BELL SIGNS LLC and shall not be reproduced or copied in whole or in part without the written permission of the above named owner.



365 OAK PLACE
 PORT ORANGE, FL 32127
 386-788-8084
 800-824-0080

NOTES:
 -LANDSCAPING BY OTHERS
 -18' MIN. SETBACK FROM RD

GATEWAY MONUMENT W/ FDOT BREAKAWAY

Scope of Work:

Don Bell Signs to fabricate & install:
 -(2) D/F intern-illum. Gateway signs
 as specified

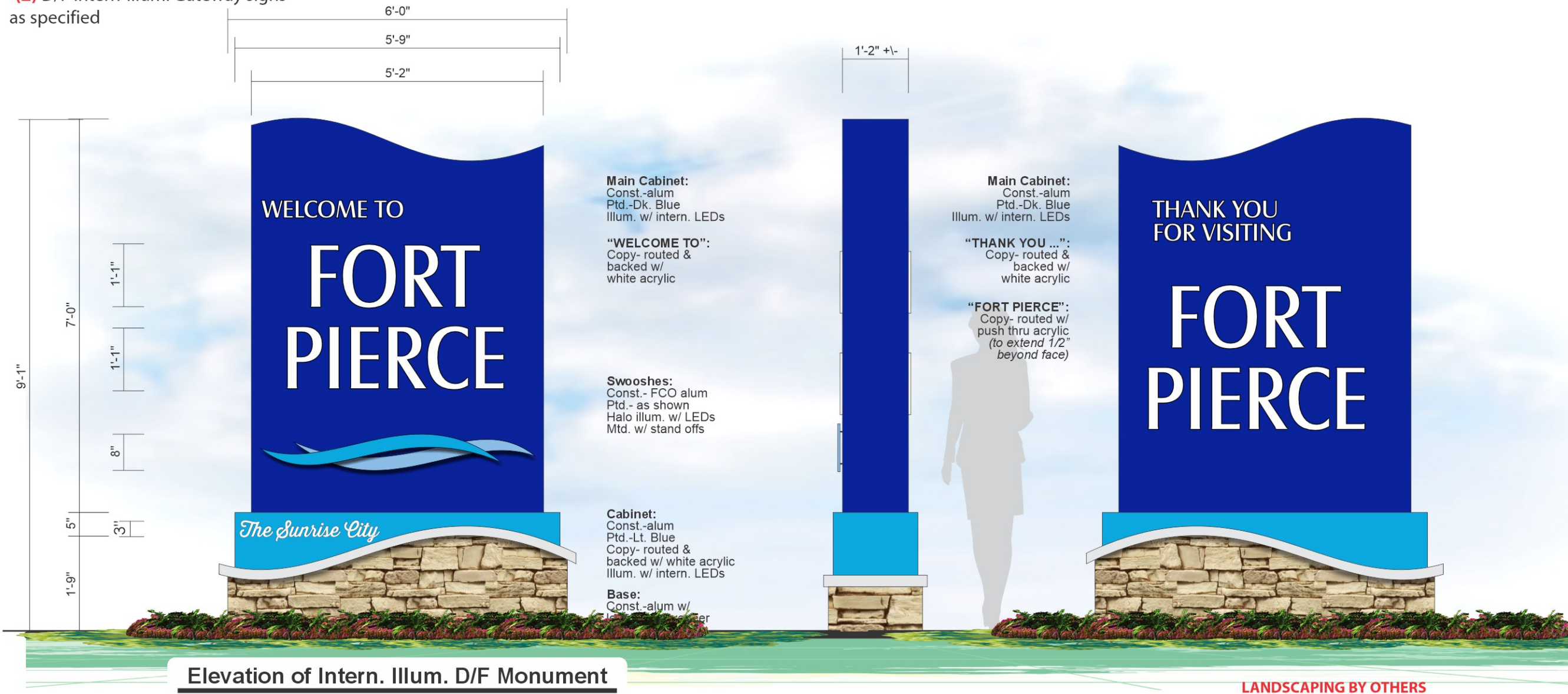

Elevation of Intern. Illum. D/F Monument

COLOR SCHEDULE

Dk Blue PMS Dark Blue	Lt Blue PMS 632	PMS 631

Note: The color on your computer screen or printer output may vary. Please consult the specifications in this drawing and proper color guide for accurate color depiction.

All signage to be installed in compliance with National Electrical Code - NEC 2017

All signage to be constructed and installed according to ETL standards.

Electrical Requirements () 20 AMP Circuit(s) @ 120v

PRIMARY ELECTRIC BY OTHERS



DESIGN #: 2100575 R12
 DATE: 04-30-24
 DRAWN BY: Andrew

Revisions / Date / Initials

R11-ADDED GATEWAY INSTALL LOCATIONS & FDOT REQUIREMENTS
R12-ADJUSTED AS PER CITY/PERMITTING NOTES

ETL Acct. #115459
 UL 48 Listed Signage
 All Sign Components shall be UL listed and Recognized in the SAM Manual
 All Wiring shall be at least 90° C rated

ACCOUNT #115459 120 Volt 277 Volt

SHEET 7

ACCOUNT: City of Ft. Pierce

Orange Ave West of Jenkins Rd

SALES REP: Frank B, Gary B
 SCALE: As Noted
 FILE NAME:
 PROGRAM: CorelDRAW
 FONTS USED:
 CUSTOMER APPROVAL: DATE:

Note: Primary power & signage lighting control by others. The primary power must be located within 5' of applicable signs installation location.

All penetrations to have bushings

PRIMARY ELECTRIC BY OTHERS

This design (except registered or existing trademarks) is the property of DON BELL SIGNS LLC and shall not be reproduced or copied in whole or in part without the written permission of the above named owner.

DON BELL SIGNS LLC

365 OAK PLACE
 PORT ORANGE, FL 32127
 386-788-8084
 800-824-0080

A.7 GATEWAY MONUMENT -INSTALL LOCATION

LOCATION 7

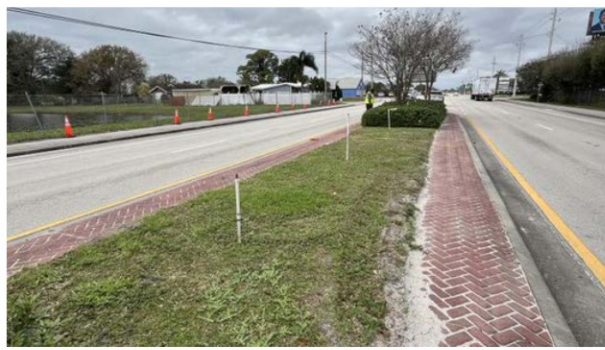
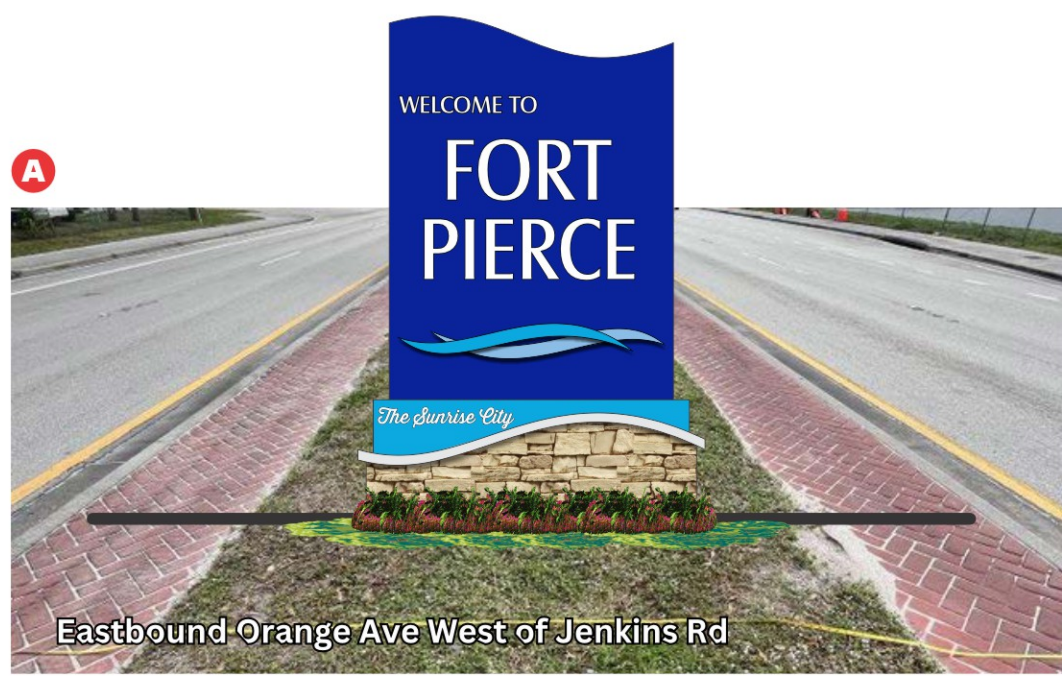
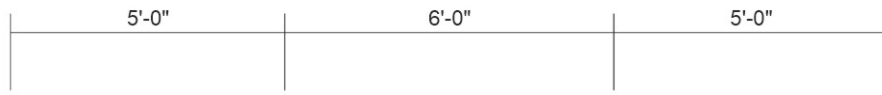

Sign Type	Location	Median Width	Design Speed
	State Road 68 (Orange Ave) West of Jenkins Rd.	16 FT	45 mph
		9ft grass strip	



DESIGN #: 2100575 R12
 DATE: 04-30-24
 DRAWN BY: Andrew

Revisions / Date / Initials

R11-ADDED GATEWAY INSTALL LOCATIONS & FDOT REQUIREMENTS
R12-ADJUSTED AS PER CITY/PERMITTING NOTES

ETL Acct. #115459
 UL 48 Listed Signage
 All Sign Components shall be UL listed and Recognized in the SAM Manual
 All Wiring shall be at least 90' C rated

ACCOUNT #115459 120 Volt
 277 Volt

SHEET 9

ACCOUNT: City of Ft. Pierce
 Orange Ave West of Jenkins Rd
 SALES REP: Frank B, Gary B
 SCALE: As Noted
 FILE NAME:
 PROGRAM: CorelDRAW
 FONTS USED:
 CUSTOMER APPROVAL: DATE:

Note: Primary power & signage lighting control by others. The primary power must be located within 5' of applicable signs installation location.

All penetrations to have bushings
PRIMARY ELECTRIC BY OTHERS

This design (except registered or existing trademarks) is the property of DON BELL SIGNS LLC and shall not be reproduced or copied in whole or in part without the written permission of the above named owner.



365 OAK PLACE
 PORT ORANGE, FL 32127
 386-788-8084
 800-824-0080

NOTES:
 -4' measurement is measured from the face of the curb to the sign base and is a minimum required setback
 -Landscaping by others

GATEWAY MONUMENT -INSTALL LOCATION

LOCATION 8

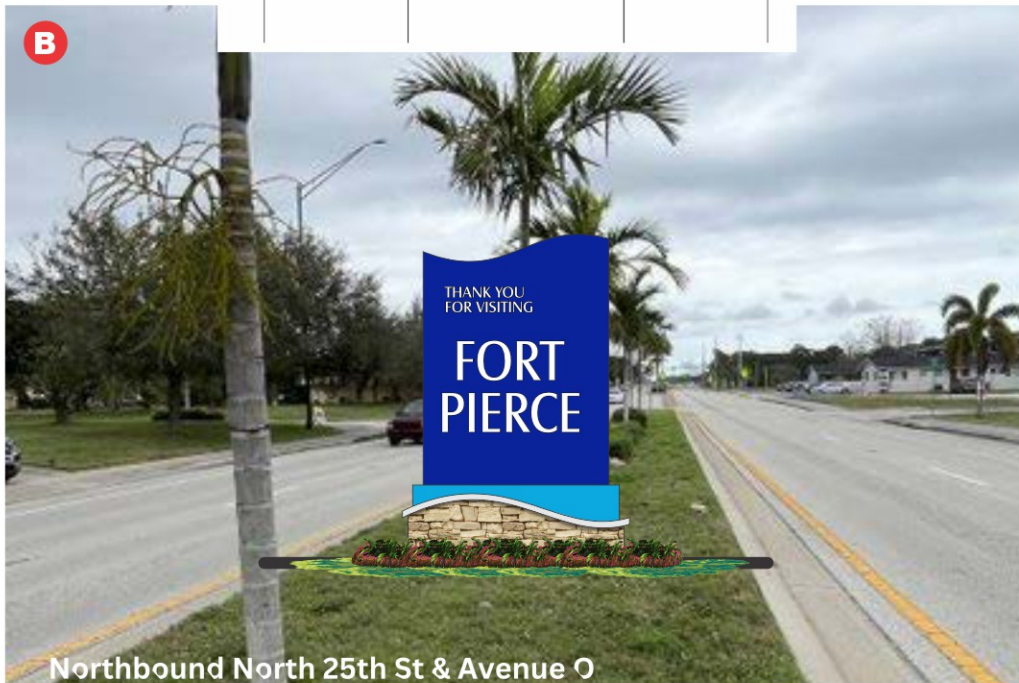
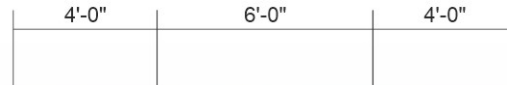

Sign Type	Location	Median Width	Design Speed
	State Road 615 (N. 25th Street) South of Avenue O	14 FT	35 mph



City of Ft. Pierce
City Signs

DESIGN #: 2100575 R12

DATE: 04-30-24

DRAWN BY: Andrew

Revisions / Date / Initials

R11-ADDED GATEWAY INSTALL LOCATIONS & FDOT REQUIREMENTS

R12-ADJUSTED AS PER CITY/PERMITTING NOTES

ETL Acct. #115459
UL 48 Listed Signage
All Sign Components shall be UL listed and Recognized in the SAM Manual
All Wiring shall be at least 90' C rated

ACCOUNT #115459 120 Volt
 277 Volt

SHEET 10

CITY OF FT. PIERCE

North 25th St & Ave O

SALES REP: Frank B, Gary B

SCALE: As Noted

FILE NAME:

PROGRAM: CorelDRAW

FONTS USED:

CUSTOMER APPROVAL:

DATE:

Note: Primary power & signage lighting control by others. The primary power must be located within 5' of applicable signs installation location.

All penetrations to have bushings

PRIMARY ELECTRIC BY OTHERS

This design (except registered or existing trademarks) is the property of DON BELL SIGNS LLC and shall not be reproduced or copied in whole or in part without the written permission of the above named owner.



365 OAK PLACE
PORT ORANGE, FL 32127
386-788-8084
800-824-0080

NOTES:

-4' measurement is measured from the face of the curb to the sign base and is a minimum required setback

-Landscaping by others

FDOT Breakaway Base

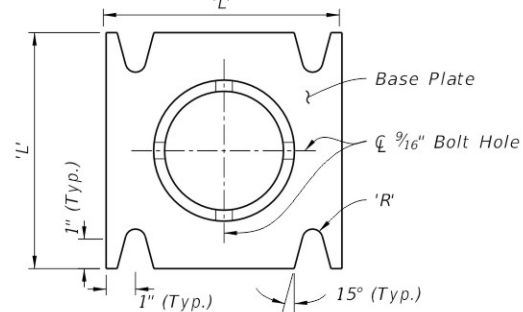
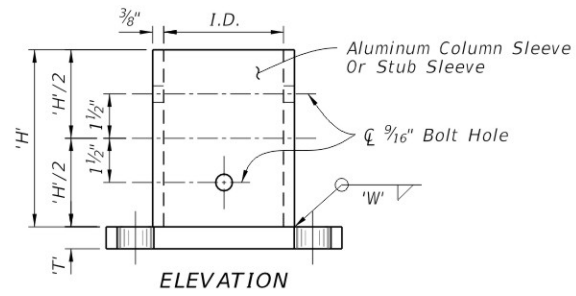

STUB/SLEEVE & BASE PLATE DETAILS

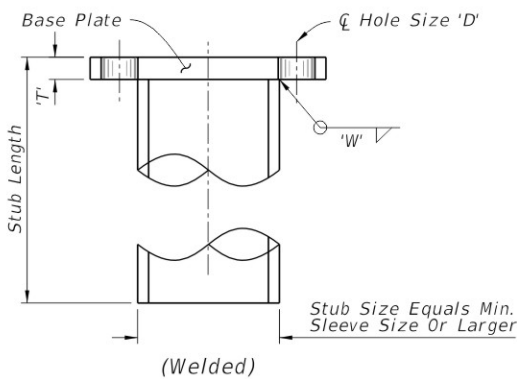

STUB DETAIL

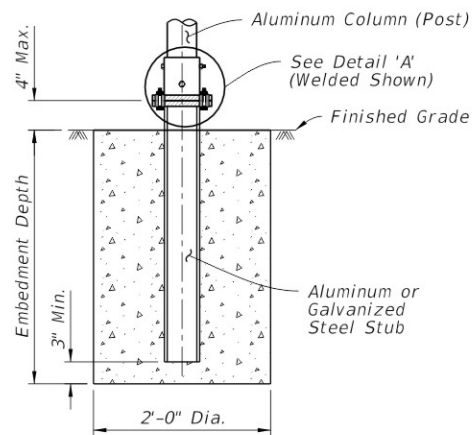

SLIP BASE AND FOUNDATION DETAIL (Non-Frangible Column, Typ.)

BOLT KEEPER PLATE DETAIL

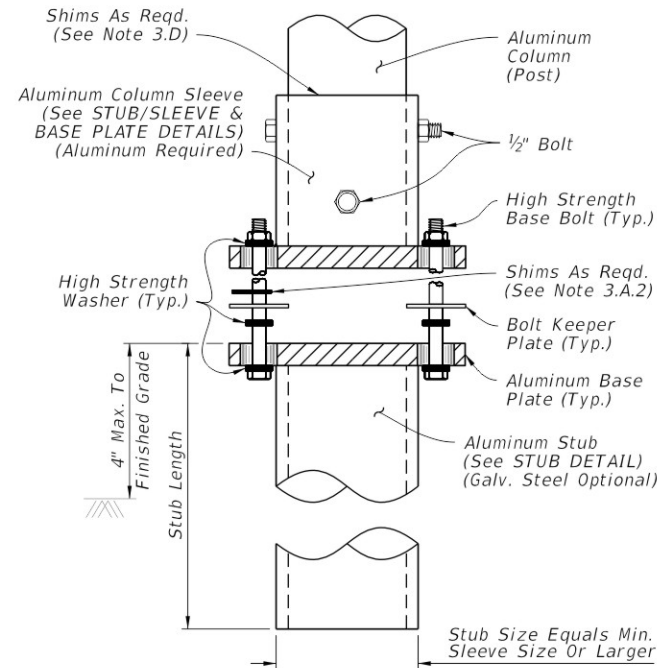

WELDED STUB BASE

DETAIL 'A'

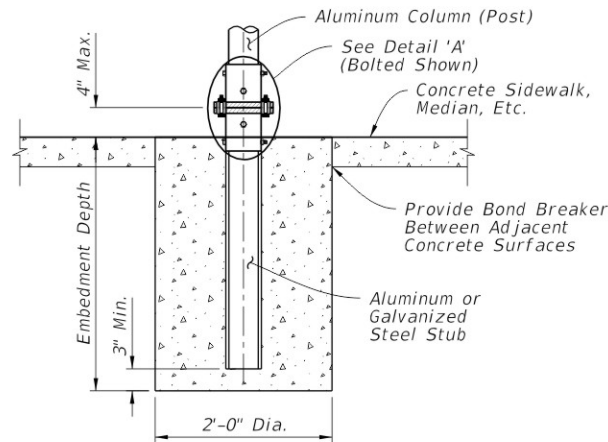

SLIP BASE AND FOUNDATION DETAIL IN CONCRETE (Non-Frangible Column In Crossovers, Medians & Sidewalks)

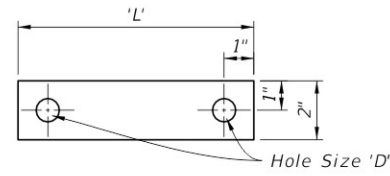

28 Ga. Thick Aluminum Strip
2 Reqd. Per Base

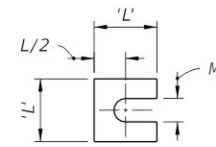

Provide 2~0.0149" Thick (28 gauge)
and 2~0.0329" Thick (21 gauge)
Brass Shims Per Post

SHIM DETAIL

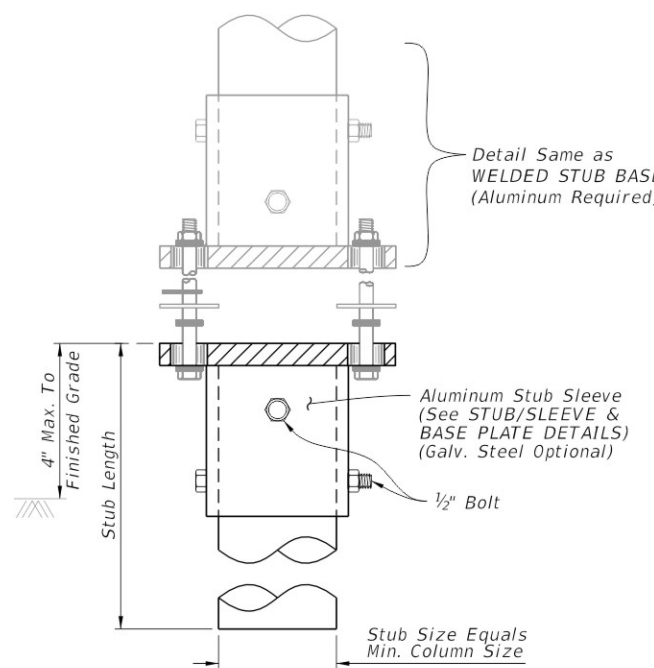

BOLTED STUB/SLEEVE BASE

NOTES:

1. Foundation Notes for Slip Base:

A. See FOUNDATION TABLE on Sheet 3 for foundation embedment depth and stub length.

2. Slip Base Fabrication Notes:

A. The difference between the O.D. of the post and I.D. of the Sleeve must be 1/16" or less.

B. The WELDED STUB BASE and lower STUB/SLEEVE BASE PLATE may be fabricated using galvanized steel as an option to aluminum. The upper portion of the SLIP BASE must be aluminum.

C. Either a Welded Stub Base or Bolted Stub/Sleeve Base may be used in Slip Base.

D. For cast base plates bolted to foundation stubs, use a foundation stub the same size as the sign column (Post).

3. Slip-Base Assembly Instructions:

A. Assemble the Slip Base as follows:

1. Insert Post into Sleeve and connect using 2 ~ 1/2" diameter Sleeve Bolts.
2. Assemble top base plate to bottom Base Plate using Base Bolts (High strength) with 3 washers per bolt. (See Detail 'A'):
 - a. Place one washer on each Base Bolt between the bottom Base Plate and the Base Bolt head.
 - b. Place the next washer between the Bottom Base Plate and the Bolt Keeper Plate.
 - c. Use brass or galvanized steel shims to plumb the post.
 - d. Add the top base plate section.
 - e. Place the third washer between the Top Base Plate and the Nut.

B. Orient the Bolt Keeper Plates in the Direction of Traffic.

C. Tighten Base Bolts as follows:

1. Tighten Base Bolts to the maximum possible with a 12" to 15" wrench (this will bed the washers and shims and clear the bolt threads).
2. Loosen each Base Bolt one turn.
3. Under the supervision of the Engineer, use a calibrated wrench to tighten bolts to the torque prescribed in the SLIP BASE DETAILS Table. Over tightened Base Bolts are not permitted.
4. Distort bolt threads at the junction with nuts to prevent loosening. Repair damaged galvanizing.

D. Obtain a tight sleeve connection by placing 4 galvanized steel shims between the column (post) and sleeve. Space the shims evenly around the perimeter of the column (1 between each bolt hole, 4 total). Use shims that are 1" shorter than the height of the sleeve.

Column (Post) Size		SLIP BASE DETAILS												
Outside Dia.	Wall Thickness	Sleeve I.D. (Max.)	Sleeve Height 'H'	Weld 'W'	Base Plate		Radius 'R'	Base Bolt Size Length	Base Plate Torque		Hole Size 'D'	SHIM		
					'L'	'T'			ft.-lbs	in.-lbs		L	M	
4"	1/4"	4 1/16"	6"	1/4"	8"	3/4"	1 1/32"	5/8"	3"	29	345	1 1/16"	1 3/8"	1 1/16"
4 1/2"	1/4"	4 9/16"	6"	1/4"	8"	7/8"	1 1/32"	5/8"	3 1/4"	29	345	1 1/16"	1 3/8"	1 1/16"
5"	1/4"	5 1/16"	7"	1/4"	8"	7/8"	1 1/32"	5/8"	3 1/4"	29	345	1 1/16"	1 3/8"	1 1/16"
6"	1/4"	6 1/16"	8"	1/4"	9"	1"	1 3/32"	3/4"	3 1/2"	46	554	1 3/16"	1 3/4"	1 3/16"
8"	1/4"	8 1/16"	10"	1/4"	11"	1"	1 5/32"	7/8"	3 3/4"	53	640	1 5/16"	2 3/8"	1 1/16"

SLIP BASE AND FOUNDATION DETAILS



City of Ft. Pierce
City Signs

DESIGN #: 2100575 R12

DATE: 04-30-24

DRAWN BY: Andrew

Revisions / Date / Initials

R11-ADDED GATEWAY INSTALL LOCATIONS & FDOT REQUIREMENTS

R12-ADJUSTED AS PER CITY/PERMITTING NOTES

ETL Acct. #115459
UL 48 Listed Signage
All Sign Components shall be UL listed and Recognized in the SAM Manual
All Wiring shall be at least 90° C rated

ACCOUNT #115459
120 Volt
277 Volt

SHEET 11

ACCOUNT City of Ft. Pierce

STREET XXXX
CITY XXXX STATE FL
SALES REP Frank B, Gary B
SCALE As Noted
FILE NAME
PROGRAM CoreIDRAW
CUSTOMER APPROVAL DATE

Note: Primary power & signage lighting control by others. The primary power must be located within 5' of applicable signs installation location.

All penetrations to have bushings

PRIMARY ELECTRIC BY OTHERS

This design (except registered or existing trademarks) is the property of DON BELL SIGNS LLC and shall not be reproduced or copied in whole or in part without the written permission of the above named owner.



365 OAK PLACE
PORT ORANGE, FL 32127
386-788-8084
800-824-0080

LAST REVISION 11/01/22

DESCRIPTION:



FY 2023-24
STANDARD PLANS

SINGLE COLUMN GROUND SIGNS

INDEX
700-010

SHEET
4 of 11

10/6/2022 2:35:21 PM

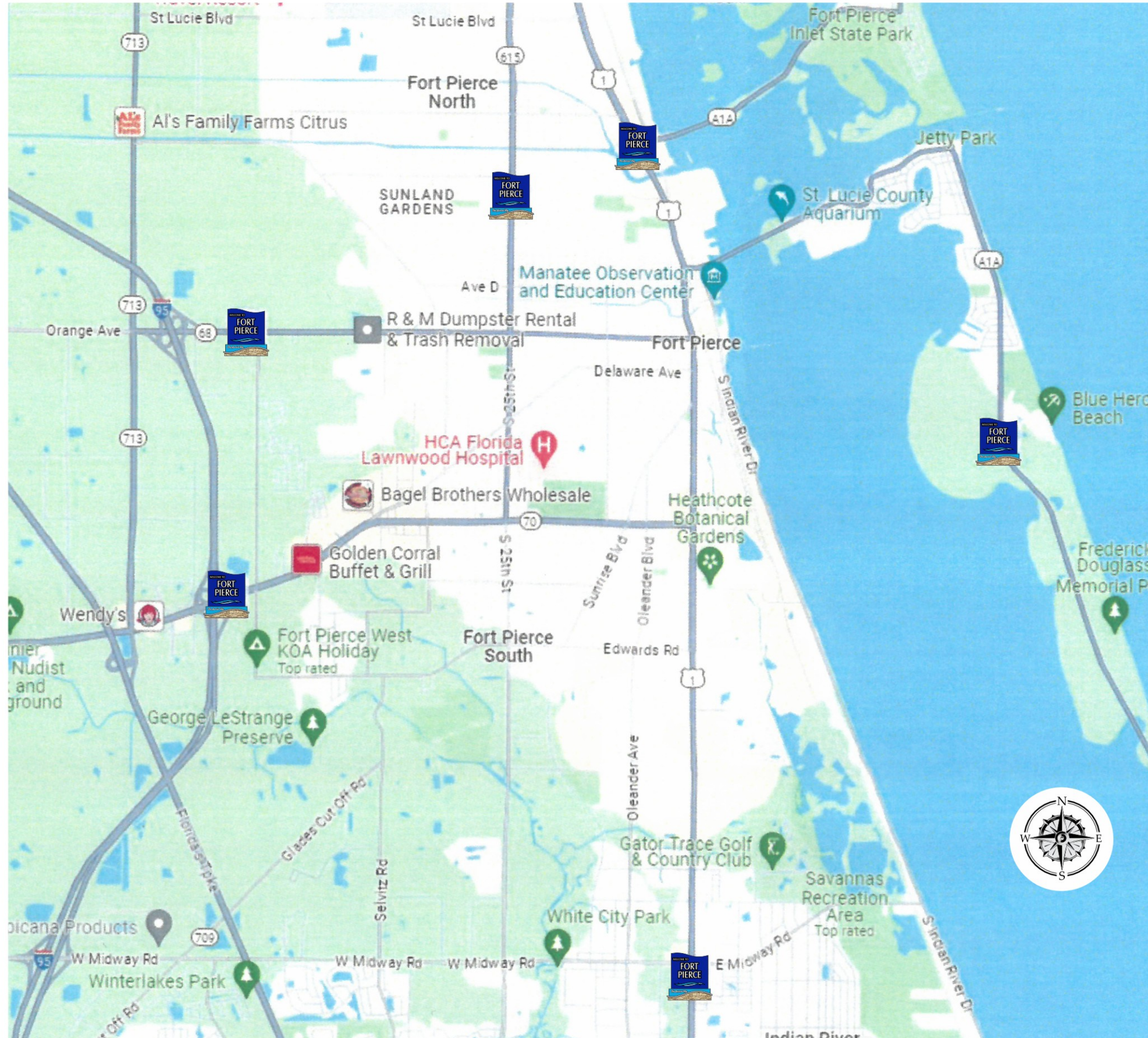

City of Ft. Pierce
City Signs

DESIGN #: 2100575 R12
DATE: 04-30-24
DRAWN BY: Andrew

Revisions / Date / Initials

R11-ADDED GATEWAY INSTALL LOCATIONS & FDOT REQUIREMENTS
R12-ADJUSTED AS PER CITY/PERMITTING NOTES

ETL Acct. #115459
UL 48 Listed Signage
All Sign Components shall be UL listed and Recognized in the SAM Manual
All Wiring shall be at least 90' C rated

ACCOUNT #115459 120 Volt
us 277 Volt

SHEET 12

ACCOUNT: City of Ft. Pierce
STREET: XXXX
CITY: XXXX STATE: FL
SALES REP: Frank B, Gary B
SCALE: As Noted
FILE NAME:
PROGRAM: CorelDRAW
FONTS USED:
CUSTOMER APPROVAL: DATE:

Note: Primary power & signage lighting control by others. The primary power must be located within 5' of applicable signs installation location.

All penetrations to have bushings
PRIMARY ELECTRIC BY OTHERS

This design (except registered or existing trademarks) is the property of DON BELL SIGNS LLC and shall not be reproduced or copied in whole or in part without the written permission of the above named owner.



365 OAK PLACE
PORT ORANGE, FL 32127
386-788-8084
800-824-0080

Section No. _____ CAFA No. _____

EXHIBIT "B"

SPECIAL PROVISIONS

N/A

Section No. _____ CAFA No. _____

EXHIBIT "C"

TERMS AND CONDITIONS FOR INSTALLATION OF THE PROJECT

N/A

Section No. _____ CAFA No. _____

EXHIBIT "D"

AGENCY RESOLUTION

RESOLUTION NO. 24-RXX

A RESOLUTION OF THE FORT PIERCE REDEVELOPMENT AGENCY, A DEPENDENT SPECIAL DISTRICT OF THE CITY OF FORT PIERCE, FLORIDA, APPROVING THE DESIGN, CONSTRUCTION, INSTALLATION AND MAINTENANCE OF LOCAL IDENTIFICATION MARKERS (GATEWAY SIGNS) ON RIGHTS-OF-WAY OWNED BY THE FLORIDA DEPARTMENT OF TRANSPORTATION AS OUTLINED IN THE COMMUNITY AESTHETIC FEATURE AGREEMENT ATTACHED; AUTHORIZING THE FORT PIERCE REDEVELOPMENT AGENCY TO FUND THE PROJECT; AUTHORIZING THE EXECUTION OF THE COMMUNITY AESTHETIC FEATURE AGREEMENT; AND PROVIDING AN EFFECTIVE DATE.

WHEREAS, a comprehensive wayfinding program is considered key to a broad strategy that will accentuate the aesthetic qualities of Fort Pierce to attract visitors, support business owners, develop a sense of community pride, and increase connectivity within the city; and

WHEREAS, the Fort Pierce Redevelopment Agency issued a Request for Proposals on December 28, 2022, for the design, permitting, production, and installation of various types and quantities of wayfinding signs throughout the city; and

WHEREAS, on August 8, 2023, the Fort Pierce Redevelopment Agency Board approved the Service Agreement with Don Bell Signs, Inc. for the Comprehensive Wayfinding Signage Program in an amount not to exceed \$499,739.00; and

WHEREAS, the Fort Pierce Redevelopment Agency has identified six (6) locations within Fort Pierce city limits to install local identification markers (gateway signs) on rights-of-way owned by the Florida Department of Transportation; and

WHEREAS, the Fort Pierce Redevelopment Agency approves the placement of gateway signs on rights-of-way owned by the Florida Department of Transportation at the following locations:

- (1) State Road 70 (Okeechobee Road) West of Jenkins Road;
- (2) State Road 68 (Orange Avenue) West of Jenkins Road;
- (3) State Road 5 (US Highway 1) South of North Causeway Bridge;
- (4) State Road 5 (US Highway 1) South of Midway Road;
- (5) State Road A1A South of Blue Heron Boulevard; and
- (6) State Road 615 (25th Street) South of Avenue O; and

WHEREAS, the Fort Pierce Redevelopment Agency agrees to fund all costs for the design, installation, and maintenance of the gateway signs on rights-of-way owned by the Florida Department of Transportation; and

WHEREAS, in order to install the gateway signs on the rights-of-way, the Florida Department of Transportation requires the execution of the Community Aesthetic Feature Agreement (attached); and

WHEREAS, the Community Aesthetic Feature Agreement requires that the Fort Pierce Redevelopment Agency pass a Resolution agreeing to the project and agreeing to fund all costs for the project described in Exhibit "A" to the Agreement; and

WHEREAS, a copy of this Resolution is required to be attached as "Exhibit D" to the Community Aesthetic Feature Agreement.

NOW, THEREFORE, BE IT RESOLVED by the Fort Pierce Redevelopment Agency, a Dependent Special District of the City of Fort Pierce, Florida, as follows:

1. The aforementioned recitals in the whereas clauses are true and correct and are hereby incorporated in this Resolution.
2. The Fort Pierce Redevelopment Agency Board approves the project consisting of the design, construction, installation, and maintenance of local identification markers (gateway signs) on rights-of-way owned by the Florida Department of Transportation as outlined in the Community Aesthetic Feature Agreement.

3. The Fort Pierce Redevelopment Agency authorizes and agrees to fund the design, construction, installation, and maintenance of local identification markers (gateway signs) on rights-of-way owned by the Florida Department of Transportation as outlined in the Community Aesthetic Feature Agreement.
4. The Fort Pierce Redevelopment Agency is authorized to execute the Community Aesthetic Feature Agreement (attached).
5. The Director of the Fort Pierce Redevelopment Agency is hereby authorized to take all steps necessary to effectuate this Resolution.
6. This Resolution shall become effective immediately upon adoption.

IN WITNESS WHEREOF, this Resolution has been duly adopted this ____ day of _____, 2024

Linda Hudson, Chair
Fort Pierce Redevelopment Agency

ATTEST:

Linda Cox, Agency Secretary

(SEAL)

Approved as to Form and Correctness:

Sara Hedges, Agency Attorney

Section No. _____ CAFA No. _____

EXHIBIT "E"

NOTICE OF COMPLETION AND RESPONSIBLE PROFESSIONAL'S
CERTIFICATE OF COMPLIANCE

NOTICE OF COMPLETION

COMMUNITY AESTHETIC FEATURE AGREEMENT
Between
THE STATE OF FLORIDA, DEPARTMENT OF TRANSPORTATION
and Fort Pierce Redevelopment Agency

PROJECT DESCRIPTION: The project involves the design, construction, installation and maintenance of 6 Gateway signs at designated locations on FDOT rights-of-way. The signs will serve as welcoming features and visually distinguish the entrances to the city.

In accordance with the Terms and Conditions of the Community Aesthetic Feature Agreement, the undersigned provides notification that the work authorized by this Agreement is complete as of _____, 20_____.

By: _____

Name: Nick Mimms

Title: FPRA Director

RESPONSIBLE PROFESSIONAL'S CERTIFICATION OF COMPLIANCE

In accordance with the Terms and Conditions of the Community Aesthetic Feature Agreement, the undersigned certifies that all work which originally required certification by a Professional Engineer has been completed in compliance with the Project construction plans and specifications. If any deviations have been made from the approved plans, a list of all deviations, along with an explanation that justifies the reason to accept each deviation, will be attached to this Certification. Also, with submittal of this certification, the Agency shall furnish the Department a set of "as-built" plans certified by the Engineer of Record.

By: _____

SEAL:

Name: _____

Date: _____