

Administrative Certificates of Appropriateness

Attached is Certificates of Appropriateness issued administratively in February 2024.

- COA #24-07, 725 S Indian River Drive – Windows
- COA #24-08, 308 S 8th Street – Windows
- COA #34-09, 736 Delaware Avenue - Sign



CERTIFICATE OF APPROPRIATENESS
 TO ALTER A DESIGNATED HISTORIC SITE

COA#24-07 HISTORIC PRESERVATION BOARD APPROVAL

ADMINISTRATIVE APPROVAL

Site address: 725 S Indian River Drive

Contributing

Non-Contributing

Individually Designated

SITE ALTERATIONS:

Request	Conditions	Applicable Standards
Remove 9 existing windows and install new impact windows, using like sizes. Please see attached.		Secretary of the Interior's Standards for Rehabilitation of Historic Properties, Standard 9.

APPROVED:

Board Approval

Administrative Approval

 Charles Hayek, Chairman
 Historic Preservation Board

Date



 Maria Lewicka, AICP
 Historic Preservation Planner

2/16/2024

Date

This alteration meets the Secretary of the Interior's Standards for the Treatment of Historic Properties and the City of Fort Pierce Code of Ordinances.

Should you have any further questions or concerns, contact Maria Lewicka, Historic Preservation Planner, at (772) 467-3738 or via e-mail at mlewicka@cityoffortpierce.com.

Thank you for your efforts to preserve and redevelop historic Fort Pierce through your participation in the Certificate of Appropriateness Application process. Staff looks forward to working with you in the future to preserve and rehabilitate our historic neighborhoods and structures.

Provided to:	Name/Address	Via
Owner	Steven E Haines 725 S Indian River Drive Fort Pierce, FL 32950	E-Mail stephenehaines@gmail.com
Applicant	Kamrell Windows & Doors/ Bruce M, Tyrrell Jr. 8200 SW Lost River Road Stuart, FL 34997	E-Mail sue@kamrell.com

Bldg. Permit # _____

COA# 24-07



CITY OF FORT PIERCE

PLANNING DEPARTMENT

COMPREHENSIVE PLANNING ◊ DEVELOPMENT REVIEW
HISTORIC PRESERVATION ◊ URBAN DESIGN ◊ URBAN FORESTRY ◊ ZONING

Certificate of Appropriateness Application

Building & Site Information

Address of the Site: 725 S INDIAN RIVER DR
Parcel ID #: 2410-805-0014-030-6
Type of Designation: Contributing Non-contributing Site within the _____ Historic District
 Individually Designated Site, City Commission Resolution No. _____

Property Owner / Applicant Information

Property Owner(s)
Name(s): Steven E Haines
Mailing Address: 725 S Indian River DR Fort Pierce, FL 34950
Phone Number(s): 772-370-7865 Email: Stephenehaines@gmail.com

Applicant
Name(s): Kamrell Windows & Doors/ Bruce M, Tyrrell Jr.
Mailing Address: 8200 SW Lost River Rd Stuart, FL 34997
Phone Number(s): 772-288-6205 Email: sue@kamrell.com

Representative
Name(s): Sue Goddard
Mailing Address: 8200 SW Lost River Rd Stuart FL 34997
Phone Number(s): 772-288-6205 Email: sue@kamrell.com

Property Owner(s) Acknowledgements:- This application will not be considered complete without the signature of all property owners of record, which shall serve as an acknowledgement of the submission of this application. The property owner's signature below shall also authorize the Applicant (if other than the property owner) and/or Representative to act in his/her behalf for the purposes of seeking approval for the application described herein. The undersigned consents to inspection and photographing of the subject property by the Historic Preservation staff for purposes of consideration of this Application and/or presentation to the Historic Preservation Board.

I / We, Steven Haines as Owner(s) of the subject property, do hereby authorize the filing of this application on my/our behalf.

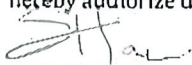
Signature of Owner

01.24.2024
Date

Description of Requested Work

Please indicate the type of work requested:

- | | | | |
|---|---|-------------------------------------|-------------------------------------|
| <input type="checkbox"/> Fence | <input type="checkbox"/> Shed | <input type="checkbox"/> Door(s) | <input type="checkbox"/> Roof |
| <input type="checkbox"/> Window(s) | <input type="checkbox"/> Signage | <input type="checkbox"/> Shutter(s) | <input type="checkbox"/> Porch |
| <input type="checkbox"/> Rehabilitation | <input type="checkbox"/> New Construction | <input type="checkbox"/> Demolition | <input type="checkbox"/> Relocation |

Site Improvements (describe) Replace 9 windows with impact. Using like sizes.

Other (describe) _____

Please provide a detailed description of the proposed work to be performed: _____

Replace 9 windows with impact. Using like sizes. Frames to be White glass to be clear .

Have other alterations been made to the site within the last 12 months? No Yes, _____

Will the proposed work require a Zoning Variance? No Yes, Code Section(s): _____

Application Requirements

- \$10.00 Application fee
 - Site Plan with dimensions.
 - Architectural Drawings:
 - Drawings should show all current and proposed floor plans and elevations, fences, walls, and any other landscape features.
 - Drawings should indicate materials to be used.
 - Photos - One (1) color photograph of the main façade of the site and photographs of any areas affected by the proposed project.
 - Material(s) specifications and/or sample(s)
 - Color samples.
-
- Demolition – Plans for what will be taking the demolished structure’s place should be submitted.

Haines - 725 South Indian River Drive, Fort Pierce FL

EXPOSURE D - RF HGT 15' - ZONE 4

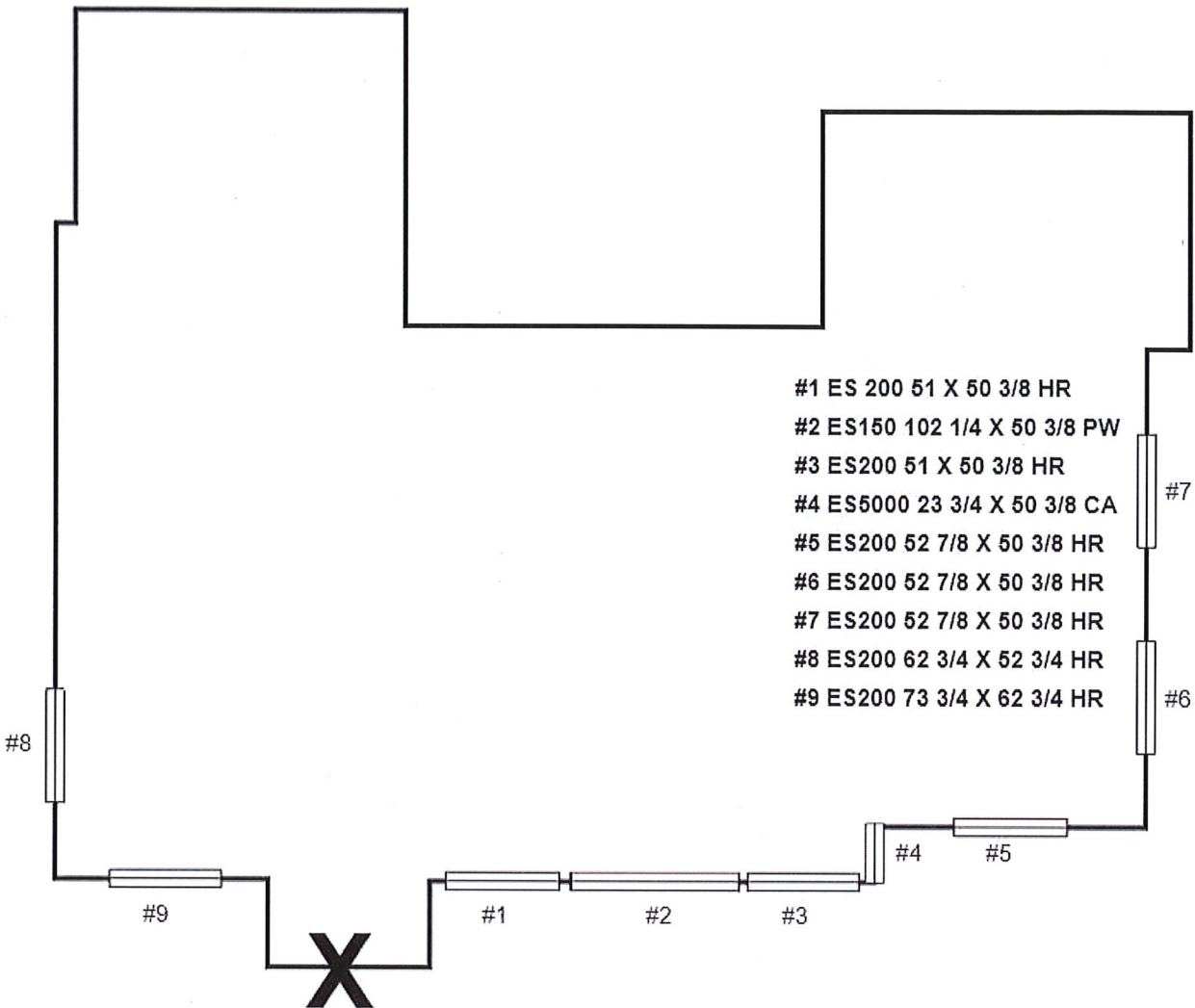













PROPOSAL NUMBER

531135

PROPOSAL NAME

Steven Haines | FP | Justin

EXTERNAL PURCHASE ORDER ID

1023350

QUOTE ITEMS

LINE NUM	LINE NAME	ASSEMBLY SYSTEM	ASSEMBLY	TOTAL QUANTITY
1	#1	ES-EL200 - HORIZONTAL ROLLER	OX	1

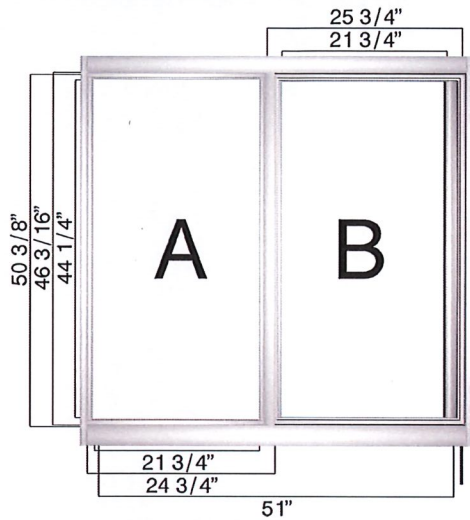

SIZE 51" X 50 3/8"
AREA 17.84 FT²
FINISH AAMA 2604 WHITE
GLASS 1/4" CLEAR HS N70/38 + 0.09 PVB CLEAR + 1/8" CLEAR HS
SCREEN YES
MUNTINS NO
SILL TYPE STANDARD
FRAME TYPE FLANGE
OPENING 4" NO
PANEL TYPE EQUAL
MEETING RAIL STANDARD WITH ALUMINUM REINFORCEMENT
PROTECTIVE FILM BOTH
LOCKING MECHANISM SWEEP LOCK MULTIMAX (2530)
PRE-GLAZED? YES

FBC CERTIFICATION
 INTERNAL PSF 80.00
 EXTERNAL PSF 75.00
CODE FL 21557.1
NOA CERTIFICATION
 INTERNAL PSF 90.00
 EXTERNAL PSF 80.00
CODE 21-0608.03

2	#2	ES-EL150 - FIXED WINDOW	O	1
---	----	-------------------------	---	---

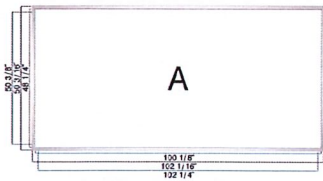

SIZE 102 1/4" X 50 3/8"
AREA 35.77 FT²
FINISH AAMA 2604 WHITE
GLASS 3/16" CLEAR HS N70/38 + 0.077 VSO2 CLEAR + 3/16" CLEAR HS
MUNTIN NO
FRAME TYPE FLANGE
PROTECTIVE FILM BOTH
PRE-GLAZED? YES

NO NOA
NO FBC

3 #3

ES-EL200 -
HORIZONTAL
ROLLER

XO 1

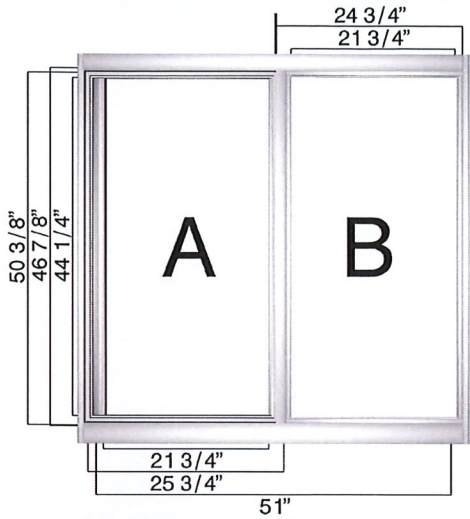

SIZE 51" X 50 3/8"
AREA 17.84 FT²
FINISH AAMA 2604 WHITE
GLASS 1/4" CLEAR HS N70/38 + 0.09 PVB
 CLEAR + 1/8" CLEAR HS
SCREEN YES
MUNTINS NO
SILL TYPE STANDARD
FRAME TYPE FLANGE
OPENING 4" NO
PANEL TYPE EQUAL
MEETING STANDARD WITH ALUMINUM
RAIL REINFORCEMENT
PROTECTIVE
FILM BOTH
LOCKING
MECHANISM SWEEP LOCK MULTIMAX (2530)
PRE-
GLAZED? YES

FBC CERTIFICATION
 INTERNAL PSF 80.00 EXTERNAL PSF 75.00
CODE FL 21557.1
NOA CERTIFICATION
 INTERNAL PSF 90.00 EXTERNAL PSF 80.00
CODE 21-0608.03

4 #4

ES-5000 -
CASEMENT

MULTIPOINT 1

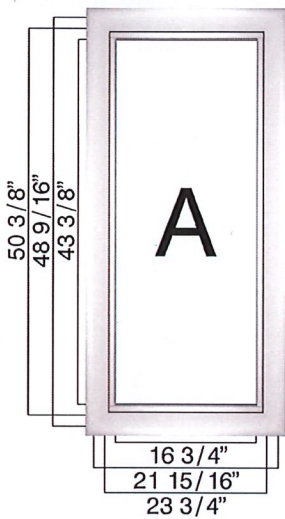

SIZE 23 3/4" X 50 3/8"
AREA 8.31 FT²
FINISH AAMA 2604 WHITE
GLASS 1/4" CLEAR HS N70/38 + 0.09 PVB
 CLEAR + 1/8" CLEAR HS
SCREEN YES
MUNTINS NO
OPENING RIGHT OPENING (XR)
FRAME TYPE FLANGE
LIMIT
DEVICE NO
PROTECTIVE
FILM BOTH
LOCKING
MECHANISM MULTIPOINT LOCK
PRE-
GLAZED? YES

FBC CERTIFICATION
 INTERNAL PSF 114.00 EXTERNAL PSF 90.00
CODE FL-41000.1

5 #5 #6 #7

ES-EL200 -
HORIZONTAL
ROLLER

XO

3

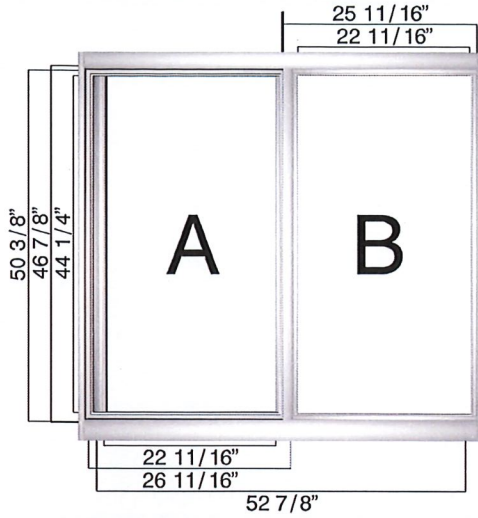

SIZE	52 7/8" X 50 3/8"
AREA	18.50 FT ²
FINISH	AAMA 2604 WHITE
GLASS	1/4" CLEAR HS N70/38 + 0.09 PVB CLEAR + 1/8" CLEAR HS
SCREEN	YES
MUNTINS	NO
SILL TYPE	STANDARD
FRAME TYPE	FLANGE
OPENING 4"	NO
PANEL TYPE	EQUAL
MEETING RAIL	STANDARD WITH ALUMINUM REINFORCEMENT
PROTECTIVE FILM	BOTH
LOCKING MECHANISM	SWEEP LOCK MULTIMAX (2530)
PRE- GLAZED?	YES

FBC CERTIFICATION	
INTERNAL PSF	EXTERNAL PSF
80.00	75.00
CODE	FL 21557.1
NOA CERTIFICATION	
INTERNAL PSF	EXTERNAL PSF
90.00	80.00
CODE	21-0608.03

6 #8

ES-EL200 -
HORIZONTAL
ROLLER

OX

1

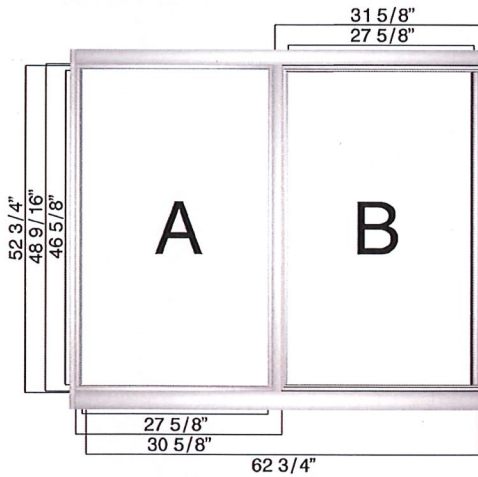

SIZE	62 3/4" X 52 3/4"
AREA	22.99 FT ²
FINISH	AAMA 2604 WHITE
GLASS	1/4" CLEAR HS N70/38 + 0.09 PVB CLEAR + 1/8" CLEAR HS
SCREEN	YES
MUNTINS	NO
SILL TYPE	STANDARD
FRAME TYPE	FLANGE
OPENING 4"	NO
PANEL TYPE	EQUAL
MEETING RAIL	STANDARD WITH ALUMINUM REINFORCEMENT
PROTECTIVE FILM	BOTH
LOCKING MECHANISM	SWEEP LOCK MULTIMAX (2530)
PRE- GLAZED?	YES

FBC CERTIFICATION	
INTERNAL PSF	EXTERNAL PSF
80.00	75.00
CODE	FL 21557.1
NOA CERTIFICATION	
INTERNAL PSF	EXTERNAL PSF
90.00	80.00
CODE	21-0608.03

ES-EL200 -
HORIZONTAL
ROLLER

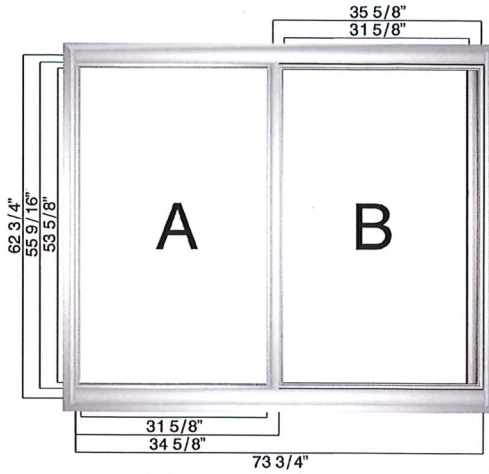

SIZE 73 3/4" X 62 3/4"
AREA 32.14 FT²
FINISH AAMA 2604 WHITE
GLASS 1/4" CLEAR HS N70/38 + 0.09 PVB CLEAR + 1/8" CLEAR HS
SCREEN YES
MUNTINS NO
SILL TYPE STANDARD
FRAME TYPE FIN
OPENING 4" NO
PANEL TYPE EQUAL
MEETING RAIL STANDARD WITH ALUMINUM REINFORCEMENT
PROTECTIVE FILM BOTH
LOCKING MECHANISM SWEEP LOCK MULTIMAX (2530)
PRE-GLAZED? YES

FBC CERTIFICATION
 INTERNAL PSF 80.00 EXTERNAL PSF 75.00
CODE FL 21557.1
NOA CERTIFICATION
 INTERNAL PSF 90.00 EXTERNAL PSF 80.00
CODE 21-0608.03

MULLION

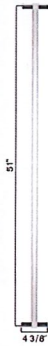

SIZE 1" X 51"
AREA 0.35 FT²
FINISH AAMA 2604 WHITE
GLASS
ANCHOR STANDARD
MULLION TYPE 3 X 1 CUSTOME
PRE-GLAZED? NO

NO NOA
NO FBC



CERTIFICATE OF APPROPRIATENESS
 TO ALTER A DESIGNATED HISTORIC SITE

COA#24-08 HISTORIC PRESERVATION BOARD APPROVAL

ADMINISTRATIVE APPROVAL

Site address: 308 S 8th Street

Contributing

Non-Contributing

Individually Designated

SITE ALTERATIONS:

Request	Conditions	Applicable Standards
Remove all existing windows and install new impact windows, using like sizes. Please see attached.		Secretary of the Interior's Standards for Rehabilitation of Historic Properties, Standard 9.

APPROVED:

Board Approval

Administrative Approval

 Charles Hayek, Chairman
 Historic Preservation Board

 Date



 Maria Lewicka, AICP
 Historic Preservation Planner

2/16/2024

 Date

This alteration meets the Secretary of the Interior's Standards for the Treatment of Historic Properties and the City of Fort Pierce Code of Ordinances.

Should you have any further questions or concerns, contact Maria Lewicka, Historic Preservation Planner, at (772) 467-3738 or via e-mail at mlewicka@cityoffortpierce.com.

Thank you for your efforts to preserve and redevelop historic Fort Pierce through your participation in the Certificate of Appropriateness Application process. Staff looks forward to working with you in the future to preserve and rehabilitate our historic neighborhoods and structures.

Provided to:	Name/Address	Via
Owner	Norace Harris-Bolt 308 S 8 th Street Fort Pierce, FL 32950	E-Mail noraceharrisbolt@yahoo.com
Applicant	JBR Exteriors, Inc. Brown Johnson 1201 SW Biltmore Street PSL, FL 34983	E-Mail info@jbrexteriors.com

FEB 14 2024

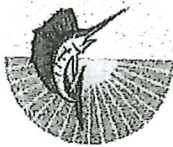

THE SUNRISE CITY
FORT PIERCE
PLANNING DEPARTMENT
Florida

CITY OF FORT PIERCE
PLANNING & ZONING

Bldg. Permit # _____

COA# 24-08

Certificate of Appropriateness Application

Building & Site Information

Address of the Site: 308 S. 8th Street

Parcel ID #: 2410-706-0086-000-8

Type of Designation: Contributing Non-contributing Site within the _____ Historic District

Individually Designated Site, City Commission Resolution No. _____

Property Owner/ Applicant Information

Property Owner(s)
Name(s): Norace Harris-Bolt

Mailing Address: 308 S. 8th St. Ft. Pierce, FL 34950

Phone Number(s): 772-882-0057 Email: noraceharrisbolt@yahoo.com

Applicant
Name(s): JBR Exteriors, Inc.

Mailing Address: 1201 SW Billmore St PSC 34953

Phone Number(s): 772 873 0600 Email: info@jbrexteriors.com

Representative
Name(s): Brown Johnson

Mailing Address: SAME

Phone Number(s): 772 370 1000 Email: SAME

Property Owner(s) Acknowledgements:- This application will not be considered complete without the signature of all property owners of record, which shall serve as an acknowledgement of the submission of this application. The property owner's signature below shall also authorize the Applicant (if other than the property owner) and/or Representative to act in his/her behalf for the purposes of seeking approval for the application described herein. The undersigned consents to inspection and photographing of the subject property by the Historic Preservation staff for purposes of consideration of this Application and/or presentation to the Historic Preservation Board.

I / We, NORACE HARRIS-BOLT as Owner(s) of the subject property do hereby authorize the filing of this application on my/our behalf.

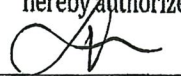
Signature of Owner

2/13/2024
Date

Description of Requested Work

Please indicate the type of work requested:

Fence

Shed

Door(s)

Roof

Window(s)

Signage

Shutter(s)

Porch

Rehabilitation

New Construction

Demolition

Relocation

Site Improvements (describe) replace all windows

Other (describe) _____

Please provide a detailed description of the proposed work to be performed: remove and replace

all windows with impact product - see attached

white color - / like for like

vinyl / white / low E 270 / impact

Have other alterations been made to the site within the last 12 months? No Yes, _____

Will the proposed work require a Zoning Variance? No Yes, Code Section(s): _____

Application Requirements

- \$10.00 Application fee
- Site Plan with dimensions.
- Architectural Drawings:
 - > Drawings should show all current and proposed floor plans and elevations, fences, walls, and any other landscape features.
 - > Drawings should indicate materials to be used.
- Photos - One (1) color photograph of the main façade of the site and photographs of any areas affected by the proposed project.
- Material(s) specifications and/or sample(s)
- Color samples.
- Demolition - Plans for what will be taking the demolished structure's place should be submitted.



front - west elevation



South side and rear
(RIGHT)



north side
(left)

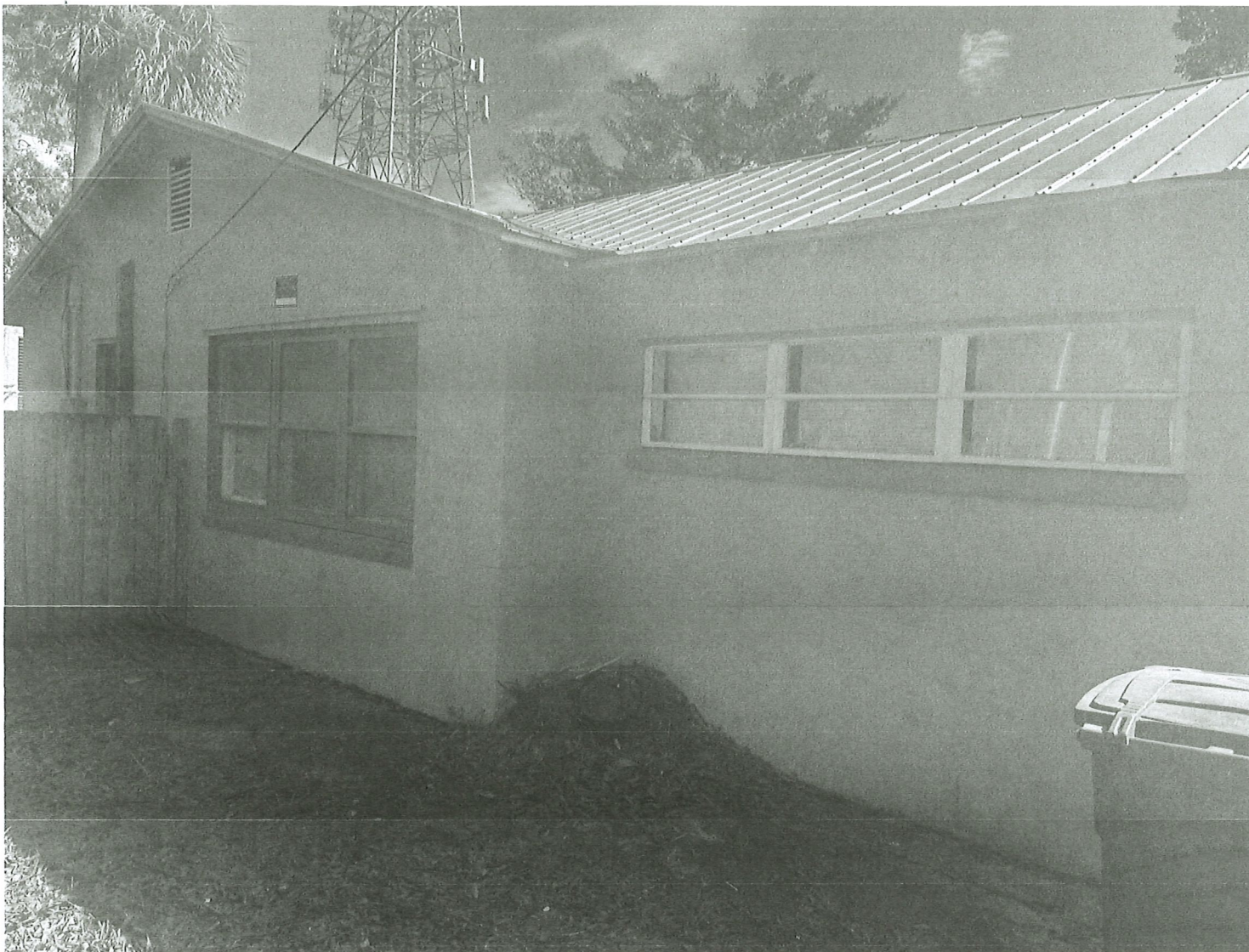

North side
(left)



South side
(RIGHT)



By: Dakota Johnson

Order

Noras Harris Bolt Order #: 2183797

1201 S.W. BILTMORE STREET, PORT ST. LUCIE, FL 34983

JBR - PREFERRED BUILDER ACCOUNT

Order Date: 10/3/2023

Est. Ship Date: 10/26/2023

Route: FtPrc

Cust PO#: Raxcie 8th St

Bill To:

Ship To:

All Window Product

Order

Item No. 4 Qty: 1
Model: 8100-SH Color: WHITE
 Desc: 8100 SINGLE HUNG DP:+70/-70, [FLANGE], WHITE FRAME, 18 x16 Screen
 OBSCURE, Insulated, IMPACT
 SCREEN
 AAMA Std. Gold Labeling
 FPA #16177.1, WHITE, [No Sill Anchors this SH-8100]
 Tempered
 DOES NOT MEET EGRESS,

Dimensions

DLO: 18 x 37
 TIP: 19 1/4 x 38 1/4
 GD: 12 1/4 x 15 7/16
 SCREEN: 18 X 16

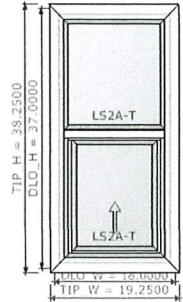

8100-SH- NFRC Rating: CWS-K-11-00877-00001 / U-Factor=0.45, Solar SHGC=0.56, V-Transmit=0.61

Item No. 5 Qty: 1
Model: 8100-SH Color: WHITE
 Desc: 8100 SINGLE HUNG DP:+70/-70, [FLANGE], WHITE FRAME, 18 x16 Screen
 LOW E 270, Insulated, IMPACT
 SCREEN
 AAMA Std. Gold Labeling
 FPA #16177.1, WHITE, [No Sill Anchors this SH-8100]
 DOES NOT MEET EGRESS,

Dimensions

DLO: 37 x 38
 TIP: 38 1/4 x 39 1/4
 GD: 31 1/4 x 15 15/16
 SCREEN: 18 X 16

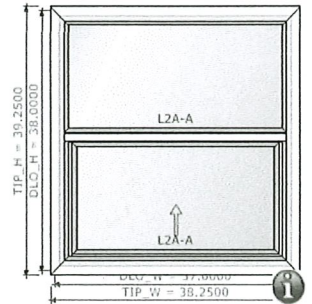

8100-SH- NFRC Rating: CWS-K-11-00922-00001 / U-Factor=0.31, Solar SHGC=0.28, V-Transmit=0.52

Item No. 6 Qty: 1
Model: PVC VERTICAL MULL KIT Color: WHITE
 Desc: PVC VERTICAL MULLBAR KIT, FPA #9520.1, [FLANGE], Standard "T" Clip for
 FLANGE or BOX frames, WHITE FRAME, 3" FLAT MULL, STD HARDWARE
 AAMA Std. Gold Labeling,

Dimensions

H=38



Windows ONLY



By: Dakota Johnson

Order

Order #: 2183797

1201 S.W. BILTMORE STREET, PORT ST. LUCIE, FL 34983

JBR - PREFERRED BUILDER ACCOUNT

Order Date: 10/3/2023

Est. Ship Date: 10/26/2023

Route: FtPrc

Cust PO#: Raxcie 8th St

Bill To:

Ship To:

Order

Item No. 7 Qty: 1
Model: 8100-SH Color: WHITE
 Desc: 8100 SINGLE HUNG DP:+70/-70, [FLANGE], WHITE FRAME, 18 x16 Screen
 LOW E 270, Insulated, IMPACT
 SCREEN
 AAMA Std. Gold Labeling
 FPA #16177.1, WHITE, [No Sill Anchors this SH-8100]
 DOES NOT MEET EGRESS,

Dimensions

DLO: 37 x 38
 TIP: 38 1/4 x 39 1/4
 GD: 31 1/4 x 15 15/16
 SCREEN: 18 X 16

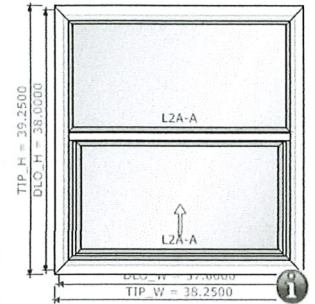

8100-SH- NFRC Rating: CWS-K-11-00922-00001 / U-Factor=0.31, Solar SHGC=0.28, V-Transmit=0.52

Item No. 8 Qty: 1
Model: 8100-SH Color: WHITE
 Desc: 8100 SINGLE HUNG DP:+70/-70, [FLANGE], WHITE FRAME, 18 x16 Screen
 LOW E 270, Insulated, IMPACT
 SCREEN
 AAMA Std. Gold Labeling
 FPA #16177.1, WHITE, [No Sill Anchors this SH-8100]
 DOES NOT MEET EGRESS,

Dimensions

DLO: 30 x 42
 TIP: 31 1/4 x 43 1/4
 GD: 24 1/4 x 17 15/16
 SCREEN: 18 X 16

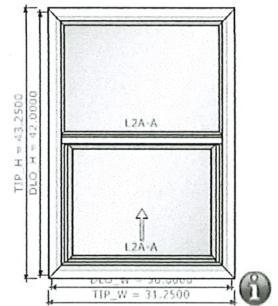

8100-SH- NFRC Rating: CWS-K-11-00922-00001 / U-Factor=0.31, Solar SHGC=0.28, V-Transmit=0.52

Item No. 9 Qty: 1
Model: 8100-SH Color: WHITE
 Desc: 8100 SINGLE HUNG DP:+70/-70, [FLANGE], WHITE FRAME, 18 x16 Screen
 LOW E 270, Insulated, IMPACT
 SCREEN
 AAMA Std. Gold Labeling
 FPA #16177.1, WHITE, [No Sill Anchors this SH-8100]
 Clr. Opng. MEETS EGRESS,

Dimensions

DLO: 37 1/2 x 58
 TIP: 38 3/4 x 59 1/4
 GD: 31 3/4 x 25 15/16
 SCREEN: 18 X 16

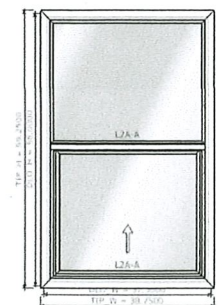

8100-SH- NFRC Rating: CWS-K-11-00922-00001 / U-Factor=0.31, Solar SHGC=0.28, V-Transmit=0.52



By: Dakota Johnson

Order

Order #: 2183797

1201 S.W. BILTMORE STREET, PORT ST. LUCIE, FL 34983

JBR - PREFERRED BUILDER ACCOUNT

Order Date: 10/3/2023

Est. Ship Date: 10/26/2023

Route: FtPrc

Cust PO#: Raxcie 8th St

Bill To:	Ship To:

Order

Item No. 10 Qty: 1
Model: 8100-SH Color: WHITE
 Desc: 8100 SINGLE HUNG DP:+70/-70, [FLANGE], WHITE FRAME, 18 x16 Screen LOW E 270, Insulated, IMPACT SCREEN
 AAMA Std. Gold Labeling
 FPA #16177.1, WHITE, [No Sill Anchors this SH-8100]
 Clr. Opng. MEETS EGRESS,

Dimensions
 DLO: 37 1/2 x 58
 TIP: 38 3/4 x 59 1/4
 GD: 31 3/4 x 25 15/16
 SCREEN: 18 X 16

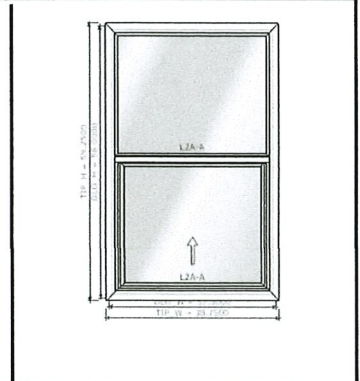
8100-SH- NFRC Rating: CWS-K-11-00922-00001 / U-Factor=0.31, Solar SHGC=0.28, V-Transmit=0.52

Item No. 11 Qty: 1
Model: PVC VERTICAL MULL KIT Color: WHITE
 Desc: PVC VERTICAL MULLBAR KIT, FPA #9520.1, [FLANGE], Standard "T" Clip for FLANGE or BOX frames, WHITE FRAME, 3" FLAT MULL, STD HARDWARE
 AAMA Std. Gold Labeling,

Dimensions
 H=58

Item No. 12 Qty: 1
Model: 8100-SH Color: WHITE
 Desc: 8100 SINGLE HUNG DP:+70/-70, [FLANGE], WHITE FRAME, 18 x16 Screen LOW E 270, Insulated, IMPACT SCREEN
 AAMA Std. Gold Labeling
 FPA #16177.1, WHITE, [No Sill Anchors this SH-8100]
 Clr. Opng. MEETS EGRESS,

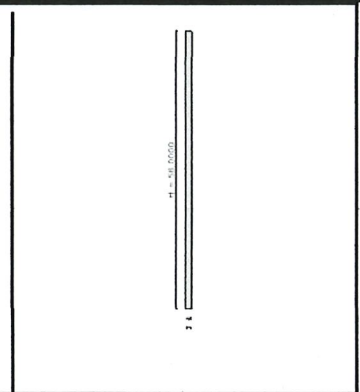
Dimensions
 DLO: 37 1/2 x 58
 TIP: 38 3/4 x 59 1/4
 GD: 31 3/4 x 25 15/16
 SCREEN: 18 X 16

8100-SH- NFRC Rating: CWS-K-11-00922-00001 / U-Factor=0.31, Solar SHGC=0.28, V-Transmit=0.52

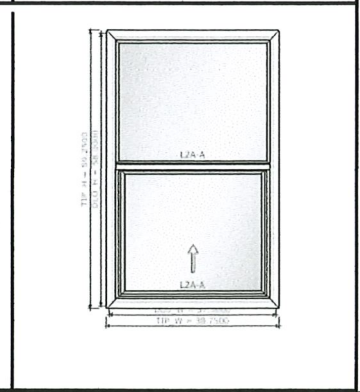

By: Dakota Johnson

Order

Order #: 2183797

1201 S.W. BILTMORE STREET, PORT ST. LUCIE,
FL 34983

JBR - PREFERRED BUILDER ACCOUNT

Order Date: 10/3/2023
Est. Ship Date: 10/26/2023
Route: FtPre

Cust PO#: Raxcie 8th St

Bill To:

Ship To:

Order

Item No. 13 Qty: 1

Model: 8100-SH Color: WHITE

Desc: 8100 SINGLE HUNG DP:+70/-70, [FLANGE], WHITE FRAME, 18 x16 Screen
LOW E 270, Insulated, IMPACT
SCREEN

AAMA Std. Gold Labeling
FPA #16177.1, WHITE, [No Sill Anchors this SH-8100]
DOES NOT MEET EGRESS,

Dimensions

DLO: 30 x 42
TIP: 31 1/4 x 43 1/4
GD: 24 1/4 x 17 15/16
SCREEN: 18 X 16

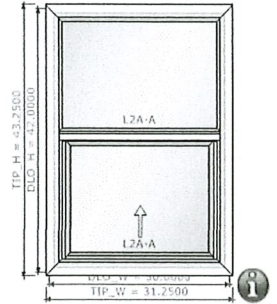

8100-SH- NFRC Rating: CWS-K-11-00922-00001 / U-Factor=0.31, Solar SHGC=0.28, V-Transmit=0.52

Item No. 14 Qty: 1

Model: 8100-SH Color: WHITE

Desc: 8100 SINGLE HUNG DP:+70/-70, [FLANGE], WHITE FRAME, 18 x16 Screen
LOW E 270, Insulated, IMPACT
SCREEN

AAMA Std. Gold Labeling
FPA #16177.1, WHITE, [No Sill Anchors this SH-8100]
DOES NOT MEET EGRESS,

Dimensions

DLO: 37 x 50 1/2
TIP: 38 1/4 x 51 3/4
GD: 31 1/4 x 22 3/16
SCREEN: 18 X 16

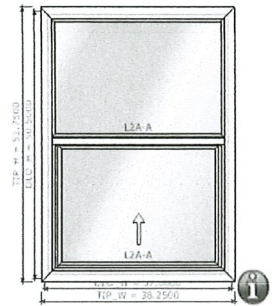

8100-SH- NFRC Rating: CWS-K-11-00922-00001 / U-Factor=0.31, Solar SHGC=0.28, V-Transmit=0.52

Item No. 15 Qty: 1

Model: 8100-SH Color: WHITE

Desc: 8100 SINGLE HUNG DP:+70/-70, [FLANGE], WHITE FRAME, 18 x16 Screen
LOW E 270, Insulated, IMPACT
SCREEN

AAMA Std. Gold Labeling
FPA #16177.1, WHITE, [No Sill Anchors this SH-8100]
DOES NOT MEET EGRESS,

Dimensions

DLO: 30 x 50 1/2
TIP: 31 1/4 x 51 3/4
GD: 24 1/4 x 22 3/16
SCREEN: 18 X 16

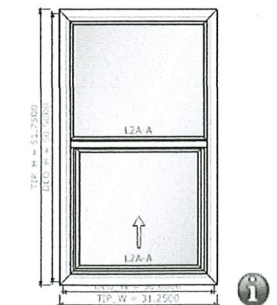

8100-SH- NFRC Rating: CWS-K-11-00922-00001 / U-Factor=0.31, Solar SHGC=0.28, V-Transmit=0.52



By: Dakota Johnson

Order

Order #: 2183797

1201 S.W. BILTMORE STREET, PORT ST. LUCIE, FL 34983

JBR - PREFERRED BUILDER ACCOUNT

Order Date: 10/3/2023

Est. Ship Date: 10/26/2023

Route: FtPrc

Cust PO#: Raxcie 8th St

Bill To:	Ship To:

Order

Item No. 16 Qty: 1
Model: 8100-SH Color: WHITE
 Desc: 8100 SINGLE HUNG DP:+70/-70, [FLANGE], WHITE FRAME, 18 x16 Screen LOW E 270, Insulated, IMPACT SCREEN
 AAMA Std. Gold Labeling
 FPA #16177.1, WHITE, [No Sill Anchors this SH-8100]
 DOES NOT MEET EGRESS,

Dimensions
 DLO: 30 x 50 1/2
 TIP: 31 1/4 x 51 3/4
 GD: 24 1/4 x 22 3/16
 SCREEN: 18 X 16

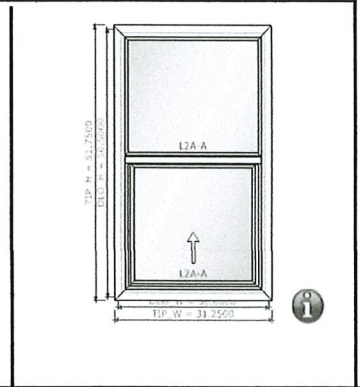
8100-SH- NFRC Rating: CWS-K-11-00922-00001 / U-Factor=0.31, Solar SHGC=0.28, V-Transmit=0.52

Item No. 17 Qty: 1
Model: 8100-SH Color: WHITE
 Desc: 8100 SINGLE HUNG DP:+70/-70, [FLANGE], WHITE FRAME, 18 x16 Screen LOW E 270, Insulated, IMPACT SCREEN
 AAMA Std. Gold Labeling
 FPA #16177.1, WHITE, [No Sill Anchors this SH-8100]
 DOES NOT MEET EGRESS,

Dimensions
 DLO: 36 1/2 x 26
 TIP: 37 3/4 x 27 1/4
 GD: 30 3/4 x 9 15/16
 SCREEN: 18 X 16

8100-SH- NFRC Rating: CWS-K-11-00922-00001 / U-Factor=0.31, Solar SHGC=0.28, V-Transmit=0.52

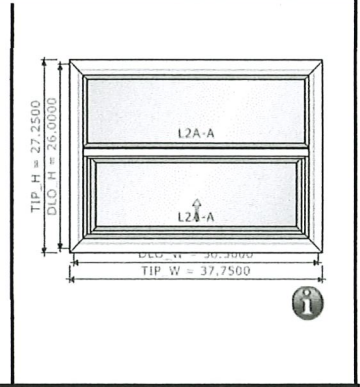
Item No. 18 Qty: 1
Model: PVC VERTICAL MULL KIT Color: WHITE
 Desc: PVC VERTICAL MULLBAR KIT, FPA #9520.1, [FLANGE], Standard "T" Clip for FLANGE or BOX frames. WHITE FRAME, 3" FLAT MULL, STD HARDWARE
 AAMA Std. Gold Labeling,

Dimensions
 H=26

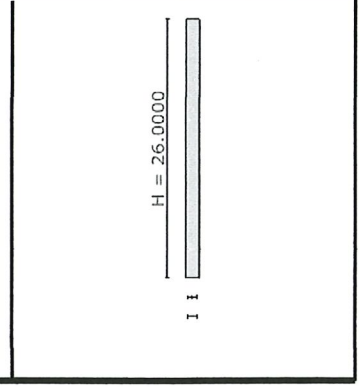

By: Dakota Johnson

Order

Order #: 2183797

1201 S.W. BILTMORE STREET, PORT ST. LUCIE,
FL 34983

JBR - PREFERRED BUILDER ACCOUNT

Order Date: 10/3/2023
Est. Ship Date: 10/26/2023
Route: FtPrc

Cust PO#: Raxcie 8th St

Bill To:	Ship To:

Order

Item No. 19 Qty: 1
Model: 8100-SH Color: WHITE
 Desc: 8100 SINGLE HUNG DP:+70/-70, [FLANGE], WHITE FRAME, 18 x16 Screen
 LOW E 270, Insulated, IMPACT
 SCREEN
 AAMA Std. Gold Labeling
 FPA #16177.1, WHITE, [No Sill Anchors this SH-8100]
 DOES NOT MEET EGRESS,

Dimensions

DLO: 36 1/2 x 26
 TIP: 37 3/4 x 27 1/4
 GD: 30 3/4 x 9 15/16
 SCREEN: 18 X 16

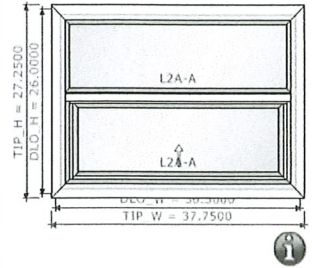

8100-SH- NFRC Rating: CWS-K-11-00922-00001 / U-Factor=0.31, Solar SHGC=0.28, V-Transmit=0.52

Item No. 20 Qty: 1
Model: 8100-SH Color: WHITE
 Desc: 8100 SINGLE HUNG DP:+70/-70, [FLANGE], WHITE FRAME, 18 x16 Screen
 LOW E 270, Insulated, IMPACT
 SCREEN
 AAMA Std. Gold Labeling
 FPA #16177.1, WHITE, [No Sill Anchors this SH-8100]
 DOES NOT MEET EGRESS,

Dimensions

DLO: 36 1/2 x 26
 TIP: 37 3/4 x 27 1/4
 GD: 30 3/4 x 9 15/16
 SCREEN: 18 X 16

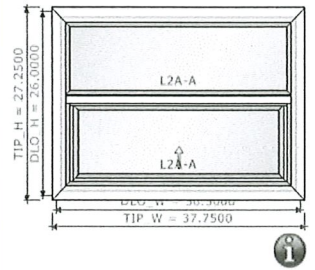

8100-SH- NFRC Rating: CWS-K-11-00922-00001 / U-Factor=0.31, Solar SHGC=0.28, V-Transmit=0.52

Item No. 21 Qty: 1
Model: PVC VERTICAL MULL KIT Color: WHITE
 Desc: PVC VERTICAL MULLBAR KIT, FPA #9520.1, [FLANGE], Standard "T" Clip for
 FLANGE or BOX frames, WHITE FRAME, 3" FLAT MULL, STD HARDWARE
 AAMA Std. Gold Labeling,

Dimensions

H=26

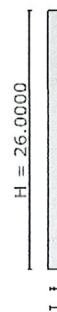



By: Dakota Johnson

Order

Order #: 2183797

1201 S.W. BILTMORE STREET, PORT ST. LUCIE,
FL 34983

JBR - PREFERRED BUILDER ACCOUNT

Order Date: 10/3/2023
Est. Ship Date: 10/26/2023
Route: FtPrc

Cust PO#: Raxcie 8th St

Bill To:	Ship To:

Order

Item No. 22 Qty: 1
Model: 8100-SH Color: WHITE
 Desc: 8100 SINGLE HUNG DP:+70/-70, [FLANGE], WHITE FRAME, 18 x16 Screen
 LOW E 270, Insulated, IMPACT
 SCREEN
 AAMA Std. Gold Labeling
 FPA #16177.1, WHITE, [No Sill Anchors this SH-8100]
 DOES NOT MEET EGRESS,

Dimensions

DLO: 36 1/2 x 26
 TIP: 37 3/4 x 27 1/4
 GD: 30 3/4 x 9 15/16
 SCREEN: 18 X 16

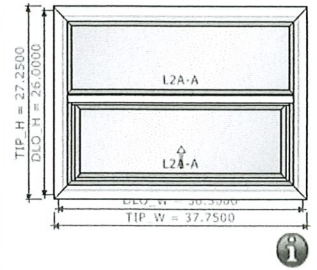

8100-SH- NFRC Rating: CWS-K-11-00922-00001 / U-Factor=0.31, Solar SHGC=0.28, V-Transmit=0.52

Item No. 23 Qty: 1
Model: 8100-SH Color: WHITE
 Desc: 8100 SINGLE HUNG DP:+70/-70, [FLANGE], WHITE FRAME, 18 x16 Screen
 LOW E 270, Insulated, IMPACT
 SCREEN
 AAMA Std. Gold Labeling
 FPA #16177.1, WHITE, [No Sill Anchors this SH-8100]
 DOES NOT MEET EGRESS,

Dimensions

DLO: 36 1/2 x 26
 TIP: 37 3/4 x 27 1/4
 GD: 30 3/4 x 9 15/16
 SCREEN: 18 X 16

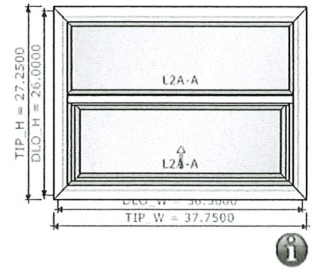

8100-SH- NFRC Rating: CWS-K-11-00922-00001 / U-Factor=0.31, Solar SHGC=0.28, V-Transmit=0.52

Item No. 24 Qty: 3
Model: 8100-SH Color: WHITE
 Desc: 8100 SINGLE HUNG DP:+70/-70, [FLANGE], WHITE FRAME, 18 x16 Screen
 LOW E 270, Insulated, IMPACT
 SCREEN
 AAMA Std. Gold Labeling
 FPA #16177.1, WHITE, [No Sill Anchors this SH-8100]
 DOES NOT MEET EGRESS,

Dimensions

DLO: 36 1/2 x 26
 TIP: 37 3/4 x 27 1/4
 GD: 30 3/4 x 9 15/16
 SCREEN: 18 X 16

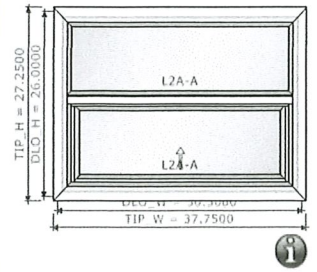

8100-SH- NFRC Rating: CWS-K-11-00922-00001 / U-Factor=0.31, Solar SHGC=0.28, V-Transmit=0.52



By: Dakota Johnson

Order

Order #: 2183797

1201 S.W. BILTMORE STREET, PORT ST. LUCIE, FL 34983

JBR - PREFERRED BUILDER ACCOUNT

Order Date: 10/3/2023

Est. Ship Date: 10/26/2023

Route: FtPrc

Cust PO#: Raxcie 8th St

Bill To:	Ship To:

Order

Item No. 25 Qty: 2
Model: PVC VERTICAL MULL KIT Color: WHITE
 Desc: PVC VERTICAL MULLBAR KIT, FPA #9520.1, [FLANGE], Standard "T" Clip for FLANGE or BOX frames, WHITE FRAME, 3" FLAT MULL, STD HARDWARE AAMA Std. Gold Labeling,

Dimensions
H=26

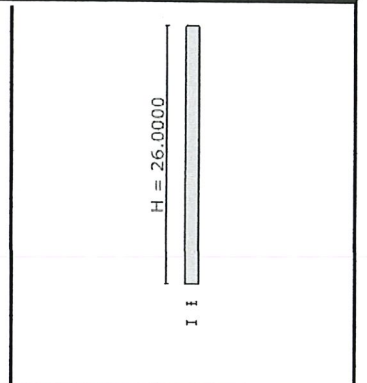
Item No. 26 Qty: 3
Model: 8100-SH Color: WHITE
 Desc: 8100 SINGLE HUNG DP:+70/-70, [FLANGE], WHITE FRAME, 18 x16 Screen LOW E 270, Insulated, IMPACT SCREEN
 AAMA Std. Gold Labeling
 FPA #16177.1, WHITE, [No Sill Anchors this SH-8100]
 DOES NOT MEET EGRESS,

Dimensions
 DLO: 37 x 58
 TIP: 38 1/4 x 59 1/4
 GD: 31 1/4 x 25 15/16
 SCREEN: 18 X 16

8100-SH- NFRC Rating: CWS-K-11-00922-00001 / U-Factor=0.31, Solar SHGC=0.28, V-Transmit=0.52

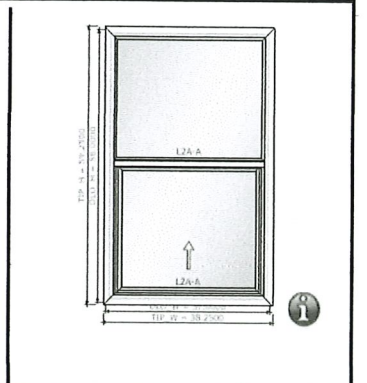
Item No. 27 Qty: 2
Model: PVC VERTICAL MULL KIT Color: WHITE
 Desc: PVC VERTICAL MULLBAR KIT, FPA #9520.1, [FLANGE], Standard "T" Clip for FLANGE or BOX frames, WHITE FRAME, 3" FLAT MULL, STD HARDWARE AAMA Std. Gold Labeling,

Dimensions
H=58

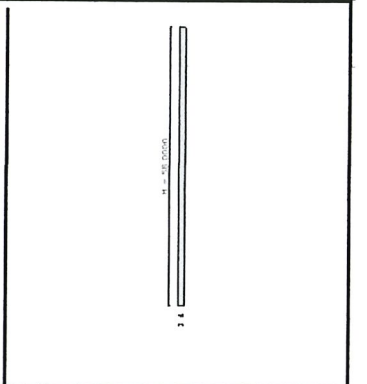

By: Dakota Johnson

Order

Norace Harris Bolt

Order #: 2183797

1201 S.W. BILTMORE STREET, PORT ST. LUCIE, FL 34983

JBR - PREFERRED BUILDER ACCOUNT

Order Date: 10/3/2023

Est. Ship Date: 10/26/2023

Route: FtPrc

Cust PO#: Raxcie 8th St

Bill To:

Ship To:

Order

Item No. 1 Qty: 1
Model: 8100-SH Color: WHITE
 Desc: 8100 SINGLE HUNG DP:+70/-70, [FLANGE], WHITE FRAME, 18 x16 Screen
 LOW E 270, Insulated, IMPACT
 SCREEN
 AAMA Std. Gold Labeling
 FPA #16177.1, WHITE, [No Sill Anchors this SH-8100]
 DOES NOT MEET EGRESS,

~~Sub did~~

Dimensions

DLO: 37 x 38
TIP: 38 1/4 x 39 1/4
GD: 31 1/4 x 15 15/16
SCREEN: 18 X 16

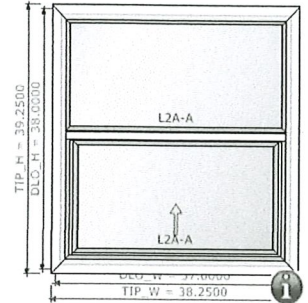

8100-SH- NFRC Rating: CWS-K-11-00922-00001 / U-Factor=0.31, Solar SHGC=0.28, V-Transmit=0.52

Item No. 2 Qty: 1
Model: PVC VERTICAL MULL KIT Color: WHITE
 Desc: PVC VERTICAL MULLBAR KIT, FPA #9520.1, [FLANGE], Standard 1/2" Clip for
 FLANGE or BOX frames, WHITE FRAME, 3" FLAT MULL, STD HARDWARE
 AAMA Std. Gold Labeling,

~~you finish~~

Dimensions

H=38

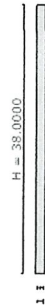

Item No. 3 Qty: 1
Model: 8100-SH Color: WHITE
 Desc: 8100 SINGLE HUNG DP:+70/-70, [FLANGE], WHITE FRAME, 18 x16 Screen
 LOW E 270, Insulated, IMPACT
 SCREEN
 AAMA Std. Gold Labeling
 FPA #16177.1, WHITE, [No Sill Anchors this SH-8100]
 DOES NOT MEET EGRESS,

~~four check~~

Dimensions

DLO: 37 x 38
TIP: 38 1/4 x 39 1/4
GD: 31 1/4 x 15 15/16
SCREEN: 18 X 16

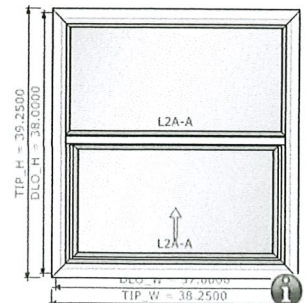

8100-SH- NFRC Rating: CWS-K-11-00922-00001 / U-Factor=0.31, Solar SHGC=0.28, V-Transmit=0.52

All window product



CERTIFICATE OF APPROPRIATENESS
TO ALTER A DESIGNATED HISTORIC SITE

COA#24-09 HISTORIC PRESERVATION BOARD APPROVAL

ADMINISTRATIVE APPROVAL

Site address: 736 Delaware Avenue

Contributing

Non-Contributing

Individually Designated

SITE ALTERATIONS:

Request	Conditions	Applicable Standards
Install new sign, perimeter planting and solar-powered landscape lighting. Please see attached.		Secretary of the Interior's Standards for Rehabilitation of Historic Properties, Standard 9.

APPROVED:

Board Approval

Administrative Approval

Charles Hayek, Chairman
Historic Preservation Board

Date



Maria Lewicka, AICP
Historic Preservation Planner

2/28/2024

Date

This alteration meets the Secretary of the Interior's Standards for the Treatment of Historic Properties and the City of Fort Pierce Code of Ordinances.

Should you have any further questions or concerns, contact Maria Lewicka, Historic Preservation Planner, at (772) 467-3738 or via e-mail at mlewicka@cityoffortpierce.com.

Thank you for your efforts to preserve and redevelop historic Fort Pierce through your participation in the Certificate of Appropriateness Application process. Staff looks forward to working with you in the future to preserve and rehabilitate our historic neighborhoods and structures.

Provided to:	Name/Address	Via
Owner	Gloria Roa Bodin 736 Delaware Avenue Fort Pierce, FL 32950	E-Mail globo@aol.com
Applicant	Eric Bodin 3815 S Indian River Drive Fort Pierce, FL 34982	E-Mail EABODIN@GMAIL.COM
Representative	Valerie Slack, AIA, NCARB, LEED BD +C 200 S Indian River Drive Fort Pierce, FL 34950	E-Mail studio@natedesign.us



Bldg. Permit # _____

COA# 24-09

Certificate of Appropriateness Application

Building & Site Information

Address of the Site: 736 Delaware Ave, Fort Pierce, Florida 34950

Parcel ID #: 2410-707-0003-000-6

Type of Designation: Contributing Non-contributing Site within the Sample Oaks Historic District

Individually Designated Site, City Commission Resolution No. _____

Property Owner/ Applicant Information

Property Owner(s) Name(s): Gloria Roa Bodin

Mailing Address: 736 Delaware Ave, Ft Pierce, FL 34950

Phone Number(s): (772)425-2888 Email: gglobo@aolmcom; germaine@gloriaroabodin.com

Applicant Name(s): Eric Bodin

Mailing Address: 3815 S. Indian River Dr., Ft. Pierce, FI 34982

Phone Number(s): (305)776-3068 Email: EABODIN@GMAIL.COM

Representative Name(s): Valerie Slack, AIA, NCARB, LEED BD + C

Mailing Address: 200 S. Indian River Drive, Fort Pierce, FL 34950

Phone Number(s): (772)519-1216 Email: studio@natedesign.us

Property Owner(s) Acknowledgements:- This application will not be considered complete without the signature of all property owners of record, which shall serve as an acknowledgement of the submission of this application. The property owner's signature below shall also authorize the Applicant (if other than the property owner) and/or Representative to act in his/her behalf for the purposes of seeking approval for the application described herein. The undersigned consents to inspection and photographing of the subject property by the Historic Preservation staff for purposes of consideration of this Application and/or presentation to the Historic Preservation Board.

I / We, _____ as Owner(s) of the subject property do hereby authorize the filing of this application on my/our behalf.

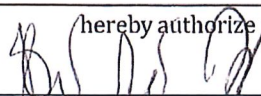
Signature of Owner

2/23/24
Date

Description of Requested Work

Please indicate the type of work requested:

- | | | | |
|---|--|-------------------------------------|-------------------------------------|
| <input type="checkbox"/> Fence | <input type="checkbox"/> Shed | <input type="checkbox"/> Door(s) | <input type="checkbox"/> Roof |
| <input type="checkbox"/> Window(s) | <input checked="" type="checkbox"/> Signage | <input type="checkbox"/> Shutter(s) | <input type="checkbox"/> Porch |
| <input type="checkbox"/> Rehabilitation | <input checked="" type="checkbox"/> New Construction | <input type="checkbox"/> Demolition | <input type="checkbox"/> Relocation |

- Site Improvements (describe) New Signage, related planting and lighting
- Other (describe) _____

Please provide a detailed description of the proposed work to be performed: _____

New Signage Approximately 5'-0" (W) X 3'-6" (D) X 5'-8"(T)
with 3'-0" perimeter planning and solar-powered landscape lighting

Have other alterations been made to the site within the last 12 months? No Yes, _____

Will the proposed work require a Zoning Variance? No Yes, Code Section(s): _____

Application Requirements

- \$10.00 Application fee
- Site Plan with dimensions.
- Architectural Drawings:
 - Drawings should show all current and proposed floor plans and elevations, fences, walls, and any other landscape features.
 - Drawings should indicate materials to be used.
- Photos - One (1) color photograph of the main façade of the site and photographs of any areas affected by the proposed project.
- Material(s) specifications and/or sample(s)
- Color samples.
- Demolition – Plans for what will be taking the demolished structure’s place should be submitted.

DATE	NO. ISSUED FOR
02.23.24	COA APP

Native Design
 Architecture, LLC
 Valerie DeKle Slack, AIA
 200 S. Indian River Dr., #902
 Ft. Pierce, FL 34920
 (772)801-9224
 admin@nativedesign.us

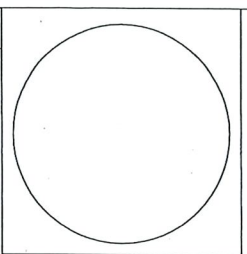

Ownership of these drawings and the design represented herein are protected by copyright and other applicable laws. Any duplication, distribution or use for any purpose without the permission of Native Design Architecture, LLC could result in criminal prosecution as well as civil liability.

SIGNAGE FOR GLORIA ROABODIN, P.A.
 ATTORNEY AT LAW
 736 Delaware Ave.
 Ft. Pierce, FL 34920

PROJ. NO.: 202401
 DRAWN: MNC
 CHECKED: VDS

TITLE:
PLANS, SECTION & ELEVATIONS

DRAWING NO.
 A-1

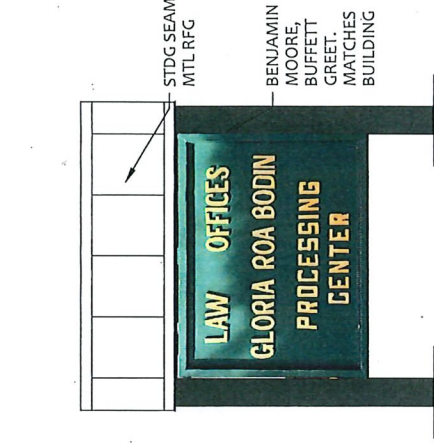

4 ELEVATION @ SIGN FACE
 1/2" = 1'-0"

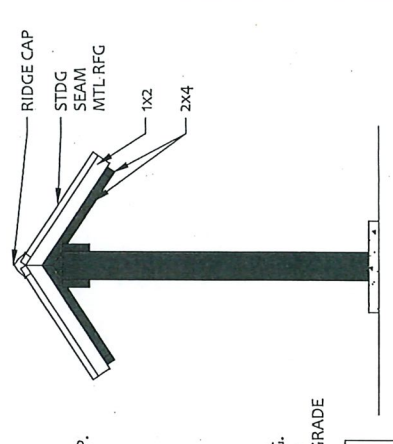

5 ELEVATION @ SIGN END
 1/2" = 1'-0"

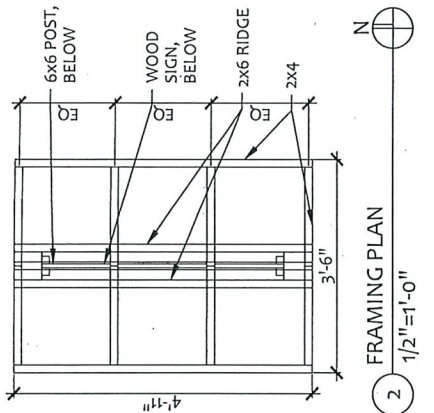

2 FRAMING PLAN
 1/2" = 1'-0"

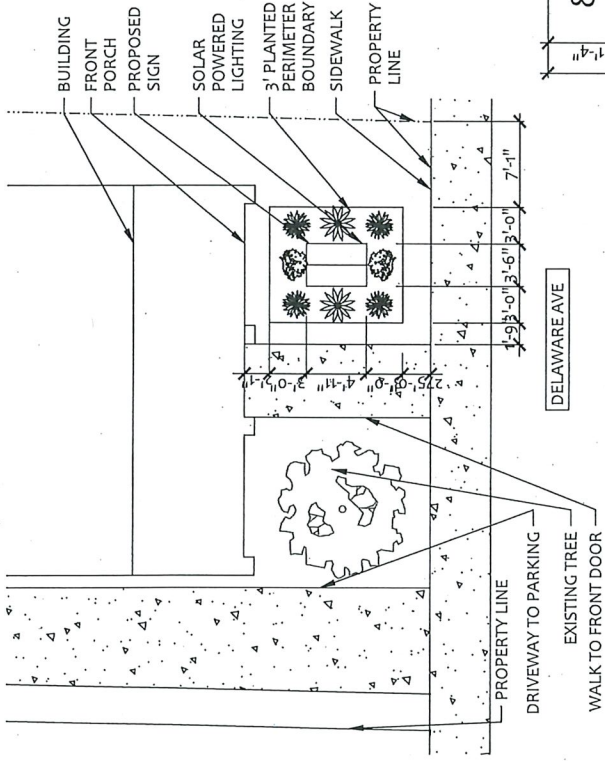

1 SITE PLAN
 1" = 10'-0"

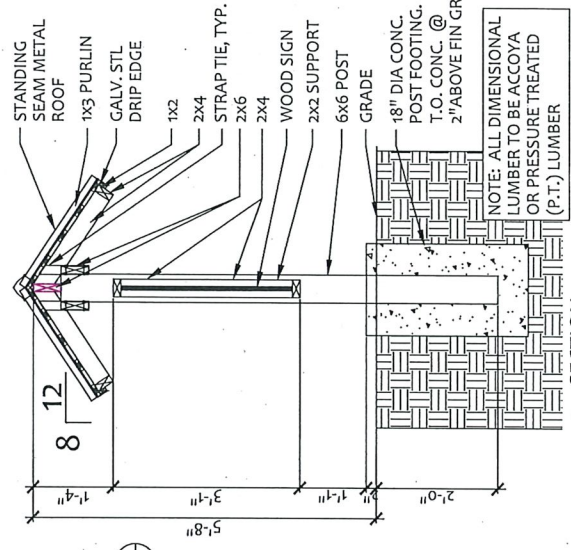

3 SECTION
 1/2" = 1'-0"

NOTE: ALL DIMENSIONAL LUMBER TO BE ACCOYA OR PRESSURE TREATED (P.T.) LUMBER

PLANT LEGEND	
	COONTIE PALM
	ZAMIA PUMILA
	MUHLY GRASS
	CORAL HONEYSUCKLE
	MUHLENBERGIA CAPILLARIS
	LONICERA SEMPERVIRENS

SCOPE	
NEW SIGN APPROXIMATELY 5'-0" (W) X 3'-6" (D) X 5'-8" (T). WITH 3'-0" PERIMETER PLANNING AND SOLAR-POWERED LANDSCAPE LIGHTING	