



Bldg. Permit # \_\_\_\_\_

COA# 24-03

## Certificate of Appropriateness Application

### Building & Site Information

Address of the Site: 616 Orange Ave. Ft. Pierce, FL

Parcel ID #: 2410-606-0007-000-4

Type of Designation:  Contributing  Non-contributing Site within the  Historic District

Individually Designated Site, City Commission Resolution No. \_\_\_\_\_

### Property Owner/Applicant Information

Property Owner(s) Name(s): First United Methodist

Mailing Address: 616 Orange Ave. Ft. Pierce, FL

Phone Number(s): 772-464-0440 Email: rosslaw@comcast.net

Applicant Name(s): Kendal Signs Inc.

Mailing Address: 580 Gus Hipp Blvd. Rockledge, FL

Phone Number(s): 321-636-5116 Email: sandraw@kendalsigns.com 32955

Representative Name(s): Rob Worrels

Mailing Address: 580 Gus Hipp Blvd. Rockledge, FL

Phone Number(s): 321-636-5116 Email: Rob@kendalsigns.com 32955

*Property Owner(s) Acknowledgements:- This application will not be considered complete without the signature of all property owners of record, which shall serve as an acknowledgement of the submission of this application. The property owner's signature below shall also authorize the Applicant (if other than the property owner) and/or Representative to act in his/her behalf for the purposes of seeking approval for the application described herein. The undersigned consents to inspection and photographing of the subject property by the Historic Preservation staff for purposes of consideration of this Application and/or presentation to the Historic Preservation Board.*

I/We, Greg Rosslaw Trustees Chairman - First United Methodist Church  
as Owner(s) of the subject property, do hereby authorize the filing of this application on my/our behalf.

[Signature]  
Signature of Owner

12/15/23  
Date

**Description of Requested Work**

Please indicate the type of work requested:

- |   |  |                                     |                                     |
|---|--|-------------------------------------|-------------------------------------|
| <input type="checkbox"/> Fence          | <input type="checkbox"/> Shed                        | <input type="checkbox"/> Door(s)    | <input type="checkbox"/> Roof       |
| <input type="checkbox"/> Window(s)      | <input checked="" type="checkbox"/> Signage          | <input type="checkbox"/> Shutter(s) | <input type="checkbox"/> Porch      |
| <input type="checkbox"/> Rehabilitation | <input checked="" type="checkbox"/> New Construction | <input type="checkbox"/> Demolition | <input type="checkbox"/> Relocation |

Site Improvements (describe) New free standing Sign  
 Other (describe) \_\_\_\_\_

Please provide a detailed description of the proposed work to be performed: \_\_\_\_\_

Manufacture and Install new Free Standing Sign for a church. Sign will have message Center

Have other alterations been made to the site within the last 12 months?  No  Yes, \_\_\_\_\_

Will the proposed work require a Zoning Variance?  No  Yes, Code Section(s): \_\_\_\_\_

**Application Requirements**

- \$10.00 Application fee
- Site Plan with dimensions.
- Architectural Drawings:
  - Drawings should show all current and proposed floor plans and elevations, fences, walls, and any other landscape features.
  - Drawings should indicate materials to be used.
- Photos - One (1) color photograph of the main façade of the site and photographs of any areas affected by the proposed project.
- Material(s) specifications and/or sample(s)
- Color samples.
- Demolition - Plans for what will be taking the demolished structure's place should be submitted.





## Maria Lewicka

---

**From:** Greg Rosslow <rosslow@comcast.net>  
**Sent:** Monday, January 8, 2024 3:48 PM  
**To:** Maria Lewicka  
**Cc:** sandraw@kendalsigns.com; rob@kendalsigns.com  
**Subject:** RE: 616 Orange Ave DPCR# 23-20000479 (Site Plan)

You don't often get email from rosslow@comcast.net. [Learn why this is important](#)

**SECURITY WARNING:** This email originated outside of the City of Fort Pierce systems. Please use caution when clicking links or opening attachments. For questions or concerns please contact IT immediately. .

Maria,

The traffic control box is 14' 9" from the wall of the church. We are proposing the 6' wide sign be placed 4' from the wall which will leave 4' 9" from the corner of our sign to the corner of the traffic control box.

As a matter of interest, according to our survey the traffic control box is actually located on our property.

Regards,  
Greg Rosslow

---

**From:** Rob Worrels [mailto:rob@kendalsigns.com]  
**Sent:** Monday, January 8, 2024 11:06 AM  
**To:** Greg Rosslow  
**Subject:** FW: 616 Orange Ave DPCR# 23-20000479 (Site Plan)  
**Importance:** High

Greg,

Please see Marias question below.

Respectfully,

Rob Worrels  
580 Gus Hipp Blvd.  
Rockledge, Fl. 32955  
(321) - 636 - 5116

**kendalSIGNS**  
DESIGN • FABRICATION • INSTALLATION  
[www.kendalsigns.com](http://www.kendalsigns.com)

---

**From:** Maria Lewicka <[mlewicka@cityoffortpierce.com](mailto:mlewicka@cityoffortpierce.com)>  
**Sent:** Monday, January 8, 2024 10:53 AM  
**To:** Sandra Rance <[sandraw@kendalsigns.com](mailto:sandraw@kendalsigns.com)>  
**Cc:** Rob Worrels <[rob@kendalsigns.com](mailto:rob@kendalsigns.com)>  
**Subject:** RE: 616 Orange Ave DPCR# 23-20000479 (Site Plan)



# MONUMENT SIGN

JOB SPECIFICATIONS:

Manufacture & install One (1) New double sided internally illuminated monument sign mounted on single support.

Cabinets to be fabricated aluminum.

Reveals & base to be fabricated aluminum prime coated & painted.

Paintbreaks for base, topper and sides

Main ID Faces to be pan formed acrylic with backsprayed with translucent "rice grain" color & copy/ decoration.

Two (2) single sided 10mm EMC displays.

1/4" FCO acrylic address numerals mounted flush to pole cover.

Stucco on base done by others

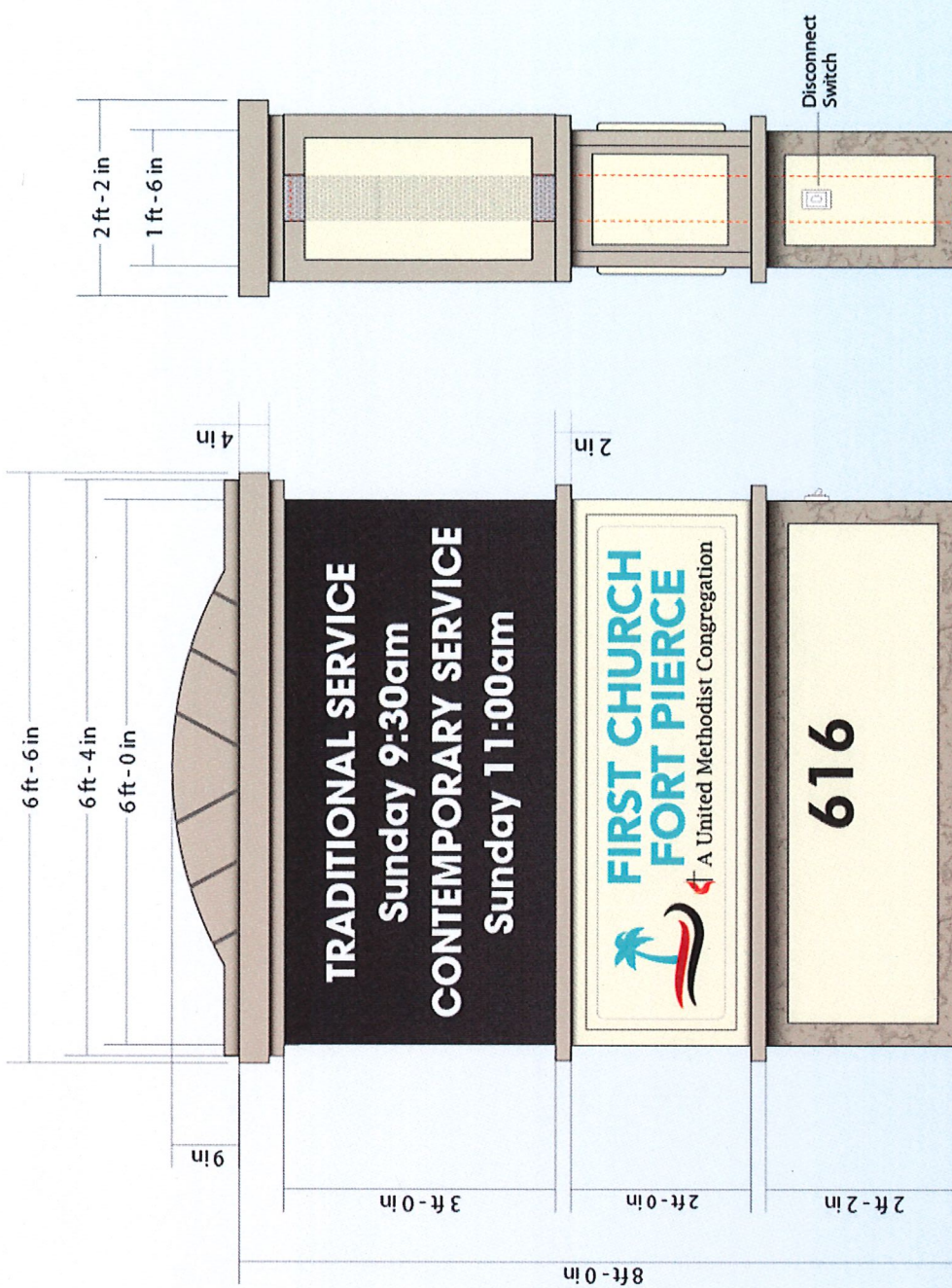

SCALE = 1/2" = 1'

LISTED



580 GUS HIPP BLVD., ROCKLEDGE, FL 32955 TEL: 321-636-5116 FAX: 321-636-0402

Customer: First United Methodist Church, Ft Pierce  
 Address: 616 Orange Ave, Ft Pierce FL  
 Designer: *Tracey Amy* Sales: Rob/Donna Date: 9-23-22  
 File Name: First United Methodist Church, Ft Pierce-Monument, REV 3-5-24

**kendalsigns**  
 DESIGN • FABRICATION • INSTALLATION

### COLOR SCHEDULE

RICHARDS PAINT "RICE GRAIN"	VINYL 017 CHERRY RED
RICHARDS PAINT "WOOD SHADOW"	VINYL 053 LITE BLUE
RICHARDS PAINT "CLOUD BURST"	VINYL BLACK

### SIGNATURE FOR APPROVAL:

**CUSTOMER NOTICE**  
 Kendal Signs will endeavor to match colors specified. We cannot guarantee exact matches due to varying compatibility of materials used. Final dimensions may vary from within this drawing. An exact scaled drawing will be provided upon your request.

DATE:	REVISED:
9-30-22	11-14-22
12-14-22	12-15-22 RL
12-15-22 RL	9-5-23-JS
9-25-23-JS	3-5-24-JS
3-25-24-JS	4-8-24-JS

THIS DOCUMENT IS THE EXCLUSIVE PROPERTY OF KENDAL SIGNS, INC. ROCKLEDGE, FLORIDA. IT MAY NOT BE COPIED, REPRODUCED, MARKETING, SOLD OR MANUFACTURED, IN OR IN PART WITHOUT THE WRITTEN CONSENT OF KENDAL SIGNS, INC.









**NOT TO SCALE**

ROCKLEDGE, FL 32955 TEL: 321-636-5116 FAX: 321-636-0402

**IGNS**  
INSTALLATION

**Customer:** First United Methodist Church, Ft Pierce  
**Address:** 616 Orange Ave, Ft Pierce FL  
**Designer:** Trade / Amy Sales: Rob / Donna **Date:** 9-23-22  
**File Name:** First United Methodist Church, Ft Pierce-Monument\_REV 3-5-24

**COLOR SCHEDULE**

- |  |  |
|--|--|
|  RICHARDS PAINT "RICE GRAIN"  |  VINYL 017 CHERRY RED |
|  RICHARDS PAINT "WOOD SHADOW" |  VINYL 053 LITE BLUE  |
|  RICHARDS PAINT "CLOUD BURST" |  VINYL BLACK          |

**SIGNATURE FOR APPROVAL:**

**CUSTOMER NOTICE**  
 Kendal Signs will endeavor to match colors spe  
 We cannot guarantee exact matches due to var  
 Compatibility of materials used. Final dimensio  
 vary from within this drawing. An exact scaled  
 Will be provided upon your request.

EXCLUSIVE PROPERTY OF KENDAL SIGNS, INC., ROCKLEDGE, FLORIDA. IT MAY NOT BE COPIED, REPRODUCED, MARKETED, SOLD OR MANUFACTURED, IN OR IN PART WITHOUT THE WRITTEN CONSENT

# TYPICAL SIGN CABINET BOX FRAME AND SADDLE DETAIL

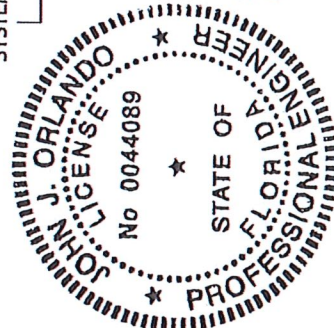
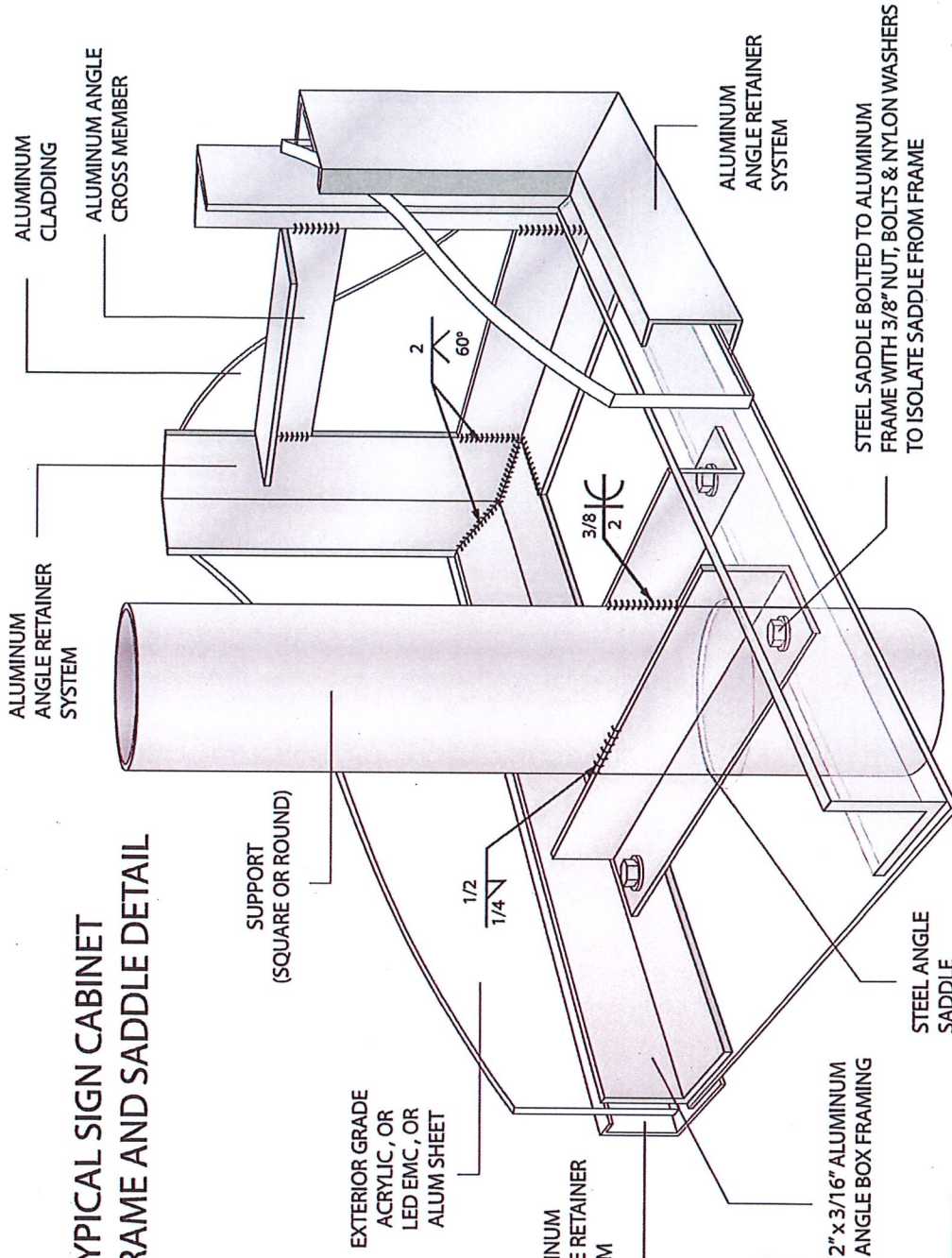

John J Orlando PE  
Digitally signed by John J Orlando PE  
Date: 2023.12.04 22:18:24 -05'00'

This item has been electronically signed and sealed by John J. Orlando, PE using a Digital Signature and date.  
Printed copies of this document are not considered signed and sealed and the signature must be verified on any electronic copies.

Conforms to the requirements of the 7th Edition (2020) of the Florida Building Code sections 1609 and 3107. V(UWP) = 160 mph. Exposure category = C, Risk category = II  
John J. Orlando PE LLC - 165 Old Ridge Road - Macon, GA 31211 - 478 731 5394 - jorlando@cox.net - Florida registration # 0044089 job 25223KS sheet 2 of 3

580 GUS HIPP BLVD. ROCKLEDGE, FL 32955 TEL: 321-636-5116 FAX: 321-636-0402

Customer: First United Methodist Church Ft Pierce  
Address: 616 Orange Ave, Ft Pierce FL  
Designer: Trace Sales: Donna Date: 9-23-22  
File Name: First United Methodist Church Ft Pierce-NEW LOGO 11-14-22



## SIGNATURE FOR APPROVAL:

REVISION	DATE
9-30-22	
11-14-22	
12-14-22	
12-15-22 AZ	
3-23-23 AZ	

## COLOR SCHEDULE

VINYL 017 CHERRY RED	RICHARDS PAINT "RICE GRAIN"
VINYL 053 LITE BLUE	RICHARDS PAINT "WOOD SHADOW"
VINYL BLACK	

**CUSTOMER NOTICE**  
Kendal Signs will endeavor to match colors specified, We cannot guarantee exact matches due to varying Compatibility of materials used. Final dimensions may vary from within this drawing. An exact scaled drawing Will be provided upon your request.



### Property Identification

Site Address: 616 ORANGE AVE  
 Sec/Town/Range: 10/35S/40E  
 Parcel ID: 2410-606-0007-000-4  
 Jurisdiction: Fort Pierce

Use Type: 7100  
 Account #: 23449  
 Map ID: 24/10N  
 Zoning: General Co

### Ownership

First United Methodist Church of Fort  
 Pierce Inc  
 616 Orange AVE  
 Fort Pierce, FL 34950

### Legal Description

RECEIVER'S S/D LOTS 10 AND 11 (MAP24/10D)

### Current Values

Just/Market Value: \$915,100  
 Assessed Value: \$915,100  
 Exemptions: \$915,100  
 Taxable Value: \$0



### Total Areas

Finished/Under Air (SF): 23,742  
 Gross Sketched Area (SF): 23,844  
 Land Size (acres): 0.51  
 Land Size (SF): 22,115

**Property taxes are subject to change upon change of ownership.**

- Past taxes are not a reliable projection of future taxes.
- The sale of a property will prompt the removal of all exemptions, assessment caps, and special classifications.

### Building Design Wind Speed

Occupancy Category	I	II	III
Speed	140	160	160

Sources/links:

Taxes for this parcel: [SLC Tax Collector's Office](#)

Download TRIM for this parcel: [Download PDF](#)

### Sale History

Date	Book/Page	Sale Code	Deed	Grantor	Price
Jan 1, 1900					\$0

### Building Information (1 of 1)

Finished Area: 23,742 SF

Gross Sketched Area: 23,844 SF

#### Exterior Data

View:  
 Building Type: CH7  
 Grade: Y\_D  
 Story Height: 1 Story

Roof Cover: Mod Bitumun  
 Year Built: 1936  
 Effective Year: 1985  
 No. Units: 1

Roof Structure: BarJst/Rigid  
 Frame:  
 Primary Wall: CB Stucco  
 Secondary Wall:

#### Interior Data

## Historical Values

Year	Just/Market	Assessed	Exemptions	Taxable
2023	\$915,100	\$915,100	\$915,100	\$0
2022	\$1,144,200	\$1,144,200	\$1,144,200	\$0
2021	\$1,113,900	\$1,113,900	\$1,113,900	\$0
2020	\$1,127,800	\$1,127,800	\$1,127,800	\$0

## Permits

Number	Issue Date	Description	Amount	Fee
BP2006-278	Apr 10, 2006	Roof	\$19,700	\$197
BP2006-405	May 24, 2006	Roof	\$12,500	\$125
F00-000051	Feb 3, 2000	Carport	\$2,000	\$0
F00-000888	Aug 10, 2000	Alterations/Remodeling	\$8,300	\$0
F91-001291	Oct 4, 1991	Roof	\$2,000	\$2,000
F92-000218	Mar 16, 1992	Alterations/Remodeling	\$185,000	\$185,000
F92-00218A	May 27, 1992	Heat and Air Conditioning	\$27,800	\$27,800
F92-00218B	Oct 13, 1992	Alterations/Remodeling	\$3,200	\$3,200
F97-000572	Jun 9, 1997	Demolition	\$600	\$600
F97-000564	Jun 30, 1997	Alterations/Remodeling	\$43,000	\$43,000
F97-001033	Sep 26, 1997	Heat and Air Conditioning	\$6,900	\$6,900
F97-001247	Dec 12, 1997	Roof	\$200,000	\$200,000
F98-001247	Jan 6, 1998	Roof	\$5,990	\$5,990
F97-01247A	Feb 23, 1998	Roof	\$61,900	\$61,900
F02-0821	Jun 5, 2002	Alterations/Remodclng	\$794	\$75
F0200000987	Jul 17, 2002	Roof	\$2,380	\$75
F0200001092	Jul 15, 2002	Air Conditioning Only	\$0	\$192
FE200631	Mar 22, 2006	Chamlink Fence	\$2,000	\$0
CR200616	Mar 31, 2006	Alterations/Remodeling	\$193,000	\$2,280
CPY20061	May 31, 2006	Awning/Shutters	\$40,000	\$475
RF20041943	Dec 17, 2004	Roof	\$72,900	\$854
FSP20071	Feb 28, 2007	Sprinkler System	\$2,500	\$50
BP12-0104	Jan 23, 2012	Air Conditioning Only	\$65,702	\$295
BP13-0111	Feb 5, 2013	Alterations/Remodeling	\$2,400	\$83
BP12-1394	Apr 16, 2013	Wall	\$25,000	\$260
BP13-1535	May 16, 2013	Fence	\$350	\$79
BP14-1098	Apr 30, 2014	Air Conditioning Only	\$22,750	\$170
BP15-1835	Aug 31, 2015	Carport	\$3,600	\$173
BP15-1009	May 21, 2015	Air Conditioning Only	\$17,650	\$273
BP16-1163	Apr 27, 2016	Re Roof Permit	\$10,400	\$0
BP17-1468	Jun 2, 2017	Roof	\$8,800	\$0
BP19-0250	Jan 24, 2019	Plumbing	\$2,000	\$0
BP19-4202	Feb 13, 2020	Electric	\$30,000	\$0

Notice: This does not necessarily represent all the permits for this property.  
 Click the following link to check for additional permit data in Fort Pierce

All information is believed to be correct at this time, but is subject to change and is provided without any warranty.  
 © Copyright 2024 Saint Lucie County Property Appraiser. All rights reserved.

082317  
2/2/17  
12/2/17

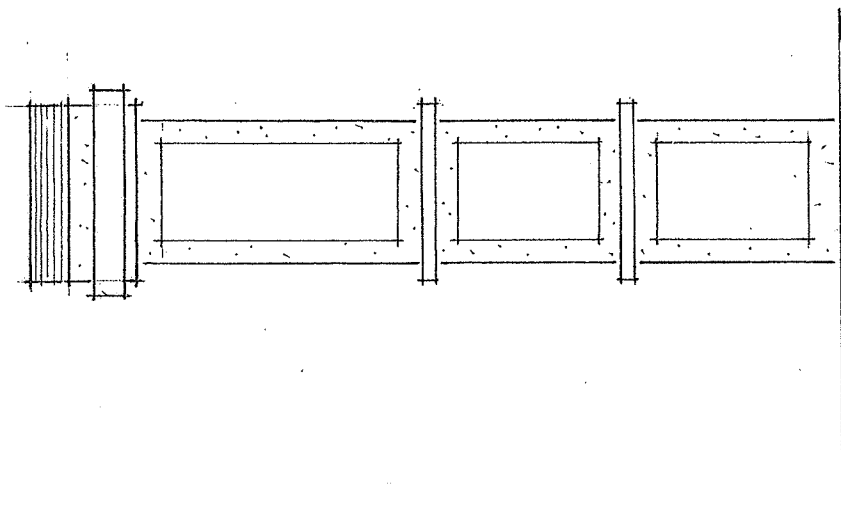
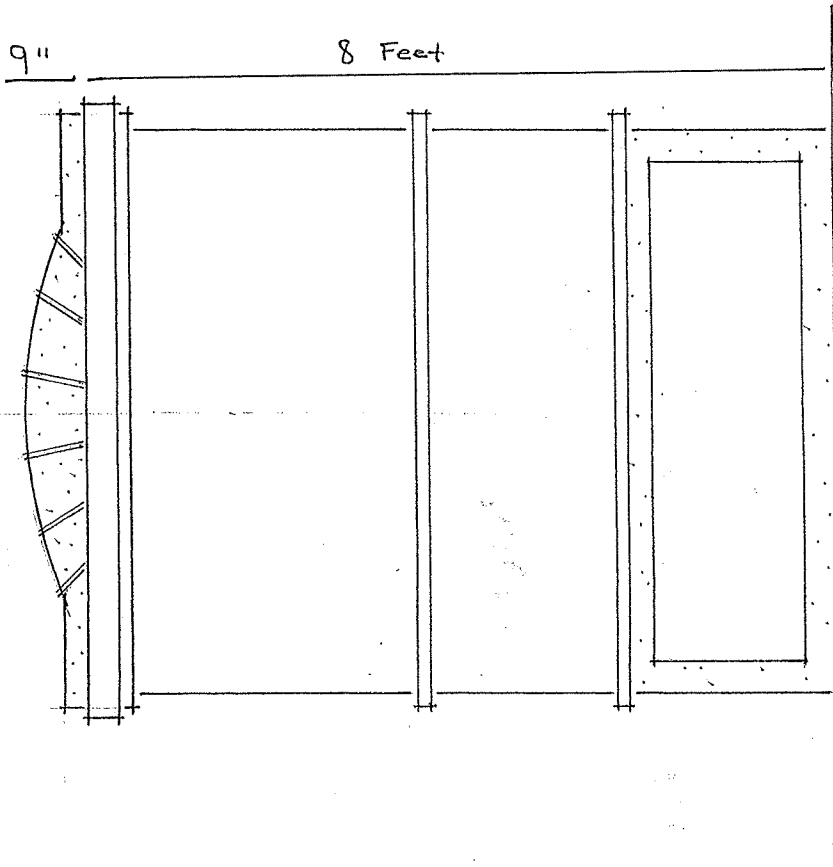

## Maria Lewicka

---

**From:** Greg Rosslow <rosslow@comcast.net>  
**Sent:** Monday, April 15, 2024 11:52 AM  
**To:** Maria Lewicka  
**Cc:** rob@kendalsigns.com  
**Subject:** FW: Sign with Architectural Elements  
**Attachments:** First United Methodist Church\_ Ft Pierce-Monument\_ REV 4-8-24-02.jpg; First United Methodist Church\_ Ft Pierce-Monument\_ REV 4-8-24-01.jpg; Sign with Architectural Element (1).pdf

SECURITY WARNING: This email has been generated from external sources and is not affiliated with the City of Fort Pierce systems. Exercise caution while clicking on links or opening attachments. If you have any questions or concerns, please reach out to the IT department promptly.

Hi Maria,

I'm not sure what you mean by "show the topper of the sign in the site view"? I attached a drawing of the added elements.

My understanding is it's an "architectural foam" like they use to add detail on buildings and it can be made to look like it is stucco finish. It would be adhered to the sign cabinet and then painted to match the church trim color..

Regards,  
Greg

---

**From:** Maria Lewicka [mailto:mlewicka@cityoffortpierce.com]  
**Sent:** Monday, April 15, 2024 10:11 AM  
**To:** Greg Rosslow; Rob Worrels  
**Cc:** Planning Department  
**Subject:** FW: Sign with Architectural Elements

Hi Greg,  
Could you please show the topper of the sign in the site view and explain what material it is made off?  
Thank you,  
Maria

---

**From:** Alicia Rosenthal <arosenthal@cityoffortpierce.com>  
**Sent:** Tuesday, April 9, 2024 8:49 AM  
**To:** Maria Lewicka <mlewicka@cityoffortpierce.com>  
**Subject:** FW: Sign with Architectural Elements

---

**From:** Greg Rosslow <rosslow@comcast.net>  
**Sent:** Monday, April 8, 2024 3:54 PM  
**To:** Alicia Rosenthal <arosenthal@cityoffortpierce.com>  
**Cc:** 'First United Methodist, Fort Pierce, FL.' <firstunitedftp@gmail.com>; rob@kendalsigns.com; gregrogolino@att.net;

'Tim Barton' <[rev.tim.barton@gmail.com](mailto:rev.tim.barton@gmail.com)>; 'Christopher Widing' <[cgwiding@gmail.com](mailto:cgwiding@gmail.com)>

**Subject:** FW: Sign with Architectural Elements

SECURITY WARNING: This email has been generated from external sources and is not affiliated with the City of Fort Pierce systems. Exercise caution while clicking on links or opening attachments. If you have any questions or concerns, please reach out to the IT department promptly.

Hi Alicia,

I am forwarding these updated sign rendering I received today from the Kendal Sign Company.

Unfortunately, the scale of the sign is not correct and is still a little too tall and wide. For proper reference, the middle of the adjacent window is 8ft above the pavers. I am submitting these as is so at least there are drawings in the file for the Review Meeting.

If you have comments or questions please don't hesitate to contact me.

Thanks,  
Greg Rosslow

---

**From:** Rob Worrels [<mailto:rob@kendalsigns.com>]

**Sent:** Monday, April 8, 2024 12:08 PM

**To:** Greg Rosslow

**Subject:** RE: Sign with Architectural Elements

Hello Greg,

Please see the revised renderings attached. Fingers crossed this will suffice for the reviewers.

Let me know if you have any questions.

Respectfully,

Rob Worrels  
580 Gus Hipp Blvd.  
Rockledge, Fl. 32955  
(321) - 636 - 5116

**kendalsigns**  
DESIGN - FABRICATION - INSTALLATION  
[www.kendalsigns.com](http://www.kendalsigns.com)

---

**From:** Greg Rosslow <[rosslow@comcast.net](mailto:rosslow@comcast.net)>

**Sent:** Thursday, April 4, 2024 3:23 PM

**To:** Rob Worrels <[rob@kendalsigns.com](mailto:rob@kendalsigns.com)>

**Subject:** FW: Sign with Architectural Elements

Hi Rob,

Do you think the revised rendering will be available soon, so I can forward it on to Planning?

Regards,  
Greg

---

**From:** Greg Rosslow [<mailto:rosslow@comcast.net>]  
**Sent:** Thursday, March 28, 2024 2:28 PM  
**To:** 'Rob Worrels'  
**Subject:** RE: Sign with Architectural Elements

Thanks

---

**From:** Rob Worrels [<mailto:rob@kendalsigns.com>]  
**Sent:** Thursday, March 28, 2024 9:55 AM  
**To:** Greg Rosslow  
**Cc:** 'First United Methodist, Fort Pierce, FL.'; 'Tim Barton'; [gregrogolino@att.net](mailto:gregrogolino@att.net); 'Christopher Widing'; Franny & Mike Foster  
**Subject:** RE: Sign with Architectural Elements

Good morning, Greg,

I will forward the revisions to the designer to support the city's comments.

I will mark my calendar to attend the review board meeting on: 4/22 @ 2 P.M.

Respectfully,

Rob Worrels  
580 Gus Hipp Blvd.  
Rockledge, Fl. 32955  
(321) - 636 - 5116  
**kendalsIGNS**  
DESIGN • FABRICATION • INSTALLATION  
[www.kendalsigns.com](http://www.kendalsigns.com)

---

**From:** Greg Rosslow <[rosslow@comcast.net](mailto:rosslow@comcast.net)>  
**Sent:** Wednesday, March 27, 2024 3:00 PM  
**To:** Rob Worrels <[rob@kendalsigns.com](mailto:rob@kendalsigns.com)>  
**Cc:** 'First United Methodist, Fort Pierce, FL.' <[firstunitedftp@gmail.com](mailto:firstunitedftp@gmail.com)>; 'Tim Barton' <[rev.tim.barton@gmail.com](mailto:rev.tim.barton@gmail.com)>; [gregrogolino@att.net](mailto:gregrogolino@att.net); 'Christopher Widing' <[cgwiding@gmail.com](mailto:cgwiding@gmail.com)>; Franny & Mike Foster <[fishncat70@gmail.com](mailto:fishncat70@gmail.com)>  
**Subject:** FW: Sign with Architectural Elements

Hi Rob,

I took the revised rendering to the Planning Board this morning. They are responsible for forwarding your rendering as well as our scale drawing of the architectural element additions to the Historic Review Board for their application review meeting.

The Planning Board representative I met with recommended the sign company (Kendal) have someone in attendance at the Review Board meeting (4/22 @ 2pm) in case there were any questions about the construction of the sign.

She asked if the overall look and placement of the sign in the rendering I presented was accurate. I told her it was not to scale and the lower portion of the sign would be the color of the church wall and not white as shown. Her advice was to update the rendering to reflect these changes because according to her, "the less things the Review Board has to question the better". With that in mind, can your designer make these final changes and send us a copy which I can then forward to the Planning Board.

1. The horizontal line in the middle of the window next to the sign is 8 ft above the pavers and the top of the window is 11'2". The sign, with architectural elements added, is 8 ft 9 in. tall. Can the sign image be reduced in size, so height is closer to scale.
2. Please colorize the white lower portion of the sign to match the wall color of the church, or the same as the background color in the sign's middle panel.

As soon as I receive the new rendering I will forward it to Planning to complete the application.

Thanks,  
Greg

---

**From:** Rob Worrels [<mailto:rob@kendalsigns.com>]

**Sent:** Tuesday, March 26, 2024 1:32 PM

**To:** Greg Rosslow

**Cc:** 'First United Methodist, Fort Pierce, FL.'; [gregrogolino@att.net](mailto:gregrogolino@att.net); 'Tim Barton'; 'Christopher Widing'; Franny & Mike Foster

**Subject:** RE: Sign with Architectural Elements

Hello Greg,

Please see attached the revised rendering. Let me know if you have any questions or need anything further at this time.

Respectfully,

Rob Worrels  
580 Gus Hipp Blvd.  
Rockledge, Fl. 32955.  
(321) - 636 - 5116

**kendalSIGNS**  
DESIGN • FABRICATION • INSTALLATION  
[www.kendalsigns.com](http://www.kendalsigns.com)

---

**From:** Greg Rosslow <[rosslow@comcast.net](mailto:rosslow@comcast.net)>

**Sent:** Saturday, March 23, 2024 5:11 PM

**To:** Rob Worrels <[rob@kendalsigns.com](mailto:rob@kendalsigns.com)>

**Cc:** 'First United Methodist, Fort Pierce, FL.' <[firstunitedftp@gmail.com](mailto:firstunitedftp@gmail.com)>; [gregrogolino@att.net](mailto:gregrogolino@att.net); 'Tim Barton' <[rev.tim.barton@gmail.com](mailto:rev.tim.barton@gmail.com)>; 'Christopher Widing' <[cgwiding@gmail.com](mailto:cgwiding@gmail.com)>; Franny & Mike Foster <[fishncat70@gmail.com](mailto:fishncat70@gmail.com)>

**Subject:** RE: Sign with Architectural Elements

Hi Rob,

Thanks for the update I will report the info to the Church Leadership on Monday. When I have the revision in hand I will resubmit to the Review Board.

Regards,  
Greg Rosslow

---

**From:** Rob Worrels [<mailto:rob@kendalsigns.com>]

**Sent:** Saturday, March 23, 2024 1:54 PM

**To:** Greg Rosslow

**Cc:** 'First United Methodist, Fort Pierce, FL.'; [gregrogolino@att.net](mailto:gregrogolino@att.net); 'Tim Barton'; 'Christopher Widing'; Franny & Mike Foster

**Subject:** RE: Sign with Architectural Elements

Hi Greg,

I will touch base with the designer Monday morning to check the status of the revision. I will let them know we need this asap the first part of the week you can resubmit.

Respectfully,

Rob Worrels  
580 Gus Hipp Blvd.  
Rockledge, Fl. 32955  
(321) - 636 - 5116

**kendalsIGNS**

DESIGN • FABRICATION • INSTALLATION

[www.kendalsigns.com](http://www.kendalsigns.com)

---

**From:** Greg Rosslow <[rosslow@comcast.net](mailto:rosslow@comcast.net)>

**Sent:** Friday, March 22, 2024 8:31 PM

**To:** Rob Worrels <[rob@kendalsigns.com](mailto:rob@kendalsigns.com)>

**Cc:** 'First United Methodist, Fort Pierce, FL.' <[firstunitedftp@gmail.com](mailto:firstunitedftp@gmail.com)>; [gregrogolino@att.net](mailto:gregrogolino@att.net); 'Tim Barton' <[rev.tim.barton@gmail.com](mailto:rev.tim.barton@gmail.com)>; 'Christopher Widing' <[cgwiding@gmail.com](mailto:cgwiding@gmail.com)>; Franny & Mike Foster <[fishncat70@gmail.com](mailto:fishncat70@gmail.com)>

**Subject:** FW: Sign with Architectural Elements

Hi Rob,

Our church has Leadership meeting on Monday at 11am and I have been asked to report on the progress of our sign permit application. Do you have a time frame for the rendering revisions I requested on 3/7.

With these revisions in hand I will be able to bring the application back before the Review Board and hopefully receive final approval to start construction.

Regards,  
Greg Rosslow

---

**From:** Greg Rosslow [<mailto:rosslow@comcast.net>]

**Sent:** Thursday, March 7, 2024 10:07 PM

**To:** [rob@kendalsigns.com](mailto:rob@kendalsigns.com)

**Cc:** 'First United Methodist, Fort Pierce, FL.'; [gregrogolino@att.net](mailto:gregrogolino@att.net); 'Tim Barton'; 'Christopher Widing'; Franny & Mike Foster ([fishncat70@gmail.com](mailto:fishncat70@gmail.com))

**Subject:** FW: Sign with Architectural Elements

Hi Rob,

Thanks for the revised renderings. After reviewing them I have a couple suggestions.

If possible could we move the placement of the monument sign in the street view image to its approved location centered between the corner of the church and the colored traffic control box to the right. And, hopefully there is a way to colorize the body of the sign and top trim to closely match the colors of the church in the photo. This will be helpful because I plan to forward this rendering to the Review Board for the hearing. I think they will be more likely to approve the sign if it appears its colors blend with the church. Sorry, to keep asking for these updates but I'm concerned if the rendering doesn't tie the sign's appearance closely to the church, then the Review Board might turn us down again.

Thanks,

Greg

---

**From:** Rob Worrels [<mailto:rob@kendalsigns.com>]

**Sent:** Thursday, March 7, 2024 10:11 AM

**To:** Greg Rosslow

**Cc:** 'First United Methodist, Fort Pierce, FL.'; [gregrogolino@att.net](mailto:gregrogolino@att.net); 'Tim Barton'; 'Christopher Widing'; Franny & Mike Foster

**Subject:** RE: Sign with Architectural Elements

Greg,

Please see attached the revised rendering. After review I look forward to our thoughts.

Respectfully,

Rob Worrels

580 Gus Hipp Blvd.

Rockledge, FL 32955

(321) - 636 - 5116

**kendalSIGNS**

DESIGN • FABRICATION • INSTALLATION

[www.kendalsigns.com](http://www.kendalsigns.com)

---

**From:** Greg Rosslow <[rosslow@comcast.net](mailto:rosslow@comcast.net)>

**Sent:** Friday, March 1, 2024 3:18 PM

**To:** Rob Worrels <[rob@kendalsigns.com](mailto:rob@kendalsigns.com)>

**Cc:** 'First United Methodist, Fort Pierce, FL.' <[firstunitedftp@gmail.com](mailto:firstunitedftp@gmail.com)>; [gregrogolino@att.net](mailto:gregrogolino@att.net); 'Tim Barton' <[rev.tim.barton@gmail.com](mailto:rev.tim.barton@gmail.com)>; 'Christopher Widing' <[cgwiding@gmail.com](mailto:cgwiding@gmail.com)>; Franny & Mike Foster <[fishncat70@gmail.com](mailto:fishncat70@gmail.com)>

**Subject:** FW: Sign with Architectural Elements

Hi Rob,

Has there been any progress on the updated sign rendering?

Regards,  
Greg Rosslow

---

**From:** Greg Rosslow [<mailto:rosslow@comcast.net>]

**Sent:** Tuesday, February 13, 2024 12:27 PM

**To:** [rob@kendalsigns.com](mailto:rob@kendalsigns.com)

**Cc:** 'First United Methodist, Fort Pierce, FL.'; [gregrogolino@att.net](mailto:gregrogolino@att.net); 'Christopher Widing'; 'Tim Barton'; Franny & Mike Foster ([fishncat70@gmail.com](mailto:fishncat70@gmail.com))

**Subject:** Sign with Architectural Elements

Hi Rob,

Attached is the updated sign drawing from our draftsman. It is the same size as your recent drawing with Architectural Elements added which are consistent with the church. The added elements, which we have a source for, will be light weight material that can be glued to the body of the sign and will resemble a stucco finish. There is an added 9 inch tall "eyebrow" feature on top of the sign that is prominent over each window of the church. Hopefully your art department can add these elements to what they already have to give the committee a good visual representation of the finished sign.

We were also wondering if the pan formed acrylic portion that is currently shown in a white background could be made in the same color as the base color (rice grain) as the rest of the sign? Or, would that possibly be too much of the same color??

The last suggestion would be to show the electronic portion of the sign as a message area---with something like "Traditional Service, Sunday 9:30am" & "Contemporary Service, Sunday 11:00am".

I have also included a photo of the church on which hopefully your art department can superimpose the new colored sign in its installed location.

Regards,  
Greg Rosslow  
First United Methodist Church