

Bldg Permit # _____

COAB _____



CITY OF FORT PIERCE

PLANNING DEPARTMENT

100 North U.S. Highway 1 • Fort Pierce, FL 34954-1430 • 772-467-3730 • Fax 772-466-5086
www.ci.fortpierce.fl.us

Certificate of Appropriateness Application

Building & Site Information

Address of the Site: 655 N 2ND ST Ft. Pierce Fl. 34950
Parcel ID #: 2403-705-0022-000-7
Type of Designation: Contributing Non-contributing Site within the Edgartown Historic District
Individually Designated Site, City Commission Resolution No. _____

Property Owner / Applicant Information

Property Owner(s) Name(s): Fur The People Real Estate LLC
Mailing Address: 153 NE Sagamore TER Port St Lucie, FL 34983
Phone Number(s): 214-769-6008 Email: lias@gunnertech.com

Applicant Name(s): Adron Fence Co.
Mailing Address: 1132 NE 12th St. Okeechobee, FL 34972
Phone Number(s): 800-282-5172 Email: permits@adronfence.com

Representative Name(s): N/A.
Mailing Address: _____
Phone Number(s): _____ Email: _____

Property Owner(s) Acknowledgements *This application will not be considered complete without the signature of all property owners of record, which shall serve as an acknowledgment of the submission of this application. The property owner's signature below shall also authorize the Applicant (if other than the property owner) and/or Representative to act in his/her behalf for the purposes of seeking approval for the application described herein. The undersigned consents to inspection and photography of the subject property by the Historic Preservation staff for purposes of consideration of this Application and/or presentation to the Historic Preservation Board.*

I/We Cody Swann as Owner(s) of the subject property do hereby authorize the filing of this application on my/our behalf.



Signature of Applicant

May 9, 2024

Date

Description of Requested Work

Please indicate the type of work requested:

- Fence Shed Door(s) Roof
- Window(s) Signage Shutter(s) Porch
- Rehabilitation New Construction Demolition Relocation

Site Improvements (describe) Installation of fence to the property

Other (describe) _____

Please provide a detailed description of the proposed work to be performed: _____

Installation of 229' of 4' high Sebring PVC with (2) 5' wide gate

Have other alterations been made to the site within the last 12 months? No Yes, _____

Will the proposed work require a Zoning Variance? No Yes, Code Section(s): _____

Application Requirements

- \$10.00 Application fee
- Site Plan with dimensions.
- Architectural Drawings:
 - Drawings should show all current and proposed floor plans and elevations, fences, walls, and any other landscape features.
 - Drawings should indicate materials to be used.
- Photos - One (1) color photograph of the main façade of the site and photographs of any areas affected by the proposed project.
- Material(s) specifications and/or sample(s)
- Color samples.
- Demolition - Plans for what will be taking the demolished structure's place should be submitted.

Treasure Coast Office
601 21st St. Suite 300
Vero Beach, FL 32960
(772) 562 0022



"FENCING YOU IN SINCE 1962"
1 800 282 5172
Email: info@adronfence.com
Fax: 863 763 8404



Main Office
1132 NE 12th St.
Okeechobee, FL 34972
(863) 763 6255

JOB NAME: Swann Court
JOB ADDRESS: 655 N 2ND ST
FL Pierce FL
MAILING ADDRESS: _____
EMAIL ADDRESS: lisa@gunnertech.com
DIRECTIONS: _____

DATE: 4-23-24
CONTACT: Lisa
PHONE: 214-769-6008
CELL: _____
FAX: _____
JOB #: 042324SWA1JRJPd

STYLE FENCE PVC SEBBIOS
POOL CODE YES NO
HEIGHT 5 FOOTAG 229'-10" = 219'
HEIGHT _____ FOOTAGE _____
WIRE _____
LINE POST 5"x5"x8'
TERMINAL POST 5"x5"x8'
TOP/BRACE/BOT TOM RAIL _____
TENSION WIRE _____
BARBED WIRE _____
WALK GATE 2 SIZE 5' FRAME _____
WALK GATE _____ SIZE _____ FRAME _____
WALK GATE POST 5"x5"x3' _____
_____ GATE _____ SIZE _____ FRAME _____
DRIVE GATE POST _____
_____ GATE _____ SIZE _____ FRAME _____
DRIVE GATE POST _____

**80# minimum wire
**aluminum

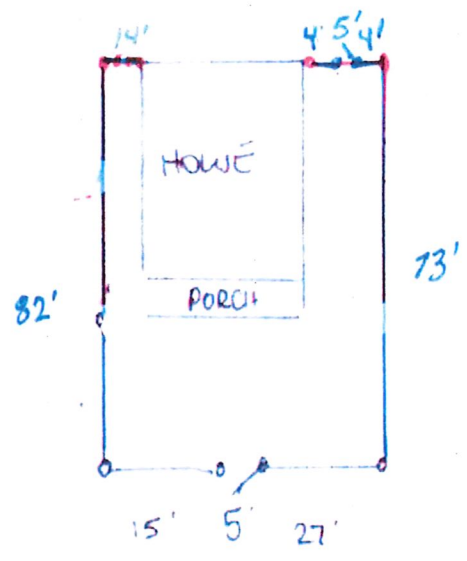

CORE DRILL/ASPHALT _____
PROP LINES CLEARED By Owner
PROP MARKS VISABLE No
PERMIT INCLUDED
SPECIAL INSTRUCTIONS _____

*Adron Fence is not responsible for being directed to dig on top of any unmarked lines.
CUSTOMER APPROVAL Cody Swann
COST 10,389.00 DEPOSIT 2751.00 BALANCE 7638.00
TERMS 1/2 down - Balance due upon completion
THIS PRICE EFFECTIVE UNTIL 30 Days
SALESMAN Jason Raulerson



There are no additional fees for credit cards.





3', 4', 5' TRADITIONAL PICKET X 72"

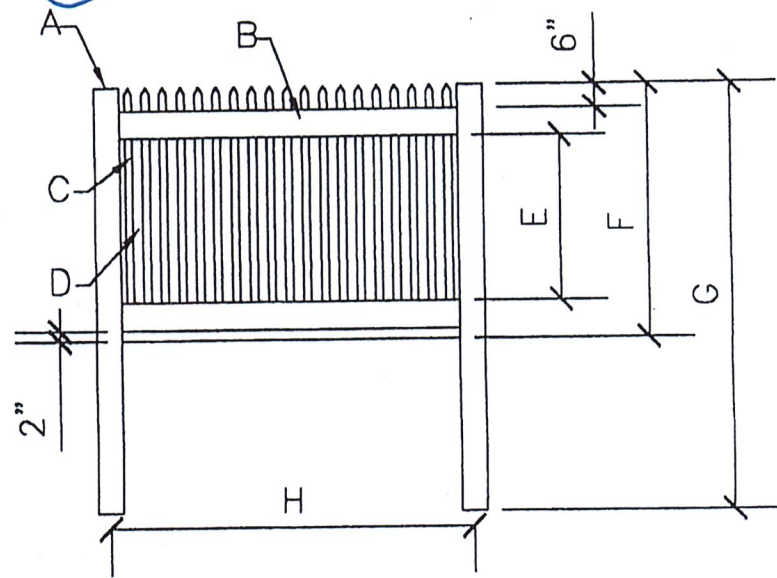

6' TRADITIONAL PICKET X 72"

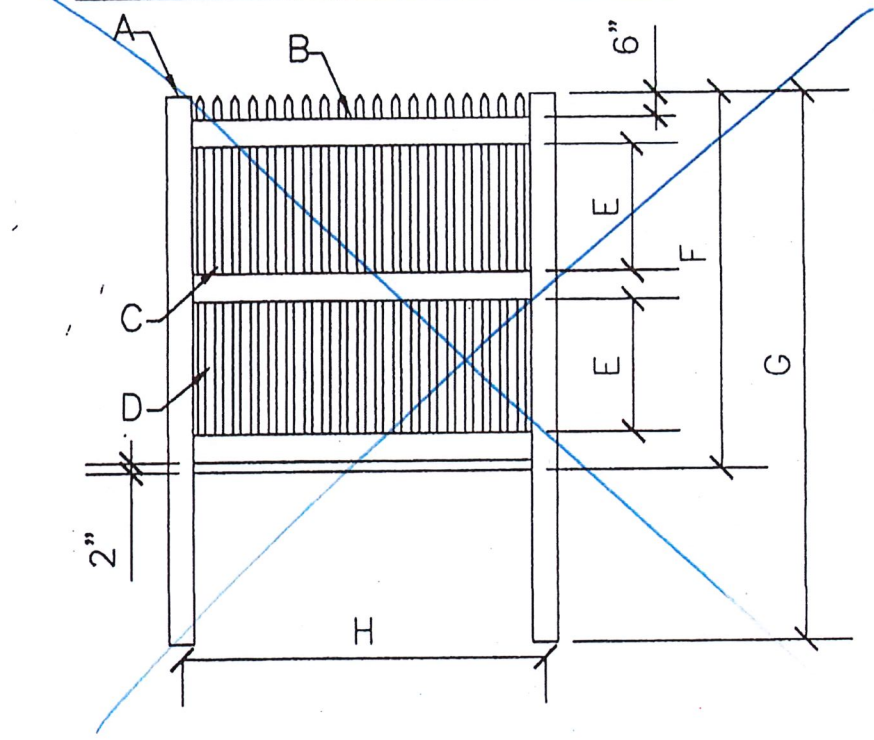

TRADITIONAL PICKET (SEBRING)

	A	B	C	D	E	F	G	H
3'	4 X 4	2 X 3.5	19 - 7/8 X 1.5 X 33.75	1.963	21	36	72	72
4'	4 X 4	2 X 3.5	19 - 7/8 X 1.5 X 45.75	1.963	33	48	84	72
5'	5 X 5	2 X 3.5	19 - 7/8 X 1.5 X 57.75	1.963	45	60	96	73
6'	5 X 5	2 X 3.5	19 - 7/8 X 1.5 X 69.75	1.963	26.75	72	108	73

CONTEMPORARY: 6' or 8' Sections, 36", 48", 60"* or 72"* H *(Has 3 Rails)

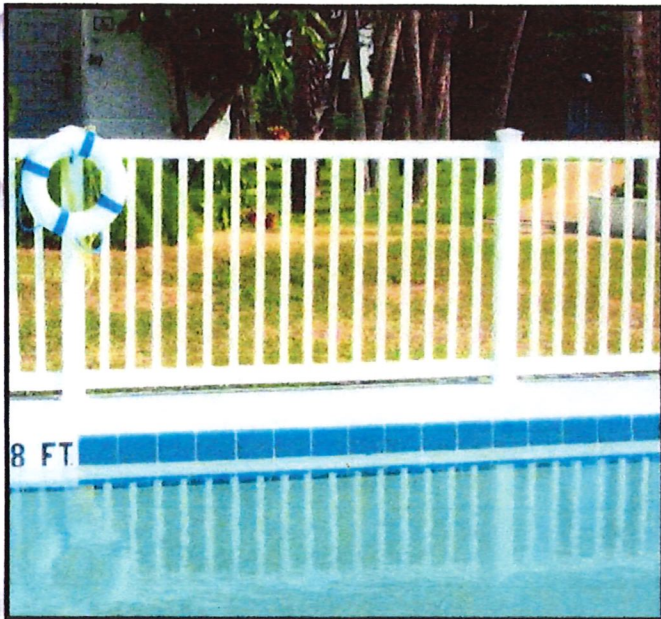

FREEPORT

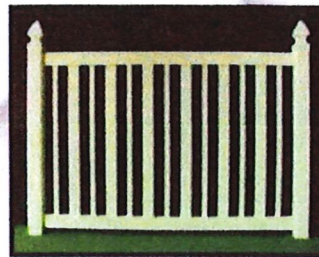

BAYONET

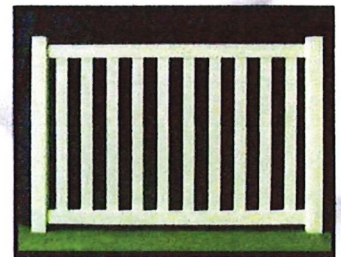

HANOVER

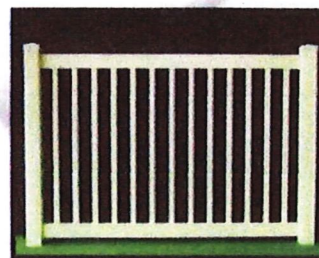

FREEPORT

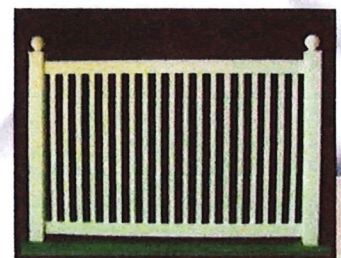

MARCO

CLASSIC: Only 6' Sections, 36", 48", 60"* or 72"* H *(Has 3 Rails)



KINGSWOOD

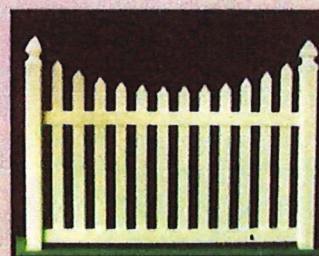

SANIBEL CONCAVE

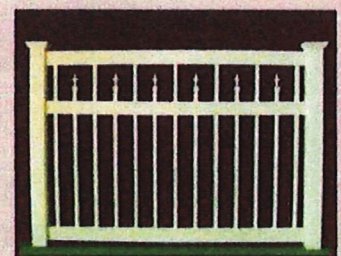

ASHLAND

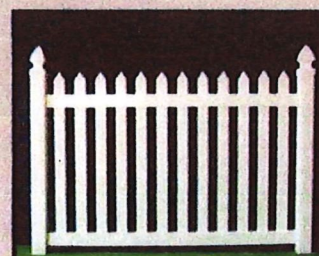

SANIBEL

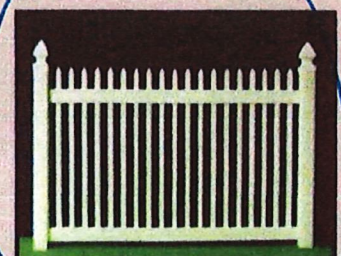

SEBRING