



THE SUNRISE CITY
FORT PIERCE
PLANNING DEPARTMENT
Florida

Andre Baxam
A-Ok Construction
909 30th Street
West Palm Beach, FL 33407

Project#: PZCON2025-00002 – Minor Site Plan application @ **209 N 18th Street**

Duplex (Conditional Use: Innovative Design)

Technical Review Committee comments for Thursday, March 20, 2025 TRC Meeting

City of Fort Pierce Planning Department

The application **Requires Resubmittal** for the following reasons:

1. The application is reviewed under the new allowable use code. Duplex development in R-3, Single-family Moderate density zoning district is based on approval through *Innovative* designs. Innovative design applies and includes landscaping, amenities, and architectural aesthetics and colors. We love the architectural designs and renderings
2. Detailed landscaping plan is missing
3. Lighting plan/details are missing
4. Please explain how refuse will be collected
5. Prior to the issuance of Building Permit approval:
 - a. A notarized Landscape Maintenance Agreement is required



THE SUNRISE CITY
FORT PIERCE
ENGINEERING
DEPARTMENT

FORT PIERCE
Florida

TO : Kerry Driver, Senior Planner
FROM : Tracy Telle, Engineering Manager
RE : 209 N. 18th Street - Minor Site Plan
TRC No. PZSITE2025-00011
DATE : March 13, 2025

This is to advise you that we have completed the review of the following documents received by this office on March 7, 2025:

- | | |
|---|---|
| <input type="checkbox"/> Development Permit Compliance Review | <input type="checkbox"/> Construction Drawings |
| <input checked="" type="checkbox"/> Minor Site Plan Application | <input type="checkbox"/> Test Reports & Related Documents |
| <input type="checkbox"/> Conditional Use | <input type="checkbox"/> Record Drawings |
| <input type="checkbox"/> Permits | <input type="checkbox"/> Other |

Based on our reviews and appropriate site final inspection, we

- | | | |
|--|--|------------------------------|
| <input type="checkbox"/> Recommend | <input checked="" type="checkbox"/> Do Not Recommend | |
| <input checked="" type="checkbox"/> Approval | <input type="checkbox"/> Variance Approval | <input type="checkbox"/> C/O |

Developer, Owner, Engineer, Contractor, and other members of the Development Team must be aware, the above recommendation is based only on the construction requirements of the engineering plans and other engineering documentation approved by this department. The Development Team shall be responsible for the compliance with other City department requirements and all approved documents, as well as Local, State and Federal regulations. The development requirements for this project may necessitate additional construction requirements that are not subject to this department's review for approval.

- See attached for engineering comments

1. The current plan proposes two driveways with a separation between the two driveways of 33.5'+/-. City of Fort Pierce Code of Ordinances Section 125-316 references that a minimum separation of 40' is requires; please revise the plans accordingly.



THE SUNRISE CITY

FORT PIERCE

POLICE DEPARTMENT
"In Honor We Serve"

Florida

Technical Review Committee meeting

March 20, 2025

Case #: PZSITE2025-00011

Planner: City of Ft. Pierce Planning Department.

Minor Site Plan

209 N 18th Street, Ft. Pierce (Innovative Development / duplex).

Comments:

No comments at this time.

Officer Damian Spotts

Crime Prevention Practitioner

Fort Pierce Police Department.

Technical Review Committee Meeting

TECHNICAL REVIEW PROJECT: PZSITE2025-00011

Minor Site Plan (Innovative Development) Duplex - 209 N. 18th Street

Comments

W/WW Engineering: Water and Wastewater Service is available to the subject property.

Water - Applicant is required to visit 206 South 6th Street (FPUA's Customer Service Building) to set up a utility account and address the required fees. Fees will include (but not limited to) the installation of a residential double water service from the existing water service at the site. The two water meters must be on private property and must be freely accessible from the public right-of-way for maintenance and billing purposes.

Wastewater – Applicant is required to Call 811, Florida's Official BEFORE YOU DIG hotline, to have the wastewater service located in the field to ensure effective and efficient connection.

The Applicant's plumber is responsible for contacting Julie Cantave @ (772) 466-1600 ext. 5520 to schedule a sewer tap inspection. The plumber must be present for the inspection with the connection fully exposed for inspection purposes. Ferncos are not allowed to be used for connection of applicant's private lateral to FPUA's point of service. Ensure that FPUA Detail S-3 (Double Lateral Service Connection) and S-4A is strictly adhered to when restoring the excavation after the inspection is complete.



S-4A.PDF

Electric Engineering: FPUA Electric & Gas Engineering has reviewed the application. **Approved.**

Please contact Sal Scimeca for electric customer requirements and project coordination.

Before work begins.

(Con't pg 2)



Sal Scimeca
Engineering Technician III
Electric & Gas Engineering
Fort Pierce Utilities Authority
sscimeca@fpu.com
772.466.1600 ext. 6957

Gas: Approved. Natural gas should be used on this project. Main is located on the east side of N 18th and would cost nothing for gas service provided its use is for a water heater and one other appliance.

FPUAnet Fiber: Approved.



Our mission is to provide our customers with economical, reliable, and friendly service in a continuous effort to enhance the quality of life in our community.



24"x24"x12" SQUARE SLAB
POURED TO GRADE IN UNPAVED
AREAS WITH FIBERGLASS MESH
REINFORCEMENT AND #4 REBAR
3" FROM OUTER PERIMETER

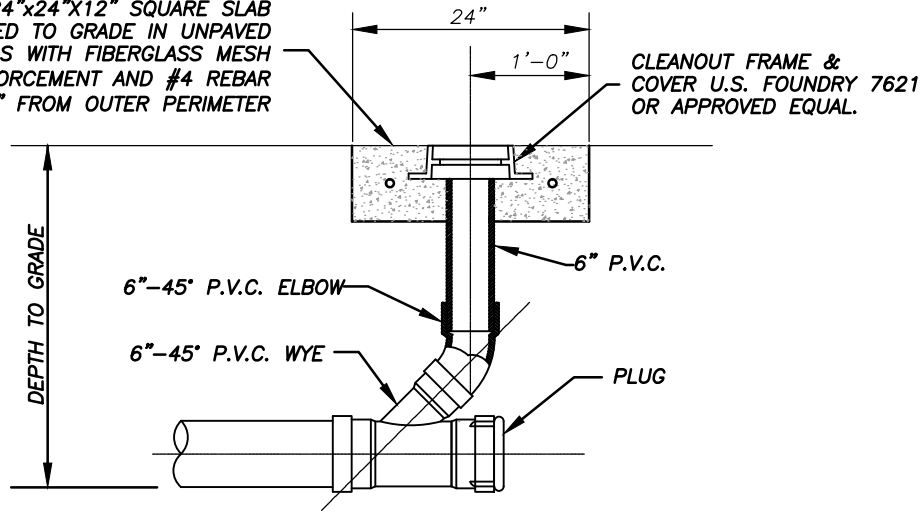

SECTION

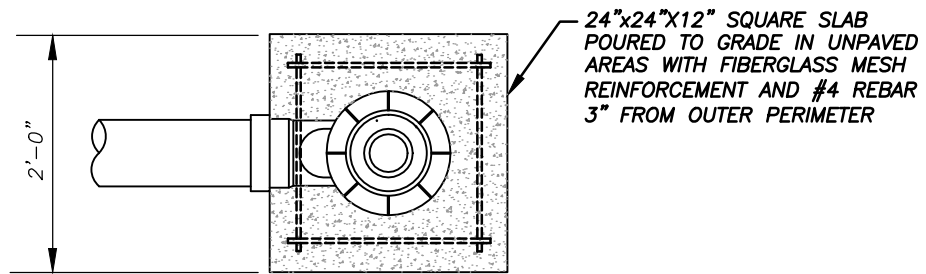

PLAN

RESIDENTIAL CLEANOUT DETAIL
(N.T.S.)

	TERMINAL CLEANOUT DETAIL				S-4A	
	<i>RESIDENTIAL</i>					
	10-06		RBE		WATER/WASTEWATER ENGINEERING	
	DATE:	REVISION:	BY:	APPD:		
	DESIGNED: JLC	COMPUTER FILE # SEWER DETAIL 200602.DWG			FT. PIERCE UTILITIES AUTHORITY	
DRAWN BY: SLL	SCALE: N.T.S.					
APPROVED:	DATE:			SHEET		
JLC	2010			1	OF 3	

JA

Jesse Almand <jalmand@slcfd.org>

To: Kerry Driver; Planning Department

😊 Reply ↩️ Reply all ↩️ Forward 🗄️ ⋮

Mon 3/10/2025 2:32 PM

SECURITY WARNING: This email has been generated from external sources and is not affiliated with the City of Fort Pierce systems. Exercise caution while clicking on links or opening attachments. If you have any questions or concerns, please reach out to the IT department promptly.

SLCFD has no comments for this review.

Respectfully,

Jesse Almand 736

Lieutenant, Development/Site Planning Review

Saint Lucie County Fire District

Community Risk Reduction

(772) 621-3385





TO: Tracy Telle, Engineering Manager

THROUGH: Kevin Freeman, Planning Director

FROM: Kerry C. Driver, Senior Planner

RE: **Minor Site Plan - Project#: PZSITE2025-00011**
209 N. 18th Street

BOARD DATE: March 13, 2025

Resubmittal of Minor Site Plan at 209 N. 18th Street
Resubmittal date: April 2, 2025

The above referenced project is being resubmitted for review and comments. The applicant is requesting a minor site plan at 209 N. 18th Street.

Please send all comments to kdriver@cityoffortpierces.com, planning@cityoffortpierces.com and/or through interoffice mail to the Planning Department

Thank you,

Kerry



THE SUNRISE CITY
FORT PIERCE
ENGINEERING
DEPARTMENT

FORT PIERCE
Florida

To : Kerry Driver, Senior Planner

FROM : Tracy Telle, Engineering Manager

RE : 209 N. 18th Street - Minor Site Plan
TRC No. PZSITE2025-00011

DATE : April 3, 2025

This is to advise you that we have completed the review of the following documents received by this office on April 3, 2025:

- | | |
|---|---|
| <input type="checkbox"/> Development Permit Compliance Review | <input type="checkbox"/> Construction Drawings |
| <input checked="" type="checkbox"/> Minor Site Plan Application | <input type="checkbox"/> Test Reports & Related Documents |
| <input type="checkbox"/> Conditional Use | <input type="checkbox"/> Record Drawings |
| <input type="checkbox"/> Permits | <input type="checkbox"/> Other |

Based on our reviews and appropriate site final inspection, we

- | | | |
|---|--|------------------------------|
| <input checked="" type="checkbox"/> Recommend | <input type="checkbox"/> Do Not Recommend | |
| <input checked="" type="checkbox"/> Approval | <input type="checkbox"/> Variance Approval | <input type="checkbox"/> C/O |

Developer, Owner, Engineer, Contractor, and other members of the Development Team must be aware, the above recommendation is based only on the construction requirements of the engineering plans and other engineering documentation approved by this department. The Development Team shall be responsible for the compliance with other City department requirements and all approved documents, as well as Local, State and Federal regulations. The development requirements for this project may necessitate additional construction requirements that are not subject to this department's review for approval.

See attached for engineering comments