

STANDARD AND ADA ON STREET PARKING DETAIL

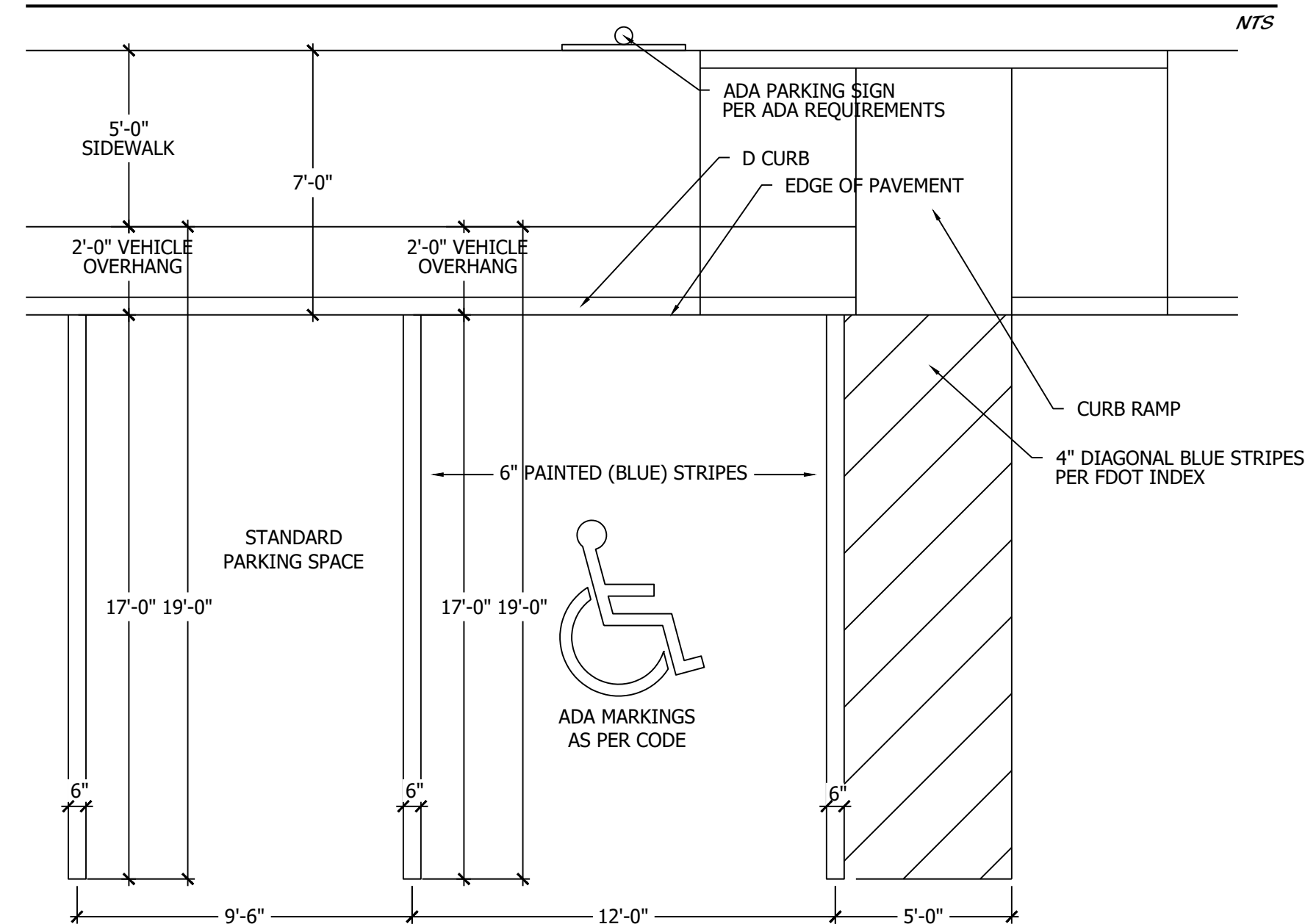

ADA RAMP DETAIL

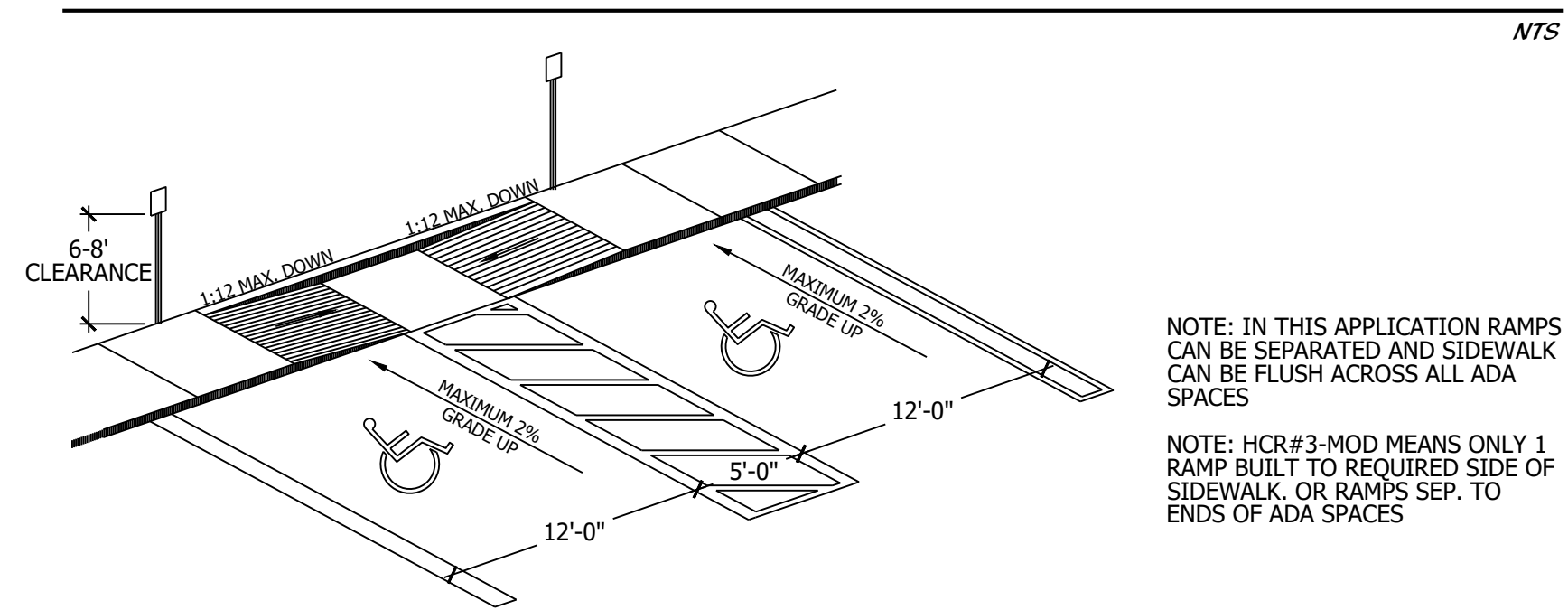

ADA SIGN DETAIL

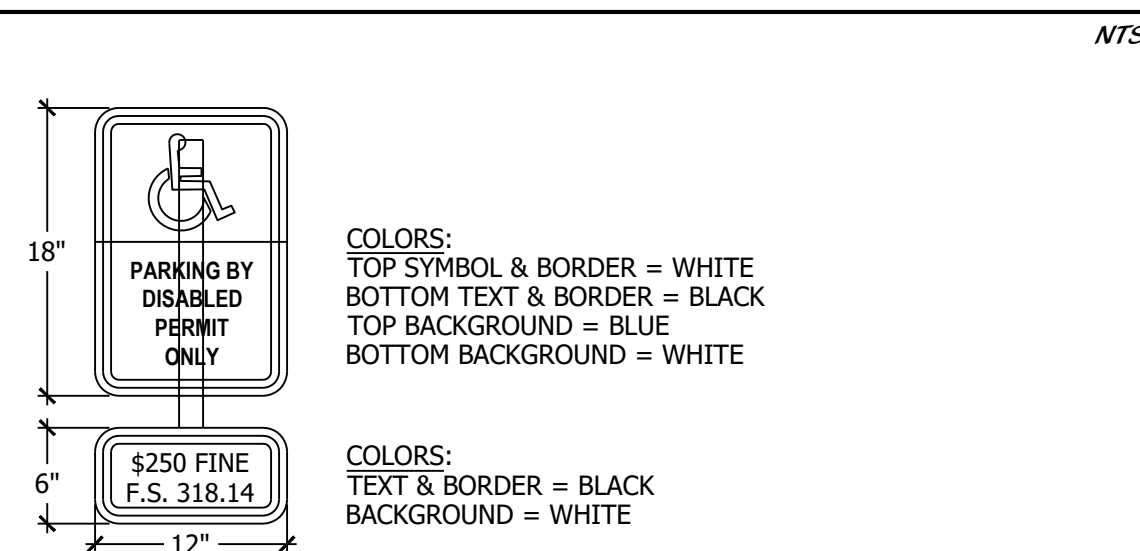

HEADER CURB DETAIL

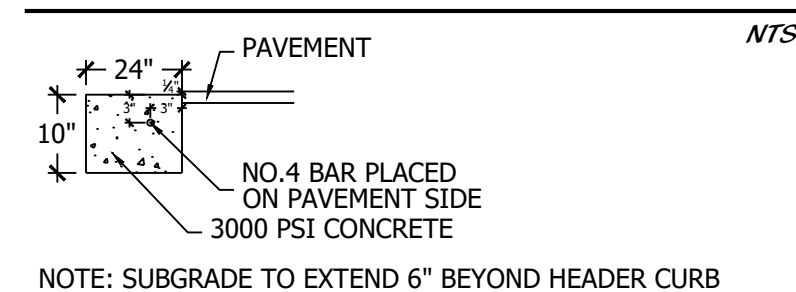

ADA SYMBOL DETAIL

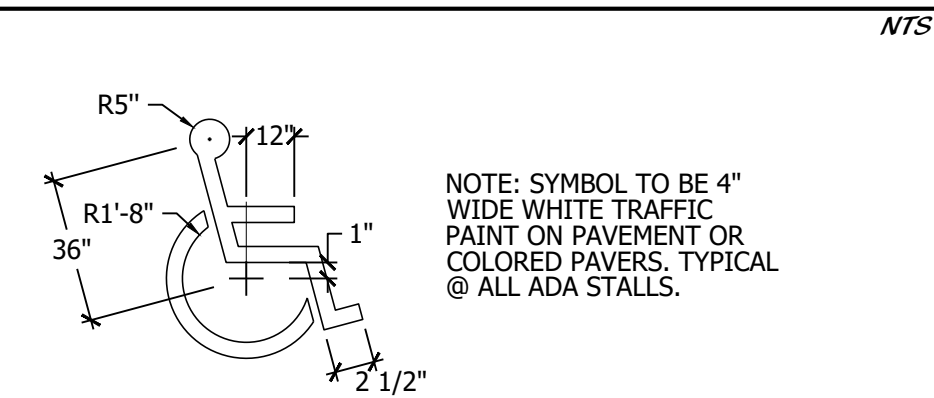

**MODEL ROW
SITE DETAILS**

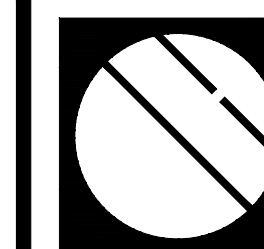

Cotleur & Hearing

Landscape Architects
Land Planners
Environmental Consultants

1934 Commerce Lane
Suite 1
Jupiter, Florida 33458

www.cotleurhearing.com
Lic# LC-C000239

SAVANNAH LAKES

Ft. Pierce, Florida

DESIGNED	VEJ/MJM
DRAWN	VEJ/MJM
APPROVED	LAH
JOB NUMBER	24-0406
DATE	08-04-25
REVISIONS	