

**FOR PERMIT**

DATE: 7 OCT 2025  
 DRAWN BY: [Name]  
 CHECKED BY: [Name]  
 PROJECT: 24-226 SITE PLAN/DWG  
 SHEET: 1 OF 6

**PRECAST SPECIALTIES, LLC**  
 CITY OF FORT PIERCE, FLORIDA

**SITE PLAN**  
 EXISTING CONDITIONS

**A DIVISION OF**  
**HALEY WARD, INC.**  
 2020 US Highway, Suite 201  
 Fort Pierce, FL 34946  
 Phone: 888-242-2454  
 Fax: 888-242-2454  
 WWW.HALEYWARD.COM

811  
 Know what's below.  
 Call before you dig.  
 www.811fl.com

**VICINITY MAP**  
N.T.S.

**LEGEND**

[Symbol]	EXISTING ELECTRIC PANEL	[Symbol]	EXISTING UTILITY POLE
[Symbol]	EXISTING ELECTRIC PANEL	[Symbol]	EXISTING ELECTRIC METER
[Symbol]	EXISTING ELECTRICION	[Symbol]	EXISTING CONCRETE LIGHT POLE
[Symbol]	HANDICAP PARKING SYMBOL	[Symbol]	EXISTING CONCRETE
[Symbol]	EXISTING CONCRETE	[Symbol]	EXISTING CONCRETE BRICK PAVEMENT
[Symbol]	EXISTING CONCRETE	[Symbol]	EXISTING CONCRETE BRICK PAVEMENT

**LEGAL DESCRIPTION:**  
 LOT 1, ACCORDING TO THE PLAT OF PRECAST SPECIALTIES AS RECORDED IN PLAT BOOK 73, PAGES 37 AND 38 OF THE PUBLIC RECORDS OF ST. LUCIE, CONTAINING 78.6 ACRES, MORE OR LESS.

**SURVEY NOTES:**  
 SURVEY POINTS SHOWN HEREON ARE RELATIVE TO THE NORTH AMERICAN VERTICAL DATUM OF 1989 (NAVD 89) AND ARE GIVEN IN U.S. SURVEY FEET UNLESS OTHERWISE NOTED.  
 \*GENERAL ACCEPTED CONVERSION NAVD - 1.175 - NGVD

Approved by the City Commission November 3, 2025, subject to the following conditions:

1. The applicant shall provide a copy of the approved site plan to the City Engineer for review and approval.
2. The applicant shall provide a copy of the approved site plan to the City Engineer for review and approval.
3. The applicant shall provide a copy of the approved site plan to the City Engineer for review and approval.
4. The applicant shall provide a copy of the approved site plan to the City Engineer for review and approval.
5. The applicant shall provide a copy of the approved site plan to the City Engineer for review and approval.
6. The applicant shall provide a copy of the approved site plan to the City Engineer for review and approval.
7. The applicant shall provide a copy of the approved site plan to the City Engineer for review and approval.
8. The applicant shall provide a copy of the approved site plan to the City Engineer for review and approval.

**Tina Rel, Office**  
**of the City**  
**Clerk**  
 Digitally signed by Tina Rel, Office of the City Clerk  
 Date: 2025.11.05 09:48:08 -0500



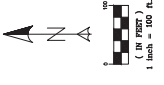

DESIGN & BOARD OF  
ST. LUCIE COUNTY  
PROJECT NO. 24-228 (13-0001-0007)

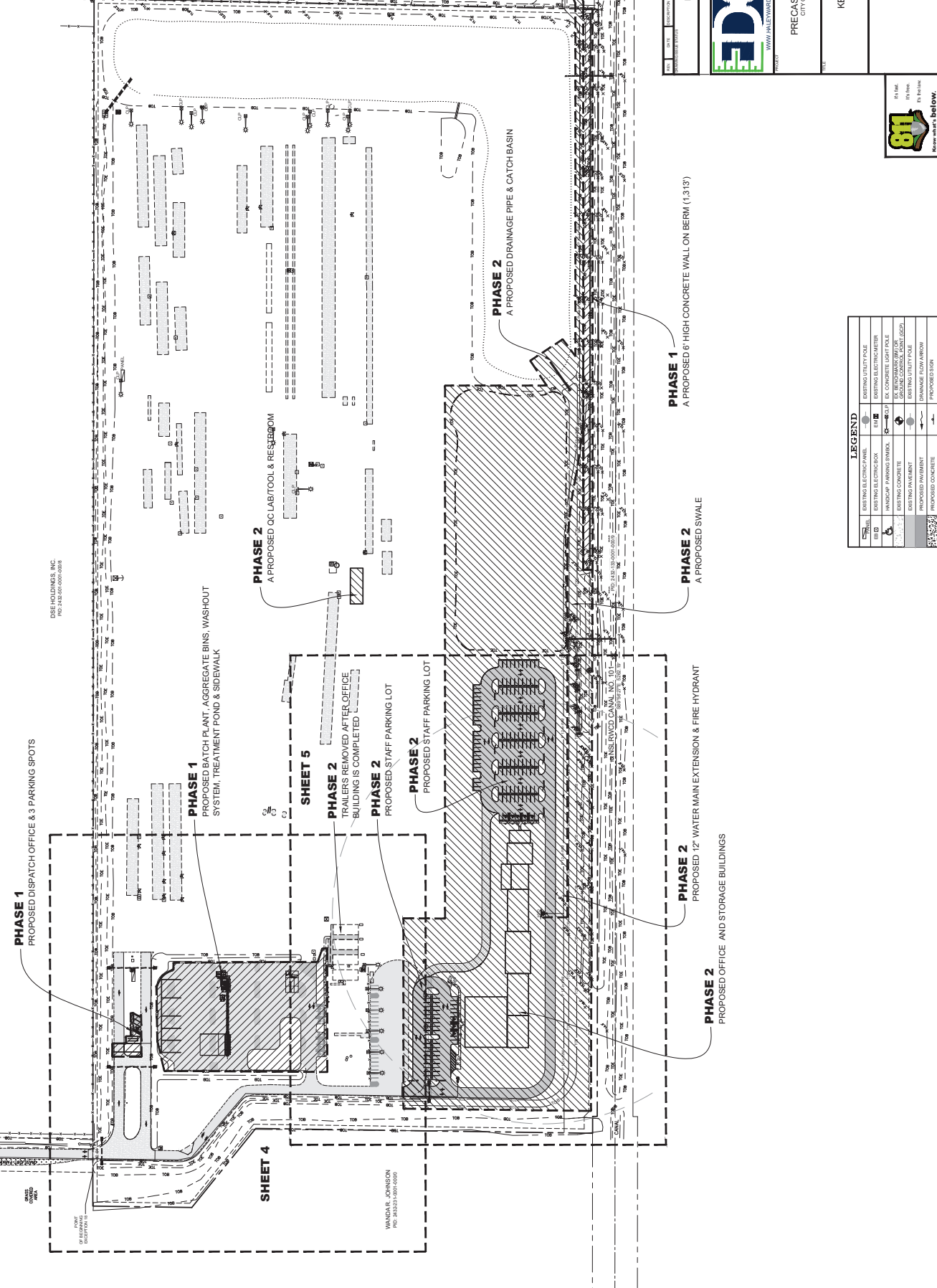

**PHASE 1**  
PROPOSED DISPATCH OFFICE & 3 PARKING SPOTS

**PHASE 1**  
PROPOSED BATCH PLANT, AGGREGATE BINS, WASHOUT SYSTEM, TREATMENT POND & SIDEWALK

**PHASE 2**  
A PROPOSED OC LAB/TOOL & RESIDUUM

**PHASE 2**  
TRAILERS REMOVED AFTER OFFICE BUILDING IS COMPLETED

**PHASE 2**  
PROPOSED STAFF PARKING LOT

**PHASE 2**  
PROPOSED STAFF PARKING LOT

**PHASE 2**  
A PROPOSED DRAINAGE PIPE & CATCH BASIN

**PHASE 1**  
A PROPOSED 6' HIGH CONCRETE WALL ON BERM (13.137)

**PHASE 2**  
A PROPOSED SWALE

**PHASE 2**  
PROPOSED 12" WATER MAIN EXTENSION & FIRE HYDRANT

**PHASE 2**  
PROPOSED OFFICE AND STORAGE BUILDINGS

POINT  
OF BEGINNING  
PROJECT NO. 24-228 (13-0001-0007)

WANDA L. JOHNSON  
PROJECT NO. 24-228 (13-0001-0007)

DSE HOLDINGS, INC.  
PROJECT NO. 24-228 (13-0001-0007)

DATE	DESCRIPTION	BY	CHK
7 OCT 2025	AS NOTED		
DATE	DESCRIPTION	BY	CHK
7 OCT 2025	AS NOTED		

**FOR PERMIT**

A DIVISION OF  
**HALEY WARD, INC.**  
2020 Village Parkway, Suite 201  
Fort Pierce, FL 34949  
Tel: 888-888-8888 Fax: 888-888-8888  
www.haleyward.com

PRECAST SPECIALTIES, LLC  
CITY OF FORT PIERCE, FLORIDA

KEY SHEET FOR  
SITE PLAN

DATE: 7 OCT 2025  
PROJECT NO.: 24-228 (13-0001-0007)  
SHEET NO.: 3 OF 6

811  
Call before you dig.  
www.811.com

LEGEND	
	EXISTING ELECTRIC PANEL
	EXISTING ELECTRIC BOX
	HANDICAP PARKING SYMBOL
	EXISTING CONCRETE
	EXISTING PAVEMENT
	PROPOSED CONCRETE
	PROPOSED TURF BLOCK
	EXISTING UTILITY POLE
	EXISTING ELECTRIC METER
	EXISTING CONCRETE LIGHT POLE
	EXISTING UTILITY POLE
	EXISTING PAVEMENT
	PROPOSED CONCRETE
	PROPOSED TURF BLOCK
	EXISTING WATER MAIN
	PROPOSED WATER MAIN
	EXISTING FIRE HYDRANT
	PROPOSED FIRE HYDRANT
	EXISTING PARKING SPOT
	PROPOSED PARKING SPOT
	EXISTING BUILDING
	PROPOSED BUILDING
	EXISTING DRAINAGE PIPE
	PROPOSED DRAINAGE PIPE
	EXISTING CATCH BASIN
	PROPOSED CATCH BASIN
	EXISTING SWALE
	PROPOSED SWALE
	EXISTING WALL
	PROPOSED WALL
	EXISTING BERM
	PROPOSED BERM
	EXISTING CANAL
	PROPOSED CANAL
	EXISTING ROAD
	PROPOSED ROAD
	EXISTING SIDEWALK
	PROPOSED SIDEWALK
	EXISTING TREATMENT POND
	PROPOSED TREATMENT POND
	EXISTING WASHOUT SYSTEM
	PROPOSED WASHOUT SYSTEM
	EXISTING AGGREGATE BINS
	PROPOSED AGGREGATE BINS
	EXISTING OC LAB/TOOL & RESIDUUM
	PROPOSED OC LAB/TOOL & RESIDUUM
	EXISTING STAFF PARKING LOT
	PROPOSED STAFF PARKING LOT
	EXISTING OFFICE AND STORAGE BUILDINGS
	PROPOSED OFFICE AND STORAGE BUILDINGS
	EXISTING WATER MAIN EXTENSION & FIRE HYDRANT
	PROPOSED WATER MAIN EXTENSION & FIRE HYDRANT
	EXISTING 6' HIGH CONCRETE WALL ON BERM
	PROPOSED 6' HIGH CONCRETE WALL ON BERM
	EXISTING SWALE
	PROPOSED SWALE

SHEET 5

SHEET 4





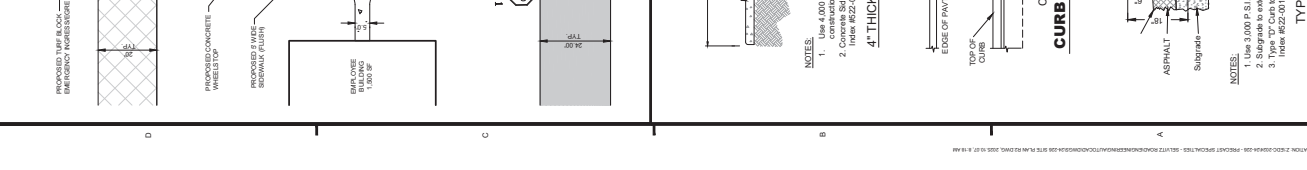
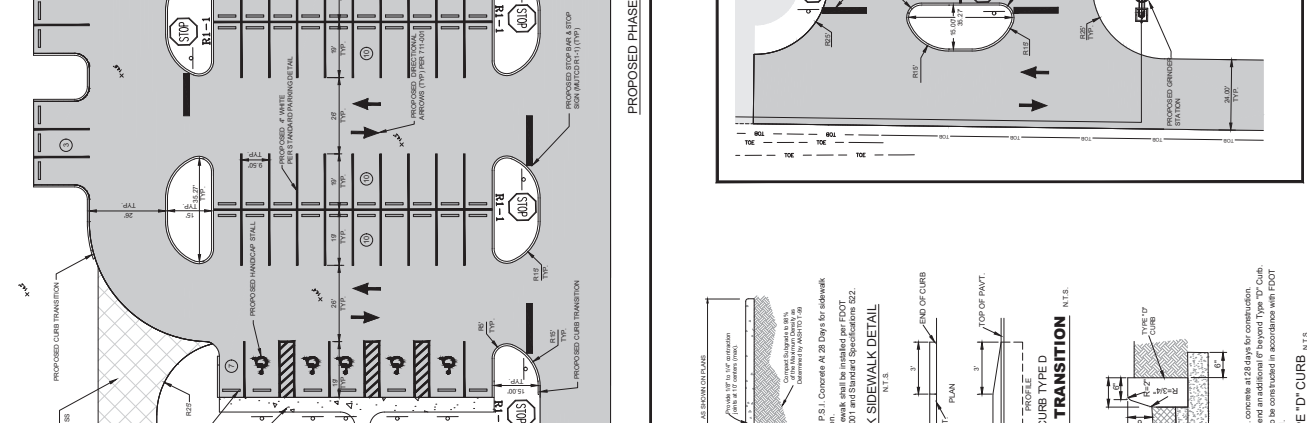
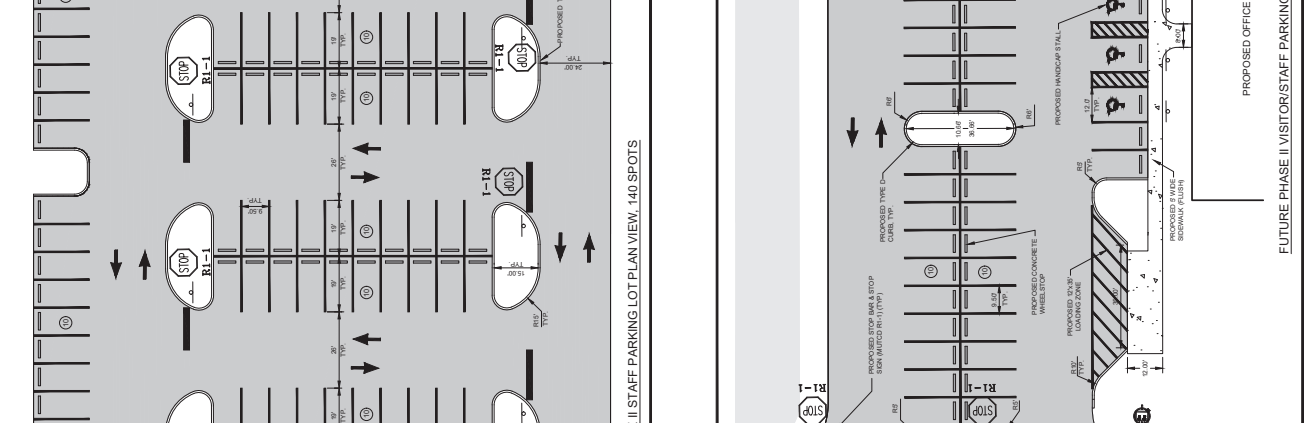
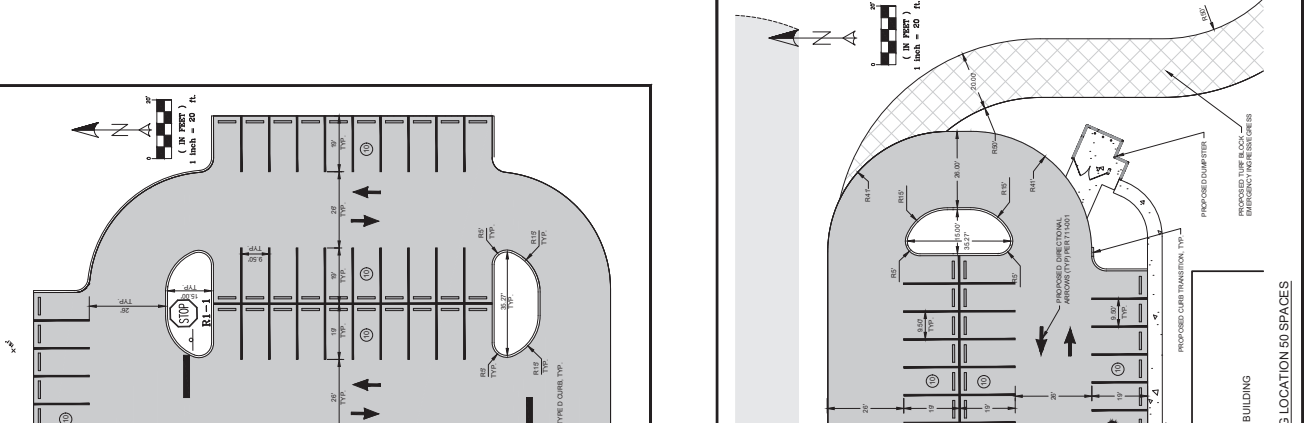
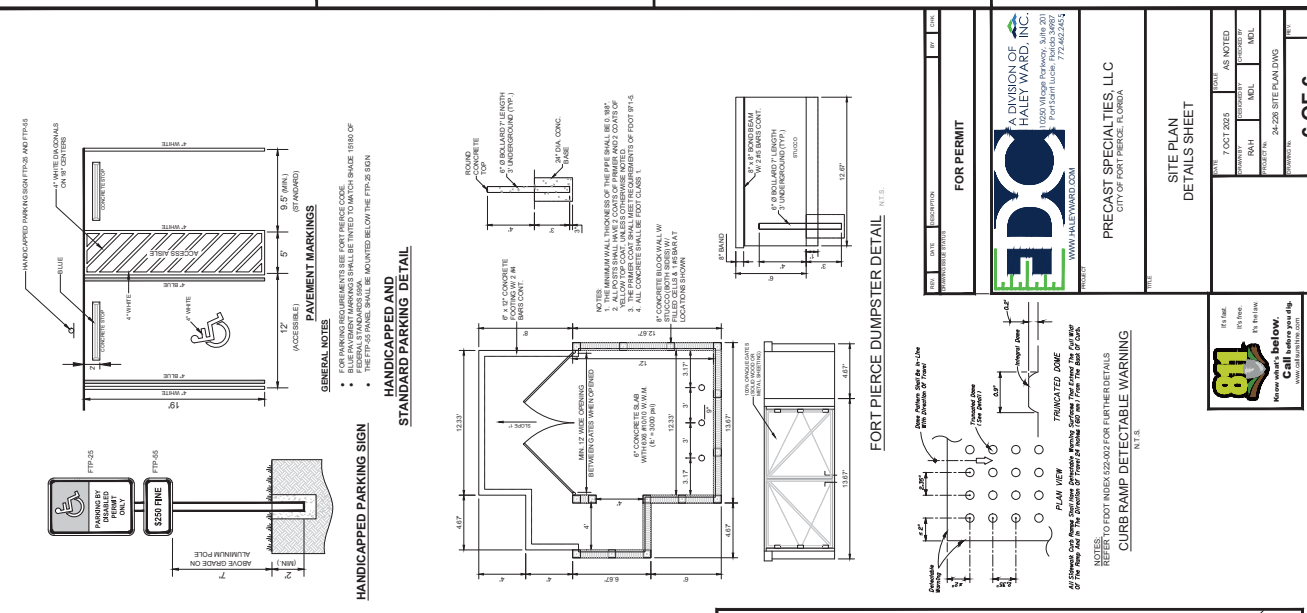

**GENERAL NOTES**

- FOR PARKING REQUIREMENTS SEE FORT PIERCE CODE.
- FEDERAL STANDARDS SHALL BE REFERRED TO FOR THE MOST CURRENT REQUIREMENTS.
- THE FDOT SIGNAGE SHALL BE INSTALLED BELOW THE FUTURE SIGN.

**FOR PERMIT**

**PRECAST SPECIALTIES, LLC**  
CITY OF FORT PIERCE, FLORIDA

**SITE PLAN DETAILS SHEET**

DATE: 7 OCT 2025  
REVISION: 15 FEB 2025  
REVISION: 15 FEB 2025  
REVISION: 24 JUN 2025

PROJECT No. 24-228 SITE PLAN DWG  
DRAWING No. 6 OF 6

**811**  
Before you dig, call 811. Know what's below. Call before you dig. www.floridastate.com

**FOR PERMIT**

**PRECAST SPECIALTIES, LLC**  
CITY OF FORT PIERCE, FLORIDA

**SITE PLAN DETAILS SHEET**

DATE: 7 OCT 2025  
REVISION: 15 FEB 2025  
REVISION: 15 FEB 2025  
REVISION: 24 JUN 2025

PROJECT No. 24-228 SITE PLAN DWG  
DRAWING No. 6 OF 6

**811**  
Before you dig, call 811. Know what's below. Call before you dig. www.floridastate.com