

FINAL PLAT
OF
"STONEHAVEN PHASE 2, PARCEL 13B"
A PLANNED AREA DEVELOPMENT
A PORTION OF THE SOUTHWEST QUARTER OF SECTION 15, TOWNSHIP 2
NORTH, RANGE 1 EAST OF THE GILA AND SALT RIVER BASE AND MERIDIAN,
MARICOPA, COUNTY, ARIZONA

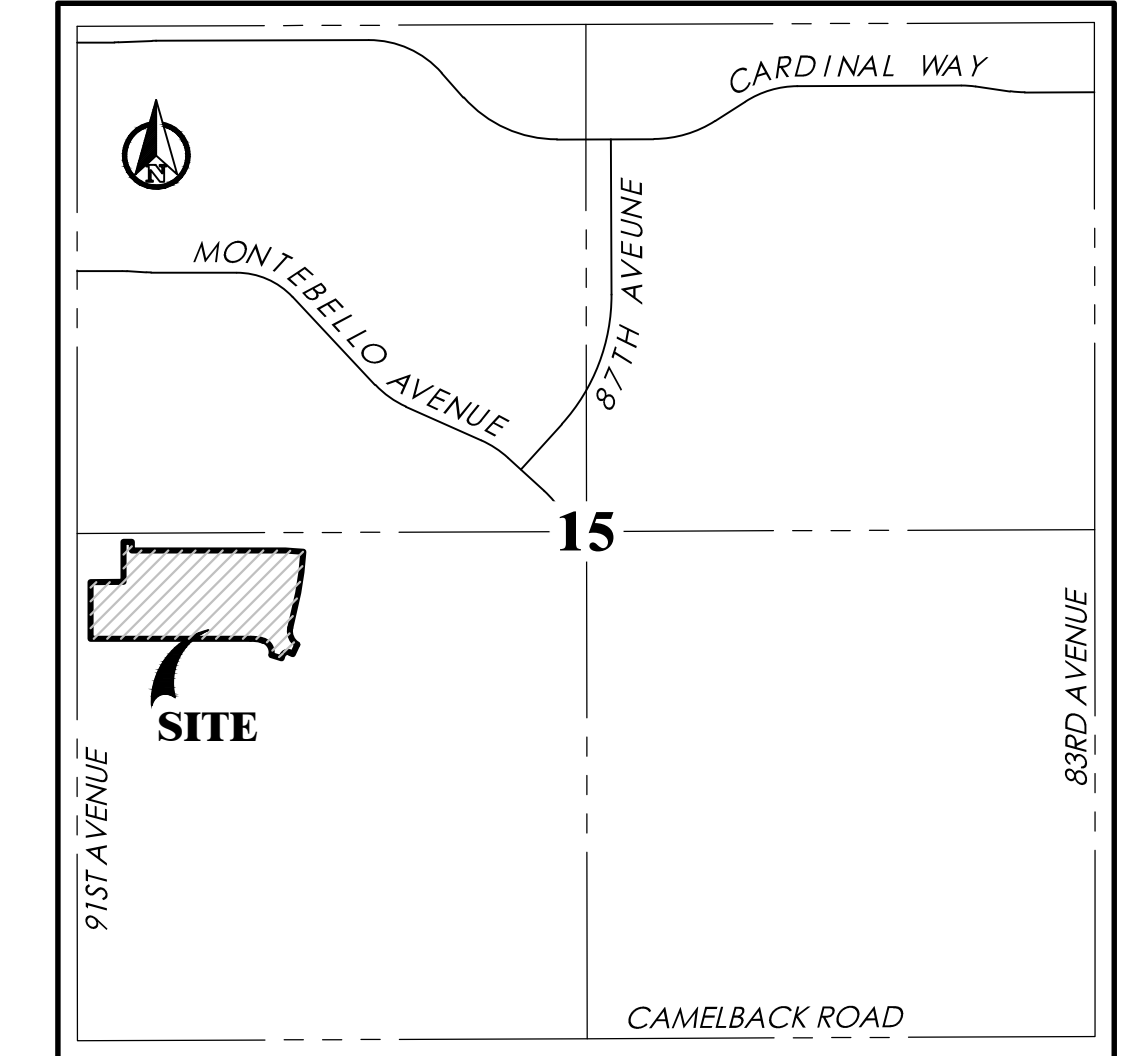

VICINITY MAP
N.T.S.

SURVEYOR'S STATEMENT

I, LANCE C. DICKSON, HEREBY CERTIFY THAT I AM A REGISTERED LAND SURVEYOR IN THE STATE OF ARIZONA, THAT THIS MAP CORRECTLY REPRESENTS A BOUNDARY SURVEY MADE UNDER MY SUPERVISION AND THE SURVEY IS TRUE AND COMPLETE AS SHOWN, MEETS THE MINIMUM STANDARDS FOR ARIZONA LAND BOUNDARY SURVEYS, ALL MONUMENTS SHOWN ACTUALLY EXIST AS SHOWN, THEIR POSITIONS ARE CORRECTLY SHOWN AND THAT SAID MONUMENTS ARE SUFFICIENT TO ENABLE THE SURVEY TO BE RETRACED.

BY: LANCE C. DICKSON, R.L.S. #46643
ARIZONA SURVEYING AND MAPPING
2440 W. MISSION LANE, SUITE 4
PHOENIX, ARIZONA 85021
(602) 246-9919



I, JOHN N. ROGERS, HEREBY CERTIFY THAT I AM A REGISTERED LAND SURVEYOR IN THE STATE OF ARIZONA, DO HEREBY DECLARE THAT THE INTERNAL LOT AND TRACT LINES, EASEMENTS, RIGHTS-OF-WAY, AND OTHER CALCULATIONS OTHER THAN PROPERTY BOUNDARY, WERE PROPERLY PREPARED UNDER MY PERSONAL SUPERVISION IN ACCORDANCE WITH THE PLATTING RULES AND REGULATIONS OF THE STATE OF ARIZONA.

BY: JOHN N. ROGERS, R.L.S. #54332
GOODWIN AND MARSHALL, INC.
2705 S. ALMA SCHOOL RD., STE. 2
CHANDLER, ARIZONA 85286
(602) 218-7285

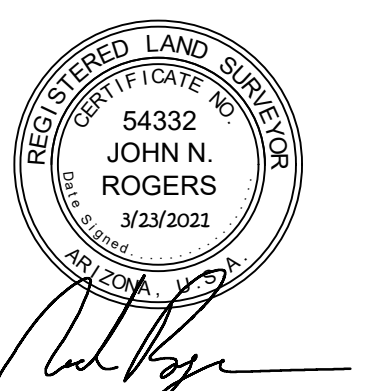

NOTE:
A.R.S. 32-151 STATES THAT THE USE OF THE WORD "CERTIFY" OR "CERTIFICATE" IS AN EXPRESSION OF PROFESSIONAL OPINION REGARDING THE FACTS OF THE SURVEY AND DOES NOT CONSTITUTE A GUARANTEE, EXPRESS OR IMPLIED.

PRELIMINARY PLAT CONFORMANCE

I HEREBY CERTIFY THAT THIS PLAT HAS BEEN PREPARED IN GENERAL CONFORMANCE TO THE PRELIMINARY PLAT OF THIS SUBDIVISION APPROVED BY THE CITY OF GLENDALE PLANNING AND ZONING COMMISSION.

BY: _____ DATE _____
PLANNING DIRECTOR
CITY OF GLENDALE

IMPROVEMENT ASSURANCES

I HEREBY ACKNOWLEDGE THAT ENGINEERING PLANS FOR PUBLIC IMPROVEMENTS ASSOCIATED WITH THIS SUBDIVISION HAVE BEEN APPROVED AND THAT ALL NECESSARY ASSURANCES FOR THESE IMPROVEMENTS HAVE BEEN RECEIVED IN A FORM ACCEPTABLE TO THE CITY.

BY: _____ DATE _____
CITY ENGINEER OR DESIGNATE

APPROVALS

APPROVED BY THE CITY COUNCIL OF THE CITY OF GLENDALE, ARIZONA.

THIS _____ DAY OF _____, 20__

MAYOR DATE _____

ATTEST CITY CLERK DATE _____

STONEHAVEN COMMUNITY ASSOCIATION RATIFICATION AND CONSENT

THE UNDERSIGNED HEREBY RATIFIES AND CONSENTS TO THIS PLAT, INCLUDING ITS MAINTENANCE OBLIGATIONS AS SET FORTH HEREIN.

STONEHAVEN COMMUNITY ASSOCIATION, AN ARIZONA NON-PROFIT CORPORATION

BY: _____

BY: LAUREN VAN TUSSENBROEK

ITS: PRESIDENT

STONEHAVEN COMMUNITY ASSOCIATION RATIFICATION ACKNOWLEDGEMENT

STATE OF ARIZONA)
) SS
COUNTY OF MARICOPA)

ON THIS _____ DAY OF _____, 20__ BEFORE ME, THE UNDERSIGNED NOTARY PUBLIC, LAUREN VAN TUSSENBROEK PERSONALLY APPEARED, WHO ACKNOWLEDGED HERSELF TO BE PRESIDENT OF THE STONEHAVEN COMMUNITY ASSOCIATION, AN ARIZONA NON-PROFIT CORPORATION AND BEING AUTHORIZED TO DO SO ON BEHALF OF SAID ENTITY, EXECUTED THIS INSTRUMENT FOR THE PURPOSES HEREIN CONTAINED.

IN WITNESS WHEREOF:
I HEREBY SET MY HAND AND OFFICIAL SEAL

NOTARY PUBLIC
MY COMMISSION EXPIRES: _____

BASIS OF BEARINGS

N 00°00'41" W ALONG THE MONUMENT LINE OF 91ST AVENUE AS MEASURED BETWEEN MONUMENTS NUMBERED 1 AND 2 SHOWN HEREON AND DESCRIBED UNDER MONUMENT NOTES.

SHEET INDEX

SHEET 1	COVER
SHEET 2	LOT AND TRACT SUMMARY TABLES, TYPICAL LOT DETAIL, KEY MAP, AND MONUMENT NOTES
SHEET 3	TYPICAL PLAN SHEET, LEGEND, LINE AND CURVE TABLES

OWNER/DEVELOPER:

taylor morrison
Homes Inspired by You
4900 North Scottsdale Road #2200
Scottsdale, AZ 85251
(480) 508-7118
Contract: Jonathan Bastianelli

PREPARED: March 2021

SHEET 1 OF 3

PREPARED BY:

GOODWIN AND MARSHALL INC.

CIVIL ENGINEERS ~ PLANNERS ~ SURVEYORS

2705 S. Alma School Road, Suite 2
Chandler, Arizona 85044
(602) 218-7285
Contact: Warren Russell, P.E.

SURVEYED BY:



Arizona Surveying and Mapping
2440 W. Mission Lane, Suite 4, Phoenix, Arizona 85021
TEL (602) 246-9919 FAX (602) 246-9944 info@asam1.com

DEDICATION

STATE OF ARIZONA)
) SS.
COUNTY OF MARICOPA)

KNOW ALL MEN BY THESE PRESENTS:

THAT TAYLOR MORRISON/ARIZONA, INC., AN ARIZONA CORPORATION, AS OWNER, DOES HEREBY PUBLISH THIS FINAL PLAT OF "STONEHAVEN PHASE 2, PARCEL 13B", SITUATED IN A PORTION OF THE SOUTHWEST QUARTER OF SECTION 15, TOWNSHIP 2 NORTH, RANGE 1 EAST OF THE GILA AND SALT RIVER BASE AND MERIDIAN, MARICOPA COUNTY, ARIZONA, AS SHOWN AND PLATTED HEREON AND DOES HEREBY PUBLISH THIS PLAT AS AND FOR THE PLAT OF SAID "STONEHAVEN PHASE 2, PARCEL 13B" AND HEREBY DECLARES THAT SAID PLAT SETS FORTH THE LOCATION AND GIVES THE DIMENSIONS OF THE LOTS, TRACTS, EASEMENTS, AND STREETS CONSTITUTING SAME, AND THAT EACH LOT, TRACT, AND STREET SHALL BE KNOWN BY THE NUMBER, LETTER OR NAME GIVEN TO EACH RESPECTIVELY ON SAID PLAT AND HEREBY DEDICATES TO THE CITY OF GLENDALE FOR USE, AS SUCH, THE EASEMENTS AND THE PUBLIC RIGHT-OF-WAY FOR ROADWAY PURPOSES AS SHOWN ON SAID PLAT AND INCLUDED IN THE ABOVE DESCRIBED PREMISES. EASEMENTS ARE DEDICATED FOR THE PURPOSES SHOWN HEREON.

TRACTS ARE HEREBY DEDICATED TO A FUTURE HOMEOWNER'S ASSOCIATION AND ARE DECLARED FOR THE SPECIFIC USES IDENTIFIED ON THE TRACT SUMMARY TABLE PROVIDED HEREON ON PAGE 2 OF THIS FINAL PLAT AND SUBJECT TO THE EASEMENTS DEDICATED TO THE CITY OF GLENDALE.

IN WITNESS WHEREOF, TAYLOR MORRISON/ARIZONA, INC. AN ARIZONA CORPORATION, AS OWNER, HAS HEREBY CAUSED ITS CORPORATE NAME TO BE AFFIXED AND THE SAME TO BE ATTESTED BY THE SIGNATURE OF THE UNDERSIGNED, DULY AUTHORIZED OFFICER THIS _____ DAY OF _____, 20__.

TAYLOR MORRISON/ARIZONA, INC., AN ARIZONA CORPORATION

BY: _____

NAME: SHANNON FRANCOEUR

ITS: VICE PRESIDENT

ACKNOWLEDGEMENT

STATE OF ARIZONA)
) SS.
COUNTY OF MARICOPA)

ON THIS _____ DAY OF _____, 20__ BEFORE ME, THE UNDERSIGNED NOTARY PUBLIC, SHANNON FRANCOEUR PERSONALLY APPEARED, WHO ACKNOWLEDGE HERSELF TO BE THE VICE PRESIDENT OF TAYLOR MORRISON/ARIZONA, INC. AN ARIZONA CORPORATION AND BEING AUTHORIZED TO DO SO ON BEHALF OF SAID ENTITY, EXECUTED THIS INSTRUMENT FOR THE PURPOSES HEREIN CONTAINED.

IN WITNESS WHEREOF:

I HEREBY SET MY HAND AND OFFICIAL SEAL

NOTARY PUBLIC
MY COMMISSION EXPIRES _____

"FINAL PLAT OF STONEHAVEN PHASE 2, PARCEL 13B"

SITE SUMMARY TABLE															
PARCEL NO	NUMBER OF LOTS	ACREAGE (GROSS)	APPROXIMATE OPEN SPACE PROVIDED (AC) [9]	PERCENTAGE OF OPEN SPACE PROVIDED (AC)	DENSITY DU/AC (GROSS) [10]	ARTERIAL / COLLECTOR / ACREAGE	ACREAGE (NET) [6]	UNBUILDABLE AREA ROADWAY TRACTS EXCLUDING PERIMETER STREETS	ZONING	MINIMUM LOT AREA (SQ. FT.) [1]	TYPICAL LOT SIZE (WIDTH X DEPTH) (FT) [7] [8]	MINIMUM YARD SETBACKS			
												FRONT [2] (FT)	REAR [3] (FT)	SIDE (FT)	MAX ALLOWABLE LOT COVERAGE
13B	50	11.021	1.114	10.11%	4.54	0.000	11.021	2.950	SHD-5 PAD	5,000	50 X 120	15	15	5	55%

PAD NOTES:

- [1] THE MINIMUM LOT AREA PERMITTED WITHIN DISTRICT. LOT DEPTH IS A FUNCTION OF MINIMUM AREA AND MINIMUM WIDTH.
- [2] THE MINIMUM SETBACK TO ANY FRONT FACING GARAGE DOOR SHALL BE 18 FEET FROM FACE OF THE GARAGE DOOR TO THE BACK OF PUBLIC SIDEWALK.
- [3] REAR COVERED PATIOS MAY ENCROACH TO WITHIN 15 FEET FROM THE REAR PROPERTY LINE.
- [4] FOR ADDITIONAL INFORMATION REGARDING YARD ENCROACHMENTS, REFER TO THE PROVISIONS OF SECTION 5.4.3. (OF APPROVED PAD)
- [5A] THE MINIMUM SIDE YARD SETBACKS MAY BE REDUCED TO 0' ALONG ONE OF THE TWO SIDE YARD PROPERTY LINES, (SHD-4 ZONING DISTRICT ONLY)
- [5B] THE COMBINED SIDE YARD SETBACKS MAY BE REDUCED TO 5' WHEN THE HOME IS PLACED ON THE OPPOSITE SIDE YARD LOT LINE. (SHD-4 ZONING DISTRICT ONLY)

ADDITIONAL NOTES:

- [6] NET ACREAGE IS THE DIFFERENCE OF GROSS ACREAGE AND COLLECTOR/ARTERIAL ROADWAY ACREAGE.
- [7] LOT WIDTH IS MEASURED AT THE "FRONT GARAGE" FRONT YARD BUILDING SETBACK.
- [8] LOT DEPTH IS TYPICAL AND NOT A MINIMUM. LOT DEPTH MAY BE REDUCED BY UP TO 10 FEET AT KNUCKLES AND CUL-DE-SACS.
- [9] AS ESTIMATED BY THE PRELIMINARY PLAT, HOWEVER THE PERCENTAGES OF OPEN SPACE MAY VARY IN THE FINAL PLAT.
- [10] NUMBER OF RESIDENTIAL UNITS DIVIDED BY THE GROSS AREA.

TRACT SUMMARY TABLE				
TRACT	AREA (SQ. FT.)	AREA (ACRES)	USAGE	MAINTENANCE RESPONSIBILITY
TRACT 13B-A	33,055	0.759	LANDSCAPE, OPEN SPACE, DRAINAGE, AND PEDESTRIAN ACCESS	HOMEOWNERS ASSOCIATION
TRACT 13B-B	2,202	0.051	LANDSCAPE AND OPEN SPACE	HOMEOWNERS ASSOCIATION
TRACT 13B-C	11,287	0.259	LANDSCAPE AND OPEN SPACE	HOMEOWNERS ASSOCIATION
TRACT 13B-D	1,979	0.045	LANDSCAPE AND OPEN SPACE	HOMEOWNERS ASSOCIATION

AREAS

TRACT AREA	=	48,522 SQ. FT.	1.114 ACRES
LOT AREA	=	303,082 SQ. FT.	6.958 ACRES
RIGHT-OF-WAY	=	128,485 SQ. FT.	2.950 ACRES
GROSS AREA	=	480,090 SQ. FT.	11.021 ACRES

NOTES:

- 1. COMMON AREAS MAY INCLUDE OPEN SPACE, LANDSCAPING, PEDESTRIAN PATHS AND/OR AMENITIES.
- 2. SPECIFIC EASEMENTS THAT ARE BEING DEDICATED AS PART OF THIS PLAT ARE FULLY DELINEATED ON THE FOLLOWING SHEETS.
- 3. THE USES SHOWN IN THE TRACT TABLE ABOVE DO NOT INTEND TO GRANT EASEMENTS THAT ARE BLANKET IN NATURE OVER THE ENTIRE TRACT.

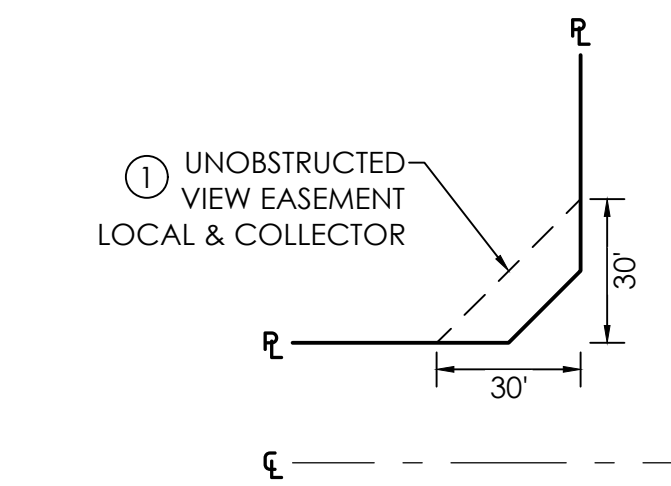
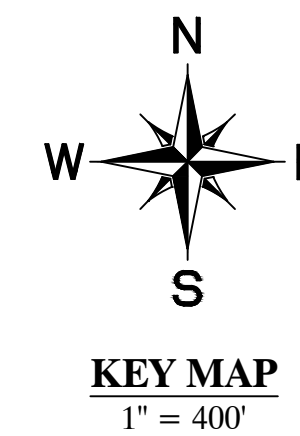
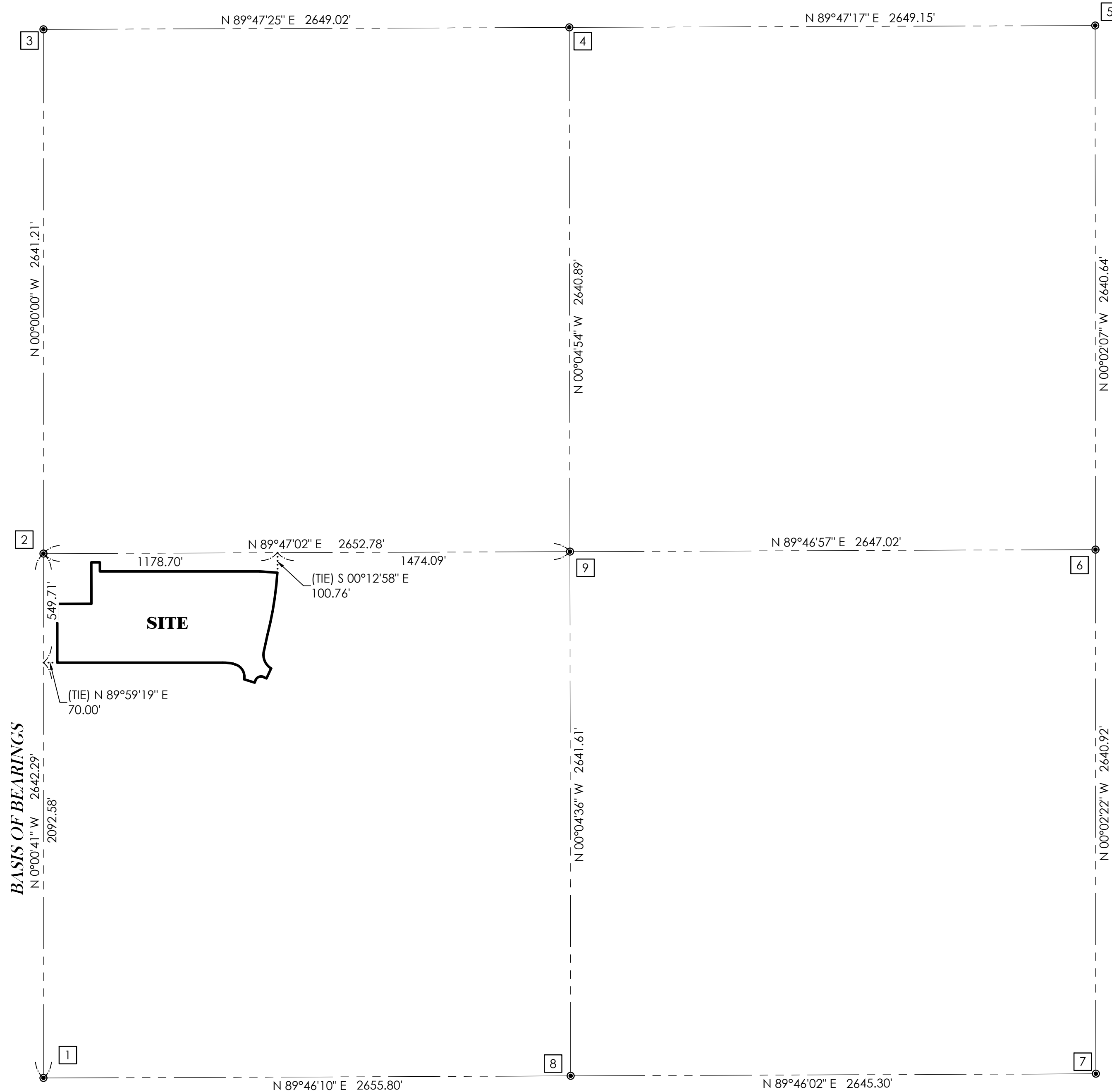

UNOBSTRUCTED VIEW EASEMENT (TYP)
N.T.S.

NOTES:

- 1. NO SIGNS, FENCES, WALLS, UTILITY BOXES, STRUCTURES, SHRUBS, HEDGES OR OTHER PLANTS (EXCLUDING TREES OVER 30 INCHES IN HEIGHT) SHALL BE PERMITTED WITHIN THE RESTRICTED AREAS, EXCEPT AS APPROVED BY THE CITY TRANSPORTATION DIRECTOR.
- 2. TREES ARE PERMITTED WITHIN THE RESTRICTED AREAS, PROVIDED:
 - A. NO LIMBS, LEAVES, NEEDLES OR OTHER FOLIAGE ABOVE 30 INCHES OR BELOW 84 INCHES ARE PERMITTED. TREES ARE PLANTED SO AS NOT TO OBSTRUCT 20% OF THE VISIBILITY WHEN COMBINED WITH OTHER OBSTRUCTIONS PRESENT.
 - B.

MONUMENT NOTES

ALL MONUMENTATION SHOWN HEREON WAS ACCEPTED UNLESS OTHERWISE NOTED.

- 1 MARICOPA COUNTY HIGHWAY DEPARTMENT BRASS CAP IN HANDHOLE FOR THE SOUTHWEST CORNER OF SECTION 15, T2N, R1E
- 2 MARICOPA COUNTY DEPARTMENT OF TRANSPORTATION BRASS CAP IN HANDHOLE FOR THE WEST QUARTER CORNER OF SECTION 15, T2N, R1E
- 3 PK NAIL WITH STADDLERS FOR THE NORTHWEST CORNER OF SECTION 15, T2N, R1E
- 4 CALCULATED POSITION OF NORTH QUARTER CORNER OF SECTION 15, T2N, R1E
- 5 CITY OF GLENDALE BRASS CAP FLUSH FOR THE NORTHEAST CORNER OF SECTION 15, T2N, R1E
- 6 BRASS CAP IN HANDHOLE FOR THE EAST QUARTER CORNER OF SECTION 15, T2N, R1E
- 7 MARICOPA COUNTY HIGHWAY DEPARTMENT BRASS CAP IN HANDHOLE FOR THE SOUTHEAST CORNER OF SECTION 15, T2N, R1E
- 8 MARICOPA COUNTY HIGHWAY DEPARTMENT BRASS CAP IN HANDHOLE FOR THE SOUTH QUARTER CORNER OF SECTION 15, T2N, R1E
- 9 FOUND 1" IRON BAR CENTER CORNER OF SECTION 15, T2N, R1E

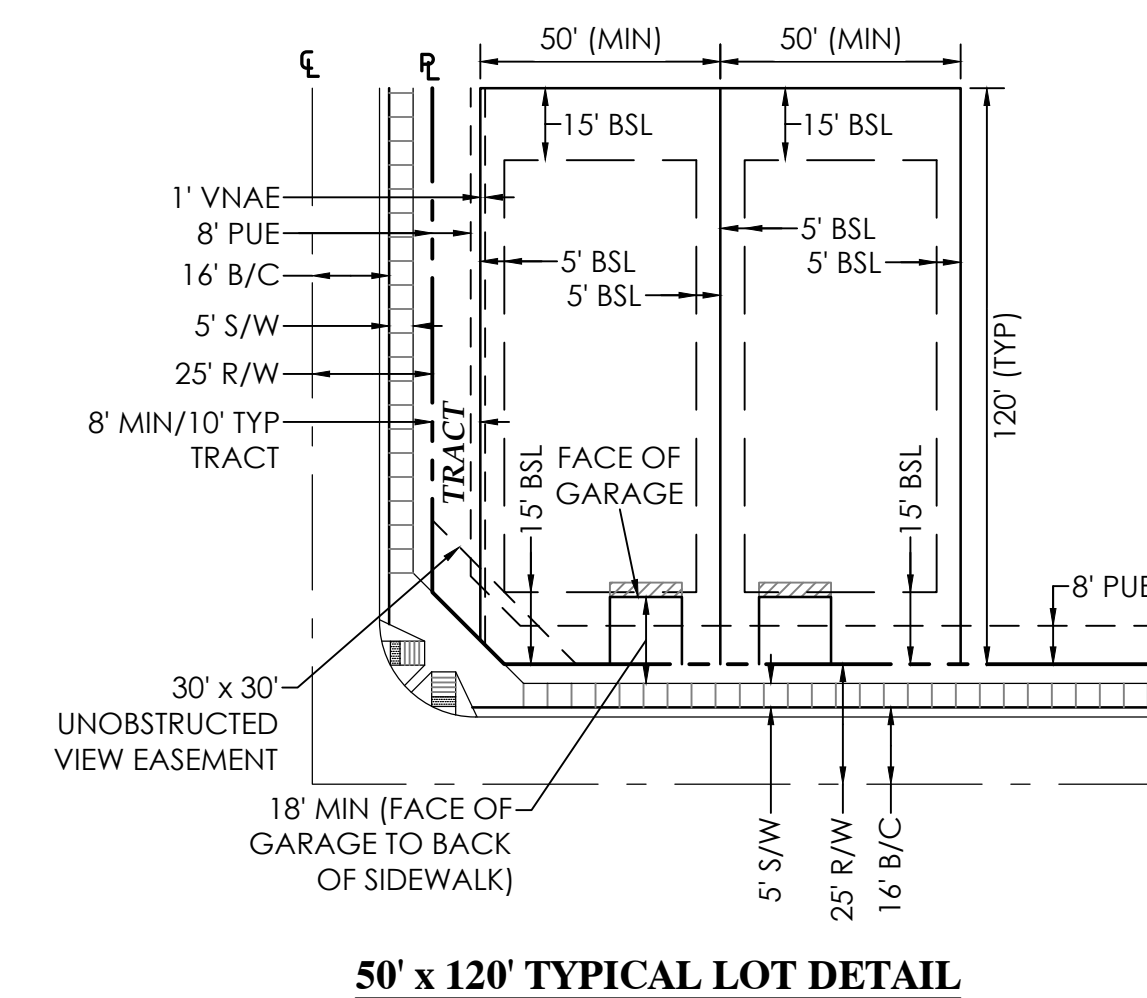

50' x 120' TYPICAL LOT DETAIL
N.T.S.

TYPICAL LOT DETAIL NOTES

- 1. FRONT YARD SETBACK IS 15' WITH 18' FROM FACE OF GARAGE DOOR TO BACK OF SIDEWALK SHALL BE PROVIDED FOR FORWARD FACING GARAGES.
- 2. MINIMUM LOT DEPTHS MAY BE DECREASED BY UP TO 10' AT CUL-DE-SACS AND KNUCKLES AS LONG AS MINIMUM LOT AREAS AND SETBACKS ARE ADHERED TO.
- 3. REAR LOT LINE IS DEFINED AS THE LOT LINE MOST NEARLY OPPOSITE TO THE FRONT PROPERTY LINE. IN THE EVENT THAT THE FRONT PROPERTY LINES IS A CURVED LINE, THEN THE REAR PROPERTY LINE SHALL BE THE LOT LINE THAT IS CONSISTENT WITH REAR LOT LINES ON ADJACENT OR NEARBY LOTS.
- 4. A MAXIMUM OF ONE LOCATION WITHIN ANY BLOCK LENGTH MAY HAVE A MINIMUM 10' DISTANCE BETWEEN BUILDINGS. THE SPECIFIC LOCATION OF THE 10' BUILDING SEPARATION WILL BE DETERMINED AT THE TIME OF BUILDING PERMIT APPROVAL, SUBJECT TO THE ADMINISTRATIVE APPROVAL BY THE PLANNING DIRECTOR OR THEIR DESIGNEE.
- 5. MAXIMUM ALLOWABLE LOT COVERAGE 55%
- 6. REAR COVERED PATIOS MAY ENCROACH TO WITHIN 15 FEET FROM THE REAR PROPERTY LINE.

SHEET 2 OF 3

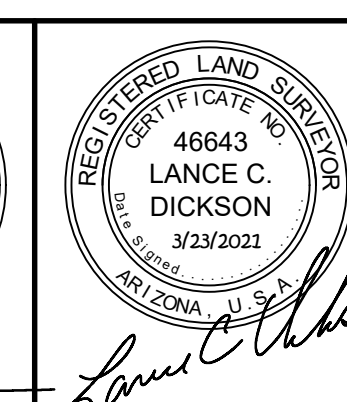
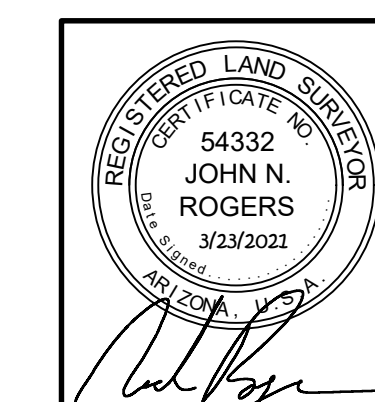

PREPARED BY:
GOODWIN AND MARSHALL INC.
CIVIL ENGINEERS ~ PLANNERS ~ SURVEYORS
2705 S. Alma School Road, Suite 2
Chandler, Arizona 85044
(602) 218-7285
Contact: Warren Russell, P.E.

SURVEYED BY:
ASAM
Arizona Surveying & Mapping
2440 W. Mission Lane, Suite 4, Phoenix, Arizona 85021
TEL (602) 246-9919 FAX (602) 246-9944 info@asam.com

2

91ST AVENUE

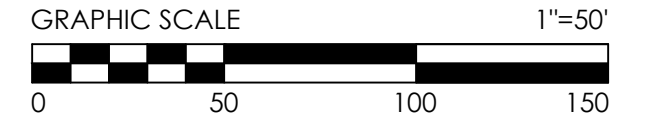
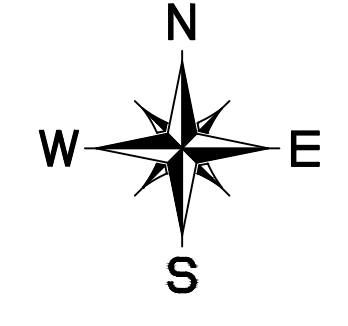
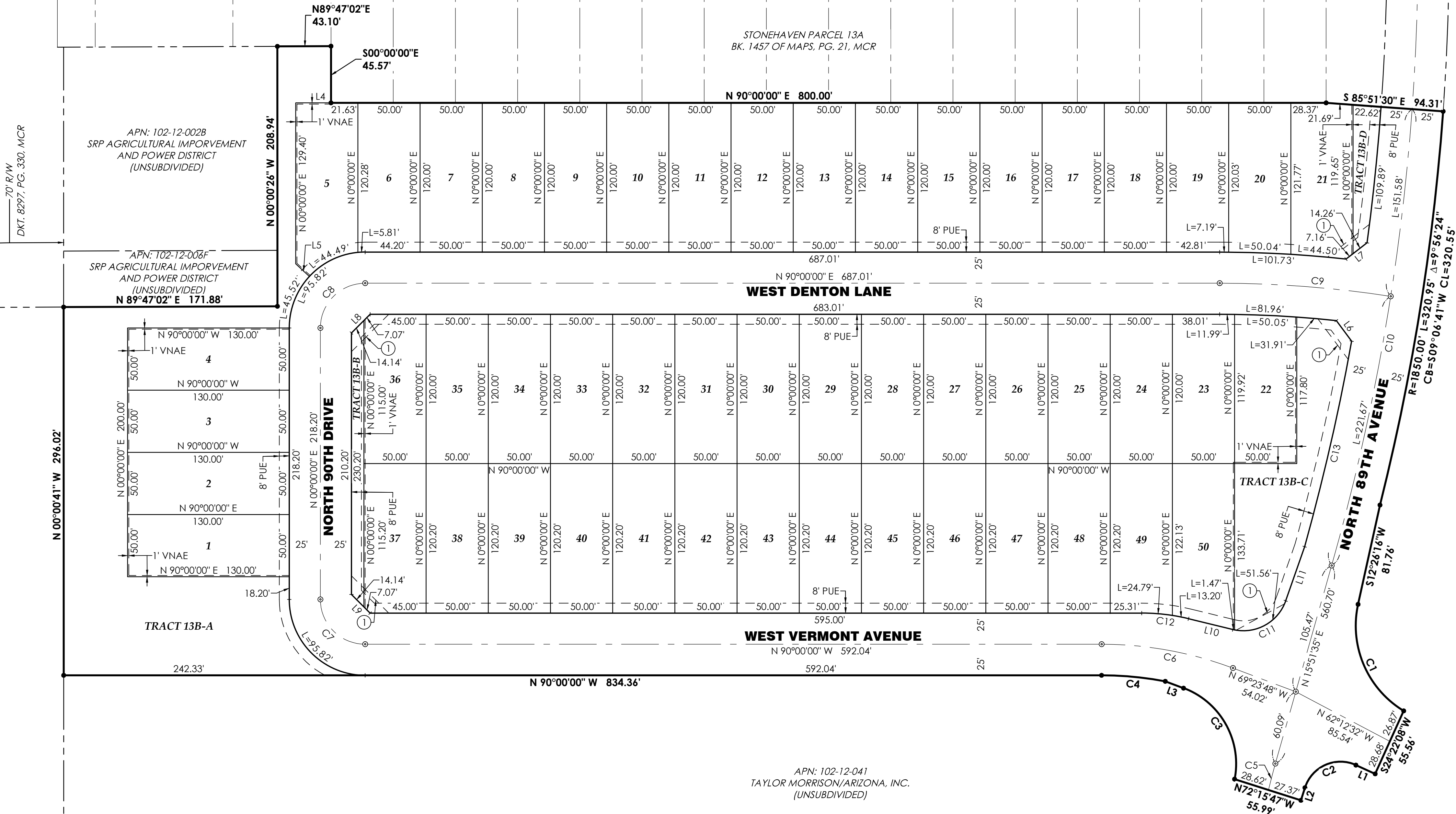

APN: 102-12-041
TAYLOR MORRISON/ARIZONA, INC.
(UNSUBDIVIDED)

LEGEND	
●	FOUND MONUMENT AS NOTED
•	SET CORNER OF THIS PLAT PER MAG. STD. DTL. 120-1 TYPE "C"
⊙	SET BRASS CAP FLUSH PER MAG. STD. DTL. 120-1 TYPE "B"
SQ. FT.	SQUARE FEET
R/W	RIGHT-OF-WAY
PUE	PUBLIC UTILITY EASEMENT
SWE	SIDEWALK EASEMENT
VNAE	VEHICLE NON-ACCESS EASEMENT
BK	BOOK
DKT	DOCKET
PG	PAGE
MCR	MARICOPA COUNTY RECORDS
APN	ASSESSOR PARCEL NUMBER
①	LOCAL & COLLECTOR UNOBSTRUCTED VIEW EASEMENT (30' X 30')
—	PLAT BOUNDARY LINE
—	LOT/TRACT LINE
---	ADJONER LINE
---	SECTION LINE
---	EASEMENT LINE
---	CENTER LINE

LINE TABLE		
LINE #	BEARING	DISTANCE
L1	N65°37'52"W	17.03
L2	S17°44'13"W	10.66
L3	N69°28'12"W	15.67
L4	N90°00'00"E	28.37
L5	N47°14'32"W	15.00
L6	N36°42'16"W	20.59
L7	N52°19'20"E	21.42
L8	S45°00'00"W	21.21
L9	S45°00'00"E	21.21
L10	S76°18'41"E	36.67
L11	N19°16'54"E	46.11

CURVE TABLE					
CURVE #	RADIUS	ARC LENGTH	DELTA ANGLE	CHORD BEARING	CHORD LENGTH
C1	80.00	99.45	71°13'28"	S23°10'28"E	93.17
C2	30.00	50.60	96°37'55"	S66°03'10"W	44.81
C3	65.00	91.17	80°21'42"	N29°17'21"W	83.88
C4	275.00	51.52	10°44'03"	N84°37'58"W	51.44
C5	500.00	21.89	2°30'31"	N14°36'19"E	21.89
C6	300.00	107.88	20°36'12"	N79°41'54"W	107.30
C7	36.00	56.55	90°00'00"	N45°00'00"W	50.91
C8	36.00	56.55	90°00'00"	N45°00'00"E	50.91
C9	900.00	138.02	8°47'12"	S85°36'24"E	137.88
C10	1825.00	373.25	11°43'05"	N10°00'02"E	372.60
C11	36.00	53.03	84°24'25"	N61°29'07"E	48.37
C12	159.00	37.99	13°41'19"	S83°09'21"E	37.90
C13	1800.00	169.56	5°23'51"	N12°53'08"E	169.50

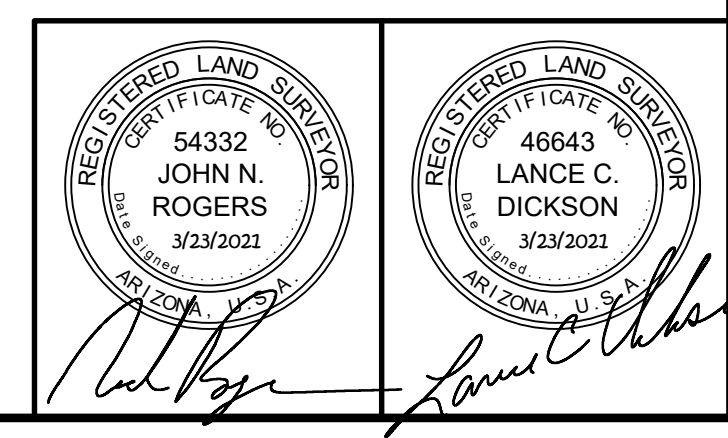

PREPARED BY:
GOODWIN AND MARSHALL INC.
CIVIL ENGINEERS ~ PLANNERS ~ SURVEYORS
2705 S. Alma School Road, Suite 2
Chandler, Arizona 85044
(602) 218-7285
Contact: Warren Russell, P.E.

SURVEYED BY:
ASAM
Arizona Surveying & Mapping
2440 W. Mission Lane, Suite 4, Phoenix, Arizona 85021
TEL (602) 246-9919 FAX (602) 246-9944 info@asam1.com

SHEET 3 OF 3

"FINAL PLAT OF STONEHAVEN PHASE 2, PARCEL 13B"

W:\10883A - TM Stonehaven\Cogno\FPLAT\PHASE 2\PARCEL 13B\10883A-FPLAT 2\13B-SHEETS.dwg