

**LINKING AGREEMENT
BETWEEN
THE CITY OF GLENDALE, ARIZONA
AND
SAFEWARE SAFETY SUPPLIES INC.**

THIS LINKING AGREEMENT (this “Agreement”) is entered into as of this ____ day of _____, 2023, between the City of Glendale, an Arizona municipal corporation (the “City”), and Safeware Safety Supplies Inc., a(n) Maryland corporation authorized to do business in Arizona (“Contractor”), collectively, the “Parties.”

RECITALS

- A. On January 1, 2022 under S.A.V.E Cooperative Purchasing Agreement, the County of Maricopa entered into a contract with Contractor to purchase the goods and services described in the Safety Equipment and Supplies Agreement, Serial 210237-C (“Cooperative Purchasing Agreement”), which is attached hereto as Exhibit A. The Cooperative Purchasing Agreement permits its cooperative use by other governmental agencies including the City.
- B. Section 2-149 of the City’s Procurement Code permits the Materials Manager to procure goods and services by participating with other governmental units in cooperative purchasing agreements when the best interests of the City would be served.
- C. Section 2-149 also provides that the Materials Manager may enter into such cooperative agreements without meeting the formal or informal solicitation and bid requirements of Glendale City Code Sections 2-145 and 2-146.
- D. The City desires to contract with Contractor for supplies or services identical, or nearly identical, to the supplies or services Contractor is providing other units of government under the Cooperative Purchasing Agreement. Contractor consents to the City’s utilization of the Cooperative Purchasing Agreement as the basis of this Agreement, and Contractor desires to enter into this Agreement to provide the supplies and services set forth in this Agreement.

AGREEMENT

NOW, THEREFORE, in consideration of the foregoing recitals, which are incorporated by reference, and the covenants and promises contained in this Linking Agreement, the parties agree as follows:

- 1. **Term of Agreement.** The City is purchasing supplies and/or services from Contractor pursuant to the Cooperative Purchasing Agreement. According to the Cooperative Purchasing Agreement, purchases can be made by governmental entities from the Effective date, which was January 1, 2022, until the date the contract expires on December 31, 2024, unless the term of the Cooperative Purchasing Agreement is extended by the mutual agreement of the original contracting parties. The Cooperative Purchasing Agreement, however, may not be extended beyond December 31, 2028. The initial period of this Agreement, therefore, is the period from the Effective Date of this Agreement until December 31, 2024. The City may renew the term of this Agreement for four (4) additional one-year periods until the Cooperative Purchasing Agreement expires on December 31, 2028. Glendale renewals are not automatic and shall only occur if the

the City gives the Contractor notice of its intent to renew. The City may give the Contractor notice of its intent to renew this Agreement 30 days prior to the anniversary of the Effective Date to effectuate such renewal.

2. Scope of Work; Terms, Conditions, and Specifications.

A. Contractor shall provide City the supplies and/or services identified in the Scope of Work attached as Exhibit B.

B. Contractor agrees to comply with all the terms, conditions and specifications of the Cooperative Purchasing Agreement. Such terms, conditions and specifications are specifically incorporated into and are an enforceable part of this Agreement.

3. Compensation.

A. City shall pay Contractor compensation at the same rate and on the same schedule as provided in the Cooperative Purchasing Agreement, which is attached hereto as Exhibit C.

B. The total purchase price for the supplies and/or services purchased under this Agreement shall not exceed one million three hundred and eleven thousand three hundred and thirty-eight dollars (\$1,311,338.00) for the entire term of the Agreement (initial term plus any renewals).

4. Cancellation. This Agreement may be cancelled pursuant to A.R.S. § 38-511.

5. Non-discrimination. Contractor must not discriminate against any employee or applicant for employment on the basis of race, color, religion, sex, national origin, age, marital status, sexual orientation, gender identity or expression, genetic characteristics, familial status, U.S. military veteran status or any disability. Contractor will require any Sub-contractor to be bound to the same requirements as stated within this section. Contractor, and on behalf of any subcontractors, warrants compliance with this section.

6. Insurance Certificate. A certificate of insurance applying to this Agreement must be provided to the City prior to the Effective Date.

7. E-verify. Contractor complies with A.R.S. § 23-214 and agrees to comply with the requirements of A.R.S. § 41-4401.

8. No Boycott of Israel. To the extent A.R.S § 35-393 through § 35-393.03 are applicable, the parties hereby certify that they are not currently engaged in and agree for the duration of the Agreement to not engage in, a boycott of goods or services from Israel, as that term is defined in A.R.S § 35-393.

9. Attestation of PCI Compliance. When applicable, the Contractor will provide the City annually with a Payment Card Industry Data Security Standard (PCI DSS) attestation of compliance certificate signed by an officer of Contractor with oversight responsibility.

10. Notices. Any notices that must be provided under this Agreement shall be sent to the Parties' respective authorized representatives at the address listed below:

City of Glendale
c/o Denise Krause
6835 North 57th Drive
Glendale, AZ 85301
DKrause@glendaleaz.com

And

Safeware Safety Supplies Inc
Rob Berner
801 W. 116th Ave
Westminster, CO 80234
303-322-3577

IN WITNESS WHEREOF, the parties hereto have executed this Agreement as of the date and year set forth above.

"City"

City of Glendale, an Arizona
municipal corporation

By: _____

Kevin R. Phelps
City Manager

"Contractor"

Safeware Safety Supplies Inc,
a Maryland corporation

By: _____

Name:
Title:

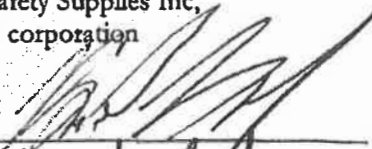
Richard L. Bird
V. ce President

ATTEST:

Julie K. Bower (SEAL)
City Clerk

APPROVED AS TO FORM:

Michael D. Bailey
City Attorney

**LINKING AGREEMENT
BETWEEN
THE CITY OF GLENDALE, ARIZONA AND
Safeware Safety Supplies Inc.**

EXHIBIT A

Maricopa County Cooperative Purchasing Agreement, Serial 210237-C

SERIAL 210237-C SAFETY EQUIPMENT AND SUPPLIES

DATE OF LAST REVISION: December 08, 2021 CONTRACT END DATE: December 31, 2023

CONTRACT PERIOD THROUGH DECEMBER 31, 2023

TO: All Departments
FROM: Office of Procurement Services
SUBJECT: Contract for **SAFETY EQUIPMENT AND SUPPLIES**

Attached to this letter is published an effective purchasing contract for products and/or services to be supplied to Maricopa County activities as awarded by Maricopa County on **December 08, 2021**.
(Eff. 01/01/2022).

All purchases of products and/or services listed on the attached pages of this letter are to be obtained from the vendor holding the contract. Individuals are responsible to the vendor for purchases made outside of contracts. The contract period is indicated above.



Kevin Tyne, Chief Procurement Officer
Office of Procurement Services

EK/mm
Attach

Copy to: Office of Procurement Services
Chuck Mayer, MCSO
Ed Waldner, MCSO
Martie Billings, MCDOT

(Please remove Serial 16056-C from your contract notebooks)

SAFEWARE, INC., 4403 FORBES BLVD., LANHAM, MD 20706

COMPANY NAME:	Safeware, Inc.
DOING BUSINESS AS (dba):	
MAILING ADDRESS:	4403 Forbes Blvd., Lanham, MD 20706
REMIT TO ADDRESS:	PO Box 76320, Baltimore, MD 21275-6320
TELEPHONE NUMBER:	800-331-6707
FAX NUMBER:	301-683-1200
WWW ADDRESS:	https://www.safewareinc.com/
REPRESENTATIVE NAME:	Jessica Faulkner
REPRESENTATIVE TELEPHONE NUMBER:	301-683-1234
REPRESENTATIVE EMAIL ADDRESS	jfaulkner@safewareinc.com

	<u>YES</u>	<u>NO</u>	<u>REBATE</u>
WILL ALLOW OTHER GOVERNMENTAL ENTITIES TO PURCHASE FROM THIS CONTRACT:	<input checked="" type="checkbox"/>	<input type="checkbox"/>	
WILL ACCEPT PROCUREMENT CARD FOR PAYMENT:	<input checked="" type="checkbox"/>	<input type="checkbox"/>	

NET 30 DAYS

Designated Line Item Pricing					
	Title	Unit Price	Qty	UofM	Bidder Notes
3rd Call	Banner Guard 3" x 1000' Yellow/Black "SHERIFF'S LINE DO NOT CROSS"	\$9.56	1	each	Manufacturer Name: Harris Model Number: HAR BT-30 Number of individual units per unit of sale: 1 roll Minimum Order Quantity (if applicable): 6 rolls Approximate Lead Time: 14 days NO warranty
3rd Call	Banner Guard 3" x 1000' Yellow/Black "DO NOT CROSS"	\$16.47	1	each	Manufacturer Name: Harris Model Number: HAR BT-DNC Number of individual units per unit of sale: 1 roll Minimum Order Quantity (if applicable): 12 rolls Approximate Lead Time: 14 days No warranty
1st Call	Collar Extraction Stifneck Select or equivalent	\$6.71	1	each	Manufacturer Name: Harris Model Number: HAR BT-DNC Number of individual units per unit of sale: 1 roll Minimum Order Quantity (if applicable): 12 rolls Approximate Lead Time: 14 days No warranty

EXHIBIT A
SERIAL 210237-C

SAFEWARE, INC

3rd Call	Cone traffic 28"w/reflective collars wide body PVC Blaze Orange 7 1/2# lettering	\$15.99	1	each	Manufacturer Name: JBC Model Number: RS70032CT3M64 Number of individual units per unit of sale: 1 Minimum Order Quantity (if applicable): 50 Approximate Lead Time: 63-77 days No warranty
3rd Call	Highway Fuse Safety Flares 20 minute without spike of wire	\$174.86	1	each	Manufacturer Name: Cortina Model Number: 95-07-21 Number of individual units per unit of sale: case of 72 Minimum Order Quantity (if applicable): 72 Approximate Lead Time: 3 days Warranty N/A
1st Call	Kit Blood Coll Vacutainer Tri-Tech BA-2	\$131.67	1	each	Manufacturer Name: Tri-Tech Forensics Model Number: BA-2 Number of individual units per unit of sale: case of 25 Minimum Order Quantity (if applicable): 1 case Approximate Lead Time: 28 days Warranty - None unless product is received with less than 6 months until expiration
2nd Call	Knife box-16"x3"x2" labeled knife box ZQ720KNF or equivalent bundles of 25	\$31.93	1	each	Manufacturer Name: Sirchie Model Number: SIR ECB001K Number of individual units per unit of sale: 25 per bundle Minimum Order Quantity (if applicable): 1 bundle Approximate Lead Time: 7-10 days Warranty N/A
3rd Call	Leg Irons Peerless Model #703	\$36.67	1	each	Manufacturer Name: Peerless/Kroll Model Number: PR-4740 Number of individual units per unit of sale: 1 Minimum Order Quantity (if applicable): 1 Approximate Lead Time: 2-4 days Lifetime warranty for manufacturers defect and workmanship (all products through Peerless have same warranty)
2nd Call	LIBERATOR II Tactical Headset w/Integrated Digital Hearing Protection Tactical PTT	\$1,685.52	1	each	Manufacturer Name: Atlantic Signal Model Number: CT6.XCY.5C/PTT.VP1.5C Number of individual units per unit of sale: 1 Minimum Order Quantity (if applicable): 1 Approximate Lead Time: 84-98 days 2 year warranty
1st Call	LIBERATOR III Basic-TACP/JTAC Secure Dual-Comm Tactical Headset-see description	\$1,685.52	1	each	Manufacturer Name: Atlantic Signal Model Number: CT6.XCY.5C/PTT.VP1.5C Number of individual units per unit of sale: 1 Minimum Order Quantity (if applicable): 1 Approximate Lead Time: 84-98 days 2 year warranty

SAFEWARE, INC

2nd Call	LIBERATOR III Lite Secure Dual-Comm Tactical Headset-see description	\$1,685.52	1	each	Manufacturer Name: Atlantic Signal Model Number: CT6.XCY.5C/PTT.VP1.5C Number of individual units per unit of sale: 1 Minimum Order Quantity (if applicable): 1 Approximate Lead Time: 84-98 days 2 year warranty
1st Call	Mask CPR w/Hard Case Laerdal #L820019	\$15.89	1	each	Manufacturer Name: Bound Tree Model Number: L820019 Number of individual units per unit of sale: 1 Minimum Order Quantity (if applicable): 1 Approximate Lead Time: in stock 1 year warranty
2nd Call	Mask Laerdal Bag II Adult Rescue w/Mask Size 5 #845211	\$11.06	1	each	Manufacturer Name: Bound Tree Model Number: L840044 Number of individual units per unit of sale: 1 Minimum Order Quantity (if applicable): 1 Approximate Lead Time: in stock 1 year warranty
3rd Call	Mask CPR Face shield Res Cue Key/Pouch	\$5.30	1	each	Manufacturer Name: Bound Tree Model Number: AMB 531102 Number of individual units per unit of sale: 1 Minimum Order Quantity (if applicable): 1 Approximate Lead Time: in stock 1 year warranty
1st Call	Pad fingerprint inkless 2" diameter round	\$9.17	1	each	Manufacturer Name: Lynn Peavey Model Number: 9703 Number of individual units per unit of sale: 1 Minimum Order Quantity (if applicable): 1 Approximate Lead Time: 30 days Warranty N/A
1st Call	Reusable evidence ties 12"-14" Nyties 100 per package EVI-PAQS NT-1 or equiva	\$8.67	1	each	Manufacturer Name: Lynn Peavey Model Number: 5673 Number of individual units per unit of sale: 100 per pack Minimum Order Quantity (if applicable): 1 pack Approximate Lead Time: 21 days 1 year warranty
1st Call	Safety vest ANSI Class I Orange with Lime Stripes	\$2.84	1	each	Manufacturer Name: Safeware Model Number: SAF 91001 Number of individual units per unit of sale: 1 Minimum Order Quantity (if applicable): 1 Approximate Lead Time: 2-3 days Warranty N/A

SAFEWARE, INC

3rd Call	Spray Pepper Foam 3.3 OZ Sabre Red H2O #52H2O30 F	\$12.75	1	each	Manufacturer Name: Sabre Model Number: 52H2O30F Number of individual units per unit of sale: 1 can Minimum Order Quantity (if applicable): 25 cans Approximate Lead Time: 3-4 weeks warranties for manufactures defects
3rd Call	Spray Pepper Stream 3.3OZ Sabre Red #52H2O30	\$13.13	1	each	Manufacturer Name: Sabre Model Number: 52CFT30 Number of individual units per unit of sale: 1 can Minimum Order Quantity (if applicable): 25 cans Approximate Lead Time: 3-4 weeks warranties for manufactures defects
2nd Call	Suicide cell smocks as per specifications in the solicitation	\$100.00	1	each	Manufacturer Name: Humane Restraints Model Number: HSS Number of individual units per unit of sale: 1 Minimum Order Quantity (if applicable): 1 Approximate Lead Time: in stock 30 day warranty
1st Call	Isolation/Suicide cell blanket as per specifications in the solicitation	\$73.34	1	each	Manufacturer Name: Humane Restraints Model Number: HSB Number of individual units per unit of sale: 1 Minimum Order Quantity (if applicable): 1 Approximate Lead Time: in stock 30 day warranty
1st Call	Sunscreen Neutrogena Cool Dry Sport WaterResistant Sunscreen Spray SPF100 5oz	\$11.08	1	each	Manufacturer Name: Banana Boat Model Number: US100 Number of individual units per unit of sale: 1 Minimum Order Quantity (if applicable): 1 Approximate Lead Time: in stock Warranty N/A
1st Call	Sun Screen SPF 25+ 4oz PABA Free	\$31.83	1	each	Manufacturer Name: Coretex Model Number: 71666 Number of individual units per unit of sale: case of 12 Minimum Order Quantity (if applicable): 1 case Approximate Lead Time: 1-2 days Warranty N/A
2nd Call	Traffic Flag 18" x 18" with 30" Staff	\$1.98	1	each	Manufacturer Name: Safety Flag Model Number: SAF SF1830 Number of individual units per unit of sale: 1 Minimum Order Quantity (if applicable): 24 Approximate Lead Time: 7 days Warranty N/A

SAFEWARE, INC

1st Call	HEARTSAVER First Aid CPR AED Student Workbook (Product # 20-1126)	\$2.95	1	each	Manufacturer Name: Heart saver Model Number: 20-1126 Number of individual units per unit of sale: 1 Minimum Order Quantity (if applicable): 1 Approximate Lead Time: in stock 30 day warranty
1st Call	HEARTSAVER First Aid Student Workbook (Product # 20-1128)	\$2.95	1	each	Manufacturer Name: Heart saver Model Number: 20-1128 Number of individual units per unit of sale: 1 Minimum Order Quantity (if applicable): 1 Approximate Lead Time: in stock 30 day warranty
1st Call	HEARTSAVER First Aid CPR AED Instructor Manual (Product # 20-1130)	\$70.00	1	each	Manufacturer Name: Heart saver Model Number: 20-1130 Number of individual units per unit of sale: 1 Minimum Order Quantity (if applicable): 1 Approximate Lead Time: in stock 30 day warranty
1st Call	BLS Instructor Essentials Course DVD (Product # 20-1134)	\$17.65	1	each	Manufacturer Name: Heart saver Model Number: 20-1134 Number of individual units per unit of sale: 1 Minimum Order Quantity (if applicable): 1 Approximate Lead Time: in stock 30 day warranty
1st Call	HEARTSAVER First Aid CPR AED Course Videos on USB Drive (Product # 20-1147)	\$211.77	1	each	Manufacturer Name: Heartsaver Model Number: 20-1147 Number of individual units per unit of sale: 1 Minimum Order Quantity (if applicable): 1 Approximate Lead Time: in stock 30 day warranty

General Catalog Discounts				
Title	Unit Price	Qty	UofM	Bidder Notes
Law Enforcement General	41.00%	1	each	Digital Copy of Price List: Files Attached Designated price column (wholesale/retail): Safeware Catalog Price Multiple files attached for this product category https://safeware.exavault.com/share/view/2rq7x-ddmsbvwr-24w908ug Any questions, please contact Karla Hyatt, Director of Government Contracts kahyatt@safewareinc.com .
Personal Protective Equipment	41.00%	1	each	Digital Copy of Price List: Files Attached Designated price column (wholesale/retail): Safeware Catalog Price Multiple files attached for this product category https://safeware.exavault.com/share/view/2rq7x-ddmsbvwr-24w908ug Any questions, please contact Karla Hyatt, Director of Government Contracts kahyatt@safewareinc.com .

ATTACHMENT B: AGREEMENT PAGE

Respondent hereby certifies that respondent has read, understands, and agrees that acceptance by Maricopa County of the respondent's offer will create a binding contract. Respondent agrees to fully comply with all terms and conditions as set forth in the Maricopa County Procurement Code, and amendments thereto, together with the specifications and other documentary forms herewith made a part of this specific agreement.

BY SIGNING THIS PAGE, THE SUBMITTING RESPONDENT CERTIFIES THAT RESPONDENT HAS REVIEWED MARICOPA COUNTY'S "STANDARD TERMS AND CONDITIONS," A COPY OF WHICH CAN BE FOUND AT <https://www.maricopa.gov/DocumentCenter/View/6453>.

Safeware, Inc.
RESPONDENT (FIRM) SUBMITTING PROPOSAL

52-1152883
FEDERAL TAX ID #

098692130
DUNS #

Jessica M. Faulkner Assistant Secretary
PRINTED NAME TITLE

Jessica M. Faulkner
AUTHORIZED SIGNATURE

4403 Forbes Blvd.
ADDRESS

1-800-331-6707
TELEPHONE #

301-683-1200
FAX #

Lanham, MD 20706
CITY STATE ZIP

7/28/2021
DATE

https://www.safewareinc.com/
WEBSITE

jfaulkner@safewareinc.com
EMAIL

MARICOPA COUNTY, ARIZONA
BY: *Josh W. Sellers*
CHAIRMAN, BOARD OF SUPERVISORS

DEC 08 2021
DATE

ATTESTED:
Maria...
CLERK OF THE BOARD

DEC 08 2021
DATE

APPROVED AS TO FORM:
Randall B. Pennington
DEPUTY COUNTY ATTORNEY

11/15/2021
DATE

SAFEWARE, INC

First Aid	41.00%	1	each	Digital Copy of Price List: Files Attached Designated price column (wholesale/retail): Safeware Catalog Price Multiple files attached for this product category https://safeware.exavault.com/share/view/2rq7x-ddmsbvwr-24w908ug Any questions, please contact Karla Hyatt, Director of Government Contracts kahyatt@safewareinc.com .
General Safety Supplies	41.00%	1	each	Digital Copy of Price List: Files Attached Designated price column (wholesale/retail): Safeware Catalog Price Multiple files attached for this product category https://safeware.exavault.com/share/view/2rq7x-ddmsbvwr-24w908ug Any questions, please contact Karla Hyatt, Director of Government Contracts kahyatt@safewareinc.com .

PRICING SHEET: NIGP CODE 34500

Terms: NET 30
 Vendor Number: VS0000005799
 Certificates of Insurance Required
 Contract Period: To cover the period ending **December 31, 2023.**

SAFETY EQUIPMENT AND SUPPLIES

1.0 INTENT

- 1.1 The intent of this solicitation is to award multiple contracts for the provision of safety equipment and supplies to Maricopa County Sheriff's Office (MCSO) and other Maricopa County (County) departments. The County seeks to establish a list of vendors from who County can purchase based on:
 - 1.1.1 pricing for various line items as listed here in (See Section 2.1-Line Item Pricing);
 - 1.1.2 general catalog discount pricing for catalog categories listed below (see Section 2.2 – General Catalog Discount Pricing); and
 - 1.1.3 a list of vendors from whom the County can solicit items for purchases on an as-needed basis, based on qualifying requirements for purchase, as per Sections 2.4 – Contractor Requirements, and all other terms, conditions, and requirements as indicated in this solicitation.
- 1.2 County's existing contract, Serial #16056-C – Safety Equipment and Supplies, will be terminated upon award of this contract.
- 1.3 Other governmental entities under agreement with the County may have access to services provided hereunder (see also Sections 3.22 and 3.23 below).
- 1.4 The County reserves the right to add additional contractors, at the County's sole discretion, in cases where the currently listed contractors are of an insufficient number or skill-set to satisfy the County's needs or to ensure adequate competition on any project or task order work.
- 1.5 The County reserves the right to award this contract to multiple vendors. The County reserves the right to award in whole or in part, by item or group of items, by section or geographic area, or make multiple awards, where such action serves the County's best interest.

2.0 SPECIFICATIONS

2.1 LINE ITEM PRICING

- 2.1.1 For all items contained in Section 2.1 - Line Item Pricing, respondents shall provide the per unit of sale (each, box, case, etc.) cost via line item section of the e-procurement portal, Periscope.
- 2.1.2 Pricing shall be held firm for the initial term of the contract. If an alternate product is offered, it is the responsibility of the respondent to provide detailed documentation as to how their proposed product meets or exceeds the listed line item requirements.
- 2.1.3 Line Items
 - 2.1.3.1 Alcohol pads, 200 per box
 - 2.1.3.2 Banner Guard 3" x 1000' Yellow/Black "SHERIFF'S LINE DO NOT CROSS"
 - 2.1.3.3 Banner Guard 3" x 1000' Yellow/Black "DO NOT CROSS"
 - 2.1.3.4 Collar, Extraction Stifneck® Select, or equivalent

- 2.1.3.5 Cone, traffic, 28" with reflective collars, wide body, PVC, Blaze Orange 7 1/2" base, includes "MCDOT" or "MCSO" 2" black lettering on cone
- 2.1.3.6 Flex cuffs, 21" plastic cable ties 100/box
- 2.1.3.7 Helmet, Safety, White, Round Brim PITH
- 2.1.3.8 Highway Fuse Safety Flares, 20 minute without spike of wire
- 2.1.3.9 Instant Cold Compress 4" x 5", Ammonium Nitrate
- 2.1.3.10 Kit Blood Coll Vacutainer Tri-Tech BA-2
- 2.1.3.11 Knife box - 16"x3"x2" labeled knife box ZQ720KNF or equivalent - bundles of 25
- 2.1.3.12 Leg irons, Peerless Model # 703
- 2.1.3.13 LIBERATOR® II Tactical Headset with Integrated Digital Hearing Protection with Tactical PTT
- 2.1.3.14 LIBERATOR® III Basic - TACP/JTAC Secure Dual-Comm Tactical Headset with Integrated Digital Hearing Protection base unit
- 2.1.3.15 LIBERATOR® III Lite Secure Dual-Comm Tactical Headset with Integrated Digital Hearing Protection base unit
- 2.1.3.16 Mask, CPR w/Hard Case Laerdal # L820019
- 2.1.3.17 Mask, Laerdal Bag II Adult Rescue w/Mask Size 5 #845211
- 2.1.3.18 Mask Face TecnoL Fluid Shield Fog-free Surgical
- 2.1.3.19 Mask, CPR Faceshield Res Cue Key/Pouch
- 2.1.3.20 Pad fingerprint inkless 2" diameter round
- 2.1.3.21 Reusable evidence ties, 12"-14" Nyties, 100 per package, EVI-PAQS NT-1 or equivalent
- 2.1.3.22 Safety vest, ANSI Class I, Orange with Lime Stripes
- 2.1.3.23 Spray Pepper
 - 2.1.3.23.1 56833 Defense Technology
 - 2.1.3.23.2 Spray Pepper Foam 3.3 OZ, Sabre Red H2O #52H2O30-F
 - 2.1.3.23.3 Spray Pepper Stream 3.3OZ, Sabre Red #52H2O30
- 2.1.3.24 Suicide Prevention
 - 2.1.3.24.1 Suicide cell smocks
 - 2.1.3.24.1.1 Color: Sherwood green or similar
 - 2.1.3.24.1.2 Suitable for both men and women

- 2.1.3.24.1.3 All fastenings shall utilize Velcro like material (no snaps or buckles) to accommodate adults with a weight range of 100 to 300lbs
- 2.1.3.24.1.4 Chest dimensions shall adjust to fit chest size 44 inches to 56 inches
- 2.1.3.24.1.5 Smock shall be constructed using two heavy duty 650-denier polyester outside fabric faces
- 2.1.3.24.1.6 Interior shall be lockstitch quilted polyester batting
- 2.1.3.24.1.7 All stitching shall utilize nylon thread
- 2.1.3.24.1.8 All fabrics shall be:
 - stain resistant
 - flame resistant
 - tear resistant
- 2.1.3.24.2 Isolation/Suicide cell blanket:
 - 2.1.3.24.2.1 Color: Sherwood green or similar
 - 2.1.3.24.2.2 Size: 54" x 80 inches.
 - 2.1.3.24.2.3 Suitable for use by both men and women
 - 2.1.3.24.2.4 Blanket shall be constructed using two heavy duty 650-denier polyester outside fabric faces
 - 2.1.3.24.2.5 All fabrics shall wash easily, dry rapidly
 - 2.1.3.24.2.6 All fabrics shall be:
 - stain resistant
 - flame resistant
 - tear resistant
- 2.1.3.25 Sunscreen, Neutrogena Cool Dry Sport Water-Resistant Sunscreen Spray, SPF 100, 5 oz
- 2.1.3.26 Sun Screen, SPF 25+ 4oz, PABA Free
- 2.1.3.27 Tape, Traffic Measuring Wheel Model #RR182 or equivalent
- 2.1.3.28 Traffic Flag, 18" x 18" with 30" Staff
- 2.1.3.29 Training: First Aid, CPR, and AED Completion Cards, Workbooks, Instructor Materials:
 - 2.1.3.29.1 BLS INSTRUCTOR CARD (3-CARD) (#15-1804)
 - 2.1.3.29.2 HEARTSAVER® CPR AED Course Completion Card (3-CARD) (Product #15-1810)
 - 2.1.3.29.3 HEARTSAVER® FIRST AID Course Completion Card (3-CARD) (#15-1811)
 - 2.1.3.29.4 BLS E-CARD (Product #20-3001)

- 2.1.3.29.5 HEARTSAVER® First Aid CPR AED E-Card (Product # 20-3004)
- 2.1.3.29.6 HEARTSAVER® First Aid E-Card (Product # 20-3005)
- 2.1.3.29.7 HEARTSAVER® First Aid CPR AED Student Workbook (Product # 20-1126)
- 2.1.3.29.8 HEARTSAVER® First Aid Student Workbook (Product # 20-1128)
- 2.1.3.29.9 HEARTSAVER® First Aid CPR AED Instructor Manual (Product # 20-1130)
- 2.1.3.29.10 BLS Instructor Essentials Course DVD (Product # 20-1134)
- 2.1.3.29.11 HEARTSAVER® First Aid CPR AED Course Videos On USB Drive (Product # 20-1147)

2.2 GENERAL CATALOG DISCOUNT PRICING

2.2.1 For all catalog categories in Section 2.2, respondents shall provide a discount rate from their published pricing catalog. Within each catalog category is a list of desired items or product types. Contractors will be awarded by catalog category (Law Enforcement Testing, Law Enforcement General, Personal Protective Equipment, First Aid, General Safety Supply) and shall provide, at a minimum, the listed items/product types within the categories as detailed in below.

2.2.1.1 Law Enforcement Testing

- 2.2.1.1.1 Intoxilyzer supplies
- 2.2.1.1.2 Alco-Sensor 4 supplies
- 2.2.1.1.3 Field drug testing kits, reagent color test
- 2.2.1.1.4 DWI blood specimen collection kit
- 2.2.1.1.5 Gunshot residue evidence collection kit

2.2.1.2 Law Enforcement - General

- 2.2.1.2.1 Reusable evidence ties
- 2.2.1.2.2 Fingerprinting supplies
- 2.2.1.2.3 Evidence storage boxes (vial size through long rifle)
- 2.2.1.2.4 Pepper spray
- 2.2.1.2.5 Paintball supplies (launchers and pepper balls)
- 2.2.1.2.6 Less than lethal munitions (hydro-kinetic projectile, smoke and sound diversionary devices)
- 2.2.1.2.7 LIBERATOR® tactical headset options and parts, and other LIBERATOR® products.

2.2.1.3 Personal Protective Equipment

2.2.1.3.1 Face masks and respirators

2.2.1.3.2 Safety glasses/goggles/face shields

2.2.1.3.3 Hardhats

2.2.1.3.4 Leather work gloves

2.2.1.3.5 PVC work gloves

2.2.1.3.6 Knee pads

2.2.1.3.7 Safety vests, shirts and pants

2.2.1.3.8 Ear plugs and muffs

2.2.1.4 First Aid

2.2.1.4.1 Extraction collars

2.2.1.4.2 CPR masks

2.2.1.4.3 First aid kits and refills

2.2.1.5 General Safety Supply

2.2.1.5.1 Flashlights

2.2.1.5.2 Traffic flags, flares, reflector triangles

2.2.1.5.3 Caution tape

2.2.1.5.4 Rain gear

2.2.1.5.5 Sun screen

2.2.2 When the price for a purchase for a commodity has a value greater than \$5,000.00 the County may opt to obtain quotes for purchases, as described in Section 2.3 Task Order Purchasing (e.g. the County may choose to purchase an order of multiple sizes or colors of a commodity through task order purchasing if the entire order for the commodity exceeds \$5,000.00).

2.2.3 Contractor shall maintain an electronic (web accessible) catalog along with toll-free phone customer service for quote/pricing/order/order tracking support.

2.2.4 Contractor's electronic version of the catalog shall display the then-current list price for the catalog category(ies) and items within those categories the contractor has been awarded to provide:

2.2.4.1 Website URL's must be maintained by the contractor at no additional cost to the County. Changes to the website address must be reported to the County within 24 hours of change of address.

2.2.4.2 County's inability to access the contractor's electronic catalog due to contractor's failure to maintain the catalog website may result in removal of the contractor from the contract for that product category.

2.2.4.3 Previous versions of catalogs in effect during the term of this contract must be maintained and accessible to the County, as per Section 4.25 - ACCESS TO AND RETENTION OF RECORDS FOR THE PURPOSE OF AUDIT AND/OR OTHER REVIEW.

2.3 TASK ORDER PURCHASING

2.3.1 Vendors who are on the list of vendors established as a result of the award of this solicitation for line item purchases and/or catalog discount purchases and/or task order purchases are able to respond to requests for quotes.

2.3.2 For items that are not awarded by line item or when the County determines the contractor awarded the line item is unable to meet the requirements of the County, and/or when the price of the order for the item(s) has a value greater than \$5,000.00, the County may opt to obtain quotes for purchases from all contractors on contract. The County reserves the right to increase or lower the \$5,000 threshold if doing so is in the best interest of the County.

2.3.3 Contractor(s) shall be notified of requests for quote issued by the County through the County's e-procurement platform (currently Periscope). The request shall contain a detailed description of the product, quantity, and desired delivery date. County shall award the item(s) based on the lowest price for the product that meets the requirements of the quote.

2.3.4 County reserves the right to obtain quotes for items as a one-time purchase, or to obtain quotes for multiple purchases of an item throughout a specified period of time not to exceed the end of the fiscal year (June 30). The request for quote will identify whether the County seeks to make a one-time purchase or is requesting a quote to make multiple purchases of the item over a period of time. The County does not guarantee any future purchases. Future use of a quote is based solely on the County's best interest.

2.3.4.1 County may issue a request for quote in a fiscal year that is intended to be purchased in the following fiscal year. The County will not issue a request for quote intended to allow for purchase of items during the course of more than one fiscal year.

2.4 CONTRACTOR REQUIREMENTS

2.4.1 Contractors shall be required to meet the following requirements:

2.4.1.1 Be an authorized dealer/reseller, authorized distributor, and/or the manufacturer of products and services being offered under this contract. The contractor shall be able to provide necessary documentation affirming their status upon request by the County.

2.4.1.2 Provide a contract representative who shall be the main point of contact for the County and who shall be knowledgeable about all aspects of the contract, will handle contract administrative requests, and solve problems that may arise.

2.4.1.3 Provide customer service to assist the County with account issues including, but not limited to, return policies, after hours service, post-sales support, out of stock items, and order tracking, and resolution of customer disputes within 24 hours of receipt of an email, phone call, or voicemail communication.

- 2.4.1.4 Have the ability to handle electronic, purchase card (P-card) (see Section 4.10 - PROCUREMENT CARD ORDERING CAPABILITY), and phone orders as described within this solicitation.
- 2.4.1.5 Ensure that invoicing includes catalog discounts as bid. Multiple occurrences of invoicing that does not include catalog discounts as bid may result in removal of the contractor from the contract.

2.5 TECHNICAL AND DESCRIPTIVE SALES LITERATURE

In response to this solicitation, the respondent shall provide copies of its sales literature and brochures and copies of any manufacturer's technical and/or descriptive literature (e.g., PDF versions of sales literature, brochures, and/or webpages) specific to the material(s) the respondent proposes to provide. Literature shall be sufficient in detail to allow for full and fair evaluation of the material(s) submitted, and must be included with the bid. Failure to include this information may result in the bid being rejected.

3.0 PURCHASING REQUIREMENTS

3.1 DELIVERY

- 3.1.1 Delivery is desired as soon as possible, and within 30 days of receipt of purchase order unless prior approval from the County for alternative arrangements have been made in writing. Details for delivery shall be stipulated on the purchase order. Contractor shall notify, in writing, the County representative listed on the purchase order if the requested delivery date and/or the anticipated lead time cannot be met. Failure to communicate to County changes in the order status may result in default proceedings.
- 3.1.2 Supplies or equipment shall be delivered between the hours of 8:00 a.m. and 4:00 p.m. Mountain Standard Time (MST), Monday through Friday, except on County recognized holidays, with the following exceptions:
 - 3.1.2.1 Unless directed otherwise via the purchase order
 - 3.1.2.2 Maricopa County Department of Transportation (MCDOT) receiving hours are Monday thru Thursday 6 a.m. to 3 p.m. MST
- 3.1.3 Delivery shall be F.O.B. Destination Freight Prepaid.

3.2 EXPEDITED DELIVERY

- 3.2.1 If the department determines that expedited delivery or other alternate shipping is required, it shall notify the contractor. The contractor shall determine any additional costs associated with such delivery terms and communicate that cost to the department.
- 3.2.2 The department shall not advise the contractor to proceed with an expedited shipment until acceptable terms are agreed upon and a purchase order is issued. Upon agreeing to the additional costs, the department shall advise the contractor to proceed.
- 3.2.3 Upon receipt of material(s) and invoicing, the department shall ensure that any additional charges are in compliance with and do not exceed agreed to costs. The department shall retain all documents related to these costs within the agency purchase file.

3.3 SHIPPING DOCUMENTS

A packing list or other suitable shipping document shall accompany each shipment and shall include the following:

3.3.1 Contract serial number

3.3.2 Contractor's name and address

3.3.3 Department name and address

3.3.4 Department purchase order number

3.3.5 A description of product(s) shipped, including item number(s), quantity(ies), number of containers and package number(s), as applicable

3.4 SHIPPING TERMS

Bid price(s) and terms shall be F.O.B. Destination Freight Prepaid at the location(s) stipulated on the purchase order. All delivery locations are within Maricopa County.

3.5 OPERATING MANUALS

Upon delivery, contractor shall provide comprehensive operational manuals, service manuals, and schematic diagrams, as applicable and if required by the department.

3.6 SAMPLES

The contractor may be requested to furnish samples of material(s) bid to allow for examination by the County. Any materials so requested shall be furnished within 10 working days from the date of request and furnished at no cost to the County and sent to the address designated in the requesting correspondence.

3.7 TESTING

Unless otherwise specified, materials purchased will be inspected by the department to ensure the materials meet the quality and quantity requirements of the specifications. When deemed necessary by the County, samples of the materials may be taken at random from stock received for submission to a commercial laboratory or other appropriate agency for analysis and tests to determine whether the materials conform in all respects to the specifications. In cases where commercial laboratory reports determine that the materials do not meet the specifications, the expense of such analysis shall be borne by the contractor.

3.8 ACCEPTANCE

Upon delivery and successful installation, the material(s) shall be deemed accepted and the warranty period shall begin. Successful installation shall be defined as a) the material(s)/equipment is installed (as necessary) and fully operational; and b) initial training, if any, is complete. All documentation shall be completed prior to final acceptance.

3.9 STOCK

The contractor shall be expected to stock sufficient quantities as may be necessary to meet the County's needs and deliver as stated in the Invitation for Bids.

3.10 DISCONTINUED MATERIALS

3.10.1 In the event that a manufacturer discontinues materials, the County may allow the contractor to provide a substitute for the discontinued item or may cancel the discontinued item from the contract. If the contractor requests permission to substitute a new material, the contractor shall provide the following to the County:

3.10.1.1 Documentation from the manufacturer that the material has been discontinued.

3.10.1.2 Documentation that names the replacement material.

3.10.1.3 Documentation that provides clear and convincing evidence that the replacement material meets or exceeds all specifications required by the original solicitation.

3.10.1.4 Documentation that provides clear and convincing evidence that the replacement material will be compatible with all the functions or uses of the discontinued material.

3.10.1.5 Documentation confirming that the price for the replacement is the same as or less than the discontinued material.

3.10.2 Material discontinuance applies only to those materials specifically listed on any resultant contract. This will not apply to catalog items not specifically listed on any resultant contract.

3.11 WARRANTY

3.11.1 All items furnished under this contract shall conform to the requirements of this contract and shall be free from defects in design, materials, and workmanship.

3.11.2 The warranty period for workmanship and materials shall be for a minimum initial period of 12 months and commence upon acceptance by County per Section 38 - ACCEPTANCE.

3.11.2.1 The contractor shall indicate on the price sheet the duration of the warranty and any applicable limitations or conditions which may apply.

3.11.2.2 The contractor agrees that it will, at its own expense, provide all labor and parts required to remove, repair, or replace, and reinstall any such defective workmanship and/or materials which becomes or is found to be defective during the term of this warranty. The contractor shall guarantee the equipment to be supplied complies with all applicable regulations.

3.12 MAINTENANCE

The contractor shall provide maintenance for the materials under this contract upon acceptance of materials by the department.

3.13 BRAND NAME

In some cases, brand names have been listed in order to define the desired quality and are not intended to be restrictive or to limit competition. Materials substantially equivalent to those designated shall qualify for consideration.

3.14 MODEL/YEAR OF MATERIALS

The County will only accept bids offering the most current model/year equipment/material(s).

3.15 ORDER CUTOFF INFORMATION

3.15.1 Contractors submitting bids shall advise the County of all known order cutoff dates/times for the equipment/product(s) specified in this solicitation at the time of bid submission. Notification of any subsequent cutoff date(s)/time(s) (learned after submission of bid) shall also be the contractor's responsibility. The contractor shall advise the County of subsequent cutoff date(s)/time(s) by notifying the procurement officer, in writing, of the new information.

3.15.2 If the item(s) become no longer available, contractor shall notify County of the last available ordering date for the item(s) and may provide County with alternative item(s) that the County may elect to purchase at its option. If the alternative item(s) do not meet the County's requirements, County may take action including termination of this contract for convenience per Section 4.16 – TERMINATION FOR CONVENIENCE.

3.16 ORDER LEAD-TIME NOTIFICATION

3.16.1 Contractors submitting bids shall advise the County of lead-time(s) for the required items specified in this solicitation at the time of bid submission. Notification of any changes to lead time (learned after submission of bid) shall also be the contractor's responsibility. The contractor shall also notify all County representatives included on purchase orders of lead-time information.

3.17 USAGE REPORT

The contractor shall furnish the County a usage report, upon request, delineating the acquisition activity governed by the contract. The format of the report shall be approved by the County and shall disclose the quantity and dollar value of each contract item by individual unit of measure.

3.18 BACKGROUND CHECK

Bidders/proposers may be required to pass multiple background checks (e.g. Sheriff's Office, County Attorney's Office, Courts, as well as Maricopa County general government) to determine if the respondent is acceptable to do business with the County. This applies to, but is not limited to, the company, subcontractors, and employees.

3.19 INVOICES AND PAYMENTS

3.19.1 The contractor shall submit one legible copy of their detailed invoice before payment(s) will be made. Incomplete invoices will not be processed. At a minimum, the invoice must provide the following information:

- Company name, address, and contact information
- County bill-to name and contact information
- Contract serial number
- County purchase order number
- Invoice number and date
- Payment terms
- Date of service or delivery
- Quantity
- Contract item number(s)
- Arrival and completion time

- Description of purchase (product or services)
- Pricing per unit of purchase
- Extended price
- Freight (if applicable)
- Total amount due

3.19.2 MCSO INVOICING SHALL BE SUBMITTED TO:

mcsso_accounts_payable@mcsso.maricopa.gov

3.19.2.1 Note that, for MCSO invoices, contractor shall not use other invoice submission processes that may be described on a purchase order or anywhere else, unless directed to do so, in writing, by the County's contact person for the order.

3.19.3 MARICOPA COUNTY DEPARTMENT OF TRANSPORTATION (MCDOT) INVOICING SHALL BE SUBMITTED TO:

MCDOTFinance@maricopa.gov

3.19.4 INVOICING FOR DEPARTMENTS OTHER THAN MCSO and MCDOT SHALL BE DIRECTED TO THE DEPARTMENT LISTED ON THE PURCHASE ORDER.

3.19.5 Problems regarding billing or invoicing shall be directed to the department as listed on the purchase order.

3.19.6 Payment will only be made to the contractor by Accounts Payable through the Maricopa County Vendor Express Payment Program. This is an Electronic Funds Transfer (EFT) process. After contract award, the contractor shall complete the Vendor Registration Form located on the County Department of Finance Vendor Registration website <https://www.maricopa.gov/5169/Vendor-Information>.

3.19.7 Discounts offered in the contract shall be calculated based on the date a properly completed invoice is received by the County.

3.19.8 EFT payments to the routing and account numbers designated by the contractor shall include the details on the specific invoices that the payment covers. The contractor is required to discuss remittance delivery capabilities with their designated financial institution for access to those details.

3.20 APPLICABLE TAXES

3.20.1 It is the responsibility of the contractor to determine any and all applicable taxes and include those taxes in their proposal. The legal liability to remit the tax is on the entity conducting business in Arizona. Tax is not a determining factor in contract award.

3.20.2 The County will look at the price or offer submitted and will not deduct, add, or alter pricing based on speculation or application of any taxes, nor will the County provide contractor any advice or guidance regarding taxes. If you have questions regarding your tax liability, seek advice from a tax professional prior to submitting your bid. You may also find information at <https://www.azdor.gov/Business.aspx>. Once your bid is submitted, the offer is valid for the time specified in this solicitation, regardless of mistake or omission of tax liability. If the County finds overpayment of a project due to tax consideration that was not due, the contractor shall be liable to the County for that amount, and by contracting with the County agrees to remit any overpayments back to the County for miscalculations on taxes included in a bid price.

3.20.3 Tax Indemnification: Contractor and all subcontractors shall pay all Federal, state, and local taxes applicable to their operation and any persons employed by the contractor. Contractor shall, and require all subcontractors to, hold Maricopa County harmless from any responsibility for taxes, damages, and interest, if applicable, contributions required under Federal and/or state and local laws and regulations, and any other costs including transaction privilege taxes, unemployment compensation insurance, Social Security, and Workers' Compensation. Contractor may be required to establish, to the satisfaction of County, that any and all fees and taxes due to the City or the State of Arizona for any license or transaction privilege taxes, use taxes, or similar excise taxes are currently paid (except for matters under legal protest).

3.21 POST AWARD MEETING

The contractor may be required to attend a post-award meeting with the department to discuss the terms and conditions of this contract. This meeting will be coordinated by the procurement officer of the contract.

3.22 STRATEGIC ALLIANCE for VOLUME EXPENDITURES (SAVE)

The County is a member of the SAVE cooperative purchasing group. SAVE includes the State of Arizona, many Phoenix metropolitan area municipalities, and many K-12 unified school districts. Under the SAVE Cooperative Purchasing Agreement, and with the concurrence of the successful respondent under this solicitation, a member of SAVE may access a contract resulting from a solicitation issued by the County. If contractor does not want to grant such access to a member of SAVE, state so in the bid. In the absence of a statement to the contrary, the County will assume that contractor does wish to grant access to any contract that may result from this bid. The County assumes no responsibility for any purchases by using entities.

3.23 INTERGOVERNMENTAL COOPERATIVE PURCHASING AGREEMENTS (ICPAs)

County currently holds ICPAs with numerous governmental entities. These agreements allow those entities, with the approval of the contractor, to purchase their requirements under the terms and conditions of the County contract. It is the responsibility of the non-County government entity to perform its own due diligence on the acceptability of the contract under its applicable procurement rules, processes, and procedures. Certain governmental agencies may not require an ICPA and may utilize this contract if it meets their individual requirements. Other governmental agencies may enter into a separate Statement of Work with the contractor to meet their own requirements. The County is not a party to any uses of this contract by other governmental entities.

3.24 VOLUNTARY EMPLOYEE DISCOUNTS

3.24.1 Contractors may voluntarily offer discounts to County employees for products or services provided under this contract. Whether a contractor offers or does not offer an employee discount is not a factor considered in the evaluation of responses to this solicitation.

3.24.2 Any discount offered is part of a commercial transaction between the contractor and individual County employees and the County is not a party to the transaction. Any disputes or issues arising from an individual commercial transaction between the contractor and an individual County employee is a matter between the contractor and the employee. If a discount is offered, the terms will be announced to County employees.

4.0 CONTRACTUAL TERMS CONDITIONS

4.1 CONTRACT TERM

This Invitation for Bids is for awarding a firm, fixed-price purchasing contract to cover a term of **two years**.

4.2 OPTION TO RENEW

The County may, at its option and with the concurrence of the contractor, renew the term of this contract up to a maximum of **four additional years**, (or at the County's sole discretion, extend the contract on a month-to-month basis for a maximum of six months after expiration). The contractor shall be notified in writing by the Office of Procurement Services of the County's intention to renew the contract term at least 60 calendar days prior to the expiration of the original contract term.

4.3 CONTRACT COMPLETION

In preparation for contract completion, the contractor shall make all reasonable efforts for an orderly transition of its duties and responsibilities to another provider and/or to the County. This may include, but is not limited to, preparation of a transition plan and cooperation with the County or other providers in the transition. The transition includes the transfer of all records and other data in the possession, custody, or control of the contractor that are required to be provided to the County either by the terms of this agreement or as a matter of law. The provisions of this clause shall survive the expiration or termination of this agreement.

4.4 PRICE ADJUSTMENTS

4.4.1 Any requests for reasonable price adjustments must be submitted 60 calendar days prior to the contract expiration. Requests for adjustment in cost of labor and/or materials must be supported by appropriate documentation. The reasonableness of the request will be determined by comparing the request with the Consumer Price Index or by performing a market survey. If County agrees to the adjusted price terms, County will issue written approval of the change and provide an updated version of the contract. The new change shall not be in effect until the date stipulated on the updated version of the contract.

4.4.2 In the event any price increase is requested as the result of any tariff that becomes effective during the performance of this contract, the County may adjust the price based on a request from the contractor that documents the additional price increase. If, during the performance of this contract, any tariff-related price increase is subsequently reduced or eliminated, the vendor shall notify the County of the decrease and shall apply it accordingly for remaining term of the contract. If the County finds over payment of a project due to tariff reduction that was not due, the contractor will be liable to the County for that amount, and by contracting with the County agrees to remit any overpayments back to the County for miscalculations on increases due to tariffs included in a bid price.

4.5 INDEMNIFICATION

4.5.1 To the fullest extent permitted by law, and to the extent that claims, damages, losses, or expenses are not covered and paid by insurance purchased by the contractor, the contractor shall defend, indemnify, and hold harmless the County (as Owner), its agents, representatives, officers, directors, officials, and employees from and against all claims, damages, losses, and expenses (including, but not limited to attorneys' fees, court costs, expert witness fees, and the costs and attorneys' fees for appellate proceedings) arising out of, or alleged to have resulted

from, the negligent acts, errors, omissions, or mistakes relating to the performance of this contract.

- 4.5.2 Contractor's duty to defend, indemnify, and hold harmless the County, its agents, representatives, officers, directors, officials, and employees shall arise in connection with any claim, damage, loss, or expense that is attributable to bodily injury, sickness, disease, death, or injury to, impairment of, or destruction of tangible property, including loss of use resulting therefrom, caused by negligent acts, errors, omissions, or mistakes in the performance of this contract, but only to the extent caused by the negligent acts or omissions of the contractor, a subcontractor, anyone directly or indirectly employed by them, or anyone for whose acts they may be liable, regardless of whether or not such claim, damage, loss, or expense is caused in part by a party indemnified hereunder.
- 4.5.3 The amount and type of insurance coverage requirements set forth herein will in no way be construed as limiting the scope of the indemnity in this section.
- 4.5.4 The scope of this indemnification does not extend to the sole negligence of County.

4.6 INSURANCE

- 4.6.1 Contractor, at contractor's own expense, shall purchase and maintain, at a minimum, the herein stipulated insurance from a company or companies duly licensed by the State of Arizona and possessing an AM Best, Inc. category rating of B++. In lieu of State of Arizona licensing, the stipulated insurance may be purchased from a company or companies, which are authorized to do business in the State of Arizona, provided that said insurance companies meet the approval of County. The form of any insurance policies and forms must be acceptable to County.
- 4.6.2 All insurance required herein shall be maintained in full force and effect until all work or service required to be performed under the terms of the contract is satisfactorily completed and formally accepted. Failure to do so may, at the sole discretion of County, constitute a material breach of this contract.
- 4.6.3 In the event that the insurance required is written on a claims-made basis, contractor warrants that any retroactive date under the policy shall precede the effective date of this contract and either continuous coverage will be maintained, or an extended discovery period will be exercised for a period of two years beginning at the time work under this contract is completed.
- 4.6.4 Contractor's insurance will be primary insurance as respects County, and any insurance or self-insurance maintained by County will not contribute to it.
- 4.6.5 Any failure to comply with the claim reporting provisions of the insurance policies or any breach of an insurance policy warranty shall not affect the County's right to coverage afforded under the insurance policies.
- 4.6.6 The insurance policies may provide coverage that contains deductibles or self-insured retentions. Such deductibles and/or self-insured retentions shall not be applicable with respect to the coverage provided to County under such policies. Contractor shall be solely responsible for the deductible and/or self-insured retention and County, at its option, may require contractor to secure payment of such deductibles or self-insured retentions by a surety bond or an irrevocable and unconditional letter of credit.
- 4.6.7 The insurance policies required by this contract, except Workers' Compensation and Errors and Omissions, shall name County, its agents, representatives, officers, directors, officials, and employees as additional insureds.

4.6.8 The policies required hereunder, except Workers' Compensation and Errors and Omissions, shall contain a waiver of transfer of rights of recovery (subrogation) against County, its agents, representatives, officers, directors, officials, and employees for any claims arising out of contractor's work or service.

4.6.9 If available, the insurance policies required by this contract may be combined with Commercial Umbrella Insurance policies to meet the minimum limit requirements. If a Commercial Umbrella insurance policy is utilized to meet insurance requirements, the Certificate of Insurance shall indicate which lines the Commercial Umbrella Insurance covers.

4.6.9.1 Commercial General Liability

Commercial General Liability (CGL) insurance with a limit of not less than \$1,000,000 for each occurrence, \$2,000,000 Products/Completed Operations Aggregate, and \$2,000,000 General Aggregate Limit. The policy shall include coverage for premises liability, bodily injury, broad form property damage, personal injury, products and completed operations and blanket contractual coverage, and shall not contain any provisions which would serve to limit third-party action over claims. There shall be no endorsement or modifications of the CGL limiting the scope of coverage for liability arising from explosion, collapse, or underground property damage.

4.6.9.2 Automobile Liability

Commercial/Business Automobile Liability insurance with a combined single limit for bodily injury and property damage of not less than \$2,000,000 each occurrence with respect to any of the contractor's owned, hired, and non-owned vehicles assigned to or used in performance of the contractor's work or services or use or maintenance of the premises under this contract.

4.6.9.3 Workers' Compensation

4.6.9.3.1 Workers' Compensation insurance to cover obligations imposed by Federal and state statutes having jurisdiction of contractor's employees engaged in the performance of the work or services under this contract; and Employer's Liability insurance of not less than \$1,000,000 for each accident, \$1,000,000 disease for each employee, and \$1,000,000 disease policy limit.

4.6.9.3.2 Contractor, its subcontractors, and sub-subcontractors waive all rights against this contract and its agents, officers, directors, and employees for recovery of damages to the extent these damages are covered by the Workers' Compensation and Employer's Liability or Commercial Umbrella Liability insurance obtained by contractor, its subcontractors, and its sub-subcontractors pursuant to this contract.

4.6.10 Certificates of Insurance

4.6.10.1 Prior to contract award, contractor shall furnish the County with valid and complete certificates of insurance, or formal endorsements as required by the contract in the form provided by the County, issued by contractor's insurer(s), as evidence that policies providing the required

coverage, conditions, and limits required by this contract are in full force and effect. Such certificates shall identify this contract number and title.

4.6.10.2 In the event any insurance policy(ies) required by this contract is (are) written on a claims-made basis, coverage shall extend for two years past completion and acceptance of contractor's work or services and as evidenced by annual Certificates of Insurance.

4.6.10.3 If a policy does expire during the life of the contract, a renewal certificate must be sent to County 15 calendar days prior to the expiration date.

4.6.11 Cancellation and Expiration Notice

Applicable to all insurance policies required within the insurance requirements of this contract, contractor's insurance shall not be permitted to expire, be suspended, be canceled, or be materially changed for any reason without 30 calendar days prior written notice to Maricopa County. Contractor must provide notice to Maricopa County, within two business days of receipt, if they receive notice of a policy that has been or will be suspended, canceled, materially changed for any reason, has expired, or will be expiring. Such notice shall be sent directly to Maricopa County Office of Procurement Services and shall be mailed or hand delivered to 160 South 4th Avenue, Phoenix, AZ 85003, or emailed to the procurement officer noted in the solicitation.

4.7 FORCE MAJEURE

4.7.1 Neither party shall be liable for failure of performance, nor incur any liability to the other party on account of any loss or damage resulting from any delay or failure to perform all or any part of this contract, if such delay or failure is caused by events, occurrences, or causes beyond the reasonable control and without negligence of the parties. Such events, occurrences, or causes include, but are not limited to, acts of God/nature (including fire, flood, earthquake, storm, hurricane, or other natural disaster), war, invasion, act of foreign enemies, hostilities (whether war is declared or not), civil war, riots, rebellion, revolution, insurrection, military or usurped power or confiscation, terrorist activities, nationalization, government sanction, lockout, blockage, embargo, labor dispute, strike, and interruption or failure of electricity or telecommunication service and pandemic.

4.7.2 Each party, as applicable, shall give the other party notice of its inability to perform and particulars in reasonable detail of the cause of the inability. Each party must use best efforts to remedy the situation and remove, as soon as practicable, the cause of its inability to perform or comply.

4.7.3 The party asserting Force Majeure as a cause for non-performance shall have the burden of proving that reasonable steps were taken to minimize delay or damages caused by foreseeable events, that all non-excused obligations were substantially fulfilled, and that the other party was timely notified of the likelihood or actual occurrence which would justify such an assertion, so that other prudent precautions could be contemplated.

4.8 ORDERING AUTHORITY

Any request for purchase shall be accompanied by a valid purchase order issued by a County department or directed by a Certified Agency Procurement Aid (CAPA) with a purchase card for payment.

4.9 AVAILABILITY OF FUNDS

4.9.1 The provisions of this contract relating to payment shall become effective when funds assigned for the purpose of compensating the contractor as herein provided are actually available to County for disbursement. The County shall be the sole judge and authority in determining the availability of funds under this contract. County will keep the contractor fully informed as to the availability of funds.

4.9.2 If any action is taken by any state agency, Federal department, or any other agency or instrumentality to suspend, decrease, or terminate its fiscal obligations under, or in connection with, this contract, County may amend, suspend, decrease, or terminate its obligations under, or in connection with, this contract. In the event of termination, County will be liable for payment only for services rendered prior to the effective date of the termination, provided that such services are performed in accordance with the provisions of this contract. County will give written notice of the effective date of any suspension, amendment, or termination under this section, at least 10 days in advance.

4.10 PROCUREMENT CARD ORDERING CAPABILITY

County may opt to use a procurement card (Visa or Master Card) to make payment for orders under this contract.

4.11 INTERNET ORDERING CAPABILITY

It is the intent of Maricopa County to use the Internet to communicate and to place orders under this contract.

4.12 NO MINIMUM OR MAXIMUM PURCHASE OBLIGATION

This contract does not guarantee any minimum or maximum purchases will be made. Orders will only be placed under this contract when the County identifies a need and proper authorization and documentation have been approved.

4.13 PURCHASE ORDERS

4.13.1 County reserves the right to cancel purchase orders within a reasonable period of time after issuance. Should a purchase order be canceled, the County agrees to reimburse the contractor for actual and documentable costs incurred by the contractor in response to the purchase order. The County will not reimburse the contractor for any costs incurred after receipt of County notice of cancellation, or for lost profits, or for shipment of product prior to issuance of purchase order.

4.13.2 Contractor agrees to accept verbal notification of cancellation of purchase orders from the County with written notification to follow. Contractor specifically acknowledges to be bound by this cancellation policy.

4.14 SUSPENSION OF WORK

The procurement officer may order the contractor, in writing, to suspend, delay, or interrupt all or any part of the work of this contract for the period of time that the procurement officer determines appropriate for the convenience of the County. No adjustment shall be made under this clause for any suspension, delay, or interruption to the extent that performance would have been so suspended, delayed, or interrupted by any other cause, including the fault or negligence of the contractor. No request for adjustment under this clause shall be granted unless the claim, in an amount stated, is asserted in writing as soon as practicable after the termination of the suspension, delay, or interruption, but not later than the date of final payment under the contract.

4.15 STOP WORK ORDER

4.15.1 The procurement officer may, at any time, by written order to the contractor, require the contractor to stop all, or any part, of the work called for by this contract for a period of 90 calendar days after the order is delivered to the contractor, and for any further period to which the parties may agree. The order shall be specifically identified as a stop work order issued under this clause. Upon receipt of the order, the contractor shall immediately comply with its terms and take all reasonable steps to minimize the incurrence of costs allocable to the work covered by the order during the period of work stoppage. Within a period of 90 calendar days after a stop work order is delivered to the contractor, or within any extension of that period to which the parties shall have agreed, the procurement officer shall either:

4.15.1.1 cancel the stop work order; or

4.15.1.2 terminate the work covered by the order as provided in the Termination for Default or the Termination for Convenience clause of this contract.

4.15.2 The procurement officer may make an equitable adjustment in the delivery schedule and/or contract price, and the contract shall be modified, in writing, accordingly, if the contractor demonstrates that the stop work order resulted in an increase in costs to the contractor.

4.16 TERMINATION FOR CONVENIENCE

Maricopa County may terminate the resultant contract for convenience by providing 60 calendar days advance notice to the contractor.

4.17 TERMINATION FOR DEFAULT

4.17.1 The County may, by written Notice of Default to the contractor, terminate this contract in whole or in part if the contractor fails to:

4.17.1.1 deliver the supplies or to perform the services within the time specified in this contract or any extension;

4.17.1.2 make progress, so as to endanger performance of this contract; or

4.17.1.3 perform any of the other provisions of this contract.

4.17.2 The County's right to terminate this contract under these subparagraphs may be exercised if the contractor does not cure such failure within 10 business days (or more if authorized in writing by the County) after receipt of a Notice to Cure from the procurement officer specifying the failure.

4.18 STATUTORY RIGHT OF CANCELLATION FOR CONFLICT OF INTEREST

Notice is given that, pursuant to Arizona Revised Statute (A.R.S.) § 38-511, the County may cancel any contract without penalty or further obligation within three years after execution of the contract, if any person significantly involved in initiating, negotiating, securing, drafting, or creating the contract on behalf of the County is at any time, while the contract or any extension of the contract is in effect, an employee or agent of any other party to the contract in any capacity or consultant to any other party of the contract with respect to the subject matter of the contract. Additionally, pursuant to A.R.S. § 38-511, the County may recoup any fee or commission paid or due to any person significantly involved in initiating, negotiating, securing, drafting, or creating the contract on behalf of the County from any other party to the contract arising as the result of the contract.

4.19 OFFSET FOR DAMAGES

In addition to all other remedies at Law or Equity, the County may offset from any money due to the contractor any amounts contractor owes to the County for damages resulting from breach or deficiencies in performance of the contract.

4.20 CONTRACTOR LICENSE REQUIREMENT

4.20.1 The contractor shall procure all permits, insurance, and licenses and pay the charges and fees necessary and incidental to the lawful conduct of his/her business, and, as necessary, complete any requirements, by any and all governmental or non-governmental entities as mandated to maintain compliance with and remain in good standing. The contractor shall keep fully informed of existing and future trade or industry requirements, and Federal, state, and local laws, ordinances, and regulations which in any manner affect the fulfillment of a contract and shall comply with the same. Contractor shall immediately notify both Office of Procurement Services and the department of any and all changes concerning permits, insurance, or licenses.

4.20.2 Contractor furnishing finished products, materials, or articles of merchandise that will require installation or attachment as part of the contract shall possess any licenses required. Contractor is not relieved of its obligation to obtain and possess the required licenses by subcontracting of the labor portion of the contract. Contractors are advised to contact the Arizona Registrar of Contractors, Chief of Licensing, to ascertain licensing requirements for a particular contract. Contractor shall identify which license(s), if any, the Registrar of Contractors requires for performance of the contract.

4.21 SUBCONTRACTING

4.21.1 The contractor may not assign to another contractor or subcontract to another party for performance of the terms and conditions hereof without the written consent of the County. All correspondence authorizing subcontracting must reference the bid serial number and identify the job or project.

4.21.2 The subcontractor's rate for the job shall not exceed that of the prime contractor's rate, as bid in the Pricing Sheet, unless the prime contractor is willing to absorb any higher rates. The subcontractor's invoice shall be invoiced directly to the prime contractor, who in turn shall pass-through the costs to the County, without mark-up. A copy of the subcontractor's invoice must accompany the prime contractor's invoice.

4.22 AMENDMENTS

All amendments to this contract shall be in writing and approved/signed by both parties. Maricopa County Office of Procurement Services shall be responsible for approving all amendments for Maricopa County.

4.23 ADDITIONS/DELETIONS OF COMMODITIES

The County reserves the right to add and/or delete materials to a contract. If additional materials are required from a contract, prices for such additions will be negotiated between the contractor and the County.

4.24 RIGHTS IN DATA

4.24.1 The County shall have the use of data and reports resulting from a contract without additional cost or other restriction except as may be established by law or applicable regulation. Each party shall supply to the other party, upon request, any available information that is relevant to a contract and to the performance thereunder.

4.24.2 Data, records, reports, and all other information generated for the County by a third party as the result of a contract are the property of the County and shall be provided in a format designated by the County or shall be and remain accessible to the County into perpetuity.

4.25 ACCESS TO AND RETENTION OF RECORDS FOR THE PURPOSE OF AUDIT AND/OR OTHER REVIEW

4.25.1 In accordance with Section MC1-373 of the Maricopa County Procurement Code, the contractor agrees to retain (physical or digital copies of) all books, records, accounts, statements, reports, files, and other records and back-up documentation relevant to this contract for six years after final payment or until after the resolution of any audit questions, which could be more than six years, whichever is longest. The County, Federal or state auditors and any other persons duly authorized by the department shall have full access to and the right to examine, copy, and make use of, any and all said materials.

4.25.2 If the contractor's books, records, accounts, statements, reports, files, and other records and back-up documentation relevant to this contract are not sufficient to support and document that requested services were provided, the contractor shall reimburse Maricopa County for the services not so adequately supported and documented.

4.26 AUDIT DISALLOWANCES

If at any time it is determined by the County that a cost for which payment has been made is a disallowed cost, the County will notify the contractor in writing of the disallowance. The course of action to address the disallowance shall be at sole discretion of the County, and may include either an adjustment to future invoices, request for credit, request for a check, or a deduction from current invoices submitted by the contractor equal to the amount of the disallowance, or to require reimbursement forthwith of the disallowed amount by the contractor by issuing a check payable to Maricopa County.

4.27 STRICT COMPLIANCE

Acceptance by County of a performance that is not in strict compliance with the terms of the contract shall not be deemed to be a waiver of strict compliance with respect to all other terms of the contract.

4.28 VALIDITY

The invalidity, in whole or in part, of any provision of this contract shall not void or affect the validity of any other provision of the contract.

4.29 SEVERABILITY

The removal, in whole or in part, of any provision of this contract shall not void or affect the validity of any other provision of this contract.

4.30 RELATIONSHIPS

4.30.1 In the performance of the services described herein, the contractor shall act solely as an independent contractor, and nothing herein or implied herein shall at any time be construed as to create the relationship of employer and employee, co-employee, partnership, principal and agent, or joint venture between the County and the contractor.

4.30.2 The County reserves the right of final approval on proposed staff. Also, upon request by the County, the contractor will be required to remove any employees working on County projects and substitute personnel based on the discretion of the County within two business days, unless previously approved by the County.

4.31 NON-DISCRIMINATION

Contractor agrees to comply with all provisions and requirements of Arizona Executive Order 2009-09, including flow down of all provisions and requirements to any subcontractors. Executive Order 2009-09 supersedes Executive Order 99-4 and amends Executive Order 75-5 and is hereby incorporated into this contract as if set forth in full herein. During the performance of this contract, contractor shall not discriminate against any employee, client, or any other individual in any way because of that person's age, race, creed, color, religion, sex, disability, or national origin. (Arizona Executive Order 2009-09 can be downloaded from the Arizona Memory Project at <http://azmemory.azlibrary.gov/cdm/singleitem/collection/execorders/id/680/rec/1>.)

4.32 WRITTEN CERTIFICATION PURSUANT TO A.R.S. § 35-393.01

If vendor engages in for-profit activity and has 10 or more employees, and if this agreement has a value of \$100,000 or more, vendor certifies it is not currently engaged in, and agrees for the duration of this agreement to not engage in, a boycott of goods or services from Israel. This certification does not apply to a boycott prohibited by 50 U.S.C. § 4842 or a regulation issued pursuant to 50 U.S.C. § 4842.

4.33 CERTIFICATION REGARDING DEBARMENT AND SUSPENSION

4.33.1 The undersigned (authorized official signing on behalf of the contractor) certifies to the best of his or her knowledge and belief that the contractor, its current officers, and directors:

4.33.1.1 are not presently debarred, suspended, proposed for debarment, declared ineligible, or voluntarily excluded from being awarded any contract or grant by any United States department or agency or any state, or local jurisdiction;

4.33.1.2 have not within a three-year period preceding this contract:

4.33.1.2.1 been convicted of fraud or any criminal offense in connection with obtaining, attempting to obtain, or as the result of performing a government entity (Federal, state or local) transaction or contract; or

4.33.1.2.2 been convicted of violation of any Federal or state antitrust statutes or conviction for embezzlement, theft, forgery, bribery, falsification or destruction of records, making false statements, or receiving stolen property regarding a government entity transaction or contract;

- 4.33.1.3 are not presently indicted or criminally charged by a government entity (Federal, state or local) with commission of any criminal offenses in connection with obtaining, attempting to obtain, or as the result of performing a government entity public (Federal, state or local) transaction or contract;
 - 4.33.1.4 are not presently facing any civil charges from any governmental entity regarding obtaining, attempting to obtain, or from performing any governmental entity contract or other transaction; and
 - 4.33.1.5 have not within a three-year period preceding this contract had any public transaction (Federal, state or local) terminated for cause or default.
- 4.33.2 If any of the above circumstances described in the paragraph are applicable to the entity submitting a bid for this requirement, include with your bid an explanation of the matter including any final resolution.
- 4.33.3 The contractor shall include, without modification, this clause in all lower tier covered transactions (i.e. transactions with subcontractors or sub-subcontractors) and in all solicitations for lower tier covered transactions related to this contract. If this clause is applicable to a subcontractor or sub-subcontractor, the contractor shall include the information required by this clause with their bid.
- 4.34 VERIFICATION REGARDING COMPLIANCE WITH A.R.S. § 41-4401 AND FEDERAL IMMIGRATION LAWS AND REGULATIONS
- 4.34.1 By entering into the contract, the contractor warrants compliance with the Immigration and Nationality Act (INA using E-Verify) and all other Federal immigration laws and regulations related to the immigration status of its employees and A.R.S. § 23-214(A). The contractor shall obtain statements from its subcontractors certifying compliance and shall furnish the statements to the procurement officer upon request. These warranties shall remain in effect through the term of the contract. The contractor and its subcontractors shall also maintain Employment Eligibility Verification forms (I-9) as required by the Immigration Reform and Control Act of 1986, as amended from time to time, for all employees performing work under the contract and verify employee compliance using the E-Verify system and shall keep a record of the verification for the duration of the employee's employment or at least three years, whichever is longer. I-9 forms are available for download at www.uscis.gov.
- 4.34.2 The County retains the legal right to inspect documents of contractor and subcontractor employees performing work under this contract to verify compliance with paragraph 4.34.1 of this section. Contractor and subcontractor shall be given reasonable notice of the County's intent to inspect and shall make the documents available at the time and date specified. Should the County suspect or find that the contractor or any of its subcontractors are not in compliance, the County will consider this a material breach of the contract and may pursue any and all remedies allowed by law, including, but not limited to: suspension of work, termination of the contract for default, and suspension and/or debarment of the contractor. All costs necessary to verify compliance are the responsibility of the contractor.
- 4.35 INFLUENCE
- 4.35.1 As prescribed in MC1-1203 of the Maricopa County Procurement Code, any effort to influence an employee or agent to breach the Maricopa County Ethical Code of Conduct or any ethical conduct, may be grounds for disbarment or suspension under MC1-902.

4.35.2 An attempt to influence includes, but is not limited to:

4.35.2.1 A person offering or providing a gratuity, gift, tip, present, donation, money, entertainment or educational passes or tickets, or any type of valuable contribution or subsidy that is offered or given with the intent to influence a decision, obtain a contract, garner favorable treatment, or gain favorable consideration of any kind.

4.35.3 If a person attempts to influence any employee or agent of Maricopa County, the chief procurement officer, or his designee, reserves the right to seek any remedy provided by the Maricopa County Procurement Code, any remedy in equity or in the law, or any remedy provided by this contract.

4.35.4 ABSOLUTELY NO CONTACT BETWEEN THE RESPONDENT AND ANY COUNTY PERSONNEL, OTHER THAN THE OFFICE OF PROCUREMENT SERVICES, IS ALLOWED DURING THE SOLICITATION PROCESS UNLESS THE COMMUNICATION IS IN REGARD TO PRE-EXISTING BUSINESS WITH THE COUNTY. ANY COMMUNICATIONS REGARDING THE SOLICITATION, ITS PARTICIPANTS, OR ANY DOCUMENTATION PRIOR TO THE CONTRACT AWARD MAY BE GROUNDS FOR DISMISSAL OF THE RESPONDENT FROM THE EVALUATION PROCESS.

4.36 CONFIDENTIALITY

In the course of the solicitation process, the County may disclose information that is proprietary or confidential. By submitting a bid to the solicitation, the offeror agrees that, except as necessary to prepare a response to this solicitation, neither it nor its agents or employees will communicate, divulge, or disseminate to any third-party persons or entities, any information that is disclosed to it by the County during the course of these discussions without the express written authorization of the County. If the offeror does disclose County proprietary or confidential information to a third party in preparing a response to this solicitation, it shall require the third party to acknowledge and comply with this provision.

4.37 CONFIDENTIAL INFORMATION

4.37.1 Any information obtained in the course of performing this contract may include information that is proprietary or confidential to the County. This provision establishes the contractor's obligation regarding such information.

4.37.2 The contractor shall establish and maintain procedures and controls that are adequate to assure that no information contained in its records and/or obtained from the County or from others in carrying out its functions (services) under the contract shall be used by or disclosed by it, its agents, officers, or employees, except as required to efficiently perform duties under the contract. The contractor's procedures and controls, at a minimum, must be the same procedures and controls it uses to protect its own proprietary or confidential information. If, at any time during the duration of the contract, the County determines that the procedures and controls in place are not adequate, the contractor shall institute any new and/or additional measures requested by the County within 15 business days of the written request to do so.

4.37.3 Any requests to the contractor for County proprietary or confidential information shall be referred to the County for review and approval, prior to any dissemination.

4.38 PUBLIC RECORDS

Under Arizona law, all offers submitted and opened are public records and must be retained by the County at the Maricopa County Office of Procurement Services. Offers shall be open to public inspection and copying after contract award and execution, except for such offers or sections thereof determined to contain proprietary or confidential information by the Office of Procurement Services. If an offeror believes that information in its offer or any resulting contract should not be released in response to a public record request, under Arizona law, the offeror shall indicate the specific information deemed confidential or proprietary and submit a statement with its offer detailing the reasons that the information should not be disclosed. Such reasons shall include the specific harm or prejudice which may arise from disclosure. The records manager of the Office of Procurement Services shall determine whether the identified information is confidential pursuant to the Maricopa County Procurement Code.

4.39 INTEGRATION

This contract represents the entire and integrated agreement between the parties and supersedes all prior negotiations, proposals, communications, understandings, representations, or agreements, whether oral or written, expressed, or implied.

4.40 UNIFORM ADMINISTRATIVE REQUIREMENTS

By entering into this contract, the contractor agrees to comply with all applicable provisions of Title 2, Subtitle A, Chapter II, Part 200—UNIFORM ADMINISTRATIVE REQUIREMENTS, COST PRINCIPLES, AND AUDIT REQUIREMENTS FOR FEDERAL AWARDS contained in Title 2 C.F.R. § 200 *et seq.*

4.41 GOVERNING LAW

This contract shall be governed by the laws of the State of Arizona. Venue for any actions or lawsuits involving this contract will be in Maricopa County Superior Court, Phoenix, Arizona.

**LINKING AGREEMENT
BETWEEN
THE CITY OF GLENDALE, ARIZONA
AND
Safeware Safety Supplies Inc**

**EXHIBIT B
Scope of Work**

PROJECT

Procure new Glendale Police Farber Command Vehicle

(See the attached Exhibit B for order details)



QUOTATION

801 W. 116th Avenue
 Ste #400
 Westminster, CO 80234
 303-322-3577
 www.safewareinc.com

Order Number	
1907053	
Order Date	Page
11/16/2022 16:13:22	1 of 1

Quote Expires On 1/31/2023

Bill To: **Customer ID:** 20426
 Glendale Police Administration
 Accounts Payable
 6835 N 57th Drive
 Glendale, AZ 85301-2599

Ship To:
 Glendale Police Administration
 Public Safety Annex
 6835 N 57th Drive
 Glendale, AZ 85301-2599

623-930-2863

Requested By: Commander Blanco

PO Number	Taker	Email
Farber Command Vehicle	Debbie Lundquist	dlundquist@safewareinc.com
Freight Terms	Phone	Fax
Freight Paid	303-322-3577	
Sales Representative		
Rob Berner		

<i>Quantities</i>					<i>Item ID</i>	<i>Pricing</i>	<i>Unit</i>	<i>Extended</i>
<i>Ordered</i>	<i>Allocated</i>	<i>Remaining</i>	<i>UOM</i>	<i>Unit Size</i>	<i>Item Description</i>	<i>UOM</i>	<i>Price</i>	<i>Price</i>
1.00	0.00	1.00	EA		MARICOPA CO	EA	0.00	0.00
				1.0	County Contract Serial 210237-C for Safety Equipment and Supplies Effective: December 8, 2021 - December 31, 2023			
1.00	0.00	1.00	EA		FAR MCC 32CMD/GLENDALE AZ	EA	1,208,606.00	1,208,606.00
				1.0	Glendale Az, Command Center			

Total Lines: 2

SUB-TOTAL: 1,208,606.00

TAX: 102,731.51

AMOUNT DUE: 1,311,337.51

Actual freight added per freight terms



CUSTOMER

Glendale Police Department (AZ)

C/O - Safeware
Rob Berner
Cell: (480) 433-1268
Rberner@safewareinc.com

QUOTE/PROJECT DESCRIPTION

PART NUMBER	QUANTITY	
VEHICLES - FOB Continental US		
USCFVS 100008	1	FSV Body 32 Includes Custom Floorplan Design
USCFVS 1100015	32	Custom Specialty Vehicle Unit (per foot)
USCFVS 1100018	1	Ducted AC
USCFVS 1100020	32	Insulation barrier coating to roof (per foot)
USCFVS 1100033	1	FSV Multiplex System
USCFVS 1100035	2	FSV Multiplex additional node
USCFVS 1100036	1	FSV Multiplex additional screen
INTERIOR OPTIONS		
USCFVS 1200002	4	Fixed Window (Slide-Outs, Ends)
USCFVS 1200003	1	Emergency Exit Window
USCFVS 1200006	1	Aluminum overhead cabinets in lieu of laminated, up to 45ft box
USCFVS 1200011	1	Sound deadening, color coordinated wall carpet
USCFVS 1200012	12	Upgrade high-back office chair
USCFVS 1200024	1	Table , removable
USCFVS 1200025	32	Level 1 Interior finish upgrade (solid surface counters,upgraded flooring) per foot
USCFVS 1200029	3	Custom Cabinet
FINISHES & UPGRADES		
USCFVS 1300003	1	Exterior graphics package (One to four units required)
USCFVS 1300006	1	CSI package level II
EXTERIOR OPTIONS		
USCFVS 1400008	1	Lateral arm box awning, Sunbrella color selection, up to 18' (w/LED Lighting)
USCFVS 1400009	1	Lateral arm box awning, Sunbrella color selection , up to 22' (w/LED Lighting)
USCFVS 1400013	1	Hydraulic leveling and stabilizing jacks - heavy duty
USCFVS 1400016	1	Roof rail for mounting radio antennas w/ weatherproof access hatch to interior
USCFVS 1400017	1	Roof rail, additional, for mounting antennas, eight foot section
USCFVS 1400018	1	Second right side entrance door
USCFVS 1400031	2	Paint exterior below belt rail custom color, non-metalic
USCFVS 1400032	48	Full Body Paint (per foot) Grey - (N2185EA)
USCFVS 1400033	1	Glen Denning shoreline reel, 50 amp service (No Reel, w/ Kussmaul Exterior Display Chrg)
USCFVS 1400034	1	Docking lights; left, right, rear (PELCC)
USCFVS 1400041	1	Braun electric / hydraulic power step (Compartment Fold-Out Step)
USCFVS 1400042	40	Add one foot of body length including finishes
USCFVS 1400043	32	Farber Custom Body Upgrade to .125 smooth aluminum skin and 3" aluminum frame tubing
USCFVS 1400044	32	Tread Plate Aluminum Roof (Per foot)
USCFVS 1400046	5	Exterior Storage Compartment up to 6 ft.
SLIDE-OUT ROOMS		
USCFVS 1500002	4	Custom Flat Floor slide out room up to 16'
RETROFIT OPTIONS		
USCFVS 1600002	52	Engineering Time (per hour)
USCFVS 1600006	1	Basic plumbing, sink, holding tank, water tank, monitor panel
USCFVS 1600007	32	Hourly rate for custom modifications
USCFVS 1600008	6	12 volt Aux System
AUDIO/VIDEO OPTIONS		
USCFVS 1800002	1	40" LCD monitor, exterior view w/ weather-proof door (43")
USCFVS 1800006	1	TV antenna, roof mounted w/ booster (Jack - OA8500 Digital HDTV Antenna)
USCFVS 1800010	2	Custom Cable - 50ft length
USCFVS 1800011	2	HDMI Cable with extender
USCFVS 1800017	1	Back-up camera system, 7" LCD color monitor
USCFVS 1800021	1	Extron video matrix switch 16 x 16 w/touch pads and wiring installed
USCFVS 1800036	1	360 AirCam monitoring system
USCFVS 1800038	2	Commercial LCD monitor w/ TV tuner up to 34" with mount
USCFVS 1800040	2	Commercial LCD monitor w/ TV tuner up to 55" with mount
USCFVS 2000011	1	Mast antenna plate, aluminum triangular
USCFVS 2100022	93	Install customer supplied radios and equipment per hour
USCFVS 2100048	1	Mast - Nycoil
ELECTRONICS		
USCFVS 2400002	3	Cisco #2960, network switch Allied Telesis AT-GS950/48-10 Ethernet Sw)
USCFVS 2400003	1	CAT 6 network with printer/fax/scanner
USCFVS 2400006	2	Equipment rack with, casters, Lexan door, power fan, approx. 19 x 64
USCFVS 2400009	2	Wireless router (IBR-1700 to 2200)
APPLIANCES		
USCFVS 2500001	1	Microwave oven, cabinet mounted
USCFVS 2500005	1	Under counter refrigerator with freezer, AC/DC, compressor operated,
USCFVS 2500007	1	Coffee maker (Keurig)
H.V.A.C.		

USCFSV 2600003	2	Powered reversible roof vent w/ max air cover
USCFSV 2600004	5	Roof mounted air conditioner

PLUMBING OPTIONS

USCFSV 2700002	1	Lavatory with marine toilet, pump, sink, holding & water tank, hot water heater, monitor panel
USCFSV 2700003	1	Recirculating Toilet

GENERATORS & POWER SUPPLIES

USCFSV 2800009	1	UPS, 2000 watts, 3000VA, dual output distribution switches w/bypass
USCFSV 2800022	1	25 KW Diesel Generator with compartment

LOW VOLTAGE OPTIONS

USCFSV 2900004	2	Franklin Instruments clocks, 2.5" LED display, 12 or 24 hour modes
----------------	---	--

INTERIOR LIGHTING

USCFSV 3000002	8	Replace white ceiling lights with combination red / white lights, each
USCFSV 3000005	1	LED ceiling light package

EXTERIOR LIGHTING

USCFSV 3100005	6	Scene lights, LED , each
----------------	---	--------------------------

EMERGENCY LIGHTING

USCFSV 3200001	1	LED light package, 8 emergency lights & 2 scene lights
USCFSV 3200004	1	Siren, w/ amplifier control center
USCFSV 3200006	1	Green command strobe, mounted on roof
USCFSV 3200007	6	LED emergency light

VEHICLE SPECIFIC OPTIONS

USCFSV 4800005	1	Upgrade International (HX620)
USCFSV 4800006	1	EVS Transmission
USCFSV 4900006	1	Full heating & air conditioning system

NON-CONTRACT ITEMS / OPTIONS

1	Rubber Wheel Chocks & Dolly Pads Package
1	Whelen Tail / Stop / Turn / Back-Up / Emergency - Stack (Pair)
1	Undercoat - Complete Body & Unit
1	Bench Seat - Flip Down
6	Dry Erase - Front of Cabinet Doors
1	Extron Sharelink Pro 500 Wireless Collaboration Gateway
1	Leviton 69270-U48
1	Roof Access Ladder - Zico
1	Delivery Charge to Glendale, AZ
1	Economic Price Adjustment

SPECIAL NOTES AND INSTRUCTIONS

Once signed, please fax, mail or email to the provided address.
 Above information is not an invoice and only an estimate of services/goods described above.
 Payment will be collected in prior to provision of services/goods described in this quote.
Please confirm your acceptance of this quote by signing this document.

Thank you for your business!

Signature _____

Print Name _____

Date _____

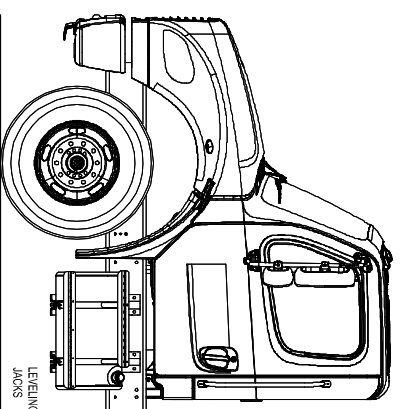
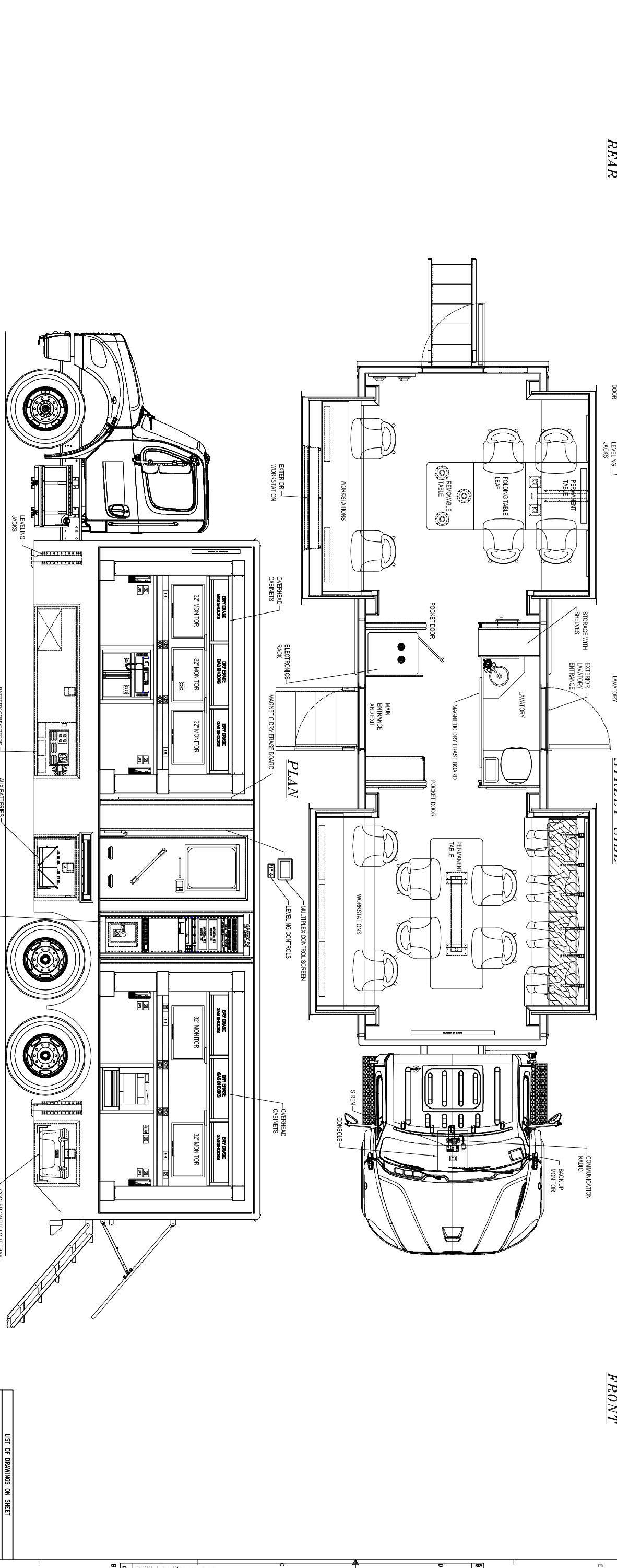
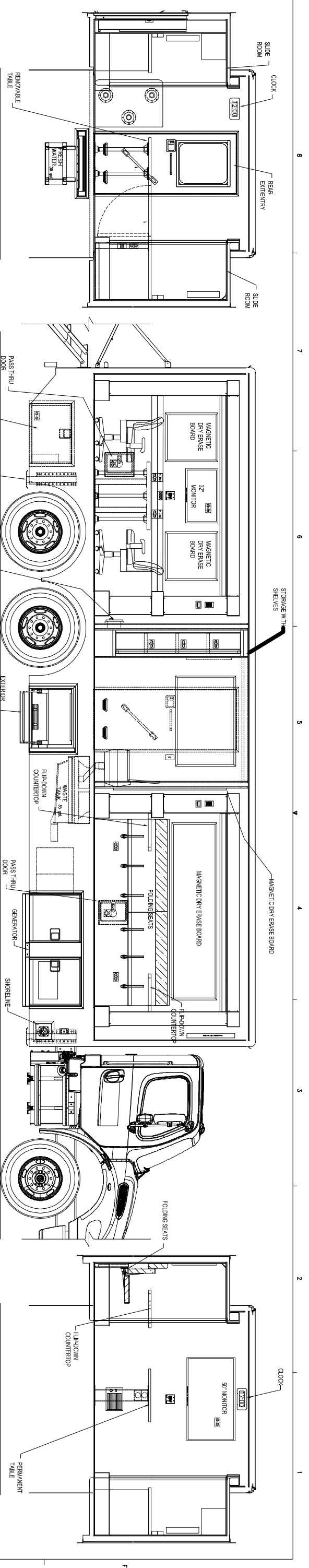

CUSTOMER APPROVAL		REVISION HISTORY	
PRINT NAME	DATE	REVISION	DESCRIPTION
DATE	DATE		
		30' FREIGHTLINER M2	
FARBBER SPECIALTY VEHICLES 7052 AMERICANA PARKWAY COLUMBUS, OH 43088 USA		DESIGN ENGINEER HARLAN DATE: 06/29/2022	
GLENDALE PD, ARIZONA		DESIGN APPROVAL XXX	
COMMAND BID DRAWING		DESIGNER D. CHAPMAN	
XXXXXX		DATE: 06/29/2022	
S.1		LIST OF DRAWINGS ON SHEET	

Body Specifications Addendum

Farber Custom Body

Body Construction and Sub Frame

The Farber Custom Body shall be of 5052-H32 aluminum construction, using the electrically welded and bolted design and assembled with 6063-T6 corner extrusions, 5052-H32 formed panels and 6061-T6 structural tubing. The body corners, both vertical and horizontal, shall be constructed with a radius extrusion framework. The body panels shall be formed from 3/16" (.197) smooth aluminum sheet. There shall be body-skirting panels extended below the chassis frame at each side. The bottom of the skirting panels shall incorporate an inward bent flange for stability.

The body framework shall also be welded directly to the body sub frame with 3" channels that run the full width of the apparatus body in a minimum of four (4) locations. Additional cross members shall be installed not more than 12" apart and shall be as wide as practical within the space provided. Longitudinal members will be added to tie the cross members together and provide a structurally sound and stable unit. Additional bracing shall be used at the manufacturers consent to enhance the durability and life of the apparatus body without affecting the overall appearance of the finished product.

The sub frame at the interior of the apparatus body shall be provided with 3/16" (.197) aluminum sheets for sub frame protection barrier with 3/4" marine grade plywood laid on top. The sheeting shall be screwed to the body sub frame cross members.

The sub frame shall be electrically welded to 2" x 3" x 1/4" wall aluminum tubing stringers that run the full length of the apparatus body, which is then U-bolted to the chassis frame.

Between the sub frame and the frame rails there shall be a 1/2" x 3" layer of fiber reinforced rubber of 60D hardness to separate the two dissimilar metals. The rubber is to prevent any electrolysis between the two dissimilar metals and absorb chassis vibration and shock. The sub frame and cross members shall be made of 3" aluminum channel.

The body uprights shall be 2 1/2" x 2 1/2" x 1/8" wall extruded aluminum tubing. These uprights shall be full height of the body and welded to the body sub frame extending upward to the roof rafters. The uprights shall be on 12" centers or evenly spaced not more than 16" apart on center.

The roof rafters shall be 2 1/2" x 2 1/2" x 1/8" wall extruded aluminum tubing. The rafters shall be on 12" centers or evenly spaced not more than 16" apart on center.

The body shall be built separate from the chassis cab to reduce undue stress to the body and cab to enhance the longevity of the apparatus.

The Farber Custom / Aluminum Body was test and certified meeting AMD Standard 001 & Triple K standards. The body was subjected to rigorous static load roof tests for safety and to reduce liability for agency's, since personnel will be transported or operating in the rear of the body.

**Note: Rivets shall not be used in the construction of the apparatus body.*

Bulkhead

At the front of the body there shall be aluminum diamond plate installed full width and height to be a stone shield and to protect the body from road debris. The aluminum diamond plate shall be completely caulked around the perimeter edges for moisture resistance and appearance.

Body to Frame Attachment

The entire body is to be electrically welded to the sub frame and be fastened down to the chassis frame with 5/8" "U" bolts.

External Body Compartments

All the body compartments shall be constructed of 1/8" smooth aluminum and to be the sweep out floor design. All compartments shall have louvers punched in the back walls for adequate ventilation. The compartments shall be properly supported and constructed to accommodate the department's equipment storage requests and requirements, as the layout of the unit drawing would indicate. The compartment door openings shall be provided with a 2 1/2" x 2 1/2" x 1/8" wall aluminum tube framework that is also wrapped with the body side sheets to form a heavy-duty door framework and support structure for maximum stability. The exact compartment layout shall be determined at the pre-build meeting.

Compartment Doors

The compartment doors shall be constructed entirely from aluminum using a flush type configuration 1 5/8" door with 1/8" diamond plate inner panel fastened to the door with stainless steel fasteners. Two (2) 1/4" holes shall be installed in the lower corners of the inside door pans for drainage. There shall be a "hat stake" section inside each door to enhance the overall strength and durability of the doors. Doors shall be fully weather stripped with hollow core tubular automotive "D" type material. The compartment doors shall have a double catching two-point safety slam heavy duty stainless steel latches 6" circle type with rubber gaskets for electrolysis protection, recessed inside the 1 5/8" thick double pan door. Latches shall meet strength requirements for passenger doors as specified in the Federal Motor Vehicle Standard. The "D" rings shall have a slight break outward to facilitate easy access while using gloves. The doors shall be securely attached to the apparatus body with full-length 16 gauge stainless steel piano type hinges with stainless steel pins and fasteners. ***(Pop Rivets shall NOT be used for attaching compartment doors to the apparatus body.)*** All horizontally hinged doors shall have a pneumatic cylinder door check device. The pneumatic door holder permits the slide to pass over center and holds the door at 90 degrees or greater to the body. The door is self-closing when pushed past the mid point of its swing. All vertically hinged doors will be provided with a spring (Cleveland) style positive door check.

Front Bulkhead

The front of the apparatus body behind the cab of the apparatus shall be all 1/8" aluminum diamond plate. The aluminum diamond plate shall be integrated and glued into the vertical corner and top horizontal extrusions, this will not only create a strong bond but also seal out moisture.

Top of Body (Roof)

The top of the apparatus body shall be finished with 3/16" (.197) aluminum and shall be capable of allowing personnel to be standing on the roof without causing any "sagging" and "dimpling" in the roof. The entire perimeter and seams shall be completely welded to form a weather-tight seal at the top of the apparatus body.

Anti-Corrosion Protection

No dissimilar metals shall contact each other. All stainless steel screws shall have a nylon washer under their heads and "ECK" (Electrolysis Corrosion Kontrol) coated threads a non-hardening isolating material. All fasteners shall be stainless steel. No pop rivets shall be used in the construction of the apparatus. "ECK" shall also be used behind all lights and mounting brackets to aid in corrosion protection.

Side Entry/Exit Provision

The apparatus body shall have one (1) entry/exit door framed into the body at the right side of the body for entry into the interior of the apparatus. An entry/exit door shall be supplied on the door opening. The exact location and size shall be determined before construction begins on the body.

Entry/Exit Door Construction

The entry/exit doors shall be constructed entirely from aluminum using a flush type configuration 1 5/8" door with 1/8" diamond plate inner panel fastened to the door with stainless steel fasteners. Two (2) 1/4" holes shall be installed in the lower corners of the inside door pans for drainage. There shall be a "hat stake" section inside the door to enhance the overall strength and durability of the door. The door shall be fully weather stripped with hollow core tubular automotive "D" type material. The entry/exit door shall have a double catching two-point safety slam, heavy duty, stainless steel latch with rubber gaskets for electrolysis protection, recessed inside the 1 5/8" thick double pan door. Latches shall meet strength requirements for passenger doors as specified in the Federal Motor Vehicle Standard #206. The doors shall be securely attached to the apparatus body with full-length 16 gauge stainless steel piano type hinges with stainless steel pins and fasteners. All doors will be provided with a Cleveland style positive door check.

Rear Bumper/Step

The rear bumper/step shall be formed from 3/16" thick "embossed" aluminum diamond plate. The step shall be approximately 18" deep and full width of the apparatus body. The step shall be supported underneath by 3" steel channels that extend off the chassis frame and have a spacer between the two dissimilar metals to reduce corrosion.

Rub Rails

There shall be rub rails installed around the perimeter of the body below the bottom compartments. The rub rail shall be an extruded aluminum channel 3" high with 1" flanges. The flat side of the channel shall be to the body side. The rub rail will then be installed using Teflon spacers to keep the rub rail away from the body and be bolted for easy removal and allow drainage between the body and the rub rail.

Alternating Red/White DOT reflective tape shall be inserted into the rub rail for reflectivity.

Wheel Liners/Fenderettes

There shall be rounded wheel liners installed in the body to protect the body from being hit with road debris. There shall also be installed a polished aluminum 1/2" radius fenderette which is bolted to the body if it needs to be removed or replaced. There shall also be black fender welting installed for corrosion protection and appearance.

Tow Eyes

There shall be a set of tow eyes at the rear of the body under the rear step. The tow eyes shall be attached directly to a steel framework that extends off the chassis frame rails and finishes under the rear step. The tow eyes shall be made from 3/4" x 4" steel with a 2" x 4" oval eye center. The tow eyes will be finish painted black.

Paint/Misc.

(The apparatus is supplied with a seven 7-year non-prorated paint warranty covered by the Sherwin-Williams Commercial Fleet Refinisher (CFR) paint warranty program.)

The entire apparatus body shall be painted one (1) solid color, per department specifications using Sherwin-Williams Genesis Polyurethane base coat/clear coat painting process. The painting process shall be done by, Sherwin-Williams trained personnel in the automotive painting industry. The following procedure shall be followed during the painting process:

- Step 1. Sand complete body with 150 grit paper.
- Step 2. Fill weld seams with fiberglass bonding agent.
- Step 3. Finish the rest of the body with body filler as needed.
- Step 4. Epoxy prime body complete.
- Step 5. Urethane prime body complete.
- Step 6. Sand primer out with 240 to 400 grit sand paper.
- Step 7. Wipe down with wax and grease remover.
- Step 8. Blow off and wipe down with tack rag.
- Step 9. Spray two coats specified color base coat paint.
- Step 10. Wipe down with tack rag.
- Step 11. Seal base coat with 2-3 coats of clear.
- Step 12. Wet sand buff and polish to finished product.

Stop, Tail, Directional Lights

There shall be installed two (2) sets of Whelen 600 Series LED stop/tail/directional, and back up lights at the rear outer most location. The red taillights shall be model 60R00XRR, the amber turn signals shall be model 60A00TAR and the halogen back up lights shall be model 60C00CR. The lights shall be wired to the chassis electrical system for operation. These lights shall be mounted in a Whelen chrome-plated 6EFLANGE kit.

Clearance Lights/Reflectors

There shall be LED clearance lights installed at the upper rear of the apparatus body. There shall be a cluster of three (3) in the center, one (1) at the outside corner facing the rear and one (1) each side at the upper rear corner facing to the side. These lights shall be red in color. There shall also be amber clearance lights installed at the upper front corners of the apparatus body, front and side facing, to meet DOT, FMVSS 108 and CMVSS 108 requirements. There shall also be clearance lights installed at the lower sides of the apparatus as needed.

Farber Custom Bodies

All Farber Custom bodies have been tested and constructed to meet AMD & Triple K standards. Our bodies are built to meet all the emergency ambulance standards, along with Federal Motor Vehicle Safety Standards.

Prepared For:

GLENDALE AZ 500 X 15 CUMMINS/9219(WHITE)
 32FT FARBER BODY
 DAVE CHAPMAN
 7052 Americana Pkwy.
 Reynoldsburg, OH 43068-4117
 (614)863 - 6470
 Reference ID: FARBER HX 32FT

Presented By:

RUSH TRUCK CENTERS
 Timothy M White
 3950 PARKWEST DR
 COLUMBUS OH 43228 -
 (614)541-4526

Thank you for the opportunity to provide you with the following quotation on a new International truck. I am sure the following detailed specification will meet your operational requirements, and I look forward to serving your business needs.

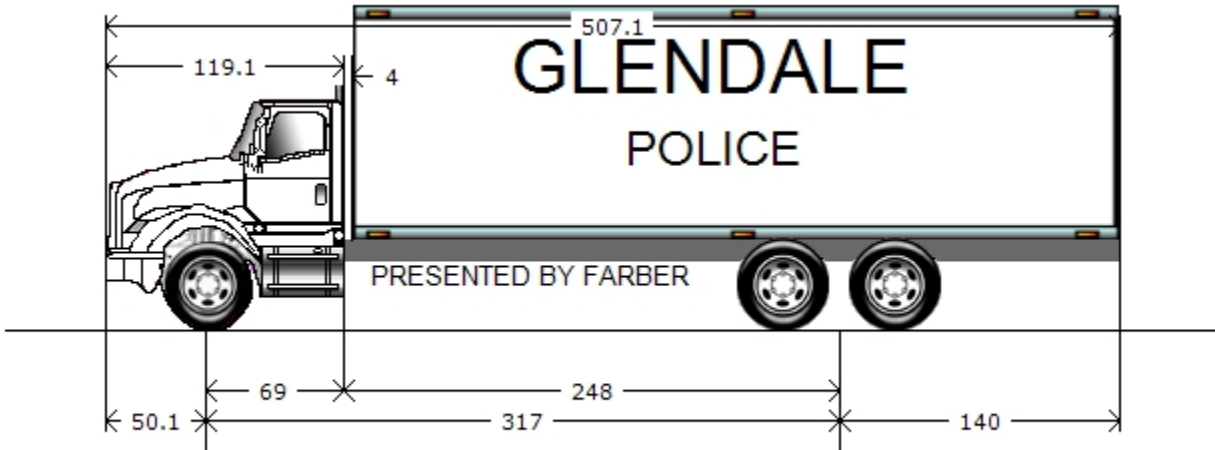

Model Profile
2025 HX620 SBA (HX620)

AXLE CONFIG:	6X4
APPLICATION:	Tank (Emergency)
MISSION:	Requested GVWR: 56000. Calc. GVWR: 62000. Calc. GCWR: 140000 Calc. Start / Grade Ability: 25.25% / 3.44% @ 55 MPH Calc. Geared Speed: 82.7 MPH
DIMENSION:	Wheelbase: 317.00, CA: 248.00, Axle to Frame: 140.00
ENGINE, DIESEL:	{Cummins X15 500 EV} Productivity Series, EPA 2021, 500HP @ 1900 RPM, 1850 lb-ft Torque @ 950 RPM, 2000 RPM Governed Speed, 512 Peak HP (Max), (RATED FOR EMERGENCY VEHICLES ONLY)
TRANSMISSION, AUTOMATIC:	{Allison 4000 EVS} 6th Generation Controls, Close Ratio, 6-Speed with Double Overdrive, with PTO Provision, Less Retarder, Includes Oil Level Sensor
CLUTCH:	Omit Item (Clutch & Control)
AXLE, FRONT NON-DRIVING:	{Meritor MFS-16-133A} Wide Track, I-Beam Type, 16,000-lb Capacity
AXLE, REAR, TANDEM:	{Meritor RT-46-160} Single Reduction, 46,000-lb Capacity, Driver Controlled Locking Differential in Rear-Rear Axle, 200 Wheel Ends Gear Ratio: 4.56
CAB:	Conventional, Day Cab
TIRE, FRONT:	(2) 315/80R22.5 Load Range L X WORKS Z (MICHELIN), 485 rev/mile, 68 MPH, All-Position
TIRE, REAR:	(8) 11R22.5 Load Range H XDN2 (MICHELIN), 497 rev/mile, 75 MPH, Drive
SUSPENSION, REAR, AIR, TANDEM:	{Hendrickson PRIMAXX EX} 46,000-lb Capacity, 56" Axle Spacing, 9.0" Ride Height, with Shock Absorbers
PAINT:	Cab schematic 100LZ Location 1: 9219, Winter White (Std) Chassis schematic N/A

<u>Code</u>	<u>Description</u>
HX62000	Base Chassis, Model HX620 SBA with 317.00 Wheelbase, 248.00 CA, and 140.00 Axle to Frame.
1652	CROSSMEMBER, REAR Relocated to End of Frame
1AND	AXLE CONFIGURATION {Navistar} 6x4
	<u>Notes</u> : Pricing may change if axle configuration is changed.
1CGC	FRAME RAILS Heat Treated Alloy Steel (120,000 PSI Yield); 12.250" x 3.380" x 0.375" (304.8mm x 85.6mm x 9.5mm); 550.0" (13970mm) Maximum OAL
1LEH	LICENSE PLATE HOLDER Single Plate, Swing Type, Mounted Below Front Bumper
1LTE	BUMPER, FRONT Contoured, Aluminum, Stainless Steel Clad, Heavy Duty
1SAR	CROSSMEMBER, REAR, AF (2) 5-Piece
1WXN	WHEELBASE RANGE 297" (755cm) Through and Including 350" (890cm)
2AUR	AXLE, FRONT NON-DRIVING {Meritor MFS-16-133A} Wide Track, I-Beam Type, 16,000-lb Capacity
3ADE	SUSPENSION, FRONT, SPRING Parabolic Taper Leaf, Shackle Type, 16,000-lb Capacity, with Shock Absorbers
4091	BRAKE SYSTEM, AIR Dual System for Straight Truck Applications
	<u>Includes</u> : BRAKE LINES Color and Size Coded Nylon : PARKING BRAKE CONTROL Yellow Knob, Located on Instrument Panel : PARKING BRAKE VALVE For Truck : QUICK RELEASE VALVE On Rear Axle for Spring Brake Release: 1 for 4x2, 2 for 6x4 : SPRING BRAKE MODULATOR VALVE SR-7 with relay valve for 6x4/8x6
4AZV	AIR BRAKE ABS {Bendix AntiLock Brake System} 6-Channel (6 Sensor/6 Modulator) Full Vehicle Wheel Control System, with Automatic Traction Control
4EDM	AIR DRYER {Bendix AD-HF} with Heater, Includes Pressure Protection Circuits, Safety Valve, Integral Purge Tank, Governor Pressure Settings 110 psi Cut-In/130 psi Cut-Out, Integrated PuraGuard Coalescing Filtration
4GBM	BRAKE, PARKING Manual Push-Pull Pneumatic Parking Brake
4SPA	AIR COMPRESSOR {Cummins} 18.7 CFM
4VGN	AIR TANK Painted Aluminum, with Straight Thread O-Ring Ports
4VJJ	AIR TANK LOCATION (3) : One Mounted Inside Right Rail, Back of Cab, Two Mounted Between Rails, Back of Cab
4VKC	AIR DRYER LOCATION Mounted Inside Left Rail, Back of Cab
4WJN	DUST SHIELDS, REAR BRAKE Pad and Rotor, with Air Disc Brakes
4WVL	DRAIN VALVE {Bendix DV-2} (3) Automatic, with Heater, for Air Tanks
4XCP	BRAKES, REAR {Meritor EX+L} Air Disc Type, Size 22.5", 23,000-lb Capacity per Axle
4XCR	BRAKES, FRONT {Meritor EX+H} Air Disc Type, Size 22.5", 23,000-lb Capacity
4XDX	BRAKE CHAMBERS, FRONT AXLE 20 Sqn, for Air Disc Brakes
4XEB	BRAKE CHAMBERS, REAR AXLE 20/24 Sqn Spring Brake, Double Diaphragm, for Air Disc Brakes
4XEE	PARK BRAKE CHAMBERS, ADDITIONAL (2) Spring Brake Type
5710	STEERING COLUMN Tilting and Telescoping
5CBE	STEERING WHEEL 4-Spoke; 18" Dia., Black Leather Wrapped

<u>Code</u>	<u>Description</u>
5PTB	STEERING GEAR (2) {Sheppard M100/M80} Dual Power
6DGX	DRIVELINE SYSTEM {Dana Spicer} Service Free SPL250 Main Driveline with SPL170 Interaxle Shaft, for 6x4
7BES	AFTERTREATMENT COVER Polished Aluminum
7BLY	EXHAUST SYSTEM Horizontal Aftertreatment System, Frame Mounted Right Side Under Cab, for Single Vertical Tail Pipe, Cab Mounted Right Side
7SAP	ENGINE COMPRESSION BRAKE {Cummins} Interbrake For Cummins Signature/ISX/X15 Engines; Furnished with Engine
7WAY	TAIL PIPE (1) Straight Type, Bright
7WBS	MUFFLER/TAIL PIPE GUARD (1) Bright Stainless Steel
7WDM	EXHAUST HEIGHT 10'
7WZX	SWITCH, FOR EXHAUST 3 Position, Momentary, Lighted Momentary, ON/CANCEL, Center Stable, INHIBIT REGEN, Mounted in IP Inhibits Diesel Particulate Filter Regeneration When Switch is Moved to ON While Engine is Running, Resets When Ignition is Turned OFF
8000	ELECTRICAL SYSTEM 12-Volt, Standard Equipment
	<u>Includes</u>
	: HAZARD SWITCH Push On/Push Off, Located on Instrument Panel to Right of Steering Wheel
	: HEADLIGHT DIMMER SWITCH Integral with Turn Signal Lever
	: PARKING LIGHT Integral with Front Turn Signal and Rear Tail Light
	: STARTER SWITCH Electric, Key Operated
	: STOP, TURN, TAIL & B/U LIGHTS Dual, Rear, Combination with Reflector
	: WINDSHIELD WIPER SWITCH 2-Speed with Wash and Intermittent Feature (5 Pre-Set Delays), Integral with Turn Signal Lever
	: WINDSHIELD WIPERS Single Motor, Electric, Cowl Mounted
8899	JUMP START STUD (2) Remote Mounted
8GXK	ALTERNATOR {Leece-Neville BLP4006HN} Brushless, 12 Volt, 325 Amp Capacity, Pad Mount, with Remote Sense
8HAE	BODY BUILDER WIRING Rear of Frame; Includes Sealed Connectors for Tail/Amber Turn/Marker/ Backup/ Accessory Power/Ground and Sealed Connector for Stop/Turn
8MMG	BATTERY SYSTEM {Deka/EAST PENN 9A31 AGM} Maintenance-Free, (3) AGM 12-Volt 2775CCA Total, Top Threaded Stud
8RBZ	SPEAKER, AUXILIARY, CB RADIO with Jack for CB; Mounted Left Side Above Driver's Door
8RMV	SPEAKERS (2) 6.5" Dual Cone Mounted in Doors
8RNB	CB RADIO Accommodation Package, Header Mounted, Feeds from Accessory Side of Ignition Switch, Includes Power Source, One Antenna and Antenna Base with Wiring on Left Side Mirror
8RPR	ANTENNA for Increased Roof Clearance Applications
8RPT	RADIO AM/FM/WB/Clock/USB Input/Auxiliary Input
8VAY	HORN, ELECTRIC Disc Style
8WCK	POWER SOURCE, TERMINAL TYPE 2-Post
8WDG	BACK-UP ALARM {Preco 1059} Electronic; Solid State, Dual Function, 112 dBA
8WEZ	TURN SIGNAL SWITCH Self-Canceling
8WHE	HORN, AIR Accommodation Package, Less Horn
8WRB	HEADLIGHTS ON W/WIPERS Headlights Will Automatically Turn on if Windshield Wipers are turned on

<u>Code</u>	<u>Description</u>
8WXB	HEADLIGHT WARNING BUZZER Sounds When Head Light Switch is on and Ignition Switch is in "Off" Position
8WXG	STARTING MOTOR {Mitsubishi Electric Automotive America 105P} 12-Volt, with Soft-Start
8XAH	CIRCUIT BREAKERS Manual-Reset (Main Panel) SAE Type III with Trip Indicators, Replaces All Fuses
8XDZ	BATTERY BOX Steel, 2-3 Battery Capacity, Mounted Inside the Cab, Under Passenger Seat
8XNB	BATTERY DISCONNECT SWITCH 300 Amp, Disconnects Power to Power Distribution Center (PDC), Does Not Disconnect Charging Circuits, Locks with Padlock, Cab Mounted
8XNY	HEADLIGHTS Halogen
9585	FENDER EXTENSIONS Rubber
9AAB	LOGOS EXTERIOR Model Badges
9AAE	LOGOS EXTERIOR, ENGINE Badges
9ASE	FRONT END Tilting, Composite
9HCN	GRILLE Chrome Vertical Accent Bars, with Black Mesh
9WAC	BUG SCREEN Mounted Behind Grille
10060	PAINT SCHEMATIC, PT-1 Single Color, Design 100
10761	PAINT TYPE Base Coat/Clear Coat, 1-2 Tone
10AGB	COMMUNICATIONS MODULE Telematics Device with Over the Air Programming; Includes Five Year Data Plan and International 360
10SLV	PROMOTIONAL PACKAGE Government Silver Package
11001	CLUTCH Omit Item (Clutch & Control)
12703	ANTI-FREEZE Red, Extended Life Coolant; To -40 Degrees F/ -40 Degrees C, Freeze Protection
12EPG	ENGINE, DIESEL {Cummins X15 500 EV} Productivity Series, EPA 2021, 500HP @ 1900 RPM, 1850 lb-ft Torque @ 950 RPM, 2000 RPM Governed Speed, 512 Peak HP (Max), (RATED FOR EMERGENCY VEHICLES ONLY)
12THT	FAN DRIVE {Horton Drivemaster} Two-Speed Type, Direct Drive, with Residual Torque Device for Disengaged Fan Speed
	<u>Includes</u> : FAN Nylon
12VCA	AIR CLEANER Single Element, with Integral Pre-Cleaner, Engine Mounted
12VGU	ENGINE CONTROL, REMOTE MOUNTED for X15 Engines
12VJJ	EMISSION, CALENDAR YEAR {Cummins X15} EPA, OBD and GHG Certified for Calendar Year 2023
12WCX	HOSE CLAMPS, RADIATOR HOSES {Gates} Shrink Band Type
12WTA	FAN DRIVE SPECIAL EFFECTS Fan Cooling Ring with Fan Shroud Effects, Engine Mounted
12WYZ	RADIATOR DRAIN & FILL FITTING SPECIAL; To Vacuum Out or Fill the Cooling System from the Bottom of Radiator, for Use with Quick-Connect Radiator Drain Tool or Shop Coolant Evacuation-Fill System
12WZE	CARB IDLE COMPLIANCE Federal, Does Not Comply with California Clean Air Idle Regulations
12XBC	RADIATOR Aluminum, Welded, Down Flow, Front to Back System, 1325 SqIn, with 806 SqIn Charge Air Cooler
	<u>Includes</u> : RADIATOR HOSES Premium, Rubber

<u>Code</u>	<u>Description</u>
12XCS	CARB EMISSION WARR COMPLIANCE Federal, Does Not Comply with CARB Emission Warranty
13BEB	TRANSMISSION, AUTOMATIC {Allison 4000 EVS} 6th Generation Controls, Close Ratio, 6-Speed with Double Overdrive, with PTO Provision, Less Retarder, Includes Oil Level Sensor
13WET	TRANSMISSION SHIFT CONTROL Column Mounted Stalk Shifter, Not for Use with Allison 1000 & 2000 Series Transmission
13WHL	OIL COOLER, AUTO TRANSMISSION Remote Mounted
13WLM	TRANSMISSION OIL Synthetic; 63 thru 76 Pints
13WUE	ALLISON SPARE INPUT/OUTPUT for Emergency Vehicle Series (EVS), Fire/Pumper, Tank, Aerial/Ladder, Package Number 198
13WYU	SHIFT CONTROL PARAMETERS {Allison} 3000 or 4000 Series Transmissions, Performance Programming
14899	SUSPENSION AIR CONTROL VALVE Pressure Release Control In Cab
14GRP	AXLE, REAR, TANDEM {Meritor RT-46-160} Single Reduction, 46,000-lb Capacity, Driver Controlled Locking Differential in Rear-Rear Axle, 200 Wheel Ends . Gear Ratio: 4.56
14UNX	SUSPENSION, REAR, AIR, TANDEM {Hendrickson PRIMAAAX EX} 46,000-lb Capacity, 56" Axle Spacing, 9.0" Ride Height, with Shock Absorbers
14WMK	AXLE, REAR, LUBE {EmGard FE-75W-90} Synthetic Oil; 65 thru 89.99 Pints
14WZY	AXLE SHAFT MODIFICATION Axle Shaft Flanges Modified for 0.625" Diameter Drive Studs with Solid Type Cone-Locks
15924	FUEL TANK STRAPS Bright Finish Stainless Steel
15BAA	DEF TANK COVER Stainless Steel
15LKX	FUEL/WATER SEPARATOR {Davco Fuel Pro 382} 12 VDC Electric Heater, Includes Pre-Heater, Includes Water-in-Fuel Sensor
15LNA	FUEL HEATER {Cummins} Plumbing for Thermal Recirculation Valve (TRV) Mounted to Cummins X15 Engines, Thermostatically Controlled
15SWE	FUEL TANK Top Draw, Non-Polished Aluminum, 26" Dia, 70 US Gal (265L), Mounted Left Side, Under Cab
15WCS	FUEL COOLER Less Thermostat; Mounted in Front of Cooling Module
15WDR	DEF TANK 10.6 US Gal (40L) Capacity, Frame Mounted Outside Left Rail, Under Cab
16030	CAB Conventional, Day Cab

Includes

- : CAB REAR SUSPENSION Air
- : CLEARANCE/MARKER LIGHTS (5) LED Roof Mounted
- : COAT HOOK, CAB Located on Rear Wall, Centered Above Rear Window
- : CONSOLE, CENTER Includes Two Cup Holders and One Additional Storage Area
- : CONSOLE, OVERHEAD Molded Plastic with Dual Storage Pockets, Retainer Nets and CB Radio Pocket; Located Above Driver and Passenger
- : COURTESY LIGHT (2) Driver and Passenger Door Mounted
- : DOME LIGHT, CAB Rectangular, Door and Instrument Panel Mounted Switch Activated, Timed Theater Dimming, Center Mounted, Integral to Console
- : FLOOR COVERING Rubber, Black
- : GLASS, ALL WINDOWS Tinted
- : GRAB HANDLE, CAB INTERIOR (1) "A" Pillar Mounted, Passenger Side
- : GRAB HANDLE, CAB INTERIOR (4) "B" Pillar and Door Mounted, Two Each Side
- : READING LIGHT, CAB Located in Overhead Console
- : STORAGE POCKET, DOOR (2) Full Length, Driver and Passenger Door

<u>Code</u>	<u>Description</u>
16BAM	AIR CONDITIONER with Integral Heater and Defroster <u>Includes</u> : HOSE CLAMPS, HEATER HOSE Mubea Constant Tension Clamps
16GEG	GAUGE CLUSTER Premium Level; English with English Electronic Speedometer <u>Includes</u> : GAUGE CLUSTER DISPLAY: Base Level (3" Monochromatic Display), Premium Level (5" LCD Color Display); Odometer, Voltmeter, Diagnostic Messages, Gear Indicator, Trip Odometer, Total Engine Hours, Trip Hours, MPG, Distance to Empty/Refill for : GAUGE CLUSTER Speedometer, Tachometer, Engine Coolant Temp, Fuel Gauge, DEF Gauge, Oil Pressure Gauge, Primary and Secondary Air Pressure : WARNING SYSTEM Low Fuel, Low DEF, Low Oil Pressure, High Engine Coolant Temp, Low Battery Voltage (Visual and Audible), Low Air Pressure (Primary and Secondary)
16HGN	GAUGE, AIR APPLICATION
16HKC	GAUGE, AIR CLEANER RESTRICTION {Filter-Minder} Under Hood Cleaner Mounted with Internal Switch, with Text Message in Cluster
16HKT	IP CLUSTER DISPLAY On Board Diagnostics Display of Fault Codes in Gauge Cluster
16LWM	SEAT, DRIVER {ISRI} Series 400, Air Suspension, High Back, Mordura, Double Chamber Lumbar, Heat, Inboard Armrest, Suspension Cover, Fore/Aft Isolator, Cushion Extension, Seat Tilt, Memory Quickdown
16SDC	GRAB HANDLE, EXTERIOR (2) Chrome, Towel Bar Type, with Anti-Slip Rubber Inserts, for Cab Entry Mounted Left and Right Side at B-Pillar
16SMZ	SEAT, PASSENGER {Seats, Inc.} Non Suspension, High Back, Fixed Back, Integral Headrest, Mordura Cloth, for use with Batteries in Cab
16SNV	MIRRORS (2) Aero Pedestal, Power Adjust, Heated, Turn Signals, Bright Heads, Black Arms, 6.5" x 14" Flat Glass, Includes 6.5" x 6" Convex Mirrors, for 102" Load Width <u>Notes</u> : Mirror Dimensions are Rounded to the Nearest 0.5"
16SNY	MIRROR, CONVEX, HOOD MOUNTED (2) Right and Left Sides, Bright, 7.5" x 7"
16VCC	SEAT BELT All Orange; 1 to 3
16VKK	CAB INTERIOR TRIM Diamond, for Day Cab
16VLV	MONITOR, TIRE PRESSURE Omit
16VSL	WINDSHIELD Heated, Single Piece
16WHJ	HOSE CLAMPS, HEATER HOSE {Breeze} Belleville Washer Type
16WJU	WINDOW, POWER (2) and Power Door Locks, Left and Right Doors, Includes Express Down Feature
16XDD	WINDOW, REAR Polycarbonate Plastic Window, Shatter Resistant
16XJP	INSTRUMENT PANEL Wing Panel
16XRX	MODESTY PANEL Painted
16XTM	ACCESS, CAB Aluminum, Driver & Passenger Sides, Two Steps per Door, for use with Day Cab or Sleeper Cab
16XWV	SUNSHADE, EXTERIOR Aerodynamic, Painted Roof Color, with Integral LED Clearance/Marker Lights
27DUR	WHEELS, FRONT {Accuride 41730} DISC; 22.5x9.00 Rims, Standard Polish Aluminum, 10-Stud, 285.75mm BC, Hub-Piloted, Flanged Nut, with Steel Hubs

<u>Code</u>	<u>Description</u>
28DWG	WHEELS, REAR {Alcoa ULT39} DUAL DISC; 22.5x8.25 Rims, Mirror Polish Aluminum, 10-Stud, 285.75mm BC, Hub-Piloted, Flanged Nut, with Steel Hubs
29WLK	WHEEL BEARING, FRONT, LUBE {EmGard FE-75W-90} Synthetic Oil
7482133264	(8) TIRE, REAR 11R22.5 Load Range H XDN2 (MICHELIN), 497 rev/mile, 75 MPH, Drive
7652543287	(2) TIRE, FRONT 315/80R22.5 Load Range L X WORKS Z (MICHELIN), 485 rev/mile, 68 MPH, All-Position

Services Section:

40132 WARRANTY Standard for HX520, HX620, Effective with Vehicles Built January 1, 2021 or Later, CTS-2015B

Body/Allied Equipment

Code Description

Goods Purchased

Code Description

FUEL TANK INLET AND OUTLETS.AIR CHUCK MOUNTING

HADLEY E-TONE EMERGENCY HORNS MOUNTED ON HOOD

DLB PROGRAMMING FOR TOP SPEED, DOOR LOCKS NFPA CERTIFICATIONS

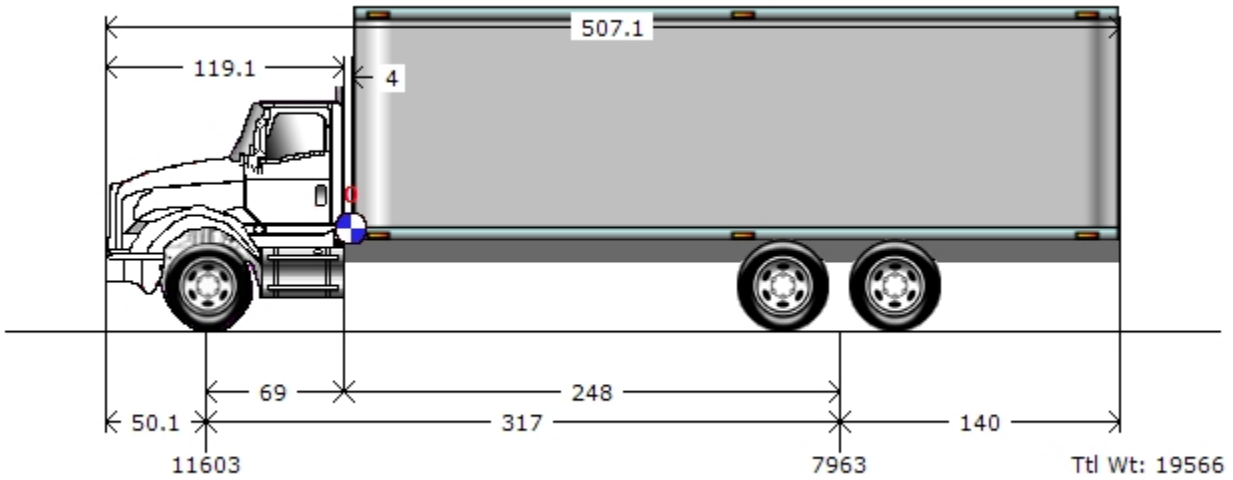

Graphics are provided as visual aids only and are not intended to represent the actual scale, shape, or color of the truck or its components. All weights are represented in lbs.

Truck			Body/Trailer			Chassis/Empty Weights	
Bumper to Axle	(BA)	50.1	Body Length	(BL)	384	Tractor Front Axle:	11,093
Wheelbase	(WB)	317.00				Tractor Rear Axle:	7,781
Axle to Frame	(AF)	140.00					
Axle to Back Cab	(ABC)	69					
Cab to Axle	(CA)	248					
Usable CA		248					
CA Reduction Adjustment		0.00					
Fuel-Diesel(Gals)		70					
DEF(Gals)		11					

Before the Cab			Cab			Payloads			Body			After the Body		
#	Weight	CG	#	Weight	CG	#	Weight	CG	#	Weight	CG	#	Weight	CG
									1	0	0			

Loads	
Payload Weight:	0
Driver:	0
Fuel-Diesel(Lbs):	497
DEF(Lbs):	95

Weight Distribution	
Total Front Axle:	11,603
Total Rear Axle:	7,963
Total Weight:	19,566

Weights and clearances in this proposal are estimates only. Navistar, Inc. is not liable for any consequences resulting from any differences between the estimated weights and clearances and the actual manufactured weights and clearances.

Weight Distribution

All weights are represented in lbs.

	<u>Truck</u>		
	Front	Rear	Total
<u>Chassis Weight</u>			
Chassis Weight:	11,093	7,781	18,874
Fuel:	408	89	497
DEF:	85	10	95
Empty Body:	17	83	100
(Curb Weight):	11,603	7,963	19,566

Loads

Payloads:	0	0	0
Driver:	0	0	0
Axle Totals (Gross Weight):	11,603	7,963	19,566

Weight Ratings

	<u>Truck</u>	
	Front	Rear
Axle(axle capacity)	16,000	46,000
Tire(tire capacity)	18,180	48,040
Suspension(suspension capacity)	16,000	46,000
Spring:	0	
Fed Bridge Law (axle spread):	20,000	34,000 (56")

Wheel Combination	Load	Limit
1 - 3	19,566	57,000

Federal Total Vehicle Weight Limit: 80,000

Maximum Gross Vehicle Weight Rating (GVWR) 62,000 - Gross Vehicle Weight(GVW) 19,566 = 42,434 Reserves

Weight Summary

* Distributed weights are within capacity limits

ENGINE/TRANSMISSION MATCHING

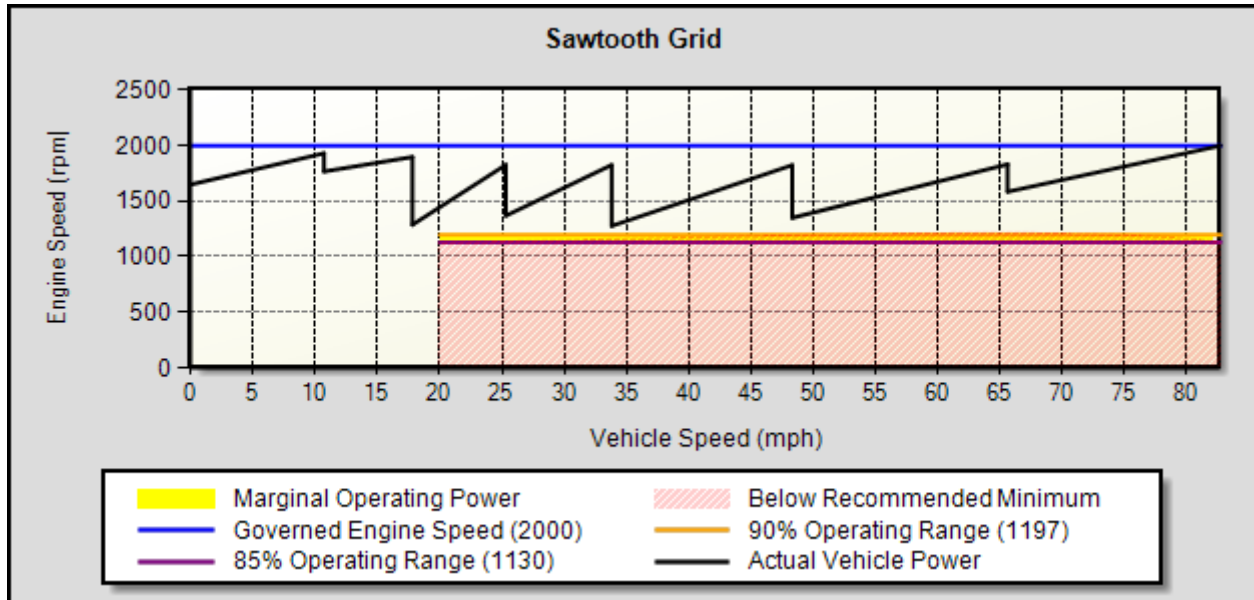

Sawtooth Details

Gear	Trans Ratio	Upshift Power Avail		Govern Power Avail		Peak Power Comparison			Warn Msg
		Veh Spd (MPH)	Eng Spd (RPM)	Veh Spd (MPH)	Eng Spd (RPM)	Gear Step (%)	85% Range (%)	90% Range (%)	
1C	3.51	0.0	1650	10.7	1931	N/A	77	67	
2C	1.91	10.7	1767	17.8	1898	N/A	77	67	
2L	1.91	17.8	1287	25.3	1828	N/A	77	67	
3L	1.43	25.3	1369	33.8	1826	N/A	77	67	
4L	1.00	33.8	1277	48.3	1825	N/A	77	67	
5L	0.74	48.3	1350	65.6	1832	N/A	77	67	
6L	0.64	65.6	1585	82.7	2000	N/A	77	67	

STEADY STATE PERFORMANCE

Performance Results	Gear	Veh Spd (mph)	Eng Spd (rpm)	Fuel Econ (mpg)	Grade (%)	Notes
LEVEL ROAD MAXIMUM SPEED	6L	82.9	2004	*****	0.00	
HI GEAR SPEED @ RATED RPM	6L	82.7	2000	*****	0.46	
55.0 MPH STEADY-STATE	6L	55.0	1330	*****	3.44	
TYPICAL OPERATING SPEED	6L	60.0	1450	*****	3.18	- Calculated Grade Ability/Fuel Economy

VEHICLE ORDER CODING ERRORS MAY RESULT IF THE "LEVEL ROAD MAX SPEED" VALUE EXCEEDS THE "HI GEAR SPEED @ RATED RPM" AND IS USED AS THE ENGINE PROGRAMMABLE VEHICLE SPEED LIMIT.

IF THE RESULTS CONTAIN "----", VEHICLE CANNOT ATTAIN THAT SPEED.

IF THE RESULTS CONTAIN "*****", THE ENGINE USED DOES NOT HAVE A FUEL MAP. FUEL ECONOMY CANNOT BE PREDICTED.

Recommendations / General Information

IDLE FUEL RATE : ***** GAL/S/HR @ 600.0 RPM

TORQUE CONVERTER : TC-561 STALL RATIO: 1.58

Fuel Economy Route: Normal Route - City, Suburban, and Highway

Key Fuel Economy Information	City	Suburban	Highway	Notes
MILES PER GALLON	*****	*****	*****	
AVERAGE MPH	19.1	40.0	54.6	
MISSION MINUTES	29.62	51.78	173.29	

IF THE RESULTS CONTAIN "*****", THE ENGINE USED DOES NOT HAVE A FUEL MAP. FUEL ECONOMY CANNOT BE PREDICTED.

GRADEABILITY PERFORMANCE

Enroute - Full Throttle Upshift Performance

Gear	Trans Ratio	Veh Spd (mph)	Eng Spd (rpm)	Whl Pwr (hp)	Grade (%)	Warn Notes Msg
1C	3.51	0.0	1650	0.00	42.47	STALL
		7.5	1820	325.06	29.41	70% EFF
		9.6	1894	362.28	25.25	80% EFF
		10.7	1931	371.70	22.92	
2C	1.91	10.7	1767	278.54	16.77	
		17.8	1898	363.43	12.87	
2L	1.91	17.8	1287	414.81	14.86	
		25.3	1828	460.14	11.27	
3L	1.43	25.3	1369	440.73	10.75	
		33.8	1826	459.82	8.03	
4L	1.00	33.8	1277	411.03	7.05	
		48.3	1825	457.11	4.89	
5L	0.74	48.3	1350	427.90	4.49	
		65.6	1832	446.17	2.55	
6L	0.64	65.6	1585	451.77	2.61	
		79.2	1916	424.41	1.00	
		82.5	1994	397.66	0.50	
		82.7	2000	395.33	0.46	RATED RPM
		82.9	2004	341.00	0.00	LEVEL ROAD

STARTING / TOP GEAR PERFORMANCE

Gear	Trans Ratio	Veh Spd (mph)	Eng Spd (rpm)	Whl Pwr (hp)	Grade (%)	Warn Notes Msg
1C	3.51	0.0		0.00	42.47	STALL
		9.6		362.28	25.25	80% EFF - Calculated Start Ability

THE TRANSMISSION WAS SIMULATED IN PERFORMANCE OPERATING MODE.

ACCELERATION PERFORMANCE RESULTS

Acceleration Performance Grid

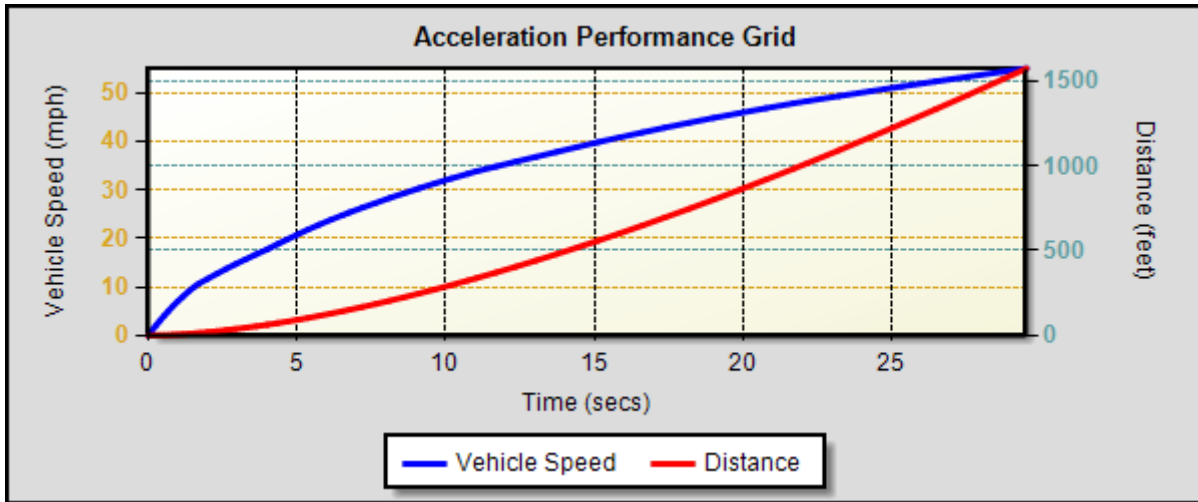

Acceleration Performance: TIME TO ACCELERATE ON A GRADE TO 55.0 (MPH) IS 29.52 (SECS)

Acceleration Performance Details

Gear	Time (secs)	Distance (feet)	Speed (mph)	Notes
1C	0.13	0.1	1.0	
	0.27	0.4	2.0	
	0.40	0.9	3.0	
	0.54	1.6	4.0	
	0.69	2.6	5.0	
	0.84	3.8	6.0	
	1.00	5.4	7.0	
	1.18	7.3	8.0	
	1.36	9.6	9.0	
	1.56	12.4	10.0	
2C	1.72	14.8	10.7	
	2.02	19.7	11.7	
	2.32	25.1	12.7	
	2.63	31.2	13.7	
	2.95	37.9	14.7	
	3.29	45.4	15.7	
	3.64	53.7	16.7	
	4.00	62.8	17.7	
2L	4.03	63.7	17.8	
	4.36	72.6	18.8	
	4.69	82.0	19.8	
	5.03	92.0	20.8	
	5.38	103.0	21.8	
	5.75	115.1	22.8	
	6.14	128.4	23.8	
	6.55	143.0	24.8	
3L	6.76	150.7	25.3	
	7.20	167.6	26.3	
	7.66	185.5	27.3	
	8.12	204.5	28.3	
	8.61	225.0	29.3	
	9.11	247.1	30.3	

Gear	Time (secs)	Distance (feet)	Speed (mph)	Notes
	9.64	270.8	31.3	
	10.18	296.3	32.3	
	10.75	323.7	33.3	
4L	11.03	337.4	33.8	
	11.70	371.1	34.8	
	12.37	405.9	35.8	
	13.05	441.9	36.8	
	13.73	479.1	37.8	
	14.42	518.0	38.8	
	15.12	558.6	39.8	
	15.85	601.5	40.8	
	16.60	646.9	41.8	
	17.37	695.1	42.8	
	18.18	746.1	43.8	
	19.01	800.2	44.8	
	19.87	857.5	45.8	
	20.76	918.0	46.8	
	21.69	982.1	47.8	
5L	22.17	1016.2	48.3	
	23.22	1091.4	49.3	
	24.28	1168.7	50.3	
	25.35	1248.8	51.3	
	26.45	1332.0	52.3	
	27.57	1418.7	53.3	
	28.71	1509.2	54.3	
	29.52	1573.7	55.0	

REQUIRED TCAPE INFORMATION

TCAPE Factors For Vehicle

Selected Rear Axle Gear Ratio(s):	4.56
Engine Fan Type:	VISCOUS
Parked PTO:	NO
Enroute PTO:	NO
ID Wheel Slip Conditions:	Yes
Road Governor/Cruise Ctrl:	No
Road Surface Type:	TYPICAL
Fuel Economy Route:	Normal Route - City, Suburban, and Highway
Vehicle Vocation:	MODERATE ON/OFF HIGHWAY
Acceleration Grade (%):	0.0
Frontal Area (FT ²):	88
Speed Limit on Route (MPH):	61.0
Relative Drag Coefficient:	105
Alternator (A):	40
Steering Gear (HP):	2.60
Air Conditioner (HP):	2.20
Vehicle Width (IN):	96
Vehicle Height (IN):	132
Weight on Drive Axle (LBF):	46000
Acceleration Vehicle Spd (MPH):	55.0
Ambient Temperature (F):	70.0
Air Compressor (HP):	2.20
TIRE, FRONT	2 - RADIAL LOWPROFILE
TIRE, REAR	8 - RADIAL NORMAL

Components

0001AND	AXLE CONFIGURATION {Navistar} 6x4
0002AUR	AXLE, FRONT NON-DRIVING {Meritor MFS-16-133A} Wide Track, I-Beam Type, 16,000-lb Capacity
0004SPA	AIR COMPRESSOR {Cummins} 18.7 CFM
0005PTB	STEERING GEAR (2) {Sheppard M100/M80} Dual Power
0008GXX	ALTERNATOR {Leece-Neville BLP4006HN} Brushless, 12 Volt, 325 Amp Capacity, Pad Mount, with Remote Sense
0012EPG	ENGINE, DIESEL {Cummins X15 500 EV} Productivity Series, EPA 2021, 500HP @ 1900 RPM, 1850 lb-ft Torque @ 950 RPM, 2000 RPM Governed Speed, 512 Peak HP (Max), (RATED FOR EMERGENCY VEHICLES ONLY)
0012THT	FAN DRIVE {Horton Drivemaster} Two-Speed Type, Direct Drive, with Residual Torque Device for Disengaged Fan Speed
0013BEB	TRANSMISSION, AUTOMATIC {Allison 4000 EVS} 6th Generation Controls, Close Ratio, 6-Speed with Double Overdrive, with PTO Provision, Less Retarder, Includes Oil Level Sensor
0014GRP	AXLE, REAR, TANDEM {Meritor RT-46-160} Single Reduction, 46,000-lb Capacity, Driver Controlled Locking Differential in Rear-Rear Axle, 200 Wheel Ends
0016030	CAB Conventional, Day Cab
0016BAM	AIR CONDITIONER with Integral Heater and Defroster
0016XWV	SUNSHADE, EXTERIOR Aerodynamic, Painted Roof Color, with Integral LED Clearance/Marker Lights
07482133264	TIRE, REAR 11R22.5 Load Range H XDN2 (MICHELIN), 497 rev/mile, 75 MPH, Drive 11R22.5 Load Range H XDN2 (MICHELIN), 497 rev/mile, 75 MPH, Drive
07652543287	TIRE, FRONT 315/80R22.5 Load Range L X WORKS Z (MICHELIN), 485 rev/mile, 68 MPH, All-Position 315/80R22.5 Load Range L X WORKS Z (MICHELIN), 485 rev/mile, 68 MPH, All-Position

TCAPE HAS BEEN DESIGNED TO GIVE ECONOMY AND PERFORMANCE PREDICTIONS WHICH HAVE BEEN SHOWN TO BE TYPICAL FOR MOST OPERATIONS. HOWEVER, DUE TO OPERATING CONDITIONS, DRIVER INFLUENCES, AND OTHER FACTORS, YOUR RESULTS MAY VARY FROM THOSE PREDICTED. ALSO, BECAUSE OF FUEL MAPPING PROCEDURES USED BY VARIOUS ENGINE MANUFACTURERS, COMPARISONS OF FUEL ECONOMY RESULTS FOR DIFFERENT BRANDS OF ENGINES MAY VARY FROM THOSE SHOWN.

NAVISTAR, INC. SHALL NOT BE LIABLE FOR ANY LOSS OF PROFITS, LOSS OF USE, INTERRUPTION OF BUSINESS OR INDIRECT, SPECIAL, INCIDENTAL OR CONSEQUENTIAL DAMAGES OF ANY KIND THAT ARE INCURRED BY DEALER OR BY

DEALER'S CUSTOMERS AS A RESULT OF RELIANCE ON TCAPE, WHETHER THE CLAIM IS IN CONTRACT, TORT (INCLUDING NEGLIGENCE), STRICT LIABILITY OR OTHERWISE.

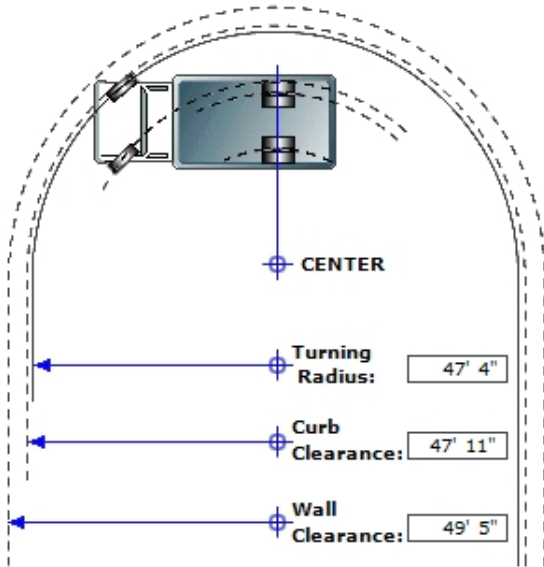

Series: HX
 Model: HX620
 Description: HX620 SBA
 Model Year: 2025

Calculation Factors

Wheelbase: 317
 Front Axle: 0002AUR
 Description: AXLE, FRONT NON-DRIVING, {Meritor MFS-16-133A} Wide Track, I-Beam Type, 16,000-lb Capacity
 Front Wheel: 0027DUR
 Description: WHEELS, FRONT, {Accuride 41730} DISC; 22.5x9.00 Rims, Standard Polish Aluminum, 10-Stud, 285.75mm BC, Hub-Piloted, Flanged Nut, with Steel Hubs
 Front Tire: 07652543287
 Description: TIRES, 315/80R22.5 Load Range L X WORKS Z (MICHELIN), 485 rev/mile, 68 MPH, All-Position
 Steering Gear: 0005PTB
 Description: STEERING GEAR, (2) {Sheppard M100/M80} Dual Power

Turning Radius Statistics

General Information

Inside Turn Angle: 40 Degrees
 Radial Overhang: 24.5

Axle Information

KingPin Inclination: 6.25 Degrees
 KingPin Center: 71

Turning Radius - Curb View

C - Curb Contact Length: 16.42
 CI - Curb Clearance Increment: 6.48
 CR - Curb Clearance Radius: 47'11"
 CH - Curb Height: 6"
 TR - Turning Radius: 47'4"
 TW - Tire Width: 12.50

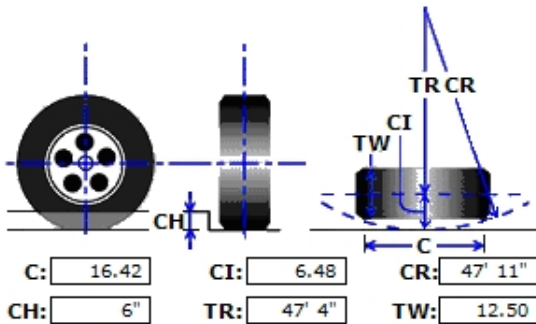

* All Measurements are in inches, unless otherwise specified.

This information is based on engineering information available at this time. Actual figures may vary. Navistar, Inc. cannot accept liability for consequences due to this variance.

(US DOLLAR)

Description

Price

No body allied/equipment chosen.

Total Body Allied/Equipment: \$0.00

**LINKING AGREEMENT
BETWEEN
THE CITY OF GLENDALE, ARIZONA
AND
Safeware Safety Supplies Inc**

EXHIBIT C

METHOD AND AMOUNT OF COMPENSATION

The method and amount of compensation is in accordance with Section 3 of this Agreement.

NOT TO EXCEED AMOUNT

The total amount of compensation paid to Contractor for full completion of all work required by the Project must not exceed \$1,311,338.00 for the entire term of the Agreement.

DETAILED PROJECT COMPENSATION

City shall pay Contractor compensation in accordance with the rates as set forth in the Maricopa County Cooperative Purchasing Agreement, Serial No. 210237-C, and upon delivery.