



# CITIZEN PARTICIPATION FINAL REPORT 8/1/2023 CUP23-15, CUP23-16

**COMPLETION OF THE FOLLOWING IS NECESSARY FOR FINAL REPORT APPROVAL**

SUMMARY / FINAL REPORT	
Total individuals notified: 65	Total Participants: 0
CONCERNS, ISSUES, PROBLEMS EXPRESSED	
None, no one came to the neighborhood meeting.	
HOW CONCERNS WILL BE ADDRESSED?	
If any concerns pop up, we will communicate and mitigate as needed	
CONCERNS APPLICANT IS UNWILLING TO ADDRESS	
None	
HOW THE PROPOSAL HAS BEEN REVISED TO ADDRESS CONCERNS	
None, no concerns expressed	
APPLICANT SIGNATURE AND DATE	
 8/1/23	

**REQUIRED ATTACHMENTS:**

- NOTIFICATION AREA MAP
- NOTIFICATION LETTER AND SITE PLAN
- ANY OTHER NOTICES, MEETING INVITATIONS, SIGN-IN SHEETS.
- LIST OF PROPERTY OWNERS WITHIN NOTIFICATION AREA.
- “INTERESTED PARTIES” LIST PROVIDED BY PLANNING
- “ADDITIONAL NOTIFICATIONS” LIST PROVIDED BY PLANNING.
- LIST OF HOME OWNERS ASSOC., REGISTERED NEIGHBORHOODS; AND THEIR REPRESENTATIVES WHO WILL BE INCLUDED IN THE PLAN.

**APPROVED**

24 AUG 2023  
CUP23-16



City of Glendale  
Planning Division



# PLANNING DIVISION

## NEIGHBORHOOD NOTIFICATION LETTER

### AFFIDAVIT OF MAILING

Case No. (if available) CUP23-15 & CUP23-16

Project Name: Shops at 75th

*I, Scott Hintze of Diversified Partners and project manager for NRM Group, LLC certify that I am the authorized applicant / representative to the City of Glendale for the above application, and do hereby affirm that notice as required for the case noted above has been completed in accordance with the Citizen Participation Process in the City of Glendale's Zoning Ordinance, and a copy of the letter and mailing labels has also been submitted.*

Applicant/Representative Signature: 

STATE OF ARIZONA )

) §§

County of Maricopa )

The foregoing instrument was acknowledged before me, the undersigned Notary Public, this 1<sup>st</sup> day of August 2023 by Scott Hintze of Diversified Partners, an Arizona limited liability company, on behalf thereof.





Notary Public

*NEIGHBORHOOD NOTIFICATION AREA*

<b>NAME OF REQUEST:</b>	<b>SHOPS AT 75<sup>TH</sup> CONDITIONAL USE PERMIT</b>		
<b>LOCATION:</b>	Southwest corner of Bethany Home Road and 75 <sup>th</sup> Avenue.		
<b>REQUEST:</b>	Conditional Use Permit to allow (4) convenience uses (drive-thru services) on the subject property.		
<b>ZONING DISTRICT:</b> CO			<b>COUNCIL DISTRICT:</b> YUCCA
<b>FORMAL APPLICATION SUBMITTED:</b> Not Yet (SR23-0076)			<b>EMAIL ADDRESS:</b> <a href="mailto:alerna@glendaleaz.com">alerna@glendaleaz.com</a>

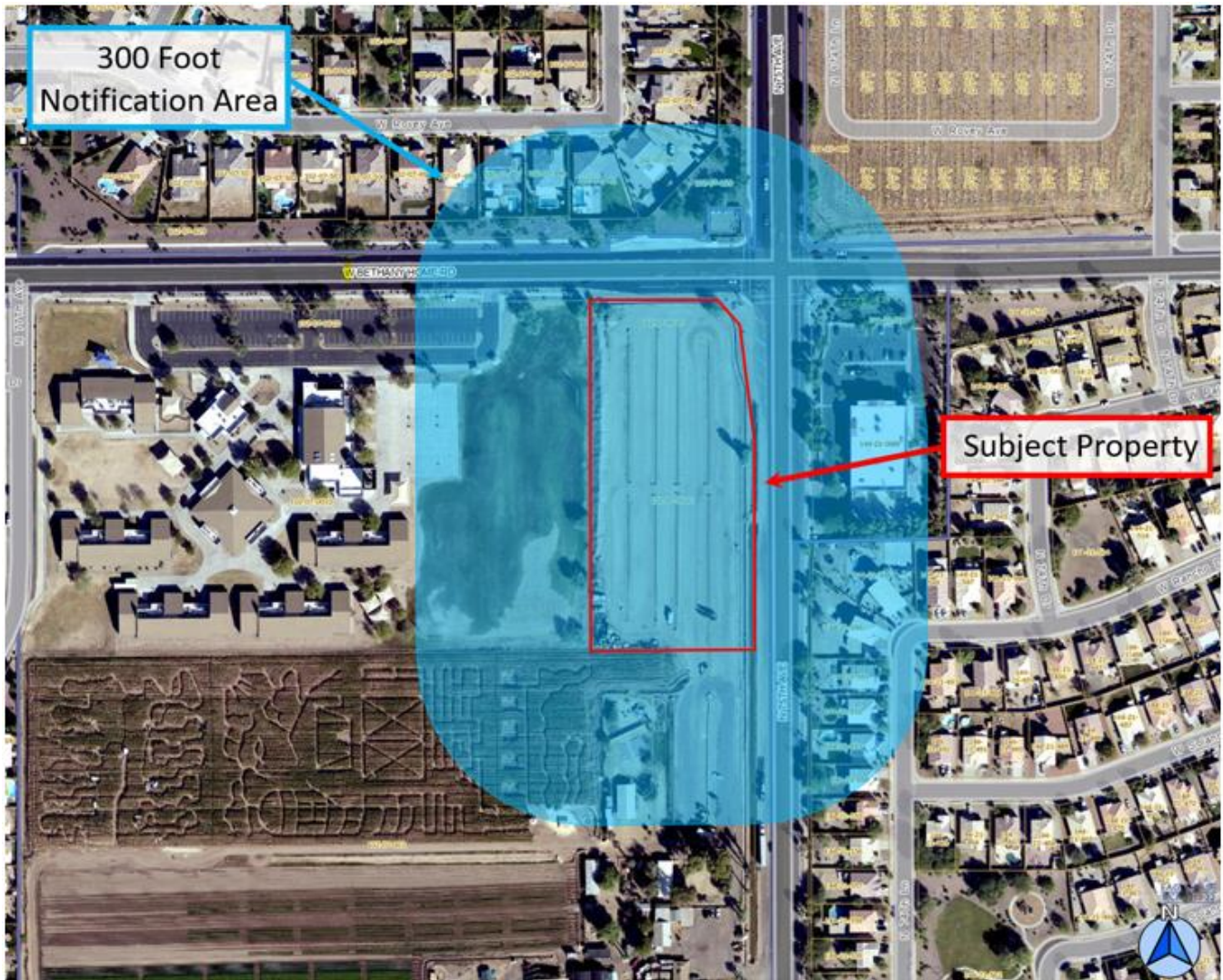

Diversified Partners  
Project Manager Scott Hintze  
7500 E McDonald Drive #100A  
Scottsdale, AZ 85250  
[Scott@dpcrc.com](mailto:Scott@dpcrc.com)  
480-947-8800

May 30th, 2023

Subject: Conditional Use Permit Request Convenience Use CUP23-15 Shops at 75 Pad A & CUP23-16 Shops at 75 Pad B

Dear Neighbor:

This letter is to inform you about our request to the City of Glendale for a conditional use permit to allow a drive thru to be constructed on Pads A & B at the Shops at 75<sup>th</sup> and invite you to the neighborhood meeting we are conducting via zoom on June 26<sup>th</sup>, 2023 at 6:00 PM (details below). The site plan (enclosed) is the same as discussed in the last neighborhood meeting and at Town Council. The property is located at the Southwest Corner of 75<sup>th</sup> Avenue & Bethany Home Road in the *Yucca* District (assessors parcel number 102-07-001C).

It is our intent to develop the 3.71 acre parcel located on the southwest corner of 75<sup>th</sup> Avenue & Bethany Home Road. To the north of the site lies Bethany Home Road, a major arterial. To the east of the site lies 75<sup>th</sup> Avenue, a major arterial. Adjacent use to the west is Coyote Ridge Elementary School which no longer operates as an elementary school and to the east (across 75<sup>th</sup> Avenue) is CVS. The rear fence to two residential homes also lies to the east (across 75<sup>th</sup> Avenue). To the south currently lies Tolmachoff Farms and on the North (across Bethany Home Road) lies the Tesserra residential community. Our project will consist of 3-4 buildings with various commercial users. The site plan includes a coffee user for Pad A and a taco restaurant for Pad B. The project will provide ample rear and side setbacks with lush landscaping per Glendale code. In addition, the irrigation canals currently on the site will be undergrounded with new sidewalk, curb and gutter to make excellent pedestrian connectivity to Bethany Home Road and along 75<sup>th</sup> Avenue.

Please join us for our neighborhood meeting on June 26<sup>th</sup>, 2023.

Navigate to <http://zoom.us> or dial in at 1-720-707-2699 and enter the meeting ID below.

Click Join at the top right hand of the screen and enter in the information below

Meeting ID: 831 1708 1059

Passcode: 123325

Attached is the latest conceptual plan for review. Please email feedback to Scott Hintze [scott@dpcrc.com](mailto:scott@dpcrc.com) or call me at 602-549-4173 or via mail at the address above by June 25<sup>th</sup>, 2023. You may also contact *Alex Lerma* with the City of Glendale at (623) 930-2810.

Sincerely,

*Scott Hintze Project Manager*  
*Encl: Conceptual Site Plan*

# PROJECT DATA

PROPERTY OWNER:  
NRM INVESTORS, LLC  
7500 E McDONALD DR. SUITE 100A  
SCOTTSDALE, AZ 85250  
PHONE: (480) 947-8800

OWNER AGENT:  
DIVERSIFIED PARTNERS, LLC  
7500 E McDONALD DR. SUITE 100A  
SCOTTSDALE, AZ 85250  
CONTACT: SCOTT HINTZE  
PHONE: (480) 947-8800

ARCHITECT:  
MCG ARCHITECTURE  
60 E RIO SALADO PARKWAY, SUITE 900  
TEMPE, AZ 85281  
CONTACT: JORGE CALDERON  
PHONE: (602) 813-0779

CIVIL ENGINEER:  
OPTIMUS CIVIL DESIGN GROUP, LLC  
4650 E. COTTON CENTER BLVD. SUITE 200  
PHOENIX, AZ 85040  
CONTACT: JEFF BEHRANA  
PHONE: (602) 393-5234

LANDSCAPE ARCHITECT:  
T.J. McQUEEN AND ASSOCIATES INC.  
10450 N 74TH STREET, SUITE 120  
SCOTTSDALE, AZ 85258  
CONTACT: TIM McQUEEN  
PHONE: (602) 265-0320

TRAFFIC ENGINEER:  
EPS GROUP, INC.  
1130 N ALMA SCHOOL ROAD, SUITE 120  
MESA, AZ 85201  
CONTACT: ERIC MACEYKO  
PHONE: (480) 503-2250

# SITE DATA

PARCEL NUMBER (APN NO.): 102-07-001C  
EXISTING ZONING: C-1

LEGAL DESCRIPTION:  
THE EAST 313.39 FEET AS MEASURED ALONG THE NORTH LINE OF THE NORTHEAST QUARTER OF SECTION 14, TOWNSHIP 2 NORTH, RANGE 1 EAST OF THE GILA AND SALT RIVER BASE AND MERIDIAN, MARICOPA COUNTY, ARIZONA.

PROPOSED USE:	RETAIL / RESTAURANTS
BUILDINGS	CONST. TYPE OCCUPANCY AREA
PAD A:	V-B B 1,242 S.F.
PATIO:	N/A N/A 405 S.F.
PAD B:	V-B B,M 6,900 S.F.

SITE COVERAGE: 9.14%

LANDSCAPE COVERAGE: 28%

PARKING REQUIRED:

PAD - A (RESTAURANT): 1 PER 100	13 SPACES
PATIO - A: 1 PER 100	4 SPACES
PAD - B (RESTAURANT): 1 PER 100	21 SPACES
PAD - B (RETAIL): 1 PER 250	19 SPACES

# LEGEND

- LANDSCAPED AREAS
- ACCESSIBLE PATH
- LIGHT STANDARDS

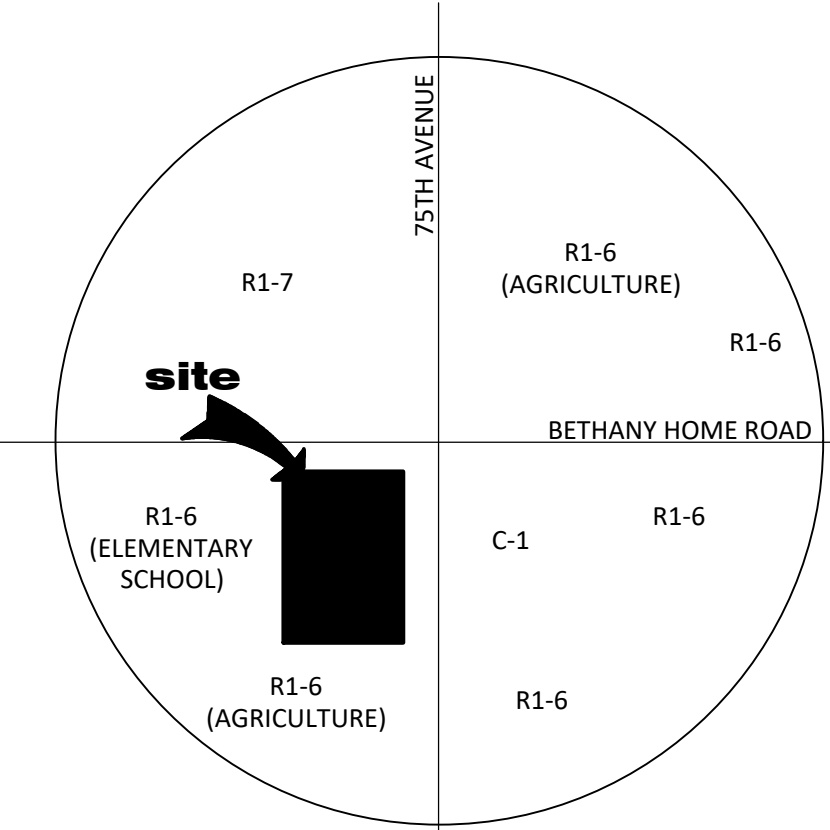
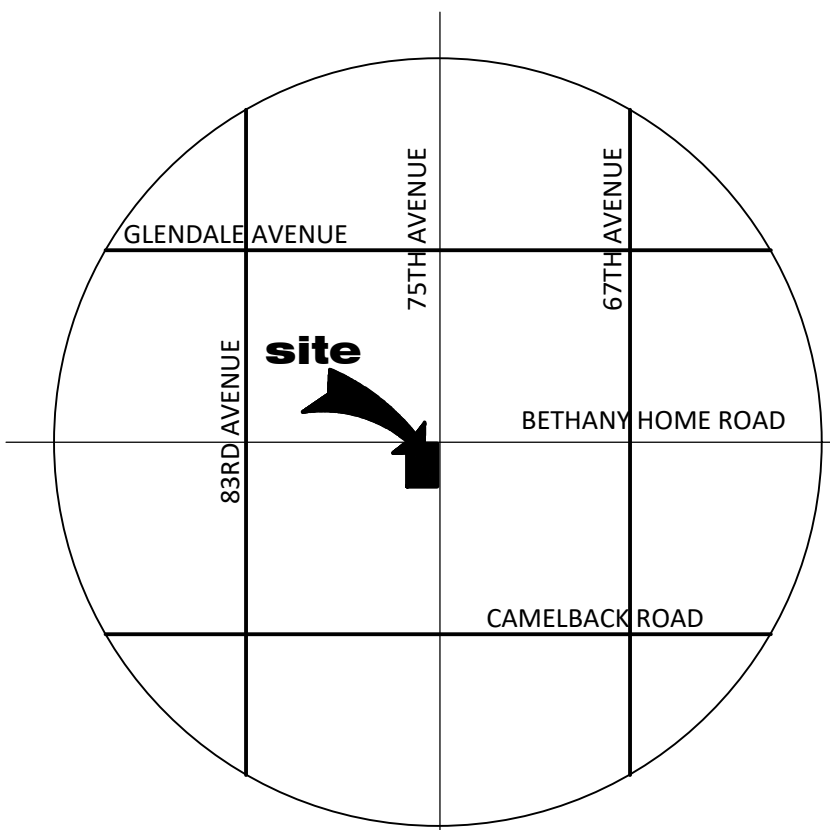
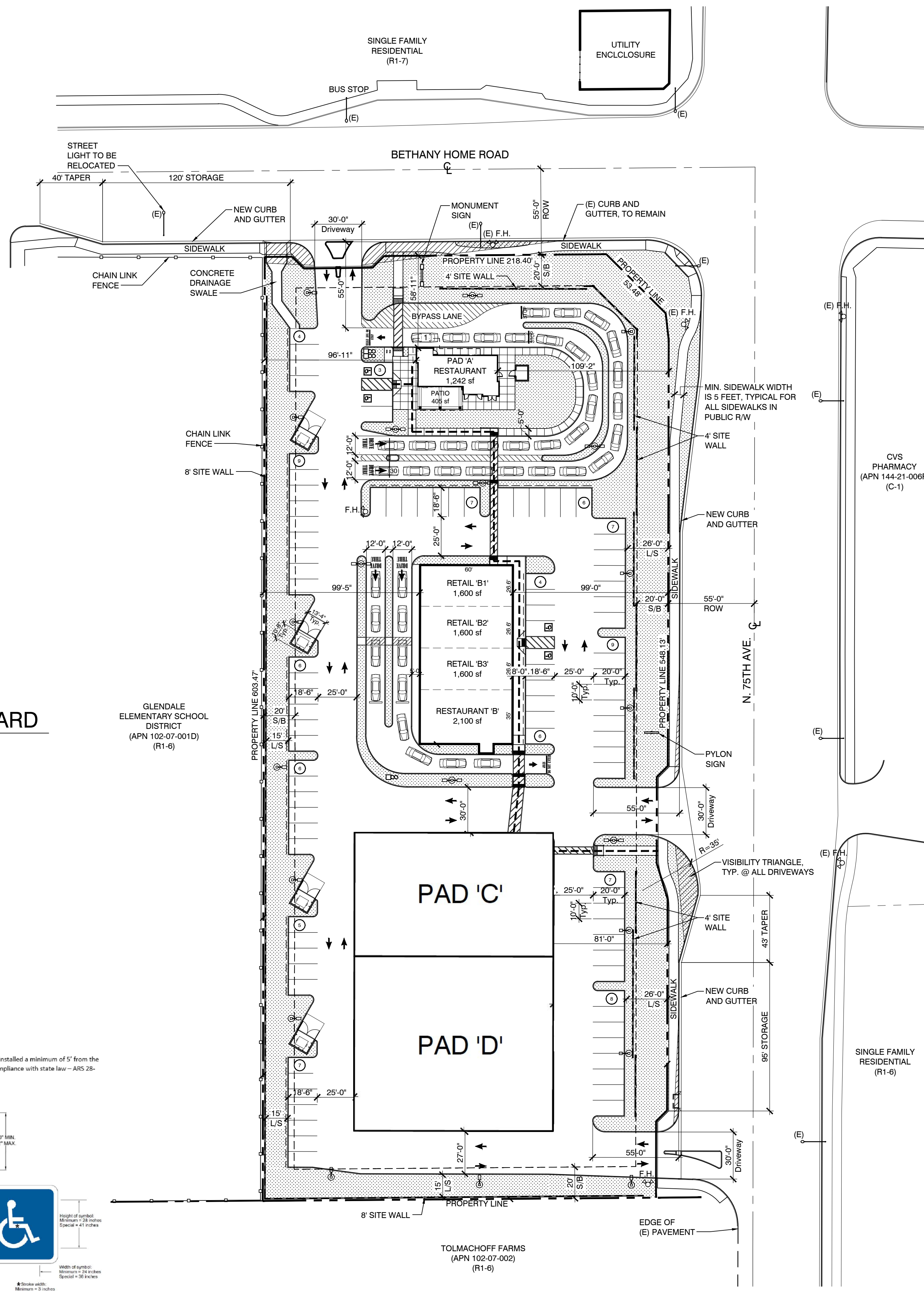

# 75TH AVENUE AND BETHANY HOME ROAD

SWC 75th Ave and Bethany Home  
Glendale, AZ 85303

- CLEVELAND
- DENVER
- GLENDORA
- IRVINE
- ORLANDO
- PHOENIX
- SAN FRANCISCO



mcgarchitecture.com

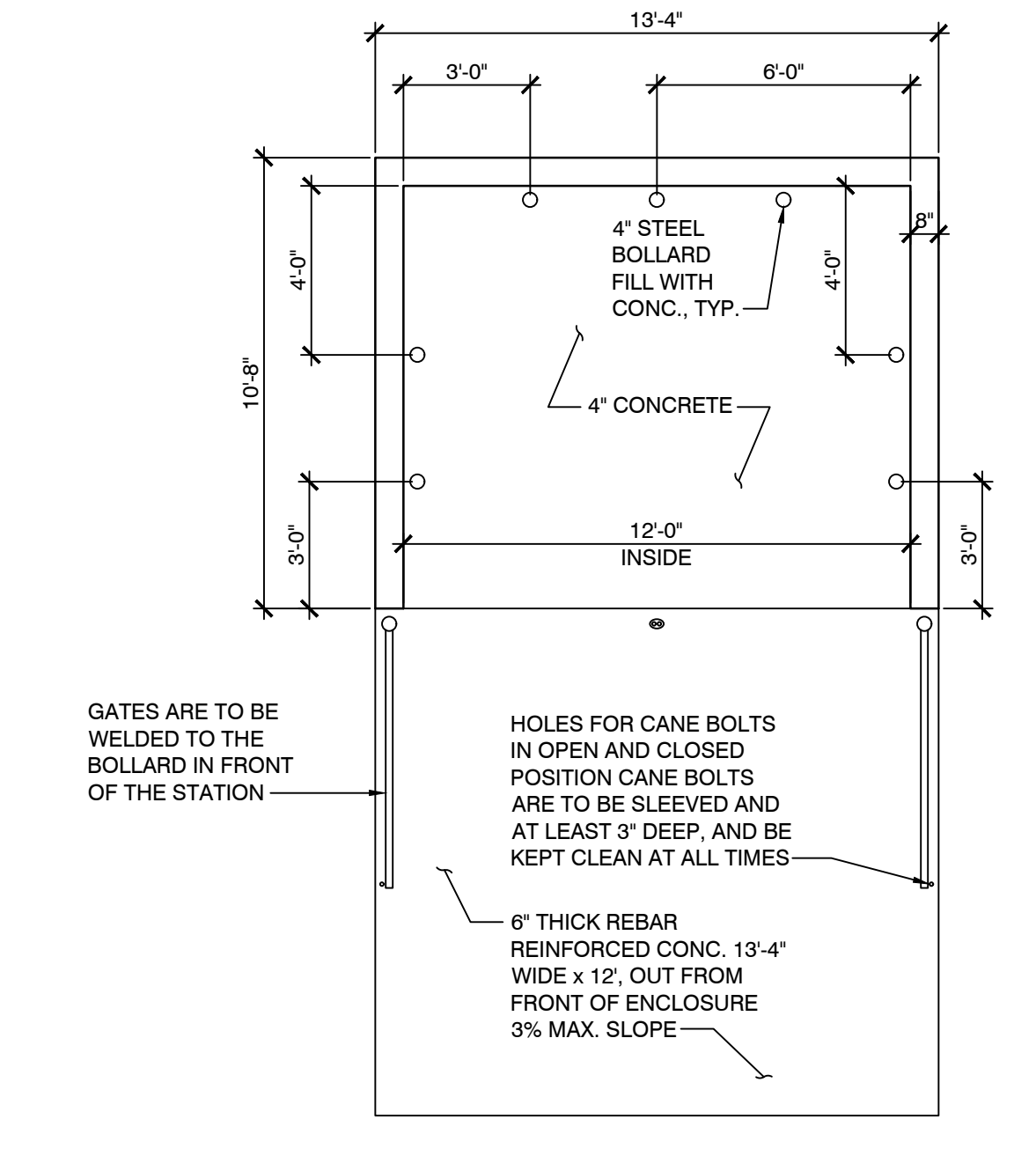
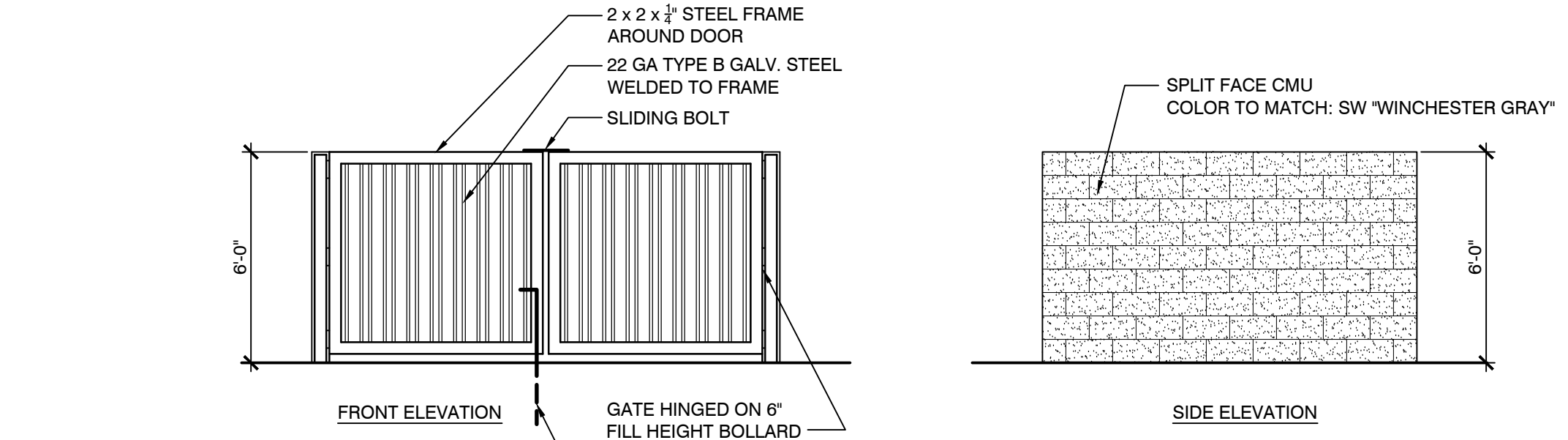

# TRASH ENCLOSURE ELEVATIONS

SCALE: 1/4" = 1'-0" (PER COG DETAIL G-934)

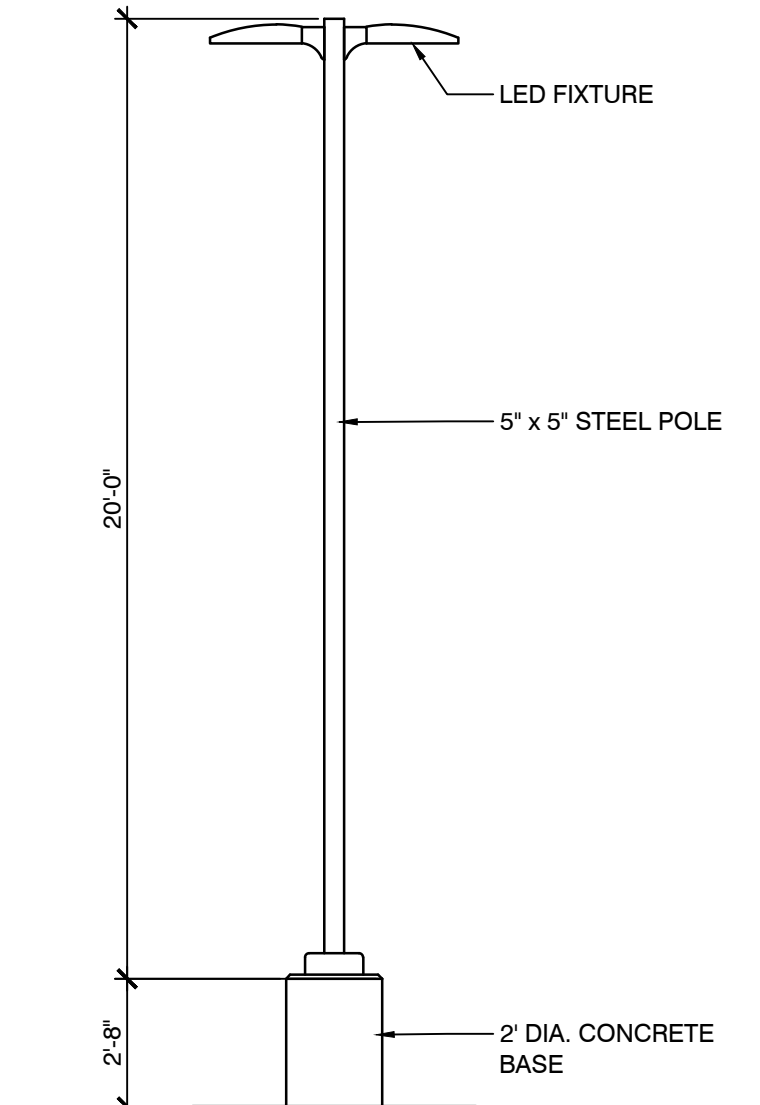

# TYPICAL LIGHT STANDARD

SCALE: 1/4" = 1'-0"

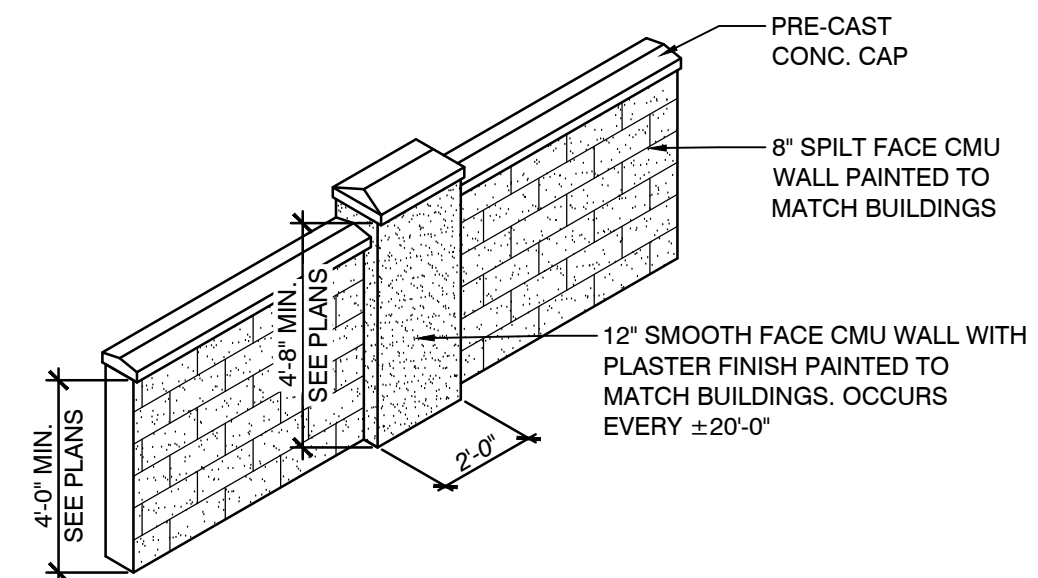

# PARTIAL ISOMETRIC VIEW - 4' & 8' HIGH SCREEN WALL

SCALE: 1/4" = 1'-0"

# GENERAL NOTES:

- FIRE DEPARTMENT ACCESS AND WATER SUPPLY REQUIREMENTS SHALL BE IN PLACE PRIOR TO COMBUSTIBLE MATERIALS BEING BROUGHT ON SITE.
- PURSUANT TO CHAPTER 32.5 OF THE GLENDALE CITY CODE, ALL NEW AND EXISTING UTILITIES WITHIN OR CONTIGUOUS TO THIS SITE SHALL BE PLACED UNDERGROUND.
- ALL UTILITY BOXES, VALVES AND BACKFLOW PREVENTION DEVICES SHALL BE PAINTED TO MATCH THE BUILDING AND SCREENED FROM PUBLIC VIEW BY A MASONRY WALL OR A ROUND-TOPPED WIRE MESH ENCLOSURE, PAINTED TO MATCH THE ADJACENT WALL.
- SIGHT DISTANCE REQUIREMENTS OF COG DETAIL G-447 (LOCAL STREETS) OR G-448 (ARTERIAL AND COLLECTOR STREETS) ARE MET FOR ALL DRIVEWAYS AND STREETS.
- STREETLIGHTS INSTALLED BY THE DEVELOPER MAY BE REQUIRED FOR CONSTRUCTION APPROVAL.
- ON-SITE LIGHTING WILL BE PLACED SO AS TO DIRECT THE LIGHT AWAY FROM ADJACENT RESIDENTIAL USES AND MUST NOT EXCEED ONE-FOOT CANDLE AT THE PROPERTY LINE. THE HEIGHT OF THE PARKING LOT LIGHTS WITHIN 150' OF RESIDENTIAL USE TO BE 15'. HIGH PRESSURE SODIUM (HPS) LIGHTING REQUIRED ADJACENT TO RESIDENCE.
- ON-SITE LIGHTING SHALL MEET OUTDOOR LIGHTING CONTROL ORDINANCE.
- MAXIMUM NOISE LEVEL 55 DECIBELS (NORMAL SPEAKING VOICE) AT PROPERTY LINE.
- CONVENIENCE USES SHALL BE SUBJECT TO A SEPARATE CITIZEN PARTICIPATION AND CONDITIONAL USE PERMIT PROCESS.
- THE PROPERTY OWNER IS RESPONSIBLE FOR MAINTAINING LANDSCAPING IN ALL PUBLIC RIGHTS-OF-WAY ADJACENT TO THE PROJECT.

ADA Signs shall comply with the layout shown below and shall be installed a minimum of 5' from the ground to the bottom of the sign but no more than 6' (to be in compliance with state law - ARS 28-882 and the requirements of the US Access Board).

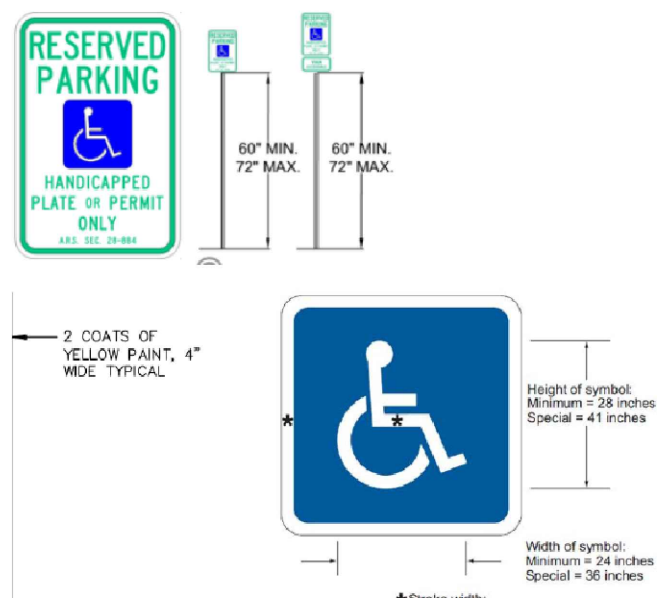

DATE: 01/26/2023  
MCG JOB #: 21.630.01

DATE	REVISIONS

# SITE PLAN

Scale: 1" = 40'



©MCG ARCHITECTURE 2023. ALL RIGHTS RESERVED.  
NOTE: This information is conceptual in nature and is subject to adjustments pending further verification and Client, Tenant, and Governmental Agency approvals. No warranties or guarantees of any kind are given or implied by the Architect.

\*THIS PAGE WAS LEFT INTENTIONALLY BLANK\*