

ORDINANCE NO. 2260

AN ORDINANCE OF THE CITY COUNCIL OF THE CITY OF HAWTHORNE, CALIFORNIA, AMENDING CHAPTERS 17.04 (DEFINITIONS), 17.38 (NONCONFORMING USES, STRUCTURES, SIGNS, AND PARCELS), 17.40 (CONDITIONAL USES—VARIANCES), 17.56 (LOADING), 17.58 (OFF-STREET PARKING), AND 17.60 (MINIMUM DRIVEWAY WIDTHS AND TURNING RADII) OF TITLE 17 (ZONING) OF THE HAWTHORNE MUNICIPAL CODE RELATED TO OFF-STREET VEHICULAR PARKING, AND MAKING A FINDING OF NON-PROJECT IN COMPLIANCE WITH CEQA IN CONNECTION THEREWITH

WHEREAS, the Hawthorne Municipal Code (HMC) regulates off-street parking in Title 17; and

WHEREAS, the parking regulations contained within the HMC consistently hinder the City's economic development, create barriers to housing development, negatively impact the City's reputation among developers and homeowners, and require the City to forego opportunities that could improve the City's overall parking situation; and

WHEREAS, commercially-zoned portions of the City are characterized by a high level of vacancies, but the parking regulations contained within the HMC do not allow commercial uses, which have a higher parking requirement to replace those with a lower parking requirement when the provision of additional parking cannot be provided; and

WHEREAS, the parking regulations contained within the HMC prohibit the City from considering public parking in the vicinity of a business when calculating required parking; and

WHEREAS, a variance is restricted to properties with physical limitations that make it otherwise impossible to enjoy the full range of property rights enjoyed by other properties in the same zone. However, the variance regulations contained within the HMC remove the option to remedy the physical constraints of a property through a reduction in the number of parking spaces required regardless of the physical limitations of the subject property; and

WHEREAS, the parking regulations contained within the HMC are mostly written in a style that is difficult to understand and the regulations are scattered throughout the Zoning Code chapters, making it difficult for the public to identify applicable regulations; and

WHEREAS, the "law: of induced demand describes the phenomenon where increasing the supply of something, such as parking capacity, leads to an increase in

consumption or demand for that thing, often resulting in the original problem persisting or even worsening; and

WHEREAS, the level of residential parking required by the HMC was raised numerous times over the decades, but no easing of demand for street parking resulted; and

WHEREAS, a high level of residential parking required by the HMC is a known impediment to development of housing, making it more expensive to build, which contributes to the housing crisis currently seen state and nationwide; and

WHEREAS, studies on garage usage consistently show that a significant portion of homeowners utilize at least half of their garage for storage, workspace, as an accessory dwelling unit (ADU), or as an informal room addition; and

WHEREAS, the HMC's requirement that most parking be in a garage, while simultaneously imposing strict limitations on accessory structures such as sheds, implies a preference for sheltering cars over providing adequate storage space, room for people to enjoy hobbies, or other activities; and

WHEREAS, HMC section 17.58.010(E) states that additions or building alterations may be made to a dwelling, which does not conform to the current standards without requiring any additional garage, carport or parking space, provided that such additions and building alterations neither increase the number of families that can reside in such building nor occupy the only portion of the lot which can be used for garages, carports or parking spaces and access thereto...", demonstrating the HMC's requirements for parking to take precedent over human living space; and

WHEREAS, on November 5, 2025, the Planning Commission of the City of Hawthorne considered the zone text amendments and, after a duly noticed public hearing where all persons in support and in opposition were heard, adopted Resolution No. PC 2025-12 recommending approval of the ordinance to the City Council;

WHEREAS, on December 9, 2025, the City Council of the City of Hawthorne considered the zone text amendments and, after a duly noticed public hearing where all persons in support and in opposition were heard, introduced this ordinance.

NOW, THEREFORE, THE CITY COUNCIL OF THE CITY OF HAWTHORNE DOES ORDAIN AS FOLLOWS:

SECTION 1. The City Council of the City of Hawthorne hereby incorporates by reference all the recitals herein.

SECTION 2. Section 17.04.010 (Definitions) of Chapter 17.04 (Definitions) of Title 17 (Zoning) of the Hawthorne Municipal Code shall be amended by the addition of the following definitions in their appropriate alphabetical order. (new language is underlined and language to be removed shown in strikethrough):

"Development" means any property improvement or properties as a unit with ~~a common parking area that is contiguous to the development.~~ single or multiple owners. ~~A shopping center under a single or multiple ownership constitutes a development.~~

"Drive-thru" means a feature, ~~an establishment~~ which by design, physical facilities, ~~and/or~~ service procedures, ~~encourages or~~ permits customers to receive goods or services at a drive-up window or station and then leave the premises without exiting parking their vehicles.

"Driveway" means a privately-owned and ~~appropriately~~ paved surface or roadway which provides vehicular access from a street to parking areas ~~lots, garages,~~ or loading facilities and includes drive aisles within parking lots.

"Floor area" means the total gross floor space contained within the interior ~~exterior~~ walls of all buildings ~~on a lot or building site~~, except for the space therein devoted to ~~vents,~~ stairways, elevator shafts, light courts, and areas within the building devoted exclusively to loading and unloading facilities and parking of motor vehicles.

"Loading space" means an area ~~on-site space or berth~~ on the same lot or site with the buildings or use served, which serves as ~~such space to serve for the~~ temporary parking of a vehicle while loading or unloading merchandise, materials, or passengers.

"Mixed use" means a type of urban development that combines residential uses into a single development with commercial, retail, office, recreational, medical, or cultural uses.

~~Parking area, private. "Private parking area" means an open area other than a street, alley or other public property, limited to the parking of automobiles of occupants or employees of a dwelling, hotel, motel, apartment hotel, apartment house, boardinghouse, lodging house, commercial or industrial establishment to which these facilities are appurtenant.~~

Parking area, public. "Public parking area" means an open area other than a street or alley where the primary purpose of which is to provide parking for the general public, with or without a charge. ~~means an open area other than a street, alley or private parking area, which open area has as its primary purpose the providing of parking facilities for the general public, with or without a charge.~~ Parking facilities provided by a public agency shall be considered as being public parking areas.

"Parking space" means an area accessible to vehicles, which is provided, improved, maintained, and used for the ~~sole~~ purpose of accommodating a motor vehicle.

Parking space, stacked. "Stacked parking space" means two or more parking spaces arranged one above the other via mechanical lift or similar devices. Stacked parking spaces are a form of tandem parking.

Parking space, tandem. "Tandem parking space" means a parking space designed to accommodate two or more motor vehicles, one behind or above the other.

~~"Shopping centers" mean commercial multiple-tenant facilities where parking is not determined by the respective requirements of each individual tenant and the center is predominantly retail commercial use.~~

~~Shopping centers, strip. "Strip shopping centers" mean any developments with a site area of less than one hundred thousand square feet, which is to be improved with more than one retail store, shop, business, service or with the structure or structures located within eighteen feet of the rear lot line and/or side lot line, and with surface parking situated between the structure or structures and the street or rear property line.~~

"Use" means a land use, which can be a broad category such as residential, commercial, or industrial, or a specific type of land use such as multi-family residential, tire shop, or manufacturing facility.

SECTION 3. Section 17.38.050 (Parking, loading and stacking facilities for nonconforming uses and structures) of Chapter 17.38 (Nonconforming uses, structures, signs, and parcels) of Title 17 (Zoning) of the Hawthorne Municipal Code shall be deleted and replaced as follows:

§ 17.38.050 Nonconforming Parking.

- A. A use lawfully established, but which does not conform to the current off-street parking or loading requirements, may continue without providing such facilities.
- B. If an existing building is altered so that there is an increase in the number of bedrooms, dwelling units, or floor area, additional parking spaces shall be required only for the increased floor area, units, or bedrooms.

SECTION 4. Chapter 17.38 (Nonconforming uses, structures, signs, and parcels) of Title 17 (Zoning) of the Hawthorne Municipal Code shall be shall be renamed "Nonconformities".

SECTION 5. Section 17.40.030 (Required showings) of Chapter 17.40 (Conditional uses—variances) of Title 17 (Zoning) of the Hawthorne Municipal Code shall be deleted and replaced as follows:

§ 17.40.030 Required Showings.

Before any variance may be granted, all of the following showings shall be made:

- A. That there are special circumstances applicable to subject property such as shape, topography, location, or surroundings that do not apply generally to other properties or classes of use in the same vicinity and zone, or to the intended use within the limitations of the definition of a variance;
- B. That such variance is necessary for the preservation and enjoyment of a substantial property right or use possessed by other properties in the same vicinity and zone but which, because of special circumstances, is denied to the property in question;
- C. That the granting of such variance will not be materially detrimental to the public welfare or injurious to the property or improvements in the vicinity and zone in which the property is located;
- D. That the granting of a variance will not adversely affect the implementation of the General Plan.

SECTION 6. Chapter 17.56 (Loading areas) of Title 17 (Zoning) of the Hawthorne Municipal Code is deleted in its entirety.

SECTION 7. Chapter 17.58 (Off-street parking) of Title 17 (Zoning) of the Hawthorne Municipal Code is deleted and replaced as follows:

Chapter 17.58 ON-SITE PARKING

§ 17.58.010 General Requirements.

- A. Every new building or addition shall be provided with parking spaces as required in this chapter unless exempted by this chapter, state law, or when existing parking is nonconforming (see chapter on nonconformities).
 - 1. Prior to the issuance of a building permit for any new or enlarged building, or if a parking area is to be commonly used, a plan of the parking area shall be approved by the Director or their designee.
 - 2. The site plan for any building permit plan check must clearly indicate parking locations, space sizes, relationship to structures, curbs, driveways, lighting, landscaping, and other features of the parking area.
- B. The number of required spaces is based on following:
 - 1. Residential uses: bedroom count
 - 2. All other uses: gross floor area, which shall be calculated by measuring the total floor area from the inside surface of the walls of the building, subject to the following modifications:

- a. Elevators, stairways, escalators, and ramps are counted only on the lowest floor they serve;
 - b. Indoor parking and loading areas, including drive aisles, are excluded from the gross floor area calculation.
- C. If a use is changed so that more off-street parking spaces are required, only the difference between the new number of spaces required and the number of spaces required by the prior use (regardless of spaces actually provided) shall be required.
- D. When a commercial business desires to provide valet parking, tandem parking is permitted for the valet parking spaces.
- E. Employee parking. When a portion of parking for a commercial use is intended to be reserved for employees who work on the property, tandem or stacked parking are permitted for those spaces.
- F. Parking spaces required by this chapter shall be available and maintained for vehicular parking only, except where other uses are expressly permitted. Storage of boats, trailers, furniture, machinery, equipment, or any inoperable vehicle is prohibited in required parking spaces, excepting construction materials and equipment used during construction on the same development site.
- G. Parking Spaces Shall Not be Reduced. Any required off-street parking spaces shall not be reduced in number or size except as permitted in this chapter.
- H. Required parking may be converted to accessible parking spaces as required by state or federal law without the need to add new spaces to compensate for the loss of spaces due to loading areas and paths of travel.

§ 17.58.020 Required Parking.

Unless reduced or exempted by this chapter or applicable state law, off-street parking is required as follows:

- A. Applicable to all uses:
 - 1. Accessible parking is part of and is not in addition to the required parking.
 - 2. If the total number of parking spaces required by this chapter is other than a whole number, the number shall be rounded to the nearest whole number.

3. Required parking is to be provided within the same development site for which it serves, except as provided for in this chapter. Parking may be shared between separate legal properties under the following scenario:

a. All property used for such shared parking shall be either under the same ownership or secured by an agreement approved as to form by the City Attorney; and

b. The property on which additional parking is available has parking spaces in excess of the minimum number required by this chapter.

B. Residential uses in any zone:

1. Single-family residence (including manufactured homes): minimum two paved, covered or uncovered parking spaces (may be tandem).

2. Multi-family residential:

a. 0-1 bedrooms: 1 space per unit;

b. 2-3 bedrooms: 2 spaces per unit;

c. 4-5 bedrooms: 3 spaces per unit;

d. For each additional bedroom in excess of five: one additional space per bedroom.

3. Senior citizen housing project and transitional or emergency housing: 1 space per unit.

4. Affordable housing projects: follow multi-family standard unless alternative parking requirements are applicable due to state laws. Affordable housing projects may provide parking through tandem spaces without requiring a conditional use permit, provided that paired tandem spaces are assigned or leased to the same unit or tenant.

5. Guest parking: on developments of four units or more, in addition to the per unit parking requirements, one additional space for every four units is required for guest parking (on the same lot). Calculations of guest parking resulting in a fractional number are to be rounded to the nearest whole number. Guest parking spaces may not be located inside security fencing or behind gates.

6. For purposes of this section only, a bedroom is defined as being any room containing 60 square feet or more and is not a living room,

dining room, kitchen, or laundry area. Any combination of bedrooms and bathrooms, or any combination of rooms, so arranged that they can be converted into separate living quarters, may, at the discretion of the Director, or the Planning Commission in cases where a discretionary permit is required, be counted as multiple dwelling units for the purpose of calculating required parking.

C. Commercial and institutional uses in any zone, except those uses set forth below, require one parking space per 400 square feet of gross floor area.

1. Outdoor display retail.

a. Primary use requires outdoor display, and lot is less than 10,000 square feet: one space for each 1,000 square feet of gross lot area.

b. Primary use requires outdoor display and lot is 10,000 square feet or more (for example, automobile sales, plant nursery): one space for each 10,000 square feet of gross lot area.

c. Where a portion of a lot is occupied by structures, but the structures are accessory to the outdoor display retail, (for example, office on a vehicle sales lot), the required parking calculation is based on gross lot area only.

d. Where outdoor display is accessory to indoor display retail (for example, a home center with outdoor garden department): the outdoor display area shall require one space per 750 square feet added to required parking for the indoor area.

2. Places of assembly, including dancehalls, nightclubs, family entertainment centers, theaters, and places of worship: one space for every 100 square feet of gross assembly floor area. Assembly floor area does not include enclosed offices, restrooms, stages, kitchens, and other such spaces that are not accessible to the general public, but does include lobbies, mezzanines, and lofts.

3. Hotels: one space per guest room.

a. Amenities intended for guest use only, such as pools, exercise rooms, retail or service businesses with access only from inside the hotel, do not require additional parking.

b. Accessory uses, such as restaurants or bars that are open to both hotel guests and non-guests, shall provide additional parking at 50% of the parking required for general commercial uses.

c. Banquet halls, conference centers, and other amenities that serve assemblies of people not strictly limited to hotel guests, must provide additional parking for such areas at 50% of the parking required for assembly uses.

4. Adult Businesses: One space for every 200 square feet of gross floor area.

5. Major and minor automobile repair: one space with public access for each service bay, and 500 square feet of additional on-site vehicle storage for each service bay. Vehicle storage is not eligible for off-site parking or parking credits as described in this chapter.

D. Industrial uses in any zone require off-street parking as follows:

1. Industrial uses in any zone with at least 1,000 square feet of indoor floor area shall provide one parking space per 1,000 square feet of gross floor area.

2. Industrial uses that have outdoor staging or storage areas of 5,000 square feet or more shall provide one parking space per 5,000 square feet of the staging area in addition to the parking required for any indoor floor area.

E. Multiple Uses in the Same Development.

1. When two or more commercial, industrial, or institutional uses are located in the same development or within the same building, the total number of parking spaces required shall equal the sum of the requirements for the various uses computed separately, multiplied by a factor of 0.75.

2. Mixed-use developments that include residential shall apply the same process described above except only the non-residential parking is multiplied by a factor of 0.75 and the required residential parking is not adjusted. Guest parking for the residential portion, however, is permitted to jointly serve as commercial parking if situated within 250 feet of the commercial uses.

F. Uses that are not covered by the above categories require off-street parking as follows:

1. Schools, public and private:

a. Elementary and junior high: one space for each employee and each faculty member.

- b. Senior high: one space for each 10 students and one space for each employee and each faculty member. Where parochial schools and churches are on the same site, the required church parking facilities may be considered as contributing to the school parking requirements.
2. Live-work units: two parking spaces for each unit or one space for each 1,000 square gross square feet of combined residential and workshop space, whichever is greater. Surplus parking spaces, if any, may be used for outdoor recreation, container gardens, display of products made on the premises, and other uses that are well maintained and do not pose a hazard or nuisance to neighbors, other residents, pedestrians, or visitors.
3. Any use which cannot be classified by the Director as fitting into one of the above categories shall provide parking on the basis of a parking study prepared by a California licensed traffic or civil engineer and must be approved by the Planning Commission.

G. Alternative Non-residential Parking Requirement.

1. If the Director determines that the parking required by this chapter is not adequate for all the uses, taking into consideration off-peak needs, potential for customers to be counted more than once (such as hotel guests at an attached restaurant), and any other relevant factors, then a parking analysis may be commissioned to determine the required parking. In such a case, either the City Engineer or an outside engineer will conduct the analysis at the applicant's expense.
 - a. The analysis must be put before the Planning Commission to confirm the parking requirement for the development.
 - b. The Planning commission must consider any parking analysis presented to the body, but are not bound by its conclusions or the opinion of the Director as to what an appropriate parking requirement is for the specific circumstances.
2. If an applicant or property owner believes the City's parking requirement or a City-commissioned parking analysis for their development will result in an oversupply of parking, then an independent parking analysis may be submitted to the Planning Commission to determine the appropriate parking ratio required.
 - a. The developer may select a qualified traffic or civil engineer to prepare a parking analysis.
 - b. In cases where both the City and developer commission separate analyses, the question of an appropriate parking

requirement shall not be put to the Planning Commission until both studies are completed.

3. A Planning Commission determination pursuant to this section is only applicable to a specific development and must be in the form of a resolution.

§ 17.58.030 Parking Credits for Certain Commercial Uses.

Required on-site parking for commercial establishments in commercial zones may be reduced in the following circumstances as follows:

- A. Establishments with curbside parking on the same block and same side of street: reduce required on-site parking by 10%.
- B. Establishments on corner lots may qualify for on-site parking reduction pursuant to above for all street frontages within a commercial zone.
- C. Where there are center median parking spaces on Hawthorne Boulevard that are partially or wholly within a 100-foot radius of the subject commercial establishment, measured from property lines: reduce required on-site parking by 25%.
- D. Food serving establishments that have an approved drive-thru: reduce required on-site parking by 50%.
- E. The above reductions are to be added prior to being applied to a parking requirement rather than compounded. For example, if a commercial enterprise qualifies for a 25% and 50% reduction, the reduction shall be 75%.

§ 17.58.040 Required Loading and Drop-off Areas.

- A. In any commercial or industrial zone, the following uses shall provide at least one loading space of the type indicated below and minimum size described in Subsection C:
 1. Retail over 100,000 square feet in gross floor area: one large loading space;
 2. Supermarkets and grocery stores over 25,000 gross square feet: one large loading space, and one additional large loading space if over 50,000 gross square feet;
 3. Liquor stores: one small loading space;
 4. Restaurants with 50 or more seats: one large loading space;

5. Garden centers and retail or wholesale nurseries: one large loading space;
6. Furniture, large appliances, and other bulky item sales; two small loading spaces;
7. Warehouses: one small loading space;
8. Freight handling and transfer facility: one large loading space;
9. Schools, all elementary, middle, and high schools, public or private: one small loading space;
10. Cannabis retail businesses: one small loading space;
11. The Director may waive loading space or drop-off requirements for any commercial or industrial use which is immediately adjacent to a curbside loading or drop-off zone, provided that the curbside area meets the minimum length dimension for the type of loading space required in this chapter.

a. Loading and drop-off zones on the opposite side of the street may be considered by the Director to be adjacent if the path of travel from the curbside loading or pick-up zone to the intended entrance does not exceed 150 feet. This allowance does not apply to arterial streets

b. Path of travel shall be measured from the edge of the loading or drop-off zone to the nearest crosswalk, crossing the street, and to the appropriate entrance.

B. The Planning Commission may waive the loading space requirement on a case by case basis when presented evidence that a loading space is not needed. For example:

1. Uses which receive or ship bulk deliveries, but restrict deliveries and pick-ups to periods before or after being open to the public may use vehicle parking spaces as a loading area, if space allows.

2. Uses that do not regularly have visits by customers and have more parking spaces or the availability of a drive aisle on the site.

C. Loading space standards.

1. The minimum length dimension of loading spaces shall be as follows:

a. Large loading space at a loading dock: 40 feet;

- b. Small loading space at a loading dock: 30 feet;
 - c. Large loading space without loading dock: 45 feet;
 - d. Small loading space without loading dock: 35 feet.
- 2. Unused loading areas may be used for other purposes, such as vehicle parking, or employee break or recreation areas.
 - 3. All loading spaces must be included on site plans and demonstrate delivery truck maneuvering room to enter and exit the space.

D. Drop-off area.

- 1. The following uses must provide a drop-off area that is wholly contained on the property for the uses it serves:
 - a. Hotels and motels.
 - b. Schools.
 - c. Hospitals and urgent care facilities.
 - d. Any business which is determined by the Planning Commission to require a drop-off area.
- 2. The minimum dimensions of a drop-off area are 40 feet by 10 feet, if adjacent to the street curb and 40 feet by 8 feet if adjacent to a driveway or parking lot aisle.

§ 17.58.050 Development and Maintenance Standards.

A. The following design and improvement standards shall apply to all off-street parking spaces:

- 1. Construction, drainage, and grading of all parking areas shall be approved by the Building Official.
- 2. All parking areas shall be continuously maintained and repaired to prevent breakage, potholes, and vegetation growth in the paved areas.
- 3. All parking spaces shall have wheel stops not less than six inches high or bumper guards not more than three feet high installed in such a manner so as to prevent vehicle overhang onto adjoining property, walkways, and abutting parking spaces.

4. Except for access driveways, parking lots that abut alleys shall be separated therefrom with a suitable permanently installed barrier of concrete, subject to the approval of the Director.
5. Any lighting used to illuminate a public or private parking area shall be arranged so as to not shine the light on adjoining premises.

B. Residential Parking Standards.

1. If residential parking is in a garage or otherwise enclosed on at least three sides, it shall be equipped with doors where the parking spaces face any street.
2. Carports or porte cocheres may be built for any parking spaces outside of the front yard setback, provided:
 - a. The roof is constructed of the same or similar materials and design as the main house, and
 - b. That all roof drainage is directed away from property lines or provides rain gutters to prevent spillage on adjacent properties.
3. Garages in residential zones may be constructed to the side and rear property lines. Porte cocheres bay be no closer than 6 inches to a property line.

C. Commercial parking standards.

1. All parking spaces shall be double striped with three-inch wide stripes and an intervening space of six inches.
2. Only parking spaces that exceed the on-site parking requirement may be compact spaces.

D. Industrial and institutional parking standards.

1. Parking spaces may be single or double striped per commercial standard.
2. Not more than 30% of required parking spaces may be compact spaces.

E. Required parking, less any parking credits, shall be located on the same development or building site as the building they are required to serve, except as follows:

1. For assembly uses located in residential zones, parking facilities shall be located on site; for those located in any other zone, parking facilities shall be located not farther than 250 feet from the site.
2. For commercial and institutional uses where required parking cannot be accommodated on site, off-site parking may be provided as follows:
 - a. Within 300 feet;
 - b. Any off-site parking facility shall be made available for the use required to be served by means of either an irrevocable lease, covenant, easement, or grant deed and approved by the Director;
 - c. No building permit shall be issued for any building or structure where the required parking facilities are located off-site until a copy of the instrument tying the parking spaces to the use is filed with the Director.

F. Parking Stall Size. Each on-site parking space, required or otherwise, shall adhere to the following minimum dimensions based on type and proximity to obstructions:

<u>Type of Stall</u>	<u>Dimensions</u>	<u>Permitted Intrusion Zones</u>
<u>Standard</u>	<u>9' x 18'</u>	<u>12" x 36"</u>
<u>Compact*</u>	<u>7' 6" x 15'</u>	<u>12" x 24"</u>
<u>Parallel</u>	<u>10' x 22'</u>	<u>n/a</u>
<u>Stall abutting a wall</u>	<u>Add one foot to width on side abutting wall</u>	<u>12" x 36"</u>

* Not permitted in residential developments.

Figure 17.58-A
Parking Space Permitted Intrusion Zones

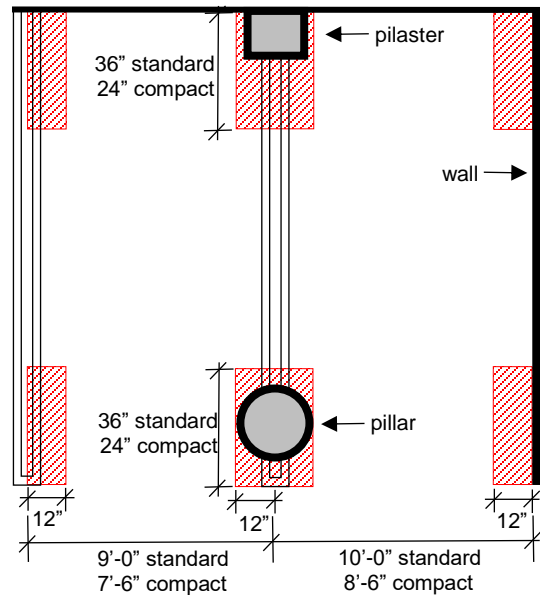

- G. Turning Radius. The minimum turning radius for parking stalls are 24 feet for standard spaces and 21 feet for compact spaces.

The turning radius for parking stalls is to be measured from the back of the parking space and may be reduced by one foot for every six inches of additional stall width, but shall not be reduced by more than three feet.

- H. Driveways and drive aisles.

1. Dimensions.

- a. All driveways and drive aisles in residential zones shall be not less than 10 feet wide, and two-way driveways and drive aisles shall be not less than 18 feet; provided, however, that fences, hose bibs, cleanouts, utilities meters, and similar obstructions may protrude up to six inches into driveways. On multifamily developments with 10 units or more, a two-way driveway shall be required.
- b. The width of a driveway shall be maintained for a vertical height of not less than 7.5 feet at any point.
- c. For a residential structure with an attached garage facing the street, driveway width may be up to 24 feet to permit pass-by parking within the front setback area, only if it can be shown that there is sufficient length to prevent vehicles overhanging

into the public right-of-way, and the curb apron width shall not exceed 18 feet.

- d. In all other zones, minimum width is 10 feet for one-way traffic and the maximum width is 30 feet. Drive aisles must accommodate the turning radius for parking stalls that abut the drive aisle as follows:

<u>Parking stall angle</u>	<u>Minimum Driveway Width (ft)</u>	
	<u>Standard</u>	<u>Compact</u>
<u>90°</u>	<u>24</u>	<u>21</u>
<u>60°</u>	<u>21</u>	<u>18</u>
<u>45°</u>	<u>17</u>	<u>15</u>
<u>30°</u>	<u>12</u>	<u>12</u>

2. Number.

- a. Parcels with 60 feet or less of street frontage shall have a maximum of one driveway.
- b. Parcels greater than 60 feet of street frontage may have up to two driveways.
- c. Corner lots may have driveways on both frontages, provided that two driveways on the same frontage are permitted only if that frontage is at least 61 feet.

3. Curb aprons. In no case shall curb aprons for driveways, including the sloped and transition areas, constitute more than 50% of the width of the parcel.

4. All driveways in C and M zones shall be located so that any vehicle exiting or entering the parking lot shall be clearly visible at a distance of not less than 10 feet to a pedestrian approaching on the sidewalk.

5. On residential parcels located adjacent to an alley, no driveway shall be permitted from the street except where two new on-site parking spaces are created and not more than one curb-side parking space is lost.

I. Landscaping of Parking Lots.

1. Perimeter landscaping. Except for driveways, all parking lots which front upon a street shall be enclosed as follows:

- a. A landscape buffer of five feet shall be built and maintained between a paved parking lot and the property line fronting a

street. The landscape buffer shall be continuously maintained and contain the following:

- i. Ground cover or shrubs planted so as to cover a minimum of 75% of the exposed ground;
- ii. One 36-inch box-sized tree for every 50 linear feet of parking lot frontage in clusters or proportionately spaced. Perimeter trees may be located away from the frontage with the approval of the Director, provided there is no reduction in the number or size of trees in the parking lot.
- iii. a minimum six-inch high and wide curb is provided on all sides, except that a two to four-foot high solid wall may be installed in lieu of the curb on the inside or outside edge of the landscape buffer, but not both. A wall may encroach into the planting area up to four inches to accommodate standard wall building materials;
- iv. an irrigation system compliant with the chapter on water efficient landscaping;
- v. Any portion of the landscape buffer not covered with plants, wall or curbs shall be covered with mulch or decorative stones.

Figure 17.58.B
Minimum Dimension and Contents of
Parking Lot Frontage Planters

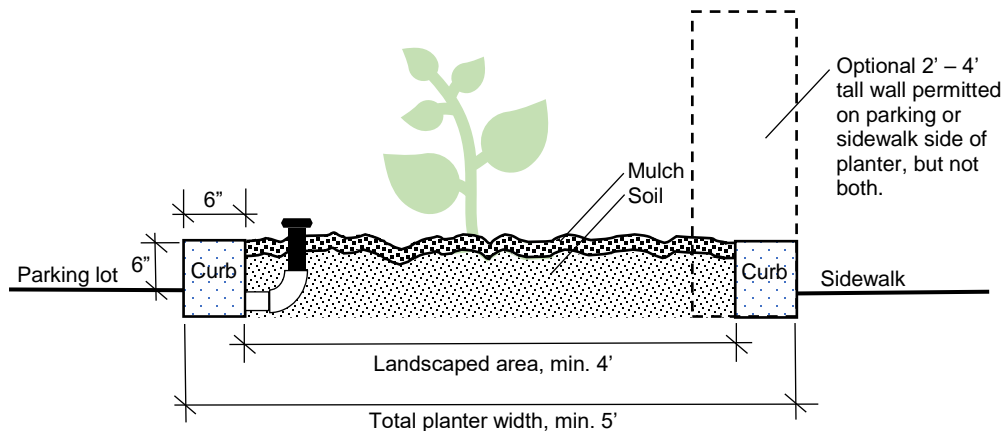

2. Parking lot interior landscaping.

- a. Any off-street parking lot which contains 10 or more parking spaces shall have not less than 10% of the parking area landscaped. Lots with nine or fewer parking spaces must be 5% landscaped.
- b. Landscaped areas required by this subsection shall be irrigated and continuously maintained.
- c. This 10% or 5% requirement does not include perimeter landscaping required above, it is in addition to the perimeter landscaping requirement.
- d. Any unused space resulting from the design of the parking lot should be used for planting purposes.
- e. Planting beds must be maintained throughout the parking area. Planting beds shall have a minimum width of three feet, excluding curbs and walls.
- f. Parking lot landscaping must conform to the standards and requirements of the chapter on water efficient landscaping.
- g. Any off-street parking lot, which contains 20 or more parking spaces, shall have not less than 1 tree per every 8 spaces and subject to the following:
 - i. Trees required by this section are in addition to those required on the lot perimeter, and shall be planted between parking spaces in "finger" or "diamond" planters and shall not be less than three feet in width and enclosed by six-inch wide curbs.
 - ii. Trees must be 24-inch box sized or larger at the time of planting on the site. Trees must be spaced across the lot but not necessarily uniformly.
 - iii. Planters must be irrigated and, in addition to trees, shall be covered with any combination of mulch, groundcover plants, shrubs, or other plant forms.
- h. All parking spaces with an adjacent drive aisle on its side or at the front of the space must be separated from the drive aisle with a finger planter as described in this section.

Figure 17.58.C
Minimum Dimension of Parking Lot Interior Landscape Planters

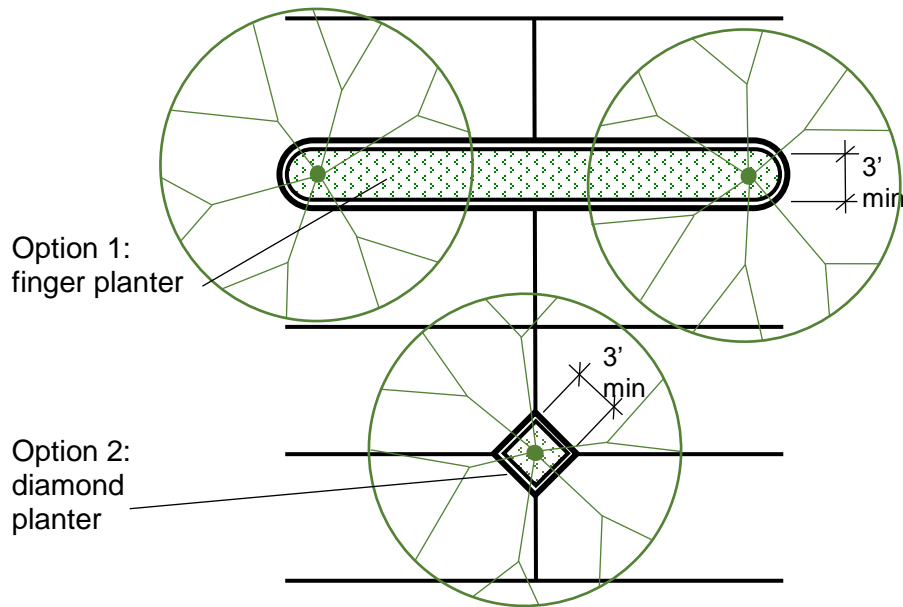

SECTION 8. Chapter 17.60 (Minimum driveway widths and turning radii) of Title 17 (Zoning) of the Hawthorne Municipal Code shall be deleted in its entirety.

SECTION 9. Any provisions of the City of Hawthorne Municipal Code or appendices that are inconsistent with any provisions of this Chapter, to the extent such inconsistencies are added, repealed or modified to affect the provisions of this Chapter, are hereby repealed or modified to the extent necessary to affect the provisions of this Chapter.

SECTION 10. CEQA. This zone text amendment endeavors to clarify portions of the zoning code that can be difficult to find and understand by those it seeks to regulate. This is determined not to be a project under CEQA (Pub. Resources Code, § 21065) and to the extent these changes result in a reduction in the available parking, any negative impact will be offset by reliance on alternate means of transportation and public parking availability.

SECTION 11. SEVERABILITY. If any section, subsection, phrase or clause of this ordinance is for any reason held to be unconstitutional or otherwise invalid, such decision shall not affect the validity of the remaining portions of this ordinance.

SECTION 12. CITY CLERK. The City Clerk shall attest to the adoption of this ordinance and shall cause this ordinance to be posted in the manner required by law.

SECTION 13. EFFECTIVE DATE. This ordinance shall take effect 30 days after passage thereof.

SECTION 14. PUBLICATION. The City Clerk is directed to forward a copy of this ordinance to General Code, LLC, 781 Elmgrove Road, Rochester, NY 14824.

PASSED, APPROVED AND ADOPTED this 13th day of January, 2026.

ALEX VARGAS, Mayor
City of Hawthorne, California

ATTEST:

DAYNA WILLIAMS-HUNTER, City Clerk
City of Hawthorne, California

APPROVED AS TO FORM

DAVID CACERES,
Interim City Attorney
City of Hawthorne, California