

# DRAFT AIA® Document A201™ - 1997

## General Conditions of the Contract for Construction

### for the following PROJECT:

(Name and location or address):

Construction of Sheriff's Office Substation in the areas of Precinct No. 1 and 3

### THE OWNER:

(Name and address):

County of Hidalgo  
100 E. Cano, 2nd Floor  
Edinburg, Texas 78539

### THE ARCHITECT:

(Name and address):

Gignac & Associates LLP  
416 Starr Street  
Corpus Christi, Texas 78401

### TABLE OF ARTICLES

- 1 GENERAL PROVISIONS
- 2 OWNER
- 3 CONTRACTOR
- 4 ADMINISTRATION OF THE CONTRACT
- 5 SUBCONTRACTORS
- 6 CONSTRUCTION BY OWNER OR BY SEPARATE CONTRACTORS
- 7 CHANGES IN THE WORK
- 8 TIME
- 9 PAYMENTS AND COMPLETION
- 10 PROTECTION OF PERSONS AND PROPERTY
- 11 INSURANCE AND BONDS
- 12 UNCOVERING AND CORRECTION OF WORK
- 13 MISCELLANEOUS PROVISIONS
- 14 TERMINATION OR SUSPENSION OF THE CONTRACT

**ADDITIONS AND DELETIONS:**  
The author of this document has added information needed for its completion. The author may also have revised the text of the original AIA standard form. An Additions and Deletions Report that notes added information as well as revisions to the standard form text is available from the author and should be reviewed.

This document has important legal consequences. Consultation with an attorney is encouraged with respect to its completion or modification.

This document has been approved and endorsed by The Associated General Contractors of America

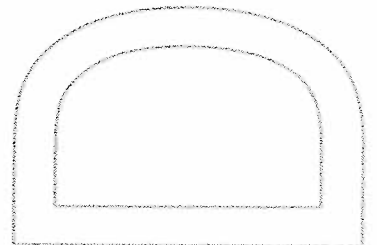

**ELECTRONIC COPYING** of any portion of this AIA® Document to another electronic file is prohibited and constitutes a violation of copyright laws as set forth in the footer of this document.

## INDEX

(Numbers and Topics in Bold are Section Headings)

### Acceptance of Nonconforming Work

9.6.6, 9.9.3, **12.3**

Acceptance of Work

9.6.6, 9.8.2, 9.9.3, 9.10.1, 9.10.3, **12.3**

### Access to Work

**3.16, 6.2.1, 12.1**

Accident Prevention

4.2.3, 10

Acts and Omissions

3.2, 3.3.2, 3.12.8, 3.18, 4.2.3, 4.3.8, 4.4.1, 8.3.1, 9.5.1, 10.2.5, 13.4.2, 13.7, 14.1

Addenda

1.1.1, 3.11

Additional Costs, Claims for

4.3.4, 4.3.5, 4.3.6, 6.1.1, 10.3

Additional Inspections and Testing

9.8.3, 12.2.1, 13.5

Additional Time, Claims for

4.3.4, 4.3.7, 8.3.2

## ADMINISTRATION OF THE CONTRACT

3.1.3, **4, 9.4, 9.5**

Advertisement or Invitation to Bid

1.1.1

Aesthetic Effect

4.2.13, 4.5.1

### Allowances

**3.8**

All-risk Insurance

11.4.1.1

### Applications for Payment

4.2.5, 7.3.8, 9.2, **9.3, 9.4, 9.5.1, 9.6.3, 9.7.1, 9.8.5, 9.10, 11.1.3, 14.2.4, 14.4.3**

Approvals

2.4, 3.1.3, 3.5, 3.10.2, 3.12, 4.2.7, 9.3.2, 13.4.2, 13.5

### Arbitration

4.3.3, 4.4, 4.5.1, 4.5.2, **4.6, 8.3.1, 9.7.1, 11.4.9, 11.4.10**

### Architect

**4.1**

Architect, Definition of

4.1.1

Architect, Extent of Authority

2.4, 3.12.7, 4.2, 4.3.6, 4.4, 5.2, 6.3, 7.1.2, 7.3.6, 7.4, 9.2, 9.3.1, 9.4, 9.5, 9.8.3, 9.10.1, 9.10.3, 12.1, 12.2.1, 13.5.1, 13.5.2, 14.2.2, 14.2.4

Architect, Limitations of Authority and Responsibility

2.1.1, 3.3.3, 3.12.4, 3.12.8, 3.12.10, 4.1.2, 4.2.1, 4.2.2, 4.2.3, 4.2.6, 4.2.7, 4.2.10, 4.2.12, 4.2.13, 4.4, 5.2.1, 7.4, 9.4.2, 9.6.4, 9.6.6

Architect's Additional Services and Expenses

2.4, 11.4.1.1, 12.2.1, 13.5.2, 13.5.3, 14.2.4

### Architect's Administration of the Contract

3.1.3, **4.2, 4.3.4, 4.4, 9.4, 9.5**

Architect's Approvals

2.4, 3.1.3, 3.5.1, 3.10.2, 4.2.7

Architect's Authority to Reject Work

3.5.1, 4.2.6, 12.1.2, 12.2.1

Architect's Copyright

1.6

Architect's Decisions

4.2.6, 4.2.7, 4.2.11, 4.2.12, 4.2.13, 4.3.4, 4.4.1, 4.4.5, 4.4.6, 4.5, 6.3, 7.3.6, 7.3.8, 8.1.3, 8.3.1, 9.2, 9.4, 9.5.1, 9.8.4, 9.9.1, 13.5.2, 14.2.2, 14.2.4

Architect's Inspections

4.2.2, 4.2.9, 4.3.4, 9.4.2, 9.8.3, 9.9.2, 9.10.1, 13.5

Architect's Instructions

3.2.3, 3.3.1, 4.2.6, 4.2.7, 4.2.8, 7.4.1, 12.1, 13.5.2

Architect's Interpretations

4.2.11, 4.2.12, 4.3.6

Architect's Project Representative

4.2.10

Architect's Relationship with Contractor

1.1.2, 1.6, 3.1.3, 3.2.1, 3.2.2, 3.2.3, 3.3.1, 3.4.2, 3.5.1, 3.7.3, 3.10, 3.11, 3.12, 3.16, 3.18, 4.1.2, 4.1.3, 4.2, 4.3.4, 4.4.1, 4.4.7, 5.2, 6.2.2, 7, 8.3.1, 9.2, 9.3, 9.4, 9.5, 9.7, 9.8, 9.9, 10.2.6, 10.3, 11.3, 11.4.7, 12, 13.4.2, 13.5

Architect's Relationship with Subcontractors

1.1.2, 4.2.3, 4.2.4, 4.2.6, 9.6.3, 9.6.4, 11.4.7

Architect's Representations

9.4.2, 9.5.1, 9.10.1

Architect's Site Visits

4.2.2, 4.2.5, 4.2.9, 4.3.4, 9.4.2, 9.5.1, 9.9.2, 9.10.1, 13.5

Asbestos

10.3.1

Attorneys' Fees

3.18.1, 9.10.2, 10.3.3

Award of Separate Contracts

6.1.1, 6.1.2

### Award of Subcontracts and Other Contracts for Portions of the Work

**5.2**

### Basic Definitions

**1.1**

Bidding Requirements

1.1.1, 1.1.7, 5.2.1, 11.5.1

### Boiler and Machinery Insurance

11.4.2

Bonds, Lien

9.10.2

Bonds, Performance, and Payment

7.3.6.4, 9.6.7, 9.10.3, 11.4.9, 11.5

Building Permit

3.7.1

### Capitalization

**1.3**

Certificate of Substantial Completion

9.8.3, 9.8.4, 9.8.5

**Certificates for Payment**

4.2.5, 4.2.9, 9.3.3, 9.4, 9.5, 9.6.1, 9.6.6, 9.7.1, 9.10.1, 9.10.3, 13.7, 14.1.1.3, 14.2.4

Certificates of Inspection, Testing or Approval  
13.5.4

Certificates of Insurance

9.10.2, 11.1.3

**Change Orders**

1.1.1, 2.4.1, 3.4.2, 3.8.2.3, 3.11.1, 3.12.8, 4.2.8, 4.3.4, 4.3.9, 5.2.3, 7.1, 7.2, 7.3, 8.3.1, 9.3.1.1, 9.10.3, 11.4.1.2, 11.4.4, 11.4.9, 12.1.2

Change Orders, Definition of  
7.2.1

**CHANGES IN THE WORK**

3.11, 4.2.8, 7, 8.3.1, 9.3.1.1, 11.4.9

Claim, Definition of

4.3.1

**Claims and Disputes**

3.2.3, 4.3, 4.4, 4.5, 4.6, 6.1.1, 6.3, 7.3.8, 9.3.3, 9.10.4, 10.3.3

Claims and Timely Assertion of Claims

4.6.5

**Claims for Additional Cost**

3.2.3, 4.3.4, 4.3.5, 4.3.6, 6.1.1, 7.3.8, 10.3.2

**Claims for Additional Time**

3.2.3, 4.3.4, 4.3.7, 6.1.1, 8.3.2, 10.3.2

**Claims for Concealed or Unknown Conditions**

4.3.4

Claims for Damages

3.2.3, 3.18, 4.3.10, 6.1.1, 8.3.3, 9.5.1, 9.6.7, 10.3.3, 11.1.1, 11.4.5, 11.4.7, 14.1.3, 14.2.4

Claims Subject to Arbitration

4.4.1, 4.5.1, 4.6.1

**Cleaning Up**

3.15, 6.3

**Commencement of Statutory Limitation Period**

13.7

Commencement of the Work, Conditions Relating to

2.2.1, 3.2.1, 3.4.1, 3.7.1, 3.10.1, 3.12.6, 4.3.5, 5.2.1, 5.2.3, 6.2.2, 8.1.2, 8.2.2, 8.3.1, 11.1, 11.4.1, 11.4.6, 11.5.1

Commencement of the Work, Definition of  
8.1.2

**Communications Facilitating Contract**

**Administration**

3.9.1, 4.2.4

Completion, Conditions Relating to

1.6.1, 3.4.1, 3.11, 3.15, 4.2.2, 4.2.9, 8.2, 9.4.2, 9.8, 9.9.1, 9.10, 12.2, 13.7, 14.1.2

**COMPLETION, PAYMENTS AND**

**9**

Completion, Substantial

4.2.9, 8.1.1, 8.1.3, 8.2.3, 9.4.2, 9.8, 9.9.1, 9.10.3, 9.10.4.2, 12.2, 13.7

Compliance with Laws

1.6.1, 3.2.2, 3.6, 3.7, 3.12.10, 3.13, 4.1.1, 4.4.8, 4.6.4, 4.6.6, 9.6.4, 10.2.2, 11.1, 11.4, 13.1, 13.4, 13.5.1, 13.5.2, 13.6, 14.1.1, 14.2.1.3

Concealed or Unknown Conditions

4.3.4, 8.3.1, 10.3

Conditions of the Contract

1.1.1, 1.1.7, 6.1.1, 6.1.4

Consent, Written

1.6, 3.4.2, 3.12.8, 3.14.2, 4.1.2, 4.3.4, 4.6.4, 9.3.2, 9.8.5, 9.9.1, 9.10.2, 9.10.3, 11.4.1, 13.2, 13.4.2

**CONSTRUCTION BY OWNER OR BY SEPARATE CONTRACTORS**

1.1.4, 6

Construction Change Directive, Definition of  
7.3.1

**Construction Change Directives**

1.1.1, 3.12.8, 4.2.8, 4.3.9, 7.1, 7.3, 9.3.1.1

Construction Schedules, Contractor's

1.4.1.2, 3.10, 3.12.1, 3.12.2, 4.3.7.2, 6.1.3

**Contingent Assignment of Subcontracts**

5.4, 14.2.2.2

**Continuing Contract Performance**

4.3.3

Contract, Definition of

1.1.2

**CONTRACT, TERMINATION OR**

**SUSPENSION OF THE**

5.4.1.1, 11.4.9, 14

Contract Administration

3.1.3, 4, 9.4, 9.5

Contract Award and Execution, Conditions Relating to

3.7.1, 3.10, 5.2, 6.1, 11.1.3, 11.4.6, 11.5.1

**Contract Documents, The**

1.1, 1.2

Contract Documents, Copies Furnished and Use of

1.6, 2.2.5, 5.3

Contract Documents, Definition of

1.1.1

**Contract Sum**

3.8, 4.3.4, 4.3.5, 4.4.5, 5.2.3, 7.2, 7.3, 7.4, 9.1, 9.4.2, 9.5.1.4, 9.6.7, 9.7, 10.3.2, 11.4.1, 14.2.4, 14.3.2

Contract Sum, Definition of

9.1

Contract Time

4.3.4, 4.3.7, 4.4.5, 5.2.3, 7.2.1.3, 7.3, 7.4, 8.1.1, 8.2, 8.3.1, 9.5.1, 9.7, 10.3.2, 12.1.1, 14.3.2

Contract Time, Definition of

8.1.1

**CONTRACTOR**

3

Contractor, Definition of

3.1, 6.1.2

**Contractor's Construction Schedules**

1.4.1.2, 3.10, 3.12.1, 3.12.2, 4.3.7.2, 6.1.3

Contractor's Employees

3.3.2, 3.4.3, 3.8.1, 3.9, 3.18.2, 4.2.3, 4.2.6, 10.2, 10.3, 11.1.1, 11.4.7, 14.1, 14.2.1.1,

### **Contractor's Liability Insurance**

#### **11.1**

Contractor's Relationship with Separate Contractors and Owner's Forces

3.12.5, 3.14.2, 4.2.4, 6, 11.4.7, 12.1.2, 12.2.4

Contractor's Relationship with Subcontractors

1.2.2, 3.3.2, 3.18.1, 3.18.2, 5, 9.6.2, 9.6.7, 9.10.2, 11.4.1.2, 11.4.7, 11.4.8

Contractor's Relationship with the Architect

1.1.2, 1.6, 3.1.3, 3.2.1, 3.2.2, 3.2.3, 3.3.1, 3.4.2, 3.5.1, 3.7.3, 3.10, 3.11, 3.12, 3.16, 3.18, 4.1.2, 4.1.3, 4.2, 4.3.4, 4.4.1, 4.4.7, 5.2, 6.2.2, 7, 8.3.1, 9.2, 9.3, 9.4, 9.5, 9.7, 9.8, 9.9, 10.2.6, 10.3, 11.3, 11.4.7, 12, 13.4.2, 13.5

Contractor's Representations

1.5.2, 3.5.1, 3.12.6, 6.2.2, 8.2.1, 9.3.3, 9.8.2

Contractor's Responsibility for Those Performing the Work

3.3.2, 3.18, 4.2.3, 4.3.8, 5.3.1, 6.1.3, 6.2, 6.3, 9.5.1, 10

Contractor's Review of Contract Documents

1.5.2, 3.2, 3.7.3

Contractor's Right to Stop the Work

9.7

Contractor's Right to Terminate the Contract

4.3.10, 14.1

Contractor's Submittals

3.10, 3.11, 3.12, 4.2.7, 5.2.1, 5.2.3, 7.3.6, 9.2, 9.3, 9.8.2, 9.8.3, 9.9.1, 9.10.2, 9.10.3, 11.1.3, 11.5.2

Contractor's Superintendent

3.9, 10.2.6

Contractor's Supervision and Construction

Procedures

1.2.2, 3.3, 3.4, 3.12.10, 4.2.2, 4.2.7, 4.3.3, 6.1.3, 6.2.4, 7.1.3, 7.3.4, 7.3.6, 8.2, 10, 12, 14

Contractual Liability Insurance

11.1.1.8, 11.2, 11.3

Coordination and Correlation

1.2, 1.5.2, 3.3.1, 3.10, 3.12.6, 6.1.3, 6.2.1

Copies Furnished of Drawings and Specifications

1.6, 2.2.5, 3.11

Copyrights

1.6, 3.17

Correction of Work

2.3, 2.4, 3.7.4, 4.2.1, 9.4.2, 9.8.2, 9.8.3, 9.9.1, 12.1.2, 12.2, 13.7.1.3

**Correlation and Intent of the Contract Documents**

#### **1.2**

Cost, Definition of

7.3.6

Costs

2.4, 3.2.3, 3.7.4, 3.8.2, 3.15.2, 4.3, 5.4.2, 6.1.1, 6.2.3, 7.3.3.3, 7.3.6, 7.3.7, 7.3.8, 9.10.2, 10.3.2, 10.5, 11.3, 11.4, 12.1, 12.2.1, 12.2.4, 13.5, 14

**Cutting and Patching**

6.2.5, **3.14**

Damage to Construction of Owner or Separate Contractors

3.14.2, 6.2.4, 9.2.1.5, 10.2.1.2, 10.2.5, 10.6, 11.1, 11.4, 12.2.4

Damage to the Work

3.14.2, 9.9.1, 10.2.1.2, 10.2.5, 10.6, 11.4, 12.2.4

Damages, Claims for

3.2.3, 3.18, 4.3.10, 6.1.1, 8.3.3, 9.5.1, 9.6.7, 10.3.3, 11.1.1, 11.4.5, 11.4.7, 14.1.3, 14.2.4

Damages for Delay

6.1.1, 8.3.3, 9.5.1.6, 9.7, 10.3.2

Date of Commencement of the Work, Definition of

8.1.2

Date of Substantial Completion, Definition of

8.1.3

Day, Definition of

8.1.4

Decisions of the Architect

4.2.6, 4.2.7, 4.2.11, 4.2.12, 4.2.13, 4.3.4, 4.4.1, 4.4.5, 4.4.6, 4.5, 6.3, 7.3.6, 7.3.8, 8.1.3, 8.3.1, 9.2, 9.4, 9.5.1, 9.8.4, 9.9.1, 13.5.2, 14.2.2, 14.2.4

**Decisions to Withhold Certification**

9.4.1, **9.5**, 9.7, 14.1.1.3

Defective or Nonconforming Work, Acceptance, Rejection and Correction of

2.3, 2.4, 3.5.1, 4.2.6, 6.2.5, 9.5.1, 9.5.2, **9.6.6**, 9.8.2, 9.9.3, 9.10.4, 12.2.1, 13.7.1.3

Defective Work, Definition of

3.5.1

Definitions

1.1, 2.1.1, 3.1, 3.5.1, 3.12.1, 3.12.2, 3.12.3, 4.1.1, 4.3.1, 5.1, 6.1.2, 7.2.1, 7.3.1, 7.3.6, 8.1, 9.1, **9.8.1**

**Delays and Extensions of Time**

3.2.3, 4.3.1, 4.3.4, 4.3.7, 4.4.5, 5.2.3, 7.2.1, 7.3.1, 7.4.1, **8.3**, 9.5.1, 9.7.1, 10.3.2, **10.6.1**, 14.3.2

Disputes

4.1.4, 4.3, 4.4, 4.5, 4.6, 6.3, 7.3.8

**Documents and Samples at the Site**

#### **3.11**

Drawings, Definition of

1.1.5

Drawings and Specifications, Use and Ownership of

1.1.1, 1.3, 2.2.5, 3.11, 5.3

Effective Date of Insurance

8.2.2, 11.1.2

**Emergencies**

4.3.5, **10.6**, 14.1.1.2

Employees, Contractor's

3.3.2, 3.4.3, 3.8.1, 3.9, 3.18.2, 4.2.3, 4.2.6, 10.2, 10.3, 11.1.1, 11.4.7, 14.1, 14.2.1.1

Equipment, Labor, Materials and

1.1.3, 1.1.6, 3.4, 3.5.1, 3.8.2, 3.8.3, 3.12, 3.13, 3.15.1, 4.2.6, 4.2.7, 5.2.1, 6.2.1, 7.3.6, 9.3.2, 9.3.3, 9.5.1.3, 9.10.2, 10.2.1, 10.2.4, 14.2.1.2

Execution and Progress of the Work

1.1.3, 1.2.1, 1.2.2, 2.2.3, 2.2.5, 3.1, 3.3, 3.4, 3.5, 3.7, 3.10, 3.12, 3.14, 4.2.2, 4.2.3, 4.3.3, 6.2.2, 7.1.3, 7.3.4, 8.2, 9.5, 9.9.1, 10.2, 10.3, 12.2, 14.2, 14.3

**Extensions of Time**

3.2.3, 4.3.1, 4.3.4, 4.3.7, 4.4.5, 5.2.3, 7.2.1, 7.3, 7.4.1, 9.5.1, 9.7.1, 10.3.2, 10.6.1, 14.3.2

**Failure of Payment**

4.3.6, 9.5.1.3, 9.7, 9.10.2, 14.1.1.3, 14.2.1.2, 13.6

**Faulty Work**

(See Defective or Nonconforming Work)

**Final Completion and Final Payment**

4.2.1, 4.2.9, 4.3.2, 9.8.2, 9.10, 11.1.2, 11.1.3, 11.4.1, 11.4.5, 12.3.1, 13.7, 14.2.4, 14.4.3

**Financial Arrangements, Owner's**

2.2.1, 13.2.2, 14.1.1.5

**Fire and Extended Coverage Insurance**

11.4

**GENERAL PROVISIONS**

**1**

**Governing Law**

**13.1**

Guarantees (See Warranty)

**Hazardous Materials**

10.2.4, 10.3, 10.5

**Identification of Contract Documents**

1.5.1

**Identification of Subcontractors and Suppliers**

5.2.1

**Indemnification**

3.17, 3.18, 9.10.2, 10.3.3, 10.5, 11.4.1.2, 11.4.7

**Information and Services Required of the Owner**

2.1.2, 2.2, 3.2.1, 3.12.4, 3.12.10, 4.2.7, 4.3.3, 6.1.3, 6.1.4, 6.2.5, 9.3.2, 9.6.1, 9.6.4, 9.9.2, 9.10.3, 10.3.3, 11.2, 11.4, 13.5.1, 13.5.2, 14.1.1.4, 14.1.4

**Injury or Damage to Person or Property**

4.3.8, 10.2, 10.6

**Inspections**

3.1.3, 3.3.3, 3.7.1, 4.2.2, 4.2.6, 4.2.9, 9.4.2, 9.8.2, 9.8.3, 9.9.2, 9.10.1, 12.2.1, 13.5

**Instructions to Bidders**

1.1.1

**Instructions to the Contractor**

3.2.3, 3.3.1, 3.8.1, 4.2.8, 5.2.1, 7, 12, 8.2.2, 13.5.2

**Insurance**

3.18.1, 6.1.1, 7.3.6, 8.2.1, 9.3.2, 9.8.4, 9.9.1, 9.10.2, 9.10.5, 11

**Insurance, Boiler and Machinery**

11.4.2

**Insurance, Contractor's Liability**

11.1

**Insurance, Effective Date of**

8.2.2, 11.1.2

**Insurance, Loss of Use**

11.4.3

**Insurance, Owner's Liability**

11.2

**Insurance, Project Management Protective Liability**

11.3

**Insurance, Property**

10.2.5, 11.4

**Insurance, Stored Materials**

9.3.2, 11.4.1.4

**INSURANCE AND BONDS**

**11**

Insurance Companies, Consent to Partial Occupancy

9.9.1, 11.4.1.5

Insurance Companies, Settlement with

11.4.10

Intent of the Contract Documents

1.2.1, 4.2.7, 4.2.12, 4.2.13, 7.4

**Interest**

13.6

**Interpretation**

1.2.3, 1.4, 4.1.1, 4.3.1, 5.1, 6.1.2, 8.1.4

Interpretations, Written

4.2.11, 4.2.12, 4.3.6

Joinder and Consolidation of Claims Required

4.6.4

**Judgment on Final Award**

4.6.6

**Labor and Materials, Equipment**

1.1.3, 1.1.6, 3.4, 3.5.1, 3.8.2, 3.8.3, 3.12, 3.13, 3.15.1,

42.6, 4.2.7, 5.2.1, 6.2.1, 7.3.6, 9.3.2, 9.3.3, 9.5.1.3,

9.10.2, 10.2.1, 10.2.4, 14.2.1.2

Labor Disputes

8.3.1

Laws and Regulations

1.6, 3.2.2, 3.6, 3.7, 3.12.10, 3.13, 4.1.1, 4.4.8, 4.6,

9.6.4, 9.9.1, 10.2.2, 11.1, 11.4, 13.1, 13.4, 13.5.1,

13.5.2, 13.6, 14

Liens

2.1.2, 4.4.8, 8.2.2, 9.3.3, 9.10

**Limitation on Consolidation or Joinder**

4.6.4

Limitations, Statutes of

4.6.3, 12.2.6, 13.7

Limitations of Liability

2.3, 3.2.1, 3.5.1, 3.7.3, 3.12.8, 3.12.10, 3.17, 3.18,

4.2.6, 4.2.7, 4.2.12, 6.2.2, 9.4.2, 9.6.4, 9.6.7, 9.10.4,

10.3.3, 10.2.5, 11.1.2, 11.2.1, 11.4.7, 12.2.5, 13.4.2

Limitations of Time

2.1.2, 2.2, 2.4, 3.2.1, 3.7.3, 3.10, 3.11, 3.12.5, 3.15.1,

4.2.7, 4.3, 4.4, 4.5, 4.6, 5.2, 5.3, 5.4, 6.2.4, 7.3, 7.4,

8.2, 9.2, 9.3.1, 9.3.3, 9.4.1, 9.5, 9.6, 9.7, 9.8, 9.9,

9.10, 11.1.3, 11.4.1.5, 11.4.6, 11.4.10, 12.2, 13.5,

13.7, 14

**Loss of Use Insurance**

11.4.3

Material Suppliers

1.6, 3.12.1, 4.2.4, 4.2.6, 5.2.1, 9.3, 9.4.2, 9.6, 9.10.5

Materials, Hazardous

10.2.4, 10.3, 10.5

Materials, Labor, Equipment and  
 1.1.3, 1.1.6, 1.6.1, 3.4, 3.5.1, 3.8.2, 3.8.23, 3.12, 3.13,  
 3.15.1, 4.2.6, 4.2.7, 5.2.1, 6.2.1, 7.3.6, 9.3.2, 9.3.3,  
 9.5.1.3, 9.10.2, 10.2.1, 10.2.4, 14.2.1.2  
 Means, Methods, Techniques, Sequences and  
 Procedures of Construction  
 3.3.1, 3.12.10, 4.2.2, 4.2.7, 9.4.2  
 Mechanic's Lien  
 4.4.8  
**Mediation**  
 4.4.1, 4.4.5, 4.4.6, 4.4.8, 4.5, 4.6.1, 4.6.2, 8.3.1, 10.5  
**Minor Changes in the Work**  
 1.1.1, 3.12.8, 4.2.8, 4.3.6, 7.1, 7.4  
**MISCELLANEOUS PROVISIONS**  
**13**  
 Modifications, Definition of  
 1.1.1  
 Modifications to the Contract  
 1.1.1, 1.1.2, 3.7.3, 3.11, 4.1.2, 4.2.1, 5.2.3, 7, 8.3.1,  
 9.7, 10.3.2, 11.4.1  
**Mutual Responsibility**  
**6.2**  
**Nonconforming Work, Acceptance of**  
 9.6.6, 9.9.3, 12.3  
 Nonconforming Work, Rejection and Correction of  
 2.3, 2.4, 3.5.1, 4.2.6, 6.2.5, 9.5.1, 9.8.2, 9.9.3, 9.10.4,  
 12.2.1, 13.7.1.3  
 Notice  
 2.2.1, 2.3, 2.4, 3.2.3, 3.3.1, 3.7.2, 3.7.4, 3.12.9, 4.3,  
 4.4.8, 4.6.5, 5.2.1, 8.2.2, 9.7, 9.10, 10.2.2, 11.1.3,  
 11.4.6, 12.2.2, 12.2.4, 13.3, 13.5.1, 13.5.2, 14.1, 14.2  
**Notice, Written**  
 2.3, 2.4, 3.3.1, 3.9, 3.12.9, 3.12.10, 4.3, 4.4.8, 4.6.5,  
 5.2.1, 8.2.2, 9.7, 9.10, 10.2.2, 10.3, 11.1.3, 11.4.6,  
 12.2.2, 12.2.4, 13.3, 14  
 Notice of Testing and Inspections  
 13.5.1, 13.5.2  
 Notice to Proceed  
 8.2.2  
**Notices, Permits, Fees and**  
 2.2.2, 3.7, 3.13, 7.3.6.4, 10.2.2  
 Observations, Contractor's  
 1.5.2, 3.2, 3.7.3, 4.3.4  
 Occupancy  
 2.2.2, 9.6.6, 9.8, 11.4.1.5  
 Orders, Written  
 1.1.1, 2.3, 3.9, 4.3.6, 7, 8.2.2, 11.4.9, 12.1, 12.2,  
 13.5.2, 14.3.1  
**OWNER**  
**2**  
 Owner, Definition of  
 2.1  
**Owner, Information and Services Required of the**  
 2.1.2, 2.2, 3.2.1, 3.12.4, 3.12.10, 4.2.7, 4.3.3, 6.1.3,  
 6.1.4, 6.2.5, 9.3.2, 9.6.1, 9.6.4, 9.9.2, 9.10.3, 10.3.3,  
 11.2, 11.4, 13.5.1, 13.5.2, 14.1.1.4, 14.1.4  
 Owner's Authority

1.6, 2.1.1, 2.3, 2.4, 3.4.2, 3.8.1, 3.12.10, 3.14.2, 4.1.2,  
 4.1.3, 4.2.4, 4.2.9, 4.3.6, 4.4.7, 5.2.1, 5.2.4, 5.4.1,  
 6.1, 6.3, 7.2.1, 7.3.1, 8.2.2, 8.3.1, 9.3.1, 9.3.2, 9.5.1,  
 9.9.1, 9.10.2, 10.3.2, 11.1.3, 11.3.1, 11.4.3, 11.4.10,  
 12.2.2, 12.3.1, 13.2.2, 14.3, 14.4  
 Owner's Financial Capability  
 2.2.1, 13.2.2, 14.1.1.5  
**Owner's Liability Insurance**  
**11.2**  
 Owner's Loss of Use Insurance  
 11.4.3  
 Owner's Relationship with Subcontractors  
 1.1.2, 5.2, 5.3, 5.4, 9.6.4, 9.10.2, 14.2.2  
**Owner's Right to Carry Out the Work**  
 2.4, 12.2.4, 14.2.2.2  
**Owner's Right to Clean Up**  
 6.3  
**Owner's Right to Perform Construction and to**  
**Award Separate Contracts**  
 6.1  
**Owner's Right to Stop the Work**  
 2.3  
 Owner's Right to Suspend the Work  
 14.3  
 Owner's Right to Terminate the Contract  
 14.2  
**Ownership and Use of Drawings, Specifications**  
**and Other Instruments of Service**  
 1.1.1, 1.6, 2.2.5, 3.2.1, 3.11.1, 3.17.1, 4.2.12, 5.3  
**Partial Occupancy or Use**  
 9.6.6, 9.9, 11.4.1.5  
**Patching, Cutting and**  
**3.14, 6.2.5**  
 Patents  
 3.17  
**Payment, Applications for**  
 4.2.5, 7.3.8, 9.2, 9.3, 9.4, 9.5.1, 9.6.3, 9.7.1, 9.8.5,  
 9.10.1, 9.10.3, 9.10.5, 11.1.3, 14.2.4, 14.4.3  
**Payment, Certificates for**  
 4.2.5, 4.2.9, 9.3.3, 9.4, 9.5, 9.6.1, 9.6.6, 9.7.1, 9.10.1,  
 9.10.3, 13.7, 14.1.1.3, 14.2.4  
**Payment, Failure of**  
 4.3.6, 9.5.1.3, 9.7, 9.10.2, 14.1.1.3, 14.2.1.2, 13.6  
 Payment, Final  
 4.2.1, 4.2.9, 4.3.2, 9.8.2, 9.10, 11.1.2, 11.1.3, 11.4.1,  
 11.4.5, 12.3.1, 13.7, 14.2.4, 14.4.3  
**Payment Bond, Performance Bond and**  
 7.3.6.4, 9.6.7, 9.10.3, 11.4.9, 11.5  
 Payments, Progress  
 4.3.3, 9.3, 9.6, 9.8.5, 9.10.3, 13.6, 14.2.3  
**PAYMENTS AND COMPLETION**  
**9**  
 Payments to Subcontractors  
 5.4.2, 9.5.1.3, 9.6.2, 9.6.3, 9.6.4, 9.6.7, 11.4.8,  
 14.2.1.2  
 PCB  
 10.3.1

**Performance Bond and Payment Bond**

7.3.6.4, 9.6.7, 9.10.3, 11.4.9, 11.5

**Permits, Fees and Notices**

2.2.2, 3.7, 3.13, 7.3.6.4, 10.2.2

**PERSONS AND PROPERTY, PROTECTION OF**  
**10**

Polychlorinated Biphenyl

10.3.1

Product Data, Definition of

3.12.2

**Product Data and Samples, Shop Drawings**

3.11, 3.12, 4.2.7

**Progress and Completion**

4.2.2, 4.3.3, 8.2, 9.8, 9.9.1, 14.1.4

**Progress Payments**

4.3.3, 9.3, 9.6, 9.8.5, 9.10.3, 13.6, 14.2.3

Project, Definition of the

1.1.4

**Project Management Protective Liability Insurance**

11.3

Project Manual, Definition of the

1.1.7

Project Manuals

2.2.5

Project Representatives

4.2.10

**Property Insurance**

10.2.5, 11.4

**PROTECTION OF PERSONS AND PROPERTY**  
**10**

Regulations and Laws

1.6, 3.2.2, 3.6, 3.7, 3.12.10, 3.13, 4.1.1, 4.4.8, 4.6, 9.6.4, 9.9.1, 10.2.2, 11.1, 11.4, 13.1, 13.4, 13.5.1, 13.5.2, 13.6, 14

Rejection of Work

3.5.1, 4.2.6, 12.2.1

Releases and Waivers of Liens

9.10.2

Representations

1.5.2, 3.5.1, 3.12.6, 6.2.2, 8.2.1, 9.3.3, 9.4.2, 9.5.1, 9.8.2, 9.10.1

Representatives

2.1.1, 3.1.1, 3.9, 4.1.1, 4.2.1, 4.2.10, 5.1.1, 5.1.2, 13.2.1

**Resolution of Claims and Disputes**  
**4.4, 4.5, 4.6**

Responsibility for Those Performing the Work

3.3.2, 3.18, 4.2.3, 4.3.8, 5.3.1, 6.1.3, 6.2, 6.3, 9.5.1, 10

Retainage

9.3.1, 9.6.2, 9.8.5, 9.9.1, 9.10.2, 9.10.3

**Review of Contract Documents and Field Conditions by Contractor**

1.5.2, 3.2, 3.7.3, 3.12.7, 6.1.3

Review of Contractor's Submittals by Owner and Architect

3.10.1, 3.10.2, 3.11, 3.12, 4.2, 5.2, 6.1.3, 9.2, 9.8.2

Review of Shop Drawings, Product Data and Samples by Contractor

3.12

**Rights and Remedies**

1.1.2, 2.3, 2.4, 3.5.1, 3.15.2, 4.2.6, 4.3.4, 4.5, 4.6, 5.3, 5.4, 6.1, 6.3, 7.3.1, 8.3, 9.5.1, 9.7, 10.2.5, 10.3, 12.2.2, 12.2.4, 13.4, 14

**Royalties, Patents and Copyrights**

3.17

Rules and Notices for Arbitration

4.6.2

**Safety of Persons and Property**

10.2, 10.6

**Safety Precautions and Programs**

3.3.1, 4.2.2, 4.2.7, 5.3.1, 10.1, 10.2, 10.6

Samples, Definition of

3.12.3

**Samples, Shop Drawings, Product Data and**

3.11, 3.12, 4.2.7

**Samples at the Site, Documents and**

3.11

**Schedule of Values**

9.2, 9.3.1

Schedules,

1.4.1.2, 3.10, 3.12.1, 3.12.2, 4.3.7.2, 6.1.3

Separate Contracts and Contractors

1.1.4, 3.12.5, 3.14.2, 4.2.4, 4.2.7, 4.6.4, 6, 8.3.1, 11.4.7, 12.1.2, 12.2.5

Shop Drawings, Definition of

3.12.1

**Shop Drawings, Product Data and Samples**

3.11, 3.12, 4.2.7

**Site, Use of**

3.13, 6.1.1, 6.2.1

Site Inspections

1.2.2, 3.2.1, 3.3.3, 3.7.1, 4.2, 4.3.4, 9.4.2, 9.10.1, 13.5

Site Visits, Architect's

4.2.2, 4.2.9, 4.3.4, 9.4.2, 9.5.1, 9.9.2, 9.10.1, 13.5

Special Inspections and Testing

4.2.6, 12.2.1, 13.5

Specifications, Definition of the

1.1.6

**Specifications, The**

1.1.1, 1.1.6, 1.1.7, 1.2.2, 1.6, 3.11, 3.12.10, 3.17

Statute of Limitations

4.6.3, 12.2.6, 13.7

Stopping the Work

2.3, 4.3.6, 9.7, 10.3, 14.1

Stored Materials

6.2.1, 9.3.2, 10.2.1.2, 10.2.4, 11.4.1.4

Subcontractor, Definition of

5.1.1

**SUBCONTRACTORS**

5

Subcontractors, Work by

1.2.2, 3.3.2, 3.12.1, 4.2.3, 5.2.3, 5.3, 5.4, 9.3.1.2, 9.6.7

**Subcontractual Relations**

**5.3, 5.4, 9.3.1.2, 9.6, 9.10 10.2.1, 11.4.7, 11.4.8, 14.1, 14.2.1, 14.3.2**

Submittals

1.6, 3.10, 3.11, 3.12, 4.2.7, 5.2.1, 5.2.3, 7.3.6, 9.2, 9.3, 9.8, 9.9.1, 9.10.2, 9.10.3, 11.1.3

**Subrogation, Waivers of**

6.1.1, 11.4.5, **11.4.7**

**Substantial Completion**

4.2.9, 8.1.1, 8.1.3, 8.2.3, 9.4.2, **9.8**, 9.9.1, 9.10.3, 9.10.4.2, 12.2, 13.7

Substantial Completion, Definition of  
9.8.1

Substitution of Subcontractors

5.2.3, 5.2.4

Substitution of Architect

4.1.3

Substitutions of Materials

3.4.2, 3.5.1, 7.3.7

Sub-subcontractor, Definition of

5.1.2

Subsurface Conditions

4.3.4

**Successors and Assigns**

**13.2**

**Superintendent**

**3.9, 10.2.6**

**Supervision and Construction Procedures**

1.2.2, **3.3**, 3.4, 3.12.10, 4.2.2, 4.2.7, 4.3.3, 6.1.3, 6.2.4, 7.1.3, 7.3.6, 8.2, 8.3.1, 9.4.2, 10, 12, 14

Surety

4.4.7, 5.4.1.2, 9.8.5, 9.10.2, 9.10.3, 14.2.2

Surety, Consent of

9.10.2, 9.10.3

Surveys

2.2.3

**Suspension by the Owner for Convenience**

**14.4**

Suspension of the Work

5.4.2, 14.3

Suspension or Termination of the Contract

4.3.6, 5.4.1.1, 11.4.9, 14

**Taxes**

**3.6, 3.8.2.1, 7.3.6.4**

**Termination by the Contractor**

4.3.10, **14.1**

**Termination by the Owner for Cause**

4.3.10, 5.4.1.1, **14.2**

Termination of the Architect

4.1.3

Termination of the Contractor

14.2.2

**TERMINATION OR SUSPENSION OF THE CONTRACT**

**14**

**Tests and Inspections**

3.1.3, 3.3.3, 4.2.2, 4.2.6, 4.2.9, 9.4.2, 9.8.3, 9.9.2, 9.10.1, 10.3.2, 11.4.1.1, 12.2.1, **13.5**

**TIME**

**8**

**Time, Delays and Extensions of**

3.2.3, 4.3.1, 4.3.4, 4.3.7, 4.4.5, 5.2.3, 7.2.1, 7.3.1, 7.4.1, **8.3**, 9.5.1, 9.7.1, 10.3.2, 10.6.1, **14.3.2**

Time Limits

2.1.2, 2.2, 2.4, 3.2.1, 3.7.3, 3.10, 3.11, 3.12.5, 3.15.1, 4.2, 4.3, 4.4, 4.5, 4.6, 5.2, 5.3, 5.4, 6.2.4, 7.3, 7.4, 8.2, 9.2, 9.3.1, 9.3.3, 9.4.1, 9.5, 9.6, 9.7, 9.8, 9.9, 9.10, 11.1.3, 11.4.1.5, 11.4.6, 11.4.10, 12.2, 13.5, 13.7, 14

**Time Limits on Claims**

**4.3.2, 4.3.4, 4.3.8, 4.4, 4.5, 4.6**

Title to Work

9.3.2, 9.3.3

**UNCOVERING AND CORRECTION OF WORK**

**12**

**Uncovering of Work**

**12.1**

Unforeseen Conditions

4.3.4, 8.3.1, 10.3

Unit Prices

4.3.9, 7.3.3.2

Use of Documents

1.1.1, 1.6, 2.2.5, 3.12.6, 5.3

**Use of Site**

**3.13, 6.1.1, 6.2.1**

**Values, Schedule of**

**9.2, 9.3.1**

Waiver of Claims by the Architect

13.4.2

Waiver of Claims by the Contractor

4.3.10, 9.10.5, 11.4.7, 13.4.2

Waiver of Claims by the Owner

4.3.10, 9.9.3, 9.10.3, 9.10.4, 11.4.3, 11.4.5, 11.4.7,

12.2.2.1, 13.4.2, 14.2.4

**Waiver of Consequential Damages**

**4.3.10, 14.2.4**

Waiver of Liens

9.10.2, 9.10.4

**Waivers of Subrogation**

6.1.1, 11.4.5, **11.4.7**

**Warranty**

**3.5, 4.2.9, 4.3.5.3, 9.3.3, 9.8.4, 9.9.1, 9.10.4, 12.2.2,**

**13.7.1.3**

Weather Delays

4.3.7.2

Work, Definition of

1.1.3

Written Consent

1.6, 3.4.2, 3.12.8, 3.14.2, 4.1.2, 4.3.4, 4.6.4, 9.3.2,  
9.8.5, 9.9.1, 9.10.2, 9.10.3, 11.4.1, 13.2, 13.4.2

Written Interpretations

4.2.11, 4.2.12, 4.3.6

**Written Notice**

2.3, 2.4, 3.3.1, 3.9, 3.12.9, 3.12.10, 4.3, 4.4.8, 4.6.5,  
5.2.1, 8.2.2, 9.7, 9.10, 10.2.2, 10.3, 11.1.3, 11.4.6,  
12.2.2, 12.2.4, **13.3**, 14

Written Orders

1.1.1, 2.3, 3.9, 4.3.6, 7, 8.2.2, 11.4.9, 12.1, 12.2,  
13.5.2, 14.3.1

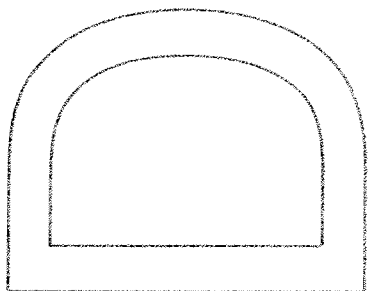
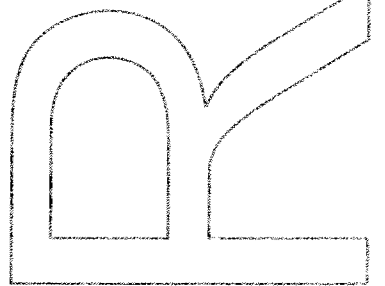
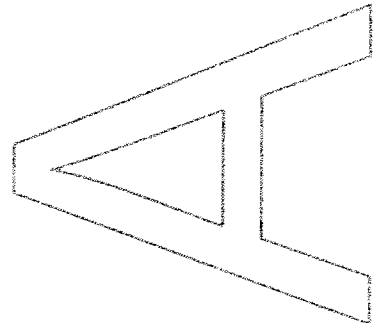
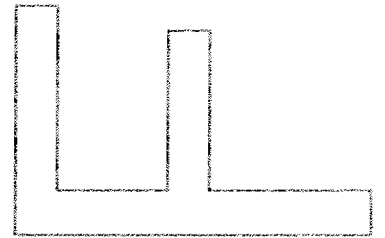
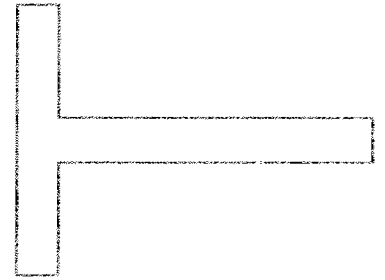

## ARTICLE 1 GENERAL PROVISIONS

### § 1.1 BASIC DEFINITIONS

#### § 1.1.1 THE CONTRACT DOCUMENTS

The Contract Documents consist of the Agreement between OWNER and Contractor (hereinafter the Agreement), Conditions of the Contract (General, Supplementary and other Conditions), Drawings, Specifications, Addenda issued prior to execution of the Contract, other documents listed in the Agreement and Modifications issued after execution of the Contract. A Modification is (1) a written amendment to the Contract signed by both parties, (2) a Change Order, (3) a Construction Change Directive or (4) a written order for a minor change in the WORK issued by the ARCHITECT pursuant to Paragraph 7.4. Unless specifically enumerated in the Agreement, the Contract Documents do not include other documents such as bidding requirements (advertisement or invitation to bid, Instructions to Bidders, sample forms, the Contractor's bid or portions of Addenda relating to bidding requirements).

§ 1.1.1.1 CONTRACTOR acknowledges and warrants that it has closely examined all the Contract Documents, that they are suitable and sufficient to enable CONTRACTOR to complete the WORK in a timely manner for the Contract sum, and that they include all WORK, whether or not shown or described, which reasonably may be inferred to be required or useful for the completion of the WORK in full compliance with all applicable codes, laws, ordinances, and regulations.

#### § 1.1.2 THE CONTRACT

The Contract Documents form the Contract for Construction. The Contract represents the entire and integrated agreement between the parties hereto and supersedes prior negotiations, representations or agreements, either written or oral. The Contract may be amended or modified only by a Modification. The Contract Documents shall not be construed to create a contractual relationship of any kind (1) between the ARCHITECT and Contractor, (2) between the OWNER and a Subcontractor (except as provided in Paragraph 5.3 and 5.4 hereof) or Sub-subcontractor, (3) between the OWNER and ARCHITECT or (4) between any persons or entities other than the OWNER and Contractor. The ARCHITECT shall, however, be entitled to performance and enforcement of obligations of CONTRACTOR under the Contract intended to facilitate performance of the ARCHITECT's duties.

#### § 1.1.3 THE WORK

The term "WORK" means the construction and services required by the Contract Documents, whether completed or partially completed, and includes all other labor, materials, equipment and services provided or to be provided by the CONTRACTOR to fulfill the Contractor's obligations. The WORK may constitute the whole or a part of the Project.

§ 1.1.3.1 The WORK shall include the obligation of CONTRACTOR to visit the site of the project before submitting a proposal. Such site visit shall be for the purpose of familiarizing CONTRACTOR with the conditions as they exist and the character of the operations to be carried on under the Contract Documents, including all existing site conditions, access to the site, physical characteristics of the site and surrounding areas.

#### § 1.1.4 THE PROJECT

The Project is the total construction of which the WORK performed under the Contract Documents may be the whole or a part and which may include construction by the OWNER or by separate contractors.

#### § 1.1.5 THE DRAWINGS

The Drawings are the graphic and pictorial portions of the Contract Documents showing the design, location and dimensions of the WORK, generally including plans, elevations, sections, details, schedules and diagrams, wherever located and whenever issued.

#### § 1.1.6 THE SPECIFICATIONS

The Specifications are that portion of the Contract Documents consisting of the written requirements for materials, equipment, systems, standards and workmanship for the WORK, and performance of related services.

#### § 1.1.7 THE PROJECT MANUAL

The Project Manual is a volume assembled for the WORK which is issued by ARCHITECT and shall include the bidding requirements, sample forms, Conditions of the Contract and Specifications.

§ 1.1.8 **ADDENDUM:** A change to Contract Documents issued by ARCHITECT which is subject to OWNER's approval prior to the execution of the Agreement and specifically listed in the Agreement.

§ 1.1.9 **ALTERNATE:** A variation in Contract requirements on which a separate price is to be received by OWNER as part of the bid. If the Alternate is accepted in writing by OWNER, the variation is then part of the Contract and the amount of money quoted to be added or deducted from the Base Bid is taken into account in determining the Contract Sum.

§ 1.1.10 **BASE BID:** The bid before any Alternates are considered.

§1.1.11 **FINAL COMPLETION:** Final Completion is achieved at the time that final inspection has been performed by ARCHITECT and the final Certificate for Payment is issued by ARCHITECT and approved by OWNER.

§1.1.12 **NOT IN CONTRACT N.I.C.:** WORK not included in the Contract.

§1.1.13 **OR APPROVED EQUAL AND EQUAL TO:** Shall mean products by manufacturers other than those specified in the Contract Documents which CONTRACTOR may submit for substitution and prove to be equal to those specified in the Contract Documents and which may be incorporated in the WORK after review and acceptance by ARCHITECT and acceptance by OWNER.

§1.1.14 **INDICATED AND SHOWN:** Shall mean as detailed, scheduled, or called for in the Contract Documents.

§1.1.15 **KNOWLEDGE:** The terms 'knowledge', 'recognize' and 'discover', their respective derivatives, and similar terms in the Contract Documents as used in reference to CONTRACTOR knows (or should know), recognized (or should recognize), and discovers (or should discover) in exercising the care, skill, and diligence required by the Contract Documents. Analogously, the expression 'reasonably inferable' and similar terms in the Contract Documents shall be interpreted to mean reasonably inferable by a contractor in Hidalgo County familiar with the Project and exercising the care, skill, and diligence required of CONTRACTOR by the Contract Documents.

§1.1.16 **DAYS:** The terms 'days' in the Contract Documents means 'calendar days.'

**§ 1.2 CORRELATION AND INTENT OF THE CONTRACT DOCUMENTS**

§ 1.2.1 The Contract Documents include all items necessary for the proper execution and completion of the WORK by CONTRACTOR. The Work shall consist of all the items specifically included in the Contract Documents as well as all additional items of WORK that are reasonably inferable from that which is specified in order to complete the WORK in accordance with the Contract Documents and in order to produce the intended results. The Contract Documents are complementary, and what is required by any one Contract Document, shall be as binding as if required by all. Any differences between the requirements of the Drawing and the Specifications or any differences noted within the Drawings themselves or within the Specifications themselves have been referred to OWNER and ARCHITECT by CONTRACTOR prior to the submission of bids and have been clarified by an Addendum issued to all bidders.

If any such differences or conflicts were not called to OWNER's and ARCHITECT's attention prior to submission of bids, ARCHITECT shall decide which of the conflicting requirements will govern based upon: the most stringent of the requirements will take precedence over the less specific and the more expensive will take precedence over the less expensive, and subject to approval of OWNER, CONTRACTOR shall perform the WORK at no additional cost and/or time to OWNER in accordance with ARCHITECT's decision. WORK not covered in the Contract Documents will not be required unless it is consistent therewith and is reasonably inferable therefrom as being necessary to produce the intended results.

§ 1.2.2 Organization of the Specifications into divisions, sections and articles, and arrangement of Drawings shall not control the Contractor in dividing the WORK among Subcontractors or in establishing the extent of WORK to be performed by any trade.

**§ 1.2.3** Unless otherwise stated in the Contract Documents, words and abbreviations which have well-known technical or construction industry meanings are used in the Contract Documents in accordance with such recognized meanings.

**§ 1.2.4** If WORK is required in a manner to make it impossible to produce WORK of the quality required by or reasonably inferred from the Contract Documents, or should discrepancies appear among the Contract Documents, CONTRACTOR shall request in writing an interpretation from ARCHITECT before proceeding with the WORK. If CONTRACTOR fails to make such request, no excuse will thereafter be entertained for the failure to carry out WORK in the required manner or provide required guarantees, warranties, or bonds and CONTRACTOR shall not be entitled to any change in the Contract Sum or the Contract Time on account of such failure.

### **§ 1.3 CAPITALIZATION**

**§ 1.3.1** Terms capitalized in these General Conditions include those which are (1) specifically defined, (2) the titles of numbered articles or (3) the titles of other documents published by the American Institute of Architects.

### **§ 1.4 INTERPRETATION**

**§ 1.4.1** In the interest of brevity the Contract Documents frequently omit modifying words such as "all" and "any" and articles such as "the" and "an," but the fact that a modifier or an article is absent from one statement and appears in another is not intended to affect the interpretation of either statement.

### **§ 1.5 EXECUTION OF CONTRACT DOCUMENTS**

**§ 1.5.1** The Contract Documents shall be signed by the OWNER and CONTRACTOR. If either the OWNER or CONTRACTOR or both do not sign all the Contract Documents, the ARCHITECT shall identify such unsigned Documents.

**§ 1.5.2** Execution of the Contract by the CONTRACTOR is a representation that said Contractor documents are full and complete, are sufficient to have enabled CONTRACTOR to determine the cost of the WORK therein to enter into the Contract and that the Contract Documents are sufficient to enable it to construct the WORK outlined therein, and otherwise to fulfill all its obligations hereunder, including, but not limited to, CONTRACTOR's obligation to construct the WORK for an amount not in excess of the Contract Sum on or before the date (s) of Substantial Completion established in the Agreement. CONTRACTOR further acknowledges and declares that it has visited and examined the site, examined all physical, legal, and other conditions affecting the WORK and is fully familiar with all of the conditions thereon and thereunder affecting the same. In connection therewith, CONTRACTOR specifically represents and warrants to OWNER that it has, by careful examination, satisfied itself as to (1) the nature, location, and character of the Project and the site, including, without limitation, the surface and subsurface conditions of the site and all structures and obstructions thereon and thereunder, both natural and manmade, and all surface and subsurface water conditions of the site and the surrounding area; (2) the nature, location, and character of the general area in which the Project is located, including, without limitation, its climatic conditions, available labor supply and labor costs, and available equipment supply and equipment costs; and (3) the quality and quantity of all materials, supplies, tools, equipment, labor, and professional services necessary to complete the WORK in the manner and within the cost and time frame required by the Contract Documents.

**§ 1.5.2.2.** In connection with the foregoing and having carefully examined all Contract Documents, as aforesaid, and having visited the site, CONTRACTOR acknowledges and declares that it has no knowledge of any discrepancies, omissions, ambiguities, or conflicts in said Contract Documents, and that if it becomes aware of any such discrepancies, omissions, ambiguities, or conflicts, it will promptly notify OWNER and ARCHITECT of such fact.

**§ 1.5.2.3** Further, CONTRACTOR recognizes the extra degree of care required under the urban site construction circumstances with respect to safety, protection of pedestrians, cleanliness of the site, health and other laws, and protection of existing utilities, adjacent streets, and property. In arriving at the Contract Sum and the Contract Time, CONTRACTOR has, as an experienced and prudent CONTRACTOR, exercised its best judgment and expertise to include the impact of such circumstances upon the Contract Sum and the Contract Time.

### **§ 1.6 OWNERSHIP AND USE OF DRAWINGS, SPECIFICATIONS AND OTHER INSTRUMENTS OF SERVICE**

**§ 1.6.1** The Drawings, Specifications and other similar or related documents and copies thereof are furnished to Contractor for the purpose of performing the WORK and are, and shall remain, the property of OWNER. Neither the Contractor nor any Subcontractor, Sub-subcontractor or material or equipment supplier shall own or claim a

copyright in the Drawings, Specifications and other similar or related documents, and OWNER shall retain all common law, statutory, and other reserved rights, in addition to the copyright(including, without limitations, the right to create derivative works therefrom). All copies of such documents shall be returned to OWNER upon Completion of the WORK. The Drawings, Specifications and other similar or related documents and copies thereof furnished to the Contractor, are for use solely with respect to this Project. They are not to be used by the Contractor or any Subcontractor, Sub-subcontractor or material or equipment supplier on other projects or for additions to this Project outside the scope of the WORK without the specific written consent of the OWNER, ARCHITECT and the Architect's consultants appropriate to and for use in the execution of their WORK under the Contract Documents.

**§1.6.2** Upon OWNER's Payment, all Plans, Drawings, Specifications and other similar documents and copies thereof, furnished by the CONTRACTOR are and shall remain the property of the OWNER and shall not be used by any person on any project without prior written consent of OWNER and ARCHITECT of Record.

## ARTICLE 2 OWNER

### § 2.1 GENERAL

**§ 2.1.1** The OWNER is the person or entity identified as such in the Agreement and is referred to throughout the Contract Documents as if singular in number. The Commissioners' Court of OWNER, by majority vote, is the only representative of the OWNER, having the power to enter into a Contract, to execute a change order requiring an increase in the Contract Sum, or agree to an extension of the contractual completion date. The Court shall designate as appropriate, an authorized representatives to act on its behalf during the course of construction. In the event that emergency changes in the scope of the WORK are required before the Court's next regular meeting or in order to facilitate and expedite the timely completion of the WORK, the Court's authorized representatives may approve construction changes that do not exceed \$5,000.00 in increased costs. Any such change shall be confirmed in writing between the CONTRACTOR and the Court at its next regular meeting. The Court will act as soon as reasonably possible to avoid undue delays in the construction completion date.

**§ 2.1.2** The OWNER shall furnish to the CONTRACTOR within fifteen (15) days after receipt of a written request, information necessary and relevant for the CONTRACTOR to evaluate, give notice of or enforce mechanic's lien rights. Such information shall include a correct statement of the record legal title to the property on which the Project is located, usually referred to as the site, and the OWNER's interest therein.

### § 2.2 INFORMATION AND SERVICES REQUIRED OF THE OWNER

**§ 2.2.1** The OWNER shall, at the written request of the CONTRACTOR, prior to commencement of the WORK and thereafter, furnish to the Contractor reasonable evidence that financial arrangements have been made to fulfill the OWNER's obligations under the Contract. Furnishing of such evidence shall be a condition precedent to commencement or continuation of the WORK. After such evidence has been furnished, the OWNER shall not materially vary such financial arrangements without prior notice to the CONTRACTOR.

**§ 2.2.2** Except for permits and fees, including those required under Section 3.7.1, which are the responsibility of the CONTRACTOR under the Contract Documents, the OWNER shall secure and pay for necessary approvals, easements, assessments and charges required for construction, use or occupancy of permanent structures or for permanent changes in existing facilities. In connection with the foregoing, CONTRACTOR shall be solely responsible for locating (and shall locate prior to performing any WORK) all utility lines, telephone company lines and cables, sewer lines, water pipes, gas lines, electrical lines, including without limitation, all buried pipelines and buried telephone cables and shall perform the WORK in such a manner so as to avoid damaging any such lines, cables, pipes, and pipelines.

**§ 2.2.3** The OWNER shall furnish surveys describing physical characteristics, legal limitations for the site of the Project, and a legal description of the site. The CONTRACTOR shall be entitled to reasonably rely on the accuracy of information furnished by the OWNER but shall exercise proper precautions relating to the safe performance of the WORK.

**§ 2.2.4** Information or services required of the OWNER by the Contract Documents shall be furnished by the OWNER with reasonable promptness. Any other information or services relevant to the CONTRACTOR's performance of the WORK under the OWNER's control shall be furnished by the OWNER after receipt from the CONTRACTOR of a written request for such information or services.

§ 2.2.5 OWNER shall furnish CONTRACTOR with one set of reproducible of Drawings and one Project Manual. Contractor is given permission to make copies of these documents for use on this Project. All costs of reproduction are the responsibility of CONTRACTOR.

### § 2.3 OWNER'S RIGHT TO STOP THE WORK

§ 2.3.1 If the CONTRACTOR fails to correct WORK which is not in accordance with the requirements of the Contract Documents as required by Section 12.2 or fails to carry out WORK in accordance with the Contract Documents, or fails to remove and discharge within ten (10) days any lien filed upon Owner's or Landlord's property by anyone claiming by, through, or under CONTRACTOR or disregards the instructions of ARCHITECT or OWNER when based on the requirement of the Contract Document, the OWNER may issue a written order to the CONTRACTOR to stop the WORK, or any portion thereof, until the cause for such order has been eliminated; however, the right of the OWNER to stop the WORK shall not give rise to a duty on the part of the OWNER to exercise this right for the benefit of the CONTRACTOR or any other person or entity, and any delays resulting from such WORK stoppage shall not extend any Milestone Date identified in the Contract for Construction or the required dates of Substantial or Final Completion.

### § 2.4 OWNER'S RIGHT TO CARRY OUT THE WORK

§ 2.4.1 If the CONTRACTOR defaults or neglects to carry out the WORK in accordance with the Contract Documents and fails within a seven-day period after receipt of written notice from the OWNER to commence and continue correction of such default or neglect with diligence and promptness or fails within such seven-day period to eliminate (or diligently commence to eliminate) the cause of any stop WORK order issued under Subparagraph 2.3.1 hereof, the OWNER may, without prejudice to other remedies the OWNER may have, correct such deficiencies. In such case an appropriate Change Order shall be issued deducting from payments then or thereafter due the CONTRACTOR the reasonable cost of correcting such deficiencies, including OWNER's expenses and compensation for the ARCHITECT's additional services made necessary by such default, neglect or failure. Such Change Order shall be deemed to have been executed by CONTRACTOR, whether or not actually signed by CONTRACTOR, unless the Change Order is shown to have been prepared in bad faith by OWNER or ARCHITECT. If payments then or thereafter due the CONTRACTOR are not sufficient to cover such amounts, the CONTRACTOR shall pay the difference to the OWNER.

§ 2.5.1 The rights stated in Article 2 shall be in addition and not in limitation of any other rights of OWNER granted in the Contract Documents or at law or in equity.

## ARTICLE 3 CONTRACTOR

### § 3.1 GENERAL

§ 3.1.1 The CONTRACTOR is the person or entity identified as such in the Agreement and is referred to throughout the Contract Documents as if singular in number. The term "CONTRACTOR" means the CONTRACTOR or the CONTRACTOR's authorized representative.

§ 3.1.2 The CONTRACTOR shall perform the WORK in accordance with the Contract Documents.

§ 3.1.3 The CONTRACTOR shall not be relieved of obligations to perform the WORK in accordance with the Contract Documents either by activities or duties of the ARCHITECT in the Architect's administration of the Contract, or by tests, inspections or approvals required or performed by persons other than the CONTRACTOR.

### § 3.2 REVIEW OF CONTRACT DOCUMENTS AND FIELD CONDITIONS BY CONTRACTOR

§ 3.2.1 Since the Contract Documents are complementary, before starting each portion of the WORK, the CONTRACTOR shall carefully study and compare the various Drawings and other Contract Documents relative to that portion of the WORK, as well as the information furnished by the OWNER pursuant to Section 2.2.3, shall take field measurements of any existing conditions related to that portion of the WORK and shall observe any conditions at the site affecting it. These obligations are for the purpose of facilitating construction by the CONTRACTOR and are not for the purpose of discovering errors, omissions, or inconsistencies in the Contract Documents; however, any errors, inconsistencies or omissions discovered by the CONTRACTOR shall be reported promptly to the ARCHITECT and OWNER as a request for design information in such form as the ARCHITECT may require.

§ 3.2.2 Any design errors or omissions noted by the CONTRACTOR during this review shall be reported promptly in written notices to the ARCHITECT and OWNER, but it is recognized that the CONTRACTOR's review is made

in the CONTRACTOR's capacity as a contractor and not as a licensed design professional unless otherwise specifically provided in the Contract Documents. The CONTRACTOR is not required to ascertain that the Contract Documents are in accordance with applicable laws, statutes, ordinances, building codes, and rules and regulations, but any nonconformity discovered by or made known to the CONTRACTOR shall be reported promptly to the ARCHITECT and OWNER.

**§ 3.2.2.1** Should any words or numbers that are necessary to a clear understanding of the WORK be illegible or omitted, or should an error, or discrepancy occur in any of the Contract Documents, CONTRACTOR shall immediately notify in writing ARCHITECT and OWNER of such omission, error, or discrepancy, and CONTRACTOR shall not proceed with the portion of the WORK until clarification is received. If CONTRACTOR proceeds without notifying ARCHITECT and OWNER, and does not get clarification, CONTRACTOR shall be responsible for the cost of correcting same, including any resulting damages.

**§ 3.2.3** If the CONTRACTOR believes that additional cost or time is involved because of clarifications or instructions issued by the ARCHITECT in response to the CONTRACTOR's notices or requests for information pursuant to Sections 3.2.1 and 3.2.2, the CONTRACTOR shall make Claims as provided in Sections 4.3.6 and 4.3.7. If the CONTRACTOR fails to perform the obligations of Sections 3.2.1 and 3.2.2, the CONTRACTOR shall pay such costs and damages to the OWNER as would have been avoided if the CONTRACTOR had performed such obligations. The CONTRACTOR shall not be liable to the OWNER or ARCHITECT for damages resulting from errors, inconsistencies or omissions in the Contract Documents or for differences between field measurements or conditions and the Contract Documents unless the CONTRACTOR recognized such error, inconsistency, omission or difference and knowingly failed to report it to the ARCHITECT.

### **§ 3.3 SUPERVISION AND CONSTRUCTION PROCEDURES**

**§ 3.3.1** The CONTRACTOR shall supervise and direct the WORK, using the CONTRACTOR's best skill and attention. The CONTRACTOR shall be solely responsible for and have control over construction means, methods, techniques, sequences and procedures and for coordinating all portions of the WORK under the Contract, unless the Contract Documents give other specific instructions concerning these matters. If the Contract Documents give specific instructions concerning construction means, methods, techniques, sequences or procedures, the CONTRACTOR shall evaluate the jobsite safety thereof and, except as stated below, shall be fully and solely responsible for the jobsite safety of such means, methods, techniques, sequences or procedures. If the CONTRACTOR determines that such means, methods, techniques, sequences or procedures may not be safe, the CONTRACTOR shall give timely written notice to the OWNER and ARCHITECT and shall not proceed with that portion of the WORK without further written instructions from the ARCHITECT.

**§ 3.3.2** The CONTRACTOR shall be responsible to the OWNER for acts and omissions of the CONTRACTOR's employees, Subcontractors and their agents and employees, and other persons or entities performing portions of the WORK for or on behalf of the CONTRACTOR or any of its Subcontractors.

**§ 3.3.3** The CONTRACTOR shall be responsible for inspection of portions of WORK already performed to determine that such portions are in proper condition to receive subsequent WORK.

**§ 3.3.4** CONTRACTOR shall be responsible to OWNER for acts and omissions of CONTRACTOR's employees, Subcontractors and their agents and employees, and other persons performing portions of the WORK under contract or other arrangements with CONTRACTOR.

**§ 3.3.5** CONTRACTOR shall give notices and comply with applicable laws, ordinances, rules, regulations, and lawful orders of public authorities bearing on the WORK, including those with respect to the safety of persons and property and their protection from damages, injury, or loss. CONTRACTOR shall promptly remedy damages and loss to property at the site caused in whole or in part by CONTRACTOR, its Subcontractor, or anyone directly or indirectly employed by any of them or by anyone for whose acts they may be liable, except for damage or loss attributable solely to acts or omissions of OWNER or ARCHITECT by anyone for whose acts either of them may be liable and not attributable to the fault or negligence of CONTRACTOR, its Subcontractor, or anyone directly or indirectly employed by them. The foregoing obligations of CONTRACTOR are in addition to Contractor's obligations under other provisions hereunder.

**§3.3.6** CONTRACTOR shall be responsible for inspections of portion of WORK already performed under the CONTRACTOR for Construction to determine that such portions are in proper condition to receive subsequent WORK.

**§ 3.3.7** CONTRACTOR has the responsibility to ensure that all material suppliers and Subcontractors, their agents, and employees adhere to the Contract Documents, and that they order materials on time, taking into account the current market and delivery conditions, and that they provide materials on time. CONTRACTOR shall coordinate its WORK with that of all others on the Project, including construction utilities.

**§3.3.8** CONTRACTOR shall establish and maintain benchmarks and all other grades, lines, and levels necessary for the WORK; report errors or inconsistencies to OWNER and ARCHITECT before commencing WORK; and if applicable, review the placement of the buildings and permanent facilities on the site with OWNER and ARCHITECT after all lines are staked out and before foundation WORK is started. CONTRACTOR shall provide access to the WORK for OWNER, ARCHITECT, other persons designated by OWNER, and governmental inspectors. Any encroachments made by CONTRACTOR or its Subcontractors on adjacent properties caused by construction as revealed by an improvements survey, except for encroachments arising from errors or omissions not reasonably discoverable by CONTRACTOR in the Contract Documents, shall be the sole responsibility of CONTRACTOR and CONTRACTOR shall correct such encroachments within thirty (30) days of the improvement survey (or as soon thereafter as reasonably possible). At CONTRACTOR's sole cost and expense, either by the removal of the encroachment (and subsequent reconstruction on the Project site) or agreement with the adjacent property owner(s) (in form and substance satisfactory to OWNER in its sole discretion) allowing the encroachments to remain.

**§ 3.3.9** CONTRACTOR shall verify at the worksite the measurements indicated on the Drawings and Specifications and shall establish correctly the lines, levels, and positions for the WORK and be responsible for their accuracy and proper correlation with control lines, monuments, and data, as established by surveys furnished by OWNER. WORK shall be created square, plumb, level true to line and grade, in the exact plane and to the correct elevation and/or slope to drain as indicated. To ensure the proper execution of its subsequent WORK, CONTRACTOR shall measure all WORK already in place (including but not limited to utilities and grades installed or prepared by others) and shall at once report to ARCHITECT and OWNER any discrepancy between said WORK and the Drawings and Specifications for the WORK.

**§ 3.3.10** Any discrepancy or omission in the dimensions or elevations shown on the Drawings and Specifications or found in previous WORK which may prevent accurate layout or construction of the WORK, shall immediately be reported to ARCHITECT and OWNER. When CONTRACTOR knows or reasonably should have known that such discrepancy or omission exists, without first obtaining further instruction from ARCHITECT or OWNER, CONTRACTOR shall bear any and all costs arising therefrom including, without limitation, the costs of correction thereof without increase or adjustment in the Contract Sum. Omissions from the Drawings or Specifications, or the misdescription of details of WORK which are reasonably inferable in order to carry out the intent of the Drawings and Specifications, or which are customarily performed, shall not relieve CONTRACTOR from performing such omitted or misdescribed details of the WORK, and they shall be performed as if fully and correctly set forth as described in the Drawings and Specifications, at no additional cost to OWNER.

**§ 3.3.11** CONTRACTOR shall engage workers who are skilled in performing the WORK, and all WORK shall be performed with care and skill and in a good workmanlike manner under the full-time supervision of an approved engineer or foreman. CONTRACTOR shall be liable for all property damage, including repairs and replacements of the WORK and economics losses, which proximately result from the breach of this duty. CONTRACTOR shall advise ARCHITECT:

- a) if a specified product deviates from good construction practices;
- b) if following the Specifications will affect any warranties; or
- c) any objections which CONTRACTOR may have to the Specifications.

Nothing contained in Subparagraph 1.1.3 shall alter the responsibilities established in this Subparagraph.

**§ 3.4 LABOR AND MATERIALS**

**§ 3.4.1** Unless otherwise provided in the Contract Documents, the CONTRACTOR shall provide and pay for labor, materials, equipment, tools, construction equipment and machinery, water, heat, utilities, transportation, and other facilities and services necessary for proper execution and completion of the WORK, whether temporary or permanent and whether or not incorporated or to be incorporated in the WORK.

**§ 3.4.2** The CONTRACTOR may make substitutions only with the consent of the OWNER, after evaluation by the ARCHITECT and in accordance with a Change Order. By making requests for substitutions based on Subparagraph 3.4.2 CONTRACTOR:

- .1 represents that CONTRACTOR has personally investigated the proposed substitute products and determined that it is equal or superior in all respects to that specified.
- .2 represents that CONTRACTOR will provide the same warranty for the substitution as CONTRACTOR would for that specified.
- .3 certifies that the cost data presented is complete and includes all related costs under this Contract except Architect's redesign costs, and waives all claims for additional costs related to the substitution which subsequently become apparent; and
- .4 will coordinate the installation of the accepted substitute, making such changes as may be required for the WORK to be complete in all respects.

**§ 3.4.3** The CONTRACTOR shall enforce strict discipline and good order among the CONTRACTOR's employees and other persons carrying out the Contract. The CONTRACTOR shall not permit employment of unfit persons or persons not skilled in tasks assigned to them. CONTRACTOR shall also be responsible for labor peace on the Project and shall at all times make its best efforts and judgments as an experienced CONTRACTOR to adopt and implement policies and practices designed to avoid WORK stoppages, slowdowns, disputes, or strikes where reasonably possible and practical under the circumstances and shall at all times maintain Project-wide labor harmony. Except as specifically provided in Subparagraph 8.3.1 hereof, CONTRACTOR shall be liable to OWNER for all damages suffered by OWNER occurring as a result of WORK stoppages, slowdowns, disputes, or strikes.

**§ 3.4.4** Materials shall conform to manufacturer's standards in effect at the date of execution of this Agreement and shall be installed in strict accordance with manufacturer's directions. CONTRACTOR shall, if required by OWNER or ARCHITECT, furnish satisfactory evidence as to the kind and quality of any materials. All packaged materials shall be shipped to the site in the original containers clearly labeled, and delivery slips shall be submitted with bulk materials identifying thereon the source, and warranting quality and compliance with Contract Documents.

**§ 3.4.5** When the Contract Documents require the WORK, or any part of same, to be above the standards required by applicable laws, ordinances, rules, and regulations, and other statutory provisions pertaining to the WORK, such WORK shall be performed and completed by CONTRACTOR in accordance with the Contract Documents.

**§ 3.4.6** When the manufacturer's name, patent number, underwriter's labels, model numbers, or similar identifying marks are required, such markings shall be located as inconspicuously as possible.

**§ 3.5 WARRANTY**

**§ 3.5.1** The CONTRACTOR warrants to the OWNER and ARCHITECT that materials and equipment furnished under the Contract will be of the best quality in accordance with the Specifications and shall be new unless otherwise required or permitted by the Contract Documents; that the WORK will be free from faults and defects, and that the WORK will conform to the requirements of the Contract Documents. WORK not conforming to these requirements, including substitutions not properly approved and authorized, may be considered defective. If required by the ARCHITECT, the CONTRACTOR shall furnish satisfactory evidence as to the kind and quality of materials and equipment.

**§ 3.5.2** ALL WARRANTIES SHALL INCLUDE LABOR AND MATERIALS AND THE MANUFACTURER'S WARRANTY SHALL BE SIGNED BY SUBCONTRACTOR AND COUNTERSIGNED BY CONTRACTOR. ALL WARRANTIES SHALL BE ADDRESSED TO OWNER AND DELIVERED TO ARCHITECT UPON COMPLETION OF THE WORK AND BEFORE OR WITH THE SUBMISSION OF REQUEST FOR FINAL PAYMENT.

§3.5.3 CONTRACTOR shall issue in writing to OWNER as a condition precedent to final payment a 'general warranty' reflecting the terms and conditions of this Paragraph 3.5 for all WORK under the Contract.

§3.5.4 The warranties provided in Paragraph 3.5.1 shall be in addition to and not in limitation of any other warranty or remedy required by law or by the Contract Documents, and such warranty shall be interpreted to require CONTRACTOR to replace defective materials and equipment and re-execute defective WORK which is disclosed to the CONTRACTOR by the OWNER within a period of one (1) year after final completion of the entire WORK unless a longer warranty time is specifically called for in the specifications.

The CONTRACTOR shall assign all components, equipment and fixture warranties to the OWNER and will deliver all manuals to the OWNER at the completion of construction.

§3.5.5 Except when a longer warranty time is specifically called for in the Specification Sections or is otherwise provided by law, the General Warranty shall be for twelve (12) months and shall be in form and content otherwise satisfactory to OWNER.

§3.5.6 Warranties shall become effective on a date established by OWNER and ARCHITECT in accordance with the Contract Documents. This date shall be the Date of Substantial Completion of the entire WORK, unless otherwise provided in any Certificate of Partial Substantial Completion approved by the parties.

§3.5.7 If ARCHITECT considers it impractical, because of unsuitable test conditions or some other factors, to execute simultaneous final acceptance of all equipment, portions of the installation may be certified by ARCHITECT for final acceptance, subject to OWNER's approval, when that portion of the system is complete and ready for operation as called for under Subparagraph 9.8.1

§3.5.8 CONTRACTOR shall warrant for a period of twelve (12) months that the building(s) shall be watertight and leak proof at every point and in every area, except where leaks can be attributed to damage to the building(s) by external forces beyond Contractor's control. CONTRACTOR shall, immediately upon notification by OWNER of water penetration, determine the source of water penetration and, at its own expense, do any WORK necessary to make the building(s) watertight. CONTRACTOR shall also, at its own expense, repair or replace any other damaged material, finishes, and furnishings, damaged as a result of this water penetration, to return the building(s) to its (their) original condition.

§3.5.9 In addition to the foregoing stipulations, CONTRACTOR shall comply with all other warranties referred to in any portions of the Contract Documents or otherwise provided by law or in equity, and where warranties overlap, the more stringent requirements shall govern.

§3.5.10 If for any reason CONTRACTOR cannot warrant any part of the WORK using material or construction methods that have been specified, or shown, it shall notify OWNER and ARCHITECT in writing before the Contract is signed, giving reasons, together with the name of product and data on a substitution it can warrant.

### § 3.6 TAXES

§ 3.6.1 The CONTRACTOR shall pay sales, consumer, use and similar taxes for the WORK provided by the CONTRACTOR which are legally enacted.

### § 3.7 PERMITS, FEES AND NOTICES

§ 3.7.1 The CONTRACTOR shall be responsible for making and submitting application for the building permits. The OWNER shall pay the municipality directly for the building permit and all other development "impact" fees, if any. The CONTRACTOR shall continue to be responsible for payment of other permits, governmental fees, licenses, and inspections and other consents for general construction including, without limitation, street opening, sidewalk, and other obstructions, access over public ways and storage necessary for proper execution of the Contract and which are legally required when bids are received.

The CONTRACTOR shall also obtain all permits and approvals, and pay all fees and expenses, if any, associated with National Pollutant Discharge Elimination System (NPDES) regulations administered by the Environmental Protection Agency (EPA) and State and local authorities, if applicable, that require completion of documentation and/or acquisition of all permits for the Project. CONTRACTOR's obligations under this paragraph do not require it

to perform engineering services during the preconstruction phase to prepare proper drainage for the construction sites. However, any drainage alterations made by CONTRACTOR during the construction process which modifies the original site drainage plan and requires the issuance of a permit shall be at CONTRACTOR's sole cost.

**§ 3.7.2** The CONTRACTOR shall comply with and give notices required by laws, ordinances, rules, regulations and lawful orders and all other requirements of public authorities applicable to performance of the WORK.

**§ 3.7.3** Subject to the other terms and conditions of these Supplementary General Conditions in general and Subparagraph 1.2.2., 1.2.3, and 3.2.2 in particular, it is not the CONTRACTOR's responsibility to ascertain that the Contract Documents are in accordance with applicable laws, statutes, ordinances, building codes, and rules and regulations unless such laws, statutes, ordinances, building codes, and rules and regulations bear upon the performance of the WORK. However, if the CONTRACTOR observes that portions of the Contract Documents are at variance therewith, the CONTRACTOR shall promptly notify the ARCHITECT and OWNER in writing, and necessary changes shall be accomplished by appropriate Modification.

**§ 3.7.4** If the CONTRACTOR performs WORK ( including, without limitation, the installation of any materials or equipment) that it knows or reasonably should have known would be contrary to laws, statutes, ordinances, building codes, and rules and regulations, the CONTRACTOR shall assume appropriate responsibility for such WORK and shall bear the costs attributable to correction.

### **§ 3.8 ALLOWANCES**

**§ 3.8.1** The CONTRACTOR shall include in the Contract Sum all allowances stated in the Contract Documents. Items covered by allowances shall be supplied for such amounts and by such persons or entities as the OWNER may direct, but the CONTRACTOR shall not be required to employ persons or entities to whom the CONTRACTOR has reasonable objection.

**§ 3.8.2** Unless otherwise provided in the Contract Documents:

- .1 allowances shall cover the cost to the CONTRACTOR of materials and equipment delivered at the site and all required taxes, less applicable trade discounts;
- .2 CONTRACTOR's costs for unloading and handling at the site, labor, installation costs, overhead, profit and other expenses contemplated for stated allowance amounts shall be included in the Contract Sum but not in the allowances;
- .3 whenever costs are more than or less than allowances, the Contract Sum shall be adjusted accordingly by Change Order. The amount of the Change Order shall reflect (1) the difference between actual costs and the allowances under Section 3.8.2.1 and (2) changes in CONTRACTOR's costs under Section 3.8.2.2.

**§ 3.8.3** Materials and equipment under an allowance shall be selected by the OWNER in sufficient time to avoid delay in the WORK.

### **§ 3.9 SUPERINTENDENT**

**§ 3.9.1** The CONTRACTOR shall employ a competent superintendent and necessary assistants who shall be in attendance at the Project site during performance of the WORK. The superintendent shall represent the CONTRACTOR, and communications given to the superintendent shall be as binding as if given to the CONTRACTOR. Important communications shall be confirmed in writing. Other communications shall be similarly confirmed on written request in each case.

### **§ 3.10 CONTRACTOR'S CONSTRUCTION SCHEDULES**

**§ 3.10.1** The CONTRACTOR, promptly after being awarded the Contract, shall prepare and submit for the OWNER's and ARCHITECT's review and approval the CONTRACTOR's construction schedule for the WORK. The schedule shall not exceed time limits current under the Contract Documents, shall be revised as required herein and at appropriate intervals as required by the conditions of the WORK and Project, shall be related to the entire Project to the extent required by the Contract Documents, and shall provide for expeditious and practicable execution of the WORK. The schedule shall indicate the proposed starting and completion dates for the various execution of the WORK as well as the totality of the WORK. The schedule shall be updated every thirty (30) days and submitted to ARCHITECT with CONTRACTOR's Applications for Payment. Each schedule shall contain a comparison of actual progress with the estimated progress for such point in time stated in the original schedule. If

any schedule submitted sets such a date for Substantial Completion for the WORK or any phase of the WORK beyond the date(s) of Substantial Completion established in the Contract (as the same may be extended as provided in the Contract Documents), then CONTRACTOR shall submit to ARCHITECT and OWNER for their review and approval a narrative description of the means and methods that CONTRACTOR intends to employ to expedite the progress of the WORK to ensure timely completion of the various phases of the WORK as well as the totality of the WORK. To ensure such timely completion, Contractor shall take all necessary action including, without limitation, increasing the number of personnel and labor on the Project and implementing overtime and double shifts. In that event, CONTRACTOR shall not be entitled to an adjustment in the Contract Sum or the schedule.

**§ 3.10.2** The CONTRACTOR shall prepare and keep current, for the ARCHITECT's approval, a schedule of submittals which is coordinated with the CONTRACTOR's construction schedule and allows the ARCHITECT reasonable time to review submittals.

**§ 3.10.3** The CONTRACTOR shall perform the WORK in general accordance with the most recent schedules submitted to the OWNER and ARCHITECT.

### **§ 3.11 DOCUMENTS AND SAMPLES AT THE SITE**

**§ 3.11.1** The CONTRACTOR shall maintain at the site for the OWNER one record copy of the Drawings, Specifications, Addenda, Change Orders and other Modifications, in good order and marked currently to record field changes and selections made during construction, and one record copy of approved Shop Drawings, Product Data, Samples and similar required submittals. These shall be available to the ARCHITECT and shall be delivered to the ARCHITECT for submittal to the OWNER upon completion of the WORK.

**§ 3.11.2** At the Date of Substantial Completion and as a condition precedent to final payment, CONTRACTOR shall furnish the following documents to ARCHITECT for submittal to OWNER: Record Drawings, showing the field changes and selections (all changes and selections to be approved by OWNER and ARCHITECT in advance) affecting the general construction, mechanical, electrical, plumbing, and all other WORK, and indicating the WORK as actually installed. These shall consist of carefully drawn markings on a set of reproducible prints of ARCHITECT's Drawings obtained and paid for by CONTRACTOR. CONTRACTOR shall maintain at the job site one (1) set of ARCHITECT's Drawings and indicate thereon each field change as it occurs.

### **§ 3.12 SHOP DRAWINGS, PRODUCT DATA AND SAMPLES**

**§ 3.12.1** Shop Drawings are drawings, diagrams, schedules and other data specially prepared for the WORK by the CONTRACTOR or a Subcontractor, Sub-subcontractor, manufacturer, supplier or distributor to illustrate some portion of the WORK.

**§ 3.12.2** Product Data are illustrations, standard schedules, performance charts, instructions, brochures, diagrams and other information furnished by the CONTRACTOR to illustrate materials or equipment for some portion of the WORK.

**§ 3.12.3** Samples are physical examples which illustrate materials, equipment or workmanship and establish standards by which the WORK will be judged.

**§ 3.12.4** Shop Drawings, Product Data, Samples and similar submittals are not Contract Documents. The purpose of their submittal is to demonstrate for those portions of the WORK for which submittals are required by the Contract Documents the way by which the CONTRACTOR proposes to conform to the information given and the design concept expressed in the Contract Documents. Review by the ARCHITECT is subject to the limitations of Section 4.2.7. Informational submittals upon which the ARCHITECT is not expected to take responsive action may be so identified in the Contract Documents. Submittals which are not required by the Contract Documents may be returned by the ARCHITECT without action.

**§ 3.12.5** The CONTRACTOR shall review for compliance with the Contract Documents, approve and submit to the Architect Shop Drawings, Product Data, Samples and similar submittals required by the Contract Documents with reasonable promptness and in such sequence as to cause no delay in the WORK or in the activities of the OWNER or of separate contractors. Submittals which are not marked as reviewed for compliance with the Contract Documents and approved by the CONTRACTOR may be returned by the ARCHITECT without action.

**§ 3.12.6** By approving and submitting Shop Drawings, Product Data, Samples and similar submittals, the CONTRACTOR represents that the CONTRACTOR has determined and verified materials, field measurements and field construction criteria related thereto, or will do so, and has checked and coordinated the information contained within such submittals with the requirements of the WORK and of the Contract Documents.

**§ 3.12.7** The CONTRACTOR shall perform no portion of the WORK for which the Contract Documents require submittal and review of Shop Drawings, Product Data, Samples or similar submittals until the respective submittal has been approved by the ARCHITECT.

**§ 3.12.8** The WORK shall be in accordance with approved submittals except that the CONTRACTOR shall not be relieved of responsibility for deviations from requirements of the Contract Documents by the ARCHITECT's approval of Shop Drawings, Product Data, Samples or similar submittals unless the CONTRACTOR has specifically informed the ARCHITECT in writing of such deviation at the time of submittal and (1) the ARCHITECT has given written approval to the specific deviation as a minor change in the WORK, or (2) a Change Order or Construction Change Directive has been issued authorizing the deviation. The CONTRACTOR shall not be relieved of responsibility for errors or omissions in Shop Drawings, Product Data, Samples or similar submittals by the ARCHITECT's approval thereof.

**§ 3.12.9** The CONTRACTOR shall direct specific attention, in writing or on resubmitted Shop Drawings, Product Data, Samples or similar submittals, to revisions other than those requested by the ARCHITECT on previous submittals. In the absence of such written notice the ARCHITECT's approval of a resubmission shall not apply to such revisions.

**§ 3.12.10** The CONTRACTOR shall not be required to provide professional services which constitute the practice of architecture or engineering unless such services are specifically required by the Contract Documents for a portion of the WORK or unless the CONTRACTOR needs to provide such services in order to carry out the CONTRACTOR's responsibilities for construction means, methods, techniques, sequences and procedures. The CONTRACTOR shall not be required to provide professional services in violation of applicable law. If professional design services or certifications by a design professional related to systems, materials or equipment are specifically required of the CONTRACTOR by the Contract Documents, the OWNER and the ARCHITECT will specify all performance and design criteria that such services must satisfy. The CONTRACTOR shall cause such services or certifications to be provided by a properly licensed design professional, and who shall comply with requirements of OWNER regarding qualifications and insurance, whose signature and seal shall appear on all drawings, calculations, specifications, certifications, Shop Drawings and other submittals prepared by such professional. Shop Drawings and other submittals related to the WORK designed or certified by such professional, if prepared by others, shall bear such professional's written approval when submitted to the ARCHITECT. The OWNER and the ARCHITECT shall be entitled to rely upon the adequacy, accuracy and completeness of the services, certifications or approvals performed by such design professionals, provided the OWNER and ARCHITECT have specified to the CONTRACTOR all performance and design criteria that such services must satisfy. Pursuant to this Section 3.12.10, the ARCHITECT will review, approve or take other appropriate action on submittals only for the limited purpose of checking for conformance with information given and the design concept expressed in the Contract Documents. The CONTRACTOR shall not be responsible for the adequacy of the performance or design criteria required by the Contract Documents.

### **§ 3.13 USE OF SITE**

**§ 3.13.1** The CONTRACTOR shall confine operations at the site to areas permitted by law, ordinances, permits and the Contract Documents and shall not unreasonably encumber the site with materials or equipment.

### **§ 3.14 CUTTING AND PATCHING**

**§ 3.14.1** The CONTRACTOR shall be responsible for cutting, fitting or patching required to complete the WORK or to make its parts fit together properly.

**§ 3.14.2** The CONTRACTOR shall not damage or endanger a portion of the WORK or fully or partially completed construction of the OWNER or separate contractors by cutting, patching or otherwise altering such construction, or by excavation. The CONTRACTOR shall not cut or otherwise alter such construction by the OWNER or a separate contractor except with written consent of the OWNER and of such separate contractor; such consent shall not be

unreasonably withheld. The CONTRACTOR shall not unreasonably withhold from the OWNER or a separate contractor the CONTRACTOR's consent to cutting or otherwise altering the WORK.

### § 3.15 CLEANING UP

§ 3.15.1 The CONTRACTOR shall keep the premises and surrounding area free from accumulation of waste materials or rubbish caused by operations under the Contract. At completion of the WORK, the CONTRACTOR shall remove from and about the Project waste materials, rubbish, the Contractor's tools, construction equipment, machinery and surplus materials.

§ 3.15.2 If the CONTRACTOR fails to clean up as provided in the Contract Documents, the OWNER may do so and the cost thereof shall be charged to the CONTRACTOR.

### § 3.16 ACCESS TO WORK

§ 3.16.1 The CONTRACTOR shall provide the OWNER and ARCHITECT access to the WORK in preparation and progress wherever located.

### § 3.17 ROYALTIES, PATENTS AND COPYRIGHTS

§ 3.17.1 The CONTRACTOR shall pay all royalties and license fees. The CONTRACTOR shall defend suits or claims for infringement of copyrights and patent rights and shall hold the OWNER and ARCHITECT harmless from loss on account thereof, but shall not be responsible for such defense or loss when a particular design, process or product of a particular manufacturer or manufacturers is required by the Contract Documents or where the copyright violations are contained in Drawings, Specifications or other documents prepared by the OWNER or ARCHITECT. However, if the CONTRACTOR has reason to believe that the required design, process or product is an infringement of a copyright or a patent, the CONTRACTOR shall be responsible for such loss unless such information is promptly furnished to the ARCHITECT.

### § 3.18 INDEMNIFICATION

§ 3.18.1 To the fullest extent permitted by law, CONTRACTOR shall indemnify, defend and hold harmless OWNER, the Commissioners' Court of OWNER, all elected officials, employees and agents of OWNER of any of the above mentioned parties (the "INDEMNIFIED PARTIES") from and against any and all loss, cost, expense, damage, injury, liability, claim, demand, penalty, or cause of action (including attorney's fees), directly or indirectly arising out of, resulting from, or related to (in whole or in part), (1) the WORK performed hereunder; (2) the Contract, or (3) the act of omission of CONTRACTOR, a Subcontractor, or an individual, partnership, joint venture, or corporation (a) directly or indirectly employed by CONTRACTOR or a Subcontractor, (b) for whose acts or omissions CONTRACTOR or a Subcontractor may be liable (excluding property damage to the WORK itself, covered by OWNER's all-risk builder's risk insurance, subject to CONTRACTOR's liability for any deductible amounts there under). The obligations of CONTRACTOR under this indemnification shall apply to all matters except those arising solely from the wanton and willful negligence or the malicious acts or omissions of OWNER. Further, the obligations of CONTRACTOR under this indemnification shall not extend to the liability of ARCHITECT, its agents, or employees, arising out of (1) the preparation or approval of maps, drawings, opinions, reports, surveys, Change Orders, designs, or Specifications, (2) the giving of or failure to give directions of instructions by ARCHITECT, its agents, or employees, provided such giving or failure to give is the primary cause of the injury or damage, or (3) any matter prohibited by Section 130.002, Texas Civil Practice and Remedies Code. CONTRACTOR shall promptly advise OWNER in writing of any action, administrative or legal proceeding, or investigation as to which this indemnification may apply, and CONTRACTOR, at Contractor's expense, shall assume on behalf of OWNER and conduct with due diligence and in good faith the defense thereof with counsel satisfactory to OWNER, provided, OWNER shall have the right to be represented therein by advisory counsel of its own selection and at its own expense; and provided further, that if the defendants, in any such action, include both CONTRACTOR and OWNER, and OWNER shall have reasonably concluded that there may be legal defenses available to it that are different from, in addition to, or inconsistent with, those available to CONTRACTOR, then OWNER shall have the right to select separate counsel to participate in the defense of such action on its own behalf at CONTRACTOR's expense. In the event of failure by CONTRACTOR to fully perform in accordance with this indemnification paragraph, OWNER, at its option, and without relieving CONTRACTOR of its obligations hereunder, may so perform, but all costs and expenses so incurred by OWNER in that event shall be reimbursed by CONTRACTOR to OWNER, together with interest on the same from the date any such expense was paid by OWNER until reimbursed by CONTRACTOR, at the rate of interest provided to be paid on judgments, by the law of the jurisdiction to which the interpretation of the Contract is subject. The obligations of CONTRACTOR under

this Section shall survive the expiration of the Contract and specifically shall survive the limitations contained in Subsection 4.3.5 hereof.

#### ARTICLE 4 ADMINISTRATION OF THE CONTRACT

##### § 4.1 ARCHITECT

§ 4.1.1 The ARCHITECT is the person lawfully licensed to practice architecture or an entity lawfully practicing architecture identified as such in the Agreement and is referred to throughout the Contract Documents as if singular in number. The term "ARCHITECT" means the ARCHITECT or the Architect's authorized representative.

§ 4.1.2 Duties, responsibilities and limitations of authority of the ARCHITECT as set forth in the Contract Documents shall not be restricted, modified or extended without written consent of the OWNER, CONTRACTOR and ARCHITECT. Consent shall not be unreasonably withheld.

§ 4.1.3 If the employment of the ARCHITECT is terminated, the OWNER shall employ a new ARCHITECT against whom the CONTRACTOR has no reasonable objection and whose status under the Contract Documents shall be that of the former ARCHITECT.

##### § 4.2 ARCHITECT'S ADMINISTRATION OF THE CONTRACT

§ 4.2.1 The ARCHITECT will provide administration of the Contract as described in the Contract Documents, and will be an Owner's representative (1) during construction, (2) until final payment is due and (3) with the Owner's concurrence, from time to time during the one-year period for correction of WORK described in Section 12.2. The ARCHITECT will have authority to act on behalf of the OWNER only to the extent provided in the Contract Documents, unless otherwise modified in writing in accordance with other provisions of the Contract.

§ 4.2.2 The ARCHITECT, as a representative of the OWNER, will visit the site at intervals appropriate to the stage of the CONTRACTOR's operations (1) to become generally familiar with and to keep the OWNER informed about the progress and quality of the portion of the WORK completed, (2) to endeavor to guard the OWNER against defects and deficiencies in the WORK, and (3) to determine in general if the WORK is being performed in a manner indicating that the WORK, when fully completed, will be in accordance with the Contract Documents. However, the ARCHITECT will not be required to make exhaustive or continuous on-site inspections to check the quality or quantity of the WORK. The ARCHITECT will neither have control over or charge of, nor be responsible for, the construction means, methods, techniques, sequences or procedures, or for the safety precautions and programs in connection with the WORK, since these are solely the CONTRACTOR's rights and responsibilities under the Contract Documents, except as provided in Section 3.3.1.

§ 4.2.3 The ARCHITECT shall not have control over or charge of and shall not be responsible for safety precautions and programs in connection with the WORK. ARCHITECT shall be responsible for promptly notifying CONTRACTOR of the failure of CONTRACTOR, Subcontractors or any other persons performing any of the WORK, in failing to use proper construction means, methods, techniques, sequences, procedures, safety precautions and programs, but only to the extent ARCHITECT becomes aware of, or should, exercising due professional diligence, be aware of same. ARCHITECT shall also promptly notify OWNER in writing of the failure of any of the foregoing parties to carry out the WORK in accordance with the Contract Documents..

§ 4.2.4 Communications Facilitating Contract Administration. Except as otherwise provided in the Contract Documents or when direct communications have been specially authorized, the OWNER and CONTRACTOR shall endeavor to communicate with each other through the ARCHITECT about matters arising out of or relating to the Contract. Communications by and with the ARCHITECT's consultants shall be through the ARCHITECT. Communications by and with Subcontractors and material suppliers shall be through the CONTRACTOR. Communications by and with separate contractors shall be through the OWNER.

§ 4.2.5 Based on the ARCHITECT's evaluations of the Contractor's Applications for Payment, the ARCHITECT will review and certify the amounts due the CONTRACTOR and will issue Certificates for Payment in such amounts.

§ 4.2.6 The ARCHITECT will have authority and the responsibility to reject WORK that does not conform to the Contract Documents. Whenever the ARCHITECT considers it necessary or advisable, the ARCHITECT will have authority to require inspection or testing of the WORK in accordance with Sections 13.5.2 and 13.5.3, whether or

not such WORK is fabricated, installed or completed. However, neither this authority of the ARCHITECT nor a decision made in good faith either to exercise or not to exercise such authority shall give rise to a duty or responsibility of the ARCHITECT to the CONTRACTOR, Subcontractors, material and equipment suppliers, their agents or employees, or other persons or entities performing portions of the WORK.

**§ 4.2.7** The ARCHITECT will review and approve or reject or take other appropriate action upon the CONTRACTOR's submittals such as Shop Drawings, Product Data and Samples, but only for the limited purpose of checking for conformance with information given and the design concept expressed in the Contract Documents. The ARCHITECT's action will be taken with such reasonable promptness as to cause no delay in the WORK or in the activities of the OWNER, CONTRACTOR or separate contractors, while allowing sufficient time in the ARCHITECT's professional judgment to permit adequate review. Review of such submittals is not conducted for the purpose of determining the accuracy and completeness of other details such as dimensions and quantities, or for substantiating instructions for installation or performance of equipment or systems, all of which remain the responsibility of the CONTRACTOR as required by the Contract Documents. The ARCHITECT's review of the CONTRACTOR's submittals shall not relieve the CONTRACTOR of the obligations under Sections 3.3, 3.5 and 3.12. The ARCHITECT's review shall not constitute approval of safety precautions or, unless otherwise specifically stated by the ARCHITECT, of any construction means, methods, techniques, sequences or procedures. The ARCHITECT's approval of a specific item shall not indicate approval of an assembly of which the item is a component.

**§ 4.2.8** The ARCHITECT will prepare Change Orders and Construction Change Directives, and may authorize minor changes in the WORK as provided in Section 7.4.

**§ 4.2.9** The ARCHITECT will conduct inspections to determine the date or dates of Substantial Completion and the date of final completion, will receive and forward to the OWNER, for the OWNER's review and records, written warranties and related documents required by the Contract and assembled by the CONTRACTOR, and will issue a final Certificate for Payment upon compliance with the requirements of the Contract Documents.

**§ 4.2.10** If the OWNER and ARCHITECT agree, the ARCHITECT will provide one or more project representatives to assist in carrying out the ARCHITECT's responsibilities at the site. The duties, responsibilities and limitations of authority of such project representatives shall be as set forth in an exhibit to be incorporated in the Contract Documents.

**§ 4.2.11** The ARCHITECT will interpret and decide matters concerning performance under and requirements of, the Contract Documents on written request of either the OWNER or CONTRACTOR. The ARCHITECT's response to such requests will be made in writing within any time limits agreed upon or otherwise with reasonable promptness. If no agreement is made concerning the time within which interpretations required of the ARCHITECT shall be furnished in compliance with this Section 4.2, then delay shall not be recognized on account of failure by the ARCHITECT to furnish such interpretations until 15 days after written request is made for them.

**§ 4.2.12** Interpretations and decisions of the ARCHITECT will be consistent with the intent of and reasonably inferable from the Contract Documents and will be in writing or in the form of drawings. When making such interpretations and initial decisions, the ARCHITECT will endeavor to secure faithful performance by both OWNER and CONTRACTOR, will not show partiality to either and will not be liable for results of interpretations or decisions so rendered in good faith.

### **§ 4.3 CLAIMS AND DISPUTES**

**§ 4.3.1** Definition. A Claim is a demand or assertion by one of the parties seeking, as a matter of right, adjustment or interpretation of Contract terms, payment of money, extension of time or other relief with respect to the terms of the Contract. The term "Claim" also includes other disputes and matters in question between the OWNER and CONTRACTOR arising out of or relating to the Contract. Claims must be initiated by written notice. The responsibility to substantiate Claims shall rest with the party making the Claim.

**§ 4.3.2** Time Limits on Claims. Claims by either party must be initiated within 21 days after occurrence of the event giving rise to such Claim or within 21 days after the claimant first recognizes the condition giving rise to the Claim, whichever is later. Claims must be initiated by written notice to the ARCHITECT and the other party. Said written

notice of Claims shall state specifically the reason for the Claim, the date or dates of the cause of causes or the Claim, and if any extension of time is requested, the number of days of extension requested.

**§ 4.3.3 Continuing Contract Performance.** Pending final resolution of a Claim except as otherwise agreed in writing or as provided in Section 9.7.1 and Article 14, the CONTRACTOR shall proceed diligently with performance of the Contract and the OWNER shall continue to make payments in accordance with the Contract Documents.

**§ 4.3.4 Claims for Concealed or Unknown Conditions.** If conditions are encountered at the site which are (1) subsurface or otherwise concealed physical conditions which differ materially from those indicated in the Contract Documents or (2) unknown physical conditions of an unusual nature, which differ materially from those ordinarily found to exist and generally recognized as inherent in construction activities of the character provided for in the Contract Documents, then notice by the observing party shall be given to the other party promptly before conditions are disturbed and in no event later than 21 days after first observance of the conditions. The ARCHITECT will promptly investigate such conditions and, if they differ materially and cause an increase or decrease in the Contractor's cost of, or time required for, performance of any part of the WORK, will recommend an equitable adjustment in the Contract Sum or Contract Time, or both. If the ARCHITECT determines that the conditions at the site are not materially different from those indicated in the Contract Documents and that no change in the terms of the Contract is justified, the ARCHITECT shall so notify the OWNER and CONTRACTOR in writing, stating the reasons. Claims by either party in opposition to such determination must be made within 21 days after the ARCHITECT has given notice of the decision. If the conditions encountered are materially different, the Contract Sum and Contract Time shall be equitably adjusted, but if the OWNER and CONTRACTOR cannot agree on an adjustment in the Contract Sum or Contract Time, the adjustment shall be referred to the ARCHITECT for initial determination, subject to further proceedings pursuant to Section 4.4. No adjustment in the Contract Time or Contract Sum shall be permitted, however, in connection with a concealed or unknown condition that does not differ materially from those conditions disclosed or that reasonably should have been disclosed by CONTRACTOR's (i) prior inspection, tests, reviews, and preconstruction services for the Project, or (ii) inspections, tests, reviews, and preconstruction services that CONTRACTOR had the opportunity to make or should have performed in connection with the Project.

**§ 4.3.5 Claims for Additional Cost.** If the CONTRACTOR wishes to make Claim for an increase in the Contract Sum, written notice as provided herein shall be given before proceeding to execute the WORK. Said notice shall itemize all claims and shall contain sufficient detail substantiating data to permit evaluation of same by OWNER and ARCHITECT. No such claims shall be of value unless so made. Prior notice is not required for Claims relating to an emergency endangering life or property arising under Section 10.6.

**§ 4.3.6** If the CONTRACTOR believes additional cost is involved for reasons including but not limited to (1) a written interpretation from the ARCHITECT, (2) an order by the OWNER to stop the WORK where the CONTRACTOR was not at fault, (3) a written order for a minor change in the WORK issued by the ARCHITECT, (4) failure of payment by the OWNER, (5) termination of the Contract by the OWNER, (6) OWNER's suspension or (7) other reasonable grounds, Claim shall be filed in accordance with this Section 4.3.

**§ 4.3.7 Claims for Additional Time**

**§ 4.3.7.1** If the CONTRACTOR wishes to make Claim for an increase in the Contract Time, written notice as provided herein shall be given. The CONTRACTOR's Claim shall include an estimate of cost and of probable effect of delay on progress of the WORK. In the case of a continuing delay only one Claim is necessary.

**§ 4.3.7.2** If adverse weather conditions are the basis for a Claim for additional time, such Claim shall be documented by data substantiating that weather conditions were abnormal for the period of time, could not have been reasonably anticipated and had an adverse effect on the scheduled construction. Extensions of time may be requested for any month of construction for days lost due to adverse weather in excess of the normally expected lost time; provided however, if ARCHITECT determines that the seasonal average of adverse weather days during construction is less than would be normally expected, no Change Order shall be issued and the request for extension of time shall be denied.

**§ 4.3.8 Injury or Damage to Person or Property.** If either party to the Contract suffers injury or damage to person or property because of an act or omission of the other party, or of others for whose acts such party is legally responsible, written notice of such injury or damage, whether or not insured, shall be given to the other party within

a reasonable time not exceeding 21 days after discovery. The notice shall provide sufficient detail to enable the other party to investigate the matter.

§ 4.3.9 If unit prices are stated in the Contract Documents or subsequently agreed upon, and if quantities originally contemplated are materially changed in a proposed Change Order or Construction Change Directive so that application of such unit prices to quantities of WORK proposed will cause substantial inequity to the OWNER or CONTRACTOR, the applicable unit prices shall be equitably adjusted.

§ 4.3.10 CONTRACTOR shall not be entitled to claims for additional time and/or increase in Contract price due to a problem or no-performance of a Subcontractor.

#### § 4.4 RESOLUTION OF CLAIMS AND DISPUTES

§ 4.4.1 Decision of ARCHITECT. Claims, including those alleging an error or omission by the ARCHITECT but excluding those arising under Sections 10.3 through 10.5, shall be referred initially to the ARCHITECT for decision. An initial decision by the ARCHITECT shall be required as a condition precedent to mediation, arbitration or litigation of all Claims between the CONTRACTOR and OWNER arising prior to the date final payment is due, unless 30 days have passed after the Claim has been referred to the ARCHITECT with no decision having been rendered by the ARCHITECT. The ARCHITECT will not decide disputes between the CONTRACTOR and persons or entities other than the OWNER.

§ 4.4.2 The ARCHITECT will review Claims and within ten (10) days of the receipt of the Claim take one or more of the following actions: (1) request additional supporting data from the claimant or a response with supporting data from the other party, (2) reject the Claim in whole or in part, (3) approve the Claim in whole or in part, (4) suggest a compromise, or (5) advise the parties that the ARCHITECT is unable to resolve the Claim if the ARCHITECT lacks sufficient information to evaluate the merits of the Claim or if the ARCHITECT concludes that, in the ARCHITECT's sole discretion, it would be inappropriate for the ARCHITECT to resolve the Claim.

§ 4.4.3 In evaluating Claims, the ARCHITECT may, but shall not be obligated to, consult with or seek information from either party or from persons with special knowledge or expertise who may assist the ARCHITECT in rendering a decision. The ARCHITECT may request the OWNER to authorize retention of such persons at the OWNER's expense.

§ 4.4.4 If the ARCHITECT requests a party to provide a response to a Claim or to furnish additional supporting data, such party shall respond, within ten (10) days after receipt of such request, and shall either provide a response on the requested supporting data, advise the ARCHITECT when the response or supporting data will be furnished or advise the ARCHITECT that no supporting data will be furnished. Upon receipt of the response or supporting data, if any, the ARCHITECT will either reject or approve the Claim in whole or in part.

§ 4.4.5 The ARCHITECT will approve or reject Claims by written decision, which shall state the reasons therefor and which shall notify the parties of any change in the Contract Sum or Contract Time or both. The approval or rejection of a Claim by the ARCHITECT shall be final and binding on the parties but subject to mediation and arbitration.

§ 4.4.7 Upon receipt of a Claim against the CONTRACTOR or at any time thereafter, the ARCHITECT or the OWNER may, but is not obligated to, notify the surety, if any, of the nature and amount of the Claim. If the Claim relates to a possibility of a CONTRACTOR's default, the ARCHITECT or the OWNER may, but is not obligated to, notify the surety and request the surety's assistance in resolving the controversy.

#### ARTICLE 5 SUBCONTRACTORS

##### § 5.1 DEFINITIONS

§ 5.1.1 A Subcontractor is a person or entity who has a direct contract with the CONTRACTOR to perform a portion of the WORK at the site or to otherwise furnish labor, material, or other services with respect to a portion of the WORK. The term "Subcontractor" is referred to throughout the Contract Documents as if singular in number and means a Subcontractor or an authorized representative of the Subcontractor. The term "Subcontractor" does not include a separate contractor or subcontractors of a separate contractor.

§ 5.1.2 A Sub-subcontractor is a person or entity who has a direct or indirect contract with a Subcontractor to perform a portion of the WORK at the site or to otherwise furnish labor, material, or other services with respect to a portion of the WORK. The term "Sub-subcontractor" is referred to throughout the Contract Documents as if singular in number and means a Sub-subcontractor or an authorized representative of the Sub-subcontractor.

**§ 5.2 AWARD OF SUBCONTRACTS AND OTHER CONTRACTS FOR PORTIONS OF THE WORK**

§ 5.2.1 Unless otherwise stated in the Contract Documents or the bidding requirements, the CONTRACTOR, as soon as practicable after award of the Contract, shall furnish in writing to the OWNER through the ARCHITECT the names of persons or entities (including those who are to furnish materials or equipment fabricated to a special design) proposed for each principal portion of the WORK. The ARCHITECT will promptly reply to the CONTRACTOR in writing stating whether or not the OWNER or the ARCHITECT, after due investigation, has reasonable objection to any such proposed person or entity. Failure of the OWNER or ARCHITECT to reply promptly shall constitute notice of no reasonable objection.

§ 5.2.2 The CONTRACTOR shall not contract with a proposed person or entity to whom the OWNER or ARCHITECT has made reasonable and timely objection. The CONTRACTOR shall not be required to contract with anyone to whom the CONTRACTOR has made reasonable objection.

§ 5.2.3 If the OWNER or ARCHITECT has reasonable objection to a person or entity proposed by the CONTRACTOR, the CONTRACTOR shall propose another to whom the OWNER or ARCHITECT has no reasonable objection.

§ 5.2.4 The CONTRACTOR shall change a Subcontractor, person or entity previously selected if the OWNER or ARCHITECT makes reasonable objection to such substitute.

**§ 5.3 SUBCONTRACTUAL RELATIONS**

§ 5.3.1 By appropriate written agreement, the CONTRACTOR shall require each Subcontractor, to the extent of the WORK to be performed by the Subcontractor, to be bound to the CONTRACTOR by terms of the Contract Documents, and to assume toward the CONTRACTOR all the obligations and responsibilities, including the responsibility for safety of the Subcontractor's Work, which the CONTRACTOR, by these Documents, assumes toward the OWNER and ARCHITECT. Each subcontract agreement shall preserve and protect the rights of the OWNER and ARCHITECT under the Contract Documents with respect to the WORK to be performed by the Subcontractor so that subcontracting thereof will not prejudice such rights, and shall allow to the Subcontractor, unless specifically provided otherwise in the subcontract agreement, the benefit of all rights, remedies and redress against the CONTRACTOR that the CONTRACTOR, by the Contract Documents, has against the OWNER. Where appropriate, the CONTRACTOR shall require each Subcontractor to enter into similar agreements with Sub-subcontractors. The Contractor shall make available to each proposed Subcontractor, prior to the execution of the subcontract agreement, copies of the Contract Documents to which the Subcontractor will be bound, and, upon written request of the Subcontractor, identify to the Subcontractor terms and conditions of the proposed subcontract agreement which may be at variance with the Contract Documents. Subcontractors will similarly make copies of applicable portions of such documents available to their respective proposed Sub-subcontractors.

§ 5.3.2 All subcontracts shall be in written form and shall specifically provide that OWNER is an intended third-party beneficiary of the subcontract.

**§ 5.4 CONTINGENT ASSIGNMENT OF SUBCONTRACTS**

§ 5.4.1 Each subcontract agreement for a portion of the WORK is assigned by the CONTRACTOR to the OWNER provided that:

- .1 assignment is effective only after termination of the Contract by the OWNER for cause pursuant to Section 14.2 and only for those subcontract agreements which the OWNER accepts by notifying the Subcontractor and CONTRACTOR in writing; and
- .2 assignment is subject to the prior rights of the surety, if any, obligated under bond relating to the Contract.

§ 5.4.2 Upon such assignment, if the WORK has been suspended for more than 30 days, the Subcontractor's compensation shall be equitably adjusted for increases in cost resulting from the suspension.

§ 5.5 CONTRACTOR shall promptly notify OWNER and ARCHITECT of any material defaults by any Subcontractor. Notwithstanding any provision contained in Article 5 to the contrary, it is hereby acknowledged and agreed that OWNER has in no way agreed expressly or implicitly, nor will OWNER agree, to allow any Subcontractor or other materialman or workman employed by CONTRACTOR the right to obtain a personal judgment or to create a lien against OWNER for the amount due from the CONTRACTOR.

## ARTICLE 6 CONSTRUCTION BY OWNER OR BY SEPARATE CONTRACTORS

### § 6.1 OWNER'S RIGHT TO PERFORM CONSTRUCTION AND TO AWARD SEPARATE CONTRACTS

§ 6.1.1 The OWNER reserves the right to perform construction or operations related to the Project with the OWNER's own forces, and to award separate contracts in connection with other portions of the Project or other construction or operations on the site under Conditions of the Contract identical or substantially similar to these including those portions related to insurance and waiver of subrogation. If the CONTRACTOR claims that delay or additional cost is involved because of such action by the OWNER, the CONTRACTOR shall make such Claim as provided in Section 4.3.

§ 6.1.2 When separate contracts are awarded for different portions of the Project or other construction or operations on the site, the term "CONTRACTOR" in the Contract Documents in each case shall mean the CONTRACTOR who executes each separate Owner-Contractor Agreement.

§ 6.1.3 The OWNER shall provide for coordination of the activities of the OWNER's own forces and of each separate contractor with the WORK of the CONTRACTOR, who shall cooperate with them. The CONTRACTOR shall participate with other separate contractors and the OWNER in reviewing their construction schedules when directed to do so. The CONTRACTOR shall make any revisions to the construction schedule deemed necessary after a joint review and mutual agreement. The construction schedules shall then constitute the schedules to be used by the CONTRACTOR, separate contractors and the OWNER until subsequently revised.

§ 6.1.4 Unless otherwise provided in the Contract Documents, when the OWNER performs construction or operations related to the Project with the OWNER's own forces, the OWNER shall be deemed to be subject to the same obligations and to have the same rights which apply to the CONTRACTOR under the Conditions of the Contract, including, without excluding others, those stated in Article 3, this Article 6 and Articles 10, 11 and 12.

### § 6.2 MUTUAL RESPONSIBILITY

§ 6.2.1 The CONTRACTOR shall afford the OWNER and separate contractors reasonable opportunity for introduction and storage of their materials and equipment and performance of their activities, and shall connect and coordinate the CONTRACTOR's construction and operations with theirs as required by the Contract Documents.

§ 6.2.2 If part of the CONTRACTOR's WORK depends for proper execution or results upon construction or operations by the OWNER or a separate contractor, the CONTRACTOR shall, prior to proceeding with that portion of the WORK, promptly report to the ARCHITECT apparent discrepancies or defects in such other construction that would render it unsuitable for such proper execution and results. Failure of the CONTRACTOR so to report shall constitute an acknowledgment that the OWNER's or separate contractor's completed or partially completed construction is fit and proper to receive the CONTRACTOR's WORK, except as to defects not then reasonably discoverable.

§ 6.2.3 The OWNER shall be reimbursed by the CONTRACTOR for costs incurred by the OWNER which are payable to a separate contractor because of delays, improperly timed activities or defective construction of the CONTRACTOR.

§ 6.2.4 The CONTRACTOR shall promptly remedy damage caused by the CONTRACTOR to completed or partially completed construction or to property of the OWNER or separate contractors as provided in Section 10.2.5.

§ 6.2.5 The OWNER and each separate contractor shall have the same responsibilities for cutting and patching as are described for the CONTRACTOR in Section 3.14.

### § 6.3 OWNER'S RIGHT TO CLEAN UP

§ 6.3.1 If a dispute arises among the CONTRACTOR, separate contractors and the OWNER as to the responsibility under their respective contracts for maintaining the premises and surrounding area free from waste materials and rubbish, the OWNER may clean up and the ARCHITECT will allocate the cost among those responsible.

## ARTICLE 7 CHANGES IN THE WORK

### § 7.1 GENERAL

§ 7.1.1 Changes in the WORK may be accomplished after execution of the Contract, and without invalidating the Contract, only by Change Order, Construction Change Directive or order for a minor change in the WORK, subject to the limitations stated in this Article 7 and elsewhere in the Contract Documents.

§ 7.1.2 A Change Order shall be based upon agreement among the OWNER, CONTRACTOR and ARCHITECT; a Construction Change Directive requires agreement by the OWNER and ARCHITECT and may or may not be agreed to by the CONTRACTOR; an order for a minor change in the WORK may be issued by the ARCHITECT and is subject to the approval of OWNER.

§ 7.1.3 Changes in the WORK shall be performed under applicable provisions of the Contract Documents, and the CONTRACTOR shall proceed promptly, unless otherwise provided in the Change Order, Construction Change Directive or order for a minor change in the WORK. Except as permitted in Paragraph 7.3 and subparagraph 9.7.2, a change in the Contract Sum or the contract Time shall be accomplished only by Change Order. Accordingly, no course of conduct or dealings between the parties, nor express or implied acceptance of alteration of additions to the WORK and no claim that OWNER has been unjustly enriched by an alteration of or addition to the WORK, whether or not there is, in fact, any unjust enrichment to the WORK, shall be the basis of any claim to an increase in any amounts due under the Contract Documents or a change in any time period provided for in the Contract Documents.

### § 7.2 CHANGE ORDERS

§ 7.2.1 A Change Order is a written instrument prepared by the ARCHITECT and signed by the OWNER, CONTRACTOR and ARCHITECT, stating their agreement upon all of the following:

- .1 change in the WORK;
- .2 the amount of the adjustment, if any, in the Contract Sum; and
- .3 the extent of the adjustment, if any, in the Contract Time.

§ 7.2.2 Methods used in determining adjustments to the Contract Sum may include those listed in Section 7.3.3.

§ 7.2.3 Agreement on any Change Order shall constitute a final settlement of all matters relating to the change in the WORK that is the subject of the Change Order, including, but not limited to, all direct and indirect cost associated with such change and any and all adjustments to the Contract Sum and the construction schedule.

§ 7.2.4 CONTRACTOR shall keep and periodically submit to OWNER copies of a log for all Change Orders.

### § 7.3 CONSTRUCTION CHANGE DIRECTIVES

§ 7.3.1 A Construction Change Directive is a written order prepared by the ARCHITECT and signed by the OWNER and ARCHITECT, directing a change in the WORK prior to agreement on adjustment, if any, in the Contract Sum or Contract Time, or both. The OWNER may by Construction Change Directive, without invalidating the Contract, order changes in the WORK within the general scope of the Contract consisting of additions, deletions or other revisions, the Contract Sum and Contract Time being adjusted accordingly. CONTRACTOR shall keep and periodically submit to OWNER copies of a log for all Construction Change Directives and a log for all requests for information.

§ 7.3.2 A Construction Change Directive shall be used in the absence of total agreement on the terms of a Change Order.

§ 7.3.3 If the Construction Change Directive provides for an adjustment to the Contract Sum, the adjustment shall be based on one of the following methods:

- .1 mutual acceptance of a lump sum properly itemized and supported by sufficient substantiating data to permit evaluation;
- .2 unit prices stated in the Contract Documents or subsequently agreed upon;

- .3 cost to be determined in a manner agreed upon by the parties and a mutually acceptable fixed or percentage fee; or
- .4 as provided in Section 7.3.6.

**§ 7.3.4** Upon receipt of a Construction Change Directive, the CONTRACTOR shall promptly proceed with the change in the WORK involved and advise the ARCHITECT of the CONTRACTOR's agreement or disagreement with the method, if any, provided in the Construction Change Directive for determining the proposed adjustment in the Contract Sum or Contract Time.

**§ 7.3.5** A Construction Change Directive signed by the CONTRACTOR indicates the agreement of the CONTRACTOR therewith, including adjustment in Contract Sum and Contract Time or the method for determining them. Such agreement shall be effective immediately and shall be recorded as a Change Order.

**§ 7.3.6** If the CONTRACTOR does not respond promptly or disagrees with the method for adjustment in the Contract Sum, the method and the adjustment shall be determined by the ARCHITECT on the basis of reasonable expenditures and savings of those performing the WORK attributable to the change, including, in case of an increase in the Contract Sum, a reasonable allowance for overhead and profit not to exceed a total maximum of fifteen percent (15%) for all WORK done by CONTRACTOR's employees and ten (10%) of such WORK's actual cost to be apportioned between any and all Subcontractors and Sub-subcontractors. In such case, and also under Section 7.3.3.3, the CONTRACTOR shall keep and present, in such form as the ARCHITECT may prescribe, an itemized accounting together with appropriate supporting data. Unless otherwise provided in the Contract Documents, costs for the purposes of this Section 7.3.6 shall be limited to the following:

- .1 costs of labor, including social security, old age and unemployment insurance, fringe benefits required by agreement or custom, and workers' compensation insurance;
- .2 costs of materials, supplies and equipment, including cost of transportation, whether incorporated or consumed;
- .3 rental costs of machinery and equipment, exclusive of hand tools, whether rented from the CONTRACTOR or others;
- .4 costs of premiums for all bonds and insurance, permit fees, and sales, use or similar taxes related to the WORK; and
- .5 additional costs of supervision and field office personnel directly attributable to the change.

Actual cost does not include any item that could be deemed to be a general conditions cost or overhead, such as, but not limited to, the cost of CONTRACTOR and Subcontractor supervisory personnel assigned to the WORK, and field office and related expenses.

**§ 7.3.7** The amount of credit to be allowed by the CONTRACTOR to the OWNER for a deletion or change which results in a net decrease in the Contract Sum shall be actual net cost as confirmed by the ARCHITECT. When both additions and credits covering related WORK or substitutions are involved in a change, the allowance for overhead and profit shall be figured on the basis of net increase, if any, with respect to that change.

**§ 7.3.8** Pending final determination of the total cost of a Construction Change Directive to the OWNER, amounts not in dispute for such changes in the WORK shall be included in Applications for Payment accompanied by a Change Order indicating the parties' agreement with part or all of such costs. For any portion of such cost that remains in dispute, the ARCHITECT will make an interim determination for purposes of monthly certification for payment for those costs. That determination of cost shall adjust the Contract Sum on the same basis as a Change Order, subject to the right of either party to disagree and assert a claim in accordance with Article 4.

**§ 7.3.9** When the OWNER and CONTRACTOR agree with the determination made by the ARCHITECT concerning the adjustments in the Contract Sum and Contract Time, or otherwise reach agreement upon the adjustments, such agreement shall be effective immediately and shall be recorded by preparation and execution of an appropriate Change Order.

#### **§ 7.4 MINOR CHANGES IN THE WORK**

**§ 7.4.1** The ARCHITECT will have authority after having obtain OWNER'S approval to order minor changes in the WORK not involving adjustment in the Contract Sum or extension of the Contract Time and not inconsistent with

the intent of the Contract Documents. Such changes shall be effected by written order and shall be binding on the OWNER and CONTRACTOR. The CONTRACTOR shall carry out such written orders promptly.

## ARTICLE 8 TIME

### § 8.1 DEFINITIONS

§ 8.1.1 Unless otherwise provided, Contract Time is the period of time, including authorized adjustments, allotted in the Contract Documents for Substantial Completion of the WORK.

§ 8.1.1.1 The WORK shall be fully completed within the time limit and/or date stated in the Contract between OWNER and CONTRACTOR.

§ 8.1.1.2 Liquidated Damages: If CONTRACTOR shall fail to fully complete the WORK within the stated time (subject however to extension of time duly granted in the manner and for the causes specified in the General Conditions), CONTRACTOR shall be charged by and shall pay to OWNER, as liquidated damages, the sum of \$100.00 (One Hundred Dollars) per calendar day for each calendar day that the WORK remains incomplete beyond the time fixed for the completion. CONTRACTOR hereby agrees that from the nature of the project it would be impracticable and extremely difficult to fix the actual damage that would or will be suffered in the event that CONTRACTOR should fail to fully complete the WORK by the time limit or date stated and the amount of the liquidated damages are fair and reasonable. The parties agree that the liquidated damages are a reasonable forecast of just compensation for the harm done to OWNER that would be caused by CONTRACTOR's failure to timely complete the WORK. CONTRACTOR agrees that the amount of liquidated damages due OWNER may be deducted by OWNER from any moneys that might otherwise be or become payable to CONTRACTOR.

§ 8.1.2 The date of commencement of the WORK is the date established in the Agreement.

§ 8.1.3 The date of Substantial Completion is the date certified by the ARCHITECT in accordance with Section 9.8.

§ 8.1.4 The term "day" as used in the Contract Documents shall mean calendar day unless otherwise specifically defined.

### § 8.2 PROGRESS AND COMPLETION

§ 8.2.1 Time limits stated in the Contract Documents are of the essence. By executing the Agreement the CONTRACTOR confirms that the Contract Time is a reasonable period for performing the WORK.

§ 8.2.2 The CONTRACTOR shall not knowingly, except by agreement or instruction of the OWNER in writing, prematurely commence operations on the site or elsewhere prior to the effective date of insurance required by Article 11 to be furnished by the CONTRACTOR and OWNER. The date of commencement of the WORK shall not be changed by the effective date of such insurance. Unless the date of commencement is established by the Contract Documents or a notice to proceed given by the OWNER, the CONTRACTOR shall notify the OWNER in writing not less than five (5) days or other agreed period before commencing the WORK to permit the timely filing of mortgages, mechanic's liens and other security interests.

§ 8.2.3 The CONTRACTOR shall proceed expeditiously with adequate forces and shall achieve Substantial Completion within the Contract Time.

### § 8.3 DELAYS AND EXTENSIONS OF TIME

§ 8.3.1 If the CONTRACTOR is delayed at any time in the commencement or progress of the WORK by an act or neglect of the OWNER or ARCHITECT, or of an employee of either, or of a separate contractor employed by the OWNER, or by changes ordered in the WORK, or by labor disputes, fire, unusual delay in deliveries, unavoidable casualties or other causes beyond the CONTRACTOR's control, or by delay authorized by the OWNER pending mediation and arbitration, or by other causes which the ARCHITECT determines may justify delay, then the Contract Time shall be extended by Change Order for such reasonable time as the ARCHITECT may determine; provided however, that such extension of Contract Time shall be net of any delays caused by or due to the fault or negligence of CONTRACTOR or that are otherwise the responsibility of CONTRACTOR and shall also be net of any contingency or 'float' time allowance included in Contractor's construction schedule. CONTRACTOR shall, in the event of any occurrence likely to cause a delay, cooperate in good faith with ARCHITECT and OWNER to

minimize and mitigate the impact of any such occurrence and do all things reasonable under circumstances to achieve this goal.

**§ 8.3.2** Claims relating to time shall be made in accordance with applicable provisions of Section 4.3.

**§ 8.3.3** This Section 8.3 does not preclude recovery of damages for delay by either party under other provisions of the Contract Documents. CONTRACTOR shall not be entitled to damages of any type for delays caused by OWNER, his servants, agents, employees, or separate contractors hired or retained by OWNER. CONTRACTOR may receive an extension or extensions, for additional time in which to complete the Contract but shall not receive any damages of any type for such delays. Changes in the WORK, regardless of the extent or number of such Changes or OWNER's exercise of any of its remedies of suspension of the WORK or requirement of correction or re-execution of any defective WORK, shall not under any circumstances be construed as intentional interference with Contractor's performance of the WORK.

## ARTICLE 9 PAYMENTS AND COMPLETION

### § 9.1 CONTRACT SUM

**§ 9.1.1** The Contract Sum is stated in the Agreement and, including authorized adjustments, is the total amount payable by the OWNER to the Contractor for performance of the WORK under the Contract Documents.

### § 9.2 SCHEDULE OF VALUES

**§ 9.2.1** Before the first Application for Payment, the CONTRACTOR shall submit to the OWNER and ARCHITECT a schedule of values allocated to various portions of the WORK, which in the aggregate equals the total Contract Sum, divided so as to facilitate payments to Subcontractors, supported by such evidence of correctness as ARCHITECT and OWNER, shall be used to monitor the progress of the WORK and as a basis for Certificates for Payment. All items with entered values will be transferred by CONTRACTOR to the "Application and Certificate for Payment," and shall include the latest approved Change Orders and Construction Change Directive. Change Order values and Construction Change Directives values shall be broken down to show the various subcontracts. The Application for Payment shall be on a form as provided by ARCHITECT and approved by OWNER. Each item shall show its total scheduled value, value of previous applications, and value of the application, percentage completed, value completed, and value yet to be completed. All blanks and columns must be filled in, including every percentage complete figure.

### § 9.3 APPLICATIONS FOR PAYMENT

**§ 9.3.1** At least ten (10) days before the date established for each progress payment, the CONTRACTOR shall submit to the ARCHITECT an itemized Application for Payment for operations completed in accordance with the schedule of values. Such application shall be notarized, if required, and supported by such data substantiating the CONTRACTOR's right to payment as the OWNER or ARCHITECT may require, such as copies of requisitions from Subcontractors and material suppliers, and reflecting retainage if provided for in the Contract Documents. Any allowances included in the Application for Payment shall be separately itemized with supporting data attached. The Application for Payment shall be accompanied by a certification by an officer of Contractor to the effect that: There are no known mechanic's, materialman's or laborers' liens or claims, or any other liens or claims, legal or equitable, contractual, statutory, or constitutional, outstanding or known to exist at the date of this Application; all due and payable bills with respect to the WORK have been paid to date or are included in the amount requested in the current Application and there is no known basis for the filing of any mechanics', materialman's or laborer's lien or claim, or any other lien or claim, legal or equitable, contractual, statutory, or constitutional, on the WORK; and waivers and releases from all Subcontractors, laborers, and materialmen for WORK done and materials furnished have been obtained in such form as to constitute an effective waiver and release of all such liens and claims under the laws of the state within which the Project is located and shall be delivered to ARCHITECT together with CONTRACTOR's waiver and release of liens and claims at the time of submission of the Application for Payment.

**§ 9.3.1.1** As provided in Section 7.3.8, such applications may include requests for payment on account of changes in the WORK which have been properly authorized by Construction Change Directives, or by interim determinations of the ARCHITECT, but not yet included in Change Orders.

**§ 9.3.1.2** Such applications may not include requests for payment for portions of the WORK for which the CONTRACTOR does not intend to pay to a Subcontractor or material supplier, unless such WORK has been performed by others whom the CONTRACTOR intends to pay.

**§ 9.3.2** Unless otherwise provided in the Contract Documents, payments shall be made on account of materials and equipment delivered and suitably stored at the site for subsequent incorporation in the WORK. If approved in advance by the OWNER, payment may similarly be made for materials and equipment suitably stored off the site at a location agreed upon in writing. Payment for materials and equipment stored on or off the site shall be conditioned upon compliance by the CONTRACTOR with procedures satisfactory to the OWNER to establish the OWNER's title to such materials and equipment or otherwise protect the OWNER's interest, and shall include the costs of applicable insurance, storage and transportation to the site for such materials and equipment stored off the site.

**§ 9.3.3** The CONTRACTOR warrants that title to all WORK covered by an Application for Payment will pass to the OWNER no later than the time of payment. The CONTRACTOR further warrants that upon submittal of an Application for Payment all WORK for which Certificates for Payment have been previously issued and payments received from the OWNER shall, to the best of the CONTRACTOR's knowledge, information and belief, be free and clear of liens, claims, security interests or encumbrances in favor of the CONTRACTOR, Subcontractors, material suppliers, or other persons or entities making a claim by reason of having provided labor, materials and equipment relating to the WORK. The vesting of such title shall not impose any obligations to OWNER or relieve CONTRACTOR of any of its obligations under the Contract, that CONTRACTOR shall remain responsible for damage to or loss of the WORK, whether completed or under construction, until responsibility for the WORK has been accepted by OWNER in the manner set forth in the Contract Documents.

#### **§ 9.4 CERTIFICATES FOR PAYMENT**

**§ 9.4.1** The ARCHITECT will, within seven (7) days after receipt of the CONTRACTOR's Application for Payment, either issue to the OWNER a Certificate for Payment, with a copy to the CONTRACTOR, for such amount as the ARCHITECT determines is properly due, or notify the CONTRACTOR and OWNER in writing of the ARCHITECT's reasons for withholding certification in whole or in part as provided in Section 9.5.1.

**§ 9.4.2** The issuance of a Certificate for Payment will constitute a representation by the ARCHITECT to the OWNER, based on the ARCHITECT's evaluation of the WORK and on all other information available to ARCHITECT including, without limitation, the data comprising the Application for Payment, that the WORK has progressed to the point indicated and that, to the best of the ARCHITECT's knowledge, information and belief, the quality of the WORK is in accordance with the Contract Documents. The foregoing representations are subject to an evaluation of the WORK for conformance with the Contract Documents upon Substantial Completion, to results of subsequent tests and inspections, to correction of minor deviations from the Contract Documents prior to completion and to specific qualifications expressed by the ARCHITECT. The issuance of a Certificate for Payment will further constitute a representation that the CONTRACTOR is entitled to payment in the amount certified and that the aggregate amount theretofore paid to CONTRACTOR plus any applicable retention does not exceed the value of the completed portion of the WORK. However, the issuance of a Certificate for Payment will not be a representation that the ARCHITECT has (1) made exhaustive or continuous on-site inspections to check the quality or quantity of the WORK, (2) reviewed construction means, methods, techniques, sequences or procedures or made examination to ascertain how or for what purpose the CONTRACTOR has used money previously paid on account of the Contract Sum.

#### **§ 9.5 DECISIONS TO WITHHOLD CERTIFICATION**

**§ 9.5.1** The ARCHITECT may withhold a Certificate for Payment in whole or in part, to the extent reasonably necessary to protect the OWNER, if in the ARCHITECT's opinion the representations to the OWNER required by Section 9.4.2 cannot be made. If the ARCHITECT is unable to certify payment in the amount of the Application, the ARCHITECT will notify the CONTRACTOR and OWNER as provided in Section 9.4.1. If the CONTRACTOR and ARCHITECT cannot agree on a revised amount, the ARCHITECT will promptly issue a Certificate for Payment for the amount for which the ARCHITECT is able to make such representations to the OWNER. The ARCHITECT may also withhold a Certificate for Payment or, because of subsequently discovered evidence, may nullify the whole or a part of a Certificate for Payment previously issued, to such extent as may be necessary in the ARCHITECT's opinion to protect the OWNER from loss for which the CONTRACTOR is responsible, including loss resulting from acts and omissions described in Section 3.3.2, because of:

- .1 defective WORK not remedied;
- .2 third party claims filed or reasonable evidence indicating probable filing of such claims unless security acceptable to the OWNER is provided by the CONTRACTOR;

- .3 failure of the CONTRACTOR to make payments properly to Subcontractors or for labor, materials or equipment;
- .4 reasonable evidence that the WORK cannot be completed for the unpaid balance of the Contract Sum;
- .5 damage to the OWNER or another contractor;
- .6 reasonable evidence that the WORK will not be completed within the Contract Time, and that the unpaid balance would not be adequate to cover actual or liquidated damages for the anticipated delay; or
- .7 failure to carry out the WORK in accordance with the Contract Documents.

§ 9.5.2 When the above reasons for withholding certification are removed, certification will be made for amounts previously withheld.

§ 9.5.3 Notwithstanding any provision contained within this Article, if the WORK has not attained Substantial Completion with the contract time, subject to extensions of time allowed under these Conditions, ARCHITECT may withhold any further payment to CONTRACTOR to the extent necessary to preserve sufficient funds to complete the construction of the Project and to cover liquidated damages assessed against CONTRACTOR up to the time of the Application for Payment and to the time it is reasonably anticipated that Substantial Completion will be achieved.

#### § 9.6 PROGRESS PAYMENTS

§ 9.6.1 After the ARCHITECT has issued a Certificate for Payment, the OWNER shall make payment in the manner and within the time provided in the Contract Documents, and shall so notify the ARCHITECT. OWNER may refuse to make payment on any Certificate for Payment for any default of the Contract, including, but not limited to, those defaults set for in Clauses 9.5.1.1 through 9.5.1.7. OWNER shall not be deemed in default by reason of withholding payment while any of such defaults remain uncured.

§ 9.6.2 The CONTRACTOR shall promptly pay each Subcontractor, upon receipt of payment from the OWNER, out of the amount paid to the CONTRACTOR on account of such Subcontractor's portion of the WORK, the amount to which said Subcontractor is entitled, reflecting percentages actually retained from payments to the CONTRACTOR on account of such Subcontractor's portion of the WORK. The CONTRACTOR shall, by appropriate agreement with each Subcontractor, require each Subcontractor to make payments to Sub-subcontractors in a similar manner.

§ 9.6.3 The ARCHITECT will, on request, furnish to a Subcontractor, if practicable, information regarding percentages of completion or amounts applied for by the CONTRACTOR and action taken thereon by the ARCHITECT and OWNER on account of portions of the WORK done by such Subcontractor.

§ 9.6.4 Neither the OWNER nor ARCHITECT shall have an obligation to pay or to see to the payment of money to a Subcontractor..

§ 9.6.5 Payment to material suppliers shall be treated in a manner similar to that provided in Sections 9.6.2, 9.6.3 and 9.6.4.

§ 9.6.6 A Certificate for Payment, a progress payment, or partial or entire use or occupancy of the Project by the OWNER shall not constitute acceptance of WORK not in accordance with the Contract Documents.

#### § 9.7 FAILURE OF PAYMENT

§ 9.7.1 If the ARCHITECT does not issue a Certificate for Payment, through no fault of the CONTRACTOR, within seven (7) days after receipt of the CONTRACTOR's Application for Payment, or if the OWNER does not, for reasons other than a default of the Contract, including, but not limited to, those defaults set forth in Clauses 9.5.1.1 through 9.5.1.7, pay the CONTRACTOR within seven (7) days after the date established in the Contract Documents the amount certified by the ARCHITECT or awarded by arbitration, then the CONTRACTOR may, upon seven (7) additional days' written notice to the OWNER and ARCHITECT, stop the WORK until payment of the amount owing has been received. The Contract Time shall be extended appropriately and the Contract Sum shall be increased by the amount of the CONTRACTOR's reasonable costs of shut-down, delay and start-up, plus interest as provided for in the Contract Documents.

**§ 9.7.2** If OWNER is entitled to reimbursement or payment from CONTRACTOR under or pursuant to the Contract Documents, such payment shall be made promptly upon demand by OWNER. Notwithstanding anything contained in the Contract Documents to the contrary, if CONTRACTOR fails to promptly make any payment due OWNER, or if OWNER incurs any costs and expenses to cure any default of CONTRACTOR or to correct defective WORK, OWNER shall have an absolute right to offset such amount against the Contract Sum and may, in Owner's sole discretion, elect either to (i) deduct an amount equal to that which OWNER is entitled from any payment then or thereafter due CONTRACTOR from OWNER, or (ii) issue a written notice to CONTRACTOR reducing the Contract Sum by an amount equal to that which OWNER is entitled.

## **§ 9.8 SUBSTANTIAL COMPLETION**

**§ 9.8.1** Substantial Completion is the stage in the progress of the WORK when the WORK or designated portion thereof (which OWNER agrees to accept separately) as sufficiently complete in accordance with the Contract Documents so that the OWNER can occupy or utilize the WORK for its intended use.

**§ 9.8.2** When the CONTRACTOR considers that the WORK, or a portion thereof which the OWNER agrees to accept separately, is substantially complete, the CONTRACTOR shall prepare and submit to the ARCHITECT a comprehensive list of items to be completed or corrected prior to final payment. Failure to include an item on such list does not alter the responsibility of the CONTRACTOR to complete all WORK in accordance with the Contract Documents.

**§ 9.8.3** Upon receipt of the CONTRACTOR's list, the ARCHITECT will make an inspection to determine whether the WORK or designated portion thereof is substantially complete. If the ARCHITECT's inspection discloses any item, whether or not included on the CONTRACTOR's list, which is not sufficiently complete in accordance with the Contract Documents so that the OWNER can occupy or utilize the WORK or designated portion thereof for its intended use, the CONTRACTOR shall, before issuance of the Certificate of Substantial Completion, complete or correct such item upon notification by the ARCHITECT. In such case, the CONTRACTOR shall then submit a request for another inspection by the ARCHITECT to determine Substantial Completion.

**§ 9.8.4** When the WORK or designated portion thereof is substantially complete, the ARCHITECT will prepare a Certificate of Substantial Completion which shall establish the date of Substantial Completion, shall establish responsibilities of the OWNER and CONTRACTOR for security, maintenance, heat, utilities, damage to the WORK and insurance, and shall fix the time within which the CONTRACTOR shall finish all items on the list accompanying the Certificate. Warranties required by the Contract Documents shall commence on the date issuance of the certificate of final payment by ARCHITECT unless otherwise provided in the Certificate of Substantial Completion. The WORK will not be considered suitable for Substantial Completion review until all Project systems included in the WORK are operational as designed and scheduled, all designated or required governmental inspections and certifications have been made and posted, designated instruction of OWNER's personnel in the operation of systems has been completed, and all final finishes within the Contract are in place. In general, the only remaining WORK shall be minor in nature, so that OWNER and /or OWNER's employees and if applicable, the public, could occupy the building on that date and the completing of the WORK by CONTRACTOR would not materially interfere or hamper OWNER's or OWNER's employees and if applicable, the public, (or those claiming by, through, or under OWNER) normal operations. As a further condition of Substantial Completion acceptance, CONTRACTOR shall certify that all remaining WORK will be completed within thirty (30) consecutive calendar days or as agreed upon following the Date of Substantial Completion. If CONTRACTOR requests a Substantial Completion review, and ARCHITECT, after performing the Substantial Completion review, finds that the project was not ready for the Substantial Completion review, then CONTRACTOR shall pay the ARCHITECT's fees for any additional Substantial Completion reviews.

**§ 9.8.5** The Certificate of Substantial Completion shall be submitted to the OWNER and CONTRACTOR for their written acceptance of responsibilities assigned to them in such Certificate. Upon such acceptance, the OWNER shall make payment up to the amount of retainage applying as adjusted for WORK that is incomplete or not in accordance with the requirements of the Contract Documents.

## **§ 9.9 PARTIAL OCCUPANCY OR USE**

**§ 9.9.1** The OWNER may occupy or use any completed or partially completed portion of the WORK at any stage when such portion is designated by separate agreement with the CONTRACTOR, provided such occupancy or use is consented to by the insurer as required under Article 11.5 and authorized by public authorities having jurisdiction

over the WORK. Such partial occupancy or use may commence whether or not the portion is substantially complete, provided the OWNER and CONTRACTOR have accepted in writing the responsibilities assigned to each of them for payments, retainage, if any, security, maintenance, heat, utilities, damage to the WORK and insurance, and have agreed in writing concerning the period for correction of the WORK and commencement of warranties required by the Contract Documents. When the CONTRACTOR considers a portion substantially complete, the CONTRACTOR shall prepare and submit a list to the ARCHITECT as provided under Section 9.8.2. Consent of the CONTRACTOR to partial occupancy or use shall not be unreasonably withheld. The stage of the progress of the WORK shall be determined by written agreement between the OWNER and CONTRACTOR or, if no agreement is reached, by decision of the ARCHITECT.

**§ 9.9.2** Immediately prior to such partial occupancy or use, the OWNER, CONTRACTOR and ARCHITECT shall jointly inspect the area to be occupied or portion of the WORK to be used in order to determine and record the condition of the WORK.

**§ 9.9.3** Unless otherwise agreed upon, partial occupancy or use of a portion or portions of the WORK shall not constitute acceptance of WORK not complying with the requirements of the Contract Documents.

### **§ 9.10 FINAL COMPLETION AND FINAL PAYMENT**

**§ 9.10.1** Upon receipt of written notice that the WORK is ready for final inspection and acceptance and upon receipt of a final Application for Payment, the ARCHITECT will promptly make such inspection and, when the ARCHITECT finds the WORK acceptable under the Contract Documents and the Contract fully performed, the ARCHITECT will promptly issue a final Certificate for Payment stating that to the best of the ARCHITECT's knowledge, information and belief, and on the basis of the ARCHITECT's on-site visits and inspections, the WORK has been completed in accordance with terms and conditions of the Contract Documents and that the entire balance found to be due the CONTRACTOR and noted in the final Certificate is due and payable. The ARCHITECT's final Certificate for Payment will constitute a further representation that conditions listed in Section 9.10.2 as precedent to the CONTRACTOR's being entitled to final payment have been fulfilled.

**§ 9.10.2** Neither final payment nor any remaining retained percentage shall become due until the CONTRACTOR submits to the ARCHITECT (1) an affidavit that payrolls, bills for materials and equipment, and other indebtedness connected with the WORK for which the OWNER or the OWNER's property might be responsible or encumbered (less amounts withheld by OWNER) have been paid or otherwise satisfied, (2) a certificate evidencing that insurance required by the Contract Documents to remain in force after final payment is currently in effect and will not be canceled or allowed to expire until at least 30 days' prior written notice has been given to the OWNER, (3) a written statement that the CONTRACTOR knows of no substantial reason that the insurance will not be renewable to cover the period required by the Contract Documents, (4) consent of surety, if any, to final payment and (5), if required by the OWNER, other data establishing payment or satisfaction of obligations, such as receipts, releases and waivers of liens, claims, security interests or encumbrances arising out of the Contract, to the extent and in such form as may be designated by the OWNER. If a Subcontractor refuses to furnish a release or waiver required by the OWNER, the CONTRACTOR may furnish a bond satisfactory to the OWNER to indemnify the OWNER against such lien. If such lien remains unsatisfied after payments are made, the CONTRACTOR shall refund to the OWNER all money that the OWNER may be compelled to pay in discharging such lien, including all costs and reasonable attorneys' fees.

**§ 9.10.3** If, after Substantial Completion of the WORK, final completion thereof is materially delayed through no fault of the CONTRACTOR or by issuance of Change Orders affecting final completion, and the ARCHITECT so confirms, the OWNER shall, upon application by the CONTRACTOR and certification by the ARCHITECT, and without terminating the Contract, make payment of the balance due for that portion of the WORK fully completed and accepted. If the remaining balance for WORK not fully completed or corrected is less than retainage stipulated in the Contract Documents, and if bonds have been furnished, the written consent of surety to payment of the balance due for that portion of the WORK fully completed and accepted shall be submitted by the CONTRACTOR to the ARCHITECT prior to certification of such payment. Such payment shall be made under terms and conditions governing final payment, except that it shall not constitute a waiver of claims.

**§ 9.10.4** The making of final payment shall constitute a waiver of Claims by the OWNER except those arising from:

- .1 liens, Claims, security interests or encumbrances arising out of the Contract and unsettled;
- .2 failure of the WORK to comply with the requirements of the Contract Documents;

- .3 terms of special warranties required by the Contract Documents.; or
- .4 faulty or defective WORK appearing after Substantial Completion.

§ 9.10.5 Acceptance of final payment by the CONTRACTOR, a Subcontractor or material supplier shall constitute a waiver of claims by that payee except those previously made in writing and identified by that payee as unsettled at the time of final Application for Payment.

## ARTICLE 10 PROTECTION OF PERSONS AND PROPERTY

### § 10.1 SAFETY PRECAUTIONS AND PROGRAMS

§ 10.1.1 The CONTRACTOR shall be responsible for initiating, maintaining and supervising all safety precautions and programs in connection with the performance of the Contract.

### § 10.2 SAFETY OF PERSONS AND PROPERTY

§ 10.2.1 The CONTRACTOR shall take reasonable precautions for safety of, and shall provide reasonable protection to prevent damage, injury or loss to:

- .1 employees on the WORK and other persons who may be affected thereby;
- .2 the WORK and materials and equipment to be incorporated therein, whether in storage on or off the site, under care, custody or control of the CONTRACTOR or the CONTRACTOR's Subcontractors or Sub-subcontractors; and
- .3 other property at the site or adjacent thereto, such as trees, shrubs, lawns, walks, pavements, roadways, structures and utilities not designated for removal, relocation or replacement in the course of construction.

§ 10.2.2 The CONTRACTOR shall give notices and comply with applicable laws, ordinances, rules, regulations and lawful orders of public authorities bearing on safety of persons or property or their protection from damage, injury or loss.

§ 10.2.3 The CONTRACTOR shall erect and maintain, as required by existing conditions and performance of the Contract, reasonable safeguards for safety and protection, including posting danger signs and other warnings against hazards, promulgating safety regulations and notifying owners and users of adjacent sites and utilities.

§ 10.2.4 When use or storage of explosives or other hazardous materials or equipment or unusual methods are necessary for execution of the WORK, the CONTRACTOR shall exercise utmost care and carry on such activities under supervision of properly qualified personnel.

§ 10.2.5 The CONTRACTOR shall promptly remedy damage and loss (other than damage or loss insured under property insurance required by the Contract Documents) to property referred to in Sections 10.2.1.2 and 10.2.1.3 caused in whole or in part by the CONTRACTOR, a Subcontractor, a Sub-subcontractor, or anyone directly or indirectly employed by any of them, or by anyone for whose acts they may be liable and for which the CONTRACTOR is responsible under Sections 10.2.1.2 and 10.2.1.3, except damage or loss attributable to acts or omissions of the OWNER or ARCHITECT or anyone directly or indirectly employed by either of them, or by anyone for whose acts either of them may be liable, and not attributable to the fault or negligence of the CONTRACTOR. The foregoing obligations of the CONTRACTOR are in addition to the CONTRACTOR's obligations under Section 3.18.

§ 10.2.6 The CONTRACTOR shall designate a responsible member of the CONTRACTOR's organization at the site whose duty shall be the prevention of accidents. This person shall be the CONTRACTOR's superintendent unless otherwise designated by the CONTRACTOR in writing to the OWNER and ARCHITECT.

§ 10.2.7 The CONTRACTOR shall not load or permit any part of the construction or site to be loaded so as to endanger its safety.

### § 10.3 HAZARDOUS MATERIALS

§ 10.3.1 If reasonable precautions will be inadequate to prevent foreseeable bodily injury or death to persons resulting from a material or substance, including but not limited to asbestos or polychlorinated biphenyl (PCB), encountered on the site by the CONTRACTOR, the CONTRACTOR shall, upon recognizing the condition, immediately stop WORK in the affected area and report the condition to the OWNER and ARCHITECT in writing.

§ 10.3.2 The OWNER shall obtain the services of a licensed laboratory to verify the presence or absence of the material or substance reported by the CONTRACTOR and, in the event such material or substance is found to be present, to verify that it has been rendered harmless. Unless otherwise required by the Contract Documents, the OWNER shall furnish in writing to the CONTRACTOR and ARCHITECT the names and qualifications of persons or entities who are to perform tests verifying the presence or absence of such material or substance or who are to perform the task of removal or safe containment of such material or substance. The CONTRACTOR and the ARCHITECT will promptly reply to the OWNER in writing stating whether or not either has reasonable objection to the persons or entities proposed by the OWNER. If either the CONTRACTOR or ARCHITECT has an objection to a person or entity proposed by the OWNER, the OWNER shall propose another to whom the CONTRACTOR and the ARCHITECT have no reasonable objection. When the material or substance has been rendered harmless, WORK in the affected area shall resume upon written agreement of the OWNER and CONTRACTOR. The Contract Time shall be extended appropriately and the Contract Sum shall be increased in the amount of the CONTRACTOR's reasonable additional costs of shut-down, delay and start-up, which adjustments shall be accomplished as provided in Article 7.

§ 10.4 The OWNER shall not be responsible under Section 10.3 for materials and substances brought to the site by the CONTRACTOR unless such materials or substances were required by the Contract Documents.

#### § 10.6 EMERGENCIES

§ 10.6.1 In an emergency affecting safety of persons or property, the CONTRACTOR shall act, at the CONTRACTOR's discretion, to prevent threatened damage, injury or loss. Additional compensation or extension of time claimed by the CONTRACTOR on account of an emergency shall be determined as provided in Section 4.3 and Article 7.

### ARTICLE 11 INSURANCE AND BONDS

#### § 11.1 CONTRACTOR'S LIABILITY INSURANCE

§ 11.1.1 The CONTRACTOR shall purchase from and maintain in a company or companies lawfully authorized to do business in the State of Texas such insurance as will protect the CONTRACTOR from claims set forth below which may arise out of or result from the CONTRACTOR's operations under the Contract and for which the CONTRACTOR may be legally liable, whether such operations be by the CONTRACTOR or by a Subcontractor or by anyone directly or indirectly employed by any of them, or by anyone for whose acts any of them may be liable, including:

- .1 claims under workers' compensation, disability benefit and other similar employee benefit acts which are applicable to the WORK to be performed;
- .2 claims for damages because of bodily injury, occupational sickness or disease, or death of the CONTRACTOR's employees;
- .3 claims for damages because of bodily injury, sickness or disease, or death of any person other than the CONTRACTOR's employees;
- .4 claims for damages insured by usual personal injury liability coverage;
- .5 claims for damages, other than to the WORK itself, because of injury to or destruction of tangible property, including loss of use resulting therefrom;
- .6 claims for damages because of bodily injury, death of a person or property damage arising out of ownership, maintenance or use of a motor vehicle;
- .7 claims for bodily injury or property damage arising out of completed operations; and
- .8 claims involving contractual liability insurance applicable to the CONTRACTOR's obligations under Section 3.18.

§ 11.1.1.1 In the event of any failure by CONTRACTOR to comply with the provisions of this Paragraph 11.1, OWNER may, at its option, on notice to CONTRACTOR, suspend the Contract for cause until there is full compliance with this paragraph 11.1 and/or terminate the Contract for cause. Alternately, OWNER may purchase such insurance at CONTRACTOR's expense, provided that OWNER shall have no obligation to do so and if such insurance amounts and coverages. CONTRACTOR shall provide to OWNER a certified copy of any and all applicable insurances policies upon request of OWNER. The obligation to procure and maintain any insurance required by Article 11 is a separate responsibility of CONTRACTOR and is independent of the duty to furnish a certified copy or a certificate of such insurance policies.

§ 11.1.1.2 Further, CONTRACTOR shall require all Subcontractors to carry similar insurances coverages and limits of liability as required under this Article 11, adjusted to the nature of Subcontractor's operations and submit same to OWNER for approval before any WORK commences.

§ 11.1.1.3 In the event CONTRACTOR fails to obtain the required certificates of insurances from the Subcontractor and a claim is made or suffered, CONTRACTOR shall indemnify, defend, and hold harmless the INDEMNIFIED PARTIES (as defined in Article 11.6.1) from any and all claims for which the required insurances would have provided coverage. This indemnity obligation is in addition to any other indemnity obligation provided in the Contract.

§ 11.1.1.4 SCHEDULE OF INSURANCE COVERAGES

Coverage	Minimum Amounts and Limits
----------	----------------------------

Workers Compensation	
----------------------	--

Workers Compensation	Statutory Limits
Employer's Liability	\$500,000.00

This policy shall include a Waiver of Subrogation in favor of the INDEMNIFIED PARTIES (11.6.1)

§ 11.1.1.5 Commercial General Liability

Bodily Injury/Property Damage	\$1,000,000.00 each occurrence
	or
(Occurrence Basis)	\$1,000,000.00 aggregate applicable to the Project.

This policy shall be on a form acceptable to OWNER, endorsed to include the INDEMNIFIED PARTIES (11.6.1) as additional insureds, contain cross-liability and severability of interest endorsements, state that this insurance is primary insurance with regard to any other insurances carried by the INDEMNIFIED PARTIES (11.6.1), and shall include the following coverages:

- .1 Premises/Operations;
- .2 Independent Contractors;
- .3 Completed Operations for a period of two (2) years following the acceptance of Contractor's Work;
- .4 Broad Form Comprehensive General Liability Endorsement to include Blanket Contractual Liability (specifically covering, but not limited to, the contractual obligations assumed by CONTRACTOR in Subparagraph 11.1.1.3 and Paragraph 11.6 hereof, Broad Form Property Damage, and Personal Injury Liability with employee and contractual exclusions removed;
- .5 Broad Form Property Damage;
- .6 Delete Exclusions relative to Collapse, Explosion, and Underground Property Damage Hazards;
- .7 Personal Injury Liability with the contractual exclusions removed; and
- .8 Cross Liability Endorsement.

§ 11.1.1.6 Comprehensive Automobile Liability

.1 Bodily Injury	\$300,000.00 per person
	\$500,000.00 per occurrence
.2 Property Damage	\$100,000.00 per occurrence, or equivalent

This policy shall be on a standard form written to cover all owned, hired, and non-owned automobiles. The policy shall be endorsed to include the INDEMNIFIED PARTIES (11.6.1) as additional insureds, contain cross-liability and severability of interest endorsements, and shall state that this insurance is primary insurance as it relates to any other insurance carried by the INDEMNIFIED PARTIES.

§ 11.1.2 The OWNER, its officers, employees, volunteers, elected officials, and ARCHITECT shall be covered as additional insureds for liability arising out of activities performed by, for, or on behalf of, the CONTRACTOR.

including general supervision of the CONTRACTOR, products and completed operations of the CONTRACTOR, premises owned, occupied or used by the CONTRACTOR, or automobiles owned, leased, hired, or borrowed by the CONTRACTOR. The coverage shall contain no specific limitations on the coverage afforded by the OWNER, its officers, elected officials, employees, or volunteers. In the event that CONTRACTOR purchases Project Management Protective Liability Insurance for the Project, CONTRACTOR shall not be required to name OWNER and ARCHITECT as additional insureds on such liability coverages.

**§ 11.1.3** Certificates of insurance acceptable to the OWNER shall be filed with the OWNER prior to commencement of the WORK. These certificates and the insurance policies required by this Section 11.1 shall contain a provision that coverages afforded under the policies will not be canceled or allowed to expire until at least thirty (30) days prior written notice has been given to the OWNER. If any of the foregoing insurance coverages are required to remain in force after final payment and are reasonably available, an additional certificate evidencing continuation of such coverage shall be submitted with the final Application for Payment as required by Section 9.10.2. Information concerning reduction of coverage on account of revised limits or claims paid under the General Aggregate, or both, shall be furnished by the CONTRACTOR with reasonable promptness in accordance with the CONTRACTOR's information and belief.

## **§ 11.2 OWNER'S LIABILITY INSURANCE**

**§ 11.2.1** The OWNER shall be responsible for purchasing and maintaining the OWNER's usual liability insurance.

**§ 11.2.1.1** By signing the Contract or providing or causing to be provided a Certificate of Coverage, the CONTRACTOR is representing to the OWNER that all employees of the CONTRACTOR who will provide services on the Project will be covered by workers' compensation coverage for the duration of the Project, that coverage will be based on proper reporting of classification codes and payroll amounts, and that all coverage agreements will be filed with the appropriate insurance carrier or, in the case of a self-insured, with the Commission of self-insurance regulations. Providing false or misleading information which may subject the CONTRACTOR to administrative penalties, criminal penalties, civil penalties, or other civil actions.

## **§ 11.3 PROJECT MANAGEMENT PROTECTIVE LIABILITY INSURANCE**

**§ 11.3.1** Optionally, the OWNER may require the CONTRACTOR to purchase and maintain Project Management Protective Liability insurance from the CONTRACTOR's usual sources as primary coverage for the OWNER's, CONTRACTOR's and ARCHITECT's vicarious liability for construction operations under the Contract. Unless otherwise required by the Contract Documents, the OWNER shall reimburse the CONTRACTOR by increasing the Contract Sum to pay the cost of purchasing and maintaining such optional insurance coverage, and the CONTRACTOR shall not be responsible for purchasing any other liability insurance on behalf of the OWNER. The minimum limits of liability purchased with such coverage shall be equal to the aggregate of the limits required for CONTRACTOR's Liability Insurance under Sections 11.1.1.1.6 through 11.1.1.1.6.1

**§ 11.3.2** To the extent damages are covered by Project Management Protective Liability insurance, the OWNER, CONTRACTOR and ARCHITECT waive all rights against each other for damages, except such rights as they may have to the proceeds of such insurance. The policy shall provide for such waivers of subrogation by endorsement or otherwise.

**§ 11.3.3** The OWNER shall not require the CONTRACTOR to include the OWNER, ARCHITECT or other persons or entities as additional insureds on the CONTRACTOR's Liability Insurance coverage under Section 11.1.

## **§ 11.4 PROPERTY INSURANCE**

**§ 11.4.1** CONTRACTOR shall purchase and maintain property insurance written on a builder's risk "all risk" or equivalent policy in the amount of the initial Contract Sum (or, if applicable Guaranteed Maximum Price), plus value of subsequent Contract Modifications and const of materials supplied or installed by other, compromising total value for the entire Project at the site on a replacement cost basis without optional deductibles. Coverage shall include material stored on-site and in transit, and shall include without limitation, insurance against the perils of fire (with extended coverage) and physical loss or damage including theft, vandalism, malicious mischief, collapse, earthquake, flood, windstorm, false work, testing and startup, temporary buildings, and debris removal including demolition occasioned by enforcement of any applicable legal requirements, compensation for Architect's and Contractor's services and expenses required as a result of such insured loss. Such insurance will be with a company or companies lawfully authorized to do business in Texas.

§ 11.4.2 For any claim made against CONTRACTOR's Builder's Risk Insurance, the deductible shall not exceed \$2,500.00 for a Contract Sum of less than \$4 million. For a Contract Sum of \$4 million or more, the deductible shall not exceed \$5,000.00.

§ 11.4.3 The CONTRACTOR waives all rights against (1) OWNER, OWNER's elected officials, agent and employees, the Subcontractors, Sub-subcontractors, agent and employees, and (2) the ARCHITECT, Architect's consultants, separate contractors, if any, and any of their subcontractors, sub-subcontractors, agents, and employees, for damages caused by fire or other perils to the extent covered by property insurance obtained pursuant to this paragraph or other property insurance applicable to the WORK, except such rights as CONTRACTOR has to proceeds of such insurance held by the CONTRACTOR as a fiduciary. The CONTRACTOR, as appropriate, shall require of any separate contractors, subcontractors, sub-subcontractors, agents, and employees of any of them by appropriate written agreements, similar waivers each in favor of other parties enumerated herein. The policies shall provide such waivers of subrogation by endorsement or otherwise, a waiver of subrogation shall be effective as to a person or entity even though that person or entity would otherwise have a duty of indemnification, contractual or otherwise, did not pay the insurance premium directly or indirectly, and whether or not the person or entity had an insurable interest in the property damaged.

§ 11.4.4 The CONTRACTOR as fiduciary shall have power to adjust and settle a loss with insurers. The CONTRACTOR shall pay all Subcontractors their just shares of insurances proceeds received by the CONTRACTOR, and by appropriate agreements shall require Subcontractors to make payment to their Sub-subcontractors in a similar manner. If required in writing by a party in interest, the CONTRACTOR as fiduciary shall, upon occurrence of insured loss, give bond for proper performance of the CONTRACTOR's duties. The cost of required bonds shall be charged against proceeds received as fiduciary. The CONTRACTOR shall deposit in accordance with such agreement as the parties in interest may reach, If after such loss no other special agreement is made and unless the OWNER terminates the Contract for convenience, replacement of damaged property shall be performed by the CONTRACTOR under the insurance proceeds.

§ 11.4.5 Partial occupancy or use shall not affect the validity or coverage of property insurance.

#### § 11.5 PERFORMANCE BOND AND PAYMENT BOND

§ 11.5.1 The CONTRACTOR shall furnish a Performance Bond in an amount equal to one hundred percent (100%) of the Contract Sum, as security for the faithful performance of the Contract and also a one hundred percent (100%) Payment Bond, as security for the payment of all persons performing labor on the Project under this Contract and furnishing materials in connection with the Contract. The Performance Bond and the Payment Bond may be in one or in separate instruments in accordance with local law. Surety companies must be authorized to write surety bonds in Texas and any such surety bond must comply with the requirements of Article 7.19-1, Texas Insurance Code.

§ 11.5.1.1 The CONTRACTOR shall deliver the required Bonds to the OWNER not later than the date of the preconstruction meeting. All bonds will be reviewed by the ARCHITECT for compliance with the Contract Documents prior to the execution of the Contract. In the event that ARCHITECT has any questions concerning the sufficiency of the bonds, ARCHITECT shall refer the bonds to OWNER or OWNER's representative for decision.

§ 11.5.1.2 All bonds shall be originals. The CONTRACTOR shall require the attorney-in-fact who executes the required Bonds on behalf of the Surety to affix thereto a certified and current copy of the power-of-attorney. The name, address, and telephone number of a contact person for the Bonding Company shall be provided.

§ 11.5.2 Upon the request of any person or entity appearing to be a potential beneficiary of bonds covering payment of obligations arising under the Contract, the CONTRACTOR shall promptly furnish a copy of the bonds or shall permit a copy to be made.

§ 11.5.3 The Bonds shall be provided to comply with the terms and provisions of Chapter 2253 of the Texas Government Code. Bonds shall be signed by an agent resident in the State of Texas and date of bond shall be the date of execution of the Contract. If at any time during the continuance of the Contract, the surety of the CONTRACTOR's bonds becomes insufficient, the OWNER shall have the right to required additional and sufficient sureties which the CONTRACTOR shall furnish to the satisfaction of the OWNER within ten (10) days after notice

to do so. In default thereof, the CONTRACTOR may be suspended, and all payment of money due to the CONTRACTOR withheld until sufficient bonds are provided by CONTRACTOR.

## ARTICLE 12 UNCOVERING AND CORRECTION OF WORK

### § 12.1 UNCOVERING OF WORK

§ 12.1.1 If a portion of the WORK is covered contrary to the ARCHITECT's request or to requirements specifically expressed in the Contract Documents, it must, if required in writing by the ARCHITECT, be uncovered for the ARCHITECT's examination and be replaced at the CONTRACTOR's expense without change in the Contract Time.

§ 12.1.2 If a portion of the WORK has been covered which the ARCHITECT has not specifically requested to examine prior to its being covered, the ARCHITECT may request to see such WORK and it shall be uncovered by the CONTRACTOR. If such WORK is in accordance with the Contract Documents, costs of uncovering and replacement shall, by appropriate Change Order, be at the OWNER's expense. If such WORK is not in accordance with the Contract Documents, correction shall be at the CONTRACTOR's expense unless the condition was caused by the OWNER or a separate contractor in which event the OWNER shall be responsible for payment of such costs.

### § 12.2 CORRECTION OF WORK

#### § 12.2.1 BEFORE OR AFTER SUBSTANTIAL COMPLETION

§ 12.2.1.1 The CONTRACTOR shall promptly correct WORK rejected by the ARCHITECT as incomplete, defective or failing to conform to the requirements of the Contract Documents, whether discovered before or after Substantial Completion and whether or not fabricated, installed or completed. Costs of correcting such rejected WORK, including additional testing and inspections and compensation for the ARCHITECT's services and expenses made necessary thereby, shall be at the CONTRACTOR's expense.

#### § 12.2.2 AFTER SUBSTANTIAL COMPLETION

§ 12.2.2.1 In addition to the CONTRACTOR's obligations under Section 3.5, if, within one (1) year after the date of Substantial Completion of the entire WORK (unless otherwise provided in any Certificate of Partial Substantial Completion approved by the parties) or within such longer period of time as may be prescribed by law or in equity, or by terms of an applicable special warranty required by the Contract Documents, any of the WORK is found to be defective or otherwise not in accordance with the requirements of the Contract Documents, the CONTRACTOR shall correct it promptly after receipt of written notice from the OWNER to do so unless the OWNER has previously given the CONTRACTOR a written acceptance of such condition. This corrective period shall be extended with respect to portions of WORK first performed after Substantial Completion by the period of time between Substantial Completion and the actual performance of the WORK. Corrective WORK shall be warranted to be free from defects for a period equal to the longer of six (6) months after the completion of the corrective WORK or one (1) year after the Date of Substantial Completion (subject to extension as previously described) or such longer period of time as may be prescribed by law or in equity, or expiration of the term of any applicable special warranty, if applicable, required by the Contract Documents. Any defect in such WORK shall be corrected again by CONTRACTOR promptly upon notice of the defect from OWNER. This obligation under this Subparagraph 12.2.2 shall survive acceptance for the WORK under the Contract and termination of the Contract. If the CONTRACTOR fails to correct nonconforming WORK within a reasonable time during that period after receipt of notice from the OWNER or ARCHITECT, the OWNER may correct it in accordance with Section 2.4. by OWNER.

§ 12.2.2.1.1 Just before the termination of the various guarantee periods, CONTRACTOR shall accompany OWNER's agent and ARCHITECT on an inspection tour of the building and shall note any defects and shall start remedying these defects within ten (10) days of the inspection tour and shall prosecute the WORK without interruption until accepted by OWNER and ARCHITECT, even though such prosecution should extend beyond the limit of the guarantee period.

§ 12.2.2.2 The one-year period for correction of WORK shall be extended with respect to portions of WORK first performed after Substantial Completion by the period of time between Substantial Completion and the actual performance of the WORK.

§ 12.2.2.3 The one-year period for correction of WORK shall not be extended by corrective WORK performed by the CONTRACTOR pursuant to this Section 12.2.

§ 12.2.3 The CONTRACTOR shall remove from the site portions of the WORK which are not in accordance with the requirements of the Contract Documents and are neither corrected by the CONTRACTOR nor accepted by the OWNER.

§ 12.2.4 The CONTRACTOR shall bear the cost of correcting destroyed or damaged construction, whether completed or partially completed, of the OWNER or separate contractors caused in whole or in part by the CONTRACTOR's correction or removal of WORK which is defective or otherwise not in accordance with the requirements of the Contract Documents.

§ 12.2.5 Nothing contained in this Section 12.2 shall be construed to establish a period of limitation with respect to other obligations which the CONTRACTOR might have under the Contract Documents or under law or in equity. Establishment of the one-year period for correction of WORK as described in Section 12.2.2 relates only to the specific obligation of the CONTRACTOR to correct the WORK, and has no relationship to the time within which the obligation to comply with the Contract Documents may be sought to be enforced, nor to the time within which proceedings may be commenced to establish the CONTRACTOR's liability with respect to the CONTRACTOR's obligations other than specifically to correct the WORK.

### § 12.3 ACCEPTANCE OF NONCONFORMING WORK

§ 12.3.1 If the OWNER prefers to accept WORK which is defective or otherwise not in accordance with the requirements of the Contract Documents, the OWNER may do so instead of requiring its removal and correction, in which case the Contract Sum will be reduced as appropriate and equitable. Such adjustment shall be effected whether or not final payment has been made.

## ARTICLE 13 MISCELLANEOUS PROVISIONS

### § 13.1 GOVERNING LAW

§ 13.1.1 The Contract shall be governed by the law of the place where the Project is located.

### § 13.2 SUCCESSORS AND ASSIGNS

§ 13.2.1 The OWNER and CONTRACTOR respectively bind themselves, their partners, successors, assigns and legal representatives to the other party hereto and to partners, successors, assigns and legal representatives of such other party in respect to covenants, agreements and obligations contained in the Contract Documents. Except as provided in Section 13.2.2, neither party to the Contract shall assign the Contract as a whole without written consent of the other. If either party attempts to make such an assignment without such consent, that party shall nevertheless remain legally responsible for all obligations under the Contract.

§ 13.2.2 The OWNER may, without consent of the CONTRACTOR, assign the Contract to an institutional lender providing construction financing for the Project. In such event, the lender shall assume the OWNER's rights and obligations under the Contract Documents. The CONTRACTOR shall execute all consents reasonably required to facilitate such assignment.

### § 13.3 WRITTEN NOTICE

§ 13.3.1 Written notice shall be deemed to have been duly served if delivered in person to the individual or a member of the firm or entity or to an officer of the corporation for which it was intended, or if delivered at or sent by registered or certified mail to the last business address known to the party giving notice.

### § 13.4 RIGHTS AND REMEDIES

§ 13.4.1 Duties and obligations imposed by the Contract Documents and rights and remedies available thereunder shall be in addition to and not a limitation of duties, obligations, rights and remedies otherwise imposed or available by law or in equity or by any other agreement, and any such rights and remedies shall survive the acceptance of the WORK and/or any termination of the Contract Documents.

§ 13.4.2 No action or failure to act by the OWNER, ARCHITECT or CONTRACTOR shall constitute a waiver of a right or duty afforded them under the Contract, nor shall such action or failure to act constitute approval of or acquiescence in a breach thereunder, except as may be specifically agreed in writing.

## § 13.5 TESTS AND INSPECTIONS

§ 13.5.1 Tests, inspections and approvals of portions of the WORK required by the Contract Documents or by laws, ordinances, rules, regulations or orders of public authorities having jurisdiction shall be made at an appropriate time. Unless otherwise provided, the CONTRACTOR shall make arrangements for such tests, inspections and approvals with an independent testing laboratory or entity acceptable to the OWNER, or with the appropriate public authority, and shall bear all related costs of tests, inspections and approvals. The CONTRACTOR shall give the ARCHITECT timely notice of when and where tests and inspections are to be made so that the ARCHITECT may be present for such procedures. ARCHITECT, OWNER, and CONTRACTOR shall be afforded a reasonable opportunity to attend, observe, and witness all inspection and tests of the WORK. ARCHITECT and OWNER may at any time request and receive from CONTRACTOR satisfactory evidence that materials, supplies, or equipment are in conformance with the Contract Documents. The conduct of any inspection or test and the receipt of any approval shall not operate to relieve CONTRACTOR from its obligations under the Contract Documents unless specifically so stated by OWNER in writing.

§ 13.5.2 If the ARCHITECT, OWNER, CONTRACTOR, or public authorities having jurisdiction determine that portions of the WORK require additional testing, inspection or approval not included under Section 13.5.1, OWNER will provide a contract for the inspection services, the testing of construction materials, engineering, or the verification testing services necessary. ARCHITECT, OWNER, and CONTRACTOR shall cooperate for the timely scheduling of such tests and inspections.

§ 13.5.3 If such procedures for testing, inspection or approval under Sections 13.5.1 and 13.5.2 reveal failure of the portions of the WORK to comply with requirements established by the Contract Documents or reveal faulty or otherwise defective WORK, or if the necessity of any such testing, inspection, or approval procedure arises out of the fault, neglect, or omission of CONTRACTOR, CONTRACTOR shall bear all costs of such testing, inspection, and approval procedures and all other costs made necessary by CONTRACTOR's failures, including, without limitation, those costs of repeated and additional procedures and compensation for ARCHITECT's services and expenses of OWNER's personnel and consultant fees and expenses. Such costs shall be paid by CONTRACTOR within ten (10) days of receipt of invoice from OWNER with supporting data attached.

§ 13.5.4 Required certificates of testing, inspection or approval shall be secured by CONTRACTOR and delivered to OWNER, unless such testing or inspection services are arranged by OWNER.

§ 13.5.5 Tests or inspections conducted pursuant to the Contract Documents shall be made promptly to avoid unreasonable delay in the WORK.

## § 13.6 INTEREST

§ 13.6.1 An overdue payment bears interest at the rate of one percent (1%) each month, or at the legal rate established by the Texas Government Code, currently in Section 2251.025. Any such payment shall be deemed overdue on the thirty-first (31<sup>st</sup>) day after OWNER receives an invoice from CONTRACTOR.

## § 13.9 EQUAL OPPORTUNITY

§ 13.9.1 The CONTRACTOR shall maintain policies of employment as follows:

§ 13.9.1.1 The CONTRACTOR and the CONTRACTOR's Subcontractors shall not discriminate against any employee or applicant for employment because of race, religion, color, sex, or national origin; CONTRACTOR shall take affirmative action to ensure that applicants are employed, and that employees are treated during employment without regard to their race, religion, color, sex, or national origin. Such action shall include but not be limited to the following: employment promotion, demotion or transfer; recruitment, or recruitment advertising; lay-off or termination; rates of pay or other forms of compensation; and selection for training, including apprenticeship. The CONTRACTOR agrees to post in conspicuous places, available to employees and applicants, notices setting forth the nondiscrimination policies.

§ 13.9.1.2 The CONTRACTOR and the CONTRACTOR's Subcontractors shall, in all solicitation or advertisements for employees placed by them or on their behalf, state that all qualified applicants will receive consideration for employment with regard to race, religion, color, sex or national origin.

## § 13.10 CERTIFICATION OF ASBESTOS-FREE PROJECT

§ 13.10.1 CONTRACTOR shall submit to the ARCHITECT a letter addressed to the OWNER certifying that all materials used in the construction of this Project contain less than 0.10% by weight of asbestos and for which it can be demonstrated that, under reasonably foreseeable job site conditions, will not release asbestos fibers in excess of 0.1 fibers per cubic centimeter. Certification letters shall be dated, shall reference this specific Project, and shall be signed by not less than two (2) officers of the construction company.

§ 13.10.2 Certification shall further state should asbestos fibers be found at this Project in concentrations greater than 0.01 fibers per cubic centimeter, that CONTRACTOR shall be responsible for determining which materials contain asbestos fibers and shall take corrective action to remove those materials from the Project at no additional cost to OWNER.

§ 13.10.3 Final payment shall not be made until this letter of certification has been received.

## ARTICLE 14 TERMINATION OR SUSPENSION OF THE CONTRACT

### § 14.1 TERMINATION BY THE CONTRACTOR

§ 14.1.1 The CONTRACTOR may terminate the Contract if the WORK is stopped for a period of sixty (60) consecutive days through no act or fault of the CONTRACTOR or a Subcontractor, Sub-subcontractor or their agents or employees or any other persons or entities performing portions of the WORK under direct or indirect contract with the CONTRACTOR, for any of the following reasons:

- .1 issuance of an order of a court or other public authority having jurisdiction which requires all WORK to be stopped;
- .2 an act of government, such as a declaration of national emergency which requires all WORK to be stopped;

§ 14.1.2 The CONTRACTOR may terminate the Contract if, through no act or fault of the CONTRACTOR or a Subcontractor, Sub-subcontractor or their agents or employees or any other persons or entities performing portions of the WORK under direct or indirect contract with the CONTRACTOR, repeated suspensions, delays or interruptions of the entire WORK by the OWNER as described in Section 14.3 constitute in the aggregate more than 100 percent of the total number of days scheduled for completion, or 120 days in any 365-day period, whichever is less.

§ 14.1.3 If one of the reasons exists, CONTRACTOR may, upon fourteen (14) days' written notice to the OWNER and ARCHITECT, terminate the Contract, unless this reason is cured prior to the expiration of the notice period, and recover from the OWNER payment of WORK properly executed in accordance with the Contract Documents (the basis for such payment shall be as provided in Contract) and for payment for costs directly related to WORK thereafter performed by CONTRACTOR in terminating such WORK including reasonable demobilization and cancellation charges provided said WORK is authorized in advance by ARCHITECT and OWNER.

§ 14.1.4 OWNER shall not be responsible for damages for loss of anticipated profits on WORK not performed on account of any termination described in Subparagraphs 14.1.1 and 14.1.2.

### § 14.2 TERMINATION BY THE OWNER FOR CAUSE

§ 14.2.1 The OWNER may terminate the Contract if the CONTRACTOR:

- .1 refuses or fails to supply enough properly skilled WORKERS or proper materials equipment;
- .2 fails to make payment to Subcontractors for materials or labor in accordance with the respective agreements between the CONTRACTOR and the Subcontractors;
- .3 disregards laws, ordinances, or rules, regulations or orders of a public authority having jurisdiction;
- .4 disregards the instructions of ARCHITECT or OWNER (when such instructions are based on the requirements of the Contract Documents);
- .5 is adjudged bankrupt or insolvent, or makes a general assignment for the benefit of Contractor's creditors, or a trustee or receiver is appointed for Contractor or for any of its property, or files a petition to take advantage of any debtor's act, or to reorganize under bankruptcy or similar laws; or
- .6 otherwise does not fully comply with the Contract Document.

§ 14.2.2 When any of the above reasons exist, the OWNER, may without prejudice to any other rights or remedies of the OWNER and after giving the CONTRACTOR and the Contractor's surety, if any, seven days' written notice, terminate employment of the CONTRACTOR and may, subject to any prior rights of the surety:

- .1 take possession of the site and of all materials, equipment, tools, and construction equipment and machinery thereon owned by the CONTRACTOR;
- .2 accept assignment of subcontracts pursuant to Section 5.4; and
- .3 finish the WORK by whatever reasonable method the OWNER may deem expedient. Upon request of the CONTRACTOR, the OWNER shall furnish to the CONTRACTOR a detailed accounting of the costs incurred by the OWNER in finishing the WORK.

§ 14.2.3 When the OWNER terminates the Contract for one of the reasons stated in Section 14.2.1, the CONTRACTOR shall not be entitled to receive further payment until the WORK is finished.

§ 14.2.4 To the extent of the costs of completing WORK, including compensation for additional professional services and expenses exceed those costs that would have been payable to CONTRACTOR to complete the WORK except for CONTRACTOR's default, CONTRACTOR will pay the difference to OWNER, and this obligation for payment shall survive termination of the Contract. Such costs incurred by OWNER will be determined by OWNER and confirmed by ARCHITECT.

§ 14.2.5 In addition to OWNER's right to remove CONTRACTOR from any part of WORK pursuant to the Contract Documents, OWNER may, at any time, at will and without cause, terminate any part of WORK or any subcontract or all remaining WORK for any reason whatsoever by giving seven (7) days' prior written notice to CONTRACTOR specifying the part of WORK or subcontract to be terminated and the effective date of termination. CONTRACTOR shall continue to prosecute the part of WORK not terminated. If any part of WORK or subcontract is so terminated, CONTRACTOR shall be entitled to payment for WORK properly executed in accordance with the Contract Documents (the basis for such payment shall be as provided in the Contract) and for costs directly related to WORK thereafter performed by CONTRACTOR in terminating such WORK or subcontract including reasonable demobilization and cancellation charges provided said WORK is authorized in advance by ARCHITECT and OWNER. No payment shall be made by OWNER, however, to the extent that such WORK or subcontract is, was, or could have been terminated under the Contract Documents or an equitable adjustment is made or denied under another provision of the Contract. In case of such termination, OWNER will issue a Construction Change Directive or authorize a Change Order making any required adjustment to the Date of Substantial Completion and/or the Contract Sum. For the remainder of the WORK, the Contract Documents shall remain in full force and effect.

§ 14.2.6 OWNER shall not be responsible for damages for loss of anticipated profits on WORK not performed on account of any termination described in Subparagraph 14.2.5.

§ 14.2.7 Upon a determination by a court of competent jurisdiction that termination of CONTRACTOR pursuant to Subparagraph 14.2.1 was wrongful, such termination will be deemed converted to a termination for convenience pursuant to Subparagraph 14.2.5 and CONTRACTOR's remedy for wrongful termination shall be limited to the recovery of the payments permitted for termination for convenience as set forth in Subparagraph 14.2.5.

#### § 14.3 SUSPENSION BY THE OWNER FOR CONVENIENCE

§ 14.3.1 The OWNER may, without cause, order the CONTRACTOR in writing to suspend, delay or interrupt the WORK in whole or in part for such period of time as the OWNER may determine.

§ 14.3.2 The Contract Sum and Contract Time shall be adjusted for increases in the cost and time caused by suspension, delay or interruption as described in Section 14.3.1. Adjustment of the Contract Sum shall include profit. No adjustment shall be made to the extent:

- .1 that performance is, was or would have been so suspended, delayed or interrupted by another cause for which the CONTRACTOR is responsible; or
- .2 that an equitable adjustment is made or denied under another provision of the Contract.

#### § 14.4 TERMINATION BY THE OWNER FOR CONVENIENCE

§ 14.4.1 The OWNER may, at any time, terminate the Contract for the OWNER's convenience and without cause.

§ 14.4.2 Upon receipt of written notice from the OWNER of such termination for the OWNER's convenience, the CONTRACTOR shall:

- .1 cease operations as directed by the OWNER in the notice;
- .2 take actions necessary, or that the OWNER may direct, for the protection and preservation of the WORK; and
- .3 except for WORK directed to be performed prior to the effective date of termination stated in the notice, terminate all existing subcontracts and purchase orders and enter into no further subcontracts and purchase orders.

§ 14.4.3 In case of such termination for the OWNER's convenience, the CONTRACTOR shall be entitled to receive payment for WORK executed, and costs incurred by reason of such termination, along with reasonable overhead and profit on the WORK not executed.

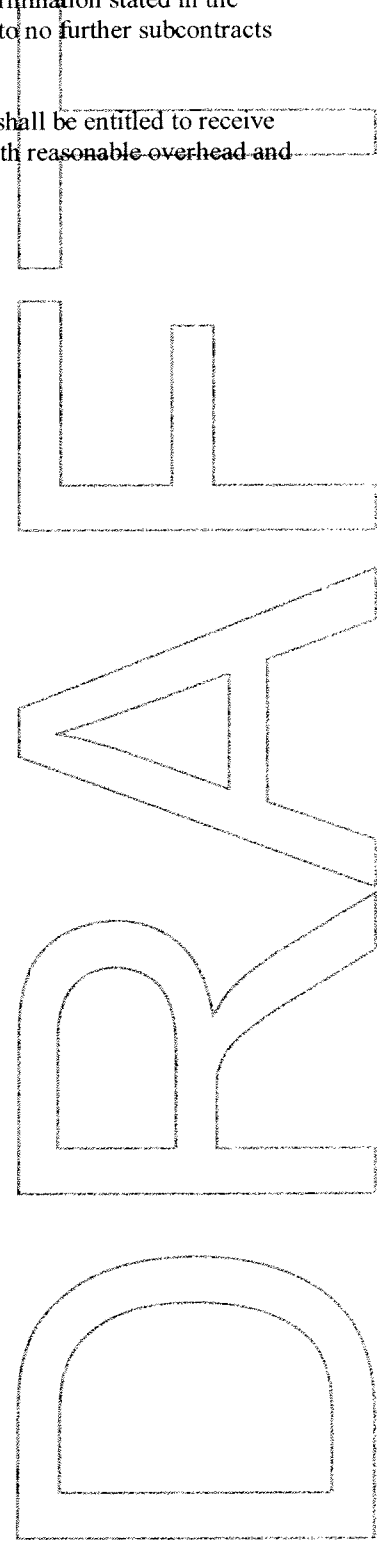

**Exhibits to AIA Document B141-1997  
Standard Form of Architect's Services:  
Design and Contract Administration**

**EXHIBIT "A"**

**Article 3**

**3.1 Request for Payment.** On or before noon of the first Monday of each month during the performance of the services, Architect shall submit to Owner for its approval a request for payment ("Request for Payment") in form and substance satisfactory to Owner. Each Request for Payment shall set forth the amount due for Services rendered, a detailed breakdown of the amount and the sum of all prior payments. Owner shall review each such Request for Payment and may make such exceptions as Owner reasonably deems necessary or appropriate under the circumstances then existing. About five (5) working days after the Owner's governing body meets approving such payment, the Owner shall make payment to Architect in the amount approved as aforesaid subject to Section 3.3, below.

**3.2 Final Payment.** After final completion of the work and acceptance thereof by Owner, Architect shall submit a final request ("Final Request") which shall set forth all amounts due and remaining unpaid to Architect and upon approval thereof by Owner, Owner shall pay to Architect the amount due ("Final Payment") under such Final Request in accordance with the provisions of 3.1.

The Final Request for Payment shall not be made until Architect delivers to Owner an affidavit that so far as Architect has knowledge or information all materials and services over which Architect has control have been paid.

**3.3 Qualifications on Obligations to Pay.** Any provision hereof to the contrary notwithstanding, Owner shall not be obligated to make any payment (whether a payment under Article 3.1 hereof or Final Payment) to Architect hereunder if any one or more of the following conditions precedent exist:

- (1.) Architect is in default of any of its obligations hereunder or otherwise is in default under this Agreement or any of the Contract documents;
- (2.) Any part of such payment is attributable to Services which are not performed in accordance with this Agreement; provided, however, such payment shall be made as to the part thereof attributable to Services which were performed in accordance with this Agreement;

- (3.) Architect has failed to make payments promptly to consultants or other third parties used in connection with the Services for which Owner has made payment to Architect;
- (4.) If Owner, in its good faith judgment, determines that the portion of the compensation then remaining unpaid will not be sufficient to complete the Services in accordance with this Agreement, no additional payments will be due Architect hereunder unless and until Architect, at its sole cost, performs a sufficient portion of the Services so that such portion of the compensation then remaining unpaid is determined by Owner to be sufficient to so complete the Services.

3.4 No partial payment made hereunder shall be or construed to be final acceptance or approval of that part of the Services to which such partial payment relates or relieves Architect of any of its obligations hereunder with respect thereto.

3.5 Architect shall promptly pay all bills for labor and material performed and furnished by others in connection with the performance of the Services.

3.6 **Waiver.** The making of the Final Payment shall constitute a waiver of all claims by the Owner except those arising from (1) faulty or defective Services appearing after completion of the Work, (2) failure of the Services to comply with the requirements of this Agreement or the Contract documents or (3) terms of any special warranties required by this Agreement or provided at law or in equity. The acceptance of Final Payment shall constitute a waiver of all claims by the Architect except those previously made in writing and identified by the Architect as unsettled at the time of the Final Request for Payment.

3.7 In the event of a conflict between the provisions of this Article 3, and those of Articles 1 and 2 of this Agreement, the provisions of this Article 3 shall control.



4.4 Architect represents, covenants and agrees that its Project Drawings and Specifications will be accurate and free from any material errors and the shop drawings that it must approve will be accurate and free from any material errors relating to design intent. Architect additionally represents, covenants and agrees to the following: the design of the Project will conform to its foreseeable use as a project with all the amenities as set forth in the Drawings and Specifications; the result of the Drawings and Specifications, if built in accordance therewith, will be suitable for purposes for which the Project is designed; the result of Architect's inspection of the Project will be suitable for purposes for which the Project is designed; and, the Project will be designed and the construction will be inspected in a workmanlike, professional manner and will be suitable for human occupancy and use. The Architect's responsibilities as set forth herein shall at no time be in any way diminished by reason of any approval by the Owner of the Drawings and Specifications nor shall the Architect be released from any liability by reason of such approval by the Owner, it being understood that the Owner at all times is ultimately relying upon the Architect's skill and knowledge in preparing the Drawings and Specifications. Notwithstanding the immediately preceding sentence, Architect may rely on any documents or information forwarded by Owner pursuant to Article 2 hereof.

4.5 The Architect represents, covenants and agrees that the person directly in charge of the professional architectural work is duly registered under Tex. Rev. Civ. Stat. Ann., art. 249(a), as amended.

4.6 **Indemnification.** To the fullest extent permitted by applicable law, the Architect and its agents, partners, and consultants (collectively "Indemnitors") shall and do agree to indemnify, protect, defend and hold harmless the Owner, Owner's respective Commissioners, elected officials, employees and agents (collectively "Indemnitees") from and against all claims, damages, losses, liens, causes of action, suits, judgments and expenses, including attorney fees, of any nature, kind or description (collectively "Liabilities") of any person or entity whomsoever arising out of, caused by or resulting from the performance of the Services or any part thereof provided that any such Liabilities (1) are attributable to bodily injury, personal injury, sickness, disease or death of any person, or to the injury to or destruction of tangible personal property including the loss of use and consequential damages resulting therefrom, and (2) are caused in whole or in part by any negligent act or omission of the Architect, anyone directly or indirectly employed by it or anyone for whose acts it may be legally liable. In this connection, it is agreed and understood that Architect shall not be responsible for any portion of the liability proximately caused by Owner's negligence.

4.7 **Joint and Several Liability.** In the event more than one of the Indemnitors are connected with an accident or occurrence covered by the

indemnification in Article 4.6 hereof, then each of such Indemnitors shall be jointly and severally responsible to the Indemnitees for indemnification and the ultimate responsibility among such Indemnitors for the loss and expense of any such indemnification shall be settled by separate proceedings and without jeopardy to any Indemnitee. The provisions of this Article shall not be construed to eliminate or reduce any other indemnification or right which Owner or any of the Indemnitees has by law.

4.8 Notwithstanding any provisions herein to the contrary, it is agreed that if the Architect's final written estimate of construction cost is less than the low bona fide bid for construction and such low bid is not accepted by the Owner, the Architect, at his expense, will make all necessary revisions to the plans and specifications to lower the construction to an amount acceptable to Owner.

4.9 The Owner agrees to give the Architect the latitude to make the required changes to plans and specifications to achieve the required reduction in construction cost; however, the Architect shall consult with the Owner on all necessary changes.

4.10 Architect covenants with Owner to obtain separate bids and/or contracts for the following phases of the construction of the Project:

1. General Construction;
- 2.
- 3.
- 4.

4.11 The final written estimate of construction cost will be reviewed and approved by the governing body of Owner prior to authorizing the Architect to issue plans and specifications for bidding.

4.12 Architect agrees to maintain a General and Professional Liability Insurance Policy to cover the liability of Architect connected with the performance of the services or any service covered by this Agreement in an amount equal to or exceeding the value of the Project, unless specifically agreed to by the Owner in a separate written agreement. Any such policy must either be for any occurrence as a result of that performance or, if limited to claims made, include at least a five (5) year extended reporting period. Architect agrees to furnish Owner Certificates of Insurance showing the said Policy to be fully paid, in full force and effect, and not subject to modification or change for the period specified in this Agreement.

4.13 In the event of a conflict between the provisions of this Article 4, and those of Articles 1 and 2 of this Agreement, the provisions of Article 4 shall control.

# ACORD CERTIFICATE OF LIABILITY INSURANCE

CSR TR  
GIGNA-1

DATE (MM/DD/YYYY)  
01/23/08

**PRODUCER**  
Carlisle Insurance Agency, Inc  
Corpus Christi Office  
500 N Water Suite 900  
Corpus Christi TX 78471-0019  
Phone: 361-884-2775 Fax: 361-884-3470

**INSURED**  
  
Gignac & Associates  
416 Starr St  
Corpus Christi TX 78401

**THIS CERTIFICATE IS ISSUED AS A MATTER OF INFORMATION ONLY AND CONFERS NO RIGHTS UPON THE CERTIFICATE HOLDER. THIS CERTIFICATE DOES NOT AMEND, EXTEND OR ALTER THE COVERAGE AFFORDED BY THE POLICIES BELOW.**

INSURERS AFFORDING COVERAGE		NAIC #
INSURER A:	Allstate	
INSURER B:	Twin City Fire Insurance Co	29459
INSURER C:	Maxum Insurance Company	
INSURER D:		
INSURER E:		

## COVERAGES

THE POLICIES OF INSURANCE LISTED BELOW HAVE BEEN ISSUED TO THE INSURED NAMED ABOVE FOR THE POLICY PERIOD INDICATED. NOTWITHSTANDING ANY REQUIREMENT, TERM OR CONDITION OF ANY CONTRACT OR OTHER DOCUMENT WITH RESPECT TO WHICH THIS CERTIFICATE MAY BE ISSUED OR MAY PERTAIN, THE INSURANCE AFFORDED BY THE POLICIES DESCRIBED HEREIN IS SUBJECT TO ALL THE TERMS, EXCLUSIONS AND CONDITIONS OF SUCH POLICIES. AGGREGATE LIMITS SHOWN MAY HAVE BEEN REDUCED BY PAID CLAIMS.

INSR ADD'L LTR	INSRD	TYPE OF INSURANCE	POLICY NUMBER	POLICY EFFECTIVE DATE (MM/DD/YY)	POLICY EXPIRATION DATE (MM/DD/YY)	LIMITS
A		<b>GENERAL LIABILITY</b>	050810044	05/02/07	05/02/08	EACH OCCURRENCE \$ 1000000
		<input checked="" type="checkbox"/> COMMERCIAL GENERAL LIABILITY				DAMAGE TO RENTED PREMISES (Ea occurrence) \$ 100000
		<input type="checkbox"/> CLAIMS MADE <input checked="" type="checkbox"/> OCCUR				MED EXP (Any one person) \$ 5000
						PERSONAL & ADV INJURY \$ included
						GENERAL AGGREGATE \$
						PRODUCTS - COMP/OP AGG \$
						GENT'L AGGREGATE LIMIT APPLIES PER: <input checked="" type="checkbox"/> POLICY <input type="checkbox"/> PRO-JECT <input type="checkbox"/> LOC
A		<b>AUTOMOBILE LIABILITY</b>	050810044	05/02/07	05/02/08	COMBINED SINGLE LIMIT (Ea accident) \$ 1000000
		<input type="checkbox"/> ANY AUTO				BODILY INJURY (Per person) \$
		<input type="checkbox"/> ALL OWNED AUTOS				BODILY INJURY (Per accident) \$
		<input checked="" type="checkbox"/> HIRED AUTOS				PROPERTY DAMAGE (Per accident) \$
<input checked="" type="checkbox"/> NON-OWNED AUTOS						
		<b>GARAGE LIABILITY</b>				AUTO ONLY - EA ACCIDENT \$
		<input type="checkbox"/> ANY AUTO				OTHER THAN EA ACC \$
						AUTO ONLY: AGG \$
		<b>EXCESS/UMBRELLA LIABILITY</b>				EACH OCCURRENCE \$
		<input type="checkbox"/> OCCUR <input type="checkbox"/> CLAIMS MADE				AGGREGATE \$
		<input type="checkbox"/> DEDUCTIBLE				\$
		<input type="checkbox"/> RETENTION \$				\$
B		<b>WORKERS COMPENSATION AND EMPLOYERS' LIABILITY</b>	65WBCGI0789	09/17/07	09/17/08	<input checked="" type="checkbox"/> WC STATU-TORY LIMITS <input type="checkbox"/> OTH-ER \$ 500000
		ANY PROPRIETOR/PARTNER/EXECUTIVE OFFICER/MEMBER EXCLUDED?				E.L. DISEASE - EA EMPLOYEE \$ 500000
		If yes, describe under SPECIAL PROVISIONS below				E.L. DISEASE - POLICY LIMIT \$ 500000
C		<b>Professional Liab</b>	PPF6001950-04	08/19/07	08/19/08	Per Claim 1000000 Aggregate 1000000

DESCRIPTION OF OPERATIONS / LOCATIONS / VEHICLES / EXCLUSIONS ADDED BY ENDORSEMENT / SPECIAL PROVISIONS

**ENGINEERS OR ARCHITECTS**

**CERTIFICATE HOLDER**

HIDAL03

Hidalgo County  
100 N. Clossner Blvd  
Edinburg TX 78539

**CANCELLATION**

SHOULD ANY OF THE ABOVE DESCRIBED POLICIES BE CANCELLED BEFORE THE EXPIRATION DATE THEREOF, THE ISSUING INSURER WILL ENDEAVOR TO MAIL 10 DAYS WRITTEN NOTICE TO THE CERTIFICATE HOLDER NAMED TO THE LEFT, BUT FAILURE TO DO SO SHALL IMPOSE NO OBLIGATION OR LIABILITY OF ANY KIND UPON THE INSURER, ITS AGENTS OR REPRESENTATIVES.

*Jim Carlisle*

## **IMPORTANT**

If the certificate holder is an **ADDITIONAL INSURED**, the policy(ies) must be endorsed. A statement on this certificate does not confer rights to the certificate holder in lieu of such endorsement(s).

If **SUBROGATION IS WAIVED**, subject to the terms and conditions of the policy, certain policies may require an endorsement. A statement on this certificate does not confer rights to the certificate holder in lieu of such endorsement(s).

## **DISCLAIMER**

The Certificate of Insurance on the reverse side of this form does not constitute a contract between the issuing insurer(s), authorized representative or producer, and the certificate holder, nor does it affirmatively or negatively amend, extend or alter the coverage afforded by the policies listed thereon.