

HIDALGO COUNTY PRECINCT NO. 2
301 EAST STATE
PHARR, TEXAS 78577
(956) 787-1891 / FAX # (956) 787-4683

DATE: 02/18/2010

I am requesting a Purchase Order Number (P.O. #) for the following:

HEADER: Park & Recreation Department
Name of Requester Yoli Cisneros

I will be purchasing the following items:
(PLEASE INCLUDE ALL CHARGES - FREIGHT, SURCHARGES ECT.)

VENDOR NAME: Elliffe Trailers CITY: Pharr, Texas
Quote provided by: Collins Stewart Phone/Quote # _____

QTY	UOM	PC	DESCRIPTION	UNIT PRICE	PRICE
1	Each	073-47	(One) 1 60"X8' 2010 Big-Tex Trailer with ramp gate		\$1,795.00

TOTAL AMOUNT \$1,795.00

CONTRACT # _____ Expire _____ BID # _____

INTERNAL: _____

FOOTER: Trailer for the department use.
Odometer# _____ License Plate # _____ VIN# _____

SAGE REQ. # 171044

PCT. REQ # 0032

ACCOUNT # 0-1212-452-00-122-008-0-748

REQUISITION APPROVED BY: _____

P. O. # _____

RE-APPROVED ON: N/A

HIDALGO COUNTY PRECINCT NO.2

QUOTE FOR UTILITY TRAILERS

Hidalgo County Object Code: #748

NIGP: Commodity Code #073-47 (Trailers not enclosed)

Specifications (or) Equivalent to:

One (1) 83" x 20' Trailer with pull out 4' Angle Iron Ramps 7000lbs. axles

One (1) 5' x 8' Trailer with ramp gate

COMPANY	DESCRIPTION	PRICE
Elliffe Trailers Collins Stewart 200 W. Exp. 83 Pharr, TX 956-702-9599	83"x 20' trailer	4495.00
	60"x 8' trailer	1795.00
	Combined Total	\$6,290.00
RD. Machen Nuehaus & Co., Ltd PO Box386 Weslaco, TX 956-423-3582	6'10" x 20' trailer	3999.00
	60" x 8' trailer	NO BID
	Total	\$3,999.00
H&V Equipment Thad Moore H&V Equipment Progreso, TX 956-565-3788	83"x 20' trailer	NO BID Not Available
	60"x 8' trailer	NO BID Not Available
Alamo Sales Corp Jamie Wilson Alamo Sales Corp 1502 East Walnut St. Sequin, TX 78155 830-372-9517	83"x 20' trailer	NO BID Not Available
	60"x 8' trailer	NO BID Not Available

19SV Vanguard

G.V.W.R.	1,995#	AXLE	2,000# EZ Lube
G.A.W.R.	1,995#	SUSPENSION	Multi-Leaf Spring
COUPLER	2" A-Frame	TIRE	ST175/80-13" Load Range C
SAFETY CHAINS	1/4" Grd. 30 w/Safety Latch Hook (2 each)	WHEEL	13 x 4.5 White Spoke 5 Bolt
JACK	2,000# Top Wind (Bolted On)	FLOOR	2" Pine
TONGUE	3" Channel	LIGHTS	D.O.T. Stop, Tail, Turn & Clearance
TOP RAIL	1-1/4" x 1-3/4" Pre-Formed Tube	ELEC. PLUG	4-Way Flat w/Loom
FRAME	3" x 2" x 3/16" Angle	FINISH (Prep)	Steel is Cleaned and Etched to Ensure Smooth, High Bond Paint Adhesion.
CROSSMEMBERS	2" x 2" x 1/8" Angle	FINISH	Painted with High-Solids Supreme Automotive Grade Enamel and Pin-Striped for a Highly Decorative and Protective Finish.
UPRIGHTS	2" x 2" x 1/8" Angle		
FENDERS	8" x 28" Rolled Formed		

Standard Features

- Safety Chains Attached w/Cold Rolled Eyelets
- Sand Foot on Jack
- Lower Jack Support Plate
- 27-3/4" Sides w/ 24" V-Crimped Steel Panels
- 4 Tie Down Loops Inside Bed
- EZ Lube Axle

Shown with Optional Gate

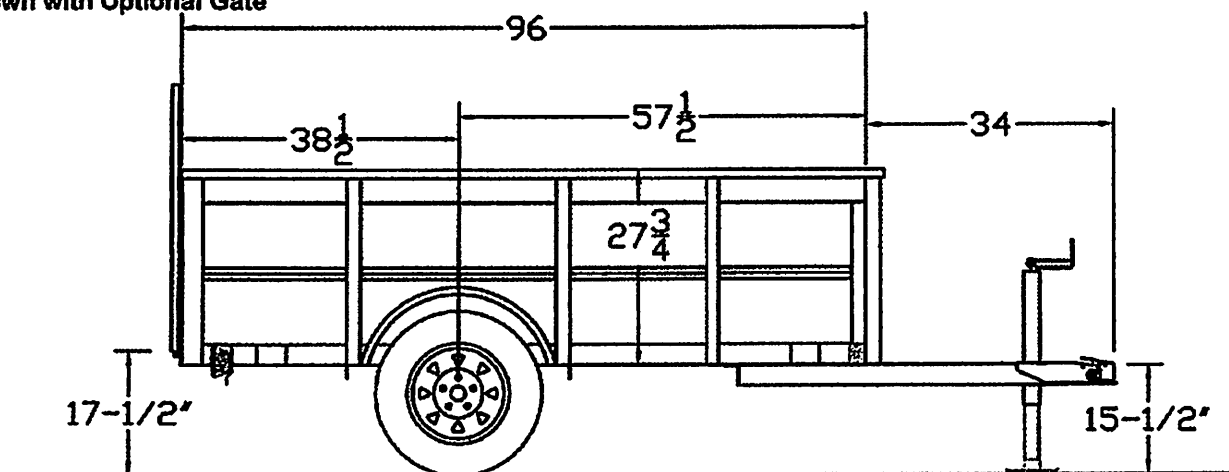

MODEL#	WEIGHT	DESCRIPTION
19SV-08	690#	50" x 8' Single Axle Vanguard

OPTIONS

3' Rampgate w/Expanded Metal



VEHICLE PURCHASE ORDER

Elliff Trailer Sales
200 W. Exp. 83
Pharr, TX 78577
956-702-9599

NAME <i>County of Hidalgo</i>		PHONE #	DATE <i>2-8-10</i>
ADDRESS <i>2802 South</i>		SALES MAN <i>Roy Carver</i>	STK. NO. <i>Pending</i>
CITY <i>Edinburg TX 78539</i>		SS# or F.I.D.#	MILEAGE
YEAR <i>2010</i>	MAKE <i>Big-Tax</i>	MODEL <i>19501-B</i>	LIC. NO
		SERIAL NO <i>pending</i>	

Sales Price	\$ <i>1795⁰⁰</i>	TRADE-IN		AWV:
Other Equip.	\$	Year	Make	Model
Other Equip.	\$			Lic. No.:
TOTAL OF CAR	XXXXXXXXXXXXXXXXXXXXXXXXXXXX \$ <i>1795⁰⁰</i>	MILEAGE	SERIAL #	
Tax	\$	PAYOFF TO:		
License	\$	ADDRESS:		
Title Fee	\$	PAYOFF AMOUNT:		
Documentary Fee	\$	(Show on Line 13)		
TOTAL OF CHARGES	XXXXXXXXXXXXXXXXXXXXXXXXXXXX \$	LIEN INFORMATION		
TOTAL PRICE	XXXXXXXXXXXXXXXXXXXXXXXXXXXX \$	<i>1 year Warranty</i>		
Cash Down	\$	EQUIPMENT		
Trade-In		<i>w/ Ramp Gate</i>		
Less Payoff		<i>60" x 8" treated wood deck</i>		
NET TRADE-IN	\$			
TOTAL DOWN PAYMENT	XXXXXXXXXXXXXXXXXXXXXXXXXXXX \$			
UNPAID BALANCE	XXXXXXXXXXXXXXXXXXXXXXXXXXXX \$			
Extended Warranty	\$			
Physical Damage Ins.	\$			
TOTAL TO FINANCE	\$			
Payments: at or at		TOTAL (Shown on Line 3)		

The information you see on the window form for this vehicle is part of this contract. Information on the window form overrides any contrary provisions in the contract of sale.

The selling dealer hereby expressly disclaims all warranties either express or implied, including any implied warranties or merchantability of fitness for a particular purpose, and neither assumes nor authorizes any other person to assume for it any liability in connection with the sale of this vehicle. Buyer shall not be entitled to recover from the selling dealer any consequential damages, damages to property, damages for loss of use, loss of time, loss of profits, or income, or any other incidental damages.

A Documentary Fee is not an official fee. A Documentary Fee is not required by law, but may be charged to buyers for handling documents and performing services relating to the closing of a sale. Buyers may avoid payment of the fee to the seller by handling the documents and performing the services relating to the closing of the sale. A Documentary Fee may not exceed \$50. This notice is required by law.

I understand and agree to the terms of this order, whether on the front or the reverse side. This order contains the entire agreement proposed for the purchase of the above described vehicle and no other agreement or understanding of any nature concerning this transaction has been made unless attached to this order and signed by the seller and buyer. Seller makes no representations concerning fuel economy of the sale unit and any information posted on this sale unit or contained in literature relating to the same reflect the results of tests performed, required or prescribed by a government agency, upon which seller has relied. If the sale unit is a used motor vehicle, (1) seller will deliver to the buyer an Odometer Disclosure Statement based on written information relating to the sale unit obtained from the previous owner and upon which seller has relied, and (2) seller has obtained from the previous owner a written Certificate of Title prepared by the State Department of Highways and Public Transportation from its official records, all of the information in which seller has relied upon in the Description of Sale Unit in this order.

Seller's Signature *Roy Carver* Purchaser's Signature _____ Date _____

14PI Heavy Duty Pipe Tandem Axle

G.V.W.R.	14,000#	AXLES	Two 7,000# EZ Lube w/Electric Brakes
G.A.W.R. (Ea. Axle)	7,000#	SUSPENSION	Multi-Leaf Slipper Spring w/Equalizer
COUPLER	Adjustable 2-5/16" 14K Cast	TIRE	ST235/16 Load Range E
SAFETY CHAINS	Grd. 70 w/Safety Latch Hook (2 each)	WHEEL	16 x 6 Heavy White Mod
JACK	7,000# Drop Leg Jack Wind (Bolted On)	FLOOR	2" Pine
TONGUE	5" Channel Fold Back	LIGHTS	D.O.T. Stop, Tail, Turn & Clearance
TOP RAIL	3" Square Tube Square Back	ELEC. PLUG	7-Way RV
FRAME	5" x 3" x 5/16" Angle	FINISH (Prep)	Steel is Cleaned and Etched to Ensure Smooth, High Bond Paint Adhesion.
CROSSMEMBERS	3" Channel	FINISH	Painted with High-Solids Supreme Automotive Grade Enamel and Pin-Striped for a Highly Decorative and Protective Finish.
UPRIGHTS	15" Tall - 3" x 2" x 3/16" Angle		
FENDERS	9" x 72" Double Broke Diamond Plate w/ Back		

Standard Features

- Adjustable 14K Cast Coupler
- Safety Chains Attached w/Cold Rolled Eyellets
- 7K Set Back Jack (Bolted On)
- Lower Jack Support Plate
- Fold Back Tongue (14' and longer)
- Reflective Marker Tape
- Tie Down Pockets, Sides & Rear
- 3" Square Tube Top Rail Capped w/Self Sealing Plugs
- Floor Secured w/Torx Screws
- Cambered EZ Lube Axles
- Two 7,000# Cambered Axles w/2 Electric Brakes
- Complete Break-A-Way System w/Charger
- Spare Tire Mount (Side)
- 4' Slide-In Ramps (Channel)
- Grommet Mount Sealed Lighting

Dimensions			
Length	A	B	C
16'	193-1/2"	115"	78-1/2"
18'	217-1/2"	127"	90-1/2"
20'	240"	138"	102"

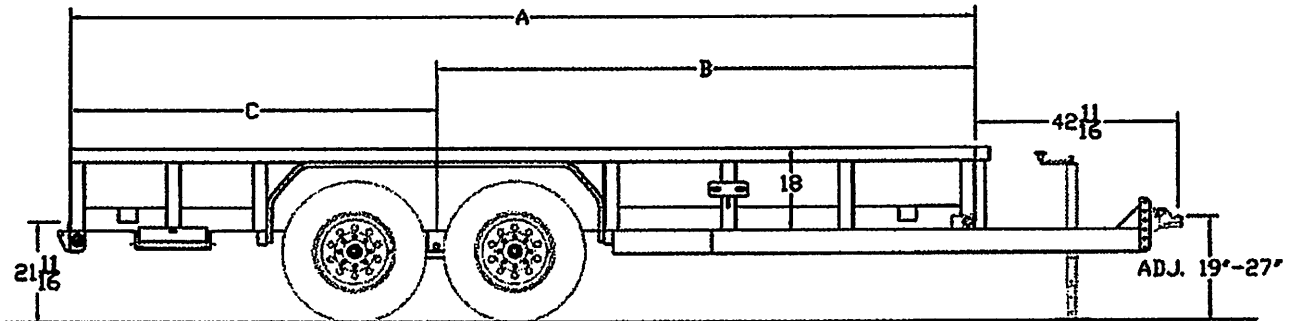

MODEL#	WEIGHT	DESCRIPTION
14PI-16	2,310#	83" x 16' Tandem Axle
14PI-18	2,470#	83" x 18' Tandem Axle
14PI-20	2,990#	83" x 20' Tandem Axle

OPTIONS

Adjustable Pintle in Channel	Spare Tire Upgrade (ST235/16 LR-G)
12K Top Wind Drop-Leg Jack	Rampgate in Lieu of Ramps
Hydraulic Brakes 2 Axles	Gas Spring Assist Option - Rampgate
Spare Tire (ST235/16 LR-E)	4' Integrated Ramp Heavy Duty Gate w/Gas Spring Assist in Lieu of Ramps
Tire Upgrade (ST235/16 LR-G)	5' Stand up Ramps in Lieu of Slide In

RECEIVED
By Oscar Garza at 3:58 pm, Feb 08, 2010



VEHICLE PURCHASE ORDER

Elliff Trailer Sales
200 W. Exp. 83
Pharr, TX 78577
956-702-9599

NAME: County of Hidalgo		PHONE #: 956-318-2626	DATE: 2-8-10
ADDRESS: 2802 South		SALESMAN: Roy Calaveo	STK. NO. (Dend)
CITY: Edinburg, TX 78539		SS# or F.I.D.#	MILEAGE
YEAR: 2010	MAKE: Big-Tex	MODEL: 14PT-20	LIC. NO.
		SERIAL NO. pending	

Sales Price	\$ 4495.00
Other Equip.	\$
Other Equip.	\$
TOTAL OF CAR	\$ 4495.00
Tax	\$ 0
License	\$ 0
Title Fee	\$ 0
Documentary Fee	\$ 0
TOTAL OF CHARGES	\$ 0
TOTAL PRICE	\$ 4495.00
Cash Down	\$
Trade-In	
Less Payoff	
NET TRADE-IN	\$
TOTAL DOWN PAYMENT	\$
UNPAID BALANCE	\$
Extended Warranty	\$
Physical Damage Ins.	\$
TOTAL TO FINANCE	\$

TRADE-IN		AWV:	
Year	Make	Model	Lic. No.:
MILEAGE	SERIAL #		
PAYOFF TO:			
ADDRESS:			
PAYOFF AMOUNT:			
(Show on Line 13)			
LIEN INFORMATION			
14,000 lb G.V.W.R.			
1 year warranty			
EQUIPMENT			
83" x 20' Deck (Treated wood)			
Pull-out 4' Angle Iron Ramps			
Channel Iron Tongue.			
Cambered Axles 7000 lb each			
TOTAL (Shown on Line 3)			

The information you see on the window form for this vehicle is part of this contract. Information on the window form overrides any contrary provisions in the contract of sale.

The selling dealer hereby expressly disclaims all warranties either express or implied, including any implied warranties or merchantability of fitness for a particular purpose, and neither assumes nor authorizes any other person to assume for it any liability in connection with the sale of this vehicle. Buyer shall not be entitled to recover from the selling dealer any consequential damages, damages to property, damages for loss of use, loss of time, loss of profits, or income, or any other incidental damages.

A Documentary Fee is not an official fee. A Documentary Fee is not required by law, but may be charged to buyers for handling documents and performing services relating to the closing of a sale. Buyers may avoid payment of the fee to the seller by handling the documents and performing the services relating to the closing of the sale. A Documentary Fee may not exceed \$50. This notice is required by law.

I understand and agree to the terms of this order, whether on the front or the reverse side. This order contains the entire agreement proposed for the purchase of the above described vehicle and no other agreement or understanding of any nature concerning this transaction has been made unless attached to this order and signed by the seller and buyer. Seller makes no representations concerning fuel economy of the sale unit and any information posted on this sale unit or contained in literature relating to the same reflect the results of tests performed, required or prescribed by a government agency, upon which seller has relied. If the sale unit is a used motor vehicle, (1) seller will deliver to the buyer an Odometer Disclosure Statement based on written information relating to the sale unit obtained from the previous owner and upon which seller has relied, and (2) seller has obtained from the previous owner a written Certificate of Title prepared by the State Department of Highways and Public Transportation from its official records, all of the information in which seller has relied upon in the Description of Sale Unit in this order.

Seller's Signature: Roy Calaveo Purchaser's Signature: _____ Date: _____

Oscar Garza

From: Oscar Garza [oscar.garza@co.hidalgo.tx.us]
Sent: Tuesday, February 09, 2010 8:48 AM
To: R.D. Machen
Subject: Quote for Uillity Trailers
Attachments: 14pi[1].jpg; 19sv.jpg; 19SV Single Axle Vanguard Trailer.pdf; 14pi.pdf

RD as per our earlier conversation please let this serve as a formal request for a quote on the following utility trailers:

Attached please find pictures and specifications for your quote to be for same kind like or quality or equivalent to.

The precinct foreman wants to purchase the following utility trailers.

For Road and Bridge: 14PI-20 with the standard specs. **Additional options will not be needed.**

For Parks: 19SV 50" X 8' single axle with standard specs and no additional options.

Should you have any questions, please let me know.

Thank you,



Oscar Garza, Procurement Specialist
2802 So Bus. Hwy 281
Postal Maining Address
2812 So. Bus 281 & Corner of Canton Rd.
Edinburg, TX 78539
Phone: 956-318-2626 Ext. 4857
Fax: 956-292-7612
oscar.garza@co.hidalgo.tx.us

County of Hidalgo, Texas
OBJECT CODE DESCRIPTIONS

Effective: April 1, 2009

747. Software

Expenditures for the purchase or contractual development of computer software with a unit cost of \$1,000 or more. Software purchased as part of an existing hardware system that cannot be readily assigned a separate cost should be capitalized as part of the computer equipment in accordance with computer equipment capitalization criteria. **NOTE:** Expenditures for software with a unit cost of less than \$300 should be charged to object code 601. Expenditures for software with a unit cost of \$300.00 to \$999.99 should be charged to object code 667. Expenditures for annual software license renewals that do not include support services should be charged to object code 812.

748. Other equipment

Other equipment not classified above with a unit cost of \$1,000 or more. Examples include lawnmowers, two-way radios, televisions, cameras, firearms, emergency light bars, tanks, refrigerators, shredders, utility trailers, bulletproof vests, surveillance equipment, and radio antennas. **NOTE:** Expenditures for other equipment with a unit cost of less than \$300 should be charged to object code 619. Expenditures for other equipment with a unit cost of \$300.00 to \$999.99 should be charged to object code 664.

Leases

780. Capital leases

Expenditures for noncancelable lease agreements and cancelable lease agreements only upon occurrences of a remote contingency that effectively transfers all of the benefits and risks of property ownership from the lessor to the lessee. Capital leases are essentially sale-purchase transactions by the lessee if any of the following four criteria is met:

1. The lease transfers title of the property to the lessee by the end of the lease term, or
2. The lease contains a "bargain purchase option", or
 - a. The lessee can purchase the leased property for a price that is significantly lower than the property's expected fair value at the date the option becomes exercisable.
 - b. Difference must be large enough to make exercise of the option reasonably assured.
3. The lease term is equal to or greater than 75% of the estimated remaining useful economic life of the leased property at the inception of the lease (e.g., lease term six years, estimated life eight years), or
Note: Economic life test is not applicable if the inception of the lease occurs during the last 25 percent of the life of the asset,
4. The present value of rental and other minimum lease payments equals or exceeds 90% of the fair market value of the leased property at the inception of the lease, net of any related investment tax credit (e.g., future minimum lease payments \$9,000, fair value \$10,000)

VIII. OTHER OBJECTS

810. Dues and memberships

Expenditures for dues and memberships in professional or other organizations or associations.

811. Licenses and permits

Expenditures for official or legal licensing and permission.

812. Software license renewals

Expenditures for annual software license renewals that do not include support services. Expenditures for annual renewals of software maintenance and support agreements should be charged to object code 336.

820. Claims and judgments not covered by insurance

Expenditures for claims and judgments that are either not filed against an insurance policy or not covered by insurance.

UTILITY LOCATER SERVICE, UNDERGROUND.....	962	91
UTILITY MAINTENANCE AND REPAIR.....	913	89
UTILITY MAINTENANCE AND REPAIR, PUBLIC.....	910	63
UTILITY MANAGEMENT SERVICES.....	958	95
UTILITY MARKERS.....	670	51
UTILITY POLE INSTALLATION, REMOVAL AND RELOCATION SERVICES.....	968	79
UTILITY POLES.....	725	44
UTILITY PROBES FOR TESTING DRILLING SITES.....	445	55
UTILITY SERVICES, ELECTRIC.....	961	83
UTILITY SERVICES, GAS.....	961	84
UTILITY SERVICES, WATER.....	961	85
UTILITY TABLES, INSTITUTIONAL.....	420	44
UTILITY TRAILERS, ENCLOSED, TAG-ALONG.....	073	43
UTILITY TRAILERS, GOOSENECK.....	073	47
UTILITY TRAYS (BARBER SHOP).....	095	21
UTILITY VEHICLE BODIES.....	065	10
UTILITY VEHICLE MAINTENANCE AND REPAIR SERVICES (NOT OTHERWISE CLASSIFIED).....	928	47
UTILITY VEHICLE RENTAL OR LEASE.....	975	88
UTILITY WORKS REMOVAL AND/OR RELOCATION SERVICES.....	968	63
UV DEVICES FOR MEASURING RADIANT ENERGY.....	220	53

[Texas Online](#) [Statewide Search from the Texas State Library](#) [State Link Policy](#) [Texas Homeland Security](#)
Susan Combs, Texas Comptroller • [Window on State Government](#) • [Contact Us](#)
[Privacy and Security Policy](#) [Accessibility Policy](#) [Link Policy](#) [Public Information Act](#) [Compact with Texans](#)

Vendor Contract Information

Proposal Documents



Vendor: Alamo Sales Corp.
Address: 1502 East Walnut St.
Sequin, TX 78155
Phone: (830) 372-9517
Contact: Jamie Wilson
Email: jwilson@alamo-industrial.com
Federal ID: 74-2494182

Accepts RFQs: Yes

Contract: Grounds Maint. Eq. & Irrigation Products & Installation #292-08

Effective Date: 6/1/2008

Expiration Date: 5/31/2011

Payment Terms: Net 30 days

Delivery Days: 190

Shipping Terms: Free Shipping

Freight Terms: FOB Destination

Ship Via: Common Carrier

Quote Reference Number:

292-08

Regions Served: All Texas Regions

States Served: All States

Vendor Exceptions: None

Return Policy: 15% restocking fee on wrong customer orders.

Additional Dealers: Alamo Ag-Con Equipment, Crockett Iron Works, Equipment Depot,
Ewald Tractor, Fuller Tractor, Future Equipment, H&V Equipment,
Landmark Equipment, Lansdowne-Moody Co.,

[[Log Out](#)]

©1996 - 2010 TASB
ALL RIGHTS RESERVED

Oscar Garza

From: Oscar Garza [oscarg.garza@co.hidalgo.tx.us]
Sent: Monday, February 08, 2010 2:14 PM
To: 'jwilson@alamo-industrial.com'
Subject: Quote for Utility Trailers

Let this serve as a formal request for information and a possible quote on utility trailers. Do you handle utility trailers for landscaping or like it.

Please advise...Thank you!



Oscar Garza, Procurement Specialist
2802 So Bus. Hwy 281
Postal Mailing Address
2812 So. Bus 281 & Corner of Canton Rd.
Edinburg, TX 78539
Phone: 956-318-2626 Ext. 4857
Fax: 956-292-7612
oscarg.garza@co.hidalgo.tx.us

Oscar Garza

From: Oscar Garza [oscarg.garza@co.hidalgo.tx.us]
Sent: Monday, February 08, 2010 11:55 AM
To: 'roycaraveo@yahoo.com'
Subject: FW: Quotes for Pct. #2 (Utility Trailers)

Please provide me quotes



Oscar Garza, Procurement Specialist
2802 So Bus. Hwy 281
Postal Maining Address
2812 So. Bus 281 & Corner of Canton Rd.
Edinburg, TX 78539
Phone: 956-318-2626 Ext. 4857
Fax: 956-292-7612
oscarg.garza@co.hidalgo.tx.us

From: Oscar Garza [mailto:oscarg.garza@co.hidalgo.tx.us]
Sent: Monday, February 08, 2010 10:42 AM
To: 'collinstewart2008@yahoo.com'
Cc: 'Agapito Vargas'; 'Humberto Garza'; 'Martha Salazar'; 'Darlene Betancourt'
Subject: Quotes for Pct. #2 (Utility Trailers)

Please let this serve as a **FORMAL REQUEST** to provide us with the following quotes as requested by Pct. #2,

Good Afternoon Oscar, The precinct foreman wants to purchase the following utility trailers.

For Road and Bridge: 14PI-20 with the standard specs. **Additional options will not be needed.**

Question:

The axles include Electric Brakes, are these brakes initiated from within the truck cab or do they function with the brake lights?

For Parks: 19SV 50" X 8' single axle with standard specs and no additional options.

Please advice me on the cost of the two pieces of equipment. Once the precinct gets the quotes we will proceed to start the requisitions.

Thanks,
AVargas



Oscar Garza, Procurement Specialist
2802 So Bus. Hwy 281
Postal Maining Address
2812 So. Bus 281 & Corner of Canton Rd.

Edinburg, TX 78539
Phone: 956-318-2626 Ext. 4857
Fax: 956-292-7612
oscar.garza@co.hidalgo.tx.us

BID LOG DATA ENTRY FORM

Bid No.

2010083

Buyer

OGG

Project Type

QUOTES

BID PROCESS STATUS

OPEN

Bid Description

Purchase of (2) New Utility Trailers (1) 83"x20' and (1) 5'x8'

10:52:28.93 AM

Department

HIDALGO COUNTY, PRECINCT 2

No. Assigned Date: 2/17/2010

Ad Date1

Ad Date2

Ad Date3

Pre Project Conf.

Bid Opening Date

CC Action Date

Type of CC Action

Awarded Vendor 1

Current Project Status

PENDING APPROVAL

DATE OF LAST UPDATE: 2/17/2010