

AI-33348

County Judge's Office 5. A.

CC REGULAR

Meeting Date: 07/24/2012

Submitted By: Monica Badillo, EXECUTIVE
OFFICE

Department: EXECUTIVE OFFICE

Information

CAPTION

1. Resolution in honor of Lewis Joseph Lodico
2. Recognition of the Food Network's Cupcake Wars Champions: Sabrina Rodriguez-Louck, Erica Rodriguez, and Johanna Saenz
3. Presentation of Public Affairs Specialist Intern

BACKGROUND

Attachments

resolution

Form Review

Inbox	Reviewed By	Date
Budget & Management	Merlen P. Munoz	07/19/2012 03:18 PM
Purchasing Department	Angela Garcia	07/20/2012 04:55 PM
Form Started By: Monica Badillo		Started On: 07/19/2012 02:34 PM
	Final Approval Date: 07/20/2012	

RESOLUTION IN HONOR OF LEWIS JOSEPH LODICO

WHEREAS, Lewis Joseph Lodico, husband and father of four children, began his service with the Edinburg Volunteer Fire Department on September 8th, 1952 and has continued since then for a total of 60 years of volunteer service; and

WHEREAS, Mr. Lodico has gained certification as both a basic and intermediate firefighter he continues serving the department and the City of Edinburg with the highest integrity, honor, and ; and

WHEREAS, he has served thousands of hours in emergency and fire service training in 31 subjects and also served as a mentor to hundreds of young firefighters during his volunteer tenure; and

WHEREAS, Mr. Lodico has held numerous leadership positions within the department including assistant fire chief and currently serves as Chief Emeritus—the highest honor in the department; and

WHEREAS, through his dedication, Mr. Lodico has distinguished himself as a vital and valued volunteer for the city of Edinburg; his many years of volunteer service show his passion for helping others and serving his community.

Now, therefore, be it RESOLVED that the Hidalgo County Commissioners’ Court hereby recognizes and honors Lewis Joseph Lodico for his 60 years of dedicated volunteer service to the Edinburg Volunteer Fire Department.

Approved this 24th day of July, 2012.

RAMON GARCIA
County Judge

JOEL QUINTANILLA
County Commissioner, Pct. 1

HECTOR “TITO” PALACIOS
County Commissioner, Pct. 2

JOE M. FLORES
County Commissioner, Pct. 3

JOSEPH PALACIOS
County Commissioner, Pct. 4

Attest: ARTURO GUAJARDO, JR.
County Clerk

AI-33351

County Judge's Office 5. B.

CC REGULAR

Meeting Date: 07/24/2012

Submitted By: Monica Badillo, EXECUTIVE
OFFICE

Department: EXECUTIVE OFFICE

Information

CAPTION

Recognition of the Hidalgo County Courthouse Historical Commission

BACKGROUND

Form Review

Inbox	Reviewed By	Date
Budget & Management	Merlen P. Munoz	07/19/2012 03:47 PM
Purchasing Department	Angela Garcia	07/20/2012 04:55 PM
Form Started By: Monica Badillo		Started On: 07/19/2012 03:22 PM
	Final Approval Date: 07/20/2012	

AI-33306

County Judge's Office 5. C.

CC REGULAR

Meeting Date: 07/24/2012

Department Head: Jaime Longoria

Submitted By: SANDRA DELEON, COUNTY JUDGE

Department: COUNTY JUDGE

Information

CAPTION

Update and presentation on utilization of funds for Energy Efficiency and Conservation Block Grant (EECBG)

BACKGROUND

Form Review

Inbox	Reviewed By	Date
Budget & Management	Merlen P. Munoz	07/18/2012 11:36 AM
Roland Garcia	Rolando Garcia	07/19/2012 01:53 PM
Purchasing Department	Angela Garcia	07/20/2012 04:55 PM
Form Started By: SANDRA DELEON		Started On: 07/18/2012 11:16 AM
	Final Approval Date: 07/20/2012	

AI-33337

County Judge's Office 5. D.

CC REGULAR

Meeting Date: 07/24/2012

Department Head: Roberto Villarreal

Submitted By: SANDRA DELEON, COUNTY JUDGE

Department: COUNTY JUDGE

Information

CAPTION

Appointment of one board member to represent the County of Hidalgo on the City of Donna's Tax Increment Reinvestment Zone Number One (1) Board of Directors.

BACKGROUND

Attachments

Texas Tax Code Sec. 311.009(b)

Form Review

Inbox	Reviewed By	Date
Budget & Management	Merlen P. Munoz	07/19/2012 09:42 AM
Roland Garcia	Rolando Garcia	07/20/2012 08:15 AM
Purchasing Department	Angela Garcia	07/20/2012 04:55 PM
Form Started By: SANDRA DELEON		Started On: 07/19/2012 08:52 AM
	Final Approval Date: 07/20/2012	

Texas Tax Code - Section 311.009. Composition Of Board Of Directors

§ 311.009. COMPOSITION OF BOARD OF DIRECTORS. (a) Except as provided by Subsection (b), the board of directors of a reinvestment zone consists of at least five and not more than 15 members, unless more than 15 members are required to satisfy the requirements of this subsection.

Each taxing unit other than the municipality or county that created the zone that levies taxes on real property in the zone may appoint one member of the board. A unit may waive its right to appoint a director. The governing body of the municipality or county that created the zone may appoint not more than 10 directors to the board; except that if there are fewer than five directors appointed by taxing units other than the municipality or county, the governing body of the municipality or county may appoint more than 10 members as long as the total membership of the board does not exceed 15.

(b) If the zone was designated under Section 311.005(a)(5), the board of directors of the zone consists of nine members. Each school district, county, or municipality, other than the municipality or county that created the zone, that levies taxes on real property in the zone may appoint one member of the board if the school district, county, or municipality has approved the payment of all or part of the tax increment produced by the unit. The member of the state senate in whose district the zone is located is a member of the board, and the member of the state house of representatives in whose district the zone is located is a member of the board, except that either may designate another individual to serve in the member's place at the pleasure of the member. If the zone is located in more than one senate or house district, this subsection applies only to the senator or representative in whose district a larger portion of the zone is located than any other senate or house district, as applicable. The remaining members of the board are appointed by the governing body of the municipality or county that created the zone.

(c) Members of the board are appointed for terms of two years unless longer terms are provided under Article XI, Section 11, of the Texas Constitution. Terms of members may be staggered.

(d) A vacancy on the board is filled for the unexpired term by appointment of the governing body of the taxing unit that appointed the director who served in the vacant position.

(e) To be eligible for appointment to the board by the

governing body of the municipality or county that created the zone, an individual must:

(1) if the board is covered by Subsection (a):

(A) be a qualified voter of the municipality or county, as applicable; or

(B) be at least 18 years of age and own real property in the zone, whether or not the individual resides in the municipality or county; or

(2) if the board is covered by Subsection (b):

(A) be at least 18 years of age; and

(B) own real property in the zone or be an employee or agent of a person that owns real property in the zone.

(f) Each year the governing body of the municipality or county that created the zone shall appoint one member of the board to serve as chairman for a term of one year that begins on January 1 of the following year. The board of directors may elect a vice-chairman to preside in the absence of the chairman or when there is a vacancy in the office of chairman. The board may elect other officers as it considers appropriate.

(g) A member of the board of directors of a reinvestment zone:

(1) is not a public official by virtue of that position; and

(2) unless otherwise ineligible, may be appointed to serve concurrently on the board of directors of a local government corporation created under Subchapter D, Chapter 431, Transportation Code.

Added by Acts 1987, 70th Leg., ch. 191, § 1, eff. Sept. 1, 1987.

Amended by Acts 1989, 71st Leg., ch. 1137, § 21, eff. Sept. 1,

1989; Acts 1999, 76th Leg., ch. 983, § 2, eff. June 18, 1999;

Acts 2005, 79th Leg., ch. 1094, § 41, eff. Sept. 1, 2005.

AI-33359

Comm. Court Executive Office 6. B.

CC REGULAR

Meeting Date: 07/24/2012

Submitted By: Monica Badillo,
EXECUTIVE OFFICE

Department: EXECUTIVE OFFICE

Information

CAPTION

Environmental Compliance:

Discussion and possible submittal of comments regarding application for extension of TCEQ Scrap Tire Registration No. 6200592 for Santa Anita Reclamation LLC until September, 2017 for a Land Reclamation Project Using Tires (LRPUT) by Commissioner's Court and County Fire Marshal's Office.

BACKGROUND

Attachments

1
2
3

Form Review

Inbox	Reviewed By	Date
Budget & Management	Erika Zamora	07/20/2012 02:43 PM
Erika Zamora	Erika Zamora	07/20/2012 02:48 PM
Purchasing Department	Angela Garcia	07/20/2012 04:55 PM
Form Started By: Monica Badillo		Started On: 07/19/2012 05:13 PM
	Final Approval Date: 07/20/2012	

Attachment A:

Monitoring Well Construction Data and
Summary of Field Groundwater Depth Measurements
for 04/14/11 and 10/04/11 Monitoring Events



MONITORING WELL CONSTRUCTION DATA

SANTA ANITA RECLAMATION, LLC
SAN MANUEL-LUNN, TEXAS

WELL/BORING NO: YUW-1

PERMIT NO: —

DATE: 7-20-10

PROJECT NAME: SANTA ANITA RECLAMATION

PROJECT NO: 328-346

WELL SITE LOCATION PLAN:

SEE MONITORING
WELL LOCATION MAP

SEC: _____ TWN: _____ RGE: _____ LAT: _____ LONG: _____

DRILLING CO: JEDI DRILLING CONTRACTORS, INC.

DRILL CREW: OSCAR GARZA, JERRY SAUCEDA

WELL TYPE: SHALLOW SINGLE CASED MONITORING
 PERMANENT INTERMEDIATE DOUBLE CASED RECOVERY
 TEMPORARY DEEP OTHER OTHER

WELL SCHEMATIC

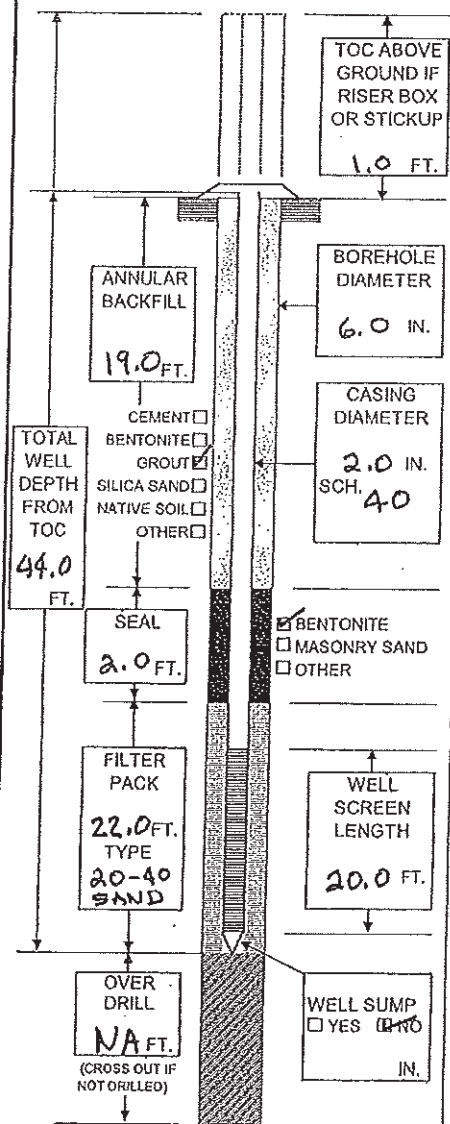

INSTALLATION DATA

DECON. STEAM CLEAN HIGH PRESSURE WASH
 SOAP WASH OTHER

CASING TYPE: PVC STAINLESS TEFLON OTHER

JOINTS: THREADED WELDED COUPLED
 SCREWED OTHER

PIT CASING: YES NO DESCRIBE
10' FT., 6 IN PVC

WELL SCREEN: PVC STAINLESS TEFLON OTHER

DIAMETER: 2" 4" 6" OTHER _____ IN

SLOT: 0.010 0.020 OTHER _____ IN

DRILLING METHOD: SOLID STEM HOLLOW STEM MUD ROTARY

AIR ROTARY DIRECT PUSH HAND AUGER

OTHER

BIT SIZE: 2" 4" 6" 8" 12" OTHER _____ IN

DRILLING MUD: NONE WATER BENTONITE

OTHER

CENTRALIZER: YES NO

COMPLETION: FLUSH MOUNT STICKUP RISER BOX

LOCK TYPE: DOLPHIN MASTER KEY NO. _____

OTHER

PAD: 2X2' 4X4' OTHER

CUTTINGS: DRUMMED NUMBER OF DRUMS _____

SPREAD OTHER

DEVELOPMENT METHOD: NONE BAILING PUMPING AIR LIFT

SURGE & BLOCK OTHER

TIME: 10 MIN 20 MIN OTHER 15 MIN

AMOUNT: 5 GAL 10 GAL OTHER _____ GAL

WATER BEFORE: SILTY TURBID OPAQUE CLEAR

WATER AFTER: SILTY TURBID OPAQUE CLEAR

EVIDENT ODOR: YES NO TYPE _____

DEVELOPMENT WATER: DRUMMED NUMBER OF DRUMS _____

SPREAD TREATED POTW OTHER

WATER LEVEL: INITIAL _____ FT BTOC BLS

DATE: _____ FT BELOW TOC

DATE: _____ FT BELOW TOC

NOTES: (DESCRIBE ALL NON-STANDARD METHODS & MATERIALS)

PREPARED BY: HPZ



MONITORING WELL CONSTRUCTION DATA

SANTA ANITA RECLAMATION, LLC
SAN MANUEL - LINN, TEXAS

WELL/BORING NO: MW-2

PERMIT NO: ---

DATE: 7-20-10

PROJECT NAME: SANTA ANITA WELL

PROJECT NO: 328-346

WELL SITE LOCATION PLAN:

SEC: TWN: RGE: LAT: LONG:

DRILLING CO: JEDI DRILLING CONTRACTORS, INC

DRILL CREW: OSCAR GARCIA, JERRY SANCEDA

WELL TYPE: SHALLOW SINGLE CASED MONITORING
 PERMANENT INTERMEDIATE DOUBLE CASED RECOVERY
 TEMPORARY DEEP OTHER OTHER

WELL SCHEMATIC

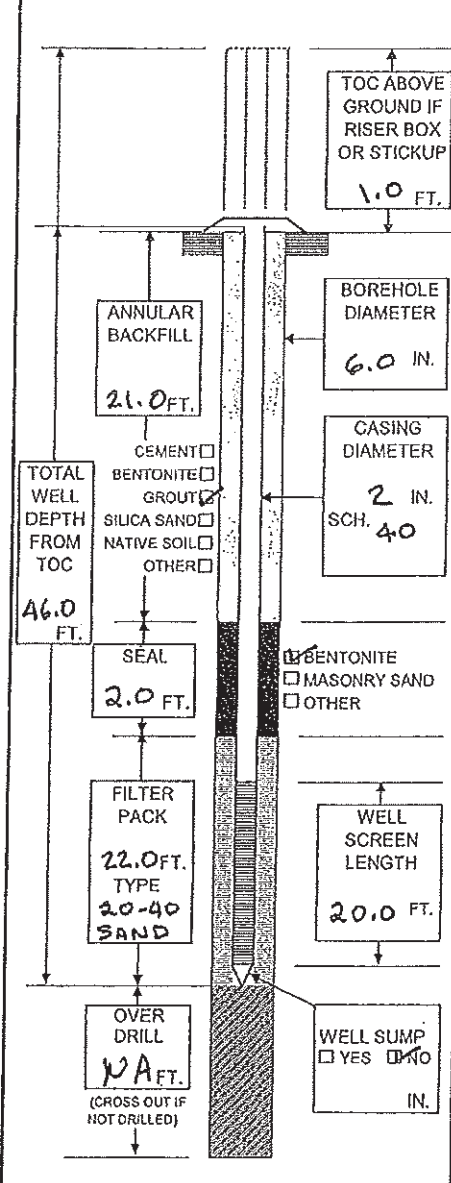

INSTALLATION DATA

DECON. STEAM CLEAN HIGH PRESSURE WASH
 SOAP WASH OTHER

CASING TYPE: PVC STAINLESS TEFLON OTHER
JOINTS: THREADED WELDED COUPLED
 SCREWED OTHER

PIT CASING: YES NO DESCRIBE

WELL SCREEN: PVC STAINLESS TEFLON OTHER
DIAMETER: 2" 4" 6" OTHER IN
SLOT: 0.010 0.020 OTHER IN

DRILLING METHOD: SOLID STEM HOLLOW STEM MUD ROTARY
 AIR ROTARY DIRECT PUSH HAND AUGER
 OTHER

BIT SIZE: 2" 4" 6" 8" 12" OTHER IN
DRILLING MUD: NONE WATER BENTONITE
 OTHER

CENTRALIZER: YES NO

COMPLETION: FLUSH MOUNT STICKUP RISER BOX
LOCK TYPE: DOLPHIN MASTER KEY NO.
 OTHER

PAD: 2'X2' 4'X4' OTHER

CUTTINGS: DRUMMED NUMBER OF DRUMS
 SPREAD OTHER

DEVELOPMENT METHOD: NONE BAILING PUMPING AIR LIFT
 SURGE & BLOCK OTHER
TIME: 10 MIN 20 MIN OTHER 15 MIN
AMOUNT: 5 GAL 10 GAL OTHER GAL

WATER BEFORE: SILTY TURBID OPAQUE CLEAR
WATER AFTER: SILTY TURBID OPAQUE CLEAR
EVIDENT ODOR: YES NO TYPE

DEVELOPMENT WATER: DRUMMED NUMBER OF DRUMS
 SPREAD TREATED POTW OTHER

WATER LEVEL: INITIAL _____ FT BTOC BLS

DATE: _____ FT BELOW TOC

DATE: _____ FT BELOW TOC

NOTES: (DESCRIBE ALL NON-STANDARD METHODS & MATERIALS)

PREPARED BY: HJZ



MONITORING WELL CONSTRUCTION DATA

SANTA ANITA RECLAMATION, LLC
 SAN MANUEL - LUN, TEXAS

WELL/BORING NO: **KW-3**

PERMIT NO: **-**

DATE: **7-21-10** PROJECT NAME: **SANTA ANITA RECL.** PROJECT NO: **328-346**

WELL SITE LOCATION PLAN: SEC: TWN: RGE: LAT: LONG:

DRILLING CO: **JEDI DRILLING CONTRACTORS, INC**

DRILL CREW: **OSCAR GARCIA, J. SAUCEDA, J. MEDRANO**

WELL TYPE: SHALLOW SINGLE CASED MONITORING
 PERMANENT INTERMEDIATE DOUBLE CASED RECOVERY
 TEMPORARY DEEP OTHER OTHER

WELL SCHEMATIC

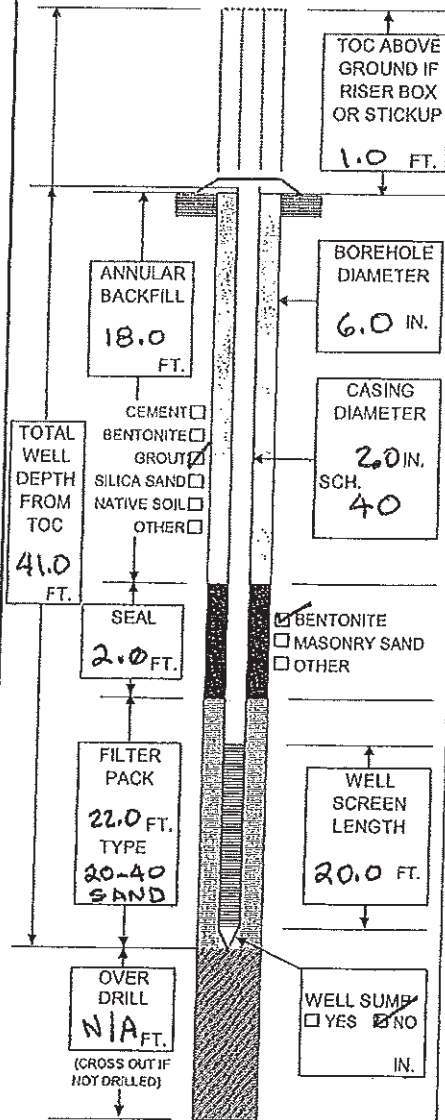

INSTALLATION DATA

DECON. STEAM CLEAN HIGH PRESSURE WASH
 SOAP WASH OTHER

CASING TYPE: PVC STAINLESS TEFLON OTHER
 JOINTS: THREADED WELDED COUPLED
 SCREWED OTHER

PIT CASING: YES NO DESCRIBE

WELL SCREEN: PVC STAINLESS TEFLON OTHER
 DIAMETER: 2" 4" 6" OTHER _____ IN
 SLOT: 0.010 0.020 OTHER _____ IN

DRILLING METHOD: SOLID STEM HOLLOW STEM MUD ROTARY
 AIR ROTARY DIRECT PUSH HAND AUGER
 OTHER

BIT SIZE: 2" 4" 6" 8" 12" OTHER _____ IN

DRILLING MUD: NONE WATER BENTONITE
 OTHER

CENTRALIZER: YES NO

COMPLETION: FLUSH MOUNT STICKUP RISER BOX
 LOCK TYPE: DOLPHIN MASTER KEY NO. _____
 OTHER

PAD: 12'x2' 4'x4' OTHER _____

CUTTINGS: DRUMMED NUMBER OF DRUMS _____
 SPREAD OTHER _____

DEVELOPMENT METHOD: NONE BAILING PUMPING AIR LIFT
 SURGE & BLOCK OTHER _____

TIME: 10 MIN 20 MIN OTHER 15 MIN
 AMOUNT: 5 GAL 10 GAL OTHER _____ GAL

WATER BEFORE: SILTY TURBID OPAQUE CLEAR
 WATER AFTER: SILTY TURBID OPAQUE CLEAR

EVIDENT ODOR: YES NO TYPE _____

DEVELOPMENT WATER: DRUMMED NUMBER OF DRUMS _____
 SPREAD TREATED POTW OTHER _____

WATER LEVEL: INITIAL _____ FT BTOC BLS

DATE: _____ FT BELOW TOC

DATE: _____ FT BELOW TOC

NOTES: (DESCRIBE ALL NON-STANDARD METHODS & MATERIALS)

PREPARED BY: **KJR**

Table 2

Summary of Field Groundwater Depth Measurements
 Santa Anita Reclamation Facility
 Linn, Hidalgo County, Texas

Monitoring Well No.	Sampling Date	Depth to GW TOC (ft)	Depth to Bott. of Well (ft)	Water Col. Height (ft)	Well Volume (gal)
MW-1	4/14/2011	3.7	42.2	38.4	6.3
	10/4/2011	5.0	42.1	37.1	6.1
MW-2	4/14/2011	4.8	46.1	41.3	6.7
	10/4/2011	6.9	45.9	39.0	6.4
MW-3	4/14/2011	4.9	41.6	36.7	6.0
	10/4/2011	7.0	40.3	33.3	5.4

Notes:

1. All depth measurements from top of casing (TOC).

Attachment B:

Compliance Evaluation Investigation Report for
Investigation # 972118 Conducted on 12/08/2011

Bryan W. Shaw, Ph.D., *Chairman*
Buddy Garcia, *Commissioner*
Carlos Rubinstein, *Commissioner*
Mark R. Vickery, P.G., *Executive Director*



TEXAS COMMISSION ON ENVIRONMENTAL QUALITY

Protecting Texas by Reducing and Preventing Pollution

February 21, 2012

CERTIFIED MAIL # 91 7108 2133 3937 1337 0380
RETURN RECEIPT REQUESTED

Mr. Lance Walker, Owner
Santa Anita Reclamation
126 South Stewart Road
San Juan, Texas 78589

Re: Notice of Violation for the Compliance Evaluation Investigation at:
Santa Anita Reclamation, located southwest of the intersection of Farm to Market 3250
and Farm to Market 1017, (Hidalgo County)
Regulated Entity No.: RN105389514, TCEQ ID No.: 6200592

Dear Mr. Walker:

On December 9-23, 2011, Monica A. Galvan of the Texas Commission on Environmental Quality (TCEQ) Harlingen Region Office conducted an investigation of the above-referenced regulated entity to evaluate compliance with applicable requirements for municipal solid waste, specifically used and scrap tires. Enclosed is a summary which lists the investigation findings. During the investigation, some violations were noted which were noncompliances that have based on subsequent corrective action. In addition, certain outstanding alleged violations were identified for which compliance documentation is required. Please submit to this office by March 22, 2012 a written description of corrective action taken and the required documentation demonstrating that compliance has been achieved for each of the outstanding alleged violations.

In the listing of the alleged violations, we have cited applicable requirements, including TCEQ rules. Please note that both the rules themselves and the agency brochure entitled *Obtaining TCEQ Rules* (GI 032) are located on our agency website at <http://www.tceq.state.tx.us> for your reference. If you would like a hard copy of this brochure mailed to you, you may call and request one from either the Harlingen Region Office at 956.425.6010 or the Central Office Publications Ordering Team at 512-239-0028.

The TCEQ appreciates your assistance in this matter. Please note that the Legislature has granted TCEQ enforcement powers which we may exercise to ensure compliance with environmental regulatory requirements.

We anticipate that you will resolve the alleged violations as required in order to protect the State's environment. If you have additional information that we are unaware of, you have the opportunity to contest the violations documented in this notice. Should you choose to do so, you must notify the Harlingen Region Office within 10 days from the date of this letter. At that time,

REPLY TO: REGION 15 • 1804 W. JEFFERSON AVE. • HARLINGEN, TEXAS 78550-5247 • 956-425-6010 • FAX 956-412-5059

Austin Headquarters: 512-239-1000 • www.tceq.state.tx.us • How is our customer service? www.tceq.state.tx.us/goto/customersurvey

Lance Walker
February 21, 2012
Page 2

we will schedule a violation review meeting to be conducted within 21 days from the date of this letter. However, please be advised that if you decide to participate in the violation review process, the TCEQ may still require you to adhere to the compliance schedule included in the attached Summary of Investigation Findings until an official decision is made regarding the status of any or all of the contested violations.

If you or members of your staff have any questions, please feel free to contact Ms. Monica A. Galvan in the Harlingen Region Office at 956.430.6032.

Sincerely,



Jaime Garza, Section Manager
Air, Waste & Water Programs
Harlingen Regional Office
Texas Commission on Environmental Quality

JG/mag

Enclosures: Summary of Investigation Findings

Summary of Investigation Findings

SANTA ANITA RECLAMATION

Investigation # 972118

, HIDALGO COUNTY,

Investigation Date: 12/08/2011

Additional ID(s): R15105389514
6200592

OUTSTANDING ALLEGED VIOLATION(S) ASSOCIATED TO A NOTICE OF VIOLATION

Track No: 458876 Compliance Due Date: 03/22/2012
30 TAC Chapter 328.66(a)(9)

Alleged Violation:

Investigation: 972118

Comment Date: 2/16/2012

Failure to operate the project in accordance with special conditions imposed by the executive director. Specifically, a revised Figure 3 shall be submitted to the TCEQ Harlingen Region Office.

Galvan observed three monitoring wells installed at the entity, located at the northeast portion, southwest portion, and midway between the northwest/southwest portions, with the tire shredding operation located just southeast of the 8.71 acre LRPOT site. By letter dated 05/10/2010 from the TCEQ, condition number four (4) states figure 3 of the Plan must be revised in order to relocate the proposed groundwater monitoring well located on the northwest corner to the location approximately halfway the remaining distance to the southwest corner of the site. By email dated 12/13/11 from Elva Walker, it states the revised map is attached; however, only a blank page was attached with the words "Figure 3 Revision" at the top left corner.

Recommended Corrective Action: A revised Figure 3, noting the current locations of the groundwater monitoring wells, shall be submitted to the TCEQ Harlingen Region Office by the compliance due date.

Track No: 458882 Compliance Due Date: 03/22/2012
30 TAC Chapter 328.66(a)(7)(A)
TWC Chapter 26.121

Alleged Violation:

Investigation: 972118

Comment Date: 2/21/2012

Failure to prevent an unauthorized discharge of any pollutant into or adjacent to any water in the state. On the day of the investigation, it was noted that an unauthorized discharge of a pollutant, specifically oil/lubricant contaminated process water, had occurred at the site.

An area of collected process water was observed while viewing the area of the shredder and conveyor. The following observations were made by Galvan - the water is placed on the blades so that overheating does not occur, the area of the blades and shredder that come into contact with the water is covered with a dark material generated from the processing of the tires, the water flows over a concreted area which is located directly underneath the shredders conveyor belt, the water flows onto the parking area of the trucks used to collect the shredded tires, with the water eventually flowing into the low lying area. During this process the water comes in contact with oils, lubricants (from either the shredder itself or the tires being processed). The water in the pond, in places, appears sludge like and a sheen was observed on the collected water. Also, a black ring can be seen where the top of the water meets the surrounding dirt.

In the Monitoring Well Plan, dated March 2010, Section 2.3 Hydrogeology, states - "The primary aquifer in Hidalgo County is the Gulf Coast Aquifer. Based on the groundwater study conducted by SWL Environmental Services for the C&T Landfill in June 1993, there are two minor aquifers in this area. The Chicot and Evangeline Aquifers yield fresh water to area wells. Groundwater movement within the two aquifers is generally to the east (Texas Water Development Board, 1990).")." Therefore, generally speaking, discharges that may occur in this general area that overlay the two minor aquifers, have the potential to impact the two minor aquifers.

Recommended Corrective Action: The process water generated from the cooling of the blades shall be captured or contained in an area that does not allow a discharge to occur, which may include lining the low lying area, and is protective of the environment. Documentation of this shall be received in the Harlingen Region Office by the compliance due date.

**ALLEGED VIOLATION(S) NOTED AND RESOLVED
ASSOCIATED TO A NOTICE OF VIOLATION**

Track No: 458873

30 TAC Chapter 328.66(a)(9)

Alleged Violation:

Investigation: 972118

Comment Date: 2/16/2012

Failure to operate the project in accordance with special conditions imposed by the executive director. Specifically, background groundwater sampling was not conducted prior to tire chips being placed into the LRPOT.

By letter dated 05/10/2010 from the TCEQ, condition number seven (7) states groundwater analysis shall be conducted at all three groundwater wells prior to tire chips being placed into the LRPOT in order to determine current groundwater characteristics (background sampling). In an email from Hector J. Lopez (Branch Manager Professional Service Industries Inc (entity contractor) dated 12/14/2011, it indicates the initial background groundwater sampling was not conducted, as this was not in the scope of work for the contractor at that time. This will be listed as a noted and resolved violation since the entity cannot conduct background sampling since tire pieces have been placed into the LRPOT.

Recommended Corrective Action: The entity cannot conduct background sampling since tire pieces have been placed into the LRPOT. However, the entity shall have the continuing obligation to conduct groundwater sampling on a semi-annual basis, as stated in the letter dated 05/10/2010 from the TCEQ, referencing the Monitor Well Plan.

Resolution: The entity cannot conduct background sampling since tire pieces have been placed into the LRPOT. However, the entity shall have the continuing obligation to adhere to the Special Conditions set forth in the letter dated 05/10/2010 from the TCEQ, referencing the Monitoring Well Plan.

Track No: 458879

30 TAC Chapter 328.66(a)(9)

Alleged Violation:

Investigation: 972118

Comment Date: 2/16/2012

Failure to operate the project in accordance with special conditions imposed by the executive director. Specifically, the entity stored approximately 15,000 tires for eleven consecutive days.

By letter dated 05/10/2010 from the TCEQ, it states the facility is authorized to store 80,000 used or scrap tires as a 30 day supply, but no more than 5,000 used or scrap tires or the equivalent in tire pieces may be stored overnight. During the course of the investigation, it was

stated by Elva Walker that during the time period of 11/21/2011-12/02/2011 approximately fifteen (15) trailers, each storing approximately 1,000 tires, were being stored, which equals approximately 15,000 tires stored for eleven (11) days. The blades on the shredder required sharpening, therefore, shredding could not be conducted since the blades were removed.

Recommended Corrective Action: The entity shall not store more than 5,000 used or scrap tires or equivalent tire pieces overnight. If instances arise that may cause more than 5,000 tires/equivalent tire pieces to be stored overnight, the entity shall notify the Harlingen Regional Office of the situation.

Resolution: During the time period of 11/21/2011-12/02/2011 approximately fifteen (15) trailers, each storing approximately 1,000 tires, were being stored, which equals approximately 15,000 tires stored for eleven (11) days. Since the blades were returned from being sharpened, these tires were then processed and this volume of tires was no longer stored overnight.

ADDITIONAL ISSUES

Description

If the facility does not provide its own fire fighting personnel or system, has it made arrangements with public or private emergency response personnel capable of complying with applicable fire and building codes or for energy recovery facilities, has the appropriate jurisdictional fire marshal reviewed and approved the fire protection system?

Additional Comments

The Hidalgo County Fire Marshal's Office (Marco Romero) conducted the annual fire inspection of the entity on 11/28/2011. During the inspection, it was noted the entity should have the fire extinguishers checked by a certified technician. In speaking with Marco Romero, he stated the noted item referencing the fire extinguisher was not a violation noted by the Fire Marshal's Office. It was requested the entity have the fire extinguishers checked to determine if they needed recharging or replacement. Of note, the fire extinguishers were checked by a certified technician on 12/09/2011.

Other violations noted during the investigation? The SOP states the tire pieces will be placed below grade in lifts no greater than 12 inches thick by means of a front end loader, dump truck, or directly off the trailer mounted shredder, after processing. The sizes of the lifts will vary depending on the amount of tire pieces available for processing. At a frequency of at least once per day, an equal size and thickness layer of inert material will be placed on top of each lift, and mechanically mixed by alternately spreading and re consolidation the materials, thus ensuring a 50 percent mixture, and leveled for placement of the next layer of tire pieces. Galvan did not observe this specific placement method being conducted, what was observed was an equal volume of inert fill material and tire pieces placed onto the edge of the LRPUT edge. The front end loader then mechanically pushes the inert material into the tire pieces, with this mixture then mechanically pushed over the edge of the LRPUT. Galvan observed this method during three separate demonstrations and this method does ensure a 50 percent mixture of inert material and tire pieces. Note, 30 TAC 328.66(a)(5) states "The method of placement and commingling of the tire shreds to achieve a mix of tire pieces with the inert fill material in a proportion no greater than 50% of tire material by volume." Additionally, while observing the method of commingling the inert material and the tire pieces, it was observed the tire pieces curl up on themselves prior to being pushed into the inert material. If not commingled in the manner demonstrated, the tire pieces would "ball up" on themselves if placed below grade in lifts, as stated in the SOP. The method of placement, as stated in the SOP, may not ensure a 50 percent mixture of inert material and tire pieces.

MSWTIRE-6200592-SANTA ANITA RECLAMATION-CO
Texas Commission on Environmental Quality
Investigation Report
SANTA ANITA RECLAMATION PROJECT, LLC
CN603280033

SANTA ANITA RECLAMATION

RN105389514

Investigation # 972118

Incident #

Investigator: MONICA GALVAN

Site Classification

LRPUT

FACILITY

PROCESSOR

Conducted: 12/08/2011 -- 12/23/2011

SIC Code: 3089

Program(s): TIRES

Investigation Type : Compliance Investigation

Location : SOUTHWEST OF
 INTERSECTION OF FM 3250 AND FM
 1017

Additional ID(s) : R15105389514
 6200592

Address: ; ,

Activity Type : REGION 15 - HARLINGEN
 TIRELRPUT - Investigation of Land
 Reclamation Project Using Tires
 TIREPROC - Investigation of scrap tire
 processor

Principal(s) :

Role	Name
RESPONDENT	SANTA ANITA RECLAMATION LLC

Contact(s) :

Role	Title	Name	Phone
Participated in Investigation	FACILITATOR	MRS ELVA WALKER	Work (956) 287-8473
Participated in Investigation	OWNER	MR LANCE WALKER	Work (956) 287-8473
Notified	FACILITATOR	MRS ELVA WALKER	
Regulated Entity Contact	FACILITATOR	MRS ELVA WALKER	Work (956) 287-8473
Regulated Entity Mail Contact	OWNER	MR LANCE WALKER	Work (956) 287-8473

Other Staff Member(s) :

Role	Name
Supervisor	JAIME GARZA
Investigator	DOUGLAS CRIST
QA Reviewer	FRANCISCO CHAVERO JR.

Associated Check List

<u>Checklist Name</u>	<u>Unit Name</u>
MSW SCRAP TIRE FACILITY	SANTA ANITA TIRE FACILITY
MSW TIRES LAND RECLAMATION PROJECT USING TIRES (LRPUT)	SantaAnitaLRPUT
MSW GENERIC OTHER ISSUES OR VIOLATIONS	MSW LRPUT Additional

Investigation Comments :

INTRODUCTION

Texas Commission on Environmental Quality (TCEQ) Environmental Investigators: Monica A. Galvan (Galvan) and Doug Crist (Crist)
Santa Anita Reclamation LLC representatives: Lance Walker (Walker), Owner, and Elva Walker (EWalker), Office Facilitator

An on-site municipal solid waste (MSW) Compliance Evaluation Investigation (CEI) of the regulated entity Santa Anita Reclamation LLC (entity, RN105389514 / CN603280033 - Santa Anita Reclamation LLC) was conducted to determine if the entity was in compliance with rules regarding waste minimization and recycling, pursuant to 30 Texas Administrative Code (TAC) § 328, subchapter F-Management of Used or Scrap Tires, specifically Land Reclamation Projects Using Tires (LRPUT). Prior notification to conduct the investigation was made on 12/07/2011 with EWalker.

The entrance and exit interviews were conducted during the onsite investigation with Walker and EWalker, with copies of RG 344 - The TCEQ Has Inspected Your Business, GI 32 - Obtaining the Rules, and TCEQ Customer Satisfaction Survey number 54068 handed out. In addition to additional issues, several alleged violations were documented (attachment C).

Attachment A: Central Registry regulated entity/customer details, scrap tire registration database results

Attachment B: Site Operating Plan (SOP)-dated 01/15/2008, monitor well plan, copies of letters dated 05/10/2010 & 06/25/2010 from the TCEQ to the entity

Attachment C: TCEQ Exit Interview form dated 12/09/2010

Attachment D: Site volume/Site Life Calculations, LRPUT notification, email dated 12/13/11, power point presentation of Scrap Tire Management in Texas; email dated 12/14/11, list of tire generators disposing of tires at the entity, email dated 12/14/11, letter dated 12/11/09 from entity to the TCEQ, daily log, inert material log, 2010 Scrap Tire Annual report, letter dated 10/20/10 to Edinburg Fire Department and letter dated 01/09/12 from entity to TCEQ
Photographic Documentation, 12 photos

BACKGROUND

The entity was previously issued TCEQ Tire Registration ID Number 6200606 (authorized 05/10/2010) and TCEQ LRPUT Registration ID Number 6200592 (authorized 12/18/2009) (attachment A). In a query of the Consolidated Compliance and Enforcement Data System (CCEDS), the following investigations were conducted for the previous five year period:

A site assessment, CCEDS investigation number 614234, was conducted 01/09/08 with no concerns or violations noted.

A compliance investigation, CCEDS investigation number 879485, was conducted 10/20/10-11/03/10 with no concerns or violations noted.

No previous enforcement actions, agreed orders, court orders, enforcement issues, compliance agreements or complaints were noted.

GENERAL ENTITY INFORMATION

Investigation conducted 12/09/2011

General Requirements

Prior to conducting the physical walk through of the entity, records were reviewed. Prior notification was provided to the executive director of the intent to fill land by means of a LRPUT (attachment B, correspondence from TCEQ to regulated entity), with prior approval provided in writing by the executive director. The entity was issued TCEQ Tire Registration ID Number 6200606 (authorized 05/10/2010) and TCEQ LRPUT Registration ID Number 6200592 (authorized 12/18/2009) for the LRPUT and its associated scrap tire storage site. Documentation

indicating the owner/operator has notified the local fire marshal or fire department of the tire placement or fill activity was viewed, which consisted of notifications to the Hidalgo County Fire Marshal and Edinburg Fire Department, letter dated 02/19/2010. The LRPOT consists of a previously excavated caliche pit that is to be filled in with a mixture of 50% shredded tires and 50% dirt, with the total acreage to be filled in as 8.71 acres with a depth of 17 feet deep. The scrap tire facility registration was authorized for 1.5 years from the date the processing/shredding of tires for placement into the LRPOT begins, with tire processing beginning on 12/22/2010. The processing (shredding) is performed on site, with the shredded tires placed into the pit. Records were reviewed which indicated stockpiles of used or scrap tires awaiting shredding are monitored for vectors on a weekly basis. Generators utilizing the entity include the City of Corpus Christi CEFEL Landfill, City of Corpus Christi Elliot Landfill, City of Kingsville Landfill, Brooks County Road & Bridge, Willacy County Precincts 1 & 2, Liberty Tire Recycling (San Antonio), Starr County, Texas Tires (Edinburg), and Pueblo Tires (McAllen, Edinburg, Alice, Kingsville, Mission) (attachment D).

An area of ponded water was observed while viewing the area of the shredder and conveyor (photos 1-2 of 12). This was brought to the attention of Walker; however, Galvan determined additional research would be conducted after returning to the Regional Office. The following observations were made by Galvan - the water is placed on the blades so that overheating does not occur, the area of the blades and shredder that come into contact with the water is covered with a dark material generated from the processing of the tires, the water flows over a concreted area which is located directly underneath the shredders conveyor belt, the water flows onto the parking area of the trucks used to collect the shredded tires, with the water eventually flowing into the low lying area. During this process the water comes in contact with oils, lubricants (from either the shredder itself or the tires being processed). The water in the pond, in places, appears sludge like and a sheen was observed on the ponded water (photo 2 of 12).

Also, a black ring can be seen where the top of the water meets the surrounding dirt. In the Monitoring Well Plan (attachment B), dated March 2010, Section 2.3 Hydrogeology, states - "The primary aquifer in Hidalgo County is the Gulf Coast Aquifer. Based on the groundwater study conducted by SWL Environmental Services for the C&T Landfill in June 1993, there are two minor aquifers in this area. The Chicot and Evangeline Aquifers yield fresh water to area wells. Groundwater movement within the two aquifers is generally to the east (Texas Water Development Board, 1990)." Therefore, generally speaking, discharges that may occur in this general area that overlay the two minor aquifers, have the potential to impact the two minor aquifers. After additional research was conducted and a more detailed explanation was provided to EWalker on 12/23/2011, it was determined this would be noted as an alleged violation of 30 TAC 328.66(a)(7)(A) / Texas Water Code 26.121, Failure to prevent an unauthorized discharge of any pollutant into or adjacent to any water in the state. On the day of the investigation, it was noted that an unauthorized discharge of a pollutant, specifically oil/lubricant contaminated process water, had occurred at the site.

Galvan observed three monitoring wells installed at the entity, located at the northeast portion, southwest portion, and midway between the northwest/southwest portions, with the tire shredding operation located just southeast of the 8.71 acre LRPOT site. By letter dated 05/10/2010 from the TCEQ (attachment B), condition number four (4) states figure 3 of the Plan must be revised in order to relocate the proposed groundwater monitoring well located on the northwest corner to the location approximately halfway the remaining distance to the southwest corner of the site. By email dated 12/13/11 from EWalker, it states the revised map is attached; however, only a blank page was attached with the words "Figure 3 Revision" at the top left corner. This will be noted as an alleged violation of 30 TAC 328.66(a)(9), Failure to operate the project in accordance with special conditions imposed by the executive director. Specifically, a revised Figure 3 shall be submitted to the TCEQ Harlingen Region Office.

By letter dated 05/10/2010 from the TCEQ (attachment B), condition number seven (7) states groundwater analysis shall be conducted at all three groundwater wells prior to tire chips being placed into the LRPOT in order to determine current groundwater characteristics (background sampling). In an email from Hector J. Lopez (Branch Manager Professional Service Industries Inc (entity contractor) dated 12/14/2011, it indicates the initial background groundwater sampling was not conducted, as this was not in the scope of work for the contractor at that time. This will be listed as a noted and resolved violation since the entity cannot conduct background sampling

since tire pieces have been placed into the LRP. This will be noted as an alleged violation of 30 TAC 328.66(a)(9), Failure to operate the project in accordance with special conditions imposed by the executive director. Specifically, background groundwater sampling was not conducted prior to tire chips being placed into the LRP.

Condition number one (1) of the letter states groundwater wells shall be sampled on a semi-annual basis, therefore, with tire pieces placed into the LRP in December 2010, the semi-annual time period would be April 2011, December 2011, April 2012 and so forth. The April 2011 and October 2011 groundwater sampling results were submitted and included the required information (attachment D).

SOP Requirements, dated 01/15/2008

General Location Map, Property Owner's Affidavit, Tire Piece Volumes, Site Life

A general location map is included with the SOP, along with the property owner's affidavit (attachment B). As of 12/08/2011, 13,308 yds³ (cubic yards) of shredded tires, along with 13,417 yds³ of inert material (dirt), have been placed into the LRP (SOP, section 1.3 states approximately 72,000 yds³ of tire pieces would be placed into the LRP). The site life is based on the maximum capacity of the shredder (SOP, section 1.4). Since tire processing of tires for placement into the LRP first began in December 2010, the expected life would be until approximately June 2012.

Placement Method

The SOP states the tire pieces will be placed below grade in lifts no greater than 12 inches thick by means of a front end loader, dump truck, or directly off the trailer mounted shredder, after processing. The sizes of the lifts will vary depending on the amount of tire pieces available for processing. At a frequency of at least once per day, an equal size and thickness layer of inert material will be placed on top of each lift, and mechanically mixed by alternately spreading and reconsolidating the materials, thus ensuring a 50 percent mixture, and leveled for placement of the next layer of tire pieces. Galvan did not observe this specific placement method being conducted, what was observed was an equal volume of inert fill material and tire pieces placed onto the edge of the LRP edge (photos 5-6 of 12). The front end loader then mechanically pushes the inert material into the tire pieces, with this mixture then mechanically pushed over the edge of the LRP (photos 5-12 of 12). Galvan observed this method during three separate demonstrations and this method does ensure a 50 percent mixture of inert material and tire pieces. Note, 30 TAC §328.66(a)(5) states "The method of placement and commingling of the tire shreds to achieve a mix of tire pieces with the inert fill material in a proportion no greater than 50% of tire material by volume." Additionally, while observing the method of commingling the inert material and the tire pieces, it was observed the tire pieces curl up on themselves prior to being pushed into the inert material. If not commingled in the manner demonstrated and shown in photos 5-12, the tire pieces would "ball up" on themselves if placed below grade in lifts, as stated in the SOP. The method of placement, as stated in the SOP, may not ensure a 50 percent mixture of inert material and tire pieces. Also, in a TCEQ power point labeled "Scrap Tire Management in Texas" that is accessible through the public web site, the manner of placement of the inert material and tire pieces is demonstrated on page 6 (attachment D), which is consistent with the method shown in photos 5-12 of this report. This deviation from the manner of placement does not contribute to a nuisance and does adhere to 30 TAC §328.66(a)(5). Therefore, this will be noted as an Additional Issue.

Professional Engineer's Statement, Affidavit by Property Owner, Applicant Affidavit and Certification, County Judge Notifications, Public Notice, Legal Description, USGS Topographic Map

These documents are included in the SOP, see attachment page dated 01/23/2008 (attachment B).

Undisturbed Land

The LRP consists of a previously excavated caliche pit, excavated by Martin Marietta for the sale of caliche (calcium carbonate) and other soil material.

Avoidance of Public Nuisance

At the time of the onsite investigation the entity was not creating a public nuisance.

Tires Split/Quartered/or Shredded

A shredder is located onsite which shreds tires for placement into the LRPOT. No whole tires were observed to have been placed into the LRPOT.

Compliance with Local Ordinances

The Hidalgo County Fire Marshal's Office (Marco Romero) conducted the annual fire inspection of the entity on 11/28/2011 (attachment D). During the inspection, it was noted the entity should have the fire extinguishers checked by a certified technician. In speaking with Marco Romero, he stated the noted item referencing the fire extinguisher was not a violation noted by the Fire Marshal's Office. It was requested the entity have the fire extinguishers checked to determine if they needed recharging or replacement. Of note, the fire extinguishers were checked by a certified technician on 12/09/2011 (attachment D). This item will be noted as an additional issue, referencing 30 TAC §328.63(d)(3) and 30 TAC §328.66(i)

Tire/Soil Mixture

Shredded tires were being mixed with inert material. Refer to "Placement Method" for additional comments regarding the placement of the shredded tires and inert material.

Final Cover

Not applicable at this time.

Scrap Tire Facility Registration

The entity was associated to TCEQ Tire Registration ID Number 6200606, which was generated as an identification number regarding correspondence to and from the regulated entity.

Scrap Tire Storage Site

In reviewing the daily logs for the entire life of the entity, it was determined all tires accepted at the site that had not been processed, were processed within 90 days of acceptance. By letter dated 05/10/2010 from the TCEQ (attachment B), it states the facility is authorized to store 80,000 used or scrap tires as a 30 day supply, but no more than 5,000 used or scrap tires or the equivalent in tire pieces may be stored overnight. During the course of the investigation, it was stated by EWalker that during the time period of 11/21/2011-12/02/2011 approximately fifteen (15) trailers, each storing approximately 1,000 tires, were being stored, which equals approximately 15,000 tires stored for eleven (11) days. The blades on the shredder required sharpening, therefore, shredding could not be conducted since the blades were removed. This will be noted and resolved as an alleged violation of 30 TAC §328.66(a)(9), Failure to operate the project in accordance with special conditions imposed by the executive director. Specifically, the entity stored approximately 15,000 tires for eleven consecutive days.

TCEQ ID Number

The TCEQ issued identification numbers are referenced in all correspondence, TCEQ Tire Registration ID Number 6200606 and TCEQ LRPOT Registration ID Number 6200592.

Final Certification

Not applicable at this time.

Design Information

These documents are included in the SOP, see attachment page dated 01/23/2008 (attachment B).

ADDITIONAL INFORMATION

On 12/13/2011 an email was received from EWalker which included a letter dated 05/10/2010 from the TCEQ (Monitor Well Plan), the Hidalgo County Fire Marshall's Annual Fire Inspection Report, power point discussing "Scrap Tire Management in Texas" and fire extinguisher technician receipt.

On 12/14/2011 an email was received from EWalker which included the groundwater monitoring well installation report, groundwater sampling report for 04/14/2011 and 10/04/2011, and field groundwater depth measurements.

On 12/14/2011 an email was received from EWalker which included the daily log dated 12/08/2011, Letter dated 12/01/2009 from the entity to the TCEQ, entity inert material log, and letter to the Edinburg Fire Department dated 10/20/2010.

On 12/23/2011 Galvan placed a telephone call to EWalker to discuss the ponded water located just west of the shredder. Elva Walker stated she was not familiar with the process that generates the water, would discuss this item with Lance Walker and provide a more detailed description to Galvan.

On 01/09/2012 an email was received detailing the generation of the water (attachment D). The email indicated that water is applied directly to the shredder blades to avoid overheating as the tires are being processed, with the water naturally flowing into the low lying area. As previously noted, this would be noted as an alleged violation of 30 TAC §328.66(a)(7)(A) / Texas Water Code §26.121, Failure to prevent an unauthorized discharge of any pollutant into or adjacent to any water in the state. On the day of the investigation, it was noted that an unauthorized discharge of a pollutant, specifically oil contaminated process water, had occurred at the site.

CONCLUSION

A Notice of Violation (NOV) will be transmitted regarding the regulated entity, listing the active alleged violations, noted and resolved alleged violation, and additional issues. The letter will be addressed to Lance Walker and mailed to the address 126 South Stewart Road, San Juan Texas 78589.

NOV Date	Method
02/21/2012	WRITTEN
OUTSTANDING ALLEGED VIOLATION(S) ASSOCIATED TO A NOTICE OF VIOLATION	

Track No: 458876 Compliance Due Date: 03/22/2012
Violation Start Date: 12/9/2012

30 TAC Chapter 328.66(a)(9)

Alleged Violation:
Investigation: 972118

Comment Date: 02/16/2012

Failure to operate the project in accordance with special conditions imposed by the executive director. Specifically, a revised Figure 3 shall be submitted to the TCEQ Harlingen Region Office.

Galvan observed three monitoring wells installed at the entity, located at the northeast portion, southwest portion, and midway between the northwest/southwest portions, with the tire shredding operation located just southeast of the 8.71 acre LRPOT site. By letter dated 05/10/2010 from the TCEQ, condition number four (4) states figure 3 of the Plan must be revised in order to relocate the proposed groundwater monitoring well located on the northwest corner to the location approximately halfway the remaining distance to the southwest corner of the site. By email dated 12/13/11 from Elva Walker, it states the revised map is attached; however, only a blank page was attached with the words "Figure 3 Revision" at the top left corner.

Recommended Corrective Action: A revised Figure 3, noting the current locations of the groundwater monitoring wells, shall be submitted to the TCEQ Harlingen Region Office by the compliance due date.

Track No: 458882 Compliance Due Date: 03/22/2012
Violation Start Date: 12/9/2011

30 TAC Chapter 328.66(a)(7)(A)

TWC Chapter 26.121

Alleged Violation:

Investigation: 972118

Comment Date: 02/21/2012

Failure to prevent an unauthorized discharge of any pollutant into or adjacent to any water in the state. On the day of the investigation, it was noted that an unauthorized discharge of a pollutant, specifically oil/lubricant contaminated process water, had occurred at the site.

An area of collected process water was observed while viewing the area of the shredder and conveyor. The following observations were made by Galvan - the water is placed on the blades so that overheating does not occur, the area of the blades and shredder that come into contact with the water is covered with a dark material generated from the processing of the tires, the water flows over a concreted area which is located directly underneath the shredders conveyor belt, the water flows onto the parking area of the trucks used to collect the shredded tires, with the water eventually flowing into the low lying area. During this process the water comes in contact with oils, lubricants (from either the shredder itself or the tires being processed). The water in the pond, in places, appears sludge like and a sheen was observed on the collected water. Also, a black ring can be seen where the top of the water meets the surrounding dirt.

In the Monitoring Well Plan, dated March 2010, Section 2.3 Hydrogeology, states - "The primary aquifer in Hidalgo County is the Gulf Coast Aquifer. Based on the groundwater study conducted by SWL Environmental Services for the C&T Landfill in June 1993, there are two minor aquifers in this area. The Chicot and Evangeline Aquifers yield fresh water to area wells. Groundwater movement within the two aquifers is generally to the east (Texas Water Development Board, 1990)." Therefore, generally speaking, discharges that may occur in this general area that overlay the two minor aquifers, have the potential to impact the two minor aquifers.

Recommended Corrective Action: The process water generated from the cooling of the blades shall be captured or contained in an area that does not allow a discharge to occur, which may include lining the low lying area, and is protective of the environment. Documentation of this shall be received in the Harlingen Region Office by the compliance due date.

**ALLEGED VIOLATION(S) NOTED AND RESOLVED
ASSOCIATED TO A NOTICE OF VIOLATION**

Track No: 458873

Resolution Status Date: 2/16/2012

Violation Start Date: 12/22/2010 Violation End Date: 12/22/2010

30 TAC Chapter 328.66(a)(9)

Alleged Violation:

Investigation: 972118

Comment Date: 02/16/2012

Failure to operate the project in accordance with special conditions imposed by the executive director. Specifically, background groundwater sampling was not conducted prior to tire chips being placed into the LRPOT.

By letter dated 05/10/2010 from the TCEQ, condition number seven (7) states groundwater analysis shall be conducted at all three groundwater wells prior to tire chips being placed into the LRPOT in order to determine current groundwater characteristics (background sampling). In an email from Hector J. Lopez (Branch Manager Professional Service Industries Inc (entity contractor) dated 12/14/2011, it indicates the initial background groundwater sampling was not conducted, as this was not in the scope of work for the contractor at that time. This will be listed as a noted and resolved violation since the entity cannot conduct background sampling since tire pieces have been placed into the LRPOT.

Recommended Corrective Action: The entity cannot conduct background sampling since tire pieces have been placed into the LRPOT. However, the entity shall have the continuing obligation to conduct groundwater sampling on a semi-annual basis, as stated in the letter dated 05/10/2010 from the TCEQ, referencing the Monitor Well Plan.

Resolution: The entity cannot conduct background sampling since tire pieces have been placed into the LRPOT. However, the entity shall have the continuing obligation to adhere to the Special Conditions set forth in the letter dated 05/10/2010 from the TCEQ, referencing the Monitoring Well Plan.

Track No: 458879

Resolution Status Date: 2/16/2012

Violation Start Date: 11/21/2011 Violation End Date: 12/2/2011

30 TAC Chapter 328.66(a)(9)

Alleged Violation:

Investigation: 972118

Comment Date: 02/16/2012

Failure to operate the project in accordance with special conditions imposed by the executive director. Specifically, the entity stored approximately 15,000 tires for eleven consecutive days.

By letter dated 05/10/2010 from the TCEQ, it states the facility is authorized to store 80,000 used or scrap tires as a 30 day supply, but no more than 5,000 used or scrap tires or the equivalent in tire pieces may be stored overnight. During the course of the investigation, it was stated by Elva Walker that during the time period of 11/21/2011-12/02/2011 approximately fifteen (15) trailers, each storing approximately 1,000 tires, were being stored, which equals approximately 15,000 tires stored for eleven (11) days. The blades on the shredder required sharpening, therefore, shredding could not be conducted since the blades were removed.

Recommended Corrective Action: The entity shall not store more than 5,000 used or scrap tires or equivalent tire pieces overnight. If instances arise that may cause more than 5,000 tires/equivalent tire pieces to be stored overnight, the entity shall notify the Harlingen Regional Office of the situation.

Resolution: During the time period of 11/21/2011-12/02/2011 approximately fifteen (15) trailers, each storing approximately 1,000 tires, were being stored, which equals approximately 15,000 tires stored for eleven (11) days. Since the blades were returned from being sharpened, these tires were then processed and this volume of tires was no longer stored overnight.

Additional Issues

Description

Other violations noted during the investigation? (If non-compliant then describe violation in the comment section.)

Additional Comments

The SOP states the tire pieces will be placed below grade in lifts no greater than 12 inches thick by means of a front end loader, dump truck, or directly off the trailer mounted shredder, after processing. The sizes of the lifts will vary depending on the amount of tire pieces available for processing. At a frequency of at least once per day, an equal size and thickness layer of inert material will be placed on top of each lift, and mechanically mixed by alternately spreading and re consolidation the materials, thus ensuring a 50 percent mixture, and leveled for placement of the next layer of tire pieces. Galvan did not observe this specific placement method being conducted, what was observed was an equal volume of inert fill material and tire pieces placed onto the edge of the LRPOT edge. The front end loader then mechanically pushes the inert material into the tire pieces, with this mixture then mechanically pushed over the edge of the LRPOT. Galvan observed this method during three separate demonstrations and this method does ensure a 50 percent mixture of inert material and tire pieces. Note, 30 TAC 328.66(a)(5) states "The method of placement and commingling of the tire shreds to achieve a mix of tire pieces with the inert fill material in a proportion no greater than 50% of tire material by volume." Additionally, while observing the method of commingling the inert material and the tire pieces, it was observed the tire pieces curl up on themselves prior to being pushed into the inert material. If not commingled in the manner demonstrated, the tire pieces would "ball up" on themselves if placed below grade in lifts, as stated in the SOP. The method of placement, as stated in the SOP, may not ensure a 50 percent mixture of inert material and tire pieces.

Description If the facility does not provide its own fire fighting personnel or system, has it made arrangements with public or private emergency response personnel capable of complying with applicable fire and building codes or for energy recovery facilities, has the appropriate jurisdictional fire marshal reviewed and approved the fire protection system?

Additional Comments

The Hidalgo County Fire Marshal's Office (Marco Romero) conducted the annual fire inspection of the entity on 11/28/2011. During the inspection, it was noted the entity should have the fire extinguishers checked by a certified technician. In speaking with Marco Romero, he stated the noted item referencing the fire extinguisher was not a violation noted by the Fire Marshal's Office. It was requested the entity have the fire extinguishers checked to determine if they needed recharging or replacement. Of note, the fire extinguishers were checked by a certified technician on 12/09/2011.

Signed Maey Lebaal
Environmental Investigator

Date 02/21/2012

Signed Jaime Saly
Supervisor

Date 2/21/12

Attachments: (in order of final report submittal)

Enforcement Action Request (EAR)

Letter to Facility (specify type) : NOR

Investigation Report

Sample Analysis Results

Manifests

NOR

Maps, Plans, Sketches

Photographs

Correspondence from the facility

Other (specify) :

Attachments A, B, C, D

Summary of Investigation Findings

SANTA ANITA RECLAMATION

Investigation # 972118

, HIDALGO COUNTY,

Investigation Date: 12/08/2011

Additional ID(s): R15105389514
6200592

OUTSTANDING ALLEGED VIOLATION(S) ASSOCIATED TO A NOTICE OF VIOLATION

Track No: 458876 Compliance Due Date: 03/22/2012
30 TAC Chapter 328.66(a)(9)

Alleged Violation:

Investigation: 972118

Comment Date: 2/16/2012

Failure to operate the project in accordance with special conditions imposed by the executive director. Specifically, a revised Figure 3 shall be submitted to the TCEQ Harlingen Region Office.

Galvan observed three monitoring wells installed at the entity, located at the northeast portion, southwest portion, and midway between the northwest/southwest portions, with the tire shredding operation located just southeast of the 8.71 acre LRPOT site. By letter dated 05/10/2010 from the TCEQ, condition number four (4) states figure 3 of the Plan must be revised in order to relocate the proposed groundwater monitoring well located on the northwest corner to the location approximately halfway the remaining distance to the southwest corner of the site. By email dated 12/13/11 from Elva Walker, it states the revised map is attached; however, only a blank page was attached with the words "Figure 3 Revision" at the top left corner.

Recommended Corrective Action: A revised Figure 3, noting the current locations of the groundwater monitoring wells, shall be submitted to the TCEQ Harlingen Region Office by the compliance due date.

Track No: 458882 Compliance Due Date: 03/22/2012
30 TAC Chapter 328.66(a)(7)(A)
TWC Chapter 26.121

Alleged Violation:

Investigation: 972118

Comment Date: 2/21/2012

Failure to prevent an unauthorized discharge of any pollutant into or adjacent to any water in the state. On the day of the investigation, it was noted that an unauthorized discharge of a pollutant, specifically oil/lubricant contaminated process water, had occurred at the site.

An area of collected process water was observed while viewing the area of the shredder and conveyor. The following observations were made by Galvan - the water is placed on the blades so that overheating does not occur, the area of the blades and shredder that come into contact with the water is covered with a dark material generated from the processing of the tires, the water flows over a concreted area which is located directly underneath the shredders conveyor belt, the water flows onto the parking area of the trucks used to collect the shredded tires, with the water eventually flowing into the low lying area. During this process the water comes in contact with oils, lubricants (from either the shredder itself or the tires being processed). The water in the pond, in places, appears sludge like and a sheen was observed on the collected water. Also, a black ring can be seen where the top of the water meets the surrounding dirt.

In the Monitoring Well Plan, dated March 2010, Section 2.3 Hydrogeology, states - "The primary aquifer in Hidalgo County is the Gulf Coast Aquifer. Based on the groundwater study conducted by SWL Environmental Services for the C&T Landfill in June 1993, there are two minor aquifers in this area. The Chicot and Evangeline Aquifers yield fresh water to area wells. Groundwater movement within the two aquifers is generally to the east (Texas Water Development Board, 1990).")." Therefore, generally speaking, discharges that may occur in this general area that overlay the two minor aquifers, have the potential to impact the two minor aquifers.

Recommended Corrective Action: The process water generated from the cooling of the blades shall be captured or contained in an area that does not allow a discharge to occur, which may include lining the low lying area, and is protective of the environment. Documentation of this shall be received in the Harlingen Region Office by the compliance due date.

**ALLEGED VIOLATION(S) NOTED AND RESOLVED
ASSOCIATED TO A NOTICE OF VIOLATION**

Track No: 458873

30 TAC Chapter 328.66(a)(9)

Alleged Violation:

Investigation: 972118

Comment Date: 2/16/2012

Failure to operate the project in accordance with special conditions imposed by the executive director. Specifically, background groundwater sampling was not conducted prior to tire chips being placed into the LRPUT.

By letter dated 05/10/2010 from the TCEQ, condition number seven (7) states groundwater analysis shall be conducted at all three groundwater wells prior to tire chips being placed into the LRPUT in order to determine current groundwater characteristics (background sampling). In an email from Hector J. Lopez (Branch Manager Professional Service Industries Inc (entity contractor) dated 12/14/2011, it indicates the initial background groundwater sampling was not conducted, as this was not in the scope of work for the contractor at that time. This will be listed as a noted and resolved violation since the entity cannot conduct background sampling since tire pieces have been placed into the LRPUT.

Recommended Corrective Action: The entity cannot conduct background sampling since tire pieces have been placed into the LRPUT. However, the entity shall have the continuing obligation to conduct groundwater sampling on a semi-annual basis, as stated in the letter dated 05/10/2010 from the TCEQ, referencing the Monitor Well Plan.

Resolution: The entity cannot conduct background sampling since tire pieces have been placed into the LRPUT. However, the entity shall have the continuing obligation to adhere to the Special Conditions set forth in the letter dated 05/10/2010 from the TCEQ, referencing the Monitoring Well Plan.

Track No: 458879

30 TAC Chapter 328.66(a)(9)

Alleged Violation:

Investigation: 972118

Comment Date: 2/16/2012

Failure to operate the project in accordance with special conditions imposed by the executive director. Specifically, the entity stored approximately 15,000 tires for eleven consecutive days.

By letter dated 05/10/2010 from the TCEQ, it states the facility is authorized to store 80,000 used or scrap tires as a 30 day supply, but no more than 5,000 used or scrap tires or the equivalent in tire pieces may be stored overnight. During the course of the investigation, it was

stated by Elva Walker that during the time period of 11/21/2011-12/02/2011 approximately fifteen (15) trailers, each storing approximately 1,000 tires, were being stored, which equals approximately 15,000 tires stored for eleven (11) days. The blades on the shredder required sharpening, therefore, shredding could not be conducted since the blades were removed.

Recommended Corrective Action: The entity shall not store more than 5,000 used or scrap tires or equivalent tire pieces overnight. If instances arise that may cause more than 5,000 tires/equivalent tire pieces to be stored overnight, the entity shall notify the Harlingen Regional Office of the situation.

Resolution: During the time period of 11/21/2011-12/02/2011 approximately fifteen (15) trailers, each storing approximately 1,000 tires, were being stored, which equals approximately 15,000 tires stored for eleven (11) days. Since the blades were returned from being sharpened, these tires were then processed and this volume of tires was no longer stored overnight.

ADDITIONAL ISSUES

Description

If the facility does not provide its own fire fighting personnel or system, has it made arrangements with public or private emergency response personnel capable of complying with applicable fire and building codes or for recovery facilities, has the appropriate jurisdictional fire marshal reviewed and approved the fire protection system?

Additional Comments

The Hidalgo County Fire Marshal's Office (Marco Romero) conducted the annual fire inspection of the entity on 11/28/2011. During the inspection, it was noted the entity should have the fire extinguishers checked by a certified technician. In speaking with Marco Romero, he stated the noted item referencing the fire extinguisher was not a violation noted by the Fire Marshal's Office. It was requested the entity have the fire extinguishers checked to determine if they needed recharging or replacement. Of note, the fire extinguishers were checked by a certified technician on 12/09/2011.

Other violations noted during the investigation? The SOP states the tire pieces will be placed below grade in lifts no greater than 12 inches thick by means of a front end loader, dump truck, or directly off the trailer mounted shredder, after processing. The sizes of the lifts will vary depending on the amount of tire pieces available for processing. At a frequency of at least once per day, an equal size and thickness layer of inert material will be placed on top of each lift, and mechanically mixed by alternately spreading and re consolidation the materials, thus ensuring a 50 percent mixture, and leveled for placement of the next layer of tire pieces. Galvan did not observe this specific placement method being conducted, what was observed was an equal volume of inert fill material and tire pieces placed onto the edge of the LRPUT edge. The front end loader then mechanically pushes the inert material into the tire pieces, with this mixture then mechanically pushed over the edge of the LRPUT. Galvan observed this method during three separate demonstrations and this method does ensure a 50 percent mixture of inert material and tire pieces. Note, 30 TAC 328.66(a)(5) states "The method of placement and commingling of the tire shreds to achieve a mix of tire pieces with the inert fill material in a proportion no greater than 50% of tire material by volume." Additionally, while observing the method of commingling the inert material and the tire pieces, it was observed the tire pieces curl up on themselves prior to being pushed into the inert material. If not commingled in the manner demonstrated, the tire pieces would "ball up" on themselves if placed below grade in lifts, as stated in the SOP. The method of placement, as stated in the SOP, may not ensure a 50 percent mixture of inert material and tire pieces.

Attachment C:

Letter to TCEQ from Barrett & Smith PLLC dated 12/11/2009

Barrett
LLP
Smith
— PLLC —
ATTORNEYS AT LAW

206 East 9th Street, Suite 1750 Austin, TX 78701 phone: 512 600-3801 fax: 512 600-3899
December 11, 2009

Ms. Cynthia Hackathorn
Region 4
Texas Commission on Environmental Quality
2309 Gravel Road
Ft. Worth, Texas 76118-6951

Re: Santa Anita Application for LRP/UT and Scrap Tire Facility Registration

Dear Ms. Hackathorn:

This letter is to clarify our letter dated December 9, 2009 regarding less than 30 days storage. In that letter, we estimated that our less than 30 day supply would be 80,000 tires. This amount is an estimate of what we would process over a 30 day period. We would not anticipate, or wish, to store 80,000 tires on site overnight.

However, we believe that our daily operation will be 8,000 tires processed as reflected in the application. As further reflected in the application, we are seeking authorization to keep no more than 5,000 tires on site overnight. Again, we understand that any tires remaining overnight must be left in trailers and not outside.

As you know, this facility has not yet been put in operation and the above numbers are only estimates. If actual operations indicate that the amount of tires processed is greater or lower, we can seek, at that time, to amend the authorization.

Thank you for your time and attention to this matter. Please feel free to contact me with any questions at your convenience at 512-600-3801.

Very truly yours,

Andrew N. Barrett



Hidalgo County
Office of Environmental Compliance
1304 S. 25th St. Edinburg, Texas 78542
(956)318-2840 Fax: (956) 318-2844

Ramon Garcia, County Judge
Joel Quintanilla, Pct. 1
Hector "Tito" Palacios, Pct. 2
Joe M. Flores, Pct. 3
Joseph Palacios, Pct. 4

Valde Guerra,
Commissioner's Court Executive Officer

July 25, 2012

Ms. Kendra Riffe
Scrap Tire Management Registration Coordinator
TCEQ DFW Region Office
2309 Gravel Drive
Fort Worth, TX 76118

Re: Application for Extension of LRPOT Registration for Santa Anita Reclamation LLC,
Scrap Tire Registration No. 6200592

Dear Ms. Riffe:

Hidalgo County has been notified by Rio Delta Engineering that Santa Anita Reclamation, LLC located at 25385 Farm to Market (FM) Road 1017, Linn, Texas 78563 has requested an extension of their authorization to operate their Land Reclamation Project Using Tires (LRPUT) under 30 Texas Administrative Code (TAC) §328.66. The letter indicates that they are requesting an extension until September, 2017 to complete their LRPOT.

The facility received a commercial development permit from Hidalgo County in 2010 after review by our Planning, Health, and Fire Marshal Departments. However, the Hidalgo County Commissioner's Court would like to take this opportunity to comment on the application due to the concerns expressed by county residents that live in the area where the facility is located; and, the Red Sands Groundwater Conservation District (Red Sands GWD) has also approached us about this facility and its potential for impact to groundwater.

Along with the concerns expressed to us by our residents and Red Sands GWD, we are also concerned about the results of a field investigation conducted by the TCEQ Harlingen Region 15 Office in December of 2011. The field investigation resulted in a Notice of Violation being issued to the facility in response to compliance issues identified during the investigation that included failure to meet the requirements of the initial registration and for discharge of a pollutant into water or waters of the state along with an additional issue dealing fire protection at the facility. These compliance issues cause us concerns about the facility's ability to meet TCEQ regulations in its day to day operations.

Areas of Concern:

1. The surrounding residents and Red Sands GWD have expressed their concerns to us regarding the potential impact to groundwater by Santa Anita Reclamation LLC. These area residents depend on groundwater for their drinking water and for agricultural purposes including livestock operations. After reviewing the results of the facility's two groundwater monitoring events that took place in April and October of 2011, we have concerns about the proximity of the water table to the bottom of the two pits that are part of the facility. Santa Anita Reclamation LLC uses two pits on their property as part of their operations- one pit is authorized to be reclaimed under the registration and the other is used by the facility for storing tires to be processed and its equipment. Taking into account that the facility's own

well logs that indicate that the top of casing (TOC) for each well is 1 foot above ground level, the depth of groundwater ranged from 2.7 to 3.9 feet deep during the October monitoring event and 3.8 to 6.0 feet in depth during the April monitoring event (See Attachment A: Monitoring Well Construction Data and Summary of Field Groundwater Depth Measurements from 04/14/11 and 10/04/11 Monitoring Events).

Our concerns are that an operational error or non compliance with TCEQ Regulations by the facility would result in a fire or a spill or release of a petroleum product or other pollutants from equipment that could impact groundwater. The Notice of Violation issued to Santa Anita Reclamation LLC included a violation for depositing waste into water or waters of the state in violation of the Texas Water Code (TWC) §26.121. They have been releasing cooling water from the tire shredder to an unlined pond or pit as identified during investigation. According to TCEQ's Central Registry Website, this violation has yet to have been resolved. We feel that our concerns regarding the facility's potential impact to groundwater in the area are justified by this violation and the depth to groundwater determined by the facility's monitoring events and TCEQ should take these concerns into account when deciding if they will approve their request for an extension (See Attachment B: Compliance Evaluation Investigation Report for Investigation # 972118 Conducted on 12/08/2011).

2. The application does not mention the continuation of groundwater monitoring. Two groundwater monitoring events have been performed with no indication of impact but the pit that is being reclaimed is less than $\frac{1}{4}$ filled according to the application. The request for the extension is asking for authorization to operate until 2017- an additional five years (See Attachment B: Compliance Evaluation Investigation Report for Investigation # 972118 Conducted on 12/08/2011). How would TCEQ be able to assure the residents that groundwater was not being impacted by Santa Anita Reclamation LLC if no groundwater monitoring was taking place?
3. During the investigation, it was noted that the facility had failed to conduct groundwater monitoring prior to starting operations and that it failed to submit an amended Groundwater Monitoring Well Site Plan as required by their original registration. Both of these violations were only addressed and resolved after they were identified by the field investigator (See Attachment B: Compliance Evaluation Investigation Report for Investigation # 972118 Conducted on 12/08/2011). Santa Anita Reclamation LLC did not fully comply with their registration's requirements that lead us to question their day to day compliance with TCEQ regulations.
4. During the TCEQ Harlingen Region 15 field investigation, it was noted that facility had exceeded their original registration's overnight storage limits of 5,000 tires due to equipment failure. They were storing a total of 15,000 tires on the site at the time of the investigation. Their response to the violation indicated that they may hold up to 80,000 tires on site since this is their 30-day supply (See Attachment C: Letter to TCEQ from Barrett & Smith PLLC dated 12/11/2009). Under 30 TAC §328, a 30-day supply applies only to a recycling or energy recovery facility and not a LRPOT. We feel that if the facility will be allowed to store a 30-day supply in the quantity that the facility has indicated, then it should be required to register as a scrap tire storage facility and meet the requirements for such a site under 30 TAC §328.60, §328.61, and §328.62 including requirements dealing with fire protection and financial assurance. Again this violation again calls into question their day to day compliance with TCEQ regulations.

5. Finally, the application does not include acknowledgement from the fire department that would respond to this facility in case of an emergency. The closest department capable of responding to a fire at Santa Anita Reclamation LLC would be the City of Edinburg Volunteer Fire Department whose closest fire station is approximately 22 miles away. No other department capable of responding to the site is currently operational in the area. The Hidalgo County Fire Marshal's Office will be submitting its own comments regarding issues concerning fire protection and the level of response that would be needed to fight a fire at the facility if the application is approved as has been submitted to TCEQ.



OFFICE OF THE COUNTY FIRE MARSHAL County Of Hidalgo

July 19, 2012

Ms. Kendra Riffe
Scrap Tire Management Registration Coordinator
TCEQ, DFW Region Office
2309 Gravel Drive
Fort Worth, TX 76118

Re: Application for extension of LRPUT Registration for Santa Anita LLC, Scrap Tire Registration No. 6200592

The Hidalgo County Fire Marshals Office has received correspondence of the above referenced registration indicating a request for extension to operate a land reclamation project utilizing tires in accordance with Texas Administrative Code 328.66. The Hidalgo County Fire Marshals Office submits the following concerns regarding this application for your review and consideration:

Fire Protection: The Hidalgo County Fire Marshals Office does not provide direct fire suppression through a County Fire Department, all fire services are contracted via city fire departments who respond to all areas of rural Hidalgo County. The immediate concern from our office is the lack of a fully staffed fire department within a reasonable response time. The Linn San Manuel Fire Department is currently non compliant with our recognized standards and therefore may not be able to respond to fires in the Linn San Manuel area. The nearest fire response available would be from the Edinburg Fire Department approximately 20 miles away. Additionally, neither department has been contacted and asked if they would be able to mitigate a fire involving up to approximately 80,000 tires, which the facility has indicated that the 80,000 tire figure is their 30-day supply of tires that they are allowed to have on site. This figure was used as a response to TCEQ for violations identified during a December, 2011 field investigation by the Harlingen Region 15 office.

Lack of Water Supply: The Santa Anita Reclamation, LLC has not provided an adequate water supply source within 500 feet of the facility as required for commercial businesses by recognized fire codes. Currently, if a fire occurs, water shuttle operations would be explicitly necessary to maintain adequate firefighting activities. This would require the activation of several fire departments to provide the required flow of water into portable tanks for supply and operations in response to a fire of this potential magnitude.

Tire Fire History: The Hidalgo County Fire Marshals Office has assisted and overseen the incident management and mitigation of two major tire fires within our jurisdiction in the last two years. In these responses we have learned of the resources that are required to mitigate a large tire fire. In the Alton tire fire, over ten (10) fire departments and multiple law enforcement agencies were required for continuous operations over a three day period. In comparison the Alton tire fire was estimated at 100,000 tires, while the Santa Anita Reclamation Project has a potential to hold up to 80,000 tires.



OFFICE OF THE COUNTY FIRE MARSHAL County Of Hidalgo

Environmental Concerns: Mitigating large tire fires has shown that it takes over one million gallons of water to suppress the heat and flames of such fires which leads to a significant potential for run off of contaminated water. Furthermore, the environmental factors and dynamics of this area pose additional hazards and threats to life and property due to the possible fire that could engulf the endless acreage of drought primed brush-land that surrounds this operational area.

In addition, this site is located adjacent to several caliche pits with depths of 15-25 feet. Processed tire pieces are being deposited to reclaim one of these pits. The facility's two groundwater monitoring events on April 14, 2011 and October 4, 2011 indicate that depth to ground water was the following:

Monitoring Wells	Sampling Dates	Depth to Groundwater in feet
1	4/14/2011	3.7
	10/4/2011	5.0
2	4/14/2011	4.8
	10/4/2011	6.9
3	4/14/2011	4.9
	10/4/2011	7.0

Since the monitoring wells are situated at the bottom of the pit where tires are being placed and the adjacent pit where tires are being stored in containers, any fire fighting activities would result in the potential for contaminated water impacting groundwater.

The Hidalgo County Fire Marshals Office is charged with the safety and preservation of life and property throughout Hidalgo County, therefore based on the inherent dangers associated with the continued or extended operation of the Santa Anita Reclamation Project has areas of serious concern of which merit our time and attention. Re-certifying this project will come with a potential of detrimental impacts to both life and property in our respective jurisdiction.

Sincerely,

Juan Martinez
Fire Marshal
Hidalgo County

STATE OF TEXAS

AI-33275

Comm. Court Executive Office 6. C.

CC REGULAR

Meeting Date: 07/24/2012

Department Head: Sergio Cruz Submitted By: Angela Garcia, BUDGET & MANAGEMENT

Department: EXECUTIVE OFFICE

Information

CAPTION

Budget & Management:

Approval to advertise/hire for the following positions:

Position Title	Slot#	Grade
Planning Analyst I	022	10
Budget Analyst I	011	10

BACKGROUND

Fiscal Impact

FISCAL YEAR: 2012

ACCT. #: 2-1100-415-14-115-001-0-113

FUNDS AVAILABLE Y/N?: Y

MATCHING FUNDS Y/N?: N

BUDGETARY IMPACT:

No Budgetary Impact. Funds budgeted within slot.

Positions currently vacant.

Attachments

backup

Form Review

Inbox	Reviewed By	Date
Budget & Management	Merlen P. Munoz	07/17/2012 11:27 AM
Sylvia Solis	Sylvia Solis	07/18/2012 09:15 AM
Purchasing Department	Angela Garcia	07/20/2012 04:55 PM
Form Started By: Angela Garcia		Started On: 07/17/2012 08:48 AM
	Final Approval Date: 07/20/2012	

HUMAN RESOURCES DEPARTMENT REQUISITION FORM

FORWARD COMPLETED FORM TO: HUMAN RESOURCES DIRECTOR

FROM (NAME OF DEPARTMENT): DBM-Budget Division

ANNOUNCE VACANCY USING (check one box)

INTERNAL ANNOUNCEMENT PROCEDURE

OPEN ANNOUNCEMENT PROCEDURE

POSITION TITLE / GRADE Planning Analyst I

NEW POSITION OR REPLACEMENT FOR: Perla Lopez EMPLOYEE NO 172529

DEPT NO 115-001

POSITION/SLOT NO 022

ADVERTISED SALARY: _____ OTHER COMPENSATION: _____ COMPENSATION TYPE: _____

\$ 35,254.00 Step 0

SPECIAL REQUIREMENTS: See attached job description

WORK LOCATION / HOURS: New Adm. Bldg - M-F 800-500pm

CONTACT PERSON: Rey Salazar

EXTENSION / PHONE NO: 292.7025

Department Head or Elected Official

2/11/2012
Date

FUNDS AVAILABLE: YES ___ NO ___ DATE OF FUND AVAILABILITY: _____

BUDGETED SALARY, GRADE & STEP: _____

BUDGETED OTHER ALLOWANCES: _____

APPROVED HR CHIEF OF STAFF / DATE

APPROVED HR DIRECTOR / DATE

Approval by Commissioner's Court Required: YES ___ NO ___. If yes, attach copy of approval and/or date of agenda and item number and have authorized representative of Commissioner's Court sign below:

Commissioner's Court Signature / Date

Closing Date

PLANNING ANALYST I

GRADE: 10

GENERAL DESCRIPTION

Performs entry-level planning and research work. Work involves developing local, regional, or state plans or programs; developing procedures for implementing plans or programs; and developing procedures for measuring progress made on operational plans or programs; Works under close supervision, with minimal latitude for the use of initiative and independent judgment.

EXAMPLES OF WORK PERFORMED

Collects, organizes, and analyzes data required in the development of plans or programs

Participates in technical, policy, and interagency planning meetings

Reviews and evaluates planning material for contractual compliance

Prepares reports

Researches federal and state regulations

Consults and communicates with other departments, agencies, and civic groups

Conducts field and telephone surveys

Assists in developing procedures for implementing plans or programs and for measuring progress

May prepare and monitor performance measures

Performs related work as assigned

GENERAL QUALIFICATION GUIDELINES

Experience and Education

One to two (1-2) years experience in planning and research work; Graduation from an accredited four-year college or university with major course work in city or regional planning, economics, business or public administration, political science, or a related field is generally preferred. Two (2) years of experience may be substituted for one (1) year of education.

Knowledge, Skills, and Abilities

Knowledge of government organization and administration; and of planning, formulating, coordinating, and implementing methodologies

Ability to evaluate planning material and to communicate effectively

PHYSICAL DEMANDS:

The physical demands described here are representative of those that must be met by an employee to successfully perform the essential functions of this job.

While performing the duties of this job, the employee is regularly required to talk or hear. The employee frequently is required to stand. The employee is occasionally required to walk; sit; use hands to find, handle, or feel objects, tools or controls; reach with hands and arms; climb or balance; stoop and kneel.

The employee must occasionally lift and/or move over 25 pounds. Specific vision abilities required by this job include close vision, depth perception, and the ability to adjust focus.

WORK ENVIRONMENT:

The work environment characteristics described here are representative of those an employee encounter while performing the essential functions of this job.

The noise level in the work environment is usually moderate.

SAFETY REQUIREMENTS:

Maintain physical conditions appropriate to the performance of assigned duties and responsibilities which may include the following:

- sitting for extended periods of time
- standing for extended periods of time
- operating assigned equipment

Maintain mental capacity which permits:

- making sound decisions and using good judgment
- demonstrating intellectual capabilities

Effectively handle a work environment and conditions which involve:

- working closely with others
- working in a multi-task environment

Maintain effective audio-visual discrimination and perception needed for:

- making observations
- reading and writing
- operating assigned equipment
- communication with others
- required to follow the Hidalgo County Accident Prevention Plan and department's safety regulations

HUMAN RESOURCES DEPARTMENT REQUISITION FORM

FORWARD COMPLETED FORM TO: HUMAN RESOURCES DIRECTOR

FROM (NAME OF DEPARTMENT): DBM-Budget Division

ANNOUNCE VACANCY USING (check one box)

INTERNAL ANNOUNCEMENT PROCEDURE

OPEN ANNOUNCEMENT PROCEDURE

POSITION TITLE / GRADE Budget Analyst I

NEW POSITION OR REPLACEMENT FOR: Erika Zamora EMPLOYEE NO 174424

DEPT NO 115-001

POSITION/SLOT NO 011

ADVERTISED SALARY: \$35,254.00 OTHER COMPENSATION: Step 0 COMPENSATION TYPE: _____

SPECIAL REQUIREMENTS: See attached job description

WORK LOCATION / HOURS: New Adm. Bldg M-F 800am-500pm

CONTACT PERSON: Damaris Sanmiguel

EXTENSION / PHONE NO: 292.7025

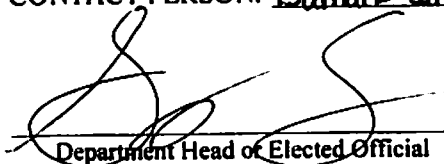
Department Head or Elected Official

7/11/2012
Date

FUNDS AVAILABLE: YES ___ NO ___ DATE OF FUND AVAILABILITY: _____

BUDGETED SALARY, GRADE & STEP: _____

BUDGETED OTHER ALLOWANCES: _____

APPROVED HR CHIEF OF STAFF / DATE

APPROVED HR DIRECTOR / DATE

Approval by Commissioner's Court Required: YES ___ NO ___. If yes, attach copy of approval and/or date of agenda and item number and have authorized representative of Commissioner's Court sign below:

Commissioner's Court Signature / Date

Closing Date

BUDGET ANALYST I

GRADE: 10

GENERAL DESCRIPTION

Performs routine (journey-level) budget preparation and analysis work. Work involves collecting, organizing, and summarizing information relevant to activities of the budget and program staff; and developing, monitoring, and adjusting budgets; Works under moderate supervision with limited latitude for the use of initiative and independent judgment.

EXAMPLES OF WORK PERFORMED

Provides advice and assistance concerning budget, funding procedures and methods

Collects, analyzes, and reports data that supports alternative solutions to budget and management problems

Maintains trend data and prepares graphs, reports, and forecasts

Studies impact of regulations and laws on agency policies and budget and makes recommendations

Reviews budgets for accuracy and recommends adjustments for more effective use of funds

Assists in the preparation of biennial legislative appropriations requests

Assists in the preparation of budget briefs to provide management with expenditure data, trends, and recommendations

Assists in the preparation, update, and publication of reports and manuals

Assists in reviewing, evaluating, and preparing requests for funds

Performs related work as assigned

GENERAL QUALIFICATION GUIDELINES

Experience and Education

One (1) year of experience in accounting, auditing, finance, budget preparation and/or analysis work; Graduation from an accredited four-year college or university with major course work in accounting, finance, business or public administration, or a related field is generally preferred. Education and experience may be substituted for one another.

Knowledge, Skills, and Abilities

Knowledge of accounting, budgetary, and management principles, practices, and procedures; of forecasting methodologies; and of automated accounting, budgeting, and forecasting programs

Ability to analyze fiscal management information, to determine appropriate use of funds, and to perform statistical analysis

PHYSICAL DEMANDS:

The physical demands described here are representative of those that must be met by an employee to successfully perform the essential functions of this job.

While performing the duties of this job, the employee is regularly required to talk or hear. The employee frequently is required to stand. The employee is occasionally required to walk; sit; use hands to find, handle, or feel objects, tools or controls; reach with hands and arms; climb or balance; stoop and kneel.

The employee must occasionally lift and/or move over 25 pounds. Specific vision abilities required by this job include close vision, depth perception, and the ability to adjust focus.

WORK ENVIRONMENT:

The work environment characteristics described here are representative of those an employee encounter while performing the essential functions of this job.

The noise level in the work environment is usually moderate.

SAFETY REQUIREMENTS:

Maintain physical conditions appropriate to the performance of assigned duties and responsibilities which may include the following:

- sitting for extended periods of time
- operating assigned equipment

Maintain mental capacity which permits:

- making sound decisions and using good judgment
- demonstrating intellectual capabilities

Effectively handle a work environment and conditions which involve:

- working closely with others
- working in a multi-task environment

Maintain effective audio-visual discrimination and perception needed for:

- making observations
- reading and writing
- operating assigned equipment
- communication with others
- required to follow the Hidalgo County Accident Prevention Plan and department's safety regulations



AI-33349

Comm. Court Executive Office 6. D.

CC REGULAR

Meeting Date: 07/24/2012

Submitted By: Monica Badillo,
EXECUTIVE OFFICE

Department: EXECUTIVE OFFICE

Information

CAPTION

Health & Human Services:

Requesting approval to advertise/hire for the following positions:

Program	Position Title	Slot #	Grade
Health Adm.	Clerk III	0031	5
Human Services	Eligibility Specialist II	0011	6
Health Clinics	Billing Specialist V	0030	9
Health Clinics	Courier	0043	2

BACKGROUND

Fiscal Impact

FISCAL YEAR: 2012

ACCT. #: See Below

FUNDS AVAILABLE Y/N?: Y

MATCHING FUNDS Y/N?: N

BUDGETARY IMPACT:

HEALTH ADM (2-1100-441-00-340-001-0-XXX)

No Budgetary Impact. Funds budgeted within slot.

HUMAN SERVICES (2-1100-444-00-240-001-0-XXX)

No Budgetary Impact. Funds budgeted within slot.

HEALTH CLINICS (2-1100-441-00-340-003-0-XXX)

No Budgetary Impact. Funds budgeted within slot.

Attachments

reqs

Form Review

Inbox
Budget & Management
Sylvia Solis
Purchasing Department

Reviewed By
Merlen P. Munoz
Sylvia Solis
Angela Garcia

Date
07/19/2012 03:19 PM
07/19/2012 04:35 PM
07/20/2012 04:55 PM
Started On: 07/19/2012

Form Started By: Monica Badillo

Final Approval Date: 07/20/2012

HUMAN RESOURCES DEPARTMENT REQUISTION FORM

FORWARD COMPLETED FORM TO: HUMAN RESOURCES DIRECTOR

FROM (NAME OF DEPARTMENT): HIDALGO COUNTY HEALTH & HUMAN SERVICES DEPARTMENT

ANNOUNCE VACANCY USING (check one box)

INTERNAL ANNOUNCEMENT PROCEDURE

OPEN ANNOUNCEMENT PROCEDURE

POSITION TITLE / GRADE CLERK III

NEW POSITION OR REPLACEMENT FOR: MARIA SANTOS GUZMAN EMPLOYEE NO 095004

DEPT NO 340

POSITION/SLOT NO 001-0031

ADVERTISED SALARY: 23,993.00 OTHER COMPENSATION: _____ COMPENSATION TYPE: _____

SPECIAL REQUIREMENTS: SEE ATTACHED

WORK LOCATION / HOURS: HIDALGO COUNTY MON. - FRI. 7:30AM - 5:30PM

CONTACT PERSON: LYDIA SERNA

EXTENSION / PHONE NO: 383-6221



Department Head or Elected Official

Date

FUNDS AVAILABLE: YES NO DATE OF FUND AVAILABILITY: 08/06/12

BUDGETED SALARY, GRADE & STEP: GRADE 5 STEP 1

BUDGETED OTHER ALLOWANCES: _____

APPROVED HR CHIEF OF STAFF / DATE

APPROVED HR DIRECTOR / DATE

Approval by Commissioner's Court Required: YES NO . If yes, attach copy of approval and/or date of agenda and item number and have authorized representative of Commissioner's Court sign below:

Commissioner's Court Signature / Date

Closing Date

CLERK III

GRADE: 05

GENERAL DESCRIPTION

Performs complex (journey-level) clerical work in areas such as bookkeeping, inventory control, statistics, employment, human resources, purchasing, and accounting; Work involves compiling and tabulating data, checking documents for accuracy, transporting documents and/or stock and inventory, and maintaining files; Works under general supervision with moderate latitude for the use of initiative and independent judgment.

EXAMPLES OF WORK PERFORMED

Produces and proofs correspondence, reports, purchase orders, summaries, manuals, vouchers, records, and other related forms

Answers inquiries regarding procedures and policies, assists the public and staff in filling out forms, and assembles and mails information packets

Posts information to agency records and modifies forms or records

Assembles, organizes, and tabulates data; and may compile and tabulate data, and prepare charts, graphs, and tables

Maintains files, materials, and supplies

Opens, stamps, classifies, sorts, and routes mail, and maintains records on postage, registered mail, and packages

Performs data entry, retrieval, and data searches

Receives, stores, and issues stock items

May perform arithmetic computations

May maintain office schedules and appointments

May perform back-up receptionist or telephone switchboard duties

May receive and forward payments to the appropriate agency staff

May screen applicants, administer employment tests, and assist in orienting employees

May arrange the scheduling, transfer, and display of surplus property

May make arrangements for repairs and services

May inspect merchandise for quality and compliance with specifications

May deliver or pick up documents, supplies, equipment, or materials

Responsible for answering and routing phone calls

Will be assisting the general public

May be required to work overtime or hours other than standard work schedule during emergencies

Performs other related duties as assigned

GENERAL QUALIFICATION GUIDELINES

Experience and Education

Two to Three (2-3) years experience in clerical work. Graduation from a standard senior high school or equivalent is generally preferred. Vocational training is preferred. Two (2) years of experience may be substituted for one (1) year of education.

Bilingual required (English/Spanish)

Certificates, Licenses & Registration

Applicant must have a current valid Texas operator's driver's license

Must be able to be insured by the County's insurance carrier

Knowledge, Skills, and Abilities

Knowledge of business or program terminology, office procedures, spelling, punctuation, grammar, and arithmetic; of warehousing procedures; of purchasing policies and procedures; of records administration and maintenance techniques and procedures; and of state purchasing policies and procedures

Skill in using a personal computer and office equipment

MS Word and Excel

Ability to maintain excellent customer service

Ability to make arithmetic computations; to prepare and maintain records, files, and reports; and to transfer stock from one location to another

PHYSICAL DEMANDS:

The physical demands described here are representative of those that must be met by an employee to successfully perform the essential functions of this job.

While performing the duties of this job, the employee is regularly required to talk or hear. The employee frequently is required to stand. The employee is occasionally required to walk; sit; use hands to find, handle, or feel objects, tools or controls; reach with hands and arms; climb or balance; stoop and kneel.

The employee must occasionally lift and/or move over 25 pounds. Specific vision abilities required by this job include close vision, depth perception, and the ability to adjust focus.

WORK ENVIRONMENT:

The work environment characteristics described here are representative of those an employee encounter while performing the essential functions of this job.

The noise level in the work environment is usually moderate.

SAFETY REQUIREMENTS:

Maintain physical conditions appropriate to the performance of assigned duties and responsibilities which may include the following:

- sitting for extended periods of time
- operating assigned equipment

Maintain mental capacity which permits:

- making sound decisions and using good judgment
- demonstrating intellectual capabilities

Effectively handle a work environment and conditions which involve:

- working closely with others
- working in a multi-task environment

Maintain effective audio-visual discrimination and perception needed for:

- making observations
- reading and writing
- operating assigned equipment
- communication with others
- required to follow the Hidalgo County Accident Prevention Plan and department's safety regulations

HUMAN RESOURCES DEPARTMENT REQUISITION FORM

FORWARD COMPLETED FORM TO: HUMAN RESOURCES DIRECTOR

FROM (NAME OF DEPARTMENT): HIDALGO COUNTY HEALTH & HUMAN SERVICES DEPARTMENT

ANNOUNCE VACANCY USING (check one box)

INTERNAL ANNOUNCEMENT PROCEDURE

OPEN ANNOUNCEMENT PROCEDURE

POSITION TITLE / GRADE ELIGIBILITY SPECIALIST II

NEW POSITION OR REPLACEMENT FOR: JORGE E. GARCIA EMPLOYEE NO 160849

DEPT NO 240

POSITION/SLOT NO 001-0011

ADVERTISED SALARY: 25,912.00 OTHER COMPENSATION: _____ COMPENSATION TYPE: _____

SPECIAL REQUIREMENTS: SEE ATTACHED

WORK LOCATION / HOURS: HIDALGO COUNTY MON. - FRI. 7:30AM - 5:30PM

CONTACT PERSON: DAIREN SARMIENTO

EXTENSION / PHONE NO: 318-2011

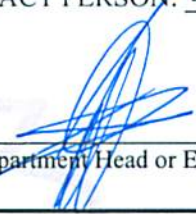

Department Head or Elected Official

Date

FUNDS AVAILABLE: YES NO DATE OF FUND AVAILABILITY: 07/17/12

BUDGETED SALARY, GRADE & STEP: GRADE 6 STEP 1

BUDGETED OTHER ALLOWANCES: _____

APPROVED HR CHIEF OF STAFF / DATE

APPROVED HR DIRECTOR / DATE

Approval by Commissioner's Court Required: YES ___ NO ___. If yes, attach copy of approval and/or date of agenda and item number and have authorized representative of Commissioner's Court sign below:

Commissioner's Court Signature / Date

Closing Date

ELIGIBILITY SPECIALIST II

GRADE: 06

GENERAL DESCRIPTION

Determine eligibility for Hidalgo County residents for County Indigent Health Care Program as well as other direct assistance programs, which include funeral assistance, medical transportation, lodging and meals. Assist County residents in identifying and obtaining various financial and health care resources; provide community resource information and make appropriate referrals.

EXAMPLES OF WORK PERFORMED

Receive, review and process applications and determine eligibility utilizing established state and county program policies and procedures within established time frames

Identify and respond to community needs and concerns and make adequate referrals to appropriate agencies and assist in the development of resources to meet anticipated demands

Prepare various reports and correspondence

Be available to answer questions and provide information to the general public and assist in identifying resources

Attend and participate in staff meetings and workshops

Stay abreast of policies and procedural changes in the Indigent Program and other related health care programs

Properly prepare and complete necessary program forms and documents

Maintain and update participant computer and hard copy case files

Assist in clerical work as needed

Studies and analyzes operations and problems, and prepares reports of findings and recommendations

Recommends activities to produce a more effective program

Prepares justifications for procedural or policy changes

Provides technical assistance on program services

Works with program staff in determining trends and resolving technical problems

Ability to work well with others

May train others

Performs related work as assigned

GENERAL QUALIFICATION GUIDELINES

Experience and Education

Four (4) years experience with Indigent Health Care, Medicaid Program, or related social programs preferred; Graduation from a high school or equivalent; Associate degree or vocational training; Experience and education may be substituted for one another.

Knowledge, Skills, and Abilities

Knowledge of local, state, and federal laws related to the program area; of public administration and management techniques; of statistical analysis processes; and of program planning and implementation

Ability to gather, assemble, correlate, and analyze facts; to devise solutions to problems; to prepare reports; to develop and evaluate policies and procedures; to communicate effectively; and to train others

PHYSICAL DEMANDS:

The physical demands described here are representative of those that must be met by an employee to successfully perform the essential functions of this job.

While performing the duties of this job, the employee is regularly required to talk or hear. The employee frequently is required to stand. The employee is occasionally required to walk; sit; use hands to find, handle, or feel objects, tools or controls; reach with hands and arms; climb or balance; stoop and kneel.

The employee must occasionally lift and/or move over 25 pounds. Specific vision abilities required by this job include close vision, depth perception, and the ability to adjust focus.

WORK ENVIRONMENT:

The work environment characteristics described here are representative of those an employee encounter while performing the essential functions of this job.

The noise level in the work environment is usually moderate.

SAFETY REQUIREMENTS:

Maintain physical conditions appropriate to the performance of assigned duties and responsibilities which may include the following:

HUMAN RESOURCES DEPARTMENT REQUISITION FORM

FORWARD COMPLETED FORM TO: HUMAN RESOURCES DIRECTOR

FROM (NAME OF DEPARTMENT): HIDALGO COUNTY HEALTH & HUMAN SERVICES DEPARTMENT

ANNOUNCE VACANCY USING (check one box)

INTERNAL ANNOUNCEMENT PROCEDURE

OPEN ANNOUNCEMENT PROCEDURE

POSITION TITLE / GRADE BILLING SPECIALIST V

NEW POSITION OR REPLACEMENT FOR: MARICELA ESPINOSA EMPLOYEE NO 021164

DEPT NO 340

POSITION/SLOT NO 003-0030

ADVERTISED SALARY: 32,642.00 OTHER COMPENSATION: _____ COMPENSATION TYPE: _____

SPECIAL REQUIREMENTS: SEE ATTACHED

WORK LOCATION / HOURS: CENTRAL OFFICE (EDINBURG) MON. - FRI. 7:30AM - 5:30PM

CONTACT PERSON: LYDIA SERNA

EXTENSION / PHONE NO: 383-6221



Department Head or Elected Official

Date

FUNDS AVAILABLE: YES NO DATE OF FUND AVAILABILITY: 07/17/12

BUDGETED SALARY, GRADE & STEP: GRADE 9 STEP 1

BUDGETED OTHER ALLOWANCES: _____

APPROVED HR CHIEF OF STAFF / DATE

APPROVED HR DIRECTOR / DATE

Approval by Commissioner's Court Required: YES NO . If yes, attach copy of approval and/or date of agenda and item number and have authorized representative of Commissioner's Court sign below:

Commissioner's Court Signature / Date

Closing Date

BILLING SPECIALIST V

GRADE: 09

GENERAL DESCRIPTION

Performs senior-level billing work; Work involves collecting, posting, and managing account payments; Works with minimal supervision with latitude for the use of initiative and independent judgment; May compile reports for upper management review; May supervise staff and train staff.

EXAMPLES OF WORK PERFORMED

Analyze and process all billing transactions

May review billing reports for analysts

Authorize billing adjustments

Performs various collection actions including calling clients by phone, correcting and resubmitting billing to proper entities

Follow up on all past due invoices and failed billing

Identifies problems and issues during billing cycles and solves them

Ensure all tasks and duties are completed within county guidelines and policies

Sets timetables for addressing resolution of problems/issues

Maintains client database

Uses software to track and analysis of data

Produces billing reports for billing supervisor

Maintains strict confidentiality and adheres to all guidelines/requirements

Will work on weekly and monthly billing process

Performs related work as assigned

GENERAL QUALIFICATION GUIDELINES

Experience and Education

Graduation from a standard senior high school required. Five (5) or more years of related experience in billing with high volume billing in the private sector or public setting; An Associate's Degree in Accounting or Business Administration preferred. Experience and education may be substituted for one another.

Knowledge, Skills, and Abilities

Must have strong knowledge of billing and financial concepts

Knowledge of MS Word and Excel

Knowledge of computer equipment and peripherals

Strong analytical skills

Excellent oral and written communication

Demonstrated supervisory experience

PHYSICAL DEMANDS:

The physical demands described here are representative of those that must be met by an employee to successfully perform the essential functions of this job.

While performing the duties of this job, the employee is regularly required to talk or hear. The employee frequently is required to stand. The employee is occasionally required to walk; sit; use hands to find, handle, or feel objects, tools or controls; reach with hands and arms; climb or balance; stoop and kneel.

The employee must occasionally lift and/or move over 25 pounds. Specific vision abilities required by this job include close vision, depth perception, and the ability to adjust focus.

WORK ENVIRONMENT:

The work environment characteristics described here are representative of those an employee encounter while performing the essential functions of this job.

The noise level in the work environment is usually moderate.

SAFETY REQUIREMENTS:

Maintain physical conditions appropriate to the performance of assigned duties and responsibilities which may include the following:

- sitting for extended periods of time
- operating assigned equipment

Maintain mental capacity which permits:

- making sound decisions and using good judgment
- demonstrating intellectual capabilities

Effectively handle a work environment and conditions which involve:

- working closely with others
- working in a multi-task environment

Maintain effective audio-visual discrimination and perception needed for:

- making observations
- reading and writing
- operating assigned equipment
- communication with others
- required to follow the Hidalgo County Accident Prevention Plan and department's safety regulations

HUMAN RESOURCES DEPARTMENT REQUISITION FORM

FORWARD COMPLETED FORM TO: HUMAN RESOURCES DIRECTOR

FROM (NAME OF DEPARTMENT): HIDALGO COUNTY HEALTH & HUMAN SERVICES DEPARTMENT

ANNOUNCE VACANCY USING (check one box)

INTERNAL ANNOUNCEMENT PROCEDURE

OPEN ANNOUNCEMENT PROCEDURE

POSITION TITLE / GRADE COURIER

NEW POSITION OR REPLACEMENT FOR: ADOLFO REQUENEZ EMPLOYEE NO 052787

DEPT NO 340

POSITION/SLOT NO 003-0043

ADVERTISED SALARY: 19,047.00 OTHER COMPENSATION: _____ COMPENSATION TYPE: _____

SPECIAL REQUIREMENTS: SEE ATTACHED

WORK LOCATION / HOURS: CENTRAL OFFICE (EDINBURG) MON. - FRI. 7:30AM - 5:30PM

CONTACT PERSON: LYDIA SERNA

EXTENSION / PHONE NO: 383-6221



Department Head or Elected Official

Date

FUNDS AVAILABLE: YES NO DATE OF FUND AVAILABILITY: 10/03/12

BUDGETED SALARY, GRADE & STEP: GRADE 2 STEP 1

BUDGETED OTHER ALLOWANCES: _____

APPROVED HR CHIEF OF STAFF / DATE

APPROVED HR DIRECTOR / DATE

Approval by Commissioner's Court Required: YES NO . If yes, attach copy of approval and/or date of agenda and item number and have authorized representative of Commissioner's Court sign below:

Commissioner's Court Signature / Date

Closing Date

COURIER

GRADE: 02

GENERAL DESCRIPTION

Runs errands and delivers mail to and from various County locations.

EXAMPLES OF WORK PERFORMED

Picks up mail and delivers to offices within the District Attorney's Office and to other County offices

Collects and distributes supplies within the District Attorney's Office and various sub-offices

Picks up and delivers graphics orders

Takes paperwork to Federal Courthouse for filings

Picks up paychecks

Operates a motor vehicle to complete various errands

Performs all other related duties as assigned

GENERAL QUALIFICATION GUIDELINES

Experience and Education

High School diploma or equivalent required; Ability to follow verbal and written instructions. Must have and maintain a valid Texas Driver's License with a good driving record.

Knowledge, Skills, and Abilities

The duties and tasks of this position are simple and repetitive

Incumbent must make motor vehicle operation decisions to insure the safe and proper operation of County vehicles and the proper transportation of materials handled

Refers questions and problems to higher levels

Ability to communicate effectively

Requires interaction with the Supervisor, Hidalgo County Departments, Vendors and the general public

PHYSICAL DEMANDS:

The physical demands described here are representative of those that must be met by an employee to successfully perform the essential functions of this job.

While performing the duties of this job, the employee is regularly required to talk or hear. The employee frequently is required to stand. The employee is occasionally required to walk; sit; use hands to find, handle, or feel objects, tools or controls; reach with hands and arms; climb or balance; stoop and kneel.

The employee must occasionally lift and/or move over 25 pounds. Specific vision abilities required by this job include close vision, depth perception, and the ability to adjust focus.

WORK ENVIRONMENT:

The work environment characteristics described here are representative of those an employee encounter while performing the essential functions of this job.

The noise level in the work environment is usually moderate.

SAFETY REQUIREMENTS:

Maintain physical conditions appropriate to the performance of assigned duties and responsibilities which may include the following:

- sitting for extended periods of time
- standing for extended periods of time
- operating assigned equipment

Maintain mental capacity which permits:

- making sound decisions and using good judgment
- demonstrating intellectual capabilities

Effectively handle a work environment and conditions which involve:

- working closely with others
- working in a multi-task environment

Maintain effective audio-visual discrimination and perception needed for:

- making observations
- reading and writing
- operating assigned equipment
- communication with others
- required to follow the Hidalgo County Accident Prevention Plan and department's safety regulations

AI-33210

7. A.

CC REGULAR

Meeting Date: 07/24/2012

Submitted By: Maria Figueroa, TAX OFFICE

Department: TAX OFFICE

Information

CAPTION

Pursuant to the Tax Code 31.11 (c-1), requesting approval to extend the tax refund deadline of three years to an additional two years for the following tax refunds.

REFUND TYPE	ACCT #	TAXPAYER	REFUND AMT	PAYMENT DATE
Erroneous Payment	L5090.97.LNJ.0086.03	Vanderbilt Mortgage	\$ 500.36	01/18/2007

BACKGROUND

Pursuant to Tax Code 31.11(c), a refund application for an overpayment or erroneous payment must be made within three years after the due date of the payment or the taxpayer waives the right to the refund. However, Tax Code 31.11(c-1) states that, the governing body of the taxing unit may extend the deadline for a single period not to exceed two years.

Fiscal Impact

FISCAL YEAR:

ACCT. #:

FUNDS AVAILABLE Y/N?:

MATCHING FUNDS Y/N?:

BUDGETARY IMPACT:

No fiscal impact.

Attachments

Vanderbilt

Form Review

Inbox	Reviewed By	Date
Budget & Management	Merlen P. Munoz	07/11/2012 04:54 PM
Perla Lopez	Perla Lopez	07/12/2012 09:20 AM
Auditor's Office	Angela Garcia	07/20/2012 05:00 PM
Form Started By: Maria Figueroa		Started On: 07/11/2012 03:41 PM
Final Approval Date: 07/20/2012		

Office of Tax Assessor-Collector
COUNTY of HIDALGO

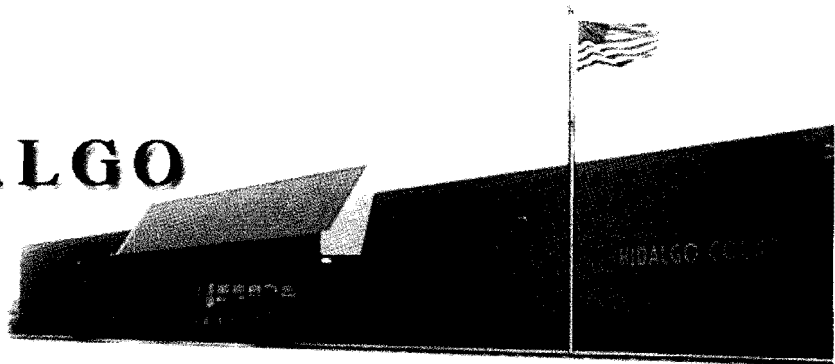

Armando Barrera Jr., RTA
Assessor and Collector

P.O. Box 178
Edinburg, Texas 78540-0178
(956) 318-2157 • Fax (956) 318-2733

July 11, 2012

The Honorable Ramon Garcia
Hidalgo County Commissioners
Edinburg, Texas 78539

Re: See attached list

Gentlemen:

As per Section 31.11 of the Property Tax Code, the governing body of each taxing unit must authorize refunds of overpayments or erroneous payments over \$ 2500.00 dollars.

I respectfully request that the Commissioner's Court approve the enclosed application for a tax refund based on an adjustment approved by the Hidalgo County Appraisal District Office.

An application for a refund must be made within three years after the date of the payment or the taxpayer waives the right to the refund. The governing body of the taxing unit may extend the deadline provided by Subsection (c) for a single period not to exceed two years on a showing of good cause by the taxpayer.

When completed, please return the attached to this office.

Thanking you for your assistance in this matter, I remain.

Very truly yours,

Armando Barrera, Jr. RTA

Abj: mm

Enclosure

Xc: Hidalgo County Auditor
Raymundo Eufrazio, CPA

Office of Tax Assessor-Collector
COUNTY of HIDALGO

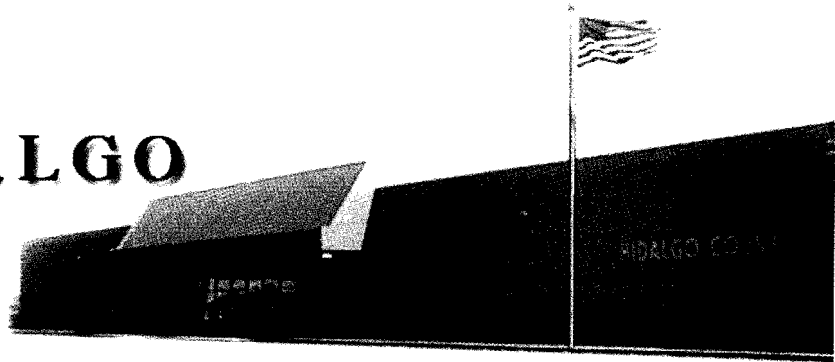

Armando Barrera Jr., RTA
Assessor and Collector

P.O. Box 178
Edinburg, Texas 78540-0178
(956) 318-2157 • Fax (956) 318-2733

ACCOUNT NUMBER	PAYER	AMOUNT
L5090.97.LNJ.0086.03	VANDERBILT MORTGAGE	\$500.36

An application for a refund must be made within three years after the date of the payment or the taxpayer waives the right to the refund.

The governing body of the taxing unit may extend the deadline provided by Subsection (c) for a single period not to exceed two years on a showing of good cause by the taxpayer.

APPLICATION FOR TAX REFUND

Collection office name HIDALGO COUNTY TAX OFFICE	Collecting tax for: (Tax Units) GHD-SST-DR1-FD1-FD2-FD3-FD4-CAN- CLV-CMS-CPN-CPO-CWL-SEB-SLV- SML-SMS-SSL-SWL-JCC
Present mailing address (number and street) P O BOX 178	
City, town or post office, state, ZIP code EDINBURG TX 78540-0178	Phone (area code and number) (956) 318-2157

To apply for a tax refund, the taxpayer must complete the following

Step 1: Owner's name and address	Owner's name HENDRICKSON DAVID & NANCY J PAYER: VANDERBILT MORTGAGE
	Present mailing address (number and street) 21538 496TH N
	City, town or post office, state, ZIP code MCGREGOR, MN 55760

Phone (area code and number)

Legal description (or attach copy of the tax bill or tax receipt): **LLANO GRANDE LAKE PARK SPACE 86**

Step 2: Describe the property	LAS NARANJAS 14x66 MARLETTE	
	Address or location of property:	
	779202	
	Account number of property: L5090.97.LNJ.0086.03	Tax receipt number: OR 8507541

Step 3: Give the tax payment information	Name Of Taxing Unit from Which Refund is Requested	Year for Which Refund is Requested	Date of the Tax Payment	Amount of Taxes Paid	Amount of Tax Refund Requested
	1. ALL ENTITIES	2006	1/18 / 2007	\$ 500.36	\$ 500.36
	2.		/	\$	\$
	3.		/	\$	\$
	4.		/	\$	\$
	5. TOTAL		/	\$	\$ 500.36

Taxpayer's reason for refund (attach supporting documentation): **AS PER PROPERTY OWNER**

THEY ARE RESPONSIBLE FOR THEIR TAXES & PER MORTGAGE CO

AS WELL (2012) MF

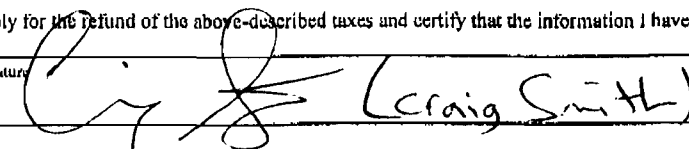
Step 4: sign the form	"I hereby apply for the refund of the above-described taxes and certify that the information I have given on this form is true and correct."	
	Signature 	Date of application for tax refund 6/21/12

If you make a false statement on this application, you could be found guilty of a Class A misdemeanor or a state jail felony under Texas Penal Code Section 37.10.

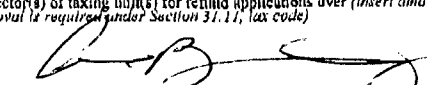
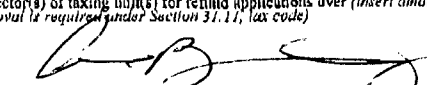
Step 5: Tax refund Determination	This tax refund is <input type="checkbox"/> Approved <input type="checkbox"/> Disapproved	
	Authorized officer sign here 	Date 7/3/12
	Collector(s) of taxing unit(s) for refund applications over (insert amount for which governing body approval is required under Section 31.11, tax code) sign here 	Date 7/3/12

AI-33339

Emergency Management 9. A.

CC REGULAR

Meeting Date: 07/24/2012

Submitted By: SANDRA DELEON,
COUNTY JUDGE

Department: COUNTY JUDGE

Information

CAPTION

Approval of request from the Lower Rio Grande Valley Development Council for local contribution in the amount of \$2,000 in support of a Spanish Language Public Safety Early Weather Warning System for the Lower Rio Grande Valley.

BACKGROUND

The HMGP application requires a 25% match, which HSAC asked the LRGVDC to seek contributions from local governments.

Match requirements were based on size of jurisdictions (small, medium, large). Hidalgo County is considered a "large" jurisdiction; therefore contribution amount is \$2,000.

Fiscal Impact

FISCAL YEAR: 2012

ACCT. #: 2-1100-413-30-125-004-0-843

FUNDS AVAILABLE Y/N?: Y

MATCHING FUNDS Y/N?: N

BUDGETARY IMPACT:

Funding available through Requisition#219862 in the amount of \$2,000.00 as of 7/20/12 for Lower RGV Development Council.

Attachments

letter & list

Invoice

Form Review

Inbox	Reviewed By	Date
Budget & Management	Merlen P. Munoz	07/19/2012 11:19 AM
Roland Garcia	Rolando Garcia	07/20/2012 03:12 PM
Purchasing Department	Angela Garcia	07/20/2012 04:55 PM
Form Started By: SANDRA DELEON		Started On: 07/19/2012 09:44 AM
	Final Approval Date: 07/20/2012	



Lower Rio Grande Valley Development Council

Mayor Steve Brewer, La Feria President
 Hon. Norma G. Garcia, Member-at-Large 1st Vice-President
 Mayor Tony Martinez, Brownsville 2nd Vice-President
 Mayor Chris Boswell, Harlingen Secretary
 Commissioner Gerardo "Jerry" Tafolla, Weslaco Treasurer
 Mayor Pro-Term Eddy Gonzalez, Edcouch Immediate Past President

BOARD MEMBERS

Sofia Benavides
 Commissioner, Cameron County

Héctor "Tito" Palacios
 Commissioner, Hidalgo County

John F. Gonzales
 Judge, Willacy County

Pilar Garza
 Commissioner, Alamo

David S. Simmons
 Mayor, Donna

Gus Garcia
 Council Member, Edinburg

Jim Darling
 Commissioner, McAllen

Henry Hinojosa
 Mayor, Mercedes

Norie Gonzalez Garza
 Council Member, Mission

Leo "Polo" Palacios, Jr.
 Mayor, Pharr

Orlando Correa
 Mayor, Raymondville

Joe D. Gonzalez
 Commissioner, San Benito

Amarido Garza
 Mayor Pro-term, San Juan

Dr. Cesar Maldonado
 TSTC, Harlingen

Roberto Loreda
 Donna I.S.D.

Gale Armstrong
 El Jardin Water Supply

J. Shane Cameron
 Willacy Navigation District

Alvin Samano
 Member-at-Large

Don Medina
 Member-at-Large

Arturo Ramirez
 Grassroots Organizations

EXECUTIVE DIRECTOR
 Kenneth N. Jones, Jr.

July 6, 2012

Honorable Ramon Garcia
 Hidalgo County
 1615 S. Closner, Suite J
 Edinburg, Texas 78539

Dear Judge Garcia,

Recently, we were contacted by the office of Senator Eddie Lucio, Jr. requesting the LRGVDC's assistance to coordinate the implementation of a Spanish Language Public Safety Early Weather Warning System for the Lower Rio Grande Valley. This effort would expand the current English only early warning messages activated through the National Weather Service regarding impending severe weather and other applicable weather and emergency information. The Spanish All-Hazards radio transmitter(s) project in this Region would be only the fourth (4th) site in the nation providing this service. Existing site locations include El Paso, TX, San Diego, CA, and Miami Dade, FL.

The LRGVDC Board of Directors considered this item, presented by Senator Lucio, on May 24, 2012 and unanimously supported the concept and authorized staff to move forward to implement this important and much needed project. Through the efforts of Senator Lucio and the support of Chief Nim Kidd of the Texas Division of Emergency Management (TDEM) funding for this regional system is available. The LRGVDC is also coordinating efforts with all 46 cities to include the three counties, Rio Grande Valley Partnership and the National Weather Service Brownsville.

Although funding is available, the LRGVDC is not identified as an eligible applicant. The Hazard Mitigation Grant Program (HMGP) parameters only allow local city and county governments to directly apply. However, those entities as the LRGVDC that are not specifically identified in a Hazard Mitigation Plan may identify a "pass-through" eligible applicant and request that an application be submitted on our behalf. With the City of Weslaco being an eligible applicant, our agency was on the City Commission agenda (June 19th) for the Commission to consider action as the "pass-through" applicant for this regional project, approval was unanimous.

The HMGP application was submitted to the TDEM, the State Agency in charge of this funding. The source of these funds is federal which require a 25% local cash match. The LRGVDC would be considered the sub-grantee and, with City Commission approval, would enter into the necessary Interlocal agreement outlining our responsibilities for implementation of the project. LRGVDC's responsibilities is to prepare the application, be responsible for meeting the match commitment with the cooperation and funding assistance by the 46 local jurisdictions and other private sector agencies, and fully implementing the project. I anticipate having additional information on all components of the project as we move further along the grant process and performance period.

Due to our vast coverage area, it has been determined that two (2) transmitters are required in order to provide adequate coverage for the LRGVDC Region. Recurring costs involved will be dependent on tower location(s). If possible, we are seeking to minimize cost by securing public tower sites, however, due to the height requirements needed for these transmitters, our choices will be limited.

Since the announcement of this project we have been actively collaborating with our local members of the Homeland Security Advisory Committee (HSAC) and Metropolitan Medical Response System (MMRS) in an effort to secure the two sites required. One of the two sites has tentatively been identified and will be located in the City of Pharr and the second site which will be in the Cameron County area is currently being reviewed.

At our regularly scheduled HSAC meetings, (June 07, 2012), our members reviewed and recommended that the LRGVDC seek local match support from our local governments. This recommendation was subsequently approved by the LRGVDC Board of Directors at the June 27, 2012 regularly scheduled monthly meeting.

July 06, 2012

For your convenience, I have attached a list of each jurisdictions requested contribution amount and an invoice noting your jurisdictions contribution towards the 25% match.

In advance, I want to thank you for your consideration and attention to this most important request and for being a part of this collaborative regional effort in saving lives and property. In order to be successful in the implementation of this extremely important project we need your participation, therefore, should you have any questions or if additional information is needed for processing this request please feel free to contact me or Manuel Cruz, Director of Homeland Security at (956) 682-3481.

Sincerely,



Kenneth N. Jones
Executive Director

cc: Oscar Montoya, EMC

Attachment A - LRGVDC NSAC Recommendation for the 25% Match

Jurisdiction	Population	Classification	Match Requirement
City of Brownsville	175,023	Large	\$2,000.00
City of Harlingen	64,849	Large	\$2,000.00
City of Edinburg	77,100	Large	\$2,000.00
City of McAllen	129,877	Large	\$2,000.00
City of Mission	77,058	Large	\$2,000.00
City of Pharr	70,400	Large	\$2,000.00
City of San Juan	33,856	Large	\$2,000.00
City of Weslaco	35,670	Large	\$2,000.00
City of San Benito	24,250	Medium	\$1,000.00
City of Alamo	19,102	Medium	\$1,000.00
City of Alton	10,934	Medium	\$1,000.00
City of Donna	18,299	Medium	\$1,000.00
City of Hidalgo	11,866	Medium	\$1,000.00
City of Mercedes	16,472	Medium	\$1,000.00
City of La Feria	8,098	Small	\$500.00
City of Los Fresnos	5,804	Small	\$500.00
City of Port Isabel	5,311	Small	\$500.00
City of Rio Hondo	2,278	Small	\$500.00
City of South Padre Island	3,177	Small	\$500.00
Town of Bayview	434	Small	\$500.00
Town of Combes	2,875	Small	\$500.00
Town of Indian Lake	605	Small	\$500.00
Town of Laguna Vista	4,150	Small	\$500.00
Town of Los Indios	1,353	Small	\$500.00
Town of Palm Valley	1,336	Small	\$500.00
Town of Primera	4,228	Small	\$500.00
Town of Rancho Viejo	2,437	Small	\$500.00
Town of Santa Rosa	3,197	Small	\$500.00
City of Edcouch	4,390	Small	\$500.00
City of Elsa	6,885	Small	\$500.00
City of Granjeno	332	Small	\$500.00
City of La Joya	4,396	Small	\$500.00
City of La Villa	1,428	Small	\$500.00
City of Palmhurst	6,376	Small	\$500.00
City of Palmview	5,652	Small	\$500.00
City of Penitas	2,439	Small	\$500.00
City of Progreso	6,138	Small	\$500.00
City of Progreso Lakes	277	Small	\$500.00
City of Sullivan City	4,002	Small	\$500.00
City of Lyford	2,897	Small	\$500.00
City of Raymondville	9,772	Small	\$500.00
City of San Perlita	722	Small	\$500.00
Cameron County	406,220		\$2,000.00
Hidalgo County	774,769		\$2,000.00
Willacy County	22,134		\$1,000.00
Total Funds:			\$41,000.00

Lower Rio Grande Valley Development Council
301 West Railroad Street
Weslaco, Texas 78596

Phone # (956) 682-3481
Fax # (956) 682-3295

INVOICE

TO: NAME: Hidalgo County
ADDRESS: 1615 S. Closner, Suite J
CITY, STATE, ZIP: Edinburg, Tx. 78539

DATE	CHARGES	BALANCE
7.6.2012	Hazard Mitigation Grant Program Contribution	\$2,000.00
	TOTAL	\$2,000.00

Please make check payable to
LOWER RIO GRANDE VALLEY DEVELOPMENT COUNCIL
If you have any question please contact Manuel Cruz at
(956) 682-3481

AI-33220

Facilities Management 10. A.

CC REGULAR

Meeting Date: 07/24/2012

Department Head: Daniel Flores, Facilities Mgmt. Submitted By: Olga Garza, BUDGET & MANAGEMENT

Department: BUDGET & MANAGEMENT

Information

CAPTION

Requesting approval to process the following invoices as claims to Verizon Wireless with authority for County Treasurer to issue payment after review, audit and processing procedures are completed by County Auditor.

Invoice #	Period	Users	Total
6674206968	12/24/11-01/23/12	Richard Sunday, Sefe Garza \$37.99+\$37.99	\$75.98
6687149261	01/24/12-02/23/12	Richard Sunday, Sefe Garza \$37.99+\$37.99	\$75.98
6700033855	02/24/12-03/23/12	Richard Sunday, Sefe Garza \$37.99+\$37.99	\$75.98
6712965447	03/24/12-04/23/12	Richard Sunday, Sefe Garza \$37.99+\$37.99	\$75.98
6725865192	04/24/12-05/23/12	Richard Sunday, Sefe Garza \$37.99+\$37.99	\$75.98
6738752971	05/24/12-06/23/12	Richard Sunday, Sefe Garza \$37.99+\$37.99	\$75.98

BACKGROUND

Mr. Richard Sunday's assigned laptop was not working properly and used the laptop assigned to Sefe Garza. A request was submitted to I.T. Dept. to delete Mr. Garza and transfer to Mr. Sunday's data card. Data cards were finally approved on June 26, 2012 but were only for the months of June - December. Therefore, Data Card usage listed on invoices from January - May for both users are past due and will require approval by Commissioners' Court in order for Auditor's Office to issue payment.

Fiscal Impact

FISCAL YEAR: 2012

ACCT. #: 2-1100-419-40-220-001-0-532

FUNDS AVAILABLE Y/N?: Y

MATCHING FUNDS Y/N?: N

BUDGETARY IMPACT:

Funds available through PO#675859 in the amount of \$730.83 as of 7/18/12 for Verizon Wireless.

Attachments

backup

Form Review

Inbox	Reviewed By	Date
Budget & Management	Merlen P. Munoz	07/12/2012 08:17 AM
Roland Garcia	Rolando Garcia	07/12/2012 02:10 PM
Purchasing Department	Angela Garcia	07/20/2012 04:55 PM
Form Started By: Olga Garza		Started On: 07/11/2012 04:38 PM
	Final Approval Date: 07/20/2012	



FACILITIES MANAGEMENT County Of Hidalgo

To: Olga Garza, Budget Office
From: Daniel Flores, Facilities Mgmt
Date: July 11, 2012

We are requesting that the attached copies of Verizon Wireless invoices listing Data Card services for Mr. Sunday and Sefe Garza, be placed on the agenda as claims to be approved for payment.

Mr. Sunday's assigned lap top messed up and he starting using the one that was assigned to Sefe, we submitted the request to delete Sefe Garza and transfer to Mr. Sunday since he is the one now using Sefe's lap top / data card to I.T Dept. unfortunately for some reason Commissioner's Court took no action, finally on June 26, 2012 data card services were approved for Mr. Sunday, but were only for the months beginning June and ending in December.

Therefore, Data Card usage listed on invoices from January through May for Mr. Sunday and Sefe Garza, are past due and will require approval by Commissioner's Court in order for the Auditor's office to issue payment.

Below is a list of invoice numbers and fee's that are past due and pending payment.

1. Invoice number 6674206968 period 12-24—01-23-12 (Mr. Sunday \$37.99, Sefe Garza \$37.99)
2. Invoice number 6687149261 period 01-24---02-23-12 (Mr. Sunday \$37.99, Sefe Garza \$37.99)
3. Invoice number 6700033855 period 02-24---03-23-12 (Mr. Sunday \$37.99, Sefe Garza \$37.99)
4. Invoice number 6712965447 period 03-24---04-23-12 (Mr. Sunday \$37.99, Sefe Garza \$37.99)
5. Invoice number 6725865192 period 04-24---05-23-12 (Mr. Sunday \$37.99, Sefe Garza \$37.99)
6. Invoice number 6738752971 period 05-24---06-23-12 (Mr. Sunday \$37.99, Sefe Garza \$37.99)

Total \$ 455.88 (Account number 2-1100-419-40-220-0-532)

Thank you in advance for your attention and consideration to this matter if you require additional information, please contact me @956-289-7850



Summary for Sefe Garza: 956-929-0433

Your Plan

Mobile Broadband
 \$37.99 monthly access charge
 \$.25 per minute

Unlimited MB Allowance
 Unlimited monthly kilobyte

Have more questions about your charges?
 Get details for all your Usage Charges at
vzw.com/mybusinessaccount

Charges

Monthly Access Charges

Mobile Broadband 12/24 - 01/23 37.99
\$37.99

Usage Charges

Messaging	Allowance	Used	Billable	Cost
Text - Rcv'd	messages	--	1	.02
Total Messaging				\$0.02

Data

Kilobyte Usage	kilobytes	unlimited	285,073	--	--
Total Data				\$0.00	

Total Usage Charges **\$0.02**

Total Current Charges for 956-929-0433 **\$38.01**

37.99 PO 654949
 1-1100-419-40-220-001-0-532
 Hidalgo Co Norina Kabitia
 Yuma 12/23/11



①

Summary for Richard Sunday: 956-587-1610

Your Plan

Mobile Broadband

\$37.99 monthly access charge

\$.25 per minute

Unlimited MB Allowance

Unlimited monthly kilobyte

Charges

Monthly Access Charges

Mobile Broadband 12/24 - 01/23

37.99

\$37.99

Total Current Charges for 956-587-1610

\$37.99

Have more questions about your charges?
 Get details for all your Usage Charges at
vzw.com/mybusinessaccount.

\$ 37.99 PO 654 949
 1-1100-419-40-220-001-0-532

Address by **IVOKIMA KALITA**
 Home 12/23/11

[Handwritten signature]
[Handwritten signature]

Summary for Sefe Garza: 956-929-0433

Your Plan

Mobile Broadband

\$37.99 monthly access charge
\$.25 per minute

Unlimited MB Allowance

Unlimited monthly kilobyte

Have more questions about your charges?
Get details for all your Usage Charges at
vzw.com/mybusinessaccount.

Charges

Monthly Access Charges

Mobile Broadband 01/24 - 02/23 37.99
\$37.99

Usage Charges

Data	Allowance	Used	Billable	Cost
Kilobyte Usage	kilobytes unlimited	272,050	---	---
Total Data				\$.00

Total Usage Charges \$.00

Total Current Charges for 956-929-0433 \$37.99

#37.99 PO 654949

1-1100-419-40-220-001-0-832

GOOD SERVICES RECEIVED BY:

ALLISON NORMA KOURA

INVOICE RECEIVED BY:

Norma ON 3/1/12



Summary for Richard Sunday: 956-587-1610

Your Plan

Mobile Broadband

\$37.99 monthly access charge

\$.25 per minute

Unlimited MB Allowance

Unlimited monthly kilobyte

Charges

Monthly Access Charges

Mobile Broadband 01/24 - 02/23	37.99
	\$37.99

Total Current Charges for 956-587-1610	\$37.99
---	----------------

Have more questions about your charges?
Get details for all your Usage Charges at
vzw.com/mybusinessaccount.

#37.99 PO 654949
1-1100-419-40-220-007-0-
GOOD SERVICES RECEIVED BY 532
ADDY CA ON "NOVEMBER KAUF"
INVOICE RECEIVED BY:
Wong ON 3/1/12





Summary for Seferino Garza: 956-929-0433

Your Plan

Mobile Broadband
 \$37.99 monthly access charge
 \$.25 per minute

Unlimited MB Allowance
 Unlimited monthly kilobyte

Have more questions about your charges?
 Get details for all your Usage Charges at
vzw.com/mybusinessaccount.

Charges

Monthly Access Charges

Mobile Broadband 02/24 - 03/23 37.99
\$37.99

Usage Charges

Data	Allowance	Used	Billable	Cost
Kilobyte Usage <i>kilobytes</i>	unlimited	64,241	--	--
Total Data				\$.00
Total Usage Charges				\$.00
Total Current Charges for 956-929-0433				\$37.99

\$37.99 PO - 675859
2-1100-419-40-220-001-0-532
 GOOD SERVICES RECEIVED BY:
Hernandez ON *3/23/12*
 INVOICE RECEIVED BY:
Chavez ON *5-31-12*



Summary for Richard Sunday: 956-587-1610

Your Plan

Mobile Broadband

\$37.99 monthly access charge

\$.25 per minute

Unlimited MB Allowance

Unlimited monthly kilobyte

Charges

Monthly Access Charges

Mobile Broadband 02/24 - 03/23	37.99
--------------------------------	-------

\$37.99

Total Current Charges for 956-587-1610

\$37.99

Have more questions about your charges?
Get details for all your Usage Charges at
vzw.com/mybusinessaccount.

Summary for Seferino Garza: 956-929-0433

Your Plan

Mobile Broadband
 \$37.99 monthly access charge
 \$.25 per minute

Unlimited MB Allowance
 Unlimited monthly kilobyte

Have more questions about your charges?
 Get details for all your Usage Charges at
vzw.com/mybusinessaccount.

Charges

Monthly Access Charges

Mobile Broadband 03/24 - 04/23	37.99
	\$37.99

Usage Charges

Data	Allowance	Used	Billable	Cost
Kilobyte Usage <i>kilobytes</i>	unlimited	36,643	--	--
Total Data				\$.00
Total Usage Charges				\$.00
Total Current Charges for 956-929-0433				\$37.99

Summary for Richard Sunday: 956-587-1610

Your Plan

Mobile Broadband

\$37.99 monthly access charge

\$.25 per minute

Unlimited MB Allowance

Unlimited monthly kilobyte

Charges

Monthly Access Charges

Mobile Broadband 03/24 - 04/23 37.99

\$37.99

Total Current Charges for 956-587-1610

\$37.99

Have more questions about your charges?
Get details for all your Usage Charges at
vzw.com/mybusinessaccount.

Summary for Seferino Garza: 956-929-0433

Your Plan

Mobile Broadband

\$37.99 monthly access charge
 \$.25 per minute

Unlimited MB Allowance

Unlimited monthly kilobyte

Have more questions about your charges?
 Get details for all your Usage Charges at
vzw.com/mybusinessaccount.

Charges

Monthly Access Charges

Mobile Broadband 04/24 - 05/23 37.99
\$37.99

Usage Charges

Data	Allowance	Used	Billable	Cost
Kilobyte Usage <i>kilobytes</i>	unlimited	4587	--	--
Total Data				\$.00
Total Usage Charges				\$.00
Total Current Charges for 956-929-0433				\$37.99

\$37.99 PO - 675859
2-1100-419-40-220-001-0-832
 GOOD SERVICES RECEIVED BY:
WORMSKOWITZ ON *5/23/12*
 INVOICE RECEIVED BY:
WORMSKOWITZ ON *5/31/12*

Summary for Richard Sunday: 956-587-1610

Your Plan

Mobile Broadband

\$37.99 monthly access charge
\$.25 per minute

Unlimited MB Allowance

Unlimited monthly kilobyte

Charges

Monthly Access Charges

Mobile Broadband 04/24 - 05/23 37.99
\$37.99

Total Current Charges for 956-587-1610 \$37.99

Have more questions about your charges?
Get details for all your Usage Charges at
vzw.com/mybusinessaccount.

#37.99 PO- 675859

2-1100-419-40-220-001-0-532

GOOD SERVICES RECEIVED BY:

Richard Sunday 5/23/12

INVOICE RECEIVED BY:

Richard Sunday ON 5/30/12

Summary for Seferino Garza: 956-929-0433

Your Plan

Mobile Broadband

\$37.99 monthly access charge
 \$.25 per minute

Unlimited MB Allowance

Unlimited monthly kilobyte

Have more questions about your charges?
 Get details for all your Usage Charges at
vzw.com/mybusinessaccount.

Charges

Monthly Access Charges

Mobile Broadband 05/24 - 06/23 37.99
\$37.99

Usage Charges

Data	Allowance	Used	Billable	Cost
Kilobyte Usage	<i>kilobytes</i> unlimited	65,465	--	--
Total Data				\$.00
Total Usage Charges				\$.00
Total Current Charges for 956-929-0433				\$37.99

#37.99 PO 075859
 2-1100-419-40-220-001-0532
 GOOD SERVICES RECEIVED BY:
Wernke ON 5/25/12
 INVOICE RECEIVED BY:
Wernke ON 6/28/12



Summary for Richard Sunday: 956-587-1610

Your Plan

Mobile Broadband

\$37.99 monthly access charge
\$.25 per minute

Unlimited MB Allowance

Unlimited monthly kilobyte

Charges

Monthly Access Charges

Mobile Broadband 05/24 - 06/23 37.99
\$37.99

Total Current Charges for 956-587-1610 \$37.99

Have more questions about your charges?
Get details for all your Usage Charges at
vzw.com/mybusinessaccount.

#37.99 PO-675859
2-1100-419-40-220-001-0-532
GOOD SERVICES RECEIVED BY:
Wema ON *5/23/12*
INVOICE RECEIVED BY:
Wema ON *6/28/12*

AI-33166

Urban County 11. A.

CC REGULAR

Meeting Date: 07/24/2012

Department Head: Carlos Jasso

Submitted By: Mary Flores, URBAN COUNTY

Department: URBAN COUNTY

Information

CAPTION

1. Approval of a resolution for designation of authorized bonded signatories for the Texas General Land Office (GLO) formally known as "TDRA", Texas Community Development Block Grant Funds (TxCDBG) for the following grant:

- a. 2012 Texas General Land Office GLO#12-406-000-6453/ DRS210068
- 2. Authorize Hidalgo County Judge to sign any and all documents regarding Round 2.1 funds.

BACKGROUND

This Resolution is required by the Texas General Land Office for the funding authorized for Hidalgo County

Round 2.1 grant. The Resolution designates certain authorized bonded signatories for the DRS\GLO Grant-The Texas General Land Office-Texas Community Development Block Grant Program.

Attachments

Grant Agreement

Resolution

Back up

Form Review

Inbox	Reviewed By	Date
Budget & Management	Merlen P. Munoz	07/09/2012 04:54 PM
Purchasing Department	Angela Garcia	07/20/2012 04:55 PM
Form Started By: Mary Flores		Started On: 07/09/2012 04:31 PM
	Final Approval Date: 07/20/2012	



PURCHASE REQUISITION

Texas General Land Office

Do not place an Order. The Purchasing Department MUST place this order in compliance with State Laws and Regulations

REQUISITION NUMBER 305 - 12-2190
SEND TO LEGAL SERVICES? YES NO
EXISTING CONTRACT NUMBER DRS210068 12-406-000-6453

Program/Division Disaster Recovery
Contact for further Information Maria Castañón
Phone Number 512-861-4939
Date Prepared February 23, 2012

Project Title or Purpose for this Requisition Round 2.1 Award for the CDBG DR Program. (Non-Housing) Total Grant = \$20,942,306. (Entitlement)

Request a NEW CONTRACT Deadline - DATE: for Contract or Amendment, if any. (Must include Deputy Memo)
Request an AMENDMENT to an existing contract due to:

FUNDING SOURCES (State or Federal / types - NOAA / MMS, etc.): HUD

Vendor I.D. 74-6000717
Vendor Name County of Hidalgo
Address 1615 South Closser, Suite J
City/State Edinburg, TX Zip 78539
DT/PCC Fund Approp. Compt. Obj. GLO Code PCA Amount
9 1111 13046 7612 480 21638 20,942,306

Table with 7 columns: ITEM, CLASS - ITEM/COMMODITY CODE, DESCRIPTION OF PRODUCT/SERVICE, QUANTITY, UOM, UNIT PRICE, EXTENDED PRICE. Row 1: CDBG Disaster Recovery Grant Program, \$0.00

ADDITIONAL PAGE TOTAL:
CONTRACT DATES: FROM: D.O.E. TO: 12/31/2015
GRAND TOTAL: 20,942,306

DIRECTOR DATE 3/5/12
DEPUTY DATE 3/15/12
IS TECHNOLOGY/COMPUTER RELATED DATE
RIO - PUBLICATIONS RELATED DATE 4/12/12
BUDGET-FUNDS AVAILABLE DATE 3/14/12
CHIEF CLERK - \$3,000 AND OVER DATE

PURCHASING USE ONLY
HUB VENDOR: RECYCLED PRODUCT POSTED ON ESBID VCID DATE TO LEGAL
Purch. Type: ELC
Processed By: DF
Order/Begin Date:
Due/End Date:
MIP Entry:

- EXEMPTION STATUTE/DESCRIPTIVE LEGAL TEXT
BOND FUND (use of funds to pay expenses related to the Land)-TX. Nat. Res. Code, Title 7, Chapter 161, Subchapter A, Section 161.175
BOND FUND (use of funds to pay bond expenses)-TX. Nat. Res. Code, Title 7, Chapter 161, Subchapter A, Section 161.176
BOND FUND (for printing)-TX. Nat. Res. Code, Chapter 161, Subchapter A, Section 161.176(3)
CEPRA-TX. Natural Resource Code, Chapter 33, Subchapter H
CEPRA-TX. Natural Resource Code, Chapter 33, Subchapter H/TX. Gov. Code, Title 10, Chapter 2155, Subchapter 2155.147
CONSULTING SERVICES-TX. Gov. Code, Title 10, Subtitle F, Sec. Ref. 2155.001, Chapter 2254, Subchapter B, Sec. 2254.021
GRANTS-TX. Gov. Code, Title 10, Subtitle D, Section 2155.140
INTERAGENCY CONTRACT-TX. Gov. Code, Title 7, Chapter 771
INTERLOCAL CONTRACT-TX. Gov. Code, Title 7, Chapter 791
MAIL SERVICES - TX. Gov. Code, Title 10, Subtitle D, Chapter 2162.105
OSPRA-TX. Nat. Res. Code, Chapter 40
OUTSIDE COUNSEL-TX. Gov. Code 2254.024
OTHER -
PERMANENT SCHOOL FUND INVESTMENTS-TX. Nat. Res. Code 51.402
POSTAGE-General Appropriations Act. 74th Leg. Session, Sec. 9, HB 1, Sec. 33 (Purchase of Postage)
PROFESSIONAL SERVICES-TX. Gov. Code, Title 10, Subtitle F, Sec. Ref. 2155.001, Chapter 2254, Subchapter A, Sec. 2254.001
PURCHASE OF LAND-TX. Nat. Res. Code, Section 51.402
REAL ESTATE TRANSACTION-TX. Nat. Resource Code, Ann 31.158(d)
TELEPHONE/UTILITIES-TX. Gov. Code, Chapter 2155 - Ref. 2155.01(d)
TRAINING-TX. Gov. Code, Title 6, Subtitle B, Section 656.044
VET HOMES-TX. Nat. Res. Code, Chapter 164 (Senate Bill)

LEGAL: 3-15-12 2:15 PM

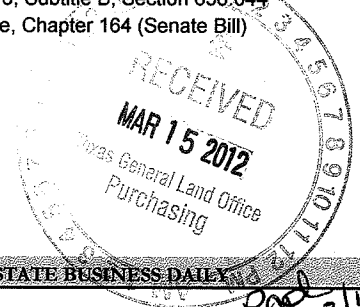

Rec'd 3/13/12 gsk



GRANT AGREEMENT
GLO CONTRACT NO. 12-406-000-6453
COMMUNITY DEVELOPMENT BLOCK GRANT – ROUND 2.1 FUNDING
DISASTER RECOVERY PROGRAM

This Community Development Block Grant Disaster Recovery (“CDBG-DR”) grant agreement (the “Contract”) is entered into by and between the **GENERAL LAND OFFICE** (“the GLO”), a Texas state agency, and the **COUNTY OF HIDALGO** (“Grantee”), hereinafter referred to collectively as “the Parties,” to provide financial assistance with funds appropriated by the Consolidated Security, Disaster Assistance, and Continuing Appropriation Act (Public Law 110-329) enacted on September 30, 2008, to facilitate disaster recovery, restoration, economic revitalization, and to affirmatively further fair housing, in accordance with Executive Order 12892, in areas affected by Hurricanes Dolly and Ike, which are Presidentially-declared major disaster areas under Title IV of the Robert T. Stafford Disaster Relief and Emergency Assistance Act (42 U.S.C. 5121 *et seq.*).

ARTICLE 1 - GENERAL PROVISIONS

1.01 SCOPE OF PROJECT AND GRANT AWARD

(a) Scope of Project

The purpose of this Contract is to set forth the terms and conditions of a Grant from the GLO to Grantee under the CDBG Disaster Recovery program (“CDBG-DR”). In strict conformance with the terms and conditions of this Contract, Grantee shall construct, or cause to be constructed, improvements to flood and drainage facilities and components, including any acquisitions, engineering and planning required, in the County of Hidalgo, Texas (the “Project”). The Project shall be conducted in strict accordance with the terms of this Contract, including all Contract Documents in **SECTION 1.02**, below.

(b) Grant Award

Grantee submitted a Grant Application for grant under the Program, and the GLO is entering into this Contract based on Grantee’s Application.

Subject to the terms and conditions of this Contract and Grantee’s Application, the GLO agrees to make a grant to Grantee in an amount not to exceed **TWENTY MILLION NINE HUNDRED FORTY-TWO THOUSAND THREE HUNDRED SIX DOLLARS (\$20,942,306.00)**, payable as reimbursement of allowable expenses incurred by Grantee, to be used in strict conformance with the terms of this Contract, and the Project Budget in **Attachment B**.

The GLO is not liable to Grantee for any costs incurred by Grantee before the effective date of this Contract or after the expiration or termination of this Contract.

However, the GLO in its sole discretion, may reimburse Grantee for allowable program costs incurred prior to the effective date of this Contract.

1.02 CONTRACT DOCUMENTS

The GLO and Grantee hereby agree that this document and the following Attachments, attached hereto and incorporated herein in their entirety for all purposes, shall govern this Contract:

- ATTACHMENT A:** Performance Statement and Implementation Schedule
- ATTACHMENT B:** Project Budget
- ATTACHMENT C:** Nonexclusive list of Applicable Laws, Rules, and Regulations
- ATTACHMENT D:** General Affirmations
- ATTACHMENT E:** Federal Assurances – Non-Construction Programs SF-424B (Rev. 7-97)
- ATTACHMENT F:** Certifications Regarding Lobbying Lower Tier Covered Transactions (Form CD-512, Rev. 12-04)
- ATTACHMENT G:** Special Conditions

1.03 GUIDANCE DOCUMENTS

Grantee shall be deemed to have read and understood and agrees to abide by all guidance documents applicable to the CDBG-DR program including but not limited to:

the CDBG-DR Project Implementation Manual found at:

<http://www.glo.texas.gov/GLO/disaster-recovery/nonhousing/forms-publications.html>;

the State of Texas Action Plan for Disaster Recovery found at;

<http://www.glo.texas.gov/GLO/disaster-recovery/action-plans.html>;

and the Conciliation Agreement between: the Texas Low Income Housing Information Service and Texas Appleseed, and the State of Texas, by and through the Texas Department of Rural Affairs and the Texas Department of Housing and Community Affairs, as approved by HUD in its letter dated May 25, 2010, to the Office of the Attorney General of Texas.

1.04 DEFINITIONS

“Act” means Title I of the Housing and Community Development Act of 1974, as amended (42 U.S.C. Sec. 5301 *et seq.*); and Public Law 110-329.

“Administrative and Audit Regulations” means the regulations included in Title 24, CFR, Part 85.

“Application” or “Grant Application” means the information provided by Grantee, which is the basis for the award of funding under this Contract.

“Budget” means the budget for the Project funded by the Contract, a copy of which is included in **Attachment B**.

“CDBG-DR” means the U.S. Department of Housing and Urban Development’s Community Development Block Grant Disaster Recovery program.

“Construction Documents” means the engineering specifications, construction plans, and/or architectural plans for the construction of improvements approved by the GLO under the Contract, if any.

“Contract Documents” means the documents listed in **SECTION 1.02**.

“C.F.R.” means the United States Code of Federal Regulations.

“Deliverable(s)” means the work product(s) required to be submitted to the GLO as set forth in the Project Implementation Manual, including all reports and other project documentation.

“Equipment” means tangible personal property have a useful life of more than one (1) year and an acquisition cost of Five Thousand Dollars (\$5,000.00) or more per unit.

“Event of Default” means the occurrence of any of the events set forth in **SECTION 3.03** herein.

“Federal Assurances” means Standard Form 424B (Rev. 7-97), as prescribed by OMB Circular A-102 (non-construction programs) in **Attachment E**.

“Federal Certifications” means U.S. Department of Commerce Form CD-512 (Rev 12-04), “Certifications Regarding Lobbying - Lower Tier Covered Transactions,” and Standard Form LLL (Rev. 7-97), Disclosure of Lobbying Activities, in **Attachment F**.

“GAAP” means “generally accepted accounting principles” as applicable.

“GASB” means accounting principals as defined by the Governmental Accounting Standards Board, as applicable.

“General Affirmations” means the affirmations in **Attachment D**, to which Grantee certifies by the signing of this Contract.

“Grant Administration Form” means one of several forms required to be submitted during the term of this Contract, which forms may be revised from time to time. The most current version of these forms should be downloaded, as needed, at <http://www.glo.texas.gov/GLO/disaster-recovery>.

“HUB” means Historically Underutilized Business as defined by Chapter 2161 of the Texas Government Code.

“HUD” means the United States Department of Housing and Urban Development.

“Implementation Schedule” means the schedule by which various project milestones must be met by Grantee, and is attached hereto as part of **Attachment A**.

“Letter of Acceptance” means a document to be executed by Grantee, Engineer, and Grantee’s construction contractor, for each construction project, indicating: (i) acceptance, (ii) substantial completion as built, and (iii) commencement of the warranty period, as discussed in **SECTION 4.01** hereof.

“Performance Statement” means the statement of work contained in **Attachment A**.

“PMC” means the GLO’s Project Management Company, HNTB Corporation.

“Program” means the Community Development Block Grant Disaster Recovery program.

“Project” means the work to be performed under this Contract, as described in **SECTION 1.01(a)** above, **SCOPE OF PROJECT**, and as detailed in **Attachment A**.

“Project Completion Report” means a report containing an “as built” accounting of all projects completed under a CDBG-DR grant, and containing all information required to completely close out a grant file.

“Project Implementation Manual” means a set of guidelines by which a CDBG-DR grant program must be operated.

“Public Information Act” means Chapter 552 of the Texas Government Code.

“Quarterly Reports” means a document detailing the status of the Project under the Contract, to be submitted to the GLO as a condition of reimbursement, as discussed in **SECTION 4.01(a)**.

“Regulations” means 24 C.F.R. Part 570.

“U.S.C.” means the United States Code.

1.05 INTERPRETIVE PROVISIONS

- (a) The meanings of defined terms are equally applicable to the singular and plural forms of the defined terms;
- (b) The words “hereof,” “herein,” “hereunder,” and similar words refer to this Contract as a whole and not to any particular provision, section, attachment, work order, or schedule of this Contract, unless otherwise specified;
- (c) The term “including” is not limiting, and means “including without limitation” and, unless otherwise expressly provided in this Contract,
- (d) references to contracts (including this Contract) and other contractual instruments shall be deemed to include all subsequent amendments and other modifications thereto, but only to the extent that such amendments and other modifications are not prohibited by the terms of this Contract, and
- (e) references to any statute or regulation are to be construed as including all statutory and regulatory provisions consolidating, amending, replacing, supplementing, or interpreting the statute or regulation;
- (d) The captions and headings of this Contract are for convenience of reference only and shall not affect the interpretation of this Contract;
- (e) All attachments within this Contract, including those incorporated by reference, and any amendments, are considered part of the terms of this Contract;
- (f) This Contract may use several different limitations, regulations, or policies to regulate the same or similar matters. All such limitations, regulations, and policies are cumulative and each shall be performed in accordance with its terms;
- (g) Unless otherwise expressly provided, reference to any action of the GLO or by the GLO by way of consent, approval, or waiver shall be deemed modified by the phrase “in the sole discretion of the GLO.”

Notwithstanding the preceding sentence, any approval, consent, or waiver required by, or requested of, the GLO shall not be unreasonably withheld or delayed;

- (h) All due dates and/or deadlines referenced in this Contract that occur on a weekend or holiday shall be considered as if occurring on the next business day;
- (i) All time periods in this Contract shall commence on the day after the date on which the applicable event occurred, report is submitted, or request is received; and
- (j) Time is of the essence in this Contract.

REMAINDER OF PAGE INTENTIONALLY LEFT BLANK

**ARTICLE 2 – REIMBURSEMENT, ADVANCE PAYMENT,
BUDGET VARIANCE, AND INCOME**

2.01 REIMBURSEMENT REQUESTS

Grantee may request reimbursement from the GLO no more often than monthly. Each invoice shall be supported by actual receipts, cancelled checks, and/or such other documentation that, in the judgment of the GLO, allows for full substantiation of the costs incurred. Requests for payment must be submitted in Word or WordPerfect format via email to the GLO monthly, on or before the 10th day of each calendar month.

2.02 REQUESTS FOR REIMBURSEMENT UNDER THIS CONTRACT MUST BE RECEIVED BY THE GLO NOT LATER THAN SIXTY (60) DAYS FROM THE DATE GRANTEE INCURS THE EXPENSE. NOTWITHSTANDING THE PRECEDING, REQUESTS FOR REIMBURSEMENT FOR EXPENSES INCURRED BY ANY SUBCONTRACTOR MUST BE RECEIVED BY THE GLO NOT LATER THAN THIRTY (30) DAYS FROM THE DATE THE GRANTEE RECEIVES THAT INVOICE FROM A SUBCONTRACTOR. FAILURE BY GRANTEE TO COMPLY IN A TIMELY MANNER WITH THESE TWO REQUIREMENTS MAY, AT THE GLO'S SOLE DISCRETION, RESULT IN DENIAL OF THE REQUEST FOR REIMBURSEMENT.

2.03 ADVANCE PAYMENTS

If necessary and if allowed by law, Grantee's requests for an advance of funds shall be limited to the minimum amount needed for effective accomplishment of the Project under this Contract, and shall be timed as closely as possible to actual cash requirements. Grantee shall establish procedures to minimize the time elapsing between the transfer of funds from the GLO to Grantee, and shall ensure that such funds are disbursed as soon as administratively possible.

2.04 BUDGET VARIANCE

Grantee may request permission to reallocate funding among budget categories by submitting a written request and detailed justification to the GLO. The GLO may allow flexibility among Budget categories to the extent that the total revisions do not exceed ten percent (10%) of the total budget. Such reallocations may not increase the amount of the grant or total Budget, and shall be effective only after written approval by the GLO. Any request for a variance that (a) exceeds ten percent (10%) of the total budget; (b) changes the total budget amount; (c) changes the Project scope; or (d) changes the Project outcome may be allowed only by formal, written Contract amendment. In addition, aggregate requests for variances which, over time, exceed twenty-five percent (25%) of the total budgeted amount, may be allowed only by formal, written Contract amendment.

REMAINDER OF PAGE INTENTIONALLY LEFT BLANK

A FINAL, ACTUAL BUDGET SHALL BE SUBMITTED BY GRANTEE NO LATER THAN SIXTY (60) DAYS FOLLOWING THE EXPIRATION OR TERMINATION OF THIS CONTRACT.

IN ADDITION, GRANTEE SHALL SUBMIT A CERTIFICATE OF EXPENDITURES TO THE GLO NO LATER THAN SIXTY (60) DAYS AFTER THE CONTRACT TERMINATION DATE OR AT THE CONCLUSION OF ALL CONTRACT ACTIVITIES AS DETERMINED BY THE GLO. THE CERTIFICATE OF EXPENDITURES SHALL BE IN A FORMAT PRESCRIBED BY THE GLO AND SHALL BE ACCOMPANIED BY A FINAL PROJECT COMPLETION REPORT OF ALL ACTIVITIES PERFORMED UNDER THIS CONTRACT.

2.05 INCOME

Grantee shall maintain records of the receipt and accrual of all Program income in the same manner as required for all other funds under this Contract, and Grantee shall provide reports of Program income to the GLO with each form submitted by Grantee in accordance with ARTICLE 4 of this Contract. All Program income must be returned to the GLO on at least a quarterly basis and must be reported to the GLO, as requested.

2.06 GRANT OFFER SUBJECT TO CANCELLATION

IF GRANTEE DOES NOT RETURN THE ORIGINAL SIGNED CONTRACT TO THE GLO WITHIN THIRTY (30) DAYS OF TRANSMITTAL OF THE CONTRACT TO GRANTEE, GRANT FUNDING FOR THE PROJECT MAY BE SUBJECT TO CANCELLATION.

REMAINDER OF PAGE INTENTIONALLY LEFT BLANK

ARTICLE 3 -- CONTRACT PERIOD, TERMINATION, AND DEFAULT

3.01 DURATION OF CONTRACT AND EXTENSION OF TERM

This Contract shall become effective on the date signed by the last party, and shall terminate on December 31, 2015 ("Contract Period"). **Notwithstanding the preceding sentence, Grantee must adhere to all Project milestones in Attachment A; failure to meet any milestone may result in termination under SECTION 3.02, below.**

Upon receipt of a written request and acceptable justification from Grantee, the GLO may amend this Contract to extend the Contract Period. **ANY REQUEST FOR EXTENSION MUST BE RECEIVED BY THE GLO AT LEAST NINETY (90) DAYS BEFORE THE ORIGINAL TERMINATION DATE OF THIS CONTRACT AND, IF APPROVED, SUCH EXTENSION SHALL BE BY WRITTEN AMENDMENT.**

3.02 EARLY TERMINATION

The GLO may terminate this Contract by giving written notice specifying a termination date at least thirty (30) days subsequent to the date of the notice. Upon receipt of such notice, Grantee shall cease work, undertake to terminate any relevant subcontracts, and incur no further expense related to this Contract. Such early termination shall be subject to the equitable settlement of the respective interests of the parties, accrued up to the date of termination.

3.03 EVENTS OF DEFAULT

Each of the following events shall constitute an Event of Default under this Contract: (i) Grantee's failure to comply with any term, covenant, or provision contained in this Contract; (ii) Grantee makes a general assignment for the benefit of creditors or takes any similar action for the protection or benefit of creditors; or (iii) if at any time, Grantee makes any representation or warranty that is incorrect in any material respect to the Performance Statement, any request for payment submitted to the GLO, or any report submitted to the GLO related to the Contract.

3.04 REMEDIES; NO WAIVER

Upon the occurrence of any such Event of Default, the GLO shall be entitled to avail itself of any equitable or legal remedy. A right or remedy conferred by this Contract upon either party is not intended to be exclusive of any other right or remedy, and each and every right and remedy shall be cumulative and in addition to any other right or remedy given under this Contract, or hereafter legally existing, upon the occurrence of an Event of Default. The failure of the GLO either to insist at any time upon the strict observance or performance of any of the provisions of this Contract, or the GLO's failure to exercise any right or remedy as provided in this Contract, shall not impair any such right or remedy or be construed as a waiver or relinquishment thereof with respect to subsequent Events of Default.

REMAINDER OF PAGE INTENTIONALLY LEFT BLANK

ARTICLE 4 - GRANT ADMINISTRATION

4.01 SUBMISSIONS - GENERALLY

Except for legal notices that must be sent by specific instructions pursuant to **SECTION 8.11** of the Contract, **NOTICES**; and all other reports and documentation as required by the Project Implementation Manual; any report, form, or request required to be submitted to the GLO under this Contract shall be sent in the format prescribed by the GLO.

In addition, Grantee acknowledges the responsibility to submit to the GLO, Engineer, and Grant Administrator, if any, all signed Letters of Acceptance (LOA), within two (2) weeks of execution by Grantee. Failure to timely submit the LOA pursuant to this paragraph may result in the withholding of the final payment under this Contract.

(a) Quarterly Reports

Accurate, timely Quarterly Reports are required as a condition of reimbursement. Each Quarterly Report shall include progress made since the prior reporting period, projected quantities if any variances are anticipated, problems encountered and detailed plans to correct them, goals to be accomplished in the subsequent reporting period, and any other information that may be required by the GLO. In the sole discretion of the GLO, reports may be requested more often than quarterly, and the Grantee shall provide such additional information to the GLO in a timely manner.

The GLO may review Quarterly Report(s) and may request revisions to be made. Grantee shall coordinate with the GLO to make such revisions in a timely manner. Reimbursement may be withheld, in the sole discretion of the GLO, if a Quarterly Report is delinquent or deficient.

(b) Project Completion Report

The Project Completion Report ("PCR"), as defined above, must be submitted to the GLO by the close of business no later than sixty (60) days from Grantee's execution of the final Certificate of Construction Completion ("COCC"). The PCR must be submitted in accordance with the specifications in the Project Implementation Manual, and must include a full description of all projects, both as originally assigned and as ultimately completed, including any revisions approved by the GLO outside the formal, written amendment process, as provided under **SECTION 8.17** hereof.

(c) Forms

Grantee must execute the forms included as **Attachments E and F**, and certifies by the execution of this Contract to all affirmations in **Attachment D**, confirming compliance with required state and federal laws applicable to the Contract.

- (i) General Affirmations are found in **Attachment D**, and Grantee certifies by the execution of this Contract to all statements therein.

- (ii) The Federal Assurances for Non-Construction Programs (Standard Form 424B), as applicable to the Project, is found in **Attachment E**, and must be executed by Grantee.
- (iii) Certifications Regarding Lobbying Lower Tier covered Transactions (Form CD-512) is found at Page 1 of **Attachment F**, and must be executed by Grantee.
- (iv) If any funds granted under this Contract have been used for lobbying purposes, Grantee must complete and execute Standard Form LLL, Disclosure of Lobbying Activities, found at Page 2 of **Attachment F**.

REMAINDER OF PAGE INTENTIONALLY LEFT BLANK

**ARTICLE 5 - STATE AND FEDERAL FUNDING
AND RECAPTURE OF FUNDS**

5.01 FEDERAL FUNDING

Funding for this Contract is appropriated under the Consolidated Security, Disaster Assistance, and Continuing Appropriation Act (Public Law 110-329) enacted on September 30, 2008, to facilitate disaster recovery, restoration, economic revitalization, and to affirmatively further fair housing in accordance with Executive Order 12892, in areas affected by Hurricanes Dolly and Ike, which are Presidentially-declared major disaster areas under Title IV of the Robert T. Stafford Disaster Relief and Emergency Assistance Act (42 U.S.C. 5121 et seq.). The fulfillment of this Contract is based on those funds being made available to the GLO as the lead administrative state agency. **ALL EXPENDITURES UNDER THIS CONTRACT MUST BE MADE IN ACCORDANCE WITH THIS CONTRACT, THE RULES AND REGULATIONS PROMULGATED UNDER THE CDBG-DR PROGRAM, AND ANY OTHER APPLICABLE LAWS. FURTHER, GRANTEE ACKNOWLEDGES THAT ALL FUNDS ARE SUBJECT TO RECAPTURE AND REPAYMENT FOR NON-COMPLIANCE.**

5.02 STATE FUNDING

This Contract shall not be construed as creating any debt on behalf of the State of Texas and/or the GLO in violation of Texas Constitution, Article III, Section 49. In compliance with Texas Constitution, Article VIII, Section 6, it is understood that all obligations of the GLO hereunder are subject to the availability of state funds. If such funds are not appropriated or become unavailable, this Contract may be terminated. In that event, the parties shall be discharged from further obligations, subject to the equitable settlement of their respective interests, accrued up to the date of termination.

5.03 RECAPTURE OF FUNDS

Grantee shall conduct, in a satisfactory manner as determined by the GLO, the Project, as set forth in the Contract. The discretionary right of the GLO to terminate for convenience under this Article; notwithstanding, it is expressly understood and agreed by Grantee that the GLO shall have the right to terminate the Contract and recapture, and be reimbursed for, any payments made by the GLO that Grantee has not used in strict accordance with the terms and conditions of this Contract.

5.04 RETAINAGE

To ensure full performance, the GLO may retain an amount equal to five percent (5%) of Grantee's grant amount until completion and acceptance by the GLO of the Project. The GLO shall make a final disbursement only upon receipt of documentation sufficient to determine that Grantee has completed the Project in accordance with the Contract Documents, and that all requirements of the Contract; all relevant provisions of the Grant; and all applicable law, rules, and regulations have been fulfilled by Grantee.

5.05 OVERPAYMENT

Grantee understands and agrees that it shall be liable to the GLO for any costs disallowed pursuant to financial and compliance audit(s) of funds received under this Contract. Grantee further understands and agrees that reimbursement of such disallowed costs shall be paid by Grantee from funds which were not provided or otherwise made available to Grantee under this Contract.

REMAINDER OF PAGE INTENTIONALLY LEFT BLANK

ARTICLE 6 - INTELLECTUAL PROPERTY

6.01 OWNERSHIP AND USE

- (a) The parties to this Contract expressly agree that all right, title, and interest in, and to, all reports, drafts of reports, or other material, data, drawings, computer programs and codes associated with this Contract, and/or any copyright or other intellectual property rights, and any material or information developed and/or required to be delivered under this Contract shall be jointly owned by the parties with each party having the right to use, reproduce, or publish any or all of such information and other materials without the necessity of obtaining permission from the other party and without expense or charge.
- (b) The GLO and HUD are granted a royalty free, non-exclusive, and irrevocable license to reproduce, publish, or otherwise use, and to authorize others to use, for U.S. Government purposes, all reports, drafts of reports, or other material, data, drawings, computer programs, and codes associated with this Contract, and/or any copyright or other intellectual property rights, and any material or information developed and/or required to be delivered under this Contract.

6.02 NONENDORSEMENT BY STATE AND THE UNITED STATES

Grantee shall not publicize or otherwise circulate promotional material (such as advertisements, sales brochures, press releases, speeches, still and motion pictures, articles, manuscripts, or other publications) that states or implies State of Texas or U.S. Government, or government employee, endorsement of a product, service, or position that the Grantee represents. No release of information relating to this Grant may state or imply that the State of Texas or the U.S. Government approves of Grantee's work products, or considers Grantee's work product to be superior to other products or services.

6.03 APPROVAL OF PUBLICATION AND SPECIFIC DISCLAIMER REQUIRED

Prior to publication, Grantee must submit to the GLO, for HUD approval, any public information releases concerning this Grant Award that refer to HUD or any bureau or employee. The specific text, layout photographs, and so forth, of the proposed release must be submitted with the request for approval. The specific acknowledgements and funding statements that must be included in certain publications funded by the Grantee are set forth in the Contract Documents.

REMAINDER OF PAGE INTENTIONALLY LEFT BLANK

**ARTICLE 7 - RECORDS, AUDIT, PROPRIETARY INFORMATION,
AND PUBLIC DISCLOSURE**

7.01 BOOKS AND RECORDS

Grantee shall keep and maintain under GAAP or GASB, as applicable, full, true, and complete records necessary to fully disclose to the GLO, the Texas State Auditor's Office, the United States Government, and/or their authorized representatives, sufficient information to determine compliance with the terms and conditions of this Contract and all state and federal rules, regulations, and statutes including, but not limited to, the applicable laws and regulations provided in **Attachment C**.

7.02 INSPECTION AND AUDIT

Grantee agrees that all relevant records related to this Contract or any work product produced, including those of its subcontractors, shall be subject at any reasonable time to inspection, examination, review, audit, and copying at any location where such records may be found, with or without notice by the Texas State Auditor's Office, the GLO, its contracted examiners, or the Texas Attorney General's Office. In addition, HUD, the Comptroller General, the General Accounting Office, the Office of Inspector General, or any authorized representative of the U.S Government shall also have this right of inspection.

The GLO reserves the right to perform periodic on-site monitoring of Grantee's compliance with the terms and conditions of this Contract, assurance of non-duplication of beneficiaries and of the adequacy and timeliness of Grantee's performances under this Contract. After each monitoring visit, the GLO shall provide Grantee with a written report of the findings. If the monitoring report notes deficiencies in Grantee's performances under the terms of this Contract, the monitoring report shall include requirements for the timely correction of such deficiencies by Grantee. Failure by Grantee to take action specified in the monitoring report may be cause for suspension or termination of this Contract.

Grantee understands that acceptance of funds under this Contract acts as acceptance of the authority of the State Auditor's Office, or any successor agency, to conduct an audit or investigation in connection with those funds. Grantee further agrees to cooperate fully with the State Auditor's Office or its successor in the conduct of the audit or investigation, including providing all records requested. **GRANTEE SHALL ENSURE THAT ALL SUBCONTRACTS AWARDED REFLECT THE REQUIREMENTS OF THIS SECTION 7.02, AND THE REQUIREMENT TO COOPERATE.**

Grantee will be deemed to have read and have knowledge of all applicable federal, state, and local laws, regulations, and rules, including, but not limited to those identified in **Attachment C**, governing audit requirements pertaining to the Project.

7.03 GRANTEE SELF-AUDIT AND TARGETED AUDITS

(a) Grantee Self-Audit

Grantee, on approval of the GLO and/or HUD may conduct an annual financial and compliance audit of funds received and performances rendered under this Contract. Grantee may utilize funds budgeted under this Contract to pay for that

portion of the cost of such audit services properly allocable to the activities funded by the GLO under this Contract, provided however that the GLO shall not make payment for the cost of such audit services until the GLO has received from Grantee a satisfactory audit report and invoice, as determined by the GLO. The invoice submitted for reimbursement should clearly show the percentage of cost relative to the total cost of the audit services. Therefore, Grantee shall submit an invoice showing the total cost of the audit and the corresponding prorated charge per funding source. If applicable, an explanation shall be submitted with the reimbursement request, explaining why the percentage of audit fees exceeds the prorated amount allowable.

(b) Targeted Audits

In addition, the GLO shall have the right at any time to perform, or to instruct the performance of, an annual program and/or fiscal audit, or to conduct a special or targeted audit of any aspect of the operation of Grantee, using an auditor of the GLO's choice. Grantee shall maintain such financial records and other records as may be prescribed by the GLO or by applicable federal and state laws, rules, and regulations. Grantee shall retain these records for a period of five (5) years after final payment or until they are audited by the GLO, whichever event occurs first. These records shall be made available during the term of this Contract and the subsequent five (5) year period for examination, transcription, and audit.

7.04 PERIOD OF RETENTION

Grantee shall retain all records relevant to this Contract for a minimum of five (5) years. The period of retention begins at the date of final payment by the GLO of reimbursable expenses, or from the date of termination of the Contract, whichever is later. The period of retention shall be extended for a period reasonably necessary to complete an audit and/or any administrative proceeding or litigation that may ensue.

REMAINDER OF PAGE INTENTIONALLY LEFT BLANK

ARTICLE 8 - MISCELLANEOUS PROVISIONS

8.01 LEGAL OBLIGATIONS

Grantee shall procure and maintain for the duration of this Contract any state, county, city, or federal license, authorization, insurance, waiver, permit, qualification, or certification required by statute, ordinance, law, or regulation to be held by Grantee to provide the goods or services required by this Contract. Grantee will be responsible for payment of all taxes, assessments, fees, premiums, permits, and licenses required by law. Grantee agrees to be responsible for payment of any such government obligations not paid by its subcontractors during performance of this Contract. Grantee shall not commence work on the Project until it has obtained the requisite licenses and/or permits, if applicable. **COPIES OF SUCH LICENSES AND PERMITS SHALL BE INCLUDED AS A PART OF THE MONTHLY REPORT FOR THE PERIOD DURING WHICH THEY ARE OBTAINED.**

8.02 INDEMNITY

AS GOVERNMENTAL ENTITIES AND REQUIRED UNDER THE CONSTITUTION AND LAWS OF THE STATE OF TEXAS, EACH PARTY UNDERSTANDS THAT THEY ARE LIABLE FOR ANY PERSONAL INJURIES, PROPERTY DAMAGE, OR DEATH RESULTING FROM THE ACTS OR OMISSIONS OF SUCH PARTY. IN THE EVENT THAT THE GLO IS NAMED AS A PARTY DEFENDANT IN ANY LITIGATION ARISING OUT OF ALLEGATIONS OF PERSONAL INJURY, DEATH, OR PROPERTY DAMAGE RESULTING FROM THE ACTS OR OMISSIONS OF GRANTEE, AND FOR WHICH THE GLO IS LIABLE, IF AT ALL, ONLY THROUGH THE VICARIOUS LIABILITY OF GRANTEE, THEN, IN SUCH EVENT, GRANTEE AGREES THAT IT WILL PAY, ON BEHALF OF THE GLO, ALL COSTS AND EXPENSES OF LITIGATION (INCLUDING ANY COURT COSTS, REASONABLE ATTORNEYS' FEES, FEES OF ATTORNEYS APPROVED BY THE OFFICE OF THE TEXAS ATTORNEY GENERAL) AS WELL AS ALL AMOUNTS PAID IN SETTLEMENT OF ANY CLAIM, ACTION, OR SUIT, INCLUDING JUDGMENT OR VERDICT, ARISING OUT OF OR IN CONNECTION WITH THIS CONTRACT. IN THE EVENT THAT GRANTEE IS NAMED AS A PARTY DEFENDANT IN ANY LITIGATION SEEKING ANY DAMAGES FOR ANY PROPERTY DAMAGE, PERSONAL INJURY, OR DEATH RESULTING OUT OF THE GLO'S ACTIONS OR OMISSIONS, AND GRANTEE'S SOLE LIABILITY, IF ANY, IS ONLY VICARIOUSLY THROUGH THE GLO, THEN, IN SUCH EVENT, THE GLO AGREES TO PAY ANY AND ALL CLAIMS, DEMANDS, OR LOSSES, INCLUDING EXPENSES OF LITIGATION (INCLUDING REASONABLE ATTORNEYS' FEES AND COURT COSTS) INCURRED BY GRANTEE, INCLUDING ANY VERDICTS OR JUDGMENTS OR AMOUNTS PAID IN SETTLEMENT OF ANY CLAIM ARISING OUT OF, OR IN CONNECTION WITH THIS CONTRACT. ANY ATTORNEYS RETAINED BY GRANTEE TO REPRESENT ANY INTEREST OF THE GLO MUST BE APPROVED BY THE GLO AND BY THE OFFICE OF THE TEXAS ATTORNEY GENERAL. ANY ATTORNEYS RETAINED BY THE GLO TO REPRESENT THE INTEREST OF GRANTEE MUST BE APPROVED BY GRANTEE.

8.03 INSURANCE AND BOND REQUIREMENTS

- (a) Unless Grantee is authorized pursuant to Chapter 2259 of the Texas Government Code, entitled "Self-Insurance by Governmental Units," to self-insure, Grantee shall carry insurance for the duration of this Contract in types and amounts necessary and appropriate for the Project.

- (b) Grantee shall require all contractors, subcontractors, vendors, service providers, or any other person or entity performing work described in **Attachment A** to carry insurance for the duration of Project in the types and amounts customarily carried by a person or entity providing such goods or services, for the duration of the Contract. Any person or entity required to obtain insurance under this Section must also be required to complete and file the declaration pages from the insurance policies with Grantee whenever a previously identified policy period expires during the term of Grantee's contract with the person or entity, as proof of continuing coverage. Grantee's contract with any such person or entity shall clearly state that acceptance of the insurance policy declaration pages by the Grantee shall not relieve or decrease the liability of the person or entity. Persons or entities shall be required to update all expired policies prior to Grantee's acceptance of an invoice for monthly payment from such parties.
- (c) Grantee shall require performance and payment bonds to the extent they are required under Chapter 2257 of the Texas Government Code.
- (d) **Grantee shall require, on all construction projects, that any person or entity required to provide Federal Construction Assurances shall timely complete SF-424D, entitled "Assurances – Construction Programs," and Grantee shall maintain such documentation.**

8.04 ASSIGNMENT AND SUBCONTRACTS

Grantee shall not convey any grant obligations or duties under this Contract without the prior written consent of the GLO. Notwithstanding this provision, it is mutually understood and agreed that Grantee may subcontract with others for some or all of the services to be performed. In any approved subcontracts, Grantee shall legally bind such subcontractor to perform and make such subcontractor subject to all the duties, requirements, and obligations of Grantee as specified in this Contract. Nothing in this Contract shall be construed to relieve Grantee of the responsibility for ensuring that the goods delivered and/or the services rendered by Grantee and/or any of its subcontractors comply with all the terms and provisions of this Contract.

8.05 PROCUREMENT

Grantee must follow all federal, state, and local procurement procedures and laws applicable to this Project, and must confirm that no vendor is debarred from receiving state or federal funds at each of the following web addresses:

Texas Comptroller's Vendor Performance Program:

http://www.window.state.tx.us/procurement/prog/vendor_performance;

and the Federal General Services Administration's Excluded Parties List System

at <https://www.epls.gov/>.

8.06 PURCHASES AND EQUIPMENT

Grantee shall not seek reimbursement for any Equipment or computer software not included as a reimbursable item in **Attachment B**. Any purchase of equipment or

computer software shall be made in accordance with all applicable laws, regulations, and rules including, but not limited to those listed in **Attachment C**. Title and possession of any Equipment or computer software will remain the property of Grantee unless and until transferred to the GLO, upon written request of the GLO. Grantee shall furnish, with its final request for reimbursement, a list of all Equipment and computer software purchased with grant funds under the Contract, including the name of the manufacturer, the model number, and the serial number. The disposition of any Equipment or computer software shall be in accordance with all applicable laws, regulations, and rules, including but not limited to those listed in **Attachment C**.

8.07 COMMUNICATION WITH THIRD PARTIES

The GLO and the authorities named in **ARTICLE 7**, above, shall have the right to initiate communications with any subcontractor, and may request access to any books, documents, papers, and records of a subcontractor which are directly pertinent to this grant. Such communications may be required to conduct audits and examinations and gather additional information as provided in **ARTICLE 7** herein.

8.08 RELATIONSHIP OF THE PARTIES

Grantee is associated with the GLO only for the purposes and to the extent specified in this Contract and, with respect to Grantee's performance pursuant to this Contract, Grantee shall have the sole right to supervise, manage, operate, control, and direct performance of the details incident to its duties under this Contract. Nothing contained in this Contract shall be deemed or construed to create a partnership or joint venture, to create relationships of an employer-employee or principal-agent, or to otherwise create for the GLO any liability whatsoever with respect to the indebtedness, liabilities, and obligations of Grantee or any other party.

8.09 COMPLIANCE WITH OTHER LAWS

In the performance of this Contract, Grantee shall comply with all applicable federal, state, and local laws, ordinances, and regulations, including, but not limited to, those listed in **Attachments C, D, E, and F**. Grantee shall make itself familiar with and at all times shall observe and comply with all federal, state, and local laws, ordinances, and regulations that in any manner affect performance under this Contract. **Grantee will be deemed to have knowledge of these laws and regulations and be deemed to understand them.**

In addition, the GLO and Grantee mutually certify to that each party is in compliance with Notice of Allocations and Common Application and Reporting Waivers Granted to and Alternative Requirements for Community Development Block Grant (CDBG) Disaster Recovery Grantees Under 2008 Supplemental CDBG Appropriations 74 Fed. Reg. 7,244-7,255 (2009).

8.10 CITIZEN PARTICIPATION

- (a)** Grantee must have written procedures to respond to written complaints within fifteen (15) business days of receipt of such complaint. Citizens must be made aware of the location and the days and hours the location is open for business so they may obtain a copy of these written procedures.

- (b) When requested, Grantee shall provide technical assistance to a representative of a group of persons of low- and moderate-income in developing proposals for the use of CDBG-DR funds. The level and type of assistance shall be determined by the Grantee based upon the specific needs of the community's residents.
- (c) Grantee shall maintain a citizen participation file which includes a copy of the Plan Requirements described in the "2008 Supplemental Disaster Recovery Fund: Hurricanes Dolly and Ike Non-Housing Activities Application Guide;" Grantee's complaint procedures; any technical assistance provided by Grantee; and public notices, minutes, and attendance lists for public hearings, if any.

8.11 NOTICES

Any notices required under this Contract shall be deemed delivered when deposited either in the United States mail, postage paid, certified, return receipt requested; or with a common carrier, overnight, signature required, to the appropriate address below:

GLO

Texas General Land Office
1700 N. Congress Avenue, Mail Code 158
Austin, TX 78701
Attention: Legal Services Division

With a copy to:

Texas General Land Office
1700 N. Congress Avenue, 7th Floor
Austin, TX 78701
Attention: CDBG Disaster Recovery Division

Grantee

County of Hidalgo
1615 South Closner, Suite J
Edinburg, TX 78539
Attention: Judge Ramon Garcia

Notice given in any other manner shall be deemed effective only if and when received by the party to be notified. Either party may change its address for notice by written notice to the other party as herein provided.

8.12 GOVERNING LAW AND VENUE

This Contract and the rights and obligations of the parties hereto shall be governed by, and construed according to, the laws of the State of Texas, exclusive of conflicts of law provisions. Venue of any suit brought under this Contract shall be in a court of competent jurisdiction in Travis County, Texas. Grantee irrevocably waives any objection, including any objection to personal jurisdiction or the laying of venue or based on the grounds of *forum non conveniens*, which it may now or hereafter have to the bringing of any action or proceeding in such jurisdiction with respect to this Contract or any document related hereto. **NOTHING IN THIS SECTION SHALL BE CONSTRUED AS A WAIVER OF SOVEREIGN IMMUNITY BY THE GLO.**

8.13 SEVERABILITY

If any provision contained in this Contract is held to be unenforceable by a court of law or equity, this Contract shall be construed as if such provision did not exist, and the non-enforceability of such provision shall not be held to render any other provision or provisions of this Contract unenforceable.

8.14 DISPUTE RESOLUTION

If a Contract dispute arises that cannot be resolved to the satisfaction of the Parties, either Party may notify the other Party in writing of the dispute. If the Parties are unable to satisfactorily resolve the dispute within fourteen (14) days of the written notification, the Parties must use the dispute resolution process provided for in Chapter 2260 of the Texas Government Code to attempt to resolve the dispute. This provision shall not apply to any matter with respect to which either Party may make a decision within its respective sole discretion.

8.15 PUBLIC INFORMATION

Pursuant to the Public Information Act, records received from Grantee may be open to public inspection and copying. The GLO will have the duty to disclose such records, unless a particular record is made confidential by law or exempted from the Public Information Act. Grantee may clearly label any individual records as a "trade secret," provided that Grantee, to the extent permitted by law, agrees to indemnify and defend the GLO for honoring such designation. The failure to so label any record shall constitute a complete waiver of any and all claims for damages caused by release of the records. If a request for a labeled record is received by the GLO, the GLO will notify Grantee of the request in accordance with the Public Information Act.

Grantee shall release, to any requestor, the following information:

The amount of CDBG-DR funds expected to be made available;

The range of activities that may be undertaken with CDBG-DR funds;

The estimated amount of CDBG-DR funds proposed to be used for activities that will meet the national objective of benefit to low- and moderate-income persons; and

The proposed CDBG-DR activities likely to result in displacement and the Grantee's anti-displacement and relocation plan.

8.16 SIGNAGE

Public buildings, facilities, and centers constructed with the CDBG-DR funds shall have permanent signage placed in a prominent, visible public area with wording provided below. The formatting of the required signage will be at Grantee's discretion to best fit the architectural design of the facility, but shall be legible from no less than three (3) feet.

Other construction projects, e.g., water transmission lines, sewer collection lines, drainage, roadways, housing rehabilitation, utilizing CDBG-DR funds, shall have temporary signage erected in a prominent location at the Project site or along a major thoroughfare within the locality, as directed by Grantee, with the wording provided below:

“This project is funded by the Texas General Land Office to provide for disaster recovery and restoration of infrastructure for communities impacted by the 2008 hurricanes. Funds for the project were allocated by the United States Department of Housing and Urban Development through the Community Development Block Grant Disaster Recovery Program.”

8.17 AMENDMENTS TO THE CONTRACT

Material changes to the Performance Statement and Implementation Schedule may be made only by written agreement of the parties, under the formal Contract amendment process. Material changes include, but are not limited to; monetary changes other than budget variances permitted under SECTION 2.04; the addition or deletion of projects or tasks; or any revision that would otherwise result in a change to the overall Performance Statement.

Notwithstanding the preceding, in the sole discretion of the GLO, extensions to Deliverable due dates within the overall Contract Period, and immaterial revisions to quantities and specifications used within the Project Performance Statement, which may be required during construction, may be approved by the GLO without formal amendment. **Such approvals must be in writing, and may be delivered by email, facsimile, or regular mail.**

Pursuant to SECTIONS 2.04 AND 4.01(b) hereof, a final **Project Completion Report** of all activities performed under this Contract shall be submitted and shall include all such informal revisions approved over the life of the Project.

8.18 ENTIRE CONTRACT AND MODIFICATIONS

This Contract and its integrated Attachments constitute the entire agreement of the parties and are intended as a complete and exclusive statement of the promises, representations, negotiations, discussions, and other agreements that may have been made in connection with the subject matter hereof. Any additional or conflicting terms in such Attachment(s) shall be harmonized with this Contract to the extent possible. Unless such integrated Attachment specifically displays a mutual intent to amend a particular part of this Contract, general conflicts in language shall be construed consistently with the terms of this Contract.

8.19 PROPER AUTHORITY

Each Party hereto represents and warrants that the person executing this Contract on its behalf has full power and authority to legally bind its respective entity. Grantee acknowledges that this Contract is effective for the period of time specified in the Contract. Any work performed by Grantee after the Contract terminates is performed at the sole risk of Grantee.

8.20 COUNTERPARTS

This Contract may be executed in any number of counterparts, each of which shall be an original, and all such counterparts shall together constitute but one and the same Contract.

8.21 SURVIVAL

The provisions of **ARTICLES 5, 6, AND 7; AND SECTIONS 1.01, 1.03, 2.04, 2.05, 3.02, 3.04, 8.02, 8.03, 8.07, 8.08, 8.09, 8.10, 8.11, 8.13, 8.14, 8.15, 8.16, AND 8.17** of this Contract, and any other continuing obligations of Grantee shall survive the termination or expiration of this Contract.

SIGNATURE PAGE FOLLOWS

**SIGNATURE PAGE
FOR GLO CONTRACT NO. 12-406-000-6453**

GENERAL LAND OFFICE



Larry L. Laine, Chief Clerk/
Deputy Land Commissioner

Date of execution: 7/12/12

10 LEGAL AA
PB DIV [Signature]
AGC _____
GC _____
[Signature]

COUNTY OF HIDALGO



By: Ramon Garcia
Title: County Judge

Date of execution: _____

Approved by Commissioners' Court
on 10-18-11 RC

ATTACHMENTS TO GLO CONTRACT NO. 12-406-000-6453

- ATTACHMENT A:** Performance Statement and Implementation Schedule
- ATTACHMENT B:** Project Budget
- ATTACHMENT C:** Nonexclusive List of Applicable Laws, Rules, and Regulations
- ATTACHMENT D:** General Affirmations
- ATTACHMENT E:** Federal Assurances – Non-Construction Programs SF-424B (Rev. 7-97,)
- ATTACHMENT F:** Certifications Regarding Lobbying Lower Tier Covered Transactions (Form CD-512, Rev. 12-04)
- ATTACHMENT G:** Special Conditions

ATTACHMENTS FOLLOW

Performance Statement

County of Hidalgo

Grantee shall carry out the following activities in the target area identified in its 2008 Texas CDBG Disaster Recovery Supplemental Grant application to aid areas most impacted and distressed by Hurricanes Ike or Dolly. The persons to benefit from the activities described in this Performance Statement must be receiving service or a benefit from the use of the new or improved facilities and activities for the contract obligations to be fulfilled. Grantee shall ensure that the amount of funds expended for each activity described does not exceed the amount specified for such activity in the budget.

As a result of Hurricane Dolly on July 23, 2008, the county sustained flooding that resulted in drainage infrastructure failure. The existing drainage system infrastructure failed to function because the current systems were unable to convey the volume of water generated during Hurricane Dolly. The failure of the drainage systems to function threatened the public health, safety, and welfare of all served by these facilities due to flooding. The County is in need of adequately-sized drainage infrastructure to reduce flooding.

Flood and Drainage Facilities-5

Penitas Drain

Grantee shall purchase and install approximately eight hundred twenty-five feet (825 ft.) of storm pipe (box and RCP) along with an associated outfall for the proposed system within the Colonias of Puerta Blanca, Daniel Ozuna, Reina, and Ramona. Work will include the installation of drainage inlets, manholes, driveway and pavement repairs, ditch excavation, concrete riprap, headwalls, associated appurtenances, and perform site work associated with the construction. Construction shall take place in Hidalgo County, Texas, from Rodriguez Road to U.S. Expressway 83. Proposed improvements will significantly increase the capacity of the storm sewer system and reduce flooding.

These activities shall benefit six thousand two hundred eighty-three (6,283) persons, of which four thousand four (4,004), or sixty-three percent (63%), are of low to moderate income.

South Fork Drain

Grantee shall purchase and install drain check valves for existing outfall structures in the South Floodwater Channel and provide a new storm lateral to drain the South Fork Colonia and surrounding area. Work will include existing ditch clearing/grubbing, channel and trench excavation, riprap, installation of storm and irrigation pipe (box and RCP), headwalls, concrete weir, associated appurtenances, and perform site work associated with the construction. Construction shall take place in Hidalgo County, Texas, from west Cage Boulevard to the USIBWC Floodway. Proposed improvements will increase the capacity of the drainage system and reduce flooding.

These activities shall benefit fourteen thousand six hundred twenty-five (14,625) persons, of which eleven thousand three hundred seventy-five (11,375), or seventy-seven percent (77%), are of low to moderate income.

Delta Area Connector and Lateral

Grantee shall construct new storm sewer collection systems, swales, culverts, and outfalls at Colonias Bernal Heights, Bar, Chapa North, Chapa South, Olivarez#10, Olivarez#4, Puesta del Sol, Sunrise Subdivision, Olivarez #7, Olivearez #9, Olivarez #18, Tijerina Estates, and Mesquite Acres. Work will include installation of box culverts, a gated box structure, concrete headwalls and weirs, irrigation pipes, and associated appurtenances. In addition, grantee shall clear and grub existing drainage system, excavate channel, install concrete riprap for erosion protection, and perform pavement repair and other site work associated with the construction. Construction shall take place in Hidalgo County, Texas, from Mile 12 ½ Road to the Hidalgo County Drainage District No. 1 Ditch. Proposed improvements will increase the capacity of the drainage system and reduce flooding.

These activities shall benefit sixty-four thousand six hundred ninety (64,690) persons, of which forty-four thousand three hundred twenty-one (44,321), or sixty-eight percent (68%), are of low to moderate income.

Acquisition-24

Grantee shall acquire easements as needed to accommodate proposed drainage system improvements. Grantee shall carry out all acquisition of needed real property, easements, and/or rights-of-way in compliance with the Uniform Relocation Assistance and Real Property Acquisition Policies Act of 1970 (42 U.S.C. 4601 *et seq.*) and HUD implementing regulations (24 CFR Part 42).

Engineering-30

Grantee shall ensure the amount of the funds expended for all eligible project-related engineering services, including preliminary and final design plans and specifications, all interim and final inspections, and all special services, does not exceed the amount specified for engineering in the Budget.

Planning / Project Delivery-33

Grantee shall ensure the amount of the funds expended for all eligible project-related "planning / project delivery" administration activities, including the required annual program compliance and fiscal audit, does not exceed the amount specified for Planning / Project Delivery in the Budget.

Project Implementation Schedule

Grantee: **Hidalgo County**

Acquisition completion is after Bid Opening.

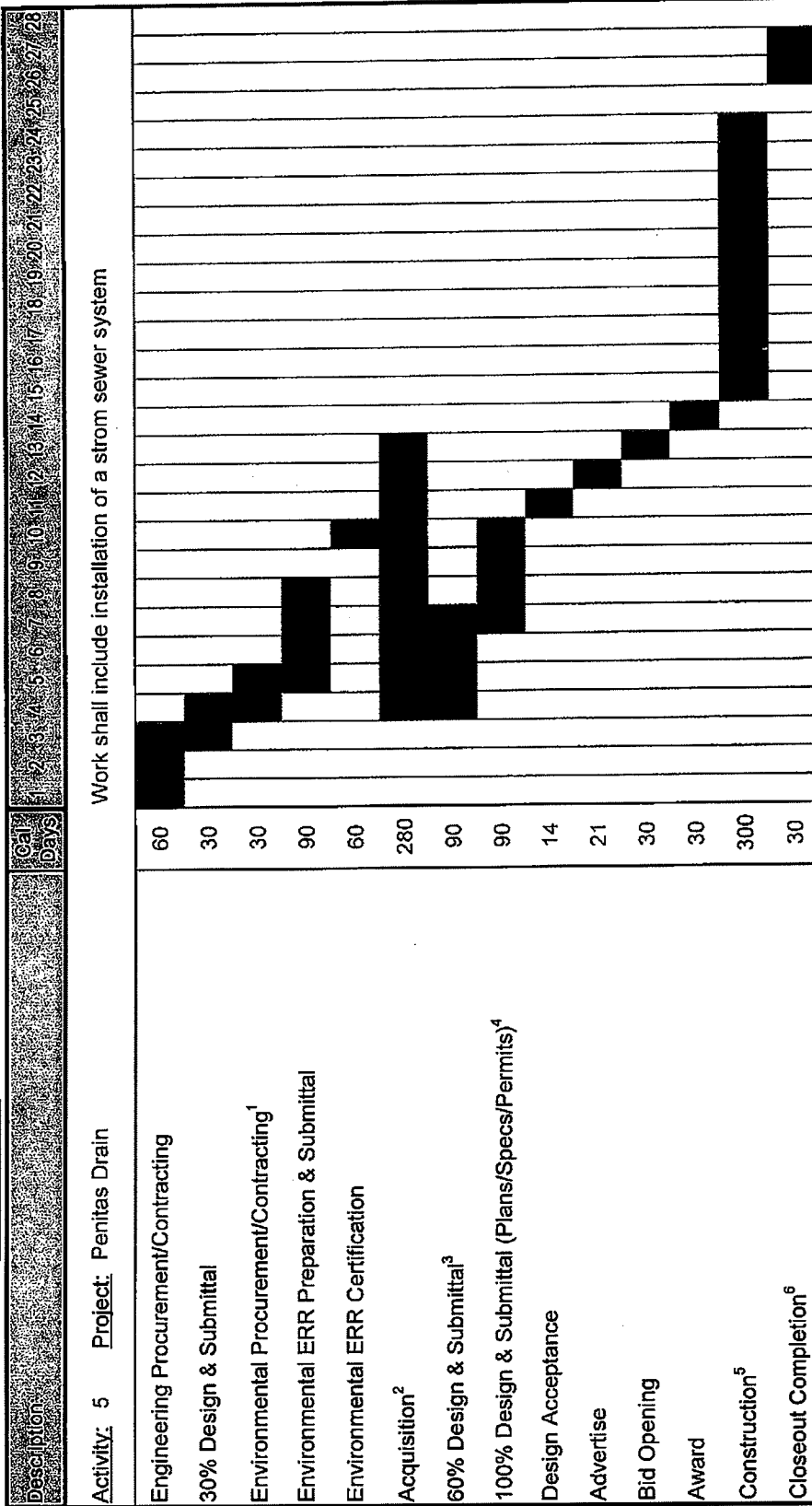

¹ Environmental procurement/contracting is assumed to start the day following the 30% design submittal.
² Acquisition is assumed to start the day following the 30% design submittal. Acquisition duration was determined by and discussed with the County during the outreach conference call. Timeframes are approximate and subject to change.
³ 60% design is assumed to start two (2) weeks after the 30% design submittal for review.
⁴ 100% design is assumed to start two (2) weeks after the 60% design submittal for review.
⁵ Construction is assumed to start four (4) weeks after construction award or four (4) weeks after design completion if bidding/award is not applicable.
⁶ Closeout completion is assumed to occur 30 calendar days after closeout documents are submitted for review/approval.

Project Implementation Schedule

Grantee: **Hidalgo County**

Description	Ca Days	1	2	3	4	5	6	7	8	9	10	11	12	13	14	15	16	17	18	19	20	21	22	23	24	25	26	27	28
Activity: 5 Project: South Fork Drain Work shall include new check valves, storm lateral and clearing/ grubbing of existing channel.																													
Engineering Procurement/Contracting	60																												
30% Design & Submittal	60																												
Environmental Procurement/Contracting ¹	30																												
Environmental ERR Preparation & Submittal	90																												
Environmental ERR Certification	60																												
Acquisition ²	90																												
60% Design & Submittal ³	120																												
100% Design & Submittal (Plans/Specs/Permits) ⁴	14																												
Design Acceptance	21																												
Advertise	30																												
Bid Opening	30																												
Award	30																												
Construction ⁵	330																												
Closeout Completion ⁶	30																												

¹ Environmental procurement/contracting is assumed to start the day following the 30% design submittal.

² Acquisition is assumed to start the day following the 30% design submittal.

³ 60% design is assumed to start two (2) weeks after the 30% design submittal for review.

⁴ 100% design is assumed to start two (2) weeks after the 60% design submittal for review.

⁵ Construction is assumed to start four (4) weeks after construction award or four (4) weeks after design completion if bidding/award is not applicable.

⁶ Closeout completion is assumed to occur 30 calendar days after closeout documents are submitted for review/approval.

Project Implementation Schedule

Grantee: **Hidalgo County**

Acquisition completion is after Bid Opening.

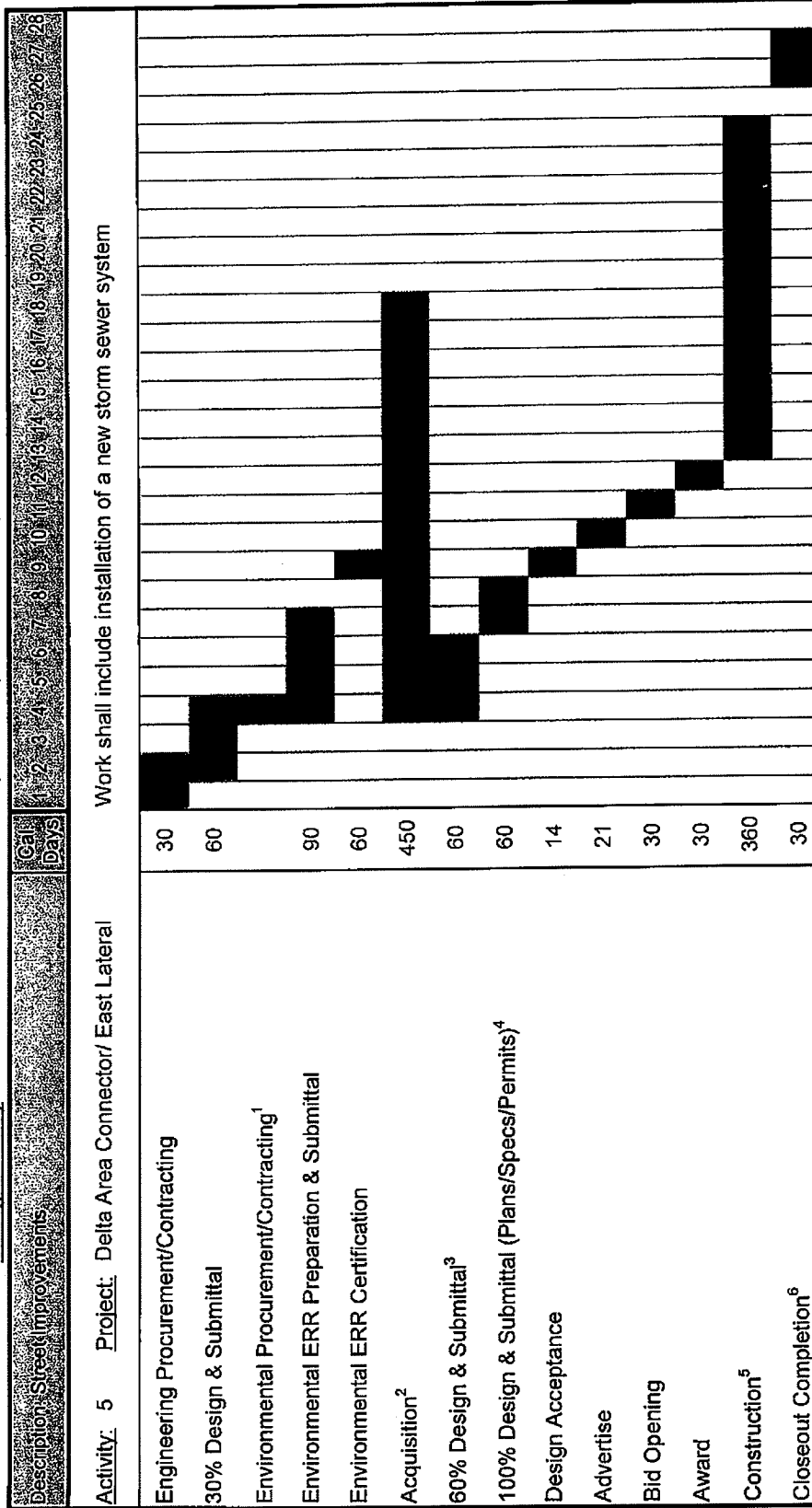

¹ Environmental procurement/contracting is assumed to start the day following the 30% design submittal.
² Acquisition is assumed to start the day following the 30% design submittal. Acquisition duration was determined by and discussed with the County during the outreach conference call. Timeframes are approximate and subject to change.
³ 60% design is assumed to start two (2) weeks after the 30% design submittal for review.
⁴ 100% design is assumed to start two (2) weeks after the 60% design submittal for review.
⁵ Construction is assumed to start four (4) weeks after construction award or four (4) weeks after design completion if bidding/award is not applicable.
⁶ Closeout completion is assumed to occur 30 calendar days after closeout documents are submitted for review/approval.

Budget
County of Hidalgo

<u>LINE CATEGORIES</u>	<u>CONTRACT FUNDS</u>	<u>OTHER FUNDS</u>	<u>TOTAL</u>
5. Flood and Drainage Facilities	\$ 15,841,012	\$	\$ 15,841,012
24. Acquisition	\$ 1,840,633	\$	\$ 1,840,633
30. Engineering/Architectural Serv. (Total for all construction accounts)	\$ 2,655,421	\$	\$ 2,655,421
33. Planning / Project Delivery	\$ <u>605,240</u>	<u>\$</u>	<u>\$ 605,240</u>
TOTALS	\$ 20,942,306	\$	\$ 20,942,306

NONEXCLUSIVE LIST OF APPLICABLE LAWS, RULES, AND REGULATIONS

If applicable to the Project, Grantee must be in compliance with the following laws, rules, and regulations; and any other state, federal, or local laws, rules, and regulations as may become applicable throughout the term of the Contract, and Grantee acknowledges that this list may not include all such applicable laws, rules, and regulations.

Grantee and is deemed to have read and understands the requirements of each of the following, if applicable to the Project under this Contract:

GENERALLY

The Act and Regulations specified in **SECTION 1.03** of this Contract;

Consolidated Security, Disaster Assistance, and Continuing Appropriation Act (Public Law 110-329);

Cash Management Improvement Act regulations (31 C.F.R. Part 205);

Community Development Block Grants (24 C.F.R. Part 570);

Disaster Recovery Implementation Manual;

Plan for Disaster Recovery;

Guidance Documents: 2008 Supplemental Disaster Recovery Fund: Hurricanes Dolly and Ike; and Non-Housing Activities Application Guide, issued by the Texas Department of Housing and Community Affairs

CIVIL RIGHTS

Title VI of the Civil Rights Act of 1964, (42 U.S.C. § 2000d *et seq.*); 24 C.F.R. Part 1, "Nondiscrimination in Federally Assisted Programs of the Department of Housing and Urban Development - Effectuation of Title VI of the Civil Rights Act of 1964;"

Title VII of the Civil Rights Act of 1964, as amended by the Equal Employment Opportunity Act of 1972 (42 U.S.C. § 2000e *et seq.*);

Title VIII of the Civil Rights Act of 1968, "The Fair Housing Act of 1968" (42 U.S.C. 3601 *et seq.*), as amended;

Executive Order 11063, as amended by Executive Order 12259, and 24 C. F.R. Part 107, "Nondiscrimination and Equal Opportunity in Housing under Executive Order 11063." The failure or refusal of Grantee to comply with the requirements of Executive Order 11063 or 24 C.F.R. Part 107 shall be a proper basis for the imposition of sanctions specified in 24 C.F.R. 107.60;

The Age Discrimination Act of 1975 (42 U.S.C. 6101 *et seq.*);

Section 504 of the Rehabilitation Act of 1973 (29 U.S.C. 794.) and "Nondiscrimination Based on Handicap in Federally-Assisted Programs and Activities of the Department of Housing and Urban Development", 24 C.F.R. Part 8. By signing this Contract, Grantee understands and agrees that the activities funded shall be performed in accordance with 24 C.F.R. Part 8; and the Architectural Barriers Act of 1968 (42 U.S.C. 4151 *et seq.*), including the use of a telecommunications device for deaf persons (TDDs) or equally effective communication system.

LABOR STANDARDS

The Davis-Bacon Act, as amended (40 U.S.C. 276a - 276a-5); 29 C.F.R. Part 5;

The Copeland "Anti-Kickback" Act (18 U.S.C. 874); 41 C.F.R. Part 3;

Sections 103 and 107 of the Contract Work Hours and Safety Standards Act (40 U.S.C. § 327A and 330);

Labor Standards Provisions Applicable to Contracts Covering Federally Financed and Assisted Construction (Also Labor Standards Provisions Applicable to Non-construction Contracts Subject to the Contract Work Hours and Safety Standards Act) (29 C.F.R. Part 5);

Federal Executive Order 11246, as amended;

EMPLOYMENT OPPORTUNITIES

Section 3 of the Housing and Urban Development Act of 1968 (12 U.S.C.1701u): 24 C.F.R. §§ 135.3(a)(2) and (a)(3);

The Vietnam Era Veterans' Readjustment Assistance Act of 1974 (38 U.S.C. § 4212);

Title IX of the Education Amendments of 1972 (20 U.S.C. §§ 1681-1688);

GRANT AND AUDIT STANDARDS

Single Audit Act Amendments of 1996, 31 U.S.C. § 7501;

Uniform Administrative Requirements for Grants and Agreements with Institutions of Higher Education, Hospitals, and Other Non-profit Organizations (24 C.F.R. Part 84);

Administrative Requirements for Grants and Cooperative Agreements to State, Local and Federally Recognized Indian Tribal Governments (24 C.F.R. Part 85);

OMB Circular A-87 (Cost Principles for State, Local, and Indian Tribal Governments);

OMB Circular A-133 – Revised as of June 27, 2007 (Audits of States, Local Governments, and Non-Profit Organizations);

Uniform Grant and Contract Management Act (Texas Government Code Chapter 783) and the Uniform Grant Management Standards issued by Governor's Office of Budget and Planning;

Title 1 Texas Administrative Code § 5.167(c);

LEAD-BASED PAINT

Section 302 of the Lead-Based Paint Poisoning Prevention Act (42 U.S.C. 4831(b)) and the procedures established by TDRA thereunder;

HISTORIC PROPERTIES

The National Historic Preservation Act of 1966 as amended (16 U.S.C. 470 *et seq.*), particularly sections 106 and 110 (16 U.S.C. 470 and 470h-2), except as provided in §58.17 for Section 17 projects;

Executive Order 11593, Protection and Enhancement of the Cultural Environment, May 13, 1971 (36 FR 8921), 3 C.F.R. 1971-1975 Comp., p. 559, particularly section 2(c);

Federal historic preservation regulations as follows: 36 C.F.R. part 800 with respect to HUD programs;

The Reservoir Salvage Act of 1960 as amended by the Archeological and Historic Preservation Act of 1974 (16 U.S.C. 469 *et seq.*), particularly section 3 (16 U.S.C. 469a-1);

ENVIRONMENTAL LAW AND AUTHORITIES

Environmental Review Procedures for Recipients assuming HUD Environmental Responsibilities (24 C.F.R. Part 58, as amended);

National Environmental Policy Act of 1969, as amended (42 U.S.C. §§ 4321-4347);

Council for Environmental Quality Regulations for Implementing NEPA (40 C.F.R. Parts 1500-1508).

FLOODPLAIN MANAGEMENT AND WETLAND PROTECTION

Executive Order 11988, Floodplain Management, May 24, 1977 (42 FR 26951), 3 CFR, 1977 Comp., p. 117, as interpreted in HUD regulations at 24 C.F.R. part 55, particularly Section 2(a) of the Order (For an explanation of the relationship between the decision-making process in 24 C.F.R. part 55 and this part, see § 55.10.);

Executive Order 11990, Protection of Wetlands, May 24, 1977 (42 FR 26961), 3 C.F.R., 1977 Comp., p. 121 particularly Sections 2 and 5;

COASTAL ZONE MANAGEMENT

The Coastal Zone Management Act of 1972 (16 U.S.C. 1451 *et seq.*), as amended, particularly sections 307(c) and (d) (16 U.S.C. 1456(c) and (d));

SOLE SOURCE AQUIFERS

The Safe Drinking Water Act of 1974 (42 U.S.C. 201, 300(f) *et seq.*, and 21 U.S.C. 349) as amended; particularly section 1424(e) (42 U.S.C. 300h-3(e));

Sole Source Aquifers (Environmental Protection Agency-40 C.F.R. part 149.);

ENDANGERED SPECIES

The Endangered Species Act of 1973 (16 U.S.C. 1531 *et seq.*) as amended, particularly section 7 (16 U.S.C. 1536);

WILD AND SCENIC RIVERS

The Wild and Scenic Rivers Act of 1968 (16 U.S.C. 1271 *et seq.*) as amended, particularly sections 7(b) and (c) (16 U.S.C. 1278(b) and (c));

AIR QUALITY

The Clean Air Act (42 U.S.C. 7401 *et seq.*) as amended, particularly sections 176(c) and (d) (42 U.S.C. 7506(c) and (d));

Determining Conformity of Federal Actions to State or Federal Implementation Plans (Environmental Protection Agency-40 C.F.R. parts 6, 51, and 93);

FARMLAND PROTECTION

Farmland Protection Policy Act of 1981 (7 U.S.C. 4201 *et seq.*) particularly sections 1540(b) and 1541 (7 U.S.C. 4201(b) and 4202);

Farmland Protection Policy (Department of Agriculture-7 C.F.R. part 658);

HUD ENVIRONMENTAL STANDARDS

Applicable criteria and standards specified in HUD environmental regulations (24 C.F.R. part 51) (other than the runway clear zone and clear zone notification requirement in 24 C.F.R. 51.303(a)(3)); and

HUD Notice 79-33, Policy Guidance to Address the Problems Posed by Toxic Chemicals and Radioactive Materials, September 10, 1979).

ENVIRONMENTAL JUSTICE

Executive Order 12898 of February 11, 1994 --- Federal Actions to Address Environmental Justice in Minority Populations and Low-Income Populations, (59 FR 7629), 3 CFR, 1994 Comp. p. 859.

OTHER REQUIREMENTS

Environmental Review Procedures for Entities Assuming HUD Environmental Responsibilities (24 C.F.R. Part 58);

ACQUISITION/RELOCATION

The Uniform Relocation Assistance and Real Property Acquisition Policies Act of 1970 (42 U.S.C. 4601 *et seq.*), 24 C.F.R. Part 42, and 24 C.F.R. Section 570.606.

FAITH-BASED ACTIVITIES

Executive Order 13279 of December 12, 2002 - Equal Protection of the Laws for Faith-Based and Community Organizations, (67 FR 77141).

REMAINDER OF PAGE INTENTIONALLY LEFT BLANK

GENERAL AFFIRMATIONS

Grantee agrees without exception to the following affirmations:

1. The Grantee has not given, offered to give, nor intends to give at anytime hereafter any economic opportunity, future employment, gift, loan, gratuity, special discount, trip, favor, or service to a public servant in connection with this Contract.
2. Pursuant to Title 10, Section 2155.004 of the Texas Government Code, the Grantee has not received compensation from the GLO for preparing any part of this Contract.
3. Under Section 231.006, Family Code, the vendor or applicant certifies that the individual or business entity named in this contract, bid, or application is not ineligible to receive the specified grant, loan, or payment and acknowledges that this contract may be terminated and payment may be withheld if this certification is inaccurate. Any Grantee subject to this section must include names and Social Security numbers of each person with at least twenty-five percent (25%) ownership in the business entity named in this Contract. This information must be provided prior to execution of any offer.
4. Grantee certifies that the individual or business entity named in this Contract: i) has not been subjected to suspension, debarment, or similar ineligibility to receive the specified contract as determined by any federal, state, or local governmental entity; ii) is in compliance with the State of Texas statutes and rules relating to procurement; and iii) is not listed on the federal government's terrorism watch list as described in executive order 13224. Entities ineligible for federal procurement are listed at <http://www.epls.gov>. Grantee acknowledges that this contract may be terminated and payment withheld if this certification is inaccurate.
5. Grantee agrees that any payments due under this Contract will be applied towards any debt, including, but not limited to, delinquent taxes and child support that is owed to the State of Texas.
6. Grantee certifies that they are in compliance with Texas Government Code, Title 6, Subtitle B, Section 669.003, relating to contracting with the executive head of a state agency. If this section applies, Grantee will complete the following information in order for the bid to be evaluated:

Name of Former Executive: _____
Name of State Agency: _____
Date of Separation from State Agency: _____
Position with Grantee: _____
Date of Employment with Grantee: _____

7. Grantee agrees to comply with Texas Government Code, Title 10, Subtitle D, Section 2155.4441, relating to the purchase of products produced in the State of Texas under service contracts.

8. Grantee understands that acceptance of funds under this Contract acts as acceptance of the authority of the State Auditor's Office, or any successor agency, to conduct an audit or investigation in connection with those funds. Grantee further agrees to cooperate fully with the State Auditor's Office, or its successor, in conducting the audit or investigation, including providing all records requested. Grantee will ensure that this clause is included in any subcontract it awards.
9. Grantee certifies that if it employs any former employee of the GLO, such employee will perform no work in connection with this Contract during the twelve (12) month period immediately following the employee's last date of employment at the GLO.
10. The Grantee shall not discriminate against any employee or applicant for employment because of race, disability, color, religion, sex, age, or national origin. The Grantee shall take affirmative action to ensure that applicants are employed and that employees are treated without regard to their race, color, sex, religion, age, disability, or national origin. Such action shall include, but is not be limited to, the following: employment, upgrading, demotion, or transfer; recruitment or recruitment advertising; layoff or termination; rates of pay or other forms of compensation; and selection for training, including apprenticeship. The Grantee agrees to post notices, which set forth the provisions of this non-discrimination article, in conspicuous places available to employees or applicants for employment. The Grantee shall include the above provisions in all subcontracts pertaining to the work.
11. Grantee understands that the GLO does not tolerate any type of fraud. The agency's policy is to promote consistent, legal, and ethical organizational behavior by assigning responsibilities and providing guidelines to enforce controls. Any violations of law, agency policies, or standards of ethical conduct will be investigated, and appropriate actions will be taken. Grantees are expected to report any possible fraudulent or dishonest acts, waste, or abuse affecting any transaction with the GLO to the GLO's Internal Audit Director at 512.463.5338 or tracey.hall@glo.state.tx.us
12. Grantee must take steps to avoid or mitigate occurrences of fraud, abuse, and mismanagement, especially with respect to the financial management of the Contract and pronouncements made under this Contract, whether so directed by the GLO or at Grantee's initiative. Upon discovery of any alleged or suspected fraud, abuse of power, kickbacks, the embezzlement or loss of funds under this Contract, or the theft of any assets provided for under this Contract, the Grantee immediately shall notify the GLO and appropriate law enforcement authorities and cooperate in any investigation and enforcement action that follows.

NOTE: Information, documentation, and other material in connection with this Contract may be subject to public disclosure pursuant to the "Public Information Act," Chapter 552 of the Texas Government Code.

ASSURANCES - NON-CONSTRUCTION PROGRAMS

Public reporting burden for this collection of information is estimated to average 15 minutes per response, including time for reviewing instructions, searching existing data sources, gathering and maintaining the data needed, and completing and reviewing the collection of information. Send comments regarding the burden estimate or any other aspect of this collection of information, including suggestions for reducing this burden, to the Office of Management and Budget, Paperwork Reduction Project (0348-0040), Washington, DC 20503.

PLEASE DO NOT RETURN YOUR COMPLETED FORM TO THE OFFICE OF MANAGEMENT AND BUDGET. SEND IT TO THE ADDRESS PROVIDED BY THE SPONSORING AGENCY.

NOTE: Certain of these assurances may not be applicable to your project or program. If you have questions, please contact the awarding agency. Further, certain Federal awarding agencies may require applicants to certify to additional assurances. If such is the case, you will be notified.

As the duly authorized representative of the applicant, I certify that the applicant:

1. Has the legal authority to apply for Federal assistance and the institutional, managerial and financial capability (including funds sufficient to pay the non-Federal share of project cost) to ensure proper planning, management and completion of the project described in this application.
2. Will give the awarding agency, the Comptroller General of the United States and, if appropriate, the State, through any authorized representative, access to and the right to examine all records, books, papers, or documents related to the award; and will establish a proper accounting system in accordance with generally accepted accounting standards or agency directives.
3. Will establish safeguards to prohibit employees from using their positions for a purpose that constitutes or presents the appearance of personal or organizational conflict of interest, or personal gain.
4. Will initiate and complete the work within the applicable time frame after receipt of approval of the awarding agency.
5. Will comply with the Intergovernmental Personnel Act of 1970 (42 U.S.C. §§4728-4763) relating to prescribed standards for merit systems for programs funded under one of the 19 statutes or regulations specified in Appendix A of OPM's Standards for a Merit System of Personnel Administration (5 C.F.R. 900, Subpart F).
6. Will comply with all Federal statutes relating to nondiscrimination. These include but are not limited to: (a) Title VI of the Civil Rights Act of 1964 (P.L. 88-352) which prohibits discrimination on the basis of race, color or national origin; (b) Title IX of the Education Amendments of 1972, as amended (20 U.S.C. §§1681-1683, and 1685-1686), which prohibits discrimination on the basis of sex; (c) Section 504 of the Rehabilitation Act of 1973, as amended (29 U.S.C. §794), which prohibits discrimination on the basis of handicaps; (d) the Age Discrimination Act of 1975, as amended (42 U.S.C. §§6101-6107), which prohibits discrimination on the basis of age; (e) the Drug Abuse Office and Treatment Act of 1972 (P.L. 92-255), as amended, relating to nondiscrimination on the basis of drug abuse; (f) the Comprehensive Alcohol Abuse and Alcoholism Prevention, Treatment and Rehabilitation Act of 1970 (P.L. 91-616), as amended, relating to nondiscrimination on the basis of alcohol abuse or alcoholism; (g) §§523 and 527 of the Public Health Service Act of 1912 (42 U.S.C. §§290 dd-3 and 290 ee-3), as amended, relating to confidentiality of alcohol and drug abuse patient records; (h) Title VIII of the Civil Rights Act of 1968 (42 U.S.C. §3601 et seq.), as amended, relating to nondiscrimination in the sale, rental or financing of housing; (i) any other nondiscrimination provisions in the specific statute(s) under which application for Federal assistance is being made; and, (j) the requirements of any other nondiscrimination statute(s) which may apply to the application.
7. Will comply, or has already complied, with the requirements of Titles II and III of the Uniform Relocation Assistance and Real Property Acquisition Policies Act of 1970 (P.L. 91-646) which provide for fair and equitable treatment of persons displaced or whose property is acquired as a result of Federal or federally-assisted programs. These requirements apply to all interests in real property acquired for project purposes regardless of Federal participation in purchases.
8. Will comply, as applicable, with provisions of the Hatch Act (5 U.S.C. §§1501-1508 and 7324-7328) which limit the political activities of employees whose principal employment activities are funded in whole or in part with Federal funds.

9. Will comply, as applicable, with the provisions of the Davis-Bacon Act (40 U.S.C. §§276a to 276a-7), the Copeland Act (40 U.S.C. §276c and 18 U.S.C. §874), and the Contract Work Hours and Safety Standards Act (40 U.S.C. §§327-333), regarding labor standards for federally-assisted construction subagreements.
10. Will comply, if applicable, with flood insurance purchase requirements of Section 102(a) of the Flood Disaster Protection Act of 1973 (P.L. 93-234) which requires recipients in a special flood hazard area to participate in the program and to purchase flood insurance if the total cost of insurable construction and acquisition is \$10,000 or more.
11. Will comply with environmental standards which may be prescribed pursuant to the following: (a) institution of environmental quality control measures under the National Environmental Policy Act of 1969 (P.L. 91-190) and Executive Order (EO) 11514; (b) notification of violating facilities pursuant to EO 11738; (c) protection of wetlands pursuant to EO 11990; (d) evaluation of flood hazards in floodplains in accordance with EO 11988; (e) assurance of project consistency with the approved State management program developed under the Coastal Zone Management Act of 1972 (16 U.S.C. §§1451 et seq.); (f) conformity of Federal actions to State (Clean Air) Implementation Plans under Section 176(c) of the Clean Air Act of 1955, as amended (42 U.S.C. §§7401 et seq.); (g) protection of underground sources of drinking water under the Safe Drinking Water Act of 1974, as amended (P.L. 93-523); and, (h) protection of endangered species under the Endangered Species Act of 1973, as amended (P.L. 93-205).
12. Will comply with the Wild and Scenic Rivers Act of 1968 (16 U.S.C. §§1271 et seq.) related to protecting components or potential components of the national wild and scenic rivers system.
13. Will assist the awarding agency in assuring compliance with Section 106 of the National Historic Preservation Act of 1966, as amended (16 U.S.C. §470), EO 11593 (identification and protection of historic properties), and the Archaeological and Historic Preservation Act of 1974 (16 U.S.C. §§469a-1 et seq.).
14. Will comply with P.L. 93-348 regarding the protection of human subjects involved in research, development, and related activities supported by this award of assistance.
15. Will comply with the Laboratory Animal Welfare Act of 1966 (P.L. 89-544, as amended, 7 U.S.C. §§2131 et seq.) pertaining to the care, handling, and treatment of warm blooded animals held for research, teaching, or other activities supported by this award of assistance.
16. Will comply with the Lead-Based Paint Poisoning Prevention Act (42 U.S.C. §§4801 et seq.) which prohibits the use of lead-based paint in construction or rehabilitation of residence structures.
17. Will cause to be performed the required financial and compliance audits in accordance with the Single Audit Act Amendments of 1996 and OMB Circular No. A-133, "Audits of States, Local Governments, and Non-Profit Organizations."
18. Will comply with all applicable requirements of all other Federal laws, executive orders, regulations, and policies governing this program.

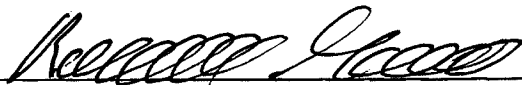
SIGNATURE OF AUTHORIZED CERTIFYING OFFICIAL 	TITLE County Judge
APPLICANT ORGANIZATION County of Hidalgo	DATE SUBMITTED 4/5/12

Standard Form 424B (Rev. 7-97) Back

THIS FORM MUST BE EXECUTED

Approved by Commissioners' Court
on 10-18-11 RW

FORM CD-512
 (REV 12-04)

U.S. DEPARTMENT OF COMMERCE

**CERTIFICATION REGARDING LOBBYING
 LOWER TIER COVERED TRANSACTIONS**

Applicants should review the instructions for certification included in the regulations before completing this form. Signature on this form provides for compliance with certification requirements under 15 CFR Part 28, "New Restrictions on Lobbying."

LOBBYING

As required by Section 1352, Title 31 of the U.S. Code, and implemented at 15 CFR Part 28, for persons entering into a grant, cooperative agreement or contract over \$100,000 or a loan or loan guarantee over \$150,000 as defined at 15 CFR Part 28, Sections 28.105 and 28.110, the applicant certifies that to the best of his or her knowledge and belief, that:

- (1) No Federal appropriated funds have been paid or will be paid, by or on behalf of the undersigned, to any person for influencing or attempting to influence an officer or employee of any agency, a Member of Congress in connection with the awarding of any Federal contract, the making of any Federal loan, the entering into of any cooperative agreement, and the extension, continuation, renewal, amendment, or modification of any Federal contract, grant, loan, or cooperative agreement.
- (2) If any funds other than Federal appropriated funds have been paid or will be paid to any person for influencing or attempting to influence an officer or employee of any agency, a Member of Congress, an officer or employee of Congress, or an employee of a member of Congress in connection with this Federal contract, grant, loan, or cooperative agreement, the undersigned shall complete and submit Standard Form-LLL, "Disclosure Form to Report Lobbying," in accordance with its instructions.
- (3) The undersigned shall require that the language of this certification be included in the award documents for all subawards at all tiers (including subcontracts, subgrants, and contracts under grants, loans, and cooperative agreements) and that all subrecipients shall certify and disclose accordingly.

This certification is a material representation of fact upon which reliance was placed when this transaction was made or entered into. Submission of this certification is a prerequisite for making or entering into this transaction imposed by section 1352, title 31, U.S. Code. Any person who fails to file the required certification shall be subject to a civil penalty of not less than \$10,000 and not more than \$100,000 for each such failure occurring on or before October 23, 1996, and of not less than \$11,000 and not more than \$110,000 for each such failure occurring after October 23, 1996.

Statement for Loan Guarantees and Loan Insurance

The undersigned states, to the best of his or her knowledge and belief, that:

In any funds have been paid or will be paid to any person for influencing or attempting to influence an officer or employee of any agency, a Member of Congress, an officer or employee of Congress, or an employee of a Member of Congress in connection with this commitment providing for the United States to insure or guarantee a loan, the undersigned shall complete and submit Standard Form-LLL, "Disclosure Form to Report Lobbying," in accordance with its instructions.

Submission of this statement is a prerequisite for making or entering into this transaction imposed by section 1352, title 31, U.S. Code. Any person who fails to file the required statement shall be subject to a civil penalty of not less than \$10,000 and not more than \$100,000 for each such failure occurring on or before October 23, 1996, and of not less than \$11,000 and not more than \$110,000 for each such failure occurring after October 23, 1996.

As the duly authorized representative of the applicant, I hereby certify that the applicant will comply with the above applicable certification.
County of Hidalgo

GLO Contract No. 12-406-000-6453

NAME OF APPLICANT

AWARD NUMBER AND/OR PROJECT NAME

Ramon Garcia, County Judge

PRINTED NAME AND TITLE OF AUTHORIZED REPRESENTATIVE

Ramon Garcia

DATE *4/15/12*

SIGNATURE

DATE

THIS FORM MUST BE EXECUTED
 Approved by Commissioners' Court
 on *10-18-11* *RE*

DISCLOSURE OF LOBBYING ACTIVITIES

Complete this form to disclose lobbying activities pursuant to 31 U.S.C. 1352
 (See reverse for public burden disclosure.)

Approved by OMB
 0348-0046

1. Type of Federal Action: <input type="checkbox"/> a. contract <input type="checkbox"/> b. grant c. cooperative agreement d. loan e. loan guarantee f. loan insurance		2. Status of Federal Action: <input type="checkbox"/> a. bid/offer/application <input type="checkbox"/> b. initial award c. post-award		3. Report Type: <input type="checkbox"/> a. initial filing <input type="checkbox"/> b. material change For Material Change Only: year _____ quarter _____ date of last report _____	
4. Name and Address of Reporting Entity: <input type="checkbox"/> Prime <input type="checkbox"/> Subawardee Tier _____, if known: Congressional District, if known: 4c			5. If Reporting Entity in No. 4 is a Subawardee, Enter Name and Address of Prime: Congressional District, if known:		
6. Federal Department/Agency:			7. Federal Program Name/Description: CFDA Number, if applicable: _____		
8. Federal Action Number, if known:			9. Award Amount, if known: \$ _____		
10. a. Name and Address of Lobbying Registrant (if individual, last name, first name, MI):			b. Individuals Performing Services (including address if different from No. 10a) (last name, first name, MI):		
11. Information requested through this form is authorized by title 31 U.S.C. section 1352. This disclosure of lobbying activities is a material representation of fact upon which reliance was placed by the tier above when this transaction was made or entered into. This disclosure is required pursuant to 31 U.S.C. 1352. This information will be available for public inspection. Any person who fails to file the required disclosure shall be subject to a civil penalty of not less than \$10,000 and not more than \$100,000 for each such failure.			Signature: _____ Print Name: _____ Title: _____ Telephone No.: _____ Date: _____		
Federal Use Only:				Authorized for Local Reproduction Standard Form LLL (Rev. 7-97)	

THIS FORM SHOULD BE EXECUTED ONLY WHEN REPORTING LOBBYING ACTIVITIES UNDERTAKEN WITH GRANT FUNDS

INSTRUCTIONS FOR COMPLETION OF SF-LLL, DISCLOSURE OF LOBBYING ACTIVITIES

This disclosure form shall be completed by the reporting entity, whether subawardee or prime Federal recipient, at the initiation or receipt of a covered Federal action, or a material change to a previous filing, pursuant to title 31 U.S.C. section 1352. The filing of a form is required for each payment or agreement to make payment to any lobbying entity for influencing or attempting to influence an officer or employee of any agency, a Member of Congress, an officer or employee of Congress, or an employee of a Member of Congress in connection with a covered Federal action. Complete all items that apply for both the initial filing and material change report. Refer to the implementing guidance published by the Office of Management and Budget for additional information.

1. Identify the type of covered Federal action for which lobbying activity is and/or has been secured to influence the outcome of a covered Federal action.
2. Identify the status of the covered Federal action.
3. Identify the appropriate classification of this report. If this is a followup report caused by a material change to the information previously reported, enter the year and quarter in which the change occurred. Enter the date of the last previously submitted report by this reporting entity for this covered Federal action.
4. Enter the full name, address, city, State and zip code of the reporting entity. Include Congressional District, if known. Check the appropriate classification of the reporting entity that designates if it is, or expects to be, a prime or subaward recipient. Identify the tier of the subawardee, e.g., the first subawardee of the prime is the 1st tier. Subawards include but are not limited to subcontracts, subgrants and contract awards under grants.
5. If the organization filing the report in item 4 checks "Subawardee," then enter the full name, address, city, State and zip code of the prime Federal recipient. Include Congressional District, if known.
6. Enter the name of the Federal agency making the award or loan commitment. Include at least one organizational level below agency name, if known. For example, Department of Transportation, United States Coast Guard.
7. Enter the Federal program name or description for the covered Federal action (item 1). If known, enter the full Catalog of Federal Domestic Assistance (CFDA) number for grants, cooperative agreements, loans, and loan commitments.
8. Enter the most appropriate Federal identifying number available for the Federal action identified in item 1 (e.g., Request for Proposal (RFP) number; Invitation for Bid (IFB) number; grant announcement number; the contract, grant, or loan award number; the application/proposal control number assigned by the Federal agency). Include prefixes, e.g., "RFP-DE-90-001."
9. For a covered Federal action where there has been an award or loan commitment by the Federal agency, enter the Federal amount of the award/loan commitment for the prime entity identified in item 4 or 5.
10. (a) Enter the full name, address, city, State and zip code of the lobbying registrant under the Lobbying Disclosure Act of 1995 engaged by the reporting entity identified in item 4 to influence the covered Federal action.

(b) Enter the full names of the individual(s) performing services, and include full address if different from 10 (a). Enter Last Name, First Name, and Middle Initial (MI).
11. The certifying official shall sign and date the form, print his/her name, title, and telephone number.

According to the Paperwork Reduction Act, as amended, no persons are required to respond to a collection of information unless it displays a valid OMB Control Number. The valid OMB control number for this information collection is OMB No. 0348-0046. Public reporting burden for this collection of information is estimated to average 10 minutes per response, including time for reviewing instructions, searching existing data sources, gathering and maintaining the data needed, and completing and reviewing the collection of information. Send comments regarding the burden estimate or any other aspect of this collection of information, including suggestions for reducing this burden, to the Office of Management and Budget, Paperwork Reduction Project (0348-0046), Washington, DC 20503.

SPECIAL CONDITIONS

IF APPLICABLE TO THE PROJECT, GRANTEE MUST BE IN COMPLIANCE WITH THE FOLLOWING SPECIAL CONDITIONS AND ANY OTHER STATE, FEDERAL, OR LOCAL LAWS, RULES, AND REGULATIONS AS MAY BE APPLICABLE, THROUGHOUT THE TERM OF THE CONTRACT, PRIOR TO THE RELEASE OF ANY GRANT FUNDS FOR THE PROJECTS ANTICIPATED.

GRANTEE AND IS DEEMED TO HAVE READ AND TO UNDERSTAND THE REQUIREMENTS OF EACH OF THE FOLLOWING, IF APPLICABLE TO THE PROJECT UNDER THIS CONTRACT:

A. REIMBURSEMENT, GENERALLY

As provided for in Public Law 110-329, the Contract funds may not be used for activities that are eligible to be reimbursed by, or for which funds are made available by, (a) the Federal Emergency Management Agency (FEMA); (b) the Army Corps of Engineers (Corps); (c) any other federal funding source; or (d) covered by insurance, and Grantee shall ensure compliance with all such requirements.

B. NATIONAL FLOOD INSURANCE PROGRAM COMPLIANCE

- (1) Grantee must provide documentation which indicates that it has received approval from the Texas Water Development Board (TWDB), the National Flood Insurance Program (NFIP) State Coordinating Agency, that appropriate ordinances or orders necessary for Grantee to be eligible to participate in the NFIP have been adopted.
- (2) Where activities specified in Attachment A, Performance Statement, involve structures that are located in Special Flood Hazard Areas (SFHA), flood insurance may be required, and Grantee shall obtain such insurance, and shall maintain documentation evidencing compliance with such requirements.
- (3) Grantee acknowledges and agrees that if any property that is the subject of a Project under this Contract located within a floodplain, that the following terms and conditions shall apply:
 - a. Under the Flood Disaster Protection Act of 1973, as amended (42 U.S.C. 4001-4128), Federal financial assistance for acquisition and construction purposes (including rehabilitation) may not be used in an area identified by the Federal Emergency Management Act (FEMA) as having special flood hazards, unless:
 - i. The community in which the area is situated is participating in the National Flood Insurance Program ("NFIP") (44 CFR parts 59 through 79), or less than one (1) year has passed since the FEMA notification regarding such hazards; and
 - ii. The community is participating in the NFIP, or that flood insurance protection is to be obtained as a condition of the approval of financial assistance to the property owner.
 - b. Where the community is participating in the NFIP and the recipient provides financial assistance for acquisition or construction purposes (including rehabilitation) for property located in an area identified by FEMA as having special flood hazards, Grantee is responsible for ensuring that flood insurance under the NFIP is obtained and maintained.

- c. Under Section 582 of the National Flood Insurance Reform Act of 1994, 42 U.S.C. 515a, HUD disaster assistance that is made available in a special flood hazard area may not be used to make a payment (including any loan assistance payment) to a person for repair, or replacement or restoration for flood damage to any personal, residential, or commercial property if:
 - i. The person had previously received Federal flood disaster assistance conditioned on obtaining and maintaining flood insurance; and
 - ii. The person failed to obtain and maintain flood insurance.
- d. Grantee understands and agrees that it has a responsibility to inform homeowners receiving disaster assistance that triggers the flood insurance purchase requirement of their statutory responsibility to notify any transferee of the requirement to obtain and maintain flood insurance, and that the transferring owner may be liable if he or she fails to do so.

C. PROJECT MAPPING/DESIGN INFORMATION

For construction projects, Grantee shall require and maintain copies in written and/or digital format, of final Project record drawing(s) and engineering schematics, as constructed.

D. WATER SYSTEM IMPROVEMENTS

- (1) Prior to the GLO's release of funds for the construction of any water system improvements, Grantee shall provide certification to the GLO that plans, specifications, and related documents for the specified water system improvements have been prepared by the engineer selected for such activities, or the engineer's duly authorized representative, and that the review of such plans, specifications, and related documents meet the applicable Texas Commission on Environmental Quality (TCEQ) review requirements described in Title 30 of the Texas Administrative Code.
- (2) Prior to construction, Grantee shall provide documentation to the GLO that an approved new or amended Certificate of Convenience and Necessity (CCN), or the equivalent permit or authority for the area to be served has been issued by the TCEQ.
- (3) Prior to Grantee submission of the Project Completion Report for any water system improvements described in Attachment A, Grantee shall provide a letter from the TCEQ that the constructed well is approved for interim use and may be temporarily placed into service pursuant to 30 Texas Administrative Code, Chapter 290 – Rules and Regulations for Public Water Systems.

E. SEWER SYSTEM IMPROVEMENTS

Prior to the construction of any sewer system improvements described , Grantee shall provide certification that plans, specifications, and related documents for the specified sewer system improvements have been prepared by the engineer selected for such activities, or the engineer's duly authorized representative, and that the review of such plans, specifications, and related documents meet the TCEQ review requirements described in 30 Texas Administrative Code, Chapter 217, Subchapter D.

Further, prior to the construction of any sewer lines or additional service connections described in Attachment A, Grantee shall provide notification of the start of construction on any sewer treatment plant of other system-related improvements included in this Contract.

F. WASTEWATER TREATMENT CONSTRUCTION

Prior to incurring costs for any wastewater treatment construction in Attachment A, Grantee shall provide documentation of an approved permit or amendment(s) to an existing permit for such activities from the TCEQ's Water Quality Division.

In addition, Grantee shall provide documentation to the GLO that an approved new or amended Certificate of Convenience and Necessity (CCN), or equivalent permit or authority for the area to be served has been issued by the TCEQ.

G. SEPTIC SYSTEM IMPROVEMENTS

- (1) Grantee shall provide documentation that final plans, specifications, and installation of its septic system improvements have been reviewed and approved by the City or County Health Department through authority granted by the TCEQ.
- (2) Grantee shall mitigate all existing septic systems in accordance with 30 Texas Administrative Code Chapter 285, Subchapter D, §285.36(b), which states, "All tanks, boreholes, cesspools, seepage pits, holding tanks, and pump tanks shall have the wastewater removed by a waste transporter, holding a current registration with the executive director. All tanks, boreholes, cesspools, seepage pits, holding tanks, and pump tanks shall be filled to ground level with fill material (less than three inches in diameter), which is free of organic and construction debris."
- (3) Prior to the selection of program recipients for proposed On-Site Sewer Facilities (OSSF), Grantee shall provide a copy of its proposed program guidelines for GLO review. All proposed OSSF programs must meet or exceed guidelines set forth in 30 Texas Administrative Code Chapter 285 Subchapter D.

H. BUILDING CONSTRUCTION

Grantee shall provide documentation that the construction of a new building and facilities are in compliance with the Texas Accessibility Standards (TAS) of the Architectural Barriers Act, Chapter 469, Texas Government Code, and the Texas Department of Licensing and Regulation (TDLR) Architectural Barriers Administrative Rules, 16 Texas Administrative Code, Part 4, Chapter 68. If the estimated construction costs exceed Fifty Thousand Dollars (\$50,000.00), Construction Documents must be submitted to the Texas Department of Licensing and Regulation (TDLR) for an accessibility plan review.

I. BRIDGE CONSTRUCTION/REHABILITATION

Grantee shall use the minimum design requirements of the Texas Department of Transportation (TxDOT) for bridge construction/rehabilitation. Final plans and specifications must be submitted to TxDOT for review and approval prior to the start of construction, and documentation of such approval must be provided to the GLO.

J. DISASTER SHELTERS

Grantee shall ensure that the primary purpose of the facility, as described in **Attachment A**, is to serve as a disaster shelter, and shall ensure the facility is operated at all times in a manner that ensures that the

priority use is to serve as a disaster shelter regardless of any other scheduled uses or commitments that existed at the time of the disaster or emergency situation. In addition Grantee shall prepare or be incorporated into an approved emergency management plan, as prescribed by the Governor's Division of Emergency Management, identifying the shelter as a facility that provides short-term lodging for evacuees during and immediately after an emergency situation. Grantee shall submit a copy of Grantee's Emergency Management Plan Annex for Shelter and Mass Care to the GLO.

K. DEBRIS REMOVAL

Grantee shall ensure that any debris to be removed consists primarily of vegetation, construction and demolition materials from damaged or destroyed structures, and personal property. Only debris identified as the responsibility of the local jurisdiction will be eligible for the reimbursement of cost of removal.

Prior to beginning debris collection operations, Grantee shall address all pertinent environmental concerns, adhere to all applicable regulations, and obtain all required permits. Further, Grantee shall adhere to the methods described herein for the collection and storage of debris prior to proper disposal.

While construction and demolition debris may be collected and disposed of at an appropriately rated landfill, woody and/or vegetative debris must be stored prior to disposal by use of temporary debris storage and reduction sites (TDSR). Grantee will prepare and operate the TDSR sites, or local jurisdictions choosing to conduct their own debris operations may review Chapter 7 of the FEMA Debris Management Guide regarding the use of TDSR sites. This document may be obtained at <http://www.fema.gov/pdf/government/grant/pa/demagde.pdf>.

In order to maintain the life expectancy of landfills, Grantees disposing of woody and/or vegetative debris must choose burning, chipping, or grinding as the method of disposal. Any project disposing of woody and/or vegetative debris must be approved in writing by the GLO.

L. USE OF BONDS

Grantee must notify the GLO of its issuance and sale of bonds for completion of the project funded under this Contract.

M. HOUSING REHABILITATION ASSISTANCE PROGRAM GUIDELINES

Prior to the selection of program recipients, Grantee shall provide a copy of its proposed housing rehabilitation assistance program guidelines for GLO review and approval. The guidelines must include provisions for compliance with the Federal Fire Prevention and Control Act of 1974 (which requires that any housing unit rehabilitated with grant funds be protected by a hard-wired or battery-operated smoke detector) and provisions for compliance with 24 CFR 35 (HUD lead-based paint regulation).

HOUSING REHABILITATION OR RECONSTRUCTION ASSISTANCE:

- (1) The housing rehabilitation or reconstruction assistance provided by Grantee shall be in the form of a five-year deferred payment loan (DPL), at zero interest. Provided all terms and conditions under which the assistance was provided continue to be fulfilled, the DPL will be forgiven at a rate of 20 percent per year, effective on the anniversary date of completion of the Project, evidenced by the date of the Certificate of Final Completion or Final Completion Form.

- (2) The full amount of the assistance provided shall be secured by a fully executed promissory note and Deed of Trust (DOT) filed against the property and recorded in the land records of each applicable county. The DPL may be in a first position (no existing indebtedness) or in a second position, subject or inferior only to an existing first mortgage.
- (3) If the homeowner occupies the home for the full five-year term, the note expires and no repayment is required, nor will any conditions be imposed relative to the disposition of the property. If any of the terms and conditions under which the assistance was provided are breached or if the property is sold, leased, transferred or vacated by the homeowner for any consecutive thirty (30) day period during the five-year lien term, the repayment provisions of the promissory note and DOT shall be enforced.
- (4) If, during the five-year lien term, the homeowner vacates the unit for any consecutive thirty (30) day period, the locality may forgive, as evidenced by city council or commissioner court action, the remaining loan balance. Prior to forgiveness of all or any portion of the assistance provided, the request for forgiveness must be approved by the local governing body and be based on documented and justifiable conditions or circumstances that would result in an unnecessary hardship to the homeowner and the determination that the national objective of benefiting low to moderate-income persons was met.
- (5) The national objective will be considered met only when the city council or county commissioners court determines that a low to moderate-income person has occupied the rehabilitated or reconstructed home for a time sufficient to meet the national objective. Grantee is liable for repayment of an amount equal to the difference in the appraised value of the home prior to reconstruction and the sales price when the home is sold during the term of the five-year forgivable loan, if the national objective was not achieved.
- (6) If the property is sold or transferred to a person other than an eligible LMI person, the remaining pro-rated balance of the DPL must be repaid by the Grantee from the sales proceeds. Notwithstanding the preceding, Grantee shall be held liable for any balance remaining over and above the sales proceeds. In all instances, upon completion of the five-year occupancy or repayment of the assistance (in full or in part), the Grantee shall prepare and record a release of lien document in the land records of the applicable county.
- (7) In instances where another occupant proposes to occupy a previously assisted unit, the locality must document that the new applicant is income eligible and has been informed of the terms and conditions under which the assistance is being provided. The new homeowner(s) must acknowledge, in writing, that they have been informed of these terms and conditions and that they are subject to all of the provisions for the full remaining term of the DPL.

N. COASTAL MANAGEMENT

Grantee acknowledges and agrees that any Project that may impact a Coastal Natural Resource Area must be consistent with the goals and policies of the Texas Coastal Management Program as described in 31 Texas Administrative Code, Part 16, Chapter 501.

REMAINDER OF PAGE INTENTIONALLY LEFT BLANK

RESOLUTION

RESOLUTION DESIGNATING AND AUTHORIZING BONDED SIGNATORIES FOR THE OFFICE OF THE TEXAS GENERAL LAND OFFICE PROGRAM FUNDS.

WHEREAS, the Urban County Program applied for and received funding from the Texas General Land Office (GLO):

2012 Texas General Land Office GLO#12-406-000-6453/ DRS210068

- Precinct No.1 Flood Drainage Improvements
- Precinct No.2 Flood Drainage Improvements
- Precinct No.3 Flood Drainage Improvements

WHEREAS, it is necessary and in the best interest of Hidalgo County to designate as needed: The County Judge, the Hidalgo county Chief Administrator, the Urban County Program Director, and/ or Urban County Program Deputy Director to act in all GLO program matters pertaining to the implementation administration, or participation in fulfilling the requirements of the GLO contractual program documents.

NOW THEREFORE, IT IS HEREBY RESOVLED AND ORDERED BY THE COMMISSIONER' COURT OF THE COUNTY OF HIDALGO, TEXAS:

That the Hidalgo County Commissioners' Court designate the persons holding the following positions as authorized bonded signatories on any account in which funds from the Office of the Texas General Land Office Program are deposited: Hidalgo County Judge, Hidalgo County Chief Administrator, Urban County Program Director, and/or Urban County Deputy Director respectively.

PASSED AND APPROVED THIS ____ DAY OF _____

**Ramon Garcia, County Judge
Hidalgo County, Texas**

ATTEST:

**Arturo Guajardo Jr., County Clerk
Hidalgo County, Texas**



CHAPTER 2

FINANCIAL MANAGEMENT

Form 2-2 Depository/Authorized Signatories Designation Form

TEXAS COMMUNITY DEVELOPMENT BLOCK GRANT PROGRAM DEPOSITORY/AUTHORIZED SIGNATORIES DESIGNATION FORM

Contractor Hidalgo County TDRA-DR Contract No. GLO12-406-000-6453

The financial lending institution listed here will serve as the depository for the Texas Community Development Block Grant Program contract funds:

First National Bank
(Name of Lending Institution)

302 E. University Drive
(Address)

Edinburg, Texas
(City, State Zip Code)

Fund Account Number: 140-101-43

The individuals listed below are designated by resolution as authorized signatories for contractual documents—(At least two (2) Signatories Required)

<u>Ramon Garcia</u> (Name) <u>Hidalgo County Judge</u> (Title) (Signature)	<u>Yolanda Chapa</u> (Name) <u>Hidalgo County Chief Administrator</u> (Title) (Signature)
<u>Diana R. Serna</u> (Name) <u>Hidalgo County UCP Director</u> (Title) (Signature)	<u>Antonio Barco</u> (Name) <u>Hidalgo County UCP Deputy Director</u> (Title) (Signature)

NOTE: A copy of a Resolution passed by the city council or county commissioner's court authorizing the signatories must be submitted along with this form.

AI-33202

Urban County 11. B.

CC REGULAR

Meeting Date: 07/24/2012

Department Head: Ester Gonzalez

Submitted By: Mary Flores, URBAN COUNTY

Department: URBAN COUNTY

Information

CAPTION

Urban County Program is requesting consideration and action to replace Exhibit "B" (Bid Page), submitted by 2GS, LLC, on a contract approved by County Commissioner's Court on July 3, 2012 for the Texas Department of Agriculture Colonia Economic Distress Area Program (CEDAP Contract No. 711195). No change to specs or funding.

BACKGROUND

Bids were requested and received for Pct. No. 3 – CEDAP 711195 Rehabilitation: Single-Unit Sewer Service Project: Village of Los Ebanos, Cuevitas, Rancho Subd., and Valle Vista Subdivision. Javier Hinojosa Engineering prepared the specification packages. Bids were received and opened at the Hidalgo County – Purchasing Dept. on June 6, 2012. UCP is requesting that the Exhibit “B” submitted by the lowest bidder, 2GS, LLC, be accepted in lieu of the format provided in the County approved Bid Package. Please see attached exhibit submitted by 2GS, LLC and the exhibit provided in the bid package.

Attachments

Exhibit B Bid Page

Form Review

Inbox	Reviewed By	Date
Budget & Management	Merlen P. Munoz	07/11/2012 03:30 PM
Purchasing Department	Angela Garcia	07/20/2012 04:55 PM
Form Started By: Mary Flores		Started On: 07/11/2012 02:59 PM
	Final Approval Date: 07/20/2012	

EXHIBIT "B"

BID PAGE

HIDALGO COUNTY-URBAN COUNTY PROGRAM
"Texas Department of Agriculture Colonia Economic Distress Area
Program (CEDAP) Sewer Service Hook-Up Project Village of Los
Ebanos, Cuevitas, Rancho Subdivision and Valle Vista Subdivision"

BID NO.: 6538-66-6591-5000-6600-UCP-PDLC

SCOPE OF WORK DESCRIPTION:

PROVIDE BIDS FOR INSTALLATION OF SANITARY SEWER YARD LINES AND
REMEDICATION OF EXISTING SEPTIC TANKS.

BID PRICE: \$ _____

ALTERNATE PRICE: \$ _____

BIDDER/COMPANY NAME: _____

ADDRESS: _____

CITY/STATE/ZIP CODE: _____

PHONE & FAX NO.'S: _____

CELLULAR & BEEPER NO.'S: _____

AUTHORIZED SIGNATURE: _____

PRINTED NAME: _____

TITLE: _____

BID FOR

HIDALGO COUNTY- URBAN COUNTY PROGRAM "Hidalgo County Precinct No. 3/Urban County Program & Texas Department of Agriculture Colonia Economic Distress Area Program (CEDAP#711195) Sewer Service Hook-Up Project Village of Los Ebanos, Cuevitas, Rancho Subdivision and Valle Vista Subdivision"

RFB No: 6538-66-6591-5000-6600-UCP-PDLC

Deliver To: Martha L. Salazar, CPPB, Purchasing Agent
Hidalgo County Purchasing Department
2802 So. Bus. Hwy 281 - Hidalgo County Administration Building
Postal Mailing Address: 2812 So. Bus. Hwy 281 (corner of Bus. 281 & Canton Rd.)
Edinburg, Texas 78539

In accordance with the Specifications, and subject to all laws and regulations of the United States and state and local laws, the undersigned bidder proposes and commits to furnish all labor, equipment, material, software and services as set forth in the documents hereinbefore mentioned. The undersigned bidder further agrees, upon acceptance of its bid, to execute a contract and/or Purchase Order issued by Hidalgo County for performing and completing the work described in the Specifications within the time stated and for the prices proposed in the documents attached hereto and made a part hereof.

Bidder acknowledges receipt of all of the pages of the documents referenced in the Invitation to Bid Checklist presented in connection with this procurement. Bidder understands that Hidalgo County reserves the right to reject any or all bids and further reserves the right to design the evaluation criteria to be used in selecting the lowest and best bid.

Bidder agrees that this bid shall be good and may not be withdrawn for a period of thirty (30) calendar days after the scheduled closing time for receiving bids, as contained in the Specifications.

Respectfully submitted,

Bidder: 2GS, LLC.
Address: P.O. BOX 595, PENITAS, TX. 78576
By: HUMBERTO GARCIA JR.
Printed Name: 
Title: SECRETARY/OFFICER

U.S. DEPARTMENT OF HOUSING AND URBAN DEVELOPMENT

BID FOR UNIT PRICE CONTRACTS

Place Hidalgo County Purchasing Dept.
 Date _____
 Project No. 6538-66-6591-5000-6600-UCP-PDLC

Proposal of 2GS, LLC (Hereinafter called "Bidder") a corporation, organized and existing under the laws of the State of TEXAS _____,* a partnership, or an individual doing business as 2GS, LLC.

To the **Hidalgo County**,

Gentlemen:

The Bidder, in compliance with your invitation for bids for the construction of **Hidalgo County Precinct No. 3/Urban County Program & Texas Department of Agriculture Colonia Economic Distress Area Program (CEDAP) Sewer Service Hook-Up Project Village of Los Ebanos, Cuevitas, Rancho Subdivision and Valle Vista Subdivision**, having examined the plans and specifications with related documents and the site of the proposed work, and being familiar with all of the conditions surrounding the construction of the proposed project including the availability of materials and labor, hereby proposes to furnish all labor, materials, and supplies, and to construct the project in accordance with the contract documents, within the time set forth therein, and at the prices stated below. These prices are to cover all expenses incurred in performing the work required under the contract documents, of which this proposal is a part.

Bidder hereby agrees to commence work under this contract on or before a date to be specified in written "Notice to Proceed" of the Owner and to fully complete the project within **120** consecutive calendar days thereafter as stipulated in the specifications. Bidder further agrees to pay as liquidated damages, the sum of **\$300.00** for each consecutive calendar day thereafter as hereinafter provided in Paragraph 19 of the General Conditions

Bidder acknowledges receipt of the following addendum:

ACKNOWLEDGES ADDENDUM #1 6/01/2012

*Insert corporation, partnership or individual as applicable.

Bidder agrees to perform all the **Hidalgo County Precinct No. 3/Urban County Program & Texas Department of Agriculture Colonia Economic Distress Area Program (CEDAP) Sewer Service Hook-Up Project Village of Los Ebanos, Cuevitas, Rancho Subdivision and Valle Vista Subdivision** work described in the specifications and show on the plans, for the following unit prices:

A. Water Distribution

<u>Item No.</u>	<u>Est. Qty.</u>	<u>Description</u>	<u>Unit Price (Each)</u>	<u>Total</u>
1.	223 EA	Clean Out Installation and Plumbing inside the property For sewer connection	One Thousand Dollars and No Cents <hr/> Dollars & Cents (\$ <u>\$1,000.00</u>)	Two hundred Twenty Three thousand dollars and no cents <hr/> Dollars & Cents (\$ <u>\$223,000.00</u>)

2.	223 EA	Final Sewer Connection And Decommission of Septic Tank	Two Hundred Fifty Dollars and <u>No Cents.</u> Dollars & Cents (\$ <u>\$250.00</u>)	Fifty Five Thousand, Seven Hundred Fifty Dollars and No Cents. Dollars & Cents (\$ <u>\$55,750.00</u>)
TOTAL OF BID (ITEMS A)			\$ <u>\$278,750.00</u>	

(Amounts are to be shown in both words and figures. In case of discrepancy, the amount shown in words will govern.)

OPENED

9:46

*NOTE: Any part of the Stated Allowance for the Utility Adjustments shall only be utilized if authorized by the Engineer. A cost proposal for this item must be submitted by the Contractor and approved by the Engineer prior to work performed.

6-06-12

Witnessed

J

The above unit prices shall include all labor, materials, bailing, shoring, removal, overhead, profit, insurance, etc., to cover the finished work of the several kinds called for.

Bidder understands that the Owner reserves the right to reject any or all bids to waive any informalities in the bidding.

The bidder agrees that this bid shall be good and may not be withdrawn for a period of 30 calendar days after the scheduled closing time for receiving bids.

Upon receipt of written notice of the acceptance of this bid, bidder will execute the formal contract attached within 10 days and deliver a Surety Bond or Bonds as required by Paragraph 29 of the General Conditions. The bid security attached in the sum of _____ 5 % _____.

(\$ _____ 5% _____) is to become the property of the Owner in the event the contract and bond are not executed within the time above set forth, as liquidated damages for the delay and additional expense to the Owner caused thereby.

Respectfully submitted:

By  Secretary
(title)

_____ P.O. BOX 595, PENITAS, TX, 78576
(Business Address and Zip Code)

(SEAL - if bid is by a corporation)

AI-33199

Urban County 11. C.

CC REGULAR

Meeting Date: 07/24/2012

Department Head: Mary Flores

Submitted By: Mary Flores, URBAN COUNTY

Department: URBAN COUNTY

Information

CAPTION

Requesting approval to Re-Authorize Urban County Program Director to sign and execute Loan Agreements, Rehabilitation Contracts, Promissory Notes, Release of Real Estate Liens on Property that has met the established Affordability Periods, and CHDO Agreements, as they relate to the HOME Program.

BACKGROUND

The Urban County Program is requesting that such authority be provided to the Urban County Program Director in order to expedite the Housing Process and comply with applicable Federal Regulations.

Form Review

Inbox	Reviewed By	Date
Budget & Management	Merlen P. Munoz	07/11/2012 03:11 PM
Purchasing Department	Angela Garcia	07/20/2012 04:55 PM
Form Started By: Mary Flores		Started On: 07/11/2012 02:01 PM
	Final Approval Date: 07/20/2012	

AI-33197

Urban County 11. D.

CC REGULAR

Meeting Date: 07/24/2012

Department Head: Mary Flores

Submitted By: Mary Flores, URBAN COUNTY

Department: URBAN COUNTY

Information

CAPTION

Requesting approval to re-Authorize Urban County Program Director to approve certain Change Orders on Urban County Projects.

BACKGROUND

On January 22, 2002 the Commissioners' Court granted authority to Urban County Interim Director Alan Kamasaki to approve Change Orders involving an increase or decrease of \$50,000 or less, and for Change Orders requesting additional time of completion.

The County of Hidalgo Procurement Procedures, in Section III, No. F(B), permits as follows:
"If a Change Order involves an increase or decrease in cost of \$50,000 or less, the Commissioners' Court may grant General Authority to an employee to approve the change orders. However, the original contract price may not be increased by more than 25% unless the Change Order is necessary to comply with a federal or state statute, rule regulation, or judicial decision enacted, adopted, or rendered after the contract was made.

The original contract price may not be decreased by 18 percent or more without the consent of the contractor."

The Urban County Program is requesting that such a Grant of General Authority be made to Director Diana R. Serna, under the conditions listed above, and are for Change Orders requesting additional time for completion. This would help to speed up project spending and completion, while Commissioners' Court would still retain responsibility for any proposed major changes

Form Review

Inbox	Reviewed By	Date
Budget & Management	Merlen P. Munoz	07/11/2012 03:10 PM
Purchasing Department	Angela Garcia	07/20/2012 04:55 PM
Form Started By: Mary Flores		Started On: 07/11/2012 01:49 PM
	Final Approval Date: 07/20/2012	

AI-33192

Urban County 11. E.

CC REGULAR

Meeting Date: 07/24/2012

Department Head: Mary Flores

Submitted By: Mary Flores, URBAN COUNTY

Department: URBAN COUNTY

Information

CAPTION

Requesting approval to Re-Authorize Urban County Program Director to sign and execute contracts and agreements after Hidalgo County Commissioners' Court approval as it relates to all Hidalgo County Urban County Program projects included in the Annual Consolidated Plan.

BACKGROUND

The Hidalgo Urban County Program Annual Action Plan outlines the intended use of CDBG, HOME, and ESG Funds administered by the Hidalgo County Urban County Program. The original authorization was approved by the Hidalgo County Commissioners' Court on June 4, 1996.

Form Review

Inbox	Reviewed By	Date
Budget & Management	Merlen P. Munoz	07/11/2012 03:05 PM
Purchasing Department	Angela Garcia	07/20/2012 04:55 PM
Form Started By: Mary Flores		Started On: 07/11/2012 11:40 AM
	Final Approval Date: 07/20/2012	

AI-33190

Urban County 11. F.

CC REGULAR

Meeting Date: 07/24/2012

Department Head: Mary Flores

Submitted By: Mary Flores, URBAN COUNTY

Department: URBAN COUNTY

Information

CAPTION

Re-Designation of Urban County Program Director as Certifying Officer Designee for Environmental Review Procedures for entities assuming HUD Environmental responsibilities (CDBG, HOME, ESG, COLONIA, TDHCA, TDRA, GLO Program and etc.)

BACKGROUND

Prior to obtain Annual Funding from the U.S. Department of Housing and Urban Development, the Urban County Program must comply with 24 CFR Part 58 of the Federal Regulations. These Regulations provide Guidance on the procedures and time periods necessary to comply with public comment periods.

The Urban County Program is requesting that such Designation be made to the Urban County Program Director in order to speed up project spending and compliance with ratio requirements.

Form Review

Inbox	Reviewed By	Date
Budget & Management	Merlen P. Munoz	07/11/2012 12:59 PM
Purchasing Department	Angela Garcia	07/20/2012 04:55 PM
Form Started By: Mary Flores		Started On: 07/11/2012 11:32 AM
	Final Approval Date: 07/20/2012	

AI-33172

Urban County 11. G.

CC REGULAR

Meeting Date: 07/24/2012

Department Head: Candace Armenta

Submitted By: Mary Flores, URBAN COUNTY

Department: URBAN COUNTY

Information

CAPTION

Urban County Program, on behalf of the City of Hidalgo, is requesting approval of a best and final negotiated contract with EGV Architects, Inc. in the amount of \$56,100.00, utilizing Year 23 (2010) funds for standard architectural services for the non-residential historical preservation of the old Hidalgo County courthouse in Hidalgo, Texas.

BACKGROUND

EGV Architects, Inc. has submitted a best and final offer for the required professional architectural services for the non-residential historical preservation of the old Hidalgo County courthouse in Hidalgo, Texas. EGV Architects, Inc. was the highest ranked firm by Commissioner's Court on June 12th 2012. Contract approval in the amount of \$56,100.00 is being requested for architectural services. See attached letter of best and final offer, scope of services, and certificate of liability insurance.

Architectural Firm: EGV Architects, Inc.

Contract Amount: \$ 56,100.00

Funds Available: \$233,190.25 – FY 23 (2010) Non-Residential Historical Preservation Funds
\$278,900.00 – FY 24 (2011) Non-Residential Historical Preservation Funds

Attachments

Backup/letter, Service Agreement. Liabilty Ins.

Form Review

Inbox	Reviewed By	Date
Budget & Management	Merlen P. Munoz	07/10/2012 10:49 AM
Purchasing Department	Angela Garcia	07/20/2012 04:55 PM
Form Started By: Mary Flores		Started On: 07/10/2012 09:55 AM
	Final Approval Date: 07/20/2012	



Martin Cepeda, Mayor
Daniel (Dan) Dillard II, Mayor Pro-Tem

COUNCILMEMBERS

Pedro Fonseca
Guillermo Ramirez
Rodolfo (Rudy) Franz
Gustavo "Gus" Sanchez

JOE VERA III , CECD, CFEE

7/06/2012

Candace J. Armenta
Program Coordinator I
Urban County Program
1916 Tesoro Blvd.
Pharr, Texas 78557

RE: Approval of EGV's Best and Final Offer

Dear Candace,

We concur with your decision to move forward with EGV's final offer of \$56,100.00.
Please let this letter serve as our approval to get the agreement finalized.

Sincerely,

Joe Vera III, CECD, CFEE
City Manager



STATE OF TEXAS §
 §
COUNTY OF HIDALGO §

Professional Services Agreement

This Agreement, entered into this 24th day of July, 2012 by and between Hidalgo County, Texas acting by and through its Urban County Program, (hereinafter called the "Party") and EGV Architects, Inc., duly authorized Architect, herein acting by Eduardo G. Vela, Architect/President (hereinafter called the "Architect").

WITNESSETH THAT:

WHEREAS, Hidalgo County has received CDBG funds from the U.S. Dept. of Housing and Urban Development to be used by Urban County Participants.

WHEREAS, the Party is interested in obtaining Architectural Services;

WHEREAS, the Architect, duly licensed and registered to practice engineer in the State of Texas, has the professional abilities to undertake the study, evaluation, analysis and recommendations in a manner which shall provide the necessary public service while preserving and enhancing to the greatest degree possible the natural and proposed environment in the Project (as hereinafter defined) area; and

WHEREAS, the Party desires to engage the Architect to render certain services in connection therewith;

NOW, THEREFORE, the participants do mutually agree as follows:

**SECTION I
EMPLOYMENT OF THE ARCHITECT**

Party and Architect agree that Party's obligations under the Agreement are subject to and contingent upon actual receipt of adequate federal funds to meet the obligations of Party under this agreement. The Party agrees to employ the Architect to furnish and provide the architectural services as stated in the following sections and upon receipt of such satisfactory services, the Party agrees to pay the Architect as stated in the sections to follow.

**SECTION II
BASIC SERVICES OF THE ARCHITECT**

The Architect shall perform the following Basic Services for City of Hidalgo Non-Residential Historical Preservation Project Account(s) 5010-35-1602-5000-3500, (the "Project") as more particularly described in Exhibit A attached hereto.

STATE OF TEXAS §
 §
COUNTY OF HIDALGO §

Professional Services Agreement

This Agreement, entered into this 24th day of July, 2012 by and between Hidalgo County, Texas acting by and through its Urban County Program, (hereinafter called the "Party") and EGV Architects, Inc., duly authorized Architect, herein acting by Eduardo G. Vela, Architect/President (hereinafter called the "Architect").

WITNESSETH THAT:

WHEREAS, Hidalgo County has received CDBG funds from the U.S. Dept. of Housing and Urban Development to be used by Urban County Participants.

WHEREAS, the Party is interested in obtaining Architectural Services;

WHEREAS, the Architect, duly licensed and registered to practice engineer in the State of Texas, has the professional abilities to undertake the study, evaluation, analysis and recommendations in a manner which shall provide the necessary public service while preserving and enhancing to the greatest degree possible the natural and proposed environment in the Project (as hereinafter defined) area; and

WHEREAS, the Party desires to engage the Architect to render certain services in connection therewith;

NOW, THEREFORE, the participants do mutually agree as follows:

**SECTION I
EMPLOYMENT OF THE ARCHITECT**

Party and Architect agree that Party's obligations under the Agreement are subject to and contingent upon actual receipt of adequate federal funds to meet the obligations of Party under this agreement. The Party agrees to employ the Architect to furnish and provide the architectural services as stated in the following sections and upon receipt of such satisfactory services, the Party agrees to pay the Architect as stated in the sections to follow.

**SECTION II
BASIC SERVICES OF THE ARCHITECT**

The Architect shall perform the following Basic Services for City of Hidalgo Non-Residential Historical Preservation Project Account(s) 5010-35-1602-5000-3500, (the "Project") as more particularly described in Exhibit A attached hereto.

2.1 Preliminary Phase

- a. Attend preliminary conferences with the Party and, if requested, with the funding agency and other government agencies or interested parties regarding the project.
- b. As may be required, comply and receive from the Party and the funding agencies approval on all work.
- c. Prepare preliminary engineering plans on the Project in sufficient detail to indicate clearly the problems involved and solutions recommended with the cost estimates.
- d. Obtain the Party's written approval of the work of this Preliminary Phase before proceeding with the next phase.

2.2 Design Phase

- a. Attend the respective Party's meetings as requested for the purpose of explaining completed design work activities.
- b. Advise the Party of any soil investigations or tests which, in the opinion of the Architect, may be required for the proper execution of the Project.
- c. Provide all field information and surveys required for the design of the Project.
- d. Plot field data and other survey information for the design of the Project.
- e. Prepare detailed plans, specifications and contract documents and drawings (reproducible tracings) for construction authorized by the Party.
- f. Furnish, if requested, the engineering data necessary for the Party to obtain permits required by local, state, and federal authorities.
- g. Prepare cost estimates of authorized construction, based on prices for work. If such estimated costs exceed the monies available, the Party shall be consulted so that revisions can be made to reduce the cost as required.
- h. Prepare all documents required for the advertisement and bidding of the Project in cooperation with the Party's staff.
- i. Preparation of property or easement descriptions.

2.3 Construction Phase

The Construction Phase will commence with the execution of the prime construction contract(s). The Party will issue a ten (10) day commence work notice which will signal the commencement of work under any construction contracts and will terminate upon the Party's approval of the Architect's written approval of final payment to the Contractor(s). During the Construction Phase, the Architect will:

- a. Assist the Party in opening and tabulating bids for the construction of the Project, and advise the Party in establishing the procedure for entering into construction phase.
- b. Prepare the formal Contract Documents for the Contractor.
- c. Make periodic visits to the site as required pursuant to the standards of Professional Architects on projects of this nature, provide project construction supervision, to observe the progress and quality of the executed work and to determine if the work is proceeding in accordance with the contract documents.
- d. Consult with and advise the Party and issue all instructions and Change Orders to the Contractor selected by the Party.
- e. During the progress of actual construction, Architect will continually keep the Owner informed with brief and concise information. A monthly progress report will be prepared and delivered to the Party including but limited to monies spent, construction time elapsed, percent of Project completed, a brief narrative of problems encountered and the anticipated completion date.
- f. Review shop and working drawings furnished by Contractor(s) for general compliance with design concept and with information given in contract documents.
- g. Review and provide a recommendation concerning samples, catalog data, schedules, shop drawings, laboratory, shape and mill tests of material and equipment and other data which the Contractor is required to submit, in compliance with the Contract Documents.
- h. Prepare monthly and final estimates for payments to Contractor(s).
- i. Architect shall accompany the Party on the Final Inspection to assure that the total work has been completed in accordance with the Contract Documents.
- j. Prior to the Party's dispersal of any retainage of funds, render a written opinion to the Party that the construction has been completed according to the Contract Documents and provide the Party with a certificate of completion and release of liens documents from subcontractors.
- k. Provide the Party with sepia copies of as-built drawings of the constructed improvements, within sixty (60) days of issuance of certificate of completion.
- l. The Architect will be responsible for interim and final inspection.
- m. Furnish to the Party six (6) sets of plans and six (6) sets of specifications and contract documents.

**SECTION III
ADDITIONAL SERVICES OF THE ARCHITECT**

If authorized in writing by the Party, the Architect will furnish or obtain from others Additional Services of the following types which are not considered normal or customary basic services; these will be paid for by the Party as indicated in Section VI.

- 3.1 Services of a Resident Project Representative, and other field personnel as required, for on-the-site observations of construction, other than periodic visits covered in Section 2.3 herein.
- 3.2 Detailed mill, shop and/or laboratory inspection of materials or equipment.
- 3.3 Major revision of Contract drawings as distinguished from modifications due to change orders, modifications to reduce the cost of the project or modifications requested to meet federal, state, or local regulations.

**SECTION IV
REIMBURSABLE EXPENSES**

- 4.1 Travel and subsistence required for the Architect and authorized by the Party to points other than within Hidalgo County and Project site.
- 4.2 Additional copies of reports and specifications over six (6) copies and additional prints of drawings over six (6) copies.
- 4.3 Reimbursable expenses as provided in Section IV herein shall be paid to the Architect on the basis of 1.1 times the Architects actual cost.

**SECTION V
THE PARTY'S RESPONSIBILITIES**

The Party will:

- 5.1 Provide full information as to requirements for the Project.
- 5.2 Assist the Architect by providing all available information pertinent to the Project including reports and any other data relative to design and construction of the Project.
- 5.3 Furnish the services or data as required such as appropriate professional interpretations of all of the foregoing; property, boundary, easement, right-of-way, zoning, and deed restrictions; all of which the Architect may rely upon in performing his services under this agreement.
- 5.4 Guarantee access to and make all provisions for the Architect to enter upon public and private property as required for the Architect to perform his services under this Agreement.
- 5.5 Examine all studies, reports, sketches, estimates, specifications, drawings, proposals, and other documents presented by the Architect.

- 5.6 Pay for all costs incident to advertising and obtaining bids or proposals from Contractors.
- 5.7 Provide such legal and accounting services required to discharge the Party's responsibility under the terms of this Agreement and any Agreement with any governmental agency as may be required for the project, and such auditing services as the Party may require to ascertain how or for what purpose any Contractor has used the monies paid to him under the construction contract.
- 5.8 Give prompt written notice to the Architect whenever the Party observes or otherwise becomes aware of any defect in the Project.

SECTION VI PAYMENTS TO THE ARCHITECT

The Party agrees to pay the Architect for completed services as identified by the Party:

- 6.1 The Architect shall be paid a total fixed amount of **Fifty-Six Thousand One Hundred Dollars and Zero Cents (\$56,100.00)** for services rendered under this contract. Payment shall be based on request for reimbursements with documentation requested by the Party. The Architect's fee shall be due and payable as outlined in Sections 6.2, 6.3, and 6.4 as follows.
- 6.2 At Architect's completion and Party's approval of the Architect's services under the Preliminary Phase, Section 2.1 of this Agreement, Party shall pay a maximum of 15% of the sum set forth in Section 6.1 above.
- 6.3 At Architect's completion and Party's approval of the Architect's services under the Design Phase, Section 2.2 of this Agreement, Party shall pay a maximum of 60% of the sum set forth in Section 6.1 above.
- 6.4 At Architect's completion and Party's approval of the Architect's services under the Construction Phase, Section 2.3 of this Agreement, Party shall pay a maximum of 25% of the sum set forth in Section 6.1 above. Such sum to be paid periodically proportionately to the percentage of construction completed by the Contractor as determined by Architect's reports.
- 6.5 For Additional Services as provided in Section III herein the Architect shall be paid a sum of 1.1 times the Architect's actual cost for such services.

SECTION VII OWNERSHIP OF DOCUMENTS

Original documents, plans, designs and survey notes developed in connection with services performed hereunder belong to, and remain the property of the Party, in consideration of which it is mutually agreed that the Party will use them solely in connection with the Project and as base material for possible future projects.

**SECTION VIII
TERMINATION**

The Party may terminate this Agreement without cause at any time by a 30-day notice in writing to the Architect. Upon receipt of such notice, the Architect shall, unless the notice directs otherwise immediately discontinue all services in connection with the performance of this Agreement and shall proceed to cancel promptly all existing orders and contracts insofar as such orders or contracts are chargeable to this Agreement. As soon as practical after receipt of notice of termination, the Architect shall submit a statement showing in detail the actual services that were performed under this Agreement to date of termination, the date such services were performed and the length of time spent by each person or party engaged in performing such services on each day,

The Party shall pay the Architect a sum of money equal to the reasonable value of the professional architect services rendered by the Architect to the Party in connection with the services performed under this Contract, less payments previously made by the Party to Architect on work performed and expenses incurred by Architect under the provisions of this Agreement. Copies of all completed or partially completed designs, plans, and specifications prepared under this Agreement shall be delivered to the Party when and if this Agreement is terminated, but subject to the restrictions as to their use, as set forth above.

Notwithstanding the above, the Architect shall not be relieved of liability to the Party for damages sustained by the Party arising from Architect's negligent acts, errors or omissions related to Architect's obligations created under this Agreement.

**SECTION IX
COUNTY AND CITY OFFICIALS**

Architect agrees that no County or City official or Party employee shall be personally liable for any of the obligation created under this Agreement, or for any matter which may arise out of the Project, or any activities related thereto and hereby holds the Party, its political bodies and its employees harmless from and indemnifies them from any liability from any matter arising from Architect's negligent acts, errors or omissions related to Architect's obligations created under this Agreement.

**SECTION X
SUCCESSORS AND ASSIGNS**

Party and Architect each binds themselves, their partners, successors, executors, administrators, and assigns to the other party of Agreement in respect to all covenants of this Agreement. Neither the Party nor Architect shall assign or transfer any interest in this Agreement without the written consent of the other.

**SECTION XI
TIME OF PERFORMANCE**

The Architect contracts and agrees to commence work within ten (10) days from the date of written authorization to proceed and will complete the preparation of the preliminary phase and estimates by 90 days and will proceed upon authorization with final drawings, specifications, and contracts documents and complete same within the earliest practical time from such notice to proceed.

**SECTION XII
LAW and VENUE**

This agreement shall be governed by the laws of the State of Texas and is performable in Hidalgo County, Texas. Venue and jurisdiction of any suit, right or cause of action arising under or in connection with this Contract shall lie exclusively in Hidalgo County, Texas.

**SECTION XIII
AMENDMENT**

This Agreement may be amended only by a written document executed by the parties hereto.

**SECTION XIV
COMPLIANCE WITH LOCAL LAWS**

The Architect shall comply with all applicable laws, ordinances, and codes of the State and local governments, and the Architect shall save the Party harmless with respect to any damages arising from any negligence of the engineer in performing any of the work embraced by this Contract.

**SECTION XV
ASSIGNABILITY**

The Architect shall not assign any interest in this Contract, and shall not transfer any interest in the same (whether by assignment or novation) without the prior written consent of the Party thereof; provided however, that claims for money due or to become due to the Architect from the Party under this Contract may be assigned to a bank, trust company, or other financial institution without such approval. Notice of any such assignment or transfer shall be furnished promptly to the Party.

**SECTION XVI
GENERAL**

- 16.1 Audit. The Party and/or any of its duly authorized representatives shall have access to any books, documents, papers, and records of the Architect which are directly pertinent to the Project for the purpose of making the audit, examination, excerpts, and transcriptions.
- 16.2 The Architect agrees to comply with the following Executive orders, Titles and Program Regulations, including any additional requirements that may be set forth by the Party.
- a. Title VI of the Civil Rights Act - requires that no one may be denied access to benefits from projects which receive federal assistance.
 - b. Section 109 of the Housing and Community Development Act of 1974 - Nondiscrimination related to benefits from projects funded specifically under Title I of the Act.
 - c. Section 3 of the HUD Act of 1968 - requires that maximum effort be made to provide employment, training, and business opportunities to low income families and/or residents of the project area.

- d. The Architect shall give the United States Department of Housing and Urban Development, the Inspector General, the Comptroller General of the United States, the Auditor of the State of Texas, access to and the right to examine all books, accounts, records, reports, files, and other papers, things, or property belonging to or in use by Architect pertaining to this Agreement. Such rights to access shall continue as long as the records are retained by Architect. Architect agrees to maintain such records in an accessible location for a period of three (3) years.
- e. Executive Order 11246 (paragraph a-c for contracts under \$10,000; paragraphs a-g for contracts over \$10,000) - Equal Employment Opportunity.

Executive Order 11246. Executive Order 11246 and the regulations issued pursuant thereto (24 CFR Part 130) which provides that no person shall be discriminated against on the basis of race, color, religion, sex, or national origin in all phases of employment during the performance of federal or federally assisted contracts. Such consultants or subcontractors shall take affirmative action to ensure fair treatment in employment, upgrading, demotion, or transfer; recruitment or recruitment advertising; layoff or termination rates of pay or other forms of compensation and selection for training and apprenticeship.

Equal Employment Opportunity for Activities and Contracts not Subject to Executive Order 11246, as amended. In carrying out the program, the Consultant shall not discriminate against any employee or applicant for employment because of race, color, religion, sex or national origin. The Architect shall take affirmative action to ensure that applicants for employment are employed and that employees are treated during employment, without regard to their race, color, religion, sex or national origin. Such action shall include, but not limited to the following: Employment, upgrading, demotion, or transfer; recruitment or other forms of compensation; and selection for training, including apprenticeship. The Architect shall post in conspicuous places, available to employees and applicants for employment, notices to be provided by the Government setting forth the provisions of this paragraph in all of its contracts for program work and will require all of its consultants for such work to incorporate such requirements in all subcontracts for program.

- 16.3 Interest of Certain Federal Officials: No member of or Delegate to the Congress of the United States and no Resident Commissioner, shall be admitted to any share or part of this Agreement or to any benefit to arise from the same.
- 16.4 Interest of Members, Officers, or Employees of Public Body, Member of Local Governing Body, or other Public Officials: No member, officer, or employee of the County or City, or its designees or agents, no member of the governing body of the locality in which the program is situated, and no other public official of such locality or localities who exercises any functions or responsibilities with respect to the program during his tenure or for one year thereafter, shall have any interest, direct or indirect, to be performed in connection with the program assisted under the Agreement. The Architect shall incorporate or cause to be incorporated in all such documents in the paragraph in this Section.

**SECTION XVII
INSURANCE**

The Engineer shall obtain and keep in force during the term of its engagement on the Project, insurance as follows:

- 17.1 A comprehensive automobile liability policy covering liability exposure to bodily injury and property damages. The Architect shall furnish Party Certificates of Insurance showing the comprehensive automobile liability insurance policies to be in effect, commencing when Architects commence operations under this Agreement, in the sum of Three Hundred Thousand Dollar (\$300,000.00) for bodily injury and \$100,000 for property damages.
- 17.2 Uninsured/Underinsured motorist coverage in an amount equal to the bodily injury limits set forth immediately above;
- 17.3 A Five Hundred Thousand Dollar (\$500,000.00) Comprehensive General Liability Insurance Policy providing additional coverage to all underlying liabilities of Party consistent with potential exposure of Party under the Texas Tort Claims Act;
- 17.4 Workers Compensation Insurance in amount established by Texas law, unless the Architect is specifically exempted from the Texas Worker's Compensation Act, Texas Labor Code Chapter 401, et. seq.
- 17.5 Professional Liability insurance in an amount of One Million Dollars (\$1,000,000.00).
- 17.6 All insurance policies must be written by an insurance company or companies acceptable to the Party.

**SECTION XVIII
WARRANTY**

- 18.1 Architect represents and warrants to Owner all services rendered to Owner under this Agreement shall, at a minimum, comply with the Texas Architectural Practices Act (Tex. Civ. St. Ann., Article 3271) and rules of the Texas Board of Professional Architects.

SECTION XIX
EFFECTIVE DATE

The effective date of this contract shall be July 24, 2012. Such date being the date Hidalgo County Commissioners' Court approved entering into contract with Architect.

This Agreement is hereby approved this _____ day of _____, 20_____.

Signature: _____
Eduardo G. Vela, Architect/President

Firm Name: EGV Architects, Inc.
Address: 220 S Bridge St
City/ST/ZIP: Hidalgo, TX 78557

FED ID #/SS #: 74-3003688

STATE OF TEXAS §

§

COUNTY OF HIDALGO §

This instrument was acknowledged before me on this the ____ day of _____, 20____,
by _____ of and on behalf of _____,
title) (a corporation)(a partnership)(a sole proprietorship).

(seal)

Notary - Signature

County of Hidalgo Urban County Program:

Witness

Diana R. Serna, UCP Director

Revised as to Form:
Atlas, Hall & Rodriguez
By: Stephen L. Crain
On: July 06, 2012

Exhibit “A”
(Scope of Services)

See Attached



25 June 2012

Urban County Program
Attn: Ms. Diana Serna,
Director of Urban County
1916 Tesoro Blvd.
Pharr, TX 78577

Re: Remodeling of Old Hidalgo Co. Court House - Final and Best Offer

Ms. Serna,

We are glad to present the following proposal to the City of Hidalgo, we offer the following:

After reviewing the requirements for the remodeling of the Old Hidalgo Co. Court House, we will provide standard Architectural services for 6% of the budget cost (or $\$935,000 \times 6\% = \$56,100.00$). See Scope of Services and Schedule of Services, Exhibit "A" below for more information.

Sincerely,

A handwritten signature in blue ink, appearing to read 'Eduardo G. Vela', is written over a horizontal line.

Eduardo G. Vela, AIA
EGV Architects, Inc.

XC: City of Hidalgo, Mr. Joe Vera III





Exhibit "A"

Re: Remodeling of Old Hidalgo Co. Court House -- Scope of Services and Schedule of Fees.

Scope of Services:

We propose our standard Architectural Scope of Services which include, Mechanical, Plumbing, Electrical and Structural services.

Not included in the services are Civil Engineer and Landscape Architect.

Preliminary Phase:

- a. Provide Schematic drawings to the City of Hidalgo for approval
- b. Contact State Historical Department to establish their requirements and submit preliminary drawings for review.
- c. Prepare preliminary cost estimate for the City of Hidalgo.

Design Phase:

- a. Prepare plans and specification for construction and approval by the City of Hidalgo.
- b. Revise the cost estimate for the design phase for approval from the City of Hidalgo.
- c. Submit one set of plans to TDLR (Handicapped Accessibility) for review and registration.
- d. Assist The City of Hidalgo in the bidding of the project.
- e. Review the bids and provide recommendation of the bids to the City of Hidalgo.

Construction Phase:

- a. Attend a pre-construction meeting with the successful General Contractor and the City of Hidalgo.
- b. Review Submittals provided by the General Contractor.
- c. Visit the construction site as requested by the General Contractor.

Schedule of Fees:

Budget \$935,000 x 6% = \$56,100.00

Preliminary Phase	15%	= \$ 8,415.00
Design Phase	60%	= \$33,660.00
Construction Phase	25%	= <u>\$14,025.00</u>
Total		\$56,100.00



Policy Number:

Date Entered: 05/01/2012

CERTIFICATE OF LIABILITY INSURANCE

DATE (MM/DD/YYYY)

5/1/2012

THIS CERTIFICATE IS ISSUED AS A MATTER OF INFORMATION ONLY AND CONFERS NO RIGHTS UPON THE CERTIFICATE HOLDER. THIS CERTIFICATE DOES NOT AFFIRMATIVELY OR NEGATIVELY AMEND, EXTEND OR ALTER THE COVERAGE AFFORDED BY THE POLICIES BELOW. THIS CERTIFICATE OF INSURANCE DOES NOT CONSTITUTE A CONTRACT BETWEEN THE ISSUING INSURER(S), AUTHORIZED REPRESENTATIVE OR PRODUCER, AND THE CERTIFICATE HOLDER.

IMPORTANT: If the certificate holder is an ADDITIONAL INSURED, the policy(ies) must be endorsed. If SUBROGATION IS WAIVED, subject to the terms and conditions of the policy, certain policies may require an endorsement. A statement on this certificate does not confer rights to the certificate holder in lieu of such endorsement(s).

PRODUCER Davis Insurance Agency 2030 E. Griffin Parkway Mission, Texas 78572	CONTACT NAME: PHONE (A/C, No, Ext): (956) 581-9838 FAX (A/C, No): (956) 519-1524 E-MAIL ADDRESS: davisinsuranceagency@yahoo.com
	INSURER(S) AFFORDING COVERAGE INSURER A: AROGONAUT INSURANCE COMPANY INSURER B: INSURER C: INSURER D: INSURER E: INSURER F:
INSURED EGV ARCHITECTS INC EDUARDO G. VELA, ARCHITECT PO BOX 8627 HIDALGO, TX 78557	NAIC #

COVERAGES **CERTIFICATE NUMBER:** **REVISION NUMBER:**

THIS IS TO CERTIFY THAT THE POLICIES OF INSURANCE LISTED BELOW HAVE BEEN ISSUED TO THE INSURED NAMED ABOVE FOR THE POLICY PERIOD INDICATED. NOTWITHSTANDING ANY REQUIREMENT, TERM OR CONDITION OF ANY CONTRACT OR OTHER DOCUMENT WITH RESPECT TO WHICH THIS CERTIFICATE MAY BE ISSUED OR MAY PERTAIN, THE INSURANCE AFFORDED BY THE POLICIES DESCRIBED HEREIN IS SUBJECT TO ALL THE TERMS, EXCLUSIONS AND CONDITIONS OF SUCH POLICIES. LIMITS SHOWN MAY HAVE BEEN REDUCED BY PAID CLAIMS.

INSR LTR	TYPE OF INSURANCE	ADDL INSR	SUBR WVD	POLICY NUMBER	POLICY EFF (MM/DD/YYYY)	POLICY EXP (MM/DD/YYYY)	LIMITS
	GENERAL LIABILITY <input type="checkbox"/> COMMERCIAL GENERAL LIABILITY <input type="checkbox"/> CLAIMS-MADE <input checked="" type="checkbox"/> OCCUR GEN'L AGGREGATE LIMIT APPLIES PER: <input type="checkbox"/> POLICY <input type="checkbox"/> PRO-JECT <input type="checkbox"/> LOC						EACH OCCURRENCE \$ DAMAGE TO RENTED PREMISES (Ea occurrence) \$ MED EXP (Any one person) \$ PERSONAL & ADV INJURY \$ GENERAL AGGREGATE \$ PRODUCTS - COMP/OP AGG \$
	AUTOMOBILE LIABILITY <input type="checkbox"/> ANY AUTO <input type="checkbox"/> ALL OWNED AUTOS <input type="checkbox"/> HIRED AUTOS <input type="checkbox"/> SCHEDULED AUTOS <input type="checkbox"/> NON-OWNED AUTOS						COMBINED SINGLE LIMIT (Ea accident) \$ BODILY INJURY (Per person) \$ BODILY INJURY (Per accident) \$ PROPERTY DAMAGE (Per accident) \$
	<input type="checkbox"/> UMBRELLA LIAB <input type="checkbox"/> EXCESS LIAB DED RETENTION \$						<input type="checkbox"/> OCCUR <input type="checkbox"/> CLAIMS-MADE EACH OCCURRENCE \$ AGGREGATE \$
	WORKERS COMPENSATION AND EMPLOYERS' LIABILITY ANY PROPRIETOR/PARTNER/EXECUTIVE OFFICER/MEMBER EXCLUDED? (Mandatory in NH) If yes, describe under DESCRIPTION OF OPERATIONS below Y/N <input type="checkbox"/> N/A						<input type="checkbox"/> WC STATU-TORY LIMITS <input checked="" type="checkbox"/> OTH-ER E.L. EACH ACCIDENT \$ E.L. DISEASE - EA EMPLOYEE \$ E.L. DISEASE - POLICY LIMIT \$
A	PROFESSIONAL LIABILITY			IAE10084	05/01/2012	05/01/2013	EACH CLAIM \$1,000,000 EACH AGGREGATE \$1,000,000

DESCRIPTION OF OPERATIONS / LOCATIONS / VEHICLES (Attach ACORD 101, Additional Remarks Schedule, if more space is required)

CERTIFICATE HOLDER **CANCELLATION**

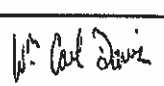
HIDALGO COUNTY 2812 S. HIGHWAY BUSINESS 281 EDINBURG, TX 78539	SHOULD ANY OF THE ABOVE DESCRIBED POLICIES BE CANCELLED BEFORE THE EXPIRATION DATE THEREOF, NOTICE WILL BE DELIVERED IN ACCORDANCE WITH THE POLICY PROVISIONS. AUTHORIZED REPRESENTATIVE 
--	--



Policy Number:

Date Entered: 07/03/2012

CERTIFICATE OF LIABILITY INSURANCE

DATE (MM/DD/YYYY)

7/3/2012

THIS CERTIFICATE IS ISSUED AS A MATTER OF INFORMATION ONLY AND CONFERS NO RIGHTS UPON THE CERTIFICATE HOLDER. THIS CERTIFICATE DOES NOT AFFIRMATIVELY OR NEGATIVELY AMEND, EXTEND OR ALTER THE COVERAGE AFFORDED BY THE POLICIES BELOW. THIS CERTIFICATE OF INSURANCE DOES NOT CONSTITUTE A CONTRACT BETWEEN THE ISSUING INSURER(S), AUTHORIZED REPRESENTATIVE OR PRODUCER, AND THE CERTIFICATE HOLDER.

IMPORTANT: If the certificate holder is an ADDITIONAL INSURED, the policy(ies) must be endorsed. If SUBROGATION IS WAIVED, subject to the terms and conditions of the policy, certain policies may require an endorsement. A statement on this certificate does not confer rights to the certificate holder in lieu of such endorsement(s).

PRODUCER Davis Insurance Agency 2030 E. Griffin Parkway Mission, Texas 78572	CONTACT NAME:	PHONE (A/C, No, Ext): (956) 581-9838	FAX (A/C, No): (956) 519-1524
	E-MAIL ADDRESS: davisinsuranceagency@yahoo.com		
INSURED EGV ARCHITECTS INC EDUARDO G. VELA, ARCHITECT PO BOX 8627 HIDALGO, TX 78557	INSURER(S) AFFORDING COVERAGE		NAIC #
	INSURER A:	FARMERS INSURANCE EXCHANGE	
	INSURER B:	FARMERS INSURANCE EXCHANGE	
	INSURER C:	FARMERS INSURANCE EXCHANGE	
	INSURER D:	ARGONAUT INSURANCE COMPANY	
	INSURER E:		
INSURER F:			

COVERAGES

CERTIFICATE NUMBER:

REVISION NUMBER:

THIS IS TO CERTIFY THAT THE POLICIES OF INSURANCE LISTED BELOW HAVE BEEN ISSUED TO THE INSURED NAMED ABOVE FOR THE POLICY PERIOD INDICATED. NOTWITHSTANDING ANY REQUIREMENT, TERM OR CONDITION OF ANY CONTRACT OR OTHER DOCUMENT WITH RESPECT TO WHICH THIS CERTIFICATE MAY BE ISSUED OR MAY PERTAIN, THE INSURANCE AFFORDED BY THE POLICIES DESCRIBED HEREIN IS SUBJECT TO ALL THE TERMS, EXCLUSIONS AND CONDITIONS OF SUCH POLICIES. LIMITS SHOWN MAY HAVE BEEN REDUCED BY PAID CLAIMS.

INSR LTR	TYPE OF INSURANCE	ADDL INSR	SUBR WVD	POLICY NUMBER	POLICY EFF (MM/DD/YYYY)	POLICY EXP (MM/DD/YYYY)	LIMITS
A	GENERAL LIABILITY <input type="checkbox"/> COMMERCIAL GENERAL LIABILITY <input type="checkbox"/> CLAIMS-MADE <input checked="" type="checkbox"/> OCCUR GEN'L AGGREGATE LIMIT APPLIES PER: <input type="checkbox"/> POLICY <input type="checkbox"/> PRO-JECT <input type="checkbox"/> LOC			605111951	06/30/2012	06/30/2013	EACH OCCURRENCE \$1,000,000 DAMAGE TO RENTED PREMISES (Ea occurrence) \$100,000 MED EXP (Any one person) \$5,000 PERSONAL & ADV INJURY \$1,000,000 GENERAL AGGREGATE \$2,000,000 PRODUCTS - COMP/OP AGG \$2,000,000 \$
B	AUTOMOBILE LIABILITY <input type="checkbox"/> ANY AUTO <input type="checkbox"/> ALL OWNED AUTOS <input checked="" type="checkbox"/> HIRED AUTOS <input checked="" type="checkbox"/> SCHEDULED AUTOS <input checked="" type="checkbox"/> NON-OWNED AUTOS			605057463	11/22/2011	11/22/2012	COMBINED SINGLE LIMIT (Ea accident) \$1,000,000 BODILY INJURY (Per person) \$ BODILY INJURY (Per accident) \$ PROPERTY DAMAGE (Per accident) \$ \$
	<input type="checkbox"/> UMBRELLA LIAB <input type="checkbox"/> EXCESS LIAB <input type="checkbox"/> OCCUR <input type="checkbox"/> CLAIMS-MADE DED RETENTION \$						EACH OCCURRENCE \$ AGGREGATE \$ \$
C	WORKERS COMPENSATION AND EMPLOYERS' LIABILITY ANY PROPRIETOR/PARTNER/EXECUTIVE OFFICER/MEMBER EXCLUDED? (Mandatory in NH) If yes, describe under DESCRIPTION OF OPERATIONS below Y/N <input checked="" type="checkbox"/> N		N/A	A07083837	06/30/2012	06/30/2013	<input type="checkbox"/> WC STATU-TORY LIMITS <input checked="" type="checkbox"/> OTH-ER E.L. EACH ACCIDENT \$1,000,000 E.L. DISEASE - EA EMPLOYEE \$1,000,000 E.L. DISEASE - POLICY LIMIT \$1,000,000
D	PROFESSIONAL LIABILITY			IAE10084	05/01/2012	05/01/2013	EACH CLAIM \$1,000,000 EACH AGGREGATE \$1,000,000

DESCRIPTION OF OPERATIONS / LOCATIONS / VEHICLES (Attach ACORD 101, Additional Remarks Schedule, if more space is required)

CERTIFICATE HOLDER

CANCELLATION

HIDALGO COUNTY
2812 S. HIGHWAY BUSINESS 281
EDINBURG, TX. 78539

SHOULD ANY OF THE ABOVE DESCRIBED POLICIES BE CANCELLED BEFORE THE EXPIRATION DATE THEREOF, NOTICE WILL BE DELIVERED IN ACCORDANCE WITH THE POLICY PROVISIONS.

AUTHORIZED REPRESENTATIVE

© 1988-2010 ACORD CORPORATION. All rights reserved.

ACORD 25 (2010/05)

The ACORD name and logo are registered marks of ACORD

AI-33169
CC REGULAR

Urban County 11. H.

Meeting Date: 07/24/2012

Department Head: Candace Armenta

Submitted By: Mary Flores, URBAN COUNTY

Department: URBAN COUNTY

Information

CAPTION

Urban County Program, on behalf of the City of La Joya, is requesting approval of a best and final negotiated engineering contract with S&B Infrastructure, Ltd. in the amount of \$19,505.00, utilizing Year 23 (2010) and YR 25 (2012) Urban County funds (anticipated release of 2012 funds is late August) for the construction of Military Park in La Joya, Texas.

BACKGROUND

: S&B Infrastructure, Ltd. has submitted a best and final offer for the required professional engineering services for the Parks, Recreational Facility improvements which consists of construction of Military Park in La Joya, Texas. S&B Infrastructure, Ltd. was the highest ranked firm by Commissioner's Court on April 3rd 2012. Contract approval in the amount of \$19,505.00 is being requested for engineering. See attached letter of best and final offer, scope of services, and certificate of liability insurance.

Engineering Firm: S&B Infrastructure, Ltd.

Contract Amount: \$ 19,505.00

Funds Available: \$101,193.25 – FY 23 (2010) Parks, Recreational Facility funds
\$ 94,000.00 – FY 25 (2012) Parks, Recreational Facility funds (To Be Awarded)
\$195,193.25 Total funding

Attachments

Backup La Joya Military Park

Form Review

Inbox	Reviewed By	Date
Budget & Management	Merlen P. Munoz	07/10/2012 10:37 AM
Purchasing Department	Angela Garcia	07/20/2012 04:55 PM
Form Started By: Mary Flores		Started On: 07/10/2012 09:18 AM
	Final Approval Date: 07/20/2012	



City of La Joya

"Jewel of the Valley"

July 2, 2012

Urban County Program
Attn: Candace J. Armenta, Program Coordinator I
1916 Tesoro Blvd.
Pharr, Texas 787577

RE: Military Park – S&B Infrastructure

Dear Ms. Armenta:

This letter is to acknowledge and accept the Scope of Services and the schedule fees submitted by S&B Infrastructure and additional documentation as described in this letter:

- W9 2012
- Certificate of Debarment
- CIQ form
- Letter of best and final offer

If you have any questions please feel free to contact me at 956-580-7001.

Sincerely,

Mike Alaniz, City Administrator

MA/jrs

Cc: Mayor Jose A. "Fito" Salinas & Board of Alderman
Dario Guerra, S&B Infrastructure

STATE OF TEXAS §
 §
COUNTY OF HIDALGO §

Professional Services Agreement

This Agreement, entered into this 24th day of July, 2012 by and between Urban County Program, (hereinafter called the "Party") and S&B Infrastructure, Ltd., duly authorized Engineer, herein acting by Daniel O. Rios, Vice President (hereinafter called the "Engineer").

WITNESSETH THAT:

WHEREAS, Hidalgo County has received CDBG funds from the U.S. Dept. of Housing and Urban Development to be used by Urban County Participants. It is understood and agreed that the Party's obligation under this Agreement is contingent upon the actual receipt of adequate federal funds to meet the liabilities under this Agreement; and

WHEREAS, the Party is interested in obtaining Engineering Services; and

WHEREAS, the Engineer, duly licensed and registered to practice engineer in the State of Texas, has the professional abilities to undertake the study, evaluation, analysis and recommendations in a manner which shall provide the necessary public service while preserving and enhancing to the greatest degree possible the natural and proposed environment in the Project (as hereinafter defined) area; and

WHEREAS, the Party desires to engage the Engineer to render certain services in connection therewith;

NOW, THEREFORE, the participants do mutually agree as follows:

**SECTION I
EMPLOYMENT OF THE ENGINEER**

The Party agrees to employ the Engineer to furnish and provide the engineering services as stated in the following sections and upon receipt of such satisfactory services, the Party agrees to pay the Engineer as stated in the sections to follow.

**SECTION II
BASIC SERVICES OF THE ENGINEER**

The Engineer shall perform the following Basic Services in connection with the precinct used La Joya Parks, Recreational Facilities Account(s) 5010-40-0306-5000-4000 (the "Project") as more particularly described in Exhibit A attached hereto.

2.1 Preliminary Phase

- a. Attend preliminary conferences with the Party and, if requested, with the funding agency and other government agencies or interested parties regarding the project.
- b. As may be required, comply and receive from the Party and the funding agencies approval on all work.
- c. Prepare preliminary engineering plans on the Project in sufficient detail to indicate clearly the problems involved and solutions recommended with the cost estimates.
- d. Obtain the Party's written approval of the work of this Preliminary Phase before proceeding with the next phase.

2.2 Design Phase

- a. Attend the respective Party's meetings as requested for the purpose of explaining completed design work activities.
- b. Advise the Party of any soil investigations or tests which, in the opinion of the Engineer, may be required for the proper execution of the Project.
- c. Provide all field information and surveys required for the design of the Project.
- d. Plot field data and other survey information for the design of the Project.
- e. Prepare detailed plans, specifications and contract documents and drawings (reproducible tracings) for construction authorized by the Party.
- f. Furnish, if requested, the engineering data necessary for the Party to obtain permits required by local, state, and federal authorities.
- g. Prepare cost estimates of authorized construction, based on prices for work. If such estimated costs exceed the monies available, the Party shall be consulted so that revisions can be made to reduce the cost as required.
- h. Prepare all documents required for the advertisement and bidding of the Project in cooperation with the Party's staff.
- i. Preparation of property or easement descriptions.

2.3 Construction Phase

The Construction Phase will commence with the execution of the prime construction contract(s). The Party will issue a ten (10) day commence work notice which will signal the commencement of work under any construction contracts and will terminate upon the Party's approval of the Engineer's written approval of final payment to the Contractor(s). During the Construction Phase, the Engineer will:

- a. Assist the Party in opening and tabulating bids for the construction of the Project, and advise the Party in establishing the procedure for entering into construction phase.
- b. Prepare the formal Contract Documents for the Contractor.
- c. Make periodic visits to the site as required pursuant to the standards of Professional Engineers on projects of this nature, provide project construction supervision, to observe the progress and quality of the executed work and to determine if the work is proceeding in accordance with the contract documents.
- d. Consult with and advise the Party and issue all instructions and Change Orders to the Contractor selected by the Party.
- e. During the progress of actual construction, Engineer will keep continually the Owner informed with brief and concise information. A monthly progress report will be prepared and delivered to the Party including but limited to monies spent, construction time elapsed, percent of Project completed, a brief narrative of problems encountered and the anticipated completion date.
- f. Review shop and working drawings furnished by Contractor(s) for general compliance with design concept and with information given in contract documents.
- g. Review and provide a recommendation concerning samples, catalog data, schedules, shop drawings, laboratory, shape and mill tests of material and equipment and other data which the Contractor is required to submit, in compliance with the Contract Documents.
- h. Prepare monthly and final estimates for payments to Contractor(s).
- i. Engineer shall accompany the Party on the Final Inspection to assure that the total work has been completed in accordance with the Contract Documents.
- j. Prior to the Party's dispersal of any retainage of funds, render a written opinion to the Party that the construction has been completed according to the Contract Documents and provide the Party with a certificate of completion and release of liens documents from subcontractors.
- k. Provide the Party with sepia copies of as-built drawings of the constructed improvements, within sixty (60) days of issuance of certificate of completion.
- l. The Engineer will be responsible for interim and final inspection.
- m. Furnish to the Party six (6) sets of plans and six (6) sets of specifications and contract documents.

**SECTION III
ADDITIONAL SERVICES OF THE ENGINEER**

If authorized in writing by the Party, the Engineer will furnish or obtain from others Additional Services of the following types which are not considered normal or customary basic services; these will be paid for by the Party as indicated in Section VI.

- 3.1 Services of a Resident Project Representative, and other field personnel as required, for on-the-site observations of construction, other than periodic visits covered in Section 2.3 herein.
- 3.2 Detailed mill, shop and/or laboratory inspection of materials or equipment.
- 3.3 Major revision of Contract drawings as distinguished from modifications due to change orders, modifications to reduce the cost of the project or modifications requested to meet federal, state, or local regulations.

**SECTION IV
REIMBURSABLE EXPENSES**

- 4.1 Travel and subsistence required for the Engineer and authorized by the Party to points other than within Hidalgo County and Project site.
- 4.2 Additional copies of reports and specifications over six (6) copies and additional prints of drawings over six (6) copies.
- 4.3 Reimbursable expenses as provided in Section IV herein shall be paid to the Engineer on the basis of 1.1 times the Engineers actual cost.

**SECTION V
THE PARTY'S RESPONSIBILITIES**

The Party will:

- 5.1 Provide full information as to requirements for the Project.
- 5.2 Assist the Engineer by providing all available information pertinent to the Project including reports and any other data relative to design and construction of the Project.
- 5.3 Furnish the services or data as required such as appropriate professional interpretations of all of the foregoing; property, boundary, easement, right-of-way, zoning, and deed restrictions; all of which the Engineer may rely upon in performing his services under this agreement.
- 5.4 Guarantee access to and make all provisions for the Engineer to enter upon public and private property as required for the Engineer to perform his services under this Agreement.

- 5.5 Examine all studies, reports, sketches, estimates, specifications, drawings, proposals, and other documents presented by the Engineer.
- 5.6 Pay for all costs incident to advertising and obtaining bids or proposals from Contractors.
- 5.7 Provide such legal and accounting services required to discharge the Party's responsibility under the terms of this Agreement and any Agreement with any governmental agency as may be required for the project, and such auditing services as the Party may require to ascertain how or for what purpose any Contractor has used the monies paid to him under the construction contract.
- 5.8 Give prompt written notice to the Engineer whenever the Party observes or otherwise becomes aware of any defect in the Project.

SECTION VI PAYMENTS TO THE ENGINEER

The Party agrees to pay the Engineer for completed services as identified by the Party:

- 6.1 The Engineer shall be paid a total fixed amount of **\$ 19,505.00** for services rendered under this contract. Payment shall be based on request for reimbursements with documentation requested by the Party. The Engineer's fee shall be due and payable as outlined in Sections 6.2, 6.3, and 6.4 as follows.
- 6.2 At Engineer's completion and Party's approval of the Engineer's services under the Preliminary Phase, Section 2.1 of this Agreement, Party shall pay a maximum of 15% of the sum set forth in Section 6.1 above.
- 6.3 At Engineer's completion and Party's approval of the Engineer's services under the Design Phase, Section 2.2 of this Agreement, Party shall pay a maximum of 60% of the sum set forth in Section 6.1 above.
- 6.4 At Engineer's completion and Party's approval of the Engineer's services under the Construction Phase, Section 2.3 of this Agreement, Party shall pay a maximum of 25% of the sum set forth in Section 6.1 above. Such sum to be paid periodically proportionately to the percentage of construction completed by the Contractor as determined by Engineer's reports.
- 6.5 For Additional Services as provided in Section III herein the Engineer shall be paid a sum of 1.1 times the Engineer's actual cost for such services.

SECTION VII OWNERSHIP OF DOCUMENTS

Original documents, plans, designs and survey notes developed in connection with services performed hereunder belong to, and remain the property of the Party, in consideration of which it is mutually agreed that the Party will use them solely in connection with the Project and as base material for possible future projects.

SECTION VIII TERMINATION

The Party may terminate this Agreement without cause at any time by a 30-day notice in writing to the Engineer. Upon receipt of such notice, the Engineer shall, unless the notice directs otherwise immediately discontinue all services in connection with the performance of this Agreement and shall proceed to cancel promptly all existing orders and contracts insofar as such orders or contracts are chargeable to this Agreement. As soon as practical after receipt of notice of termination, the Engineer shall submit a statement showing in detail the actual services that were performed under this Agreement to date of termination, the date such services were performed and the length of time spent by each person or party engaged in performing such services on each day,

The Party shall pay the Engineer a sum of money equal to the reasonable value of the professional engineer services rendered by the Engineer to the Party in connection with the services performed under this Contract, less payments previously made by the Party to Engineer on work performed and expenses incurred by Engineer under the provisions of this Agreement. Copies of all completed or partially completed designs, plans, and specifications prepared under this Agreement shall be delivered to the Party when and if this Agreement is terminated, but subject to the restrictions as to their use, as set forth above.

Notwithstanding the above, the Engineer shall not be relieved of liability to the Party for damages sustained by the Party arising from Engineer's negligent acts, errors or omissions related to Engineer's obligations created under this Agreement.

SECTION IX COUNTY AND CITY OFFICIALS

Engineer agrees that no County or City official or Party employee shall be personally liable for any of the obligation created under this Agreement, or for any matter which may arise out of the Project, or any activities related thereto and hereby holds the Party, its political bodies and its employees harmless from and indemnifies them from any liability from any matter arising from Engineer's negligent acts, errors or omissions related to Engineer's obligations created under this Agreement.

SECTION X SUCCESSORS AND ASSIGNS

Party and Engineer each binds themselves, their partners, successors, executors, administrators, and assigns to the other party of Agreement in respect to all covenants of this Agreement. Neither the Party nor Engineer shall assign or transfer any interest in this Agreement without the written consent of the other.

SECTION XI TIME OF PERFORMANCE

The Engineer contracts and agrees to commence work within ten (10) days from the date of written authorization to proceed and will complete the preparation of the preliminary phase and estimates by 90 days and will proceed upon authorization with final drawings, specifications, and contracts documents and complete same within the earliest practical time from such notice to proceed.

SECTION XII VENUE

Venue and jurisdiction of any suit, right or cause of action arising under or in connection with this Contract shall lie exclusively in Hidalgo County, Texas.

SECTION XIII AMENDMENT

This Agreement may be amended only by a written document executed by the parties hereto.

SECTION XIV COMPLIANCE WITH LOCAL LAWS

The Engineer shall comply with all applicable laws, ordinances, and codes of the State and local governments, and the Engineer shall save the Party harmless with respect to any damages arising from any negligence of the engineer in performing any of the work embraced by this Contract.

SECTION XV ASSIGNABILITY

The Engineer shall not assign any interest in this Contract, and shall not transfer any interest in the same (whether by assignment or novation) without the prior written consent of the Party thereof; provided however, that claims for money due or to become due to the Engineer from the Party under this Contract may be assigned to a bank, trust company, or other financial institution without such approval. Notice of any such assignment or transfer shall be furnished promptly to the Party.

SECTION XVI GENERAL

- 16.1 Audit. The Party and/or any of its duly authorized representatives shall have access to any books, documents, papers, and records of the Engineer which are directly pertinent to the Project for the purpose of making the audit, examination, excerpts, and transcriptions.
- 16.2 The Engineer agrees to comply with the following Executive orders, Titles and Program Regulations, including any additional requirements that may be set forth by the Party.
 - a. Title VI of the Civil Rights Act - requires that no one may be denied access to benefits from projects which receive federal assistance.

- b. Section 109 of the Housing and Community Development Act of 1974 - Nondiscrimination related to benefits from projects funded specifically under Title I of the Act.
- c. Section 3 of the HUD Act of 1968 - requires that maximum effort be made to provide employment, training, and business opportunities to low income families and/or residents of the project area.
- d. The Engineer shall give the United States Department of Housing and Urban Development, the Inspector General, the Comptroller General of the United States, the Auditor of the State of Texas, access to and the right to examine all books, accounts, records, reports, files, and other papers, things, or property belonging to or in use by Engineer pertaining to this Agreement. Such rights to access shall continue as long as the records are retained by Engineer. Engineer agrees to maintain such records in an accessible location for a period of three (3) years.
- e. Executive Order 11246 (paragraph a-c for contracts under \$10,000; paragraphs a-g for contracts over \$10,000) - Equal Employment Opportunity.

Executive Order 11246. Executive Order 11246 and the regulations issued pursuant thereto (24 CFR Part 130) which provides that no person shall be discriminated against on the basis of race, color, religion, sex, or national origin in all phases of employment during the performance of federal or federally assisted contracts. Such consultants or subcontractors shall take affirmative action to ensure fair treatment in employment, upgrading, demotion, or transfer; recruitment or recruitment advertising; layoff or termination rates of pay or other forms of compensation and selection for training and apprenticeship.

Equal Employment Opportunity for Activities and Contracts not Subject to Executive Order 11246, as amended. In carrying out the program, the Consultant shall not discriminate against any employee or applicant for employment because of race, color, religion, sex or national origin. The Engineer shall take affirmative action to ensure that applicants for employment are employed and that employees are treated during employment, without regard to their race, color, religion, sex or national origin. Such action shall include, but not limited to the following: Employment, upgrading, demotion, or transfer; recruitment or other forms of compensation; and selection for training, including apprenticeship. The Engineer shall post in conspicuous places, available to employees and applicants for employment, notices to be provided by the Government setting forth the provisions of this paragraph in all of its contracts for program work and will require all of its consultants for such work to incorporate such requirements in all subcontracts for program.

16.3 Interest of Certain Federal Officials: No member of or Delegate to the Congress of the United States and no Resident Commissioner, shall be admitted to any share or part of this Agreement or to any benefit to arise from the same.

- 16.4 Interest of Members, Officers, or Employees of Public Body, Member of Local Governing Body, or other Public Officials: No member, officer, or employee of the County or City, or its designees or agents, no member of the governing body of the locality in which the program is situated, and no other public official of such locality or localities who exercises any functions or responsibilities with respect to the program during his tenure or for one year thereafter, shall have any interest, direct or indirect, to be performed in connection with the program assisted under the Agreement. The Engineer shall incorporate or cause to be incorporated in all such documents in the paragraph in this Section.

SECTION XVII INSURANCE

The Engineer shall obtain and keep in force during the term of its engagement on the Project, insurance as follows:

- 17.1 A comprehensive automobile liability policy covering liability exposure to bodily injury and property damages. The Engineer shall furnish Party Certificates of Insurance showing the comprehensive automobile liability insurance policies to be in effect, commencing when Engineers commence operations under this Agreement, in the sum of \$300,000 for bodily injury and \$100,000 for property damages.
- 17.2 Uninsured/Underinsured motorist coverage in an amount equal to the bodily injury limits set forth immediately above;
- 17.3 Five Hundred Thousand Dollar (\$500,000.00) Comprehensive General Liability Insurance providing additional coverage to all underlying liabilities of County consistent with potential exposure of County under the Texas Tort Claims Act;
- 17.4 Workers Compensation Insurance in amount established by Texas law, unless the engineer is specifically exempted from the Texas Worker's Compensation Act, Texas Labor Code Chapter 401, et. seq.
- 17.5 All insurance policies must be written by an insurance company or companies acceptable to the Party.

SECTION XVIII WARRANTY

- 18.1 Engineer represents and warrants to Owner all services rendered to Owner under this Agreement shall, at a minimum, comply with the Texas Engineering Practices Act (Tex. Civ. St. Ann., Article 3271) and rules of the Texas Board of Professional Engineers.

**SECTION XIX
EFFECTIVE DATE**

The effective date of this contract shall be July 24, 2012. Such date being the date the County Commissioners' Court approved entering into contract with Engineer.

This Agreement is hereby approved this _____ day of _____, 20_____.

Signature: _____
Daniel O. Rios, Vice President

Firm Name: S&B Infrastructure, Ltd.
Address: 3535 Sage Road
City/ST/ZIP: Houston, TX 77056

FED ID #/SS #: 76-0431527

STATE OF TEXAS §
§
COUNTY OF HIDALGO §

This instrument was acknowledged before me on this the ____ day of _____, 20____,
by _____ of and on behalf of _____,
title) (a corporation)(a partnership)(a sole proprietorship).

(seal)

Notary - Signature

County of Hidalgo Urban County Program:

Witness

Diana R. Serna, UCP Director

Revised as to Form:
Atlas & Hall, L.L.P.
By Stephen L. Crain
on April 26, 2012

Exhibit “A”
(Scope of Services)

See Attached



Mike Alaniz
City of La Joya
City Administrator

Date: June 14, 2012

RE: Military Park Engineering Proposal

Mr, Alaniz,

Please accept our agreed upon Engineering proposal Exhibit A which details the scope of Engineering Services that S&B Infrastructure, Ltd. will provide for the Military Park Project. As also previously discussed and agreed to the total fees for this project will be \$19,505.00 which calculates out to 10% of total project budget of approximately \$195,000.00. The breakdown of charges including hours is included in the attached spreadsheet for your review.

We look forward to working together with the City of La Joya on this community project. Please forward this information to Urban County at your earliest. Please call feel free to call me with any questions that you may have.

Thank you,

A handwritten signature in black ink, appearing to read 'Juan-Pablo Cantu', enclosed within a large, hand-drawn oval.

Juan-Pablo Cantu, PE
S&B Infrastructure, Ltd.
5408 North 10th Street
McAllen Texas 78504
(956) 926-5077

EXHIBIT "A"

Services to be Provided by Engineer

The following, though not limited to, provides an outline of services to be provided by the Engineer that shall be incorporated in to a Work Authorization in the development of the Military Park Project.

Military Park Project:

The Consultant/Engineers shall perform the following Engineering as this scope of work, to be compiled into an agreement with the City of La Joya:

- Preliminary site analysis to include:
 - Detailed site survey to show property boundaries and detailed elevations of existing grounds
 - Geotechnical analysis (Special Services)
 - Conceptual park layout including grounds, parking lot, sprinkler system utilizing reclaimed water from the new WWTP and conceptual lighting layout
- Produce Engineering Drawings and Specifications that will detail the work needed for construction of this project of by Contractor. This task shall include the following:
 - Drafting as required
 - Detailed Structural design of foundations for Concession/Maintenance buildings, Area lighting poles, etc
 - Detailed design of Concession/Maintenance Buildings including, bathroom facilities, Kitchen area, building materials and design etc.; plumbing needs for water and wastewater, sprinkler system etc.
 - Detailed Civil design of field layouts including amounts of soil and which types of soil to be brought in, cutting of ground as needed,
 - Detailed Civil design of sidewalks, Parking lot asphalt, entrances, curbs and gutters etc.
 - Detailed Electrical design of kitchen area electrical for Concessions, areal lighting; parking lot lighting, field lighting, service entrance design, etc.
- Contract Management assistance as needed for this task will include the following:
 - Development of Bid Documents
 - RFI review and response
 - Bidding assistance and required, etc.
- Construction Phase assistance as needed this task will include the following:
 - Onsite inspection of work as needed (Special Services)
 - Meeting attendance as needed
 - Review of RFI and Submittal data as needed.

Preliminary work		Elec		Civil		Structural		Project Mngr.	
	CAD Draftsman	Hours	Engineer	Hours	Engineer	Hours	Engineer	Hours	Project Mngr.
Preliminary Analysis	37.5	0	137.5	3	412.5	3	137.5	0	200
Reports	37.5	0	137.5	3	412.5	3	137.5	0	200
Estimating	37.5	0	137.5	3	412.5	3	137.5	0	200
Total Engineering		\$ 3,075.00		\$ 4,125.00		\$ 4,125.00		\$ 200.00	

Design		Electrical		Civil		Structural		Project Mngr.	
	CAD Draftsman	Hours	Engineer	Hours	Engineer	Hours	Engineer	Hours	Project Mngr.
Design	37.5	30	137.5	20	2750	20	2750	5	687.5
Specifications	37.5	1	137.5	10	1375	8.4	1155		200
Total Engineering		\$ 12,080.00		\$ 1,125.00		\$ 1,155		\$ 800	

Contract Admin		Inspector		Engineer		Project Mngr.	
	Inspector	Hours	Engineer	Hours	Engineer	Hours	Project Mngr.
Bidding	50	1	137.5	2	275	2	275
Inspector	50	40	137.5	2	275	2	275
Project Closeout	50	1	137.5	2	275	2	275
Total Engineering		\$ 4,350.00		\$ 1,375.00		\$ 1,375.00	



CERTIFICATE OF LIABILITY INSURANCE

DATE (MM/DD/YYYY)

12/30/2011

THIS CERTIFICATE IS ISSUED AS A MATTER OF INFORMATION ONLY AND CONFERS NO RIGHTS UPON THE CERTIFICATE HOLDER. THIS CERTIFICATE DOES NOT AFFIRMATIVELY OR NEGATIVELY AMEND, EXTEND OR ALTER THE COVERAGE AFFORDED BY THE POLICIES BELOW. THIS CERTIFICATE OF INSURANCE DOES NOT CONSTITUTE A CONTRACT BETWEEN THE ISSUING INSURER(S), AUTHORIZED REPRESENTATIVE OR PRODUCER, AND THE CERTIFICATE HOLDER.

IMPORTANT: If the certificate holder is an ADDITIONAL INSURED, the policy(ies) must be endorsed. If SUBROGATION IS WAIVED, subject to the terms and conditions of the policy, certain policies may require an endorsement. A statement on this certificate does not confer rights to the certificate holder in lieu of such endorsement(s).

PRODUCER License # 7570
ProTECH Insurance Agency, Inc.
3120 Southwest Freeway, #100
Houston, TX 77098-4520

CONTACT NAME:
PHONE (A/C, No, Ext): (713) 520-1090
E-MAIL ADDRESS:
FAX (A/C, No): (713) 529-7505

INSURER(S) AFFORDING COVERAGE		NAIC #
INSURER A : Zurich American Insurance Co		16535
INSURER B : American Guarantee & Liability		26247
INSURER C : Steadfast Insurance Co		26387
INSURER D :		
INSURER E :		
INSURER F :		

INSURED

S & B Infrastructure, Ltd.
P.O. Box 266245
Houston, TX 77207-6245

COVERAGES **CERTIFICATE NUMBER:** **REVISION NUMBER:**

THIS IS TO CERTIFY THAT THE POLICIES OF INSURANCE LISTED BELOW HAVE BEEN ISSUED TO THE INSURED NAMED ABOVE FOR THE POLICY PERIOD INDICATED. NOTWITHSTANDING ANY REQUIREMENT, TERM OR CONDITION OF ANY CONTRACT OR OTHER DOCUMENT WITH RESPECT TO WHICH THIS CERTIFICATE MAY BE ISSUED OR MAY PERTAIN, THE INSURANCE AFFORDED BY THE POLICIES DESCRIBED HEREIN IS SUBJECT TO ALL THE TERMS, EXCLUSIONS AND CONDITIONS OF SUCH POLICIES. LIMITS SHOWN MAY HAVE BEEN REDUCED BY PAID CLAIMS.

INSR LTR	TYPE OF INSURANCE	ADDL SUBR		POLICY NUMBER	POLICY EFF (MM/DD/YYYY)	POLICY EXP (MM/DD/YYYY)	LIMITS	
		INSR	WVD					
A	GENERAL LIABILITY			GLO 3729647-07	1/1/2012	1/1/2013	EACH OCCURRENCE	\$ 1,000,000
	<input checked="" type="checkbox"/> COMMERCIAL GENERAL LIABILITY	<input checked="" type="checkbox"/>					DAMAGE TO RENTED PREMISES (Ea occurrence)	\$ 1,000,000
	<input type="checkbox"/> CLAIMS-MADE <input checked="" type="checkbox"/> OCCUR						MED EXP (Any one person)	\$ 10,000
	GEN'L AGGREGATE LIMIT APPLIES PER:							PERSONAL & ADV INJURY
							GENERAL AGGREGATE	\$ 2,000,000
							PRODUCTS - COM/OP AGG	\$ 2,000,000
								\$
B	AUTOMOBILE LIABILITY			BAP 3729648-07	1/1/2012	1/1/2013	COMBINED SINGLE LIMIT (Ea accident)	\$ 1,000,000
	<input checked="" type="checkbox"/> ANY AUTO						BODILY INJURY (Per person)	\$
	<input type="checkbox"/> ALL OWNED AUTOS		<input type="checkbox"/> SCHEDULED AUTOS				BODILY INJURY (Per accident)	\$
	<input checked="" type="checkbox"/> HIRED AUTOS		<input checked="" type="checkbox"/> NON-OWNED AUTOS				PROPERTY DAMAGE (Per accident)	\$
								\$
	UMBRELLA LIAB						EACH OCCURRENCE	\$
	EXCESS LIAB						AGGREGATE	\$
								\$
A	WORKERS COMPENSATION AND EMPLOYERS' LIABILITY			WC 04857517-01	1/1/2012	1/1/2013	<input checked="" type="checkbox"/> WC STATUTORY LIMITS	OTHER
	ANY PROPRIETOR/PARTNER/EXECUTIVE OFFICER/MEMBER EXCLUDED? (Mandatory in NH)	Y/N	N/A				E.L. EACH ACCIDENT	\$ 1,000,000
	If yes, describe under DESCRIPTION OF OPERATIONS below						E.L. DISEASE - EA EMPLOYEE	\$ 1,000,000
							E.L. DISEASE - POLICY LIMIT	\$ 1,000,000
C	Professional Liab			EOC 5343434-07	1/1/2012	1/1/2013	Each Claim/Aggregate	1,000,000

DESCRIPTION OF OPERATIONS / LOCATIONS / VEHICLES (Attach ACORD 101, Additional Remarks Schedule, If more space is required)
County of Hidalgo shall be named as Additional Insured on all Commercial General Liability Policies. 30 Day Notice of Cancellation applies.

CERTIFICATE HOLDER

Hidalgo County
ATTN: Purchasing Department
2812 S Highway Bus 281
Edinburg, TX 78539

CANCELLATION

SHOULD ANY OF THE ABOVE DESCRIBED POLICIES BE CANCELLED BEFORE THE EXPIRATION DATE THEREOF, NOTICE WILL BE DELIVERED IN ACCORDANCE WITH THE POLICY PROVISIONS.

AUTHORIZED REPRESENTATIVE
C.S. Madeira

AI-33167

Urban County 11. I.

CC REGULAR

Meeting Date: 07/24/2012

Department Head: Carlos Jasso

Submitted By: Mary Flores, URBAN COUNTY

Department: URBAN COUNTY

Information

CAPTION

1. Approval of a revised resolution for designation of authorized bonded signatories for the Texas Department of Rural Affairs (TDRA) now known as "GLO" Texas General Land Office, Texas Community Development Block Grant Funds (TxCDBG) for the following grant:

- a. 2008 Disaster Recovery TxCDBG Contract No. 10-5066-000-5043/DRS 010068
2. Authorize the Hidalgo County Judge to sign any and all documents regarding Round One funds.

BACKGROUND

This revised Resolution is required by the Texas General Land Office for the funding authorized for Hidalgo County for the DRS Grant. The Resolution designates certain authorized bonded signatories for the DRS\GLO Grant-The Texas General Land Office-Texas Community Development Block Grant Program

Attachments

Resolution Amendment # 1

Auth Signatories Designation Form TDRA-DR

Form Review

Inbox	Reviewed By	Date
Budget & Management	Merlen P. Munoz	07/10/2012 07:58 AM
Purchasing Department	Angela Garcia	07/20/2012 04:55 PM
Form Started By: Mary Flores		Started On: 07/09/2012 04:45 PM
	Final Approval Date: 07/20/2012	

RESOLUTION

Amendment # 1

A REVISED RESOLUTION DESIGNATING AND AUTHORIZING BONDED SIGNATORIES FOR THE OFFICE OF THE TEXAS GENERAL LAND OFFICE PROGRAM FUNDS.

WHEREAS, the Urban County Program applied for and received funding from the Office of the Texas Department of Rural Affairs (TDRA) now known as Texas General Land Office (GLO):

2008 Disaster Recovery TxCDBG Program Contract No. DRS 010068/GLO 10-5066-000-5043

Precinct No.1 Flood Drainage Improvements
Precinct No.2 Flood Drainage Improvements
Precinct No.3 Flood Drainage Improvements

WHEREAS, it is necessary and in the best interest of Hidalgo County to designate as needed: The County Judge, the Hidalgo county Chief Administrator, the Urban County Program Director, and/ or Urban County Program Deputy Director to act in all DRS/GLO program matters pertaining to the implementation administration, or participation in fulfilling the requirements of the DRS/GLO contractual program documents.

NOW THEREFORE, IT IS HEREBY RESOVLED AND ORDERED BY THE COMMISSIONER' COURT OF THE COUNTY OF HIDALGO, TEXAS:

That the Hidalgo County Commissioners' Court designate the persons holding the following positions as authorized bonded signatories on any account in which funds from the Office of the Texas General Land Office Program are deposited: Hidalgo County Judge, Hidalgo County Chief Administrator, Urban County Program Director, and/or Urban County Deputy Director respectively.

PASSED AND APPROVED THIS ____ DAY OF _____

**Ramon Garcia, County Judge
Hidalgo County, Texas**

ATTEST:

**Arturo Guajardo Jr., County Clerk
Hidalgo County, Texas**



URBAN COUNTY PROGRAM

1916 TESORO BLVD ● PHARR, TEXAS 78577 ● (956) 787-8127 FAX (956) 787-5291
E-mail: ucp@bizrgv.rr.com

February 8, 2011

The Honorable Ramon Garcia
Hidalgo County Judge
1615 S. Closner, Suite J
Edinburg, Texas 78539

Re: Texas Department of Rural Affairs (TDRA) Disaster Recovery (DR) Contract # 010068
Texas Department of Rural Affairs (TDRA) - Colonia Construction Contract #729055
Texas Department Housing And Community Affairs (TDHCA) - SHC Contract #728003

Depository/Authorized Signatories Designation Forms &
Direct Deposit Authorization Form

Dear Judge Garcia:

Attached please find the updated Depository/Authorization Signatories Designation Forms and Direct Deposit Authorization Forms for our TDRA - Disaster Recovery Contract # 010068 and the Depository/Authorization Signatories Designation Forms for the TDRA - Colonia Construction Contract #729055 and TDHCA - SHC Contract #728003 for your review and signature.

I have reviewed the above referenced authorization forms and direct deposit form and find everything in order. Also attached is the approved Hidalgo County Commissioners' Court Agenda Request Forms for the Resolutions, the Hidalgo County Commissioners' Court Agenda Request Forms on the approval authorizing the County Judge as the County's Chief Executive Officer to act in all matters in connection with these grant, and the actual Resolutions.

Please sign where indicated and return the documents to my office. If you have any questions, please call me at 787-8127.

Sincerely,

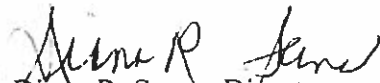
Diana R. Serna, Director
Urban County Program

Enclosures

Equal Housing Opportunity
Equal Employment Opportunity Employer



CHAPTER 2 FINANCIAL MANAGEMENT

Form 2-2 Depository/Authorized Signatories Designation Form

TEXAS COMMUNITY DEVELOPMENT BLOCK GRANT PROGRAM DEPOSITORY/AUTHORIZED SIGNATORIES DESIGNATION FORM

Contractor Hidalgo County TDRA-DR Contract No. DRS 010068

The financial lending institution listed here will serve as the depository for the Texas Community Development Block Grant Program contract funds:

First National Bank
(Name of Lending Institution)
302 E. University Drive
(Address)
Edinburg, Texas 78539
(City, State Zip Code)

Fund Account Number: 140-101-43

The individuals listed below are designated by resolution as authorized signatories for contractual documents—(At least two (2) Signatories Required)

Ramon Garcia
(Name)
Hidalgo County Judge
(Title)
Ramon Garcia
(Signature)

Yolanda Chapa
(Name)
Hidalgo County Chief Administrator
(Title)
Yolanda Chapa
(Signature)

Diana R. Serna
(Name)
Hidalgo County Program
(Title)
Diana R Serna
(Signature)

Pete De La Cruz
(Name)
Colonia Coordinator
(Title)
Pete De La Cruz
(Signature)

NOTE: A copy of a Resolution passed by the city council or county commissioner's court authorizing the signatories must be submitted along with this form.

APPROVED Co. Comm. Ct.
DATE 12-8-11 *AKS*

AI-33227

Texas Agri-Life Extension Serv. 13. A.

CC REGULAR

Meeting Date: 07/24/2012

Submitted By: Nora Linda Cruz, TX.
AGRILIFE EXT.
SERVICES

Department: TX. AGRILIFE EXT. SERVICES

Information

CAPTION

Proclamation to recognize the Junior and Intermediate winners of the District Fashion Show, Senior Fashion Show winners of the State 4-H Roundup, and the Consumer Decision Making Team for winning first place at district.

BACKGROUND

Fiscal Impact

FISCAL YEAR: _____ **ACCT. #:** _____
FUNDS AVAILABLE Y/N?: _____ **MATCHING FUNDS Y/N?:** _____

BUDGETARY IMPACT:

No fiscal impact.

Attachments

Proclamation

Winners

Form Review

Inbox	Reviewed By	Date
Budget & Management	Merlen P. Munoz	07/12/2012 08:20 AM
Purchasing Department	Angela Garcia	07/20/2012 04:55 PM
Form Started By: Nora Linda Cruz		Started On: 07/11/2012 05:41 PM
	Final Approval Date: 07/20/2012	

Proclamation

Hidalgo County 4-H Family and Consumer Science Champions

WHEREAS, The Hidalgo County Commissioners Court is proud to recognize members of the 4-H Youth Development Program of The Texas AgriLife Extension Service for achievements in competitive events in the areas of clothing and textiles, fashion design, and consumer decision making at the district and state level; and

WHEREAS, The Texas 4-H and Youth Development Program places great value on the 4-H Family and Consumer Sciences projects; and

WHEREAS, These projects expose 4-H members to the academic disciplines for Family and Consumer Science and help them gain valuable skills and knowledge that meets the immediate needs of students today, and tomorrow's workforce and citizens of the community.

WHEREAS, These projects also teach leadership skills; and

WHEREAS, Hidalgo County youths have excelled in Family and Consumer Science projects and have enriched themselves and others through community service and; now therefore, be it

RESOLVED, That the Hidalgo County Commissioners Court, does hereby commend the Hidalgo County 4-H Family and Consumer Science Program and its many members and adult leaders for their numerous achievements, for their willingness to represent the great County of Hidalgo while exhibiting the highest standard of character in various competitions, and for their dedication and commitment to the education of today's youth and future leaders of tomorrow.

The Honorable Ramon Garcia, County Judge

Joel Quintanilla, Commissioner Precinct 1

Hector "Tito" Palacios, Commissioner Precinct 2

Joe M. Flores, Commissioner Precinct 3

Joseph Palacios, Commissioner Precinct 4

Date

8	Deanna	Hairell	Burleson	9
9	Carolyn	Swize	Goliad	11
10	Christy	Mahaffey	Wise	3

NATURAL FIBER - WOOL

RANK	FIRST NAME	LAST NAME	COUNTY	DISTRICT
1	Amanda	Merrifield	McLennan	8
2	Hillary	Koncaba	Fayette	11
3	Kimberly	Rennspies	Guadalupe	10
4	Ashby	Ragsdale	Schleicher	7

CONSTRUCTION - CASUAL

RANK	FIRST NAME	LAST NAME	COUNTY	DISTRICT
1	Rachel	McDaniel	Hays	10
2	Renee	Boyle	Hidalgo	12
3	Melanie	Craig	Ellis	8
4	Carolyn	Swize	Goliad	11
5	Jessica	Deville	Jefferson	9
6	Kaci	Vaughn	Tyler	5
7	Ivie	Mynatt	Schleicher	7
8	Megan	Bland	Wise	3
9	Mary	Spurlock	Sherman	1

CONSTRUCTION - DRESSY

RANK	FIRST NAME	LAST NAME	COUNTY	DISTRICT
1	Rhonda	Grmela	Coryell	8
2	Kimberly	Rennspies	Guadalupe	10
3	Jodie	Detten	Carson	1
4	Hilary	Koncaba	Fayette	11
5	Laura	Thieme	Jim Wells	12
6	Jessi	Jordan	Tyler	5
7	DeLynn	Butler	Lamb	2
8	Victoria	Barksdale	Mcculloch	7
9	Sarah	Gerstenberg	Jefferson	9
10	Melody	Hurd	Parker	3
11	Jessica	Marshall	Andrews	6

CONSTRUCTION - FORMAL

RANK	FIRST NAME	LAST NAME	COUNTY	DISTRICT
1	Melanie	Sera	Brazos	9
2	Kimberly	Phelan	Comal	10
3	Corinna	Mendez	San Patricio	11
4	Rochelle	Fangman	Oldham	1
5	Peyton	Warren	Lamb	2
6	Allison	Hurd	Parker	3
7	Elizabeth	Raabe	Denton	4
8	Ashleigh	Snyder	Williamson	8

CONSTRUCTION - SPECIALTY

RANK	FIRST NAME	LAST NAME	COUNTY	DISTRICT
1	Rebekah	Jackson	Ellis	8
2	Emily	Fouts	Haskell	3
3	Samantha	Green	Nueces	11
4	Ashley	Byers	Carson	1
5	Arden	Lange	Atascosa	12
6	Emily	Williams	Smith	5
7	Tabitha	Milliron	Lubbock	2
8	Cloudi	Bland	Fannin	4

Texas 4-H Round Up June 12, 2012

FASHION SHOW

Donors: American Sewing Guild Austin/Capitol Area Chapter, American Sewing Guild Wichita Falls Area Chapter, Texas Cotton Ginners' Association, Texas Cotton Producers Inc, Women's Auxillary of the Texas Sheep & Goat Raisers' Association San Antonio Chapter ASG

BUYING - CASUAL

RANK	FIRST NAME	LAST NAME	COUNTY	DISTRICT
1	Autumn	Posey	Fisher	7
2	Jessi	Stark	Swisher	2
3	Jennifer	Foil	Mclennan	8
4	Hannah	Allemand	Oldham	1
5	Tara	Liska	Live Oak	12
6	Cierra	Myles-Williams	Grimes	9

BUYING - DRESSY

RANK	FIRST NAME	LAST NAME	COUNTY	DISTRICT
1	Daniel	Craig	Ellis	8
2	Rachel	Howell	Gillespie	10
3	Kalynn	Hardegree	Mitchell	2
4	Kendall	Kristynik	Lavaca	11
5	Sarah	Posey	Fisher	7
6	Jaci	Wagner	Oldham	1
7	Deanna	Hairrell	Burleson	9

BUYING - FORMAL

RANK	FIRST NAME	LAST NAME	COUNTY	DISTRICT
1	Kelley	Royal	Erath	8
2	Brylee	Matschek	Runnels	7
3	Jill	Walker	Cooke	4
4	Jessica	Fischbacher	Moore	1
5	Anna	Ingram	Brazoria	9
6	Katelyn	Miller	Austin	11
7	Whitney	Stone	Young	3
8	Sydney	White	Lamb	2
9	Patience	Cannon	Kleberg	12
10	Destiny	Roath	Wilson	10

BUYING - SPECIALTY

RANK	FIRST NAME	LAST NAME	COUNTY	DISTRICT
1	Mallory	Graham	Floyd	2
2	Kendall	Pearse	Cooke	4
3	Clarissa	Olivarez	Hidalgo	12
4	Thea	Coffman	Randall	1
5	Mikel'	Duderstadt	Hamilton	8
6	Lairen	Calhoun	Jefferson	9
7	Abigail	Boynton	Kendall	10
8	Danna	Carey	Jones	7

NATURAL FIBER - COTTON

RANK	FIRST NAME	LAST NAME	COUNTY	DISTRICT
1	Rachel	Smith	Randall	1
2	Rachel	McDaniel	Hays	10
3	Melanie	Craig	Ellis	8
4	Catherine	Rainbow	Fannin	4
5	Renee	Boyle	Hidalgo	12
6	Letti	Cheyne	Hale	2
7	Rebekah	Jimenez	Jasper	5

2012 District 12 4-H Consumer Decision Making Contest
Results

Junior					
1 st Place Atascosa County #2 Caitlyn Nieschwitz (Hi Point) Autumn Hagen Kendall Hagen	2 nd Place Hidalgo County Timothy Bradford Anixa Hernandez Elyssa Rodriguez Beth Quintanilla	3 rd Place Atascosa County #1 Kate McNeill (2 nd Hi Point) Shelby Henson Emma Smith	Participation Jim Wells County Mikayla Hesselstine (3 rd Hi Point) Noah Buegeler Macy Buegeler		
Intermediate					
1 st Place Hidalgo County Matthew Salinas Amanda Salinas Vanessa Martinez Claudia Martinez	2 nd Place Jim Wells County #3 Logan McBryde (Hi Point) Katie Buegeler Anna Baldeschwieler	3 rd Place Jim Wells County #1 Kyleigh Carr (2 nd Hi Point) Madison Lockard (3 rd Hi Point) David Gebert	Participation Atascosa County Hannah Ward Cassie Lotus Lindsay Tudyk	Participation Jim Wells County #2 Kendall Karasek Elise Hesselstine Ashlyn Hesselstine	
Senior					
1 st Place Jim Wells County #1 Anissa Valverde (Hi Point) Brianna Saenz Kristopher Gebert	2 nd Place Atascosa County Justin Smith (2 nd Hi Point) Jaclyn Bonner Sarah Lotas Paige Smith	3 rd Place Jim Wells County #2 Logan Gawlik (3 rd Hi Point) Cody White Amber Paz	Participation Hidalgo County Clarissa Olivarez Onelisa Garza		

2012 District 12 4-H Fashion Show Official Results

County	Name	Age Division	Division	Category	Color Award	Winner / Placing
Storyboard Division						
Jim Wells	Iliana Trevino	Senior	Storyboard	Accessory	Blue	1
Webb	Chamonix Mejia	Senior	Storyboard	Accessory	Blue	2
Jim Wells	Kendall Karasek	Intermediate	Storyboard	Accessory	Blue	1
Hidalgo	Anixa Hernandez	Junior	Storyboard	Accessory	Blue	1
Jim Wells	Gretchen Bernsen	Intermediates	Storyboard	Jewelry	Blue	1
Maverick	Elisabeth White	Junior	Storyboard	Jewelry	Blue	1
Live Oak	Shelby James	Senior	Storyboard	Non-Wearable	Blue	1
Jim Wells	Kyleigh Carr	Intermediates	Storyboard	Non-Wearable	Blue	1
Jim Wells	Mikayla Hesseltine	Junior	Storyboard	Non-Wearable	Blue	1
Live Oak	Victoria Culpepper	Senior	Storyboard	Pet Clothing	Blue	1
Jim Wells	Cody White	Senior	Storyboard	Pet Clothing	Blue	2
Maverick	Kathryn White	Intermediates	Storyboard	Pet Clothing	Blue	1
Jim Wells	Mary Baldeschwiler	Intermediates	Storyboard	Pet Clothing	Blue	2
Maverick	Nathan White	Junior	Storyboard	Pet Clothing	Blue	2
Jim Wells	Emily Kalinec	Junior	Storyboard	Pet Clothing	Blue	1
Webb	Jose Mejia	Junior	Storyboard	Pet Clothing	Blue	3
Atascosa	Jaclyn Bonner	Senior	Storyboard	Wearable	Blue	1
Jim Wells	Sara Ruiz	Intermediates	Storyboard	Wearable	Blue	1
Hidalgo	Jysela Gonzalez	Junior	Storyboard	Wearable	Blue	1
Jim Wells	William Bernsen	Junior	Storyboard	Wearable	Blue	2

2012 District 12 4-H Fashion Show Official Results

County	Name	Age Division	Division	Category	Color Award	Winner / Placing
Construction Division						
Atascosa	Paige Smith	Senior	Construction	Casual	Blue	Runner Up
Hidalgo	Renee Boyle	Senior	Construction	Casual	Blue	Winner
Dimmit	Katryna John	Intermediate	Construction	Casual	Blue	
Hidalgo	Claudia Martinez	Intermediate	Construction	Casual	Blue	Winner
Atascosa	Allyson Bautista	Junior	Construction	Casual	Blue	
Cameron	Carissa Cantu	Junior	Construction	Casual	Blue	
Hidalgo	Timothy Bradford	Junior	Construction	Casual	Blue	Winner
Live Oak	Kyndall Gonzales	Junior	Construction	Casual	Blue	
Maverick	Nathan White	Junior	Construction	Casual	Blue	
Atascosa	Jaclyn Bonner	Senior	Construction	Dressy	Blue	Winner
Jim Wells	Laura Thieme	Senior	Construction	Dressy	Blue	Runner Up
Dimmit	Stephanie Bullard	Intermediate	Construction	Dressy	Blue	
Hidalgo	Brianna Bullion	Intermediate	Construction	Dressy	Blue	Winner
Maverick	Kathryn White	Intermediate	Construction	Dressy	Blue	
Atascosa	Kendall Hagen	Junior	Construction	Dressy	Blue	
Cameron	Heather Cantu	Junior	Construction	Dressy	Blue	
Live Oak	Erynn Studlar	Junior	Construction	Dressy	Blue	Winner
Maverick	Elisabeth White	Junior	Construction	Dressy	Blue	
Dimmit	Laura Bullard	Senior	Construction	Formal	Blue	Runner Up
Kleberg-Kenedy	Kelsey Richerson	Senior	Construction	Formal	Blue	Winner
Atascosa	Christine Diemert	Intermediate	Construction	Formal	Blue	
Jim Wells	Kyleigh Carr	Intermediate	Construction	Formal	Blue	Winner
Atascosa	Arden Lange	Senior	Construction	Specialty	Blue	Winner
Cameron	Rebecca Goad	Senior	Construction	Specialty	Blue	
Jim Wells	Sarah Thieme	Senior	Construction	Specialty	Blue	
Live Oak	Victoria Culpepper	Senior	Construction	Specialty	Blue	Runner Up
Hidalgo	Vanessa Martinez	Intermediate	Construction	Specialty	Blue	Winner
Atascosa	Elizabeth West	Junior	Construction	Specialty	Blue	
Hidalgo	Olivia Vela	Junior	Construction	Specialty	Blue	
Maverick	Gunner Purcell	Junior	Construction	Specialty	Blue	Winner
Natural Fiber Division						
Hidalgo	Clarissa Olivarez	Senior	Natural Fiber	Cotton	Blue	Runner Up
Hidalgo	Renee Boyle	Senior	Natural Fiber	Cotton	Blue	Winner
Jim Wells	Sarah Thieme	Senior	Natural Fiber	Cotton	Red	
Live Oak	Victoria Culpepper	Senior	Natural Fiber	Cotton	Blue	
Maverick	Caleb White	Senior	Natural Fiber	Cotton	Blue	

2012 District 12 4-H Fashion Show Official Results

County	Name	Age Division	Division	Category	Color Award	Winner / Placing
Buying Division						
Brooks	Preston Wise	Senior	Buying	Casual	Red	
Jim Wells	Kristopher Gebert	Senior	Buying	Casual	Blue	Runner Up
Live Oak	Tara Liska	Senior	Buying	Casual	Blue	Winner
Maverick	Caleb White	Senior	Buying	Casual	Red	
Starr	Kimberly Perez	Senior	Buying	Casual	Blue	
Hidalgo	Dallas Goldammer	Intermediate	Buying	Casual	Blue	Winner
Jim Wells	David Gebert	Intermediate	Buying	Casual	Blue	
Live Oak	Nathan Culpepper	Intermediate	Buying	Casual	Blue	
Live Oak	Kara Rodriguez	Intermediate	Buying	Casual	Blue	
Cameron	Shanna Stubbs	Junior	Buying	Casual	Blue	
Kleberg-Kenedy	Jessica Pena	Junior	Buying	Casual	Blue	Winner
Hidalgo	Onelisa Garza	Senior	Buying	Dressy	Blue	Winner
Brooks	Christopher Vela	Intermediate	Buying	Dressy	Blue	
Hidalgo	Bianca Garcia	Intermediate	Buying	Dressy	Blue	Winner
Starr	Hilary Barrera	Intermediate	Buying	Dressy	Blue	
Atascosa	Hannah West	Junior	Buying	Dressy	Blue	
Hidalgo	Elyssa Rodriguez	Junior	Buying	Dressy	Blue	
Kleberg-Kenedy	Sidney Zimmerman	Junior	Buying	Dressy	Blue	
Starr	Natalie Anderson	Junior	Buying	Dressy	Blue	Winner
Atascosa	Gabriela Lopez	Senior	Buying	Formal	Red	
Kleberg-Kenedy	Patience Cannon	Senior	Buying	Formal	Blue	Winner
Hidalgo	Talia Fuentes	Senior	Buying	Formal	Blue	Runner Up
Atascosa	Clarisa Lopez	Intermediate	Buying	Formal	Blue	
Brooks	Melissa Wise	Intermediate	Buying	Formal	Blue	
Hidalgo	Krista Olivarez	Intermediate	Buying	Formal	Blue	
Jim Wells	Katie Buegeler	Intermediate	Buying	Formal	Blue	Winner
Starr	Lucia Lamcke	Intermediate	Buying	Formal	Blue	
Brooks	Eusebio Benavides	Junior	Buying	Formal	Blue	
Hidalgo	Anixa Hernandez	Junior	Buying	Formal	Blue	Winner
Hidalgo	Clarissa Olivarez	Senior	Buying	Specialty	Blue	Winner
Jim Wells	Taylor Gunn	Intermediate	Buying	Specialty	Blue	
Starr	Kelsey Silva	Intermediate	Buying	Specialty	Blue	Winner
Hidalgo	Jocelyn Boyle	Junior	Buying	Specialty	Blue	
Kleberg-Kenedy	Robert Grimes II	Junior	Buying	Specialty	Blue	Winner

AI-33221

Planning Department 14. A.

CC REGULAR

Meeting Date: 07/24/2012

Department Head: Raul E. Segin, P.E.

Submitted By: Nora Cavazos, PLANNING DEPT.

Department: PLANNING DEPT.

Information

CAPTION

1. Partial Release of Letter of Credit
 - a. Brushline LTD Subdivision – Pct. 3 (Pat Fletcher)

2. Reimbursement of a Cash Deposit
 - a. Brushline LTD Subdivision – Pct. 3 (Pat Fletcher)

BACKGROUND

Attachments

Paving Partial Release

Street Sign Escrow Reimbursement

Form Review

Inbox	Reviewed By	Date
Budget & Management	Merlen P. Munoz	07/12/2012 08:18 AM
Olga Garza	Olga Garza	07/12/2012 04:44 PM
Purchasing Department	Angela Garcia	07/20/2012 04:55 PM
Form Started By: Nora Cavazos		Started On: 07/11/2012 04:46 PM
	Final Approval Date: 07/20/2012	



Hidalgo County Planning Department

Raul E. Sesin, PE, CFM
Planning Administrator

Main Office

1304 S. 25th Street
Edinburg, Texas 78542
Phone (956) 318-2840
Fax (956) 318-2844

Engineering Projects Office

301 E. State Street
Pharr, Texas 78577
Phone (956) 318-2840
Fax (956) 318-2844

Precinct No. 1 Substation

1902 Joe Stephens Ave.
Weslaco, Texas 78596
Phone (956) 968-4734
Fax (956) 973-7850

Precinct No. 3 Substation

2401 N. Moorefield Rd.
Mission, Texas 78572
Phone (956) 205-7045
Fax (956) 205-7049

MEMORANDUM

**To: JUDGE RAMON GARCIA
COUNTY COMMISSIONER'S COURT**

From: RAUL E. SESIN, P.E., PLANNING ADMINISTRATOR

Date: JULY 11, 2012

Re: BRUSHLINE, LTD SUBDIVISION

ON MARCH 6, 2012, THE COUNTY COMMISSIONERS COURT GRANTED FINAL APPROVAL WITH FINANCIAL GUARANTEE FOR THE ABOVE REFERENCED SUBDIVISION. LETTER OF CREDIT NO. 50063-101087892 WAS USED TO SECURE THE FUNDS FOR THE PAVING AND DRAINAGE IMPROVEMENTS AND THE INSTALLATION OF EIGHTY FOUR (84) SEPTC TANK SYSTEMS.

THE DEVELOPER IS REQUESTING A PARTIAL RELEASE OF THE LETTER OF CREDIT IN THE AMOUNT OF \$328,435.00 DOLLARS. THE DEVELOPER HAS COMPLETED ALL OF THE REQUIREMENTS IN ACCORDANCE WITH THE MODEL SUBDIVISION RULES. ATTACHED ARE COPIES OF THE INSPECTION AND STREET TESTING REPORTS FROM THE OUR OFFICE.

STAFF HAS NO OBJECTION TO A PARTIAL RELEASE OF THE LETTER OF CREDIT IN THE AMOUNT OF \$328,435.00 FOR THE AFOREMENTIONED IMPROVEMENTS.

BORDER CAPITAL BANK NO. 50063-101087892

ORIGINAL AMOUNT: \$454,435.00
1ST RELEASE: \$328,435.00

BALANCE REMAINING:\$126,000.00

*** END OF MEMORANDUM ***



Hidalgo County Planning Department

Raul E. Sesin, PE, CFM
Planning Administrator

Main Office

1304 S. 25th Street
Edinburg, Texas 78542
Phone (956) 318-2840
Fax (956) 318-2844

Engineering Projects Office

301 E. State Street
Pharr, Texas 78577
Phone (956) 318-2840
Fax (956) 318-2844

Precinct No. 1 Substation

1902 Joe Stephens Ave.
Weslaco, Texas 78596
Phone (956) 968-4734
Fax (956) 973-7850

Precinct No. 3 Substation

2401 N. Moorefield Rd.
Mission, Texas 78572
Phone (956) 205-7045
Fax (956) 205-7049



IRREVOCABLE LETTER OF CREDIT NO 50063-101087892

TO: Ramon Garcia, County Judge (in his official capacity) Hidalgo County, Texas

DATE: February 10, 2012

We hereby authorize you to draw at sight on Border Capital Bank, for the account of BRUSHLINE, LTD, By: CASA VERDE GROUP, LC, its General Partner, By: PATRICIA B. FLETCHER, President (the Customer), up to the aggregate amount of Four Hundred Fifty Four Thousand Four Hundred Thirty Five and no/100ths Dollars (\$454,435.00) (the Stated Amount) available by our draft, accompanied by a certification by the county judge, any county commissioner, or the county treasurer that the following condition exists:

"A Condition of Draw exists under Subdivision Construction Agreement dated February 10, 2012, by and between Subdivider and the County of Hidalgo (the Agreement). County is in substantial compliance with the terms of said Agreement and has calculated the amount of this draft in accordance with the terms of the Agreement."

Drafts must be drawn and presented by or on - no later than the maturity date - February 10, 2013, by the close of business of the Issuer of this credit and must specify the date and number of this credit. Drafts will be honored within five calendar days of presentment. We hereby engage all drawers that drafts drawn and presented in accordance with this credit shall be duly honored. Partial draws are permitted and the letter of credit shall be reduced by the amount of such partial draws as well as by any reduction letters authorized by the County. The sum of such partial draws shall on no account exceed the Stated Amount of this credit, and upon any draw or reduction letter which exhausts this credit, the original of this credit will be surrendered to us.

Except as expressly stated, this credit shall be subject to the Uniform Customs and Practice for Documentary Credits (1993 Revision), International Chamber of Commerce (Publication No. 500).

This credit is irrevocable prior to its expiration date unless both parties consent to revocation in writing.

Issuer: BORDER CAPITAL BANK

Address of Issuer: 1801 S. McCOLL ROAD, McALLEN, TX 78503

Signature of Issuer's Authorized Officer *Rutha Drawe*

Printed Name: RUTHA DRAWE

Title: SENIOR VICE PRESIDENT

1801 South McColl Road Post Office Box 5555 McAllen, Texas 78502-5555
Telephone 956-682-2265 Fax 956-972-5417 www.bordercapitalbank.com



**Hidalgo County
Planning
Department**

Raul E. Sesin, PE, CFM
Planning Administrator

Main Office

1304 S. 25th Street
Edinburg, Texas 78542
Phone (956) 318-2840
Fax (956) 318-2844

Engineering Projects Office

301 E. State Street
Pharr, Texas 78577
Phone (956) 318-2840
Fax (956) 318-2844

Precinct No. 1 Substation

1902 Joe Stephens Ave.
Weslaco, Texas 78596
Phone (956) 968-4734
Fax (956) 973-7850

Precinct No. 3 Substation

2401 N. Moorefield Rd.
Mission, Texas 78572
Phone (956) 205-7045
Fax (956) 205-7049



Raul E. Sesin, P.E.
Planning Administrator

PLANNING DEPARTMENT

COUNTY OF HIDALGO

1304 South 25th Street
Edinburg, Texas 78539

Tel. (956) 318-2840 • Fax. (956) 318-2844

www.co.hidalgo.tx.us

**Brushline LTD Subdivision
ONSITE INSPECTION**

WATER FACILITIES:

- Service Lines: All water services have been installed.
- Meter boxes: All meter boxes have been installed.
- 30 Year letter: Original 30 year letter has been submitted
- Fire Hydrant (if applicable): N/A fire hydrant were not part of the proposed subdivision improvements.

OSSF / SANITARY SEWER:

- Sewer Service Lines: N/A sewer service will be provided by septic tanks
- 30 Year Letter: N/A Subdivision will be serve by septic tanks
- Septic Tanks: Septic tanks have not been installed.
- Health Dept. Inspection Letter: Pending on the completion of the installation of all septic tanks.

PAVING:

- Street pavement & curb and gutter: All Street have been constructed to specification with curb and gutter.
- Street testing results: Street testing results have been submitted from Raba-Kisner Lab. And are satisfactory.
- Street Signs / Street Name: All Street signs have been installed
- Temporary Turn Around (if applicable): N/A not part of the proposed subdivision improvements.
- Share Driveways (if applicable): N/A not part of the proposed subdivision improvements.
- Type III barricade: N/A not part of the proposed subdivision improvements.
- Valley Gutters: N/A not part of the proposed subdivision improvements.

DRAINAGE:

- Detention Swales: All drainage detention swales have been constructed to county specifications.
- Culvert with Safety Ends: Culverts and safety ends at subdivision street entrance have been installed.
- Re-grade of Road side Ditch: Brushline Road has been re-graded to county specifications.
- Gravel Bench Swale System (If Applicable): N/A not part of the proposed subdivision improvements.
- Erosion Control Points (If Applicable): All Erosion control points have been removed.
- Overflow structure with RIP – RAP (If applicable) :Concrete overflow structure have been constructed.
- Storm Drainage Inlets (If Applicable): N/A not part of the proposed subdivision improvements.
- Outfall with RIP - RAP (If Applicable): N/A not part of the proposed subdivision improvements.
- Concrete Spill Ways (If Applicable): N/A not part of the proposed subdivision improvements.
- Gridded Down Drain (If Applicable): N/A not part of the proposed subdivision improvements.

OTHER IMPROVEMENTS:

- Lot Staking :All subdivision lots have been staked
- Existing Structure On Lots (If applicable) : No permanent structures were on site at time of inspection.
- Gas Markers (If applicable): N/A not part of the proposed subdivision improvements.
- Elevated Pad Site (If Applicable) : N/A not part of the proposed subdivision improvements.
- Street Lights (If Applicable): N/A not part of the proposed subdivision improvements.
- Buffer Fence (If Applicable): N/A not part of the proposed subdivision improvements.
- Any Other: _____

INSPECTED BY: _____

José R. Jara

DATE: 07-11-2012



**Hidalgo County
Planning
Department**

Raul E. Sesin, PE, CFM
Planning Administrator

Main Office

1304 S. 25th Street
Edinburg, Texas 78542
Phone (956) 318-2840
Fax (956) 318-2844

Engineering Projects Office

301 E. State Street
Pharr, Texas 78577
Phone (956) 318-2840
Fax (956) 318-2844

Precinct No. 1 Substation

1902 Joe Stephens Ave.
Weslaco, Texas 78596
Phone (956) 968-4734
Fax (956) 973-7850

Precinct No. 3 Substation

2401 N. Moorefield Rd.
Mission, Texas 78572
Phone (956) 205-7045
Fax (956) 205-7049



Raul E. Sesin, P.E.
Planning Administrator

PLANNING DEPARTMENT

COUNTY OF HIDALGO
1304 South 25th Street
Edinburg, Texas 78539
Tel. (956) 318-2840 • Fax. (956) 318-2844
www.co.hidalgo.tx.us

CALICHE BASE STREET TESTING

SUBDIVISION NAME: BRUSHLINE 110 DEVELOPER: PAT FLETCHER
SITE LOCATION: BRUSHLINE ROAD & ENGINEER: R.E. GARCIA ENGINEERING.
P.M. 2021
CONTRACTOR: VALLEY PAVING LABORATORY: RABA-KISTNER
FIELD SUPERVISOR: OSCAR CORDOVA TECH: ALEX BERNAL

TESTING RESULTS:

8" $\frac{+2}{8.5}$ 128.

BORE No.	STATION No.	STREET NAME & CORE LOCATION	THICKNESS	MOISTER	COMPACTION
①	0+00	E OF MARTINA	8"	7.2	104.5
2	3+50	E OF MARTINA	8"	6.9	104.5
3	6+50	NORTH BOUND MARTINA	8"	7.5	102.7

COMMENTS: ALL CALICHE BORINGS ARE SATISFACTORY

COUNTY INSPECTOR [Signature] DATE: 05/14/2012



Hidalgo County Planning Department

Raul E. Sesin, PE, CFM
Planning Administrator

Main Office

1304 S. 25th Street
Edinburg, Texas 78542
Phone (956) 318-2840
Fax (956) 318-2844

Engineering Projects Office

301 E. State Street
Pharr, Texas 78577
Phone (956) 318-2840
Fax (956) 318-2844

Precinct No. 1 Substation

1902 Joe Stephens Ave.
Weslaco, Texas 78596
Phone (956) 968-4734
Fax (956) 973-7850

Precinct No. 3 Substation

2401 N. Moorefield Rd.
Mission, Texas 78572
Phone (956) 205-7045
Fax (956) 205-7049



Raul E. Sesin, P.E.
Planning Administrator

PLANNING DEPARTMENT

COUNTY OF HIDALGO

1304 South 25th Street
Edinburg, Texas 78539

Tel. (956) 318-2840 • Fax. (956) 318-2844

www.co.hidalgo.tx.us

CALICHE BASE STREET TESTING

SUBDIVISION NAME: BRUSHLINE LTD DEVELOPER: DAVE SWICHER
 SITE LOCATION: BRUSHLINE ROAD & FM 2221 ENGINEER: R.E. GARCIA ENGINEERING
 CONTRACTOR: VALLEY PAVING LABORATORY: KABA-KISTNER
 FIELD SUPERVISOR: JAIIME CORDOVA TECH: VICTOR SAVINAS

STREET TESTING RESULTS:

CORE No.	STATION No.	STREET NAME & CORE LOCATION	THICKNESS	MOISTER	COMPACTION
^{BORING} 1	1+40	DELAIA E of ST.	8"	8.2	100.5
2	4+20	DELAIA E of ST.	8"	6.9	101.4
3	2+00	DELAIA NORTH BOUND.	8"	6.9	102.4
4	7+60	JAY KEITH EAST BOUND.	8"	8.4	100.0
5	10+60	JAY KEITH E of ST.	8"	7.0	103.2

COMMENTS: ALL CALICHE BORINGS ARE SATISFACTORY

COUNTY INSPECTOR [Signature] DATE: 05/02/2012



**Hidalgo County
Planning
Department**

Raul E. Sesin, PE, CFM
Planning Administrator

Main Office
1304 S. 25th Street
Edinburg, Texas 78542
Phone (956) 318-2840
Fax (956) 318-2844

Engineering Projects Office
301 E. State Street
Pharr, Texas 78577
Phone (956) 318-2840
Fax (956) 318-2844

Precinct No. 1 Substation
1902 Joe Stephens Ave.
Weslaco, Texas 78596
Phone (956) 968-4734
Fax (956) 973-7850

Precinct No. 3 Substation
2401 N. Moorefield Rd.
Mission, Texas 78572
Phone (956) 205-7045
Fax (956) 205-7049



Raul E. Sesin, P.E.
Planning Administrator

PLANNING DEPARTMENT

COUNTY OF HIDALGO

1304 South 25th Street

Edinburg, Texas 78539

Tel. (956) 318-2840 • Fax. (956) 318-2844

www.co.hidalgo.tx.us

HMAC STREET CORE TESTING

SUBDIVISION NAME: BRUSHLINE LTD DEVELOPER: PAT FLEISCHER
SITE LOCATION: BRUSHLINE ROAD @ ENGINEER: R.E. GARCIA & ASSOC.
7 MILE HWY
CONTRACTOR: VALLEY PAVING LABORATORY: RABA-KRNER
FIELD SUPERVISOR: OSCAR TECH: VICTOR SALINAS

STREET TESTING RESULTS:

CORE No.	STATION No.	STREET NAME & CORE LOCATION	THICKNESS REQUIRED	ACTUAL THICKNESS	RESULTS
1	FRONT WY 27	MARTINA ST. N. BOUND	1 1/2"	1 1/2"	✓
2	CLIP WY 34	MARTINA ST @ JAY KEITH	1 1/2"	2"	✓
3	FRONT WY 35	DELAILA ST. S. BOUND.	1 1/2"	1 1/2"	✓
4	FRONT WY 26	DELAILA ST. S. BOUND	1 1/2"	1 1/2"	✓
5	FRONT WY 69	ADRIANA ST. S. BOUND.	1 1/2"	1 1/2"	✓
6	CLIP WY 76	ADRIANA ST @ JAY KEITH	1 1/2"	1 1/2"	✓
7	MID WY 62	INER ST. S. BOUND.	1 1/2"	2"	✓
8	FRONT WY 67	INER ST. N. BOUND.	1 1/2"	1 3/4"	✓
			1 1/2"		
			1 1/2"		
			1 1/2"		
			1 1/2"		

COMMENTS: ALL ASPHALT CORE TESTING ARE SATISFACTORY

COUNTY INSPECTOR [Signature] DATE: 06/07/2012



**Hidalgo County
Planning
Department**

Raul E. Sesin, PE, CFM
Planning Administrator

Main Office
1304 S. 25th Street
Edinburg, Texas 78542
Phone (956) 318-2840
Fax (956) 318-2844

Engineering Projects Office
301 E. State Street
Pharr, Texas 78577
Phone (956) 318-2840
Fax (956) 318-2844

Precinct No. 1 Substation
1902 Joe Stephens Ave.
Weslaco, Texas 78596
Phone (956) 968-4734
Fax (956) 973-7850

Precinct No. 3 Substation
2401 N. Moorefield Rd.
Mission, Texas 78572
Phone (956) 205-7045
Fax (956) 205-7049

MEMORANDUM

**To: JUDGE RAMON GARCIA
COUNTY COMMISSIONER'S COURT**

From: RAUL E. SESIN, P.E., PLANNING ADMINISTRATOR

Date: JULY 11, 2012

Re: BRUSHLINE, LTD SUBDIVISION

ON MARCH 6, 2012, THE COUNTY COMMISSIONERS COURT GRANTED FINAL APPROVAL WITH FINANCIAL GUARANTEE FOR THE ABOVE REFERENCED SUBDIVISION. A CASH DEPOSIT IN THE AMOUNT OF TWO THOUSAND FIVE HUNDRED FIFTY TWO DOLLARS AND THIRTEEN CENTS (\$2,552.13) WAS USED TO SECURE THE FUNDS FOR THE INSTALLATION OF ALL STREET SIGNS.

THE DEVELOPER IS REQUESTING REIMBURSEMENT IN THE AMOUNT OF \$2,552.13 DOLLARS. THIS REFLECTS THE INSTALLATION OF ALL STREET SIGNS. ATTACHED IS AN INSPECTION REPORT AND PICTURES FROM OUR DEPARTMENT CONFIRMING INSTALLATION OF ALL STREET SIGNS.

STAFF HAS NO OBJECTION TO THE REIMBURSEMENT IN THE AMOUNT OF \$2,552.13 FOR THE AFOREMENTIONED IMPROVEMENTS.

***** END OF MEMORANDUM *****



Hidalgo County Planning Department

Raul E. Sesin, PE, CFM
Planning Administrator

Main Office

1304 S. 25th Street
Edinburg, Texas 78542
Phone (956) 318-2840
Fax (956) 318-2844

Engineering Projects Office

301 E. State Street
Pharr, Texas 78577
Phone (956) 318-2840
Fax (956) 318-2844

Precinct No. 1 Substation

1902 Joe Stephens Ave.
Weslaco, Texas 78596
Phone (956) 968-4734
Fax (956) 973-7850

Precinct No. 3 Substation

2401 N. Moorefield Rd.
Mission, Texas 78572
Phone (956) 205-7045
Fax (956) 205-7049

HIDALGO COUNTY PLANNING DEPARTMENT

◦ UTILITY CERTIFICATE REVIEW FEE Acct # - 1100-341-30-210-003-0-000 Permit No. _____ TOTAL _____		Date <u>2-10</u> 20 <u>12</u>
◦ SUBDIVISION FEES Acct # - 1100-341-30-210-003-0-000 Filing/Review Fee _____ 2% Inspection Fee _____ Maps _____ Subd. Bates Book _____ Other _____ TOTAL _____		Received of: <u>Brushline L.T.O.</u> <u>2552.13</u> <u>Two thousand five hundred fifty two and 13/100</u> Dollars
◦ ESCROW Acct # - 1100-341-30-210-003-0-000 1/3 Paving _____ Septic Tank - _____ Other <u>street sign escrow</u> <u>\$2552.13</u> TOTAL <u>\$2552.13</u>		Subdivision: <u>Brushline, LTD. subd.</u> Cash _____ Check # <u>001012</u> M.O. # _____ Received by: <u>Fla J. Castillo</u>

 THE STATE OF TEXAS
 COUNTY OF HIDALGO

Precinct No. 2 & 4
RECEIPT
 N^o 65945 - 2/4
COUNTY AUDITOR'S FORM RE-PD-0001

White - Customer Copy • Yellow - Auditor's Copy • Pink - Office Copy

TXD# 04081282 PH# 239-2037
 100-37-57 BRUSHLINE, LTD.
 P.O. BOX 1675 PHARR, TX 78577 PH# 381-1001

BORDER CAPITAL BANK
 McALLEN, TEXAS
 88-1161/1149

001012

Memo: street sign escrow

PAY Two Thousand Five Hundred Fifty-Two and 13/100 Dollars

TO THE ORDER OF: Hidalgo County
 Edinburg, TX 78539

DATE: Feb 10, 2012
 AMOUNT: 2552.13

Fla J. Castillo
 AUTHORIZED SIGNATURE



⑈001012⑈ ⑆114911616⑆ ⑈0034010⑈



Hidalgo County Planning Department

Raul E. Sesin, PE, CFM Planning Administrator

Main Office 1304 S. 25th Street Edinburg, Texas 78542

Engineering Projects Office 301 E. State Street Pharr, Texas 78577

Precinct No. 1 Substation 1902 Joe Stephens Ave. Weslaco, Texas 78596

Precinct No. 3 Substation 2401 N. Moorefield Rd. Mission, Texas 78572



Raul E. Sesin, P.E. Planning Administrator

PLANNING DEPARTMENT

COUNTY OF HIDALGO

1304 South 25th Street Edinburg, Texas 78539

Tel. (956) 318-2840 • Fax. (956) 318-2844

www.co.hidalgo.tx.us

BRUSH LINE LTD SUBD.

ONSITE INSPECTION

WATER FACILITIES:

- Service Lines: Meter boxes: 30 Year letter: Fire Hydrant (if applicable):

OSSF / SANITARY SEWER:

- Sewer Service Lines: 30 Year Letter: Septic Tanks: Health Dept. Inspection Letter:

PAVING:

- Street pavement & curb and gutter: Street testing results: Street Signs / Street Name: Temporary Turn Around (if applicable): Share Driveways (if applicable): Type III barricade: Valley Gutters:

DRAINAGE:

- Detention Swales: Culvert with Safety Ends: Re-grade of Road side Ditch: Gravel Bench Swale System (If Applicable): Erosion Control Points (If Applicable): Overflow structure with RIP - RAP (If applicable): Storm Drainage Inlets (If Applicable): Outfall with RIP - RAP (If Applicable): Concrete Spill Ways (If Applicable): Gridded Down Drain (If Applicable):

OTHER IMPROVEMENTS:

- Lot Staking: Existing Structure On Lots (if applicable): Gas Markers (if applicable): Lot Sell Advertisement Sign (If Applicable): Elevated Pad Site (If Applicable): Street Lights (If Applicable): Buffer Fence (If Applicable): Any Other: ALL TREE BRUSH DEBRIS HAS BEEN CLEARED FROM LOTS

INSPECTED BY: [Signature] DATE: 07/11/2012



Hidalgo County Planning Department

Raul E. Sesin, PE, CFM
Planning Administrator

Main Office

1304 S. 25th Street
Edinburg, Texas 78542
Phone (956) 318-2840
Fax (956) 318-2844

Engineering Projects Office

301 E. State Street
Pharr, Texas 78577
Phone (956) 318-2840
Fax (956) 318-2844

Precinct No. 1 Substation

1902 Joe Stephens Ave.
Weslaco, Texas 78596
Phone (956) 968-4734
Fax (956) 973-7850

Precinct No. 3 Substation

2401 N. Moorefield Rd.
Mission, Texas 78572
Phone (956) 205-7045
Fax (956) 205-7049

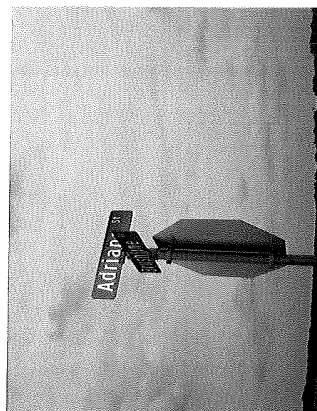
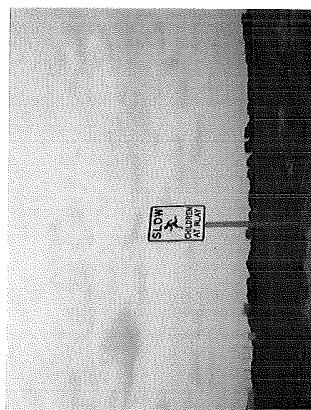
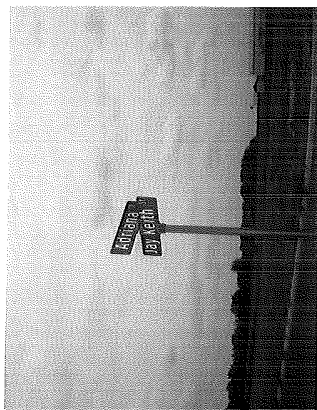
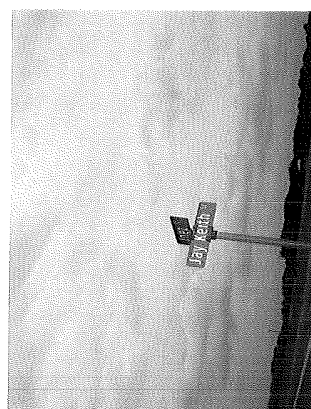
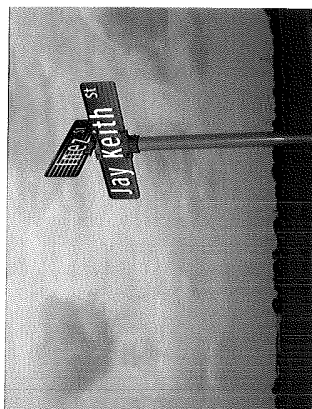
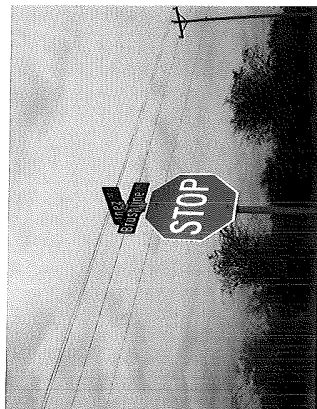



Hidalgo County Planning Department

Raul E. Sesin, PE, CFM
Planning Administrator

Main Office

1304 S. 25th Street
Edinburg, Texas 78542
Phone (956) 318-2840
Fax (956) 318-2844

Engineering Projects Office

301 E. State Street
Pharr, Texas 78577
Phone (956) 318-2840
Fax (956) 318-2844

Precinct No. 1 Substation

1902 Joe Stephens Ave.
Weslaco, Texas 78596
Phone (956) 968-4734
Fax (956) 973-7850

Precinct No. 3 Substation

2401 N. Moorefield Rd.
Mission, Texas 78572
Phone (956) 205-7045
Fax (956) 205-7049

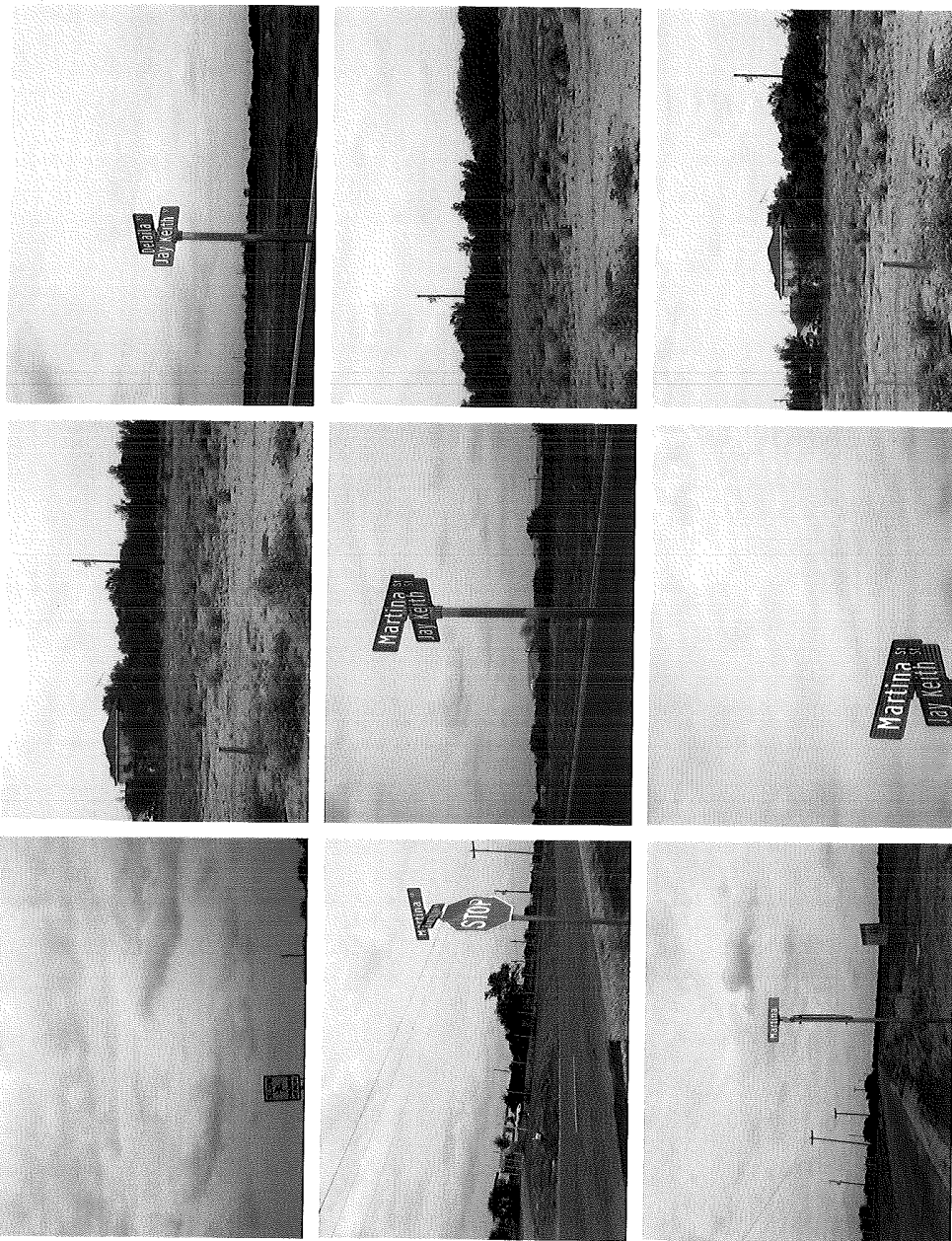

AI-33311

Planning Department 14. B.

CC REGULAR

Meeting Date: 07/24/2012

Department Head: Raul E. Sesin, P.E.

Submitted By: Nora Cavazos, PLANNING DEPT.

Department: PLANNING DEPT.

Information

CAPTION

1. Preliminary Approval
 - a. D & D Estates Subdivision – Pct.4 (Magdalena Rodriguez)
 - b. Idalia Subdivision – Pct.4 (Vicente Garza)
 - c. Aza Subdivision – Pct.1 (Jose Cruz Aza)
 - d. Acres of Santa Cruz Phase 1 Subdivision – Pct.3 (Richard Ruppert)
 - e. Iowa Subdivision – Pct.3 (Norberto Salinas)
 - f. Vista Ridge Acres Phase 4 Subdivision – Pct.1 (Jack McClelland)
2. Final Approval
 - a. Evergreen Valley Estates Phase 4 Subdivision – Pct.4 (Tillmin Welch)
 - b. Evergreen Valley Estates Phase 6 Subdivision – Pct.4 (Tillmin Welch)
3. Final Approval with Variance Request
 - a. Pifalo Subdivision – Pct.4 (Mario Pifalo)

BACKGROUND

Attachments

D & D Estates; Preliminary

D & D Estates; Plat

Idalia; Preliminary

Idalia; Plat

Aza; Preliminary

Aza; Plat

Acres of Santa Cruz Ph I; Preliminary

Acres of Santa Cruz Ph I; Plat

Iowa; Preliminary

Iowa; Plat

Vista Ridge Acres 4; Preliminary

Vista Ridge Acres 4; Plat

Evergreen Valley 4; Final

Evergreen Valley 4; Plat

Evergreen Valley 6; Final

Evergreen Valley 6; Plat

Pifalo; Final

Pifalo; Plat

Form Review

Inbox	Reviewed By	Date
Budget & Management	Merlen P. Munoz	07/18/2012 03:58 PM
Olga Garza	Olga Garza	07/20/2012 11:28 AM
Purchasing Department	Angela Garcia	07/20/2012 04:55 PM
Form Started By: Nora Cavazos		Started On: 07/18/2012 12:57 PM
	Final Approval Date: 07/20/2012	



HIDALGO COUNTY PLANNING DEPARTMENT

1304 SOUTH 25TH STREET
EDINBURG TEXAS 78539
Tel. 956-318-2840 Fax. 956-318-2844

Raul E. Sesin, P.E., CFM
Planning Administrator

HIDALGO COUNTY COMMISSIONER'S COURT MEETING

DATE: 07-24-2012

PROPOSED D & D ESTATES SUBDIVISION, PRECINCT No. 4.

ENGINEER: CORTAN ENGINEERING DEVELOPER: MAGDALENA RODRIGUEZ

PRELIMINARY APPROVAL FINAL APPROVAL FINAL APPROVAL WITH FINANCIAL GUARANTEE WITH VARIANCE

NUMBER OF LOTS: 2 *SINGLE FAMILY *MULTI-FAMILY COMMERCIAL INSTITUTIONAL

LOCATION DESCRIPTION: North of Benito Ramirez road approximate 1/4 mile east of Kenyon road

The rural area of the County.

SUBDIVISION LIES WITHIN THE: ETJ of _____ and was approved administratively by said City.

ETJ of EDINBURG and was approved by the P & Z and City Commission of said City

DRAINAGE REPORT WAS APPROVED BY HCDD#1: ON 05-10-2012 PROPERTY LIES WITHIN FLOOD ZONE: "X" AS PER FEMA.

DRAINAGE DESIGN: Drainage detention swales

DISTANCE TO A DRAIN DITCH: Approximately 900 feet east of development.

ROAD R.O.W. DEDICATION: 10.00 feet on Benito A. Rodriguez Road by this plat

H.C.R.O.W. APPROVED DATE: 06-27-2012 : By, Joe Peña R.O.W. DIRECTOR

SEWER SYSTEM: OSSF & SOIL ANALYSIS WERE CONDUCTED BY: Issac Mata

OSSF HAVE BEEN INSTALLED AND INSPECTED BY HCHD ON: _____

SANITARY SEWER BY: _____ LINE SIZE: _____ LOCATION: _____

WATER SERVICE PROVIDER: N.A.W.S.C. LINE SIZE: 8" LOCATION: Benito Ramirez

H.C.O.E.C. APPROVED DATE: 07-09-2012 : By Ann Marie De La Fuente, Administrative Assistant

SMALL CONSTRUCTION

The applicant has submitted the required small construction site notice as per Part II, Section E of the TPDES General Permit for Construction Activities (TXR150000) along with a copy of the Erosion Control Plan for the proposed project.

LARGE CONSTRUCTION

The applicant has submitted the required NOI as per Part II, Section E of the TPDES General Permit for Construction Activities (TXR150000) along with a copy of the Erosion Control Plan for the proposed project.

REQUEST FOR FINAL APPROVAL WITH: **Cash Deposit:** Amount: \$ _____ For: OSSF(S) _____ PAVING DRAINAGE STREET SIGNS

A Letter of Credit Financial Institution: _____ L.O.C No. _____

Amount: \$ _____ For: OSSF(S) _____ PAVING DRAINAGE STREET SIGNS

PRELIMINARY APPROVAL FROM
THE HIDALGO COUNTY ADVISORY BOARD ON:
_____, 20__.

STAFF RECOMMENDS: **Preliminary Approval** subject to comments and future recommendations by planning,

other departments and the approval of the City of EDINBURG.

Preliminary Approval subject comments and future recommendations by planning and other Departments

Final Approval subject to recommendations other departments

Final Approval with financial guarantee.

This subdivision plat has been reviewed and complies with the Hidalgo County Subdivision Rules, Texas Water Development Board Model Subdivision Rules and The Texas Local Government Code.



HIDALGO COUNTY PLANNING DEPARTMENT

1304 SOUTH 25TH STREET
EDINBURG TEXAS 78539
Tel. 956-318-2840 Fax. 956-318-2844

Raul E. Sesin, P.E., CFM
Planning Administrator

HIDALGO COUNTY COMMISSIONER'S COURT MEETING

DATE: 07-24-2012

PROPOSED IDALIA SUBDIVISION, PRECINCT No. 4.

ENGINEER: NAIN ENGINEERING DEVELOPER: VICENTE GARZA

PRELIMINARY APPROVAL FINAL APPROVAL FINAL APPROVAL WITH FINANCIAL GUARANTEE WITH VARIANCE

NUMBER OF LOTS: 2 *SINGLE FAMILY *MULTI-FAMILY COMMERCIAL INSTITUTIONAL

LOCATION DESCRIPTION: West of Val Verde Road approximate ¼ mile North of Iowa Road.

The rural area of the County.

SUBDIVISION LIES WITHIN THE: ETJ of _____ and was approved administratively by said City.

ETJ of _____ and was approved by the P & Z and City Commission of said City

DRAINAGE REPORT WAS APPROVED BY HCDD#1: ON 06-14-2012 PROPERTY LIES WITHIN FLOOD ZONE: "X" AS PER FEMA.

DRAINAGE DESIGN: Drainage detention swales

DISTANCE TO A DRAIN DITCH: Approximately 60 feet south of development.

ROAD R.O.W. DEDICATION: Additional ROW will not be required. Road Right of Way in accordance with the Hidalgo County Thoroughfare Plan.

H.C.R.O.W. APPROVED DATE: 07-09-2012 : By, Roy Gonzales R.O.W. AGENT

OSSF & SOIL ANALYSIS WERE CONDUCTED BY: Jose A. Gonzalez

OSSF HAVE BEEN INSTALLED AND INSPECTED BY HCHD NO: _____

SANITARY SEWER BY: _____ LINE SIZE: _____ LOCATION: _____

WATER SERVICE PROVIDER: N.A.W.S.C. LINE SIZE: 2" LOCATION: Val Verde Road

H.C.O.E.C. APPROVED DATE: 07-06-2012 : By Ann Marie De La Fuente, Administrative Assistant

SMALL CONSTRUCTION

The applicant has submitted the required small construction site notice as per Part II, Section E of the TPDES General Permit for Construction Activities (TXR150000) along with a copy of the Erosion Control Plan for the proposed project.

LARGE CONSTRUCTION

The applicant has submitted the required NOI as per Part II, Section E of the TPDES General Permit for Construction Activities (TXR150000) along with a copy of the Erosion Control Plan for the proposed project.

REQUEST FOR FINAL APPROVAL WITH: **Cash Deposit:** Amount: \$ _____ For: OSSF(S) PAVING DRAINAGE STREET SIGNS

A Letter of Credit Financial Institution: _____ L.O.C No. _____

Amount: \$ _____ For: OSSF(S) PAVING DRAINAGE STREET SIGNS

PRELIMINARY APPROVAL FROM
THE HIDALGO COUNTY ADVISORY BOARD ON: _____, 20____.

STAFF RECOMMENDS: **Preliminary Approval** subject to comments and future recommendations by planning, other departments and the approval of the City of _____.

Preliminary Approval subject comments and future recommendations by planning and other departments

Final Approval subject to recommendations other departments

Final Approval with financial guarantee.

* This subdivision plat has been reviewed and complies with the Hidalgo County Subdivision Rules, Texas Water Development Board Model Subdivision Rules and The Texas Local Government Code.



HIDALGO COUNTY PLANNING DEPARTMENT

1304 SOUTH 25TH STREET
EDINBURG TEXAS 78539
Tel. 956-318-2840 Fax. 956-318-2844

Raul E. Sesin, P.E., CFM
Planning Administrator

HIDALGO COUNTY COMMISSIONER'S COURT MEETING

DATE: 07-24-2012

PROPOSED AZA SUBDIVISION, PRECINCT No. 1.

ENGINEER: NAIN ENGINEERING DEVELOPER: RENEE A. AZA

PRELIMINARY APPROVAL FINAL APPROVAL FINAL APPROVAL WITH FINANCIAL GUARANTEE WITH VARIANCE
NUMBER OF LOTS: 3 *SINGLE FAMILY *MULTI-FAMILY COMMERCIAL INSTITUTIONAL

LOCATION DESCRIPTION: North of Mile 13 1/2 North Road Approximate 660 feet East of FM 1015

SUBDIVISION LIES WITHIN THE: *The rural area of the County.*
 ETJ of _____ and was approved administratively by said City.
 ETJ of _____ and was approved by the P & Z and City Commission of said City

DRAINAGE REPORT WAS APPROVED BY HCDD#1: ON 06-14-2012 PROPERTY LIES WITHIN FLOOD ZONE: "X" AS PER FEMA.

DRAINAGE DESIGN: Drainage detention swales

DISTANCE TO A DRAIN DITCH: Approximately 700 feet south of development.

ROAD R.O.W. DEDICATION: 40.00 feet on Mile 13 1/2 North Road by this plat

H.C.R.O.W. APPROVED DATE: 07-09-2012 : By, Roy Gonzales R.O.W. AGENT

SEWER SYSTEM: OSSF & SOIL ANALYSIS WERE CONDUCTED BY: Jose A. Gonzalez
 OSSF HAVE BEEN INSTALLED AND INSPECTED BY HCHD ON: _____
 SANITARY SEWER BY: _____ LINE SIZE: _____ LOCATION: _____

WATER SERVICE PROVIDER: N.A.W.S.C. LINE SIZE: 2 1/2" LOCATION: Mile 13 1/2 North Road

H.C.O.E.C. APPROVED DATE: 07-09-2012 : By Ann Marie De La Fuente, Administrative Assistant

SMALL CONSTRUCTION

The applicant has submitted the required small construction site notice as per Part II, Section E of the TPDES General Permit for Construction Activities (TXR150000) along with a copy of the Erosion Control Plan for the proposed project.

LARGE CONSTRUCTION

The applicant has submitted the required NOI as per Part II, Section E of the TPDES General Permit for Construction Activities (TXR150000) along with a copy of the Erosion Control Plan for the proposed project.

REQUEST FOR FINAL APPROVAL WITH: **Cash Deposit:** Amount: \$ _____ For: OSSF(S) _____ PAVING DRAINAGE STREET SIGNS
 A Letter of Credit Financial Institution: _____ L.O.C No. _____
Amount: \$ _____ For: OSSF(S) _____ PAVING DRAINAGE STREET SIGNS

PRELIMINARY APPROVAL FROM
THE HIDALGO COUNTY ADVISORY BOARD ON: _____, 20__.

STAFF RECOMMENDS: **Preliminary Approval** subject to comments and future recommendations by planning, other departments and the approval of the City of _____.

Preliminary Approval subject comments and future recommendations by planning and other departments

Final Approval subject to recommendations other departments

Final Approval with financial guarantee.

This subdivision plat has been reviewed and complies with the Hidalgo County Subdivision Rules, Texas Water Development Board Model Subdivision Rules and The Texas Local Government Code.

*



HIDALGO COUNTY PLANNING DEPARTMENT

1304 SOUTH 25TH STREET
EDINBURG TEXAS 78539
Tel. 956-318-2840 Fax. 956-318-2844

Raul E. Sesin, P.E., CFM
Planning Administrator

HIDALGO COUNTY COMMISSIONER'S COURT MEETING

DATE: 07-24-2012

PROPOSED ACRES OF SANTA CRUZ PHASE 1 SUBDIVISION, PRECINCT No. 3

ENGINEER: QUINTANILLA, HEADLEY AND ASSOC. DEVELOPER: RICHARD W. RUPPERT

PRELIMINARY APPROVAL FINAL APPROVAL FINAL APPROVAL WITH FINANCIAL GUARANTEE WITH VARIANCE

NUMBER OF LOTS: 115 *SINGLE FAMILY *MULTI-FAMILY COMMERCIAL INSTITUTIONAL

LOCATION DESCRIPTION: North West corner of Inspiration Road and Monte Cristo Road (FM 1925)

SUBDIVISION LIES WITHIN THE: *The rural area of the County.*
 ETJ of _____ and was approved administratively by said City.
 ETJ of _____ and was approved by the P & Z and City Commission of said City

DRAINAGE REPORT WAS APPROVED BY HCDD#1: ON 07-02-2012 PROPERTY LIES WITHIN FLOOD ZONE: "X" AS PER FEMA.

DRAINAGE DESIGN: Drainage detention swales.

DISTANCE TO A DRAIN DITCH: Approximate 1.5 miles south west from subdivision development.

ROAD R.O.W. DEDICATION: 35 feet on Monte Cristo Road (FM 1925).

H.C.R.O.W. APPROVED DATE: 07-11-2012 : By, Victor Gallardo R.O.W. AGENT

SEWER SYSTEM: OSSF & SOIL ANALYSIS WERE CONDUCTED BY: Jose A. Gonzalez
 OSSF HAVE BEEN INSTALLED AND INSPECTED BY HCHD ON: _____
 SANITARY SEWER BY: _____ LINE SIZE: _____ LOCATION: _____

WATER SERVICE PROVIDER: S.W.S.C. LINE SIZE: 6" LOCATION: Mile 10 1/2 North Road

H.C.O.E.C. APPROVED DATE: 07-06-2012 : By Ann Marie De La Fuente, Administrative Assistant

SMALL CONSTRUCTION

The applicant has submitted the required small construction site notice as per Part II, Section E of the TPDES General Permit for Construction Activities (TXR150000) along with a copy of the Erosion Control Plan for the proposed project.

LARGE CONSTRUCTION

The applicant has submitted the required NOI as per Part II, Section E of the TPDES General Permit for Construction Activities (TXR150000) along with a copy of the Erosion Control Plan for the proposed project.

REQUEST FOR FINAL APPROVAL WITH: **Cash Deposit:** Amount: \$ _____ For: OSSF(S) PAVING DRAINAGE STREET SIGNS
 A Letter of Credit Financial Institution: _____ L.O.C No. _____
Amount: \$ _____ For: OSSF(S) PAVING DRAINAGE STREET SIGNS

PRELIMINARY APPROVAL FROM
THE HIDALGO COUNTY ADVISORY BOARD ON: _____, 20__.

STAFF RECOMMENDS: **Preliminary Approval** subject to comments and future recommendations by planning, other departments and the approval of the City of _____.

Preliminary Approval subject comments and future recommendations by planning and other departments

Final Approval subject to recommendations other departments

Final Approval with financial guarantee.

This subdivision plat has been reviewed and complies with the Hidalgo County Subdivision Rules, Texas Water Development Board Model Subdivision Rules and The Texas Local Government Code.

*

ACRES OF SANTA CRUZ SUBDIVISION PHASE I

A 71.20 ACRE TRACT OF LAND BEING PART OR A PORTION OF LOTS 4 AND 5, ALL OF LOTS 8 AND 9, BLOCK 1, AND ALL OF LOTS 4, 5, 8 AND 9, BLOCK 20, JACKSON SUBDIVISION OF THE MELADO TRACT, HIDALGO COUNTY, TEXAS, ACCORDING TO THE MAP OR PLAT THEREOF RECORDED IN VOLUME 4, PAGES 579 AND 580, DEED RECORDS, HIDALGO COUNTY, TEXAS, AND ACCORDING TO SPECIAL WARRANTY DEED RECORDED UNDER COUNTY CLERK'S DOCUMENT NUMBER 1557921, OFFICIAL RECORDS, HIDALGO COUNTY.

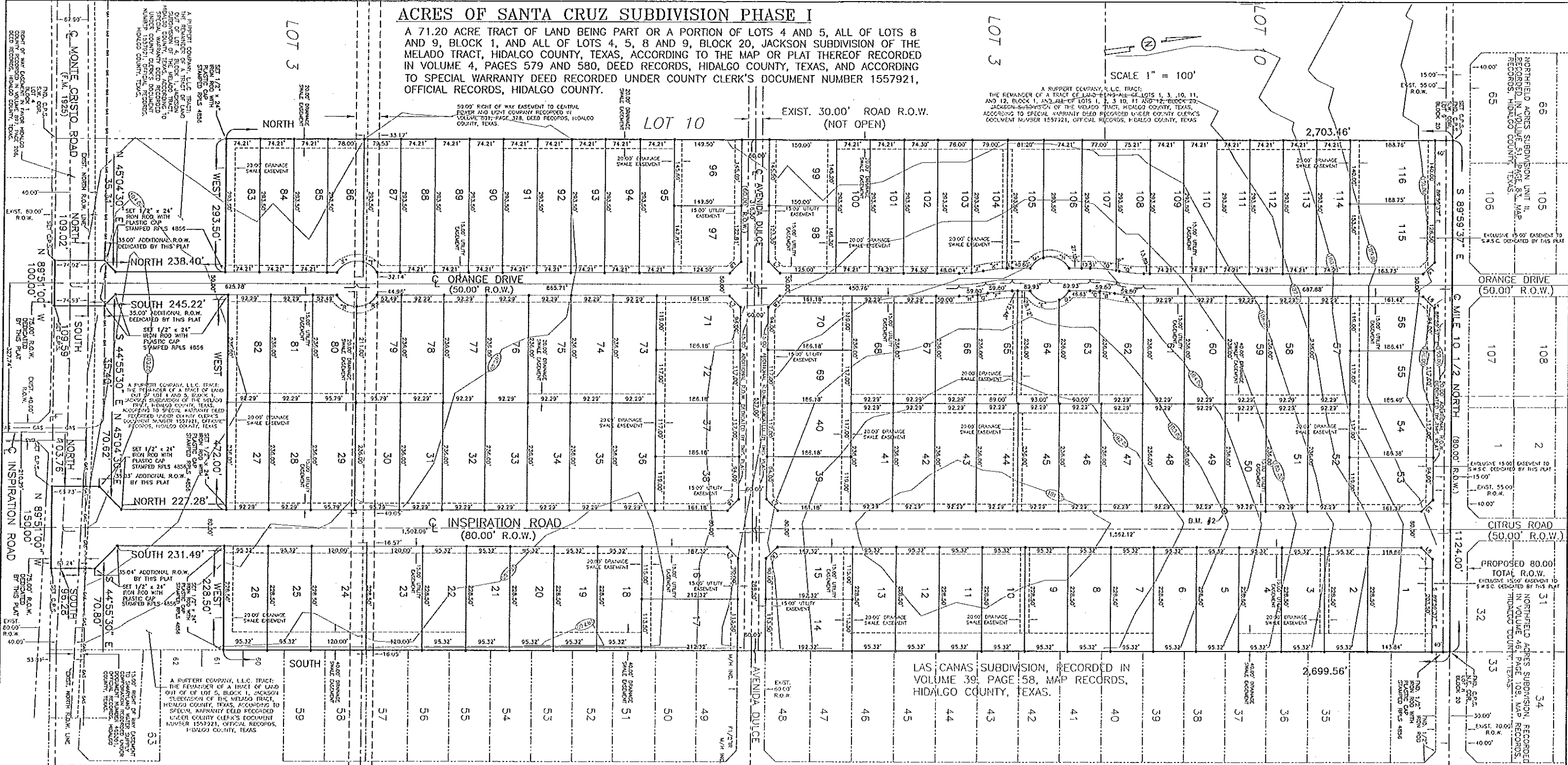

A SUPPORT COMPANY, L.L.C. TRACT: THE REMAINDER OF A TRACT OF LAND BEING ALL OF LOTS 1, 3, 10, 11, AND 12, BLOCK 1, AND ALL OF LOTS 1, 2, 3, 10, 11 AND 12, BLOCK 20, JACKSON SUBDIVISION OF THE MELADO TRACT, HIDALGO COUNTY, TEXAS, ACCORDING TO SPECIAL WARRANTY DEED RECORDED UNDER COUNTY CLERK'S DOCUMENT NUMBER 1557921, OFFICIAL RECORDS, HIDALGO COUNTY, TEXAS.

SCALE 1" = 100'



CURVE DATA

CURVE	Δ	RADIUS	LENGTH
"A"	117°51'16"	325.00'	64.78'
"B"	02°41'12"	275.00'	33.14'
"C"	04°30'57"	275.00'	275.00'
"D"	34°25'51"	50.00'	30.05'
"E"	05°34'03"	50.00'	74.67'
"F"	117°51'16"	275.00'	54.82'
"G"	03°56'40"	325.00'	22.37'
"H"	07°28'35"	325.00'	12.41'
"I"	05°50'09"	275.00'	28.01'
"J"	05°35'08"	275.00'	26.81'
"K"	08°19'51"	325.00'	52.93'
"L"	02°05'24"	325.00'	11.65'
"M"	43°04'56"	50.00'	37.69'
"N"	76°59'04"	50.00'	67.12'
"O"	10°11'21"	325.00'	57.80'
"P"	01°11'55"	325.00'	6.97'
"Q"	117°51'16"	275.00'	52.82'
"R"	67°00'00"	50.00'	52.36'
"S"	75°04'22"	50.00'	65.51'
"T"	44°55'38"	50.00'	33.21'

AREA DATA TABLE

LOT	AREA (S.F.)	AC.
1	32,557.20	0.747
2-13	21,780.62	0.500
14	21,804.30	0.501
15	21,828.32	0.501
16	24,104.30	0.553
17	24,698.32	0.563
18-22	21,780.62	0.500
23-24	27,420.00	0.629
25-26	21,780.62	0.500
27-28	21,780.44	0.500
29-30	22,695.44	0.519
31-35	21,780.44	0.500
37	21,783.05	0.500
38-39	21,842.92	0.501
40	21,783.05	0.500
41-52	21,780.44	0.500
53	21,866.52	0.502
54	21,897.80	0.501
55	21,809.34	0.501
56	21,871.22	0.502
57-61	21,780.44	0.500

AREA DATA TABLE

LOT	AREA (S.F.)	AC.
62	23,364.72	0.536
63	22,040.41	0.506
64	21,780.22	0.500
65	21,799.42	0.501
66	21,819.33	0.501
67-68	21,780.44	0.500
69	21,793.05	0.500
70-71	21,842.92	0.501
72	21,783.05	0.500
73-78	21,780.44	0.500
79-80	21,833.71	0.501
81-82	21,780.44	0.500
83-85	21,780.64	0.500
86	22,807.61	0.501
87	22,821.39	0.526
88-95	21,780.63	0.500
96	21,783.05	0.500
97	21,785.10	0.500
98	21,932.50	0.503
99	21,780.00	0.500
100-102	21,780.64	0.500

AREA DATA TABLE

LOT	AREA (S.F.)	AC.
103	22,232.73	0.512
104	22,614.15	0.519
105	22,453.92	0.515
106	22,838.07	0.524
107	21,782.56	0.500
108	21,933.72	0.501
109-114	21,780.64	0.500
115	28,623.68	0.658
116	26,425.71	0.607

LINE DATA TABLE

DATA	BEARING	LENGTH
L1	N 45°04'30" E	70.82'
L2	S 44°55'30" E	70.80'
L3	N 45°04'30" E	35.31'
L4	S 44°55'30" E	35.40'
L5	S 44°59'48" E	21.21'
L6	N 45°00'12" E	21.70'
L7	S 45°00'00" E	96.79'
L8	S 45°00'00" W	110.91'

STATE OF TEXAS
COUNTY OF HIDALGO
I, THE UNDERSIGNED, A LICENSED PROFESSIONAL ENGINEER IN THE STATE OF TEXAS, DO HEREBY CERTIFY THAT THE PROPER ENGINEERING CONSIDERATIONS HAVE BEEN GIVEN TO THIS PLAT.



Alfonso Quintanilla
P.E. No. 95534
DATE: 7-6-12

STATE OF TEXAS
COUNTY OF HIDALGO
I, THE UNDERSIGNED, A REGISTERED PROFESSIONAL LAND SURVEYOR IN THE STATE OF TEXAS, DO HEREBY CERTIFY THAT THIS PLAT IS TRUE AND CORRECT AND WAS MADE AND PREPARED FROM AN ACTUAL SURVEY OF THE PROPERTY SHOWN ON THE GROUND UNDER MY SUPERVISION.

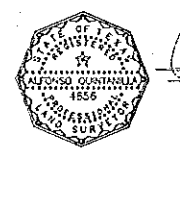

Alfonso Quintanilla
R.P.C.S. No. 4856
DATE: 5-16-12

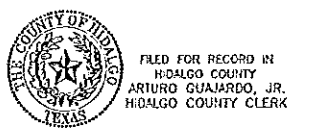

FILED FOR RECORD IN
HIDALGO COUNTY
ARTURO GUJARDO, JR.
HIDALGO COUNTY CLERK
ON: _____ AT _____ AM/PM
INSTRUMENT NUMBER _____
OF THE MAP RECORDS OF HIDALGO COUNTY, TEXAS
BY: _____ DEPUTY

REVISION NOTES

No.	Sheet	REVISION	Date	Prepared

FILE NAME	DATE PREPARED	DATE REVISION	DATE REVISION



HIDALGO COUNTY PLANNING DEPARTMENT

1304 SOUTH 25TH STREET
EDINBURG TEXAS 78539
Tel. 956-318-2840 Fax. 956-318-2844

Raul E. Sesin, P.E., CFM
Planning Administrator

HIDALGO COUNTY COMMISSIONER'S COURT MEETING

DATE: 07-24-2012

PROPOSED IOWA SUBDIVISION, PRECINCT No. 3.

ENGINEER: QUINTANILLA, HEADLEY AND ASSOC. DEVELOPER: NORBERTO SALINAS

PRELIMINARY APPROVAL FINAL APPROVAL FINAL APPROVAL WITH FINANCIAL GUARANTEE WITH VARIANCE
NUMBER OF LOTS: 52 *SINGLE FAMILY *MULTI-FAMILY COMMERCIAL INSTITUTIONAL

LOCATION DESCRIPTION: South west corner of Mile 8 North Road and Iowa Road.

SUBDIVISION LIES WITHIN THE: The rural area of the County.
 ETJ of _____ and was approved administratively by said City.
 ETJ of _____ and was approved by the P & Z and City Commission of said City

DRAINAGE REPORT WAS APPROVED BY HCDD#1: ON 07-03-2012 PROPERTY LIES WITHIN FLOOD ZONE: "X" & "A" AS PER FEMA.

DRAINAGE DESIGN: Drainage detention swales.

DISTANCE TO A DRAIN DITCH: Approximate 3 miles south west from subdivision development.

ROAD R.O.W. DEDICATION: 3 feet on Iowa Road.

H.C.R.O.W. APPROVED DATE: 07-11-2012 : By, Victor Gallardo R.O.W. AGENT

SEWER SYSTEM: OSSF & SOIL ANALYSIS WERE CONDUCTED BY: Issac Mata
 OSSF HAVE BEEN INSTALLED AND INSPECTED BY HCHD ON: _____
 SANITARY SEWER BY: _____ LINE SIZE: _____ LOCATION: _____

WATER SERVICE PROVIDER: AGUA S.U.D. LINE SIZE: 8" LOCATION: Iowa Road & Vaquero Ave.

H.C.O.E.C. APPROVED DATE: 07-06-2012 : By Ann Marie De La Fuente, Administrative Assistant

SMALL CONSTRUCTION

The applicant has submitted the required small construction site notice as per Part II, Section E of the TPDES General Permit for Construction Activities (TXR150000) along with a copy of the Erosion Control Plan for the proposed project.

LARGE CONSTRUCTION

The applicant has submitted the required NOI as per Part II, Section E of the TPDES General Permit for Construction Activities (TXR150000) along with a copy of the Erosion Control Plan for the proposed project.

REQUEST FOR FINAL APPROVAL WITH: **Cash Deposit:** Amount: \$ _____ For: OSSF(S) _____ PAVING DRAINAGE STREET SIGNS
 A Letter of Credit Financial Institution: _____ L.O.C No. _____
Amount: \$ _____ For: OSSF(S) _____ PAVING DRAINAGE STREET SIGNS

PRELIMINARY APPROVAL FROM
THE HIDALGO COUNTY ADVISORY BOARD ON: _____, 20__.

STAFF RECOMMENDS: **Preliminary Approval** subject to comments and future recommendations by planning, other departments and the approval of the City of _____.

Preliminary Approval subject comments and future recommendations by planning and other Departments

Final Approval subject to recommendations other departments

Final Approval with financial guarantee.

This subdivision plat has been reviewed and complies with the Hidalgo County Subdivision Rules, Texas Water Development Board Model Subdivision Rules and The Texas Local Government Code.



HIDALGO COUNTY PLANNING DEPARTMENT

1304 SOUTH 25TH STREET
EDINBURG TEXAS 78539
Tel. 956-318-2840 Fax. 956-318-2844

Raul E. Sesin, P.E., CFM
Planning Administrator

HIDALGO COUNTY COMMISSIONER'S COURT MEETING

DATE: 07-24-2012

PROPOSED VISTA RIDGE ACRES PHASE 4 SUBDIVISION, PRECINCT No. 1

ENGINEER: QUINTANILLA, HEADLEY AND ASSOC. DEVELOPER: JACK McCLAND

PRELIMINARY APPROVAL FINAL APPROVAL FINAL APPROVAL WITH FINANCIAL GUARANTEE WITH VARIANCE
NUMBER OF LOTS: 31 *SINGLE FAMILY *MULTI-FAMILY COMMERCIAL INSTITUTIONAL

LOCATION DESCRIPTION: West of Noren Drive Approximate 1/4 mile North of Mile 19 North Road

SUBDIVISION LIES WITHIN THE: The rural area of the County.
 ETJ of _____ and was approved administratively by said City.
 ETJ of _____ and was approved by the P & Z and City Commission of said City

DRAINAGE REPORT WAS APPROVED BY HCDD#1: ON 05-22-2012 PROPERTY LIES WITHIN FLOOD ZONE: "X" (shaded) & "A" AS PER FEMA.

DRAINAGE DESIGN: Drainage detention swales and storm drainage pipe system.

DISTANCE TO A DRAIN DITCH: South East corner of subdivision development.

ROAD R.O.W. DEDICATION: 20 feet on Noren Drive.

H.C.R.O.W. APPROVED DATE: 07-09-2012 : By, Roy Gonzales R.O.W. AGENT

SEWER SYSTEM: OSSF & SOIL ANALYSIS WERE CONDUCTED BY: Jose A. Gonzalez
 OSSF HAVE BEEN INSTALLED AND INSPECTED BY HCHD ON: _____
 SANITARY SEWER BY: _____ LINE SIZE: _____ LOCATION: _____

WATER SERVICE PROVIDER: N.A.W.S.C. LINE SIZE: 8" LOCATION: Vista Ridge Drive

H.C.O.E.C. APPROVED DATE: 07-09-2012 : By Ann Marie De La Fuente, Administrative Assistant

SMALL CONSTRUCTION

The applicant has submitted the required small construction site notice as per Part II, Section E of the TPDES General Permit for Construction Activities (TXR150000) along with a copy of the Erosion Control Plan for the proposed project.

LARGE CONSTRUCTION

The applicant has submitted the required NOI as per Part II, Section E of the TPDES General Permit for Construction Activities (TXR150000) along with a copy of the Erosion Control Plan for the proposed project.

REQUEST FOR FINAL APPROVAL WITH: **Cash Deposit:** Amount: \$ _____ For: OSSF(S) PAVING DRAINAGE STREET SIGNS
 A Letter of Credit Financial Institution: _____ L.O.C No. _____
Amount: \$ _____ For: OSSF(S) PAVING DRAINAGE STREET SIGNS

PRELIMINARY APPROVAL FROM
THE HIDALGO COUNTY ADVISORY BOARD ON: _____, 20__.

STAFF RECOMMENDS: **Preliminary Approval** subject to comments and future recommendations by planning, other departments and the approval of the City of _____.

Preliminary Approval subject comments and future recommendations by planning and other departments

Final Approval subject to recommendations other departments

Final Approval with financial guarantee.

This subdivision plat has been reviewed and complies with the Hidalgo County Subdivision Rules, Texas Water Development Board Model Subdivision Rules and The Texas Local Government Code.

*

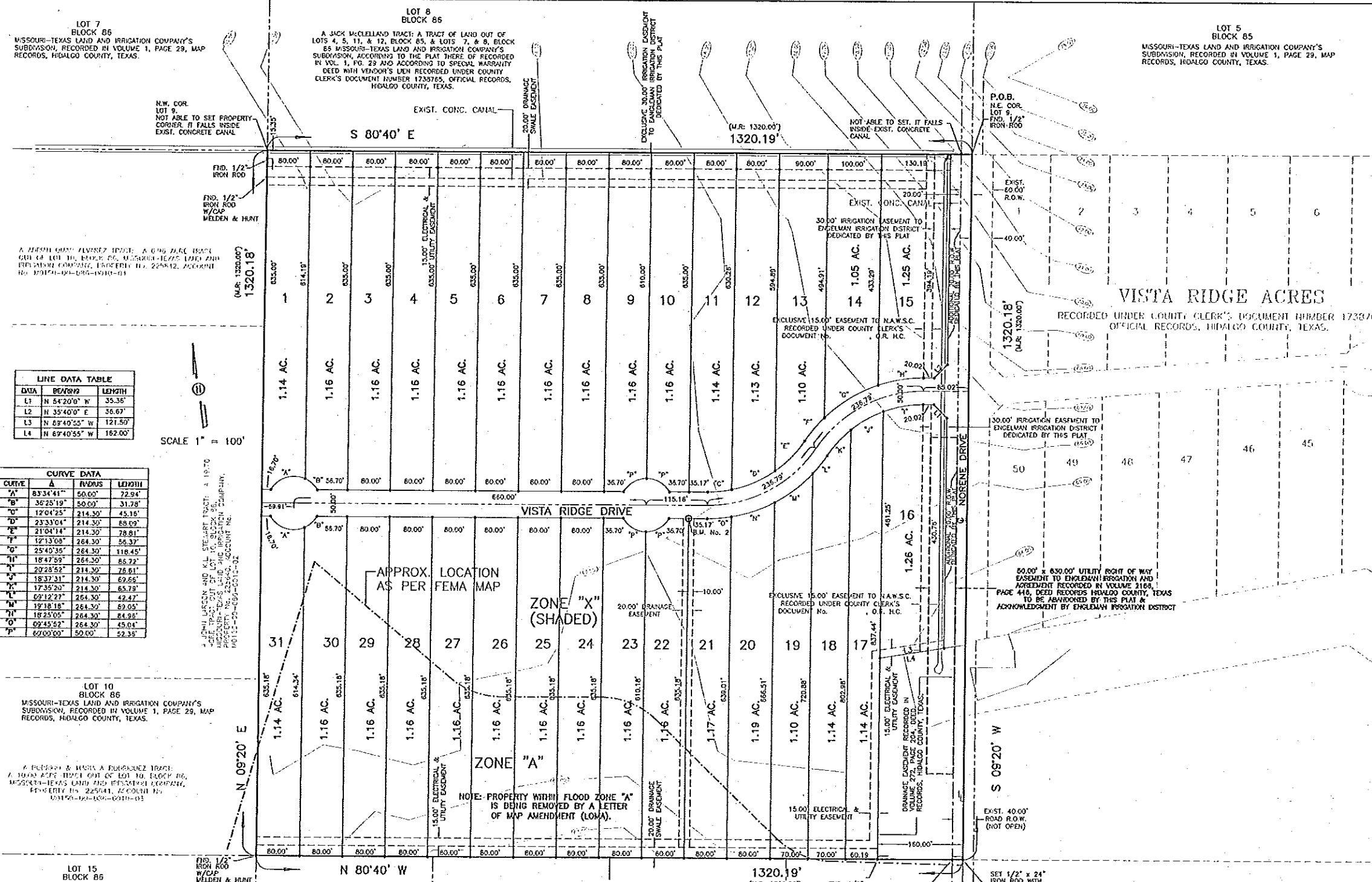

LINE DATA TABLE

DATA	BEARING	LENGTH
L1	N 84°20'0" W	35.35'
L2	N 35°40'0" E	36.67'
L3	N 69°40'55" W	121.50'
L4	N 69°40'55" W	162.00'

CURVE DATA

CURVE	Δ	RADIUS	LENGTH
"A"	83°34'41"	50.00'	72.94'
"B"	36°25'19"	50.00'	31.78'
"C"	12°04'25"	214.30'	45.18'
"D"	23°37'04"	214.30'	68.09'
"E"	21°04'14"	214.30'	78.81'
"F"	12°13'30"	264.30'	56.37'
"G"	25°40'35"	264.30'	118.45'
"H"	18°47'59"	264.30'	85.72'
"I"	29°28'52"	214.30'	78.81'
"J"	18°37'31"	214.30'	69.66'
"K"	17°35'20"	214.30'	65.73'
"L"	02°12'27"	264.30'	42.47'
"M"	19°18'18"	264.30'	89.05'
"N"	18°25'05"	264.30'	84.95'
"O"	09°45'52"	264.30'	45.04'
"P"	60°00'00"	50.00'	52.35'

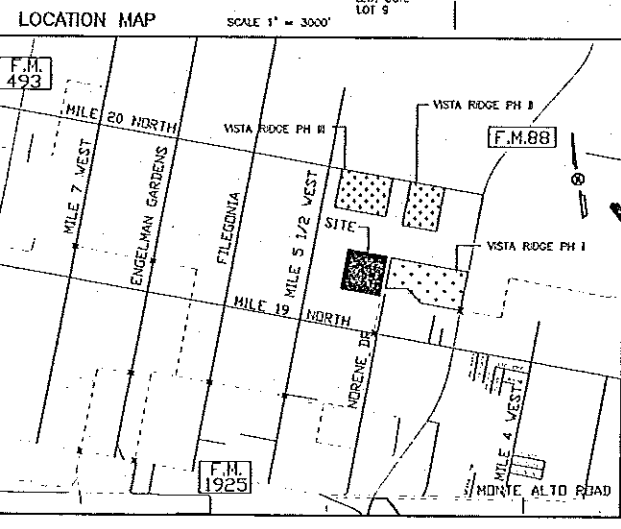

**SUBDIVISION PLAT OF:
VISTA RIDGE ACRES
PHASE IV**

A 40.01 ACRE TRACT OF LAND OUT OF LOT 9, BLOCK 86, MISSOURI-TEXAS LAND AND IRRIGATION COMPANY'S SUBDIVISION, HIDALGO COUNTY, TEXAS, ACCORDING TO THE MAP OR PLAT THEREOF RECORDED IN VOLUME 1, PAGE 29, MAP RECORDS, HIDALGO COUNTY, TEXAS, AND ACCORDING TO WARRANTY DEED WITH VENDOR'S LIEN RECORDED UNDER COUNTY CLERK'S DOCUMENT NUMBER 1736765, OFFICIAL RECORDS, HIDALGO COUNTY, TEXAS.

METES AND BOUNDS
A 40.01 ACRE TRACT OF LAND OUT OF LOT 9, BLOCK 86, MISSOURI-TEXAS LAND AND IRRIGATION COMPANY'S SUBDIVISION, HIDALGO COUNTY, TEXAS, ACCORDING TO THE MAP OR PLAT THEREOF RECORDED IN VOLUME 1, PAGE 29, MAP RECORDS, HIDALGO COUNTY, TEXAS, AND ACCORDING TO WARRANTY DEED WITH VENDOR'S LIEN RECORDED UNDER COUNTY CLERK'S DOCUMENT NUMBER 1736765, OFFICIAL RECORDS, HIDALGO COUNTY, TEXAS, REFERENCE TO WHICH IS HERE MADE FOR ALL PURPOSES AND BEING MORE PARTICULARLY DESCRIBED BY METES AND BOUNDS AS FOLLOWS:

BEGINNING AT A 1/2" IRON ROD FOUND IN THE CENTERLINE OF MORENE DRIVE FOR THE NORTHEAST CORNER OF LOT 9 AND THE NORTHEAST CORNER OF THIS TRACT.

THENCE S 09°20' W, ALONG THE EAST LINE OF LOT 9 AND THE CENTERLINE OF MORENE DRIVE, A DISTANCE OF 1,320.18 FEET (MAP RECORD: 1,320.00 FEET) TO A 1/2" IRON ROD WITH CAP STAMPED RPLS 4856 SET FOR THE SOUTHWEST CORNER OF LOT 9 AND THE SOUTHWEST CORNER OF THIS TRACT.

THENCE N 80°40' W, ALONG THE SOUTH LINE OF LOT 9, PASSING A 1/2" IRON ROD WITH CAP STAMPED WELDEN & HUNT FOR THE WEST RIGHT OF WAY LINE OF MORENE DRIVE, A TOTAL DISTANCE OF 1,320.19 FEET (MAP RECORD: 1,320.00 FEET) TO A 1/2" IRON ROD WITH CAP STAMPED WELDEN & HUNT FOUND FOR THE SOUTHWEST CORNER OF LOT 9 AND THE SOUTHWEST CORNER OF THIS TRACT.

THENCE N 09°20' E, ALONG THE WEST LINE OF LOT 9, A DISTANCE OF 1,320.19 FEET (MAP RECORD: 1,320.00 FEET) TO A POINT FOR THE NORTHEAST CORNER OF LOT 9 AND THE NORTHEAST CORNER OF THIS TRACT.

THENCE S 80°40' E, ALONG THE NORTH LINE OF LOT 9, PASSING A DISTANCE OF 1,320.19 FEET FOR THE WEST RIGHT OF WAY LINE OF MORENE DRIVE, A TOTAL DISTANCE OF 1,320.19 FEET TO THE POINT OF BEGINNING AND CONTAINING 40.01 ACRES OF LAND MORE OR LESS.

BEARINGS ARE IN ACCORDANCE WITH VISTA RIDGE ACRES, RECORDED IN INSTRUMENT NUMBER 1736765, MAP RECORDS, HIDALGO COUNTY, TEXAS.

STATE OF TEXAS
COUNTY OF HIDALGO

I, THE UNDERSIGNED, A LICENSED PROFESSIONAL ENGINEER IN THE STATE OF TEXAS, DO HEREBY CERTIFY THAT THE PROPER ENGINEERING CONSIDERATIONS HAVE BEEN GIVEN TO THIS PLAT.

 **Alfonso Quintanilla**
P.E. No. 95634
DATE: **2-27-12**

STATE OF TEXAS
COUNTY OF HIDALGO

I, THE UNDERSIGNED, A REGISTERED PROFESSIONAL LAND SURVEYOR IN THE STATE OF TEXAS, DO HEREBY CERTIFY THAT THIS PLAT IS TRUE AND CORRECT, AND WAS MADE AND PREPARED FROM AN ACTUAL SURVEY OF THE PROPERTY DONE ON THE GROUND UNDER MY SUPERVISION.

 **Alfonso Quintanilla**
R.P.L.S. No. 4856
DATE: **2-27-12**

 FILED FOR RECORD IN
HIDALGO COUNTY
ARTURO GUJARDO, JR.
HIDALGO COUNTY CLERK

ON: _____ AT _____ AM/PM
INSTRUMENT NUMBER _____
OF THE MAP RECORDS OF HIDALGO COUNTY, TEXAS
BY: _____ DEPUTY

REVISION NOTES

No.	Date	Revised	By	Approved

PRINCIPAL CONTACTS:

Name	Address	City & Zip	Phone	Fax
OWNER: JACK McCLELLAND, OWNER	2814 W. FREDDY GONZALEZ DRIVE	EDINBURG, TX 78539	(956)318-0956	318-4547
ENGINEER: ALFONSO QUINTANILLA	124 E. STUBBS	EDINBURG, TX 78539	(956)381-6490	381-0527
SURVEYOR: ALFONSO QUINTANILLA	124 E. STUBBS	EDINBURG, TX 78539	(956)381-6480	381-0527

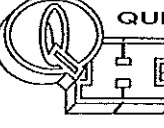
 **QUINTANILLA, HEADLEY AND ASSOCIATES, INC.**
CONSULTING ENGINEERS • LAND SURVEYORS
124 E. STUBBS ST.
EDINBURG, TEXAS 78539
PHONE 956-381-6480
FAX 956-381-0527
ENGINEERING REGISTRATION NUMBER F-1613
SURVEYING REGISTRATION NUMBER 100411-00
office@qhengineering.com

FILED NAME	DATE PREPARED	PREPARED BY	CHECKED BY	APPROVED BY
F:\DATA\SUB\HIDALGO CO\VISTA RIDGE ACRES\VISTA RIDGE PH IV PLAT	FEB 27 2012	M. GONZALEZ		
DATE REVISION	REVISION BY	CHECKED BY	APPROVED BY	



HIDALGO COUNTY PLANNING DEPARTMENT

1304 SOUTH 25TH STREET
EDINBURG TEXAS 78539
Tel. 956-318-2840 Fax. 956-318-2844

Raul E. Sesin, P.E., CFM
Planning Administrator

HIDALGO COUNTY COMMISSIONER'S COURT MEETING

DATE: 07-24-2012

PROPOSED EVERGREEN VALLEY ESTATES PHASE 4 SUBDIVISION, PRECINCT No. 4

ENGINEER: QUINTANILLA, HEADLEY AND ASSOC. DEVELOPER: TILLMIN WELCH

PRELIMINARY APPROVAL FINAL APPROVAL FINAL APPROVAL WITH FINANCIAL GUARANTEE WITH VARIANCE
NUMBER OF LOTS: 12 *SINGLE FAMILY *MULTI-FAMILY COMMERCIAL INSTITUTIONAL

LOCATION DESCRIPTION: North west corner of Skinner Road and Mile 19 North Road.

SUBDIVISION LIES WITHIN THE: *The rural area of the County.*
 ETJ of _____ and was approved administratively by said City.
 ETJ of _____ and was approved by the P & Z and City Commission of said City

DRAINAGE REPORT WAS APPROVED BY HCDD#1: ON 10-25-2012 PROPERTY LIES WITHIN FLOOD ZONE: "X" (shaded) AS PER FEMA.

DRAINAGE DESIGN: Drainage detention swales and positive outfall via a 15" bleeder line.

DISTANCE TO A DRAIN DITCH: West adjacent to subdivision development.

ROAD R.O.W. DEDICATION: 20 feet on Mile 19 North Road and 20 feet on Skinner Road.

H.C.R.O.W. APPROVED DATE: 11-14-2011: By, Benito Rodriguez R.O.W. AGENT

SEWER SYSTEM: OSSF & SOIL ANALYSIS WERE CONDUCTED BY: Jose A. Gonzalez
 OSSF HAVE BEEN INSTALLED AND INSPECTED BY HCHD ON: 06-07-2012

SANITARY SEWER BY: _____ LINE SIZE: _____ LOCATION: _____

WATER SERVICE PROVIDER: N.A.W.S.C. LINE SIZE: 8" LOCATION: Mile 19 North Road.

H.C.O.E.C. APPROVED DATE: 07-09-2012 : By Ann Marie De La Fuente, Administrative Assistant

SMALL CONSTRUCTION

The applicant has submitted the required small construction site notice as per Part II, Section E of the TPDES General Permit for Construction Activities (TXR150000) along with a copy of the Erosion Control Plan for the proposed project.

LARGE CONSTRUCTION

The applicant has submitted the required NOI as per Part II, Section E of the TPDES General Permit for Construction Activities (TXR150000) along with a copy of the Erosion Control Plan for the proposed project.

Notice Of Termination (NOT) has been submitted. Final stabilization has been achieved on site.

REQUEST FOR FINAL APPROVAL WITH: Cash Deposit: Amount: \$ _____ For: OSSF(S) PAVING DRAINAGE STREET SIGNS

A Letter of Credit Financial Institution: _____ L.O.C No. _____

Amount: \$ _____ For: OSSF(S) PAVING DRAINAGE STREET SIGNS

PRELIMINARY APPROVAL FROM
THE HIDALGO COUNTY ADVISORY BOARD ON:

April 30, 2012.

STAFF RECOMMENDS:

Preliminary Approval subject to comments and future recommendations by planning, other departments and the approval of the City of _____.

Preliminary Approval subject comments and future recommendations by planning and other Departments

Final Approval subject to recommendations other departments

Final Approval with financial guarantee.

This subdivision plat has been reviewed and complies with the Hidalgo County Subdivision Rules, Texas Water Development Board Model Subdivision Rules and The Texas Local Government Code.



HIDALGO COUNTY PLANNING DEPARTMENT

1304 SOUTH 25TH STREET
EDINBURG TEXAS 78539
Tel. 956-318-2840 Fax. 956-318-2844

Raul E. Sesin, P.E., CFM
Planning Administrator

HIDALGO COUNTY COMMISSIONER'S COURT MEETING

DATE: 07-24-2012

PROPOSED EVERGREEN VALLEY ESTATES PHASE 6 SUBDIVISION, PRECINCT No. 4

ENGINEER: QUINTANILLA, HEADLEY AND ASSOC. DEVELOPER: TILLMIN WELCH

PRELIMINARY APPROVAL FINAL APPROVAL FINAL APPROVAL WITH FINANCIAL GUARANTEE WITH VARIANCE
NUMBER OF LOTS: 16 *SINGLE FAMILY *MULTI-FAMILY COMMERCIAL INSTITUTIONAL

LOCATION DESCRIPTION: North west corner of Val Verde Road and Mile 19 North Road.

The rural area of the County.

SUBDIVISION LIES WITHIN THE: ETJ of _____ and was approved administratively by said City.

ETJ of _____ and was approved by the P & Z and City Commission of said City

DRAINAGE REPORT WAS APPROVED BY HCDD#1: ON 02-16-2012 ROPERTY LIES WITHIN FLOOD ZONE: "X" AS PER FEMA.

DRAINAGE DESIGN: Drainage detention swales and positive outfall via road side ditch.

DISTANCE TO A DRAIN DITCH: Approximate ¼ mile east from subdivision development.

ROAD R.O.W. DEDICATION: 20 feet on Mile 19 North Road. Additional ROW will not be required for Val Verde Road. ROW is in accordance with the Hidalgo County Thoroughfare Plan.

H.C.R.O.W. APPROVED DATE: 11-14-2011 : By, Benito Rodriguez R.O.W. AGENT

OSSF & SOIL ANALYSIS WERE CONDUCTED BY: Jose A. Gonzalez

SEWER SYSTEM: OSSF HAVE BEEN INSTALLED AND INSPECTED BY HCHD ON: 06-14-2012

SANITARY SEWER BY: _____ LINE SIZE: _____ LOCATION: _____

WATER SERVICE PROVIDER: N.A.W.S.C. LINE SIZE: 8" LOCATION: Val Verde Road

H.C.O.E.C. APPROVED DATE: 07-09-2012 : By Ann Marie De La Fuente, Administrative Assistant

SMALL CONSTRUCTION

The applicant has submitted the required small construction site notice as per Part II, Section E of the TPDES General Permit for Construction Activities (TXR150000) along with a copy of the Erosion Control Plan for the proposed project.

LARGE CONSTRUCTION

The applicant has submitted the required NOI as per Part II, Section E of the TPDES General Permit for Construction Activities (TXR150000) along with a copy of the Erosion Control Plan for the proposed project.

Notice Of Termination (NOT) has been submitted. Final stabilization has been achieved on site.

REQUEST FOR FINAL APPROVAL WITH: **Cash Deposit:** Amount: \$ _____ For: OSSF(S) PAVING DRAINAGE STREET SIGNS

A Letter of Credit Financial Institution: _____ L.O.C No. _____

Amount: \$ _____ For: OSSF(S) PAVING DRAINAGE STREET SIGNS

PRELIMINARY APPROVAL FROM
THE HIDALGO COUNTY ADVISORY BOARD ON:

Apri 30, 2012.

STAFF RECOMMENDS:

Preliminary Approval subject to comments and future recommendations by planning, other departments and the approval of the City of _____.

Preliminary Approval subject comments and future recommendations by planning and other Departments

Final Approval subject to recommendations other departments

Final Approval with financial guarantee.

* This subdivision plat has been reviewed and complies with the Hidalgo County Subdivision Rules, Texas Water Development Board Model Subdivision Rules and The Texas Local Government Code.

SUBDIVISION PLAT OF:

EVERGREEN VALLEY ESTATES PHASE VI

A 38.50 ACRE TRACT OF LAND OUT ACRES OF LOT 16, BLOCK 90, MISSOURI-TEXAS LAND AND IRRIGATION COMPANY'S SUBDIVISION, HIDALGO COUNTY, TEXAS, ACCORDING TO THE MAP OR PLAT THEREOF RECORDED IN VOLUME 1, PAGE 29, MAP RECORDS, HIDALGO COUNTY, TEXAS, AND ACCORDING TO WARRANTY DEED WITH VENDOR'S LIEN RECORDED UNDER COUNTY CLERK'S DOCUMENT NUMBER 1703890, OFFICIAL RECORDS, HIDALGO COUNTY, TEXAS, REFERENCE TO WHICH IS HERE MADE FOR ALL PURPOSES AND BEING MORE PARTICULARLY DESCRIBED BY METES AND BOUNDS AS FOLLOWS.

EVERGREEN VALLEY ESTATES PHASE II
RECORDED IN VOL. 47, PAGE 85-91
MAP RECORDS, HIDALGO COUNTY, TEXAS.

EVERGREEN VALLEY ESTATES PHASE I
RECORDED IN VOL. 42, PAGE 52-55
MAP RECORDS, HIDALGO COUNTY, TEXAS.

STATE OF TEXAS
COUNTY OF HIDALGO

I, THE UNDERSIGNED, A REGISTERED PROFESSIONAL LAND SURVEYOR IN THE STATE OF TEXAS, DO HEREBY CERTIFY THAT THIS PLAT IS TRUE AND CORRECT, AND WAS MADE AND PREPARED FROM AN ACTUAL SURVEY OF THE PROPERTY DONE ON THE GROUND UNDER MY SUPERVISION.



Alfonso Quintanilla
ALFONSO QUINTANILLA
R.P.L.S. No. 4856

10-17-11
DATE

STATE OF TEXAS
COUNTY OF HIDALGO

I, THE UNDERSIGNED, A LICENSED PROFESSIONAL ENGINEER IN THE STATE OF TEXAS, DO HEREBY CERTIFY THAT THE PROPER ENGINEERING CONSIDERATIONS HAVE BEEN GIVEN TO THIS PLAT.



Alfonso Quintanilla
ALFONSO QUINTANILLA
P.E. No. 55534

6-5-12
DATE

LOT 15, BLOCK 90, MISSOURI TEXAS LAND & IRRIGATION COMPANY SUBDIVISION, RECORDED IN VOLUME 1, PAGE 29, MAP RECORDS, HIDALGO COUNTY, TEXAS.

EXIST. EASEMENT TO WILLACY COUNTY WATER CONTROL & IMPROVEMENTS DISTRICT NO. 1 RECORDED IN VOLUME 448, PAGE 550, DEED RECORDS, HIDALGO COUNTY, TEXAS. (VARIED WIDTH)

PROP. EASEMENT TO DELTA LAKE IRRIGATION DISTRICT IRRIGATION DISTRICT DEDICATED BY THIS PLAT (VARIED WIDTH)

EXCLUSIVE 15.00' N.A.W.S.C. EASEMENT RECORDED UNDER DOC. NO. 2321386 OFFICIAL RECORDS, HIDALGO CO., TX

EVERGREEN VALLEY ESTATES PHASE I RECORDED IN VOL. 42, PAGE 52-55 MAP RECORDS, HIDALGO COUNTY, TEXAS.

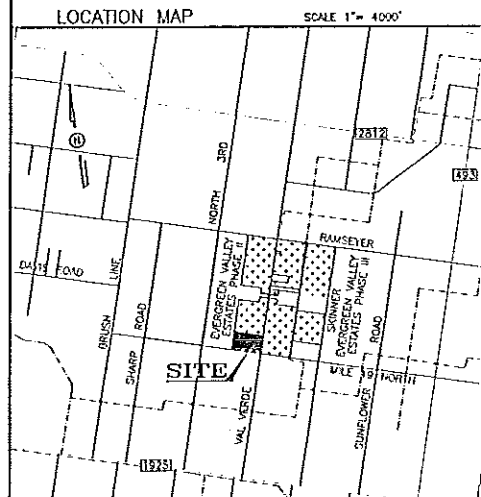

LOCATION OF SUBDIVISION WITH RESPECT TO THE EXTRATERRITORIAL JURISDICTION OF A MUNICIPALITY:
EVERGREEN VALLEY ESTATES PHASE VI, IS LOCATED IN EASTERN HIDALGO COUNTY ON THE NORTHWEST CORNER OF THE INTERSECTION OF MILE 19 NORTH AND VAL VERDE ROAD. THE ONLY NEARBY MUNICIPALITY IS THE CITY OF EDINBURG ACCORDING TO THE OFFICIAL MAP IN THE OFFICE OF THE SECRETARY OF THE CITY OF EDINBURG (POPULATION 72,100). EVERGREEN VALLEY ESTATES PHASE VI, LIES APPROXIMATELY 3.65 MILES FROM THE CITY LIMITS AND FALLS IN THE RURAL AREA OF THE COUNTY, IT LIES IN PREDNCT No. 4.

PRINCIPAL CONTACTS:	Name	Address	City & Zip	Phone	Fax
OWNER:	TILLMAN WELCH	3714 S. EXPRESSWAY 281	EDINBURG, TX 78539	(956)366-0726	(956)380-4395
BROWNER:	ALFONSO QUINTANILLA	124 E. STUBBS	EDINBURG, TX 78539	(956)381-6480	(956)391-0527
SURVEYOR:	ALFONSO QUINTANILLA	124 E. STUBBS	EDINBURG, TX 78539	(956)381-6480	(956)391-0527

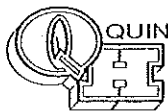

QUINTANILLA, HEADLEY AND ASSOCIATES, INC.
CONSULTING ENGINEERS
LAND SURVEYORS
124 E. STUBBS ST.
EDINBURG, TEXAS 78539
REGISTRATION NUMBER F-1513
PHONE 956-381-6480
FAX 956-381-0527
OFFICE@QHAENGINEERING.COM



FILED FOR RECORD IN
HIDALGO COUNTY
ARTURO GUJARDO, JR.
HIDALGO COUNTY CLERK

OH: _____ AT _____ AM/PM
INSTRUMENT NUMBER _____
OF THE MAP RECORDS OF HIDALGO COUNTY, TEXAS
BY: _____ DEPUTY

SHEET NO. 2	PREPARED BY	CHECKED BY	APPROVED BY
OF 3 SHEETS	DATE PREPARED	DATE CHECKED	DATE APPROVED



HIDALGO COUNTY PLANNING DEPARTMENT

1304 SOUTH 25TH STREET
EDINBURG TEXAS 78539
Tel. 956-318-2840 Fax. 956-318-2844

Raul E. Sesin, P.E., CFM
Planning Administrator

HIDALGO COUNTY COMMISSIONER'S COURT MEETING

DATE: 07-24-2012

PROPOSED PIFALO SUBDIVISION, PRECINCT No. 4.

ENGINEER: SALINAS ENGINEERING & ASSOC. DEVELOPER: MARIO PIFALO

PRELIMINARY APPROVAL FINAL APPROVAL FINAL APPROVAL WITH FINANCIAL GUARANTEE WITH VARIANCE
NUMBER OF LOTS: 2 *SINGLE FAMILY *MULTI-FAMILY COMMERCIAL INSTITUTIONAL

LOCATION DESCRIPTION: North of FM 2812 approximate 330 feet West of Skinner Road.

SUBDIVISION LIES WITHIN THE: *The rural area of the County.*
 ETJ of _____ and was approved administratively by said City.
 ETJ of _____ and was approved by the P & Z and City Commission of said City

DRAINAGE REPORT WAS APPROVED BY HCDD#1: ON 05-10-2012 PROPERTY LIES WITHIN FLOOD ZONE: "X" AS PER FEMA.

DRAINAGE DESIGN: Drainage detention swales.

DISTANCE TO A DRAIN DITCH: Approximate 2 miles North of subdivision development.

ROAD R.O.W. DEDICATION: 19 feet on FM 2812.

H.C.R.O.W. APPROVED DATE: 05-22-2012 : By, Jose Peña R.O.W. DIRECTOR

OSSF & SOIL ANALYSIS WERE CONDUCTED BY: Issac Mata

SEWER SYSTEM: OSSF HAVE BEEN INSTALLED AND INSPECTED BY HCHD ON: 07-12-2012

SANITARY SEWER BY: _____ LINE SIZE: _____ LOCATION: _____

WATER SERVICE PROVIDER: N.A.W.S.C. LINE SIZE: 10" LOCATION: FM 2812.

H.C.O.E.C. APPROVED DATE: 07-09-2012 : By Ann Marie De La Fuente, Administrative Assistant

SMALL CONSTRUCTION

The applicant has submitted the required small construction site notice as per Part II, Section E of the TPDES General Permit for Construction Activities (TXR150000) along with a copy of the Erosion Control Plan for the proposed project.

LARGE CONSTRUCTION

The applicant has submitted the required NOI as per Part II, Section E of the TPDES General Permit for Construction Activities (TXR150000) along with a copy of the Erosion Control Plan for the proposed project.

Notice Of Termination (NOT) has been submitted. Final stabilization has been achieved on site.

REQUEST FOR FINAL APPROVAL WITH: **Cash Deposit:** Amount: \$ _____ For: OSSF(S) PAVING DRAINAGE STREET SIGNS
 A Letter of Credit Financial Institution: _____ L.O.C No. _____
Amount: \$ _____ For: OSSF(S) PAVING DRAINAGE STREET SIGNS

VARIANCE REQUEST: A variance from the minimum 15 feet easement width requirement in Chapter 2 section 2.7 of the Hidalgo County Model Subdivision Rules. The easement should be 15 feet in width; however, the developer is proposing the easement at 5 feet in width.

STAFF RECOMMENDS: **Preliminary Approval** subject to comments and future recommendations by planning, other departments and the approval of the City of _____.

Preliminary Approval subject comments and future recommendations by planning and other Departments

Final Approval with Variance Request subject to recommendations other departments

Final Approval with financial guarantee.

This subdivision plat has been reviewed and complies with the Hidalgo County Subdivision Rules, Texas Water Development Board Model Subdivision Rules and The Texas Local Government Code.

LOT 11, BLOCK 69

ADDITIONER: OWNER: BERNARD S. ROWLAND II PROPERTY I.D. NO.: 241131 HO-TEX LOT 7 SUBDIVISION & ALL 1/2, 13 E.C. 2AC, W/1/4C-1/4, B/LK 69 WARRANTY DEED DOCUMENT NO. UNDETERMINED H.C.D.R.

ADDITIONER: OWNER: STEVE R. & TIFFANY D. MILLER PROPERTY I.D. NO.: 808263 HO-TEX LOT 14, B/LK 69 E1/2 1/2 1/4 AC. - EXC. SE 0.50 AC. FOR BPS 2.5 AC. OR, 2.3 AC. NET WARRANTY DEED DOCUMENT NO. 157795, H.C.D.R.

ADDITIONER: OWNER: VICTORIANO B. SYLVA CAJZA PROPERTY I.D. NO.: 241158 HO-TEX LOT 14, B/LK 69 E1/2 1/2 1/4 AC. - EXC. SE 0.50 AC. FOR BPS 2.5 AC. OR, 2.3 AC. NET WARRANTY DEED DOCUMENT NO. 130282, H.C.D.R.

ADDITIONER: OWNER: BERNARD S. ROWLAND II PROPERTY I.D. NO.: 241131 HO-TEX LOT 7 SUBDIVISION & ALL 1/2, 13 E.C. 2AC, W/1/4C-1/4, B/LK 69 WARRANTY DEED DOCUMENT NO. UNDETERMINED H.C.D.R.

ADDITIONER: OWNER: BERNARD S. ROWLAND II PROPERTY I.D. NO.: 241131 HO-TEX LOT 7 SUBDIVISION & ALL 1/2, 13 E.C. 2AC, W/1/4C-1/4, B/LK 69 WARRANTY DEED DOCUMENT NO. UNDETERMINED H.C.D.R.

REVISION NOTES table with columns: NO, SHEET, REVISION, DATE, APPROVED

LOT 14, BLOCK 69 THE MISSOURI-TEXAS LAND AND IRRIGATION COMPANY VOL. 6, PG. 7, H.C.M.R.

PIFALO SUBDIVISION

HIDALGO COUNTY, TEXAS.

BEING A 10.0 GROSS ACRE TRACT OF LAND, MORE OR LESS, OUT OF AND FORMING A PART OF LOT 14, BLOCK 69, THE MISSOURI-TEXAS LAND AND IRRIGATION COMPANY, HIDALGO COUNTY, TEXAS, AS PER THE MAP OR PLAT THEREOF RECORDED IN VOLUME 06, PAGE 28, MAP RECORDS OF HIDALGO COUNTY, TEXAS.

- GENERAL PLAT NOTES: 1. MINIMUM SETBACK LINES: FRONT 50.00', REAR 15.00', SIDE 6.00'... 2. FLOOD ZONE STATEMENT: FLOOD ZONE DESIGNATION: ZONE "X"... 3. MINIMUM FINISH FLOOR NOTE: MINIMUM FINISH FLOOR ELEVATION SHALL BE 18" ABOVE THE CENTERLINE OF PAVEMENT OR 18" ABOVE NATURAL GROUND...

- 4. DRAINAGE: IN ACCORDANCE WITH THE HIDALGO COUNTY DRAINAGE DISTRICT NO. 1 AND HIDALGO COUNTY REQUIREMENTS, THIS DEVELOPMENT WILL BE REQUIRED TO OBTAIN A TOTAL OF 13,262.68 CUBIC FEET OR 0.50 ACRE-FEET OF STORM RUNOFF... 5. NO MORE THAN ONE SINGLE FAMILY DETACHED DWELLING SHALL BE LOCATED ON EACH LOT... 6. THERE ARE NO WATER WELLS WITHIN 150 FEET FROM THE BOUNDARIES ON THIS SUBDIVISION... 7. UNLESS OTHERWISE NOTED ON THIS PLAT, THE LOT IS MONUMENTED BY 1/2 INCH WIDE BY 18 INCH LONG IRON RODS... 8. THE SEPTIC TANK SYSTEM SHALL BE APPROVED BY THE HIDALGO COUNTY HEALTH DEPARTMENT... 9. ON-SITE SEWAGE FACILITIES (OSSF) NOTE: THIS SUBDIVISION SHALL USE ON-SITE SEWAGE FACILITIES IN ACCORDANCE WITH ILL. AND HIDALGO COUNTY REGULATIONS FOR SEWAGE DISPOSAL... 10. NO STRUCTURE SHALL BE PERMITTED OVER ANY EASEMENT, EASEMENTS SHALL BE KEPT CLEAR OF FENCES, BULDINGS, SHEDS, SHRUBS, TREES, AND OTHER PLANTINGS...

SCALE: 1"=100' LEGEND: 1/4" DIA. 3/4" IRON PIPE, 1/2" DIA. 1/2" IRON PIPE, SET 1/2" IRON PDS, POB, POINT OF BEGINNING, H.C.D.R., HIDALGO COUNTY DEED RECORDS, HIDALGO COUNTY MAP RECORDS

ADDITIONER: OWNER: BERNARD S. ROWLAND II PROPERTY I.D. NO.: 241131 HO-TEX LOT 7 SUBDIVISION & ALL 1/2, 13 E.C. 2AC, W/1/4C-1/4, B/LK 69 WARRANTY DEED DOCUMENT NO. UNDETERMINED H.C.D.R.

ADDITIONER: OWNER: BERNARD S. ROWLAND II PROPERTY I.D. NO.: 241131 HO-TEX LOT 7 SUBDIVISION & ALL 1/2, 13 E.C. 2AC, W/1/4C-1/4, B/LK 69 WARRANTY DEED DOCUMENT NO. UNDETERMINED H.C.D.R.

ADDITIONER: OWNER: BERNARD S. ROWLAND II PROPERTY I.D. NO.: 241131 HO-TEX LOT 7 SUBDIVISION & ALL 1/2, 13 E.C. 2AC, W/1/4C-1/4, B/LK 69 WARRANTY DEED DOCUMENT NO. UNDETERMINED H.C.D.R.

ADDITIONER: OWNER: BERNARD S. ROWLAND II PROPERTY I.D. NO.: 241131 HO-TEX LOT 7 SUBDIVISION & ALL 1/2, 13 E.C. 2AC, W/1/4C-1/4, B/LK 69 WARRANTY DEED DOCUMENT NO. UNDETERMINED H.C.D.R.

STATE OF TEXAS COUNTY OF HIDALGO OWNER'S DEDICATION, CERTIFICATION, AND ATTESTATION: 1. MARO AND MARIA PIFALO, AS OWNER (S) OF THE 10.00-ACRE TRACT OF LAND ENCOMPASSED WITHIN THE PROPOSED PIFALO SUBDIVISION, HEREBY SUBDIVIDE THE LAND AS DEPICTED IN THIS SUBDIVISION PLAT AND DEDICATE TO PUBLIC USE THE STREET, PARK, AND EASEMENTS SHOWN HEREON. I CERTIFY THAT I HAVE COMPLIED WITH THE REQUIREMENTS OF TEXAS LOCAL GOVERNMENT CODE 232.032 AND THAT: (A) THE WATER QUALITY AND CONNECTIONS TO THE LOTS MEET, OR WILL MEET, THE MINIMUM STATE STANDARDS. (B) SEWER CONNECTIONS TO THE LOTS OR SEPTIC TANKS MEET, OR WILL MEET, THE MINIMUM REQUIREMENTS OF THE STATE STANDARDS. (C) ELECTRICAL CONNECTIONS PROVIDED TO THE LOTS MEET, OR WILL MEET, THE MINIMUM STATE STANDARDS; AND (D) GAS CONNECTIONS, IF AVAILABLE, PROVIDED TO THE LOTS MEET, OR WILL MEET, THE MINIMUM STATE STANDARDS. I ATTEST THAT THE MATTERS ASSERTED IN THIS PLAT ARE TRUE AND COMPLETE.

STATE OF TEXAS COUNTY OF HIDALGO BEFORE ME, THE UNDERSIGNED AUTHORITY ON THIS DAY PERSONALLY APPEARED THE PERSON OR PERSONS, KNOWN TO ME TO BE THE PERSON WHOSE NAME IS SUBSCRIBED TO THE FOREGOING INSTRUMENT, AND ACKNOWLEDGED TO ME THAT HE EXECUTED THE SAME FOR THE PURPOSES AND CONSIDERATIONS THEREIN STATED. GIVEN UNDER MY HAND AND SEAL OF OFFICE, THIS THE _____ DAY OF _____, 2012. NOTARY PUBLIC IN AND FOR THE STATE OF TEXAS MY COMMISSION EXPIRES: _____ HIDALGO COUNTY CERTIFICATE OF PLAT APPROVAL I, THE UNDERSIGNED, CERTIFY THAT THIS PLAT OF PIFALO SUBDIVISION, WAS REVIEWED AND APPROVED BY THE HIDALGO COUNTY RIGHT OF WAY DEPARTMENT ON _____ DATE

HIDALGO COUNTY RIGHT OF WAY DIRECTOR DATE HIDALGO COUNTY CERTIFICATE OF PLAT APPROVAL I, THE UNDERSIGNED, CERTIFY THAT THIS PLAT OF PIFALO SUBDIVISION, WAS REVIEWED AND APPROVED BY THE HIDALGO COUNTY HEALTH DEPARTMENT ON _____ DATE ENVIRONMENTAL HEALTH DIVISION MANAGER DATE

HIDALGO COUNTY CERTIFICATE OF PLAT APPROVAL UNDER LOCAL GOVERNMENT CODE 232.028 (A) WE THE UNDERSIGNED CERTIFY THAT THIS PLAT OF PIFALO SUBDIVISION WAS REVIEWED AND APPROVED BY THE HIDALGO COUNTY COMMISSIONER ON _____ 2012. ATTEST: HIDALGO COUNTY JUDGE DATE HIDALGO COUNTY CLERK DATE

COUNTY CLERK'S RECORDING CERTIFICATE I, _____ COUNTY CLERK OF HIDALGO COUNTY, THAT THE PLAT BEARING THIS CERTIFICATE WAS FILED FOR RECORD AT _____ O'CLOCK _____ M. ON _____ AND WAS RECORDED IN BOOK _____ SHEET(S) _____ THE PLAT RECORDS OF HIDALGO COUNTY AT _____ O'CLOCK _____ M. ON _____ 2012. HIDALGO COUNTY CLERK DATE

STATE OF TEXAS COUNTY OF HIDALGO I, DAVID OVAR SALINAS, P.E., A REGISTERED PROFESSIONAL ENGINEER LICENSED TO PRACTICE IN THE STATE OF TEXAS, REGISTRATION NUMBER TX 71973, DO HEREBY CERTIFY THAT THIS PLAT HAS BEEN GIVEN PROPER AND ADEQUATE ENGINEERING CONSIDERATION, AND, FURTHER, DO HEREBY CERTIFY THAT NONE OF THE AREAS BEING PLATTED HEREIN AS PIFALO SUBDIVISION, AS DESCRIBED BY METES AND BOUNDS DESCRIPTION (SEE METES AND BOUNDS DESCRIPTION AT THE RIGHT) ARE NOT LOCATED IN A FLOOD PRONE AREA DESIGNATED AS ZONES "A" OR "AH" DEFINED AND DETERMINED BY THE FEDERAL EMERGENCY MANAGEMENT AGENCY.

DAVID OVAR SALINAS, P.E. REG. PROFESSIONAL ENGINEER #11973 DATE STATE OF TEXAS COUNTY OF HIDALGO I, DAVID O. SALINAS, THE UNDERSIGNED A REGISTERED PROFESSIONAL LAND SURVEYOR IN THE STATE OF TEXAS, HEREBY CERTIFY THAT THIS PLAT IS TRUE AND CORRECTLY MADE AND IS PREPARED FROM AN ACTUAL SURVEY OF THE PROPERTY MADE UNDER MY SUPERVISION ON THE GROUND.

DAVID O. SALINAS, R.P.L.S. REG. PROFESSIONAL LAND SURVEYOR #5762 DATE HIDALGO COUNTY DRAINAGE DISTRICT NO. 1 CERTIFICATION HIDALGO COUNTY DRAINAGE DISTRICT NO. 1 HEREBY CERTIFIES THAT THE DRAINAGE PLANS FOR THIS SUBDIVISION COMPLY WITH THE MINIMUM STANDARDS OF THE DISTRICT ADOPTED UNDER TEXAS WATER CODE 49.211(C). THE DISTRICT HAS NOT REVIEWED AND DOES NOT CERTIFY THAT THE DRAINAGE STRUCTURES DESCRIBED ARE APPROPRIATE FOR THE SPECIFIC SUBDIVISION, BASED ON GENERALLY ACCEPTED ENGINEERING CRITERIA. IT IS THE RESPONSIBILITY OF THE DEVELOPER OF THE SUBDIVISION AND ITS ENGINEER TO MAKE THESE DETERMINATIONS.

HIDALGO COUNTY DRAINAGE DISTRICT NO. 1 BENCHMARK NOTE: B.M. #1 ELEV.=89.00, TOP OF COTTON PICKER SPINDLE IN THE CENTERLINE OF VALVERDE ROAD AND MILE 21 NORTH ROAD. N.A.V.D. 88 DATUM. B.M. #2 ELEV.=65.69, TOP OF 3/4" IRON PIPE AT INTERSECTION OF EXISTING NORTH R.O.W. LINE OF F.M. 2812 AND WEST LINE OF PROPOSED LOT 2. N.A.V.D. 88 DATUM.

PRINCIPAL CONTACTS table with columns: NAME, ADDRESS, CITY & ZIP, PHONE, FAX. OWNER: MARLO PIFALO, 14554 E. F.M. 2812, EDDOUGH, TEXAS 78538 (956) 373-8890 NONE. OWNER: MARIA PIFALO, 14554 E. F.M. 2812, EDDOUGH, TEXAS 78538 (956) 373-8890 NONE. ENGINEER: DAVID O. SALINAS, 2221 DAFFODIL AVE., McALLEN, TEXAS 78501 (956) 682-9081 (956) 686-1489. SURVEYOR: DAVID O. SALINAS, 2221 DAFFODIL AVE., McALLEN, TEXAS 78501 (956) 682-9081 (956) 686-1489.

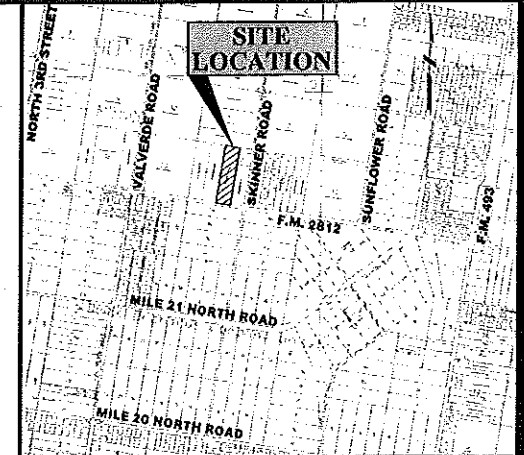

LOCATION MAP SCALE 1"=2000' PREPARED BY: SALINAS ENGINEERING & ASSOCIATES 2221 DAFFODIL AVENUE - McALLEN, TEXAS 78501 JOB NUMBER: SP-12-22586 DATE OF SURVEY: APRIL 23, 2012 DATE PREPARED: JULY 06, 2012 PLAT SHEET 1 OF 2

METES AND BOUNDS DESCRIPTION BEING A 10.0 GROSS ACRE TRACT OF LAND, MORE OR LESS, OUT OF AND FORMING A PART OF LOT 14, BLOCK 69, THE MISSOURI-TEXAS LAND AND IRRIGATION COMPANY, HIDALGO COUNTY, TEXAS, AS PER THE MAP OR PLAT THEREOF RECORDED IN VOLUME 06, PAGE 28, MAP RECORDS OF HIDALGO COUNTY, TEXAS; SAID 10.0 ACRE TRACT OF LAND IS MORE PARTICULARLY DESCRIBED BY METES AND BOUNDS AS FOLLOWS: COMMENCING AT A POINT ON THE SOUTHEAST CORNER OF SAID LOT 14 LOCATED WITHIN THE INTERSECTION OF SKINNER ROAD AND F.M. 2812, THENCE, AS FOLLOWS: NORTH 80 DEGREES 40 MINUTES WEST, COINCIDENT WITH THE SOUTH LINE OF SAID LOT 14, A DISTANCE OF 330.00 FEET TO A POINT IN SAID F.M. 2812 FOR THE SOUTHEAST CORNER AND POINT OF BEGINNING OF THIS HEREBIN DESCRIBED TRACT;

- (1) THENCE, NORTH 80 DEGREES 40 MINUTES WEST, CONTINUING COINCIDENT WITH THE SOUTH LINE OF SAID LOT 14, A DISTANCE OF 330.00 FEET TO A POINT FOR THE SOUTHWEST CORNER OF THIS HEREBIN DESCRIBED TRACT; (2) THENCE, NORTH 09 DEGREES 20 MINUTES EAST, AT A RIGHT ANGLE FROM THE PREVIOUS CALL, A DISTANCE OF 21.0 FEET PASS A 1/2 INCH DIAMETER IRON PIPE FOUND ON INTERSECTION WITH THE NORTH RIGHT-OF-WAY LINE OF SAID F.M. 2812, AT A DISTANCE OF 1,320.00 FEET IN ALL TO A 1/2 INCH DIAMETER IRON ROD FOUND ON INTERSECTION WITH THE NORTH LINE OF SAID LOT 14 FOR THE NORTHWEST CORNER OF THIS HEREBIN DESCRIBED TRACT; (3) THENCE, SOUTH 80 DEGREES 40 MINUTES EAST, COINCIDENT WITH THE NORTH LINE OF SAID LOT 14, A DISTANCE OF 330.00 FEET TO A 1/2 INCH DIAMETER IRON ROD FOUND FOR THE NORTHEAST CORNER OF THIS HEREBIN DESCRIBED TRACT; (4) THENCE, SOUTH 09 DEGREES 20 MINUTES WEST, AT A RIGHT ANGLE FROM THE NORTH LINE OF SAID LOT 14, A DISTANCE OF 1,299.00 FEET PASS A 1/2 INCH DIAMETER IRON PIPE FOUND ON INTERSECTION WITH THE NORTH RIGHT-OF-WAY LINE OF SAID F.M. 2812, AT A DISTANCE OF 1,320.00 FEET IN ALL TO THE POINT OF BEGINNING, CONTAINING 10.0 GROSS ACRES OF LAND, MORE OR LESS, OF WHICH THE SOUTH 21.0 FEET (OR 0.16 ACRES, MORE OR LESS) ARE CURRENTLY LOCATED WITHIN THE RIGHT-OF-WAY OF SAID F.M. 2812, LEAVING 9.84 NET ACRES OF LAND, MORE OR LESS. BEARING SOURCE: WARRANTY DEED. N:\SUBDIVISION\PLATS\PIFALO\SUBDIVISION\M&B.10.0.050412

STATE OF TEXAS ENCLERMAN IRRIGATION DISTRICT THIS PLAN IS HEREBY APPROVED BY THE ENCLERMAN IRRIGATION DISTRICT SUBJECT TO THE CONDITION THAT IF IRRIGATION FROM SAID DISTRICT IS DESIRED TO THE INDIVIDUAL LOTS IN SAID SUBDIVISION, PROVISION SHALL BE MADE FOR APPROPRIATE EASEMENT FOR THE INSTALLATION OF NECESSARY IRRIGATION FACILITIES TO SUCH LOTS FROM THE CLOSEST WATER DISTRIB. DELIVERY POINT AND IT SHALL BE THE RESPONSIBILITY OF THE OWNER OF THE PROPERTY TO INSTALL SUCH NECESSARY FACILITIES. DISTRICT PRESIDENT DATE SECRETARY DATE

INDEX SHEET OF PIFALO SUBDIVISION SHEET 1: HEADING, INDEX, LOCATION MAP, PRINCIPAL CONTACTS, PLAT WITH LOTS, STREETS, AND EASEMENT DESIGNATIONS, LEGAL DESCRIPTION, METES & BOUNDS, SURVEYORS AND ENGINEER'S CERTIFICATION, PLAT NOTES AND RESTRICTIONS, OWNER'S DEDICATION, CERTIFICATION, AND ATTESTATION, COUNTY CLERK'S RECORDING CERTIFICATE, HIDALGO COUNTY CERTIFICATE OF PLAT APPROVAL, DESCRIPTION OF LOCATION OF SUBDIVISION WITH RESPECT TO THE S.E. 1/4 OF A QUARTER AND TO THE PROPERTY OF THE DISTRICT, STATE OF TEXAS, HIDALGO COUNTY, AND DISTRICT OF WATER DISTRICT CERTIFICATE OF APPROVAL, HIDALGO COUNTY RIGHT OF WAY DIST. CERTIFICATE OF APPROVAL, REVISION NOTES SHEET 2: WATER DISTRIBUTION AND SANITARY SEWER (OSSF) MAP, ENGINEERING REPORT (ENCLERMAN AND SPANISH REGIONS) INCLUDING DESCRIPTION OF WATER AND WASTE WATER (SSWF) AND ENGINEER'S CERTIFICATION (ENGLISH AND SPANISH), SCALE OF LOG LOG FOR OSSF SYSTEM, TYPICAL WATER SERVICE CONNECTION SUBDRAINAGE CERTIFICATE AND STATEMENT, GRANULAR REPORT MAPPING, DESCRIPTION OF DRAINAGE AND HOW IT WILL SERVE THE DEVELOPMENT, MAP OF TOPOGRAPHY AND DRAINAGE, AND ENGINEER'S CERTIFICATION, REVISION NOTES

SEA SALINAS ENGINEERING & ASSOCIATES CONSULTING ENGINEERS & SURVEYORS (F-6876) 2221 DAFFODIL - McALLEN, TEXAS 78501 (956) 682-9081 (956) 686-1489 (FAX)

AI-33316

Precinct #2 15. A.

CC REGULAR

Meeting Date: 07/24/2012

Submitted By: Katia Garcia, COMM. PCT. #2

Department: COMM. PCT. #2

Information

CAPTION

Approval of a Joint Use Agreement with Hidalgo County Irrigation District #2 for the Minnesota Drainage Project.

BACKGROUND

Fiscal Impact

FISCAL YEAR:

ACCT. #:

FUNDS AVAILABLE Y/N?:

MATCHING FUNDS Y/N?:

BUDGETARY IMPACT:

As per Precinct No.2, there is No Fiscal Impact

Attachments

Joint Use Agreement

Form Review

Inbox	Reviewed By	Date
Budget & Management	Merlen P. Munoz	07/18/2012 04:02 PM
Roland Garcia	Rolando Garcia	07/20/2012 08:14 AM
Purchasing Department	Angela Garcia	07/20/2012 04:55 PM
Form Started By: Katia Garcia		Started On: 07/18/2012 02:46 PM
	Final Approval Date: 07/20/2012	

STATE OF TEXAS §

JOINT USE AGREEMENT

COUNTY OF HIDALGO §

This Agreement is entered into effective the 24th day of July, 2012, by and between Hidalgo County Irrigation District No. 2 (the "District") and the County of Hidalgo (the "County") as follows:

WHEREAS, District has a right of way the legal description of which is more particularly described in Exhibit "A" attached hereto (the "ROW"), and the County desires to make certain drainage improvements on a portion of the ROW; and

WHEREAS, the County desires to jointly use the ROW with District for the purpose of installation, construction, repair and maintenance of a drainage pipeline and District has no objection to County's use;

WHEREAS, in consideration for consideration for District agreeing to this Joint Use Agreement County agrees at County's expense to replace District's water irrigation pipeline that lies within the boundaries of the ROW with a fifteen (15) inch water irrigation pipeline; and

WHEREAS, the parties desire to enter into a Joint use Agreement in order to utilize the ROW described above.

NOW, THEREFORE, IT IS MUTUALLY AGREED by and between the County and District that each of the parties hereto may use the ROW described above for the purposes expressed under the terms, conditions and covenants as follows:

1. District hereby consents to the use by the County in perpetuity of the ROW so that County may utilize the ROW for the installation, construction, repair and maintenance of drainage improvements within the District's ROW.
2. In consideration of the District's agreement to allow the County to utilize the ROW, County shall replace and only replace at County's expense District's existing irrigation water pipeline located solely within the boundaries of the ROW with a fifteen (15) inch irrigation water pipeline. Upon completion of the replacement of such irrigation water pipeline, District shall repair and maintain at District's expense such replaced irrigation water pipeline and District agrees County shall have no responsibility to repair, replace, reconstruct or maintain such fifteen (15) inch irrigation water pipeline constructed by County.
3. Both District and County, agree that if their joint use of the ROW interferes with each other's use of the ROW and in the event it is necessary for either District or the County to alter, modify, or add to the facilities presently located within the ROW, each party agrees to notify the other party at least sixty (60) days prior to

any such activity and furnish necessary plans, specifications, and sketches showing the location and type of construction. Any such alterations, modifications, or additions shall be at the sole expense of the party conducting the same, and in, in the event it is necessary to relocate, alter, or modify the other party's improvements situated within the ROW, the party conducting the alteration, modification, or addition activities shall pay for all reasonable costs necessarily incurred by the other party in relocating or altering their improvements to accommodate the new alterations, modifications, or additions to the improvements situated within the ROW.

4. If in the opinion of either party, such alteration, modification, or new construction will injure, impair, or adversely affect the other party's use of the ROW premises, such party may prescribe such reasonable regulations as necessary for its protection provided however, that such regulations shall not extend to rerouting or relocation of any lines or improvements outside of the ROW described in Exhibit "A".
5. In the event of any emergency, when immediate action is necessary for the protection of the public and to minimize property damage and loss of investment, either party hereto may make such necessary emergency repairs as required under the circumstances. Immediately following such repairs, the party making same shall notify the other party of its action in writing, as soon as practical.
6. **Conflict with Applicable Law.** Nothing in this Agreement shall be construed so as to require the commission of any act contrary to law, and whenever there is any conflict between and provision of their Agreement and any present or future law, ordinance or administrative, executive or judicial regulation, order or decree, or amendment thereof, contrary to which the parties have no legal right to contract, the latter shall prevail, but in such event the affected provision or provision of this Agreement shall be modified only to The extent necessary to bring them within the legal requirements and only during the times such conflict exists.
7. **No Waiver.** No waiver by any party hereto of any breach of any provision of this Agreement shall be deemed to be a waiver of any preceding or succeeding breach of the same or any other provision hereof.
8. **Entire Agreement.** This Agreement contains the entire agreement between the parties hereto, reflecting the subject matter hereto and each party acknowledges that neither has made (either directly or through any agent or representative) any representation or agreement in connection with this Agreement not specifically set forth herein. This Agreement may be modified or amended only by agreement in writing executed by District and County, and not otherwise.
9. **Texas Law to Apply.** This Agreement shall be construed under and in accordance with the laws of the State of Texas, and all obligations of the parties

created hereunder are performable in Hidalgo County, Texas. The parties hereby consent to personal jurisdiction in Hidalgo County, Texas.

10. **Notice.** Except as may be otherwise specifically provided in this Agreement, all notices, demands, requests or communication required or permitted hereunder shall be in writing and shall either be (i) personally delivered against a written receipt, or (ii) sent by registered or certified mail, return receipt requested, postage prepaid and addressed to the parties at the addresses set forth below, or at such other addresses as may have been theretofore specified by written notice delivered in accordance herewith:

If to District: Hidalgo County Irrigation District No. 2
Attention: Manager
P. O. Box 6
San Juan, Texas 78589

If to County: Hidalgo County
Attention: County Judge
1615 S. Closner, Suite J
Edinburg, Texas 78539

Each notice, demand, request or communication which shall be delivered or mailed in the manner described above shall be deemed sufficiently given for all purposes at such time as it is personally delivered to the addressee or, if mailed, at such time as it is deposited in the United States mail.

11. **Additional Documents.** The parties hereto covenant and agree that they will execute such other and further instruments and documents as are or may become necessary or convenient to effectuate and carry out the terms of this Agreement.
12. **Successors.** This Agreement shall be binding upon and inure to the benefit of the parties hereto and their respective heirs, executors, administrators, legal representatives, successors, and assigns where permitted by this Agreement.
13. **Assignment.** This Agreement shall not be assignable.
14. **Headings.** The headings and captions contained in this Agreement are solely for convenience reference and shall not be deemed to affect the meaning or interpretation of any provision of paragraph hereof.
15. **Gender and Number.** All pronouns used in this Agreement shall include the other gender, whether used in the masculine, feminine or neuter gender, and singular shall include the plural whenever and so often as may be appropriate.

16. **Authority to Execute.** The execution and performance of this Agreement by District and County have been duly authorized by all necessary laws, resolutions or corporate action, and this Agreement constitutes the valid and enforceable obligations of District and County in accordance with its terms.
17. **Governmental Purpose.** Each party hereto is entering into this agreement for the purpose of providing for governmental services or functions and will pay for such services out of current revenues available to the paying party as herein provided.
18. **Commitment of Current Revenues Only.** In the event that, during any term hereof, the governing body of any party does not appropriate sufficient funds to meet the obligations of such party under this Agreement, then any party may terminate this Agreement upon ninety (90) days written notice to the other party. Each of the parties hereto agrees, however, to use its best efforts to secure funds necessary for the continued performance of this Agreement. The parties intend this provision to be a continuing right to terminate this Agreement at the expiration of each budget period of each party hereto pursuant to the provisions of Tex. Loc. Govt. Code Ann. §271.903.

WITNESS THE HANDS OF THE PARTIES effective as of the day and year first written above.

**HIDALGO COUNTY IRRIGATION DISTRICT
No. 2**

Allen Arnold, Board President

HIDALGO COUNTY

Ramon Garcia, County Judge

ATTEST:

Arturo Guajardo, County Clerk

APPROVED AS TO FORM:

ATLAS, HALL & RODRIGUEZ, LLP

BY: _____

Stephen L. Crain



Professional Engineers & Land Surveyors

130 E. PARK AVENUE • PILARR, TEXAS 78577

(TEL) 956-782-2557 • (FAX) 956-782-2558

Engineering Firm #156 • Surveying Firm #101650

ENG09.001
MAY 10, 2012
SHEET 1 OF 3

**EXHIBIT-A
SURVEY PLAT
OF
(A 30 FOOT HIDALGO COUNTY IRRIGATION DISTRICT No. 2
IRRIGATION EASEMENT AND DRAINAGE EASEMENT)
A 0.892-ACRE TRACT OF LAND
BEING 0.444 OF AN ACRE OF LAND OUT OF
PRIMAVERA II SUBDIVISION, PHASE I,
HIDALGO COUNTY, TEXAS,
AS PER MAP RECORDED IN
VOLUME 25, PAGE 9B, M.R.H.C.
AND A 0.448 OF AN ACRE OF LAND
OUT OF LOT 7, BLOCK 8,
JOHN CLOSNER et. al. SUBDIVISION,
HIDALGO COUNTY, TEXAS,
AS PER MAP RECORDED IN
VOLUME 0, PAGE 4, M.R.H.C.**

A 0.892-acre tract of land being 0.444 of an acre of land out of Primavera II Subdivision, Phase I, Hidalgo County, Texas, as per map recorded in Volume 25, Page 9B, Map Records of Hidalgo County, Texas, and a 0.448 of an acre of land out of Lot 7, Block 8, John Closner et. al. Subdivision, Hidalgo County, Texas, as per map recorded in Volume 0, Page 4, Map Records of Hidalgo County, Texas. Said 0.892-acre tract of land being more particularly described by metes and bounds follows;

Commencing at a 60 D nail found at the Northwest corner of Primavera II Subdivision, Phase I, **Thence** South 08 degrees 35 minutes 00 seconds West (South 08 degrees 26 minutes 18 seconds West), with the common line of the West line of Primavera II Subdivision, Phase I and the East line of Lot 7, Block 8, John Closner et. al. Subdivision, a distance of 20.00 feet to a No. 4 rebar set (with a plastic cap stamped RGEC) for the most Northerly Northeast corner of this tract of land and the **POINT OF BEGINNING**;

THENCE, continuing South 08 degrees 35 minutes 00 seconds West, with the common line of the West line of said Primavera II Subdivision, Phase I and the East line of said Lot 7, Block 8, a distance of 7.92 feet to a No. 4 rebar set (with a plastic cap stamped RGEC) at the South Right of Way line of Minnesota Road for an interior corner of this tract of land;

THENCE, South 81 degrees 25 minutes 00 seconds East, with the South Right of Way line of said Minnesota Road, a distance of 15.00 feet to a No. 4 rebar set (with a plastic cap stamped RGEC) for the most Southerly Northeast corner of this tract of land;

THENCE, South 08 degrees 35 minutes 00 seconds West, with the East line of an Irrigation Easement of said Primavera II Subdivision, Phase I, a distance of 1290.00 feet to a No. 4

rebar set (with a plastic cap stamped RGEC) at the South line of said Primavera II Subdivision, Phase I for the Southeast corner of this tract of land;

THENCE, North 81 degrees 25 minutes 00 seconds West, with the South line of said Primavera II Subdivision, Phase I, a distance of 15.00 feet to a No. 4 rebar set (with a plastic cap stamped RGEC) at the Southeast corner of said Primavera II Subdivision, Phase I and the East line of said Lot 7, Block 8, for an interior corner of this tract of land;

THENCE, South 08 degrees 35 minutes 00 West, with East line of said Lot 7, Block 8, a distance of 2.09 feet to a No. 4 rebar set (with a plastic cap stamped RGEC) at the Southeast corner of said Lot 7, Block 8, for an exterior corner of this tract of land;

THENCE, North 81 degrees 21 minutes 18 seconds West (North 81 degrees 31 minutes 00 seconds West), with the South line of said Lot 7, Block 8, a distance of 15.00 feet to a No. 4 rebar set (with a plastic cap stamped RGEC) for the Southwest corner of this tract of land;

THENCE, North 08 degrees 35 minutes 00 seconds East (North 08 degrees 26 minutes 18 seconds East), parallel to the East line of said Lot 7, Block 8, a distance of 1300.00 feet to a No. 4 rebar set (with a plastic cap stamped RGEC) at the South Right of Way line of said Minnesota Road for the Northwest corner of this tract of land;

THENCE, South 81 degrees 21 minutes 18 seconds East (South 81 degrees 31 minutes 00 seconds East, with the South Right of Way line of said Minnesota Road, a distance of 15.00 feet to the **POINT OF BEGINNING** and containing 0.892 of an acre of land, more or less.

Note: Bearing basis as per Alamo Land and Sugar Company, bearing in parenthesis are as per John Closner et. al. Subdivision bearing basis.

I, Pablo Soto, Jr., a Registered Professional Land Surveyor in the State of Texas, do hereby state that the above metes and bounds are true and are the result of an actual survey performed on the ground under my direction.

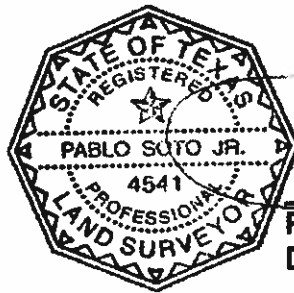

Pablo Soto, Jr.
Pablo Soto, Jr. - R.P.L.S. No. 4541
Date: 6/26/12

MINNESOTA ROAD

S 08°35'00" W
(S 08°26'18" W)
20.00'

P.O.C.
FND. 60 D NAR.
S W.W. CORNER OF
PRIMAVERA II SUBD
PHASE I.
VOL. 25, PG 9B, M.R.H.C.

40.00' ROAD
R.O.W.
20.00'

JOHN CLOSNER et. al.
SUBDIVISION
VOL. 0, PAGE 4, M.R.H.C

LOT 7, BLOCK 8

Scale: 1" = 100'

Bearing Basis as per A 0mo
Land & Sugar Company Subd.
Bearings in Parenthesis are as
per John Closner et al. Subd
bearing basis.

SUNSET ESTATES
VOL. 26, PAGE 43, M.R.H.C.

7 8

SUNSET ESTATES No. 2
VOL. 26, PAGE 197A, M.R.H.C

7 8

EXHIBIT-A
SURVEY PLAT
OF

(A 30 FOOT H.C.I.D. No. 2 IRRIGATION
EASEMENT AND DRAINAGE EASEMENT)
A 0.892 ACRE TRACT OF LAND
BEING 0.444 OF AN ACRE OF LAND
OUT OF PRIMAVERA II SUBDIVISION,
PHASE I,

AS PER MAP RECORDED IN
VOLUME 25, PAGE 9B, M.R.H.C.
AND 0.448 OF AN ACRE OF LAND
OUT OF LOT 7, BLOCK 8,
JOHN CLOSNER et. al., SUBDIVISION,
HIDALGO COUNTY, TEXAS
AS PER MAP RECORDED IN
VOLUME 0, PAGES 4, M.R.H.C.

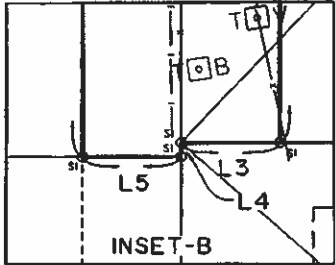

SI - SET No. 4 REBAR WITH A PLASTIC CAP STAMPED
RQEC UNLESS OTHERWISE NOTED

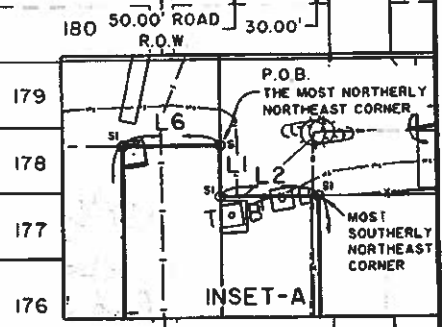
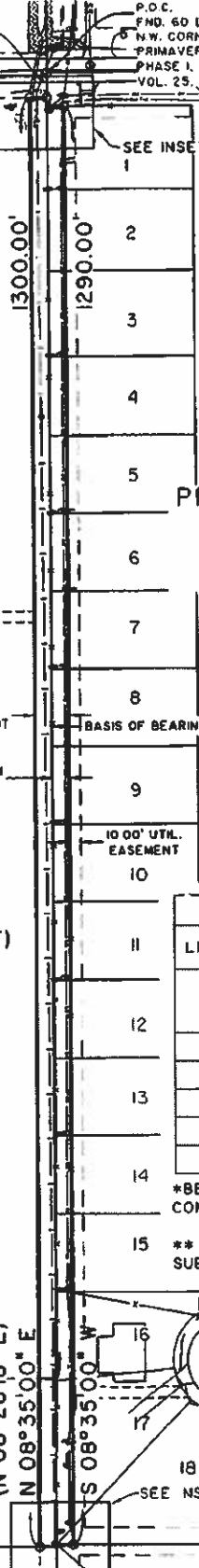

PRIMAVERA II SUBDIVISION,
PHASE I
VOL. 25, PAGE 9B, M.R.H.C.

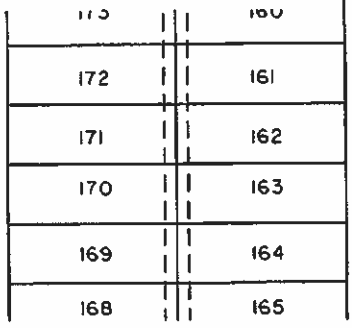

LINE DATA			
LINE No.	* BEARING	** BEARING	DISTANCE
L1	S 08°35'00" W	-	7.92'
L2	S 81°25'00" E	-	15.00'
L3	N 81°25'00" W	-	15.00'
L4	S 08°35'00" W	-	2.09'
L5	N 81°21'18" W	N 81°31'00" W	15.00
L6	S 81°21'18" E	S 81°31'00" E	15.00'

*BEARING BASIS AS PER ALAMO LAND AND SUGAR
COMPANY SUBDIVISION

** BEARING BASIS AS PER JOHN CLOSNER
SUBDIVISION

The undersigned hereby state that this survey,
as described hereon, was made on the ground
and that the only improvements on the ground
are as shown and that there are no visible
encroachments, visible overlapping, apparent
conflicts, or visible easements, except as shown
hereon. This Survey substantially conforms to the
Minimum Standards of Practice as approved by
the Texas Board of Professional Land Surveyors.

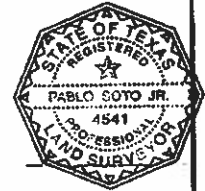

Pablo Soto Jr.
PABLO SOTO, JR. - R.P.L.S. No. 4541
Date: 6/26/12

R. Gutierrez
Engineering Corporation
Professional Engineers & Land Surveyors
130 E. PARK AVENUE • PHARR, TEXAS 78577
(TEL) 956 782-2557 • (FAX) 956 782-2558
ENGINEERING F.R.M No. 486 • SURVEYING F.R.M No.: 101650-00

JOB No.: ENG09.001 DATE: 03 09 2012
DRAWN BY: RG PAGE: 3 OF 3



Professional Engineers & Land Surveyors

130 E. PARK AVENUE • PHARR, TEXAS 79577

(TEL.) 956-782-2537 • (FAX) 956-782-2538

Engineering Firm #486 • Surveying Firm #101650

ENG09.001
October 11, 2011
SHEET 1 OF 3

**EXHIBIT-A
SURVEY PLAT
OF
(15.00 FOOT HIDALGO COUNTY IRRIGATION
DISTRICT No. 2 EASEMENT AND PROPOSED DRAINAGE EASEMENT)
A 0.472 ACRE OF LAND OUT OF LOT 8, BLOCK 47,
ALAMO LAND AND SUGAR COMPANY SUBDIVISION,
HIDALGO COUNTY, TEXAS
AS PER MAP RECORDED IN
VOLUME 1, PAGES 24-26, M.R.H.C.**

A 0.472 acre of land out of Lot 8, Block 47, Alamo Land and Sugar Company Subdivision, Hidalgo County, Texas, as per map recorded in Volume 1, Pages 24-26, Map Records of Hidalgo County, Texas. Said 0.472 of an acre of land being more particularly described by metes and bounds as follows;

Commencing at a 60 D nail found at the Southwest corner of Lot 8, Block 47, Alamo Land and Sugar Company; **Thence**, North 08 degrees 35 minutes 00 seconds East with the West line of Lot 8, Block 47, Alamo Land and Sugar Company, a distance of 20.00 feet to a No. 4 rebar set (with a plastic cap stamped RGEC) at the North Right of Way line of Minnesota Road for the Southwest corner of this tract of land and the **POINT OF BEGINNING**;

THENCE, continuing North 08 degrees 35 minutes 00 seconds East, with the West line of said Lot 8, Block 47, a distance of 1300.00 feet to a No. 4 rebar set (with a plastic cap stamped RGEC) at the Northwest corner of said Lot 8, Block 47 for the Northwest corner of this tract of land;

THENCE, South 81 degrees 25 minutes 00 seconds East, with the North line of said Lot 8, Block 47, a distance of 44.37 feet to a No. 2 rebar set (with a plastic cap stamped RGEC) at the East line of a 20.00 foot City of San Juan Utility Easement (Document No. 1277962, O.R.H.C.) for the Northeast corner of this tract of land;

THENCE, South 08 degrees 35 minutes 00 seconds West, with the existing East line of said City of San Juan Utility Easement, a distance of 31.53 feet to a No. 4 rebar set (with a plastic cap stamped RGEC) for an exterior corner of this tract of land;

THENCE, South 82 degrees 09 minutes 20 seconds West, with a clip, a distance of 30.62 feet to a No. 4 rebar set (with a plastic cap stamped RGEC) at the existing East 30.00 foot line of Hidalgo County Irrigation District No. 2 Drainage Easement for an interior corner of this tract of land;

THENCE, South 08 degree 35 minutes 00 seconds West, with the existing East line of said Hidalgo County Irrigation District No. 2 Drainage Easement, a distance of 1259.81 feet to a No. 4 rebar set (with a plastic cap stamped RGE) at the existing North Right of Way line of Minnesota Road for the Southeast corner of this tract of land;

THENCE, North 81 degrees 25 minutes 00 seconds West, with the existing North Right of Way line of said Minnesota Road, a distance of 15.00 feet to the **POINT OF BEGINNING** and containing **0.472** of an acre of land, more or less.

I, Pablo Soto, Jr., a Registered Professional Land Surveyor in the State of Texas, do hereby state that the above metes and bounds are true and are the result of an actual survey performed on the ground under my direction.

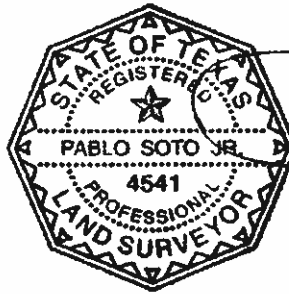

Pablo Soto, Jr.
Pablo Soto, Jr. - R.P.L.S. No. 4541
Date: 10-11-2011

Revised: 6/25/12

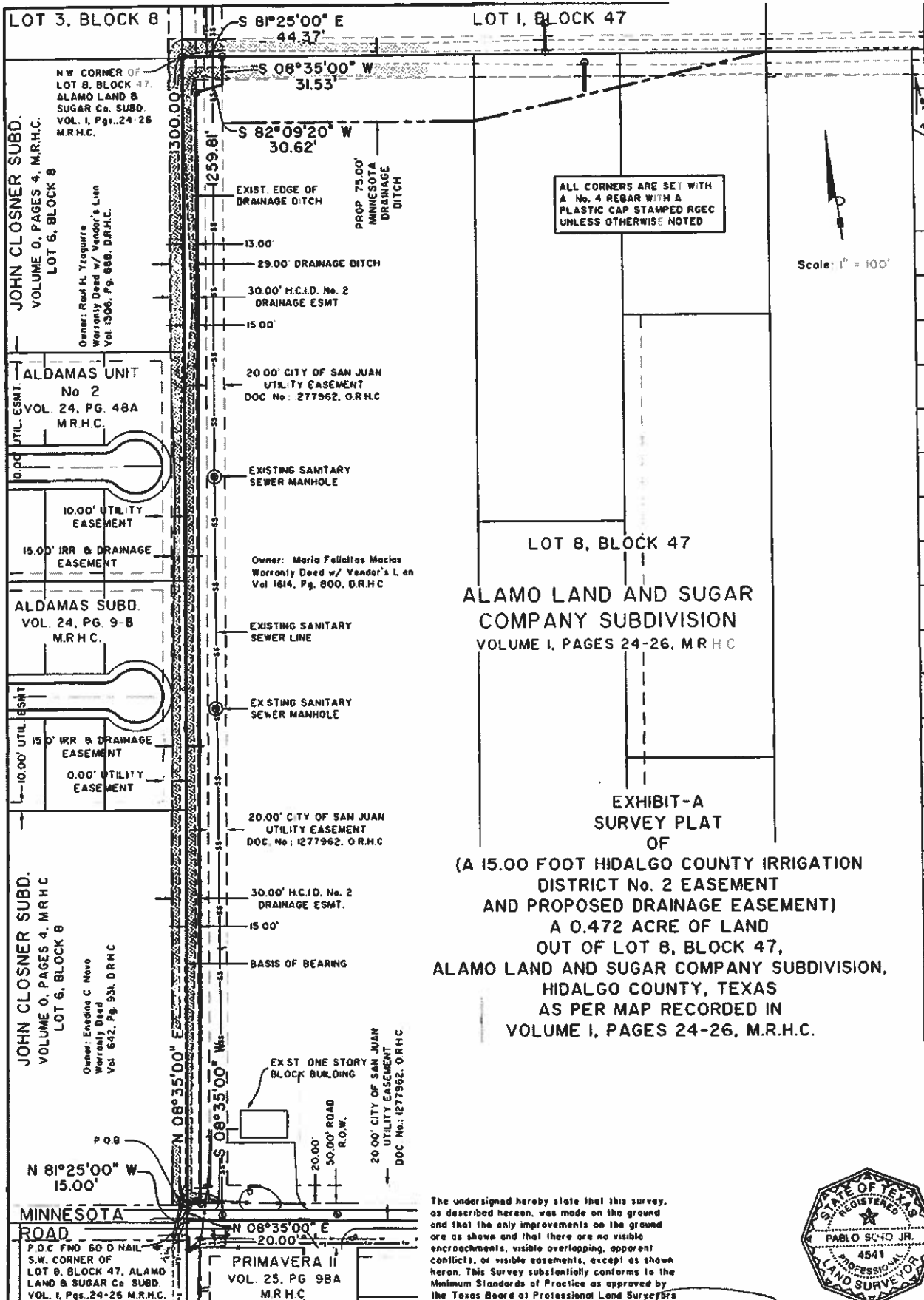

EXHIBIT-A
SURVEY PLAT
OF
(A 15.00 FOOT HIDALGO COUNTY IRRIGATION
DISTRICT No. 2 EASEMENT
AND PROPOSED DRAINAGE EASEMENT)
A 0.472 ACRE OF LAND
OUT OF LOT 8, BLOCK 47,
ALAMO LAND AND SUGAR COMPANY SUBDIVISION,
HIDALGO COUNTY, TEXAS
AS PER MAP RECORDED IN
VOLUME I, PAGES 24-26, M.R.H.C.

The undersigned hereby state that this survey, as described herein, was made on the ground and that the only improvements on the ground are as shown and that there are no visible encroachments, visible overlapping, apparent conflicts, or visible easements, except as shown hereon. This Survey substantially conforms to the Minimum Standards of Practice as approved by the Texas Board of Professional Land Surveyors.



PABLO SOTO, JR. - R.P.L.S. No. 4541
 Date: 10-11-2011 Revised 6/25/12

R. Gutierrez Professional Engineers & Land Surveyors
 Engineering Corporation
 130 E. PARK AVENUE • PHARR, TEXAS 78577
 (TEL) 956 782-2557 • (FAX) 956 782-2558
 ENGINEERING FIRM No. 486 • SURVEYING FIRM No. 101653 00

JOB No.: ENG09 001	DATE: OCT. 11, 2011
DRAWN BY: RG	PAGE: 3 OF 3

AI-33305

Precinct #4 16. A.

CC REGULAR

Meeting Date: 07/24/2012

Submitted By: Monica Badillo, EXECUTIVE OFFICE

Department: EXECUTIVE OFFICE

Information

CAPTION

Approval to name roads as follows:

1. LALO SR - A private service road located at Del Tule track 94 on the west side of Brushline RD and south of Highway 186.
2. CLEMENCIA SR - A private service road located at Del Tule track 94 on the west side of Brushline RD and south of Highway 186.

BACKGROUND

Fiscal Impact

<u>FISCAL YEAR:</u>	<u>ACCT. #:</u>
<u>FUNDS AVAILABLE Y/N?:</u>	<u>MATCHING FUNDS Y/N?:</u>

BUDGETARY IMPACT:

No Budgetary Impact

Attachments

- 1
- 2
- 3

Form Review

Inbox	Reviewed By	Date
Budget & Management	Merlen P. Munoz	07/18/2012 11:34 AM
Manuel Chapa	Manuel Chapa	07/18/2012 01:38 PM
Purchasing Department	Angela Garcia	07/20/2012 04:55 PM
Form Started By: Monica Badillo		Started On: 07/18/2012 11:09 AM
	Final Approval Date: 07/20/2012	



Lower Rio Grande Valley Development Council

Mayor Steve Brewer, La Feria President
 Hon. Norma G. Garcia, Member-at-Large 1st Vice-President
 Mayor Tony Martinez, Brownsville 2nd Vice-President
 Mayor Chris Boswell, Harlingen Secretary
 Commissioner Gerardo "Jerry" Tafolla, Weslaco Treasurer
 Mayor Pro-Tem Eddy Gonzalez, Edcouch Immediate Past President

BOARD MEMBERS

Sofia Benavides
 Commissioner, Cameron County

Hector "Tito" Palacios
 Commissioner, Hidalgo County

John F. Gonzales
 Judge, Willacy County

Pilar Garza
 Commissioner, Alamo

David S. Simmons
 Mayor, Donna

Gus Garcia
 Council Member, Edinburg

Jim Darling
 Commissioner, McAllen

Henry Hinojosa
 Mayor, Mercedes

Norie Gonzalez Garza
 Council Member, Mission

Leo "Polo" Palacios, Jr.
 Mayor, Pharr

Orlando Correa
 Mayor, Raymondville

Jose D. Gonzalez
 Commissioner, San Benito

Armando Garza
 Mayor Pro-Tem, San Juan

Dr. Cesar Maldonado
 TSTC, Harlingen

Roberto Loredo
 Donna I.S.D.

Gale Armstrong
 El Jardin Water Supply

J. Shane Cameron
 Willacy Navigation District

Alvin Samano
 Member-At-Large

Don Medina
 Member-At-Large

Arturo Ramirez
 Grassroots Organizations

EXECUTIVE DIRECTOR
 Kenneth N. Jones, Jr.

July 17, 2012

Hidalgo County Precinct 4
 Juanita Alejos
 102 N Doolittle Rd
 Edinburg, TX 78539

The LRGVDC 9-1-1 Department acknowledges notification on the following:
PROPOSED NAME: CLEMENCIA SR - A private service road located at Del Tule track 94 on the west side of Brushline RD and south of Highway 186.

We have done a query on the state 9-1-1 database and found no match for the recommended name in the system what so ever. So, we recommend this name to be utilized for naming the road specified.

Unlimited MSAG Query [Hide](#)

House # Dir Street

Community

Entity ESN MSAG System

Query Results

There are no Streets that match the specified criteria!

ACKNOWLEDGED ON: July 17, 2012
RESEARCHED BY: Maggie Garza
TITLE: Planner I



Lower Rio Grande Valley Development Council

Mayor Steve Brewer, La Feria President
 Hon. Norma G. Garcia, Member-at-Large 1st Vice-President
 Mayor Tony Martinez, Brownsville 2nd Vice-President
 Mayor Chris Boswell, Harlingen Secretary
 Commissioner Gerardo "Jerry" Tafolla, Weslaco Treasurer
 Mayor Pro-Tem Eddy Gonzalez, Edcouch Immediate Past President

BOARD MEMBERS

Sofia Benavides
 Commissioner, Cameron County

Hector "Tito" Palacios
 Commissioner, Hidalgo County

John F. Gonzales
 Judge, Willacy County

Pilar Garza
 Commissioner, Alamo

David S. Simmons
 Mayor, Donna

Gus Garcia
 Council Member, Edinburg

Jim Darling
 Commissioner, McAllen

Henry Hinojosa
 Mayor, Mercedes

Norie Gonzalez Garza
 Council Member, Mission

Leo "Polo" Palacios, Jr.
 Mayor, Pharr

Orlando Correa
 Mayor, Raymondville

Jose D. Gonzalez
 Commissioner, San Benito

Armando Garza
 Mayor Pro-Tem, San Juan

Dr. Cesar Maldonado
 TSTC, Harlingen

Roberto Loreda
 Donna I.S.D.

Gale Armstrong
 El Jardin Water Supply

J. Shane Cameron
 Willacy Navigation District

Alvin Samano
 Member-At-Large

Don Medina
 Member-At-Large

Arturo Ramirez
 Grassroots Organizations

EXECUTIVE DIRECTOR
 Kenneth N. Jones, Jr.

July 17, 2012

Hidalgo County Precinct 4
 Juanita Alejos
 102 N Doolittle Rd
 Edinburg, TX 78539

The LRGVDC 9-1-1 Department acknowledges notification on the following:
PROPOSED NAME: LALO SR - A private service road located at Del Tule track 94 on the west side of Brushline RD and south of Highway 186.

We have done a query on the state 9-1-1 database and found no match for the recommended name in the system what so ever. So, we recommend this name to be utilized for naming the road specified.

Unlimited MSAG Query [Hide](#)

House # Dir Street

Community

Entity ESN MSAG System

Query Results

There are no Streets that match the specified criteria!

ACKNOWLEDGED ON: July 17, 2012
RESEARCHED BY: Maggie Garza
TITLE: Planner I

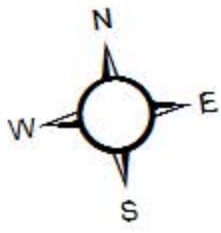

PROPOSED ST NAMES
PRECINCT #4
CLEMENCIA SR AND LALO SR
COMMUNITY OF SAN MANUEL



AI-33372

Budget and Management 17. A.

CC REGULAR

Meeting Date: 07/24/2012

Department Head: Sergio Cruz

Submitted By: Angela Garcia, BUDGET &
MANAGEMENT

Department: BUDGET & MANAGEMENT

Information

CAPTION

Presentation and discussion on "Operation Clean Slate".

BACKGROUND

Form Review

Inbox	Reviewed By	Date
Purchasing Department	Angela Garcia	07/20/2012 04:55 PM
Form Started By: Angela Garcia		Started On: 07/20/2012 04:11 PM
	Final Approval Date: 07/20/2012	

AI-33185
CC REGULAR

Budget and Management 17. B.

Meeting Date: 07/24/2012

Department Head: Sergio Cruz

Submitted By: Angela Garcia, BUDGET &
MANAGEMENT

Department: BUDGET & MANAGEMENT

Information

CAPTION

Approval of payment of invoice dated 07/05/12 from Montalvo Insurance Agency in the amount of \$2,263.00 for Business Automobile Insurance with authority for County Treasurer to issue check after review and processing procedures are completed by the County Auditor.

BACKGROUND

Fiscal Impact

FISCAL YEAR: 2012

ACCT. #: 2-1100-419-00-125-009-0-522

FUNDS AVAILABLE Y/N?: Y

MATCHING FUNDS Y/N?: N

BUDGETARY IMPACT:

Funding available through Requisition#219853 in the amount of \$2,263.00 as of 7/20/12 for Montalvo Insurance Agency.

Attachments

invoice

Form Review

Inbox	Reviewed By	Date
Budget & Management	Merlen P. Munoz	07/11/2012 03:03 PM
Olga Garza	Olga Garza	07/13/2012 04:07 PM
Purchasing Department	Angela Garcia	07/20/2012 04:55 PM
Form Started By: Angela Garcia		Started On: 07/11/2012 10:29 AM
	Final Approval Date: 07/20/2012	

HIDALGO COUNTY
 DBM SAFETY DIVISION

2012 JUL 10 AM 8 52

Invoice
 07/05/2012

Montalvo Insurance Agency
 PO Box 2
 Weslaco, Texas 78599
 956-968-5521

To: Hidalgo County
 PO Box 1356
 Edinburg, TX 78540

Type of Coverage: Business Automobile	
Company: Travelers Property Casualty Company of America	
Term: 01/01/2011 – 01/01/2012	
Premium Audit:	\$2,263.00
Total Premium:	\$2,263.00

An additional premium has generated for the audit that was completed for the policy term listed above.

Payment due upon receipt.
Thank you for your business!

2-1100-419-00-125-009-0-522

INVOICE RECEIVED BY: aa ON 7/10/12
 GOODS/SERVICES RECEIVED BY: Hid. Co. Health ON 07/11-01/01/12

AI-33245

Budget and Management 17. C. 1.

CC REGULAR

Meeting Date: 07/24/2012

Department Head: Joel Rivera, Pct. 4
Chief Deputy
Constable

Submitted By:

Ivan Cantu, BUDGET & MANAGEMENT

Department: BUDGET & MANAGEMENT

Information

CAPTION

Constable Pct. 4 Investigation HB 65 (1231):
Approval of 2012 appropriation of funds in the amount of \$4,945.95 into the Constable Pct. 4 Investigation HB 65 to fund minor equipment and court cost expenditures.

BACKGROUND

Fiscal Impact

FISCAL YEAR: 2012

ACCT. #: 2-1231-421-00-294-003-0-664

FUNDS AVAILABLE Y/N?: Y

MATCHING FUNDS Y/N?:

BUDGETARY IMPACT:

Appropriation of funds for the Constable Pct. 4 Investigation HB 65 in the amount of \$4,945.95.

Funds available in unreserved f/b as of 7-13-12.

Attachments

Appropriation Revised

Form Review

Inbox	Reviewed By	Date
Ivan Cantu (Originator)	Ivan Cantu	07/13/2012 11:13 AM
Budget & Management	Merlen P. Munoz	07/13/2012 11:46 AM
Rosalinda Cantu	Rosie Cantu	07/13/2012 02:32 PM
Purchasing Department	Angela Garcia	07/20/2012 04:55 PM
Form Started By: Ivan Cantu		Started On: 07/13/2012 09:51 AM
	Final Approval Date: 07/20/2012	

DATE: July 17, 2012

DEPARTMENT HEAD: Sergio Cruz, Budget Officer

DEPARTMENT NAME: DBM for Constable Pct. 4 Investigation HB 65

ACCOUNT NUMBER: 2-1231-421-00-294-003-0-664

Contact Person: Ivan Cantu Ph#: (956) 292-7025 ext. 5425

2012
Appropriation



SUBJECT: Budget Amendments (increase (decrease)) in accordance with Local Government Code, Chapter 111, § 111.070, Item C (2).

Honorable Commissioners' Court of Hidalgo County:

I would like to request the following Budget Amendments (increase (decrease)) in accordance with Local Government Code, Chapter 111, § 111.070, Item C (2).

INCREASE ACCOUNT NUMBER(S)	ACCOUNT (OBJECT) NAME		AMOUNT
2-1231-421-00-294-003-0-664	Constable Pct. 4 Investig. HB65-	Other Minor Equipment	3,522.95
2-1231-421-00-294-003-0-831	Constable Pct. 4 Investig. HB65-	Court Costs & Investigation	1,423.00
TOTAL BUDGET INCREASE (DECREASE)			4,945.95

REASON:

Appropriation of funds for the Constable Pct. 4 Investigation HB 65 to purchase two (2) LCD TV's for office use and personnel training and pay 3 outstanding invoices from the District Clerk.

DEPARTMENT HEAD SIGNATURE

APPROVED COMMISSIONERS' COURT

____ / ____ / ____
DATE

ATTEST COUNTY CLERK

AI-33303

Budget and Management 17. C. 2.

CC REGULAR

Meeting Date: 07/24/2012

Department Head: Pct. 1 Drainage
Improv.

Submitted By: Ivan Cantu, BUDGET & MANAGEMENT

Department: BUDGET & MANAGEMENT

Information

CAPTION

Pct. #1 Drainage Improvement Project (1200):

- a. Approval of certification of revenues as certified by the County Auditor for Pct. 1 Drainage Improvement labor reimbursements.
- b. Approval of 2012 appropriation of funds for the Pct. 1 Drainage Improvement Project (fund 1200, program 052) in the amount of \$24,557.63 to fund payroll expenditures.

BACKGROUND

Pct. 1 Drainage Improvement labor reimbursements were posted by Auditors office for the month of May 2012 (PP #9 & 10).

Fiscal Impact

FISCAL YEAR: 2012

ACCT. #: 2-1200-431-00-121-052-0-XXX

FUNDS AVAILABLE Y/N?: Y

MATCHING FUNDS Y/N?:

BUDGETARY IMPACT:

2012 Appropriation of funds in relation to Pct. 1 Drainage Prj. labor reimbursments for the month of May 2012 (PP #9 & 10) in the amount of \$24,557.63.

Revenue acct #2-1200-360-00-121-002-0-000 "R & B Pct. 1-Misc-Drain Reim." Total actual YTD labor reimbursements from Jan.-May 2012 (PP #1-10) are \$115,842.15.

Attachments

Appropriation- Pct 1 May 2012

Cert. of Revenues letter

Form Review

Inbox	Reviewed By	Date
Ivan Cantu (Originator)	Ivan Cantu	07/19/2012 01:19 PM
Budget & Management	Merlen P. Munoz	07/19/2012 03:16 PM
Rosalinda Cantu	Rosie Cantu	07/20/2012 08:58 AM
Purchasing Department	Angela Garcia	07/20/2012 04:55 PM
Form Started By: Ivan Cantu		Started On: 07/18/2012
Final Approval Date: 07/20/2012		

DATE: July 24, 2012

2012
Appropriation



DEPARTMENT HEAD: Sergio Cruz, Budget Officer

DEPARTMENT NAME: DBM for Pct. 1 Drainage Improvement Project

ACCOUNT NUMBER: 2-1200-431-00-121-052-0-XXX

Contact Person: Ivan Cantu Ph#: (956) 292-7025 ext. 5425

SUBJECT: Budget Amendments (increase (decrease)) in accordance with Local Government Code, Chapter 111, § 111.070, Item C (2).

Honorable Commissioners' Court of Hidalgo County:

I would like to request the following Budget Amendments (increase (decrease)) in accordance with Local Government Code, Chapter 111, § 111.070, Item C (2).

INCREASE ACCOUNT NUMBER(S)		ACCOUNT (OBJECT) NAME		AMOUNT
2-1200-431-00-121-052-0-	113	Pct. 1 Drain Improv. Prj-	Reg. F/T Employees	18,560.66
2-1200-431-00-121-052-0-	115	Pct. 1 Drain Improv. Prj-	Longevity Pay	105.60
2-1200-431-00-121-052-0-	211	Pct. 1 Drain Improv. Prj-	Health Insurance	2,536.80
2-1200-431-00-121-052-0-	212	Pct. 1 Drain Improv. Prj-	Life Insurance	17.21
2-1200-431-00-121-052-0-	220	Pct. 1 Drain Improv. Prj-	FICA	1,389.96
2-1200-431-00-121-052-0-	230	Pct. 1 Drain Improv. Prj-	Retirement	1,856.56
2-1200-431-00-121-052-0-	250	Pct. 1 Drain Improv. Prj-	Unemployment Comp.	90.84
2-1200-360-00-121-002-0-	000	R & B Pct. 1-Misc.-	Drain Reim.	24,557.63
TOTAL BUDGET INCREASE (DECREASE)				24,557.63

REASON: Appropriation of the Pct. 1 Drainage Improvement labor reimbursements for the month of May 2012 (PP #9 & 10).

DEPARTMENT HEAD SIGNATURE

APPROVED COMMISSIONERS' COURT

/ /
DATE

ATTEST COUNTY CLERK

COUNTY of HIDALGO



EDINBURG, TEXAS 78539

HIDALGO COUNTY AUDITOR'S OFFICE
Hidalgo County Administration Building
2808 South Business Highway 281
Edinburg, Texas 78539-6243
PHONE: (956) 318-2511
FAX: (956) 318-2577
WEBSITE: www.co.hidalgo.tx.us/auditor

July 19, 2012

The Honorable Ramon Garcia, Hidalgo County Judge
The Honorable Joel Quintanilla, Commissioner, Precinct No. 1
The Honorable Hector "Tito" Palacios, Commissioner, Precinct No. 2
The Honorable Jose M. Flores, Commissioner, Precinct No. 3
The Honorable Joseph Palacios, Commissioner, Precinct No. 4

RE: Certification of Revenue

Dear Judge and Commissioners:

Pursuant to Local Government Code § 111.07075 SPECIAL BUDGET FOR REVENUE RECEIVED AFTER START OF FISCAL YEAR:

The county auditor shall certify to the commissioners court the receipt of revenue from a new source not anticipated before the adoption of the budget and not included in the budget for that fiscal year. On certification, the court may adopt a special budget for the limited purpose of spending the revenue for general purposes or for any of its intended purposes.

I, Ray Eufrazio, County Auditor of Hidalgo County, certify to the Hidalgo County Commissioners Court Drainage Improvement labor reimbursements in amount of \$24,557.63. These funds may now be made available by creating a new special budget or amending a current budget for its intended purposes.

CERTIFIED BY:

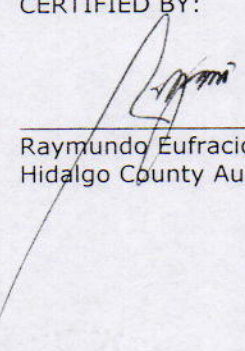
Raymundo Eufrazio, CPA
Hidalgo County Auditor

7/19/12
Date

HIDALGO COUNTY DISTRICT JUDGES

RICARDO P. RODRIGUEZ, JR. JUDGE, 92ND D.C. RODOLFO DELGADO JUDGE, 93RD D.C. J. R. "BOBBY" FLORES JUDGE, 139TH D.C. ROSE GUERRA REYNA JUDGE, 206TH D.C. JUAN R. PARTIDA JUDGE, 275TH D.C. MARIO E. RAMIREZ, JR. JUDGE, 332ND D.C. NOE GONZALEZ JUDGE, 370TH D.C. OVERSEER LETICIA LOPEZ JUDGE, 389TH D.C. AIDA SALINAS FLORES JUDGE, 398TH D.C. ISRAEL RAMON, JR. JUDGE, 430TH D.C. JESSE CONTRERAS JUDGE, 449TH D.C.

AI-33318

Budget and Management 17. C. 3.

CC REGULAR

Meeting Date: 07/24/2012

Department Head: Katia Garcia

Submitted By: Erika Zamora, BUDGET & MANAGEMENT

Department: BUDGET & MANAGEMENT

Information

CAPTION

Pct. 2 Border Rd (Moore-El Gato) (1200):

Approval of 2012 unappropriation of funds in the amount of \$100,000.00 for the Pct. 2 Border Rd (Moore-El Gato).

BACKGROUND

Fiscal Impact

FISCAL YEAR: 2012

ACCT. #: 2-1200-431-00-122-063-0-731

FUNDS AVAILABLE Y/N?: Y

MATCHING FUNDS Y/N?: N

BUDGETARY IMPACT:

Unappropriation of funds in the amount of \$100,000 from Pct. 2 Border (Moore-El Gato)-Roads into Fund 1200 Fund Balance.

Funds available as of 7/18/12.

Attachments

Unappropriation

Form Review

Inbox	Reviewed By	Date
Erika Zamora (Originator)	Erika Zamora	07/18/2012 03:40 PM
Budget & Management	Merlen P. Munoz	07/18/2012 04:03 PM
Roland Garcia	Rolando Garcia	07/19/2012 10:43 AM
Purchasing Department	Angela Garcia	07/20/2012 04:55 PM
Form Started By: Erika Zamora		Started On: 07/18/2012 02:53 PM
	Final Approval Date: 07/20/2012	

DATE: July 18, 2012

2012 Appropriation



DEPARTMENT HEAD: Hector "Tito" Palacios

DEPARTMENT NAME: Pct. 2 R&B (1200)

ACCOUNT NUMBER: 2-1200-431-00-122-063-0-731

Contact Person: Katia Garcia Ph#: 787-1891 ext.2027

SUBJECT: Budget Amendments (increase (decrease)) in accordance with Local Government Code, Chapter 111, § 111.070, Item C (2).

Honorable Commissioners' Court of Hidalgo County:

I would like to request the following Budget Amendments (increase (decrease)) in accordance with Local Government Code, Chapter 111, § 111.070, Item C (2).

Table with 3 columns: INCREASE ACCOUNT NUMBER(S), ACCOUNT (OBJECT) NAME, and AMOUNT. Includes one entry for PCT2 BORDER RD (MOORE-EL GATO) - ROADS with a decrease of \$100,000.00.

REASON: To unappropriate funds for BORDER ROAD Project.

DEPARTMENT HEAD SIGNATURE

APPROVED COMMISSIONERS' COURT

DATE

ATTEST COUNTY CLERK

AI-33307

Budget and Management 17. C. 4.

CC REGULAR

Meeting Date: 07/24/2012

Department Head: Norma Ceballos Submitted By: Erika Zamora, BUDGET & MANAGEMENT

Department: BUDGET & MANAGEMENT

Information

CAPTION

Pct. #3 Rd Maintenance (1200):

Approval of 2012 appropriation of funds into Precinct #3 Rd Maint in the total amount of \$120,000.00 to fund operating expenditures.

BACKGROUND

Fiscal Impact

FISCAL YEAR: 2012

ACCT. #: 2-1200-431-00-123-005-0-XXX

FUNDS AVAILABLE Y/N?: Y

MATCHING FUNDS Y/N?: N

BUDGETARY IMPACT:

Appropriation of funds in the amount of \$120,000 into Pct. 3 Rd Maint.

Funds available from Pct. 3 R&B Fund Balance (1200).

Attachments

Appropriation

Form Review

Inbox	Reviewed By	Date
Erika Zamora (Originator)	Erika Zamora	07/18/2012 01:20 PM
Budget & Management	Merlen P. Munoz	07/18/2012 03:55 PM
Perla Lopez	Perla Lopez	07/19/2012 01:35 PM
Purchasing Department	Angela Garcia	07/20/2012 04:55 PM
Form Started By: Erika Zamora		Started On: 07/18/2012 11:29 AM
	Final Approval Date: 07/20/2012	

DATE: July 17, 2012

DEPARTMENT HEAD: Commissioner Joe Flores - Pct. No. 3

DEPARTMENT NAME: Pct. 3 Rd. Maint. - Fund (#1200)

ACCOUNT NUMBER: 2-1200-431-00-123-005-0-XXX

SUBJECT: Budget Amendments (Increases) in Accordance with Local Government Code, Chapter 111, Subchapter C

Honorable Commissioners' Court of Hidalgo County:

I would like to request the following amendments (increases) to my department budget in accordance with Local Government Code, Chapter 111, Subchapter C.

INCREASE OBJECT	ACCOUNT (OBJECT) NAME	AMOUNT
2 1200 431 00 123 005 0 432	Pct #3 Rd. Maint - Equip & Veh R&M Srv.	20,000.00
2 1200 431 00 123 005 0 607	Pct #3 Rd. Maint - Household & Janitorial	1,000.00
2 1200 431 00 123 005 0 672	Pct #3 Rd. Maint- Equip & Veh R&M Supplies	25,000.00
2 1200 431 00 123 005 0 673	Pct #3 Rd. Maint - R&B R&M Supplies	30,000.00
2 1200 431 00 123 005 0 679	Pct #3 Rd. Maint - Other R&M Supplies	5,000.00
2 1200 431 00 123 005 0 890	Pct #3 Rd. Maint - Other	38,500.00
2 1200 431 00 123 005 0 630	Pct #3 Rd. Maint - Food	500.00
TOTAL BUDGET INCREASE -FUND 1100		120,000.00

REASON: Expected expenses.

DEPARTMENT HEAD SIGNATURE *Joe Flores* 7/17/12

DATE

ATTEST COUNTY CLERK

APPROVED COMMISSIONERS' COURT

AI-33218

Budget and Management 17. C. 5.

CC REGULAR

Meeting Date: 07/24/2012

Submitted By: Jr. Munoz, COMM. PCT. #4

Department: COMM. PCT. #4

Information

CAPTION

Pct. #4 (1200):

a. Approval of Certification of Revenues as certified by the County Auditor for JO-9 reimbursement in the total amount of \$65,561.13.

b. Approval of 2012 appropriation of funds into Precinct #4 Rd. Maint (program 007 - \$39,245.45) and Drainage Improvement Project (program 036 - \$26,315.68) in the total amount of \$65,561.13 (Reimbursement from HCDD#1 for JO-9 Ditch Project).

BACKGROUND

Fiscal Impact

FISCAL YEAR: 2012

ACCT. #: 2-1200-431-00-124-0XX-0-XXX

FUNDS AVAILABLE Y/N?:

MATCHING FUNDS Y/N?:

BUDGETARY IMPACT:

Approval of 2012 appropriation of funds in the amount of \$65,561.13 into Pct #4 Rd Maint. & Drainage Improvement Project (HCDD# 1 J09 Drainage Project)

Revenue account# 2-1200-341-50-124-002-0-000 HCDD#1 Drainage Revenue.

Attachments

Receipt

Reimbursement Sheet

appropriation

cert

Form Review

Inbox
Budget & Management
Manuel Chapa
Purchasing Department

Reviewed By
Merlen P. Munoz
Manuel Chapa
Angela Garcia

Date
07/12/2012 08:15 AM
07/13/2012 03:28 PM
07/20/2012 04:55 PM

Form Started By: Jr. Munoz

Started On: 07/11/2012 04:32 PM

Final Approval Date: 07/20/2012



OFFICIAL HIDALGO COUNTY RECEIPT
OFFICE OF THE COUNTY TREASURER
NORMA G. GARCIA

Receipt No: 157299

Received From: DRAINAGE DISTRICT #1 PCT. 4

Date 07/11/12

1 000013122 J09 REIMBURSEMENT-MAY 2012 2-1200-341-50-124-002-0-000 65,561.13

Total: 65,561.13

Check Total	65,561.13
Cash Total	.00
Credit Total	.00
Other Total	.00



**HIDALGO COUNTY
DRAINAGE DISTRICT #1**

902 N. DOOLITTLE
EDINBURG, TEXAS 78542

GENERAL FUND

FIRST NATIONAL BANK
MEMBER FDIC
88-2141/1149

No. 015178

Check Date	Check No.	Amount
07/10/12	000013122	\$65,561.13

VOID AFTER 90 DAYS

was allowed by the Board of Directors of Hidalgo County, Texas at its term meeting indicated above and to be paid out of the General Fund

PAY

****Sixty Five Thousand Five Hundred Sixty One and 13/100 Dollars

TO THE **HIDALGO COUNTY PCT. NO. 4**
ORDER **C/O JOSEPH PALACIOS**
OF **1102 N. DOOLITTLE RD.**
EDINBURG, TX 78542

Pay the above stated amount to the order of the payee named.

Norma G. Garcia

COUNTY TREASURER

Lea Brown

FINANCIAL OFFICER

⑈000013122⑈ ⑆114921415⑆ ⑈0014020270⑈

Payee **HIDALGO COUNTY PCT. NO. 4**

Account #:

000013122
07/10/2012

Invoice	Description	Amount
MAY 4-JUN 03, 2012	J09 REIMBURSEMENT-MAY 2012	\$65,561.13

2-1200-431-50-124-062-0-000

HIDALGO COUNTY PCT.#4
RECEIVED BY

JUL 11 2012

EDINBURG, TEXAS 78542

Total :

\$65,561.13

HCDD #1 JO9 DRAINAGE PROJECT						
Reimbursement Sheet						
Date: May 4 to Jun. 3 2012						
Week	Fuel		Labor		Equipment	
	# of Gallons	Gal x Fuel	Hours	Hrs x Salary	Excavator 30	Equipment x Rate
5/4/12 - 5/6/12	125	\$390.80	30	\$824.40	N/A	N/A
5/7/12 - 5/9/12	124	\$387.67	30	\$824.40	N/A	N/A
5/21/12-5/27/12	360	\$1,125.51	49	\$1,346.52	N/A	N/A
5/29/12 - 6/3/12	328	\$1,025.46	60	\$1,648.80	N/A	N/A
		\$0.00	0	\$0.00	N/A	N/A
	# of Gallons	Gal. x Fuel	Hours (JM)	Hrs x Salary	D6N Dozzer	Equipment x Rate
5/25/12-5/27/12	44	\$137.56	30	\$616.80	23.9	\$806.63
5/29/12 - 6/3/12	50	\$156.32	16	\$328.96	13.6	\$459.00
		\$0.00	0	\$0.00	0	\$0.00
		\$0.00	0	\$0.00	0	\$0.00
		\$0.00	0	\$0.00	0	\$0.00
	# of Gallons	Gal. x Fuel	Hours (LG)	Hrs x Salary	D6N Dozzer	Equipment x Rate
5/4/12 - 5/6/12	0	\$0.00	23.5	\$645.78	9.3	\$313.88
5/7/12-5/9-12	80	\$250.11	30	\$824.40	24.4	\$823.50
5/21/12-5/24/12	55	\$171.95	39.5	\$1,085.46	26.3	\$887.63
5/29/12 -5/3/12	50	\$156.32	30	\$824.40	20.9	\$705.38
		\$0.00	0	\$0.00	0	\$0.00
	# of Gallons	Gal. x Fuel	Hours	Hrs x Salary	Dump Trucks	Equipment x Rate
5/4/12 - 5/6/12	125	\$414.51	101	\$1,963.44	101	\$2,672.46
5/7/12-5/9/12	211	\$699.70	130	\$2,527.20	130	\$3,439.80
5/21/12-5/27/12	523	\$1,734.33	378	\$7,348.32	378	\$10,001.88
5/29/12 - 6/3/12	294	\$974.94	175	\$3,402.00	175	\$4,630.50
		\$0.00	0	\$0.00	0	\$0.00
	# of Gallons	Gal x Fuel	Hours	Hrs x Salary	Excavator PD8	Equipment x Rate
5/23/12-5/24/12	90	\$281.38	20	\$549.60	14.2	\$837.80
		\$0.00	0	\$0.00	0	\$0.00
		\$0.00	0	\$0.00	0	\$0.00
		\$0.00	0	\$0.00	0	\$0.00
		\$0.00	0	\$0.00	0	\$0.00
	# of Gallons	Gal x Fuel	Hours	Hrs x Salary	Scrapper Hauler	Equipment x Rate
5/4/12 - 5/6/12	0	\$0.00	0	\$0.00	0	\$0.00
5/7/12 - 5/9/12	60	\$187.58	20	\$388.80	15	\$1,356.90
5/29/12 - 6/3/12	249	\$778.48	60	\$1,166.40	38	\$3,437.48
		\$0.00	0	\$0.00	0	\$0.00
		\$0.00	0	\$0.00	0	\$0.00
	# of Gallons	Gal x Fuel	Hours	Hrs x Salary	Back Hoe	Equipment x Rate
		\$0.00	0	\$0.00		\$0.00
		\$0.00	0	\$0.00	0	\$0.00
		\$0.00	0	\$0.00	0	\$0.00
		\$0.00	0	\$0.00	0	\$0.00
		\$0.00	0	\$0.00	0	\$0.00
		\$0.00	0	\$0.00	0	\$0.00
TOTALS		\$8,872.63		\$26,315.68		\$30,372.82
GRAND TOTAL	\$65,561.13					

Equipment Detail-Pct.4				R.E.R Rental Guide 2012							
Tag #	Year	Make	Model	Description	Vin #	Rate	O.W.	Day	Week	4 Weeks	R.E.R Pp.
48423	2008	Caterpillar	330DL	Hydraulic Excavator(268hp)	MWV033300	\$59.00	80,027 LB	\$1,050.00	\$3,150.00	\$9,450.00	42
48762	2008	Caterpillar	D6N	Dozer(177hp)	DJA01021	\$33.75	36,670 LB	\$600.00	\$1,800.00	\$5,400.00	41
49190	2010	Peterbilt	340	Tandem Dump Truck	2NPRLN9X4AM101471	\$26.46	70,000 LB	\$295.00	\$1,185.00	\$4,235.00	TXDot
49191	2010	Peterbilt	340	Tandem Dump Truck	2NPRLN9X6AM101469	\$26.46	70,000 LB	\$295.00	\$1,185.00	\$4,235.00	TXDot
49192	2010	Peterbilt	340	Tandem Dump Truck	2NPRLN9X64AM101469	\$26.46	70,000 LB	\$295.00	\$1,185.00	\$4,235.00	TXDot
49193	2010	Peterbilt	340	Tandem Dump Truck	2NPRLN9X2AM101470	\$26.46	70,000 LB	\$295.00	\$1,185.00	\$4,235.00	TXDot
30206	1991	INT		Tandem Dump Truck	2HSFEGUFRMCC048387	\$26.46	70,000 LB	\$295.00	\$1,185.00	\$4,235.00	TXDot
47643	2009	Peterbilt	340	Tandem Dump Truck	2NPRLN9X39M772495	\$26.46	70,000 LB	\$295.00	\$1,185.00	\$4,235.00	TXDot
47645	2009	Peterbilt	340	Tandem Dump Truck	2NPRLN9X69M772491	\$26.46	70,000 LB	\$295.00	\$1,185.00	\$4,235.00	TXDot
47646	2009	Peterbilt	340	Tandem Dump Truck	2NPRLN9X59M772496	\$26.46	70,000 LB	\$295.00	\$1,185.00	\$4,235.00	TXDot
47973	2002	Peterbilt	330	Tandem Dump Truck	2NPNLD9X32M577222	\$26.46	70,000 LB	\$295.00	\$1,185.00	\$4,235.00	TXDot
37760	2002	Peterbilt	330	Tandem Dump Truck	2NPNLD9X52M577223	\$26.46	70,000 LB	\$295.00	\$1,185.00	\$4,235.00	TXDot
47973	2002	Peterbilt	330	Tandem Dump Truck	2NPNLD9X32M577222	\$26.46	70,000 LB	\$295.00	\$1,185.00	\$4,235.00	TXDot
49052	2008	Volvo	T450	Scraper Hauler-20 cu yd	17016	\$90.46	6,800 LB	\$1,625.00	\$4,875.00	\$14,475.00	43
49052	2008	Volvo	T450	Scraper Hauler-20 cu yd	17030	\$90.46	6,800 LB	\$1,625.00	\$4,875.00	\$14,475.00	43
49051	2009	Caterpillar	420E	Back Hoe (93HP)	PRA00799	\$15.75	15,201 LB	\$280.00	\$840.00	\$2,520.00	41
48760	2009	Caterpillar	420E	Back Hoe (93HP)	PRA00798	\$15.75	15,201 LB	\$280.00	\$840.00	\$2,520.00	42
Employees											
Name	ID #	Position	Equipment	Salary (Hrly Rate)							
Agüero, Fermín	170968	Heavy Equipment Op.	excavator	\$27.48							
Botello, Sylvestre	174173	Truck Driver III	dump truck	\$19.44							
Clayton, Harley B.	173657	Heavy Equipment Op.	excavator	\$27.48							
Garza, Iñigo	181064	Truck Driver III	dump truck	\$19.44							
Govea, Luis Manuel	173681	Heavy Equipment Op.	dozzer	\$27.48							
Gracia, Jose Luis	181994	Truck Driver III	dump truck	\$19.44							
Guerra, Mauricio	173975	Truck Driver III	dump truck	\$19.44							
Martínez, Ediberto G	173703	Heavy Equipment Op.	excavator	\$27.48							
Molina, Reynaldo	173983	Truck Driver III	dump truck	\$19.44							
Moore, James M.	170992	Heavy Equipment Op.	dozzer	\$20.56							
Moreno, Jose A	174785	Truck Driver III	dump truck	\$19.44							
Navarro, Guadalupe	089737	Truck Driver III	dump truck	\$19.44							
Pineda Gutierrez, Oscar	181072	Truck Driver III	dump truck	\$19.44							
Rodríguez, Israel	160466	Truck Driver III	dump truck	\$19.44							
Rodríguez, Israel	182028	Truck Driver III	dump truck	\$19.44							
Rodríguez, Omar	160466	Truck Driver III	dump truck	\$19.44							
Trevino, Omar	182028	Truck Driver III	dump truck	\$19.44							
Vasquez, Benito	171018	Heavy Equipment Op.	excavator	\$27.48							
Gonzalez, Juan	170984	Pipe Layer	survey elev.	\$17.03							
Cisneros, Joe	171212	Heavy Equipment Op.	back hoe	\$27.48							
Adelaido, Serna	171247	Heavy Equipment Op.	back hoe	\$27.48							
Rios, Raquel	174815	Truck Driver III	scraper hauler	\$19.44							
Sanchez, Jose	182001	Truck Driver III	scraper hauler	\$19.44							



ARGUINDEGUI OIL CO. II, LTD.

QUALITY FUELS, LUBRICANTS, CHEMICALS & FILTERS

http://www.argpetro.com

PHONE: (800) 722-5251 FAX: (956) 727-7636

Invoice Number: B314848-IN

Invoice Date: 5/18/2012

Ship Date: 5/16/2012

Customer Number: 22-0001499

Order Number: V14492

FOR REMITTANCE: P.O. BOX 1367 - LAREDO, TEXAS 78042

SOLD TO:	SHIP TO:
Hidalgo Co Admin/Shop Pct.# 4 ADMIN/SHOP - PRECINCT 4 - ASTs 1051 N. DOOLITTLE ROAD EDINBURG, TX 78542-0337 (956) 383-3112	Hidalgo Co Admin/Shop Pct.# 4 ADMIN/SHOP - PRECINCT 4 - ASTs 1051 N. DOOLITTLE ROAD MUNOZ 383-3112 EDINBURG, TX 78542-0337

CUSTOMER P.O.	INV. DUE DATE	DEL. TICKET	TERMS
636795	6/17/2012	131546	NET 30 DAYS

WHSE:	ITEM NO.	UNIT	ORDERED	SHIPPED	BACK ORD.	PRICE	AMOUNT
664	B5 DIESEL FUEL , 3, UN1202 PGIII	GAL	3,000.00	2,000.00	0.00	3.1233	6,246.60
						+ .1900	+ .0018
						+ .0000	
664	B5D Ultra Low Dyed Diesel	GAL	3,000.00	3,000.00	0.00	3.1236	9,370.80
						+ .00100	
						+ .00181	

\$ 3,316.11
\$ 3,126.41

FUEL TAX RECAP

STATE DIESEL FUEL TAX	0.19000	380.00
FEDERAL LUST FEE	0.00100	5.00
FEDERAL OIL SPILL FEE	0.00181	9.05

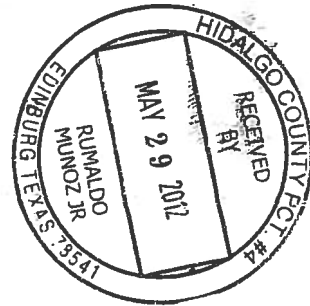

RECEIVED BY: _____
SIGNATURE

RECEIVED BY: _____ DATE: _____
PRINT NAME

Net Invoice: 16,011.45
 Less Discount: 0.00
 Freight: 0.00
 Sales Tax: 0.00
 Invoice Total: 16,011.45

ALL INVOICES WHICH ARE PAST DUE WILL BE SUBJECT TO A FINANCE CHARGE OF 1.5% PER MONTH (18% APR) OR THE MAXIMUM RATE ALLOWABLE BY LAW. FINANCE CHARGES WILL BE APPLIED TO ALL PAST DUE BALANCES ACCORDING TO YOUR BILLING TERMS.

HIDALGO COUNTY PRECINCT #4

DRAINAGE IMPROVEMENT PROJECT

Work Log

Employee Name: Harley Clayton

Project Name: 509 Artek

Employee Name: _____

Week: _____

Day	Date	Time		Total Hrs Worked	Unit#		Total Miles	Equip#		Total Equip Hrs	Fuel	Job description	
		in	out		beg.	end		EX 30	beg.				end
Monday		in	:		beg.			beg.					
		out	:		end			end					
Tuesday		in	:		beg.			beg.					
		out	:		end			end					
Wednesday		in	:		beg.			beg.					
		out	:		end			end					
Thursday		in	:		beg.			beg.					
		out	:		end			end					
Friday	5/4	in	7:10	10	beg.			beg.					
		out	5:30		end			end					
Saturday	5/5	in	7:00	10	beg.			beg.					
		out	5:30		end			end					
Sunday	5/6	in	7:00	10	beg.			beg.					
		out	5:30		end			end					
Employee Hrs.				30	Equip. Miles				Equip. Hrs		18.3	Fuel Used	12.5

Employee's signature: Harley Clayton

Date: 5/6/12

Employee's signature: _____

Date: _____

Project supervisor: Jimmy [Signature]

Date: 5/7/12

HIDALGO COUNTY PRECINCT #4 DRAINAGE IMPROVEMENT PROJECT Work Log

Employee Name: Luis S. Garcia

Project Name: JOP

Employee Name: _____

Week: 1

Day	Date	Time		Total Hrs Worked	Unit#		Total Miles	Equip# <u>P111</u>		Total Equip Hrs	Fuel	Job description
		in	out		beg.	end		beg.	end			
Monday		in	out		beg.	end		beg.	end			
Tuesday		in	out		beg.	end		beg.	end			
Wednesday		in	out		beg.	end		beg.	end			
Thursday		in	out		beg.	end		beg.	end			
Friday	5/4/12	in	out	2:00	beg.	end		5412.5		2.9	0	speed limit
		in	out	5:00	beg.	end		5414.4				
Saturday	5/5/12	in	out	7:00	beg.	end		5414.4		4.6		" "
		in	out	5:30	beg.	end		5419.0				
Sunday	5/6/12	in	out	7:00	beg.	end		5419.0		2.8		" "
		in	out	5:30	beg.	end		5421.6				
				23.5				9.3			15.1	

Employee Hrs. 23.5

Equip. Miles

Equip. Hrs 9.3

Fuel Used 15.1

Employee's signature: _____

Date: 5-6-12

Employee's signature: _____

Date: _____

Project supervisor: _____

[Signature]

Date: 5/7/12

HIDALGO COUNTY PRECINCT #4 DRAINAGE IMPROVEMENT PROJECT

Work Log

Employee Name: Jose L. Garcia

Employee Name: _____

Project Name: 209

Week: _____

Day	Date	Time		Total Hrs Worked	Unit#	Total Miles	Equip#		Total Equip Hrs	Fuel	Job description
		in	out				beg.	end			
Monday											
Tuesday											
Wednesday											
Thursday											
Friday											
Saturday	5-5-12	in: 7:00	out: 5:30	10	71518	42	beg. end				Hauling Dirt
Sunday	5-6-12	in: 10:30	out: 5:30	7	71539	36	beg. end				Hauling Dirt
		Employee Hrs. 17		Equip. Miles 78		Equip. Hrs _____		Fuel Used 20			

Employee's signature: Jose L. Garcia

Employee's signature: _____

Project supervisor: Johnny Anthony

Project supervisor: _____

Date: 5-6-12

Date: _____

Date: 5/7/12

Date: _____

HIDALGO COUNTY PRECINCT #4 DRAINAGE IMPROVEMENT PROJECT

Work Log

Employee Name: Frank Trevino

Project Name: 509

Employee Name: Frank Trevino

Week: _____

Day	Date	Time		Total Hrs Worked	Unit# <u>PD15</u>		Total Miles	Equip# _____		Total Equip Hrs	Fuel	Job description
		in	out		beg.	end.		beg.	end.			
Monday		in	out		beg.	end.		beg.	end.			
Tuesday		in	out		beg.	end.		beg.	end.			
Wednesday		in	out		beg.	end.		beg.	end.			
Thursday		in	out		beg.	end.		beg.	end.			
Friday ^{OT}	5-4-12	in 11:00	out 5:30	5 1/2 hrs	beg. 68571	end. 68606	35	beg.	end.	10 1/2		Hauling Dirt
Saturday ^{OT}	5-5-12	in 7:00	out 5:30	1 1/2 hrs	beg. 68606	end. 68638	32	beg.	end.			Hauling dirt
Sunday ^{OT}	5-6-12	in 10:30	out 9:30	6 1/2 hrs	beg. 68638	end. 68638	33	beg.	end.			Hauling dirt

Employee Hrs. **22.5**

Equip. Miles **115**

Equip. Hrs _____

Fuel Used **32**

Employee's signature: _____

Date: _____

Employee's signature: Frank Trevino

Date: 5-6-12

Project supervisor: _____

Date: 5/7/12

Frank Trevino

Frank Trevino

HIDALGO COUNTY PRECINCT #4 DRAINAGE IMPROVEMENT PROJECT

Work Log

Employee Name: Sylvester Boffle

Project Name: 509 project

Employee Name: _____

Week: _____

Day	Date	Time		Total Hrs Worked	Unit# <u>16</u>		Total Miles	Equip# _____		Total Equip Hrs	Fuel	Job description
		in	out		beg.	end		beg.	end			
Monday												
Tuesday												
Wednesday												
Thursday												
Friday <i>S/B</i>	5-4-12	in 11:00	out 5:30	6 hrs	beg. 660444	end 660479	35	beg. :	end :			Hauling dirt
Saturday <i>S/B</i>	5-5-12	in 7:00	out 5:30	10 hrs	beg. 660479	end 660520	41	beg. :	end :			Hauling dirt
Sunday <i>S/B</i>	5-6-12	in 10:30	out 5:30	2 hrs	beg. 660520	end 660557	37	beg. :	end :			Hauling dirt
		Employee Hrs. <u>22.5</u>		Equip. Miles <u>113</u>		Equip. Hrs _____		Fuel Used <u>19</u>				

Employee's signature: [Signature]

Date: 5-16-12

Employee's signature: _____

Date: _____

Project supervisor: _____

[Signature]

Date: 5/7/12

**HIDALGO COUNTY PRECINCT #4
DRAINAGE IMPROVEMENT PROJECT
Work Log**

Employee Name: Oscar Pineda

Project Name: 109

Employee Name: _____

Week: _____

Day	Date	Time		Total Hrs Worked	Unit# <u>PD17</u>		Total Miles	Equip# _____		Total Equip Hrs	Fuel	Job description
		in	out		beg.	end		beg.	end			
Monday		in	:		beg.			beg.				
		out	:		end			end				
Tuesday		in	:		beg.			beg.				
		out	:		end			end				
Wednesday		in	:		beg.			beg.				
		out	:		end			end				
Thursday		in	:		beg.			beg.				
		out	:		end			end				
<i>OP</i> Friday	5-4-12	in	11:00	6	beg. <u>67779</u>		36	beg.				<u>Hauling Dirt</u>
		out	5:30		end <u>67815</u>			end				
<i>OP</i> Saturday	5-5-12	in	7:00	10	beg. <u>67815</u>		42	beg.			11 gal	<u>Hauling Dirt</u>
		out	5:30		end <u>67857</u>			end				
<i>OP</i> Sunday	5-6-12	in	10:30	6.5	beg. <u>67857</u>		36	beg.			20 gal	<u>Hauling Dirt</u>
		out	5:30		end <u>67893</u>			end				
				22.5	114					31		

Employee Hrs.

Equip. Miles

Equip. Hrs

Fuel Used

Employee's signature: Oscar Pineda

Date: 5-6-12

Employee's signature: _____

Date: _____

Project supervisor: [Signature]

Date: 5/9/12

HIDALGO COUNTY PRECINCT #4

DRAINAGE IMPROVEMENT PROJECT

Work Log

Employee Name: Trivedi GARZA

Employee Name: _____

Project Name: 509

Week: _____

Day	Date	Time		Total Hrs Worked	Unit# <u>74</u>		Total Miles	Equip# _____		Total Equip Hrs	Fuel	Job description
		in	out		beg.	end		beg.	end			
Monday												
Tuesday												
Wednesday												
Thursday												
Friday												
<u>NE</u> Saturday	<u>5-5-12</u>	in	7:00	10	beg.	19247	43	beg.				<u>Reefing Dirt</u>
		out	5:30		end	19290		end				
<u>NE</u> Sunday	<u>5-6-12</u>	in	10:30	6.5	beg.	19290	31	beg.				<u>Reefing Dirt</u>
		out	5:30		end	19327		end				
				16.5	80						23	

Employee Hrs. 16.5

Equip. Miles 80

Equip. Hrs _____

Fuel Used 23

Employee's signature: Trivedi Garza

Employee's signature: _____

Project supervisor: [Signature]

Date: 5-6-12

Date: 5/7/12

HIDALGO COUNTY PRECINCT #4 DRAINAGE IMPROVEMENT PROJECT

Work Log

Employee Name: Harley Clayton

Project Name: TOE

Employee Name: _____

Week: _____

Day	Date	Time		Total Hrs Worked	Unit#	Total Miles	Equip#		Total Equip Hrs	Fuel	Job description
		in	out				beg.	end			
Monday	5/1/12	7:00	5:30	10			4149.5	4157.9	8.4 hrs	40.0 gal	Sloping
Tuesday	5/8/12	7:00	5:30	10			4157.9	4163.2	5.3 hrs	34.0 gal	Sloping
Wednesday	5/9/12	7:00	5:30	10			4163.2	4171.5	8.3 hrs	50.0 gal	(serviced machine) Sloping
Thursday											
Friday											
Saturday											
Sunday											
		30.0		Equip. Miles		22.0		Equip. Hrs		134	

Employee's signature: Harley Clayton

Employee's signature: _____

Project supervisor: Jeremy Anderson

Date: 5/9/12

Date: 5/14/12

HIDALGO COUNTY PRECINCT #4 DRAINAGE IMPROVEMENT PROJECT

Work Log

Employee Name: Luis Gomez

Project Name: J.O.9

Employee Name: _____

Week: _____

Day	Date	Time		Total Hrs Worked	Unit#		Total Miles	Equip# <u>DD11</u>		Total Equip Hrs	Fuel	Job description
		in	out		beg.	end		beg.	end			
Monday	5-7-12	7:00	5:50	10				5421.8	5438.9	7.1	40	Spread dirt
Tuesday	5-8-12	7:00	5:30	10				5435.7	5438.9	8.8		
Wednesday	5-9-12	7:00	5:30	10				5448.2	5448.2	8.8	40	111
Thursday												
Friday												
Saturday												
Sunday												
		Employee Hrs. <u>30</u>		Equip. Miles		Equip. Hrs <u>24.4</u>		Fuel Used <u>800</u>				

Employee's signature: [Signature]

Employee's signature: _____

Project supervisor: [Signature]

Project supervisor: _____

Date: _____

Date: _____

Date: 5/14/12

HIDALGO COUNTY PRECINCT #4

DRAINAGE IMPROVEMENT PROJECT

Work Log

Employee Name: Rose L. Harris

Employee Name: _____

Project Name: 209

Project Name: _____

Week: _____

Day	Date	Time		Total Hrs Worked	Unit#	Total Miles	Equip#		Total Equip Hrs	Fuel	Job description	
		in	out				beg.	end				
Monday	5-2-12	7:00	5:30	10	71595	50	beg.	end			Hauling Dirt	
		7:00	5:30	10	71645	50	beg.	end			Hauling Dirt	
		7:00	5:30	10	71695	47	beg.	end			Hauling Dirt	
Wednesday	5-9-12	7:00	5:30	10	71745	47	beg.	end			Hauling Dirt	
Thursday							beg.	end				
Friday							beg.	end				
Saturday							beg.	end				
Sunday							beg.	end				
		Employee Hrs.		30	Equip. Miles		147		Equip. Hrs		Fuel Used	43.0

Employee's signature: Rose L. Harris

Employee's signature: _____

Project supervisor: Henry Anthony

Project supervisor: _____

Date: 5-9-12

Date: _____

Date: 5/24/12

Date: _____

HIDALGO COUNTY PRECINCT #4

DRAINAGE IMPROVEMENT PROJECT

Work Log

Employee Name: Erinno Garza

Employee Name: Mark Trevino

Project Name: 509

Week: _____

Day	Date	Time		Total Hrs Worked	Unit#	Total Miles	Equip#		Total Equip Hrs	Fuel	Job description
		in	out				beg.	end			
MOG	5-9-12	in	7:00		15	49	beg.	end			Hauling Dirt
		out	5:30		68686		end				
OT	5-8-12	in	7:00	14.15	68735	48	beg.	end			Hauling Dirt
		out	5:30		68783		end				
OT	5-9-12	in	7:00	14.15	68827	44	beg.	end		48.15	Hauling Dirt
		out	5:30				end				
Thursday		in	:				beg.	end			
		out	:				end				
Friday		in	:				beg.	end			
		out	:				end				
Saturday		in	:				beg.	end			
		out	:				end				
Sunday		in	:				beg.	end			
		out	:				end				
		Employee Hrs.		20	Equip. Miles		144	Equip. Hrs		Fuel Used	48.0

Employee's signature: Erinno Garza

Employee's signature: Mark Trevino

Project supervisor: Jimmy Anthony

Date: 5-9-12

Date: 5-8-12

Date: 5/14/12

**HIDALGO COUNTY PRECINCT #4
DRAINAGE IMPROVEMENT PROJECT**

Work Log

Employee Name: Sylvestre Botello

Employee Name: _____

Project Name: 509 project

Week: _____

Day	Date	Time		Total Hrs Worked	Unit# <u>16</u>		Total Miles	Equip# _____		Total Equip Hrs	Fuel	Job description	
		in	out		beg.	end		beg.	end				
Monday	5-7-12	7:00	5:30	10 1/2	66557	66607	50					Hauling dirt	
Tuesday	5-8-12	7:00	5:30	10 1/2	66607	66655	48					Hauling dirt	
Wednesday	5-9-12	7:00	5:30	10 1/2	66655	66703	48				47	Fueling dirt Fuel lights no working	
Thursday													
Friday													
Saturday													
Sunday													
				<u>31</u>	<u>146.2</u>			<u>47</u>					

Employee Hrs. 31
Equip. Miles 146.2

Equip. Hrs _____

Fuel Used 47

Employee's signature: [Signature]

Employee's signature: _____

Date: 5-9-12

Date: _____

Project supervisor: [Signature]

Date: 5/14/12

Date: _____

HIDALGO COUNTY PRECINCT #4

DRAINAGE IMPROVEMENT PROJECT

Work Log

Employee Name: Oscar Pineda
 Employee Name: Olivera, Oscar

Project Name: TD9

Week: _____

Day	Date	Time		Total Hrs Worked	Unit# PD17		Total Miles	Equip#		Total Equip Hrs	Fuel	Job description
		In	Out		beg.	end		beg.	end			
Monday	5-7-12	7:00	5:30	10	67893	67944	51					Hauling Dirt
Tuesday	5-8-12	7:00	5:30	10	67944	67993	49				29 gal	Hauling Dirt
Wednesday	5-9-12	7:00	5:30	10	67993	68046	53				17 gals	Hauling Dirt
Thursday												
Friday												
Saturday												
Sunday												
		Employee Hrs.		Equip. Miles		Equip. Hrs		Fuel Used				
		30		153				46.0				

Employee's signature: Oscar Pineda

Employee's signature: Olivera, Oscar

Project supervisor: [Signature]

Date: 5-8-12

Date: 5-9-12

Date: 5-11-12

HIDALGO COUNTY PRECINCT #4 DRAINAGE IMPROVEMENT PROJECT

Work Log

Employee Name: M. Rieck

Project Name: J-0-9

Employee Name: _____

Week: _____

Day	Date	Time		Total Hrs Worked	Unit# 173		Total Miles	Equip#		Total Equip Hrs	Fuel	Job description
		In	Out		beg.	end		beg.	end			
Monday	5-7-12	7:00	5:30	10.115	97768	97811	43					Handling Dirt
Tuesday												
Wednesday	5-9-12	7:00	5:30	10.115	97811	97862	51				27%	Handling Dirt
Thursday												
Friday												
Saturday												
Sunday												
		Employee Hrs.		Equip. Miles		Equip. Hrs		Fuel Used				
		20		94				22.0				

Employee's signature: [Signature]

Employee's signature: _____

Project supervisor: [Signature]

Project supervisor: _____

Date: 5-9-12

Date: _____

Date: 5/14/12

Date: _____

**HIDALGO COUNTY PRECINCT #4
DRAINAGE IMPROVEMENT PROJECT**

Work Log

Employee Name: Ivino Garza

Project Name: 509

Employee Name: _____

Week: _____

Day	Date	Time		Total Hrs Worked	Unit#		Total Miles	Equip# <u>R112</u>		Total Equip Hrs	Fuel	Job description
		in	out		beg.	end		beg.	end			
Monday		in	:		beg.			beg.				
		out	:		end			end				
Tuesday	<u>5-8-12</u>	in	<u>7:00</u>	<u>10</u>	beg.			beg.	<u>5490</u>	<u>9</u>		<u>Remedial Dist</u>
		out	<u>5:30</u>		end			end	<u>5497</u>			
Wednesday		in	:		beg.			beg.				
		out	:		end			end				
Thursday		in	:		beg.			beg.				
		out	:		end			end				
Friday		in	:		beg.			beg.				
		out	:		end			end				
Saturday		in	:		beg.			beg.				
		out	:		end			end				
Sunday		in	:		beg.			beg.				
		out	:		end			end				
		Employee Hrs. <u>10</u>		Equip. Miles <u>7</u>		Equip. Hrs <u>9</u>		Fuel Used <u> </u>				

Employee's signature: Ivino Garza

Date: 5-8-12

Employee's signature: _____

Date: _____

Project supervisor: Jerry Aubrey

Date: 5/14/12

HIDALGO COUNTY PRECINCT #4 DRAINAGE IMPROVEMENT PROJECT

Work Log

Employee Name: 11/11/11 [Signature]

Project Name: 5-0-9

Employee Name: _____

Week: _____

Day	Date	Time		Total Hrs Worked	Unit#		Total Miles	Equip# <u>D13</u>		Total Equip Hrs	Fuel	Job description
		in	out		beg.	end		beg.	end			
Monday												
Tuesday	<u>11/15/11</u>	<u>7:00</u>	<u>3:00</u>	<u>10.00</u>	beg.	end		beg.	end	<u>8</u>	<u>60%</u>	<u>Maintain dirt</u>
Wednesday					beg.	end		beg.	end			
Thursday					beg.	end		beg.	end			
Friday					beg.	end		beg.	end			
Saturday					beg.	end		beg.	end			
Sunday					beg.	end		beg.	end			
				<u>10</u>				<u>8</u>			<u>60.0</u>	

Employee Hrs. _____

Equip. Miles _____

Equip. Hrs _____

Fuel Used _____

Employee's signature: [Signature]

Date: 5-8-11

Employee's signature: _____

Date: _____

Project supervisor: _____

[Signature]

Date: 5/14/12

HIDALGO COUNTY PRECINCT #4

DRAINAGE IMPROVEMENT PROJECT

Work Log

Employee Name: Harvey Clayton

Project Name: 509

Week: _____

Day	Date	Time		Total Hrs Worked	Unit#		Total Miles	Equip#		Total Equip Hrs	Fuel	Job description
		in	out		beg.	end		beg.	end			
Monday	5/11/12	7:00	7:30	9				4172.6	7.0	60.0	gal	Stopping
Tuesday	5/22/12	7:00	5:30	10				4179.6	7.6	75.0	gal	Stopping
Wednesday	5/23/12	7:00	9:00	10				4187.2	7.2	70.0	gal	Stopping
Thursday								4187.2				Stopping
Friday												
Saturday												
Sunday												
				19				1406	205			

Employee's signature: Harvey Clayton

Employee's signature: _____

Project supervisor: Lawrence Anthony

Date: 5/25/12

Date: 5/30/12

HIDALGO COUNTY PRECINCT #4 DRAINAGE IMPROVEMENT PROJECT

Work Log

Employee Name: Robert Martinez

Project Name: 709

Employee Name:

Week:

Day	Date	Time		Total Hrs Worked	Unit#		Total Miles	Equip. # <u>Rx 30</u>		Total Equip Hrs	Fuel	Job description	
		in	out		beg.	end		beg.	end				
Monday		in	out		beg.	end		beg.	end				
Tuesday		in	out		beg.	end		beg.	end				
Wednesday		in	out		beg.	end		beg.	end				
Thursday		in	out		beg.	end		beg.	end				
Friday	5/25/12	in	out	16	beg.	end		beg.	end	8.3 hrs		Stoping	
Saturday	5/26/12	in	out	10	beg.	end		beg.	end	8.9 hrs	95% gal	Leading trucks	
Sunday	5/27/12	in	out	5	beg.	end		beg.	end	7.4 hrs	60% gal		
		Employee Hrs.		30	Equip. Miles			Equip. Hrs		29.6	Fuel Used		155

Employee's signature: 

Employee's signature:

Project supervisor: 

Date: 5/27/12

Date: 5/30/12

HIDALGO COUNTY PRECINCT #4
DRAINAGE IMPROVEMENT PROJECT

Work Log

Employee Name:

Luis Galva

Employee Name:

James Moore

Project Name:

Job 2

Week:

Day	Date	Time		Total Hrs Worked	Unit#	Total Miles	Equip#		Total Equip Hrs	Fuel	Job description	
		in	out				beg.	end				
Monday	5-21-12	7:00	5:30	10			5446.4	5451.7	4.9		Fill in pond	
Tuesday	5-22-12	7:00	4:30	9.5			5451.7	5459.6	8	15		
Wednesday	5-23-12	7:00	5:30	10			5463.7	5473.0	6.1	40		
Thursday	5-24-12	7:00	5:30	10			5473.0	5481.6	7.3			
Friday	5-25-12	7:00	5:30	10			5481.6	5489.7	8.6	44		
Saturday	5-26-12	7:00	5:30	10			5489.7	5496.9	8.1			
Sunday	5-27-12	7:00	5:30	10			5496.9		7.2			
				69.5	Employee Hrs.		50.2		Equip. Miles		99	Fuel Used

Employee's signature:

[Signature]

Employee's signature:

[Signature]

Project supervisor:

[Signature]

Date:

5-23-12

Date:

5-27-12

Date:

5/30/12



GEORGEY GARZA, JR.
MANAGER

902 NORTH DOOLITTLE

EDINBURG, TEXAS 70542

(956) 292-7080

FAX (956) 292-7089

Work Log

EMPLOYEE NAME

Harley Clapp

PROJECT NAME

Soq

DAY	DATE MM/DD	TIME		TOTAL HRS WORKED	UNIT #		FUEL TOTAL MILES	EQUIP #		TOTAL EQUIP HRS	JOB DESCRIPTION
		IN	OUT		BEG.	END		BEG.	END		
MONDAY											
TUESDAY											
WEDNESDAY	5/23/12	IN	7:00	10			40.0	28370	6.5		Stopping
THURSDAY	5/24/12	IN	7:00	10			50.0	2843.5	7.1		Stop at Center
FRIDAY											
SATURDAY											
SUNDAY											

EMPLOYEE'S SIGNATURE

Harley Clapp

DATE *5/24/12*

IMMEDIATE SUPERVISOR

Georgey Garza

DATE *5/31/12*

Employee Has *20*

Equipment Has *14.2*

FUEL Used *90.0*

HIDALGO COUNTY PRECINCT #4

DRAINAGE IMPROVEMENT PROJECT

Work Log

Employee Name: Sylvestre Barillo

Project Name: 709

Employee Name: _____

Week: _____

Day	Date	Time		Total Hrs Worked	Unit# <u>23</u>		Total Miles	Equip#		Total Equip Hrs	Fuel	Job description	
		in	out		beg.	end		beg.	end				
Monday		in	:		beg.			beg.					
		out	:		end			end					
Tuesday	<u>5-22-12</u>	in	<u>10:15</u>		beg.			beg.					
		out	<u>5:30</u>	<u>7 Hrs</u>	end	<u>97863</u>	<u>38</u>	end			<u>10.0</u>	<u>Hauling Dirt</u>	
Wednesday		in	:		beg.			beg.					
		out	:		end			end					
Thursday		in	:		beg.			beg.					
		out	:		end			end					
Friday		in	:		beg.			beg.					
		out	:		end			end					
Saturday		in	:		beg.			beg.					
		out	:		end			end					
Sunday		in	:		beg.			beg.					
		out	:		end			end					
Employee Hrs.				<u>7</u>	Equip. Miles				<u>38</u>	Equip. Hrs		Fuel Used	<u>10</u>

Employee's signature: _____

Employee's signature: _____

Project supervisor: _____

Date: _____

Date: _____

Date: 5/30/12

HIDALGO COUNTY PRECINCT #4 DRAINAGE IMPROVEMENT PROJECT Work Log

Work Log

Employee Name: Melvin GERRARD

Project Name: J-0-9

Employee Name: [Signature]

Week: _____

Day	Date	Time		Total Hrs Worked	Unit# <u>74</u>		Total Miles	Equip# _____		Total Equip Hrs	Fuel	Job description	
		in	out		beg.	end		beg.	end				
Monday	5/21/12	7:00	4:30	9 hrs	19768	19806	41					Mowing dirt	
Tuesday	5/22/12	7:00	4:00	10 hrs	19806	19851	45					Mowing dirt	
Wednesday	5/23/12	7:00	5:30	10 hrs	19851	19856	55					Mowing dirt	
Thursday	5/24/12	7:00	5:30	10 hrs	19856	19932	76					Mowing dirt	
Friday	5/25/12	7:00	5:30	10 hrs	19932	19967	35					Mowing dirt	
Saturday	5/26/12	7:00	5:30	10	19967	20010	43					Mowing dirt	
Sunday													
				59	245			Equip. Hrs			71	Fuel Used	

Employee's signature: [Signature]

Employee's signature: [Signature]

Project supervisor: [Signature]

Date: 5/24/12

Date: 5/27/12

Date: 5/30/12

HIDALGO COUNTY PRECINCT #4 DRAINAGE IMPROVEMENT PROJECT

Work Log

Employee Name: Rose L Connor
 Employee Name: Teresa Marrero

Project Name: 209

Week: _____

Day	Date	Time		Total Hrs Worked	Unit# <u>DD14</u>		Total Miles	Equip# _____		Total Equip Hrs	Fuel	Job description	
		in	out		beg.	end		beg.	end				
Monday	5-21-12	7:00	4:20	9	71743	71784	41					Hauling Dirt	
Tuesday	5-22-12	7:00	5:30	10	71782	71829	45					Hauling Dirt	
Wednesday	5-23-12	7:00	5:30	10	71867	71829	33				38	Hauling Dirt	
Thursday	5-24-12	7:00	5:30	10	71867	71867	58					Hauling Dirt	
Friday	5-25-12	7:00	5:30	10	71925	71925	36					Hauling Dirt	
Saturday	5-26-12	7:00	5:30	10	71961	71961	48					Hauling Dirt	
Sunday	5-27-12	7:00	5:30	10	72009	72063	54					53	Hauling Dirt
				69	320			Equip. Hrs			91		

Employee Hrs. **69**

Equip. Miles **320**

Equip. Hrs _____

Fuel Used **91**

Employee's signature: Rose L Connor

Employee's signature: Teresa Marrero

Project supervisor: Francis Kelly

Date: 5-23-12

Date: 5-27-12

Date: 5/30/12

HIDALGO COUNTY PRECINCT #4 DRAINAGE IMPROVEMENT PROJECT

Work Log

Employee Name: Israel Rodriguez

Project Name: 709

Employee Name: Israel Rodriguez

Week: _____

Day	Date	Time		Total Hrs Worked	Unit# <u>PD15</u>		Total Miles	Equip# _____		Total Equip Hrs	Fuel	Job description
		In	Out		beg.	end		beg.	end			
Monday	5-21-12	8:30	4:30	7.5	68945	68985	42					Hauling Dirt
Tuesday	5-22-12	7:00	5:30	10	68985	69030	45					Hauling Dirt
Wednesday	5-23-12	7:00	5:30	7	69030	69050	36				419 lbs	Hauling Dirt
Thursday	5-24-12	7:00	5:30	10	69050	69066	43					Hauling Dirt
Friday	5-25-12	7:00	5:30	10	69066	69109	35					Hauling Dirt
Saturday	5-26-12	7:00	5:30	10	69109	69144	47					Hauling Dirt
Sunday	5-27-12	7:00	5:30	10	69144	69242	51				519 lbs	Hauling Dirt
				64.5	799						92	

Employee Hrs. **64.5**

Equip. Miles **799**

Equip. Hrs _____

Fuel Used **92**

Employee's signature: Israel Rodriguez

Employee's signature: Israel Rodriguez

Project supervisor: Israel Rodriguez

Date: 5-27-12

Date: 5-27-12

Date: 5/31/12

**HIDALGO COUNTY PRECINCT #4
DRAINAGE IMPROVEMENT PROJECT
Work Log**

Employee Name: Alester Borillo

Employee Name: Key Molina

Project Name: 709

Week: _____

Day	Date	Time		Total Hrs Worked	Unit# <u>16</u>		Total Miles	Equip#		Total Equip Hrs	Fuel	Job description
		in	out		beg.	end		beg.	end			
Monday ^{5/8}	5-21-12	7:00	4:30	9	66703		39					Hauling Dirt
Tuesday ^{5/8}	5-22-12	:	:		66742							Truck IN The Shop
Wednesday ^{5/8}	5-23-12	7:00	5:30	10 1/2	66742		40					Hauling Dirt
Thursday ^{5/8}	5-24-12	7:00	5:30	10 1/2	66837		38					Hauling Dirt
Friday ^{5/8}	5-25-12	7:00	5:30	10	66837		50					Hauling Dirt
Saturday ^{5/8}	5-26-12	7:00	5:30	10	66874		51					Hauling Dirt
Sunday ^{5/8}	5-27-12	7:00	5:30	10	66924							Hauling Dirt
				59	225					79		

Employee's signature: [Signature]

Employee's signature: [Signature]

Project supervisor: [Signature]

Date: 5/24/12

Date: 5/27/12

Date: 5/30/12

HIDALGO COUNTY PRECINCT #4 DRAINAGE IMPROVEMENT PROJECT Work Log

Employee Name: OsCar Pineda Gutierrez
 Employee Name: Lupe Navarro

Project Name: 209
 Week: _____

Day	Date	Time		Total Hrs Worked	Unit# <u>PD17</u>		Total Miles	Equip#		Total Equip Hrs	Fuel	Job description	
		In	Out		beg.	end		beg.	end				
Monday	5-21-12	7:00	4:30	9	68153	68195	42					Hauling Dirt	
Tuesday	5-22-12	7:00	5:30	10	68195	68241	46					Hauling Dirt	
Wednesday	5-23-12	7:00	5:30	10	68241	68279	38				37 gal	Hauling Dirt	
Thursday	5-24-12	7:00	5:30	10	68279	68325	46					Hauling Dirt	
Friday	5-25-12	7:00	5:30	10	68325	68364	40				24 gal	Hauling Dirt	
Saturday	5-26-12	7:00	5:30	10	68364	68413	48					Hauling Dirt	
Sunday	5-27-12	7:00	5:30	8	68413	68456	43				29 gal	Hauling Dirt	
Employee Hrs.				67	Equip. Miles				303	Equip. Hrs		90	Fuel Used

Employee's signature: [Signature]

Employee's signature: [Signature]

Project supervisor: [Signature]

Date: 5-24-12

Date: 5-29-12

Date: 5/30/12

HIDALGO COUNTY PRECINCT #4 DRAINAGE IMPROVEMENT PROJECT Work Log

Employee Name: Itineo Garza
Employee Name: Jose C Sanchez

Project Name: 509
Week: _____

Day	Date	Time		Total Hrs Worked	Unit# <u>311</u>		Total Miles	Equip# _____		Total Equip Hrs	Fuel	Job description
		in	out		beg.	end		beg.	end			
Monday	5-21-12	7:00	9:30	9	218457	218500	43					Handing Dirt
Tuesday	5-22-12	7:00	5:30	10	218500	218518	48					Handing Dirt
Wednesday	5-23-12	7:00	5:30	10	218518	218589	41				4 gals	Handing Dirt
Thursday	5/24/12	2:00	5:30	3 1/2	218734	218763	29				23 gals	Handing Dirt
Friday	5-25-12	7:00	5:30	10	218763	218799	36					Handing Dirt
Saturday	5-26-12	7:00	5:30	11	218799	218846	47				26	Handing Dirt
Sunday												

Employee Hrs. 52.5 Equip. Miles 244 Equip. Hrs _____ Fuel Used 90

Employee's signature: [Signature] Date: 5-23-12
 Employee's signature: [Signature] Date: 5-26-12
 Project supervisor: [Signature] Date: 5/30/12

HIDALGO COUNTY PRECINCT #4
DRAINAGE IMPROVEMENT PROJECT
 Work Log

Employee Name: Harvey Clayton
 Employee Name: Debbie Martinez

Project Name: J08

Week: _____

Day	Date	Time		Total Hrs Worked	Unit#		Total Miles	Equip#		Total Equip Hrs	Fuel	Job description	
		in	out		beg.	end		beg.	end				beg.
Monday	5/28	in	:		beg.	end							
Holiday													
Tuesday	5/29/12	in	7:00	10	beg.	end		4212.0	beg.	7.4 hrs	55.0 gal	Slope	
		out	5:30		end	beg.		4219.4	end	8.3 hrs	50.0 gal	Slope	
Wednesday	5/30/12	in	7:00	10	beg.	end		4219.4	beg.	8.3 hrs	50.0 gal	Slope	
		out	5:30		end	beg.		4227.7	end	hrs			
Thursday	5/31/12	in	7:00	10	beg.	end		4227.7	beg.	8.1 hrs	51.0 gal	Load Topsoil	
		out	5:30		end	beg.		4235.8	end	hrs			
Friday	6/1/12	in	7:00	10	beg.	end		4235.8	beg.	8.6 hrs	50.0 gal	Load Topsoil	
		out	5:30		end	beg.		4244.4	end	hrs			
Saturday	6/2/12	in	7:00	10	beg.	end		4244.4	beg.	7.9 hrs	72.0 gal	Load Topsoil	
		out	5:30		end	beg.		4252.3	end	hrs			
Sunday	6/3/12	in	7:00	10	beg.	end		4252.3	beg.	8.7 hrs	50.0 gal	Sloping	
		out	5:30		end	beg.		4261.0	end	hrs			
Employee Hrs: <u>60</u>				Equip. Miles				Equip. Hrs: <u>99</u>				Fuel Used: <u>328</u>	

Employee's signature: Harvey Clayton
 Employee's signature: Debbie Martinez
 Project supervisor: Harvey Clayton

Date: 5/30/12
 Date: 6/2/12
 Date: 6/4/12

**HIDALGO COUNTY PRECINCT #4
DRAINAGE IMPROVEMENT PROJECT
Work Log**

Employee Name: Chris Govea

Project Name: J.O.P

Employee Name: _____

Week: _____

Day	Date	Time		Total Hrs Worked	Unit#		Total Miles	Equip#		Total Equip Hrs	Fuel	Job description	
		in	out		beg.	end		beg.	end				beg.
Monday		:	:										
Tuesday	5/29/12	7:00	8:30	10				5497	5402.4	5.4	50 gal		
Wednesday	5/30/12	7:00	8:30	10				5402.4	8.7				
Thursday	5/31/12	5:40	7:00	10				5510.5	6.6				
Friday		:	:										
Saturday		:	:										
Sunday		:	:										
				30	Equip. Miles			Equip. Hrs		20.9	Fuel Used		50

Employee's signature: _____

Chris Govea

Employee's signature: _____

James Anthony

Project supervisor: _____

Date: 5-30-12

Date: _____

Date: 5/31/12

HIDALGO COUNTY PRECINCT #4 DRAINAGE IMPROVEMENT PROJECT

Work Log

Employee Name: James Moore

Employee Name: _____

Project Name: 509

Week: 6-1 - 6-3

Day	Date	Time		Total Hrs Worked	Unit#		Total Miles	Equip# <u>PA #11</u>		Total Equip Hrs	Fuel	Job description	
		in	out		beg.	end		beg.	end				
Monday		in	out		beg.	end		beg.	end				
Tuesday		in	out		beg.	end		beg.	end				
Wednesday		in	out		beg.	end		beg.	end				
Thursday		in	out		beg.	end		beg.	end				
Friday	6-1	in	out	6	beg.	end		5516.2	5.1	30%		509	
Saturday		in	out		beg.	end		5520.3					
Sunday	6-3	in	out	10	beg.	end		5510.3	8.5	20%		509	
		in	out		beg.	end		5528.8					
Employee Hrs.				16	Equip. Miles			Equip. Hrs		13.6	Fuel Used		50

Employee's signature: James Moore

Employee's signature: _____

Date: 6/2/12

Date: _____

Project supervisor: _____

[Signature]

Date: 6/2/12

Date: _____

HIDALGO COUNTY PRECINCT #4 DRAINAGE IMPROVEMENT PROJECT

Work Log

Employee Name: Jose L. Garcia

Employee Name: Jose Moreno

Project Name: Top

Week: _____

Day	Date	Time		Total Hrs Worked	Unit# <u>DD14</u>		Total Miles	Equip#		Total Equip Hrs	Fuel	Job description
		in	out		beg.	end		beg.	end			
Monday		in	out		beg.	end		beg.	end			
<u>16</u> Tuesday	5-29-12	in	out	10	72063		58	beg.	end			Harling Dist
<u>16</u> Wednesday	5-30-12	in	out	10	72121		55	beg.	end		5-31-12 32 gm 1	Harling Dist
Thursday		in	out		72121			beg.	end			
Friday	6-1-12	in	out	5	72385		40	beg.	end			Harling Dist
Saturday	6-2-12	in	out	10	72425		51	beg.	end			Harling Dist
Sunday	6-3-12	in	out	10	72476		43	beg.	end			Harling Dist
		in	out		72496			beg.	end			
		in	out		72519			beg.	end			
				Employee Hrs.	Equip. Miles		Equip. Hrs		Fuel Used			
				45	297				69			

Employee's signature: Jose L. Garcia

Employee's signature: Jose Moreno

Project supervisor: Jose L. Garcia

Date: 5-31-12

Date: 6-3-12

Date: 6/4/12

HIDALGO COUNTY PRECINCT #4 DRAINAGE IMPROVEMENT PROJECT Work Log

Employee Name: Isracl Rodriguez

Project Name: 509

Week: _____

Day	Date	Time		Total Hrs Worked	Unit# <u>DD15</u>		Total Miles	Equip# _____		Total Equip Hrs	Fuel	Job description
		in	out		beg. end	beg. end						
Monday		in	out									
OT Tuesday	5/29/12	in	out	10 hrs	beg. 692442	end 693002	60	beg. end				Hauling Dirt
OT Wednesday	5/31/12	in	out	10 hrs	beg. 693002	end 693558	56	beg. end				Hauling Dirt
OT Thursday	6/1/12	in	out								35 gals	
Friday	6-1-12	in	out	12:30	beg. 69575	end 69616	41	beg. end				Hauling Dirt
OT Saturday	6-2-12	in	out	7:00	beg. 69616	end 69665	49	beg. end				Hauling Dirt
OT Sunday	6-3-12	in	out	7:00	beg. 69665	end 69710	45	beg. end			34 gals	Hauling Dirt
		Employee Hrs.		45	Equip. Miles		251	Equip. Hrs			Fuel Used	69

Employee's signature: _____

Employee's signature: _____

Project supervisor: _____

Date: _____
Date: 6-3-12
Date: 6/4/12

**HIDALGO COUNTY PRECINCT #4
DRAINAGE IMPROVEMENT PROJECT
Work Log**

Employee Name: Syvestre Botello
 Employee Name: Regy Malina

Project Name: 509

Week: _____

Day	Date	Time		Total Hrs Worked	Unit#	Total Miles	Equip#		Total Equip Hrs	Fuel	Job description			
		in	out				beg.	end.						
Monday SB	5-29-12	7:00	5:30	10 hrs	66975	56	beg.	end.	39.0		Hauling Dirt			
Tuesday SB	5-30-12	7:00	5:30	10 hrs	67033	53	beg.	end.			Hauling Dirt			
Wednesday					67086		beg.	end.						
Thursday							beg.	end.						
Friday M	6-1-12	7:30	7:30	5	67198	41	beg.	end.			Hauling Dirt			
Saturday Rm	6/2/12	7:00	5:30	10	67217	49	beg.	end.			Hauling Dirt			
Sunday Rm	6/3/12	7:00	5:30	10	67266	46	beg.	end.			Hauling Dirt			
					67312		beg.	end.						
Employee Hrs.				<u>45</u>	Equip. Miles				<u>245</u>	Equip. Hrs		<u>74</u>	Fuel Used	<u>35</u>

Employee's signature: _____

Employee's signature: _____

Project supervisor: _____

Date: 5/31/12

Date: 6/3/12

Date: 6/4/12

HIDALGO COUNTY PRECINCT #4

DRAINAGE IMPROVEMENT PROJECT

Work Log

Employee Name: Oscar Pineda
 Employee Name: Sup - Navarro

Project Name: 509

Week: _____

Day	Date	Time		Total Hrs Worked	Unit# <u>PD17</u>		Total Miles	Equip# _____		Total Equip Hrs	Fuel	Job description
		in	out		beg.	end		beg.	end			
Monday												
Tuesday <u>DP</u>	5-29-12	in 7:00	out 5:30	10	beg. 68456	end 68517	61	beg.	end			Hauling Dirt
Wednesday <u>DP</u>	5-30-12	in 7:00	out 5:30	10	beg. 68517	end 68577	60	beg.	end		5-31-12 37 gal	Hauling Dirt
Thursday												
Friday												
Saturday <u>W</u>	6-2-12	in 7:00	out 5:30	10	beg. 68792	end 68843	51	beg.	end			Hauling Dirt
Sunday <u>W</u>	6-3-12	in 7:00	out 5:30	10	beg. 68843	end 68899	46	beg.	end		45 gal	Hauling Dirt
		Employee Hrs. <u>40</u>		Equip. Miles <u>218</u>		Equip. Hrs _____		Fuel Used <u>82</u>				

Employee's signature: Oscar Pineda

Employee's signature: [Signature]

Project supervisor: [Signature]

Date: 5-30-12

Date: _____

Date: 6/4/12

HIDALGO COUNTY PRECINCT #4 DRAINAGE IMPROVEMENT PROJECT

Work Log

Employee Name: NCO Garza

Project Name: 509

Week: _____

Day	Date	Time		Total Hrs Worked	Unit# PD12		Total Miles	Equip#		Total Equip Hrs	Fuel	Job description
		in	out		beg.	end.		beg.	end.			
Monday		in	:		beg.			beg.				
		out	:		end.			end.				
<u>NG</u>	<u>5-29-12</u>	in	<u>7:00</u>	<u>10</u>	beg.	<u>SS02</u>	<u>3</u>	beg.			<u>45gals</u>	<u>Pumping Water</u>
		out	<u>5:30</u>		end.	<u>SS05</u>		end.				
<u>NG</u>	<u>5-30-12</u>	in	<u>7:00</u>	<u>10</u>	beg.	<u>SS05</u>	<u>7</u>	beg.			<u>50gals</u>	<u>Mowing Dirt</u>
		out	<u>5:30</u>		end.	<u>SS12</u>		end.				
<u>NG</u>	<u>5-31-12</u>	in	<u>7:00</u>	<u>10</u>	beg.	<u>SS12</u>	<u>8</u>	beg.			<u>50gals</u>	<u>Mowing Dirt</u>
		out	<u>5:30</u>		end.	<u>SS20</u>		end.				
Friday		in	:		beg.			beg.				
		out	:		end.			end.				
Saturday		in	:		beg.			beg.				
		out	:		end.			end.				
Sunday		in	:		beg.			beg.				
		out	:		end.			end.				
				Employee Hrs.	Equip. Miles				Equip. Hrs		Fuel Used	
				<u>30</u>	<u>18</u>				<u>145</u>			

Employee's signature: James Ortega

Employee's signature: _____

Project supervisor: James Ortega

Project supervisor: _____

Date: 5-31-12

Date: _____

Date: 6/4/12

Date: _____

HIDALGO COUNTY PRECINCT #4 DRAINAGE IMPROVEMENT PROJECT Work Log

Employee Name: William Garcia

Project Name: San Joaquin

Employee Name: _____

Week: _____

Day	Date	Time		Total Hrs Worked	Unit# <u>11112</u>		Total Miles	Equip# _____		Total Equip Hrs	Fuel	Job description
		in	out		beg.	end		beg.	end			
Monday		in	:		beg.			beg.				
		out	:		end			end				
Tuesday	6/27/12	in	7:20	10 hrs	beg.	4499	4 hrs	beg.			50%	Manholes to be dug
		out	8:30		end	4789		end				
Wednesday	6/28/12	in	7:00	10 hrs	beg.	4789	7 hrs	beg.				Manholes dug
		out	5:30		end	4789		end				
Thursday	6/28/12	in	7:00	10	beg.	4789	7 hrs	beg.			50%	Manholes dug
		out	5:30		end	4789		end				
Friday		in	:		beg.			beg.				
		out	:		end			end				
Saturday		in	:		beg.			beg.				
		out	:		end			end				
Sunday		in	:		beg.			beg.				
		out	:		end			end				
				Employee Hrs.	Equip. Miles		Equip. Hrs		Fuel Used			
				30	20				104			

Employee's signature: William Garcia

Employee's signature: _____

Project supervisor: Jenny Shady

Date: 6/28/12
Date: 6/4/12

**DRAINAGE IMPROVEMENT PROJECT
MONTHLY FUEL USAGE DISTRIBUTION**

EQUIPMENT TYPE: PD # 8 2008 CAT. 330DL. EXCAVATOR

PRECINCT NO.: 4

ASSET NUMBER: 48423

FUEL TYPE: Off Road
Diesel

EMPLOYEE(S) NAME: BENITO VASQUEZ

EMPLOYEE(S) NUMBER: 171018

FUEL USAGE							
DATE	TRANSFER TANK	MILEAGE/HOURS	Dickerson Pond	North Branch Drain	J O 9 Project	TOTAL	OPERATOR INITIAL
5-1-12		2806.2				-	B, B, V
5-2-12		2814.3				-	B, B, V
5-3-12	PD # 2	2822.2				-	B, B, V
5-8-12		2829.5				-	FA
5-23-12	PD 6	2840.0			✓	40.0	HBC
5-24-12	PD 2	2843.5			✓	50.0	HBC
5-27-12	PD 5	2851.5			✓	32.0	RR
5-29-12	PD # 5	2854.4			✓	50.0	FA
5-30-12	PD # 5	2862.0			✓	30.0	FA
6-3-12	PD # 2	2873.6			✓	50 2/3	RR
						-	
						-	
						-	
						-	
						-	
						-	
						-	
						-	
						-	
						-	
						-	
						-	
						-	
						-	
						-	
						-	
						-	
						-	
						-	
						-	
TOTAL GALLONS USED	-	-	-	-	-	-	

SUPERVISOR SIGNATURE: _____ DATE: _____

DRAINAGE IMPROVEMENT PROJECT

MONTHLY FUEL USAGE DISTRIBUTION

EQUIPMENT TYPE: PD # 11 2008 CAT. D6N DOZER

PRECINCT NO.: 4

ASSET NUMBER: 48762

FUEL TYPE: Off Road
Diesel

EMPLOYEE(S) NAME: LUIS GOVEA
JAMES MOORE

EMPLOYEE(S) NUMBER: 173681
170992

FUEL USAGE

DATE	TRANSFER TANK	MILEAGE/HOURS	Dickerson Pond		J O 9 Project	TOTAL	OPERATOR INITIAL
5-7-12	PD 5	5421			☒	40.	LG
5-22-12	PD 7	5452.4				15.0	LM
5-23-12	PD 6	5461.2				40.	LM
5-26-12	PD 2	5482.3			✓	44.0	J.M
	PD 6	5491.0				20.	LM
TOTAL GALLONS USED	-	-	-	-	-	-	

SUPERVISOR SIGNATURE: _____

DATE: _____

DRAINAGE IMPROVEMENT PROJECT MONTHLY FUEL USAGE DISTRIBUTION

EQUIPMENT TYPE: PD # 12 2008 VOLVO T450 SCRAPER

PRECINCT NO.: 4

ASSET NUMBER: 49052

FUEL TYPE: Off Road
Diesel

EMPLOYEE(S) NAME: _____

EMPLOYEE(S) NUMBER: _____

Irineo Garza

181064

Jose Sanchez

182001

FUEL USAGE							
DATE	TRANSFER TANK	MILEAGE/HOURS	Dickerson Pond	HCDD # 1 JO9	JO9	TOTAL	OPERATOR INITIAL
5-4-12	PD 2	5487	✓			89	NG
5-29-12	PD 5	5503			✓	45	NG
5-30-12	PD 2	5508			✓	50	NG
TOTAL GALLONS USED	-	-	-	-	-	-	-

SUPERVISOR SIGNATURE: _____ DATE: _____

FORM DP-2009-003

DRAINAGE IMPROVEMENT PROJECT MONTHLY FUEL USAGE DISTRIBUTION

EQUIPMENT TYPE: PD # 13 2008 VOLVO T450 SCRAPER

PRECINCT NO.: 4

ASSET NUMBER: 49051

FUEL TYPE: Off Road
Diesel

EMPLOYEE(S) NAME: _____

EMPLOYEE(S) NUMBER: _____

Raquel Rios

174815

Mauricio Guerra

173975

FUEL USAGE							
DATE	TRANSFER TANK	MILEAGE/HOURS	Dickerson Pond		JO 9 Project	TOTAL	OPERATOR INITIAL
8-8-12	PD 5	1690			✓	60 1/2	M.G.
8-27-12	PD 5	1700			✓	52 1/2	M.G.
8-31-12	PD 6	1710			✓	54 1/2	M.G.
						-	
						-	
						-	
						-	
						-	
						-	
						-	
						-	
						-	
						-	
						-	
						-	
						-	
						-	
						-	
						-	
						-	
						-	
						-	
						-	
						-	
						-	
						-	
TOTAL GALLONS USED	-	-	-	-	-	-	

SUPERVISOR SIGNATURE: _____ DATE: _____

DRAINAGE IMPROVEMENT PROJECT MONTHLY FUEL USAGE DISTRIBUTION

EQUIPMENT TYPE: PD # 14 340 PETERBUILT DUMP TRK.

PRECINCT NO.: 4

ASSET NUMBER: 49190

FUEL TYPE: ON Road

EMPLOYEE(S) NAME: JOSE LUIS GRACIA

EMPLOYEE(S) NUMBER: 173975

JOE MORENO

Diesel

174785

FUEL USAGE							
DATE	POND/PCT. 4	MILEAGE/HOURS	Dickerson Pond		J O 9 Project	TOTAL	OPERATOR INITIAL
5-5-12		71518				2 gal -	JL
5-6-12		71595			✓	20 gal -	JL
5-9-12		71742			✓	4 gal -	JL
5-24-12		71867			✓	50 gal	JM
5-27-12		72063			✓	53 -	
5-31-12		72176			✓	32 -	JL
5-31-12	✓	72276				15 gal	JL
TOTAL GALLONS USED	-	-	-	-	-	-	

SUPERVISOR SIGNATURE: _____ DATE: _____

DRAINAGE IMPROVEMENT PROJECT MONTHLY FUEL USAGE DISTRIBUTION

EQUIPMENT TYPE: PD # 16 340 PETERBUILT DUMP TRK.

PRECINCT NO.: 4

ASSET NUMBER: 49192

FUEL TYPE: On Road

Diesel

EMPLOYEE(S) NAME: REYNALDO MOLINA

EMPLOYEE(S) NUMBER: 173983

SYLVESTRE BETELLO

174173

FUEL USAGE							
DATE	POND/PCT.4	MILEAGE/HOURS	Dickerson Pond		J O 9 Project	TOTAL	OPERATOR INITIAL
5/1/12		65982	✓			36-	RM
5/2/12		66205	✓			34-	RM
5/3/12		66381	✓			29-	RM
5/4/12		66444	✓		✓	12 g/g	SB
5/5/12		66479	✓		✓	12 g/g	SB
5/6/12		66547	✓		✓	49	SB
5/7/12		66705	✓		✓	39	SB
5/29/12		66837			✓	40-	RM
5/27/12		66975			✓	20-	IL
5-31-12	✓	67128					
TOTAL GALLONS USED	-	-	-	-	-	-	

SUPERVISOR SIGNATURE: _____ DATE: _____

DRAINAGE IMPROVEMENT PROJECT

MONTHLY FUEL USAGE DISTRIBUTION

EQUIPMENT TYPE: PD # 17 340 PETERBUILT DUMP TRK.

PRECINCT NO.: 4

ASSET NUMBER: 49193

FUEL TYPE: On Road

EMPLOYEE(S) NAME: GUADALUPE NAVARRO

EMPLOYEE(S) NUMBER: 89737

OSCAR GUTIERREZ

Diesel

181072

FUEL USAGE							
DATE	POND/PCT 4	MILEAGE/HOURS	Dickerson Pond		JO 9 Project	TOTAL	OPERATOR INITIAL
5-1-12		67339	✓			33-0	HN
5-2-12		67560	✓			40-0	HN
5-3-12		67721	-			27-0	HN
5-4-12		67779				10-0	OP
5-5-12		67815			✓	11-0	OP
5-6-12		67893			✓	20-0	OP
5-8-12		67993			✓	29-0	OP
5-14-12		68046			✓	12-	WG
5-21-12		68153				20-0	OP
5-23-12		68276			✓	37-0	OP
5-25-12		68364			✓	24-0	HN
5-27-12		68456			✓	29-0	HN
5-31-12		68577			✓	37-0	OP
5-31-12		68682		RET4		19-0	OP
						-	
						-	
						-	
						-	
						-	
						-	
						-	
						-	
						-	
						-	
						-	
						-	
						-	
						-	
						-	
						-	
						-	
						-	
TOTAL GALLONS USED	-	-	-	-	-	-	

SUPERVISOR SIGNATURE: _____ DATE: _____

DRAINAGE IMPROVEMENT PROJECT MONTHLY FUEL USAGE DISTRIBUTION

EQUIPMENT TYPE: EC # 30 VOLVO EXCAVATOR EC 460

HCDD # 1

ASSET NUMBER: 50568

FUEL TYPE: Off Road

Diesel

EMPLOYEE(S) NAME: HARLEY CLAYTON

EMPLOYEE(S) NUMBER: 173657

EDDIE MARTINEZ

173707

FUEL USAGE							
DATE	TRANSFER TANK	MILEAGE/HOURS	Dickerson Pond		J O 9 Project	TOTAL	OPERATOR INITIAL
5/1/12	PD4	4112.1	✓			65.4 ¹⁰	EC
5/2/12	PD4	4121.0	✓			73.0 ¹⁰	EC
5/4/12	PD5	4131.2			✓	80.0	ABL
5/5/12	PD5	4145.2			✓	48.0	ABL
5/7/12	PD5	4149.5			✓	40.0	ABL
5/8/12	PD5	4157.9			✓	34.0	ABL
5/9/12	PD5	4163.2			✓	50.0	ABL
5/21/12	PD3	4172.6			✓	60.0	ABL
5/22/12	PD2	4179.6			✓	75.0	ABL
5/23/12	PD2	4187.2			✓	70.0	ABL
5/26/12	PD5	4195.7			✓	95.0 ¹⁰	EC
5/27/12	PD5	4204.6			✓	60.0 ¹⁰	EC
5/29/12	PD5	4212.0			✓	55.0	ABL
5/30/12	PD5	4219.4			✓	50.0	ABL
5/31/12	PD2	4227.7			✓	51.0	ABL
						.	
						.	
						.	
						.	
						.	
						.	
						.	
						.	
						.	
						.	
						.	
						.	
						.	
						.	
						.	
						.	
						.	
						.	
						.	
						.	
						.	
TOTAL GALLONS USED						-	

SUPERVISOR SIGNATURE: _____ DATE: _____

DRAINAGE IMPROVEMENT PROJECT MONTHLY FUEL USAGE DISTRIBUTION

EQUIPMENT TYPE: 2002 Peterbuilt 330 Dump Truck # 31L

PRECINCT NO.: 4

ASSET NUMBER: 37760

FUEL TYPE: On Road
Diesel

EMPLOYEE(S) NAME: James Garret

EMPLOYEE(S) NUMBER: _____

FUEL USAGE							
DATE	POND/PCT.4	MILEAGE/HOURS	Dickerson Pond		J O 9 Project	TOTAL	OPERATOR INITIAL
5-23-12		218589			✓	41	NG
5/24/12		218734			✓	23	Rm
TOTAL GALLONS USED	-	-	-	-	-	640	

SUPERVISOR SIGNATURE: *James Garret*

DATE: 6-6-12

DRAINAGE IMPROVEMENT PROJECT MONTHLY FUEL USAGE DISTRIBUTION

EQUIPMENT TYPE: 2009 Peterbuilt 340 Dump Truck # 74

PRECINCT NO.: 4

ASSET NUMBER: 47645

FUEL TYPE: On Road Diesel

EMPLOYEE(S) NAME: _____

EMPLOYEE(S) NUMBER: _____

FUEL USAGE

DATE	POND/PCT.4	MILEAGE/HOURS	Dickerson Pond		JO 9 Project	TOTAL	OPERATOR INITIAL
5-6-12		19327			✓	23-	NG
5-23-12		19886			✓	32 1/4	M.G.
5-25-12		19967			✓	24 1/4	IRK
5-29-12		20151			✓	20 1/4	AS
						-	
						-	
						-	
						-	
						-	
						-	
						-	
						-	
						-	
						-	
						-	
						-	
						-	
						-	
						-	
						-	
						-	
						-	
TOTAL GALLONS USED	-	-	-	-	-	77 - 0	

SUPERVISOR SIGNATURE: 

DATE: 6-6-12

DATE: July 03, 1012

2012

Appropriation

DEPARTMENT HEAD: Joseph Palacios, Commissioner Pct. 4

AI# 33218

DEPARTMENT NAME: Pct# 4 - Rd Maintenance

ACCOUNT NUMBER: 2-1200-431-00-124-007-0-XXX
2-1200-431-00-124-036-0-113



Contact Person: Rumaldo Munoz Jr **Ph#:** (956) 383-3112 Ext. 4002

SUBJECT: **Budget Amendments** (increase (decrease)) in accordance with Local Government Code, Chapter 111, § 111.070, Item C (2).

Honorable Commissioners' Court of Hidalgo County:

I would like to request the following Budget Amendments (increase (decrease)) in accordance with Local Government Code, Chapter 111, § 111.070, Item C (2).

INCREASE ACCOUNT NUMBER(S)	ACCOUNT (OBJECT) NAME	AMOUNT
2-1200-431-00-124-007-0-890	Pct 4 Rd Maint. - Other	39,245.45
2-1200-431-00-124-036-0-113	Pct 4 Drain. Improv. Prj - Reg F/T Employees	26,315.68
2-1200-341-50-124-002-0-000	JO9 Drainage Project Reimbursment	65,561.13
TOTAL BUDGET INCREASE (DECREASE)		

REASON: To appropriate funding to cover day to day expenses of the Pct. Reimb. From HCDD#1 JO9 Drainage Project.

DEPARTMENT HEAD SIGNATURE

APPROVED COMMISSIONERS' COURT

DATE

ATTEST COUNTY CLERK

COUNTY of HIDALGO



EDINBURG, TEXAS 78539

HIDALGO COUNTY AUDITOR'S OFFICE
Hidalgo County Administration Building
2808 South Business Highway 281
Edinburg, Texas 78539-6243
PHONE: (956) 318-2511
FAX: (956) 318-2577
WEBSITE: www.co.hidalgo.tx.us/auditor

July 19, 2012

The Honorable Ramon Garcia, Hidalgo County Judge
The Honorable Joel Quintanilla, Commissioner, Precinct No. 1
The Honorable Hector "Tito" Palacios, Commissioner, Precinct No. 2
The Honorable Jose M. Flores, Commissioner, Precinct No. 3
The Honorable Joseph Palacios, Commissioner, Precinct No. 4

RE: Certification of Revenue

Dear Judge and Commissioners:

Pursuant to Local Government Code § 111.07075 SPECIAL BUDGET FOR REVENUE RECEIVED AFTER START OF FISCAL YEAR:

The county auditor shall certify to the commissioners court the receipt of revenue from a new source not anticipated before the adoption of the budget and not included in the budget for that fiscal year. On certification, the court may adopt a special budget for the limited purpose of spending the revenue for general purposes or for any of its intended purposes.

I, Ray Eufrazio, County Auditor of Hidalgo County, certify to the Hidalgo County Commissioners Court the Pct. #4 JO9 May 2012 reimbursement revenues in amount of \$65,561.13. These funds may now be made available by creating a new special budget or amending a current budget for its intended purposes.

CERTIFIED BY:

Raymundo Eufrazio, CPA
Hidalgo County Auditor

Date 7/19/12

HIDALGO COUNTY DISTRICT JUDGES

RICARDO P. RODRIGUEZ, JR. JUDGE, 92ND D.C. RODOLFO DELGADO JUDGE, 93RD D.C. J. R. "BOBBY" FLORES JUDGE, 139TH D.C. ROSE GUERRA REYNA JUDGE, 206TH D.C. JUAN R. PARTIDA JUDGE, 275TH D.C. MARIO E. RAMIREZ, JR. JUDGE, 332ND D.C. NOE GONZALEZ JUDGE, 370TH D.C. OVERSEER LETICIA LOPEZ JUDGE, 389TH D.C. AIDA SALINAS FLORES JUDGE, 398TH D.C. ISRAEL RAMON, JR. JUDGE, 430TH D.C. JESSE CONTRERAS JUDGE, 449TH D.C.

AI-33262

Purchasing Department 18. A. 4.

CC REGULAR

Meeting Date: 07/24/2012

Department Head: Martha Salazar Submitted By: Vangie Garcia, PURCHASING DEPT.

Department: PURCHASING DEPT.

Information

CAPTION

Acceptance and approval of an "Amendment" to the current DIR Contract No. DIR-SDD-IC427(approved by CC-12/01/09) as submitted by Texas.gov Contracts, acting by and through the Texas Department of Information Resources and Texas NICUSA, LLC., for the purposes of a transition that will begin September 1, 2012 with new fees, terms and conditions as utilized by the Hidalgo County Clerk and District Clerk Offices.

BACKGROUND

Said service customer agreement provides the Texas.gov services for eFiling and ePay services for Hidalgo County Clerk and District Clerk Offices.

Fiscal Impact

FISCAL YEAR:

ACCT. #:

FUNDS AVAILABLE Y/N?:

MATCHING FUNDS Y/N?:

BUDGETARY IMPACT:

Services are at no cost to the County. Rates are incurred and paid by customers utilizing these on-line services as offered by the County Clerk and District Clerk Offices through this contract with Texas NICUSA.

Attachments

Current Agreement with Texas NICUSA

Amendment to agreement and legal's approval

Form Review

Inbox	Reviewed By	Date
Purchasing Department	Marty Salazar	07/19/2012 04:36 PM
Budget & Management	Merlen P. Munoz	07/19/2012 04:50 PM
Sylvia Solis	Sylvia Solis	07/20/2012 11:11 AM
Auditor's Office	Angela Garcia	07/20/2012 04:55 PM
Form Started By: Vangie Garcia		Started On: 07/13/2012 05:03 PM
	Final Approval Date: 07/20/2012	

TexasOnline 2.0 Customer Agreement

Between

**The State of Texas, acting by and through
the Texas Department of Information Resources**

and

Texas NICUSA, LLC

and

Hidalgo County

DIR Contract No. DIR-SDD-IC427

This Customer Agreement is effective on the 1st day of January, 2010 by and between the Texas Department of Information Resources (DIR), Texas NICUSA, LLC (Vendor), and Hidalgo County (Customer). DIR, Vendor, and Customer may each be referred to as Party, and collectively DIR, Vendor, and Customer may be referred to as the Parties herein.

Capitalized terms not defined herein shall have the meaning set forth in the Master Agreement.

BACKGROUND

TexasOnline 2.0 is based on, and subject to, the TexasOnline 2.0 Master Agreement between DIR and Vendor dated July 31, 2009, including the Customer Agreement Standard Terms and Conditions. TexasOnline 2.0 is the name of the official web portal and application delivery framework for the State of Texas.

AGREEMENT

IN CONSIDERATION of mutual covenants and agreements contained in this Customer Agreement, DIR, Vendor, and Customer agree as follows:

1. Customer may receive Services provided by TexasOnline 2.0 by agreeing to abide by this Customer Agreement, including the Customer Agreement Standard Terms and Conditions. The TexasOnline 2.0 Master Agreement and this Customer Agreement represent the entire agreement for access to, and use of, TexasOnline 2.0 Services by Customer.
2. TexasOnline 2.0 offers a variety of website development and hosting, e-commerce and related support services to Customers. Exhibit A provides the List of Applications, List of Services, and Fee Schedule for this Customer Agreement. Specifications and additional terms for a service or application may be described in a Business Case. The applicable approved Business Case will be listed in Exhibit A and attached thereto, and is incorporated by reference for all purposes into this Customer Agreement.
3. All notices permitted or required under this Customer Agreement will be in writing and will be by personal delivery, a nationally recognized overnight courier service, e-mail, or certified mail, return receipt requested. Notices will be deemed given upon the earlier of actual receipt or one (1) day after deposit with the courier service, receipt by sender of confirmation of electronic transmission or five (5) days after deposit with the U.S. Postal Service. Notices will be sent to the addresses listed below, or to such other address as each Party may specify in writing.

If to DIR:

Texas Department of Information Resources
300 W. 15th Street, Suite 1300
Austin, TX 78701

If to Vendor:

Texas NICUSA, LLC
301 Congress Avenue, Suite 400
Austin, TX 78701

With a copy to:

NIC, Inc. General Counsel (Legal Notice)
25501 West Valley Parkway, Suite 300
Olathe, Kansas 66061

If to Customer:

Hidalgo County: Attn Martha L. Salazar
2802 S Business Hwy 281, New Administration Building
Edinburg, TX 78539

AGREED AND ACCEPTED:

Vendor:

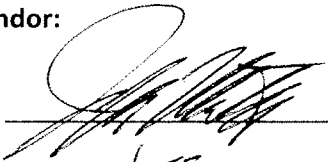
By: 
Name: Jeffrey A. McCreary
Title: President

Texas Department of Information Resources:

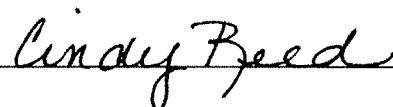
By:  MR
Name: Cindy Reed
Title: Deputy Executive Director

Customer:

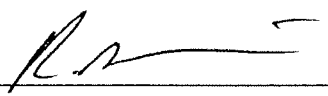
By: HIDALGO COUNTY
Name: 
Title: HIDALGO COUNTY JUDGE

Customer Agreement—Standard Terms and Conditions

These terms and conditions apply to each Customer Agreement, to which they are incorporated, by and between the Texas Department of Information Resources (DIR), TexasOnline 2.0 Vendor (Vendor) and Customer of TexasOnline 2.0. DIR, Vendor, and Customer may each be referred to herein as Party, and collectively DIR, Vendor, and Customer may be referred to as the Parties herein.

BACKGROUND

A. TexasOnline 2.0 is based on, and subject to, the TexasOnline 2.0 Master Agreement between DIR and Vendor dated July 31, 2009. TexasOnline 2.0 is the name of the official web portal and application delivery framework for the State of Texas.

B. DIR executed a contract with International Business Machines Corporation (IBM) on November 22, 2006, (Data Center Services Master Services Agreement) based on House Bill 1516, 79th Legislature (Regular Session) to establish a consolidated Data Center, and accordingly all data center services provided by Vendor, excluding DIR-approved Services under the TexasOnline 2.0 Master Agreement are managed and provided by IBM under the Data Center Services Master Services Agreement.

STANDARD TERMS AND CONDITIONS

1. Customer Agreement Elements

1.1 The Parties acknowledge and agree that the terms of the TexasOnline 2.0 Master Agreement will apply to the Customer Agreement, and will remain in full force and effect except as may be expressly modified by the terms of a Customer Agreement or any amendment to the TexasOnline 2.0 Master Agreement made in accordance with specific provisions of the TexasOnline 2.0 Master Agreement, Section 5 Contract Amendments. In the event of any conflict between the terms and conditions of a Customer Agreement and those of the TexasOnline 2.0 Master Agreement, the terms and conditions in the TexasOnline 2.0 Master Agreement will govern with respect to the Parties and the Services delivered, unless the Customer Agreement specifically identifies by section number a clause of the TexasOnline 2.0 Master Agreement and indicates that the Customer Agreement will be controlling. Notwithstanding the foregoing, the Parties agree that as between Vendor and DIR on the one hand, and Customer on the other, Sections 8.1, 8.2 and 9.7 in the Customer Agreement Terms and Conditions will control over any expressly conflicting statement contained in the TexasOnline 2.0 Master Agreement, if any. The Parties acknowledge the TexasOnline 2.0 Master Agreement is subject to subsequent amendment by Vendor and DIR pursuant to its terms and agree that, to the extent any such amendments impact any Customer Agreement terms and conditions, such amendments will automatically apply to the Customer Agreement with no further action by the Parties.

1.2 These Customer Agreement Standard Terms and Conditions may be modified by DIR and Vendor pursuant to the modification of terms of the TexasOnline 2.0 Master Agreement. Such modifications will be effective as to the affected Customer Agreements following thirty days written notice to the Customers.

1.3 Customer Agreements will continue until terminated as specified therein, and subject to the terms of the TexasOnline 2.0 Master Agreement, and Vendor will provide the Services described in the agreed attachments to the Customer Agreement.

2. DIR Approval

Customer acknowledges that in order for Vendor to provide services pursuant to a Customer Agreement, DIR must approve placing Customer's website and/or applications (each approved website or application is an "Application") on the TexasOnline 2.0 system. A list of websites and/or applications using services under a Customer Agreement is included in the Customer Agreement (which also includes information on the specific applications and fees).

3. Services Available to Customer

Vendor offers a variety of website development and hosting, e-commerce and related support services to participants. The specific list of services and applications that Vendor has agreed to provide Customer will be specified in each Customer's Customer Agreement.

4. Customer Website Security

If Customer is hosting its own website, Customer will follow recommended security standards for Texas State and local government websites, and will conform to security policies and procedures in the TexasOnline 2.0 Master Agreement, Attachment G-9 Security Plan. Customer acknowledges that any failure on its part to follow recommended security standards may place its own data and operations at risk as well as those of Vendor and other governmental entities. Vendor will not be liable for violations of security policies and procedures by Customer. Additionally, failure to comply with security standards may lead to the suspension or termination of the availability of the Applications on TexasOnline 2.0 by Vendor and DIR. Vendor will give DIR and the Customer notification of non-compliance immediately upon suspension.

5. Strategic Outreach

In marketing Customer services accessible through TexasOnline 2.0 through brochures, press releases, advertisements, and other mail-outs and information pieces, Customer will include in any marketing piece in any medium that the services are provided in affiliation with TexasOnline 2.0 and will use the TexasOnline 2.0 logo and universal resource locator (URL) provided by Vendor for such purpose. Customer agrees to explore the possibility of co-marketing with Vendor the Customer services available through TexasOnline 2.0 so that marketing costs are shared. There will be a link to the Customer URL from TexasOnline 2.0.

6. Fees

For the Services provided by Vendor, Vendor is entitled to the fees set out in Exhibit A to this Customer Agreement. A Customer Agreement can be modified for the addition of fees as new Applications are included in Customer Services based on mutual agreement of DIR, Vendor, and Customer.

7. Customer Obligations

In addition to any other Customer obligations set out in the Exhibits to this Customer Agreement and the TexasOnline 2.0 Master Agreement, Customer will have the obligations herein.

7.1 Customer will utilize a single merchant ID for the Application(s) listed on Exhibit A, unless expressly set out in Exhibit A.

- 7.2 Customer will provide a contact number for the Application or Application(s) on an 8:00 a.m. - 5:00 p.m. CT (Monday through Friday) basis to receive 2nd level inquiries routed from the Help Desk.
- 7.3 Customer will cooperate with Vendor in Vendor's performance of its obligations under this Agreement. Customer will agree to an online security audit if requested by Vendor. Customer will not store or retain any credit card number or the automated clearing house (ACH) account number captured on its systems.
- 7.4 Customer will comply with the terms of use and privacy statements, which are displayed on the TexasOnline 2.0 Website, and with all applicable laws related to information received from or distributed to individuals using the TexasOnline 2.0 Applications. Customer acknowledges that no personally identifiable or private information collected through TexasOnline 2.0 may be used by Customer for any purpose or provided to any third party unless: (i) the user is given clear prior notice of the possibility of such other use, and (ii) the user affirmatively consents to such use (i.e., the user "opts-in" to the contemplated use of his or her personally identifiable or private information), and (iii) the Customer agrees to its use or the use is otherwise permitted under the privacy statement. Notwithstanding the foregoing, the Parties acknowledge that such information may be required by law to be provided to law enforcement, or may be used in investigating unauthorized use of TexasOnline 2.0.
- 7.5 Customer will provide access to information and systems as necessary to assist Vendor in performing its obligations hereunder and under the TexasOnline 2.0 Master Agreement.
- 7.6 Customer will follow reasonable security standards regarding physical security, data, and systems, and will not knowingly or negligently take actions to, or by omissions put, State Information or Customer at risk of loss, damage, or breach of security.
- 7.7 Customer will at all times be responsible for the backup and preservation of any data within its control, which does not reside on TexasOnline 2.0.
- 7.8 Customer will process all refunds for its users. Customer will use the Vendor Customer Service interface application to process credit card refunds requested by its users.
- 7.9 Customer will notify Vendor in writing of all laws, rules and regulations, and changes thereto, that affect TexasOnline 2.0.

8. Representations and Warranties by Vendor

- 8.1 VENDOR REPRESENTS AND WARRANTS THAT ALL SERVICES PERFORMED UNDER THIS CUSTOMER AGREEMENT WILL BE PERFORMED IN A GOOD AND WORKMANLIKE MANNER. VENDOR DISCLAIMS ALL OTHER WARRANTIES, EITHER EXPRESS OR IMPLIED, INCLUDING, WITHOUT LIMITATION, WARRANTIES OF MERCHANTABILITY AND FITNESS FOR A PARTICULAR PURPOSE.
- 8.2 NEITHER DIR NOR VENDOR WILL HAVE ANY LIABILITY WHATSOEVER TO CUSTOMER FOR ANY INCIDENTAL, PUNITIVE, INDIRECT, CONSEQUENTIAL, OR SPECIAL DAMAGES OF ANY KIND (INCLUDING LOST REVENUES OR PROFITS, LOSS OF BUSINESS, OR LOSS OF DATA) ARISING OUT OF OR IN CONNECTION WITH OR RELATED TO THIS CUSTOMER AGREEMENT OR THE RIGHTS PROVIDED HEREUNDER SUFFERED BY CUSTOMER EVEN IF VENDOR IS INFORMED IN ADVANCE OF THE POSSIBILITY OF SUCH DAMAGES. IN NO EVENT WILL DIR'S OR VENDOR'S TOTAL LIABILITY TO

CUSTOMER HEREUNDER FOR ANY REASON EXCEED THE SHARE OF TOTAL REVENUE RECEIVED, BY VENDOR OR DIR AS APPROPRIATE, UNDER THIS AGREEMENT IN THE TWELVE MONTHS PRECEDING SUCH CLAIM. THE PARTIES AGREE AND ACKNOWLEDGE THAT THIS LIMITATION OF DAMAGES IS A FREELY BARGAINED FOR ALLOCATION OF RISK.

- 8.3 Vendor represents and warrants that Vendor, to the best of its knowledge, has no actual or potential conflicts of interest in providing services to Customer under the Customer Agreement and that Vendor's provision of services under the Customer Agreement to the best of its knowledge would not reasonably create an appearance of impropriety.
- 8.4 Vendor represents and warrants that neither Vendor nor any person or entity, which will participate financially in the Customer Agreement, has received compensation from Customer for participation in preparation of specifications for the Customer Agreement. Vendor represents and warrants that it has not given, offered to give, and does not intend to give at any time hereafter, any economic opportunity, future employment, gift, loan, gratuity, special discount, trip, favor or service to any public servant or employee in connection with the Customer Agreement.

9. General Terms

- 9.1 Customer agrees and acknowledges that the terms of the TexasOnline 2.0 Master Agreement related to force majeure, confidentiality, and any additional limitations on damages will apply to the Customer Agreement. This section only applies to the extent authorized by law.
- 9.2 Except as expressly provided herein, no provision of the Customer Agreement will constitute or be construed as a waiver of any of the privileges, rights, defenses, remedies or immunities available to Customer. The failure to enforce or any delay in the enforcement of any privileges, rights, defenses, remedies, or immunities available to Customer by law will not constitute a waiver of said privileges, rights, defenses, remedies, or immunities or be considered as a basis for estoppel. Except as expressly provided herein, Customer does not waive any privileges, rights, defenses, remedies or immunities available to Customer.
- 9.3 This Customer Agreement will be construed and governed by the laws of the State of Texas and is performable in Travis County, Texas. Venue for any action relating to a Customer Agreement is in Texas state courts in Austin, Travis County, Texas, or, with respect to any matter in which the federal courts have exclusive jurisdiction, the federal courts for Travis County, Texas.
- 9.4 If one or more provisions of this Customer Agreement, or the application of any provision to any Party or circumstance, is held invalid, unenforceable, or illegal in any respect, the remainder of the Customer Agreement and the application of the provision to other Parties or circumstances will remain valid and in full force and effect
- 9.5 Except as provided in Section 1.2 above, the Customer Agreement may be amended only upon written agreement between DIR, Vendor, and Customer, but in no case will the Customer Agreement be amended so as to make it conflict with the laws of the State of Texas.
- 9.6 Neither DIR, nor Vendor, nor Customer may assign or transfer this Customer Agreement without the written consent of the other Parties, which consent will not be unreasonably withheld, except that upon written notice to DIR and Customer, Vendor may assign the Customer Agreement without

DIR's and Customer's consent to any entity that Vendor controls, is controlled by, or is under common control with, (provided such entity is adequately capitalized) or to any entity which acquires or succeeds to all or substantially all of the business or assets of Vendor whether by consolidation, merger, sale or otherwise (such as a spin-off of Vendor).

- 9.7 *Exhibit B Terms and Conditions*, Section 14.01 Ownership of Intellectual Property; Infringement and Misappropriation of the TexasOnline 2.0 Master Agreement is incorporated herein by reference and will apply to work product created by Vendor pursuant to the Customer Agreement.
- 9.8 Vendor will serve as an independent contractor in providing services under this Customer Agreement. Vendor's employees are not and will not be construed as employees of Customer.
- 9.9 Vendor will have no authority to act for or on behalf of Customer except as provided for in the Customer Agreement and the TexasOnline 2.0 Master Agreement; no other authority, power, or use is granted or implied. Vendor may not incur any debts, obligations, expenses, or liabilities of any kind on behalf of Customer other than those incurred in performance of the Customer Agreement.
- 9.10 In addition to the requirements of Exhibit B Terms and Conditions, Section 8.01 Financial record retention and audit of the TexasOnline 2.0 Master Agreement, Vendor will maintain and retain supporting fiscal documents adequate to ensure that claims for Customer Agreement funds associated with the Customer Agreement are in accordance with applicable State of Texas requirements. These supporting fiscal documents will be retained by Vendor for a period of four (4) years after the date of submission of the final invoices.
- 9.11 *Exhibit D Performance Criteria* of the TexasOnline 2.0 Master Agreement addresses the agreed upon performance criteria for TexasOnline 2.0, including Applications developed or maintained by Vendor, or otherwise provided to Customer by Vendor. Customer may notify DIR in writing of alleged performance failures and DIR may, in its sole and exclusive discretion as between DIR and Customer, determine that a performance failure may have occurred.

10. Termination

- 10.1 The Customer Agreement is effective upon execution by representatives of DIR, Vendor, and Customer and expires upon termination or expiration of the TexasOnline 2.0 Master Agreement (as renewed or extended), unless the Customer Agreement is earlier terminated as set forth below, or extended in accordance with Section 10.5 below.
- 10.2 In the event that any Party fails to carry out or comply with any of the material terms and conditions of the Customer Agreement, another Party may notify the breaching Party of such failure or default in writing and demand that the failure or default be remedied within thirty (30) days. In the event that the breaching Party fails to remedy such failure or default within thirty (30) days of receiving written notice, each other Party will have the right to cancel the Customer Agreement upon thirty (30) days written notice. Notwithstanding the foregoing, Customer will not have the right to cancel the Customer Agreement if Vendor's failure or inability to comply with the terms and conditions of the Customer Agreement is caused by or arises from, in whole or in part, the refusal or inability, for whatever reason, of Customer to provide the support and assistance that Vendor requires from Customer to perform its obligations under the Customer Agreement, and which Customer previously agreed to provide to Vendor. If Customer does not provide Vendor with the

requisite level or amount of support, for whatever reason, Vendor will, upon receipt of DIR approval, be entitled, but not obligated, to suspend or cancel any further work on the particular service or product or Application for which adequate support is not available, and focus its efforts on other services, products or Applications.

- 10.3 Except as otherwise provided in the TexasOnline 2.0 Master Agreement, or as provided below, DIR or Vendor may terminate the Customer Agreement without cause and without cost or penalty upon ninety (90) days' prior written notice. Notwithstanding the foregoing, with respect to services under Business Cases which are funded through Convenience Fees or Premium Subscription Fees, DIR or Vendor may terminate said Business Case without cost or penalty upon one hundred and eighty (180) days' prior written notice.
- 10.4 Upon written amendment signed by all Parties, Customer and Vendor may elect to continue Vendor's services under the Customer Agreement, notwithstanding the expiration or termination of the TexasOnline 2.0 Master Agreement.
- 10.5 Unless otherwise provided in Exhibit A herein, pursuant to the provisions of TexasOnline 2.0 Master Agreement and with respect to services that are not funded through Transaction Fees and Premium Subscription Fees, the Customer will pay any unrecovered costs associated with Vendor providing service to them through TexasOnline 2.0, if the Customer terminates the Customer Agreement for convenience or lack of funding before those costs are fully recovered. Such unrecovered costs will be calculated in accordance with Exhibit B Terms and Conditions, Section 11.03(d) Termination fee of the Master Agreement.
- 10.6 DIR may terminate this Customer Agreement following the determination by a competent judicial or quasi-judicial authority and Vendor's exhaustion of all legal remedies that Vendor, its employees, agents or Subcontractors have either offered or given any thing of value to an officer or employee of Customer or the State of Texas in violation of State law.

11. Dispute Resolution

If a dispute seeking money damages is identified by DIR, Vendor, or Customer, dispute resolution will follow the procedures outlined in Exhibit B Terms and Conditions, Section 11.11 Dispute Resolution of the TexasOnline 2.0 Master Agreement, which references Chapter 2260 of the Texas Government Code. Any pursuit of equitable relief will not constitute a waiver by DIR or Customer of any immunity from suit or liability. Notwithstanding the foregoing, DIR and Customer are not precluded from initiating a lawsuit for damages against Vendor in a court of competent jurisdiction and may do so without engaging in the process provided by Chapter 2260 of the Texas Government Code or 37 TEX. ADMIN. CODE § 34.1, et seq. (2001) (Department of Public Safety, Negotiation and Mediation of Certain Contract Disputes).

12. Miscellaneous Provisions

- 12.1 Customer Copyright and Content Non-Supervision Acknowledgment. The Customer represents to Vendor and DIR that the content and other materials furnished to Vendor by the Customer for TexasOnline 2.0 do not (i) violate any third party's copyright, intellectual property rights, rights of privacy or publicity or other similar rights and (ii) violate any applicable law or State rules and regulations for TexasOnline 2.0. The Customer acknowledges that neither Vendor nor DIR is responsible for investigation or approval of the content of any third party sites to which Customer's

links on TexasOnline 2.0. Further, the Customer acknowledges that neither DIR nor Vendor is responsible for the accuracy, completeness, or review of the content of the Customer's public records or text furnished by the Customer to Vendor or TexasOnline 2.0.

- 12.2 Any situation that could adversely affect TexasOnline 2.0 may lead to the suspension of the Customer's Applications on TexasOnline 2.0. Vendor will give DIR and the Customer written notice immediately upon suspension.

Exhibit A

List of Application(s) Supported Under this Customer Agreement
1. Electronic Filing Manager (EFM) Application <ul style="list-style-type: none"> a) Court Intake Application b) Court Profile c) Court Registration d) Filer Registration e) Payment Services

List of Service(s) Provided Under this Customer Agreement
1. Electronic Filing Manager (EFM) Application <ul style="list-style-type: none"> • Electronic Payments System Credit Card Authorization Services/Settlement Services • Electronic Payments Chargeback Services • Filing Purge Services • Customer Information Center Services for Government Entity Applications • Customer Information Center Services for Electronic Payments transaction services • TexasOnline Hosting and Application Service Provider (ASP) Services • TexasOnline Training • Strategic Outreach • Physical Environment Management • Network Infrastructure Management • Hardware Management • Operating System Administration

Fee Schedule	
1. Electronic Filing Manager (EFM) Application The fee schedule listed below outlines the convenience fees required from the Internet user for each completed transaction.	
Government Entity Service Type	TxO Services Fee
Electronic Filing Manager Court Intake Services	\$4.00 TexasOnline \$2.00 County*
Cost Recovery on all Credit Card transactions	Based on the credit card type and starting at 2.25% the first year
*NIC will pay to Government Entity on a daily basis, for each accepted e-Filing the fee for cost recovery as approved by the Department of Information Resources Board.	

C-09-498-12-01

APPROVED BY COMMISSIONERS COURT: 12/01/09

"TEXAS NICUSA"-DIR STATE CONTRACT'S AWARDED VENDOR
"E-PAY AND E-FILING SERVICES" FOR HIDALGO COUNTY CLERK'S AND DISTRICT CLERK'S
OFFICES

ATTEST:

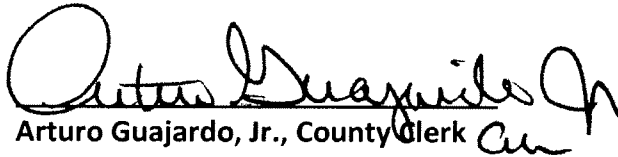
Arturo Guajardo, Jr., County Clerk

AI-18714

13.C.

Texas Online- "E-pay" and "E-filing Services"-Hidalgo County Clerk and District Clerk Offices

CC CONSENT

Date: 12/01/2009
Submitted By: Vangie Garcia, PURCHASING DEPT.
Submitted For: Marty Salazar
Department: PURCHASING DEPT.
Agenda Category: Purchasing Department

Information

CAPTION

A. Requesting approval for the continuation of services for the Texas Online for "E-pay" (e-commerce transactions) and "E-filing Services" with the newly selected awarded vendor "Texas NICUSA" through the Texas Department Of Information Resources (DIR) for the Texas Electronic Framework Standard Service Level Agreement-(TEF) for Hidalgo County Clerk's Office and District Clerk's Office;

B. Requesting approval for the new service agreement for the Texas Online for "E-pay" (e-commerce transactions) and "E-filing Services" with Texas NICUSA-DIR-TXO-001, newly selected and awarded vendor through the Texas Department Of Information Resources (DIR) for Hidalgo County Clerk's Office and District Clerk's Office.

BACKGROUND

Department of Information Resources (DIR) went out on Request For Offers again for these services and a new vendor (Texas NICUSA) was selected and awarded for a seven (7) year term. For the first contract year, a period commencing on the effective date of July 31, 2009 and ending on August 31, 2010, and for each ensuing contract year thereafter will be commencing on September 1st and ending August 31st. The new vendor will manage the Texas Online, the state's Internet portal. (see attachment for further information)

Original service agreement previously approved by Commissioners Court on July 29, 2004 for Hidalgo County Clerk's Office and was amended to include Hidalgo County District Clerk's Office on October 18, 2005 with awarded vendor then being "BearingPoint". (see attachment for review)

Department Of Information Resources (DIR) has notified "BearingPoint, Inc." that they are no longer the contracted vendor for these services thus officially closing out the service agreement in place with them for Hidalgo County.

Fiscal Impact

FISCAL YEAR: ACCT. #:
FUNDS AVAILABLE Y/N?: MATCHING FUNDS Y/N?:

BUDGETARY IMPACT:

Will bear no fiscal impact to Hidalgo County. Services are at no cost.

Attachments

Link: [County Clerk's Agreement with Minutes](#)

Link: [District Clerk's Amendment to Agreement with Minutes](#)

Link: [Service Agreement](#)

Link: [DIR'S NOTICE OF AWARD](#)

Form Routing/Status

Route Seq	Inbox	Approved By	Date	Status
	(Originator)	Vangie Garcia	11/23/2009 12:48 PM	CREATED
1	Purchasing Department	Marty Salazar	11/24/2009 04:44 PM	APRV
2	Budget & Management	Erika Zamora	11/24/2009 04:48 PM	APRV
3	Sylvia Solis			PEND
4	Auditor's Office			
Form Started By: Vangie Garcia		Started On: 11/23/2009 12:48 PM		



texas.gov

100 Congress Avenue
Suite 600
Austin, Texas 78701
tel 512.651.9300
fax 512.651.9334

Texas.gov is a service of Texa

June 28, 2012

Arturo Guajardo Jr.
County Clerk
Hidalgo County
100 N. Closner
Edinburg, Texas 78540

RE: Customer Agreement Amendment for eFiling services

Dear Mr. Guajardo Jr.:

As you are aware, the Texas eFiling program is entering a period of transition that will begin September 1, 2012. As detailed in the letter from the Office of Court Administration (OCA), dated June 1, 2012, the transition requires new fees and new terms and conditions, requiring an amendment to your Texas.gov Customer Agreement.

Attached is the Customer Agreement amendment supporting the following changes:

- The OCA and Texas Supreme Court anticipate requiring eFiling services from Texas.gov through February 2014.
- The Customer Agreement for eFiling will expire at the same time the Texas Supreme Court eFiling Agreement expires or is terminated.
- Early termination of the Customer Agreement requires 12-months prior written notice.
- The eFiling and eService fees have been increased by \$1 each.

Please have the appropriate individual with signatory authority sign the amendment and return the executed document no later than August 31, 2012, via electronic delivery or via postal service to the following address:

Texas.gov Contracts
100 Congress Ave, Suite 600
Austin, TX 78701
TXNICUSA-Contracts@egov.com

We will continue to update you on the progress of the transition, communications with constituents, and materials that will assist you in updating your website, written materials, etc. so that you can better serve your constituents. We will also be working with OCA to communicate with constituents regarding the transition to the new vendor for Texas eFiling.

We appreciate your continued support of the eFiling service and will work diligently to ensure a smooth transition. Please contact our Contract Manager, Brittany Perkins via phone at 512.501.5981 or email bperkins@e.gov, should you have any questions or comments.

Respectfully,

A handwritten signature in black ink, appearing to read "Erin Hutchins". The signature is stylized with a large initial "E" and a long horizontal flourish.

Erin Hutchins
Director of Portal Operations
Texas NICUSA, LLC

**AMENDMENT 1 TO THE CUSTOMER AGREEMENT
BETWEEN
THE STATE OF TEXAS, ACTING BY AND THROUGH THE
TEXAS DEPARTMENT OF INFORMATION RESOURCES
AND,
TEXAS NICUSA, LLC
AND
HIDALGO COUNTY**

Purpose: The purpose of this amendment is to edit the Customer Agreement.

Whereas, effective January 1, 2010, the Texas Department of Information Resources (DIR), Hidalgo County (Customer), and Texas NICUSA, LLC (Vendor) entered into a Customer Agreement to provide Texas.gov services.

BACKGROUND

The Office of Court Administration (OCA), the Texas Supreme Court, and the Judicial Committee on Information Technology (JCIT), have jointly extended eFiling service through Texas.gov, for up to 18 months, to February, 2014, to accommodate OCA procurement of a new eFiling provider and transition to the new solution.

AUTHORITY

This amendment is coterminous with the Texas Supreme Court Customer Agreement for the eFiling service.

EFFECTIVE DATE

This amendment is effective as of **September 1, 2012**.

For good and valuable consideration, the receipt and sufficiency of which is hereby mutually acknowledged, the Parties do hereby amend the Customer Agreement as follows, all other terms and conditions remain the same.

1. Edit Customer Agreement:

1.1. Customer Agreement—Standard Terms and Conditions, delete Section 10 in its entirety and replace with the following:

10. Termination

10.1 The Customer Agreement is effective on September 1, 2012 and expires no later than the earlier of February 28, 2014 or the termination or expiration of either the TexasOnline 2.0 Master Agreement or the Texas Supreme Court eFiling Customer Agreement, unless this Customer Agreement is earlier terminated as set forth below, or extended in accordance with Section 10.4 below.

10.2 In the event that any Party fails to carry out or comply with any of the material terms and conditions of the Customer Agreement, another Party may notify the breaching Party of

such failure or default in writing and demand that the failure or default be remedied within thirty (30) days. In the event that the breaching Party fails to remedy such failure or default within thirty (30) days of receiving written notice, each other Party will have the right to cancel the Customer Agreement upon thirty (30) days written notice. Notwithstanding the foregoing, Customer will not have the right to cancel the Customer Agreement if Vendor's failure or inability to comply with the terms and conditions of the Customer Agreement is caused by or arises from, in whole or in part, the refusal or inability, for whatever reason, of Customer to provide the support and assistance that Vendor requires from Customer to perform its obligations under the Customer Agreement, and which Customer previously agreed to provide to Vendor. If Customer does not provide Vendor with the requisite level or amount of support, for whatever reason, Vendor will, upon receipt of DIR approval, be entitled, but not obligated, to suspend or cancel any further work on the particular service or product or Application for which adequate support is not available, and focus its efforts on other services, products or Applications.

10.3 Except as otherwise provided in the Texas Online 2.0 Master Agreement or as provided below, DIR and Vendor may terminate the Customer Agreement without cause and without cost or penalty no earlier than August 31, 2013 and with 90-day prior written notice.

10.4 Upon written amendment signed by all Parties, Customer and Vendor may elect to continue Vendor's services under the Customer Agreement, notwithstanding the expiration or termination of the TexasOnline 2.0 Master Agreement.

10.5 Except as otherwise provided in the Texas Online 2.0 Master Agreement or as provided below, Customer may terminate the Customer Agreement without cause and without cost or penalty no earlier than August 31, 2013 and with 45-day prior written notice.

10.6 Unless otherwise provided in Exhibit A herein, pursuant to the provisions of TexasOnline 2.0 Master Agreement and with respect to services that are not funded through Transaction Fees and Premium Subscription Fees, the Customer will pay any unrecovered costs associated with Vendor providing service to them through Texas.gov, if the Customer terminates the Customer Agreement for convenience or lack of funding prior to August 31, 2013 and before those costs are fully recovered. Such unrecovered costs will be calculated in accordance with Exhibit B Terms and Conditions, Section 11.03(d) Termination fee of the Master Agreement.

10.7 DIR may terminate this Customer Agreement following the determination by a competent judicial or quasi-judicial authority and Vendor's exhaustion of all legal remedies that Vendor, its employees, agents or Subcontractors have either offered or given anything of value to an officer or employee of Customer or the State of Texas in violation of State law.

2. Replace Exhibit A in its entirety with the attached Exhibit A to apply the following changes:

2.1. Edit Fee Schedule – Section 1. Electronic Filing Manager (EFM) Application, as follows:

2.1.1. Update Texas.gov Filing Fee

2.1.2. Update payment terms

3. Add Exhibit B in its entirety with the attached Exhibit B.

AGREED AND ACCEPTED:

Vendor:

By: 

Print Name: Erin Hutchins

Title: Director of Portal Operations

Date: 6/28/12

Texas Department of Information Resources:

By: _____

Print Name: Carl D. Marsh

Title: Chief Operating Officer

Date: _____

Legal: _____

Customer:

By: _____

Print Name: _____

Title: _____

Date: _____

Phone: _____

Email: _____

Exhibit A: Amendment 1

Customer: Hidalgo County

List of Application(s) Supported Under this Customer Agreement

- 1. Electronic Filing Manager (EFM) Application**
 - A. Court Intake Application
 - B. Court Profile
 - C. Court Registration
 - D. Filer Registration
 - E. Payment Services

List of Service(s) Provided Under this Customer Agreement

- **Electronic Filing Manager (EFM) Application**
 - Electronic Payments System Credit Card Authorization Services/Settlement Services
 - Electronic Payments Chargeback Services
 - Filing Purge Services
 - Customer Information Center Services for Government Entity Applications
 - Customer Information Center Services for Electronic Payments transaction services
 - TexasOnline Hosting and Application Service Provider (ASP) Services
 - TexasOnline Training
 - Strategic Outreach
 - Physical Environment Management
 - Network Infrastructure Management
 - Hardware Management
 - Operating System Administration

Fee Schedule

1. Electronic Filing Manager (EFM) Application

Fee Schedule

1. Electronic Filing Manager (EFM) Application

The fee schedule listed below outlines the Texas.gov Services Fees required from the Internet user for each completed transaction.

Service Type	Texas.gov Services Fee
Electronic Filing Manager Court Intake Services	<ul style="list-style-type: none">• \$5.00 Texas.gov Filing Fee• \$2.00 Customer Fee
Credit Card Payment Processing (not applicable to Indigent Filing)	2.25% of all fees collected – Credit Card Payment Processing Fee

- Vendor will be paid a Texas.gov Filing Fee plus the Credit Card Payment Processing Fee as indicated in the above table.
- Vendor will process payment and pay to Customer the Customer Fee identified in the above table along with the statutory filing fees associated to filing cases in Brooks County as approved by the Department of Information Resources Board.
- Vendor will pay any applicable credit card fees per the terms of its agreement(s) with the payment card companies.
- Vendor is responsible for processing Texas.gov Filing Fee refunds.
- Customer is responsible for processing all Customer Fee refunds.
- Customer is responsible for financial reconciliation of chargebacks and any associated fees.
- Vendor understands and agrees that Vendor may not change the Customer Fee unless the Vendor receives the express written approval of the Customer and approval by the DIR Board.

Customer Initials & Date

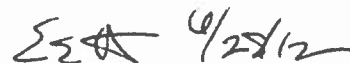

Vendor Initials & Date

Exhibit B: Application and Services Description

The Vendor offers a variety of support services to Customers. The specific list of services and applications that Vendor has agreed to provide to Customer under this Agreement are set forth in Exhibit A of the Agreement between the Customer and Vendor.

The following table is a comprehensive list of all services currently offered by Vendor, and may be amended from time to time by Vendor.

Service	Description
<p>A. Electronic Payment Engine Payment Interface Services</p>	<p>Vendor will provide a Payment interface (“Electronic Payment Engine”) that will be hosted at a Vendor web site. The Customer applications will pass encrypted transaction data to the site using a secured connection. The interface will include:</p> <ul style="list-style-type: none"> • SSL 128bit encryption or greater secure interface to Electronic Payment Engine • Pre-load validation of record packet submitted by the Customer application • Response record packet returned to the Customer application <p>If the Customer is hosting the application, they will be responsible for submitting to Electronic Payment Engine, hosted by Vendor, the required record as specified in the Texas.gov Payment Engine, Payment Services Specifications.</p>
<p>B. Electronic Payment Engine Credit Card Authorization Services/Settlement Services</p>	<ul style="list-style-type: none"> • Vendor will provide authorization and settlement transaction services for credit cards (Visa, MasterCard, Discover, and American Express). • Vendor will receive the encrypted pay request transaction through a secure (minimum SSL 128bit) interface. • Each incoming transaction will be logged for auditing. • Pre-authorization validation will be performed against the payment record, which includes all required information to process an electronic payment. • If valid, the transaction will be submitted for approved credit and process authorization. • A response record will be returned to the Customer application containing either authorization data or denial/error codes. • An outgoing transaction record will be recorded for auditing. • The cutoff for transactions will be 2:00 a.m. ET daily. • The processor will transfer all funds to the Customer bank account. Vendor is not responsible for actual fund transfers.
<p>C. Electronic Payment Engine ACH Services</p>	<p>For Automated Clearing House (ACH), Vendor will provide the following services: Vendor will receive the encrypted pay request transaction</p>

	<p>through a secure (minimum SSL 128 bit) interface.</p> <ul style="list-style-type: none"> • Each incoming transaction will be recorded for auditing. • Pre-authorization validation will be performed against the payment record, to verify that all information required to process an electronic payment is provided. • If valid, the transaction will be authorized using current financial data. Only the ABA routing number is validated. • A response record will be returned to the Customer application containing either authorization data or denial/error codes. • An outgoing transaction record will be recorded for auditing.
<p>D. Automated USAS Interface</p>	<p>Vendor will prepare a file of online transactions and forward it to the Comptroller each banking day. In turn, the file is provided to the Customer via the Comptroller. The file will be formatted according to the specification defined in the Texas.gov Payment Engine Specifications.</p>
<p>E. Application for Electronic Payment Engine Refund Services for Credit Cards</p>	<p>Vendor will provide an online, secured application for the Customer to access in order to process refunds to Visa, MasterCard, American Express, and Discover.</p> <ul style="list-style-type: none"> • Only authorized users will have access to the Refund application, which will be controlled by login. • A unique identifier for the transaction that is being refunded will be required to initiate the refund. • Users will enter the Customer program specific data and the amount to be refunded. • The transaction will be submitted to the credit card processor for settlement, which will result in funds being debited from the Customer's accounts and the user's card being credited with the refund. • Incoming and outgoing transactions will be recorded for audit. • Refund transactions will be included with other authorized transactions that are sent to the Comptroller each day as a batch file. Transfers will only occur on bank business days. • The Customer will be able to print and save a record of the refund transaction.
<p>F. Application for Electronic Payment Engine Refund Services for ACH (non-USAS Vendor)</p>	<p>Vendor will provide an online, secured application for the Customer to access in order to process refunds to ACH transactions.</p> <ul style="list-style-type: none"> • Only authorized users will have access to the Refund application, which will be controlled by login. • A unique identifier for the transaction that is being refunded will be required to initiate the refund.

	<ul style="list-style-type: none"> • Users will enter the Customer program specific data and the amount to be refunded. • The transaction will be submitted to the NACHA network for settlement, which will result in funds being debited from the Customer's accounts and the user's bank account being credited with the refund. • Incoming and outgoing transactions will be recorded for audit. • Refund transactions will be included with other authorized transactions that are sent to the Customer each day as a batch file. Transfers will only occur on bank business days. <p>The Customer will be able to print and save a record of the refund transaction.</p>
<p>G. Hosting Support Services</p>	<p>Vendor may provide services related to the support of Texas.gov. These services include, but are not limited to:</p> <ul style="list-style-type: none"> • Application hosting • Architecture development and/or review • Security services as they relate to the Master Agreement • System monitoring and administration • Log-in credentialing • Offsite back-up storage • Operational maintenance • Remote management • SSL certificate services
<p>H. Texas.gov Authentication Service</p>	<ul style="list-style-type: none"> • Section 2054.271 of the Texas Government Code allows for Texas.gov to authenticate customers against Customer databases in lieu of requiring a signed or notarized document. <ul style="list-style-type: none"> • The Texas.gov Authentication Service is a web service that allows the Customer to collect data from a user and verify that the data elements match the Texas.gov Authentication Database. • Vendor provides Texas.gov Authentication Service • Customer agrees to use the service solely for the Customer Application specified in Exhibit A.
<p>I. Helpdesk Services for Texas.gov Applications</p>	<p>Vendor may provide first through third level customer support through the Texas.gov Helpdesk.</p> <p>Level 1 Support duties:</p> <ul style="list-style-type: none"> • Responding to user phone calls via a published toll free number • Responding to user email queries via a published help desk email address. • Following established procedures to answer questions

	<ul style="list-style-type: none"> Escalating issues that are not resolved to Level 2 support Recording all issues in a tracking system. <p>Level 2 Support duties:</p> <ul style="list-style-type: none"> Responding to phone calls escalated from Level 1 support Responding to emails escalated from Level 1 Support Following established procedures to answer questions and issues Escalating issues that are not resolved to Level 3 Support Recording issue resolution into the tracking system <p>Level 3 Support duties:</p> <ul style="list-style-type: none"> Responding to issues escalated from Level 2 support Conducting a systems analysis to determine cause for issue Development of a work around or fix for the issue <p>Vendor may provide Level 1 and Level 2 support for the Customer hosted application(s) through the Texas.gov Helpdesk. If Helpdesk support is not able to resolve the issue, the issue will be escalated to the Customer for Level 3 support.</p> <p>For Texas.gov Hosted applications, Vendor may provide Level 1 through Level 3 support.</p> <p>A live call center operation will handle user phone calls and email 24 hours a day, 7 days a week. However, future alterations to these times and days may occur periodically throughout the term of this Agreement if Vendor determines that peak usage of the Framework is at times other than those described above. The call center services are offered in English and Spanish.</p>
J. Change Management	<p>Change Management is a process used to ensure that changes are introduced and managed in a way that provides quality assurance and prevents unnecessary changes. The process is described in the Master Agreement, Exhibit H: Governance, Attachment H1: Policies and Procedures Manual, Section 6.3 Change Management Process.</p>
K. Texas.gov Service Desk	<p>The primary point of contact for Customers regarding day-to-day customer, technical, and planning support. Additionally, the Service Desk will be responsible for providing communications regarding impairments and outages.</p>
L. Filing Purge Services	<ul style="list-style-type: none"> Customer will check and accept or reject all filings on at least a daily basis. Vendor will purge all filings 10 days after the Customer acts on the filing by accepting or rejecting the filing.

	<ul style="list-style-type: none"> All filings will be purged no later than 30 days after they are submitted by the filer.
M. Texas.gov Training	Vendor will provide training support documentation on the appropriate use of the Texas.gov EFM.
N. Physical Environment Management	Vendor will provide physical security and access management, protected power supply, air conditioning and fire suppression through its eGovernment Data Center.
O. Network Infrastructure Management	<ul style="list-style-type: none"> Vendor will provide Front-End Network Management, Firewall Infrastructure and Support Services, Intrusion Detection Services, Back-End Network Management and technical support for the Texas.gov EFM located at Vendor's eGovernment Data Center. Vendor will manage all the Texas.gov EFM resources necessary to get users to Customer's applications and return the information to them. This includes the switches, load-balancing devices, bandwidth regulating devices, and other related devices.
P. Hardware Management	<ul style="list-style-type: none"> Vendor will provide Hardware Installation, Hardware Management and support for Texas.gov EFM components located at Vendor's eGovernment Data Center. Vendor will install and maintain Texas.gov EFM servers and server components and will ensure third-party service providers for hardware are notified appropriately, when required.
Q. Operating System Administration	<ul style="list-style-type: none"> Vendor will provide Operating System Software installation, configuration, optimization, and support for Texas.gov EFM components located at Vendor's eGovernment Data Center. Vendor will create the underlying Texas.gov EFM environment and work with Customer to ensure that systems are configured and tuned appropriately to support the needs of Customer applications.
S. Point of Sale Payment Services	<ul style="list-style-type: none"> Vendor will provide application for over-the-counter processing and a magnetic card reader for credit card data collection. MagTek devices encrypt data at the moment of swipe for data security and meet PCI DSS compliance requirements.
T. Card-swiping Device-Support	Vendor will provide specialized Service Desk support to assist Customer with changes, upgrades, and replacement of MagTek card-swiping devices used for data collection, ID validation, and access control at the point of sale (POS).

Electronic Filing Manager (EFM) Application: Specific Descriptions and Definitions

Vendor Obligations

Service	Description
<p>A. EFM Training</p>	<p>Vendor agrees to provide training to the Customer concerning profile, intake functions and financial reconciliation related to the services provided under this Agreement. Vendor agrees to assist the Customer in understanding and implementing the security policies and procedures as needed.</p>
<p>B. EFM Privacy and Security</p>	<p>Vendor agrees that the Customer's information is owned by the Customer, and Vendor agrees that it will not use the Customer's information for any purpose except as authorized by the Customer. Vendor will make commercially reasonable efforts to meet the security standards described in the Master Contract and provide for the security and integrity of all information obtained pursuant to this Agreement.</p>
<p>C. EFM Service Levels - Page Loading Time</p>	<p>Vendor will provide page loading time to the User on an average of 5 seconds, measured at the Web server.</p> <ul style="list-style-type: none"> • Page loading performance will be measured by opening respective pages through a browser at a Web server located at the site hosting the pages. • Pages containing specialized content, specifically those containing eFiling documents, are not exempted from the average page loading time commitment. • The User is the third party who requests service. • Submission of the filing by the filer is exempted from the average loading time commitment. <p>Under no circumstances shall the Customer be construed to be the User under this Agreement.</p>
<p>D. EFM Service Levels- Up-Time and Availability</p>	<p>Vendor will provide up-time and availability of the Texas.gov network and electronic payment system of 99.5%.</p> <ul style="list-style-type: none"> • Service level will be measured monthly by Vendor. • Vendor reserves the right to restrict the size of eFiling attached documents to preserve performance commitments. <p>The following will <u>not</u> be included in Vendor's up-time and availability computation:</p> <ul style="list-style-type: none"> • Scheduled and planned outages for the purposes of upgrades or maintenance. <p>Upon receipt of TDIR approval, Vendor will promptly notify the Customer of all scheduled and planned outages.</p> <ul style="list-style-type: none"> • All outages will be scheduled with a minimum of 72 hours of advance notice to the TDIR, and shall occur only during non-peak hours, unless otherwise agreed

	<p>by the parties.</p> <ul style="list-style-type: none"> • If less than 72 hour notice is given or the TDIR does not approve the upgrade or maintenance, the outage will be considered down-time. <p>Special Circumstances</p> <ul style="list-style-type: none"> • The Customer may request an outage with respect to services and that outage will not be considered down-time. • If systems or components not owned, controlled, or contracted by Vendor fail resulting in an outage, that outage will not be considered down-time, unless the cause of the failure can be shown to have been a result of Vendor negligence or malfeasance. • Service outages caused by the failure of the Customer's application code or Customer maintained portions of the application or infrastructure are not considered down-time.
E. EFM Service Failure	<p>If for any reason Texas.gov or Vendor are unable to electronically receive or transmit a document, then Vendor will deliver the document to the Customer in a form acceptable to the Customer by 5 p.m. on the first business day following Vendor receipt of notice from the Customer of the failure.</p>
F. EFM Convenience Fee	<p>Vendor will submit convenience fee change requests to DIR for approval and fee changes will be implemented within thirty (30) days of approval.</p> <ul style="list-style-type: none"> • The convenience fee charged to users of Texas.gov will be clearly indicated to users. • Users will be required to give explicit confirmation that they have agreed to pay the convenience fee.
G. EFM Unsuccessful Payment	<p>It is the Electronic Filing Service Provider's responsibility to collect the payment amount from the filer for all filings submitted with unsuccessful payment. Outstanding funds for all filings that are accepted without successful payment for a given month will be transferred from the Vendor Bank account to the Customer's bank account by the tenth (10th) business day of the following month.</p>
H. EFM Electronic Payments Chargeback Services	<p>Vendor and the Customer will develop mutually acceptable procedures for the Customer to follow in order to process chargebacks for applicable credit card transactions.</p>
I. EFM Information Center (CIC) Services for County Applications	<p>Vendor will provide first level customer support for the Customer applications through the Texas.gov CIC.</p> <ul style="list-style-type: none"> • First level support includes responding to phone calls

	<p>and email requests for assistance in using the application.</p> <ul style="list-style-type: none"> • Questions that cannot be answered by a first level technician will be forwarded either to the Customer contact or level two support for resolution. • First and second level support is limited to technical support regarding the Texas.gov network or availability and application functionality. <p>Customer business questions or filing rules, as they pertain to eFiling, are the responsibility of the Customer.</p> <ul style="list-style-type: none"> • Questions that require the Customer's response will be forwarded to the Customer for resolution. • Users will be referred appropriately. <p>A live call center operation will handle user phone calls daily from 7:00a.m. to 7:00p.m. CST, 7 days a week. If Vendor determines that peak usage of the framework is at times other than those described above, then alterations to these times and days may occur in accordance with the Agreement.</p>
<p>J. EFM Customer Information Center Services for Electronic Payment Transaction Services</p>	<p>Vendor will provide first through third level customer support through the Texas.gov CIC for the payment transactions processed through the Electronic Payments System.</p> <ul style="list-style-type: none"> • First level support includes responding to phone calls and email requests for assistance in using the application. • Questions that require a Customer response will be forwarded to the Customer contact for resolution. • Questions that require the Electronic Payments Systems investigation or response will be forwarded to the Electronic Payments Customer Support areas. <p>A live call center operation will handle user phone calls daily from 7:00a.m. to 7:00p.m. CST, 7 days a week. If Vendor determines that peak usage of the framework is at times other than those described above, then alterations to these times and days may occur in accordance with the Agreement.</p>
<p>K. EFM Texas.gov Hosting and Application Service provider (ASP) Services</p>	<p>Services provided by Vendor include all services related to the hosting of eFiling applications including:</p> <ul style="list-style-type: none"> • Application design • Database design and setup • Standard interface design to meet the statewide court filing standard. • Interface design for exchange between Texas.gov and the Electronic Payments System • Support secure communications standards between

	<p>Texas.gov and the Customer.</p> <ul style="list-style-type: none"> • Application development and testing. • Page and form development • Continued application enhancements and modifications. • Applications support and maintenance
L. EFM Strategic Outreach	<p>Services provided by Vendor include the following strategic outreach services:</p> <ul style="list-style-type: none"> • Provide a sample communication plan for the Customer; and if appropriate, consider the possibility of a joint marketing plan and/or expenditure with the Customer.
M. EFM Web Service Interface	<p>Service provided by Vendor to provide the Customer with a standard interface for the exchange of files.</p>

Customers Obligations

Service	Description
A. EFM Financial Information	<p>Not later than 60 days prior to implementation, the Customer must provide to Vendor banking information for all required financial accounts including, but not limited to:</p> <ul style="list-style-type: none"> • Customer's Financial Contact's Name, Title, Mailing Address. Telephone Number, and Email Address. • Customer's Bank's Name, Address, Account Number, and ABA number. • Customer's Bank's Contact Name and Phone Number • Voided Check or Bank letter on Customer's Bank's Letterhead
EFM Financial Information (cont.)	<p>The required financial information is subject to change according to what is needed to correctly process fees and disburse payments to the Customer. Vendor shall maintain the confidentiality of the Customer's banking information by keeping it in a secure location and Vendor shall not use the information for any purposes whatsoever, other than those consistent with this Agreement.</p>
B. EFM Testing Applications and Interfaces	<p>The Customer is responsible for testing the performance of the following:</p> <ul style="list-style-type: none"> • Customer produced and maintained applications and interfaces to Texas.gov and; • the User acceptance eFiling services and enhancements. <p>The Customer and Vendor agree to one forty-five (45) day Pilot Phase beginning on the inception of service so that the</p>

	<p>Customer can evaluate the services and test for performance and reliability of services.</p> <ul style="list-style-type: none"> • If the Customer is dissatisfied during the initial Pilot Phase, Vendor shall have thirty (30) days from receipt of notice of Customer's dissatisfaction to make changes and satisfy the Customer.
C. EFM Training	After the initial training provided by Vendor, the Customer is responsible for training Customer employees concerning profile, intake functions, and financial reconciliation.
D. EFM Contact Number	The Customer agrees to provide a contact number so that inquiries from the Customer Information Center may be received between 8:00 a.m. and 5:00 p.m. central standard time.
E. EFM Texas.gov Logo and Hyperlink	The Customer agrees to provide on the Customer's web page a hyperlink to Texas.gov home page and display the Texas.gov logo. The Customer will maintain the hyperlink to Texas.gov and change the URL as requested by Texas.gov.
F. EFM Receipt of Electronic Filings	<ul style="list-style-type: none"> • The Customer is responsible for receipt of filings made on Texas.gov, when the filing is available for access on the Texas.gov browser. • The Customer agrees to review electronic filings that occur on regular Customer business days and accept or reject electronic filings, unless the Customer is down or otherwise unable to review electronic filings due to circumstances beyond the Customer's control. • The Customer shall notify Vendor within fifteen (15) minutes or as soon as possible that the Customer is down or otherwise unable to electronically receive documents.
G. EFM System, Software, and Interface	<ul style="list-style-type: none"> • The Customer agrees to support reasonable efforts by Vendor to upgrade the Texas Department of Information Resources environment operating system, application server software, web server software, and hardware on Customer environments, as hosted by Vendor. • The Customer is responsible for reasonable costs associated with the development of an automated interface application that would process data available from eFiling into the Customer's systems, subject to prior written approval by the Customer. • Vendor agrees to support the Customer in creating an interface to the Department of Information Resources in a timely manner, subject to the approval of the Department of Information Resources.

<p>H. EFM Convenience Fee</p>	<p>A convenience fee is paid by the User for each completed transaction.</p> <ul style="list-style-type: none"> • Under no condition shall the Customer be responsible for payment of the convenience fee or any other payment of money under this Agreement or in relation to this Agreement. • The amount of the convenience fee is set out in Exhibit A, attached hereto and incorporated herein.
<p>I. EFM Security and Privacy</p>	<ul style="list-style-type: none"> • The Customer agrees to follow recommended security policies and procedures promulgated by Vendor from time to time. • The Vendor will assist the Customer in understanding and implementing these security policies and procedures to avoid identified risks. • The Customer agrees to comply with the privacy statements displayed on the Texas.gov site.

Evangelina Garcia

From: Steve Crain [scrain@atlashall.com]
Sent: Wednesday, July 18, 2012 8:57 AM
To: 'Evangelina Garcia'
Subject: RE: TEXAS NICUSA-E-filing and E-pay Agreement

Vangie: Ignore my previous email. The amendment is fine.

From: Evangelina Garcia [mailto:evangelina.garcia@co.hidalgo.tx.us]
Sent: Tuesday, July 17, 2012 5:17 PM
To: 'Steve Crain'
Subject: FW: TEXAS NICUSA-E-filing and E-pay Agreement

Here you go Mr. Crain.

Thank you

Vangie Y. Garcia, Contract's Manager
2802 S. Business Hwy. 281
New Administration Building
Edinburg, Texas 78539
(956) 292-7000-Extension 4856
email: evangelina.garcia@co.hidalgo.tx.us

From: Martha Salazar [mailto:martha.salazar@co.hidalgo.tx.us]
Sent: Tuesday, July 17, 2012 4:45 PM
To: 'Evangelina Garcia'
Subject: FW: TEXAS NICUSA-E-filing and E-pay Agreement

From: Steve Crain [mailto:scrain@atlashall.com]
Sent: Tuesday, July 17, 2012 3:43 PM
To: 'Martha Salazar'
Subject: RE: TEXAS NICUSA-E-filing and E-pay Agreement

Marty: Can you resend as I cannot open the amendment. Thanks.

From: Martha Salazar [mailto:martha.salazar@co.hidalgo.tx.us]
Sent: Tuesday, July 17, 2012 8:04 AM
To: scrain@atlashall.com
Cc: 'Evangelina Garcia'; 'Darlene Betancourt'
Subject: FW: TEXAS NICUSA-E-filing and E-pay Agreement
Importance: High

Mr. Crain:
Please review and comment on attached agreement. I suggest you read the text below first as it gives information.
Marty

AI-31596

Purchasing Department 18. B. 1.

CC REGULAR

Meeting Date: 07/24/2012

Department Head: Martha Salazar Submitted By: Vangie Garcia, PURCHASING DEPT.

Department: PURCHASING DEPT.

Information

CAPTION

- a. Acceptance and approval of an Interlocal Cooperation Agreement between the County Of Hidalgo and Monte Alto School Independent School District for the provision of assisting the School District by the County to pave and install curbs for the "Road Project" as identified under the following line item;
- b. Acceptance and approval of the Interlocal Cooperation Agreement Project: provision of the "Paving and Curbing of the westward extension of Valdez Street and to install curbing on the access roads and parking lots for the forthcoming Monte Alto High School" pursuant to the approval of the Interlocal Agreement as stated above

BACKGROUND

Fiscal Impact

FISCAL YEAR: _____ **ACCT. #:** _____
FUNDS AVAILABLE Y/N?: _____ **MATCHING FUNDS Y/N?:** _____

BUDGETARY IMPACT:

Please refer to Internal Comments.

Interlocal Agreement#4 - (excerpts) - District agrees to pay County for entire costs of materials, equipment and personnel used by the County for the School project. District will escrow the amount of the County's estimate for the project. County may draw from the escrow the costs of materials, equipment and personnel for such project (7) business days of receipt by District of an invoice and supporting documentation from the County.

Attachments

1
2
email

Form Review

Inbox	Reviewed By	Date
Purchasing Department	Marty Salazar	07/20/2012 02:18 PM
Budget & Management	Erika Zamora	07/20/2012 02:42 PM
Auditor's Office	Angela Garcia	07/20/2012 04:55 PM
Form Started By: Vangie Garcia		Started On: 03/21/2012 03:56 PM
	Final Approval Date: 07/20/2012	

STATE OF TEXAS §
 §
COUNTY OF HIDALGO §

**APPROVAL OF
INTERLOCAL COOPERATION AGREEMENT
PROJECT**

In accordance with Texas Government Code §791.014, Hidalgo County, Texas, acting by and through the Hidalgo County Commissioners Court, has been advised of a proposed project for the paving of the parking lot(s) for the forthcoming Monte Alto High School located as depicted in Attachment "A" attached hereto, through an Interlocal Cooperation Agreement to be entered into with the Monte Alto Independent School District and Hidalgo County.

By vote on _____ 2012, the Hidalgo County Commissioners Court has approved the Project identified above.

By: Ramon Garcia, County Judge

ATTEST:

Arturo Guajardo, County Clerk

APPROVED AS TO FORM:

Atlas, Hall & Rodriguez, L.L.P.

By: _____
Stephen L. Crain

ATTACHMENT "A"

STATE OF TEXAS §
 §
COUNTY OF HIDALGO §

INTERLOCAL COOPERATION AGREEMENT BETWEEN THE COUNTY OF HIDALGO AND MONTE ALTO INDEPENDENT SCHOOL DISTRICT

THIS Agreement is made on this the ____ day of _____, 2012, by and between the **MONTE ALTO INDEPENDENT SCHOOL DISTRICT**, hereinafter referred to as "District" and the **COUNTY OF HIDALGO, TEXAS**, hereinafter referred to as "County," pursuant to the provisions of the Texas Interlocal Cooperation Act, as follows:

WITNESSETH:

WHEREAS, the District is an independent school district located in Hidalgo County, Texas; and

WHEREAS, County is a county created in the State of Texas;

WHEREAS, District desires County to assist in paving parking lots for the new Monte Alto High School (as hereinafter defined) as more specifically depicted in Attachment A (the "Project") that is currently under construction (the "High School");

WHEREAS, District and County are authorized to enter into this Agreement pursuant to the Interlocal Cooperation Act, Tex. Gov't Code 791.001 et. seq., which authorizes local governments to contract with each other to perform governmental functions and services under the terms of the Act;

WHEREAS, District will benefit from the paving of the Project; and

WHEREAS, Hidalgo County has determined it is feasible for Hidalgo County to undertake the Project.

NOW, THEREFORE, District and County, in consideration of the mutual covenants expressed herein, agree as follows:

1. County agrees to provide all labor and equipment necessary for the Project. The District agrees to provide all materials necessary for the Project and in no event shall the County be obligated to provide materials necessary for the Project.
2. County shall provide District with man power at the current hourly rates for individuals required to complete the Project. Prior to District utilizing County

manpower, District shall request and School receive the current hourly rates of County individuals, required to complete the Project. Hourly rates shall include all benefits and other costs associated with the employment of each individual. County shall be solely responsible for determining the current rate of its personnel. Any request for use by District of County individuals shall be subject to the approval by the Commissioner of Precinct No. 1 determining that the County individuals so requested by the District are not required for projects of Precinct No. 1 at the time requested by District.

3. County will provide invoices to District with supporting documentation, including but not limited to receipts and invoices for all labor and equipment used or purchased by Hidalgo County for the Project in accordance with paragraph 4 below.
4. The District agrees to pay County for the entire cost of equipment and personnel used by the County for the Project. District agrees to make payments to County within thirty (30) days of receipt of invoices from County for same.
5. Upon a change in price for manpower for County personnel or equipment, the County shall notify the District within ten (10) working days during the term of the Project and before beginning any new work on the Project.
6. District and County shall coordinate work schedules in order to provide for minimal disruption to the construction of the High School and will use their best efforts to complete the Project within one hundred and eighty days (180) days of the date of this Agreement.
7. Following completion of the work described herein, the parties agree District shall be responsible for the maintenance of the Project.
8. Following completion of the work described herein, the parties agree that County will be released of any and all duties imposed by this Agreement.
9. Each party agrees to conform to its own applicable purchasing laws, regulations, policies, and procedures with respect to the portion of the work under this Agreement performed by each party.
10. **Termination.** Either party may terminate this Agreement with or without cause upon thirty (30) days written notice to the other.
11. **Conflict of Applicable Law.** Nothing in this Agreement shall be construed so as to require the commission of any act contrary to law, and whenever there is any conflict between and provision of their Agreement and any present or future law,

ordinance or administrative, executive or judicial regulation, order or decree, or amendment thereof, contrary to which the parties have no legal right to contract, the latter shall prevail, but in such event the affected provision or provision of this Agreement shall be modified only to the extent necessary to bring them within the legal requirements and only during the times such conflict exists.

12. **No Waiver.** No waiver by any party hereto of any breach of any provision of the Agreement shall be deemed to be a waiver of any preceding or succeeding breach of the same or any other provision hereof.
13. **Entire Agreement.** This Agreement contains the entire contract between the parties hereto and each party acknowledges that neither has made (either directly or through any agent or representative) any representation or agreement in connection with this Agreement not specifically set forth herein. This Agreement may be modified or amended only by agreement in writing executed by County and District, and not otherwise.
14. **TEXAS LAW TO APPLY.** THIS AGREEMENT SHALL BE CONSTRUED UNDER AND IN ACCORDANCE WITH THE LAWS OF THE STATE OF TEXAS, AND ALL OBLIGATION OF THE PARTIES CREATED HEREUNDER ARE PERFORMABLE IN HIDALGO COUNTY, TEXAS. THE PARTIES HEREBY CONSENT TO PERSONAL JURISDICTION IN HIDALGO COUNTY, TEXAS.
15. **Notice.** Except as may be otherwise specifically provided in this Agreement, all notices, demands, requests or communication required or permitted hereunder shall be in writing and shall either be (i) personally delivered against a written receipt, or (ii) sent by registered or certified mail, return receipt requested, postage prepaid and addressed to the parties at the addresses set forth below, or at such other addresses as may have been theretofore specified by written notice delivered in accordance herewith:

If to District: Monte Alto Independent School District
Attention: Donna Hillard, Superintendent
25149 1st Street
Monte Alto, Texas 78538

If to County: Hidalgo County, Texas
Attention: Ramon Garcia, County Judge
P.O. Box 758
Edinburg, Texas 78540-0758

With copy to : Joel Quintanilla, Commissioner, Precinct No. 1
1902 Joe Stephens Avenue

Weslaco, Texas 78596

Each notice, demand, request or communication which shall be delivered or mailed in the manner described above shall be deemed sufficiently given for all purposes at such time as it is personally delivered to the addressee or, if mailed, at such time as it is deposited in the United States mail.

16. **Additional Documents.** The parties hereto covenant and agree that they will execute such other and further instruments and documents as are or may become necessary or convenient to effectuate and carry out the terms of this Agreement.
17. **Successors.** This Agreement shall be binding upon and inure to the benefit of the parties hereto and their respective heirs, executors, administrators, legal representatives, successors, and assigns where permitted by this Agreement.
18. **Assignment.** This Agreement shall not be assignable.
19. **Headings.** The headings and captions contained in this Agreement are solely for convenience reference and shall not be deemed to affect the meaning or interpretation of any provision or paragraph hereof.
20. **Gender and Number.** All pronouns used in this Agreement shall include the other gender, whether used in the masculine, feminine or neuter gender, and singular shall include the plural whenever and so often as may be appropriate.
21. **Authority to Execute.** The execution and performance of this Agreement by District and County have been duly authorized by all necessary laws, resolutions or corporate action, and this Agreement constitutes the valid and enforceable obligations of District and County in accordance with its terms.
22. **Governmental Purpose.** Each party hereto is entering into this Agreement for the purpose of providing for governmental services or functions and will pay for such services out of current revenues available to the paying party as herein provided.
23. **Commitment of Current Revenues Only.** In the event that during any term hereof, the governing body of any party does not appropriate sufficient funds to meet the obligations of such party under this Agreement, then any party may terminate this Agreement upon ninety (90) days written notice to the other party. Each of the parties hereto agrees, however, to use its best efforts to secure funds necessary for the continued performance of this Agreement. The parties intend this provision to be a continuing right to terminate this Agreement at the expiration of each budget period of each party hereto pursuant to the provisions of Tex. Loc.

Govt. Code Ann. §271.903.

WITNESS THE HANDS OF THE PARTIES effective as of the day and year first written above.

MONTE ALTO INDEPENDENT SCHOOL DISTRICT

Donna Hilliard, Superintendent

ATTEST:

_____, Secretary

HIDALGO COUNTY

Ramon Garcia, County Judge

ATTEST:

Arturo Guajardo, County Clerk

APPROVED AS TO FORM:

ATLAS, HALL, & RODRIGUEZ, L.L.P.

BY: _____
Stephen L. Crain

ATTACHMENT A

Angela Garcia

From: Evangelina Garcia <evangelina.garcia@co.hidalgo.tx.us>
Sent: Monday, July 23, 2012 1:51 PM
To: 'Monica Badillo'; 'Angela Garcia'
Cc: 'Martha Salazar'; 'Joann'; 'Noe Montez'; 'PR county'; 'ivan.cantu';
valde.guerra@co.hidalgo.tx.us
Subject: FW: Revised ILA between County & Monte Alto ISD
Importance: High

Ladies:

As per Marty's request, please attach this email to AI#31596 for supporting documentation. Let me know if you have any questions.

Thank you

Vangie Y. Garcia, Contract's Manager
2802 S. Business Hwy. 281
New Administration Building
Edinburg, Texas 78539
(956) 292-7000-Extension 4856
email: evangelina.garcia@co.hidalgo.tx.us

From: Heather De La Garza [mailto:hdelagarza@atlashall.com]
Sent: Monday, July 23, 2012 11:48 AM
To: 'Evangelina Garcia'
Cc: 'Martha Salazar'; 'Monica Badillo'; 'Joann'; 'Noe Montez'; 'PR county'; valde.guerra@co.hidalgo.tx.us; 'ivan.cantu'
Subject: RE: Revised ILA between County & Monte Alto ISD

Hi Vangie,

I have not received confirmation from Mr. Montez or Mr. Avila that the revised documents sent to them on Friday adequately address the agreed upon terms between the County and the School District.

I also advised Mr. Montez on Friday and spoke with JoAnn Gonzalez this morning that a new Attachment A would be needed; the current one could either be revised to state that only the highlighted parking lots are what compose the scope of the project or a new Attachment A should be provided with only the parking lots highlighted. Mr. Crain has reviewed the draft of the Interlocal forwarded on Friday, but he will not sign it until he has seen and reviewed the new Attachment A. As for an escrow it was my understanding from Mr. Montez and Mr. Avila that this term needed to be removed as it was no longer an agreed upon term between the County and the School District. I hope this helps.

Regards,
Heather

Heather De La Garza
ATLAS, HALL & RODRIGUEZ, LLP
818 Pecan Blvd. (78501)
P. O. Box 3725
McAllen, Texas 78502

Main Number (956) 682-5501
Fax Number (956) 686-6109
E-mail Address hdelagarza@atlashall.com



Atlas Hall
Rodriguez

E-MAIL NOTICE -- This transmission may be: (1) subject to the Attorney-Client Privilege, (2) an attorney work product, or (3) strictly confidential. If you are not the intended recipient of this message, you may not disclose, print, copy or disseminate this information. If you have received this in error, please reply and notify the sender (only) and delete the message. Unauthorized interception of this e-mail is a violation of federal criminal law.

This communication does not reflect an intention by the sender or the sender's client or principal to conduct a transaction or make any agreement by electronic means. Nothing contained in this message or in any attachment shall satisfy the requirements for a writing, and nothing contained herein shall constitute a contract or electronic signature under the Electronic Signatures in Global and National Commerce Act, any version of the Uniform Electronic Transactions Act or any other statute governing electronic transactions.

From: Evangelina Garcia [mailto:evangelina.garcia@co.hidalgo.tx.us]
Sent: Monday, July 23, 2012 10:15 AM
To: 'Heather De La Garza'
Cc: 'Martha Salazar'; 'Monica Badillo'; 'Joann'; 'Noe Montez'; 'PR county'; valde.guerra@co.hidalgo.tx.us; 'ivan.cantu'
Subject: FW: Revised ILA between County & Monte Alto ISD
Importance: High

Good Morning Ms. De La Garza:

Did Noe and or PR Avila respond to your request of this revised Interlocal being adequate to what they discussed with you on Friday? What I had attached is what was sent to me by the Precinct, however according to that backup it would required an escrow account to be setup. I know that Noe and PR Avila spoke to me and stated otherwise which in fact would not require any escrow to be setup.

I have received several calls regarding this agenda item with some concerns and for this agenda to be on for tomorrow, I need the revised Interlocal with attached "Attachment A" including legal's approval of the Interlocal and the Project Interlocal.

At this point, I don't know if the Precinct has provided you with the response that you were asking for, if "Attachment A" is finalized and if Mr. Crain has reviewed and approved as to form in order to proceed ahead with this agenda.

Can you please get back to me on this so as to advise Marty of the situation.

Thank you

Vangie Y. Garcia, Contract's Manager
2802 S. Business Hwy. 281
New Administration Building
Edinburg, Texas 78539
(956) 292-7000-Extension 4856
email: evangelina.garcia@co.hidalgo.tx.us

From: Heather De La Garza [mailto:hdelagarza@atlashall.com]
Sent: Friday, July 20, 2012 4:43 PM
To: pr.avila@co.hidalgo.tx.us; noe.montez@co.hidalgo.tx.us

Cc: 'Evangelina Garcia'; Steve Crain

Subject: RE: Revised ILA between County & Monte Alto ISD

Importance: High

PR & Noe,

Per your request please find attached a revised draft of the Interlocal pursuant to the new terms discussed with me over the phone. If this draft adequately presents the terms of the proposed agreement please let me know. If you need any further changes please let me know as soon as possible before noon on Monday, July 23, 2012. Finally the Agreement may need a new Attachment A. I sent you a separate email regarding Attachment A. Mr. Crain has indicated he will not sign the Agreement until he has seen the new Attachment A.

Regards,
Heather

Heather De La Garza

ATLAS, HALL & RODRIGUEZ, LLP

818 Pecan Blvd. (78501)

P. O. Box 3725

McAllen, Texas 78502

Main Number (956) 682-5501

Fax Number (956) 686-6109

E-mail Address hdelagarza@atlashall.com



Atlas Hall
Rodriguez

E-MAIL NOTICE -- This transmission may be: (1) subject to the Attorney-Client Privilege, (2) an attorney work product, or (3) strictly confidential. If you are not the intended recipient of this message, you may not disclose, print, copy or disseminate this information. If you have received this in error, please reply and notify the sender (only) and delete the message. Unauthorized interception of this e-mail is a violation of federal criminal law.

This communication does not reflect an intention by the sender or the sender's client or principal to conduct a transaction or make any agreement by electronic means. Nothing contained in this message or in any attachment shall satisfy the requirements for a writing, and nothing contained herein shall constitute a contract or electronic signature under the Electronic Signatures in Global and National Commerce Act, any version of the Uniform Electronic Transactions Act or any other statute governing electronic transactions.

AI-33323

Purchasing Department 18. B. 2.

CC REGULAR

Meeting Date: 07/24/2012

Department Head: Martha Salazar Submitted By: Vangie Garcia, PURCHASING DEPT.

Department: PURCHASING DEPT.

Information

CAPTION

a. Requesting for Hidalgo County Commissioners' Court to designate and approve an Owner's Representative _____ pursuant to Article 8.3 as referred on the AIA Document A101-Agreement between Owner and Contractor and **AIA Document A201-2007-General Conditions** of the Contract for Construction (under Article 2.1.1) so as to proceed with action on the next agenda item;

b. Acceptance and approval of the Final AIA Document A101 form of agreement between Hidalgo County-Owner and Holchemont, LTD.-Contractor for the "Construction Of New Constable Precinct No. 1 Offices".

BACKGROUND

FYI: There is a "Construction Project Manager" under Contract #C-11-201-11-29 with G.A.S. Enterprises (Rene Salinas) for the "Construction Of New Constable Precinct No. 1 Offices".

Fiscal Impact

FISCAL YEAR: 2012

ACCT. #: 1336-421-00-220-042-0-720

FUNDS AVAILABLE Y/N?:

MATCHING FUNDS Y/N?:

BUDGETARY IMPACT:

FISCAL YEAR:

ACCT. #:

FUNDS AVAILABLE Y/N?:

MATCHING FUNDS Y/N?:

BUDGETARY IMPACT:

Available Balance as of 07/19/12: \$766,847.49

Attachments

Precinct's Request

Holchemont's Bid

Holchemont's Email

BACKUP

BACKUP 2

Form Review

Inbox
Purchasing Department
Auditor's Office

Reviewed By
Marty Salazar
Angela Garcia

Date
07/20/2012 04:41 PM
07/20/2012 04:55 PM
Started On: 07/18/2012 03:28 PM

Form Started By: Vangie Garcia

Final Approval Date: 07/20/2012

Evangelina Garcia

From: Joann [joann.gonzalez@co.hidalgo.tx.us]
Sent: Thursday, July 19, 2012 4:55 PM
To: 'Evangelina Garcia'
Cc: joel.quintanilla@co.hidalgo.tx.us; 'Martha Salazar'
Subject: RE: Agenda Item for Construction Of New Constable Building

Vangie,

As per the meeting I sat in with Commissioner Quintanilla, Constable Avila and Mr. Rene Salinas he is requesting that the item be placed on the agenda for the approval of awarding to Holchemont on Tuesday, July 24, 2012.

Should you have any questions or concerns please call or email me and I will inform Commissioner Quintanilla. Thank you!

Sincerely,

Joann Gonzalez

Administrative Assistant
Hidalgo County Precinct One
1902 Joe Stephens Ave, Ste. 101
Weslaco, Texas 78596
Phone: 956-973-7815
Fax: 956-973-7853
Email: joann.gonzalez@co.hidalgo.tx.us



Please consider the environment before printing this email



This e-mail and its attachments are intended only for the use of the individual or entity who is the intended recipient and may contain information that is privileged, confidential and exempt from disclosure or any type of use under applicable law. If the reader of this e-mail is not the intended recipient, or the employee, agent or representative responsible for delivering the e-mail to the intended recipient, you are hereby notified that any dissemination, distribution, copying, or other use of this e-mail is strictly prohibited. If you have received this e-mail in error, please reply immediately to the sender and delete.

From: Evangelina Garcia [mailto:evangelina.garcia@co.hidalgo.tx.us]
Sent: Thursday, July 19, 2012 4:36 PM
To: 'Joann'
Subject: Agenda Item for Construction Of New Constable Building

Ms. Joann:

Can you send me an email of the agenda request for the Constable's Construction Project so as to have supporting documentation to request to have the agenda moved to next week's court date. I know you advised me of this via telephone but if it's possible to send me the request via email for supporting backup.

As I explained to you, I have the agenda ready however, it's pending the contract since the vendor has not submitted the P&P Bonds and Insurances including legal's review as to form.

Appreciate your assistance on this.

Thanks

Vangie Y. Garcia, Contract's Manager
2802 S. Business Hwy. 281
New Administration Building
Edinburg, Texas 78539
(956) 292-7000-Extension 4856
email: evangelina.garcia@co.hidalgo.tx.us

H O L C H E M O N T , L T D .

P R O P O S A L

F O R C O N S T R U C T I O N S E R V I C E S

**BID-2012-028-05-09-MSS-
HIDALGO COUNTY
CONSTRUCTION OF NEW CONSTABLE
PRECINCT NO. 1 OFFICES
WESLACO, TEXAS**

**County's Purchasing Department
2802 S. Business Hwy 281
Edinburg, TEXAS 78541
Wednesday, May 09, 2012 at 03:00PM**

Respectfully Submitted By:
H O L C H E M O N T , L T D .
900 N. Main Street McAllen, Texas 78501
O: 956 686 2901 F: 956 686 2925

HIDALGO COUNTY PCT. 1 NEW CONSTABLE OFFICES

ALLOWANCES:

BETTERMENT	specs	\$5,000.00
Water line extension	addendum	\$2,800.00
		\$7,800.00

THE ABOVE LISTED ALLOWANCES ARE INCLUDED IN BASE BID.

SUBMITTED BY: MICHAEL CHE MONTALVO
HOLCHEMONT LTD.
9-May-12





PURCHASING DEPARTMENT
County Of Hidalgo

May 7, 2012

RE: ADDENDUM NO. 1
Project No.: 2012-028-05-09-MSS
Hidalgo County- "CONSTRUCTION OF NEW
CONSTABLE PRECINCT NO. 1 OFFICES"

Dear Gentlemen:

Attached you will find **ADDENDUM NO. 1**, in connection with **Hidalgo County**-request for Request for Bids for –**"CONSTRUCTION OF NEW CONSTABLE PRECINCT NO. 1 OFFICES"**.

Please add this **ADDENDUM NO. 1** to your bid packet so as to permit your company to submit a complete response. See original request for packet LEGAL NOTICE page 3, paragraph 9.

Acknowledge receipt of ADDENDUM NO. 1 in the bid form and signing and returning this page to us VIA FAX AT (956) 292-7612 or VIA E-MAIL TO moises.salazar@co.hidalgo.tx.us .

If you do not receive a complete **ADDENDUM NO. 1**, please notify us immediately at (956) 318-2626.

Please be advised that this **ADDENDUM NO. 1** will complete your RFB packet for **"Hidalgo County-
CONSTRUCTION OF NEW CONSTABLE PRECINCT NO. 1 OFFICES"**.

Thank you for your prompt attention to this matter.

Martha L. Salazar, CPPB
Hidalgo County Purchasing Agent

BY:

HOLCHEMONT, Ltd.
COMPANY NAME

ADDENDUM NO. 1

ACKNOWLEDGMENT OF RECEIPT

MLS/mss
Enclosures

ADDENDUM NO. 1

May 7, 2012

Hidalgo County

–“CONSTRUCTION OF NEW CONSTABLE PRECINCT NO. 1 OFFICES ”

PROJECT NO.: 2012-028-05-09-MSS

ATTACHED YOU WILL FIND ADDENDUM INFORMATION ISSUED BY ARCHITECT
CONSISTING OF 1 (one) PAGE.

I, Michael Che Montalvo acknowledge receipt of ADDENDUM NO. 1 dated, March 07, 2012, for –“Hidalgo
County-“CONSTRUCTION OF NEW CONSTABLE PRECINCT NO. 1 OFFICES ” PROJECT NO.:
2012-028-05-09-MSS.

Michael Che Montalvo

Printed Bidder Name

05-09-2012

Date

Holchemont Ltd.

Company Name

NOTE: PLEASE SUBMIT THIS ADDENDUM WITH YOUR RESPONSE, IN ORDER TO
COMPLETE PROJECT PACKET.





PURCHASING DEPARTMENT
County Of Hidalgo

May 8, 2012

RE: ADDENDUM NO. 2
Project No.: 2012-028-05-09-MSS
Hidalgo County- "CONSTRUCTION OF NEW
CONSTABLE PRECINCT NO. 1 OFFICES"

Dear Gentlemen:

Attached you will find **ADDENDUM NO. 2**, in connection with **Hidalgo County**-request for Request for Bids for **"CONSTRUCTION OF NEW CONSTABLE PRECINCT NO. 1 OFFICES"**.

Please add this **ADDENDUM NO. 2** to your bid packet so as to permit your company to submit a complete response. See original request for packet LEGAL NOTICE page 3, paragraph 9.

Acknowledge receipt of ADDENDUM NO. 2 in the bid form and signing and returning this page to us VIA FAX AT (956) 292-7612 or VIA E-MAIL TO moises.salazar@co.hidalgo.tx.us .

If you do not receive a complete **ADDENDUM NO. 2**, please notify us immediately at (956) 318-2626.

Please be advised that this **ADDENDUM NO. 2** will complete your RFB packet for **"Hidalgo County-
CONSTRUCTION OF NEW CONSTABLE PRECINCT NO. 1 OFFICES"**.

Thank you for your prompt attention to this matter.

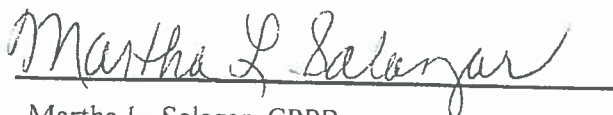

Martha L. Salazar, CPPB
Hidalgo County Purchasing Agent

BY:

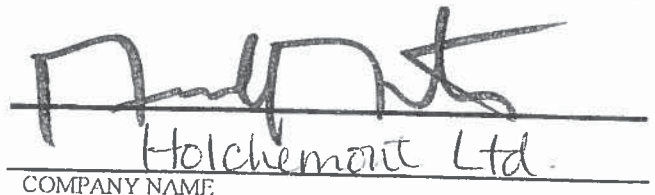
COMPANY NAME

ADDENDUM NO. 2

ACKNOWLEDGMENT OF RECEIPT

MLS/mss
Enclosures

ADDENDUM NO. 2

May 8, 2012

Hidalgo County

–“CONSTRUCTION OF NEW CONSTABLE PRECINCT NO. 1 OFFICES ”

PROJECT NO.: 2012-028-05-09-MSS

ATTACHED YOU WILL FIND ADDENDUM INFORMATION ISSUED BY ARCHITECT
CONSISTING OF 8 (eight) PAGES.

I, Michael Che Montalvo acknowledge receipt of ADDENDUM NO. 2 dated, March 08, 2012, for –“Hidalgo
County-“CONSTRUCTION OF NEW CONSTABLE PRECINCT NO. 1 OFFICES ” PROJECT NO.:
2012-028-05-09-MSS.

Michael Che Montalvo

Printed Bidder Name

05-09-2012

Date

Holchemont Ltd.

Company Name

NOTE: PLEASE SUBMIT THIS ADDENDUM WITH YOUR RESPONSE, IN ORDER TO
COMPLETE PROJECT PACKET.



ADDENDUM NO. 3

May 9, 2012

Hidalgo County

-“CONSTRUCTION OF NEW CONSTABLE PRECINCT NO. 1 OFFICES ”

PROJECT NO.: 2012-028-05-09-MSS

**ATTACHED YOU WILL FIND ADDENDUM INFORMATION ISSUED BY ARCHITECT
CONSISTING OF 3 (three) PAGES.**

I, Michael Montalvo, acknowledge receipt of ADDENDUM NO. 3 dated, March 09, 2012, for --“Hidalgo County-“CONSTRUCTION OF NEW CONSTABLE PRECINCT NO. 1 OFFICES ” PROJECT NO.: 2012-028-05-09-MSS.

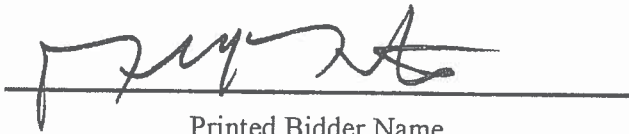

Printed Bidder Name

May 09, 2012

Date

Holchemont, Ltd

Company Name

NOTE: PLEASE SUBMIT THIS ADDENDUM WITH YOUR RESPONSE, IN ORDER TO
COMPLETE PROJECT PACKET.



PURCHASING DEPARTMENT
County Of Hidalgo

May 9, 2012

RE: ADDENDUM NO. 3
Project No.: 2012-028-05-09-MSS
Hidalgo County- "CONSTRUCTION OF NEW
CONSTABLE PRECINCT NO. 1 OFFICES "

Dear Gentlemen:

Attached you will find **ADDENDUM NO. 3**, in connection with **Hidalgo County**-request for Request for Bids for –**"CONSTRUCTION OF NEW CONSTABLE PRECINCT NO. 1 OFFICES "**.

Please add this **ADDENDUM NO. 3** to your bid packet so as to permit your company to submit a complete response. See original request for packet LEGAL NOTICE page 3, paragraph 9.

Acknowledge receipt of ADDENDUM NO. 3 in the bid form and signing and returning this page to us VIA FAX AT (956) 292-7612 or VIA E-MAIL TO moises.salazar@co.hidalgo.tx.us .

If you do not receive a complete **ADDENDUM NO. 3**, please notify us immediately at (956) 318-2626.

Please be advised that this **ADDENDUM NO. 3** will complete your RFB packet for **"Hidalgo County–
CONSTRUCTION OF NEW CONSTABLE PRECINCT NO. 1 OFFICES "**.

Thank you for your prompt attention to this matter.



Martha L. Salazar, CPPB
Hidalgo County Purchasing Agent

BY:

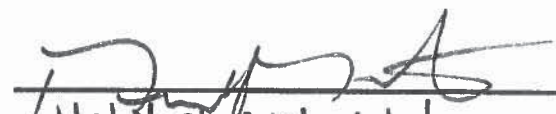

Holchemont, Ltd.
COMPANY NAME
ADDENDUM NO. 3
ACKNOWLEDGMENT OF RECEIPT

MLS/mss
Enclosures



HIDALGO COUNTY
"CONSTRUCTION OF NEW CONSTABLE PRECINCT NO. 1 OFFICES"

BID No. -2012-028-05-09-MSS

SUBMITTAL CHECK LIST
FOR COUNTY FRONT END FORMS

The following list of forms from the County "Front End Documents" must be included in the RFB response, failure to submit any of these forms may be considered non responsive.

Indicate with a check mark (✓) the Forms completed and included in response:

- Page 9 of Legal Notice
- Exhibit "C" -Acknowledgement forms (pages 3 and 4)
- Exhibit "D" -CIQ Form.
- Exhibit "E" -Proposers Affidavit
- Certification Regarding Debarment
- Vendor Bidder Application and IRS form W-9

One (1) original, Three (3) copies of complete Response, including any other documentation requested in this RFB not listed in County Front Document Forms (i.e. Bid Form, Bid Bond, Sub-Contractors List, references, etc).

Name: Holchemont, Ltd.

Signature: 

Date: 05/09/2012

EXHIBIT 'B'

BID

PROJECT: Constable's Office Building
Hidalgo County Precinct 1
Hidalgo County, Texas
RFB No. 2012-028-05-09-MSS

OPENED

3:21

5-9-12

Witnessed

PROPOSAL FROM: Holchemont, Ltd.

TO OWNER: County of Hidalgo
2802 S. Business Hwy 281
Edinburg, TX 78539



Having fully examined the Legal Notice, the General Conditions, Bonds Requirements, Specifications and Drawings related to the above project, as well as the site and conditions affecting the work, bidder proposes to furnish all materials, equipment and labor called for by the entire and completed work in accordance with before mentioned documents for the sum of:

BID: Seven Hundred and twenty four thousand DOLLARS

In words

(\$ 724,000⁰⁰)
In figures

The Undersigned hereby declares that he has visited the Site and has carefully examined the Drawings, Specifications, Contract Documents and Bidding Documents related to the Work covered by his Bid.

Upon receipt of "NOTICE OF AWARD", the Undersigned will immediately execute the formal Contract (Agreement). Bidder agrees to commence the work within 10 days of receipt of "NOTICE TO PROCEED" and to complete the construction of the project within 275 calendar days of the starting date to be stated in the "NOTICE TO PROCEED".

The Proposal, the Agreement, the Drawings, the General Conditions, Supplementary General Conditions, the Specifications and any Addenda shall all become a part of the Contract.

Bidder acknowledges receipt of the following Addenda: #1, #2, #3

If Bidder is notified of the acceptance of this Bid Proposal with sixty(90) calendar days after bid opening, bidder will enter into an agreement with the County of Hidalgo. The contract required will be AIA Document A101, latest edition, Standard Form of Agreement Between Owner and Contractor, Stipulated Sum. The corresponding General Conditions of the Contract for Construction, are a part of these specifications as if herein included in its entirety.

The Bidder, if awarded the contract, agrees to execute and deliver to the Architect within ten (10) calendar days of the Notice of Award date, satisfactory bonds in the amount of one hundred (100%) percent of Contract Sum conditioned on faithful Performance of Contract and one hundred (100%) percent Payment Bond .

The Bidder shall furnish with this proposal a cashier's check, or bid bond, in the amount of five (5%) percent of greatest amount bid. The check or bid bond shall be made payable to the Owner. The check or bid bond shall be left in escrow with the Architect at bid opening and is the measure of liquidated damages which Owner will sustain by the failure of the bidder to execute and deliver the above named agreement and bonds within ten (10) calendar days of written notification of award of contract to the bidder. The bidder agrees to forfeit to the Owner the cashier's check of bid bond if bidder does not comply with the foregoing. However, if this proposal is not accepted by the Owner within ninety (90) calendar days of the bid opening, or if the bidder is awarded the contract and executes and delivers said contract, the check, or bond, will be returned to the bidder upon receipt of the signed contract and bonds by the Owner.

In addition to Bid Bond, refer to Submittal Check List for County Front End Forms. Include items required to be submitted with Bid.

FIRM: **Holchemont, Ltd.**

SIGNED BY:

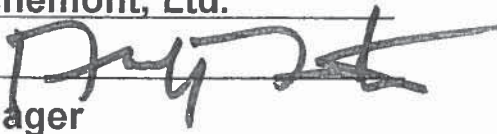

if corporation affix seal here

TITLE: **Manager**

DATE: **May 09, 2012**

ADDRESS: **900 North Main Street**
McAllen, Texas 78501

TELEPHONE: **956-686-2901**

FAX: **956-686-2925**

Insurance Requirement Acknowledgment

I, Lori A Hernandez, authorized representative for Holchemont, Ltd
Company/Vendor

hereby acknowledge receipt of the County's required insurance limits. Said requirements:

- will be acquired within 10 working days after notification from Purchasing Department of bid awarded by the Hidalgo County Commissioners' Court;
- will acquire additional amounts required to meet the County's requirements within 10 working days after notification from Purchasing Department of bid award by the Hidalgo County Commissioners' Court; currently carry the following:

Automobile Liability: \$ _____ General Liability: \$ _____

- have already been met, see attached copy of insurance certificate.

Lori A Hernandez
Authorized Representative

05-09-2012
Date

Notice to Bidder:

A certificate of insurance for the required insurance limits shall be provided to the Purchasing Department's Contract Managers in order to qualify for award of bid and to execute a contract between your Company and the County

Failure to provide Certificates of Insurance to the Purchasing Department's Contract Managers will cause the bid award to be rescinded and re-awarded to next lowest bidder. Certificates of Insurance will be monitored and verified on a **quarterly basis** to ensure coverage policy is in place. It is the Company's obligation to maintain the appropriate insurance coverage throughout the term of the contract.

THIS FORM MUST ACCOMPANY BID PACKET

**PROJECT REQUIREMENTS
ACKNOWLEDGMENT**

This is to certify that I, Michael Montalvo, possess all of the APPLICABLE:

- 1. Licenses: _____
- 2. Bonds: _____
- 3. Certificates: _____
- 4. Permits: _____
- 5. Other: _____

necessary to carry out the required project. Furthermore, I am providing copies of the required documentation so that, if my company is awarded this bid, I may be eligible to enter into a contract with Hidalgo County and proceed to complete the project in a timely manner.

* Any licenses, bonds, certificates, permits, etc. which are required must be presented as part of the bid packet in order to expedite the bid evaluation process. Failure to provide said documentation will result in the disqualification of your bid.

Authorized Signature

05/09/2012
Date

Holchemont, Ltd.
Company

900 North Main Street
Address

McAllen, Texas 78501
City, State, Zip

CONFLICT OF INTEREST QUESTIONNAIRE

FORM CIQ

For vendor or other person doing business with local governmental entity

This questionnaire reflects changes made to the law by H.B. 1491, 80th Leg., Regular Session. This questionnaire is being filed in accordance with Chapter 176, Local Government Code by a person who has a business relationship as defined by Section 176.001(1-a) with a local governmental entity and the person meets requirements under Section 176.006(a).

By law this questionnaire must be filed with the records administrator of the local governmental entity not later than the 7th business day after the date the person becomes aware of facts that require the statement to be filed. See Section 176.006, Local Government Code.

A person commits an offense if the person knowingly violates Section 176.006, Local Government Code. An offense under this section is a Class C misdemeanor.

OFFICE USE ONLY

Date Received

1 Name of person who has a business relationship with local governmental entity.

2 Check this box if you are filing an update to a previously filed questionnaire.

(The law requires that you file an updated completed questionnaire with the appropriate filing authority not later than the 7th business day after the date the originally filed questionnaire becomes incomplete or inaccurate.)

3 Name of local government officer with whom filer has employment or business relationship.

Name of Officer

This section (item 3 including subparts A, B, C & D) must be completed for each officer with whom the filer has an employment or other business relationship as defined by Section 176.001(1-a), Local Government Code. Attach additional pages to this Form CIQ as necessary.

A. Is the local government officer named in this section receiving or likely to receive taxable income, other than investment income, from the filer of the questionnaire?

Yes No

B. Is the filer of the questionnaire receiving or likely to receive taxable income, other than investment income, from or at the direction of the local government officer named in this section AND the taxable income is not received from the local governmental entity?

Yes No

C. Is the filer of this questionnaire employed by a corporation or other business entity with respect to which the local government officer serves as an officer or director, or holds an ownership of 10 percent or more?

Yes No

D. Describe each employment or business relationship with the local government officer named in this section.

4

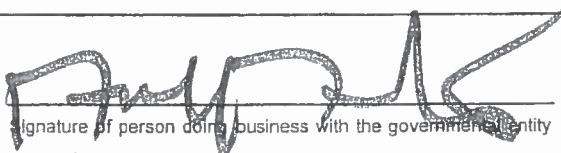
Signature of person doing business with the governmental entity

05/09/2012

Date

PROPOSER'S AFFIDAVIT
Exhibit "E"

PROPOSER'S AFFIDAVIT OF NON-COLLUSION
NON-CONFLICT OF INTEREST, AND ANTI-LOBBYING

STATE OF TEXAS
COUNTY OF HIDALGO

Affiant, Michael Montalvo, being first duly sworn, deposes that:

(1) Affiant does hereby state neither the Proposer nor any of the Proposer's officers, partners, owners, agents, representatives, employees, or parties in interest, has in any way colluded, conspired, agreed, directly or indirectly with any person, firm, corporation, or other proposer, or potential proposer, to provide any money or other valuable consideration for assistance in procuring or attempting to procure a contract or fix the prices in the attached proposed or the proposal of any other proposer, and further states that no such money or other reward will be hereinafter paid.

(2) Affiant further states they have neither recommended or suggested to Hidalgo County or any of its officials or employees, any of the terms or provisions set forth in their Request for Proposal and subsequent agreement, except at a meeting open to all interested proposers, of which proper notice was given.

(3) Affiant, further states their officers, employees, or agents have not, and will not attempt to lobby, directly or indirectly, the Hidalgo County Commissioner's Court between proposal submission date and award by the Hidalgo County Commissioner's Court.

(4) Affiant further states no officer, or stockholder of the Proposer is a member of the staff, or related to any employee of the Hidalgo County except as noted herein below:

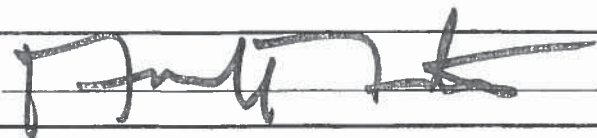
Signature/Title: 

Subscribed and sworn to before me this 09 day of 05, 2012.

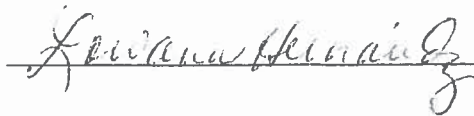

Notary Public

My commission expires: January 18, 2016



**Certification
Regarding Debarment, Suspension Ineligibility**

As is required by the Federal Regulations Implementing Executive Order 12549, Debarment and Suspension, 45 CFR Part 76, Government-wide Debarment and Suspension, in the applicant certifies, to the best of his or her knowledge and belief, that both it and its principals:

- a. Are not presently debarred, suspended, proposed for debarment, declared ineligible, or voluntarily excluded from participation in this transaction by any federal department or agency;
- b. Have not within a three-year period preceding this bid/proposal and/or application been convicted of or had a civil judgment rendered against them for commission of fraud or a criminal offense in connection with obtaining, attempting to obtain, or performing a public (federal, state or local) transaction or contract under a public transaction, violation of federal or state antitrust statutes or commission of embezzlement, theft, forgery, bribery, falsification or destruction of records, making false statements, or receiving stolen property;
- c. Are not presently indicted for or otherwise criminally or civilly charged by a government entity with commission of any of the offenses enumerated herein; and
- d. Have not within a three-year period preceding this bid/proposal and/or application had one or more public transactions terminated of cause or default.

Signature: _____



Print Name: **Michael Montalvo**

Title: **Manager**

Telephone Number: **956-686-2901**

Date: **May 09, 2012**

If the proposer is unable to certify to all of the statements in this Certification, such proposer should attach an explanation to this proposal.

HIDALGO COUNTY PURCHASING DEPARTMENT Proposer/Vendor Application

Complete in print or type. Please return this application to the Hidalgo County Purchasing Department
thru Facsimile: (956) 318-2629,
in person or regular mail to: 2802 South Hwy 281, Edinburg, Texas 78539
or e-mail: purchasing@co.hidalgo.tx.us

Company Name: Holchemont, Ltd. Telephone No. (956) 686 2901	
dba Name:	
Legal Name: Holchemont, Ltd.	
Mailing Address : 900 N. Main Street Fax No. (956) 686 2925	
Physical Address:	
City, State, Zip McAllen, TX 78501 Tax I.D. No. 26-3913182	
Remit to Address : City, State, Zip McAllen, TX, 78501	
E-Mail Address: bids@holchemont.com	
Representative(s) Name(s) & Title(s) Michael Montalvo - Manager	
Type of Organization (check one): <input type="checkbox"/> Individual <input checked="" type="checkbox"/> Partnership <input type="checkbox"/> Corporation <input type="checkbox"/> Non-Profit <input type="checkbox"/> LLC <input type="checkbox"/> Sole Proprietor <input type="checkbox"/> Other, Specify _____	
State Identification No. _____ (Please attached completed W-9 form with this application)	
Federal Identification No. or (if individual) SS No. _____	
State of Incorporation: _____ Date: _____ Other: _____	
Type of Business (check one): <input type="checkbox"/> Manufacturer <input type="checkbox"/> Wholesaler <input type="checkbox"/> Retailer <input type="checkbox"/> Broker <input type="checkbox"/> Distributor <input type="checkbox"/> Service Organization <input type="checkbox"/> Other, Specify _____	
Name & Title of Person(s) Authorized to Sign Bids, Proposals, and/or Contracts: Michael Montalvo - Manager	
Small and/or Disadvantaged Business Information (check application criteria)	
Small Business:	Disadvantaged Business (At Least 51% Ownership)
<ul style="list-style-type: none"> •• Less than 125,000 annual gross receipt •• Less than 250,000 annual gross receipt •• Less than 499,000 annual gross receipt •• More than 500,000 annual gross receipt 	<ul style="list-style-type: none"> •• Black American •• Hispanic American •• Asian Pacific American •• Native American •• Women •• Other
Have you been certified as a HUB or an MBE/WBE source?: •• Yes •• No	
Indicate Certification No.(s): _____ or are Certificate(s) attached?: •• Yes •• No	
What type of product(s) is/are solicited by your company?: _____	
Would you like to be provided with specifications for procurements of such products?: • Yes • No	
To Be Completed by the County: Rec'd by (Purchasing): _____ Date Rec'd by (Purchasing): _____	
Date Forwarded Information to Auditor's Office: _____ Entry Date: _____ Vendor No.: _____	

**Request for Taxpayer
 Identification Number and Certification**

Give Form to the
 requester. Do not
 send to the IRS.

See Specific Instructions on page 2.

Name (as shown on your income tax return)
HOLCHEMONT, LTD.

Business name/disregarded entity name, if different from above

Check appropriate box for federal tax classification:
 Individual/sole proprietor C Corporation S Corporation Partnership Trust/estate

Limited liability company. Enter the tax classification (C=C corporation, S=S corporation, P=partnership) ▶ **P** Exempt payee

Other (see instructions) ▶

Address (number, street, and apt. or suite no.)
900 N MAIN ST

City, state, and ZIP code
MCALLEN TX 78501-4327

List account number(s) here (optional)

Requester's name and address (optional)

Part I Taxpayer Identification Number (TIN)

Enter your TIN in the appropriate box. The TIN provided must match the name given on the "Name" line to avoid backup withholding. For individuals, this is your social security number (SSN). However, for a resident alien, sole proprietor, or disregarded entity, see the Part I instructions on page 3. For other entities, it is your employer identification number (EIN). If you do not have a number, see *How to get a TIN* on page 3.

Social security number

			-			-					
--	--	--	---	--	--	---	--	--	--	--	--

Note. If the account is in more than one name, see the chart on page 4 for guidelines on whose number to enter.

Employer identification number

2	6	-	3	9	1	3	1	8	2
---	---	---	---	---	---	---	---	---	---

Part II Certification

- Under penalties of perjury, I certify that:
- The number shown on this form is my correct taxpayer identification number (or I am waiting for a number to be issued to me), and
 - I am not subject to backup withholding because: (a) I am exempt from backup withholding, or (b) I have not been notified by the Internal Revenue Service (IRS) that I am subject to backup withholding as a result of a failure to report all interest or dividends, or (c) the IRS has notified me that I am no longer subject to backup withholding, and
 - I am a U.S. citizen or other U.S. person (defined below)

Certification instructions. You must cross out item 2 above if you have been notified by the IRS that you are currently subject to backup withholding because you have failed to report all interest and dividends on your tax return. For real estate transactions, item 2 does not apply. For mortgage interest paid, acquisition or abandonment of secured property, cancellation of debt, contributions to an individual retirement arrangement (IRA), and generally, payments other than interest and dividends, you are not required to sign the certification, but you must provide your correct TIN. See the instructions on page 4.

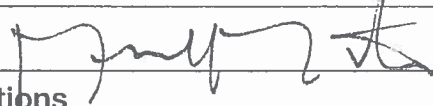
Sign Here Signature of U.S. person ▶ 

Date ▶ **07 MAR 12**

General Instructions

Section references are to the Internal Revenue Code unless otherwise noted.

Purpose of Form

A person who is required to file an information return with the IRS must obtain your correct taxpayer identification number (TIN) to report, for example, income paid to you, real estate transactions, mortgage interest you paid, acquisition or abandonment of secured property, cancellation of debt, or contributions you made to an IRA.

Use Form W-9 only if you are a U.S. person (including a resident alien), to provide your correct TIN to the person requesting it (the requester) and, when applicable, to:

- Certify that the TIN you are giving is correct (or you are waiting for a number to be issued),
- Certify that you are not subject to backup withholding, or
- Claim exemption from backup withholding if you are a U.S. exempt payee. If applicable, you are also certifying that as a U.S. person, your allocable share of any partnership income from a U.S. trade or business is not subject to the withholding tax on foreign partners' share of effectively connected income.

Note. If a requester gives you a form other than Form W-9 to request your TIN, you must use the requester's form if it is substantially similar to this Form W-9.

Definition of a U.S. person. For federal tax purposes, you are considered a U.S. person if you are:

- An individual who is a U.S. citizen or U.S. resident alien,
- A partnership, corporation, company, or association created or organized in the United States or under the laws of the United States,
- An estate (other than a foreign estate), or
- A domestic trust (as defined in Regulations section 301.7701-7).

Special rules for partnerships. Partnerships that conduct a trade or business in the United States are generally required to pay a withholding tax on any foreign partners' share of income from such business. Further, in certain cases where a Form W-9 has not been received, a partnership is required to presume that a partner is a foreign person, and pay the withholding tax. Therefore, if you are a U.S. person that is a partner in a partnership conducting a trade or business in the United States, provide Form W-9 to the partnership to establish your U.S. status and avoid withholding on your share of partnership income.

AIA[®] Document A305™ – 1986

Contractor's Qualification Statement

The Undersigned certifies under oath that the information provided herein is true and sufficiently complete so as not to be misleading.

SUBMITTED TO: 2010 Updated Document

ADDRESS:

SUBMITTED BY: Holchenont, Ltd.

NAME: Michael Montalvo

ADDRESS: 900 N. Main St.
McAllen, Texas 78501

PRINCIPAL OFFICE:

- Corporation
 Partnership
 Individual
 Joint Venture
 Other

NAME OF PROJECT (if applicable):

FOR POTENTIAL PROJECTS,

TYPE OF WORK (file separate form for each Classification of Work):

- General Construction
 HVAC
 Electrical
 Plumbing
 Other (please specify)

§ 1. ORGANIZATION

§ 1.1 How many years has your organization been in business as a Contractor?
3 Years

§ 1.2 How many years has your organization been in business under its present business name?
3 Years

§ 1.2.1 Under what other or former names has your organization operated?

None

§ 1.3 If your organization is a corporation, answer the following:

§ 1.3.1 Date of Incorporation: 8-22-07

AIA Document A305™ – 1986. Copyright © 1984, 1987, 1979 and 1984 by The American Institute of Architects. All rights reserved. WARNING: This AIA[®] Document is protected by U.S. Copyright Law and International Treaties. Unauthorized reproduction or distribution of this AIA[®] Document, or any portion of it, may result in severe civil and criminal penalties, and will be prosecuted to the maximum extent possible under the law. This document was produced by AIA software at 16:40:50 on 11/11/2009 under Order No. 1000370510_1 which expires on 09/20/09, and is not for resale. User Notice

ADDITIONS AND DELETIONS:

The author of this document has added information needed for its completion. The author may also have revised the text of the original AIA standard form. An *Additions and Deletions Report* that notes added information as well as revisions to the standard form text is available from the author and should be reviewed. A vertical line in the left margin of this document indicates where the author has added necessary information and where the author has added to or deleted from the original AIA text.

This document has important legal consequences. Consultation with an attorney is encouraged with respect to its completion or modification.

This form is approved and recommended by the American Institute of Architects (AIA) and The Associated General Contractors of America (AGC) for use in evaluating the qualifications of contractors. No endorsement of the submitting party or verification of the information is made by AIA or AGC.

§ 1.3.2 State of incorporation:
§ 1.3.3 President's name:
§ 1.3.4 Vice-president's name(s):

§ 1.3.5 Secretary's name:
§ 1.3.6 Treasurer's name:

§ 1.4 If your organization is a partnership, answer the following:

§ 1.4.1 Date of organization: 8-22-07
§ 1.4.2 Type of partnership (if applicable): Domestic Limited Partnership
§ 1.4.3 Name(s) of general partner(s): Holchemont Management, LLC
Michael Montalvo, Its Manager

§ 1.5 If your organization is individually owned, answer the following:

§ 1.5.1 Date of organization:
§ 1.5.2 Name of owner:

§ 1.6 If the form of your organization is other than those listed above, describe it and name the principals:

§ 2. LICENSING

§ 2.1 List jurisdictions and trade categories in which your organization is legally qualified to do business, and indicate registration or license numbers, if applicable.

§ 2.2 List jurisdictions in which your organization's partnership or trade name is filed.

§ 3. EXPERIENCE

§ 3.1 List the categories of work that your organization normally performs with its own forces.

Construction Management	Fixture Installation	Specialties
Demolition	Doors & Hardware	Rough Carpentry

§ 3.2 Claims and Suits. (If the answer to any of the questions below is yes, please attach details.)

§ 3.2.1 Has your organization ever failed to complete any work awarded to it?

No.

§ 3.2.2 Are there any judgments, claims, arbitration proceedings or suits pending or outstanding against your organization or its officers?

No.

§ 3.2.3 Has your organization filed any law suits or requested arbitration with regard to construction contracts within the last five years?

No.

§ 3.3 Within the last five years, has any officer or principal of your organization ever been an officer or principal of another organization when it failed to complete a construction contract? (If the answer is yes, please attach details.)

No.

§ 3.4 On a separate sheet, list major construction projects your organization has in progress, giving the name of project, owner, architect, contract amount, percent complete and scheduled completion date.

Schedule A

§ 3.4.1 State total worth of work in progress and under contract:

\$1,079,934.00

§ 3.5 On a separate sheet, list the major projects your organization has completed in the past five years, giving the name of project, owner, architect, contract amount, date of completion and percentage of the cost of the work performed with your own forces.

Schedule B

§ 3.5.1 State average annual amount of construction work performed during the past five years:

\$1.5M

§ 3.8 On a separate sheet, list the construction experience and present commitments of the key individuals of your organization.

Schedule C

§ 4. REFERENCES

§ 4.1 Trade References:

Schedule D

§ 4.2 Bank References:

Schedule E

§ 4.3 Surety:

§ 4.3.1 Name of bonding company:

GBA Contract Bond Agency

§ 4.3.2 Name and address of agent:

Fred A. Thetford, Jr.
3817 Alamo Avenue
Fort Worth, TX 76107

§ 5. FINANCING

§ 5.1 Financial Statement.

§ 5.1.1 Attach a financial statement, preferably audited, including your organization's latest balance sheet and income statement showing the following items:

Furnished upon written request only.

Current Assets (e.g., cash, joint venture accounts, accounts receivable, notes receivable, accrued income, deposits, materials inventory and prepaid expenses);

Net Fixed Assets;

Other Assets;

Current Liabilities (e.g., accounts payable, notes payable, accrued expenses, provision for income taxes, advances, accrued salaries and accrued payroll taxes);

Other Liabilities (e.g., capital, capital stock, authorized and outstanding shares par values, earned surplus and retained earnings).

§ 5.1.2 Name and address of firm preparing attached financial statement, and date thereof:

LORENA CASTILLO, CPA with NEGRETE & ASSOCIATES
956.683.8171

§ 5.1.3 Is the attached financial statement for the identical organization named on page one?

NOT APPLICABLE

§ 5.1.4 If not, explain the relationship and financial responsibility of the organization whose financial statement is provided (e.g., parent-subsidiary).

§ 5.2 Will the organization whose financial statement is attached act as guarantor of the contract for construction?

§ 6. SIGNATURE

§ 6.1 Dated at this  th day of December, 2010

Name of Organization: Holchemont, Ltd.

By: Michael Montalvo

Title: Manager

§ 6.2

I, being duly sworn, deposes and says that the information provided herein is true and sufficiently complete so as not to be misleading.

Subscribed and sworn before me this th day of Dec20 2010

Notary Public:

My Commission Expires: January 18, 2012

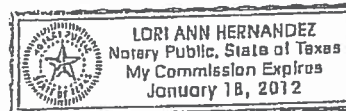

SCHEDULE A

Projects	Owner	Architect/Designer	Contract Amount	Percent Complete	Scheduled Completion
1 Nuestra Clinica del Valle SAN JUAN	Nuestra Clinica	ROFA Architects Inc.	1.4M	80%	15-Dec-11
2 Our Lady of Mercy Classroom Renovations	Diocese of Brownsville	Diocese of Brownsville	80m	50%	1-Oct-11
3 HCA Cath Lab Expansion VRMC	HCA Facilities Corp	Neas Architects, Inc.	997m	95%	23-Sep-11
4 Sharyland ISD Science Lab Reno	Sharyland ISD	Gomez Mendez Saenz	189m	100%	15-Sep-11
5 City of Escobares Fire Station	City of Escobares	Milnet Architectural Svcs.	503m	100%	27-Jun-11
6 Sun Strip Center Remodel	Sun Investments	Milnet Architectural Svcs.	307m	100%	30-Apr-11
7 COM Northbound Canopy	City of McAllen	McAllen Engineering	55 m	100%	16-Feb-11
8 Pollo Palenque Restaurant Remodel	Palenque Real Esialta	Arqcarpa	331m	100%	15-Feb-11

SCHEDULE B

Projects	Owner	Architect/Designer	Contract Amount	Completed	Self Performed
1 Inter National Bank	Carlos Garza	PBSJ	1.2 M	SEPT 05	1%
2 Inter National Bank (TI)	Carlos Garza	PBSJ	285 K	AUG 06	1%
3 Orange Plaza	Mario Von Chong	IDEO	860 K	NOV 07	1%
4 Rio Grande Regional Hospital (PICU)	HCA	HCA/ Facilities Services Group	638 K	MAY 08	1%
5 Rio Grande Regional Hospital (ER)	HCA	HCA/ Facilities Services Group	400 K	NOV 07	1%
7 Boot Jack Plaza	Alex Masso	N/A	1.1 M	NOV 07	1%

SCHEDULE C

	Key Personnel	Experience	Responsibilities	Commitments
1	Michael C. Montalvo	15 yrs	Senior Project Manager	Project Management for ALL projects
2	Bernardo Gonzalez	28 yrs	Superintendent	Superintendent
3	Fred Lopez	23 yrs	Estimator - Project Management	Estimating, Project Management
4	Rumaldo Guerra	11 yrs	Superintendent	Managing single project
5	Lori A. Hernandez	4 yrs	General Project Management (OFFICE)	General Project Management (ALL)
6	Samantha Rodriguez	1 yr	General Office	Clerical support

SCHEDULE D

Trade References

*** Spence Concrete**

P.O.Box 2767
McAllen, TX 78502
Contact: Esmer Mirabal
Phone: 956-682-5551
Fax: 956-682-2607

*** RGV Reprographics**

519 S. Broadway
McAllen, TX 78505
Contact: Teresa Smith
Phone: 956-686-1525
Fax: 956-686-1528

*** ERICO Building Systems, LLC**

3719 W. Mile 17 ½ Rd.
Edinburg, TX 78539
Contact: Eric Garcia
Phone: 956-789-0794
Fax: 956-287-8692

*** Faires Plumbing Co., Inc.**

P O Box 1199
Edinburg, TX 78540
Contact: Kenny Faires
Phone: 956-802-9308
Fax: 956-383-7382

SCHEDULE E

INTER NATIONAL BANK
730 W. NOLANA LOOP
MC ALLEN, TX 78504
Joel Castellano, Branch Manager
956 682-3243

LONE STAR NATIONAL BANK
206 W. FERGERSON
PHARR, TX 78577
DAVID DEANDA, PRESIDENT
956 984-2684

IBC
1 SOUTH BROADWAY
MC ALLEN, TX 78501
DAVID GUERRA, PRESIDENT
956 686-0263

Joel Castellano
Branch Manager/Administrative Officer

May 8 2012

**RE: Michael Montalvo
Holchemont Ltd**

To Whom It May Concern:

It gives us great pleasure to introduce Mr. Michael Montalvo, owner of Holchemont LTD to your company. Mr. Montalvo is currently a customer of Inter National Bank and has maintained an excellent relationship with our financial institution since 2005.

Mr. Montalvo has a Business Checking Accounts with a large balances.

Any courtesies extended to him will be greatly appreciated by us.

If we may be of further assistance, please feel free to contact me personally at 956-682-3243.

Sincerely,



Joel Castellano
Branch Manager



PREVIOUS CLIENTS

Organizations for whom Respondent has previously provided services of equal type and scope within the past five (5) years as verbal request at the pre-bid conference.

- | | | |
|---|--|--------------|
| 1. Karen Valdez, VP, Inter National Bank, | INB-Weslaco Branch Project | 956-664-8400 |
| 2. Yoghesh Bhatt, Subway Development, | Subway Restaurant, McAllen, TX | 956-928-0686 |
| 3. Greg Seiler, CEO, HCA | Rio Grande Reg. Hosp. McAllen, TX | 956-632-6000 |
| 4. Sergio Loya, HCA | Valley Reg. Med. Ctr., Brownsville, TX | 956-350-7101 |
| 5. John Sun, Owner | Nolana Strip Center, McAllen, TX | 956-279-9837 |

PROJECT TEAM

Michael C. Montalvo - Manager

Responsibilities:

- Coordinate all preconstruction activities and oversee the administration of the construction phase of the contract.
- Develop an overall project schedule from preconstruction through construction.
- Negotiate subcontracts
- Be responsible for cost control
- Administer all subcontracts
- Planning for efficiency and coordination of trades
- Review project shop drawings and coordinate field dimensions
- Accurate pricing for each phase of the project
- Package competitively bid subcontracted work

Bernardo Gonzalez - Superintendent and Project Manager

Responsibilities:

- Attendance at preconstruction meetings
- Be responsible to the owner for all project communication through preconstruction, construction, closeout and commissioning
- Managing all on-site construction activity
- Coordinate weekly progress meetings and safety meetings
- Subcontractor coordination
- Submit daily reports on a weekly basis including meeting attendance

Lori Hernandez - Assistant Project Manager

Responsibilities:

- Assist with distribution of subcontracts
- Administer all purchase orders
- Maintaining records of field testing
- Oversee document control
- Expedite approvals and deliveries

MICHAEL C. MONTALVO

Objective: providing quality commercial construction services.

2004 - Present

HOLCHEMONT, LTD.: Manager

MONTALVO CONSTRUCTION, LLC: President

Responsible for project management, estimating, administration of staff, general supervision of jobsites; and all other aspects of commercial construction from start to finish.

PROJECTS include:

- OSUKA Restaurant, McAllen, TX - \$1.1 M
- Boot Jack Plaza, Boot Jack TI McAllen, TX - \$1.4 M
- Rio Grande Regional Hospital RICU & PACU, McAllen, TX \$550 K
- Rio Grande Regional Hospital ER Renovations, McAllen, TX \$425 K
- Trenton Plaza, McAllen, TX - \$950 K
- Inter National Bank, McAllen, TX - \$1.1 M
- Tex Best Travel Center, Dilley, TX - \$1.3 M
- Centro Plaza, McAllen, TX - \$527 K
- Church's Chicken Restaurant, Edinburg, TX - \$330 K
- Orange Plaza, McAllen, TX - \$900 K
- Subway Restaurant, McAllen, TX - \$282 K
- Inter National Bank, Weslaco, TX - \$1.3 M
- Villarreal Restaurant, McAllen, TX - \$650 K
- City of Escobares Fire Station, Escobares, TX - \$475 K
- HCA Cath Lab Expansion VRMC, Brownsville, TX - \$996 K
- Nolana Strip Center Remodel, McAllen, TX - \$285 K

SPAUGLASS Contractors Inc.

Superintendent

2000-2004

- *Edinburg North HS Auditorium and Renovation* \$7.24 M
- Lantana Trade Center, Harlingen, TX - \$1.4 M
- Air Traffic Control Tower, Corpus Christi, TX - \$18.7 M
- UT Pan American General Classroom and Computer Center Building, Edinburg, TX - \$14.5 M
- Austin Convention Center Expansion & Remodel \$72.2 M



VALLEY REGIONAL Hospital Corporation of America
Medical Center



STC
South Texas College



09 MAY 2012

PROPOSAL RESPONSE

SIMILAR PROJECTS INCLUDE

HCA CATH LAB EXPANSION

BROWNSVILLE, TEXAS

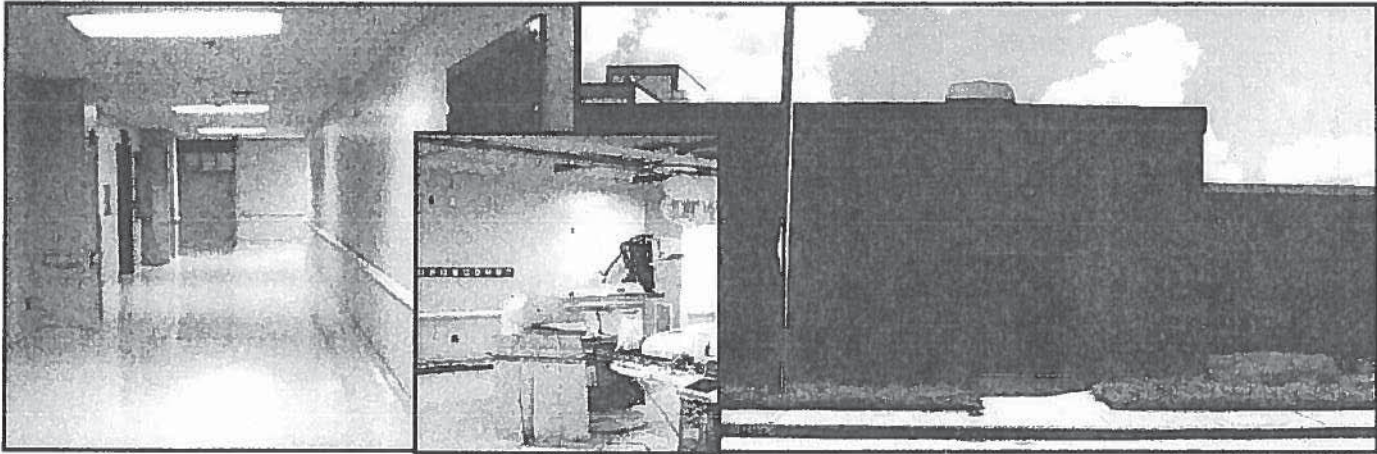

NUESTRA CLINICA DEL VALLE

SAN JUAN, TEXAS

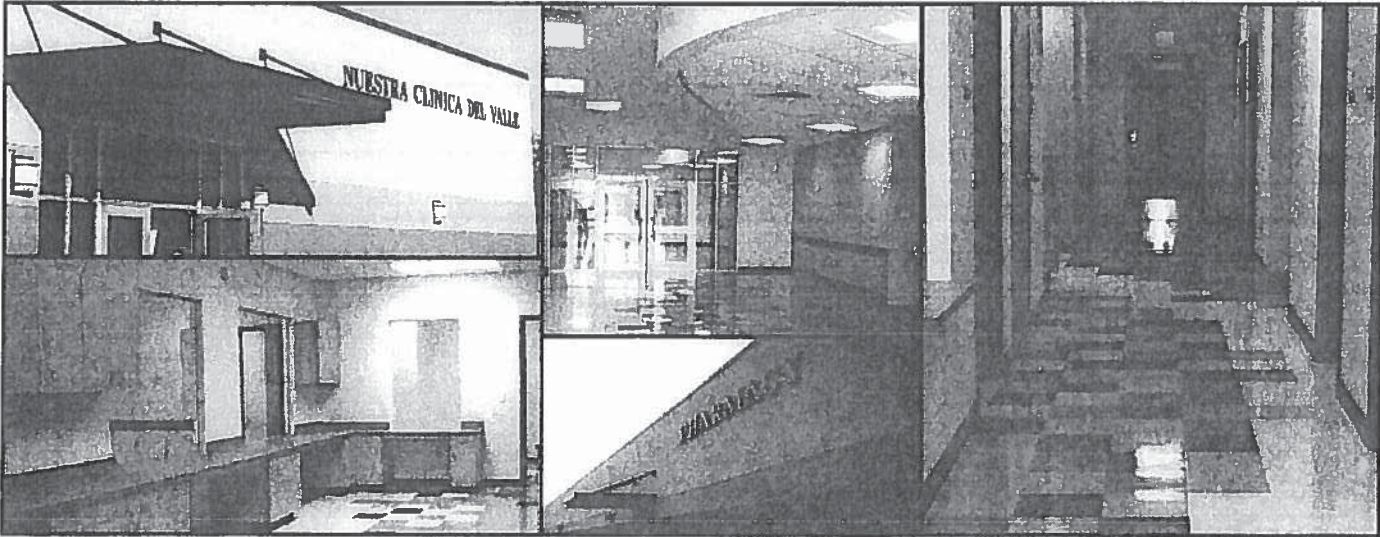

SIMILAR PROJECTS INCLUDE

SHARYLAND HIGH SCHOOL SCIENCE LAB RENOVATIONS

SHARYLAND, TEXAS

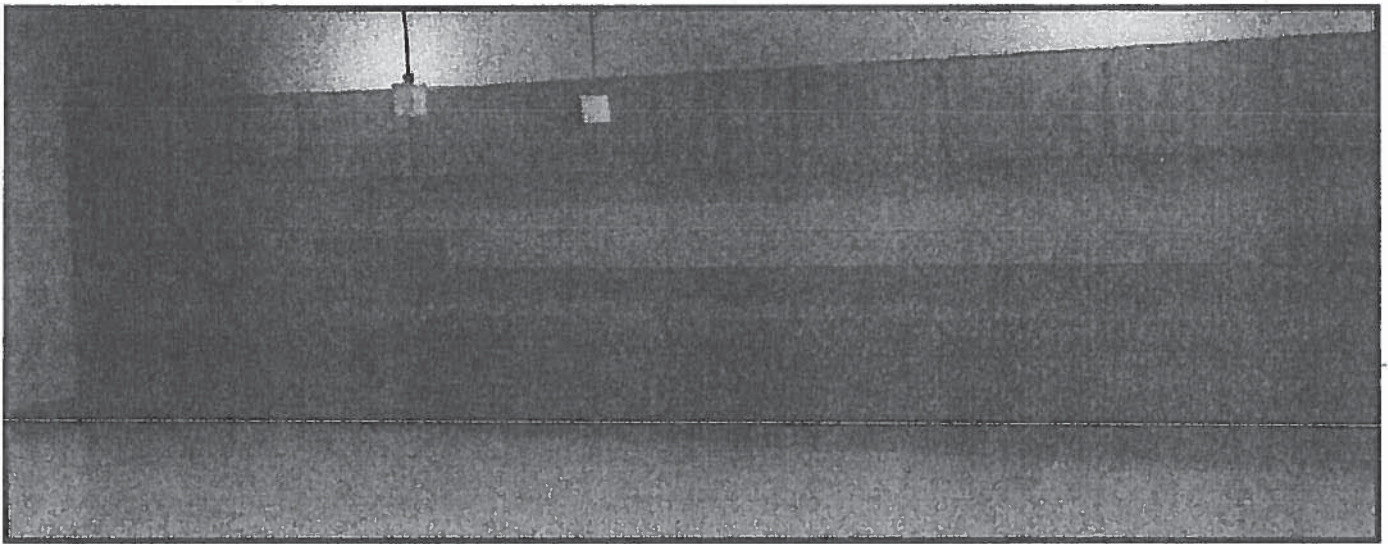

RIO GRANDE REGIONAL HOSPITAL - PICU REMODEL

MCALLEN, TEXAS

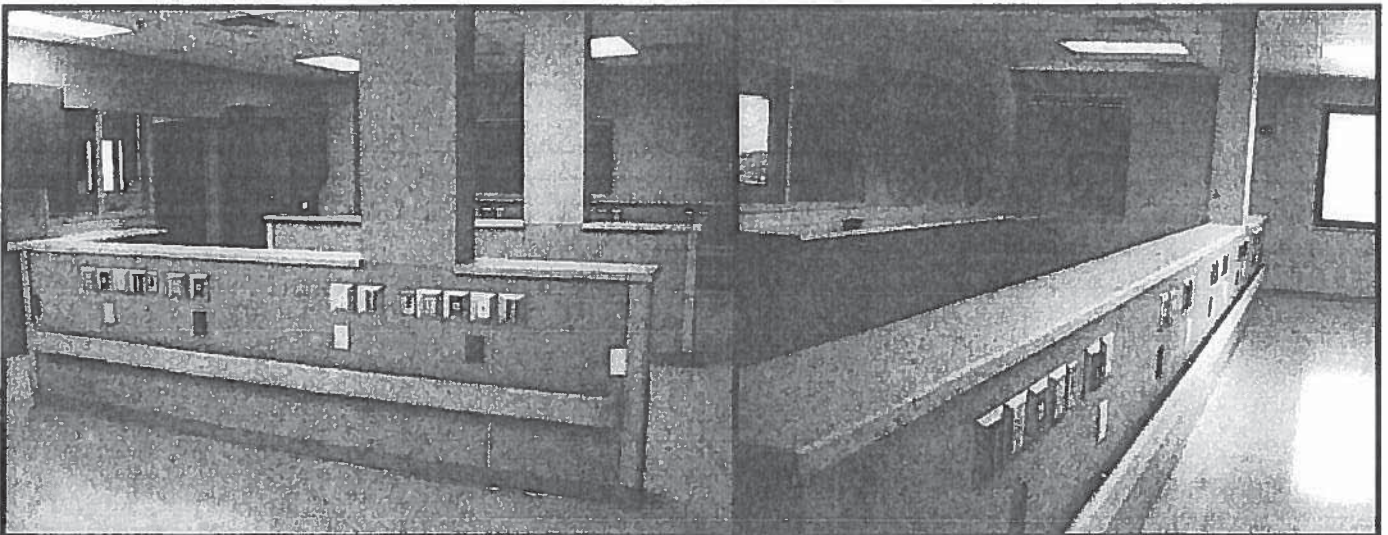

SIMILAR PROJECTS

Michael C. Montalvo

- STC Child Development Center Covered Walkways, McAllen, TX
- HCA Cath Lab Expansion VRMC Brownsville, TX
- STC Modular Building Improvements, Weslaco, TX
- TSTC Engineering Center Upgrade, Harlingen, TX
- Sharyland High School Science Lab Renovations, Mission, TX

President - Montalvo Construction

- IDEA New Administration Building, Weslaco, TX
- Rio Grande Regional Hospital RICU & PICU McAllen, TX
- Rio Grande Regional Hospital ER Renovations McAllen, TX

Superintendent - SpawGlass

- Edinburg North HS Auditorium and Renovation, Edinburg, TX
- UT Pan American General Classroom and Computer Center Building, Edinburg, TX
- Americo Paredes Elementary School, Brownsville, TX

Bernardo Gonzalez

Superintendent and Project Manager - Holchemont, Ltd.

- STC Child Development Center Covered Walkways, McAllen, TX
- STC Modular Building Improvements, Weslaco, TX
- TSTC Engineering Center Upgrade, Harlingen, TX

Superintendent - D Wilson Construction Co.

- Veterans High School, Brownsville, TX

Superintendent - SpawGlass

- Americo Paredes Elementary School, Brownsville, TX
- UT Pan American Academic Health Center, Edinburg, TX

Superintendent - Terry Ray Construction

- Olivera Middle School Classroom Addition, Brownsville, TX
- Stell Middle School Faculty Addition, Brownsville, TX

Evangelina Garcia

From: Evangelina Garcia [evangelina.garcia@co.hidalgo.tx.us]
Sent: Friday, July 20, 2012 4:13 PM
To: 'Martha Salazar'
Subject: FW: Hid Co Pct 1 New Constable Offices

Marty:

Here's the email from Holchemont on the P&P Bonds and I still have not received the copies and or the insurance certificates.

Thank you

Vangie Y. Garcia, Contract's Manager
2802 S. Business Hwy. 281
New Administration Building
Edinburg, Texas 78539
(956) 292-7000-Extension 4856
email: evangelina.garcia@co.hidalgo.tx.us

From: Evangelina Garcia [mailto:evangelina.garcia@co.hidalgo.tx.us]
Sent: Friday, July 20, 2012 2:38 PM
To: 'lori@holchemont.com'
Cc: 'Melissa Perez'
Subject: RE: Hid Co Pct 1 New Constable Offices

Ms. Hernandez:

Send me the copy of the P&P Bond including the insurance certificate so as to have our legal review as form of the AIA including the P&P and insurances. I'm not sure if he will accept the copy but go ahead and send me the information. Should he accept the copy and the insurances then have the originals delivered to my attention at the Hidalgo County Purchasing Department at the following address as listed below. I will let you know if legal accepts the copy.

Thank you

Vangie Y. Garcia, Contract's Manager
2802 S. Business Hwy. 281
New Administration Building
Edinburg, Texas 78539
(956) 292-7000-Extension 4856
email: evangelina.garcia@co.hidalgo.tx.us

From: Lori Hernandez [mailto:lori@holchemont.com]
Sent: Friday, July 20, 2012 2:14 PM
To: Rene Salinas; 'Evangelina Garcia'
Cc: Michael Che Montalvo
Subject: Hid Co Pct 1 New Constable Offices

Good afternoon to all:

I have received a copy of the P&P Bonds that will be sent to us via overnight delivery on Monday for Tuesday's meeting.

Who needs this information at this time?

Once we receive the original 5 copies as requested by the County, who needs to receive those? Delivery address?

Respectfully,

Lori A. Hernandez
Holchemont, Ltd.
900 N. Main St.
McAllen, Texas 78501
(956) 686-2901 voice
(956) 686-2925 fax
lori@holchemont.com

_____ Information from ESET NOD32 Antivirus, version of virus signature database 7316 (20120720)

The message was checked by ESET NOD32 Antivirus.

<http://www.eset.com>



AIA® Document A201™ – 2007

General Conditions of the Contract for Construction

for the following PROJECT:

(Name and location or address)

Construction Of A New Constable Precinct 1 Offices
consisting of 4245Sq. Ft., Located at 1902 Joe Stevens
Blvd., Weslaco, Texas 78596

THE OWNER:

(Name, legal status and address)

Hidalgo County
1615 S. Clossner, Suite J
Edinburg, Texas 78539

THE ARCHITECT:

(Name, legal status and address)

Alcocer Garcia Associates, Inc.
1333 E. Jasmine Avenue
McAllen, Texas 78501

TABLE OF ARTICLES

- 1 GENERAL PROVISIONS
- 2 OWNER
- 3 CONTRACTOR
- 4 ARCHITECT
- 5 SUBCONTRACTORS
- 6 CONSTRUCTION BY OWNER OR BY SEPARATE CONTRACTORS
- 7 CHANGES IN THE WORK
- 8 TIME
- 9 PAYMENTS AND COMPLETION
- 10 PROTECTION OF PERSONS AND PROPERTY
- 11 INSURANCE AND BONDS
- 12 UNCOVERING AND CORRECTION OF WORK
- 13 MISCELLANEOUS PROVISIONS

14 TERMINATION OR
SUSPENSION OF
THE CONTRACT

15 CLAIMS AND
DISPUTES

ADDITIONS AND DELETIONS:

The author of this document has added information needed for its completion. The author may also have revised the text of the original AIA standard form. An *Additions and Deletions Report* that notes added information as well as revisions to the standard form text is available from the author and should be reviewed. A vertical line in the left margin of this document indicates where the author has added necessary information and where the author has added to or deleted from the original AIA text.

This document has important legal consequences. Consultation with an attorney is encouraged with respect to its completion or modification.

Init.

AIA Document A201™ – 2007. Copyright © 1911, 1915, 1918, 1925, 1937, 1951, 1958, 1961, 1963, 1966, 1970, 1976, 1987, 1997 and 2007 by The American Institute of Architects. All rights reserved. **WARNING: This AIA® Document is protected by U.S. Copyright Law and International Treaties. Unauthorized reproduction or distribution of this AIA® Document, or any portion of it, may result in severe civil and criminal penalties, and will be prosecuted to the maximum extent possible under the law.** This document was produced by AIA software at 16:56:15 on 07/20/2012 under Order No.1180968477_1 which expires on 03/20/2013, and is not for resale.

User Notes:

(959998329)

INDEX

(Numbers and Topics in Bold are Section Headings)

Acceptance of Nonconforming Work

9.6.6, 9.9.3, **12.3**

Acceptance of Work

9.6.6, 9.8.2, 9.9.3, 9.10.1, 9.10.3, **12.3**

Access to Work

3.16, 6.2.1, 12.1

Accident Prevention

10

Acts and Omissions

3.2, 3.3.2, 3.12.8, 3.18, 4.2.3, 8.3.1, 9.5.1, 10.2.5,
10.2.8, 13.4.2, 13.7.1, 14.1, 15.2

Addenda

1.1.1, 3.11.1

Additional Costs, Claims for

3.7.4, 3.7.5, 6.1.1, 7.3.7.5, 10.3, 15.1.4

Additional Inspections and Testing

9.4.2, 9.8.3, 12.2.1, **13.5**

Additional Insured

11.1.4

Additional Time, Claims for

3.2.4, 3.7.4, 3.7.5, 3.10.2, 8.3.2, **15.1.5**

Administration of the Contract

3.1.3, **4.2**, 9.4, 9.5

Advertisement or Invitation to Bid

1.1.1

Aesthetic Effect

4.2.13

Allowances

3.8, 7.3.8

All-risk Insurance

11.3.1, 11.3.1.1

Applications for Payment

4.2.5, 7.3.9, 9.2, **9.3**, 9.4, 9.5.1, 9.6.3, 9.7.1, 9.10,

11.1.3

Approvals

2.1.1, 2.2.2, 2.4, 3.1.3, 3.10.2, 3.12.8, 3.12.9, 3.12.10,

4.2.7, 9.3.2, 13.5.1

Arbitration

8.3.1, 11.3.10, 13.1.1, 15.3.2, **15.4**

ARCHITECT

4

Architect, Definition of

4.1.1

Architect, Extent of Authority

2.4.1, 3.12.7, 4.1, 4.2, 5.2, 6.3.1, 7.1.2, 7.3.7, 7.4,
9.2.1, 9.3.1, 9.4, 9.5, 9.6.3, 9.8, 9.10.1, 9.10.3, 12.1,
12.2.1, 13.5.1, 13.5.2, 14.2.2, 14.2.4, 15.1.3, 15.2.1

Architect, Limitations of Authority and Responsibility

2.1.1, 3.12.4, 3.12.8, 3.12.10, 4.1.2, 4.2.1, 4.2.2, 4.2.3,
4.2.6, 4.2.7, 4.2.10, 4.2.12, 4.2.13, 5.2.1, 7.4.1, 9.4.2,
9.5.3, 9.6.4, 15.1.3, 15.2

Architect's Additional Services and Expenses

2.4.1, 11.3.1.1, 12.2.1, 13.5.2, 13.5.3, 14.2.4

Architect's Administration of the Contract

3.1.3, 4.2, 3.7.4, 15.2, 9.4.1, 9.5

Architect's Approvals

2.4.1, 3.1.3, 3.5.1, 3.10.2, 4.2.7

Architect's Authority to Reject Work

3.5.1, 4.2.6, 12.1.2, 12.2.1

Architect's Copyright

1.1.7, 1.5

Architect's Decisions

3.7.4, 4.2.6, 4.2.7, 4.2.11, 4.2.12, 4.2.13, 4.2.14, 6.3.1,
7.3.7, 7.3.9, 8.1.3, 8.3.1, 9.2.1, 9.4.1, 9.5, 9.8.4, 9.9.1,
13.5.2, 15.2, 15.3

Architect's Inspections

3.7.4, 4.2.2, 4.2.9, 9.4.2, 9.8.3, 9.9.2, 9.10.1, 13.5

Architect's Instructions

3.2.4, 3.3.1, 4.2.6, 4.2.7, 13.5.2

Architect's Interpretations

4.2.11, 4.2.12

Architect's Project Representative

4.2.10

Architect's Relationship with Contractor

1.1.2, 1.5, 3.1.3, 3.2.2, 3.2.3, 3.2.4, 3.3.1, 3.4.2, 3.5.1,
3.7.4, 3.7.5, 3.9.2, 3.9.3, 3.10, 3.11, 3.12, 3.16, 3.18,
4.1.2, 4.1.3, 4.2, 5.2, 6.2.2, 7, 8.3.1, 9.2, 9.3, 9.4, 9.5,
9.7, 9.8, 9.9, 10.2.6, 10.3, 11.3.7, 12, 13.4.2, 13.5, 15.2

Architect's Relationship with Subcontractors

1.1.2, 4.2.3, 4.2.4, 4.2.6, 9.6.3, 9.6.4, 11.3.7

Architect's Representations

9.4.2, 9.5.1, 9.10.1

Architect's Site Visits

3.7.4, 4.2.2, 4.2.9, 9.4.2, 9.5.1, 9.9.2, 9.10.1, 13.5

Asbestos

10.3.1

Attorneys' Fees

3.18.1, 9.10.2, 10.3.3

Award of Separate Contracts

6.1.1, 6.1.2

**Award of Subcontracts and Other Contracts for
Portions of the Work**

5.2

Basic Definitions

1.1

Bidding Requirements

1.1.1, 5.2.1, 11.4.1

Binding Dispute Resolution

9.7.1, 11.3.9, 11.3.10, 13.1.1, 15.2.5, 15.2.6.1, 15.3.1,
15.3.2, 15.4.1

Boiler and Machinery Insurance

11.3.2

Bonds, Lien

7.3.7.4, 9.10.2, 9.10.3

Bonds, Performance, and Payment

7.3.7.4, 9.6.7, 9.10.3, 11.3.9, **11.4**

Building Permit

3.7.1

Init.

AIA Document A201™ – 2007. Copyright © 1911, 1915, 1918, 1925, 1937, 1951, 1958, 1961, 1963, 1966, 1970, 1976, 1987, 1997 and 2007 by The American Institute of Architects. All rights reserved. **WARNING: This AIA® Document is protected by U.S. Copyright Law and International Treaties. Unauthorized reproduction or distribution of this AIA® Document, or any portion of it, may result in severe civil and criminal penalties, and will be prosecuted to the maximum extent possible under the law.** This document was produced by AIA software at 16:56:15 on 07/20/2012 under Order No.1180968477_1 which expires on 03/20/2013, and is not for resale.

User Notes:

(959998329)

Capitalization

1.3

Certificate of Substantial Completion

9.8.3, 9.8.4, 9.8.5

Certificates for Payment

4.2.1, 4.2.5, 4.2.9, 9.3.3, 9.4, 9.5, 9.6.1, 9.6.6, 9.7.1, 9.10.1, 9.10.3, 14.1.1.3, 14.2.4, 15.1.3

Certificates of Inspection, Testing or Approval

13.5.4

Certificates of Insurance

9.10.2, 11.1.3

Change Orders

1.1.1, 2.4.1, 3.4.2, 3.7.4, 3.8.2.3, 3.11.1, 3.12.8, 4.2.8, 5.2.3, 7.1.2, 7.1.3, 7.2, 7.3.2, 7.3.6, 7.3.9, 7.3.10, 8.3.1, 9.3.1.1, 9.10.3, 10.3.2, 11.3.1.2, 11.3.4, 11.3.9, 12.1.2, 15.1.3

Change Orders, Definition of

7.2.1

CHANGES IN THE WORK

2.2.1, 3.11, 4.2.8, 7, 7.2.1, 7.3.1, 7.4, 7.4.1, 8.3.1, 9.3.1.1, 11.3.9

Claims, Definition of

15.1.1

CLAIMS AND DISPUTES

3.2.4, 6.1.1, 6.3.1, 7.3.9, 9.3.3, 9.10.4, 10.3.3, 15, 15.4

Claims and Timely Assertion of Claims

15.4.1

Claims for Additional Cost

3.2.4, 3.7.4, 6.1.1, 7.3.9, 10.3.2, 15.1.4

Claims for Additional Time

3.2.4, 3.7.4.6.1.1, 8.3.2, 10.3.2, 15.1.5

Concealed or Unknown Conditions, Claims for

3.7.4

Claims for Damages

3.2.4, 3.18, 6.1.1, 8.3.3, 9.5.1, 9.6.7, 10.3.3, 11.1.1, 11.3.5, 11.3.7, 14.1.3, 14.2.4, 15.1.6

Claims Subject to Arbitration

15.3.1, 15.4.1

Cleaning Up

3.15, 6.3

Commencement of the Work, Conditions Relating to

2.2.1, 3.2.2, 3.4.1, 3.7.1, 3.10.1, 3.12.6, 5.2.1, 5.2.3, 6.2.2, 8.1.2, 8.2.2, 8.3.1, 11.1, 11.3.1, 11.3.6, 11.4.1, 15.1.4

Commencement of the Work, Definition of

8.1.2

Communications Facilitating Contract

Administration

3.9.1, 4.2.4

Completion, Conditions Relating to

3.4.1, 3.11, 3.15, 4.2.2, 4.2.9, 8.2, 9.4.2, 9.8, 9.9.1, 9.10, 12.2, 13.7, 14.1.2

COMPLETION, PAYMENTS AND

9

Completion, Substantial

4.2.9, 8.1.1, 8.1.3, 8.2.3, 9.4.2, 9.8, 9.9.1, 9.10.3, 12.2, 13.7

Compliance with Laws

1.6.1, 3.2.3, 3.6, 3.7, 3.12.10, 3.13, 4.1.1, 9.6.4, 10.2.2, 11.1, 11.3, 13.1, 13.4, 13.5.1, 13.5.2, 13.6, 14.1.1, 14.2.1.3, 15.2.8, 15.4.2, 15.4.3

Concealed or Unknown Conditions

3.7.4, 4.2.8, 8.3.1, 10.3

Conditions of the Contract

1.1.1, 6.1.1, 6.1.4

Consent, Written

3.4.2, 3.7.4, 3.12.8, 3.14.2, 4.1.2, 9.3.2, 9.8.5, 9.9.1, 9.10.2, 9.10.3, 11.3.1, 13.2, 13.4.2, 15.4.4.2

Consolidation or Joinder

15.4.4

CONSTRUCTION BY OWNER OR BY SEPARATE CONTRACTORS

1.1.4, 6

Construction Change Directive, Definition of

7.3.1

Construction Change Directives

1.1.1, 3.4.2, 3.12.8, 4.2.8, 7.1.1, 7.1.2, 7.1.3, 7.3, 9.3.1.1

Construction Schedules, Contractor's

3.10, 3.12.1, 3.12.2, 6.1.3, 15.1.5.2

Contingent Assignment of Subcontracts

5.4, 14.2.2.2

Continuing Contract Performance

15.1.3

Contract, Definition of

1.1.2

CONTRACT, TERMINATION OR SUSPENSION OF THE

5.4.1.1, 11.3.9, 14

Contract Administration

3.1.3, 4, 9.4, 9.5

Contract Award and Execution, Conditions Relating to

3.7.1, 3.10, 5.2, 6.1, 11.1.3, 11.3.6, 11.4.1

Contract Documents, The

1.1.1

Contract Documents, Copies Furnished and Use of

1.5.2, 2.2.5, 5.3

Contract Documents, Definition of

1.1.1

Contract Sum

3.7.4, 3.8, 5.2.3, 7.2, 7.3, 7.4, 9.1, 9.4.2, 9.5.1.4, 9.6.7, 9.7, 10.3.2, 11.3.1, 14.2.4, 14.3.2, 15.1.4, 15.2.5

Contract Sum, Definition of

9.1

Contract Time

3.7.4, 3.7.5, 3.10.2, 5.2.3, 7.2.1.3, 7.3.1, 7.3.5, 7.4, 8.1.1, 8.2.1, 8.3.1, 9.5.1, 9.7.1, 10.3.2, 12.1.1, 14.3.2, 15.1.5.1, 15.2.5

Contract Time, Definition of

8.1.1

Init.

AIA Document A201™ – 2007. Copyright © 1911, 1915, 1918, 1925, 1937, 1951, 1958, 1961, 1963, 1966, 1970, 1976, 1987, 1997 and 2007 by The American Institute of Architects. All rights reserved. **WARNING: This AIA® Document is protected by U.S. Copyright Law and International Treaties. Unauthorized reproduction or distribution of this AIA® Document, or any portion of it, may result in severe civil and criminal penalties, and will be prosecuted to the maximum extent possible under the law.** This document was produced by AIA software at 16:56:15 on 07/20/2012 under Order No.1180968477_1 which expires on 03/20/2013, and is not for resale.

User Notes:

(959998329)

CONTRACTOR

3

Contractor, Definition of

3.1, 6.1.2

Contractor's Construction Schedules

3.10, 3.12.1, 3.12.2, 6.1.3, 15.1.5.2

Contractor's Employees

3.3.2, 3.4.3, 3.8.1, 3.9, 3.18.2, 4.2.3, 4.2.6, 10.2, 10.3, 11.1.1, 11.3.7, 14.1, 14.2.1.1,

Contractor's Liability Insurance

11.1

Contractor's Relationship with Separate Contractors and Owner's Forces

3.12.5, 3.14.2, 4.2.4, 6, 11.3.7, 12.1.2, 12.2.4

Contractor's Relationship with Subcontractors

1.2.2, 3.3.2, 3.18.1, 3.18.2, 5, 9.6.2, 9.6.7, 9.10.2, 11.3.1.2, 11.3.7, 11.3.8

Contractor's Relationship with the Architect

1.1.2, 1.5, 3.1.3, 3.2.2, 3.2.3, 3.2.4, 3.3.1, 3.4.2, 3.5.1, 3.7.4, 3.10, 3.11, 3.12, 3.16, 3.18, 4.1.3, 4.2, 5.2, 6.2.2, 7, 8.3.1, 9.2, 9.3, 9.4, 9.5, 9.7, 9.8, 9.9, 10.2.6, 10.3, 11.3.7, 12, 13.5, 15.1.2, 15.2.1

Contractor's Representations

3.2.1, 3.2.2, 3.5.1, 3.12.6, 6.2.2, 8.2.1, 9.3.3, 9.8.2

Contractor's Responsibility for Those Performing the Work

3.3.2, 3.18, 5.3.1, 6.1.3, 6.2, 9.5.1, 10.2.8

Contractor's Review of Contract Documents

3.2

Contractor's Right to Stop the Work

9.7

Contractor's Right to Terminate the Contract

14.1, 15.1.6

Contractor's Submittals

3.10, 3.11, 3.12.4, 4.2.7, 5.2.1, 5.2.3, 9.2, 9.3, 9.8.2, 9.8.3, 9.9.1, 9.10.2, 9.10.3, 11.1.3, 11.4.2

Contractor's Superintendent

3.9, 10.2.6

Contractor's Supervision and Construction

Procedures

1.2.2, 3.3, 3.4, 3.12.10, 4.2.2, 4.2.7, 6.1.3, 6.2.4, 7.1.3, 7.3.5, 7.3.7, 8.2, 10, 12, 14, 15.1.3

Contractual Liability Insurance

11.1.1.8, 11.2

Coordination and Correlation

1.2, 3.2.1, 3.3.1, 3.10, 3.12.6, 6.1.3, 6.2.1

Copies Furnished of Drawings and Specifications

1.5, 2.2.5, 3.11

Copyrights

1.5, 3.17

Correction of Work

2.3, 2.4, 3.7.3, 9.4.2, 9.8.2, 9.8.3, 9.9.1, 12.1.2, 12.2

Correlation and Intent of the Contract Documents

1.2

Cost, Definition of

7.3.7

Costs

2.4.1, 3.2.4, 3.7.3, 3.8.2, 3.15.2, 5.4.2, 6.1.1, 6.2.3, 7.3.3.3, 7.3.7, 7.3.8, 7.3.9, 9.10.2, 10.3.2, 10.3.6, 11.3, 12.1.2, 12.2.1, 12.2.4, 13.5, 14

Cutting and Patching

3.14, 6.2.5

Damage to Construction of Owner or Separate

Contractors

3.14.2, 6.2.4, 10.2.1.2, 10.2.5, 10.4, 11.1.1, 11.3, 12.2.4

Damage to the Work

3.14.2, 9.9.1, 10.2.1.2, 10.2.5, 10.4.1, 11.3.1, 12.2.4

Damages, Claims for

3.2.4, 3.18, 6.1.1, 8.3.3, 9.5.1, 9.6.7, 10.3.3, 11.1.1, 11.3.5, 11.3.7, 14.1.3, 14.2.4, 15.1.6

Damages for Delay

6.1.1, 8.3.3, 9.5.1.6, 9.7, 10.3.2

Date of Commencement of the Work, Definition of

8.1.2

Date of Substantial Completion, Definition of

8.1.3

Day, Definition of

8.1.4

Decisions of the Architect

3.7.4, 4.2.6, 4.2.7, 4.2.11, 4.2.12, 4.2.13, 15.2, 6.3, 7.3.7, 7.3.9, 8.1.3, 8.3.1, 9.2.1, 9.4, 9.5.1, 9.8.4, 9.9.1, 13.5.2, 14.2.2, 14.2.4, 15.1, 15.2

Decisions to Withhold Certification

9.4.1, 9.5, 9.7, 14.1.1.3

Defective or Nonconforming Work, Acceptance, Rejection and Correction of

2.3.1, 2.4.1, 3.5.1, 4.2.6, 6.2.5, 9.5.1, 9.5.2, 9.6.6, 9.8.2, 9.9.3, 9.10.4, 12.2.1

Defective Work, Definition of

3.5.1

Definitions

1.1, 2.1.1, 3.1.1, 3.5.1, 3.12.1, 3.12.2, 3.12.3, 4.1.1, 15.1.1, 5.1, 6.1.2, 7.2.1, 7.3.1, 8.1, 9.1, 9.8.1

Delays and Extensions of Time

3.2., 3.7.4, 5.2.3, 7.2.1, 7.3.1, 7.4.1, 8.3, 9.5.1, 9.7.1, 10.3.2, 10.4.1, 14.3.2, 15.1.5, 15.2.5

Disputes

6.3.1, 7.3.9, 15.1, 15.2

Documents and Samples at the Site

3.11

Drawings, Definition of

1.1.5

Drawings and Specifications, Use and Ownership of

3.11

Effective Date of Insurance

8.2.2, 11.1.2

Emergencies

10.4, 14.1.1.2, 15.1.4

Employees, Contractor's

3.3.2, 3.4.3, 3.8.1, 3.9, 3.18.2, 4.2.3, 4.2.6, 10.2, 10.3.3, 11.1.1, 11.3.7, 14.1, 14.2.1.1

Init.

AIA Document A201™ – 2007. Copyright © 1911, 1915, 1918, 1925, 1937, 1951, 1958, 1961, 1963, 1966, 1970, 1976, 1987, 1997 and 2007 by The American Institute of Architects. All rights reserved. **WARNING: This AIA® Document is protected by U.S. Copyright Law and International Treaties. Unauthorized reproduction or distribution of this AIA® Document, or any portion of it, may result in severe civil and criminal penalties, and will be prosecuted to the maximum extent possible under the law.** This document was produced by AIA software at 16:56:15 on 07/20/2012 under Order No. 1180968477_1 which expires on 03/20/2013, and is not for resale.

User Notes:

(959998329)

Equipment, Labor, Materials or
1.1.3, 1.1.6, 3.4, 3.5.1, 3.8.2, 3.8.3, 3.12, 3.13.1,
3.15.1, 4.2.6, 4.2.7, 5.2.1, 6.2.1, 7.3.7, 9.3.2, 9.3.3,
9.5.1.3, 9.10.2, 10.2.1, 10.2.4, 14.2.1.1, 14.2.1.2
Execution and Progress of the Work
1.1.3, 1.2.1, 1.2.2, 2.2.3, 2.2.5, 3.1, 3.3.1, 3.4.1, 3.5.1,
3.7.1, 3.10.1, 3.12, 3.14, 4.2, 6.2.2, 7.1.3, 7.3.5, 8.2,
9.5.1, 9.9.1, 10.2, 10.3, 12.2, 14.2, 14.3.1, 15.1.3
Extensions of Time
3.2.4, 3.7.4, 5.2.3, 7.2.1, 7.3, 7.4.1, 9.5.1, 9.7.1, 10.3.2,
10.4.1, 14.3, 15.1.5, 15.2.5
Failure of Payment
9.5.1.3, 9.7, 9.10.2, 13.6, 14.1.1.3, 14.2.1.2
Faulty Work
(See Defective or Nonconforming Work)
Final Completion and Final Payment
4.2.1, 4.2.9, 9.8.2, 9.10, 11.1.2, 11.1.3, 11.3.1, 11.3.5,
12.3.1, 14.2.4, 14.4.3
Financial Arrangements, Owner's
2.2.1, 13.2.2, 14.1.1.4
Fire and Extended Coverage Insurance
11.3.1.1

GENERAL PROVISIONS

1

Governing Law

13.1

Guarantees (See Warranty)

Hazardous Materials

10.2.4, 10.3

Identification of Subcontractors and Suppliers

5.2.1

Indemnification

3.17.1, 3.18, 9.10.2, 10.3.3, 10.3.5, 10.3.6, 11.3.1.2,
11.3.7

Information and Services Required of the Owner

2.1.2, 2.2, 3.2.2, 3.12.4, 3.12.10, 6.1.3, 6.1.4, 6.2.5,
9.6.1, 9.6.4, 9.9.2, 9.10.3, 10.3.3, 11.2, 11.4, 13.5.1,
13.5.2, 14.1.1.4, 14.1.4, 15.1.3

Initial Decision

15.2

Initial Decision Maker, Definition of

1.1.8

Initial Decision Maker, Decisions

14.2.2, 14.2.4, 15.2.1, 15.2.2, 15.2.3, 15.2.4, 15.2.5

Initial Decision Maker, Extent of Authority

14.2.2, 14.2.4, 15.1.3, 15.2.1, 15.2.2, 15.2.3, 15.2.4,
15.2.5

Injury or Damage to Person or Property

10.2.8, 10.4.1

Inspections

3.1.3, 3.3.3, 3.7.1, 4.2.2, 4.2.6, 4.2.9, 9.4.2, 9.8.3,
9.9.2, 9.10.1, 12.2.1, 13.5

Instructions to Bidders

1.1.1

Instructions to the Contractor

3.2.4, 3.3.1, 3.8.1, 5.2.1, 7, 8.2.2, 12, 13.5.2

Instruments of Service, Definition of

1.1.7

Insurance

3.18.1, 6.1.1, 7.3.7, 9.3.2, 9.8.4, 9.9.1, 9.10.2, 11

Insurance, Boiler and Machinery

11.3.2

Insurance, Contractor's Liability

11.1

Insurance, Effective Date of

8.2.2, 11.1.2

Insurance, Loss of Use

11.3.3

Insurance, Owner's Liability

11.2

Insurance, Property

10.2.5, 11.3

Insurance, Stored Materials

9.3.2, 11.4.1.4

INSURANCE AND BONDS

11

Insurance Companies, Consent to Partial Occupancy

9.9.1, 11.4.1.5

Insurance Companies, Settlement with

11.4.10

Intent of the Contract Documents

1.2.1, 4.2.7, 4.2.12, 4.2.13, 7.4

Interest

13.6

Interpretation

1.2.3, 1.4, 4.1.1, 5.1, 6.1.2, 15.1.1

Interpretations, Written

4.2.11, 4.2.12, 15.1.4

Judgment on Final Award

15.4.2

Labor and Materials, Equipment

1.1.3, 1.1.6, 3.4, 3.5.1, 3.8.2, 3.8.3, 3.12, 3.13, 3.15.1,

4.2.6, 4.2.7, 5.2.1, 6.2.1, 7.3.7, 9.3.2, 9.3.3, 9.5.1.3,

9.10.2, 10.2.1, 10.2.4, 14.2.1.1, 14.2.1.2

Labor Disputes

8.3.1

Laws and Regulations

1.5, 3.2.3, 3.6, 3.7, 3.12.10, 3.13.1, 4.1.1, 9.6.4, 9.9.1,

10.2.2, 11.1.1, 11.3, 13.1.1, 13.4, 13.5.1, 13.5.2,

13.6.1, 14, 15.2.8, 15.4

Liens

2.1.2, 9.3.3, 9.10.2, 9.10.4, 15.2.8

Limitations, Statutes of

12.2.5, 13.7, 15.4.1.1

Limitations of Liability

2.3.1, 3.2.2, 3.5.1, 3.12.10, 3.17.1, 3.18.1, 4.2.6, 4.2.7,

4.2.12, 6.2.2, 9.4.2, 9.6.4, 9.6.7, 10.2.5, 10.3.3, 11.1.2,

11.2, 11.3.7, 12.2.5, 13.4.2

Limitations of Time

2.1.2, 2.2, 2.4, 3.2.2, 3.10, 3.11, 3.12.5, 3.15.1, 4.2.7,

5.2, 5.3.1, 5.4.1, 6.2.4, 7.3, 7.4, 8.2, 9.2.1, 9.3.1, 9.3.3,

9.4.1, 9.5, 9.6, 9.7.1, 9.8, 9.9, 9.10, 11.1.3, 11.3.1.5,

11.3.6, 11.3.10, 12.2, 13.5, 13.7, 14, 15

Init.

AIA Document A201™ – 2007. Copyright © 1911, 1915, 1918, 1925, 1937, 1951, 1958, 1961, 1963, 1966, 1970, 1976, 1987, 1997 and 2007 by The American Institute of Architects. All rights reserved. **WARNING: This AIA® Document is protected by U.S. Copyright Law and International Treaties. Unauthorized reproduction or distribution of this AIA® Document, or any portion of it, may result in severe civil and criminal penalties, and will be prosecuted to the maximum extent possible under the law.** This document was produced by AIA software at 16:56:15 on 07/20/2012 under Order No.1180968477_1 which expires on 03/20/2013, and is not for resale.

User Notes:

(959998329)

Loss of Use Insurance

11.3.3

Material Suppliers

1.5, 3.12.1, 4.2.4, 4.2.6, 5.2.1, 9.3, 9.4.2, 9.6, 9.10.5

Materials, Hazardous

10.2.4, 10.3

Materials, Labor, Equipment and

1.1.3, 1.1.6, 1.5.1, 3.4.1, 3.5.1, 3.8.2, 3.8.3, 3.12, 3.13.1, 3.15.1, 4.2.6, 4.2.7, 5.2.1, 6.2.1, 7.3.7, 9.3.2, 9.3.3, 9.5.1.3, 9.10.2, 10.2.1.2, 10.2.4, 14.2.1.1, 14.2.1.2

Means, Methods, Techniques, Sequences and Procedures of Construction

3.3.1, 3.12.10, 4.2.2, 4.2.7, 9.4.2

Mechanic's Lien

2.1.2, 15.2.8

Mediation

8.3.1, 10.3.5, 10.3.6, 15.2.1, 15.2.5, 15.2.6, 15.3, 15.4.1

Minor Changes in the Work

1.1.1, 3.12.8, 4.2.8, 7.1, 7.4

MISCELLANEOUS PROVISIONS

13

Modifications, Definition of

1.1.1

Modifications to the Contract

1.1.1, 1.1.2, 3.11, 4.1.2, 4.2.1, 5.2.3, 7, 8.3.1, 9.7.1, 10.3.2, 11.3.1

Mutual Responsibility

6.2

Nonconforming Work, Acceptance of

9.6.6, 9.9.3, 12.3

Nonconforming Work, Rejection and Correction of

2.3.1, 2.4.1, 3.5.1, 4.2.6, 6.2.4, 9.5.1, 9.8.2, 9.9.3, 9.10.4, 12.2.1

Notice

2.2.1, 2.3.1, 2.4.1, 3.2.4, 3.3.1, 3.7.2, 3.12.9, 5.2.1, 9.7.1, 9.10, 10.2.2, 11.1.3, 11.4.6, 12.2.2.1, 13.3, 13.5.1, 13.5.2, 14.1, 14.2, 15.2.8, 15.4.1

Notice, Written

2.3.1, 2.4.1, 3.3.1, 3.9.2, 3.12.9, 3.12.10, 5.2.1, 9.7.1, 9.10, 10.2.2, 10.3, 11.1.3, 11.3.6, 12.2.2.1, 13.3, 14, 15.2.8, 15.4.1

Notice of Claims

3.7.4, 4.5, 10.2.8, 15.1.2, 15.4

Notice of Testing and Inspections

13.5.1, 13.5.2

Observations, Contractor's

3.2, 3.7.4

Occupancy

2.2.2, 9.6.6, 9.8, 11.3.1.5

Orders, Written

1.1.1, 2.3, 3.9.2, 7, 8.2.2, 11.3.9, 12.1, 12.2.2.1, 13.5.2, 14.3.1

OWNER

2

Owner, Definition of

2.1.1

Owner, Information and Services Required of the

2.1.2, 2.2, 3.2.2, 3.12.10, 6.1.3, 6.1.4, 6.2.5, 9.3.2, 9.6.1, 9.6.4, 9.9.2, 9.10.3, 10.3.3, 11.2, 11.3, 13.5.1, 13.5.2, 14.1.1.4, 14.1.4, 15.1.3

Owner's Authority

1.5, 2.1.1, 2.3.1, 2.4.1, 3.4.2, 3.8.1, 3.12.10, 3.14.2, 4.1.2, 4.1.3, 4.2.4, 4.2.9, 5.2.1, 5.2.4, 5.4.1, 6.1, 6.3.1, 7.2.1, 7.3.1, 8.2.2, 8.3.1, 9.3.1, 9.3.2, 9.5.1, 9.6.4, 9.9.1, 9.10.2, 10.3.2, 11.1.3, 11.3.3, 11.3.10, 12.2.2, 12.3.1, 13.2.2, 14.3, 14.4, 15.2.7

Owner's Financial Capability

2.2.1, 13.2.2, 14.1.1.4

Owner's Liability Insurance

11.2

Owner's Loss of Use Insurance

11.3.3

Owner's Relationship with Subcontractors

1.1.2, 5.2, 5.3, 5.4, 9.6.4, 9.10.2, 14.2.2

Owner's Right to Carry Out the Work

2.4, 14.2.2

Owner's Right to Clean Up

6.3

Owner's Right to Perform Construction and to Award Separate Contracts

6.1

Owner's Right to Stop the Work

2.3

Owner's Right to Suspend the Work

14.3

Owner's Right to Terminate the Contract

14.2

Ownership and Use of Drawings, Specifications and Other Instruments of Service

1.1.1, 1.1.6, 1.1.7, 1.5, 2.2.5, 3.2.2, 3.11.1, 3.17.1, 4.2.12, 5.3.1

Partial Occupancy or Use

9.6.6, 9.9, 11.3.1.5

Patching, Cutting and

3.14, 6.2.5

Patents

3.17

Payment, Applications for

4.2.5, 7.3.9, 9.2.1, 9.3, 9.4, 9.5, 9.6.3, 9.7.1, 9.8.5, 9.10.1, 14.2.3, 14.2.4, 14.4.3

Payment, Certificates for

4.2.5, 4.2.9, 9.3.3, 9.4, 9.5, 9.6.1, 9.6.6, 9.7.1, 9.10.1, 9.10.3, 13.7, 14.1.1.3, 14.2.4

Payment, Failure of

9.5.1.3, 9.7, 9.10.2, 13.6, 14.1.1.3, 14.2.1.2

Payment, Final

4.2.1, 4.2.9, 9.8.2, 9.10, 11.1.2, 11.1.3, 11.4.1, 11.4.5, 12.3.1, 13.7, 14.2.4, 14.4.3

Payment Bond, Performance Bond and

7.3.7.4, 9.6.7, 9.10.3, 11.4.9, 11.4

Init.

Payments, Progress

9.3, 9.6, 9.8.5, 9.10.3, 13.6, 14.2.3, 15.1.3

PAYMENTS AND COMPLETION

9

Payments to Subcontractors

5.4.2, 9.5.1.3, 9.6.2, 9.6.3, 9.6.4, 9.6.7, 11.4.8,
14.2.1.2

PCB

10.3.1

Performance Bond and Payment Bond

7.3.7.4, 9.6.7, 9.10.3, 11.4.9, 11.4

Permits, Fees, Notices and Compliance with Laws

2.2.2, 3.7, 3.13, 7.3.7.4, 10.2.2

PERSONS AND PROPERTY, PROTECTION OF

10

Polychlorinated Biphenyl

10.3.1

Product Data, Definition of

3.12.2

Product Data and Samples, Shop Drawings

3.11, 3.12, 4.2.7

Progress and Completion

4.2.2, 8.2, 9.8, 9.9.1, 14.1.4, 15.1.3

Progress Payments

9.3, 9.6, 9.8.5, 9.10.3, 13.6, 14.2.3, 15.1.3

Project, Definition of the

1.1.4

Project Representatives

4.2.10

Property Insurance

10.2.5, 11.3

PROTECTION OF PERSONS AND PROPERTY

10

Regulations and Laws

1.5, 3.2.3, 3.6, 3.7, 3.12.10, 3.13, 4.1.1, 9.6.4, 9.9.1,
10.2.2, 11.1, 11.4, 13.1, 13.4, 13.5.1, 13.5.2, 13.6, 14,
15.2.8, 15.4

Rejection of Work

3.5.1, 4.2.6, 12.2.1

Releases and Waivers of Liens

9.10.2

Representations

3.2.1, 3.5.1, 3.12.6, 6.2.2, 8.2.1, 9.3.3, 9.4.2, 9.5.1,
9.8.2, 9.10.1

Representatives

2.1.1, 3.1.1, 3.9, 4.1.1, 4.2.1, 4.2.2, 4.2.10, 5.1.1, 5.1.2,
13.2.1

Responsibility for Those Performing the Work

3.3.2, 3.18, 4.2.3, 5.3.1, 6.1.3, 6.2, 6.3, 9.5.1, 10

Retainage

9.3.1, 9.6.2, 9.8.5, 9.9.1, 9.10.2, 9.10.3

Review of Contract Documents and Field

Conditions by Contractor

3.2, 3.12.7, 6.1.3

Review of Contractor's Submittals by Owner and Architect

3.10.1, 3.10.2, 3.11, 3.12, 4.2, 5.2, 6.1.3, 9.2, 9.8.2

Review of Shop Drawings, Product Data and Samples by Contractor

3.12

Rights and Remedies

1.1.2, 2.3, 2.4, 3.5.1, 3.7.4, 3.15.2, 4.2.6, 4.5, 5.3, 5.4,
6.1, 6.3, 7.3.1, 8.3, 9.5.1, 9.7, 10.2.5, 10.3, 12.2.2,
12.2.4, 13.4, 14, 15.4

Royalties, Patents and Copyrights

3.17

Rules and Notices for Arbitration

15.4.1

Safety of Persons and Property

10.2, 10.4

Safety Precautions and Programs

3.3.1, 4.2.2, 4.2.7, 5.3.1, 10.1, 10.2, 10.4

Samples, Definition of

3.12.3

Samples, Shop Drawings, Product Data and

3.11, 3.12, 4.2.7

Samples at the Site, Documents and

3.11

Schedule of Values

9.2, 9.3.1

Schedules, Construction

3.10, 3.12.1, 3.12.2, 6.1.3, 15.1.5.2

Separate Contracts and Contractors

1.1.4, 3.12.5, 3.14.2, 4.2.4, 4.2.7, 6, 8.3.1, 11.4.7,
12.1.2

Shop Drawings, Definition of

3.12.1

Shop Drawings, Product Data and Samples

3.11, 3.12, 4.2.7

Site, Use of

3.13, 6.1.1, 6.2.1

Site Inspections

3.2.2, 3.3.3, 3.7.1, 3.7.4, 4.2, 9.4.2, 9.10.1, 13.5

Site Visits, Architect's

3.7.4, 4.2.2, 4.2.9, 9.4.2, 9.5.1, 9.9.2, 9.10.1, 13.5

Special Inspections and Testing

4.2.6, 12.2.1, 13.5

Specifications, Definition of the

1.1.6

Specifications, The

1.1.1, 1.1.6, 1.2.2, 1.5, 3.11, 3.12.10, 3.17, 4.2.14

Statute of Limitations

13.7, 15.4.1.1

Stopping the Work

2.3, 9.7, 10.3, 14.1

Stored Materials

6.2.1, 9.3.2, 10.2.1.2, 10.2.4, 11.4.1.4

Subcontractor, Definition of

5.1.1

SUBCONTRACTORS

5

Subcontractors, Work by

1.2.2, 3.3.2, 3.12.1, 4.2.3, 5.2.3, 5.3, 5.4, 9.3.1.2, 9.6.7

Init.

AIA Document A201™ – 2007. Copyright © 1911, 1915, 1918, 1925, 1937, 1951, 1958, 1961, 1963, 1966, 1970, 1976, 1987, 1997 and 2007 by The American Institute of Architects. All rights reserved. **WARNING: This AIA® Document is protected by U.S. Copyright Law and International Treaties. Unauthorized reproduction or distribution of this AIA® Document, or any portion of it, may result in severe civil and criminal penalties, and will be prosecuted to the maximum extent possible under the law.** This document was produced by AIA software at 16:56:15 on 07/20/2012 under Order No.1180968477_1 which expires on 03/20/2013, and is not for resale.

User Notes:

(959998329)

Subcontractual Relations

5.3, 5.4, 9.3.1.2, 9.6, 9.10, 10.2.1, 11.4.7, 11.4.8, 14.1, 14.2.1

Submittals

3.10, 3.11, 3.12, 4.2.7, 5.2.1, 5.2.3, 7.3.7, 9.2, 9.3, 9.8, 9.9.1, 9.10.2, 9.10.3, 11.1.3

Submittal Schedule

3.10.2, 3.12.5, 4.2.7

Subrogation, Waivers of

6.1.1, 11.4.5, 11.3.7

Substantial Completion

4.2.9, 8.1.1, 8.1.3, 8.2.3, 9.4.2, 9.8, 9.9.1, 9.10.3, 12.2, 13.7

Substantial Completion, Definition of**9.8.1****Substitution of Subcontractors**

5.2.3, 5.2.4

Substitution of Architect

4.1.3

Substitutions of Materials

3.4.2, 3.5.1, 7.3.8

Sub-subcontractor, Definition of**5.1.2****Subsurface Conditions**

3.7.4

Successors and Assigns**13.2****Superintendent**

3.9, 10.2.6

Supervision and Construction Procedures

1.2.2, 3.3, 3.4, 3.12.10, 4.2.2, 4.2.7, 6.1.3, 6.2.4, 7.1.3, 7.3.7, 8.2, 8.3.1, 9.4.2, 10, 12, 14, 15.1.3

Surety

5.4.1.2, 9.8.5, 9.10.2, 9.10.3, 14.2.2, 15.2.7

Surety, Consent of

9.10.2, 9.10.3

Surveys

2.2.3

Suspension by the Owner for Convenience**14.3****Suspension of the Work**

5.4.2, 14.3

Suspension or Termination of the Contract

5.4.1.1, 11.4.9, 14

Taxes

3.6, 3.8.2.1, 7.3.7.4

Termination by the Contractor

14.1, 15.1.6

Termination by the Owner for Cause

5.4.1.1, 14.2, 15.1.6

Termination by the Owner for Convenience**14.4****Termination of the Architect**

4.1.3

Termination of the Contractor

14.2.2

TERMINATION OR SUSPENSION OF THE**CONTRACT****14****Tests and Inspections**

3.1.3, 3.3.3, 4.2.2, 4.2.6, 4.2.9, 9.4.2, 9.8.3, 9.9.2, 9.10.1, 10.3.2, 11.4.1.1, 12.2.1, 13.5

TIME**8****Time, Delays and Extensions of**

3.2.4, 3.7.4, 5.2.3, 7.2.1, 7.3.1, 7.4.1, 8.3, 9.5.1, 9.7.1, 10.3.2, 10.4.1, 14.3.2, 15.1.5, 15.2.5

Time Limits

2.1.2, 2.2, 2.4, 3.2.2, 3.10, 3.11, 3.12.5, 3.15.1, 4.2, 4.4, 4.5, 5.2, 5.3, 5.4, 6.2.4, 7.3, 7.4, 8.2, 9.2, 9.3.1, 9.3.3, 9.4.1, 9.5, 9.6, 9.7, 9.8, 9.9, 9.10, 11.1.3, 11.4.1.5, 11.4.6, 11.4.10, 12.2, 13.5, 13.7, 14, 15.1.2, 15.4

Time Limits on Claims

3.7.4, 10.2.8, 13.7, 15.1.2

Title to Work

9.3.2, 9.3.3

Transmission of Data in Digital Form**1.6****UNCOVERING AND CORRECTION OF WORK****12****Uncovering of Work****12.1****Unforeseen Conditions, Concealed or Unknown**

3.7.4, 8.3.1, 10.3

Unit Prices

7.3.3.2, 7.3.4

Use of Documents

1.1.1, 1.5, 2.2.5, 3.12.6, 5.3

Use of Site

3.13, 6.1.1, 6.2.1

Values, Schedule of

9.2, 9.3.1

Waiver of Claims by the Architect

13.4.2

Waiver of Claims by the Contractor

9.10.5, 11.4.7, 13.4.2, 15.1.6

Waiver of Claims by the Owner

9.9.3, 9.10.3, 9.10.4, 11.4.3, 11.4.5, 11.4.7, 12.2.2.1, 13.4.2, 14.2.4, 15.1.6

Waiver of Consequential Damages

14.2.4, 15.1.6

Waiver of Liens

9.10.2, 9.10.4

Waivers of Subrogation

6.1.1, 11.4.5, 11.3.7

Warranty

3.5, 4.2.9, 9.3.3, 9.8.4, 9.9.1, 9.10.4, 12.2.2, 13.7.1

Weather Delays

15.1.5.2

Work, Definition of

1.1.3

Init.

AIA Document A201™ – 2007. Copyright © 1911, 1915, 1918, 1925, 1937, 1951, 1958, 1961, 1963, 1966, 1970, 1976, 1987, 1997 and 2007 by The American Institute of Architects. All rights reserved. **WARNING: This AIA® Document is protected by U.S. Copyright Law and International Treaties. Unauthorized reproduction or distribution of this AIA® Document, or any portion of it, may result in severe civil and criminal penalties, and will be prosecuted to the maximum extent possible under the law.** This document was produced by AIA software at 16:56:15 on 07/20/2012 under Order No.1180968477_1 which expires on 03/20/2013, and is not for resale.

User Notes:

(959998329)

Written Consent

1.5.2, 3.4.2, 3.7.4, 3.12.8, 3.14.2, 4.1.2, 9.3.2, 9.8.5,
9.9.1, 9.10.2, 9.10.3, 11.4.1, 13.2, 13.4.2, 15.4.4.2

Written Interpretations

4.2.11, 4.2.12

Written Notice

2.3, 2.4, 3.3.1, 3.9, 3.12.9, 3.12.10, 5.2.1, 8.2.2, 9.7,
9.10, 10.2.2, 10.3, 11.1.3, 11.4.6, 12.2.2, 12.2.4, 13.3,
14, 15.4.1

Written Orders

1.1.1, 2.3, 3.9, 7, 8.2.2, 11.4.9, 12.1, 12.2, 13.5.2,
14.3.1, 15.1.2

Init.

User Notes:

(959998329)

| § 15.4.1 DELETED..

| § 15.4.1.1 DELETED.

| § 15.4.2 DELETED.

| § 15.4.3 DELETED.

§ 15.4.4 CONSOLIDATION OR JOINDER

| § 15.4.4.1 DELETED.

| § 15.4.4.2 DELETED.

| § 15.4.4.3 DELETED.

Init.

AIA Document A201™ – 2007. Copyright © 1911, 1915, 1918, 1925, 1937, 1951, 1958, 1961, 1963, 1966, 1970, 1976, 1987, 1997 and 2007 by The American Institute of Architects. All rights reserved. **WARNING: This AIA® Document is protected by U.S. Copyright Law and International Treaties. Unauthorized reproduction or distribution of this AIA® Document, or any portion of it, may result in severe civil and criminal penalties, and will be prosecuted to the maximum extent possible under the law.** This document was produced by AIA software at 16:56:15 on 07/20/2012 under Order No.1180968477_1 which expires on 03/20/2013, and is not for resale.
User Notes:

ARTICLE 1 GENERAL PROVISIONS

§ 1.1 BASIC DEFINITIONS

§ 1.1.1 THE CONTRACT DOCUMENTS

The Contract Documents are enumerated in the Agreement between the Owner and Contractor (hereinafter the Agreement) and consist of the Agreement, Conditions of the Contract (General, Supplementary and other Conditions), Drawings, Specifications, Addenda issued prior to execution of the Contract, other documents listed in the Agreement and Modifications issued after execution of the Contract. A Modification is (1) a written amendment to the Contract signed by both parties, (2) a Change Order, (3) a Construction Change Directive or (4) a written order for a minor change in the Work issued by the Architect pursuant to Paragraph 7.4. At the Owner's option, the Contract Documents do not include the advertisement or invitation to bid, Instructions to Bidders, sample forms, other information furnished by the Owner in anticipation of receiving bids or proposals, the Contractor's bid or proposal, or portions of Addenda relating to bidding requirements.

§ 1.1.1.1 Contractor acknowledges and warrants that it has closely examined all the Contract Documents and is unaware of any instance where the documents are not suitable or are insufficient, to enable the Contractor to complete the Work in a timely manner for the Contract sum, and that they include all Work, whether or not shown or described, which reasonably may be inferred or useful for the completion of the Work in full compliance with all applicable codes, laws, ordinances, and regulations.

§ 1.1.2 THE CONTRACT

The Contract Documents form the Contract for Construction. The Contract represents the entire and integrated agreement between the parties hereto and supersedes prior negotiations, representations or agreements, either written or oral. The Contract may be amended or modified only by a Modification. The Contract Documents shall not be construed to create a contractual relationship of any kind (1) between the Contractor and the Architect or the Architect's consultants, (2) between the Owner and a Subcontractor or a Sub-subcontractor (except as provided in Paragraph 5.3 and 5.4 hereof), (3) between the Owner and the Architect or the Architect's consultants or (4) between any persons or entities other than the Owner and the Contractor. The Architect shall, however, be entitled to performance and enforcement of obligations of the Contractor under the Contract intended to facilitate performance of the Architect's duties.

§ 1.1.3 THE WORK

The term "Work" means the construction and services required by the Contract Documents, whether completed or partially completed, and includes all other labor, materials, equipment and services provided or to be provided by the Contractor to fulfill the Contractor's obligations. The Work may constitute the whole or a part of the Project.

§ 1.1.3.1 The Work shall include the obligation of the Contractor to visit the site of the project before submitting a proposal. Such site visit shall be for the purpose of familiarizing Contractor with the conditions as they exist and the character of the operations to be carried on under the Contract Documents, including all existing site conditions, access to the site, physical characteristics of the site and surrounding areas. It also includes all supplies, skill, supervision, transportation services and other facilities and things necessary, proper or incidental to the carrying out and completion of the terms of the Contract and all other items of cost or value needed to produce, construct and fully complete the public work identified by the Contract Documents.

§ 1.1.4 THE PROJECT

The Project is the total construction of which the Work performed under the Contract Documents may be the whole or a part and which may include construction by the Owner and by separate contractors.

§ 1.1.5 THE DRAWINGS

The Drawings are the graphic and pictorial portions of the Contract Documents showing the design, location and dimensions of the Work, generally including plans, elevations, sections, details, schedules and diagrams wherever located and whenever issued.

§ 1.1.6 THE SPECIFICATIONS

The Specifications are that portion of the Contract Documents consisting of the written requirements for materials, equipment, systems, standards and workmanship for the Work, and performance of related services.

Init.

§ 1.1.7 INSTRUMENTS OF SERVICE

Instruments of Service are representations, in any medium of expression now known or later developed, of the tangible and intangible creative work performed by the Architect and the Architect's consultants under their respective professional services agreements. Instruments of Service may include, without limitation, studies, surveys, models, sketches, drawings, specifications, and other similar materials.

§ 1.1.8 INITIAL DECISION MAKER

The Initial Decision Maker is the person identified in the Agreement to render initial decisions on Claims in accordance with Section 15.2 and certify termination of the Agreement under Section 14.2.2.

§ 1.2 CORRELATION AND INTENT OF THE CONTRACT DOCUMENTS

§ 1.2.1 The intent of the Contract Documents is to include all items necessary for the proper execution and completion of the Work by the Contractor. The Contract Documents are complementary, and what is required by one shall be as binding as if required by all; performance by the Contractor shall be required only to the extent consistent with the Contract Documents and reasonably inferable from them as being necessary to produce the indicated results. Any differences between the requirements of the Drawings and the Specifications or any differences noted within the Drawings themselves or within the Specifications themselves have been referred to Owner and Architect by Contractor prior to the submission of bids and have been clarified by an Addendum issued to all bidders.

If such differences or conflicts were not called to Owner's and Architect's attention prior to submission of bids, Architect shall decide which of the conflicting requirements will govern based upon the following: the most stringent of the requirements will take precedence over the less stringent; the most expensive item will take precedence over the less expensive, and subject to the approval of Owner, Contractor shall perform the Work at no additional cost and/or time to Owner in accordance with the Architect's decision. Work not covered in the Contract Documents will not be required unless it is consistent therewith and is reasonably inferable as being necessary to produce the intended results.

§ 1.2.1.1 In the event of conflicts or discrepancies among the Contract Documents, interpretations will be based on the following priorities:

- .1 The Agreement;
- .2 Addenda, with those of later date having precedence over those of earlier date;
- .3 Supplemental Conditions, if any;
- .4 The General Conditions of the Contract for Construction;
- .5 Specifications
- .6 Drawings, in the case of inconsistency between the Drawings and Specifications or within either document, not clarified by Addendum, the better quality or greater quantity of Work shall be included in the Contract Documents. Clarifications of the inconsistency will be accomplished with the Contractor and, if necessary, an appropriate reduction in the contract will be accomplished with the Contractor and, if necessary, an appropriate reduction in the contract will be accomplished by Change Order. Figures given on drawings govern scale measurements. Large scale drawings take precedence over small scale drawings. Written words, take precedence over numbers. Handwritten documents take precedence over typewritten documents. Existing conditions take precedence over drawings and specifications for dimensions and shall be verified by the Contractor. The Contractor proceeds at his own risk if conflicts or discrepancies are not resolved prior to the execution of the Work.

§ 1.2.1.2 If Work is required in a manner to make it impossible to produce Work of the quality required by or reasonably inferred from the Contract Documents, or should discrepancies appear among the Contract Documents, Contractor shall request in writing an interpretation from Architect before proceeding with the Work. If Contractor fails to make such request, no excuse will thereafter be entertained for failure to carryout Work in the required manner or provide required guarantees, warranties, or bonds, and Contractor shall not be entitled to any change in the Contract Sum or the Contract Time on account of such failure.

§ 1.2.2 Organization of the Specifications into divisions, sections and articles, and arrangement of Drawings shall not control the Contractor in dividing the Work among Subcontractors or in establishing the extent of Work to be performed by any trade.

Init.

AIA Document A201™ – 2007. Copyright © 1911, 1915, 1918, 1925, 1937, 1951, 1958, 1961, 1963, 1966, 1970, 1976, 1987, 1997 and 2007 by The American Institute of Architects. All rights reserved. **WARNING: This AIA® Document is protected by U.S. Copyright Law and International Treaties. Unauthorized reproduction or distribution of this AIA® Document, or any portion of it, may result in severe civil and criminal penalties, and will be prosecuted to the maximum extent possible under the law.** This document was produced by AIA software at 16:56:15 on 07/20/2012 under Order No.1180968477_1 which expires on 03/20/2013, and is not for resale.

User Notes:

(959998329)

§ 1.2.3 Unless otherwise stated in the Contract Documents, words that have well-known technical or construction industry meanings are used in the Contract Documents in accordance with such recognized meanings.

§ 1.3 CAPITALIZATION

Terms capitalized in these General Conditions include those that are (1) specifically defined, (2) the titles of numbered articles or (3) the titles of other documents published by the American Institute of Architects.

§ 1.4 INTERPRETATION

In the interest of brevity the Contract Documents frequently omit modifying words such as "all" and "any" and articles such as "the" and "an," but the fact that a modifier or an article is absent from one statement and appears in another is not intended to affect the interpretation of either statement.

§ 1.5 OWNERSHIP AND USE OF DRAWINGS, SPECIFICATIONS AND OTHER INSTRUMENTS OF SERVICE

§ 1.5.1 Instruments of Service, including the Drawings, Specifications, and other similar or related documents and copies thereof are furnished to Contractor for the purpose of performing the Work and are, and shall remain, the property of Owner and Owner will retain all common law, statutory and other reserved rights, including copyrights. The Contractor, Subcontractors, Sub-subcontractors, and material or equipment suppliers shall not own or claim a copyright in the Instruments of Service. Submittal or distribution to meet official regulatory requirements or for other purposes in connection with this Project is not to be construed as publication in derogation of the Owner or Owners' consultants reserved rights.

§ 1.5.2 The Contractor, Subcontractors, Sub-subcontractors and material or equipment suppliers are authorized to use and reproduce the Instruments of Service provided to them solely and exclusively for execution of the Work. All copies made under this authorization shall bear the copyright notice, if any, shown on the Instruments of Service. The Contractor, Subcontractors, Sub-subcontractors, and material or equipment suppliers may not use the Instruments of Service on other projects or for additions to this Project outside the scope of the Work without the specific written consent of the Owner, Architect and the Architect's consultants.

§ 1.6 TRANSMISSION OF DATA IN DIGITAL FORM

If the parties intend to transmit Instruments of Service or any other information or documentation in digital form, they shall endeavor to establish necessary protocols governing such transmissions, unless otherwise already provided in the Agreement or the Contract Documents.

ARTICLE 2 OWNER

§ 2.1 GENERAL

§ 2.1.1 The Owner is the person or entity identified as such in the Agreement and is referred to throughout the Contract Documents as if singular in number. The Commissioners Court of Owner, by majority vote, is the only representative of Owner, having the power to enter into a Contract, to execute a change order requiring an increase in the Contract Sum, or agree to an extension of the contractual completion date. The Commissioners Court shall designate, as appropriate, an authorized representative(s) to act on its behalf during the course of construction. In the event that an emergency changes the scope of the Work before the next regular meeting or in order to facilitate and expedite the timely completion of the Work, the Commissioners Court's authorized representative(s) may approve construction changes that do not exceed \$10,000.00 in increased costs. Any such changes shall be confirmed in writing between the Contractor and the Commissioner Court's authorized representative(s) and notice of such approved changes shall be given to the Commissioners Court at its next regular meeting. The Commissioners Court will act as soon as reasonably possible to avoid undue delays in the construction completion date.

§ 2.1.2 DELETE.

§ 2.2 INFORMATION AND SERVICES REQUIRED OF THE OWNER

§ 2.2.1 Prior to commencement of the Work, the Contractor may request in writing that the Owner provide reasonable evidence that the Owner has made financial arrangements to fulfill the Owner's obligations under the Contract. Thereafter, the Contractor may only request such evidence if (1) the Owner fails to make payments to the Contractor as the Contract Documents require; (2) a change in the Work materially changes the Contract Sum; or (3) the Contractor identifies in writing a reasonable concern regarding the Owner's ability to make payment when due. The Owner shall furnish such evidence as a condition precedent to commencement or continuation of the Work or the

Init.

portion of the Work affected by a material change. After the Owner furnishes the evidence, the Owner shall not materially vary such financial arrangements without prior notice to the Contractor.

§ 2.2.2 Except for permits and fees that are the responsibility of the Contractor under the Contract Documents, including those required under Section 3.7.1, the Owner shall secure and pay for necessary approvals, easements, assessments and charges required for construction, use or occupancy of permanent structures or for permanent changes in existing facilities.

§ 2.2.3 The Owner shall furnish surveys describing physical characteristics and legal limitations for the site of the Project, and a legal description of the site. The Contractor shall be entitled to rely on the accuracy of information furnished by the Owner but shall exercise proper precautions relating to the safe performance of the Work. In connection with the foregoing, Contractor shall be solely responsible for locating (and shall locate prior to performing any Work) all utilities lines, telephone company lines and cable, sewer lines, water pipes, gas lines, electrical lines, including without limitation, all buried pipelines and buried telephone cables and shall perform the Work in such a manner so as to avoid damaging any such lines, cables, pipes and pipelines. Under this provision the Architect and Engineer are in no way relieved of their responsibilities outlined in the Contract or other attached contracts for identification of existing conditions.

§ 2.2.4 The Owner shall furnish information or services required of the Owner by the Contract Documents with reasonable promptness. The Owner shall also furnish any other information or services under the Owner's control and relevant to the Contractor's performance of the Work with reasonable promptness after receiving the Contractor's written request for such information or services.

§ 2.2.5 Unless otherwise provided in the Contract Documents, the Owner shall furnish to the Contractor one copy of the Contract Documents for purposes of making reproductions pursuant to Section 1.5.2 for use on this Project. All costs of reproduction are the responsibility of Contractor.

§ 2.3 OWNER'S RIGHT TO STOP THE WORK

If the Contractor fails to correct Work that is not in accordance with the requirements of the Contract Documents as required by Section 12.2 or repeatedly fails to carry out Work in accordance with the Contract Documents or fails to remove and discharge (within ten (10) days) any lien filed upon Owner's or Landlord's property by anyone claiming by, through, or under Contractor; or disregards the instructions of Architect or Owner when based on the requirements of the Contract Documents, the Owner may issue a written order to the Contractor to stop the Work, or any portion thereof, until the cause for such order has been eliminated; however, the right of the Owner to stop the Work shall not give rise to a duty on the part of the Owner to exercise this right for the benefit of the Contractor or any other person or entity, except to the extent required by Section 6.1.3, and any delay resulting from such Work stoppage shall not extend any Milestone Date identified in the Contract for Construction or the required dates of Substantial or Final Completion.

§ 2.4 OWNER'S RIGHT TO CARRY OUT THE WORK

If the Contractor defaults or neglects to carry out the Work in accordance with the Contract Documents and fails within a ten-day period after receipt of written notice from the Owner to commence and continue correction of such default or neglect with diligence and promptness, the Owner may, without prejudice to other remedies the Owner may have, correct such deficiencies. In such case an appropriate Change Order shall be issued deducting from payments then or thereafter due the Contractor the reasonable cost of correcting such deficiencies, including Owner's expenses and compensation for the Architect's additional services made necessary by such default, neglect or failure. Such action by the Owner and amounts charged to the Contractor are both subject to prior approval of the Architect. If payments then or thereafter due the Contractor are not sufficient to cover such amounts, the Contractor shall pay the difference to the Owner.

§ 2.4.1 The rights stated in Article 2 shall be in addition to and not in limitation of any other rights of Owner granted in the Contract Documents or at law or in equity.

ARTICLE 3 CONTRACTOR

§ 3.1 GENERAL

§ 3.1.1 The Contractor is the person or entity identified as such in the Agreement and is referred to throughout the Contract Documents as if singular in number. The Contractor shall be lawfully licensed, if required in the jurisdiction

Init.

where the Project is located. The Contractor shall designate in writing a representative who shall have express authority to bind the Contractor with respect to all matters under this Contract. The term "Contractor" means the Contractor or the Contractor's authorized representative.

§ 3.1.2 The Contractor shall perform the Work in accordance with the Contract Documents.

§ 3.1.3 The Contractor shall not be relieved of obligations to perform the Work in accordance with the Contract Documents either by activities or duties of the Architect in the Architect's administration of the Contract, or by tests, inspections or approvals required or performed by persons or entities other than the Contractor.

§ 3.2 REVIEW OF CONTRACT DOCUMENTS AND FIELD CONDITIONS BY CONTRACTOR

§ 3.2.1 Execution of the Contract by the Contractor is a representation that the Contractor has visited the site, become generally familiar with local conditions under which the Work is to be performed and correlated personal observations with requirements of the Contract Documents.

§ 3.2.2 Because the Contract Documents are complementary, the Contractor shall, before starting each portion of the Work, carefully study and compare the various Contract Documents relative to that portion of the Work, as well as the information furnished by the Owner pursuant to Section 2.2.3, shall take field measurements of any existing conditions related to that portion of the Work, and shall observe any conditions at the site affecting it. These obligations are for the purpose of facilitating coordination and construction by the Contractor and are not for the purpose of discovering errors, omissions, or inconsistencies in the Contract Documents; however, the Contractor shall promptly report to the Architect and Owner in writing any errors, inconsistencies or omissions discovered by or made known to the Contractor as a request for design information in such form as the Architect may require.

§ 3.2.3 The Contractor is not required to ascertain that the Contract Documents are in accordance with applicable laws, statutes, ordinances, codes, rules and regulations, or lawful orders of public authorities, but the Contractor shall promptly report to the Architect and Owner in writing any nonconformity discovered by or made known to the Contractor as a request for design information in such form as the Architect may require.

§ 3.2.4 If the Contractor believes that additional cost or time is involved because of clarifications or instructions the Architect issues in response to the Contractor's notices or requests for information pursuant to Sections 3.2.2 or 3.2.3, the Contractor shall make Claims as provided in Article 15. If the Contractor fails to perform the obligations of Sections 3.2.2 or 3.2.3, the Contractor shall pay such costs and damages to the Owner as would have been avoided if the Contractor had performed such obligations. If the Contractor performs those obligations, the Contractor shall not be liable to the Owner or Architect for damages resulting from errors, inconsistencies or omissions in the Contract Documents, for differences between field measurements or conditions and the Contract Documents, or for nonconformities of the Contract Documents to applicable laws, statutes, ordinances, codes, rules and regulations, and lawful orders of public authorities unless the Contractor recognized or reasonably should have recognized such error, inconsistency, omission or difference and knowingly failed to report it to the Architect and Owner.

§ 3.2.5 The Contractor shall not be entitled to additional compensation for the "rework portion" of any additional work caused by his failure to carefully study and compare the Contract Documents prior to execution of the Work.

§ 3.2.6 The Contractor shall make reasonable attempt to interpret the Contract Documents before asking the Architect for assistance in interpretation. The Contractor shall not ask the Architect for observation of work prior to the Contractor's field superintendent's personal inspection of the work and his determination that the work complies with the Contract Documents.

§ 3.2.7 If, in the opinion of the Architect, the Contractor does not make a reasonable effort to comply with the above requirements of the Contract Documents and this causes the Architect or his consultants to expend an unreasonable amount of the time in the discharge of the duties imposed on him by the Contract Documents, then the Contractor shall bear the cost of compensation for the Architect's additional services made necessary by such failure. The Architect will give the Contractor prior notice of intent to bill for additional services related to 3.2.6, 3.2.7, and 3.12 before additional services are performed.

§ 3.2.8 If the Contractor has knowledge that any of the products or systems specified will perform in a manner that will limit the Contractor's ability to satisfactorily perform the work or to honor his Warranty, Contractor shall promptly

Init.

notify the Architect in writing, providing substantiation for the position. Any necessary changes, including substitutions of materials, may only be accomplished by an appropriate Modification.

§ 3.3 SUPERVISION AND CONSTRUCTION PROCEDURES

§ 3.3.1 The Contractor shall supervise and direct the Work, using the Contractor's best skill and attention. The Contractor shall be solely responsible for, and have control over, construction means, methods, techniques, sequences and procedures and for coordinating all portions of the Work under the Contract, unless the Contract Documents give other specific instructions concerning these matters. If the Contract Documents give specific instructions concerning construction means, methods, techniques, sequences or procedures, the Contractor shall evaluate the jobsite safety thereof and, except as stated below, shall be fully and solely responsible for the jobsite safety of such means, methods, techniques, sequences or procedures. If the Contractor determines that such means, methods, techniques, sequences or procedures may not be safe, the Contractor shall give timely written notice to the Owner and Architect and shall not proceed with that portion of the Work without further written instructions from the Architect.

§ 3.3.2 The Contractor shall be responsible to the Owner for acts and omissions of the Contractor's employees, Subcontractors and their agents and employees, and other persons or entities performing portions of the Work for, or on behalf of, the Contractor or any of its Subcontractors.

§ 3.3.3 The Contractor shall be responsible for inspection of portions of Work already performed to determine that such portions are in proper condition to receive subsequent Work.

§ 3.3.4 Contractor shall be responsible to Owner for acts and omissions of Contractor's employees, Subcontractors, and their agents and employees, and other persons performing portions of the Work under the Contract Documents or other arrangements with Contractor.

§ 3.3.5 Contractor shall give notices and comply with applicable laws, ordinances, rules, regulations, and lawful orders of public authorities bearing on the Work, including those with respect to the safety of persons and property and their protection from damages, injury, or loss. Contractor shall promptly remedy damage and loss to property at the site caused in whole or in part by Contractor, its Subcontractor, or anyone directly or indirectly employed by any of them or by anyone for whose acts they may be liable, except for damage or loss attributable solely to acts or omissions of Owner or Architect or by anyone for whose acts either of them may be liable and not attributable to the fault or negligence of Contractor, its Subcontractor, or anyone directly or indirectly employed by them. The foregoing obligations of Contractor are in addition to Contractor's obligations under other provisions hereunder.

§ 3.3.6 Contractor shall be responsible for inspection of portion of Work already performed under the Contract for Construction to determine that such portions are in proper condition to receive subsequent Work.

§ 3.3.7 Contractor has the responsibility to ensure that all material suppliers and Subcontractors, their agents, and employees adhere to the Contract Documents, and that they order materials on time, taking into account the current market and delivery conditions, and that they provide materials on time. Contractor shall coordinate its Work with that of all others on the Project, including of construction utilities.

§ 3.3.8 Contractor shall establish and maintain bench marks and all other grades, lines, and levels necessary for the Work; report errors or inconsistencies to Owner and Architect before commencing Work; and, if applicable, review the placement of the buildings and permanent facilities on the site with Owner and Architect after all lines are staked out and before foundation Work is started. Contractor shall provide access to the Work for Owner, Architect, other persons designated by Owner, and governmental inspectors. Any encroachments made by Contractor or its Subcontractors on adjacent properties caused by construction as revealed by an improvements survey, except for encroachments arising from errors or omissions not reasonably discoverable by Contractor in the Contract Documents, shall be the sole responsibility of Contractor, and Contractor shall correct such encroachments within thirty (30) days of the improvement survey (or as soon thereafter as reasonably possible), at Contractor's sole cost and expense, either by the removal of the encroachment (and subsequent reconstruction on the Project site) or agreement with the adjacent property owner (s) (in form and substance satisfactory to Owner in its sole discretion) allowing the encroachments to remain.

§ 3.3.9 Contractor shall verify at the Work site the measurements indicated on the Drawings and Specifications and shall establish correctly the lines, levels, and positions for the Work and be responsible for their accuracy and proper

Init.

correlation with control lines, monuments, and data, as established by surveys furnished by Owner. Work shall be erected square, plumb, level, true to line and grade, in the exact plane and to the correct elevation and/or sloped to drain as indicated. To ensure the proper execution of its subsequent Work, Contractor shall measure all Work already in place (including but not limited to utilities and grades installed or prepared by others) and shall at once report to Architect and Owner any discrepancy between said Work and the Drawings and Specifications for the Work.

§ 3.3.10 Any discrepancy or omission in the dimensions or elections shown on the Drawings and Specifications or found in previous Work which may prevent accurate layout or construction of the Work, shall immediately be reported by Contractor to Owner and Architect. If Contractor performs, permits, or causes performance of any Work when Contractor knows or reasonably should have known that such discrepancy or omission exists, without first obtaining further instruction from Architect or Owner, Contractor shall bear any and all costs arising therefrom including, without limitation, the costs of correction thereof without increase or adjustment in the Contract Sum. Omissions from the Drawings or Specifications, or the misdescription of details of Work which are reasonably inferable in order to carry out the intent of the Drawings and Specifications, or which are customarily performed, shall not relieve contractor from performing such omitted or mis-described details of the Work, and they shall be performed as if fully and correctly set forth and described in the Drawings and Specifications, at no additional cost to Owner.

§ 3.3.11 Contractor shall engage workers who are skilled in performing the Work, and all Work shall be performed with care and skill and in a good workmanlike manner under the full-time supervision of an approved engineer or foreman. Contractor shall be liable for all property damage, including repairs and replacements of the Work and economic losses, which proximately result from the breach of this duty. Contractor shall advise Architect:

1. if a specified product deviates from good construction practices;
2. if following the Specifications will affect any warranties; or
3. any objections which Contractor may have the Specifications.

Nothing contained in Subparagraph 1.1.3 shall alter the responsibilities established in this Subparagraph.

§ 3.4 LABOR AND MATERIALS

§ 3.4.1 Unless otherwise provided in the Contract Documents, the Contractor shall provide and pay for labor, materials, equipment, tools, construction equipment and machinery, water, heat, utilities, transportation, and other facilities and services necessary for proper execution and completion of the Work, whether temporary or permanent and whether or not incorporated or to be incorporated in the Work.

§ 3.4.2 Except in the case of minor changes in the Work authorized by the Architect in accordance with Sections 3.12.8 or 7.4, the Contractor may make substitutions only with the consent of the Owner, after evaluation by the Architect and in accordance with a Change Order or Construction Change Directive. By making requests for substitutions based on Subparagraph 3.4.2, Contractor:

1. represents that Contractor has personally investigated the proposed substitute product and determined that it is equal or superior in all respects to that specified;
2. represents that Contractor will provide the same warranty for the substitution that Contractor would for that specified;
3. certifies that the cost data presented is complete and includes all related costs under this Contract except Architect's redesign costs, and waives all claims for additional costs related to the substitution which subsequently become apparent; and
4. will coordinate the installation for the accepted substitute, making such changes as may be required for the Work to be complete in all respects.

§ 3.4.3 The Contractor shall enforce strict discipline and good order among the Contractor's employees and other persons carrying out the Work. The Contractor shall not permit employment of unfit persons or persons not properly skilled in tasks assigned to them. Contractor shall also be responsible for labor peace on the Project and shall at all times make its best efforts and judgments as an experienced Contractor to adopt and implement policies and practices designed to avoid Work stoppages, slowdowns, disputes, or strikes where reasonably possible and practical under the circumstances and shall at all times maintain Project-wide labor harmony. Except as specifically provided in Subparagraph 8.3 hereof, Contractor shall be liable to Owner for all damages suffered by Owner.

Init.

§ 3.4.4 Materials shall conform to manufacturer's standards in effect at the date of execution of the Agreement and shall be installed in strict accordance with manufacturer's directions. Contractor shall, if required by Owner or Architect, furnish satisfactory evidence as to the kind and quality of any materials. All packaged materials shall be shipped to the site in the original containers clearly labeled, and delivery slips shall be submitted with bulk materials identifying thereon the source, and warranting quality and compliance with Contract Documents.

§ 3.4.5 When the Contract Documents require the Work, or any part of same, to be above the standards required by applicable laws, ordinances, rules and regulations, and other statutory provisions pertaining to the Work, such Work shall be performed and completed by Contractor in accordance with the Contract Documents.

§ 3.4.6 When the manufacturer's name, patent numbers, underwriter's labels, model numbers or similar identifying marks are required, such markings shall be located as inconspicuously as possible.

§ 3.5 WARRANTY

§ 3.5.1

The Contractor warrants to the Owner and Architect that materials and equipment furnished under the Contract will be of the best quality and new unless the Contract Documents require or permit otherwise. The Contractor further warrants that the Work will conform to the requirements of the Contract Documents and will be free from defects. Work, materials, or equipment not conforming to these requirements may be considered defective. If required by the Architect or Owner, the Contractor shall furnish satisfactory evidence as to the kind and quality of materials and equipment.

§ 3.5.2 ALL WARRANTIES SHALL INCLUDE LABOR AND MATERIALS AND THE MANUFACTURER'S WARRANTY SHALL BE SIGNED BY SUBCONTRACTOR AND COUNTERSIGNED BY CONTRACTOR. ALL WARRANTIES SHALL BE ADDRESSED TO OWNER AND DELIVERED TO ARCHITECT UPON COMPLETION OF THE WORK AND BEFORE OR WITH THE SUBMISSION OF REQUEST FOR FINAL PAYMENT.

§ 3.5.3 Contractor shall issue in writing to Owner as a condition precedent to final payment a "general warranty" reflecting the terms and conditions of this Paragraph 3.5 for all Work under the Contract.

§ 3.5.4 The warranties provided in Paragraph 3.5 shall be in addition to and not in limitation of any other warranty or remedy required by law or by the Contract Documents, and such warranty or remedy required by law or by the Contract Documents, and such warranty shall be interpreted to require Contractor to replace defective materials and equipment and re-execute defective Work which is disclosed to the Contractor by the Owner within a period of one (1) year after final completion of the entire Work unless a longer time is specifically called for in the specifications. The Contractor shall assign all components, equipment and fixture warranties to the Owner and will deliver all manuals to the Owner at the completion of construction.

§3.5.5 Except when a longer warranty time is specifically called for in the Specification Sections or is otherwise provided by law, the General Warranty shall be for twelve (12) months and shall be in form and content otherwise satisfactory to Owner.

§3.5.6 Warranties shall become effective on a date established by Owner and Architect in accordance with the Contract Documents. This date shall be the Date of Substantial Completion of the entire Work, unless otherwise provided in any Certificate of Partial Substantial Completion approved by the parties.

§3.5.7 If Architect considers it impractical, because of unsuitable test conditions or some other factors, to execute simultaneous final acceptance of all equipment, portions of properly installed and functioning equipment may be certified by Architect for final acceptance, subject to Owner's approval, when that portion of the system is complete and ready for operation as called for under Subparagraph 9.8.1.

§3.5.8 Contractor shall warrant for a period of twelve (12) months that the building(s) shall be watertight and leak proof at every point and in every area, except where leaks can be attributed to damage to the building(s) by external forces beyond Contractor's control. Contractor shall, immediately upon notification by Owner of water penetration, determine the source of water penetration and, at its own expense, do any Work necessary to make the building(s)

Init.

watertight. Contractor shall also, at its own expense, repair or replace any other damaged material, finishes, and furnishings, damaged as a result of this water penetration, to return the building(s) to its (their) original condition.

§3.5.9 In addition to the foregoing stipulations, Contractor shall comply with all other warranties referred to in any portions of the Contract Documents or otherwise provided by law or in equity, and where warranties overlap, the more stringent requirement shall govern.

§3.5.10 If for any reason Contractor cannot warrant any part of the Work using material or construction methods that have been specified, or shown, it shall notify Owner and Architect in writing before the Contract is signed, giving reasons, together with the name of product and data on a substitution it can warrant.

§ 3.6 TAXES

The Contractor shall pay sales, consumer, use and similar taxes for the Work provided by the Contractor that are legally enacted when bids are received or negotiations concluded, whether or not yet effective or merely scheduled to go into effect.

§ 3.7 PERMITS, FEES, NOTICES, AND COMPLIANCE WITH LAWS

§ 3.7.1 Unless otherwise provided in the Contract Documents, the Contractor shall make application, secure and pay for the building permit as well as for other permits, fees, licenses, and inspections by government agencies necessary for proper execution and completion of the Work that are customarily secured after execution of the Contract including, without limitation, street openings, sidewalk, and other obstructions, access over public ways and storage necessary for proper execution of the Contract and which are, legally required at the time bids are received or negotiations concluded.

§3.7.1.1 The Contractor shall also obtain all permits and approvals, and pay all fees and expenses, if any, associated with National Pollutant Discharge Elimination System (NPDES) regulations administered by the Environmental Protection Agency and state and local authorities, that require completion of documentation and/or acquisition of all permits for the Project. Contractor's obligations under this paragraph do not require it to perform engineering services during the pre-construction phase to prepare proper drainage for the construction sites. However, any drainage alterations made by Contractor during construction phase which modifies the original site drainage plan and requires the issuance of a permit shall be at Contractor's sole cost.

- a. The Owner shall pay directly to the governing authority the cost of all permanent property utility assessments and similar utility connection charges.
- b. The Contractor shall be responsible for obtaining and paying for all City and County Building Permits, Inspection Fees and Plan Checking Fees; temporary utility charges, tap charges and water meter charges and any other similar fees assessed by jurisdictional authorities having control over the Project.
- c. The Owner shall pay fees payable to the Texas Department of Licensing and Regulations (TDLR) for document review relative to the Elimination of Architectural Barriers Act and the Architect will submit the documents to the TDLR for review and approval.

§ 3.7.2 The Contractor shall comply with and give notices required by applicable laws, statutes, ordinances, codes, rules and regulations, and lawful orders and all other requirements of public authorities applicable to performance of the Work.

§ 3.7.3 If the Contractor performs Work (including, without limitation, the installation of any materials or equipment) that it knows or reasonably should have known would be contrary to applicable laws, statutes, ordinances, codes, rules and regulations, or lawful orders of public authorities, the Contractor shall assume appropriate responsibility for such Work and shall bear the costs attributable to correction.

§ 3.7.4 Concealed or Unknown Conditions. If the Contractor encounters conditions at the site that are (1) subsurface or otherwise concealed physical conditions that differ materially from those indicated in the Contract Documents or (2) unknown physical conditions of an unusual nature, that differ materially from those ordinarily found to exist and generally recognized as inherent in construction activities of the character provided for in the Contract Documents, the Contractor shall promptly provide notice to the Owner and the Architect before conditions are disturbed and in no

Init.

event later than 21 days after first observance of the conditions. The Architect will promptly investigate such conditions and, if the Architect determines that they differ materially and cause an increase or decrease in the Contractor's cost of, or time required for, performance of any part of the Work, will recommend to the Owner in writing, an equitable adjustment in the Contract Sum or Contract Time, or both. If the Architect determines that the conditions at the site are not materially different from those indicated in the Contract Documents and that no change in the terms of the Contract is justified, the Architect shall promptly notify the Owner and Contractor in writing, stating the reasons. If either party disputes the Architect's determination or recommendation, that party may proceed as provided in Article 15. No adjustment in the Contract Time or Contract Sum shall be permitted in connection with a concealed or unknown condition that does not differ materially from those conditions disclosed or based on data provided to Contractor and by the Contractor's prior inspections, tests, reviews, and pre-construction services for the Project; or by the Contractor's inspections, tests, reviews and pre-construction services that Contractor had the opportunity and obligation to make in connection with the Project but did not do so.

§ 3.7.5 If, in the course of the Work, the Contractor encounters human remains or recognizes the existence of burial markers, archaeological sites or wetlands not indicated in the Contract Documents, the Contractor shall immediately suspend any operations that would affect them and shall notify the Owner and Architect in writing. Upon receipt of such notice, the Owner shall promptly take any action necessary to obtain governmental authorization required to resume the operations. The Contractor shall continue to suspend such operations until otherwise instructed by the Owner but shall continue with all other operations that do not affect those remains or features. Requests for adjustments in the Contract Sum and Contract Time arising from the existence of such remains or features may be made as provided in Article 15.

§ 3.8 ALLOWANCES

§ 3.8.1 The Contractor shall include in the Contract Sum all allowances stated in the Contract Documents. Items covered by allowances shall be supplied for such amounts and by such persons or entities as the Owner may direct, but the Contractor shall not be required to employ persons or entities to whom the Contractor has reasonable objection.

§ 3.8.2 Unless otherwise provided in the Contract Documents,

- .1 allowances shall cover the cost to the Contractor of materials and equipment delivered at the site and all required taxes, less applicable trade discounts;
- .2 Contractor's costs for unloading and handling at the site, labor, installation costs, overhead, profit and other expenses contemplated for stated allowance amounts shall be included in the Contract Sum but not in the allowances; and
- .3 whenever costs are more than or less than allowances, the Contract Sum shall be adjusted accordingly by Change Order. The amount of the Change Order shall reflect (1) the difference between actual costs and the allowances under Section 3.8.2.1 and (2) changes in Contractor's costs under Section 3.8.2.2.

§ 3.8.3 Materials and equipment under an allowance shall be selected by the Owner with reasonable promptness. If a decision is needed to avoid a delay, Contractor shall notify Architect, Construction manager and Owner in writing sufficiently in advance of needed date to allow reasonable time for selections to be made.

§ 3.9 SUPERINTENDENT

§ 3.9.1 The Contractor shall employ a competent superintendent and necessary assistants who shall be in attendance at the Project site during performance of the Work. The superintendent shall represent the Contractor, and communications given to the superintendent shall be as binding as if given to the Contractor.

§ 3.9.2 The Contractor, as soon as practicable after award of the Contract, shall furnish in writing to the Owner through the Architect the name and qualifications of a proposed superintendent. The Superintendent shall be satisfactory to the Owner and shall not be changed except with the consent of the Architect, unless the Superintendent leaves the employment of the Contractor. No increase in Contract Time or Contract Sum shall be allowed in the event the Owner or Architects object to any nominated superintendent. Such approval by the Owner shall not be unreasonably withheld.

§ 3.9.3 DELETED.

§ 3.10 CONTRACTOR'S CONSTRUCTION SCHEDULES

§ 3.10.1 The Contractor, promptly after being awarded the Contract, shall prepare and submit for the Owner's and Architect's review and approval a Contractor's construction schedule for the Work. The schedule shall not exceed

Init.

time limits current under the Contract Documents, shall be revised as required herein and at appropriate intervals as required by the conditions of the Work and Project, shall be related to the entire Project to the extent required by the Contract Documents, and shall provide for expeditious and practicable execution of the Work. The schedule shall indicate the proposed starting and completion dates for the various subdivisions of the Work as well as the totality of the Work. The schedule shall be updated every thirty (30) days and submitted to Architect with Contractor's Applications for Payment. Each schedule shall contain a comparison of actual progress with the estimated progress for such point in time stated in the original schedule. If any schedule submitted sets such a date for Substantial Completion for the Work or any phase of the Work beyond the date(s) of Substantial Completion established in the Contract (as the same may be extended as provided in the Contract Documents), then Contractor shall submit to Architect and Owner for their review and approval a narrative description of the means and methods that Contractor intends to employ to expedite the progress of the Work to ensure timely completion of the various phases of the Work as well as the totality of the Work. To ensure such timely completion, Contractor shall take all necessary action including, without limitation, increasing the number of personnel and labor on the Project and implementing overtime and double shifts. In that event, Contractor shall not be entitled to an adjustment in the Contract Sum or the schedule.

§ 3.10.2 The Contractor shall prepare a submittal schedule, promptly after being awarded the Contract and thereafter as necessary to maintain a current submittal schedule, and shall submit the schedule(s) for the Architect's and Owner's approval. The Architect's and Owner's approval shall not unreasonably be delayed or withheld. The submittal schedule shall (1) be coordinated with the Contractor's construction schedule, and (2) allow the Architect reasonable time to review submittals. If the Contractor fails to submit a submittal schedule, the Contractor shall not be entitled to any increase in Contract Sum or extension of Contract Time based on the time required for review of submittals.

§ 3.10.3 The Contractor shall perform the Work in general accordance with the most recent schedules submitted to the Owner and Architect.

§ 3.10.4 The process of approving Contractor's schedules and updates to Contractor's schedule shall not constitute a warranty by the Owner that any non-Contractor milestones or activities will occur as set out on Contractor's schedule. Approval of a Contractor's schedule does not constitute a commitment by the Owner to furnish any Owner-furnished information or material any earlier than Owner would otherwise be obligated to furnish that information or material under the Contract Documents. Failure of the Work to proceed in the sequence scheduled by Contractor shall not alone serve as the basis for a Claim for additional compensation or time. In the event there is interference with the Work, which is beyond its control, Contractor shall attempt to reschedule the Work in a manner that will hold resulting additional time and cost to a minimum. The construction schedule shall be in a detailed format satisfactory to the Owner and the Architect and shall also:

- .1 Provide a graphic representation of all activities and events that will occur during performance of the Work;
- .2 identify each phase of construction and occupancy; and
- .3 set forth dates that are critical in ensuring the timely and orderly completion of the Work in accordance with the requirements of the Contract Documents hereinafter referred to as Milestone Dates.

§ 3.10.5 The Owner shall have the right to reschedule the time of day for the performance of any part of the Work that may interfere with the operation of the Owner's premises or any tenants or invitees thereof. The Contractor shall, upon the Owner's request, reschedule any portion of the Work affecting operation of the premises during hours when the premises are not in operation. Any rescheduling of performance of the Work under this Subparagraph 3.10.5 may be grounds for an extension of the Contract Time, if permitted under Subparagraph 8.3.1 and an equitable adjustments in the Contract Sum, if: (1) the performance of the Work was properly scheduled by the Contractor in compliance with the requirements of the Contract Documents, (2) such rescheduling is required for the convenience of the Owner and is not attributable to any act of omission of Contractor, and (3) if Owner agrees to the Contract Sum adjustment prior to any rescheduling.

§ 3.11 DOCUMENTS AND SAMPLES AT THE SITE

The Contractor shall maintain at the site for the Owner one copy of the Drawings, Specifications, Addenda, Change Orders and other Modifications, in good order and marked currently to indicate field changes and selections (all changes and selections to be approved by Owner and Architect in advance) made during construction, and one copy of approved Shop Drawings, Product Data, Samples and similar required submittals. These shall be available to the

Init.

Architect and shall be delivered to the Architect for submittal to the Owner upon completion of the Work as a record of the Work as constructed.

§ 3.11.1 At the Date of Substantial Completion and as a condition precedent to final payment, Contractor shall furnish the following documents to Architect for submittal to Owner: Record Drawings showing the field changes and selections (all changes and selections to be approved by Owner and Architect in advance) affecting the general construction, mechanical, electrical, plumbing, and all other Work, and indicating the Work as actually installed. These shall consist of carefully drawn markings on a set of reproducible prints of Architect's Drawings obtained and paid for by Contractor. Contractor shall maintain at the job site one (1) set of Architect's Drawings and indicate thereon each field change as it occurs. The Contractor shall post all Addenda on Construction Documents prior to commencing work on the site.

§ 3.12 SHOP DRAWINGS, PRODUCT DATA AND SAMPLES

§ 3.12.1 Shop Drawings are drawings, diagrams, schedules and other data specially prepared for the Work by the Contractor or a Subcontractor, Sub-subcontractor, manufacturer, supplier or distributor to illustrate some portion of the Work.

§ 3.12.2 Product Data are illustrations, standard schedules, performance charts, instructions, brochures, diagrams and other information furnished by the Contractor to illustrate materials or equipment for some portion of the Work.

§ 3.12.3 Samples are physical examples that illustrate materials, equipment or workmanship and establish standards by which the Work will be judged.

§ 3.12.4 Shop Drawings, Product Data, Samples and similar submittals are not Contract Documents. Their purpose is to demonstrate the way by which the Contractor proposes to conform to the information given and the design concept expressed in the Contract Documents for those portions of the Work for which the Contract Documents require submittals. Review by the Architect is subject to the limitations of Section 4.2.7. Informational submittals upon which the Architect is not expected to take responsive action may be so identified in the Contract Documents. Submittals that are not required by the Contract Documents may be returned by the Architect without action.

§ 3.12.5 The Contractor shall review for compliance with the Contract Documents, approve and submit to the Architect Shop Drawings, Product Data, Samples and similar submittals required by the Contract Documents in accordance with the submittal schedule approved by the Architect or, in the absence of an approved submittal schedule, with reasonable promptness and in such sequence as to cause no delay in the Work or in the activities of the Owner or of separate contractors. If, in the opinion of the Architect, the Shop Drawings, Product Data, Samples and similar submittals are incomplete, indicate an inadequate understanding of the work covered by the submittals, or indicate a lack of study and review by the Contractor prior to submittal to the Architect, the submittals will be returned, unchecked, to the Contractor for correction of these three deficiencies and subsequent re-submittal. Additional service charges as outlined in 3.2.7 may be charged by the Architect in this event.

§ 3.12.6 By submitting Shop Drawings, Product Data, Samples and similar submittals, the Contractor represents to the Owner and Architect that the Contractor has (1) reviewed and approved them, (2) determined and verified materials, field measurements and field construction criteria related thereto, or will do so and (3) checked and coordinated the information contained within such submittals with the requirements of the Work and of the Contract Documents.

§ 3.12.7 The Contractor shall perform no portion of the Work for which the Contract Documents require submittal and review of Shop Drawings, Product Data, Samples or similar submittals until the respective submittal has been approved by the Architect.

§ 3.12.8 The Work shall be in accordance with approved submittals except that the Contractor shall not be relieved of responsibility for deviations from requirements of the Contract Documents by the Architect's approval of Shop Drawings, Product Data, Samples or similar submittals unless the Contractor has specifically informed the Architect in writing of such deviation at the time of submittal and (1) the Architect has given written approval to the specific deviation as a minor change in the Work, or (2) a Change Order or Construction Change Directive has been issued authorizing the deviation. The Contractor shall not be relieved of responsibility for errors or omissions in Shop Drawings, Product Data, Samples or similar submittals by the Architect's approval thereof.

Init.

§ 3.12.9 The Contractor shall direct specific attention, in writing or on resubmitted Shop Drawings, Product Data, Samples or similar submittals, to revisions other than those requested by the Architect on previous submittals. In the absence of such written notice, the Architect's approval of a resubmission shall not apply to such revisions.

§ 3.12.10 The Contractor shall not be required to provide professional services that constitute the practice of architecture or engineering unless such services are specifically required by the Contract Documents for a portion of the Work or unless the Contractor needs to provide such services in order to carry out the Contractor's responsibilities for construction means, methods, techniques, sequences and procedures. The Contractor shall not be required to provide professional services in violation of applicable law. If professional design services or certifications by a design professional related to systems, materials or equipment are specifically required of the Contractor by the Contract Documents, the Owner and the Architect will specify all performance and design criteria that such services must satisfy. The Contractor shall cause such services or certifications to be provided by a properly licensed design professional and who shall comply with requirements of Owner regarding qualifications and insurance and, whose signature and seal shall appear on all drawings, calculations, specifications, certifications, Shop Drawings and other submittals prepared by such professional. Shop Drawings and other submittals related to the Work designed or certified by such professional, if prepared by others, shall bear such professional's written approval when submitted to the Architect. The Owner and the Architect shall be entitled to rely upon the adequacy, accuracy and completeness of the services, certifications and approvals performed or provided by such design professionals, provided the Owner and Architect have specified to the Contractor all performance and design criteria that such services must satisfy. Pursuant to this Section 3.12.10, the Architect will review, approve or take other appropriate action on submittals only for the limited purpose of checking for conformance with information given and the design concept expressed in the Contract Documents. The Contractor shall not be responsible for the adequacy of the performance and design criteria specified in the Contract Documents.

§ 3.12.11 The Contractor shall submit Shop Drawings, Product Data, Samples and similar submittals required by the Contract Documents to the Architect at least 30 days prior to the date the Contractor needs the reviewed submittals returned. Where colors are to be selected by the Architect, the Contractor shall submit all Samples in adequate time to allow the Architect to prepare a complete selection schedule. In general, all submittals requiring color selection shall be submitted to the Architect within four weeks of the date of the Contract for construction.

§3.12.12 The Contractor shall submit the number of copies of Shop Drawings, Product Data, Samples and similar submittals which the Contractor and his Subcontractors need for their use plus two additional sets for the Architect and one additional set for each of the Architect's consultants involved with the particular section of work. Where shop drawings are involved, the Contractor shall submit one high quality reproducible transparency and one opaque print of the shop drawing for the Architect plus one additional opaque print for each of the Architect's consultants involved with the particular section of work. The reproducible transparency will be marked by the Architect and/or his consultants and returned to the Contractor for his use, distribution, correction or re-submittal as required. The Architect and his consultants will retain the marked up prints. After final review and correction of the submittal, the Contractor shall send two corrected sets to the Architect, and one to each of the Architect's consultants involved with the particular section of work.

§ 3.13 USE OF SITE

The Contractor shall confine operations at the site to areas permitted by applicable laws, statutes, ordinances, codes, rules and regulations, and lawful orders of public authorities and the Contract Documents and shall not unreasonably encumber the site with materials or equipment.

§3.13.1 Only materials and equipment which are to be used directly in the Work shall be brought to and stored on the Project site by the Contractor. After equipment is no longer required for the Work, it shall be promptly removed from the Project site. Protection of construction materials and equipment stored at the Project site from weather, theft, damage and all other adversity is solely the responsibility of the Contractor.

§3.13.2 The Contractor and any entity for whom the Contractor is responsible shall not erect any sign on the Project site without written consent of the Owner.

§3.13.3 Contractor shall ensure that the Work, at all times, is performed in a manner that affords reasonable access, both vehicular and pedestrian, to the site of the Work and all adjacent areas. The Work shall be performed to the fullest extent reasonably possible, in such a manner that public areas adjacent to the site of the Work shall be free from

Init.

AIA Document A201™ – 2007. Copyright © 1911, 1915, 1918, 1925, 1937, 1951, 1958, 1961, 1963, 1966, 1970, 1976, 1987, 1997 and 2007 by The American Institute of Architects. All rights reserved. **WARNING: This AIA® Document is protected by U.S. Copyright Law and International Treaties. Unauthorized reproduction or distribution of this AIA® Document, or any portion of it, may result in severe civil and criminal penalties, and will be prosecuted to the maximum extent possible under the law.** This document was produced by AIA software at 16:56:15 on 07/20/2012 under Order No.1180968477_1 which expires on 03/20/2013, and is not for resale.

User Notes:

(959998329)

all debris, building materials and equipment likely to cause hazardous conditions. Without limitation of any other provision on the Contract Documents, Contractor shall use its best efforts to minimize any interference with the occupancy or beneficial use of: (1) any area and buildings adjacent to the site or the Work or (2) the Building in the event of partial occupancy.

§3.13.4 Without prior approval of the Owner, the Contractor shall not permit any workers to use any existing facilities at the Project site, including without limitation, lavatories, toilets, entrance and parking areas other than those designated by Owner. Without limitation of any other provisions of the Contract Documents, the Contractor shall use its best efforts to comply with all rules and regulations promulgated by the Owner in connection with the use and occupancy of the Project site and the Building, as amended from time to time.

§ 3.14 CUTTING AND PATCHING

§ 3.14.1 The Contractor shall be responsible for cutting, fitting or patching required to complete the Work or to make its parts fit together properly. All areas requiring cutting, fitting and patching shall be restored to the condition existing prior to the cutting, fitting and patching, unless otherwise required by the Contract Documents.

§ 3.14.2 The Contractor shall not damage or endanger a portion of the Work or fully or partially completed construction of the Owner or separate contractors by cutting, patching or otherwise altering such construction, or by excavation. The Contractor shall not cut or otherwise alter such construction by the Owner or a separate contractor except with written consent of the Owner and of such separate contractor; such consent shall not be unreasonably withheld. The Contractor shall not unreasonably withhold from the Owner or a separate contractor the Contractor's consent to cutting or otherwise altering the Work.

§ 3.15 CLEANING UP

§ 3.15.1 The Contractor shall keep the premises and surrounding area free from accumulation of waste materials or rubbish caused by operations under the Contract. At completion of the Work, the Contractor shall remove waste materials, rubbish, the Contractor's tools, construction equipment, machinery and surplus materials from and about the Project.

§ 3.15.2 If the Contractor fails to clean up as provided in the Contract Documents, the Owner may do so and Owner shall be entitled to reimbursement from the Contractor.

§ 3.15.3 Prior to the Architect's inspection for Submittal Completion the Contractor shall clean exterior and interior surfaces exposed to view; remove temporary labels, stains, and foreign substances; polish transparent and glossy surfaces; clean equipment and fixtures to a sanitary condition; replace air filters in mechanical equipment; clean roof, gutters and downspouts; remove obstructions and flush debris from drainage systems; clean site; sweep paved areas and rake clean other surfaces; remove trash and surplus materials from the site.

§ 3.16 ACCESS TO WORK

The Contractor shall provide the Owner and Architect access to the Work in preparation and progress wherever located.

§ 3.17 ROYALTIES, PATENTS AND COPYRIGHTS

The Contractor shall pay all royalties and license fees. The Contractor shall defend suits or claims for infringement of copyrights and patent rights and shall hold the Owner and Architect harmless from loss on account thereof, but shall not be responsible for such defense or loss when a particular design, process or product of a particular manufacturer or manufacturers is required by the Contract Documents, or where the copyright violations are contained in Drawings, Specifications or other documents prepared by the Owner or Architect. However, if the Contractor has reason to believe that the required design, process or product is an infringement of a copyright or a patent, the Contractor shall be responsible for such loss unless such information is promptly furnished to the Architect.

§ 3.18 INDEMNIFICATION

§ 3.18.1 To the fullest extent permitted by law, Contractor shall indemnify, defend, and hold harmless Owner, the Commissioners Court of Owner, all elected officials, employees and agents of Owner of any of the above mentioned parties (the "INDEMNIFIED PARTIES") from and against any and all loss, cost, expense, damage, injury, liability, claim, demand, penalty, or cause of action (including attorneys' fees), directly or indirectly arising out of, resulting

Init.

from, or related to (in whole or in part), (1) the Work performed hereunder, (2) the Contract, or (3) the act or omission of Contractor, a Subcontractor, or an individual, partnership, joint venture, or corporation (a) directly or indirectly employed by Contractor or a Subcontractor, or (b) for whose acts or omissions Contractor or a Subcontractor may be liable (excluding property damage to the Work itself, covered by Owner's all-risk builder's risk insurance, subject to Contractor's liability for any deductible amounts thereunder). The obligations of Contractor under this indemnification shall apply to all matters except those arising solely from the wanton and willful negligence or the malicious acts or omissions of Owner. Further, the obligations of Contractor under this indemnification shall not extend to the liability of Architect, its agents, or employees, arising out of (1) the preparation or approval of maps, drawings, opinions, reports, surveys, Change Orders, designs, or Specifications, (2) the giving of or failure to give directions or instructions by Architect, its agents, or employees, provided such giving or failure to give is the primary cause of the injury or damage, or (3) any matter prohibited by Section 130.002, Texas Civil Practice and Remedies Code. Contractor shall promptly advise Owner in writing of any action, administrative or legal proceeding, or investigation as to which this indemnification may apply, and Contractor, at Contractor's expense, shall assume on behalf of Owner and conduct with due diligence and in good faith the defense thereof with counsel satisfactory to Owner; provided, Owner shall have the right to be represented therein by advisory counsel of its own selection and at its own expense; and provided further, that if the defendants in any such action include both Contractor and Owner and Owner shall have reasonably concluded that they may be legal defenses available to it that are different from, or additional to, or inconsistent with, those available to it that are different from, or additional to, or inconsistent with, those available to Contractor. Owner shall have the right to select separate counsel to participate in the defense of such action on its own behalf at Contractor's expense. In the event of failure by Contractor to fully perform in accordance with this indemnification paragraph. Owner, at its option, and without relieving Contractor of its obligations hereunder, may so perform, but all costs and expenses so incurred by Owner in that event shall be reimbursed by Contractor to Owner, together with interest on the same from the date any such expense was paid by Owner until reimbursed by Contractor, at the rate of interest provided to be paid on judgments, by the law of the jurisdiction to which the interpretation of the Contract is subject. The obligations of Contractor under this Section shall survive the expiration of the Contract and specifically shall survive the limitations contained in Subparagraph 15.1 hereof.

§ 3.18.2 In claims against any person or entity indemnified under this Section 3.18 by an employee of the Contractor, a Subcontractor, anyone directly or indirectly employed by them or anyone for whose acts they may be liable, the indemnification obligation under Section 3.18.1 shall not be limited by a limitation on amount or type of damages, compensation or benefits payable by or for the Contractor or a Subcontractor under workers' compensation acts, disability benefit acts or other employee benefit acts.

§ 3.19 SUBSTITUTIONS OF PRODUCTS AND SYSTEMS, "OR EQUAL" BRANDS

§ 3.19.1 The materials, products and the systems covered by these specifications have been selected as a standard because of quality, particular suitability, or record of satisfactory performance. It is not intended to preclude the use of equivalent or better materials, products or systems provided that it meet the requirements of the particular project and have been approved in an addendum as a substitution prior to the submission of bids. If prior written approval in an addendum has not been obtained, it will be assumed that the Bid is based upon the materials, products, and systems described in the Bidding Documents and no substitutions will be permitted, except as provided hereinafter.

§3.19.2 If, after award of contract, the Contractor or one of his Subcontractors or Suppliers determines that any of the products or systems specified will perform in a manner that will limit the Contractor's ability to satisfactorily perform the work or to honor the Warranty, the Contractor shall promptly notify the Architect, in writing, providing detailed substantiation for his position. Any changes deemed necessary by the Owner and Architect, including substitution of materials and change in Contract Sum, either upward or downward, if any, shall be accompanied by appropriate modification.

§3.20 RECORD DRAWINGS

§3.20.1 At the completion of the project, the Contractor shall submit one complete set of blue lines showing all changes and routing of utilities made during construction, excluding Architect made CAD changes, to the Architect. Drafting shall be legible to the Architect's satisfaction. The Contractor shall pay for the cost of the required recording/drafting. The record set shall be kept up to date on a daily basis and the Architect shall review its status at the project meetings. The Architect shall furnish the Contractor with a blueline set at contract award which shall have all Addenda incorporated. The Owner will pay for the printing of the blueline set. The Architect will incorporate any record information into the construction (CAD) documents and provide the Owner with an electronic copy of the record information on the Construction documents that have all bid and construction changes incorporated. The cost for

Init.

incorporating the record information into the CD will be paid for by the Owner. The Architect will transmit the electronic CD to the Owner with a copy of the transmittal to the Contractor's construction manager.

ARTICLE 4 ARCHITECT

§ 4.1 GENERAL

§ 4.1.1 The Owner shall retain an architect lawfully licensed to practice architecture or an entity lawfully practicing architecture in the jurisdiction where the Project is located. That person or entity is identified as the Architect in the Agreement and is referred to throughout the Contract Documents as if singular in number.

§ 4.1.2 Duties, responsibilities and limitations of authority of the Architect as set forth in the Contract Documents shall not be restricted, modified or extended without written consent of the Owner, Contractor and Architect. Consent shall not be unreasonably withheld.

§ 4.1.3 If the employment of the Architect is terminated, the Owner shall employ a successor architect whose status under the Contract Documents shall be that of the former Architect.

§ 4.2 ADMINISTRATION OF THE CONTRACT

§ 4.2.1 The Architect will provide administration of the Contract as described in the Contract Documents and will be an Owner's representative, along with a representative designated by the Owner, during construction until the date the Architect issues the final Certificate For Payment. The Architect will have authority to act on behalf of the Owner only to the extent provided in the Contract Documents.

§ 4.2.2 The Architect as a representative of the Owner, will visit the site at intervals appropriate to the stage of construction, or as otherwise agreed with the Owner, to become generally familiar with the progress and quality of the portion of the Work completed, and to determine in general if the Work observed is being performed in a manner indicating that the Work, when fully completed, will be in accordance with the Contract Documents. The Architect will be required to make on-site inspections as necessary to keep the Owner informed of the progress of the Work and as necessary to guard the Owner against defects and deficiencies in the Work. However, the Architect will not be required to make exhaustive or continuous on-site inspections to check the quality or quantity of the Work. The Architect will not have control over, charge of, or responsibility for, the construction means, methods, techniques, sequences or procedures, or for the safety precautions and programs in connection with the Work, since these are solely the Contractor's rights and responsibilities under the Contract Documents, except as provided in Section 3.3.1.

§ 4.2.3 On the basis of the site visits, the Architect will keep the Owner reasonably informed about the progress and quality of the portion of the Work completed, and report to the Owner (1) known deviations from the Contract Documents and from the most recent construction schedule submitted by the Contractor, and (2) defects and deficiencies observed in the Work. Architect shall not have control over or charge of and shall not be responsible for safety precautions and programs in connection with the Work. Architect shall be responsible for promptly notifying Contractor of the failure of Contractor, Subcontractors or any other persons performing any of the Work, in failing to use proper construction means, methods, techniques, sequences, procedures, safety precautions and programs, but only to the extent Architect becomes aware of, or should, exercising due professional diligence, be aware of, same. Architect shall also promptly notify Owner in writing of the failure of any of the foregoing parties to carry out the Work in accordance with the Contract Documents.

§ 4.2.4 COMMUNICATIONS FACILITATING CONTRACT ADMINISTRATION

Except as otherwise provided in the Contract Documents or when direct communications have been specially authorized, the Owner and Contractor shall endeavor to communicate with each other through the Architect about matters arising out of or relating to the Contract. Communications by and with the Architect's consultants shall be through the Architect. Communications by and with Subcontractors and material suppliers shall be through the Contractor. Communications by and with separate contractors shall be through the Owner.

§ 4.2.5 Based on the Architect's and Construction Manager's evaluations of the Contractor's Applications for Payment, the Architect and Construction Manager will review and certify the amounts due the Contractor and will issue Certificates for Payment in such amounts.

Init.

§ 4.2.6 The Architect has authority and the responsibility to reject Work that does not conform to the Contract Documents. Whenever the Architect considers it necessary or advisable, the Architect will have authority to require inspection or testing of the Work in accordance with Sections 13.5.2 and 13.5.3, whether or not such Work is fabricated, installed or completed. However, neither this authority of the Architect nor a decision made in good faith either to exercise or not to exercise such authority shall give rise to a duty or responsibility of the Architect to the Contractor, Subcontractors, material and equipment suppliers, their agents or employees, or other persons or entities performing portions of the Work.

§ 4.2.7 The Architect will review and approve or reject, or take other appropriate action upon, the Contractor's submittals such as Shop Drawings, Product Data and Samples, for conformance with information given and the design concept expressed in the Contract Documents. The Architect's action will be taken in accordance with the submittal schedule approved by the Architect or, in the absence of an approved submittal schedule, with reasonable promptness while allowing sufficient time in the Architect's professional judgment to permit adequate review. Review of such submittals is not conducted for the purpose of determining the accuracy and completeness of other details such as dimensions and quantities, or for substantiating instructions for installation or performance of equipment or systems, all of which remain the responsibility of the Contractor as required by the Contract Documents. The Architect's review of the Contractor's submittals shall not relieve the Contractor of the obligations under Sections 3.3, 3.5 and 3.12. The Architect's review shall not constitute approval of safety precautions or, unless otherwise specifically stated by the Architect, of any construction means, methods, techniques, sequences or procedures. The Architect's approval of a specific item shall not indicate approval of an assembly of which the item is a component.

§ 4.2.8 The Architect will prepare Change Orders and Construction Change Directives, and may authorize minor changes in the Work as provided in Section 7.4. The Architect will investigate and make determinations and recommendations regarding concealed and unknown conditions as provided in Section 3.7.4.

§ 4.2.9 The Architect will conduct inspections to determine the date or dates of Substantial Completion and the date of final completion; issue Certificates of Substantial Completion pursuant to Section 9.8; receive and forward to the Owner, for the Owner's review and records, written warranties and related documents required by the Contract and assembled by the Contractor pursuant to Section 9.10; and issue a final Certificate for Payment pursuant to Section 9.10.

§ 4.2.10 If the Owner and Architect agree, the Architect will provide one or more project representatives to assist in carrying out the Architect's responsibilities at the site. The duties, responsibilities and limitations of authority of such project representatives shall be as set forth in an exhibit to be incorporated in the Contract Documents.

§ 4.2.11 The Architect will interpret and decide matters concerning performance under, and requirements of, the Contract Documents on written request of either the Owner or Contractor. The Architect's response to such requests will be made in writing within any time limits agreed upon or otherwise with reasonable promptness.

§ 4.2.12 Interpretations and decisions of the Architect will be consistent with the intent of, and reasonably inferable from, the Contract Documents and will be in writing or in the form of drawings. When making such interpretations and decisions, the Architect will endeavor to secure faithful performance by both Owner and Contractor, and will not be liable for results of interpretations or decisions rendered in good faith.

§ 4.2.13 DELETED.

§ 4.2.14 The Architect will review and respond to requests for information about the Contract Documents. The Architect's response to such requests will be made in writing within any time limits agreed upon or otherwise with reasonable promptness. If appropriate, the Architect will prepare and issue supplemental Drawings and Specifications in response to the requests for information.

ARTICLE 5 SUBCONTRACTORS

§ 5.1 DEFINITIONS

§ 5.1.1 A Subcontractor is a person or entity who has a direct contract with the Contractor to perform a portion of the Work at the site or to otherwise furnish labor, material, or other services with respect to a portion of the Work. The term "Subcontractor" is referred to throughout the Contract Documents as if singular in number and means a

Init.

Subcontractor or an authorized representative of the Subcontractor. The term "Subcontractor" does not include a separate contractor or subcontractors of a separate contractor.

§ 5.1.2 A Sub-subcontractor is a person or entity who has a direct or indirect contract with a Subcontractor to perform a portion of the Work at the site or to otherwise furnish labor, material, or other services with respect to a portion of the Work. The term "Sub-subcontractor" is referred to throughout the Contract Documents as if singular in number and means a Sub-subcontractor or an authorized representative of the Sub-subcontractor.

§ 5.2 AWARD OF SUBCONTRACTS AND OTHER CONTRACTS FOR PORTIONS OF THE WORK

§ 5.2.1 Unless otherwise stated in the Contract Documents or the bidding requirements, the Contractor, as soon as practicable after award of the Contract, but no later than 10 days prior to the submittal date for the Contractor's first Application for Payment, shall furnish in writing to the Owner through the Architect the names of persons or entities (including those who are to furnish materials or equipment fabricated to a special design) proposed for each principal portion of the Work. The Architect may reply within 14 days to the Contractor in writing stating (1) whether the Owner or the Architect has reasonable objection to any such proposed person or entity or (2) that the Architect requires additional time for review. Failure of the Owner or Architect to reply within the 14 day period shall constitute notice of no reasonable objection. Failure of the Contractor to submit the subject names in a timely manner may delay processing of the Contractor's Application for Payment.

§ 5.2.2 The Contractor shall not contract with a proposed person or entity to whom the Owner or Architect has made reasonable and timely objection. The Contractor shall not be required to contract with anyone to whom the Contractor has made reasonable objection.

§ 5.2.3 If the Owner or Architect has reasonable objection to a person or entity proposed by the Contractor, the Contractor shall propose another to whom the Owner or Architect has no reasonable objection.

§ 5.2.4 The Contractor shall not substitute a Subcontractor, person or entity previously selected if the Owner or Architect makes reasonable objection to such substitution.

§ 5.3 SUBCONTRACTUAL RELATIONS

By appropriate written agreement, the Contractor shall require each Subcontractor, to the extent of the Work to be performed by the Subcontractor, to be bound to the Contractor by terms of the Contract Documents, and to assume toward the Contractor all the obligations and responsibilities, including the responsibility for safety of the Subcontractor's Work, which the Contractor, by these Documents, assumes toward the Owner and Architect. Each subcontract agreement shall preserve and protect the rights of the Owner and Architect under the Contract Documents with respect to the Work to be performed by the Subcontractor so that subcontracting thereof will not prejudice such rights, and shall allow to the Subcontractor, unless specifically provided otherwise in the subcontract agreement, the benefit of all rights, remedies and redress against the Contractor that the Contractor, by the Contract Documents, has against the Owner. Where appropriate, the Contractor shall require each Subcontractor to enter into similar agreements with Sub-subcontractors. The Contractor shall make available to each proposed Subcontractor, prior to the execution of the subcontract agreement, copies of the Contract Documents to which the Subcontractor will be bound, and, upon written request of the Subcontractor, identify to the Subcontractor terms and conditions of the proposed subcontract agreement that may be at variance with the Contract Documents. Subcontractors will similarly make copies of applicable portions of such documents available to their respective proposed Sub-subcontractors.

§ 5.3.1 All subcontracts shall be in written form and shall specifically provide that Owner is an intended third-party beneficiary of the subcontract.

§ 5.4 CONTINGENT ASSIGNMENT OF SUBCONTRACTS

§ 5.4.1 Each subcontract agreement for a portion of the Work is assigned by the Contractor to the Owner, provided that

- .1 assignment is effective only after termination of the Contract by the Owner for cause pursuant to Section 14.2 and only for those subcontract agreements that the Owner accepts by notifying the Subcontractor and Contractor in writing; and
- .2 assignment is subject to the prior rights of the surety, if any, obligated under bond relating to the Contract.

Init.

When the Owner accepts the assignment of a subcontract agreement, the Owner assumes the Contractor's rights and obligations under the subcontract.

§ 5.4.2 Upon such assignment, if the Work has been suspended for more than 30 days, the Subcontractor's compensation shall be equitably adjusted for increases in cost resulting from the suspension.

§ 5.4.3 Upon such assignment to the Owner under this Section 5.4, the Owner may further assign the subcontract to a successor contractor or other entity.

§ 5.5 Contractor shall promptly notify Owner and Architect of any material defaults by any Sub-contractor. Notwithstanding any provision contained in Article 5 to the contrary, it is hereby acknowledged and agreed that Owner has in no way agreed, expressly or implicitly, nor will Owner agree, to allow any Sub-contractor or other materialman or workman employed by Contractor the right to obtain a personal judgment or to create a lien against Owner for the amount due from the Contractor.

ARTICLE 6 CONSTRUCTION BY OWNER OR BY SEPARATE CONTRACTORS

§ 6.1 OWNER'S RIGHT TO PERFORM CONSTRUCTION AND TO AWARD SEPARATE CONTRACTS

§ 6.1.1 The Owner reserves the right to perform construction or operations related to the Project with the Owner's own forces, and to award separate contracts in connection with other portions of the Project or other construction or operations on the site under Conditions of the Contract identical or substantially similar to these including those portions related to insurance and waiver of subrogation. If the Contractor claims that delay or additional cost is involved because of such action by the Owner, the Contractor shall make such Claim as provided in Article 15.

§ 6.1.2 When separate contracts are awarded for different portions of the Project or other construction or operations on the site, the term "Contractor" in the Contract Documents in each case shall mean the Contractor who executes each separate Owner-Contractor Agreement.

§ 6.1.3 The Owner shall provide for coordination of the activities of the Owner's own forces and of each separate contractor with the Work of the Contractor, who shall cooperate with them. The Contractor shall participate with other separate contractors and the Owner in reviewing their construction schedules. The Contractor shall make any revisions to the construction schedule deemed necessary after a joint review and mutual agreement. The construction schedules shall then constitute the schedules to be used by the Contractor, separate contractors and the Owner until subsequently revised.

§ 6.1.4 Unless otherwise provided in the Contract Documents, when the Owner performs construction or operations related to the Project with the Owner's own forces, the Owner shall be deemed to be subject to the same obligations and to have the same rights that apply to the Contractor under the Conditions of the Contract, including, without excluding others, those stated in Article 3, this Article 6 and Articles 10, 11 and 12.

§ 6.2 MUTUAL RESPONSIBILITY

§ 6.2.1 The Contractor shall afford the Owner and separate contractors reasonable opportunity for introduction and storage of their materials and equipment and performance of their activities, and shall connect and coordinate the Contractor's construction and operations with theirs as required by the Contract Documents.

§ 6.2.2 If part of the Contractor's Work depends for proper execution or results upon construction or operations by the Owner or a separate contractor, the Contractor shall, prior to proceeding with that portion of the Work, promptly report to the Architect apparent discrepancies or defects in such other construction that would render it unsuitable for such proper execution and results. Failure of the Contractor so to report shall constitute an acknowledgment that the Owner's or separate contractor's completed or partially completed construction is fit and proper to receive the Contractor's Work, except as to defects not then reasonably discoverable.

§ 6.2.3 DELETED.

§ 6.2.4 The Contractor shall promptly remedy damage the Contractor causes to completed or partially completed construction or to property of the Owner or separate contractors as provided in Section 10.2.5.

§ 6.2.5 The Owner and each separate contractor shall have the same responsibilities for cutting and patching as are described for the Contractor in Section 3.14.

Init.

§ 6.3 OWNER'S RIGHT TO CLEAN UP

If a dispute arises among the Contractor, separate contractors and the Owner as to the responsibility under their respective contracts for maintaining the premises and surrounding area free from waste materials and rubbish, the Owner may clean up and the Architect will allocate the cost among those responsible.

ARTICLE 7 CHANGES IN THE WORK

§ 7.1 GENERAL

§ 7.1.1 Changes in the Work may only be accomplished after execution of the Contract, and without invalidating the Contract, by Change Order, Construction Change Directive or order for a minor change in the Work, subject to the limitations stated in this Article 7 and elsewhere in the Contract Documents and is subject to the approval of Owner.

§ 7.1.2 A Change Order shall be only based upon agreement among the Owner, Contractor and Architect; a Construction Change Directive requires agreement by the Owner and Architect and may or may not be agreed to by the Contractor; an order for a minor change in the Work may be issued by the Architect and is subject to the approval of Owner.

§ 7.1.3 Changes in the Work shall be performed under applicable provisions of the Contract Documents, and the Contractor shall proceed promptly, unless otherwise provided in the Change Order, Construction Change Directive or order for a minor change in the Work. Except as permitted in Paragraph 7.3 and 9.7, a change in the Contract Sum or the Contract Time shall be accomplished only by Change Order. Accordingly, no course of conduct or dealings between the parties, nor express or implied acceptance of alterations or additions to the Work and no claim that Owner has been unjustly enriched by any alteration of or addition to the Work, whether or not there is, in fact, any unjust enrichment to the Work, shall be the basis of any claim to an increase in any amounts due under the Contract Documents or a change in any time period provided for in the Contract Documents.

§ 7.2 CHANGE ORDERS

§ 7.2.1 A Change Order is a written instrument prepared by the Architect and signed by the Owner, Contractor and Architect stating their agreement upon all of the following:

- .1 The change in the Work;
- .2 The amount of the adjustment, if any, in the Contract Sum; and
- .3 The extent of the adjustment, if any, in the Contract Time.

§ 7.2.2 Agreement on any Change Order shall constitute a final settlement of all matters relating to the change in the Work that is the subject of the Change Order, including, but not limited, to all direct and indirect costs associated with such change and any and all adjustments to the Contract Sum and the construction schedule.

§ 7.2.3 Contractor shall keep and periodically submit to Owner copies of a log for all Change Orders.

§ 7.3 CONSTRUCTION CHANGE DIRECTIVES

§ 7.3.1 A Construction Change Directive is a written order prepared by the Architect and signed by the Owner and Architect, directing a change in the Work prior to agreement on adjustment, if any, in the Contract Sum or Contract Time, or both. The Owner may by Construction Change Directive, without invalidating the Contract, order changes in the Work within the general scope of the Contract consisting of additions, deletions or other revisions, the Contract Sum and Contract Time being adjusted accordingly. Contractor shall keep and periodically submit to Owner copies of a log for all Construction Change Directives and a log for all requests for information.

§ 7.3.2 A Construction Change Directive shall be used in the absence of total agreement on the terms of a Change Order.

§ 7.3.3 If the Construction Change Directive provides for an adjustment to the Contract Sum, the adjustment shall be based on one of the following methods:

- .1 Mutual acceptance of a lump sum properly itemized and supported by sufficient substantiating data to permit evaluation;
- .2 Unit prices stated in the Contract Documents or subsequently agreed upon;
- .3 Cost to be determined in a manner agreed upon by the parties and a mutually acceptable fixed or percentage fee; or

Init.

.4 As provided in Section 7.3.7.

§ 7.3.4 If unit prices are stated in the Contract Documents or subsequently agreed upon, and if quantities originally contemplated are materially changed in a proposed Change Order or Construction Change Directive so that application of such unit prices to quantities of Work proposed will cause substantial inequity to the Owner or Contractor, the applicable unit prices shall be equitably adjusted.

§ 7.3.5 Upon receipt of a Construction Change Directive, the Contractor shall promptly proceed with the change in the Work involved and advise the Architect of the Contractor's agreement or disagreement with the method, if any, provided in the Construction Change Directive for determining the proposed adjustment in the Contract Sum or Contract Time.

§ 7.3.6 A Construction Change Directive signed by the Contractor indicates the Contractor's agreement therewith, including adjustment in Contract Sum and Contract Time or the method for determining them. Such agreement shall be effective immediately and shall be recorded as a Change Order.

§ 7.3.7 If the Contractor does not respond promptly or disagrees with the method for adjustment in the Contract Sum, the Architect shall determine the method and the adjustment on the basis of reasonable expenditures and savings of those performing the Work attributable to the change, including, in case of an increase in the Contract Sum, an amount for overhead and profit not to exceed a total maximum of fifteen percent (15%) for all Work, and further limited to as follows, not to exceed five percent (5%) for Work done by Contractor's employees and ten percent (10%) of such Work's actual cost to be apportioned between any and all Subcontractors and Sub-subcontractor. "Actual cost" does not include any item that could be deemed to be a general conditions cost or overhead, such as, but not limited to, the cost of Contractor and Subcontractor supervisory personnel assigned to the Work, and field office and related expenses. In such case, and also under Section 7.3.3.3, the Contractor shall keep and present, in such form as the Architect may prescribe, an itemized accounting together with appropriate supporting data. Unless otherwise provided in the Contract Documents, costs for the purposes of this Section 7.3.7 shall be limited to the following:

- .1 Costs of labor, including social security, old age and unemployment insurance, fringe benefits required by agreement or custom, and workers' compensation insurance;
- .2 Costs of materials, supplies and equipment, including cost of transportation, whether incorporated or consumed;
- .3 Rental costs of machinery and equipment, exclusive of hand tools, whether rented from the Contractor or others;
- .4 Costs of premiums for all bonds and insurance, permit fees, and sales, use or similar taxes related to the Work; and
- .5 Additional costs of supervision and field office personnel directly attributable to the change.

§ 7.3.8 The amount of credit to be allowed by the Contractor to the Owner for a deletion or change that results in a net decrease in the Contract Sum shall be actual net cost as confirmed by the Architect. When both additions and credits covering related Work or substitutions are involved in a change, the allowance for overhead and profit shall be figured on the basis of net increase, if any, with respect to that change.

§ 7.3.9 Pending final determination of the total cost of a Construction Change Directive to the Owner, the Contractor may request payment for Work completed under the Construction Change Directive in Applications for Payment. The Architect will make an interim determination for purposes of monthly certification for payment for those costs and certify for payment the amount that the Architect determines, in the Architect's professional judgment, to be reasonably justified. The Architect's interim determination of cost shall adjust the Contract Sum on the same basis as a Change Order, subject to the right of either party to disagree and assert a Claim in accordance with Article 15.

§ 7.3.10 When the Owner and Contractor agree with a determination made by the Architect concerning the adjustments in the Contract Sum and Contract Time, or otherwise reach agreement upon the adjustments, such agreement shall be effective immediately and the Architect will prepare a Change Order. Change Orders may be issued for all or any part of a Construction Change Directive.

§ 7.4 MINOR CHANGES IN THE WORK

The Architect has authority after having obtained Owner's approval to order minor changes in the Work not involving adjustment in the Contract Sum or extension of the Contract Time and not inconsistent with the intent of the Contract

Init.

Documents. Such changes will be effected by written order signed by the Architect and shall be binding on the Owner and Contractor.

ARTICLE 8 TIME

§ 8.1 DEFINITIONS

§ 8.1.1 Unless otherwise provided, Contract Time is the period of time, including authorized adjustments, allotted in the Contract Documents for Substantial Completion of the Work.

§ 8.1.1.1 The Work shall be fully completed within the time limit and/or date stated in the Contract between Owner and Contractor.

§ 8.1.1.2 **Liquidated Damages:** If the Contractor should fail to fully complete the Work within the stated time (subject however to extension of time duly granted in the manner and for the causes specified in the General Conditions), Contractor shall be charged by and shall pay to Owner, as liquidated damages, the sum specified in Article 3 of the AIA document A101 – 2007 Edition, as modified by the Owner, per calendar day that the Work remains incomplete beyond the time fixed for completion. Contractor hereby agrees that from the nature of the project it would be impracticable and extremely difficult to fix the actual damage that would or will be suffered in the event that Contractor should fail to fully complete the Work by the time limit or date stated and the amount of the liquidated damages are fair and reasonable. The parties agree that the liquidated damages are a reasonable forecast of just compensation for the harm done to Owner that would be caused by Contractor's failure to timely complete the Work. Contractor agrees that the amount of liquidated damages due Owner may be deducted by Owner from any monies that might otherwise be or become payable to Contractor.

§ 8.1.2 The date of commencement of the Work is the date established in the Agreement.

§ 8.1.3 The date of Substantial Completion is the date certified by the Architect in accordance with Section 9.8.

§ 8.1.4 The term "day" as used in the Contract Documents shall mean calendar day unless otherwise specifically defined.

§ 8.2 PROGRESS AND COMPLETION

§ 8.2.1 Time limits stated in the Contract Documents are of the essence of the Contract. By executing the Agreement the Contractor confirms that the Contract Time is a reasonable period for performing the Work.

§ 8.2.2 The Contractor shall not knowingly, except by agreement or instruction of the Owner in writing, prematurely commence operations on the site or elsewhere prior to the effective date of insurance required by Article 11 to be furnished by the Contractor and Owner. The date of commencement of the Work shall not be changed by the effective date of such insurance.

§ 8.2.3 The Contractor shall proceed expeditiously with adequate forces and shall achieve Substantial Completion within the Contract Time.

§ 8.3 DELAYS AND EXTENSIONS OF TIME

§ 8.3.1 If the Contractor is delayed at any time in the commencement or progress of the Work by an act or neglect of the Owner or Architect, or of an employee of either, or of a separate contractor employed by the Owner; or by changes ordered in the Work; or by labor disputes, fire, unusual delay in deliveries, unavoidable casualties or other causes beyond the Contractor's control; or by delay authorized by the Owner pending mediation, or by other causes that the Architect determines may justify delay, then the Contract Time shall be extended by Change Order for such reasonable time as the Architect may determine provided, however, that such extension of Contract time shall be net of any delays caused by or due to the fault or negligence of Contractor or that are otherwise the responsibility of Contractor and shall also be net of any contingency or "float" time allowance included in Contractor's construction schedule. Contractor shall, in the event of any occurrence likely to cause a delay, cooperate in good faith with Architect and Owner to minimize and mitigate the impact of any such occurrence and do all things reasonable under the circumstances to achieve this goal..

§ 8.3.2 Claims relating to time shall be made in accordance with applicable provisions of Article 15.

Init.

§ 8.3.3 This Section 8.3 does not preclude recovery of damages for delay by either party under other provisions of the Contract Documents. Contactor shall not be entitled to damages of any type for delays caused by Owner, his servant, agents, employees, or separate Contractors hired or retained by Owner. Contractor may receive an extension or extensions for additional time in which to complete the Contract but shall not receive any damages of any type for such delays. Changes in the Work, regardless of the extent or number of such Changes or Owner's exercise of any of its remedies of suspension of the Work or requirement of correction or re-execution of any defective Work, shall not under any circumstances be construed as intentional interference with Contractor's performance of the Work.

ARTICLE 9 PAYMENTS AND COMPLETION

§ 9.1 CONTRACT SUM

The Contract Sum is stated in the Agreement and, including authorized adjustments, is the total amount payable by the Owner to the Contractor for performance of the Work under the Contract Documents.

§ 9.1.1 COMMITMENT OF CURRENT REVENUES ONLY

As reflected in paragraph 4.5 of the modified AIA document A 101 – 2007 Edition by and between Owner and Contractor dated of even date herewith, in the event that, during any term hereof, the governing body of any party does not appropriate sufficient funds to meet the obligations of such party under this Contract, then any party may terminate this Contract upon ninety (90) days written notice to the other party. Each of the parties hereto agrees, however, to use its best efforts to secure funds necessary for the continued performance of this Agreement. The parties intend this provision to be a continuing right to terminate this Agreement at the expiration of each budget period of each party hereto pursuant to the provisions of Tex. Loc. Govt. Code Ann. 271.903.

§ 9.2 SCHEDULE OF VALUES

Where the Contract is based on a stipulated sum or Guaranteed Maximum Price, the Contractor shall submit to the Owner and to the Architect, before the first Application for Payment, a schedule of values allocating the entire Contract Sum to the various portions of the Work which in the aggregate equals the total Contract Sum, divided so as to facilitate payments to Subcontractors, supported by such evidence of correctness as Architect may direct or as required by Owner or by Owner upon consultation with Construction Manager ("Construction Manager" shall have the same meaning as defined in the AIA Document A101-2007 as modified by the Owner). This schedule, when approved by Architect and Owner, shall be used to monitor the progress of the Work and as a basis for Certificates for Payment. All items with entered values will be transferred by Contractor to the "Application and Certificate for Payment," and shall include the latest approved Change Orders and Construction Change Directives. Change Order values and Construction Change Directives values shall be broken down to show the various subcontracts. The Application for Payment shall be on a form as provided by Architect and approved by Owner. Each item shall show its total scheduled value, value of previous applications, value of the application, percentage completed, value completed, and value yet to be completed. All blanks and columns must be filled in, including every percentage complete figure. This schedule, unless objected to by the Architect and Construction Manager, shall be used as a basis for reviewing the Contractor's Applications for Payment.

§ 9.3 APPLICATIONS FOR PAYMENT

§ 9.3.1 At least ten days before the date established for each progress payment, the Contractor shall submit to the Architect an itemized Application for Payment prepared in accordance with the schedule of values, for completed portions of the Work. Such application shall be notarized, if required, and supported by such data substantiating the Contractor's right to payment as the Owner or Architect may require, such as copies of requisitions from Subcontractors and material suppliers, and shall reflect retainage if provided for in the Contract Documents. Any allowances included in the Application for Payment shall be separately itemized with supporting data attached. The Application for Payment shall be accompanied by a certification by an office of Contractor to the effect that:

There are no known mechanics', materialman's or laborers' liens or claims, or any other liens or claims, legal or equitable, contractual, statutory, or constitutional, outstanding or known to exist at the date of this Application; all due and payable bills with respect to the Work have been paid to date or are included in the amount requested in the current Application and there is no known basis for the filing of any mechanics', materialman's or laborers' lien or claim, or any other lien or claim, legal or equitable, contractual, statutory, or constitutional, on the Work; and waivers and releases from all Subcontractors, laborers, and material men for Work done and materials furnished have been obtained in such form as to constitute an effective waiver and release of all such liens and claims under the laws of the state within which the Project is located and shall be delivered to

Init.

Architect together with Contractor's waiver and release of liens and claims at the time of submission of the Application for Payment.

§ 9.3.1.1 As provided in Section 7.3.9, such applications may include requests for payment on account of changes in the Work that have been properly authorized by Construction Change Directives, or by interim determinations of the Architect, but not yet included in Change Orders.

§ 9.3.1.2 Applications for Payment shall not include requests for payment for portions of the Work for which the Contractor does not intend to pay a Subcontractor or material supplier, unless such Work has been performed by others whom the Contractor intends to pay.

§ 9.3.2 Unless otherwise provided in the Contract Documents, payments shall be made on account of materials and equipment delivered and suitably stored at the site for subsequent incorporation in the Work. If approved in advance by the Owner, payment may similarly be made for materials and equipment suitably stored off the site at a location agreed upon in writing by the Owner and Surety. Payment for materials and equipment stored on or off the site shall be conditioned upon compliance by the Contractor with procedures satisfactory to the Owner to establish the Owner's title to such materials and equipment or otherwise protect the Owner's interest, and shall include the costs of applicable insurance, storage and transportation to the site for such materials and equipment stored off the site. Under no circumstances will the Owner reimburse the Contractor for down payments, deposits, or other advance payments for materials or equipment.

§ 9.3.3 The Contractor warrants that title to all Work covered by an Application for Payment will pass to the Owner no later than the time of payment. The Contractor further warrants that upon submittal of an Application for Payment all Work for which Certificates for Payment have been previously issued and payments received from the Owner shall, to the best of the Contractor's knowledge, information and belief, be free and clear of liens, claims, security interests or encumbrances in favor of the Contractor, Subcontractors, material suppliers, or other persons or entities making a claim by reason of having provided labor, materials and equipment relating to the Work. The vesting of such title shall not impose any obligations on Owner or relieve Contractor of any of its obligations under the Contract, that Contractor shall remain responsible for damage to or loss of the Work, whether completed or under construction, until responsibility for the Work has been accepted by Owner in the manner set forth in the Contract Documents.

§ 9.4 CERTIFICATES FOR PAYMENT

§ 9.4.1 The Architect will, within seven (7) days after receipt of the Contractor's Application for Payment (which such Application for Payment shall be reviewed by the Construction Manager as evidenced by the Construction Manager's signature in the Certificate for Payment provided to the Owner), either issue to the Owner a Certificate for Payment, with a copy to the Contractor, for such amount as the Architect determines is properly due, or notify the Contractor and Owner in writing of the Architect's reasons for withholding certification in whole or in part as provided in Section 9.5.1. The Construction Manager's review shall be conducted concurrently with the Architect's review and completed in time for the Architect to certify the Application for Payment within seven (7) days.

§ 9.4.2 The issuance of a Certificate for Payment will constitute a representation by the Architect to the Owner, based on the Architect's evaluation of the Work and on all other information available to Architect including, without limitation, the data comprising the Application for Payment, that, to the best of the Architect's knowledge, information and belief, the Work has progressed to the point indicated and that the quality of the Work is in accordance with the Contract Documents. The foregoing representations are subject to an evaluation of the Work for conformance with the Contract Documents upon Substantial Completion, to results of subsequent tests and inspections, to correction of minor deviations from the Contract Documents prior to completion and to specific qualifications expressed by the Architect. The issuance of a Certificate for Payment will further constitute a representation that the Contractor is entitled to payment in the amount certified and that the aggregate amount theretofore paid to Contractor plus any applicable retention does not exceed the value of the completed portion of the Work. However, the issuance of a Certificate for Payment will not be a representation that the Architect has (1) made exhaustive or continuous on-site inspections to check the quality or quantity of the Work, (2) reviewed construction means, methods, techniques, sequences or procedures, or (3) made examination to ascertain how or for what purpose the Contractor has used money previously paid on account of the Contract Sum.

Init.

§ 9.5 DECISIONS TO WITHHOLD CERTIFICATION

§ 9.5.1 The Architect may withhold a Certificate for Payment in whole or in part, to the extent reasonably necessary to protect the Owner, if in the Architect's opinion the representations to the Owner required by Section 9.4.2 cannot be made. If the Architect is unable to certify payment in the amount of the Application, the Architect will notify the Contractor and Owner as provided in Section 9.4.1. If the Contractor and Architect cannot agree on a revised amount, the Architect will promptly issue a Certificate for Payment for the amount for which the Architect is able to make such representations to the Owner. The Architect may also withhold a Certificate for Payment or, because of subsequently discovered evidence, may nullify the whole or a part of a Certificate for Payment previously issued, to such extent as may be necessary in the Architect's opinion to protect the Owner from loss for which the Contractor is responsible, including loss resulting from acts and omissions described in Section 3.3.2, because of

- .1 defective Work not remedied;
- .2 third party claims filed or reasonable evidence indicating probable filing of such claims unless security acceptable to the Owner is provided by the Contractor;
- .3 failure of the Contractor to make payments properly to Subcontractors or for labor, materials or equipment;
- .4 reasonable evidence that the Work cannot be completed for the unpaid balance of the Contract Sum;
- .5 damage to the Owner or a separate contractor;
- .6 reasonable evidence that the Work will not be completed within the Contract Time, or that the unpaid balance would not be adequate to cover actual or liquidated damages for the anticipated delay; or
- .7 failure to carry out the Work in accordance with the Contract Documents.

§ 9.5.2 When the above reasons for withholding certification are removed, certification will be made for amounts previously withheld.

§ 9.5.3 If the Architect withholds certification for payment under Section 9.5.1.3, the Owner may, at its sole option, issue joint checks to the Contractor and to any Subcontractor or material or equipment suppliers to whom the Contractor failed to make payment for Work properly performed or material or equipment suitably delivered. If the Owner makes payments by joint check, the Owner shall notify the Architect and the Architect will reflect such payment on the next Certificate for Payment.

§ 9.5.4 Notwithstanding any provision contained within this Article, if the Work has not attained Substantial Completion with the contract time, subject to extensions of time allowed under these Conditions, Architect may withhold any further payment to Contractor to the extent necessary to preserve sufficient funds to complete the construction of the Project and to cover liquidated damages assessed against Contractor up to the time of the Application for Payment and to the time it is reasonably anticipated that Substantial Completion will be achieved.

§ 9.6 PROGRESS PAYMENTS

§ 9.6.1 After the Architect has issued a Certificate for Payment, the Owner shall make payment in the manner and within the time provided in the Contract Documents, and shall so notify the Architect. Owner may refuse to make payment on any Certificate for Payment for any default of the Contract, including, but not limited to, those defaults set forth in Clauses 9.5.1.1 through 9.5.1.7. Owner shall not be deemed in default by reason of withholding payment while any of such defaults remain uncured.

§ 9.6.2 The Contractor shall pay each Subcontractor no later than seven days after receipt of payment from the Owner the amount to which the Subcontractor is entitled, reflecting percentages actually retained from payments to the Contractor on account of the Subcontractor's portion of the Work. The Contractor shall, by appropriate agreement with each Subcontractor, require each Subcontractor to make payments to Sub-subcontractors in a similar manner.

§ 9.6.3 The Architect will, on request, furnish to a Subcontractor, if practicable, information regarding percentages of completion or amounts applied for by the Contractor and action taken thereon by the Architect and Owner on account of portions of the Work done by such Subcontractor.

§ 9.6.4 The Owner has the right to request written evidence from the Contractor that the Contractor has properly paid Subcontractors and material and equipment suppliers amounts paid by the Owner to the Contractor for subcontracted Work. If the Contractor fails to furnish such evidence within seven days, the Owner shall have the right to contact Subcontractors to ascertain whether they have been properly paid. Neither the Owner nor Architect shall have an obligation to pay or to see to the payment of money to a Subcontractor.

Init.

§ 9.6.5 Contractor payments to material and equipment suppliers shall be treated in a manner similar to that provided in Sections 9.6.2, 9.6.3 and 9.6.4.

§ 9.6.6 A Certificate for Payment, a progress payment, or partial or entire use or occupancy of the Project by the Owner shall not constitute acceptance of Work not in accordance with the Contract Documents.

§ 9.6.7 DELETED.

§ 9.7 FAILURE OF PAYMENT

If the Architect does not issue a Certificate for Payment, through no fault of the Contractor, within seven days after receipt of the Contractor's Application for Payment, or if the Owner does not, for reasons other than a default of the Contract, including, but not limited to, those defaults set forth in Clauses 9.5.1.1 through 9.5.1.7 pay the Contractor within seven days after the date established in the Contract Documents the amount certified by the Architect, then the Contractor may, upon seven additional days' written notice to the Owner and Architect, stop the Work until payment of the amount owing has been received. The Contract Time shall be extended appropriately and the Contract Sum shall be increased by the amount of the Contractor's reasonable costs of shut-down, delay and start-up, plus interest as provided for in the Contract Documents.

§ 9.7.1 If Owner is entitled to reimbursement or payment from Contractor under or pursuant to the Contract Documents, such payment shall be made promptly upon demand by Owner. Notwithstanding anything contained in the Contract Documents to the contrary, if Contractor fails to promptly make any payment due Owner, or if Owner incurs any costs and expenses to cure any default of Contractor or to correct defective Work, Owner shall have an absolute right to offset such amount against the Contract Sum and may, in Owner sole discretion, elect either to (i) deduct an amount equal to that which Owner is entitled from any payment then or thereafter due Contractor from Owner, or (ii) issue a written notice to Contractor reducing the Contract Sum by an amount equal to that which Owner is entitled.

§ 9.8 SUBSTANTIAL COMPLETION

§ 9.8.1 Substantial Completion is the stage in the progress of the Work when the Work or designated portion thereof (which Owner agrees to accept separately) is sufficiently complete in accordance with the Contract Documents so that the Owner can occupy or utilize the Work for its intended use.

§ 9.8.2 When the Contractor considers that the Work, or a portion thereof which the Owner agrees to accept separately, is substantially complete, the Contractor shall prepare and submit to the Architect a comprehensive list of items to be completed or corrected prior to final payment. Failure to include an item on such list does not alter the responsibility of the Contractor to complete all Work in accordance with the Contract Documents.

§ 9.8.3 Upon receipt of the Contractor's list, the Architect will make an inspection to determine whether the Work or designated portion thereof is substantially complete. If the Architect's inspection discloses any item, whether or not included on the Contractor's list, which is not sufficiently complete in accordance with the Contract Documents so that the Owner can occupy or utilize the Work or designated portion thereof for its intended use, the Contractor shall, before issuance of the Certificate of Substantial Completion, complete or correct such item upon notification by the Architect. In such case, the Contractor shall then submit a request for another inspection by the Architect to determine Substantial Completion.

§ 9.8.4 When the Work or designated portion thereof is substantially complete, the Architect will prepare a Certificate of Substantial Completion that shall establish the date of Substantial Completion, shall establish responsibilities of the Owner and Contractor for security, maintenance, heat, utilities, damage to the Work and insurance, and shall fix the time within which the Contractor shall finish all items on the list accompanying the Certificate. Warranties required by the Contract Documents shall commence on the date of issuance of the certificate of final payment by Architect unless otherwise provided in the Certificate of Substantial Completion. The Work will not be considered suitable for Substantial Completion review until all Project systems included in the Work are operational as designed and scheduled, all designated or required governmental inspections and certifications have been made and posted, designated instruction of Owner's personnel in the operation of systems has been completed, and all final finishes within the Contract are in place. In general, the only remaining Work shall be minor in nature, so that Owner and/or Owner's employees and if applicable, the public, could occupy the building on that date and the completing of the

Init.

Work by Contractor would not materially interfere or hamper Owner's or Owner's employees and if applicable, the public, (or those claiming by, through, or under Owner) from normal County operations. As a further condition of Substantial Completion acceptance, Contractor shall certify that all remaining Work will be completed within thirty (30) consecutive calendar days or as agreed upon following the Date of Substantial Completion. If Contractor requests a Substantial Completion review, and Architect, after performing the Substantial Completion review, finds that the Project was not ready for the Substantial Completion review, then Contractor shall pay the Architect's fees for any additional Substantial Completion reviews.

§ 9.8.5 The Certificate of Substantial Completion shall be submitted to the Owner and Contractor for their written acceptance of responsibilities assigned to them in such Certificate. Upon such acceptance and consent of surety, if any, the Owner shall make payment of retainage applying to such Work or designated portion thereof. Such payment shall be adjusted for Work that is incomplete or not in accordance with the requirements of the Contract Documents.

§9.8.6 In order for the project or a major portion thereof to be considered substantially complete, the following conditions must be met: (1) All inspections by governmental authorities have jurisdiction over the project must have been finalized, any remedial work required by those authorities must have been completed, and Certificates of Occupancy and similar governmental approval forms must have been issued and copies delivered to the Owner and Architect. (2) All work, both interior and exterior, shall have been completed and cleaned except minor items which if completed after occupancy, will not, in the Owner's opinion, cause interference to the Owner's use of the building or any portion thereof. A significantly large number of items to be completed or corrected will preclude the Architect from issuing a Certificate of Substantial Completion. The Owner and Architect will be the sole judge of what constitutes a significantly large number of items.

§9.8.7 After the date of Substantial Completion of the Project is evidenced by the Certificate of Substantial Completion, the Contractor will be allowed a period of thirty (30) days, unless extended by mutual agreement or provision of the Contract, within which to correct all deficiencies attached to the Certificate of Substantial Completion. Failure of the Contractor to complete such corrections within the stipulated time will be reported to the Contractor's surety. In this report, the Contractor and surety will be informed that, should correction remain incomplete for fifteen (15) days, the Owner may initiate action to complete corrective work out of the remaining Contract funds in accordance with Article 14.

§ 9.9 PARTIAL OCCUPANCY OR USE

§ 9.9.1 The Owner may occupy or use any completed or partially completed portion of the Work at any stage when such portion is designated by separate agreement with the Contractor, provided such occupancy or use is consented to by the insurer as required under Section 11.3.1.5 and authorized by public authorities having jurisdiction over the Project. Such partial occupancy or use may commence whether or not the portion is substantially complete, provided the Owner and Contractor have accepted in writing the responsibilities assigned to each of them for payments, retainage, if any, security, maintenance, heat, utilities, damage to the Work and insurance, and have agreed in writing concerning the period for correction of the Work and commencement of warranties required by the Contract Documents. When the Contractor considers a portion substantially complete, the Contractor shall prepare and submit a list to the Architect as provided under Section 9.8.2. Consent of the Contractor to partial occupancy or use shall not be unreasonably withheld. The stage of the progress of the Work shall be determined by written agreement between the Owner and Contractor or, if no agreement is reached, by decision of the Architect.

§ 9.9.2 Immediately prior to such partial occupancy or use, the Owner, Contractor and Architect shall jointly inspect the area to be occupied or portion of the Work to be used in order to determine and record the condition of the Work.

§ 9.9.3 Unless otherwise agreed upon, partial occupancy or use of a portion or portions of the Work shall not constitute acceptance of Work not complying with the requirements of the Contract Documents.

§ 9.10 FINAL COMPLETION AND FINAL PAYMENT

§ 9.10.1 Upon receipt of the Contractor's written notice that the Work is ready for final inspection and acceptance and upon receipt of a final Application for Payment, the Architect will promptly make such inspection and, when the Architect finds the Work acceptable under the Contract Documents and the Contract fully performed, the Architect will promptly issue a final Certificate for Payment stating that to the best of the Architect's knowledge, information and belief, and on the basis of the Architect's on-site visits and inspections, the Work has been completed in accordance with terms and conditions of the Contract Documents and that the entire balance found to be due the

Init.

Contractor and noted in the final Certificate is due and payable. The Architect's final Certificate for Payment will constitute a further representation that conditions listed in Section 9.10.2 as precedent to the Contractor's being entitled to final payment have been fulfilled.

§ 9.10.2 Neither final payment nor any remaining retained percentage shall become due until the Contractor submits to the Architect (1) an affidavit that payrolls, bills for materials and equipment, and other indebtedness connected with the Work for which the Owner or the Owner's property might be responsible or encumbered (less amounts withheld by Owner) have been paid or otherwise satisfied, (2) a certificate evidencing that insurance required by the Contract Documents to remain in force after final payment is currently in effect and will not be canceled or allowed to expire until at least 30 days' prior written notice has been given to the Owner, (3) a written statement that the Contractor knows of no substantial reason that the insurance will not be renewable to cover the period required by the Contract Documents, (4) consent of surety, if any, to final payment and (5), if required by the Owner, other data establishing payment or satisfaction of obligations, such as receipts, releases and waivers of liens, claims, security interests or encumbrances arising out of the Contract, to the extent and in such form as may be designated by the Owner. If a Subcontractor refuses to furnish a release or waiver required by the Owner, the Contractor may furnish a bond satisfactory to the Owner to indemnify the Owner against such lien. If such lien remains unsatisfied after payments are made, the Contractor shall refund to the Owner all money that the Owner may be compelled to pay in discharging such lien, including all costs and reasonable attorneys' fees.

§ 9.10.3 If, after Substantial Completion of the Work, final completion thereof is materially delayed through no fault of the Contractor or by issuance of Change Orders affecting final completion, and the Architect so confirms, the Owner shall, upon application by the Contractor and certification by the Architect, and without terminating the Contract, make payment of the balance due for that portion of the Work fully completed and accepted. If the remaining balance for Work not fully completed or corrected is less than retainage stipulated in the Contract Documents, and if bonds have been furnished, the written consent of surety to payment of the balance due for that portion of the Work fully completed and accepted shall be submitted by the Contractor to the Architect prior to certification of such payment. Such payment shall be made under terms and conditions governing final payment, except that it shall not constitute a waiver of claims.

§ 9.10.4 The making of final payment shall constitute a waiver of Claims by the Owner except those arising from

- .1 liens, Claims, security interests or encumbrances arising out of the Contract and unsettled;
- .2 failure of the Work to comply with the requirements of the Contract Documents;
- .3 terms of special warranties required by the Contract Documents; or
- .4 faulty or defective Work appearing after Substantial Completion.

§ 9.10.5 Acceptance of final payment by the Contractor, a Subcontractor or material supplier shall constitute a waiver of claims by that payee except those previously made in writing and identified by that payee as unsettled at the time of final Application for Payment.

ARTICLE 10 PROTECTION OF PERSONS AND PROPERTY

§ 10.1 SAFETY PRECAUTIONS AND PROGRAMS

The Contractor shall be responsible for initiating, maintaining and supervising all safety precautions and programs in connection with the performance of the Contract.

§ 10.2 SAFETY OF PERSONS AND PROPERTY

§ 10.2.1 The Contractor shall take reasonable precautions for safety of, and shall provide reasonable protection to prevent damage, injury or loss to

- .1 employees on the Work and other persons who may be affected thereby;
- .2 the Work and materials and equipment to be incorporated therein, whether in storage on or off the site, under care, custody or control of the Contractor or the Contractor's Subcontractors or Sub-subcontractors; and
- .3 other property at the site or adjacent thereto, such as trees, shrubs, lawns, walks, pavements, roadways, structures and utilities not designated for removal, relocation or replacement in the course of construction.

Init.

§ 10.2.2 The Contractor shall comply with and give notices required by applicable laws, statutes, ordinances, codes, rules and regulations, and lawful orders of public authorities bearing on safety of persons or property or their protection from damage, injury or loss.

§ 10.2.3 The Contractor shall erect and maintain, as required by existing conditions and performance of the Contract, reasonable safeguards for safety and protection, including posting danger signs and other warnings against hazards, promulgating safety regulations and notifying owners and users of adjacent sites and utilities. The Contractor shall also be responsible, at the Contractor's sole cost and expense, for all measures necessary to protect any property adjacent to the project and improvements therein. Any damage to such property or improvements shall be promptly repaired by the Contractor.

§ 10.2.4 When use or storage of explosives or other hazardous materials or equipment or unusual methods are necessary for execution of the Work, the Contractor shall exercise utmost care and carry on such activities under supervision of properly qualified personnel.

§ 10.2.5 The Contractor shall promptly remedy damage and loss (other than damage or loss insured under property insurance required by the Contract Documents) to property referred to in Sections 10.2.1.2 and 10.2.1.3 caused in whole or in part by the Contractor, a Subcontractor, a Sub-subcontractor, or anyone directly or indirectly employed by any of them, or by anyone for whose acts they may be liable and for which the Contractor is responsible under Sections 10.2.1.2 and 10.2.1.3, except damage or loss attributable to acts or omissions of the Owner or Architect or anyone directly or indirectly employed by either of them, or by anyone for whose acts either of them may be liable, and not attributable to the fault or negligence of the Contractor. The foregoing obligations of the Contractor are in addition to the Contractor's obligations under Section 3.18.

§ 10.2.6 The Contractor shall designate a responsible member of the Contractor's organization at the site whose duty shall be the prevention of accidents. This person shall be the Contractor's superintendent unless otherwise designated by the Contractor in writing to the Owner and Architect.

§ 10.2.7 The Contractor shall not permit any part of the construction or site to be loaded so as to cause damage or create an unsafe condition.

§ 10.2.8 INJURY OR DAMAGE TO PERSON OR PROPERTY

If either party suffers injury or damage to person or property because of an act or omission of the other party, or of others for whose acts such party is legally responsible, written notice of such injury or damage, whether or not insured, shall be given to the other party within a reasonable time not exceeding 21 days after discovery. The notice shall provide sufficient detail to enable the other party to investigate the matter.

§ 10.3 HAZARDOUS MATERIALS

§ 10.3.1 The Contractor is responsible for compliance with any requirements included in the Contract Documents regarding hazardous materials. If the Contractor encounters a hazardous material or substance not addressed in the Contract Documents and if reasonable precautions will be inadequate to prevent foreseeable bodily injury or death to persons resulting from a material or substance, including but not limited to asbestos or polychlorinated biphenyl (PCB), encountered on the site by the Contractor, the Contractor shall, upon recognizing the condition, immediately stop Work in the affected area and report the condition to the Owner and Architect in writing.

§ 10.3.2 Upon receipt of the Contractor's written notice, the Owner shall obtain the services of a licensed laboratory to verify the presence or absence of the material or substance reported by the Contractor and, in the event such material or substance is found to be present, to cause it to be rendered harmless. Unless otherwise required by the Contract Documents, the Owner shall furnish in writing to the Contractor and Architect the names and qualifications of persons or entities who are to perform tests verifying the presence or absence of such material or substance or who are to perform the task of removal or safe containment of such material or substance. The Contractor and the Architect will promptly reply to the Owner in writing stating whether or not either has reasonable objection to the persons or entities proposed by the Owner. If either the Contractor or Architect has an objection to a person or entity proposed by the Owner, the Owner shall propose another to whom the Contractor and the Architect have no reasonable objection. When the material or substance has been rendered harmless, Work in the affected area shall resume upon written agreement of the Owner and Contractor. By Change Order, the Contract Time shall be extended appropriately and the

Init.

Contract Sum shall be increased in the amount of the Contractor's reasonable additional costs of shut-down, delay and start-up.

§ 10.3.3 DELETED.

§ 10.3.4 The Owner shall not be responsible under this Section 10.3 for materials or substances the Contractor brings to the site unless such materials or substances are required by the Contract Documents.

§ 10.3.5 The Contractor shall indemnify the Owner for the cost and expense the Owner incurs (1) for remediation of a material or substance the Contractor brings to the site and negligently handles, or (2) where the Contractor fails to perform its obligations under Section 10.3.1, except to the extent that the cost and expense are due to the Owner's fault or negligence.

§ 10.3.6 DELETED.

§ 10.4 EMERGENCIES

In an emergency affecting safety of persons or property, the Contractor shall act, at the Contractor's discretion, to prevent threatened damage, injury or loss. Additional compensation or extension of time claimed by the Contractor on account of an emergency shall be determined as provided in Article 15 and Article 7.

ARTICLE 11 INSURANCE AND BONDS

§ 11.1 CONTRACTOR'S LIABILITY INSURANCE

§ 11.1.1 The Contractor shall purchase from and maintain in a company or companies lawfully authorized to do business in the jurisdiction in which the Project is located such insurance as will protect the Contractor and Owner from claims set forth below which may arise out of or result from the Contractor's operations and completed operations under the Contract and for which the Contractor may be legally liable, whether such operations be by the Contractor or by a Subcontractor or by anyone directly or indirectly employed by any of them, or by anyone for whose acts any of them may be liable:

- .1 Claims under workers' compensation, disability benefit and other similar employee benefit acts that are applicable to the Work to be performed;
- .2 Claims for damages because of bodily injury, occupational sickness or disease, or death of the Contractor's employees;
- .3 Claims for damages because of bodily injury, sickness or disease, or death of any person other than the Contractor's employees;
- .4 Claims for damages insured by usual personal injury liability coverage;
- .5 Claims for damages, other than to the Work itself, because of injury to or destruction of tangible property, including loss of use resulting therefrom;
- .6 Claims for damages because of bodily injury, death of a person or property damage arising out of ownership, maintenance or use of a motor vehicle;
- .7 Claims for bodily injury or property damage arising out of completed operations; and
- .8 Claims involving contractual liability insurance applicable to the Contractor's obligations under Section 3.18.

§ 11.1.2 The insurance required by Section 11.1.1 shall be written for not less than limits of liability specified in the Contract Documents or required by law, whichever coverage is greater. Coverages, whether written on an occurrence or claims-made basis, shall be maintained without interruption from the date of commencement of the Work until the date of final payment and termination of any coverage required to be maintained after final payment, and, with respect to the Contractor's completed operations coverage, until the expiration of the period for correction of Work or for such other period for maintenance of completed operations coverage as specified in the Contract Documents.

§ 11.1.3 Certificates of insurance acceptable to the Owner shall be filed with the Owner prior to commencement of the Work and thereafter upon renewal or replacement of each required policy of insurance. These certificates and the insurance policies required by this Section 11.1 shall contain a provision that coverages afforded under the policies will not be canceled or allowed to expire until at least 30 days' prior written notice has been given to the Owner. An additional certificate evidencing continuation of liability coverage, including coverage for completed operations, shall be submitted with the final Application for Payment as required by Section 9.10.2 and thereafter upon renewal or replacement of such coverage until the expiration of the time required by Section 11.1.2. Information concerning reduction of coverage on account of revised limits or claims paid under the General Aggregate, or both, shall be furnished by the Contractor with reasonable promptness.

Init.

§ 11.1.4 The Contractor shall cause the commercial liability coverage required by the Contract Documents to include (1) the Owner, the Architect and the Architect's Consultants as additional insureds for claims caused in whole or in part by the Contractor's negligent acts or omissions during the Contractor's operations; and (2) the Owner as an additional insured for claims caused in whole or in part by the Contractor's negligent acts or omissions during the Contractor's completed operations.

§ 11.1.5 SCHEDULE OF INSURANCE COVERAGES

§ 11.1.5.1 Contractor shall carry and keep in full force for the duration of the project the following Coverage.

Coverage	Minimum Amounts and Limits
Worker's Compensation	Statutory Limits
Employer's Liability:	
Bodily Injury by Accident	\$500,000.00/each accident
Bodily Injury by Disease	\$500,000.00/each employee
Bodily Injury by Disease	\$500,000.00/Policy Limit
Commercial General Liability	
Bodily Injury/Property Damage	\$1,000,000.00 per occurrence \$2,000,000.00 aggregate

(Premises Operations, Independent Contractors, Product/Completed Operations, Personal Injury, Contractual Liability, Explosion, Collapse, Underground and Broad Form Property Damage).

Comprehensive Automobile Liability \$1,000,000.00 Combined Single
Limit per Occurrence

Auto liability insurance shall be on a standard form written to cover all owned, hired, and non-owned automobiles. The policy shall be endorsed to include the Indemnified Parties (paragraph 3.18) as additional insured, contain cross-liability and severability of interest endorsements, and state that this insurance is primary insurance as regards to any other insurance carried by the Indemnified Parties (see paragraph 3.18).

§11.1.5.2 All policies shall contain special endorsements to include:

- .1 The Owner as an additional insured (except for Worker's Compensation) and all other parties identified in 3.18 (Indemnified Parties);
- .2 Waiver of Subrogation in favor of Owner under the Worker's Compensation and Employer's Liability policies.
- .3 A statement that a notice shall be given to Owner by certified mail thirty (30) days prior to cancellation or upon any material changes in coverage.
4. Contain cross-liability and severability of interest endorsements;
5. state that this insurance is primary insurance in regard to any other insurance carried by the an Indemnified Party (see 3.18);
- .6 the following coverage:
 - a. Premises/Operations;
 - b. Independent Contractors;
 - c. Completed Operations for a period of two years following the acceptance of Contractor's Work;
 - d. Comprehensive General Liability Endorsement to include Blanket Contractual Liability (specifically covering, but not limited to, the contractual obligations assumed by Contractor, Broad Form Property Damage, and Personal Injury Liability with employee and contractual exclusions removed;

Init.

- e. Deletion of exclusions relative to Collapse, Explosion, and Underground Property Damage Hazards;
- f. Personal Injury Liability with the contractual exclusions removed;
- g. Cross Liability Endorsement.

§11.1.5.6 Umbrella Excess Liability Insurance

Bodily Injury and	\$2,000,000.00 per occurrence
Property Damage	\$2,000,000.00 aggregate

This policy shall be written on an umbrella excess basis above, the coverage described in this Article 11. The policy shall be endorsed to include the Indemnified Parties (3.18) as additional insureds. The policy shall contain cross-liability and severability of interest endorsements and shall state, as regard the Indemnified Parties that the insurance is primary insurance as to any other insurance carried by any Indemnified Party. The policy shall be endorsed to provide the defense coverage obligation.

§11.1.6 Further, Contractor shall require all Subcontractors to carry similar insurance coverage and limits of liability as required under this Article 11, adjusted to the nature of Subcontractor's operations and submit same to Owner for approval before any Work commences.

§11.1.7 In the event Contractor fails to obtain the required certificates of insurance from the Subcontractor and a claim is made or suffered, Contractor shall indemnify, defend, and hold harmless the indemnified parties from any and all claims for which the required insurance would have provided coverage.

§ 11.2 OWNER'S LIABILITY INSURANCE

The Owner shall be responsible for purchasing and maintaining the Owner's usual liability insurance.

§ 11.2.1 By signing the Contract or providing or causing to be provided a Certificate of Coverage, the Contractor is representing to the Owner that all employees of the Contractor who will provide services on the Project will be covered by workers' compensation coverage for the duration of the Project, that coverage will be based on proper reporting or classification codes and payroll amounts, and that all coverage agreements will be filed with the appropriate insurance carrier or, in the case of a self-insured, with the commission's Division of Self-Insurance Regulation. Providing false or misleading information may subject the Contractor to administrative penalties, criminal penalties, civil penalties, or other civil actions.

§11.2.2 Optionally, the Owner may require the Contractor to purchase and maintain Project Management Protective Liability insurance from the Contractor's usual sources as primary coverage for the Owner's, Contractor's and Architect's vicarious liability for construction operations under the contract. Unless otherwise required by the Contract Documents, the Owner shall reimburse the Contractor by increasing the Contract Sum to pay the cost of purchasing and maintaining such optional insurance coverage and the Contractor shall not be responsible for purchasing any other liability insurance on behalf of the Owner. The minimum limits of liability purchased with such coverage shall be equal to the aggregate of the limits required for Contractor's Liability Insurance under Article 11.

§ 11.3 PROPERTY INSURANCE

§ 11.3.1 Contractor shall obtain a builder's risk "all-risk" or equivalent policy in the amount of the initial Contract Sum (or, if applicable Guaranteed Maximum Price), plus value of subsequent Contract modifications and cost of materials supplied or installed by others, comprising total value for the entire Project at the site on a replacement cost basis without optional deductibles. The policy must also name its subcontractors and the Owner as additional insured, as their respective interests may appear. Coverage shall include material stored on-site and in transit. Such insurance will be with a company or companies lawfully authorized to do business in Texas. The policy must have the following endorsement: "This insurance shall be specific as to coverage and not considered as contributing insurance with any permanent insurance maintained on the present premises".

§ 11.3.1.1 Property insurance shall be on an "all-risk" or equivalent policy form and shall include, without limitation, insurance against the perils of fire (with extended coverage) and physical loss or damage including, without duplication of coverage, theft, vandalism, malicious mischief, collapse, earthquake, flood, windstorm, falsework,

Init.

testing and startup, temporary buildings and debris removal including demolition occasioned by enforcement of any applicable legal requirements, and shall cover reasonable compensation for Architect's and Contractor's services and expenses required as a result of such insured loss.

§ 11.3.1.1.1 For any claim made against Contractor's Builder's Risk Insurance, the deductible shall not exceed \$2,500.00 for a Contract Sum of less than \$4 million. For a Contract Sum of \$4 million or more, the deductible shall not exceed \$5,000.00.

§11.3.1.1.2 The Contractor waives all rights against (1) Owner, the Subcontractors, Sub-subcontractors, agents, and employees, and (2) the Architect, Architect's consultants, separate contractors, if any, and any of their Subcontractors, Sub-subcontractors, agents, and employees, for damages caused by fire or other perils to the extent covered by property insurance obtained pursuant to this paragraph or other property insurance applicable to the Work, except such rights as Contractor has to proceeds of such insurance held by the Contractor as a fiduciary. The Contractor, as appropriate, shall require of any separate contractors, Subcontractors, Sub-subcontractors, agents, and employees of any of them by appropriate written agreements, similar waivers each in favor of other parties enumerated herein. The policies shall provide such waivers of subrogation by endorsement or otherwise. A waiver of subrogation shall be effective as to a person or entity even though that person or entity would otherwise have a duty of indemnification, contractual or otherwise, did not pay the insurance premium directly or indirectly, and whether or not the person or entity had a insurable interest in the property damaged.

§11.3.1.1.3 The Contractor as fiduciary shall have power to adjust and settle a loss with insurers. The Contractor shall pay all Subcontractors their just shares of insurance proceeds received by the Contractor, and by appropriate agreements shall require Subcontractors to make payment to their Sub-subcontractors in similar manner. If required in writing by a party in interest, the Contractor as fiduciary shall, upon occurrence of insured loss, give bond for proper performance of the Contractor's duties. The cost of required bonds shall be charged against proceeds received as fiduciary. The Contractor shall deposit in a separate account proceeds so received, which the Contractor shall distribute in accordance with such agreement as the parties in interest may reach. If after such loss no other special agreement is made and unless the Owner terminates the Contract for convenience, replacement of damaged property shall be performed by the Contractor under the insurance proceeds.

§ 11.3.1.2 DELETED.

§ 11.3.1.3 DELETED.

§ 11.3.1.4 This property insurance shall cover portions of the Work stored off the site, and also portions of the Work in transit.

§ 11.3.1.5 Partial occupancy or use shall not affect the validity or coverage of property insurance.

§ 11.3.2 BOILER AND MACHINERY INSURANCE
DELETED.

§ 11.3.3 LOSS OF USE INSURANCE
DELETED.

§ 11.3.4 If the Contractor requests in writing that insurance for risks other than those described herein or other special causes of loss be included in the property insurance policy, the Owner shall, if possible, include such insurance, and the cost thereof shall be charged to the Contractor by appropriate Change Order.

§ 11.3.5 DELETED.

§ 11.3.6 DELETED.

§ 11.3.7 WAIVERS OF SUBROGATION

The Contractor waives all rights against (1) Owner, the Subcontractors, Sub-subcontractors, agents, and employees, and (2) the Architect, Architect's consultants, separate contractors, if any, and any of their Subcontractors, Sub-subcontractors, agents, and employees, for damages caused by fire or other perils to the extent covered by

Init.

property insurance obtained pursuant to Article 11 or other property insurance applicable to the Work, except such rights as Contractor has to proceeds of such insurance held by the Contractor as a fiduciary. The Contractor, as appropriate, shall require of any separate contractors, Subcontractors, Sub-subcontractors, agents, and employees of any of them by appropriate written agreements, similar waivers each in favor of other parties enumerated herein. The policies shall provide such waivers of subrogation by endorsement or otherwise. A waiver of subrogation shall be effective as to a person or entity even though that person or entity would otherwise have a duty of indemnification, contractual or otherwise, did not pay the insurance premium directly or indirectly, and whether or not the person or entity had a insurable interest in the property damaged.

§ 11.3.8 A loss insured under the Owner's property insurance shall be adjusted by the Owner as fiduciary and made payable to the Owner as fiduciary for the insureds, as their interests may appear, subject to requirements of any applicable mortgagee clause and of Section 11.3.10. The Contractor shall pay Subcontractors their just shares of insurance proceeds received by the Contractor, and by appropriate agreements, written where legally required for validity, shall require Subcontractors to make payments to their Sub-subcontractors in similar manner.

§ 11.3.9 DELETED.

§ 11.3.10 The Owner as fiduciary shall have power to adjust and settle a loss with insurers.

§ 11.4 PERFORMANCE BOND AND PAYMENT BOND

§ 11.4.1 The Contractor shall furnish a Performance Bond in an amount equal to one hundred percent (100%) of the Contract Sum, as security for the faithful performance of the Contract and also a one hundred percent (100%) Payment Bond, as security for the payment of all persons performing labor on the Project under this Contract and furnishing materials in connection with the Contract. The Performance Bond and the Payment Bond may be in one or in separate instruments in accordance with local law. Surety companies must be authorized to write surety bonds in Texas and any such surety bond must comply with the requirements of Subchapter A of Chapter 3503 of the Texas Insurance Code.

§11.4.1.1 The Contractor shall deliver the required Bonds to the Owner not later than the date of the preconstruction meeting. All Bonds will be reviewed by the Architect for compliance with the Contract Documents prior to the execution of the Contract. In the event that Architect has any questions concerning the sufficiency of the bonds, Architect shall refer the bonds to Owner or Owner's representative for decision.

§11.4.1.2 All bonds shall be originals. The Contractor shall require the attorney-in-fact who executes the required Bonds on behalf of the Surety to affix thereto a certified and current copy of the power-of-attorney. The name, address, and telephone number of a contact person for the Bonding Company shall be provided.

§ 11.4.2 Upon the request of any person or entity appearing to be a potential beneficiary of bonds covering payment of obligations arising under the Contract, the Contractor shall promptly furnish a copy of the bonds or shall authorize a copy to be furnished.

§ 11.4.3 The Bonds shall be provided to comply with the terms and provisions of Chapter 2253 of the Texas Government Code. Bonds shall be signed by an agent resident in the State of Texas and date of bond shall be on or after the date of execution of the Contract but prior to the date of the notice to proceed. If at any time during the continuance of the Contract, the surety of the Contractor's bonds becomes insufficient, the Owner shall have the right to require additional and sufficient sureties which the Contractor shall furnish to the satisfaction of the Owner within ten (10) days after notice to do so. In default thereof, the Contractor may be suspended, and all payment or money due to the Contractor withheld until sufficient bonds are provided by Contractor.

ARTICLE 12 UNCOVERING AND CORRECTION OF WORK

§ 12.1 UNCOVERING OF WORK

§ 12.1.1 If a portion of the Work is covered contrary to the Architect's request or to requirements specifically expressed in the Contract Documents, it must, if requested in writing by the Architect, be uncovered for the Architect's examination and be replaced at the Contractor's expense without change in the Contract Time or Contract Sum.

§ 12.1.2 If a portion of the Work has been covered that the Architect has not specifically requested to examine prior to its being covered, the Architect may request to see such Work and it shall be uncovered by the Contractor. If such Work is in accordance with the Contract Documents, costs of uncovering and replacement shall, by appropriate

Init.

Change Order, be at the Owner's expense. If such Work is not in accordance with the Contract Documents, such costs and the cost of correction shall be at the Contractor's expense unless the condition was caused by the Owner or a separate contractor in which event the Owner shall be responsible for payment of such costs.

§ 12.2 CORRECTION OF WORK

§ 12.2.1 BEFORE OR AFTER SUBSTANTIAL COMPLETION

The Contractor shall promptly correct Work rejected by the Architect as incomplete, defective, or failing to conform to the requirements of the Contract Documents, whether discovered before or after Substantial Completion and whether or not fabricated, installed or completed. Costs of correcting such rejected Work, including additional testing and inspections, the cost of uncovering and replacement, and compensation for the Architect's services and expenses made necessary thereby, shall be at the Contractor's expense.

§ 12.2.2 AFTER SUBSTANTIAL COMPLETION

§ 12.2.2.1 In addition to the Contractor's obligations under Section 3.5, if, within one year after the date of Substantial Completion of the entire Work (unless otherwise provided in any Certificate of Partial Substantial Completion approved by the parties), or within such longer period of time as may be prescribed by law or in equity, or by terms of an applicable special warranty required by the Contract Documents, any of the Work is found to be defective or otherwise not in accordance with the requirements of the Contract Documents, the Contractor shall correct it promptly after receipt of written notice from the Owner to do so unless the Owner has previously given the Contractor a written acceptance of such condition. This corrective period shall be extended with respect to portions of Work first performed after Substantial Completion by the period of time between Substantial Completion and the actual performance of the Work. Corrective Work shall be warranted to be free from defects for a period equal to the longer of six (6) months after the completion of the corrective Work or one (1) year after the Date of Substantial Completion (subject to extension as previously described) or such longer period of time as may be prescribed by law or in equity, or expiration of the term of any applicable special warranty, if applicable, required by the Contract Documents. Any defect in such Work shall be corrected again by Contractor promptly upon notice of the defect from Owner. This obligation under this Subparagraph 12.2.2.1 shall survive acceptance of the Work under the Contract and termination of the Contract by the Owner. If the Contractor fails to correct nonconforming Work within a reasonable time during that period after receipt of notice from the Owner or Architect, the Owner may correct it in accordance with Section 2.4.

§ 12.2.2.2 The one-year period for correction of Work shall be extended with respect to portions of Work first performed after Substantial Completion by the period of time between Substantial Completion and the actual completion of that portion of the Work.

§ 12.2.2.3 The one-year period for correction of Work shall not be extended by corrective Work performed by the Contractor pursuant to this Section 12.2.

§12.2.2.4 Just before the termination of the various guarantee periods, Contractor shall accompany Owner's agent and Architect on an inspection tour of the building and shall note any defects and shall start remedying these defects within ten (10) days of the inspection tour and shall prosecute the Work without interruption until accepted by Owner and Architect, even though such prosecution should extend beyond the limit of the guarantee period.

§ 12.2.3 The Contractor shall remove from the site portions of the Work that are not in accordance with the requirements of the Contract Documents and are neither corrected by the Contractor nor accepted by the Owner.

§ 12.2.4 The Contractor shall bear the cost of correcting destroyed or damaged construction, whether completed or partially completed, of the Owner or separate contractors caused in whole or in part by the Contractor's correction or removal of Work that is defective or otherwise not in accordance with the requirements of the Contract Documents.

§ 12.2.5 Nothing contained in this Section 12.2 shall be construed to establish a period of limitation with respect to other obligations the Contractor has under the Contract Documents or under law or in equity. Establishment of the period for correction of Work as described in Section 12.2.2 relates only to the specific obligation of the Contractor to correct the Work, and has no relationship to the time within which the obligation to comply with the Contract Documents may be sought to be enforced, nor to the time within which proceedings may be commenced to establish the Contractor's liability with respect to the Contractor's obligations other than specifically to correct the Work.

Init.

§ 12.3 ACCEPTANCE OF NONCONFORMING WORK

If the Owner prefers to accept Work that is defective or otherwise not in accordance with the requirements of the Contract Documents, the Owner may do so instead of requiring its removal and correction, in which case the Contract Sum will be reduced as appropriate and equitable. Such adjustment shall be effected whether or not final payment has been made.

ARTICLE 13 MISCELLANEOUS PROVISIONS

§ 13.1 GOVERNING LAW

The Contract shall be governed by the law of the place where the Project is located.

§ 13.2 SUCCESSORS AND ASSIGNS

§ 13.2.1 The Owner and Contractor respectively bind themselves, their partners, successors, assigns and legal representatives to covenants, agreements and obligations contained in the Contract Documents. Except as provided in Section 13.2.2, neither party to the Contract shall assign the Contract as a whole without written consent of the other. If either party attempts to make such an assignment without such consent, that party shall nevertheless remain legally responsible for all obligations under the Contract.

§ 13.2.2 The Owner may, without consent of the Contractor, assign the Contract to a lender providing construction financing for the Project, if the lender assumes the Owner's rights and obligations under the Contract Documents. The Contractor shall execute all consents reasonably required to facilitate such assignment.

§ 13.3 WRITTEN NOTICE

§13.3.1 Written notice shall be deemed to have been duly served if delivered in person to the individual, to a member of the firm or entity, or to an officer of the corporation for which it was intended; or if delivered at, or sent by registered or certified mail or by courier service providing proof of delivery to, the last business address known to the party giving notice or if delivered by facsimile to the offices of the person or corporation for which it was intended. Facsimiles received after 5:00 p.m. on a business day, or on a weekend or legal holiday on which the recipient's offices are closed, notice shall be deemed to have been duly served on the next business day.

§ 13.4 RIGHTS AND REMEDIES

§ 13.4.1 Duties and obligations imposed by the Contract Documents and rights and remedies available thereunder shall be in addition to and not a limitation of duties, obligations, rights and remedies otherwise imposed or available by law or in equity or by any other agreement, and any such rights and remedies shall survive the acceptance of the Work and/or any termination of the Contract Documents.

§ 13.4.2 No action or failure to act by the Owner, Architect or Contractor shall constitute a waiver of a right or duty afforded them under the Contract, nor shall such action or failure to act constitute approval of or acquiescence in a breach there under, except as may be specifically agreed in writing.

§ 13.5 TESTS AND INSPECTIONS

§ 13.5.1 Tests, inspections and approvals of portions of the Work shall be made as required by the Contract Documents and by applicable laws, statutes, ordinances, codes, rules and regulations or lawful orders of public authorities. Unless otherwise provided, the Contractor shall make arrangements for such tests, inspections and approvals with an independent testing laboratory or entity acceptable to the Owner, or with the appropriate public authority, and shall bear all related costs of tests, inspections and approvals. The Contractor shall give the Architect timely notice of when and where tests and inspections are to be made so that the Architect may be present for such procedures. Architect, Owner and Contractor shall be afforded a reasonable opportunity to attend, observe, and witness all inspections and tests of the Work. Architect or Owner may at any time request and receive from Contractor satisfactory evidence that materials, supplies, or equipment are in conformance with the Contract Documents. The conduct of any inspection or test and the receipt of any approval shall not operate to relieve Contractor from its obligations under the Contract Documents unless specifically so stated by Owner in writing.

§ 13.5.2 If the Architect, Owner or public authorities having jurisdiction determine that portions of the Work require additional testing, inspection or approval not included under Section 13.5.1, the Architect will, upon written authorization from the Owner, instruct the Contractor to make arrangements for such additional testing, inspection or approval by an entity acceptable to the Owner, and the Contractor shall give timely notice to the Architect of when and where tests and inspections are to be made so that the Architect may be present for such procedures.

Init.

§ 13.5.3 If such procedures for testing, inspection or approval under Sections 13.5.1 and 13.5.2 reveal failure of the portions of the Work to comply with requirements established by the Contract Documents, or reveal faulty or otherwise defective Work, or if the necessity of any such testing, inspection, or approval procedures arises out of the fault, neglect, or omission of Contractor, Contractor shall bear all costs of such testing, inspection, and approval procedures and all other costs made necessary by Contractor's failures, including, without limitation, those costs of repeated and additional procedures and compensation for Architect's services and expenses of Owner's personnel and consultant fees and expenses. Such costs shall be paid by Contractor within ten (10) days of receipt of invoice from Owner with supporting data attached.

§ 13.5.4 Required certificates of testing, inspection or approval shall, be secured by the Contractor and delivered to Owner, unless such testing or inspection services are arranged by Owner.

§ 13.5.5 If the Architect is to observe tests, inspections or approvals required by the Contract Documents, the Architect will do so promptly and, where practicable, at the normal place of testing.

§ 13.5.6 Tests or inspections conducted pursuant to the Contract Documents shall be made promptly to avoid unreasonable delay in the Work.

§ 13.6 INTEREST

An overdue payment bears interest at the rate of one percent (1%) each month, or at the legal rate established by the Texas Government Code, currently in Section 2251.025. Any such payment shall be deemed overdue on the thirty-first (31st) day after Owner receives an invoice from Contractor.

§ 13.7 TIME LIMITS ON CLAIMS

The Owner and Contractor shall commence all claims and causes of action, whether in contract, tort, breach of warranty or otherwise, against the other arising out of or related to the Contract within the time period specified by applicable law.

§ 13.8 EQUAL OPPORTUNITY

§ 13.8.1 The Contractor shall maintain policies of employment as follows: "The Contractor and the Contractor's Subcontractors shall not discriminate against any employee or applicant for employment because of race, religion, color, sex, or national origin. Contractor shall take affirmative action to ensure that applicants are employed, and that employees are treated during employment without regard to their race, religion, color, sex, or national origin. Such action shall include, but not be limited to, the following: employment, promotion, demotion, or transfer; recruitment, or recruitment advertising; lay-off or termination; rates of pay or other forms of compensation; and selection for training, including apprenticeship. The Contractor agrees to post in conspicuous places, available to employees and applicants, notices setting forth the nondiscrimination policies."

§13.8.1.1 The Contractor and the Contractor's Subcontractors shall, in all solicitations or advertisements for employees placed by them or on their behalf; state that all qualified applicants will receive consideration for employment with regard to race, religion, color, sex, or national origin.

§13.9 CERTIFICATION OF ASBESTOS-FREE PROJECT

§13.9.1 Contractor shall submit to the Architect a letter addressed to the Owner certifying that all materials used in the construction of this Project contain less than 0.10 by weight of asbestos and for which it can be demonstrated that, under reasonably foreseeable job site conditions, will not release asbestos fibers in excess of 0.1 fibers per cubic centimeter. Certification letters shall be dated, shall reference this specific Project, and shall be signed by not less than two (2) officers of the construction company.

§13.9.2 Certification shall further state that should asbestos fibers be found at this Project in concentrations greater than 0.1 fibers per cubic centimeter, that Contractor shall be responsible for determining which materials contain asbestos fibers and shall take corrective action to remove those materials from the Project at no additional cost to the Owner.

§13.9.3 Final payment shall not be made until this letter of certification has been received.

Init.

ARTICLE 14 TERMINATION OR SUSPENSION OF THE CONTRACT

§ 14.1 TERMINATION BY THE CONTRACTOR

§ 14.1.1 The Contractor may terminate the Contract if the Work is stopped for a period of 30 consecutive days through no act or fault of the Contractor or a Subcontractor, Sub-subcontractor or their agents or employees or any other persons or entities performing portions of the Work under direct or indirect contract with the Contractor, for any of the following reasons:

- .1 Issuance of an order of a court or other public authority having jurisdiction that requires all Work to be stopped; or
- .2 An act of government, such as a declaration of national emergency that requires all Work to be stopped;

(Paragraphs deleted)

§ 14.1.2 The Contractor may terminate the Contract if, through no act or fault of the Contractor or a Subcontractor, Sub-subcontractor or their agents or employees or any other persons or entities performing portions of the Work under direct or indirect contract with the Contractor, repeated suspensions, delays or interruptions of the entire Work by the Owner as described in Section 14.3 constitute in the aggregate more than 100 percent of the total number of days scheduled for completion, or 120 days in any 365-day period, whichever is less.

§ 14.1.3 If one of the reasons described in Section 14.1.1 or 14.1.2 exists, the Contractor may, upon seven days' written notice to the Owner and Architect, terminate the Contract and recover from the Owner payment for Work properly executed in accordance with the Contract Documents.

§ 14.1.4 Owner shall not be responsible for damages for loss of anticipated profits on Work not performed on account of any termination described in Subparagraphs 14.1.1 and 14.1.2.

§ 14.2 TERMINATION BY THE OWNER FOR CAUSE

§ 14.2.1 The Owner may terminate the Contract if the Contractor

- .1 refuses or fails to supply enough properly skilled workers or proper materials and equipment;
- .2 fails to make payment to Subcontractors for materials or labor in accordance with the respective agreements between the Contractor and the Subcontractors;
- .3 disregards applicable laws, statutes, ordinances, codes, rules and regulations, or lawful orders of a public authority;
- .4 disregards the instructions of Architect or Owner (when such instructions are based on the requirements of the Contract Documents);
- .5 is adjudged bankrupt or insolvent, or makes a general assignment for the benefit of Contractor's creditors, or a trustee or receiver is appointed for Contractor or for any of its property, or files a petition to take advantage of any debtor's act, or to reorganize under bankruptcy or similar law; or
- .6 otherwise does not fully comply with the Contract Documents.

§ 14.2.2 When any of the above reasons exist, the Owner, may without prejudice to any other rights or remedies of the Owner and after giving the Contractor and the Contractor's surety, if any, seven days' written notice, terminate employment of the Contractor and may, subject to any prior rights of the surety:

- .1 Exclude the Contractor from the site and take possession of all materials, equipment, tools, and construction equipment and machinery thereon owned by the Contractor;
- .2 Accept assignment of subcontracts pursuant to Section 5.4; and
- .3 Finish the Work by whatever reasonable method the Owner may deem expedient. Upon written request of the Contractor, the Owner shall furnish to the Contractor a detailed accounting of the costs incurred by the Owner in finishing the Work.

§ 14.2.3 When the Owner terminates the Contract for one of the reasons stated in Section 14.2.1, the Contractor shall not be entitled to receive further payment until the Work is finished.

§ 14.2.4 To the extent the costs of completing Work, including compensation for additional professional services and expenses, exceed those costs that would have been payable to Contractor to complete the Work except for Contractor's default, Contractor will pay the difference to Owner, and this obligation for payment shall survive termination of the Contract. Such costs incurred by Owner will be determined by Owner and confirmed by Architect.

Init.

§14.2.5 In addition to Owner's right to remove Contractor from any part of Work pursuant to the Contract Documents, Owner may, at any time, at will and without cause, terminate any part of Work or any subcontract or all remaining Work for any reason whatsoever by giving seven (7) days' prior written notice to Contractor specifying the part of Work or subcontract to be terminated and the effective date of termination. Contractor shall continue to prosecute the part of Work not terminated. If any part of Work or subcontract is so terminated, Contractor shall be entitled to payment for Work properly executed in accordance with the Contract Documents (the basis for such payment shall be as provided in the Contract) and for costs directly related to Work thereafter performed by Contractor in terminating such Work or subcontract including reasonable demobilization and cancellation charges provided said Work is authorized in advance by Architect and Owner. No payment shall be made by Owner, however, to the extent that such Work or subcontract is, was, or could have been terminated under the Contract Documents or an equitable adjustment is made or denied under another provision of the Contract. In case of such termination, Owner will issue a Construction Change Directive or authorize a Change Order making any required adjustment to the Date of Substantial Completion and/or the Contract Sum. For the remainder of the Work, the Contract Documents shall remain in full force and effect.

§14.2.6 Owner shall not be responsible for damages for loss of anticipated profits on Work not performed on account of any termination described in Subparagraph 14.2.5.

§14.2.7 Upon a determination by a court of competent jurisdiction that termination of Contractor pursuant to Subparagraph 14.2.1 was wrongful, such termination will be deemed converted to a termination for convenience pursuant to Subparagraph 14.2.5 and Contractor's remedy for wrongful termination shall be limited to the recovery of the payments permitted for termination for convenience as set forth in Subparagraph 14.2.5

§ 14.3 SUSPENSION BY THE OWNER FOR CONVENIENCE

§ 14.3.1 The Owner may, without cause, order the Contractor in writing to suspend, delay or interrupt the Work in whole or in part for such period of time as the Owner may determine.

§ 14.3.2 The Contract Sum and Contract Time shall be adjusted for increases in the cost and time caused by suspension, delay or interruption as described in Section 14.3.1. Adjustment of the Contract Sum shall include profit. No adjustment shall be made to the extent

- .1 that performance is, was or would have been so suspended, delayed or interrupted by another cause for which the Contractor is responsible; or
- .2 that an equitable adjustment is made or denied under another provision of the Contract.

§ 14.4 TERMINATION BY THE OWNER FOR CONVENIENCE

§ 14.4.1 The Owner may, at any time, terminate the Contract for the Owner's convenience and without cause.

§ 14.4.2 Upon receipt of written notice from the Owner of such termination for the Owner's convenience, the Contractor shall

- .1 cease operations as directed by the Owner in the notice;
- .2 take actions necessary, or that the Owner may direct, for the protection and preservation of the Work; and
- .3 except for Work directed to be performed prior to the effective date of termination stated in the notice, terminate all existing subcontracts and purchase orders and enter into no further subcontracts and purchase orders.

§ 14.4.3 In case of such termination for the Owner's convenience, the Contractor shall be entitled to receive payment for Work executed, and costs incurred by reason of such termination, along with reasonable overhead and profit on the Work not executed.

ARTICLE 15 CLAIMS AND DISPUTES

§ 15.1 CLAIMS

§ 15.1.1 DEFINITION

A Claim is a demand or assertion by one of the parties seeking, as a matter of right adjustment or interpretation of the Contract Terms, payment of money, extension of time, or other relief with respect to the terms of the Contract. The term "Claim" also includes other disputes and matters in question between the Owner and Contractor arising out of or

Init.

relating to the Contract. The responsibility to substantiate Claims shall rest with the party making the Claim. Claims must be by written notice.

§ 15.1.2 NOTICE OF CLAIMS

Claims by either the Owner or Contractor must be initiated by written notice to the other party and to the Initial Decision Maker with a copy sent to the Architect, if the Architect is not serving as the Initial Decision Maker. Claims by either party must be initiated within 21 days after occurrence of the event giving rise to such Claim or within 21 days after the claimant first recognizes the condition giving rise to the Claim, whichever is later. Said written notice of claims shall state specifically the reason for the claim, the date or dates of the cause or causes of the claim, and if any extension of time is requested, the number of days of extension requested.

§ 15.1.3 CONTINUING CONTRACT PERFORMANCE

Pending final resolution of a Claim, except as otherwise agreed in writing or as provided in Section 9.7 and Article 14, the Contractor shall proceed diligently with performance of the Contract and the Owner shall continue to make payments in accordance with the Contract Documents. The Architect will prepare Change Orders and issue Certificates for Payment in accordance with the decisions of the Initial Decision Maker.

§ 15.1.4 CLAIMS FOR ADDITIONAL COST

If the Contractor wishes to make a Claim for an increase in the Contract Sum, written notice as provided herein shall be given before proceeding to execute the Work. Said notice shall itemize all claims and shall contain sufficient detail and substantiating data to permit evaluation of same by Owner and Architect. No such claim shall be value unless so made. Prior notice is not required for Claims relating to an emergency endangering life or property arising under Section 10.4.

§ 15.1.5 CLAIMS FOR ADDITIONAL TIME

§ 15.1.5.1 If the Contractor wishes to make a Claim for an increase in the Contract Time, written notice as provided herein shall be given. The Contractor's Claim shall include an estimate of cost and of probable effect of delay on progress of the Work. In the case of a continuing delay, only one Claim is necessary.

§ 15.1.5.2 If adverse weather conditions are the basis for a Claim for additional time, such Claim shall be documented by data substantiating that weather conditions were abnormal for the period of time, could not have been reasonably anticipated and had an adverse effect on the scheduled construction. Extensions of time may be requested for any month of construction for days lost due to adverse weather in excess of the normally expected lost time; provided, however, if Architect determines that the seasonal average of adverse weather days during construction is less than would be normally expected, no Change Order shall be issued and the request for extension of time shall be denied.

§ 15.1.6 CLAIMS FOR CONSEQUENTIAL DAMAGES

(Paragraph deleted)

Contractor shall not be entitled to claims for additional time and/or increase in Contract Price due to a problem or non-performance of a subcontractor.

§ 15.1.7 In the event the Contractor fails to achieve substantial completion by the date indicated in the Contract, and extended by approved Change Order, the Owner shall be entitled to liquidated damages in the amount as stated in Article 3 of the AIA document A 101 – 2007 Edition, as modified by the Owner, by and between Owner and Contractor dated of even date herewith per day until the Work is substantially completed. It is expressly understood that the said sum per day is agreed upon as a fair estimate of the pecuniary damages, which will be sustained by Owner in the event that the Work is not completed within the agreed time, or within the legally extended time, if any. Said sum shall be considered as liquidated damages only, the exact ascertainment of which is difficult and in no sense be considered a penalty.

This mutual waiver is applicable, without limitation, to all consequential damages due to either party's termination in accordance with Article 14. Nothing contained in this Section 15.1.6 shall be deemed to preclude an award of liquidated damages, when applicable, in accordance with the requirements of the Contract Documents.

§ 15.2 INITIAL DECISION

§ 15.2.1 Claims, excluding those arising under Sections 10.3, 10.4, 11.3.9, and 11.3.10, shall be referred to the Initial Decision Maker for initial decision. The Architect will serve as the Initial Decision Maker, unless otherwise indicated

Init.

AIA Document A201™ – 2007. Copyright © 1911, 1915, 1918, 1925, 1937, 1951, 1958, 1961, 1963, 1966, 1970, 1976, 1987, 1997 and 2007 by The American Institute of Architects. All rights reserved. **WARNING: This AIA® Document is protected by U.S. Copyright Law and International Treaties. Unauthorized reproduction or distribution of this AIA® Document, or any portion of it, may result in severe civil and criminal penalties, and will be prosecuted to the maximum extent possible under the law.** This document was produced by AIA software at 16:56:15 on 07/20/2012 under Order No.1180968477_1 which expires on 03/20/2013, and is not for resale.

User Notes:

(959998329)

in the Agreement. Except for those Claims excluded by this Section 15.2.1, an initial decision shall be required as a condition precedent to mediation of any Claim arising prior to the date final payment is due, unless 30 days have passed after the Claim has been referred to the Initial Decision Maker with no decision having been rendered. Unless the Initial Decision Maker and all affected parties agree, the Initial Decision Maker will not decide disputes between the Contractor and persons or entities other than the Owner.

§ 15.2.2 The Initial Decision Maker will review Claims and within ten days of the receipt of a Claim take one or more of the following actions: (1) request additional supporting data from the claimant or a response with supporting data from the other party, (2) reject the Claim in whole or in part, (3) approve the Claim in whole or in part, (4) suggest a compromise, or (5) advise the parties that the Initial Decision Maker is unable to resolve the Claim if the Initial Decision Maker lacks sufficient information to evaluate the merits of the Claim or if the Initial Decision Maker concludes that, in the Initial Decision Maker's sole discretion, it would be inappropriate for the Initial Decision Maker to resolve the Claim.

§ 15.2.3 In evaluating Claims, the Initial Decision Maker may, but shall not be obligated to, consult with or seek information from either party or from persons with special knowledge or expertise who may assist the Initial Decision Maker in rendering a decision. The Initial Decision Maker may request the Owner to authorize retention of such persons at the Owner's expense.

§ 15.2.4 If the Initial Decision Maker requests a party to provide a response to a Claim or to furnish additional supporting data, such party shall respond, within ten days after receipt of such request, and shall either (1) provide a response on the requested supporting data, (2) advise the Initial Decision Maker when the response or supporting data will be furnished or (3) advise the Initial Decision Maker that no supporting data will be furnished. Upon receipt of the response or supporting data, if any, the Initial Decision Maker will either reject or approve the Claim in whole or in part.

§ 15.2.5 The Initial Decision Maker will render an initial decision approving or rejecting the Claim, or indicating that the Initial Decision Maker is unable to resolve the Claim. This initial decision shall (1) be in writing; (2) state the reasons therefor; and (3) notify the parties and the Architect, if the Architect is not serving as the Initial Decision Maker, of any change in the Contract Sum or Contract Time or both. The initial decision shall be final and binding on the parties but subject to mediation and, if the parties fail to resolve their dispute through mediation, to litigation.

§ 15.2.6 DELETED.

§ 15.2.6.1 DELETED.

§ 15.2.7 In the event of a Claim against the Contractor, the Owner may, but is not obligated to, notify the surety, if any, of the nature and amount of the Claim. If the Claim relates to a possibility of a Contractor's default, the Owner may, but is not obligated to, notify the surety and request the surety's assistance in resolving the controversy.

§ 15.2.8 DELETED.

§ 15.3 MEDIATION

§ 15.3.1 Claims, disputes, or other matters in controversy arising out of or related to the Contract may be subject to mediation as a condition precedent to litigation.

§ 15.3.2 The parties shall endeavor to resolve their Claims by mediation. A request for mediation shall be made in writing, delivered to the other party to the Contract, and filed with the person or entity administering the mediation.

§ 15.3.3 The parties shall share the mediator's fee. The mediation shall be held in the place where the Project is located, unless another location is mutually agreed upon. Agreements reached in mediation shall be enforceable as settlement agreements in any court having jurisdiction thereof.

§ 15.4 ARBITRATION

The parties expressly agree that disputes or claims arising under the Contract Documents shall not be subject to arbitration unless mutually agreed by the parties in writing.

Init.

Certification of Document's Authenticity

AIA® Document D401™ – 2003

I, Hidalgo County Judge Ramon Garcia, hereby certify, to the best of my knowledge, information and belief, that I created the attached final document simultaneously with its associated Additions and Deletions Report and this certification at 16:56:15 on 07/20/2012 under Order No. 1180968477_1 from AIA Contract Documents software and that in preparing the attached final document I made no changes to the original text of AIA® Document A201™ – 2007, General Conditions of the Contract for Construction, as published by the AIA in its software, other than those additions and deletions shown in the associated Additions and Deletions Report.

(Signed)

(Title)

(Dated)

AIA[®] Document A101[™] – 2007

Standard Form of Agreement Between Owner and Contractor where the basis of payment is a Stipulated Sum

AGREEMENT made as of the 24th day of July in the year 2012
(In words, indicate day, month and year)

BETWEEN the Owner:
(Name, legal status, address and other information)

County of Hidalgo
1615 South Closner, Suite J
Edinburg, Texas 78539

and the Contractor:
(Name, legal status, address and other information)

Holchemont, LTD.
900 North Main Street
McAllen, Texas 78501

for the following Project:
(Paragraphs deleted)

Construction Of A New Constable Precinct No. 1 Offices to consist of 4245Sq. Ft. located at Joe Stevens Blvd., Weslaco, Texas

The Architect:
(Name, legal status, address and other information)

Alcocer-Garcia Associates, Inc.
1333 E. Jasmine Avenue
McAllen, Texas 78501

The Owner and Contractor agree as follows.

ADDITIONS AND DELETIONS:

The author of this document has added information needed for its completion. The author may also have revised the text of the original AIA standard form. An *Additions and Deletions Report* that notes added information as well as revisions to the standard form text is available from the author and should be reviewed. A vertical line in the left margin of this document indicates where the author has added necessary information and where the author has added to or deleted from the original AIA text.

This document has important legal consequences. Consultation with an attorney is encouraged with respect to its completion or modification.

AIA Document A201[™]–2007, General Conditions of the Contract for Construction, is adopted in this document by reference. Do not use with other general conditions unless this document is modified.

TABLE OF ARTICLES

1	THE CONTRACT DOCUMENTS
2	THE WORK OF THIS CONTRACT
3	DATE OF COMMENCEMENT AND SUBSTANTIAL COMPLETION
4	CONTRACT SUM
5	PAYMENTS
6	DISPUTE RESOLUTION
7	TERMINATION OR SUSPENSION
8	MISCELLANEOUS PROVISIONS
9	ENUMERATION OF CONTRACT DOCUMENTS
10	INSURANCE AND BONDS

ARTICLE 1 THE CONTRACT DOCUMENTS

The Contract Documents consist of this Agreement, Conditions of the Contract (General, Supplementary and other Conditions), Drawings, Specifications, Addenda issued prior to execution of this Agreement, other documents listed in this Agreement and Modifications issued after execution of this Agreement, all of which form the Contract, and are as fully a part of the Contract as if attached to this Agreement or repeated herein. The Contract represents the entire and integrated agreement between the parties hereto and supersedes prior negotiations, representations or agreements, either written or oral. An enumeration of the Contract Documents, other than a Modification, appears in Article 9.

ARTICLE 2 THE WORK OF THIS CONTRACT

The Contractor shall fully execute the Work described in the Contract Documents, except as specifically indicated in the Contract Documents to be the responsibility of others.

ARTICLE 3 DATE OF COMMENCEMENT AND SUBSTANTIAL COMPLETION

§ 3.1 The date of commencement of the Work shall be the date of this Agreement unless a different date is stated below or provision is made for the date to be fixed in a notice to proceed issued by the Owner.

(Insert the date of commencement if it differs from the date of this Agreement or, if applicable, state that the date will be fixed in a notice to proceed.)

| Date will be in the Notice to Proceed.

If, prior to the commencement of the Work, the Owner requires time to file mortgages and other security interests, the Owner's time requirement shall be as follows:

3.1.1 Liquidated Damages: Owner and Contractor recognize that time is of the essence in this Agreement and that Owner will suffer financial loss if the Work is not completed within the time specified in this Article 3 above, plus any extension thereof allowed in accordance with Article 8 of the General Conditions. Owner and Contractor also recognize the delays, expense and difficulties involved in providing in a legal proceeding, the actual loss suffered by Owner if the Work is not completed on time. Accordingly, instead of requiring such proof, Owner and Contractor agree that as liquidated damages for delay (but not as penalty) Contractor shall pay Owner, One Hundred Fifty Dollars (\$150.00) per calendar day after the time specified in Paragraph 3.1 for Substantial Completion until the work is substantially complete.

§ 3.2 The Contract Time shall be measured from the date of commencement.

§ 3.3 The Contractor shall achieve Substantial Completion of the entire Work not later than (275) days from the date of commencement, or as follows:

(Insert number of calendar days. Alternatively, a calendar date may be used when coordinated with the date of commencement. If appropriate, insert requirements for earlier Substantial Completion of certain portions of the Work.)

Portion of Work

Substantial Completion Date

, subject to adjustments of this Contract Time as provided in the Contract Documents.

(Insert provisions, if any, for liquidated damages relating to failure to achieve Substantial Completion on time or for bonus payments for early completion of the Work.)

See 3.1.1 above.

ARTICLE 4 CONTRACT SUM

§ 4.1 The Owner shall pay the Contractor the Contract Sum in current funds for the Contractor's performance of the Contract. The Contract Sum shall be Seven Hundred and Twenty Four Thousand (\$724,000.00), subject to additions and deductions as provided in the Contract Documents.

§ 4.2 The Contract Sum is based upon the following alternates, if any, which are described in the Contract Documents and are hereby accepted by the Owner:

(State the numbers or other identification of accepted alternates. If the bidding or proposal documents permit the Owner to accept other alternates subsequent to the execution of this Agreement, attach a schedule of such other alternates showing the amount for each and the date when that amount expires.)

§ 4.3 Unit prices, if any:

(Identify and state the unit price; state quantity limitations, if any, to which the unit price will be applicable.)

Item	Units and Limitations	Price Per Unit (\$ 0.00)
------	-----------------------	--------------------------

§ 4.4 Allowances included in the Contract Sum, if any:

(Identify allowance and state exclusions, if any, from the allowance price.)

Betterment Allowance		
Contingency/Betterment Allowance	\$5,000.00	
Addendum No.1-Waterline Extensions Allowance	\$2,800.00	

TOTAL AMOUNT	\$7,800.00	
---------------------	-------------------	--

4.5 Commitment of Current Revenues Only. In the event that, during any term hereof, the governing body of any party does not appropriate sufficient funds to meet the obligations of such party under this Agreement, then any party may terminate this Contract upon ninety (90) days written notice to the other party. Each of the parties hereto agrees, however, to use its best efforts to secure funds necessary for the continued performance of this Contract. The parties intend this provision to be a continuing right to terminate this Agreement at the expiration of each budget period of each party hereto pursuant to the provisions of Tex. Loc. Govt. Code Ann. ' 271.903.

Init.

ARTICLE 5 PAYMENTS

§ 5.1 PROGRESS PAYMENTS

§ 5.1.1 Based upon Applications for Payment submitted to the Architect by the Contractor and Certificates for Payment issued by the Architect and reviewed by the Construction Manager (as such term is hereinafter defined), as evidenced by the Construction Manager's signature, the Owner shall make progress payments on account of the Contract Sum to the Contractor as provided below and elsewhere in the Contract Documents.

§ 5.1.2 The period covered by each Application for Payment shall be one calendar month ending on the last day of the month, or as follows:

§ 5.1.3 Provided that an Application for Payment is received by the Architect not later than the 30th day of a month, the Owner shall make payment of the certified amount to the Contractor not later than **the fifth day following approval by Commissioners Court.** .

(Federal, state or local laws may require payment within a certain period of time.)

§ 5.1.4 Each Application for Payment shall be based on the most recent schedule of values submitted by the Contractor in accordance with the Contract Documents. The schedule of values shall allocate the entire Contract Sum among the various portions of the Work. The schedule of values shall be prepared in such form and supported by such data to substantiate its accuracy as the Owner, Construction Manager, and Architect may require. This schedule, unless objected to by the Architect or the Owner and Construction Manager, shall be used as a basis for reviewing the Contractor's Applications for Payment. For purposes of this Agreement "Construction Manager" is defined as G.A.S. Enterprises, Inc.

§ 5.1.5 Applications for Payment shall show the percentage of completion of each portion of the Work as of the end of the period covered by the Application for Payment.

§ 5.1.6 Subject to other provisions of the Contract Documents, the amount of each progress payment shall be computed as follows:

- .1 Take that portion of the Contract Sum properly allocable to completed Work as determined by multiplying the percentage completion of each portion of the Work by the share of the Contract Sum allocated to that portion of the Work in the schedule of values, less retainage of Five Percent (5 %). Pending final determination of cost to the Owner of changes in the Work, amounts not in dispute shall be included as provided in Section 7.3.9 of AIA Document A201™-2007, General Conditions of the Contract for Construction, **as modified by Owner and attached hereto as Exhibit ;**
- .2 Add that portion of the Contract Sum properly allocable to materials and equipment delivered and suitably stored at the site for subsequent incorporation in the completed construction (or, if approved in advance by the Owner, suitably stored off the site at a location agreed upon in writing), less retainage of Five Percent (5 %);
- .3 Subtract the aggregate of previous payments made by the Owner; and
- .4 Subtract amounts, if any, for which the Architect has withheld or nullified a Certificate for Payment as provided in Section 9.5 of AIA Document A201-2007, **as modified by Owner and attached hereto as Exhibit "";**

§ 5.1.7 The progress payment amount determined in accordance with Section 5.1.6 shall be further modified under the following circumstances:

- .1 Add, upon Substantial Completion of the Work, a sum sufficient to increase the total payments to the full amount of the Contract Sum, less such amounts as the Construction Manager and the Architect shall determine for incomplete Work, retainage applicable to such work and unsettled claims; and *(Section 9.8.5 of AIA Document A201-2007 requires release of applicable retainage upon Substantial Completion of Work with consent of surety, if any.)*
- .2 Add, if final completion of the Work is thereafter materially delayed through no fault of the Contractor, any additional amounts payable in accordance with Section 9.10.3 of AIA Document A201-2007, **as modified by Owner and attached hereto as Exhibit "";**

Init.

§ 5.1.8 Reduction or limitation of retainage, if any, shall be as follows:

(If it is intended, prior to Substantial Completion of the entire Work, to reduce or limit the retainage resulting from the percentages inserted in Sections 5.1.6.1 and 5.1.6.2 above, and this is not explained elsewhere in the Contract Documents, insert here provisions for such reduction or limitation.)

Not Applicable

§ 5.1.9 Except with the Owner's prior approval, the Contractor shall not make advance payments to suppliers for materials or equipment which have not been delivered and stored at the site.

§ 5.2 FINAL PAYMENT

§ 5.2.1 Final payment, constituting the entire unpaid balance of the Contract Sum, shall be made by the Owner to the Contractor when

- .1 the Contractor has fully performed the Contract except for the Contractor's responsibility to correct Work as provided in Section 12.2.2 of AIA Document A201-2007, **as modified by Owner and attached hereto as Exhibit "C"**; and to satisfy other requirements, if any, which extend beyond final payment; and
- .2 a final Certificate for Payment has been issued by the Architect. The Architect may not issue the final Certificate for Payment until it has been reviewed by the Construction Manager and approved by the Owner.

§ 5.2.2 The Owner's final payment to the Contractor shall be made no later than 30 days after the issuance of the Architect's final Certificate for Payment **and upon acceptance by the Owner and Architect, and after satisfactory evidence has been given by the Contractor that all his bills have been paid and the entire project is free from liens.**

ARTICLE 6 DISPUTE RESOLUTION

§ 6.1 INITIAL DECISION MAKER

The Architect will serve as Initial Decision Maker pursuant to Section 15.2 of AIA Document A201-2007, **as modified by Owner and attached hereto as Exhibit ""**, unless the parties appoint below another individual, not a party to this Agreement, to serve as Initial Decision Maker.

(If the parties mutually agree, insert the name, address and other contact information of the Initial Decision Maker, if other than the Architect.)

§ 6.2 BINDING DISPUTE RESOLUTION

For any Claim subject to, but not resolved by, mediation pursuant to Section 15.3 of AIA Document A201-2007, **as modified by Owner and attached hereto as Exhibit ""**, the method of binding dispute resolution shall be as follows:

(Check the appropriate box. If the Owner and Contractor do not select a method of binding dispute resolution below, or do not subsequently agree in writing to a binding dispute resolution method other than litigation, Claims will be resolved by litigation in a court of competent jurisdiction.)

Arbitration pursuant to Section 15.4 of AIA Document A201-2007

Litigation in a court of competent jurisdiction

Other *(Specify)*

Init.

ARTICLE 7 TERMINATION OR SUSPENSION

§ 7.1 The Contract may be terminated by the Owner or the Contractor as provided in Article 14 of AIA Document A201-2007.

§ 7.2 The Work may be suspended by the Owner as provided in Article 14 of AIA Document A201-2007.

ARTICLE 8 MISCELLANEOUS PROVISIONS

§ 8.1 Where reference is made in this Agreement to a provision of AIA Document A201-2007 or another Contract Document, the reference refers to that provision as amended or supplemented by other provisions of the Contract Documents.

§ 8.2 Payments due and unpaid under the Contract shall bear interest from the date payment is due at the rate stated below, or in the absence thereof, at the legal rate prevailing from time to time at the place where the Project is located. *(Insert rate of interest agreed upon, if any.)*

§ 8.3 The Owner's representative:

(Name, address and other information)

Hidalgo County Commissioner's Court and _____, as referenced in the AIA A201-2007 General Conditions, as modified by the Owner in Section 2.1.1. as authorized representatives.

§ 8.4 The Contractor's representative:

(Name, address and other information)

Holchemont, LTD.
Micahel Che Montalvo
900 North Main Street
McAllen, Texas 78501

§ 8.5 Neither the Owner's nor the Contractor's representative shall be changed without ten days written notice to the other party.

§ 8.6 Other provisions:

ARTICLE 9 ENUMERATION OF CONTRACT DOCUMENTS

§ 9.1 The Contract Documents, except for Modifications issued after execution of this Agreement, are enumerated in the sections below.

§ 9.1.1 The Agreement is this executed AIA Document A101-2007, Standard Form of Agreement Between Owner and Contractor, as modified by Owner and attached hereto as Exhibit ""',

§ 9.1.2 The General Conditions are AIA Document A201-2007, General Conditions of the Contract for Construction, as modified by Owner and attached hereto as Exhibit ""'.

§ 9.1.3 The Supplementary and other Conditions of the Contract: Not Applicable.

Document	Title	Date	Pages
----------	-------	------	-------

§ 9.1.4 The Specifications:

(Either list the Specifications here or refer to an exhibit attached to this Agreement.)

Section	Title	Date	Pages
---------	-------	------	-------

§ 9.1.5 The Drawings:
(Either list the Drawings here or refer to an exhibit attached to this Agreement.)

Number	Title	Date
--------	-------	------

§ 9.1.6 The Addenda, if any:

Number	Date	Pages
Addendum No. 1	May 7, 2012	2
Addendum No. 2	May 8, 2012	8
Addendum No.3	May 9, 2012	3

Portions of Addenda relating to bidding requirements are not part of the Contract Documents unless the bidding requirements are also enumerated in this Article 9.

§ 9.1.7 Additional documents, if any, forming part of the Contract Documents:

- .1 AIA Document E201™–2007 Digital Data Protocol Exhibit, if completed by the parties, or the following:

- .2 Other documents, if any, listed below:
(List here any additional documents that are intended to form part of the Contract Documents. AIA Document A201–2007 provides that bidding requirements such as advertisement or invitation to bid, Instructions to Bidders, sample forms and the Contractor’s bid are not part of the Contract Documents unless enumerated in this Agreement. They should be listed here only if intended to be part of the Contract Documents.)
 1. Exhibit ” Bid Form and Addendums from
 2. Exhibit ” Project Manual (Specifications)
 3. Exhibit ” AIA A201-2007, as modified by the Owner.
 4. Exhibit ” Notice to Proceed
 5. Exhibit ” Certificate of Insurance
 6. Exhibit ” Performance and Payment Bonds

ARTICLE 10 INSURANCE AND BONDS

The Contractor shall purchase and maintain insurance and provide bonds as set forth in Article 11 of AIA Document A201–2007, as modified by Owner and attached hereto as Exhibit "",
(State bonding requirements, if any, and limits of liability for insurance required in Article 11 of AIA Document A201–2007,,as modified by Owner and attached hereto as Exhibit "").

Type of insurance or bond	Limit of liability or bond amount (\$ 0.00)
---------------------------	---

This Agreement entered into as of the day and year first written above and is executed in three (3) original copies, of which one is to be delivered to the Contractor, one to the Architect for use in the administration of the Contract, and the remainder to the Owner.

OWNER *(Signature)*

By: Ramon Garcia, County Judge

(Printed name and title)

APPROVED AS TO FORM:

(Signature)

By: Stephen L. Crain

(Printed name and title)

CONTRACTOR *(Signature)*

By: Michael Che Montalvo Manager

(Printed name and title)

ATTEST:

(Signature)

By: Arturo Guajardo Jr., County Clerk

(Printed name and title)

Additions and Deletions Report for AIA[®] Document A101[™] – 2007

This Additions and Deletions Report, as defined on page 1 of the associated document, reproduces below all text the author has added to the standard form AIA document in order to complete it, as well as any text the author may have added to or deleted from the original AIA text. Added text is shown underlined. Deleted text is indicated with a horizontal line through the original AIA text.

Note: This Additions and Deletions Report is provided for information purposes only and is not incorporated into or constitute any part of the associated AIA document. This Additions and Deletions Report and its associated document were generated simultaneously by AIA software at 16:54:44 on 07/20/2012.

PAGE 1

AGREEMENT made as of the 24th day of July in the year 2012
(In words, indicate day, month and ~~year~~-year)

...

County of Hidalgo
1615 South Closner, Suite J
Edinburg, Texas 78539

...

Holchemont, LTD.
900 North Main Street
McAllen, Texas 78501

...

(Name, location and detailed description)

Construction Of A New Constable Precinct No. 1 Offices to consist of 4245Sq. Ft. located at Joe Stevens Blvd.,
Weslaco, Texas

...

Alcocer-Garcia Associates, Inc.
1333 E. Jasmine Avenue
McAllen, Texas 78501

PAGE 2

Date will be in the Notice to Proceed.

...

3.1.1 Liquidated Damages: Owner and Contractor recognize that time is of the essence in this Agreement and that Owner will suffer financial loss if the Work is not completed within the time specified in this Article 3 above, plus any extension thereof allowed in accordance with Article 8 of the General Conditions. Owner and Contractor also recognize the delays, expense and difficulties involved in providing in a legal proceeding, the actual loss suffered by Owner if the Work is not completed on time. Accordingly, instead of requiring such proof, Owner and Contractor

agree that as liquidated damages for delay (but not as penalty) Contractor shall pay Owner, One Hundred Fifty Dollars (\$150.00) per calendar day after the time specified in Paragraph 3.1 for Substantial Completion until the work is substantially complete.

PAGE 3

§ 3.3 The Contractor shall achieve Substantial Completion of the entire Work not later than ~~(—275)~~ days from the date of commencement, or as follows:

...

See 3.1.1 above.

...

§ 4.1 The Owner shall pay the Contractor the Contract Sum in current funds for the Contractor's performance of the Contract. The Contract Sum shall be ~~(\$—Seven Hundred and Twenty Four Thousand (\$724,000.00)~~, subject to additions and deductions as provided in the Contract Documents.

...

Item	Units and Limitations	Price Per Unit (\$0.00) <u>(\$ 0.00)</u>
<u>Betterment Allowance</u>		
<u>Contingency/Betterment Allowance</u>	<u>\$5,000.00</u>	
<u>Addendum No.1-Waterline Extensions Allowance</u>	<u>\$2,800.00</u>	
Item		Price
<u>TOTAL AMOUNT</u>	<hr/>	<u>\$7,800.00</u>

4.5 Commitment of Current Revenues Only. In the event that, during any term hereof, the governing body of any party does not appropriate sufficient funds to meet the obligations of such party under this Agreement, then any party may terminate this Contract upon ninety (90) days written notice to the other party. Each of the parties hereto agrees, however, to use its best efforts to secure funds necessary for the continued performance of this Contract. The parties intend this provision to be a continuing right to terminate this Agreement at the expiration of each budget period of each party hereto pursuant to the provisions of Tex. Loc. Govt. Code Ann. ' 271.903.

PAGE 4

§ 5.1.1 Based upon Applications for Payment submitted to the Architect by the Contractor and Certificates for Payment issued by the ~~Architect,~~ Architect and reviewed by the Construction Manager (as such term is hereinafter defined), as evidenced by the Construction Manager's signature, the Owner shall make progress payments on account of the Contract Sum to the Contractor as provided below and elsewhere in the Contract Documents.

...

§ 5.1.3 Provided that an Application for Payment is received by the Architect not later than the 30th day of a month, the Owner shall make payment of the certified amount to the Contractor not later than ~~the day of the—month. If an Application for Payment is received by the Architect after the application date fixed above, payment shall be made by the Owner not later than — () days after the Architect receives the Application for Payment~~ fifth day following approval by Commissioners Court. .

...

§ 5.1.4 Each Application for Payment shall be based on the most recent schedule of values submitted by the Contractor in accordance with the Contract Documents. The schedule of values shall allocate the entire Contract Sum among the various portions of the Work. The schedule of values shall be prepared in such form and supported by such data to substantiate its accuracy as the Owner, Construction Manager, and Architect may require. This schedule, unless objected to by ~~the Architect,~~ the Architect or the Owner and Construction Manager, shall be used as a basis for reviewing the Contractor's Applications for Payment. For purposes of this Agreement "Construction Manager" is defined as G.A.S. Enterprises, Inc.

...

- .1 Take that portion of the Contract Sum properly allocable to completed Work as determined by multiplying the percentage completion of each portion of the Work by the share of the Contract Sum allocated to that portion of the Work in the schedule of values, less retainage of ~~percent (—Five Percent (5 %)).~~ Pending final determination of cost to the Owner of changes in the Work, amounts not in dispute shall be included as provided in Section 7.3.9 of AIA Document A201™–2007, General Conditions of the Contract for ~~Construction;~~ Construction, as modified by Owner and attached hereto as Exhibit ;
- .2 Add that portion of the Contract Sum properly allocable to materials and equipment delivered and suitably stored at the site for subsequent incorporation in the completed construction (or, if approved in advance by the Owner, suitably stored off the site at a location agreed upon in writing), less retainage of ~~percent (—%);~~ Five Percent (5 %);

...

- .4 Subtract amounts, if any, for which the Architect has withheld or nullified a Certificate for Payment as provided in Section 9.5 of AIA Document ~~A201–2007.~~ A201–2007, as modified by Owner and attached hereto as Exhibit "";

...

- .1 Add, upon Substantial Completion of the Work, a sum sufficient to increase the total payments to the full amount of the Contract Sum, less such amounts as the Construction Manager and the Architect shall determine for incomplete Work, retainage applicable to such work and unsettled claims; and

...

- .2 Add, if final completion of the Work is thereafter materially delayed through no fault of the Contractor, any additional amounts payable in accordance with Section 9.10.3 of AIA Document ~~A201–2007.~~ A201–2007, as modified by Owner and attached hereto as Exhibit "";

PAGE 5

Not Applicable

...

- .1 the Contractor has fully performed the Contract except for the Contractor's responsibility to correct Work as provided in Section 12.2.2 of AIA Document A201–2007, as modified by Owner and attached hereto as Exhibit "C"; and to satisfy other requirements, if any, which extend beyond final payment; and
- .2 a final Certificate for Payment has been issued by the Architect. The Architect may not issue the final Certificate for Payment until it has been reviewed by the Construction Manager and approved by the Owner.

§ 5.2.2 The Owner's final payment to the Contractor shall be made no later than 30 days after the issuance of the Architect's final Certificate for ~~Payment,~~ Payment and upon acceptance by the Owner and Architect,

and after satisfactory evidence has been given by the Contractor that all his bills have been paid and the entire project is free from liens.

...

The Architect will serve as Initial Decision Maker pursuant to Section 15.2 of AIA Document A201-2007, **as modified by Owner and attached hereto as Exhibit ""**, unless the parties appoint below another individual, not a party to this Agreement, to serve as Initial Decision Maker.

...

For any Claim subject to, but not resolved by, mediation pursuant to Section 15.3 of AIA Document A201-2007, **as modified by Owner and attached hereto as Exhibit ""**, the method of binding dispute resolution shall be as follows:

...

Litigation in a court of competent jurisdiction

PAGE 6

%

...

Hidalgo County Commissioner's Court and _____, as referenced in the AIA A201-2007 General Conditions, as modified by the Owner in Section 2.1.1. as authorized representatives.

...

Holchemont, LTD.
Micahel Che Montalvo
900 North Main Street
McAllen, Texas 78501

...

§ 9.1.1 The Agreement is this executed AIA Document A101-2007, Standard Form of Agreement Between Owner and ~~Contractor~~**Contractor, as modified by Owner and attached hereto as Exhibit ""**,

§ 9.1.2 The General Conditions are AIA Document A201-2007, General Conditions of the Contract for ~~Construction~~**Construction, as modified by Owner and attached hereto as Exhibit ""**.

§ 9.1.3 The Supplementary and other Conditions of the Contract: Not Applicable.

PAGE 7

<u>Addendum No. 1</u>	<u>May 7, 2012</u>	<u>2</u>
<u>Addendum No. 2</u>	<u>May 8, 2012</u>	<u>8</u>
<u>Addendum No.3</u>	<u>May 9, 2012</u>	<u>3</u>

...

.1 AIA Document ~~E201™-2007~~, E201™-2007 Digital Data Protocol Exhibit, if completed by the parties, or the following:

...

(List here any additional documents that are intended to form part of the Contract Documents. AIA Document A201-2007 provides that bidding requirements such as advertisement or invitation to bid, Instructions to Bidders, sample forms and the Contractor's bid are not part of the Contract Documents unless enumerated in this Agreement. They should be listed here only if intended to be part of the Contract Documents.)

1. Exhibit " Bid Form and Addendums from
2. Exhibit " Project Manual (Specifications)
3. Exhibit " AIA A201-2007, as modified by the Owner.
4. Exhibit " Notice to Proceed
5. Exhibit " Certificate of Insurance
6. Exhibit " Performance and Payment Bonds

...

The Contractor shall purchase and maintain insurance and provide bonds as set forth in Article 11 of AIA Document A201-2007, A201-2007, as modified by Owner and attached hereto as Exhibit "", (State bonding requirements, if any, and limits of liability for insurance required in Article 11 of AIA Document A201-2007.) A201-2007, as modified by Owner and attached hereto as Exhibit "").

Type of insurance or bond

Limit of liability or bond amount ~~(\$0.00)~~ (\$ 0.00)

PAGE 8

This Agreement entered into as of the day and year first written ~~above~~ above and is executed in three (3) original copies, of which one is to be delivered to the Contractor, one to the Architect for use in the administration of the Contract, and the remainder to the Owner.

OWNER (Signature)

By: Ramon Garcia, County Judge
(Printed name and title)

APPROVED AS TO FORM:

OWNER (Signature)

By: Stephen L. Crain

CONTRACTOR (Signature)

By: Michael Che Montalvo Manager
(Printed name and title)

ATTEST:

CONTRACTOR (Signature)

By: Arturo Guajardo Jr., County Clerk

Certification of Document's Authenticity

AIA® Document D401™ – 2003

I, Hidalgo County Judge Ramon Garcia, hereby certify, to the best of my knowledge, information and belief, that I created the attached final document simultaneously with its associated Additions and Deletions Report and this certification at 16:54:44 on 07/20/2012 under Order No. 1180968477_1 from AIA Contract Documents software and that in preparing the attached final document I made no changes to the original text of AIA® Document A101™ – 2007, Standard Form of Agreement Between Owner and Contractor where the basis of payment is a Stipulated Sum, as published by the AIA in its software, other than those additions and deletions shown in the associated Additions and Deletions Report.

(Signed)

(Title)

(Dated)

AI-33277

Purchasing Department 18. C. 1.

CC REGULAR

Meeting Date: 07/24/2012

Department Head: Comm. Hector

Submitted By: Katia Garcia, COMM. PCT. #2

Department: COMM. PCT. #2

Information

CAPTION

Requesting approval of "License Agreement" for the Minnesota Drainage Project.

BACKGROUND

Fiscal Impact

FISCAL YEAR:

ACCT. #:

FUNDS AVAILABLE Y/N?:

MATCHING FUNDS Y/N?:

BUDGETARY IMPACT:

No fiscal impact as per Precinct personnel (K. Garcia).

Attachments

License Agreement-Revised

Legal Approval

Form Review

Inbox	Reviewed By	Date
Purchasing Department	Marty Salazar	07/19/2012 02:57 PM
Budget & Management	Merlen P. Munoz	07/19/2012 03:15 PM
Roland Garcia	Rolando Garcia	07/20/2012 08:13 AM
Auditor's Office	Angela Garcia	07/20/2012 04:55 PM
Form Started By: Katia Garcia		Started On: 07/17/2012 09:14 AM
	Final Approval Date: 07/20/2012	

LICENSE AGREEMENT

THIS LICENSE AGREEMENT (the "Agreement") is made and entered into as of the 24th day of July, 2012, by and between Maria Imelda Garza whose address is 1117 S. Peking, McAllen, Texas 78501 ("Licensor") and HIDALGO COUNTY whose address is 1615 S. Closner, Suite J, Edinburg, Texas 78539 ("Licensee").

WITNESSETH:

1. License. Subject to the terms and conditions contained in this Agreement, Licensor hereby grants to Licensee a non-exclusive license (the "**License**") in, over, under and across that certain real property described on Exhibit A attached hereto (the "**Parcel**") to clean the area, store construction equipment, and construction materials (the "**Permitted Use**"), and for no other purpose (the "**Project**"). The License is granted solely to the extent of Licensor's right, title and interest in the Parcel, without any express or implied warranties. **LICENSOR HAS NOT MADE AND DOES NOT HEREBY MAKE AND HEREBY SPECIFICALLY DISCLAIMS ANY REPRESENTATIONS OR WARRANTIES OF ANY KIND OR CHARACTER WHATSOEVER, EXPRESS OR IMPLIED, WITH RESPECT TO THE PARCEL.** Licensee has inspected the Parcel, accepts the same "**AS IS, WHERE IS, WITH ALL FAULTS,**" and agrees that Licensor is under no obligation to perform any work or provide any maintenance, repairs or materials to the Parcel for the benefit of Licensee.

2. Term of License. The term of the License shall begin on the date of this Agreement and, subject to paragraph 8 below, shall continue until the earlier of (a) the completion of the Project or (b) July 31, 2014. Following the termination of the License, the parties shall have no further rights or obligations under this Agreement (except for those obligations that survive the termination or expiration of the License). In the event Licensee retains possession of the Parcel or any portion thereof after the termination of the License, such possession and use shall be an unlawful detainer, and no tenancy or interest shall result from such possession; Licensee shall be subject to immediate removal. Licensee shall also pay all damages sustained by Licensor as a result of such holdover. The damages payable during any holdover period shall be payable to Licensor on demand.

3. Access to Parcel. Subject to the terms and conditions of this Agreement, Licensee shall have continuous access to the Parcel on a non-exclusive basis for the Permitted Use; provided, however, such access shall be limited to Licensee, its employees, contractors and other persons under its direct supervision who need to access the Parcel for the Permitted Use. Neither Licensor nor any of its affiliates, elected officials, officers, employees, agents, representatives, licensees or invitees (collectively, "**Licensor Parties**") shall have any responsibility or liability for the conduct or safety of any of Licensee's elected officials, agents, representatives, contractors, employees, licensees, invitees or any other person afforded access to the Parcel by or on behalf of Licensee while such parties are using any part of the Parcel, **EVEN IF ANY LIABILITY, DAMAGE, LOSS, COST, EXPENSE, CLAIM, DEMAND, OR**

INJURY IS CAUSED BY THE STRICT LIABILITY OR NEGLIGENCE, (BUT NOT THE GROSS NEGLIGENCE OR WILLFUL MISCONDUCT) OF ANY LICENSOR PARTY, it being understood and agreed that Licensee shall be solely liable for any liability, damage, loss, costs, expenses, claims, demands, actions, injury to or death of any such person (or any third party) which results from or arises out of the use of the Parcel by Licensee and/or its elected officials, agents, representatives, contractors, subcontractors, employees, licensees, invitees or any other such person from any cause. Licensee will keep the Parcel free from all liens and claims, legal or equitable, arising out of its activities, including mechanics' and materialmen's liens. If a lien or claim is filed by anyone claiming by, through or under Licensee, Licensee will discharge same within 10 days of filing by payment or posting of a surety bond. The provisions of this paragraph shall survive the termination or expiration of the License.

4. Maintenance of Parcel. At all times during the term of the License, Licensee shall maintain the Parcel in a good and safe condition. Licensee shall comply with all federal, state and local laws, rules, regulations, ordinances applicable to its use of the Parcel. Without limiting the foregoing, Licensee shall obtain any permits required for the Permitted Use prior to commencing such Permitted Use and shall at all times comply with the requirements of such permits.

5. Hazardous Materials. Licensee will not cause or permit the storage, use, generation or disposition of Hazardous Materials in or about the Parcel without the prior written consent of the Licensor. A "**Hazardous Material**" is any substance (a) the presence of which requires notification, investigation or remediation under applicable federal, state or local laws, rules, regulations, ordinances and permits; or (b) which is defined, listed or regulated by any governmental authority as a "hazardous waste", "extremely hazardous waste", "solid waste", "toxic substance", "hazardous substance", "hazardous material" or "regulated substance", or otherwise regulated under applicable laws, rules, regulations, ordinances and permits, including the Comprehensive Environmental Response, Compensation and Liability Act of 1980 and similar statutes.

6. No Sublicense or Assignment. Licensee shall not assign its rights under this Agreement or grant any sublicense with respect to all or any portion of the Parcel without the prior written consent of Licensor. Any occupancy or use arrangement, assignment or sublease made without the prior written consent of Licensor shall be null and void.

7. No Interest in Real Property. The License, this Agreement nor the use of the Parcel for the Permitted Use or otherwise shall be construed to confer any interest or estate of any kind whatsoever in the Parcel to Licensee or to create a partnership or joint venture between Licensor and Licensee.

8. Subordination to Mortgages. The License and this Agreement shall be subject and subordinate to any mortgage, deed of trust or other lien presently existing or hereafter filed against the Parcel by any bona fide third party lender of Licensor and to any renewals, modifications, consolidations, refinancings, and extensions thereof.

This provision is hereby declared by the parties to be self-operative and no further instrument shall be required to effect such subordination.

9. Default By Licensee. It shall be a default by Licensee under this Agreement if Licensee fails to comply with any term, provision, condition or covenant of this Agreement. Upon the occurrence of such a default, Licensor shall have the option to (a) proceed to cure such failure and Licensee shall immediately reimburse Licensor for the costs thereof upon demand, (b) terminate the License by giving notice of such termination to Licensee, in which event Licensee shall immediately surrender the Parcel to Licensor and the parties shall have no further obligations under this Agreement (except for those obligations that survive the termination or expiration of the License) or (c) exercise any remedies that may be available to it at law or in equity.

10. **Notice**. Except as may be otherwise specifically provided in this Agreement, all notices, demands, requests or communication required or permitted hereunder shall be in writing and shall either be (i) personally delivered against a written receipt, or (ii) sent by registered or certified mail, return receipt requested, postage prepaid and addressed to the parties at the addresses set forth below, or at such other addresses as may have been theretofore specified by written notice delivered in accordance herewith:

If to County: County of Hidalgo
 Attention: County Judge Ramon Garcia
 P.O. Box 758
 Edinburg, Texas 78540-0758

If to Licensor: Maria Imelda Garza
 1117 S. Peking
 McAllen, Texas 78501

Each notice, demand, request or communication which shall be delivered or mailed in the manner described above shall be deemed sufficiently given for all purposes at such time as it is personally delivered to the addressee or, if mailed, at such time as it is deposited in the United States mail.

11. **Texas Law to Apply**. This Agreement shall be construed under and in accordance with the laws of the State of Texas, and all obligations of the parties created hereunder are performable in Hidalgo County, Texas. The parties hereby consent to personal jurisdiction in Hidalgo County, Texas.

IN WITNESS WHEREOF, this Agreement is executed as of the day first written above.

LICENSOR:

LICENSEE:

HIDALGO COUNTY

By: _____

Name:

Title:

Erika Zamora

From: Katia Garcia <katia.garcia@co.hidalgo.tx.us>
Sent: Monday, July 23, 2012 2:18 PM
To: 'Erika Zamora'
Subject: FW: License Agreement
Attachments: image001.jpg; Final License Agreement MIG.pdf

Ms. Erika,

Below please find email confirming Legal Counsel's review and approval of attached License Agreement (AI-33277).

Thank You,
Katia

From: Marynel Trevino [mailto:mntrevino@atlashall.com]
Sent: Monday, July 23, 2012 2:08 PM
To: 'katia.garcia@co.hidalgo.us.tx'
Subject: FW: License Agreement

Hi Katia,

Pursuant to our conversation this afternoon the attached (final) License Agreement has been reviewed and approved by counsel.

Should you have concerns or questions, please have the auditor's office call our office.

Thanks,

Marynel Trevino, Secretary for

Stephen L. Crain
ATLAS, HALL & RODRIGUEZ, LLP
818 Pecan Blvd. (78501)
P. O. Box 3725
McAllen, Texas 78502
Direct Dial Number (956) 632-8221
Main Number (956) 682-5501
Fax Number (956) 686-6109
E-mail Address scrain@atlashall.com



Atlas Hall
Rodriguez

E-MAIL NOTICE -- This transmission may be: (1) subject to the Attorney-Client Privilege, (2) an attorney work product, or (3) strictly confidential. If you are not the intended recipient of this message, you may not disclose, print, copy or disseminate this information. If you have received this in error, please reply and notify the sender (only) and delete the message. Unauthorized interception of this e-mail is a violation of federal criminal law.

This communication does not reflect an intention by the sender or the sender's client or principal to conduct a transaction or make any agreement by electronic means. Nothing contained in this message or in any attachment shall satisfy the requirements for a writing, and nothing contained

herein shall constitute a contract or electronic signature under the Electronic Signatures in Global and National Commerce Act, any version of the Uniform Electronic Transactions Act or any other statute governing electronic transactions.

From: Marynel Trevino [<mailto:mntrevino@atlashall.com>]
Sent: Monday, July 23, 2012 1:27 PM
To: 'Jaime Salinas'
Subject: FW: License Agreement

From: Jaime Salinas [<mailto:jaime.salinas@co.hidalgo.tx.us>]
Sent: Monday, July 23, 2012 10:47 AM
To: 'Marynel Trevino'
Subject: RE: License Agreement

Marynel,

2) B can you please put July 31, 2014, and the date that we entered into the agreement with Mrs., Garza can you put tomorrows date on it. Call me or e-mail when it's ready to pickup.

Thank You,

Jaime Salinas

From: Stephen L. Crain [<mailto:scrain@atlashall.com>]
Sent: Monday, July 23, 2012 9:29 AM
To: 'Jaime Salinas'
Subject: License Agreement

Jaime,

Attached is the License Agreement, as per Mr. Crain, please review the agreement and on # 2 (b) term of license please provide us the date ...

If you have any questions, please call our office.

Thanks,

Marynel Trevino, Secretary for
Stephen L. Crain & Heather De La Garza

ATLAS, HALL & RODRIGUEZ, LLP

818 Pecan Blvd. (78501)

P. O. Box 3725

McAllen, Texas 78502

Direct Dial Number (956) 632-8221

Main Number (956) 682-5501

Fax Number (956) 686-6109

E-mail Address scrain@atlashall.com



Atlas Hall
Rodriguez

E-MAIL NOTICE -- This transmission may be: (1) subject to the Attorney-Client Privilege, (2) an attorney work product, or (3) strictly confidential. If you are not the intended recipient of this message, you may not disclose, print, copy or disseminate this information. If you have received this in error, please reply and notify the sender (only) and delete the message. Unauthorized interception of this e-mail is a violation of federal criminal law.

This communication does not reflect an intention by the sender or the sender's client or principal to conduct a transaction or make any agreement by electronic means. Nothing contained in this message or in any attachment shall satisfy the requirements for a writing, and nothing contained herein shall constitute a contract or electronic signature under the Electronic Signatures in Global and National Commerce Act, any version of the Uniform Electronic Transactions Act or any other statute governing electronic transactions.

AI-33163

Purchasing Department 18. D. 1.

CC REGULAR

Meeting Date: 07/24/2012

Department Head: Martha Salazar Submitted By: Vangie Garcia, PURCHASING DEPT.

Department: PURCHASING DEPT.

Information

CAPTION

The following is the **continuation** of the "**Maintenance Plan Agreement**" with CROSSMATCH TECHNOLOGIES awarded vendor through the Texas DIR-Contract No.-DIR-SDD-1024 for the procurement of hardware/software equipment previously approved by Commissioners Court on September 28, 2010;

- a. Requesting CC grants and order for the exemption from competitive bidding requirements under Texas Local Government Code, 262.024 (a)(7)-'an item that can be obtained from only one source';
- b. Approval of a "Sole Source Declaration" with CROSSMATCH TECHNOLOGIES and authority to purchase the continuation of the "Maintenance Plan Agreement"(reviewed and approved as to form by legal counsel) with said sole source designation remaining in effect as long as HIDTA possess and utilizes the hardware and software commencing with services until 4-30-13 in the amount of \$1,620.00.

BACKGROUND

Will be procured through Requisition #219114.

Fiscal Impact

FISCAL YEAR: 2012

ACCT. #: 2-1254-412-00-270-014-0-432

FUNDS AVAILABLE Y/N?: Y

MATCHING FUNDS Y/N?: N

BUDGETARY IMPACT:

Funds available as of 07/13/2012. (REF: Req #00219114)

FISCAL YEAR: 2012

ACCT. #: 2-1291-412-00-270-003-1-432

FUNDS AVAILABLE Y/N?: Y

MATCHING FUNDS Y/N?: N

BUDGETARY IMPACT:

Funds available as of 07/13/2012. (REF: Req #00219114)

Attachments

262.024(a)(7) Tex. Loc. Gov. Code

Declaration

Maintenance Plan Documentation

Requisition

Previous Documentation

Form Review

Inbox

Reviewed By

Date

Purchasing Department

Marty Salazar

07/13/2012 10:34 AM

Budget & Management

Merlen P. Munoz

07/13/2012 10:40 AM

Sylvia Solis

Sylvia Solis

07/20/2012 09:18 AM

Auditor's Office

Angela Garcia

07/20/2012 04:55 PM

Form Started By: Vangie Garcia

Started On: 07/09/2012 02:12 PM

Final Approval Date: 07/20/2012

Chapter 271.

(b) The requirements established by Subsection (a) apply to contracts for which payment will be made from current funds or bond funds or through time warrants. Contracts for which payments will be made through certificates of obligation are governed by The Certificate of Obligation Act of 1971 (Subchapter C, Chapter 271). Contracts for which payment will be made through anticipation notes are subject to the competitive bidding provisions of The Certificate of Obligation Act of 1971 (Subchapter C, Chapter 271) in the same manner as certificates of obligation.

(c) In applying the requirements established by Subsection (a), all separate, sequential, or component purchases of items ordered or purchased, with the intent of avoiding the requirements of this subchapter, from the same supplier by the same county officer, department, or institution are treated as if they are part of a single purchase and of a single contract. In applying this provision to the purchase of office supplies, separate purchases of supplies by an individual department are not considered to be part of a single purchase and single contract by the county if a specific intent to avoid the requirements of this subchapter is not present.

Acts 1987, 70th Leg., ch. 149, § 1, eff. Sept. 1, 1987. Amended by Acts 1989, 71st Leg., ch. 1, § 57(a), eff. Aug. 28, 1989; Acts 1989, 71st Leg., ch. 1250, § 9, eff. Sept. 1, 1989; Acts 1991, 72nd Leg., ch. 16, § 13.02(b), eff. Aug. 26, 1991; Acts 1993, 73rd Leg., ch. 757, § 13, 38, eff. Sept. 1, 1993; Acts 1997, 75th Leg., ch. 442, § 1, eff. Sept. 1, 1997; Acts 1999, 76th Leg., ch. 505, § 2, eff. Sept. 1, 1999; Acts 2001, 77th Leg., ch. 436, § 4, eff. May 28, 2001; Acts 2001, 77th Leg., ch. 1063, § 2, eff. Sept. 1, 2001; Acts 2001, 77th Leg., ch. 1409, § 4, eff. Sept. 1, 2001; Acts 2003, 78th Leg., ch. 1276, § 12.004, eff. Sept. 1, 2003.

§ 262.0235. PROCEDURES ADOPTED BY COUNTY PURCHASING AGENTS FOR ELECTRONIC BIDS OR PROPOSALS. The county purchasing agent, before receiving electronic bids or proposals, shall adopt rules in conformance with Section 262.011(o) to ensure the identification, security, and confidentiality of electronic bids or proposals.

Added by Acts 2001, 77th Leg., ch. 1063, § 3, eff. Sept. 1, 2001.

§ 262.024. DISCRETIONARY EXEMPTIONS. (a) A contract for the purchase of any of the following items is exempt from the requirement established by Section 262.023 if the commissioners court by order grants the exemption:

(1) an item that must be purchased in a case of public calamity if it is necessary to make the purchase promptly to relieve the necessity of the citizens or to preserve the property of the county;

(2) an item necessary to preserve or protect the public health or safety of the residents of the county;

(3) an item necessary because of unforeseen damage to public property;

(4) a personal or professional service;

(5) any individual work performed and paid for by the day, as the work progresses, provided that no individual is compensated under this subsection for more than 20 working days in any three month period;

(6) any land or right-of-way;

(7) an item that can be obtained from only one source,

including:

(A) items for which competition is precluded because of the existence of patents, copyrights, secret processes, or monopolies;

(B) films, manuscripts, or books;

(C) electric power, gas, water, and other utility

services; and



Hidalgo County Purchasing Department
2812 S. Business Highway 281
New Administration Building
Edinburg, Texas 78539
(956) 318-2626/ Fax: (956) 318-2629

MEMORANDUM

“SOLE SOURCE DECLARATION”

TO: Hidalgo County Commissioner’s Court

FROM: Martha L. Salazar, CPPB
Hidalgo County Purchasing Agent *mls*

DATE: July 10, 2012

RE: “Sole Source Declaration” – Cross Match Technologies

On September 28, 2010, Hidalgo County Commissioners Court approved to purchase law enforcement hardware/software equipment for Hidalgo County HIDTA Task Force from Cross Match Technologies, an awarded vendor through the Texas DIR-Contract #DIR-SDD-1024 for an amount of \$13,644.50 utilizing 2009 grant monies for such purchase.

Due to the sensitivity of accuracy and maintaining compliance with strict FBI image quality requirements that is provided by these hardware/software equipment procured through Cross Match Technologies as the developer and manufacturer of such equipment, it is of the utmost importance for the continuation of the maintenance services for accurate efficiency.

Therefore, Hidalgo County HIDTA Task Force requires the continuance of the maintenance plan from the sole source vendor as the developer and manufacture of the LSCAN Guardian USB W/LSMS On Desk Top. Duration of the term of the sole source declaration is through the possession of the hardware/software equipment by HIDTA Task Force.



Dear Cross Match Customer:

***This is your quotation for maintenance contract renewal.
It is important that you verify your serial number for accuracy.***

Cross Match quotations for live scan system maintenance contract renewals are sent based on the serial number of the fingerprint or palm print scanner at the time of expiration. Customers with multiple scanners may receive several notices from our automated system throughout the year. For questions, or for a customized, comprehensive quotation, please contact us at: maintenancecontracts@crossmatch.com. We will need your company name, contact, phone and the serial numbers of all your scanners.

The renewal process is simple: If your company has credit terms, SIGN and DATE the quote page and return it by FAX to (561) 622-9938 prior to the expiration date (or FAX a signed Purchase Order accompanied by quote). The Accounting Office will issue Credit Customers an invoice based on signature or PO. If paying by Credit Card (MasterCard/VISA), attached to this quote find our credit authorize form. Fill out form completely, sign and FAX it to (561) 828-7717. If you do not feel comfortable adding your card number on the form please fill out the form, sign, FAX back then call 561-630-0468 with the credit card number. The Accounting Office will issue Credit Card Customers a paid invoice with the charge receipt.

Maintenance Contract Benefits:

- § **Unlimited repairs, all parts and labor covered by Cross Match for failures occurring under normal use. Avoid \$800 minimum repair charge applicable for units not under maintenance contract.**
- § **24/7 help-desk telephone support. Most Software issues to be resolved via modem connection to customer system. Avoid \$200 hourly rate charge applicable for systems not under maintenance contract.**
- § **Twenty-four hour (next business day) cross ship to replace field unit if failure is hardware related. Avoid delay in shipping unit to Cross Match Headquarters for repair.**
- § **Agency-mandated software updates provided under maintenance. Avoid \$1,000 fee per update.**
- § **Cross Match pays all shipping costs. Avoid freight charges.**

Please return your order for maintenance renewal by the expiration date to avoid a lapse in coverage after which time service calls will be at time/materials. **For lapsed contracts, we require a remote technical audit at a fee of \$300 for ten-print and \$500 for palm-print to confirm your system (s) is operable prior to moving forward with a maintenance contract.** If the audit reveals a need for repairs, they can be purchased at time/materials before the contract goes into effect. If systems are not kept under contract, systems older than three (3) years may require a computer upgrade.

The Customer Care Service Group Desk is toll free: 866-276-7761 or email: cmcc@crossmatch.com.

Cross Match provides on-site or campus training as well as remote training. Please let us know if you are interested in receiving a training quotation.

Special Notes:

GSA Contract: GS 35F-0199R; US Courts BPA USCA-05-C0198

Taxes are different in every state and are added to your invoice, if applicable, unless you fax current tax exempt certificate with your order.

For maintenance contract questions, contact us at: maintenancecontracts@crossmatch.com

Andres Munoz
Maintenance Contracts Administrator
561-624-5279



EXHIBIT D
MAINTENANCE PLAN

Reference Purchase Order: _____

The undersigned hereby elects to purchase from Cross Match Technologies, Inc. ("Cross Match") the Maintenance Plan as described herein for the period of time specified on the applicable Purchase Order.

Product Eligibility: The contract period for the Maintenance Plan commences after the warranty ends. Products are eligible for a Maintenance Plan provided that the warranty has not expired. Any such Product deemed ineligible by reason of not being covered by a current warranty is subject to a technical audit conducted by Cross Match prior to the product being eligible for a Maintenance Plan. This audit may be conducted on-site or through a remote data connection to the Product. If the result of the audit indicates the Product is ineligible for Maintenance, Cross Match will indicate what changes to the Product are required to make the Product eligible. The audit and any required changes to the Product are a billable service at the hourly and material rates in effect at the time the service is ordered.

This Maintenance Plan shall not apply to any software product or interface customized by Cross Match to meet Purchaser's specific requirements. Purchaser-furnished equipment or software, third party software or End-User-furnished equipment is not eligible.

Fees and Charges: The prices for the Maintenance Plan can be found in the Cross Match Price List in effect at the time the plan is purchased. Services requested by Purchaser and delivered by Cross Match that are outside the scope of the Maintenance Plan are billable to Purchaser at Cross Match's hourly and material prices in effect at the time of service.

Technical Support: This Maintenance Plan provides Purchaser with post-warranty remedies for Product defects. To obtain service under this Maintenance Plan, Purchaser must contact the Cross Match Customer Care Center. **The deliverables as described herein do not flow through Purchaser to Purchaser's End Users.**

Hardware: Purchasers may report any defects in the hardware Products by contacting Cross Match's Customer Care Center twenty-four (24) hours a day, seven days per week, excluding national holidays. Once the defect is verified by Customer Care Center, Cross Match will ship replacement equipment no later than the next business day. CrossMatch will also facilitate the return of the defective equipment. With certain equipment, the Purchaser may be required to transmit to Cross Match certain electronic files so that the replacement unit can be preconfigured prior to shipment. The Purchaser must pack the defective unit and make it available to Cross Match's common carrier agent at the time of scheduled pickup. Not doing so may result in extra charges to the Purchaser.

Software: In the event of the discovery of any software non-conformance, the Purchaser may report such alleged non-conformance to the Cross Match Customer Care Center. The Customer Care Center will work with the Cross Match-trained on-site caller to verify and resolve the problem. If unable to resolve the problem through telephone consultation, the Customer Care Center will remotely connect to the Purchaser's system through a Purchaser-provided data connection to perform advanced diagnosis and analysis. During the time of the remote data connection, the Purchaser must provide a voice telephone line for the on-site caller. If Cross Match is unable to resolve the problem through the remote data connection, then Cross Match, at its sole discretion, may dispatch a Cross Match technician for on-site diagnosis and analysis. If the problem is determined to be a defect in the Cross Match-supplied software, then the on-site work shall be provided free of charge and at no additional cost to the Purchaser. Cross Match will deliver a software correction to remedy the nonconformance. If the problem is determined not to be a defect covered for any reason under this Maintenance, then the on-site work may be billable.

THE FOREGOING CONSTITUTES YOUR SOLE AND EXCLUSIVE REMEDY AND CROSS MATCH'S SOLE AND EXCLUSIVE LIABILITY IN CONNECTION WITH YOUR CROSS MATCH PRODUCT, AND IS IN LIEU OF ANY AND ALL OTHER REMEDIES WHICH MAY BE AVAILABLE TO YOU.

Exclusions: Cross Match shall incur no liability under this Maintenance Plan and is voidable by Cross Match if in Cross Match's sole reasonable opinion: (a) the Product is used other than under normal use and under proper environmental and/or electrical conditions, as specified in the Product manual; (b) the Product is not maintained as specified in the product manual; (c) the Product is subject to abuse, misuse, neglect, accident, flooding, storm, lightning, power surges, dirty power, third-party errors or omissions, or acts of God; (d) the Product is modified or altered (unless expressly authorized in writing by Cross Match); (e) the Product is installed or used in combination or in assembly with products not supplied or authorized by Cross Match; (f) there is a failure to follow specific restrictions or operating instructions; or (g) payment for the Product has not been timely made.

This Maintenance Plan does not provide additional hardware or computing platform software or its installation when required by



Cross Match software supplied hereunder. If required, these may be obtained from Cross Match at the published prices in effect at such time.

The Maintenance Plan does not cover nondurable consumable items including, but not limited to, batteries, paper, silicone membranes, cleaning solution, towels, printer cartridges and cables. Replacement supplies of these items may be ordered by contacting Cross Match Sales at 866-725-3926. The Maintenance Plan does not cover third party peripheral equipment (such as laptops and printers) that is connected or otherwise used in conjunction with the Cross Match Product. Customers should contact the manufacturer of such third party equipment regarding suspected defects in such equipment.

Cross Match's obligations hereunder are contingent upon your providing the Product serial number as proof-of-purchase, and upon Cross Match's determination that the suspected malfunction is actually due to defects in material or workmanship.

THIS MAINTENANCE PLAN IS NOT TRANSFERABLE OR ASSIGNABLE TO ANY THIRD PARTY AND SHALL BE FOR THE SOLE AND EXCLUSIVE BENEFIT OF THE ORIGINAL PURCHASER OF THE PRODUCT COVERED HEREUNDER; ANY ATTEMPTED TRANSFER OR ASSIGNMENT HEREOF SHALL BE VOID AB INITIO.

Cross Match reserves the right to improve/modify products at any time, at its sole discretion, as it deems necessary.

The ID 2500 system is not eligible for the Maintenance Plan.

The purchase of this Maintenance Plan is a final sale; it is neither returnable nor refundable.

By signing this Agreement, Purchaser agrees to pay for the Maintenance Plan covering the Products set forth in the above referenced Purchase Order.

CROSS MATCH TECHNOLOGIES, INC.

PURCHASER:

By: _____

Name of Purchaser

Name: _____

By: _____

Title: _____

Name: _____

Title: _____



June 14, 2012

Evangelina Garcia
Hidalgo County

Dear Ms. Garcia:

As the developer and manufacturer of the Cross Match 10-Print Live Scan Systems and Single Finger Capture Units (Guardian, ID 1000, ID 500, ID 2500, Verifier Series and MV-5 Handheld) we are the sole vendor authorized to provide warranty and maintenance services.

Due to the sensitivity of accuracy and maintaining compliance with strict FBI image quality requirements, we provide depot repair only on all our forensic products . There are no third party providers of internal optics service. We provide strict compliance to the highest standards.

We certainly appreciate your continued confidence in choosing Cross Match Technologies as your Live-Scan system and we will always show our responsiveness to your needs.

Sincerely,

Marygrace Cox

Marygrace Cox
Senior Sales Operations Specialist
Cross Match Technologies Inc.

Cross Match Technologies, Inc.

3960 RCA Boulevard, Suite 6001, Palm Beach Gardens, Florida 33410

Tel. (561) 622 1650 - Fax (561) 622 9938

Internet: www.crossmatch.net - E-mail: sales@crossmatch.net

HIDALGO COUNTY PURCHASING DEPARTMENT
SOLE SOURCE AFFIDAVIT

THIS IS AN OFFICIAL PURCHASING DOCUMENT-RETAIN WITH PURCHASE ORDER

Before me, the undersigned official, on this day, personally appeared Marygrace Cox
a person known to me to be the person whose signature appears below, whom after being duly sworn
upon his/her oath deposed and said:

1. My name is Marygrace Cox. I am over the age of 18, have never been convicted of crime and am competent to make this affidavit.
2. I am an authorized representative of the following company or firm: Cross Match Technologies Inc.
3. The above named company or firm is the sole source for the following item(s), product(s) or service(s):
Maintenance for the LSCAN Guardian USB
4. Competition in providing the above named item(s), product(s), service(s) is precluded by the existence of a patent, copyright, secret process or monopoly as stated under Section 262.024(a)(7)(A), of the Local Government Code. Also, attached hereto is a sole source letter, which sets forth the reasons why this Vendor is a sole source provider (dated and signed).
5. There is/are no other like item(s) or product(s) available for purchase that would serve the same purpose or function.
6. Note: This Vendor understands that by providing false information on this Sole Source Affidavit, it may be considered a non-responsible Vendor on this and future purchases and may result in discontinuations of any/all business with Hidalgo County.

Signature _____

SWORN AND SUBSCRIBED TO under oath before me on 14 day of June, 2012.

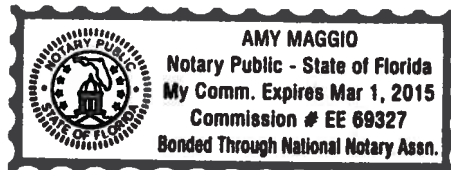

NOTARY PUBLIC

PRINTED NAME

3-1-15
MY COMMISSION EXPIRES

COMPANY NAME: Cross Match Technologies Inc
ADDRESS, CITY, STATE & ZIP CODE: 3950 RCA Blvd Suite 5001 Palm Beach Gardens FL 33410
PHONE: 561-622-1650 NUMBER: _____
CONTACT NAME AND TITLE: Marygrace Cox Sr. Sales Operations Specialist
WEB ADDRESS: _____ EMAIL: Marygrace.cox@crossmatch.com
FEDERAL TAX ID NUMBER: 65-0637546 TEXAS SALES TAX NUMBER: _____

Evangelina Garcia

From: Josephine L. Ramirez [josephine.ramirez@da.co.hidalgo.tx.us]
Sent: Monday, July 09, 2012 1:04 PM
To: 'Evangelina Garcia'
Subject: RE: Maintenance Plan-CrossMatch Technologies

Hi Vangie,

Long time no talk....hope you are doing well. I don't believe I had seen this one before. I have reviewed the attached maintenance plan and approve as to the form of the agreement.

Josephine Ramirez Solis
Assistant Criminal District Attorney
County Affairs Section
Office of Criminal District Attorney
Hidalgo County, Texas
100 N Closner Rm 303
Edinburg, TX 78539
(956) 318-2313 ext. 3823
(956) 318-2079 FAX
josephine.ramirez@da.co.hidalgo.tx.us

The information contained in this e-mail may be 1.SUBJECT TO THE ATTORNEY-CLIENT PRIVILEGE; 2.ATTORNEY WORK PRODUCT; and/or 3.CONFIDENTIAL. It is intended only for the individual or entity designated above. Any distribution, copying, or use of or reliance upon the information contained in this e-mail by or to anyone other than the recipient designated above by the sender is unauthorized and strictly prohibited. **IF YOU HAVE RECEIVED THIS COMMUNICATION IN ERROR, PLEASE ADVISE THE SENDER BY REPLY E-MAIL TO josephine.ramirez@da.co.hidalgo.tx.us AND DELETE THE COMMUNICATION.**

From: Evangelina Garcia [mailto:evangelina.garcia@co.hidalgo.tx.us]
Sent: Monday, July 09, 2012 11:59 AM
To: josephine.ramirez@da.co.hidalgo.tx.us
Subject: FW: Maintenance Plan-CrossMatch Technologies
Importance: High

Good Morning Josie:

Hope you're doing well, listen, I'm not sure if Marty sent you the following correspondence. It has to do with HIDTA Task Force and I will be sole sourcing this item, however, it has a maintenance agreement to it. When I ran this by Marty, she told me to forward to her so that she could sent it to you for your review as to form. Since I haven't heard from Marty on this and I need to follow up, I'm just sending it directly to you for your review as to form.

Appreciate your help on this and please let me know if there's any questions.

Thank you

Vangie Y. Garcia, Contract's Manager

Evangelina Garcia

From: Marygrace Cox [marygrace.cox@CrossMatch.com]
Sent: Wednesday, June 27, 2012 3:18 PM
To: Evangelina Garcia
Subject: RE: Expiring - Cross Match Maintenance - Renewal Notice for Contract Number: 019902

Yes this is only a continuation of what you've purchased last year. As our contracts run annually.

Marygrace Cox

Sr. Sales Operations Specialist

Cross Match Technologies, Inc.
3950 RCA Boulevard, Suite 5001
Palm Beach Gardens, FL 33410
U.S.A

T +1 561 630 0468

F +1 561 828 7717

Marygrace.cox@crossmatch.com



The content of this communication and any files transmitted with it are proprietary and confidential and intended solely for internal dissemination and use within Cross Match Technologies, Inc. As a recipient you are responsible for the protection and safeguard of this information from being copied, transmitted and/or shared in violation of the above restriction.

From: Evangelina Garcia [mailto:evangelina.garcia@co.hidalgo.tx.us]
Sent: Wednesday, June 27, 2012 4:16 PM
To: Marygrace Cox
Subject: RE: Expiring - Cross Match Maintenance - Renewal Notice for Contract Number: 019902

Ms Cox:

You actually had already sent me the sole source letter already but what I just wanted to clarify with you was that if when Hidalgo County purchased this back in 2010, did it include the maintenance and warranty. In other words, is this a continuation of that maintenance plan before the current one expires next month. Please let me know.

Thanks

Vangie Y. Garcia, Contract's Manager
2802 S. Business Hwy. 281
New Administration Building
Edinburg, Texas 78539
(956) 292-7000-Extension 4856
email: evangelina.garcia@co.hidalgo.tx.us



Requisition # 00219114 [Print Requisition](#) Date Entered 07-10-2012 Account Year 2 PO # Item Total 1,620.00
 Enter Req's Only Approve Approve By Year Requisition Status Needs Approval by PURC [View](#) Acct Total 1,620.00

[Order Header](#) [Items](#) [Accounts](#) [Inquire](#) [Approval](#)

[Inquire](#) [Stipend Vendor:](#) [Approve as Vendor](#) [Allow Stipend](#) [Order:](#) [Approve](#) [Disapprove](#)
[Vendor Documents](#) [Approval Level](#) Owner [View](#)

CROSS MATCH TECHNOLOGIES INC.
 3950 RCA BLVD. SUITE 5001
 PALM BEACH GARDENS FL 33410

Type:
 Order: HIDTA
 Ship: HIDTA
 Special Inst Internal: MAINTENACE, 12 MONTHY, 10-PRINT SYSTEM (MAY 1, 2012 -
 Po Special Inst: 170
 Owner: SLOPEZ

Line No	Qty Ordered	Description	Product Class	Unit Price	Final Cost
1	12	MAINTENACE, 12 MONTHY, 10-PRINT SYSTEM (MAY 1, 2012 - APRII	93921	135.00	1,620.00

Account Number	Description	Account Balance	Amount
2-1254-412-00-270-014-0-432	HIDTA US JUSTICE-EQUIP&VEH R&M SRV	7,960.00	540.00
2-1291-412-00-270-003-1-432	HIDTA TASK FORCE-EQUIP&VEH R&M SRV	6,149.74	1,080.00

10. Purchasing Department: (Exhibit J)

- A. **AI-23187** Acceptance of proposal received from awarded vendor, Facility Solutions Group (FSG) through the County's participation/membership with TASB/Buyboard-Contract No. 290-08 for the "Purchase of 48" 15 watt LED Tube Lighting for the following County Buildings:

New Administration Building (Corner of Highway 281 & Canton Rd-Edinburg, TX)	\$134,487.60
Precinct No. 3 Mutiplex & Mansion Buildings (Mission, TX)	\$ 78,917.10
Total Amount	\$ 213,404.70

- B. **AI-23028** Acceptance and approval of Change Order No. 2 with contractor M Construction, LTD for Brenda Gay Subdivision, Pct. No. 1 reflecting an increase of \$9,730.00-addition of driveways, gates and line extensions added as submitted through project engineer, Izaguirre Engineering Group, LLC-C-CAP-09-371-11-24.
- C. **AI-23069** Acceptance and approval of revised schedule--extending completion time for Phase III to December 31, 2010 at no additional cost, as requested by RCC Consultants, awarded consultant as recommended by Chief Deputy, Anacleto Martinez for Hidalgo County Sheriff's Office- "Professional Engineering Consulting Services for the Design of a New Communications System"- Contract No. C-09-122-10-20.
- D. AI-23073** Authority to purchase law enforcement hardware/software equipment for Hidalgo County HIDTA Task Force from Cross Match Technologies, an awarded vendor through the Texas DIR-Contract No.-DIR-SDD-1024 totaling \$13,664.50.
- E. **AI-23132** Requesting authority to advertise and approval of procurement packet (draft specifications/requirements, legal notice) for: "RFP for Quality Claims Administration for Workers Compensation"-RFP No. 2010-266-10-27-otm.
- F. **AI-23095** 1. Approval to utilize the following cooperative purchasing vendors (as listed in detailed revised Exhibit(s) attached) for purchases on an "AS NEEDED BASIS" through our membership/participation with Texas Procurement and Support Services (TPASS), (DIR) Department of Information Resources, (TCPN) The Cooperative Purchasing Network, (HGAC), US Communities, (GSA) General Service Administration, (TASB-Buy Board) Texas Association of School Board, (TIPS) The Interlocal Purchasing System awarded pricing including, but not limited to, Precincts, Department, Programs, Agencies, etc. with term of authority to purchase from contract detailed herein commencing upon approval and expiring December 31, 2010.
2. Requesting authority to enter into a 36-month new Oce ColorWave 300 (LTOP) Lease to Ownership (capital) lease through our membership/participation with (TPSS) Texas Procurement & Support Services awarded vendor, Oce North America, Inc. contract #2-36010 for the County Clerk's Department through requisition #182490 for the lease payment in the amount of \$823.00/month, also requesting authority to enter a 36-month maintenance agreement for the amount of \$125.00/month, effective upon approval (0-1237-415-40-180-003-0-780/432):
- G. **AI-22766** Requesting authority to advertise and approval of procurement packet (i.e. specifications/requirements, legal notice, draft requirement agreement etc.) as attached hereto for:



AI-23073

16.0.0.

DIR-SDD-1024-Cross Match Technologies

CC CONSENT

Date: 09/28/2010

Submitted By: Vangie Garcia, PURCHASING DEPT.

Submitted For: Marty Salazar

Department: PURCHASING DEPT.

Agenda Category: Purchasing Department

Information

CAPTION

Authority to purchase law enforcement hardware/software equipment for Hidalgo County HIDTA Task Force from Cross Match Technologies,, an awarded vendor through the Texas DIR-Contract No.-DIR-SDD-1024 totaling \$13,644.50.

BACKGROUND

HIDTA Task Force will be utilizing a 2009 Grant for purchase of items plus subject to line item transfers accordingly in connection to fixed asset item categories.

Fiscal Impact

FISCAL YEAR:

ACCT. #:

FUNDS AVAILABLE Y/N?:

MATCHING FUNDS Y/N?:

BUDGETARY IMPACT:

Funding appropriation subject to line item transfer accordingly to each item in connection to fixed asset category.

Attachments

Link: [DIR Item Pricing](#)

Link: [Contract Documentation](#)

Link: [Vendor's Price Quote](#)

Form Routing/Status

Route Seq	Inbox	Approved By	Date	Status
	(Originator)	Vangie Garcia	09/21/2010 09:38 AM	CREATED
1	Purchasing Department	Marty Salazar	09/22/2010 03:06 PM	APRV
2	Budget & Management	Sylvia Solis	09/22/2010 04:09 PM	APRV
3	Sylvia Solis			NEW
4	Auditor's Office			
Form Started By: Vangie Garcia		Started On: 09/21/2010 09:38 AM		

Cross Match Technologies, Inc.
 3950 RCA Blvd Suite 5001
 Palm Beach Gardens, FL 33410
 US Headquarters: 561 622 1650
 Washington, D.C.: 703 841 6280
 German Office: + 49 (0) 3641 4297
 Canada: 418 692 3137
<http://www.crossmatch.com>

Cross Match Technologies

Sales Quotation

Quote# 2171 - 2
 Date: 21-SEP-2010
 Expires: 10-OCT-2010
 Page: 1/5

Account Manager Stein, Mike	Inside Sales	Sales Channel Texas State Contract DIR-SDD-1024
Phone 561-622-1650	Phone	Quote Status Approved
Mobile 619-244-8922	Mobile	
Fax 866-729-2313	Fax	
Email mike.stein@crossmatch.com	Email	

Customer Hidalgo County Criminal District Attorney HIDTA Task Force 9563810444 (Phone)	Bill To Hidalgo County Criminal District Attorney HIDTA Task Force 3100 South Closner Foxtrot Building Edinburg, TX 78539 United States	Ship To Attn:Chris Yates Hidalgo County Criminal District Attorney HIDTA Task Force 3100 South Closner Foxtrot Building Edinburg, TX 78539 United States 956 381-0444 (Phone) cyates@hidtaskforce.com
---	---	--

Line	CMT Part#	Qty	Unit Selling Price (USD)	Total Selling Price (USD)
1.0	925160 LSCAN Guardian,USB with LSMS on Desktop,Guardian USB Fingerprint Scanner (500ppi) with manual, Runtime License for LSCAN, Essentials driver, Autocapture and Rolls Licences, Desktop computer, Live Scan Management Software (LSMS), LSMS Manual	1	7,335.00	7,335.00
2.0	420093 Flat Panel LCD Monitor, 17",Flat Panel Monitor, non-touch, non-ruggedized Standard one year limited warranty	1	229.50	229.50
3.0	850181-122 SOFTWARE, SUBMISSION, TEXAS, SEAT LICENSE,One year limited warranty for media included.	1	450.00	450.00

Cross Match Technologies, Inc.
 3950 RCA Blvd Suite 5001
 Palm Beach Gardens, FL 33410
 US Headquarters: 561 622 1650
 Washington, D.C.: 703 841 6280
 German Office: + 49 (0) 3641 4297
 Canada: 418 692 3137
<http://www.crossmatch.com>

Cross Match Technologies

Sales Quotation

Quote# 2171 - 2
 Date: 21-SEP-2010
 Expires: 10-OCT-2010
 Page: 2/5

Line	CMT Part#	Qty	Unit Selling Price (USD)	Total Selling Price (USD)
4.0	930100-01 IMPLEMENTATION, LSMS, FIRST DAY ON-SITE, System implementation and training, first day on-site	1	2,300.00	2,300.00
5.0	900266 FBI Approved Network System Printer w/2 Universal Trays, one 150 sheet tray and one 550 sheet tray. Single Sided printing - Applicant Cards., Xerox Phaser 4510N, 2 Universal Trays (150, 550), 10 foot printer cable, Xerox next day cross-ship	1	1,080.00	1,080.00
6.0	850085 Import Demographics Interface, Import of demographic data using CMT Standard XML Tier 1 Specifications. Includes standard one year limited warranty.	1	1,350.00	1,350.00
7.0	930000-5 Implementation and Training, Subsequent Day On-site, Day subsequent to the first day of Implementation and Training	1	920.00	920.00
8.0	850391-022 SOFTWARE, LSMS CONFIGURATION, TEXAS DPS, One year limited warranty for media included.	1	0.00	0.00
Subtotal				
Selling Price			13,664.50	
Total(-USD)			13,664.50	

CROSSMATCH TECHNOLOGIES

Cross Match Technologies, Inc.
3950 RCA Blvd Suite 5001
Palm Beach Gardens, FL 33410
US Headquarters: 561 622 1650
Washington, D.C.: 703 841 6280
German Office: + 49 (0) 3641 4297
Canada: 418 692 3137
<http://www.crossmatch.com>

Cross Match Technologies

Sales Quotation

Quote# 2171 - 2
Date: 21-SEP-2010
Expires: 10-OCT-2010
Page: 3/5

STANDARD SALES TERMS AND CONDITIONS

Purchase Order # _____

UNLESS THE PARTIES HAVE EXECUTED A SEPARATE PURCHASE AGREEMENT, THE FOLLOWING TERMS AND CONDITIONS APPLY:

Prices.

Prices are valid for 90 days from the date of quotation. All sales are final; no refunds, credits or exchanges will be accepted. The price for the Products does not include sales, use, excise or similar taxes assessed at any time. All applicable taxes shall be paid by Purchaser including applicable sales tax unless a valid sales tax exemption certificate is provided.

Installation and Training.

If installation and training services are purchased, Purchaser shall appoint a contact person to coordinate the installation to be performed by CMT, its agent or contractor. The number of days allocated, and charges for installation and training are stated herein. If CMT cannot complete the installation or extensions into additional days or additional trips are caused by Purchaser's failure to complete its assigned tasks, or issues beyond the reasonable control of CMT such as, but not limited to, Purchaser network problems, Purchaser firewall problems or delays of schedule due to unavailability of Purchaser resources, Purchaser shall be responsible for additional charges required to complete the installation. Such charges shall be billable at CMT's rates in effect at the time of the service extension or additional trip. A minimum charge of \$500 will be assessed if Purchaser cancels or re-schedules on-site installation and/or training within 14 days of the originally scheduled installation. Upon completion of installation and training (including delivery of the training materials), Purchaser agrees to sign CMT's Professional Services Acceptance Form acknowledging receipt of installation and training services.

Software License.

The term "Software" refers to the Software installed on the Product and any custom software or interfaces developed by CMT for Purchaser. Purchaser will be required to accept CMT's standard license agreement prior to using any Software.

Invoicing and Payment.

CMT will invoice Purchaser for all Products (including services) within thirty (30) calendar days of shipment of the Products. Purchaser shall pay all invoices within thirty (30) calendar days after the date of CMT's invoice. A late charge of the lesser of 1.5% per month or the maximum amount permitted by law, will be added to past due accounts. All reasonable costs and expenses, including but not limited to attorneys' fees, court costs and service charges incurred by CMT in collecting payment will be an expense of and charged to Purchaser.

Terms of Order.

Notwithstanding any term or provision to the contrary contained in any Purchase Order, the terms of this Agreement shall apply to all of Purchaser's Purchase Orders. In no event shall the pre-printed terms and conditions of any Purchase Order alter, amend or supersede any provision of this Agreement. In the case of any conflict between the terms of a Purchase Order and the terms of this Agreement, the terms of this Agreement shall prevail. An omission of reference to this Agreement in a Purchase Order shall not affect the application of this Agreement to such Purchase Order.

Indemnification.

By Purchaser. Purchaser shall indemnify, defend and hold CMT and its respective directors, officers, employees and agents harmless against any and all losses, claims, damages or expenses (including reasonable attorneys' fees) arising out of or related to: (i) any personal injury to or death of any person or persons, any loss or damage of any property or any interruption of services which are caused or claimed to have been caused directly or indirectly from Purchaser's (including its employees or independent contractors) negligent operation and/or related use or misuse of the Product; (ii) use of any equipment not provided or approved for use with the Product by CMT.

By CMT. CMT hereby agrees to indemnify, defend and hold Purchaser harmless from and against any and all claims, demands, actions, costs, liabilities and losses resulting from the Software infringing a United States patent, copyright or trademark or misappropriating the trade secret of a third party provided that: (i) Purchaser promptly notifies CMT in writing of the claim; (ii) CMT has control of the defense and all related settlement negotiations, provided however that Purchaser must approve in writing any settlements before they are executed (provided, however, that Purchaser shall not unreasonably withhold its approval thereof); and (iii) Purchaser fully cooperates with CMT, at CMT's cost, in the defense or settlement of such actions. CMT's obligation under this Article is conditioned on Purchaser's agreement that if the Software, or the use or operation thereof, becomes, or in CMT's opinion is likely to become, the subject of such a claim, Purchaser will permit CMT at CMT's option and expense, either to procure the right for Purchaser to continue using the Software or to replace or modify the same so that it becomes non infringing. If neither of the foregoing alternatives is available on terms which are reasonable in CMT's reasonable judgment, then (1) Purchaser will return or destroy the Software on written request of CMT; and (2) CMT shall pay Purchaser an amount equal to the amount paid for the Software less an amount equal to the current depreciation of such Software (such depreciation amount calculated on a straight line basis over four years commencing on the Effective Date).

Limitation of Liability.

IN NO EVENT SHALL CMT BE LIABLE TO PURCHASER FOR ANY CONSEQUENTIAL OR SPECIAL DAMAGES, INCLUDING BUT NOT LIMITED TO ANY LOST PROFITS, LOST SAVINGS, BUSINESS INTERRUPTION OR OTHER INCIDENTAL DAMAGES ARISING OUT OF THE USE OR INABILITY TO USE, OR THE DELIVERY OF, OR FAILURE TO DELIVER, THE PRODUCT, EVEN IF CMT HAS BEEN ADVISED OF THE POSSIBILITY OF SUCH DAMAGES. FURTHER, THE ENTIRE LIABILITY OF CMT FOR ANY CLAIM OR CAUSE OF ACTION ARISING HEREUNDER (WHETHER IN CONTRACT, TORT, OR OTHERWISE) SHALL NOT EXCEED THE PURCHASE PRICE PAID FOR THE PRODUCT THAT IS THE SUBJECT OF SUCH CLAIM OR CAUSE OF ACTION.

Cross Match Technologies, Inc.
3950 RCA Blvd Suite 5001
Palm Beach Gardens, FL 33410
US Headquarters: 561 622 1650
Washington, D.C.: 703 841 6280
German Office: + 49 (0) 3641 4297
Canada: 418 692 3137
<http://www.crossmatch.com>

Cross Match Technologies

Sales Quotation

Quote# 2171 - 2
Date: 21-SEP-2010
Expires: 10-OCT-2010
Page: 4/5

Intellectual Property and Use Limitations.

The sale of the Product to Purchaser does not convey to Purchaser any intellectual property rights in the Product or Software, including but not limited to any copyright, patent or trademark rights (except for any license rights granted hereunder). Further, the sale of the Products confers on Purchaser no license, express or implied, by estoppel or otherwise, under any patents of CMT or others covering or relating to any other product or invention or any combination, machine, or process in which such Product might be used. All intellectual property rights in the Products and Software, any documentation therefore, and other materials supplied by CMT, are owned by CMT and are protected by United States copyright laws, other applicable copyright laws, and international treaty provisions.

Cancellation by CMT.

CMT shall have the right to cancel or hold any and/or all orders placed by Purchaser and any and/or all shipments of the Product, regardless of any prior confirmation or acceptance by CMT, if: (a) Purchaser is or becomes insolvent, (b) Purchaser makes an assignment for the benefit of creditors, or a receiver or trustee is appointed to take charge of any of Purchaser's assets; or (c) Purchaser is the subject of a bankruptcy or reorganization proceeding, whether voluntary or involuntary.

Choice of Law and Forum.

This Agreement shall be governed by and construed under the laws of the State of Florida, without reference to its conflict of laws provisions. All disputes arising hereunder shall be heard only by a Florida State court or U.S. District Court with competent jurisdiction in Palm Beach County, Florida.

Compliance with Laws.

Each party to the Agreement shall comply with all applicable laws and regulations. Purchaser will not directly or indirectly export or re-export any Products or "technical data" furnished to Purchaser under this Agreement without obtaining appropriate authorizations from the U.S. Department of Commerce or other U.S. government agency and will otherwise comply with all U.S. export control laws applicable thereto.

Entire Agreement.

These terms and conditions constitute the entire agreement between CMT and Purchaser with respect to the sale and purchase of the Products and license of the Software and shall supersede all prior agreements, understandings and representations between Purchaser and CMT, both written and oral, with respect to the subject matter hereof. No additions or modifications of this Agreement or any Exhibit hereto shall be effective unless made in writing and signed by the authorized representatives of CMT and Purchaser. CMT's delay or failure to enforce at any time any provision of this Agreement shall not constitute a waiver of CMT's right thereafter to enforce each and every provision of the Agreement. If any of the provision(s) of this Agreement is determined to be invalid, illegal, or otherwise unenforceable, the remaining provisions of the Agreement shall remain in full force and effect.

PURCHASER ACKNOWLEDGEMENT:

By: _____

Name: _____

Title: _____

Date: _____

CROSSMATCH
TECHNOLOGIES

Cross Match Technologies, Inc.
3950 RCA Blvd Suite 5001
Palm Beach Gardens, FL 33410
US Headquarters: 561 622 1650
Washington, D.C.: 703 841 6280
German Office: + 49 (0) 3641 4297
Canada: 418 692 3137
<http://www.crossmatch.com>

Cross Match Technologies

Sales Quotation

Quote# 2171 - 2
Date: 21-SEP-2010
Expires: 10-OCT-2010
Page: 5/5

Credit Card Authorization Section

Visa, MasterCard or American Express Only

By initialing this section _____, you are giving Cross Match Technologies, Inc. authorization to charge your company's credit card.

Credit Card Number _____

Expiration Date _____

SEC Code _____

Amount Authorized \$ _____

Credit Card Bill to Address _____

Credit Card State & Zip Code _____

Please note: Prices may vary depending on applicable sales tax. If sales tax is over \$500.00, you will receive a revised Credit Card Authorization form to approve.

CROSSMATCH[®]
TECHNOLOGIES

Texas DIR - Contract Price List (DIR SDD-1024)



More on the Go DIRect Program

Cross Match Technologies' DIR Contract Page

For Quotes and questions on products and services call:
 Jon Miraglio
 Cross Match Technologies, Inc.
 Inside Sales Manager
 Cross Match Technologies, Inc.
 3950 RCA Boulevard, Ste. 5001
 Palm Beach Gardens, FL 33410
 Office: (561) 639-8124
 Fax: (251) 217-9247
 Email: jon.miraglio@crossmatch.com
<http://www.crossmatch.com/>

For Ordering call:
 Sherri Lyles
 Austin Biometrics, LLC
 900 FR 520 South C101-179
 Lakeview, Texas 78734
 Office: (512) 919-4949
 Mobile: (512) 825-9908
 Fax: (866) 519-6646
 Email: sherri@austinbiometrics.com
<http://austinbiometrics.com/>

For Warranty & Maintenance service plan information, please [click here](#).

| Search | Reset

PART NUMBER	DESCRIPTION	PRICE	DETAILS
925159	LSCAN Guardian USB with LSMS (no PC)	\$6,300.00	Product Page
925160	LSCAN Guardian with LSMS on Desktop	\$7,335.00	Product Page
925161	LSCAN Guardian with LSMS on Laptop	\$7,695.00	Product Page
920107-001	Shipping Assembly, Guardian - Universal Cabinet	\$3,487.50	Product Page
900252	Guardian Travel Case, Softside	\$340.20	
900258	Guardian Travel Case, Hard Case	\$170.10	
900232	Kit, Supply-Guardian	\$360.00	
900242	Kit, Small Supply-Guardian	\$90.00	
920123	Tilt and Swivel Mounting Base for Guardian Scanner	\$270.00	
925169	Bundled System, Deluxe - Child ID w/Guardian	\$11,875.50	
930097	Enhanced warranty for 10-Print System, 12-months	\$1,242.00	
930097-12	System Maintenance for 10-Print System, 12-months	\$1,656.00	
930097-24	System Maintenance for 10-Print System, 24-months	\$3,146.40	
B10477	LSCAN 500P, 500 ppi Single Platen Palm Print Scanner (deck only)	\$10,791.00	Product Page
926183-022	500P W/LSMS, Texas DPS	\$11,880.00	
926184-022	500P W/LSMS, Laptop, Texas DPS	\$13,499.10	
926185-022	500P W/LSMS, Desktop PC, Texas DPS	\$13,050.00	
900074	Ten-Print Workstation Desktop system, Can be used with any 10-print livescan unit.	\$2,025.00	
900084	Ten-Print Workstation Laptop system, Can be used with any 10-print livescan unit.	\$2,655.00	
920107-005	LSCAN 500P - Universal Cabinet	\$3,487.50	
900280	LSCAN 500P Supply Kit, Silicone Membrane, 5 pieces	\$135.00	
900283	Travel Case, LSCAN 500P only, no wheels	\$247.50	
900299	Travel Case, LSCAN 500P and laptop, wheeled	\$517.50	
930098	Warranty, Enhanced, Palm Print Systems	\$2,484.00	
930098-12	System Maintenance, Palm Scanner, 12-months	\$3,312.00	
930098-24	System Maintenance, Palm Scanner, 24-months	\$6,292.80	
925142	Bundled Ass'y, Guardian R Jumpkit with Finger, Face, and Iris, MOBS Software	\$19,800.00	Product Page
920027-10	MV-5 Mobile Verifier with Extract & Match License	\$1,345.50	Product Page
SMC-800M	SMC-800M Be.U Mobile Handheld Device (basic model with fingerprint sensor and contact/contactless card readers)	\$2,092.50	Product Page
920081	Verifier 310 USB LC2.0	\$504.00	Product Page
920075	Verifier 300 USB LC2.0	\$414.00	Product Page
900226	Kit, Supply-Verifier 310	\$153.90	
900225	Kit, Supply-Verifier 300	\$135.00	
B96500	FaceSnap Recorder BASE Recorder System (appliance) with integrated computer	\$7,200.00	Product Page
B96501	"FaceSnap Recorder ""Law Enforcement"" LEF Recorder system (appliance) with integrated computer"	\$14,850.00	Product Page
B96502	FaceSnap Server for FaceSnap Recorder LEF	\$4,500.00	Product Page
B96504	FaceCheck Server XC Face Check system (appliance) with integrated computer	\$1,287.00	Product Page
B96505	FaceCam Server Iqeye (for camera Iqeye 511 and 700 series)	\$1,287.00	Product Page

B96515	FaceSnap ISOSHOT (Enrollment Tool)	\$1,345.50	Product Page
900266	FBI Approved Network System Printer w/2 Universal Trays, one 150 sheet tray and one 550 sheet tray. Single Sided printing - Applicant Cards.	\$1,080.00	
420360	Duplexer for Xerox Phaser 4510 Printer	\$360.00	
900267	FBI Approved Network System Printer w/3 Universal Trays, one 150 sheet tray and two 550 sheet trays. Duplex printing - Criminal Cards.	\$1,755.00	
420093	"Flat Panel LCD Monitor, 17"	\$229.50	
420030-10	"17" Flat Panel Touch Screen"	\$742.50	
900139	Camera Kit - Image capture Camera for Live scan system (USB 2.0)	\$1,282.50	
920121	I SCAN2. Iris scanner	\$2,250.00	Product Page
930084-12	Xerox 12 month Maintenance (post-warranty)	\$134.32	
930084-24	Xerox Years 24 month Maintenance (post-warranty)	\$231.84	
850181-022	Software, Submission, Texas	\$1,350.00	
850181-122	Software, Submission, Texas, Seat License	\$450.00	
850085	Import Demographics Interface**	\$1,350.00	
850085-001	Import Demographics Interface-Seat License	\$450.00	
850106	Export Demographics Interface**	\$4,500.00	
850106-101	Export Demographics Interface-Seat License	\$450.00	
850040	Import/Export Demographics Interface**	\$6,750.00	
850040-001	Import / Export Demographics Interface-Seat License	\$450.00	
852007-0025	Import Demographics To Texas Dps Software System	\$1,350.00	
850026	Software Only, Live Scan Management System(LSMS)	\$1,350.00	
855009	MOBS Software	\$1,620.00	Product Page
850371	Software, Mugshot Best Practices - LSMS Optional Component	\$1,080.00	
932000	Custom Software Development (rate per hour)	\$180.00	Product Page
930100-01	Implementation and Training, First Day	\$2,300.00	Product Page
930000-5	Implementation and Training, Subsequent Day On-site	\$920.00	Product Page

**Please note that this pricing is for standard, Tier 1, XML interfaces only; all others require a custom quote.

Notes:

1. Purchases above \$500,000 are subject to additional discount to customer based on project scope.
2. Cross Match offers it's Texas DIR customers a 1% prompt payment is received within 10 days of receipt of invoice.
3. Prices include Standard Ground Shipping. Expedited shipping is available on request, please contact Cross Match for more information.
4. All sales are final; no refunds, credits or exchanges will be accepted.

Search bar with 'All' dropdown, 'Enter Search Criteria' input, and 'Go' button.

- Home Co-op Contracts Texas.gov Security DCS CTS IT Leadership About DIR Contact Us



< Return to search results

Cross Match Technologies, Inc.

URL Vendor Website
Vendor ID 1650637546400
HUB Type Non HUB

DIR Contract Number DIR-SDD-1024
Contract Term End Date 7/17/2011
Contract Exp Date 7/17/2013

Cross Match Technologies, Inc.

Contact Michael Stein
Phone (866) 526-6223
Fax (251) 217-9247

DIR
Contact Sergio Upton
Phone (512) 936-3101
Fax (512) 475-4759

How to Order

- 1. For product and pricing information, visit the Cross Match Technologies, Inc. website or contact Michael Stein at (866) 526-6223.
2. Generate a purchase order, made payable to Cross Match Technologies, Inc.. You must reference the DIR Contract Number DIR-SDD-1024 on your purchase order.
3. E-mail or Fax your purchase order and quote form to your designated vendor sales representative.

Contract Overview

Get Adobe Reader

Contract: DIR-SDD-1024

Standard Terms and Conditions PDF - 148 KB

This appendix contains the standard DIR Terms and Conditions for the contract as of the date identified. Any initial exceptions to these Terms will be contained in the original contract. All subsequent changes or updates to the Terms and Conditions will be reflected in contract amendments.

HUB Subcontracting Plan (HSP) PDF - 89 KB | Updated 07/26/2010

The purpose of the HUB Program is to promote full and equal business opportunities for all businesses in State contracting in accordance with the goals specified in the State of Texas Disparity Study. The HSP identifies all authorized resellers and/or all subcontractors performing services.

Pricing PDF - 43 KB | Updated 07/26/2010

Pricing for available products and/or services under this contract are limited to those identified in the appendix.

Available Brands

Cross Match Technologies

Available Products & Services

Emergency Preparedness Hardware and Related Services

Additional Contract Information

Appendix D, Sales and Installation Quote Form (77 KB)
Amendment 1 (118 KB)

< No thanks, return to search

Reseller Vendor Contacts

There are no resellers associated with this contract

- Capitol Complex Directory
Statewide Search
Sponsored Sites
Planned Procurement Schedule

- Document Library
SAO Fraud Reporting
Homeland Security
Sunset Review Notification

- FAQs
Site Policies
Site Map
Job Postings

Dept. of Information Resources
300 W. 15th St. Ste. 1300
Austin, TX 78701 MAP
512.475.4700

STATE OF TEXAS
DEPARTMENT OF INFORMATION RESOURCES
CONTRACT FOR PRODUCTS AND RELATED SERVICES

Cross Match Technologies, Inc.

1. Introduction

A. Parties

This Contract for products and related services is entered into between the State of Texas, acting by and through the Department of Information Resources (hereinafter "DIR") with its principal place of business at 300 West 15th Street, Suite 1300, Austin, Texas 78701, and Cross Match Technologies, Inc. (hereinafter "Vendor"), with its principal place of business at 3950 RCA Boulevard, Suite 5001, Palm Beach Gardens, Florida 33410.

B. Compliance with Procurement Laws

This Contract is the result of compliance with applicable procurement laws of the State of Texas. DIR issued a solicitation on the Comptroller of Public Accounts' Electronic State Business Daily, Request for Offer (RFO) DIR-SDD-TMP-119, on August 28, 2008, for Emergency Preparedness Hardware and Related Services. Upon execution of this Contract, a notice of award for RFO DIR-SDD-TMP-119 shall be posted by DIR on the Electronic State Business Daily.

C. Order of Precedence

This Contract; Appendix A, Standard Terms and Conditions For Products and Related Services Contracts; Appendix B, Vendor's Historically Underutilized Businesses Subcontracting Plan; Appendix C, Pricing Index; Appendix D, Cross Match Sales and Installation Quote Form; Exhibit 1, Vendor's Response to RFO DIR-SDD-TMP-119, including all addenda; and Exhibit 2, RFO DIR-SDD-TMP-119, including all addenda; are incorporated by reference and constitute the entire agreement between DIR and Vendor. In the event of a conflict between the documents listed in this paragraph, the controlling document shall be this Contract, then Appendix A, then Appendix B, then Appendix C, then Appendix D, then Exhibit 1, and finally Exhibit 2. In the event and to the extent any provisions contained in multiple documents address the same or substantially the same subject matter but do not actually conflict, the more recent provisions shall be deemed to have superseded earlier provisions.

2. Term of Contract

The term of this Contract shall be one (1) year commencing on the last date of approval by DIR and Vendor. Prior to expiration of the original term, DIR and Vendor may extend the Contract, upon mutual agreement, for up to three (3) optional one-year terms.

3. Product and Service Offerings**A. Products**

Products available under this Contract are limited to emergency preparedness hardware as specified in Appendix C, Pricing Index. Vendor may incorporate changes to their product offering; however, any changes must be within the scope of products awarded based on the posting described in Section 1.B above. Vendor may not add a manufacturer's product line which was not included in the Vendor's response to the solicitation described in Section 1.B above.

B. Services

Services available under this Contract are limited to those services specifically related to emergency preparedness hardware and specified in Appendix C, Pricing Index. Vendor may incorporate changes to their service offering; however, any changes must be within the scope of services awarded based on the posting described in Section 1.B above.

4. Pricing**A. Manufacturer's Suggested Retail Price (MSRP)**

MSRP is defined as the product sales price suggested by the manufacturer or publisher of a product.

B. Customer Discount

The minimum Customer discount for all products and services will be the percentage off MSRP as specified in Appendix C, Pricing index.

C. Customer Price

1) The price to the Customer shall be calculated as follows:

$$\text{Customer Price} = \text{MSRP} - \text{Customer Discount}$$

2) Customers purchasing products and services under this Contract may negotiate more advantageous pricing or participate in special promotional offers. In such event, a copy of such better offerings shall be furnished to DIR upon request.

3) If pricing for products or services available under this Contract are provided at a lower price to: (i) an eligible Customer who is not purchasing those products or services under this Contract or (ii) any other entity or consortia authorized by Texas law to sell said products and services to eligible Customers, then the available Customer Price in this Contract shall be adjusted to that lower price. This Contract shall be amended within ten (10) business days to reflect the lower price.

D. DIR Administrative Fee

The administrative fee specified in Section 5 below shall not be broken out as a separate line item when pricing or invoice is provided to Customer.

E. Shipping and Handling Fees

The price to the Customer under this Contract shall include all shipping and handling fees. Shipments will be Free On Board Customer's destination. No additional fees shall be charged to the Customer for standard shipping and handling. If the Customer requests expedited delivery, Customer will be responsible for any charges for expedited delivery.

F. Tax-Exempt

As per Section 151.309, Texas Tax Code, Customers under this Contract are exempt from the assessment of State sales, use and excise taxes. Further, Customers under this Contract are exempt from Federal Excise Taxes, 26 United States Code Sections 4253(i) and (j).

G. Travel Expense Reimbursement

Pricing for services provided under this Contract are exclusive of any travel expenses that may be incurred in the performance of those services. Travel expense reimbursement may include personal vehicle mileage or commercial coach transportation, hotel accommodations, parking and meals; provided, however, the amount of reimbursement by Customers shall not exceed the amounts authorized by the current State Travel Regulations. Travel time may not be included as part of the amounts payable by Customer for any services rendered under this Contract. The DIR administrative fee specified in Section 5 below is not applicable to travel expense reimbursement. Anticipated travel expenses must be pre-approved in writing by Customer.

H. Changes to Prices

Vendor may change the price of any product or service at any time, based upon changes to the MSRP, but discount levels shall remain consistent with the discount levels specified in this Contract. Price decreases shall take effect automatically during the term of this Contract and shall be passed onto the Customer immediately.

5. DIR Administrative Fee

A) The administrative fee to be paid by the Vendor to DIR based on the dollar value of all sales to Customers pursuant to this Contract is two percent (2%). Payment will be calculated for all sales, net of returns and credits. For example, the administrative fee for sales totaling \$100,000 shall be \$2,000.

B) All prices quoted to Customers shall include the administrative fee. DIR reserves the right to change this fee upwards or downwards during the term of this Contract, upon written notice to Vendor. Any change in the administrative fee shall be incorporated in the price to the Customer.

6. Notification

All notices under this Contract shall be sent to a party at the respective address indicated below.

If sent to the State:

Sherry Parks, Director
Contracting & Procurement Services
Department of Information Resources
300 West 15th Street, Suite 1300
Austin, Texas 78701
Phone: (512) 475-4700
Facsimile: (512) 475-4759
Email: sherry.parks@dir.state.tx.us

If sent to the Vendor:

Kristi J. Romer
Senior Account Manager
Cross Match Technologies, Inc.
116 Wagonwheel Court
Marlton, NJ 08053
Phone: (866) 260-2763
Facsimile: (251) 217-9247
Email: Kristie.romer@crossmatch.com

7. Software License Agreements

A. Shrink/Click-wrap License Agreement

Regardless of any other provision or other license terms which may be issued by Vendor after the effective date of this Contract, and irrespective of whether any such provisions have been proposed prior to or after the issuance of a Purchase Order for products licensed under this Contract, or the fact that such other agreement may be affixed to or accompany software upon delivery (shrink-wrap), the terms and conditions set forth in this Contract shall supersede and govern the license terms between Customers and Vendor. **It is the Customer's responsibility to read the Shrink/Click-wrap License agreement and determine if the Customer accepts the license terms. If the Customer does not agree with the license terms, Customer shall be responsible for negotiating with the reseller to obtain changes in the Shrink/Click-wrap License Agreement language from the software publisher.**

8. Intellectual Property Matters

A. Definitions

1. "Work Product" means any and all deliverables produced by Vendor for Customer under a Statement of Work issued pursuant to this Contract, including any and all tangible or intangible items or things that have been or will be prepared, created, developed, invented or conceived at any time following the effective date of the Contract, including but not limited to any (i) works of authorship (such as manuals, instructions, printed material, graphics, artwork, images, illustrations, photographs, computer programs, computer software, scripts, object code, source code or other programming code, HTML code, flow charts, notes, outlines, lists, compilations, manuscripts, writings, pictorial materials, schematics, formulae, processes, algorithms, data, information, multimedia files, text web pages or web sites, other written or machine readable expression of such works fixed in any tangible media, and all other copyrightable works), (ii) trademarks, service marks, trade dress, trade names, logos, or other indicia of source or origin, (iii) ideas, designs, concepts, personality rights, methods, processes, techniques, apparatuses, inventions, formulas, discoveries, or improvements, including any patents, trade secrets and know-how, (iv) domain names, (v) any copies, and similar or derivative works to any of the foregoing, (vi) all documentation and materials related to any of the foregoing, (vii) all other goods, services or deliverables to be provided to Customer under the Contract or a Statement of Work, and (viii) all Intellectual Property Rights in any of the foregoing, and which are or were created, prepared, developed, invented or conceived for the use or benefit of Customer in connection with this Contract or a Statement of Work, or with funds appropriated by or for Customer or Customer's benefit: (a) by any Vendor personnel or Customer personnel, or (b) any Customer personnel who then became personnel to Vendor or any of its affiliates or subcontractors, where, although creation or reduction-to-practice is completed while the person is affiliated with Vendor or its personnel, any portion of same was created, invented or conceived by such person while affiliated with Customer.

2. "Intellectual Property Rights" means the worldwide legal rights or interests evidenced by or embodied in: (i) any idea, design, concept, personality right, method, process, technique, apparatus, invention, discovery, or improvement, including any patents, trade secrets, and know-how; (ii) any work of authorship, including any copyrights, moral rights or neighboring rights; (iii) any trademark, service mark, trade dress, trade name, or other indicia of source or origin; (iv) domain name registrations; and (v) any other proprietary or similar rights. The Intellectual Property Rights of a party include all worldwide legal rights or interests that the party may have acquired by assignment or license with the right to grant sublicenses.

3. "Statement of Work" means a document signed by Customer and Vendor describing a specific set of activities and/or deliverables, which may include Work

Vendor Contract No. _____

Product and Intellectual Property Rights, that Vendor is to provide Customer, issued pursuant to the Contract.

4. "Third Party IP" means the Intellectual Property Rights of any third party not a party to this Contract, and which is not directly or indirectly providing any goods or services to Customer under this Contract.

5. "Vendor IP" shall mean all tangible or intangible items or things, including the Intellectual Property Rights therein, created or developed by Vendor (a) prior to providing any Services or Work Product to Customer and prior to receiving any documents, materials, information or funding from or on behalf of Customer relating to the Services or Work Product, or (b) after the Effective Date of the Contract if such tangible or intangible items or things were independently developed by Vendor outside Vendor's provision of Services or Work Product for Customer hereunder and were not created, prepared, developed, invented or conceived by any Customer personnel who then became personnel to Vendor or any of its affiliates or subcontractors, where, although creation or reduction-to-practice is completed while the person is affiliated with Vendor or its personnel, any portion of same was created, invented or conceived by such person while affiliated with Customer.

B. Ownership.

As between Vendor and Customer, the Work Product and Intellectual Property Rights therein are and shall be owned exclusively by Customer, and not Vendor. Vendor specifically agrees that the Work Product shall be considered "works made for hire" and that the Work Product shall, upon creation, be owned exclusively by Customer. To the extent that the Work Product, under applicable law, may not be considered works made for hire, Vendor hereby agrees that the Contract effectively transfers, grants, conveys, assigns, and relinquishes exclusively to Customer all right, title and interest in and to all ownership rights in the Work Product, and all Intellectual Property Rights in the Work Product, without the necessity of any further consideration, and Customer shall be entitled to obtain and hold in its own name all Intellectual Property Rights in and to the Work Product. Vendor acknowledges that Vendor and Customer do not intend Vendor to be a joint author of the Work Product within the meaning of the Copyright Act of 1976. Customer shall have access, during normal business hours and upon reasonable prior notice to Vendor, to all Vendor materials, premises and computer files containing the Work Product. Vendor and Customer, as appropriate, will cooperate with one another and execute such other documents as may be reasonably appropriate to achieve the objectives herein. No license or other right is granted hereunder to any Third Party IP, except as may be incorporated in the Work Product by Vendor.

C. Further Actions.

Vendor, upon request and without further consideration, shall perform any acts that may be deemed reasonably necessary or desirable by Customer to evidence more fully the transfer of ownership and/or registration of all Intellectual Property Rights in all Work Product to Customer to the fullest extent possible, including but not limited to the execution, acknowledgement and delivery of such further documents in a form

Vendor Contract No. _____

determined by Customer. In the event Customer shall be unable to obtain Vendor's signature due to the dissolution of Vendor or Vendor's unreasonable failure to respond to Customer's repeated requests for such signature on any document reasonably necessary for any purpose set forth in the foregoing sentence, Vendor hereby irrevocably designates and appoints Customer and its duly authorized officers and agents as Vendor's agent and Vendor's attorney-in-fact to act for and in Vendor's behalf and stead to execute and file any such document and to do all other lawfully permitted acts to further any such purpose with the same force and effect as if executed and delivered by Vendor, provided however that no such grant of right to Customer is applicable if Vendor fails to execute any document due to a good faith dispute by Vendor with respect to such document. It is understood that such power is coupled with an interest and is therefore irrevocable. Customer shall have the full and sole power to prosecute such applications and to take all other action concerning the Work Product, and Vendor shall cooperate, at Customer's sole expense, in the preparation and prosecution of all such applications and in any legal actions and proceedings concerning the Work Product.

D. Waiver of Moral Rights.

Vendor hereby irrevocably and forever waives, and agrees never to assert, any Moral Rights in or to the Work Product which Vendor may now have or which may accrue to Vendor's benefit under U.S. or foreign copyright or other laws and any and all other residual rights and benefits which arise under any other applicable law now in force or hereafter enacted. Vendor acknowledges the receipt of equitable compensation for its assignment and waiver of such Moral Rights. The term "Moral Rights" shall mean any and all rights of paternity or integrity of the Work Product and the right to object to any modification, translation or use of the Work Product, and any similar rights existing under the judicial or statutory law of any country in the world or under any treaty, regardless of whether or not such right is denominated or referred to as a moral right.

E. Confidentiality.

All documents, information and materials forwarded to Vendor by Customer for use in and preparation of the Work Product, shall be deemed the confidential information of Customer, and subject to the license granted by Customer to Vendor under sub-paragraph h hereunder, Vendor shall not use, disclose, or permit any person to use or obtain the Work Product, or any portion thereof, in any manner without the prior written approval of Customer.

F. Injunctive Relief.

The Contract is intended to protect Customer's proprietary rights pertaining to the Work Product, and the Intellectual Property Rights therein, and any misuse of such rights would cause substantial and irreparable harm to Customer's business. Therefore, Vendor acknowledges and stipulates that a court of competent jurisdiction may immediately enjoin any material breach of the intellectual property, use, and confidentiality provisions of this Contract, upon a request by Customer, without requiring proof of irreparable injury as same should be presumed.

G. Return of Materials Pertaining to Work Product.

Upon the request of Customer, but in any event upon termination or expiration of this Contract or a Statement of Work, Vendor shall surrender to Customer all documents and things pertaining to the Work Product, including but not limited to drafts, memoranda, notes, records, drawings, manuals, computer software, reports, data, and all other documents or materials (and copies of same) generated or developed by Vendor or furnished by Customer to Vendor, including all materials embodying the Work Product, any Customer confidential information, or Intellectual Property Rights in such Work Product, regardless of whether complete or incomplete. This section is intended to apply to all Work Product as well as to all documents and things furnished to Vendor by Customer or by anyone else that pertains to the Work Product.

H. Vendor License to Use.

Customer hereby grants to Vendor a non-transferable, non-exclusive, royalty-free, fully paid-up license to use any Work Product solely as necessary to provide the Services to Customer. Except as provided in this Section, neither Vendor nor any Subcontractor shall have the right to use the Work Product in connection with the provision of services to its other customers without the prior written consent of Customer, which consent may be withheld in Customer's sole discretion.

I. Third-Party Underlying and Derivative Works.

To the extent that any Vendor IP or Third Party IP are embodied or reflected in the Work Product, or are necessary to provide the Services, Vendor hereby grants to the Customer, or shall obtain from the applicable third party for Customer's benefit, the irrevocable, perpetual, non-exclusive, worldwide, royalty-free right and license, for Customer's internal business purposes only, to (i) use, execute, reproduce, display, perform, distribute copies of, and prepare derivative works based upon such Vendor IP or Third Party IP and any derivative works thereof embodied in or delivered to Customer in conjunction with the Work Product, and (ii) authorize others to do any or all of the foregoing. Vendor agrees to notify Customer on delivery of the Work Product or Services if such materials include any Third Party IP. On request, Vendor shall provide Customer with documentation indicating a third party's written approval for Vendor to use any Third Party IP that may be embodied or reflected in the Work Product.

J. Agreement with Subcontracts.

Vendor agrees that it shall have written agreement(s) that are consistent with the provisions hereof related to Work Product and Intellectual Property Rights with any employees, agents, consultants, contractors or subcontractors providing Services or Work Product pursuant to the Contract, prior to their providing such Services or Work Product, and that it shall maintain such written agreements at all times during performance of this Contract, which are sufficient to support all performance and grants of rights by Vendor. Copies of such agreements shall be provided to the Customer promptly upon request.

K. License to Customer.

Vendor grants to Customer, a perpetual, irrevocable, royalty free license, solely for the Customer's internal business purposes, to use, copy, modify, display, perform (by any means), transmit and prepare derivative works of any Vendor IP embodied in or delivered to Customer in conjunction with the Work Product. The foregoing license includes the right to sublicense third parties, solely for the purpose of engaging such third parties to assist or carryout Customer's internal business use of the Work Product. Except for the preceding license, all rights in Vendor IP remain in Vendor.

L. Vendor Development Rights.

To the extent not inconsistent with Customer's rights in the Work Product or as set forth herein, nothing in this Contract shall preclude Vendor from developing for itself, or for others, materials which are competitive with those produced as a result of the Services provided hereunder, provided that no Work Product is utilized, and no Intellectual Property Rights of Customer therein are infringed by such competitive materials. To the extent that Vendor wishes to use the Work Product, or acquire licensed rights in certain Intellectual Property Rights of Customer therein in order to offer competitive goods or services to third parties, Vendor and Customer agree to negotiate in good faith regarding an appropriate license and royalty agreement to allow for such.

9. Authorized Exceptions to Appendix A, Standard Terms and Conditions for Product and Related Services Contracts.

No exceptions.

(Remainder of this page intentionally left blank)

This Contract is executed to be effective as of the date of last signature.

Cross Match Technologies, Inc.

Authorized By: Signature on File

Name: Martin K. Wienbaum

Title: CFO

Date: 7-09-09

**The State of Texas, acting by and through the
Department of Information Resources**

Authorized By: Signature on File

Name: Cindy Reed

Title: Deputy Executive Director
Operations & Statewide Technology Sourcing

Date: 7-17-09

Legal: 7-16-09

AI-33207

Purchasing Department 18. E. 1.

CC REGULAR

Meeting Date: 07/24/2012

Department Head: Agapito Vargas Submitted By: Yvette Islas, PURCHASING DEPT.

Department: PURCHASING DEPT.

Information

CAPTION

Requesting approval to reject all bids submitted and authority to re-advertise the following BCAP Pct No. 1 projects (cc previously approved on 04-10-12) as bids received were higher than the budgeted amount for each project.

- a. Road & Drainage Construction for El Mesquite Subdivision;
- b. Road & Drainage Construction for North Capisallo Subdivision.

BACKGROUND

Fiscal Impact

FISCAL YEAR: 2012

ACCT. #: 2-1312-431-00-121-244-1-731 & 733

FUNDS AVAILABLE Y/N?: Y **MATCHING FUNDS Y/N?:**

BUDGETARY IMPACT:

Funds available as of 7-13-12

FISCAL YEAR: 2012

ACCT. #: 2-1312-431-00-121-495-1-731 & 733

FUNDS AVAILABLE Y/N?: Y **MATCHING FUNDS Y/N?:**

BUDGETARY IMPACT:

Funds available as of 7-13-12.

Attachments

bid docs el mesquite

plans el mesquite

bid docs n capisallo

plans n capisallo

Form Review

Inbox	Reviewed By	Date
Purchasing Department	Marty Salazar	07/13/2012 11:02 AM
Budget & Management	Merlen P. Munoz	07/13/2012 11:42 AM
Ivan Cantu	Ivan Cantu	07/13/2012 02:52 PM
Auditor's Office	Angela Garcia	07/20/2012 04:55 PM
Form Started By: Yvette Islas		Started On: 07/11/2012 03:27 PM
	Final Approval Date: 07/20/2012	

HIDALGO COUNTY



**BID PROPOSAL
FOR**

**CAP-12-113-07-03-YSI
“ROAD & DRAINAGE CONSTRUCTION FOR
EL MESQUITE SUBDIVISION”**

IN ACCORDANCE WITH BORDER COLONIA ACCESS PROGRAM ROUND III

IN

HIDALGO COUNTY PRECINCT NO. 1

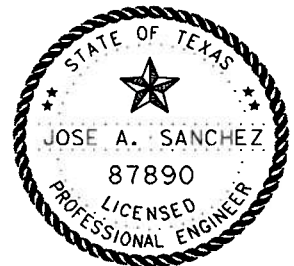

[Handwritten Signature]
06/18/2012

Prepared by:



TEDSI
TBPE Firm No. 1640

TEDSI INFRASTRUCTURE GROUP

Consulting Engineers

1201 East Expressway 83 ♦ Mission, Texas 78572

Tel: (956) 424-7898

Fax: (956) 424-7022

TABLE OF CONTENTS
CAP-12-113-07-03-YSI
ROAD & DRAINAGE CONSTRUCTION FOR
EL MESQUITE SUBDIVISION

- 1) [Advertisement and Invitation for Bids](#)
- 2) [Hidalgo County Legal Notice](#)
- 3) [Bidder Acknowledgement](#)
- 4) [Information for Bidders](#)
- 5) [Bid Form](#)
- 6) Bid Bond
- 7) [Draft Contract](#)
- 8) [Non Collusion](#)
- 9) Payment Bond
- 10) Performance Bond

- 11) **Exhibit C**
 - a. [Insurance](#)

- 12) [General Conditions of the Agreement](#)
- 13) [Title 29 Labor](#)
- 14) [Standard General Condition of Construction Contract](#)
- 15) [Supplemental General Condition](#)

- 16) **Exhibit A** [General Notes & Standard Specifications](#)
 - a. [Technical Specifications](#)
 - b. Hidalgo County Specifications as per 340
 - c. [Government Specifications & Special Provisions](#)

- 17) **Exhibit B**
 - a. [Debarment](#)
 - b. [W-9](#)
 - c. [Bidder/Vendor Application](#)
 - d. [Conflict of Interest Memo](#)
 - e. [Conflict of Interest Form](#)
 - f. [Sales Tax and Local Sales Tax Certificate](#)

- 18) **Exhibit D Border Wage Rates**
 - a. [Government code Ch 2258](#)
 - b. [Prevailing Wage Rate](#)
 - c. [Davis Bacon](#)

- 19) **Exhibit E**
 - a. [Checklist](#)
 - b. [Change Order](#)
 - c. [Payment of Application](#)
 - d. [Estimate Quantity Update](#)
 - e. [Schedule of Values](#)
 - f. [Contract Time Statement](#)

- g.** [Colonia Testing Requirement](#)
- h.** [List of Suppliers](#)
- i.** [Partial Release of Lien](#)
- j.** [Contractor's Affidavit of Payment of Debts and Claims](#)
- k.** [Prevailing Wage Rates Certificate Statement](#)
- l.** [Certificate of Construction Completion](#)
- m.** [Contractor's Affidavit of Release of Liens](#)

20) [Construction Identification Sign](#)

REQUEST FOR BIDS

(Colonia Access Program Project)

TO SUPPLY HIDALGO COUNTY PRECINCT NO 1 with sealed bids on:

CAP-12-113-07-03-YSI "ROAD & DRAINAGE CONSTRUCTION FOR EL MESQUITE SUBDIVISION" & CAP-12-114-07-03-YSI "ROAD & DRAINAGE CONSTRUCTION FOR NORTH CAPISALLO SUBDIVISION"

A **BIDDER'S BOND** from a reliable surety company licensed to operate in the State of Texas or certified Cashier's Check, payable without recourse to the County of Hidalgo, for the amount of not less than **5%** of the total bid shall accompany the bid as guaranty that, if awarded the contract, the bidder will enter into a contract with the County of Hidalgo. Payment and Performance Bonds shall be executed except in the event into a single payment contract with the County of Hidalgo in lieu of a Performance Bond. In the event the total amount bid is \$25,000 or less, the successful contract has the option to enter into a single payment contract with the County of Hidalgo in lieu of a Payment and Performance Bond.

Bid Packets may be obtained from the office of **TEDSI INFRASTRUCTURE GROUP, INC. 1201 E. EXPRESSWAY 83, Mission, Texas 78572**, Phone No **(956) 424-7898** for the amount of **\$100.00 each**. General and/or Prime Contractors submitting bids and/or proposals to the County of Hidalgo shall be **non-refundable**.

PRE-BID CONFERENCE is scheduled for **WEDNESDAY, June 27, 2012 at 2:30 PM** at **HIDALGO COUNTY NEW ADMINISTRATION BUILDING - PURCHASING DEPARTMENT 2812 S Business Hwy 281, EDINBURG, TEXAS 78539**.

UPON SUBMITTING SEALED BID(S), bidders are required to properly identify (handwritten, typed or printed) sealed envelope and/or packet as follows: Bidder's name and address on the upper left hand corner of the sealed envelope(s) and/or package(s) and Bid No(s):

CAP-12-113-07-03-YSI "ROAD & DRAINAGE CONSTRUCTION FOR EL MESQUITE SUBDIVISION" &/OR CAP-12-114-07-03-YSI "ROAD & DRAINAGE CONSTRUCTION FOR NORTH CAPISALLO SUBDIVISION" on the lower left hand corner of sealed envelope/and or packet. **OVERNIGHT MAIL MUST ALSO BE PROPERLY LABELED ON THE OUTSIDE OF EXPRESS ENVELOPE OR PACKAGE.**

The sealed bid must contain one (1) original and three (3) copies of bid and must be clearly identified and addressed for delivery to:

**Martha L. Salazar, CPPB, Hidalgo County Purchasing Agent
Hidalgo County Purchasing Department**

US Postal Mail/Courier Address

**Hidalgo County New Administration Building
2812 S. Business Hwy 281
Edinburg, Texas 78539**

Physical Location:

**Hidalgo County New Administration Building
2802 S. Business Hwy. 281
(Southeast of Canton Rd & Business 281)
Edinburg, Texas 78539**

Sealed bids will be accepted until **9:30 a.m. on Tuesday, July 03, 2012** at which time they will be opened in the Hidalgo County Purchasing Department Conference Room at **Physical Location: 2802 S. Business Hwy 281, Hidalgo County New Administration Building, Edinburg, Texas 78539**. **NO FACSIMILES OR LATE ARRIVALS WILL BE ACCEPTED. ANY BID RECEIVED AFTER THAT TIME WILL NOT BE OPENED AND WILL BE RETURNED**

The project is to be funded with Border Colonia Access Program funds through Proposition II Funding from the Texas Department of Transportation (Tx.D.O.T.).

Attention is called to the fact that not less than, the federally determined prevailing (**Davis-Bacon and Related Acts**) wage rate, as issued and contained in the contract documents, must be paid on this project. In addition, the successful bidder must ensure that employees and applicants for employment are not discriminated against because of race, color, religion, sex, age, disability or national origin.

BIDS MAY BE HELD by the County of Hidalgo for a period not to exceed ninety (90) days from the date of the opening of bids for the purpose of reviewing the bids and investigating the qualifications of bidders, prior to awarding of the contract.

THE COUNTY reserves the right to refuse and reject any/all bids and to waive any/all formalities or technicalities, or to accept the bids considered the best and most advantageous to the County.

BY ORDER OF THE COMMISSIONERS COURT OF HIDALGO COUNTY, TEXAS on this the **10TH** day of **APRIL, 2012**.

**MARTHA L. SALAZAR, CPPB
HIDALGO COUNTY PURCHASING AGENT**

REPORT ROAD HAZARDS @ 1-866-HCR-SAFE OR 1-866-427-7233

LEGAL NOTICE

BID NO: CAP-12-113-07-03-YSI

1. Sealed bids will be received for **“HIDALGO COUNTY - ROAD & DRAINAGE CONSTRUCTION FOR EL MESQUITE SUBDIVISION”** in accordance with the specifications attached as Exhibit "A" hereto. Bids should address all specifications set forth. Bidders may suggest substitutions of features which they feel would be in the best interest of Hidalgo County ("County"). Strong rationale must be presented for any deviation from the specifications. Hidalgo County reserves the right to reject the deviation and its effect on the overall bid.
2. One (1) original and Three (3) copies of all bids are required with the bidders name and return address clearly typed/printed on upper left hand corner and the proper notation clearly typed/printed on the lower left hand corner of the envelope and/or package: **BID NO: CAP-12-113-07-03-YSI “ROAD & DRAINAGE CONSTRUCTION FOR EL MESQUITE SUBDIVISION”** and in County's Purchasing Department, 2802 S. Business Hwy. 281, Hidalgo County New Administration Building, Edinburg, Texas, 78539 **on or before 9:30 a.m., TUESDAY, JULY 03, 2012.** NO FACSIMILES OR LATE ARRIVALS WILL BE ACCEPTED. ANY RFB RECEIVED AFTER THAT TIME WILL NOT BE OPENED AND WILL BE RETURNED. OVERNIGHT MAIL MUST ALSO BE PROPERLY LABELED ON THE OUTSIDE OF EXPRESS ENVELOPE OR PACKAGE WITH REFERENCE TO: **BID NO: CAP-12-113-07-03-YSI “ROAD & DRAINAGE CONSTRUCTION FOR EL MESQUITE SUBDIVISION”**. Hidalgo County reserves the right to refuse and reject any/all RFB and to waive any/all formalities or technicalities, or to accept the RFB considered the best and most advantageous to Hidalgo County Hidalgo County reserves the right to refuse and reject any/all bids and to waive any/all formalities or technicalities, or to accept the bid considered the best and most advantageous to Hidalgo County
3. Hidalgo County reserves the right to: A. separate and accept, or eliminate any item(s) listed under this bid that it deems necessary to accommodate budgetary and/or operational requirements; B. reject any or all bids submitted and further reserves the right to design the evaluation criteria to be used in selecting the lowest and best bid for approval; and C. award the bid to one bidder or to multiple bidders if the County determines it is in its best interest to do so.”
4. The Bidder shall not substitute items named in the bid without the express written consent of Hidalgo County. Failure of the delivered item(s) to perform as specified, or failure to meet the stated delivery schedule shall release Hidalgo County from all obligations to the contracting party with regard to the item(s) in question. In such event, County may elect to award the contract to the next-lowest responsible bidder, or to reject all bids and re-advertise.
5. For work to be performed at a County owned or operated location, each bidder shall, in its sole discretion, visit the job site before preparing the bid and thoroughly familiarize himself/herself with existing conditions. Bidder should take field dimensions and note all circumstances which affect the dollar amount of the bid.
6. Descriptive specifications are referenced in this document to indicate the general kind and quality of equipment desired by Hidalgo County. Due to various styles and models

of equipment, bidders are required to include illustrations, specifications, explanation of warranties, and service data with their bid including catalogue numbers and any necessary references.

7. No bid may be withdrawn within thirty (30) days from the scheduled time to open bids.
8. Proposed prices are to remain firm for a minimum of ninety (90) days after bid opening.
9. Any interpretations, amendments, corrections or changes to this bid document must be in a written addendum and signed by the County Judge or his designee. Addenda will be mailed to all who are known to have received a copy of the Request for Bids. Bidders shall acknowledge receipt of all addenda as a part of their bid.
10. County reserves the right to accept or reject any or all bids.
11. Costs are to be net F.O.B., County Prepaid.
12. County is exempt from Federal Excise Tax, State Tax and Local Tax. Do Not include tax in cost figure. If it is determined that tax was included in the cost figures it will not be included in the tabulation of any awards. Tax exemption certificates will be furnished upon request.
13. Funds for this procurement have been provided through the County budget for this fiscal year only. County, on an annual basis, has the right to reconsider a contract during the budget process for ensuing years if financial resources of County are insufficient to meet the liabilities of said contract. The award of a bid or contract hereunder will not be construed to create a debt of the County which is payable out of funds beyond the current fiscal year.
14. Upon award and prior to execution of a contract, Sole Proprietorships are required to submit a copy of their social security cards to the Hidalgo County Auditor's Office in order to establish an account with the County. All awarded vendors must submit a completed W-9 and a copy of their Federal ID Number Certificate.
15. DELIVERY INSTRUCTIONS:
 - . No deliveries accepted after 3:00 P.M., Monday-Friday.
 - . At least seventy two (72) hours prior notice of delivery must be given to Martha L. Salazar, Purchasing Agent before delivery will be accepted.
 - . If you need additional information call the office listed below:

Hidalgo County Purchasing Department
Martha L. Salazar, Purchasing Agent
(956) 318-2626

16. BILLING AND PAYMENT INSTRUCTIONS:

- . Invoices must include:
 - a) Name and address of successful bidder
 - b) Name and address of receiving department or official
 - c) Purchase Order Number (if any)
 - d) Notation - "**HIDALGO COUNTY - ROAD & DRAINAGE CONSTRUCTION FOR EL MESQUITE SUBDIVISION**" Descriptive information as to the items or services delivered, including product code, item number, quantity, etc.

- . Discount payments will be considered when offered.

- . Contact person for Billing and Payment questions:

Hidalgo County Border Colonia Access Program
301 E. State St
Pharr TX 78577
Attn: Marcie Jackson

17. Schedule of Events

Bid Opening, 9:30 AM	_____ July 03, 2012
Award of Contract	_____, 2012
Commence Work or Deliver Products	_____, 2012

18. Bid or Performance Bond and Debarment Certification; Payment Under Contract:

- . If the contract proposed is for the construction of public works or is for a contract for goods & services exceeding \$100,000, all bidders shall furnish a good and sufficient bid bond in the amount of five percent of the total contract price. A bid bond must be executed with a surety company authorized to do business in Texas. All bidders are also required to furnish a certification or acknowledgment stating that the contractor or vendor is free from suspension or debarment pursuant to federal regulation 45CFR Part 76.

- . Together with the signing of a contract or issuance of a purchase order following the acceptance of a bid, and prior to commencement of the actual work, the bidder shall furnish a performance bond to the County for the full amount of the contract, if that contract exceeds \$50,000.

- . If the contract is for \$50,000 or less, no money will be paid to the contractor until completion and acceptance of the work or the fulfillment of the purchase obligation to the County, and, if applicable, the receipt by County of satisfactory evidence that all subcontractors and material men have been paid.

- . If a contract is for the construction, alteration or repair of public buildings or public works, the contractor *shall* provide a payment bond for a contract in excess of Twenty Five Thousand Dollars (\$25,000.00), as required by Tex. Govt. Code Ch. 2253.

- . For requirements contracts, bond requirements are determined by applying the proposed unit price to the estimated quantities included in the specifications.

19. Ethical Standards:

. It shall be a breach of ethics to offer, give or agree to give any elected official, department head or employee, or former elected official, department head or employee, of the County, or for any elected official, department head or employee or former elected official, department head or employee of the County, to solicit, demand, accept or agree to accept from another person, entity or organization, a gratuity or an offer of employment in connection with any decision, approval, disapproval, recommendation, preparation or any part of a program requirement or purchase request, influencing the content of any specification or procurement standard, rendering of advice, investigation, auditing, or in any other advisory capacity in any proceeding or application, request for ruling, determination, claim or controversy, or other particular matter pertaining to any program requirement or a contract or subcontract, or to any solicitation or proposal therefore pending before any department or agency of the County.

. It shall be a breach of ethics for any payment, gratuity or offer of employment to be made by or on behalf of a subcontractor under a contract to the prime contractor or higher tier subcontractor for any contract for the County, or any person associated therewith, as an inducement for the award of a subcontract or order.

. No public official shall have an interest in a contract awarded hereunder except in accordance with Tex. Loc. Govt. Code Chapter 171.

20. Disclosure of Conflict of Interest

. Effective January 1, 2006, Chapter 176 of the Texas Local Government Code requires that any vendor, person, consultant or contractor considering doing business with Hidalgo County (“the County”) to disclose in the Conflict of Interest Questionnaire (the “CIQ”) attached as Exhibit D, the vendor, person, consultant or contractor’s affiliation or business relationship that might cause a conflict of interest with the County. By law, the CIQ must be filed with the Hidalgo County Clerk’s Office no later than the seventh business day after the date the person becomes aware of facts that require that statement to be filed. The disclosure requirement applies to a person or business who contracts or seeks to contract with Hidalgo County for the sale or purchase of property, goods or service. Any purchase order or contract resulting from this process shall be considered null and void if the successful bidder fails to comply with Texas Local Government Code Chapter 176. Vendors, consultants, contractors and others who desire to conduct business with Hidalgo County are encouraged to refer to Texas Local Government Code Chapter 176 for the details of this law. An offense under Texas Local Government Code Chapter 176 is a Class C Misdemeanor.

Please Submit completed CIQ forms to the Hidalgo County Clerk’s Office located at 100 N. Closner, Edinburg, Texas 78539-Hidalgo County Courthouse
COMPLETION AND SUBMISSION OF FORM CIQ IS THE SOLE RESPONSIBILITY OF THE PROSPECTIVE BIDDER.

21. If, during the life of any contract or bid awarded, the successful bidder's net prices generally available to other customers for items awarded herein are reduced below the contracted price, it is understood and agreed that the benefits of such reduction shall be extended to County.
22. Bids, and all goods and services provided thereunder, shall comply with all federal, state and local laws concerning this type(s) of goods and/or services.
23. Minimum Standards For Responsible Prospective Bidders: A prospective bidder must affirmatively demonstrate bidder's responsibility. A prospective bidder, by submitting a bid, represents to County that it meets the following requirements:
 - . Possess or is able to obtain adequate financial resources as required to perform under the bid;
 - . Be able to comply with the required or proposed delivery schedule;
 - . Have a satisfactory record of performance;
 - . Have a satisfactory record of integrity and ethics;
 - . Be otherwise qualified and eligible to receive an award.
24. Successful bidder will pay or cause to be paid, without cost or expenses to County, all FICA, FUTA/SUTA and Federal Income Withholding Taxes of all employees, and all wages and benefits as required by Federal or State law. Successful bidder's officers, agents and/or employees will not be entitled to any benefits of an employee or elected official of County, including, but not limited to, benefits associated with County's civil service system.
25. Any contract award to a successful bidder will be in effect until (a) the contract expires, (b) delivery and acceptance of products, and/or performance of services ordered, or (c) terminated by County with thirty day's written notice prior to cancellation.
26. County reserves the right to enforce performance of any contract awarded hereunder in any manner prescribed by law or deemed to be in the best interest of the County in the event of breach or default by successful bidder; County reserves the right to terminate any contract immediately in the event a successful bidder fails to:
 - A. Meet schedules;
 - B. Pay any required fees or taxes; or
 - C. Otherwise perform in accordance with the specifications.
27. Successful bidder shall defend, indemnify and save harmless County and all its elected officials, officers, agents and employees from all suits, actions, or other claims of any character, name and description brought for or on account of any injuries or damages received or sustained by any person, persons, or property on account of any negligent act or fault of the successful bidder, or of any agent, employee, subcontractor or supplier of successful bidder in the execution of, or performance under, any contract which may result from bid award or which arises from any event or casualty happening on or within County premises themselves or happening upon or in any halls, elevators, entrances, stairways or approaches of or to such County facilities. Successful bidder shall pay any

judgement with costs which may be obtained against County growing out of such injury or damages, and shall, upon request, provide a defense to County by counsel reasonably acceptable to County. Successful bidder's indemnity hereunder shall include, but is not limited to, claims relating to patent, copyright or trademark infringement, and the like, arising out of the goods and services provided by successful bidder.

28. Successful bidder shall warrant that all items/services shall conform with the specifications and/or all warranties provided under the Uniform Commercial Code and be free from all defects in material, workmanship and the like. Items supplied under a contract pursuant to this Request for Bids shall be subject to County's approval. Items found to be defective or not meeting specifications shall be replaced by successful bidder within two business days at no expense to County. Items not picked up within one (1) week after notification shall be deemed a donation to County and may be used or disposed of at County's discretion and without waiver of any other rights of County as to the item's nonconformity.
29. This document and any disputes arising hereunder shall be governed and construed according to the laws of the State of Texas, and will be performable exclusively in Hidalgo County, Texas.
30. The successful bidder shall not assign, sell, transfer or convey its rights under any awarded contract, in whole or in part, without the prior written consent of County.

BIDDERS ACKNOWLEDGEMENT

Bid for

HIDALGO COUNTY

“ROAD & DRAINAGE CONSTRUCTION FOR EL MESQUITE SUBDIVISION”

BID NO.: CAP-12-113-07-03-YSI

To: Martha L. Salazar, CPPB, Purchasing Agent
Hidalgo County Purchasing Department
Hidalgo County New Administration Building
2802 S Business Hwy 281
Edinburg, Texas 78539

US Postal Mail/Courier Address

**Hidalgo County New Administration Building
2812 S Business Hwy 281
Edinburg, Texas 78539**

Physical Location:

**Hidalgo County New Administration Building
2802 S Business Hwy 281
Edinburg, Texas 78539
(Southeast corner of Canton Rd & Business 281)**

In accordance with the Specifications, and subject to all laws and regulations of the United States and state and local laws, the undersigned bidder proposes and commits to furnish all labor, equipment, material, software and services as set forth in the documents hereinbefore mentioned. The undersigned bidder further agrees, upon acceptance of its bid, to execute a contract and/or Purchase Order issued by Hidalgo County for performing and completing the work described in the Specifications within the time stated and for the prices proposed in the documents attached hereto and made a part hereof.

Bidder acknowledges receipt of all of the pages of the documents referenced in the Invitation to Bid Checklist presented in connection with this procurement. Bidder understands that Hidalgo County reserves the right to reject any or all bids and further reserves the right to design the evaluation criteria to be used in selecting the lowest and best bid.

Bidder agrees that this bid shall be good and may not be withdrawn for a period of ninety (90) calendar days after the scheduled closing time for receiving bids, as contained in the Specifications.

Respectfully submitted,

Bidder:

Address:

By:

Printed Name:

Title:

INFORMATION FOR BIDDERS

1. Receipt and Opening of Bids

The Hidalgo County (herein called the "Owner"), invites bids on the form attached hereto, all blanks of which must be appropriately filled in. Bids will be received by the Owner at the Hidalgo County Purchasing department until Tuesday **JULY 03, 2012** at 9:30 a.m. and then at said office publicly open and read aloud. The envelopes containing the bids must be sealed, addressed to Martha L. Salazar, Hidalgo County Purchasing Agent at 2812 S Business 281, Edinburg, Texas 78539 and designated as **BID NO: CAP-12-113-07-03-YSI "ROAD & DRAINAGE CONSTRUCTION FOR EL MESQUITE SUBDIVISION"**.

The owner may consider informal any bid not prepared and submitted in accordance with provisions hereof and may waive any informalities or reject any and all bids. Any bid may be withdrawn prior to the above scheduled time for the opening of bids or authorized postponement thereof. Any bid received after the time and date specified shall not be considered. No bidder may withdraw a bid within 60 days after the actual date of the opening thereof.

2. Preparation of Bid

Each bid must be submitted on the prescribed form and accompanied by Certification by Bidder Regarding Equal Employment Opportunity, Form, and Certification by Bidder (contractor), concerning Labor Standards and Prevailing Wage Requirements. All blank spaces for bid prices must be filled in, in ink or typewritten, in both words and figures, and the foregoing Certificates must be fully completed and executed when submitted.

Each bid must be submitted in a sealed envelope bearing on the outside the name of the bidder, his address, and the name of the project for which the bid is submitted. If forwarded by mail, the sealed envelope containing the bid must be enclosed in another envelope addressed as specified in the bid form.

3. Subcontracts

The bidder is specifically advised that any person, firm, or other party to whom is proposed to award a subcontract under this contract –

- a** Must be acceptable to the Owner after verification of the current eligibility status, and,
- b** Approval of the proposed subcontract award cannot be given by the Owner unless and until the proposed subcontractor has submitted the Certification and/or other evidence showing that it has fully complied with any reporting requirements to which it is or was subject. Although the bidder is not required to attach such Certification by proposed subcontractors to his bid, the bidder is here advised of this requirement so that appropriate action can be taken to prevent subsequent delay in subcontract awards.

4. Telegraphic Modification

Any bidder may modify his bid by telegraphic communication at any time prior to the scheduled closing time for receipt of bids, provided such telegraphic communication is received by the Owner prior to the closing time, and provided further, the Owner is satisfied that a written confirmation of the telegraphic modification over the signature of the bidder was mailed prior to the closing time. The telegraphic communication should not reveal the bid price but should provide the additional or subtraction or other modification so that the final prices or terms will not be known by the Owner until the sealed bid is opened. If written confirmation is not received within two days from the closing time, no consideration will be given to the telegraphic modification.

5. Method of Bidding

The Owner invites the following bid(s): Border Access Colonia Project Round 3
Grant No. _____
Subdivision Name: **El Mesquite**

6. Qualifications of Bidder

The Owner may make such investigations as he deems necessary to determine the ability of the bidder to perform the work, and the bidder shall furnish to the Owner all such information and data for this purpose as the Owner may request, the Owner reserves the right to reject any bid if the evidence submitted by, or investigation of, such bidder fails to satisfy the Owner that such bidder is properly qualified to carry out the obligations of the contract to complete the work contemplated therein. Conditional bids will not be accepted.

7. Bid Security

Each bid must be accompanied by certified check of the bidder, or a bid bond prepared on the form of bid bond attached hereto, duly executed by the bidder as principal and having as surety thereon a surety company approved by the Owner, in the amount of 5% of the bid. Such checks or bid bonds will be returned to all except the three lowest bidders within three days after the opening of bids, and the remaining checks, or bid bonds will be returned promptly after the Owner and the accepted bidder have executed the contract, or if no award has been made within 60 days after the date of the opening of bids, upon demand of the bidder at any time thereafter, so long as he has not been notified of the acceptance of his bid.

8. Liquidated Damages for Failure to enter into Contract

The successful bidder, upon his failure or refusal to execute and deliver the contract and bonds required within 10 days after he has received notice of the acceptance of his bid, shall forfeit to the Owner, as liquidated damages for such failure or refusal, the security deposited with his bid.

9. Time of Completion and Liquidated Damages

Bidder must agree to commence on or before a date to be specified in a Written “Notice to Proceed” of the Owner and to fully complete the project within **150** consecutive calendar days thereafter. **150** consecutive calendar days breakdown as follows: **60** days for substantial completion (all work except vegetative watering). Liquidated damages will apply if contractor does not finish substantial completion within **60** consecutive calendar days or all construction is not completed within **150** consecutive calendar days. Bidder must agree also to pay as liquidated damages, the sum of **\$200.00** for each consecutive calendar day thereafter as hereinafter provided in the General Conditions.

10. Condition of Work

Each bidder must inform himself fully of the conditions relating to the construction of the project and the employment of labor thereon. Failure to do so will not relieve a successful bidder of his obligation to furnish all material and labor necessary to carry out the provisions of his contract. Insofar as possible the contractor, in carrying out his work, must employ such methods or means as will not cause any interruption of or interference with work of any other contractor.

11. Addenda and Interpretations

No interpretation of the meaning of the plans, specifications or other pre-bid documents will be made to any bidder orally.

Every request for such interpretation should be in writing addressed to **TEDSI Infrastructure Group 1201 E. Expressway 83, Mission TX 78572. Attn Jose A. Sanchez, P.E.** and to be given consideration must be received at least five days prior to the date fixed for the opening of bids. Any all such interpretations and any supplemental instructions will be in the form of written addenda to the specifications which, if issued, will mailed by certified mail with return receipt requested to all prospective bidders (at the respective addresses furnished for such purposes), not later than three days prior to the date fixed for the opening of bids. Failure of any bidder to receive any such addendum or interpretation shall not relieve such bidder from any obligation under his bid as submitted. All addenda so issued shall become part of the contract documents.

12. Security for Faithful Performance

Simultaneously with his delivery of the executed contract; the contractor shall furnish a surety bond or bonds as security for faithful performance of this contract and for the payment of all persons performing labor on the project under this contract and furnishing materials in connection with this contract, as specified in the General Conditions included herein. The surety on such bond or bonds shall be a duly authorized surety company satisfactory to the Owner.

13. Power of Attorney

Attorney-in-fact who sign bonds or contract bonds must file with each bond a certified and effectively dated copy of their power of attorney.

14. Notice of Special Conditions

Attention is particularly called to those parts of the contract documents and specification which deal with the following;

- a** Inspection and testing of materials
- b** Insurance requirements
- c** Wage rates
- d** States allowances

15. Laws and Regulations

The bidder's attention is directed to the fact that all applicable State laws, municipal ordinances, and the rules and regulations of all authorities having jurisdiction of the project shall apply to the contract throughout, and they will be deemed to be included in the contract the same as though herein written out in full.

16. Method of Award – Lowest Qualified Bidder

If at the time this contract is to be awarded, the lowest base bid submitted by a responsible bidder does not exceed the amount of funds then estimated by the Owner as available to finance the contract the contract will be awarded on the base bid only. If such bid exceeds such amount, the Owner may reject all bids or may award the contract on the base bid combined with such deductible alternates applied in numerical order in which they are listed in the form of Bid, as produces a net amount which is within the available funds.

17. Obligation of Bidder

At the time of the opening of bids each bidder will be presumed to have inspected the site and to have read and to be thoroughly familiar with the plans and contract documents (including all addenda). The failure or omission of any bidder to examine any form, instrument or document shall in no way relieve any bidder from any obligation in respect of his bid.

**Supplement to Form HUD-4238-B®
INFORMATION FOR BIDDERS**

18. SAFETY STANDARDS AND ACCIDENTS PREVENTION

With respect to all work performed under this contract, the contractor shall:

- 1 Comply with the safety standards provision of applicable laws, building and construction codes and the “Manual of Accident Prevention in Construction” published by the Associates General Contractors or America, the requirements of the Occupational Safety and Health Act of 1970 (Public Laws 91-596), and the requirements of Title 29 of the Code of Federal Regulations, Section 1518 as published in the “Federal Register”, Volume 36, No 75, Saturday, April 17, 1971.
- 2 Exercise every precaution at all times for the prevention of accidents and the protection of persons (including employees) and property.
- 3 Maintain at his office or other well known place at the job site, all articles necessary for giving first aid to the injured, and shall make standing arrangements for the immediate removal to a hospital or a doctor’s care of persons (including employee), whom may be injured on the job site. In no case shall employee be permitted to work at a job site before the employer has made a standing arrangement for removal of injured person to a hospital or a doctor’s care.

SPECIAL PROVISIONS

- 1.** The County of Hidalgo reserves the right to partially award the contract in order to meet the budget.
- 2.** It shall be the Contractor's responsibility to locate underground utilities, whether shown or not shown on the drawings, sufficiently in advance of operations to preclude damage to same.
- 3.** Water, sewer, or other utility serves shall not be interrupted. Any damages to existing utilities will be Contractor's responsibility.
- 4.** In the event of damage to underground facilities, whether shown or not shown in the drawings, the Contractor shall make the necessary repairs to place the facilities back in service at no increase in the Contractors price and all such repairs shall conform to the requirements of the company or agency servicing the facility
- 5.** The Contractor shall exercise extra care to prevent damage to all other structures in the area including, fence, roads, pipelines, utilities, etc., whether publicly or privately owned.
- 6.** Until acceptance by the Engineer of any part or all of the construction, as provided for in the plans and these specifications, it shall be under the charge and care of the contractor, and he shall take every necessary precaution against injury or damage to any part of the work. The Contractor shall rebuild, repair, restore and make good, at his own expense, all injuries or damage to any portion of the work before its completion and acceptance.
- 7.** In case the Contractor deems extra compensation is due him for proposed work not covered in the contract, the Contractor shall notify the Engineer in writing of his claim for such extra compensation before he begins the work. Failure on the part of the Contractor to give such notification shall constitute a waiver of claim for such extra compensation. The Contractor shall not proceed until a written Change Order is approved by the Owner, Engineer, and Contractor.
- 8.** Prospective bidders should make a careful examination of the projects sites.
- 9.** Contractor shall review his overall method and schedule of construction with the County Prior to construction for proper coordination of inspection.
- 10.** No open trenches or excavation shall be left open overnight.

BID FORM
BORDER COLONIA ACCESS PROJECT - HIDALGO COUNTY PRECINCT NO 1
CAP-12-113-07-03-YSI "ROAD AND DRAINAGE CONSTRUCTION FOR EL MESQUITE SUBDIVISION"

ROADWAY IMPROVEMENTS						
ITEM	TOTAL	UNIT	DESCRIPTION	UNIT PRICE		TOTAL (In Figures)
				(In Words)		
0100	25.41	STA	PREPARING ROW		Dollars	\$
					Cents	
0110	1153	CY	EXCAVATION(ROADWAY)		Dollars	\$
					Cents	
0132	304	CY	EMBANKMENT(FINAL)(DENS CONT)(TY C)		Dollars	\$
					Cents	
0164	7209	SY	CELL FBR MLCH SEED(PERM)(URBAN)(CLAY)		Dollars	\$
					Cents	
0168	360.5	MG	VEGETATIVE WATERING		Dollars	\$
					Cents	
0247	8010	SY	FL BS(CMP IN PLC)(TY E GR 4)(FNAL POS)		Dollars	\$
					Cents	
0260	60.2	TON	LIME(HYD,COM OR QK)(SLRY)OR QK(DRY)		Dollars	\$
					Cents	
0260	8010	SY	LIME TRT(NEW BASE)(8")		Dollars	\$
					Cents	
0310	1369	GAL	PRIME COAT(MC-30)		Dollars	\$
					Cents	
0340	6839	SY	D-GR HMA(METH)TY-D SAC-B PG64-22		Dollars	\$
					Cents	
0500	1	LS	MOBILIZATION		Dollars	\$
					Cents	
0502	2	MO	BARRICADES, SIGNS AND TRAFFIC HANDLING		Dollars	\$
					Cents	
0666	5000	LF	REFL PAV MRK TY I(W)4"(SLD)(100MIL)		Dollars	\$
					Cents	
0666	30	LF	REFL PAV MRK TY I(W)24"(SLD)(100MIL)		Dollars	\$
					Cents	
0666	580	LF	REFL PAV MRK TY I(Y)4"(BRK)(100MIL)		Dollars	\$
					Cents	
0666	400	LF	REFL PAV MRK TY I(Y)4"(SLD)(100MIL)		Dollars	\$
					Cents	
ROADWAY IMPROVEMENTS TOTAL						\$

DRAINAGE IMPROVEMENTS						
ITEM	TOTAL	UNIT	DESCRIPTION	UNIT PRICE		TOTAL (In Figures)
				(In Words)		
0464	80	LF	RC PIPE(CL III)(18 IN)		Dollars	\$
					Cents	
0506	52	LF	TEMPORARY SEDIMENT CONTROL FENCE		Dollars	\$
					Cents	
0530	335	SY	DRIVEWAYS(CONC)		Dollars	\$
					Cents	
0530	861	SY	DRIVEWAYS(ACP)		Dollars	\$
					Cents	
4378	1020	LF	THERMOPLASTIC PIPE (15 IN)(TY III)		Dollars	\$
					Cents	
DRAINAGE IMPROVEMENTS TOTAL						\$

GRAND TOTAL	\$
--------------------	----

BIDDER/COMPANY NAME: _____
 AUTHORIZED SIGNATURE: _____
 PRINTED NAME: _____
 TITLE: _____

CONTINUATION OF BID PAGE

The undersigned **Bidder** agrees to commence work after written notice to commence work and to substantially complete the work on which he has bid **150** calendar days as provided in Article 18 of the General Conditions of the Agreement.

Enclosed with this Proposal is a Cashier’s check or Certified Check for _____ Dollars (_____) or a Bid Bond in the Sum of _____ Dollars (_____), which is agreed shall be collected and retained by the **Owner** under the conditions hereof within ten (10) days after the date this proposals is accepted; then otherwise the said bond or check shall be returned to the undersigned upon demand.

Receipts of the following Addenda on these dates shown is acknowledged:

	DATE	ACKNOWLEDGE	DATE	ACKNOWLEDGE
#1	_____	_____	#2	_____
#3	_____	_____	#4	_____

Respectfully submitted,

Name of Firm

By: _____
Signature Date

Title

Address

Telephone Number

**THIS PROPOSAL MUST BE
SIGNED BY AN OFFICER OF
REPRESENTATIVE DULY
AUTHORIZED BY THE BIDDER.**

(Seal, if Bid is by a Corporation)

Attest: _____

HIDALGO COUNTY PRECINCT #1 BORDER ACCESS COLONIA PROJECT

BID BOND

KNOW ALL MEN BY THESE PRESENTS, That we, the undersigned _____
_____ as Principal, and _____
_____ as Surety, are hereby held and firmly bound
unto _____ as OWNER in the penal sum of _____

for the payment of which, well and truly to be made, we hereby jointly and severally bind ourselves, successors and assigns.

Signed, this _____ day of _____, 20_____.

The condition of the above obligation is such that whereas the Principal has submitted to _____
_____ a certain BID, attached hereto and
hereby made a part hereof to enter into a contract in writing for the

NOW, THEREFORE,

- (a) If said Bid shall be rejected, or
- (b) If said Bid shall be accepted and the Principal shall execute and deliver a contract in the Form of Contract attached hereto (properly completed in accordance with said BID) and Shall furnish a BOND for his faithful performance of said contract, and for the payment of all persons performing labor or furnishing materials in connection therewith, and shall in all other respects perform the agreement created by the acceptance of said BID, then, this obligation shall be void, otherwise the same shall remain in force and effect; it being expressly understood and agreed that the liability of the Surety for any and all claims hereunder shall, in no event, exceed the penal amount of this obligation is herein stated.

The Surety, for value received, hereby stipulates and agrees that the obligations of said Surety and its BOND shall be in no way impaired or affected by any extension of the time within which the OWNER may accept such Bid; and said Surety does hereby waive notice of any such extension.

IN WITNESS WHEREOF, the Principal and the Surety have hereunto set their hands and seals, and such of them as are corporations have caused their corporate seals to be hereto affixed and these presents to be signed by their proper officers, the day and year first set forth above.

_____(L.S.)
Principal

Surety

By: _____

IMPORTANT – Surety companies executing BONDS must appear on the Treasury Department’s most current list (circular 570 as amended) and be authorized to transact business in the state where the project is located.

5THE STATE OF TEXAS §
§
COUNTY OF HIDALGO §

CONSTRUCTION CONTRACT
C-CAP-12-113-XX-XX

This Agreement, entered into this _____ day of _____, 2012 by and between Hidalgo County (hereinafter called the "OWNER," and, _____ (a Texas corporation), of County of Hidalgo, and State of Texas, hereinafter called "CONTRACTOR".

WITNESSETH

That for and in consideration of the payments and agreement hereinafter mentioned, to be made and performed by the OWNER, the CONTRACTOR hereby agrees with the OWNER to commence and complete the construction described as follows:

ROAD & DRAINAGE CONSTRUCTION FOR EL MESQUITE SUBDIVISION

Hereinafter called the project, for the sum of _____ Dollars and all extra work in connection therewith, under the terms and stated in the General and Special Conditions of the Contract; and at his (its or their) own proper cost and expense to furnish all the materials, supplies, machinery, equipment, tools, superintendence, labor, insurance, and other accessories and services necessary to complete the said project in accordance with the conditions and prices stated in the Proposal, the General Conditions and Special Conditions printed or written explanatory matter thereof, the specifications and contract documents therefore as prepared by **TEDSI Infrastructure Group**, entitled the Architect/Engineer, and as enumerated in Paragraph 1.01.A.12 of the General Conditions, all of which are made a part hereof and collectively evidence and constitute the contract.

The CONTRACTOR hereby agrees to commence work under this contract on or after a date to be specified in written "Notice to Proceed" of the OWNER and to fully complete the project within **150** consecutive calendar days thereafter. The CONTRACTOR further agrees to pay, as liquidated damages, the sum of **\$200.00** for each consecutive calendar day thereafter.

The OWNER agrees to pay the CONTRACTOR in current funds for the performance of the contract, subject to additions and deductions, as provided in the General Conditions of the contract, and to make payments on account thereof as provided in Paragraphs 14.02.C and 14.07.C of the General Conditions.

IN WITNESS WHEREOF, the parties to these present have executed this contract in six (6) counterparts, each of which shall be deemed an original, in year and day first above mentioned.

APPROVED BY COMMISSIONERS COURT ON _____, **2012**.

CONTRACTOR: _____

Print Name & Title: _____

Name of Firm: _____

Address: _____

Fed I.D. #/SS #: _____

STATE OF TEXAS

COUNTY OF HIDALGO

This instrument was acknowledged before me on this the _____ day of _____,

20__, by _____ Of and on behalf of _____
(Title) (A corporation)

Notary Public-Signature

APPROVED AS TO FORM:

Atlas & Hall, L.L.P.

800 Pecan

McAllen, Texas 78504

BY: _____

ATTEST:

COUNTY OF HIDALGO:

Arturo Guajardo, Jr., County Clerk

Ramon Garcia, County Judge

NON-COLLUSION AFFIDAVIT OF PRIME BIDDER

State of)

County of.....)

_____, being first duly sworn,
deposes and says that:

(1) He is _____, of _____, the Bidder that has submitted the attached Bid;

(2) He is fully informed respecting the preparation and contents of this attached bid and of all pertinent circumstances respecting such bid;

(3) Such bid is genuine and is not a collusive or sham Bid;

(4) Neither the said Bidder nor any of its officers, partners, owners, agents, representative:, employees or parties in interest, including this affiant, has in any way colluded, conspired a collusive or sham Bid in connection with the Contract for which the attaché Bid has been submitted or to refrain from bidding in connection with such Contract, or has in any manner, directly or indirectly, sought by agreement or collusion or communication of conference with any other Bidder, firm or person to fix the price or prices in the attached Bid or of any other Bidder, or to fix any overhead, profit or cost element of the Bid price or the Bid price of any other Bidder, or to secure through any collusion, conspiracy, connivance or unlawful agreement any advantage against the Owner or any person interested in the proposed Contract; and

(5) The price or prices quoted in the attached Bid are fair and proper and are not tainted by any collusion, conspiracy, connivance, connivance or unlawful agreement on the part of the Bidder or any of its agents, representatives, owners, employees, or parties in interest, including this affiant.

(Signed) _____

(Title)

Subscribed and sworn to before me on this _____

Day of _____

Title

PAYMENT BOND

(To be used in Texas under V.A.T.S. 5160)

THE STATE OF _____

COUNTY OF _____

KNOW ALL MEN BY THESE PRESENTS: That we (1) _____,
a (2) _____, hereinafter called
Principal and (3) _____ of
_____, hereinafter called the
Surety, are held and firmly bound unto (4) _____ of
_____, hereinafter called Owner, and unto all persons,
firms, and corporations who may furnish materials for, or perform labor
upon the building or improvements hereinafter referred to the penal sum
of _____ (\$ _____) Dollars in lawful money of the
United States to be paid in (5) _____, for the
payment of which sum well and truly to be made, we bind ourselves, our
heirs, executors, administrators, and successors, jointly and severally,
firmly be these presents.

THE CONDITION OF THIS OBLIGATION is such that Whereas, the Principal
entered into a certain contract with (6) _____,
_____, the Owner, dated
the _____ day of _____, A.D. 200__, a copy of which is
hereto attached and made a part hereof for the construction of:

**HIDALGO COUNTY PRECINCT #3 BORDER ACCESS COLONIA PROJECT
SUBDIVISION**

These footnotes refer to numbers in body of contract above:

Date of Bond must not be prior to date of contract

- (1) Correct name of Contractor
- (2) A Corporation, a Partnership or an Individual, as case may be
- (3) Correct name of Surety
- (4) Correct name of Owner
- (5) County and State
- (6) Owner

NOW, THEREFORE, the condition of this obligation is such that, if the
-1- Principal shall promptly make payment to all claimants as defined
in Article 5160 Revised Civil Statutes of Texas, 1925, as amended by
House Bill 344, Act 56th Legislature, Regular Session, 1925 effective
April 27, 1959, supplying labor and materials in the prosecution of
the work provided for in said Contract, then this obligation shall be
null and void, otherwise it shall remain in full force and effect.

This bond is made and entered into solely for the prosecution of all
claimants supplying labor and material in the prosecution of the work
provided for in said Contract, and all such claimants shall have a
direct right of action under the bond as provided in Article 5160,
Revised Civil Statutes 1925, as amended by House Bill 344, Acts 56th
Legislature, Regular Session, 1959

PROVIDED FURTHER, that if any legal action be filed upon this bond, venue shall lie in Hidalgo County, State of Texas, and that the said surety, for value received hereby stipulates and agrees that no change, extension of time, alteration or addition to the terms of the contract or to the work to be performed thereunder or the specification accompanying the same shall in any way affect its obligation on this bond, and it does hereby waive notice of any such change, extension of time, alteration or addition to the terms of the contract or to the work or to the specifications.

PROVIDED FURTHER, that no final settlement between the Owner and the Contractor shall abridge the right of any beneficiary hereunder, whose claim may be unsatisfied.

IN WITNESS WHEREOF, this instrument is executed in six counterparts, each one of which shall be deemed an original, this the _____ day of _____ . A.D., 200_____.

ATTEST:

(Principal) Secretary

(Seal)

Witness as to Principal

(Address)

Principal _____
By _____

(Address) _____

Telephone Number: _____

Surety

ATTEST:

(Surety) Secretary

(Seal)

Witness as to Surety

(Address)

By _____

(Address) _____

NOTE: If Contractor is partnership all Partners should execute bond

Telephone Number: _____

PAYMENT BOND FORM

(Address)
Telephone Number: _____

(Individual Principal)

(Business Address)
Telephone Number: _____

(Corporate Principal)

(Business Address) (Affix Corporate SEAL)
Telephone Number: _____
BY _____

ATTEST:

(Business Address) (Affix Corporate SEAL)
BY _____
Telephone Number: _____

CERTIFICATES AS TO CORPORATE PRINCIPAL

I, _____, certify that I am the _____
Secretary of the corporation named as Principal in the within bond; that
_____, who signed the said bond on behalf of the
Principal was then _____ of said corporation; and I
know his signature, and his signature thereto is genuine; and that said
bond was duly signed, sealed, and attested for and in behalf of said
corporation by authority of its governing body.

(TITLE)
DATE _____

(AFFIX CORPORATE SEAL)

Telephone Number: _____

The rate of premium on this bond is _____ per thousand. Total
amount of premium charge \$_____.
(The above must be filled in by corporate surety.) (Power-of-Attorney of
person signing for surety company must be attached.)

PERFORMANCE BOND
(To be used in Texas under V.A.T.S. 5160)

THE STATE OF _____

COUNTY OF _____

KNOW ALL MEN BY THESE PRESENTS: That we (1) _____, a (2) _____ OF _____, hereinafter called Principal and (3) _____ of _____, State of _____, hereinafter called the Surety, are held and firmly bound unto (4) _____ of _____, hereinafter called Owner, in the penal sum of _____ (\$ _____) Dollars in lawful money of the United States to be paid in (5) _____, for the payment of which sum well and truly to be made, we bind ourselves, our heirs, executors, administrators, and successors, jointly and severally, firmly be these presents.

THE CONDITION OF THIS OBLIGATION is such that Whereas, the Principal entered into a certain contract with (6) _____, the Owner, dated the _____ day of _____, A.D. 200__, a copy of which is hereto attached and made a part hereof for the construction of:

HIDALGO COUNTY PRECINCT #3 BORDER ACCESS COLONIA PROJECT
_____ SUBDIVISION
hereinafter called the "Work").

These footnotes refer to the numbers in body of contract above:

Date of Bond must not be prior to date of contract

- (1) Correct name of Contractor
- (2) A Corporation, a Partnership or an Individual, as case may be
- (3) Correct name of Surety
- (4) Correct name of Owner
- (5) County and State
- (6) Owner

(Texas Performance Bond) - Page 2.

NOW, THEREFORE, if the Principal shall well, truly and faithfully perform the work in accordance with the plans, specifications, and contract documents during the original term thereof, and any extensions thereof which may be granted by the Owner, with or without notice to the Surety, and if he shall satisfy all claims and demands incurred under such contract, and shall fully indemnify and save harmless the Owner from all costs and damages which it may suffer by reason of failure to do so, and shall reimburse and repay the Owner all outlay and expense which the Owner may incur in making good any default, then this obligation shall be void; otherwise to remain in full force and effect.

PROVIDED FURTHER, that if any legal action be filed upon this bond, venue shall lie in Hidalgo County, State of Texas, and that the said surety, for value received hereby stipulates and agrees that no change, extension of time, alteration or addition to the terms of the contract or to the

work to be performed thereunder or the specifications accompanying the same shall in any way affect its obligation on this bond, and it does hereby waive notice of any such change, extension of time, alternation or addition to the terms of the contract or to the work or to the specifications.

IN WITNESS WHEREOF, this instrument is executed in six counterparts, each one of which shall be deemed an original, this the _____ day of _____ . A.D.

ATTEST:

(Principal) Secretary

(Seal)

Witness as to Principal

(Address)

Principal _____

By _____

(Address) _____

Telephone Number: _____

ATTEST:

(Surety) Secretary

(Seal)

Witness as to Surety

(Address)

By _____

(Address) _____

Telephone Number: _____

NOTE: If Contractor is a partnership, all partners should execute bond.

PERFORMANCE-PAYMENT BOND FORM

(Address)
Telephone Number: _____

(Individual Principal)

(Business Address)
Telephone Number: _____

(Corporate Principal)

(Business Address) (Affix Corporate SEAL)
Telephone Number: _____
BY _____

ATTEST:

(Business Address) (Affix Corporate SEAL)
BY _____
Telephone Number: _____

CERTIFICATES AS TO CORPORATE PRINCIPAL

I, _____, certify that I am the _____
Secretary of the corporation named as Principal in the within bond; that
_____, who signed the said bond on behalf of the
Principal was then _____ of said corporation; and I
know his signature, and his signature thereto is genuine; and that said
bond was duly signed, sealed, and attested for and in behalf of said
corporation by authority of its governing body.

(TITLE)
DATE _____

(AFFIX CORPORATE SEAL)

Telephone Number: _____

The rate of premium on this bond is _____ per thousand. Total
amount of premium charge \$_____.
(The above must be filled in by corporate surety.) (Power-of-Attorney of
person signing for surety company must be attached.)

EXHIBIT “C”

Insurance Requirements

The Bidder awarded the contract shall furnish proof of insurance, which will also include any subcontractor that is subcontracted by the bidder in at least the following limits, to be in place prior to providing any services under this Contract and to continue at all times in force in effect during the term of this Contract:

1. A Five Hundred Thousand Dollar (\$500,000.00) Comprehensive General Liability insurance policy providing additional coverage to all underlying liabilities of County.
2. Automobile liability insurance policy with limits of at least Three Hundred Thousand Dollars (\$300,000.00) per person and Five Hundred Thousand Dollars (\$500,000.00) per occurrence. Coverage should include injury to or death of persons and property damage claims with limits up to Five Hundred Thousand (\$500,000.00) arising out of the services provided to County hereunder.
3. Uninsured/Underinsured motorist coverage in an amount equal to the bodily injury limits set forth immediately above;
4. Workers compensation insurance in amounts established by Texas law, unless the Bidder is specifically exempted from the Texas Workers Compensation Act, Texas Labor Code Chapter 401, et. seq.

Certificates of insurance naming County as an additional insured shall be submitted to County for approval prior to any services being performed by Contractor. Each policy of insurance required hereunder shall extend for a period equivalent to, or longer than the term of the Contract, and any insurer hereunder shall be required to give at least thirty (30) days written notice to the County prior to the cancellation of any such coverage on the termination date, or otherwise. This Contract shall be automatically suspended upon the cancellation, or other termination, of any required policy of insurance hereunder, and such suspension shall continue until evidence adequate replacement coverage is provided to County. If replacement coverage is not provided within thirty (30) days following suspension of the Contract, this Contract shall automatically terminate.

Insurance Requirement Acknowledgment

I, _____, authorized representative for _____,
Company/Vendor

hereby acknowledge receipt of the County's required insurance limits. Said requirements:

- will be acquired within 10 working days after notification from Purchasing Department of bid awarded by the Hidalgo County Commissioners' Court;
- will acquire additional amounts required to meet the County's requirements within 10 working days after notification from Purchasing Department of bid award by the Hidalgo County Commissioners' Court; currently carry the following:

Automobile Liability: \$ _____ General Liability: \$ _____
- have already been met, see attached copy of insurance certificate.

Authorized Representative

Date

Notice to Bidder:

A certificate of insurance for the required insurance limits shall be provided to the Purchasing Department's Contract Managers in order to qualify for award of bid and to execute a contract between your Company and the County

Failure to provide Certificates of Insurance to the Purchasing Department's Contract Managers will cause the bid award to be rescinded and re-awarded to next lowest bidder. Certificates of Insurance will be monitored and verified on a **quarterly basis** to ensure coverage policy is in place. It is the Company's obligation to maintain the appropriate insurance coverage throughout the term of the contract.

THIS FORM MUST ACCOMPANY BID PACKET

PROJECT REQUIREMENTS ACKNOWLEDGMENT

This is to certify that I, _____, possess all of the APPLICABLE:

1. Licenses: _____.

2. Bonds: _____.

3. Certificates: _____.

4. Permits: _____.

5. Other: _____.

necessary to carry out the required project. Furthermore, I am providing copies of the required documentation so that, if my company is awarded this bid, I may be eligible to enter into a contract with Hidalgo County and proceed to complete the project in a timely manner.

* Any licenses, bonds, certificates, permits, etc. which are required must be presented as part of the bid packet in order to expedite the bid evaluation process. Failure to provide said documentation will result in the disqualification of your bid.

Authorized Signature

Date

Company

Address

City, State, Zip

PRODUCER	THIS CERTIFICATE IS ISSUED AS A MATTER OF INFORMATION ONLY AND CONFERS NO RIGHTS UPON THE CERTIFICATE HOLDER. THIS CERTIFICATE DOES NOT AMEND, EXTEND OR ALTER THE COVERAGE AFFORDED BY THE POLICIES BELOW.
	INSURERS AFFORDING COVERAGE
INSURED	INSURER A:
	INSURER B:
	INSURER C:
	INSURER D:
	INSURER E:

COVERAGES

THE POLICIES OF INSURANCE LISTED BELOW HAVE BEEN ISSUED TO THE INSURED NAMED ABOVE FOR THE POLICY PERIOD INDICATED. NOTWITHSTANDING ANY REQUIREMENT, TERM OR CONDITION OF ANY CONTRACT OR OTHER DOCUMENT WITH RESPECT TO WHICH THIS CERTIFICATE MAY BE ISSUED OR MAY PERTAIN, THE INSURANCE AFFORDED BY THE POLICIES DESCRIBED HEREIN IS SUBJECT TO ALL THEIR TERMS, EXCLUSIONS AND CONDITIONS OF SUCH POLICIES. AGGREGATE LIMITS SHOWN MAY HAVE BEEN REDUCED BY PAID CLAIMS.

INSR LTR	TYPE OF INSURANCE	POLICY NUMBER	POLICY EFFECTIVE DATE (MM/DD/YY)	POLICY EXPIRATION DATE (MM/DD/YY)	LIMITS	
A	GENERAL LIABILITY COMMERCIAL GENERAL LIABILITY CLAIMS MADE OCCUR OWNER'S & CONT. PROT OWNER'S PROTECTIVE LIABILITY GEN'L AGGREGATE LIMIT APPLIES PER: POLICY PROJECT LOC				EACH OCCURRENCE	\$
					FIRE DAMAGE (Any one fire)	\$
					MED EXP (Any one person)	\$
					PERSONAL & ADV INJURY	\$
					GENERAL AGGREGATE	\$
					PRODUCTS - COMP/OP AGG	\$
B	AUTOMOBILE LIABILITY ANY AUTO ALL OWNED AUTOS SCHEDULED AUTOS HIRED AUTOS NON-OWNED AUTOS				COMBINED SINGLE LIMIT (Ea accident)	\$
					BODILY INJURY (Per person)	\$
					BODILY INJURY (Per accident)	\$
					PROPERTY DAMAGE (Per accident)	\$
	GARAGE LIABILITY ANY AUTO				AUTO ONLY-EA ACCIDENT	\$
					OTHER THAN AUTO ONLY EA ACC AGG	\$
C	EXCESS LIABILITY OCCUR CLAIMS MADE DEDUCTIBLE RETENTION \$				EACH OCCURENCE	\$
					AGGREGATE	\$
						\$
						\$
						\$
D	WORKERS COMPENSATION AND EMPLOYER'S LIABILITY				WC STATUTORY LIMITS OTHER	
					E.L. EACH ACCIDENT	\$
					E.L. DISEASE-EA EMPLOYEE	\$
					E.L. DISEASE-POLICY LIMIT	\$
	OTHER					

DESCRIPTION OF OPERATIONS / LOCATION / VEHICLES / EXCLUSIONS ADDED BY ENDORSEMENT / SPECIAL PROVISIONS

County of Hidalgo shall be named as additional insured on all Commercial General Liability policies.

CERTIFICATE HOLDER	ADDITIONAL INSURED; INSURER LETTER: _____ CANCELLATION
Hidalgo County Attn: Purchasing Department 2812 S Highway Bus. 281 Edinburg, Texas 78539	SHOULD ANY OF THE ABOVE DESCRIBED POLICIES BY CANCELLED BEFORE THE EXPIRATION DATE THEREOF, THE ISSUING INSURER WILL ENDEAVOR TO MAIL 30 DAYS WRITTEN NOTICE TO THE CERTIFICATE HOLDER NAMED TO THE LEFT, BUT FAILURE TO DO SO SHALL IMPOSE NO OBLIGATION OR LIABILITY OF ANY KIND UPON THE INSURER, ITS AGENTS OR REPRESENTATIVES. AUTHORIZED REPRESENTATIVE

GENERAL CONDITIONS OF THE AGREEMENT

1. GENERAL

It is the intent of these instructions, plans and specifications to provide guidance for the construction of this project.

2. REGULATIONS AND DISCREPANCIES

All applicable laws, ordinances, policy, rules, regulations and other directives of all authorities having jurisdiction over the projects shall apply to the contract throughout and will be deemed to be included in the contract the same as those written out in full. Discrepancies between regulations or conflicting parts of the Specifications shall be brought to the attention of an clarified by the Engineer before proceeding with any work. Proceeding with affected work without instructions from the Engineer can result in the Contractor being responsible for taking the necessary steps to insure the work conforms to the governing regulation.

3. ENGINEER

Whenever the work "ENGINEER" is used in this contract with reference to the preparation of plans, specifications, and contract documents, it shall be understood as referring to the firm **TEDSI Infrastructure Group**.

4. INTERPRETATION OF PHRASES

Whenever the words "Directed", "Required", "Permitted", "Designated", "Considered Necessary", "Prescribed", or words of like importance are used, it shall be understood that the direction, requirements, permission, order, designation or prescription, of the ENGINEER is intended and similarly, the words "Approval", "Acceptable", "Satisfactory", or words of like importance shall mean approved by or acceptable of satisfactory to the ENGINEER. The preceeding to the contrary notwithstanding, Engineer's approval or acceptance of the work shall by advisory to OWNER, and shall not bind the OWNER to accept or approve the same.

Whenever, in the specifications or drawings accompanying this agreement, the terms or description of various qualities relative to finish, workmanship, or other qualities of similar kind which cannot,, from their nature, be specifically and clearly described and specified, but are necessarily described in general terms, then, in all such cases, any question of the fulfillment of said specifications shall be decided by the ENGINEER, and said work shall be done in accordance with his interpretations of the meaning of the words, terms, or clauses defining the character of the work.

Title 29 - LABOR

Subtitle A - Office of the Secretary of Labor

PART 3 - CONTRACTORS AND SUBCONTRACTORS ON PUBLIC BUILDING OR PUBLIC WORK FINANCED IN WHOLE OR IN PART BY LOANS OR GRANTS FROM THE UNITED STATES

- Sec.
- 3.1 Purpose and scope
 - 3.2 Definitions
 - 3.3 Weekly statement with respect to payment of wages
 - 3.4 Submission of weekly statements and the preservation and inspection of weekly payroll records.
 - 3.5 Payroll deductions permissible without application to or approval of the Secretary of Labor.
 - 3.6 Payroll deductions permissible with the approval of the Secretary of Labor.
 - 3.7 Applications for the approval of the Secretary of Labor
 - 3.8 Action by the Secretary of Labor upon applications.
 - 3.9 Prohibited payroll deductions.
 - 3.10 Methods of payment of wages.
 - 3.11 Regulations part of contract.

AUTHORITY: The provisions of this Part 3 issued under R.S. 16 1, sec. 2, 48 Stat. §48; Reorg. Plan No. 14 of 1950, 64 Stat. 1267, 5 U.S.C. Appendix; 5 U.S.C. 301; 40 U.S.C. 276c.

SOURCE: The provisions of this Part 3 appear at 29 F.R. 97, Jan. 4, 1964, unless otherwise noted.

Section 3.1 Purpose and Scope.

This part prescribes "anti-kickback" regulations under section 2 of the Act of June 13, 1934, as amended (40 U.S.C. 276c), popularly known as the Copeland Act. This part applies to any contract which is subject to Federal wage standards and which is for the construction, prosecution, completion, or repair of public buildings, public works or buildings or works financed in whole or in part by loans or grants from the United States. The part is intended to aid in the enforcement of the minimum wage provisions of the Davis-Bacon Act and the various statutes dealing with Federally assisted construction that contain similar minimum wage provisions, including those provisions which are not subject to Reorganization

Plan No. 14 (e.g., the College Housing Act of 1950, the Federal Water Pollution Control Act, and the Housing Act of 1959), and in the enforcement of the overtime provisions of the Contract Work Hours Standards Act whenever they are applicable to construction work. The part details the obligation of contractors and subcontractors relative to the weekly submission of statements regarding the wages paid on work covered thereby; sets forth the circumstances and procedures governing the making of payroll deductions from the wages of those employed on such work; and delineates the methods of payment permissible on such work.

Section 3.2 Definitions.

As used in the regulations in this part:

(a) The terms "building" or "work" generally include construction activity as distinguished from manufacturing, furnishing of materials, or servicing and maintenance work. The terms include, without limitation, buildings, structures, and improvements of all @s, such as bridges, dams, plants, highways, parkways, streets, subways, tunnels, sewers, mains, powerlines, pumping stations, railways, airports, terminals, docks, piers, wharves, ways, lighthouses, buoys, jetties, breakwaters, levees, and canals; dredging, shoring, scaffolding, drilling, blasting, excavating, clearing, and landscaping. Unless conducted in connection with and at the site of such a building or work as is described in the foregoing sentence, the manufacture or furnishing of materials, articles, supplies, or equipment (whether or not a Federal or State agency acquires title to such materials,

Copeland Act Regulations

articles, supplies, or equipment during the course of the manufacture or furnishing, or owns the materials from which they are manufactured or furnished) is not a "building" or "work" within the meaning of the regulations in this part.

(b) The terms "construction," "prosecution," "completion," or "repair" mean all types of work done on a particular building or work at the site thereof, including, without limitation, altering, remodeling, painting and decorating, the transporting of materials and supplies to or from the building or work by the employees of the construction contractor or construction subcontractor, and the manufacturing or furnishing of materials, articles, supplies, or equipment on the site of the building or work, by persons employed at the site by the contractor or subcontractor.

(c) The terms "public building" or "public work" include building or work for whose construction, prosecution, completion, or repair, as defined above, a Federal agency is a contracting party, regardless of whether title thereof is in a Federal agency.

(d) The term "building or work financed in whole or in part by loans or grants from the United States" includes building or work for whose construction, prosecution, completion, or repair, as defined above, payment or part payment is made directly or indirectly from funds provided by loans or grants by a Federal agency. The term includes building or work for which the Federal assistance granted is in the form of loan guarantees or insurance.

(e) Every person paid by a contractor or subcontractor in any manner for his labor in the construction, prosecution, completion, or repair of a public building or public work or building or work financed in whole or in part by loans or grants from the United States is "employed" and receiving "wages," regardless of any contractual relationship alleged to exist between him and the real employer.

(f) The term "any affiliated person" includes a spouse, child, parent, or other close relative of the contractor or subcontractor; a partner or officer of the contractor or subcontractor; a corporation closely connected with the contractor or subcontractor as parent, subsidiary or otherwise, and an officer or agent of such corporation.

(g) The term "Federal agency" means the United States, the District of Columbia, and all executive departments, independent establishments, administrative agencies, and instrumentality's of the United States and of the District of Columbia, including corporations, all or substantially all of the stock of which is beneficially owned by the United States, by the District of Columbia, or any of the foregoing departments, establishments, agencies, and

(a) Each weekly statement required under §3.3 shall be delivered by the contractor or subcontractor, within seven days after the regular payment date of the payroll period, to a representative of a Federal or

instrumentality's.

(29 FR 97, Jan. 4, 1964, as amended at 33 FR 32575, Nov. 27, 1973)

Section 3.3 Weekly statement with respect to payment of wages.

(a) As used in this section, the term "employee" shall not apply to persons in classifications higher than that of laborer or mechanic and those who are the immediate supervisors of such employees.

(b) Each contractor or subcontractor engaged in the construction, prosecution, completion, or repair of any public building or public work, or building or work financed in whole or in part by loans or grants from the United States, shall furnish each week a statement with respect to the wages paid each of its employees engaged on work covered by 29 CFR Parts 3 and 5 during the preceding weekly payroll period. This statement shall be executed by the contractor or subcontractor or by an authorized officer of employee of the contractor or subcontractor who supervises the payment of wages, and shall be on form @ 348, "Statement of Compliance," or on an identical form on the back of @ 347, "Payroll (For Contractors Optional Use)" or on any form with identical wording. Sample copies of @ 347 and @ 348 may be obtained from the Government contracting or sponsoring agency, and copies of these forms may be purchased at the Government Printing Office.

(c) The requirements of this section shall not apply to any contract of \$2,000 or less.

(d) Upon a written finding by the head of a Federal agency, the Secretary of Labor may provide reasonable limitations, variations, tolerances, and exemptions from the requirements of this section subject to such conditions as the Secretary of Labor may specify.

(29 F.R. 95, Jan. 4, 1964, as amended at 33 F.R. 10186, July 17, 1968)

Copeland Act Regulations

Section 3.4 Submission of weekly statements and the preservation and inspection of weekly payroll records.

State agency in charge at the site of the building or work, or if there is no representative of a Federal or State agency at the site of the building or work, the statement shall be mailed by the contractor or

subcontractor, within such time, to a Federal or State agency contracting for or financing the building or work. After such examination and check as may be made, such statement, or a copy thereof, shall be kept available, or shall be transmitted together with a report of any violation, in accordance with applicable procedures prescribed by the United States Department of Labor.

(b) Each contractor or subcontractor shall preserve his weekly payroll records for a period of three years from date of completion of the contract. The payroll records shall set out accurately and completely the name and address of each laborer and mechanic, his correct classification, rate of pay, daily and weekly number of hours worked, deductions made, and actual wages paid. Such payroll records shall be made available at all times for inspection by the contracting officer or his authorized representative, and by authorized representatives of the Department of Labor.

Section 3.5 Payroll deductions permissible without application to or approval of the Secretary of Labor.

Deductions made under the circumstances or in the situations described in the paragraphs of this section may be made without application to and approval of the Secretary of Labor:

(a) Any deduction made in compliance with the requirements of Federal, State, or local law, such as Federal or State withholding income taxes and Federal social security taxes.

(b) Any deduction of sums previously paid to the employee as a bona fide prepayment of wages when such prepayment is made without discount or interest. A "bona fide prepayment of wages" is considered to have been made only when cash or its equivalent has been advanced to the person employed in such manner as to give him complete freedom of disposition of the advanced funds.

(c) Any deduction of amounts required by court process to be paid to another, unless, the deduction is in favor of the contractor, subcontractor or any affiliated person, or when collusion or collaboration exists.

(d) Any deduction constituting a contribution on behalf of the person employed to funds established by the employer or representatives of employees, or both, for the purpose of providing either from principal or income, or both, medical or hospital care, pensions, or annuities on retirement, death benefits, compensation for injuries, illness, accidents, sickness,

(k) Any deduction for the cost of safety equipment of nominal value purchased by the

or disability, or for insurance to provide any of the foregoing, or unemployment benefits, vacation pay, savings accounts, or similar payments for the benefit of employees, their families and dependents:

Provided, however, That the following standards are met: (1) The deduction is not otherwise prohibited by law; (2) it is either: (i) Voluntarily consented to by the employee in writing and in advance of the period in which the work is to be done and such consent is not a condition either for the obtaining of or for the continuation of employment, or (ii) provided for in a bona fide collective bargaining agreement between the contractor or subcontractor and representatives of its employees; (3) no profit or other benefit is otherwise obtained, directly or indirectly, by the contractor or subcontractor or any affiliated person in the form of commission, dividend, or otherwise; and (4) the deductions shall serve the convenience and interest of the employee. (e) Any deduction contributing toward the purchase of United States Defense Stamps and Bonds when voluntarily authorized by the employee.

(f) Any deduction requested by the employee to enable him to repay loans to or to purchase shares in credit unions organized and operated in accordance with Federal and State credit union statutes.

(g) Any deduction voluntarily authorized by the employee for the making of contributions to

Copeland Act Regulations

governmental or quasi-governmental agencies, such as the American Red Cross.

(h) Any deduction voluntarily authorized by the employee for the making of contributions to Community Chests, United Givers Funds, and similar charitable organizations.

(i) Any deductions to pay regular union initiation fees and membership dues, not including fines or special assessments: Provided, however, That a collective bargaining agreement between the contractor or subcontractor and representatives of its employees provides for such deductions and the deductions are not otherwise prohibited by law.

(j) Any deduction not more than for the "reasonable cost" of board, lodging, or other facilities meeting the requirements of section 3(m) of the Fair Labor Standards Act of 1938, as amended, and Part 531 of this title. When such a deduction is made the additional records required under §516.27(a) of this title shall be kept.

(k) Any deduction for the cost of safety equipment for his personal protection in his work, such as safety shoes, safety

glasses, safety gloves, and hard hats, if such equipment is not required by law to be furnished by the employer, if such deduction is not violative of the Fair Labor Standards Act or prohibited by other law, if the cost on which the deduction is based does not exceed the actual cost to the employer where the equipment is purchased from him and does not include any direct or indirect monetary return to the employer where the equipment is purchased from a third person, and if the deduction is either (1) voluntarily consented to by the employee in writing and in advance of the period in which the work is to be done and such consent is not a condition either for the obtaining of employment or its continuance; or (2) provided for in a bona fide collective bargaining agreement between the contractor or subcontractor and representatives of its employees. (36 F.R. 9770, May 28, 1971.)

Section 3.6 Payroll deductions permissible with the approval of the Secretary of Labor.

Any contractor or subcontractor may apply to the Secretary of Labor for permission to make any

deduction not permitted under §3.5. The Secretary may grant permission whenever he finds that:

- (a) The contractor, subcontractor, or any affiliated person does not make a profit or benefit

directly or indirectly from the deduction either in the form of a commission, dividend, or otherwise;

- (b) The deduction is not otherwise prohibited by law;

- (c) The deduction is either (1) voluntarily consented to by the employee in writing and in advance of the period in which the work is to be done and such consent is not a condition either for the obtaining of employment or its continuance, or (2) provided for in a bona fide collective bargaining agreement between the contractor or subcontractor and representatives of its employees; and

- (d) The deduction serves the convenience and interest of the employee.

Section 3.7 Applications for the approval of the Secretary of Labor.

Any application for the making of payroll deductions under §3.6 shall comply with the requirements prescribed in the following paragraphs of this section:

- (a) The application shall be in writing and shall be addressed to the Secretary of Labor.

- (b) The application need not identify the

contract or contracts under which the work in question is to be performed. Permission will be given for deductions on all current and future contracts of the applicant for a period of 1 year. A renewal of permission to make such payroll deduction will be granted upon the submission of an application which makes reference to the original application, recites the date of the Secretary of Labor's approval of such deductions, states affirmatively that there is continued compliance with the standards set forth in the provisions of §3.6, and specifies any conditions which have changed in regard to the payroll deductions.

(36 F.R. 9770, May 29, 1971.)

- (c) The application shall state affirmatively that there is compliance with the standards set forth in the provisions of §3.6. The affirmation shall be accompanied by a full statement of the facts indicating such compliance.

Copeland Act Regulations

(d) The application shall include a description of the proposed deduction, the purpose to be served there by, and the classes of laborers or mechanics from whose wages the proposed deduction would be made.

(e) The application shall state the name and business of any third person to whom any funds obtained from the proposed deductions are to be transmitted and the affiliation of such person, if any, with the applicant. -

Section 3.8 Action by the Secretary of Labor upon applications.

The Secretary of Labor shall decide whether or not the requested deduction is permissible under provisions of §3.6; and shall notify the applicant in writing of his decision.

Section 3.9 Prohibited payroll deductions.

Deductions not elsewhere provided for by this part and which **are** not found to be permissible under §3.6 are prohibited.

Section 3.10 Methods of payment of wages.

The payment of wages shall be by cash, negotiable instruments payable on demand, or the additional forms of compensation for which deductions are permissible under this part. No other methods of payment shall be recognized on work subject to the Copeland Act.

Section 3.11 Regulations part of contract.

All contracts made with respect to the construction, prosecution, completion, or repair of any public building or public work or building or work financed in whole or in part by loans or grants from the United States covered by the regulations in this part shall expressly bind the contractor or subcontractor to comply with such of the regulations in this part as may be applicable. In this regard, see §5.5(a) of this subtitle.

STANDARD
GENERAL CONDITIONS
OF THE
CONSTRUCTION CONTRACT

Prepared by

ENGINEERS JOINT CONTRACT DOCUMENTS COMMITTEE

and

Issued and Published Jointly By

PROFESSIONAL ENGINEERS IN PRIVATE PRACTICE
a practice division of the
NATIONAL SOCIETY OF PROFESSIONAL ENGINEERS

AMERICAN CONSULTING ENGINEERS COUNCIL

AMERICAN SOCIETY OF CIVIL ENGINEERS

This document has been approved and endorsed by

The Associated General Contractors of America

Construction Specifications Institute

Copyright ©1996

National Society of Professional Engineers
1420 King Street, Alexandria, VA 22314

American Consulting Engineers Council
1015 15th Street N.W., Washington, DC 20005

American Society of Civil Engineers
345 East 47th Street, New York, NY 10017

TABLE OF CONTENTS

	<u>Page</u>
ARTICLE 1 - DEFINITIONS AND TERMINOLOGY	6
1.01 <i>Defined Terms</i>	6
1.02 <i>Terminology</i>	8
ARTICLE 2 - PRELIMINARY MATTERS	9
2.01 <i>Delivery of Bonds</i>	9
2.02 <i>Copies of Documents</i>	9
2.03 <i>Commencement of Contract Times; Notice to Proceed</i>	9
2.04 <i>Starting the Work</i>	9
2.05 <i>Before Starting Construction</i>	9
2.06 <i>Preconstruction Conference</i>	10
2.07 <i>Initial Acceptance of Schedules</i>	10
ARTICLE 3 - CONTRACT DOCUMENTS: INTENT, AMENDING, REUSE.....	10
3.01 <i>Intent</i>	10
3.02 <i>Reference Standards</i>	10
3.03 <i>Reporting and Resolving Discrepancies</i>	10
3.04 <i>Amending and Supplementing Contract Documents</i>	11
3.05 <i>Reuse of Documents</i>	11
ARTICLE 4 - AVAILABILITY OF LANDS; SUBSURFACE AND PHYSICAL CONDITIONS; REFERENCE POINTS.....	11
4.01 <i>Availability of Lands</i>	11
4.02 <i>Subsurface and Physical Conditions</i>	12
4.03 <i>Differing Subsurface or Physical Conditions</i>	12
4.04 <i>Underground Facilities</i>	13
4.05 <i>Reference Points</i>	13
4.06 <i>Hazardous Environmental Condition at Site</i>	14
ARTICLE 5 - BONDS AND INSURANCE.....	15
5.01 <i>Performance, Payment, and Other Bonds</i>	15
5.02 <i>Licensed Sureties and Insurers</i>	15
5.03 <i>Certificates of Insurance</i>	15
5.04 <i>CONTRACTOR's Liability Insurance</i>	15
5.05 <i>OWNER's Liability Insurance</i>	16
5.06 <i>Property Insurance</i>	16
5.07 <i>Waiver of Rights</i>	17
5.08 <i>Receipt and Application of Insurance Proceeds</i>	18
5.09 <i>Acceptance of Bonds and Insurance; Option to Replace</i>	18
5.10 <i>Partial Utilization, Acknowledgment of Property Insurer</i>	18
ARTICLE 6 - CONTRACTOR'S RESPONSIBILITIES	18
6.01 <i>Supervision and Superintendence</i>	18
6.02 <i>Labor; Working Hours</i>	19
6.03 <i>Services, Materials, and Equipment</i>	19
6.04 <i>Progress Schedule</i>	19
6.05 <i>Substitutes and "Or-Equals"</i>	19
6.06 <i>Concerning Subcontractors, Suppliers, and Others</i>	21

6.07 Patent Fees and Royalties	21
6.08 Permits	22
6.09 Laws and Regulations	22
6.10 Taxes	22
6.11 Use of Site and Other Areas	22
6.12 Record Documents	22
6.13 Safety and Protection	23
6.14 Safety Representative	23
6.15 Hazard Communication Programs	23
6.16 Emergencies	23
6.17 Shop Drawings and Samples	24
6.18 Continuing the Work	25
6.19 CONTRACTOR's General Warranty and Guarantee	25
6.20 Indemnification	25
ARTICLE 7 - OTHER WORK	26
7.01 Related Work at Site	26
7.02 Coordination	26
ARTICLE 8 - OWNER'S RESPONSIBILITIES	27
8.01 Communications to Contractor	27
8.02 Replacement of ENGINEER	27
8.03 Furnish Data	27
8.04 Pay Promptly When Due	27
8.05 Lands and Easements; Reports and Tests	27
8.06 Insurance	27
8.07 Change Orders	27
8.08 Inspections, Tests, and Approvals	27
8.09 Limitations on OWNER's Responsibilities	27
8.10 Undisclosed Hazardous Environmental Condition	27
8.11 Evidence of Financial Arrangements	27
ARTICLE 9 - ENGINEER'S STATUS DURING CONSTRUCTION	27
9.01 OWNER'S Representative	27
9.02 Visits to Site	28
9.03 Project Representative	28
9.04 Clarifications and Interpretations	28
9.05 Authorized Variations in Work	28
9.06 Rejecting Defective Work	29
9.07 Shop Drawings, Change Orders and Payments	29
9.08 Determinations for Unit Price Work	28
9.09 Decisions on Requirements of Contract Documents and Acceptability of Work	28
9.10 Limitations on ENGINEER's Authority and Responsibilities	28
ARTICLE 10 - CHANGES IN THE WORK; CLAIMS	29
10.01 Authorized Changes in the Work	29
10.02 Unauthorized Changes in the Work	29
10.03 Execution of Change Orders	30
10.04 Notification to Surety	30
10.05 Claims and Disputes	30
ARTICLE 11 - COST OF THE WORK; CASH ALLOWANCES; UNIT PRICE WORK	30
11.01 Cost of the Work	30

11.02 <i>Cash Allowances</i>	32
11.03 <i>Unit Price Work</i>	33
ARTICLE 12 - CHANGE OF CONTRACT PRICE; CHANGE OF CONTRACT TIMES	33
12.01 <i>Change of Contract Price</i>	33
12.02 <i>Change of Contract Times</i>	34
12.03 <i>Delays Beyond CONTRACTOR's Control</i>	34
12.04 <i>Delays Within CONTRACTOR's Control</i>	34
12.05 <i>Delays Beyond OWNER's and CONTRACTOR'S Control</i>	34
12.06 <i>Delay Damages</i>	34
ARTICLE 13 - TESTS AND INSPECTIONS; CORRECTION, REMOVAL OR ACCEPTANCE OF DEFECTIVE WORK.....	34
13.01 <i>Notice of Defects</i>	34
13.02 <i>Access to Work</i>	34
13.03 <i>Tests and Inspections</i>	35
13.04 <i>Uncovering Work</i>	35
13.05 <i>OWNER May Stop the Work</i>	35
13.06 <i>Correction or Removal of Defective Work</i>	36
13.07 <i>Correction Period</i>	36
13.08 <i>Acceptance of Defective Work</i>	36
13.09 <i>OWNER May Correct Defective Work</i>	36
ARTICLE 14 - PAYMENTS TO CONTRACTOR AND COMPLETION	37
14.01 <i>Schedule of Values</i>	37
14.02 <i>Progress Payments</i>	37
14.03 <i>CONTRACTOR's Warranty of Title</i>	38
14.04 <i>Substantial Completion</i>	39
14.05 <i>Partial Utilization</i>	39
14.06 <i>Final Inspection</i>	39
14.07 <i>Final Payment</i>	40
14.08 <i>Final Completion Delayed</i>	40
14.09 <i>Waiver of Claims</i>	41
ARTICLE 15 - SUSPENSION OF WORK AND TERMINATION.....	41
15.01 <i>OWNER May Suspend Work</i>	41
15.02 <i>OWNER May Terminate for Cause</i>	41
15.03 <i>OWNER May Terminate For Convenience</i>	41
15.04 <i>CONTRACTOR May Stop Work or Terminate</i>	42
ARTICLE 16 - DISPUTE RESOLUTION	42
16.01 <i>Methods and Procedures</i>	42
ARTICLE 17 - MISCELLANEOUS.....	43
17.01 <i>Giving Notice</i>	43
17.02 <i>Computation of Times</i>	43
17.03 <i>Cumulative Remedies</i>	43
17.04 <i>Survival of Obligations</i>	43
17.05 <i>Controlling Law</i>	43

GENERAL CONDITIONS

ARTICLE 1 - DEFINITIONS AND TERMINOLOGY

1.01 *Defined Terms*

A. Wherever used in the Contract Documents and printed with initial or all capital letters, the terms listed below will have the meanings indicated which are applicable to both the singular and plural thereof.

1. *Addenda*--Written or graphic instruments issued prior to the opening of Bids which clarify, correct, or change the Bidding Requirements or the Contract Documents.

2. *Agreement*--The written instrument which is evidence of the agreement between OWNER and CONTRACTOR covering the Work.

3. *Application for Payment*--The form acceptable to ENGINEER which is to be used by CONTRACTOR during the course of the Work in requesting progress or final payments and which is to be accompanied by such supporting documentation as is required by the Contract Documents.

4. *Asbestos*--Any material that contains more than one percent asbestos and is friable or is releasing asbestos fibers into the air above current action levels established by the United States Occupational Safety and Health Administration.

5. *Bid*--The offer or proposal of a bidder submitted on the prescribed form setting forth the prices for the Work to be performed.

6. *Bidding Documents*--The Bidding Requirements and the proposed Contract Documents (including all Addenda issued prior to receipt of Bids).

7. *Bidding Requirements*--The Advertisement or Invitation to Bid, Instructions to Bidders, Bid security form, if any, and the Bid form with any supplements.

8. *Bonds*--Performance and payment bonds and other instruments of security.

9. *Change Order*--A document recommended by ENGINEER which is signed by CONTRACTOR and OWNER and authorizes an addition, deletion, or revision in the Work or an adjustment in the Contract Price or the

Contract Times, issued on or after the Effective Date of the Agreement.

10. *Claim*--A demand or assertion by OWNER or CONTRACTOR seeking an adjustment of Contract Price or Contract Times, or both, or other relief with respect to the terms of the Contract. A demand for money or services by a third party is not a Claim.

11. *Contract*--The entire and integrated written agreement between the OWNER and CONTRACTOR concerning the Work. The Contract supersedes prior negotiations, representations, or agreements, whether written or oral.

12. *Contract Documents*--The Contract Documents establish the rights and obligations of the parties and include the Agreement, Addenda (which pertain to the Contract Documents), CONTRACTOR's Bid (including documentation accompanying the Bid and any post Bid documentation submitted prior to the Notice of Award) when attached as an exhibit to the Agreement, the Notice to Proceed, the Bonds, these General Conditions, the Supplementary Conditions, the Specifications and the Drawings as the same are more specifically identified in the Agreement, together with all Written Amendments, Change Orders, Work Change Directives, Field Orders, and ENGINEER's written interpretations and clarifications issued on or after the Effective Date of the Agreement. Approved Shop Drawings and the reports and drawings of subsurface and physical conditions are not Contract Documents. Only printed or hard copies of the items listed in this paragraph are Contract Documents. Files in electronic media format of text, data, graphics, and the like that may be furnished by OWNER to CONTRACTOR are not Contract Documents.

13. *Contract Price*--The moneys payable by OWNER to CONTRACTOR for completion of the Work in accordance with the Contract Documents as stated in the Agreement (subject to the provisions of paragraph 11.03 in the case of Unit Price Work).

14. *Contract Times*--The number of days or the dates stated in the Agreement to: (i) achieve Substantial Completion; and (ii) complete the Work so that it is ready for final payment as evidenced by ENGINEER's written recommendation of final payment.

15. *CONTRACTOR*--The individual or entity with whom OWNER has entered into the Agreement.

16. *Cost of the Work*--See paragraph 11.01.A for definition.

17. *Drawings*--That part of the Contract Documents prepared or approved by ENGINEER which graphically shows the scope, extent, and character of the Work to be performed by CONTRACTOR. Shop Drawings and other CONTRACTOR submittals are not Drawings as so defined.

18. *Effective Date of the Agreement*--The date indicated in the Agreement on which it becomes effective, but if no such date is indicated, it means the date on which the Agreement is signed and delivered by the last of the two parties to sign and deliver.

19. *ENGINEER*--The individual or entity named as such in the Agreement.

20. *ENGINEER's Consultant*--An individual or entity having a contract with ENGINEER to furnish services as ENGINEER's independent professional associate or consultant with respect to the Project and who is identified as such in the Supplementary Conditions.

21. *Field Order*--A written order issued by ENGINEER which requires minor changes in the Work but which does not involve a change in the Contract Price or the Contract Times.

22. *General Requirements*--Sections of Division 1 of the Specifications. The General Requirements pertain to all sections of the Specifications.

23. *Hazardous Environmental Condition*--The presence at the Site of Asbestos, PCBs, Petroleum, Hazardous Waste, or Radioactive Material in such quantities or circumstances that may present a substantial danger to persons or property exposed thereto in connection with the Work.

24. *Hazardous Waste*--The term Hazardous Waste shall have the meaning provided in Section 1004 of the Solid Waste Disposal Act (42 USC Section 6903) as amended from time to time.

25. *Laws and Regulations; Laws or Regulations*--Any and all applicable laws, rules, regulations, ordinances, codes, and orders of any and all governmental bodies, agencies, authorities, and courts having jurisdiction.

26. *Liens*--Charges, security interests, or encumbrances upon Project funds, real property, or personal property.

27. *Milestone*--A principal event specified in the Contract Documents relating to an intermediate completion date or time prior to Substantial Completion of all the Work.

28. *Notice of Award*--The written notice by OWNER to the apparent successful bidder stating that upon timely compliance by the apparent successful bidder with the conditions precedent listed therein, OWNER will sign and deliver the Agreement.

29. *Notice to Proceed*--A written notice given by OWNER to CONTRACTOR fixing the date on which the Contract Times will commence to run and on which CONTRACTOR shall start to perform the Work under the Contract Documents.

30. *OWNER*--The individual, entity, public body, or authority with whom CONTRACTOR has entered into the Agreement and for whom the Work is to be performed.

31. *Partial Utilization*--Use by OWNER of a substantially completed part of the Work for the purpose for which it is intended (or a related purpose) prior to Substantial Completion of all the Work.

32. *PCBs*--Polychlorinated biphenyls.

33. *Petroleum*--Petroleum, including crude oil or any fraction thereof which is liquid at standard conditions of temperature and pressure (60 degrees Fahrenheit and 14.7 pounds per square inch absolute), such as oil, petroleum, fuel oil, oil sludge, oil refuse, gasoline, kerosene, and oil mixed with other non-Hazardous Waste and crude oils.

34. *Project*--The total construction of which the Work to be performed under the Contract Documents may be the whole, or a part as may be indicated elsewhere in the Contract Documents.

35. *Project Manual*--The bound documentary information prepared for bidding and constructing the Work. A listing of the contents of the Project Manual, which may be bound in one or more volumes, is contained in the table(s) of contents.

36. *Radioactive Material*--Source, special nuclear, or byproduct material as defined by the Atomic Energy Act of 1954 (42 USC Section 2011 et seq.) as amended from time to time.

37. *Resident Project Representative*--The authorized representative of ENGINEER who may be assigned to the Site or any part thereof.

38. *Samples*--Physical examples of materials, equipment, or workmanship that are representative of some portion of the Work and which establish the standards by which such portion of the Work will be judged.

39. *Shop Drawings*--All drawings, diagrams, illustrations, schedules, and other data or information which are specifically prepared or assembled by or for CONTRACTOR and submitted by CONTRACTOR to illustrate some portion of the Work.

40. *Site*--Lands or areas indicated in the Contract Documents as being furnished by OWNER upon which the Work is to be performed, including rights-of-way and easements for access thereto, and such other lands furnished by OWNER which are designated for the use of CONTRACTOR.

41. *Specifications*--That part of the Contract Documents consisting of written technical descriptions of materials, equipment, systems, standards, and workmanship as applied to the Work and certain administrative details applicable thereto.

42. *Subcontractor*--An individual or entity having a direct contract with CONTRACTOR or with any other Subcontractor for the performance of a part of the Work at the Site.

43. *Substantial Completion*--The time at which the Work (or a specified part thereof) has progressed to the point where, in the opinion of ENGINEER, the Work (or a specified part thereof) is sufficiently complete, in accordance with the Contract Documents, so that the Work (or a specified part thereof) can be utilized for the purposes for which it is intended. The terms "substantially complete" and "substantially completed" as applied to all or part of the Work refer to Substantial Completion thereof.

44. *Supplementary Conditions*--That part of the Contract Documents which amends or supplements these General Conditions.

45. *Supplier*--A manufacturer, fabricator, supplier, distributor, materialman, or vendor having a direct contract with CONTRACTOR or with any Subcontractor to furnish materials or equipment to be incorporated in the Work by CONTRACTOR or any Subcontractor.

46. *Underground Facilities*--All underground pipelines, conduits, ducts, cables, wires, manholes, vaults, tanks, tunnels, or other such facilities or attachments, and any encasements containing such facilities, including those that convey electricity, gases, steam, liquid petroleum products, telephone or other communications, cable television, water, wastewater, storm water, other liquids or chemicals, or traffic or other control systems.

47. *Unit Price Work*--Work to be paid for on the basis of unit prices.

48. *Work*--The entire completed construction or the various separately identifiable parts thereof required to be provided under the Contract Documents. Work includes and is the result of performing or providing all labor, services, and documentation necessary to produce such construction, and furnishing, installing, and incorporating all materials and equipment into such construction, all as required by the Contract Documents.

49. *Work Change Directive*--A written statement to CONTRACTOR issued on or after the Effective Date of the Agreement and signed by OWNER and recommended by ENGINEER ordering an addition, deletion, or revision in the Work, or responding to differing or unforeseen subsurface or physical conditions under which the Work is to be performed or to emergencies. A Work Change Directive will not change the Contract Price or the Contract Times but is evidence that the parties expect that the change ordered or documented by a Work Change Directive will be incorporated in a subsequently issued Change Order following negotiations by the parties as to its effect, if any, on the Contract Price or Contract Times.

50. *Written Amendment*--A written statement modifying the Contract Documents, signed by OWNER and CONTRACTOR on or after the Effective Date of the Agreement and normally dealing with the nonengineering or nontechnical rather than strictly construction-related aspects of the Contract Documents.

1.02 Terminology

A. Intent of Certain Terms or Adjectives

1. Whenever in the Contract Documents the terms "as allowed," "as approved," or terms of like effect or import are used, or the adjectives "reasonable," "suitable," "acceptable," "proper," "satisfactory," or adjectives of like effect or import are used to describe an action or determination of ENGINEER as to the Work, it is intended that such action or determination will be solely to evaluate, in general, the completed Work for compliance with the requirements of and information in the Contract Documents and conformance with the design concept of the completed Project as a functioning whole as shown or indicated in the Contract Documents (unless there is a specific statement indicating otherwise). The use of any such term or adjective shall not be effective to assign to ENGINEER any duty or authority to supervise or direct the performance of the Work or any duty or authority to undertake responsibility contrary to the provisions of paragraph 9.10 or any other provision of the Contract Documents.

B. Day

1. The word "day" shall constitute a calendar day of 24 hours measured from midnight to the next midnight.

C. Defective

1. The word "defective," when modifying the word "Work," refers to Work that is unsatisfactory, faulty, or deficient in that it does not conform to the Contract Documents or does not meet the requirements of any inspection, reference standard, test, or approval referred to in the Contract Documents, or has been damaged prior to ENGINEER's recommendation of final payment (unless responsibility for the protection thereof has been assumed by OWNER at Substantial Completion in accordance with paragraph 14.04 or 14.05).

D. Furnish, Install, Perform, Provide

1. The word "furnish," when used in connection with services, materials, or equipment, shall mean to supply and deliver said services, materials, or equipment to the Site (or some other

specified location) ready for use or installation and in usable or operable condition.

2. The word "install," when used in connection with services, materials, or equipment, shall mean to put into use or place in final position said services, materials, or equipment complete and ready for intended use.

3. The words "perform" or "provide," when used in connection with services, materials, or equipment, shall mean to furnish and install said services, materials, or equipment complete and ready for intended use.

4. When "furnish," "install," "perform," or "provide" is not used in connection with services, materials, or equipment in a context clearly requiring an obligation of CONTRACTOR, "provide" is implied.

E. Unless stated otherwise in the Contract Documents, words or phrases which have a well-known technical or construction industry or trade meaning are used in the Contract Documents in accordance with such recognized meaning.

ARTICLE 2 - PRELIMINARY MATTERS

2.01 Delivery of Bonds

A. When CONTRACTOR delivers the executed Agreements to OWNER, CONTRACTOR shall also deliver to OWNER such Bonds as CONTRACTOR may be required to furnish.

2.02* Copies of Documents

A. OWNER shall furnish to CONTRACTOR up to ten copies of the Contract Documents. Additional copies will be furnished upon request at the cost of reproduction.

2.03 Commencement of Contract Times; Notice to Proceed

A. The Contract Times will commence to run on the thirtieth day after the Effective Date of the Agreement or, if a Notice to Proceed is given, on the day indicated in the Notice to Proceed. A Notice to Proceed may be given at any time within 30 days after the Effective Date of the Agreement. In no event will the Contract Times com-

mence to run later than the sixtieth day after the day of Bid opening or the thirtieth day after the Effective Date of the Agreement, whichever date is earlier.

2.04 *Starting the Work*

A. CONTRACTOR shall start to perform the Work on the date when the Contract Times commence to run. No Work shall be done at the Site prior to the date on which the Contract Times commence to run.

*See Supplementary Conditions

2.05* *Before Starting Construction*

A. *CONTRACTOR's Review of Contract Documents:* Before undertaking each part of the Work, CONTRACTOR shall carefully study and compare the Contract Documents and check and verify pertinent figures therein and all applicable field measurements. CONTRACTOR shall promptly report in writing to ENGINEER any conflict, error, ambiguity, or discrepancy which CONTRACTOR may discover and shall obtain a written interpretation or clarification from ENGINEER before proceeding with any Work affected thereby; however, CONTRACTOR shall not be liable to OWNER or ENGINEER for failure to report any conflict, error, ambiguity, or discrepancy in the Contract Documents unless CONTRACTOR knew or reasonably should have known thereof.

B. *Preliminary Schedules:* Within ten days after the Effective Date of the Agreement (unless otherwise specified in the General Requirements), CONTRACTOR shall submit to ENGINEER for its timely review:

1. a preliminary progress schedule indicating the times (numbers of days or dates) for starting and completing the various stages of the Work, including any Milestones specified in the Contract Documents;
2. a preliminary schedule of Shop Drawing and Sample submittals which will list each required submittal and the times for submitting, reviewing, and processing such submittal; and
3. a preliminary schedule of values for all of the Work which includes quantities and prices of items which when added together equal the Contract Price and subdivides the Work into

component parts in sufficient detail to serve as the basis for progress payments during performance of the Work. Such prices will include an appropriate amount of overhead and profit applicable to each item of Work.

* C. *Evidence of Insurance:* Before any Work at the Site is started, CONTRACTOR and OWNER shall each deliver to the other, with copies to each additional insured identified in the Supplementary Conditions, certificates of insurance (and other evidence of insurance which either of them or any additional insured may reasonably request) which CONTRACTOR and OWNER respectively are required to purchase and maintain in accordance with Article 5.

2.06 *Preconstruction Conference*

A. Within 20 days after the Contract Times start to run, but before any Work at the Site is started, a conference attended by CONTRACTOR, ENGINEER, and others as appropriate will be held to establish a working understanding among the parties as to the Work and to discuss the schedules referred to in paragraph 2.05.B, procedures for handling Shop Drawings and other submittals, processing Applications for Payment, and maintaining required records.

2.07 *Initial Acceptance of Schedules*

A. Unless otherwise provided in the Contract Documents, at least ten days before submission of the first Application for Payment a conference attended by CONTRACTOR, ENGINEER, and others as appropriate will be held to review for acceptability to ENGINEER as provided below the schedules submitted in accordance with paragraph 2.05.B. CONTRACTOR shall have an additional ten days to make corrections and adjustments and to complete and resubmit the schedules. No progress payment shall be made to CONTRACTOR until acceptable schedules are submitted to ENGINEER.

1. The progress schedule will be acceptable to ENGINEER if it provides an orderly progression of the Work to completion within any specified Milestones and the Contract Times. Such acceptance will not impose on ENGINEER responsibility for the progress schedule, for sequencing, scheduling, or progress of the Work nor interfere with or relieve CONTRACTOR from CONTRACTOR's full responsibility therefor.

2. CONTRACTOR's schedule of Shop Drawing and Sample submittals will be acceptable to ENGINEER if it provides a workable arrangement for reviewing and processing the required submittals.

3. CONTRACTOR's schedule of values will be acceptable to ENGINEER as to form and substance if it provides a reasonable allocation of the Contract Price to component parts of the Work.

*See Supplementary Conditions

ARTICLE 3 - CONTRACT DOCUMENTS: INTENT, AMENDING, REUSE

3.01* *Intent*

A. The Contract Documents are complementary; what is called for by one is as binding as if called for by all.

B. It is the intent of the Contract Documents to describe a functionally complete Project (or part thereof) to be constructed in accordance with the Contract Documents. Any labor, documentation, services, materials, or equipment that may reasonably be inferred from the Contract Documents or from prevailing custom or trade usage as being required to produce the intended result will be provided whether or not specifically called for at no additional cost to OWNER.

C. Clarifications and interpretations of the Contract Documents shall be issued by ENGINEER as provided in Article 9.

3.02 *Reference Standards*

A. *Standards, Specifications, Codes, Laws, and Regulations*

1. Reference to standards, specifications, manuals, or codes of any technical society, organization, or association, or to Laws or Regulations, whether such reference be specific or by implication, shall mean the standard, specification, manual, code, or Laws or Regulations in effect at the time of opening of Bids (or on the Effective Date of the Agreement if there were no Bids), except as may be otherwise specifically stated in the Contract Documents.

2. No provision of any such standard, specification, manual or code, or any instruction of a Supplier shall be effective to change the duties or responsibilities of OWNER, CONTRACTOR, or ENGINEER, or any of their subcontractors, consultants, agents, or employees from those set forth in the Contract Documents, nor shall any such provision or instruction be effective to assign to OWNER, ENGINEER, or any of ENGINEER's Consultants, agents, or employees any duty or authority to supervise or direct the performance of the Work or any duty or authority to undertake responsibility inconsistent with the provisions of the Contract Documents.

3.03 *Reporting and Resolving Discrepancies*

A. *Reporting Discrepancies*

1. If, during the performance of the Work, CONTRACTOR discovers any conflict, error, ambiguity, or discrepancy within the Contract Documents or between the Contract Documents and any provision of any Law or Regulation applicable to the performance of the Work or of any standard, specification, manual or code, or of any instruction of any Supplier, CONTRACTOR shall report it to ENGINEER in writing at once. CONTRACTOR shall not proceed with the Work affected thereby (except in an emergency as required by paragraph 6.16.A) until an amendment or supplement to the Contract Documents has been issued by one of the methods indicated in paragraph 3.04; provided, however, that CONTRACTOR shall not be liable to OWNER or ENGINEER for failure to report any such conflict, error, ambiguity, or discrepancy unless CONTRACTOR knew or reasonably should have known thereof.

B. *Resolving Discrepancies*

1. Except as may be otherwise specifically stated in the Contract Documents, the provisions of the Contract Documents shall take precedence in resolving any conflict, error, ambiguity, or discrepancy between the provisions of the Contract Documents and:

a. the provisions of any standard, specification, manual, code, or instruction (whether or not specifically incorporated by reference in the Contract Documents); or

b. the provisions of any Laws or Regulations applicable to the performance of the Work (unless such an interpretation of the provisions of the Contract Documents would result in violation of such Law or Regulation).

3.04 *Amending and Supplementing Contract Documents*

A. The Contract Documents may be amended to provide for additions, deletions, and revisions in the Work or to modify the terms and conditions thereof in one or

*See Supplementary Conditions

B. The requirements of the Contract Documents may be supplemented, and minor variations and deviations in the Work may be authorized, by one or more of the following ways: (i) a Field Order; (ii) ENGINEER's approval of a Shop Drawing or Sample; or (iii) ENGINEER's written interpretation or clarification.

3.05 *Reuse of Documents*

A. CONTRACTOR and any Subcontractor or Supplier or other individual or entity performing or furnishing any of the Work under a direct or indirect contract with OWNER: (i) shall not have or acquire any title to or ownership rights in any of the Drawings, Specifications, or other documents (or copies of any thereof) prepared by or bearing the seal of ENGINEER or ENGINEER's Consultant, including electronic media editions; and (ii) shall not reuse any of such Drawings, Specifications, other documents, or copies thereof on extensions of the Project or any other project without written consent of OWNER and ENGINEER and specific written verification or adaption by ENGINEER. This prohibition will survive final payment, completion, and acceptance of the Work, or termination or completion of the Contract. Nothing herein shall preclude CONTRACTOR from retaining copies of the Contract Documents for record purposes.

ARTICLE 4 - AVAILABILITY OF LANDS; SUBSURFACE AND PHYSICAL CONDITIONS; REFERENCE POINTS

4.01 *Availability of Lands*

A. OWNER shall furnish the Site. OWNER shall notify CONTRACTOR of any encumbrances or

restrictions not of general application but specifically related to use of the Site with which CONTRACTOR must comply in performing the Work. OWNER will obtain in a timely manner and pay for easements for permanent structures or permanent changes in existing facilities. If CONTRACTOR and OWNER are unable to agree on entitlement to or on the amount or extent, if any, of any adjustment in the Contract Price or Contract Times, or both, as a result of any delay in OWNER's furnishing the Site, CONTRACTOR may make a Claim therefor as provided in paragraph 10.05.

B. Upon reasonable written request, OWNER shall furnish CONTRACTOR with a current statement of record legal title and legal description of the lands upon which the Work is to be performed and OWNER's interest therein as necessary for giving notice of or filing a mechanic's or construction lien against such lands in accordance with applicable Laws and Regulations.

C. CONTRACTOR shall provide for all additional lands and access thereto that may be required for temporary construction facilities or storage of materials and equipment.

4.02* *Subsurface and Physical Conditions*

A.* *Reports and Drawings:* The Supplementary Conditions identify:

1. those reports of explorations and tests of subsurface conditions at or contiguous to the Site that ENGINEER has used in preparing the Contract Documents; and

2. those drawings of physical conditions in or relating to existing surface or subsurface structures at or contiguous to the Site (except Underground Facilities) that ENGINEER has used in preparing the Contract Documents.

B. *Limited Reliance by CONTRACTOR on Technical Data Authorized:* CONTRACTOR may rely upon the general accuracy of the "technical data" contained in such reports and drawings, but such reports and drawings are not Contract Documents. Such "technical data" is identified in the Supplementary Conditions. Except for such reliance on such "technical data," CONTRACTOR may not rely upon or make any Claim against OWNER, ENGINEER, or any of ENGINEER's Consultants with respect to:

1. the completeness of such reports and drawings for CONTRACTOR's purposes, includ-

ing, but not limited to, any aspects of the means, methods, techniques, sequences, and procedures of construction to be employed by CONTRACTOR, and safety precautions and programs incident thereto; or

2. other data, interpretations, opinions, and information contained in such reports or shown or indicated in such drawings; or

3. any CONTRACTOR interpretation of or conclusion drawn from any "technical data" or any such other data, interpretations, opinions, or information.

*See Supplementary Conditions

4.03 *Differing Subsurface or Physical Conditions*

A. *Notice:* If CONTRACTOR believes that any subsurface or physical condition at or contiguous to the Site that is uncovered or revealed either:

1. is of such a nature as to establish that any "technical data" on which CONTRACTOR is entitled to rely as provided in paragraph 4.02 is materially inaccurate; or

2. is of such a nature as to require a change in the Contract Documents; or

3. differs materially from that shown or indicated in the Contract Documents; or

4. is of an unusual nature, and differs materially from conditions ordinarily encountered and generally recognized as inherent in work of the character provided for in the Contract Documents; then CONTRACTOR shall, promptly after becoming aware thereof and before further disturbing the subsurface or physical conditions or performing any Work in connection therewith (except in an emergency as required by paragraph 6.16.A), notify OWNER and ENGINEER in writing about such condition. CONTRACTOR shall not further disturb such condition or perform any Work in connection therewith (except as aforesaid) until receipt of written order to do so.

B. *ENGINEER's Review:* After receipt of written notice as required by paragraph 4.03.A, ENGINEER will promptly review the pertinent condition, determine the

necessity of OWNER's obtaining additional exploration or tests with respect thereto, and advise OWNER in writing (with a copy to CONTRACTOR) of ENGINEER's findings and conclusions.

C. *Possible Price and Times Adjustments*

1. The Contract Price or the Contract Times, or both, will be equitably adjusted to the extent that the existence of such differing subsurface or physical condition causes an increase or decrease in CONTRACTOR's cost of, or time required for, performance of the Work; subject, however, to the following:

a. such condition must meet any one or more of the categories described in paragraph 4.03.A; and

b. with respect to Work that is paid for on a Unit Price Basis, any adjustment in Contract Price will be subject to the provisions of paragraphs 9.08 and 11.03.

2. CONTRACTOR shall not be entitled to any adjustment in the Contract Price or Contract Times if:

a. CONTRACTOR knew of the existence of such conditions at the time CONTRACTOR made a final commitment to OWNER in respect of Contract Price and Contract Times by the submission of a Bid or becoming bound under a negotiated contract; or

b. the existence of such condition could reasonably have been discovered or revealed as a result of any examination, investigation, exploration, test, or study of the Site and contiguous areas required by the Bidding Requirements or Contract Documents to be conducted by or for CONTRACTOR prior to CONTRACTOR's making such final commitment; or

c. CONTRACTOR failed to give the written notice within the time and as required by paragraph 4.03.A.

3. If OWNER and CONTRACTOR are unable to agree on entitlement to or on the amount or extent, if any, of any adjustment in the Contract Price or Contract Times, or both, a Claim may be

made therefor as provided in paragraph 10.05. However, OWNER, ENGINEER, and ENGINEER's Consultants shall not be liable to CONTRACTOR for any claims, costs, losses, or damages (including but not limited to all fees and charges of engineers, architects, attorneys, and other professionals and all court or arbitration or other dispute resolution costs) sustained by CONTRACTOR on or in connection with any other project or anticipated project.

4.04 *Underground Facilities*

A. *Shown or Indicated:* The information and data shown or indicated in the Contract Documents with respect to existing Underground Facilities at or contiguous to the Site is based on information and data furnished to OWNER or ENGINEER by the owners of such Underground Facilities, including OWNER, or by others. Unless it is otherwise expressly provided in the Supplementary Conditions:

1. OWNER and ENGINEER shall not be responsible for the accuracy or completeness of any such information or data; and

2. the cost of all of the following will be included in the Contract Price, and CONTRACTOR shall have full responsibility for:

a. reviewing and checking all such information and data,

b. locating all Underground Facilities shown or indicated in the Contract Documents,

c. coordination of the Work with the owners of such Underground Facilities, including OWNER, during construction, and

d. the safety and protection of all such Underground Facilities and repairing any damage thereto resulting from the Work.

B. *Not Shown or Indicated*

1. If an Underground Facility is uncovered or revealed at or contiguous to the Site which was not shown or indicated, or not shown or indicated with reasonable accuracy in the Contract Documents, CONTRACTOR shall, promptly after becoming aware thereof and before further disturbing conditions affected thereby or

performing any Work in connection therewith (except in an emergency as required by paragraph 6.16.A), identify the owner of such Underground Facility and give written notice to that owner and to OWNER and ENGINEER. ENGINEER will promptly review the Underground Facility and determine the extent, if any, to which a change is required in the Contract Documents to reflect and document the consequences of the existence or location of the Underground Facility. During such time, CONTRACTOR shall be responsible for the safety and protection of such Underground Facility.

2. If ENGINEER concludes that a change in the Contract Documents is required, a Work Change Directive or a Change Order will be issued to reflect and document such consequences. An equitable adjustment shall be made in the Contract Price of Contract Times, or both, to the extent that they are attributable to the existence or location of any Underground Facility that was not shown or indicated or not shown or indicated with reasonable accuracy in the Contract Documents and that CONTRACTOR did not know of and could not reasonably have been expected to be aware of or to have anticipated. If OWNER and CONTRACTOR are unable to agree on entitlement to or on the amount or extent, if any, of any such adjustment in Contract Price or Contract Times, OWNER or CONTRACTOR may make a Claim therefor as provided in paragraph 10.05.

4.05* *Reference Points*

A. OWNER shall provide engineering surveys to establish reference points for construction which in ENGINEER's judgment are necessary to enable CONTRACTOR to proceed with the Work. CONTRACTOR shall be responsible for laying out the Work, shall protect and preserve the established reference points and property monuments, and shall make no changes or relocations without the prior written approval of OWNER.

CONTRACTOR shall report to ENGINEER whenever any reference point or property monument is lost or destroyed or requires relocation because of necessary changes in grades or locations, and shall be responsible for the accurate replacement or relocation of such reference points or property monuments by professionally qualified personnel.

4.06 *Hazardous Environmental Condition at Site*

A. *Reports and Drawings*: Reference is made to the Supplementary Conditions for the identification of those reports and drawings relating to a Hazardous Environmental Condition identified at the Site, if any, that have been utilized by the ENGINEER in the preparation of the Contract Documents.

B. *Limited Reliance by CONTRACTOR on Technical Data Authorized*: CONTRACTOR may rely upon the general accuracy of the "technical data" contained in such reports and drawings, but such reports and drawings are not Contract Documents. Such "technical data" is identified in the Supplementary Conditions. Except for such reliance on such "technical data," CONTRACTOR may not rely upon or make any Claim against OWNER, ENGINEER or any of ENGINEER's Consultants with respect to:

1. the completeness of such reports and drawings for CONTRACTOR's purposes, including, but not limited to, any aspects of the means, methods, techniques, sequences and procedures of construction to be employed by CONTRACTOR and safety precautions and programs incident thereto; or

*See Supplementary Conditions

2. other data, interpretations, opinions and information contained in such reports or shown or indicated in such drawings; or

3. any CONTRACTOR interpretation of or conclusion drawn from any "technical data" or any such other data, interpretations, opinions or information.

C. CONTRACTOR shall not be responsible for any Hazardous Environmental Condition uncovered or revealed at the Site which was not shown or indicated in Drawings or Specifications or identified in the Contract Documents to be within the scope of the Work. CONTRACTOR shall be responsible for a Hazardous Environmental Condition created with any materials brought to the Site by CONTRACTOR, Subcontractors, Suppliers, or anyone else for whom CONTRACTOR is responsible.

D. If CONTRACTOR encounters a Hazardous Environmental Condition or if CONTRACTOR or anyone for whom CONTRACTOR is responsible creates a Hazardous Environmental Condition, CONTRACTOR shall immediately: (i) secure or otherwise isolate such condition;

(ii) stop all Work in connection with such condition and in any area affected thereby (except in an emergency as required by paragraph 6.16); and (iii) notify OWNER and ENGINEER (and promptly thereafter confirm such notice in writing). OWNER shall promptly consult with ENGINEER concerning the necessity for OWNER to retain a qualified expert to evaluate such condition or take corrective action, if any.

E. CONTRACTOR shall not be required to resume Work in connection with such condition or in any affected area until after OWNER has obtained any required permits related thereto and delivered to CONTRACTOR written notice: (i) specifying that such condition and any affected area is or has been rendered safe for the resumption of Work; or (ii) specifying any special conditions under which such Work may be resumed safely. If OWNER and CONTRACTOR cannot agree as to entitlement to or on the amount or extent, if any, of any adjustment in Contract Price or Contract Times, or both, as a result of such Work stoppage or such special conditions under which Work is agreed to be resumed by CONTRACTOR, either party may make a Claim therefor as provided in paragraph 10.05.

F. If after receipt of such written notice CONTRACTOR does not agree to resume such Work based on a reasonable belief it is unsafe, or does not agree to resume such Work under such special conditions, then OWNER may order the portion of the Work that is in the area affected by such condition to be deleted from the Work. If OWNER and CONTRACTOR cannot agree as to entitlement to or on the amount or extent, if any, of an adjustment in Contract Price or Contract Times as a result of deleting such portion of the Work, then either party may make a Claim therefor as provided in paragraph 10.05. OWNER may have such deleted portion of the Work performed by OWNER's own forces or others in accordance with Article 7.

G. To the fullest extent permitted by Laws and Regulations, OWNER shall indemnify and hold harmless CONTRACTOR, Subcontractors, ENGINEER, ENGINEER's Consultants and the officers, directors, partners, employees, agents, other consultants, and subcontractors of each and any of them from and against all claims, costs, losses, and damages (including but not limited to all fees and charges of engineers, architects, attorneys, and other professionals and all court or arbitration or other dispute resolution costs) arising out of or relating to a Hazardous Environmental Condition, provided that such Hazardous Environmental Condition: (i) was not shown or indicated in the Drawings or

Specifications or identified in the Contract Documents to be included within the scope of the Work, and (ii) was not created by CONTRACTOR or by anyone for whom CONTRACTOR is responsible. Nothing in this paragraph 4.06.E shall obligate OWNER to indemnify any individual or entity from and against the consequences of that individual's or entity's own negligence.

H. To the fullest extent permitted by Laws and Regulations, CONTRACTOR shall indemnify and hold harmless OWNER, ENGINEER, ENGINEER's Consultants, and the officers, directors, partners, employees, agents, other consultants, and subcontractors of each and any of them from and against all claims, costs, losses, and damages (including but not limited to all fees and charges of engineers, architects, attorneys, and other professionals and all court or arbitration or other dispute resolution costs) arising out of or relating to a Hazardous Environmental Condition created by CONTRACTOR or by anyone for whom CONTRACTOR is responsible. Nothing in this paragraph 4.06.F shall obligate CONTRACTOR to indemnify any individual or entity from and against the consequences of that individual's or entity's own negligence.

I. The provisions of paragraphs 4.02, 4.03, and 4.04 are not intended to apply to a Hazardous Environmental Condition uncovered or revealed at the Site.

*See Supplementary Conditions

ARTICLE 5 - BONDS AND INSURANCE

5.01* *Performance, Payment, and Other Bonds*

A. CONTRACTOR shall furnish performance and payment Bonds, each in an amount at least equal to the Contract Price as security for the faithful performance and payment of all CONTRACTOR's obligations under the Contract Documents. These Bonds shall remain in effect at least until one year after the date when final payment becomes due, except as provided otherwise by Laws or Regulations or by the Contract Documents. CONTRACTOR shall also furnish such other Bonds as are required by the Contract Documents.

B.* All Bonds shall be in the form prescribed by the Contract Documents except as provided otherwise by Laws or Regulations, and shall be executed by such sureties as are named in the current list of "Companies Holding Certificates of Authority as Acceptable Sureties on Federal Bonds and as Acceptable Reinsuring Compa-

nies" as published in Circular 570 (amended) by the Financial Management Service, Surety Bond Branch, U.S. Department of the Treasury. All Bonds signed by an agent must be accompanied by a certified copy of such agent's authority to act.

C. If the surety on any Bond furnished by CONTRACTOR is declared bankrupt or becomes insolvent or its right to do business is terminated in any state where any part of the Project is located or it ceases to meet the requirements of paragraph 5.01.B, CONTRACTOR shall within 20 days thereafter substitute another Bond and surety, both of which shall comply with the requirements of paragraphs 5.01.B and 5.02.

5.02 *Licensed Sureties and Insurers*

A. All Bonds and insurance required by the Contract Documents to be purchased and maintained by OWNER or CONTRACTOR shall be obtained from surety or insurance companies that are duly licensed or authorized in the jurisdiction in which the Project is located to issue Bonds or insurance policies for the limits and coverages so required. Such surety and insurance companies shall also meet such additional requirements and qualifications as may be provided in the Supplementary Conditions.

5.03 *Certificates of Insurance*

A. CONTRACTOR shall deliver to OWNER, with copies to each additional insured identified in the Supplementary Conditions, certificates of insurance (and other evidence of insurance requested by OWNER or any other additional insured) which CONTRACTOR is required to purchase and maintain. OWNER shall deliver to CONTRACTOR, with copies to each additional insured identified in the Supplementary Conditions, certificates of insurance (and other evidence of insurance requested by CONTRACTOR or any other additional insured) which OWNER is required to purchase and maintain.

5.04* *CONTRACTOR's Liability Insurance*

A. CONTRACTOR shall purchase and maintain such liability and other insurance as is appropriate for the Work being performed and as will provide protection from claims set forth below which may arise out of or result from CONTRACTOR's performance of the Work and CONTRACTOR's other obligations under the Contract Documents, whether it is to be performed by CONTRACTOR, any Subcontractor or Supplier, or by anyone directly or indirectly employed by any of them to

perform any of the Work, or by anyone for whose acts any of them may be liable:

1. claims under workers' compensation, disability benefits, and other similar employee benefit acts;
2. claims for damages because of bodily injury, occupational sickness or disease, or death of CONTRACTOR's employees;
3. claims for damages because of bodily injury, sickness or disease, or death of any person other than CONTRACTOR's employees;
4. claims for damages insured by reasonably available personal injury liability coverage which are sustained: (i) by any person as a result of an offense directly or indirectly related to the employment of such person by CONTRACTOR, or (ii) by any other person for any other reason;
5. claims for damages, other than to the Work itself, because of injury to or destruction of tangible property wherever located, including loss of use resulting therefrom; and
6. claims for damages because of bodily injury or death of any person or property damage arising out of the ownership, maintenance or use of any motor vehicle.

B. The policies of insurance so required by this paragraph 5.04 to be purchased and maintained shall:

*See Supplementary Conditions

1. with respect to insurance required by paragraphs 5.04.A.3 through 5.04.A.6 inclusive, include as additional insureds (subject to any customary exclusion in respect of professional liability) OWNER, ENGINEER, ENGINEER's Consultants, and any other individuals or entities identified in the Supplementary Conditions, all of whom shall be listed as additional insureds, and include coverage for the respective officers, directors, partners, employees, agents, and other consultants and subcontractors of each and any of all such additional insureds, and the insurance afforded to these additional insureds shall provide primary coverage for all claims covered thereby;

2. include at least the specific coverages and be written for not less than the limits of liability provided in the Supplementary Conditions or required by Laws or Regulations, whichever is greater;

3. include completed operations insurance;

4. include contractual liability insurance covering CONTRACTOR's indemnity obligations under paragraphs 6.07, 6.11, and 6.20;

5. contain a provision or endorsement that the coverage afforded will not be canceled, materially changed or renewal refused until at least thirty days prior written notice has been given to OWNER and CONTRACTOR and to each other additional insured identified in the Supplementary Conditions to whom a certificate of insurance has been issued (and the certificates of insurance furnished by the CONTRACTOR pursuant to paragraph 5.03 will so provide);

6. remain in effect at least until final payment and at all times thereafter when CONTRACTOR may be correcting, removing, or replacing defective Work in accordance with paragraph 13.07; and

7. with respect to completed operations insurance, and any insurance coverage written on a claims-made basis, remain in effect for at least two years after final payment (and CONTRACTOR shall furnish OWNER and each other additional insured identified in the Supplementary Conditions, to whom a certificate of insurance has been issued, evidence satisfactory to OWNER and any such additional insured of continuation of such insurance at final payment and one year thereafter).

5.05 *OWNER's Liability Insurance*

A.* In addition to the insurance required to be provided by CONTRACTOR under paragraph 5.04, OWNER, at OWNER's option, may purchase and maintain at OWNER's expense OWNER's own liability insurance as will protect OWNER against claims which may arise from operations under the Contract Documents.

5.06* *Property Insurance*

A. Unless otherwise provided in the Supplementary Conditions, OWNER shall purchase and maintain property

insurance upon the Work at the Site in the amount of the full replacement cost thereof (subject to such deductible amounts as may be provided in the Supplementary Conditions or required by Laws and Regulations). This insurance shall:

1. include the interests of OWNER, CONTRACTOR, Subcontractors, ENGINEER, ENGINEER's Consultants, and any other individuals or entities identified in the Supplementary Conditions, and the officers, directors, partners, employees, agents, and other consultants and subcontractors of each and any of them, each of whom is deemed to have an insurable interest and shall be listed as an additional insured;

2. be written on a Builder's Risk "all-risk" or open peril or special causes of loss policy form that shall at least include insurance for physical loss or damage to the Work, temporary buildings, false work, and materials and equipment in transit, and shall insure against at least the following perils or causes of loss: fire, lightning, extended coverage, theft, vandalism and malicious mischief, earthquake, collapse, debris removal, demolition occasioned by enforcement of Laws and Regulations, water damage, and such other perils or causes of loss as may be specifically required by the Supplementary Conditions;

3. include expenses incurred in the repair or replacement of any insured property (including but not limited to fees and charges of engineers and architects);

*See Supplementary Conditions

4. cover materials and equipment stored at the Site or at another location that was agreed to in writing by OWNER prior to being incorporated in the Work, provided that such materials and equipment have been included in an Application for Payment recommended by ENGINEER;

5. allow for partial utilization of the Work by OWNER;

6. include testing and startup; and

7. be maintained in effect until final payment is made unless otherwise agreed to in writing by OWNER, CONTRACTOR, and ENGINEER with

30 days written notice to each other additional insured to whom a certificate of insurance has been issued.

B.* OWNER shall purchase and maintain such boiler and machinery insurance or additional property insurance as may be required by the Supplementary Conditions or Laws and Regulations which will include the interests of OWNER, CONTRACTOR, Subcontractors, ENGINEER, ENGINEER's Consultants, and any other individuals or entities identified in the Supplementary Conditions, each of whom is deemed to have an insurable interest and shall be listed as an insured or additional insured.

C.* All the policies of insurance (and the certificates or other evidence thereof) required to be purchased and maintained in accordance with paragraph 5.06 will contain a provision or endorsement that the coverage afforded will not be canceled or materially changed or renewal refused until at least 30 days prior written notice has been given to OWNER and CONTRACTOR and to each other additional insured to whom a certificate of insurance has been issued and will contain waiver provisions in accordance with paragraph 5.07.

D.* OWNER shall not be responsible for purchasing and maintaining any property insurance specified in this paragraph 5.06 to protect the interests of CONTRACTOR, Subcontractors, or others in the Work to the extent of any deductible amounts that are identified in the Supplementary Conditions. The risk of loss within such identified deductible amount will be borne by CONTRACTOR, Subcontractors, or others suffering any such loss, and if any of them wishes property insurance coverage within the limits of such amounts, each may purchase and maintain it at the purchaser's own expense.

E.* If CONTRACTOR requests in writing that other special insurance be included in the property insurance policies provided under paragraph 5.06, OWNER shall, if possible, include such insurance, and the cost thereof will be charged to CONTRACTOR by appropriate Change Order or Written Amendment. Prior to commencement of the Work at the Site, OWNER shall in writing advise CONTRACTOR whether or not such other insurance has been procured by OWNER.

5.07 *Waiver of Rights*

A.* OWNER and CONTRACTOR intend that all policies purchased in accordance with paragraph 5.06 will protect OWNER, CONTRACTOR, Subcontractors, ENGINEER, ENGINEER's Consultants, and all other

individuals or entities identified in the Supplementary Conditions to be listed as insureds or additional insureds (and the officers, directors, partners, employees, agents, and other consultants and subcontractors of each and any of them) in such policies and will provide primary coverage for all losses and damages caused by the perils or causes of loss covered thereby. All such policies shall contain provisions to the effect that in the event of payment of any loss or damage the insurers will have no rights of recovery against any of the insureds or additional insureds thereunder. OWNER and CONTRACTOR waive all rights against each other and their respective officers, directors, partners, employees, agents, and other consultants and subcontractors of each and any of them for all losses and damages caused by, arising out of or resulting from any of the perils or causes of loss covered by such policies and any other property insurance applicable to the Work; and, in addition, waive all such rights against Subcontractors, ENGINEER, ENGINEER's Consultants, and all other individuals or entities identified in the Supplementary Conditions to be listed as insureds or additional insureds (and the officers, directors, partners, employees, agents, and other consultants and subcontractors of each and any of them) under such policies for losses and damages so caused.

None of the above waivers shall extend to the rights that any party making such waiver may have to the proceeds of insurance held by OWNER as trustee or otherwise payable under any policy so issued.

B. OWNER waives all rights against CONTRACTOR, Subcontractors, ENGINEER, ENGINEER's Consultants, and the officers, directors, partners, employees, agents, and other consultants and subcontractors of each and any of them for:

*See Supplementary Conditions

1. loss due to business interruption, loss of use, or other consequential loss extending beyond direct physical loss or damage to OWNER's property or the Work caused by, arising out of, or resulting from fire or other peril whether or not insured by OWNER; and
2. loss or damage to the completed Project or part thereof caused by, arising out of, or resulting from fire or other insured peril or cause of loss covered by any property insurance maintained on the completed Project or part thereof by OWNER during partial utilization pursuant to

paragraph 14.05, after Substantial Completion pursuant to paragraph 14.04, or after final payment pursuant to paragraph 14.07.

C. Any insurance policy maintained by OWNER covering any loss, damage or consequential loss referred to in paragraph 5.07.B shall contain provisions to the effect that in the event of payment of any such loss, damage, or consequential loss, the insurers will have no rights of recovery against CONTRACTOR, Subcontractors, ENGINEER, or ENGINEER's Consultants and the officers, directors, partners, employees, agents, and other consultants and subcontractors of each and any of them.

5.08 Receipt and Application of Insurance Proceeds*

A.* Any insured loss under the policies of insurance required by paragraph 5.06 will be adjusted with OWNER and made payable to OWNER as fiduciary for the insureds, as their interests may appear, subject to the requirements of any applicable mortgage clause and of paragraph 5.08.B. OWNER shall deposit in a separate account any money so received and shall distribute it in accordance with such agreement as the parties in interest may reach. If no other special agreement is reached, the damaged Work shall be repaired or replaced, the moneys so received applied on account thereof, and the Work and the cost thereof covered by an appropriate Change Order or Written Amendment.

B.* OWNER as fiduciary shall have power to adjust and settle any loss with the insurers unless one of the parties in interest shall object in writing within 15 days after the occurrence of loss to OWNER's exercise of this power. If such objection be made, OWNER as fiduciary shall make settlement with the insurers in accordance with such agreement as the parties in interest may reach. If no such agreement among the parties in interest is reached, OWNER as fiduciary shall adjust and settle the loss with the insurers and, if required in writing by any party in interest, OWNER as fiduciary shall give bond for the proper performance of such duties.

5.09 Acceptance of Bonds and Insurance; Option to Replace*

A.* If either OWNER or CONTRACTOR has any objection to the coverage afforded by or other provisions of the Bonds or insurance required to be purchased and maintained by the other party in accordance with Article 5 on the basis of non-conformance with the Contract Documents, the objecting party shall so notify the other party in writing within 10 days after receipt of the

certificates (or other evidence requested) required by paragraph 2.05.C. OWNER and CONTRACTOR shall each provide to the other such additional information in respect of insurance provided as the other may reasonably request. If either party does not purchase or maintain all of the Bonds and insurance required of such party by the Contract Documents, such party shall notify the other party in writing of such failure to purchase prior to the start of the Work, or of such failure to maintain prior to any change in the required coverage. Without prejudice to any other right or remedy, the other party may elect to obtain equivalent Bonds or insurance to protect such other party's interests at the expense of the party who was required to provide such coverage, and a Change Order shall be issued to adjust the Contract Price accordingly.

5.10 *Partial Utilization, Acknowledgment of Property Insurer*

A. If OWNER finds it necessary to occupy or use a portion or portions of the Work prior to Substantial Completion of all the Work as provided in paragraph 14.05, no such use or occupancy shall commence before the insurers providing the property insurance pursuant to paragraph 5.06 have acknowledged notice thereof and in writing effected any changes in coverage necessitated thereby. The insurers providing the property insurance shall consent by endorsement on the policy or policies, but the property insurance shall not be canceled or permitted to lapse on account of any such partial use or occupancy.

ARTICLE 6 - CONTRACTOR'S RESPONSIBILITIES

6.01 *Supervision and Superintendence*

A. CONTRACTOR shall supervise, inspect, and direct the Work competently and efficiently, devoting such attention thereto and applying such skills and expertise as may be necessary to perform the Work in accordance with

*See Supplementary Conditions

the Contract Documents. CONTRACTOR shall be solely responsible for the means, methods, techniques, sequences, and procedures of construction, but CONTRACTOR shall not be responsible for the negligence of OWNER or ENGINEER in the design or specification of a specific means, method, technique, sequence, or procedure of

construction which is shown or indicated in and expressly required by the Contract Documents. CONTRACTOR shall be responsible to see that the completed Work complies accurately with the Contract Documents.

B. At all times during the progress of the Work, CONTRACTOR shall assign a competent resident superintendent thereto who shall not be replaced without written notice to OWNER and ENGINEER except under extraordinary circumstances. The superintendent will be CONTRACTOR's representative at the Site and shall have authority to act on behalf of CONTRACTOR. All communications given to or received from the superintendent shall be binding on CONTRACTOR.

6.02 *Labor; Working Hours*

A. CONTRACTOR shall provide competent, suitably qualified personnel to survey, lay out, and construct the

Work as required by the Contract Documents. CONTRACTOR shall at all times maintain good discipline and order at the Site.

B. Except as otherwise required for the safety or protection of persons or the Work or property at the Site or adjacent thereto, and except as otherwise stated in the Contract Documents, all Work at the Site shall be performed during regular working hours, and CONTRACTOR will not permit overtime work or the performance of Work on Saturday, Sunday, or any legal holiday without OWNER's written consent (which will not be unreasonably withheld) given after prior written notice to ENGINEER.

6.03 *Services, Materials, and Equipment*

A. Unless otherwise specified in the General Requirements, CONTRACTOR shall provide and assume full responsibility for all services, materials, equipment, labor, transportation, construction equipment and machinery, tools, appliances, fuel, power, light, heat, telephone, water, sanitary facilities, temporary facilities, and all other facilities and incidentals necessary for the performance, testing, start-up, and completion of the Work.

B. All materials and equipment incorporated into the Work shall be as specified or, if not specified, shall be of good quality and new, except as otherwise provided in the Contract Documents. All warranties and guarantees specifically called for by the Specifications shall expressly

run to the benefit of OWNER. If required by ENGINEER, CONTRACTOR shall furnish satisfactory evidence (including reports of required tests) as to the source, kind, and quality of materials and equipment. All materials and equipment shall be stored, applied, installed, connected, erected, protected, used, cleaned, and conditioned in accordance with instructions of the applicable Supplier, except as otherwise may be provided in the Contract Documents.

6.04 *Progress Schedule*

A. CONTRACTOR shall adhere to the progress schedule established in accordance with paragraph 2.07 as it may be adjusted from time to time as provided below.

1. CONTRACTOR shall submit to ENGINEER for acceptance (to the extent indicated in paragraph 2.07) proposed adjustments in the progress schedule that will not result in changing the Contract Times (or Milestones). Such adjustments will conform generally to the progress schedule then in effect and additionally will comply with any provisions of the General Requirements applicable thereto.

2. Proposed adjustments in the progress schedule that will change the Contract Times (or Milestones) shall be submitted in accordance with the requirements of Article 12. Such adjustments may only be made by a Change Order or Written Amendment in accordance with Article 12.

6.05 *Substitutes and "Or-Equals"*

A. Whenever an item of material or equipment is specified or described in the Contract Documents by using the name of a proprietary item or the name of a particular Supplier, the specification or description is intended to establish the type, function, appearance, and quality required. Unless the specification or description contains or is followed by words reading that no like, equivalent, or "or-equal" item or no substitution is permitted, other items of material or equipment or material or equipment of other Suppliers may be submitted to ENGINEER for review under the circumstances described below.

1. *"Or-Equal" Items:* If in ENGINEER's sole discretion an item of material or equipment proposed by CONTRACTOR is functionally equal to that named and sufficiently similar so that no change in related Work will be required, it may be

considered by ENGINEER as an "or-equal" item, in which case review and approval of the proposed item may, in ENGINEER's sole discretion, be accomplished without compliance with some or all of the requirements for approval of proposed substitute items. For the purposes of this paragraph 6.05.A.1, a proposed item of material or equipment will be considered functionally equal to an item so named if:

a. in the exercise of reasonable judgment ENGINEER determines that: (i) it is at least equal in quality, durability, appearance, strength, and design characteristics; (ii) it will reliably perform at least equally well the function imposed by the design concept of the completed Project as a functioning whole, and;

b. CONTRACTOR certifies that: (i) there is no increase in cost to the OWNER; and (ii) it will conform substantially, even with deviations, to the detailed requirements of the item named in the Contract Documents.

2. *Substitute Items*

a. If in ENGINEER's sole discretion an item of material or equipment proposed by CONTRACTOR does not qualify as an "or-equal" item under paragraph 6.05.A.1, it will be considered a proposed substitute item.

b. CONTRACTOR shall submit sufficient information as provided below to allow ENGINEER to determine that the item of material or equipment proposed is essentially equivalent to that named and an acceptable substitute therefor. Requests for review of proposed substitute items of material or equipment will not be accepted by ENGINEER from anyone other than CONTRACTOR.

c. The procedure for review by ENGINEER will be as set forth in paragraph 6.05.A.2.d, as supplemented in the General Requirements and as ENGINEER may decide is appropriate under the circumstances.

d. CONTRACTOR shall first make written application to ENGINEER for review of a proposed substitute item of material or equipment that CONTRACTOR seeks to furnish or use. The application shall certify

that the proposed substitute item will perform adequately the functions and achieve the results called for by the general design, be similar in substance to that specified, and be suited to the same use as that specified. The application will state the extent, if any, to which the use of the proposed substitute item will prejudice CONTRACTOR's achievement of Substantial Completion on time, whether or not use of the proposed substitute item in the Work will require a change in any of the Contract Documents (or in the provisions of any other direct contract with OWNER for work on the Project) to adapt the design to the proposed substitute item and whether or not incorporation or use of the proposed substitute item in connection with the Work is subject to payment of any license fee or royalty. All variations of the proposed substitute item from that specified will be identified in the application, and available engineering, sales, maintenance, repair, and replacement services will be indicated. The application will also contain an itemized estimate of all costs or credits that will result directly or indirectly from use of such substitute item, including costs of redesign and claims of other contractors affected by any resulting change, all of which will be considered by ENGINEER in evaluating the proposed substitute item. ENGINEER may require CONTRACTOR to furnish additional data about the proposed substitute item.

B. *Substitute Construction Methods or Procedures:* If a specific means, method, technique, sequence, or procedure of construction is shown or indicated in and expressly required by the Contract Documents, CONTRACTOR may furnish or utilize a substitute means, method, technique, sequence, or procedure of construction approved by ENGINEER. CONTRACTOR shall submit sufficient information to allow ENGINEER, in ENGINEER's sole discretion, to determine that the substitute proposed is equivalent to that expressly called for by the Contract Documents. The procedure for review by ENGINEER will be similar to that provided in subparagraph 6.05.A.2.

C. *Engineer's Evaluation:* ENGINEER will be allowed a reasonable time within which to evaluate each proposal or submittal made pursuant to paragraphs 6.05.A and 6.05.B. ENGINEER will be the sole judge of acceptability. No "or-equal" or substitute will be ordered, installed or utilized until ENGINEER's review is complete, which will be evidenced by either a Change Order for a

substitute or an approved Shop Drawing for an "or equal." ENGINEER will advise CONTRACTOR in writing of any negative determination.

D. *Special Guarantee:* OWNER may require CONTRACTOR to furnish at CONTRACTOR's expense a special performance guarantee or other surety with respect to any substitute.

E. *ENGINEER's Cost Reimbursement:* ENGINEER will record time required by ENGINEER and ENGINEER's Consultants in evaluating substitute proposed or submitted by CONTRACTOR pursuant to paragraphs 6.05.A.2 and 6.05.B and in making changes in the Contract Documents (or in the provisions of any other direct contract with OWNER for work on the Project) occasioned thereby. Whether or not ENGINEER approves a substitute item so proposed or submitted by CONTRACTOR, CONTRACTOR shall reimburse OWNER for the charges of ENGINEER and ENGINEER's Consultants for evaluating each such proposed substitute.

F. *CONTRACTOR's Expense:* CONTRACTOR shall provide all data in support of any proposed substitute or "or-equal" at CONTRACTOR's expense.

6.06 *Concerning Subcontractors, Suppliers, and Others*

A. CONTRACTOR shall not employ any Subcontractor, Supplier, or other individual or entity (including those acceptable to OWNER as indicated in paragraph 6.06.B), whether initially or as a replacement, against whom OWNER may have reasonable objection. CONTRACTOR shall not be required to employ any Subcontractor, Supplier, or other individual or entity to furnish or perform any of the Work against whom CONTRACTOR has reasonable objection.

B. If the Supplementary Conditions require the identity of certain Subcontractors, Suppliers, or other individuals or entities to be submitted to OWNER in advance for acceptance by OWNER by a specified date prior to the Effective Date of the Agreement, and if CONTRACTOR has submitted a list thereof in accordance with the Supplementary Conditions, OWNER's acceptance (either in writing or by failing to make written objection thereto by the date indicated for acceptance or objection in the Bidding Documents or the Contract Documents) of any such Subcontractor, Supplier, or other individual or entity so identified may be revoked on the basis of reasonable objection after due investigation. CONTRACTOR shall submit an acceptable replacement

for the rejected Subcontractor, Supplier, or other individual or entity, and the Contract Price will be adjusted by the difference in the cost occasioned by such replacement, and an appropriate Change Order will be issued or Written Amendment signed. No acceptance by OWNER of any such Subcontractor, Supplier, or other individual or entity, whether initially or as a replacement, shall constitute a waiver of any right of OWNER or ENGINEER to reject defective Work.

C. CONTRACTOR shall be fully responsible to OWNER and ENGINEER for all acts and omissions of the Subcontractors, Suppliers, and other individuals or entities performing or furnishing any of the Work just as CONTRACTOR is responsible for CONTRACTOR's own acts and omissions. Nothing in the Contract Documents shall create for the benefit of any such Subcontractor, Supplier, or other individual or entity any contractual relationship between OWNER or ENGINEER and any such Subcontractor, Supplier or other individual or entity, nor shall it create any obligation on the part of OWNER or ENGINEER to pay or to see to the payment of any moneys due any such Subcontractor, Supplier, or other individual or entity except as may otherwise be required by Laws and Regulations.

D. CONTRACTOR shall be solely responsible for scheduling and coordinating the Work of Subcontractors, Suppliers, and other individuals or entities performing or furnishing any of the Work under a direct or indirect contract with CONTRACTOR.

E. CONTRACTOR shall require all Subcontractors, Suppliers, and such other individuals or entities performing or furnishing any of the Work to communicate with ENGINEER through CONTRACTOR.

F. The divisions and sections of the Specifications and the identifications of any Drawings shall not control CONTRACTOR in dividing the Work among Subcontractors or Suppliers or delineating the Work to be performed by any specific trade.

G. All Work performed for CONTRACTOR by a Subcontractor or Supplier will be pursuant to an appropriate agreement between CONTRACTOR and the Subcontractor or Supplier which specifically binds the Subcontractor or Supplier to the applicable terms and conditions of the Contract Documents for the benefit of OWNER and ENGINEER. Whenever any such agreement is with a Subcontractor or Supplier who is listed as an additional insured on the property insurance provided in paragraph 5.06, the agreement between the CONTRAC-

TOR and the Subcontractor or Supplier will contain provisions whereby the Subcontractor or Supplier waives all rights against OWNER, CONTRACTOR, ENGINEER, ENGINEER's Consultants, and all other individuals or entities identified in the Supplementary Conditions to be listed as insureds or additional insureds (and the officers, directors, partners, employees, agents, and other consultants and subcontractors of each and any of them) for all losses and damages caused by, arising out of, relating to, or resulting from any of the perils or causes of loss covered by such policies and any other property insurance applicable to the Work. If the insurers on any such policies require separate waiver forms to be signed by any Subcontractor or Supplier, CONTRACTOR will obtain the same.

6.07 *Patent Fees and Royalties*

A. CONTRACTOR shall pay all license fees and royalties and assume all costs incident to the use in the performance of the Work or the incorporation in the Work of any invention, design, process, product, or device which is the subject of patent rights or copyrights held by others. If a particular invention, design, process, product, or device is specified in the Contract Documents for use in the performance of the Work and if to the actual knowledge of OWNER or ENGINEER its use is subject to patent rights or copyrights calling for the payment of any license fee or royalty to others, the existence of such rights shall be disclosed by OWNER in the Contract Documents. To the fullest extent permitted by Laws and Regulations, CONTRACTOR shall indemnify and hold harmless OWNER, ENGINEER, ENGINEER's Consultants, and the officers, directors, partners, employees or agents, and other consultants of each and any of them from and against all claims, costs, losses, and damages (including but not limited to all fees and charges of engineers, architects, attorneys, and other professionals and all court or arbitration or other dispute resolution costs) arising out of or relating to any infringement of patent rights or copyrights incident to the use in the performance of the Work or resulting from the incorporation in the Work of any invention, design, process, product, or device not specified in the Contract Documents.

6.08 *Permits*

A. Unless otherwise provided in the Supplementary Conditions, CONTRACTOR shall obtain and pay for all construction permits and licenses. OWNER shall assist CONTRACTOR, when necessary, in obtaining such permits and licenses. CONTRACTOR shall pay all governmental charges and inspection fees necessary for

the prosecution of the Work which are applicable at the time of opening of Bids, or, if there are no Bids, on the Effective Date of the Agreement. CONTRACTOR shall pay all charges of utility owners for connections to the Work, and OWNER shall pay all charges of such utility owners for capital costs related thereto, such as plant investment fees.

6.09 *Laws and Regulations*

A. CONTRACTOR shall give all notices and comply with all Laws and Regulations applicable to the performance of the Work. Except where otherwise expressly required by applicable Laws and Regulations, neither OWNER nor ENGINEER shall be responsible for monitoring CONTRACTOR's compliance with any Laws or Regulations.

B. If CONTRACTOR performs any Work knowing or having reason to know that it is contrary to Laws or Regulations, CONTRACTOR shall bear all claims, costs, losses, and damages (including but not limited to all fees and charges of engineers, architects, attorneys, and other professionals and all court or arbitration or other dispute resolution costs) arising out of or relating to such Work; however, it shall not be CONTRACTOR's primary responsibility to make certain that the Specifications and Drawings are in accordance with Laws and Regulations, but this shall not relieve CONTRACTOR of CONTRACTOR's obligations under paragraph 3.03.

C. Changes in Laws or Regulations not known at the time of opening of Bids (or, on the Effective Date of the Agreement if there were no Bids) having an effect on the cost or time of performance of the Work may be the subject of an adjustment in Contract Price or Contract Times. If OWNER and CONTRACTOR are unable to agree on entitlement to or on the amount or extent, if any, of any such adjustment, a Claim may be made therefor as provided in paragraph 10.05.

6.10* *Taxes*

A. CONTRACTOR shall pay all sales, consumer, use, and other similar taxes required to be paid by CONTRACTOR in accordance with the Laws and Regulations of the place of the Project which are applicable during the performance of the Work.

6.11* *Use of Site and Other Areas*

A.* *Limitation on Use of Site and Other Areas*

1. CONTRACTOR shall confine construction equipment, the storage of materials and equipment, and the operations of workers to the Site and other areas permitted by Laws and Regulations,

*See Supplementary Conditions

and shall not unreasonably encumber the Site and other areas with construction equipment or other materials or equipment. CONTRACTOR shall assume full responsibility for any damage to any such land or area, or to the owner or occupant thereof, or of any adjacent land or areas resulting from the performance of the Work.

2. Should any claim be made by any such owner or occupant because of the performance of the Work, CONTRACTOR shall promptly settle with such other party by negotiation or otherwise resolve the claim by arbitration or other dispute resolution proceeding or at law.

3. To the fullest extent permitted by Laws and Regulations, CONTRACTOR shall indemnify and hold harmless OWNER, ENGINEER, ENGINEER's Consultant, and the officers, directors, partners, employees, agents, and other consultants of each and any of them from and against all claims, costs, losses, and damages (including but not limited to all fees and charges of engineers, architects, attorneys, and other professionals and all court or arbitration or other dispute resolution costs) arising out of or relating to any claim or action, legal or equitable, brought by any such owner or occupant against OWNER, ENGINEER, or any other party indemnified hereunder to the extent caused by or based upon CONTRACTOR's performance of the Work.

B. *Removal of Debris During Performance of the Work:* During the progress of the Work CONTRACTOR shall keep the Site and other areas free from accumulations of waste materials, rubbish, and other debris. Removal and disposal of such waste materials, rubbish, and other debris shall conform to applicable Laws and Regulations.

C. *Cleaning*: Prior to Substantial Completion of the Work CONTRACTOR shall clean the Site and make it ready for utilization by OWNER. At the completion of the Work CONTRACTOR shall remove from the Site all tools, appliances, construction equipment and machinery, and surplus materials and shall restore to original condition all property not designated for alteration by the Contract Documents.

D. *Loading Structures*: CONTRACTOR shall not load nor permit any part of any structure to be loaded in any manner that will endanger the structure, nor shall CONTRACTOR subject any part of the Work or adjacent property to stresses or pressures that will endanger it.

6.12 *Record Documents*

A. CONTRACTOR shall maintain in a safe place at the Site one record copy of all Drawings, Specifications, Addenda, Written Amendments, Change Orders, Work Change Directives, Field Orders, and written interpretations and clarifications in good order and annotated to show changes made during construction. These record documents together with all approved Samples and a counterpart of all approved Shop Drawings will be available to ENGINEER for reference. Upon completion of the Work, these record documents, Samples, and Shop Drawings will be delivered to ENGINEER for OWNER.

6.13 *Safety and Protection*

A. CONTRACTOR shall be solely responsible for initiating, maintaining and supervising all safety precautions and programs in connection with the Work. CONTRACTOR shall take all necessary precautions for the safety of, and shall provide the necessary protection to prevent damage, injury or loss to:

1. all persons on the Site or who may be affected by the Work;
2. all the Work and materials and equipment to be incorporated therein, whether in storage on or off the Site; and
3. other property at the Site or adjacent thereto, including trees, shrubs, lawns, walks, pavements, roadways, structures, utilities, and Underground Facilities not designated for removal, relocation, or replacement in the course of construction.

B. CONTRACTOR shall comply with all applicable Laws and Regulations relating to the safety of persons or property, or to the protection of persons or property from damage, injury, or loss; and shall erect and maintain all necessary safeguards for such safety and protection. CONTRACTOR shall notify owners of adjacent property and of Underground Facilities and other utility owners when prosecution of the Work may affect them, and shall cooperate with them in the protection, removal, relocation, and replacement of their property. All damage, injury, or loss to any property referred to in paragraph 6.13.A.2 or 6.13.A.3 caused, directly or indirectly, in whole or in part, by CONTRACTOR, any Subcontractor, Supplier, or any other individual or entity directly or indirectly employed by any of them to perform any of the Work, or anyone for whose acts any of them may be liable, shall be remedied by CONTRACTOR (except damage or loss attributable to the fault of Drawings or Specifications or to the acts or omissions of OWNER or ENGINEER or ENGINEER's Consultant, or anyone employed by any of them, or anyone for whose acts any of them may be liable, and not attributable, directly or indirectly, in whole or in part, to the fault or negligence of CONTRACTOR or any Subcontractor, Supplier, or other individual or entity directly or indirectly employed by any of them). CONTRACTOR's duties and responsibilities for safety and for protection of the Work shall continue until such time as all the Work is completed and ENGINEER has issued a notice to OWNER and CONTRACTOR in accordance with paragraph 14.07.B that the Work is acceptable (except as otherwise expressly provided in connection with Substantial Completion).

6.14 *Safety Representative*

A. CONTRACTOR shall designate a qualified and experienced safety representative at the Site whose duties and responsibilities shall be the prevention of accidents and the maintaining and supervising of safety precautions and programs.

6.15 *Hazard Communication Programs*

A. CONTRACTOR shall be responsible for coordinating any exchange of material safety data sheets or other hazard communication information required to be made available to or exchanged between or among employers at the Site in accordance with Laws or Regulations.

6.16 *Emergencies*

A. In emergencies affecting the safety or protection of persons or the Work or property at the Site or adjacent thereto, CONTRACTOR is obligated to act to prevent threatened damage, injury, or loss. CONTRACTOR shall give ENGINEER prompt written notice if CONTRACTOR believes that any significant changes in the Work or variations from the Contract Documents have been caused thereby or are required as a result thereof. If ENGINEER determines that a change in the Contract Documents is required because of the action taken by CONTRACTOR in response to such an emergency, a Work Change Directive or Change Order will be issued.

6.17* *Shop Drawings and Samples*

A.* CONTRACTOR shall submit Shop Drawings to ENGINEER for review and approval in accordance with the acceptable schedule of Shop Drawings and Sample submittals. All submittals will be identified as ENGINEER may require and in the number of copies specified in the General Requirements. The data shown on the Shop Drawings will be complete with respect to quantities, dimensions, specified performance and design criteria, materials, and similar data to show ENGINEER the services, materials, and equipment CONTRACTOR proposes to provide and to enable ENGINEER to review the information for the limited purposes required by paragraph 6.17.E.

B.* CONTRACTOR shall also submit six (6) Samples to ENGINEER for review and approval in accordance with the acceptable schedule of Shop Drawings and Sample submittals. Each Sample will be identified clearly as to material, Supplier, pertinent data such as catalog numbers, and the use for which intended and otherwise as ENGINEER may require to enable ENGINEER to review the submittal for the limited purposes required by paragraph 6.17.E. The numbers of each Sample to be submitted will be as specified in the Specifications.

C. Where a Shop Drawing or Sample is required by the Contract Documents or the schedule of Shop Drawings and Sample submittals acceptable to ENGINEER as required by paragraph 2.07, any related Work performed prior to ENGINEER's review and approval of the pertinent submittal will be at the sole expense and responsibility of CONTRACTOR.

D. *Submittal Procedures*

1. Before submitting each Shop Drawing or Sample, CONTRACTOR shall have determined and verified:

a. all field measurements, quantities, dimensions, specified performance criteria, installation requirements, materials, catalog numbers, and similar information with respect thereto;

b. all materials with respect to intended use, fabrication, shipping, handling, storage, assembly, and installation pertaining to the performance of the Work;

c. all information relative to means, methods, techniques, sequences, and procedures of construction and safety precautions and programs incident thereto; and

d. CONTRACTOR shall also have reviewed and coordinated each Shop Drawing or

*See Supplementary Conditions

Sample with other Shop Drawings and Samples and with the requirements of the Work and the Contract Documents.

2. Each submittal shall bear a stamp or specific written indication that CONTRACTOR has satisfied CONTRACTOR's obligations under the Contract Documents with respect to CONTRACTOR's review and approval of that submittal.

3. At the time of each submittal, CONTRACTOR shall give ENGINEER specific written notice of such variations, if any, that the Shop Drawing or Sample submitted may have from the requirements of the Contract Documents, such notice to be in a written communication separate from the submittal; and, in addition, shall cause a specific notation to be made on each Shop Drawing and Sample submitted to ENGINEER for review and approval of each such variation.

E. *ENGINEER's Review*

1. ENGINEER will timely review and approve Shop Drawings and Samples in accordance with the schedule of Shop Drawings and Sample submittals acceptable to ENGINEER. ENGINEER's review and approval will be only to determine if the items covered by the submittals

will, after installation or incorporation in the Work, conform to the information given in the Contract Documents and be compatible with the design concept of the completed Project as a functioning whole as indicated by the Contract Documents.

2. ENGINEER's review and approval will not extend to means, methods, techniques, sequences, or procedures of construction (except where a particular means, method, technique, sequence, or procedure of construction is specifically and expressly called for by the Contract Documents) or to safety precautions or programs incident thereto. The review and approval of a separate item as such will not indicate approval of the assembly in which the item functions.

3. ENGINEER's review and approval of Shop Drawings or Samples shall not relieve CONTRACTOR from responsibility for any variation from the requirements of the Contract Documents unless CONTRACTOR has in writing called ENGINEER's attention to each such variation at the time of each submittal as required by paragraph 6.17.D.3 and ENGINEER has given written approval of each such variation by specific written notation thereof incorporated in or accompanying the Shop Drawing or Sample approval; nor will any approval by ENGINEER relieve CONTRACTOR from responsibility for complying with the requirements of paragraph 6.17.D.1.

F. *Resubmittal Procedures*

1. CONTRACTOR shall make corrections required by ENGINEER and shall return the required number of corrected copies of Shop Drawings and submit as required new Samples for review and approval. CONTRACTOR shall direct specific attention in writing to revisions other than the corrections called for by ENGINEER on previous submittals.

6.18 *Continuing the Work*

A. CONTRACTOR shall carry on the Work and adhere to the progress schedule during all disputes or disagreements with OWNER. No Work shall be delayed or postponed pending resolution of any disputes or disagreements, except as permitted by paragraph 15.04 or as OWNER and CONTRACTOR may otherwise agree in writing.

6.19 *CONTRACTOR's General Warranty and Guarantee*

A. CONTRACTOR warrants and guarantees to OWNER, ENGINEER, and ENGINEER's Consultants that all Work will be in accordance with the Contract Documents and will not be defective. CONTRACTOR's warranty and guarantee hereunder excludes defects or damage caused by:

1. abuse, modification, or improper maintenance or operation by persons other than CONTRACTOR, Subcontractors, Suppliers, or any other individual or entity for whom CONTRACTOR is responsible; or
2. normal wear and tear under normal usage.

B. CONTRACTOR's obligation to perform and complete the Work in accordance with the Contract Documents shall be absolute. None of the following will constitute an acceptance of Work that is not in accordance with the Contract Documents or a release of CONTRACTOR's obligation to perform the Work in accordance with the Contract Documents:

1. observations by ENGINEER;
2. recommendation by ENGINEER or payment by OWNER of any progress or final payment;
3. the issuance of a certificate of Substantial Completion by ENGINEER or any payment related thereto by OWNER;
4. use or occupancy of the Work or any part thereof by OWNER;
5. any acceptance by OWNER or any failure to do so;
6. any review and approval of a Shop Drawing or Sample submittal or the issuance of a notice of acceptability by ENGINEER;
7. any inspection, test, or approval by others; or
8. any correction of defective Work by OWNER.

6.20 *Indemnification*

A. To the fullest extent permitted by Laws and Regulations, CONTRACTOR shall indemnify and hold harmless OWNER, ENGINEER, ENGINEER's Consultants, and the officers, directors, partners, employees, agents, and other consultants and subcontractors of each and any of them from and against all claims, costs, losses, and damages (including but not limited to all fees and charges of engineers, architects, attorneys, and other professionals and all court or arbitration or other dispute resolution costs) arising out of or relating to the performance of the Work, provided that any such claim, cost, loss, or damage:

1. is attributable to bodily injury, sickness, disease, or death, or to injury to or destruction of tangible property (other than the Work itself), including the loss of use resulting therefrom; and

2. is caused in whole or in part by any negligent act or omission of CONTRACTOR, any Subcontractor, any Supplier, or any individual or entity directly or indirectly employed by any of them to perform any of the Work or anyone for whose acts any of them may be liable, regardless of whether or not caused in part by any negligence or omission of an individual or entity indemnified hereunder or whether liability is imposed upon such indemnified party by Laws and Regulations regardless of the negligence of any such individual or entity.

B. In any and all claims against OWNER or ENGINEER or any of their respective consultants, agents, officers, directors, partners, or employees by any employee (or the survivor or personal representative of such employee) of CONTRACTOR, any Subcontractor, any Supplier, or any individual or entity directly or indirectly employed by any of them to perform any of the Work, or anyone for whose acts any of them may be liable, the indemnification obligation under paragraph 6.20.A shall not be limited in any way by any limitation on the amount or type of damages, compensation, or benefits payable by or for CONTRACTOR or any such Subcontractor, Supplier, or other individual or entity under workers' compensation acts, disability benefit acts, or other employee benefit acts.

C. The indemnification obligations of CONTRACTOR under paragraph 6.20.A shall not extend to the liability of ENGINEER and ENGINEER's Consultants or to the officers, directors, partners, employees, agents, and

other consultants and subcontractors of each and any of them arising out of:

1. the preparation or approval of, or the failure to prepare or approve, maps, Drawings, opinions, reports, surveys, Change Orders, designs, or Specifications; or

2. giving directions or instructions, or failing to give them, if that is the primary cause of the injury or damage.

ARTICLE 7 - OTHER WORK

7.01 *Related Work at Site*

A. OWNER may perform other work related to the Project at the Site by OWNER's employees, or let other direct contracts therefor, or have other work performed by utility owners. If such other work is not noted in the Contract Documents, then:

1. written notice thereof will be given to CONTRACTOR prior to starting any such other work; and

2. if OWNER and CONTRACTOR are unable to agree on entitlement to or on the amount or extent, if any, of any adjustment in the Contract Price or Contract Times that should be allowed as a result of such other work, a Claim may be made therefor as provided in paragraph 10.05.

B. CONTRACTOR shall afford each other contractor who is a party to such a direct contract and each utility owner (and OWNER, if OWNER is performing the other work with OWNER's employees) proper and safe access to the Site and a reasonable opportunity for the introduction and storage of materials and equipment and the execution of such other work and shall properly coordinate the Work with theirs. Unless otherwise provided in the Contract Documents, CONTRACTOR shall do all cutting, fitting, and patching of the Work that may be required to properly connect or otherwise make its several parts come together and properly integrate with such other work. CONTRACTOR shall not endanger any work of others by cutting, excavating, or otherwise altering their work and will only cut or alter their work with the written consent of ENGINEER and the others whose work will be affected. The duties and responsibilities of CONTRACTOR under this paragraph are for the benefit of

such utility owners and other contractors to the extent that there are comparable provisions for the benefit of CONTRACTOR in said direct contracts between OWNER and such utility owners and other contractors.

C. If the proper execution or results of any part of CONTRACTOR's Work depends upon work performed by others under this Article 7, CONTRACTOR shall inspect such other work and promptly report to ENGINEER in writing any delays, defects, or deficiencies in such other work that render it unavailable or unsuitable for the proper execution and results of CONTRACTOR's Work. CONTRACTOR's failure to so report will constitute an acceptance of such other work as fit and proper for integration with CONTRACTOR's Work except for latent defects and deficiencies in such other work.

7.02 *Coordination*

A. If OWNER intends to contract with others for the performance of other work on the Project at the Site, the following will be set forth in Supplementary Conditions:

1. the individual or entity who will have authority and responsibility for coordination of the activities among the various contractors will be identified;
2. the specific matters to be covered by such authority and responsibility will be itemized; and
3. the extent of such authority and responsibilities will be provided.

B. Unless otherwise provided in the Supplementary Conditions, OWNER shall have sole authority and responsibility for such coordination.

ARTICLE 8 - OWNER'S RESPONSIBILITIES

8.01 *Communications to Contractor*

A. Except as otherwise provided in these General Conditions, OWNER shall issue all communications to CONTRACTOR through ENGINEER.

8.02 *Replacement of ENGINEER*

A. In case of termination of the employment of ENGINEER, OWNER shall appoint an engineer to whom CONTRACTOR makes no reasonable objection, whose status under the Contract Documents shall be that of the former ENGINEER.

8.03 *Furnish Data*

A. OWNER shall promptly furnish the data required of OWNER under the Contract Documents.

8.04 *Pay Promptly When Due*

A. OWNER shall make payments to CONTRACTOR promptly when they are due as provided in paragraphs 14.02.C and 14.07.C.

8.05 *Lands and Easements; Reports and Tests*

A. OWNER's duties in respect of providing lands and easements and providing engineering surveys to establish reference points are set forth in paragraphs 4.01 and 4.05. Paragraph 4.02 refers to OWNER's identifying and making available to CONTRACTOR copies of reports of explorations and tests of subsurface conditions and drawings of physical conditions in or relating to existing surface or subsurface structures at or contiguous to the Site that have been utilized by ENGINEER in preparing the Contract Documents.

*See Supplementary Conditions

8.06* *Insurance*

A.* OWNER's responsibilities, if any, in respect to purchasing and maintaining liability and property insurance are set forth in Article 5.

8.07 *Change Orders*

A. OWNER is obligated to execute Change Orders as indicated in paragraph 10.03.

8.08 *Inspections, Tests, and Approvals*

A. OWNER's responsibility in respect to certain inspections, tests, and approvals is set forth in paragraph 13.03.B.

8.09 *Limitations on OWNER's Responsibilities*

A. The OWNER shall not supervise, direct, or have control or authority over, nor be responsible for, CONTRACTOR's means, methods, techniques, sequences, or procedures of construction, or the safety precautions and programs incident thereto, or for any failure of CONTRACTOR to comply with Laws and Regulations applicable to the performance of the Work. OWNER will not be responsible for CONTRACTOR's failure to perform the Work in accordance with the Contract Documents.

8.10 *Undisclosed Hazardous Environmental Condition*

A. OWNER's responsibility in respect to an undisclosed Hazardous Environmental Condition is set forth in paragraph 4.06.

8.11 *Evidence of Financial Arrangements*

A. If and to the extent OWNER has agreed to furnish CONTRACTOR reasonable evidence that financial arrangements have been made to satisfy OWNER's obligations under the Contract Documents, OWNER's responsibility in respect thereof will be as set forth in the Supplementary Conditions.

ARTICLE 9 - ENGINEER'S STATUS DURING CONSTRUCTION

9.01 *OWNER'S Representative*

A. ENGINEER will be OWNER's representative during the construction period. The duties and responsibilities and the limitations of authority of ENGINEER as OWNER's representative during construction are set forth in the Contract Documents and will not be changed without written consent of OWNER and ENGINEER.

9.02 *Visits to Site*

A. ENGINEER will make visits to the Site at intervals appropriate to the various stages of construction as ENGINEER deems necessary in order to observe as an experienced and qualified design professional the progress that has been made and the quality of the various aspects of CONTRACTOR's executed Work. Based on information obtained during such visits and

observations, ENGINEER, for the benefit of OWNER, will determine, in general, if the Work is proceeding in accordance with the Contract Documents. ENGINEER will not be required to make exhaustive or continuous inspections on the Site to check the quality or quantity of the Work. ENGINEER's efforts will be directed toward providing for OWNER a greater degree of confidence that the completed Work will conform generally to the Contract Documents. On the basis of such visits and observations, ENGINEER will keep OWNER informed of the progress of the Work and will endeavor to guard OWNER against defective Work.

B. ENGINEER's visits and observations are subject to all the limitations on ENGINEER's authority and responsibility set forth in paragraph 9.10, and particularly, but without limitation, during or as a result of ENGINEER's visits or observations of CONTRACTOR's Work ENGINEER will not supervise, direct, control, or have authority over or be responsible for CONTRACTOR's means, methods, techniques, sequences, or procedures of construction, or the safety precautions and programs incident thereto, or for any failure of CONTRACTOR to comply with Laws and Regulations applicable to the performance of the Work.

9.03* *Project Representative*

A. If OWNER and ENGINEER agree, ENGINEER will furnish a Resident Project Representative to assist ENGINEER in providing more extensive observation of the Work. The responsibilities and authority and limitations thereon of any such Resident Project Representative and assistants will be as provided in paragraph 9.10 and in the Supplementary Conditions. If OWNER designates another representative or agent to represent OWNER at the Site who is not ENGINEER's Consultant, agent or employee,

*See Supplementary Conditions

the responsibilities and authority and limitations thereon of such other individual or entity will be as provided in the Supplementary Conditions.

9.04 *Clarifications and Interpretations*

A. ENGINEER will issue with reasonable promptness such written clarifications or interpretations of the requirements of the Contract Documents as ENGINEER may determine necessary, which shall be consistent with the intent of and reasonably inferable from the Contract Documents.

ments. Such written clarifications and interpretations will be binding on OWNER and CONTRACTOR. If OWNER and CONTRACTOR are unable to agree on entitlement to or on the amount or extent, if any, of any adjustment in the Contract Price or Contract Times, or both, that should be allowed as a result of a written clarification or interpretation, a Claim may be made therefor as provided in paragraph 10.05.

9.05 *Authorized Variations in Work*

A. ENGINEER may authorize minor variations in the Work from the requirements of the Contract Documents which do not involve an adjustment in the Contract Price or the Contract Times and are compatible with the design concept of the completed Project as a functioning whole as indicated by the Contract Documents. These may be accomplished by a Field Order and will be binding on OWNER and also on CONTRACTOR, who shall perform the Work involved promptly. If OWNER and CONTRACTOR are unable to agree on entitlement to or on the amount or extent, if any, of any adjustment in the Contract Price or Contract Times, or both, as a result of a Field Order, a Claim may be made therefor as provided in paragraph 10.05.

9.06 *Rejecting Defective Work*

A. ENGINEER will have authority to disapprove or reject Work which ENGINEER believes to be defective, or that ENGINEER believes will not produce a completed Project that conforms to the Contract Documents or that will prejudice the integrity of the design concept of the completed Project as a functioning whole as indicated by the Contract Documents. ENGINEER will also have authority to require special inspection or testing of the Work as provided in paragraph 13.04, whether or not the Work is fabricated, installed, or completed.

9.07 *Shop Drawings, Change Orders and Payments*

A. In connection with ENGINEER's authority as to Shop Drawings and Samples, see paragraph 6.17.

B. In connection with ENGINEER's authority as to Change Orders, see Articles 10, 11, and 12.

C. In connection with ENGINEER's authority as to Applications for Payment, see Article 14.

9.08 *Determinations for Unit Price Work*

A. ENGINEER will determine the actual quantities and classifications of Unit Price Work performed by CONTRACTOR. ENGINEER will review with CONTRACTOR the ENGINEER's preliminary determinations on such matters before rendering a written decision thereon (by recommendation of an Application for Payment or otherwise). ENGINEER's written decision thereon will be final and binding (except as modified by ENGINEER to reflect changed factual conditions or more accurate data) upon OWNER and CONTRACTOR, subject to the provisions of paragraph 10.05.

9.09 *Decisions on Requirements of Contract Documents and Acceptability of Work*

A. ENGINEER will be the initial interpreter of the requirements of the Contract Documents and judge of the acceptability of the Work thereunder. Claims, disputes and other matters relating to the acceptability of the Work, the quantities and classifications of Unit Price Work, the interpretation of the requirements of the Contract Documents pertaining to the performance of the Work, and Claims seeking changes in the Contract Price or Contract Times will be referred initially to ENGINEER in writing, in accordance with the provisions of paragraph 10.05, with a request for a formal decision.

B. When functioning as interpreter and judge under this paragraph 9.09, ENGINEER will not show partiality to OWNER or CONTRACTOR and will not be liable in connection with any interpretation or decision rendered in good faith in such capacity. The rendering of a decision by ENGINEER pursuant to this paragraph 9.09 with respect to any such Claim, dispute, or other matter (except any which have been waived by the making or acceptance of final payment as provided in paragraph 14.07) will be a condition precedent to any exercise by OWNER or CONTRACTOR of such rights or remedies as either may otherwise have under the Contract Documents or by Laws or Regulations in respect of any such Claim, dispute, or other matter.

*See Supplementary Conditions

9.10 *Limitations on ENGINEER's Authority and Responsibilities*

A. Neither ENGINEER's authority or responsibility under this Article 9 or under any other provision of the Contract Documents nor any decision made by ENGINEER in good faith either to exercise or not exercise such

authority or responsibility or the undertaking, exercise, or performance of any authority or responsibility by ENGINEER shall create, impose, or give rise to any duty in contract, tort, or otherwise owed by ENGINEER to CONTRACTOR, any Subcontractor, any Supplier, any other individual or entity, or to any surety for or employee or agent of any of them.

B. ENGINEER will not supervise, direct, control, or have authority over or be responsible for CONTRACTOR's means, methods, techniques, sequences, or procedures of construction, or the safety precautions and programs incident thereto, or for any failure of CONTRACTOR to comply with Laws and Regulations applicable to the performance of the Work. ENGINEER will not be responsible for CONTRACTOR's failure to perform the Work in accordance with the Contract Documents.

C. ENGINEER will not be responsible for the acts or omissions of CONTRACTOR or of any Subcontractor, any Supplier, or of any other individual or entity performing any of the Work.

D. ENGINEER's review of the final Application for Payment and accompanying documentation and all maintenance and operating instructions, schedules, guarantees, Bonds, certificates of inspection, tests and approvals, and other documentation required to be delivered by paragraph 14.07.A will only be to determine generally that their content complies with the requirements of, and in the case of certificates of inspections, tests, and approvals that the results certified indicate compliance with, the Contract Documents.

E. The limitations upon authority and responsibility set forth in this paragraph 9.10 shall also apply to ENGINEER's Consultants, Resident Project Representative, and assistants. See Article 18.

ARTICLE 10 - CHANGES IN THE WORK; CLAIMS

10.01 *Authorized Changes in the Work*

A. Without invalidating the Agreement and without notice to any surety, OWNER may, at any time or from time to time, order additions, deletions, or revisions in the Work by a Written Amendment, a Change Order, or a Work Change Directive. Upon receipt of any such document, CONTRACTOR shall promptly proceed with the Work involved which will be performed under the

applicable conditions of the Contract Documents (except as otherwise specifically provided).

B. If OWNER and CONTRACTOR are unable to agree on entitlement to, or on the amount or extent, if any, of an adjustment in the Contract Price or Contract Times, or both, that should be allowed as a result of a Work Change Directive, a Claim may be made therefor as provided in paragraph 10.05.

10.02 *Unauthorized Changes in the Work*

A. CONTRACTOR shall not be entitled to an increase in the Contract Price or an extension of the Contract Times with respect to any work performed that is not required by the Contract Documents as amended, modified, or supplemented as provided in paragraph 3.04, except in the case of an emergency as provided in paragraph 6.16 or in the case of uncovering Work as provided in paragraph 13.04.B.

10.03 *Execution of Change Orders*

A. OWNER and CONTRACTOR shall execute appropriate Change Orders recommended by ENGINEER (or Written Amendments) covering:

1. changes in the Work which are: (i) ordered by OWNER pursuant to paragraph 10.01.A, (ii) required because of acceptance of defective Work under paragraph 13.08.A or OWNER's correction of defective Work under paragraph 13.09, or (iii) agreed to by the parties;

2. changes in the Contract Price or Contract Times which are agreed to by the parties, including any undisputed sum or amount of time for Work actually performed in accordance with a Work Change Directive; and

3. changes in the Contract Price or Contract Times which embody the substance of any written decision rendered by ENGINEER pursuant to paragraph 10.05; provided that, in lieu of executing any such Change Order, an appeal may be taken from any such decision in accordance with the provisions of the Contract Documents and applicable Laws and Regulations, but during any such appeal, CONTRACTOR shall carry on the Work and adhere to the progress schedule as provided in paragraph 6.18.A.

10.04 *Notification to Surety*

A. If notice of any change affecting the general scope of the Work or the provisions of the Contract Documents (including, but not limited to, Contract Price or Contract Times) is required by the provisions of any Bond to be given to a surety, the giving of any such notice will be CONTRACTOR's responsibility. The amount of each applicable Bond will be adjusted to reflect the effect of any such change.

10.05 *Claims and Disputes*

A. *Notice:* Written notice stating the general nature of each Claim, dispute, or other matter shall be delivered by the claimant to ENGINEER and the other party to the Contract promptly (but in no event later than 30 days) after the start of the event giving rise thereto. Notice of the amount or extent of the Claim, dispute, or other matter with supporting data shall be delivered to the ENGINEER and the other party to the Contract within 60 days after the start of such event (unless ENGINEER allows additional time for claimant to submit additional or more accurate data in support of such Claim, dispute, or other matter). A Claim for an adjustment in Contract Price shall be prepared in accordance with the provisions of paragraph 12.01.B. A Claim for an adjustment in Contract Time shall be prepared in accordance with the provisions of paragraph 12.02.B. Each Claim shall be accompanied by claimant's written statement that the adjustment claimed is the entire adjustment to which the claimant believes it is entitled as a result of said event. The opposing party shall submit any response to ENGINEER and the claimant within 30 days after receipt of the claimant's last submittal (unless ENGINEER allows additional time).

B. *ENGINEER's Decision:* ENGINEER will render a formal decision in writing within 30 days after receipt of the last submittal of the claimant or the last submittal of the opposing party, if any. ENGINEER's written decision on such Claim, dispute, or other matter will be final and binding upon OWNER and CONTRACTOR unless:

1. an appeal from ENGINEER's decision is taken within the time limits and in accordance with the dispute resolution procedures set forth in Article 16; or
2. if no such dispute resolution procedures have been set forth in Article 16, a written notice of intention to appeal from ENGINEER's written decision is delivered by OWNER or CONTRACTOR to the other and to ENGINEER within 30 days

after the date of such decision, and a formal proceeding is instituted by the appealing party in a forum of competent jurisdiction within 60 days after the date of such decision or within 60 days after Substantial Completion, whichever is later (unless otherwise agreed in writing by OWNER and CONTRACTOR), to exercise such rights or remedies as the appealing party may have with respect to such Claim, dispute, or other matter in accordance with applicable Laws and Regulations.

C. If ENGINEER does not render a formal decision in writing within the time stated in paragraph 10.05.B, a decision denying the Claim in its entirety shall be deemed to have been issued 31 days after receipt of the last submittal of the claimant or the last submittal of the opposing party, if any.

D. No Claim for an adjustment in Contract Price or Contract Times (or Milestones) will be valid if not submitted in accordance with this paragraph 10.05.

ARTICLE 11 - COST OF THE WORK; CASH ALLOWANCES; UNIT PRICE WORK

11.01 *Cost of the Work*

A. *Costs Included:* The term Cost of the Work means the sum of all costs necessarily incurred and paid by CONTRACTOR in the proper performance of the Work. When the value of any Work covered by a Change Order or when a Claim for an adjustment in Contract Price is determined on the basis of Cost of the Work, the costs to be reimbursed to CONTRACTOR will be only those additional or incremental costs required because of the change in the Work or because of the event giving rise to the Claim. Except as otherwise may be agreed to in writing by OWNER, such costs shall be in amounts no higher than those prevailing in the locality of the Project, shall include only the following items, and shall not include any of the costs itemized in paragraph 11.01.B.

1. Payroll costs for employees in the direct employ of CONTRACTOR in the performance of the Work under schedules of job classifications agreed upon by OWNER and CONTRACTOR. Such employees shall include without limitation superintendents, foremen, and other personnel employed full time at the Site. Payroll costs for employees not employed full time on the Work

shall be apportioned on the basis of their time spent on the Work. Payroll costs shall include, but not be limited to, salaries and wages plus the cost of fringe benefits, which shall include social security contributions, unemployment, excise, and payroll taxes, workers' compensation, health and retirement benefits, bonuses, sick leave, vacation and holiday pay applicable thereto. The expenses of performing Work outside of regular working hours, on Saturday, Sunday, or legal holidays, shall be included in the above to the extent authorized by OWNER.

2. Cost of all materials and equipment furnished and incorporated in the Work, including costs of transportation and storage thereof, and Suppliers' field services required in connection therewith. All cash discounts shall accrue to CONTRACTOR unless OWNER deposits funds with CONTRACTOR with which to make payments, in which case the cash discounts shall accrue to OWNER. All trade discounts, rebates and refunds and returns from sale of surplus materials and equipment shall accrue to OWNER, and CONTRACTOR shall make provisions so that they may be obtained.

3. Payments made by CONTRACTOR to Subcontractors for Work performed by Subcontractors. If required by OWNER, CONTRACTOR shall obtain competitive bids from subcontractors acceptable to OWNER and CONTRACTOR and shall deliver such bids to OWNER, who will then determine, with the advice of ENGINEER, which bids, if any, will be acceptable. If any subcontract provides that the Subcontractor is to be paid on the basis of Cost of the Work plus a fee, the Subcontractor's Cost of the Work and fee shall be determined in the same manner as CONTRACTOR's Cost of the Work and fee as provided in this paragraph 11.01.

4. Costs of special consultants (including but not limited to engineers, architects, testing laboratories, surveyors, attorneys, and accountants) employed for services specifically related to the Work.

5. Supplemental costs including the following:

a. The proportion of necessary transportation, travel, and subsistence expenses of

CONTRACTOR's employees incurred in discharge of duties connected with the Work.

b. Cost, including transportation and maintenance, of all materials, supplies, equipment, machinery, appliances, office, and temporary facilities at the Site, and hand tools not owned by the workers, which are consumed in the performance of the Work, and cost, less market value, of such items used but not consumed which remain the property of CONTRACTOR.

c. Rentals of all construction equipment and machinery, and the parts thereof whether rented from CONTRACTOR or others in accordance with rental agreements approved by OWNER with the advice of ENGINEER, and the costs of transportation, loading, unloading, assembly, dismantling, and removal thereof. All such costs shall be in accordance with the terms of said rental agreements. The rental of any such equipment, machinery, or parts shall cease when the use thereof is no longer necessary for the Work.

d. Sales, consumer, use, and other similar taxes related to the Work, and for which CONTRACTOR is liable, imposed by Laws and Regulations.

e. Deposits lost for causes other than negligence of CONTRACTOR, any Subcontractor, or anyone directly or indirectly employed by any of them or for whose acts any of them may be liable, and royalty payments and fees for permits and licenses.

f. Losses and damages (and related expenses) caused by damage to the Work, not compensated by insurance or otherwise, sustained by CONTRACTOR in connection with the performance of the Work (except losses and damages within the deductible amounts of property insurance established in accordance with paragraph 5.06.D), provided such losses and damages have resulted from causes other than the negligence of CONTRACTOR, any Subcontractor, or anyone directly or indirectly employed by any of them or for whose acts any of them may be liable. Such losses shall include settlements made with the written consent and approval of OWNER. No such losses, damages, and expenses shall be included in the Cost of the Work for the purpose of determining CONTRACTOR's fee.

g. The cost of utilities, fuel, and sanitary facilities at the Site.

h. Minor expenses such as telegrams, long distance telephone calls, telephone service at the Site, expressage, and similar petty cash items in connection with the Work.

i. When the Cost of the Work is used to determine the value of a Change Order or of a Claim, the cost of premiums for additional Bonds and insurance required because of the changes in the Work or caused by the event giving rise to the Claim.

j. When all the Work is performed on the basis of cost-plus, the costs of premiums for all Bonds and insurance CONTRACTOR is required by the Contract Documents to purchase and maintain.

B. *Costs Excluded:* The term Cost of the Work shall not include any of the following items:

1. Payroll costs and other compensation of CONTRACTOR's officers, executives, principals (of partnerships and sole proprietorships), general managers, engineers, architects, estimators, attorneys, auditors, accountants, purchasing and contracting agents, expeditors, timekeepers, clerks, and other personnel employed by CONTRACTOR, whether at the Site or in CONTRACTOR's principal or branch office for general administration of the Work and not specifically included in the agreed upon schedule of job classifications referred to in paragraph 11.01.A.1 or specifically covered by paragraph 11.01.A.4, all of which are to be considered administrative costs covered by the CONTRACTOR's fee.

2. Expenses of CONTRACTOR's principal and branch offices other than CONTRACTOR's office at the Site.

3. Any part of CONTRACTOR's capital expenses, including interest on CONTRACTOR's capital employed for the Work and charges against CONTRACTOR for delinquent payments.

4. Costs due to the negligence of CONTRACTOR, any Subcontractor, or anyone directly or indirectly employed by any of them or for whose acts any of them may be liable, including but not

limited to, the correction of defective Work, disposal of materials or equipment wrongly supplied, and making good any damage to property.

5. Other overhead or general expense costs of any kind and the costs of any item not specifically and expressly included in paragraphs 11.01.A and 11.01.B.

C. *CONTRACTOR's Fee:* When all the Work is performed on the basis of cost-plus, CONTRACTOR's fee shall be determined as set forth in the Agreement. When the value of any Work covered by a Change Order or when a Claim for an adjustment in Contract Price is determined on the basis of Cost of the Work, CONTRACTOR's fee shall be determined as set forth in paragraph 12.01.C.

D. *Documentation:* Whenever the Cost of the Work for any purpose is to be determined pursuant to paragraphs 11.01.A and 11.01.B, CONTRACTOR will establish and maintain records thereof in accordance with generally accepted accounting practices and submit in a form acceptable to ENGINEER an itemized cost breakdown together with supporting data.

11.02 *Cash Allowances*

A. It is understood that CONTRACTOR has included in the Contract Price all allowances so named in the Contract Documents and shall cause the Work so covered to be performed for such sums as may be acceptable to OWNER and ENGINEER. CONTRACTOR agrees that:

1. the allowances include the cost to CONTRACTOR (less any applicable trade discounts) of materials and equipment required by the allowances to be delivered at the Site, and all applicable taxes; and

2. CONTRACTOR's costs for unloading and handling on the Site, labor, installation costs, overhead, profit, and other expenses contemplated for the allowances have been included in the Contract Price and not in the allowances, and no demand for additional payment on account of any of the foregoing will be valid.

B. Prior to final payment, an appropriate Change Order will be issued as recommended by ENGINEER to reflect actual amounts due CONTRACTOR on account of

Work covered by allowances, and the Contract Price shall be correspondingly adjusted.

11.03 *Unit Price Work*

A. Where the Contract Documents provide that all or part of the Work is to be Unit Price Work, initially the Contract Price will be deemed to include for all Unit Price Work an amount equal to the sum of the unit price for each separately identified item of Unit Price Work times the estimated quantity of each item as indicated in the Agreement. The estimated quantities of items of Unit Price Work are not guaranteed and are solely for the purpose of comparison of Bids and determining an initial Contract Price. Determinations of the actual quantities and classifications of Unit Price Work performed by CONTRACTOR will be made by ENGINEER subject to the provisions of paragraph 9.08.

B. Each unit price will be deemed to include an amount considered by CONTRACTOR to be adequate to cover CONTRACTOR's overhead and profit for each separately identified item.

C. OWNER or CONTRACTOR may make a Claim for an adjustment in the Contract Price in accordance with paragraph 10.05 if:

1. the quantity of any item of Unit Price Work performed by CONTRACTOR differs materially and significantly from the estimated quantity of such item indicated in the Agreement; and
2. there is no corresponding adjustment with respect any other item of Work; and
3. if CONTRACTOR believes that CONTRACTOR is entitled to an increase in Contract Price as a result of having incurred additional expense or OWNER believes that OWNER is entitled to a decrease in Contract Price and the parties are unable to agree as to the amount of any such increase or decrease.

ARTICLE 12 - CHANGE OF CONTRACT PRICE; CHANGE OF CONTRACT TIMES

12.01* *Change of Contract Price*

A. The Contract Price may only be changed by a Change Order or by a Written Amendment. Any Claim for an adjustment in the Contract Price shall be based on written notice submitted by the party making the Claim to the ENGINEER and the other party to the Contract in accordance with the provisions of paragraph 10.05.

B.* The value of any Work covered by a Change Order or of any Claim for an adjustment in the Contract Price will be determined as follows:

1. where the Work involved is covered by unit prices contained in the Contract Documents, by application of such unit prices to the quantities of the items involved (subject to the provisions of paragraph 11.03); or

2. where the Work involved is not covered by unit prices contained in the Contract Documents, by a mutually agreed lump sum (which may include an allowance for overhead and profit not necessarily in accordance with paragraph 12.01.C.2); or

3. where the Work involved is not covered by unit prices contained in the Contract Documents and agreement to a lump sum is not reached under paragraph 12.01.B.2, on the basis of the Cost of the Work (determined as provided in paragraph 11.01) plus a CONTRACTOR's fee for overhead and profit (determined as provided in paragraph 12.01.C).

C. *CONTRACTOR's Fee*: The CONTRACTOR's fee for overhead and profit shall be determined as follows:

1. a mutually acceptable fixed fee; or
2. if a fixed fee is not agreed upon, then a fee based on the following percentages of the various portions of the Cost of the Work:
 - a. for costs incurred under paragraphs 11.01.A.1 and 11.01.A.2, the CONTRACTOR's fee shall be 15 percent;

b. for costs incurred under paragraph 11.01.A.3, the CONTRACTOR's fee shall be five percent;

c. where one or more tiers of subcontracts are on the basis of Cost of the Work plus a fee and no fixed fee is agreed upon, the intent of paragraph 12.01.C.2.a is that the Subcontractor who actually performs the Work, at whatever tier, will be paid a fee of 15 percent of the costs incurred by such Subcontractor under paragraphs 11.01.A.1 and 11.01.A.2 and that any higher tier Subcontractor and CONTRACTOR will each be paid a fee of five percent of the amount paid to the next lower tier Subcontractor;

*See Supplementary Conditions

d. no fee shall be payable on the basis of costs itemized under paragraphs 11.01.A.4, 11.01.A.5, and 11.01.B;

e. the amount of credit to be allowed by CONTRACTOR to OWNER for any change which results in a net decrease in cost will be the amount of the actual net decrease in cost plus a deduction in CONTRACTOR's fee by an amount equal to five percent of such net decrease; and

f. when both additions and credits are involved in any one change, the adjustment in CONTRACTOR's fee shall be computed on the basis of the net change in accordance with paragraphs 12.01.C.2.a through 12.01.C.2.e, inclusive.

12.02 *Change of Contract Times*

A. The Contract Times (or Milestones) may only be changed by a Change Order or by a Written Amendment. Any Claim for an adjustment in the Contract Times (or Milestones) shall be based on written notice submitted by the party making the claim to the ENGINEER and the other party to the Contract in accordance with the provisions of paragraph 10.05.

B. Any adjustment of the Contract Times (or Milestones) covered by a Change Order or of any Claim for an adjustment in the Contract Times (or Milestones)

will be determined in accordance with the provisions of this Article 12.

12.03 *Delays Beyond CONTRACTOR's Control*

A. Where CONTRACTOR is prevented from completing any part of the Work within the Contract Times (or Milestones) due to delay beyond the control of CONTRACTOR, the Contract Times (or Milestones) will be extended in an amount equal to the time lost due to such delay if a Claim is made therefor as provided in paragraph 12.02.A. Delays beyond the control of CONTRACTOR shall include, but not be limited to, acts or neglect by OWNER, acts or neglect of utility owners or other contractors performing other work as contemplated by Article 7, fires, floods, epidemics, abnormal weather conditions, or acts of God.

12.04 *Delays Within CONTRACTOR's Control*

A. The Contract Times (or Milestones) will not be extended due to delays within the control of CONTRACTOR. Delays attributable to and within the control of a Subcontractor or Supplier shall be deemed to be delays within the control of CONTRACTOR.

12.05 *Delays Beyond OWNER's and CONTRACTOR's Control*

A. Where CONTRACTOR is prevented from completing any part of the Work within the Contract Times (or Milestones) due to delay beyond the control of both OWNER and CONTRACTOR, an extension of the Contract Times (or Milestones) in an amount equal to the time lost due to such delay shall be CONTRACTOR's sole and exclusive remedy for such delay.

12.06 *Delay Damages*

A. In no event shall OWNER or ENGINEER be liable to CONTRACTOR, any Subcontractor, any Supplier, or any other person or organization, or to any surety for or employee or agent of any of them, for damages arising out of or resulting from:

1. delays caused by or within the control of CONTRACTOR; or

2. delays beyond the control of both OWNER and CONTRACTOR including but not limited to fires, floods, epidemics, abnormal weather conditions, acts of God, or acts or neglect by utility

owners or other contractors performing other work as contemplated by Article 7.

B. Nothing in this paragraph 12.06 bars a change in Contract Price pursuant to this Article 12 to compensate CONTRACTOR due to delay, interference, or disruption directly attributable to actions or inactions of OWNER or anyone for whom OWNER is responsible.

ARTICLE 13 - TESTS AND INSPECTIONS;
CORRECTION, REMOVAL OR ACCEPTANCE OF
DEFECTIVE WORK

13.01 *Notice of Defects*

A. Prompt notice of all defective Work of which OWNER or ENGINEER has actual knowledge will be given to CONTRACTOR. All defective Work may be rejected, corrected, or accepted as provided in this Article 13.

13.02* *Access to Work*

A. OWNER, ENGINEER, ENGINEER's Consultants, other representatives and personnel of OWNER, independent testing laboratories, and governmental agencies with jurisdictional interests will have access to the Site and the Work at reasonable times for their observation, inspecting, and testing. CONTRACTOR shall provide them proper and safe conditions for such access and advise them of CONTRACTOR's Site safety procedures and programs so that they may comply therewith as applicable.

13.03* *Tests and Inspections*

A. CONTRACTOR shall give ENGINEER timely notice of readiness of the Work for all required inspections, tests, or approvals and shall cooperate with inspection and testing personnel to facilitate required inspections or tests.

B.* OWNER shall employ and pay for the services of an independent testing laboratory to perform all inspections, tests, or approvals required by the Contract Documents except:

1. for inspections, tests, or approvals covered by paragraphs 13.03.C and 13.03.D below;

2. that costs incurred in connection with tests or inspections conducted pursuant to paragraph 13.04.B shall be paid as provided in said paragraph 13.04.B; and

3. as otherwise specifically provided in the Contract Documents.

C. If Laws or Regulations of any public body having jurisdiction require any Work (or part thereof) specifically to be inspected, tested, or approved by an employee or other representative of such public body, CONTRACTOR shall assume full responsibility for arranging and obtaining such inspections, tests, or approvals, pay all costs in connection therewith, and furnish ENGINEER the required certificates of inspection or approval.

D. CONTRACTOR shall be responsible for arranging and obtaining and shall pay all costs in connection with any inspections, tests, or approvals required for OWNER's and ENGINEER's acceptance of materials or equipment to be incorporated in the Work; or acceptance of materials, mix designs, or equipment submitted for approval prior to CONTRACTOR's purchase thereof for incorporation in the Work. Such inspections, tests, or approvals shall be performed by organizations acceptable to OWNER and ENGINEER.

E. If any Work (or the work of others) that is to be inspected, tested, or approved is covered by CONTRACTOR without written concurrence of ENGINEER, it must, if requested by ENGINEER, be uncovered for observation.

F. Uncovering Work as provided in paragraph 13.03.E shall be at CONTRACTOR's expense unless CONTRACTOR has given ENGINEER timely notice of CONTRACTOR's intention to cover the same and ENGINEER has not acted with reasonable promptness in response to such notice.

13.04 *Uncovering Work*

A. If any Work is covered contrary to the written request of ENGINEER, it must, if requested by ENGINEER, be uncovered for ENGINEER's observation and replaced at CONTRACTOR's expense.

B. If ENGINEER considers it necessary or advisable that covered Work be observed by ENGINEER or inspected or tested by others, CONTRACTOR, at ENGINEER's request, shall uncover, expose, or otherwise make available for observation, inspection, or testing as ENGINEER may require, that portion of the Work in

question, furnishing all necessary labor, material, and equipment. If it is found that such Work is defective, CONTRACTOR shall pay all Claims, costs, losses, and damages (including but not limited to all fees and charges of engineers, architects, attorneys, and other professionals and all court or arbitration or other dispute resolution costs) arising out of or relating to such uncovering, exposure, observation, inspection, and testing, and of satisfactory replacement or reconstruction (including but not limited to all costs of repair or replacement of work of others); and OWNER shall be entitled to an appropriate decrease in the Contract Price. If the parties are unable to agree as to the amount thereof, OWNER may make a Claim therefor as provided in paragraph 10.05. If, however, such Work is not found to be defective, CONTRACTOR shall be allowed an increase in the Contract Price or an extension of the Contract Times (or Milestones), or both, directly attributable to such uncovering, exposure, observation, inspection, testing, replacement, and reconstruction. If the parties are unable to agree as to the amount or extent thereof, CONTRACTOR may make a Claim therefor as provided in paragraph 10.05.

*See Supplementary Conditions

13.05 *OWNER May Stop the Work*

A. If the Work is defective, or CONTRACTOR fails to supply sufficient skilled workers or suitable materials or equipment, or fails to perform the Work in such a way that the completed Work will conform to the Contract Documents, OWNER may order CONTRACTOR to stop the Work, or any portion thereof, until the cause for such order has been eliminated; however, this right of OWNER to stop the Work shall not give rise to any duty on the part of OWNER to exercise this right for the benefit of CONTRACTOR, any Subcontractor, any Supplier, any other individual or entity, or any surety for, or employee or agent of any of them.

13.06 *Correction or Removal of Defective Work*

A. CONTRACTOR shall correct all defective Work, whether or not fabricated, installed, or completed, or, if the Work has been rejected by ENGINEER, remove it from the Project and replace it with Work that is not defective. CONTRACTOR shall pay all Claims, costs, losses, and damages (including but not limited to all fees and charges of engineers, architects, attorneys, and other professionals and all court or arbitration or other dispute resolution costs) arising out of or relating to such correction or removal (including but not limited to all costs of repair or replacement of work of others).

13.07 *Correction Period*

A. If within one year after the date of Substantial Completion or such longer period of time as may be prescribed by Laws or Regulations or by the terms of any applicable special guarantee required by the Contract Documents or by any specific provision of the Contract Documents, any Work is found to be defective, or if the repair of any damages to the land or areas made available for CONTRACTOR's use by OWNER or permitted by Laws and Regulations as contemplated in paragraph 6.11.A is found to be defective, CONTRACTOR shall promptly, without cost to OWNER and in accordance with OWNER's written instructions: (i) repair such defective land or areas, or (ii) correct such defective Work or, if the defective Work has been rejected by OWNER, remove it from the Project and replace it with Work that is not defective, and (iii) satisfactorily correct or repair or remove and replace any damage to other Work, to the work of others or other land or areas resulting therefrom. If CONTRACTOR does not promptly comply with the terms of such instructions, or in an emergency where delay would cause serious risk of loss or damage, OWNER may have the defective Work corrected or repaired or may have the rejected Work removed and replaced, and all Claims, costs, losses, and damages (including but not limited to all fees and charges of engineers, architects, attorneys, and other professionals and all court or arbitration or other dispute resolution costs) arising out of or relating to such correction or repair or such removal and replacement (including but not limited to all costs of repair or replacement of work of others) will be paid by CONTRACTOR.

B. In special circumstances where a particular item of equipment is placed in continuous service before Substantial Completion of all the Work, the correction period for that item may start to run from an earlier date if so provided in the Specifications or by Written Amendment.

C. Where defective Work (and damage to other Work resulting therefrom) has been corrected or removed and replaced under this paragraph 13.07, the correction period hereunder with respect to such Work will be extended for an additional period of one year after such correction or removal and replacement has been satisfactorily completed.

D. CONTRACTOR's obligations under this paragraph 13.07 are in addition to any other obligation or warranty. The provisions of this paragraph 13.07 shall not be construed as a substitute for or a waiver of the provisions of any applicable statute of limitation or repose.

13.08 *Acceptance of Defective Work*

A. If, instead of requiring correction or removal and replacement of defective Work, OWNER (and, prior to ENGINEER's recommendation of final payment, ENGINEER) prefers to accept it, OWNER may do so. CONTRACTOR shall pay all Claims, costs, losses, and damages (including but not limited to all fees and charges of engineers, architects, attorneys, and other professionals and all court or arbitration or other dispute resolution costs) attributable to OWNER's evaluation of and determination to accept such defective Work (such costs to be approved by ENGINEER as to reasonableness) and the diminished value of the Work to the extent not otherwise paid by CONTRACTOR pursuant to this sentence. If any such acceptance occurs prior to ENGINEER's recommendation of final payment, a Change Order will be issued incorporating the necessary revisions in the Contract Documents with respect to the Work, and OWNER shall be entitled to an appropriate decrease in the Contract Price, reflecting the diminished value of Work so accepted. If the parties are unable to agree as to the amount thereof, OWNER may make a Claim therefor as provided in paragraph 10.05. If the acceptance occurs after such recommendation, an appropriate amount will be paid by CONTRACTOR to OWNER.

13.09 *OWNER May Correct Defective Work*

A. If CONTRACTOR fails within a reasonable time after written notice from ENGINEER to correct defective Work or to remove and replace rejected Work as required by ENGINEER in accordance with paragraph 13.06.A, or if CONTRACTOR fails to perform the Work in accordance with the Contract Documents, or if CONTRACTOR fails to comply with any other provision of the Contract Documents, OWNER may, after seven days written notice

to CONTRACTOR, correct and remedy any such deficiency.

B. In exercising the rights and remedies under this paragraph, OWNER shall proceed expeditiously. In connection with such corrective and remedial action, OWNER may exclude CONTRACTOR from all or part of the Site, take possession of all or part of the Work and suspend CONTRACTOR's services related thereto, take possession of CONTRACTOR's tools, appliances, construction equipment and machinery at the Site, and incorporate in the Work all materials and equipment stored at the Site or for which OWNER has paid CONTRACTOR but which are stored elsewhere. CONTRACTOR shall allow OWNER, OWNER's representatives, agents and employees, OWNER's other contractors, and ENGINEER and ENGINEER's Consultants access to the Site to enable OWNER to exercise the rights and remedies under this paragraph.

C. All Claims, costs, losses, and damages (including but not limited to all fees and charges of engineers, architects, attorneys, and other professionals and all court or arbitration or other dispute resolution costs) incurred or sustained by OWNER in exercising the rights and remedies under this paragraph 13.09 will be charged against CONTRACTOR, and a Change Order will be issued incorporating the necessary revisions in the Contract Documents with respect to the Work; and OWNER shall be entitled to an appropriate decrease in the Contract Price. If the parties are unable to agree as to the amount of the adjustment, OWNER may make a Claim therefor as provided in paragraph 10.05. Such claims, costs, losses and damages will include but not be limited to all costs of repair, or replacement of work of others destroyed or damaged by correction, removal, or replacement of CONTRACTOR's defective Work.

D. CONTRACTOR shall not be allowed an extension of the Contract Times (or Milestones) because of any delay in the performance of the Work attributable to the exercise by OWNER of OWNER's rights and remedies under this paragraph 13.09.

ARTICLE 14 - PAYMENTS TO CONTRACTOR AND COMPLETION

14.01 *Schedule of Values*

A. The schedule of values established as provided in paragraph 2.07.A will serve as the basis for progress payments and will be incorporated into a form of Application for Payment acceptable to ENGINEER. Progress payments on account of Unit Price Work will be based on the number of units completed.

14.02 *Progress Payments*

A.* *Applications for Payments*

1. At least 20 days before the date established for each progress payment (but not more often than once a month), CONTRACTOR shall submit to ENGINEER for review an Application for Payment filled out and signed by CONTRACTOR covering the Work completed as of the date of the Application and accompanied by such supporting documentation as is required by the Contract Documents. If payment is requested on the basis of materials and equipment not incorporated in the Work but delivered and suitably stored at the Site or at another location agreed to in writing, the Application for Payment shall also be accompanied by a bill of sale, invoice, or other documentation warranting that OWNER has received the materials and equipment free and clear of all Liens and evidence that the materials and equipment are covered by appropriate property insurance or other arrangements to protect OWNER's interest therein, all of which must be satisfactory to OWNER.

2. Beginning with the second Application for Payment, each Application shall include an affidavit of CONTRACTOR stating that all previous progress payments received on account of the Work have been applied on account to discharge CONTRACTOR's legitimate obligations associated with prior Applications for Payment.

3. The amount of retainage with respect to pro-gress payments will be as stipulated in the Agreement.

*See Supplementary Conditions

B. *Review of Applications*

1. ENGINEER will, within 10 days after receipt of each Application for Payment, either indicate in writing a recommendation of payment and present the Application to OWNER or return the Application to CONTRACTOR indicating in writing ENGINEER's reasons for refusing to recommend payment. In the latter case, CONTRACTOR may make the necessary corrections and resubmit the Application.

2. ENGINEER's recommendation of any payment requested in an Application for Payment will constitute a representation by ENGINEER to OWNER, based on ENGINEER's observations on the Site of the executed Work as an experienced and qualified design professional and on ENGINEER's review of the Application for Payment and the accompanying data and schedules, that to the best of ENGINEER's knowledge, information and belief:

a. the Work has progressed to the point indicated;

b. the quality of the Work is generally in accordance with the Contract Documents (subject to an evaluation of the Work as a functioning whole prior to or upon Substantial Completion, to the results of any subsequent tests called for in the Contract Documents, to a final determination of quantities and classifications for Unit Price Work under paragraph 9.08, and to any other qualifications stated in the recommendation); and

c. the conditions precedent to CONTRACTOR's being entitled to such payment appear to have been fulfilled in so far as it is ENGINEER's responsibility to observe the Work.

3. By recommending any such payment ENGINEER will not thereby be deemed to have represented that: (i) inspections made to check the quality or the quantity of the Work as it has been performed have been exhaustive, extended to every aspect of the Work in progress, or involved detailed inspections of the Work beyond the responsibilities specifically assigned to ENGINEER in the Contract Documents; or (ii) that there may not be other matters or issues between the parties

that might entitle CONTRACTOR to be paid additionally by OWNER or entitle OWNER to withhold payment to CONTRACTOR.

4. Neither ENGINEER's review of CONTRACTOR's Work for the purposes of recommending payments nor ENGINEER's recommendation of any payment, including final payment, will impose responsibility on ENGINEER to supervise, direct, or control the Work or for the means, methods, techniques, sequences, or procedures of construction, or the safety precautions and programs incident thereto, or for CONTRACTOR's failure to comply with Laws and Regulations applicable to CONTRACTOR's performance of the Work. Additionally, said review or recommendation will not impose responsibility on ENGINEER to make any examination to ascertain how or for what purposes CONTRACTOR has used the moneys paid on account of the Contract Price, or to determine that title to any of the Work, materials, or equipment has passed to OWNER free and clear of any Liens.

5. ENGINEER may refuse to recommend the whole or any part of any payment if, in ENGINEER's opinion, it would be incorrect to make the representations to OWNER referred to in paragraph 14.02.B.2. ENGINEER may also refuse to recommend any such payment or, because of subsequently discovered evidence or the results of subsequent inspections or tests, revise or revoke any such payment recommendation previously made, to such extent as may be necessary in ENGINEER's opinion to protect OWNER from loss because:

- a. the Work is defective, or completed Work has been damaged, requiring correction or replacement;
- b. the Contract Price has been reduced by Written Amendment or Change Orders;
- c. OWNER has been required to correct defective Work or complete Work in accordance with paragraph 13.09; or
- d. ENGINEER has actual knowledge of the occurrence of any of the events enumerated in paragraph 15.02.A.

C. *Payment Becomes Due*

1. Ten days after presentation of the Application for Payment to OWNER with ENGINEER's recommendation, the amount recommended will (subject to the provisions of paragraph 14.02.D) become due, and when due will be paid by OWNER to CONTRACTOR.

D. *Reduction in Payment*

1. OWNER may refuse to make payment of the full amount recommended by ENGINEER because:

a. claims have been made against OWNER on account of CONTRACTOR's performance or furnishing of the Work;

b. Liens have been filed in connection with the Work, except where CONTRACTOR has delivered a specific Bond satisfactory to OWNER to secure the satisfaction and discharge of such Liens;

c. there are other items entitling OWNER to a set-off against the amount recommended; or

d. OWNER has actual knowledge of the occurrence of any of the events enumerated in paragraphs 14.02.B.5.a through 14.02.B.5.c or paragraph 15.02.A.

2. If OWNER refuses to make payment of the full amount recommended by ENGINEER, OWNER must give CONTRACTOR immediate written notice (with a copy to ENGINEER) stating the reasons for such action and promptly pay CONTRACTOR any amount remaining after deduction of the amount so withheld. OWNER shall promptly pay CONTRACTOR the amount so withheld, or any adjustment thereto agreed to by OWNER and CONTRACTOR, when CONTRACTOR corrects to OWNER's satisfaction the reasons for such action.

3. If it is subsequently determined that OWNER's refusal of payment was not justified, the amount wrongfully withheld shall be treated as an amount due as determined by paragraph 14.02.C.1.

14.03 *CONTRACTOR's Warranty of Title*

A. CONTRACTOR warrants and guarantees that title to all Work, materials, and equipment covered by any Application for Payment, whether incorporated in the Project or not, will pass to OWNER no later than the time of payment free and clear of all Liens.

14.04 *Substantial Completion*

A. When CONTRACTOR considers the entire Work ready for its intended use CONTRACTOR shall notify OWNER and ENGINEER in writing that the entire Work is substantially complete (except for items specifically listed by CONTRACTOR as incomplete) and request that ENGINEER issue a certificate of Substantial Completion. Promptly thereafter, OWNER, CONTRACTOR, and ENGINEER shall make an inspection of the Work to determine the status of completion. If ENGINEER does not consider the Work substantially complete, ENGINEER will notify CONTRACTOR in writing giving the reasons therefor. If ENGINEER considers the Work substantially complete, ENGINEER will prepare and deliver to OWNER a tentative certificate of Substantial Completion which shall fix the date of Substantial Completion. There shall be attached to the certificate a tentative list of items to be completed or corrected before final payment. OWNER shall have seven days after receipt of the tentative certificate during which to make written objection to ENGINEER as to any provisions of the certificate or attached list. If, after considering such objections, ENGINEER concludes that the Work is not substantially complete, ENGINEER will within 14 days after submission of the tentative certificate to OWNER notify CONTRACTOR in writing, stating the reasons therefor. If, after consideration of OWNER's objections, ENGINEER considers the Work substantially complete, ENGINEER will within said 14 days execute and deliver to OWNER and CONTRACTOR a definitive certificate of Substantial Completion (with a revised tentative list of items to be completed or corrected) reflecting such changes from the tentative certificate as ENGINEER believes justified after consideration of any objections from OWNER. At the time of delivery of the tentative certificate of Substantial Completion ENGINEER will deliver to OWNER and CONTRACTOR a written recommendation as to division of responsibilities pending final payment between OWNER and CONTRACTOR with respect to security, operation, safety, and protection of the Work, maintenance, heat, utilities, insurance, and warranties and guarantees. Unless OWNER and CONTRACTOR agree otherwise in writing and so inform ENGINEER in writing prior to ENGINEER's issuing the definitive certificate of Substantial Completion,

ENGINEER's aforesaid recommendation will be binding on OWNER and CONTRACTOR until final payment.

B. OWNER shall have the right to exclude CONTRACTOR from the Site after the date of Substantial Completion, but OWNER shall allow CONTRACTOR reasonable access to complete or correct items on the tentative list.

14.05 *Partial Utilization*

A. Use by OWNER at OWNER's option of any substantially completed part of the Work which has specifically been identified in the Contract Documents, or which OWNER, ENGINEER, and CONTRACTOR agree constitutes a separately functioning and usable part of the Work that can be used by OWNER for its intended purpose without significant interference with CONTRACTOR's performance of the remainder of the Work, may be accomplished prior to Substantial Completion of all the Work subject to the following conditions.

1. OWNER at any time may request CONTRACTOR in writing to permit OWNER to use any such part of the Work which OWNER believes to be ready for its intended use and substantially complete. If CONTRACTOR agrees that such part of the Work is substantially complete, CONTRACTOR will certify to OWNER and ENGINEER that such part of the Work is substantially complete and request ENGINEER to issue a certificate of Substantial Completion for that part of the Work. CONTRACTOR at any time may notify OWNER and ENGINEER in writing that CONTRACTOR considers any such part of the Work ready for its intended use and substantially complete and request ENGINEER to issue a certificate of Substantial Completion for that part of the Work. Within a reasonable time after either such request, OWNER, CONTRACTOR, and ENGINEER shall make an inspection of that part of the Work to determine its status of completion. If ENGINEER does not consider that part of the Work to be substantially complete, ENGINEER will notify OWNER and CONTRACTOR in writing giving the reasons therefor. If ENGINEER considers that part of the Work to be substantially complete, the provisions of paragraph 14.04 will apply with respect to certification of Substantial Completion of that part of the Work and the division of responsibility in respect thereof and access thereto.

2. No occupancy or separate operation of part of the Work may occur prior to compliance with the requirements of paragraph 5.10 regarding property insurance.

14.06 *Final Inspection*

A. Upon written notice from CONTRACTOR that the entire Work or an agreed portion thereof is complete, ENGINEER will promptly make a final inspection with OWNER and CONTRACTOR and will notify CONTRACTOR in writing of all particulars in which this inspection reveals that the Work is incomplete or defective. CONTRACTOR shall immediately take such measures as are necessary to complete such Work or remedy such deficiencies.

14.07 *Final Payment*

A. *Application for Payment*

1. After CONTRACTOR has, in the opinion of ENGINEER, satisfactorily completed all corrections identified during the final inspection and has delivered, in accordance with the Contract Documents, all maintenance and operating instructions, schedules, guarantees, Bonds, certificates or other evidence of insurance certificates of inspection, marked-up record documents (as provided in paragraph 6.12), and other documents, CONTRACTOR may make application for final payment following the procedure for progress payments.

2. The final Application for Payment shall be accompanied (except as previously delivered) by: (i) all documentation called for in the Contract Documents, including but not limited to the evidence of insurance required by subparagraph 5.04.B.7; (ii) consent of the surety, if any, to final payment; and (iii) complete and legally effective releases or waivers (satisfactory to OWNER) of all Lien rights arising out of or Liens filed in connection with the Work.

3. In lieu of the releases or waivers of Liens specified in paragraph 14.07.A.2 and as approved by OWNER, CONTRACTOR may furnish receipts or releases in full and an affidavit of CONTRACTOR that: (i) the releases and receipts include all labor, services, material, and equipment for which a Lien could be filed; and (ii) all payrolls, material and equipment bills, and other

indebtedness connected with the Work for which OWNER or OWNER's property might in any way be responsible have been paid or otherwise satisfied. If any Subcontractor or Supplier fails to furnish such a release or receipt in full, CONTRACTOR may furnish a Bond or other collateral satisfactory to OWNER to indemnify OWNER against any Lien.

B. *Review of Application and Acceptance*

1. If, on the basis of ENGINEER's observation of the Work during construction and final inspection, and ENGINEER's review of the final Application for Payment and accompanying documentation as required by the Contract Documents, ENGINEER is satisfied that the Work has been completed and CONTRACTOR's other obligations under the Contract Documents have been fulfilled, ENGINEER will, within ten days after receipt of the final Application for Payment, indicate in writing ENGINEER's recommendation of payment and present the Application for Payment to OWNER for payment. At the same time ENGINEER will also give written notice to OWNER and CONTRACTOR that the Work is acceptable subject to the provisions of paragraph 14.09. Otherwise, ENGINEER will return the Application for Payment to CONTRACTOR, indicating in writing the reasons for refusing to recommend final payment, in which case CONTRACTOR shall make the necessary corrections and resubmit the Application for Payment.

C. *Payment Becomes Due*

1. Thirty days after the presentation to OWNER of the Application for Payment and accompanying documentation, the amount recommended by ENGINEER will become due and, when due, will be paid by OWNER to CONTRACTOR.

14.08 *Final Completion Delayed*

A. If, through no fault of CONTRACTOR, final completion of the Work is significantly delayed, and if ENGINEER so confirms, OWNER shall, upon receipt of CONTRACTOR's final Application for Payment and recommendation of ENGINEER, and without terminating the Agreement, make payment of the balance due for that portion of the Work fully completed and accepted. If the remaining balance to be held by OWNER for Work not

fully completed or corrected is less than the retainage stipulated in the Agreement, and if Bonds have been furnished as required in paragraph 5.01, the written consent of the surety to the payment of the balance due for that portion of the Work fully completed and accepted shall be submitted by CONTRACTOR to ENGINEER with the Application for such payment. Such payment shall be made under the terms and conditions governing final payment, except that it shall not constitute a waiver of Claims.

14.09 *Waiver of Claims*

A. The making and acceptance of final payment will constitute:

1. a waiver of all Claims by OWNER against CONTRACTOR, except Claims arising from unsettled Liens, from defective Work appearing after final inspection pursuant to paragraph 14.06, from failure to comply with the Contract Documents or the terms of any special guarantees specified therein, or from CONTRACTOR's continuing obligations under the Contract Documents; and

2. a waiver of all Claims by CONTRACTOR against OWNER other than those previously made in writing which are still unsettled.

ARTICLE 15 - SUSPENSION OF WORK AND TERMINATION

15.01 OWNER May Suspend Work

A. At any time and without cause, OWNER may suspend the Work or any portion thereof for a period of not more than 90 consecutive days by notice in writing to CONTRACTOR and ENGINEER which will fix the date on which Work will be resumed. CONTRACTOR shall resume the Work on the date so fixed. CONTRACTOR shall be allowed an adjustment in the Contract Price or an extension of the Contract Times, or both, directly attributable to any such suspension if CONTRACTOR makes a Claim therefor as provided in paragraph 10.05.

15.02 *OWNER May Terminate for Cause*

A. The occurrence of any one or more of the following events will justify termination for cause:

1. CONTRACTOR's persistent failure to perform the Work in accordance with the Contract Documents (including, but not limited to, failure to supply sufficient skilled workers or suitable materials or equipment or failure to adhere to the progress schedule established under paragraph 2.07 as adjusted from time to time pursuant to paragraph 6.04);

2. CONTRACTOR's disregard of Laws or Regulations of any public body having jurisdiction;

3. CONTRACTOR's disregard of the authority of ENGINEER; or

4. CONTRACTOR's violation in any substantial way of any provisions of the Contract Documents.

B. If one or more of the events identified in paragraph 15.02.A occur, OWNER may, after giving CONTRACTOR (and the surety, if any) seven days written notice, terminate the services of CONTRACTOR, exclude CONTRACTOR from the Site, and take possession of the Work and of all CONTRACTOR's tools, appliances, construction equipment, and machinery at the Site, and use the same to the full extent they could be used by CONTRACTOR (without liability to CONTRACTOR for trespass or conversion), incorporate in the Work all materials and equipment stored at the Site or for which OWNER has paid CONTRACTOR but which are stored elsewhere, and finish the Work as OWNER may deem expedient. In such case, CONTRACTOR shall not be entitled to receive any further payment until the Work is finished. If the unpaid balance of the Contract Price exceeds all claims, costs, losses, and damages (including but not limited to all fees and charges of engineers, architects, attorneys, and other professionals and all court or arbitration or other dispute resolution costs) sustained by OWNER arising out of or relating to completing the Work, such excess will be paid to CONTRACTOR. If such claims, costs, losses, and damages exceed such unpaid balance, CONTRACTOR shall pay the difference to OWNER. Such claims, costs, losses, and damages incurred by OWNER will be reviewed by ENGINEER as to their reasonableness and, when so approved by ENGINEER, incorporated in a Change Order. When exercising any rights or remedies under this paragraph OWNER shall not be required to obtain the lowest price for the Work performed.

C. Where CONTRACTOR's services have been so terminated by OWNER, the termination will not affect any rights or remedies of OWNER against CONTRACTOR then existing or which may thereafter accrue. Any retention or payment of moneys due CONTRACTOR by OWNER will not release CONTRACTOR from liability.

15.03 *OWNER May Terminate For Convenience*

A. Upon seven days written notice to CONTRACTOR and ENGINEER, OWNER may, without cause and without prejudice to any other right or remedy of OWNER, elect to terminate the Contract. In such case, CONTRACTOR shall be paid (without duplication of any items):

1. for completed and acceptable Work executed in accordance with the Contract Documents prior to the effective date of termination, including fair and reasonable sums for overhead and profit on such Work;

2. for expenses sustained prior to the effective date of termination in performing services and furnishing labor, materials, or equipment as required by the Contract Documents in connection with uncompleted Work, plus fair and reasonable sums for overhead and profit on such expenses;

3. for all claims, costs, losses, and damages (including but not limited to all fees and charges of engineers, architects, attorneys, and other professionals and all court or arbitration or other dispute resolution costs) incurred in settlement of terminated contracts with Subcontractors, Suppliers, and others; and

4. for reasonable expenses directly attributable to termination.

B. CONTRACTOR shall not be paid on account of loss of anticipated profits or revenue or other economic loss arising out of or resulting from such termination.

15.04 *CONTRACTOR May Stop Work or Terminate*

A. If, through no act or fault of CONTRACTOR, the Work is suspended for more than 90 consecutive days by OWNER or under an order of court or other public authority, or ENGINEER fails to act on any Application for Payment within 30 days after it is submitted, or OWNER fails for 30 days to pay CONTRACTOR any sum finally determined to be due, then CONTRACTOR may, upon

seven days written notice to OWNER and ENGINEER, and provided OWNER or ENGINEER do not remedy such suspension or failure within that time, terminate the Contract and recover from OWNER payment on the same terms as provided in paragraph 15.03. In lieu of terminating the Contract and without prejudice to any other right or remedy, if ENGINEER has failed to act on an Application for Payment within 30 days after it is submitted, or OWNER has failed for 30 days to pay CONTRACTOR any sum finally determined to be due, CONTRACTOR may, seven days after written notice to OWNER and ENGINEER, stop the Work until payment is made of all such amounts due CONTRACTOR, including interest thereon. The provisions of this paragraph 15.04 are not intended to preclude CONTRACTOR from making a Claim under paragraph 10.05 for an adjustment in Contract Price or Contract Times or otherwise for expenses or damage directly attributable to CONTRACTOR's stopping the Work as permitted by this paragraph.

ARTICLE 16 - DISPUTE RESOLUTION*

16.01 *Methods and Procedures*

A. Dispute resolution methods and procedures, if any, shall be as set forth in the Supplementary Conditions. If no method and procedure has been set forth, and subject to the provisions of paragraphs 9.09 and 10.05, OWNER and CONTRACTOR may exercise such rights or remedies as either may otherwise have under the Contract Documents or by Laws or Regulations in respect of any dispute.

ARTICLE 17 - MISCELLANEOUS*

17.01 *Giving Notice*

A. Whenever any provision of the Contract Documents requires the giving of written notice, it will be deemed to have been validly given if delivered in person to the individual or to a member of the firm or to an officer of the corporation for whom it is intended, or if delivered at or sent by registered or certified mail, postage prepaid, to the last business address known to the giver of the notice.

17.02 *Computation of Times*

A. When any period of time is referred to in the Contract Documents by days, it will be computed to

exclude the first and include the last day of such period. If the last day of any such period falls on a Saturday or Sunday or on a day made a legal holiday by the law of the applicable jurisdiction, such day will be omitted from the computation.

17.03 *Cumulative Remedies*

A. The duties and obligations imposed by these General Conditions and the rights and remedies available hereunder to the parties hereto are in addition to, and are not to be construed in any way as a limitation of, any rights and remedies available to any or all of them which are otherwise imposed or available by Laws or Regulations, by special warranty or guarantee, or by other provisions of the Contract Documents, and the provisions of this paragraph will be as effective as if repeated specifically in the Contract Documents in connection with each particular duty, obligation, right, and remedy to which they apply.

17.04 *Survival of Obligations*

A. All representations, indemnifications, warranties, and guarantees made in, required by, or given in accordance with the Contract Documents, as well as all continuing obligations indicated in the Contract Documents, will survive final payment, completion, and acceptance of the Work or termination or completion of the Agreement.

17.05 *Controlling Law*

A. This Contract is to be governed by the law of the state in which the Project is located.

SUPPLEMENTAL GENERAL CONDITIONS

These Supplementary Conditions amend or supplement the Standard General Conditions of the Construction Contract (No. 1910-8, 1996 Edition) and other provisions of the Contract Documents as indicated below. All provisions, which are not so amended or supplemental, remain in full force and effect.

The terms used in these Supplementary Conditions will have the meanings indicated in the General Conditions. Additional terms used in these Supplementary Conditions have the meanings indicated below, which are applicable to both the singular and plural thereof.

SC-6.10 Delete paragraph 6.10 in its entirety and insert the following in its place:

The owner qualifies for the state and local tax exemption in the purchase of certain materials and equipment the Contractor shall utilize the form provided herewith in exhibit "D".

SC-11.01 Delete paragraph 11.01 in its entirety.

SC-11.02 Delete paragraph 11.02 in its entirety.

SC-12.01B.25 & B.3. Delete paragraph 12.01B.2 & B.3 in its entirety.

SC-12.01.C.2 Delete paragraph 12.01.C.2 in its entirety.

SC Article 14.02 C.1 Replace "**Ten days**" with "**Thirty days**" to read as follows: Thirty days after presentation of the Application for Payment to OWNER with ENGINEER'S recommendation, the amount recommended will (subject to the provisions of paragraph 14.02.D) become due, and when due will be paid by OWNER TO CONTRACTOR.

SC Article 16 Add the following language at the end of the paragraph of Article 16:

There are no dispute resolution methods and procedures set forth in the Supplemental Conditions:

GENERAL PREVAILING WAGE LEGAL REQUIREMENTS

The Contractor's attention is called to Texas Government Code Chapter 2258, which must be complied with attached herewith as Exhibit "C"

**GENERAL NOTES AND
STANDARD SPECIFICATIONS**

For all pits or quarries, comply with the “Texas Aggregate Quarry and Pit Safety Act.”

Provide on a weekly basis a list of equipment, including idle equipment, utilized on the project that week.

The 1-800 call services for utility locations do not include TxDOT facilities.

ITEM 3. Scope of Work

This Contract includes non-site specific work. Multiple work orders will be used to procure work of the type identified in the contract at locations that have not yet been determined.

ITEM 5. Control of the Work

Prior to contract letting, bidders may obtain a free computer diskette or a computerized transfer of files (from the Engineer’s office) that contains the earthwork information. If copies of the actual cross-sections in addition to, or instead of, the diskette are requested, they will be available at the Engineers office for borrowing by copying companies for the purpose of making copies for the bidder at the bidders expense.

ITEM 8. Prosecution and Progress

Where road closures or detours around structures are necessary to accomplish proposed work, the removal of existing structures and/or cutting of existing pavement will not be permitted until all pre-cast members for the proposed structure have been cast, tested and approved for use.

Working days will be computed and charged in accordance with Article 8.3.A.6 defined as follows:

Upon issuance of written authorization to begin work, all of Item 100, "Preparing Right of Way" will commence. Item 100 work shall be completed before work begins on other items, unless otherwise authorized by the project engineer.

Work and time charges will continue until completion of Item 100. Upon completion of Item 100, work and time charges will stop for a maximum period of 120 days for utility work to be completed. Time charges in accordance with Article 8.3.A.1 will resume at the end of the 120 day utility work period or earlier if mutually agreed in writing by the engineer and contractor.

ITEM 100. Preparing Right of Way

Clearing & grubbing shall be executed in accordance with the District Clearing and Grubbing detail sheets.

ITEMS 134. Backfilling Pavement Edges

Areas to be backfilled shall extend approximately 3-ft out from the edges of the proposed overlay. Final slopes shall be uniform and smooth. The 100-foot station payment includes Backfilling of both sides.

Backfill Ty A shall not contain particles more than two inches in size and shall have a minimum PI of 10 and a maximum PI of 20.

Any additional backfill material necessary due to pre-existing edge conditions or to replace existing fill removed during blading operations will not be paid for directly. It will be considered subsidiary to this bid item.

ITEM 164. Seeding for Erosion Control

During drill seeding operations, application methods shall be in accordance with the method shown in the Standard Specification Book.

Cool Season or Warm Season Grasses shall be included as part of Item 164 (See Table 3 and/or Table 4 in the Standard Specification Manual for dates and seed type).

Seed mixture

Seed mixture shall be as specified under Item 164.

ITEM 166. Fertilizer

Fertilizer rate is based on a rate of 100 Lbs. of Nitrogen per acre. The Nitrogen-Phosphorous-Potassium (NPK) ratio shall include a minimum of 5 percent phosphorous and 5 percent Potassium. Fertilizer shall be homogenized.

ITEM 216. Proof Rolling

Work shall be done in accordance to Item 216, except for measurement and payment. This work will not be paid for directly, but shall be considered subsidiary to the various bid items.

ITEM 247. Flexible Base

Flexible Base Type E will be composed of caliche (argillaceous Limestone, calcareous or calcareous clay particles) and may contain stone, conglomerate, gravel, sand or granular materials when these materials are in situ with the caliche.

Blended material for Flexible Base TY E GR 4

The Contractor may blend base material with another caliche source or with crushed concrete, meeting the requirements for TY “D” materials, provided a minimum of 50% caliche is used. The crushed concrete may contain sand or granular materials. Stabilizing additives will not be allowed in the raw crushed concrete base. Acceptance will be under the following conditions:

Condition One (1): When both components of the blend in their individual stockpiles meet all the physical requirements of this Item, then field blending will be allowed.

Condition Two (2): When only one component of the blend passes the physical requirements of this Item, the materials shall be blended through a plant for stockpile testing and approval.

Flexible Base (TY E GR 4) shall conform to the following requirements:

BEFORE LIME IS ADDED

Retained on Sq. Sieve	Percent Retained
2”	0
1/2”	20-60
No. 4	40-75
No. 40	70-90
Max. PI:	15
Max. Wet Ball PI:	15
Wet Ball Mill Max Amount:	50
Min. Comp. Strength PSI:	150 at 15 PSI lateral pressure
Triaxial Test	Tex-117-E

The Wet Ball Test (Tex-116-E) shall be run and the Plasticity Index of the material passing the No. 40 sieve shall be determined (Wet Ball PI).

After 1% lime (laboratory) is added to unlimed material

Max PI	12
Min. Comp. Strength PSI:	180 at 15 PSI Lateral Pressure
Triaxial Test (Lime Treated)	Tex-121-E

Two (2) percent lime (by weight) will be incorporated into the Flexible Base in the field at the Owner's expense in accordance with the provisions of Items 260.

The percent of density as determined by Compaction Ratio (Tex-113-E) for the new Flexible Base shall be a minimum of 98%.

The Contractor's attention is called to the fact that certain existing and/or proposed structures may be within the limits of the Flexible Base. It shall be the Contractor's responsibility to perform construction operations without damage to these structures.

For water added under Item 247, the sulfate content will not exceed 3000-ppm and the chloride content will not exceed 3000-ppm.

Perform base ride quality testing for all base with only one lift of ACP or a seal coat as the final surface in accordance with the Pharr District Special Provision for flexbase ride testing. Perform base ride quality testing before placing the ACP or seal coat.

ITEM 251. Reworking Base Material

Quantities of Flexible Base to be salvaged, shown on the typical sections, are for estimating purposes only. All acceptable base material encountered in existing base is to be salvaged as directed by the Engineer regardless of the quantities involved.

Salvaged base shall be used in the bottom course on any of the proposed roadway and/or turnout sections.

Salvaged base may be used on any of the proposed driveway sections.

ITEM 260. Lime Treatment (Road Mixed)

The Contractor's attention is called to the fact that certain existing and/or proposed structures are within the limits of the lime-treated Subgrade. Unless otherwise directed by the Engineer, these structures shall be installed before the final rolling of this Subgrade. It shall be the Contractor's responsibility to perform the proper lime treating operation without damage to these structures.

The slurry method of applying lime will be required, except when the lime is to be added to naturally wet materials as directed by the Engineer.

For this project, the Engineer will direct a random number of lime trucks to be check weighed.

The percent of density as determined by Tex-121-E for the new and salvage Flexible Base shall be a minimum of 98% for all courses.

ITEM 300. Asphalt's, Oils and Emulsions

Temporary ramps/detours and driveways may use performance grade binder 64-22.

ITEM 301. Asphalt Antistripping Agents

Lime TY A or B shall be added as an Antistripping additive between the rates of 1 % minimum 2.0% maximum by weight for item 341. If the Hamburg wheel test cannot be met within these limits, Liquid Antistripping agents as approved by the Engineer may be used in conjunction with lime for item 341.

ITEM 310. Prime Coat (Cutback Asphaltic Material)

The Contractor shall exercise diligence in the application of asphalt by the use of flagging and rolling procedures to keep from spraying or splattering the traveling public with asphaltic material.

All existing Flexible Base, which may become exposed by the milling operation, shall be primed at the rate of 0.2 Gal/SY.

Do not apply subsequent courses over the initial prime coat any earlier than the day after the prime coat was applied, unless otherwise authorized or directed by the Engineer.

ITEM 314. Emulsified Asphalt Treatment

The Contractor shall exercise diligence in the application of emulsified asphalt by the use of flagging to keep from spraying or splattering the traveling public with asphaltic material.

ITEM 400. Excavation and Backfill for Structures

If the Contractor elects to cut pavement (existing/detour) for structural work beyond that required by the construction phasing shown in the plans and approved by the Engineer, it shall be restored at his expense and backfilled to its original condition or better in accordance with Item 400.

Unless shown otherwise in the plans, use a 1-ft depth for Item 400 Structural Excavation (Special) for gravel bedding needed below drainage structures with unstable material.

ITEM 420. Concrete Structures

Use membrane curing, Type 2, for concrete curb, gutter and combined curb and gutter, concrete medians, directional islands and sidewalks.

Pay bent concrete as plan quantity.

ITEM 421. Portland cement Concrete

Provide Sulfate Resistant Concrete for all concrete piling and drilled shafts.

Provide equipment at the batch plant for determining the free moisture and/or absorption of aggregates in accordance with applicable TXDOT Test.

Provide the following items for concrete batch inspection in accordance with specifications outlined in DMS-10101, "Computer Equipment":

- (1) One Desktop Microcomputer or One Laptop Microcomputer
- (2) One Integrated Printer/Scanner/Copier/Fax Unit
- (3) Contractor-Furnished Software
- (4) Hardware

Air entrain all concrete used in Drilled Shafts.

ITEM 432. Riprap

Provide Class "A" concrete minimum for riprap aprons placed around all box culvert and pipe safety end treatments.

ITEM 462. Concrete Box Culverts and Storm Drains

Provide joints in pre-cast concrete box culverts using any of the methods specified in Item 464, except mortar joints.

Provide pre-cast concrete boxes to expedite traffic handling unless otherwise shown on the plans.

Provide the Area Engineer with the casting schedule of all pre-cast concrete boxes prior to beginning any fabrication.

ITEM 464. Reinforced Concrete Pipe

Use tongue and groove pipe where the RCP extends into the lime treated subgrade. The 4-foot depth restriction for heavy equipment passage over pipe structures is voided. The Contractor will be responsible for any construction damage to these facilities.

Do not use mortar joints.

All reinforced concrete pipe shall include rubber gaskets unless shown otherwise on the plans or directed by the engineer.

ITEM 466. Headwalls and Wingwalls

Do not use pre-cast headwalls/wingwalls.

ITEM 467. Safety End Treatment

All Type II SET's shall have riprap, Class "A" minimum, aprons as shown on the plans. The contractor may submit an alternate precast SET design for approval by the Engineer.

ITEM 471. Frames, Grates, Rings and Covers

All grates will be tack welded to the frames in a manner satisfactory to the Engineer.

ITEM 496. Removing Old Structures

Store the following items to be salvaged at a location designated by the Engineer:

ITEM 502. Barricades, Signs and Traffic Handling

Shadow vehicles equipped with Truck-Mounted Attenuators are required.

A pilot car and radio equipped flaggers shall be required for all undivided roadway locations as directed by the Engineer. The pilot car with necessary flaggers and/or radio equipped flaggers and all signs, equipment, labor and incidentals required for this method of traffic control will not be paid for directly, but shall be considered subsidiary to Item 502.

Replace/relocate all regulatory signs removed due to construction operations with a same sign on fixed support(s) immediately upon its removal. First obtain project Engineer approval before removing any regulatory roadway sign. Required flaggers are to be available to direct traffic during sign intermediate down time.

Relocate any Directional Sign Assemblies removed during construction operations immediately upon their removal.

These signs shall be relocated to a location in accordance with the Latest Version of the “Texas Manual on Uniform Traffic Control Devices”. In no case will a sign be removed without a replacement sign and support(s) being readily available and a location established. Removal and relocation of these signs required for traffic control will not be paid for directly, but shall be considered subsidiary to Item 502.

ITEM 504. Field Office and Laboratory

For this project a field office will not be required at the project site.

ITEM 506. Temporary Erosion, Sedimentation, and Environmental Controls

Due to the nature of this project, it is unlikely a significant amount of soil will be disturbed. However, if for unforeseen reasons a sediment control fence is needed; it shall be placed as directed by the Engineer.

ITEM 508. Constructing Detours

Flexible Base, prime coat, and Asphaltic Concrete Pavement used for detours shall meet the requirements of Items 247, 310, and 341 respectively, except for measurement and payment.

ITEM 529. Concrete Curb, Gutter and Combined Curb and Gutter

Before final acceptance of the project, remove discoloration caused by tire marks, mud, asphalt, paint or other similar material by any method satisfactory to the Engineer to achieve a uniform color and texture of the finished surface exposed to view.

ITEM 530. Public & Private Driveways

Prime coat shall meet the requirements of Item 310.

Daily testing requirements for Hot Mix Asphaltic Concrete Pavements for drives, commercial entrances and/or turnouts may be waived by the Engineer.

ITEM 531. Sidewalks

Construct ¼-inch thick score joints at a maximum 6-foot spacing and expansion joints at a maximum 30-foot spacing. Construct a joint in the center of the sidewalk if it is over 15-feet

wide. For steel reinforcement, use 6x6-inch spacing with #3 bars or 6x6 – D6 welded wire fabric.

ITEM 538. Right of Way Markers

Right of Way markers will be set under the supervision of a registered public land surveyor.

Existing Right of Way monuments to be reset with proposed Right of Way markers will be referenced to a minimum of three reference points set under the supervision of a registered public land surveyor.

he Contractor will inform the Engineer when all reference points have been installed and allow the TXDOT survey crew to survey the reference points before installing the proposed Right of Way markers.

ITEM 540. Metal Beam Guard Fence

The optional terminal anchor post with the terminal connector will be required as shown on the Metal Beam Guard Fence Standard.

ITEM 542. Removing Metal Beam Guard Fence

Dispose all metal beam guard fence materials unless shown otherwise in the plans.

ITEM 544. Guardrail End Treatments

Label “end treatment type” on backside of unit at time of installation.

ITEM 552. Wire Fence

Contractor is to repair any wire fence that is damaged by the contractor to insure the retention of livestock, if any, in their respective pastures along the project.

ITEM 585. Ride Quality for Pavement Surfaces

Use Surface Test Type "B" for service roads and ramps.

Quality control results shall be submitted to TxDOT the next working day after each day's paving.

Pavement areas with public turnout intersections that carry major traffic volumes will not be subjected to inertial profiler testing. These areas shall be evaluated using the 10-ft. Straightedge.

Diamond grinding shall be used to remove localized roughness.

ITEMS 662 AND 666, Work Zone Pavement Markings and Reflectorized Pavement Markings

All permanent pavement markings and work zone pavement markings for this project under these Items shall be 0.100 inches (100 mil) thick thermoplastic.

Any permanent pavement markings or non-removal work zone pavement markings lacking reflectivity in accordance with test method Tex 828-B, will not be paid for, as per district policy. The roadway will be re-stripped at no additional compensation.

Pavement surface preparation for markings and markers will not be paid for directly, but shall be considered subsidiary to Item 666.

Prior to any striping operations, an on-site coordination meeting between all the parties involved will be required to review striping details and requirements to ensure quality work.

The beads used on this project shall meet the requirements of Departmental Materials Specification DMS-8290, Glass Traffic Beads Texas Type II & III. Use a 50% Type II/ 50% Type III mix utilizing a double drop system with Type II beads dropped first.

ITEM 677, Eliminating Existing Pavement Markings and Markers

Asphalt and aggregate types and grades shall be as approved in writing when a surface treatment is used to eliminate existing pavement markings.

GOVERNING SPECIFICATIONS AND SPECIAL PROVISIONS

All specifications and special provisions applicable to this project are identified as follows:

STANDARD SPECIFICATIONS: Adopted by the Texas Department of Transportation, June 1, 2004. Standard Specifications are incorporated into the contract by reference.

- ITEM 100 PREPARING RIGHT OF WAY
- ITEM 104 REMOVING CONCRETE
- ITEM 132 EMBANKMENT
- ITEM 164 SEEDING FOR EROSION CONTROL
- ITEM 166 FERTILIZER
- ITEM 168 VEGETATIVE WATER
- ITEM 216 PROOF ROLLING
- ITEM 247 FLEXIBLE BASE
- ITEM 251 REWORKING BASE COURSES
- ITEM 260 LIME TREATMENT (ROAD MIXED)
- ITEM 300 ASPHALTS, OILS AND EMULSIONS
- ITEM 310 PRIME COAT
- ITEM 340 DENSE GRADED HOT MIX ASPHALT (METHOD)
- ITEM 354 PLANING AND TEXTURING PAVEMENT
- ITEM 464 REINFORCED CONCRETE PIPE
- ITEM 465 MANHOLES AND INLETS
- ITEM 496 REMOVING STRUCTURES
- ITEM 500 MOBILIZATION
- ITEM 502 BARRICADES, SIGNS AND TRAFFIC HANDLING
- ITEM 506 TEMPORARY EROSION, SEDIMENTATIONS AND ENVIRONMENTAL CONTROLS
- ITEM 529 CONCRETE CURB, GUTTER AND COMBINED CURB-GUTTER
- ITEM 530 INTERSECTIONS, DRIVEWAYS AND TURNOUTS
- ITEM 556 PIPE UNDERDRAINS
- ITEM 585 RIDE QUALITY FOR PAVEMENT STRUCTURES
- ITEM 666 REFLECTORIZED PAVEMENT MARKINGS
- ITEM 760 CLEANING AND RESHAPING DITCHES
- ITEM 2500 EN-1 ROADBOND

SPECIAL SPECIFICATIONS: Adopted by the Texas Department of Transportation, June 1, 2004 are incorporated into the contract by reference.

SS 3035 BLADE LEVEL-UP

SPECIAL PROVISIONS: Special Provisions will govern and take precedence over the Specifications enumerated hereon wherever in conflict therewith. (Enclosed herewith)

- PREPARING RIGHT OF WAY: SP 100-002
- SEEDING FOR EROSION CONTROL: SP 164-002 & 004
- FERTILIZER: SP 166-001
- FLEXIBLE BASE: SP 247-033,036,038,039,040 & 041
- LIME TREATMENT (ROAD MIXED): SP 260-001
- ASPHALTS, OILS AND EMULSIONS: SP 300-008, 016, 020 & 025

- DENSE GRADED HOT MIX ASPHALT (METHOD): SP 340-001 & 003
- REINFORCED CONCRETE PIPE: SP 464-003
- MANHOLES AND INLETS: SP 465-001
- MOBILIZATION: SP 500
- BARRICADES, SIGNS AND TRAFFIC HANDLING: SP 502-006 & 033
- TEMPORARY EROSION, SEDIMENTATIONS AND ENVIRONMENTAL CONTROLS: SP 506-010,011,012&013
- REFLECTORIZED PAVEMENT MARKINGS: SP 666-001, 008 & 014

General: The above listed specifications items are those under which payment is to be made. These, together with such other pertinent items, if any, as may be referred to in the above-listed specification items, and including the special provisions listed above, constitute the complete specifications for this project.

All item numbers noted in these plans are the same as those referenced in the Texas Department of Transportation 2004 Standard Specifications for Construction and Maintenance of Highways, Streets, and Bridges book (June 1, 2004) and Texas Department of Transportation Website.

**Certification
Regarding Debarment, Suspension and Ineligibility**

As is required by the Federal Regulations Implementing Executive Order 12549, Debarment and Suspension, 45 CFR Part 76, Government-wide Debarment and Suspension, the applicant certifies, to the best of his or her knowledge and belief, that both it and its principals:

- a. Are not presently debarred, suspended, proposed for debarment, declared ineligible, or voluntarily excluded from participation in this transaction by any federal department or agency;
- b. Have not within a three-year period preceding this bid proposal and/or application been convicted of or had a civil judgment rendered against them for commission of fraud or a criminal offense in connection with obtaining, attempting to obtain, or performing a public (federal, state, or local) transaction or contract under a public transaction, violation of federal or state antitrust statutes or commission of embezzlement, theft, forgery, bribery, falsification or destruction of records, making false statements, or receiving stolen property;
- c. Are not presently indicted for or otherwise criminally or civilly charged by a government entity with commission of any of the offenses enumerated herein; and
- d. Have not within a three-year period preceding this bid proposal and/or application had one or more public transactions terminated for cause or default.

Signature: _____
Print Name: _____
Title: _____
Telephone Number: _____
Date: _____

If the bidder is unable to certify to all of the statements in this Certification, such bidder should attach an explanation to this proposal.

Request for Taxpayer Identification Number and Certification

**Give form to the
 requester. Do not
 send to the IRS.**

Print or type See Specific instructions on page 2.	Name (as shown on your income tax return)	
	Business name, if different from above	
	Check appropriate box: <input type="checkbox"/> Individual/ Sole proprietor <input type="checkbox"/> Corporation <input type="checkbox"/> Partnership <input type="checkbox"/> Other ▶	
	<input type="checkbox"/> Exempt from backup withholding	
	Address (number, street, and apt. or suite no.)	Requester's name and address (optional)
	City, state, and ZIP code	
List account number(s) here (optional)		

Part I Taxpayer Identification Number (TIN)

Enter your TIN in the appropriate box. The TIN provided must match the name given on Line 1 to avoid backup withholding. For individuals, this is your social security number (SSN). However, for a resident alien, sole proprietor, or disregarded entity, see the Part I instructions on page 3. For other entities, it is your employer identification number (EIN). If you do not have a number, see *How to get a TIN* on page 3.

Note. If the account is in more than one name, see the chart on page 4 for guidelines on whose number to enter.

Social security number								
			+			+		
or								
Employer identification number								
			+					

Part II Certification

Under penalties of perjury, I certify that:

1. The number shown on this form is my correct taxpayer identification number (or I am waiting for a number to be issued to me), and
2. I am not subject to backup withholding because: (a) I am exempt from backup withholding, or (b) I have not been notified by the Internal Revenue Service (IRS) that I am subject to backup withholding as a result of a failure to report all interest or dividends, or (c) the IRS has notified me that I am no longer subject to backup withholding, and
3. I am a U.S. person (including a U.S. resident alien).

Certification instructions. You must cross out item 2 above if you have been notified by the IRS that you are currently subject to backup withholding because you have failed to report all interest and dividends on your tax return. For real estate transactions, item 2 does not apply. For mortgage interest paid, acquisition or abandonment of secured property, cancellation of debt, contributions to an individual retirement arrangement (IRA), and generally, payments other than interest and dividends, you are not required to sign the Certification, but you must provide your correct TIN. (See the instructions on page 4.)

Sign Here	Signature of U.S. person ▶	Date ▶
------------------	----------------------------	--------

Purpose of Form

A person who is required to file an information return with the IRS, must obtain your correct taxpayer identification number (TIN) to report, for example, income paid to you, real estate transactions, mortgage interest you paid, acquisition or abandonment of secured property, cancellation of debt, or contributions you made to an IRA.

U.S. person. Use Form W-9 only if you are a U.S. person (including a resident alien), to provide your correct TIN to the person requesting it (the requester) and, when applicable, to:

1. Certify that the TIN you are giving is correct (or you are waiting for a number to be issued),
2. Certify that you are not subject to backup withholding, or
3. Claim exemption from backup withholding if you are a U.S. exempt payee.

In 3 above, if applicable, you are also certifying that as a U.S. person, your allocable share of any partnership income from a U.S. trade or business is not subject to the withholding tax on foreign partners' share of effectively connected income.

Note. If a requester gives you a form other than Form W-9 to request your TIN, you must use the requester's form if it is substantially similar to this Form W-9.

For federal tax purposes, you are considered a person if you are:

- An individual who is a citizen or resident of the United States,
- A partnership, corporation, company, or association created or organized in the United States or under the laws of the United States, or
- Any estate (other than a foreign estate) or trust. See Regulations sections 301.7701-6(a) and 7(a) for additional information.

Special rules for partnerships. Partnerships that conduct a trade or business in the United States are generally required to pay a withholding tax on any foreign partners' share of income from such business. Further, in certain cases where a Form W-9 has not been received, a partnership is required to presume that a partner is a foreign person, and pay the withholding tax. Therefore, if you are a U.S. person that is a partner in a partnership conducting a trade or business in the United States, provide Form W-9 to the partnership to establish your U.S. status and avoid withholding on your share of partnership income.

The person who gives Form W-9 to the partnership for purposes of establishing its U.S. status and avoiding withholding on its allocable share of net income from the partnership conducting a trade or business in the United States is in the following cases:

- The U.S. owner of a disregarded entity and not the entity,

- The U.S. grantor or other owner of a grantor trust and not the trust, and
- The U.S. trust (other than a grantor trust) and not the beneficiaries of the trust.

Foreign person. If you are a foreign person, do not use Form W-9. Instead, use the appropriate Form W-8 (see Publication 515, Withholding of Tax on Nonresident Aliens and Foreign Entities).

Nonresident alien who becomes a resident alien.

Generally, only a nonresident alien individual may use the terms of a tax treaty to reduce or eliminate U.S. tax on certain types of income. However, most tax treaties contain a provision known as a "saving clause." Exceptions specified in the saving clause may permit an exemption from tax to continue for certain types of income even after the recipient has otherwise become a U.S. resident alien for tax purposes.

If you are a U.S. resident alien who is relying on an exception contained in the saving clause of a tax treaty to claim an exemption from U.S. tax on certain types of income, you must attach a statement to Form W-9 that specifies the following five items:

1. The treaty country. Generally, this must be the same treaty under which you claimed exemption from tax as a nonresident alien.
2. The treaty article addressing the income.
3. The article number (or location) in the tax treaty that contains the saving clause and its exceptions.
4. The type and amount of income that qualifies for the exemption from tax.
5. Sufficient facts to justify the exemption from tax under the terms of the treaty article.

Example. Article 20 of the U.S.-China income tax treaty allows an exemption from tax for scholarship income received by a Chinese student temporarily present in the United States. Under U.S. law, this student will become a resident alien for tax purposes if his or her stay in the United States exceeds 5 calendar years. However, paragraph 2 of the first Protocol to the U.S.-China treaty (dated April 30, 1984) allows the provisions of Article 20 to continue to apply even after the Chinese student becomes a resident alien of the United States. A Chinese student who qualifies for this exception (under paragraph 2 of the first protocol) and is relying on this exception to claim an exemption from tax on his or her scholarship or fellowship income would attach to Form W-9 a statement that includes the information described above to support that exemption.

If you are a nonresident alien or a foreign entity not subject to backup withholding, give the requester the appropriate completed Form W-8.

What is backup withholding? Persons making certain payments to you must under certain conditions withhold and pay to the IRS 28% of such payments (after December 31, 2002). This is called "backup withholding." Payments that may be subject to backup withholding include interest, dividends, broker and barter exchange transactions, rents, royalties, nonemployee pay, and certain payments from fishing boat operators. Real estate transactions are not subject to backup withholding.

You will not be subject to backup withholding on payments you receive if you give the requester your correct TIN, make the proper certifications, and report all your taxable interest and dividends on your tax return.

Payments you receive will be subject to backup withholding if:

1. You do not furnish your TIN to the requester,
2. You do not certify your TIN when required (see the Part II instructions on page 4 for details),

3. The IRS tells the requester that you furnished an incorrect TIN,

4. The IRS tells you that you are subject to backup withholding because you did not report all your interest and dividends on your tax return (for reportable interest and dividends only), or

5. You do not certify to the requester that you are not subject to backup withholding under 4 above (for reportable interest and dividend accounts opened after 1983 only).

Certain payees and payments are exempt from backup withholding. See the instructions below and the separate Instructions for the Requester of Form W-9.

Also see *Special rules regarding partnerships* on page 1.

Penalties

Failure to furnish TIN. If you fail to furnish your correct TIN to a requester, you are subject to a penalty of \$50 for each such failure unless your failure is due to reasonable cause and not to willful neglect.

Civil penalty for false information with respect to withholding. If you make a false statement with no reasonable basis that results in no backup withholding, you are subject to a \$500 penalty.

Criminal penalty for falsifying information. Willfully falsifying certifications or affirmations may subject you to criminal penalties including fines and/or imprisonment.

Misuse of TINs. If the requester discloses or uses TINs in violation of federal law, the requester may be subject to civil and criminal penalties.

Specific Instructions

Name

If you are an individual, you must generally enter the name shown on your income tax return. However, if you have changed your last name, for instance, due to marriage without informing the Social Security Administration of the name change, enter your first name, the last name shown on your social security card, and your new last name.

If the account is in joint names, list first, and then circle, the name of the person or entity whose number you entered in Part I of the form.

Sole proprietor. Enter your individual name as shown on your income tax return on the "Name" line. You may enter your business, trade, or "doing business as (DBA)" name on the "Business name" line.

Limited liability company (LLC). If you are a single-member LLC (including a foreign LLC with a domestic owner) that is disregarded as an entity separate from its owner under Treasury regulations section 301.7701-3, enter the owner's name on the "Name" line. Enter the LLC's name on the "Business name" line. Check the appropriate box for your filing status (sole proprietor, corporation, etc.), then check the box for "Other" and enter "LLC" in the space provided.

Other entities. Enter your business name as shown on required federal tax documents on the "Name" line. This name should match the name shown on the charter or other legal document creating the entity. You may enter any business, trade, or DBA name on the "Business name" line.

Note. You are requested to check the appropriate box for your status (individual/sole proprietor, corporation, etc.).

Exempt From Backup Withholding

If you are exempt, enter your name as described above and check the appropriate box for your status, then check the "Exempt from backup withholding" box in the line following the business name, sign and date the form.

Generally, individuals (including sole proprietors) are not exempt from backup withholding. Corporations are exempt from backup withholding for certain payments, such as interest and dividends.

Note. If you are exempt from backup withholding, you should still complete this form to avoid possible erroneous backup withholding.

Exempt payees. Backup withholding is not required on any payments made to the following payees:

1. An organization exempt from tax under section 501(a), any IRA, or a custodial account under section 403(b)(7) if the account satisfies the requirements of section 401(f)(2),
 2. The United States or any of its agencies or instrumentalities,
 3. A state, the District of Columbia, a possession of the United States, or any of their political subdivisions or instrumentalities,
 4. A foreign government or any of its political subdivisions, agencies, or instrumentalities, or
 5. An international organization or any of its agencies or instrumentalities.
- Other payees that may be exempt from backup withholding include:
6. A corporation,
 7. A foreign central bank of issue,
 8. A dealer in securities or commodities required to register in the United States, the District of Columbia, or a possession of the United States,
 9. A futures commission merchant registered with the Commodity Futures Trading Commission,
 10. A real estate investment trust,
 11. An entity registered at all times during the tax year under the Investment Company Act of 1940,
 12. A common trust fund operated by a bank under section 584(a),
 13. A financial institution,
 14. A middleman known in the investment community as a nominee or custodian, or
 15. A trust exempt from tax under section 664 or described in section 4947.

The chart below shows types of payments that may be exempt from backup withholding. The chart applies to the exempt recipients listed above, 1 through 15.

IF the payment is for . . .	THEN the payment is exempt for . . .
Interest and dividend payments	All exempt recipients except for 9
Broker transactions	Exempt recipients 1 through 13. Also, a person registered under the Investment Advisers Act of 1940 who regularly acts as a broker
Barter exchange transactions and patronage dividends	Exempt recipients 1 through 5
Payments over \$600 required to be reported and direct sales over \$5,000 ¹	Generally, exempt recipients 1 through 7 ²

¹ See Form 1099-MISC, Miscellaneous Income, and its instructions.

² However, the following payments made to a corporation (including gross proceeds paid to an attorney under section 6045(f), even if the attorney is a corporation) and reportable on Form 1099-MISC are not exempt from backup withholding: medical and health care payments, attorneys' fees; and payments for services paid by a federal executive agency.

Part I. Taxpayer Identification Number (TIN)

Enter your TIN in the appropriate box. If you are a resident alien and you do not have and are not eligible to get an SSN, your TIN is your IRS individual taxpayer identification number (ITIN). Enter it in the social security number box. If you do not have an ITIN, see *How to get a TIN* below.

If you are a sole proprietor and you have an EIN, you may enter either your SSN or EIN. However, the IRS prefers that you use your SSN.

If you are a single-owner LLC that is disregarded as an entity separate from its owner (see *Limited liability company (LLC)* on page 2), enter your SSN (or EIN, if you have one). If the LLC is a corporation, partnership, etc., enter the entity's EIN.

Note. See the chart on page 4 for further clarification of name and TIN combinations.

How to get a TIN. If you do not have a TIN, apply for one immediately. To apply for an SSN, get Form SS-5, Application for a Social Security Card, from your local Social Security Administration office or get this form online at www.socialsecurity.gov. You may also get this form by calling 1-800-772-1213. Use Form W-7, Application for IRS Individual Taxpayer Identification Number, to apply for an ITIN, or Form SS-4, Application for Employer Identification Number, to apply for an EIN. You can apply for an EIN online by accessing the IRS website at www.irs.gov/businesses and clicking on Employer ID Numbers under Related Topics. You can get Forms W-7 and SS-4 from the IRS by visiting www.irs.gov or by calling 1-800-TAX-FORM (1-800-829-3676).

If you are asked to complete Form W-9 but do not have a TIN, write "Applied For" in the space for the TIN, sign and date the form, and give it to the requester. For interest and dividend payments, and certain payments made with respect to readily tradable instruments, generally you will have 60 days to get a TIN and give it to the requester before you are subject to backup withholding on payments. The 60-day rule does not apply to other types of payments. You will be subject to backup withholding on all such payments until you provide your TIN to the requester.

Note. Writing "Applied For" means that you have already applied for a TIN or that you intend to apply for one soon.

Caution: A disregarded domestic entity that has a foreign owner must use the appropriate Form W-8.

Part II. Certification

To establish to the withholding agent that you are a U.S. person, or resident alien, sign Form W-9. You may be requested to sign by the withholding agent even if items 1, 4, and 5 below indicate otherwise.

For a joint account, only the person whose TIN is shown in Part I should sign (when required). Exempt recipients, see *Exempt From Backup Withholding* on page 2.

Signature requirements. Complete the certification as indicated in 1 through 5 below.

1. Interest, dividend, and barter exchange accounts opened before 1984 and broker accounts considered active during 1983. You must give your correct TIN, but you do not have to sign the certification.

2. Interest, dividend, broker, and barter exchange accounts opened after 1983 and broker accounts considered inactive during 1983. You must sign the certification or backup withholding will apply. If you are subject to backup withholding and you are merely providing your correct TIN to the requester, you must cross out item 2 in the certification before signing the form.

3. Real estate transactions. You must sign the certification. You may cross out item 2 of the certification.

4. Other payments. You must give your correct TIN, but you do not have to sign the certification unless you have been notified that you have previously given an incorrect TIN. "Other payments" include payments made in the course of the requester's trade or business for rents, royalties, goods (other than bills for merchandise), medical and health care services (including payments to corporations), payments to a nonemployee for services, payments to certain fishing boat crew members and fishermen, and gross proceeds paid to attorneys (including payments to corporations).

5. Mortgage interest paid by you, acquisition or abandonment of secured property, cancellation of debt, qualified tuition program payments (under section 529), IRA, Coverdell ESA, Archer MSA or HSA contributions or distributions, and pension distributions. You must give your correct TIN, but you do not have to sign the certification.

What Name and Number To Give the Requester

For this type of account:	Give name and SSN of:
1. Individual	The individual
2. Two or more individuals (joint account)	The actual owner of the account or, if combined funds, the first individual on the account ¹
3. Custodian account of a minor (Uniform Gift to Minors Act)	The minor ²
4. a. The usual revocable savings trust (grantor is also trustee)	The grantor-trustee ¹
b. So-called trust account that is not a legal or valid trust under state law	The actual owner ¹
5. Sole proprietorship or single-owner LLC	The owner ³
For this type of account:	Give name and EIN of:
6. Sole proprietorship or single-owner LLC	The owner ³
7. A valid trust, estate, or pension trust	Legal entity ⁴
8. Corporate or LLC electing corporate status on Form 8832	The corporation
9. Association, club, religious, charitable, educational, or other tax-exempt organization	The organization
10. Partnership or multi-member LLC	The partnership
11. A broker or registered nominee	The broker or nominee
12. Account with the Department of Agriculture in the name of a public entity (such as a state or local government, school district, or prison) that receives agricultural program payments	The public entity

¹ List first and circle the name of the person whose number you furnish. If only one person on a joint account has an SSN, that person's number must be furnished.

² Circle the minor's name and furnish the minor's SSN.

³ You must show your individual name and you may also enter your business or "DBA" name on the second name line. You may use either your SSN or EIN (if you have one). If you are a sole proprietor, IRS encourages you to use your SSN.

⁴ List first and circle the name of the legal trust, estate, or pension trust. (Do not furnish the TIN of the personal representative or trustee unless the legal entity itself is not designated in the account title.) Also see *Special rules regarding partnerships* on page 1.

Note. If no name is circled when more than one name is listed, the number will be considered to be that of the first name listed.

Privacy Act Notice

Section 6109 of the Internal Revenue Code requires you to provide your correct TIN to persons who must file information returns with the IRS to report interest, dividends, and certain other income paid to you, mortgage interest you paid, the acquisition or abandonment of secured property, cancellation of debt, or contributions you made to an IRA, or Archer MSA or HSA. The IRS uses the numbers for identification purposes and to help verify the accuracy of your tax return. The IRS may also provide this information to the Department of Justice for civil and criminal litigation, and to cities, states, the District of Columbia, and U.S. possessions to carry out their tax laws. We may also disclose this information to other countries under a tax treaty, to federal and state agencies to enforce federal nontax criminal laws, or to federal law enforcement and intelligence agencies to combat terrorism.

You must provide your TIN whether or not you are required to file a tax return. Payers must generally withhold 28% of taxable interest, dividend, and certain other payments to a payee who does not give a TIN to a payer. Certain penalties may also apply.

HISTORICALLY UNDERUTILIZED BUSINESS (HUB) DECLARATION

The primary objective of the Hidalgo County HUB Program is to ensure Historically Underutilized Businesses receive a fair and equal opportunity for participation in the County's procurement process. This fact holds true for Services (Professional & Non-Professional), Commodities, and Construction contracts and any subcontracts thereto. The program strongly encourages Prime Contractors to provide subcontracting opportunities to Certified Hub Contractors/Vendors. Our goal for HUB contractor/vendor participation, as well as HUB subcontractor participation is 30%. To be considered as a "Certified HUB Contractor/Vendor" the contractor/vendor must have been certified by, and hold a current and valid certification with any of the three agencies listed below.

Have you been Certified as a HUB or an MBE/WBE source?: Yes No

If yes, by whom?: Texas Building & Procurement Commission Other _____

Indicate Certification No(s): _____ or Are Certificate(s) Attached?: Yes No

LIST OF CERTIFIED HUB SUBCONTRACTORS
(Attach additional pages if necessary)

What percentage of the Bid, RFP, or RFQ is to be subcontracted with Certified HUB sources?: _____%
(List HUB Subcontractor information below).

HUB Subcontractor Name: _____ HUB Status:
Certifying Agency (Check all applicable): Texas Building & Procurement Commission Other
Address: _____ City: _____ State: _____ Zip:
Contact Person: _____ Title: _____ Phone No.: ()
Subcontract Amount: \$_____ Description of Work to be Performed:

HUB Subcontractor Name: _____ HUB Status:
Certifying Agency (Check all applicable): Texas Building & Procurement Commission Other
Address: _____ City: _____ State: _____ Zip:
Contact Person: _____ Title: _____ Phone No.: ()
Subcontract Amount: \$_____ Description of Work to be Performed:

HUB Subcontractor Name: _____ HUB Status:
Certifying Agency (Check all applicable): Texas Building & Procurement Commission Other
Address: _____ City: _____ State: _____ Zip:
Contact Person: _____ Title: _____ Phone No.: ()
Subcontract Amount: \$_____ Description of Work to be Performed:

DISCLOSURE OF CONFLICT OF INTEREST

Effective January 1, 2006, Chapter 176 of the Texas Local Government Code requires that any vendor, person, consultant or contractor considering doing business with Hidalgo County (“the County”) to disclose in the Conflict of Interest Questionnaire (the “CIQ”) attached as Exhibit D, the vendor, person, consultant or contractor’s affiliation or business relationship that might cause a conflict of interest with the County. By law, the CIQ must be filed with the Hidalgo County Clerk’s Office no later than the seventh business day after the date the person becomes aware of facts that require that statement to be filed. The disclosure requirement applies to a person or business who contracts or seeks to contract with Hidalgo County for the sale or purchase of property, goods or service. Any purchase order or contract resulting from this process shall be considered null and void if the successful bidder fails to comply with Texas Local Government Code Chapter 176. Vendors, consultants, contractors and others who desire to conduct business with Hidalgo County are encouraged to refer to Texas Local Government Code Chapter 176 for the details of this law. An offense under Texas Local Government Code Chapter 176 is a Class C Misdemeanor.

Please Submit completed forms to the Hidalgo County Clerk’s Office located at 100 N. Closner, Edinburg, Texas 78539-Hidalgo County Courthouse

COMPLETION AND SUBMISSION OF FORM CIQ IS THE SOLE RESPONSIBILITY OF THE PROSPECTIVE BIDDER.

CONFLICT OF INTEREST QUESTIONNAIRE
For vendor or other person doing business with local governmental entity

FORM CIQ

This questionnaire reflects changes made to the law by H.B. 1491, 80th Leg., Regular Session.
This questionnaire is being filed in accordance with Chapter 176, Local Government Code by a person who has a business relationship as defined by Section 176.001(1-a) with a local governmental entity and the person meets requirements under Section 176.006(a).
By law this questionnaire must be filed with the records administrator of the local governmental entity not later than the 7th business day after the date the person becomes aware of facts that require the statement to be filed. See Section 176.006, Local Government Code.
A person commits an offense if the person knowingly violates Section 176.006, Local Government Code. An offense under this section is a Class C misdemeanor.

OFFICE USE ONLY

Date Received

1 Name of person who has a business relationship with local governmental entity.

2 **Check this box if you are filing an update to a previously filed questionnaire.**

(The law requires that you file an updated completed questionnaire with the appropriate filing authority not later than the 7th business day after the date the originally filed questionnaire becomes incomplete or inaccurate.)

3 Name of local government officer with whom filer has employment or business relationship.

Name of Officer

This section (item 3 including subparts A, B, C & D) must be completed for each officer with whom the filer has an employment or other business relationship as defined by Section 176.001(1-a), Local Government Code. Attach additional pages to this Form CIQ as necessary.

A. Is the local government officer named in this section receiving or likely to receive taxable income, other than investment income, from the filer of the questionnaire?

Yes No

B. Is the filer of the questionnaire receiving or likely to receive taxable income, other than investment income, from or at the direction of the local government officer named in this section AND the taxable income is not received from the local governmental entity?

Yes No

C. Is the filer of this questionnaire employed by a corporation or other business entity with respect to which the local government officer serves as an officer or director, or holds an ownership of 10 percent or more?

Yes No

D. Describe each employment or business relationship with the local government officer named in this section.

4

Signature of person doing business with the governmental entity

Date

**SALES TAX AND LOCAL SALES TAX
EXEMPTION CERTIFICATE FOR CONTRACTORS**

This Contract is to be performed for an exempt organization as defined by Article 20.04 (H) (4) of the Texas Limited Sales, Excise, and Use Tax Act and the undersigned hereby claims an exemption from payment of taxes under Chapter 20, title 122A, revised hereby claims an exemption from payment of taxes under Chapter 20, title 122A, revised civil statues of Texas, and Article 1066 ©, entitle Local Sales and Use Tax, revised civil statues of Texas.

The Contractor performing this Contract may purchase, rent, or lease all materials, supplies, equipment used for consumed in the performance of this Contract by issuing to his retailer an exemption certificate in lieu of the tax, said exemption certificate complying with State Comptroller's Ruling No 95-9.07. Any such exemption certificate issue by the Contractor in lieu of the tax shall be subject to the provisions of the State Comptroller's Ruling No. 95.0.09 as amended to be effective October 2, 1968.

EXECUTED this the _____ day of _____, 20_____.

Contractor

GOVERNMENT CODE

CHAPTER 2258. PREVAILING WAGE RATES

SUBCHAPTER A. GENERAL PROVISIONS

§Sec. 2258.001. DEFINITIONS. In this chapter:

(1) "Locality in which the work is performed" means:

(A) for a contract for a public work awarded by the state, the political subdivision of the state in which the public work is located:

(i) which may include a county, municipality, county and municipality, or district, except as provided by Subparagraph (ii); and

(ii) which, in a municipality with a population of 500,000 or more, may only include the geographic limits of the municipality; or

(B) for a contract for a public work awarded by a political subdivision of the state, the geographical limits of the political subdivision.

(2) "Public body" means a public body awarding a contract for a public work on behalf of the state or a political subdivision of the state.

(3) "Worker" includes a laborer or mechanic.

Added by Acts 1995, 74th Leg., ch. 76, Sec. 5.49(a), eff. Sept. 1, 1995. Amended by Acts 2001, 77th Leg., ch. 1422, Sec. 14.04, eff. Sept. 1, 2001.

§Sec. 2258.002. APPLICABILITY OF CHAPTER TO PUBLIC WORKS. (a) This chapter applies only to the construction of a public work, including a building, highway, road, excavation, and repair work or other project development or improvement, paid for in whole or in part from public funds, without regard to whether the work is done under public supervision or direction.

(b) This chapter does not apply to work done directly by a public utility company under an order of a public authority.

Added by Acts 1995, 74th Leg., ch. 76, Sec. 5.49(a), eff. Sept. 1, 1995.

§Sec. 2258.003. LIABILITY. An officer, agent, or employee of a public body is not liable in a civil action for any act or omission implementing or enforcing this chapter unless the action was made in bad faith.

Added by Acts 1995, 74th Leg., ch. 76, Sec. 5.49(a), eff. Sept. 1, 1995.

SUBCHAPTER B. PAYMENT OF PREVAILING WAGE RATES

§Sec. 2258.021. RIGHT TO BE PAID PREVAILING WAGE RATES. (a) A worker employed on a public work by or on behalf of the state or a political subdivision of the state shall be paid:

(1) not less than the general prevailing rate of per diem wages for work of a similar

character in the locality in which the work is performed; and

(2) not less than the general prevailing rate of per diem wages for legal holiday and overtime work.

(b) Subsection (a) does not apply to maintenance work.

(c) A worker is employed on a public work for the purposes of this section if the worker is employed by a contractor or subcontractor in the execution of a contract for the public work with the state, a political subdivision of the state, or any officer or public body of the state or a political subdivision of the state.

Added by Acts 1995, 74th Leg., ch. 76, Sec. 5.49(a), eff. Sept. 1, 1995. Amended by Acts 1997, 75th Leg., ch. 165, Sec. 18.01, eff. Sept. 1, 1997.

§Sec. 2258.022. DETERMINATION OF PREVAILING WAGE RATES.

(a) For a contract for a public work awarded by a political subdivision of the state, the public body shall determine the general prevailing rate of per diem wages in the locality in which the public work is to be performed for each craft or type of worker needed to execute the contract and the prevailing rate for legal holiday and overtime work by:

(1) conducting a survey of the wages received by classes of workers employed on projects of a character similar to the contract work in the political subdivision of the state in which the public work is to be performed; or

(2) using the prevailing wage rate as determined by the United States Department of Labor in accordance with the Davis-Bacon Act (40 U.S.C. Section 276a et seq.), and its subsequent amendments.

(b) This subsection applies only to a public work located in a county bordering the United Mexican States or in a county adjacent to a county bordering the United Mexican States. For a contract for a public work awarded by the state, the public body shall determine the general prevailing rate of per diem wages in the locality in which the public work is to be performed for each craft or type of worker needed to execute the contract and the prevailing rate for legal holiday and overtime work as follows. The public body shall conduct a survey of the wages received by classes of workers employed on projects of a character similar to the contract work both statewide and in the political subdivision of the state in which the public work is to be performed. The public body shall also consider the prevailing wage rate as determined by the United States Department of Labor in accordance with the Davis-Bacon Act (40 U.S.C. Section 276a et seq.), and its subsequent amendments, but only if the survey used to determine that rate was conducted within a three-year period preceding the date the public body calls for bids for the public work. The public body shall determine the general prevailing rate of per diem wages in the locality based on the higher of:

(1) the rate determined from the survey conducted in the political subdivision;

(2) the arithmetic mean between the rate determined from the survey conducted in the political subdivision and the rate determined from the statewide survey; and

(3) if applicable, the arithmetic mean between the rate determined from the survey conducted in the political subdivision and the rate determined by the United States Department of Labor.

(c) The public body shall determine the general prevailing rate of per diem wages as a sum certain, expressed in dollars and cents.

(d) A public body shall specify in the call for bids for the contract and in the contract itself the wage rates determined under this section.

(e) The public body's determination of the general prevailing rate of per diem wages is final.

Added by Acts 1995, 74th Leg., ch. 76, Sec. 5.49(a), eff. Sept. 1, 1995. Amended by Acts 1997, 75th Leg., ch. 165, Sec. 18.02, eff. Sept. 1, 1997; Acts 2001, 77th Leg., ch. 1422, Sec. 14.05, eff. Sept. 1, 2001.

Amended by: Acts 2007, 80th Leg., R.S., Ch. 728, Sec. 1, eff. September 1, 2007.

§Sec. 2258.023. PREVAILING WAGE RATES TO BE PAID BY CONTRACTOR AND SUBCONTRACTOR; PENALTY.

(a) The contractor who is awarded a contract by a public body or a subcontractor of the contractor shall pay not less than the rates determined under Section 2258.022 to a worker employed by it in the execution of the contract.

(b) A contractor or subcontractor who violates this section shall pay to the state or a political subdivision of the state on whose behalf the contract is made, \$60 for each worker employed for each calendar day or part of the day that the worker is paid less than the wage rates stipulated in the contract. A public body awarding a contract shall specify this penalty in the contract.

(c) A contractor or subcontractor does not violate this section if a public body awarding a contract does not determine the prevailing wage rates and specify the rates in the contract as provided by Section 2258.022.

(d) The public body shall use any money collected under this section to offset the costs incurred in the administration of this chapter.

(e) A municipality is entitled to collect a penalty under this section only if the municipality has a population of more than 10,000.

Added by Acts 1995, 74th Leg., ch. 76, Sec. 5.49(a), eff. Sept. 1, 1995.

§Sec. 2258.024. RECORDS.

(a) A contractor and subcontractor shall keep a record showing:

(1) the name and occupation of each worker employed by the contractor or subcontractor in the construction of the public work; and

(2) the actual per diem wages paid to each worker.

(b) The record shall be open at all reasonable hours to inspection by the officers and agents of the public body.

Added by Acts 1995, 74th Leg., ch. 76, Sec. 5.49(a), eff. Sept. 1, 1995.

§Sec. 2258.025. PAYMENT GREATER THAN PREVAILING RATE NOT PROHIBITED.

This chapter does not prohibit the payment to a worker employed on a public work an amount greater than the general prevailing rate of per diem wages.

Added by Acts 1995, 74th Leg., ch. 76, Sec. 5.49(a), eff. Sept. 1, 1995.

§Sec. 2258.026. RELIANCE ON CERTIFICATE OF SUBCONTRACTOR. A contractor is entitled to rely on a certificate by a subcontractor regarding the payment of all sums due those working for the subcontractor until the contrary has been determined.

Added by Acts 1995, 74th Leg., ch. 76, Sec. 5.49(a), eff. Sept. 1, 1995.

SUBCHAPTER C. ENFORCEMENT; CIVIL AND CRIMINAL PENALTIES

§Sec. 2258.051. DUTY OF PUBLIC BODY TO HEAR COMPLAINTS AND WITHHOLD PAYMENT. A public body awarding a contract, and an agent or officer of the public body, shall:

(1) take cognizance of complaints of all violations of this chapter committed in the execution of the contract; and

(2) withhold money forfeited or required to be withheld under this chapter from the payments to the contractor under the contract, except that the public body may not withhold money from other than the final payment without a determination by the public body that there is good cause to believe that the contractor has violated this chapter.

Added by Acts 1995, 74th Leg., ch. 76, Sec. 5.49(a), eff. Sept. 1, 1995.

§Sec. 2258.052. COMPLAINT; INITIAL DETERMINATION.

(a) On receipt of information, including a complaint by a worker, concerning an alleged violation of Section 2258.023 by a contractor or subcontractor, a public body shall make an initial determination as to whether good cause exists to believe that the violation occurred.

(b) A public body must make its determination under Subsection (a) before the 31st day after the date the public body receives the information.

(c) A public body shall notify in writing the contractor or subcontractor and any affected worker of its initial determination.

(d) A public body shall retain any amount due under the contract pending a final determination of the violation.

Added by Acts 1995, 74th Leg., ch. 76, Sec. 5.49(a), eff. Sept. 1, 1995.

§Sec. 2258.053. ARBITRATION REQUIRED FOR UNRESOLVED ISSUE.

(a) An issue relating to an alleged violation of Section 2258.023, including a penalty owed to a public body or an affected worker, shall be submitted to binding arbitration in accordance with the Texas General Arbitration Act (Article 224 et seq., Revised Statutes) if the contractor or subcontractor and any affected worker do not resolve the issue by agreement before the 15th day after the date the public body makes its initial determination under Section 2258.052.

(b) If the persons required to arbitrate under this section do not agree on an arbitrator before the 11th day after the date that arbitration is required under Subsection (a), a district court shall appoint an arbitrator on the petition of any of the persons.

(c) A public body is not a party in the arbitration.

Added by Acts 1995, 74th Leg., ch. 76, Sec. 5.49(a), eff. Sept. 1, 1995.

§Sec. 2258.054. ARBITRATION AWARD; COSTS. (a) If an arbitrator determines that Section 2258.023 has been violated, the arbitrator shall assess and award against the contractor or subcontractor:

- (1) penalties as provided by Section 2258.023 and this section; and
- (2) all amounts owed to the affected worker.

(b) An arbitrator shall assess and award all reasonable costs, including the arbitrator's fee, against the party who does not prevail. Costs may be assessed against the worker only if the arbitrator finds that the claim is frivolous. If the arbitrator does not find that the claim is frivolous and does not make an award to the worker, costs are shared equally by the parties.

Added by Acts 1995, 74th Leg., ch. 76, Sec. 5.49(a), eff. Sept. 1, 1995.

§Sec. 2258.055. ARBITRATION DECISION AND AWARD FINAL. The decision and award of the arbitrator is final and binding on all parties and may be enforced in any court of competent jurisdiction.

Added by Acts 1995, 74th Leg., ch. 76, Sec. 5.49(a), eff. Sept. 1, 1995.

§Sec. 2258.056. PAYMENT BY PUBLIC BODY TO WORKER; ACTION TO RECOVER PAYMENT.

(a) A public body shall use any amounts retained under this chapter to pay the worker the difference between the amount the worker received in wages for labor on the public work at the rate paid by the contractor or subcontractor and the amount the worker would have received at the general prevailing wage rate as provided in the arbitrator's award.

(b) The public body may adopt rules, orders, or ordinances relating to the manner in which a reimbursement is made.

(c) If the amounts retained by a public body under this chapter are not sufficient for the public body to pay the worker the full amount owed, the worker has a right of action against the contractor or subcontractor and the surety of the contractor or subcontractor to recover the amount owed, reasonable attorney's fees, and court costs.

Added by Acts 1995, 74th Leg., ch. 76, Sec. 5.49(a), eff. Sept. 1, 1995.

§Sec. 2258.057. WITHHOLDING BY CONTRACTOR.

(a) A contractor may withhold from a subcontractor sufficient money to cover an amount withheld from the contractor by a public body because the subcontractor violated this chapter.

(b) If the contractor has made a payment to the subcontractor, the contractor may withhold money from any future payments owed to the subcontractor or sue the subcontractor or the subcontractor's surety for the amount withheld from the contractor by a public body because of the subcontractor's violation.

Added by Acts 1995, 74th Leg., ch. 76, Sec. 5.49(a), eff. Sept. 1, 1995.

§Sec. 2258.058. CRIMINAL OFFENSE.

(a) An officer, agent, or representative of the state or of a political subdivision of the state commits an offense if the person wilfully violates or does not comply with a provision of this chapter.

(b) A contractor or subcontractor of a public work under this chapter, or an agent or representative of the contractor or subcontractor, commits an offense if the person violates Section 2258.024.

(c) An offense under this section is punishable by:

- (1) a fine not to exceed \$500;
- (2) confinement in jail for a term not to exceed six months; or
- (3) both a fine and confinement.

Added by Acts 1995, 74th Leg., ch. 76, Sec. 5.49(a), eff. Sept. 1, 1995.

**Prevailing Wage Rates
Certification Statement**

Date _____

Project Name _____

CSJ# _____

Contractor _____

Application# _____

I, _____ do hereby state:
(Name of Project Director)

1. That a payroll (form WH-347 or similar form) was submitted for contract work Performed for the period covered by the attached application.
2. That a statement of compliance(form WH-347 or similar form) was submitted with the payroll.
3. The certified payroll complies with the classifications and minimum wage rates Stipulated in the contract.
4. That a minimum of one interview was conducted with laborers using Form HUD-11 or similar.

Signature

Date _____

(Name of Signatory Party)

(Title)

do hereby state

(1) That I pay or supervise the payment of the persons employed by

(Contractor or Subcontractor)

on the

(Building or Work)

that during the payroll period commencing on the

day of _____ and ending the _____ day of _____

all persons employed on said project have been paid the full weekly wages earned, that no rebates have been or will be made either directly or indirectly to or on behalf of said

(Contractor or Subcontractor)

from the full

weekly wages earned by any person and that no deductions have been made either directly or indirectly from the full wages earned by any person, other than permissible deductions as defined in Regulations, Part 3 (29 CFR Subtitle A), issued by the Secretary of Labor under the Copeland Act, as amended (48 Stat. 948, 65 Stat. 108, 72 Stat. 967, 76 Stat. 357, 40 U.S.C. 276c), and described below

(2) That any payrolls otherwise under this contract required to be submitted for the above period are correct and complete, that the wage rates for laborers or mechanics contained therein are not less than the applicable wage rates contained in any wage determination incorporated into the contract, that the classifications set forth therein for each laborer or mechanic conform with the work he performed

(3) That any apprentices employed in the above period are duly registered in a bona fide apprenticeship program registered with a State apprenticeship agency recognized by the Bureau of Apprenticeship and Training, United States Department of Labor, or if no such recognized agency exists in a State, are registered with the Bureau of Apprenticeship and Training, United States Department of Labor.

(4) That

(a) WHERE FRINGE BENEFITS ARE PAID TO APPROVED PLANS, FUNDS, OR PROGRAMS

in addition to the basic hourly wage rates paid to each laborer or mechanic listed in the above referenced payroll, payments of fringe benefits as listed in the contract have been or will be made to appropriate programs for the benefit of such employees, except as noted in Section 4(c) below

(b) WHERE FRINGE BENEFITS ARE PAID IN CASH

Each laborer or mechanic listed in the above referenced payroll has been paid, as indicated on the payroll, an amount not less than the sum of the applicable basic hourly wage rate plus the amount of the required fringe benefits, as listed in the contract, except as noted in Section 4(c) below

(c) EXCEPTIONS

EXCEPTION (CRAFT)	EXPLANATION

REMARKS

NAME AND TITLE

SIGNATURE

THE WILLFUL FALSIFICATION OF ANY OF THE ABOVE STATEMENTS MAY SUBJECT THE CONTRACTOR OR SUBCONTRACTOR TO CIVIL OR CRIMINAL PROSECUTION SEE SECTION 100 OF TITLE 18 AND SECTION 40 OF TITLE 31 OF THE UNITED STATES CODE



Contract Time Statement

ESTIMATE NO. 0 CONTRACTOR

PROJECT NO. COUNTY DATE WORK BEGAN

TIME COMPUTED FROM DATE WORK COMPLETED

Table with columns: MONTH, DATE OR DAYS, WORKING DAYS CHARGED, DAYS CREDITED AND REASONS THEREFORE. Includes a 'TOTALS' row at the bottom with values 0 and 0.

NO. OF CONTRACT WORKING DAYS NO. WORKING DAYS CHARGED TO DATE 0
ASSESSED LIQUIDATED DAMAGES: NO. PER DAY \$ TOTAL \$ 0.00
CERTIFIED AS CORRECT (ONE COPY HAS BEEN GIVEN TO THE

RESIDENT ENGINEER

INSTRUCTIONS: PROJECT IDENTIFICATION SHOULD COVER CONTRACT. TIME CREDITED AND REASONS THEREFORE MUST CONFORM TO PROVISIONS OF CONTRACT. NO HOLIDAY CREDIT ALLOWED FOR DAYS PRECEDING OR FOLLOWING LEGAL HOLIDAYS. TIME SUSPENDED AND RESUMED MUST BE SUPPORTED BY COPY EACH OF LETTERS TO CONTRACTOR DATED ON OR BEFORE EFFECTIVE DATES. TIME EXTENSION MUST BE INDICATED AND REFERENCED TO RELATED PROVISION OF CONTRACT. SEE BOOKLET OF INSTRUCTIONS, CONSTRUCTION ESTIMATES DATED SEPTEMBER 1, 1998

General Decision Number: TX120008 01/06/2012 TX8

Superseded General Decision Number: TX20100009

State: Texas

Construction Types: Heavy and Highway

Counties: Cameron, Hidalgo and Webb Counties in Texas.

HEAVY & HIGHWAY CONSTRUCTION PROJECTS

Modification Number Publication Date

0 01/06/2012

* SUTX2011-003 08/02/2011

Rates Fringes

CEMENT MASON/CONCRETE FINISHER (Paving & Structures)...\$ 12.46

FORM BUILDER/FORM SETTER (Structures).....\$ 12.30

FORM SETTER (Paving & Curb).....\$ 12.16

LABORER

Asphalt Raker.....\$ 10.61

Flagger.....\$ 9.10

Laborer, Common.....\$ 9.86

Laborer, Utility.....\$ 11.53

Pipelayer.....\$ 11.87

Work Zone Barricade Servicer.....\$ 12.88

POWER EQUIPMENT OPERATOR:

Asphalt Distributor.....\$ 13.48

Asphalt Paving Machine.....\$ 12.25

Broom or Sweeper.....\$ 10.33

Crane, Lattice Boom 80 Tons or Less.....\$ 14.39

Crawler Tractor.....\$ 16.63

Excavator, 50,000 lbs or less.....\$ 12.56

Excavator, over 50,000 lbs..\$ 15.23

Foundation Drill, Truck Mounted.....\$ 16.86

Front End Loader Operator, Over 3 CY.....\$ 13.69

Front End Loader, 3 CY or less.....\$ 13.49

Loader/Backhoe.....\$ 12.77

Mechanic.....\$ 15.47

Milling Machine.....\$ 14.64

Motor Grader Operator, Rough.....\$ 14.62

Motor Grader, Fine Grade....\$ 16.52

Scraper.....\$ 11.07

Servicer.....\$ 12.34

Steel Worker (Reinforcing).....\$ 14.07

TRUCK DRIVER

- Lowboy-Float.....\$ 13.63
- Single Axle.....\$ 10.82
- Single or Tandem Axle Dump..\$ 14.53
- Tandem Axle Tractor with
Semi Trailer.....\$ 12.12

WELDER.....\$ 14.02

WELDERS - Receive rate prescribed for craft performing operation to which welding is incidental.

=====
Unlisted classifications needed for work not included within the scope of the classifications listed may be added after award only as provided in the labor standards contract clauses (29CFR 5.5 (a) (1) (ii)).

The body of each wage determination lists the classification and wage rates that have been found to be prevailing for the cited type(s) of construction in the area covered by the wage determination. The classifications are listed in alphabetical order of "identifiers" that indicate whether the particular rate is union or non-union.

Union Identifiers

An identifier enclosed in dotted lines beginning with characters other than "SU" denotes that the union classification and rate have found to be prevailing for that classification. Example: PLUM0198-005 07/01/2011. The first four letters , PLUM, indicate the international union and the four-digit number, 0198, that follows indicates the local union number or district council number where applicable , i.e., Plumbers Local 0198. The next number, 005 in the example, is an internal number used in processing the wage determination. The date, 07/01/2011, following these characters is the effective date of the most current negotiated rate/collective bargaining agreement which would be July 1, 2011 in the above example.

Union prevailing wage rates will be updated to reflect any changes in the collective bargaining agreements governing the rate.

Non-Union Identifiers

Classifications listed under an "SU" identifier were derived from survey data by computing average rates and are not union rates; however, the data used in computing these rates may include both union and non-union data. Example: SULA2004-007 5/13/2010. SU indicates the rates are not union rates, LA indicates the State of Louisiana; 2004 is the year of the survey; and 007 is an internal number used in producing the wage determination. A 1993 or later date, 5/13/2010, indicates the classifications and rates under that identifier were issued as a General Wage Determination on that date.

Survey wage rates will remain in effect and will not change until a new survey is conducted.

WAGE DETERMINATION APPEALS PROCESS

1.) Has there been an initial decision in the matter? This can be:

- * an existing published wage determination
- * a survey underlying a wage determination
- * a Wage and Hour Division letter setting forth a position on a wage determination matter
- * a conformance (additional classification and rate) ruling

On survey related matters, initial contact, including requests for summaries of surveys, should be with the Wage and Hour Regional Office for the area in which the survey was conducted because those Regional Offices have responsibility for the Davis-Bacon survey program. If the response from this initial contact is not satisfactory, then the process described in 2.) and 3.) should be followed.

With regard to any other matter not yet ripe for the formal process described here, initial contact should be with the Branch of Construction Wage Determinations. Write to:

Branch of Construction Wage Determinations
 Wage and Hour Division
 U.S. Department of Labor
 200 Constitution Avenue, N.W.
 Washington, DC 20210

2.) If the answer to the question in 1.) is yes, then an interested party (those affected by the action) can request review and reconsideration from the Wage and Hour Administrator (See 29 CFR Part 1.8 and 29 CFR Part 7). Write to:

Wage and Hour Administrator
 U.S. Department of Labor
 200 Constitution Avenue, N.W.
 Washington, DC 20210

The request should be accompanied by a full statement of the interested party's position and by any information (wage payment data, project description, area practice material, etc.) that the requestor considers relevant to the issue.

3.) If the decision of the Administrator is not favorable, an interested party may appeal directly to the Administrative Review Board (formerly the Wage Appeals Board). Write to:

Administrative Review Board
 U.S. Department of Labor
 200 Constitution Avenue, N.W.
 Washington, DC 20210

4.) All decisions by the Administrative Review Board are final.

=====

END OF GENERAL DECISION

Border Colonia Access Program
Checklist for Documentation Required for Road Construction

Contractor: _____

Contract Amount: _____

Project/Precinct: _____

Owner's Contract No.: _____

Item	Required Documents	Submitted & Reviewed	Approved	Comments:
	INITIATION OF PROJECT:			
1	Approval to Bid (Purchasing)			
2	Contract - Signed and Executed			
3	Gen. Liability Insurance - (Expiration Date)			
4	Automobile Liab. Insurance - (Expiration Date)			
5	Worker's Comp. & Empl. Liab. (Expiration Date)			
6	Notice to Proceed			
7	Material Sample & Testing Table Sent to Auditor's Office			
	PAYMENT REQUESTS, INCLUDING FINAL:			
8	Application and Certification of Payment (A)			
9	Schedule of Values a/k/a 1257/1258			
10	Estimate Quantity Update Worksheet			
11	List of Suppliers and Sub-contractors			
12	Partial Waiver of Liens (Sub-contractors/suppliers)			
13	TxDot Form 252 Contract Time Statement			
14	Payroll Report w/signed Wage Form			
15	Change Order (Requires TxDot Concurrence)			
	RETAINAGE PAYMENT: - Final request and request for retainage must be billed separately and approved by C.C.			
16	Punch List			
17	Certificate of Construction Completion			
18	Approval by Commissioner's Court			
19	Contractor's Affidavit of Release (Waiver) of Liens (with power of attorney)(B)			
20	Affidavit of Payment of Debts & Claims-lien bond & indemnity bonds(w/power of attorney)(B)			
21	Consent of Surety to Final Payment(with power of attorney)(B)			
22	Final Blue Prints			

CHANGE ORDER NUMBER ONE(1)

Project: _____

DATE OF ISSUANCE: _____ EFFECTIVE DATE: _____

OWNER: _____

OWNER'S CONTRACT NO: _____

CONTRACTOR: _____ ENGINEER: _____

You are directed to make the following changes in the Contract Documents.

Description: 1.
 2.
 3.
 4.
 5.
 6.

Reason for Change Order: 1.
 2.
 3.
 4.
 5.
 6.

Attachments:

CHANGE IN CONTRACT PRICE:		CHANGE IN CONTRACT TIME:	
Original Contract Price		Original Contract Time for	
\$ 0.00		Substantial Completion:	0 <small>calendar days or dates</small>
Net Changes from previous Change Order		Net Change from previous Change Orders	0 <small>calendar days</small>
\$ 0.00			
Contract Price prior to this Change Order		Contract Time prior to this Change Order	
\$ 0.00		Substantial Completion:	0 <small>calendar days or dates</small>
Net Increase(decrease) of this Change Order		Net Increase(decrease) of this Change Order	0 <small>calendar days</small>
\$ 0.00			
Contract Price with all approved Change Orders	Net % increase(decrease)from original contract price. #DIV/O! %	Contract Time with all approved Change Orders	
\$ 0.00		Substantial Completion:	0 <small>calendar days or dates</small>

RECOMMENDED:
By: _____
Engineer (Authorized Signature)

APPROVED:
By: _____
Owner (Authorized Signature)

ACCEPTED:
By: _____
Contractor (Authorized Signature)

Date: _____

Date: _____

Date: _____

Exhibit E-B

APPLICATION FOR PAYMENT NO.

To: _____ (OWNER)
From: _____ (CONTRACTOR)
Contract: _____
Project: _____
Owner's Contract No. _____ Engineer's Project No. _____
For Work accomplished through the date of: _____

-
- | | |
|--|-------|
| 1. Original Contract Price: | _____ |
| 2. Net change by Change Order and Written Agreements(+or-): | _____ |
| 3. Current Contract Price (1 plus 2): | _____ |
| 4. Total completed and stored to date: | _____ |
| 5. Retainage (per Agreement): | _____ |
| _____ 10% of completed Work: | _____ |
| _____ of stored material | _____ |
| Total Retainage: | _____ |
| 6. Total completed and stored to date less retainage (4 minus 5) | _____ |
| 7. Less previous Application for Payments: | _____ |
| 8. AMOUNT DUE THIS APPLICATION (6 MINUS 7) | _____ |
-

Accompanying Documentation:

CONTRACTOR'S Certification:

The undersigned CONTRACTOR certifies that (1) all previous progress payments received from OWNER on account of Work done under the Contract referred to above have been applied on account to discharge CONTRACTOR'S legitimate obligations incurred in connection with Work covered by prior Applications for Payment numbered 1 through 2 inclusive; (2) title of all Work, materials and equipment incorporated in said Work or otherwise listed in or covered by this Application for Payment will pass to OWNER at time of payment free and clear of all Liens, security interests and encumbrances (except such as are covered by a Bond acceptable to OWNER indemnifying OWNER against any such Lien, security interest or encumbrance); and (3) all Work covered by this Application for Payments is in accordance with the Contract Documents and not defective.

Date _____

CONTRACTOR

State of _____
County of _____
Subscribed and sworn to before me this _____
day of _____

By: _____

Notary Public
My Commission expires: _____

Payment of the above AMOUNT DUE THIS APPLICATION is recommended.

Date _____

ENGINEER

By: _____

Estimate Quantity Update Worksheet

Colonia: _____ Date: _____
 Roadway: _____ Contractor: _____
 Control: _____ Contract Price: _____
 Project No.: _____ Work Done this Mo.: _____
 County: _____ % Complete: #DIV/0!
 Est. No.: 1

Work Type: Paving & Drainage
 Limits: _____
 From: _____
 To: _____

Date Began: ?
 Contract Time: 120
 Time Charged: 90
 % Time Used: 75.00%

ITEM NO.	DESCRIPTION	UNIT	PROJECT QTY	Unit Price	Project Amount	FIRST MONTH			SECOND MONTH			THIRD MONTH		
						MONTHLY QUANTITY	QTY to Date	Item Cost (Monthly)	MONTHLY QUANTITY	QTY to Date	Item Cost (Monthly)	MONTHLY QUANTITY	QTY to Date	Item Cost (Monthly)
(901) ADMINISTRATIVE														
(902) PRELIMINARY ENGINEERING														
(903) CONSTRUCTION ENGINEERING														
(904) RIGHT-OF-WAY														
(905) ROADWAY CONSTRUCTION														
100	PREP ROW	Sta.	1.100	\$1,800.00	\$1,980.00	1.000	1.000	\$0.00	0	0	\$0.00	0	0	0.00
110	BACKFILL (TY A)	Sta.	1.000	\$600.00	\$600.00	0.000	0	\$0.00	0	0	\$0.00	0	0	0.00
247	FLEX BASE (RDWY DEL)(TY D GR 6 CL 4)	CY	76.000	\$28.00	\$2,128.00	0.000	0	\$0.00	0	0	\$0.00	0	0	0.00
260	LIME (TY A SLURRY) OR (TY B)	TON	1036.000	\$2.00	\$2,072.00	0.000	0	\$0.00	0	0	\$0.00	0	0	0.00
260	LIME TREAT SUBGR (DC)(12")	SY	0.000	\$6,000.00	\$0.00	0.000	0	\$0.00	0	0	\$0.00	0	0	0.00
262	LIME (TY A SLURRY) OR (TY B)	TON	7.800	\$3,000.00	\$23,400.00	0.000	0	\$0.00	0	0	\$0.00	0	0	0.00
262	LME TRT FOR BS CRS (NEW/EXT BS)(DC)(6")	SY	1277.800	\$6.00	\$7,666.80	0.000	0	\$0.00	0	0	\$0.00	0	0	0.00
310	ASPH MATRL (MC-30)	GAL	246.7	\$6.00	\$1,480.20	0.000	0	\$0.00	0	0	\$0.00	0	0	0.00
500	MOBILIZATION	LS	1.000	\$3,000.00	\$3,000.00	0.000	0	\$0.00	0	0	\$0.00	0	0	0.00
502	BARRICADES, SIGNS, AND TRAF HANDLE	MO	1.000	\$1,000.00	\$1,000.00	0.000	0	\$0.00	0	0	\$0.00	0	0	0.00
529	CONC CURB AND GUTTER (TY A)(BARRIER)	LF	600.000	\$7.50	\$4,500.00	0.000	0	\$0.00	0	0	\$0.00	0	0	0.00
644	SMALL RDS SGN ASSM (TY A)	EA	2.000	\$300.00	\$600.00	0.000	0	\$0.00	0	0	\$0.00	0	0	0.00
644	SMALL RDS SGN ASSM (TY F)	EA	2.000	\$500.00	\$1,000.00	0.000	0	\$0.00	0	0	\$0.00	0	0	0.00
658	DEL ASM TY A (D-SY)	EA	4.000	\$100.00	\$400.00	0.000	0	\$0.00	0	0	\$0.00	0	0	0.00
666	REFL PAV MRK TY I (Y)(SLD)(4")	LF	400.000	\$0.25	\$100.00	0.000	0	\$0.00	0	0	\$0.00	0	0	0.00
666	REFL PAV MRK TY I (Y)(BRK)(4")	LF	140.000	\$0.25	\$35.00	0.000	0	\$0.00	0	0	\$0.00	0	0	0.00
672	RAIS PAV MRKR CL B (REFL)(TY II-A-A)	EA	24.000	\$3.50	\$84.00	0.000	0	\$0.00	0	0	\$0.00	0	0	0.00
3146	HOT MIX (TY D)	TON	105.5	\$34.00	\$3,587.00	0.000	0	\$0.00	0	0	\$0.00	0	0	0.00
5249	TEMP SEDMT CONT FENCE	LF	70.000	\$3.00	\$210.00	0.000	0	\$0.00	0	0	\$0.00	0	0	0.00
(906) DRAINAGE														
464	RC PIPE (CL III)(18")	LF	404.000	\$25.00	\$10,100.00	0.000	0	\$0.00	0	0	\$0.00	0	0	0.00
464	RC PIPE (CL III)(24")	LF	120.000	\$30.00	\$3,600.00	0.000	0	\$0.00	0	0	\$0.00	0	0	0.00
465	INLET (COMPL)(TY A)	EA	2.000	\$2,000.00	\$4,000.00	0.000	0	\$0.00	0	0	\$0.00	0	0	0.00
465	INLET (COMPL)(TY C)	EA	2.000	\$1,500.00	\$3,000.00	0.000	0	\$0.00	0	0	\$0.00	0	0	0.00
465	MANH (COMPL)(TYM)	EA	1.000	\$2,000.00	\$2,000.00	0.000	0	\$0.00	0	0	\$0.00	0	0	0.00
465	INLET EXT.	EA	2.000	\$700.00	\$1,400.00	0.000	0	\$0.00	0	0	\$0.00	0	0	0.00
467	SET (TY II)(18")(RCP)(1:6)	EA	4.000	\$550.00	\$2,200.00	0.000	0	\$0.00	0	0	\$0.00	0	0	0.00
467	SET (TY II)(24")(RCP)(1:6)	EA	1.000	\$650.00	\$650.00	0.000	0	\$0.00	0	0	\$0.00	0	0	0.00

Monthly Totals:	\$0.00	\$0.00	\$0.00	0.00
ADMINISTRATIVE (901)				
PRELIMINARY ENGINEERING (902)				
CONSTRUCTION ENGINEERING (903)				
RIGHT-OF-WAY (904)				
Roadway (905):	\$0.00	\$0.00	\$0.00	0.00
Drainage (906):	\$0.00	\$0.00	\$0.00	0.00

Total to Date
 Roadway (905): \$0.00
 Drainage (906): \$0.00
 Total \$0.00

Prepared and Checked By: _____ Signature: _____
 Date: _____ Printed Name: _____

Contractor Name _____
 Starting Date _____
 Project Ending Date _____
 Retainage Percent _____

Application No.: _____
 Application Date: _____
 Period To: _____
 Engineer Firm: _____

Summary												
CSJ#	PROJECT NAME	Original Schedule Value	Revised Schedule Value	Payment Application No 1	Payment Application No 2	Payment Application No 3	Total To Date	Balance To Finish	Retainage	Net	Payment To Date	Payment Due
		\$ -	\$ -	\$ -	\$ -	\$ -	\$ -	\$ -	\$ -	\$ -	\$ -	\$ -
		\$ -	\$ -	\$ -	\$ -	\$ -	\$ -	\$ -	\$ -	\$ -	\$ -	\$ -
		\$ -	\$ -	\$ -	\$ -	\$ -	\$ -	\$ -	\$ -	\$ -	\$ -	\$ -
		\$ -	\$ -	\$ -	\$ -	\$ -	\$ -	\$ -	\$ -	\$ -	\$ -	\$ -
		\$ -	\$ -	\$ -	\$ -	\$ -	\$ -	\$ -	\$ -	\$ -	\$ -	\$ -
		\$ -	\$ -	\$ -	\$ -	\$ -	\$ -	\$ -	\$ -	\$ -	\$ -	\$ -
		\$ -	\$ -	\$ -	\$ -	\$ -	\$ -	\$ -	\$ -	\$ -	\$ -	\$ -
		\$ -	\$ -	\$ -	\$ -	\$ -	\$ -	\$ -	\$ -	\$ -	\$ -	\$ -
		\$ -	\$ -	\$ -	\$ -	\$ -	\$ -	\$ -	\$ -	\$ -	\$ -	\$ -
		\$ -	\$ -	\$ -	\$ -	\$ -	\$ -	\$ -	\$ -	\$ -	\$ -	\$ -
		\$ -	\$ -	\$ -	\$ -	\$ -	\$ -	\$ -	\$ -	\$ -	\$ -	\$ -
		\$ -	\$ -	\$ -	\$ -	\$ -	\$ -	\$ -	\$ -	\$ -	\$ -	\$ -
		\$ -	\$ -	\$ -	\$ -	\$ -	\$ -	\$ -	\$ -	\$ -	\$ -	\$ -
		\$ -	\$ -	\$ -	\$ -	\$ -	\$ -	\$ -	\$ -	\$ -	\$ -	\$ -
		\$ -	\$ -	\$ -	\$ -	\$ -	\$ -	\$ -	\$ -	\$ -	\$ -	\$ -

Test Report Table

Material	Test	Description	Required	Remarks	Contractor Name			
					CSJ#	CSJ#	CSJ#	CSJ#
Subgrade	Tex-101-E Part III	Pulverization						
	Tex-113	Moist. Density Curve						
	Tex-115-E	In-place Density						
		Thickness						
		Proof Roll						
Flex Base	Tex-101-E	Preparing Soils and Flex Bases						
	Tex-104-E	Determining Liquid Limit of Soils						
	Tex-105-E	Determining Plastic Limit of Soils						
	Tex-106-E	Calculating the Plasticity Index						
	Tex-107-E	Linear Shrinkage						
	Tex-110-E	Particle Size Analysis						
	Tex-113-E	Moisture Density Relationship of Base Materials(includes Limed)						
	Tex-116-E	Wet Ball Mill Method Tex						
	Tex-117-E	Triaxial Compression for Base Material (includes Limed)						
	Tex-115-E	In-place Density						
En-1		Thickness						
	IAW ASTM 4609							
	Tex-103-E							
	Tex-114-E							
	TexDOT 121 E							
	ASTM D 4546							
	ASTM D 1587							
	Tex115-E							
	Tex-207-F	Determining Density of Compacted Bituminous Mixtures						
	Tex-208-F	Test for Stabilometer Value of Bituminous Mixtures						
Hot Mix	Tex-210-F	Determining Asphalt Content of Bituminous Mixtures by Extraction						
	Tex-228-F	Determining Asphalt Content of Bituminous Mixtures by the Nuclear Method						
Tex-229-F	Combined HMAC Cold Belt Sampling and Testing Procedure							
Tex-236-F	Determining Asphalt Content from Asphalt Paving Mixtures By the Ignition Method							
Tex-207-E	Determining Density of Compacted Bituminous Mixtures							
Tex-212-E	Determining Moisture Content of Bituminous Mixtures							
Tex-213-E	Determining Hydrocarbon-Volatile Content of Bituminous Mixtures							
In-Place Density	Texas SDHPT							
	Bullentin C-14							
	ASTM D-2950.76							
Lime	AASHTO T-166							
	Tex-600-J	Lime Testing Procedure						Waive testing if less than 50 Tons from a Pre-Approved Source
Rcp		Three Edge Bearing Test						1 pipe for each 100 pipe

ASAGO CONSTRUCTION
“QUALITY AND SERVICE”

RAUL IGLESIAS
Manager

ASAGO, LLC
2113 Pecos
Mission, TX 78572
(956)607-0741 office
(956)585-7040 fax
iglesias@hiline.net

October 1, 2008

Mr. Javier Hinojosa, P.E.
Javier Hinojosa Engineering
4126 E. Dove Ave.
McAllen, TX 78504

RE: Hidalgo County Colonia Access Program
Drainage and Paving Construction at El Sol Subdivision Unit # 1 & 2
Contract No.: C-CAP-08-021-7-01

Mr. Hinojosa:

The following is the list of suppliers used in the above mentioned projects as per the County's request:

Rio Valley Pipe 7301 W. Exp. 83 Mission, TX 78572 (956)-584-5770

If you have any questions, please call me at (956) 607-0741

Best regards,
Raul Iglesias
Raul Iglesias, Manager

PARTIAL/FINAL WAIVER OF LEIN

THE STATE OF TEXAS

COUNTY OF _____

The undersigned contracted with _____
_____ to furnish _____
in connection with certain improvements to real property located in _____
County, Texas, and owned by _____
Which improvements are described as follows:

In consideration of Pay Estimate No _____ in the amount of _____
_____ DOLLAR(\$ _____) and other good and
valuable consideration, the receipt and sufficiency of which is hereby acknowledged and
confessed, the undersigned does hereby waive and release any mechanic's lien or materialmen's
lien or claims of lien that the undersigned has or hereafter has on the above mentioned real
property on account of any labor performed or materials furnished or to be furnished or labor
performed and materials furnished by the undersigned pursuant to the above-mentioned contract
or any constitutional lien that the undersigned may have.

Undersigned hereby guarantees that all bids for labor performed and/or materials furnished in the
erection and construction of such improvements on the Property have been fully paid and
satisfied and Undersigned does further guarantee that if for any reason a lien or liens are filed for
material or labor against said Property arising out of any bills for material or labor in connection
with the erection or construction of said improvements thereon, Undersigned will obtain a
settlement of such lien or liens and a proper release thereof shall be obtained.

CONTRACTOR

BY: _____
TITLE

SWORN TO AND SUBSCRIBED BEFORE ME, on this the _____ day of _____, 20__ to
certify which witness my hand and seal of office.

NOTARY PUBLIC in and for the State of Texas

My Commission Expires: _____

**CONTRACTOR'S AFFIDAVIT OF
PAYMENTS OF DEBTS AND CLAIMS**

PROJECT: OWNER: CONTRACTOR: ENGINEER:	PROJECT NO.
--	--------------------

The Contractor in accordance with the Contract Documents, hereby certifies that, except as listed below, all obligations for all materials and equipment furnished, for all work labor, and services performed, and for all known indebtedness and claims against the Contractor for damages arising in any manner in connection with the performance of the Contract referenced above for which the Owner or his property might in any way be held responsible have been paid in full or have otherwise been satisfied in full.

EXCEPTIONS: (If none, write "NONE". The Contractor shall furnish a bond acceptable to the Owner for each exception.)

CONTRACTOR

By

Title

Subscribed and sworn to before me this

day of

Notary Public:

My Commission Expires:

**Prevailing Wage Rates
Certification Statement**

Date _____

Project Name _____

CSJ# _____

Contractor _____

Application# _____

I, _____ do hereby state:
(Name of Project Director)

1. That a payroll (form WH-347 or similar form) was submitted for contract work Performed for the period covered by the attached application.
2. That a statement of compliance(form WH-347 or similar form) was submitted with the payroll.
3. The certified payroll complies with the classifications and minimum wage rates Stipulated in the contract.
4. That a minimum of one interview was conducted with laborers using Form HUD-11 or similar.

Signature

CERTIFICATE OF CONSTRUCTION COMPLETION

THIS IS TO CERTIFY THAT ON _____ DAY OF _____ A FINAL INSPECTION was made of the project herein described.

CONTRACT

CONTRACT DATE: _____
OWNER: _____
CONSTRUCTION CONTRACTOR: _____
OF THE CITY OF _____ STATE OF _____

PROJECT DESCRIPTION

CONSTRUCTION OF _____

CONTRACT NO: _____
Located in or near the City/Precinct Of _____

THIS IS TO CERTIFY”

1. That the work has been completed in accordance with the plans and specifications and all addenda, change orders, supplemental agreements thereto, and with the following exceptions:

- 2. That the sum of _____, deducted from the final payment of the Contractor is a fair and equitable settlement for the foregoing except work.
- 3. That the contractor has presented a “Certificate of Release” starting under oath, that all claims arising out of the performance of work have been fulfilled, and the Owner is released from all claims arising under or by virtue of said contract.
- 4. That the CONTRACTOR has presented in behalf of itself and its sureties, satisfactory evidence that it is bound to repair, replace, and make good any faulty workmanship and/or materials discovered in the work within a period of one year from this date, as provided in said contract.

5. Amount of Original Contract	_____
Present Amount of Contract	_____
Total Amount of earned to Date	_____
Less: previous payments	_____
Balance	_____
Authorized deductions	_____
AMOUNTY OF FINAL PAYMENT	_____

6. That the final payment in the amount of _____
_____ is now due and payable.

Engineer's Signature

CONCURRED BY:

Contractor's Name

By: _____

Title: _____

CONCURRED BY:

Hidalgo County Judge

CONTRACTOR'S AFFIDAVIT OF RELEASE OF LIENS

PROJECT:	PROJECT NO.
OWNER:	
CONTRACTOR:	
ENGINEER:	

The Contractor, in accordance with the Contract Documents, and in consideration for the full and final payment to the Contractor for all services in connection with the project, does hereby waive and release any and all liens, or any and all claims to liens which the Contractor may have on or affecting the project as a result of its contract(s) for the Project or for performing labor and/or furnishing materials in any way connected with the construction of any aspect of the project. The Contractor further certifies and warrants that all subcontractors of labor and/or materials for the Project, except as listed below, have been paid in full for all labor and/or materials supplied to, for through or at the direct or indirect request of the Contractor prior to, through and including the date of this affidavit.

EXCEPTIONS: (If none, write "NONE". The Contractor shall furnish a bond acceptable to the Owner for each exception.)

CONTRACTOR

By _____

Title _____

Subscribed and sworn to before me this _____ day of _____

Notary Public: _____

My Commission Expires: _____

CONSTRUCTION IDENTIFICATION SIGN:

Size, 4' – 0" X 8' – 0"

Letters to be brown with beige background

Construction Identification Signs To Be Erected Prior To Beginning of Actual Construction

Wood for Signs Shall Be $\frac{3}{4}$ " Waterproofing Resin Bonded Exterior Grade Plywood (Douglas Fir Plywood Association of Equal)

Payment for Furnishing, Erecting, Maintenance and Removing Construction Identification Signs Will Not Be made Directly. Such Costs Shall be Included in the Overall Bid Submitted.

To Be Erected as Indicated on title Sheet.



Your Tax Dollars at Work

Hidalgo County Pct 1

Joel Quintanilla, Commissioner
Border Colonia Access Program

In Partnership with Texas Department of Transportation

El Mesquite Subdivision Paving Projects

Hidalgo County Commissioner's Court

Ramon Garcia	-	County Judge
Joel Quintanilla	-	Commissioner Pct #1
Hector "Tito" Palacios	-	Commissioner Pct #2
Joe M. Flores	-	Commissioner Pct #3
Joseph Palacios	-	Commissioner Pct #4

Contractor: _____

Engineer: _____ TEDSI Infrastructure Group

HIDALGO COUNTY PRECINCT NO. 1

CONSTRUCTION PLANS EL MESQUITE SUBDIVISION BORDER ACCESS COLONIA PROJECT ROUND III COMPETITIVE CSJ 2C-1080-244

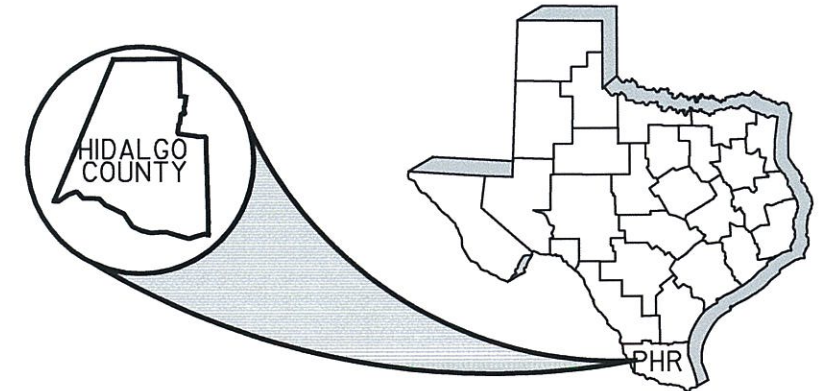

PROJECT LIMITS:
DIANA ST = 1271' = 0.24 MI
JULIE ST = 1272' = 0.24 MI

TOTAL LENGTH OF PROJECT = 2543' = 0.49 MI
TOTAL AREA OF DISTURBED SOIL = 2.90 AC

INDEX OF SHEETS

SHEET NO.	DESCRIPTION
1	TITLE SHEET
2	PROJECT LAYOUT
3	SUMMARY OF QUANTITIES
4	GENERAL NOTES
5	TYPICAL SECTIONS
6	TRAFFIC CONTROL PLAN GENERAL NOTES
7	TRAFFIC CONTROL PLAN TYPICAL SECTIONS
8-13	PLAN & PROFILE
14	DRIVEWAY TABLES
15	EARTHWORKS
16-21	CROSS-SECTIONS
22	PAVEMENT MARKINGS
23	SW3P

STANDARDS

24	DRIVEWAY PROFILE DETAILS
25	DRIVEWAY DETAILS PRIVATE
26-37	BC(1)-07 THRU BC(12)-07
38	WZ(TD)-03
39	WZ(UL)-03
40	WZ(DERD)-03
41	TCP(1-2)-12
42	TCP(2-2)-12
43	TCP(3-3)-98
44	TCP(7-1)-98
45	PM(1)-12
46	TECL-06(PHR)

CONSTRUCTION WILL CONSIST OF HOT MIX ASPHALT, NEW FLEXBASE, ROADSIDE DITCHES AND STRIPING.

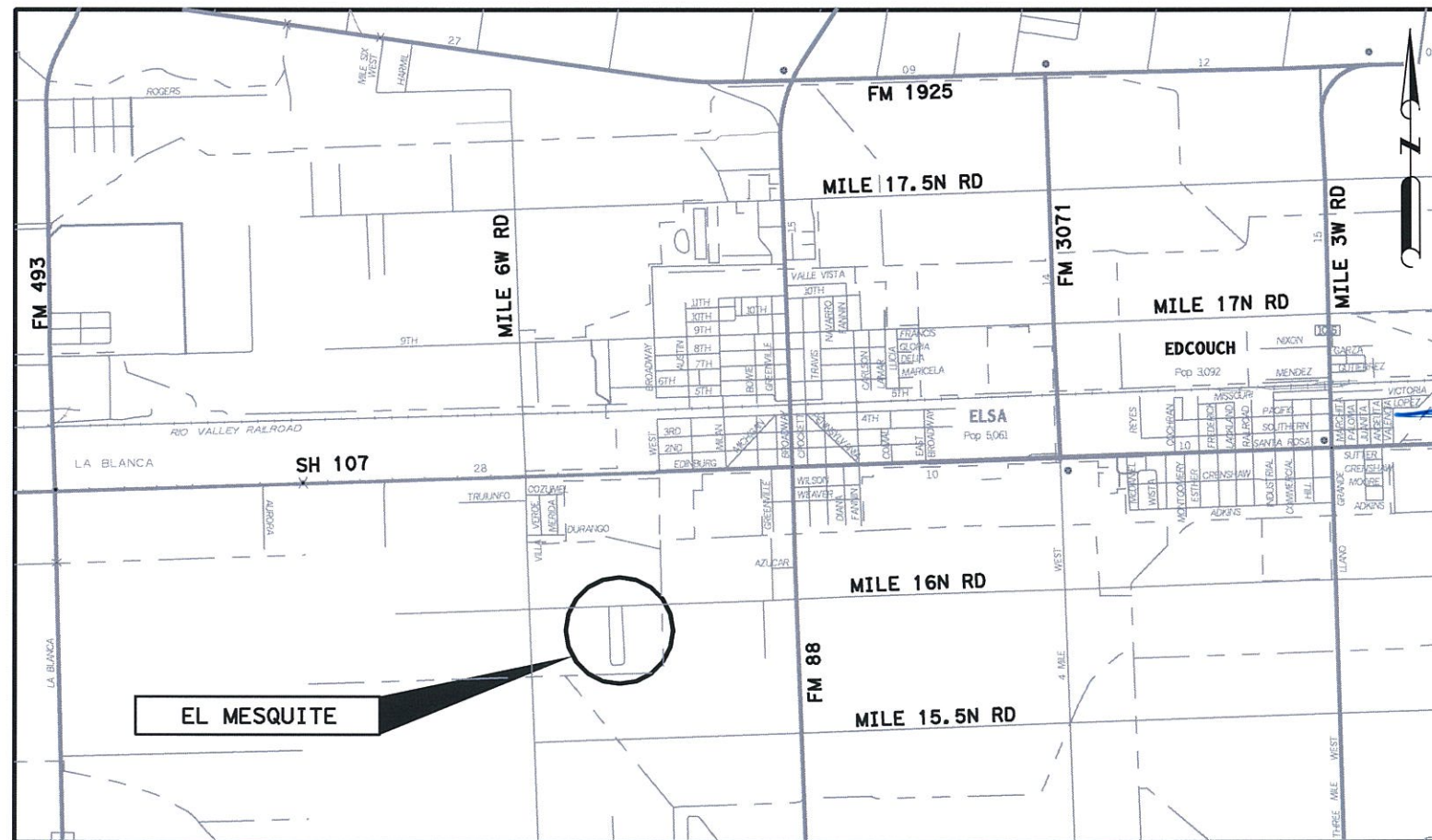

LOCATION MAP
N.T.S.

APPROVAL
HIDALGO COUNTY
COLONIA ACCESS PROGRAM
DATE : 03/20/2012

APPROVAL
HIDALGO COUNTY
COUNTY PRECINCT No 1
DATE : 03/20/12

APPROVAL
HIDALGO COUNTY PLANNER
DATE : 03/20/12
JOSIE FE PLAN ADM.

CONCURRENCE:
HIDALGO COUNTY DRAINAGE
DISTRICT No 1
DATE : 3/20/12

THE STANDARD SHEETS SPECIFICALLY IDENTIFIED ABOVE, HAVE BEEN SELECTED BY ME OR UNDER MY RESPONSIBLE SUPERVISION AS BEING APPLICABLE TO THIS PROJECT.



[Signature]
03/19/2012

HIDALGO COUNTY OFFICIALS

RAMON GARCIA	- COUNTY JUDGE
JOEL QUINTANILLA	- PCT 1 COMMISSIONER
HECTOR "TITO" PALACIOS	- PCT 2 COMMISSIONER
JOE M. FLORES	- PCT 3 COMMISSIONER
JOSEPH PALACIOS	- PCT 4 COMMISSIONER



SPECIFICATIONS ADOPTED BY THE TEXAS DEPARTMENT OF TRANSPORTATION, JUNE 1, 2004 AND SPECIFICATION ITEMS LISTED SHALL GOVERN ON THIS PROJECT.

NO EXCEPTIONS
NO EQUATIONS
NO RAILROAD CROSSINGS

TEDSI INFRASTRUCTURE GROUP



Consulting Engineers
1201 E. Expressway 83
Mission, Texas 78572
(956) 424-7898

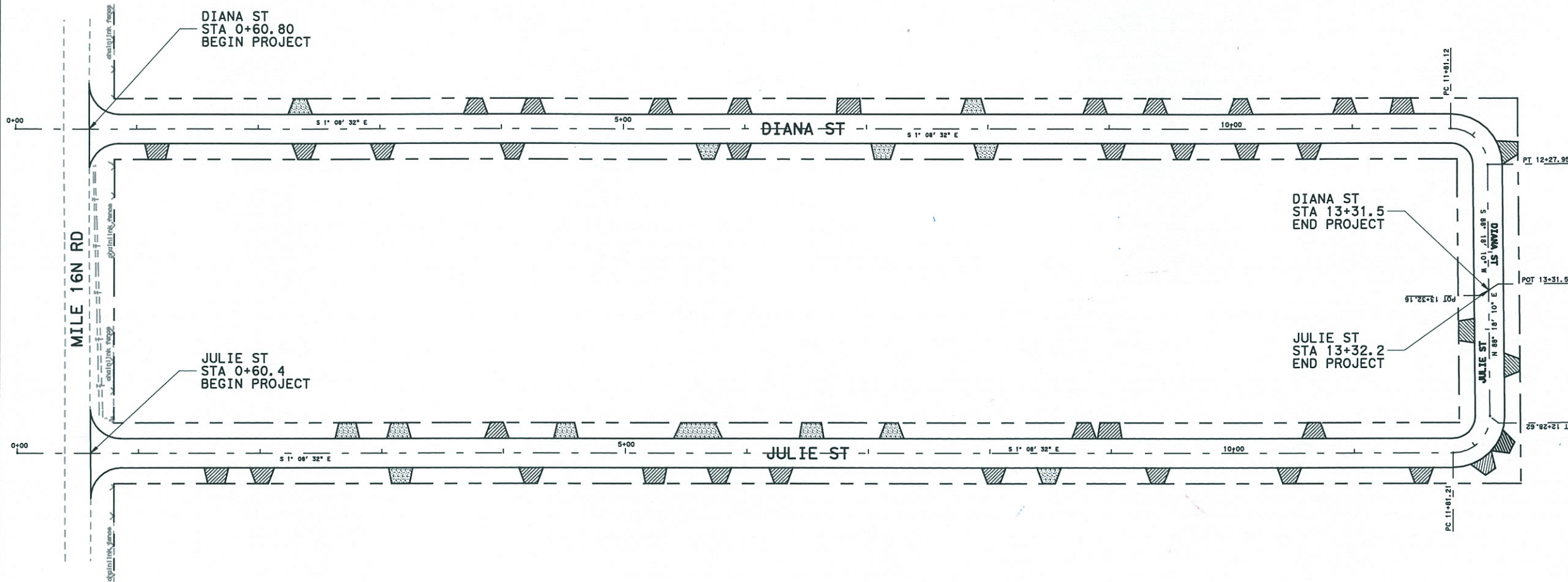

NO.	DATE	REVISION	APP.

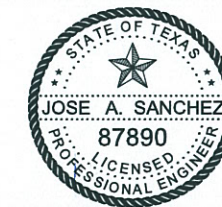

[Signature]
03/19/2012



HIDALGO COUNTY

TEDSI INFRASTRUCTURE GROUP
TEDSI Consulting Engineers
 1201 E. Expressway 83
 Mission, Texas 78572
 (956) 424-7898
 TBPE F-1640

EL MESQUITE

PROJECT LAYOUT

SHEET 1 OF 1

FED. RD. DIV. NO.	PROJECT NO.	SHEET NO.
6		2
STATE	DIST.	COUNTY
TEXAS	PHR	HIDALGO
CSJ	PCT	HIGHWAY NO.
2C-1080-244	1	VARIOUS

3/19/2012 3:42:41 PM p:\2009\2009-1027-02 hobcap III additional_colon\cs\des\gn\03 el mesquite\cs\Roadway\MES-project.dgn

GENERAL NOTES AND SPECIFICATION DATA

For all pits or quarries, comply with the "Texas Aggregate Quarry and Pit Safety Act." Provide on a weekly basis a list of equipment, including idle equipment, utilized on the project that week.

The 1-800 call services for utility locations do not include TxDOT facilities. Contact the Pharr District Signal Section (956-702-6225) for coordination with TxDOT underground lines.

ITEM 5. Control of the Work

Prior to contract letting, bidders may obtain a free computer diskette or a computerized transfer of files (from the Engineer's office) that contains the earthwork information. If copies of the actual cross-sections in addition to, or instead of, the diskette are requested, they will be available at the Engineer's office for borrowing by copying companies for the purpose of making copies for the bidder at the bidders expense.

ITEM 8. Prosecution and Progress

Working days will be computed and charged in accordance with Article 8.3.A.1 Five-Day Workweek.

ITEM 132. Embankment

The native soils within the project area are not considered suitable for use as select fill materials. Borrow used as embankment material in the top two feet (Select Fill) below the bottom of pavement flexible base shall meet the following requirements:

1. TxDOT Bid Item 247, Type E, Grade 4
2. Alternative select fill material

- a. The following soils, as classified according to the USCS, may be considered satisfactory for use as select fill materials at this site: SC,GC,CL and combinations of these soils.
- b. In addition to the USCS classification, alternative select fill materials shall have a maximum liquid limit of 35 percent, a plasticity index between 5 and 17 percent and a maximum particle size not exceeding 4 inches or one-half the loose lift thickness, whichever is smaller.
- c. In addition, if these materials are utilized, grain size analyses and Atterberg Limits must be performed during placement at a minimum rate of one test each per 5,000 cubic yards of material due to the high degree of variability associated with pit-run materials.
- d. If the above listed alternative materials are being considered for bidding purposes, the materials should be submitted to the Geotechnical Engineer for pre-approval at a minimum of 10 working days or more prior to the bid date. Failure to do so will be the responsibility of the General Contractor.
- e. The General Contractor will be responsible for ensuring that the properties of all delivered alternate select fill materials are similar to those of the pre-approved submittal. It should also be noted that when using alternative fill materials, difficulties may be experienced with respect to moisture control during and subsequent to fill placement, as well as with erosion, particularly when exposed to inclement weather. This may result in sloughing of beam trenches and/or pumping of the fill materials.
- f. Soils classified as CH, CL, MH, ML, SM, GM, OH,OL and Pt under the USCS and not meeting the alternative select fill material requirements are not considered suitable for use as select fill materials at this site.
- g. Select fill should be placed in loose lifts not exceeding 8 inches in thickness and compacted to at least 98 percent of maximum dry density as determined by ASTM D698. The moisture content of the fill should be maintained within the range of two percentage points below the optimum moisture content to two percentage points above the optimum moisture content until the final lift of fill is permanently covered.
- h. The select fill should be properly compacted in accordance with these recommendations and tested by the Geotechnical Engineer for compaction as specified.

ITEMS 134. Backfilling Pavement Edges

Areas to be backfilled shall extend approximately 3-ft out from the edges of the proposed overlay. Final slopes shall be uniform and smooth. The 100-foot station payment includes Backfilling of both sides.

Backfill Ty A shall not contain particles more than two inches in size and shall have a minimum PI of 10 and a maximum PI of 20.

Any additional backfill material necessary due to pre-existing edge conditions or to replace existing fill removed during blading operations will not be paid for directly. It will be considered subsidiary to this bid item.

ITEM 247. Flexible Base

Flexible Base Type E will be composed of caliche (argillaceous Limestone, calcareous or calcareous clay particles) and may contain stone, conglomerate, gravel, sand or granular materials when these materials are in situ with the caliche.

Blended material for Flexible Base TY E GR 4

Flexible Base TY E GR 4 (caliche base) does not meet the requirements of TY A GR 1 base material. The Contractor may blend base material with another caliche source or with crushed concrete, meeting the requirements for TY "D" materials provided a minimum of 50% caliche is used. The crushed concrete may contain sand or granular materials. Stabilizing additives will not be allowed in the raw crushed concrete base. Acceptance will be under the following conditions:

Condition One (1): When both components of the blend in their individual stockpiles meet all the physical requirements of this Item, then field blending will be allowed.

Condition Two (2): When only one component of the blend passes the physical requirements of this Item, the materials shall be blended through a plant for stockpile testing and approval.

Flexible Base (TY E GR 4) shall conform to the following requirements:

BEFORE LIME IS ADDED

Retained on Sq. Sieve	Percent Retained
2"	0
1/2"	20-60
No. 4	40-75
No. 40	70-90
Max. PI:	15
Max Wet Ball PI:	15
Wet Ball Mill Max Amount:	20
Min. Comp. Strength PSI	150 at 15 psi lateral pressure

The Wet Ball Test (Tex-116-E) shall be run and the Plasticity Index of the material passing the No. 40 sieve shall be determined (Wet Ball PI).

After 1% lime (laboratory) is added to unlimed material

Max PI	12
Min. Comp. Strength PSI:	180 at 15 psi Lateral Pressure
Triaxial Test (Lime Treated)	Tex-121-E

2% lime shall be incorporated into the Flexible Base in the field at the owner's expense.

The percent of density as determined by Compaction Ratio (Tex-113-E) for the new Flexible Base shall be a minimum of 98%.

The percent of density as determined by Tex-121-E for the new and salvage Flexible Base shall be a minimum of 98% for all courses.

The Contractor's attention is called to the fact that certain existing and/or proposed structures may be within the limits of the Flexible Base. It shall be the Contractor's responsibility to perform construction operations without damage to these structures.

ITEM 300. Asphalt's, Oils and Emulsions

Temporary ramps/detours and driveways may use performance grade binder 76-22.

ITEM 310. Prime Coat (Cutback Asphaltic Material)

The Contractor shall exercise diligence in the application of asphalt by the use of flagging and rolling procedures to keep from spraying or splattering the traveling public with asphaltic material.

ITEM 400. Excavation and Backfill for Structures

If the Contractor elects to cut pavement (existing/detour) for structural work beyond that required by the construction phasing shown in the plans and approved by the Engineer, it shall be restored at his expense and backfilled to its original condition or better in accordance with Item 400.

ITEM 464. Reinforced Concrete Pipe

Use tongue and groove pipe where the RCP extends into the lime treated subgrade. The 4-foot depth restriction for heavy equipment passage over pipe structures is voided. The Contractor will be responsible for any construction damage to these facilities.

Do not use mortar joints.

All reinforced concrete pipe shall include rubber gaskets unless shown otherwise on the plans or directed by the engineer.

ITEM 467. Safety End Treatment

All Type II SET's shall have riprap, Class "A" minimum, aprons as shown on the plans. The contractor may submit an alternate precast SET design for approval by the Engineer.

ITEM 496. Removing Old Structures

Store the following items to be salvaged at a location designated by the Engineer.

ITEM 502. Barricades, Signs and Traffic Handling

A pilot car and radio equipped flagmen shall be required for all undivided roadway locations as directed by the Engineer. The pilot car with necessary flagmen and/or radio equipped flagmen and all signs, equipment, labor and incidentals required for this method of traffic control will not be paid for directly, but shall be considered subsidiary to Item 502.

Replace/relocate all regulatory signs removed due to construction operations with a same sign on fixed support(s) immediately upon its removal. First obtain project Engineer approval before removing any regulatory roadway sign. Required flaggers are to be available to direct traffic during sign intermediate down time.

Relocate any Directional Sign Assemblies removed during construction operations immediately upon their removal.

These signs shall be relocated to a location in accordance with the Latest Version of the "Texas Manual on Uniform Traffic Control Devices". In no case will a sign be removed without a replaceable sign and support(s) being readily available and a location established. Removal and relocation of these signs required for traffic control will not be paid for directly, but shall be considered subsidiary to Item 502.

ITEM 504. Field Office and Laboratory

For this project a field office will not be required at the project site.

ITEM 530. Driveways and Turnouts





Prime coat shall meet the requirements of Item 310.

Daily testing requirements for Hot Mix Asphaltic Concrete Pavements for drives, commercial entrances and/or turnouts may be waived by the Engineer.

MISC

The contractor shall be responsible for maintenance of sediment traps. Damaged/missing sediment traps shall be replaced by the contractor at no additional cost. R.O.W. sediment traps may be shown on plans for clarity purposes only. Actual placement shall be done within R.O.W.

The contractor shall be responsible for posting Small Construction Site Notice and any additional permits required by T.E.C.Q.

NO.	DATE	REVISION	APP.
  03/19/2012			
 HIDALGO COUNTY			
 TEDSI INFRASTRUCTURE GROUP Consulting Engineers 1201 E. Expressway 83 Mission, Texas 78572 (956) 424-7898			
EL MESQUITE			
GENERAL NOTES			
SHEET 1 OF 1			
FED. RD. DIV. NO.	PROJECT NO.		SHEET NO.
6			4
STATE	DIST.	COUNTY	
TEXAS	PHR	HIDALGO	
CSJ		PCT	HIGHWAY NO.
2C-1080-244		1	VARIOUS

3/19/2012 3:42:58 PM P:\2009\2009-1027-02 hncbcp III additonal_colon\cas\des\gn\03 el mesquite\res\Roadway\MES-gn.dgn

NOTES:

- PGL - PROFILE GRADE LINE
- PERMISSIBLE CONSTRUCTION JOINTS SHALL FALL ON THE PROPOSED ROADWAY CENTERLINE.
- ALL GRADING SHALL BE WITHIN THE EXISTING RIGHT OF WAY LIMITS.
- WHERE REQUIRED BY FIXTURES OR UNUSUAL CONDITIONS THE GOVERNING SLOPES MAY BE VARIED WHEN SPECIFICALLY DIRECTED BY THE ENGINEER.
- REMOVAL OF EXISTING MILLING SHALL BE SUBSIDIARY TO EXCAVATION.
- THE SUBGRADE SHALL BE SHAPED, BLADED, ROLLED AND PROOF ROLLED A MINIMUM DISTANCE OF 12" BEYOND THE EDGE OF THE PROPOSED BASE COURSE.
- THE COMPLETE BASE SHALL BE PROOF ROLLED BEFORE THE EARTH SHOULDER IS SHAPED. FINAL COMPACTION WILL BE DONE OVER BASE AND EDGE OF SHOULDER.
- PROOF ROLLING WILL NOT BE PAID FOR DIRECTLY BUT SHALL BE CONSIDERED SUBSIDIARY TO THE VARIOUS ITEMS.
- A STATION EQUAL TO 100 FT.
- APPLICATION RATES AS FOLLOWS:
 - HOT MIX ASPHALT - 1.5" = 175 LB/SY
 - PRIME COAT - 0.2 GAL/SY
 - LIME (FLEXBASE) - 2% BY WT
 - FLEXBASE WT - 3375 LB/CY (APPROX)

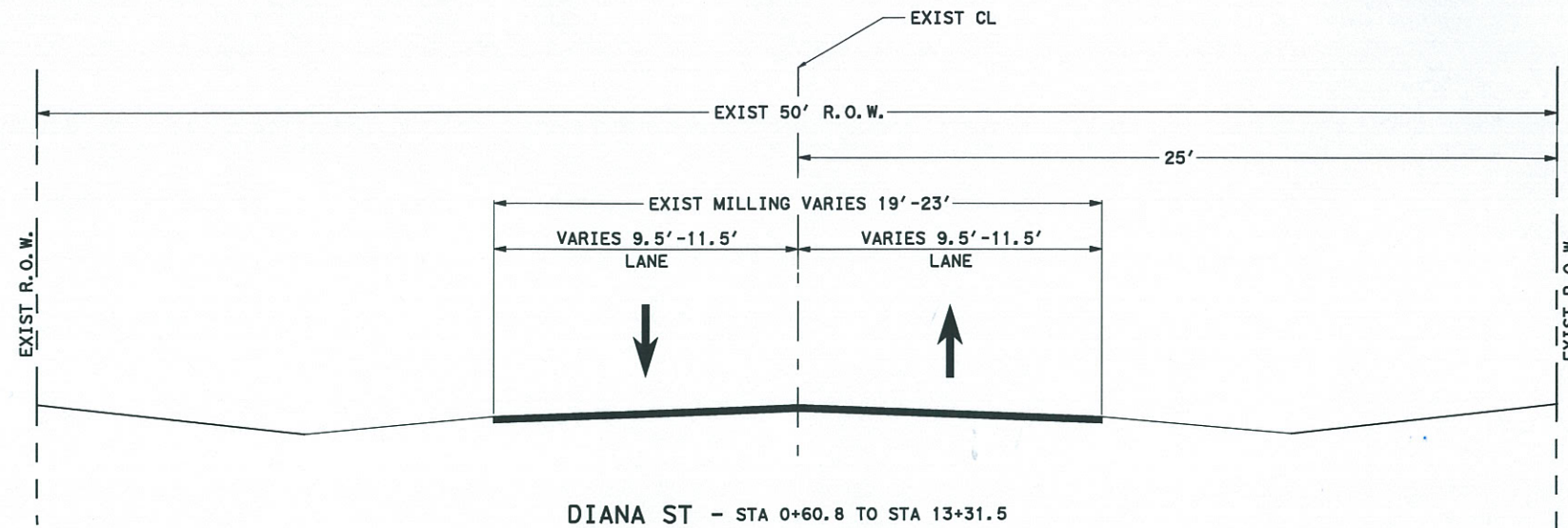

DIANA ST - STA 0+60.8 TO STA 13+31.5
JULIE ST - STA 0+60.4 TO STA 13+32.2

EXISTING TYPICAL SECTION
N. T. S.

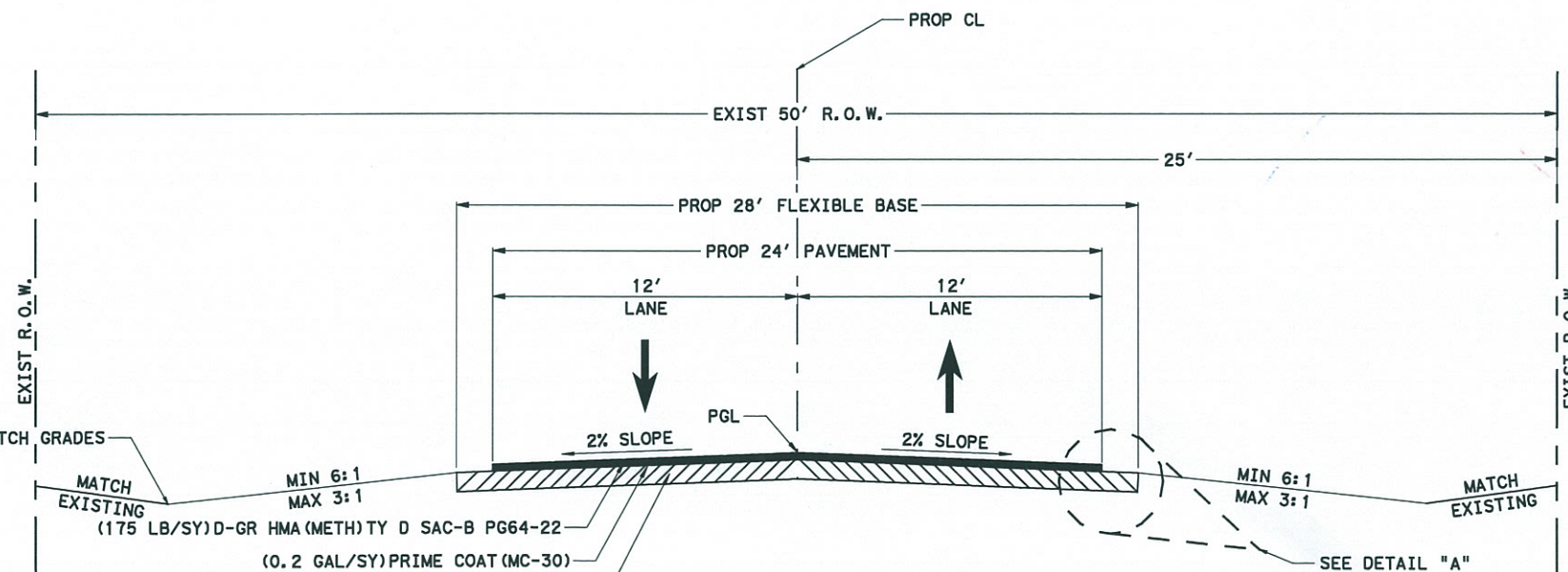
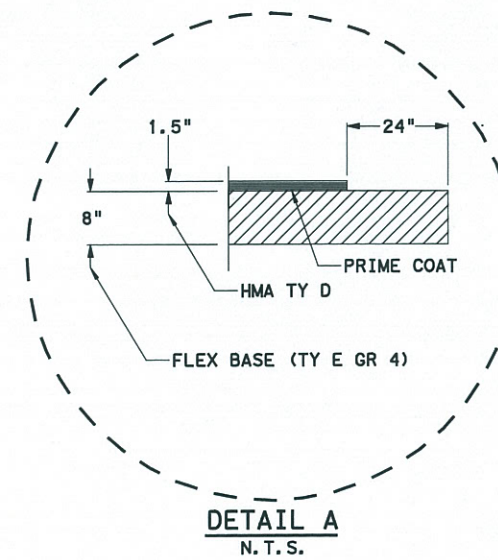

DIANA ST - STA 0+60.8 TO STA 13+31.5
JULIE ST - STA 0+60.4 TO STA 13+32.2

PROPOSED TYPICAL SECTION
N. T. S.

NO.	DATE	REVISION	APP.
TEDSI INFRASTRUCTURE GROUP Consulting Engineers 1201 E. Expressway 83 Mission, Texas 78572 (956) 424-7898			
EL MESQUITE			
TYPICAL SECTIONS			
N. T. S.			SHEET 1 OF 1
FED. RD. DIV. NO.	PROJECT NO.	SHEET NO.	
6		5	
STATE	DIST.	COUNTY	
TEXAS	PHR	HIDALGO	
CSJ	PCT	HIGHWAY NO.	
2C-1080-244	1	VARIOUS	

3/19/2012 3:43:35 PM P:\2009\2009-1027-02 hobcap III additional\colonia\as\design\03 el_mesquite\res\Roadway\MES-tyr.dgn

GENERAL NOTES

THE CONTRACTOR MAY SUBMIT AN ALTERNATE TRAFFIC CONTROL PLAN TO THE ENGINEER FOR APPROVAL. APPROVED ALTERNATE TRAFFIC CONTROL PLANS SHALL REQUIRE THE SEAL OF A LICENSED ENGINEER. NO PHASE OF CONSTRUCTION SHALL START UNLESS OTHERWISE APPROVED BY ENGINEER.

BARRICADES/DEVICES/SIGNS SHALL BE ERECTED AND PLACED PRIOR TO COMMENCING ANY PROPOSED ROADWAY CONSTRUCTION AND SHALL REMAIN IN PLACE FOR THE DURATION OF THE PROJECT AND UNTIL COMPLETION AND ACCEPTANCE OF THE PROJECT BY OWNER.

BARRICADES, SIGNS, CHANNELIZATION DEVICES AND OTHER TRAFFIC HANDLING DEVICES MAY BE ADJUSTED OR SHIFTED TO FIT FIELD CONDITIONS AS REQUIRED FOR CONSTRUCTION.

ADEQUATE SIGNS AND BARRICADES SHALL BE INSTALLED BY THE CONTRACTOR AND APPROVED BY ENGINEER PRIOR TO OPENING ANY ROADWAY SECTIONS TO TRAFFIC. THE ENGINEER MAY DIRECT THE CONTRACTOR TO FURNISH ADDITIONAL SIGNS, BARRICADES AND CHANNELIZING DEVICES AS REQUIRED TO MAINTAIN TRAFFIC AND MOTORIST SAFETY DURING CONSTRUCTION. ANY SUCH ADDITIONAL SIGNS AND BARRICADES, ETC, SHALL BE CONSIDERED SUBSIDIARY TO THE VARIOUS ITEMS.

THE CONTRACTOR SHALL INSURE THAT BARRICADES, SIGNS, CHANNELIZING DEVICES AND TRAFFIC HANDLING DEVICES ARE MAINTAINED IN A CLEAN AND FUNCTIONAL CONDITIONS AT ALL TIMES, INCLUDING MAINTENANCE DUE TO VANDALISM OR ACCIDENTS. THE CONTRACTOR SHALL HAVE ENOUGH BARRICADES AND SIGNS AVAILABLE, AT ALL TIMES, TO REPLACE THOSE DAMAGED.

ALL STRIPING AND SIGNING SHALL BE THE RESPONSIBILITY OF THE CONTRACTOR AND SHALL BE IN ACCORDANCE WITH THE PLANS, BC STANDARDS AND THE LATEST VERSION OF THE TMTCD.

EXISTING SIGNS SHALL NOT BE REMOVED UNTIL CONSTRUCTION SIGNS HAVE BEEN INSTALLED. THE CONTRACTOR WILL BE RESPONSIBLE FOR REMOVING EXISTING SIGNS IN CONFLICT WITH PROPOSED CONSTRUCTION SIGNS. ANY SUCH REMOVAL OF SIGNS SHALL BE CONSIDERED SUBSIDIARY TO THE VARIOUS ITEMS.

WHEN CONNECTING PROPOSED ROADWAY TO SECTIONS OF EXISTING TRAFFIC BEING USED BY TRAFFIC AND SUCH OPERATIONS RESULT IN A DROP-OFF OF MORE THAN 2" A 4' BUFFER ZONE AND 3:1 SLOPE WILL BE REQUIRED. THE SLOPE MUST BE CONSTRUCTED WITH A COMPACTED MATERIAL CAPABLE OF SUPPORTING VEHICLES AND/OR AS APPROVED BY ENGINEER. THIS WORK SHALL BE DONE EXPEDITIOUSLY DURING DAYLIGHT HOURS. FLAGGERS AND APPROPRIATE SIGNING TO SAFELY GUIDE TRAFFIC THROUGH THE WORK ARE WILL BE REQUIRED, AS APPROVED BY ENGINEER.

THE PORTION OF THIS PROJECT WHICH COINCIDES WITH THE EXISTING ROADS AND/OR PRIVATE DRIVEWAYS SHALL BE KEPT OPEN TO TRAFFIC AT ALL TIMES, UNLESS OTHERWISE SPECIFIED IN THE PLANS OR APPROVED BY THE ENGINEER. THE CONTRACTOR WILL BE REQUIRED TO COORDINATE WITH ADJACENT PROPERTY OWNERS TO PROVIDE ADEQUATE EGRESS AND INGRESS DURING ALL PHASES OF CONSTRUCTION.

THE CONTRACTOR SHALL KEEP TRAVELED PAVED SURFACES USED IN HIS HAULING OPERATIONS CLEAR AND FREE OF DIRT AND OTHER UNACCEPTABLE MATERIAL AT ALL TIMES. A POWER BROOM SHALL ONLY BE USED TO CLEAN THE ROADWAY.

THE CONTRACTOR SHALL COORDINATE THE TRAFFIC CONTROL PLAN WITH ANY ADJACENT CONSTRUCTION PROJECTS TO INSURE THE UNINTERRUPTED FLOW OF TRAFFIC WITHIN THE VICINITY OF THE PROJECT AREAS.

THE CONTRACTOR SHALL BE RESPONSIBLE FOR MAINTAINING TEMPORARY DRAINAGE DURING CONSTRUCTION THROUGHOUT THE PROJECT LIMITS DURING ALL PHASES OF CONSTRUCTION. EXCAVATED MATERIALS SHALL BE HANDLED BY THE CONTRACTOR IN SUCH WAY IT DOES NOT BLOCK DRAINAGE.

THE CONTRACTOR SHALL NOT LEAVE ANY OPEN TRENCHES OR EXCAVATIONS OVERNIGHT, UNLESS PROPERLY PROTECTED AND/OR AS APPROVED BY THE ENGINEER.

CONSTRUCTION FENCING (4' HIGH MINIMUM) SHALL BE USED AROUND ALL OPEN TRENCHES OR EXCAVATIONS, AS APPROVED BY THE ENGINEER. THIS WORK SHALL NOT BE PAID FOR DIRECTLY, BUT SHALL BE CONSIDERED SUBSIDIARY TO VARIOUS BID ITEMS.

ALL DRUMS USED IN THIS PROJECT FOR TRAFFIC CONTROL DEVICES SHALL BE REMOVED FROM THE PROJECTS. MATERIALS FURNISHED, INSTALLED AND REMOVED BY THE CONTRACTOR SHALL BECOME PROPERTY OF THE CONTRACTOR.

ALL EXISTING UTILITIES THAT ARE IN CONFLICT WITH THE PROPOSED ROADWAY IMPROVEMENTS FOR THIS PROJECT SHALL BE RELOCATED AND/OR ADJUSTED BY OTHERS EXCEPT AS NOTED IN THE PLANS. THE CONTRACTOR SHALL COORDINATE WITH THE VARIOUS UTILITY COMPANIES THE RELOCATION, ADJUSTMENT AND INSTALLATION OF UTILITY LINES. THE ROADWAY WORK SHALL BE ONGOING DURING ADJUSTMENT, RELOCATION AND INSTALLATION OF UTILITY LINES.

THE CONTRACTOR'S ATTENTION IS DIRECTED TO THE REQUIREMENTS OF ITEM 7 "LEGAL RELATIONS AND RESPONSIBILITIES" OF THE STANDARD SPECIFICATIONS.

THE PORTION OF THIS PROJECT WHICH COINCIDES WITH EXISTING ROADS AND/OR PRIVATE DRIVEWAYS WILL BE KEPT OPEN TO TRAFFIC AT ALL TIMES, UNLESS OTHERWISE PROVIDED FOR AND APPROVED BY THE ENGINEER.

THE CONTRACTOR WILL BE ALLOWED TO CLOSE ROADWAY TO THRU TRAFFIC, BUT MUST ALLOW ALL LOCAL TRAFFIC EGRESS AND INGRESS AT ALL TIMES.

THE CONTRACTOR WILL BE ALLOWED TO WORK ONE HALF OF THE PROPOSED SECTION AT A TIME UNLESS OTHERWISE APPROVED BY THE ENGINEER.

THE CONTRACTOR MUST REMOVE EXISTING GRASS AND TOPSOIL FROM THE SHOULDER.



AFTER PREPARATION OF THE SUBGRADE AND/OR FLEXBASE, THE ROADWAY SHALL BE ADEQUATELY FINISHED TO SAFELY CARRY TRAFFIC AFTER WORKING HOURS.

THE CONTRACTOR SHALL WORK ONLY THAT LENGTH OF ROADWAY IN ONE WORKING DAY WHICH HE CAN ADEQUATELY FINISH TO SAFELY CARRY TRAFFIC AFTER WORKING HOURS.

ALL SIGNS AND MAILBOXES AFFECTED BY CONSTRUCTION SHALL BE RELOCATED. RELOCATION WILL NOT BE PAID FOR DIRECTLY BUT SHALL BE CONSIDERED SUBSIDIARY TO THE VARIOUS BID ITEMS.

ALL SIGNS AND MAILBOXES DAMAGED DURING CONSTRUCTION SHALL BE REPLACED NEW AT CONTRACTOR'S EXPENSE.

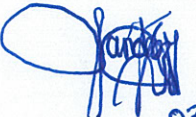
ALL EXISTING SIGNS SHALL REMAIN IN PLACE DURING CONSTRUCTION, THE CONTRACTOR IS TO RELOCATE/ADJUST SIGNS DURING CONSTRUCTION AT NO ADDITIONAL COST.

NO.	DATE	REVISION	APP.
  03/19/2012			
 HIDALGO COUNTY			
 TEDSI INFRASTRUCTURE GROUP <i>Consulting Engineers</i> <small>1201 E. Expressway 83 Mission, Texas 78572 (956) 424-7898</small>			
EL MESQUITE			
TRAFFIC CONTROL PLAN GENERAL NOTES			
N. T. S.			SHEET 1 OF 1
FED. RD. DIV. NO.	PROJECT NO.		SHEET NO.
6			6
STATE	DIST.	COUNTY	
TEXAS	PHR	HIDALGO	
CSJ		PCT	HIGHWAY NO.
2C-1080-244		1	VARIOUS

3/19/2012 3:43:46 PM P:\2009\2009-1027-02 hobcap III additional\00\om\cs\des\gn\03 el mesquite\res\Roadway\MES-top-gn.dgn

3/19/2012 3:43:46 PM P:\2009\2009-1027-02 hobcap III additional_colon\cas\des\ign\03 el mesquite\te\esj\Roadway\MES-top-typ.dgn

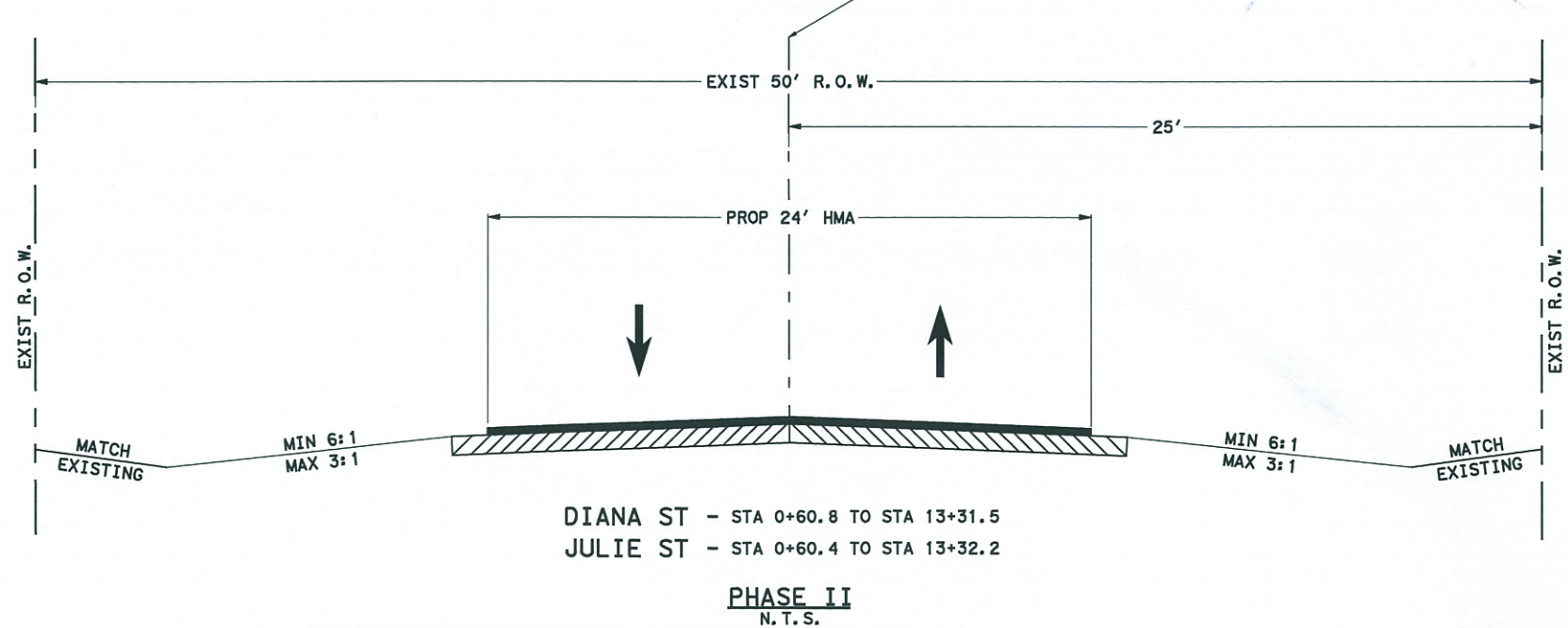
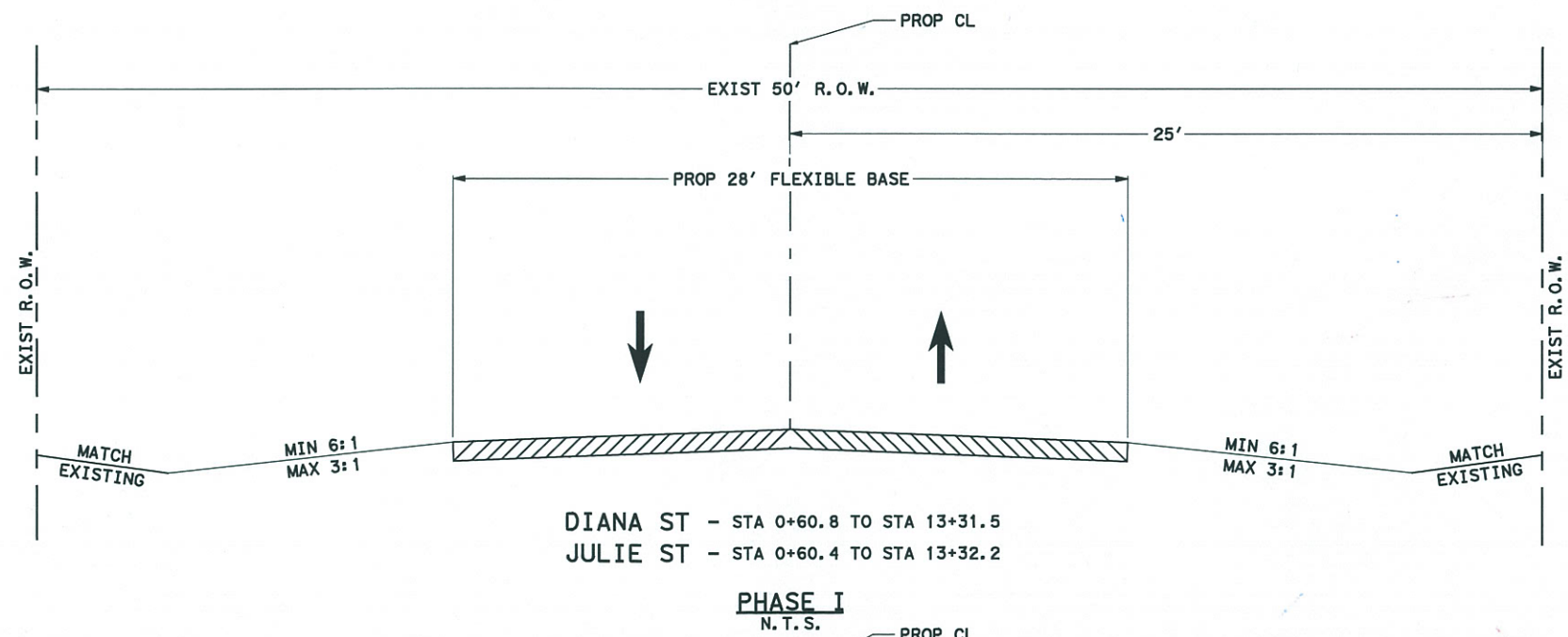
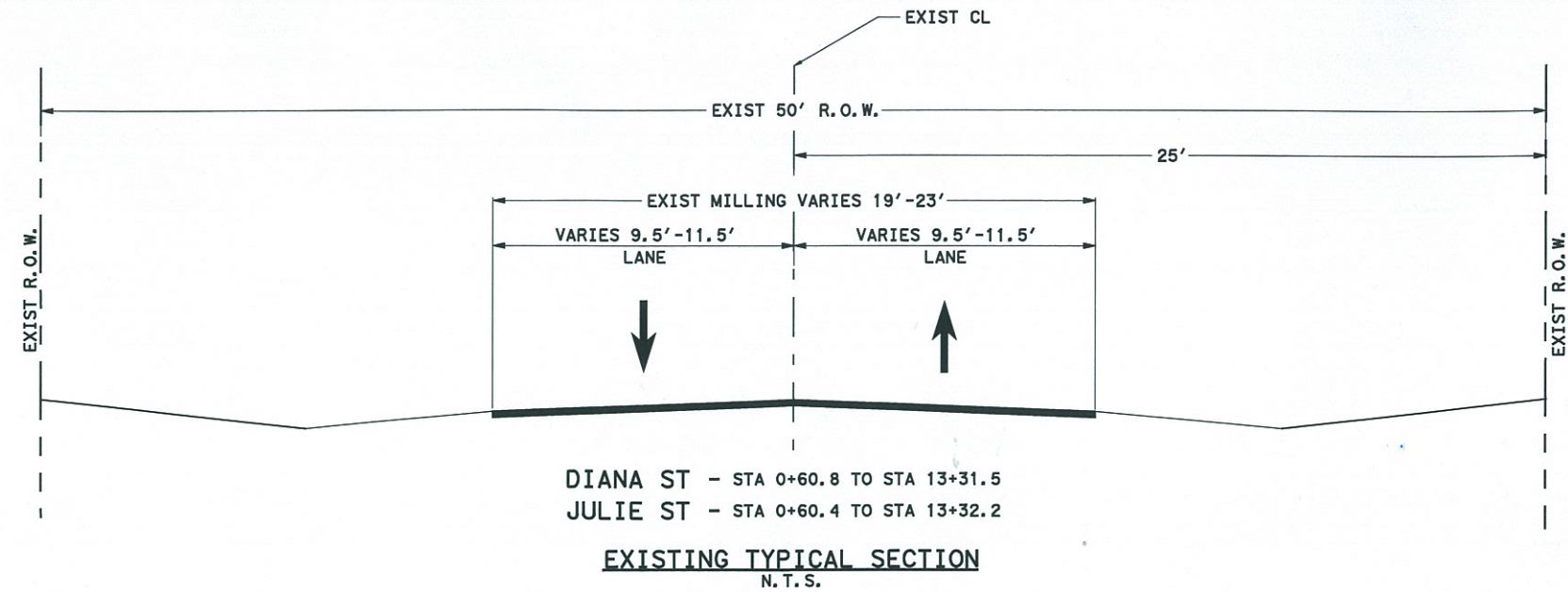

SEQUENCE OF CONSTRUCTION

- PHASE I
1. INSTALL PROJECT LIMITS AND ADVANCE WARNING SIGNS
 2. INSTALL CROSSROAD BARRICADES/SIGNS, IN ACCORDANCE WITH MUTCD, BC STANDARDS AND/OR AS DIRECTED BY ENGINEER
 3. INSTALL STORM WATER POLLUTION CONTROLS
 4. EXCAVATION WORK/INSTALL STORM DRAINAGE STRUCTURES
 5. FLEXIBLE BASE WORK
- PHASE II
1. APPLY HOT MIX ASPHALT MATERIAL IN ONE COURSE
 2. BACKFILL PAVEMENT EDGES
 3. REINSTALL EXISTING SIGNS/MAILBOXES
 4. REMOVE STORM WATER POLLUTION CONTROLS
 5. INSTALL PAVEMENT MARKINGS
 6. FINAL CLEANUP

NO.	DATE	REVISION	APP.
 HIDALGO COUNTY			
 TEDSI INFRASTRUCTURE GROUP Consulting Engineers 1201 E. Expressway 83 Mission, Texas 78572 (956) 424-7898			
EL MESQUITE			
TRAFFIC CONTROL PLAN TYPICAL SECTIONS			
N. T. S.			SHEET 1 OF 1
FED. RD. DIV. NO.	PROJECT NO.	SHEET NO.	
6		7	
STATE	DIST.	COUNTY	
TEXAS	PHR	HIDALGO	
CSJ	PCT	HIGHWAY NO.	
2C-1080-244	1	VARIOUS	

LEGEND

- GAS — EXIST GAS LINE
- T — EXIST UG PHONE LINE
- W — EXIST WATER LINE
- x-x-x-x- EXIST CHAINLINK FENCE
- [Hatched Box] ASPHALT DRIVEWAY
- [Dotted Box] CONCRETE DRIVEWAY
- - - - - PROP DITCH
- (*) DRIVEWAY ID NUMBER
- [Mailbox Symbol] EXIST MAILBOX
- [Water Meter Symbol] EXIST WATER METER
- [Water Valve Symbol] EXIST WATER VALVE
- [Power Pole Symbol] EXIST POWER POLE
- [Fire Hydrant Symbol] EXIST FIRE HYDRANT
- [Telephone Box Symbol] EXIST TELEPHONE BOX
- [Gas Meter Symbol] EXIST GAS METER
- [SCF Symbol] TEMP SED CTRL FENCE

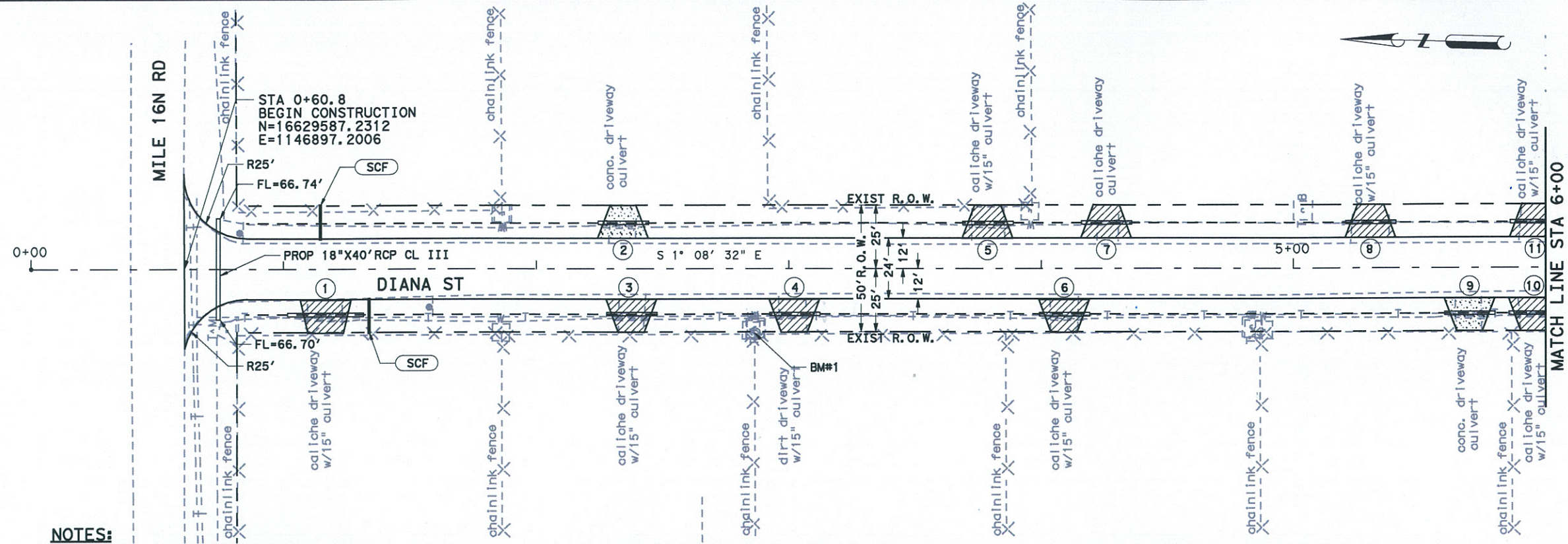

NOTES:

1. EXISTING ABOVE GROUND UTILITIES AND TOPOGRAPHY HAVE BEEN PLOTTED BY DIRECT FIELD INFORMATION AND AS SPOTTED BY UTILITY LOCATE REQUEST. THE CONTRACTOR WILL BE RESPONSIBLE FOR COORDINATING WITH UTILITY COMPANIES THE ESTABLISHING OF EXACT LOCATION, DEPTH, AND SIZE OF UTILITY LINES. THE CONTRACTOR WILL ALSO BE RESPONSIBLE FOR COORDINATING WITH THE UTILITY COMPANIES FOR REPLACEMENT OR REPAIRS OF ALL CUT OR BROKEN WATER LINES, IRRIGATION LINES, FORCE MAINS, SPRINKLER SYSTEMS, GAS LINES, POWER LINES, TELEPHONE CABLES, AND/OR ANY OTHER UTILITIES.
2. MAILBOXES AND SIGNS TO BE ADJUSTED/REPLACED/RELOCATED DURING CONSTRUCTION. ITEMS WILL NOT BE PAID FOR DIRECTLY BUT SHALL BE CONSIDERED SUBSIDIARY TO THE VARIOUS ITEMS.
3. UNLESS OTHERWISE SPECIFIED IN THE PLANS, TREES OR OTHER OBSTRUCTIONS IN CONFLICT WITH CONSTRUCTION SHALL BE REMOVED. REMOVAL WILL NOT BE PAID FOR DIRECTLY BUT SHALL BE CONSIDERED SUBSIDIARY TO THE VARIOUS ITEMS.
4. CONTRACTOR SHALL SEED ALL NON-PAVED AREAS WITHIN R.O.W.
5. PROPOSED SIDE DRAINS TO BE INSTALLED WITH MINIMUM COVER FROM BOTTOM OF ASPHALT AS FOLLOWS:
RESIDENTIAL AND COMMERCIAL DRIVEWAYS: 6"
COUNTY AND CITY ROADWAYS: 15"
6. STATIONS/OFFSETS MEASURED FROM CENTERLINE OF ROAD TO CENTER OF DRAINAGE STRUCTURES.
7. CONTRACTOR SHALL PERFORM ITS OWN CONSTRUCTION STAKING.

BM DATA:

BM#1
IRON ROD
STA 2+86.5 (DIANA ST)
OFFSET 25' RT
EL=67.76'

PROP PGL & EXIST PVMT @ PROP CL

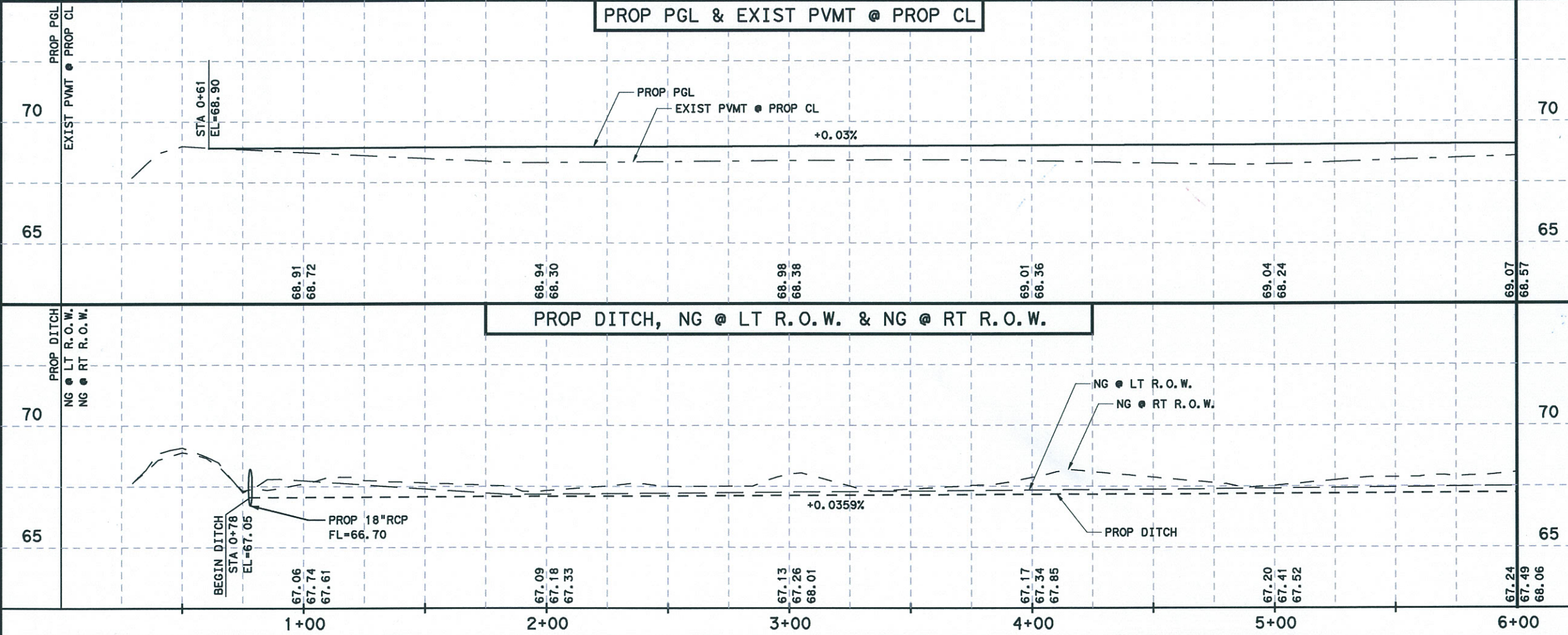

NO.	DATE	REVISION	APP.

03/19/2012

HIDALGO COUNTY

TEDSI INFRASTRUCTURE GROUP
Consulting Engineers
1201 E. Expressway 83
Mission, Texas 78572
(936) 424-7898

EL MESQUITE

**DIANA ST
PLAN & PROFILE**

SCALE:
HORZ: 1" = 50'
VERT: 1" = 5'

SHEET 1 OF 3

FED. RD. DIV. NO. 6	PROJECT NO.	SHEET NO. 8
STATE TEXAS	DIST. PHR	COUNTY HIDALGO
CSJ	PCT 1	HIGHWAY NO. VARIOUS

3/19/2012 6:43:54 PM P:\2009\2009-1027-02 hobcap III add\1\1\l\col\l\cas\des\gr\03 el_mesquite\to\ves\Roadway\MES-pp.dgn

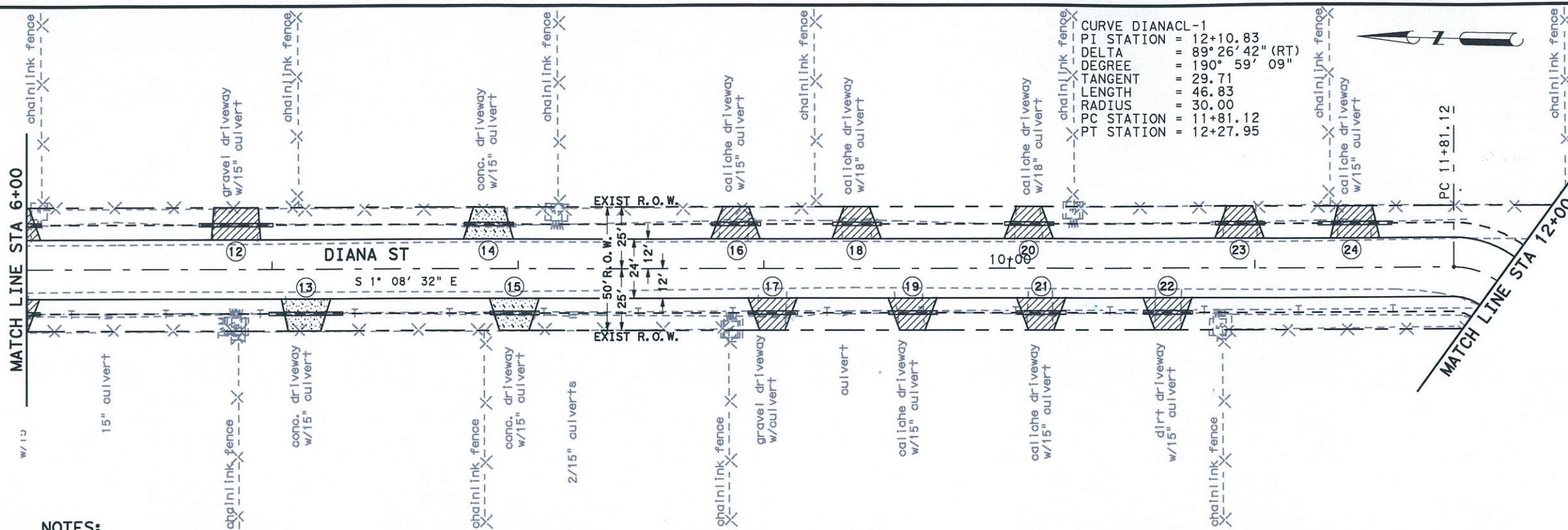

LEGEND

— GAS —	EXIST GAS LINE
— T —	EXIST UG PHONE LINE
— W —	EXIST WATER LINE
— X — X — X —	EXIST CHAINLINK FENCE
	ASPHALT DRIVEWAY
	CONCRETE DRIVEWAY
- - - - -	PROP DITCH
(#)	DRIVEWAY ID NUMBER
	EXIST MAILBOX
	EXIST WATER METER
	EXIST WATER VALVE
	EXIST POWER POLE
	EXIST FIRE HYDRANT
	EXIST TELEPHONE BOX
	EXIST GAS METER
	TEMP SED CTRL FENCE

NOTES:

- EXISTING ABOVE GROUND UTILITIES AND TOPOGRAPHY HAVE BEEN PLOTTED BY DIRECT FIELD INFORMATION AND AS SPOTTED BY UTILITY LOCATE REQUEST. THE CONTRACTOR WILL BE RESPONSIBLE FOR COORDINATING WITH UTILITY COMPANIES THE ESTABLISHING OF EXACT LOCATION, DEPTH, AND SIZE OF UTILITY LINES. THE CONTRACTOR WILL ALSO BE RESPONSIBLE FOR COORDINATING WITH THE UTILITY COMPANIES FOR REPLACEMENT OR REPAIRS OF ALL CUT OR BROKEN WATER LINES, IRRIGATION LINES, FORCE MAINS, SPRINKLER SYSTEMS, GAS LINES, POWER LINES, TELEPHONE CABLES, AND/OR ANY OTHER UTILITIES.
- MAILBOXES AND SIGNS TO BE ADJUSTED/REPLACED/RELOCATED DURING CONSTRUCTION. ITEMS WILL NOT BE PAID FOR DIRECTLY BUT SHALL BE CONSIDERED SUBSIDIARY TO THE VARIOUS ITEMS.
- UNLESS OTHERWISE SPECIFIED IN THE PLANS, TREES OR OTHER OBSTRUCTIONS IN CONFLICT WITH CONSTRUCTION SHALL BE REMOVED. REMOVAL WILL NOT BE PAID FOR DIRECTLY BUT SHALL BE CONSIDERED SUBSIDIARY TO THE VARIOUS ITEMS.
- CONTRACTOR SHALL SEED ALL NON-PAVED AREAS WITHIN R.O.W.
- PROPOSED SIDE DRAINS TO BE INSTALLED WITH MINIMUM COVER FROM BOTTOM OF ASPHALT AS FOLLOWS:
 RESIDENTIAL AND COMMERCIAL DRIVEWAYS: 6"
 COUNTY AND CITY ROADWAYS: 15"
- STATIONS/OFFSETS MEASURED FROM CENTERLINE OF ROAD TO CENTER OF DRAINAGE STRUCTURES.
- CONTRACTOR SHALL PERFORM ITS OWN CONSTRUCTION STAKING.

BM DATA:
 BM#1
 IRON ROD
 STA 2+86.5 (DIANA ST)
 OFFSET 25' RT
 EL=67.76'

PROP PGL & EXIST PVMT @ PROP CL

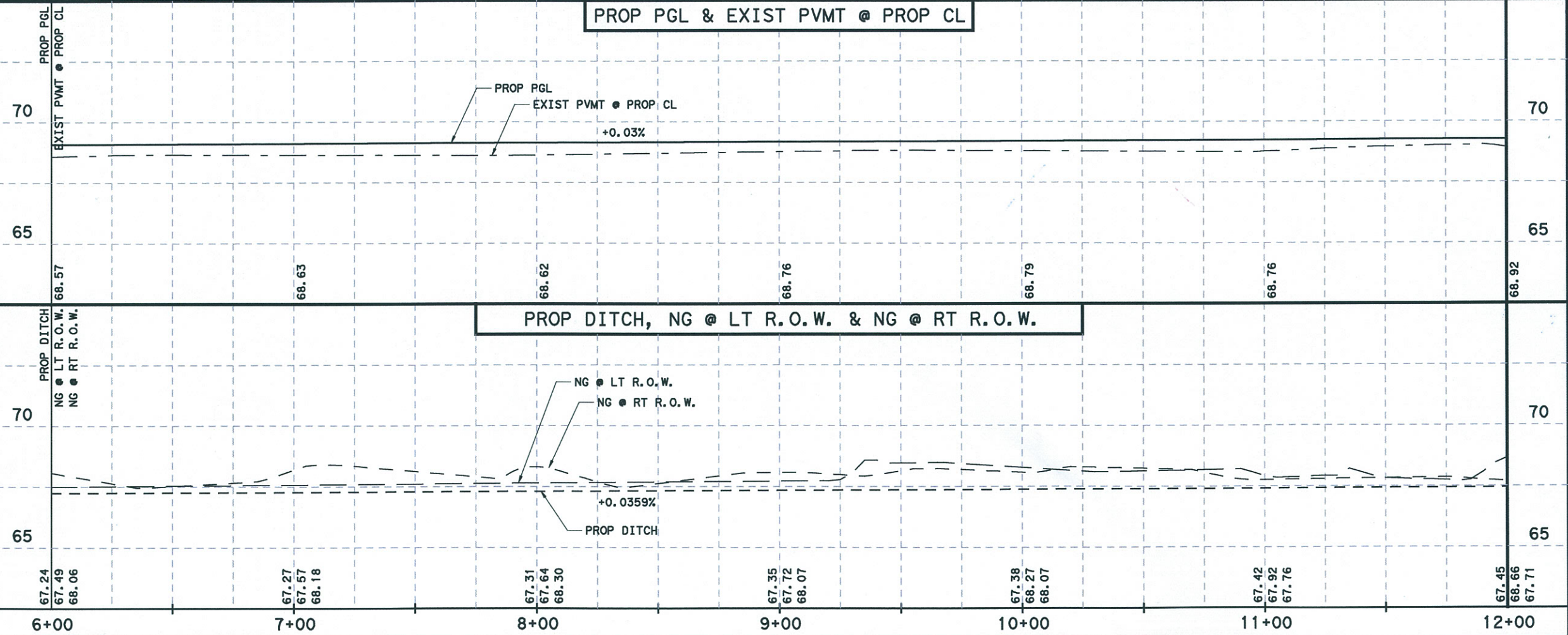

NO.	DATE	REVISION	APP.

03/19/2012

HIDALGO COUNTY

TEDSI INFRASTRUCTURE GROUP
 Consulting Engineers
 1201 E. Expressway 83
 Mission, Texas 78572
 (956) 424-7898

EL MESQUITE

**DIANA ST
 PLAN & PROFILE**











SCALE:
 HORZ: 1" = 50'
 VERT: 1" = 5'

SHEET 2 OF 3

FED. RD. DIV. NO. 6	PROJECT NO.	SHEET NO. 9
STATE TEXAS	DIST. PHR	COUNTY HIDALGO
CSJ	PCT 1	HIGHWAY NO. VARIOUS

3/19/2012 6:44:00 PM
 D:\2009\2009-1027-02_hobcap III_additional\colonia\as\des\ign\03 el_mesquite\res\Roadway\MES-pp.dgn

LEGEND

- GAS — EXIST GAS LINE
- T — EXIST UG PHONE LINE
- W — EXIST WATER LINE
- x-x-x-x- EXIST CHAINLINK FENCE
-  ASPHALT DRIVEWAY
-  CONCRETE DRIVEWAY
- - - - - PROP DITCH
-  DRIVEWAY ID NUMBER
-  EXIST MAILBOX
-  EXIST WATER METER
-  EXIST WATER VALVE
-  EXIST POWER POLE
-  EXIST FIRE HYDRANT
-  EXIST TELEPHONE BOX
-  EXIST GAS METER
-  TEMP SED CTRL FENCE

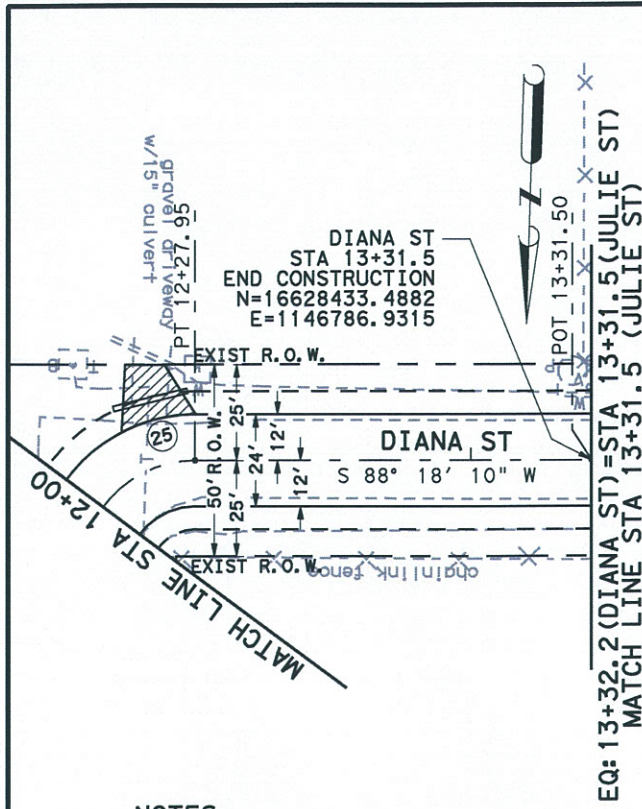

NOTES:

1. EXISTING ABOVE GROUND UTILITIES AND TOPOGRAPHY HAVE BEEN PLOTTED BY DIRECT FIELD INFORMATION AND AS SPOTTED BY UTILITY LOCATE REQUEST. THE CONTRACTOR WILL BE RESPONSIBLE FOR COORDINATING WITH UTILITY COMPANIES THE ESTABLISHING OF EXACT LOCATION, DEPTH, AND SIZE OF UTILITY LINES. THE CONTRACTOR WILL ALSO BE RESPONSIBLE FOR COORDINATING WITH THE UTILITY COMPANIES FOR REPLACEMENT OR REPAIRS OF ALL CUT OR BROKEN WATER LINES, IRRIGATION LINES, FORCE MAINS, SPRINKLER SYSTEMS, GAS LINES, POWER LINES, TELEPHONE CABLES, AND/OR ANY OTHER UTILITIES.
2. MAILBOXES AND SIGNS TO BE ADJUSTED/REPLACED/RELOCATED DURING CONSTRUCTION. ITEMS WILL NOT BE PAID FOR DIRECTLY BUT SHALL BE CONSIDERED SUBSIDIARY TO THE VARIOUS ITEMS.
3. UNLESS OTHERWISE SPECIFIED IN THE PLANS, TREES OR OTHER OBSTRUCTIONS IN CONFLICT WITH CONSTRUCTION SHALL BE REMOVED. REMOVAL WILL NOT BE PAID FOR DIRECTLY BUT SHALL BE CONSIDERED SUBSIDIARY TO THE VARIOUS ITEMS.
4. CONTRACTOR SHALL SEED ALL NON-PAVED AREAS WITHIN R.O.W.
5. PROPOSED SIDE DRAINS TO BE INSTALLED WITH MINIMUM COVER FROM BOTTOM OF ASPHALT AS FOLLOWS:
RESIDENTIAL AND COMMERCIAL DRIVEWAYS: 6"
COUNTY AND CITY ROADWAYS: 15"
6. STATIONS/OFFSETS MEASURED FROM CENTERLINE OF ROAD TO CENTER OF DRAINAGE STRUCTURES.
7. CONTRACTOR SHALL PERFORM TS OWN CONSTRUCTION STAKING.

BM DATA:

BM#1
IRON ROD
STA 2+86.5 (DIANA ST)
OFFSET 25' RT
EL=67.76'

PROP PGL & EXIST PVMT @ PROP CL

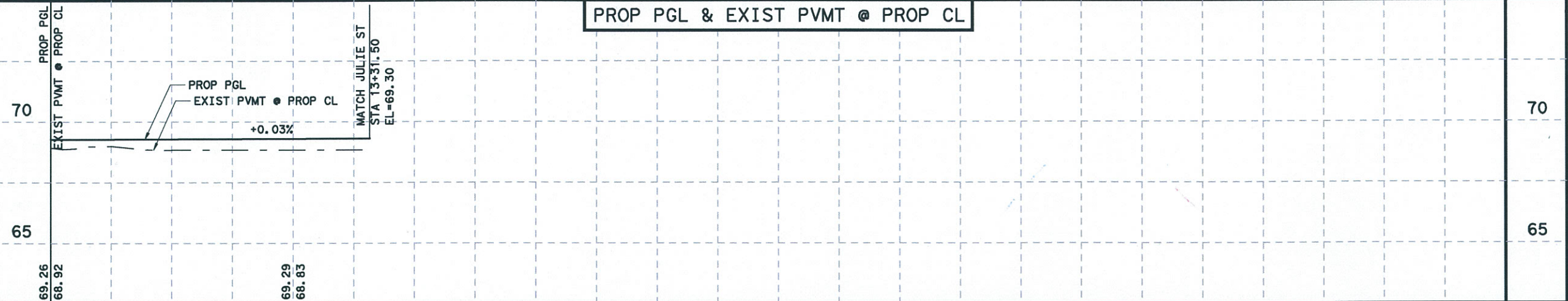

PROP DITCH, NG @ LT R.O.W. & NG @ RT R.O.W.

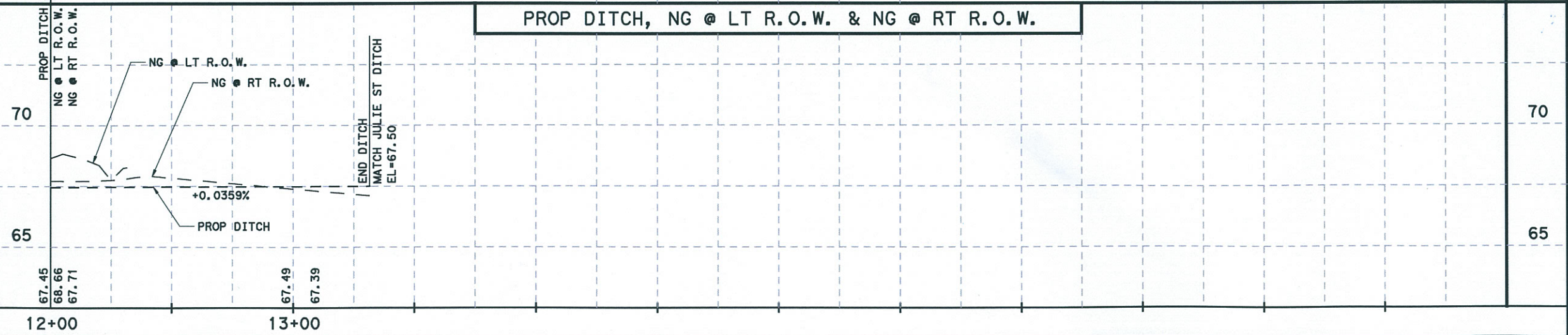

NO.	DATE	REVISION	APP.



03/10/2012



HIDALGO COUNTY

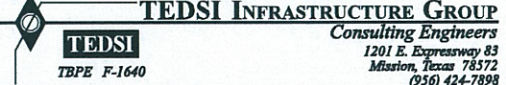

TEDSI INFRASTRUCTURE GROUP
Consulting Engineers
1201 E. Expressway 83
Mission, Texas 78572
(936) 424-7898

EL MESQUITE

**DIANA ST
PLAN & PROFILE**

SCALE:
HORZ: 1" = 50'
VERT: 1" = 5'

SHEET 3 OF 3

FED. RD. DIV. NO. 6	PROJECT NO.	SHEET NO. 10
STATE TEXAS	DIST. PHR	COUNTY HIDALGO
CSJ	PCT 1	HIGHWAY NO. VARIOUS

3/19/2012 6:44:05 PM C:\2009\2009-1027-02 hobcap III additional\col\cas\des\gr\03 el_mesquite\tes\Roadway\MES-pp.dgn

3/19/2012 6:44:10 PM D:\2009\2009-1027-02 hobcap III additl\lncal_colon\lcs\des\gr\03 el_mesquite\tes\Roadway\MES-pp.dgn

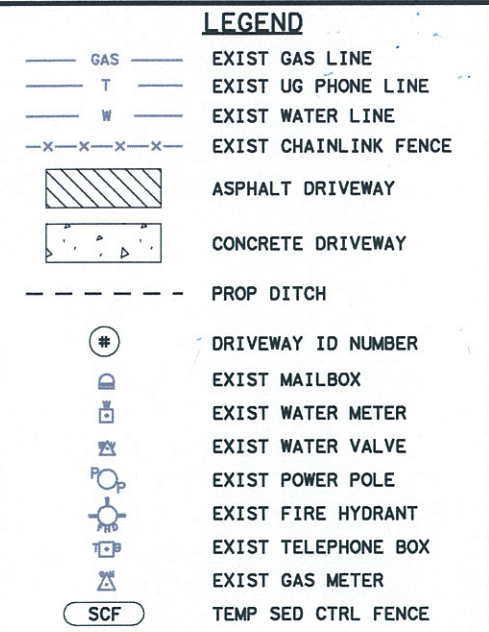
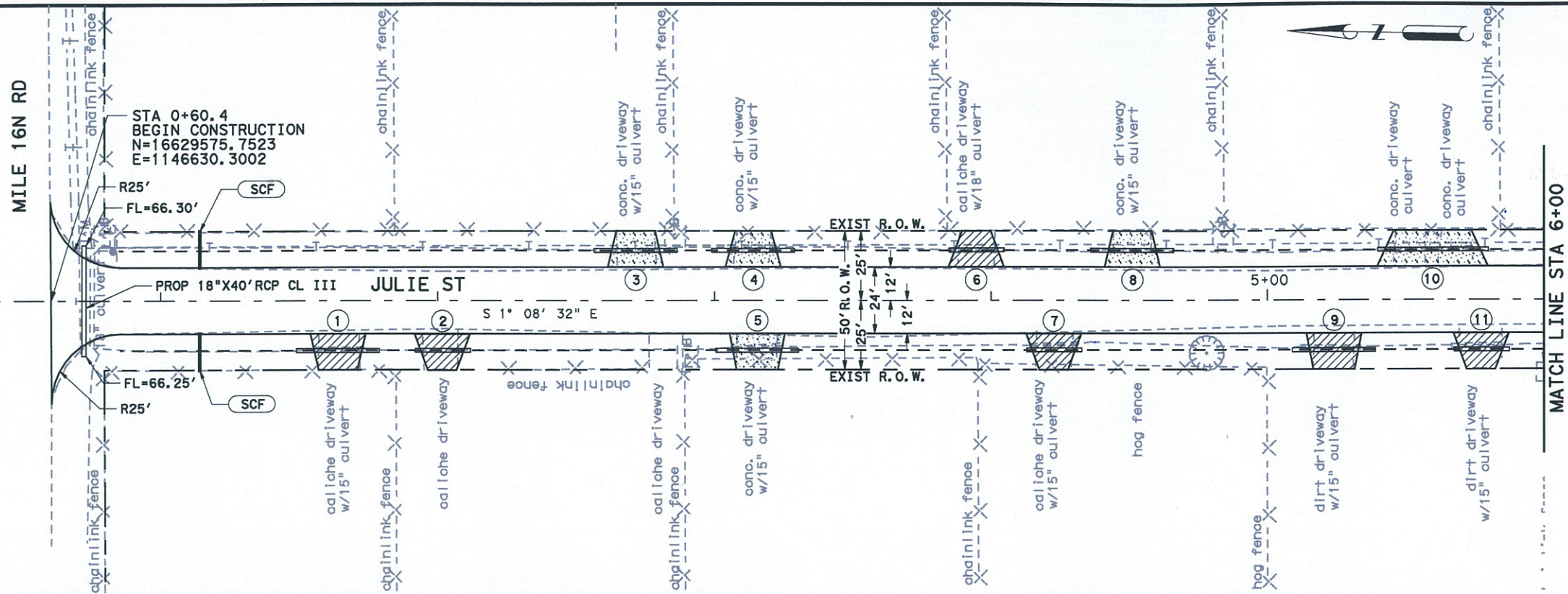

NOTES:

- EXISTING ABOVE GROUND UTILITIES AND TOPOGRAPHY HAVE BEEN PLOTTED BY DIRECT FIELD INFORMATION AND AS SPOTTED BY UTILITY LOCATE REQUEST. THE CONTRACTOR WILL BE RESPONSIBLE FOR COORDINATING WITH UTILITY COMPANIES THE ESTABLISHING OF EXACT LOCATION, DEPTH, AND SIZE OF UTILITY LINES. THE CONTRACTOR WILL ALSO BE RESPONSIBLE FOR COORDINATING WITH THE UTILITY COMPANIES FOR REPLACEMENT OR REPAIRS OF ALL CUT OR BROKEN WATER LINES, IRRIGATION LINES, FORCE MAINS, SPRINKLER SYSTEMS, GAS LINES, POWER LINES, TELEPHONE CABLES, AND/OR ANY OTHER UTILITIES.
- MAILBOXES AND SIGNS TO BE ADJUSTED/REPLACED/RELOCATED DURING CONSTRUCTION. ITEMS WILL NOT BE PAID FOR DIRECTLY BUT SHALL BE CONSIDERED SUBSIDIARY TO THE VARIOUS ITEMS.
- UNLESS OTHERWISE SPECIFIED IN THE PLANS, TREES OR OTHER OBSTRUCTIONS IN CONFLICT WITH CONSTRUCTION SHALL BE REMOVED. REMOVAL WILL NOT BE PAID FOR DIRECTLY BUT SHALL BE CONSIDERED SUBSIDIARY TO THE VARIOUS ITEMS.
- CONTRACTOR SHALL SEED ALL NON-PAVED AREAS WITHIN R.O.W.
- PROPOSED SIDE DRAINS TO BE INSTALLED WITH MINIMUM COVER FROM BOTTOM OF ASPHALT AS FOLLOWS:
RESIDENTIAL AND COMMERCIAL DRIVEWAYS: 6"
COUNTY AND CITY ROADWAYS: 15"
- STATIONS/OFFSETS MEASURED FROM CENTERLINE OF ROAD TO CENTER OF DRAINAGE STRUCTURES.
- CONTRACTOR SHALL PERFORM ITS OWN CONSTRUCTION STAKING.

BM DATA:

BM#1
IRON ROD
STA 2+86.5 (DIANA ST)
OFFSET 25' RT
EL=67.76'

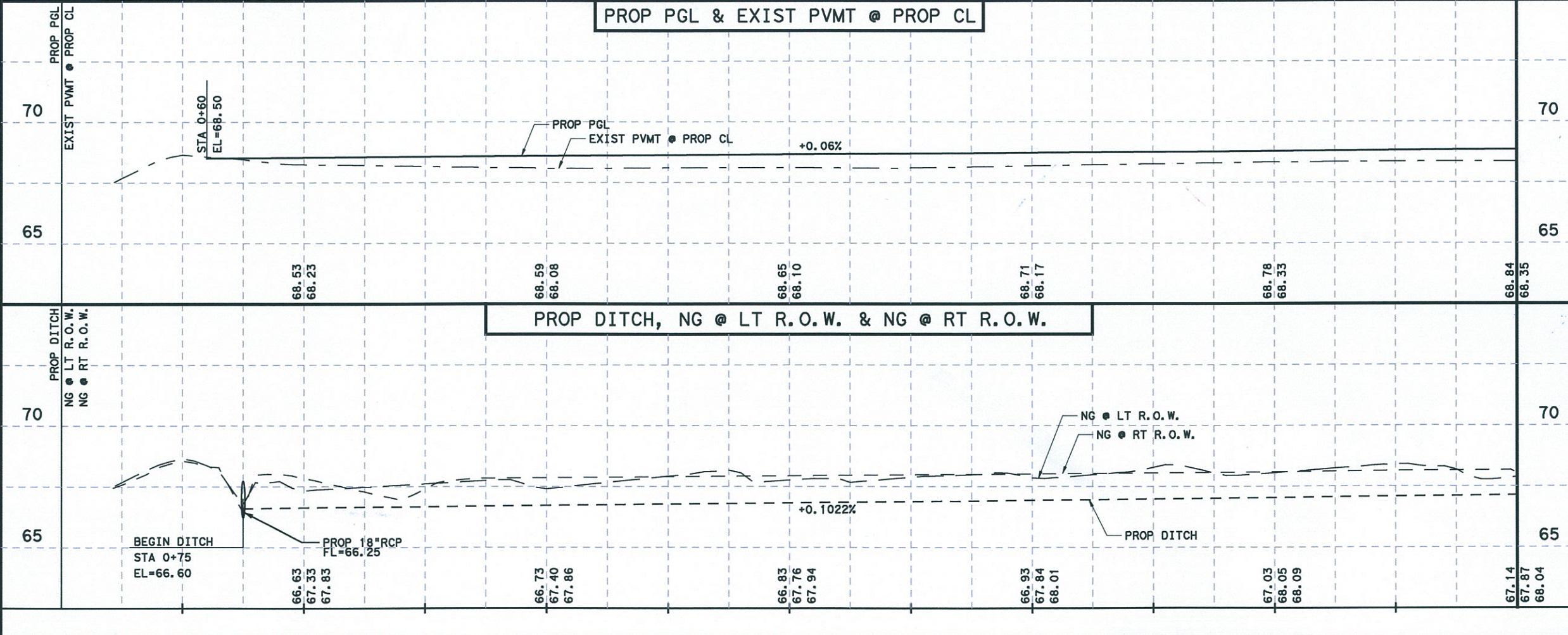

NO.	DATE	REVISION	APP.

03/19/2012

HIDALGO COUNTY

TEDSI INFRASTRUCTURE GROUP
Consulting Engineers
1201 E. Expressway 83
Mission, Texas 78172
(956) 424-7898

EL MESQUITE

**JULIE ST
PLAN & PROFILE**

SCALE:
HORZ: 1" = 50'
VERT: 1" = 5'

SHEET 1 OF 3

FED. RD. DIV. NO. 6	PROJECT NO.	SHEET NO. 11
STATE TEXAS	DIST. PHR	COUNTY HIDALGO
CSJ	PCT 1	HIGHWAY NO. VARIOUS

LEGEND

- GAS — EXIST GAS LINE
- T — EXIST UG PHONE LINE
- W — EXIST WATER LINE
- x-x-x-x- EXIST CHAINLINK FENCE
- [Hatched Box] ASPHALT DRIVEWAY
- [Dotted Box] CONCRETE DRIVEWAY
- - - - - PROP DITCH
- (*) DRIVEWAY ID NUMBER
- [Mailbox Symbol] EXIST MAILBOX
- [Water Meter Symbol] EXIST WATER METER
- [Water Valve Symbol] EXIST WATER VALVE
- [Power Pole Symbol] EXIST POWER POLE
- [Fire Hydrant Symbol] EXIST FIRE HYDRANT
- [Telephone Box Symbol] EXIST TELEPHONE BOX
- [Gas Meter Symbol] EXIST GAS METER
- [Temp Sed Ctrl Fence Symbol] TEMP SED CTRL FENCE
- [SCF Symbol] SCF

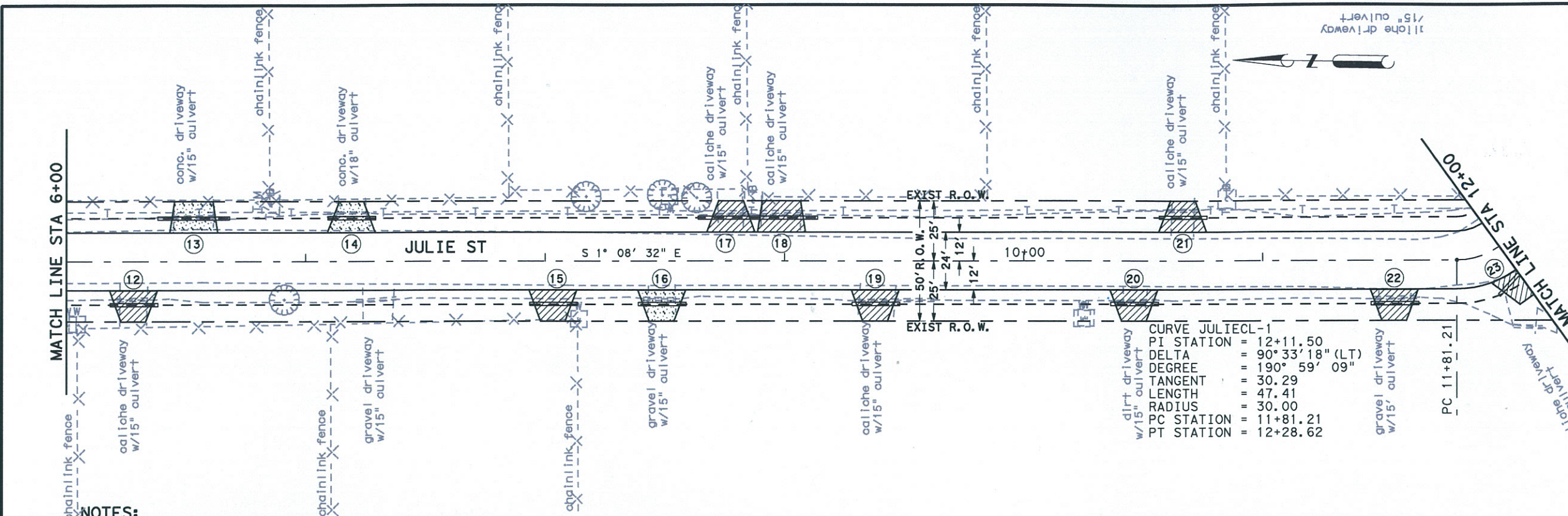

NOTES:

1. EXISTING ABOVE GROUND UTILITIES AND TOPOGRAPHY HAVE BEEN PLOTTED BY DIRECT FIELD INFORMATION AND AS SPOTTED BY UTILITY LOCATE REQUEST. THE CONTRACTOR WILL BE RESPONSIBLE FOR COORDINATING WITH UTILITY COMPANIES THE ESTABLISHING OF EXACT LOCATION, DEPTH, AND SIZE OF UTILITY LINES. THE CONTRACTOR WILL ALSO BE RESPONSIBLE FOR COORDINATING WITH THE UTILITY COMPANIES FOR REPLACEMENT OR REPAIRS OF ALL CUT OR BROKEN WATER LINES, IRRIGATION LINES, FORCE MAINS, SPRINKLER SYSTEMS, GAS LINES, POWER LINES, TELEPHONE CABLES, AND/OR ANY OTHER UTILITIES.
2. MAILBOXES AND SIGNS TO BE ADJUSTED/REPLACED/RELOCATED DURING CONSTRUCTION. ITEMS WILL NOT BE PAID FOR DIRECTLY BUT SHALL BE CONSIDERED SUBSIDIARY TO THE VARIOUS ITEMS.
3. UNLESS OTHERWISE SPECIFIED IN THE PLANS, TREES OR OTHER OBSTRUCTIONS IN CONFLICT WITH CONSTRUCTION SHALL BE REMOVED. REMOVAL WILL NOT BE PAID FOR DIRECTLY BUT SHALL BE CONSIDERED SUBSIDIARY TO THE VARIOUS ITEMS.
4. CONTRACTOR SHALL SEED ALL NON-PAVED AREAS WITHIN R.O.W.
5. PROPOSED SIDE DRAINS TO BE INSTALLED WITH MINIMUM COVER FROM BOTTOM OF ASPHALT AS FOLLOWS:
RESIDENTIAL AND COMMERCIAL DRIVEWAYS: 6"
COUNTY AND CITY ROADWAYS: 15"
6. STATIONS/OFFSETS MEASURED FROM CENTERLINE OF ROAD TO CENTER OF DRAINAGE STRUCTURES.
7. CONTRACTOR SHALL PERFORM ITS OWN CONSTRUCTION STAKING.

BM DATA:

BM#1
IRON ROD
STA 2+86.5 (DIANA ST)
OFFSET 25' RT
EL=67.76'

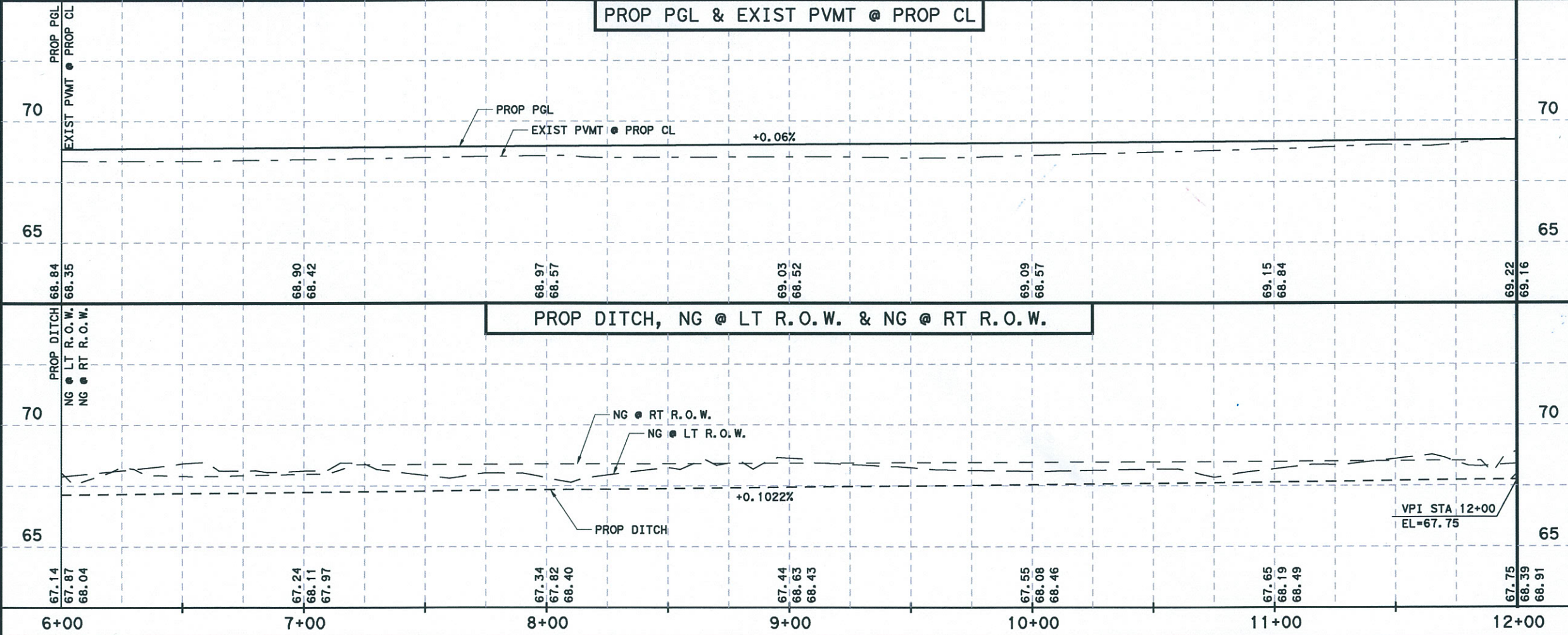

NO.	DATE	REVISION	APP.



[Signature]
03/19/2012



TEDSI INFRASTRUCTURE GROUP
Consulting Engineers
1201 E. Expressway 83
Mission, Texas 78572
(936) 424-7898

EL MESQUITE











**JULIE ST
PLAN & PROFILE**

SCALE:
HORZ: 1" = 50'
VERT: 1" = 5'

FED. RD. DIV. NO.	PROJECT NO.	SHEET NO.
6	2C-1080-244	12
STATE	DIST.	COUNTY
TEXAS	PHR	HIDALGO
CSJ	PCT	HIGHWAY NO.
2C-1080-244	1	VARIOUS

3/19/2012 6:44:17 PM D:\2009\2009-1027-02 hobcap III additional\colinas\des\gn\03 el_mesquite\des\Roadway\MES-pp.dgn

LEGEND

- GAS — EXIST GAS LINE
- T — EXIST UG PHONE LINE
- W — EXIST WATER LINE
- x-x-x-x- EXIST CHAINLINK FENCE
-  ASPHALT DRIVEWAY
-  CONCRETE DRIVEWAY
- - - - - PROP DITCH
-  DRIVEWAY ID NUMBER
-  EXIST MAILBOX
-  EXIST WATER METER
-  EXIST WATER VALVE
-  EXIST POWER POLE
-  EXIST FIRE HYDRANT
-  EXIST TELEPHONE BOX
-  EXIST GAS METER
-  TEMP SED CTRL FENCE

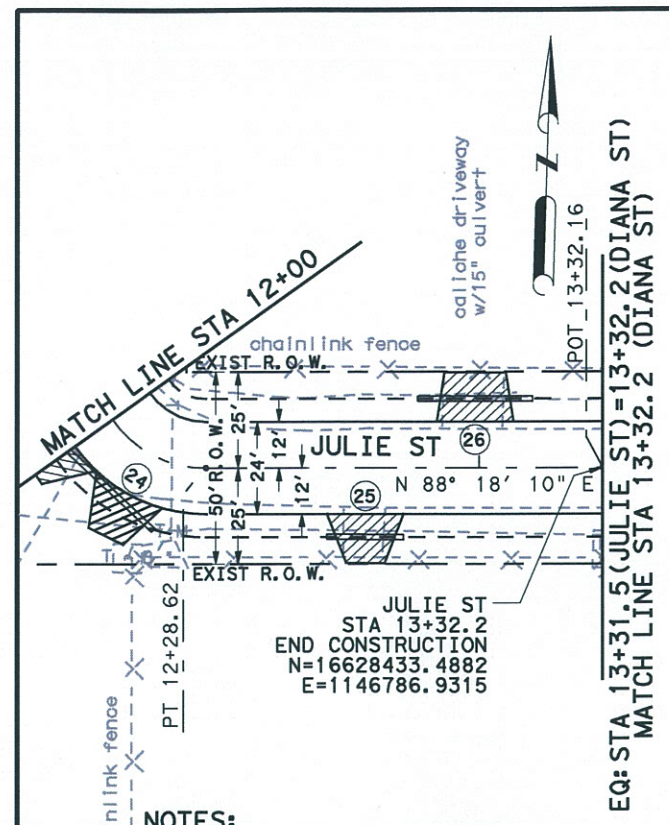

JULIE ST
STA 13+32.2
END CONSTRUCTION
N=16628433.4882
E=1146786.9315

NOTES:

1. EXISTING ABOVE GROUND UTILITIES AND TOPOGRAPHY HAVE BEEN PLOTTED BY DIRECT FIELD INFORMATION AND AS SPOTTED BY UTILITY LOCATE REQUEST. THE CONTRACTOR WILL BE RESPONSIBLE FOR COORDINATING WITH UTILITY COMPANIES THE ESTABLISHING OF EXACT LOCATION, DEPTH, AND SIZE OF UTILITY LINES. THE CONTRACTOR WILL ALSO BE RESPONSIBLE FOR COORDINATING WITH THE UTILITY COMPANIES FOR REPLACEMENT OR REPAIRS OF ALL CUT OR BROKEN WATER LINES, IRRIGATION LINES, FORCE MAINS, SPRINKLER SYSTEMS, GAS LINES, POWER LINES, TELEPHONE CABLES, AND/OR ANY OTHER UTILITIES.
2. MAILBOXES AND SIGNS TO BE ADJUSTED/REPLACED/RELOCATED DURING CONSTRUCTION. ITEMS WILL NOT BE PAID FOR DIRECTLY BUT SHALL BE CONSIDERED SUBSIDIARY TO THE VARIOUS ITEMS.
3. UNLESS OTHERWISE SPECIFIED IN THE PLANS, TREES OR OTHER OBSTRUCTIONS IN CONFLICT WITH CONSTRUCTION SHALL BE REMOVED. REMOVAL WILL NOT BE PAID FOR DIRECTLY BUT SHALL BE CONSIDERED SUBSIDIARY TO THE VARIOUS ITEMS.
4. CONTRACTOR SHALL SEED ALL NON-PAVED AREAS WITHIN R.O.W.
5. PROPOSED SIDE DRAINS TO BE INSTALLED WITH MINIMUM COVER FROM BOTTOM OF ASPHALT AS FOLLOWS:
RESIDENTIAL AND COMMERCIAL DRIVEWAYS: 6"
COUNTY AND CITY ROADWAYS: 15"
6. STATIONS/OFFSETS MEASURED FROM CENTERLINE OF ROAD TO CENTER OF DRAINAGE STRUCTURES.
7. CONTRACTOR SHALL PERFORM ITS OWN CONSTRUCTION STAKING.

BM DATA:

BM#1
IRON ROD
STA 2+86.5 (DIANA ST)
OFFSET 25' RT
EL=67.76'

PROP PGL & EXIST PVMT @ PROP CL

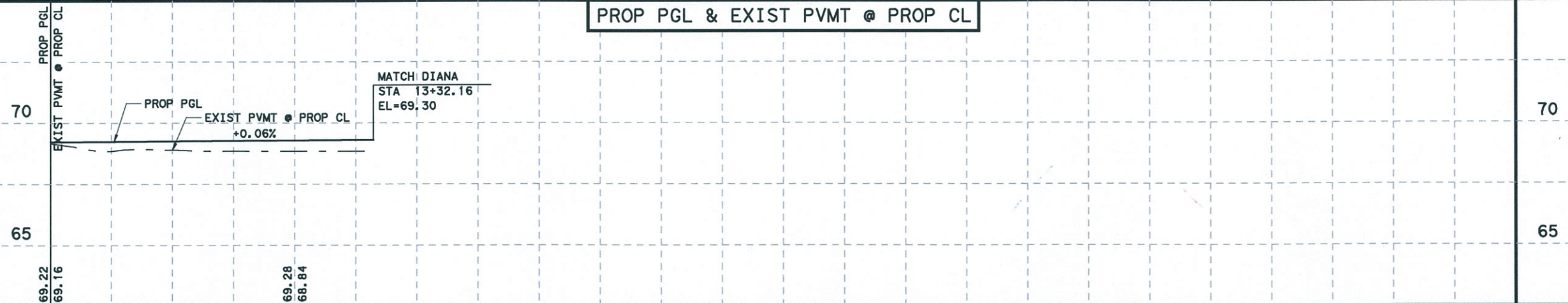

PROP DITCH, NG @ LT R.O.W. & NG @ RT R.O.W.

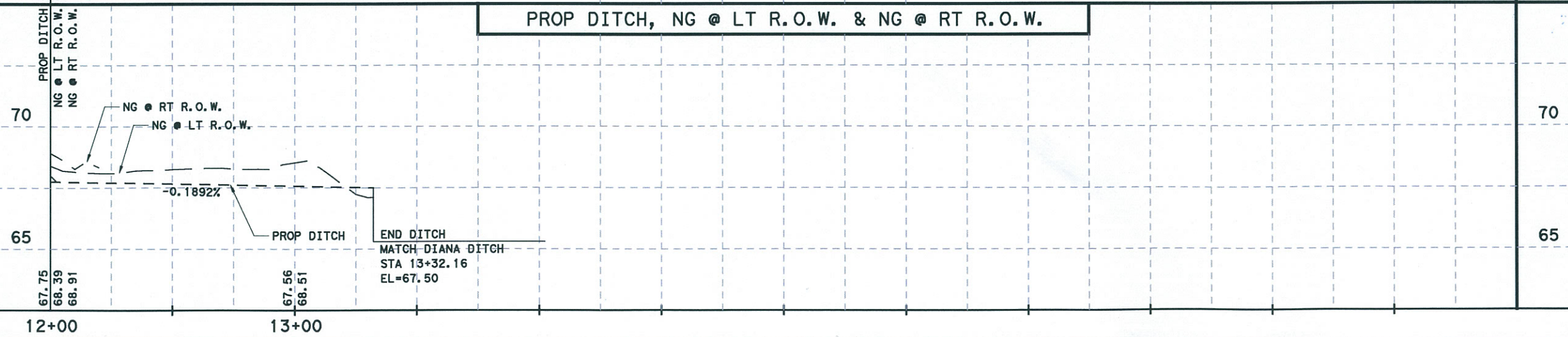

NO.	DATE	REVISION	APP.

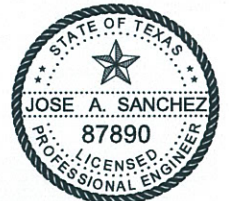

03/19/2012



HIDALGO COUNTY



TEDSI INFRASTRUCTURE GROUP
Consulting Engineers
1201 E. Expressway 83
Mission, Texas 78572
(936) 424-7898

EL MESQUITE

**JULIE ST
PLAN & PROFILE**

SCALE:
HORZ: 1" = 50'
VERT: 1" = 5'

SHEET 3 OF 3

FED. RD. DIV. NO. 6	PROJECT NO.	SHEET NO. 13
STATE TEXAS	DIST. PHR	COUNTY HIDALGO
CSJ	PCT 1	HIGHWAY NO. VARIOUS

3/19/2012 6:44:28 PM P:\2009\2009-1027-02_hobcap III_addit\oncl_col\cn\cas\des\gr\03_e_mesquite\to\es\Roadway\MES-pp.dgn

3/19/2012 3:44:27 PM P:\2009\2009-1027-02 hrbcap III additional_colon\cas\des\gn\03 el mesquite\tes\Roadway\MES-drwy.dgn

DIANA ST								
ID	STATION	OFFSET	EXISTING STRUCTURE	EXISTING DRIVEWAY DESCRIPTION	4378	0496-2016	0530-2010	0530-2011
					THERMOPLASTIC PIPE (15 IN) (TY III)	REMOV STR (PIPE)	DRIVEWAYS (CONC)	DRIVEWAYS (ACP)
					LF	LF	SY	SY
1	1+17	RT	18" PIPE	UNPAVED	20	14		25
2	2+34	LT		UNPAVED	20	13	22	
3	2+38	RT	18" PIPE	CONCRETE	20	12		22
4	3+02	RT		CONCRETE	20	15		22
5	3+79	LT	18" PIPE	CONCRETE	20	13		22
6	4+09	RT	18" PIPE	UNPAVED	20	9		22
7	4+26	LT	18" PIPE	UNPAVED	20	21		22
8	5+31	LT	18" PIPE	CONCRETE	20	18		22
9	5+69	RT	18" PIPE	UNPAVED	20	11	22	
10	5+95	RT	18" PIPE	CONCRETE	20	13		22
11	5+95	LT	18" PIPE	UNPAVED	20	17		22
12	6+85	LT	18" PIPE	UNPAVED	20	21		28
13	7+13	RT	18" PIPE	CONCRETE	20	18	24	
14	7+87	LT	18" PIPE	CONCRETE	20	21	24	
15	7+98	RT	18" PIPE	UNPAVED	20	18	24	
16	8+87	LT	18" PIPE	CONCRETE	20	14		22
17	9+03	RT	18" PIPE	UNPAVED	20	14		22
18	9+37	LT	18" PIPE	UNPAVED	20	15		22
19	9+60	RT	18" PIPE	UNPAVED	20	15		22
20	10+08	LT	18" PIPE	UNPAVED	20	16		22
21	10+13	RT	18" PIPE	UNPAVED	20	13		22
22	10+64	RT	18" PIPE	UNPAVED	20	14		22
23	10+93	LT	18" PIPE	UNPAVED	20	21		22
24	11+40	LT	18" PIPE	UNPAVED	20	14		25
25	12+20	LT		UNPAVED	20	18		25
TOTAL					500	388	116	455
GRAND TOTAL					1020	799	335	861

DRIVEWAY NOTES:
 ASPHALT THICKNESS = 1.5"
 CONCRETE THICKNESS = 4"
 FLEXIBLE BASE THICKNESS = 6"

JULIE ST								
ID	STATION	OFFSET	EXISTING STRUCTURE	EXISTING DRIVEWAY DESCRIPTION	4378	0496-2016	0530-2010	0530-2011
					THERMOPLASTIC PIPE (15 IN) (TY III)	REMOV STR (PIPE)	DRIVEWAYS (CONC)	DRIVEWAYS (ACP)
					LF	LF	SY	SY
1	1+64	RT	18" PIPE	UNPAVED	20	19		25
2	2+02	RT		UNPAVED	20			22
3	2+72	LT	18" PIPE	CONCRETE	20	18	25	
4	2+83	RT		CONCRETE	20		24	
5	3+14	LT	18" PIPE	CONCRETE	20	18	26	
6	3+16	RT	18" PIPE	UNPAVED	20	18		22
7	3+95	LT	18" PIPE	UNPAVED	20	19		22
8	4+23	RT	18" PIPE	CONCRETE	20	17	25	
9	4+51	LT	18" PIPE	UNPAVED	20	19		26
10	5+24	RT	18" PIPE	CONCRETE	20	22	49	
11	5+60	LT	18" PIPE	UNPAVED	20	13		22
12	5+77	RT	18" PIPE	UNPAVED	20	20		22
13	6+28	RT	18" PIPE	CONCRETE	20	15	26	
14	6+53	LT	18" PIPE	CONCRETE	20	19	22	
15	8+01	RT	18" PIPE	UNPAVED	20	18		22
16	7+30	RT	18" PIPE	CONCRETE	20	16	22	
17	8+49	RT	18" PIPE	UNPAVED	20	15		22
18	8+79	LT	18" PIPE	UNPAVED	20	12		22
19	8+98	LT	18" PIPE	UNPAVED	20	18		22
20	9+38	RT	18" PIPE	UNPAVED	20	33		22
21	10+46	RT	18" PIPE	UNPAVED	20	16		22
22	10+67	LT	18" PIPE	UNPAVED	20	15		22
23	12+00	RT	18" PIPE	UNPAVED	20	18		22
24	12+15	RT	18" PIPE	UNPAVED	20	12		21
25	12+70	RT		UNPAVED	20			22
26	12+99	LT	18" PIPE	UNPAVED	20	21		26
TOTAL					520	411	219	406

DRIVEWAY NOTES:
 ASPHALT THICKNESS = 1.5"
 CONCRETE THICKNESS = 4"
 FLEXIBLE BASE THICKNESS = 6"

NO.	DATE	REVISION	APP.

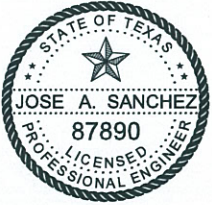

03/19/2012



HIDALGO COUNTY



TEDSI INFRASTRUCTURE GROUP
 Consulting Engineers
 1201 E. Expressway 83
 Mission, Texas 78572
 (956) 424-7898

EL MESQUITE

DRIVEWAY TABLES

SHEET 1 OF 1

FED. RD. DIV. NO.	PROJECT NO.	SHEET NO.
6		14
STATE	DIST.	COUNTY
TEXAS	PHR	HIDALGO
CSJ	PCT	HIGHWAY NO.
2C-1080-244	1	VARIOUS

FOR CONTRACTOR'S INFORMATION ONLY

DIANA ST

Station	Material Name	End Areas (sq. ft.)	Unadjusted Volumes (cu. yd.)	Adjusted Volumes (cu. yd.)	Mult	Mass Factor	Ordinate	
	Exoavation	0+90.00 PROP	0.0	0	0	1.00	1.00	
	FIII	3.3	0	0	0	1.00	0	
	Exoavation	EXIST	13.9	0	0	1.00	1.00	
	FIII	0.0	0	0	0	1.00	0	
	Exoavation	2+00.00 PROP	0.0	0	0	1.00	1.00	
	FIII	8.0	23	23	0	1.00	-23	
	Exoavation	EXIST	2.5	33	33	1.00	1.00	
	FIII	0.0	0	0	0	1.00	10	
	Exoavation	3+00.00 PROP	0.0	0	0	1.00	1.00	
	FIII	4.1	22	22	0	1.00	-12	
	Exoavation	EXIST	8.2	20	20	1.00	1.00	
	FIII	0.0	0	0	0	1.00	8	
	Exoavation	4+00.00 PROP	0.0	0	0	1.00	1.00	
	FIII	3.9	15	15	0	1.00	-7	
	Exoavation	EXIST	3.1	21	21	1.00	1.00	
	FIII	0.0	0	0	0	1.00	14	
	Exoavation	5+00.00 PROP	0.0	0	0	1.00	1.00	
	FIII	8.8	24	24	0	1.00	-10	
	Exoavation	EXIST	1.7	9	9	1.00	1.00	
	FIII	0.0	0	0	0	1.00	-1	
	Exoavation	6+00.00 PROP	0.0	0	0	1.00	1.00	
	FIII	0.5	17	17	0	1.00	-18	
	Exoavation	EXIST	15.4	32	32	1.00	1.00	
	FIII	0.0	0	0	0	1.00	14	
	Exoavation	7+00.00 PROP	0.0	0	0	1.00	1.00	
	FIII	4.9	10	10	0	1.00	4	
	Exoavation	EXIST	6.8	41	41	1.00	1.00	
	FIII	0.0	0	0	0	1.00	45	
	Exoavation	8+00.00 PROP	0.0	0	0	1.00	1.00	
	FIII	2.0	13	13	0	1.00	32	
	Exoavation	EXIST	11.7	34	34	1.00	1.00	
	FIII	0.0	0	0	0	1.00	66	
	Exoavation	9+00.00 PROP	0.0	0	0	1.00	1.00	
	FIII	3.0	9	9	0	1.00	57	
	Exoavation	EXIST	15.6	51	51	1.00	1.00	
	FIII	0.0	0	0	0	1.00	108	
	Exoavation	10+00.00 PROP	0.0	0	0	1.00	1.00	
	FIII	4.3	14	14	0	1.00	94	
	Exoavation	EXIST	10.2	48	48	1.00	1.00	
	FIII	0.0	0	0	0	1.00	142	
	Exoavation	11+00.00 PROP	0.0	0	0	1.00	1.00	
	FIII	3.5	15	15	0	1.00	127	
	Exoavation	EXIST	11.3	40	40	1.00	1.00	
	FIII	0.0	0	0	0	1.00	167	
	Exoavation	12+00.00 PROP	0.0	0	0	1.00	1.00	
	FIII	1.0	8	8	0	1.00	159	
	Exoavation	EXIST	32.7	82	82	1.00	1.00	
	FIII	0.0	0	0	0	1.00	241	
	Exoavation	13+00.00 PROP	0.0	0	0	1.00	1.00	
	FIII	4.3	10	10	0	1.00	231	
	Exoavation	EXIST	7.9	75	75	1.00	1.00	
	FIII	0.0	0	0	0	1.00	306	
	Exoavation	13+28.66 PROP	0.0	0	0	1.00	1.00	
	FIII	5.6	5	5	0	1.00	301	
	Exoavation	EXIST	9.1	9	9	1.00	1.00	
	FIII	0.0	0	0	0	1.00	310	
	GRAND SUMMARY TOTALS							
	Material Name		Unadjusted Volumes (cu. yd.)	Adjusted Volumes (cu. yd.)	Mult	Mass Factor	Ordinate	
	Exoavation	PROP	0	0	0	1.00		
	FIII	EXIST	185	185	0	1.00		
	Exoavation	PROP	495	495	0	1.00		
	FIII	EXIST	0	0	0	1.00		

JULIE ST

Station	Material Name	End Areas (sq. ft.)	Unadjusted Volumes (cu. yd.)	Adjusted Volumes (cu. yd.)	Mult	Mass Factor	Ordinate	
	Exoavation	0+87.00 PROP	0.0	0	0	1.00	1.00	
	FIII	0.6	0	0	0	1.00	0	
	Exoavation	EXIST	18.3	0	0	1.00	1.00	
	FIII	0.0	0	0	0	1.00	0	
	Exoavation	2+00.00 PROP	0.0	0	0	1.00	1.00	
	FIII	1.2	4	4	0	1.00	-4	
	Exoavation	EXIST	11.6	63	63	1.00	1.00	
	FIII	0.0	0	0	0	1.00	59	
	Exoavation	3+00.00 PROP	0.0	0	0	1.00	1.00	
	FIII	0.7	4	4	0	1.00	55	
	Exoavation	EXIST	14.6	48	48	1.00	1.00	
	FIII	0.0	0	0	0	1.00	103	
	Exoavation	4+00.00 PROP	0.0	0	0	1.00	1.00	
	FIII	1.8	5	5	0	1.00	98	
	Exoavation	EXIST	16.7	58	58	1.00	1.00	
	FIII	0.0	0	0	0	1.00	156	
	Exoavation	5+00.00 PROP	0.0	0	0	1.00	1.00	
	FIII	2.1	7	7	0	1.00	149	
	Exoavation	EXIST	12.1	53	53	1.00	1.00	
	FIII	0.0	0	0	0	1.00	202	
	Exoavation	6+00.00 PROP	0.0	0	0	1.00	1.00	
	FIII	6.7	16	16	0	1.00	186	
	Exoavation	EXIST	9.5	40	40	1.00	1.00	
	FIII	0.0	0	0	0	1.00	226	
	Exoavation	7+00.00 PROP	0.0	0	0	1.00	1.00	
	FIII	5.2	22	22	0	1.00	204	
	Exoavation	EXIST	8.4	33	33	1.00	1.00	
	FIII	0.0	0	0	0	1.00	237	
	Exoavation	8+00.00 PROP	0.0	0	0	1.00	1.00	
	FIII	4.2	17	17	0	1.00	220	
	Exoavation	EXIST	10.3	35	35	1.00	1.00	
	FIII	0.0	0	0	0	1.00	255	
	Exoavation	9+00.00 PROP	0.0	0	0	1.00	1.00	
	FIII	2.3	12	12	0	1.00	243	
	Exoavation	EXIST	12.2	42	42	1.00	1.00	
	FIII	0.0	0	0	0	1.00	285	
	Exoavation	10+00.00 PROP	0.0	0	0	1.00	1.00	
	FIII	2.2	8	8	0	1.00	277	
	Exoavation	EXIST	9.2	40	40	1.00	1.00	
	FIII	0.0	0	0	0	1.00	317	
	Exoavation	11+00.00 PROP	0.0	0	0	1.00	1.00	
	FIII	3.0	10	10	0	1.00	307	
	Exoavation	EXIST	12.5	40	40	1.00	1.00	
	FIII	0.0	0	0	0	1.00	347	
	Exoavation	12+00.00 PROP	0.0	0	0	1.00	1.00	
	FIII	0.5	6	6	0	1.00	341	
	Exoavation	EXIST	38.9	95	95	1.00	1.00	
	FIII	0.0	0	0	0	1.00	436	
	Exoavation	13+00.00 PROP	0.0	0	0	1.00	1.00	
	FIII	1.5	4	4	0	1.00	432	
	Exoavation	EXIST	14.3	98	98	1.00	1.00	
	FIII	0.0	0	0	0	1.00	530	
	Exoavation	13+30.00 PROP	0.0	0	0	1.00	1.00	
	FIII	5.9	4	4	0	1.00	526	
	Exoavation	EXIST	9.1	13	13	1.00	1.00	
	FIII	0.0	0	0	0	1.00	539	
	GRAND SUMMARY TOTALS							
	Material Name		Unadjusted Volumes (cu. yd.)	Adjusted Volumes (cu. yd.)	Mult	Mass Factor	Ordinate	
	Exoavation	PROP	0	0	0	1.00		
	FIII	EXIST	119	119	0	1.00		
	Exoavation	PROP	658	658	0	1.00		
	FIII	EXIST	0	0	0	1.00		

NO.	DATE	REVISION	APP.
 HIDALGO COUNTY			
TEDSI INFRASTRUCTURE GROUP <i>Consulting Engineers</i> 1201 E. Expressway 83 Mission, Texas 78372 (936) 424-7898			
EL MESQUITE			
EARTHWORK			
SHEET 1 OF 1			
FED. RD. DIV. NO. 6	PROJECT NO.		SHEET NO. 15
STATE TEXAS	DIST. PHR	COUNTY HIDALGO	
CSJ	PCT 1	HIGHWAY NO. VARIOUS	

3/19/2012 3:44:33 PM D:\2009\2009-1027-02 hobcap_111_addit\onal_colon\cas\des\ign\03_el_mesquite\tes\Roadway\MES-EW.dgn

FOR CONTRACTOR'S INFORMATION ONLY

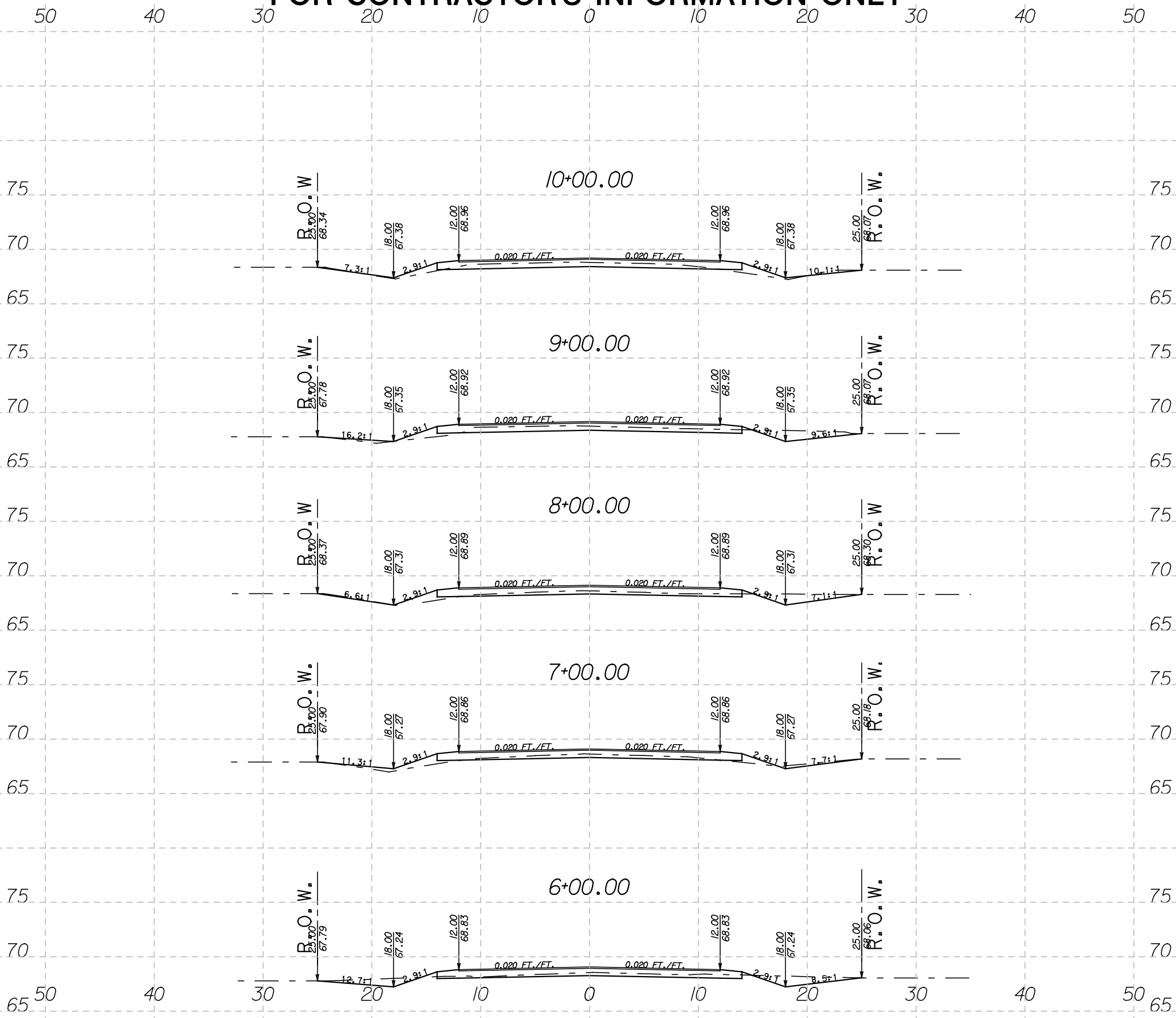

NO.	DATE	REVISION	APP.



HIDALGO COUNTY

TEDSI INFRASTRUCTURE GROUP
 Consulting Engineers
 1201 E. Expressway 83
 Mission, Texas 78372
 (936) 424-7898
 TBPE F-1640

EL MESQUITE
DIANA ROADWAY
CROSS-SECTIONS

N. T. S. SHEET 2 OF 3

FED. RD. DIV. NO. 6	PROJECT NO.	SHEET NO. 17
STATE TEXAS	DIST. PHR	COUNTY HIDALGO
CSJ	PCT 1	HIGHWAY NO. VARIOUS
2C-1080-244		

3/19/2012 3:44:45 PM
 D:\2009\2009-1027-02 hobcap 111 additional\anal_colonias\des\ign\03 el_mesquite\tes\j\seco\lancr-pxs-11x17.dgn

FOR CONTRACTOR'S INFORMATION ONLY

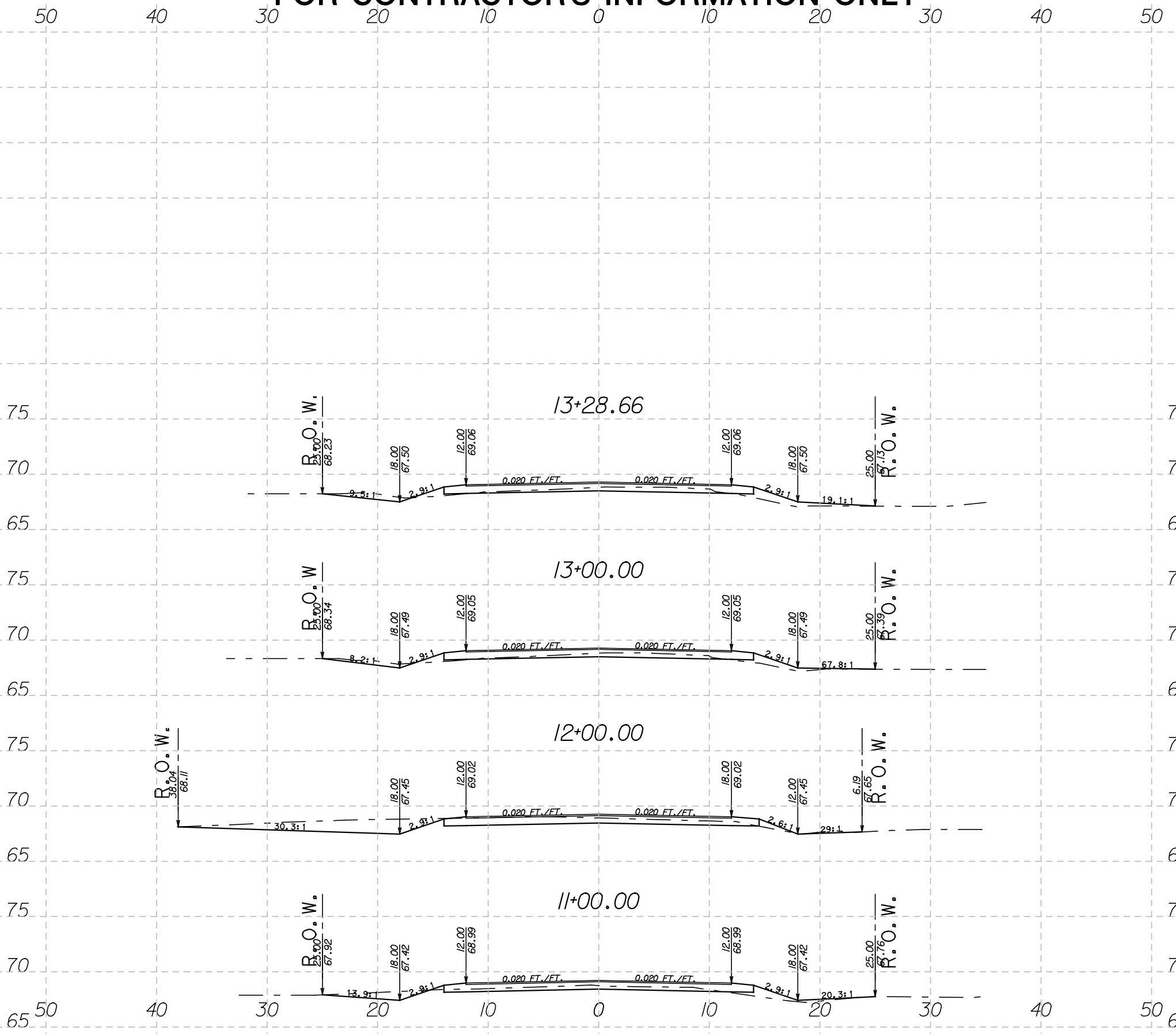

NO.	DATE	REVISION	APP.



HIDALGO COUNTY

TEDSI INFRASTRUCTURE GROUP
 Consulting Engineers
 1201 E. Expressway 83
 Mission, Texas 78372
 (936) 424-7898
 TBPE F-1640

EL MESQUITE
DIANA ROADWAY
CROSS-SECTIONS

N. T. S.		SHEET 3 OF 3	
FED. RD. DIV. NO. 6	PROJECT NO.	SHEET NO. 18	
STATE TEXAS	DIST. PHR	COUNTY HIDALGO	
CSJ	PCT 1	HIGHWAY NO. VARIOUS	
2C-1080-244			

3/19/2012 3:44:49 PM
 p:\2009\2009-1027-02 hobcap 111 additional\anal_colonias\des\gn\03 el_mesquite\tes\j\kseeo\lancr-pxe-11x17.dgn

FOR CONTRACTOR'S INFORMATION ONLY

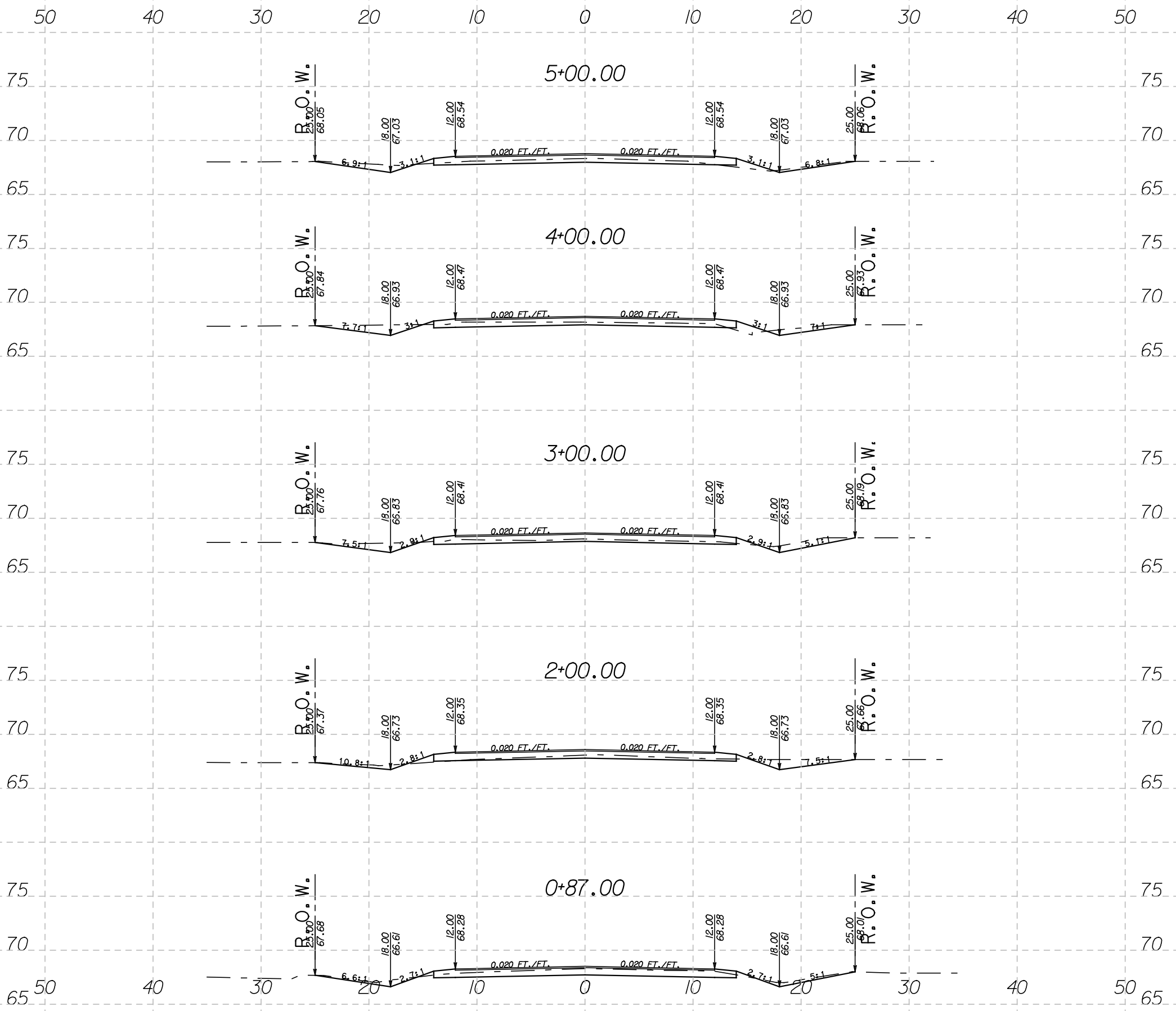

3/19/2012 3:44:54 PM
 ps:\2009\2009-1027-02 hobcap 111 additional\anl_colonias\des\ign\03 el_mesquite\tes\j\j\seco\julie-pxe-11x17.dgn

NO.	DATE	REVISION	APP.



HIDALGO COUNTY

TEDSI INFRASTRUCTURE GROUP
 Consulting Engineers
 1201 E. Expressway 83
 Mission, Texas 78372
 (936) 424-7898

EL MESQUITE		SHEET 1 OF 3	
JULIE ROADWAY		CROSS-SECTIONS	
N. T. S.		FED. RD. DIV. NO.	SHEET NO.
		6	19
STATE	DIST.	COUNTY	
TEXAS	PHR	HIDALGO	
CSJ	PCT	HIGHWAY NO.	
2C-1080-244	1	VARIOUS	

FOR CONTRACTOR'S INFORMATION ONLY

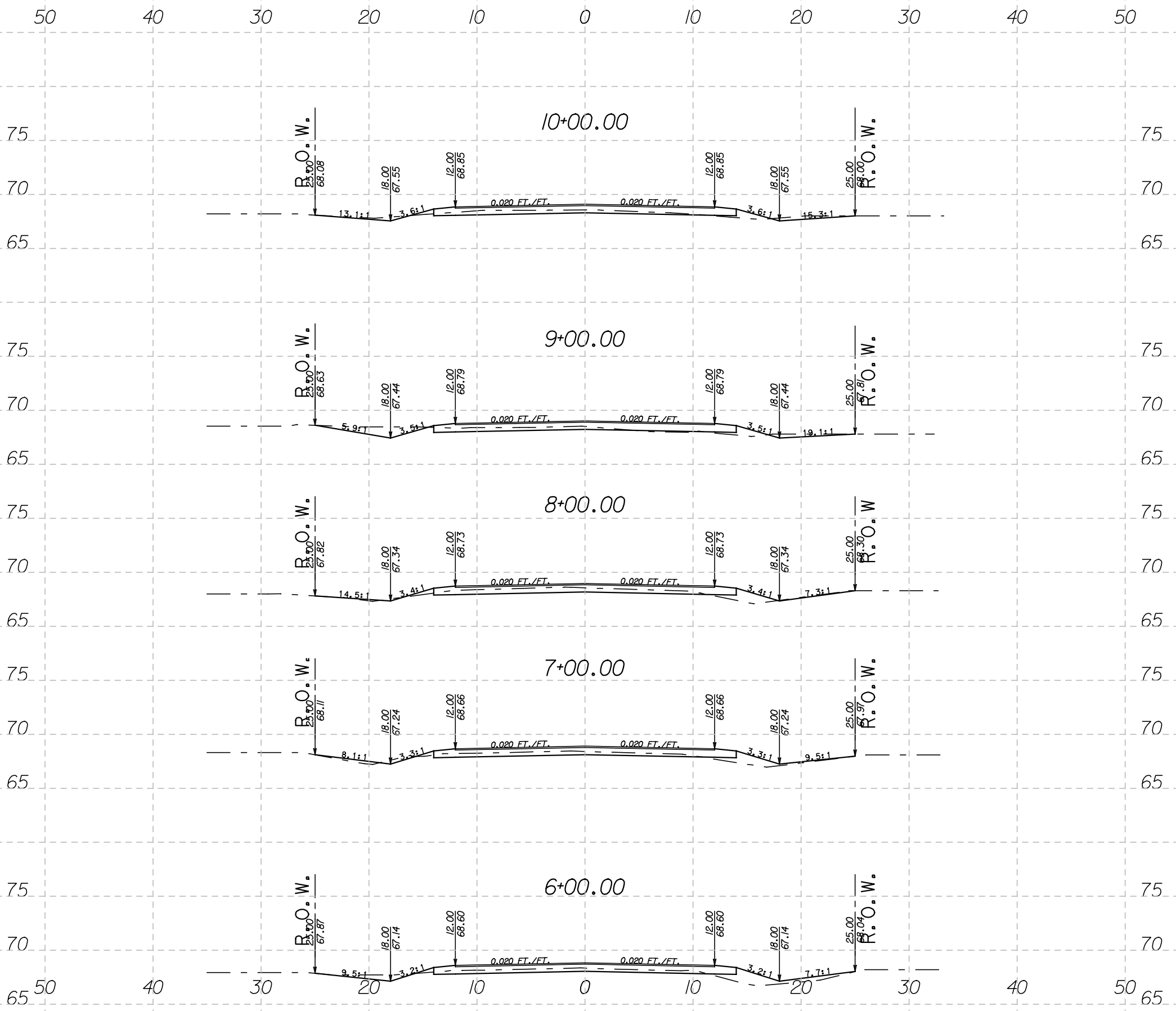

NO.	DATE	REVISION	APP.



TEDSI INFRASTRUCTURE GROUP
 Consulting Engineers
 1201 E. Expressway 83
 Mission, Texas 78372
 (936) 424-7898

**EL MESQUITE
 JULIE
 ROADWAY
 CROSS-SECTIONS**

N. T. S.		SHEET 2 OF 3	
FED. RD. DIV. NO. 6	PROJECT NO.	SHEET NO. 20	
STATE TEXAS	DIST. PHR	COUNTY HIDALGO	
CSJ	PCT 1	HIGHWAY NO. VARIOUS	
2C-1080-244			

3/19/2012 3:44:59 PM
 ps:\2009\2009-1027-02 hobcap 111 additional\colanicas\des\ign\03 el mesquite\tes\j\j\seco\julie-pxe-11x17.dgn

FOR CONTRACTOR'S INFORMATION ONLY

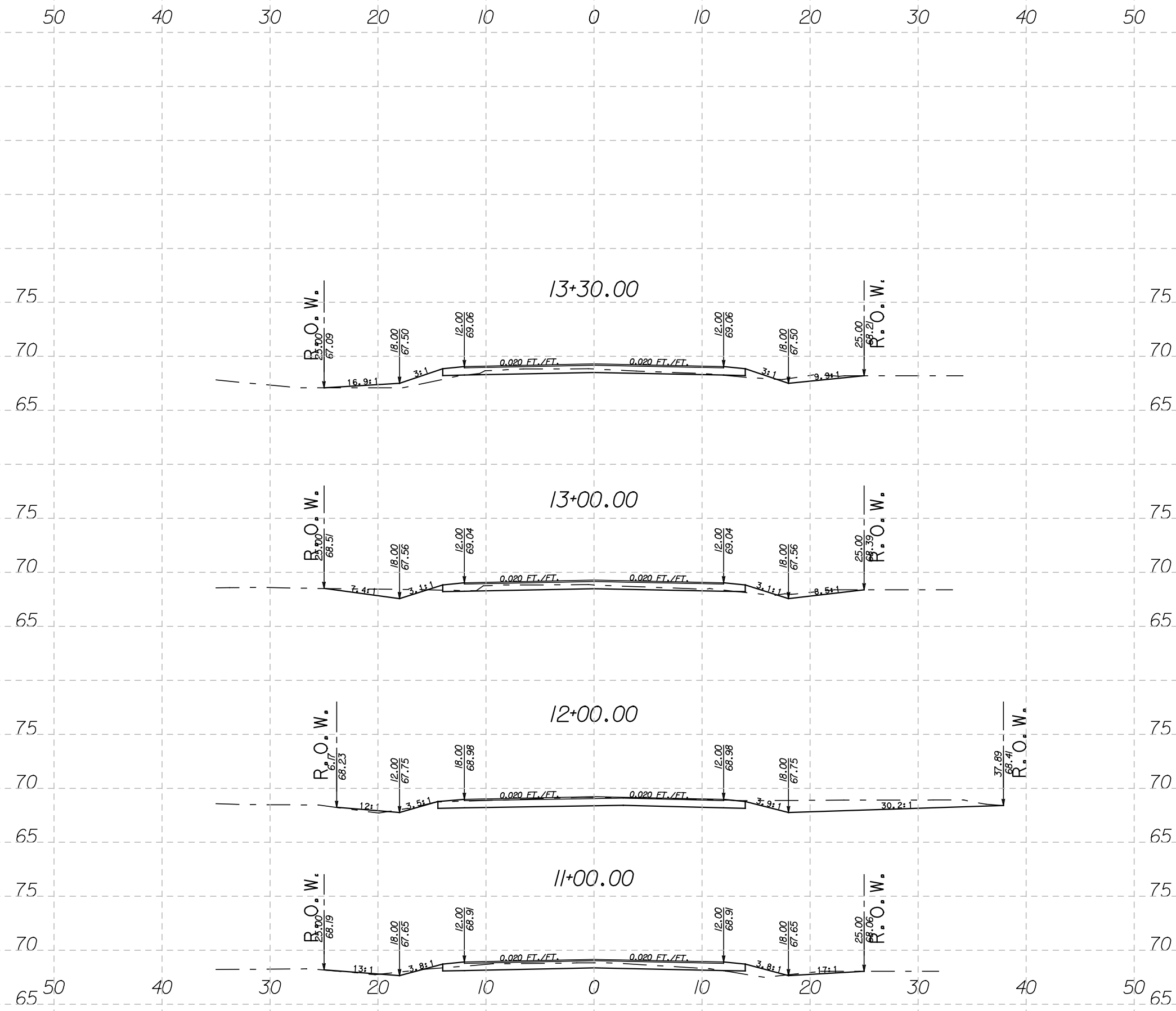

NO.	DATE	REVISION	APP.

NO.	DATE	REVISION	APP.



TEDSI INFRASTRUCTURE GROUP
Consulting Engineers
 1201 E. Expressway 83
 Mission, Texas 78372
 (936) 424-7898

**EL MESQUITE
 JULIE
 ROADWAY
 CROSS-SECTIONS**

N. T. S.		SHEET 3 OF 3	
FED. RD. DIV. NO. 6	PROJECT NO.	SHEET NO. 21	
STATE TEXAS	DIST. PHR	COUNTY HIDALGO	
CSJ	PCT 1	HIGHWAY NO. VARIOUS	
2C-1080-244			

3/19/2012 3:45:03 PM
 ps:\2009\2009-1027-02 hobcap 111 additional\oncal colonias\des\ign\03 el mesquite\tes\j\ksee\julle-pxs-11x17.dgn

PAVEMENT MARKINGS LEGEND

(REFL PAV MRK TYPE I) (100 MIL)

- A (W) (04") (SLD)
- B (W) (24") (SLD)
- C (Y) (04") (BRK)
- D (Y) (04") (SLD)

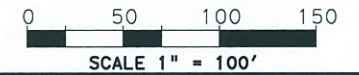
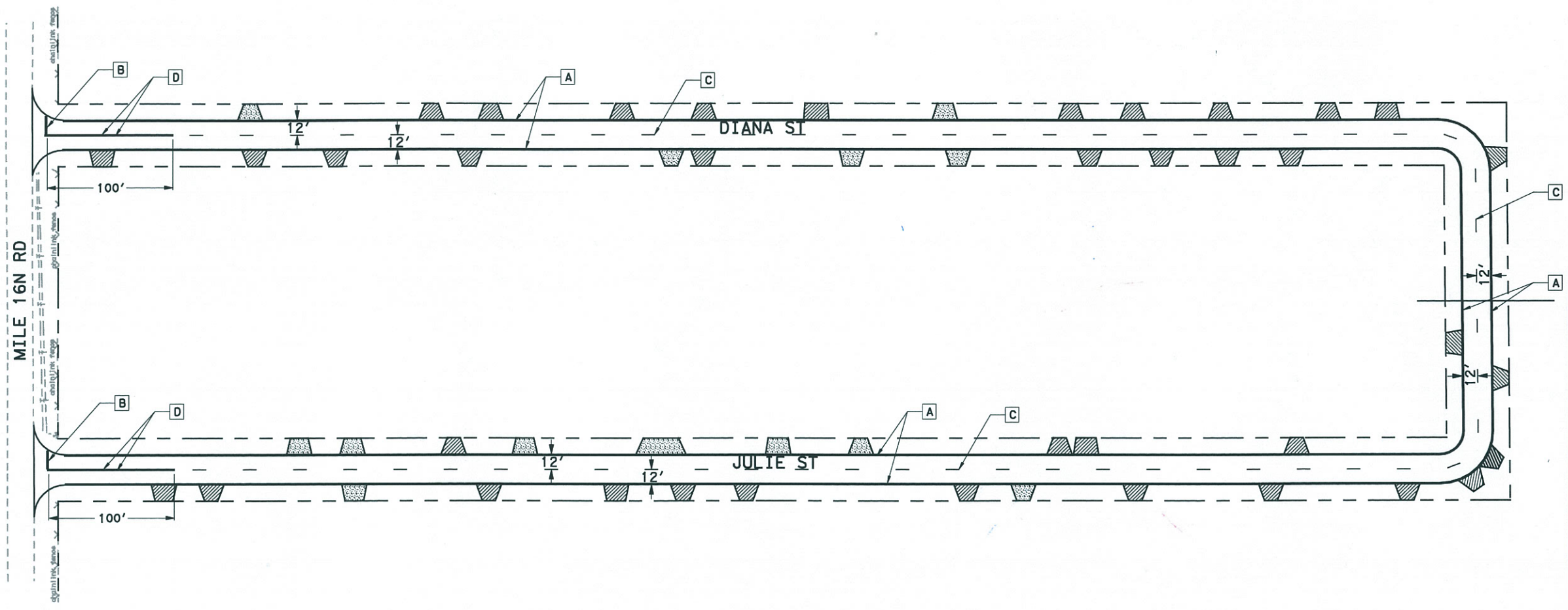

NO.	DATE	REVISION	APP.

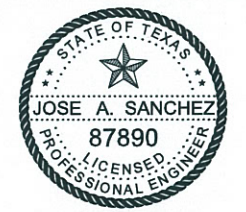

[Signature]
03/19/2012



HIDALGO COUNTY

TEDSI INFRASTRUCTURE GROUP
Consulting Engineers
1201 E. Expressway 83
Mission, Texas 78572
(956) 424-7898



EL MESQUITE

PAVEMENT MARKINGS

SHEET 1 OF 1

FED. RD. DIV. NO.	PROJECT NO.		SHEET NO.
6			22
STATE	DIST.	COUNTY	
TEXAS	PHR	HIDALGO	
CSJ	PCT	HIGHWAY NO.	
2C-1080-244	1	VARIOUS	

3/19/2012 3:45:06 PM
 p:\2009\2009-1027-02_habcap\111_cadd\1\onal_o\lon\cas\des\ign\03_e\mesquite\rd\Roadway\MES-spm.dgn

SITE DESCRIPTION

PROJECT LIMITS: Mesquite Subdivision: Diana St-127', Julie St-127'

PROJECT SITE MAPS: *Project Location Map: Title Sheet (Sheet 1)
*Approx. Slopes Anticipated After Major Gradients and Areas of Soil Disturbance: Typ Sects (Sheet 5)
*Major Controls and Locations of Stabilization Practices: SW3P Site Map Sheets (Sheets 8-13)
*Project Specific Locations: To be specified by Project Field Office and located in the Project SW3P File

PROJECT DESCRIPTION: Construction will consist of hot mix asphalt, flexible base, subgrade and roadside ditches.

MAJOR SOIL DISTURBING ACTIVITIES: Roadway reconstruction

TOTAL PROJECT AREA: 2.90 Acres

TOTAL AREA TO BE DISTURBED: 2.90 Acres (100%)

WEIGHTED RUNOFF COEFFICIENT: Before Construction: 0.56
After Construction: 0.59

EXISTING CONDITION OF SOIL & VEGETATIVE: Existing asphalt roadway (43%), Short grass between edge of pavement and ROW 57%

NAME OF RECEIVING WATERS: Drainage from site drains into the IBWC Levee System which eventually empties into the lower Laguna Madre.

ENDANGERED SPECIES, DESIGNATED CRITICAL HABITAT AND HISTORICAL PROPERTY:

A. No Endangered Species, Designated Critical Habitat or Historic Property has not been found on this project site.

EROSION AND SEDIMENT CONTROLS

SOIL STABILIZATION PRACTICES: (Select T = Temporary or P = Permanent, as applicable)

- T TEMPORARY SEEDING
- MULCHING (Hay or Straw)
- BUFFER ZONES
- PLANTING
- SEEDING
- SODDING
- PRESERVATION OF NATURAL RESOURCES
- FLEXIBLE CHANNEL LINER
- RIGID CHANNEL LINER
- SOIL RETENTION BLANKET
- COMPOST MANUFACTURED COMPOST
- OTHER: (Specify Practice)

STRUCTURAL PRACTICES: (Select T = Temporary or P = Permanent, as applicable)

- T SILT FENCES
- HAY BALES
- ROCK FILTER DAMS
- DIVERSION, INTERCEPTOR, OR PERIMETER DIKES
- DIVERSION, INTERCEPTOR, OR PERIMETER SWALES
- DIVERSION DIKE AND SWALE COMBINATIONS
- PIPE SLOPE DRAINS
- PAVED FLUMES
- ROCK BEDDING AT CONSTRUCTION EXIT
- TIMBER MATTING AT CONSTRUCTION EXIT
- CHANNEL LINERS
- SEDIMENT TRAPS
- SEDIMENT BASINS
- STORM INLET SEDIMENT TRAP
- STONE OUTLET STRUCTURES
- CURBS AND GUTTERS
- STORM SEWERS
- VELOCITY CONTROL DEVICES
- OTHER: (Specify Practice)

STORM WATER MANAGEMENT:

Storm water drainage is provided by existing open ditches and culverts. System will carry drainage within the ROW to designated outfalls

STORM WATER MANAGEMENT ACTIVITIES:

- The order of activities will be as follows:
1. Install perimeter controls, clear R.O.W. on side where construction will take place, and make required utility adjustments
 2. Install proposed culverts, Install sediment control fence as specified in plans.
 3. Construct proposed roadway.
 4. Once all construction activity is complete, permanent seeding on proposed areas shall be done according to plans or as instructed by the engineer.

NON-STORM WATER MANAGEMENT DISCHARGES:

Non-storm water discharges should be filtered, or held in retention basins, before being allowed to mix with storm water. These discharges consist of non-polluted ground water, spring water, foundation and/or footing drain water and water used for dust control, pavement washing and vehicle wastewater containing no detergents.

OTHER REQUIREMENTS & PRACTICES

OTHER EROSION AND SEDIMENT CONTROLS:

MAINTENANCE: All erosion and sediment controls will be maintained in good working order. If a repair is necessary, it will be done at the earliest date possible, but no later than 7 calendar days after the surrounding exposed ground has dried sufficiently to prevent further damage from heavy equipment. The areas adjacent to creeks and drainage ways shall have priority followed by devices protecting storm sewer inlets.

INSPECTION: For areas of the construction site that have not been finally stabilized, area used for storage of materials, structural control measures, and locations where vehicles enter or exit the site, personnel provided by the permittee and familiar with the SW3P must inspect disturbed areas at least once every fourteen (14) calendar days and within twenty-four (24) hours of the end of a storm event 0.5 inches or greater.

WASTE MATERIALS: All waste materials will be collected and stored in a securely lidded dumpster. All trash and construction debris from the site will be deposited as necessary at a local dump. No construction waste material will be buried on site.

HAZARDOUS WASTE (INCLUDING SPILL REPORTING): At a minimum, any products in the following categories to be hazardous: Paints, Acids for cleaning masonry surfaces, Cleaning Solvents, Asphalt products, Chemical additives for soil stabilization, or Concrete curing compounds and additives. In the event of a spill which may be hazardous, the spill coordinator should be contacted immediately. Emptying of excess concrete should not be allowed on site. Likewise, washout of concrete trucks should not be performed on site. These discharges are considered non-allowable non-storm water discharges. Concrete trucks should never be allowed to dump into storm drains or sanitary sewers.

SANITARY WASTE: All sanitary waste will be collected from the portable units as necessary or as required by local regulation by a licensed sanitary waste management contractor.

OFFSITE VEHICLE TRACKING: The Contractor shall be required, on a regular basis or as may be directed by the Engineer, to dampen haul roads for dust control, stabilize construction entrances and to remove excess dirt from the roadway.

- MANAGEMENT PRACTICES: (Example Below - May be used as applicable, revised or expanded)
1. Disposal areas, stockpiles, and haul roads shall be constructed in a manner that will minimize and control the amount of sediment that may enter receiving waters. Disposal areas shall not be located in any wet land, water body or stream bed.
 2. Construction staging areas and vehicle maintenance areas shall be constructed by the Contractor in a manner to minimize the runoff of pollutants.
 3. All waterways shall be cleared as soon as practicable of temporary embankment, temporary bridges, matting, falsework, piling, or debris or other obstructions placed during construction operations that are not a part of the finished work.

- OTHER:
1. Construction materials stored on site to be provided by Project Field Office.
 2. The project SW3P File located at the project field office shall contain the Small Construction Site Notice and any additional permits required by T.E.C.G.

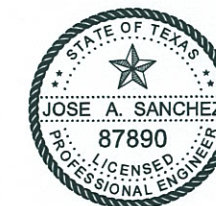

[Handwritten Signature]
 03/19/2012

© 2004
 Texas Department of Transportation
TxDOT STORM WATER POLLUTION PREVENTION PLAN (SW3P)

REV. 4/04 SW3P.DGN

FED. RD. DIV. NO.	PROJECT NO.	SHEET NO.
6		23
STATE	DIST.	COUNTY
TEXAS	PHARR	HIDALGO
CONT.	SECT.	JOB
2C	1080	230
		HIGHWAY NO.
		VARIOUS

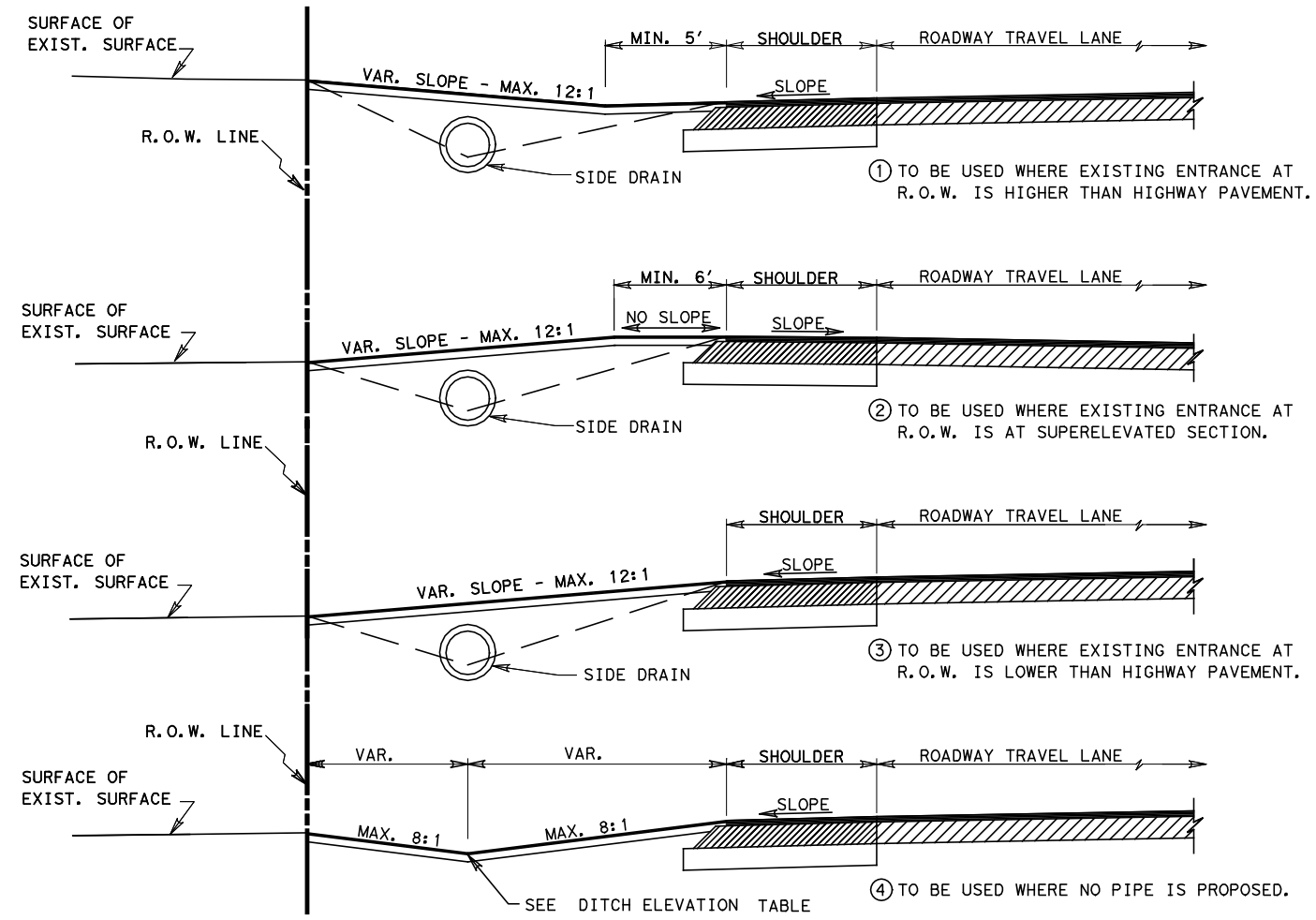

NOTES:

- ALL ENTRANCES CONSTRUCTED ON THIS PROJECT ARE SUBJECT TO CONCURRENCE WITH EXISTING GOVERNING REGULATIONS AS SET OUT BY THE STATE HIGHWAY COMMISSION.
- ENTRANCE'S BASE AND SURFACING MAY BE EXTENDED BEYOND R.O.W. LINE AS REQUIRED TO MEET EXISTING GRADE IN A SATISFACTORY MANNER OF WHICH NO STEEPER THAN 12:1 SLOPE WILL BE CONSTRUCTED.
- ALL FLEXIBLE BASE USED FOR PRIVATE DRIVES & COMMERCIAL DRIVES WILL NOT REQUIRE LIME TREATMENT.
- EXACT LOCATIONS, DIMENSIONS, AND TYPE TO BE ESTABLISHED DURING CONSTRUCTION BY THE ENGINEER.
- PROP. WIDTH OF DRIVEWAYS TO MATCH EXISTING WIDTH AT R.O.W. LINE.
- 114 #/SY ACP (COMPACTED) IS EQUAL TO 1 IN. DEPTH
171 #/SY ACP (COMPACTED) IS EQUAL TO 1/2 IN. DEPTH.
- SIDE DRAINS TO BE INSTALLED WHERE ROADWAY DITCH DRAINAGE IS NECESSARY, AS INDICATED ON PLANS AND/OR AS DIRECTED BY THE ENGINEER.
- SIDE DRAINS TO BE INSTALLED WITH A MINIMUM OF 6" COVER BY PROPOSED RESIDENTIAL & COMMERCIAL MATERIAL OR 15" COVER OF PROPOSED COUNTY RD. & CITY STREET ROADWAY MATERIAL.
- AVERAGE DIMENSIONS SHOWN ON TABLE OF DRIVEWAYS ARE FOR ESTIMATING PURPOSES ONLY.
- THE RATE OF PRIME SHALL BE 0.10 GAL/SY FOR PRIVATE AND/OR COMMERCIAL DRIVEWAYS AND 0.20 GAL/SY FOR PUBLIC DRIVEWAYS.

TYPICAL ENTRANCE PROFILE FOR DRIVEWAYS W/OUT C&G

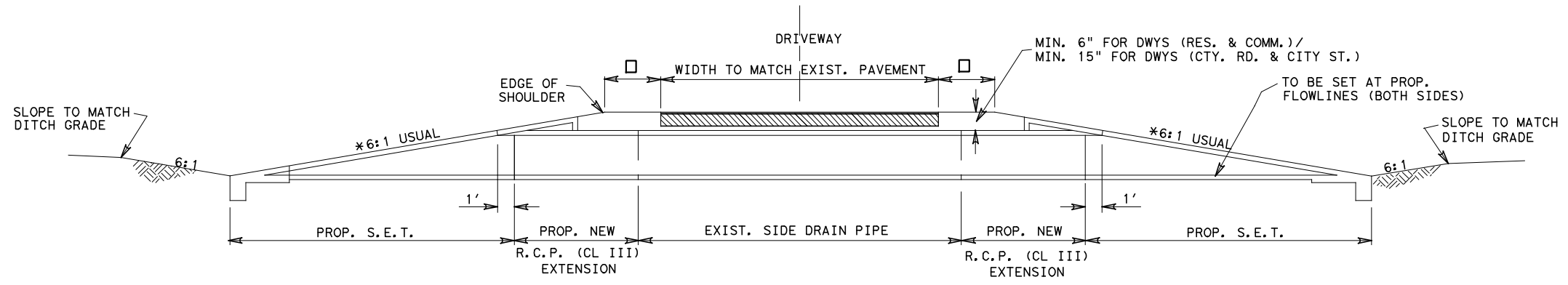

- - 1' MIN. ON DRIVEWAYS (RES. & COMM.)
2' MIN. ON DRIVEWAYS (COUNTY RD. & CITY ST.)
- * - 6:1 SLOPE USUAL
UNLESS OTHERWISE NOTED ON PLANS

© TxDOT 2005 PHARR DISTRICT STANDARD



TEXAS DEPARTMENT OF TRANSPORTATION

**DRIVEWAY
PROFILE DETAILS**

REV. 4/05		DRIVEWAY1.DGN	
STATE AID PROJECT NO.	FILE NO.	SHEET NO.	24
6			
STATE	STATE DIST. NO.	COUNTY	CONT. SECT. JOB HIGHWAY NO.
TEXAS	PHR	HIDALGO	2C 1080 244 VAR

PRIVATE AND COMMERCIAL DRIVES WITH CURB & GUTTER

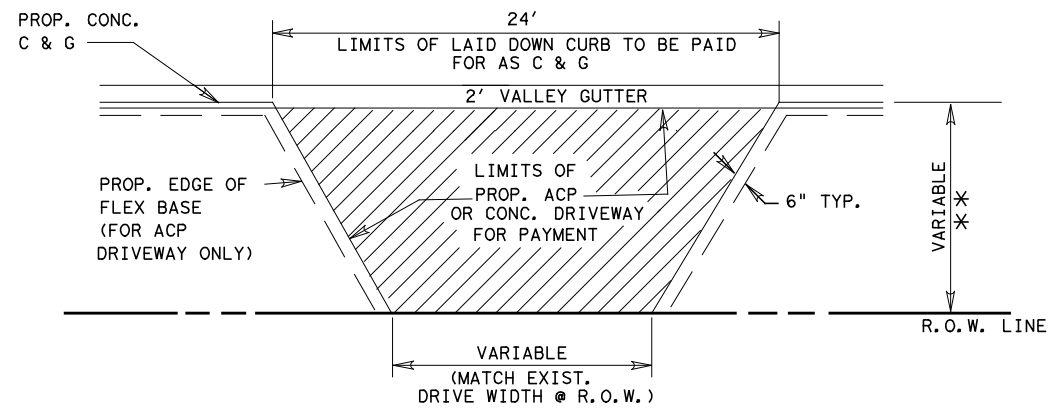

PLAN OF PRIVATE AND COMMERCIAL DRIVES
(W/DRIVEWAY WIDTH LESS THAN 24')

** SEE P&P SHEETS

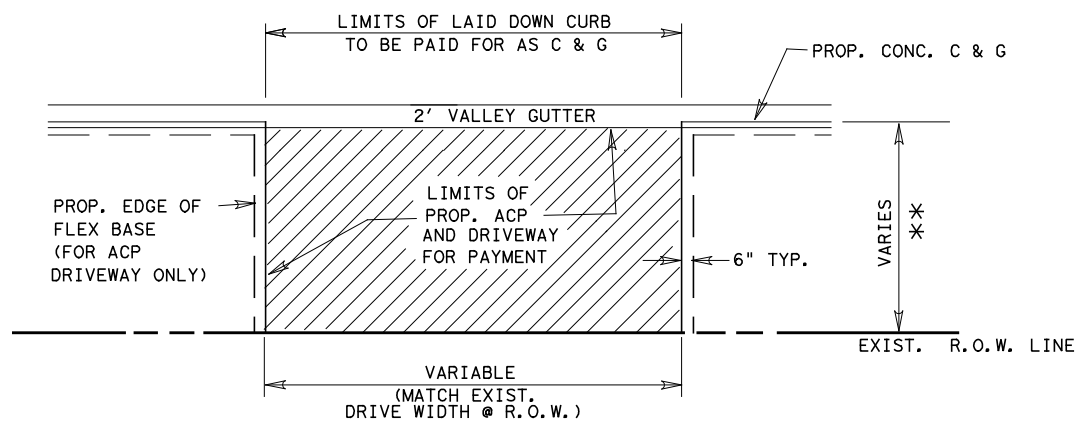

PLAN OF PRIVATE AND COMMERCIAL DRIVES
(W/DRIVEWAY WIDTH EQUAL TO OR GREATER THAN 24' @ R.O.W. LINE)

N. T. S.

PRIVATE AND COMMERCIAL DRIVES WITHOUT CURB & GUTTER

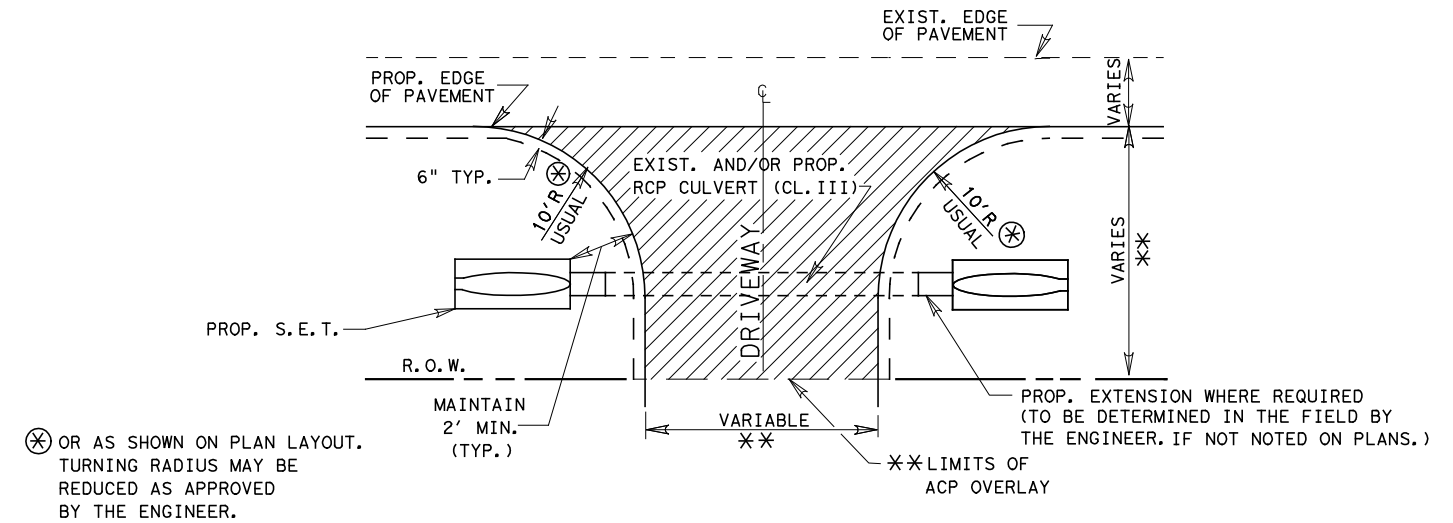

PLAN OF PRIVATE AND COMMERCIAL DRIVES

*W/DRIVEWAY WIDTH LESS THAN 24'

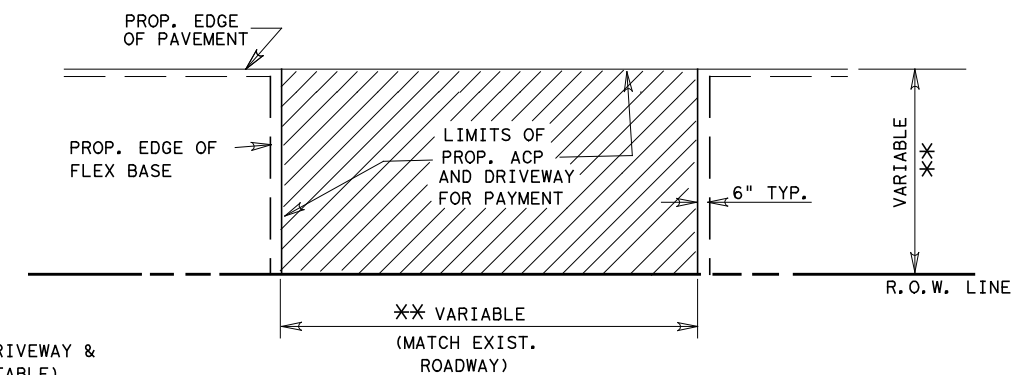

PLAN OF PRIVATE AND COMMERCIAL DRIVES
(W/DRIVEWAY WIDTH EQUAL TO OR GREATER THAN 24' @ R.O.W. LINE)

N. T. S.

PRIVATE AND COMMERCIAL DRIVES WITH CURB & GUTTER

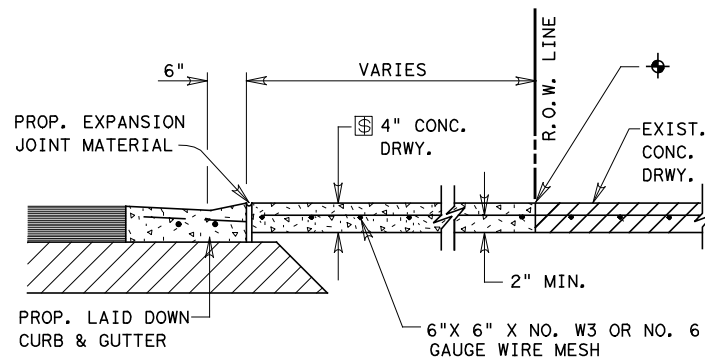

TYPICAL CONCRETE DRIVEWAY SECTION

◆ CONC. SHALL BE SAW CUT TO THE LIMITS OF REMOVAL WHERE APPLICABLE.

⊞ 6" FOR COMMERCIAL DRIVES

N. T. S.

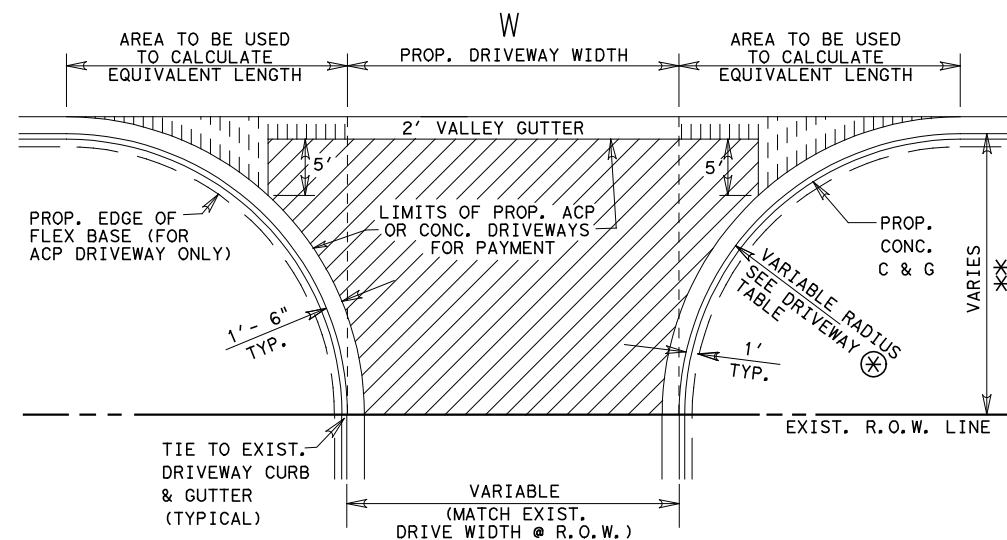

PLAN OF PRIVATE AND COMMERCIAL DRIVES

SEE P&P SHEETS FOR LOCATIONS OF DRIVES

N. T. S.

LF EQUIVALENT TABLE FOR PAYMENT LIMITS OF 2' VALLEY GUTTER

LF OF VALLEY GUTTER = W + X1 + X2	
WHERE X1 AND X2 MAY VARY DEPENDING ON RADIUS	
Prop. Driveway Radius	X1 or X2 (Sq Ft Area / 2')
5'	1
8'	2
10'	4
12'	6
15'	9
18'	12
20'	15
22'	18
25'	24
28'	30
30'	34

SEE DRIVEWAY TABLE FOR LIMITS OF LAID DOWN CURB TO BE PAID FOR AS CURB AND GUTTER

DRIVEWAY TYPES

- TY PRB-1
EXIST. PAVED CALICHE AND /OR GRAVEL DRIVEWAYS TO BE SCARIFIED AND RECONSTRUCTED WITH 3" NEW AND/OR SALVAGE FLEX. BASE TO MATCH THE PROPOSED WIDENED SECTION. THEN PRIMED AND SURFACED WITH 114#/SY ACP (TY "D")
- TY PB-1
EXIST. UNPAVED PRIVATE OR COMMERCIAL DRIVEWAYS TO BE CONSTRUCTED AS SHOWN WITH 4" NEW AND/OR SALVAGE FLEX. BASE, PRIMED AND SURFACED WITH 114#/SY ACP.
- TY P1
EXIST. PAVED DRIVEWAYS TO BE PAVED WITH 114#/SY ACP TY "D".

© TxDOT 2005 PHARR DISTRICT STANDARD

TEXAS DEPARTMENT OF TRANSPORTATION

DRIVEWAY DETAILS

PRIVATE

(RESIDENTIAL-COMMERCIAL)

REV. 4/05	DRIVEWAY2.DGN
FED. RD. DIV. NO. 6	SHEET NO. 25
STATE TEXAS	PHR
COUNTY HIDALGO	CONT. 2C
SECT. 1080	JOB 244
HIGHWAY NO. VAR	

DISCLAIMER: The use of this standard is governed by the "Texas Engineering Practice Act". No warranty of any kind is made by TxDOT for any purpose whatsoever. TxDOT assumes no responsibility for the conversion of this standard to other formats or for incorrect results or damages resulting from its use.
 DATE: 3/19/2012 3:45:26 PM
 FILE: p:\2009\2009-1027-02_hboap.iii_additional_colonias.design\03_e1_mesquite\csj_standards\Traffic Control\BC07.DGN

Barricade and Construction (BC) Standard Sheets General Notes:

1. The Barricade and Construction Standard Sheets (BC sheets) are intended to show typical examples for placement of temporary traffic control devices, construction pavement markings, and typical work zone signs. The information contained in these sheets meet or exceed the requirements shown in the "Texas Manual on Uniform Traffic Control Devices" (TMUTCD).
2. The development and design of the Traffic Control Plan (TCP) is the responsibility of the Engineer.
3. The Contractor may propose changes to the TCP that are signed and sealed by a licensed professional engineer for approval. The Engineer may develop, sign and seal Contractor proposed changes.
4. The Contractor is responsible for installing and maintaining the traffic control devices as shown in the plans. The Contractor may not move or change the approximate location of any device without the approval of the Engineer.
5. Geometric design of lane shifts and detours should, when possible, meet the applicable design criteria contained in manuals such as the American Association of State Highway and Transportation Officials (AASHTO), "A Policy on Geometric Design of Highways and Streets", the TxDOT "Roadway Design Manual" or engineering judgment.
6. When projects abut, the Engineer(s) may omit the END ROAD WORK, TRAFFIC FINES DOUBLE, and other advance warning signs if the signing would be redundant and the work areas appear continuous to the motorists. If the adjacent project is completed first, the Contractor shall erect the necessary warning signs as shown on these sheets, the TCP sheets or as directed by the Engineer. The BEGIN ROAD WORK NEXT X MILES sign shall be revised to show appropriate work zone distance.
7. The Engineer may require duplicate warning signs on the median side of divided highways where median width will permit and traffic volumes justify the signing.
8. All signs shall be constructed in accordance with the details found in the "Standard Highway Sign Designs for Texas," latest edition. Sign details not shown in this manual shall be shown in the plans or the Engineer shall provide a detail to the Contractor before the sign is manufactured.
9. The temporary traffic control devices shown in the illustrations of the BC sheets are examples. As necessary, the Engineer will determine the most appropriate traffic control devices to be used.
10. As shown on BC(2), the OBEY WARNING SIGNS STATE LAW sign and the WORK ZONE TRAFFIC FINES DOUBLE sign with plaque shall be erected in advance of the CSJ limits. The BEGIN ROAD WORK NEXT X MILES, CONTRACTOR and END ROAD WORK signs shall be erected at or near the CSJ limits.
11. Except for devices required by Note 10, traffic control devices should be in place only while work is actually in progress or a definite need exists.
12. The Engineer has the final decision on the location of all traffic control devices.
13. Inactive equipment and work vehicles, including workers' private vehicles must be parked away from travel lanes. They should be as close to the right-of-way line as possible, or located behind a barrier or guardrail, or as approved by the Engineer.

Worker Safety Apparel Notes:

1. Workers on foot who are exposed to traffic or to construction equipment within the right-of-way shall wear high-visibility safety apparel meeting the requirements of ISEA "American National Standard for High-Visibility Apparel" labeled as ANSI 107-2004 standard performance for Class 2 or 3 risk exposure. Class 3 garments should be considered for high traffic volume work areas or night time work.

Only pre-qualified products shall be used. The "Compliant Work Zone Traffic Control Devices List" (CWZTCD) describes prequalified products and their sources and may be found on-line at the web address given below or by contacting:

Texas Department of Transportation
 Traffic Operations Division - TE
 Phone (512) 416-3134

WEB ADDRESSES FOR REFERENCED DOCUMENTS

- Compliant Work Zone Traffic Control Devices List (CWZTCD)
<http://www.txdot.gov/publications/traffic.htm>
- Texas Manual on Uniform Traffic Control Devices (TMUTCD)
<http://www.txdot.gov/publications/traffic.htm>
- Standard Highway Sign Designs for Texas (SHSD)
<http://www.txdot.gov/publications/traffic.htm>
- Traffic Engineering Standard Sheets
<http://www.txdot.gov/business/disclaim.htm>
- Material Producer List
http://www.txdot.gov/business/producer*list.htm
- Departmental Material Specifications (DMS)
http://www.txdot.gov/services/construction/material*specifications/
- Roadway Design Manual
http://www.txdot.gov/services/general*services/manuals.htm



**BARRICADE AND CONSTRUCTION
 GENERAL NOTES
 AND REQUIREMENTS**

1 of 12 BC(1)-07

© TxDOT 11-4-02		DN: TxDOT	CK: TxDOT	DW: TxDOT	CK: TxDOT
4-03	REVISIONS	CONT	SECT	JOB	HIGHWAY
9-07		3C	1080	103	BERNAL
		DIST	COUNTY	SHEET NO.	
		PHR	HIDALGO	26	

DATE: 3/19/2012 3:45:33 PM
 FILE: p:\2009\2009-1027-02_hoboap_iii_additional_colonias.design\03_el_mesquite.csj\Standards\Traffic Control\BC07.DGN
 DISCLAIMER: The use of this standard is governed by the "Texas Engineering Practice Act". No warranty of any kind is made by TxDOT for any purpose whatsoever. TxDOT assumes no responsibility for the conversion of this standard to other formats or for incorrect results or damages resulting from its use.

TYPICAL LOCATION OF CROSSROAD SIGNS

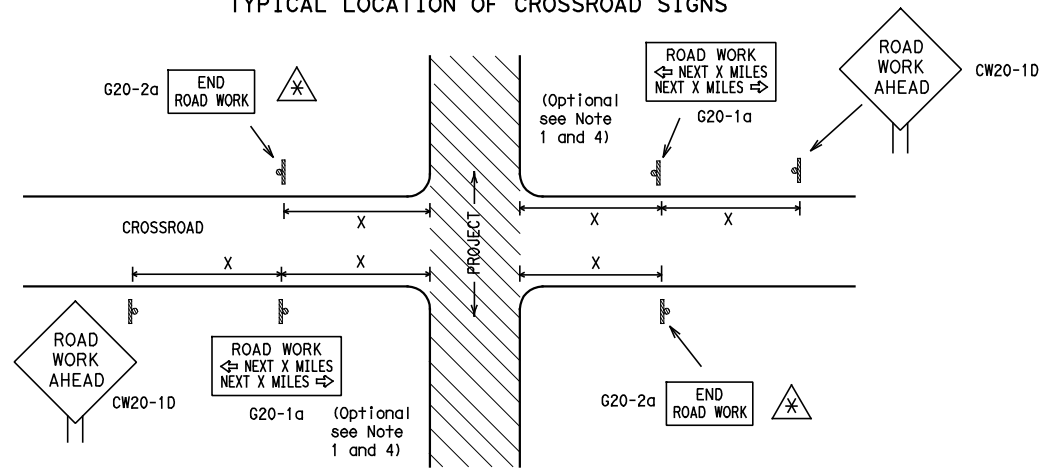

- May be mounted on back of CW20-10 sign with approval of engineer. (See note 2 below)
- The typical minimum signing on a crossroad approach should be a CW20-10 ROAD WORK AHEAD sign and a G20-2a END ROAD WORK sign, unless noted otherwise in plans.
 - The Engineer may use the reduced size 36" x 36" ROAD WORK AHEAD (CW20-10) sign mounted back to back with the reduced size 36" x 18" END ROAD WORK (G20-2a) sign on low volume crossroads (see Note 4 under "Typical Construction Warning Sign Size and Spacing"). See the "Standard Highway Sign Designs for Texas" manual for sign details. The Engineer may omit the advance warning signs on low volume crossroads. The Engineer will determine whether a road is low volume. This information shall be shown in the plans.
 - Based on existing field conditions, the Engineer/Inspector may require additional signs such as FLAGGER AHEAD, LOOSE GRAVEL, or other appropriate signs. When additional signs are required, these signs will be considered part of the minimum requirements. The Engineer/Inspector will determine the proper location and spacing of any sign not shown on the BC sheets, Traffic Control Plan sheets or the Work Zone Standard Sheets.
 - The G20-1a sign shall be required at high volume crossroads to advise motorists of the length of construction in either direction from the intersection. The Engineer will determine whether a roadway is considered high volume.
 - Additional traffic control devices may be shown elsewhere in the plans for higher volume crossroads.
 - When work occurs in the intersection area, appropriate traffic control devices, as shown elsewhere in the plans or as determined by the Engineer/Inspector, shall be in place.

T-INTERSECTION

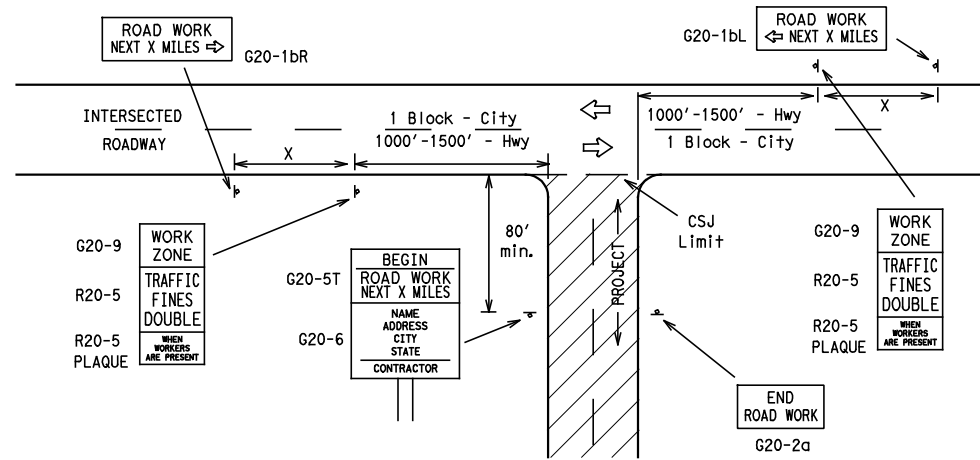

CSJ LIMITS AT T-INTERSECTION

- The Engineer will determine the types and location of any additional traffic control devices, such as a flagger and accompanying signs, or other signs, that should be used when work is being performed at or near an intersection.
- If construction closes the road at a T-Intersection the Contractor shall place the G20-6 "Contractor Name" sign behind the Type III Barricades for the road closure (see BC(10) also). The G20-1bL and G20-1bR signs shall be replaced by the detour signing called for in the plans.

TYPICAL CONSTRUCTION WARNING SIGN SIZE AND SPACING^{1,5,6}

Sign Number or Series	SIZE		SPACING	
	Conventional Road	Expressway/Freeway	Posted Speed MPH	Sign Spacing "x" (Feet (Apprx.))
CW20 CW21 CW22 CW23 CW25	48" x 48"	48" x 48"	30	120
CW1, CW2, CW7, CW8, CW9, CW11, CW14	36" x 36"	48" x 48"	45	320
			50	400
			55	500 ²
			60	600 ²
CW3, CW4, CW5, CW6, CW8-3, CW10, CW12	48" x 48"	48" x 48"	65	700 ²
			70	800 ²
			75	900 ²
			80	1000 ²
			*	*

* For typical sign spacings on divided highways, expressways and freeways, see Part 6 of the "Texas Manual on Uniform Traffic Control Devices" (TMUTCD) typical application diagrams or TCP Standard Sheets.
 Δ Minimum distance from work area to first Advance Warning sign nearest the work area and/or distance between each additional sign.

General Notes:

- Special or larger size signs may be used as necessary.
- Distance between signs should be increased as required to have 1500 feet advance warning.
- Distance between signs should be increased as required to have 1/2 mile or more advance warning.
- 36" x 36" ROAD WORK AHEAD (CW20-10) signs may be used on low volume crossroads at the discretion of the Engineer. See Note 2 under "Typical Location of Crossroad Signs".
- Only diamond shaped warning sign sizes are indicated.
- See sign size listing in "TMUTCD", Sign Appendix or the "Standard Highway Sign Designs for Texas" manual for complete list of available sign design sizes.

WORK AREAS IN MULTIPLE LOCATIONS WITHIN CSJ LIMITS

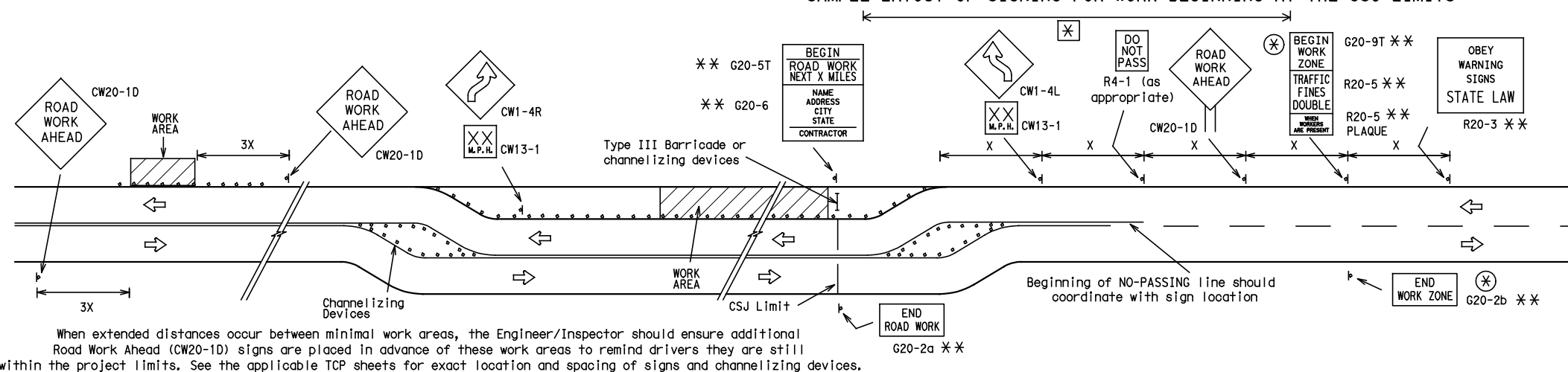

When extended distances occur between minimal work areas, the Engineer/Inspector should ensure additional Road Work Ahead (CW20-10) signs are placed in advance of these work areas to remind drivers they are still within the project limits. See the applicable TCP sheets for exact location and spacing of signs and channelizing devices.

SAMPLE LAYOUT OF SIGNING FOR WORK BEGINNING AT THE CSJ LIMITS

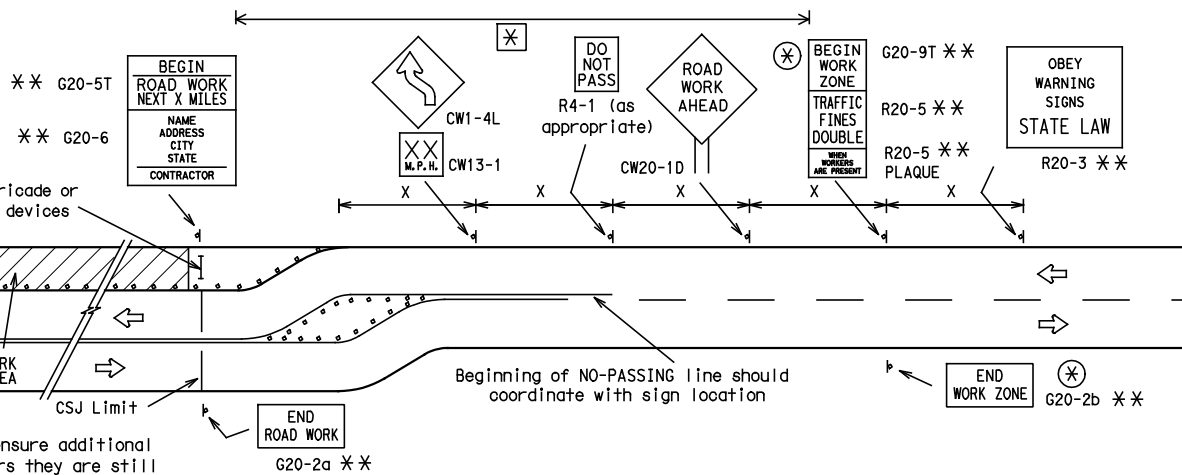

SAMPLE LAYOUT OF SIGNING FOR WORK BEGINNING DOWNSTREAM OF THE CSJ LIMITS

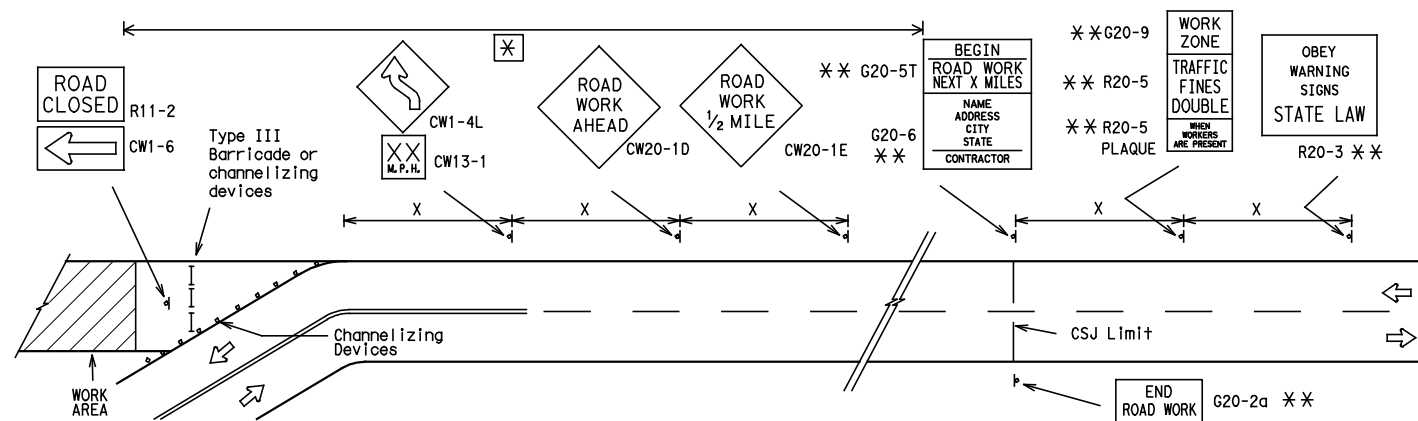

NOTES

- The Contractor shall determine the appropriate distance to be placed on the G20-1 series signs and G20-5T sign for each specific project. This distance shall replace the "X" and shall be rounded to the nearest whole mile with the approval of the Engineer. No decimals shall be used.
- ⊗ The G20-9T and G20-2b shall be used when advance signs are required outside the CSJ Limits. They inform the motorist of entering or leaving a work zone where traffic fines may double if workers are present.
- ** Required CSJ Limit signing. See Note 10 on BC(1).
- ⊗ Area for placement of "ROAD WORK AHEAD" sign and other signs or devices as called for on the Traffic Control Plan.

LEGEND

- ⊙ sign
- Channelizing Devices
- I Type III Barricade
- X See Typical Construction Warning Sign Size and Spacing chart or the TMUTCD for sign spacing requirements.

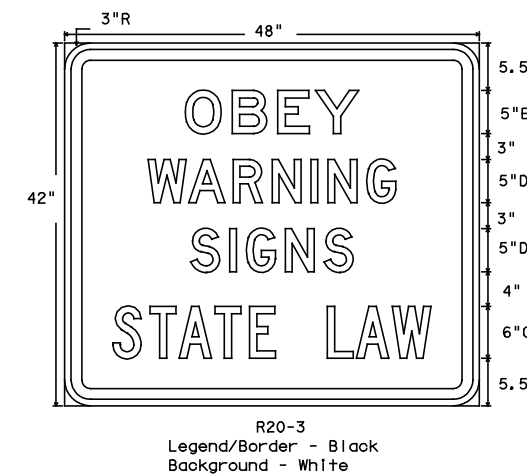

Texas Department of Transportation
 Traffic Operations Division

BARRICADE AND CONSTRUCTION PROJECT LIMIT STANDARD

2 of 12 BC(2)-07

© TxDOT 11-4-02		DN: TxDOT	CK: TxDOT	DW: TxDOT	CK: TxDOT
9-07	REVISONS	CONT	SECT	JOB	HIGHWAY
		3C	1080	103	BERNAL
		DIST	COUNTY		SHEET NO.
		PHR	HIDALGO		27

TYPICAL APPLICATION OF WORK ZONE SPEED LIMIT SIGNS

Work zone speed limits shall be regulatory, established in accordance with the "Procedures for Establishing Speed Zones," and approved by the Texas Transportation Commission, or by City Ordinance when within Incorporated City Limits.

Reduced speeds should only be posted in the vicinity of work activity and not throughout the entire project. Regulatory work zone speed signs (R2-1) shall be removed or covered during periods when they are not needed.

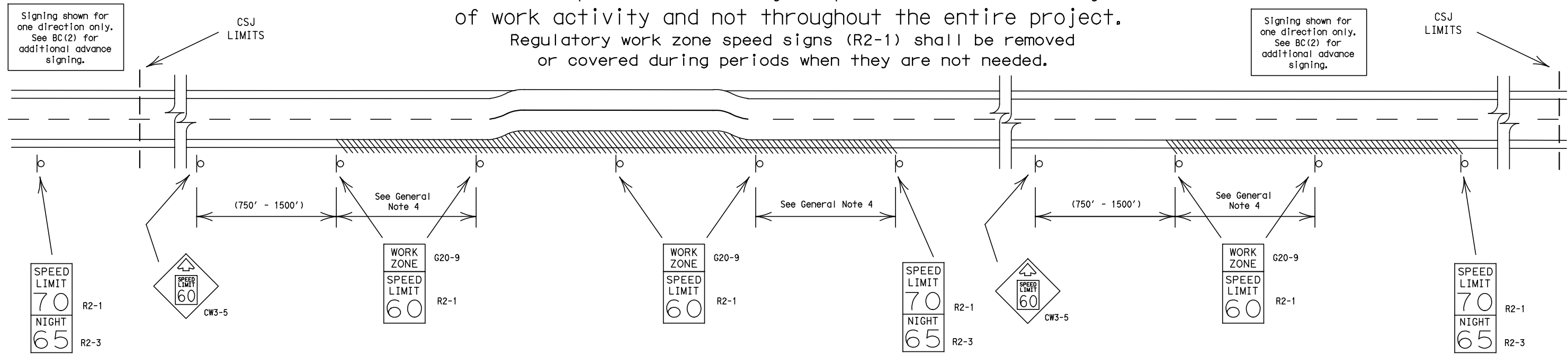

GUIDANCE FOR USE:

LONG/INTERMEDIATE TERM WORK ZONE SPEED LIMITS

This type of work zone speed limit should be included on the design of the traffic control plans when restricted geometrics with a lower design speed are present in the work zone and modification of the geometrics to a higher design speed is not feasible.

Long/Intermediate Term Work Zone Speed Limit signs, when approved as described above, should be posted and visible to the motorist when work activity is present.

Work activity may also be defined as a change in the roadway that requires a reduced speed for motorists to safely negotiate the work area, including:

- rough road or damaged pavement surface
- substantial alteration of roadway geometrics (diversions)
- construction detours
- grade
- width
- other conditions readily apparent to the driver

As long as any of these conditions exist, the work zone speed limit signs should remain in place.

SHORT TERM WORK ZONE SPEED LIMITS

This type of work zone speed limit should be included on the design of the traffic control plans when workers or equipment are not behind concrete barrier, when work activity is within 15 feet of pavement edge or actually on the pavement.

Short Term Work Zone Speed Limit signs should be posted and visible to the motorists only when work activity is present. When work activity is not present, signs shall be removed or covered. (See Removing or Covering on BC(4)).

GENERAL NOTES:

- Regulatory work zone speed limits should be used only for sections of construction projects where speed control is of major importance.
- Regulatory work zone speed limit signs shall be placed on supports at a 7 foot minimum mounting height.
- Speed zone signs are illustrated for one direction of travel and are normally posted for each direction of travel.
- Frequency of work zone speed limit signs should be:
 - 40 mph and greater 0.2 to 2 miles
 - 35 mph and less 0.2 to 1 mile
- Regulatory speed limit signs shall have black legend and border on a white reflective background (See "Reflective Sheeting" on BC(4)).
- Fabrication, erection and maintenance of the CW3-5 sign, G20-9 plaque and the R2-1 and R2-3 signs shall not be paid for directly, but shall be considered subsidiary to Item 502.
- Turning signs from view, laying signs over or down will not be allowed, unless otherwise noted.
- Techniques that may help reduce traffic speeds include but are not limited to:
 - Law enforcement.
 - Flagger stationed next to sign.
 - Portable changeable message sign (PCMS).
 - Low-power (drone) radar transmitter.
 - Speed monitor trailers or signs.
- Speeds shown on details above are for illustration only. Work Zone Speed Limits should only be posted as approved for each project.

DISCLAIMER: The use of this standard is governed by the "Texas Engineering Practice Act". No warranty of any kind is made by TxDOT for any purpose whatsoever. TxDOT assumes no responsibility for the conversion of this standard to other formats or for incorrect results or damages resulting from its use.

DATE: 3/19/2012 3:45:40 PM
FILE: p:\2009\2009-1027-02_heboap.ill_additional_colonias\design\03_e1_mesquite\csj_standards\Traffic Control\BC07.DGN



BARRICADE AND CONSTRUCTION WORK ZONE SPEED LIMIT STANDARD

3 of 12

BC(3)-07

© TxDOT 11-4-02	DN: TxDOT	CK: TxDOT	DW: TxDOT	CK: TxDOT
9-07	REVISIONS			
3C	080	103	BERNAL	
	DIST	COUNTY	SHEET NO.	
	PHR	HIDALGO	28	

DISCLAIMER: The use of this standard is governed by the "Texas Engineering Practice Act". No warranty of any kind is made by TxDOT for any purpose whatsoever. TxDOT assumes no responsibility for the conversion of this standard to other formats or for incorrect results or damages resulting from its use.

DATE: 3/19/2012 3:45:45 PM
 FILE: p:\2009\2009-1027-02_heboap_iii_additional_colonias.design\03_e1_mesquite\cs\Standards\Traffic Control\BC07.DGN

TYPICAL MINIMUM CLEARANCES FOR LONG TERM AND INTERMEDIATE TERM SIGNS

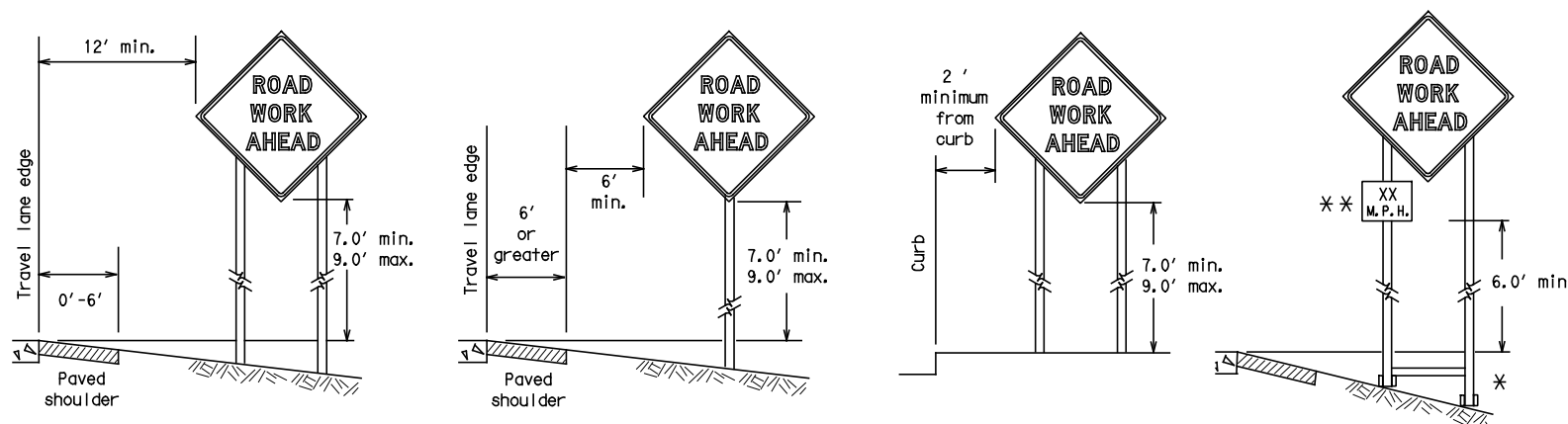

* When placing skid supports on unlevel ground, the leg post lengths must be adjusted so the sign appears straight and plumb. Objects shall NOT be placed under skids as a means of leveling.

** When plaques are placed on dual-leg supports, they should be attached to the upright nearest the travel lane. Supplemental plaques (advisory or distance) should not cover the surface of the parent sign.

ATTACHMENT FOR SIGN SUPPORTS

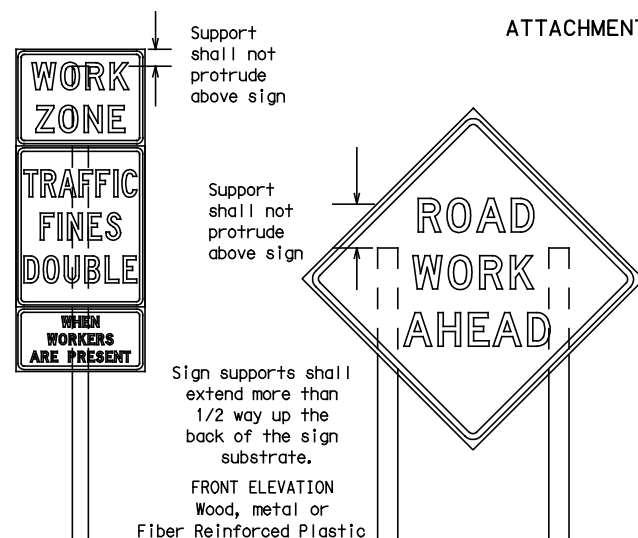

Splicing embedded perforated square metal tubing in order to extend post height will only be allowed when the splice is made using four bolts, two above and two below the splice point. Splice must be located entirely behind the sign substrate, not near the base of the support. Splice insert lengths should be at least 5 times nominal post size, centered on the splice and of at least the same gauge material.

Attachment to wooden supports will be by bolts and nuts or screws. Use TxDOT's or manufacturer's recommended procedures for attaching sign substrates to other types of sign supports

Nails will NOT be allowed.

Each sign shall be attached directly to the sign support. Multiple signs shall not be joined or spliced by any means. Wood supports shall not be extended or repaired by splicing or other means.

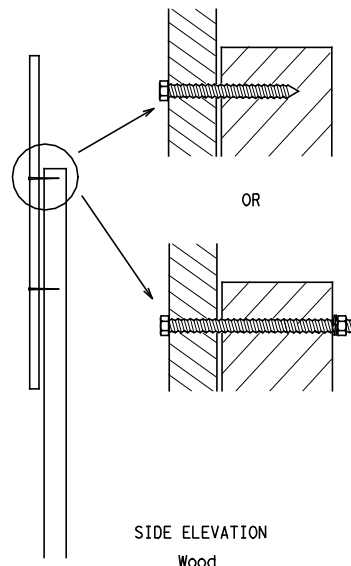

GENERAL NOTES FOR WORK ZONE SIGNS

- Contractor shall install and maintain signs in a straight and plumb condition and/or as directed by the Engineer.
- Wooden sign posts shall be painted white.
- Barricades shall NOT be used as sign supports.
- Nails shall NOT be used to attach signs to any support.
- All signs shall be installed in accordance with the plans or as directed by the Engineer. Signs shall be used to regulate, warn, and guide the traveling public safely through the work zone.
- The Contractor may furnish either the sign design shown in the plans or in the "Standard Highway Sign Designs for Texas" (SHSD). The Engineer/Inspector may require the Contractor to furnish other work zone signs that are shown in the TMUTCD but may have been omitted from the plans. Any variation in the plans shall be documented by written agreement between the Engineer and the Contractor's Responsible Person. All changes must be documented in writing before being implemented. This can include documenting the changes in the Inspector's TxDOT diary and having both the Inspector and Contractor initial and date the agreed upon changes.
- The Contractor shall furnish sign supports listed in the "Compliant Work Zone Traffic Control Device List" (CWZTCD). The Contractor shall install the sign support in accordance with the manufacturer's recommendations. If there is a question regarding installation procedures, the Contractor shall furnish the Engineer a copy of the manufacturer's installation recommendations so the Engineer can verify the correct procedures are being followed.
- The Contractor is responsible for installing signs on approved supports and replacing signs with damaged or cracked substrates and/or damaged or marred reflective sheeting as directed by the Engineer/Inspector.
- Identification markings may be shown only on the back of the sign substrate. The maximum height of letters and/or company logos used for identification shall be 1 inch.
- The Contractor shall replace damaged wood posts. New or damaged wood sign posts shall not be spliced.

DURATION OF WORK (as defined by the Texas Manual on Uniform Traffic Control Devices Part 6)

- The types of sign supports, sign mounting height, the size of signs, and the type of sign substrates can vary based on the type of work being performed. The Engineer is responsible for selecting the appropriate size sign for the type of work being performed. The Contractor is responsible for ensuring the sign support, sign mounting height and substrate meets manufacturer's recommendations in regard to crashworthiness and duration of work requirements.
 - Long-term stationary - work that occupies a location more than 3 days.
 - Intermediate-term stationary - work that occupies a location more than one daylight period up to 3 days, or nighttime work lasting more than one hour.
 - Short-term stationary - daytime work that occupies a location for more than 1 hour in a single daylight period.
 - Short, duration - work that occupies a location up to 1 hour.
 - Mobile - work that moves continuously or intermittently (stopping for up to approximately 15 minutes.)

SIGN MOUNTING HEIGHT

- The bottom of Long-term/Intermediate-term signs shall be at least 7 feet, but not more than 9 feet, above the paved surface, except as shown for supplemental plaques mounted below other signs.
- The bottom of Short-term/Short Duration signs shall be a minimum of 1 foot above the pavement surface but no more than 2 feet above the ground.
- Long-term/Intermediate-term Signs may be used in lieu of Short-term/Short Duration signing.
- Short-term/Short Duration signs shall be used only during daylight and shall be removed at the end of the workday, or raised to appropriate Long-term/Intermediate sign height.
- Regulatory signs shall be mounted at least 7 feet, but not more than 9 feet, above the paved surface regardless of work duration.

SIZE OF SIGNS

- The Engineer may allow the use of smaller size construction warning signs on secondary roads or city streets where speeds are low if the sign size is listed as an option on the "Typical Construction Warning Sign Size and Spacing" chart shown on BC(2).
- The Contractor shall furnish the sign sizes shown in plans, the BC Sheets, the TCP sheets or as directed by the Engineer.

SIGN SUBSTRATES

- The Contractor shall ensure the sign substrate is installed in accordance with the manufacturer's recommendations for the type of sign support that is being used. The CWZTCD lists each substrate that can be used on the different types and models of sign supports.
- "Mesh" type materials are NOT an approved sign substrate, regardless of the tightness of the weave.
- All wooden individual sign panels fabricated from 2 or more pieces shall have one or more plywood cleat, 1/2" thick by 6" wide, fastened to the back of the sign and extending fully across the sign. The cleat shall be attached to the back of the sign using wood screws that do not penetrate the face of the sign panel. The screws shall be placed on both sides of the splice and spaced at 6" centers. The Engineer may approve other methods of splicing the sign face.

REFLECTIVE SHEETING

- All signs shall be retroreflective and constructed of sheeting meeting the color and retro-reflectivity requirements of DMS-8300 for rigid signs or DMS-8310 for roll-up signs. The web address for DMS specifications is shown on BC(1).
- White sheeting, meeting the requirements of DMS-8300 Type C (High Specific Intensity), shall be used for signs with a white background.
- Orange sheeting, meeting the requirements of DMS-8300 Type E (Fluorescent Prismatic), shall be used for rigid signs with orange backgrounds.

SIGN LETTERS

- All sign letters and numbers shall be clear, and open rounded type uppercase alphabet letters as approved by the Federal Highway Administration (FHWA) and as published in the "Standard Highway Sign Design for Texas" manual. Signs, letters and numbers shall be of first class workmanship in accordance with Department Standards and Specifications.

REMOVING OR COVERING

- When sign messages may be confusing or do not apply, the signs shall be removed or completely covered.
- Long-term stationary or intermediate stationary signs installed on square metal tubing may be turned away from traffic 90 degrees when the sign message is not applicable. This type of sign support meets the crashworthiness standards regardless of the direction of impact. This technique may not be used for signs installed in the median of divided highways or near any intersections where the sign may be seen from approaching traffic.
- Signs installed on wooden skids shall not be turned at 90 degree angles to the roadway. These signs should be removed or completely covered when not required.
- When signs are covered, the material used shall be opaque, such as heavy mil black plastic, or other materials which will cover the entire sign face and maintain their opaque properties under automobile headlights at night, without damaging the sign sheeting.
- Burlap shall NOT be used to cover signs.
- Duct tape or other adhesive material shall NOT be affixed to a sign face. These materials can damage the retroreflectivity of sheeting.
- Signs and anchor stubs shall be removed and holes backfilled upon completion of work.

SIGN SUPPORT WEIGHTS

- Where sign supports require the use of weights to keep from turning over, the use of sandbags with dry, cohesionless sand is recommended.
- The sandbags will be tied shut to keep the sand from spilling and to maintain a constant weight.
- Rock, concrete, iron, steel or other solid objects shall not be permitted for use as sign support weights.
- Sandbags should weigh a minimum of 35 lbs and a maximum of 50 lbs.
- Sandbags shall be made of a durable material that tears upon vehicular impact.
- Rubber (such as tire inner tubes) shall NOT be used for sandbags.
- Rubber ballasts designed for channelizing devices should not be used for ballast on portable sign supports. Sign supports designed and manufactured with rubber bases may be used when shown on the CWZTCD list.
- Sandbags shall only be placed along or laid over the base supports of the traffic control device and shall not be suspended above ground level or hung with rope, wire, chains or other fasteners. Sandbags shall be placed along the length of the skids to weigh down the sign support.
- Sandbags shall NOT be placed under the skid and shall not be used to level sign supports placed on slopes.

STOP/SLOW PADDLES

- STOP/SLOW paddles are the primary method to control traffic by flaggers. The STOP/SLOW paddle size should be 24" x 24" as detailed below.
- When used at night, the STOP/SLOW paddle shall be retroreflectORIZED.
- STOP/SLOW paddles may be attached to a staff with a minimum length of 6' to the bottom of the sign.
- Any lights incorporated into the STOP or SLOW paddle faces shall only be as specifically described in Section 6E.03 Hand Signaling Devices in the TMUTCD.

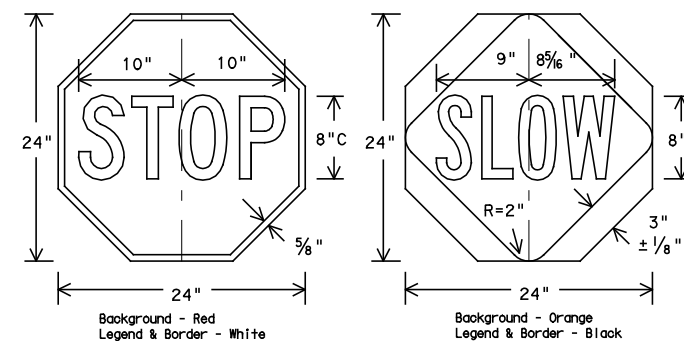

CONTRACTOR REQUIREMENTS FOR MAINTAINING PERMANENT SIGNS WITHIN THE PROJECT LIMITS

- Permanent signs are used to give notice of traffic laws or regulations, call attention to conditions that are potentially hazardous to traffic operations, show route designations, destinations, directions, distances, services, points of interest, and other geographical, recreational, or cultural information. Drivers proceeding through a work zone need the same, if not better route guidance as normally installed on a roadway without construction.
- When permanent regulatory or warning signs conflict with work zone conditions, remove or cover the permanent signs until the permanent sign message matches the roadway condition.
- When existing permanent signs are moved and relocated due to construction purposes, they shall be visible to motorists at all times.
- If existing signs are to be relocated on their original supports, they shall be installed on crashworthy bases as shown on the SMD Standard sheets. The signs shall meet the required mounting heights shown on the BC Sheets or the SMD Standards. This work should be paid for under the appropriate pay item for relocating existing signs.
- If permanent signs are to be removed and relocated using temporary supports, the Contractor shall use crashworthy supports as shown on the BC sheets or the CWZTCD. The signs shall meet the required mounting heights shown on the BC Sheets or the SMD Standards during construction. This work should be paid for under the appropriate pay item for relocating existing signs.
- Any sign or traffic control device that is struck or damaged by the Contractor or his/her construction equipment shall be replaced as soon as possible by the Contractor to ensure proper guidance for the motorists. This will be subsidiary to Item 502.



BARRICADE AND CONSTRUCTION TEMPORARY SIGN NOTES STANDARD

4 of 12

BC(4)-07

© TxDOT 11-4-02	DN: TxDOT	CK: TxDOT	DW: TxDOT	CK: TxDOT
9-07	REVISIONS	CONT	SECT	JOB
		3C	080	103
		DIST	COUNTY	SHEET NO.
		PHR	HIDALGO	29

DATE: 3/19/2012 3:46:00 PM
 FILE: p:\2009\2009-1027-02_heboap_iii_additional_colonias.design\03_el_mesquite\csj\Standards\Traffic Control\BC07.DGN
 DISCLAIMER: The use of this standard is governed by the "Texas Engineering Practice Act". No warranty of any kind is made by TxDOT for any purpose whatsoever. TxDOT assumes no responsibility for the conversion of this standard to other formats or for incorrect results or damages resulting from its use.

SKID MOUNTED WOOD SIGN SUPPORTS

LONG/INTERMEDIATE TERM STATIONARY - PORTABLE SKID MOUNTED SIGN SUPPORTS □

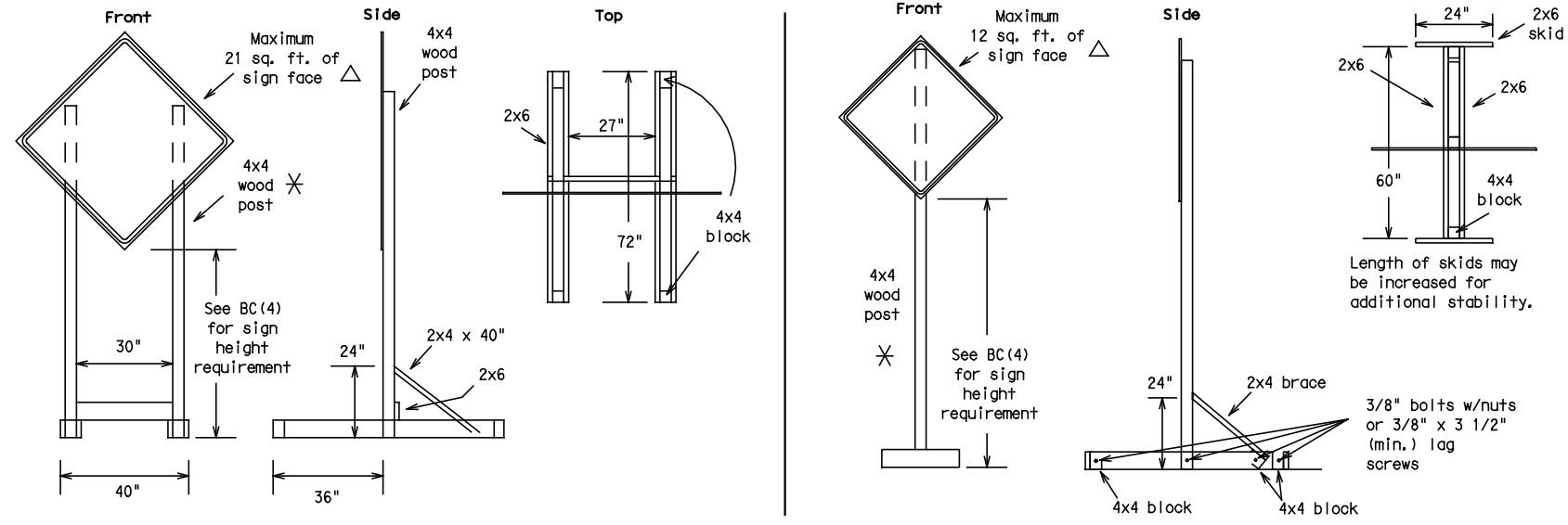

SKID MOUNTED PERFORATED SQUARE STEEL TUBING SIGN SUPPORTS

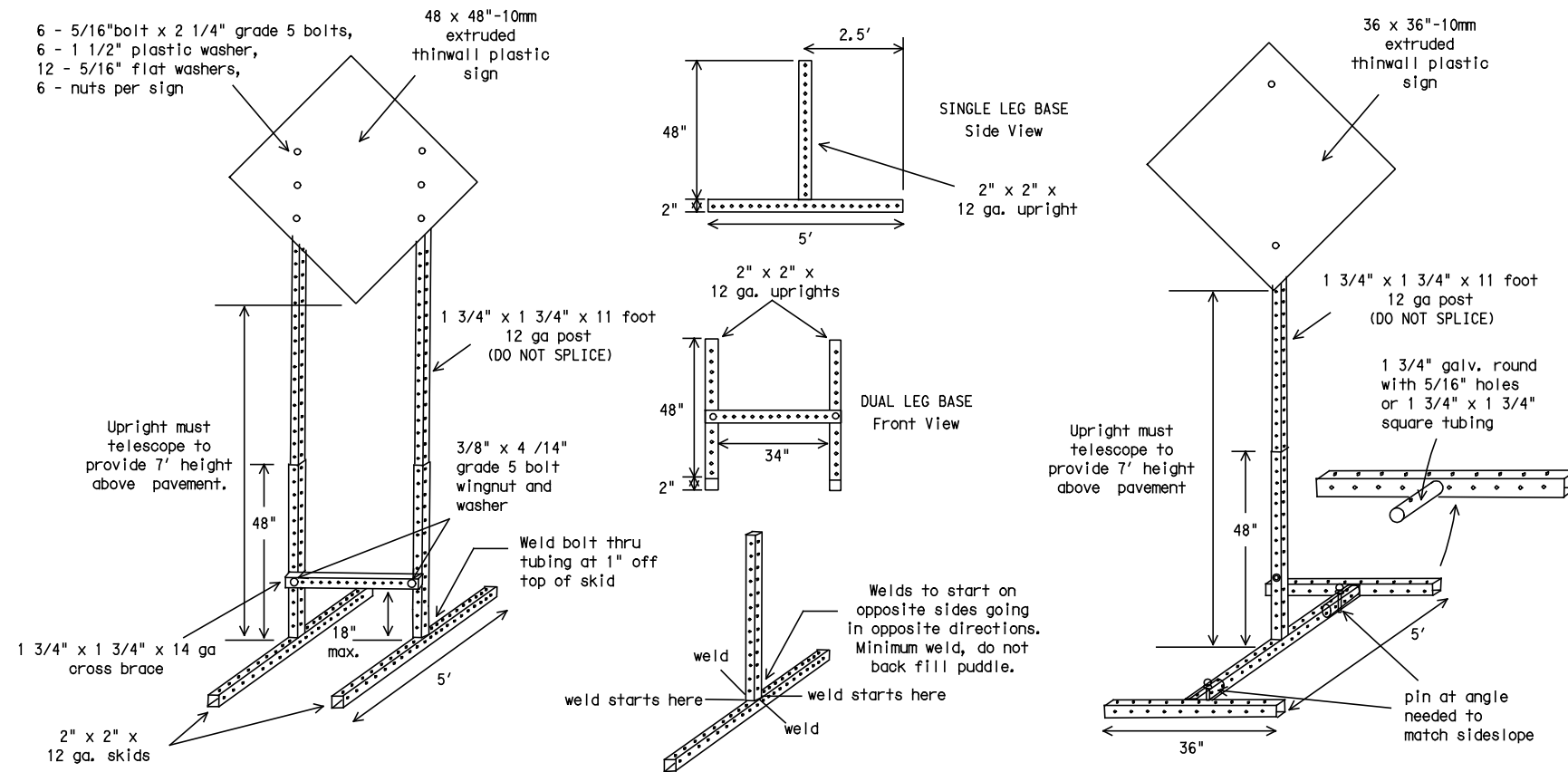

WEDGE ANCHORS

Both steel and plastic Wedge Anchor Systems as shown on the SMD Standard Sheets may be used as temporary sign supports for signs up to 10 square feet of sign face. They may be set in concrete or in sturdy soils if approved by the Engineer. (See web address for "Traffic Engineering Standard Sheets" on BC(1)).

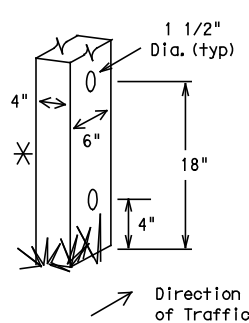

WOOD POST SYSTEM FOR GROUND MOUNTED SIGN SUPPORTS

Nominal Post Size	No. of Posts	Maximum Sq. feet of Sign Face	Minimum Soil Embedment	Drilled Hole(s) Required
4 x 4	1	12	36"	NO
4 x 4	2	21	36"	NO
4 x 6	1	21	36"	YES
4 x 6	2	36	36"	YES

GROUND MOUNTED SIGN SUPPORTS

Refer to the CWZTCD and the manufacturer's installation procedure for each type sign support. The maximum sign square footage shall adhere to the manufacturer's recommendation. Two post installations can be used for larger signs.

PERFORATED SQUARE METAL TUBING

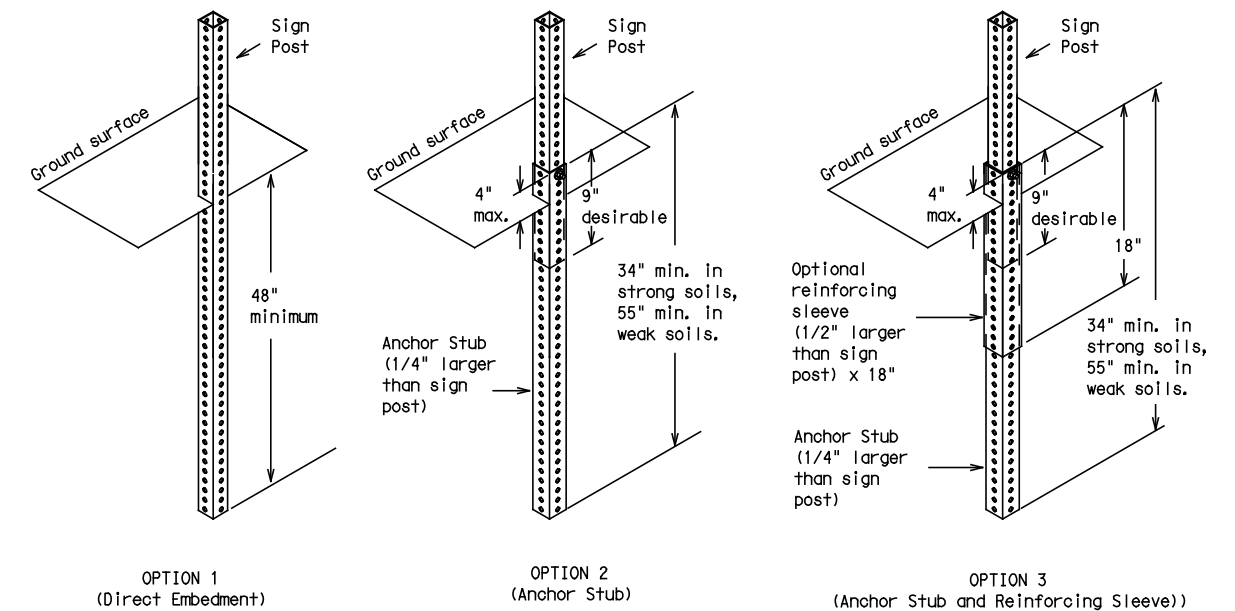

WING CHANNEL

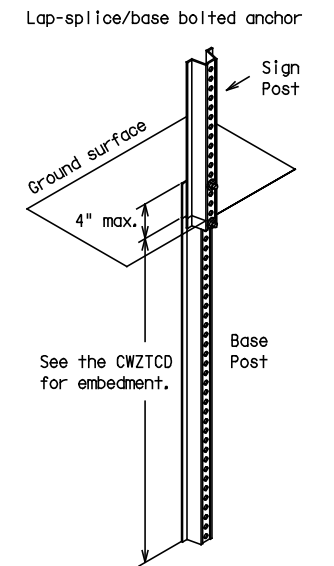

GENERAL NOTES

- Nails may be used in the assembly of wooden sign supports, but 3/8" bolts with nuts or 3/8" x 3 1/2" lag screws must be used on every joint for final connection.
- More details of approved Long/Intermediate and Short Term supports can be found on the CWZTCD list. See BC(1) for website location.
- No more than 2 sign posts shall be placed within a 7 ft. circle, except for specific materials noted on the CWZTCD List.
- When project is completed, all sign supports and foundations shall be removed from the project site. This will be considered subsidiary to Item 502.

□ See BC(4) for definition of "Work Duration."

✱ Wood sign posts MUST be one piece. Splicing will NOT be allowed. Posts shall be painted white.

△ See the CWZTCD for the type of sign substrate that can be used for each approved sign support.

Texas Department of Transportation
Traffic Operations Division

BARRICADE AND CONSTRUCTION TYPICAL SIGN SUPPORT STANDARD

5 of 12

BC(5)-07

© TxDOT 11-4-02	DW: TxDOT	CK: TxDOT	DW: TxDOT	CK: TxDOT
9-07	REVISIONS	CONT	SECT	JOB
		3C	080	103
		DIST	COUNTY	SHEET NO.
		PHR	HIDALGO	30

DATE: 3/19/2012 3:46:07 PM
 FILE: p:\2009\2009-1027-02_hboap_iii_additional_colonias\design\03_el_mesquite\csj\Standards\Traffic Control\BC07.DGN
 DISCLAIMER: The use of this standard is governed by the "Texas Engineering Practice Act". No warranty of any kind is made by TxDOT for any purpose whatsoever. TxDOT assumes no responsibility for the conversion of this standard to other formats or for incorrect results or damages resulting from its use.

PORTABLE CHANGEABLE MESSAGE SIGNS

- The Engineer/Inspector shall approve all messages used on portable changeable message signs (PCMS).
- Messages on PCMS should contain no more than 8 words (about four to eight characters per word), not including simple words such as "TO," "FOR," "AT," etc.
- Messages should consist of a single phase, or two phases that alternate. Three-phase messages are not allowed. Each phase of the message should convey a single thought, and must be understood by itself.
- Use the word "EXIT" to refer to an exit ramp on a freeway; i.e., "EXIT CLOSED." Do not use the term "RAMP."
- Always use the route or interstate designation (IH, US, SH, FM) along with the number when referring to a roadway.
- When in use the bottom of a stationary PCMS message panel should be a minimum 7 feet above the roadway, where possible.
- The message term "WEEKEND" should be used only if the work is to start on Saturday morning and end by Sunday evening at midnight. Actual days and hours of work should be displayed on the PCMS if work is to begin on Friday evening and/or continue into Monday morning.
- The Engineer/Inspector may select one of two options which are available for displaying a two-phase message on a PCMS. Each phase may be displayed for either four seconds each or for three seconds each.
- Do not "flash" messages or words included in a message. The message should be steady burn or continuous while displayed.
- Do not present redundant information on a two-phase message; i.e., keeping two lines of the message the same and changing the third line.
- Do not use the word "Danger" in message.
- Do not display the message "LANES SHIFT LEFT" or "LANES SHIFT RIGHT" on a PCMS. Drivers do not understand the message.
- Do not display messages that scroll horizontally or vertically across the face of the sign.
- The following table lists abbreviated words and two-word phrases that are acceptable for use on a PCMS. Both words in a phrase must be displayed together. Words or phrases not on this list should not be abbreviated.
- PCMS character height should be at least 18 inches for trailer mounted units. They should be visible from at least 1/2 (.5) mile and the text should be legible from at least 720 feet. Truck mounted units must have a character height of 10 inches and must be legible from at least 400 feet.
- Each line of text should be centered on the message board rather than left or right justified.
- If disabled, the PCMS should default to an illegible display that will not alarm motorists and will only be used to alert workers that the PCMS has malfunctioned. A pattern such as a series of horizontal solid bars is appropriate.

Word or Phrase	Abb.	Word or Phrase	Abb.
Access Road	ACCS RD	Major	MAJ
Air Quality	AIR QLT	Miles	MI
Alternate	ALT	Miles Per Hour	MPH
Avenue	AVE	Minor	MNR
Best Route	BEST RTE	Monday	MON
Boulevard	BLVD	Normal	NORM
Bridge	BRDG	North	N
Cannot	CANT	Northbound	(route) N
Center	CNTR	Parking	PKING
Construction Ahead	CONST AHEAD	Parking Lot	PRK LOT
Detour Route	DETOUR RTE	Road	RD
Do Not	DONT	Right Lane	RGT LN
East	E	Saturday	SAT
Eastbound	(route) E	Service Road	SERV RD
Emergency	EMER	Shoulder	SHLDR
Emergency Vehicle	EMER VEH	Slippery	SLIP
Entrance, Enter	ENT	South	S
Express Lanes	EXP LANE	Southbound	(route) S
Expressway	EXPWY	Speed	SPD
XXXX Feet	XXXX FT	Street	ST
Fog Ahead	FOG AHD	Sunday	SUN
Freeway	FRWY, FWY	Telephone	PHONE
Freeway Blocked	FWY BLKD	Temporary	TEMP
Friday	FRI	Thursday	THURS
Hazardous Driving	HAZ DRIVING	To Downtown	TO DWN TN
Hazardous Material	HAZMAT	Traffic	TRAF
High-Occupancy Vehicle	HOV	Travelers	TRV LRS
Highway	HWY	Tuesday	TUES
Hours	HR	Time Minutes	TIME MIN
Information	INFO	Upper Level	UPPR LVL
It Is	ITS	Vehicle	VEH
Junction	JCT	Warning	WARN
Left	LFT	Wednesday	WED
Left Lane	LFT LN	Weight Limit	WT LIMIT
Lane Closed	LN CLSD	West	W
Lower Level	LOWR LVL	Westbound	(route) W
Maintenance	MAINT	Wet Pavement	WET PVMT
		Will Not	WONT

Roadway designation # IH-number, US-number, SH-number, FM-number

WHEN NOT IN USE, REMOVE THE PCMS FROM THE RIGHT-OF-WAY OR PLACE THE PCMS BEHIND BARRIER OR GUARDRAIL WITH SIGN PANEL TURNED PARALLEL TO TRAFFIC

RECOMMENDED PHASES AND FORMATS FOR PCMS MESSAGES DURING ROADWORK ACTIVITIES

(The Engineer may approve other messages not specifically covered here.)

Phase 1: Condition Lists

Road/Lane/Ramp Closure List

FREEWAY CLOSED X MILE
ROAD CLOSED AT SH XXX
ROAD CLSD AT FM XXXX
RIGHT X LANES CLOSED
CENTER LANE CLOSED
NIGHT LANE CLOSURES
VARIOUS LANES CLOSED
EXIT CLOSED
MALL DRIVEWAY CLOSED
XXXXXXXXX BLVD CLOSED

Other Condition List

FRONTAGE ROAD CLOSED	ROADWORK XXX FT	ROAD REPAIRS XXXX FT
SHOULDER CLOSED XXX FT	FLAGGER XXXX FT	LANE NARROWS XXXX FT
RIGHT LN CLOSED XXX FT	RIGHT LN NARROWS XXXX FT	TWO-WAY TRAFFIC XX MILE
RIGHT X LANES OPEN	MERGING TRAFFIC XXXX FT	CONST TRAFFIC XXX FT
DAYTIME LANE CLOSURES	LOOSE GRAVEL XXXX FT	UNEVEN LANES XXXX FT
I-XX SOUTH EXIT CLOSED	DETOUR X MILE	ROUGH ROAD XXXX FT
EXIT XXX CLOSED X MILE	ROADWORK PAST SH XXXX	ROADWORK NEXT FRI-SUN
RIGHT LN TO BE CLOSED	BUMP XXXX FT	US XXX EXIT X MILES
X LANES CLOSED TUE - FRI	TRAFFIC SIGNAL XXXX FT	LANES SHIFT *

* LANES SHIFT in Phase 1 must be used with STAY IN LANE in Phase 2.

Application Guidelines

- Only 1 or 2 phases are to be used on a PCMS.
- The 1st phase (or both) should be selected from the "Road/Lane/Ramp Closure List" and the "Other Condition List".
- A 2nd phase can be selected from the "Action to Take/Effect on Travel, Location, General Warning, or Advance Notice Phase Lists".
- A Location Phase is necessary only if a distance or location is not included in the first phase selected.
- If two PCMS are used in sequence, they must be separated by a minimum of 1000 ft. Each PCMS shall be limited to two phases, and should be understandable by themselves.
- For advance notice, when the current date is within seven days of the actual work date, calendar days should be replaced with days of the week. Advance notification should typically be for no more than one week prior to the work

Phase 2: Possible Component Lists

Action to Take/Effect on Travel List

MERGE RIGHT	FORM X LINES RIGHT
DETOUR NEXT X EXITS	USE XXXXX RD EXIT
USE EXIT XXX	USE EXIT I-XX NORTH
STAY ON US XXX SOUTH	USE I-XX E TO I-XX N
TRUCKS USE US XXX N	WATCH FOR TRUCKS
WATCH FOR TRUCKS	EXPECT DELAYS
EXPECT DELAYS	PREPARE TO STOP
REDUCE SPEED XXX FT	END SHOULDER USE
USE OTHER ROUTES	WATCH FOR WORKERS
STAY IN LANE *	

Location List

AT FM XXXX
BEFORE RAILROAD CROSSING
NEXT X MILES
PAST US XXX EXIT
XXXXXXXXX TO XXXXXXXX
US XXX TO FM XXXX

Warning List

SPEED LIMIT XX MPH
MAXIMUM SPEED XX MPH
MINIMUM SPEED XX MPH
ADVISORY SPEED XX MPH
RIGHT LANE EXIT
USE CAUTION
DRIVE SAFELY
DRIVE WITH CARE

** Advance Notice List

TUE-FRI XX AM-X PM
APR XX-XX X PM-X AM
BEGINS MONDAY
BEGINS MAY XX
MAY X-X XX PM - XX AM
NEXT FRI-SUN
XX AM TO XX PM
NEXT TUE AUG XX
TONIGHT XX PM-XX AM

** See Application Guidelines Note 6.

Wording Alternatives

- The words RIGHT, LEFT and ALL can be interchanged as appropriate.
- Roadway designations IH, US, SH, FM and LP can be interchanged as appropriate.
- EAST, WEST, NORTH and SOUTH (or abbreviations E, W, N and S) can be interchanged as appropriate.
- Highway names and numbers replaced as appropriate.
- ROAD, HIGHWAY and FREEWAY can be interchanged as needed.
- AHEAD may be used instead of distances if necessary.
- FT and MI, MILE and MILES interchanged as appropriate.
- AT, BEFORE and PAST interchanged as needed.
- Distances or AHEAD can be eliminated from the message if a location phase is used.

PCMS SIGNS WITHIN THE R.O.W. SHALL BE BEHIND GUARDRAIL OR CONCRETE BARRIER OR SHALL HAVE A MINIMUM OF FOUR (4) PLASTIC DRUMS PLACED PERPENDICULAR TO TRAFFIC ON THE UPSTREAM SIDE OF THE PCMS.

FULL MATRIX PCMS SIGNS

- When Full Matrix PCMS signs are used, the character height and legibility/visibility requirements shall be maintained as listed in Note 15 under "PORTABLE CHANGEABLE MESSAGE SIGNS" above.
- When symbol signs, such as the CW20-7a Flagger Symbol, are represented graphically on the Full Matrix PCMS sign and, with the approval of the Engineer, it shall maintain the legibility/visibility requirement listed above.
- When symbol signs are represented graphically on the Full Matrix PCMS, they shall only supplement the use of the static sign represented, and shall not substitute for, or replace that sign.
- A full matrix PCMS may be used to simulate a flashing arrow panel provided it meets the visibility, flash rate and dimming requirements on BC(7), for the same size arrow.



BARRICADE AND CONSTRUCTION PORTABLE CHANGEABLE MESSAGE SIGN (PCMS) STANDARD

6 of 12 BC(6)-07

© TxDOT 11-4-02	DNF: TxDOT	CK: TxDOT	DW: TxDOT	CK: TxDOT
9-07	REVISONS	CONT	SECT	JOB
		3C	1080	103
		DIST	COUNTY	SHEET NO.
		PHR	HIDALGO	31

DATE: 3/19/2012 3:46:17 PM
 FILE: p:\2009\2009-1027-02_heboap_iii_additional_colonias\design\03_el_mesquite\cs\Standards\Traffic Control\BC07.DGN
 DISCLAIMER: The use of this standard is governed by the "Texas Engineering Practice Act". No warranty of any kind is made by TxDOT for any purpose whatsoever. TxDOT assumes no responsibility for the conversion of this standard to other formats or for incorrect results or damages resulting from its use.

BARRIER REFLECTORS FOR CONCRETE TRAFFIC BARRIER AND ATTENUATORS

- Barrier Reflectors shall be prequalified, and conform to the color and reflectivity requirements of DMS-8600. A list of prequalified Barrier Reflectors (Type C Delineators) can be found at the Material Producer List web address shown on BC(1).
- Color of Barrier Reflectors shall be as specified in the TMUTCD. The cost of the reflectors shall be considered subsidiary to Item 502.

CONCRETE TRAFFIC BARRIER (CTB)

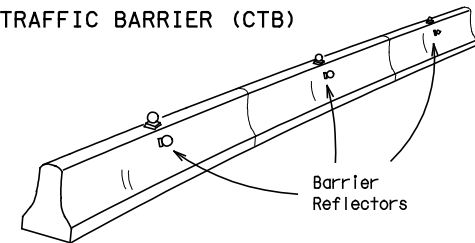

- Where traffic is on one side of the CTB, two (2) Barrier Reflectors shall be mounted in approximately the midsection of each section of CTB. An alternate mounting location is uniformly spaced at one end of each CTB. This will allow for attachment of a barrier grapple without damaging the reflector. The Barrier Reflector mounted on the side of the CTB shall be located directly below the reflector mounted on top of the barrier, as shown in the detail above.
- Where CTB separates two-way traffic, three barrier reflectors shall be mounted on each section of CTB. The reflector unit on top shall have two yellow reflective faces (Bi-Directional) while the reflectors on each side of the barrier shall have one yellow reflective face, as shown in the detail above.
- When CTB separates traffic traveling in the same direction, no barrier reflectors will be required on top of the CTB.
- Barrier Reflector units shall be yellow or white in color to match the edgeline being supplemented. Yellow Barrier Reflectors shall be made with Type E Fluorescent Prismatic Yellow Retroreflective Sheeting. White reflectors shall be made with Type D White Prismatic sheeting.
- Maximum spacing of Barrier Reflectors is forty (40) feet.
- Pavement markers or temporary flexible-reflective roadway marker tabs shall NOT be used as CTB delineation.
- Attachment of Barrier Reflectors to CTB shall be per manufacturer's recommendations.
- Missing or damaged Barrier Reflectors shall be replaced as directed by the Engineer.
- Single slope barriers shall be delineated as shown on the above detail.

LOW PROFILE CONCRETE BARRIER (LPCB)

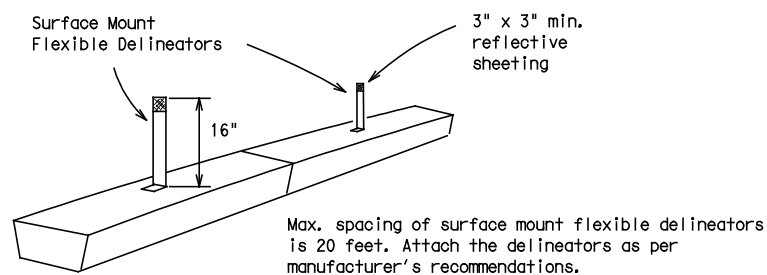

DELINEATION OF END TREATMENTS

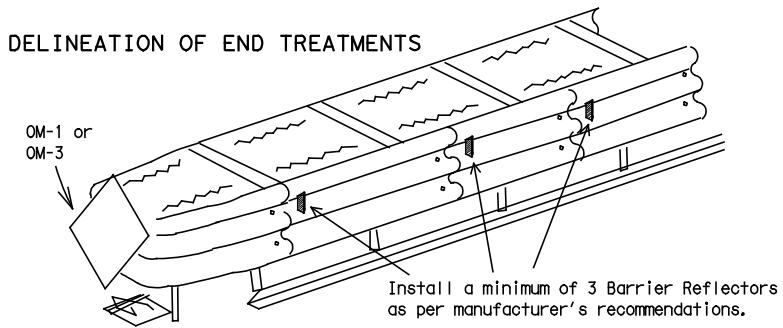

	APPROACHING TRAFFIC	
	BOTH SIDES	ONE SIDE
DELINEATION	OM-1	OM-3 or Vertical Panel

END TREATMENTS FOR CTB'S USED IN WORK ZONES

End treatments used on CTB's in work zones shall meet crashworthy standards as defined in the National Cooperative Highway Research Report 350. Refer to the CWZTCD List for approved end treatments and manufacturers.

TYPICAL FLASHING ARROW PANEL

Arrow Panels may be located behind channelizing devices in place for a shoulder taper or merging taper, otherwise they shall be delineated with four (4) channelizing devices placed perpendicular to traffic on the upstream side of traffic.

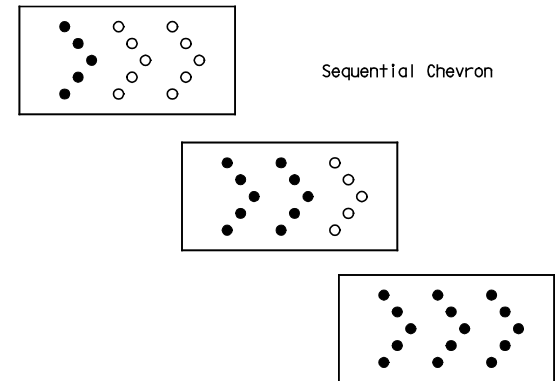

- The Flashing Arrow Panel should be used for all lane closures on multi-lane roadways, or slow moving maintenance or construction activities on the travel lanes.
- Flashing Arrow Panels should not be used on two-lane, two-way roadways, detours, diversions or work on shoulders unless the "CAUTION" display (see detail below) is used.
- The Engineer/Inspector shall choose all appropriate signs, barricades and/or other traffic control devices that should be used in conjunction with the Flashing Arrow Panel.
- The Flashing Arrow Panel should be able to display the following symbols:

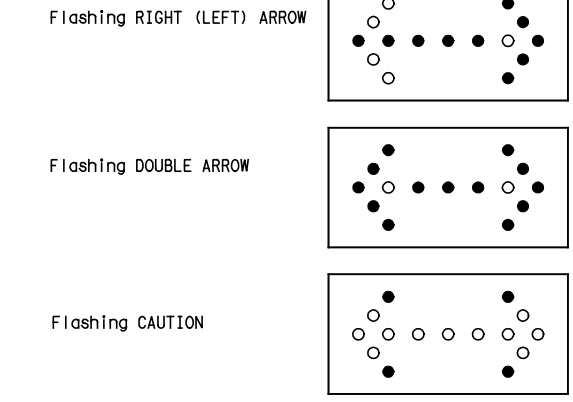

TYPE	REQUIREMENTS		MINIMUM VISIBILITY DISTANCE
	MINIMUM SIZE	MINIMUM NUMBER OF PANEL LAMPS	
B	30 x 60	13	3/4 mile
C	48 x 96	15	1 mile

ATTENTION: Flashing Arrow Panels shall be equipped with automatic dimming devices.

WHEN NOT IN USE, REMOVE THE ARROW PANEL FROM THE RIGHT-OF-WAY OR PLACE THE ARROW PANEL BEHIND CONCRETE TRAFFIC BARRIER OR GUARDRAIL.

- The "CAUTION" display consists of four corner lamps flashing simultaneously.
- The straight line caution display is NOT ALLOWED.
- The Flashing Arrow Panel shall be capable of minimum 50 percent dimming from rated lamp voltage. The flashing rate of the lamps shall not be less than 25 nor more than 40 flashes per minute.
- Minimum lamp "on time" shall be approximately 50 percent for the flashing arrow and equal intervals of 25 percent for each sequential phase of the flashing chevron.
- The sequential arrow display is NOT ALLOWED.
- The flashing arrow display is the TxDOT standard; however, the sequential Chevron display may be used during daylight operations.

- The Flashing Arrow Panel shall be mounted on a vehicle, trailer or other suitable support.
- A Flashing Arrow Panel SHALL NOT BE USED to laterally shift traffic.
- A full matrix PCMS may be used to simulate a Flashing Arrow Panel provided it meets visibility, flash rate and dimming requirements on this sheet for the same size arrow.
- Minimum mounting height of trailer mounted arrow panels should be 7 feet from roadway to bottom of panel.

WARNING LIGHTS

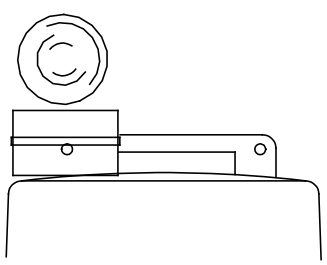

Type C Warning Light or approved substitute mounted adjacent to the travel way.

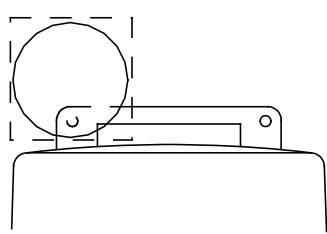

Warning reflector may be round or square. Must have a reflective surface area of at least 30 square inches

- Warning lights shall meet the requirements of the TMUTCD.
- Warning lights shall NOT be installed on barricades.
- Type A-Low Intensity Flashing Warning Lights are commonly used with drums. They are intended to warn of or mark a potentially hazardous area. Their use shall be as indicated on this sheet and/or other sheets of the plans by the designation "FL". The Type A Warning Lights shall not be used with signs manufactured with Type E Sheeting (Fluorescent Prismatic) meeting the requirements of Departmental Material Specification DMS-8300.
- Type-C and Type D 360 degree Steady Burn Lights are intended to be used in a series for delineation to supplement other traffic control devices. Their use shall be as indicated on this sheet and/or other sheets of the plans by the designation "SB".
- The Engineer/Inspector or the plans shall specify the location and type of warning lights to be installed on the traffic control devices.
- When required by the Engineer, the Contractor shall furnish a copy of the warning lights certification. The warning light manufacturer will certify the warning lights meet the requirements of the latest ITE Purchase Specifications for Flashing and Steady-Burn Warning Lights.
- When used to delineate curves, Type-C and Type D Steady Burn Lights should only be placed on the outside of the curve, not the inside.

WARNING LIGHTS MOUNTED ON PLASTIC DRUMS

- Type A flashing warning lights are intended to warn drivers that they are approaching or are in a potentially hazardous area.
- Type A random flashing warning lights are not intended for delineation and shall not be used in a series.
- A series of sequential flashing warning lights placed on channelizing devices to form a merging taper may be used for delineation. If used, the successive flashing of the sequential warning lights should occur from the beginning of the taper to the end of the merging taper in order to identify the desired vehicle path. The rate of flashing for each light shall be 65 flashes per minute, plus or minus 10 flashes.
- Type C and D steady-burn warning lights are intended to be used in a series to delineate the edge of the travel lane on detours, on lane changes, on lane closures, and on other similar conditions.
- Type A, Type C and Type D warning lights shall be installed at locations as detailed on other sheets in the plans.
- Warning lights shall not be installed on a drum that has a sign, chevron or vertical panel.
- The maximum spacing for warning lights on drums should be identical to the channelizing device spacing.

WARNING REFLECTORS MOUNTED ON PLASTIC DRUMS AS A SUBSTITUTE FOR TYPE C (STEADY BURN) WARNING LIGHTS

- A warning reflector or approved substitute may be mounted on a plastic drum as a substitute for a Type C, steady burn warning light at the discretion of the Contractor unless otherwise noted in the plans.
- The warning reflector shall be yellow in color and shall be manufactured using a sign substrate approved for use with plastic drums listed on the CWZTCD.
- The warning reflector shall have a minimum retroreflective surface area (one-side) of 30 square inches.
- Round reflectors shall be fully reflectorized, including the area where attached to the drum.
- Square substrates must have a minimum of 30 square inches of reflectorized sheeting. They do not have to be reflectorized where it attaches to the drum.
- The side of the warning reflector facing approaching traffic shall have sheeting meeting the color and retroreflectivity requirements for DMS 8300-Type D (Non-fluorescent Prismatic).
- When used near two-way traffic, both sides of the warning reflector shall be reflectorized.
- The warning reflector should be mounted on the side of the handle nearest approaching traffic.
- The maximum spacing for warning reflectors should be identical to the channelizing device spacing requirements.

TRUCK-MOUNTED ATTENUATORS

- Truck-mounted attenuators (TMA) used on TxDOT facilities must meet the requirements outlined in the National Cooperative Highway Research Report No. 350 (NCHRP 350).
- Refer to the CWZTCD for the requirements of Level 2 or Level 3 TMAs.
- Refer to the dates shown in the CWZTCD to ensure that the TMA meets the age requirements and the crashworthiness criteria established by the Federal Highway Administration (FHWA) for TMAs.
- Refer to the CWZTCD for a list of approved TMAs.
- TMAs are required on freeways unless otherwise noted in the plans.
- A TMA should be used anytime that it can be positioned approximately 30 to 100 feet in advance of the area of crew exposure without adversely affecting the work performance.
- The only reason a TMA should not be required is when a work area is spread down the roadway and the work crew is an extended distance from the TMA.

Texas Department of Transportation
Traffic Operations Division

BARRICADE AND CONSTRUCTION ARROW PANEL, REFLECTORS, WARNING LIGHTS & ATTENUATOR STANDARD

7 of 12 BC(7)-07

© TxDOT 11-4-02		DN: TxDOT	CK: TxDOT	DW: TxDOT	CK: TxDOT
9-07	REVISIONS	CONT	SECT	JOB	HIGHWAY
		3C	1080	103	BERNAL
		DIST	COUNTY		SHEET NO.
		PHR	HIDALGO		32

DATE: 3/19/2012 3:46:29 PM
 FILE: p:\2009\2009-1027-02_heboap_iii_additional_colonias\design\03_el_mesquite\csj\Standards\Traffic Control\BC07.DGN
 DISCLAIMER: The use of this standard is governed by the "Texas Engineering Practice Act". No warranty of any kind is made by TxDOT for any purpose whatsoever. TxDOT assumes no responsibility for the conversion of this standard to other formats or for incorrect results or damages resulting from its use.
 BC07.DGN

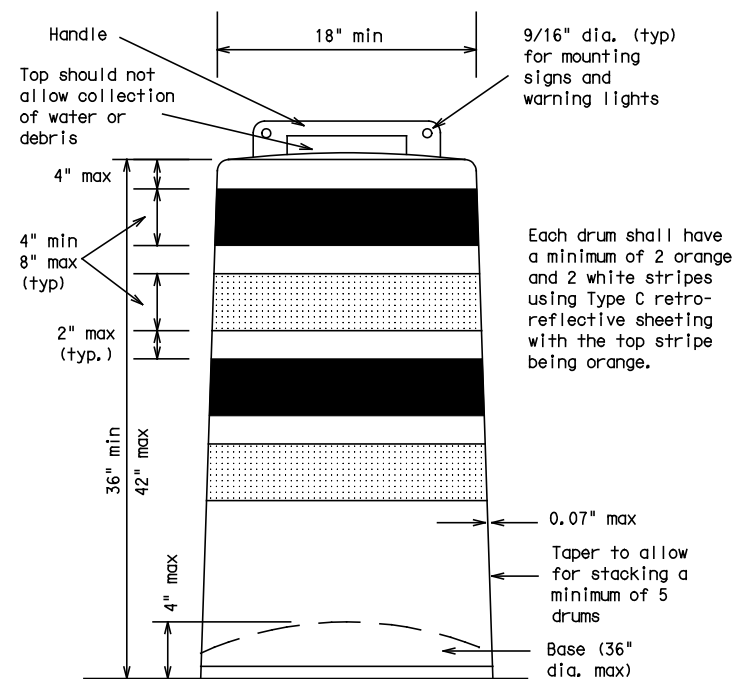

GENERAL NOTES

- For long term stationary work zones on freeways, drums shall be used as the primary channelizing device.
- For intermediate term stationary work zones on freeways, drums should be used as the primary channelizing device but may be replaced in tangent sections by vertical panels, or 42" two-piece cones. In tangent sections one-piece cones may be used with the approval of the Engineer but only if personnel are present on the project at all times to maintain the cones in proper position and location.
- For short term stationary work zones on freeways, drums are the preferred channelizing device but may be replaced in tapers, transitions and tangent sections by vertical panels, two-piece cones or one-piece cones as approved by the Engineer.
- Drums and all related items shall comply with the requirements of the current version of the "Texas Manual on Uniform Traffic Control Devices" (TMUTCD) and the "Compliant Work Zone Traffic Control Devices List" (CWZTCD).
- Drums, bases, and related materials shall exhibit good workmanship and shall be free from objectionable marks or defects that would adversely affect their appearance or serviceability.
- The Contractor shall have a maximum of 24 hours to replace any plastic drums identified for replacement by the Engineer/Inspector. The replacement device must be an approved device.

GENERAL DESIGN REQUIREMENTS

Prequalified plastic drums shall meet the following requirements:

- Plastic drums shall be a two-piece design; the "body" of the drum shall be the top portion and the "base" shall be the bottom.
- The body and base shall lock together in such a manner that the body separates from the base when impacted by a vehicle traveling at a speed of 20 MPH or greater but prevents accidental separation due to normal handling and/or air turbulence created by passing vehicles.
- Plastic drums shall be constructed of lightweight flexible, and deformable materials. The Contractor shall NOT use metal drums or single piece plastic drums as channelization devices or sign supports.
- Drums shall present a profile that is a minimum of 18 inches in width at the 36 inch height when viewed from any direction. The height of drum unit (body installed on base) shall be a minimum of 36 inches and a maximum of 42 inches.
- The top of the drum shall have a built-in handle for easy pickup and shall be designed to drain water and not collect debris. The handle shall have a minimum of two widely spaced 9/16 inch diameter holes to allow attachment of a warning light, warning reflector unit or approved compliant sign.
- The exterior of the drum body shall have a minimum of four alternating orange and white retroreflective circumferential stripes not less than 4 inches nor greater than 8 inches in width. Any non-reflectORIZED space between any two adjacent stripes shall not exceed 2 inches in width.
- Bases shall have a maximum width of 36 inches, a maximum height of 4 inches, and a minimum of two footholds of sufficient size to allow base to be held down while separating the drum body from the base.
- Plastic drums shall be constructed of ultra-violet stabilized, orange, high-density polyethylene (HDPE) or other approved material.

- Drum body shall have a minimum unballasted weight of 7.7 lbs. and maximum unballasted weight of 11 lbs. The wall of the drum body shall be a minimum of 0.07 inch in thickness. Weight of any drum supplied shall not vary more than 0.5 lb. from that of the prequalified sample.
- Drum and base shall be marked with manufacturer's name and model number.

RETROREFLECTIVE SHEETING

- The stripes used on drums shall be constructed of sheeting meeting the color and retroreflectivity requirements of Departmental Materials Specification DMS-8300, "Flat Surface Reflective Sheeting." High Specific Intensity (Type C) retroreflective sheeting shall be supplied unless otherwise specified in the plans.
- The sheeting shall be suitable for use on and shall adhere to the drum surface such that, upon vehicular impact, the sheeting shall remain adhered in-place and exhibit no delaminating, cracking, or loss of retroreflectivity other than that loss due to abrasion of the sheeting surface.

BALLAST

- Unballasted bases shall be large enough to hold up to 50 lbs. of sand. This base, when filled with the ballast material, should weigh between 35 lbs (minimum) and 50 lbs (maximum). The ballast may be sand in one to three sandbags separate from the base, sand in a sand-filled plastic base, or other ballasting devices as approved by the Engineer. Stacking of sandbags will be allowed, however height of sandbags above pavement surface may not exceed 12 inches.
- Bases with built-in ballast shall weigh between 40 lbs. and 50 lbs. Built-in ballast can be constructed of an integral crumb rubber base or a solid rubber base.
- The ballast shall not be heavy objects, water, or any material that would become hazardous to motorists, pedestrians, or workers when the drum is struck by a vehicle.
- When used in regions susceptible to freezing, drums shall have drainage holes in the bottoms so that water will not collect and freeze becoming a hazard when struck by a vehicle.
- Ballast shall not be placed on top of drums.
- Adhesives may be used to secure base of drums to pavement.

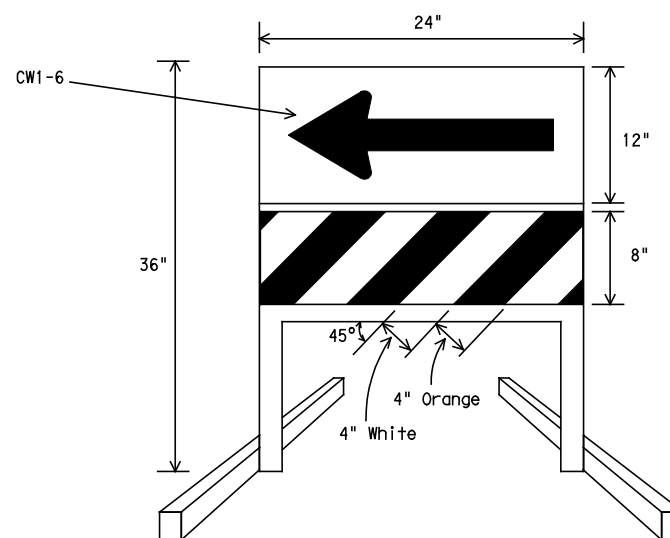

DIRECTION INDICATOR BARRICADE

- The Direction Indicator Barricade may be used in tapers, transitions, and other areas where specific directional guidance to drivers is necessary.
- If used, the Direction Indicator Barricade should be used in series to direct the driver through the transition and into the intended travel lane.
- The Direction Indicator Barricade shall consist of One-Direction Large Arrow (CW1-6) sign in the size shown with a black arrow on a background of Type E Fluorescent Prismatic Orange above a rail with Type C High Specific Intensity retroreflective sheeting in alternation 4" white and orange stripes sloping downward at an angle of 45 degrees in the direction road users are to pass.
- Double arrows on the Direction Indicator Barricade will not be allowed.
- Approved manufacturers are shown on the CWZTCD List. Ballast shall be as approved by the manufacturers instructions.

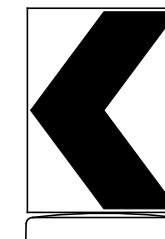

18" x 24" Sign
(Maximum Sign Dimension)
Chevron CW1-8, Opposing Traffic Lane Divider, Driveway sign D70a, Keep Right R4 series or other signs as approved by Engineer

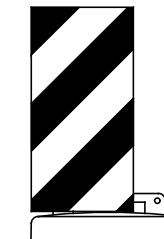

12" x 24" Vertical Panel
mount with diagonals sloping down towards travel way

Plywood, Aluminum or Metal sign substrates shall NOT be used on plastic drums

SIGNS, CHEVRONS, AND VERTICAL PANELS MOUNTED ON PLASTIC DRUMS

- Signs used on plastic drums shall be manufactured using substrates listed on the CWZTCD.
- Chevrons and other work zone signs with an orange background shall be manufactured with Type E (Fluorescent Prismatic) sheeting meeting the color and retroreflectivity requirements of DMS-8300, "Sign Face Material," unless otherwise specified in the plans.
- Vertical Panels shall be manufactured with orange and white sheeting meeting the requirements of DMS-8300 Type C (High Specific Intensity). Diagonal stripes on Vertical Panels shall slope down toward the intended traveled lane.
- Other sign messages (text or symbolic) may be used as approved by the Engineer. Sign dimensions shall not exceed 18 inches in width or 24 inches in height.
- Signs shall be installed using a 1/2 inch bolt (nominal) and nut, two washers, and one locking washer for each connection.
- Mounting bolts and nuts shall be fully engaged and adequately torqued. Bolts should not extend more than 1/2 inch beyond nuts.
- Chevrons may be placed on drums on the outside of curves, on merging tapers or on shifting tapers. When used in these locations they may be placed on every drum or spaced not more than on every third drum. A minimum of three (3) should be used at each location called for in the plans.
- R9-9, R9-10, R9-11 and R9-11a Sidewalk Closed signs which are 24 inches wide may be mounted on plastic drums, with approval of the Engineer.



BARRICADE AND CONSTRUCTION CHANNELIZING DEVICES STANDARD

8 of 12

BC(8)-07

© TxDOT 11-4-02		DW: TxDOT	CK: TxDOT	DW: TxDOT	CK: TxDOT
4-03	REVISIONS	CONT	SECT	JOB	HIGHWAY
9-07		3C	1080	103	BERNAL
		DIST	COUNTY		SHEET NO.
		PHR	HIDALGO		33

DATE: 3/19/2012 3:46:39 PM
 FILE: p:\2009\2009-1027-02 hobcap.iii additional_colonias.design\03 el mesquite\csj\Standards\Traffic Control\BC07.DGN
 DISCLAIMER: The use of this standard is governed by the "Texas Engineering Practice Act". No warranty of any kind is made by TxDOT for any purpose whatsoever. TxDOT assumes no responsibility for the conversion of this standard to other formats or for incorrect results or damages resulting from its use.

CHANNELIZING DEVICES

VERTICAL PANELS (VPs)

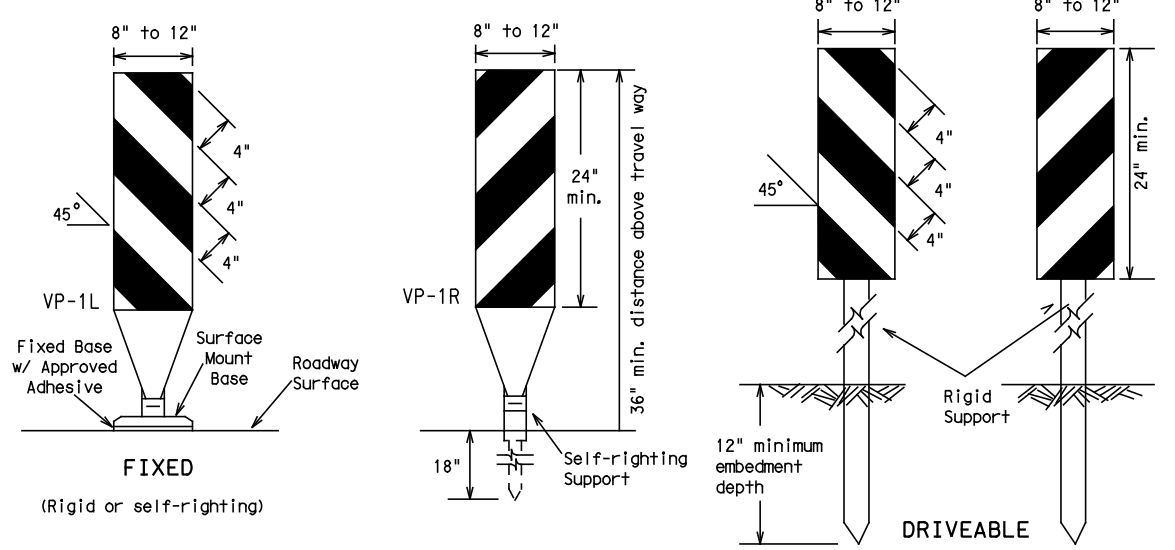

CHEVRONS

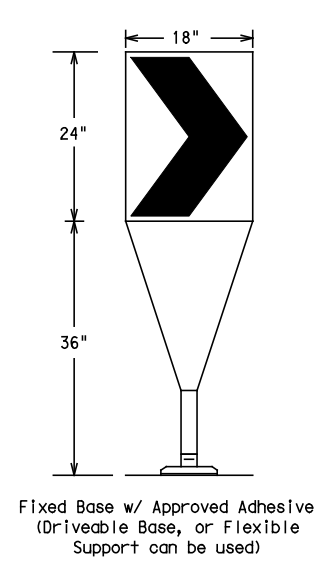

- The chevron shall be a vertical rectangle with a minimum size of 12 by 18 inches.
- Chevrons are intended to give notice of a sharp change of alignment with the direction of travel and provide additional emphasis and guidance for vehicle operators with regard to changes in horizontal alignment of the roadway.
- Chevrons, when used, shall be erected on the outside of a sharp curve or turn, or on the far side of an intersection. They shall be in line with and at right angles to approaching traffic. Spacing should be such that the motorist always has three in view, until the change in alignment eliminates its need.
- To be effective, the chevron should be visible for at least 500 feet.
- Chevrons shall be orange with a black nonreflective legend. Sheeting for the chevron shall be retroreflective Type E (Fluorescent Prismatic) conforming to Departmental Material Specification DMS-8300, unless noted otherwise. The legend shall be black vinyl non-reflective decal sheeting meeting the requirements of DMS-8300.
- For Long Term Stationary use on tapers or transitions on freeways and divided highways self-righting chevrons may be used to supplement plastic drums but not to replace plastic drums.

GENERAL NOTES:

- Work Zone channelizing devices illustrated on this sheet may be installed in close proximity to traffic and are suitable for use on high or low speed roadways. The Engineer/Inspector shall ensure that spacing and placement is uniform and in accordance with the "Texas Manual on Uniform Traffic Control Devices" (TMUTCD).
- Channelizing devices shown on this sheet may have a driveable, fixed or portable base. The requirement for self-righting channelizing devices must be specified in the General Notes or other plan sheets.
- Channelizing devices on self-righting supports should be used in work zone areas where channelizing devices are frequently impacted by errant vehicles or vehicle related wind gusts making alignment of the channelizing devices difficult to maintain. Locations of these devices shall be detailed elsewhere in the plans. These devices shall conform to the TMUTCD and the "Compliant Work Zone Traffic Control Devices List" (CWZTCD).
- The Contractor shall maintain devices in a clean condition and replace damaged, nonreflective, faded, or broken devices and bases as required by the Engineer/Inspector. The Contractor shall be required to maintain proper device spacing and alignment.
- Portable bases shall be fabricated from virgin and/or recycled rubber. The portable bases shall weigh approximately 35 lbs.
- Pavement surfaces shall be prepared in a manner that ensures proper bonding between the adhesives, the fixed mount bases and the pavement surface. Adhesives shall be prepared and applied according to the manufacturer's recommendations.
- The installation and removal of channelizing devices shall not cause detrimental effects to the final pavement surfaces, including pavement surface discoloration or surface integrity. Driveable/bases shall not be permitted on final pavement surfaces. The Engineer/Inspector shall approve all application and removal procedures of fixed bases.
- Examples on this sheet are commonly used channelizing devices in work zones. For other devices, refer to the CWZTCD.

- Vertical Panels (VP's) are normally used to channelize traffic or divide opposing lanes of traffic.
- VP's may be used in daytime or nighttime situations. They may be used at the edge of shoulder drop-offs and other areas such as lane transitions where positive daytime and nighttime delineation is required. The Engineer/Inspector shall refer to the Roadway Design Manual Appendix B "Treatment of Pavement Drop-offs in Work Zones" for additional guidelines on the use of VP's for drop-offs.
- VP's should be mounted back to back if used at the edge of cuts adjacent to two-way two lane roadways. Stripes are to be reflective orange and reflective white and should always slope downward toward the travel lane.
- VP's used on expressways and freeways or other high speed roadways, shall have a minimum of 270 square inches of retroreflective area facing traffic.
- Self-righting supports are available with portable base. See "Compliant Work Zone Traffic Control Devices List" (CWZTCD).
- Sheeting for the VP's shall be retroreflective Type C (High Specific Intensity) conforming to Departmental Material Specification DMS-8300, unless noted otherwise.
- Where the height of reflective material on the vertical panel is greater than 36 inches, a panel stripe of 6 inches shall be used.

OPPOSING TRAFFIC LANE DIVIDERS (OTLD)

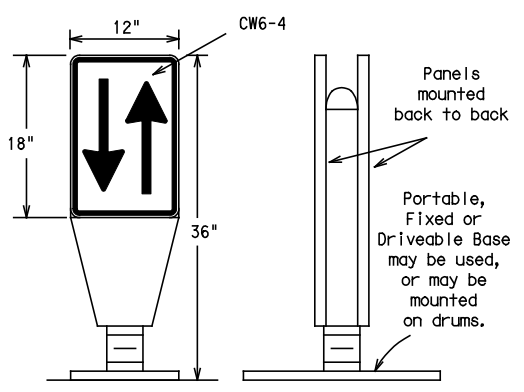

- Opposing Traffic Lane Dividers (OTLD) are delineation devices designed to convert a normal one-way roadway section to two-way operation. OTLD's are used on temporary centerlines. The upward and downward arrows on the sign's face indicate the direction of traffic on either side of the divider. The base is secured to the pavement with an adhesive or rubber weight to minimize movement caused by a vehicle impact or wind gust.
- The OTLD may be used in combination with simple tubular markers or VPs.
- Spacing between the OTLD shall not exceed 500 feet. Tubular markers or VPs placed between the OTLD's should not exceed 100 foot spacing.
- The OTLD shall be orange with a black non-reflective legend. Sheeting for the OTLD shall be retroreflective Type E (Fluorescent Prismatic) conforming to Departmental Material Specification DMS-8300, unless noted otherwise. The legend shall be black vinyl non-reflective decal sheeting meeting the requirements of DMS-8300.

Posted Speed	Formula	Minimum Desirable Taper Lengths $\frac{W}{S}$			Suggested Maximum Spacing of Channelizing Devices	
		10' Offset	11' Offset	12' Offset	On a Taper	On a Tangent
30	$L = \frac{WS^2}{60}$	150'	165'	180'	30'	60' - 75'
35		205'	225'	245'	35'	70' - 90'
40		265'	295'	320'	40'	80' - 100'
45	L=WS	450'	495'	540'	45'	90' - 110'
50		500'	550'	600'	50'	100' - 125'
55		550'	605'	660'	55'	110' - 140'
60		600'	660'	720'	60'	120' - 150'
65		650'	715'	780'	65'	130' - 165'
70	700'	770'	840'	70'	140' - 175'	
75	750'	825'	900'	75'	150' - 185'	
80	800'	880'	960'	80'	160' - 195'	

**Taper lengths have been rounded off.
 L=Length of Taper (FT.) W=Width of Offset (FT.)
 S=Posted Speed (MPH)

HOLLOW OR WATER BALLASTED SYSTEMS USED AS LONGITUDINAL CHANNELIZING DEVICES OR BARRIERS

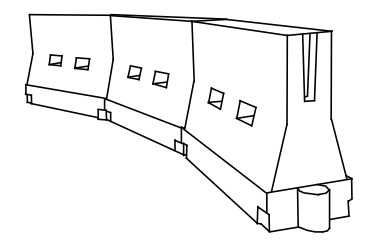

LONGITUDINAL CHANNELIZING DEVICES

- Longitudinal channelizing devices are crashworthy, lightweight, deformable devices that are highly visible, have good target value and can be connected together. **They are not designed to contain or redirect a vehicle on impact.**
- Longitudinal channelizing devices may be used instead of a line of cones or drums.
- Longitudinal channelizing devices shall be placed in accordance to application and installation requirements specific to the device, and used only when shown on the CWZTCD list.
- Longitudinal channelizing devices should not be used to provide positive protection for obstacles, pedestrians or workers.
- Longitudinal channelizing devices shall be retroreflective, or supplemented with retroreflective delineation as required for temporary barriers on BC(7)-07.

WATER BALLASTED SYSTEMS USED AS BARRIERS

- Water ballasted systems used as barriers shall not be used solely to channelize road users, but also to protect the work space per the appropriate NCHRP 350 crashworthiness requirements based on roadway speed and barrier application.
- Water ballasted systems used to channelize vehicular traffic shall be supplemented with retroreflective delineation or channelizing devices to improve daytime/nighttime visibility. They may also be supplemented with pavement markings.
- Water ballasted systems used as barriers shall be placed in accordance to application and installation requirements specific to the device, and used only when shown on the CWZTCD list.
- Water ballasted systems used as barriers should not be used for a merging taper except in low speed (less than 45 MPH) urban areas. When used on a taper in a low speed urban area, the taper shall be delineated and the taper length should be designed to optimize road user operations considering the available geometric conditions.
- When water ballasted systems used as barriers have blunt ends exposed to traffic, they should be attenuated as per manufacturer recommendations or flared to point outside the clear zone.

If used to channelize pedestrians, longitudinal channelizing devices or water ballasted systems must have a continuous detectable bottom for users of long canes and the top of the unit shall be not less than 32 inches in height.

VERTICAL PANELS & OPPOSING TRAFFIC LANE DIVIDERS SEPARATING TWO-WAY TRAFFIC (Typical application)

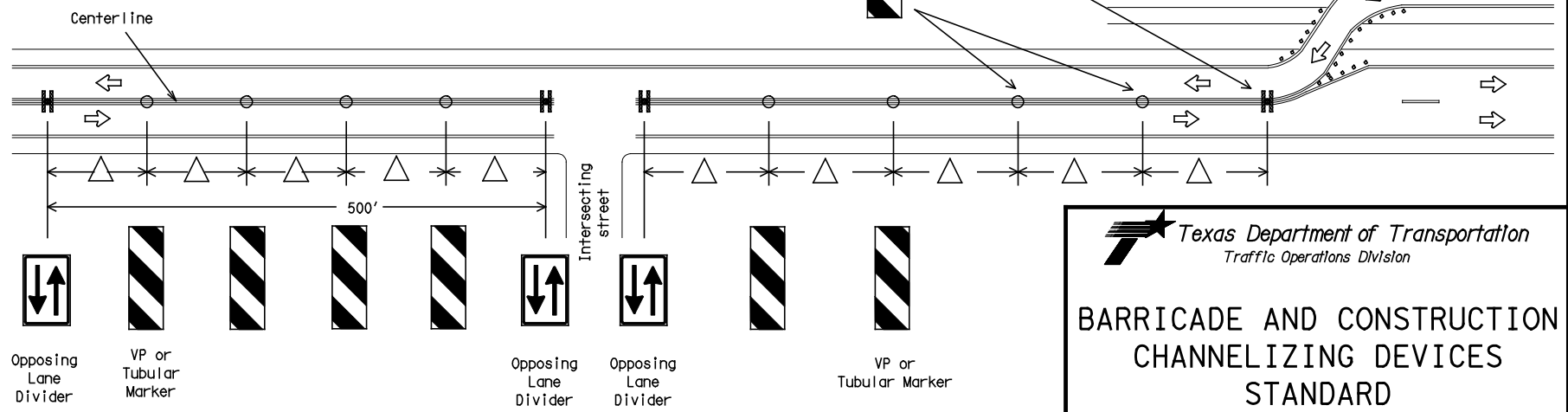

\triangle Spacing between the VP's or tubular markers shall not exceed 100 feet. On roadways with speeds less than 45 MPH, spacing between the tubular markers or VP's shall be as shown on the channelizing spacing table shown on this page. If the table shows spacing greater than 100 feet based on the roadway speed, then use a maximum of 100 feet spacing between the tubular markers or VP's. Every fifth channelizing device shall be an OTLD, except when the OTLD must be spaced closer to accommodate an intersection. Spacing between the OTLD shall not exceed 500 feet.



BARRICADE AND CONSTRUCTION CHANNELIZING DEVICES STANDARD

9 of 12 BC(9)-07

© TxDOT 11-4-02	DNF: TxDOT	CK: TxDOT	DW: TxDOT	CK: TxDOT	
9-07	REVISIONS	CONT	SECT	JOB	HIGHWAY
		3C	1080	103	BERNAL
		DIST	COUNTY		SHEET NO.
		PHR	HIDALGO		34

DATE: 3/19/2012 3:46:52 PM
 FILE: p:\2009\2009-1027-02_hobcap_iii_additional_colonias.design\03_el_mesquite\csj\Standards\Traffic Control\BC07.DGN
 DISCLAIMER: The use of this standard is governed by the "Texas Engineering Practice Act". No warranty of any kind is made by TxDOT for any purpose whatsoever. TxDOT assumes no responsibility for the conversion of this standard to other formats or for incorrect results or damages resulting from its use.

TYPE III BARRICADES

1. Refer to the Compliant Work Zone Traffic Control Devices List (CWZTCD) for details of the Type III Barricades and a list of all materials used in the construction of Type III Barricades.
2. Type III Barricades shall be used at each end of construction projects closed to all traffic.
3. Barricades extending across a roadway should have stripes that slope downward in the direction toward which traffic must turn in detouring. When both right and left turns are provided, the chevron striping may slope downward in both directions from the center of the barricade. Where no turns are provided at a closed road striping should slope downward in both directions toward the center of roadway.
4. Striping of rails, for the right side of the roadway, should slope downward to the left. For the left side of the roadway, striping should slope downward to the right.
5. Identification markings may be shown only on the back of the barricade rails. The maximum height of letters and/or company logos used for identification shall be 1".
6. Barricades shall not be placed parallel to traffic unless an adequate clear zone is provided.
7. Warning lights shall NOT be installed on barricades.
8. Where barricades require the use of weights to keep from turning over, the use of sandbags with dry, cohesionless sand is recommended. The sandbags will be tied shut to keep the sand from spilling and to maintain a constant weight. Sand bags shall not be stacked in a manner that covers any portion of a barricade rails reflective sheeting. Rock, concrete, iron, steel or other solid objects will NOT be permitted. Sandbags should weigh a minimum of 35 lbs and a maximum of 50 lbs. Sandbags shall be made of a durable material that tears upon vehicular impact. Rubber (such as tire inner tubes) shall not be used for sandbags. Sandbags shall only be placed along or upon the base supports of the device and shall not be suspended above ground level or hung with rope, wire, chains or other fasteners.
9. Sheeting for barricades shall be retroreflective Type C (High Specific Intensity) conforming to Departmental Material Specification DMS-8300 unless otherwise noted.

Barricades shall NOT be used as a sign support.

TYPICAL STRIPING DETAIL FOR BARRICADE RAIL



TYPICAL PANEL DETAIL FOR SKID OR POST TYPE BARRICADES

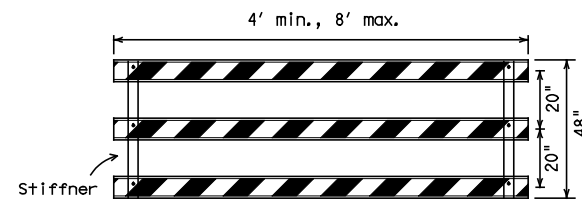

TYPE III BARRICADE (POST AND SKID) TYPICAL APPLICATION

Each roadway of a divided highway shall be barricaded in the same manner.

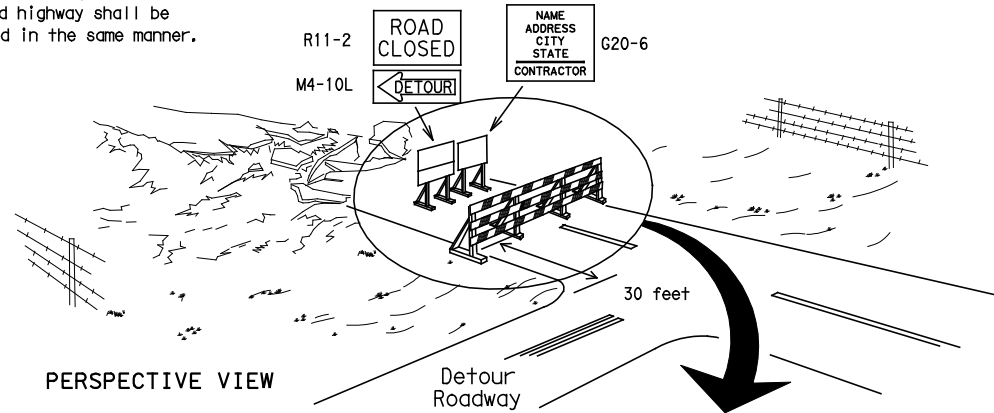

PERSPECTIVE VIEW

The three rails on Type III barricades shall be reflectorized orange and reflective white stripes on one side facing one-way traffic and both sides for two-way traffic. Barricade striping should slant downward in the direction of detour.

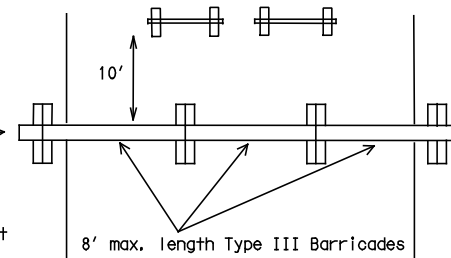

PLAN VIEW

1. Signs should be mounted on independent supports at a 7 foot mounting height in center of roadway. The signs should be a minimum of 10 feet behind Type III Barricades.
2. Advance signing shall be as specified elsewhere in the plans.

CULVERT WIDENING OR OTHER ISOLATED WORK WITHIN THE PROJECT LIMITS

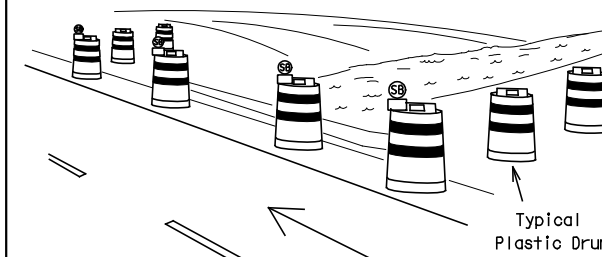

PERSPECTIVE VIEW

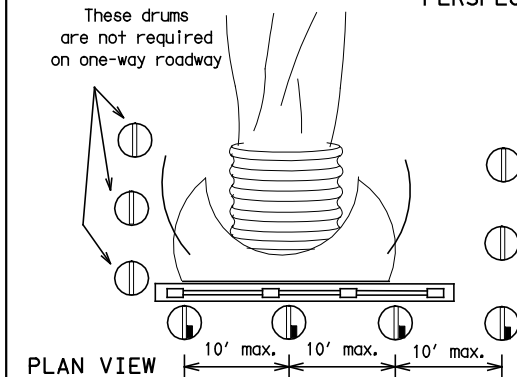

PLAN VIEW

1. Where positive redirection capability is provided, drums may be omitted.
2. Plastic construction fencing may be used with drums for safety as required in the plans.
3. Vertical Panels on flexible support may be substituted for drums when the shoulder width is less than 4 feet.
4. When the shoulder width is greater than 12 feet, steady-burn lights may be omitted if drums are used.
5. Drums must extend the length of the culvert widening.

Increase number of plastic drums on the side of approaching traffic if the crown width makes it necessary. (minimum of 2 and maximum of 4 drums)

Legend

- Plastic drum
- Plastic drum with steady burn light or yellow warning reflector
- Steady burn warning light or yellow warning reflector

CONES

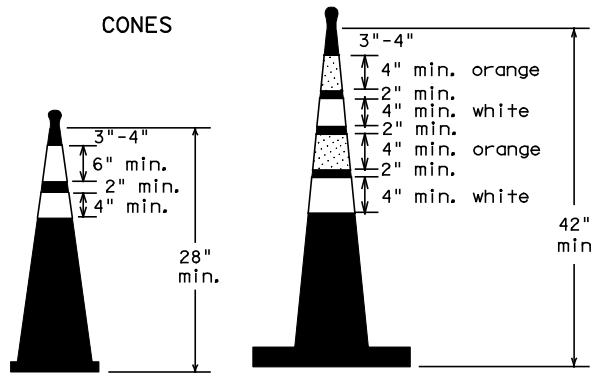

Two-Piece cones

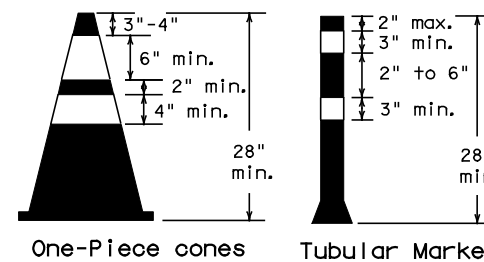

28" Cones shall have a minimum weight of 9 1/2 lbs.
 42" 2-piece cones shall have a minimum weight of 30 lbs. including base.

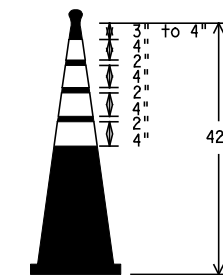

EDGE LINE CHANNELIZER

1. This device is intended only for use in place of a vertical panel to channelize traffic by indicating the edge of the travel lane. It is not intended to be used in transitions or tapers.
2. This device shall not be used to separate lanes of traffic (opposing or otherwise) or warn of objects.
3. This device is based on a 42 inch, two-piece cone with an alternate striping pattern: four 4 inch retroreflective bands, with an approximate 2 inch gap between bands. The color of the band should correspond to the color of the edgeline (yellow for left edgeline, white for right edgeline) for which the device is substituted or for which it supplements. The reflectorized bands shall be retroreflective Type C encapsulated bead (High Specific Intensity) conforming to Departmental Material Specification DMS-8300, unless otherwise noted.
4. The base must weigh a minimum of 30 lbs.

TRAFFIC CONTROL FOR MATERIAL STOCKPILES

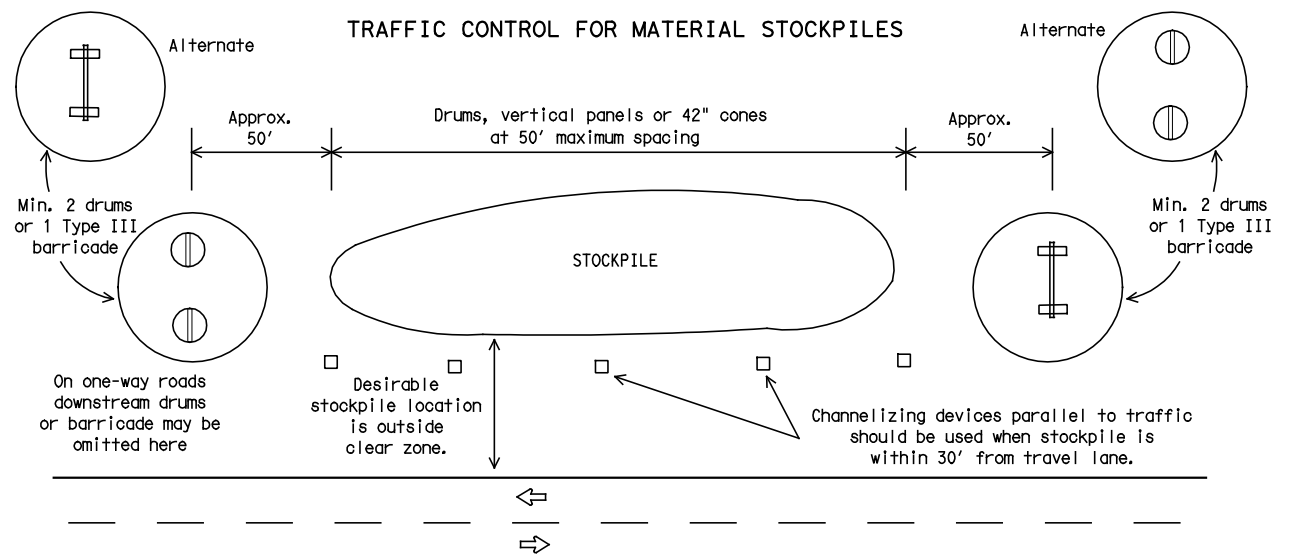

1. Traffic cones and tubular markers shall be a minimum of 28 inches in height when used either on freeways or at nighttime.
2. Cones or tubular markers shall be predominantly orange, fluorescent red-orange, or fluorescent yellow-orange. They should be kept clean and bright for maximum visibility.
3. Cones used only for daytime operations do not require the reflectorized bands.
4. Cones and tubular markers used for nighttime operations shall be reflectorized. Reflectorized material shall have a smooth, sealed outer surface that displays the same approximate color during the day and night. The reflectorized bands shall be retroreflective Type C (High Specific Intensity) conforming to Departmental Material Specification DMS-8300, unless otherwise noted.
5. When used at night, appropriate personnel shall ensure that cones and tubular markers remain in their proper location and in an upright position.
6. Reflectorization of 28" cones shall consist of a minimum 6 inch band placed at least 3 inches but not more than 4 inches from the top, supplemented by a minimum 4 inch band spaced a minimum of 2 inches below the 6 inch band.
7. Reflectorization of 42" cones shall be provided by alternating 4 to 6" orange and white stripes with orange on top.
8. Reflectorization of tubular markers shall be a minimum of two 3 inch bands placed a maximum of 2 inches from the top with a maximum of 6 inches between bands.
9. One-piece cones or tubular markers are generally suitable for temporary usage (up to 8 hours) with other channelization devices such as vertical panels, drums or two-piece cones for long term usage. Care should be taken to ensure they remain in their proper location and in an upright position.
10. Cones or tubular markers used on each project shall be of the same size and shape.
11. The handle may be designed as a hook or other shape, fabricated from non-rigid materials similar to the cone material, and may extend up to a maximum of 8 inches above the top of cone. Length of the handle shall not be considered with regard to the overall height of the cone.

BARRICADE AND CONSTRUCTION CHANNELIZING DEVICES STANDARD

10 of 12

BC(10)-07

© TxDOT 11-4-02	DN: TxDOT	CK: TxDOT	DW: TxDOT	CK: TxDOT
9-07	REVISIONS	CONT	SECT	JOB
		3C	1080	103
		DIST	COUNTY	SHEET NO.
		PHR	HIDALGO	35

The use of this standard is governed by the "Texas Engineering Practice Act". No warranty of any kind is made by TxDOT for any purpose whatsoever. TxDOT assumes no responsibility for the conversion of this standard to other formats or for incorrect results or damages resulting from its use.
 DISCLAIMER: This standard is made by TxDOT for any purpose whatsoever. TxDOT assumes no responsibility for the conversion of this standard to other formats or for incorrect results or damages resulting from its use.
 DATE: 3/19/2012 3:47:02 PM
 FILE: p:\2009\2009-1027-02_heboap_iii_additional_colonias\design\03_el_mesquite\csj\standards\Traffic Control\BC07.DGN

WORK ZONE PAVEMENT MARKINGS

GENERAL

- The Contractor shall be responsible for maintaining work zone and existing pavement markings, in accordance with the standard specifications and special provisions, on all roadways open to traffic within the CSJ limits unless otherwise stated in the plans.
- Color, patterns and dimensions shall be in conformance with the "Texas Manual on Uniform Traffic Control Devices" (TMUTCD).
- Additional supplemental pavement marking details may be found in the plans or specifications.
- Pavement markings shall be installed in accordance with the TMUTCD and as shown on the plans.
- When short term markings are required on the plans, short term markings shall conform with the TMUTCD, the plans and details as shown on the Standard Plan Sheet WZ(STPM).
- When standard pavement markings are not in place and the roadway is opened to traffic, DO NOT PASS signs shall be erected to mark the beginning of the sections where passing is prohibited and PASS WITH CARE signs at the beginning of sections where passing is permitted.
- All work zone pavement markings shall be installed in accordance with Item 662, "Work Zone Pavement Markings."

RAISED PAVEMENT MARKERS

- Raised pavement markers are to be placed according to the patterns on BC(12).
- All raised pavement markers used for work zone markings shall meet the requirements of Item 672, "RAISED PAVEMENT MARKERS" and Departmental Material Specification DMS-4200 or DMS-4300.

PREFABRICATED PAVEMENT MARKINGS

- Removable prefabricated pavement markings shall meet the requirements of DMS-8241.
- Non-removable prefabricated pavement markings (foil back) shall meet the requirements of DMS-8240.

MAINTAINING WORK ZONE PAVEMENT MARKINGS

- The Contractor will be responsible for maintaining work zone pavement markings within the work limits.
- Work zone pavement markings shall be inspected in accordance with the frequency and reporting requirements of work zone traffic control device inspections as required by Form 599.
- The markings should provide a visible reference for a minimum distance of 300 feet during normal daylight hours and 160 feet when illuminated by automobile low-beam headlights at night, unless sight distance is restricted by roadway geometrics.
- Markings failing to meet this criteria within the first 30 days after placement shall be replaced at the expense of the Contractor as per Specification Item 662.

REMOVAL OF PAVEMENT MARKINGS

- Pavement markings that are no longer applicable, could create confusion or direct a motorist toward or into the closed portion of the roadway, shall be removed or obliterated before the roadway is opened to traffic.
- The above shall not apply to detours in place for less than two weeks, where flaggers and/or sufficient channelizing devices are used in lieu of markings to outline the detour route.
- Pavement markings shall be removed to the fullest extent possible, so as not to leave a discernable marking. This shall be by any method approved by TxDOT Specification Item 677 for "Eliminating Existing Pavement Markings and Markers".
- The removal of pavement markings may require resurfacing or seal coating portions of the roadway.
- Subject to the approval of the Engineer, any method that proves to be successful on a particular type pavement may be used.
- Blast cleaning may be used but will not be required unless specifically shown in the plans.
- Over-painting of the markings SHALL NOT BE permitted.
- Removal of raised pavement markers shall be as directed by the Engineer.
- Removal of existing pavement markings and markers will be paid for directly in accordance with Item 677, "ELIMINATING EXISTING PAVEMENT MARKINGS AND MARKERS," unless otherwise stated in the plans.
- Black-out marking tape may be used to cover conflicting existing markings for periods less than two weeks when approved by the Engineer.

Temporary Flexible-Reflective Roadway Marker Tabs

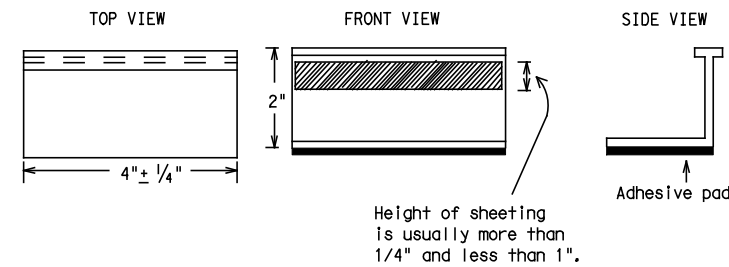

**STAPLES OR NAILS SHALL NOT BE USED TO SECURE
TEMPORARY FLEXIBLE-REFLECTIVE ROADWAY MARKER
TABS TO THE PAVEMENT SURFACE**

- Temporary flexible-reflective roadway marker tabs used as guidemarks shall meet the requirements of DMS-8242.
- Tabs detailed on this sheet are to be inspected and accepted by the Engineer or designated representative. Sampling and testing is not normally required, however at the option of the Engineer, either "A" or "B" below may be imposed to assure quality before placement on the roadway.
 - Select five (5) or more tabs at random from each lot or shipment and submit to the Construction Division, Materials and Pavement Section to determine specification compliance.
 - Select five (5) tabs and perform the following test. Affix five (5) tabs at 24 inch intervals on an asphaltic pavement in a straight line. Using a medium size passenger vehicle or pickup, run over the markers with the front and rear tires at a speed of 35 to 40 miles per hour, four (4) times in each direction. No more than one (1) out of the five (5) reflective surfaces shall be lost or displaced as a result of this test.
- Small design variances may be noted between tab manufacturers.
- See Standard Sheet WZ(STPM) for tab placement on new pavements. See Standard Sheet TCP(7-1) for tab placement on seal coat work.

Raised Pavement Markers used as Guidemarks

- Raised pavement markers used as guidemarks shall be from the approved product list, and meet the requirements of DMS-4200.
- All temporary construction raised pavement markers provided on a project shall be of the same manufacturer.
- Adhesive for guidemarks shall be bituminous material hot applied or butyl rubber pad for all surfaces, or thermoplastic for concrete surfaces.

Guidemarks shall be designated as:

- YELLOW - (two amber reflective surfaces with yellow body).
- WHITE - (one silver reflective surface with white body).

DEPARTMENTAL MATERIAL SPECIFICATIONS

PAVEMENT MARKERS (REFLECTORIZED)	DMS-4200
TRAFFIC BUTTONS	DMS-4300
EPOXY AND ADHESIVES	DMS-6100
BITUMINOUS ADHESIVE FOR PAVEMENT MARKERS	DMS-6130
PREFABRICATED PAVEMENT MARKINGS-PERMANENT	DMS-8240
PREFABRICATED PAVEMENT MARKINGS-REMOVABLE	DMS-8241
TEMPORARY FLEXIBLE-REFLECTIVE ROADWAY MARKER TABS	DMS-8242

A list of prequalified reflective raised pavement markers, non-reflective traffic buttons, roadway marker tabs and other pavement markings can be found at the Material Producer List web address shown on BC(1).



BARRICADE AND CONSTRUCTION PAVEMENT MARKINGS STANDARD

11 of 12

BC(11)-07

© TxDOT February 1998	DN: TxDOT	CK: TxDOT	DW: TxDOT	CK: TxDOT
2-98	REVISIONS		CONTR	SECT
1-02	3C	1080	103	BERNAL
11-02	DIST	COUNTY	SHEET NO.	
9-07	PHR	HIDALGO	36	

DATE: 3/19/2012 3:47:10 PM
 FILE: p:\2009\2009-1027-02_heboap_iii_additional_colonias_design\03_el_mesquite\csj_standards\Traffic Control\BC07.DGN
 DISCLAIMER: The use of this standard is governed by the "Texas Engineering Practice Act". No warranty of any kind is made by TXDOT for any purpose whatsoever. TXDOT assumes no responsibility for the conversion of this standard to other formats or for incorrect results or damages resulting from its use.

PAVEMENT MARKING PATTERNS

CENTER LINE & NO-PASSING ZONE BARRIER LINES FOR TWO-LANE, TWO-WAY HIGHWAYS

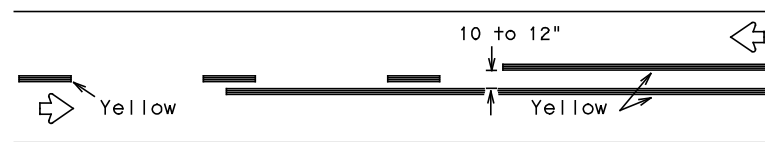

REFLECTORIZED PAVEMENT MARKINGS - PATTERN A

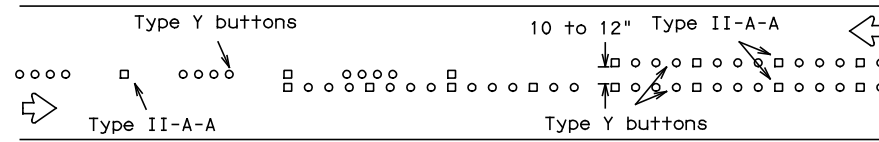

RAISED PAVEMENT MARKERS - PATTERN A

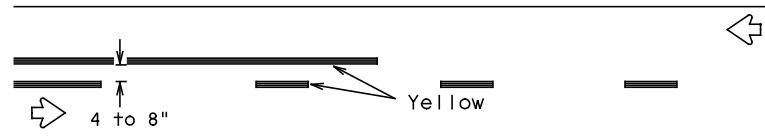

REFLECTORIZED PAVEMENT MARKINGS - PATTERN B

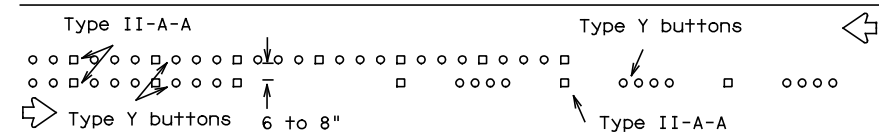

RAISED PAVEMENT MARKERS - PATTERN B

Pattern A is the TXDOT Standard, however Pattern B may be used if approved by the Engineer. Prefabricated markings may be substituted for reflectorized pavement markings.

EDGE & LANE LINES FOR DIVIDED HIGHWAY

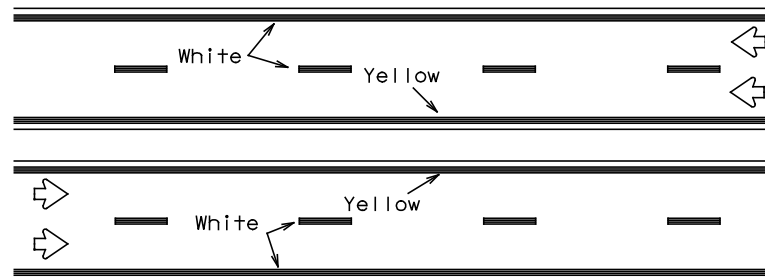

REFLECTORIZED PAVEMENT MARKINGS

Prefabricated markings may be substituted for reflectorized pavement markings.

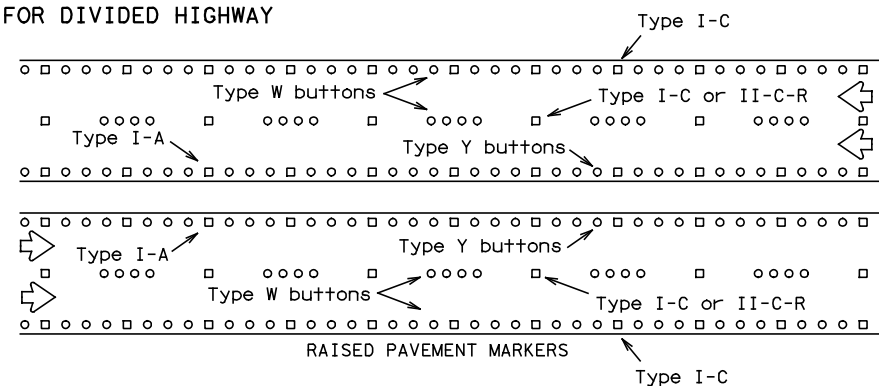

RAISED PAVEMENT MARKERS

LANE & CENTER LINES FOR MULTILANE UNDIVIDED HIGHWAYS

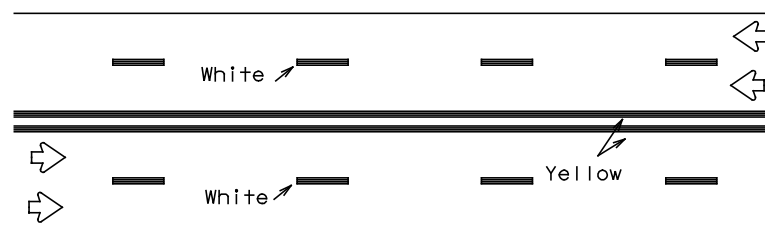

REFLECTORIZED PAVEMENT MARKINGS

Prefabricated markings may be substituted for reflectorized pavement markings.

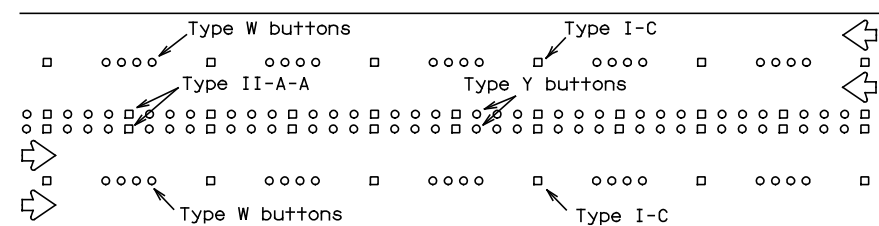

RAISED PAVEMENT MARKERS

TWO-WAY LEFT TURN LANE

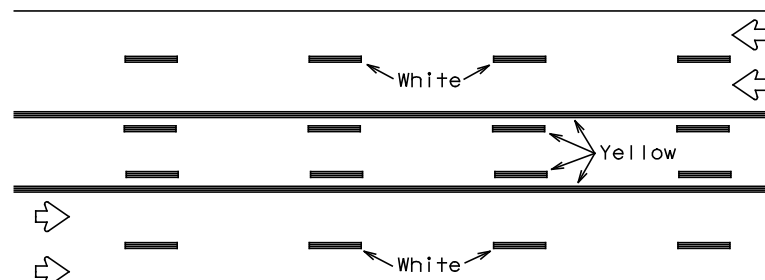

REFLECTORIZED PAVEMENT MARKINGS

Prefabricated markings may be substituted for reflectorized pavement markings.

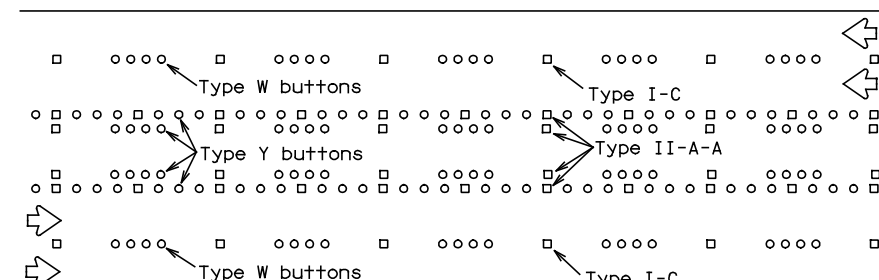

RAISED PAVEMENT MARKERS

STANDARD WORK ZONE PAVEMENT MARKINGS DETAILS

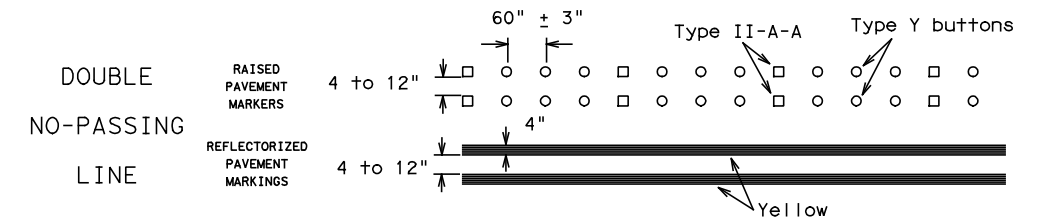

SOLID LINES

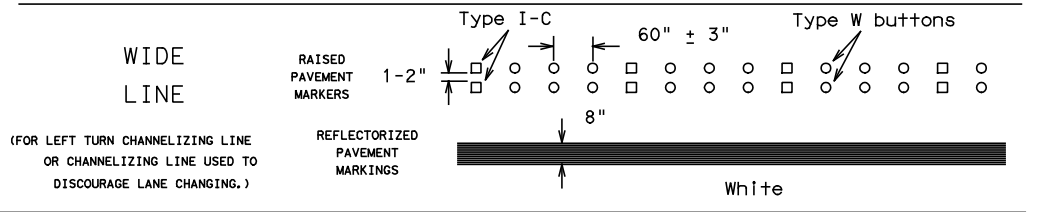
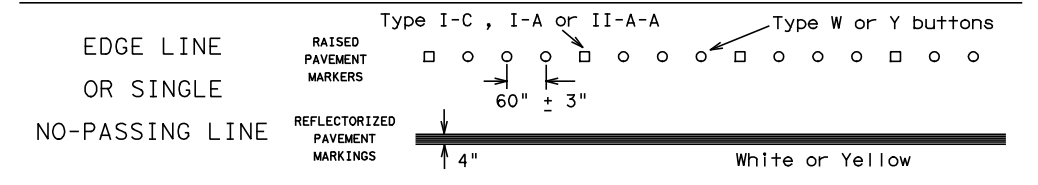

BROKEN LINE
(FOR CENTER LINE OR LANE LINE.)

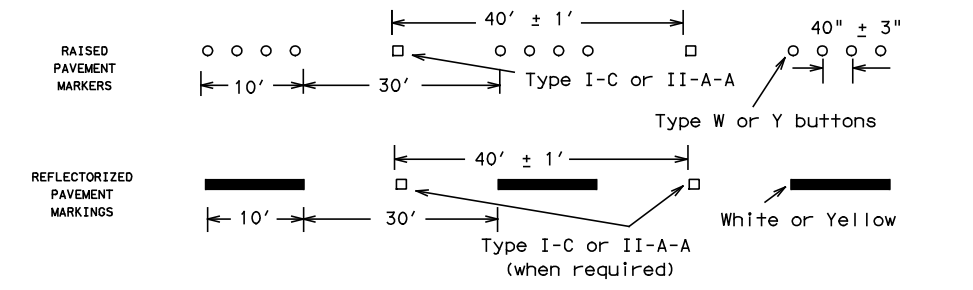

REMOVABLE MARKINGS WITH RAISED PAVEMENT MARKERS

If raised pavement markers are used to supplement REMOVABLE markings, the markers shall be applied to the top of the tape at the approximate mid length of tape used for broken lines or at 20 foot spacing for solid lines. This allows an easier removal of raised pavement markers and tape.

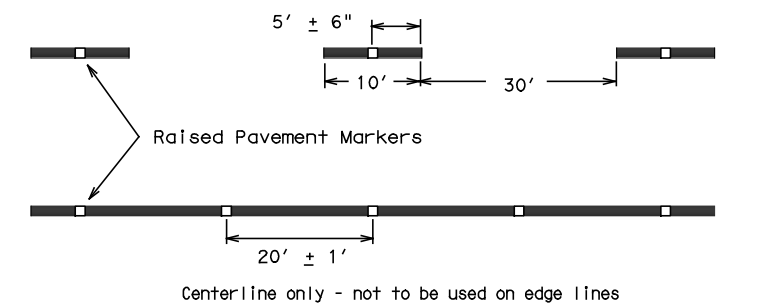

Raised pavement markers used as standard pavement markings shall be from the approved products list and meet the requirements of Item 672 "RAISED PAVEMENT MARKERS."

Texas Department of Transportation
 Traffic Operations Division

BARRICADE AND CONSTRUCTION PAVEMENT MARKING PATTERNS STANDARD

12 of 12 BC(12)-07

© TXDOT February 1998		DN: TXDOT	CK: TXDOT	DW: TXDOT	CK: TXDOT
1-97	REVISIONS	CONT	SECT	JOB	HIGHWAY
2-98		3C	1080	103	BERNAL
11-02		DIST	COUNTY		SHEET NO.
9-07		PHR	HIDALGO		37

109C

DATE: 3/19/2012 3:47:14 PM
 FILE: p:\2009\2009-1027-02_hoboap_iii_additional_colonias\design\03_el_mesquite\csj\standards\Traffic Control\WZTD.dgn
 DISCLAIMER: The use of this standard is governed by the "Texas Engineering Practice Act". No warranty of any kind is made by TxDOT for any purpose whatsoever. TxDOT assumes no responsibility for the conversion of this standard to other formats or for incorrect results or damages resulting from its use.

CHANNELIZING DEVICES FOR URBAN ROADWAY TYPE PROJECT

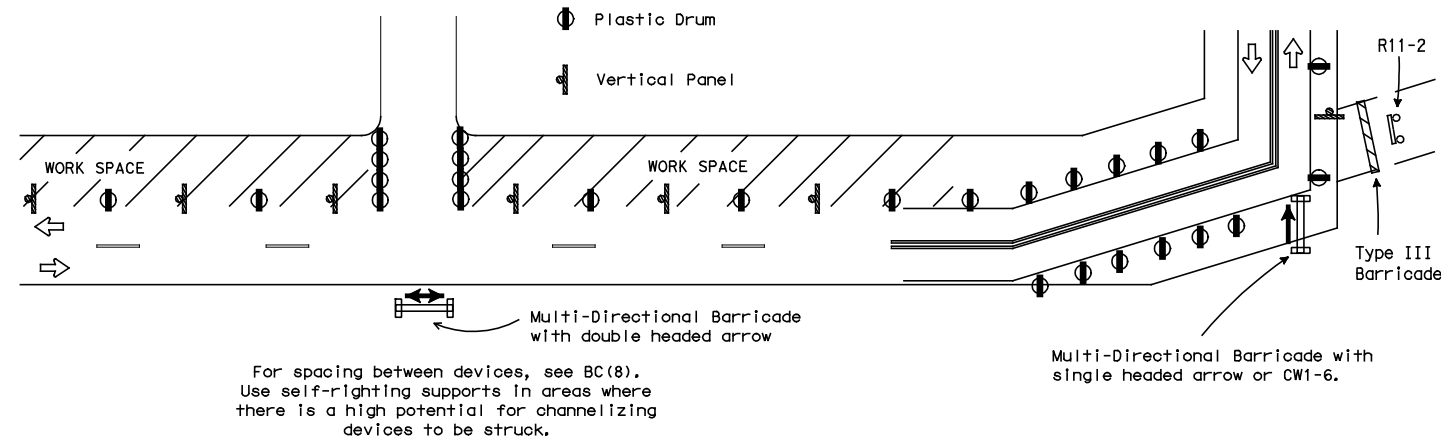

For spacing between devices, see BC(8).
Use self-righting supports in areas where there is a high potential for channelizing devices to be struck.

MULTI-DIRECTIONAL BARRICADE

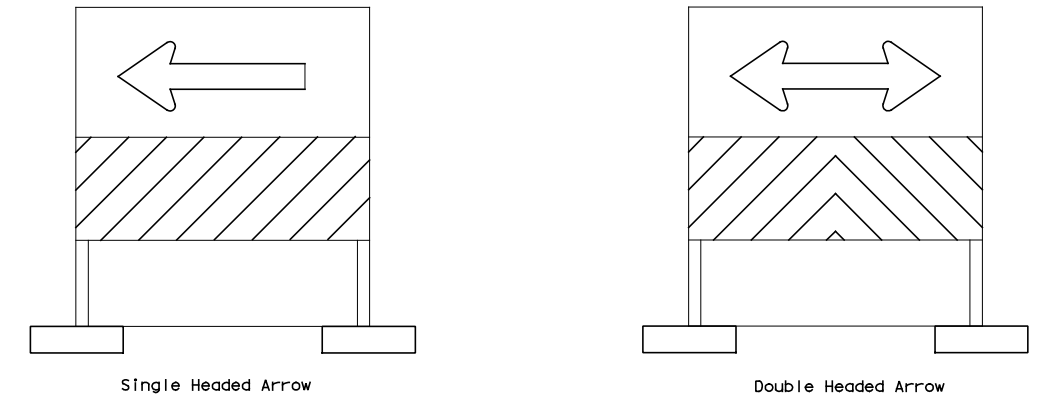

1. Multi-directional barricade shall not be used for lane closures.
2. May be used for sharp changes in alignment, or across roadway from stem of "T" Intersection.
3. Typically used for Intermediate Term Stationary, Short Term Stationary or Short Duration work zone operations.
4. See the CWZTCD List for approved designs.

BARRIER DELINEATION WITH SAFETY GLARE FENCE

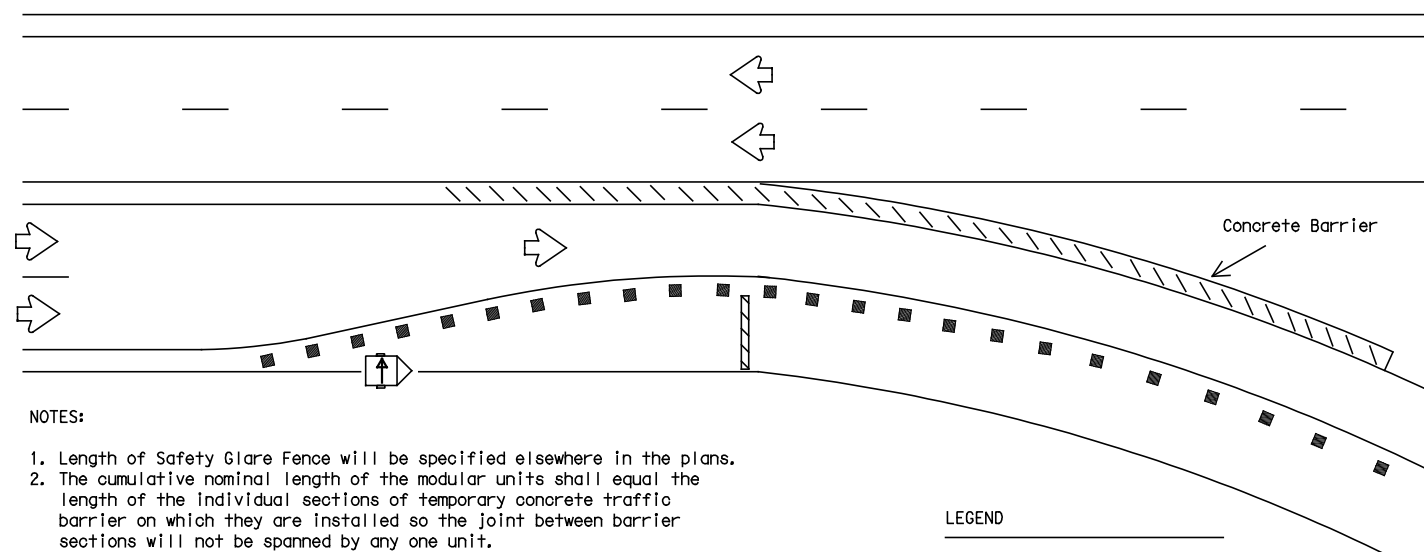

NOTES:

1. Length of Safety Glare Fence will be specified elsewhere in the plans.
2. The cumulative nominal length of the modular units shall equal the length of the individual sections of temporary concrete traffic barrier on which they are installed so the joint between barrier sections will not be spanned by any one unit.
3. Panel/blades will be designed such that reflective sheeting conforming with Departmental Material Specification DMS-8300, Flat Surface Reflective Sheeting, Type C (High Specific Intensity), minimum size of 2 inches by 12 inches can be attached to the edge of the panel/blade. The sheeting shall be attached to one panel/blade per section of concrete barrier not to exceed a spacing of 30 feet. Barrier reflectors are not necessary when panel/blades are installed.
4. Moduler Glare Screens for head light barrier shall meet the requirements of DMS-8610.

LEGEND

- Barrier
- Channelizing devices
- Trailer mounted flashing arrow panel
- Safety glare fence

USAGE OF CW1-6, ECW1-6a AND CW1-8 SIGNS

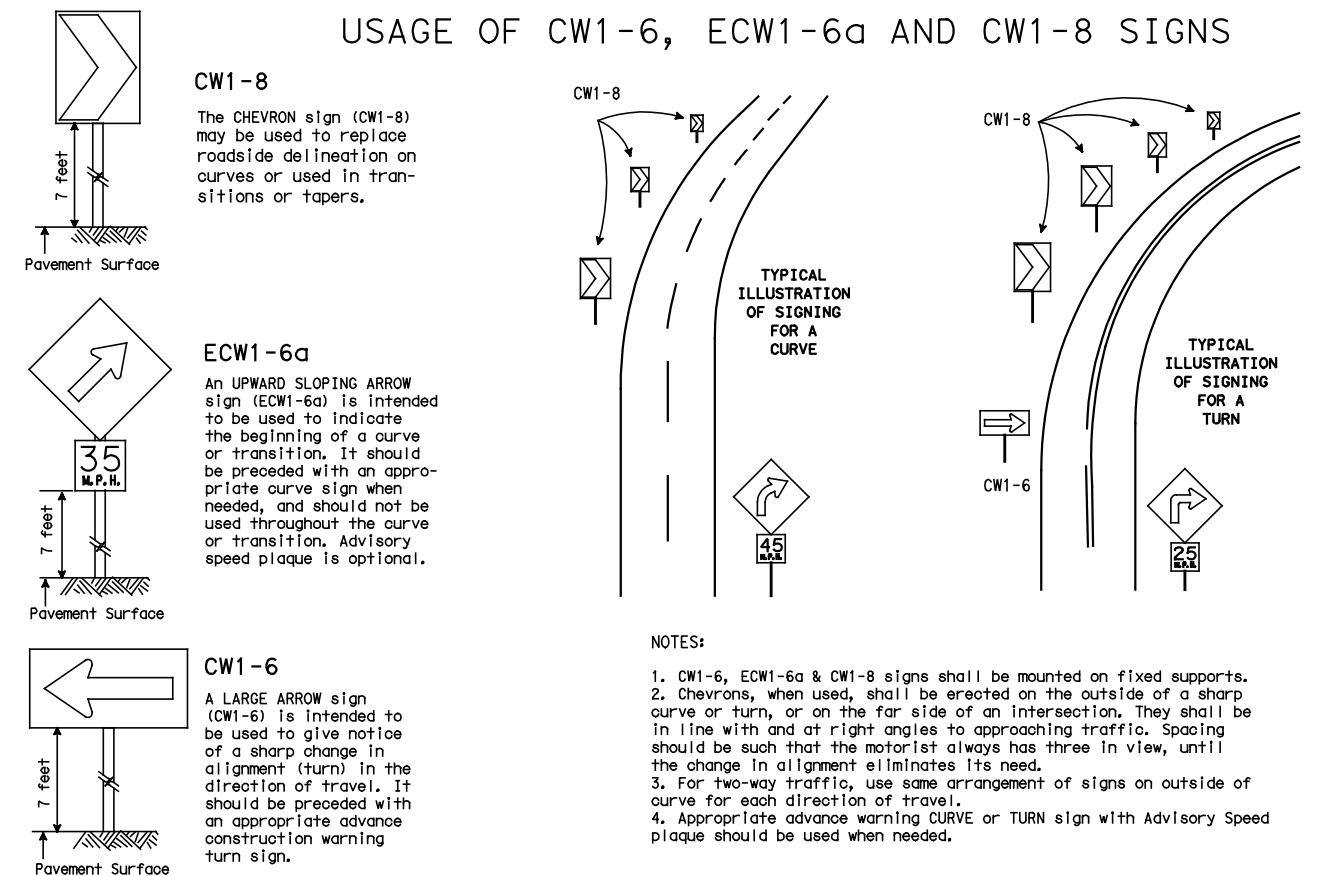

Only pre-qualified products shall be used. A copy of the "Compliant Work Zone Traffic Control Devices List" (CWZTCD) describes pre-qualified products and their sources and may be obtained by contacting:

Standards Engineer
Traffic Operations Division - TE
Texas Department of Transportation
125 East 11th Street
Austin, Texas 78701-2483
Phone (512) 416-3120
Fax (512) 416-3299

Instructions to locate the "CWZTCD" on TxDOT website are:

Start at website - www.dot.state.tx.us
Click on "About TxDOT",
Click on "Organizational Chart",
Click on Traffic Operations Box,
Click on "Compliant Work Zone Traffic Control Devices",
Click on "View PDF".
This site is printable.

PREQUALIFICATION PROCEDURES ARE OBTAINED FROM:

CONSTRUCTION DIVISION-MATERIALS AND TESTS SECTION
TEXAS DEPARTMENT OF TRANSPORTATION (TxDOT)
125 EAST 11th STREET
AUSTIN, TX 78701-2483

DEPARTMENTAL MATERIAL SPECIFICATIONS

FLAT SURFACE REFLECTIVE SHEETING	DMS-8300
DELINEATORS AND OBJECT MARKERS	DMS-8600
MODULER GLARE SCREENS	DMS-8610

COLOR	USAGE	SIGN SHEETING
ORANGE	BACKGROUND	TYPE E (FLUORESCENT PRISMATIC)
WHITE	BACKGROUND	TYPE C (HIGH SPECIFIC INTENSITY)
BLACK	LEGEND & BORDERS	VINYL NON-REFLECTIVE SHEETING

REFER TO THE BC SHEETS FOR SHEETING REQUIREMENT ON CHANNELIZING DEVICES.

The five categories of work duration and their time at a location shall be:

- A. Long-term stationary is work that occupies a location more than 3 days.
- B. Intermediate-term stationary is work that occupies a location more than one daylight period up to 3 days, or nighttime work lasting more than 1 hour.
- C. Short-term stationary is daytime work that occupies a location for more than 1 hour, but less than 12 hours.
- D. Short duration is work that occupies a location up to 1 hour.
- E. Mobile is work that moves intermittently or continuously.

Texas Department of Transportation
Traffic Operations Division

TRAFFIC CONTROL PLAN TYPICAL DETAILS

WZ (TD) -03

© TxDOT February 1998	DN: TxDOT	CK: TxDOT	DW: TxDOT	CK: TxDOT	
4-98	REVISIONS	CONT	SECT	JOB	HIGHWAY
3-03		3C	1080	103	BERNAL
		DIST	COUNTY		SHEET NO.
		PHR	HIDALGO		38

DISCLAIMER: The use of this standard is governed by the "Texas Engineering Practice Act". No warranty of any kind is made by TxDOT for any purpose whatsoever. TxDOT assumes no responsibility for the conversion of this standard to other formats or for incorrect results or damages resulting from its use.

DATE: 3/19/2012 3:47:20 PM
 FILE: p:\2009\2009-1027-02_hoboap_iii_additional_colonias.design\03_e1_mesquite\csj\standards\Traffic Control\WZUL.dgn

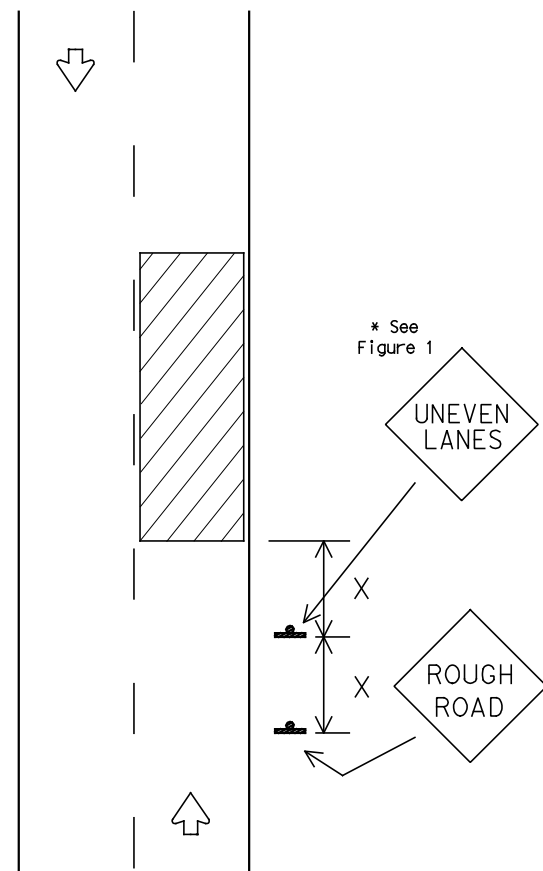

Signing shown for one direction.

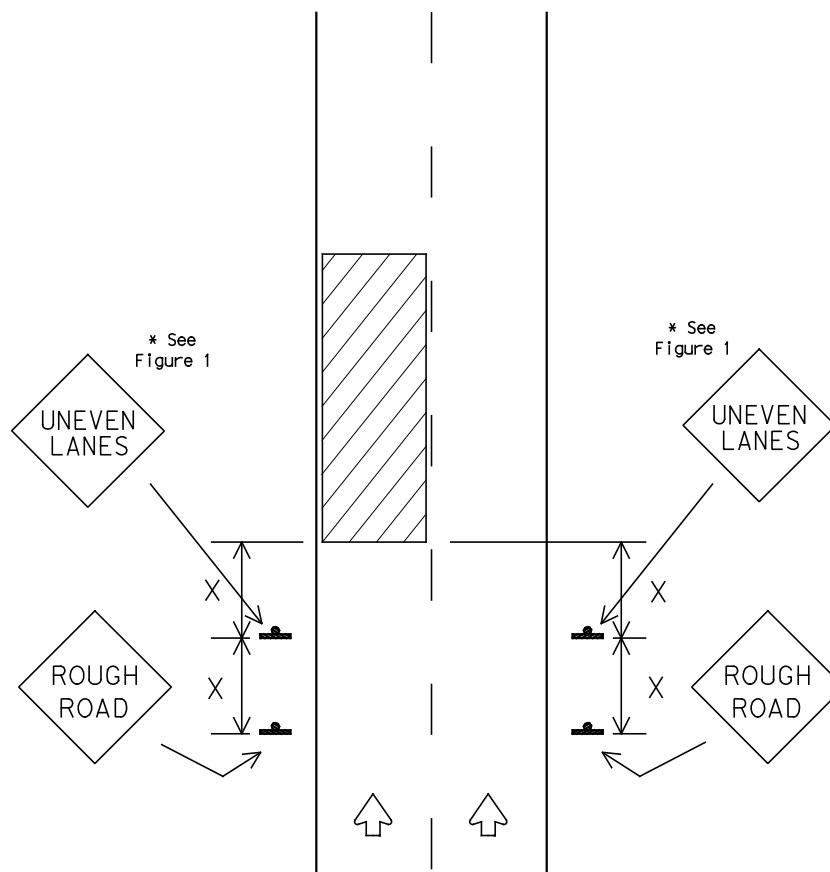
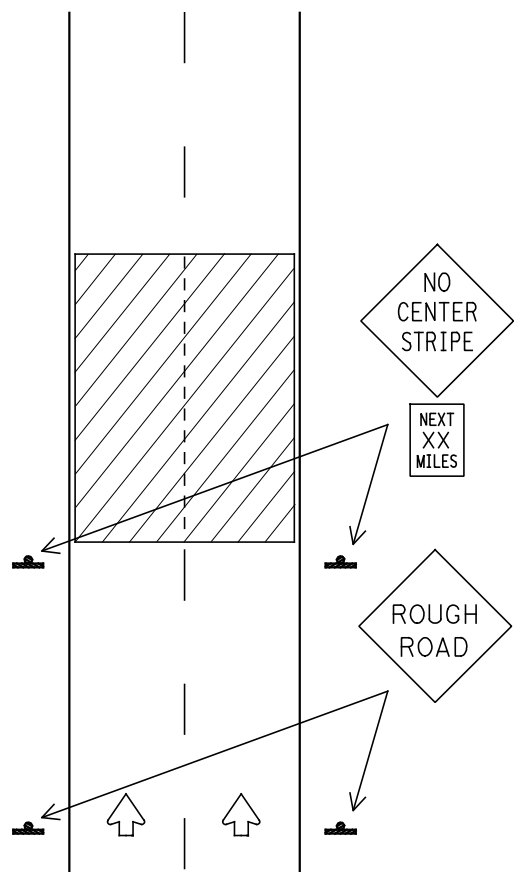
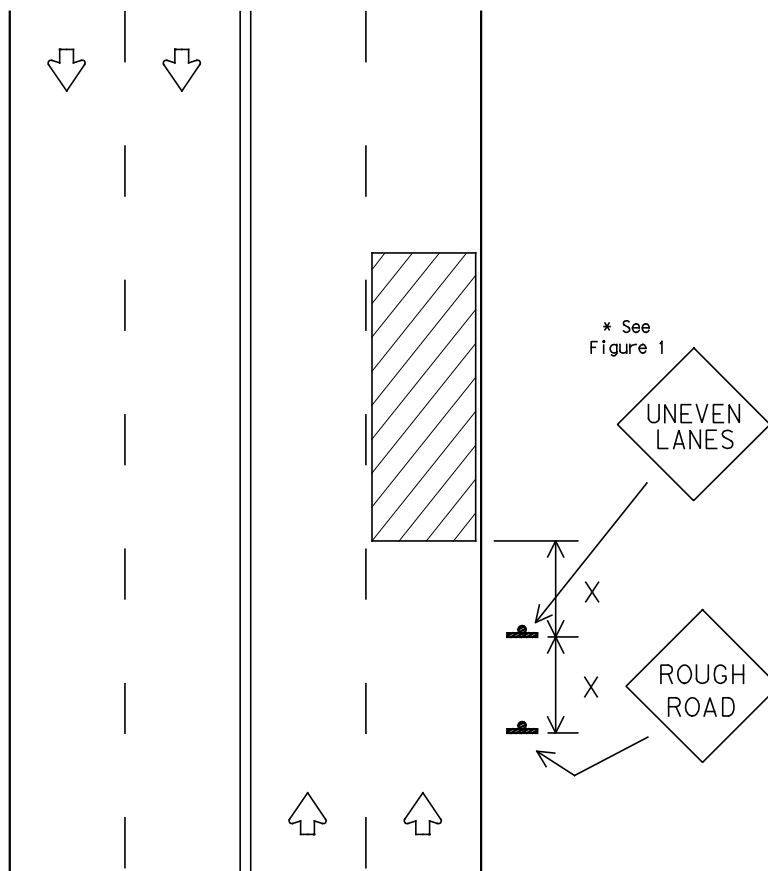

DEPARTMENTAL MATERIAL SPECIFICATIONS		
PLYWOOD SIGN BLANKS		DMS-7100
ALUMINUM SIGN BLANKS		DMS-7110
SIGN HARDWARE		DMS-7120
PREFABRICATED PAVEMENT MARKINGS-PERMANENT		DMS-8240
PREFABRICATED PAVEMENT MARKINGS-REMOVABLE		DMS-8241
FLAT SURFACE REFLECTIVE SHEETING		DMS-8300
VINYL NON-REFLECTIVE DECAL SHEETING		DMS-8320

COLOR	USAGE	SHEETING MATERIAL
ORANGE	BACKGROUND	TYPE E (FLUORESCENT PRISMATIC)
BLACK	LEGEND & BORDERS	VINYL NON-REFLECTIVE DECAL SHEETING

GENERAL NOTES:

1. If spalling or holes occur, ROUGH ROAD signs should be placed in advance of the condition and may be repeated throughout the project.
2. UNEVEN LANES sign (CW8-11) should be installed in advance of the condition and repeated every mile. Signs installed along the uneven lane condition may be supplemented with the NEXT XX MILES sign (CW21-16) or Advisory Speed sign (CW13-1).
3. NO CENTER STRIPE signs (CW8-12) should be installed if centerlines or lane lines are obscured or obliterated. The signs should remain in place until permanent pavement markings are installed.
4. Signs shall be spaced at the distances recommended as per BC standards.
5. When operations are completed and final surface treatment will not be applied as part of this project, advance signs shall be left in place and become the property of the State. These signs shall be installed on approved permanent sign supports as per TxDOT standards. Additional signs may be required as directed by the Engineer. Minimum mounting height of signs is 7 feet. Signs shall remain in place until final surface is applied. Signs shall be considered subsidiary to the item "BARRICADES, SIGNS AND TRAFFIC HANDLING."
6. Pavement markings shall be replaced as operations proceed.
7. Short term markings shall not be used to simulate edge lines.
8. All signs shall be constructed in accordance with the details found in the "Standard Highway Sign Designs for Texas," latest edition. Sign details not shown in this manual shall be shown in the plans or the Engineer shall provide a detail to the Contractor before the sign is manufactured.

TRAFFIC CONTROL DURING PLANING,
 OVERLAY AND LEVELING OPERATIONS
 ARE SHOWN ELSEWHERE IN THE PLANS.

FIGURE 1		
Edge Condition	Edge Height (D)	Warning Devices
	less than or equal to 1"	Signs: ECW8-8
	greater than 1" to: 1/4" (maximum-planing) 1/2" (typical-overlay)	Signs: CW8-11, ECW8-8
Distance "D" may be a maximum of 1/4" for planing operations and 2" for overlay operations if uneven lanes are open to traffic after work operations cease.		

"X" distance - See Note 4 on this page.



SIGNING FOR
 UNEVEN LANES

WZ (UL) -03

© TxDOT April 1992		DN: TxDOT	CK: TxDOT	DW: TxDOT	CK: TxDOT
REVISIONS		CONT	SECT	JOB	HIGHWAY
8-95		3C	1080	103	BERNAL
1-97		DIST	COUNTY		SHEET NO.
2-98		PHR	HIDALGO		39
3-03					

DISCLAIMER: The use of this standard is governed by the "Texas Engineering Practice Act". No warranty of any kind is made by TxDOT for any purpose whatsoever. TxDOT assumes no responsibility for the conversion of this standard to other formats or for incorrect results or damages resulting from its use.

DATE: 3/19/2012 3:47:24 PM
 FILE: p:\2009\2009-1027-02_heboap_iii_additional_colonias.design\03_el_mesquite.csj\Standards\Traffic Control\WZDERD.dgn

TYPICAL DEAD END BARRICADE INSTALLATION

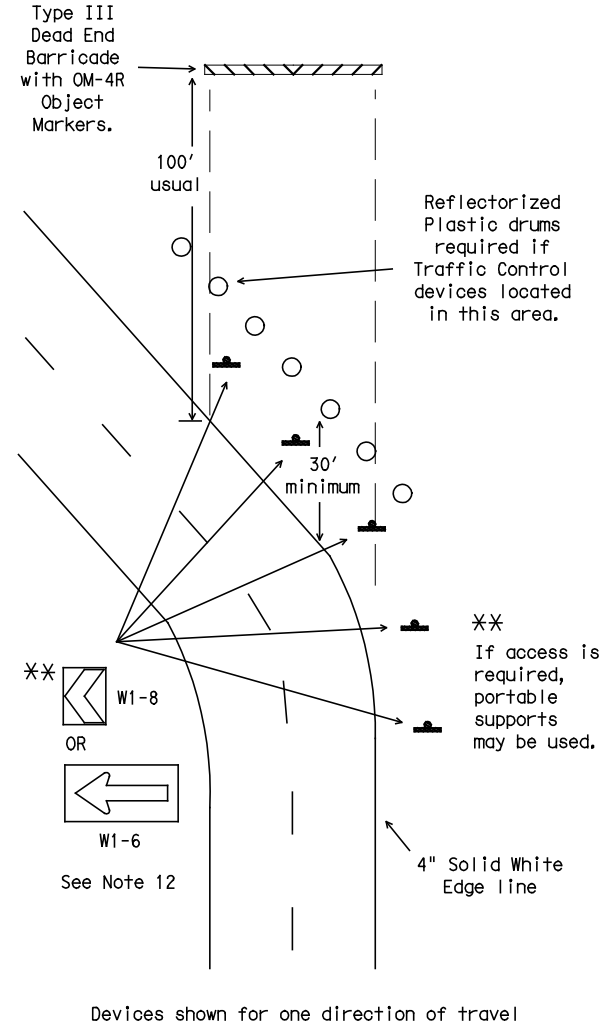
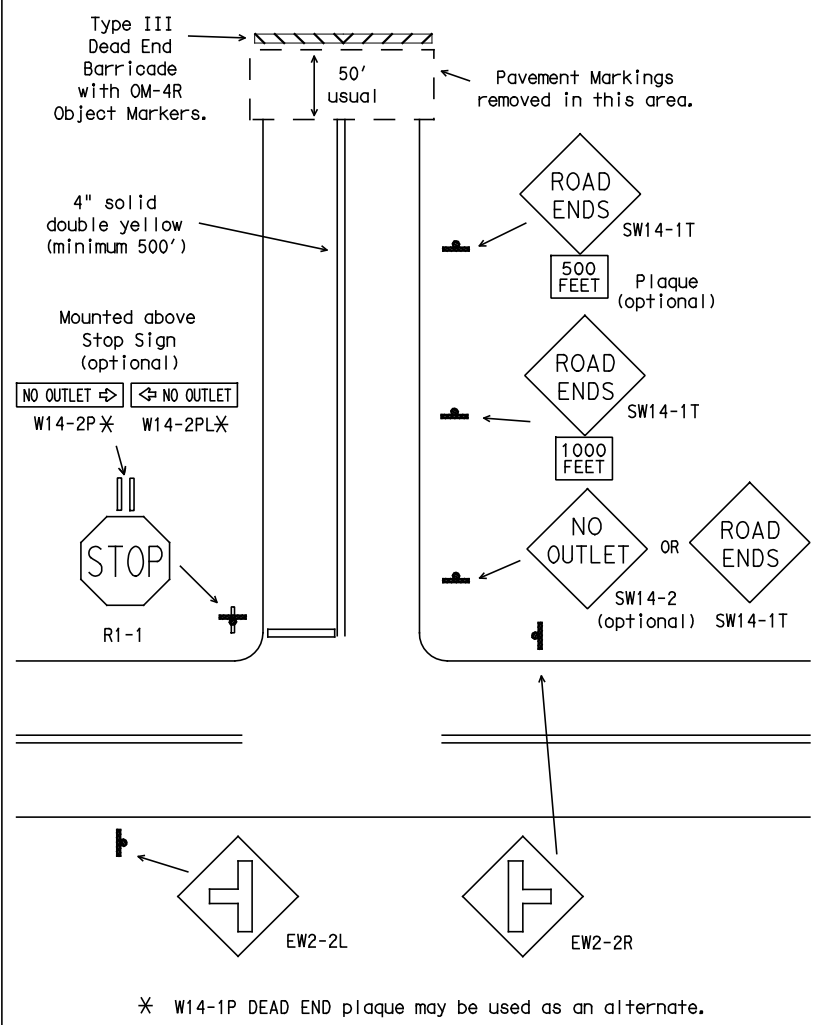
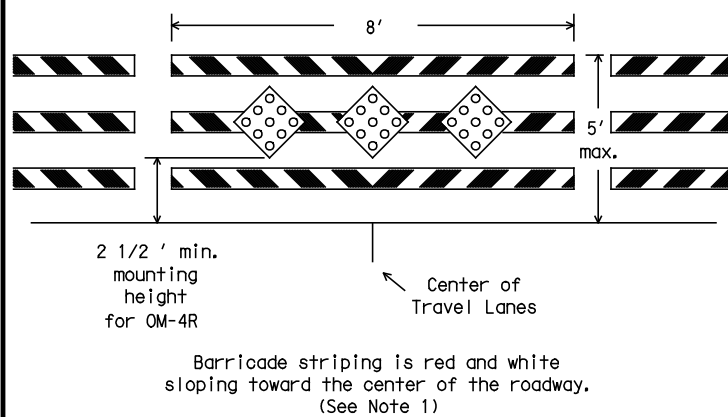

DEPARTMENTAL MATERIAL SPECIFICATIONS		
COLOR	USAGE	SHEETING MATERIAL
RED	BACKGROUND	TYPE C (HIGH SPECIFIC INTENSITY)
WHITE	BACKGROUND	TYPE C (HIGH SPECIFIC INTENSITY)
YELLOW	BACKGROUND	TYPE C (HIGH SPECIFIC INTENSITY)
BLACK	LEGEND & BORDERS	VINYL NON-REFLECTIVE SHEETING
PLYWOOD SIGN BLANKS		DMS-7100
ALUMINUM SIGN BLANKS		DMS-7110
SIGN HARDWARE		DMS-7120
WINGED CHANNEL POSTS		DMS-7130
FLAT SURFACE REFLECTIVE SHEETING		DMS-8300
VINYL NON-REFLECTIVE DECAL SHEETING		DMS-8320
DELINEATORS AND OBJECT MARKERS		DMS-8600

- GENERAL NOTES:
- Barricade striping shall be red and white reflective sheeting for all permanent road closures. Orange and white reflective sheeting may be substituted for locations where duration of road closure is expected to be 18 months or less, or when approved by the Engineer. Red and orange reflective sheeting shall not be combined on barricades or locations.
 - Barricades shall be designed and constructed to Compliant Work Zone Traffic Control Device List (CWZTCD) standards in a first-class workmanship manner of clean sound material. Components made of lumber shall be painted with a minimum of two coats of white paint to ensure thorough coverage and a uniform white color. Barricade striping material shall meet the color and retroreflective requirements of Departmental Material Specification DMS-8300, Type C.
 - Post type breakaway supports shall be used as barricade supports. Barricades may be fabricated with "skid" supports if approved by the Engineer. Skid supports should be anchored using sand bags to prevent movement. For construction details of post (fixed Type III barricades) see CWZTCD list Part D.2.f. The dead end road barricades may also be anchored to the pavement using the bolt down median anchor manufactured by Universal Anchor System shown on SMD (FRP). The barricades shall be built using FRP posts and approved rails as shown on the CWZTCD List.
 - Barricades shall not be placed parallel to traffic unless a minimum adequate clear zone of 30 feet from edge of travel lane is provided.
 - A minimum of one 8-foot wide barricade and three OM-4R object markers shall be required for all locations. Barricades shall extend across all travel lanes and shoulders if shoulders are present. Barricades may be extended to the ROW as directed by Engineer.
 - Stockpiled materials shall not be placed on traffic side of barricades.
 - OM-4 object markers shall be mounted to the middle rail using two 1/2" through bolts with flat washers and lock washers.
 - OM-4 object markers shall be constructed of 0.063 aluminum and shall meet the color and reflective requirements of DMS-8300 Type C and DMS-8600.
 - Plastic drums shall meet the requirements as listed on the CWZTCD list or the BC Standards. Plastic drums may be anchored with adhesive to prevent movement.
 - All signs and chevrons shall be installed with hardware and support at the minimum mounting height in accordance with the SMD and BC Standards. Signs shall be mounted at a 7 foot minimum height. Signs shall not be attached to barricades.
 - Motorists should be able to see at least three chevron signs as they approach the curve and as they drive through the curve from either direction.
 - Delineation devices such as the chevron or large arrow signs shall only be placed on the outside portion of a curve.

- GENERAL NOTE FOR SIGNS:
- The alphabets and lateral spacing between letters and numerals shall conform with the "Texas Manual on Uniform Traffic Control Devices for Streets and Highways" (TMUTCD), latest edition, and any approved changes thereto.
 - Lateral spacing of text shall provide a balanced appearance.
 - All materials shall conform to Departmental Material Specifications.
 - Legend shall be black and applied by screening process, cut-out vinyl non-reflective sheeting or combination thereof.
 - Sign blanks shall be any material that meets the DMS requirements for permanent sign substrates.

Only pre-qualified products shall be used. A copy of the "Compliant Work Zone Traffic Control Devices List" (CWZTCD) describes pre-qualified products and their sources and may be obtained by contacting:

Standards Engineer
 Traffic Operations Division - TE
 Texas Department of Transportation
 125 East 11th Street
 Austin, Texas 78701-2483
 Phone (512) 416-3120
 Fax (512) 416-3299

Instructions to locate the "CWZTCD" on TxDOT website are:

Start at website - www.dot.state.tx.us
 Click on "About TxDOT",
 Click on "Organizational Chart",
 Click on Traffic Operations Box,
 Click on "Compliant Work Zone Traffic Control Devices",
 Click on "View PDF".
 This site is printable.

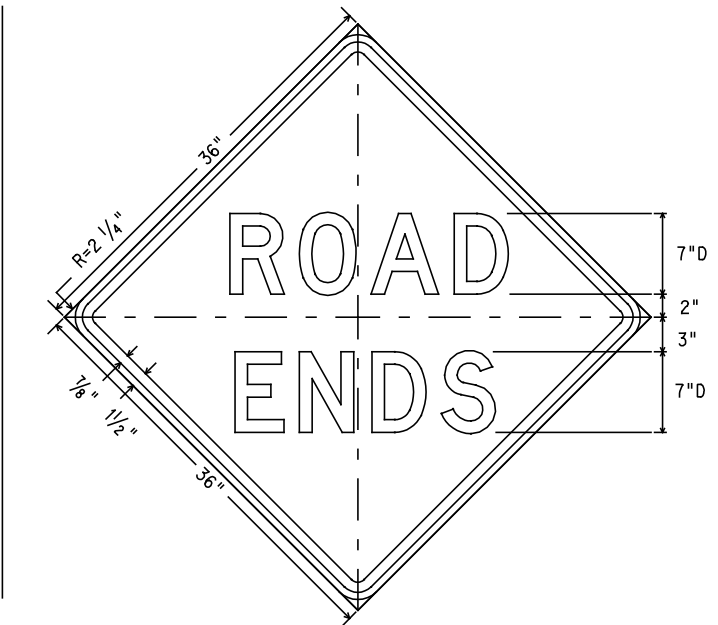

SW14-1T
 36" X 36"
 Letters - Black
 Border - Black
 Background - Yellow Refl.

Texas Department of Transportation
 Traffic Operations Division

WORK ZONE
 DEAD END
 ROADWAY DETAILS

WZ (DERD) -03

© TxDOT August 1995		DN: TxDOT	CK: TxDOT	DW: TxDOT	CK: TxDOT
1-97	REVISIONS	CONT	SECT	JOB	HIGHWAY
2-98		3C	1080	103	BERNAL
4-98		DIST	COUNTY		SHEET NO.
3-03		PHR	HIDALGO		40

DATE: 3/19/2012 3:47:30 PM
 FILE: p:\2009\2009-1027-02_heboap_iii_additional_colonias.design\03_el_mesquite.csj\Standards\Traffic Control\TCP1-2.dgn

DISCLAIMER: The use of this standard is governed by the "Texas Engineering Practice Act". No warranty of any kind is made by TxDOT for any purpose whatsoever. TxDOT assumes no responsibility for the conversion of this standard to other formats or for incorrect results or damages resulting from its use.

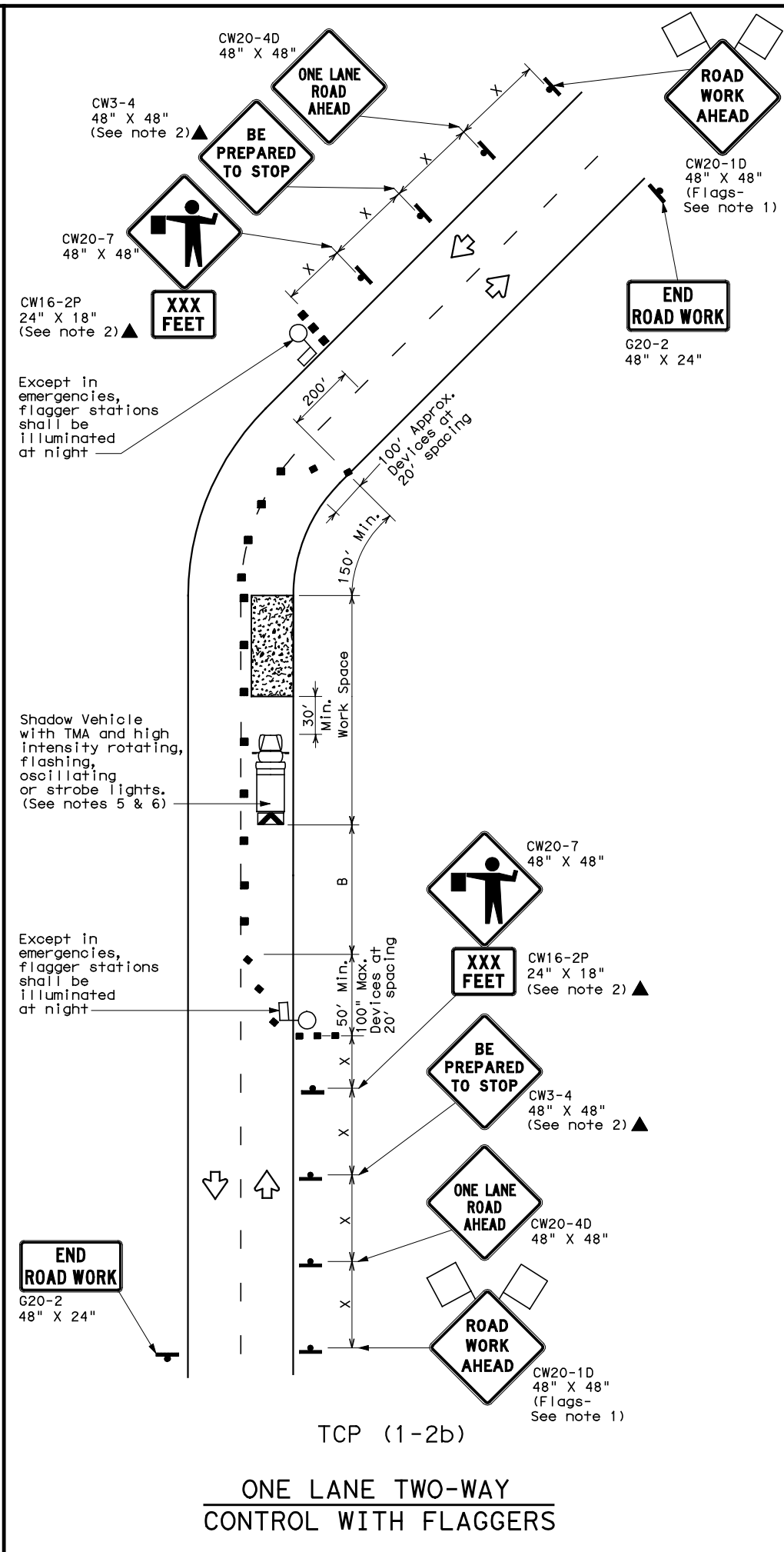
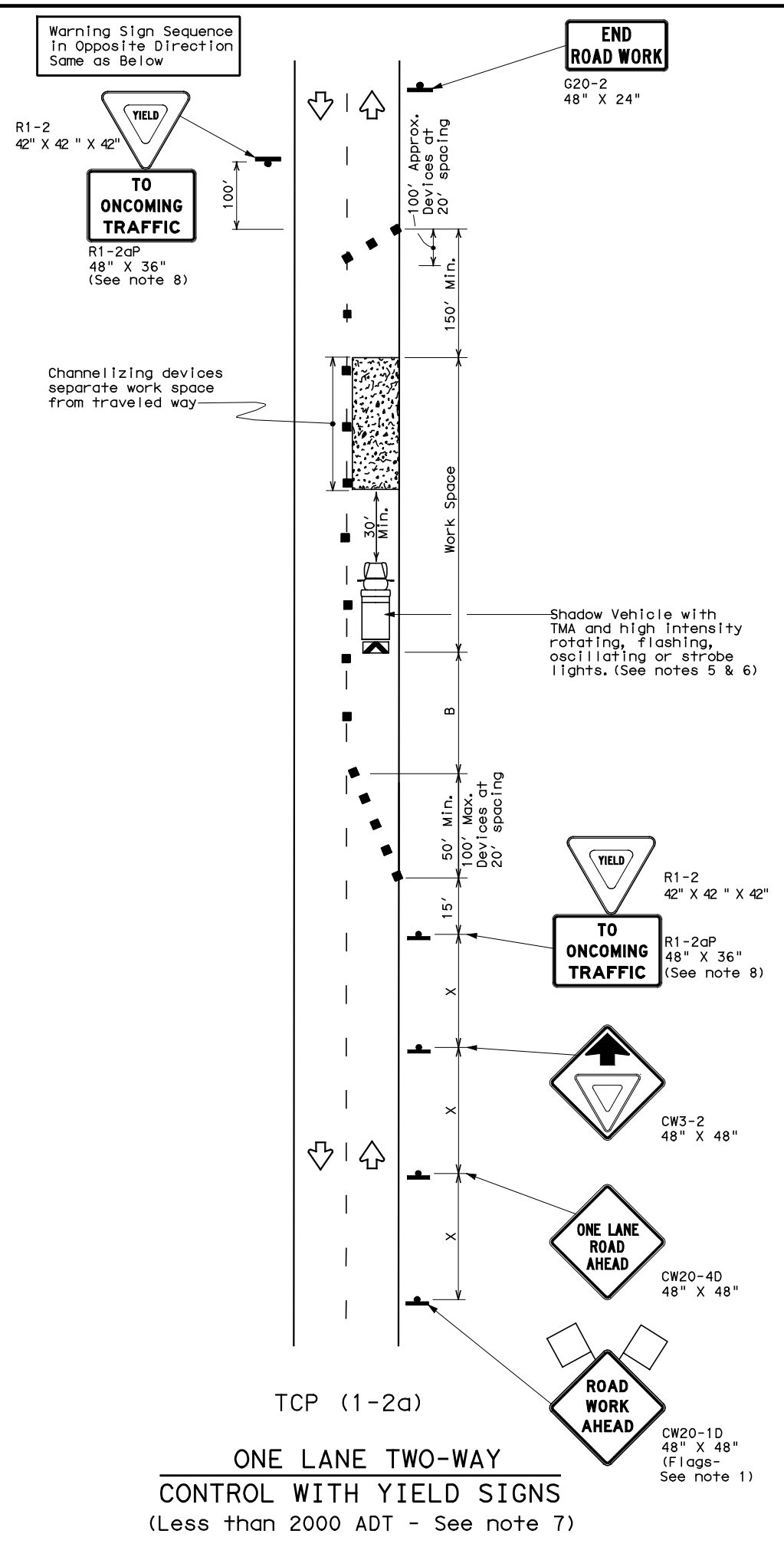

LEGEND

	Type 3 Barricade		Channelizing Devices
	Heavy Work Vehicle		Truck Mounted Attenuator (TMA)
	Trailer Mounted Flashing Arrow Board		Portable Changeable Message Sign (PCMS)
	Sign		Traffic Flow
	Flag		Flagger

Posted Speed * X	Formula L = WS ² / 60	Minimum Desirable Taper Lengths **			Suggested Maximum Spacing of Channelizing Devices		Minimum Sign Spacing "X" Distance	Suggested Longitudinal Buffer Space "B"	Stopping Sight Distance
		10' Offset	11' Offset	12' Offset	On a Taper	On a Tangent			
30	L = WS ² / 60	150'	165'	180'	30'	60'	120'	90'	200'
35		205'	225'	245'	35'	70'	160'	120'	250'
40		265'	295'	320'	40'	80'	240'	155'	305'
45		450'	495'	540'	45'	90'	320'	195'	360'
50		500'	550'	600'	50'	100'	400'	240'	425'
55		550'	605'	660'	55'	110'	500'	295'	495'
60		600'	660'	720'	60'	120'	600'	350'	570'
65		650'	715'	780'	65'	130'	700'	410'	645'
70		700'	770'	840'	70'	140'	800'	475'	730'
75		750'	825'	900'	75'	150'	900'	540'	820'

* Conventional Roads Only
 ** Taper lengths have been rounded off.
 L=Length of Taper (FT) W=Width of Offset (FT) S=Posted Speed (MPH)

TYPICAL USAGE

	MOBILE	SHORT DURATION	SHORT TERM STATIONARY	INTERMEDIATE TERM STATIONARY	LONG TERM STATIONARY
		✓	✓		

GENERAL NOTES

- Flags attached to signs where shown are REQUIRED.
 - All traffic control devices illustrated are REQUIRED, except those denoted with the triangle symbol may be omitted when stated elsewhere in the plans, or for routine maintenance work, when approved by the Engineer.
 - The CW3-4 "BE PREPARED TO STOP" sign may be installed after the CW20-4D "ONE LANE ROAD AHEAD" sign, but proper sign spacing shall be maintained.
 - Sign spacing may be increased or an additional CW20-1D "ROAD WORK AHEAD" sign may be used if advance warning ahead of the flagger or R1-2 "YIELD" sign is less than 1500 feet.
 - A Shadow Vehicle with a TMA should be used anytime it can be positioned 30 to 100 feet in advance of the area of crew exposure without adversely affecting the performance or quality of the work. If workers are no longer present but road or work conditions require the traffic control to remain in place, Type 3 Barricades or other channelizing devices may be substituted for the Shadow Vehicle and TMA.
 - Additional Shadow Vehicles with TMAs may be positioned off the paved surface, next to those shown in order to protect wider work spaces.
- TCP (1-2a)**
- R1-2 "YIELD" sign traffic control may be used on projects with approaches that have adequate sight distance. For projects in urban areas, work spaces should be no longer than one half city block. In rural areas on roadways with less than 2000 ADT, work spaces should be no longer than 400 feet.
 - R1-2 "YIELD" sign with R1-2aP "TO ONCOMING TRAFFIC" plaque shall be placed on a support at a 7 foot minimum mounting height.
- TCP (1-2b)**
- Flaggers should use two-way radios or other methods of communication to control traffic.
 - Length of work space should be based on the ability of flaggers to communicate.
 - If the work space is located near a horizontal or vertical curve, the buffer distances should be increased in order to maintain adequate stopping sight distance to the flagger and a queue of stopped vehicles (see table above).
 - Channelizing devices on the center-line may be omitted when a pilot car is leading traffic and approved by the Engineer.
 - Flaggers should use 24" STOP/SLOW paddles to control traffic. Flags should be limited to emergency situations.

For construction or maintenance contract work, specific project requirements for shadow vehicles can be found in the project GENERAL NOTES for Item 502, Barricades, Signs and Traffic Handling.



**TRAFFIC CONTROL PLAN
 ONE-LANE TWO-WAY
 TRAFFIC CONTROL**

TCP (1-2) - 12

© TxDOT December 1985		DN: TxDOT	CK: TxDOT	DW: TxDOT	CK: TxDOT
REVISIONS		CONT	SECT	JOB	HIGHWAY
4-90	2-12	3C	080	103	BERNAL
2-94		DIST	COUNTY		SHEET NO.
1-97		PHR	HIDALGO		41
4-98					

DATE: 3/19/2012 3:47:38 PM
 FILE: p:\2009\2009-1027-02_heboap_iii_additional_colonias_design\03_el_mesquite\csj_standards\Traffic Control\TCP2-2.dgn

DISCLAIMER: The use of this standard is governed by the "Texas Engineering Practice Act". No warranty of any kind is made by TxDOT for any purpose whatsoever. TxDOT assumes no responsibility for the conversion of this standard to other formats or for incorrect results or damages resulting from its use.

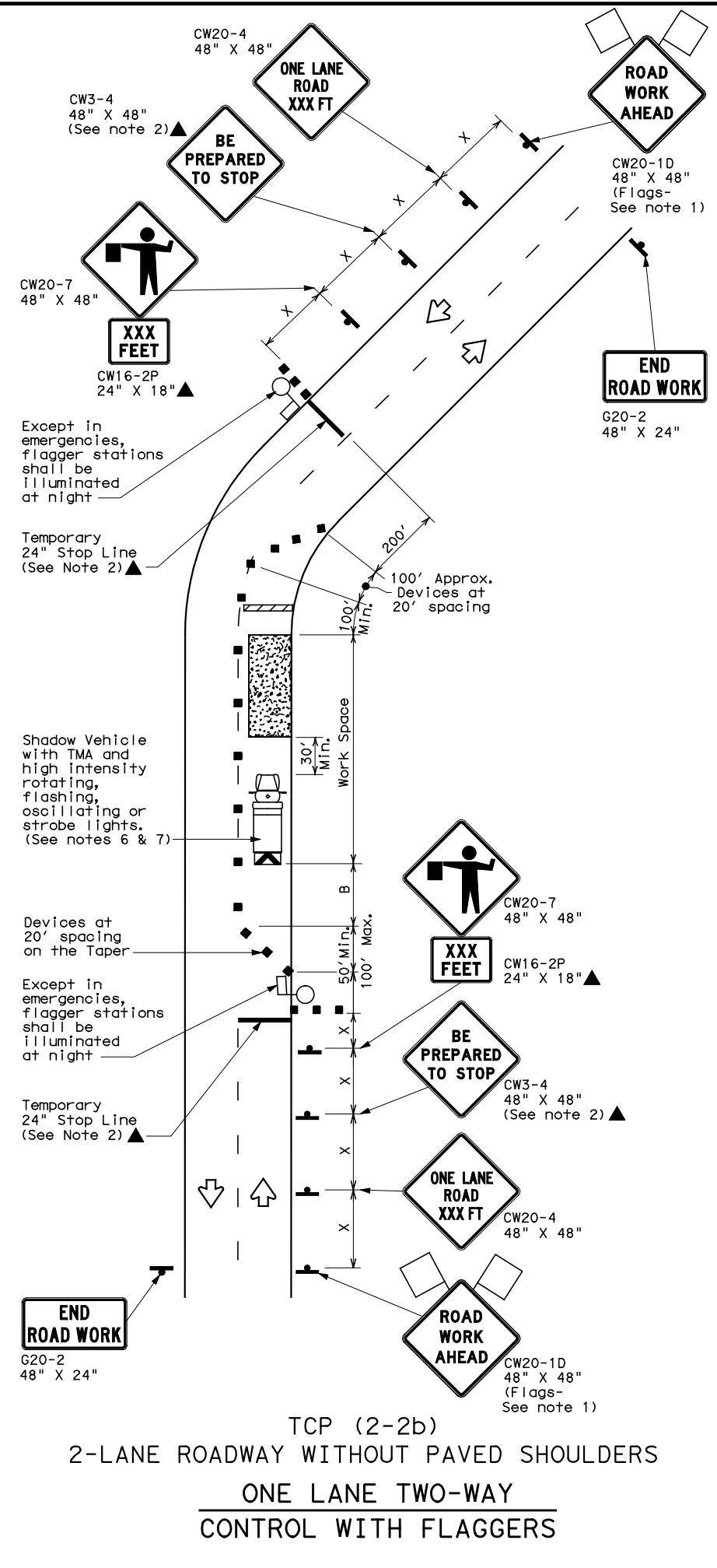
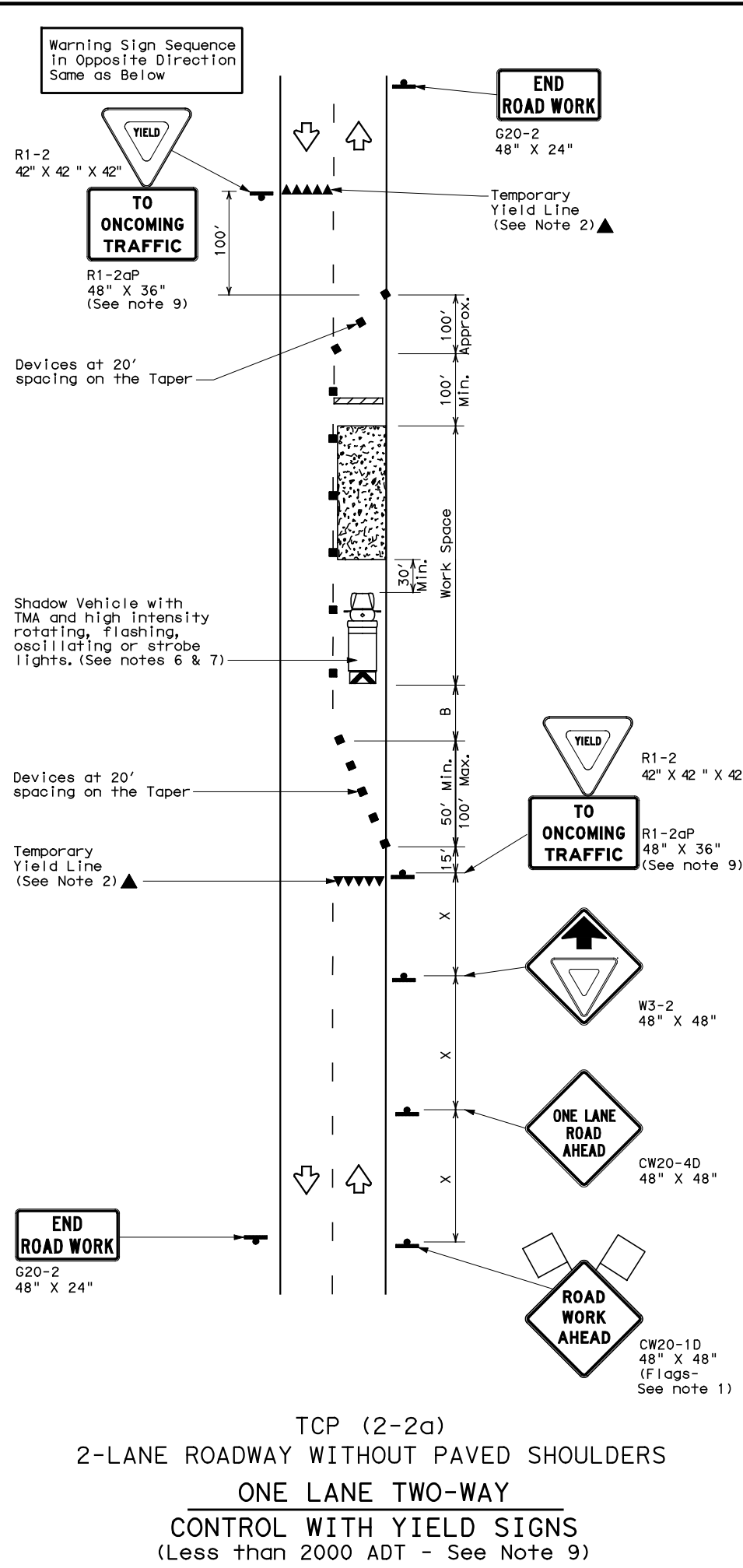

LEGEND

	Type 3 Barricade		Channelizing Devices
	Heavy Work Vehicle		Truck Mounted Attenuator (TMA)
	Trailer Mounted Flashing Arrow Board		Portable Changeable Message Sign (PCMS)
	Sign		Traffic Flow
	Flag		Flagger

Posted Speed *	Formula	Minimum Desirable Taper Lengths **			Suggested Maximum Spacing of Channelizing Devices		Minimum Sign Spacing "X" Distance	Suggested Longitudinal Buffer Space "B"	Stopping Sight Distance
		10' Offset	11' Offset	12' Offset	On a Taper	On a Tangent			
30	L = WS ² / 60	150'	165'	180'	30'	60'	120'	90'	200'
35		205'	225'	245'	35'	70'	160'	120'	250'
40		265'	295'	320'	40'	80'	240'	155'	305'
45	L = WS	450'	495'	540'	45'	90'	320'	195'	360'
50		500'	550'	600'	50'	100'	400'	240'	425'
55		550'	605'	660'	55'	110'	500'	295'	495'
60		600'	660'	720'	60'	120'	600'	350'	575'
65		650'	715'	780'	65'	130'	700'	410'	645'
70		700'	770'	840'	70'	140'	800'	475'	730'
75		750'	825'	900'	75'	150'	900'	540'	820'

* Conventional Roads Only
 ** Taper lengths have been rounded off.
 L=Length of Taper (FT) W=Width of Offset (FT) S=Posted Speed (MPH)

TYPICAL USAGE

	MOBILE	SHORT DURATION	SHORT TERM STATIONARY	INTERMEDIATE TERM STATIONARY	LONG TERM STATIONARY
		✓	✓	✓	

- GENERAL NOTES**
- Flags attached to signs where shown, are REQUIRED.
 - All traffic control devices illustrated are REQUIRED, except those denoted with the triangle symbol may be omitted when stated elsewhere in the plans, or for routine maintenance work, when approved by the Engineer.
 - The CW3-4 "BE PREPARED TO STOP" sign may be installed after the CW20-4 "ONE LANE ROAD XXX FT" sign, but proper sign spacing shall be maintained.
 - Flaggers should use two-way radios or other methods of communication to control traffic.
 - Length of work space should be based on the ability of flaggers to communicate.
 - A Shadow Vehicle with a TMA should be used anytime it can be positioned 30 to 100 feet in advance of the area of crew exposure without adversely affecting the performance or quality of the work. If workers are no longer present but road or work conditions require the traffic control to remain in place, Type 3 Barricades or other channelizing devices may be substituted for the Shadow Vehicle and TMA. If workers are no longer present but road or work conditions require the traffic control to remain in place, Type 3 Barricades or other channelizing devices may be substituted for the Shadow Vehicle and TMA.
 - Additional Shadow Vehicles with TMAs may be positioned off the paved surface, next to those shown in order to protect a wider work space.
- TCP (2-2a)**
- The R1-2 "YIELD" sign traffic control may be used on projects with approaches that have adequate sight distance. For projects in urban areas, work space should be no longer than one half city block. In rural areas, roadways with less than 2000 ADT, work space should be no longer than 400 feet.
 - The R1-2aP "YIELD TO ONCOMING TRAFFIC" sign shall be placed on a support at a 7 foot minimum mounting height.
- TCP (2-2b)**
- Channelizing devices on the center line may be omitted when a pilot car is leading traffic and approved by the Engineer.
 - If the work space is located near a horizontal or vertical curve, the buffer distances should be increased in order to maintain stopping sight distance to the flagger and a queue of stopped vehicles. (See table above).
 - Flaggers should use 24" STOP/SLOW paddles to control traffic. Flags should be limited to emergency situations.

For construction or maintenance contract work, specific project requirements for shadow vehicles can be found in the project GENERAL NOTES for Item 502, Barricades, Signs and Traffic Handling.

Texas Department of Transportation
 Traffic Operations Division

TRAFFIC CONTROL PLAN
ONE-LANE TWO-WAY
TRAFFIC CONTROL

TCP (2-2) -12

© TxDOT December 1985		DN: TxDOT	CK: TxDOT	DW: TxDOT	CK: TxDOT
REVISIONS		CONT	SECT	JOB	HIGHWAY
8-95	2-12	3C	1080	103	BERNAL
1-97		DIST	COUNTY		SHEET NO.
4-98		PHR	HIDALGO		42
3-03					

162

DISCLAIMER: The use of this standard is governed by the "Texas Engineering Practice Act". No warranty of any kind is made by TxDOT for any purpose whatsoever. TxDOT assumes no responsibility for the conversion of this standard to other formats or for incorrect results or damages resulting from its use.
 DATE: 3/19/2012 3:47:47 PM
 FILE: p:\2009\2009-1027-02_hobcap_iii_additional_colonias_design\03_el_mesquite\csj\Standards\Traffic Control\TCP3-3.dgn

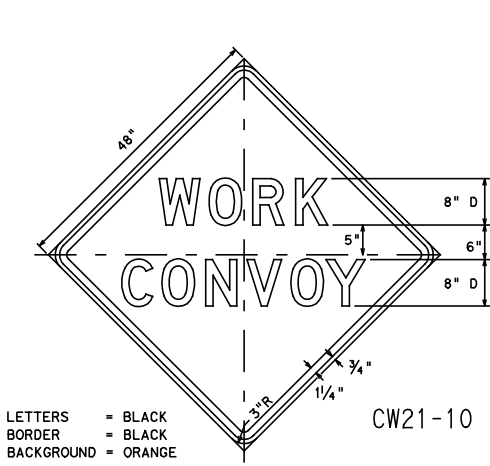
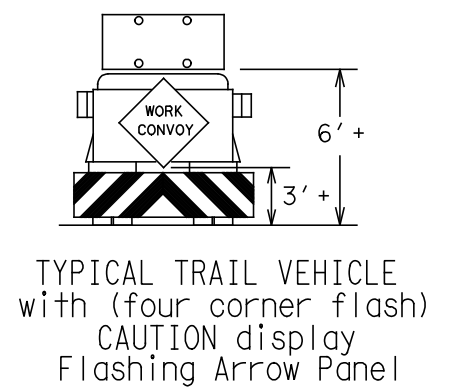
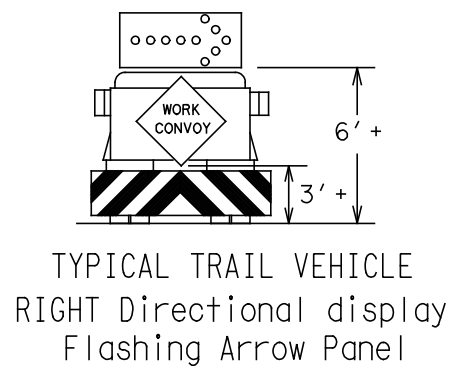
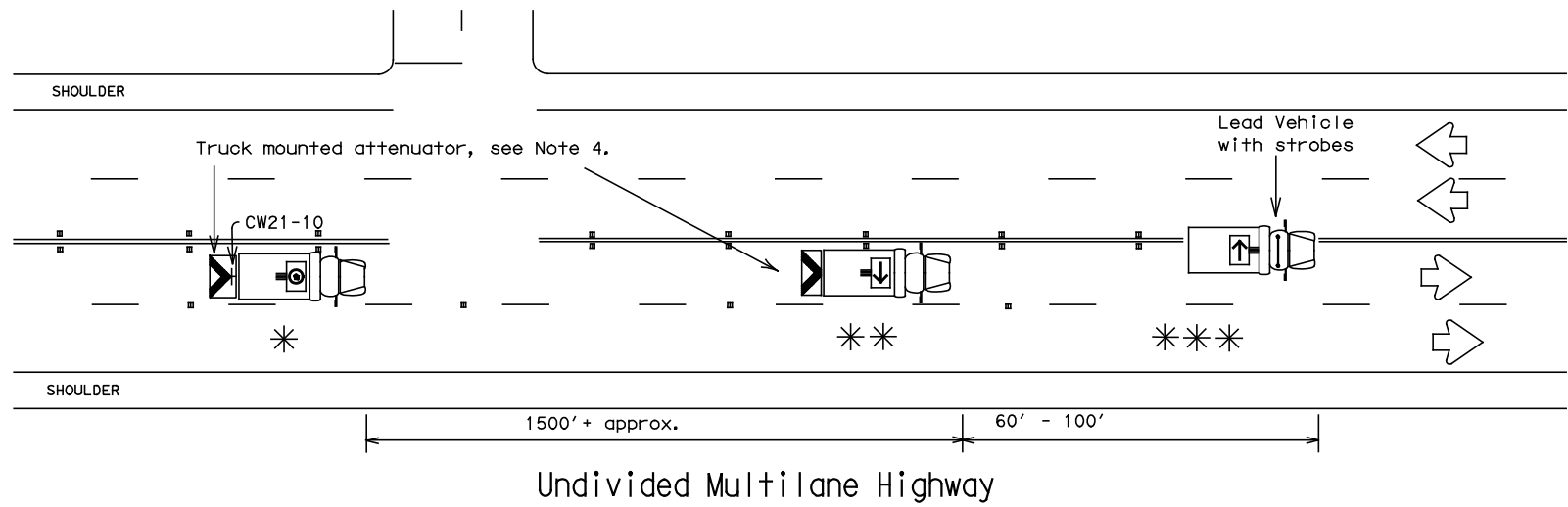
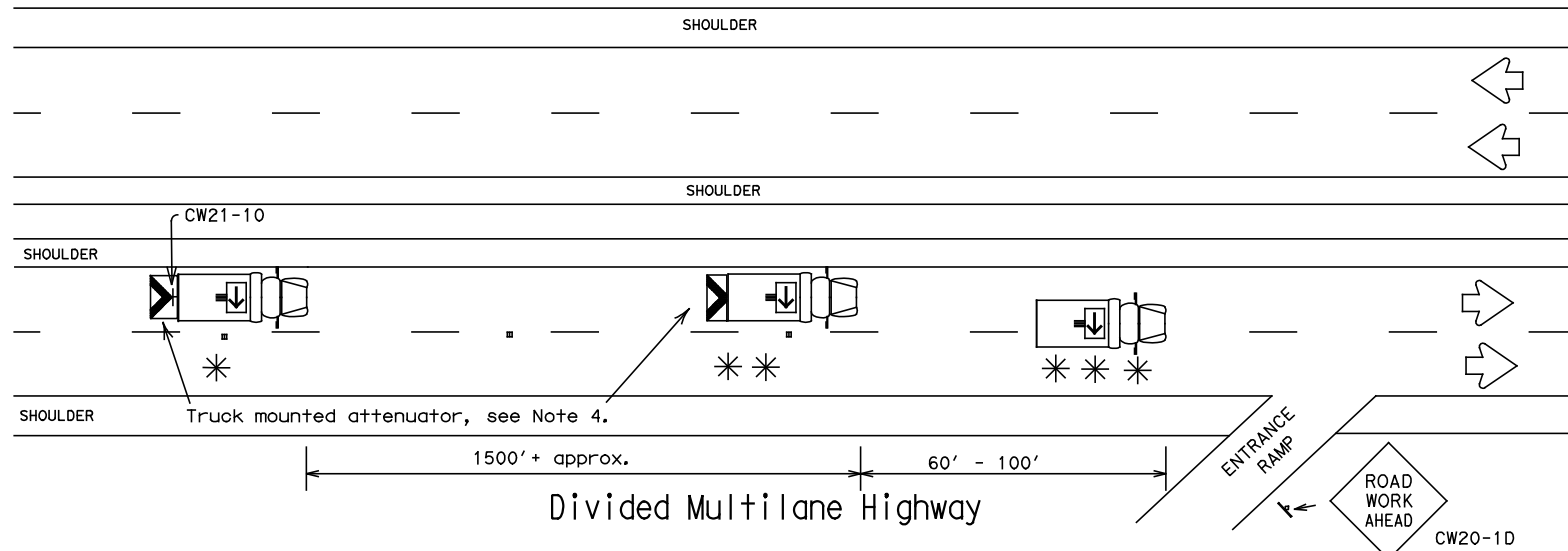
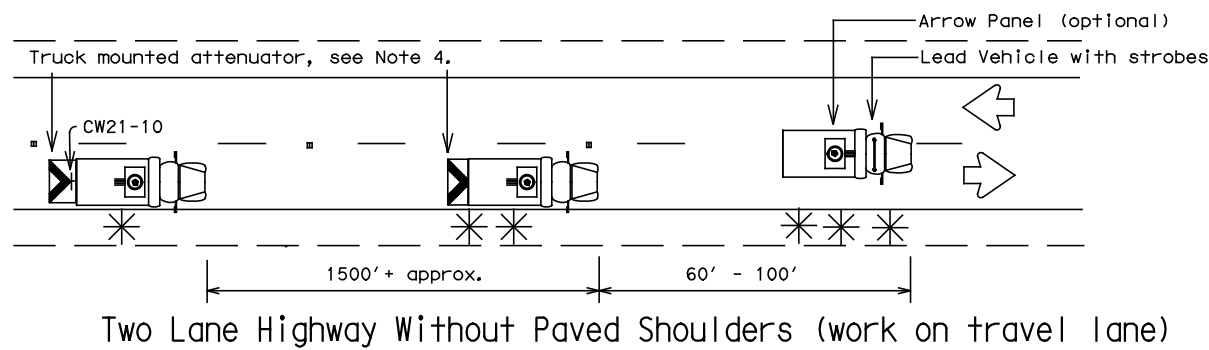
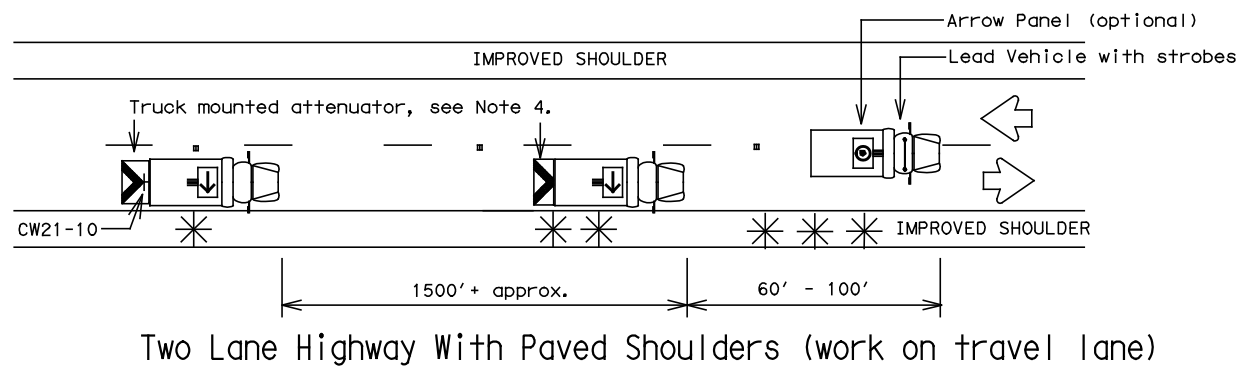

- Legend:**
- * TRAIL VEHICLE
 - ** SHADOW VEHICLE
 - *** WORK VEHICLE
 - Truck mounted attenuator
 - HEAVY WORK VEHICLE
- Arrow Panel Displays**
- RIGHT Directional
 - LEFT Directional
 - RIGHT or LEFT Directional
 - CAUTION mode

GENERAL NOTES:

1. TRAIL, SHADOW, LEAD, and work vehicles shall be equipped with arrow panels as illustrated. The Engineer will determine if the LEAD VEHICLE and/or TRAIL VEHICLE are required based on prevailing roadway conditions, traffic volume, and sight distance restrictions.
2. All traffic control devices shall be in accordance with the "Texas Manual on Uniform Traffic Control Devices" (TMUTCD), latest edition.
3. The use of yellow rotating beacons or strobe lights on vehicles are required unless otherwise stated elsewhere in the plans.
4. The use of truck mounted attenuators (TMA) on the SHADOW VEHICLE and the TRAIL VEHICLE are required.
5. Optional striping on the back panel of all truck mounted attenuators shall be 8" red and white reflective sheeting placed in an inverted "V" design. Reflective sheeting shall meet or exceed the reflectivity and color requirements of DEPARTMENTAL MATERIAL SPECIFICATION D-9-8300, TYPE C.
6. Flashing Arrow Panels shall be Type B or Type C as per BC Standards. The panel operation shall be controlled from inside the vehicle.
7. Each vehicle shall have two-way radio communication capability.
8. When work convoys must change lanes, the TRAIL VEHICLE should change lanes first to shadow the other convoy vehicles.
9. Vehicle spacing between TRAIL VEHICLE and SHADOW VEHICLE will vary depending on sight distance restrictions. Motorists approaching the work convoy should be able to see the TRAIL VEHICLE in time to slow down and/or change lanes as they approach the TRAIL VEHICLE.

Only pre-qualified products shall be used. A list of compliant products and their sources may be obtained by writing or faxing:

Standards Engineer
 Traffic Operations Division - TE
 Texas Department of Transportation
 125 East 11th Street
 Austin, Texas 78701-2483
 Phone (512) 416-3335
 Fax (512) 416-3161
 E-mail TRF-STANDARD@mailgw.dot.state.tx.us

Shadow and trail vehicle shall be equipped with Truck Mounted Attenuator.

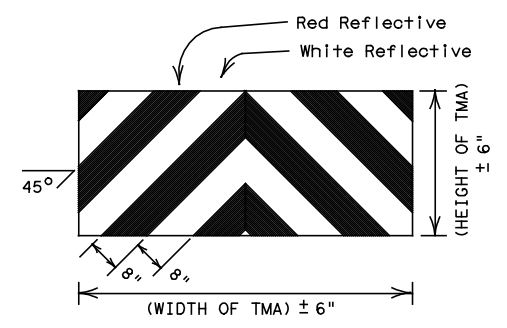

OPTIONAL STRIPING FOR TMA

STRIPING FOR TMA WILL BE REQUIRED ON ALL PROJECTS AWARDED AFTER JANUARY 1, 2000

Texas Department of Transportation
 Traffic Operations Division

**TRAFFIC CONTROL PLAN
 MOBILE OPERATIONS
 RAISED PAVEMENT
 MARKER INSTALLATION**

TCP (3-3) -98

© TxDOT September 1987		DN: TxDOT	CK: TxDOT	DW: TxDOT	CK: TxDOT
2-94	8-95	3C	1080	103	BERNAL
1-97	4-98	DIST	COUNTY		SHEET NO.
		PHR	HIDALGO		43

DISCLAIMER: The use of this standard is governed by the "Texas Engineering Practice Act". No warranty of any kind is made by TxDOT for any purpose whatsoever. TxDOT assumes no responsibility for the conversion of this standard to other formats or for incorrect results or damages resulting from its use.

DATE: 3/19/2012 3:47:52 PM
 FILE: p:\2009\2009-1027-02_heboap_iii_additional_colonias_design\03_e1_mesquite\csj\Standards\Traffic Control\TCP71.dgn

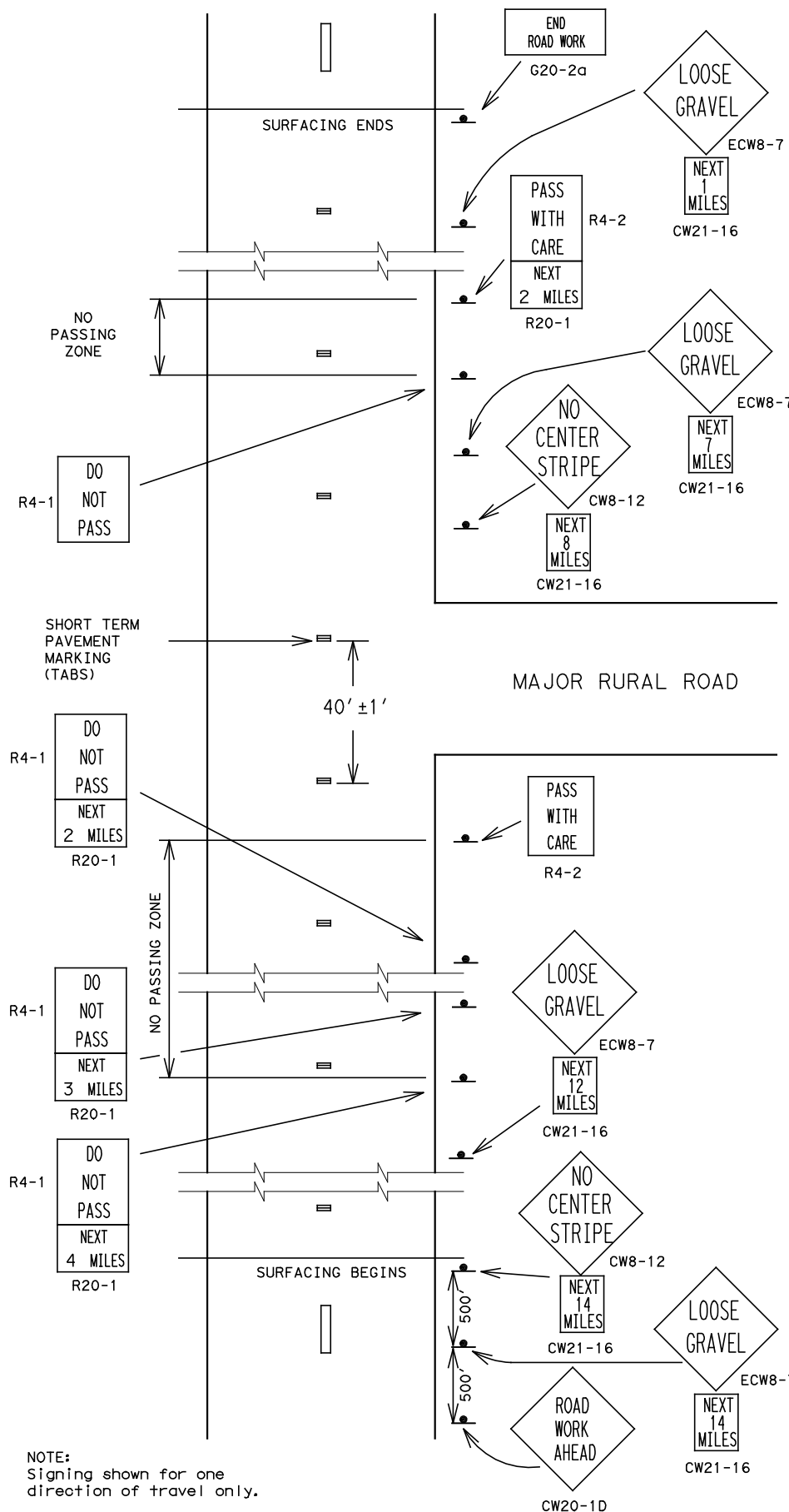

NOTE: Signing shown for one direction of travel only.

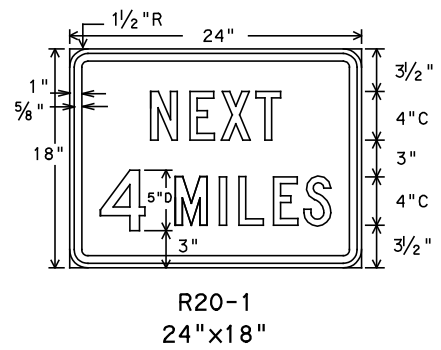

Legend - Black
 Border - Black
 Background - White Refl.

FOR USE WITH REGULATORY SIGNS ONLY

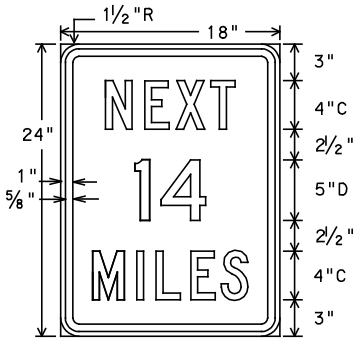

Legend - Black
 Border - Black
 Background - Orange Refl.

FOR USE WITH CONSTRUCTION WARNING SIGNS ONLY

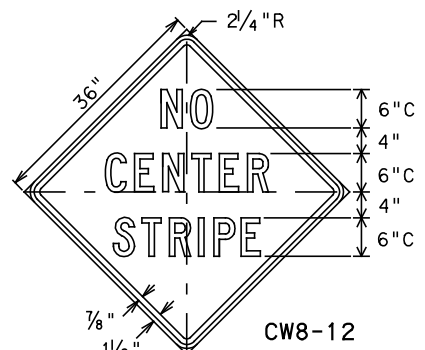

Legend - Black
 Border - Black
 Background - Orange Refl.

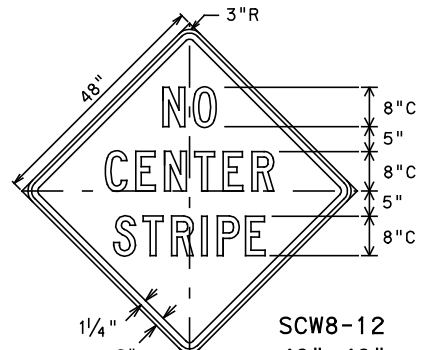

Legend - Black
 Border - Black
 Background - Orange Refl.

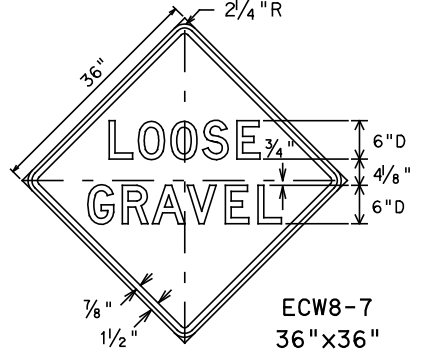

Legend - Black
 Border - Black
 Background - Orange Refl.

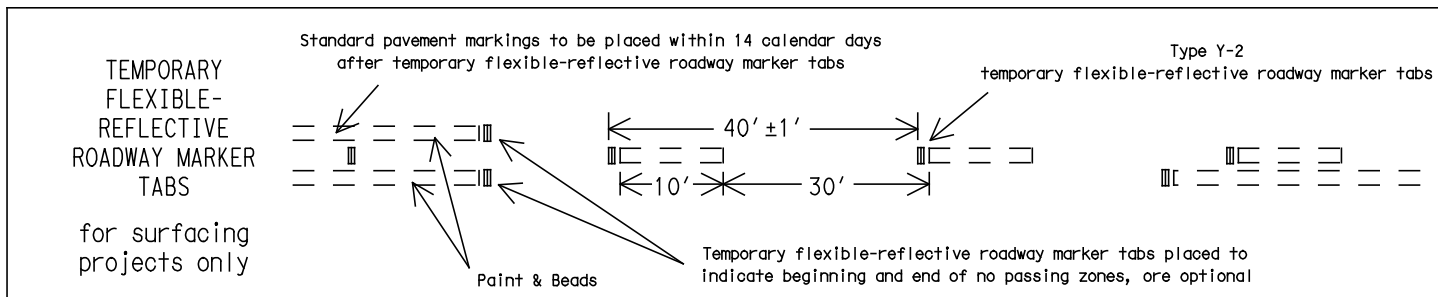

GENERAL NOTES

The traffic control devices detailed on this sheet will be furnished and erected as directed by the Engineer on sections of roadway where the surfacing operation has covered or obliterated existing pavement markings. These traffic control devices are to be used to supplement those required by BC Standards.

"DO NOT PASS" SIGN (R4-1) and NO-PASSING ZONES

Prior to the beginning of construction, all currently striped no-passing zones should be signed with the DO NOT PASS sign (R4-1) and PASS WITH CARE sign (R4-2) placed at the beginning and end of each zone for each direction of travel except as otherwise provided herein. Signs marking these individual no-passing zones need not be covered prior to construction if the signs supplement the existing pavement markings.

At the discretion of the Engineer, in areas of numerous no-passing zones, several zones may be combined and signed as a single zone. If passing is to be prohibited over one or more lengthy sections, a DO NOT PASS sign and a NEXT XX MILES sign (R20-1) may be used at the beginning of such zones. The DO NOT PASS and NEXT XX MILES signs should be repeated every mile to the end of the no-passing zone. In areas where there is considerable distance between no-passing zones, the end of a no-passing zone may be signed with a PASS WITH CARE and NEXT XX MILES sign.

Depending on traffic volumes and length of sections, it may be desirable to prohibit passing throughout the project to prevent damage to windshields and lights. The DO NOT PASS and NEXT XX MILES sign should be used and repeated as often as necessary for this purpose. Where several existing zones are to be combined into one individual no-passing zone, the sign at the beginning of the zone should be covered until the surfacing operation has passed this location so as not to have the DO NOT PASS sign conflict with existing pavement markings. Also, unless one days operation completes the entire length of such combined zones, care must be taken to place DO NOT PASS and PASS WITH CARE signs in order to sign the beginning and end of the no-passing zones in the area where the surfacing operation has stopped for the day.

R4-1 and R4-2 signs should be mounted on fixed supports as detailed on BC Standards. These signs are to remain in place until standard pavement markings are placed.

"NO CENTER STRIPE" SIGN (CW21-15)

At the time construction activity obliterates the existing centerline (low volume roads may not have an existing centerline), a NO CENTER STRIPE sign (CW8-12) should be erected at each end of the work area and just beyond major rural intersections and other location deemed necessary by the Engineer. Where possible, the signs erected at each end of the work area should be located in such a manner that drivers can read the sign and immediately see the change to no centerline. The NO CENTER STRIPE sign should be supplemented with the NEXT XX MILES sign (CW21-16) mounted below it. The NO CENTER STRIPE sign should be erected as detailed on BC Standards. These signs are to remain in place until standard pavement markings are placed.

"LOOSE GRAVEL" SIGN (ECW8-7)

When construction begins, a LOOSE GRAVEL sign (ECW8-7) should be erected at each end of the work area and repeated at intervals of approximately two (2) miles in rural areas and closer in urban areas. The LOOSE GRAVEL sign should be supplemented with the NEXT XX MILES sign (CW21-16) mounted below it.

The LOOSE GRAVEL sign should be erected as detailed on BC Standards. They should remain in place until the loose gravel condition no longer exists.

PAVEMENT MARKINGS

Short term pavement markings for surfacing projects shall use Temporary Flexible-reflective Roadway Marker Tabs. Tabs are to be installed to provide true alignment for striping crews or as directed by the Engineer. Tabs will be placed at the spacing indicated. Tabs should be applied to the pavement no more than two (2) days before the surfacing is applied. After the surfacing is rolled and swept the cover over the reflective strip shall be removed. Tabs shall NOT be used to simulate edge lines.

Only pre-qualified products shall be used. A list of compliant products and their sources may be obtained by writing or faxing:

Standards Engineer
 Traffic Operations Division - TE
 Texas Department of Transportation
 125 East 11th Street
 Austin, Texas 78701-2483
 Phone (512) 416-3335
 Fax (512) 416-3161
 E-mail TRF-STANDARD@mailgw.dot.state.tx.us

TYPICAL USAGE:				
MOBILE	SHORT DURATION	SHORT TERM STATIONARY	INTERMEDIATE TERM STATIONARY	LONG TERM STATIONARY
	✓	✓	✓	✓



TRAFFIC CONTROL DETAILS
 for
 SURFACING OPERATIONS
 TCP (7-1) - 98

© TxDOT March 1991		DN: TxDOT	CK: TxDOT	DW: TxDOT	CK: TxDOT
REVISIONS		CONT	SECT	JOB	HIGHWAY
4-92		3C	080	103	BERNAL
1-97		DIST	COUNTY		SHEET NO.
4-98		PHR	HIDALGO		44

DATE: 3/19/2012 3:47:59 PM
 FILE: p:\2009\2009-1027-02_heboap_iii_additional_colonias_design\03_el_mesquite\cs\Standards\Pavement Markers\PM1-12.dgn
 DISCLAIMER: The use of this standard is governed by the "Texas Engineering Practice Act". No warranty of any kind is made by TxDOT for any purpose whatsoever. TxDOT assumes no responsibility for the conversion of this standard to other formats or for incorrect results or damages resulting from its use.

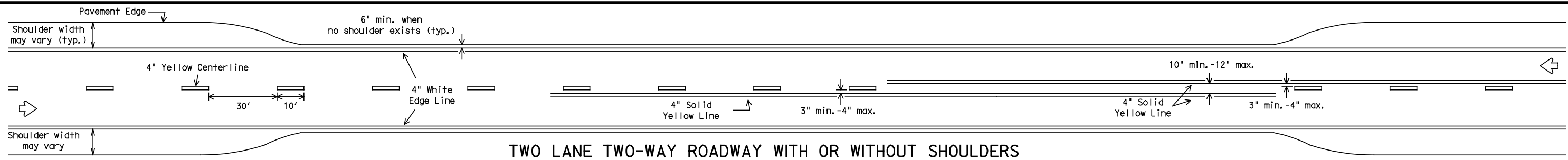

TWO LANE TWO-WAY ROADWAY WITH OR WITHOUT SHOULDERS

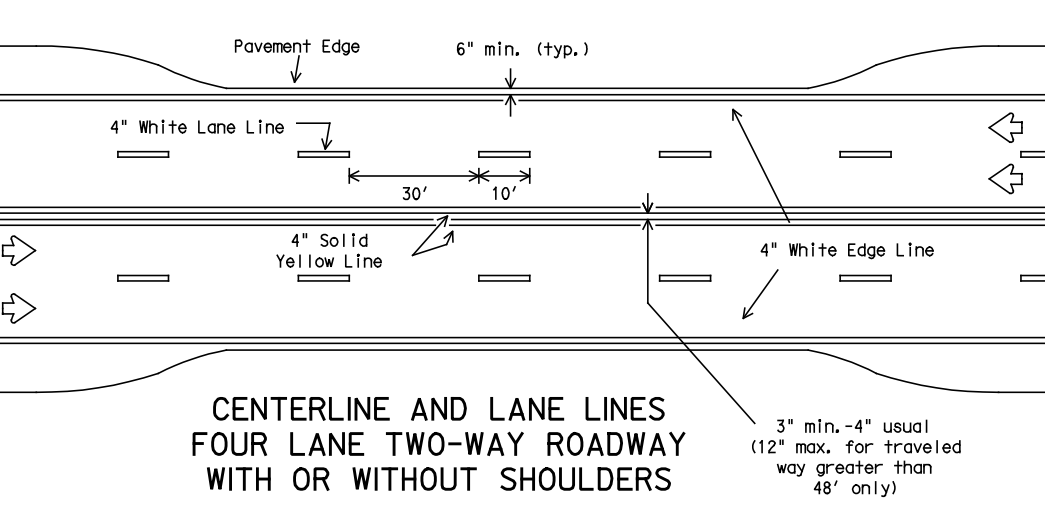

**CENTERLINE AND LANE LINES
FOUR LANE TWO-WAY ROADWAY
WITH OR WITHOUT SHOULDERS**

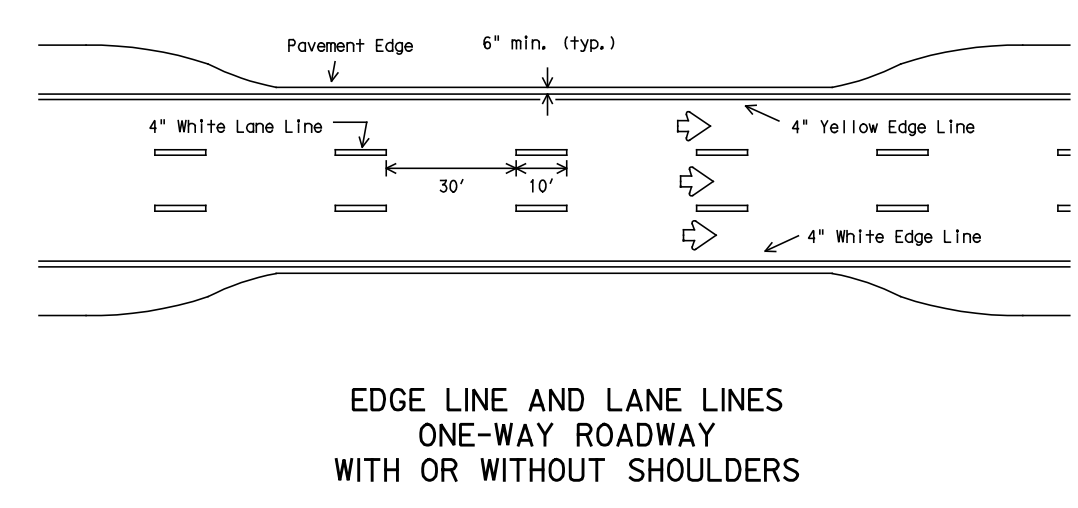

**EDGE LINE AND LANE LINES
ONE-WAY ROADWAY
WITH OR WITHOUT SHOULDERS**

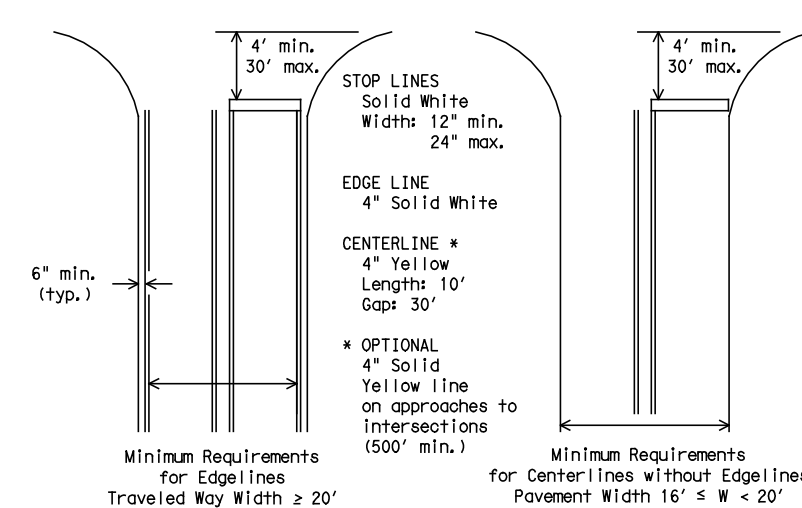

**GUIDE FOR PLACEMENT OF STOP LINES,
EDGE LINE & CENTERLINE**
Based on Traveled Way and Pavement Widths for Undivided Highways

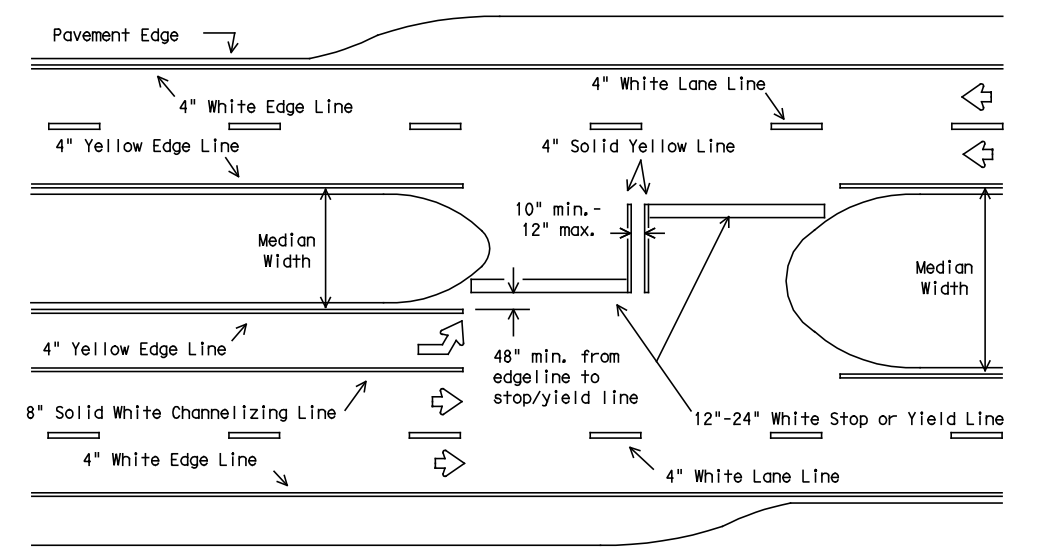

FOUR LANE DIVIDED ROADWAY INTERSECTIONS

All medians shall be field measured to determine the location of necessary striping. Stop/Yield bars and centerlines shall be placed when the median width is greater than 30 ft. The median width is defined as the area between two roadways of a divided highway measured from edge of traveled way to edge of traveled way. The median excludes turn lanes. The median width might be different between intersections, interchanges and of opposite approaches of the same intersection. The narrow median width will be the controlling width to determine if markings are required.

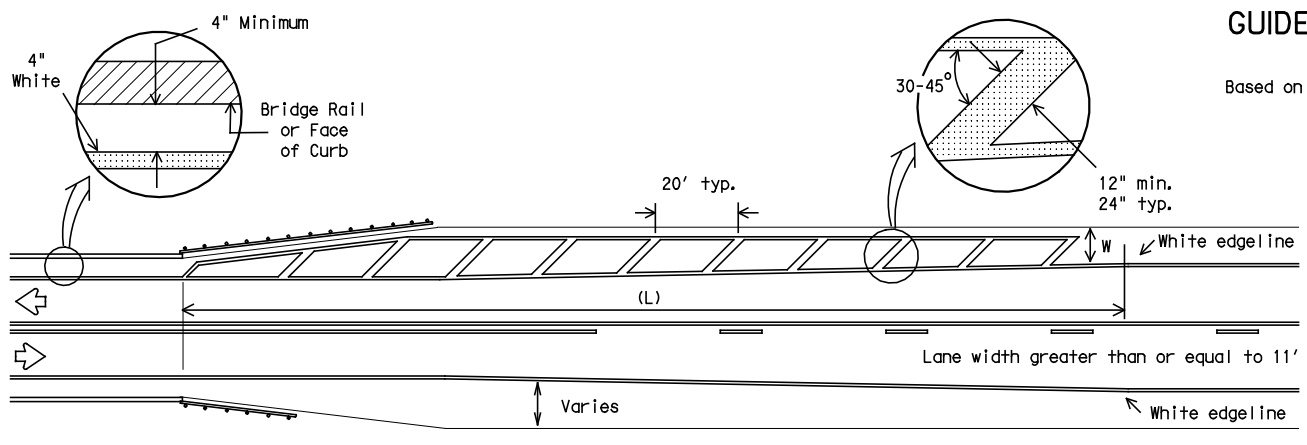

**ROADWAYS WITH REDUCED SHOULDER
WIDTHS ACROSS BRIDGE OR CULVERT**

- NOTES:
- No-passing zone on bridge approach is optional but if used, it shall be a minimum 500 feet long.
 - For crosshatching length (L) see Table 1.
 - The width of the offset (W) and the required crosshatching width is the full shoulder width in advance of the bridge.
 - The crosshatching is not required if delineators or barrier reflectors are used along the structure.
 - For guard fence details, refer elsewhere in the plans.

TABLE 1 - TYPICAL LENGTH (L)

Posted Speed *	Formula
≤ 40	$L = \frac{WS^2}{60}$
≥ 45	$L = WS$

*85th Percentile Speed may be used on roads where traffic speeds normally exceed the posted speed limit. Crosshatching length should be rounded up to nearest 5 foot increment.
 L=Length of Crosshatching (FT.) W=Width of Offset (FT.)
 S=Posted Speed (MPH)

EXAMPLES:
 An 8 foot shoulder in advance of a bridge reduces to 4 feet on a 70 MPH roadway. The length of the crosshatching should be:
 $L = 8 \times 70 = 560$ ft.
 A 4 foot shoulder in advance of a bridge reduces to 2 feet on a 40 MPH roadway. The length of the crosshatching should be:
 $L = 4(40)^2 / 60 = 106.67$ ft. rounded to 110 ft.

GENERAL NOTES

- Edgeline striping shall be as shown in the plans or as directed by the Engineer. The edgeline should typically be placed a minimum of 6 inches from the edge of pavement. This distance may vary due to pavement raveling or other conditions. Edgelines are not required in curb and gutter sections of roadways.
- The traveled way includes only that portion of the roadway used for vehicular travel and not the parking lanes, sidewalks, berms and shoulders. The traveled ways shall be measured from the inside of edgeline to inside of edgeline of a two lane roadway.

MATERIAL SPECIFICATIONS	
PAVEMENT MARKERS (REFLECTORIZED)	DMS-4200
EPOXY AND ADHESIVES	DMS-6100
BITUMINOUS ADHESIVE FOR PAVEMENT MARKERS	DMS-6130
TRAFFIC PAINT	DMS-8200
HOT APPLIED THERMOPLASTIC	DMS-8220
PERMANENT PREFABRICATED PAVEMENT MARKINGS	DMS-8240

All pavement marking materials shall meet the required Departmental Material Specifications as specified by the plans.

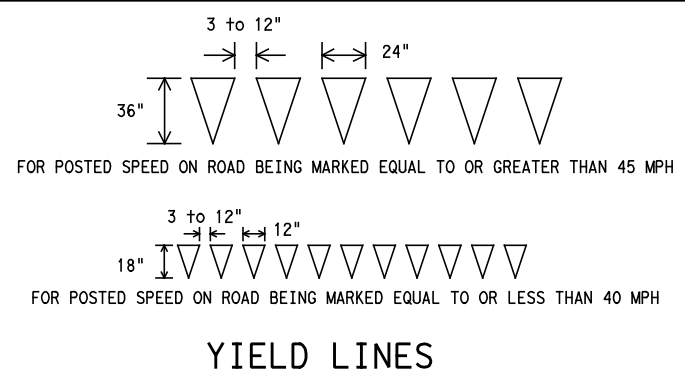

YIELD LINES

Texas Department of Transportation
Traffic Operations Division

**TYPICAL STANDARD
PAVEMENT MARKINGS**

PM(1)-12

© TxDOT November 1978	DN: TxDOT	CK: TxDOT	DW: TxDOT	CK: TxDOT
REVISIONS	CONT	SECT	JOB	HIGHWAY
8-95 2-12	3C	1080	103	BERNAL
5-00	DIST	COUNTY		SHEET NO.
8-00	PHR	HIDALGO		45
3-03				

DISCLAIMER: The use of this standard is governed by the "Texas Engineering Practice Act". No warranty of any kind is made by TxDOT for any purpose whatsoever. TxDOT assumes no responsibility for the conversion of this standard to other formats or for incorrect results or damages resulting from its use.

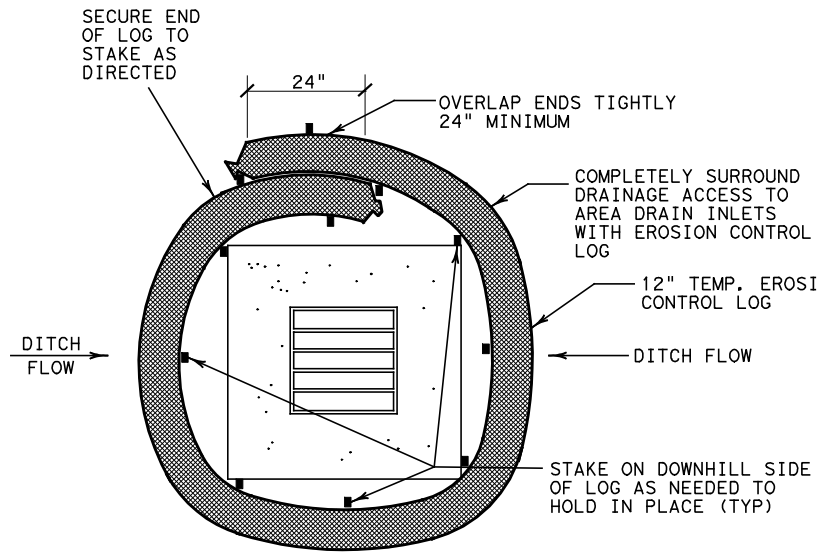

DROP INLET SEDIMENT TRAP
DI-ST
NTS

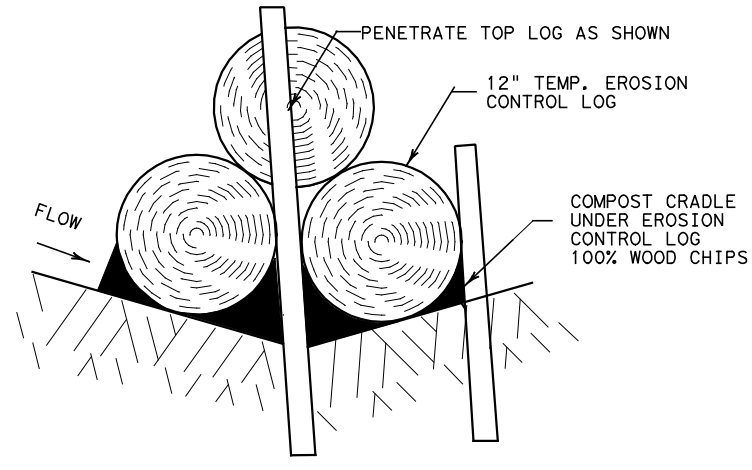

DITCH LINE SEDIMENT TRAP A-A
DL-ST

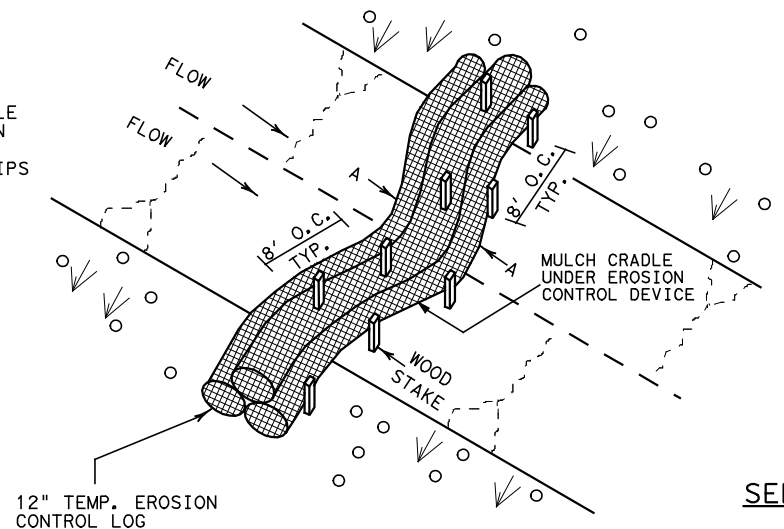

DITCH LINE SEDIMENT TRAP
DL-ST

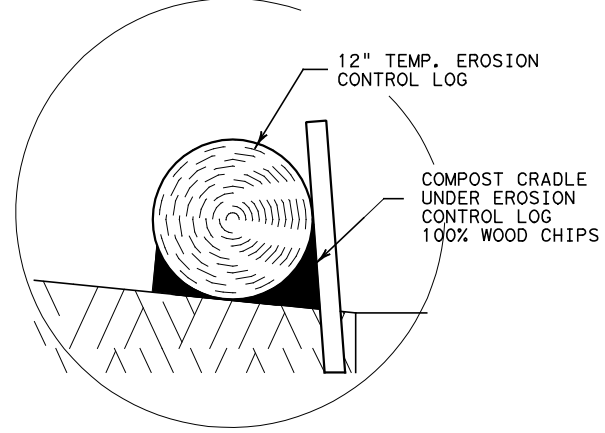

COMPOST CRADLE

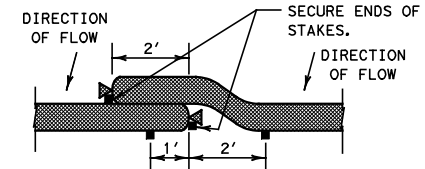

LAP DETAIL
NTS

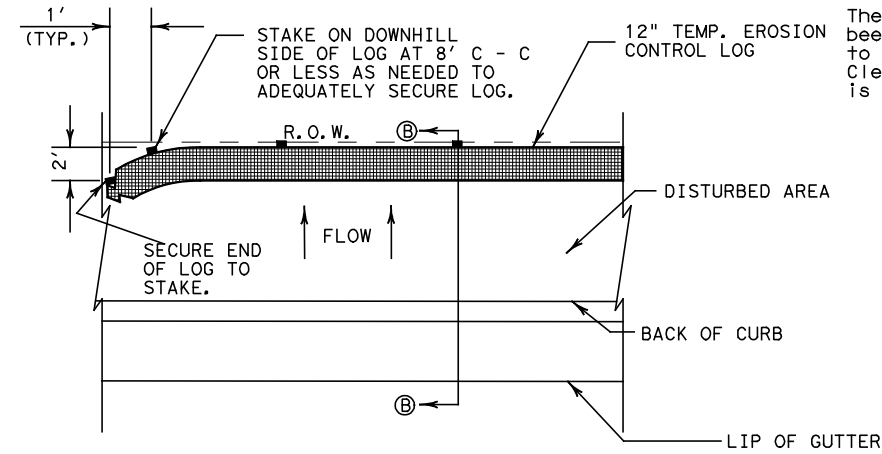

PLAN VIEW
NTS

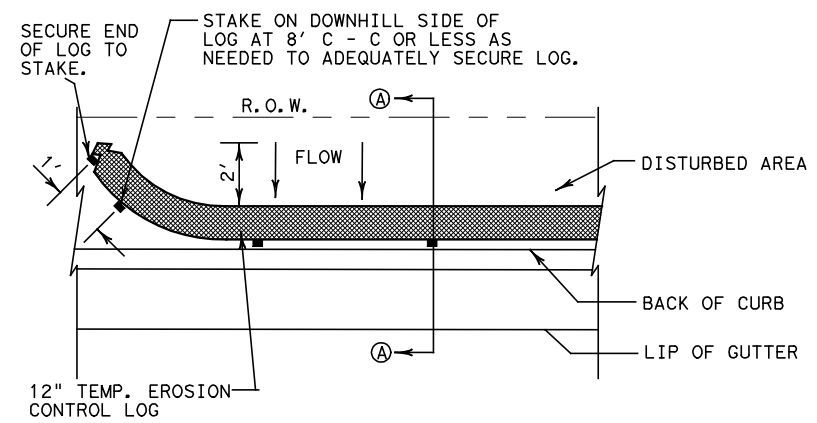

PLAN VIEW
NTS

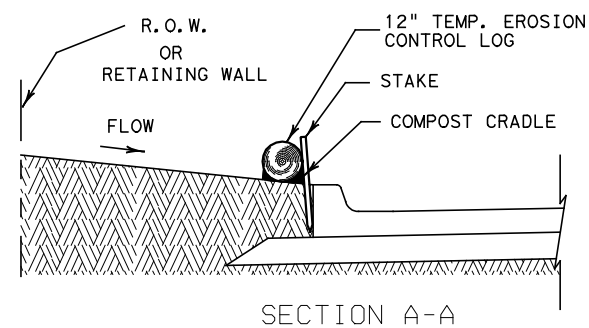

BACK OF CURB INLET SEDIMENT TRAP
BOCI-ST
NTS

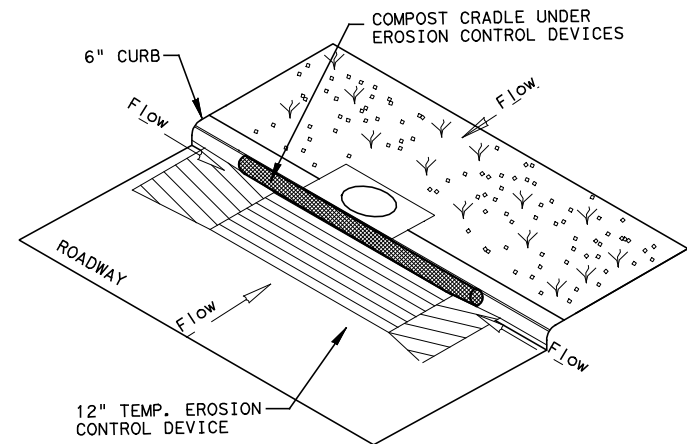

CURB INLET SEDIMENT TRAP
CI-ST
NTS

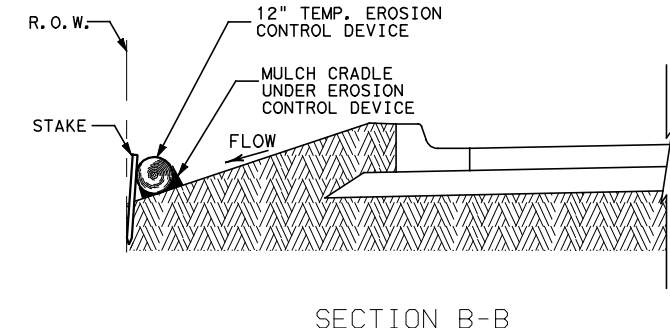

SECTION B-B
RIGHT-OF-WAY SEDIMENT TRAP
ROW-ST
NTS

PLANS SHEET LEGEND

- DI-ST DROP INLET SEDIMENT TRAP
- DL-ST DITCH LINE SEDIMENT TRAP
- BOCI-ST BACK OF CURB INLET SEDIMENT TRAP
- ROW-ST RIGHT OF WAY SEDIMENT TRAP
- CI-ST CURB INLET SEDIMENT TRAP

SEDIMENT BASIN & TRAP USAGE GUIDELINES

A sediment trap may be used to precipitate sediment out of runoff draining from an unstabilized area.

Traps: the drainage area for a sediment trap should not exceed 5 acres. The trap capacity should be 1800 CF/Acre (0.5" over the drainage area).

Sediment traps should be placed in the following locations:

1. Immediately preceding drain inlets
2. Just before the drainage enters a water course
3. Just before the drainage leaves the right of way
4. Just before the drainage leaves the construction limits where drainage flows away from the project

The trap should be cleaned when the capacity has been reduced by 1/2 or the sediment has accumulated to a depth of 1', whichever is less. Cleaning and removal of accumulated sediment deposits is incidental and will not be paid for separately.

GENERAL NOTES

1. LENGTHS OF EROSION CONTROL LOGS SHALL BE IN ACCORDANCE WITH MANUFACTURER'S RECOMMENDATIONS AND AS REQUIRED FOR THE PURPOSE INTENDED. MAXIMUM LENGTH OF LOGS SHALL BE 30' FOR 12" DIAMETER LOGS.
2. UNLESS OTHERWISE DIRECTED, USE BIODEGRADABLE OR PHOTODEGRADABLE CONTAINMENT MESH ONLY WHERE LOG WILL REMAIN IN PLACE AS PART OF A VEGETATIVE SYSTEM. FOR TEMPORARY INSTALLATIONS, USE RECYCLABLE CONTAINMENT MESH.
3. STUFF LOGS WITH SUFFICIENT FILTER MATERIAL TO ACHIEVE DENSITY THAT WILL HOLD SHAPE WITHOUT EXCESSIVE DEFORMATION.
4. STAKES SHALL BE 2" X 2" WOOD 4' LONG, EMBEDDED SUCH THAT 2" PROTRUDES ABOVE LOG.
5. COMPOST CRADLE MATERIAL IS INCIDENTAL AND WILL NOT BE PAID FOR SEPARATELY.

PHARR DISTRICT STANDARD



**TEMPORARY EROSION CONTROL LOGS
TECL-06 (PHR)**

FED. RD. DIV. NO.	PROJECT NO.		HIGHWAY NO.
6			VAR
STATE	DISTRICT	COUNTY	SHEET NO.
TEXAS	PHR	HIDALGO	46
CONTROL	SECTION	JOB	
2C	1080	244	

LEVELS DISPLAYED:
1 2 3 4 5 6 7 8 9 10 11 12 13 14 15 16 17 18 19 20 21 22 23 24 25 26 27 28 29 30 31 32 33 34 35 36 37 38 39 40 41 42 43 44 45 46 47 48 49 50 51 52 53 54 55 56 57 58 59 60 61 62 63 64 65 66 67 68 69 70 71 72 73 74 75 76 77 78 79 80 81 82 83 84 85 86 87 88 89 90 91 92 93 94 95 96 97 98 99 100

HIDALGO COUNTY



**BID PROPOSAL
FOR**

**CAP-12-114-07-03-YSI
"ROAD & DRAINAGE CONSTRUCTION FOR
NORTH CAPISSALLO SUBDIVISION"**

IN ACCORDANCE WITH BORDER COLONIA ACCESS PROGRAM ROUND III

IN

HIDALGO COUNTY PRECINCT NO. 1

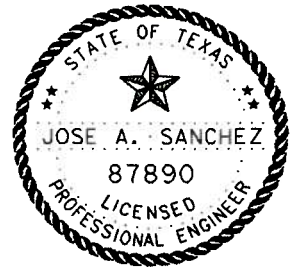

A handwritten signature in blue ink, appearing to read "José A. Sánchez".

06/18/2012

Prepared by:



TEDSI
TBPE Firm No. 1640

TEDSI INFRASTRUCTURE GROUP

Consulting Engineers

1201 East Expressway 83 ♦ Mission, Texas 78572

Tel: (956) 424-7898

Fax: (956) 424-7022

TABLE OF CONTENTS
CAP-12-114-07-03-YSI
ROAD & DRAINAGE CONSTRUCTION FOR
NORTH CAPISALLO SUBDIVISION

- 1) [Advertisement and Invitation for Bids](#)
- 2) [Hidalgo County Legal Notice](#)
- 3) [Bidder Acknowledgement](#)
- 4) [Information for Bidders](#)
- 5) [Bid Form](#)
- 6) Bid Bond
- 7) [Draft Contract](#)
- 8) [Non Collusion](#)
- 9) Payment Bond
- 10) Performance Bond

- 11) **Exhibit C**
 - a. [Insurance](#)

- 12) [General Conditions of the Agreement](#)
- 13) [Title 29 Labor](#)
- 14) [Standard General Condition of Construction Contract](#)
- 15) [Supplemental General Condition](#)

- 16) **Exhibit A** [General Notes & Standard Specifications](#)
 - a. [Technical Specifications](#)
 - b. Hidalgo County Specifications as per 340
 - c. [Government Specifications & Special Provisions](#)

- 17) **Exhibit B**
 - a. [Debarment](#)
 - b. [W-9](#)
 - c. [Bidder/Vendor Application](#)
 - d. [Conflict of Interest Memo](#)
 - e. [Conflict of Interest Form](#)
 - f. [Sales Tax and Local Sales Tax Certificate](#)

- 18) **Exhibit D Border Wage Rates**
 - a. [Government code Ch 2258](#)
 - b. [Prevailing Wage Rate](#)
 - c. [Davis Bacon](#)

- 19) **Exhibit E**
 - a. [Checklist](#)
 - b. [Change Order](#)
 - c. [Payment of Application](#)
 - d. [Estimate Quantity Update](#)
 - e. [Schedule of Values](#)
 - f. [Contract Time Statement](#)

- g.** [Colonia Testing Requirement](#)
- h.** [List of Suppliers](#)
- i.** [Partial Release of Lien](#)
- j.** [Contractor's Affidavit of Payment of Debts and Claims](#)
- k.** [Prevailing Wage Rates Certificate Statement](#)
- l.** [Certificate of Construction Completion](#)
- m.** [Contractor's Affidavit of Release of Liens](#)

20) [Construction Identification Sign](#)

REQUEST FOR BIDS

(Colonia Access Program Project)

TO SUPPLY HIDALGO COUNTY PRECINCT NO 1 with sealed bids on:

CAP-12-113-07-03-YSI "ROAD & DRAINAGE CONSTRUCTION FOR EL MESQUITE SUBDIVISION" & CAP-12-114-07-03-YSI "ROAD & DRAINAGE CONSTRUCTION FOR NORTH CAPISALLO SUBDIVISION"

A **BIDDER'S BOND** from a reliable surety company licensed to operate in the State of Texas or certified Cashier's Check, payable without recourse to the County of Hidalgo, for the amount of not less than **5%** of the total bid shall accompany the bid as guaranty that, if awarded the contract, the bidder will enter into a contract with the County of Hidalgo. Payment and Performance Bonds shall be executed except in the event into a single payment contract with the County of Hidalgo in lieu of a Performance Bond. In the event the total amount bid is \$25,000 or less, the successful contract has the option to enter into a single payment contract with the County of Hidalgo in lieu of a Payment and Performance Bond.

Bid Packets may be obtained from the office of **TEDSI INFRASTRUCTURE GROUP, INC. 1201 E. EXPRESSWAY 83, Mission, Texas 78572**, Phone No **(956) 424-7898** for the amount of **\$100.00 each**. General and/or Prime Contractors submitting bids and/or proposals to the County of Hidalgo shall be **non-refundable**.

PRE-BID CONFERENCE is scheduled for **WEDNESDAY, June 27, 2012 at 2:30 PM** at **HIDALGO COUNTY NEW ADMINISTRATION BUILDING - PURCHASING DEPARTMENT 2812 S Business Hwy 281, EDINBURG, TEXAS 78539**.

UPON SUBMITTING SEALED BID(S), bidders are required to properly identify (handwritten, typed or printed) sealed envelope and/or packet as follows: Bidder's name and address on the upper left hand corner of the sealed envelope(s) and/or package(s) and Bid No(s):

CAP-12-113-07-03-YSI "ROAD & DRAINAGE CONSTRUCTION FOR EL MESQUITE SUBDIVISION" &/OR CAP-12-114-07-03-YSI "ROAD & DRAINAGE CONSTRUCTION FOR NORTH CAPISALLO SUBDIVISION" on the lower left hand corner of sealed envelope/and or packet. **OVERNIGHT MAIL MUST ALSO BE PROPERLY LABELED ON THE OUTSIDE OF EXPRESS ENVELOPE OR PACKAGE.**

The sealed bid must contain one (1) original and three (3) copies of bid and must be clearly identified and addressed for delivery to:

**Martha L. Salazar, CPPB, Hidalgo County Purchasing Agent
Hidalgo County Purchasing Department**

US Postal Mail/Courier Address

**Hidalgo County New Administration Building
2812 S. Business Hwy 281
Edinburg, Texas 78539**

Physical Location:

**Hidalgo County New Administration Building
2802 S. Business Hwy. 281
(Southeast of Canton Rd & Business 281)
Edinburg, Texas 78539**

Sealed bids will be accepted until **9:30 a.m. on Tuesday, July 03, 2012** at which time they will be opened in the Hidalgo County Purchasing Department Conference Room at **Physical Location: 2802 S. Business Hwy 281, Hidalgo County New Administration Building, Edinburg, Texas 78539**. **NO FACSIMILES OR LATE ARRIVALS WILL BE ACCEPTED. ANY BID RECEIVED AFTER THAT TIME WILL NOT BE OPENED AND WILL BE RETURNED**

The project is to be funded with Border Colonia Access Program funds through Proposition II Funding from the Texas Department of Transportation (Tx.D.O.T.).

Attention is called to the fact that not less than, the federally determined prevailing (**Davis-Bacon and Related Acts**) wage rate, as issued and contained in the contract documents, must be paid on this project. In addition, the successful bidder must ensure that employees and applicants for employment are not discriminated against because of race, color, religion, sex, age, disability or national origin.

BIDS MAY BE HELD by the County of Hidalgo for a period not to exceed ninety (90) days from the date of the opening of bids for the purpose of reviewing the bids and investigating the qualifications of bidders, prior to awarding of the contract.

THE COUNTY reserves the right to refuse and reject any/all bids and to waive any/all formalities or technicalities, or to accept the bids considered the best and most advantageous to the County.

BY ORDER OF THE COMMISSIONERS COURT OF HIDALGO COUNTY, TEXAS on this the **10TH** day of **APRIL, 2012**.

**MARTHA L. SALAZAR, CPPB
HIDALGO COUNTY PURCHASING AGENT**

REPORT ROAD HAZARDS @ 1-866-HCR-SAFE OR 1-866-427-7233

LEGAL NOTICE

BID NO: CAP-12-114-07-03-YSI

1. Sealed bids will be received for **“HIDALGO COUNTY - ROAD & DRAINAGE CONSTRUCTION FOR NORTH CAPISALLO SUBDIVISION”** in accordance with the specifications attached as Exhibit "A" hereto. Bids should address all specifications set forth. Bidders may suggest substitutions of features which they feel would be in the best interest of Hidalgo County ("County"). Strong rationale must be presented for any deviation from the specifications. Hidalgo County reserves the right to reject the deviation and its effect on the overall bid.
2. One (1) original and Three (3) copies of all bids are required with the bidders name and return address clearly typed/printed on upper left hand corner and the proper notation clearly typed/printed on the lower left hand corner of the envelope and/or package: **BID NO: CAP-12-114-07-03-YSI “ROAD & DRAINAGE CONSTRUCTION FOR NORTH CAPISALLO SUBDIVISION”** and in County's Purchasing Department, 2802 S. Business Hwy. 281, Hidalgo County New Administration Building, Edinburg, Texas, 78539 **on or before 9:30 a.m., TUESDAY, JULY 03, 2012.** NO FACSIMILES OR LATE ARRIVALS WILL BE ACCEPTED. ANY RFB RECEIVED AFTER THAT TIME WILL NOT BE OPENED AND WILL BE RETURNED. OVERNIGHT MAIL MUST ALSO BE PROPERLY LABELED ON THE OUTSIDE OF EXPRESS ENVELOPE OR PACKAGE WITH REFERENCE TO: **BID NO: CAP-12-114-07-03-YSI “ROAD & DRAINAGE CONSTRUCTION FOR NORTH CAPISALLO SUBDIVISION”**. Hidalgo County reserves the right to refuse and reject any/all RFB and to waive any/all formalities or technicalities, or to accept the RFB considered the best and most advantageous to Hidalgo County Hidalgo County reserves the right to refuse and reject any/all bids and to waive any/all formalities or technicalities, or to accept the bid considered the best and most advantageous to Hidalgo County
3. Hidalgo County reserves the right to: A. separate and accept, or eliminate any item(s) listed under this bid that it deems necessary to accommodate budgetary and/or operational requirements; B. reject any or all bids submitted and further reserves the right to design the evaluation criteria to be used in selecting the lowest and best bid for approval; and C. award the bid to one bidder or to multiple bidders if the County determines it is in its best interest to do so.”
4. The Bidder shall not substitute items named in the bid without the express written consent of Hidalgo County. Failure of the delivered item(s) to perform as specified, or failure to meet the stated delivery schedule shall release Hidalgo County from all obligations to the contracting party with regard to the item(s) in question. In such event, County may elect to award the contract to the next-lowest responsible bidder, or to reject all bids and re-advertise.
5. For work to be performed at a County owned or operated location, each bidder shall, in its sole discretion, visit the job site before preparing the bid and thoroughly familiarize himself/herself with existing conditions. Bidder should take field dimensions and note all circumstances which affect the dollar amount of the bid.
6. Descriptive specifications are referenced in this document to indicate the general kind and quality of equipment desired by Hidalgo County. Due to various styles and models

of equipment, bidders are required to include illustrations, specifications, explanation of warranties, and service data with their bid including catalogue numbers and any necessary references.

7. No bid may be withdrawn within thirty (30) days from the scheduled time to open bids.
8. Proposed prices are to remain firm for a minimum of ninety (90) days after bid opening.
9. Any interpretations, amendments, corrections or changes to this bid document must be in a written addendum and signed by the County Judge or his designee. Addenda will be mailed to all who are known to have received a copy of the Request for Bids. Bidders shall acknowledge receipt of all addenda as a part of their bid.
10. County reserves the right to accept or reject any or all bids.
11. Costs are to be net F.O.B., County Prepaid.
12. County is exempt from Federal Excise Tax, State Tax and Local Tax. Do Not include tax in cost figure. If it is determined that tax was included in the cost figures it will not be included in the tabulation of any awards. Tax exemption certificates will be furnished upon request.
13. Funds for this procurement have been provided through the County budget for this fiscal year only. County, on an annual basis, has the right to reconsider a contract during the budget process for ensuing years if financial resources of County are insufficient to meet the liabilities of said contract. The award of a bid or contract hereunder will not be construed to create a debt of the County which is payable out of funds beyond the current fiscal year.
14. Upon award and prior to execution of a contract, Sole Proprietorships are required to submit a copy of their social security cards to the Hidalgo County Auditor's Office in order to establish an account with the County. All awarded vendors must submit a completed W-9 and a copy of their Federal ID Number Certificate.
15. DELIVERY INSTRUCTIONS:
 - . No deliveries accepted after 3:00 P.M., Monday-Friday.
 - . At least seventy two (72) hours prior notice of delivery must be given to Martha L. Salazar, Purchasing Agent before delivery will be accepted.
 - . If you need additional information call the office listed below:

Hidalgo County Purchasing Department
Martha L. Salazar, Purchasing Agent
(956) 318-2626

16. BILLING AND PAYMENT INSTRUCTIONS:

- . Invoices must include:
 - a) Name and address of successful bidder
 - b) Name and address of receiving department or official
 - c) Purchase Order Number (if any)
 - d) Notation - **"HIDALGO COUNTY - ROAD & DRAINAGE CONSTRUCTION FOR NORTH CAPISALLO SUBDIVISION"**
Descriptive information as to the items or services delivered, including product code, item number, quantity, etc.

- . Discount payments will be considered when offered.

- . Contact person for Billing and Payment questions:

Hidalgo County Border Colonia Access Program
301 E. State St
Pharr TX 78577
Attn: Marcie Jackson

17. Schedule of Events

Bid Opening, 9:30 AM	<u> </u> July 03 , 2012
Award of Contract	<u> </u> , 2012
Commence Work or Deliver Products	<u> </u> , 2012

18. Bid or Performance Bond and Debarment Certification; Payment Under Contract:

- . If the contract proposed is for the construction of public works or is for a contract for goods & services exceeding \$100,000, all bidders shall furnish a good and sufficient bid bond in the amount of five percent of the total contract price. A bid bond must be executed with a surety company authorized to do business in Texas. All bidders are also required to furnish a certification or acknowledgment stating that the contractor or vendor is free from suspension or debarment pursuant to federal regulation 45CFR Part 76.

- . Together with the signing of a contract or issuance of a purchase order following the acceptance of a bid, and prior to commencement of the actual work, the bidder shall furnish a performance bond to the County for the full amount of the contract, if that contract exceeds \$50,000.

- . If the contract is for \$50,000 or less, no money will be paid to the contractor until completion and acceptance of the work or the fulfillment of the purchase obligation to the County, and, if applicable, the receipt by County of satisfactory evidence that all subcontractors and material men have been paid.

- . If a contract is for the construction, alteration or repair of public buildings or public works, the contractor *shall* provide a payment bond for a contract in excess of Twenty Five Thousand Dollars (\$25,000.00), as required by Tex. Govt. Code Ch. 2253.

- . For requirements contracts, bond requirements are determined by applying the proposed unit price to the estimated quantities included in the specifications.

19. Ethical Standards:

. It shall be a breach of ethics to offer, give or agree to give any elected official, department head or employee, or former elected official, department head or employee, of the County, or for any elected official, department head or employee or former elected official, department head or employee of the County, to solicit, demand, accept or agree to accept from another person, entity or organization, a gratuity or an offer of employment in connection with any decision, approval, disapproval, recommendation, preparation or any part of a program requirement or purchase request, influencing the content of any specification or procurement standard, rendering of advice, investigation, auditing, or in any other advisory capacity in any proceeding or application, request for ruling, determination, claim or controversy, or other particular matter pertaining to any program requirement or a contract or subcontract, or to any solicitation or proposal therefore pending before any department or agency of the County.

. It shall be a breach of ethics for any payment, gratuity or offer of employment to be made by or on behalf of a subcontractor under a contract to the prime contractor or higher tier subcontractor for any contract for the County, or any person associated therewith, as an inducement for the award of a subcontract or order.

. No public official shall have an interest in a contract awarded hereunder except in accordance with Tex. Loc. Govt. Code Chapter 171.

20. Disclosure of Conflict of Interest

. Effective January 1, 2006, Chapter 176 of the Texas Local Government Code requires that any vendor, person, consultant or contractor considering doing business with Hidalgo County (“the County”) to disclose in the Conflict of Interest Questionnaire (the “CIQ”) attached as Exhibit D, the vendor, person, consultant or contractor’s affiliation or business relationship that might cause a conflict of interest with the County. By law, the CIQ must be filed with the Hidalgo County Clerk’s Office no later than the seventh business day after the date the person becomes aware of facts that require that statement to be filed. The disclosure requirement applies to a person or business who contracts or seeks to contract with Hidalgo County for the sale or purchase of property, goods or service. Any purchase order or contract resulting from this process shall be considered null and void if the successful bidder fails to comply with Texas Local Government Code Chapter 176. Vendors, consultants, contractors and others who desire to conduct business with Hidalgo County are encouraged to refer to Texas Local Government Code Chapter 176 for the details of this law. An offense under Texas Local Government Code Chapter 176 is a Class C Misdemeanor.

Please Submit completed CIQ forms to the Hidalgo County Clerk’s Office located at 100 N. Closner, Edinburg, Texas 78539-Hidalgo County Courthouse
COMPLETION AND SUBMISSION OF FORM CIQ IS THE SOLE RESPONSIBILITY OF THE PROSPECTIVE BIDDER.

21. If, during the life of any contract or bid awarded, the successful bidder's net prices generally available to other customers for items awarded herein are reduced below the contracted price, it is understood and agreed that the benefits of such reduction shall be extended to County.
22. Bids, and all goods and services provided thereunder, shall comply with all federal, state and local laws concerning this type(s) of goods and/or services.
23. Minimum Standards For Responsible Prospective Bidders: A prospective bidder must affirmatively demonstrate bidder's responsibility. A prospective bidder, by submitting a bid, represents to County that it meets the following requirements:
 - . Possess or is able to obtain adequate financial resources as required to perform under the bid;
 - . Be able to comply with the required or proposed delivery schedule;
 - . Have a satisfactory record of performance;
 - . Have a satisfactory record of integrity and ethics;
 - . Be otherwise qualified and eligible to receive an award.
24. Successful bidder will pay or cause to be paid, without cost or expenses to County, all FICA, FUTA/SUTA and Federal Income Withholding Taxes of all employees, and all wages and benefits as required by Federal or State law. Successful bidder's officers, agents and/or employees will not be entitled to any benefits of an employee or elected official of County, including, but not limited to, benefits associated with County's civil service system.
25. Any contract award to a successful bidder will be in effect until (a) the contract expires, (b) delivery and acceptance of products, and/or performance of services ordered, or (c) terminated by County with thirty day's written notice prior to cancellation.
26. County reserves the right to enforce performance of any contract awarded hereunder in any manner prescribed by law or deemed to be in the best interest of the County in the event of breach or default by successful bidder; County reserves the right to terminate any contract immediately in the event a successful bidder fails to:
 - A. Meet schedules;
 - B. Pay any required fees or taxes; or
 - C. Otherwise perform in accordance with the specifications.
27. Successful bidder shall defend, indemnify and save harmless County and all its elected officials, officers, agents and employees from all suits, actions, or other claims of any character, name and description brought for or on account of any injuries or damages received or sustained by any person, persons, or property on account of any negligent act or fault of the successful bidder, or of any agent, employee, subcontractor or supplier of successful bidder in the execution of, or performance under, any contract which may result from bid award or which arises from any event or casualty happening on or within County premises themselves or happening upon or in any halls, elevators, entrances, stairways or approaches of or to such County facilities. Successful bidder shall pay any

judgement with costs which may be obtained against County growing out of such injury or damages, and shall, upon request, provide a defense to County by counsel reasonably acceptable to County. Successful bidder's indemnity hereunder shall include, but is not limited to, claims relating to patent, copyright or trademark infringement, and the like, arising out of the goods and services provided by successful bidder.

28. Successful bidder shall warrant that all items/services shall conform with the specifications and/or all warranties provided under the Uniform Commercial Code and be free from all defects in material, workmanship and the like. Items supplied under a contract pursuant to this Request for Bids shall be subject to County's approval. Items found to be defective or not meeting specifications shall be replaced by successful bidder within two business days at no expense to County. Items not picked up within one (1) week after notification shall be deemed a donation to County and may be used or disposed of at County's discretion and without waiver of any other rights of County as to the item's nonconformity.
29. This document and any disputes arising hereunder shall be governed and construed according to the laws of the State of Texas, and will be performable exclusively in Hidalgo County, Texas.
30. The successful bidder shall not assign, sell, transfer or convey its rights under any awarded contract, in whole or in part, without the prior written consent of County.

BIDDERS ACKNOWLEDGEMENT

Bid for

HIDALGO COUNTY

“ROAD & DRAINAGE CONSTRUCTION FOR NORTH CAPISALLO SUBDIVISION”

BID NO.: CAP-12-114-07-03-YSI

To: Martha L. Salazar, CPPB, Purchasing Agent
Hidalgo County Purchasing Department
Hidalgo County New Administration Building
2802 S Business Hwy 281
Edinburg, Texas 78539

US Postal Mail/Courier Address

**Hidalgo County New Administration Building
2812 S Business Hwy 281
Edinburg, Texas 78539**

Physical Location:

**Hidalgo County New Administration Building
2802 S Business Hwy 281
Edinburg, Texas 78539
(Southeast corner of Canton Rd & Business 281)**

In accordance with the Specifications, and subject to all laws and regulations of the United States and state and local laws, the undersigned bidder proposes and commits to furnish all labor, equipment, material, software and services as set forth in the documents hereinbefore mentioned. The undersigned bidder further agrees, upon acceptance of its bid, to execute a contract and/or Purchase Order issued by Hidalgo County for performing and completing the work described in the Specifications within the time stated and for the prices proposed in the documents attached hereto and made a part hereof.

Bidder acknowledges receipt of all of the pages of the documents referenced in the Invitation to Bid Checklist presented in connection with this procurement. Bidder understands that Hidalgo County reserves the right to reject any or all bids and further reserves the right to design the evaluation criteria to be used in selecting the lowest and best bid.

Bidder agrees that this bid shall be good and may not be withdrawn for a period of ninety (90) calendar days after the scheduled closing time for receiving bids, as contained in the Specifications.

Respectfully submitted,

Bidder: _____
Address: _____
By: _____
Printed Name: _____
Title: _____

INFORMATION FOR BIDDERS

1. Receipt and Opening of Bids

The Hidalgo County (herein called the "Owner"), invites bids on the form attached hereto, all blanks of which must be appropriately filled in. Bids will be received by the Owner at the Hidalgo County Purchasing department until Tuesday **July 03, 2012** at 9:30 a.m. and then at said office publicly open and read aloud. The envelopes containing the bids must be sealed, addressed to Martha L. Salazar, Hidalgo County Purchasing Agent at 2812 S Business 281, Edinburg, Texas 78539 and designated as **BID NO: CAP-12-114-07-03-YSI "ROAD & DRAINAGE CONSTRUCTION FOR NORTH CAPISALLO SUBDIVISION"**.

The owner may consider informal any bid not prepared and submitted in accordance with provisions hereof and may waive any informalities or reject any and all bids. Any bid may be withdrawn prior to the above scheduled time for the opening of bids or authorized postponement thereof. Any bid received after the time and date specified shall not be considered. No bidder may withdraw a bid within 60 days after the actual date of the opening thereof.

2. Preparation of Bid

Each bid must be submitted on the prescribed form and accompanied by Certification by Bidder Regarding Equal Employment Opportunity, Form, and Certification by Bidder (contractor), concerning Labor Standards and Prevailing Wage Requirements. All blank spaces for bid prices must be filled in, in ink or typewritten, in both words and figures, and the foregoing Certificates must be fully completed and executed when submitted.

Each bid must be submitted in a sealed envelope bearing on the outside the name of the bidder, his address, and the name of the project for which the bid is submitted. If forwarded by mail, the sealed envelope containing the bid must be enclosed in another envelope addressed as specified in the bid form.

3. Subcontracts

The bidder is specifically advised that any person, firm, or other party to whom is proposed to award a subcontract under this contract –

- a** Must be acceptable to the Owner after verification of the current eligibility status, and,
- b** Approval of the proposed subcontract award cannot be given by the Owner unless and until the proposed subcontractor has submitted the Certification and/or other evidence showing that it has fully complied with any reporting requirements to which it is or was subject. Although the bidder is not required to attach such Certification by proposed subcontractors to his bid, the bidder is here advised of this requirement so that appropriate action can be taken to prevent subsequent delay in subcontract awards.

4. Telegraphic Modification

Any bidder may modify his bid by telegraphic communication at any time prior to the scheduled closing time for receipt of bids, provided such telegraphic communication is received by the Owner prior to the closing time, and provided further, the Owner is satisfied that a written confirmation of the telegraphic modification over the signature of the bidder was mailed prior to the closing time. The telegraphic communication should not reveal the bid price but should provide the additional or subtraction or other modification so that the final prices or terms will not be known by the Owner until the sealed bid is opened. If written confirmation is not received within two days from the closing time, no consideration will be given to the telegraphic modification.

5. Method of Bidding

The Owner invites the following bid(s): Border Access Colonia Project Round 3
Grant No. _____
Subdivision Name: North Capisallo

6. Qualifications of Bidder

The Owner may make such investigations as he deems necessary to determine the ability of the bidder to perform the work, and the bidder shall furnish to the Owner all such information and data for this purpose as the Owner may request, the Owner reserves the right to reject any bid if the evidence submitted by, or investigation of, such bidder fails to satisfy the Owner that such bidder is properly qualified to carry out the obligations of the contract to complete the work contemplated therein. Conditional bids will not be accepted.

7. Bid Security

Each bid must be accompanied by certified check of the bidder, or a bid bond prepared on the form of bid bond attached hereto, duly executed by the bidder as principal and having as surety thereon a surety company approved by the Owner, in the amount of 5% of the bid. Such checks or bid bonds will be returned to all except the three lowest bidders within three days after the opening of bids, and the remaining checks, or bid bonds will be returned promptly after the Owner and the accepted bidder have executed the contract, or if no award has been made within 60 days after the date of the opening of bids, upon demand of the bidder at any time thereafter, so long as he has not been notified of the acceptance of his bid.

8. Liquidated Damages for Failure to enter into Contract

The successful bidder, upon his failure or refusal to execute and deliver the contract and bonds required within 10 days after he has received notice of the acceptance of his bid, shall forfeit to the Owner, as liquidated damages for such failure or refusal, the security deposited with his bid.

9. Time of Completion and Liquidated Damages

Bidder must agree to commence on or before a date to be specified in a Written “Notice to Proceed” of the Owner and to fully complete the project within **150** consecutive calendar days thereafter. **150** consecutive calendar days breakdown as follows: **60** days for substantial completion (all work except vegetative watering). Liquidated damages will apply if contractor does not finish substantial completion within **60** consecutive calendar days or all construction is not completed within **150** consecutive calendar days. Bidder must agree also to pay as liquidated damages, the sum of **\$200.00** for each consecutive calendar day thereafter as hereinafter provided in the General Conditions.

10. Condition of Work

Each bidder must inform himself fully of the conditions relating to the construction of the project and the employment of labor thereon. Failure to do so will not relieve a successful bidder of his obligation to furnish all material and labor necessary to carry out the provisions of his contract. Insofar as possible the contractor, in carrying out his work, must employ such methods or means as will not cause any interruption of or interference with work of any other contractor.

11. Addenda and Interpretations

No interpretation of the meaning of the plans, specifications or other pre-bid documents will be made to any bidder orally.

Every request for such interpretation should be in writing addressed to **TEDSI Infrastructure Group 1201 E. Expressway 83, Mission TX 78572. Attn Jose A. Sanchez, P.E.** and to be given consideration must be received at least five days prior to the date fixed for the opening of bids. Any all such interpretations and any supplemental instructions will be in the form of written addenda to the specifications which, if issued, will mailed by certified mail with return receipt requested to all prospective bidders (at the respective addresses furnished for such purposes), not later than three days prior to the date fixed for the opening of bids. Failure of any bidder to receive any such addendum or interpretation shall not relieve such bidder from any obligation under his bid as submitted. All addenda so issued shall become part of the contract documents.

12. Security for Faithful Performance

Simultaneously with his delivery of the executed contract; the contractor shall furnish a surety bond or bonds as security for faithful performance of this contract and for the payment of all persons performing labor on the project under this contract and furnishing materials in connection with this contract, as specified in the General Conditions included herein. The surety on such bond or bonds shall be a duly authorized surety company satisfactory to the Owner.

13. Power of Attorney

Attorney-in-fact who sign bonds or contract bonds must file with each bond a certified and effectively dated copy of their power of attorney.

14. Notice of Special Conditions

Attention is particularly called to those parts of the contract documents and specification which deal with the following;

- a** Inspection and testing of materials
- b** Insurance requirements
- c** Wage rates
- d** States allowances

15. Laws and Regulations

The bidder's attention is directed to the fact that all applicable State laws, municipal ordinances, and the rules and regulations of all authorities having jurisdiction of the project shall apply to the contract throughout, and they will be deemed to be included in the contract the same as though herein written out in full.

16. Method of Award – Lowest Qualified Bidder

If at the time this contract is to be awarded, the lowest base bid submitted by a responsible bidder does not exceed the amount of funds then estimated by the Owner as available to finance the contract the contract will be awarded on the base bid only. If such bid exceeds such amount, the Owner may reject all bids or may award the contract on the base bid combined with such deductible alternates applied in numerical order in which they are listed in the form of Bid, as produces a net amount which is within the available funds.

17. Obligation of Bidder

At the time of the opening of bids each bidder will be presumed to have inspected the site and to have read and to be thoroughly familiar with the plans and contract documents (including all addenda). The failure or omission of any bidder to examine any form, instrument or document shall in no way relieve any bidder from any obligation in respect of his bid.

**Supplement to Form HUD-4238-B®
INFORMATION FOR BIDDERS**

18. SAFETY STANDARDS AND ACCIDENTS PREVENTION

With respect to all work performed under this contract, the contractor shall:

- 1 Comply with the safety standards provision of applicable laws, building and construction codes and the “Manual of Accident Prevention in Construction” published by the Associates General Contractors or America, the requirements of the Occupational Safety and Health Act of 1970 (Public Laws 91-596), and the requirements of Title 29 of the Code of Federal Regulations, Section 1518 as published in the “Federal Register”, Volume 36, No 75, Saturday, April 17, 1971.
- 2 Exercise every precaution at all times for the prevention of accidents and the protection of persons (including employees) and property.
- 3 Maintain at his office or other well known place at the job site, all articles necessary for giving first aid to the injured, and shall make standing arrangements for the immediate removal to a hospital or a doctor’s care of persons (including employee), whom may be injured on the job site. In no case shall employee be permitted to work at a job site before the employer has made a standing arrangement for removal of injured person to a hospital or a doctor’s care.

SPECIAL PROVISIONS

- 1.** The County of Hidalgo reserves the right to partially award the contract in order to meet the budget.
- 2.** It shall be the Contractor's responsibility to locate underground utilities, whether shown or not shown on the drawings, sufficiently in advance of operations to preclude damage to same.
- 3.** Water, sewer, or other utility serves shall not be interrupted. Any damages to existing utilities will be Contractor's responsibility.
- 4.** In the event of damage to underground facilities, whether shown or not shown in the drawings, the Contractor shall make the necessary repairs to place the facilities back in service at no increase in the Contractors price and all such repairs shall conform to the requirements of the company or agency servicing the facility
- 5.** The Contractor shall exercise extra care to prevent damage to all other structures in the area including, fence, roads, pipelines, utilities, etc., whether publicly or privately owned.
- 6.** Until acceptance by the Engineer of any part or all of the construction, as provided for in the plans and these specifications, it shall be under the charge and care of the contractor, and he shall take every necessary precaution against injury or damage to any part of the work. The Contractor shall rebuild, repair, restore and make good, at his own expense, all injuries or damage to any portion of the work before its completion and acceptance.
- 7.** In case the Contractor deems extra compensation is due him for proposed work not covered in the contract, the Contractor shall notify the Engineer in writing of his claim for such extra compensation before he begins the work. Failure on the part of the Contractor to give such notification shall constitute a waiver of claim for such extra compensation. The Contractor shall not proceed until a written Change Order is approved by the Owner, Engineer, and Contractor.
- 8.** Prospective bidders should make a careful examination of the projects sites.
- 9.** Contractor shall review his overall method and schedule of construction with the County Prior to construction for proper coordination of inspection.
- 10.** No open trenches or excavation shall be left open overnight.

BID FORM
BORDER COLONIA ACCESS PROJECT - HIDALGO COUNTY PRECINCT NO 1
CAP-12-114-07-03-YSI "ROAD AND DRAINAGE CONSTRUCTION FOR NORTH CAPISALLO SUBDIVISION"

ROADWAY IMPROVEMENTS						
ITEM	TOTAL	UNIT	DESCRIPTION	UNIT PRICE		TOTAL (In Figures)
				(In Words)		
0100	11.92	STA	PREPARING ROW		Dollars	\$
					Cents	\$
0110	723	CY	EXCAVATION(ROADWAY)		Dollars	\$
					Cents	\$
0132	46	CY	EMBANKMENT(FINAL)(DENS CONT)(TY C)		Dollars	\$
					Cents	\$
0164	3382	SY	CELL FBR MLCH SEED(PERM)(URBAN)(CLAY)		Dollars	\$
					Cents	\$
0168	169.1	MG	VEGETATIVE WATERING		Dollars	\$
					Cents	\$
0247	3734	SY	FL BS(CMP IN PLC)(TY E GR 4)(FNAL POS)		Dollars	\$
					Cents	\$
0260	4004	SY	LIME TRT(EXST MATL)(6")		Dollars	\$
					Cents	\$
0260	28.1	TON	LIME(HYD,COM OR QK)(SLRY)OR QK(DRY)		Dollars	\$
					Cents	\$
0260	29.8	TON	LIME(HYD,COM OR QK)(SLRY)OR QK(DRY)		Dollars	\$
					Cents	\$
0260	4002	SY	LIME TRT(NEW BASE)(8")		Dollars	\$
					Cents	\$
0310	640	GAL	PRIME COAT(MC-30)		Dollars	\$
					Cents	\$
0340	3200	SY	D-GR HMA(METH)TY-D SAC-B PG64-22		Dollars	\$
					Cents	\$
0500	1	LS	MOBILIZATION		Dollars	\$
					Cents	\$
0502	2	MO	BARRICADES, SIGNS AND TRAFFIC HANDLING		Dollars	\$
					Cents	\$
0666	2350	LF	REFL PAV MRK TY I(W)4"(SLD)(100MIL)		Dollars	\$
					Cents	\$
0666	12	LF	REFL PAV MRK TY I(W)24"(SLD)(100MIL)		Dollars	\$
					Cents	\$
0666	270	LF	REFL PAV MRK TY I(Y)4"(BRK)(100MIL)		Dollars	\$
					Cents	\$
0666	200	LF	REFL PAV MRK TY I(Y)4"(SLD)(100MIL)		Dollars	\$
					Cents	\$
ROADWAY IMPROVEMENTS TOTAL						\$

DRAINAGE IMPROVEMENTS						
ITEM	TOTAL	UNIT	DESCRIPTION	UNIT PRICE		TOTAL (In Figures)
				(In Words)		
0506	26	LF	TEMPORARY SEDIMENT CONTROL FENCE		Dollars	\$
					Cents	\$
0530	390	SY	DRIVEWAYS(ACP)		Dollars	\$
					Cents	\$
4378	320	LF	THERMOPLASTIC PIPE (15 IN)(TY III)		Dollars	\$
					Cents	\$
DRAINAGE IMPROVEMENTS TOTAL						\$

GRAND TOTAL	\$
--------------------	----

BIDDER/COMPANY NAME: _____

AUTHORIZED SIGNATURE: _____

PRINTED NAME: _____

TITLE: _____

CONTINUATION OF BID PAGE

The undersigned **Bidder** agrees to commence work after written notice to commence work and to substantially complete the work on which he has bid **150** calendar days as provided in Article 18 of the General Conditions of the Agreement.

Enclosed with this Proposal is a Cashier’s check or Certified Check for _____ Dollars (_____) or a Bid Bond in the Sum of _____ Dollars (_____), which is agreed shall be collected and retained by the **Owner** under the conditions hereof within ten (10) days after the date this proposals is accepted; then otherwise the said bond or check shall be returned to the undersigned upon demand.

Receipts of the following Addenda on these dates shown is acknowledged:

	DATE	ACKNOWLEDGE		DATE	ACKNOWLEDGE
#1	_____	_____	#2	_____	_____
#3	_____	_____	#4	_____	_____

Respectfully submitted,

Name of Firm

By: _____
Signature Date

Title

Address

Telephone Number

**THIS PROPOSAL MUST BE
SIGNED BY AN OFFICER OF
REPRESENTATIVE DULY
AUTHORIZED BY THE BIDDER.**

(Seal, if Bid is by a Corporation)

Attest: _____

HIDALGO COUNTY PRECINCT #1 BORDER ACCESS COLONIA PROJECT

BID BOND

KNOW ALL MEN BY THESE PRESENTS, That we, the undersigned _____
_____ as Principal, and _____
_____ as Surety, are hereby held and firmly bound
unto _____ as OWNER in the penal sum of _____

for the payment of which, well and truly to be made, we hereby jointly and severally bind ourselves, successors and assigns.

Signed, this _____ day of _____, 20_____.

The condition of the above obligation is such that whereas the Principal has submitted to _____
_____ a certain BID, attached hereto and
hereby made a part hereof to enter into a contract in writing for the

NOW, THEREFORE,

- (a) If said Bid shall be rejected, or
- (b) If said Bid shall be accepted and the Principal shall execute and deliver a contract in the Form of Contract attached hereto (properly completed in accordance with said BID) and Shall furnish a BOND for his faithful performance of said contract, and for the payment of all persons performing labor or furnishing materials in connection therewith, and shall in all other respects perform the agreement created by the acceptance of said BID, then, this obligation shall be void, otherwise the same shall remain in force and effect; it being expressly understood and agreed that the liability of the Surety for any and all claims hereunder shall, in no event, exceed the penal amount of this obligation is herein stated.

The Surety, for value received, hereby stipulates and agrees that the obligations of said Surety and its BOND shall be in no way impaired or affected by any extension of the time within which the OWNER may accept such Bid; and said Surety does hereby waive notice of any such extension.

IN WITNESS WHEREOF, the Principal and the Surety have hereunto set their hands and seals, and such of them as are corporations have caused their corporate seals to be hereto affixed and these presents to be signed by their proper officers, the day and year first set forth above.

_____(L.S.)
Principal

Surety

By: _____

IMPORTANT – Surety companies executing BONDS must appear on the Treasury Department’s most current list (circular 570 as amended) and be authorized to transact business in the state where the project is located.

5THE STATE OF TEXAS §
§
COUNTY OF HIDALGO §

CONSTRUCTION CONTRACT
C-CAP-12-114-XX-XX

This Agreement, entered into this _____ day of _____, 2012 by and between Hidalgo County (hereinafter called the "OWNER," and, _____ (a Texas corporation), of County of Hidalgo, and State of Texas, hereinafter called "CONTRACTOR".

WITNESSETH

That for and in consideration of the payments and agreement hereinafter mentioned, to be made and performed by the OWNER, the CONTRACTOR hereby agrees with the OWNER to commence and complete the construction described as follows:

ROAD & DRAINAGE CONSTRUCTION FOR EL NORTH CAPISALLO SUBDIVISION

Hereinafter called the project, for the sum of _____ Dollars and all extra work in connection therewith, under the terms and stated in the General and Special Conditions of the Contract; and at his (its or their) own proper cost and expense to furnish all the materials, supplies, machinery, equipment, tools, superintendence, labor, insurance, and other accessories and services necessary to complete the said project in accordance with the conditions and prices stated in the Proposal, the General Conditions and Special Conditions printed or written explanatory matter thereof, the specifications and contract documents therefore as prepared by **TEDSI Infrastructure Group**, entitled the Architect/Engineer, and as enumerated in Paragraph 1.01.A.12 of the General Conditions, all of which are made a part hereof and collectively evidence and constitute the contract.

The CONTRACTOR hereby agrees to commence work under this contract on or after a date to be specified in written "Notice to Proceed" of the OWNER and to fully complete the project within **150** consecutive calendar days thereafter. The CONTRACTOR further agrees to pay, as liquidated damages, the sum of **\$200.00** for each consecutive calendar day thereafter.

The OWNER agrees to pay the CONTRACTOR in current funds for the performance of the contract, subject to additions and deductions, as provided in the General Conditions of the contract, and to make payments on account thereof as provided in Paragraphs 14.02.C and 14.07.C of the General Conditions.

IN WITNESS WHEREOF, the parties to these present have executed this contract in six (6) counterparts, each of which shall be deemed an original, in year and day first above mentioned.

APPROVED BY COMMISSIONERS COURT ON _____, **2012**.

CONTRACTOR: _____

Print Name & Title: _____

Name of Firm: _____

Address: _____

Fed I.D. #/SS #: _____

STATE OF TEXAS

COUNTY OF HIDALGO

This instrument was acknowledged before me on this the _____ day of _____,

20__, by _____ Of and on behalf of _____
(Title) (A corporation)

Notary Public-Signature

APPROVED AS TO FORM:

Atlas & Hall, L.L.P.

800 Pecan

McAllen, Texas 78504

BY: _____

ATTEST:

COUNTY OF HIDALGO:

Arturo Guajardo, Jr., County Clerk

Ramon Garcia, County Judge

NON-COLLUSION AFFIDAVIT OF PRIME BIDDER

State of

County of.....)

_____, being first duly sworn,
deposes and says that:

(1) He is _____, of

_____, the Bidder that has submitted the attached Bid;

(2) He is fully informed respecting the preparation and contents of this attached bid and of all pertinent circumstances respecting such bid;

(3) Such bid is genuine and is not a collusive or sham Bid;

(4) Neither the said Bidder nor any of its officers, partners, owners, agents, representative:, employees or parties in interest, including this affiant, has in any way colluded, conspired a collusive or sham Bid in connection with the Contract for which the attaché Bid has been submitted or to refrain from bidding in connection with such Contract, or has in any manner, directly or indirectly, sought by agreement or collusion or communication of conference with any other Bidder, firm or person to fix the price or prices in the attached Bid or of any other Bidder, or to fix any overhead, profit or cost element of the Bid price or the Bid price of any other Bidder, or to secure through any collusion, conspiracy, connivance or unlawful agreement any advantage against the Owner or any person interested in the proposed Contract; and

(5) The price or prices quoted in the attached Bid are fair and proper and are not tainted by any collusion, conspiracy, connivance, connivance or unlawful agreement on the part of the Bidder or any of its agents, representatives, owners, employees, or parties in interest, including this affiant.

(Signed) _____

(Title)

Subscribed and sworn to before me on this _____

Day of _____

Title

PAYMENT BOND

(To be used in Texas under V.A.T.S. 5160)

THE STATE OF _____

COUNTY OF _____

KNOW ALL MEN BY THESE PRESENTS: That we (1) _____, a (2) _____, hereinafter called Principal and (3) _____ of _____, hereinafter called the Surety, are held and firmly bound unto (4) _____ of _____, hereinafter called Owner, and unto all persons, firms, and corporations who may furnish materials for, or perform labor upon the building or improvements hereinafter referred to the penal sum of _____ (\$ _____) Dollars in lawful money of the United States to be paid in (5) _____, for the payment of which sum well and truly to be made, we bind ourselves, our heirs, executors, administrators, and successors, jointly and severally, firmly be these presents.

THE CONDITION OF THIS OBLIGATION is such that Whereas, the Principal entered into a certain contract with (6) _____, the Owner, dated the _____ day of _____, A.D. 200__, a copy of which is hereto attached and made a part hereof for the construction of:

**HIDALGO COUNTY PRECINCT #3 BORDER ACCESS COLONIA PROJECT
SUBDIVISION**

These footnotes refer to numbers in body of contract above:

Date of Bond must not be prior to date of contract

- (1) Correct name of Contractor
- (2) A Corporation, a Partnership or an Individual, as case may be
- (3) Correct name of Surety
- (4) Correct name of Owner
- (5) County and State
- (6) Owner

NOW, THEREFORE, the condition of this obligation is such that, if the -1- Principal shall promptly make payment to all claimants as defined in Article 5160 Revised Civil Statutes of Texas, 1925, as amended by House Bill 344, Act 56th Legislature, Regular Session, 1925 effective April 27, 1959, supplying labor and materials in the prosecution of the work provided for in said Contract, then this obligation shall be null and void, otherwise it shall remain in full force and effect.

This bond is made and entered into solely for the prosecution of all claimants supplying labor and material in the prosecution of the work provided for in said Contract, and all such claimants shall have a direct right of action under the bond as provided in Article 5160, Revised Civil Statutes 1925, as amended by House Bill 344, Acts 56th Legislature, Regular Session, 1959

PROVIDED FURTHER, that if any legal action be filed upon this bond, venue shall lie in Hidalgo County, State of Texas, and that the said surety, for value received hereby stipulates and agrees that no change, extension of time, alteration or addition to the terms of the contract or to the work to be performed thereunder or the specification accompanying the same shall in any way affect its obligation on this bond, and it does hereby waive notice of any such change, extension of time, alteration or addition to the terms of the contract or to the work or to the specifications.

PROVIDED FURTHER, that no final settlement between the Owner and the Contractor shall abridge the right of any beneficiary hereunder, whose claim may be unsatisfied.

IN WITNESS WHEREOF, this instrument is executed in six counterparts, each one of which shall be deemed an original, this the _____ day of _____ . A.D., 200_____.

ATTEST:

(Principal) Secretary

(Seal)

Witness as to Principal

(Address)

Principal _____
By _____

(Address) _____

Telephone Number: _____

Surety

ATTEST:

(Surety) Secretary

(Seal)

Witness as to Surety

(Address)

By _____

(Address) _____

NOTE: If Contractor is partnership all Partners should execute bond

Telephone Number: _____

PAYMENT BOND FORM

(Address)
Telephone Number: _____

(Individual Principal)

(Business Address)
Telephone Number: _____

(Corporate Principal)

(Business Address) (Affix Corporate SEAL)
Telephone Number: _____
BY _____

ATTEST:

(Business Address) (Affix Corporate SEAL)
BY _____
Telephone Number: _____

CERTIFICATES AS TO CORPORATE PRINCIPAL

I, _____, certify that I am the _____
Secretary of the corporation named as Principal in the within bond; that
_____, who signed the said bond on behalf of the
Principal was then _____ of said corporation; and I
know his signature, and his signature thereto is genuine; and that said
bond was duly signed, sealed, and attested for and in behalf of said
corporation by authority of its governing body.

(TITLE)
DATE _____

(AFFIX CORPORATE SEAL)

Telephone Number: _____

The rate of premium on this bond is _____ per thousand. Total
amount of premium charge \$_____.
(The above must be filled in by corporate surety.) (Power-of-Attorney of
person signing for surety company must be attached.)

PERFORMANCE BOND
(To be used in Texas under V.A.T.S. 5160)

THE STATE OF _____

COUNTY OF _____

KNOW ALL MEN BY THESE PRESENTS: That we (1) _____, a (2) _____ OF _____, hereinafter called Principal and (3) _____ of _____, State of _____, hereinafter called the Surety, are held and firmly bound unto (4) _____ of _____, hereinafter called Owner, in the penal sum of _____ (\$ _____) Dollars in lawful money of the United States to be paid in (5) _____, for the payment of which sum well and truly to be made, we bind ourselves, our heirs, executors, administrators, and successors, jointly and severally, firmly be these presents.

THE CONDITION OF THIS OBLIGATION is such that Whereas, the Principal entered into a certain contract with (6) _____, the Owner, dated the _____ day of _____, A.D. 200__, a copy of which is hereto attached and made a part hereof for the construction of:

HIDALGO COUNTY PRECINCT #3 BORDER ACCESS COLONIA PROJECT
_____ SUBDIVISION
hereinafter called the "Work").

These footnotes refer to the numbers in body of contract above:

Date of Bond must not be prior to date of contract

- (1) Correct name of Contractor
- (2) A Corporation, a Partnership or an Individual, as case may be
- (3) Correct name of Surety
- (4) Correct name of Owner
- (5) County and State
- (6) Owner

(Texas Performance Bond) - Page 2.

NOW, THEREFORE, if the Principal shall well, truly and faithfully perform the work in accordance with the plans, specifications, and contract documents during the original term thereof, and any extensions thereof which may be granted by the Owner, with or without notice to the Surety, and if he shall satisfy all claims and demands incurred under such contract, and shall fully indemnify and save harmless the Owner from all costs and damages which it may suffer by reason of failure to do so, and shall reimburse and repay the Owner all outlay and expense which the Owner may incur in making good any default, then this obligation shall be void; otherwise to remain in full force and effect.

PROVIDED FURTHER, that if any legal action be filed upon this bond, venue shall lie in Hidalgo County, State of Texas, and that the said surety, for value received hereby stipulates and agrees that no change, extension of time, alteration or addition to the terms of the contract or to the

work to be performed thereunder or the specifications accompanying the same shall in any way affect its obligation on this bond, and it does hereby waive notice of any such change, extension of time, alternation or addition to the terms of the contract or to the work or to the specifications.

IN WITNESS WHEREOF, this instrument is executed in six counterparts, each one of which shall be deemed an original, this the _____ day of _____ . A.D.

ATTEST:

(Principal) Secretary

(Seal)

Witness as to Principal

(Address)

Principal _____
By _____

(Address) _____

Telephone Number: _____

ATTEST:

(Surety) Secretary

(Seal)

Witness as to Surety

(Address)

By _____

(Address) _____

Telephone Number: _____

NOTE: If Contractor is a partnership, all partners should execute bond.

PERFORMANCE-PAYMENT BOND FORM

(Address)
Telephone Number: _____

(Individual Principal)

(Business Address)
Telephone Number: _____

(Corporate Principal)

(Business Address) (Affix Corporate SEAL)
Telephone Number: _____
BY _____

ATTEST:

(Business Address) (Affix Corporate SEAL)
BY _____
Telephone Number: _____

CERTIFICATES AS TO CORPORATE PRINCIPAL

I, _____, certify that I am the _____
Secretary of the corporation named as Principal in the within bond; that
_____, who signed the said bond on behalf of the
Principal was then _____ of said corporation; and I
know his signature, and his signature thereto is genuine; and that said
bond was duly signed, sealed, and attested for and in behalf of said
corporation by authority of its governing body.

(TITLE)
DATE _____

(AFFIX CORPORATE SEAL)

Telephone Number: _____

The rate of premium on this bond is _____ per thousand. Total
amount of premium charge \$_____.
(The above must be filled in by corporate surety.) (Power-of-Attorney of
person signing for surety company must be attached.)

EXHIBIT “C” Insurance Requirements

The Bidder awarded the contract shall furnish proof of insurance, which will also include any subcontractor that is subcontracted by the bidder in at least the following limits, to be in place prior to providing any services under this Contract and to continue at all times in force in effect during the term of this Contract:

1. A Five Hundred Thousand Dollar (\$500,000.00) Comprehensive General Liability insurance policy providing additional coverage to all underlying liabilities of County.
2. Automobile liability insurance policy with limits of at least Three Hundred Thousand Dollars (\$300,000.00) per person and Five Hundred Thousand Dollars (\$500,000.00) per occurrence. Coverage should include injury to or death of persons and property damage claims with limits up to Five Hundred Thousand (\$500,000.00) arising out of the services provided to County hereunder.
3. Uninsured/Underinsured motorist coverage in an amount equal to the bodily injury limits set forth immediately above;
4. Workers compensation insurance in amounts established by Texas law, unless the Bidder is specifically exempted from the Texas Workers Compensation Act, Texas Labor Code Chapter 401, et. seq.

Certificates of insurance naming County as an additional insured shall be submitted to County for approval prior to any services being performed by Contractor. Each policy of insurance required hereunder shall extend for a period equivalent to, or longer than the term of the Contract, and any insurer hereunder shall be required to give at least thirty (30) days written notice to the County prior to the cancellation of any such coverage on the termination date, or otherwise. This Contract shall be automatically suspended upon the cancellation, or other termination, of any required policy of insurance hereunder, and such suspension shall continue until evidence adequate replacement coverage is provided to County. If replacement coverage is not provided within thirty (30) days following suspension of the Contract, this Contract shall automatically terminate.

Insurance Requirement Acknowledgment

I, _____, authorized representative for _____,
Company/Vendor

hereby acknowledge receipt of the County's required insurance limits. Said requirements:

- will be acquired within 10 working days after notification from Purchasing Department of bid awarded by the Hidalgo County Commissioners' Court;
- will acquire additional amounts required to meet the County's requirements within 10 working days after notification from Purchasing Department of bid award by the Hidalgo County Commissioners' Court; currently carry the following:

Automobile Liability: \$ _____ General Liability: \$ _____

- have already been met, see attached copy of insurance certificate.

Authorized Representative

Date

Notice to Bidder:

A certificate of insurance for the required insurance limits shall be provided to the Purchasing Department's Contract Managers in order to qualify for award of bid and to execute a contract between your Company and the County

Failure to provide Certificates of Insurance to the Purchasing Department's Contract Managers will cause the bid award to be rescinded and re-awarded to next lowest bidder. Certificates of Insurance will be monitored and verified on a **quarterly basis** to ensure coverage policy is in place. It is the Company's obligation to maintain the appropriate insurance coverage throughout the term of the contract.

THIS FORM MUST ACCOMPANY BID PACKET

PROJECT REQUIREMENTS ACKNOWLEDGMENT

This is to certify that I, _____, possess all of the APPLICABLE:

1. Licenses: _____.

2. Bonds: _____.

3. Certificates: _____.

4. Permits: _____.

5. Other: _____.

necessary to carry out the required project. Furthermore, I am providing copies of the required documentation so that, if my company is awarded this bid, I may be eligible to enter into a contract with Hidalgo County and proceed to complete the project in a timely manner.

* Any licenses, bonds, certificates, permits, etc. which are required must be presented as part of the bid packet in order to expedite the bid evaluation process. Failure to provide said documentation will result in the disqualification of your bid.

Authorized Signature

Date

Company

Address

City, State, Zip

PRODUCER	THIS CERTIFICATE IS ISSUED AS A MATTER OF INFORMATION ONLY AND CONFERS NO RIGHTS UPON THE CERTIFICATE HOLDER. THIS CERTIFICATE DOES NOT AMEND, EXTEND OR ALTER THE COVERAGE AFFORDED BY THE POLICIES BELOW.
	INSURERS AFFORDING COVERAGE
INSURED	INSURER A:
	INSURER B:
	INSURER C:
	INSURER D:
	INSURER E:

COVERAGES

THE POLICIES OF INSURANCE LISTED BELOW HAVE BEEN ISSUED TO THE INSURED NAMED ABOVE FOR THE POLICY PERIOD INDICATED. NOTWITHSTANDING ANY REQUIREMENT, TERM OR CONDITION OF ANY CONTRACT OR OTHER DOCUMENT WITH RESPECT TO WHICH THIS CERTIFICATE MAY BE ISSUED OR MAY PERTAIN, THE INSURANCE AFFORDED BY THE POLICIES DESCRIBED HEREIN IS SUBJECT TO ALL THEIR TERMS, EXCLUSIONS AND CONDITIONS OF SUCH POLICIES. AGGREGATE LIMITS SHOWN MAY HAVE BEEN REDUCED BY PAID CLAIMS.

INSR LTR	TYPE OF INSURANCE	POLICY NUMBER	POLICY EFFECTIVE DATE (MM/DD/YY)	POLICY EXPIRATION DATE (MM/DD/YY)	LIMITS	
A	GENERAL LIABILITY COMMERCIAL GENERAL LIABILITY CLAIMS MADE OCCUR OWNER'S & CONT. PROT OWNER'S PROTECTIVE LIABILITY GEN'L AGGREGATE LIMIT APPLIES PER: POLICY PROJECT LOC				EACH OCCURRENCE	\$
					FIRE DAMAGE (Any one fire)	\$
					MED EXP (Any one person)	\$
					PERSONAL & ADV INJURY	\$
					GENERAL AGGREGATE	\$
					PRODUCTS - COMP/OP AGG	\$
B	AUTOMOBILE LIABILITY ANY AUTO ALL OWNED AUTOS SCHEDULED AUTOS HIRED AUTOS NON-OWNED AUTOS				COMBINED SINGLE LIMIT (Ea accident)	\$
					BODILY INJURY (Per person)	\$
					BODILY INJURY (Per accident)	\$
					PROPERTY DAMAGE (Per accident)	\$
	GARAGE LIABILITY ANY AUTO				AUTO ONLY-EA ACCIDENT	\$
					OTHER THAN AUTO ONLY EA ACC AGG	\$
C	EXCESS LIABILITY OCCUR CLAIMS MADE DEDUCTIBLE RETENTION \$				EACH OCCURENCE	\$
					AGGREGATE	\$
						\$
						\$
						\$
D	WORKERS COMPENSATION AND EMPLOYER'S LIABILITY				WC STATU-TORY LIMITS OTHER	
					E.L. EACH ACCIDENT	\$
					E.L. DISEASE-EA EMPLOYEE	\$
					E.L. DISEASE-POLICY LIMIT	\$
	OTHER					

DESCRIPTION OF OPERATIONS / LOCATION / VEHICLES / EXCLUSIONS ADDED BY ENDORSEMENT / SPECIAL PROVISIONS

County of Hidalgo shall be named as additional insured on all Commercial General Liability policies.

CERTIFICATE HOLDER	ADDITIONAL INSURED; INSURER LETTER: _____ CANCELLATION
Hidalgo County Attn: Purchasing Department 2812 S Highway Bus. 281 Edinburg, Texas 78539	SHOULD ANY OF THE ABOVE DESCRIBED POLICIES BY CANCELLED BEFORE THE EXPIRATION DATE THEREOF, THE ISSUING INSURER WILL ENDEAVOR TO MAIL 30 DAYS WRITTEN NOTICE TO THE CERTIFICATE HOLDER NAMED TO THE LEFT, BUT FAILURE TO DO SO SHALL IMPOSE NO OBLIGATION OR LIABILITY OF ANY KIND UPON THE INSURER, ITS AGENTS OR REPRESENTATIVES. AUTHORIZED REPRESENTATIVE

GENERAL CONDITIONS OF THE AGREEMENT

1. GENERAL

It is the intent of these instructions, plans and specifications to provide guidance for the construction of this project.

2. REGULATIONS AND DISCREPANCIES

All applicable laws, ordinances, policy, rules, regulations and other directives of all authorities having jurisdiction over the projects shall apply to the contract throughout and will be deemed to be included in the contract the same as those written out in full. Discrepancies between regulations or conflicting parts of the Specifications shall be brought to the attention of an clarified by the Engineer before proceeding with any work. Proceeding with affected work without instructions from the Engineer can result in the Contractor being responsible for taking the necessary steps to insure the work conforms to the governing regulation.

3. ENGINEER

Whenever the work "ENGINEER" is used in this contract with reference to the preparation of plans, specifications, and contract documents, it shall be understood as referring to the firm **TEDSI Infrastructure Group**.

4. INTERPRETATION OF PHRASES

Whenever the words "Directed", "Required", "Permitted", "Designated", "Considered Necessary", "Prescribed", or words of like importance are used, it shall be understood that the direction, requirements, permission, order, designation or prescription, of the ENGINEER is intended and similarly, the words "Approval", "Acceptable", "Satisfactory", or words of like importance shall mean approved by or acceptable of satisfactory to the ENGINEER. The preceeding to the contrary notwithstanding, Engineer's approval or acceptance of the work shall by advisory to OWNER, and shall not bind the OWNER to accept or approve the same.

Whenever, in the specifications or drawings accompanying this agreement, the terms or description of various qualities relative to finish, workmanship, or other qualities of similar kind which cannot,, from their nature, be specifically and clearly described and specified, but are necessarily described in general terms, then, in all such cases, any question of the fulfillment of said specifications shall be decided by the ENGINEER, and said work shall be done in accordance with his interpretations of the meaning of the words, terms, or clauses defining the character of the work.

Title 29 - LABOR

Subtitle A - Office of the Secretary of Labor

PART 3 - CONTRACTORS AND SUBCONTRACTORS ON PUBLIC BUILDING OR PUBLIC WORK FINANCED IN WHOLE OR IN PART BY LOANS OR GRANTS FROM THE UNITED STATES

- Sec.
- 3.1 Purpose and scope
 - 3.2 Definitions
 - 3.3 Weekly statement with respect to payment of wages
 - 3.4 Submission of weekly statements and the preservation and inspection of weekly payroll records.
 - 3.5 Payroll deductions permissible without application to or approval of the Secretary of Labor.
 - 3.6 Payroll deductions permissible with the approval of the Secretary of Labor.
 - 3.7 Applications for the approval of the Secretary of Labor
 - 3.8 Action by the Secretary of Labor upon applications.
 - 3.9 Prohibited payroll deductions.
 - 3.10 Methods of payment of wages.
 - 3.11 Regulations part of contract.

AUTHORITY: The provisions of this Part 3 issued under R.S. 16 1, sec. 2, 48 Stat. §48; Reorg. Plan No. 14 of 1950, 64 Stat. 1267, 5 U.S.C. Appendix; 5 U.S.C. 301; 40 U.S.C. 276c.

SOURCE: The provisions of this Part 3 appear at 29 F.R. 97, Jan. 4, 1964, unless otherwise noted.

Section 3.1 Purpose and Scope.

This part prescribes "anti-kickback" regulations under section 2 of the Act of June 13, 1934, as amended (40 U.S.C. 276c), popularly known as the Copeland Act. This part applies to any contract which is subject to Federal wage standards and which is for the construction, prosecution, completion, or repair of public buildings, public works or buildings or works financed in whole or in part by loans or grants from the United States. The part is intended to aid in the enforcement of the minimum wage provisions of the Davis-Bacon Act and the various statutes dealing with Federally assisted construction that contain similar minimum wage provisions, including those provisions which are not subject to Reorganization

Plan No. 14 (e.g., the College Housing Act of 1950, the Federal Water Pollution Control Act, and the Housing Act of 1959), and in the enforcement of the overtime provisions of the Contract Work Hours Standards Act whenever they are applicable to construction work. The part details the obligation of contractors and subcontractors relative to the weekly submission of statements regarding the wages paid on work covered thereby; sets forth the circumstances and procedures governing the making of payroll deductions from the wages of those employed on such work; and delineates the methods of payment permissible on such work.

Section 3.2 Definitions.

As used in the regulations in this part:

(a) The terms "building" or "work" generally include construction activity as distinguished from manufacturing, furnishing of materials, or servicing and maintenance work. The terms include, without limitation, buildings, structures, and improvements of all @s, such as bridges, dams, plants, highways, parkways, streets, subways, tunnels, sewers, mains, powerlines, pumping stations, railways, airports, terminals, docks, piers, wharves, ways, lighthouses, buoys, jetties, breakwaters, levees, and canals; dredging, shoring, scaffolding, drilling, blasting, excavating, clearing, and landscaping. Unless conducted in connection with and at the site of such a building or work as is described in the foregoing sentence, the manufacture or furnishing of materials, articles, supplies, or equipment (whether or not a Federal or State agency acquires title to such materials,

Copeland Act Regulations

articles, supplies, or equipment during the course of the manufacture or furnishing, or owns the materials from which they are manufactured or furnished) is not a "building" or "work" within the meaning of the regulations in this part.

(b) The terms "construction," "prosecution," "completion," or "repair" mean all types of work done on a particular building or work at the site thereof, including, without limitation, altering, remodeling, painting and decorating, the transporting of materials and supplies to or from the building or work by the employees of the construction contractor or construction subcontractor, and the manufacturing or furnishing of materials, articles, supplies, or equipment on the site of the building or work, by persons employed at the site by the contractor or subcontractor.

(c) The terms "public building" or "public work" include building or work for whose construction, prosecution, completion, or repair, as defined above, a Federal agency is a contracting party, regardless of whether title thereof is in a Federal agency.

(d) The term "building or work financed in whole or in part by loans or grants from the United States" includes building or work for whose construction, prosecution, completion, or repair, as defined above, payment or part payment is made directly or indirectly from funds provided by loans or grants by a Federal agency. The term includes building or work for which the Federal assistance granted is in the form of loan guarantees or insurance.

(e) Every person paid by a contractor or subcontractor in any manner for his labor in the construction, prosecution, completion, or repair of a public building or public work or building or work financed in whole or in part by loans or grants from the United States is "employed" and receiving "wages," regardless of any contractual relationship alleged to exist between him and the real employer.

(f) The term "any affiliated person" includes a spouse, child, parent, or other close relative of the contractor or subcontractor; a partner or officer of the contractor or subcontractor; a corporation closely connected with the contractor or subcontractor as parent, subsidiary or otherwise, and an officer or agent of such corporation.

(g) The term "Federal agency" means the United States, the District of Columbia, and all executive departments, independent establishments, administrative agencies, and instrumentality's of the United States and of the District of Columbia, including corporations, all or substantially all of the stock of which is beneficially owned by the United States, by the District of Columbia, or any of the foregoing departments, establishments, agencies, and

(a) Each weekly statement required under §3.3 shall be delivered by the contractor or subcontractor, within seven days after the regular payment date of the payroll period, to a representative of a Federal or

instrumentality's.

(29 FR 97, Jan. 4, 1964, as amended at 33 FR 32575, Nov. 27, 1973)

Section 3.3 Weekly statement with respect to payment of wages.

(a) As used in this section, the term "employee" shall not apply to persons in classifications higher than that of laborer or mechanic and those who are the immediate supervisors of such employees.

(b) Each contractor or subcontractor engaged in the construction, prosecution, completion, or repair of any public building or public work, or building or work financed in whole or in part by loans or grants from the United States, shall furnish each week a statement with respect to the wages paid each of its employees engaged on work covered by 29 CFR Parts 3 and 5 during the preceding weekly payroll period. This statement shall be executed by the contractor or subcontractor or by an authorized officer of employee of the contractor or subcontractor who supervises the payment of wages, and shall be on form @ 348, "Statement of Compliance," or on an identical form on the back of @ 347, "Payroll (For Contractors Optional Use)" or on any form with identical wording. Sample copies of @ 347 and @ 348 may be obtained from the Government contracting or sponsoring agency, and copies of these forms may be purchased at the Government Printing Office.

(c) The requirements of this section shall not apply to any contract of \$2,000 or less.

(d) Upon a written finding by the head of a Federal agency, the Secretary of Labor may provide reasonable limitations, variations, tolerances, and exemptions from the requirements of this section subject to such conditions as the Secretary of Labor may specify.

(29 F.R. 95, Jan. 4, 1964, as amended at 33 F.R. 10186, July 17, 1968)

Copeland Act Regulations

Section 3.4 Submission of weekly statements and the preservation and inspection of weekly payroll records.

State agency in charge at the site of the building or work, or if there is no representative of a Federal or State agency at the site of the building or work, the statement shall be mailed by the contractor or

subcontractor, within such time, to a Federal or State agency contracting for or financing the building or work. After such examination and check as may be made, such statement, or a copy thereof, shall be kept available, or shall be transmitted together with a report of any violation, in accordance with applicable procedures prescribed by the United States Department of Labor.

(b) Each contractor or subcontractor shall preserve his weekly payroll records for a period of three years from date of completion of the contract. The payroll records shall set out accurately and completely the name and address of each laborer and mechanic, his correct classification, rate of pay, daily and weekly number of hours worked, deductions made, and actual wages paid. Such payroll records shall be made available at all times for inspection by the contracting officer or his authorized representative, and by authorized representatives of the Department of Labor.

Section 3.5 Payroll deductions permissible without application to or approval of the Secretary of Labor.

Deductions made under the circumstances or in the situations described in the paragraphs of this section may be made without application to and approval of the Secretary of Labor:

(a) Any deduction made in compliance with the requirements of Federal, State, or local law, such as Federal or State withholding income taxes and Federal social security taxes.

(b) Any deduction of sums previously paid to the employee as a bona fide prepayment of wages when such prepayment is made without discount or interest. A "bona fide prepayment of wages" is considered to have been made only when cash or its equivalent has been advanced to the person employed in such manner as to give him complete freedom of disposition of the advanced funds.

(c) Any deduction of amounts required by court process to be paid to another, unless, the deduction is in favor of the contractor, subcontractor or any affiliated person, or when collusion or collaboration exists.

(d) Any deduction constituting a contribution on behalf of the person employed to funds established by the employer or representatives of employees, or both, for the purpose of providing either from principal or income, or both, medical or hospital care, pensions, or annuities on retirement, death benefits, compensation for injuries, illness, accidents, sickness,

(k) Any deduction for the cost of safety equipment of nominal value purchased by the

or disability, or for insurance to provide any of the foregoing, or unemployment benefits, vacation pay, savings accounts, or similar payments for the benefit of employees, their families and dependents:

Provided, however, That the following standards are met: (1) The deduction is not otherwise prohibited by law; (2) it is either: (i) Voluntarily consented to by the employee in writing and in advance of the period in which the work is to be done and such consent is not a condition either for the obtaining of or for the continuation of employment, or (ii) provided for in a bona fide collective bargaining agreement between the contractor or subcontractor and representatives of its employees; (3) no profit or other benefit is otherwise obtained, directly or indirectly, by the contractor or subcontractor or any affiliated person in the form of commission, dividend, or otherwise; and (4) the deductions shall serve the convenience and interest of the employee. (e) Any deduction contributing toward the purchase of United States Defense Stamps and Bonds when voluntarily authorized by the employee.

(f) Any deduction requested by the employee to enable him to repay loans to or to purchase shares in credit unions organized and operated in accordance with Federal and State credit union statutes.

(g) Any deduction voluntarily authorized by the employee for the making of contributions to

Copeland Act Regulations

governmental or quasi-governmental agencies, such as the American Red Cross.

(h) Any deduction voluntarily authorized by the employee for the making of contributions to Community Chests, United Givers Funds, and similar charitable organizations.

(i) Any deductions to pay regular union initiation fees and membership dues, not including fines or special assessments: Provided, however, That a collective bargaining agreement between the contractor or subcontractor and representatives of its employees provides for such deductions and the deductions are not otherwise prohibited by law.

(j) Any deduction not more than for the "reasonable cost" of board, lodging, or other facilities meeting the requirements of section 3(m) of the Fair Labor Standards Act of 1938, as amended, and Part 531 of this title. When such a deduction is made the additional records required under §516.27(a) of this title shall be kept.

(k) Any deduction for the cost of safety equipment for his personal protection in his work, such as safety shoes, safety

glasses, safety gloves, and hard hats, if such equipment is not required by law to be furnish by the employer, if such deduction is not violative of the Fair Labor Standards Act or prohibited by other law, if the cost on which the deduction is based does not exceed the actual cost to the employer where the equipment is purchased from him and does not include any direct or indirect monetary return to the employer where the equipment is purchased from a third person, and if the deduction is either (1) voluntarily consented to be the employee in writing and in advance of the period in which the work is to be done and such consent is not a condition either for the obtaining of employment or its continuance; or (2) provided for in a bona fide collective bargaining agreement between the contractor or subcontractor and representatives of its employees. (36 F.R. 9770, May 28,1971.)

Section 3.6 Payroll deductions permissible with the approval of the Secretary of Labor.

Any contractor or subcontractor may apply to the Secretary of Labor for permission to make any

deduction not permitted under §3.5. The Secretary may grant permission whenever he finds that:

- (a) The contractor, subcontractor, or any affiliated person does not make a profit or benefit

directly or indirectly from the deduction either in the form of a commission, dividend, or otherwise;

- (b) The deduction is not otherwise prohibited by law;

- (c) The deduction is either (1) voluntarily consented to by the employee **in** writing and in advance of the period in which the work is to be done and such consent is not a condition either for the obtaining of employment or its continuance, or (2) provided for in a bona **fide** collective bargaining agreement between the contractor or subcontractor and representatives of its employees; and

- (d) The deduction serves the convenience and interest of the employee.

Section 3.7 Applications for the approval of the Secretary of Labor.

Any application for the making of payroll deductions under §3.6 shall comply with the requirements prescribed in the following paragraphs of this section:

- (a) The application shall be in writing and shall be addressed to the Secretary of Labor.

- (b) The application need not identify the

contract or contracts under which the work in question is to be performed. Permission will be given for deductions on all current and future contracts of the applicant for a period of I year. A renewal of permission to make such payroll deduction will be granted upon the submission of an application which makes reference to the original application, recites the date of the Secretary of Labor's approval of such deductions, states affirmatively that there is continued compliance with the standards set forth in the provisions of §3.6, and specifies any conditions which have changed in regard to the payroll deductions.

(36 F.IL 9770, May 29, 1971.)

- (c) The application shall state affirmatively that there is compliance with the standards set forth in the provisions of §3.6. The affirmation shall be accompanied by a full statement of the facts indicating such compliance.

Copeland Act Regulations

(d) The application shall include a description of the proposed deduction, the purpose to be served there by, and the classes of laborers or mechanics from whose wages the proposed deduction would be made.

(e) The application shall state the name and business of any third person to whom any funds obtained from the proposed deductions are to be transmitted and the affiliation of such person, if any, with the applicant. -

Section 3.8 Action by the Secretary of Labor upon applications.

The Secretary of Labor shall decide whether or not the requested deduction is permissible under provisions of §3.6; and shall notify the applicant in writing of his decision.

Section 3.9 Prohibited payroll deductions.

Deductions not elsewhere provided for by this part and which **are** not found to be permissible under §3.6 are prohibited.

Section 3.10 Methods of payment of wages.

The payment of wages shall be by cash, negotiable instruments payable on demand, or the additional forms of compensation for which deductions are permissible under this part. No other methods of payment shall be recognized on work subject to the Copeland Act.

Section 3.11 Regulations part of contract.

All contracts made with respect to the construction, prosecution, completion, or repair of any public building or public work or building or work financed in whole or in part by loans or grants from the United States covered by the regulations in this part shall expressly bind the contractor or subcontractor to comply with such of the regulations in this part as may be applicable. In this regard, see §5.5(a) of this subtitle.

STANDARD
GENERAL CONDITIONS
OF THE
CONSTRUCTION CONTRACT

Prepared by

ENGINEERS JOINT CONTRACT DOCUMENTS COMMITTEE

and

Issued and Published Jointly By

PROFESSIONAL ENGINEERS IN PRIVATE PRACTICE
a practice division of the
NATIONAL SOCIETY OF PROFESSIONAL ENGINEERS

AMERICAN CONSULTING ENGINEERS COUNCIL

AMERICAN SOCIETY OF CIVIL ENGINEERS

This document has been approved and endorsed by

The Associated General Contractors of America

Construction Specifications Institute

Copyright ©1996

National Society of Professional Engineers
1420 King Street, Alexandria, VA 22314

American Consulting Engineers Council
1015 15th Street N.W., Washington, DC 20005

American Society of Civil Engineers
345 East 47th Street, New York, NY 10017

TABLE OF CONTENTS

	<u>Page</u>
ARTICLE 1 - DEFINITIONS AND TERMINOLOGY	6
1.01 <i>Defined Terms</i>	6
1.02 <i>Terminology</i>	8
ARTICLE 2 - PRELIMINARY MATTERS	9
2.01 <i>Delivery of Bonds</i>	9
2.02 <i>Copies of Documents</i>	9
2.03 <i>Commencement of Contract Times; Notice to Proceed</i>	9
2.04 <i>Starting the Work</i>	9
2.05 <i>Before Starting Construction</i>	9
2.06 <i>Preconstruction Conference</i>	10
2.07 <i>Initial Acceptance of Schedules</i>	10
ARTICLE 3 - CONTRACT DOCUMENTS: INTENT, AMENDING, REUSE.....	10
3.01 <i>Intent</i>	10
3.02 <i>Reference Standards</i>	10
3.03 <i>Reporting and Resolving Discrepancies</i>	10
3.04 <i>Amending and Supplementing Contract Documents</i>	11
3.05 <i>Reuse of Documents</i>	11
ARTICLE 4 - AVAILABILITY OF LANDS; SUBSURFACE AND PHYSICAL CONDITIONS; REFERENCE POINTS.....	11
4.01 <i>Availability of Lands</i>	11
4.02 <i>Subsurface and Physical Conditions</i>	12
4.03 <i>Differing Subsurface or Physical Conditions</i>	12
4.04 <i>Underground Facilities</i>	13
4.05 <i>Reference Points</i>	13
4.06 <i>Hazardous Environmental Condition at Site</i>	14
ARTICLE 5 - BONDS AND INSURANCE.....	15
5.01 <i>Performance, Payment, and Other Bonds</i>	15
5.02 <i>Licensed Sureties and Insurers</i>	15
5.03 <i>Certificates of Insurance</i>	15
5.04 <i>CONTRACTOR's Liability Insurance</i>	15
5.05 <i>OWNER's Liability Insurance</i>	16
5.06 <i>Property Insurance</i>	16
5.07 <i>Waiver of Rights</i>	17
5.08 <i>Receipt and Application of Insurance Proceeds</i>	18
5.09 <i>Acceptance of Bonds and Insurance; Option to Replace</i>	18
5.10 <i>Partial Utilization, Acknowledgment of Property Insurer</i>	18
ARTICLE 6 - CONTRACTOR'S RESPONSIBILITIES	18
6.01 <i>Supervision and Superintendence</i>	18
6.02 <i>Labor; Working Hours</i>	19
6.03 <i>Services, Materials, and Equipment</i>	19
6.04 <i>Progress Schedule</i>	19
6.05 <i>Substitutes and "Or-Equals"</i>	19
6.06 <i>Concerning Subcontractors, Suppliers, and Others</i>	21

6.07 Patent Fees and Royalties	21
6.08 Permits	22
6.09 Laws and Regulations	22
6.10 Taxes	22
6.11 Use of Site and Other Areas	22
6.12 Record Documents	22
6.13 Safety and Protection	23
6.14 Safety Representative	23
6.15 Hazard Communication Programs	23
6.16 Emergencies	23
6.17 Shop Drawings and Samples	24
6.18 Continuing the Work	25
6.19 CONTRACTOR's General Warranty and Guarantee	25
6.20 Indemnification	25
ARTICLE 7 - OTHER WORK	26
7.01 Related Work at Site	26
7.02 Coordination	26
ARTICLE 8 - OWNER'S RESPONSIBILITIES	27
8.01 Communications to Contractor	27
8.02 Replacement of ENGINEER	27
8.03 Furnish Data	27
8.04 Pay Promptly When Due	27
8.05 Lands and Easements; Reports and Tests	27
8.06 Insurance	27
8.07 Change Orders	27
8.08 Inspections, Tests, and Approvals	27
8.09 Limitations on OWNER's Responsibilities	27
8.10 Undisclosed Hazardous Environmental Condition	27
8.11 Evidence of Financial Arrangements	27
ARTICLE 9 - ENGINEER'S STATUS DURING CONSTRUCTION	27
9.01 OWNER'S Representative	27
9.02 Visits to Site	28
9.03 Project Representative	28
9.04 Clarifications and Interpretations	28
9.05 Authorized Variations in Work	28
9.06 Rejecting Defective Work	29
9.07 Shop Drawings, Change Orders and Payments	29
9.08 Determinations for Unit Price Work	28
9.09 Decisions on Requirements of Contract Documents and Acceptability of Work	28
9.10 Limitations on ENGINEER's Authority and Responsibilities	28
ARTICLE 10 - CHANGES IN THE WORK; CLAIMS	29
10.01 Authorized Changes in the Work	29
10.02 Unauthorized Changes in the Work	29
10.03 Execution of Change Orders	30
10.04 Notification to Surety	30
10.05 Claims and Disputes	30
ARTICLE 11 - COST OF THE WORK; CASH ALLOWANCES; UNIT PRICE WORK	30
11.01 Cost of the Work	30

11.02 <i>Cash Allowances</i>	32
11.03 <i>Unit Price Work</i>	33
ARTICLE 12 - CHANGE OF CONTRACT PRICE; CHANGE OF CONTRACT TIMES	33
12.01 <i>Change of Contract Price</i>	33
12.02 <i>Change of Contract Times</i>	34
12.03 <i>Delays Beyond CONTRACTOR's Control</i>	34
12.04 <i>Delays Within CONTRACTOR's Control</i>	34
12.05 <i>Delays Beyond OWNER's and CONTRACTOR'S Control</i>	34
12.06 <i>Delay Damages</i>	34
ARTICLE 13 - TESTS AND INSPECTIONS; CORRECTION, REMOVAL OR ACCEPTANCE OF DEFECTIVE WORK	34
13.01 <i>Notice of Defects</i>	34
13.02 <i>Access to Work</i>	34
13.03 <i>Tests and Inspections</i>	35
13.04 <i>Uncovering Work</i>	35
13.05 <i>OWNER May Stop the Work</i>	35
13.06 <i>Correction or Removal of Defective Work</i>	36
13.07 <i>Correction Period</i>	36
13.08 <i>Acceptance of Defective Work</i>	36
13.09 <i>OWNER May Correct Defective Work</i>	36
ARTICLE 14 - PAYMENTS TO CONTRACTOR AND COMPLETION	37
14.01 <i>Schedule of Values</i>	37
14.02 <i>Progress Payments</i>	37
14.03 <i>CONTRACTOR's Warranty of Title</i>	38
14.04 <i>Substantial Completion</i>	39
14.05 <i>Partial Utilization</i>	39
14.06 <i>Final Inspection</i>	39
14.07 <i>Final Payment</i>	40
14.08 <i>Final Completion Delayed</i>	40
14.09 <i>Waiver of Claims</i>	41
ARTICLE 15 - SUSPENSION OF WORK AND TERMINATION	41
15.01 <i>OWNER May Suspend Work</i>	41
15.02 <i>OWNER May Terminate for Cause</i>	41
15.03 <i>OWNER May Terminate For Convenience</i>	41
15.04 <i>CONTRACTOR May Stop Work or Terminate</i>	42
ARTICLE 16 - DISPUTE RESOLUTION	42
16.01 <i>Methods and Procedures</i>	42
ARTICLE 17 - MISCELLANEOUS	43
17.01 <i>Giving Notice</i>	43
17.02 <i>Computation of Times</i>	43
17.03 <i>Cumulative Remedies</i>	43
17.04 <i>Survival of Obligations</i>	43
17.05 <i>Controlling Law</i>	43

GENERAL CONDITIONS

ARTICLE 1 - DEFINITIONS AND TERMINOLOGY

1.01 *Defined Terms*

A. Wherever used in the Contract Documents and printed with initial or all capital letters, the terms listed below will have the meanings indicated which are applicable to both the singular and plural thereof.

1. *Addenda*--Written or graphic instruments issued prior to the opening of Bids which clarify, correct, or change the Bidding Requirements or the Contract Documents.

2. *Agreement*--The written instrument which is evidence of the agreement between OWNER and CONTRACTOR covering the Work.

3. *Application for Payment*--The form acceptable to ENGINEER which is to be used by CONTRACTOR during the course of the Work in requesting progress or final payments and which is to be accompanied by such supporting documentation as is required by the Contract Documents.

4. *Asbestos*--Any material that contains more than one percent asbestos and is friable or is releasing asbestos fibers into the air above current action levels established by the United States Occupational Safety and Health Administration.

5. *Bid*--The offer or proposal of a bidder submitted on the prescribed form setting forth the prices for the Work to be performed.

6. *Bidding Documents*--The Bidding Requirements and the proposed Contract Documents (including all Addenda issued prior to receipt of Bids).

7. *Bidding Requirements*--The Advertisement or Invitation to Bid, Instructions to Bidders, Bid security form, if any, and the Bid form with any supplements.

8. *Bonds*--Performance and payment bonds and other instruments of security.

9. *Change Order*--A document recommended by ENGINEER which is signed by CONTRACTOR and OWNER and authorizes an addition, deletion, or revision in the Work or an adjustment in the Contract Price or the

Contract Times, issued on or after the Effective Date of the Agreement.

10. *Claim*--A demand or assertion by OWNER or CONTRACTOR seeking an adjustment of Contract Price or Contract Times, or both, or other relief with respect to the terms of the Contract. A demand for money or services by a third party is not a Claim.

11. *Contract*--The entire and integrated written agreement between the OWNER and CONTRACTOR concerning the Work. The Contract supersedes prior negotiations, representations, or agreements, whether written or oral.

12. *Contract Documents*--The Contract Documents establish the rights and obligations of the parties and include the Agreement, Addenda (which pertain to the Contract Documents), CONTRACTOR's Bid (including documentation accompanying the Bid and any post Bid documentation submitted prior to the Notice of Award) when attached as an exhibit to the Agreement, the Notice to Proceed, the Bonds, these General Conditions, the Supplementary Conditions, the Specifications and the Drawings as the same are more specifically identified in the Agreement, together with all Written Amendments, Change Orders, Work Change Directives, Field Orders, and ENGINEER's written interpretations and clarifications issued on or after the Effective Date of the Agreement. Approved Shop Drawings and the reports and drawings of subsurface and physical conditions are not Contract Documents. Only printed or hard copies of the items listed in this paragraph are Contract Documents. Files in electronic media format of text, data, graphics, and the like that may be furnished by OWNER to CONTRACTOR are not Contract Documents.

13. *Contract Price*--The moneys payable by OWNER to CONTRACTOR for completion of the Work in accordance with the Contract Documents as stated in the Agreement (subject to the provisions of paragraph 11.03 in the case of Unit Price Work).

14. *Contract Times*--The number of days or the dates stated in the Agreement to: (i) achieve Substantial Completion; and (ii) complete the Work so that it is ready for final payment as evidenced by ENGINEER's written recommendation of final payment.

15. *CONTRACTOR*--The individual or entity with whom OWNER has entered into the Agreement.

16. *Cost of the Work*--See paragraph 11.01.A for definition.

17. *Drawings*--That part of the Contract Documents prepared or approved by ENGINEER which graphically shows the scope, extent, and character of the Work to be performed by CONTRACTOR. Shop Drawings and other CONTRACTOR submittals are not Drawings as so defined.

18. *Effective Date of the Agreement*--The date indicated in the Agreement on which it becomes effective, but if no such date is indicated, it means the date on which the Agreement is signed and delivered by the last of the two parties to sign and deliver.

19. *ENGINEER*--The individual or entity named as such in the Agreement.

20. *ENGINEER's Consultant*--An individual or entity having a contract with ENGINEER to furnish services as ENGINEER's independent professional associate or consultant with respect to the Project and who is identified as such in the Supplementary Conditions.

21. *Field Order*--A written order issued by ENGINEER which requires minor changes in the Work but which does not involve a change in the Contract Price or the Contract Times.

22. *General Requirements*--Sections of Division 1 of the Specifications. The General Requirements pertain to all sections of the Specifications.

23. *Hazardous Environmental Condition*--The presence at the Site of Asbestos, PCBs, Petroleum, Hazardous Waste, or Radioactive Material in such quantities or circumstances that may present a substantial danger to persons or property exposed thereto in connection with the Work.

24. *Hazardous Waste*--The term Hazardous Waste shall have the meaning provided in Section 1004 of the Solid Waste Disposal Act (42 USC Section 6903) as amended from time to time.

25. *Laws and Regulations; Laws or Regulations*--Any and all applicable laws, rules, regulations, ordinances, codes, and orders of any and all governmental bodies, agencies, authorities, and courts having jurisdiction.

26. *Liens*--Charges, security interests, or encumbrances upon Project funds, real property, or personal property.

27. *Milestone*--A principal event specified in the Contract Documents relating to an intermediate completion date or time prior to Substantial Completion of all the Work.

28. *Notice of Award*--The written notice by OWNER to the apparent successful bidder stating that upon timely compliance by the apparent successful bidder with the conditions precedent listed therein, OWNER will sign and deliver the Agreement.

29. *Notice to Proceed*--A written notice given by OWNER to CONTRACTOR fixing the date on which the Contract Times will commence to run and on which CONTRACTOR shall start to perform the Work under the Contract Documents.

30. *OWNER*--The individual, entity, public body, or authority with whom CONTRACTOR has entered into the Agreement and for whom the Work is to be performed.

31. *Partial Utilization*--Use by OWNER of a substantially completed part of the Work for the purpose for which it is intended (or a related purpose) prior to Substantial Completion of all the Work.

32. *PCBs*--Polychlorinated biphenyls.

33. *Petroleum*--Petroleum, including crude oil or any fraction thereof which is liquid at standard conditions of temperature and pressure (60 degrees Fahrenheit and 14.7 pounds per square inch absolute), such as oil, petroleum, fuel oil, oil sludge, oil refuse, gasoline, kerosene, and oil mixed with other non-Hazardous Waste and crude oils.

34. *Project*--The total construction of which the Work to be performed under the Contract Documents may be the whole, or a part as may be indicated elsewhere in the Contract Documents.

35. *Project Manual*--The bound documentary information prepared for bidding and constructing the Work. A listing of the contents of the Project Manual, which may be bound in one or more volumes, is contained in the table(s) of contents.

36. *Radioactive Material*--Source, special nuclear, or byproduct material as defined by the Atomic Energy Act of 1954 (42 USC Section 2011 et seq.) as amended from time to time.

37. *Resident Project Representative*--The authorized representative of ENGINEER who may be assigned to the Site or any part thereof.

38. *Samples*--Physical examples of materials, equipment, or workmanship that are representative of some portion of the Work and which establish the standards by which such portion of the Work will be judged.

39. *Shop Drawings*--All drawings, diagrams, illustrations, schedules, and other data or information which are specifically prepared or assembled by or for CONTRACTOR and submitted by CONTRACTOR to illustrate some portion of the Work.

40. *Site*--Lands or areas indicated in the Contract Documents as being furnished by OWNER upon which the Work is to be performed, including rights-of-way and easements for access thereto, and such other lands furnished by OWNER which are designated for the use of CONTRACTOR.

41. *Specifications*--That part of the Contract Documents consisting of written technical descriptions of materials, equipment, systems, standards, and workmanship as applied to the Work and certain administrative details applicable thereto.

42. *Subcontractor*--An individual or entity having a direct contract with CONTRACTOR or with any other Subcontractor for the performance of a part of the Work at the Site.

43. *Substantial Completion*--The time at which the Work (or a specified part thereof) has progressed to the point where, in the opinion of ENGINEER, the Work (or a specified part thereof) is sufficiently complete, in accordance with the Contract Documents, so that the Work (or a specified part thereof) can be utilized for the purposes for which it is intended. The terms "substantially complete" and "substantially completed" as applied to all or part of the Work refer to Substantial Completion thereof.

44. *Supplementary Conditions*--That part of the Contract Documents which amends or supplements these General Conditions.

45. *Supplier*--A manufacturer, fabricator, supplier, distributor, materialman, or vendor having a direct contract with CONTRACTOR or with any Subcontractor to furnish materials or equipment to be incorporated in the Work by CONTRACTOR or any Subcontractor.

46. *Underground Facilities*--All underground pipelines, conduits, ducts, cables, wires, manholes, vaults, tanks, tunnels, or other such facilities or attachments, and any encasements containing such facilities, including those that convey electricity, gases, steam, liquid petroleum products, telephone or other communications, cable television, water, wastewater, storm water, other liquids or chemicals, or traffic or other control systems.

47. *Unit Price Work*--Work to be paid for on the basis of unit prices.

48. *Work*--The entire completed construction or the various separately identifiable parts thereof required to be provided under the Contract Documents. Work includes and is the result of performing or providing all labor, services, and documentation necessary to produce such construction, and furnishing, installing, and incorporating all materials and equipment into such construction, all as required by the Contract Documents.

49. *Work Change Directive*--A written statement to CONTRACTOR issued on or after the Effective Date of the Agreement and signed by OWNER and recommended by ENGINEER ordering an addition, deletion, or revision in the Work, or responding to differing or unforeseen subsurface or physical conditions under which the Work is to be performed or to emergencies. A Work Change Directive will not change the Contract Price or the Contract Times but is evidence that the parties expect that the change ordered or documented by a Work Change Directive will be incorporated in a subsequently issued Change Order following negotiations by the parties as to its effect, if any, on the Contract Price or Contract Times.

50. *Written Amendment*--A written statement modifying the Contract Documents, signed by OWNER and CONTRACTOR on or after the Effective Date of the Agreement and normally dealing with the nonengineering or nontechnical rather than strictly construction-related aspects of the Contract Documents.

1.02 Terminology

A. Intent of Certain Terms or Adjectives

1. Whenever in the Contract Documents the terms "as allowed," "as approved," or terms of like effect or import are used, or the adjectives "reasonable," "suitable," "acceptable," "proper," "satisfactory," or adjectives of like effect or import are used to describe an action or determination of ENGINEER as to the Work, it is intended that such action or determination will be solely to evaluate, in general, the completed Work for compliance with the requirements of and information in the Contract Documents and conformance with the design concept of the completed Project as a functioning whole as shown or indicated in the Contract Documents (unless there is a specific statement indicating otherwise). The use of any such term or adjective shall not be effective to assign to ENGINEER any duty or authority to supervise or direct the performance of the Work or any duty or authority to undertake responsibility contrary to the provisions of paragraph 9.10 or any other provision of the Contract Documents.

B. Day

1. The word "day" shall constitute a calendar day of 24 hours measured from midnight to the next midnight.

C. Defective

1. The word "defective," when modifying the word "Work," refers to Work that is unsatisfactory, faulty, or deficient in that it does not conform to the Contract Documents or does not meet the requirements of any inspection, reference standard, test, or approval referred to in the Contract Documents, or has been damaged prior to ENGINEER's recommendation of final payment (unless responsibility for the protection thereof has been assumed by OWNER at Substantial Completion in accordance with paragraph 14.04 or 14.05).

D. Furnish, Install, Perform, Provide

1. The word "furnish," when used in connection with services, materials, or equipment, shall mean to supply and deliver said services, materials, or equipment to the Site (or some other

specified location) ready for use or installation and in usable or operable condition.

2. The word "install," when used in connection with services, materials, or equipment, shall mean to put into use or place in final position said services, materials, or equipment complete and ready for intended use.

3. The words "perform" or "provide," when used in connection with services, materials, or equipment, shall mean to furnish and install said services, materials, or equipment complete and ready for intended use.

4. When "furnish," "install," "perform," or "provide" is not used in connection with services, materials, or equipment in a context clearly requiring an obligation of CONTRACTOR, "provide" is implied.

E. Unless stated otherwise in the Contract Documents, words or phrases which have a well-known technical or construction industry or trade meaning are used in the Contract Documents in accordance with such recognized meaning.

ARTICLE 2 - PRELIMINARY MATTERS

2.01 Delivery of Bonds

A. When CONTRACTOR delivers the executed Agreements to OWNER, CONTRACTOR shall also deliver to OWNER such Bonds as CONTRACTOR may be required to furnish.

2.02* Copies of Documents

A. OWNER shall furnish to CONTRACTOR up to ten copies of the Contract Documents. Additional copies will be furnished upon request at the cost of reproduction.

2.03 Commencement of Contract Times; Notice to Proceed

A. The Contract Times will commence to run on the thirtieth day after the Effective Date of the Agreement or, if a Notice to Proceed is given, on the day indicated in the Notice to Proceed. A Notice to Proceed may be given at any time within 30 days after the Effective Date of the Agreement. In no event will the Contract Times com-

mence to run later than the sixtieth day after the day of Bid opening or the thirtieth day after the Effective Date of the Agreement, whichever date is earlier.

2.04 *Starting the Work*

A. CONTRACTOR shall start to perform the Work on the date when the Contract Times commence to run. No Work shall be done at the Site prior to the date on which the Contract Times commence to run.

*See Supplementary Conditions

2.05* *Before Starting Construction*

A. *CONTRACTOR's Review of Contract Documents:* Before undertaking each part of the Work, CONTRACTOR shall carefully study and compare the Contract Documents and check and verify pertinent figures therein and all applicable field measurements. CONTRACTOR shall promptly report in writing to ENGINEER any conflict, error, ambiguity, or discrepancy which CONTRACTOR may discover and shall obtain a written interpretation or clarification from ENGINEER before proceeding with any Work affected thereby; however, CONTRACTOR shall not be liable to OWNER or ENGINEER for failure to report any conflict, error, ambiguity, or discrepancy in the Contract Documents unless CONTRACTOR knew or reasonably should have known thereof.

B. *Preliminary Schedules:* Within ten days after the Effective Date of the Agreement (unless otherwise specified in the General Requirements), CONTRACTOR shall submit to ENGINEER for its timely review:

1. a preliminary progress schedule indicating the times (numbers of days or dates) for starting and completing the various stages of the Work, including any Milestones specified in the Contract Documents;
2. a preliminary schedule of Shop Drawing and Sample submittals which will list each required submittal and the times for submitting, reviewing, and processing such submittal; and
3. a preliminary schedule of values for all of the Work which includes quantities and prices of items which when added together equal the Contract Price and subdivides the Work into

component parts in sufficient detail to serve as the basis for progress payments during performance of the Work. Such prices will include an appropriate amount of overhead and profit applicable to each item of Work.

* C. *Evidence of Insurance:* Before any Work at the Site is started, CONTRACTOR and OWNER shall each deliver to the other, with copies to each additional insured identified in the Supplementary Conditions, certificates of insurance (and other evidence of insurance which either of them or any additional insured may reasonably request) which CONTRACTOR and OWNER respectively are required to purchase and maintain in accordance with Article 5.

2.06 *Preconstruction Conference*

A. Within 20 days after the Contract Times start to run, but before any Work at the Site is started, a conference attended by CONTRACTOR, ENGINEER, and others as appropriate will be held to establish a working understanding among the parties as to the Work and to discuss the schedules referred to in paragraph 2.05.B, procedures for handling Shop Drawings and other submittals, processing Applications for Payment, and maintaining required records.

2.07 *Initial Acceptance of Schedules*

A. Unless otherwise provided in the Contract Documents, at least ten days before submission of the first Application for Payment a conference attended by CONTRACTOR, ENGINEER, and others as appropriate will be held to review for acceptability to ENGINEER as provided below the schedules submitted in accordance with paragraph 2.05.B. CONTRACTOR shall have an additional ten days to make corrections and adjustments and to complete and resubmit the schedules. No progress payment shall be made to CONTRACTOR until acceptable schedules are submitted to ENGINEER.

1. The progress schedule will be acceptable to ENGINEER if it provides an orderly progression of the Work to completion within any specified Milestones and the Contract Times. Such acceptance will not impose on ENGINEER responsibility for the progress schedule, for sequencing, scheduling, or progress of the Work nor interfere with or relieve CONTRACTOR from CONTRACTOR's full responsibility therefor.

2. CONTRACTOR's schedule of Shop Drawing and Sample submittals will be acceptable to ENGINEER if it provides a workable arrangement for reviewing and processing the required submittals.

3. CONTRACTOR's schedule of values will be acceptable to ENGINEER as to form and substance if it provides a reasonable allocation of the Contract Price to component parts of the Work.

*See Supplementary Conditions

ARTICLE 3 - CONTRACT DOCUMENTS: INTENT, AMENDING, REUSE

3.01* *Intent*

A. The Contract Documents are complementary; what is called for by one is as binding as if called for by all.

B. It is the intent of the Contract Documents to describe a functionally complete Project (or part thereof) to be constructed in accordance with the Contract Documents. Any labor, documentation, services, materials, or equipment that may reasonably be inferred from the Contract Documents or from prevailing custom or trade usage as being required to produce the intended result will be provided whether or not specifically called for at no additional cost to OWNER.

C. Clarifications and interpretations of the Contract Documents shall be issued by ENGINEER as provided in Article 9.

3.02 *Reference Standards*

A. *Standards, Specifications, Codes, Laws, and Regulations*

1. Reference to standards, specifications, manuals, or codes of any technical society, organization, or association, or to Laws or Regulations, whether such reference be specific or by implication, shall mean the standard, specification, manual, code, or Laws or Regulations in effect at the time of opening of Bids (or on the Effective Date of the Agreement if there were no Bids), except as may be otherwise specifically stated in the Contract Documents.

2. No provision of any such standard, specification, manual or code, or any instruction of a Supplier shall be effective to change the duties or responsibilities of OWNER, CONTRACTOR, or ENGINEER, or any of their subcontractors, consultants, agents, or employees from those set forth in the Contract Documents, nor shall any such provision or instruction be effective to assign to OWNER, ENGINEER, or any of ENGINEER's Consultants, agents, or employees any duty or authority to supervise or direct the performance of the Work or any duty or authority to undertake responsibility inconsistent with the provisions of the Contract Documents.

3.03 *Reporting and Resolving Discrepancies*

A. *Reporting Discrepancies*

1. If, during the performance of the Work, CONTRACTOR discovers any conflict, error, ambiguity, or discrepancy within the Contract Documents or between the Contract Documents and any provision of any Law or Regulation applicable to the performance of the Work or of any standard, specification, manual or code, or of any instruction of any Supplier, CONTRACTOR shall report it to ENGINEER in writing at once. CONTRACTOR shall not proceed with the Work affected thereby (except in an emergency as required by paragraph 6.16.A) until an amendment or supplement to the Contract Documents has been issued by one of the methods indicated in paragraph 3.04; provided, however, that CONTRACTOR shall not be liable to OWNER or ENGINEER for failure to report any such conflict, error, ambiguity, or discrepancy unless CONTRACTOR knew or reasonably should have known thereof.

B. *Resolving Discrepancies*

1. Except as may be otherwise specifically stated in the Contract Documents, the provisions of the Contract Documents shall take precedence in resolving any conflict, error, ambiguity, or discrepancy between the provisions of the Contract Documents and:

a. the provisions of any standard, specification, manual, code, or instruction (whether or not specifically incorporated by reference in the Contract Documents); or

b. the provisions of any Laws or Regulations applicable to the performance of the Work (unless such an interpretation of the provisions of the Contract Documents would result in violation of such Law or Regulation).

3.04 *Amending and Supplementing Contract Documents*

A. The Contract Documents may be amended to provide for additions, deletions, and revisions in the Work or to modify the terms and conditions thereof in one or

*See Supplementary Conditions

B. The requirements of the Contract Documents may be supplemented, and minor variations and deviations in the Work may be authorized, by one or more of the following ways: (i) a Field Order; (ii) ENGINEER's approval of a Shop Drawing or Sample; or (iii) ENGINEER's written interpretation or clarification.

3.05 *Reuse of Documents*

A. CONTRACTOR and any Subcontractor or Supplier or other individual or entity performing or furnishing any of the Work under a direct or indirect contract with OWNER: (i) shall not have or acquire any title to or ownership rights in any of the Drawings, Specifications, or other documents (or copies of any thereof) prepared by or bearing the seal of ENGINEER or ENGINEER's Consultant, including electronic media editions; and (ii) shall not reuse any of such Drawings, Specifications, other documents, or copies thereof on extensions of the Project or any other project without written consent of OWNER and ENGINEER and specific written verification or adaption by ENGINEER. This prohibition will survive final payment, completion, and acceptance of the Work, or termination or completion of the Contract. Nothing herein shall preclude CONTRACTOR from retaining copies of the Contract Documents for record purposes.

ARTICLE 4 - AVAILABILITY OF LANDS; SUBSURFACE AND PHYSICAL CONDITIONS; REFERENCE POINTS

4.01 *Availability of Lands*

A. OWNER shall furnish the Site. OWNER shall notify CONTRACTOR of any encumbrances or

restrictions not of general application but specifically related to use of the Site with which CONTRACTOR must comply in performing the Work. OWNER will obtain in a timely manner and pay for easements for permanent structures or permanent changes in existing facilities. If CONTRACTOR and OWNER are unable to agree on entitlement to or on the amount or extent, if any, of any adjustment in the Contract Price or Contract Times, or both, as a result of any delay in OWNER's furnishing the Site, CONTRACTOR may make a Claim therefor as provided in paragraph 10.05.

B. Upon reasonable written request, OWNER shall furnish CONTRACTOR with a current statement of record legal title and legal description of the lands upon which the Work is to be performed and OWNER's interest therein as necessary for giving notice of or filing a mechanic's or construction lien against such lands in accordance with applicable Laws and Regulations.

C. CONTRACTOR shall provide for all additional lands and access thereto that may be required for temporary construction facilities or storage of materials and equipment.

4.02* *Subsurface and Physical Conditions*

A.* *Reports and Drawings:* The Supplementary Conditions identify:

1. those reports of explorations and tests of subsurface conditions at or contiguous to the Site that ENGINEER has used in preparing the Contract Documents; and

2. those drawings of physical conditions in or relating to existing surface or subsurface structures at or contiguous to the Site (except Underground Facilities) that ENGINEER has used in preparing the Contract Documents.

B. *Limited Reliance by CONTRACTOR on Technical Data Authorized:* CONTRACTOR may rely upon the general accuracy of the "technical data" contained in such reports and drawings, but such reports and drawings are not Contract Documents. Such "technical data" is identified in the Supplementary Conditions. Except for such reliance on such "technical data," CONTRACTOR may not rely upon or make any Claim against OWNER, ENGINEER, or any of ENGINEER's Consultants with respect to:

1. the completeness of such reports and drawings for CONTRACTOR's purposes, includ-

ing, but not limited to, any aspects of the means, methods, techniques, sequences, and procedures of construction to be employed by CONTRACTOR, and safety precautions and programs incident thereto; or

2. other data, interpretations, opinions, and information contained in such reports or shown or indicated in such drawings; or

3. any CONTRACTOR interpretation of or conclusion drawn from any "technical data" or any such other data, interpretations, opinions, or information.

*See Supplementary Conditions

4.03 *Differing Subsurface or Physical Conditions*

A. *Notice:* If CONTRACTOR believes that any subsurface or physical condition at or contiguous to the Site that is uncovered or revealed either:

1. is of such a nature as to establish that any "technical data" on which CONTRACTOR is entitled to rely as provided in paragraph 4.02 is materially inaccurate; or

2. is of such a nature as to require a change in the Contract Documents; or

3. differs materially from that shown or indicated in the Contract Documents; or

4. is of an unusual nature, and differs materially from conditions ordinarily encountered and generally recognized as inherent in work of the character provided for in the Contract Documents; then CONTRACTOR shall, promptly after becoming aware thereof and before further disturbing the subsurface or physical conditions or performing any Work in connection therewith (except in an emergency as required by paragraph 6.16.A), notify OWNER and ENGINEER in writing about such condition. CONTRACTOR shall not further disturb such condition or perform any Work in connection therewith (except as aforesaid) until receipt of written order to do so.

B. *ENGINEER's Review:* After receipt of written notice as required by paragraph 4.03.A, ENGINEER will promptly review the pertinent condition, determine the

necessity of OWNER's obtaining additional exploration or tests with respect thereto, and advise OWNER in writing (with a copy to CONTRACTOR) of ENGINEER's findings and conclusions.

C. *Possible Price and Times Adjustments*

1. The Contract Price or the Contract Times, or both, will be equitably adjusted to the extent that the existence of such differing subsurface or physical condition causes an increase or decrease in CONTRACTOR's cost of, or time required for, performance of the Work; subject, however, to the following:

a. such condition must meet any one or more of the categories described in paragraph 4.03.A; and

b. with respect to Work that is paid for on a Unit Price Basis, any adjustment in Contract Price will be subject to the provisions of paragraphs 9.08 and 11.03.

2. CONTRACTOR shall not be entitled to any adjustment in the Contract Price or Contract Times if:

a. CONTRACTOR knew of the existence of such conditions at the time CONTRACTOR made a final commitment to OWNER in respect of Contract Price and Contract Times by the submission of a Bid or becoming bound under a negotiated contract; or

b. the existence of such condition could reasonably have been discovered or revealed as a result of any examination, investigation, exploration, test, or study of the Site and contiguous areas required by the Bidding Requirements or Contract Documents to be conducted by or for CONTRACTOR prior to CONTRACTOR's making such final commitment; or

c. CONTRACTOR failed to give the written notice within the time and as required by paragraph 4.03.A.

3. If OWNER and CONTRACTOR are unable to agree on entitlement to or on the amount or extent, if any, of any adjustment in the Contract Price or Contract Times, or both, a Claim may be

made therefor as provided in paragraph 10.05. However, OWNER, ENGINEER, and ENGINEER's Consultants shall not be liable to CONTRACTOR for any claims, costs, losses, or damages (including but not limited to all fees and charges of engineers, architects, attorneys, and other professionals and all court or arbitration or other dispute resolution costs) sustained by CONTRACTOR on or in connection with any other project or anticipated project.

4.04 *Underground Facilities*

A. *Shown or Indicated:* The information and data shown or indicated in the Contract Documents with respect to existing Underground Facilities at or contiguous to the Site is based on information and data furnished to OWNER or ENGINEER by the owners of such Underground Facilities, including OWNER, or by others. Unless it is otherwise expressly provided in the Supplementary Conditions:

1. OWNER and ENGINEER shall not be responsible for the accuracy or completeness of any such information or data; and

2. the cost of all of the following will be included in the Contract Price, and CONTRACTOR shall have full responsibility for:

a. reviewing and checking all such information and data,

b. locating all Underground Facilities shown or indicated in the Contract Documents,

c. coordination of the Work with the owners of such Underground Facilities, including OWNER, during construction, and

d. the safety and protection of all such Underground Facilities and repairing any damage thereto resulting from the Work.

B. *Not Shown or Indicated*

1. If an Underground Facility is uncovered or revealed at or contiguous to the Site which was not shown or indicated, or not shown or indicated with reasonable accuracy in the Contract Documents, CONTRACTOR shall, promptly after becoming aware thereof and before further disturbing conditions affected thereby or

performing any Work in connection therewith (except in an emergency as required by paragraph 6.16.A), identify the owner of such Underground Facility and give written notice to that owner and to OWNER and ENGINEER. ENGINEER will promptly review the Underground Facility and determine the extent, if any, to which a change is required in the Contract Documents to reflect and document the consequences of the existence or location of the Underground Facility. During such time, CONTRACTOR shall be responsible for the safety and protection of such Underground Facility.

2. If ENGINEER concludes that a change in the Contract Documents is required, a Work Change Directive or a Change Order will be issued to reflect and document such consequences. An equitable adjustment shall be made in the Contract Price of Contract Times, or both, to the extent that they are attributable to the existence or location of any Underground Facility that was not shown or indicated or not shown or indicated with reasonable accuracy in the Contract Documents and that CONTRACTOR did not know of and could not reasonably have been expected to be aware of or to have anticipated. If OWNER and CONTRACTOR are unable to agree on entitlement to or on the amount or extent, if any, of any such adjustment in Contract Price or Contract Times, OWNER or CONTRACTOR may make a Claim therefor as provided in paragraph 10.05.

4.05* *Reference Points*

A. OWNER shall provide engineering surveys to establish reference points for construction which in ENGINEER's judgment are necessary to enable CONTRACTOR to proceed with the Work. CONTRACTOR shall be responsible for laying out the Work, shall protect and preserve the established reference points and property monuments, and shall make no changes or relocations without the prior written approval of OWNER.

CONTRACTOR shall report to ENGINEER whenever any reference point or property monument is lost or destroyed or requires relocation because of necessary changes in grades or locations, and shall be responsible for the accurate replacement or relocation of such reference points or property monuments by professionally qualified personnel.

4.06 *Hazardous Environmental Condition at Site*

A. *Reports and Drawings*: Reference is made to the Supplementary Conditions for the identification of those reports and drawings relating to a Hazardous Environmental Condition identified at the Site, if any, that have been utilized by the ENGINEER in the preparation of the Contract Documents.

B. *Limited Reliance by CONTRACTOR on Technical Data Authorized*: CONTRACTOR may rely upon the general accuracy of the "technical data" contained in such reports and drawings, but such reports and drawings are not Contract Documents. Such "technical data" is identified in the Supplementary Conditions. Except for such reliance on such "technical data," CONTRACTOR may not rely upon or make any Claim against OWNER, ENGINEER or any of ENGINEER's Consultants with respect to:

1. the completeness of such reports and drawings for CONTRACTOR's purposes, including, but not limited to, any aspects of the means, methods, techniques, sequences and procedures of construction to be employed by CONTRACTOR and safety precautions and programs incident thereto; or

*See Supplementary Conditions

2. other data, interpretations, opinions and information contained in such reports or shown or indicated in such drawings; or

3. any CONTRACTOR interpretation of or conclusion drawn from any "technical data" or any such other data, interpretations, opinions or information.

C. CONTRACTOR shall not be responsible for any Hazardous Environmental Condition uncovered or revealed at the Site which was not shown or indicated in Drawings or Specifications or identified in the Contract Documents to be within the scope of the Work. CONTRACTOR shall be responsible for a Hazardous Environmental Condition created with any materials brought to the Site by CONTRACTOR, Subcontractors, Suppliers, or anyone else for whom CONTRACTOR is responsible.

D. If CONTRACTOR encounters a Hazardous Environmental Condition or if CONTRACTOR or anyone for whom CONTRACTOR is responsible creates a Hazardous Environmental Condition, CONTRACTOR shall immediately: (i) secure or otherwise isolate such condition;

(ii) stop all Work in connection with such condition and in any area affected thereby (except in an emergency as required by paragraph 6.16); and (iii) notify OWNER and ENGINEER (and promptly thereafter confirm such notice in writing). OWNER shall promptly consult with ENGINEER concerning the necessity for OWNER to retain a qualified expert to evaluate such condition or take corrective action, if any.

E. CONTRACTOR shall not be required to resume Work in connection with such condition or in any affected area until after OWNER has obtained any required permits related thereto and delivered to CONTRACTOR written notice: (i) specifying that such condition and any affected area is or has been rendered safe for the resumption of Work; or (ii) specifying any special conditions under which such Work may be resumed safely. If OWNER and CONTRACTOR cannot agree as to entitlement to or on the amount or extent, if any, of any adjustment in Contract Price or Contract Times, or both, as a result of such Work stoppage or such special conditions under which Work is agreed to be resumed by CONTRACTOR, either party may make a Claim therefor as provided in paragraph 10.05.

F. If after receipt of such written notice CONTRACTOR does not agree to resume such Work based on a reasonable belief it is unsafe, or does not agree to resume such Work under such special conditions, then OWNER may order the portion of the Work that is in the area affected by such condition to be deleted from the Work. If OWNER and CONTRACTOR cannot agree as to entitlement to or on the amount or extent, if any, of an adjustment in Contract Price or Contract Times as a result of deleting such portion of the Work, then either party may make a Claim therefor as provided in paragraph 10.05. OWNER may have such deleted portion of the Work performed by OWNER's own forces or others in accordance with Article 7.

G. To the fullest extent permitted by Laws and Regulations, OWNER shall indemnify and hold harmless CONTRACTOR, Subcontractors, ENGINEER, ENGINEER's Consultants and the officers, directors, partners, employees, agents, other consultants, and subcontractors of each and any of them from and against all claims, costs, losses, and damages (including but not limited to all fees and charges of engineers, architects, attorneys, and other professionals and all court or arbitration or other dispute resolution costs) arising out of or relating to a Hazardous Environmental Condition, provided that such Hazardous Environmental Condition: (i) was not shown or indicated in the Drawings or

Specifications or identified in the Contract Documents to be included within the scope of the Work, and (ii) was not created by CONTRACTOR or by anyone for whom CONTRACTOR is responsible. Nothing in this paragraph 4.06.E shall obligate OWNER to indemnify any individual or entity from and against the consequences of that individual's or entity's own negligence.

H. To the fullest extent permitted by Laws and Regulations, CONTRACTOR shall indemnify and hold harmless OWNER, ENGINEER, ENGINEER's Consultants, and the officers, directors, partners, employees, agents, other consultants, and subcontractors of each and any of them from and against all claims, costs, losses, and damages (including but not limited to all fees and charges of engineers, architects, attorneys, and other professionals and all court or arbitration or other dispute resolution costs) arising out of or relating to a Hazardous Environmental Condition created by CONTRACTOR or by anyone for whom CONTRACTOR is responsible. Nothing in this paragraph 4.06.F shall obligate CONTRACTOR to indemnify any individual or entity from and against the consequences of that individual's or entity's own negligence.

I. The provisions of paragraphs 4.02, 4.03, and 4.04 are not intended to apply to a Hazardous Environmental Condition uncovered or revealed at the Site.

*See Supplementary Conditions

ARTICLE 5 - BONDS AND INSURANCE

5.01* *Performance, Payment, and Other Bonds*

A. CONTRACTOR shall furnish performance and payment Bonds, each in an amount at least equal to the Contract Price as security for the faithful performance and payment of all CONTRACTOR's obligations under the Contract Documents. These Bonds shall remain in effect at least until one year after the date when final payment becomes due, except as provided otherwise by Laws or Regulations or by the Contract Documents. CONTRACTOR shall also furnish such other Bonds as are required by the Contract Documents.

B.* All Bonds shall be in the form prescribed by the Contract Documents except as provided otherwise by Laws or Regulations, and shall be executed by such sureties as are named in the current list of "Companies Holding Certificates of Authority as Acceptable Sureties on Federal Bonds and as Acceptable Reinsuring Compa-

nies" as published in Circular 570 (amended) by the Financial Management Service, Surety Bond Branch, U.S. Department of the Treasury. All Bonds signed by an agent must be accompanied by a certified copy of such agent's authority to act.

C. If the surety on any Bond furnished by CONTRACTOR is declared bankrupt or becomes insolvent or its right to do business is terminated in any state where any part of the Project is located or it ceases to meet the requirements of paragraph 5.01.B, CONTRACTOR shall within 20 days thereafter substitute another Bond and surety, both of which shall comply with the requirements of paragraphs 5.01.B and 5.02.

5.02 *Licensed Sureties and Insurers*

A. All Bonds and insurance required by the Contract Documents to be purchased and maintained by OWNER or CONTRACTOR shall be obtained from surety or insurance companies that are duly licensed or authorized in the jurisdiction in which the Project is located to issue Bonds or insurance policies for the limits and coverages so required. Such surety and insurance companies shall also meet such additional requirements and qualifications as may be provided in the Supplementary Conditions.

5.03 *Certificates of Insurance*

A. CONTRACTOR shall deliver to OWNER, with copies to each additional insured identified in the Supplementary Conditions, certificates of insurance (and other evidence of insurance requested by OWNER or any other additional insured) which CONTRACTOR is required to purchase and maintain. OWNER shall deliver to CONTRACTOR, with copies to each additional insured identified in the Supplementary Conditions, certificates of insurance (and other evidence of insurance requested by CONTRACTOR or any other additional insured) which OWNER is required to purchase and maintain.

5.04* *CONTRACTOR's Liability Insurance*

A. CONTRACTOR shall purchase and maintain such liability and other insurance as is appropriate for the Work being performed and as will provide protection from claims set forth below which may arise out of or result from CONTRACTOR's performance of the Work and CONTRACTOR's other obligations under the Contract Documents, whether it is to be performed by CONTRACTOR, any Subcontractor or Supplier, or by anyone directly or indirectly employed by any of them to

perform any of the Work, or by anyone for whose acts any of them may be liable:

1. claims under workers' compensation, disability benefits, and other similar employee benefit acts;
2. claims for damages because of bodily injury, occupational sickness or disease, or death of CONTRACTOR's employees;
3. claims for damages because of bodily injury, sickness or disease, or death of any person other than CONTRACTOR's employees;
4. claims for damages insured by reasonably available personal injury liability coverage which are sustained: (i) by any person as a result of an offense directly or indirectly related to the employment of such person by CONTRACTOR, or (ii) by any other person for any other reason;
5. claims for damages, other than to the Work itself, because of injury to or destruction of tangible property wherever located, including loss of use resulting therefrom; and
6. claims for damages because of bodily injury or death of any person or property damage arising out of the ownership, maintenance or use of any motor vehicle.

B. The policies of insurance so required by this paragraph 5.04 to be purchased and maintained shall:

*See Supplementary Conditions

1. with respect to insurance required by paragraphs 5.04.A.3 through 5.04.A.6 inclusive, include as additional insureds (subject to any customary exclusion in respect of professional liability) OWNER, ENGINEER, ENGINEER's Consultants, and any other individuals or entities identified in the Supplementary Conditions, all of whom shall be listed as additional insureds, and include coverage for the respective officers, directors, partners, employees, agents, and other consultants and subcontractors of each and any of all such additional insureds, and the insurance afforded to these additional insureds shall provide primary coverage for all claims covered thereby;

2. include at least the specific coverages and be written for not less than the limits of liability provided in the Supplementary Conditions or required by Laws or Regulations, whichever is greater;

3. include completed operations insurance;

4. include contractual liability insurance covering CONTRACTOR's indemnity obligations under paragraphs 6.07, 6.11, and 6.20;

5. contain a provision or endorsement that the coverage afforded will not be canceled, materially changed or renewal refused until at least thirty days prior written notice has been given to OWNER and CONTRACTOR and to each other additional insured identified in the Supplementary Conditions to whom a certificate of insurance has been issued (and the certificates of insurance furnished by the CONTRACTOR pursuant to paragraph 5.03 will so provide);

6. remain in effect at least until final payment and at all times thereafter when CONTRACTOR may be correcting, removing, or replacing defective Work in accordance with paragraph 13.07; and

7. with respect to completed operations insurance, and any insurance coverage written on a claims-made basis, remain in effect for at least two years after final payment (and CONTRACTOR shall furnish OWNER and each other additional insured identified in the Supplementary Conditions, to whom a certificate of insurance has been issued, evidence satisfactory to OWNER and any such additional insured of continuation of such insurance at final payment and one year thereafter).

5.05 *OWNER's Liability Insurance*

A.* In addition to the insurance required to be provided by CONTRACTOR under paragraph 5.04, OWNER, at OWNER's option, may purchase and maintain at OWNER's expense OWNER's own liability insurance as will protect OWNER against claims which may arise from operations under the Contract Documents.

5.06* *Property Insurance*

A. Unless otherwise provided in the Supplementary Conditions, OWNER shall purchase and maintain property

insurance upon the Work at the Site in the amount of the full replacement cost thereof (subject to such deductible amounts as may be provided in the Supplementary Conditions or required by Laws and Regulations). This insurance shall:

1. include the interests of OWNER, CONTRACTOR, Subcontractors, ENGINEER, ENGINEER's Consultants, and any other individuals or entities identified in the Supplementary Conditions, and the officers, directors, partners, employees, agents, and other consultants and subcontractors of each and any of them, each of whom is deemed to have an insurable interest and shall be listed as an additional insured;

2. be written on a Builder's Risk "all-risk" or open peril or special causes of loss policy form that shall at least include insurance for physical loss or damage to the Work, temporary buildings, false work, and materials and equipment in transit, and shall insure against at least the following perils or causes of loss: fire, lightning, extended coverage, theft, vandalism and malicious mischief, earthquake, collapse, debris removal, demolition occasioned by enforcement of Laws and Regulations, water damage, and such other perils or causes of loss as may be specifically required by the Supplementary Conditions;

3. include expenses incurred in the repair or replacement of any insured property (including but not limited to fees and charges of engineers and architects);

*See Supplementary Conditions

4. cover materials and equipment stored at the Site or at another location that was agreed to in writing by OWNER prior to being incorporated in the Work, provided that such materials and equipment have been included in an Application for Payment recommended by ENGINEER;

5. allow for partial utilization of the Work by OWNER;

6. include testing and startup; and

7. be maintained in effect until final payment is made unless otherwise agreed to in writing by OWNER, CONTRACTOR, and ENGINEER with

30 days written notice to each other additional insured to whom a certificate of insurance has been issued.

B.* OWNER shall purchase and maintain such boiler and machinery insurance or additional property insurance as may be required by the Supplementary Conditions or Laws and Regulations which will include the interests of OWNER, CONTRACTOR, Subcontractors, ENGINEER, ENGINEER's Consultants, and any other individuals or entities identified in the Supplementary Conditions, each of whom is deemed to have an insurable interest and shall be listed as an insured or additional insured.

C.* All the policies of insurance (and the certificates or other evidence thereof) required to be purchased and maintained in accordance with paragraph 5.06 will contain a provision or endorsement that the coverage afforded will not be canceled or materially changed or renewal refused until at least 30 days prior written notice has been given to OWNER and CONTRACTOR and to each other additional insured to whom a certificate of insurance has been issued and will contain waiver provisions in accordance with paragraph 5.07.

D.* OWNER shall not be responsible for purchasing and maintaining any property insurance specified in this paragraph 5.06 to protect the interests of CONTRACTOR, Subcontractors, or others in the Work to the extent of any deductible amounts that are identified in the Supplementary Conditions. The risk of loss within such identified deductible amount will be borne by CONTRACTOR, Subcontractors, or others suffering any such loss, and if any of them wishes property insurance coverage within the limits of such amounts, each may purchase and maintain it at the purchaser's own expense.

E.* If CONTRACTOR requests in writing that other special insurance be included in the property insurance policies provided under paragraph 5.06, OWNER shall, if possible, include such insurance, and the cost thereof will be charged to CONTRACTOR by appropriate Change Order or Written Amendment. Prior to commencement of the Work at the Site, OWNER shall in writing advise CONTRACTOR whether or not such other insurance has been procured by OWNER.

5.07 *Waiver of Rights*

A.* OWNER and CONTRACTOR intend that all policies purchased in accordance with paragraph 5.06 will protect OWNER, CONTRACTOR, Subcontractors, ENGINEER, ENGINEER's Consultants, and all other

individuals or entities identified in the Supplementary Conditions to be listed as insureds or additional insureds (and the officers, directors, partners, employees, agents, and other consultants and subcontractors of each and any of them) in such policies and will provide primary coverage for all losses and damages caused by the perils or causes of loss covered thereby. All such policies shall contain provisions to the effect that in the event of payment of any loss or damage the insurers will have no rights of recovery against any of the insureds or additional insureds thereunder. OWNER and CONTRACTOR waive all rights against each other and their respective officers, directors, partners, employees, agents, and other consultants and subcontractors of each and any of them for all losses and damages caused by, arising out of or resulting from any of the perils or causes of loss covered by such policies and any other property insurance applicable to the Work; and, in addition, waive all such rights against Subcontractors, ENGINEER, ENGINEER's Consultants, and all other individuals or entities identified in the Supplementary Conditions to be listed as insureds or additional insureds (and the officers, directors, partners, employees, agents, and other consultants and subcontractors of each and any of them) under such policies for losses and damages so caused.

None of the above waivers shall extend to the rights that any party making such waiver may have to the proceeds of insurance held by OWNER as trustee or otherwise payable under any policy so issued.

B. OWNER waives all rights against CONTRACTOR, Subcontractors, ENGINEER, ENGINEER's Consultants, and the officers, directors, partners, employees, agents, and other consultants and subcontractors of each and any of them for:

*See Supplementary Conditions

1. loss due to business interruption, loss of use, or other consequential loss extending beyond direct physical loss or damage to OWNER's property or the Work caused by, arising out of, or resulting from fire or other peril whether or not insured by OWNER; and
2. loss or damage to the completed Project or part thereof caused by, arising out of, or resulting from fire or other insured peril or cause of loss covered by any property insurance maintained on the completed Project or part thereof by OWNER during partial utilization pursuant to

paragraph 14.05, after Substantial Completion pursuant to paragraph 14.04, or after final payment pursuant to paragraph 14.07.

C. Any insurance policy maintained by OWNER covering any loss, damage or consequential loss referred to in paragraph 5.07.B shall contain provisions to the effect that in the event of payment of any such loss, damage, or consequential loss, the insurers will have no rights of recovery against CONTRACTOR, Subcontractors, ENGINEER, or ENGINEER's Consultants and the officers, directors, partners, employees, agents, and other consultants and subcontractors of each and any of them.

5.08 Receipt and Application of Insurance Proceeds*

A.* Any insured loss under the policies of insurance required by paragraph 5.06 will be adjusted with OWNER and made payable to OWNER as fiduciary for the insureds, as their interests may appear, subject to the requirements of any applicable mortgage clause and of paragraph 5.08.B. OWNER shall deposit in a separate account any money so received and shall distribute it in accordance with such agreement as the parties in interest may reach. If no other special agreement is reached, the damaged Work shall be repaired or replaced, the moneys so received applied on account thereof, and the Work and the cost thereof covered by an appropriate Change Order or Written Amendment.

B.* OWNER as fiduciary shall have power to adjust and settle any loss with the insurers unless one of the parties in interest shall object in writing within 15 days after the occurrence of loss to OWNER's exercise of this power. If such objection be made, OWNER as fiduciary shall make settlement with the insurers in accordance with such agreement as the parties in interest may reach. If no such agreement among the parties in interest is reached, OWNER as fiduciary shall adjust and settle the loss with the insurers and, if required in writing by any party in interest, OWNER as fiduciary shall give bond for the proper performance of such duties.

5.09 Acceptance of Bonds and Insurance; Option to Replace*

A.* If either OWNER or CONTRACTOR has any objection to the coverage afforded by or other provisions of the Bonds or insurance required to be purchased and maintained by the other party in accordance with Article 5 on the basis of non-conformance with the Contract Documents, the objecting party shall so notify the other party in writing within 10 days after receipt of the

certificates (or other evidence requested) required by paragraph 2.05.C. OWNER and CONTRACTOR shall each provide to the other such additional information in respect of insurance provided as the other may reasonably request. If either party does not purchase or maintain all of the Bonds and insurance required of such party by the Contract Documents, such party shall notify the other party in writing of such failure to purchase prior to the start of the Work, or of such failure to maintain prior to any change in the required coverage. Without prejudice to any other right or remedy, the other party may elect to obtain equivalent Bonds or insurance to protect such other party's interests at the expense of the party who was required to provide such coverage, and a Change Order shall be issued to adjust the Contract Price accordingly.

5.10 *Partial Utilization, Acknowledgment of Property Insurer*

A. If OWNER finds it necessary to occupy or use a portion or portions of the Work prior to Substantial Completion of all the Work as provided in paragraph 14.05, no such use or occupancy shall commence before the insurers providing the property insurance pursuant to paragraph 5.06 have acknowledged notice thereof and in writing effected any changes in coverage necessitated thereby. The insurers providing the property insurance shall consent by endorsement on the policy or policies, but the property insurance shall not be canceled or permitted to lapse on account of any such partial use or occupancy.

ARTICLE 6 - CONTRACTOR'S RESPONSIBILITIES

6.01 *Supervision and Superintendence*

A. CONTRACTOR shall supervise, inspect, and direct the Work competently and efficiently, devoting such attention thereto and applying such skills and expertise as may be necessary to perform the Work in accordance with

*See Supplementary Conditions

the Contract Documents. CONTRACTOR shall be solely responsible for the means, methods, techniques, sequences, and procedures of construction, but CONTRACTOR shall not be responsible for the negligence of OWNER or ENGINEER in the design or specification of a specific means, method, technique, sequence, or procedure of

construction which is shown or indicated in and expressly required by the Contract Documents. CONTRACTOR shall be responsible to see that the completed Work complies accurately with the Contract Documents.

B. At all times during the progress of the Work, CONTRACTOR shall assign a competent resident superintendent thereto who shall not be replaced without written notice to OWNER and ENGINEER except under extraordinary circumstances. The superintendent will be CONTRACTOR's representative at the Site and shall have authority to act on behalf of CONTRACTOR. All communications given to or received from the superintendent shall be binding on CONTRACTOR.

6.02 *Labor; Working Hours*

A. CONTRACTOR shall provide competent, suitably qualified personnel to survey, lay out, and construct the

Work as required by the Contract Documents. CONTRACTOR shall at all times maintain good discipline and order at the Site.

B. Except as otherwise required for the safety or protection of persons or the Work or property at the Site or adjacent thereto, and except as otherwise stated in the Contract Documents, all Work at the Site shall be performed during regular working hours, and CONTRACTOR will not permit overtime work or the performance of Work on Saturday, Sunday, or any legal holiday without OWNER's written consent (which will not be unreasonably withheld) given after prior written notice to ENGINEER.

6.03 *Services, Materials, and Equipment*

A. Unless otherwise specified in the General Requirements, CONTRACTOR shall provide and assume full responsibility for all services, materials, equipment, labor, transportation, construction equipment and machinery, tools, appliances, fuel, power, light, heat, telephone, water, sanitary facilities, temporary facilities, and all other facilities and incidentals necessary for the performance, testing, start-up, and completion of the Work.

B. All materials and equipment incorporated into the Work shall be as specified or, if not specified, shall be of good quality and new, except as otherwise provided in the Contract Documents. All warranties and guarantees specifically called for by the Specifications shall expressly

run to the benefit of OWNER. If required by ENGINEER, CONTRACTOR shall furnish satisfactory evidence (including reports of required tests) as to the source, kind, and quality of materials and equipment. All materials and equipment shall be stored, applied, installed, connected, erected, protected, used, cleaned, and conditioned in accordance with instructions of the applicable Supplier, except as otherwise may be provided in the Contract Documents.

6.04 *Progress Schedule*

A. CONTRACTOR shall adhere to the progress schedule established in accordance with paragraph 2.07 as it may be adjusted from time to time as provided below.

1. CONTRACTOR shall submit to ENGINEER for acceptance (to the extent indicated in paragraph 2.07) proposed adjustments in the progress schedule that will not result in changing the Contract Times (or Milestones). Such adjustments will conform generally to the progress schedule then in effect and additionally will comply with any provisions of the General Requirements applicable thereto.

2. Proposed adjustments in the progress schedule that will change the Contract Times (or Milestones) shall be submitted in accordance with the requirements of Article 12. Such adjustments may only be made by a Change Order or Written Amendment in accordance with Article 12.

6.05 *Substitutes and "Or-Equals"*

A. Whenever an item of material or equipment is specified or described in the Contract Documents by using the name of a proprietary item or the name of a particular Supplier, the specification or description is intended to establish the type, function, appearance, and quality required. Unless the specification or description contains or is followed by words reading that no like, equivalent, or "or-equal" item or no substitution is permitted, other items of material or equipment or material or equipment of other Suppliers may be submitted to ENGINEER for review under the circumstances described below.

1. *"Or-Equal" Items:* If in ENGINEER's sole discretion an item of material or equipment proposed by CONTRACTOR is functionally equal to that named and sufficiently similar so that no change in related Work will be required, it may be

considered by ENGINEER as an "or-equal" item, in which case review and approval of the proposed item may, in ENGINEER's sole discretion, be accomplished without compliance with some or all of the requirements for approval of proposed substitute items. For the purposes of this paragraph 6.05.A.1, a proposed item of material or equipment will be considered functionally equal to an item so named if:

a. in the exercise of reasonable judgment ENGINEER determines that: (i) it is at least equal in quality, durability, appearance, strength, and design characteristics; (ii) it will reliably perform at least equally well the function imposed by the design concept of the completed Project as a functioning whole, and;

b. CONTRACTOR certifies that: (i) there is no increase in cost to the OWNER; and (ii) it will conform substantially, even with deviations, to the detailed requirements of the item named in the Contract Documents.

2. *Substitute Items*

a. If in ENGINEER's sole discretion an item of material or equipment proposed by CONTRACTOR does not qualify as an "or-equal" item under paragraph 6.05.A.1, it will be considered a proposed substitute item.

b. CONTRACTOR shall submit sufficient information as provided below to allow ENGINEER to determine that the item of material or equipment proposed is essentially equivalent to that named and an acceptable substitute therefor. Requests for review of proposed substitute items of material or equipment will not be accepted by ENGINEER from anyone other than CONTRACTOR.

c. The procedure for review by ENGINEER will be as set forth in paragraph 6.05.A.2.d, as supplemented in the General Requirements and as ENGINEER may decide is appropriate under the circumstances.

d. CONTRACTOR shall first make written application to ENGINEER for review of a proposed substitute item of material or equipment that CONTRACTOR seeks to furnish or use. The application shall certify

that the proposed substitute item will perform adequately the functions and achieve the results called for by the general design, be similar in substance to that specified, and be suited to the same use as that specified. The application will state the extent, if any, to which the use of the proposed substitute item will prejudice CONTRACTOR's achievement of Substantial Completion on time, whether or not use of the proposed substitute item in the Work will require a change in any of the Contract Documents (or in the provisions of any other direct contract with OWNER for work on the Project) to adapt the design to the proposed substitute item and whether or not incorporation or use of the proposed substitute item in connection with the Work is subject to payment of any license fee or royalty. All variations of the proposed substitute item from that specified will be identified in the application, and available engineering, sales, maintenance, repair, and replacement services will be indicated. The application will also contain an itemized estimate of all costs or credits that will result directly or indirectly from use of such substitute item, including costs of redesign and claims of other contractors affected by any resulting change, all of which will be considered by ENGINEER in evaluating the proposed substitute item. ENGINEER may require CONTRACTOR to furnish additional data about the proposed substitute item.

B. *Substitute Construction Methods or Procedures:* If a specific means, method, technique, sequence, or procedure of construction is shown or indicated in and expressly required by the Contract Documents, CONTRACTOR may furnish or utilize a substitute means, method, technique, sequence, or procedure of construction approved by ENGINEER. CONTRACTOR shall submit sufficient information to allow ENGINEER, in ENGINEER's sole discretion, to determine that the substitute proposed is equivalent to that expressly called for by the Contract Documents. The procedure for review by ENGINEER will be similar to that provided in subparagraph 6.05.A.2.

C. *Engineer's Evaluation:* ENGINEER will be allowed a reasonable time within which to evaluate each proposal or submittal made pursuant to paragraphs 6.05.A and 6.05.B. ENGINEER will be the sole judge of acceptability. No "or-equal" or substitute will be ordered, installed or utilized until ENGINEER's review is complete, which will be evidenced by either a Change Order for a

substitute or an approved Shop Drawing for an "or equal." ENGINEER will advise CONTRACTOR in writing of any negative determination.

D. *Special Guarantee:* OWNER may require CONTRACTOR to furnish at CONTRACTOR's expense a special performance guarantee or other surety with respect to any substitute.

E. *ENGINEER's Cost Reimbursement:* ENGINEER will record time required by ENGINEER and ENGINEER's Consultants in evaluating substitute proposed or submitted by CONTRACTOR pursuant to paragraphs 6.05.A.2 and 6.05.B and in making changes in the Contract Documents (or in the provisions of any other direct contract with OWNER for work on the Project) occasioned thereby. Whether or not ENGINEER approves a substitute item so proposed or submitted by CONTRACTOR, CONTRACTOR shall reimburse OWNER for the charges of ENGINEER and ENGINEER's Consultants for evaluating each such proposed substitute.

F. *CONTRACTOR's Expense:* CONTRACTOR shall provide all data in support of any proposed substitute or "or-equal" at CONTRACTOR's expense.

6.06 *Concerning Subcontractors, Suppliers, and Others*

A. CONTRACTOR shall not employ any Subcontractor, Supplier, or other individual or entity (including those acceptable to OWNER as indicated in paragraph 6.06.B), whether initially or as a replacement, against whom OWNER may have reasonable objection. CONTRACTOR shall not be required to employ any Subcontractor, Supplier, or other individual or entity to furnish or perform any of the Work against whom CONTRACTOR has reasonable objection.

B. If the Supplementary Conditions require the identity of certain Subcontractors, Suppliers, or other individuals or entities to be submitted to OWNER in advance for acceptance by OWNER by a specified date prior to the Effective Date of the Agreement, and if CONTRACTOR has submitted a list thereof in accordance with the Supplementary Conditions, OWNER's acceptance (either in writing or by failing to make written objection thereto by the date indicated for acceptance or objection in the Bidding Documents or the Contract Documents) of any such Subcontractor, Supplier, or other individual or entity so identified may be revoked on the basis of reasonable objection after due investigation. CONTRACTOR shall submit an acceptable replacement

for the rejected Subcontractor, Supplier, or other individual or entity, and the Contract Price will be adjusted by the difference in the cost occasioned by such replacement, and an appropriate Change Order will be issued or Written Amendment signed. No acceptance by OWNER of any such Subcontractor, Supplier, or other individual or entity, whether initially or as a replacement, shall constitute a waiver of any right of OWNER or ENGINEER to reject defective Work.

C. CONTRACTOR shall be fully responsible to OWNER and ENGINEER for all acts and omissions of the Subcontractors, Suppliers, and other individuals or entities performing or furnishing any of the Work just as CONTRACTOR is responsible for CONTRACTOR's own acts and omissions. Nothing in the Contract Documents shall create for the benefit of any such Subcontractor, Supplier, or other individual or entity any contractual relationship between OWNER or ENGINEER and any such Subcontractor, Supplier or other individual or entity, nor shall it create any obligation on the part of OWNER or ENGINEER to pay or to see to the payment of any moneys due any such Subcontractor, Supplier, or other individual or entity except as may otherwise be required by Laws and Regulations.

D. CONTRACTOR shall be solely responsible for scheduling and coordinating the Work of Subcontractors, Suppliers, and other individuals or entities performing or furnishing any of the Work under a direct or indirect contract with CONTRACTOR.

E. CONTRACTOR shall require all Subcontractors, Suppliers, and such other individuals or entities performing or furnishing any of the Work to communicate with ENGINEER through CONTRACTOR.

F. The divisions and sections of the Specifications and the identifications of any Drawings shall not control CONTRACTOR in dividing the Work among Subcontractors or Suppliers or delineating the Work to be performed by any specific trade.

G. All Work performed for CONTRACTOR by a Subcontractor or Supplier will be pursuant to an appropriate agreement between CONTRACTOR and the Subcontractor or Supplier which specifically binds the Subcontractor or Supplier to the applicable terms and conditions of the Contract Documents for the benefit of OWNER and ENGINEER. Whenever any such agreement is with a Subcontractor or Supplier who is listed as an additional insured on the property insurance provided in paragraph 5.06, the agreement between the CONTRAC-

TOR and the Subcontractor or Supplier will contain provisions whereby the Subcontractor or Supplier waives all rights against OWNER, CONTRACTOR, ENGINEER, ENGINEER's Consultants, and all other individuals or entities identified in the Supplementary Conditions to be listed as insureds or additional insureds (and the officers, directors, partners, employees, agents, and other consultants and subcontractors of each and any of them) for all losses and damages caused by, arising out of, relating to, or resulting from any of the perils or causes of loss covered by such policies and any other property insurance applicable to the Work. If the insurers on any such policies require separate waiver forms to be signed by any Subcontractor or Supplier, CONTRACTOR will obtain the same.

6.07 *Patent Fees and Royalties*

A. CONTRACTOR shall pay all license fees and royalties and assume all costs incident to the use in the performance of the Work or the incorporation in the Work of any invention, design, process, product, or device which is the subject of patent rights or copyrights held by others. If a particular invention, design, process, product, or device is specified in the Contract Documents for use in the performance of the Work and if to the actual knowledge of OWNER or ENGINEER its use is subject to patent rights or copyrights calling for the payment of any license fee or royalty to others, the existence of such rights shall be disclosed by OWNER in the Contract Documents. To the fullest extent permitted by Laws and Regulations, CONTRACTOR shall indemnify and hold harmless OWNER, ENGINEER, ENGINEER's Consultants, and the officers, directors, partners, employees or agents, and other consultants of each and any of them from and against all claims, costs, losses, and damages (including but not limited to all fees and charges of engineers, architects, attorneys, and other professionals and all court or arbitration or other dispute resolution costs) arising out of or relating to any infringement of patent rights or copyrights incident to the use in the performance of the Work or resulting from the incorporation in the Work of any invention, design, process, product, or device not specified in the Contract Documents.

6.08 *Permits*

A. Unless otherwise provided in the Supplementary Conditions, CONTRACTOR shall obtain and pay for all construction permits and licenses. OWNER shall assist CONTRACTOR, when necessary, in obtaining such permits and licenses. CONTRACTOR shall pay all governmental charges and inspection fees necessary for

the prosecution of the Work which are applicable at the time of opening of Bids, or, if there are no Bids, on the Effective Date of the Agreement. CONTRACTOR shall pay all charges of utility owners for connections to the Work, and OWNER shall pay all charges of such utility owners for capital costs related thereto, such as plant investment fees.

6.09 *Laws and Regulations*

A. CONTRACTOR shall give all notices and comply with all Laws and Regulations applicable to the performance of the Work. Except where otherwise expressly required by applicable Laws and Regulations, neither OWNER nor ENGINEER shall be responsible for monitoring CONTRACTOR's compliance with any Laws or Regulations.

B. If CONTRACTOR performs any Work knowing or having reason to know that it is contrary to Laws or Regulations, CONTRACTOR shall bear all claims, costs, losses, and damages (including but not limited to all fees and charges of engineers, architects, attorneys, and other professionals and all court or arbitration or other dispute resolution costs) arising out of or relating to such Work; however, it shall not be CONTRACTOR's primary responsibility to make certain that the Specifications and Drawings are in accordance with Laws and Regulations, but this shall not relieve CONTRACTOR of CONTRACTOR's obligations under paragraph 3.03.

C. Changes in Laws or Regulations not known at the time of opening of Bids (or, on the Effective Date of the Agreement if there were no Bids) having an effect on the cost or time of performance of the Work may be the subject of an adjustment in Contract Price or Contract Times. If OWNER and CONTRACTOR are unable to agree on entitlement to or on the amount or extent, if any, of any such adjustment, a Claim may be made therefor as provided in paragraph 10.05.

6.10* *Taxes*

A. CONTRACTOR shall pay all sales, consumer, use, and other similar taxes required to be paid by CONTRACTOR in accordance with the Laws and Regulations of the place of the Project which are applicable during the performance of the Work.

6.11* *Use of Site and Other Areas*

A.* *Limitation on Use of Site and Other Areas*

1. CONTRACTOR shall confine construction equipment, the storage of materials and equipment, and the operations of workers to the Site and other areas permitted by Laws and Regulations,

*See Supplementary Conditions

and shall not unreasonably encumber the Site and other areas with construction equipment or other materials or equipment. CONTRACTOR shall assume full responsibility for any damage to any such land or area, or to the owner or occupant thereof, or of any adjacent land or areas resulting from the performance of the Work.

2. Should any claim be made by any such owner or occupant because of the performance of the Work, CONTRACTOR shall promptly settle with such other party by negotiation or otherwise resolve the claim by arbitration or other dispute resolution proceeding or at law.

3. To the fullest extent permitted by Laws and Regulations, CONTRACTOR shall indemnify and hold harmless OWNER, ENGINEER, ENGINEER's Consultant, and the officers, directors, partners, employees, agents, and other consultants of each and any of them from and against all claims, costs, losses, and damages (including but not limited to all fees and charges of engineers, architects, attorneys, and other professionals and all court or arbitration or other dispute resolution costs) arising out of or relating to any claim or action, legal or equitable, brought by any such owner or occupant against OWNER, ENGINEER, or any other party indemnified hereunder to the extent caused by or based upon CONTRACTOR's performance of the Work.

B. *Removal of Debris During Performance of the Work:* During the progress of the Work CONTRACTOR shall keep the Site and other areas free from accumulations of waste materials, rubbish, and other debris. Removal and disposal of such waste materials, rubbish, and other debris shall conform to applicable Laws and Regulations.

C. *Cleaning*: Prior to Substantial Completion of the Work CONTRACTOR shall clean the Site and make it ready for utilization by OWNER. At the completion of the Work CONTRACTOR shall remove from the Site all tools, appliances, construction equipment and machinery, and surplus materials and shall restore to original condition all property not designated for alteration by the Contract Documents.

D. *Loading Structures*: CONTRACTOR shall not load nor permit any part of any structure to be loaded in any manner that will endanger the structure, nor shall CONTRACTOR subject any part of the Work or adjacent property to stresses or pressures that will endanger it.

6.12 *Record Documents*

A. CONTRACTOR shall maintain in a safe place at the Site one record copy of all Drawings, Specifications, Addenda, Written Amendments, Change Orders, Work Change Directives, Field Orders, and written interpretations and clarifications in good order and annotated to show changes made during construction. These record documents together with all approved Samples and a counterpart of all approved Shop Drawings will be available to ENGINEER for reference. Upon completion of the Work, these record documents, Samples, and Shop Drawings will be delivered to ENGINEER for OWNER.

6.13 *Safety and Protection*

A. CONTRACTOR shall be solely responsible for initiating, maintaining and supervising all safety precautions and programs in connection with the Work. CONTRACTOR shall take all necessary precautions for the safety of, and shall provide the necessary protection to prevent damage, injury or loss to:

1. all persons on the Site or who may be affected by the Work;
2. all the Work and materials and equipment to be incorporated therein, whether in storage on or off the Site; and
3. other property at the Site or adjacent thereto, including trees, shrubs, lawns, walks, pavements, roadways, structures, utilities, and Underground Facilities not designated for removal, relocation, or replacement in the course of construction.

B. CONTRACTOR shall comply with all applicable Laws and Regulations relating to the safety of persons or property, or to the protection of persons or property from damage, injury, or loss; and shall erect and maintain all necessary safeguards for such safety and protection. CONTRACTOR shall notify owners of adjacent property and of Underground Facilities and other utility owners when prosecution of the Work may affect them, and shall cooperate with them in the protection, removal, relocation, and replacement of their property. All damage, injury, or loss to any property referred to in paragraph 6.13.A.2 or 6.13.A.3 caused, directly or indirectly, in whole or in part, by CONTRACTOR, any Subcontractor, Supplier, or any other individual or entity directly or indirectly employed by any of them to perform any of the Work, or anyone for whose acts any of them may be liable, shall be remedied by CONTRACTOR (except damage or loss attributable to the fault of Drawings or Specifications or to the acts or omissions of OWNER or ENGINEER or ENGINEER's Consultant, or anyone employed by any of them, or anyone for whose acts any of them may be liable, and not attributable, directly or indirectly, in whole or in part, to the fault or negligence of CONTRACTOR or any Subcontractor, Supplier, or other individual or entity directly or indirectly employed by any of them). CONTRACTOR's duties and responsibilities for safety and for protection of the Work shall continue until such time as all the Work is completed and ENGINEER has issued a notice to OWNER and CONTRACTOR in accordance with paragraph 14.07.B that the Work is acceptable (except as otherwise expressly provided in connection with Substantial Completion).

6.14 *Safety Representative*

A. CONTRACTOR shall designate a qualified and experienced safety representative at the Site whose duties and responsibilities shall be the prevention of accidents and the maintaining and supervising of safety precautions and programs.

6.15 *Hazard Communication Programs*

A. CONTRACTOR shall be responsible for coordinating any exchange of material safety data sheets or other hazard communication information required to be made available to or exchanged between or among employers at the Site in accordance with Laws or Regulations.

6.16 *Emergencies*

A. In emergencies affecting the safety or protection of persons or the Work or property at the Site or adjacent thereto, CONTRACTOR is obligated to act to prevent threatened damage, injury, or loss. CONTRACTOR shall give ENGINEER prompt written notice if CONTRACTOR believes that any significant changes in the Work or variations from the Contract Documents have been caused thereby or are required as a result thereof. If ENGINEER determines that a change in the Contract Documents is required because of the action taken by CONTRACTOR in response to such an emergency, a Work Change Directive or Change Order will be issued.

6.17* *Shop Drawings and Samples*

A.* CONTRACTOR shall submit Shop Drawings to ENGINEER for review and approval in accordance with the acceptable schedule of Shop Drawings and Sample submittals. All submittals will be identified as ENGINEER may require and in the number of copies specified in the General Requirements. The data shown on the Shop Drawings will be complete with respect to quantities, dimensions, specified performance and design criteria, materials, and similar data to show ENGINEER the services, materials, and equipment CONTRACTOR proposes to provide and to enable ENGINEER to review the information for the limited purposes required by paragraph 6.17.E.

B.* CONTRACTOR shall also submit six (6) Samples to ENGINEER for review and approval in accordance with the acceptable schedule of Shop Drawings and Sample submittals. Each Sample will be identified clearly as to material, Supplier, pertinent data such as catalog numbers, and the use for which intended and otherwise as ENGINEER may require to enable ENGINEER to review the submittal for the limited purposes required by paragraph 6.17.E. The numbers of each Sample to be submitted will be as specified in the Specifications.

C. Where a Shop Drawing or Sample is required by the Contract Documents or the schedule of Shop Drawings and Sample submittals acceptable to ENGINEER as required by paragraph 2.07, any related Work performed prior to ENGINEER's review and approval of the pertinent submittal will be at the sole expense and responsibility of CONTRACTOR.

D. *Submittal Procedures*

1. Before submitting each Shop Drawing or Sample, CONTRACTOR shall have determined and verified:

a. all field measurements, quantities, dimensions, specified performance criteria, installation requirements, materials, catalog numbers, and similar information with respect thereto;

b. all materials with respect to intended use, fabrication, shipping, handling, storage, assembly, and installation pertaining to the performance of the Work;

c. all information relative to means, methods, techniques, sequences, and procedures of construction and safety precautions and programs incident thereto; and

d. CONTRACTOR shall also have reviewed and coordinated each Shop Drawing or

*See Supplementary Conditions

Sample with other Shop Drawings and Samples and with the requirements of the Work and the Contract Documents.

2. Each submittal shall bear a stamp or specific written indication that CONTRACTOR has satisfied CONTRACTOR's obligations under the Contract Documents with respect to CONTRACTOR's review and approval of that submittal.

3. At the time of each submittal, CONTRACTOR shall give ENGINEER specific written notice of such variations, if any, that the Shop Drawing or Sample submitted may have from the requirements of the Contract Documents, such notice to be in a written communication separate from the submittal; and, in addition, shall cause a specific notation to be made on each Shop Drawing and Sample submitted to ENGINEER for review and approval of each such variation.

E. *ENGINEER's Review*

1. ENGINEER will timely review and approve Shop Drawings and Samples in accordance with the schedule of Shop Drawings and Sample submittals acceptable to ENGINEER. ENGINEER's review and approval will be only to determine if the items covered by the submittals

will, after installation or incorporation in the Work, conform to the information given in the Contract Documents and be compatible with the design concept of the completed Project as a functioning whole as indicated by the Contract Documents.

2. ENGINEER's review and approval will not extend to means, methods, techniques, sequences, or procedures of construction (except where a particular means, method, technique, sequence, or procedure of construction is specifically and expressly called for by the Contract Documents) or to safety precautions or programs incident thereto. The review and approval of a separate item as such will not indicate approval of the assembly in which the item functions.

3. ENGINEER's review and approval of Shop Drawings or Samples shall not relieve CONTRACTOR from responsibility for any variation from the requirements of the Contract Documents unless CONTRACTOR has in writing called ENGINEER's attention to each such variation at the time of each submittal as required by paragraph 6.17.D.3 and ENGINEER has given written approval of each such variation by specific written notation thereof incorporated in or accompanying the Shop Drawing or Sample approval; nor will any approval by ENGINEER relieve CONTRACTOR from responsibility for complying with the requirements of paragraph 6.17.D.1.

F. Resubmittal Procedures

1. CONTRACTOR shall make corrections required by ENGINEER and shall return the required number of corrected copies of Shop Drawings and submit as required new Samples for review and approval. CONTRACTOR shall direct specific attention in writing to revisions other than the corrections called for by ENGINEER on previous submittals.

6.18 Continuing the Work

A. CONTRACTOR shall carry on the Work and adhere to the progress schedule during all disputes or disagreements with OWNER. No Work shall be delayed or postponed pending resolution of any disputes or disagreements, except as permitted by paragraph 15.04 or as OWNER and CONTRACTOR may otherwise agree in writing.

6.19 CONTRACTOR's General Warranty and Guarantee

A. CONTRACTOR warrants and guarantees to OWNER, ENGINEER, and ENGINEER's Consultants that all Work will be in accordance with the Contract Documents and will not be defective. CONTRACTOR's warranty and guarantee hereunder excludes defects or damage caused by:

1. abuse, modification, or improper maintenance or operation by persons other than CONTRACTOR, Subcontractors, Suppliers, or any other individual or entity for whom CONTRACTOR is responsible; or
2. normal wear and tear under normal usage.

B. CONTRACTOR's obligation to perform and complete the Work in accordance with the Contract Documents shall be absolute. None of the following will constitute an acceptance of Work that is not in accordance with the Contract Documents or a release of CONTRACTOR's obligation to perform the Work in accordance with the Contract Documents:

1. observations by ENGINEER;
2. recommendation by ENGINEER or payment by OWNER of any progress or final payment;
3. the issuance of a certificate of Substantial Completion by ENGINEER or any payment related thereto by OWNER;
4. use or occupancy of the Work or any part thereof by OWNER;
5. any acceptance by OWNER or any failure to do so;
6. any review and approval of a Shop Drawing or Sample submittal or the issuance of a notice of acceptability by ENGINEER;
7. any inspection, test, or approval by others; or
8. any correction of defective Work by OWNER.

6.20 *Indemnification*

A. To the fullest extent permitted by Laws and Regulations, CONTRACTOR shall indemnify and hold harmless OWNER, ENGINEER, ENGINEER's Consultants, and the officers, directors, partners, employees, agents, and other consultants and subcontractors of each and any of them from and against all claims, costs, losses, and damages (including but not limited to all fees and charges of engineers, architects, attorneys, and other professionals and all court or arbitration or other dispute resolution costs) arising out of or relating to the performance of the Work, provided that any such claim, cost, loss, or damage:

1. is attributable to bodily injury, sickness, disease, or death, or to injury to or destruction of tangible property (other than the Work itself), including the loss of use resulting therefrom; and

2. is caused in whole or in part by any negligent act or omission of CONTRACTOR, any Subcontractor, any Supplier, or any individual or entity directly or indirectly employed by any of them to perform any of the Work or anyone for whose acts any of them may be liable, regardless of whether or not caused in part by any negligence or omission of an individual or entity indemnified hereunder or whether liability is imposed upon such indemnified party by Laws and Regulations regardless of the negligence of any such individual or entity.

B. In any and all claims against OWNER or ENGINEER or any of their respective consultants, agents, officers, directors, partners, or employees by any employee (or the survivor or personal representative of such employee) of CONTRACTOR, any Subcontractor, any Supplier, or any individual or entity directly or indirectly employed by any of them to perform any of the Work, or anyone for whose acts any of them may be liable, the indemnification obligation under paragraph 6.20.A shall not be limited in any way by any limitation on the amount or type of damages, compensation, or benefits payable by or for CONTRACTOR or any such Subcontractor, Supplier, or other individual or entity under workers' compensation acts, disability benefit acts, or other employee benefit acts.

C. The indemnification obligations of CONTRACTOR under paragraph 6.20.A shall not extend to the liability of ENGINEER and ENGINEER's Consultants or to the officers, directors, partners, employees, agents, and

other consultants and subcontractors of each and any of them arising out of:

1. the preparation or approval of, or the failure to prepare or approve, maps, Drawings, opinions, reports, surveys, Change Orders, designs, or Specifications; or

2. giving directions or instructions, or failing to give them, if that is the primary cause of the injury or damage.

ARTICLE 7 - OTHER WORK

7.01 *Related Work at Site*

A. OWNER may perform other work related to the Project at the Site by OWNER's employees, or let other direct contracts therefor, or have other work performed by utility owners. If such other work is not noted in the Contract Documents, then:

1. written notice thereof will be given to CONTRACTOR prior to starting any such other work; and

2. if OWNER and CONTRACTOR are unable to agree on entitlement to or on the amount or extent, if any, of any adjustment in the Contract Price or Contract Times that should be allowed as a result of such other work, a Claim may be made therefor as provided in paragraph 10.05.

B. CONTRACTOR shall afford each other contractor who is a party to such a direct contract and each utility owner (and OWNER, if OWNER is performing the other work with OWNER's employees) proper and safe access to the Site and a reasonable opportunity for the introduction and storage of materials and equipment and the execution of such other work and shall properly coordinate the Work with theirs. Unless otherwise provided in the Contract Documents, CONTRACTOR shall do all cutting, fitting, and patching of the Work that may be required to properly connect or otherwise make its several parts come together and properly integrate with such other work. CONTRACTOR shall not endanger any work of others by cutting, excavating, or otherwise altering their work and will only cut or alter their work with the written consent of ENGINEER and the others whose work will be affected. The duties and responsibilities of CONTRACTOR under this paragraph are for the benefit of

such utility owners and other contractors to the extent that there are comparable provisions for the benefit of CONTRACTOR in said direct contracts between OWNER and such utility owners and other contractors.

C. If the proper execution or results of any part of CONTRACTOR's Work depends upon work performed by others under this Article 7, CONTRACTOR shall inspect such other work and promptly report to ENGINEER in writing any delays, defects, or deficiencies in such other work that render it unavailable or unsuitable for the proper execution and results of CONTRACTOR's Work. CONTRACTOR's failure to so report will constitute an acceptance of such other work as fit and proper for integration with CONTRACTOR's Work except for latent defects and deficiencies in such other work.

7.02 *Coordination*

A. If OWNER intends to contract with others for the performance of other work on the Project at the Site, the following will be set forth in Supplementary Conditions:

1. the individual or entity who will have authority and responsibility for coordination of the activities among the various contractors will be identified;
2. the specific matters to be covered by such authority and responsibility will be itemized; and
3. the extent of such authority and responsibilities will be provided.

B. Unless otherwise provided in the Supplementary Conditions, OWNER shall have sole authority and responsibility for such coordination.

ARTICLE 8 - OWNER'S RESPONSIBILITIES

8.01 *Communications to Contractor*

A. Except as otherwise provided in these General Conditions, OWNER shall issue all communications to CONTRACTOR through ENGINEER.

8.02 *Replacement of ENGINEER*

A. In case of termination of the employment of ENGINEER, OWNER shall appoint an engineer to whom CONTRACTOR makes no reasonable objection, whose status under the Contract Documents shall be that of the former ENGINEER.

8.03 *Furnish Data*

A. OWNER shall promptly furnish the data required of OWNER under the Contract Documents.

8.04 *Pay Promptly When Due*

A. OWNER shall make payments to CONTRACTOR promptly when they are due as provided in paragraphs 14.02.C and 14.07.C.

8.05 *Lands and Easements; Reports and Tests*

A. OWNER's duties in respect of providing lands and easements and providing engineering surveys to establish reference points are set forth in paragraphs 4.01 and 4.05. Paragraph 4.02 refers to OWNER's identifying and making available to CONTRACTOR copies of reports of explorations and tests of subsurface conditions and drawings of physical conditions in or relating to existing surface or subsurface structures at or contiguous to the Site that have been utilized by ENGINEER in preparing the Contract Documents.

*See Supplementary Conditions

8.06* *Insurance*

A.* OWNER's responsibilities, if any, in respect to purchasing and maintaining liability and property insurance are set forth in Article 5.

8.07 *Change Orders*

A. OWNER is obligated to execute Change Orders as indicated in paragraph 10.03.

8.08 *Inspections, Tests, and Approvals*

A. OWNER's responsibility in respect to certain inspections, tests, and approvals is set forth in paragraph 13.03.B.

8.09 *Limitations on OWNER's Responsibilities*

A. The OWNER shall not supervise, direct, or have control or authority over, nor be responsible for, CONTRACTOR's means, methods, techniques, sequences, or procedures of construction, or the safety precautions and programs incident thereto, or for any failure of CONTRACTOR to comply with Laws and Regulations applicable to the performance of the Work. OWNER will not be responsible for CONTRACTOR's failure to perform the Work in accordance with the Contract Documents.

8.10 *Undisclosed Hazardous Environmental Condition*

A. OWNER's responsibility in respect to an undisclosed Hazardous Environmental Condition is set forth in paragraph 4.06.

8.11 *Evidence of Financial Arrangements*

A. If and to the extent OWNER has agreed to furnish CONTRACTOR reasonable evidence that financial arrangements have been made to satisfy OWNER's obligations under the Contract Documents, OWNER's responsibility in respect thereof will be as set forth in the Supplementary Conditions.

ARTICLE 9 - ENGINEER'S STATUS DURING CONSTRUCTION

9.01 *OWNER'S Representative*

A. ENGINEER will be OWNER's representative during the construction period. The duties and responsibilities and the limitations of authority of ENGINEER as OWNER's representative during construction are set forth in the Contract Documents and will not be changed without written consent of OWNER and ENGINEER.

9.02 *Visits to Site*

A. ENGINEER will make visits to the Site at intervals appropriate to the various stages of construction as ENGINEER deems necessary in order to observe as an experienced and qualified design professional the progress that has been made and the quality of the various aspects of CONTRACTOR's executed Work. Based on information obtained during such visits and

observations, ENGINEER, for the benefit of OWNER, will determine, in general, if the Work is proceeding in accordance with the Contract Documents. ENGINEER will not be required to make exhaustive or continuous inspections on the Site to check the quality or quantity of the Work. ENGINEER's efforts will be directed toward providing for OWNER a greater degree of confidence that the completed Work will conform generally to the Contract Documents. On the basis of such visits and observations, ENGINEER will keep OWNER informed of the progress of the Work and will endeavor to guard OWNER against defective Work.

B. ENGINEER's visits and observations are subject to all the limitations on ENGINEER's authority and responsibility set forth in paragraph 9.10, and particularly, but without limitation, during or as a result of ENGINEER's visits or observations of CONTRACTOR's Work ENGINEER will not supervise, direct, control, or have authority over or be responsible for CONTRACTOR's means, methods, techniques, sequences, or procedures of construction, or the safety precautions and programs incident thereto, or for any failure of CONTRACTOR to comply with Laws and Regulations applicable to the performance of the Work.

9.03* *Project Representative*

A. If OWNER and ENGINEER agree, ENGINEER will furnish a Resident Project Representative to assist ENGINEER in providing more extensive observation of the Work. The responsibilities and authority and limitations thereon of any such Resident Project Representative and assistants will be as provided in paragraph 9.10 and in the Supplementary Conditions. If OWNER designates another representative or agent to represent OWNER at the Site who is not ENGINEER's Consultant, agent or employee,

*See Supplementary Conditions

the responsibilities and authority and limitations thereon of such other individual or entity will be as provided in the Supplementary Conditions.

9.04 *Clarifications and Interpretations*

A. ENGINEER will issue with reasonable promptness such written clarifications or interpretations of the requirements of the Contract Documents as ENGINEER may determine necessary, which shall be consistent with the intent of and reasonably inferable from the Contract Documents.

ments. Such written clarifications and interpretations will be binding on OWNER and CONTRACTOR. If OWNER and CONTRACTOR are unable to agree on entitlement to or on the amount or extent, if any, of any adjustment in the Contract Price or Contract Times, or both, that should be allowed as a result of a written clarification or interpretation, a Claim may be made therefor as provided in paragraph 10.05.

9.05 *Authorized Variations in Work*

A. ENGINEER may authorize minor variations in the Work from the requirements of the Contract Documents which do not involve an adjustment in the Contract Price or the Contract Times and are compatible with the design concept of the completed Project as a functioning whole as indicated by the Contract Documents. These may be accomplished by a Field Order and will be binding on OWNER and also on CONTRACTOR, who shall perform the Work involved promptly. If OWNER and CONTRACTOR are unable to agree on entitlement to or on the amount or extent, if any, of any adjustment in the Contract Price or Contract Times, or both, as a result of a Field Order, a Claim may be made therefor as provided in paragraph 10.05.

9.06 *Rejecting Defective Work*

A. ENGINEER will have authority to disapprove or reject Work which ENGINEER believes to be defective, or that ENGINEER believes will not produce a completed Project that conforms to the Contract Documents or that will prejudice the integrity of the design concept of the completed Project as a functioning whole as indicated by the Contract Documents. ENGINEER will also have authority to require special inspection or testing of the Work as provided in paragraph 13.04, whether or not the Work is fabricated, installed, or completed.

9.07 *Shop Drawings, Change Orders and Payments*

A. In connection with ENGINEER's authority as to Shop Drawings and Samples, see paragraph 6.17.

B. In connection with ENGINEER's authority as to Change Orders, see Articles 10, 11, and 12.

C. In connection with ENGINEER's authority as to Applications for Payment, see Article 14.

9.08 *Determinations for Unit Price Work*

A. ENGINEER will determine the actual quantities and classifications of Unit Price Work performed by CONTRACTOR. ENGINEER will review with CONTRACTOR the ENGINEER's preliminary determinations on such matters before rendering a written decision thereon (by recommendation of an Application for Payment or otherwise). ENGINEER's written decision thereon will be final and binding (except as modified by ENGINEER to reflect changed factual conditions or more accurate data) upon OWNER and CONTRACTOR, subject to the provisions of paragraph 10.05.

9.09 *Decisions on Requirements of Contract Documents and Acceptability of Work*

A. ENGINEER will be the initial interpreter of the requirements of the Contract Documents and judge of the acceptability of the Work thereunder. Claims, disputes and other matters relating to the acceptability of the Work, the quantities and classifications of Unit Price Work, the interpretation of the requirements of the Contract Documents pertaining to the performance of the Work, and Claims seeking changes in the Contract Price or Contract Times will be referred initially to ENGINEER in writing, in accordance with the provisions of paragraph 10.05, with a request for a formal decision.

B. When functioning as interpreter and judge under this paragraph 9.09, ENGINEER will not show partiality to OWNER or CONTRACTOR and will not be liable in connection with any interpretation or decision rendered in good faith in such capacity. The rendering of a decision by ENGINEER pursuant to this paragraph 9.09 with respect to any such Claim, dispute, or other matter (except any which have been waived by the making or acceptance of final payment as provided in paragraph 14.07) will be a condition precedent to any exercise by OWNER or CONTRACTOR of such rights or remedies as either may otherwise have under the Contract Documents or by Laws or Regulations in respect of any such Claim, dispute, or other matter.

*See Supplementary Conditions

9.10 *Limitations on ENGINEER's Authority and Responsibilities*

A. Neither ENGINEER's authority or responsibility under this Article 9 or under any other provision of the Contract Documents nor any decision made by ENGINEER in good faith either to exercise or not exercise such

authority or responsibility or the undertaking, exercise, or performance of any authority or responsibility by ENGINEER shall create, impose, or give rise to any duty in contract, tort, or otherwise owed by ENGINEER to CONTRACTOR, any Subcontractor, any Supplier, any other individual or entity, or to any surety for or employee or agent of any of them.

B. ENGINEER will not supervise, direct, control, or have authority over or be responsible for CONTRACTOR's means, methods, techniques, sequences, or procedures of construction, or the safety precautions and programs incident thereto, or for any failure of CONTRACTOR to comply with Laws and Regulations applicable to the performance of the Work. ENGINEER will not be responsible for CONTRACTOR's failure to perform the Work in accordance with the Contract Documents.

C. ENGINEER will not be responsible for the acts or omissions of CONTRACTOR or of any Subcontractor, any Supplier, or of any other individual or entity performing any of the Work.

D. ENGINEER's review of the final Application for Payment and accompanying documentation and all maintenance and operating instructions, schedules, guarantees, Bonds, certificates of inspection, tests and approvals, and other documentation required to be delivered by paragraph 14.07.A will only be to determine generally that their content complies with the requirements of, and in the case of certificates of inspections, tests, and approvals that the results certified indicate compliance with, the Contract Documents.

E. The limitations upon authority and responsibility set forth in this paragraph 9.10 shall also apply to ENGINEER's Consultants, Resident Project Representative, and assistants. See Article 18.

ARTICLE 10 - CHANGES IN THE WORK; CLAIMS

10.01 *Authorized Changes in the Work*

A. Without invalidating the Agreement and without notice to any surety, OWNER may, at any time or from time to time, order additions, deletions, or revisions in the Work by a Written Amendment, a Change Order, or a Work Change Directive. Upon receipt of any such document, CONTRACTOR shall promptly proceed with the Work involved which will be performed under the

applicable conditions of the Contract Documents (except as otherwise specifically provided).

B. If OWNER and CONTRACTOR are unable to agree on entitlement to, or on the amount or extent, if any, of an adjustment in the Contract Price or Contract Times, or both, that should be allowed as a result of a Work Change Directive, a Claim may be made therefor as provided in paragraph 10.05.

10.02 *Unauthorized Changes in the Work*

A. CONTRACTOR shall not be entitled to an increase in the Contract Price or an extension of the Contract Times with respect to any work performed that is not required by the Contract Documents as amended, modified, or supplemented as provided in paragraph 3.04, except in the case of an emergency as provided in paragraph 6.16 or in the case of uncovering Work as provided in paragraph 13.04.B.

10.03 *Execution of Change Orders*

A. OWNER and CONTRACTOR shall execute appropriate Change Orders recommended by ENGINEER (or Written Amendments) covering:

1. changes in the Work which are: (i) ordered by OWNER pursuant to paragraph 10.01.A, (ii) required because of acceptance of defective Work under paragraph 13.08.A or OWNER's correction of defective Work under paragraph 13.09, or (iii) agreed to by the parties;

2. changes in the Contract Price or Contract Times which are agreed to by the parties, including any undisputed sum or amount of time for Work actually performed in accordance with a Work Change Directive; and

3. changes in the Contract Price or Contract Times which embody the substance of any written decision rendered by ENGINEER pursuant to paragraph 10.05; provided that, in lieu of executing any such Change Order, an appeal may be taken from any such decision in accordance with the provisions of the Contract Documents and applicable Laws and Regulations, but during any such appeal, CONTRACTOR shall carry on the Work and adhere to the progress schedule as provided in paragraph 6.18.A.

10.04 *Notification to Surety*

A. If notice of any change affecting the general scope of the Work or the provisions of the Contract Documents (including, but not limited to, Contract Price or Contract Times) is required by the provisions of any Bond to be given to a surety, the giving of any such notice will be CONTRACTOR's responsibility. The amount of each applicable Bond will be adjusted to reflect the effect of any such change.

10.05 *Claims and Disputes*

A. *Notice:* Written notice stating the general nature of each Claim, dispute, or other matter shall be delivered by the claimant to ENGINEER and the other party to the Contract promptly (but in no event later than 30 days) after the start of the event giving rise thereto. Notice of the amount or extent of the Claim, dispute, or other matter with supporting data shall be delivered to the ENGINEER and the other party to the Contract within 60 days after the start of such event (unless ENGINEER allows additional time for claimant to submit additional or more accurate data in support of such Claim, dispute, or other matter). A Claim for an adjustment in Contract Price shall be prepared in accordance with the provisions of paragraph 12.01.B. A Claim for an adjustment in Contract Time shall be prepared in accordance with the provisions of paragraph 12.02.B. Each Claim shall be accompanied by claimant's written statement that the adjustment claimed is the entire adjustment to which the claimant believes it is entitled as a result of said event. The opposing party shall submit any response to ENGINEER and the claimant within 30 days after receipt of the claimant's last submittal (unless ENGINEER allows additional time).

B. *ENGINEER's Decision:* ENGINEER will render a formal decision in writing within 30 days after receipt of the last submittal of the claimant or the last submittal of the opposing party, if any. ENGINEER's written decision on such Claim, dispute, or other matter will be final and binding upon OWNER and CONTRACTOR unless:

1. an appeal from ENGINEER's decision is taken within the time limits and in accordance with the dispute resolution procedures set forth in Article 16; or
2. if no such dispute resolution procedures have been set forth in Article 16, a written notice of intention to appeal from ENGINEER's written decision is delivered by OWNER or CONTRACTOR to the other and to ENGINEER within 30 days

after the date of such decision, and a formal proceeding is instituted by the appealing party in a forum of competent jurisdiction within 60 days after the date of such decision or within 60 days after Substantial Completion, whichever is later (unless otherwise agreed in writing by OWNER and CONTRACTOR), to exercise such rights or remedies as the appealing party may have with respect to such Claim, dispute, or other matter in accordance with applicable Laws and Regulations.

C. If ENGINEER does not render a formal decision in writing within the time stated in paragraph 10.05.B, a decision denying the Claim in its entirety shall be deemed to have been issued 31 days after receipt of the last submittal of the claimant or the last submittal of the opposing party, if any.

D. No Claim for an adjustment in Contract Price or Contract Times (or Milestones) will be valid if not submitted in accordance with this paragraph 10.05.

ARTICLE 11 - COST OF THE WORK; CASH ALLOWANCES; UNIT PRICE WORK

11.01 *Cost of the Work*

A. *Costs Included:* The term Cost of the Work means the sum of all costs necessarily incurred and paid by CONTRACTOR in the proper performance of the Work. When the value of any Work covered by a Change Order or when a Claim for an adjustment in Contract Price is determined on the basis of Cost of the Work, the costs to be reimbursed to CONTRACTOR will be only those additional or incremental costs required because of the change in the Work or because of the event giving rise to the Claim. Except as otherwise may be agreed to in writing by OWNER, such costs shall be in amounts no higher than those prevailing in the locality of the Project, shall include only the following items, and shall not include any of the costs itemized in paragraph 11.01.B.

1. Payroll costs for employees in the direct employ of CONTRACTOR in the performance of the Work under schedules of job classifications agreed upon by OWNER and CONTRACTOR. Such employees shall include without limitation superintendents, foremen, and other personnel employed full time at the Site. Payroll costs for employees not employed full time on the Work

shall be apportioned on the basis of their time spent on the Work. Payroll costs shall include, but not be limited to, salaries and wages plus the cost of fringe benefits, which shall include social security contributions, unemployment, excise, and payroll taxes, workers' compensation, health and retirement benefits, bonuses, sick leave, vacation and holiday pay applicable thereto. The expenses of performing Work outside of regular working hours, on Saturday, Sunday, or legal holidays, shall be included in the above to the extent authorized by OWNER.

2. Cost of all materials and equipment furnished and incorporated in the Work, including costs of transportation and storage thereof, and Suppliers' field services required in connection therewith. All cash discounts shall accrue to CONTRACTOR unless OWNER deposits funds with CONTRACTOR with which to make payments, in which case the cash discounts shall accrue to OWNER. All trade discounts, rebates and refunds and returns from sale of surplus materials and equipment shall accrue to OWNER, and CONTRACTOR shall make provisions so that they may be obtained.

3. Payments made by CONTRACTOR to Subcontractors for Work performed by Subcontractors. If required by OWNER, CONTRACTOR shall obtain competitive bids from subcontractors acceptable to OWNER and CONTRACTOR and shall deliver such bids to OWNER, who will then determine, with the advice of ENGINEER, which bids, if any, will be acceptable. If any subcontract provides that the Subcontractor is to be paid on the basis of Cost of the Work plus a fee, the Subcontractor's Cost of the Work and fee shall be determined in the same manner as CONTRACTOR's Cost of the Work and fee as provided in this paragraph 11.01.

4. Costs of special consultants (including but not limited to engineers, architects, testing laboratories, surveyors, attorneys, and accountants) employed for services specifically related to the Work.

5. Supplemental costs including the following:

a. The proportion of necessary transportation, travel, and subsistence expenses of

CONTRACTOR's employees incurred in discharge of duties connected with the Work.

b. Cost, including transportation and maintenance, of all materials, supplies, equipment, machinery, appliances, office, and temporary facilities at the Site, and hand tools not owned by the workers, which are consumed in the performance of the Work, and cost, less market value, of such items used but not consumed which remain the property of CONTRACTOR.

c. Rentals of all construction equipment and machinery, and the parts thereof whether rented from CONTRACTOR or others in accordance with rental agreements approved by OWNER with the advice of ENGINEER, and the costs of transportation, loading, unloading, assembly, dismantling, and removal thereof. All such costs shall be in accordance with the terms of said rental agreements. The rental of any such equipment, machinery, or parts shall cease when the use thereof is no longer necessary for the Work.

d. Sales, consumer, use, and other similar taxes related to the Work, and for which CONTRACTOR is liable, imposed by Laws and Regulations.

e. Deposits lost for causes other than negligence of CONTRACTOR, any Subcontractor, or anyone directly or indirectly employed by any of them or for whose acts any of them may be liable, and royalty payments and fees for permits and licenses.

f. Losses and damages (and related expenses) caused by damage to the Work, not compensated by insurance or otherwise, sustained by CONTRACTOR in connection with the performance of the Work (except losses and damages within the deductible amounts of property insurance established in accordance with paragraph 5.06.D), provided such losses and damages have resulted from causes other than the negligence of CONTRACTOR, any Subcontractor, or anyone directly or indirectly employed by any of them or for whose acts any of them may be liable. Such losses shall include settlements made with the written consent and approval of OWNER. No such losses, damages, and expenses shall be included in the Cost of the Work for the purpose of determining CONTRACTOR's fee.

g. The cost of utilities, fuel, and sanitary facilities at the Site.

h. Minor expenses such as telegrams, long distance telephone calls, telephone service at the Site, expressage, and similar petty cash items in connection with the Work.

i. When the Cost of the Work is used to determine the value of a Change Order or of a Claim, the cost of premiums for additional Bonds and insurance required because of the changes in the Work or caused by the event giving rise to the Claim.

j. When all the Work is performed on the basis of cost-plus, the costs of premiums for all Bonds and insurance CONTRACTOR is required by the Contract Documents to purchase and maintain.

B. *Costs Excluded:* The term Cost of the Work shall not include any of the following items:

1. Payroll costs and other compensation of CONTRACTOR's officers, executives, principals (of partnerships and sole proprietorships), general managers, engineers, architects, estimators, attorneys, auditors, accountants, purchasing and contracting agents, expeditors, timekeepers, clerks, and other personnel employed by CONTRACTOR, whether at the Site or in CONTRACTOR's principal or branch office for general administration of the Work and not specifically included in the agreed upon schedule of job classifications referred to in paragraph 11.01.A.1 or specifically covered by paragraph 11.01.A.4, all of which are to be considered administrative costs covered by the CONTRACTOR's fee.

2. Expenses of CONTRACTOR's principal and branch offices other than CONTRACTOR's office at the Site.

3. Any part of CONTRACTOR's capital expenses, including interest on CONTRACTOR's capital employed for the Work and charges against CONTRACTOR for delinquent payments.

4. Costs due to the negligence of CONTRACTOR, any Subcontractor, or anyone directly or indirectly employed by any of them or for whose acts any of them may be liable, including but not

limited to, the correction of defective Work, disposal of materials or equipment wrongly supplied, and making good any damage to property.

5. Other overhead or general expense costs of any kind and the costs of any item not specifically and expressly included in paragraphs 11.01.A and 11.01.B.

C. *CONTRACTOR's Fee:* When all the Work is performed on the basis of cost-plus, CONTRACTOR's fee shall be determined as set forth in the Agreement. When the value of any Work covered by a Change Order or when a Claim for an adjustment in Contract Price is determined on the basis of Cost of the Work, CONTRACTOR's fee shall be determined as set forth in paragraph 12.01.C.

D. *Documentation:* Whenever the Cost of the Work for any purpose is to be determined pursuant to paragraphs 11.01.A and 11.01.B, CONTRACTOR will establish and maintain records thereof in accordance with generally accepted accounting practices and submit in a form acceptable to ENGINEER an itemized cost breakdown together with supporting data.

11.02 *Cash Allowances*

A. It is understood that CONTRACTOR has included in the Contract Price all allowances so named in the Contract Documents and shall cause the Work so covered to be performed for such sums as may be acceptable to OWNER and ENGINEER. CONTRACTOR agrees that:

1. the allowances include the cost to CONTRACTOR (less any applicable trade discounts) of materials and equipment required by the allowances to be delivered at the Site, and all applicable taxes; and

2. CONTRACTOR's costs for unloading and handling on the Site, labor, installation costs, overhead, profit, and other expenses contemplated for the allowances have been included in the Contract Price and not in the allowances, and no demand for additional payment on account of any of the foregoing will be valid.

B. Prior to final payment, an appropriate Change Order will be issued as recommended by ENGINEER to reflect actual amounts due CONTRACTOR on account of

Work covered by allowances, and the Contract Price shall be correspondingly adjusted.

11.03 *Unit Price Work*

A. Where the Contract Documents provide that all or part of the Work is to be Unit Price Work, initially the Contract Price will be deemed to include for all Unit Price Work an amount equal to the sum of the unit price for each separately identified item of Unit Price Work times the estimated quantity of each item as indicated in the Agreement. The estimated quantities of items of Unit Price Work are not guaranteed and are solely for the purpose of comparison of Bids and determining an initial Contract Price. Determinations of the actual quantities and classifications of Unit Price Work performed by CONTRACTOR will be made by ENGINEER subject to the provisions of paragraph 9.08.

B. Each unit price will be deemed to include an amount considered by CONTRACTOR to be adequate to cover CONTRACTOR's overhead and profit for each separately identified item.

C. OWNER or CONTRACTOR may make a Claim for an adjustment in the Contract Price in accordance with paragraph 10.05 if:

1. the quantity of any item of Unit Price Work performed by CONTRACTOR differs materially and significantly from the estimated quantity of such item indicated in the Agreement; and
2. there is no corresponding adjustment with respect any other item of Work; and
3. if CONTRACTOR believes that CONTRACTOR is entitled to an increase in Contract Price as a result of having incurred additional expense or OWNER believes that OWNER is entitled to a decrease in Contract Price and the parties are unable to agree as to the amount of any such increase or decrease.

ARTICLE 12 - CHANGE OF CONTRACT PRICE; CHANGE OF CONTRACT TIMES

12.01* *Change of Contract Price*

A. The Contract Price may only be changed by a Change Order or by a Written Amendment. Any Claim for an adjustment in the Contract Price shall be based on written notice submitted by the party making the Claim to the ENGINEER and the other party to the Contract in accordance with the provisions of paragraph 10.05.

B.* The value of any Work covered by a Change Order or of any Claim for an adjustment in the Contract Price will be determined as follows:

1. where the Work involved is covered by unit prices contained in the Contract Documents, by application of such unit prices to the quantities of the items involved (subject to the provisions of paragraph 11.03); or
2. where the Work involved is not covered by unit prices contained in the Contract Documents, by a mutually agreed lump sum (which may include an allowance for overhead and profit not necessarily in accordance with paragraph 12.01.C.2); or
3. where the Work involved is not covered by unit prices contained in the Contract Documents and agreement to a lump sum is not reached under paragraph 12.01.B.2, on the basis of the Cost of the Work (determined as provided in paragraph 11.01) plus a CONTRACTOR's fee for overhead and profit (determined as provided in paragraph 12.01.C).

C. *CONTRACTOR's Fee*: The CONTRACTOR's fee for overhead and profit shall be determined as follows:

1. a mutually acceptable fixed fee; or
2. if a fixed fee is not agreed upon, then a fee based on the following percentages of the various portions of the Cost of the Work:
 - a. for costs incurred under paragraphs 11.01.A.1 and 11.01.A.2, the CONTRACTOR's fee shall be 15 percent;

b. for costs incurred under paragraph 11.01.A.3, the CONTRACTOR's fee shall be five percent;

c. where one or more tiers of subcontracts are on the basis of Cost of the Work plus a fee and no fixed fee is agreed upon, the intent of paragraph 12.01.C.2.a is that the Subcontractor who actually performs the Work, at whatever tier, will be paid a fee of 15 percent of the costs incurred by such Subcontractor under paragraphs 11.01.A.1 and 11.01.A.2 and that any higher tier Subcontractor and CONTRACTOR will each be paid a fee of five percent of the amount paid to the next lower tier Subcontractor;

*See Supplementary Conditions

d. no fee shall be payable on the basis of costs itemized under paragraphs 11.01.A.4, 11.01.A.5, and 11.01.B;

e. the amount of credit to be allowed by CONTRACTOR to OWNER for any change which results in a net decrease in cost will be the amount of the actual net decrease in cost plus a deduction in CONTRACTOR's fee by an amount equal to five percent of such net decrease; and

f. when both additions and credits are involved in any one change, the adjustment in CONTRACTOR's fee shall be computed on the basis of the net change in accordance with paragraphs 12.01.C.2.a through 12.01.C.2.e, inclusive.

12.02 *Change of Contract Times*

A. The Contract Times (or Milestones) may only be changed by a Change Order or by a Written Amendment. Any Claim for an adjustment in the Contract Times (or Milestones) shall be based on written notice submitted by the party making the claim to the ENGINEER and the other party to the Contract in accordance with the provisions of paragraph 10.05.

B. Any adjustment of the Contract Times (or Milestones) covered by a Change Order or of any Claim for an adjustment in the Contract Times (or Milestones)

will be determined in accordance with the provisions of this Article 12.

12.03 *Delays Beyond CONTRACTOR's Control*

A. Where CONTRACTOR is prevented from completing any part of the Work within the Contract Times (or Milestones) due to delay beyond the control of CONTRACTOR, the Contract Times (or Milestones) will be extended in an amount equal to the time lost due to such delay if a Claim is made therefor as provided in paragraph 12.02.A. Delays beyond the control of CONTRACTOR shall include, but not be limited to, acts or neglect by OWNER, acts or neglect of utility owners or other contractors performing other work as contemplated by Article 7, fires, floods, epidemics, abnormal weather conditions, or acts of God.

12.04 *Delays Within CONTRACTOR's Control*

A. The Contract Times (or Milestones) will not be extended due to delays within the control of CONTRACTOR. Delays attributable to and within the control of a Subcontractor or Supplier shall be deemed to be delays within the control of CONTRACTOR.

12.05 *Delays Beyond OWNER's and CONTRACTOR's Control*

A. Where CONTRACTOR is prevented from completing any part of the Work within the Contract Times (or Milestones) due to delay beyond the control of both OWNER and CONTRACTOR, an extension of the Contract Times (or Milestones) in an amount equal to the time lost due to such delay shall be CONTRACTOR's sole and exclusive remedy for such delay.

12.06 *Delay Damages*

A. In no event shall OWNER or ENGINEER be liable to CONTRACTOR, any Subcontractor, any Supplier, or any other person or organization, or to any surety for or employee or agent of any of them, for damages arising out of or resulting from:

1. delays caused by or within the control of CONTRACTOR; or

2. delays beyond the control of both OWNER and CONTRACTOR including but not limited to fires, floods, epidemics, abnormal weather conditions, acts of God, or acts or neglect by utility

owners or other contractors performing other work as contemplated by Article 7.

B. Nothing in this paragraph 12.06 bars a change in Contract Price pursuant to this Article 12 to compensate CONTRACTOR due to delay, interference, or disruption directly attributable to actions or inactions of OWNER or anyone for whom OWNER is responsible.

ARTICLE 13 - TESTS AND INSPECTIONS;
CORRECTION, REMOVAL OR ACCEPTANCE OF
DEFECTIVE WORK

13.01 *Notice of Defects*

A. Prompt notice of all defective Work of which OWNER or ENGINEER has actual knowledge will be given to CONTRACTOR. All defective Work may be rejected, corrected, or accepted as provided in this Article 13.

13.02* *Access to Work*

A. OWNER, ENGINEER, ENGINEER's Consultants, other representatives and personnel of OWNER, independent testing laboratories, and governmental agencies with jurisdictional interests will have access to the Site and the Work at reasonable times for their observation, inspecting, and testing. CONTRACTOR shall provide them proper and safe conditions for such access and advise them of CONTRACTOR's Site safety procedures and programs so that they may comply therewith as applicable.

13.03* *Tests and Inspections*

A. CONTRACTOR shall give ENGINEER timely notice of readiness of the Work for all required inspections, tests, or approvals and shall cooperate with inspection and testing personnel to facilitate required inspections or tests.

B.* OWNER shall employ and pay for the services of an independent testing laboratory to perform all inspections, tests, or approvals required by the Contract Documents except:

1. for inspections, tests, or approvals covered by paragraphs 13.03.C and 13.03.D below;

2. that costs incurred in connection with tests or inspections conducted pursuant to paragraph 13.04.B shall be paid as provided in said paragraph 13.04.B; and

3. as otherwise specifically provided in the Contract Documents.

C. If Laws or Regulations of any public body having jurisdiction require any Work (or part thereof) specifically to be inspected, tested, or approved by an employee or other representative of such public body, CONTRACTOR shall assume full responsibility for arranging and obtaining such inspections, tests, or approvals, pay all costs in connection therewith, and furnish ENGINEER the required certificates of inspection or approval.

D. CONTRACTOR shall be responsible for arranging and obtaining and shall pay all costs in connection with any inspections, tests, or approvals required for OWNER's and ENGINEER's acceptance of materials or equipment to be incorporated in the Work; or acceptance of materials, mix designs, or equipment submitted for approval prior to CONTRACTOR's purchase thereof for incorporation in the Work. Such inspections, tests, or approvals shall be performed by organizations acceptable to OWNER and ENGINEER.

E. If any Work (or the work of others) that is to be inspected, tested, or approved is covered by CONTRACTOR without written concurrence of ENGINEER, it must, if requested by ENGINEER, be uncovered for observation.

F. Uncovering Work as provided in paragraph 13.03.E shall be at CONTRACTOR's expense unless CONTRACTOR has given ENGINEER timely notice of CONTRACTOR's intention to cover the same and ENGINEER has not acted with reasonable promptness in response to such notice.

13.04 *Uncovering Work*

A. If any Work is covered contrary to the written request of ENGINEER, it must, if requested by ENGINEER, be uncovered for ENGINEER's observation and replaced at CONTRACTOR's expense.

B. If ENGINEER considers it necessary or advisable that covered Work be observed by ENGINEER or inspected or tested by others, CONTRACTOR, at ENGINEER's request, shall uncover, expose, or otherwise make available for observation, inspection, or testing as ENGINEER may require, that portion of the Work in

question, furnishing all necessary labor, material, and equipment. If it is found that such Work is defective, CONTRACTOR shall pay all Claims, costs, losses, and damages (including but not limited to all fees and charges of engineers, architects, attorneys, and other professionals and all court or arbitration or other dispute resolution costs) arising out of or relating to such uncovering, exposure, observation, inspection, and testing, and of satisfactory replacement or reconstruction (including but not limited to all costs of repair or replacement of work of others); and OWNER shall be entitled to an appropriate decrease in the Contract Price. If the parties are unable to agree as to the amount thereof, OWNER may make a Claim therefor as provided in paragraph 10.05. If, however, such Work is not found to be defective, CONTRACTOR shall be allowed an increase in the Contract Price or an extension of the Contract Times (or Milestones), or both, directly attributable to such uncovering, exposure, observation, inspection, testing, replacement, and reconstruction. If the parties are unable to agree as to the amount or extent thereof, CONTRACTOR may make a Claim therefor as provided in paragraph 10.05.

*See Supplementary Conditions

13.05 *OWNER May Stop the Work*

A. If the Work is defective, or CONTRACTOR fails to supply sufficient skilled workers or suitable materials or equipment, or fails to perform the Work in such a way that the completed Work will conform to the Contract Documents, OWNER may order CONTRACTOR to stop the Work, or any portion thereof, until the cause for such order has been eliminated; however, this right of OWNER to stop the Work shall not give rise to any duty on the part of OWNER to exercise this right for the benefit of CONTRACTOR, any Subcontractor, any Supplier, any other individual or entity, or any surety for, or employee or agent of any of them.

13.06 *Correction or Removal of Defective Work*

A. CONTRACTOR shall correct all defective Work, whether or not fabricated, installed, or completed, or, if the Work has been rejected by ENGINEER, remove it from the Project and replace it with Work that is not defective. CONTRACTOR shall pay all Claims, costs, losses, and damages (including but not limited to all fees and charges of engineers, architects, attorneys, and other professionals and all court or arbitration or other dispute resolution costs) arising out of or relating to such correction or removal (including but not limited to all costs of repair or replacement of work of others).

13.07 *Correction Period*

A. If within one year after the date of Substantial Completion or such longer period of time as may be prescribed by Laws or Regulations or by the terms of any applicable special guarantee required by the Contract Documents or by any specific provision of the Contract Documents, any Work is found to be defective, or if the repair of any damages to the land or areas made available for CONTRACTOR's use by OWNER or permitted by Laws and Regulations as contemplated in paragraph 6.11.A is found to be defective, CONTRACTOR shall promptly, without cost to OWNER and in accordance with OWNER's written instructions: (i) repair such defective land or areas, or (ii) correct such defective Work or, if the defective Work has been rejected by OWNER, remove it from the Project and replace it with Work that is not defective, and (iii) satisfactorily correct or repair or remove and replace any damage to other Work, to the work of others or other land or areas resulting therefrom. If CONTRACTOR does not promptly comply with the terms of such instructions, or in an emergency where delay would cause serious risk of loss or damage, OWNER may have the defective Work corrected or repaired or may have the rejected Work removed and replaced, and all Claims, costs, losses, and damages (including but not limited to all fees and charges of engineers, architects, attorneys, and other professionals and all court or arbitration or other dispute resolution costs) arising out of or relating to such correction or repair or such removal and replacement (including but not limited to all costs of repair or replacement of work of others) will be paid by CONTRACTOR.

B. In special circumstances where a particular item of equipment is placed in continuous service before Substantial Completion of all the Work, the correction period for that item may start to run from an earlier date if so provided in the Specifications or by Written Amendment.

C. Where defective Work (and damage to other Work resulting therefrom) has been corrected or removed and replaced under this paragraph 13.07, the correction period hereunder with respect to such Work will be extended for an additional period of one year after such correction or removal and replacement has been satisfactorily completed.

D. CONTRACTOR's obligations under this paragraph 13.07 are in addition to any other obligation or warranty. The provisions of this paragraph 13.07 shall not be construed as a substitute for or a waiver of the provisions of any applicable statute of limitation or repose.

13.08 *Acceptance of Defective Work*

A. If, instead of requiring correction or removal and replacement of defective Work, OWNER (and, prior to ENGINEER's recommendation of final payment, ENGINEER) prefers to accept it, OWNER may do so. CONTRACTOR shall pay all Claims, costs, losses, and damages (including but not limited to all fees and charges of engineers, architects, attorneys, and other professionals and all court or arbitration or other dispute resolution costs) attributable to OWNER's evaluation of and determination to accept such defective Work (such costs to be approved by ENGINEER as to reasonableness) and the diminished value of the Work to the extent not otherwise paid by CONTRACTOR pursuant to this sentence. If any such acceptance occurs prior to ENGINEER's recommendation of final payment, a Change Order will be issued incorporating the necessary revisions in the Contract Documents with respect to the Work, and OWNER shall be entitled to an appropriate decrease in the Contract Price, reflecting the diminished value of Work so accepted. If the parties are unable to agree as to the amount thereof, OWNER may make a Claim therefor as provided in paragraph 10.05. If the acceptance occurs after such recommendation, an appropriate amount will be paid by CONTRACTOR to OWNER.

13.09 *OWNER May Correct Defective Work*

A. If CONTRACTOR fails within a reasonable time after written notice from ENGINEER to correct defective Work or to remove and replace rejected Work as required by ENGINEER in accordance with paragraph 13.06.A, or if CONTRACTOR fails to perform the Work in accordance with the Contract Documents, or if CONTRACTOR fails to comply with any other provision of the Contract Documents, OWNER may, after seven days written notice

to CONTRACTOR, correct and remedy any such deficiency.

B. In exercising the rights and remedies under this paragraph, OWNER shall proceed expeditiously. In connection with such corrective and remedial action, OWNER may exclude CONTRACTOR from all or part of the Site, take possession of all or part of the Work and suspend CONTRACTOR's services related thereto, take possession of CONTRACTOR's tools, appliances, construction equipment and machinery at the Site, and incorporate in the Work all materials and equipment stored at the Site or for which OWNER has paid CONTRACTOR but which are stored elsewhere. CONTRACTOR shall allow OWNER, OWNER's representatives, agents and employees, OWNER's other contractors, and ENGINEER and ENGINEER's Consultants access to the Site to enable OWNER to exercise the rights and remedies under this paragraph.

C. All Claims, costs, losses, and damages (including but not limited to all fees and charges of engineers, architects, attorneys, and other professionals and all court or arbitration or other dispute resolution costs) incurred or sustained by OWNER in exercising the rights and remedies under this paragraph 13.09 will be charged against CONTRACTOR, and a Change Order will be issued incorporating the necessary revisions in the Contract Documents with respect to the Work; and OWNER shall be entitled to an appropriate decrease in the Contract Price. If the parties are unable to agree as to the amount of the adjustment, OWNER may make a Claim therefor as provided in paragraph 10.05. Such claims, costs, losses and damages will include but not be limited to all costs of repair, or replacement of work of others destroyed or damaged by correction, removal, or replacement of CONTRACTOR's defective Work.

D. CONTRACTOR shall not be allowed an extension of the Contract Times (or Milestones) because of any delay in the performance of the Work attributable to the exercise by OWNER of OWNER's rights and remedies under this paragraph 13.09.

ARTICLE 14 - PAYMENTS TO CONTRACTOR AND COMPLETION

14.01 *Schedule of Values*

A. The schedule of values established as provided in paragraph 2.07.A will serve as the basis for progress payments and will be incorporated into a form of Application for Payment acceptable to ENGINEER. Progress payments on account of Unit Price Work will be based on the number of units completed.

14.02 *Progress Payments*

A.* *Applications for Payments*

1. At least 20 days before the date established for each progress payment (but not more often than once a month), CONTRACTOR shall submit to ENGINEER for review an Application for Payment filled out and signed by CONTRACTOR covering the Work completed as of the date of the Application and accompanied by such supporting documentation as is required by the Contract Documents. If payment is requested on the basis of materials and equipment not incorporated in the Work but delivered and suitably stored at the Site or at another location agreed to in writing, the Application for Payment shall also be accompanied by a bill of sale, invoice, or other documentation warranting that OWNER has received the materials and equipment free and clear of all Liens and evidence that the materials and equipment are covered by appropriate property insurance or other arrangements to protect OWNER's interest therein, all of which must be satisfactory to OWNER.

2. Beginning with the second Application for Payment, each Application shall include an affidavit of CONTRACTOR stating that all previous progress payments received on account of the Work have been applied on account to discharge CONTRACTOR's legitimate obligations associated with prior Applications for Payment.

3. The amount of retainage with respect to pro-gress payments will be as stipulated in the Agreement.

*See Supplementary Conditions

B. *Review of Applications*

1. ENGINEER will, within 10 days after receipt of each Application for Payment, either indicate in writing a recommendation of payment and present the Application to OWNER or return the Application to CONTRACTOR indicating in writing ENGINEER's reasons for refusing to recommend payment. In the latter case, CONTRACTOR may make the necessary corrections and resubmit the Application.

2. ENGINEER's recommendation of any payment requested in an Application for Payment will constitute a representation by ENGINEER to OWNER, based on ENGINEER's observations on the Site of the executed Work as an experienced and qualified design professional and on ENGINEER's review of the Application for Payment and the accompanying data and schedules, that to the best of ENGINEER's knowledge, information and belief:

a. the Work has progressed to the point indicated;

b. the quality of the Work is generally in accordance with the Contract Documents (subject to an evaluation of the Work as a functioning whole prior to or upon Substantial Completion, to the results of any subsequent tests called for in the Contract Documents, to a final determination of quantities and classifications for Unit Price Work under paragraph 9.08, and to any other qualifications stated in the recommendation); and

c. the conditions precedent to CONTRACTOR's being entitled to such payment appear to have been fulfilled in so far as it is ENGINEER's responsibility to observe the Work.

3. By recommending any such payment ENGINEER will not thereby be deemed to have represented that: (i) inspections made to check the quality or the quantity of the Work as it has been performed have been exhaustive, extended to every aspect of the Work in progress, or involved detailed inspections of the Work beyond the responsibilities specifically assigned to ENGINEER in the Contract Documents; or (ii) that there may not be other matters or issues between the parties

that might entitle CONTRACTOR to be paid additionally by OWNER or entitle OWNER to withhold payment to CONTRACTOR.

4. Neither ENGINEER's review of CONTRACTOR's Work for the purposes of recommending payments nor ENGINEER's recommendation of any payment, including final payment, will impose responsibility on ENGINEER to supervise, direct, or control the Work or for the means, methods, techniques, sequences, or procedures of construction, or the safety precautions and programs incident thereto, or for CONTRACTOR's failure to comply with Laws and Regulations applicable to CONTRACTOR's performance of the Work. Additionally, said review or recommendation will not impose responsibility on ENGINEER to make any examination to ascertain how or for what purposes CONTRACTOR has used the moneys paid on account of the Contract Price, or to determine that title to any of the Work, materials, or equipment has passed to OWNER free and clear of any Liens.

5. ENGINEER may refuse to recommend the whole or any part of any payment if, in ENGINEER's opinion, it would be incorrect to make the representations to OWNER referred to in paragraph 14.02.B.2. ENGINEER may also refuse to recommend any such payment or, because of subsequently discovered evidence or the results of subsequent inspections or tests, revise or revoke any such payment recommendation previously made, to such extent as may be necessary in ENGINEER's opinion to protect OWNER from loss because:

- a. the Work is defective, or completed Work has been damaged, requiring correction or replacement;
- b. the Contract Price has been reduced by Written Amendment or Change Orders;
- c. OWNER has been required to correct defective Work or complete Work in accordance with paragraph 13.09; or
- d. ENGINEER has actual knowledge of the occurrence of any of the events enumerated in paragraph 15.02.A.

C. *Payment Becomes Due*

1. Ten days after presentation of the Application for Payment to OWNER with ENGINEER's recommendation, the amount recommended will (subject to the provisions of paragraph 14.02.D) become due, and when due will be paid by OWNER to CONTRACTOR.

D. *Reduction in Payment*

1. OWNER may refuse to make payment of the full amount recommended by ENGINEER because:

a. claims have been made against OWNER on account of CONTRACTOR's performance or furnishing of the Work;

b. Liens have been filed in connection with the Work, except where CONTRACTOR has delivered a specific Bond satisfactory to OWNER to secure the satisfaction and discharge of such Liens;

c. there are other items entitling OWNER to a set-off against the amount recommended; or

d. OWNER has actual knowledge of the occurrence of any of the events enumerated in paragraphs 14.02.B.5.a through 14.02.B.5.c or paragraph 15.02.A.

2. If OWNER refuses to make payment of the full amount recommended by ENGINEER, OWNER must give CONTRACTOR immediate written notice (with a copy to ENGINEER) stating the reasons for such action and promptly pay CONTRACTOR any amount remaining after deduction of the amount so withheld. OWNER shall promptly pay CONTRACTOR the amount so withheld, or any adjustment thereto agreed to by OWNER and CONTRACTOR, when CONTRACTOR corrects to OWNER's satisfaction the reasons for such action.

3. If it is subsequently determined that OWNER's refusal of payment was not justified, the amount wrongfully withheld shall be treated as an amount due as determined by paragraph 14.02.C.1.

14.03 *CONTRACTOR's Warranty of Title*

A. CONTRACTOR warrants and guarantees that title to all Work, materials, and equipment covered by any Application for Payment, whether incorporated in the Project or not, will pass to OWNER no later than the time of payment free and clear of all Liens.

14.04 *Substantial Completion*

A. When CONTRACTOR considers the entire Work ready for its intended use CONTRACTOR shall notify OWNER and ENGINEER in writing that the entire Work is substantially complete (except for items specifically listed by CONTRACTOR as incomplete) and request that ENGINEER issue a certificate of Substantial Completion. Promptly thereafter, OWNER, CONTRACTOR, and ENGINEER shall make an inspection of the Work to determine the status of completion. If ENGINEER does not consider the Work substantially complete, ENGINEER will notify CONTRACTOR in writing giving the reasons therefor. If ENGINEER considers the Work substantially complete, ENGINEER will prepare and deliver to OWNER a tentative certificate of Substantial Completion which shall fix the date of Substantial Completion. There shall be attached to the certificate a tentative list of items to be completed or corrected before final payment. OWNER shall have seven days after receipt of the tentative certificate during which to make written objection to ENGINEER as to any provisions of the certificate or attached list. If, after considering such objections, ENGINEER concludes that the Work is not substantially complete, ENGINEER will within 14 days after submission of the tentative certificate to OWNER notify CONTRACTOR in writing, stating the reasons therefor. If, after consideration of OWNER's objections, ENGINEER considers the Work substantially complete, ENGINEER will within said 14 days execute and deliver to OWNER and CONTRACTOR a definitive certificate of Substantial Completion (with a revised tentative list of items to be completed or corrected) reflecting such changes from the tentative certificate as ENGINEER believes justified after consideration of any objections from OWNER. At the time of delivery of the tentative certificate of Substantial Completion ENGINEER will deliver to OWNER and CONTRACTOR a written recommendation as to division of responsibilities pending final payment between OWNER and CONTRACTOR with respect to security, operation, safety, and protection of the Work, maintenance, heat, utilities, insurance, and warranties and guarantees. Unless OWNER and CONTRACTOR agree otherwise in writing and so inform ENGINEER in writing prior to ENGINEER's issuing the definitive certificate of Substantial Completion,

ENGINEER's aforesaid recommendation will be binding on OWNER and CONTRACTOR until final payment.

B. OWNER shall have the right to exclude CONTRACTOR from the Site after the date of Substantial Completion, but OWNER shall allow CONTRACTOR reasonable access to complete or correct items on the tentative list.

14.05 *Partial Utilization*

A. Use by OWNER at OWNER's option of any substantially completed part of the Work which has specifically been identified in the Contract Documents, or which OWNER, ENGINEER, and CONTRACTOR agree constitutes a separately functioning and usable part of the Work that can be used by OWNER for its intended purpose without significant interference with CONTRACTOR's performance of the remainder of the Work, may be accomplished prior to Substantial Completion of all the Work subject to the following conditions.

1. OWNER at any time may request CONTRACTOR in writing to permit OWNER to use any such part of the Work which OWNER believes to be ready for its intended use and substantially complete. If CONTRACTOR agrees that such part of the Work is substantially complete, CONTRACTOR will certify to OWNER and ENGINEER that such part of the Work is substantially complete and request ENGINEER to issue a certificate of Substantial Completion for that part of the Work. CONTRACTOR at any time may notify OWNER and ENGINEER in writing that CONTRACTOR considers any such part of the Work ready for its intended use and substantially complete and request ENGINEER to issue a certificate of Substantial Completion for that part of the Work. Within a reasonable time after either such request, OWNER, CONTRACTOR, and ENGINEER shall make an inspection of that part of the Work to determine its status of completion. If ENGINEER does not consider that part of the Work to be substantially complete, ENGINEER will notify OWNER and CONTRACTOR in writing giving the reasons therefor. If ENGINEER considers that part of the Work to be substantially complete, the provisions of paragraph 14.04 will apply with respect to certification of Substantial Completion of that part of the Work and the division of responsibility in respect thereof and access thereto.

2. No occupancy or separate operation of part of the Work may occur prior to compliance with the requirements of paragraph 5.10 regarding property insurance.

14.06 *Final Inspection*

A. Upon written notice from CONTRACTOR that the entire Work or an agreed portion thereof is complete, ENGINEER will promptly make a final inspection with OWNER and CONTRACTOR and will notify CONTRACTOR in writing of all particulars in which this inspection reveals that the Work is incomplete or defective. CONTRACTOR shall immediately take such measures as are necessary to complete such Work or remedy such deficiencies.

14.07 *Final Payment*

A. *Application for Payment*

1. After CONTRACTOR has, in the opinion of ENGINEER, satisfactorily completed all corrections identified during the final inspection and has delivered, in accordance with the Contract Documents, all maintenance and operating instructions, schedules, guarantees, Bonds, certificates or other evidence of insurance certificates of inspection, marked-up record documents (as provided in paragraph 6.12), and other documents, CONTRACTOR may make application for final payment following the procedure for progress payments.

2. The final Application for Payment shall be accompanied (except as previously delivered) by: (i) all documentation called for in the Contract Documents, including but not limited to the evidence of insurance required by subparagraph 5.04.B.7; (ii) consent of the surety, if any, to final payment; and (iii) complete and legally effective releases or waivers (satisfactory to OWNER) of all Lien rights arising out of or Liens filed in connection with the Work.

3. In lieu of the releases or waivers of Liens specified in paragraph 14.07.A.2 and as approved by OWNER, CONTRACTOR may furnish receipts or releases in full and an affidavit of CONTRACTOR that: (i) the releases and receipts include all labor, services, material, and equipment for which a Lien could be filed; and (ii) all payrolls, material and equipment bills, and other

indebtedness connected with the Work for which OWNER or OWNER's property might in any way be responsible have been paid or otherwise satisfied. If any Subcontractor or Supplier fails to furnish such a release or receipt in full, CONTRACTOR may furnish a Bond or other collateral satisfactory to OWNER to indemnify OWNER against any Lien.

B. *Review of Application and Acceptance*

1. If, on the basis of ENGINEER's observation of the Work during construction and final inspection, and ENGINEER's review of the final Application for Payment and accompanying documentation as required by the Contract Documents, ENGINEER is satisfied that the Work has been completed and CONTRACTOR's other obligations under the Contract Documents have been fulfilled, ENGINEER will, within ten days after receipt of the final Application for Payment, indicate in writing ENGINEER's recommendation of payment and present the Application for Payment to OWNER for payment. At the same time ENGINEER will also give written notice to OWNER and CONTRACTOR that the Work is acceptable subject to the provisions of paragraph 14.09. Otherwise, ENGINEER will return the Application for Payment to CONTRACTOR, indicating in writing the reasons for refusing to recommend final payment, in which case CONTRACTOR shall make the necessary corrections and resubmit the Application for Payment.

C. *Payment Becomes Due*

1. Thirty days after the presentation to OWNER of the Application for Payment and accompanying documentation, the amount recommended by ENGINEER will become due and, when due, will be paid by OWNER to CONTRACTOR.

14.08 *Final Completion Delayed*

A. If, through no fault of CONTRACTOR, final completion of the Work is significantly delayed, and if ENGINEER so confirms, OWNER shall, upon receipt of CONTRACTOR's final Application for Payment and recommendation of ENGINEER, and without terminating the Agreement, make payment of the balance due for that portion of the Work fully completed and accepted. If the remaining balance to be held by OWNER for Work not

fully completed or corrected is less than the retainage stipulated in the Agreement, and if Bonds have been furnished as required in paragraph 5.01, the written consent of the surety to the payment of the balance due for that portion of the Work fully completed and accepted shall be submitted by CONTRACTOR to ENGINEER with the Application for such payment. Such payment shall be made under the terms and conditions governing final payment, except that it shall not constitute a waiver of Claims.

14.09 *Waiver of Claims*

A. The making and acceptance of final payment will constitute:

1. a waiver of all Claims by OWNER against CONTRACTOR, except Claims arising from unsettled Liens, from defective Work appearing after final inspection pursuant to paragraph 14.06, from failure to comply with the Contract Documents or the terms of any special guarantees specified therein, or from CONTRACTOR's continuing obligations under the Contract Documents; and

2. a waiver of all Claims by CONTRACTOR against OWNER other than those previously made in writing which are still unsettled.

ARTICLE 15 - SUSPENSION OF WORK AND TERMINATION

15.01 OWNER May Suspend Work

A. At any time and without cause, OWNER may suspend the Work or any portion thereof for a period of not more than 90 consecutive days by notice in writing to CONTRACTOR and ENGINEER which will fix the date on which Work will be resumed. CONTRACTOR shall resume the Work on the date so fixed. CONTRACTOR shall be allowed an adjustment in the Contract Price or an extension of the Contract Times, or both, directly attributable to any such suspension if CONTRACTOR makes a Claim therefor as provided in paragraph 10.05.

15.02 *OWNER May Terminate for Cause*

A. The occurrence of any one or more of the following events will justify termination for cause:

1. CONTRACTOR's persistent failure to perform the Work in accordance with the Contract Documents (including, but not limited to, failure to supply sufficient skilled workers or suitable materials or equipment or failure to adhere to the progress schedule established under paragraph 2.07 as adjusted from time to time pursuant to paragraph 6.04);

2. CONTRACTOR's disregard of Laws or Regulations of any public body having jurisdiction;

3. CONTRACTOR's disregard of the authority of ENGINEER; or

4. CONTRACTOR's violation in any substantial way of any provisions of the Contract Documents.

B. If one or more of the events identified in paragraph 15.02.A occur, OWNER may, after giving CONTRACTOR (and the surety, if any) seven days written notice, terminate the services of CONTRACTOR, exclude CONTRACTOR from the Site, and take possession of the Work and of all CONTRACTOR's tools, appliances, construction equipment, and machinery at the Site, and use the same to the full extent they could be used by CONTRACTOR (without liability to CONTRACTOR for trespass or conversion), incorporate in the Work all materials and equipment stored at the Site or for which OWNER has paid CONTRACTOR but which are stored elsewhere, and finish the Work as OWNER may deem expedient. In such case, CONTRACTOR shall not be entitled to receive any further payment until the Work is finished. If the unpaid balance of the Contract Price exceeds all claims, costs, losses, and damages (including but not limited to all fees and charges of engineers, architects, attorneys, and other professionals and all court or arbitration or other dispute resolution costs) sustained by OWNER arising out of or relating to completing the Work, such excess will be paid to CONTRACTOR. If such claims, costs, losses, and damages exceed such unpaid balance, CONTRACTOR shall pay the difference to OWNER. Such claims, costs, losses, and damages incurred by OWNER will be reviewed by ENGINEER as to their reasonableness and, when so approved by ENGINEER, incorporated in a Change Order. When exercising any rights or remedies under this paragraph OWNER shall not be required to obtain the lowest price for the Work performed.

C. Where CONTRACTOR's services have been so terminated by OWNER, the termination will not affect any rights or remedies of OWNER against CONTRACTOR then existing or which may thereafter accrue. Any retention or payment of moneys due CONTRACTOR by OWNER will not release CONTRACTOR from liability.

15.03 *OWNER May Terminate For Convenience*

A. Upon seven days written notice to CONTRACTOR and ENGINEER, OWNER may, without cause and without prejudice to any other right or remedy of OWNER, elect to terminate the Contract. In such case, CONTRACTOR shall be paid (without duplication of any items):

1. for completed and acceptable Work executed in accordance with the Contract Documents prior to the effective date of termination, including fair and reasonable sums for overhead and profit on such Work;

2. for expenses sustained prior to the effective date of termination in performing services and furnishing labor, materials, or equipment as required by the Contract Documents in connection with uncompleted Work, plus fair and reasonable sums for overhead and profit on such expenses;

3. for all claims, costs, losses, and damages (including but not limited to all fees and charges of engineers, architects, attorneys, and other professionals and all court or arbitration or other dispute resolution costs) incurred in settlement of terminated contracts with Subcontractors, Suppliers, and others; and

4. for reasonable expenses directly attributable to termination.

B. CONTRACTOR shall not be paid on account of loss of anticipated profits or revenue or other economic loss arising out of or resulting from such termination.

15.04 *CONTRACTOR May Stop Work or Terminate*

A. If, through no act or fault of CONTRACTOR, the Work is suspended for more than 90 consecutive days by OWNER or under an order of court or other public authority, or ENGINEER fails to act on any Application for Payment within 30 days after it is submitted, or OWNER fails for 30 days to pay CONTRACTOR any sum finally determined to be due, then CONTRACTOR may, upon

seven days written notice to OWNER and ENGINEER, and provided OWNER or ENGINEER do not remedy such suspension or failure within that time, terminate the Contract and recover from OWNER payment on the same terms as provided in paragraph 15.03. In lieu of terminating the Contract and without prejudice to any other right or remedy, if ENGINEER has failed to act on an Application for Payment within 30 days after it is submitted, or OWNER has failed for 30 days to pay CONTRACTOR any sum finally determined to be due, CONTRACTOR may, seven days after written notice to OWNER and ENGINEER, stop the Work until payment is made of all such amounts due CONTRACTOR, including interest thereon. The provisions of this paragraph 15.04 are not intended to preclude CONTRACTOR from making a Claim under paragraph 10.05 for an adjustment in Contract Price or Contract Times or otherwise for expenses or damage directly attributable to CONTRACTOR's stopping the Work as permitted by this paragraph.

ARTICLE 16 - DISPUTE RESOLUTION*

16.01 *Methods and Procedures*

A. Dispute resolution methods and procedures, if any, shall be as set forth in the Supplementary Conditions. If no method and procedure has been set forth, and subject to the provisions of paragraphs 9.09 and 10.05, OWNER and CONTRACTOR may exercise such rights or remedies as either may otherwise have under the Contract Documents or by Laws or Regulations in respect of any dispute.

ARTICLE 17 - MISCELLANEOUS*

17.01 *Giving Notice*

A. Whenever any provision of the Contract Documents requires the giving of written notice, it will be deemed to have been validly given if delivered in person to the individual or to a member of the firm or to an officer of the corporation for whom it is intended, or if delivered at or sent by registered or certified mail, postage prepaid, to the last business address known to the giver of the notice.

17.02 *Computation of Times*

A. When any period of time is referred to in the Contract Documents by days, it will be computed to

exclude the first and include the last day of such period. If the last day of any such period falls on a Saturday or Sunday or on a day made a legal holiday by the law of the applicable jurisdiction, such day will be omitted from the computation.

17.03 *Cumulative Remedies*

A. The duties and obligations imposed by these General Conditions and the rights and remedies available hereunder to the parties hereto are in addition to, and are not to be construed in any way as a limitation of, any rights and remedies available to any or all of them which are otherwise imposed or available by Laws or Regulations, by special warranty or guarantee, or by other provisions of the Contract Documents, and the provisions of this paragraph will be as effective as if repeated specifically in the Contract Documents in connection with each particular duty, obligation, right, and remedy to which they apply.

17.04 *Survival of Obligations*

A. All representations, indemnifications, warranties, and guarantees made in, required by, or given in accordance with the Contract Documents, as well as all continuing obligations indicated in the Contract Documents, will survive final payment, completion, and acceptance of the Work or termination or completion of the Agreement.

17.05 *Controlling Law*

A. This Contract is to be governed by the law of the state in which the Project is located.

SUPPLEMENTAL GENERAL CONDITIONS

These Supplementary Conditions amend or supplement the Standard General Conditions of the Construction Contract (No. 1910-8, 1996 Edition) and other provisions of the Contract Documents as indicated below. All provisions, which are not so amended or supplemental, remain in full force and effect.

The terms used in these Supplementary Conditions will have the meanings indicated in the General Conditions. Additional terms used in these Supplementary Conditions have the meanings indicated below, which are applicable to both the singular and plural thereof.

SC-6.10 Delete paragraph 6.10 in its entirety and insert the following in its place:

The owner qualifies for the state and local tax exemption in the purchase of certain materials and equipment the Contractor shall utilize the form provided herewith in exhibit "D".

SC-11.01 Delete paragraph 11.01 in its entirety.

SC-11.02 Delete paragraph 11.02 in its entirety.

SC-12.01B.25 & B.3. Delete paragraph 12.01B.2 & B.3 in its entirety.

SC-12.01.C.2 Delete paragraph 12.01.C.2 in its entirety.

SC Article 14.02 C.1 Replace "**Ten days**" with "**Thirty days**" to read as follows: Thirty days after presentation of the Application for Payment to OWNER with ENGINEER'S recommendation, the amount recommended will (subject to the provisions of paragraph 14.02.D) become due, and when due will be paid by OWNER TO CONTRACTOR.

SC Article 16 Add the following language at the end of the paragraph of Article 16:

There are no dispute resolution methods and procedures set forth in the Supplemental Conditions:

GENERAL PREVAILING WAGE LEGAL REQUIREMENTS

The Contractor's attention is called to Texas Government Code Chapter 2258, which must be complied with attached herewith as Exhibit "C"

GENERAL NOTES AND STANDARD SPECIFICATIONS

For all pits or quarries, comply with the "Texas Aggregate Quarry and Pit Safety Act."

Provide on a weekly basis a list of equipment, including idle equipment, utilized on the project that week.

The 1-800 call services for utility locations do not include TxDOT facilities.

ITEM 3. Scope of Work

This Contract includes non-site specific work. Multiple work orders will be used to procure work of the type identified in the contract at locations that have not yet been determined.

ITEM 5. Control of the Work

Prior to contract letting, bidders may obtain a free computer diskette or a computerized transfer of files (from the Engineer's office) that contains the earthwork information. If copies of the actual cross-sections in addition to, or instead of, the diskette are requested, they will be available at the Engineers office for borrowing by copying companies for the purpose of making copies for the bidder at the bidders expense.

ITEM 8. Prosecution and Progress

Where road closures or detours around structures are necessary to accomplish proposed work, the removal of existing structures and/or cutting of existing pavement will not be permitted until all pre-cast members for the proposed structure have been cast, tested and approved for use.

Working days will be computed and charged in accordance with Article 8.3.A.6 defined as follows:

Upon issuance of written authorization to begin work, all of Item 100, "Preparing Right of Way" will commence. Item 100 work shall be completed before work begins on other items, unless otherwise authorized by the project engineer.

Work and time charges will continue until completion of Item 100. Upon completion of Item 100, work and time charges will stop for a maximum period of 120 days for utility work to be completed. Time charges in accordance with Article 8.3.A.1 will resume at the end of the 120 day utility work period or earlier if mutually agreed in writing by the engineer and contractor.

ITEM 100. Preparing Right of Way

Clearing & grubbing shall be executed in accordance with the District Clearing and Grubbing detail sheets.

ITEMS 134. Backfilling Pavement Edges

Areas to be backfilled shall extend approximately 3-ft out from the edges of the proposed overlay. Final slopes shall be uniform and smooth. The 100-foot station payment includes Backfilling of both sides.

Backfill Ty A shall not contain particles more than two inches in size and shall have a minimum PI of 10 and a maximum PI of 20.

Any additional backfill material necessary due to pre-existing edge conditions or to replace existing fill removed during blading operations will not be paid for directly. It will be considered subsidiary to this bid item.

ITEM 164. Seeding for Erosion Control

During drill seeding operations, application methods shall be in accordance with the method shown in the Standard Specification Book.

Cool Season or Warm Season Grasses shall be included as part of Item 164 (See Table 3 and/or Table 4 in the Standard Specification Manual for dates and seed type).

Seed mixture

Seed mixture shall be as specified under Item 164.

ITEM 166. Fertilizer

Fertilizer rate is based on a rate of 100 Lbs. of Nitrogen per acre. The Nitrogen-Phosphorous-Potassium (NPK) ratio shall include a minimum of 5 percent phosphorous and 5 percent Potassium. Fertilizer shall be homogenized.

ITEM 216. Proof Rolling

Work shall be done in accordance to Item 216, except for measurement and payment. This work will not be paid for directly, but shall be considered subsidiary to the various bid items.

ITEM 247. Flexible Base

Flexible Base Type E will be composed of caliche (argillaceous Limestone, calcareous or calcareous clay particles) and may contain stone, conglomerate, gravel, sand or granular materials when these materials are in situ with the caliche.

Blended material for Flexible Base TY E GR 4

The Contractor may blend base material with another caliche source or with crushed concrete, meeting the requirements for TY “D” materials, provided a minimum of 50% caliche is used. The crushed concrete may contain sand or granular materials. Stabilizing additives will not be allowed in the raw crushed concrete base. Acceptance will be under the following conditions:

Condition One (1): When both components of the blend in their individual stockpiles meet all the physical requirements of this Item, then field blending will be allowed.

Condition Two (2): When only one component of the blend passes the physical requirements of this Item, the materials shall be blended through a plant for stockpile testing and approval.

Flexible Base (TY E GR 4) shall conform to the following requirements:

BEFORE LIME IS ADDED

Retained on Sq. Sieve	Percent Retained
2”	0
1/2”	20-60
No. 4	40-75
No. 40	70-90
Max. PI:	15
Max. Wet Ball PI:	15
Wet Ball Mill Max Amount:	50
Min. Comp. Strength PSI:	150 at 15 PSI lateral pressure
Triaxial Test	Tex-117-E

The Wet Ball Test (Tex-116-E) shall be run and the Plasticity Index of the material passing the No. 40 sieve shall be determined (Wet Ball PI).

After 1% lime (laboratory) is added to unlimed material

Max PI	12
Min. Comp. Strength PSI:	180 at 15 PSI Lateral Pressure
Triaxial Test (Lime Treated)	Tex-121-E

Two (2) percent lime (by weight) will be incorporated into the Flexible Base in the field at the Owner's expense in accordance with the provisions of Items 260.

The percent of density as determined by Compaction Ratio (Tex-113-E) for the new Flexible Base shall be a minimum of 98%.

The Contractor's attention is called to the fact that certain existing and/or proposed structures may be within the limits of the Flexible Base. It shall be the Contractor's responsibility to perform construction operations without damage to these structures.

For water added under Item 247, the sulfate content will not exceed 3000-ppm and the chloride content will not exceed 3000-ppm.

Perform base ride quality testing for all base with only one lift of ACP or a seal coat as the final surface in accordance with the Pharr District Special Provision for flexbase ride testing. Perform base ride quality testing before placing the ACP or seal coat.

ITEM 251. Reworking Base Material

Quantities of Flexible Base to be salvaged, shown on the typical sections, are for estimating purposes only. All acceptable base material encountered in existing base is to be salvaged as directed by the Engineer regardless of the quantities involved.

Salvaged base shall be used in the bottom course on any of the proposed roadway and/or turnout sections.

Salvaged base may be used on any of the proposed driveway sections.

ITEM 260. Lime Treatment (Road Mixed)

The Contractor's attention is called to the fact that certain existing and/or proposed structures are within the limits of the lime-treated Subgrade. Unless otherwise directed by the Engineer, these structures shall be installed before the final rolling of this Subgrade. It shall be the Contractor's responsibility to perform the proper lime treating operation without damage to these structures.

The slurry method of applying lime will be required, except when the lime is to be added to naturally wet materials as directed by the Engineer.

For this project, the Engineer will direct a random number of lime trucks to be check weighed.

The percent of density as determined by Tex-121-E for the new and salvage Flexible Base shall be a minimum of 98% for all courses.

ITEM 300. Asphalt's, Oils and Emulsions

Temporary ramps/detours and driveways may use performance grade binder 64-22.

ITEM 301. Asphalt Antistripping Agents

Lime TY A or B shall be added as an Antistripping additive between the rates of 1 % minimum 2.0% maximum by weight for item 341. If the Hamburg wheel test cannot be met within these limits, Liquid Antistripping agents as approved by the Engineer may be used in conjunction with lime for item 341.

ITEM 310. Prime Coat (Cutback Asphaltic Material)

The Contractor shall exercise diligence in the application of asphalt by the use of flagging and rolling procedures to keep from spraying or splattering the traveling public with asphaltic material.

All existing Flexible Base, which may become exposed by the milling operation, shall be primed at the rate of 0.2 Gal/SY.

Do not apply subsequent courses over the initial prime coat any earlier than the day after the prime coat was applied, unless otherwise authorized or directed by the Engineer.

ITEM 314. Emulsified Asphalt Treatment

The Contractor shall exercise diligence in the application of emulsified asphalt by the use of flagging to keep from spraying or splattering the traveling public with asphaltic material.

ITEM 400. Excavation and Backfill for Structures

If the Contractor elects to cut pavement (existing/detour) for structural work beyond that required by the construction phasing shown in the plans and approved by the Engineer, it shall be restored at his expense and backfilled to its original condition or better in accordance with Item 400.

Unless shown otherwise in the plans, use a 1-ft depth for Item 400 Structural Excavation (Special) for gravel bedding needed below drainage structures with unstable material.

ITEM 420. Concrete Structures

Use membrane curing, Type 2, for concrete curb, gutter and combined curb and gutter, concrete medians, directional islands and sidewalks.

Pay bent concrete as plan quantity.

ITEM 421. Portland cement Concrete

Provide Sulfate Resistant Concrete for all concrete piling and drilled shafts.

Provide equipment at the batch plant for determining the free moisture and/or absorption of aggregates in accordance with applicable TXDOT Test.

Provide the following items for concrete batch inspection in accordance with specifications outlined in DMS-10101, "Computer Equipment":

- (1) One Desktop Microcomputer or One Laptop Microcomputer
- (2) One Integrated Printer/Scanner/Copier/Fax Unit
- (3) Contractor-Furnished Software
- (4) Hardware

Air entrain all concrete used in Drilled Shafts.

ITEM 432. Riprap

Provide Class "A" concrete minimum for riprap aprons placed around all box culvert and pipe safety end treatments.

ITEM 462. Concrete Box Culverts and Storm Drains

Provide joints in pre-cast concrete box culverts using any of the methods specified in Item 464, except mortar joints.

Provide pre-cast concrete boxes to expedite traffic handling unless otherwise shown on the plans.

Provide the Area Engineer with the casting schedule of all pre-cast concrete boxes prior to beginning any fabrication.

ITEM 464. Reinforced Concrete Pipe

Use tongue and groove pipe where the RCP extends into the lime treated subgrade. The 4-foot depth restriction for heavy equipment passage over pipe structures is voided. The Contractor will be responsible for any construction damage to these facilities.

Do not use mortar joints.

All reinforced concrete pipe shall include rubber gaskets unless shown otherwise on the plans or directed by the engineer.

ITEM 466. Headwalls and Wingwalls

Do not use pre-cast headwalls/wingwalls.

ITEM 467. Safety End Treatment

All Type II SET's shall have riprap, Class "A" minimum, aprons as shown on the plans. The contractor may submit an alternate precast SET design for approval by the Engineer.

ITEM 471. Frames, Grates, Rings and Covers

All grates will be tack welded to the frames in a manner satisfactory to the Engineer.

ITEM 496. Removing Old Structures

Store the following items to be salvaged at a location designated by the Engineer:

ITEM 502. Barricades, Signs and Traffic Handling

Shadow vehicles equipped with Truck-Mounted Attenuators are required.

A pilot car and radio equipped flaggers shall be required for all undivided roadway locations as directed by the Engineer. The pilot car with necessary flaggers and/or radio equipped flaggers and all signs, equipment, labor and incidentals required for this method of traffic control will not be paid for directly, but shall be considered subsidiary to Item 502.

Replace/relocate all regulatory signs removed due to construction operations with a same sign on fixed support(s) immediately upon its removal. First obtain project Engineer approval before removing any regulatory roadway sign. Required flaggers are to be available to direct traffic during sign intermediate down time.

Relocate any Directional Sign Assemblies removed during construction operations immediately upon their removal.

These signs shall be relocated to a location in accordance with the Latest Version of the “Texas Manual on Uniform Traffic Control Devices”. In no case will a sign be removed without a replacement sign and support(s) being readily available and a location established. Removal and relocation of these signs required for traffic control will not be paid for directly, but shall be considered subsidiary to Item 502.

ITEM 504. Field Office and Laboratory

For this project a field office will not be required at the project site.

ITEM 506. Temporary Erosion, Sedimentation, and Environmental Controls

Due to the nature of this project, it is unlikely a significant amount of soil will be disturbed. However, if for unforeseen reasons a sediment control fence is needed; it shall be placed as directed by the Engineer.

ITEM 508. Constructing Detours

Flexible Base, prime coat, and Asphaltic Concrete Pavement used for detours shall meet the requirements of Items 247, 310, and 341 respectively, except for measurement and payment.

ITEM 529. Concrete Curb, Gutter and Combined Curb and Gutter

Before final acceptance of the project, remove discoloration caused by tire marks, mud, asphalt, paint or other similar material by any method satisfactory to the Engineer to achieve a uniform color and texture of the finished surface exposed to view.

ITEM 530. Public & Private Driveways

Prime coat shall meet the requirements of Item 310.

Daily testing requirements for Hot Mix Asphaltic Concrete Pavements for drives, commercial entrances and/or turnouts may be waived by the Engineer.

ITEM 531. Sidewalks

Construct ¼-inch thick score joints at a maximum 6-foot spacing and expansion joints at a maximum 30-foot spacing. Construct a joint in the center of the sidewalk if it is over 15-feet

wide. For steel reinforcement, use 6x6-inch spacing with #3 bars or 6x6 – D6 welded wire fabric.

ITEM 538. Right of Way Markers

Right of Way markers will be set under the supervision of a registered public land surveyor.

Existing Right of Way monuments to be reset with proposed Right of Way markers will be referenced to a minimum of three reference points set under the supervision of a registered public land surveyor.

he Contractor will inform the Engineer when all reference points have been installed and allow the TXDOT survey crew to survey the reference points before installing the proposed Right of Way markers.

ITEM 540. Metal Beam Guard Fence

The optional terminal anchor post with the terminal connector will be required as shown on the Metal Beam Guard Fence Standard.

ITEM 542. Removing Metal Beam Guard Fence

Dispose all metal beam guard fence materials unless shown otherwise in the plans.

ITEM 544. Guardrail End Treatments

Label “end treatment type” on backside of unit at time of installation.

ITEM 552. Wire Fence

Contractor is to repair any wire fence that is damaged by the contractor to insure the retention of livestock, if any, in their respective pastures along the project.

ITEM 585. Ride Quality for Pavement Surfaces

Use Surface Test Type "B" for service roads and ramps.

Quality control results shall be submitted to TxDOT the next working day after each day's paving.

Pavement areas with public turnout intersections that carry major traffic volumes will not be subjected to inertial profiler testing. These areas shall be evaluated using the 10-ft. Straightedge.

Diamond grinding shall be used to remove localized roughness.

ITEMS 662 AND 666, Work Zone Pavement Markings and Reflectorized Pavement Markings

All permanent pavement markings and work zone pavement markings for this project under these Items shall be 0.100 inches (100 mil) thick thermoplastic.

Any permanent pavement markings or non-removal work zone pavement markings lacking reflectivity in accordance with test method Tex 828-B, will not be paid for, as per district policy. The roadway will be re-stripped at no additional compensation.

Pavement surface preparation for markings and markers will not be paid for directly, but shall be considered subsidiary to Item 666.

Prior to any striping operations, an on-site coordination meeting between all the parties involved will be required to review striping details and requirements to ensure quality work.

The beads used on this project shall meet the requirements of Departmental Materials Specification DMS-8290, Glass Traffic Beads Texas Type II & III. Use a 50% Type II/ 50% Type III mix utilizing a double drop system with Type II beads dropped first.

ITEM 677, Eliminating Existing Pavement Markings and Markers

Asphalt and aggregate types and grades shall be as approved in writing when a surface treatment is used to eliminate existing pavement markings.

GOVERNING SPECIFICATIONS AND SPECIAL PROVISIONS

All specifications and special provisions applicable to this project are identified as follows:

STANDARD SPECIFICATIONS: Adopted by the Texas Department of Transportation, June 1, 2004. Standard Specifications are incorporated into the contract by reference.

- ITEM 100 PREPARING RIGHT OF WAY
- ITEM 104 REMOVING CONCRETE
- ITEM 132 EMBANKMENT
- ITEM 164 SEEDING FOR EROSION CONTROL
- ITEM 166 FERTILIZER
- ITEM 168 VEGETATIVE WATER
- ITEM 216 PROOF ROLLING
- ITEM 247 FLEXIBLE BASE
- ITEM 251 REWORKING BASE COURSES
- ITEM 260 LIME TREATMENT (ROAD MIXED)
- ITEM 300 ASPHALTS, OILS AND EMULSIONS
- ITEM 310 PRIME COAT
- ITEM 340 DENSE GRADED HOT MIX ASPHALT (METHOD)
- ITEM 354 PLANING AND TEXTURING PAVEMENT
- ITEM 464 REINFORCED CONCRETE PIPE
- ITEM 465 MANHOLES AND INLETS
- ITEM 496 REMOVING STRUCTURES
- ITEM 500 MOBILIZATION
- ITEM 502 BARRICADES, SIGNS AND TRAFFIC HANDLING
- ITEM 506 TEMPORARY EROSION, SEDIMENTATIONS AND ENVIRONMENTAL CONTROLS
- ITEM 529 CONCRETE CURB, GUTTER AND COMBINED CURB-GUTTER
- ITEM 530 INTERSECTIONS, DRIVEWAYS AND TURNOUTS
- ITEM 556 PIPE UNDERDRAINS
- ITEM 585 RIDE QUALITY FOR PAVEMENT STRUCTURES
- ITEM 666 REFLECTORIZED PAVEMENT MARKINGS
- ITEM 760 CLEANING AND RESHAPING DITCHES
- ITEM 2500 EN-1 ROADBOND

SPECIAL SPECIFICATIONS: Adopted by the Texas Department of Transportation, June 1, 2004 are incorporated into the contract by reference.

SS 3035 BLADE LEVEL-UP

SPECIAL PROVISIONS: Special Provisions will govern and take precedence over the Specifications enumerated hereon wherever in conflict therewith. (Enclosed herewith)

- PREPARING RIGHT OF WAY: SP 100-002
- SEEDING FOR EROSION CONTROL: SP 164-002 & 004
- FERTILIZER: SP 166-001
- FLEXIBLE BASE: SP 247-033,036,038,039,040 & 041
- LIME TREATMENT (ROAD MIXED): SP 260-001
- ASPHALTS, OILS AND EMULSIONS: SP 300-008, 016, 020 & 025

- DENSE GRADED HOT MIX ASPHALT (METHOD): SP 340-001 & 003
- REINFORCED CONCRETE PIPE: SP 464-003
- MANHOLES AND INLETS: SP 465-001
- MOBILIZATION: SP 500
- BARRICADES, SIGNS AND TRAFFIC HANDLING: SP 502-006 & 033
- TEMPORARY EROSION, SEDIMENTATIONS AND ENVIRONMENTAL CONTROLS: SP 506-010,011,012&013
- REFLECTORIZED PAVEMENT MARKINGS: SP 666-001, 008 & 014

General: The above listed specifications items are those under which payment is to be made. These, together with such other pertinent items, if any, as may be referred to in the above-listed specification items, and including the special provisions listed above, constitute the complete specifications for this project.

All item numbers noted in these plans are the same as those referenced in the Texas Department of Transportation 2004 Standard Specifications for Construction and Maintenance of Highways, Streets, and Bridges book (June 1, 2004) and Texas Department of Transportation Website.

**Certification
Regarding Debarment, Suspension and Ineligibility**

As is required by the Federal Regulations Implementing Executive Order 12549, Debarment and Suspension, 45 CFR Part 76, Government-wide Debarment and Suspension, the applicant certifies, to the best of his or her knowledge and belief, that both it and its principals:

- a. Are not presently debarred, suspended, proposed for debarment, declared ineligible, or voluntarily excluded from participation in this transaction by any federal department or agency;
- b. Have not within a three-year period preceding this bid proposal and/or application been convicted of or had a civil judgment rendered against them for commission of fraud or a criminal offense in connection with obtaining, attempting to obtain, or performing a public (federal, state, or local) transaction or contract under a public transaction, violation of federal or state antitrust statutes or commission of embezzlement, theft, forgery, bribery, falsification or destruction of records, making false statements, or receiving stolen property;
- c. Are not presently indicted for or otherwise criminally or civilly charged by a government entity with commission of any of the offenses enumerated herein; and
- d. Have not within a three-year period preceding this bid proposal and/or application had one or more public transactions terminated for cause or default.

Signature: _____
Print Name: _____
Title: _____
Telephone Number: _____
Date: _____

If the bidder is unable to certify to all of the statements in this Certification, such bidder should attach an explanation to this proposal.

Request for Taxpayer Identification Number and Certification

**Give form to the
 requester. Do not
 send to the IRS.**

Print or type See Specific instructions on page 2.	Name (as shown on your income tax return)	
	Business name, if different from above	
	Check appropriate box: <input type="checkbox"/> Individual/Sole proprietor <input type="checkbox"/> Corporation <input type="checkbox"/> Partnership <input type="checkbox"/> Other ▶	
	<input type="checkbox"/> Exempt from backup withholding	
	Address (number, street, and apt. or suite no.)	Requester's name and address (optional)
	City, state, and ZIP code	
List account number(s) here (optional)		

Part I Taxpayer Identification Number (TIN)

Enter your TIN in the appropriate box. The TIN provided must match the name given on Line 1 to avoid backup withholding. For individuals, this is your social security number (SSN). However, for a resident alien, sole proprietor, or disregarded entity, see the Part I instructions on page 3. For other entities, it is your employer identification number (EIN). If you do not have a number, see *How to get a TIN* on page 3.

Note. If the account is in more than one name, see the chart on page 4 for guidelines on whose number to enter.

Social security number								
or								
Employer identification number								

Part II Certification

Under penalties of perjury, I certify that:

1. The number shown on this form is my correct taxpayer identification number (or I am waiting for a number to be issued to me), and
2. I am not subject to backup withholding because: (a) I am exempt from backup withholding, or (b) I have not been notified by the Internal Revenue Service (IRS) that I am subject to backup withholding as a result of a failure to report all interest or dividends, or (c) the IRS has notified me that I am no longer subject to backup withholding, and
3. I am a U.S. person (including a U.S. resident alien).

Certification instructions. You must cross out item 2 above if you have been notified by the IRS that you are currently subject to backup withholding because you have failed to report all interest and dividends on your tax return. For real estate transactions, item 2 does not apply. For mortgage interest paid, acquisition or abandonment of secured property, cancellation of debt, contributions to an individual retirement arrangement (IRA), and generally, payments other than interest and dividends, you are not required to sign the Certification, but you must provide your correct TIN. (See the instructions on page 4.)

Sign Here	Signature of U.S. person ▶	Date ▶
------------------	----------------------------	--------

Purpose of Form

A person who is required to file an information return with the IRS, must obtain your correct taxpayer identification number (TIN) to report, for example, income paid to you, real estate transactions, mortgage interest you paid, acquisition or abandonment of secured property, cancellation of debt, or contributions you made to an IRA.

U.S. person. Use Form W-9 only if you are a U.S. person (including a resident alien), to provide your correct TIN to the person requesting it (the requester) and, when applicable, to:

1. Certify that the TIN you are giving is correct (or you are waiting for a number to be issued),
2. Certify that you are not subject to backup withholding, or
3. Claim exemption from backup withholding if you are a U.S. exempt payee.

In 3 above, if applicable, you are also certifying that as a U.S. person, your allocable share of any partnership income from a U.S. trade or business is not subject to the withholding tax on foreign partners' share of effectively connected income.

Note. If a requester gives you a form other than Form W-9 to request your TIN, you must use the requester's form if it is substantially similar to this Form W-9.

For federal tax purposes, you are considered a person if you are:

- An individual who is a citizen or resident of the United States,
- A partnership, corporation, company, or association created or organized in the United States or under the laws of the United States, or
- Any estate (other than a foreign estate) or trust. See Regulations sections 301.7701-6(a) and 7(a) for additional information.

Special rules for partnerships. Partnerships that conduct a trade or business in the United States are generally required to pay a withholding tax on any foreign partners' share of income from such business. Further, in certain cases where a Form W-9 has not been received, a partnership is required to presume that a partner is a foreign person, and pay the withholding tax. Therefore, if you are a U.S. person that is a partner in a partnership conducting a trade or business in the United States, provide Form W-9 to the partnership to establish your U.S. status and avoid withholding on your share of partnership income.

The person who gives Form W-9 to the partnership for purposes of establishing its U.S. status and avoiding withholding on its allocable share of net income from the partnership conducting a trade or business in the United States is in the following cases:

- The U.S. owner of a disregarded entity and not the entity,

- The U.S. grantor or other owner of a grantor trust and not the trust, and
- The U.S. trust (other than a grantor trust) and not the beneficiaries of the trust.

Foreign person. If you are a foreign person, do not use Form W-9. Instead, use the appropriate Form W-8 (see Publication 515, Withholding of Tax on Nonresident Aliens and Foreign Entities).

Nonresident alien who becomes a resident alien.

Generally, only a nonresident alien individual may use the terms of a tax treaty to reduce or eliminate U.S. tax on certain types of income. However, most tax treaties contain a provision known as a "saving clause." Exceptions specified in the saving clause may permit an exemption from tax to continue for certain types of income even after the recipient has otherwise become a U.S. resident alien for tax purposes.

If you are a U.S. resident alien who is relying on an exception contained in the saving clause of a tax treaty to claim an exemption from U.S. tax on certain types of income, you must attach a statement to Form W-9 that specifies the following five items:

1. The treaty country. Generally, this must be the same treaty under which you claimed exemption from tax as a nonresident alien.
2. The treaty article addressing the income.
3. The article number (or location) in the tax treaty that contains the saving clause and its exceptions.
4. The type and amount of income that qualifies for the exemption from tax.
5. Sufficient facts to justify the exemption from tax under the terms of the treaty article.

Example. Article 20 of the U.S.-China income tax treaty allows an exemption from tax for scholarship income received by a Chinese student temporarily present in the United States. Under U.S. law, this student will become a resident alien for tax purposes if his or her stay in the United States exceeds 5 calendar years. However, paragraph 2 of the first Protocol to the U.S.-China treaty (dated April 30, 1984) allows the provisions of Article 20 to continue to apply even after the Chinese student becomes a resident alien of the United States. A Chinese student who qualifies for this exception (under paragraph 2 of the first protocol) and is relying on this exception to claim an exemption from tax on his or her scholarship or fellowship income would attach to Form W-9 a statement that includes the information described above to support that exemption.

If you are a nonresident alien or a foreign entity not subject to backup withholding, give the requester the appropriate completed Form W-8.

What is backup withholding? Persons making certain payments to you must under certain conditions withhold and pay to the IRS 28% of such payments (after December 31, 2002). This is called "backup withholding." Payments that may be subject to backup withholding include interest, dividends, broker and barter exchange transactions, rents, royalties, nonemployee pay, and certain payments from fishing boat operators. Real estate transactions are not subject to backup withholding.

You will not be subject to backup withholding on payments you receive if you give the requester your correct TIN, make the proper certifications, and report all your taxable interest and dividends on your tax return.

Payments you receive will be subject to backup withholding if:

1. You do not furnish your TIN to the requester,
2. You do not certify your TIN when required (see the Part II instructions on page 4 for details),

3. The IRS tells the requester that you furnished an incorrect TIN,

4. The IRS tells you that you are subject to backup withholding because you did not report all your interest and dividends on your tax return (for reportable interest and dividends only), or

5. You do not certify to the requester that you are not subject to backup withholding under 4 above (for reportable interest and dividend accounts opened after 1983 only).

Certain payees and payments are exempt from backup withholding. See the instructions below and the separate Instructions for the Requester of Form W-9.

Also see *Special rules regarding partnerships* on page 1.

Penalties

Failure to furnish TIN. If you fail to furnish your correct TIN to a requester, you are subject to a penalty of \$50 for each such failure unless your failure is due to reasonable cause and not to willful neglect.

Civil penalty for false information with respect to withholding. If you make a false statement with no reasonable basis that results in no backup withholding, you are subject to a \$500 penalty.

Criminal penalty for falsifying information. Willfully falsifying certifications or affirmations may subject you to criminal penalties including fines and/or imprisonment.

Misuse of TINs. If the requester discloses or uses TINs in violation of federal law, the requester may be subject to civil and criminal penalties.

Specific Instructions

Name

If you are an individual, you must generally enter the name shown on your income tax return. However, if you have changed your last name, for instance, due to marriage without informing the Social Security Administration of the name change, enter your first name, the last name shown on your social security card, and your new last name.

If the account is in joint names, list first, and then circle, the name of the person or entity whose number you entered in Part I of the form.

Sole proprietor. Enter your individual name as shown on your income tax return on the "Name" line. You may enter your business, trade, or "doing business as (DBA)" name on the "Business name" line.

Limited liability company (LLC). If you are a single-member LLC (including a foreign LLC with a domestic owner) that is disregarded as an entity separate from its owner under Treasury regulations section 301.7701-3, enter the owner's name on the "Name" line. Enter the LLC's name on the "Business name" line. Check the appropriate box for your filing status (sole proprietor, corporation, etc.), then check the box for "Other" and enter "LLC" in the space provided.

Other entities. Enter your business name as shown on required federal tax documents on the "Name" line. This name should match the name shown on the charter or other legal document creating the entity. You may enter any business, trade, or DBA name on the "Business name" line.

Note. You are requested to check the appropriate box for your status (individual/sole proprietor, corporation, etc.).

Exempt From Backup Withholding

If you are exempt, enter your name as described above and check the appropriate box for your status, then check the "Exempt from backup withholding" box in the line following the business name, sign and date the form.

Generally, individuals (including sole proprietors) are not exempt from backup withholding. Corporations are exempt from backup withholding for certain payments, such as interest and dividends.

Note. If you are exempt from backup withholding, you should still complete this form to avoid possible erroneous backup withholding.

Exempt payees. Backup withholding is not required on any payments made to the following payees:

1. An organization exempt from tax under section 501(a), any IRA, or a custodial account under section 403(b)(7) if the account satisfies the requirements of section 401(f)(2),
 2. The United States or any of its agencies or instrumentalities,
 3. A state, the District of Columbia, a possession of the United States, or any of their political subdivisions or instrumentalities,
 4. A foreign government or any of its political subdivisions, agencies, or instrumentalities, or
 5. An international organization or any of its agencies or instrumentalities.
- Other payees that may be exempt from backup withholding include:
6. A corporation,
 7. A foreign central bank of issue,
 8. A dealer in securities or commodities required to register in the United States, the District of Columbia, or a possession of the United States,
 9. A futures commission merchant registered with the Commodity Futures Trading Commission,
 10. A real estate investment trust,
 11. An entity registered at all times during the tax year under the Investment Company Act of 1940,
 12. A common trust fund operated by a bank under section 584(a),
 13. A financial institution,
 14. A middleman known in the investment community as a nominee or custodian, or
 15. A trust exempt from tax under section 664 or described in section 4947.

The chart below shows types of payments that may be exempt from backup withholding. The chart applies to the exempt recipients listed above, 1 through 15.

IF the payment is for . . .	THEN the payment is exempt for . . .
Interest and dividend payments	All exempt recipients except for 9
Broker transactions	Exempt recipients 1 through 13. Also, a person registered under the Investment Advisers Act of 1940 who regularly acts as a broker
Barter exchange transactions and patronage dividends	Exempt recipients 1 through 5
Payments over \$600 required to be reported and direct sales over \$5,000 ¹	Generally, exempt recipients 1 through 7 ²

¹ See Form 1099-MISC, Miscellaneous Income, and its instructions.

² However, the following payments made to a corporation (including gross proceeds paid to an attorney under section 6045(f), even if the attorney is a corporation) and reportable on Form 1099-MISC are not exempt from backup withholding: medical and health care payments, attorneys' fees; and payments for services paid by a federal executive agency.

Part I. Taxpayer Identification Number (TIN)

Enter your TIN in the appropriate box. If you are a resident alien and you do not have and are not eligible to get an SSN, your TIN is your IRS individual taxpayer identification number (ITIN). Enter it in the social security number box. If you do not have an ITIN, see *How to get a TIN* below.

If you are a sole proprietor and you have an EIN, you may enter either your SSN or EIN. However, the IRS prefers that you use your SSN.

If you are a single-owner LLC that is disregarded as an entity separate from its owner (see *Limited liability company (LLC)* on page 2), enter your SSN (or EIN, if you have one). If the LLC is a corporation, partnership, etc., enter the entity's EIN.

Note. See the chart on page 4 for further clarification of name and TIN combinations.

How to get a TIN. If you do not have a TIN, apply for one immediately. To apply for an SSN, get Form SS-5, Application for a Social Security Card, from your local Social Security Administration office or get this form online at www.socialsecurity.gov. You may also get this form by calling 1-800-772-1213. Use Form W-7, Application for IRS Individual Taxpayer Identification Number, to apply for an ITIN, or Form SS-4, Application for Employer Identification Number, to apply for an EIN. You can apply for an EIN online by accessing the IRS website at www.irs.gov/businesses and clicking on Employer ID Numbers under Related Topics. You can get Forms W-7 and SS-4 from the IRS by visiting www.irs.gov or by calling 1-800-TAX-FORM (1-800-829-3676).

If you are asked to complete Form W-9 but do not have a TIN, write "Applied For" in the space for the TIN, sign and date the form, and give it to the requester. For interest and dividend payments, and certain payments made with respect to readily tradable instruments, generally you will have 60 days to get a TIN and give it to the requester before you are subject to backup withholding on payments. The 60-day rule does not apply to other types of payments. You will be subject to backup withholding on all such payments until you provide your TIN to the requester.

Note. Writing "Applied For" means that you have already applied for a TIN or that you intend to apply for one soon.

Caution: A disregarded domestic entity that has a foreign owner must use the appropriate Form W-8.

Part II. Certification

To establish to the withholding agent that you are a U.S. person, or resident alien, sign Form W-9. You may be requested to sign by the withholding agent even if items 1, 4, and 5 below indicate otherwise.

For a joint account, only the person whose TIN is shown in Part I should sign (when required). Exempt recipients, see *Exempt From Backup Withholding* on page 2.

Signature requirements. Complete the certification as indicated in 1 through 5 below.

1. Interest, dividend, and barter exchange accounts opened before 1984 and broker accounts considered active during 1983. You must give your correct TIN, but you do not have to sign the certification.

2. Interest, dividend, broker, and barter exchange accounts opened after 1983 and broker accounts considered inactive during 1983. You must sign the certification or backup withholding will apply. If you are subject to backup withholding and you are merely providing your correct TIN to the requester, you must cross out item 2 in the certification before signing the form.

3. Real estate transactions. You must sign the certification. You may cross out item 2 of the certification.

4. Other payments. You must give your correct TIN, but you do not have to sign the certification unless you have been notified that you have previously given an incorrect TIN. "Other payments" include payments made in the course of the requester's trade or business for rents, royalties, goods (other than bills for merchandise), medical and health care services (including payments to corporations), payments to a nonemployee for services, payments to certain fishing boat crew members and fishermen, and gross proceeds paid to attorneys (including payments to corporations).

5. Mortgage interest paid by you, acquisition or abandonment of secured property, cancellation of debt, qualified tuition program payments (under section 529), IRA, Coverdell ESA, Archer MSA or HSA contributions or distributions, and pension distributions. You must give your correct TIN, but you do not have to sign the certification.

What Name and Number To Give the Requester

For this type of account:	Give name and SSN of:
1. Individual	The individual
2. Two or more individuals (joint account)	The actual owner of the account or, if combined funds, the first individual on the account ¹
3. Custodian account of a minor (Uniform Gift to Minors Act)	The minor ²
4. a. The usual revocable savings trust (grantor is also trustee)	The grantor-trustee ¹
b. So-called trust account that is not a legal or valid trust under state law	The actual owner ¹
5. Sole proprietorship or single-owner LLC	The owner ³
For this type of account:	Give name and EIN of:
6. Sole proprietorship or single-owner LLC	The owner ³
7. A valid trust, estate, or pension trust	Legal entity ⁴
8. Corporate or LLC electing corporate status on Form 8832	The corporation
9. Association, club, religious, charitable, educational, or other tax-exempt organization	The organization
10. Partnership or multi-member LLC	The partnership
11. A broker or registered nominee	The broker or nominee
12. Account with the Department of Agriculture in the name of a public entity (such as a state or local government, school district, or prison) that receives agricultural program payments	The public entity

¹ List first and circle the name of the person whose number you furnish. If only one person on a joint account has an SSN, that person's number must be furnished.

² Circle the minor's name and furnish the minor's SSN.

³ You must show your individual name and you may also enter your business or "DBA" name on the second name line. You may use either your SSN or EIN (if you have one). If you are a sole proprietor, IRS encourages you to use your SSN.

⁴ List first and circle the name of the legal trust, estate, or pension trust. (Do not furnish the TIN of the personal representative or trustee unless the legal entity itself is not designated in the account title.) Also see *Special rules regarding partnerships* on page 1.

Note. If no name is circled when more than one name is listed, the number will be considered to be that of the first name listed.

Privacy Act Notice

Section 6109 of the Internal Revenue Code requires you to provide your correct TIN to persons who must file information returns with the IRS to report interest, dividends, and certain other income paid to you, mortgage interest you paid, the acquisition or abandonment of secured property, cancellation of debt, or contributions you made to an IRA, or Archer MSA or HSA. The IRS uses the numbers for identification purposes and to help verify the accuracy of your tax return. The IRS may also provide this information to the Department of Justice for civil and criminal litigation, and to cities, states, the District of Columbia, and U.S. possessions to carry out their tax laws. We may also disclose this information to other countries under a tax treaty, to federal and state agencies to enforce federal nontax criminal laws, or to federal law enforcement and intelligence agencies to combat terrorism.

You must provide your TIN whether or not you are required to file a tax return. Payers must generally withhold 28% of taxable interest, dividend, and certain other payments to a payee who does not give a TIN to a payer. Certain penalties may also apply.

HISTORICALLY UNDERUTILIZED BUSINESS (HUB) DECLARATION

The primary objective of the Hidalgo County HUB Program is to ensure Historically Underutilized Businesses receive a fair and equal opportunity for participation in the County’s procurement process. This fact holds true for Services (Professional & Non-Professional), Commodities, and Construction contracts and any subcontracts thereto. The program strongly encourages Prime Contractors to provide subcontracting opportunities to Certified Hub Contractors/Vendors. Our goal for HUB contractor/vendor participation, as well as HUB subcontractor participation is 30%. To be considered as a “Certified HUB Contractor/Vendor” the contractor/vendor must have been certified by, and hold a current and valid certification with any of the three agencies listed below.

Have you been Certified as a HUB or an MBE/WBE source?: Yes No

If yes, by whom?: Texas Building & Procurement Commission Other _____

Indicate Certification No(s): _____ or Are Certificate(s) Attached?: Yes No

LIST OF CERTIFIED HUB SUBCONTRACTORS
(Attach additional pages if necessary)

What percentage of the Bid, RFP, or RFQ is to be subcontracted with Certified HUB sources?: _____%
(List HUB Subcontractor information below).

HUB Subcontractor Name: _____ HUB Status:
Certifying Agency (Check all applicable): Texas Building & Procurement Commission Other
Address: _____ City: _____ State: _____ Zip:
Contact Person: _____ Title: _____ Phone No.: ()
Subcontract Amount: \$_____ Description of Work to be Performed:

HUB Subcontractor Name: _____ HUB Status:
Certifying Agency (Check all applicable): Texas Building & Procurement Commission Other
Address: _____ City: _____ State: _____ Zip:
Contact Person: _____ Title: _____ Phone No.: ()
Subcontract Amount: \$_____ Description of Work to be Performed:

HUB Subcontractor Name: _____ HUB Status:
Certifying Agency (Check all applicable): Texas Building & Procurement Commission Other
Address: _____ City: _____ State: _____ Zip:
Contact Person: _____ Title: _____ Phone No.: ()
Subcontract Amount: \$_____ Description of Work to be Performed:

DISCLOSURE OF CONFLICT OF INTEREST

Effective January 1, 2006, Chapter 176 of the Texas Local Government Code requires that any vendor, person, consultant or contractor considering doing business with Hidalgo County (“the County”) to disclose in the Conflict of Interest Questionnaire (the “CIQ”) attached as Exhibit D, the vendor, person, consultant or contractor’s affiliation or business relationship that might cause a conflict of interest with the County. By law, the CIQ must be filed with the Hidalgo County Clerk’s Office no later than the seventh business day after the date the person becomes aware of facts that require that statement to be filed. The disclosure requirement applies to a person or business who contracts or seeks to contract with Hidalgo County for the sale or purchase of property, goods or service. Any purchase order or contract resulting from this process shall be considered null and void if the successful bidder fails to comply with Texas Local Government Code Chapter 176. Vendors, consultants, contractors and others who desire to conduct business with Hidalgo County are encouraged to refer to Texas Local Government Code Chapter 176 for the details of this law. An offense under Texas Local Government Code Chapter 176 is a Class C Misdemeanor.

Please Submit completed forms to the Hidalgo County Clerk’s Office located at 100 N. Closner, Edinburg, Texas 78539-Hidalgo County Courthouse

COMPLETION AND SUBMISSION OF FORM CIQ IS THE SOLE RESPONSIBILITY OF THE PROSPECTIVE BIDDER.

CONFLICT OF INTEREST QUESTIONNAIRE

For vendor or other person doing business with local governmental entity

FORM CIQ

This questionnaire reflects changes made to the law by H.B. 1491, 80th Leg., Regular Session.

This questionnaire is being filed in accordance with Chapter 176, Local Government Code by a person who has a business relationship as defined by Section 176.001(1-a) with a local governmental entity and the person meets requirements under Section 176.006(a).

By law this questionnaire must be filed with the records administrator of the local governmental entity not later than the 7th business day after the date the person becomes aware of facts that require the statement to be filed. See Section 176.006, Local Government Code.

A person commits an offense if the person knowingly violates Section 176.006, Local Government Code. An offense under this section is a Class C misdemeanor.

OFFICE USE ONLY

Date Received

1 Name of person who has a business relationship with local governmental entity.

2 **Check this box if you are filing an update to a previously filed questionnaire.**

(The law requires that you file an updated completed questionnaire with the appropriate filing authority not later than the 7th business day after the date the originally filed questionnaire becomes incomplete or inaccurate.)

3 Name of local government officer with whom filer has employment or business relationship.

Name of Officer

This section (item 3 including subparts A, B, C & D) must be completed for each officer with whom the filer has an employment or other business relationship as defined by Section 176.001(1-a), Local Government Code. Attach additional pages to this Form CIQ as necessary.

A. Is the local government officer named in this section receiving or likely to receive taxable income, other than investment income, from the filer of the questionnaire?

Yes No

B. Is the filer of the questionnaire receiving or likely to receive taxable income, other than investment income, from or at the direction of the local government officer named in this section AND the taxable income is not received from the local governmental entity?

Yes No

C. Is the filer of this questionnaire employed by a corporation or other business entity with respect to which the local government officer serves as an officer or director, or holds an ownership of 10 percent or more?

Yes No

D. Describe each employment or business relationship with the local government officer named in this section.

4

Signature of person doing business with the governmental entity

Date

**SALES TAX AND LOCAL SALES TAX
EXEMPTION CERTIFICATE FOR CONTRACTORS**

This Contract is to be performed for an exempt organization as defined by Article 20.04 (H) (4) of the Texas Limited Sales, Excise, and Use Tax Act and the undersigned hereby claims an exemption from payment of taxes under Chapter 20, title 122A, revised hereby claims an exemption from payment of taxes under Chapter 20, title 122A, revised civil statues of Texas, and Article 1066 ©, entitle Local Sales and Use Tax, revised civil statues of Texas.

The Contractor performing this Contract may purchase, rent, or lease all materials, supplies, equipment used for consumed in the performance of this Contract by issuing to his retailer an exemption certificate in lieu of the tax, said exemption certificate complying with State Comptroller's Ruling No 95-9.07. Any such exemption certificate issue by the Contractor in lieu of the tax shall be subject to the provisions of the State Comptroller's Ruling No. 95.0.09 as amended to be effective October 2, 1968.

EXECUTED this the _____ day of _____, 20_____.

Contractor

GOVERNMENT CODE

CHAPTER 2258. PREVAILING WAGE RATES

SUBCHAPTER A. GENERAL PROVISIONS

§Sec. 2258.001. DEFINITIONS. In this chapter:

(1) "Locality in which the work is performed" means:

(A) for a contract for a public work awarded by the state, the political subdivision of the state in which the public work is located:

(i) which may include a county, municipality, county and municipality, or district, except as provided by Subparagraph (ii); and

(ii) which, in a municipality with a population of 500,000 or more, may only include the geographic limits of the municipality; or

(B) for a contract for a public work awarded by a political subdivision of the state, the geographical limits of the political subdivision.

(2) "Public body" means a public body awarding a contract for a public work on behalf of the state or a political subdivision of the state.

(3) "Worker" includes a laborer or mechanic.

Added by Acts 1995, 74th Leg., ch. 76, Sec. 5.49(a), eff. Sept. 1, 1995. Amended by Acts 2001, 77th Leg., ch. 1422, Sec. 14.04, eff. Sept. 1, 2001.

§Sec. 2258.002. APPLICABILITY OF CHAPTER TO PUBLIC WORKS. (a) This chapter applies only to the construction of a public work, including a building, highway, road, excavation, and repair work or other project development or improvement, paid for in whole or in part from public funds, without regard to whether the work is done under public supervision or direction.

(b) This chapter does not apply to work done directly by a public utility company under an order of a public authority.

Added by Acts 1995, 74th Leg., ch. 76, Sec. 5.49(a), eff. Sept. 1, 1995.

§Sec. 2258.003. LIABILITY. An officer, agent, or employee of a public body is not liable in a civil action for any act or omission implementing or enforcing this chapter unless the action was made in bad faith.

Added by Acts 1995, 74th Leg., ch. 76, Sec. 5.49(a), eff. Sept. 1, 1995.

SUBCHAPTER B. PAYMENT OF PREVAILING WAGE RATES

§Sec. 2258.021. RIGHT TO BE PAID PREVAILING WAGE RATES. (a) A worker employed on a public work by or on behalf of the state or a political subdivision of the state shall be paid:

(1) not less than the general prevailing rate of per diem wages for work of a similar

character in the locality in which the work is performed; and

(2) not less than the general prevailing rate of per diem wages for legal holiday and overtime work.

(b) Subsection (a) does not apply to maintenance work.

(c) A worker is employed on a public work for the purposes of this section if the worker is employed by a contractor or subcontractor in the execution of a contract for the public work with the state, a political subdivision of the state, or any officer or public body of the state or a political subdivision of the state.

Added by Acts 1995, 74th Leg., ch. 76, Sec. 5.49(a), eff. Sept. 1, 1995. Amended by Acts 1997, 75th Leg., ch. 165, Sec. 18.01, eff. Sept. 1, 1997.

§Sec. 2258.022. DETERMINATION OF PREVAILING WAGE RATES.

(a) For a contract for a public work awarded by a political subdivision of the state, the public body shall determine the general prevailing rate of per diem wages in the locality in which the public work is to be performed for each craft or type of worker needed to execute the contract and the prevailing rate for legal holiday and overtime work by:

(1) conducting a survey of the wages received by classes of workers employed on projects of a character similar to the contract work in the political subdivision of the state in which the public work is to be performed; or

(2) using the prevailing wage rate as determined by the United States Department of Labor in accordance with the Davis-Bacon Act (40 U.S.C. Section 276a et seq.), and its subsequent amendments.

(b) This subsection applies only to a public work located in a county bordering the United Mexican States or in a county adjacent to a county bordering the United Mexican States. For a contract for a public work awarded by the state, the public body shall determine the general prevailing rate of per diem wages in the locality in which the public work is to be performed for each craft or type of worker needed to execute the contract and the prevailing rate for legal holiday and overtime work as follows. The public body shall conduct a survey of the wages received by classes of workers employed on projects of a character similar to the contract work both statewide and in the political subdivision of the state in which the public work is to be performed. The public body shall also consider the prevailing wage rate as determined by the United States Department of Labor in accordance with the Davis-Bacon Act (40 U.S.C. Section 276a et seq.), and its subsequent amendments, but only if the survey used to determine that rate was conducted within a three-year period preceding the date the public body calls for bids for the public work. The public body shall determine the general prevailing rate of per diem wages in the locality based on the higher of:

(1) the rate determined from the survey conducted in the political subdivision;

(2) the arithmetic mean between the rate determined from the survey conducted in the political subdivision and the rate determined from the statewide survey; and

(3) if applicable, the arithmetic mean between the rate determined from the survey conducted in the political subdivision and the rate determined by the United States Department of Labor.

(c) The public body shall determine the general prevailing rate of per diem wages as a sum certain, expressed in dollars and cents.

(d) A public body shall specify in the call for bids for the contract and in the contract itself the wage rates determined under this section.

(e) The public body's determination of the general prevailing rate of per diem wages is final.

Added by Acts 1995, 74th Leg., ch. 76, Sec. 5.49(a), eff. Sept. 1, 1995. Amended by Acts 1997, 75th Leg., ch. 165, Sec. 18.02, eff. Sept. 1, 1997; Acts 2001, 77th Leg., ch. 1422, Sec. 14.05, eff. Sept. 1, 2001.

Amended by: Acts 2007, 80th Leg., R.S., Ch. 728, Sec. 1, eff. September 1, 2007.

§Sec. 2258.023. PREVAILING WAGE RATES TO BE PAID BY CONTRACTOR AND SUBCONTRACTOR; PENALTY.

(a) The contractor who is awarded a contract by a public body or a subcontractor of the contractor shall pay not less than the rates determined under Section 2258.022 to a worker employed by it in the execution of the contract.

(b) A contractor or subcontractor who violates this section shall pay to the state or a political subdivision of the state on whose behalf the contract is made, \$60 for each worker employed for each calendar day or part of the day that the worker is paid less than the wage rates stipulated in the contract. A public body awarding a contract shall specify this penalty in the contract.

(c) A contractor or subcontractor does not violate this section if a public body awarding a contract does not determine the prevailing wage rates and specify the rates in the contract as provided by Section 2258.022.

(d) The public body shall use any money collected under this section to offset the costs incurred in the administration of this chapter.

(e) A municipality is entitled to collect a penalty under this section only if the municipality has a population of more than 10,000.

Added by Acts 1995, 74th Leg., ch. 76, Sec. 5.49(a), eff. Sept. 1, 1995.

§Sec. 2258.024. RECORDS.

(a) A contractor and subcontractor shall keep a record showing:

(1) the name and occupation of each worker employed by the contractor or subcontractor in the construction of the public work; and

(2) the actual per diem wages paid to each worker.

(b) The record shall be open at all reasonable hours to inspection by the officers and agents of the public body.

Added by Acts 1995, 74th Leg., ch. 76, Sec. 5.49(a), eff. Sept. 1, 1995.

§Sec. 2258.025. PAYMENT GREATER THAN PREVAILING RATE NOT PROHIBITED.

This chapter does not prohibit the payment to a worker employed on a public work an amount greater than the general prevailing rate of per diem wages.

Added by Acts 1995, 74th Leg., ch. 76, Sec. 5.49(a), eff. Sept. 1, 1995.

§Sec. 2258.026. RELIANCE ON CERTIFICATE OF SUBCONTRACTOR. A contractor is entitled to rely on a certificate by a subcontractor regarding the payment of all sums due those working for the subcontractor until the contrary has been determined.

Added by Acts 1995, 74th Leg., ch. 76, Sec. 5.49(a), eff. Sept. 1, 1995.

SUBCHAPTER C. ENFORCEMENT; CIVIL AND CRIMINAL PENALTIES

§Sec. 2258.051. DUTY OF PUBLIC BODY TO HEAR COMPLAINTS AND WITHHOLD PAYMENT. A public body awarding a contract, and an agent or officer of the public body, shall:

(1) take cognizance of complaints of all violations of this chapter committed in the execution of the contract; and

(2) withhold money forfeited or required to be withheld under this chapter from the payments to the contractor under the contract, except that the public body may not withhold money from other than the final payment without a determination by the public body that there is good cause to believe that the contractor has violated this chapter.

Added by Acts 1995, 74th Leg., ch. 76, Sec. 5.49(a), eff. Sept. 1, 1995.

§Sec. 2258.052. COMPLAINT; INITIAL DETERMINATION.

(a) On receipt of information, including a complaint by a worker, concerning an alleged violation of Section 2258.023 by a contractor or subcontractor, a public body shall make an initial determination as to whether good cause exists to believe that the violation occurred.

(b) A public body must make its determination under Subsection (a) before the 31st day after the date the public body receives the information.

(c) A public body shall notify in writing the contractor or subcontractor and any affected worker of its initial determination.

(d) A public body shall retain any amount due under the contract pending a final determination of the violation.

Added by Acts 1995, 74th Leg., ch. 76, Sec. 5.49(a), eff. Sept. 1, 1995.

§Sec. 2258.053. ARBITRATION REQUIRED FOR UNRESOLVED ISSUE.

(a) An issue relating to an alleged violation of Section 2258.023, including a penalty owed to a public body or an affected worker, shall be submitted to binding arbitration in accordance with the Texas General Arbitration Act (Article 224 et seq., Revised Statutes) if the contractor or subcontractor and any affected worker do not resolve the issue by agreement before the 15th day after the date the public body makes its initial determination under Section 2258.052.

(b) If the persons required to arbitrate under this section do not agree on an arbitrator before the 11th day after the date that arbitration is required under Subsection (a), a district court shall appoint an arbitrator on the petition of any of the persons.

(c) A public body is not a party in the arbitration.

Added by Acts 1995, 74th Leg., ch. 76, Sec. 5.49(a), eff. Sept. 1, 1995.

§Sec. 2258.054. ARBITRATION AWARD; COSTS. (a) If an arbitrator determines that Section 2258.023 has been violated, the arbitrator shall assess and award against the contractor or subcontractor:

- (1) penalties as provided by Section 2258.023 and this section; and
- (2) all amounts owed to the affected worker.

(b) An arbitrator shall assess and award all reasonable costs, including the arbitrator's fee, against the party who does not prevail. Costs may be assessed against the worker only if the arbitrator finds that the claim is frivolous. If the arbitrator does not find that the claim is frivolous and does not make an award to the worker, costs are shared equally by the parties.

Added by Acts 1995, 74th Leg., ch. 76, Sec. 5.49(a), eff. Sept. 1, 1995.

§Sec. 2258.055. ARBITRATION DECISION AND AWARD FINAL. The decision and award of the arbitrator is final and binding on all parties and may be enforced in any court of competent jurisdiction.

Added by Acts 1995, 74th Leg., ch. 76, Sec. 5.49(a), eff. Sept. 1, 1995.

§Sec. 2258.056. PAYMENT BY PUBLIC BODY TO WORKER; ACTION TO RECOVER PAYMENT.

(a) A public body shall use any amounts retained under this chapter to pay the worker the difference between the amount the worker received in wages for labor on the public work at the rate paid by the contractor or subcontractor and the amount the worker would have received at the general prevailing wage rate as provided in the arbitrator's award.

(b) The public body may adopt rules, orders, or ordinances relating to the manner in which a reimbursement is made.

(c) If the amounts retained by a public body under this chapter are not sufficient for the public body to pay the worker the full amount owed, the worker has a right of action against the contractor or subcontractor and the surety of the contractor or subcontractor to recover the amount owed, reasonable attorney's fees, and court costs.

Added by Acts 1995, 74th Leg., ch. 76, Sec. 5.49(a), eff. Sept. 1, 1995.

§Sec. 2258.057. WITHHOLDING BY CONTRACTOR.

(a) A contractor may withhold from a subcontractor sufficient money to cover an amount withheld from the contractor by a public body because the subcontractor violated this chapter.

(b) If the contractor has made a payment to the subcontractor, the contractor may withhold money from any future payments owed to the subcontractor or sue the subcontractor or the subcontractor's surety for the amount withheld from the contractor by a public body because of the subcontractor's violation.

Added by Acts 1995, 74th Leg., ch. 76, Sec. 5.49(a), eff. Sept. 1, 1995.

§Sec. 2258.058. CRIMINAL OFFENSE.

(a) An officer, agent, or representative of the state or of a political subdivision of the state commits an offense if the person wilfully violates or does not comply with a provision of this chapter.

(b) A contractor or subcontractor of a public work under this chapter, or an agent or representative of the contractor or subcontractor, commits an offense if the person violates Section 2258.024.

(c) An offense under this section is punishable by:

- (1) a fine not to exceed \$500;
- (2) confinement in jail for a term not to exceed six months; or
- (3) both a fine and confinement.

Added by Acts 1995, 74th Leg., ch. 76, Sec. 5.49(a), eff. Sept. 1, 1995.

**Prevailing Wage Rates
Certification Statement**

Date _____

Project Name _____

CSJ# _____

Contractor _____

Application# _____

I, _____ do hereby state:
(Name of Project Director)

- 1. That a payroll (form WH-347 or similar form) was submitted for contract work Performed for the period covered by the attached application.
- 2. That a statement of compliance(form WH-347 or similar form) was submitted with the payroll.
- 3. The certified payroll complies with the classifications and minimum wage rates Stipulated in the contract.
- 4. That a minimum of one interview was conducted with laborers using Form HUD-11 or similar.

Signature

General Decision Number: TX120008 01/06/2012 TX8

Superseded General Decision Number: TX20100009

State: Texas

Construction Types: Heavy and Highway

Counties: Cameron, Hidalgo and Webb Counties in Texas.

HEAVY & HIGHWAY CONSTRUCTION PROJECTS

Modification Number Publication Date

0 01/06/2012

* SUTX2011-003 08/02/2011

Rates Fringes

CEMENT MASON/CONCRETE FINISHER (Paving & Structures)...\$ 12.46

FORM BUILDER/FORM SETTER (Structures).....\$ 12.30

FORM SETTER (Paving & Curb).....\$ 12.16

LABORER

Asphalt Raker.....\$ 10.61

Flagger.....\$ 9.10

Laborer, Common.....\$ 9.86

Laborer, Utility.....\$ 11.53

Pipelayer.....\$ 11.87

Work Zone Barricade Servicer.....\$ 12.88

POWER EQUIPMENT OPERATOR:

Asphalt Distributor.....\$ 13.48

Asphalt Paving Machine.....\$ 12.25

Broom or Sweeper.....\$ 10.33

Crane, Lattice Boom 80 Tons or Less.....\$ 14.39

Crawler Tractor.....\$ 16.63

Excavator, 50,000 lbs or less.....\$ 12.56

Excavator, over 50,000 lbs..\$ 15.23

Foundation Drill, Truck Mounted.....\$ 16.86

Front End Loader Operator, Over 3 CY.....\$ 13.69

Front End Loader, 3 CY or less.....\$ 13.49

Loader/Backhoe.....\$ 12.77

Mechanic.....\$ 15.47

Milling Machine.....\$ 14.64

Motor Grader Operator, Rough.....\$ 14.62

Motor Grader, Fine Grade....\$ 16.52

Scraper.....\$ 11.07

Servicer.....\$ 12.34

Steel Worker (Reinforcing).....\$ 14.07

TRUCK DRIVER

- Lowboy-Float.....\$ 13.63
- Single Axle.....\$ 10.82
- Single or Tandem Axle Dump..\$ 14.53
- Tandem Axle Tractor with
Semi Trailer.....\$ 12.12

WELDER.....\$ 14.02

WELDERS - Receive rate prescribed for craft performing operation to which welding is incidental.

=====
Unlisted classifications needed for work not included within the scope of the classifications listed may be added after award only as provided in the labor standards contract clauses (29CFR 5.5 (a) (1) (ii)).

The body of each wage determination lists the classification and wage rates that have been found to be prevailing for the cited type(s) of construction in the area covered by the wage determination. The classifications are listed in alphabetical order of "identifiers" that indicate whether the particular rate is union or non-union.

Union Identifiers

An identifier enclosed in dotted lines beginning with characters other than "SU" denotes that the union classification and rate have found to be prevailing for that classification. Example: PLUM0198-005 07/01/2011. The first four letters , PLUM, indicate the international union and the four-digit number, 0198, that follows indicates the local union number or district council number where applicable , i.e., Plumbers Local 0198. The next number, 005 in the example, is an internal number used in processing the wage determination. The date, 07/01/2011, following these characters is the effective date of the most current negotiated rate/collective bargaining agreement which would be July 1, 2011 in the above example.

Union prevailing wage rates will be updated to reflect any changes in the collective bargaining agreements governing the rate.

Non-Union Identifiers

Classifications listed under an "SU" identifier were derived from survey data by computing average rates and are not union rates; however, the data used in computing these rates may include both union and non-union data. Example: SULA2004-007 5/13/2010. SU indicates the rates are not union rates, LA indicates the State of Louisiana; 2004 is the year of the survey; and 007 is an internal number used in producing the wage determination. A 1993 or later date, 5/13/2010, indicates the classifications and rates under that identifier were issued as a General Wage Determination on that date.

Survey wage rates will remain in effect and will not change until a new survey is conducted.

WAGE DETERMINATION APPEALS PROCESS

1.) Has there been an initial decision in the matter? This can be:

- * an existing published wage determination
- * a survey underlying a wage determination
- * a Wage and Hour Division letter setting forth a position on a wage determination matter
- * a conformance (additional classification and rate) ruling

On survey related matters, initial contact, including requests for summaries of surveys, should be with the Wage and Hour Regional Office for the area in which the survey was conducted because those Regional Offices have responsibility for the Davis-Bacon survey program. If the response from this initial contact is not satisfactory, then the process described in 2.) and 3.) should be followed.

With regard to any other matter not yet ripe for the formal process described here, initial contact should be with the Branch of Construction Wage Determinations. Write to:

Branch of Construction Wage Determinations
 Wage and Hour Division
 U.S. Department of Labor
 200 Constitution Avenue, N.W.
 Washington, DC 20210

2.) If the answer to the question in 1.) is yes, then an interested party (those affected by the action) can request review and reconsideration from the Wage and Hour Administrator (See 29 CFR Part 1.8 and 29 CFR Part 7). Write to:

Wage and Hour Administrator
 U.S. Department of Labor
 200 Constitution Avenue, N.W.
 Washington, DC 20210

The request should be accompanied by a full statement of the interested party's position and by any information (wage payment data, project description, area practice material, etc.) that the requestor considers relevant to the issue.

3.) If the decision of the Administrator is not favorable, an interested party may appeal directly to the Administrative Review Board (formerly the Wage Appeals Board). Write to:

Administrative Review Board
 U.S. Department of Labor
 200 Constitution Avenue, N.W.
 Washington, DC 20210

4.) All decisions by the Administrative Review Board are final.

=====

END OF GENERAL DECISION

Border Colonia Access Program
Checklist for Documentation Required for Road Construction

Contractor: _____

Contract Amount: _____

Project/Precinct: _____

Owner's Contract No.: _____

Item	Required Documents	Submitted & Reviewed	Approved	Comments:
	INITIATION OF PROJECT:			
1	Approval to Bid (Purchasing)			
2	Contract - Signed and Executed			
3	Gen. Liability Insurance - (Expiration Date)			
4	Automobile Liab. Insurance - (Expiration Date)			
5	Worker's Comp. & Empl. Liab. (Expiration Date)			
6	Notice to Proceed			
7	Material Sample & Testing Table Sent to Auditor's Office			
	PAYMENT REQUESTS, INCLUDING FINAL:			
8	Application and Certification of Payment (A)			
9	Schedule of Values a/k/a 1257/1258			
10	Estimate Quantity Update Worksheet			
11	List of Suppliers and Sub-contractors			
12	Partial Waiver of Liens (Sub-contractors/suppliers)			
13	TxDot Form 252 Contract Time Statement			
14	Payroll Report w/signed Wage Form			
15	Change Order (Requires TxDot Concurrence)			
	RETAINAGE PAYMENT: - Final request and request for retainage must be billed separately and approved by C.C.			
16	Punch List			
17	Certificate of Construction Completion			
18	Approval by Commissioner's Court			
19	Contractor's Affidavit of Release (Waiver) of Liens (with power of attorney)(B)			
20	Affidavit of Payment of Debts & Claims-lien bond & indemnity bonds(w/power of attorney)(B)			
21	Consent of Surety to Final Payment(with power of attorney)(B)			
22	Final Blue Prints			

CHANGE ORDER NUMBER ONE(1)

Project: _____

DATE OF ISSUANCE: _____ EFFECTIVE DATE: _____

OWNER: _____

OWNER'S CONTRACT NO: _____

CONTRACTOR: _____ ENGINEER: _____

You are directed to make the following changes in the Contract Documents.

Description: 1.
 2.
 3.
 4.
 5.
 6.

Reason for Change Order: 1.
 2.
 3.
 4.
 5.
 6.

Attachments:

CHANGE IN CONTRACT PRICE:		CHANGE IN CONTRACT TIME:	
Original Contract Price		Original Contract Time for	
\$ 0.00		Substantial Completion:	0 <small>calendar days or dates</small>
Net Changes from previous Change Order		Net Change from previous Change Orders	0 <small>calendar days</small>
\$ 0.00			
Contract Price prior to this Change Order		Contract Time prior to this Change Order	
\$ 0.00		Substantial Completion:	0 <small>calendar days or dates</small>
Net Increase(decrease) of this Change Order		Net Increase(decrease) of this Change Order	0 <small>calendar days</small>
\$ 0.00			
Contract Price with all approved Change Orders	Net % increase(decrease)from original contract price. #DIV/O! %	Contract Time with all approved Change Orders	
\$ 0.00		Substantial Completion:	0 <small>calendar days or dates</small>

RECOMMENDED:

APPROVED:

ACCEPTED:

By: _____
Engineer (Authorized Signature)

By: _____
Owner (Authorized Signature)

By: _____
Contractor (Authorized Signature)

Date: _____

Date: _____

Date: _____

Exhibit E-B

APPLICATION FOR PAYMENT NO.

To: _____ (OWNER)
From: _____ (CONTRACTOR)
Contract: _____
Project: _____
Owner's Contract No. _____ Engineer's Project No. _____
For Work accomplished through the date of: _____

- 1. Original Contract Price: _____
- 2. Net change by Change Order and Written Agreements(+or-): _____
- 3. Current Contract Price (1 plus 2): _____
- 4. Total completed and stored to date: _____
- 5. Retainage (per Agreement):
 _____ 10% of completed Work: _____
 _____ of stored material _____
 Total Retainage: _____
- 6. Total completed and stored to date less retainage (4 minus 5) _____
- 7. Less previous Application for Payments: _____
- 8. AMOUNT DUE THIS APPLICATION (6 MINUS 7) _____

Accompanying Documentation:

CONTRACTOR'S Certification:

The undersigned CONTRACTOR certifies that (1) all previous progress payments received from OWNER on account of Work done under the Contract referred to above have been applied on account to discharge CONTRACTOR'S legitimate obligations incurred in connection with Work covered by prior Applications for Payment numbered 1 through 2 inclusive; (2) title of all Work, materials and equipment incorporated in said Work or otherwise listed in or covered by this Application for Payment will pass to OWNER at time of payment free and clear of all Liens, security interests and encumbrances (except such as are covered by a Bond acceptable to OWNER indemnifying OWNER against any such Lien, security interest or encumbrance); and (3) all Work covered by this Application for Payments is in accordance with the Contract Documents and not defective.

Date _____

CONTRACTOR

State of _____
County of _____
Subscribed and sworn to before me this _____
day of _____

By: _____

Notary Public
My Commission expires: _____

Payment of the above AMOUNT DUE THIS APPLICATION is recommended.

Date _____

ENGINEER

By: _____

Estimate Quantity Update Worksheet

Colonia: _____ Date: _____
 Roadway: _____ Contractor: _____
 Control: _____ Contract Price: _____
 Project No.: _____ Work Done this Mo.: _____
 County: _____ % Complete: #DIV/0!
 Est. No.: 1
 Work Type: Paving & Drainage
 Limits: _____
 From: _____
 To: _____

Date Began: ?
 Contract Time: 120
 Time Charged: 90
 % Time Used: 75.00%

ITEM NO.	DESCRIPTION	UNIT	PROJECT QTY	Unit Price	Project Amount	FIRST MONTH			SECOND MONTH			THIRD MONTH		
						MONTHLY QUANTITY	QTY to Date	Item Cost (Monthly)	MONTHLY QUANTITY	QTY to Date	Item Cost (Monthly)	MONTHLY QUANTITY	QTY to Date	Item Cost (Monthly)
(901) ADMINISTRATIVE														
(902) PRELIMINARY ENGINEERING														
(903) CONSTRUCTION ENGINEERING														
(904) RIGHT-OF-WAY														
(905) ROADWAY CONSTRUCTION														
100	PREP ROW	Sta.	1.100	\$1,800.00	\$1,980.00	1.000	1.000	\$0.00	0	0	\$0.00	0	0	0.00
110	BACKFILL (TY A)	Sta.	1.000	\$600.00	\$600.00	0.000	0	\$0.00	0	0	\$0.00	0	0	0.00
247	FLEX BASE (RDWY DEL)(TY D GR 6 CL 4)	CY	76.000	\$28.00	\$2,128.00	0.000	0	\$0.00	0	0	\$0.00	0	0	0.00
260	LIME (TY A SLURRY) OR (TY B)	TON	1036.000	\$2.00	\$2,072.00	0.000	0	\$0.00	0	0	\$0.00	0	0	0.00
260	LIME TREAT SUBGR (DC)(12")	SY	0.000	\$6,000.00	\$0.00	0.000	0	\$0.00	0	0	\$0.00	0	0	0.00
262	LIME (TY A SLURRY) OR (TY B)	TON	7.800	\$3,000.00	\$23,400.00	0.000	0	\$0.00	0	0	\$0.00	0	0	0.00
262	LME TRT FOR BS CRS (NEW/EXT BS)(DC)(6")	SY	1277.800	\$6.00	\$7,666.80	0.000	0	\$0.00	0	0	\$0.00	0	0	0.00
310	ASPH MATRL (MC-30)	GAL	246.7	\$6.00	\$1,480.20	0.000	0	\$0.00	0	0	\$0.00	0	0	0.00
500	MOBILIZATION	LS	1.000	\$3,000.00	\$3,000.00	0.000	0	\$0.00	0	0	\$0.00	0	0	0.00
502	BARRICADES, SIGNS, AND TRAF HANDLE	MO	1.000	\$1,000.00	\$1,000.00	0.000	0	\$0.00	0	0	\$0.00	0	0	0.00
529	CONC CURB AND GUTTER (TY A)(BARRIER)	LF	600.000	\$7.50	\$4,500.00	0.000	0	\$0.00	0	0	\$0.00	0	0	0.00
644	SMALL RDS SGN ASSM (TY A)	EA	2.000	\$300.00	\$600.00	0.000	0	\$0.00	0	0	\$0.00	0	0	0.00
644	SMALL RDS SGN ASSM (TY F)	EA	2.000	\$500.00	\$1,000.00	0.000	0	\$0.00	0	0	\$0.00	0	0	0.00
658	DEL ASM TY A (D-SY)	EA	4.000	\$100.00	\$400.00	0.000	0	\$0.00	0	0	\$0.00	0	0	0.00
666	REFL PAV MRK TY I (Y)(SLD)(4")	LF	400.000	\$0.25	\$100.00	0.000	0	\$0.00	0	0	\$0.00	0	0	0.00
666	REFL PAV MRK TY I (Y)(BRK)(4")	LF	140.000	\$0.25	\$35.00	0.000	0	\$0.00	0	0	\$0.00	0	0	0.00
672	RAIS PAV MRKR CL B (REFL)(TY II-A-A)	EA	24.000	\$3.50	\$84.00	0.000	0	\$0.00	0	0	\$0.00	0	0	0.00
3146	HOT MIX (TY D)	TON	105.5	\$34.00	\$3,587.00	0.000	0	\$0.00	0	0	\$0.00	0	0	0.00
5249	TEMP SEDMT CONT FENCE	LF	70.000	\$3.00	\$210.00	0.000	0	\$0.00	0	0	\$0.00	0	0	0.00
(906) DRAINAGE														
464	RC PIPE (CL III)(18")	LF	404.000	\$25.00	\$10,100.00	0.000	0	\$0.00	0	0	\$0.00	0	0	0.00
464	RC PIPE (CL III)(24")	LF	120.000	\$30.00	\$3,600.00	0.000	0	\$0.00	0	0	\$0.00	0	0	0.00
465	INLET (COMPL)(TY A)	EA	2.000	\$2,000.00	\$4,000.00	0.000	0	\$0.00	0	0	\$0.00	0	0	0.00
465	INLET (COMPL)(TY C)	EA	2.000	\$1,500.00	\$3,000.00	0.000	0	\$0.00	0	0	\$0.00	0	0	0.00
465	MANH (COMPL)(TYM)	EA	1.000	\$2,000.00	\$2,000.00	0.000	0	\$0.00	0	0	\$0.00	0	0	0.00
465	INLET EXT.	EA	2.000	\$700.00	\$1,400.00	0.000	0	\$0.00	0	0	\$0.00	0	0	0.00
467	SET (TY II)(18")(RCP)(1:6)	EA	4.000	\$550.00	\$2,200.00	0.000	0	\$0.00	0	0	\$0.00	0	0	0.00
467	SET (TY II)(24")(RCP)(1:6)	EA	1.000	\$650.00	\$650.00	0.000	0	\$0.00	0	0	\$0.00	0	0	0.00

Monthly Totals:	\$0.00	\$0.00	\$0.00	0.00
ADMINISTRATIVE (901)				
PRELIMINARY ENGINEERING (902)				
CONSTRUCTION ENGINEERING (903)				
RIGHT-OF-WAY (904)				
Roadway (905):	\$0.00	\$0.00	\$0.00	0.00
Drainage (906):	\$0.00	\$0.00	\$0.00	0.00

Total to Date
 Roadway (905): \$0.00
 Drainage (906): \$0.00
 Total \$0.00

Prepared and Checked By: _____ Signature: _____
 Date: _____ Printed Name: _____

Test Report Table

Material	Test	Description	Required	Remarks	Contractor Name			
					CSJ#	CSJ#	CSJ#	CSJ#
Subgrade	Tex-101-E Part III	Pulverization						
	Tex-113	Moist. Density Curve						
	Tex-115-E	In-place Density						
		Thickness						
		Proof Roll						
Flex Base	Tex-101-E	Preparing Soils and Flex Bases						
	Tex-104-E	Determining Liquid Limit of Soils						
	Tex-105-E	Determining Plastic Limit of Soils						
	Tex-106-E	Calculating the Plasticity Index						
	Tex-107-E	Linear Shrinkage						
	Tex-110-E	Particle Size Analysis						
	Tex-113-E	Moisture Density Relationship of Base Materials(includes Limed)						
	Tex-116-E	Wet Ball Mill Method Tex						
	Tex-117-E	Triaxial Compression for Base Material (includes Limed)						
	Tex-115-E	In-place Density						
En-1		Thickness						
	IAW ASTM 4609							
	Tex-103-E							
	Tex-114-E							
	TexDOT 121 E							
	ASTM D 4546							
	ASTM D 1587							
	Tex115-E							
	Tex-207-F	Determining Density of Compacted Bituminous Mixtures						
	Tex-208-F	Test for Stabilometer Value of Bituminous Mixtures						
Hot Mix	Tex-210-F	Determining Asphalt Content of Bituminous Mixtures by Extraction						
	Tex-228-F	Determining Asphalt Content of Bituminous Mixtures by the Nuclear Method						
Tex-229-F	Combined HMAC Cold Belt Sampling and Testing Procedure							
Tex-236-F	Determining Asphalt Content from Asphalt Paving Mixtures By the Ignition Method							
Tex-207-E	Determining Density of Compacted Bituminous Mixtures							
Tex-212-E	Determining Moisture Content of Bituminous Mixtures							
Tex-213-E	Determining Hydrocarbon-Volatile Content of Bituminous Mixtures							
In-Place Density	Texas SDHPT							
	Bullentin C-14							
	ASTM D-2950.76							
Lime	AASHTO T-166							
	Tex-600-J	Lime Testing Procedure						Waive testing if less than 50 Tons from a Pre-Approved Source
Rcp		Three Edge Bearing Test						1 pipe for each 100 pipe

ASAGO CONSTRUCTION
“QUALITY AND SERVICE”

RAUL IGLESIAS
Manager

ASAGO, LLC
2113 Pecos
Mission, TX 78572
(956)607-0741 office
(956)585-7040 fax
iglesias@hiline.net

October 1, 2008

Mr. Javier Hinojosa, P.E.
Javier Hinojosa Engineering
4126 E. Dove Ave.
McAllen, TX 78504

RE: Hidalgo County Colonia Access Program
Drainage and Paving Construction at El Sol Subdivision Unit # 1 & 2
Contract No.: C-CAP-08-021-7-01

Mr. Hinojosa:

The following is the list of suppliers used in the above mentioned projects as per the County's request:

Rio Valley Pipe 7301 W. Exp. 83 Mission, TX 78572 (956)-584-5770

If you have any questions, please call me at (956) 607-0741

Best regards,
Raul Iglesias
Raul Iglesias, Manager

PARTIAL/FINAL WAIVER OF LEIN

THE STATE OF TEXAS

COUNTY OF _____

The undersigned contracted with _____
_____ to furnish _____
in connection with certain improvements to real property located in _____
County, Texas, and owned by _____
Which improvements are described as follows:

In consideration of Pay Estimate No _____ in the amount of _____
_____ DOLLAR(\$ _____) and other good and
valuable consideration, the receipt and sufficiency of which is hereby acknowledged and
confessed, the undersigned does hereby waive and release any mechanic's lien or materialmen's
lien or claims of lien that the undersigned has or hereafter has on the above mentioned real
property on account of any labor performed or materials furnished or to be furnished or labor
performed and materials furnished by the undersigned pursuant to the above-mentioned contract
or any constitutional lien that the undersigned may have.

Undersigned hereby guarantees that all bids for labor performed and/or materials furnished in the
erection and construction of such improvements on the Property have been fully paid and
satisfied and Undersigned does further guarantee that if for any reason a lien or liens are filed for
material or labor against said Property arising out of any bills for material or labor in connection
with the erection or construction of said improvements thereon, Undersigned will obtain a
settlement of such lien or liens and a proper release thereof shall be obtained.

CONTRACTOR

BY: _____
TITLE

SWORN TO AND SUBSCRIBED BEFORE ME, on this the _____ day of _____, 20__ to
certify which witness my hand and seal of office.

NOTARY PUBLIC in and for the State of Texas

My Commission Expires: _____

**CONTRACTOR'S AFFIDAVIT OF
PAYMENTS OF DEBTS AND CLAIMS**

PROJECT: OWNER: CONTRACTOR: ENGINEER:	PROJECT NO.
--	--------------------

The Contractor in accordance with the Contract Documents, hereby certifies that, except as listed below, all obligations for all materials and equipment furnished, for all work labor, and services performed, and for all known indebtedness and claims against the Contractor for damages arising in any manner in connection with the performance of the Contract referenced above for which the Owner or his property might in any way be held responsible have been paid in full or have otherwise been satisfied in full.

EXCEPTIONS: (If none, write "NONE". The Contractor shall furnish a bond acceptable to the Owner for each exception.)

CONTRACTOR

By

Title

Subscribed and sworn to before me this

day of

Notary Public:

My Commission Expires:

**Prevailing Wage Rates
Certification Statement**

Date _____

Project Name _____

CSJ# _____

Contractor _____

Application# _____

I, _____ do hereby state:
(Name of Project Director)

1. That a payroll (form WH-347 or similar form) was submitted for contract work Performed for the period covered by the attached application.
2. That a statement of compliance(form WH-347 or similar form) was submitted with the payroll.
3. The certified payroll complies with the classifications and minimum wage rates Stipulated in the contract.
4. That a minimum of one interview was conducted with laborers using Form HUD-11 or similar.

Signature

CERTIFICATE OF CONSTRUCTION COMPLETION

THIS IS TO CERTIFY THAT ON _____ DAY OF _____ A FINAL INSPECTION was made of the project herein described.

CONTRACT

CONTRACT DATE: _____
OWNER: _____
CONSTRUCTION CONTRACTOR: _____
OF THE CITY OF _____ STATE OF _____

PROJECT DESCRIPTION

CONSTRUCTION OF _____

CONTRACT NO: _____
Located in or near the City/Precinct Of _____

THIS IS TO CERTIFY”

1. That the work has been completed in accordance with the plans and specifications and all addenda, change orders, supplemental agreements thereto, and with the following exceptions:

- 2. That the sum of _____, deducted from the final payment of the Contractor is a fair and equitable settlement for the foregoing except work.
- 3. That the contractor has presented a “Certificate of Release” starting under oath, that all claims arising out of the performance of work have been fulfilled, and the Owner is released from all claims arising under or by virtue of said contract.
- 4. That the CONTRACTOR has presented in behalf of itself and its sureties, satisfactory evidence that it is bound to repair, replace, and make good any faulty workmanship and/or materials discovered in the work within a period of one year from this date, as provided in said contract.

5. Amount of Original Contract	_____
Present Amount of Contract	_____
Total Amount of earned to Date	_____
Less: previous payments	_____
Balance	_____
Authorized deductions	_____
AMOUNTY OF FINAL PAYMENT	_____

6. That the final payment in the amount of _____
_____ is now due and payable.

Engineer's Signature

CONCURRED BY:

Contractor's Name

By: _____

Title: _____

CONCURRED BY:

Hidalgo County Judge

CONTRACTOR'S AFFIDAVIT OF RELEASE OF LIENS

PROJECT: OWNER: CONTRACTOR: ENGINEER:	PROJECT NO.
--	--------------------

The Contractor, in accordance with the Contract Documents, and in consideration for the full and final payment to the Contractor for all services in connection with the project, does hereby waive and release any and all liens, or any and all claims to liens which the Contractor may have on or affecting the project as a result of its contract(s) for the Project or for performing labor and/or furnishing materials in any way connected with the construction of any aspect of the project. The Contractor further certifies and warrants that all subcontractors of labor and/or materials for the Project, except as listed below, have been paid in full for all labor and/or materials supplied to, for through or at the direct or indirect request of the Contractor prior to, through and including the date of this affidavit.

EXCEPTIONS: (If none, write "NONE". The Contractor shall furnish a bond acceptable to the Owner for each exception.)

CONTRACTOR

By _____

Title _____

Subscribed and sworn to before me this _____ day of _____

Notary Public: _____

My Commission Expires: _____

CONSTRUCTION IDENTIFICATION SIGN:

Size, 4' – 0" X 8' – 0"

Letters to be brown with beige background

Construction Identification Signs To Be Erected Prior To Beginning of Actual Construction

Wood for Signs Shall Be $\frac{3}{4}$ " Waterproofing Resin Bonded Exterior Grade Plywood (Douglas Fir Plywood Association of Equal)

Payment for Furnishing, Erecting, Maintenance and Removing Construction Identification Signs Will Not Be made Directly. Such Costs Shall be Included in the Overall Bid Submitted.

To Be Erected as Indicated on title Sheet.



Your Tax Dollars at Work

Hidalgo County Pct 1

Joel Quintanilla, Commissioner
Border Colonia Access Program

In Partnership with Texas Department of Transportation

North Capisallo Subdivision Paving Projects

Hidalgo County Commissioner's Court

Ramon Garcia	-	County Judge
Joel Quintanilla	-	Commissioner Pct #1
Hector "Tito" Palacios	-	Commissioner Pct #2
Joe M. Flores	-	Commissioner Pct #3
Joseph Palacios	-	Commissioner Pct #4

Contractor: _____

Engineer: _____ TEDSI Infrastructure Group

HIDALGO COUNTY PRECINCT NO. 1

CONSTRUCTION PLANS NORTH CAPISALLO SUBDIVISION BORDER ACCESS COLONIA PROJECT ROUND III COMPETITIVE CSJ 2C-1080-495

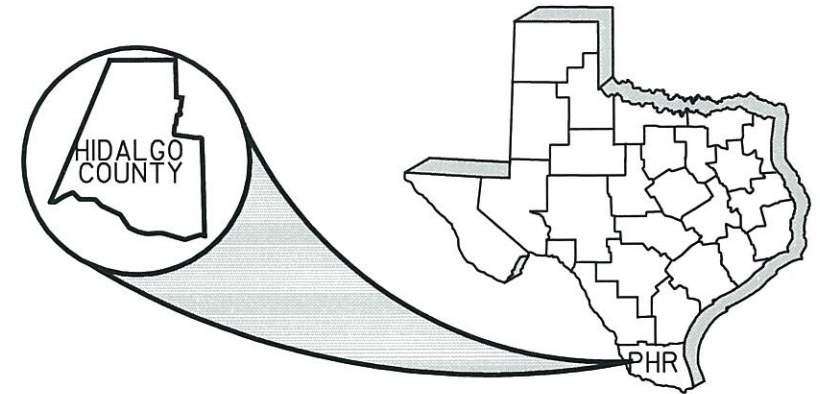

PROJECT LIMITS:

JUDGE BETO GARZA DR = 1192.5' = 0.23 MI

TOTAL LENGTH OF PROJECT = 1192.5' = 0.23 MI

TOTAL AREA OF DISTURBED SOIL = 1.32 AC

INDEX OF SHEETS

SHEET NO.	DESCRIPTION
1	TITLE SHEET
2	PROJECT LAYOUT
3	SUMMARY OF QUANTITIES
4	GENERAL NOTES
5	TYPICAL SECTIONS
6	TRAFFIC CONTROL PLAN GENERAL NOTES
7	TRAFFIC CONTROL PLAN TYPICAL SECTIONS
8-10	PLAN & PROFILE
11	DRIVEWAY TABLES
12	EARTHWORKS
13-15	CROSS-SECTIONS
16	PAVEMENT MARKINGS
17	SW3P
STANDARDS	
18	DRIVEWAY PROFILE DETAILS
19	DRIVEWAY DETAILS PRIVATE
20-31	BC(1)-07 THRU BC(12)-07
32	WZ(TD)-03
33	WZ(UL)-03
34	WZ(DERD)-03
35	TCP(1-2)-12
36	TCP(2-2)-12
37	TCP(3-3)-98
38	TCP(7-1)-98
39	PM(1)-12
40	TECL-06(PHR)

CONSTRUCTION WILL CONSIST OF HOT MIX ASPHALT, NEW FLEXBASE, SUBGRADE, ROADSIDE DITCHES AND STRIPING.

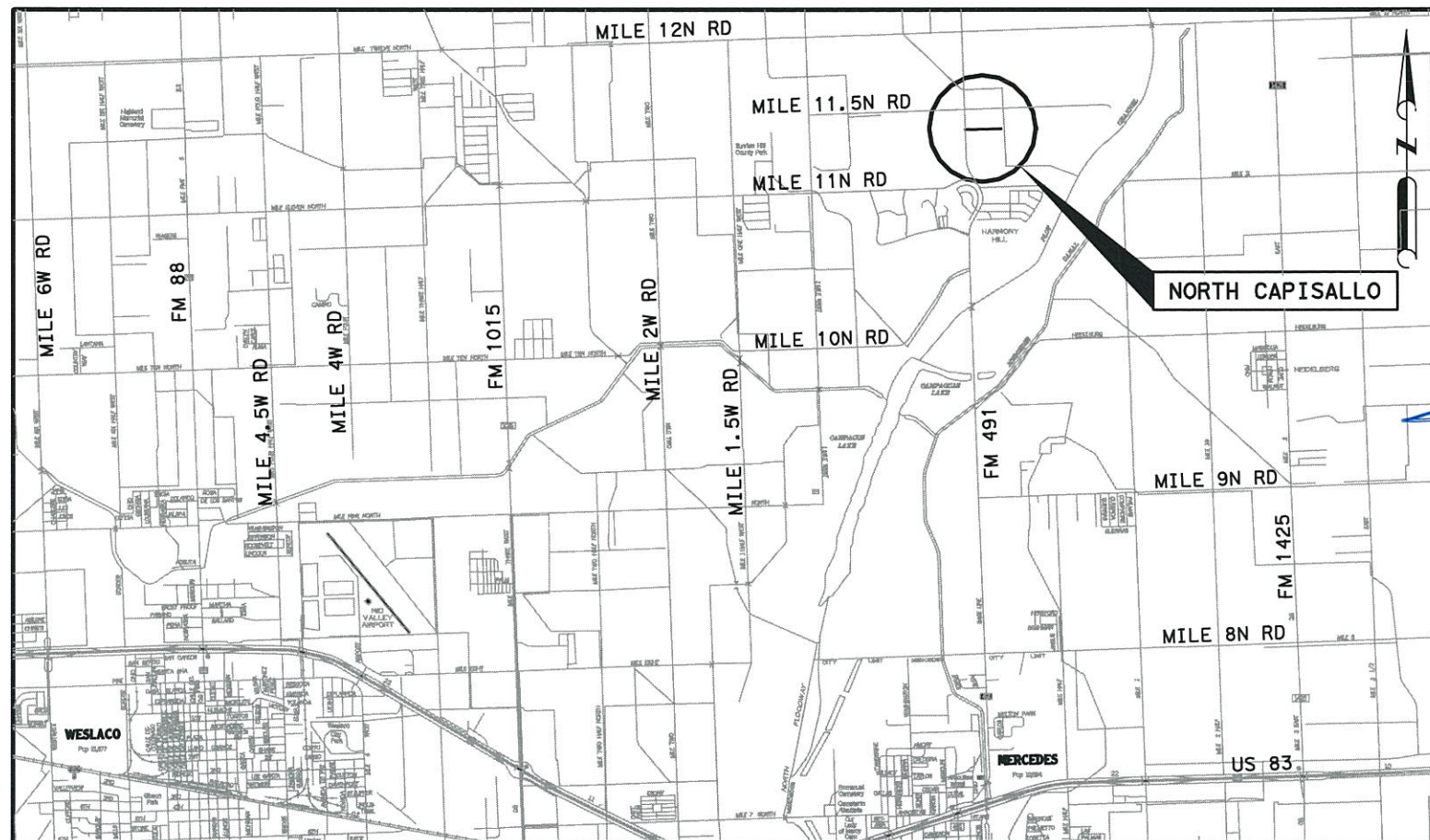

LOCATION MAP
N.T.S.

APPROVAL HIDALGO COUNTY COLONIA ACCESS PROGRAM	DATE : 03/20/2012
APPROVAL HIDALGO COUNTY COUNTY PRECINCT No 1	DATE : 03/20/2012
APPROVAL HIDALGO COUNTY PLANNER	DATE : 03/20/12
CONCURRENCE: HIDALGO COUNTY DRAINAGE DISTRICT No 1	DATE : 3/21/12

THE STANDARD SHEETS SPECIFICALLY IDENTIFIED ABOVE, HAVE BEEN SELECTED BY ME OR UNDER MY RESPONSIBLE SUPERVISION AS BEING APPLICABLE TO THIS PROJECT.



[Signature]
03/19/2012

TEDSI INFRASTRUCTURE GROUP

TEDSI
TBPE F-1640

Consulting Engineers
1201 E. Expressway 83
Mission, Texas 78572
(956) 424-7898

HIDALGO COUNTY OFFICIALS

RAMON GARCIA	- COUNTY JUDGE
JOEL QUINTANILLA	- PCT 1 COMMISSIONER
HECTOR "TITO" PALACIOS	- PCT 2 COMMISSIONER
JOE M. FLORES	- PCT 3 COMMISSIONER
JOSEPH PALACIOS	- PCT 4 COMMISSIONER



SPECIFICATIONS ADOPTED BY THE TEXAS DEPARTMENT OF TRANSPORTATION, JUNE 1, 2004 AND SPECIFICATION ITEMS LISTED SHALL GOVERN ON THIS PROJECT.

NO EXCEPTIONS
NO EQUATIONS
NO RAILROAD CROSSINGS

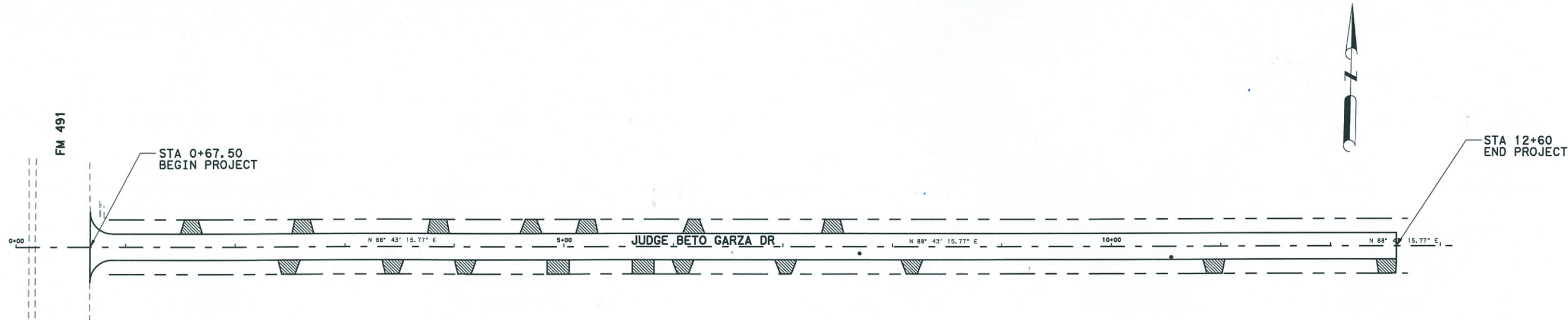

NO.	DATE	REVISION	APP.

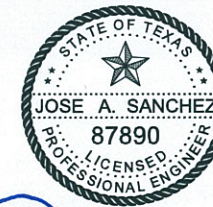

Jose A. Sanchez
03/19/2012



HIDALGO COUNTY

TEDSI INFRASTRUCTURE GROUP
Consulting Engineers
1201 E. Expressway 83
Mission, Texas 78572
(936) 424-7898

TBPE F-1640

NORTH CAPISALLO

PROJECT LAYOUT

SHEET 1 OF 1

FED. RD. DIV. NO. 6	PROJECT NO.	SHEET NO. 2
STATE TEXAS	DIST. PHR	COUNTY HIDALGO
CSJ	PCT 1	HIGHWAY NO. JUDGE BETO GARZA DR

3/19/2012 4:00:56 PM P:\2009\2009-1027-02 hobeap III additional_colon\cas\des\ign\04 north_capisallo\cas\Roadway\NC-pro\lect.dgn

APPLICATION RATES:

HOT MIX ASPHALT - 1" = 114 LB/SY
 PRIME COAT - 0.2 GAL/SY
 LIME (FLEXBASE) - 2% BY WT
 LIME (SUBGRADE) - 3% BY WT
 FLEXBASE WT - 3375 LB/CY (APPROX)
 SUBGRADE WT - 2970 LB/CY (APPROX)
 WATERING - FIRST 4 WKS - 3 CYCLES/WK AT 2.5 GAL/SY/CYCLE
 NEXT 8 WKS - 1 CYCLE/WK AT 2.5 GAL/SY/CYCLE
 FERTILIZER - 100 LBS OF NITROGEN/ACRE
 THE N-P-K RATIO TO INCLUDE AT LEAST 5%P AND 5%K

ROADWAY SUMMARY			
ITEM-CODE	DESCRIPTION	UNIT	TOTAL
0100-2002	PREPARING ROW	STA	11.92
0110-2001	EXCAVATION(ROADWAY)	CY	723
0132-2006	EMBANKMENT(FINAL)(DENS CONT)(TY C)	CY	46
0164-2027	CELL FBR MLCH SEED(PERM)(URBAN)(CLAY)	SY	3382
⊕ 0166-2001	FERTILIZER	AC	0.7
0168-2001	VEGETATIVE WATERING	MG	169.1
0247-	FL BS(CMP IN PLC)(TY E GR 4)(FNAL POS)	SY	3734
0260-2006	LIME TRT(EXST MATL)(6")	SY	4004
0260-2012	LIME(HYD,COM OR QK)(SLRY)OR QK(DRY)	TON	28.1
0260-2012	LIME(HYD,COM OR QK)(SLRY)OR QK(DRY)	TON	45.1
0260-2015	LIME TRT(NEW BASE)(8")	SY	4002
0310-2001	PRIME COAT(MC-30)	GAL	640
0340-	D-GR HMA(METH)TY-D SAC-B PG64-22	SY	3200
⊕ 0496-2007	REMOV STR(PIPE)	LF	246
0500-2001	MOBILIZATION	LS	1
0502-2001	BARRICADES, SIGNS AND TRAFFIC HANDLING	MO	2
0666-2012	REFL PAV MRK TY I(W)4"(SLD)(100MIL)	LF	2350
0666-2048	REFL PAV MRK TY I(W)24"(SLD)(100MIL)	LF	12
0666-2105	REFL PAV MRK TY I(Y)4"(BRK)(100MIL)	LF	270
0666-2111	REFL PAV MRK TY I(Y)4"(SLD)(100MIL)	LF	200

DRAINAGE SUMMARY			
ITEM-CODE	DESCRIPTION	UNIT	TOTAL
0506-2034	TEMPORARY SEDIMENT CONTROL FENCE	LF	26
0530-2011	DRIVEWAYS(ACP)	SY	390
4378-	THERMOPLASTIC PIPE (15 IN)(TY III)	LF	320

⊕ FOR CONTRACTOR'S INFORMATION ONLY. ITEM WILL NOT BE PAID FOR DIRECTLY BUT SHALL BE CONSIDERED SUBSIDIARY TO THE VARIOUS ITEMS.

NO.	DATE	REVISION	APP.



HIDALGO COUNTY



TEDSI INFRASTRUCTURE GROUP
 Consulting Engineers
 1201 E. Expressway 83
 Mission, Texas 78372
 (956) 424-7898

NORTH CAPISALLO

SUMMARY OF QUANTITIES

SHEET 1 OF 1

FED. RD. DIV. NO. 6	PROJECT NO.	SHEET NO. 3
STATE TEXAS	DIST. PHR	COUNTY HIDALGO
CSJ	PCT 1	HIGHWAY NO. JUDGE BETO GARZA DR

GENERAL NOTES AND SPECIFICATION DATA

For all pits or quarries, comply with the "Texas Aggregate Quarry and Pit Safety Act." Provide on a weekly basis a list of equipment, including idle equipment, utilized on the project that week.

The 1-800 call services for utility locations do not include TxDOT facilities. Contact the Pharr District Signal Section (956-702-6225) for coordination with TxDOT underground lines.

ITEM 5. Control of the Work

Prior to contract letting, bidders may obtain a free computer diskette or a computerized transfer of files (from the Engineer's office) that contains the earthwork information. If copies of the actual cross-sections in addition to, or instead of, the diskette are requested, they will be available at the Engineers office for borrowing by copying companies for the purpose of making copies for the bidder at the bidders expense.

ITEM 8. Prosecution and Progress

Working days will be computed and charged in accordance with Article 8.3.A.1 Five-Day Workweek.

ITEM 132. Embankment

The native soils within the project area are not considered suitable for use as select fill materials. Borrow used as embankment material in the top two feet (Select Fill) below the bottom of pavement flexible base shall meet the following requirements:

1. TxDOT Bid Item 247, Type E, Grade 4

2. Alternative select fill material

- a. The following soils, as classified according to the USCS, may be considered satisfactory for use as select fill materials at this site: SC,GC,CL and combinations of these soils.
- b. In addition to the USCS classification, alternative select fill materials shall have a maximum liquid limit of 35 percent, a plasticity index between 5 and 17 percent and a maximum particle size not exceeding 4 inches or one-half the loose lift thickness, whichever is smaller.
- c. In addition, if these materials are utilized, grain size analyses and Atterberg Limits must be performed during placement at a minimum rate of one test each per 5,000 cubic yards of material due to the high degree of variability associated with pit-run materials.
- d. If the above listed alternative materials are being considered for bidding purposes, the materials should be submitted to the Geotechnical Engineer for pre-approval at a minimum of 10 working days or more prior to the bid date. Failure to do so will be the responsibility of the General Contractor.
- e. The General Contractor will be responsible for ensuring that the properties of all delivered alternate select fill materials are similar to those of the pre-approved submittal. It should also be noted that when using alternative fill materials, difficulties may be experienced with respect to moisture control during and subsequent to fill placement, as well as with erosion, particularly when exposed to inclement weather. This may result in sloughing of beam trenches and/or pumping of the fill materials.
- f. Soils classified as CH, CL, MH, ML, SM, GM, OH,OL and Pt under the USCS and not meeting the alternative select fill material requirements are not considered suitable for use as select fill materials at this site.
- g. Select fill should be placed in loose lifts not exceeding 8 inches in thickness and compacted to at least 98 percent of maximum dry density as determined by ASTM D698. The moisture content of the fill should be maintained within the range of two percentage points below the optimum moisture content to two percentage points above the optimum moisture content until the final lift of fill is permanently covered.
- h. The select fill should be properly compacted in accordance with these recommendations and tested by the Geotechnical Engineer for compaction as specified.

ITEMS 134. Backfilling Pavement Edges

Areas to be backfilled shall extend approximately 3-ft out from the edges of the proposed overlay. Final slopes shall be uniform and smooth. The 100-foot station payment includes Backfilling of both sides.

Backfill Ty A shall not contain particles more than two inches in size and shall have a minimum PI of 10 and a maximum PI of 20.

Any additional backfill material necessary due to pre-existing edge conditions or to replace existing fill removed during blading operations will not be paid for directly. It will be considered subsidiary to this bid item.

ITEM 247. Flexible Base

Flexible Base Type E will be composed of caliche (argillaceous Limestone, calcareous or calcareous clay particles) and may contain stone, conglomerate, gravel, sand or granular materials when these materials are in situ with the caliche.

Blended material for Flexible Base TY E GR 4

Flexible Base TY E GR 4 (caliche base) does not meet the requirements of TY A GR 1 base material. The Contractor may blend base material with another caliche source or with crushed concrete, meeting the requirements for TY "D" materials provided a minimum of 50% caliche is used. The crushed concrete may contain sand or granular materials. Stabilizing additives will not be allowed in the raw crushed concrete base. Acceptance will be under the following conditions:

Condition One (1): When both components of the blend in their individual stockpiles meet all the physical requirements of this Item, then field blending will be allowed.

Condition Two (2): When only one component of the blend passes the physical requirements of this Item, the materials shall be blended through a plant for stockpile testing and approval.

Flexible Base (TY E GR 4) shall conform to the following requirements:

BEFORE LIME IS ADDED

Retained on Sq. Sieve	Percent Retained
2"	0
1/2"	20-60
No. 4	40-75
No. 40	70-90
Max. PI:	15
Max Wet Ball PI:	15
Wet Ball Mill Max Amount:	20
Min. Comp. Strength PSI	150 at 15 psi lateral pressure

The Wet Ball Test (Tex-116-E) shall be run and the Plasticity Index of the material passing the No. 40 sieve shall be determined (Wet Ball PI).

After 1% lime (laboratory) is added to unlimed material

Max PI	12
Min. Comp. Strength PSI:	180 at 15 psi Lateral Pressure
Triaxial Test (Lime Treated)	Tex-121-E

2% lime shall be incorporated into the Flexible Base in the field at the owner's expense.

The percent of density as determined by Compaction Ratio (Tex-113-E) for the new Flexible Base shall be a minimum of 98%.

The percent of density as determined by Tex-121-E for the new and salvage Flexible Base shall be a minimum of 98% for all courses.

The Contractor's attention is called to the fact that certain existing and/or proposed structures may be within the limits of the Flexible Base. It shall be the Contractor's responsibility to perform construction operations without damage to these structures.

ITEM 300. Asphalt's, Oils and Emulsions

Temporary ramps/detours and driveways may use performance grade binder 76-22.

ITEM 310. Prime Coat (Cutback Asphaltic Material)

The Contractor shall exercise diligence in the application of asphalt by the use of flagging and rolling procedures to keep from spraying or splattering the traveling public with asphaltic material.

ITEM 400. Excavation and Backfill for Structures

If the Contractor elects to cut pavement (existing/detour) for structural work beyond that required by the construction phasing shown in the plans and approved by the Engineer, it shall be restored at his expense and backfilled to its original condition or better in accordance with Item 400.

ITEM 464. Reinforced Concrete Pipe

Use tongue and groove pipe where the RCP extends into the lime treated subgrade. The 4-foot depth restriction for heavy equipment passage over pipe structures is voided. The Contractor will be responsible for any construction damage to these facilities.

Do not use mortar joints.

All reinforced concrete pipe shall include rubber gaskets unless shown otherwise on the plans or directed by the engineer.

ITEM 467. Safety End Treatment

All Type II SET's shall have riprap, Class "A" minimum, aprons as shown on the plans. The contractor may submit an alternate precast SET design for approval by the Engineer.

ITEM 496. Removing Old Structures

Store the following items to be salvaged at a location designated by the Engineer.

ITEM 502. Barricades, Signs and Traffic Handling

A pilot car and radio equipped flagmen shall be required for all undivided roadway locations as directed by the Engineer. The pilot car with necessary flagmen and/or radio equipped flagmen and all signs, equipment, labor and incidentals required for this method of traffic control will not be paid for directly, but shall be considered subsidiary to Item 502.

Replace/relocate all regulatory signs removed due to construction operations with a same sign on fixed support(s) immediately upon its removal. First obtain project Engineer approval before removing any regulatory roadway sign. Required flaggers are to be available to direct traffic during sign intermediate down time.

Relocate any Directional Sign Assemblies removed during construction operations immediately upon their removal.

These signs shall be relocated to a location in accordance with the Latest Version of the "Texas Manual on Uniform Traffic Control Devices". In no case will a sign be removed without a replaceable sign and support(s) being readily available and a location established. Removal and relocation of these signs required for traffic control will not be paid for directly, but shall be considered subsidiary to Item 502.

ITEM 504. Field Office and Laboratory

For this project a field office will not be required at the project site.

ITEM 530. Driveways and Turnouts





Prime coat shall meet the requirements of Item 310.

Daily testing requirements for Hot Mix Asphaltic Concrete Pavements for drives, commercial entrances and/or turnouts may be waived by the Engineer.

MISC

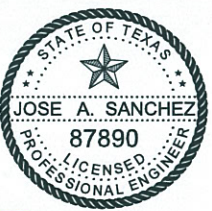
The contractor shall be responsible for maintenance of sediment traps. Damaged/missing sediment traps shall be replaced by the contractor at no additional cost. R.O.W. sediment traps may be shown on plans for clarity purposes only. Actual placement shall be done within R.O.W.

The contractor shall be responsible for posting Small Construction Site Notice and any additional permits required by T.E.C.Q.

NO.	DATE	REVISION	APP.
  03/19/2012			
 HIDALGO COUNTY			
 TEDSI INFRASTRUCTURE GROUP Consulting Engineers 1201 E. Expressway 83 Mission, Texas 78572 (956) 424-7898			
NORTH CAPISALLO			
GENERAL NOTES			
SHEET 1 OF 1			
FED. RD. DIV. NO. 6	PROJECT NO.		SHEET NO. 4
STATE TEXAS	DIST. PHR	COUNTY HIDALGO	
CSJ		PCT	HIGHWAY NO.
2C-1080-495		1	JUDGE BETO GARZA DR

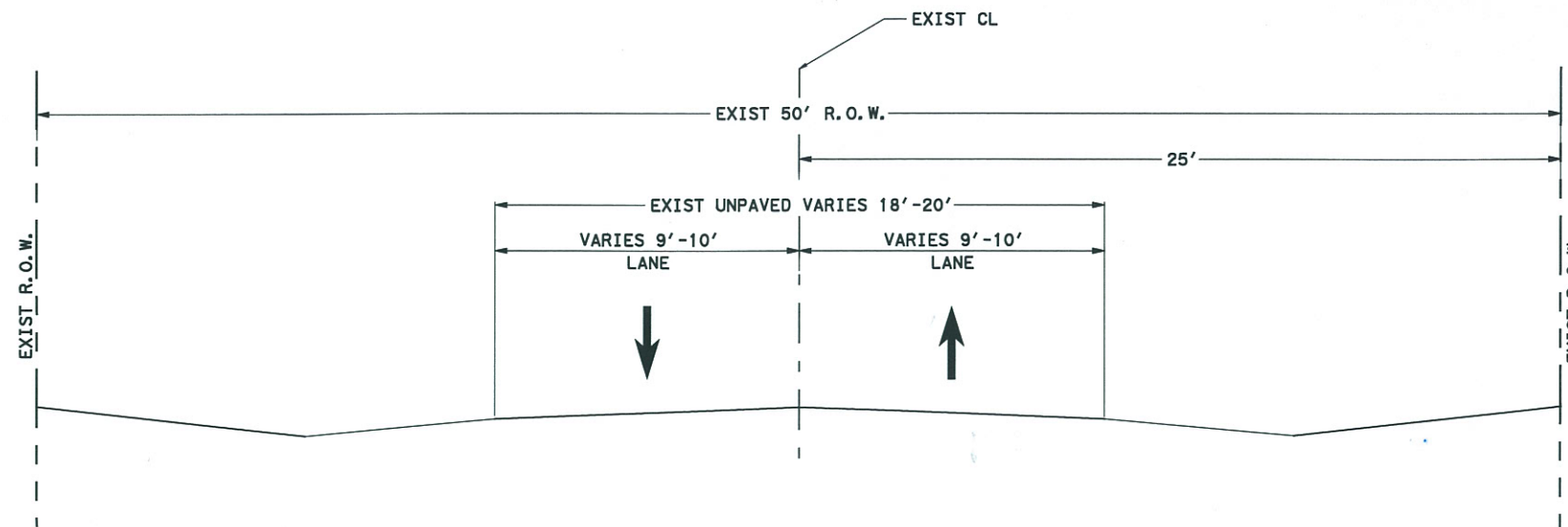

**JUDGE BETO GARZA DR
EXISTING TYPICAL SECTION**
N. T. S.
STA 0+67.5 TO STA 12+60

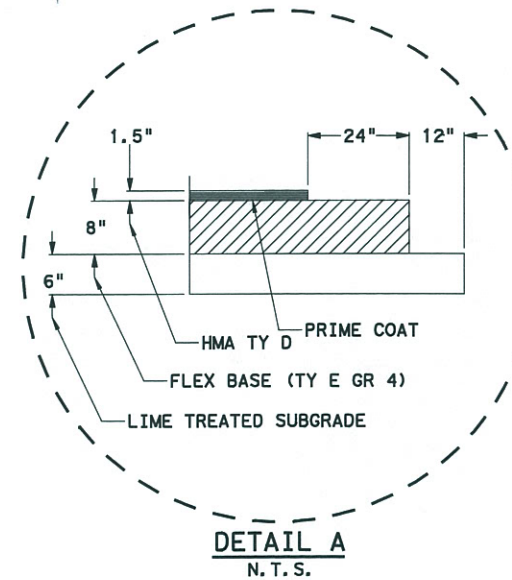

DETAIL A
N. T. S.

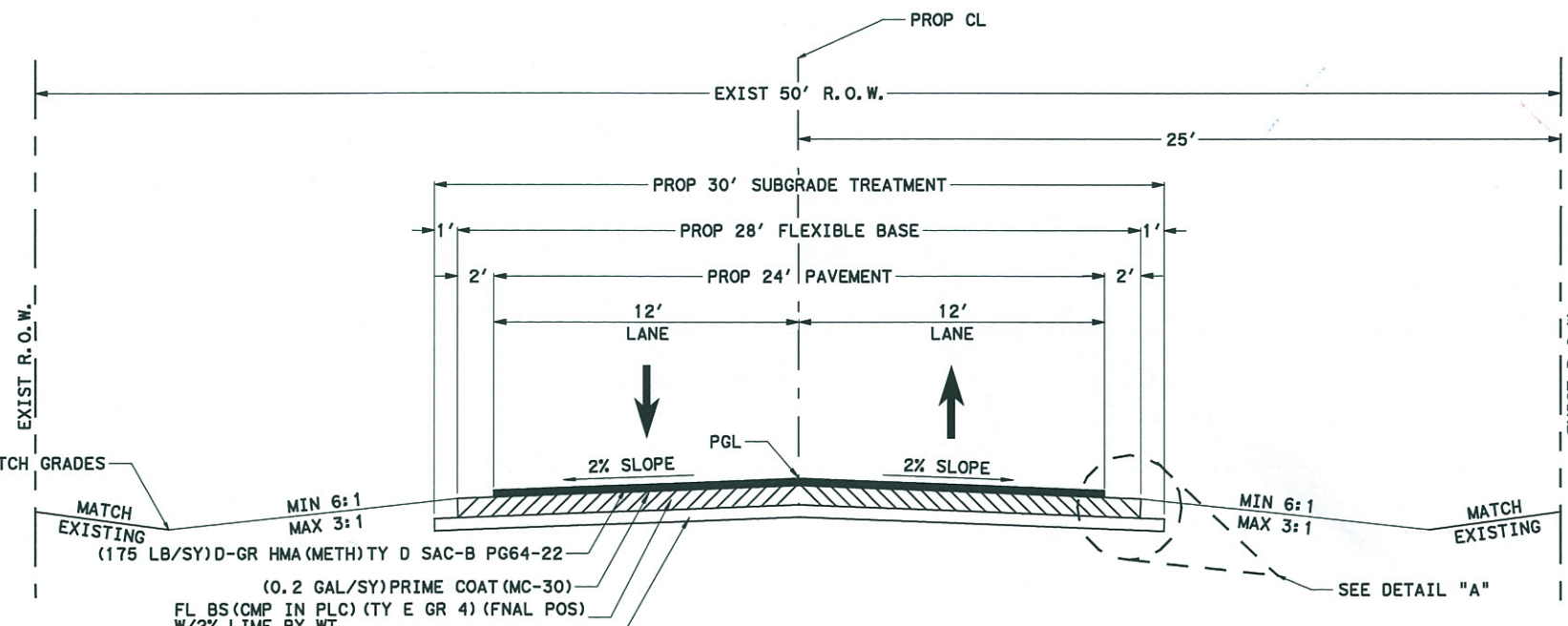

MIN 6:1
MAX 3:1
(175 LB/SY) D-GR HMA (METH) TY D SAC-B PG64-22
(0.2 GAL/SY) PRIME COAT (MC-30)
FL BS (CMP IN PLC) (TY E GR 4) (FNAL POS)
W/2% LIME BY WT
LIME TRT (EXIST MATL) (6")
W/3% LIME BY WT

**JUDGE BETO GARZA DR
PROPOSED TYPICAL SECTION**
N. T. S.
STA 0+67.5 TO STA 12+60

NOTES:

- PGL - PROFILE GRADE LINE
- PERMISSIBLE CONSTRUCTION JOINTS SHALL FALL ON THE PROPOSED ROADWAY CENTERLINE.
- ALL GRADING SHALL BE WITHIN THE EXISTING RIGHT OF WAY LIMITS.
- WHERE REQUIRED BY FIXTURES OR UNUSUAL CONDITIONS THE GOVERNING SLOPES MAY BE VARIED WHEN SPECIFICALLY DIRECTED BY THE ENGINEER.
- THE SUBGRADE SHALL BE SHAPED, BLADED, ROLLED AND PROOF ROLLED A MINIMUM DISTANCE OF 12" BEYOND THE EDGE OF THE PROPOSED BASE COURSE.
- THE COMPLETE BASE SHALL BE PROOF ROLLED BEFORE THE EARTH SHOULDER IS SHAPED. FINAL COMPACTION WILL BE DONE OVER BASE AND EDGE OF SHOULDER.
- PROOF ROLLING WILL NOT BE PAID FOR DIRECTLY BUT SHALL BE CONSIDERED SUBSIDIARY TO THE VARIOUS ITEMS.
- A STATION EQUAL TO 100 FT.
- APPLICATION RATES AS FOLLOWS:

- HOT MIX ASPHALT - 1.5" = 175 LB/SY
- PRIME COAT - 0.2 GAL/SY
- LIME (FLEXBASE) - 2% BY WT
- LIME (SUBGRADE) - 3% BY WT
- FLEXBASE WT - 3375 LB/CY (APPROX)
- SUBGRADE WT - 2970 LB/CY (APPROX)

NO.	DATE	REVISION	APP.



[Signature]
03/19/2012



HIDALGO COUNTY

TEDSI INFRASTRUCTURE GROUP
Consulting Engineers
1201 E. Expressway 83
Mission, Texas 78572
(956) 424-7898

NORTH CAPISALLO

TYPICAL SECTIONS

N. T. S.		SHEET 1 OF 1	
FED. RD. DIV. NO. 6	PROJECT NO. 2C-1080-495	SHEET NO. 5	
STATE TEXAS	DIST. PHR	COUNTY HIDALGO	
CSJ	PCT 1	HIGHWAY NO. JUDGE BETO GARZA DR	

GENERAL NOTES

THE CONTRACTOR MAY SUBMIT AN ALTERNATE TRAFFIC CONTROL PLAN TO THE ENGINEER FOR APPROVAL. APPROVED ALTERNATE TRAFFIC CONTROL PLANS SHALL REQUIRE THE SEAL OF A LICENSED ENGINEER. NO PHASE OF CONSTRUCTION SHALL START UNLESS OTHERWISE APPROVED BY ENGINEER.

BARRICADES/DEVICES/SIGNS SHALL BE ERECTED AND PLACED PRIOR TO COMMENCING ANY PROPOSED ROADWAY CONSTRUCTION AND SHALL REMAIN IN PLACE FOR THE DURATION OF THE PROJECT AND UNTIL COMPLETION AND ACCEPTANCE OF THE PROJECT BY OWNER.

BARRICADES, SIGNS, CHANNELIZATION DEVICES AND OTHER TRAFFIC HANDLING DEVICES MAY BE ADJUSTED OR SHIFTED TO FIT FIELD CONDITIONS AS REQUIRED FOR CONSTRUCTION.

ADEQUATE SIGNS AND BARRICADES SHALL BE INSTALLED BY THE CONTRACTOR AND APPROVED BY ENGINEER PRIOR TO OPENING ANY ROADWAY SECTIONS TO TRAFFIC. THE ENGINEER MAY DIRECT THE CONTRACTOR TO FURNISH ADDITIONAL SIGNS, BARRICADES AND CHANNELIZING DEVICES AS REQUIRED TO MAINTAIN TRAFFIC AND MOTORIST SAFETY DURING CONSTRUCTION. ANY SUCH ADDITIONAL SIGNS AND BARRICADES, ETC, SHALL BE CONSIDERED SUBSIDIARY TO THE VARIOUS ITEMS.

THE CONTRACTOR SHALL INSURE THAT BARRICADES, SIGNS, CHANNELIZING DEVICES AND TRAFFIC HANDLING DEVICES ARE MAINTAINED IN A CLEAN AND FUNCTIONAL CONDITIONS AT ALL TIMES, INCLUDING MAINTENANCE DUE TO VANDALISM OR ACCIDENTS. THE CONTRACTOR SHALL HAVE ENOUGH BARRICADES AND SIGNS AVAILABLE, AT ALL TIMES, TO REPLACE THOSE DAMAGED.

ALL STRIPING AND SIGNING SHALL BE THE RESPONSIBILITY OF THE CONTRACTOR AND SHALL BE IN ACCORDANCE WITH THE PLANS, BC STANDARDS AND THE LATEST VERSION OF THE TMTCD.

EXISTING SIGNS SHALL NOT BE REMOVED UNTIL CONSTRUCTION SIGNS HAVE BEEN INSTALLED. THE CONTRACTOR WILL BE RESPONSIBLE FOR REMOVING EXISTING SIGNS IN CONFLICT WITH PROPOSED CONSTRUCTION SIGNS. ANY SUCH REMOVAL OF SIGNS SHALL BE CONSIDERED SUBSIDIARY TO THE VARIOUS ITEMS.

WHEN CONNECTING PROPOSED ROADWAY TO SECTIONS OF EXISTING TRAFFIC BEING USED BY TRAFFIC AND SUCH OPERATIONS RESULT IN A DROP-OFF OF MORE THAN 2" A 4' BUFFER ZONE AND 3:1 SLOPE WILL BE REQUIRED. THE SLOPE MUST BE CONSTRUCTED WITH A COMPACTED MATERIAL CAPABLE OF SUPPORTING VEHICLES AND/OR AS APPROVED BY ENGINEER. THIS WORK SHALL BE DONE EXPEDITIOUSLY DURING DAYLIGHT HOURS. FLAGGERS AND APPROPRIATE SIGNING TO SAFELY GUIDE TRAFFIC THROUGH THE WORK ARE WILL BE REQUIRED, AS APPROVED BY ENGINEER.

THE PORTION OF THIS PROJECT WHICH COINCIDES WITH THE EXISTING ROADS AND/OR PRIVATE DRIVEWAYS SHALL BE KEPT OPEN TO TRAFFIC AT ALL TIMES, UNLESS OTHERWISE SPECIFIED IN THE PLANS OR APPROVED BY THE ENGINEER. THE CONTRACTOR WILL BE REQUIRED TO COORDINATE WITH ADJACENT PROPERTY OWNERS TO PROVIDE ADEQUATE EGRESS AND INGRESS DURING ALL PHASES OF CONSTRUCTION.

THE CONTRACTOR SHALL KEEP TRAVELED PAVED SURFACES USED IN HIS HAULING OPERATIONS CLEAR AND FREE OF DIRT AND OTHER UNACCEPTABLE MATERIAL AT ALL TIMES. A POWER BROOM SHALL ONLY BE USED TO CLEAN THE ROADWAY.

THE CONTRACTOR SHALL COORDINATE THE TRAFFIC CONTROL PLAN WITH ANY ADJACENT CONSTRUCTION PROJECTS TO INSURE THE UNINTERRUPTED FLOW OF TRAFFIC WITHIN THE VICINITY OF THE PROJECT AREAS.

THE CONTRACTOR SHALL BE RESPONSIBLE FOR MAINTAINING TEMPORARY DRAINAGE DURING CONSTRUCTION THROUGHOUT THE PROJECT LIMITS DURING ALL PHASES OF CONSTRUCTION. EXCAVATED MATERIALS SHALL BE HANDLED BY THE CONTRACTOR IN SUCH WAY IT DOES NOT BLOCK DRAINAGE.

THE CONTRACTOR SHALL NOT LEAVE ANY OPEN TRENCHES OR EXCAVATIONS OVERNIGHT, UNLESS PROPERLY PROTECTED AND/OR AS APPROVED BY THE ENGINEER.

CONSTRUCTION FENCING (4' HIGH MINIMUM) SHALL BE USED AROUND ALL OPEN TRENCHES OR EXCAVATIONS, AS APPROVED BY THE ENGINEER. THIS WORK SHALL NOT BE PAID FOR DIRECTLY, BUT SHALL BE CONSIDERED SUBSIDIARY TO VARIOUS BID ITEMS.

ALL DRUMS USED IN THIS PROJECT FOR TRAFFIC CONTROL DEVICES SHALL BE REMOVED FROM THE PROJECTS. MATERIALS FURNISHED, INSTALLED AND REMOVED BY THE CONTRACTOR SHALL BECOME PROPERTY OF THE CONTRACTOR.

ALL EXISTING UTILITIES THAT ARE IN CONFLICT WITH THE PROPOSED ROADWAY IMPROVEMENTS FOR THIS PROJECT SHALL BE RELOCATED AND/OR ADJUSTED BY OTHERS EXCEPT AS NOTED IN THE PLANS. THE CONTRACTOR SHALL COORDINATE WITH THE VARIOUS UTILITY COMPANIES THE RELOCATION, ADJUSTMENT AND INSTALLATION OF UTILITY LINES. THE ROADWAY WORK SHALL BE ONGOING DURING ADJUSTMENT, RELOCATION AND INSTALLATION OF UTILITY LINES.

THE CONTRACTOR'S ATTENTION IS DIRECTED TO THE REQUIREMENTS OF ITEM 7 "LEGAL RELATIONS AND RESPONSIBILITIES" OF THE STANDARD SPECIFICATIONS.

THE PORTION OF THIS PROJECT WHICH COINCIDES WITH EXISTING ROADS AND/OR PRIVATE DRIVEWAYS WILL BE KEPT OPEN TO TRAFFIC AT ALL TIMES, UNLESS OTHERWISE PROVIDED FOR AND APPROVED BY THE ENGINEER.

THE CONTRACTOR WILL BE ALLOWED TO CLOSE ROADWAY TO THRU TRAFFIC, BUT MUST ALLOW ALL LOCAL TRAFFIC EGRESS AND INGRESS AT ALL TIMES.

THE CONTRACTOR WILL BE ALLOWED TO WORK ONE HALF OF THE PROPOSED SECTION AT A TIME UNLESS OTHERWISE APPROVED BY THE ENGINEER.

THE CONTRACTOR MUST REMOVE EXISTING GRASS AND TOPSOIL FROM THE SHOULDER.





AFTER PREPARATION OF THE SUBGRADE AND/OR FLEXBASE, THE ROADWAY SHALL BE ADEQUATELY FINISHED TO SAFELY CARRY TRAFFIC AFTER WORKING HOURS.

THE CONTRACTOR SHALL WORK ONLY THAT LENGTH OF ROADWAY IN ONE WORKING DAY WHICH HE CAN ADEQUATELY FINISH TO SAFELY CARRY TRAFFIC AFTER WORKING HOURS.

ALL SIGNS AND MAILBOXES AFFECTED BY CONSTRUCTION SHALL BE RELOCATED. RELOCATION WILL NOT BE PAID FOR DIRECTLY BUT SHALL BE CONSIDERED SUBSIDIARY TO THE VARIOUS BID ITEMS.

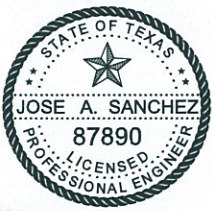
ALL SIGNS AND MAILBOXES DAMAGED DURING CONSTRUCTION SHALL BE REPLACED NEW AT CONTRACTOR'S EXPENSE.

ALL EXISTING SIGNS SHALL REMAIN IN PLACE DURING CONSTRUCTION, THE CONTRACTOR IS TO RELOCATE/ADJUST SIGNS DURING CONSTRUCTION AT NO ADDITIONAL COST.

NO.	DATE	REVISION	APP.
  03/19/2012			
 HIDALGO COUNTY			
 TEDSI INFRASTRUCTURE GROUP Consulting Engineers 1201 E. Expressway 83 Mission, Texas 78572 (956) 424-7898			
NORTH CAPISALLO			
TRAFFIC CONTROL PLAN GENERAL NOTES			
N. T. S.			SHEET 1 OF 1
FED. RD. DIV. NO. 6	PROJECT NO.		SHEET NO. 6
STATE TEXAS	DIST. PHR	COUNTY HIDALGO	
CSJ		PCT 1	HIGHWAY NO. JUDGE BETO GARZA DR
2C-1080-495			

3/19/2012 4:01:33 PM p:\2009\2009-1027-02 hobeap\111 addit\1\onal\o\om\cs\des\gn\04 north\oap\sal\o\cs\Roadway\NC-top-gn.dgn

3/19/2012 4:01:42 PM ps:\2009\2009-1027-02 hobcap III additional column\design\04 north cap\ssd\04\Roadway\NC-top-typ.dgn

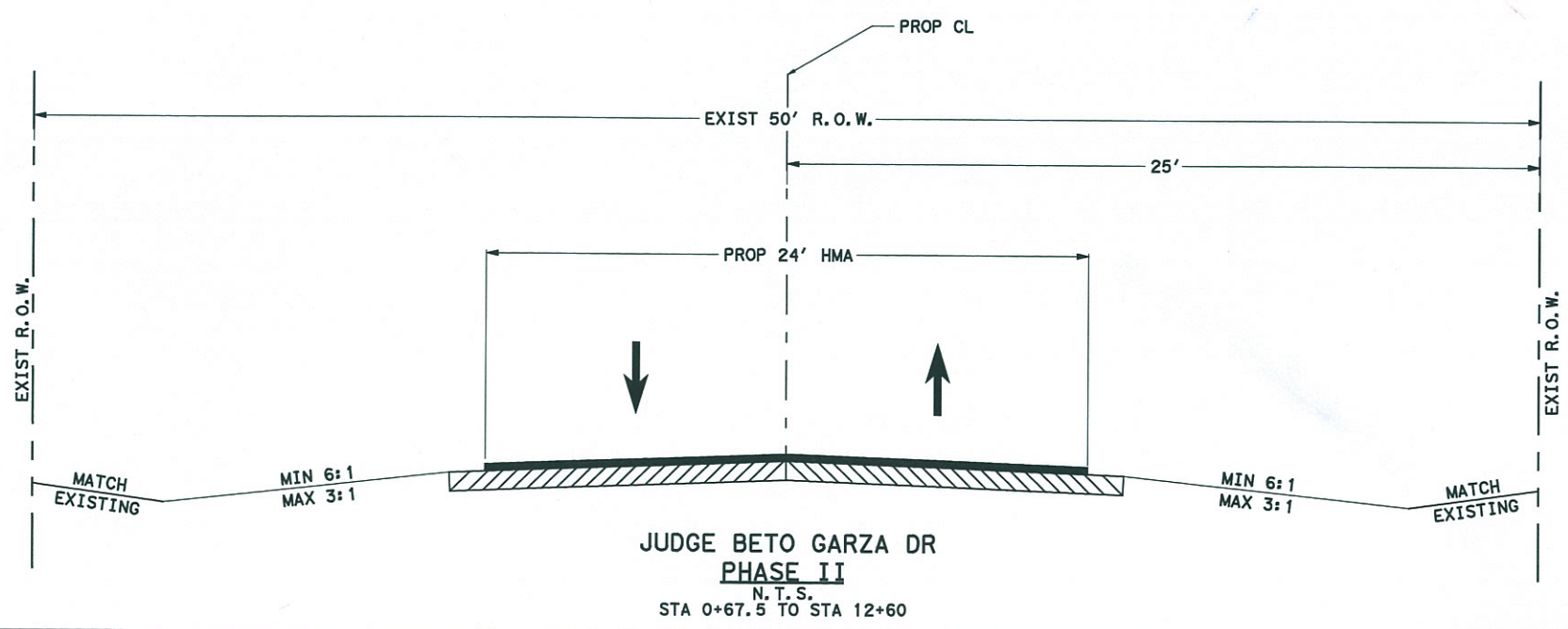
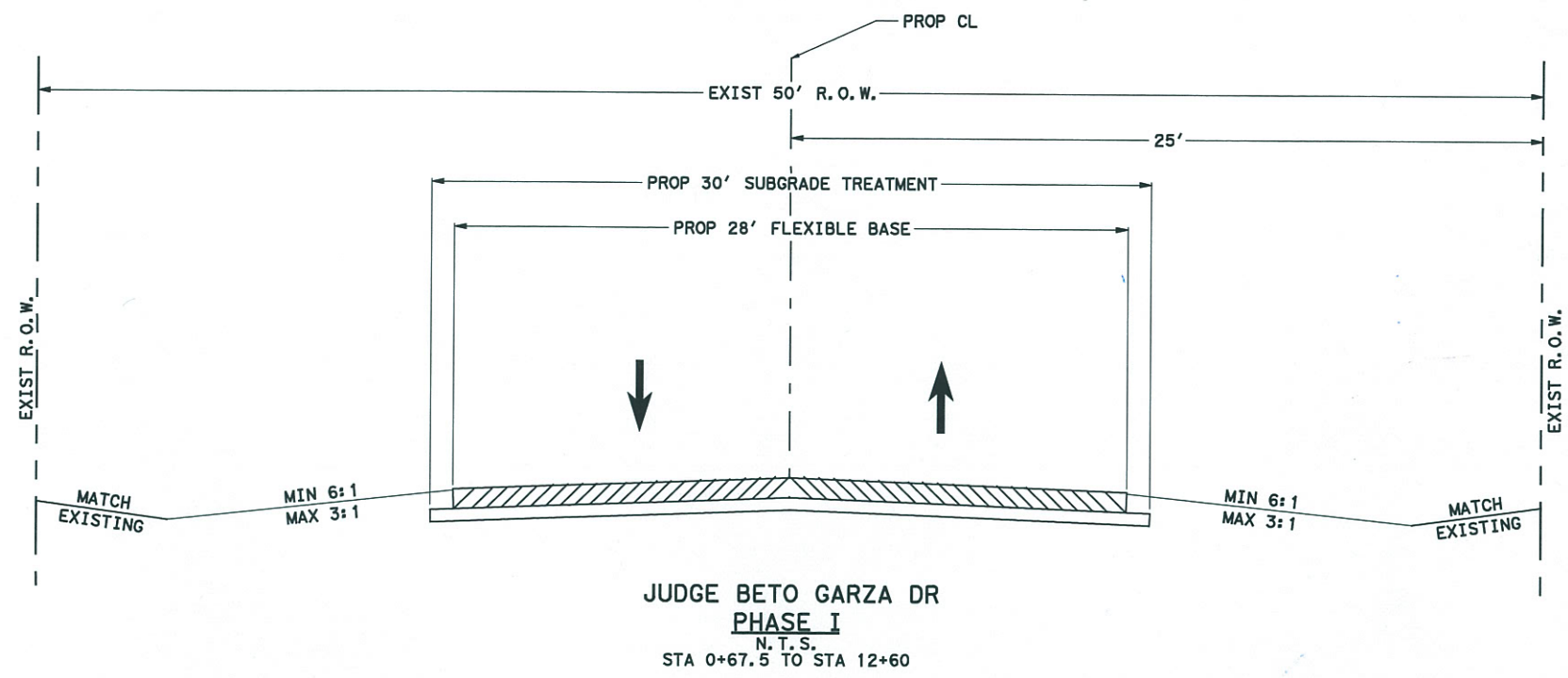
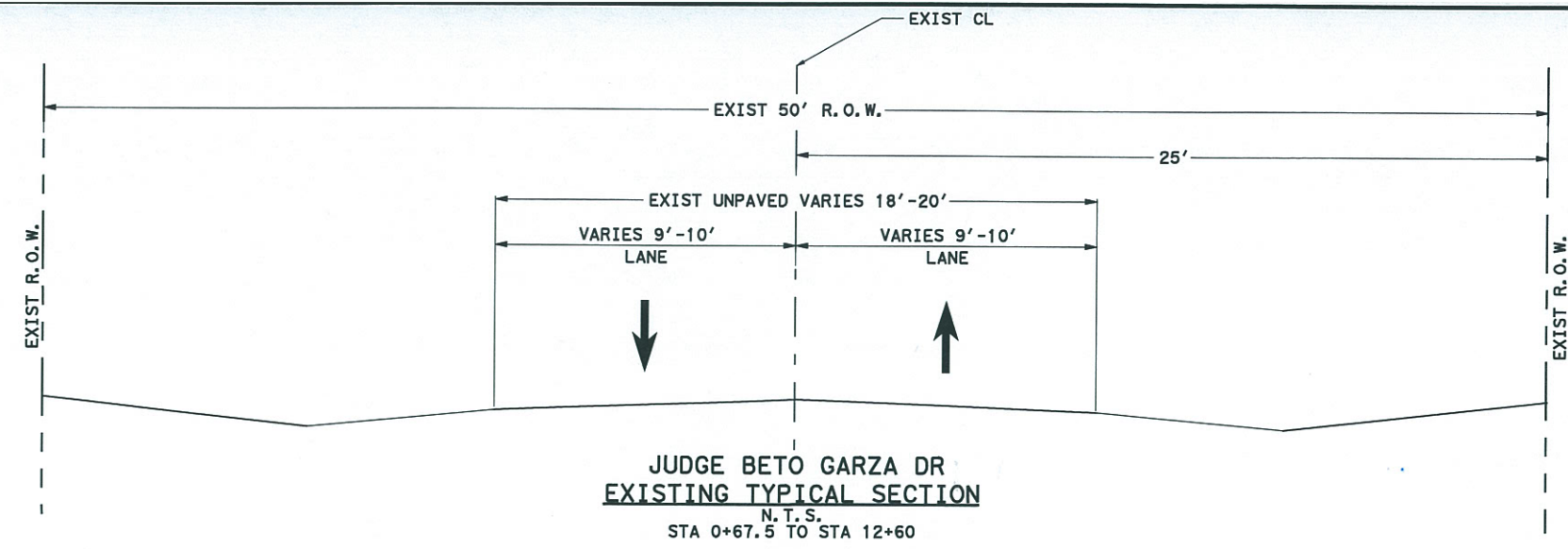

SEQUENCE OF CONSTRUCTION

- PHASE I**
1. INSTALL PROJECT LIMITS AND ADVANCE WARNING SIGNS
 2. INSTALL CROSSROAD BARRICADES/SIGNS, IN ACCORDANCE WITH MUTCD, BC STANDARDS AND/OR AS DIRECTED BY ENGINEER
 3. INSTALL STORM WATER POLLUTION CONTROLS
 4. EXCAVATION WORK/INSTALL STORM DRAINAGE STRUCTURES
 5. SUBGRADE WORK
 6. FLEXIBLE BASE WORK
- PHASE II**
1. APPLY HOT MIX ASPHALT MATERIAL IN ONE COURSE
 2. BACKFILL PAVEMENT EDGES
 3. REINSTALL EXISTING SIGNS/MAILBOXES
 4. REMOVE STORM WATER POLLUTION CONTROLS
 5. INSTALL PAVEMENT MARKINGS
 6. FINAL CLEANUP

NO.	DATE	REVISION	APP.



[Signature] 03/19/2012



HIDALGO COUNTY

TEDSI INFRASTRUCTURE GROUP
 Consulting Engineers
 1201 E. Expressway 83
 Mission, Texas 78572
 (956) 424-7898

NORTH CAPISALLO

TRAFFIC CONTROL PLAN
TYPICAL SECTIONS

N. T. S.		SHEET 1 OF 1	
FED. RD. DIV. NO. 6	PROJECT NO.	SHEET NO. 7	
STATE TEXAS	DIST. PHR	COUNTY HIDALGO	
CSJ 2C-1080-495	PCT 1	HIGHWAY NO. JUDGE BETO GARZA DR	

LEGEND

- GAS — EXIST GAS LINE
- T — EXIST UG PHONE LINE
- W — EXIST WATER LINE
- x-x-x-x- EXIST CHAINLINK FENCE
- [Hatched Box] ASPHALT DRIVEWAY
- [Dotted Box] CONCRETE DRIVEWAY
- - - - - PROP DITCH
- (*) DRIVEWAY ID NUMBER
- (M) EXIST MAILBOX
- (W) EXIST WATER METER
- (V) EXIST WATER VALVE
- (P) EXIST POWER POLE
- (F) EXIST FIRE HYDRANT
- (T) EXIST TELEPHONE BOX
- (G) EXIST GAS METER
- (SCF) TEMP SED CTRL FENCE

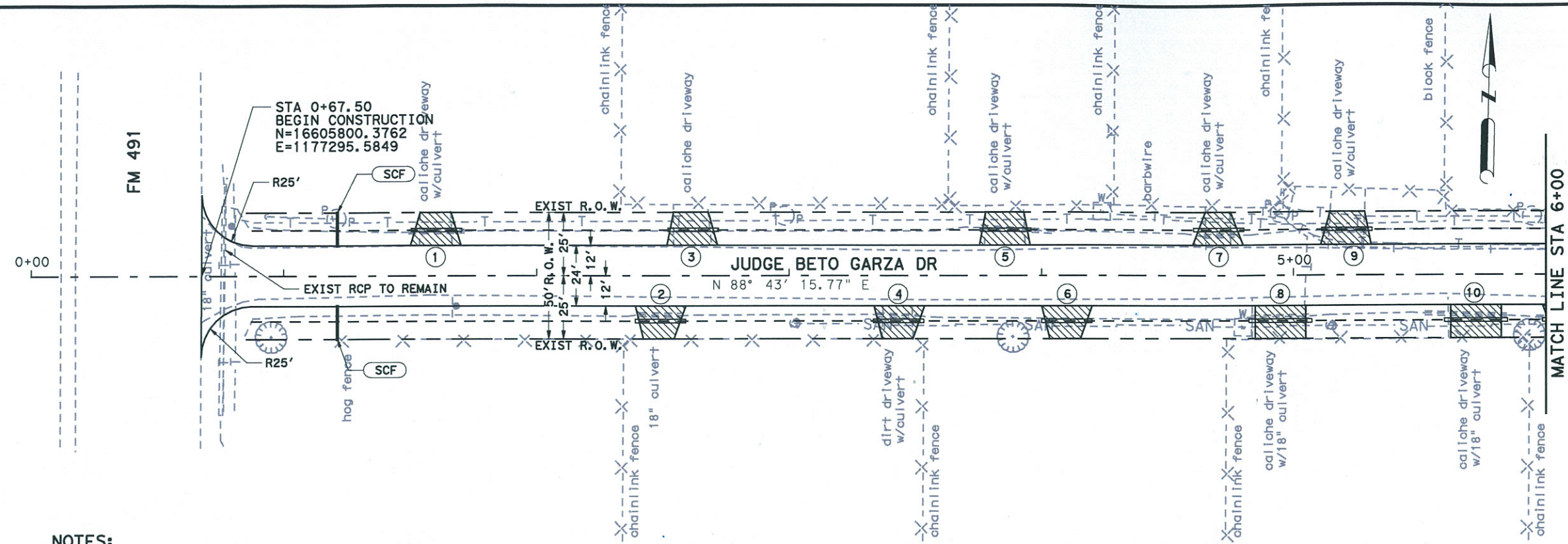

NOTES:

1. EXISTING ABOVE GROUND UTILITIES AND TOPOGRAPHY HAVE BEEN PLOTTED BY DIRECT FIELD INFORMATION AND AS SPOTTED BY UTILITY LOCATE REQUEST. THE CONTRACTOR WILL BE RESPONSIBLE FOR COORDINATING WITH UTILITY COMPANIES THE ESTABLISHING OF EXACT LOCATION, DEPTH, AND SIZE OF UTILITY LINES. THE CONTRACTOR WILL ALSO BE RESPONSIBLE FOR COORDINATING WITH THE UTILITY COMPANIES FOR REPLACEMENT OR REPAIRS OF ALL CUT OR BROKEN WATER LINES, IRRIGATION LINES, FORCE MAINS, SPRINKLER SYSTEMS, GAS LINES, POWER LINES, TELEPHONE CABLES, AND/OR ANY OTHER UTILITIES.
2. MAILBOXES AND SIGNS TO BE ADJUSTED/REPLACED/RELOCATED DURING CONSTRUCTION. ITEMS WILL NOT BE PAID FOR DIRECTLY BUT SHALL BE CONSIDERED SUBSIDIARY TO THE VARIOUS ITEMS.
3. UNLESS OTHERWISE SPECIFIED IN THE PLANS, TREES OR OTHER OBSTRUCTIONS IN CONFLICT WITH CONSTRUCTION SHALL BE REMOVED. REMOVAL WILL NOT BE PAID FOR DIRECTLY BUT SHALL BE CONSIDERED SUBSIDIARY TO THE VARIOUS ITEMS.
4. CONTRACTOR SHALL SEED ALL NON-PAVED AREAS WITHIN R.O.W.
5. PROPOSED SIDE DRAINS TO BE INSTALLED WITH MINIMUM COVER FROM BOTTOM OF ASPHALT AS FOLLOWS:
RESIDENTIAL AND COMMERCIAL DRIVEWAYS: 6"
COUNTY AND CITY ROADWAYS: 15"
6. STATIONS/OFFSETS MEASURED FROM CENTERLINE OF ROAD TO CENTER OF DRAINAGE STRUCTURES.
7. CONTRACTOR SHALL PERFORM ITS OWN CONSTRUCTION STAKING.

BM DATA:

BM#1 NAIL STA 7+69.8 OFFSET 6.3' RT EL=61.80'	BM#2 NAIL STA 10+54.7 OFFSET 10' RT EL=62.10
---	--

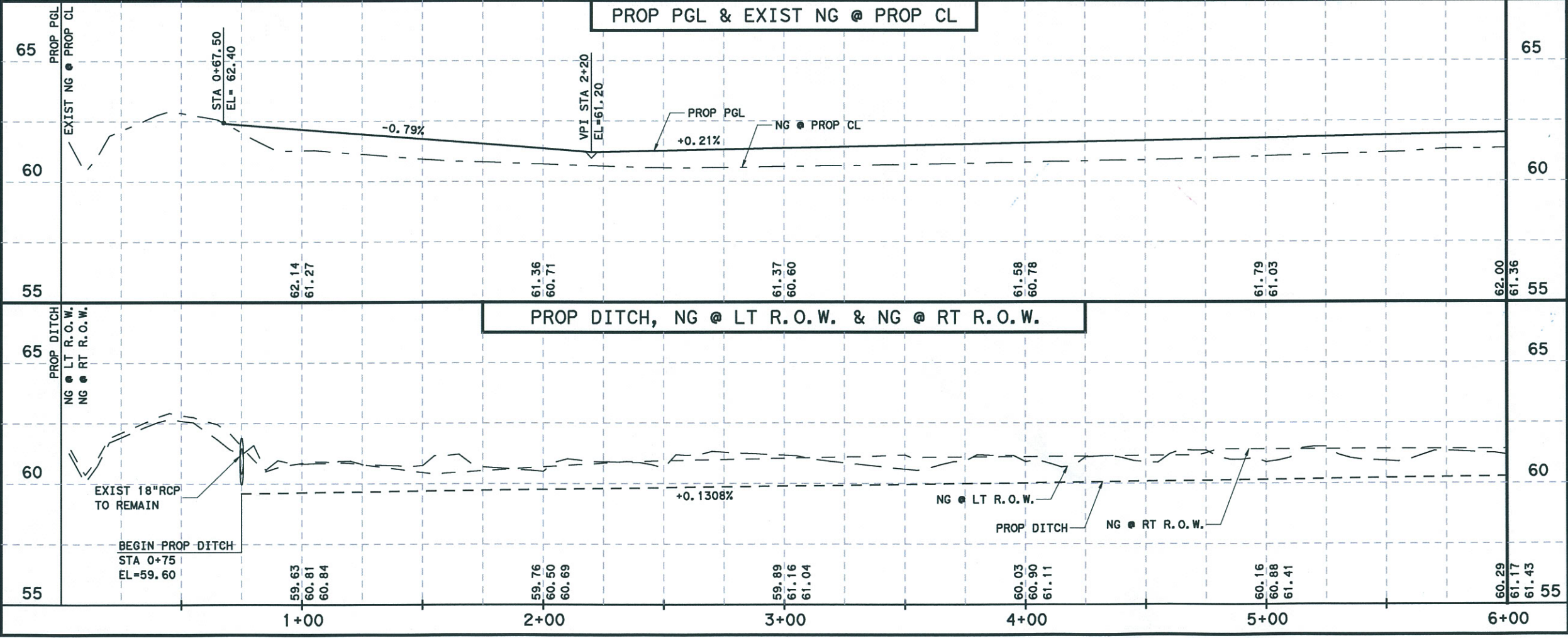

NO.	DATE	REVISION	APP.



[Signature]
03/19/2012



HIDALGO COUNTY

TEDSI INFRASTRUCTURE GROUP
Consulting Engineers
1201 E. Expressway 83
Mission, Texas 78572
(956) 424-7898

NORTH CAPISALLO

PLAN & PROFILE









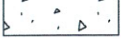

SCALE:
HORZ: 1" = 50'
VERT: 1" = 5'

SHEET 1 OF 3

FED. RD. DIV. NO. 6	PROJECT NO.	SHEET NO. 8
STATE TEXAS	DIST. PHR	COUNTY HIDALGO
CSJ	PCT 1	HIGHWAY NO. JUDGE BETO GARZA DR

3/19/2012 6:53:39 PM D:\2009\2009-1027-02_hobcap III_additional\colonia\des\ign\04_north_cap\is\l\o\es\Roadway\NC-pp.dgn

LEGEND

- GAS — EXIST GAS LINE
- T — EXIST UG PHONE LINE
- W — EXIST WATER LINE
- x-x-x-x- EXIST CHAINLINK FENCE
-  ASPHALT DRIVEWAY
-  CONCRETE DRIVEWAY
- - - - - PROP DITCH
-  DRIVEWAY ID NUMBER
-  EXIST MAILBOX
-  EXIST WATER METER
-  EXIST WATER VALVE
-  EXIST POWER POLE
-  EXIST FIRE HYDRANT
-  EXIST TELEPHONE BOX
-  EXIST GAS METER
-  TEMP SED CTRL FENCE

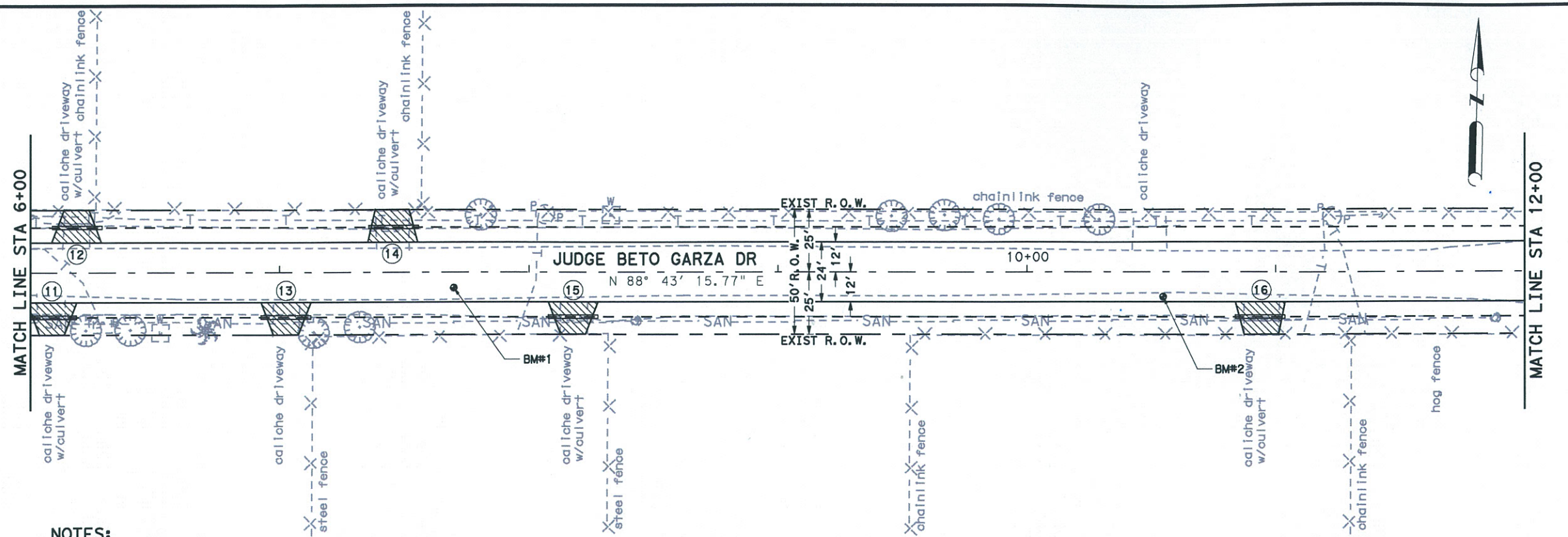

NOTES:

1. EXISTING ABOVE GROUND UTILITIES AND TOPOGRAPHY HAVE BEEN PLOTTED BY DIRECT FIELD INFORMATION AND AS SPOTTED BY UTILITY LOCATE REQUEST. THE CONTRACTOR WILL BE RESPONSIBLE FOR COORDINATING WITH UTILITY COMPANIES THE ESTABLISHING OF EXACT LOCATION, DEPTH, AND SIZE OF UTILITY LINES. THE CONTRACTOR WILL ALSO BE RESPONSIBLE FOR COORDINATING WITH THE UTILITY COMPANIES FOR REPLACEMENT OR REPAIRS OF ALL CUT OR BROKEN WATER LINES, IRRIGATION LINES, FORCE MAINS, SPRINKLER SYSTEMS, GAS LINES, POWER LINES, TELEPHONE CABLES, AND/OR ANY OTHER UTILITIES.
2. MAILBOXES AND SIGNS TO BE ADJUSTED/REPLACED/RELOCATED DURING CONSTRUCTION. ITEMS WILL NOT BE PAID FOR DIRECTLY BUT SHALL BE CONSIDERED SUBSIDIARY TO THE VARIOUS ITEMS.
3. UNLESS OTHERWISE SPECIFIED IN THE PLANS, TREES OR OTHER OBSTRUCTIONS IN CONFLICT WITH CONSTRUCTION SHALL BE REMOVED. REMOVAL WILL NOT BE PAID FOR DIRECTLY BUT SHALL BE CONSIDERED SUBSIDIARY TO THE VARIOUS ITEMS.
4. CONTRACTOR SHALL SEED ALL NON-PAVED AREAS WITHIN R.O.W.
5. PROPOSED SIDE DRAINS TO BE INSTALLED WITH MINIMUM COVER FROM BOTTOM OF ASPHALT AS FOLLOWS:
RESIDENTIAL AND COMMERCIAL DRIVEWAYS: 6"
COUNTY AND CITY ROADWAYS: 15"
6. STATIONS/OFFSETS MEASURED FROM CENTERLINE OF ROAD TO CENTER OF DRAINAGE STRUCTURES.
7. CONTRACTOR SHALL PERFORM ITS OWN CONSTRUCTION STAKING.

BM DATA:

BM#1 NAIL STA 7+69.8 OFFSET 6.3' RT EL=61.80'	BM#2 NAIL STA 10+54.7 OFFSET 10' RT EL=62.10
---	--

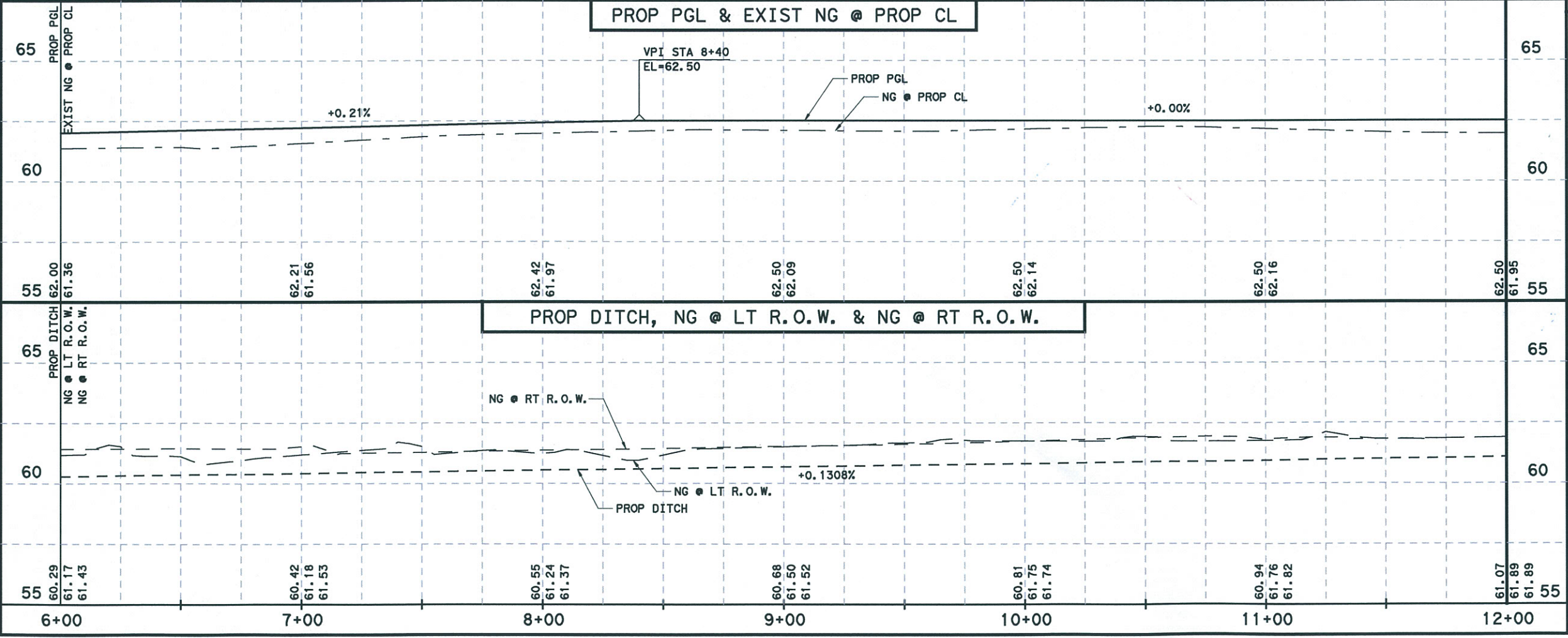

NO.	DATE	REVISION	APP.



[Signature]
03/19/2012



HIDALGO COUNTY

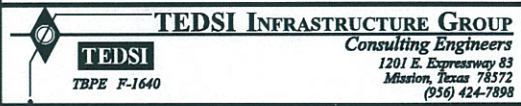

NORTH CAPISALLO

PLAN & PROFILE











SCALE:
HORZ: 1" = 50'
VERT: 1" = 5'

SHEET 2 OF 3

FED. RD. DIV. NO. 6	PROJECT NO. 2C-1080-495	SHEET NO. 9
STATE TEXAS	DIST. PHR	COUNTY HIDALGO
CSJ	PCT 1	HIGHWAY NO. JUDGE BETO GARZA DR

3/19/2012 6:53:45 PM D:\2009\2009-1027-02_hobcop III_addit\l\oncl_col\on\as\des\gr\04_north_cap\sa\l\o\es\Roadway\NC-pp.dgn

LEGEND

- GAS — EXIST GAS LINE
- T — EXIST UG PHONE LINE
- W — EXIST WATER LINE
- x-x-x-x- EXIST CHAINLINK FENCE
-  ASPHALT DRIVEWAY
-  CONCRETE DRIVEWAY
- - - - - PROP DITCH
-  DRIVEWAY ID NUMBER
-  EXIST MAILBOX
-  EXIST WATER METER
-  EXIST WATER VALVE
-  EXIST POWER POLE
-  EXIST FIRE HYDRANT
-  EXIST TELEPHONE BOX
-  EXIST GAS METER
-  TEMP SED CTRL FENCE

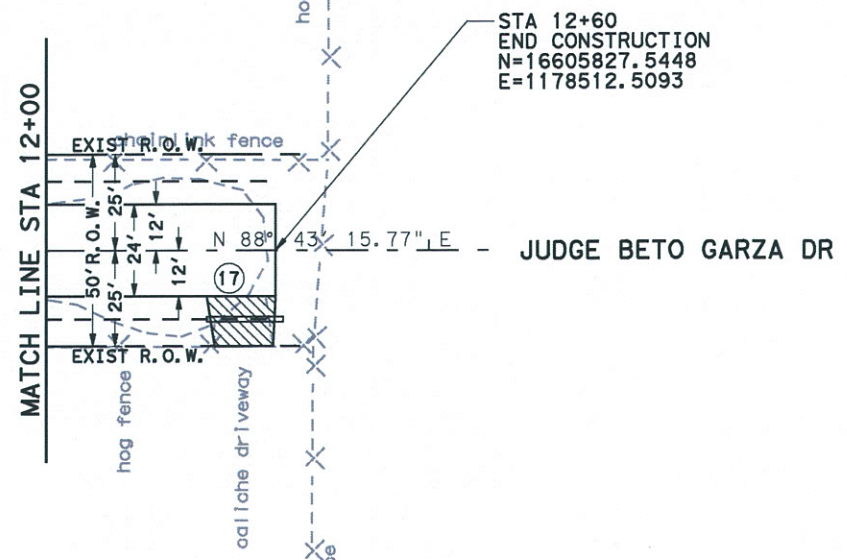

NOTES:

1. EXISTING ABOVE GROUND UTILITIES AND TOPOGRAPHY HAVE BEEN PLOTTED BY DIRECT FIELD INFORMATION AND AS SPOTTED BY UTILITY LOCATE REQUEST. THE CONTRACTOR WILL BE RESPONSIBLE FOR COORDINATING WITH UTILITY COMPANIES THE ESTABLISHING OF EXACT LOCATION, DEPTH, AND SIZE OF UTILITY LINES. THE CONTRACTOR WILL ALSO BE RESPONSIBLE FOR COORDINATING WITH THE UTILITY COMPANIES FOR REPLACEMENT OR REPAIRS OF ALL CUT OR BROKEN WATER LINES, IRRIGATION LINES, FORCE MAINS, SPRINKLER SYSTEMS, GAS LINES, POWER LINES, TELEPHONE CABLES, AND/OR ANY OTHER UTILITIES.
2. MAILBOXES AND SIGNS TO BE ADJUSTED/REPLACED/RELOCATED DURING CONSTRUCTION. ITEMS WILL NOT BE PAID FOR DIRECTLY BUT SHALL BE CONSIDERED SUBSIDIARY TO THE VARIOUS ITEMS.
3. UNLESS OTHERWISE SPECIFIED IN THE PLANS, TREES OR OTHER OBSTRUCTIONS IN CONFLICT WITH CONSTRUCTION SHALL BE REMOVED. REMOVAL WILL NOT BE PAID FOR DIRECTLY BUT SHALL BE CONSIDERED SUBSIDIARY TO THE VARIOUS ITEMS.
4. CONTRACTOR SHALL SEED ALL NON-PAVED AREAS WITHIN R.O.W.
5. PROPOSED SIDE DRAINS TO BE INSTALLED WITH MINIMUM COVER FROM BOTTOM OF ASPHALT AS FOLLOWS:
RESIDENTIAL AND COMMERCIAL DRIVEWAYS: 6"
COUNTY AND CITY ROADWAYS: 15"
6. STATIONS/OFFSETS MEASURED FROM CENTERLINE OF ROAD TO CENTER OF DRAINAGE STRUCTURES.
7. CONTRACTOR SHALL PERFORM TS OWN CONSTRUCTION STAKING.

BM DATA:

BM#1 NAIL STA 7+69.8 OFFSET 6.3' RT EL=61.80'	BM#2 NAIL STA 10+54.7 OFFSET 10' RT EL=62.10
---	--

PROP PGL & EXIST NG @ PROP CL

PROP DITCH, NG @ LT R.O.W. & NG @ RT R.O.W.

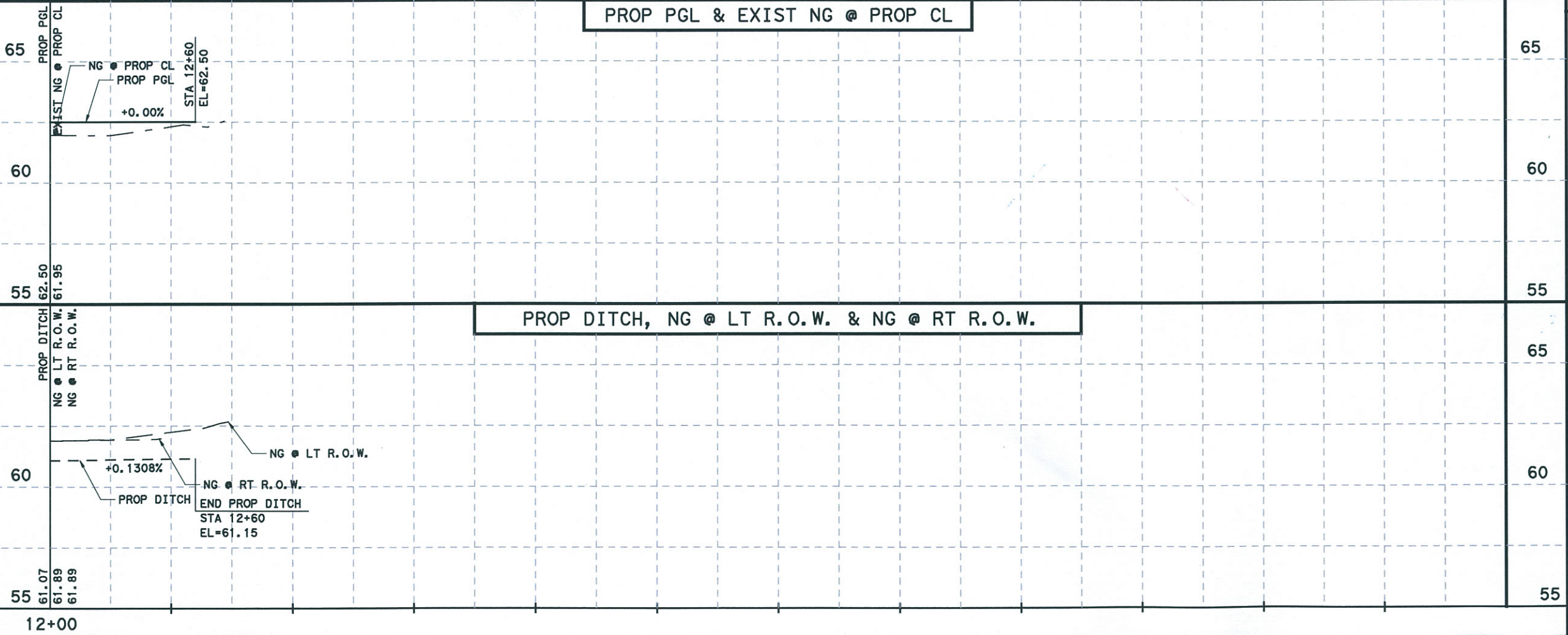

NO.	DATE	REVISION	APP.



(Handwritten signature)



HIDALGO COUNTY



NORTH CAPISALLO

PLAN & PROFILE

SCALE:
HORZ: 1" = 50'
VERT: 1" = 5'

SHEET 3 OF 3

FED. RD. DIV. NO. 6	PROJECT NO.	SHEET NO. 10
STATE TEXAS	DIST. PHR	COUNTY HIDALGO
CSJ	PCT 1	HIGHWAY NO. JUDGE BETO GARZA DR

3/19/2012 6:53:50 PM C:\2009\2009-1027-02_hobcap III add\1\oncl_col\en\cas\des\gr\04_north_cap\sc\l\o\es\Roadway\NC-pp.dgn

3/19/2012 4:02:06 PM
 pt:\2009\2009-1027-02 hobcap\11\additional\colonia\des\gn\04 north op\sal\lo\cbs\Roadway\NC-drwy.dgn

NORH CAPIHALLO								
ID	STATION	OFFSET	EXISTING STRUCTURE	EXISTING DRIVEWAY DESCRIPTION	556	0496-2016	0530-2010	0530-2011
					ADS PIPE 15"	REMOV STR (PIPE)	DRIVEWAYS (CONC)	DRIVEWAYS (ACP)
					LF	LF	SY	SY
1	1+60	LT	18" RCP	UNPAVED	20	20		24
2	2+48	RT	18" RCP	UNPAVED	20	16		24
3	2+61	LT		UNPAVED	20			25
4	3+43	RT	18" RCP	UNPAVED	20	16		24
5	3+85	LT	18" RCP	UNPAVED	20	28		26
6	4+09	RT		UNPAVED	20			24
7	4+70	LT	18" RCP	UNPAVED	20	12		22
8	4+95	RT	18" RCP	UNPAVED	20	24		29
9	5+21	LT	18" RCP	UNPAVED	20	18		25
10	5+72	RT	18" RCP	UNPAVED	20	32		29
11	6+08	RT	18" RCP	UNPAVED	20	20		22
12	6+18	LT	18" RCP	UNPAVED	20	14		22
13	7+02	RT		UNPAVED	20			22
14	7+45	LT	18" RCP	UNPAVED	20	10		25
15	8+18	RT		UNPAVED	20	16		22
16	10+94	RT	18" RCP	UNPAVED	20	20		25
TOTAL					320	246	0	390

DRIVEWAY NOTES:
 ASPHALT THICKNESS = 1.5"
 CONCRETE THICKNESS = 4"
 FLEXIBLE BASE THICKNESS = 6"

NO.	DATE	REVISION	APP.

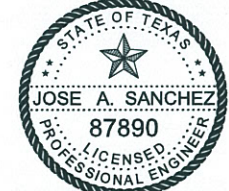

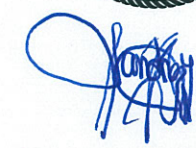
03/19/2012



HIDALGO COUNTY



TEDSI INFRASTRUCTURE GROUP
 Consulting Engineers
 1201 E. Expressway 83
 Mission, Texas 78572
 (956) 424-7898

NORTH CAPIHALLO



DRIVEWAY TABLES

SHEET 1 OF 1

FED. RD. DIV. NO.	PROJECT NO.	SHEET NO.
6		11
STATE	DIST.	COUNTY
TEXAS	PHR	HIDALGO
CSJ	PCT	HIGHWAY NO.
2C-1080-495	1	JUDGE BETO GARZA DR

FOR CONTRACTOR'S INFORMATION ONLY

Station	Material Name	End Areas (sq. ft.)	Unadjusted Volumes (cu. yd.)	Adjusted Volumes (cu. yd.)	Mult Factor	Mass Ordinate	
		0+90.00 PROP					
	Excavation	10.1	0.0	0	0	1.00	
	Fill			0	1.00	0	
			EXIST				
	Excavation	0.0	8.0	0	0	1.00	
	Fill			0	1.00	0	
		2+00.00 PROP					
	Excavation	0.3	0.0	0	0	1.00	
	Fill			21	1.00	-21	
			EXIST				
	Excavation	0.0	17.7	52	52	1.00	
	Fill			0	1.00	31	
		3+00.00 PROP					
	Excavation	0.2	0.0	0	0	1.00	
	Fill			1	1.00	30	
			EXIST				
	Excavation	0.0	18.2	66	66	1.00	
	Fill			0	1.00	96	
		4+00.00 PROP					
	Excavation	0.1	0.0	0	0	1.00	
	Fill			1	1.00	95	
			EXIST				
	Excavation	0.0	14.1	60	60	1.00	
	Fill			0	1.00	155	
		5+00.00 PROP					
	Excavation	0.1	0.0	0	0	1.00	
	Fill			1	1.00	154	
			EXIST				
	Excavation	0.0	16.3	56	56	1.00	
	Fill			0	1.00	210	
		6+00.00 PROP					
	Excavation	0.7	0.0	0	0	1.00	
	Fill			2	1.00	208	
			EXIST				
	Excavation	0.0	17.6	63	63	1.00	
	Fill			0	1.00	271	
		7+00.00 PROP					
	Excavation	1.1	0.0	0	0	1.00	
	Fill			3	1.00	268	
			EXIST				
	Excavation	0.0	13.9	58	58	1.00	
	Fill			0	1.00	326	
		8+00.00 PROP					
	Excavation	3.0	0.0	0	0	1.00	
	Fill			8	1.00	318	
			EXIST				
	Excavation	0.0	12.1	48	48	1.00	
	Fill			0	1.00	366	
		9+00.00 PROP					
	Excavation	0.3	0.0	0	0	1.00	
	Fill			6	1.00	360	
			EXIST				
	Excavation	0.0	16.3	53	53	1.00	
	Fill			0	1.00	413	
		10+00.00 PROP					
	Excavation	0.2	0.0	0	0	1.00	
	Fill			1	1.00	412	
			EXIST				
	Excavation	0.0	21.1	69	69	1.00	
	Fill			0	1.00	481	
		11+00.00 PROP					
	Excavation	0.3	0.0	0	0	1.00	
	Fill			1	1.00	480	
			EXIST				
	Excavation	0.0	20.0	76	76	1.00	
	Fill			0	1.00	556	
		12+00.00 PROP					
	Excavation	0.3	0.0	0	0	1.00	
	Fill			1	1.00	555	
			EXIST				
	Excavation	0.0	15.8	66	66	1.00	
	Fill			0	1.00	621	
		12+58.00 PROP					
	Excavation	0.0	0.0	0	0	1.00	
	Fill			0	1.00	621	
			EXIST				
	Excavation	0.0	36.2	56	56	1.00	
	Fill			0	1.00	677	
	G R A N D S U M M A R Y T O T A L S						
	Material Name		Unadjusted Volumes (cu. yd.)	Adjusted Volumes (cu. yd.)	Mult Factor		
	Excavation	PROP	0	0	1.00		
	Fill	EXIST	46	46	1.00		
	Excavation		723	723	1.00		
	Fill		0	0	1.00		

NO.	DATE	REVISION		APP.			
 HIDALGO COUNTY							
 TEDSI INFRASTRUCTURE GROUP <i>Consulting Engineers</i> 1201 E. Expressway 83 Mission, Texas 78372 (956) 424-7898							
NORTH CAPISALLO							
EARTHWORK							
SHEET 1 OF 1							
FED. RD. DIV. NO.	PROJECT NO.					SHEET NO.	
6						12	
STATE	DIST.	COUNTY					
TEXAS	PHR	HIDALGO					
CSJ		PCT	HIGHWAY NO.				
2C-1080-495		1	JUDGE BETO GARZA DR				

3/19/2012 4:02:11 PM ps:\2009\2009-1027-02 hobcap_111_additional\onal_colon\cas\des\ign\04_north_cap\isall\o\os\Roadway\NC-EW.dgn

FOR CONTRACTOR'S INFORMATION ONLY

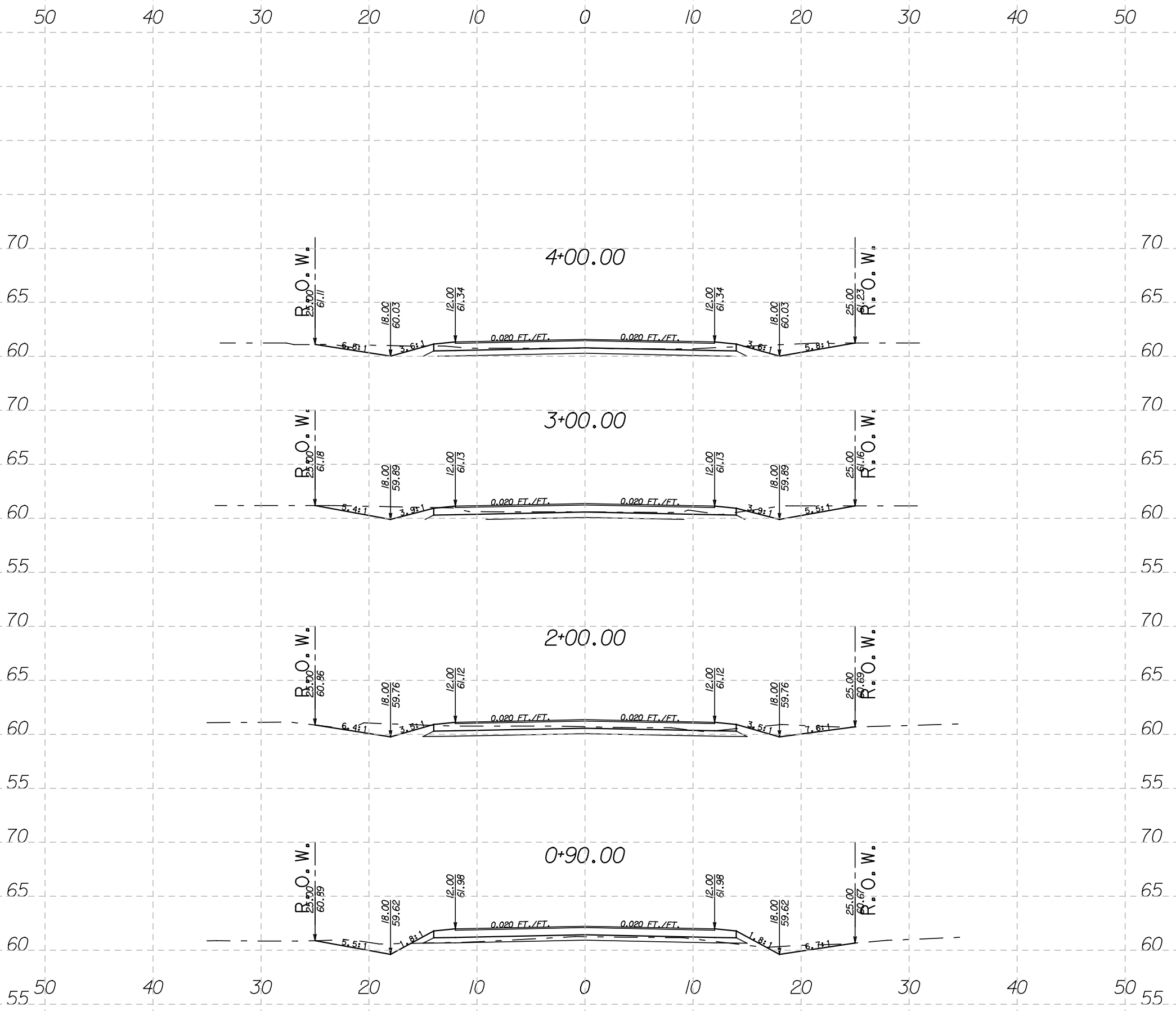

3/19/2012 4:02:18 PM
 ps:\2009\2009-1027-02 hobcap III additional\anal_colonias\des\ign\04_north_cap\isa\lo\os\Xsec\north-pxs-11\X17.dgn

NO.	DATE	REVISION	APP.



TEDSI INFRASTRUCTURE GROUP
 Consulting Engineers
 1201 E. Expressway 83
 Mission, Texas 78372
 (936) 424-7898

NORTH CAPISALLO

ROADWAY CROSS-SECTIONS

N. T. S.		PROJECT NO.	SHEET NO.
FED. RD. DIV. NO.	6		13
STATE	TEXAS	DIST.	PHR
		COUNTY	
		HIDALGO	
CSJ	PCT	HIGHWAY NO.	
2C-1080-495	1	JUDGE BETO GARZA DR	

FOR CONTRACTOR'S INFORMATION ONLY

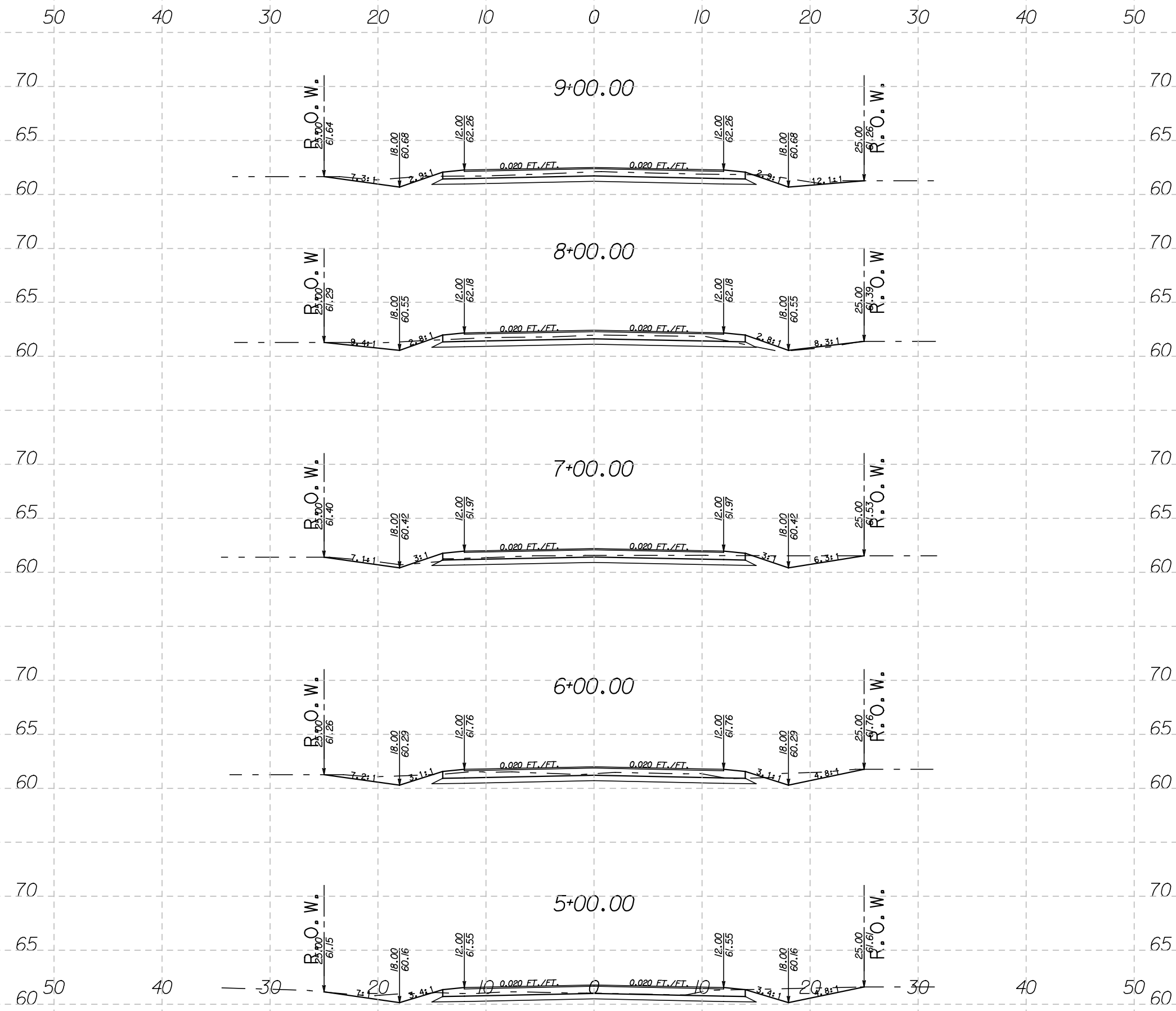

3/19/2012 4:02:23 PM p:\2009\2009-1027-02 hobcap 111 addit\onal_colonias\des\ign\04 north_cap\isa\lo\osj\Xsec\north-pxs-11X17.dgn

NO.	DATE	REVISION	APP.

HIDALGO COUNTY

TEDSI INFRASTRUCTURE GROUP
Consulting Engineers
 1201 E. Expressway 83
 Mission, Texas 78372
 (936) 424-7898

NORTH CAPISALLO

ROADWAY CROSS-SECTIONS

N. T. S.		PROJECT NO.	SHEET NO.
FED. RD. DIV. NO.	6		14
STATE	TEXAS	DIST.	PHR
		COUNTY	
		HIDALGO	
CSJ	PCT	HIGHWAY NO.	
2C-1080-495	1	JUDGE BETO GARZA DR	

FOR CONTRACTOR'S INFORMATION ONLY

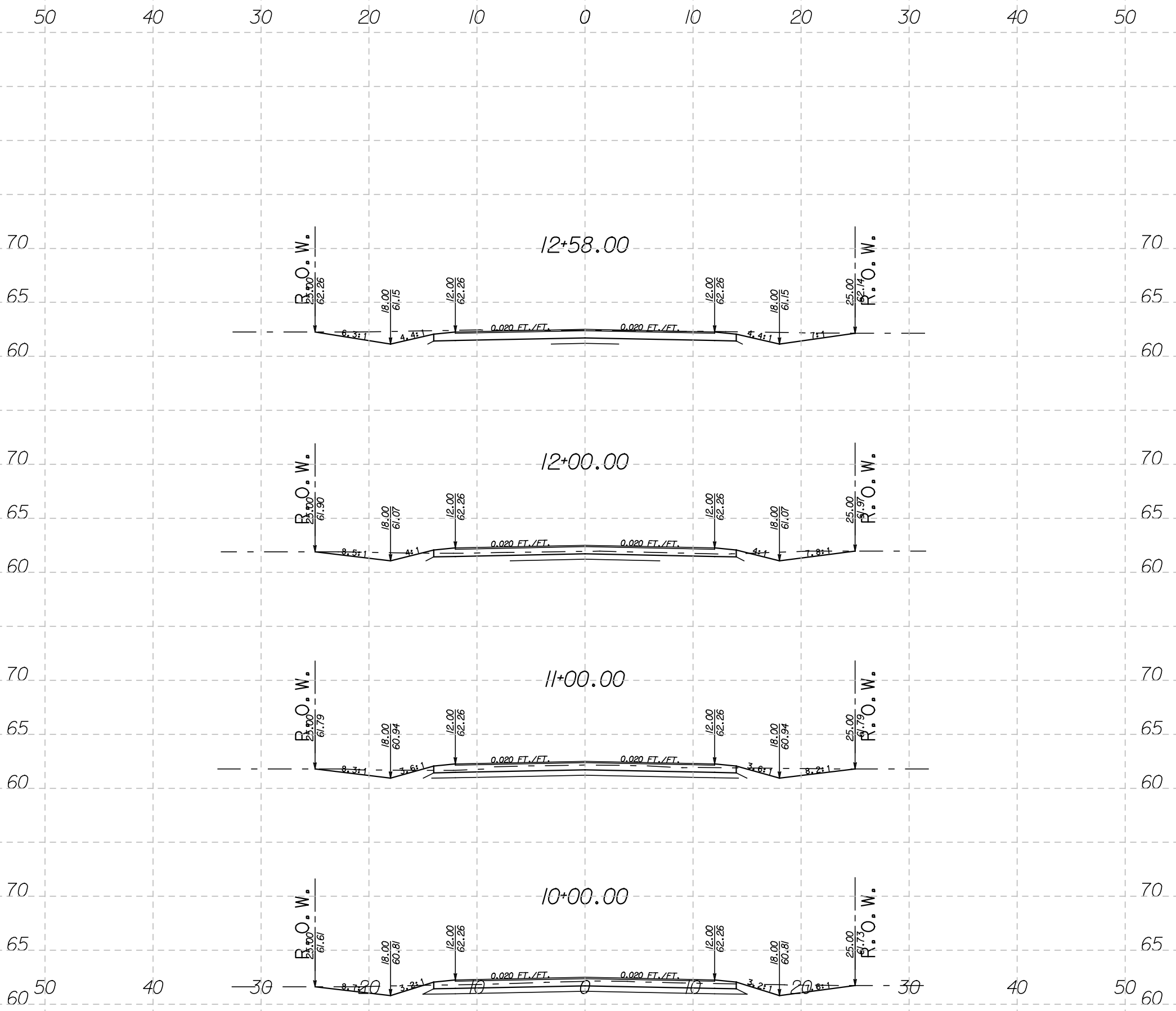

NO.	DATE	REVISION	APP.



TEDSI INFRASTRUCTURE GROUP
 Consulting Engineers
 1201 E. Expressway 83
 Mission, Texas 78372
 (956) 424-7898

NORTH CAPISALLO

ROADWAY CROSS-SECTIONS

N. T. S.		PROJECT NO.	SHEET NO.
FED. RD. DIV. NO.	6		15
STATE	TEXAS	DIST.	PHR
		COUNTY	
		HIDALGO	
CSJ	PCT	HIGHWAY NO.	
2C-1080-495	1	JUDGE BETO GARZA DR	

3/19/2012 4:02:27 PM ps:\2009\2009-1027-02 hobcap 111 addit\final_colonias.dwg\04 north_cap.isa\10\osj\Xsec\north-pxs-11X17.dgn

PAVEMENT MARKINGS LEGEND

(REFL PAV MRK TYPE 1) (100 MIL)

- A (W) (04") (SLD)
- B (W) (24") (SLD)
- C (Y) (04") (BRK)
- D (Y) (04") (SLD)

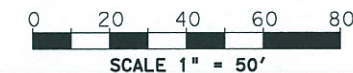
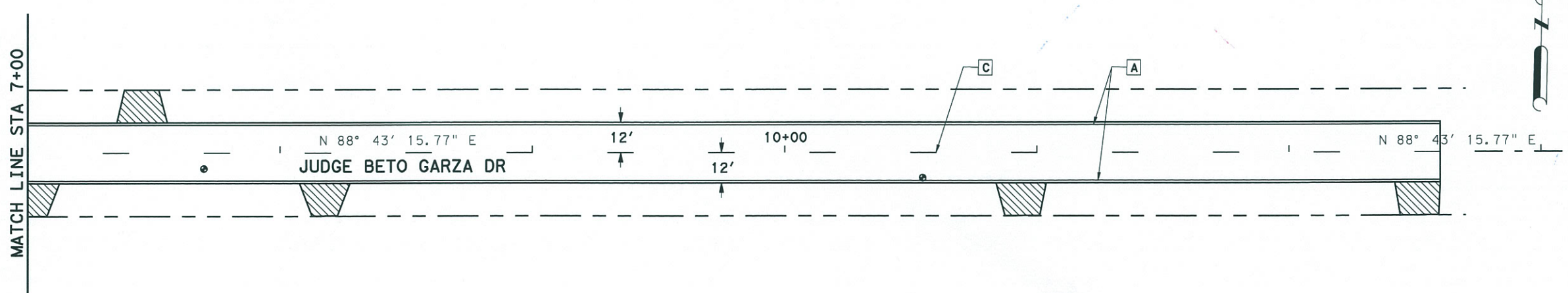
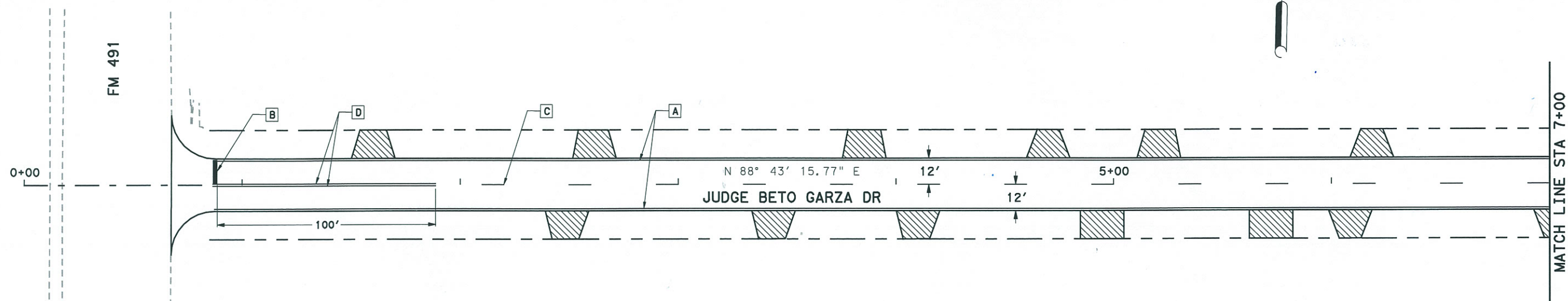

NO.	DATE	REVISION	APP.

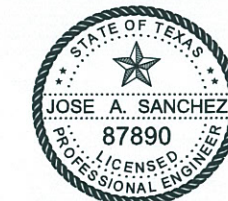

[Signature]
03/19/2012



HIDALGO COUNTY

TEDSI INFRASTRUCTURE GROUP
Consulting Engineers
1201 E. Expressway 83
Mission, Texas 78572
(936) 424-7898

NORTH CAPISALLO

PAVEMENT MARKINGS

SHEET 1 OF 1

FED. RD. DIV. NO.	PROJECT NO.	SHEET NO.
6		16
STATE	DIST.	COUNTY
TEXAS	PHR	HIDALGO
CSJ	PCT	HIGHWAY NO.
2C-1080-495	1	JUDGE BETO GARZA DR

3/19/2012 4:42:45 PM P:\2009\2009-1027-02 HCBGAP III Additional Coloni cas\Des\gn\04 North Capisallo\Roadway\NC-spm.dgn

SITE DESCRIPTION

PROJECT LIMITS: North Capisallo Subdivision: Judge Beto Garza Dr-1192.5'

PROJECT SITE MAPS: *Project Location Map: Title Sheet (Sheet 1)
*Approx. Slopes Anticipated After Major Gradients and Areas of Soil Disturbance: Typ Sects (Sheet 5)
*Major Controls and Locations of Stabilization Practices: SW3P Site Map Sheets (Sheets 8-10)
*Project Specific Locations: To be specified by Project Field Office and located in the Project SW3P File

PROJECT DESCRIPTION: Construction will consist of hot mix asphalt, flexible base, subgrade and roadside ditches.

MAJOR SOIL DISTURBING ACTIVITIES: Roadway reconstruction

TOTAL PROJECT AREA: 1.36 Acres

TOTAL AREA TO BE DISTURBED: 1.36 Acres (100%)

WEIGHTED RUNOFF COEFFICIENT:
Before Construction: 0.30
After Construction: 0.59

EXISTING CONDITION OF SOIL & VEGETATIVE
Existing dirt roadway (41%), Short grass between edge of pavement and ROW 59%

NAME OF RECEIVING WATERS:
Drainage from site drains into the IBWC Levee System which eventually empties into the lower Laguna Madre.

ENDANGERED SPECIES, DESIGNATED CRITICAL HABITAT AND HISTORICAL PROPERTY:

A. No Endangered Species. Designated Critical Habitat or Historic Property has not been found on this project site.

EROSION AND SEDIMENT CONTROLS

SOIL STABILIZATION PRACTICES: (Select T = Temporary or P = Permanent, as applicable)

- T TEMPORARY SEEDING
- MULCHING (Hay or Straw)
- BUFFER ZONES
- PLANTING
- SEEDING
- SODDING
- PRESERVATION OF NATURAL RESOURCES
- FLEXIBLE CHANNEL LINER
- RIGID CHANNEL LINER
- SOIL RETENTION BLANKET
- COMPOST MANUFACTURED COMPOST
- OTHER: (Specify Practice)

STRUCTURAL PRACTICES: (Select T = Temporary or P = Permanent, as applicable)

- T SILT FENCES
- HAY BALES
- ROCK FILTER DAMS
- DIVERSION, INTERCEPTOR, OR PERIMETER DIKES
- DIVERSION, INTERCEPTOR, OR PERIMETER SWALES
- DIVERSION DIKE AND SWALE COMBINATIONS
- PIPE SLOPE DRAINS
- PAVED FLUMES
- ROCK BEDDING AT CONSTRUCTION EXIT
- TIMBER MATTING AT CONSTRUCTION EXIT
- CHANNEL LINERS
- SEDIMENT TRAPS
- SEDIMENT BASINS
- STORM INLET SEDIMENT TRAP
- STONE OUTLET STRUCTURES
- CURBS AND GUTTERS
- STORM SEWERS
- VELOCITY CONTROL DEVICES
- OTHER: (Specify Practice)

STORM WATER MANAGEMENT:

Storm water drainage is provided by existing open ditches and culverts. System will carry drainage within the ROW to designated outfalls

STORM WATER MANAGEMENT ACTIVITIES:

The order of activities will be as follows:
1. Install perimeter controls, clear R.O.W. on side where construction will take place, and make required utility adjustments
2. Install proposed culverts, install sediment control fence as specified in plans.
3. Construct proposed roadway.
4. Once all construction activity is complete, permanent seeding on proposed areas shall be done according to plans or as instructed by the engineer.

NON-STORM WATER MANAGEMENT DISCHARGES:

Non-storm water discharges should be filtered, or held in retention basins, before being allowed to mix with storm water. These discharges consist of non-polluted ground water, spring water, foundation and/or footing drain water, and water used for dust control, pavement washing and vehicle wastewater containing no detergents.

OTHER REQUIREMENTS & PRACTICES

OTHER EROSION AND SEDIMENT CONTROLS:

MAINTENANCE: All erosion and sediment controls will be maintained in good working order. If a repair is necessary, it will be done at the earliest date possible, but no later than 7 calendar days after the surrounding exposed ground has dried sufficiently to prevent further damage from heavy equipment. The areas adjacent to creeks and drainage ways shall have priority followed by devices protecting storm sewer inlets.

INSPECTION: For areas of the construction site that have not been finally stabilized, area used for storage of materials, structural control measures, and locations where vehicles enter or exit the site, personnel provided by the permittee and familiar with the SW3P must inspect disturbed areas at least once every fourteen (14) calendar days and within twenty-four (24) hours of the end of a storm event 0.5 inches or greater.

WASTE MATERIALS: All waste materials will be collected and stored in a securely lidded dumpster. All trash and construction debris from the site will be deposited as necessary at a local dump. No construction waste material will be buried on site.

HAZARDOUS WASTE (INCLUDING SPILL REPORTING): At a minimum, any products in the following categories to be hazardous: Paints, Aids for cleaning masonry surfaces, Cleaning Solvents, Asphalt products, Chemical additives for soil stabilization, or Concrete curing compounds and additives. In the event of a spill which may be hazardous, the spill coordinator should be contacted immediately. Emptying of excess concrete should not be allowed on site. Likewise, washout of concrete trucks should not be performed on site. These discharges are considered non-allowable non-storm water discharges. Concrete trucks should never be allowed to dump into storm drains or sanitary sewers.

SANITARY WASTE: All sanitary waste will be collected from the portable units as necessary or as required by local regulation by a licensed sanitary waste management contractor.

OFFSITE VEHICLE TRACKING: The Contractor shall be required, on a regular basis or as may be directed by the Engineer, to dampen haul roads for dust control, stabilize construction entrances and to remove excess dirt from the roadway.

MANAGEMENT PRACTICES: (Example Below - May be used as applicable, revised or expanded)
1. Disposal areas, stockpiles, and haul roads shall be constructed in a manner that will minimize and control the amount of sediment that may enter receiving waters. Disposal areas shall not be located in any wet land, water body or stream bed.
2. Construction staging areas and vehicle maintenance areas shall be constructed by the Contractor in a manner to minimize the runoff of pollutants.
3. All waterways shall be cleared as soon as practicable of temporary embankment, temporary bridges, matting, falsework, piling, or debris or other obstructions placed during construction operations that are not a part of the finished work.

OTHER:
1. Construction materials stored on site to be provided by Project Field Office.
2. The project SW3P File located at the project field office shall contain the Small Construction Site Notice and any additional permits required by T.E.C.O.

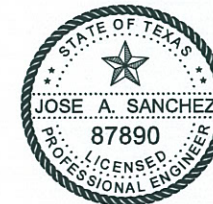

[Handwritten Signature]
 03/19/2012

© 2004

TxDOT STORM WATER POLLUTION PREVENTION PLAN (SW3P)

REV. 4/04		SW3P.DGN	
FED. RD. DIV. NO. 6	PROJECT NO.	SHEET NO. 17	
STATE TEXAS	DIST. PHARR	COUNTY HIDALGO	
CONT. 2C	SECT. 1080	JOB 230	HIGHWAY NO. VARIOUS

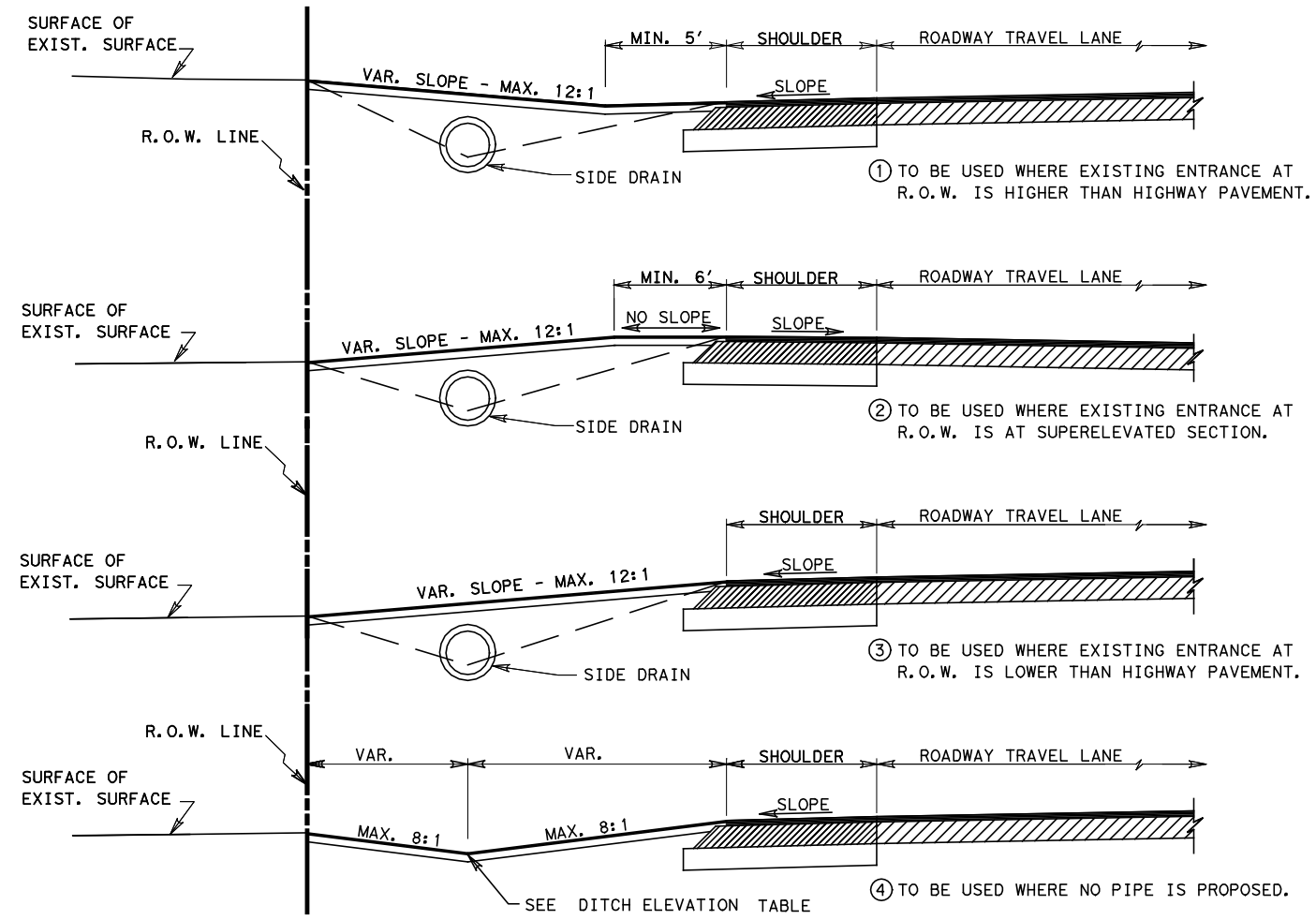

NOTES:

ALL ENTRANCES CONSTRUCTED ON THIS PROJECT ARE SUBJECT TO CONCURRENCE WITH EXISTING GOVERNING REGULATIONS AS SET OUT BY THE STATE HIGHWAY COMMISSION.

ENTRANCE'S BASE AND SURFACING MAY BE EXTENDED BEYOND R.O.W. LINE AS REQUIRED TO MEET EXISTING GRADE IN A SATISFACTORY MANNER OF WHICH NO STEEPER THAN 12:1 SLOPE WILL BE CONSTRUCTED.

ALL FLEXIBLE BASE USED FOR PRIVATE DRIVES & COMMERCIAL DRIVES WILL NOT REQUIRE LIME TREATMENT.

EXACT LOCATIONS, DIMENSIONS, AND TYPE TO BE ESTABLISHED DURING CONSTRUCTION BY THE ENGINEER.

PROP. WIDTH OF DRIVEWAYS TO MATCH EXISTING WIDTH AT R.O.W. LINE.

114 #/SY ACP (COMPACTED) IS EQUAL TO 1 IN. DEPTH
171 #/SY ACP (COMPACTED) IS EQUAL TO 1/2 IN. DEPTH.

SIDE DRAINS TO BE INSTALLED WHERE ROADWAY DITCH DRAINAGE IS NECESSARY, AS INDICATED ON PLANS AND/OR AS DIRECTED BY THE ENGINEER.

SIDE DRAINS TO BE INSTALLED WITH A MINIMUM OF 6" COVER BY PROPOSED RESIDENTIAL & COMMERCIAL MATERIAL OR 15" COVER OF PROPOSED COUNTY RD. & CITY STREET ROADWAY MATERIAL.

AVERAGE DIMENSIONS SHOWN ON TABLE OF DRIVEWAYS ARE FOR ESTIMATING PURPOSES ONLY.

THE RATE OF PRIME SHALL BE 0.10 GAL/SY FOR PRIVATE AND/OR COMMERCIAL DRIVEWAYS AND 0.20 GAL/SY FOR PUBLIC DRIVEWAYS.

TYPICAL ENTRANCE PROFILE FOR DRIVEWAYS W/OUT C&G

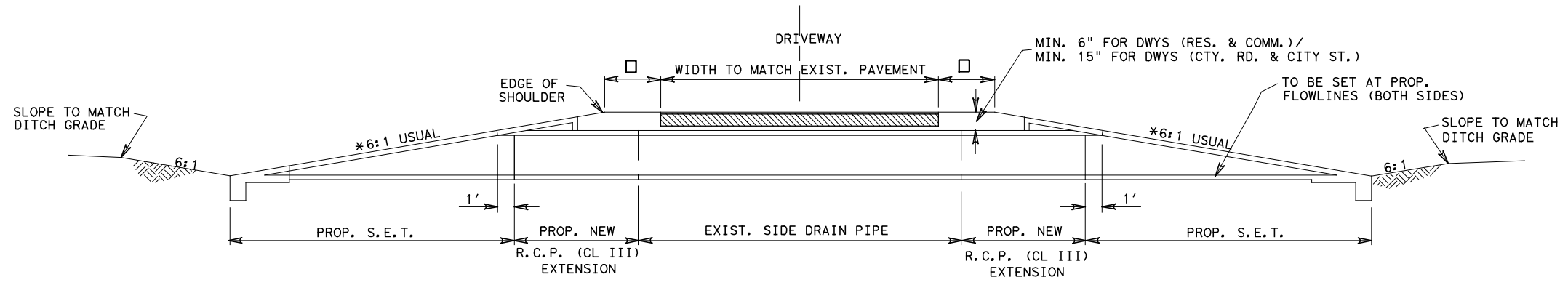

- - 1' MIN. ON DRIVEWAYS (RES. & COMM.)
2' MIN. ON DRIVEWAYS (COUNTY RD. & CITY ST.)
- * - 6:1 SLOPE USUAL
UNLESS OTHERWISE NOTED ON PLANS

© TxDOT 2005 PHARR DISTRICT STANDARD



TEXAS DEPARTMENT OF TRANSPORTATION

**DRIVEWAY
PROFILE DETAILS**

REV. 4/05		DRIVEWAY1.DGN					
STATE AID PROJECT NO.	FILE NO.	SHEET NO.					
6		18					
STATE	STATE DIST. NO.	COUNTY	CONT.	SECT.	JOB	HIGHWAY NO.	
TEXAS	PHR	HIDALGO	2C	1080	495	BETO GARZA	

PRIVATE AND COMMERCIAL DRIVES WITH CURB & GUTTER

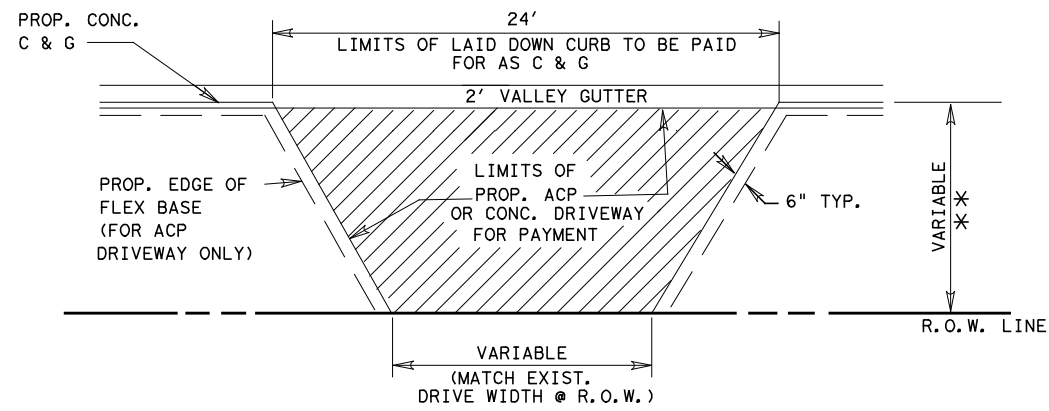

PLAN OF PRIVATE AND COMMERCIAL DRIVES
(W/DRIVEWAY WIDTH LESS THAN 24')

** SEE P&P SHEETS

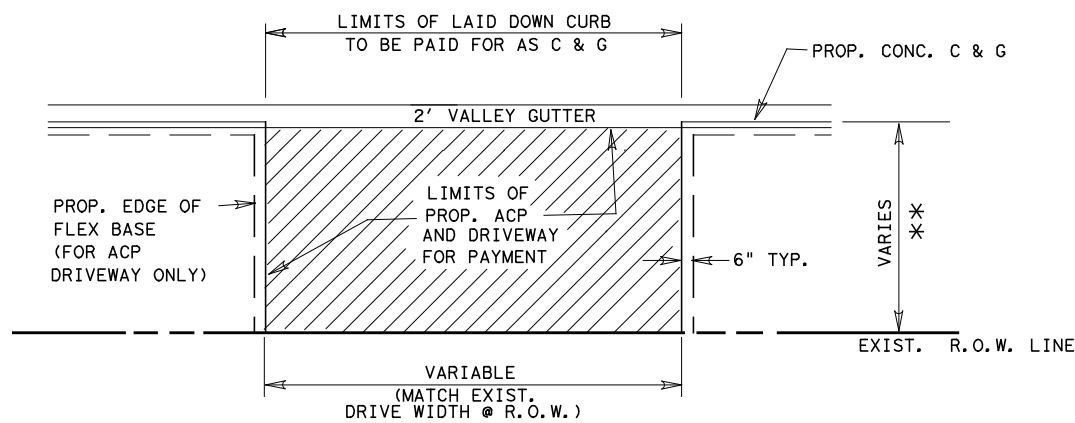

PLAN OF PRIVATE AND COMMERCIAL DRIVES
(W/DRIVEWAY WIDTH EQUAL TO OR GREATER THAN 24' @ R.O.W. LINE)

N. T. S.

PRIVATE AND COMMERCIAL DRIVES WITHOUT CURB & GUTTER

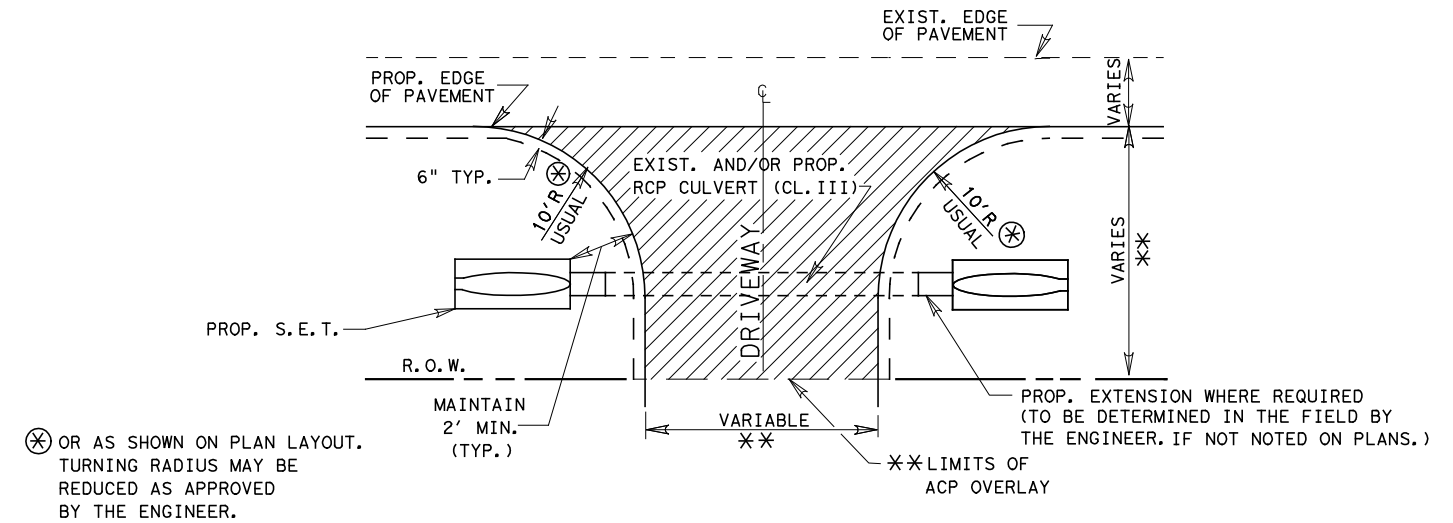

PLAN OF PRIVATE AND COMMERCIAL DRIVES

*W/DRIVEWAY WIDTH LESS THAN 24'

⊗ OR AS SHOWN ON PLAN LAYOUT. TURNING RADIUS MAY BE REDUCED AS APPROVED BY THE ENGINEER.

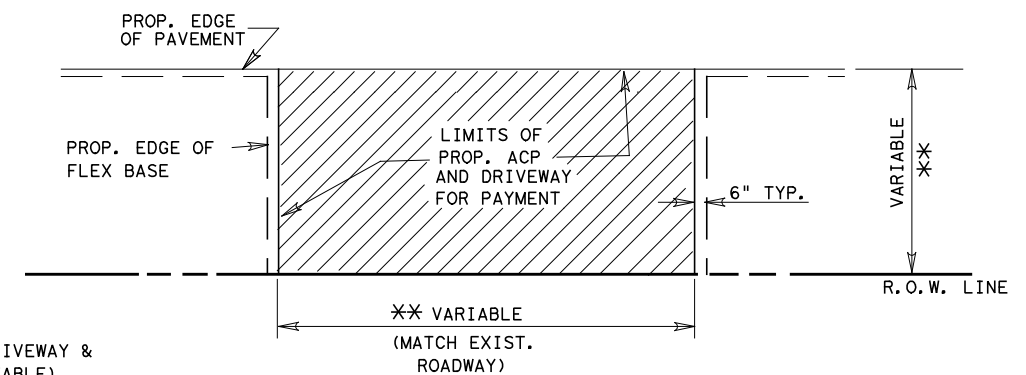

PLAN OF PRIVATE AND COMMERCIAL DRIVES
(W/DRIVEWAY WIDTH EQUAL TO OR GREATER THAN 24' @ R.O.W. LINE)

N. T. S.

** FOR DETAILS SEE DRIVEWAY & TURNOUT DETAILS (TABLE)

PRIVATE AND COMMERCIAL DRIVES WITH CURB & GUTTER

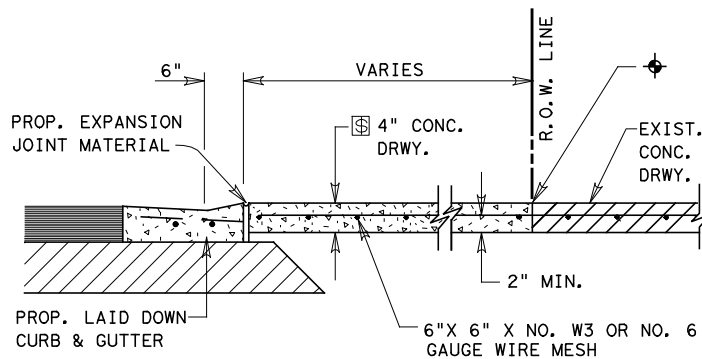

TYPICAL CONCRETE DRIVEWAY SECTION

◆ CONC. SHALL BE SAW CUT TO THE LIMITS OF REMOVAL WHERE APPLICABLE.

⊞ 6" FOR COMMERCIAL DRIVES

N. T. S.

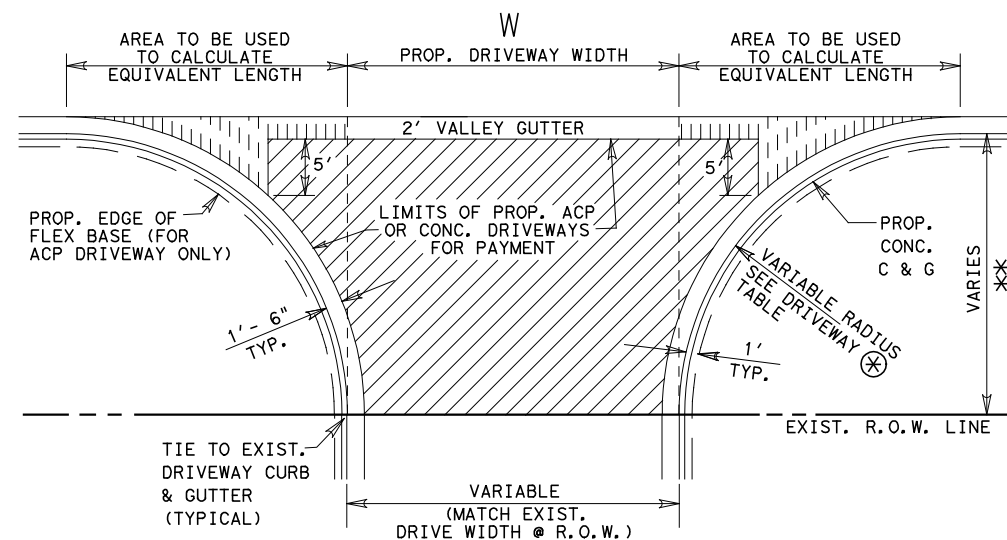

PLAN OF PRIVATE AND COMMERCIAL DRIVES

SEE P&P SHEETS FOR LOCATIONS OF DRIVES

N. T. S.

LF EQUIVALENT TABLE FOR PAYMENT LIMITS OF 2' VALLEY GUTTER

LF OF VALLEY GUTTER = W + X1 + X2	
WHERE X1 AND X2 MAY VARY DEPENDING ON RADIUS	
Prop. Driveway Radius	X1 or X2 (Sq Ft Area / 2')
5'	1
8'	2
10'	4
12'	6
15'	9
18'	12
20'	15
22'	18
25'	24
28'	30
30'	34

SEE DRIVEWAY TABLE FOR LIMITS OF LAID DOWN CURB TO BE PAID FOR AS CURB AND GUTTER

DRIVEWAY TYPES

- TY PRB-1
EXIST. PAVED CALICHE AND /OR GRAVEL DRIVEWAYS TO BE SCARIFIED AND RECONSTRUCTED WITH 3" NEW AND/OR SALVAGE FLEX. BASE TO MATCH THE PROPOSED WIDENED SECTION. THEN PRIMED AND SURFACED WITH 114#/SY ACP (TY "D")
- TY PB-1
EXIST. UNPAVED PRIVATE OR COMMERCIAL DRIVEWAYS TO BE CONSTRUCTED AS SHOWN WITH 4" NEW AND/OR SALVAGE FLEX. BASE, PRIMED AND SURFACED WITH 114#/SY ACP.
- TY P1
EXIST. PAVED DRIVEWAYS TO BE PAVED WITH 114#/SY ACP TY "D".

© TxDOT 2005 PHARR DISTRICT STANDARD

TEXAS DEPARTMENT OF TRANSPORTATION

DRIVEWAY DETAILS

PRIVATE

(RESIDENTIAL-COMMERCIAL)

REV. 4/05	DRIVEWAY2.DGN		
FED. RD. DIV. NO. 6	PROJECT NO.	FILE NO.	SHEET NO. 19
STATE TEXAS	STATE DIST. NO. PHR	COUNTY HIDALGO	CONT. 2C
		SECT. 1080	JOB 495
			HIGHWAY NO. BETO GARZA

DISCLAIMER: The use of this standard is governed by the "Texas Engineering Practice Act". No warranty of any kind is made by TxDOT for any purpose whatsoever. TxDOT assumes no responsibility for the conversion of this standard to other formats or for incorrect results or damages resulting from its use.
 DATE: 3/19/2012 4:02:51 PM
 FILE: p:\2009\2009-1027-02_heboap_iii_additional_colonias\design\04_north_capital\05\Standards\Traffic Control\BC07.DGN

Barricade and Construction (BC) Standard Sheets General Notes:

1. The Barricade and Construction Standard Sheets (BC sheets) are intended to show typical examples for placement of temporary traffic control devices, construction pavement markings, and typical work zone signs. The information contained in these sheets meet or exceed the requirements shown in the "Texas Manual on Uniform Traffic Control Devices" (TMUTCD).
2. The development and design of the Traffic Control Plan (TCP) is the responsibility of the Engineer.
3. The Contractor may propose changes to the TCP that are signed and sealed by a licensed professional engineer for approval. The Engineer may develop, sign and seal Contractor proposed changes.
4. The Contractor is responsible for installing and maintaining the traffic control devices as shown in the plans. The Contractor may not move or change the approximate location of any device without the approval of the Engineer.
5. Geometric design of lane shifts and detours should, when possible, meet the applicable design criteria contained in manuals such as the American Association of State Highway and Transportation Officials (AASHTO), "A Policy on Geometric Design of Highways and Streets", the TxDOT "Roadway Design Manual" or engineering judgment.
6. When projects abut, the Engineer(s) may omit the END ROAD WORK, TRAFFIC FINES DOUBLE, and other advance warning signs if the signing would be redundant and the work areas appear continuous to the motorists. If the adjacent project is completed first, the Contractor shall erect the necessary warning signs as shown on these sheets, the TCP sheets or as directed by the Engineer. The BEGIN ROAD WORK NEXT X MILES sign shall be revised to show appropriate work zone distance.
7. The Engineer may require duplicate warning signs on the median side of divided highways where median width will permit and traffic volumes justify the signing.
8. All signs shall be constructed in accordance with the details found in the "Standard Highway Sign Designs for Texas," latest edition. Sign details not shown in this manual shall be shown in the plans or the Engineer shall provide a detail to the Contractor before the sign is manufactured.
9. The temporary traffic control devices shown in the illustrations of the BC sheets are examples. As necessary, the Engineer will determine the most appropriate traffic control devices to be used.
10. As shown on BC(2), the OBEY WARNING SIGNS STATE LAW sign and the WORK ZONE TRAFFIC FINES DOUBLE sign with plaque shall be erected in advance of the CSJ limits. The BEGIN ROAD WORK NEXT X MILES, CONTRACTOR and END ROAD WORK signs shall be erected at or near the CSJ limits.
11. Except for devices required by Note 10, traffic control devices should be in place only while work is actually in progress or a definite need exists.
12. The Engineer has the final decision on the location of all traffic control devices.
13. Inactive equipment and work vehicles, including workers' private vehicles must be parked away from travel lanes. They should be as close to the right-of-way line as possible, or located behind a barrier or guardrail, or as approved by the Engineer.

Worker Safety Apparel Notes:

1. Workers on foot who are exposed to traffic or to construction equipment within the right-of-way shall wear high-visibility safety apparel meeting the requirements of ISEA "American National Standard for High-Visibility Apparel" labeled as ANSI 107-2004 standard performance for Class 2 or 3 risk exposure. Class 3 garments should be considered for high traffic volume work areas or night time work.

Only pre-qualified products shall be used. The "Compliant Work Zone Traffic Control Devices List" (CWZTCD) describes prequalified products and their sources and may be found on-line at the web address given below or by contacting:

Texas Department of Transportation
 Traffic Operations Division - TE
 Phone (512) 416-3134

WEB ADDRESSES FOR REFERENCED DOCUMENTS

- Compliant Work Zone Traffic Control Devices List (CWZTCD)
<http://www.txdot.gov/publications/traffic.htm>
- Texas Manual on Uniform Traffic Control Devices (TMUTCD)
<http://www.txdot.gov/publications/traffic.htm>
- Standard Highway Sign Designs for Texas (SHSD)
<http://www.txdot.gov/publications/traffic.htm>
- Traffic Engineering Standard Sheets
<http://www.txdot.gov/business/discclaim.htm>
- Material Producer List
http://www.txdot.gov/business/producer*list.htm
- Departmental Material Specifications (DMS)
http://www.txdot.gov/services/construction/material*specifications/
- Roadway Design Manual
http://www.txdot.gov/services/general*services/manuals.htm



**BARRICADE AND CONSTRUCTION
 GENERAL NOTES
 AND REQUIREMENTS**

1 of 12 BC(1)-07

© TxDOT 11-4-02		DN: TxDOT	CK: TxDOT	DW: TxDOT	CK: TxDOT
4-03	REVISIONS	CONT	SECT	JOB	HIGHWAY
9-07		2C	1080	495	GARZA
		DIST	COUNTY	SHEET NO.	
		PHR	HIDALGO	20	

DATE: 3/19/2012 4:02:57 PM
 FILE: p:\2009\2009-1027-02_heboap_iii_additional_colonias.design\04_north_capital\05\Standards\Traffic Control\BC07.DGN
 DISCLAIMER: The use of this standard is governed by the "Texas Engineering Practice Act". No warranty of any kind is made by TxDOT for any purpose whatsoever. TxDOT assumes no responsibility for the conversion of this standard to other formats or for incorrect results or damages resulting from its use.

TYPICAL LOCATION OF CROSSROAD SIGNS

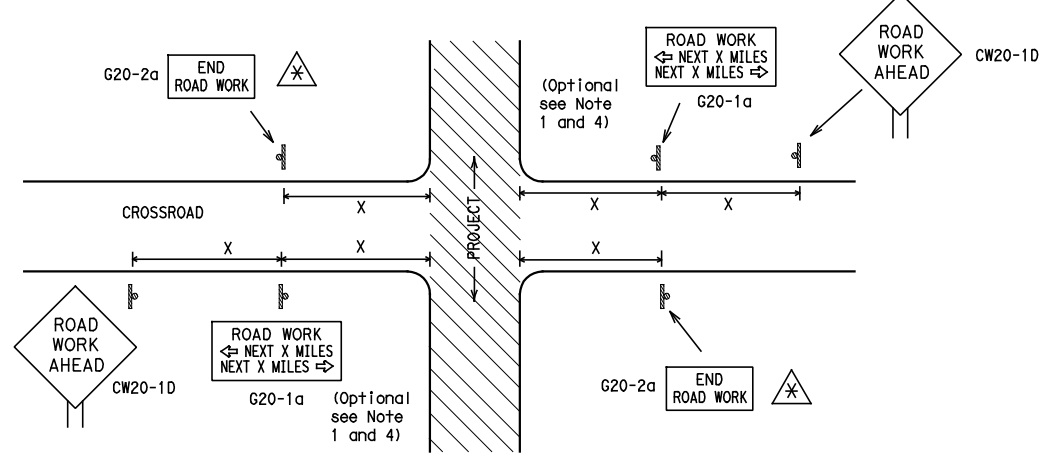

- May be mounted on back of CW20-10 sign with approval of engineer. (See note 2 below)
- The typical minimum signing on a crossroad approach should be a CW20-10 ROAD WORK AHEAD sign and a G20-2a END ROAD WORK sign, unless noted otherwise in plans.
 - The Engineer may use the reduced size 36" x 36" ROAD WORK AHEAD (CW20-10) sign mounted back to back with the reduced size 36" x 18" END ROAD WORK (G20-2a) sign on low volume crossroads (see Note 4 under "Typical Construction Warning Sign Size and Spacing"). See the "Standard Highway Sign Designs for Texas" manual for sign details. The Engineer may omit the advance warning signs on low volume crossroads. The Engineer will determine whether a road is low volume. This information shall be shown in the plans.
 - Based on existing field conditions, the Engineer/Inspector may require additional signs such as FLAGGER AHEAD, LOOSE GRAVEL, or other appropriate signs. When additional signs are required, these signs will be considered part of the minimum requirements. The Engineer/Inspector will determine the proper location and spacing of any sign not shown on the BC sheets, Traffic Control Plan sheets or the Work Zone Standard Sheets.
 - The G20-1a sign shall be required at high volume crossroads to advise motorists of the length of construction in either direction from the intersection. The Engineer will determine whether a roadway is considered high volume.
 - Additional traffic control devices may be shown elsewhere in the plans for higher volume crossroads.
 - When work occurs in the intersection area, appropriate traffic control devices, as shown elsewhere in the plans or as determined by the Engineer/Inspector, shall be in place.

T-INTERSECTION

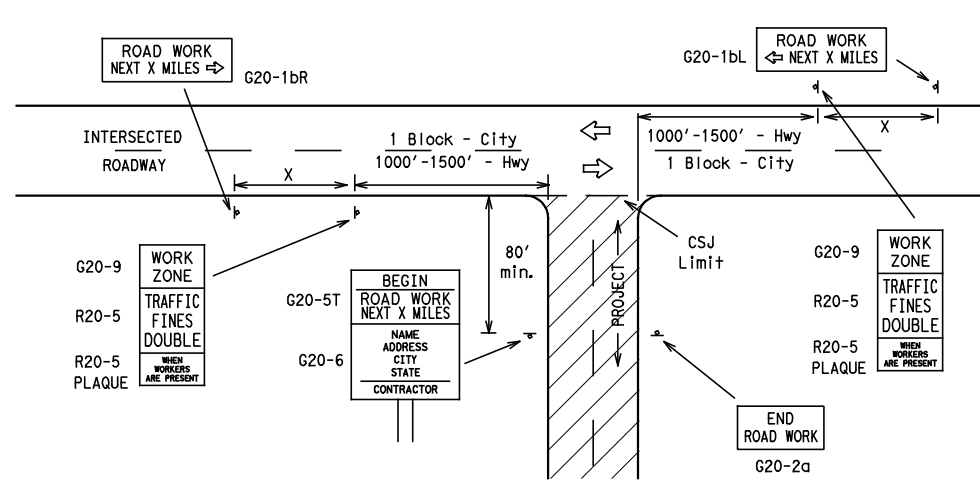

CSJ LIMITS AT T-INTERSECTION

- The Engineer will determine the types and location of any additional traffic control devices, such as a flagger and accompanying signs, or other signs, that should be used when work is being performed at or near an intersection.
- If construction closes the road at a T-Intersection the Contractor shall place the G20-6 "Contractor Name" sign behind the Type III Barricades for the road closure (see BC(10) also). The G20-1bL and G20-1bR signs shall be replaced by the detour signing called for in the plans.

TYPICAL CONSTRUCTION WARNING SIGN SIZE AND SPACING^{1,5,6}

Sign Number or Series	SIZE		SPACING	
	Conventional Road	Expressway/Freeway	Posted Speed MPH	Sign Spacing "x" (Feet (Apprx.))
CW20 CW21 CW22 CW23 CW25	48" x 48"	48" x 48"	30	120
CW1, CW2, CW7, CW8, CW9, CW11, CW14	36" x 36"	48" x 48"	35	160
CW3, CW4, CW5, CW6, CW8-3, CW10, CW12	48" x 48"	48" x 48"	40	240
			45	320
			50	400
			55	500 ²
			60	600 ²
			65	700 ²
			70	800 ²
			75	900 ²
			80	1000 ²
			*	*

* For typical sign spacings on divided highways, expressways and freeways, see Part 6 of the "Texas Manual on Uniform Traffic Control Devices" (TMUTCD) typical application diagrams or TCP Standard Sheets.
 Δ Minimum distance from work area to first Advance Warning sign nearest the work area and/or distance between each additional sign.

General Notes:

- Special or larger size signs may be used as necessary.
- Distance between signs should be increased as required to have 1500 feet advance warning.
- Distance between signs should be increased as required to have 1/2 mile or more advance warning.
- 36" x 36" ROAD WORK AHEAD (CW20-10) signs may be used on low volume crossroads at the discretion of the Engineer. See Note 2 under "Typical Location of Crossroad Signs".
- Only diamond shaped warning sign sizes are indicated.
- See sign size listing in "TMUTCD", Sign Appendix or the "Standard Highway Sign Designs for Texas" manual for complete list of available sign design sizes.

WORK AREAS IN MULTIPLE LOCATIONS WITHIN CSJ LIMITS

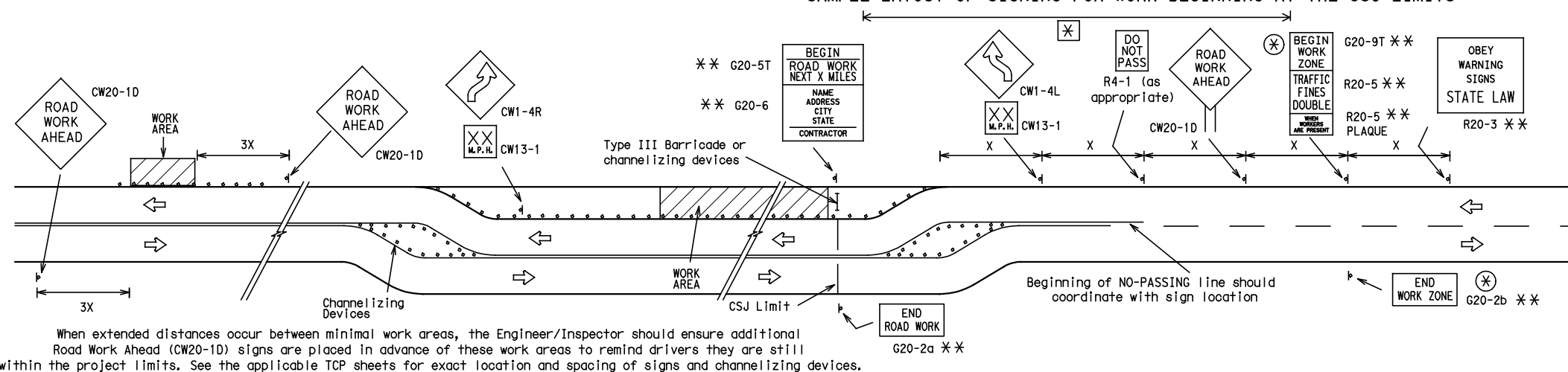

When extended distances occur between minimal work areas, the Engineer/Inspector should ensure additional Road Work Ahead (CW20-10) signs are placed in advance of these work areas to remind drivers they are still within the project limits. See the applicable TCP sheets for exact location and spacing of signs and channelizing devices.

SAMPLE LAYOUT OF SIGNING FOR WORK BEGINNING AT THE CSJ LIMITS

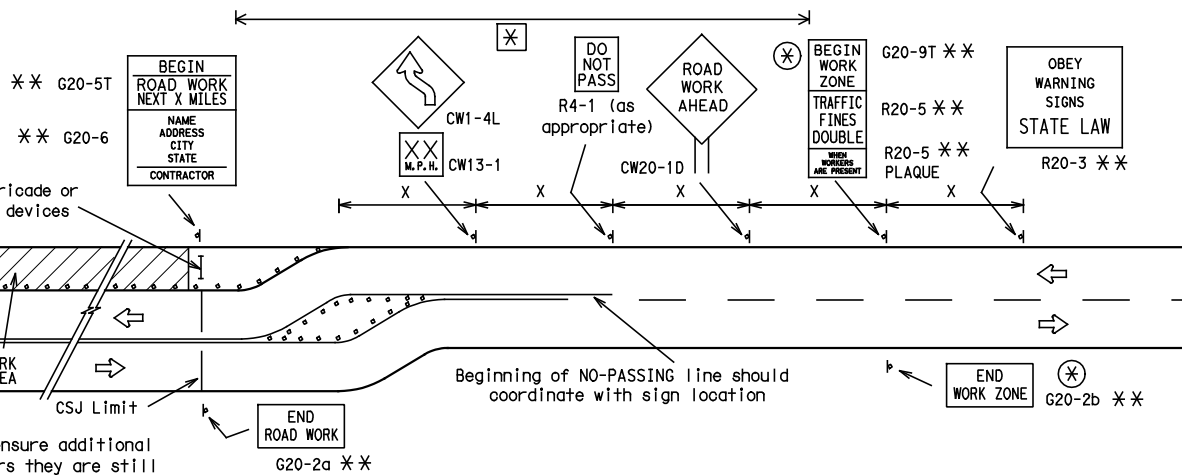

SAMPLE LAYOUT OF SIGNING FOR WORK BEGINNING DOWNSTREAM OF THE CSJ LIMITS

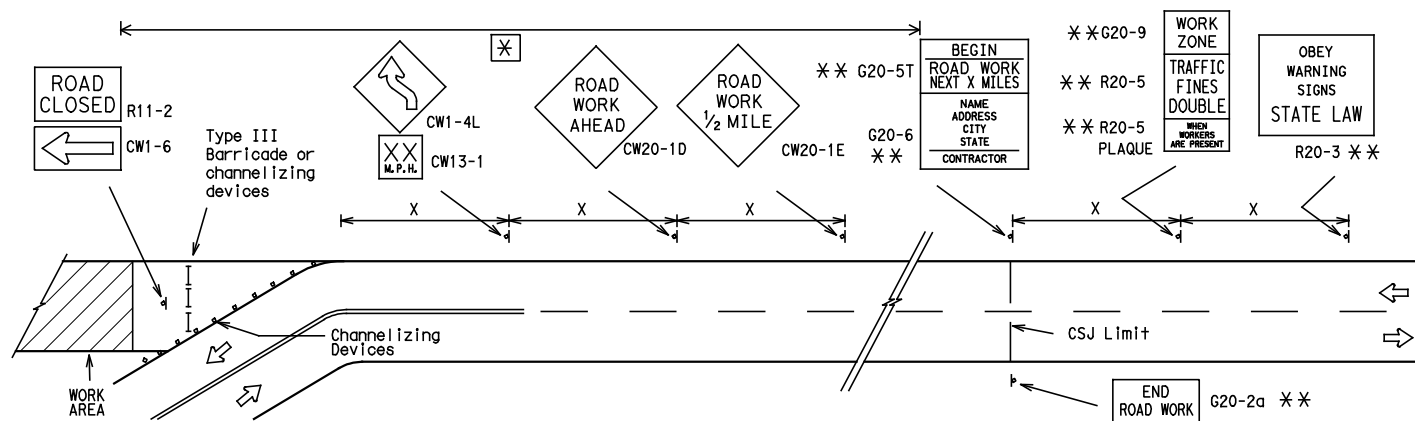

NOTES

- The Contractor shall determine the appropriate distance to be placed on the G20-1 series signs and G20-5T sign for each specific project. This distance shall replace the "X" and shall be rounded to the nearest whole mile with the approval of the Engineer. No decimals shall be used.
- The G20-9T and G20-2b shall be used when advance signs are required outside the CSJ Limits. They inform the motorist of entering or leaving a work zone where traffic fines may double if workers are present.
- ** Required CSJ Limit signing. See Note 10 on BC(1).
- * Area for placement of "ROAD WORK AHEAD" sign and other signs or devices as called for on the Traffic Control Plan.

LEGEND

- sign
- Channelizing Devices
- I Type III Barricade
- X See Typical Construction Warning Sign Size and Spacing chart or the TMUTCD for sign spacing requirements.



R20-3
Legend/Border - Black
Background - White

Texas Department of Transportation
 Traffic Operations Division

BARRICADE AND CONSTRUCTION PROJECT LIMIT STANDARD

2 of 12 BC(2)-07

© TxDOT 11-4-02		DN: TxDOT	CK: TxDOT	DW: TxDOT	CK: TxDOT
9-07	REVISIONS	CONT	SECT	JOB	HIGHWAY
		2C	1080	495	GARZA
		DIST	COUNTY		SHEET NO.
		PHR	HIDALGO		21

TYPICAL APPLICATION OF WORK ZONE SPEED LIMIT SIGNS

Work zone speed limits shall be regulatory, established in accordance with the "Procedures for Establishing Speed Zones," and approved by the Texas Transportation Commission, or by City Ordinance when within Incorporated City Limits.

Reduced speeds should only be posted in the vicinity of work activity and not throughout the entire project. Regulatory work zone speed signs (R2-1) shall be removed or covered during periods when they are not needed.

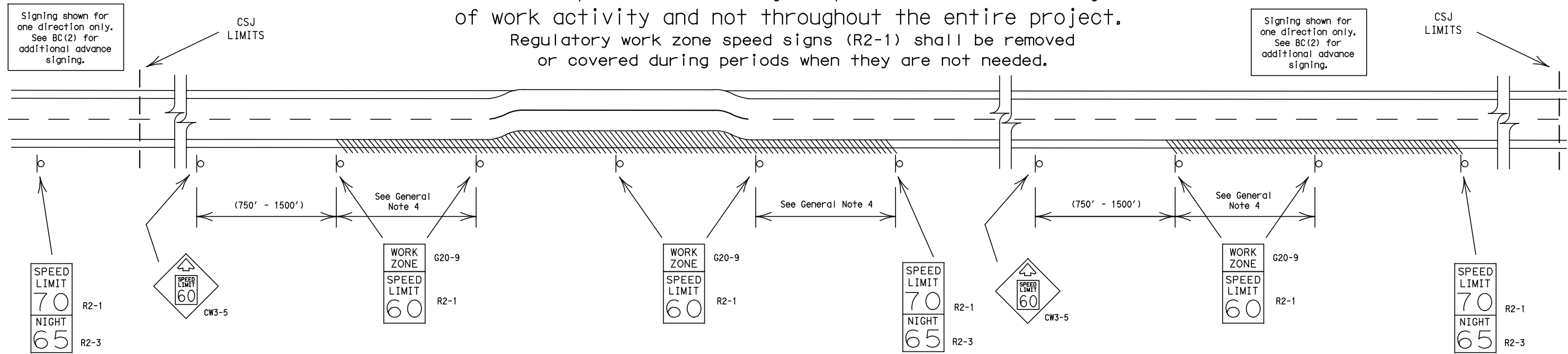

GUIDANCE FOR USE:

LONG/INTERMEDIATE TERM WORK ZONE SPEED LIMITS

This type of work zone speed limit should be included on the design of the traffic control plans when restricted geometrics with a lower design speed are present in the work zone and modification of the geometrics to a higher design speed is not feasible.

Long/Intermediate Term Work Zone Speed Limit signs, when approved as described above, should be posted and visible to the motorist when work activity is present. Work activity may also be defined as a change in the roadway that requires a reduced speed for motorists to safely negotiate the work area, including:

- rough road or damaged pavement surface
- substantial alteration of roadway geometrics (diversions)
- construction detours
- grade
- width
- other conditions readily apparent to the driver

As long as any of these conditions exist, the work zone speed limit signs should remain in place.

SHORT TERM WORK ZONE SPEED LIMITS

This type of work zone speed limit should be included on the design of the traffic control plans when workers or equipment are not behind concrete barrier, when work activity is within 15 feet of pavement edge or actually on the pavement.

Short Term Work Zone Speed Limit signs should be posted and visible to the motorists only when work activity is present. When work activity is not present, signs shall be removed or covered. (See Removing or Covering on BC(4)).

GENERAL NOTES:

- Regulatory work zone speed limits should be used only for sections of construction projects where speed control is of major importance.
- Regulatory work zone speed limit signs shall be placed on supports at a 7 foot minimum mounting height.
- Speed zone signs are illustrated for one direction of travel and are normally posted for each direction of travel.
- Frequency of work zone speed limit signs should be:
 - 40 mph and greater 0.2 to 2 miles
 - 35 mph and less 0.2 to 1 mile
- Regulatory speed limit signs shall have black legend and border on a white reflective background (See "Reflective Sheeting" on BC(4)).
- Fabrication, erection and maintenance of the CW3-5 sign, G20-9 plaque and the R2-1 and R2-3 signs shall not be paid for directly, but shall be considered subsidiary to Item 502.
- Turning signs from view, laying signs over or down will not be allowed, unless otherwise noted.
- Techniques that may help reduce traffic speeds include but are not limited to:
 - Law enforcement.
 - Flagger stationed next to sign.
 - Portable changeable message sign (PCMS).
 - Low-power (drone) radar transmitter.
 - Speed monitor trailers or signs.
- Speeds shown on details above are for illustration only. Work Zone Speed Limits should only be posted as approved for each project.

DISCLAIMER: The use of this standard is governed by the "Texas Engineering Practice Act". No warranty of any kind is made by TxDOT for any purpose whatsoever. TxDOT assumes no responsibility for the conversion of this standard to other formats or for incorrect results or damages resulting from its use.

DATE: 3/19/2012 4:03:06 PM
FILE: p:\2009\2009-1027-02_heboap.iii_additional_colonias.design\04_north_capital\04csj\Standards\Traffic Control\BC07.DGN



BARRICADE AND CONSTRUCTION WORK ZONE SPEED LIMIT STANDARD

3 of 12

BC(3)-07

© TxDOT 11-4-02	DN: TxDOT	CK: TxDOT	DW: TxDOT	CK: TxDOT
9-07	REVISIONS			
2C	080	495	GARZA	
	DIST	COUNTY	SHEET NO.	
	PHR	HIDALGO	22	

DATE: 3/19/2012 4:03:11 PM
 FILE: p:\2009\2009-1027-02_heboap_iii_additional_colonias.design\04_north_capisallo.cs\Standards\Traffic Control\BC07.DGN
 DISCLAIMER: The use of this standard is governed by the "Texas Engineering Practice Act". No warranty of any kind is made by TxDOT for any purpose whatsoever. TxDOT assumes no responsibility for the conversion of this standard to other formats or for incorrect results or damages resulting from its use.

TYPICAL MINIMUM CLEARANCES FOR LONG TERM AND INTERMEDIATE TERM SIGNS

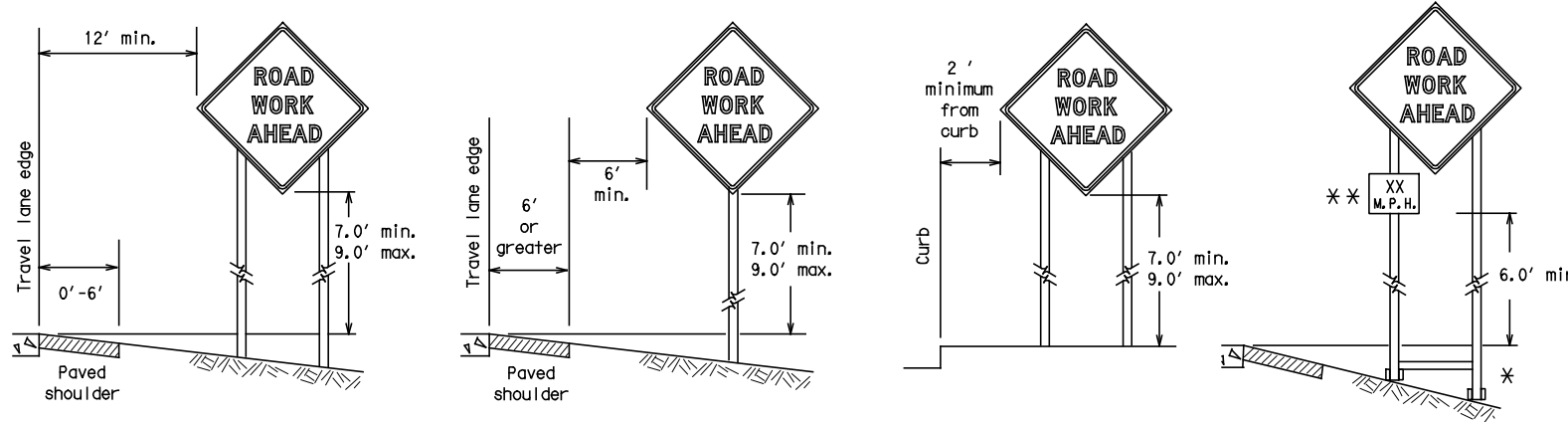

* When placing skid supports on unlevel ground, the leg post lengths must be adjusted so the sign appears straight and plumb. Objects shall NOT be placed under skids as a means of leveling.

** When plaques are placed on dual-leg supports, they should be attached to the upright nearest the travel lane. Supplemental plaques (advisory or distance) should not cover the surface of the parent sign.

ATTACHMENT FOR SIGN SUPPORTS

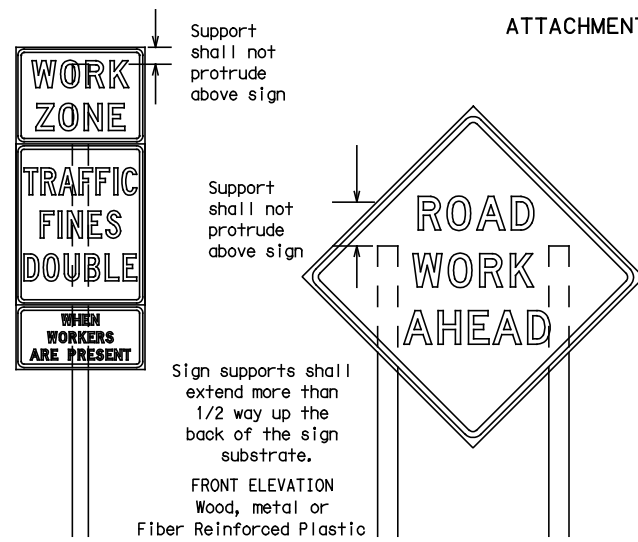

Splicing embedded perforated square metal tubing in order to extend post height will only be allowed when the splice is made using four bolts, two above and two below the splice point. Splice must be located entirely behind the sign substrate, not near the base of the support. Splice insert lengths should be at least 5 times nominal post size, centered on the splice and of at least the same gauge material.

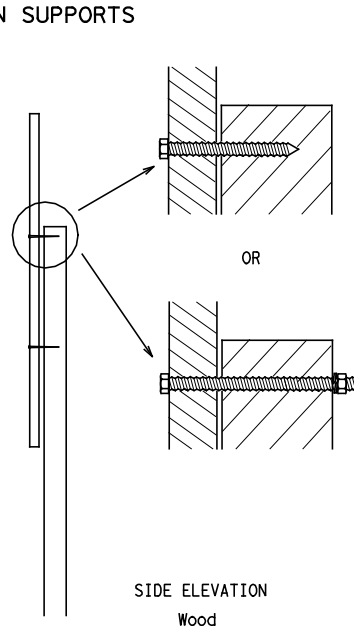

Attachment to wooden supports will be by bolts and nuts or screws. Use TxDOT's or manufacturer's recommended procedures for attaching sign substrates to other types of sign supports.

Nails will NOT be allowed.

Each sign shall be attached directly to the sign support. Multiple signs shall not be joined or spliced by any means. Wood supports shall not be extended or repaired by splicing or other means.

STOP/SLOW PADDLES

- STOP/SLOW paddles are the primary method to control traffic by flaggers. The STOP/SLOW paddle size should be 24" x 24" as detailed below.
- When used at night, the STOP/SLOW paddle shall be retroreflectORIZED.
- STOP/SLOW paddles may be attached to a staff with a minimum length of 6' to the bottom of the sign.
- Any lights incorporated into the STOP or SLOW paddle faces shall only be as specifically described in Section 6E.03 Hand Signaling Devices in the TMUTCD.

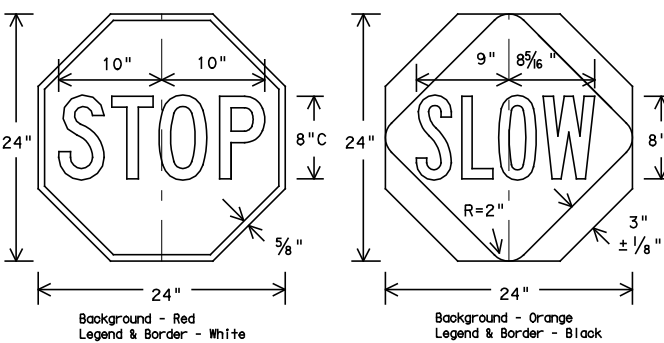

CONTRACTOR REQUIREMENTS FOR MAINTAINING PERMANENT SIGNS WITHIN THE PROJECT LIMITS

- Permanent signs are used to give notice of traffic laws or regulations, call attention to conditions that are potentially hazardous to traffic operations, show route designations, destinations, directions, distances, services, points of interest, and other geographical, recreational, or cultural information. Drivers proceeding through a work zone need the same, if not better route guidance as normally installed on a roadway without construction.
- When permanent regulatory or warning signs conflict with work zone conditions, remove or cover the permanent signs until the permanent sign message matches the roadway condition.
- When existing permanent signs are moved and relocated due to construction purposes, they shall be visible to motorists at all times.
- If existing signs are to be relocated on their original supports, they shall be installed on crashworthy bases as shown on the SMD Standard sheets. The signs shall meet the required mounting heights shown on the BC Sheets or the SMD Standards. This work should be paid for under the appropriate pay item for relocating existing signs.
- If permanent signs are to be removed and relocated using temporary supports, the Contractor shall use crashworthy supports as shown on the BC sheets or the CWZTCD. The signs shall meet the required mounting heights shown on the BC Sheets or the SMD Standards during construction. This work should be paid for under the appropriate pay item for relocating existing signs.
- Any sign or traffic control device that is struck or damaged by the Contractor or his/her construction equipment shall be replaced as soon as possible by the Contractor to ensure proper guidance for the motorists. This will be subsidiary to Item 502.

GENERAL NOTES FOR WORK ZONE SIGNS

- Contractor shall install and maintain signs in a straight and plumb condition and/or as directed by the Engineer.
 - Wooden sign posts shall be painted white.
 - Barricades shall NOT be used as sign supports.
 - Nails shall NOT be used to attach signs to any support.
 - All signs shall be installed in accordance with the plans or as directed by the Engineer. Signs shall be used to regulate, warn, and guide the traveling public safely through the work zone.
 - The Contractor may furnish either the sign design shown in the plans or in the "Standard Highway Sign Designs for Texas" (SHSD). The Engineer/Inspector may require the Contractor to furnish other work zone signs that are shown in the TMUTCD but may have been omitted from the plans. Any variation in the plans shall be documented by written agreement between the Engineer and the Contractor's Responsible Person. All changes must be documented in writing before being implemented. This can include documenting the changes in the Inspector's TxDOT diary and having both the Inspector and Contractor initial and date the agreed upon changes.
 - The Contractor shall furnish sign supports listed in the "Compliant Work Zone Traffic Control Device List" (CWZTCD). The Contractor shall install the sign support in accordance with the manufacturer's recommendations. If there is a question regarding installation procedures, the Contractor shall furnish the Engineer a copy of the manufacturer's installation recommendations so the Engineer can verify the correct procedures are being followed.
 - The Contractor is responsible for installing signs on approved supports and replacing signs with damaged or cracked substrates and/or damaged or marred reflective sheeting as directed by the Engineer/Inspector.
 - Identification markings may be shown only on the back of the sign substrate. The maximum height of letters and/or company logos used for identification shall be 1 inch.
 - The Contractor shall replace damaged wood posts. New or damaged wood sign posts shall not be spliced.
- DURATION OF WORK (as defined by the Texas Manual on Uniform Traffic Control Devices Part 6)**
- The types of sign supports, sign mounting height, the size of signs, and the type of sign substrates can vary based on the type of work being performed. The Engineer is responsible for selecting the appropriate size sign for the type of work being performed. The Contractor is responsible for ensuring the sign support, sign mounting height and substrate meets manufacturer's recommendations in regard to crashworthiness and duration of work requirements.
 - Long-term stationary - work that occupies a location more than 3 days.
 - Intermediate-term stationary - work that occupies a location more than one daylight period up to 3 days, or nighttime work lasting more than one hour.
 - Short-term stationary - daytime work that occupies a location for more than 1 hour in a single daylight period.
 - Short, duration - work that occupies a location up to 1 hour.
 - Mobile - work that moves continuously or intermittently (stopping for up to approximately 15 minutes.)

SIGN MOUNTING HEIGHT

- The bottom of Long-term/Intermediate-term signs shall be at least 7 feet, but not more than 9 feet, above the paved surface, except as shown for supplemental plaques mounted below other signs.
- The bottom of Short-term/Short Duration signs shall be a minimum of 1 foot above the pavement surface but no more than 2 feet above the ground.
- Long-term/Intermediate-term Signs may be used in lieu of Short-term/Short Duration signing.
- Short-term/Short Duration signs shall be used only during daylight and shall be removed at the end of the workday, or raised to appropriate Long-term/Intermediate sign height.
- Regulatory signs shall be mounted at least 7 feet, but not more than 9 feet, above the paved surface regardless of work duration.

SIZE OF SIGNS

- The Engineer may allow the use of smaller size construction warning signs on secondary roads or city streets where speeds are low if the sign size is listed as an option on the "Typical Construction Warning Sign Size and Spacing" chart shown on BC(2).
- The Contractor shall furnish the sign sizes shown in plans, the BC Sheets, the TCP sheets or as directed by the Engineer.

SIGN SUBSTRATES

- The Contractor shall ensure the sign substrate is installed in accordance with the manufacturer's recommendations for the type of sign support that is being used. The CWZTCD lists each substrate that can be used on the different types and models of sign supports.
- "Mesh" type materials are NOT an approved sign substrate, regardless of the tightness of the weave.
- All wooden individual sign panels fabricated from 2 or more pieces shall have one or more plywood cleat, 1/2" thick by 6" wide, fastened to the back of the sign and extending fully across the sign. The cleat shall be attached to the back of the sign using wood screws that do not penetrate the face of the sign panel. The screws shall be placed on both sides of the splice and spaced at 6" centers. The Engineer may approve other methods of splicing the sign face.

REFLECTIVE SHEETING

- All signs shall be retroreflective and constructed of sheeting meeting the color and retro-reflectivity requirements of DMS-8300 for rigid signs or DMS-8310 for roll-up signs. The web address for DMS specifications is shown on BC(1).
- White sheeting, meeting the requirements of DMS-8300 Type C (High Specific Intensity), shall be used for signs with a white background.
- Orange sheeting, meeting the requirements of DMS-8300 Type E (Fluorescent Prismatic), shall be used for rigid signs with orange backgrounds.

SIGN LETTERS

- All sign letters and numbers shall be clear, and open rounded type uppercase alphabet letters as approved by the Federal Highway Administration (FHWA) and as published in the "Standard Highway Sign Design for Texas" manual. Signs, letters and numbers shall be of first class workmanship in accordance with Department Standards and Specifications.

REMOVING OR COVERING

- When sign messages may be confusing or do not apply, the signs shall be removed or completely covered.
- Long-term stationary or intermediate stationary signs installed on square metal tubing may be turned away from traffic 90 degrees when the sign message is not applicable. This type of sign support meets the crashworthiness standards regardless of the direction of impact. This technique may not be used for signs installed in the median of divided highways or near any intersections where the sign may be seen from approaching traffic.
- Signs installed on wooden skids shall not be turned at 90 degree angles to the roadway. These signs should be removed or completely covered when not required.
- When signs are covered, the material used shall be opaque, such as heavy mil black plastic, or other materials which will cover the entire sign face and maintain their opaque properties under automobile headlights at night, without damaging the sign sheeting.
- Burlap shall NOT be used to cover signs.
- Duct tape or other adhesive material shall NOT be affixed to a sign face. These materials can damage the retroreflectivity of sheeting.
- Signs and anchor stubs shall be removed and holes backfilled upon completion of work.

SIGN SUPPORT WEIGHTS

- Where sign supports require the use of weights to keep from turning over, the use of sandbags with dry, cohesionless sand is recommended.
- The sandbags will be tied shut to keep the sand from spilling and to maintain a constant weight.
- Rock, concrete, iron, steel or other solid objects shall not be permitted for use as sign support weights.
- Sandbags should weigh a minimum of 35 lbs and a maximum of 50 lbs.
- Sandbags shall be made of a durable material that tears upon vehicular impact.
- Rubber (such as tire inner tubes) shall NOT be used for sandbags.
- Rubber ballasts designed for channelizing devices should not be used for ballast on portable sign supports. Sign supports designed and manufactured with rubber bases may be used when shown on the CWZTCD list.
- Sandbags shall only be placed along or laid over the base supports of the traffic control device and shall not be suspended above ground level or hung with rope, wire, chains or other fasteners. Sandbags shall be placed along the length of the skids to weigh down the sign support.
- Sandbags shall NOT be placed under the skid and shall not be used to level sign supports placed on slopes.



BARRICADE AND CONSTRUCTION TEMPORARY SIGN NOTES STANDARD

4 of 12

BC(4)-07

© TxDOT 11-4-02	DN: TxDOT	CK: TxDOT	DW: TxDOT	CK: TxDOT	
9-07	REVISIONS	CONT	SECT	JOB	HIGHWAY
		2C	080	495	GARZA
		DIST	COUNTY		SHEET NO.
		PHR	HIDALGO		23

DATE: 3/19/2012 4:03:27 PM
 FILE: p:\2009\2009-1027-02_heboap_iii_additional_colonias\design\04_north_capisallo\cs\Standards\Traffic Control\BC07.DGN
 DISCLAIMER: The use of this standard is governed by the "Texas Engineering Practice Act". No warranty of any kind is made by TxDOT for any purpose whatsoever. TxDOT assumes no responsibility for the conversion of this standard to other formats or for incorrect results or damages resulting from its use.

SKID MOUNTED WOOD SIGN SUPPORTS

LONG/INTERMEDIATE TERM STATIONARY - PORTABLE SKID MOUNTED SIGN SUPPORTS □

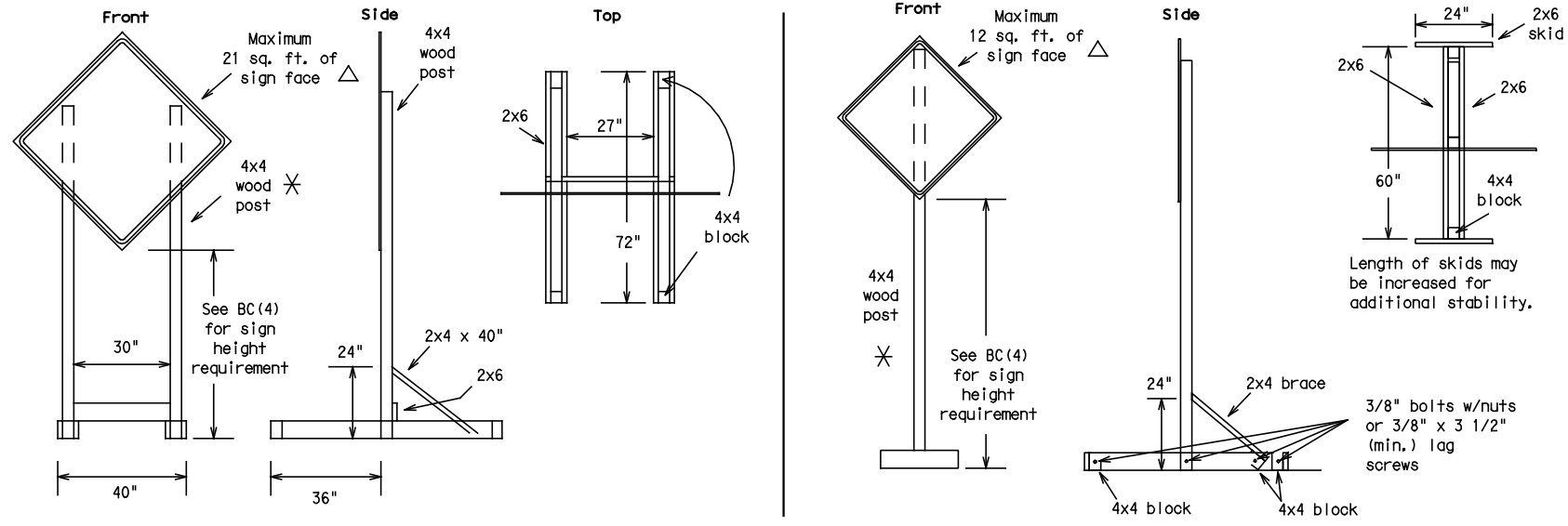

SKID MOUNTED PERFORATED SQUARE STEEL TUBING SIGN SUPPORTS

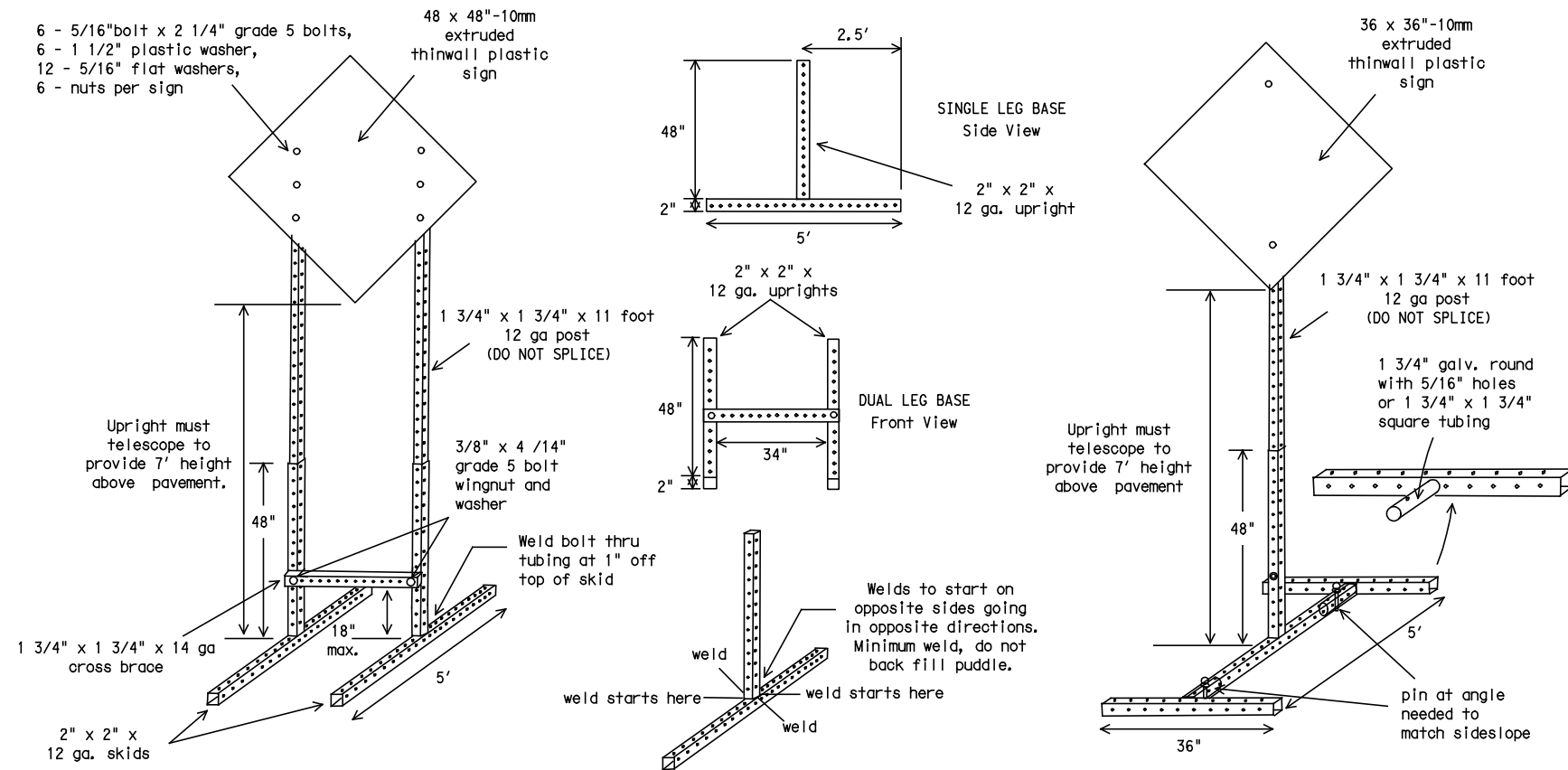

WEDGE ANCHORS

Both steel and plastic Wedge Anchor Systems as shown on the SMD Standard Sheets may be used as temporary sign supports for signs up to 10 square feet of sign face. They may be set in concrete or in sturdy soils if approved by the Engineer. (See web address for "Traffic Engineering Standard Sheets" on BC(1)).

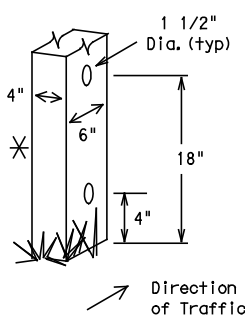

WOOD POST SYSTEM FOR GROUND MOUNTED SIGN SUPPORTS

Nominal Post Size	No. of Posts	Maximum Sq. feet of Sign Face	Minimum Soil Embedment	Drilled Hole(s) Required
4 x 4	1	12	36"	NO
4 x 4	2	21	36"	NO
4 x 6	1	21	36"	YES
4 x 6	2	36	36"	YES

GROUND MOUNTED SIGN SUPPORTS

Refer to the CWZTCD and the manufacturer's installation procedure for each type sign support. The maximum sign square footage shall adhere to the manufacturer's recommendation. Two post installations can be used for larger signs.

PERFORATED SQUARE METAL TUBING

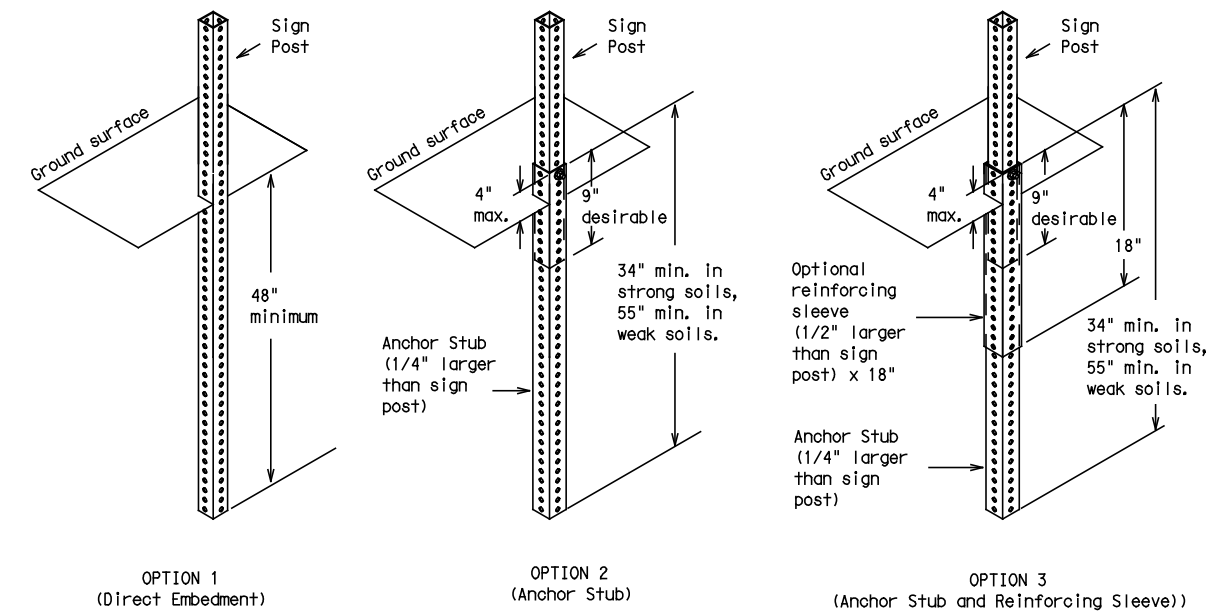

WING CHANNEL

Lap-splice/base bolted anchor

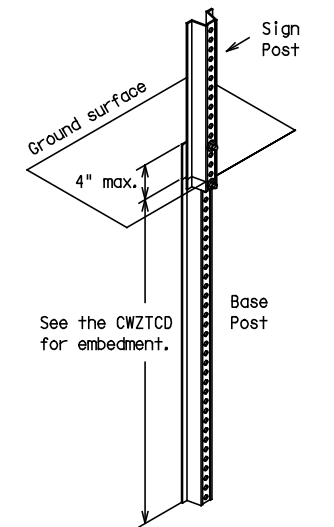

GENERAL NOTES

- Nails may be used in the assembly of wooden sign supports, but 3/8" bolts with nuts or 3/8" x 3 1/2" lag screws must be used on every joint for final connection.
- More details of approved Long/Intermediate and Short Term supports can be found on the CWZTCD list. See BC(1) for website location.
- No more than 2 sign posts shall be placed within a 7 ft. circle, except for specific materials noted on the CWZTCD List.
- When project is completed, all sign supports and foundations shall be removed from the project site. This will be considered subsidiary to Item 502.

□ See BC(4) for definition of "Work Duration."

✱ Wood sign posts MUST be one piece. Splicing will NOT be allowed. Posts shall be painted white.

△ See the CWZTCD for the type of sign substrate that can be used for each approved sign support.

Texas Department of Transportation
 Traffic Operations Division

BARRICADE AND CONSTRUCTION TYPICAL SIGN SUPPORT STANDARD

5 of 12

BC(5)-07

REV	DATE	BY	CHKD	APP'D	REVISIONS
9-07					
2C	080	495			HIGHWAY
					SHEET NO.
					24

DATE: 3/19/2012 4:03:34 PM
 FILE: p:\2009\2009-1027-02 heboap iii additional_colonias\design\04_north_capitol\04\Standards\Traffic Control\BC07.DGN
 DISCLAIMER: The use of this standard is governed by the "Texas Engineering Practice Act". No warranty of any kind is made by TxDOT for any purpose whatsoever. TxDOT assumes no responsibility for the conversion of this standard to other formats or for incorrect results or damages resulting from its use.

PORTABLE CHANGEABLE MESSAGE SIGNS

- The Engineer/Inspector shall approve all messages used on portable changeable message signs (PCMS).
- Messages on PCMS should contain no more than 8 words (about four to eight characters per word), not including simple words such as "TO," "FOR," "AT," etc.
- Messages should consist of a single phase, or two phases that alternate. Three-phase messages are not allowed. Each phase of the message should convey a single thought, and must be understood by itself.
- Use the word "EXIT" to refer to an exit ramp on a freeway; i.e., "EXIT CLOSED." Do not use the term "RAMP."
- Always use the route or interstate designation (IH, US, SH, FM) along with the number when referring to a roadway.
- When in use the bottom of a stationary PCMS message panel should be a minimum 7 feet above the roadway, where possible.
- The message term "WEEKEND" should be used only if the work is to start on Saturday morning and end by Sunday evening at midnight. Actual days and hours of work should be displayed on the PCMS if work is to begin on Friday evening and/or continue into Monday morning.
- The Engineer/Inspector may select one of two options which are available for displaying a two-phase message on a PCMS. Each phase may be displayed for either four seconds each or for three seconds each.
- Do not "flash" messages or words included in a message. The message should be steady burn or continuous while displayed.
- Do not present redundant information on a two-phase message; i.e., keeping two lines of the message the same and changing the third line.
- Do not use the word "Danger" in message.
- Do not display the message "LANES SHIFT LEFT" or "LANES SHIFT RIGHT" on a PCMS. Drivers do not understand the message.
- Do not display messages that scroll horizontally or vertically across the face of the sign.
- The following table lists abbreviated words and two-word phrases that are acceptable for use on a PCMS. Both words in a phrase must be displayed together. Words or phrases not on this list should not be abbreviated.
- PCMS character height should be at least 18 inches for trailer mounted units. They should be visible from at least 1/2 (.5) mile and the text should be legible from at least 720 feet. Truck mounted units must have a character height of 10 inches and must be legible from at least 400 feet.
- Each line of text should be centered on the message board rather than left or right justified.
- If disabled, the PCMS should default to an illegible display that will not alarm motorists and will only be used to alert workers that the PCMS has malfunctioned. A pattern such as a series of horizontal solid bars is appropriate.

Word or Phrase	Abb.	Word or Phrase	Abb.
Access Road	ACCS RD	Major	MAJ
Air Quality	AIR QLT	Miles	MI
Alternate	ALT	Miles Per Hour	MPH
Avenue	AVE	Minor	MNR
Best Route	BEST RTE	Monday	MON
Boulevard	BLVD	Normal	NORM
Bridge	BRDG	North	N
Cannot	CANT	Northbound	(route) N
Center	CNTR	Parking	PKING
Construction Ahead	CONST AHEAD	Parking Lot	PRK LOT
Detour Route	DETOUR RTE	Road	RD
Do Not	DONT	Right Lane	RGT LN
East	E	Saturday	SAT
Eastbound	(route) E	Service Road	SERV RD
Emergency	EMER	Shoulder	SHLDR
Emergency Vehicle	EMER VEH	Slippery	SLIP
Entrance, Enter	ENT	South	S
Express Lanes	EXP LANE	Southbound	(route) S
Expressway	EXPWY	Speed	SPD
XXXX Feet	XXXX FT	Street	ST
Fog Ahead	FOG AHD	Sunday	SUN
Freeway	FRWY, FWY	Telephone	PHONE
Freeway Blocked	FWY BLKD	Temporary	TEMP
Friday	FRI	Thursday	THURS
Hazardous Driving	HAZ DRIVING	To Downtown	TO DWN TN
Hazardous Material	HAZMAT	Traffic	TRAF
High-Occupancy Vehicle	HOV	Travelers	TRVLRS
Highway	HWY	Tuesday	TUES
Hours	HR	Time Minutes	TIME MIN
Information	INFO	Upper Level	UPPR LVL
It Is	ITS	Vehicle	VEH
Junction	JCT	Warning	WARN
Left	LFT	Wednesday	WED
Left Lane	LFT LN	Weight Limit	WT LIMIT
Lane Closed	LN CLSD	West	W
Lower Level	LOWR LVL	Westbound	(route) W
Maintenance	MAINT	Wet Pavement	WET PVMT
		Will Not	WONT

Roadway designation # IH-number, US-number, SH-number, FM-number

WHEN NOT IN USE, REMOVE THE PCMS FROM THE RIGHT-OF-WAY OR PLACE THE PCMS BEHIND BARRIER OR GUARDRAIL WITH SIGN PANEL TURNED PARALLEL TO TRAFFIC

RECOMMENDED PHASES AND FORMATS FOR PCMS MESSAGES DURING ROADWORK ACTIVITIES

(The Engineer may approve other messages not specifically covered here.)

Phase 1: Condition Lists

Road/Lane/Ramp Closure List

FREEWAY CLOSED X MILE
ROAD CLOSED AT SH XXX
ROAD CLSD AT FM XXXX
RIGHT X LANES CLOSED
CENTER LANE CLOSED
NIGHT LANE CLOSURES
VARIOUS LANES CLOSED
EXIT CLOSED
MALL DRIVEWAY CLOSED
XXXXXXXXX BLVD CLOSED

Other Condition List

FRONTAGE ROAD CLOSED
SHOULDER CLOSED XXX FT
RIGHT LN CLOSED XXX FT
RIGHT X LANES OPEN
DAYTIME LANE CLOSURES
I-XX SOUTH EXIT CLOSED
EXIT XXX CLOSED X MILE
RIGHT LN TO BE CLOSED
X LANES CLOSED TUE - FRI
ROADWORK XXX FT
FLAGGER XXXX FT
RIGHT LN NARROWS XXXX FT
MERGING TRAFFIC XXXX FT
LOOSE GRAVEL XXXX FT
DETOUR X MILE
ROADWORK PAST SH XXXX
BUMP XXXX FT
TRAFFIC SIGNAL XXXX FT
ROAD REPAIRS XXXX FT
LANE NARROWS XXXX FT
TWO-WAY TRAFFIC XX MILE
CONST TRAFFIC XXX FT
UNEVEN LANES XXXX FT
ROUGH ROAD XXXX FT
ROADWORK NEXT FRI-SUN
US XXX EXIT X MILES
LANES SHIFT *

* LANES SHIFT in Phase 1 must be used with STAY IN LANE in Phase 2.

Application Guidelines

- Only 1 or 2 phases are to be used on a PCMS.
- The 1st phase (or both) should be selected from the "Road/Lane/Ramp Closure List" and the "Other Condition List".
- A 2nd phase can be selected from the "Action to Take/Effect on Travel, Location, General Warning, or Advance Notice Phase Lists".
- A Location Phase is necessary only if a distance or location is not included in the first phase selected.
- If two PCMS are used in sequence, they must be separated by a minimum of 1000 ft. Each PCMS shall be limited to two phases, and should be understandable by themselves.
- For advance notice, when the current date is within seven days of the actual work date, calendar days should be replaced with days of the week. Advance notification should typically be for no more than one week prior to the work

Phase 2: Possible Component Lists

Action to Take/Effect on Travel List

MERGE RIGHT
DETOUR NEXT X EXITS
USE EXIT XXX
STAY ON US XXX SOUTH
TRUCKS USE US XXX N
WATCH FOR TRUCKS
EXPECT DELAYS
REDUCE SPEED XXX FT
USE OTHER ROUTES
STAY IN LANE *
FORM X LINES RIGHT
USE XXXXX RD EXIT
USE EXIT I-XX NORTH
USE I-XX E TO I-XX N
WATCH FOR TRUCKS
EXPECT DELAYS
END SHOULDER USE
WATCH FOR WORKERS

Location List

AT FM XXXX
BEFORE RAILROAD CROSSING
NEXT X MILES
PAST US XXX EXIT
XXXXXXXXX TO XXXXXXXX
US XXX TO FM XXXX

Warning List

SPEED LIMIT XX MPH
MAXIMUM SPEED XX MPH
MINIMUM SPEED XX MPH
ADVISORY SPEED XX MPH
RIGHT LANE EXIT
USE CAUTION
DRIVE SAFELY
DRIVE WITH CARE

** Advance Notice List

TUE-FRI XX AM-X PM
APR XX-XX X PM-X AM
BEGINS MONDAY
BEGINS MAY XX
MAY X-X XX PM - XX AM
NEXT FRI-SUN
XX AM TO XX PM
NEXT TUE AUG XX
TONIGHT XX PM-XX AM

** See Application Guidelines Note 6.

Wording Alternatives

- The words RIGHT, LEFT and ALL can be interchanged as appropriate.
- Roadway designations IH, US, SH, FM and LP can be interchanged as appropriate.
- EAST, WEST, NORTH and SOUTH (or abbreviations E, W, N and S) can be interchanged as appropriate.
- Highway names and numbers replaced as appropriate.
- ROAD, HIGHWAY and FREEWAY can be interchanged as needed.
- AHEAD may be used instead of distances if necessary.
- FT and MI, MILE and MILES interchanged as appropriate.
- AT, BEFORE and PAST interchanged as needed.
- Distances or AHEAD can be eliminated from the message if a location phase is used.

PCMS SIGNS WITHIN THE R.O.W. SHALL BE BEHIND GUARDRAIL OR CONCRETE BARRIER OR SHALL HAVE A MINIMUM OF FOUR (4) PLASTIC DRUMS PLACED PERPENDICULAR TO TRAFFIC ON THE UPSTREAM SIDE OF THE PCMS.

FULL MATRIX PCMS SIGNS

- When Full Matrix PCMS signs are used, the character height and legibility/visibility requirements shall be maintained as listed in Note 15 under "PORTABLE CHANGEABLE MESSAGE SIGNS" above.
- When symbol signs, such as the CW20-7a Flagger Symbol, are represented graphically on the Full Matrix PCMS sign and, with the approval of the Engineer, it shall maintain the legibility/visibility requirement listed above.
- When symbol signs are represented graphically on the Full Matrix PCMS, they shall only supplement the use of the static sign represented, and shall not substitute for, or replace that sign.
- A full matrix PCMS may be used to simulate a flashing arrow panel provided it meets the visibility, flash rate and dimming requirements on BC(7), for the same size arrow.



BARRICADE AND CONSTRUCTION PORTABLE CHANGEABLE MESSAGE SIGN (PCMS) STANDARD

6 of 12 BC(6)-07

© TxDOT 11-4-02	DNF: TxDOT	CK: TxDOT	DW: TxDOT	CK: TxDOT
9-07 REVISIONS	CONT	SECT	JOB	HIGHWAY
	2C	1080	495	GARZA
	DIST	COUNTY	SHEET NO.	
	PHR	HIDALGO	25	

DISCLAIMER: The use of this standard is governed by the "Texas Engineering Practice Act". No warranty of any kind is made by TxDOT for any purpose whatsoever. TxDOT assumes no responsibility for the conversion of this standard to other formats or for incorrect results or damages resulting from its use.

DATE: 3/19/2012 4:03:45 PM
 FILE: p:\2009\2009-1027-02_heboap_iii_additional_colonias\design\04_north_capital\06\Standards\Traffic Control\BC07.DGN

BARRIER REFLECTORS FOR CONCRETE TRAFFIC BARRIER AND ATTENUATORS

- Barrier Reflectors shall be prequalified, and conform to the color and reflectivity requirements of DMS-8600. A list of prequalified Barrier Reflectors (Type C Delineators) can be found at the Material Producer List web address shown on BC(1).
- Color of Barrier Reflectors shall be as specified in the TMUTCD. The cost of the reflectors shall be considered subsidiary to Item 502.

CONCRETE TRAFFIC BARRIER (CTB)

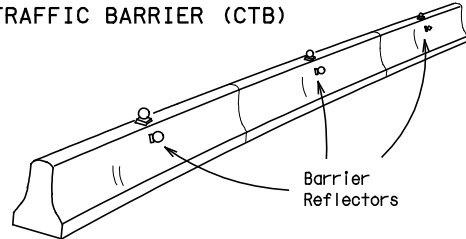

- Where traffic is on one side of the CTB, two (2) Barrier Reflectors shall be mounted in approximately the midsection of each section of CTB. An alternate mounting location is uniformly spaced at one end of each CTB. This will allow for attachment of a barrier grapple without damaging the reflector. The Barrier Reflector mounted on the side of the CTB shall be located directly below the reflector mounted on top of the barrier, as shown in the detail above.
- Where CTB separates two-way traffic, three barrier reflectors shall be mounted on each section of CTB. The reflector unit on top shall have two yellow reflective faces (Bi-Directional) while the reflectors on each side of the barrier shall have one yellow reflective face, as shown in the detail above.
- When CTB separates traffic traveling in the same direction, no barrier reflectors will be required on top of the CTB.
- Barrier Reflector units shall be yellow or white in color to match the edgeline being supplemented. Yellow Barrier Reflectors shall be made with Type E Fluorescent Prismatic Yellow Retroreflective Sheeting. White reflectors shall be made with Type D White Prismatic sheeting.
- Maximum spacing of Barrier Reflectors is forty (40) feet.
- Pavement markers or temporary flexible-reflective roadway marker tabs shall NOT be used as CTB delineation.
- Attachment of Barrier Reflectors to CTB shall be per manufacturer's recommendations.
- Missing or damaged Barrier Reflectors shall be replaced as directed by the Engineer.
- Single slope barriers shall be delineated as shown on the above detail.

LOW PROFILE CONCRETE BARRIER (LPCB)

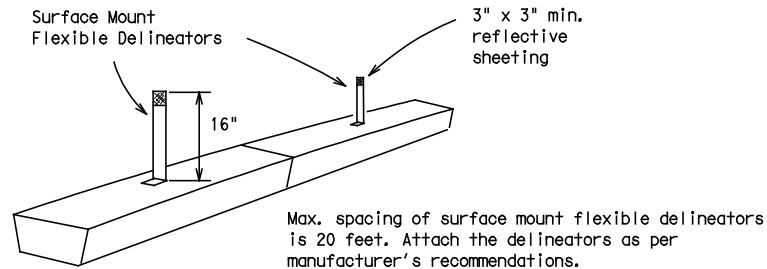

DELINEATION OF END TREATMENTS

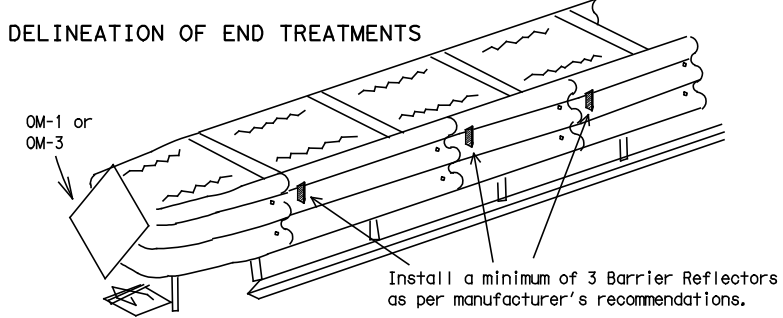

	APPROACHING TRAFFIC	
	BOTH SIDES	ONE SIDE
DELINEATION	OM-1	OM-3 or Vertical Panel

END TREATMENTS FOR CTB'S USED IN WORK ZONES

End treatments used on CTB's in work zones shall meet crashworthy standards as defined in the National Cooperative Highway Research Report 350. Refer to the CWZTCD List for approved end treatments and manufacturers.

WARNING LIGHTS

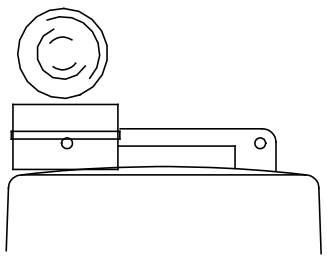

Type C Warning Light or approved substitute mounted adjacent to the travel way.

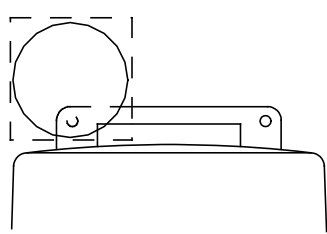

Warning reflector may be round or square. Must have a reflective surface area of at least 30 square inches

- Warning lights shall meet the requirements of the TMUTCD.
- Warning lights shall NOT be installed on barricades.
- Type A-Low Intensity Flashing Warning Lights are commonly used with drums. They are intended to warn of or mark a potentially hazardous area. Their use shall be as indicated on this sheet and/or other sheets of the plans by the designation "FL". The Type A Warning Lights shall not be used with signs manufactured with Type E Sheeting (Fluorescent Prismatic) meeting the requirements of Departmental Material Specification DMS-8300.
- Type-C and Type D 360 degree Steady Burn Lights are intended to be used in a series for delineation to supplement other traffic control devices. Their use shall be as indicated on this sheet and/or other sheets of the plans by the designation "SB".
- The Engineer/Inspector or the plans shall specify the location and type of warning lights to be installed on the traffic control devices.
- When required by the Engineer, the Contractor shall furnish a copy of the warning lights certification. The warning light manufacturer will certify the warning lights meet the requirements of the latest ITE Purchase Specifications for Flashing and Steady-Burn Warning Lights.
- When used to delineate curves, Type-C and Type D Steady Burn Lights should only be placed on the outside of the curve, not the inside.

WARNING LIGHTS MOUNTED ON PLASTIC DRUMS

- Type A flashing warning lights are intended to warn drivers that they are approaching or are in a potentially hazardous area.
- Type A random flashing warning lights are not intended for delineation and shall not be used in a series.
- A series of sequential flashing warning lights placed on channelizing devices to form a merging taper may be used for delineation. If used, the successive flashing of the sequential warning lights should occur from the beginning of the taper to the end of the merging taper in order to identify the desired vehicle path. The rate of flashing for each light shall be 65 flashes per minute, plus or minus 10 flashes.
- Type C and D steady-burn warning lights are intended to be used in a series to delineate the edge of the travel lane on detours, on lane changes, on lane closures, and on other similar conditions.
- Type A, Type C and Type D warning lights shall be installed at locations as detailed on other sheets in the plans.
- Warning lights shall not be installed on a drum that has a sign, chevron or vertical panel.
- The maximum spacing for warning lights on drums should be identical to the channelizing device spacing.

WARNING REFLECTORS MOUNTED ON PLASTIC DRUMS AS A SUBSTITUTE FOR TYPE C (STEADY BURN) WARNING LIGHTS

- A warning reflector or approved substitute may be mounted on a plastic drum as a substitute for a Type C, steady burn warning light at the discretion of the Contractor unless otherwise noted in the plans.
- The warning reflector shall be yellow in color and shall be manufactured using a sign substrate approved for use with plastic drums listed on the CWZTCD.
- The warning reflector shall have a minimum retroreflective surface area (one-side) of 30 square inches.
- Round reflectors shall be fully reflectorized, including the area where attached to the drum.
- Square substrates must have a minimum of 30 square inches of reflectorized sheeting. They do not have to be reflectorized where it attaches to the drum.
- The side of the warning reflector facing approaching traffic shall have sheeting meeting the color and retroreflectivity requirements for DMS 8300-Type D (Non-fluorescent Prismatic).
- When used near two-way traffic, both sides of the warning reflector shall be reflectorized.
- The warning reflector should be mounted on the side of the handle nearest approaching traffic.
- The maximum spacing for warning reflectors should be identical to the channelizing device spacing requirements.

TYPICAL FLASHING ARROW PANEL

Arrow Panels may be located behind channelizing devices in place for a shoulder taper or merging taper, otherwise they shall be delineated with four (4) channelizing devices placed perpendicular to traffic on the upstream side of traffic.

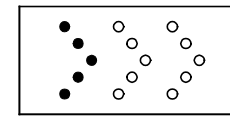

Sequential Chevron

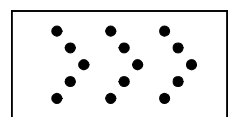
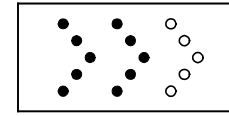

- The Flashing Arrow Panel should be used for all lane closures on multi-lane roadways, or slow moving maintenance or construction activities on the travel lanes.
- Flashing Arrow Panels should not be used on two-lane, two-way roadways, detours, diversions or work on shoulders unless the "CAUTION" display (see detail below) is used.
- The Engineer/Inspector shall choose all appropriate signs, barricades and/or other traffic control devices that should be used in conjunction with the Flashing Arrow Panel.
- The Flashing Arrow Panel should be able to display the following symbols:

Flashing RIGHT (LEFT) ARROW

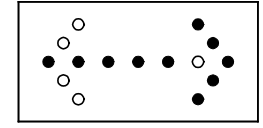

Flashing DOUBLE ARROW

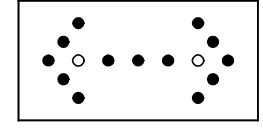

Flashing CAUTION

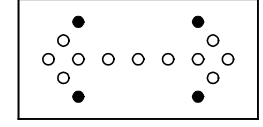

TYPE	REQUIREMENTS		MINIMUM VISIBILITY DISTANCE
	MINIMUM SIZE	MINIMUM NUMBER OF PANEL LAMPS	
B	30 x 60	13	3/4 mile
C	48 x 96	15	1 mile

ATTENTION: Flashing Arrow Panels shall be equipped with automatic dimming devices.

WHEN NOT IN USE, REMOVE THE ARROW PANEL FROM THE RIGHT-OF-WAY OR PLACE THE ARROW PANEL BEHIND CONCRETE TRAFFIC BARRIER OR GUARDRAIL.

- The "CAUTION" display consists of four corner lamps flashing simultaneously.
- The straight line caution display is NOT ALLOWED.
- The Flashing Arrow Panel shall be capable of minimum 50 percent dimming from rated lamp voltage. The flashing rate of the lamps shall not be less than 25 nor more than 40 flashes per minute.
- Minimum lamp "on time" shall be approximately 50 percent for the flashing arrow and equal intervals of 25 percent for each sequential phase of the flashing chevron.
- The sequential arrow display is NOT ALLOWED.
- The flashing arrow display is the TxDOT standard; however, the sequential Chevron display may be used during daylight operations.

- The Flashing Arrow Panel shall be mounted on a vehicle, trailer or other suitable support.
- A Flashing Arrow Panel SHALL NOT BE USED to laterally shift traffic.
- A full matrix PCMS may be used to simulate a Flashing Arrow Panel provided it meets visibility, flash rate and dimming requirements on this sheet for the same size arrow.
- Minimum mounting height of trailer mounted arrow panels should be 7 feet from roadway to bottom of panel.

TRUCK-MOUNTED ATTENUATORS

- Truck-mounted attenuators (TMA) used on TxDOT facilities must meet the requirements outlined in the National Cooperative Highway Research Report No. 350 (NCHRP 350).
- Refer to the CWZTCD for the requirements of Level 2 or Level 3 TMAs.
- Refer to the dates shown in the CWZTCD to ensure that the TMA meets the age requirements and the crashworthiness criteria established by the Federal Highway Administration (FHWA) for TMAs.
- Refer to the CWZTCD for a list of approved TMAs.
- TMAs are required on freeways unless otherwise noted in the plans.
- A TMA should be used anytime that it can be positioned approximately 30 to 100 feet in advance of the area of crew exposure without adversely affecting the work performance.
- The only reason a TMA should not be required is when a work area is spread down the roadway and the work crew is an extended distance from the TMA.

Texas Department of Transportation
Traffic Operations Division

BARRICADE AND CONSTRUCTION ARROW PANEL, REFLECTORS, WARNING LIGHTS & ATTENUATOR STANDARD

7 of 12 BC(7)-07

© TxDOT 11-4-02		DN: TxDOT	CK: TxDOT	DW: TxDOT	CK: TxDOT
9-07	REVISIONS	CONT	SECT	JOB	HIGHWAY
		2C	1080	495	GARZA
		DIST	COUNTY	SHEET NO.	
		PHR	HIDALGO	26	

DATE: 3/19/2012 4:03:58 PM
 FILE: p:\2009\2009-1027-02_heboap_iii_additional_colonias\design\04_north_capitol\04\Standards\Traffic Control\BC07.DGN
 DISCLAIMER: The use of this standard is governed by the "Texas Engineering Practice Act". No warranty of any kind is made by TxDOT for any purpose whatsoever. TxDOT assumes no responsibility for the conversion of this standard to other formats or for incorrect results or damages resulting from its use.

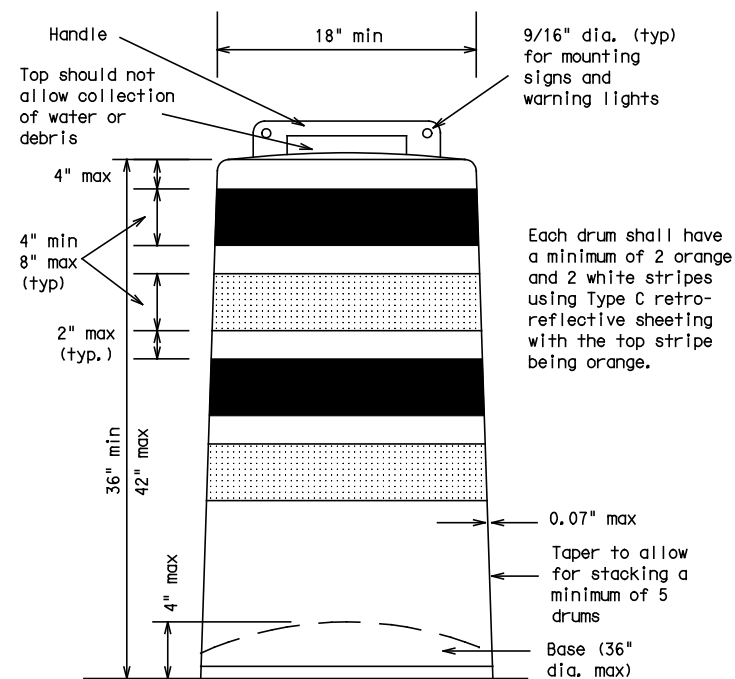

GENERAL NOTES

- For long term stationary work zones on freeways, drums shall be used as the primary channelizing device.
- For intermediate term stationary work zones on freeways, drums should be used as the primary channelizing device but may be replaced in tangent sections by vertical panels, or 42" two-piece cones. In tangent sections one-piece cones may be used with the approval of the Engineer but only if personnel are present on the project at all times to maintain the cones in proper position and location.
- For short term stationary work zones on freeways, drums are the preferred channelizing device but may be replaced in tapers, transitions and tangent sections by vertical panels, two-piece cones or one-piece cones as approved by the Engineer.
- Drums and all related items shall comply with the requirements of the current version of the "Texas Manual on Uniform Traffic Control Devices" (TMUTCD) and the "Compliant Work Zone Traffic Control Devices List" (CWZTCD).
- Drums, bases, and related materials shall exhibit good workmanship and shall be free from objectionable marks or defects that would adversely affect their appearance or serviceability.
- The Contractor shall have a maximum of 24 hours to replace any plastic drums identified for replacement by the Engineer/Inspector. The replacement device must be an approved device.

GENERAL DESIGN REQUIREMENTS

Prequalified plastic drums shall meet the following requirements:

- Plastic drums shall be a two-piece design; the "body" of the drum shall be the top portion and the "base" shall be the bottom.
- The body and base shall lock together in such a manner that the body separates from the base when impacted by a vehicle traveling at a speed of 20 MPH or greater but prevents accidental separation due to normal handling and/or air turbulence created by passing vehicles.
- Plastic drums shall be constructed of lightweight flexible, and deformable materials. The Contractor shall NOT use metal drums or single piece plastic drums as channelization devices or sign supports.
- Drums shall present a profile that is a minimum of 18 inches in width at the 36 inch height when viewed from any direction. The height of drum unit (body installed on base) shall be a minimum of 36 inches and a maximum of 42 inches.
- The top of the drum shall have a built-in handle for easy pickup and shall be designed to drain water and not collect debris. The handle shall have a minimum of two widely spaced 9/16 inch diameter holes to allow attachment of a warning light, warning reflector unit or approved compliant sign.
- The exterior of the drum body shall have a minimum of four alternating orange and white retroreflective circumferential stripes not less than 4 inches nor greater than 8 inches in width. Any non-reflectORIZED space between any two adjacent stripes shall not exceed 2 inches in width.
- Bases shall have a maximum width of 36 inches, a maximum height of 4 inches, and a minimum of two footholds of sufficient size to allow base to be held down while separating the drum body from the base.
- Plastic drums shall be constructed of ultra-violet stabilized, orange, high-density polyethylene (HDPE) or other approved material.

- Drum body shall have a minimum unballasted weight of 7.7 lbs. and maximum unballasted weight of 11 lbs. The wall of the drum body shall be a minimum of 0.07 inch in thickness. Weight of any drum supplied shall not vary more than 0.5 lb. from that of the prequalified sample.
- Drum and base shall be marked with manufacturer's name and model number.

RETROREFLECTIVE SHEETING

- The stripes used on drums shall be constructed of sheeting meeting the color and retroreflectivity requirements of Departmental Materials Specification DMS-8300, "Flat Surface Reflective Sheeting." High Specific Intensity (Type C) retroreflective sheeting shall be supplied unless otherwise specified in the plans.
- The sheeting shall be suitable for use on and shall adhere to the drum surface such that, upon vehicular impact, the sheeting shall remain adhered in-place and exhibit no delaminating, cracking, or loss of retroreflectivity other than that loss due to abrasion of the sheeting surface.

BALLAST

- Unballasted bases shall be large enough to hold up to 50 lbs. of sand. This base, when filled with the ballast material, should weigh between 35 lbs (minimum) and 50 lbs (maximum). The ballast may be sand in one to three sandbags separate from the base, sand in a sand-filled plastic base, or other ballasting devices as approved by the Engineer. Stacking of sandbags will be allowed, however height of sandbags above pavement surface may not exceed 12 inches.
- Bases with built-in ballast shall weigh between 40 lbs. and 50 lbs. Built-in ballast can be constructed of an integral crumb rubber base or a solid rubber base.
- The ballast shall not be heavy objects, water, or any material that would become hazardous to motorists, pedestrians, or workers when the drum is struck by a vehicle.
- When used in regions susceptible to freezing, drums shall have drainage holes in the bottoms so that water will not collect and freeze becoming a hazard when struck by a vehicle.
- Ballast shall not be placed on top of drums.
- Adhesives may be used to secure base of drums to pavement.

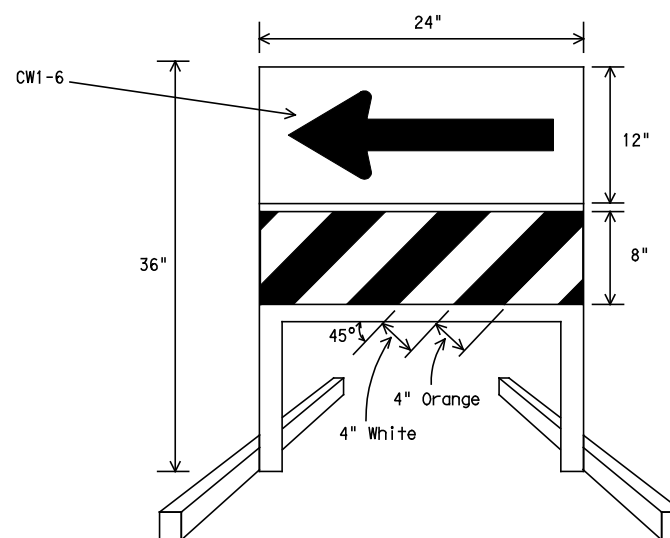

DIRECTION INDICATOR BARRICADE

- The Direction Indicator Barricade may be used in tapers, transitions, and other areas where specific directional guidance to drivers is necessary.
- If used, the Direction Indicator Barricade should be used in series to direct the driver through the transition and into the intended travel lane.
- The Direction Indicator Barricade shall consist of One-Direction Large Arrow (CW1-6) sign in the size shown with a black arrow on a background of Type E Fluorescent Prismatic Orange above a rail with Type C High Specific Intensity retroreflective sheeting in alternation 4" white and orange stripes sloping downward at an angle of 45 degrees in the direction road users are to pass.
- Double arrows on the Direction Indicator Barricade will not be allowed.
- Approved manufacturers are shown on the CWZTCD List. Ballast shall be as approved by the manufacturers instructions.

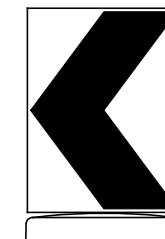

18" x 24" Sign
(Maximum Sign Dimension)
Chevron CW1-8, Opposing Traffic Lane Divider, Driveway sign D70a, Keep Right R4 series or other signs as approved by Engineer

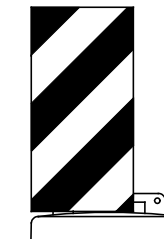

12" x 24" Vertical Panel
mount with diagonals sloping down towards travel way

Plywood, Aluminum or Metal sign substrates shall NOT be used on plastic drums

SIGNS, CHEVRONS, AND VERTICAL PANELS MOUNTED ON PLASTIC DRUMS

- Signs used on plastic drums shall be manufactured using substrates listed on the CWZTCD.
- Chevrons and other work zone signs with an orange background shall be manufactured with Type E (Fluorescent Prismatic) sheeting meeting the color and retroreflectivity requirements of DMS-8300, "Sign Face Material," unless otherwise specified in the plans.
- Vertical Panels shall be manufactured with orange and white sheeting meeting the requirements of DMS-8300 Type C (High Specific Intensity). Diagonal stripes on Vertical Panels shall slope down toward the intended traveled lane.
- Other sign messages (text or symbolic) may be used as approved by the Engineer. Sign dimensions shall not exceed 18 inches in width or 24 inches in height.
- Signs shall be installed using a 1/2 inch bolt (nominal) and nut, two washers, and one locking washer for each connection.
- Mounting bolts and nuts shall be fully engaged and adequately torqued. Bolts should not extend more than 1/2 inch beyond nuts.
- Chevrons may be placed on drums on the outside of curves, on merging tapers or on shifting tapers. When used in these locations they may be placed on every drum or spaced not more than on every third drum. A minimum of three (3) should be used at each location called for in the plans.
- R9-9, R9-10, R9-11 and R9-11a Sidewalk Closed signs which are 24 inches wide may be mounted on plastic drums, with approval of the Engineer.



BARRICADE AND CONSTRUCTION CHANNELIZING DEVICES STANDARD

8 of 12

BC(8)-07

© TxDOT 11-4-02		DW: TxDOT	CK: TxDOT	DW: TxDOT	CK: TxDOT
4-03	REVISIONS	CONT	SECT	JOB	HIGHWAY
9-07		2C	080	495	GARZA
		DIST	COUNTY		SHEET NO.
		PHR	HIDALGO		27

DISCLAIMER: The use of this standard is governed by the "Texas Engineering Practice Act". No warranty of any kind is made by TxDOT for any purpose whatsoever. TxDOT assumes no responsibility for the conversion of this standard to other formats or for incorrect results or damages resulting from its use.

DATE: 3/19/2012 4:04:09 PM
 FILE: p:\2009\2009-1027-02_hobcap_iii_additional_colonias.design\04_north_capisall\o.cs\Standards\Traffic Control\BC07.DGN

CHANNELIZING DEVICES

VERTICAL PANELS (VPs)

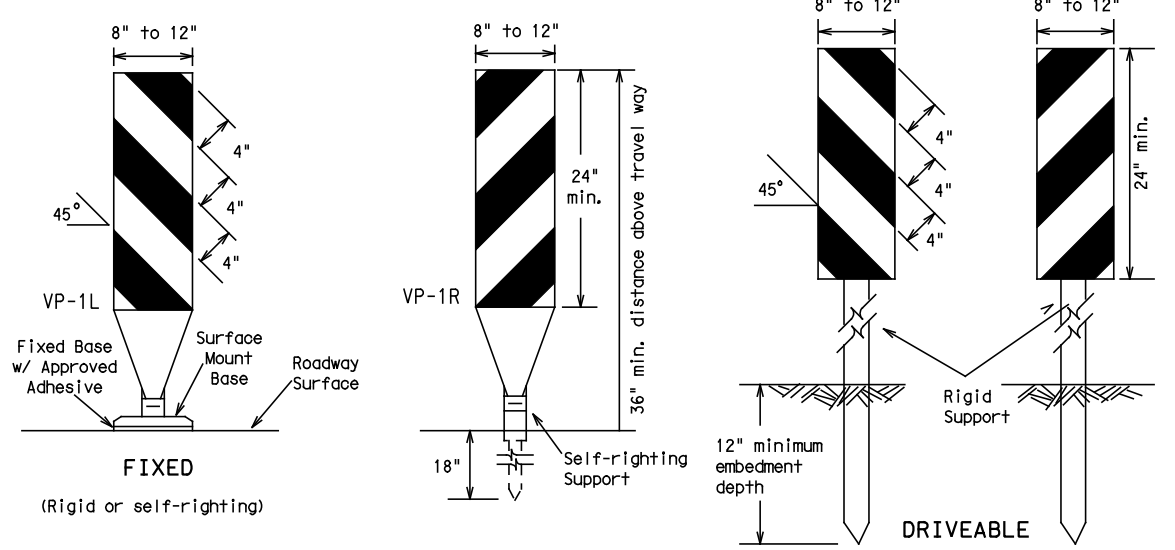

CHEVRONS

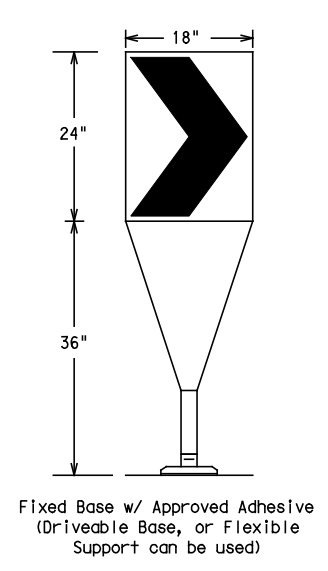

1. The chevron shall be a vertical rectangle with a minimum size of 12 by 18 inches.
2. Chevrons are intended to give notice of a sharp change of alignment with the direction of travel and provide additional emphasis and guidance for vehicle operators with regard to changes in horizontal alignment of the roadway.
3. Chevrons, when used, shall be erected on the outside of a sharp curve or turn, or on the far side of an intersection. They shall be in line with and at right angles to approaching traffic. Spacing should be such that the motorist always has three in view, until the change in alignment eliminates its need.
4. To be effective, the chevron should be visible for at least 500 feet.
5. Chevrons shall be orange with a black nonreflective legend. Sheeting for the chevron shall be retroreflective Type E (Fluorescent Prismatic) conforming to Departmental Material Specification DMS-8300, unless noted otherwise. The legend shall be black vinyl non-reflective decal sheeting meeting the requirements of DMS-8300.
6. For Long Term Stationary use on tapers or transitions on freeways and divided highways self-righting chevrons may be used to supplement plastic drums but not to replace plastic drums.

GENERAL NOTES:

1. Work Zone channelizing devices illustrated on this sheet may be installed in close proximity to traffic and are suitable for use on high or low speed roadways. The Engineer/Inspector shall ensure that spacing and placement is uniform and in accordance with the "Texas Manual on Uniform Traffic Control Devices" (TMUTCD).
2. Channelizing devices shown on this sheet may have a driveable, fixed or portable base. The requirement for self-righting channelizing devices must be specified in the General Notes or other plan sheets.
3. Channelizing devices on self-righting supports should be used in work zone areas where channelizing devices are frequently impacted by errant vehicles or vehicle related wind gusts making alignment of the channelizing devices difficult to maintain. Locations of these devices shall be detailed elsewhere in the plans. These devices shall conform to the TMUTCD and the "Compliant Work Zone Traffic Control Devices List" (CWZTCD).
4. The Contractor shall maintain devices in a clean condition and replace damaged, nonreflective, faded, or broken devices and bases as required by the Engineer/Inspector. The Contractor shall be required to maintain proper device spacing and alignment.
5. Portable bases shall be fabricated from virgin and/or recycled rubber. The portable bases shall weigh approximately 35 lbs.
6. Pavement surfaces shall be prepared in a manner that ensures proper bonding between the adhesives, the fixed mount bases and the pavement surface. Adhesives shall be prepared and applied according to the manufacturer's recommendations.
7. The installation and removal of channelizing devices shall not cause detrimental effects to the final pavement surfaces, including pavement surface discoloration or surface integrity. Driveable/bases shall not be permitted on final pavement surfaces. The Engineer/Inspector shall approve all application and removal procedures of fixed bases.
8. Examples on this sheet are commonly used channelizing devices in work zones. For other devices, refer to the CWZTCD.

1. Vertical Panels (VP's) are normally used to channelize traffic or divide opposing lanes of traffic.
2. VP's may be used in daytime or nighttime situations. They may be used at the edge of shoulder drop-offs and other areas such as lane transitions where positive daytime and nighttime delineation is required. The Engineer/Inspector shall refer to the Roadway Design Manual Appendix B "Treatment of Pavement Drop-offs in Work Zones" for additional guidelines on the use of VP's for drop-offs.
3. VP's should be mounted back to back if used at the edge of cuts adjacent to two-way two lane roadways. Stripes are to be reflective orange and reflective white and should always slope downward toward the travel lane.
4. VP's used on expressways and freeways or other high speed roadways, shall have a minimum of 270 square inches of retroreflective area facing traffic.
5. Self-righting supports are available with portable base. See "Compliant Work Zone Traffic Control Devices List" (CWZTCD).
6. Sheeting for the VP's shall be retroreflective Type C (High Specific Intensity) conforming to Departmental Material Specification DMS-8300, unless noted otherwise.
7. Where the height of reflective material on the vertical panel is greater than 36 inches, a panel stripe of 6 inches shall be used.

OPPOSING TRAFFIC LANE DIVIDERS (OTLD)

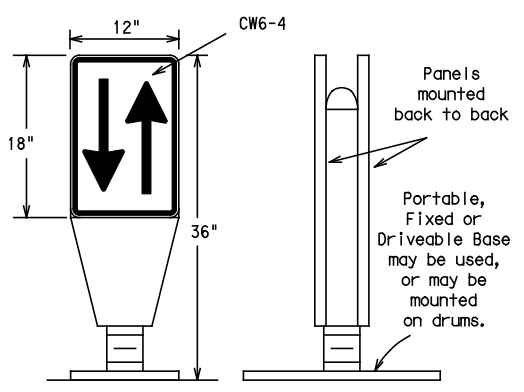

1. Opposing Traffic Lane Dividers (OTLD) are delineation devices designed to convert a normal one-way roadway section to two-way operation. OTLD's are used on temporary centerlines. The upward and downward arrows on the sign's face indicate the direction of traffic on either side of the divider. The base is secured to the pavement with an adhesive or rubber weight to minimize movement caused by a vehicle impact or wind gust.
2. The OTLD may be used in combination with simple tubular markers or VPs.
3. Spacing between the OTLD shall not exceed 500 feet. Tubular markers or VPs placed between the OTLD's should not exceed 100 foot spacing.
4. The OTLD shall be orange with a black non-reflective legend. Sheeting for the OTLD shall be retroreflective Type E (Fluorescent Prismatic) conforming to Departmental Material Specification DMS-8300, unless noted otherwise. The legend shall be black vinyl non-reflective decal sheeting meeting the requirements of DMS-8300.

Posted Speed	Formula	Minimum Desirable Taper Lengths $\frac{WS}{60}$			Suggested Maximum Spacing of Channelizing Devices	
		10' Offset	11' Offset	12' Offset	On a Taper	On a Tangent
30	$L = \frac{WS^2}{60}$	150'	165'	180'	30'	60' - 75'
35		205'	225'	245'	35'	70' - 90'
40		265'	295'	320'	40'	80' - 100'
45	L=WS	450'	495'	540'	45'	90' - 110'
50		500'	550'	600'	50'	100' - 125'
55		550'	605'	660'	55'	110' - 140'
60		600'	660'	720'	60'	120' - 150'
65		650'	715'	780'	65'	130' - 165'
70	700'	770'	840'	70'	140' - 175'	
75	750'	825'	900'	75'	150' - 185'	
80	800'	880'	960'	80'	160' - 195'	

***Taper lengths have been rounded off.
 L=Length of Taper (FT.) W=Width of Offset (FT.)
 S=Posted Speed (MPH)

HOLLOW OR WATER BALLASTED SYSTEMS USED AS LONGITUDINAL CHANNELIZING DEVICES OR BARRIERS

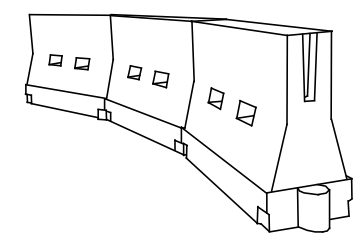

LONGITUDINAL CHANNELIZING DEVICES

1. Longitudinal channelizing devices are crashworthy, lightweight, deformable devices that are highly visible, have good target value and can be connected together. **They are not designed to contain or redirect a vehicle on impact.**
2. Longitudinal channelizing devices may be used instead of a line of cones or drums.
3. Longitudinal channelizing devices shall be placed in accordance to application and installation requirements specific to the device, and used only when shown on the CWZTCD list.
4. Longitudinal channelizing devices should not be used to provide positive protection for obstacles, pedestrians or workers.
5. Longitudinal channelizing devices shall be retroreflective, or supplemented with retroreflective delineation as required for temporary barriers on BC(7)-07.

WATER BALLASTED SYSTEMS USED AS BARRIERS

1. Water ballasted systems used as barriers shall not be used solely to channelize road users, but also to protect the work space per the appropriate NCHRP 350 crashworthiness requirements based on roadway speed and barrier application.
2. Water ballasted systems used to channelize vehicular traffic shall be supplemented with retroreflective delineation or channelizing devices to improve daytime/nighttime visibility. They may also be supplemented with pavement markings.
3. Water ballasted systems used as barriers shall be placed in accordance to application and installation requirements specific to the device, and used only when shown on the CWZTCD list.
4. Water ballasted systems used as barriers should not be used for a merging taper except in low speed (less than 45 MPH) urban areas. When used on a taper in a low speed urban area, the taper shall be delineated and the taper length should be designed to optimize road user operations considering the available geometric conditions.
5. When water ballasted systems used as barriers have blunt ends exposed to traffic, they should be attenuated as per manufacturer recommendations or flared to point outside the clear zone.

If used to channelize pedestrians, longitudinal channelizing devices or water ballasted systems must have a continuous detectable bottom for users of long canes and the top of the unit shall be not less than 32 inches in height.

VERTICAL PANELS & OPPOSING TRAFFIC LANE DIVIDERS SEPARATING TWO-WAY TRAFFIC (Typical application)

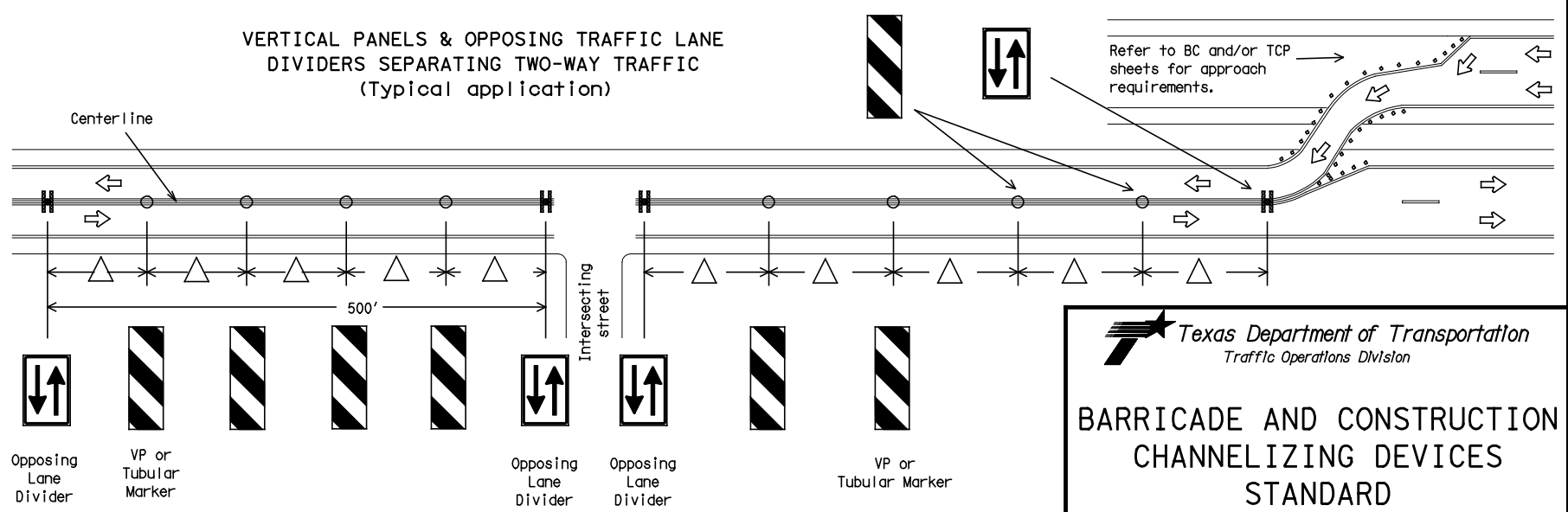

△ Spacing between the VP's or tubular markers shall not exceed 100 feet. On roadways with speeds less than 45 MPH, spacing between the tubular markers or VP's shall be as shown on the channelizing spacing table shown on this page. If the table shows spacing greater than 100 feet based on the roadway speed, then use a maximum of 100 feet spacing between the tubular markers or VP's. Every fifth channelizing device shall be an OTLD, except when the OTLD must be spaced closer to accommodate an intersection. Spacing between the OTLD shall not exceed 500 feet.

Texas Department of Transportation
 Traffic Operations Division

BARRICADE AND CONSTRUCTION CHANNELIZING DEVICES STANDARD

9 of 12 BC(9)-07

© TxDOT 11-4-02	DNF: TxDOT	CK: TxDOT	DW: TxDOT	CK: TxDOT	
9-07	REVISIONS	CONT	SECT	JOB	HIGHWAY
		2C	1080	495	GARZA
		DIST	COUNTY		SHEET NO.
		PHR	HIDALGO		28

DATE: 3/19/2012 4:04:21 PM
 FILE: p:\2009\2009-1027-02_hoboap_iii_additional_colonias.design\04_north_capisallo.cs\Standards\Traffic Control\BC07.DGN
 DISCLAIMER: The use of this standard is governed by the "Texas Engineering Practice Act". No warranty of any kind is made by TxDOT for any purpose whatsoever. TxDOT assumes no responsibility for the construction of this standard to other formats or for incorrect results or damages resulting from its use.

TYPE III BARRICADES

1. Refer to the Compliant Work Zone Traffic Control Devices List (CWZTCD) for details of the Type III Barricades and a list of all materials used in the construction of Type III Barricades.
2. Type III Barricades shall be used at each end of construction projects closed to all traffic.
3. Barricades extending across a roadway should have stripes that slope downward in the direction toward which traffic must turn in detouring. When both right and left turns are provided, the chevron striping may slope downward in both directions from the center of the barricade. Where no turns are provided at a closed road striping should slope downward in both directions toward the center of roadway.
4. Striping of rails, for the right side of the roadway, should slope downward to the left. For the left side of the roadway, striping should slope downward to the right.
5. Identification markings may be shown only on the back of the barricade rails. The maximum height of letters and/or company logos used for identification shall be 1".
6. Barricades shall not be placed parallel to traffic unless an adequate clear zone is provided.
7. Warning lights shall NOT be installed on barricades.
8. Where barricades require the use of weights to keep from turning over, the use of sandbags with dry, cohesionless sand is recommended. The sandbags will be tied shut to keep the sand from spilling and to maintain a constant weight. Sand bags shall not be stacked in a manner that covers any portion of a barricade rails reflective sheeting. Rock, concrete, iron, steel or other solid objects will NOT be permitted. Sandbags should weigh a minimum of 35 lbs and a maximum of 50 lbs. Sandbags shall be made of a durable material that tears upon vehicular impact. Rubber (such as tire inner tubes) shall not be used for sandbags. Sandbags shall only be placed along or upon the base supports of the device and shall not be suspended above ground level or hung with rope, wire, chains or other fasteners.
9. Sheeting for barricades shall be retroreflective Type C (High Specific Intensity) conforming to Departmental Material Specification DMS-8300 unless otherwise noted.

Barricades shall NOT be used as a sign support.

TYPICAL STRIPING DETAIL FOR BARRICADE RAIL

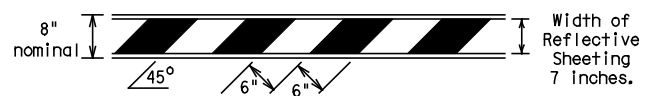

TYPICAL PANEL DETAIL FOR SKID OR POST TYPE BARRICADES

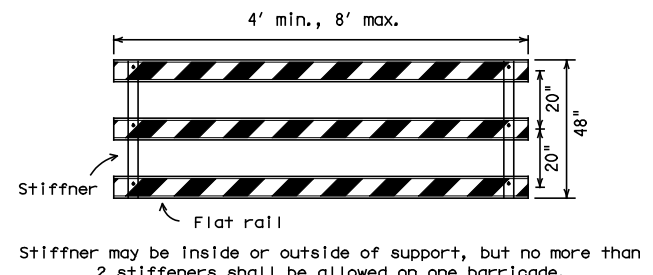

TYPE III BARRICADE (POST AND SKID) TYPICAL APPLICATION

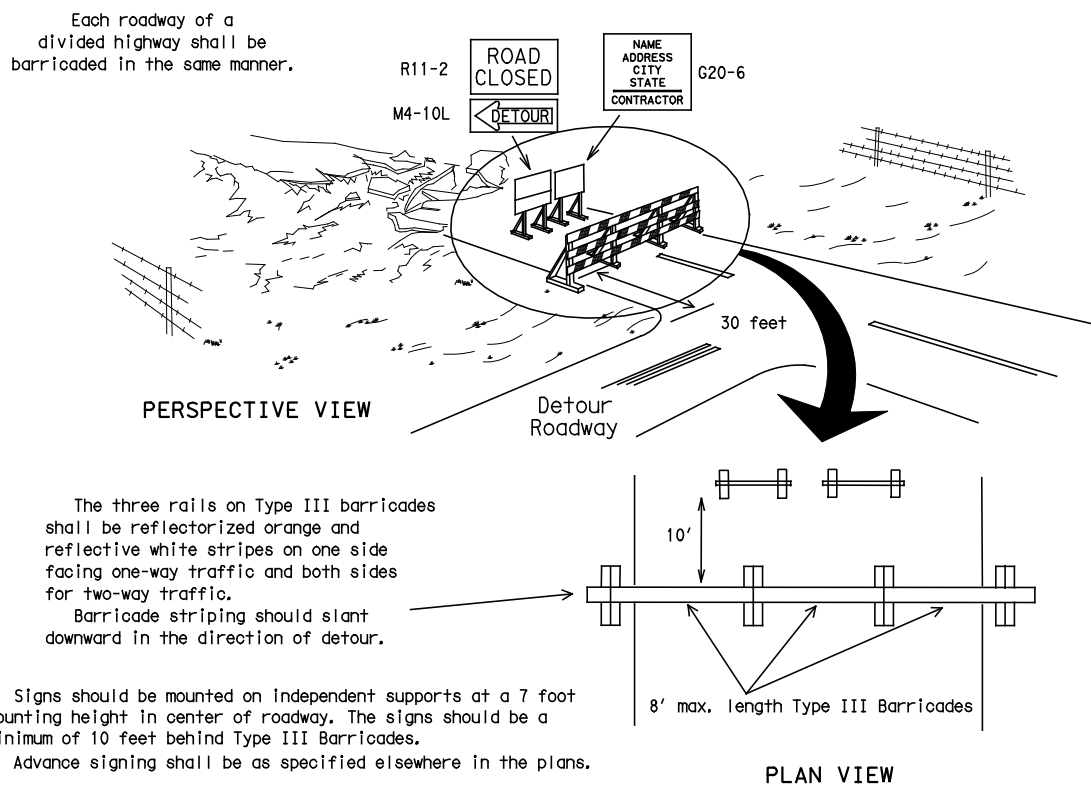

CULVERT WIDENING OR OTHER ISOLATED WORK WITHIN THE PROJECT LIMITS

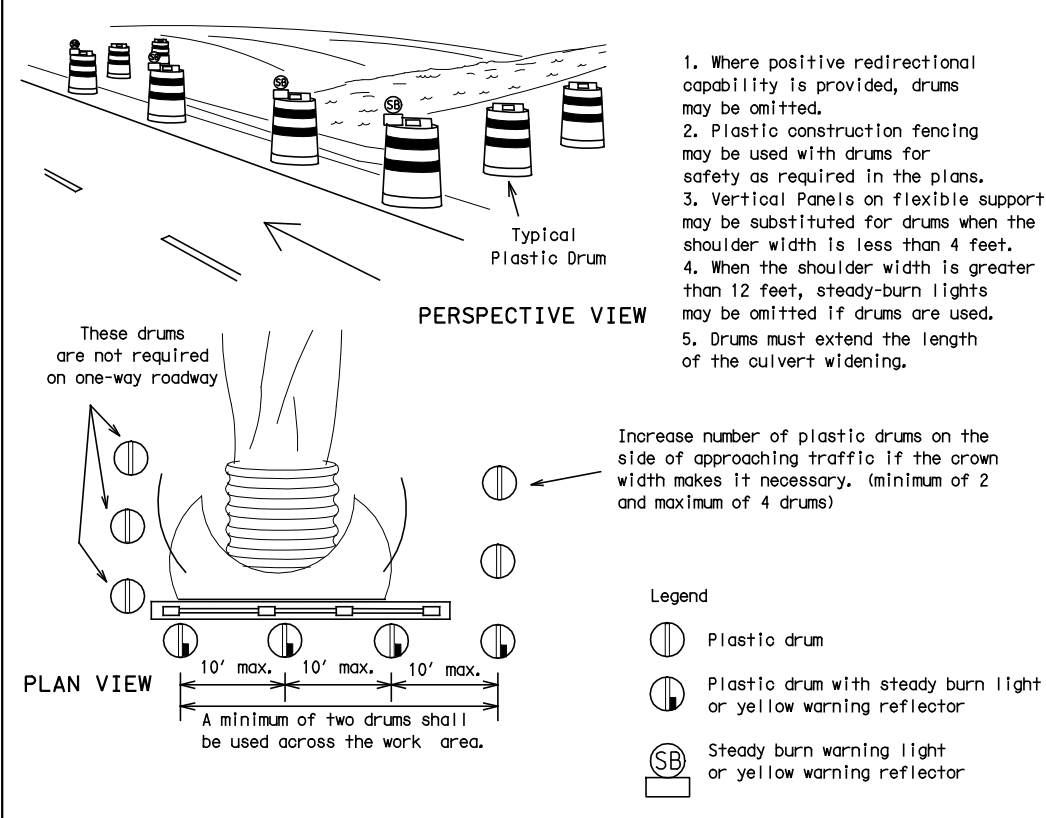

1. Signs should be mounted on independent supports at a 7 foot mounting height in center of roadway. The signs should be a minimum of 10 feet behind Type III Barricades.
2. Advance signing shall be as specified elsewhere in the plans.

CONES

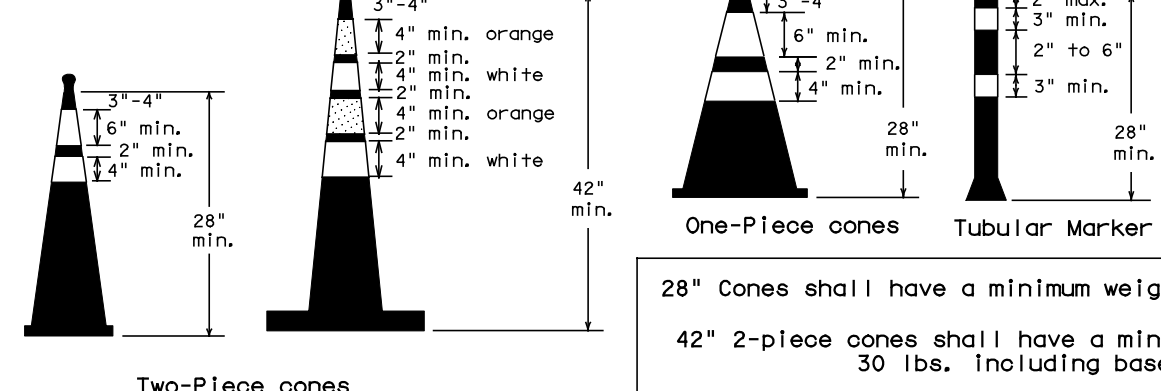

28" Cones shall have a minimum weight of 9 1/2 lbs.
 42" 2-piece cones shall have a minimum weight of 30 lbs. including base.

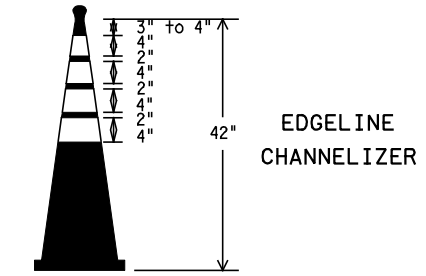

1. This device is intended only for use in place of a vertical panel to channelize traffic by indicating the edge of the travel lane. It is not intended to be used in transitions or tapers.
2. This device shall not be used to separate lanes of traffic (opposing or otherwise) or warn of objects.
3. This device is based on a 42 inch, two-piece cone with an alternate striping pattern: four 4 inch retroreflective bands, with an approximate 2 inch gap between bands. The color of the band should correspond to the color of the edgeline (yellow for left edgeline, white for right edgeline) for which the device is substituted or for which it supplements. The reflectorized bands shall be retroreflective Type C encapsulated bead (High Specific Intensity) conforming to Departmental Material Specification DMS-8300, unless otherwise noted.
4. The base must weigh a minimum of 30 lbs.

TRAFFIC CONTROL FOR MATERIAL STOCKPILES

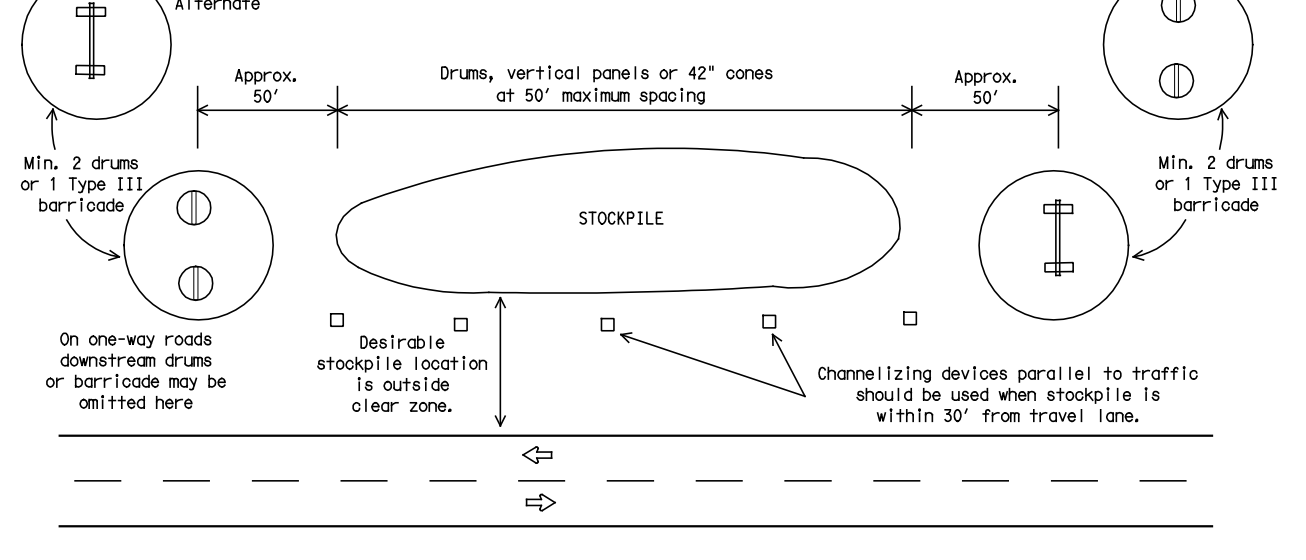

1. Traffic cones and tubular markers shall be a minimum of 28 inches in height when used either on freeways or at nighttime.
2. Cones or tubular markers shall be predominantly orange, fluorescent red-orange, or fluorescent yellow-orange. They should be kept clean and bright for maximum visibility.
3. Cones used only for daytime operations do not require the reflectorized bands.
4. Cones and tubular markers used for nighttime operations shall be reflectorized. Reflectorized material shall have a smooth, sealed outer surface that displays the same approximate color during the day and night. The reflectorized bands shall be retroreflective Type C (High Specific Intensity) conforming to Departmental Material Specification DMS-8300, unless otherwise noted.
5. When used at night, appropriate personnel shall ensure that cones and tubular markers remain in their proper location and in an upright position.
6. Reflectorization of 28" cones shall consist of a minimum 6 inch band placed at least 3 inches but not more than 4 inches from the top, supplemented by a minimum 4 inch band spaced a minimum of 2 inches below the 6 inch band.
7. Reflectorization of 42" cones shall be provided by alternating 4 to 6" orange and white stripes with orange on top.
8. Reflectorization of tubular markers shall be a minimum of two 3 inch bands placed a maximum of 2 inches from the top with a maximum of 6 inches between bands.
9. One-piece cones or tubular markers are generally suitable for temporary usage (up to 8 hours) with other channelization devices such as vertical panels, drums or two-piece cones for long term usage. Care should be taken to ensure they remain in their proper location and in an upright position.
10. Cones or tubular markers used on each project shall be of the same size and shape.
11. The handle may be designed as a hook or other shape, fabricated from non-rigid materials similar to the cone material, and may extend up to a maximum of 8 inches above the top of cone. Length of the handle shall not be considered with regard to the overall height of the cone.

Texas Department of Transportation
 Traffic Operations Division

BARRICADE AND CONSTRUCTION CHANNELIZING DEVICES STANDARD

10 of 12 BC(10)-07

© TxDOT 11-4-02		DN: TxDOT	CK: TxDOT	DW: TxDOT	CK: TxDOT
9-07	REVISIONS	CONT	SECT	JOB	HIGHWAY
		2C	080	495	GARZA
		DIST	COUNTY		SHEET NO.
		PHR	HIDALGO		29

DISCLAIMER: The use of this standard is governed by the "Texas Engineering Practice Act". No warranty of any kind is made by TxDOT for any purpose whatsoever. TxDOT assumes no responsibility for the conversion of this standard to other formats or for incorrect results or damages resulting from its use.

DATE: 3/19/2012 4:04:31 PM
 FILE: p:\2009\2009-1027-02_heboap_iii_additional_colonias\design\04_north_capitol\Traffic Control\BC07.DGN

WORK ZONE PAVEMENT MARKINGS

GENERAL

- The Contractor shall be responsible for maintaining work zone and existing pavement markings, in accordance with the standard specifications and special provisions, on all roadways open to traffic within the CSJ limits unless otherwise stated in the plans.
- Color, patterns and dimensions shall be in conformance with the "Texas Manual on Uniform Traffic Control Devices" (TMUTCD).
- Additional supplemental pavement marking details may be found in the plans or specifications.
- Pavement markings shall be installed in accordance with the TMUTCD and as shown on the plans.
- When short term markings are required on the plans, short term markings shall conform with the TMUTCD, the plans and details as shown on the Standard Plan Sheet WZ(STPM).
- When standard pavement markings are not in place and the roadway is opened to traffic, DO NOT PASS signs shall be erected to mark the beginning of the sections where passing is prohibited and PASS WITH CARE signs at the beginning of sections where passing is permitted.
- All work zone pavement markings shall be installed in accordance with Item 662, "Work Zone Pavement Markings."

RAISED PAVEMENT MARKERS

- Raised pavement markers are to be placed according to the patterns on BC(12).
- All raised pavement markers used for work zone markings shall meet the requirements of Item 672, "RAISED PAVEMENT MARKERS" and Departmental Material Specification DMS-4200 or DMS-4300.

PREFABRICATED PAVEMENT MARKINGS

- Removable prefabricated pavement markings shall meet the requirements of DMS-8241.
- Non-removable prefabricated pavement markings (foil back) shall meet the requirements of DMS-8240.

MAINTAINING WORK ZONE PAVEMENT MARKINGS

- The Contractor will be responsible for maintaining work zone pavement markings within the work limits.
- Work zone pavement markings shall be inspected in accordance with the frequency and reporting requirements of work zone traffic control device inspections as required by Form 599.
- The markings should provide a visible reference for a minimum distance of 300 feet during normal daylight hours and 160 feet when illuminated by automobile low-beam headlights at night, unless sight distance is restricted by roadway geometrics.
- Markings failing to meet this criteria within the first 30 days after placement shall be replaced at the expense of the Contractor as per Specification Item 662.

REMOVAL OF PAVEMENT MARKINGS

- Pavement markings that are no longer applicable, could create confusion or direct a motorist toward or into the closed portion of the roadway, shall be removed or obliterated before the roadway is opened to traffic.
- The above shall not apply to detours in place for less than two weeks, where flaggers and/or sufficient channelizing devices are used in lieu of markings to outline the detour route.
- Pavement markings shall be removed to the fullest extent possible, so as not to leave a discernable marking. This shall be by any method approved by TxDOT Specification Item 677 for "Eliminating Existing Pavement Markings and Markers".
- The removal of pavement markings may require resurfacing or seal coating portions of the roadway.
- Subject to the approval of the Engineer, any method that proves to be successful on a particular type pavement may be used.
- Blast cleaning may be used but will not be required unless specifically shown in the plans.
- Over-painting of the markings SHALL NOT BE permitted.
- Removal of raised pavement markers shall be as directed by the Engineer.
- Removal of existing pavement markings and markers will be paid for directly in accordance with Item 677, "ELIMINATING EXISTING PAVEMENT MARKINGS AND MARKERS," unless otherwise stated in the plans.
- Black-out marking tape may be used to cover conflicting existing markings for periods less than two weeks when approved by the Engineer.

Temporary Flexible-Reflective Roadway Marker Tabs

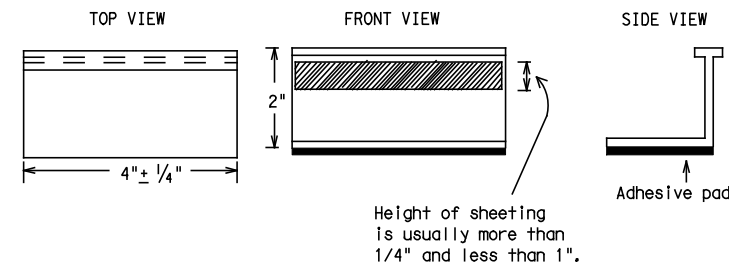

**STAPLES OR NAILS SHALL NOT BE USED TO SECURE
TEMPORARY FLEXIBLE-REFLECTIVE ROADWAY MARKER
TABS TO THE PAVEMENT SURFACE**

- Temporary flexible-reflective roadway marker tabs used as guidemarks shall meet the requirements of DMS-8242.
- Tabs detailed on this sheet are to be inspected and accepted by the Engineer or designated representative. Sampling and testing is not normally required, however at the option of the Engineer, either "A" or "B" below may be imposed to assure quality before placement on the roadway.
 - Select five (5) or more tabs at random from each lot or shipment and submit to the Construction Division, Materials and Pavement Section to determine specification compliance.
 - Select five (5) tabs and perform the following test. Affix five (5) tabs at 24 inch intervals on an asphaltic pavement in a straight line. Using a medium size passenger vehicle or pickup, run over the markers with the front and rear tires at a speed of 35 to 40 miles per hour, four (4) times in each direction. No more than one (1) out of the five (5) reflective surfaces shall be lost or displaced as a result of this test.
- Small design variances may be noted between tab manufacturers.
- See Standard Sheet WZ(STPM) for tab placement on new pavements. See Standard Sheet TCP(7-1) for tab placement on seal coat work.

Raised Pavement Markers used as Guidemarks

- Raised pavement markers used as guidemarks shall be from the approved product list, and meet the requirements of DMS-4200.
- All temporary construction raised pavement markers provided on a project shall be of the same manufacturer.
- Adhesive for guidemarks shall be bituminous material hot applied or butyl rubber pad for all surfaces, or thermoplastic for concrete surfaces.

Guidemarks shall be designated as:

- YELLOW - (two amber reflective surfaces with yellow body).
- WHITE - (one silver reflective surface with white body).

DEPARTMENTAL MATERIAL SPECIFICATIONS

PAVEMENT MARKERS (REFLECTORIZED)	DMS-4200
TRAFFIC BUTTONS	DMS-4300
EPOXY AND ADHESIVES	DMS-6100
BITUMINOUS ADHESIVE FOR PAVEMENT MARKERS	DMS-6130
PREFABRICATED PAVEMENT MARKINGS-PERMANENT	DMS-8240
PREFABRICATED PAVEMENT MARKINGS-REMOVABLE	DMS-8241
TEMPORARY FLEXIBLE-REFLECTIVE ROADWAY MARKER TABS	DMS-8242

A list of prequalified reflective raised pavement markers, non-reflective traffic buttons, roadway marker tabs and other pavement markings can be found at the Material Producer List web address shown on BC(1).



Texas Department of Transportation
Traffic Operations Division

BARRICADE AND CONSTRUCTION PAVEMENT MARKINGS STANDARD

11 of 12 BC(11)-07

© TxDOT February 1998		DN: TxDOT	CK: TxDOT	DW: TxDOT	CK: TxDOT
2-98	REVISIONS	CONT	SECT	JOB	HIGHWAY
1-02		2C	1080	495	GARZA
11-02		DIST	COUNTY		SHEET NO.
9-07		PHR	HIDALGO		30

DATE: 3/19/2012 4:04:38 PM
 FILE: p:\2009\2009-1027-02_heboap_iii_additional_colonias\design\04_north_capital\04cs\Standards\Traffic Control\BC07.DGN
 DISCLAIMER: The use of this standard is governed by the "Texas Engineering Practice Act". No warranty of any kind is made by TXDOT for any purpose whatsoever. TXDOT assumes no responsibility for the conversion of this standard to other formats or for incorrect results or damages resulting from its use.

PAVEMENT MARKING PATTERNS

CENTER LINE & NO-PASSING ZONE BARRIER LINES FOR TWO-LANE, TWO-WAY HIGHWAYS

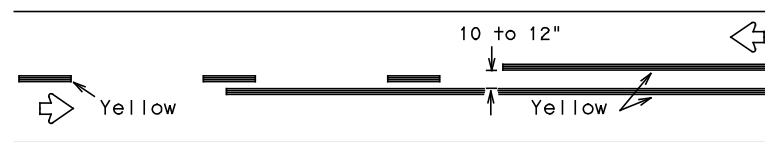

REFLECTORIZED PAVEMENT MARKINGS - PATTERN A

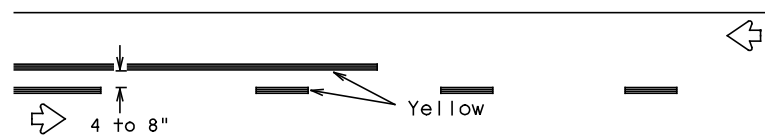

REFLECTORIZED PAVEMENT MARKINGS - PATTERN B

Pattern A is the TXDOT Standard, however Pattern B may be used if approved by the Engineer. Prefabricated markings may be substituted for reflectorized pavement markings.

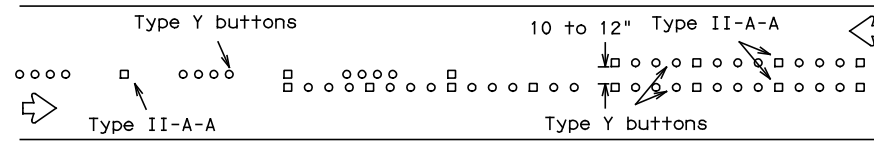

RAISED PAVEMENT MARKERS - PATTERN A

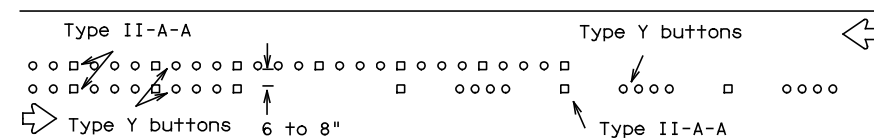

RAISED PAVEMENT MARKERS - PATTERN B

EDGE & LANE LINES FOR DIVIDED HIGHWAY

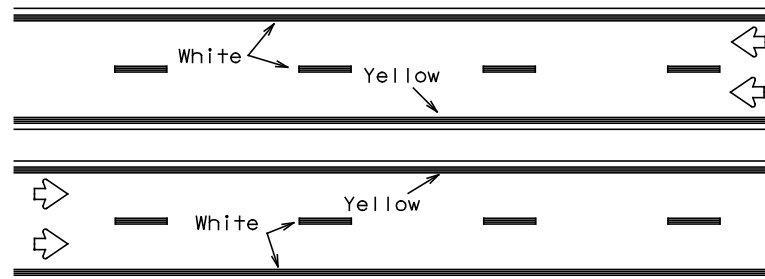

REFLECTORIZED PAVEMENT MARKINGS

Prefabricated markings may be substituted for reflectorized pavement markings.

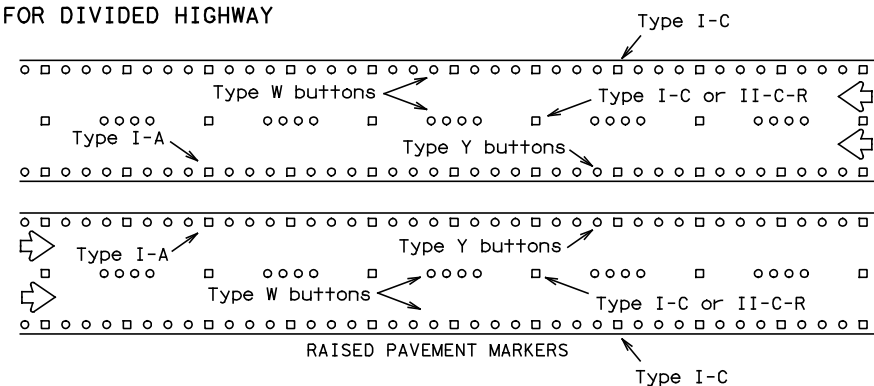

RAISED PAVEMENT MARKERS

LANE & CENTER LINES FOR MULTILANE UNDIVIDED HIGHWAYS

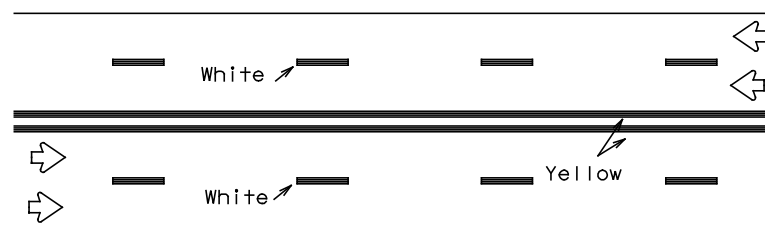

REFLECTORIZED PAVEMENT MARKINGS

Prefabricated markings may be substituted for reflectorized pavement markings.

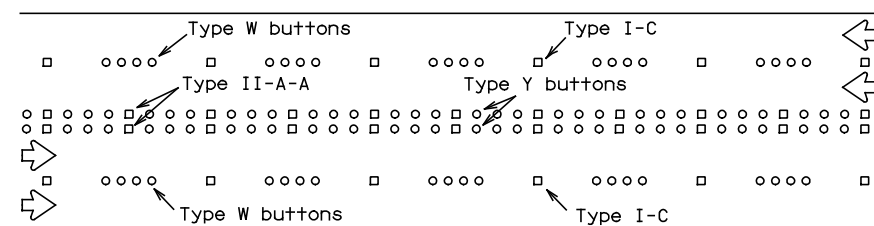

RAISED PAVEMENT MARKERS

TWO-WAY LEFT TURN LANE

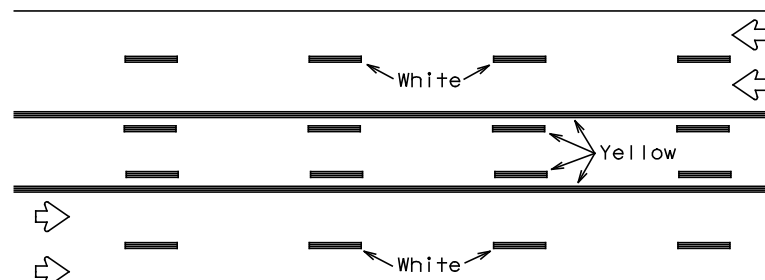

REFLECTORIZED PAVEMENT MARKINGS

Prefabricated markings may be substituted for reflectorized pavement markings.

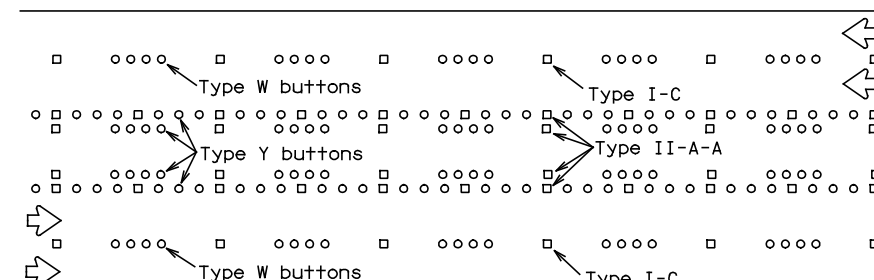

RAISED PAVEMENT MARKERS

STANDARD WORK ZONE PAVEMENT MARKINGS DETAILS

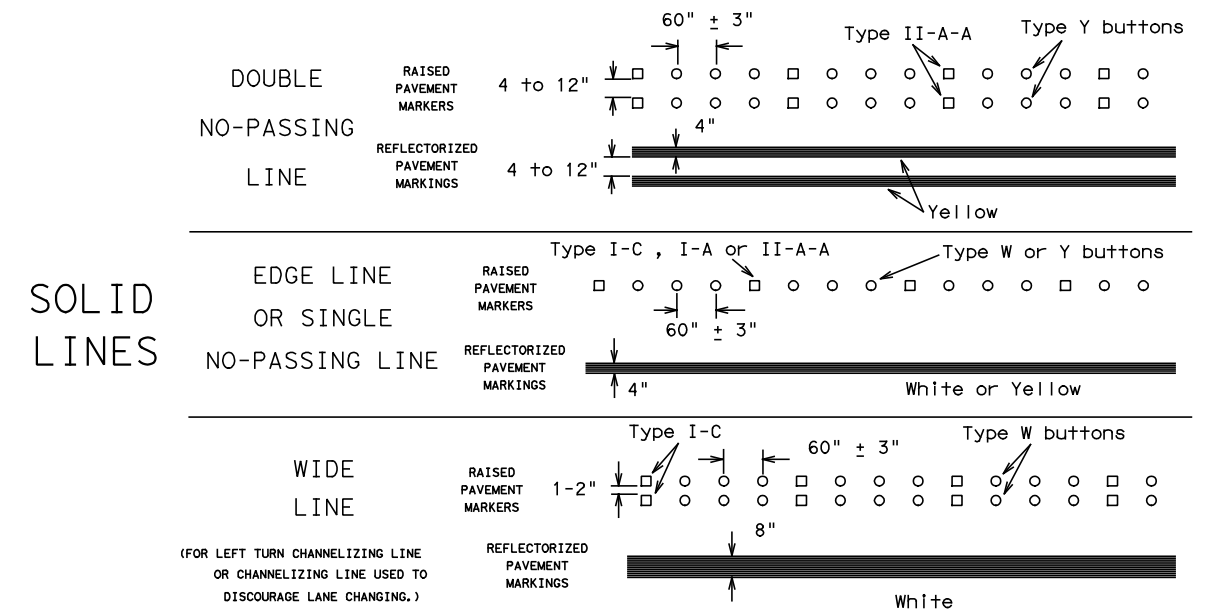

BROKEN LINE

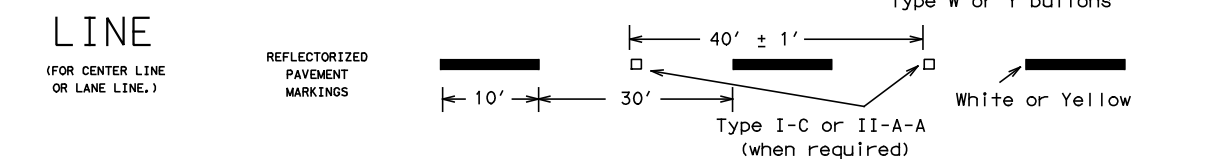

REMOVABLE MARKINGS WITH RAISED PAVEMENT MARKERS

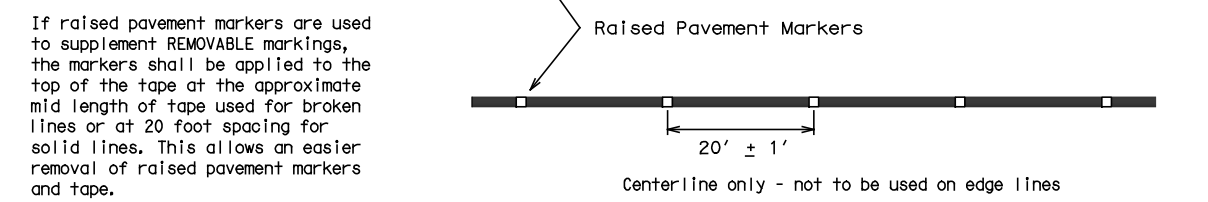

Raised pavement markers used as standard pavement markings shall be from the approved products list and meet the requirements of Item 672 "RAISED PAVEMENT MARKERS."



BARRICADE AND CONSTRUCTION PAVEMENT MARKING PATTERNS STANDARD

12 of 12 BC(12)-07

© TXDOT February 1998		DW: TXDOT	CK: TXDOT	DW: TXDOT	CK: TXDOT
1-97	REVISIONS	CONT	SECT	JOB	HIGHWAY
2-98		2C	1080	495	GARZA
11-02		DIST	COUNTY		SHEET NO.
9-07		PHR	HIDALGO		31

DATE: 3/19/2012 4:04:43 PM
 FILE: p:\2009\2009-1027-02_heboap_iii_additional_colonias\design\04_north_capital\05\Standards\Traffic Control\WZTD.dgn
 DISCLAIMER: The use of this standard is governed by the "Texas Engineering Practice Act". No warranty of any kind is made by TxDOT for any purpose whatsoever. TxDOT assumes no responsibility for the conversion of this standard to other formats or for incorrect results or damages resulting from its use.

CHANNELIZING DEVICES FOR URBAN ROADWAY TYPE PROJECT

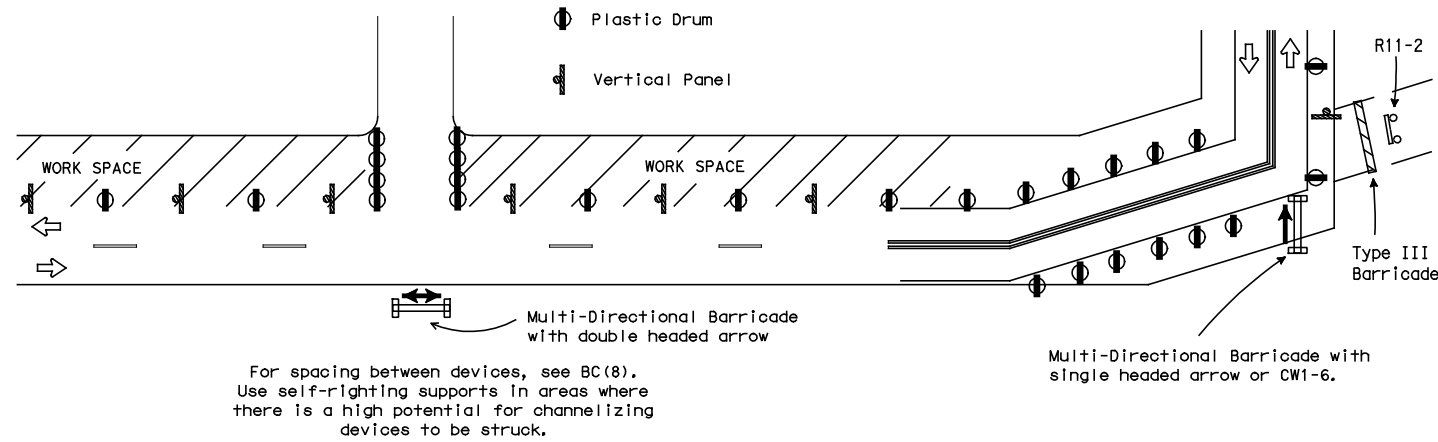

BARRIER DELINEATION WITH SAFETY GLARE FENCE

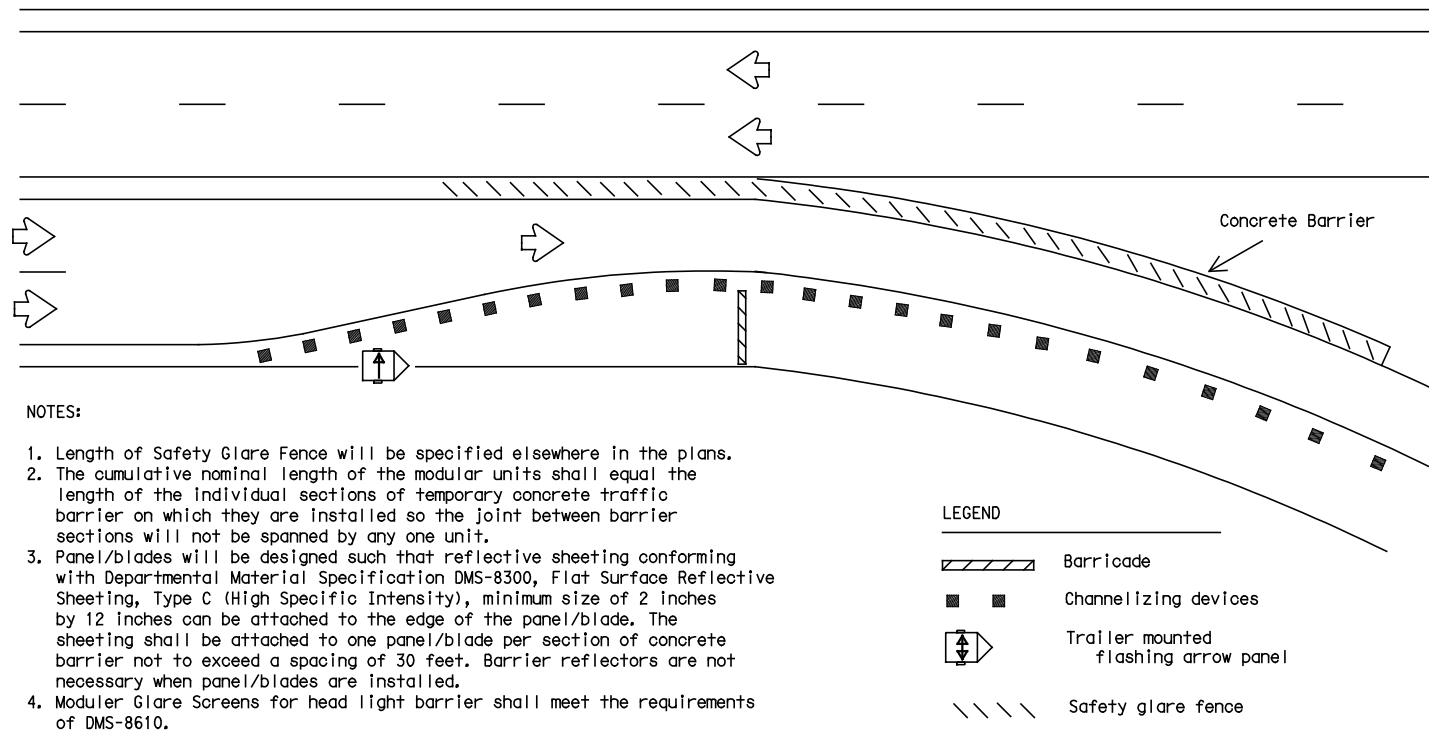

MULTI-DIRECTIONAL BARRICADE

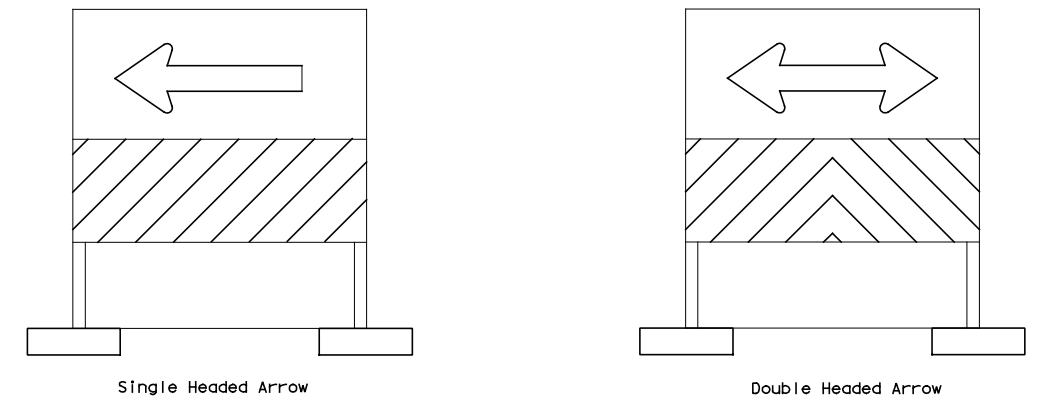

- Multi-directional barricade shall not be used for lane closures.
- May be used for sharp changes in alignment, or across roadway from stem of "T" Intersection.
- Typically used for Intermediate Term Stationary, Short Term Stationary or Short Duration work zone operations.
- See the CWZTCD List for approved designs.

USAGE OF CW1-6, ECW1-6a AND CW1-8 SIGNS

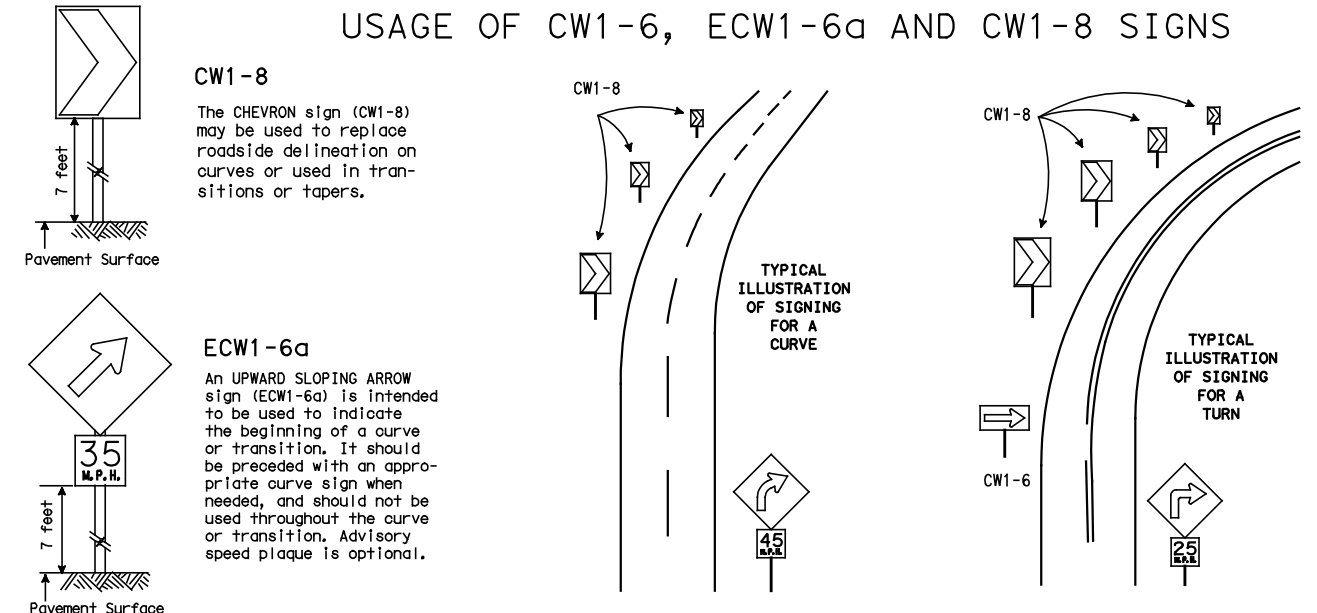

Only pre-qualified products shall be used. A copy of the "Compliant Work Zone Traffic Control Devices List" (CWZTCD) describes pre-qualified products and their sources and may be obtained by contacting:

Standards Engineer
Traffic Operations Division - TE
Texas Department of Transportation
125 East 11th Street
Austin, Texas 78701-2483
Phone (512) 416-3120
Fax (512) 416-3299

Instructions to locate the "CWZTCD" on TxDOT website are:

Start at website - www.dot.state.tx.us
Click on "About TxDOT",
Click on "Organizational Chart",
Click on Traffic Operations Box,
Click on "Compliant Work Zone Traffic Control Devices",
Click on "View PDF".
This site is printable.

PREQUALIFICATION PROCEDURES ARE OBTAINED FROM:
CONSTRUCTION DIVISION-MATERIALS AND TESTS SECTION
TEXAS DEPARTMENT OF TRANSPORTATION (TxDOT)
125 EAST 11th STREET
AUSTIN, TX 78701-2483

DEPARTMENTAL MATERIAL SPECIFICATIONS

FLAT SURFACE REFLECTIVE SHEETING	DMS-8300
DELINEATORS AND OBJECT MARKERS	DMS-8600
MODULER GLARE SCREENS	DMS-8610

COLOR	USAGE	SIGN SHEETING
ORANGE	BACKGROUND	TYPE E (FLUORESCENT PRISMATIC)
WHITE	BACKGROUND	TYPE C (HIGH SPECIFIC INTENSITY)
BLACK	LEGEND & BORDERS	VINYL NON-REFLECTIVE SHEETING

REFER TO THE BC SHEETS FOR SHEETING REQUIREMENT ON CHANNELIZING DEVICES.

The five categories of work duration and their time at a location shall be:

- Long-term stationary is work that occupies a location more than 3 days.
- Intermediate-term stationary is work that occupies a location more than one daylight period up to 3 days, or nighttime work lasting more than 1 hour.
- Short-term stationary is daytime work that occupies a location for more than 1 hour, but less than 12 hours.
- Short duration is work that occupies a location up to 1 hour.
- Mobile is work that moves intermittently or continuously.

Texas Department of Transportation
Traffic Operations Division

TRAFFIC CONTROL PLAN TYPICAL DETAILS

WZ (TD) -03

© TxDOT February 1998	DN: TxDOT	CK: TxDOT	DW: TxDOT	CK: TxDOT	
4-98	REVISIONS	CONT	SECT	JOB	HIGHWAY
3-03		2C	1080	495	GARZA
		DIST	COUNTY		SHEET NO.
		PHR	HIDALGO		32

DISCLAIMER: The use of this standard is governed by the "Texas Engineering Practice Act". No warranty of any kind is made by TxDOT for any purpose whatsoever. TxDOT assumes no responsibility for the conversion of this standard to other formats or for incorrect results or damages resulting from its use.

DATE: 3/19/2012 4:04:49 PM
 FILE: p:\2009\2009-1027-02_heboap_iii_additional_colonias.design\04_north_capisallo\cs\Standards\Traffic Control\WZUL.dgn

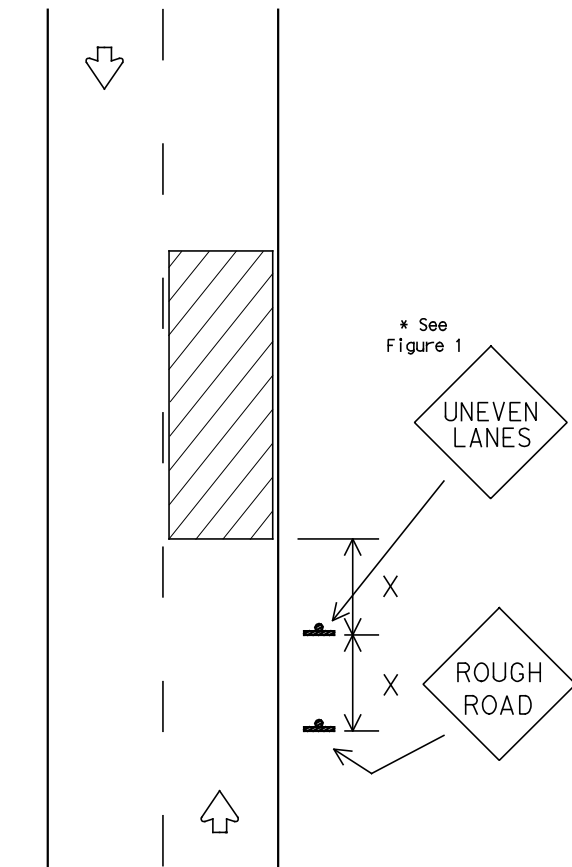

Signing shown for one direction.

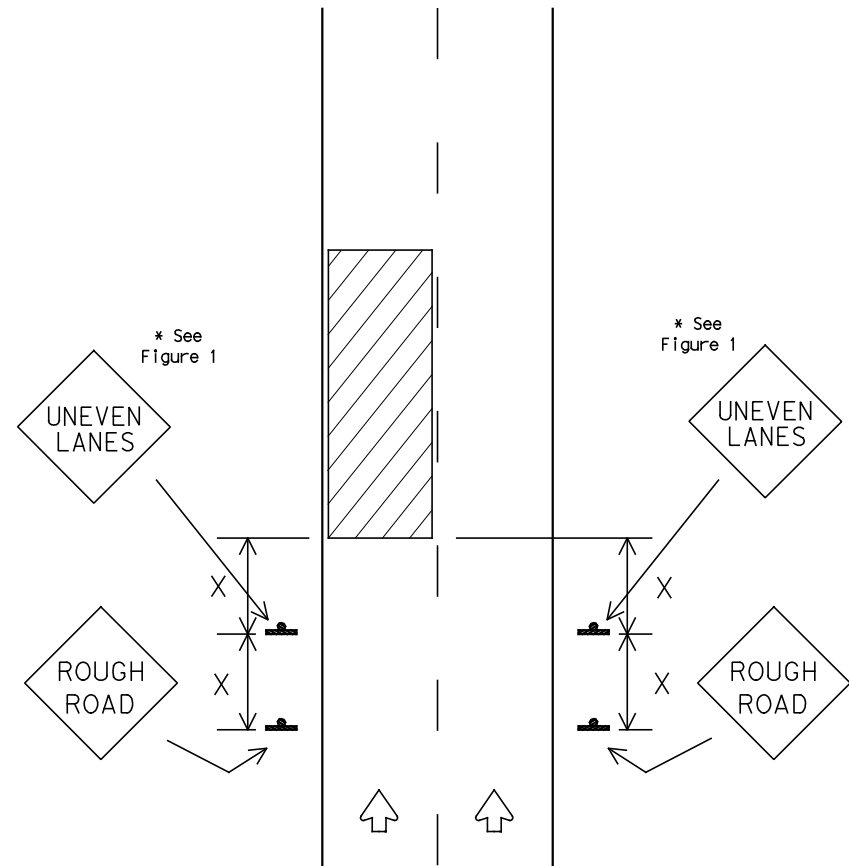
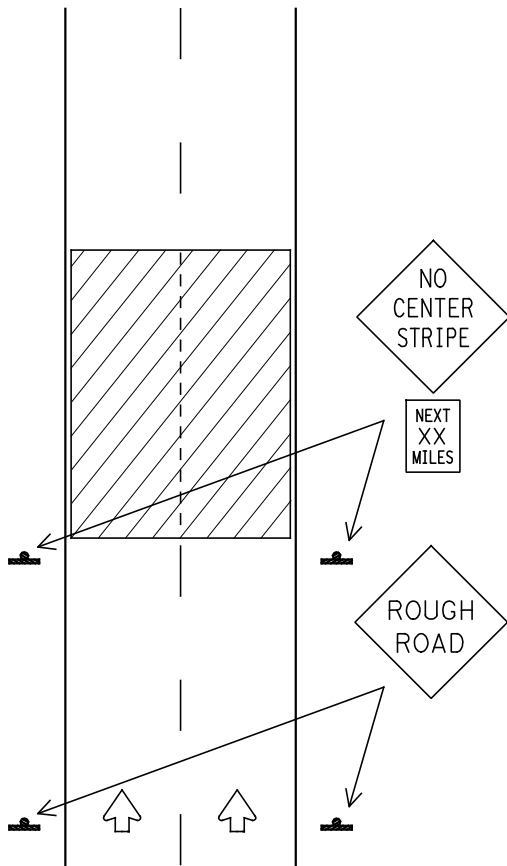
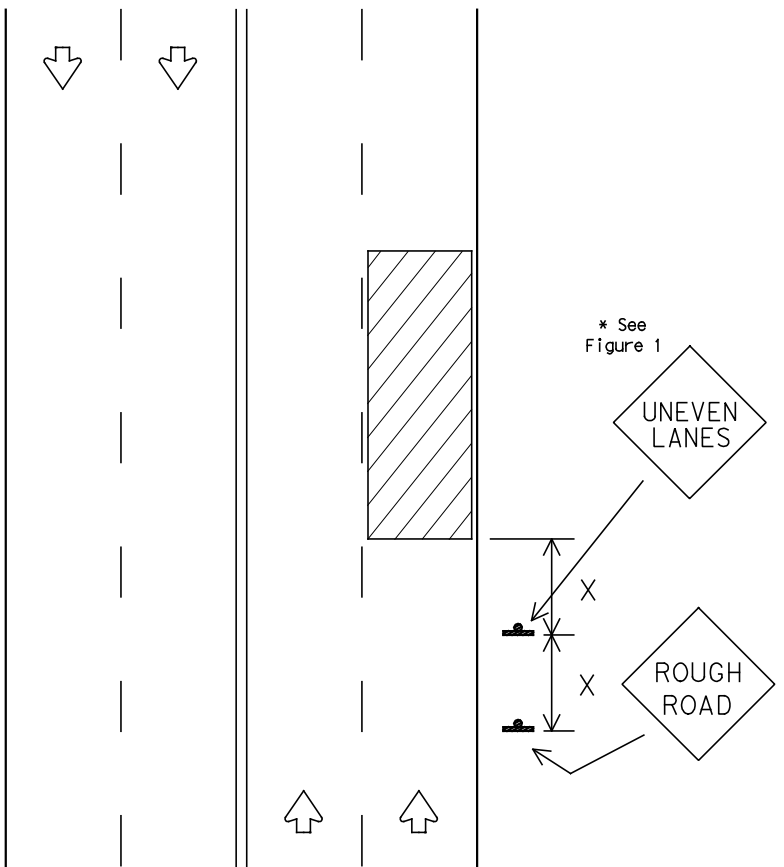

DEPARTMENTAL MATERIAL SPECIFICATIONS		
PLYWOOD SIGN BLANKS		DMS-7100
ALUMINUM SIGN BLANKS		DMS-7110
SIGN HARDWARE		DMS-7120
PREFABRICATED PAVEMENT MARKINGS-PERMANENT		DMS-8240
PREFABRICATED PAVEMENT MARKINGS-REMOVABLE		DMS-8241
FLAT SURFACE REFLECTIVE SHEETING		DMS-8300
VINYL NON-REFLECTIVE DECAL SHEETING		DMS-8320

COLOR	USAGE	SHEETING MATERIAL
ORANGE	BACKGROUND	TYPE E (FLUORESCENT PRISMATIC)
BLACK	LEGEND & BORDERS	VINYL NON-REFLECTIVE DECAL SHEETING

- GENERAL NOTES:
1. If spalling or holes occur, ROUGH ROAD signs should be placed in advance of the condition and may be repeated throughout the project.
 2. UNEVEN LANES sign (CW8-11) should be installed in advance of the condition and repeated every mile. Signs installed along the uneven lane condition may be supplemented with the NEXT XX MILES sign (CW21-16) or Advisory Speed sign (CW13-1).
 3. NO CENTER STRIPE signs (CW8-12) should be installed if centerlines or lane lines are obscured or obliterated. The signs should remain in place until permanent pavement markings are installed.
 4. Signs shall be spaced at the distances recommended as per BC standards.
 5. When operations are completed and final surface treatment will not be applied as part of this project, advance signs shall be left in place and become the property of the State. These signs shall be installed on approved permanent sign supports as per TxDOT standards. Additional signs may be required as directed by the Engineer. Minimum mounting height of signs is 7 feet. Signs shall remain in place until final surface is applied. Signs shall be considered subsidiary to the item "BARRICADES, SIGNS AND TRAFFIC HANDLING."
 6. Pavement markings shall be replaced as operations proceed.
 7. Short term markings shall not be used to simulate edge lines.
 8. All signs shall be constructed in accordance with the details found in the "Standard Highway Sign Designs for Texas," latest edition. Sign details not shown in this manual shall be shown in the plans or the Engineer shall provide a detail to the Contractor before the sign is manufactured.

TRAFFIC CONTROL DURING PLANING, OVERLAY AND LEVELING OPERATIONS ARE SHOWN ELSEWHERE IN THE PLANS.

FIGURE 1		
Edge Condition	Edge Height (D)	Warning Devices
	less than or equal to 1"	Signs: ECW8-8
	greater than 1" to: 1/4" (maximum-planing) 1/2" (typical-overlay)	Signs: CW8-11, ECW8-8
Distance "D" may be a maximum of 1/4" for planing operations and 2" for overlay operations if uneven lanes are open to traffic after work operations cease.		

"X" distance - See Note 4 on this page.

Texas Department of Transportation
 Traffic Operations Division

SIGNING FOR UNEVEN LANES
WZ (UL) -03

© TxDOT April 1992		DN: TxDOT	CK: TxDOT	DW: TxDOT	CK: TxDOT
REVISIONS		CONT	SECT	JOB	HIGHWAY
8-95		2C	1080	495	GARZA
1-97		DIST	COUNTY		SHEET NO.
2-98		PHR	HIDALGO		33
3-03					

DISCLAIMER: The use of this standard is governed by the "Texas Engineering Practice Act". No warranty of any kind is made by TxDOT for any purpose whatsoever. TxDOT assumes no responsibility for the conversion of this standard to other formats or for incorrect results or damages resulting from its use.

DISCLAIMER:

DATE: 3/19/2012 4:04:53 PM
 FILE: p:\2009\2009-1027-02_heboap_iii_additional_colonias_design\04_north_capital\o.ccs\Standards\Traffic Control\WZDERD.dgn

TYPICAL DEAD END BARRICADE INSTALLATION

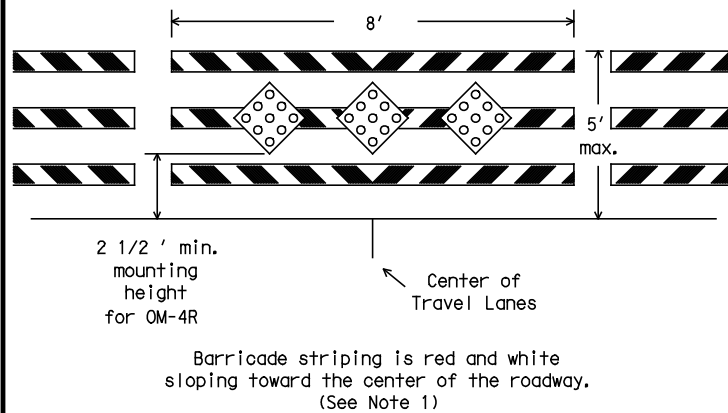

Type III Dead End Barricade with OM-4R Object Markers.

4" solid double yellow (minimum 500')

Mounted above Stop Sign (optional)

NO OUTLET → ← NO OUTLET
 W14-2P* W14-2PL*



R1-1

50' usual
 Pavement Markings removed in this area.



SW14-1T

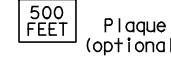

500 FEET
 Plaque (optional)



SW14-1T



1000 FEET
 Plaque (optional)

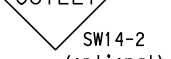

NO OUTLET OR ROAD ENDS
 SW14-2 (optional) SW14-1T

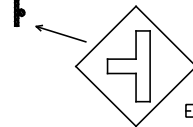

EW2-2L

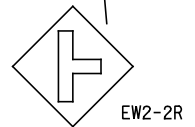

EW2-2R

* W14-1P DEAD END plaque may be used as an alternate.

Type III Dead End Barricade with OM-4R Object Markers.

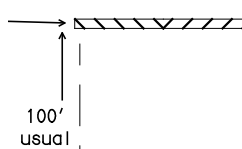

ReflectORIZED Plastic drums required if Traffic Control devices located in this area.

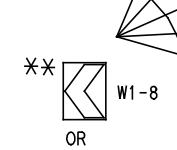

W1-8 OR W1-6

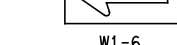

See Note 12

** If access is required, portable supports may be used.

4" Solid White Edge line

Devices shown for one direction of travel

DEPARTMENTAL MATERIAL SPECIFICATIONS		
PLYWOOD SIGN BLANKS		DMS-7100
ALUMINUM SIGN BLANKS		DMS-7110
SIGN HARDWARE		DMS-7120
WINGED CHANNEL POSTS		DMS-7130
FLAT SURFACE REFLECTIVE SHEETING		DMS-8300
VINYL NON-REFLECTIVE DECAL SHEETING		DMS-8320
DELINEATORS AND OBJECT MARKERS		DMS-8600

COLOR	USAGE	SHEETING MATERIAL
RED	BACKGROUND	TYPE C (HIGH SPECIFIC INTENSITY)
WHITE	BACKGROUND	TYPE C (HIGH SPECIFIC INTENSITY)
YELLOW	BACKGROUND	TYPE C (HIGH SPECIFIC INTENSITY)
BLACK	LEGEND & BORDERS	VINYL NON-REFLECTIVE SHEETING

GENERAL NOTES:

- Barricade striping shall be red and white reflective sheeting for all permanent road closures. Orange and white reflective sheeting may be substituted for locations where duration of road closure is expected to be 18 months or less, or when approved by the Engineer. Red and orange reflective sheeting shall not be combined on barricades or locations.
- Barricades shall be designed and constructed to Compliant Work Zone Traffic Control Device List (CWZTCD) standards in a first-class workmanship manner of clean sound material. Components made of lumber shall be painted with a minimum of two coats of white paint to ensure thorough coverage and a uniform white color. Barricade striping material shall meet the color and retroreflective requirements of Departmental Material Specification DMS-8300, Type C.
- Post type breakaway supports shall be used as barricade supports. Barricades may be fabricated with "skid" supports if approved by the Engineer. Skid supports should be anchored using sand bags to prevent movement. For construction details of post (fixed Type III barricades) see CWZTCD list Part D.2.f. The dead end road barricades may also be anchored to the pavement using the bolt down median anchor manufactured by Universal Anchor System shown on SMD (FRP). The barricades shall be built using FRP posts and approved rails as shown on the CWZTCD List.
- Barricades shall not be placed parallel to traffic unless a minimum adequate clear zone of 30 feet from edge of travel lane is provided.
- A minimum of one 8-foot wide barricade and three OM-4R object markers shall be required for all locations. Barricades shall extend across all travel lanes and shoulders if shoulders are present. Barricades may be extended to the ROW as directed by Engineer.
- Stockpiled materials shall not be placed on traffic side of barricades.
- OM-4 object markers shall be mounted to the middle rail using two 1/2" through bolts with flat washers and lock washers.
- OM-4 object markers shall be constructed of 0.063 aluminum and shall meet the color and reflective requirements of DMS-8300 Type C and DMS-8600.
- Plastic drums shall meet the requirements as listed on the CWZTCD list or the BC Standards. Plastic drums may be anchored with adhesive to prevent movement.
- All signs and chevrons shall be installed with hardware and support at the minimum mounting height in accordance with the SMD and BC Standards. Signs shall be mounted at a 7 foot minimum height. Signs shall not be attached to barricades.
- Motorists should be able to see at least three chevron signs as they approach the curve and as they drive through the curve from either direction.
- Delineation devices such as the chevron or large arrow signs shall only be placed on the outside portion of a curve.

GENERAL NOTE FOR SIGNS:

- The alphabets and lateral spacing between letters and numerals shall conform with the "Texas Manual on Uniform Traffic Control Devices for Streets and Highways" (TMUTCD), latest edition, and any approved changes thereto.
- Lateral spacing of text shall provide a balanced appearance.
- All materials shall conform to Departmental Material Specifications.
- Legend shall be black and applied by screening process, cut-out vinyl non-reflective sheeting or combination thereof.
- Sign blanks shall be any material that meets the DMS requirements for permanent sign substrates.

Only pre-qualified products shall be used. A copy of the "Compliant Work Zone Traffic Control Devices List" (CWZTCD) describes pre-qualified products and their sources and may be obtained by contacting:

Standards Engineer
 Traffic Operations Division - TE
 Texas Department of Transportation
 125 East 11th Street
 Austin, Texas 78701-2483
 Phone (512) 416-3120
 Fax (512) 416-3299

Instructions to locate the "CWZTCD" on TxDOT website are:

Start at website - www.dot.state.tx.us
 Click on "About TxDOT",
 Click on "Organizational Chart",
 Click on Traffic Operations Box,
 Click on "Compliant Work Zone Traffic Control Devices",
 Click on "View PDF".
 This site is printable.

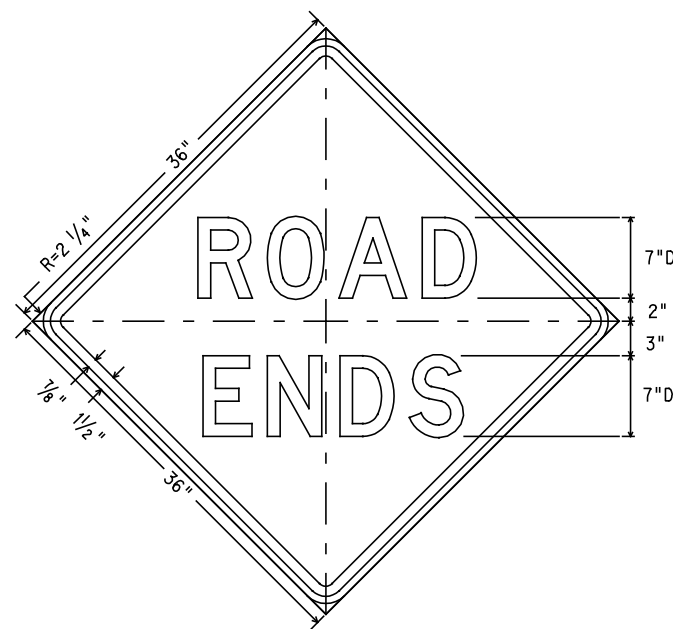

SW14-1T
 36" X 36"

Letters - Black
 Border - Black
 Background - Yellow Refl.



WORK ZONE
 DEAD END
 ROADWAY DETAILS

WZ (DERD) -03

© TxDOT August 1995	DN: TxDOT	CK: TxDOT	DW: TxDOT	CK: TxDOT
1-97	REVISIONS	CONT	SECT	JOB
2-98		2C	1080	495
4-98		DIST	COUNTY	HIGHWAY
3-03		PHR	HIDALGO	34

DATE: 3/19/2012 4:05:00 PM
 FILE: p:\2009\2009-1027-02_heboap_iii_additional_colonias.design\04_north_capisallo.cs\Standards\Traffic Control\TCPI-2.dgn

DISCLAIMER:

The use of this standard is governed by the "Texas Engineering Practice Act". No warranty of any kind is made by TxDOT for any purpose whatsoever. TxDOT assumes no responsibility for the conversion of this standard to other formats or for incorrect results or damages resulting from its use.

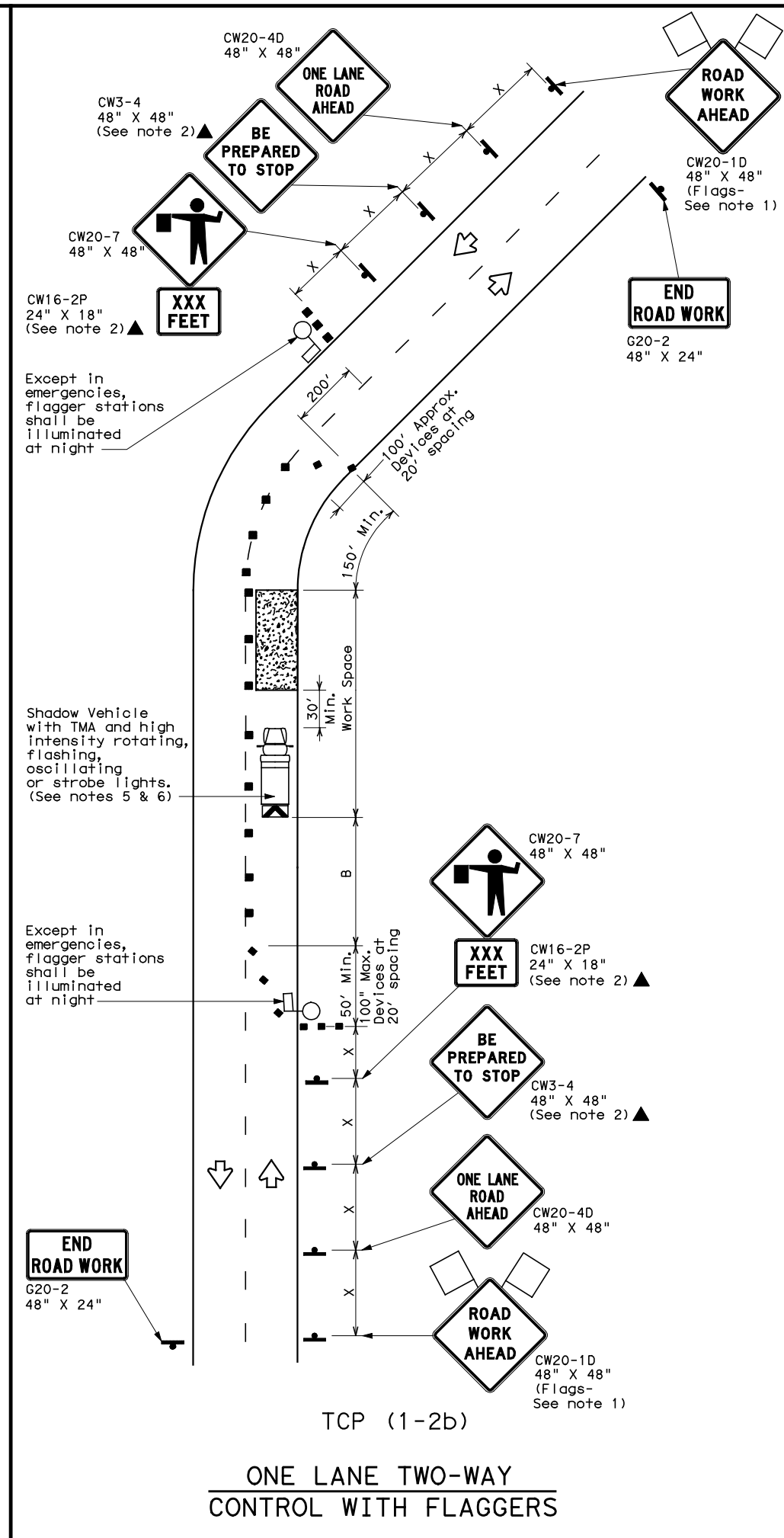
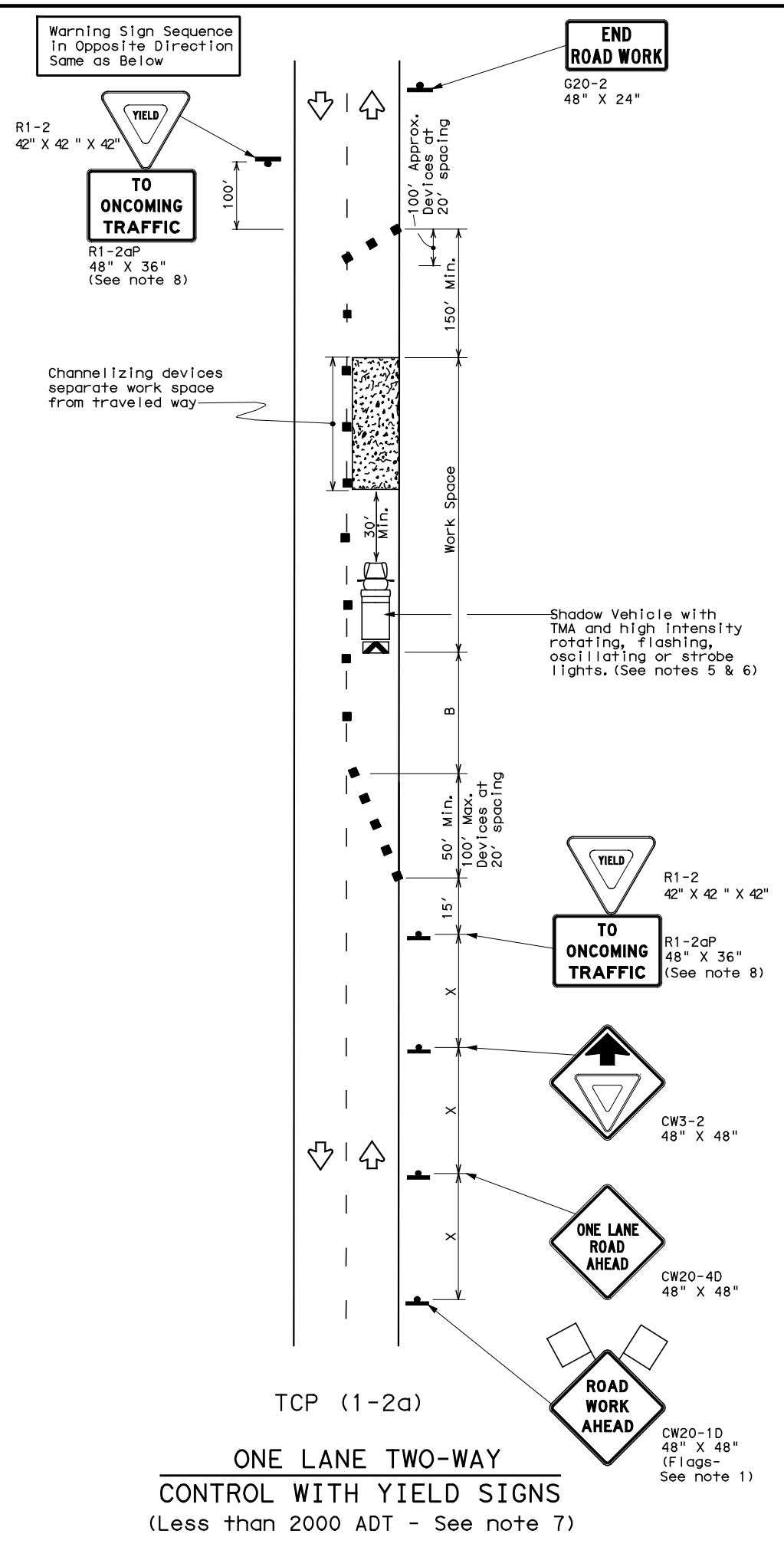

LEGEND

	Type 3 Barricade		Channelizing Devices
	Heavy Work Vehicle		Truck Mounted Attenuator (TMA)
	Trailer Mounted Flashing Arrow Board		Portable Changeable Message Sign (PCMS)
	Sign		Traffic Flow
	Flag		Flagger

Posted Speed *	Formula	Minimum Desirable Taper Lengths **			Suggested Maximum Spacing of Channelizing Devices		Minimum Sign Spacing "X" Distance	Suggested Longitudinal Buffer Space "B"	Stopping Sight Distance
		10' Offset	11' Offset	12' Offset	On a Taper	On a Tangent			
30	L = WS ² / 60	150'	165'	180'	30'	60'	120'	90'	200'
35		205'	225'	245'	35'	70'	160'	120'	250'
40		265'	295'	320'	40'	80'	240'	155'	305'
45		450'	495'	540'	45'	90'	320'	195'	360'
50	L = WS	500'	550'	600'	50'	100'	400'	240'	425'
55		550'	605'	660'	55'	110'	500'	295'	495'
60		600'	660'	720'	60'	120'	600'	350'	570'
65		650'	715'	780'	65'	130'	700'	410'	645'
70		700'	770'	840'	70'	140'	800'	475'	730'
75		750'	825'	900'	75'	150'	900'	540'	820'

* Conventional Roads Only
 ** Taper lengths have been rounded off.
 L=Length of Taper (FT) W=Width of Offset (FT) S=Posted Speed (MPH)

TYPICAL USAGE

	MOBILE	SHORT DURATION	SHORT TERM STATIONARY	INTERMEDIATE TERM STATIONARY	LONG TERM STATIONARY
		✓	✓		

GENERAL NOTES

- Flags attached to signs where shown are REQUIRED.
 - All traffic control devices illustrated are REQUIRED, except those denoted with the triangle symbol may be omitted when stated elsewhere in the plans, or for routine maintenance work, when approved by the Engineer.
 - The CW3-4 "BE PREPARED TO STOP" sign may be installed after the CW20-4D "ONE LANE ROAD AHEAD" sign, but proper sign spacing shall be maintained.
 - Sign spacing may be increased or an additional CW20-1D "ROAD WORK AHEAD" sign may be used if advance warning ahead of the flagger or R1-2 "YIELD" sign is less than 1500 feet.
 - A Shadow Vehicle with a TMA should be used anytime it can be positioned 30 to 100 feet in advance of the area of crew exposure without adversely affecting the performance or quality of the work. If workers are no longer present but road or work conditions require the traffic control to remain in place, Type 3 Barricades or other channelizing devices may be substituted for the Shadow Vehicle and TMA.
 - Additional Shadow Vehicles with TMAs may be positioned off the paved surface, next to those shown in order to protect wider work spaces.
- TCP (1-2a)**
- R1-2 "YIELD" sign traffic control may be used on projects with approaches that have adequate sight distance. For projects in urban areas, work spaces should be no longer than one half city block. In rural areas on roadways with less than 2000 ADT, work spaces should be no longer than 400 feet.
 - R1-2 "YIELD" sign with R1-2aP "TO ONCOMING TRAFFIC" plaque shall be placed on a support at a 7 foot minimum mounting height.
- TCP (1-2b)**
- Flaggers should use two-way radios or other methods of communication to control traffic.
 - Length of work space should be based on the ability of flaggers to communicate.
 - If the work space is located near a horizontal or vertical curve, the buffer distances should be increased in order to maintain adequate stopping sight distance to the flagger and a queue of stopped vehicles (see table above).
 - Channelizing devices on the center-line may be omitted when a pilot car is leading traffic and approved by the Engineer.
 - Flaggers should use 24" STOP/SLOW paddles to control traffic. Flags should be limited to emergency situations.

For construction or maintenance contract work, specific project requirements for shadow vehicles can be found in the project GENERAL NOTES for Item 502, Barricades, Signs and Traffic Handling.



TRAFFIC CONTROL PLAN
ONE-LANE TWO-WAY
TRAFFIC CONTROL

TCP (1-2) - 12

© TxDOT December 1985		DN: TxDOT	CK: TxDOT	DW: TxDOT	CK: TxDOT
REVISIONS		CONT	SECT	JOB	HIGHWAY
4-90	2-12	2C	080	495	GARZA
2-94		DIST	COUNTY		SHEET NO.
1-97		PHR	HIDALGO		35
4-98					

DATE: 3/19/2012 4:05:08 PM
 FILE: p:\2009\2009-1027-02_heboap_iii_additional_colonias\design\04_north_capital\05\Standards\Traffic Control\TCP2-2.dgn

DISCLAIMER: The use of this standard is governed by the "Texas Engineering Practice Act". No warranty of any kind is made by TxDOT for any purpose whatsoever. TxDOT assumes no responsibility for the conversion of this standard to other formats or for incorrect results or damages resulting from its use.

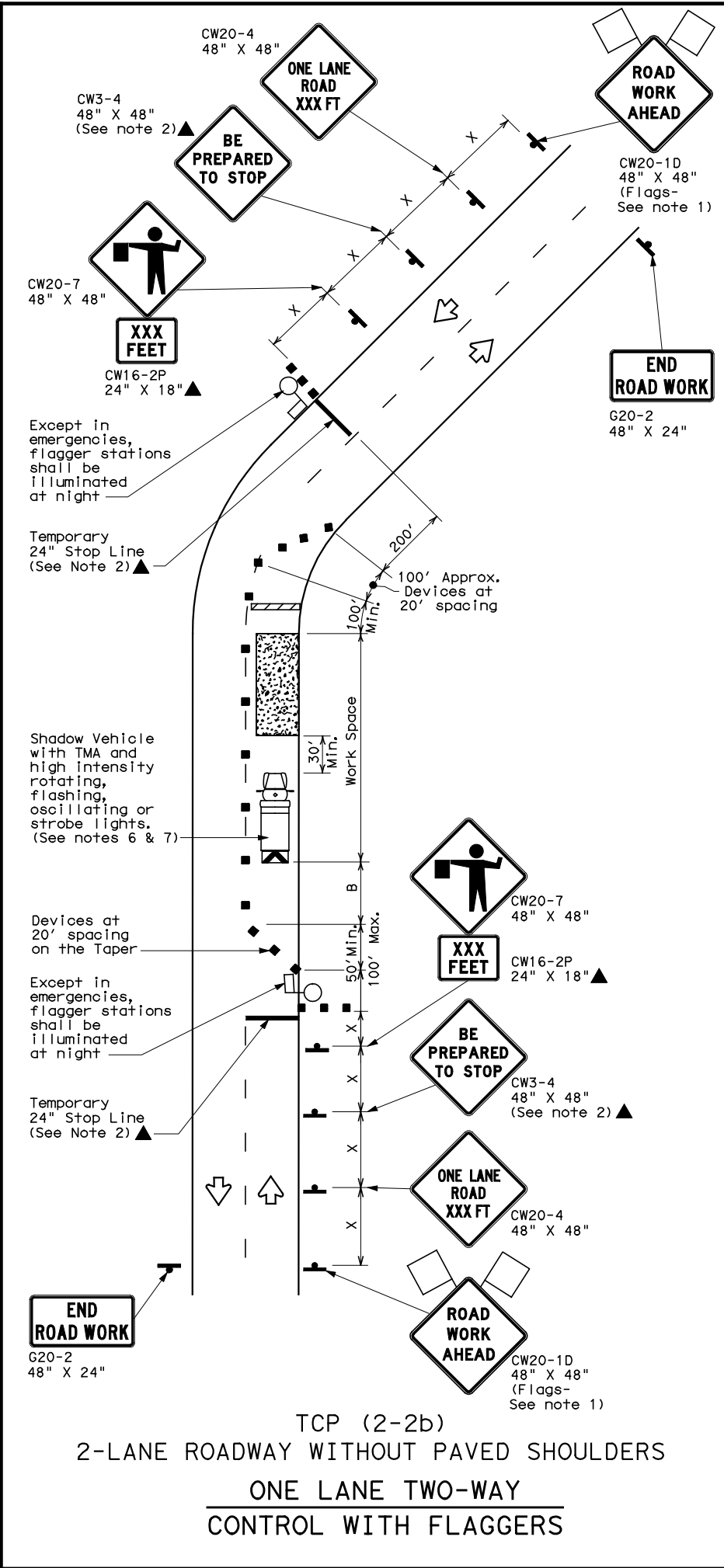
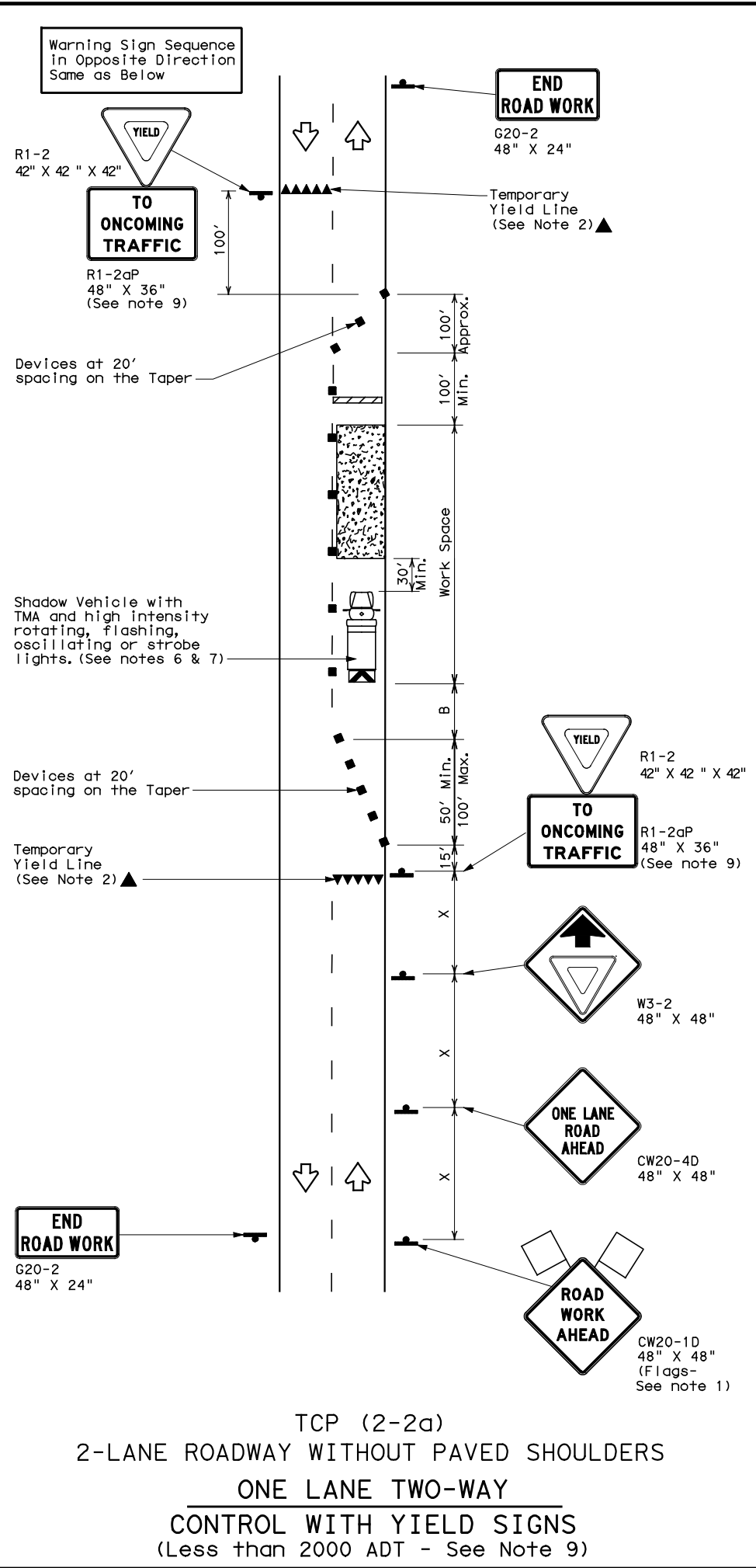

LEGEND

	Type 3 Barricade		Channelizing Devices
	Heavy Work Vehicle		Truck Mounted Attenuator (TMA)
	Trailer Mounted Flashing Arrow Board		Portable Changeable Message Sign (PCMS)
	Sign		Traffic Flow
	Flag		Flagger

Posted Speed *	Formula	Minimum Desirable Taper Lengths **			Suggested Maximum Spacing of Channelizing Devices		Minimum Sign Spacing "X" Distance	Suggested Longitudinal Buffer Space "B"	Stopping Sight Distance
		10' Offset	11' Offset	12' Offset	On a Taper	On a Tangent			
30	L = WS ² / 60	150'	165'	180'	30'	60'	120'	90'	200'
35		205'	225'	245'	35'	70'	160'	120'	250'
40		265'	295'	320'	40'	80'	240'	155'	305'
45	L = WS	450'	495'	540'	45'	90'	320'	195'	360'
50		500'	550'	600'	50'	100'	400'	240'	425'
55		550'	605'	660'	55'	110'	500'	295'	495'
60		600'	660'	720'	60'	120'	600'	350'	575'
65		650'	715'	780'	65'	130'	700'	410'	645'
70	700'	770'	840'	70'	140'	800'	475'	730'	
75	750'	825'	900'	75'	150'	900'	540'	820'	

* Conventional Roads Only
 ** Taper lengths have been rounded off.
 L=Length of Taper (FT) W=Width of Offset (FT) S=Posted Speed (MPH)

TYPICAL USAGE

	MOBILE	SHORT DURATION	SHORT TERM STATIONARY	INTERMEDIATE TERM STATIONARY	LONG TERM STATIONARY
		✓	✓	✓	

- GENERAL NOTES**
- Flags attached to signs where shown, are REQUIRED.
 - All traffic control devices illustrated are REQUIRED, except those denoted with the triangle symbol may be omitted when stated elsewhere in the plans, or for routine maintenance work, when approved by the Engineer.
 - The CW3-4 "BE PREPARED TO STOP" sign may be installed after the CW20-4 "ONE LANE ROAD XXX FT" sign, but proper sign spacing shall be maintained.
 - Flaggers should use two-way radios or other methods of communication to control traffic.
 - Length of work space should be based on the ability of flaggers to communicate.
 - A Shadow Vehicle with a TMA should be used anytime it can be positioned 30 to 100 feet in advance of the area of crew exposure without adversely affecting the performance or quality of the work. If workers are no longer present but road or work conditions require the traffic control to remain in place, Type 3 Barricades or other channelizing devices may be substituted for the Shadow Vehicle and TMA. If workers are no longer present but road or work conditions require the traffic control to remain in place, Type 3 Barricades or other channelizing devices may be substituted for the Shadow Vehicle and TMA.
 - Additional Shadow Vehicles with TMAs may be positioned off the paved surface, next to those shown in order to protect a wider work space.
- TCP (2-2a)**
- The R1-2 "YIELD" sign traffic control may be used on projects with approaches that have adequate sight distance. For projects in urban areas, work space should be no longer than one half city block. In rural areas, roadways with less than 2000 ADT, work space should be no longer than 400 feet.
 - The R1-2aP "YIELD TO ONCOMING TRAFFIC" sign shall be placed on a support at a 7 foot minimum mounting height.
- TCP (2-2b)**
- Channelizing devices on the center line may be omitted when a pilot car is leading traffic and approved by the Engineer.
 - If the work space is located near a horizontal or vertical curve, the buffer distances should be increased in order to maintain stopping sight distance to the flagger and a queue of stopped vehicles. (See table above).
 - Flaggers should use 24" STOP/SLOW paddles to control traffic. Flags should be limited to emergency situations.

For construction or maintenance contract work, specific project requirements for shadow vehicles can be found in the project GENERAL NOTES for Item 502, Barricades, Signs and Traffic Handling.

Texas Department of Transportation
 Traffic Operations Division

**TRAFFIC CONTROL PLAN
 ONE-LANE TWO-WAY
 TRAFFIC CONTROL**

TCP (2-2) - 12

© TxDOT December 1985		DN: TxDOT	CK: TxDOT	DW: TxDOT	CK: TxDOT
REVISIONS		CONT	SECT	JOB	HIGHWAY
8-95	2-12	2C	080	495	GARZA
1-97		DIST	COUNTY		SHEET NO.
4-98		PHR	HIDALGO		36
3-03					

162

DISCLAIMER: The use of this standard is governed by the "Texas Engineering Practice Act". No warranty of any kind is made by TxDOT for any purpose whatsoever. TxDOT assumes no responsibility for the conversion of this standard to other formats or for incorrect results or damages resulting from its use.

DISCLAIMER:

DATE: 3/19/2012 4:05:16 PM
 FILE: p:\2009\2009-1027-02 heboap iii additional_colonias_design\04_north_capital\o\cs\Standards\Traffic Control\TCP3-3.dgn

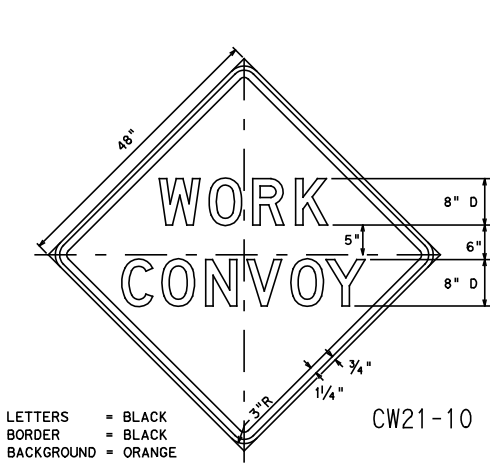
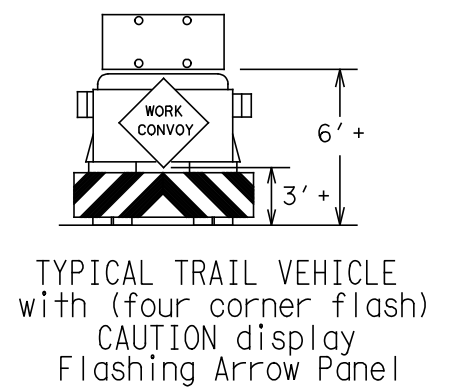
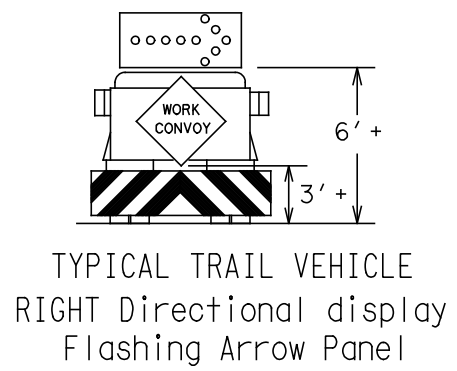
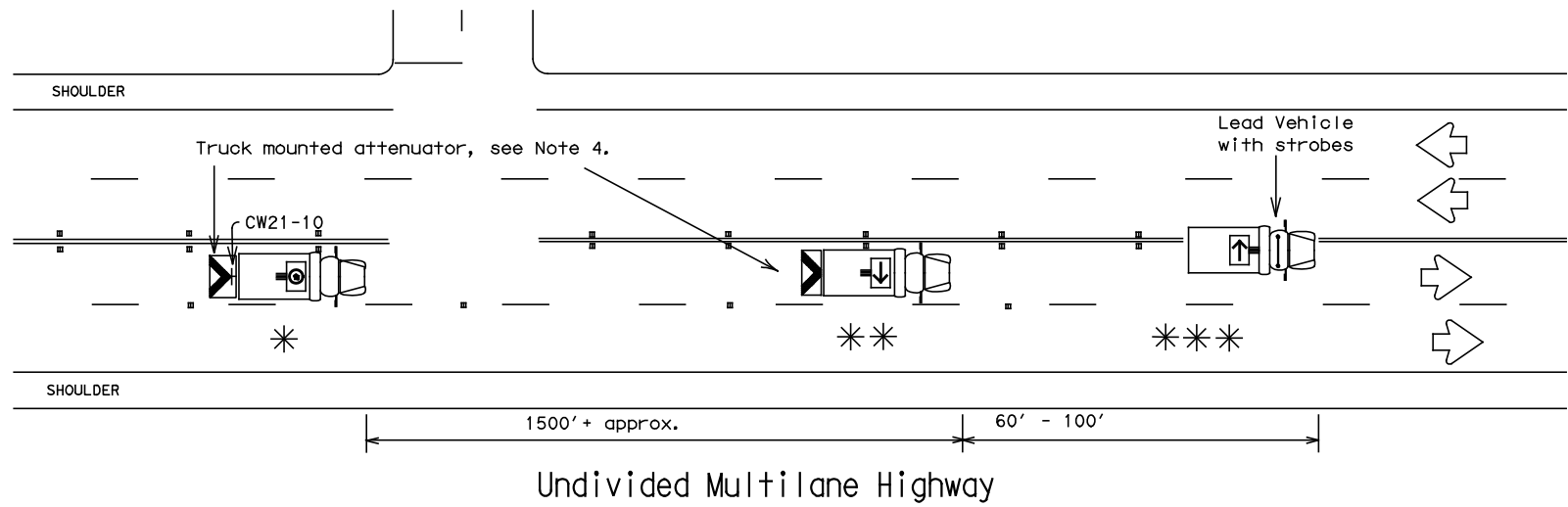
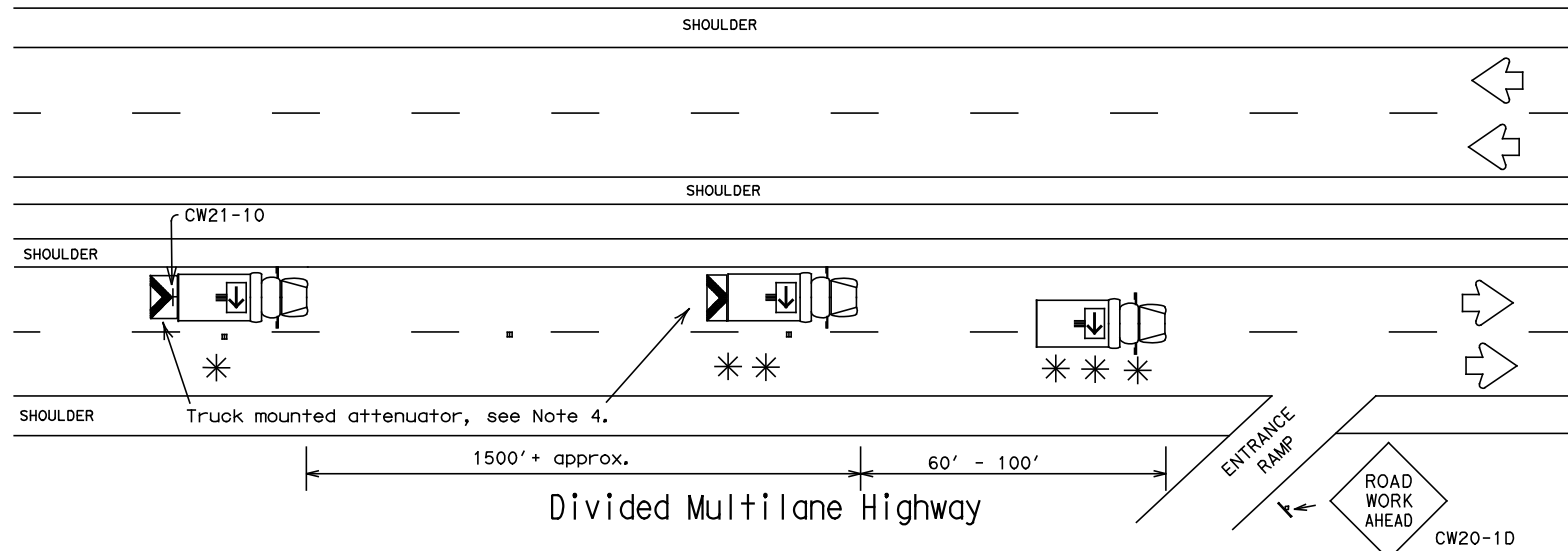
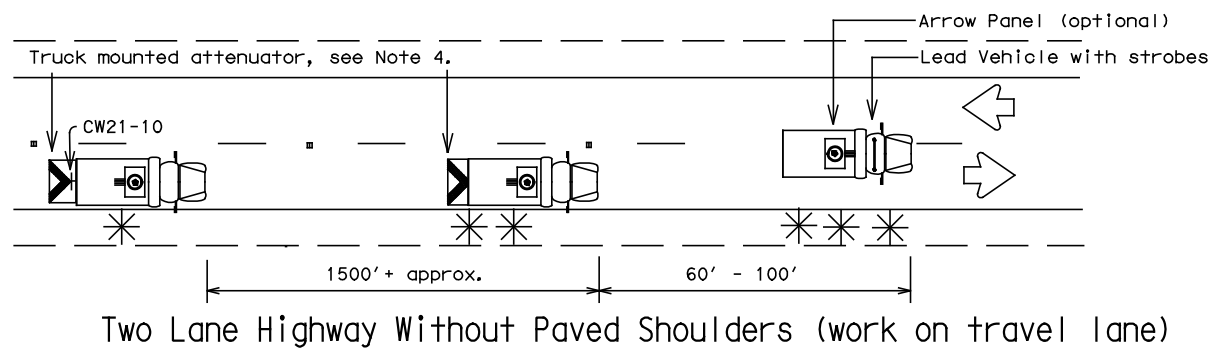
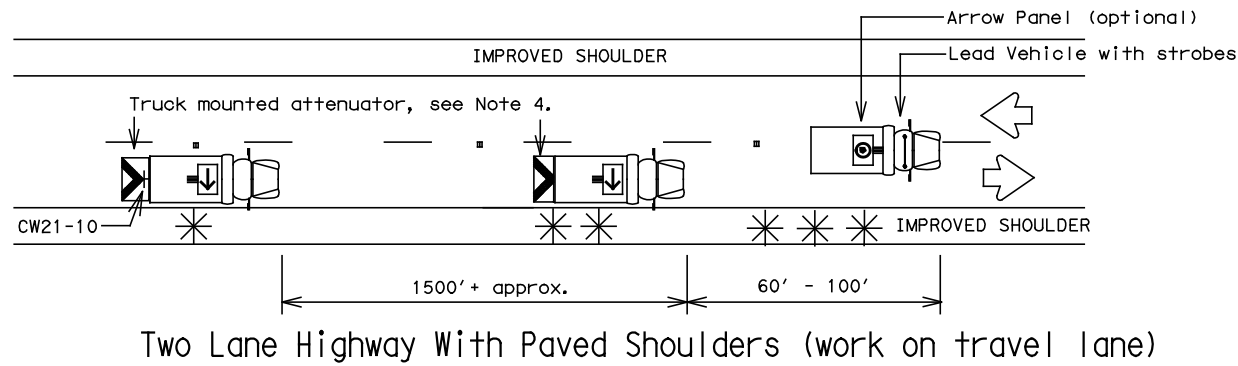

LETTERS = BLACK
 BORDER = BLACK
 BACKGROUND = ORANGE

- Legend:
- * TRAIL VEHICLE
 - ** SHADOW VEHICLE
 - *** WORK VEHICLE
 - Truck mounted attenuator
 - HEAVY WORK VEHICLE
- Arrow Panel Displays
- RIGHT Directional
 - LEFT Directional
 - RIGHT or LEFT Directional
 - CAUTION mode

GENERAL NOTES:

1. TRAIL, SHADOW, LEAD, and work vehicles shall be equipped with arrow panels as illustrated. The Engineer will determine if the LEAD VEHICLE and/or TRAIL VEHICLE are required based on prevailing roadway conditions, traffic volume, and sight distance restrictions.
2. All traffic control devices shall be in accordance with the "Texas Manual on Uniform Traffic Control Devices" (TMUTCD), latest edition.
3. The use of yellow rotating beacons or strobe lights on vehicles are required unless otherwise stated elsewhere in the plans.
4. The use of truck mounted attenuators (TMA) on the SHADOW VEHICLE and the TRAIL VEHICLE are required.
5. Optional striping on the back panel of all truck mounted attenuators shall be 8" red and white reflective sheeting placed in an inverted "V" design. Reflective sheeting shall meet or exceed the reflectivity and color requirements of DEPARTMENTAL MATERIAL SPECIFICATION D-9-8300, TYPE C.
6. Flashing Arrow Panels shall be Type B or Type C as per BC Standards. The panel operation shall be controlled from inside the vehicle.
7. Each vehicle shall have two-way radio communication capability.
8. When work convoys must change lanes, the TRAIL VEHICLE should change lanes first to shadow the other convoy vehicles.
9. Vehicle spacing between TRAIL VEHICLE and SHADOW VEHICLE will vary depending on sight distance restrictions. Motorists approaching the work convoy should be able to see the TRAIL VEHICLE in time to slow down and/or change lanes as they approach the TRAIL VEHICLE.

Only pre-qualified products shall be used. A list of compliant products and their sources may be obtained by writing or faxing:

Standards Engineer
 Traffic Operations Division - TE
 Texas Department of Transportation
 125 East 11th Street
 Austin, Texas 78701-2483
 Phone (512) 416-3335
 Fax (512) 416-3161
 E-mail TRF-STANDARD@mailgw.dot.state.tx.us

Shadow and trail vehicle shall be equipped with Truck Mounted Attenuator.

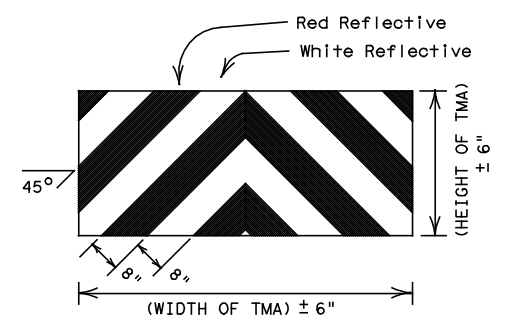

STRIPING FOR TMA WILL BE REQUIRED ON ALL PROJECTS AWARDED AFTER JANUARY 1, 2000

Texas Department of Transportation
 Traffic Operations Division

**TRAFFIC CONTROL PLAN
 MOBILE OPERATIONS
 RAISED PAVEMENT
 MARKER INSTALLATION**

TCP (3-3) -98

© TxDOT September 1987		DN: TxDOT	CK: TxDOT	DW: TxDOT	CK: TxDOT
REVISIONS					
2-94	CONT	SECT	JOB	HIGHWAY	
8-95	2C	1080	495	GARZA	
1-97	DIST	COUNTY		SHEET NO.	
4-98	PHR	HIDALGO		37	

DISCLAIMER: The use of this standard is governed by the "Texas Engineering Practice Act". No warranty of any kind is made by TxDOT for any purpose whatsoever. TxDOT assumes no responsibility for the conversion of this standard to other formats or for incorrect results or damages resulting from its use.

DATE: 3/19/2012 4:05:20 PM
 FILE: p:\2009\2009-1027-02_heboap_iii_additional_colonias\design\04_north_capital\o\cs\Standards\Traffic Control\TCP71.dgn

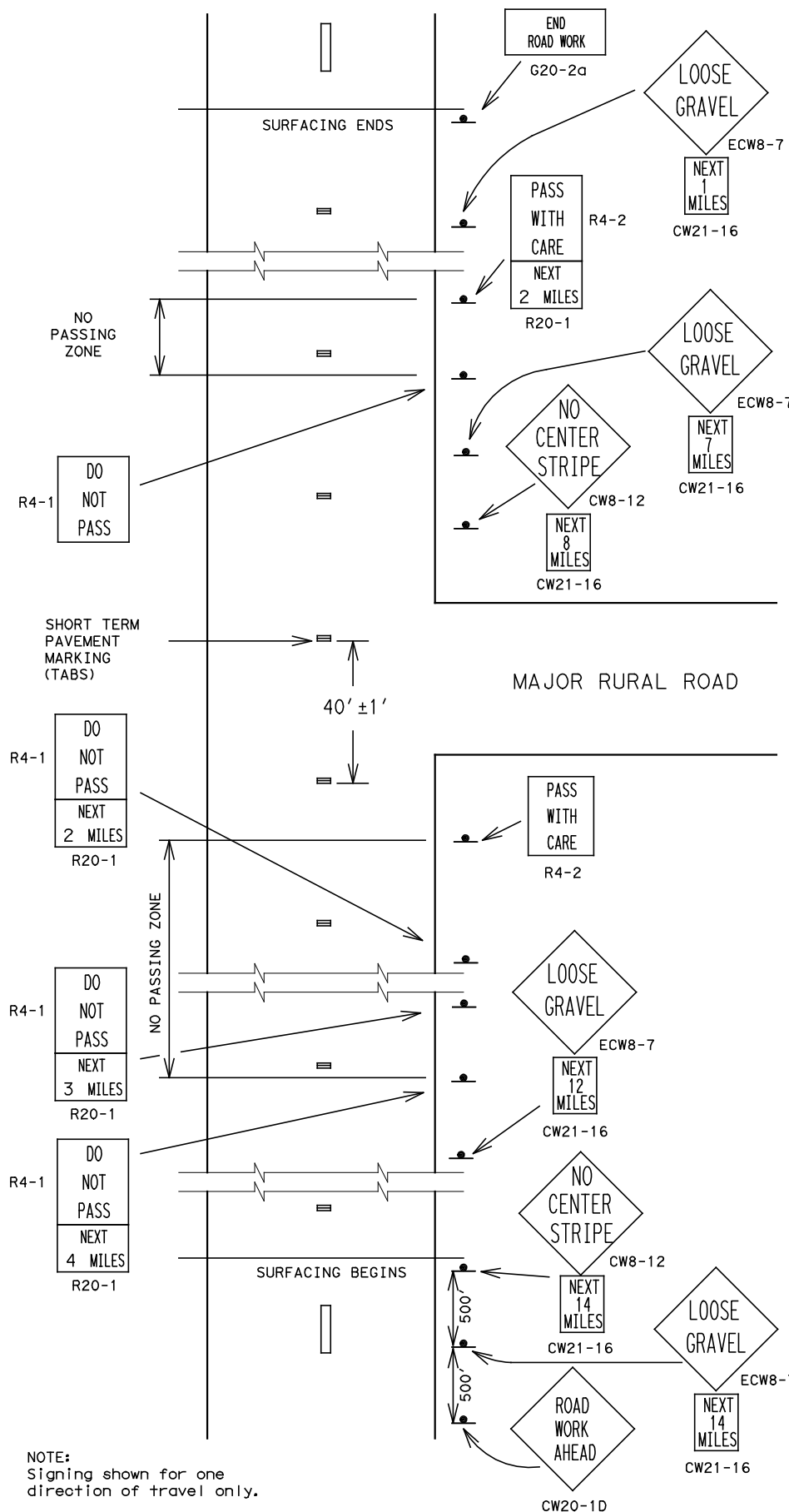

NOTE: Signing shown for one direction of travel only.

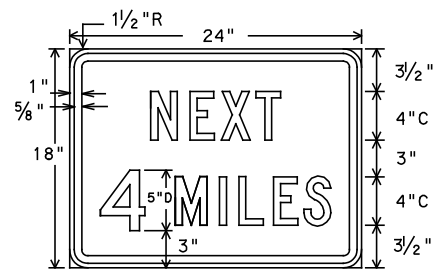

R20-1
24"x18"

Legend - Black
 Border - Black
 Background - White Refl.

FOR USE WITH REGULATORY SIGNS ONLY

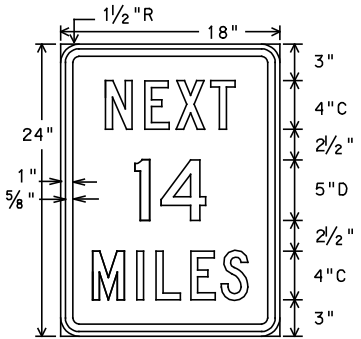

CW21-16
18"x24"

Legend - Black
 Border - Black
 Background - Orange Refl.

FOR USE WITH CONSTRUCTION WARNING SIGNS ONLY

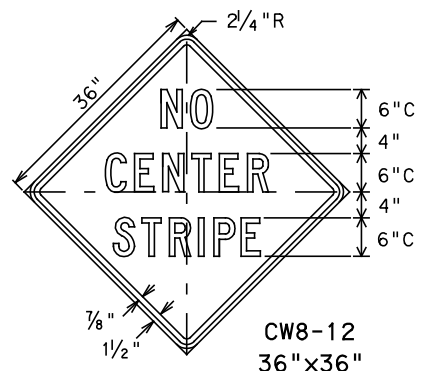

CW8-12
36"x36"

Legend - Black
 Border - Black
 Background - Orange Refl.

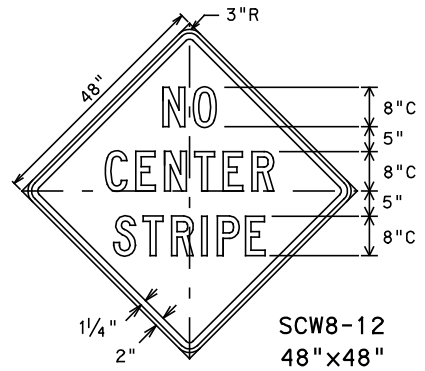

SCW8-12
48"x48"

Legend - Black
 Border - Black
 Background - Orange Refl.

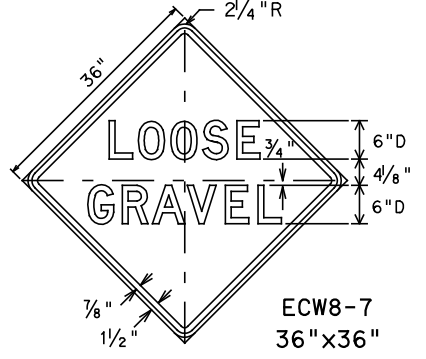

ECW8-7
36"x36"

Legend - Black
 Border - Black
 Background - Orange Refl.

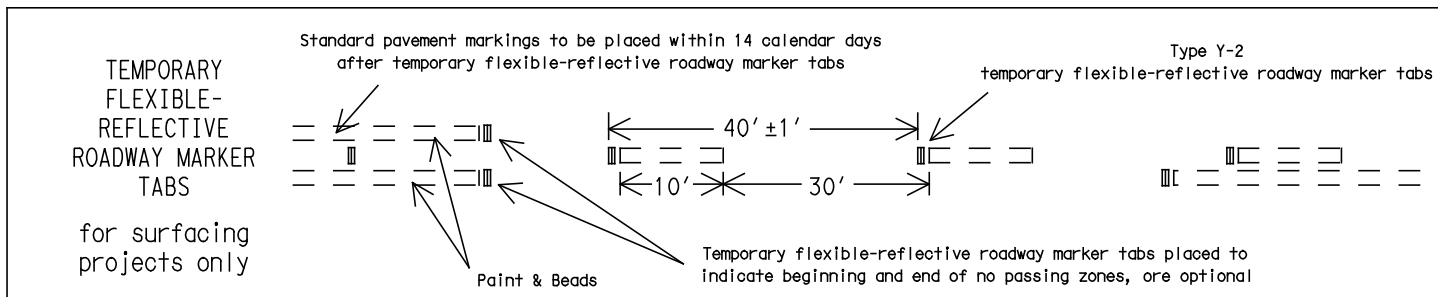

TEMPORARY FLEXIBLE-REFLECTIVE ROADWAY MARKER TABS
 for surfacing projects only

Temporary flexible-reflective roadway marker tabs placed to indicate beginning and end of no passing zones, or optional

GENERAL NOTES

The traffic control devices detailed on this sheet will be furnished and erected as directed by the Engineer on sections of roadway where the surfacing operation has covered or obliterated existing pavement markings. These traffic control devices are to be used to supplement those required by BC Standards.

"DO NOT PASS" SIGN (R4-1) and NO-PASSING ZONES

Prior to the beginning of construction, all currently striped no-passing zones should be signed with the DO NOT PASS sign (R4-1) and PASS WITH CARE sign (R4-2) placed at the beginning and end of each zone for each direction of travel except as otherwise provided herein. Signs marking these individual no-passing zones need not be covered prior to construction if the signs supplement the existing pavement markings.

At the discretion of the Engineer, in areas of numerous no-passing zones, several zones may be combined and signed as a single zone. If passing is to be prohibited over one or more lengthy sections, a DO NOT PASS sign and a NEXT XX MILES sign (R20-1) may be used at the beginning of such zones. The DO NOT PASS and NEXT XX MILES signs should be repeated every mile to the end of the no-passing zone. In areas where there is considerable distance between no-passing zones, the end of a no-passing zone may be signed with a PASS WITH CARE and NEXT XX MILES sign.

Depending on traffic volumes and length of sections, it may be desirable to prohibit passing throughout the project to prevent damage to windshields and lights. The DO NOT PASS and NEXT XX MILES sign should be used and repeated as often as necessary for this purpose. Where several existing zones are to be combined into one individual no-passing zone, the sign at the beginning of the zone should be covered until the surfacing operation has passed this location so as not to have the DO NOT PASS sign conflict with existing pavement markings. Also, unless one day's operation completes the entire length of such combined zones, care must be taken to place DO NOT PASS and PASS WITH CARE signs in order to sign the beginning and end of the no-passing zones in the area where the surfacing operation has stopped for the day.

R4-1 and R4-2 signs should be mounted on fixed supports as detailed on BC Standards. These signs are to remain in place until standard pavement markings are placed.

"NO CENTER STRIPE" SIGN (CW21-15)

At the time construction activity obliterates the existing centerline (low volume roads may not have an existing centerline), a NO CENTER STRIPE sign (CW8-12) should be erected at each end of the work area and just beyond major rural intersections and other location deemed necessary by the Engineer. Where possible, the signs erected at each end of the work area should be located in such a manner that drivers can read the sign and immediately see the change to no centerline. The NO CENTER STRIPE sign should be supplemented with the NEXT XX MILES sign (CW21-16) mounted below it.

The NO CENTER STRIPE sign should be erected as detailed on BC Standards. These signs are to remain in place until standard pavement markings are placed.

"LOOSE GRAVEL" SIGN (ECW8-7)

When construction begins, a LOOSE GRAVEL sign (ECW8-7) should be erected at each end of the work area and repeated at intervals of approximately two (2) miles in rural areas and closer in urban areas. The LOOSE GRAVEL sign should be supplemented with the NEXT XX MILES sign (CW21-16) mounted below it.

The LOOSE GRAVEL sign should be erected as detailed on BC Standards. They should remain in place until the loose gravel condition no longer exists.

PAVEMENT MARKINGS

Short term pavement markings for surfacing projects shall use Temporary Flexible-reflective Roadway Marker Tabs. Tabs are to be installed to provide true alignment for striping crews or as directed by the Engineer. Tabs will be placed at the spacing indicated. Tabs should be applied to the pavement no more than two (2) days before the surfacing is applied. After the surfacing is rolled and swept the cover over the reflective strip shall be removed. Tabs shall NOT be used to simulate edge lines.

Only pre-qualified products shall be used. A list of compliant products and their sources may be obtained by writing or faxing:

Standards Engineer
 Traffic Operations Division - TE
 Texas Department of Transportation
 125 East 11th Street
 Austin, Texas 78701-2483
 Phone (512) 416-3335
 Fax (512) 416-3161
 E-mail TRF-STANDARD@mailgw.dot.state.tx.us

TYPICAL USAGE:				
MOBILE	SHORT DURATION	SHORT TERM STATIONARY	INTERMEDIATE TERM STATIONARY	LONG TERM STATIONARY
	✓	✓	✓	✓

Texas Department of Transportation
 Traffic Operations Division

TRAFFIC CONTROL DETAILS
 for
 SURFACING OPERATIONS
 TCP (7-1) - 98

© TxDOT March 1991		DN: TxDOT	CK: TxDOT	DW: TxDOT	CK: TxDOT
4-92	REVISIONS	CONT	SECT	JOB	HIGHWAY
1-97		2C	1080	495	GARZA
4-98		DIST	COUNTY		SHEET NO.
		PHR	HIDALGO		38

DATE: 3/19/2012 4:05:28 PM
 FILE: p:\2009\2009-1027-02_heboap_iii_additional_colonias_design\04_north_capital\o\cs\Standards\Pavement Markers\PM1-12.dgn
 The use of this standard is governed by the "Texas Engineering Practice Act". No warranty of any kind is made by TxDOT for any purpose whatsoever. TxDOT assumes no responsibility for the conversion of this standard to other formats or for incorrect results or damages resulting from its use.

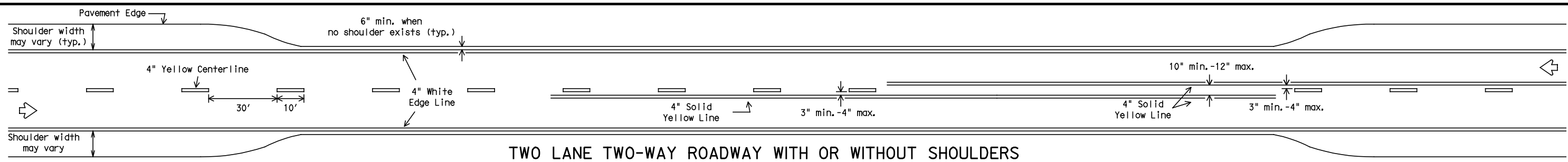

TWO LANE TWO-WAY ROADWAY WITH OR WITHOUT SHOULDERS

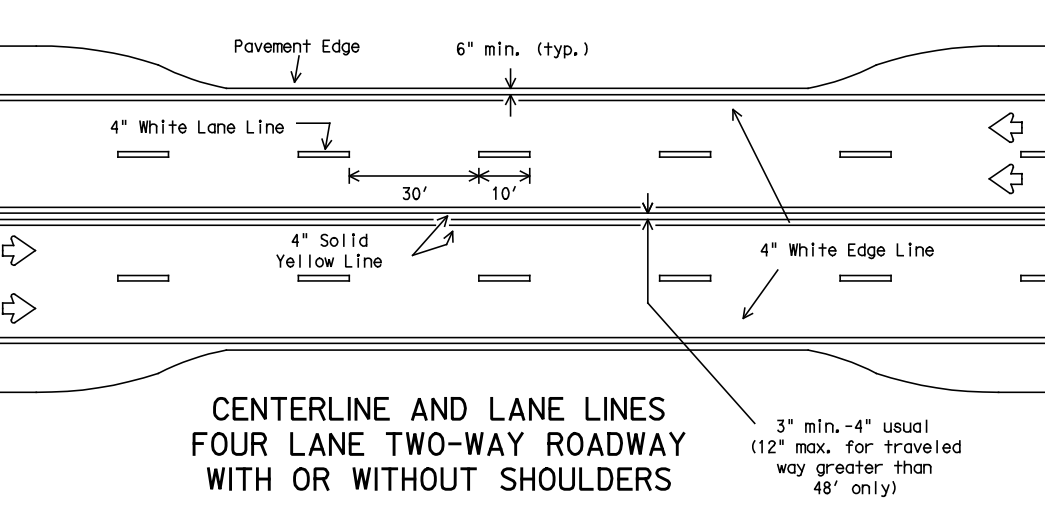

**CENTERLINE AND LANE LINES
FOUR LANE TWO-WAY ROADWAY
WITH OR WITHOUT SHOULDERS**

3" min. - 4" usual
(12" max. for traveled
way greater than
48' only)

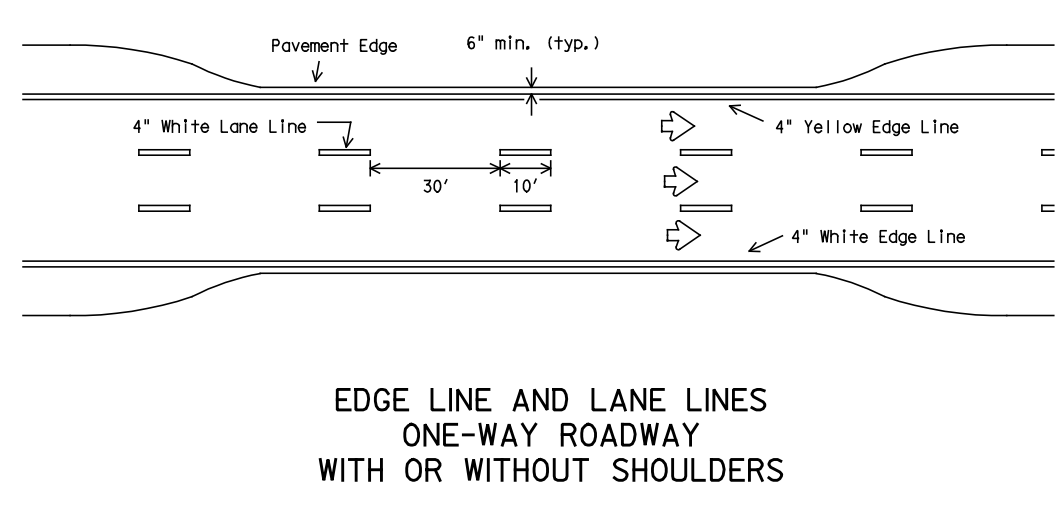

**EDGE LINE AND LANE LINES
ONE-WAY ROADWAY
WITH OR WITHOUT SHOULDERS**

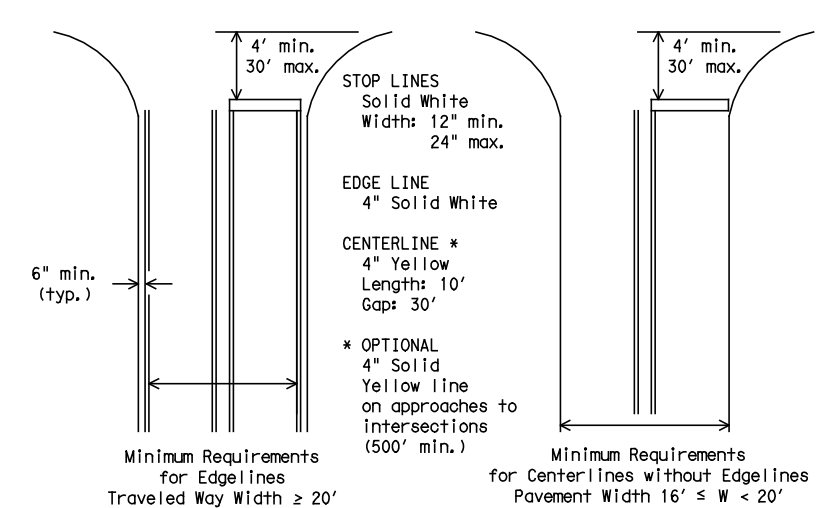

Minimum Requirements for Edgelines
Traveled Way Width ≥ 20'

Minimum Requirements for Centerlines without Edgelines
Pavement Width 16' ≤ W < 20'

**GUIDE FOR PLACEMENT OF STOP LINES,
EDGE LINE & CENTERLINE**
Based on Traveled Way and Pavement Widths for Undivided Highways

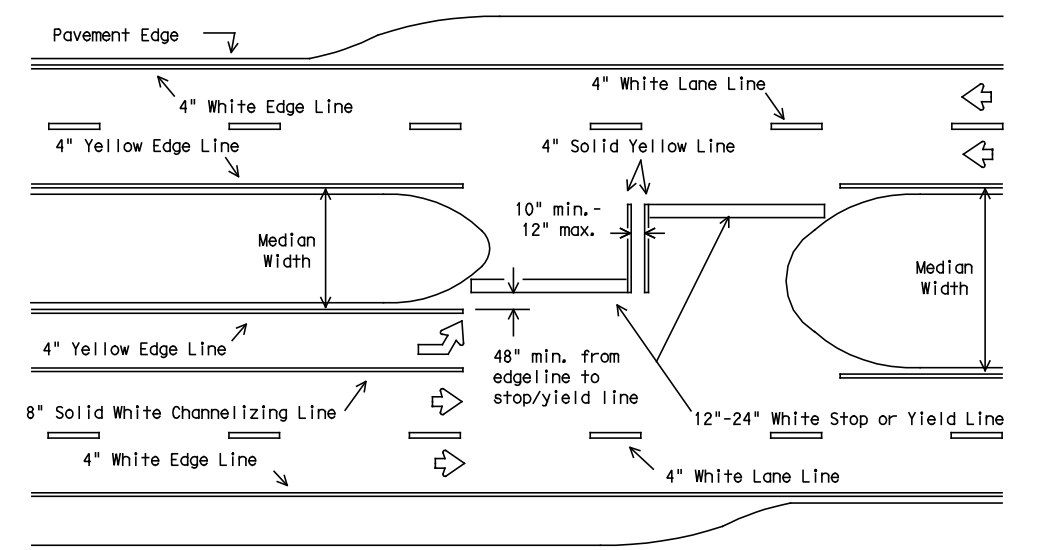

FOUR LANE DIVIDED ROADWAY INTERSECTIONS

All medians shall be field measured to determine the location of necessary striping. Stop/Yield bars and centerlines shall be placed when the median width is greater than 30 ft. The median width is defined as the area between two roadways of a divided highway measured from edge of traveled way to edge of traveled way. The median excludes turn lanes. The median width might be different between intersections, interchanges and of opposite approaches of the same intersection. The narrow median width will be the controlling width to determine if markings are required.

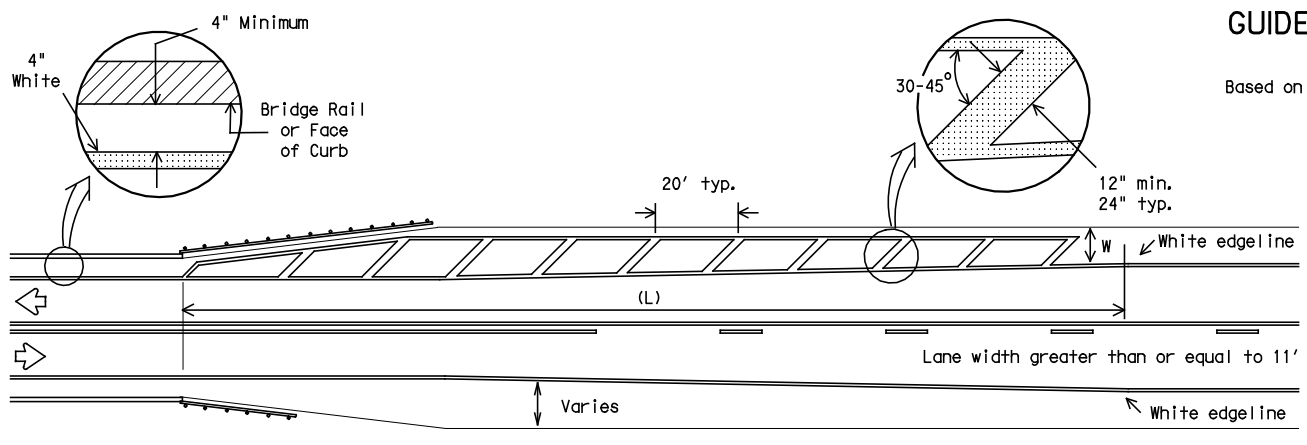

**ROADWAYS WITH REDUCED SHOULDER
WIDTHS ACROSS BRIDGE OR CULVERT**

- NOTES:
- No-passing zone on bridge approach is optional but if used, it shall be a minimum 500 feet long.
 - For crosshatching length (L) see Table 1.
 - The width of the offset (W) and the required crosshatching width is the full shoulder width in advance of the bridge.
 - The crosshatching is not required if delineators or barrier reflectors are used along the structure.
 - For guard fence details, refer elsewhere in the plans.

TABLE 1 - TYPICAL LENGTH (L)

Posted Speed *	Formula
≤ 40	$L = \frac{WS^2}{60}$
≥ 45	$L = WS$

* 85th Percentile Speed may be used on roads where traffic speeds normally exceed the posted speed limit. Crosshatching length should be rounded up to nearest 5 foot increment.
L=Length of Crosshatching (FT.) W=Width of Offset (FT.) S=Posted Speed (MPH)

EXAMPLES:

An 8 foot shoulder in advance of a bridge reduces to 4 feet on a 70 MPH roadway. The length of the crosshatching should be:
 $L = 8 \times 70 = 560$ ft.

A 4 foot shoulder in advance of a bridge reduces to 2 feet on a 40 MPH roadway. The length of the crosshatching should be:
 $L = 4(40)^2 / 60 = 106.67$ ft. rounded to 110 ft.

GENERAL NOTES

- Edgeline striping shall be as shown in the plans or as directed by the Engineer. The edgeline should typically be placed a minimum of 6 inches from the edge of pavement. This distance may vary due to pavement raveling or other conditions. Edgelines are not required in curb and gutter sections of roadways.
- The traveled way includes only that portion of the roadway used for vehicular travel and not the parking lanes, sidewalks, berms and shoulders. The traveled ways shall be measured from the inside of edgeline to inside of edgeline of a two lane roadway.

MATERIAL SPECIFICATIONS	
PAVEMENT MARKERS (REFLECTORIZED)	DMS-4200
EPOXY AND ADHESIVES	DMS-6100
BITUMINOUS ADHESIVE FOR PAVEMENT MARKERS	DMS-6130
TRAFFIC PAINT	DMS-8200
HOT APPLIED THERMOPLASTIC	DMS-8220
PERMANENT PREFABRICATED PAVEMENT MARKINGS	DMS-8240

All pavement marking materials shall meet the required Departmental Material Specifications as specified by the plans.

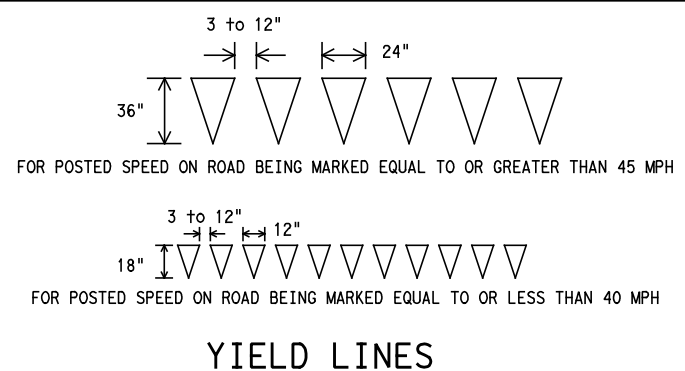

YIELD LINES

Texas Department of Transportation
Traffic Operations Division

**TYPICAL STANDARD
PAVEMENT MARKINGS**

PM(1)-12

© TxDOT November 1978	DN: TxDOT	CK: TxDOT	DW: TxDOT	CK: TxDOT
REVISIONS	CONT	SECT	JOB	HIGHWAY
8-95 2-12	2C	1080	495	GARZA
5-00	DIST	COUNTY		SHEET NO.
8-00	PHR	HIDALGO		39
3-03				

DISCLAIMER: The use of this standard is governed by the "Texas Engineering Practice Act". No warranty of any kind is made by TxDOT for any purpose whatsoever. TxDOT assumes no responsibility for the conversion of this standard to other formats or for incorrect results or damages resulting from its use.

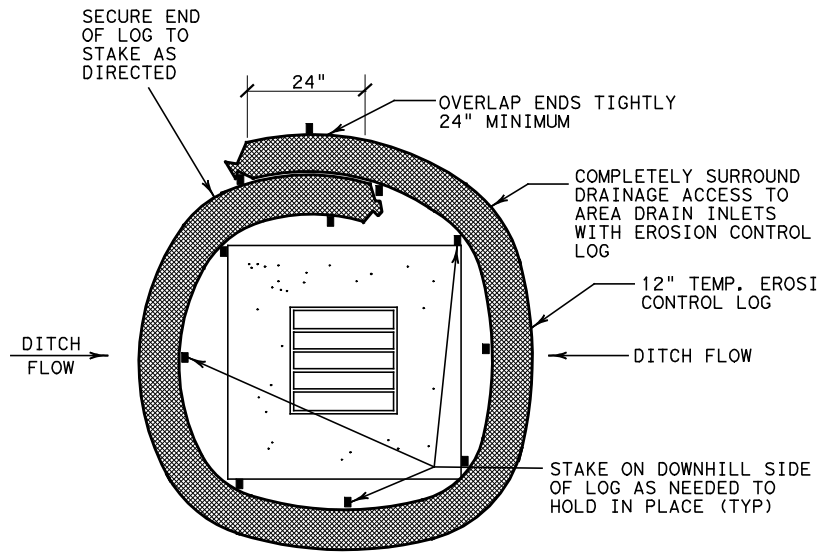

DROP INLET SEDIMENT TRAP
DI-ST NTS

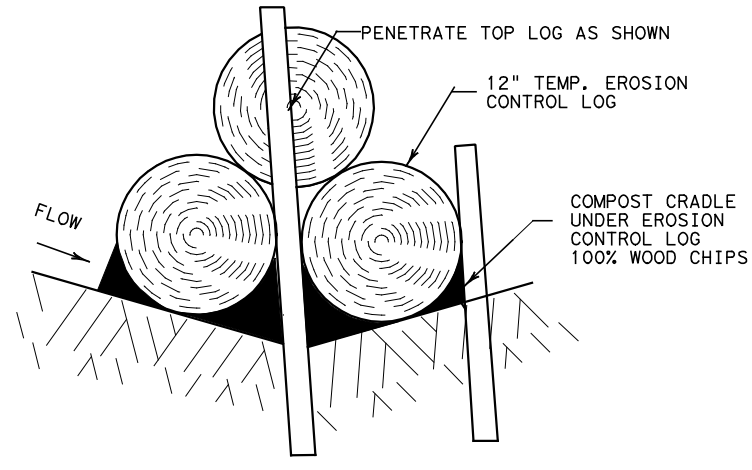

DITCH LINE SEDIMENT TRAP A-A
DL-ST

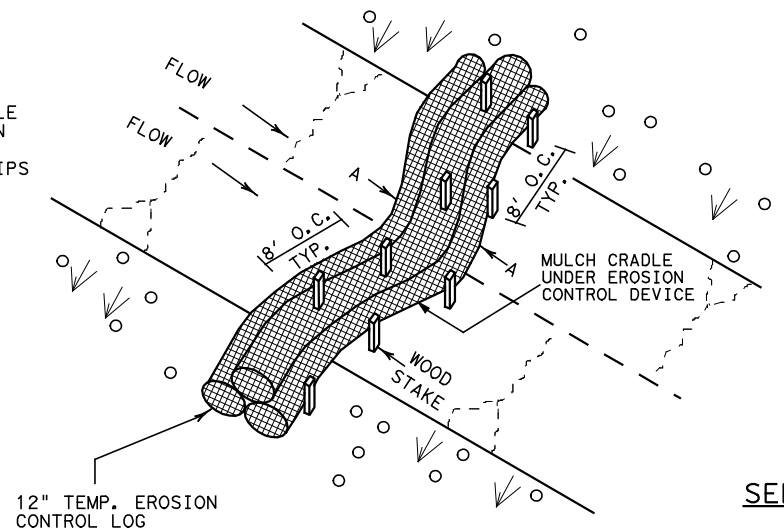

DITCH LINE SEDIMENT TRAP
DL-ST

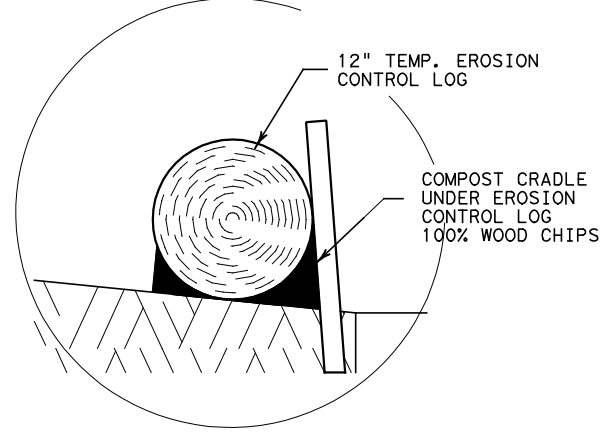

COMPOST CRADLE

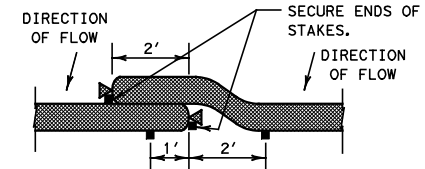

LAP DETAIL
NTS

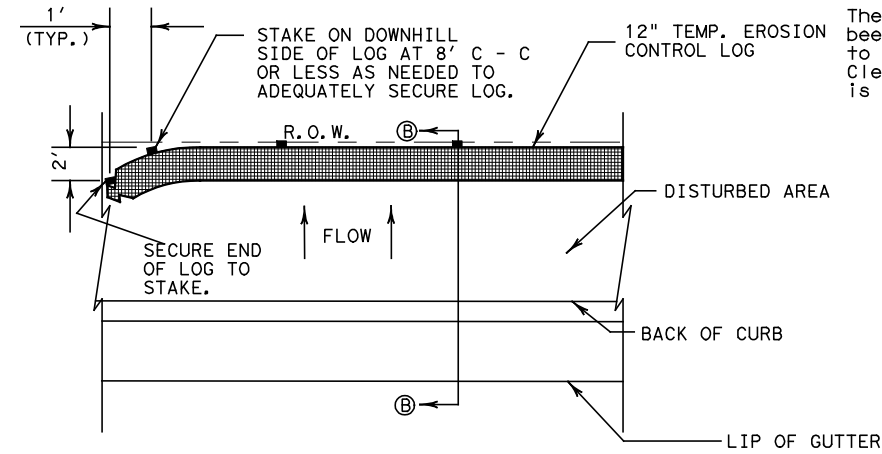

PLAN VIEW
NTS

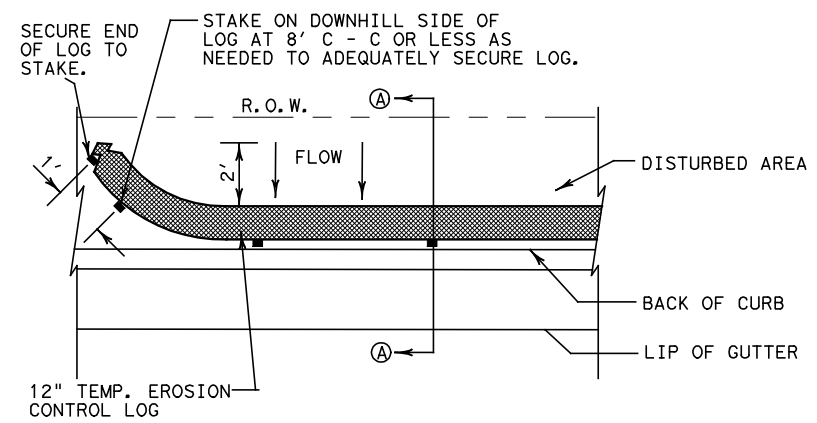

PLAN VIEW
NTS

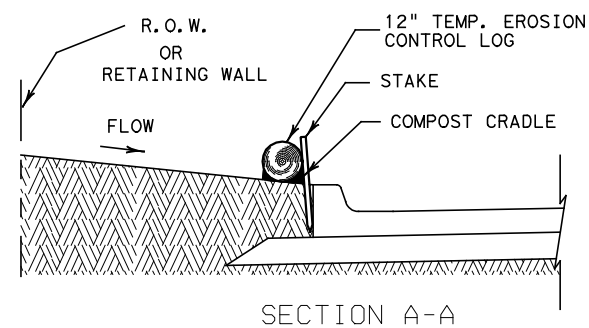

SECTION A-A

BACK OF CURB INLET SEDIMENT TRAP
BOCI-ST NTS

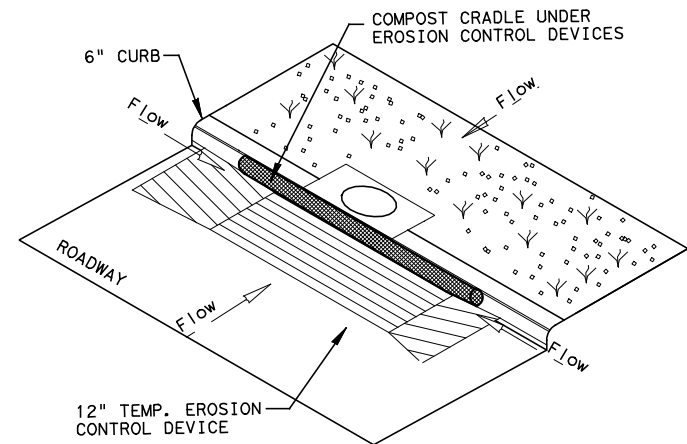

CURB INLET SEDIMENT TRAP
CI-ST NTS

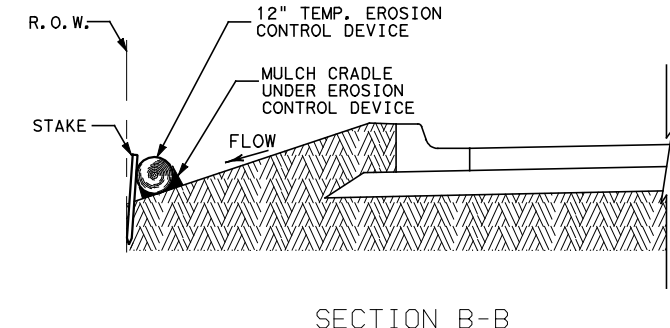

SECTION B-B

RIGHT-OF-WAY SEDIMENT TRAP
ROW-ST NTS

PLANS SHEET LEGEND

- DI-ST DROP INLET SEDIMENT TRAP
- DL-ST DITCH LINE SEDIMENT TRAP
- BOCI-ST BACK OF CURB INLET SEDIMENT TRAP
- ROW-ST RIGHT OF WAY SEDIMENT TRAP
- CI-ST CURB INLET SEDIMENT TRAP

SEDIMENT BASIN & TRAP USAGE GUIDELINES

A sediment trap may be used to precipitate sediment out of runoff draining from an unstabilized area.

Traps: the drainage area for a sediment trap should not exceed 5 acres. The trap capacity should be 1800 CF/Acre (0.5" over the drainage area).

Sediment traps should be placed in the following locations:

1. Immediately preceding drain inlets
2. Just before the drainage enters a water course
3. Just before the drainage leaves the right of way
4. Just before the drainage leaves the construction limits where drainage flows away from the project

The trap should be cleaned when the capacity has been reduced by 1/2" or the sediment has accumulated to a depth of 1", whichever is less. Cleaning and removal of accumulated sediment deposits is incidental and will not be paid for separately.

GENERAL NOTES

1. LENGTHS OF EROSION CONTROL LOGS SHALL BE IN ACCORDANCE WITH MANUFACTURER'S RECOMMENDATIONS AND AS REQUIRED FOR THE PURPOSE INTENDED. MAXIMUM LENGTH OF LOGS SHALL BE 30' FOR 12" DIAMETER LOGS.
2. UNLESS OTHERWISE DIRECTED, USE BIODEGRADABLE OR PHOTODEGRADABLE CONTAINMENT MESH ONLY WHERE LOG WILL REMAIN IN PLACE AS PART OF A VEGETATIVE SYSTEM. FOR TEMPORARY INSTALLATIONS, USE RECYCLABLE CONTAINMENT MESH.
3. STUFF LOGS WITH SUFFICIENT FILTER MATERIAL TO ACHIEVE DENSITY THAT WILL HOLD SHAPE WITHOUT EXCESSIVE DEFORMATION.
4. STAKES SHALL BE 2" X 2" WOOD 4' LONG, EMBEDDED SUCH THAT 2" PROTRUDES ABOVE LOG.
5. COMPOST CRADLE MATERIAL IS INCIDENTAL AND WILL NOT BE PAID FOR SEPARATELY.

LEVELS DISPLAYED:
1 2 3 4 5 6 7 8 9 10 11 12 13 14 15 16 17 18 19 20 21 22 23 24 25 26 27 28 29 30 31 32 33 34 35 36 37 38 39 40 41 42 43 44 45 46 47 48 49 50 51 52 53 54 55 56 57 58 59 60 61 62 63 64 65 66 67 68 69 70 71 72 73 74 75 76 77 78 79 80 81 82 83 84 85 86 87 88 89 90 91 92 93 94 95 96 97 98 99 100

PHARR DISTRICT STANDARD

Texas Department of Transportation
© TxDOT 2006

**TEMPORARY EROSION CONTROL LOGS
TECL-06 (PHR)**

FED. RD. DIV. NO.	PROJECT NO.		HIGHWAY NO.
6			BETO GARZA
STATE	DISTRICT	COUNTY	SHEET NO.
TEXAS	PHR	HIDALGO	40
CONTROL	SECTION	JOB	
2C	1080	495	

AI-33189

Purchasing Department 18. F. 1.

CC REGULAR

Meeting Date: 07/24/2012

Department Head: Agapito Vargas Submitted By: Yvette Islas, PURCHASING DEPT.

Department: PURCHASING DEPT.

Information

CAPTION

Presentation of a recommendation by project engineer, Javier Hinojosa Engineering for Commissioners' Court to award to lowest bidder meeting all specifications: 2GS, LLC in the amount of \$346,509.20 for Bid No. CAP-12-138-07-03-YSI "Road & Drainage Construction for Acevedo #4 Subdivision".

BACKGROUND

Fiscal Impact

FISCAL YEAR: 2012

ACCT. #: 2-1312-431-00-123-014-1-731/733

FUNDS AVAILABLE Y/N?: Y/Pending **MATCHING FUNDS Y/N?:** N

BUDGETARY IMPACT:

Available funds pending approval of transfer. Refer to AI - 33201 (7/24/12 CC).

Available funding

Obj Code 731: \$209,711.50

\$ 2,367.70 (transfer - AI-33201)

Obj Code 733: \$145,460.00

Attachments

c bdown acevedo4

for tx dot conc acevedo4

eng recomnd acevedo4

b tab sheet acevedo4

ai req acevedo4

exp report acevedo4

Form Review

Inbox	Reviewed By	Date
Purchasing Department	Marty Salazar	07/13/2012 11:01 AM
Budget & Management	Merlen P. Munoz	07/13/2012 11:35 AM
Perla Lopez	Perla Lopez	07/13/2012 02:12 PM
Auditor's Office	Angela Garcia	07/20/2012 04:55 PM
Form Started By: Yvette Islas		Started On: 07/11/2012 11:25 AM
	Final Approval Date: 07/20/2012	

Acevedo No. 4 Subdivision
 CSJ: 3C1080014
 Cost Breakdown
 Precinct 3

Item No.	Bid Item No.	Item Description	Unit	Original Contract Amounts			Change Order 1		
				Original Quantities	Original Rates	Amount Bid	Revised Rates	Revised Quantities	Amount Increase/Decrease
ROADWAY									
1	100	Preparing ROW	STA	31.35	\$1,000.00	\$31,350.00			
2	247	Flex Base (Complete in Place) TY "E" GR4 (8")	CY	9766	\$6.00	\$58,596.00			
3	251	Reworking Flex Material (DC) (TY D CLII)	SY	9766	\$3.50	\$34,181.00			
4	310	Prime Coat (MC-30)	GAL	1957	\$4.25	\$8,317.25			
5	340	Asph Conc ACP Surface (TY "D") (1.5")	SY	8371	\$8.45	\$70,734.95			
6	502	Barricades, Signs and Traffic Handling	MO	3	\$1,500.00	\$4,500.00			
7	530	Turnouts (Asphalt, Concrete, Pavement) (PBS-2)	SY	180	\$20.00	\$3,600.00			
9		Relocate Mail Boxes	LS	1	800	\$800.00			
SubTotal Base Bid						\$212,079.20			

DRAINAGE									
1	464	15" ADS Culvert Pipe	LF	1970	\$ 20.00	\$39,400.00			
2	464	RCP (CL III) (18")	LF	420	\$30.00	\$12,600.00			
3	467	Safety End Treatment (Pre-Cast) (Ty II) (18") RCP) (1:6)	EA	12	\$800.00	\$9,600.00			
4	506	Temp Sedmt Cont Fence (Install)	LF	1040	\$3.00	\$3,120.00			
5	506	Temp Sedmt Cont Fence (Remove)	LF	1040	\$1.00	\$1,040.00			
6	530	Driveways (Asphalt, Concrete, Pavement)	SY	1400	\$25.00	\$35,000.00			
7	530	Driveways (Concrete)	SY	962	\$35.00	\$33,670.00			
SubTotal Drainage						\$134,430.00			
GrandTotal Roadwork Base Bid and Drainage						\$346,509.20			

Project Length: (LF)	3135
Cost Per Linear Feet @ \$500K/mile:	\$ 94.70
Tot. Proj. Allowable (Cost per LF @\$500K/mi X Proj. Lngth):	\$ 296,884.50
Roadwork Allocation (Eng, Road Const and Contingency):	\$ 282,198.55
Allowed Increase:	\$ 14,685.95

Amt Inc.: \$ 70,549.64

Road Construction Allocation:	\$ 209,711.50 *
Possible 25% Transfer In Other Projects:	\$ -
Contingency Transfer In:	\$ 2,367.70
Total Allocation, 25% Transfer and Contingency Transfer	\$ 212,079.20
Low Base Bid Roadwork	\$212,079.20
Overrun/Underrun	\$0.00

Drainage Allocation:	\$ 145,460.00 *
Transfer In: Other Projects	
Total Allocation and Transfer	\$145,460.00
Drainage Cost:	\$134,430.00
Overrun/Underrun	\$11,030.00

* Expense report dated 07.11.2012

Acevedo No. 4 Subdivision
CSJ: 3C1080014
Cost Breakdown
Precinct 3

Change Order

Road Construction Allocation:	\$	-
Transfer In:	\$	-
Total Allocation, 25% Transfer and Contingency Transfer	\$	-
Low Base Bid Roadwork After Change Order	\$	-
Overrun/Underrun		\$0.00

Change Order

Drainage Allocation:	\$	-
Transfer In: Other Projects		
Total Allocation and Transfer		\$0.00
Drainage Cost:		\$0.00
Overrun/Underrun		\$0.00

** Expense report dated 07.11.2012



COLONIA ACCESS PROGRAM County of Hidalgo

Agapito Vargas, Jr.
Executive Director

11 July 2012

Judy Sanchez, Colonia Project Manager
Texas Department of Transportation
600 West Expressway 83
Pharr, TX 78577

Re: Bid Award Number CAP-12-138-07-03-YSI 3rd Call Project Acevedo #4 Subdivision CSJ:
3C1080014

Dear Judy:

Attached please find information regarding the award of the above-referenced 3rd Call Colonias Project for road construction and drainage.

Please be advised that the County will proceed to award the bid on the following:

1. Engineer's Recommendation
2. Bidder meets all County requirements
3. Bids is the lowest of bids received
4. Cost breakdown

Javier Hinojosa Engineering has reviewed bids and tabulations and is recommending 2GS, LLC of Peñitas, TX as the low bidder for the above-referenced project. The County was awarded \$282,198.55 for Road Work and \$145,460.00 for Drainage for a total of \$427,658.55. Based on the apparent low bidder, the County will have underruns of \$33,937.61 for Road Work and \$11,030.00 for Drainage.

The award will be to the low bidder 2GS, LLC with a low bid amount of \$346,509.20.

The bids were as follows:

Contractor	Read Total	Correct Total
Valley Paving Inc.	\$408,838.25	\$408,838.25
Clore Construction, LLC	\$382,467.70	\$382,467.70

J.M. Construction	\$400,967.90	\$400,967.90
2GS, LLC	\$346,509.20	\$346,509.20

Commissioner Jose M. Flores concurs with the engineering firm's recommendation and will present the recommendation to Commissioner's Court for approval, once concurrence has been provided by TXDOT.

Please note that the County Commissioner's Court will award the contract pending TXDOT concurrence.

If you require additional information, please feel free to contact me at 787-1891 or on my cell phone at 460-6364.

Sincerely Yours,

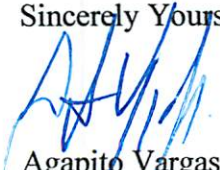

Agapito Vargas Jr., Director
Hidalgo County Colonias Access Program

Cc: Commissioner Jose M Flores, Hidalgo County Precinct 3 (Ltr Copy Only)
Valde Guerra, Commissioner's Court Executive Officer (email)
Norma Ceballos, Executive Assistant, Precinct 3 (email)
Eralio Palacios, HCBCAP County Wide Coordinator (email)
Rossana Schettino, Grant Accountant II (email)
Yvette Islas, HCCAP Buyer II (email)
Project files

JAVIER HINOJOSA ENGINEERING/Consulting Engineers

416 E. Dove Avenue • McAllen, Texas 78504

Tel: (956) 668-1588 • Fax: (956) 994-8102

javhin@rgv.rr.com

TBPE FIRM NO. F-1295

July 3, 2012

Commissioner Joe M. Flores
Hidalgo County Precinct 3
724 N. Breyfogle
Mission, Texas 78572

**Re: Acevedo #4 Subdivision
Bid No. CAP-12-138-07-03-YSI**

Dear Commissioner Flores,

Bids were received and opened for the Colonia Access Program Bid No. CAP-12-138-07-03-YSI Acevedo #4 Subdivisions on July 3, 2012. A total of four bids were received with 2GS, LLC being the low bidder with a total base bid of \$346,509.20. Attached is a copy of the bid tabulation for your review. This project involves the reconstruction of Daniel Road, 1st Street, 2nd Street 3rd Street and 4th Street within Acevedo #4 Subdivision. 2GS, LLC is a reputable firm who has constructed several projects within Hidalgo County. We recommend award of the contract to 2GS, LLC in the amount of \$346,509.20.

If you have any questions or require further information, please feel free to contact me at your convenience.

Sincerely,

JAVIER HINOJOSA ENGINEERING

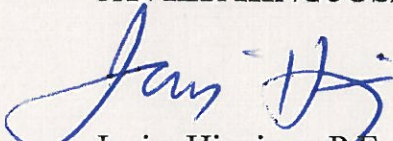

Javier Hinojosa, P.E.

cc: Mr. Agapito Vargas, Director, Colonia Access Program
Ms. Yvette S. Islas, Hidalgo County Purchasing Dept.

BID TABULATION SHEET
Hidalgo County Precinct No. 3
Acevedo #4 Subdivision
Bid No: CAP-12-138-07-03-YSI
Bid Date: July 3, 2012 @ 9:30 a.m.

<u>Paving</u>	<u>QUANTITIES</u>	<u>ZGS, LLC</u>	<u>Clore Construction, LLC</u>	<u>J.M. Construction</u>	<u>Valley Paving</u>
1 Preparing ROW	31.35 STA	\$1,000.00	\$2,500.00	\$650.00	\$1,250.00
2 8" Flex Base (Compl in Place) (TY D GR4)	9,766 SY	\$6.00	\$8.50	\$8.50	\$7.00
3 Rewking BS Matl (DC) (TY D CL6)	9,766 SY	\$3.50	\$6.50	\$4.00	\$3.75
4 ASPH Matrl (MC-30)	1,957 GAL	\$4.25	\$6.10	\$6.50	\$4.25
5 ASPH Conc (TY D)(1 1/2")	8,371 SY	\$8.45	\$8.00	\$9.90	\$9.00
6 Barricades, Signs and Traffic Handling	3.0 MO	\$1,500.00	\$1,800.00	\$1,000.00	\$2,500.00
7 Turnouts (ASPH-CONC-PAV)(PB-2)	180 SY	\$20.00	\$15.00	\$25.00	\$30.00
8 Temporary Sediment Control Fence	1,040 LF	\$3.00	\$2.50	\$1.00	\$2.00
9 Temporary Sediment Control Fence (Remove)	1,040 LF	\$1.00	\$1.50	\$1.00	\$1.00
10 Relocate Mail Boxes	Lump Sum	\$800.00	\$2,000.00	\$10,000.00	\$8,500.00
Subtotal Paving		\$216,239.20	\$318,030.70	\$257,625.90	\$252,348.25
<u>Drainage</u>					
10 Driveway (ASPH-CON-PAV)(PB-1)	1,400 SY	\$25.00	\$8.50	\$17.00	\$30.00
11 Driveway (Concrete 3000 PSI)	962 SY	\$35.00	\$8.50	\$56.00	\$45.00
12 15" ADS Culvert Pipe	1,970 LF	\$20.00	\$16.00	\$21.00	\$20.00
13 18" RCP Culvert Pipe	420 LF	\$30.00	\$22.00	\$35.00	\$50.00
14 Safety End Treatment	12 EA	\$800.00	\$300.00	\$800.00	\$900.00
Subtotal Drainage		\$130,270.00	\$64,437.00	\$143,342.00	\$156,490.00
TOTAL BASE BID		\$346,509.20	\$382,467.70	\$400,967.90	\$408,838.25

BID TABULATION SHEET
Hidalgo County Precinct #3
Hidalgo County Colonia Access Program
Acevedo #4 Subdivision
Bid # CAP-12-138-07-03-YSI
Engineer: Javier Hinojosa Engineering
Bid Date: July 3, 2012 @ 9:30 a.m.

<u>Bidder</u>	<u>Total Base Bid</u>	<u>Bid Bond</u>
1. 2GS, LLC	<u>\$346,509.20</u>	<u>Yes</u>
2. Clore Construction, LLC	<u>\$382,467.70</u>	<u>Yes</u>
3. J.M. Construction	<u>\$400,967.90</u>	<u>Yes</u>
4. Valley Paving, Inc.	<u>\$408,838.25</u>	<u>Yes</u>

HIDALGO COUNTY PURCHASING DEPARTMENT BID TABULATION SHEET

DEPARTMENT NAME: HIDALGO COUNTY PRECINCT NO. 3 - BORDER COLONIA ACCESS PROGRAM

BID OPENING DATE: July 03, 2012

BID OPENING TIME: 9:30 A.M.

DESCRIPTION OF BID: "ROAD & DRAINAGE CONSTRUCTION FOR ACEVEDO #4 SUBDIVISION"

BID NO: CAP-12-138-07-03-YSI

RFB NO.	NAME OF COMPANY	TOTAL BID AMOUNT FOR CONSTRUCTION	BID BOND/ CASHIER'S CHECK
1.	Valley Paving Inc.	\$408,838.25	Bid Bond
2.	Clore Construction, LLC	\$382,467.70	Bid Bond
3.	J. M. Construction	\$400,967.90	Bid Bond
4.	2GS, LLC	\$346,509.20	Bid Bond
5.			
6.			
7.			
8.			
9.			
10.			

From: [Agapito Vargas](#)
To: "Yvette Islas"
Cc: "[marcie.jackson](#)"; "[Eralio Palacios](#)"; "[Norma Ceballos](#)"; "[Rossana Schettino](#)"; valde.guerra@co.hidalgo.tx.us
Subject: Agenda Item - Award Low Bid Acevedo #4
Date: Wednesday, July 11, 2012 1:57:02 PM
Attachments: [Cost Breakdown Acevedo no 4 07112012 2nd bid.xls](#)
[ltr txdot req concurrence low bid award acevedo #4 07112012.pdf](#)
[engineers ltr of recommendation acevedo 4 second bid 07112012.pdf](#)
[exp report 07112012.pdf](#)

Yvette, please place the following item on CC agenda for Tuesday 24th July 2012:

Approval to award contract to sole low bidder for 3rd Call Border Colonias Access Program

Project

Project Name: Acevedo No. 4 Subdivision (CSJ: 3C1080014)

Project Location: Precinct 4

Low Bidder: GS2, LLC, Peñitas, TX

Project Engineer: Javier Hinojosa Engineering

Account: 1-1312-431-00-123-014-1-731 & 733

Attached is correspondence to TXDOT requesting concurrence, engineer's letter of recommendation, cost breakdown, engineer's tabulation sheet and expense report.

Agapito Vargas, Executive Director

Hidalgo County Border Colonias Access Program

301 East State

Pharr, TX 78577

Office Tel: 956/787-1891

Fax: 956/787-4683

Cell: 956/460-6364

email: agapito.vargas@co.hidalgo.tx.us

email smart phone: canics49@gmail.com



Please refrain from printing this email unless completely necessary. Go Green!

Hidalgo County
Expenditure Summary Report

Standard Report Format

1001 - Standard Report Spec

Account No/Description	Original Budget	Adjusted Budget	Y-T-D Encumbrance	Period Expended	Y-T-D Expended	Available Balance	Percent
1312 BORDER COLONIA ACCESS PROGRAM ROUND 3							
2-1312-431-00-123-014-1-312 ACEVEDO S/D #4-INDIRECT COST	.00	12,497.33	.00	7,922.49	7,922.49	4,574.84	63.39
2-1312-431-00-123-014-1-334 ACEVEDO S/D #4-ARCH & ENG SR	.00	7,813.77	7,813.77	.00	.00	.00	100.00
2-1312-431-00-123-014-1-339 ACEVEDO S/D #4-OTHER PROF SR	.00	12,431.00	12,431.00	.00	.00	.00	100.00
2-1312-431-00-123-014-1-540 ACEVEDO S/D #4-ADVERTISING	.00	3,107.20	761.80	791.80	791.80	1,553.60	50.00
2-1312-431-00-123-014-1-731 ACEVEDO S/D #4-ROADS	.00	209,711.50	.00	.00	.00	209,711.50	.00
2-1312-431-00-123-014-1-733 ACEVEDO S/D #4-DRAINAGE DITCH	.00	145,460.00	.00	.00	.00	145,460.00	.00
2-1312-431-00-123-014-1-899 ACEVEDO S/D #4-CONTINGENCY	.00	36,305.31	.00	.00	.00	36,305.31	.00
1312 BORDER COLONIA ACCESS PROGRAM ROUND 3	.00	427,326.11	21,006.57	8,714.29	8,714.29	397,605.25	6.96
2 YEAR 2	.00	427,326.11	21,006.57	8,714.29	8,714.29	397,605.25	6.96

AI-33332

Closed Session 20. C.

CC REGULAR

Meeting Date: 07/24/2012

Submitted By: Monica Badillo, EXECUTIVE
OFFICE

Department: EXECUTIVE OFFICE

Information

CAPTION

CL-12-2088-A; Erasmo Chapa v. Hidalgo County, Texas

BACKGROUND

Peralez Franz, LLP was engaged on 8/30/11 to represent county on Claim. (we have now been served with citation)

Form Review

Inbox	Reviewed By	Date
Budget & Management	Merlen P. Munoz	07/18/2012 04:41 PM
Purchasing Department	Angela Garcia	07/20/2012 04:55 PM
Form Started By: Monica Badillo		Started On: 07/18/2012 04:31 PM
	Final Approval Date: 07/20/2012	

AI-33335

Closed Session 20. D.

CC REGULAR

Meeting Date: 07/24/2012

Submitted By: Monica Badillo, EXECUTIVE
OFFICE

Department: EXECUTIVE OFFICE

Information

CAPTION

Notice of Claim - Shelia Pruitt-Orr

BACKGROUND

Form Review

Inbox	Reviewed By	Date
Budget & Management	Merlen P. Munoz	07/18/2012 04:41 PM
Purchasing Department	Angela Garcia	07/20/2012 04:55 PM
Form Started By: Monica Badillo		Started On: 07/18/2012 04:36 PM
	Final Approval Date: 07/20/2012	

AI-33333

Open Session 21. C.

CC REGULAR

Meeting Date: 07/24/2012

Submitted By: Monica Badillo, EXECUTIVE
OFFICE

Department: EXECUTIVE OFFICE

Information

CAPTION

CL-12-2088-A; Erasmo Chapa v. Hidalgo County, Texas

BACKGROUND

Form Review

Inbox	Reviewed By	Date
Budget & Management	Merlen P. Munoz	07/18/2012 04:41 PM
Purchasing Department	Angela Garcia	07/20/2012 04:55 PM
Form Started By: Monica Badillo		Started On: 07/18/2012 04:34 PM
	Final Approval Date: 07/20/2012	

AI-33336

Open Session 21. D.

CC REGULAR

Meeting Date: 07/24/2012

Submitted By: Monica Badillo, EXECUTIVE
OFFICE

Department: EXECUTIVE OFFICE

Information

CAPTION

Notice of Claim - Shelia Pruitt-Orr

BACKGROUND

Form Review

Inbox	Reviewed By	Date
Budget & Management	Merlen P. Munoz	07/18/2012 04:41 PM
Purchasing Department	Angela Garcia	07/20/2012 04:55 PM
Form Started By: Monica Badillo		Started On: 07/18/2012 04:38 PM
	Final Approval Date: 07/20/2012	