



## Hidalgo County Head Start Program Policy Council Agenda

**DATE:** August 7, 2012

**SUBJECT:** Discussion/Approval to Advertise for Sealed Bids and Approval of Draft Specifications for The Relocation of the Palmview I Head Start building located at 501 Commercial Blvd., Palmview, TX 78572 to be moved to 1208 Paula Drive, Palmview, TX.

**RATIONALE/NEED:** Building must be moved due to termination of Interlocal agreement. Commissioner's Court Approved Request to Solicit Proposal from Awarded Job Order Contractors on June 5, 2012 (AI-32632). This request is being made in order to obtain the best and lowest price.

**RECOMMENDATION:** Administration Recommends Approval

**COST:** Head Start Funds for this project are available.  
Equipment Repair: Account 19-5505-20-10000-505

**RELATED INFORMATION INCLUDED:** Specifications

\*\*\*\*\*  
**INITIATED BY:** Ambrosio Tovar, Procurement Director *A. Tovar*

**REVIEWED BY:** Mr. Edmundo Garcia, Assistant Director *E. Garcia*

**PROGRAM DIRECTOR'S APPROVAL:** Teressa Flores *Teressa Flores*

BID NO:2012-021-08-31	BUYER: Ambrosio Tovar	TEL. NO: (956) 380-4149
-----------------------	-----------------------	-------------------------

HIDALGO COUNTY HEAD START PROGRAM  
McAllen, Texas

August 7, 2012

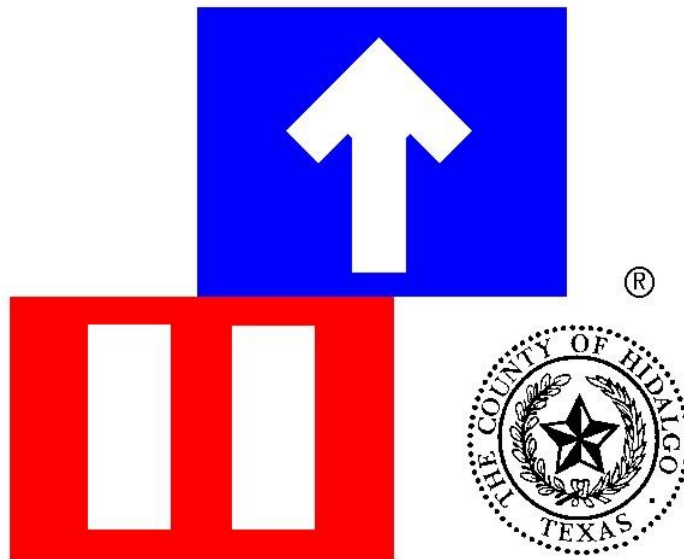

REQUEST FOR SEALED BIDS  
"BUILDING RELOCATION - PALMVIEW I HEAD START"

Contact Person:

Ambrosio Tovar, Procurement Director  
Hidalgo County Head Start Program  
1901 West State Hwy 107  
McAllen, Texas 78504  
(956) 380-4149

REQUEST FOR SEALED BIDS  
HIDALGO COUNTY HEAD START PROGRAM  
“BUILDING RELOCATION – PALMVIEW I HEAD START”  
August 7, 2012  
BID NO: 2012-021-08-31

- 1) Request For Sealed Bids Letter, 1 page
- 2) Request for Sealed Bids, Legal Notice, 6 pages
- 3) Exhibit A: Requirements Criteria, 5 pages
- 4) Exhibit B: Bid Page, 3 pages
- 5) Exhibit C: Insurance Requirements, 3 pages
- 6) Exhibit D: Conflict of Interest Questionnaire, 2 pages
- 7) Respondent/Vendor Application, 1 page
- 8) Historically Underutilized Business (HUB) Declaration, 1 page
- 9) Certification for Primary Covered Transactions, 1 pages
- 10) Draft Contract for Professional Services, 6 pages
- 11) W-9 Form (Request for Taxpayer ID) 1 pages

The above mentioned items shall be found in the Request for Sealed Bids packet that is attached herewith. Should you find that any of the items are not attached in its entirety please contact Hidalgo County Head Start Program Procurement Department by calling Ambrosio Tovar at (956) 380-4149, advise of missing documentation, and Procurement Department will forward information either through facsimile or by U.S. Mail.

Thank you.

AUGUST 7, 2012

---

---

---

RE: HIDALGO COUNTY HEAD START PROGRAM  
REQUEST FOR SEALED BIDS  
"BUILDING RELOCATION - PALMVIEW I HEAD START"  
BID NO: 2012-021-08-31

Dear Sir/Madam:

Enclosed please find a Sealed Bids packet for your review and consideration. Hidalgo County Head Start Program Procurement Department welcomes and appreciates your participation in the bid process.

If any further assistance is required, please do not hesitate to call the Hidalgo County Head Start Program Procurement Department at (956) 380-4149.

Sincerely,

Ambrosio Tovar  
Procurement Director  
Hidalgo County Head Start Program

1. Sealed Bids will be received for "BUILDING RELOCATION – PALMVIEW I HEAD START" in accordance with the requirements attached as Exhibit "A" hereto. Bids should address all requirements set forth. Strong rationale must be presented for any deviation from the requirements. Hidalgo County Head Start Program reserves the right to reject the deviation and its effect on the overall bids.
2. One (1) original and Three (3) copies of Bids must be enclosed in a Sealed Envelope And/or Package With Vendor's Name And Return Address Clearly Typed/printed on Upper Left Hand Corner And The Proper Notation Clearly Typed/printed on The Lower Left Hand Corner: **SEALED BID "BUILDING RELOCATION - PALMVIEW I HEAD START"** and delivered to Hidalgo County Head Start Program- Administration Office located: 1901 W. State Hwy 107, McAllen, Texas ON OR BEFORE **2:00 p.m. Friday August 31, 2012.** NO FACSIMILES OR LATE ARRIVALS WILL BE ACCEPTED. ANY SEALED BIDS RECEIVED AFTER THAT TIME WILL NOT BE OPENED AND WILL BE RETURNED. OVERNIGHT MAIL MUST ALSO BE PROPERLY LABELED ON THE OUTSIDE OF EXPRESS ENVELOPE OR PACKAGE IN REFERENCE TO THE SEALED BID.
3. Hidalgo County Head Start Program reserves the right to separate and accept, or eliminate any items(s) listed under this bid that it deems necessary to accommodate budgetary and/or operational requirements. Hidalgo County Head Start Program also reserves the right to reject any or all bids submitted and further reserves the right to design the evaluation criteria to be used in selecting the lowest and best bid for approval. Receipt of any bid shall under no circumstances obligate Hidalgo County Head Start Program to accept the lowest dollar bid. The award of this contract shall be made to the responsible offer or whose bid is determined to be the best evaluated offer resulting from negotiation, taking into consideration the relative importance of price and other evaluation factors as herein set forth.
4. Failure of the delivered item(s) to perform as specified, or failure to meet the stated delivery schedule, shall release Hidalgo County Head Start Program from all obligations to the contracting party with regard to the item(s) in question. In such event, Hidalgo County Head Start Program may elect to award the contract to the next-lowest responsible vendor, or to reject all bids and re-advertise. Descriptive specifications are referenced in this document to indicate the general kind and quality of equipment desired by Hidalgo County Head Start Program. Due to various styles and models of equipment, bidders are required to include illustrations, specifications, explanation of warranties, and service data with their bid including catalogue numbers and any necessary references.

5. No bid may be withdrawn within sixty (60) days from the scheduled time to open bids.
6. Bid prices are to remain firm for a minimum of ninety (90) days after priced bid opening.
7. Any interpretations, amendments, corrections or changes to this bid document must be in a written addendum and signed by Teresa Flores, Executive Director or her designee. Addenda will be mailed to all who are known to have received a copy of the Request for Bids. Bidder shall acknowledge receipt of all addenda as a part of their bid.
8. Hidalgo County Head Start Program reserves the right to accept or reject any or all bids.
9. Costs are to be Net F.O.B., Hidalgo County Head Start Program prepaid.
10. Hidalgo County Head Start Program is exempt from Federal Excise Tax, State Tax and Local Tax. Do not include tax in cost figure. If it is determined that tax was included in the cost figures it will not be included in the tabulation of any awards. Tax exemption certificates will be furnished upon request.
11. Funds for this procurement have been provided through the Hidalgo County Head Start Program budget for this fiscal year only. Hidalgo County Head Start Program, on an annual basis, has the right to reconsider a contract during the budget process for ensuing years if financial resources of Hidalgo County Head Start Program are insufficient to meet the liabilities of said contract. The award of a Sealed Bid or contract hereunder will not be construed to create a debt of the Hidalgo County Head Start Program which is payable out of funds beyond the current fiscal year.
12. DELIVERY INSTRUCTIONS:
  - . No deliveries accepted after 4:30 P.M., Monday-Friday.
  - . If you need additional information call the office listed below:

Hidalgo County Head Start Program  
Ambrosio Tovar, Procurement Director  
(956) 380-4149
13. BILLING INSTRUCTIONS:

Contact person for Billing and Payment questions:  
HIDALGO COUNTY HEAD START PROGRAM  
Elma Keller, Finance Director  
P. O. Box 0117  
Edinburg, TX 78540

14. Schedule of Events

Sealed Bid Acceptance, 2:00 P.M.

August 31, 2012

Award of Contract

Commence Work or Deliver Products

\_\_\_\_\_

15. Bid or Performance Bond; Payment under Contract:

- If the contract proposed is for the construction of public works or is for a contract exceeding \$100,000, all bidders shall furnish a good and sufficient bid bond in the amount of five percent of the total contract price. A bid bond must be executed with a surety company authorized to do business in Texas.
- Together with the signing of a contract or issuance of a purchase order following the acceptance of a bid, and prior to commencement of the actual work, the bid shall furnish a performance bond to the Hidalgo County Head Start Program for the full amount of the contract, if that contract exceeds \$50,000.
- If the contract is for \$50,000 or less, no money will be paid to the contractor until completion and acceptance of the work or the fulfillment of the purchase obligation to the Hidalgo County Head Start Program, and, if applicable, the receipt by Hidalgo County Head Start Program of satisfactory evidence that all subcontractors and material men have been paid.
- If a contract is for the construction, alteration or repair of public buildings or public works, the contractor shall provide a payment bond for a contract in excess of Twenty Five Thousand Dollars (\$25,000), as required by Tex. Govt. Code Ch. 2253.
- For requirements contracts, bond requirements are determined by applying the bid unit price to the estimated quantities included in the requirements.

16. Ethical Standards:

- It shall be a breach of ethics to offer, give or agree to give any elected official, department head or employee, of the County, Hidalgo County Head Start Program to solicit, demand, accept or agree to accept from another person, entity or organization, a gratuity or an offer of employment in connection with any decision, approval, disapproval, recommendation, preparation or any part of a program requirement or purchase request,

influencing the content of any specification or procurement standard, rendering of advice, investigation, auditing, or in any other advisory capacity in any proceeding or application, request for ruling, determination, claim or controversy, or other particular matter pertaining to any program requirement or a contract or subcontract, or to any solicitation or bid therefore pending before any department or agency of the County, Hidalgo County Head Start Program.

- It shall be a breach of ethics for any payment, gratuity or offer of employment to be made by or on behalf of a subcontractor under a contract to the prime contractor or higher tier subcontractor for any contract for the County, Hidalgo County Head Start Program or any person associated therewith, as an inducement for the award of a subcontract or order.
  - No public official shall have an interest in a contract awarded hereunder except in accordance with Tex. Loc. Govt. Code Chapter 171.
17. If, during the life of any contract or bid awarded, the successful bidder's net prices generally available to other customers for items awarded herein are reduced below the contracted price, it is understood and agreed that the benefits of such reduction shall be extended to Hidalgo County Head Start Program.
18. Bids, and all goods and services provided there under, shall comply with all federal, state and local laws concerning this type(s) of goods and/or services.
19. Minimum Standards for Responsible Prospective Bids: A prospective bid must affirmatively demonstrate bidder's responsibility. A prospective bid, by submitting a bid, represents to Hidalgo County Head Start Program that it meets the following requirements:
- Possess or is able to obtain adequate financial resources as required to perform under the bid;
  - Be able to comply with the required or bided delivery schedule;
  - Have a satisfactory record of performance;
  - Have a satisfactory record of integrity and ethics;
  - Be otherwise qualified and eligible to receive an award.

20. Successful bidder will pay or cause to be paid, without cost or expenses to Hidalgo County Head Start Program, all FICA, FUTA/SUTA and Federal Income Withholding Taxes of all employees, and all wages and benefits as required by Federal or State law. Successful bidder's officers, agents and/or employees will not be entitled to any benefits of an employee or elected official of County or Hidalgo County Head Start Program including, but not limited to, benefits associated with County's civil service system.
  
21. Any contract award to a successful bidder will be in effect until (a) the contract expires, (b) delivery and acceptance of products, and/or performance of services ordered, or (c) terminated by Hidalgo County Head Start Program with thirty (30) day written notice prior to cancellation.
  
22. Hidalgo County Head Start Program reserves the right to enforce performance of any contract awarded hereunder in any manner prescribed by law or deemed to be in the best interest of the Hidalgo County Head Start Program in the event of breach or default by successful bidder; Hidalgo County Head Start Program reserves the right to terminate any contract immediately in the event a successful bidder fails to:
  - A. Meet schedules;
  - B. Pay any required fees or taxes; or
  - C. Otherwise perform in accordance with the requirements.
  
23. Successful bidder shall defend, indemnify and hold harmless Hidalgo County Head Start Program and all its elected officials, officers, agents and employees from all suits, actions, or other claims of any character, name and description brought for or on account of any injuries or damages received or sustained by any person, persons, or property on account of any negligent act or fault of the successful bidder, or of any agent, employee, subcontractor or supplier in the execution of, or performance under, any contract which may result from bid award. Successful bidder indemnifies and will indemnify and save harmless Hidalgo County Head Start Program from liability, claim or demand on their part, agents, servants, customers, and/or employees whether such liability, claim or demand arise from event or casualty happening or within the occupied premises themselves or happening upon or in any of the halls, elevators, entrances, stairways or approaches of or to the facilities within which the occupied premises are located. Successful bidder shall pay any judgment with costs which may be obtained against Hidalgo County Head Start Program growing out of such injury or damages, and shall, upon request, provide a defense to Hidalgo County Head Start Program by counsel reasonably acceptable to Hidalgo County Head Start Program. Successful bidder's indemnity hereunder shall include, but is not limited to, claims relating to patent, copyright or trademark infringement, and the like, arising out of the goods or services provided by successful bidder.

24. Successful bid shall warrant that all items/services shall conform to the requirements and/or all warranties provided under the Uniform Commercial Code and be free from all defects in material, workmanship and the like. Items supplied under a contract pursuant to this Request for Qualifications shall be subject to County's approval.

Items found to be defective or not meeting specifications shall be replaced by successful bidder within two business days at no expense to Hidalgo County Head Start Program. Items not picked up within one (1) week after notification shall be deemed a donation to Hidalgo County Head Start Program and may be used or disposed of at Hidalgo County Head Start Program's discretion and without waiver of any other rights of Hidalgo County Head Start Program as to the item's nonconformity.

25. This document and any disputes arising hereunder shall be governed and construed according to the laws of the State of Texas, and will be performable exclusively in Hidalgo County, Texas.
26. The successful bidder shall not assign, sell, transfer or convey its rights under any awarded contract, in whole or in part, without the prior written consent of Hidalgo County Head Start Program.
27. Bidder shall provide with the bid response, a list of at least three (3) references where like services have been supplied by their firm. Include the name of the business or government, address, telephone number and name of representative or contact person.
28. Bidder must provide all documentation requested with this Bid in their response. Failure to provide this information may result in rejection of the bid as non-conforming.

**HIDALGO COUNTY HEAD START PROGRAM  
REQUEST FOR SEALED BIDS**

**“BUILDING RELOCATION –  
PALMVIEW I HEAD START”**

**EXHIBIT A  
REQUIREMENTS**

# ACKNOWLEDGMENT FORM

SEALED BID FOR  
HIDALGO COUNTY HEAD START PROGRAM  
"BUILDING RELOCATION - PALMVIEW I HEAD START"  
BID No. 2012-021-08-31

We, as an interested party, agree to the criteria and the requirements of the SEALED BID and have submitted our sealed bid as requested.

All costs involved in submitting this statement to Hidalgo County Head Start Program shall be borne in full by the bidding company.

COMPANY: \_\_\_\_\_

ADDRESS: \_\_\_\_\_

AUTHORIZED REPRESENTATIVE: \_\_\_\_\_

SIGNATURE: \_\_\_\_\_

TITLE: \_\_\_\_\_

TELEPHONE: \_\_\_\_\_ FAX NO. \_\_\_\_\_

E-MAIL: \_\_\_\_\_

DATE: \_\_\_\_\_

The Hidalgo County Head Start Program is seeking to engage BUILDING RELOCAITON. The Procurement Department will receive sealed envelopes containing BID for the provision of "BUILDING RELOCATION – PALMVIEW I HEAD START. Sealed Bids will be accepted until 2:00 p.m., Friday, August 31, 2012. Any BID received after that time will not be opened and will be returned.

Deliver Submittal to:

RFB Number: 2012-021-08-31  
Hidalgo County Head Start Program  
Procurement Department  
1901 West State Highway 107  
McAllen, TX 78504

The submittal Envelope must show the Submittal Number, Name and Opening Date.

The following outlines the Request for Sealed Bid:

## **SECTION I: GENERAL TERMS AND CONDITIONS**

ADDITIONAL INFORMATION: Hidalgo County Head Start Program is requesting that bids be routed to Ambrosio Tovar, Procurement Director, 1901 W. State Highway 107, McAllen, TX 78504. Written questions will be accepted via facsimile (956) 380-4149 no later than Friday, August 24, 2012 no later than 2:00 p.m. TELEPHONE INQUIRIES WILL NOT BE ACCEPTED.

CONFLICT OF INTEREST: Submitters must have a "non-conflict of interest" affidavit submitted to the County Clerk's office prior to contract award.

NON-COLLUSION: Submitters, by submitting a signed submission, certify that the accompanying submission is not the result of, or affected by, any unlawful act of collusion with any other person or company engaged in the same line of business or commerce, or any other fraudulent act punishable under Texas or United States law.

DAVIS-BACON ACT: Contractor must adhere to Davis-Bacon Act requirements Reports must be submitted timely.

NON-DISCRIMINATION: Submitters, during the performance of this contract, will not discriminate against any employee or applicant for employment because of race, religion, sex, national origin or disability except where religion, sex, national origin or disability is a bona fide occupational qualification reasonably necessary to the normal operation of the contractor.

OCCUPATIONS CODE: Bids exceeding a cost of \$20,000.00 are required to comply with the Occupations Code, Chapter 1001, Section 053, Public Works.

PROCESSING TIME FOR PAYMENT: Submitters are advised that a minimum of thirty (30) is required to process invoices for payment.

ELECTRONIC TRANSMISSION OF BIDS: Hidalgo County Head Start Program Procurement Department will not accept telegraphic or electronically transmitted submissions.

PROOF OF FINANCIAL AND BUSINESS CAPABILITY: Submitters must, upon request, furnish satisfactory evidence of their ability to furnish products or services in accordance with the terms and conditions of these specifications. Hidalgo County Head Start Program will make the final determination as to the vendor's ability.

SUBMITTER DEFAULT: Hidalgo County Head Start Program reserves the right, in case of submitter default, to procure the articles or services from other sources and hold the defaulting vendor responsible for any excess costs occasioned thereby.

RESTRICTIVE OR AMBIGUOUS SPECIFICATIONS: It is the responsibility of the submitter to review the request for qualifications (RFB) packet and to notify the Procurement Department if the specifications are formulated in a manner that would unnecessarily restrict competition. Any such protest or question regarding the specifications or bidding procedures must be received in the Procurement Department not less than seventy-two (72) hours prior to the time set for the opening. These requirements also apply to specifications that are ambiguous.

SEALED BID DELIVERY: Hidalgo County Head Start Program requires submitters, when hand delivering qualifications, to time date and stamp the envelope before depositing it in the bid box.

SIGNING OF BIDS: In order to be considered, all submittals must be signed. Please sign the original in **blue** ink.

WAIVING OF INFORMALITIES: Hidalgo County Head Start Program reserves the right to waive minor informalities or technicalities when it is in the best interest of Hidalgo County Head Start Program.

SUBCONTRACTING: The successful submitter may not subcontract the award without the written consent of the Commissioner's Court of Hidalgo County.

## SECTION II: REQUIREMENTS

**REQUEST FOR SEALED BIDS:** The required contents and limitations for the preparation of the BID are described in this section. Failure to provide the requested information or adhere to any County limitations will result in disqualification of the submitted BID. A total of one (1) original and three (3) copies of the RFB shall be submitted to the address on the cover letter.

**Project Overview:**

It is the intention of the Hidalgo County Head Start Program to receive BIDS from interested individuals for the purposes of Building Relocation for the centers referenced within.

**Contents:**

The required contents for the sealed bids are presented below in the order they should be incorporated into the submitted document.

**SPECIFICATIONS – GENERAL:** All replacement materials must be at minimum, equal to or better than the existing materials

**I. Scope of Services:**

**The specifications of this project may be picked up at:**

**Dannenbaum Engineering Company – McAllen, LLC**

1109 Nolana Loop, Suite 208

McAllen, Texas 78504

(956)682-3677 Office

(956)686-1822 Fax

[steve.mcgarraugh@dannenbaum.com](mailto:steve.mcgarraugh@dannenbaum.com)

*Steven L McGarraugh AIA/ Project Architect*

**SITE VISIT:**

Bidders must visit the Centers to suggest any other necessary work required to complete the project. Bidder shall not be relieved of responsibility for improperly estimating cost of serviced required. The visit must be coordinated in advance with Field Operations Director for the Hidalgo County Head Start Program, or designated representative, at (956) 383-0706 ext. 217. Building located at: 501 Palmview Commercial Dr. in Palmview TX, to be moved to 1208 Paula Dr. Palmview TX

**BILLING SPECIFICATIONS:**

All Invoices must be submitted to the Finance Department upon satisfactory completion of project. There will be NO Advance Payments.

Contact person for Billing and Payment questions:

HIDALGO COUNTY HEAD START PROGRAM

Elma Keller, Finance Director

P. O. Box 0117

Edinburg, TX 78540 / 956-380-4131

**HIDALGO COUNTY HEAD START PROGRAM  
REQUEST FOR SEALED BID**

**“BUILDING RELOCATION –  
PALMVIEW I HEAD START”**

**EXHIBIT B**

**BID PAGE**

**BID PAGE**  
**REQUEST FOR SEALED BIDS**  
**HIDALGO COUNTY HEAD START PROGRAM**  
**“BUILDING RELOCATION – PALMVIEW I HEAD START”**  
**August 7, 2012**

To: Hidalgo County Head Start Program  
Ambrosio Tovar, Procurement Director  
1901 West State Hwy 107  
McAllen, Texas 78504

In accordance with the requirements, and subject to all laws and regulations of the United States and state and local laws, the undersigned respondent proposes and commits to furnish all labor, equipment, material, software and services as set forth in the documents hereinbefore mentioned. The undersigned respondent further agrees, upon acceptance of its bid, to execute a contract and/or Purchase Order issued by Hidalgo County Head Start Program for performing and completing the work described in the requirements within the time stated and for the prices bided in the documents attached hereto and made a part hereof.

Respondent acknowledges receipt of all of the pages of the documents referenced in the Request for Sealed Bids Checklist presented in connection with this procurement. Respondent understands that Hidalgo County Head Start Program reserves the right to reject any or all BIDS and further reserves the right to design the evaluation criteria to be used in selecting the lowest and best bid.

Respondent agrees that this bid shall be good and may not be withdrawn for a period of ninety (90) calendar days after the scheduled closing time for accepting BID, as contained in the requirements.

Respectfully submitted,

Respondent: \_\_\_\_\_

Address: \_\_\_\_\_

\_\_\_\_\_

By: \_\_\_\_\_

Printed Name: \_\_\_\_\_

Title: \_\_\_\_\_

SELECTION PROCEDURES: The SEALED BID shall be submitted according to the schedule below. The respondent should be able to submit a Cost Bid.

SEALED BID SUBMITTED TO: An original and three (3) copies of Sealed Bid should be submitted to:

Ambrosio Tovar, Procurement Director  
Hidalgo County Head Start Program  
P. O. Box 0117  
Edinburg, TX 78540-0117

BID must be submitted NO LATER THAN 2:00 p.m. on Friday, August 31, 2012.

COST:

PALMVIEW I CENTER

Building Relocation Cost: \$\_\_\_\_\_

Bidder's signature indicates an understanding and intent to comply with all Federal state and local regulations associated with implementing a Head Start Program and that the listed bid price will be valid for a period of ninety (90) days.

BIDDER'S NAME: \_\_\_\_\_

ADDRESS: \_\_\_\_\_

CITY/STATE/ZIP CODE: \_\_\_\_\_

PHONE NUMBER: \_\_\_\_\_ FAX NUMBER: \_\_\_\_\_

---

---

AUTHORIZED SIGNATURE: \_\_\_\_\_

TITLE: \_\_\_\_\_

DATE: \_\_\_\_\_

**\*\*\*\*\*It is Mandatory that Bid Page be included in Bid Package\*\*\*\*\***

**HIDALGO COUNTY HEAD START PROGRAM  
REQUEST FOR SEALED BID**

**“BUILDING RELOCATION –  
PALMVIEW I HEAD START”**

**EXHIBIT C**

**INSURANCE REQUIREMENTS**

# INSURANCE REQUIREMENTS

## Exhibit "C"

The bidder awarded the contract shall furnish proof of insurance, which will also include any subcontractor(s) that is subcontracted by the bidder in at least the following limits, to be in place prior to providing any services under this "Contract" and to continue at all times in force in effect during the term of this contract.

Certificates of insurance naming Hidalgo County Head Start Program as an additional insured shall be submitted to Hidalgo County Head Start Program for approval prior to any services being performed by Contract. Each policy of insurance required hereunder shall extend for a period equivalent to or longer than the term of service, and any insurer hereunder shall be required to give at least thirty (30) days written notice to the Hidalgo County Head Start Program prior to the cancellation suspended upon the cancellation or other termination or any required policy of insurance hereunder, and such suspension shall continue until evidence adequate replacement coverage is provided to the Hidalgo County Head Start Program.

The Respondent awarded the contract shall furnish proof of insurance, which will also include any subcontractor that is subcontracted by the respondent in at least the following limits, to be in place prior to providing any services under this Contract and to continue at all times in force in effect during the term of this Contract:

1. A Five Hundred Thousand Dollar (\$500,000) Comprehensive General Liability insurance policy providing additional coverage to all underlying liabilities of County.
2. Automobile liability insurance policy with limits of at least Three Hundred Thousand Dollars (\$300,000) per person and Five Hundred Thousand Dollars (\$500,000) per occurrence. Coverage should include injury to or death of persons and property damage claims with limits up to Five Hundred Thousand (\$500,000) arising out of the services provided to County hereunder;
3. Uninsured/Underinsured motorist coverage in an amount equal to the bodily injury limits set forth immediately above;
4. Workers compensation insurance in amounts established by Texas law, unless the Respondent is specifically exempted from the Texas Workers' Compensation Act, Texas Labor Code Chapter 401, et. seq.

Certificates of insurance naming County as an additional insured shall be submitted to County for approval prior to any services being performed by Contractor. Each policy of insurance required hereunder shall extend for a period equivalent to, or longer than the term of the Contract, and any insurer hereunder shall be required to give at least thirty (30) days written notice to the County prior to the cancellation of any such coverage on the termination date, or otherwise. This Contract shall be automatically suspended upon the cancellation, or other termination, of any required policy of insurance hereunder, and such suspension shall continue until evidence adequate replacement coverage is provided to County. If replacement coverage is not provided within thirty (30) days following suspension of the Contract, this Contract shall automatically terminate.

# INSURANCE REQUIREMENT ACKNOWLEDGMENT

I, \_\_\_\_\_ authorized representative for \_\_\_\_\_

Company/Vendor. Hereby acknowledge receipt of the County's required insurance limits. Said requirements:

- will be acquired upon notification of intent to award bid at the next regularly scheduled Hidalgo County Commissioners' Court; (\*An insurance certificate for the required insurance limits shall be provided to the Purchasing Department by no later 9:30 a.m., the morning of the Commissioner's Court meeting, in order to qualify for award of bid and to execute a contract between our Company and the County.)
  
- will acquire additional amount needed to meet the County's requirements upon notification of intent to award bid at the next scheduled Hidalgo County Commissioners' Court; currently carry the following:

Automobile Liability: \$ \_\_\_\_\_ General Liability: \$ \_\_\_\_\_

(\*An insurance certificate for the required insurance limits shall be provided to the Purchasing Department by no later 9:30 a.m., the morning of the Commissioner's Court meeting, in order to qualify for award of bid and to execute a contract between our Company and the County.) OR

- have already been met, see attached copy of insurance certificate.

\_\_\_\_\_  
Authorized Representative

\_\_\_\_\_  
Date

Notice to Respondent: Failure to provide Certificates of Insurance at Commissioners' Court will cause the bid award to be rescinded and then awarded to next lowest respondent.

**THIS FORM MUST ACCOMPANY BID PACKET**

# PROJECT REQUIREMENTS ACKNOWLEDGMENT

This is to certify that I, \_\_\_\_\_, possess all of the APPLICABLE;

1)Licenses:\_\_\_\_\_

2)Bonds:\_\_\_\_\_

3)Certificates:\_\_\_\_\_

4) Permits:\_\_\_\_\_

5) Other:\_\_\_\_\_

Necessary to carry out the required project. Furthermore, I am providing copies of the required documentation so that, if my company is awarded this bid, I may be eligible to enter into a contract with Hidalgo County Head Start Program and proceed to complete the project in a timely manner.

\* Any licenses, bonds, certificates, and permits, etc. which are required must be presented as part of the bid packet in order to expedite the bid evaluation process. Failure to provide said documentation will result in the disqualification of your bid.

\_\_\_\_\_  
Authorized Signature

\_\_\_\_\_  
Date

\_\_\_\_\_  
Company

\_\_\_\_\_  
Address

\_\_\_\_\_  
City, State, Zip

HIDALGO COUNTY HEAD START PROGRAM  
REQUEST FOR BIDS

“BUILDING RELOCATION –  
PALMVIEW I HEAD START”

EXHIBIT D

PROPOSER’S AFFIDAVIT

EXHIBIT "D"  
PROPOSER'S AFFIDAVIT

**PROPOSER'S AFFIDAVIT OF NON-COLLUSION  
NON-CONFLICT OF INTREST, AND ANTI-LOBBYING  
FOR "BUILDING RELOCATION FOR PALMVIEW I HEAD START CENTER"**

STATE OF TEXAS  
COUNTY OF HIDALGO

Affiant, \_\_\_\_\_, being first duly sworn, deposes that:

- (1) Affiant does hereby state neither the Proposer nor any of the Proposer's officers, partners, owners, agents, representatives, employees, or parties in interest, has in any way colluded, conspired, agreed, directly or indirectly with any person, firm, corporation, or other proposer, or potential proposer, to provide any money or other valuable consideration for assistance in procuring or attempting to procure a contract or fix the prices in the attached proposed or the proposal of any other proposer, and further states that no such money or other reward will be hereinafter paid.
- (2) Affiant further states they have neither recommended or suggested to Hidalgo County or any of its officials or employees, any of the terms or provisions set forth in their Request for Proposal and subsequent agreement, except at a meeting open to all interested proposers, of which proper notice was give.
- (3) Affiant, further states their officers, employees, or agents have not, and will not attempt to lobby, directly or indirectly, the Hidalgo County Commissioner's Court between proposal submission date and award by the Hidalgo County Commissioner's Court.
- (4) Affiant further States no officer, or stockholder of the Proposer is a member of the staff, or related to any employee of the Hidalgo County except as noted herein below:

---

Signature/ Title:

---

Subscribed and sworn to before me this \_\_\_\_\_ day of \_\_\_\_\_, 2012.

\_\_\_\_\_  
Notary Public

My Commission expires: \_\_\_\_\_ 2012.

# HIDALGO COUNTY

## Respondent/Vendor Application

VENDOR NO.: \_\_\_\_\_

ENTRY DATE: \_\_\_\_\_.

Complete in print or type. It is the vendor's responsibility to return this application to Hidalgo County Head Start Purchasing Department.

Company Name	Telephone No. (      )
Mailing Address	Fax No. (      )
City, State, Zip	Tax I.D. No.
E-Mail Address:	Website Address:
Representative(s) Name(s) & Title(s)	
Type of Organization (check one): ___ Individual ___ Partnership ___ Corporation ___ LLC ___ Other, Specify Federal Identification No. or (if individual) SS No.	
State of Incorporation: _____ Other:	
Type of Business (check one): ___ Manufacturer ___ Wholesaler ___ Retailer ___ broker ___ Distributor ___ Service Organization ___ Other, Specify	
Name & Title of Person(s) Authorized to Sign Bids, Proposals, and/or Contracts:	
Small and/or Disadvantaged Business Information (check application criteria) Small Business: _____ Disadvantaged Business (At Least 51% Ownership) <input type="checkbox"/> Less than 125,000 annual gross receipt <input type="checkbox"/> Black American <input type="checkbox"/> Native American <input type="checkbox"/> Less than 250,000 annual gross receipt <input type="checkbox"/> Hispanic American <input type="checkbox"/> Women <input type="checkbox"/> Less than 499,000 annual gross receipt <input type="checkbox"/> Asian Pacific American <input type="checkbox"/> Other <input type="checkbox"/> More than 500,000 annual gross receipt Have you been certified as a HUB or an MBE/WBE source?: <input type="checkbox"/> Yes <input type="checkbox"/> No Indicate Certification No.(s): _____ or are Certificate(s) attached?: <input type="checkbox"/> Yes <input type="checkbox"/> No	
What type of product(s) is/are solicited by your company?: Would you like to be provided with requirements for procurements of such products?: <input type="checkbox"/> Yes <input type="checkbox"/> No	

**HISTORICALLY UNDERUTILIZED BUSINESS (HUB) DECLARATION**

The primary objective of the Hidalgo County HUB Program is to ensure Historically Underutilized Businesses receive a fair and equal opportunity for participation in the County’s procurement process. This fact holds true for Services (Professional & Non-Professional), Commodities, and Construction contracts and any subcontracts thereto. The program strongly encourages Prime Contractors to provide subcontracting opportunities to Certified Hub Contractors/Vendors. Our goal for HUB contractor/vendor participation, as well as HUB subcontractor participation is 30%. To be considered as a “Certified HUB Contractor/Vendor” the contractor/vendor must have been certified by, and hold a current and valid certification with any of the three agencies listed below.

Have you been Certified as a HUB or an MBE/WBE source?:  Yes  No

If yes, by whom?  State General Services Commission  Other

Indicate Certification No(s): \_\_\_\_\_ or Are Certificate(s) Attached:  Yes  No

**LIST OF CERTIFIED HUB SUBCONTRACTORS**

(Attach additional pages if necessary)

What percentage of the Bid or RFQ is to be subcontracted with Certified HUB sources?: \_\_\_\_\_%  
(List HUB Subcontractor information below).

HUB Subcontractor Name:  
HUB Status:

Certifying Agency (Check all applicable):  State General Services Commission  Other

Address: \_\_\_\_\_ City: \_\_\_\_\_ State: \_\_\_\_\_ Zip: \_\_\_\_\_  
Contact Person: \_\_\_\_\_ Title: \_\_\_\_\_ Phone No.: ( ) \_\_\_\_\_  
Subcontract Amount: \$ \_\_\_\_\_  
Description of Work to be performed: \_\_\_\_\_

HUB Subcontractor Name: \_\_\_\_\_ HUB Status: \_\_\_\_\_

Certifying Agency (Check all applicable):  State General Services Commission  
 Other

Address: \_\_\_\_\_ City: \_\_\_\_\_ State: \_\_\_\_\_ Zip: \_\_\_\_\_  
Contact Person: \_\_\_\_\_ Title: \_\_\_\_\_ Phone No.: ( ) \_\_\_\_\_  
Subcontract Amount: \$ \_\_\_\_\_  
Description of Work to be performed: \_\_\_\_\_

HUB Subcontractor Name: \_\_\_\_\_ HUB Status: \_\_\_\_\_

Certifying Agency (Check all applicable):  State General Services Commission  Other

Address: \_\_\_\_\_ City: \_\_\_\_\_ State: \_\_\_\_\_ Zip: \_\_\_\_\_  
Contact Person: \_\_\_\_\_ Title: \_\_\_\_\_ Phone No.: ( ) \_\_\_\_\_  
Subcontract Amount: \$ \_\_\_\_\_  
Description of Work to be performed: \_\_\_\_\_

## Certification For Primary Covered Transactions

1. The \_\_\_\_\_ (Vendor Name) certifies to the best of its knowledge and belief, that it and its principals:
  - a) Are not presently debarred, suspended, proposed for debarment, declared ineligible, or voluntarily excluded by any Federal department or agency;
  - b) Have not within a three-year period preceding this proposal been convicted of or had a civil judgment rendered against them for commission of fraud or a criminal offense in connection with obtaining, attempting to obtain, or performing a public (Federal, State or local) transaction or contract under a public transaction; violation of Federal or State antitrust statutes or commission of embezzlement, theft, forgery, bribery, falsification or destruction of records, making false statements, or receiving stolen property;
  - c) Are not presently indicted for or otherwise criminally or civilly charged by a governmental entity (Federal, State or local) with commission of any of the offenses enumerated in paragraph (1)(b) of this certification; and
  - d) Have not within a three-year period preceding this request for qualifications had one or more public transactions (Federal, State or local) terminated for cause or default.
  
2. Where the \_\_\_\_\_ (Vendor Name) is unable to certify to any of the statements in this certification, such prospective vendor shall attach an explanation to this RFQ.

Signature: \_\_\_\_\_

Print Name: \_\_\_\_\_

Title: \_\_\_\_\_

Telephone No.: \_\_\_\_\_ Date: \_\_\_\_\_

# Request for Taxpayer Identification Number and Certification

Completed form should be given to the requesting department or the department you are currently doing business with.

**Name** ( List legal name, if joint names, list first & circle the name of the person whose TIN you enter in Part I-See Specific instruction on page 2)

**Business name**, if different from above. (See Specific instruction on page 2)

Check the appropriate box:  Individual/Sole proprietor  Corporation  Partnership  Other ▶

**Legal Address:** number, street, and apt. or suite no.

**Remittance Address:** if different from legal address number, street, and apt. or suite no.

**City, state and ZIP code**

**City, state and ZIP code**

Phone # ( )

Fax # ( )

Email address:

## Part I Taxpayer Identification Number (TIN)

Enter your TIN in the appropriate box. For individuals, this is your social security number (SSN). However, for a resident alien, sole proprietor, or disregarded entity, see the Part I instruction on page 2. For other entities, it is your employer identification number (EIN). If you do not have a number, see How to get a TIN on page 2.

*Note: If the account is in more than one name, see the chart on page 2 for guidelines on whose number to enter.*

**Social security number**

□□□-□□-□□□□

OR

**Employer identification number**

□□-□□□□□□

**Vendors:**

Dunn and Bradstreet Universal Numbering System (DUNS)

**DUNS**

□□□□□□□□

## Part II Certification

Under penalties of perjury, I certify that:

- The number shown on this form is my correct taxpayer identification number (or I am waiting for a number to be issued to me), and
- I am not subject to backup withholding because: (a) I am exempt from backup withholding, or (b) I have not been notified by the Internal Revenue Services (IRS) that I am subject to backup withholding as a result of a failure to report all interest or dividends, or (c) the IRS has notified me that I am no longer subject to backup withholding, and
- I am an U.S. person (including an U.S. resident alien).
- I am currently a Commonwealth of Massachusetts's state employee: (check one): No  Yes  If yes, in compliance with the State Ethics Commission requirements.

**Certification instructions:** You must cross out item 2 above if you have been notified by the IRS that you are currently subject to backup withholding because you have failed to report all interest and dividends on your tax return. For real estate transactions, item 2 does not apply.

Sign

Here **Authorized Signature** ▶

**Date** ▶

### Purpose of Form

A person who is required to file an information return with the IRS must get your correct taxpayer identification number (TIN) to report, for example, income paid to you, real estate transactions, mortgage interest you paid, acquisition or debt, or contributions you made to an IRA.

Use Form W-9 only if you are a U.S. person (including a resident alien), to give your correct TIN to the person requesting it (the requester) and, when applicable, to:

- Certify the TIN you are giving is correct (or you are waiting for a number to be issued).
- Certify you are not subject to backup withholding.

If you are a foreign person, use the appropriate Form W-8. See Pub 515, Withholding of Tax on Nonresident Aliens and Foreign Corporations.

**What is backup withholding?** Persons making certain payments to you must withhold a designated percentage, currently 28% and pay to the IRS of such payments under certain

conditions. This is called "backup withholding." Payments that may be subject to backup withholding include interest, dividends, broker and barter exchange transactions, rents, royalties, nonemployee pay, and certain payments from fishing boat operators. Real estate transactions are not subject to backup withholding.

If you give the requester your correct TIN, make the proper certifications, and report all your taxable interest and dividends on your tax return, payments you receive will not be subject to backup withholding. Payments you receive will be subject to backup withholding if:

- You do not furnish your TIN to the requester, or
- You do not certify your TIN when required (see the Part II instructions on page 2 for details), or
- The IRS tells the requester that you furnished an incorrect TIN, or
- The IRS tells you that you are subject to backup withholding because you did not report all your interest and dividends only), or

5. You do not certify to the requester that you are not subject to backup withholding under 4 above (for reportable interest and dividend accounts opened after 1983 only).

Certain payees and payments are exempt from backup withholding. See the Part II instructions on page 2.

### Penalties

**Failure to furnish TIN.** If you fail to furnish your correct TIN to a requester, you are subject to a penalty of \$50 for each such failure unless your failure is due to reasonable cause and not to willful neglect.

**Civil penalty for false information with respect to withholding.** If you make a false statement with no reasonable basis that results in no backup withholding, you are subject to a \$500 penalty.

**Criminal penalty for falsifying information.** Willfully falsifying certifications or affirmations may subject you to criminal penalties including fines and/or imprisonment.

**Misuse of TINs.** If the requester discloses or uses TINs in violation of Federal law, the requester may be subject to civil and criminal penalties.

**HIDALGO COUNTY HEAD START PROGRAM  
PROCUREMENT DEPARTMENT  
BID TABULATION SHEET**

DEPARTMENT NAME: **Hidalgo County Head Start Program**

BID OPENING DATE: **AUGUST 31, 2012**

BID OPENING TIME: **2:00 P.M.**

DESCRIPTION OF BID: **"BUILDING RELOCATION - PALMVIEW I HEAD START"**

BID NUMBER 2012-021-08-31

BID # RFB#	NAME OF COMPANY		CONTRACTOR'S PRICE	
#1				
#2				
#3				
#4				
#5				
#6				
#7				
#8				

HIDALGO COUNTY HEAD START  
PROGRAM  
REQUEST FOR BIDS

“BUILDING RELOCATION –  
PALMVIEW I HEAD START”

EXHIBIT “D”

CONFLICT OF INTEREST

EXHIBIT D

CONFLICT OF INTEREST QUESTIONNAIRE

FORM CIQ

For vendor or other person doing business with local governmental entity

This questionnaire is being filed in accordance with chapter 176 of the Local Government Code by a person doing business with the governmental entity.

OFFICE USE ONLY

Date Received

By law this questionnaire must be filed with the records administrator of the local government not later than the 7th business day after the date the person Becomes aware of facts that require the statement to be filed. See Section 176.006, Local Government Code.

A person commits an offense if the person violates Section 176.006 Local Government Code. An Offense under this section is a Class C misdemeanor.

1 Name of person doing business with local governmental entity.

2 [ ] Check this box if you are filling an update to a previously filed questionnaire.

(The law requires that you file an updated completed questionnaire with the appropriate filing authority not later than the 7th business day after the date the originally filed questionnaire becomes incomplete or inaccurate.)

3 Name of local government officer with whom filer has employment or business relationship.

Name of Officer

This section (item 3 including subparts A,B, C & D) must be completed for each officer with whom the filer has an employment or other business relationship as defined by Section 176.001 (1-a), Local Government Code. Attach additional pages to this Form CIQ as necessary.

A. Is the local government officer named in this section receiving or likely to receive taxable income other than investment income from the filer of the questionnaire?

[ ] Yes [ ] No

B. Is the filer of the questionnaire receiving or likely to receive taxable income, other than investment income, from or at the direction of the local government officer named in this section AND the taxable income is not received from the local government entity?

[ ] Yes [ ] No

C. Is the filer of the questionnaire employed by a corporation or other business entity with respect to which the local government officer serves as an officer or director, or holds an ownership of 10 percent or more?

[ ] Yes [ ] No

D. Describe each employment or business relationship with the local government officer named in this section.

4 Signature of person doing business with the governmental entity

Date

## **EXHIBIT D**

### **DISCLOSURE OF CONFLICT OF INTEREST**

Effective January 1, 2006, Chapter 176 of the Texas Local Government Code requires that any vendor, person, consultant or contractor considering doing business with Hidalgo County ("the County") to disclose in the Conflict of Interest Questionnaire (the "CIQ") attached as Exhibit D, the vendor, person, consultant or contractor's affiliation or business relationship that might cause a conflict of interest with the Hidalgo County Head Start Program. By law, the CIQ must be filed with the Hidalgo County Clerk's Office no later than the seventh business day after the date the person becomes aware of facts that require that statement to be filed. The disclosure requirement applies to a person or business that contracts or seeks to contract with Hidalgo County for the sale or purchase of property, goods or service. Any purchase order or contract resulting from this process shall be considered null and void if the successful participant fails to comply with Texas Local Government Code Chapter 176. Vendors, consultants, contractor and others who desire to conduct business with Hidalgo County Head Start Program are encouraged to refer to Texas Local Government Code Chapter 176 for the details of this law. An offense under Texas Local Government Code Chapter 176 is a Class C. Misdemeanor.

Please Submit completed forms to the Hidalgo County Clerk's Office located at 100 North Closner, Edinburg, Texas 78539-Hidalgo County Courthouse.

**COMPLETION AND SUBMISSION OF FORM CIQ IS THE SOLE RESPONSIBILITY OF THE RESPECTIVE PARTICIPANT.**





7. Company shall provide current insurance on all its vehicles and all persons connected with providing the Services under this Contract naming Program as an additional insured (with coverage in the amounts described in Exhibit "C" attached hereto and incorporated herein for all purposes), and shall furnish to Program certificates of such insurance coverage.

8. Company shall provide a sufficient number of trucks, vehicles, personnel and equipment available to safely and efficiently provide the Services.

9. Company shall indemnify and hold harmless Program, its elected officials, employees and agents from any and all claims, damages, losses, and expenses including attorney's fees for the defense of any action against Program arising out of, resulting from, or connected with the provision of the Service by Company under this Contract. Said indemnity shall cover any act or failure to act by the Company, its agents or employees.

10. **Entire Agreement.** This Agreement contains the entire contract between the parties hereto and each party acknowledges that neither has made (either directly or through any agent or representative) any representation or agreement in connection with this Agreement not specifically set forth herein. This Agreement may be modified or amended only by agreement in writing executed by Program, and not otherwise.

11. **Non-Assignment.** This Contract shall not be assignable in whole or in part by either party without prior written consent of the other party, which consent shall not be unreasonably withheld.

12. **No Waiver.** No waiver of a breach of any provision of this Agreement shall be construed to be a waiver of any breach of any other provision. No delay in acting with regard to any breach of any provision of this Agreement shall be construed to be a waiver of such breach.



Agreement shall be construed as if such invalid, illegal, or unenforceable provision had never been contained herein.

17. **Amendments.** This Contract shall constitute the entire understanding of the parties with respect to the subject matter and supersedes any prior understandings or written or oral agreement between the parties respecting the subject matter within. Further, no amendment, modification or alteration of terms shall be binding unless the same is in writing, and duly executed by the parties.

18. **Successors.** This Contract shall be binding upon and inure to the benefit of the parties hereto and their respective heirs, executors, administrators, legal representatives, successors, and assigns where permitted by this Contract.

19. **TEXAS LAW TO APPLY.** The provisions of this Contract will be construed under and in accordance with the provisions of the laws of the State of Texas, and all obligations of the parties created hereunder and performable in Hidalgo County, Texas.

20. **Termination.** Any contract award to a successful bidder will be in effect until (a) the contract expires, (b) delivery and acceptance of products, and/or performance of services ordered, or (c) terminated without cause by Program with thirty day's written notice prior to cancellation.

21. **Commitment of Current Revenues.** In the event that, during any term hereof, the governing body of any party does not appropriate sufficient funds to meet the obligations of such party under this Contract, then any party may terminate this Contract upon sixty (60) days written notice to the other party. Each of the parties hereto agrees, however, to use its best efforts to secure funds necessary for the continued performance of this Agreement. The parties intend this provision to be a continuing right to terminate this Agreement at the expiration of each budget period of each party hereto pursuant to the provisions of Tex. Loc. Govt. Code Ann. § 271.903.

22. **Warranty.** Company warrants that its work is Free of defect for a period of one year from the date of completion of the work performed under this contract.

WITNESS our hands in duplicate originals this \_\_\_\_\_, 2012

APPROVED BY COMMISSIONERS COURT ON: 2012

Company:

By: \_\_\_\_\_  
(Company Name)

By: \_\_\_\_\_  
(Print Name)

By: \_\_\_\_\_  
(Title )

By: \_\_\_\_\_  
Ramon Garcia, County Judge

By: \_\_\_\_\_  
Teresa Flores, Executive Director

APPROVED AS TO FROM:  
OXFORD & GONZALEZ

By: \_\_\_\_\_  
Ricardo Gonzalez

By: \_\_\_\_\_  
Arturo Guajardo, Jr., County Clerk

APPROVED AS TO FROM  
ATLAS & HALL, L.L.P.

By: \_\_\_\_\_  
Stephen L. Crain

# HIDALGO COUNTY HEAD START PROGRAM

EDINBURG, TEXAS

## PALMVIEW I - RELOCATION

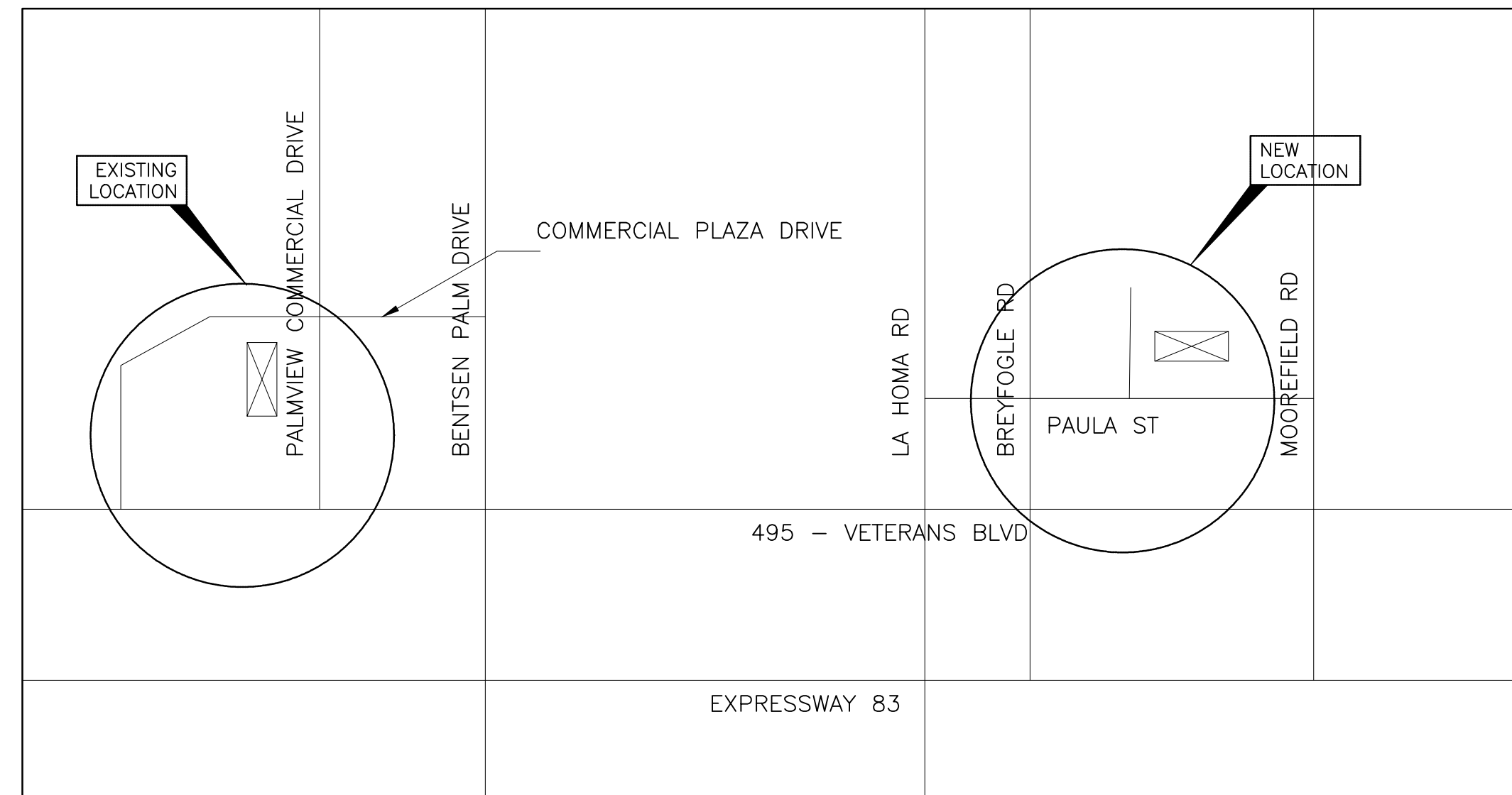

LOCATION MAP  
NTS

G1.0 COVER SHEET

CIVIL PLANS

C1 OVERALL SITE LAYOUT  
C2 CIVIL SITE PLAN

ARCHITECTURAL PLANS

A1.0 ARCHITECTURAL SITE PLAN & DETAILS  
A1.1 FLOOR PLAN & BUILDING SECTIONS

STRUCTURAL PLANS

S1.00 GENERAL NOTES  
S2.00 FLOOR FRAMING CUT LINES  
S3.00 ROOF FRAMING CUT LINES  
S4.00 NEW ROOF FRAMING PLAN  
SD1.00 ROOF FRAMING DETAILS  
SD2.00 FRAMING SECTIONS

MEP

M1.1 MECHANICAL & PLUMBING PLAN  
E1.1 ELECTRICAL PLAN

Hidalgo County Judge Ramon Garcia  
Hidalgo County Precinct No. 3 Commissioner Joe Flores  
Hidalgo County Head Start Program Director Teresa Flores

### DANNENBAUM

ENGINEERING COMPANY - McALLEN, LLC  
T.B.P.E. FIRM REGISTRATION #8999  
T.B.A.E. FIRM REGISTRATION #19734  
1109 NOLANA LOOP, STE 208 McALLEN, TX 78504 (956) 682-3677

## JULY 2012

DESIGNED BY:	REVISIONS		
	NO	DATE	APP
DRAWN BY:			
CHECKED BY:			
APPROVED BY:			
DATE: JULY 2012			

**DANNENBAUM**  
ENGINEERING COMPANY - McALLEN, LLC  
T.B.P.E. FIRM REGISTRATION #8999  
1109 NOLANA LOOP, STE 208 McALLEN, TX 78504 (956) 682-3677

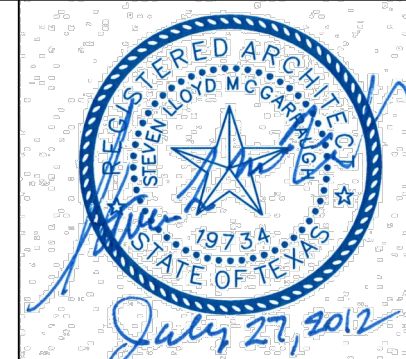

HEADSTART BUILDING RELOCATION PROJECT  
CITY OF PALMVIEW  
URBAN COUNTY PROJECT YEAR 2012

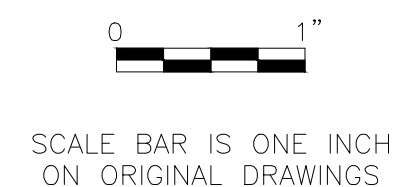

PROJECT No:  
4689-01

DRAWING No:

SHEET No:  
COVER

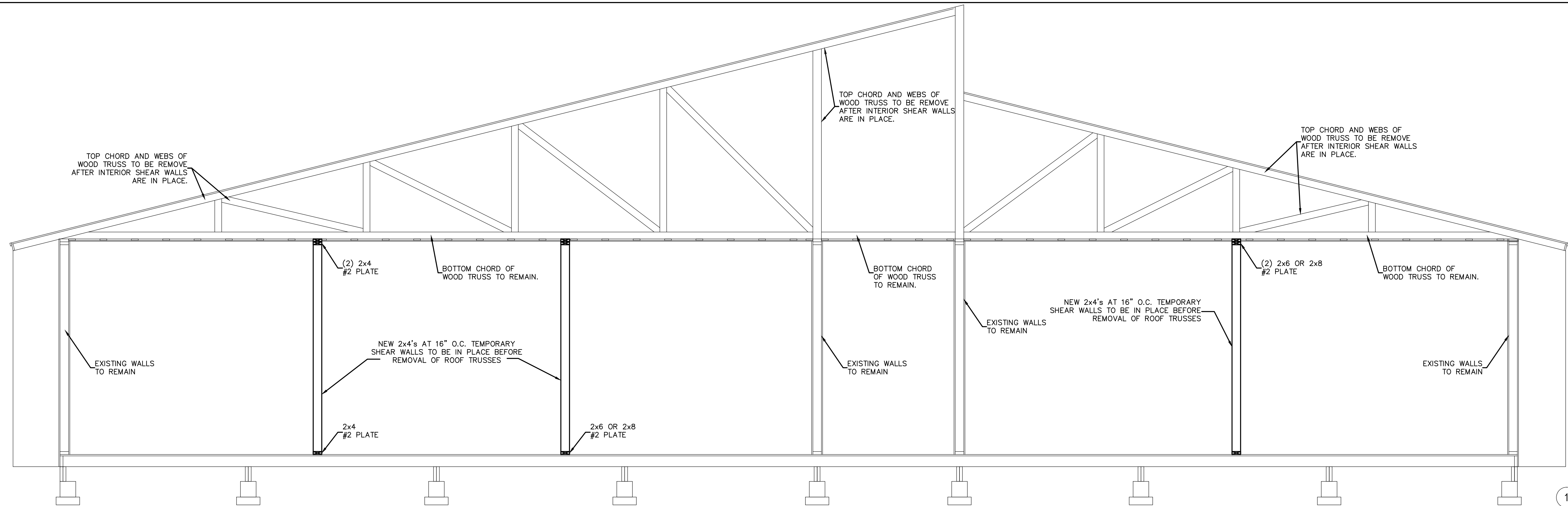

1 EXISTING ROOF SECTION  
NOT TO SCALE

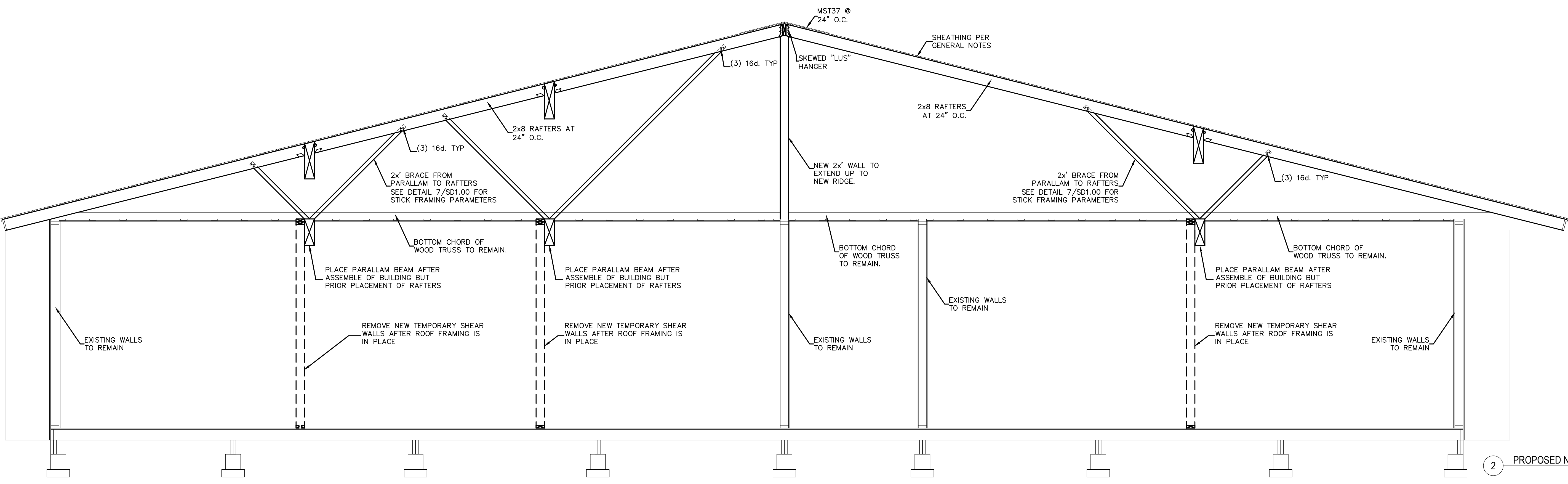

2 PROPOSED NEW ROOF SECTION  
NOT TO SCALE

DESIGNED BY:	REVISIONS		
DRAWN BY:	NO	DATE	APP
CHECKED BY:			
APPROVED BY:			
DATE: JULY 2012			

**CLH**  
ENGINEERING, INC.  
T.B.P.E. FIRM No. F-8719  
701 S. 15th STREET McALLEN, TX. 78501  
(956) 687-5560 (956) 687-5561 FAX

**DANNENBAUM**  
ENGINEERING COMPANY - McALLEN, LLC  
T.B.P.E. FIRM REGISTRATION #8999  
1109 NOLANA LOOP, STE 208 McALLEN, TX 78504 (956) 682-3677

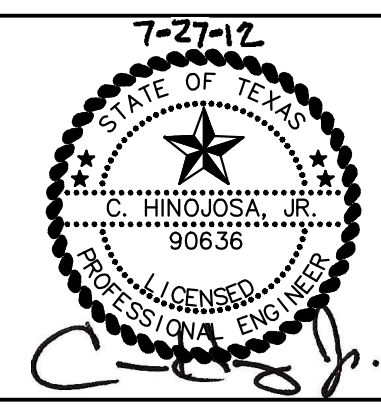

HEADSTART BUILDING RELOCATION PROJECT  
CITY OF PALMVIEW  
URBAN COUNTY PROJECT YEAR 2012

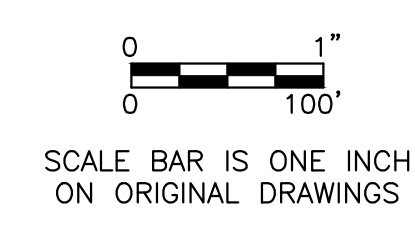

PROJECT No: 4689-01
DRAWING No:
SHEET No: <b>SD2.00</b>

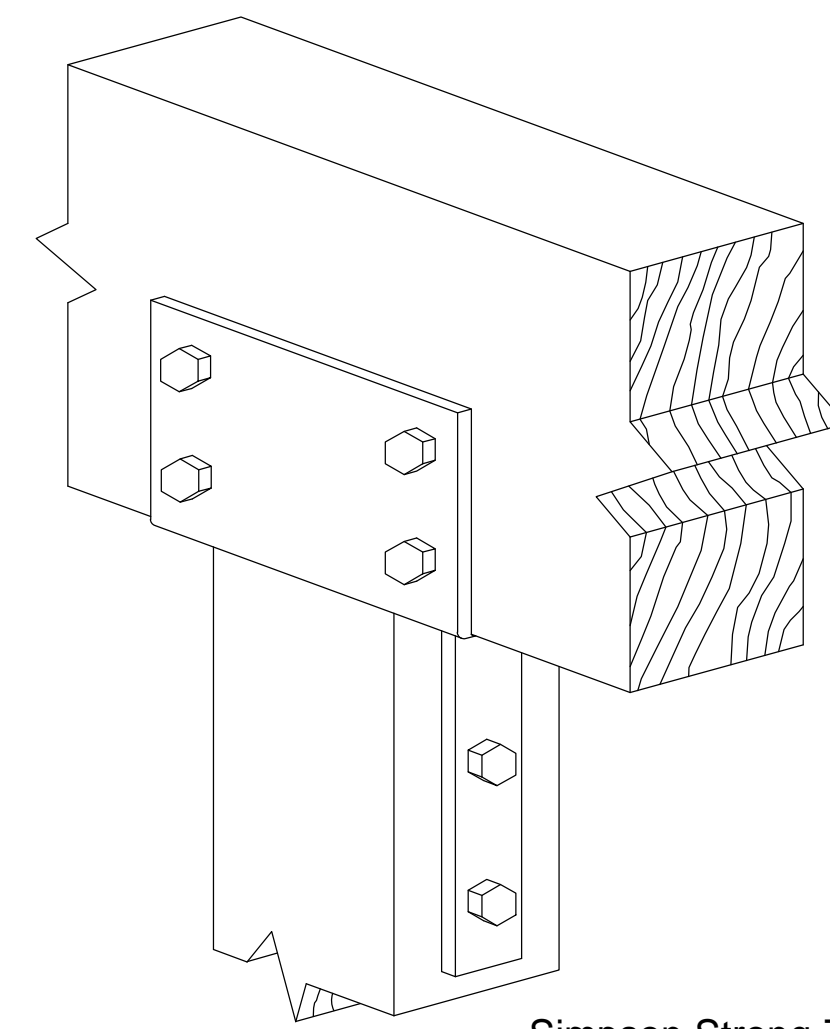

Simpson Strong-Tie  
CC66

6 WOOD BEAMS TO POST  
SCALE: NOT TO SCALE

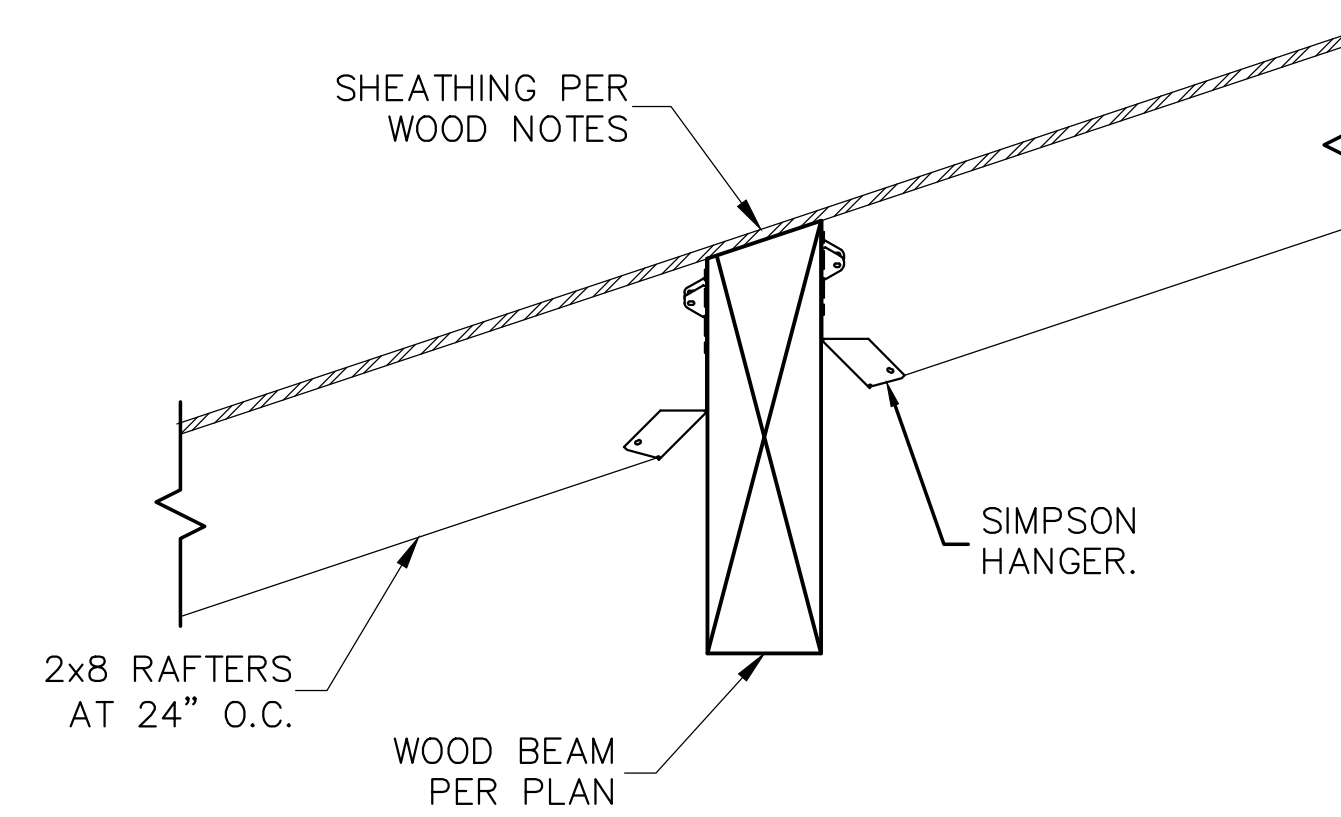

4 RAFTER TO WOOD BEAM  
SCALE: NOT TO SCALE

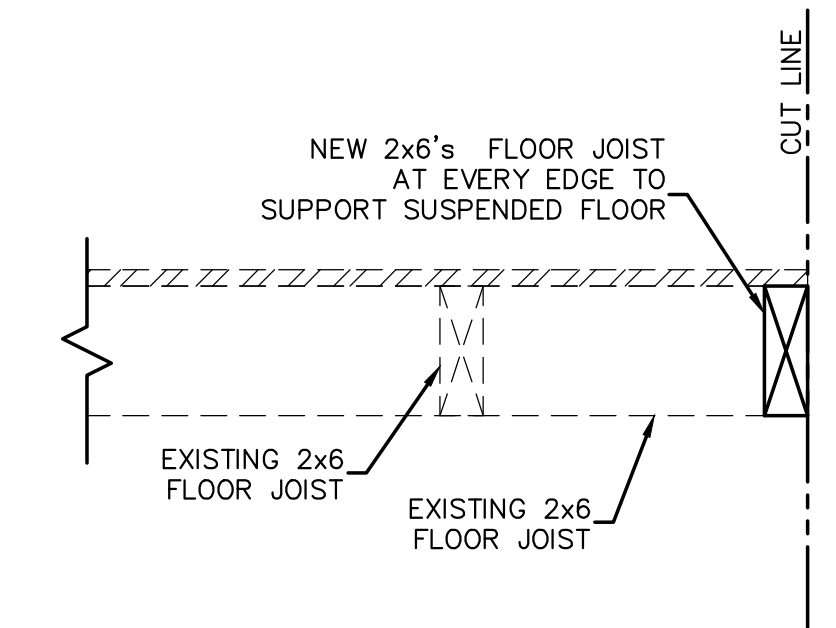

1 EXISTING FLOOR SECTION  
SCALE: NOT TO SCALE

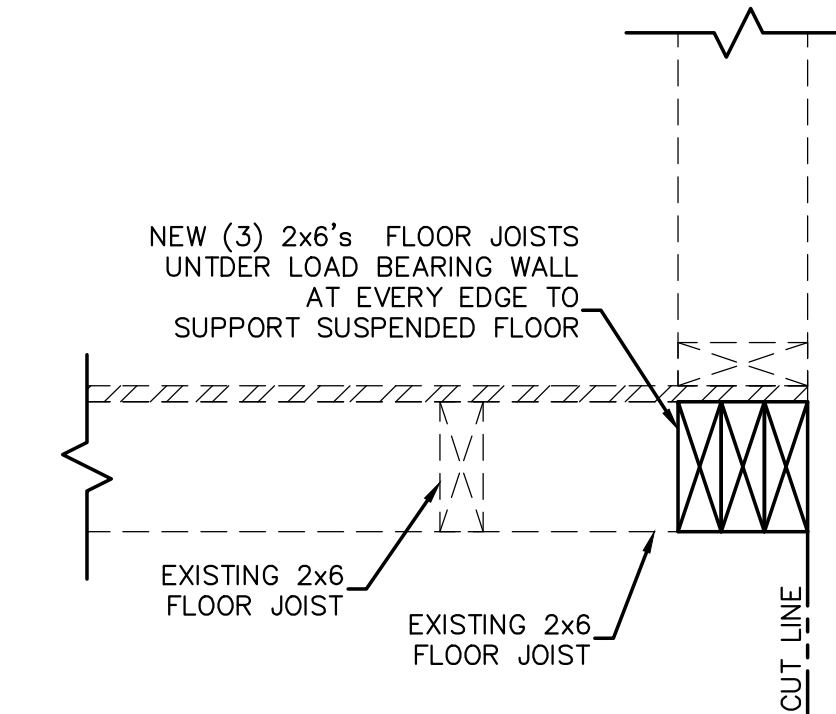

2 EXISTING FLOOR SECTION  
SCALE: NOT TO SCALE

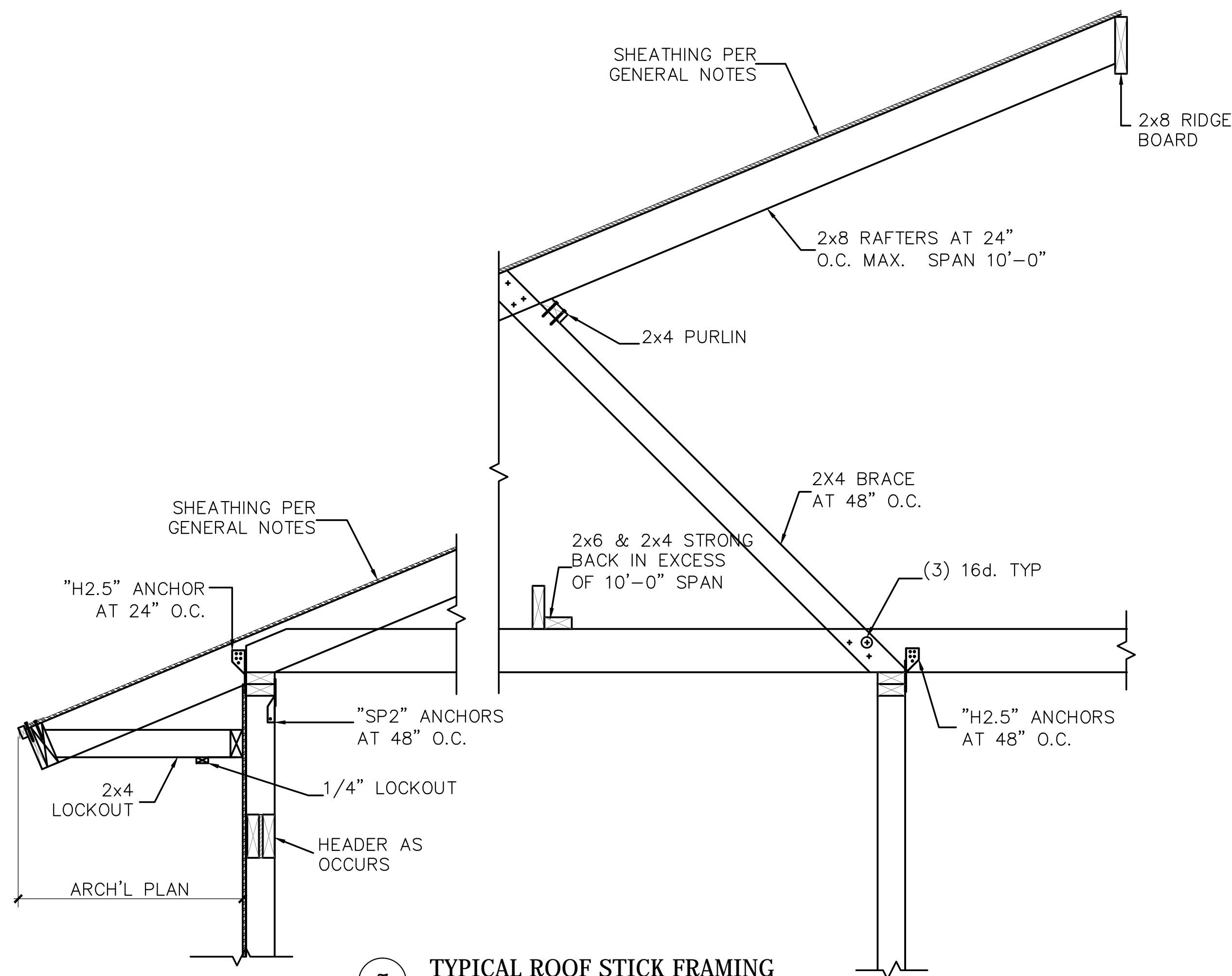

7 TYPICAL ROOF STICK FRAMING  
SCALE: NOT TO SCALE

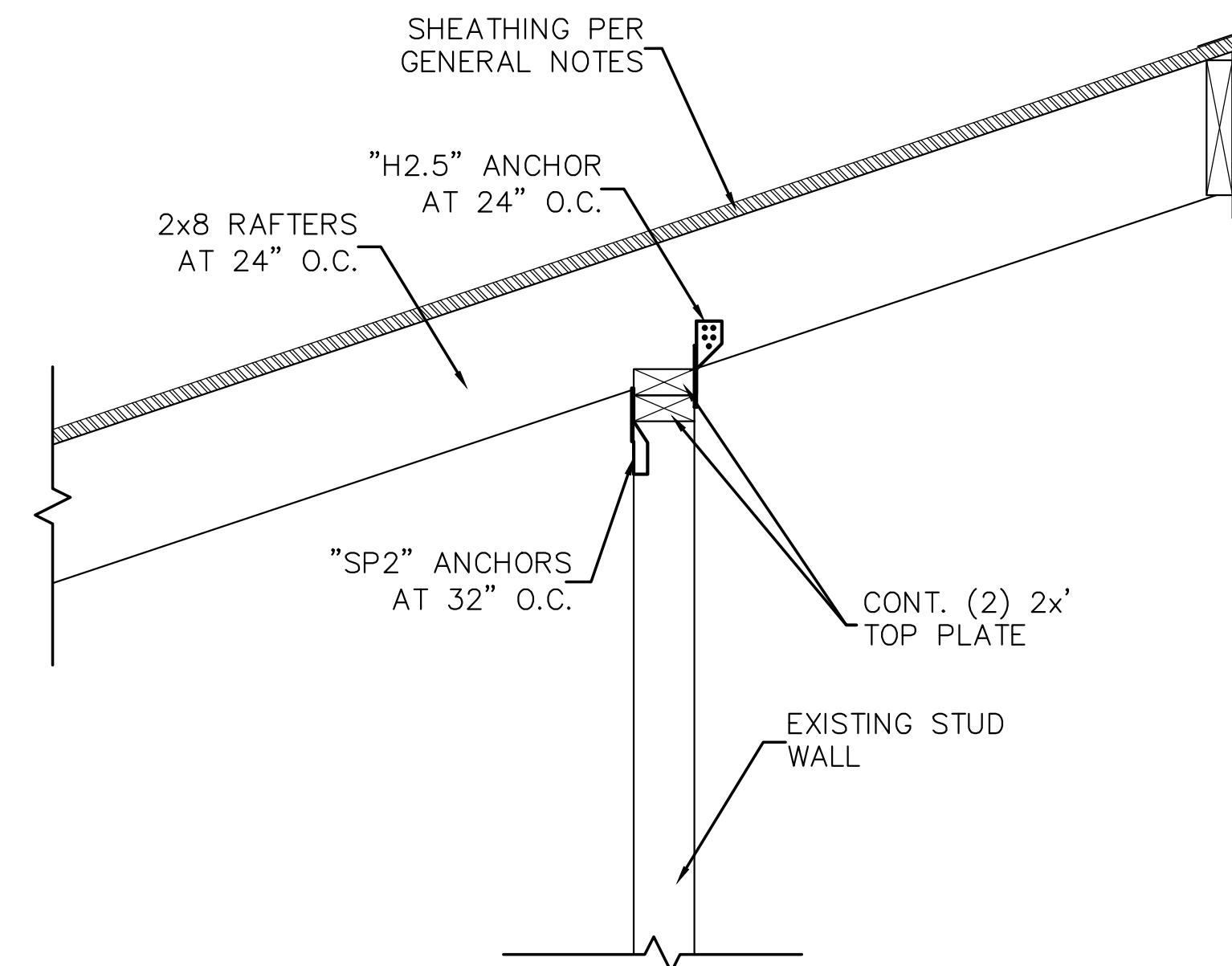

5 RAFTER TO STUD WALL  
SCALE: NOT TO SCALE

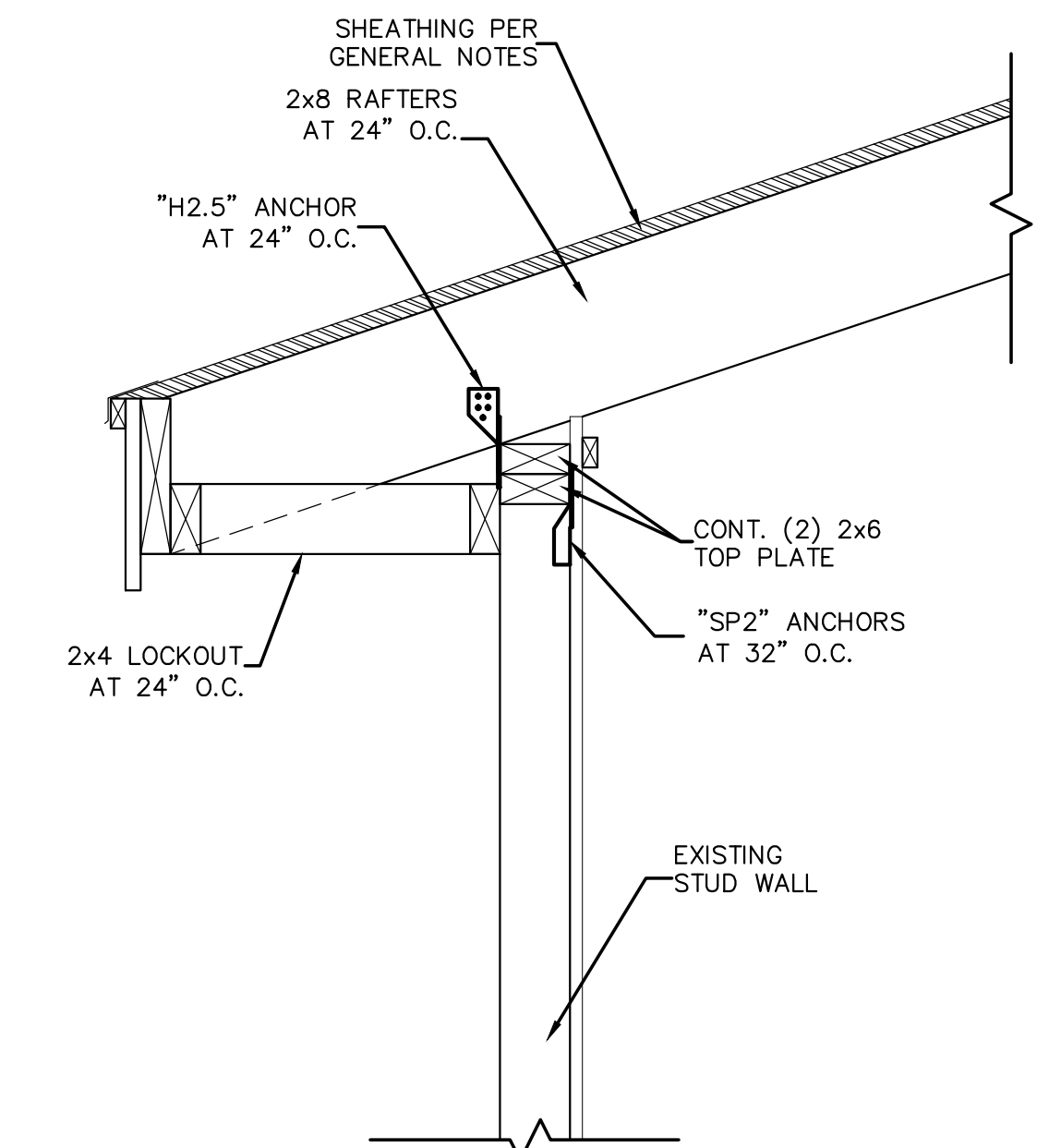

3 RAFTER TO STUD WALL  
SCALE: NOT TO SCALE

DESIGNED BY:  
DRAWN BY:  
CHECKED BY:  
APPROVED BY:  
DATE: JULY 2012

REVISIONS			
NO	DATE		APP

**CLH**  
ENGINEERING, INC.  
T.B.P.E. FIRM No. F-8719  
701 S. 15th STREET McALLEN, TX. 78501  
(956) 687-5560 (956) 687-5561 FAX

**DANNENBAUM**  
ENGINEERING COMPANY - McALLEN, LLC  
T.B.P.E. FIRM REGISTRATION #8999  
1109 NOLANA LOOP, STE 208 McALLEN, TX 78504 (956) 682-3677

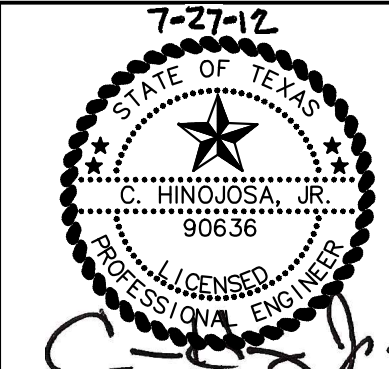

HEADSTART BUILDING RELOCATION PROJECT  
CITY OF PALMVIEW  
URBAN COUNTY PROJECT YEAR 2012

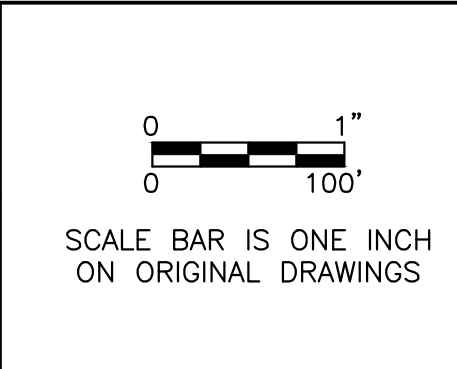

PROJECT No:  
4689-01  
DRAWING No:  
SHEET No:  
**SD1.00**

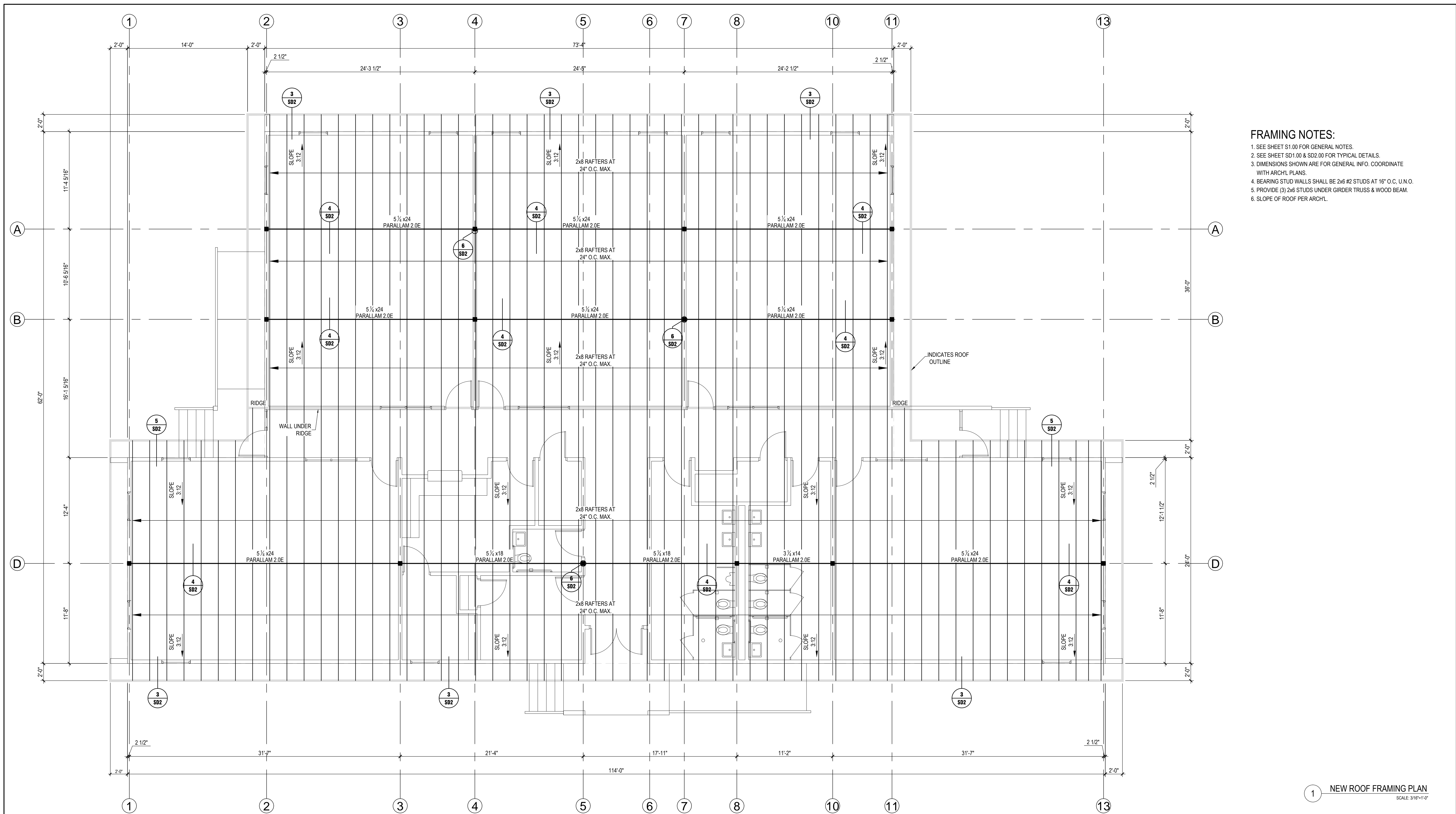

- FRAMING NOTES:**
1. SEE SHEET S1.00 FOR GENERAL NOTES.
  2. SEE SHEET SD1.00 & SD2.00 FOR TYPICAL DETAILS.
  3. DIMENSIONS SHOWN ARE FOR GENERAL INFO. COORDINATE WITH ARCHT. PLANS.
  4. BEARING STUD WALLS SHALL BE 2x6 #2 STUDS AT 16\"/>

1 NEW ROOF FRAMING PLAN  
SCALE: 3/16"=1'-0"

DESIGNED BY:	REVISIONS		
DRAWN BY:	NO	DATE	APP
CHECKED BY:			
APPROVED BY:			
DATE: JULY 2012			

**CLH**  
ENGINEERING, INC.  
T.B.P.E. FIRM No. F-8719  
701 S. 15th STREET McALLEN, TX. 78501  
(956) 687-5560 (956) 687-5561 FAX

**DANNENBAUM**  
ENGINEERING COMPANY - McALLEN, LLC  
T.B.P.E. FIRM REGISTRATION #8999  
1109 NOLANA LOOP, STE 208 McALLEN, TX 78504 (956) 682-3677

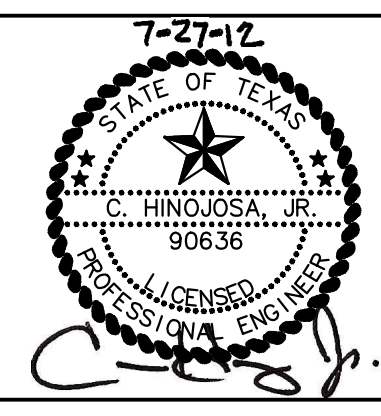

HEADSTART BUILDING RELOCATION PROJECT  
CITY OF PALMVIEW  
URBAN COUNTY PROJECT YEAR 2012

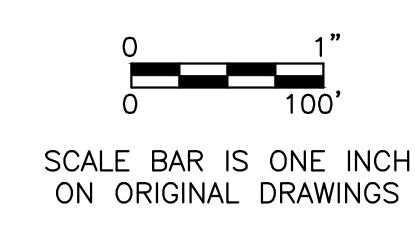

PROJECT No: 4689-01
DRAWING No:
SHEET No: <b>S4.00</b>

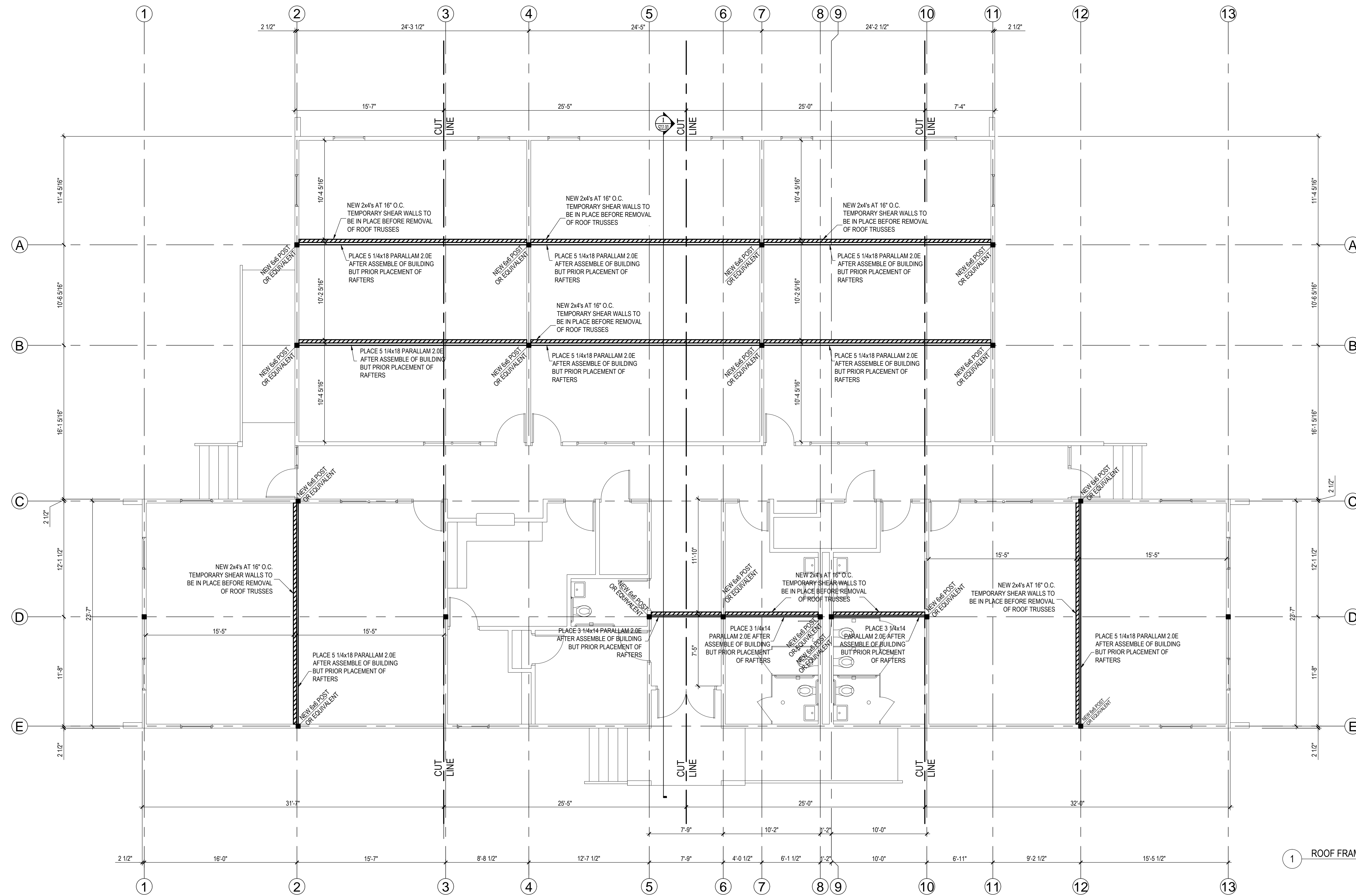

1 ROOF FRAMING CUT LINE PLAN  
SCALE 3/16"=1'-0"

DESIGNED BY:	REVISIONS			
DRAWN BY:	NO	DATE		APP
CHECKED BY:				
APPROVED BY:				
DATE: JULY 2012				

**CLH**  
ENGINEERING, INC.  
TBPE FIRM No. F-8719  
701 S. 15th STREET McALLEN, TX. 78501  
(956) 687-5560 (956) 687-5561 FAX

**DANNENBAUM**  
ENGINEERING COMPANY - McALLEN, LLC  
T.B.P.E. FIRM REGISTRATION #8999  
1109 NOLANA LOOP, STE 208 McALLEN, TX 78504 (956) 682-3677

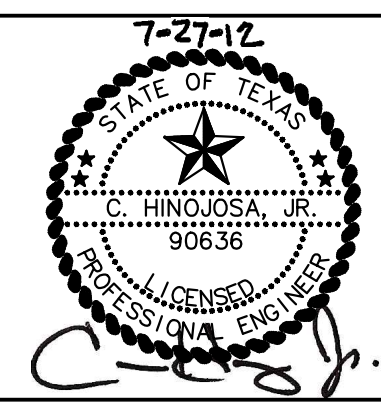

HEADSTART BUILDING RELOCATION PROJECT  
CITY OF PALMVIEW  
URBAN COUNTY PROJECT YEAR 2012

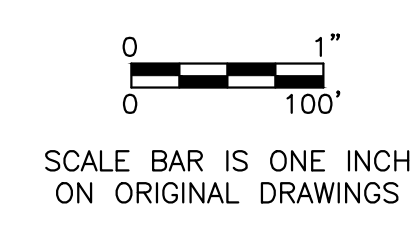

PROJECT No: 4689-01
DRAWING No:
SHEET No: <b>S3.00</b>

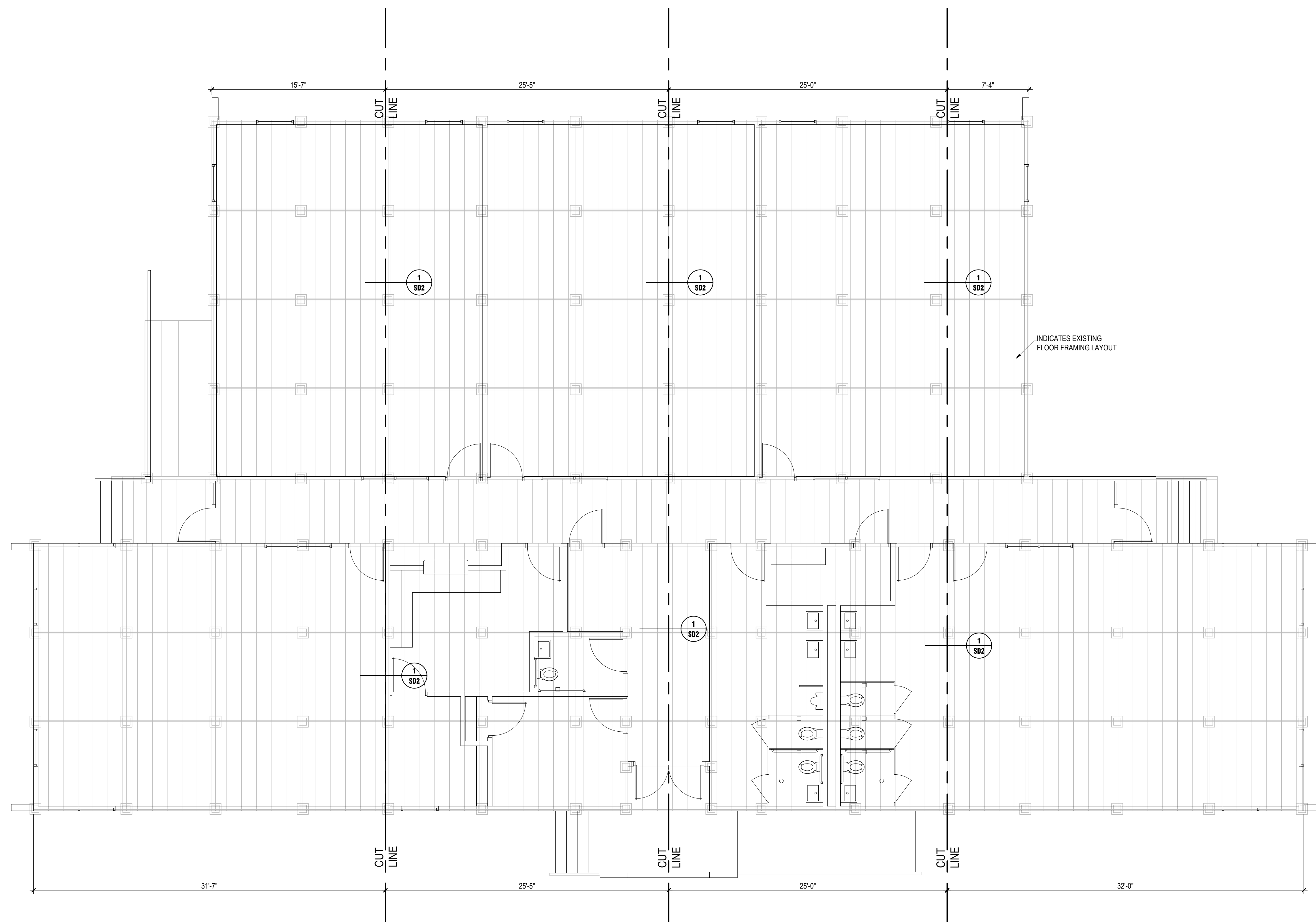

1 FLOOR FRAMING CUT LINE PLAN  
SCALE: 3/16"=1'-0"

DESIGNED BY:	REVISIONS		
DRAWN BY:	NO	DATE	APP
CHECKED BY:			
APPROVED BY:			
DATE: JULY 2012			

**CLH**  
ENGINEERING, INC.  
T.B.P.E. FIRM No. F-8719  
701 S. 15th STREET McALLEN, TX. 78501  
(956) 687-5560 (956) 687-5561 FAX

**DANNENBAUM**  
ENGINEERING COMPANY - McALLEN, LLC  
T.B.P.E. FIRM REGISTRATION #8999  
1109 NOLANA LOOP, STE 208 McALLEN, TX 78504 (956) 682-3677

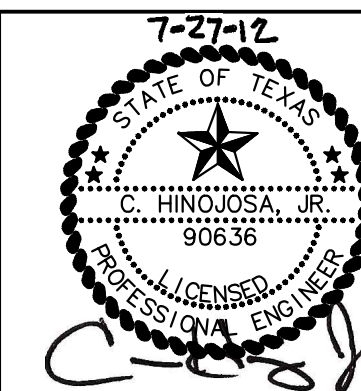

HEADSTART BUILDING RELOCATION PROJECT  
CITY OF PALMVIEW  
URBAN COUNTY PROJECT YEAR 2012

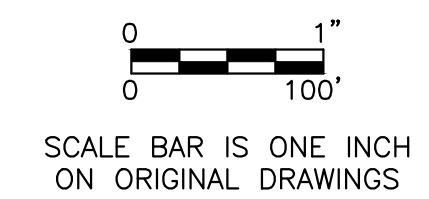

PROJECT No: 4689-01
DRAWING No:
SHEET No: <b>S2.00</b>



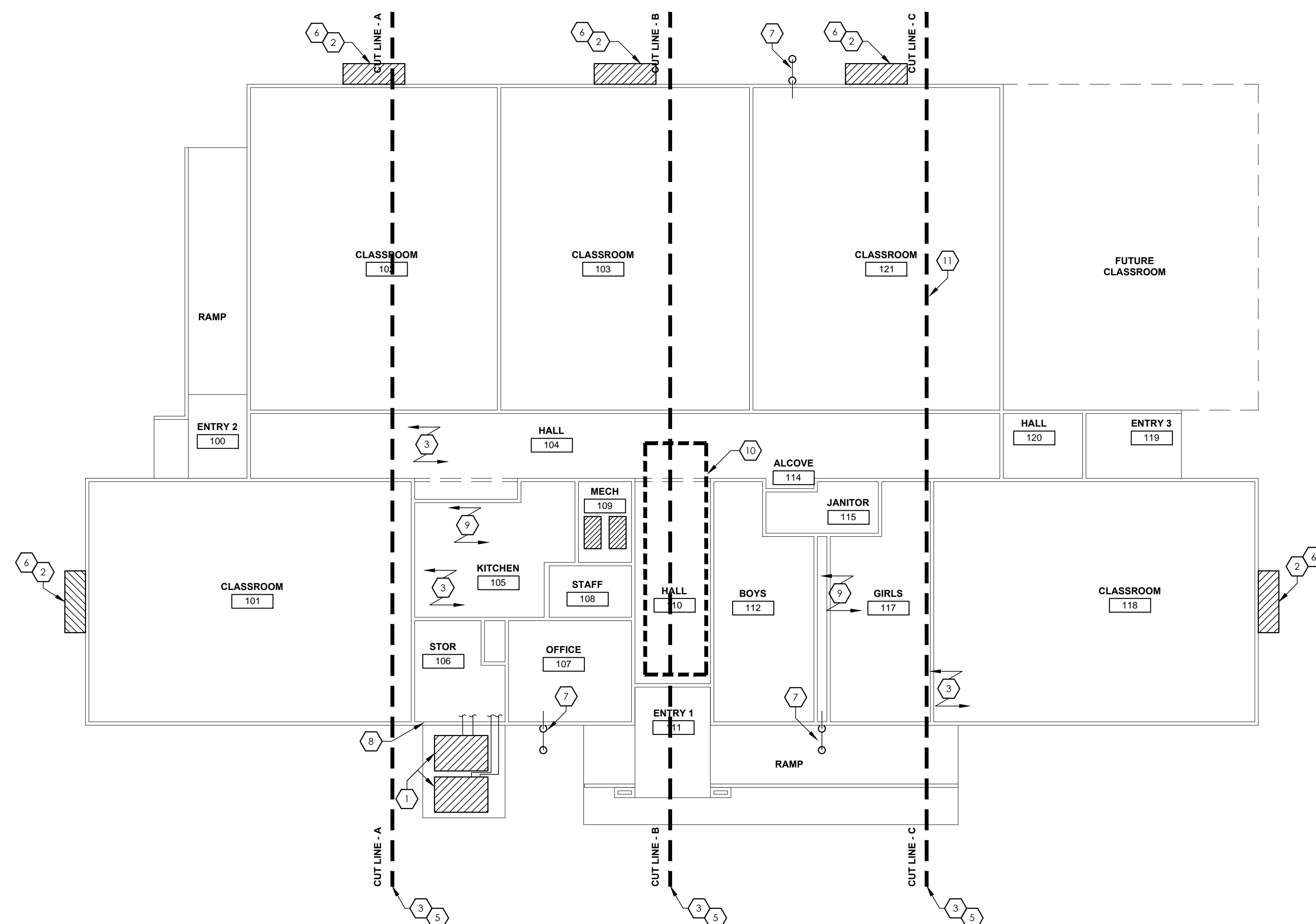

1 OVERALL MECHANICAL & PLUMBING PLAN  
SCALE: 1/8"=1'-0"

**KEYED NOTES: MECHANICAL/PLUMBING**

- 1 VACUUM ALL REFRIGERANT IN SPLIT SYSTEMS & STORE REFRIGERANT IN CONDENSING UNITS. CUT REFRIGERANT LINES @ EXTERIOR WALL & SEAL REFRIGERANT LINES TO PREVENT MOISTURE/DEBRIS FROM ENTERING.
- 2 REMOVE WALL MOUNTED UNITS & ELECTRICAL. DISCONNECT ALL SERVICES ASSOCIATED W/ UNIT. STORE UNIT (TO BE RE-MOUNTED @ ASSEMBLY SITE).
- 3 CUT ALL DUCTS THAT CROSS CUT LINE (INCLUDED BUT NOT LIMITED TO SUPPLY, RETURN, AND EXHAUST). IF DUCT TO BE CUT IS FLEX DUCT, REMOVE FLEX DUCT & DISPOSE OF. SEAL ALL CUT DUCT W/ PLASTIC WRAP ON CUT END TO PREVENT DEBRIS FROM ENTERING. IF EXISTING GRILLES ARE RE-USABLE, TAKE OFF CEILING & STORE AWAY.
- 4 IF DUCT THAT RUNS DOWN "HALL 110" TO "HALL 104" IS @ CUT LINE, REMOVE DUCT WORK. DUCT WORK TO BE RE-INSTALLED @ RE-ASSEMBLY SITE. CLEAN OUT DUCT INTERIOR PRIOR TO MOVE & COVER CUT PORTIONS W/ PLASTIC WRAP.
- 5 CUT & TEMPORARY CAP ALL PLUMBING LINES CROSSING CUT LINE(S). PIPING TO BE RE-ASSEMBLED USING PIPING UNIONS @ RE-ASSEMBLY SITE.
- 6 PROVIDE RE-INSTALLED UNIT W/ A NEW DRY WELL @ RE-ASSEMBLY SITE. FOR UNIT CONDENSATE. PROVIDE W/ 1" PVC PIPE INTO A 2" PVC PIPE @ GRADE LEVEL W/ CLEAN OUT, HORIZONTALLY THROUGH A CONCRETE ENCASUREMENT INTO A 36" TALL DRY WELL 6" BENEATH GRADE.
- 7 DISCONNECT DOMESTIC WATER & SEWER UTILITIES, RE-CONNECT/RE-ROUTE @ RE-ASSEMBLY SITE.
- 8 WALL HYDRANT TO BE RE-INSTALLED IF DAMAGED DURING DEMOLITION.
- 9 ALL PLUMBING IN KITCHEN/RESTROOM DEMOLISHED SHALL BE RE-CONNECTED AT RE-ASSEMBLY SITE.
- 10 ANY WATER LINE CUT DURING DEMO IN THIS ARE TO BE RE-CONNECTED.
- 11 VENT THROUGH ROOF IS DEMOLISHED TO BE RE-CONNECTED.

**GENERAL MECHANICAL/PLUMBING NOTES**

- A. THE EXTENT OF DEMOLITION WORK IS INDICATED ON THE ARCHITECTURAL DRAWINGS A, AND BY THE REQUIREMENTS OF THIS SECTION. A VISIT TO THE SITE WILL BE REQUIRED TO PROPERLY BID THE DEMOLITION WORK.
- B. PROVIDE ALL DEMOLITION WORK REQUIRED FOR THE REMOVAL AND/OR RELOCATION OF HVAC & PLUMBING FIXTURES AND EQUIPMENTS AND ASSOCIATED SERVICES TO PROVIDE A COMPLETE AND OPERABLE SYSTEM UPON COMPLETION OF THE PROJECT.
- C. PLUMBING CONTRACTOR SHALL BE RESPONSIBLE TO REVIEW THE ARCHITECTURAL DOCUMENTS IN ADDITION TO THE DIVISION 15 AND 16 DOCUMENTS TO DETERMINE THE COMPLETE SCOPE OF WORK.
- D. WHERE FIXTURES OR EQUIPMENT ARE INDICATED OR REQUIRED TO BE REMOVED, THE ASSOCIATED SERVICES SHALL BE CAPPED AT A CONCEALED LOCATION.
- E. WHERE FIXTURES OR EQUIPMENT ARE INDICATED OR REQUIRED TO BE RELOCATED, THE ASSOCIATED SERVICES SHALL BE REMOVED AND CAPPED. NEW MATERIALS SHALL BE USED TO EXTEND SERVICES TO NEW LOCATION.
- F. WHERE SERVICES RUN ABOVE INACCESSIBLE CEILINGS OR IN WALLS WHICH ARE TO REMAIN UNDISTURBED, SERVICES SHALL BE CAPPED AT CONCEALED LOCATION AND ABANDONED.
- G. WHERE THE REMOVAL OF FIXTURES OR EQUIPMENT RENDERS EQUIPMENT DOWNSTREAM INOPERABLE, SERVICES SHALL BE EXTENDED TO THE DOWNSTREAM FIXTURES OR EQUIPMENT SO THAT THE FIXTURES OR EQUIPMENT IS LEFT IN OPERATING CONDITION.
- H. COORDINATE DEMOLITION OF DIVISION 15 SYSTEMS AS REQUIRED WITH ALL OTHER TRADES.
- I. ALL EXISTING H.V.A.C. AND EQUIPMENTS REMOVED DURING CONSTRUCTION THAT ARE NOT TO BE REUSED SHALL BE REMOVED FROM THE JOB SITE AND PROPERLY RETURNED TO THE OWNER, IF DESIRED BY OWNER.
- J. WHERE EXISTING FIXTURE OR EQUIPMENT IS TO BE RELOCATED, BE CAUTIOUS TO PREVENT DAMAGE DURING THE REMOVAL AND REINSTALLATION. WHERE DAMAGE OCCURS, THE EQUIPMENT SHALL BE REPLACED OR REPAIRED TO THE SATISFACTION AND APPROVAL OF THE ARCHITECT AT NO ADDITIONAL COST TO THE OWNER.
- K. EXISTING FIXTURES OR EQUIPMENT TO BE REUSED SHALL BE CLEANED AND REPAIRED AT THE DISCRETION OF THE ARCHITECT WHERE APPLICABLE.
- L. ALL MECHANICAL AND PLUMBING ITEMS DAMAGED DURING DEMOLITION SHALL BE REPAIRED DURING RE-ASSEMBLY.
- M. CONTRACTOR SHALL FIELD VERIFY PLUMBING CONNECTIONS AT NEW SITE AND MODIFY EXISTING CONNECTIONS TO ACCOMMODATE NEW SITE REQUIREMENTS.

**MECHANICAL/PLUMBING OUTLINE:**

- A. CONTRACTOR SHALL DISCONNECT ALL UTILITIES PRIOR TO ANY WORK ON BUILDING. COORDINATE WITH OWNER PRIOR TO DISCONNECTION.
- B. CONTRACTOR SHALL FIELD VERIFY EXISTING CONDITIONS AND DOCUMENT EXISTING CONDITIONS FOR RECORD.
- C. CONTRACTOR SHALL DISCONNECT ALL EXTERIOR ELECTRICAL AND PLUMBING CONNECTIONS TO ANY EXISTING EXTERIOR EQUIPMENT. FIELD VERIFY EXISTING CONDITIONS.
- D. COORDINATE, IF NEEDED TO REMOVE EXISTING WALL A/C UNITS FOR TRANSPORT. DISCONNECT ELECTRICAL CONNECTIONS. FIELD VERIFY EXISTING CONDITIONS.
- E. CONTRACTOR SHALL FOLLOW ALL SAFETY PRECAUTION PRIOR TO COMMENCING ANY WORK.

07/27/12

**TRINITY**  
MEP ENGINEERING

3533 Moreland Dr. Ste A | Weslaco, TX 78596  
p:956-673-0500 | f:956-351-5750  
www.trinitymep.com | Copyright 2012  
Texas Registered Engineering Firm - F10362  
Project number: 12.3.04

DESIGNED BY:	REVISIONS			
	NO	DATE		APP
DRAWN BY:				
CHECKED BY:				
APPROVED BY:				
DATE: JULY 2012				

**DANNENBAUM**  
ENGINEERING COMPANY - McALLEN, LLC  
T.B.P.E. FIRM REGISTRATION #8999  
1109 NOLANA LOOP, STE 208 McALLEN, TX 78504 (956) 682-3677

HEADSTART BUILDING RELOCATION PROJECT  
CITY OF PALMVIEW  
URBAN COUNTY PROJECT YEAR 2012

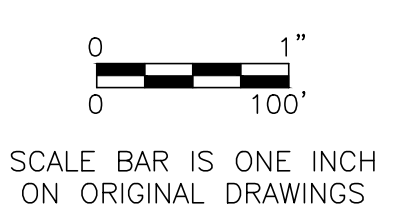

PROJECT No: 4689-01
DRAWING No:
SHEET No: M1.1

**GENERAL ELECTRICAL NOTES**

**ELECTRICAL OUTLINE:**

- A. CONTRACTOR SHALL DISCONNECT ALL UTILITIES PRIOR TO ANY WORK ON BUILDING. COORDINATE WITH OWNER PRIOR TO DISCONNECTION.
- B. CONTRACTOR SHALL FIELD VERIFY EXISTING CONDITIONS AND DOCUMENT EXISTING CONDITIONS FOR RECORD.
- C. CONTRACTOR SHALL DISCONNECT ALL EXTERIOR ELECTRICAL CONNECTIONS TO ANY EXISTING EXTERIOR EQUIPMENT. FIELD VERIFY EXISTING CONDITIONS.
- D. COORDINATE, IF NEEDED TO REMOVE EXISTING WALL A/C UNITS FOR TRANSPORT. DISCONNECT ELECTRICAL CONNECTIONS. FIELD VERIFY EXISTING CONDITIONS.
- E. CONTRACTOR SHALL SALVAGE EXISTING WIRING, CONDUIT, OR ETC. . ALL SALVAGE MATERIAL TO BE REUSE ONCE THE BUILDING IS SET.
- F. CONTRACTOR SHALL FIELD VERIFY EXISTING CONDITIONS TO DETERMINE WHAT OTHER ELECTRICAL FIXTURES, WIRING DEVICES, FIRE ALARM, SECURITY, A/C, PLUMBING, ETC., TO BE REMOVED TEMPORARY AND REINSTALL BACK TO ITS EXISTING CONDITIONS.
- G. CONTRACTOR SHALL FOLLOW ALL SAFETY PRECAUTION PRIOR TO COMMENCING ANY WORK.

- A. CONTRACTOR TO VERIFY ALL EXISTING MAIN POWER SERVICES AND COORDINATE WITH POWER COMPANY FOR ALL NEW REQUIREMENTS AND ALL COST ASSOCIATED. CONTRACTOR SHALL INCLUDE ANY COST FOR THE NEW TRANSFORMER AND OTHER ASSOCIATED FEES IN BID. CONTRACTOR IS RESPONSIBLE TO VERIFY ALL FEES WITH POWER COMPANY AND TO INCLUDE IN BID. CONTRACTOR IS RESPONSIBLE TO COORDINATE WITH POWER COMPANY AS SOON THE CONTRACT IS AWARDED TO ORDER TRANSFORMER AND THE RELATED ELECTRICAL SERVICE EQUIPMENT AS SOON AS POSSIBLE.
- B. CONTRACTOR IS RESPONSIBLE FOR ALL EXCAVATION, TRENCHING AND BACKFILLING. COORDINATE WITH ALL UTILITIES PRIOR TO EXCAVATION.
- C. CONTRACTOR TO VERIFY ALL EXISTING MAIN TELEPHONE SERVICES AND COORDINATE WITH TELEPHONE COMPANY FOR ALL REQUIREMENTS AND ALL COST ASSOCIATED. INCLUDE ALL COST IN BID. CONDUIT FROM MAIN TELEPHONE RISER SHALL BE FURNISHED AND INSTALLED BY ELECTRICAL CONTRACTOR.
- D. ALL ELECTRICAL EQUIPMENT OUTDOORS SHALL BE RATED TYPE NEMA 3R UNLESS OTHERWISE NOTED.
- E. CONTRACTOR SHALL HAVE A WORKING KNOWLEDGE OF LOCAL CODES AND ORDINANCES. ALL WORK SHALL CONFORM TO NATIONAL ELECTRICAL CODES AND ALL OTHER AUTHORITY HAVING JURISDICTION. OBTAIN PERMITS AND PAY ALL FEES. PERFORM MODIFICATIONS TO MEET CODE AND ORDINANCE REQUIREMENTS AT NO ADDITIONAL COST TO OWNER, ARCHITECT OR ENGINEER. VERIFY PRIOR TO BID DATE.
- F. ALL NEW WIRING SHALL BE COPPER.
- G. ALL SLEEVES, PENETRATIONS, ETC. SHALL BE SEALED SOLID NON-SHRINKING MATERIAL IMMEDIATELY UPON FILLING OF THE OPENING WITH PIPE OR CONDUIT.
- H. GROUND ENTIRE ELECTRICAL SYSTEM IN STRICT ACCORDANCE WITH THE NATIONAL ELECTRICAL CODE.
- I. VERIFY AT JOB SITE GENERAL WORK TO BE DONE AS SPECIFIED, AS NOTED, OR AS REQUIRED FOR INSTALLATION ELECTRICAL SYSTEMS PRIOR TO SUBMISSION OF BIDS.
- J. CONTRACTOR SHALL FIELD VERIFY EXISTING CONDITIONS AND EQUIPMENT TO BE REMOVED AND REPLACED BEFORE SUBMITTING HIS BID.
- K. COMPLY WITH NFPA 70E SAFETY REQUIREMENTS.

**KEYED NOTES: ELECTRICAL**

- 1 REMOVE ALL WIRING FROM THIS CUT BACK TO ITS SOURCE. REMOVE WIRING AND PROTECTED FOR POSSIBLE REUSE. CONTRACTOR SHALL DOCUMENT THE CONDITIONS PRIOR TO ANY WORK. FIELD VERIFY EXISTING CONDITIONS.
- 2 PROVIDE NEW JUNCTION BOXES TO RECONNECT CONDUITS. REUSE EXISTING WIRE IF POSSIBLE. IF NOT PROVIDE NEW WIRING. EXISTING WIRING SHALL BE INSPECTED PRIOR TO REUSE. CONTRACTOR IS RESPONSIBLE TO FIELD VERIFY EXISTING CONDITIONS.
- 3 ANY LIGHT FIXTURES, J-BOXES, RECEPTACLES, FIREALARM, SECURITY, OR ANY OTHER ELECTRICAL DEVICE THAT IS LOCATED IN THE WAY OF THE CUT, SHALL BE REMOVED TEMPORARY AND PLACE BACK IN ITS PLACE WHEN SECTIONS ARE UNITED AGAIN.
- 4 EXISTING ELECTRICAL SERVICE SHALL BE DISCONNECTED. ELECTRICAL SERVICE EQUIPMENT TO BE REMOVED WITH CARE. REINSTALL ELECTRICAL SERVICE EQUIPMENT ONCE THE BUILDING IS SET IN PLACE. FIELD VERIFY EXISTING CONDITIONS FOR NEW ELECTRICAL SERVICE CONNECTION.
- 5 REMOVE CONDUIT AND WIRING FROM EXISTING ELECTRICAL SERVICE DISCONNECT TO EXISTING PANEL-LA. EXISTING WIRING CAN BE USE ONCE THE BUILDING IS SET IN PLACE. THE CONTRACTOR IS RESPONSIBLE TO CONFIRM THE EXISTING WIRE CAN BE USE. CONTRACTOR SHALL PROVIDE ADDITIONAL CONDUIT AND JBOXES AS NEEDED TO CONNECT EXISTING CONDUITS.
- 6 REMOVE CONDUIT AND WIRING FROM EXISTING PANEL-LA TO EXISTING PANEL-LB. EXISTING WIRING CAN BE USE ONCE THE BUILDING IS SET IN PLACE. HE CONTRACTOR IS RESPONSIBLE TO CONFIRM THE EXISTING WIRE CAN BE USE. CONTRACTOR SHALL PROVIDE ADDITIONAL CONDUIT AND JBOXES AS NEEDED TO CONNECT EXISTING CONDUITS.
- 7 REMOVE EXISTING COMMUNICATION CONDUITS. PROVIDE NEW CONDUITS ONCE THE BUILDING IS SET IN PLACE. VERIFY WITH TELEPHONE/CABLE COMPANY FOR CONDUIT REQUIREMENTS.

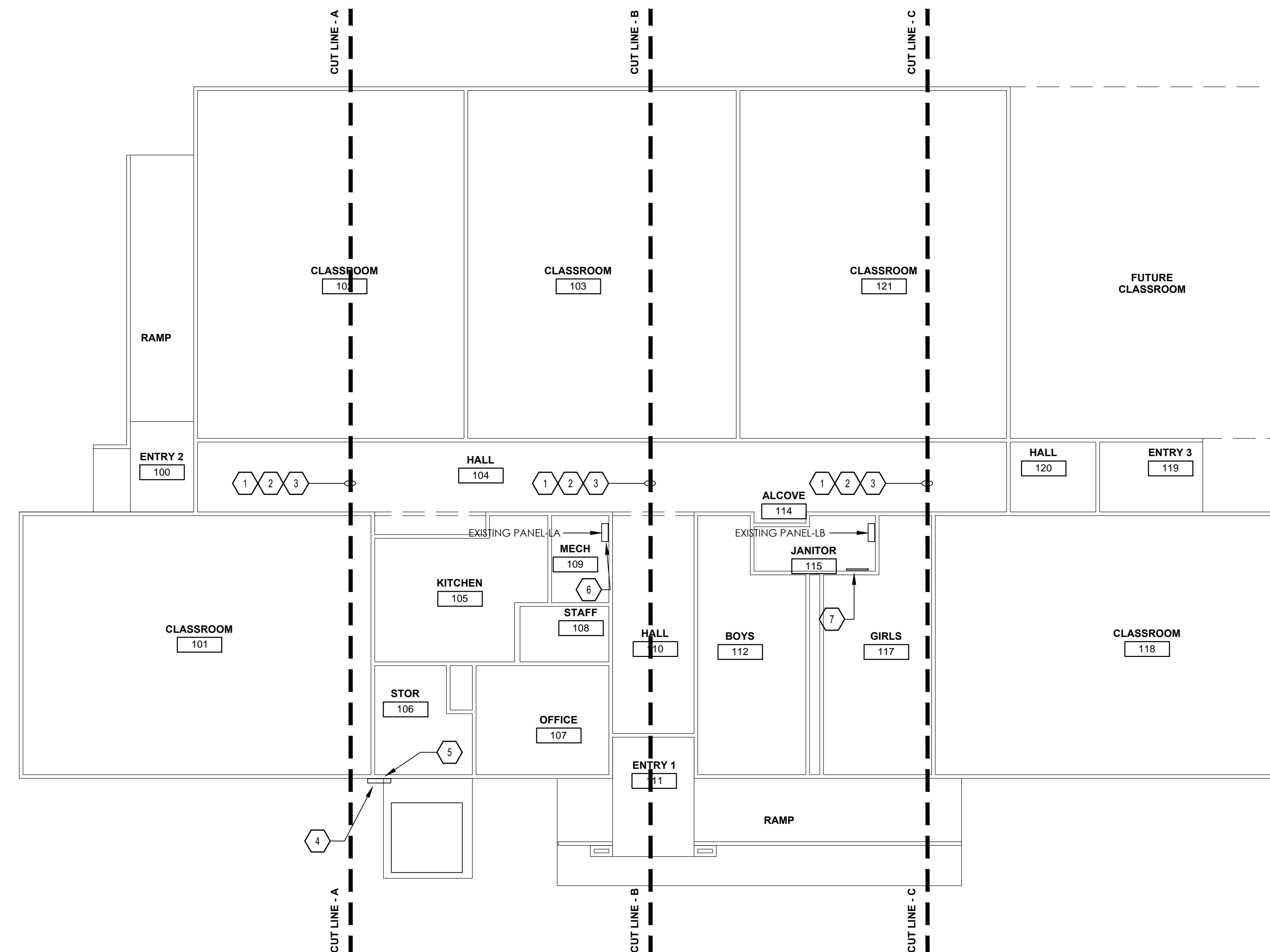

**1 OVERALL ELECTRICAL PLAN**  
SCALE: 1/8"=1'-0"

**TRINITY**  
MEP ENGINEERING  
3535 Moreland Dr. Ste A | Weslaco, Tx 78596  
p:956-878-0500 | f:956-351-5750  
www.trinitymep.com | Copyright 2012  
Texas Registered Engineering Firm - F10362  
Project number: 12.3.04

DESIGNED BY:	REVISIONS			APP
	NO	DATE		
DRAWN BY:				
CHECKED BY:				
APPROVED BY:				
DATE: JULY 2012				

**DANNENBAUM**  
ENGINEERING COMPANY - McALLEN, LLC  
T.B.P.E. FIRM REGISTRATION #8999  
1109 NOLANA LOOP, STE 208 McALLEN, TX 78504 (956) 682-3677

HEADSTART BUILDING RELOCATION PROJECT  
CITY OF PALMVIEW  
URBAN COUNTY PROJECT YEAR 2012

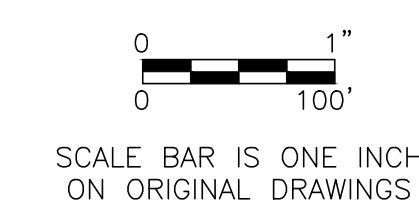

PROJECT No:  
4689-01

DRAWING No:

SHEET No:  
E1.1

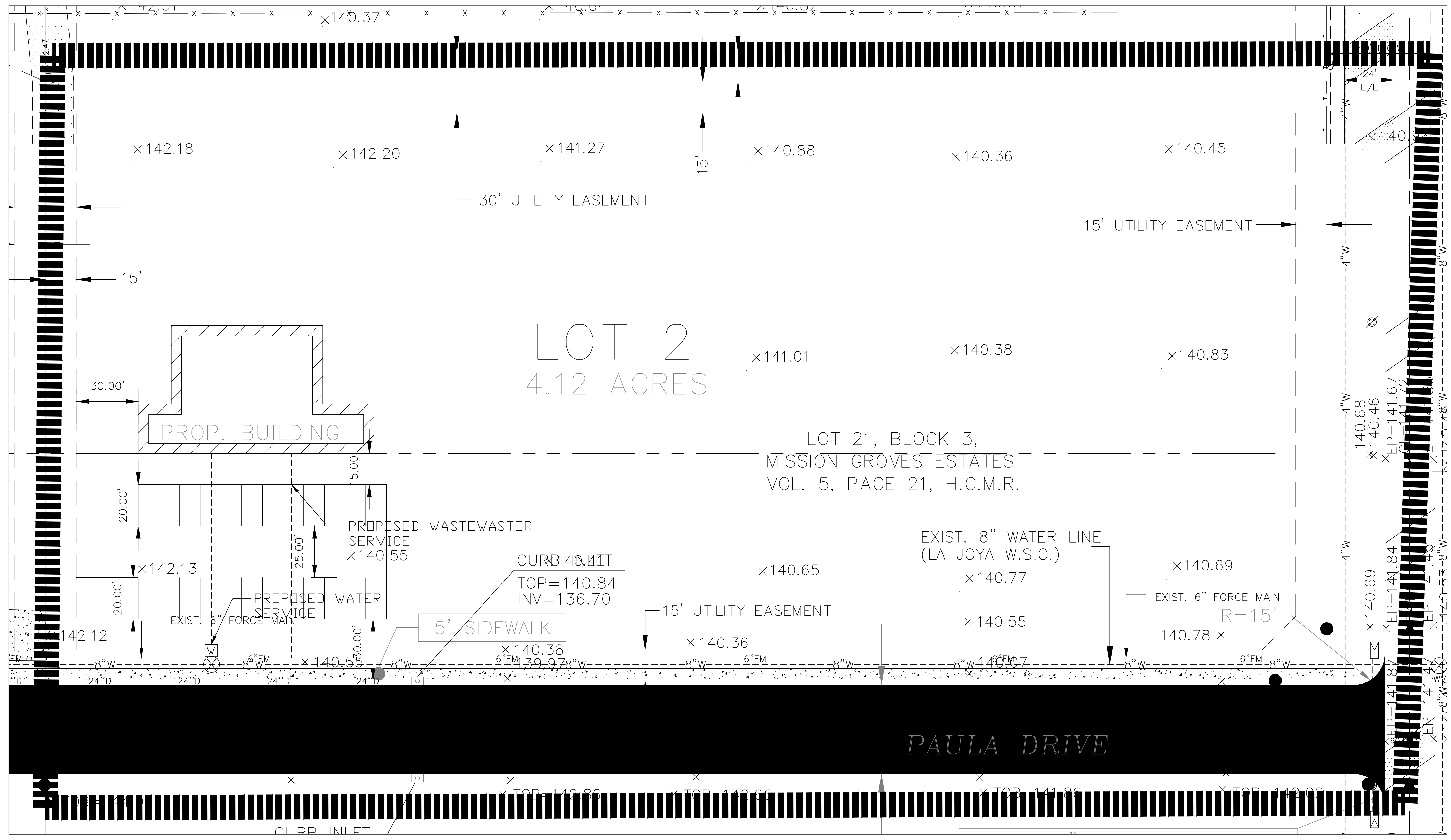
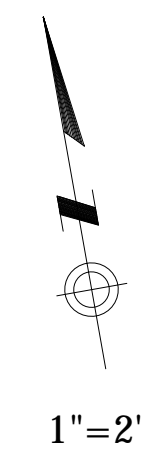

DESIGNED BY:	REVISIONS		
DRAWN BY:	NO	DATE	APP
CHECKED BY:			
APPROVED BY:			
DATE: JULY 2012			

**DANNENBAUM**  
ENGINEERING COMPANY - McALLEN, LLC  
T.B.P.E. FIRM REGISTRATION #8999  
1109 NOLANA LOOP, STE 208 McALLEN, TX 78504 (956) 682-3677

HEADSTART BUILDING RELOCATION PROJECT  
CITY OF PALMVIEW  
URBAN COUNTY PROJECT YEAR 2012

---

LOT 2 - PROPOSED BUILDING

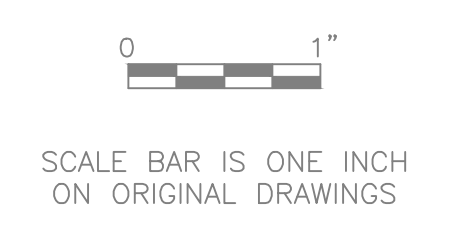

PROJECT No:  
4689-01

DRAWING No:

SHEET No:

Jul 25, 2012 10:35am MichaelChappo  
 M:\1540\4689-01 Headstart Palmview 1 - Relocate\03 Prim Dgn Ph Serv\03.06 Dwg\C1\_4689\_Overall\_Site Layout\_071512.dwg

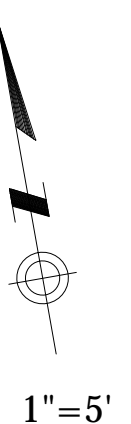
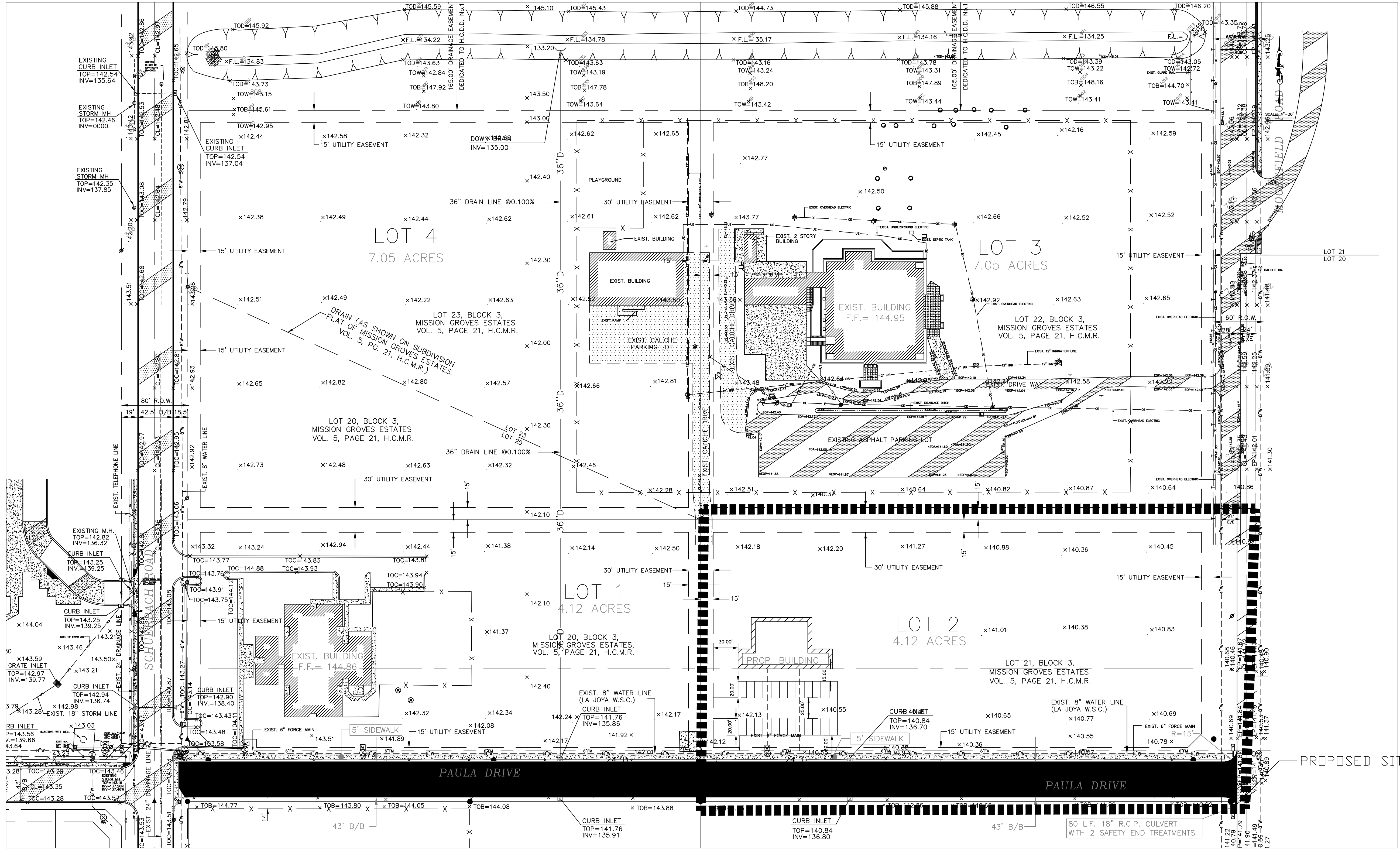

DESIGNED BY:  
 DRAWN BY:  
 CHECKED BY:  
 APPROVED BY:  
 DATE: JULY 2012

REVISIONS			
NO	DATE	DESCRIPTION	APP

**DANNENBAUM**  
 ENGINEERING COMPANY - McALLEN, LLC  
 T.B.P.E. FIRM REGISTRATION #8999  
 1109 NOLANA LOOP, STE 208 McALLEN, TX 78504 (956) 682-3677

HEADSTART BUILDING RELOCATION PROJECT  
 CITY OF PALMVIEW  
 URBAN COUNTY PROJECT YEAR 2012

OVERALL SITE LAYOUT

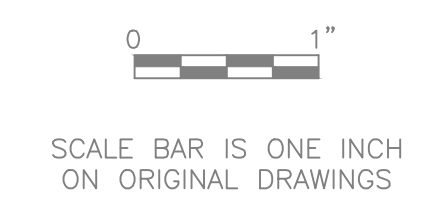

PROJECT No:  
 4689-01  
 DRAWING No:  
 SHEET No:

Jul 31, 2012 - 9:56pm - steve.mcgarraugh  
 G:\1540\4689-01 Headstart Palmview 1 - Relocate\03 Prim Dgn Ph Serv\03.06 Dwg\10 Arch Site Plan.dwg

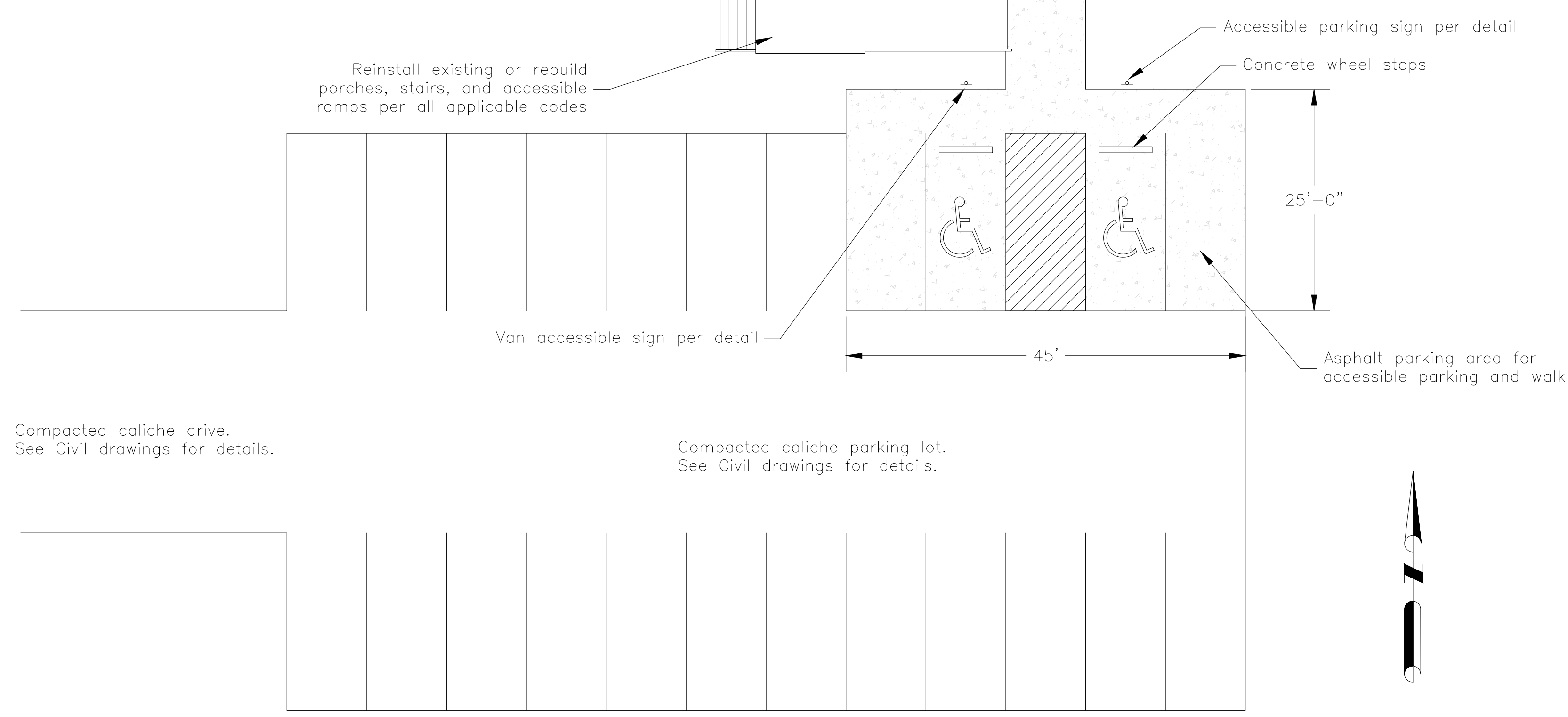
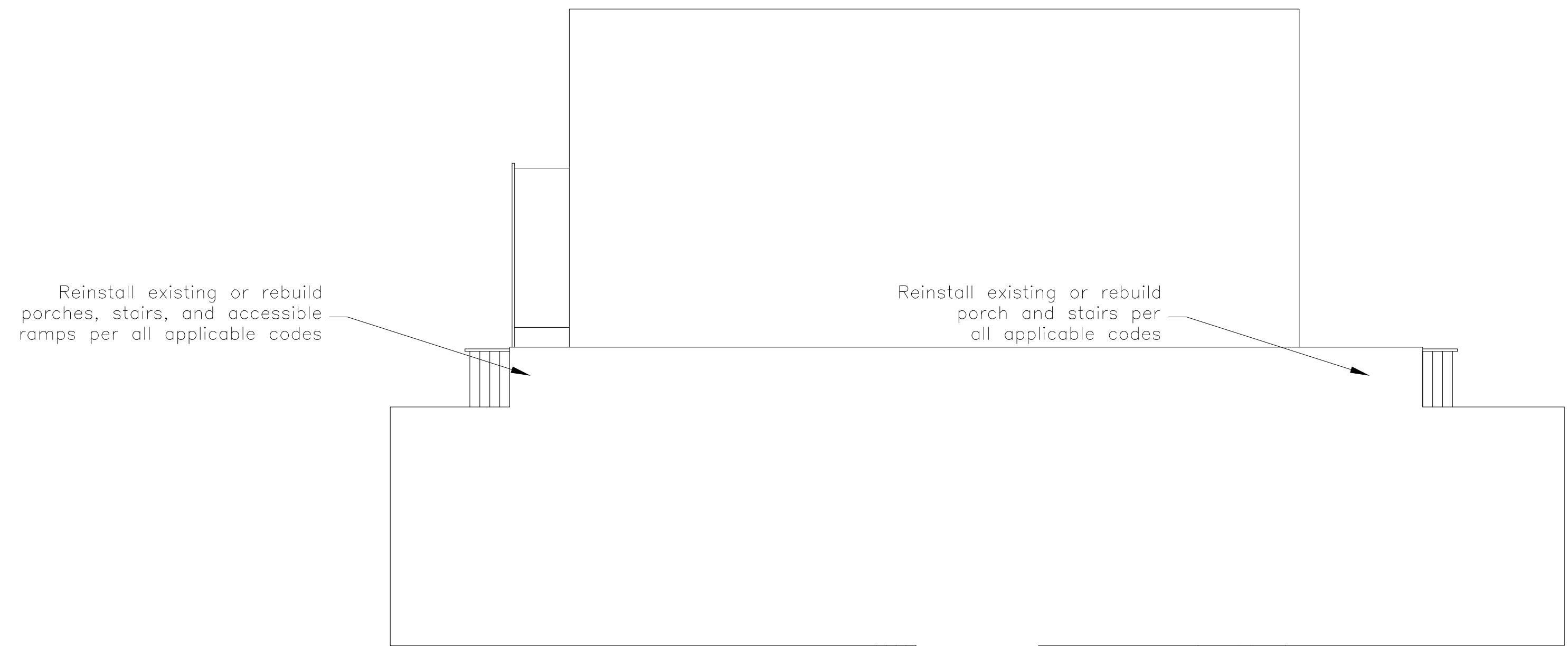

**1 Architectural Site Plan**

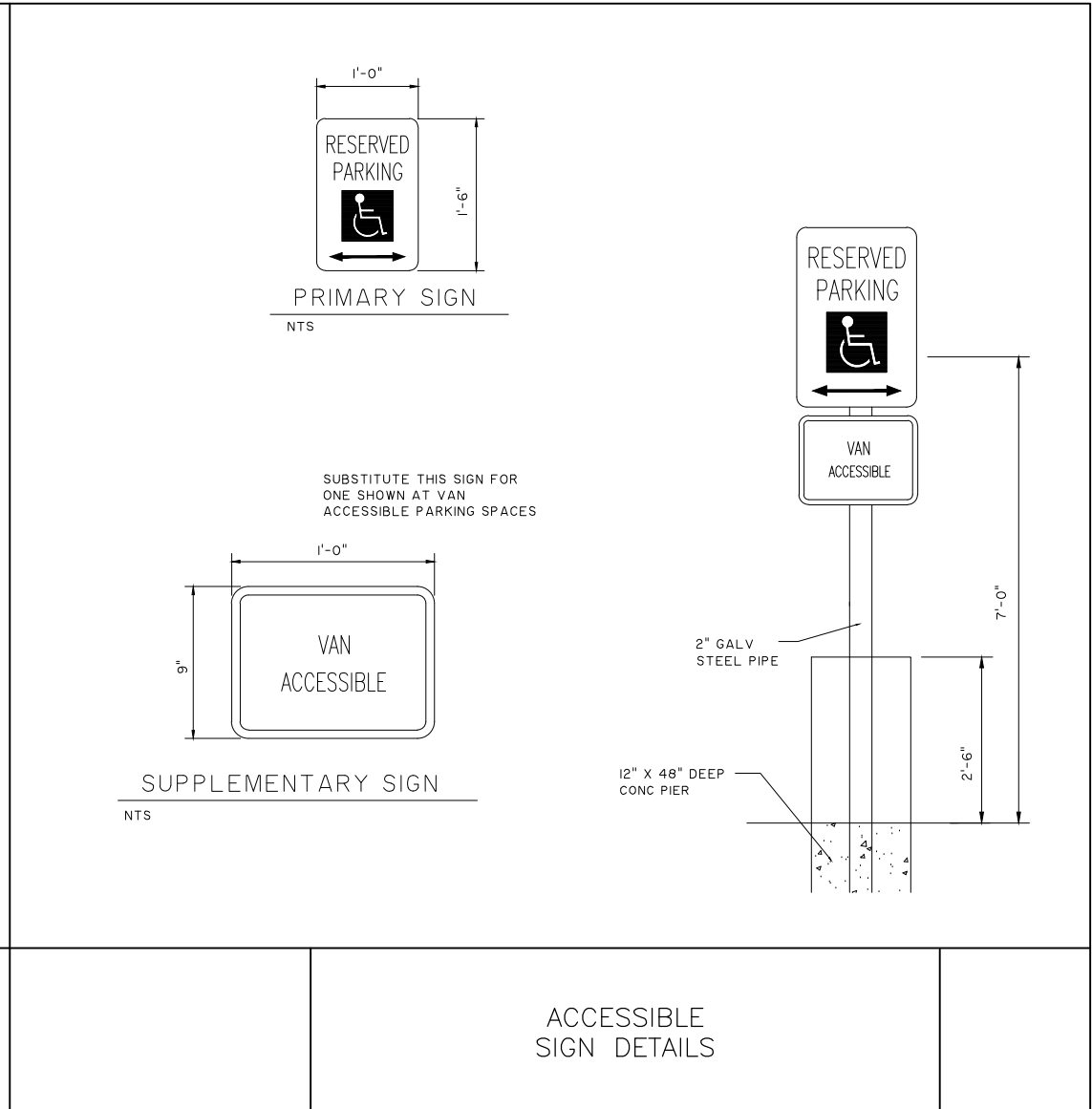
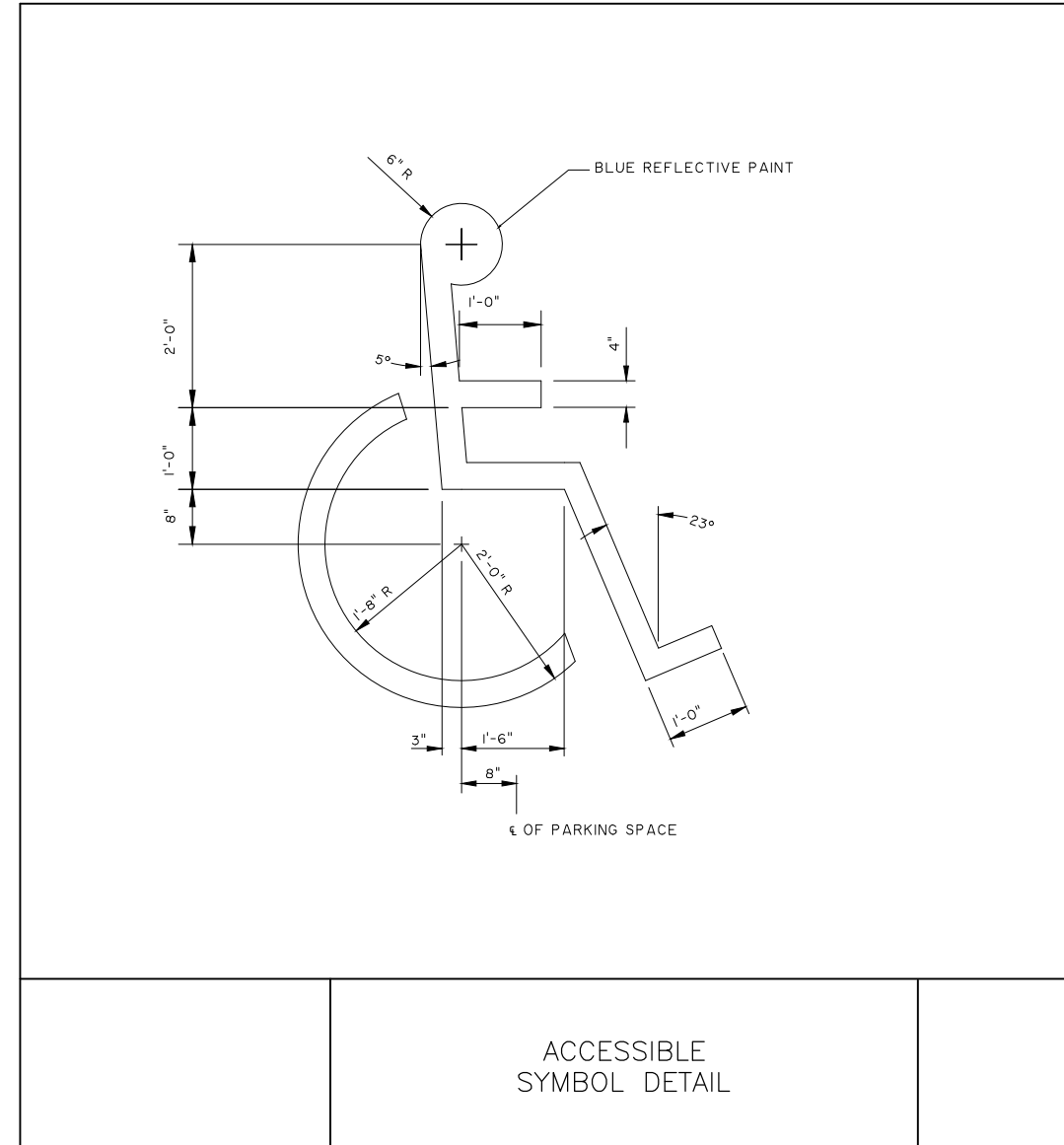

- NOTES:**
1. NEW ASPHALT DRIVE AND WALKWAY SHALL BE CONSTRUCTED TO MEET THE REQUIREMENTS OF ALL LOCAL CODES AS WELL AS STATE ACCESSIBILITY REQUIREMENTS. SLOPES SHALL NOT BE STEEPER THAN 1:12 AND CROSS SLOPES SHALL NOT EXCEED 1/4":12.
  2. NEW AND REINSTALLED PORCHES, STAIRS, RAMPS AND RAILINGS FOR EACH MUST MEET ALL LOCAL AND STATE CODE REQUIREMENTS INCLUDING TAS REQUIREMENTS.
  3. INSTALL CONCRETE CURB STOPS SO AS TO ALLOW A MINIMUM 5'-0" WALKWAY IN FRONT OF PARKED CARS. INSTALL ACCESSIBLE PARKING POLE MOUNTED SIGNS BEHIND THE ASPHALT WALKWAY.

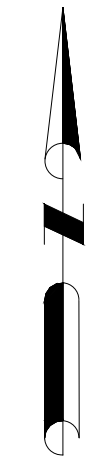

DESIGNED BY:  
 DRAWN BY:  
 CHECKED BY:  
 APPROVED BY:  
 DATE: JULY 2012

REVISIONS			
NO	DATE		APP

**DANNENBAUM**  
 ENGINEERING COMPANY - McALLEN, LLC  
 T.B.P.E. FIRM REGISTRATION #8999  
 1109 NOLANA LOOP, STE 208 McALLEN, TX 78504 (956) 682-3677

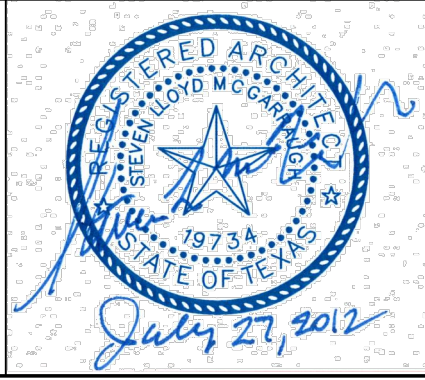

HEADSTART BUILDING RELOCATION PROJECT  
 CITY OF PALMVIEW  
 URBAN COUNTY PROJECT YEAR 2012

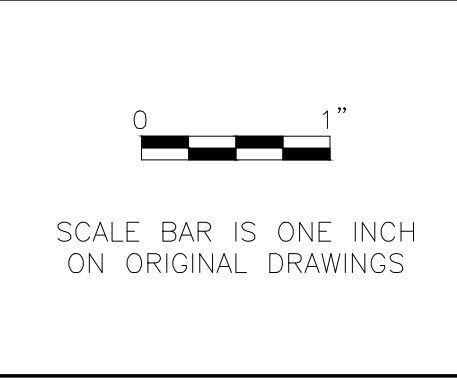

PROJECT No:  
4689-01

DRAWING No:

SHEET No:  
**A1.0**