

# COUNTY OF HIDALGO - URBAN COUNTY PROGRAM

## Price Proposal Form

Price Proposal Form must be submitted to Urban County for pre-approval prior to the purchase. Use additional forms as needed. 23 2013

Name of Cooperative: Buyboard      Person Contacted: Dan Libby  
 Vendor #1: The Playwell Group      Contract No.: 346-10      Phone: 800-726-1816

Quantity	Description of Items	Price per Unit	Total Amount	
1	4 PWS-350-1306 Playworld Wilderness Hideout Challenger (5% Discount)	\$62,522.00	\$59,395.90	✓
1	5 PWS-35-1311.2B Playworld Custom Challenger (5% Discount)	\$18,667.00	\$17,733.65	✓
1	6 PWS-35-1311.4B Playworld Custom Challenger (5% Discount)	\$15,043.00	\$14,290.85	✓
8	7 PWS-ZZXX0038 Playworld Wear Mats (5% Discount)	\$104.00	\$790.40	✓
2	8 PWS-ZZXX0165 Playworld 2-5 Year Old Risk Mgmt Sign (5% Discount)	\$655.00	\$1,244.50	✓
1	9 PWS-ZZXX0175 Playworld 5-12 Year Old Risk Sign (5% Discount)	\$655.00	\$622.25	✓
1	10 YRC- Direct Shipping & Handling	\$4,573.15	\$4,573.15	✓
175	12 SSI-Fiber Safesurf Engineered Wood Fiber (10% Discount)	\$17.33	\$2,730.00	✓
96	13 SSI-Timber Safesurf 4' Timbers W/ Spikes (10% Discount)	\$28.00	\$2,419.20	✓
3	14 SSI-Ramp Safesurf Handicap Ramp (10% Discount)	\$654.00	\$1,765.80	✓
2	15 SSI-GEO-2700 Safesurf Geo Fabric 2700 sf per roll (10% Discount)	\$360.00	\$648.00	✓
1	16 SH Shipping & Handling	\$5,140.98	\$5,140.98	✓
1	4 IGAS-INSTALL GAS Installation of (3) Playsystems, Wood Fiber, Geofab and Timbers. Includes Unloading and Receiving of Equipment and Trash Receipts.	\$34,219.36	\$34,219.36	✓
<b>TOTAL:</b>			<b>\$ 145,574.04</b>	

Recommendation: Purchase of playground equipment from The Playwell Group in the amount of \$145,574.04.

Requested by:

*Joseph Polovina*

Date

*7-22-13*

UCP Approval:

*William R. Stone*

Date

*7/29/13*

# The PlayWell Group

Toll free: (800) 726-1816

Free Fax: (800) 560-9150

New Mexico  
9430 San Mateo., NE, Unit G  
Albuquerque, NM 87113  
(505) 899-1762

Texas  
4743 Iberia Ave., Suite C  
Dallas, TX 75207  
(972) 488-9355

QUOTATION

SQ-33173

7/12/2013

Customer	Contact	Ship To
Hidalgo County Precinct 4 1051 N Doolittle Road EDINBURG TX 78542 UNITED STATES	Hidalgo County Precinct 4/Sunflower Park Steve Cruz 1051 N Doolittle Road EDINBURG TX 78542 UNITED STATES Tel: (956)-383-3112	Hidalgo County Precinct 4/Sunflower Park Steve Cruz 1051 N Doolittle Road EDINBURG TX 78542 UNITED STATES Tel: (956)-383-3112 Fax: (956)-381-5905

Account	Terms	Due Date	Account Rep	Schedule Date
3257	NET 30	8/11/2013	Dan Libby	9/12/2013

Quotation	PO #	Reference	Ship VIA
SQ-33173			Default Carrier

L Item	Description	Qty	Price UM	Discount	Amount
1	BuyBoard	1	\$0 EA		\$0.00
2	This is a BuyBoard Purchasing Cooperative Quote. Pricing Reflects BuyBoard Discounts As Listed On Web Site www.buyboard.com Under The Vendor Listing For The PlayWell Group, Inc.Contract # 346-10. Expires 09/30/2013				
4	PWS-350-1306	1	\$62,522.00 EA	\$3,126.10 5%	\$59,395.90 ✓
5	PWS-35-1311.2B	1	\$18,667.00 EA	\$933.35 5%	\$17,733.65 ✓
6	PWS-35-1311.4B	1	\$15,043.00 EA	\$752.15 5%	\$14,290.85 ✓
7	PWS-ZZXX0038	8	\$104.00 EA	\$41.60 5%	\$790.40 ✓
8	PWS-ZZXX0165	2	\$655.00 EA	\$65.50 5%	\$1,244.50 ✓
9	PWS-ZZXX0175	1	\$655.00 EA	\$32.75 5%	\$622.25 ✓
10	YRC-DIRECT	1	\$4,573.15 EA	0%	\$4,573.15 ✓
12	SSI-FIBER	175	\$17.33 CY	\$302.75 10%	\$2,730.00 ✓
13	SSI-TIMBER	96	\$28.00 EA	\$268.80 10%	\$2,419.20 ✓
14	SSI-RAMP	3	\$654.00 EA	\$196.20 10%	\$1,765.80 ✓
15	SSI-GEO-2700	2	\$360.00 EA	\$72.00 10%	\$648.00 ✓
16	SH	1	\$5,140.98 EA	0%	\$5,140.98 ✓
4	IGAS-INSTALL	1	\$34,219.36 EA	0%	\$34,219.36 ✓

This Quotation is good for 30 Days from the date listed above. We appreciate the opportunity to quote and look forward to serving your needs. To order, please fax this signed form including color choices, if necessary, and confirm the shipping address. This ship date is approximate. We reserve the right to change and collect interest in the amount of 1.5% per month if payment is not received in full in accordance with the terms set forth. Play Safely and PlayWell.

**Tax Details**  
EXEMPT \$0.000

**Taxable** \$0.00

Customer PO No. \_\_\_\_\_

Approved By: \_\_\_\_\_ Date: \_\_\_\_\_

**Total Tax** \$0.00  
**Exempt** \$145,574.04  
**Total** \$145,574.04

**Balance** \$145,574.04

# The PlayWell Group

Toll free: (800) 726-1816

Free Fax: (800) 560-9150

New Mexico  
9430 San Mateo., NE, Unit G  
Albuquerque, NM 87113  
(505) 899-1762

Texas  
4743 Iberia Ave., Suite C  
Dallas, TX 75207  
(972) 488-9355

Hidalgo County Precinct  
4/Sunflower Park  
Steve Cruz  
1051 N Doolittle Road  
EDINBURG TX 78542  
UNITED STATES  
Tel: (956)-383-3112

7/17/2013

## TERMS AND CONDITIONS

### PRICES AND PROJECT QUOTATION

PRICES shown in all of our Quotations are subject to change without notice. All shipments are subject to price in effect at time of shipment.

QUOTATION: Is for acceptance within a maximum of 30 days from date of Quotation and prices are guaranteed only for materials which can be scheduled and shipped within one year from date of quotation.

### TERMS, TAXES AND INVOICES

TERMS: All invoices are due net within 30 days. If legal action is necessary to enforce payment, purchaser will pay any court costs and reasonable attorney fees.

Full payment is required on material ordered under \$1000.00, no exceptions. Visa, MasterCard, and American Express accepted. Please disregard if you have established prior credit with us.

### FREIGHT AND DELIVERY

All shipment is F.O.B Factory, except where specifically stated otherwise. Delivery of materials is six weeks from the order date, plus a few days for transit. Every effort is made to comply with scheduled shipping dates: The PlayWell Group, Inc. is not liable for any loss or damage arising out of delay in delivery of any of its materials due to causes beyond the control of the Company.

### RETURNED GOODS AND/OR CANCELLATION

No material shall be returned without written permission. When granted, no credit will be issued until purchaser supplies correct invoice number and date covering original shipment or material. All credits, when issued, are subject to 25% restocking charge; and charges necessary to put the material back in saleable condition, any outgoing freight charges paid by The PlayWell Group, Inc. Orders cancelled prior to shipment will be charged 10% of the material price. Once the material has been installed, no refund will be granted.

### STATE OF TEXAS HISTORICALLY

Underutilized Business Certification - The PlayWell Group, Inc. is certified by the Texas Building & Procurement Commission as an Historically Underutilized Business (HUB). A copy of the certificate is available upon request.

### INSTALLATION NOT INCLUDED

Installation/Prices are not included on this Quotation. A separate installation quotation must be included with your order if installation is required.

Material will be ordered immediately upon receipt of written approval. Please fax all pages included color choices, if necessary and confirm shipping address.

QUOTE #: \_\_\_\_\_ DATE: \_\_\_\_\_

SIGNATURE: \_\_\_\_\_

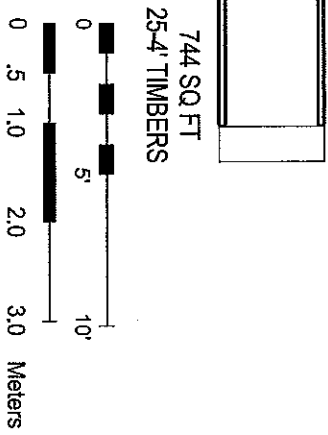
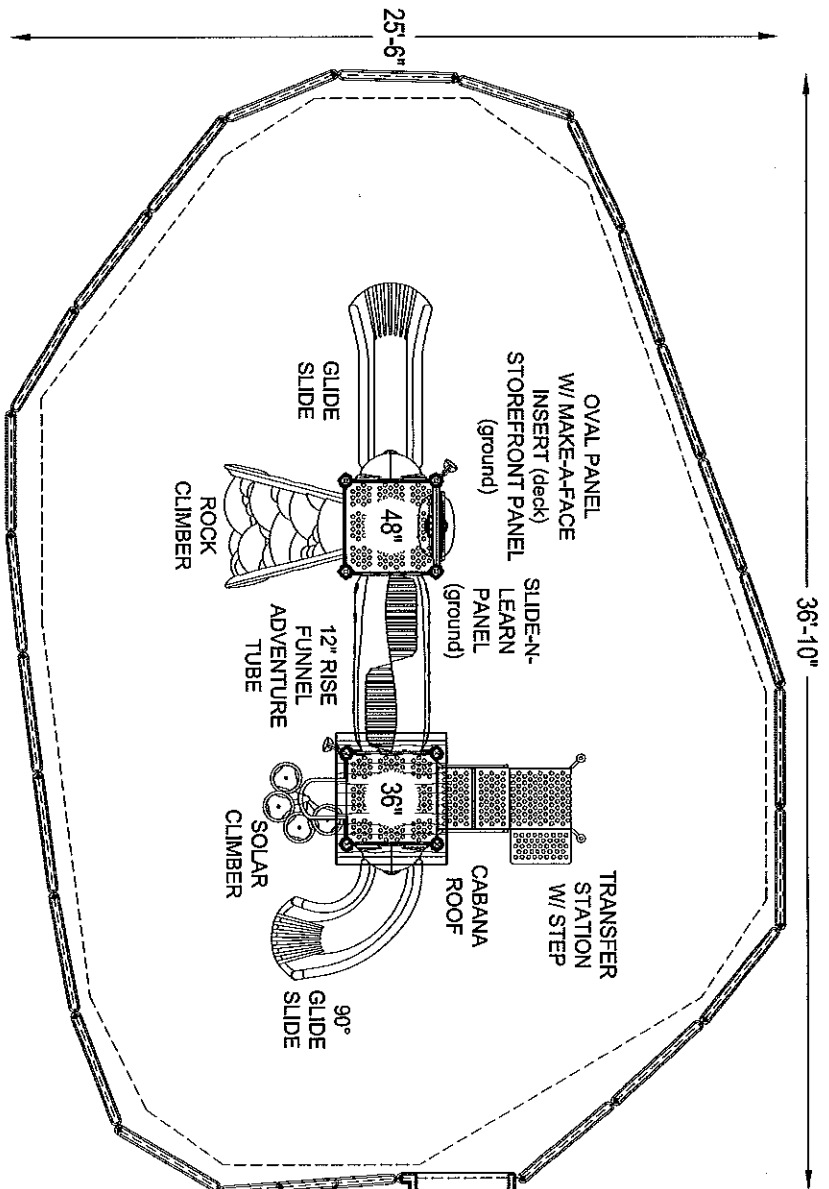

USERS 2-12

**PLAYWORLD**  
TM  
©2007 Playworld Systems, Inc.  
Playworld is a brand of Playworld Systems, Inc.

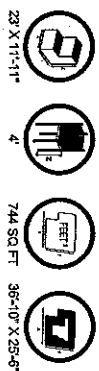

PROJECT NO:	351300	REV:	3B	DATE:	03/29/2013
SYSTEM:	CHALLENGERS	SCALE:	3/16" = 1'-0"	DRAWN BY:	CARRIE CHAVEZ
SITE PLAN			CARRIE CHAVEZ		

**TBD PARK**  
HIDALGO COUNTY PRECINCT 4

Company Name  
Address  
Address  
Phone #

\*Playground Supervision Required

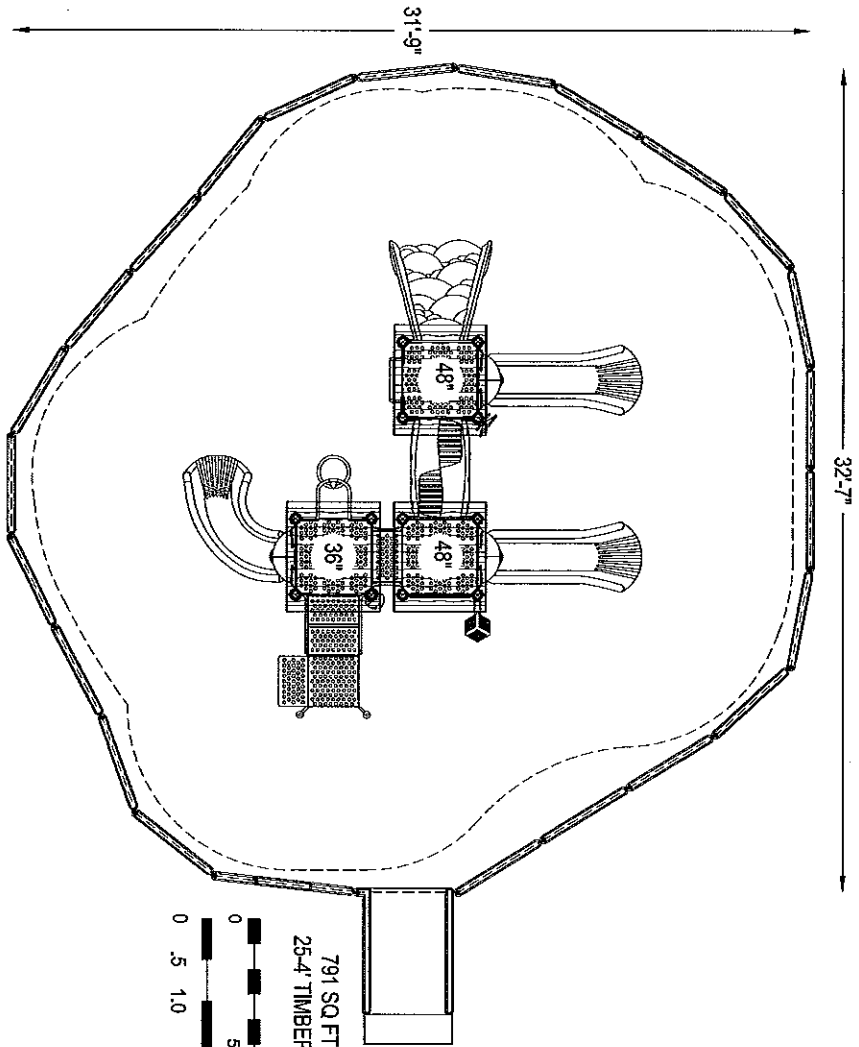

\*Playground Supervision Required



**PLAYWORLD**<sup>TM</sup>  
© 2007 Playworld Systems, Inc.  
 Approved by American Society of Safety Engineers, Inc.

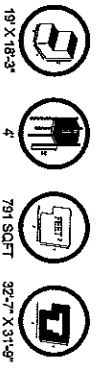

PROJECT NO:	351311	REV:	1B	DATE:	03/29/2013
SYSTEM:	CHALLENGERS	SCALE:	3/16" = 1'-0"	DRAWN BY:	CARRIE CHAVEZ
SITE PLAN					

**TBD PARK**  
 HIDALGO COUNTY PRECINCT 4

Company Name  
 Address  
 Phone #

