



HIDALGO COUNTY PLANNING DEPARTMENT

1304 SOUTH 25TH STREET
EDINBURG TEXAS 78539
Tel. 956-318-2840 Fax. 956-318-2844

Raul E. Sesin, P.E., CFM
Planning Administrator

HIDALGO COUNTY COMMISSIONERS COURT MEETING

DATE: 07-01-2014

PROPOSED REPLAT OF A & V SUBDIVISION, PRECINCT No. 4.

ENGINEER: RODRIGUEZ ENGINEERING DEVELOPER: ALDO QUINTANILLA

PRELIMINARY APPROVAL FINAL APPROVAL FINAL APPROVAL WITH FINANCIAL GUARANTEE WITH VARIANCE

NUMBER OF LOTS: *SINGLE FAMILY 1 *MULTI-FAMILY COMMERCIAL INSTITUTIONAL

LOCATION DESCRIPTION: South of Alberta Road, approx. 1/4 mile East of North "I" Rd.

SUBDIVISION LIES WITHIN THE: ETJ of Edinburg and was approved by the P & Z and City Commission of said City

DRAINAGE REPORT WAS APPROVED BY HCDD#1: ON 01-16-14 PROPERTY LIES WITHIN FLOOD ZONE: "B" AS PER FEMA.

DRAINAGE DESIGN: Drainage detention will be accomplished by onsite detention pond as per drainage parking site plan

ROAD R.O.W. DEDICATION: 20 feet on Alberta Road

H.C.R.O.W. FINAL APPROVAL DATE: 04-15-13 : By, Joe Ochoa PCT 4 R.O.W. AGENT

H.C.H.D FINAL APPROVAL DATE: 11-15-13 by: Elizardo "Chardo" Ramos, Environmental Health Division Manager

SEWER SYSTEM: OSSF & SOIL ANALYSIS WERE CONDUCTED BY: Jose Angel Gonzalez

OSSF HAVE BEEN INSTALLED AND INSPECTED BY HCHD ON: 05-21-2014

WATER SERVICE PROVIDER: N.A.W.S.C. LINE SIZE: 8" LOCATION: North side of Alberta Rd

STAFF RECOMMENDS: Preliminary Approval subject to comments and future recommendations by planning, other departments and the approval of the City of _____.

Final Approval subject to recommendations other departments

Final Approval with financial guarantee.

This subdivision plat has been reviewed and complies with the Hidalgo County Subdivision Rules,

* Texas Water Development Board Model Subdivision Rules and The Texas Local Government Code.

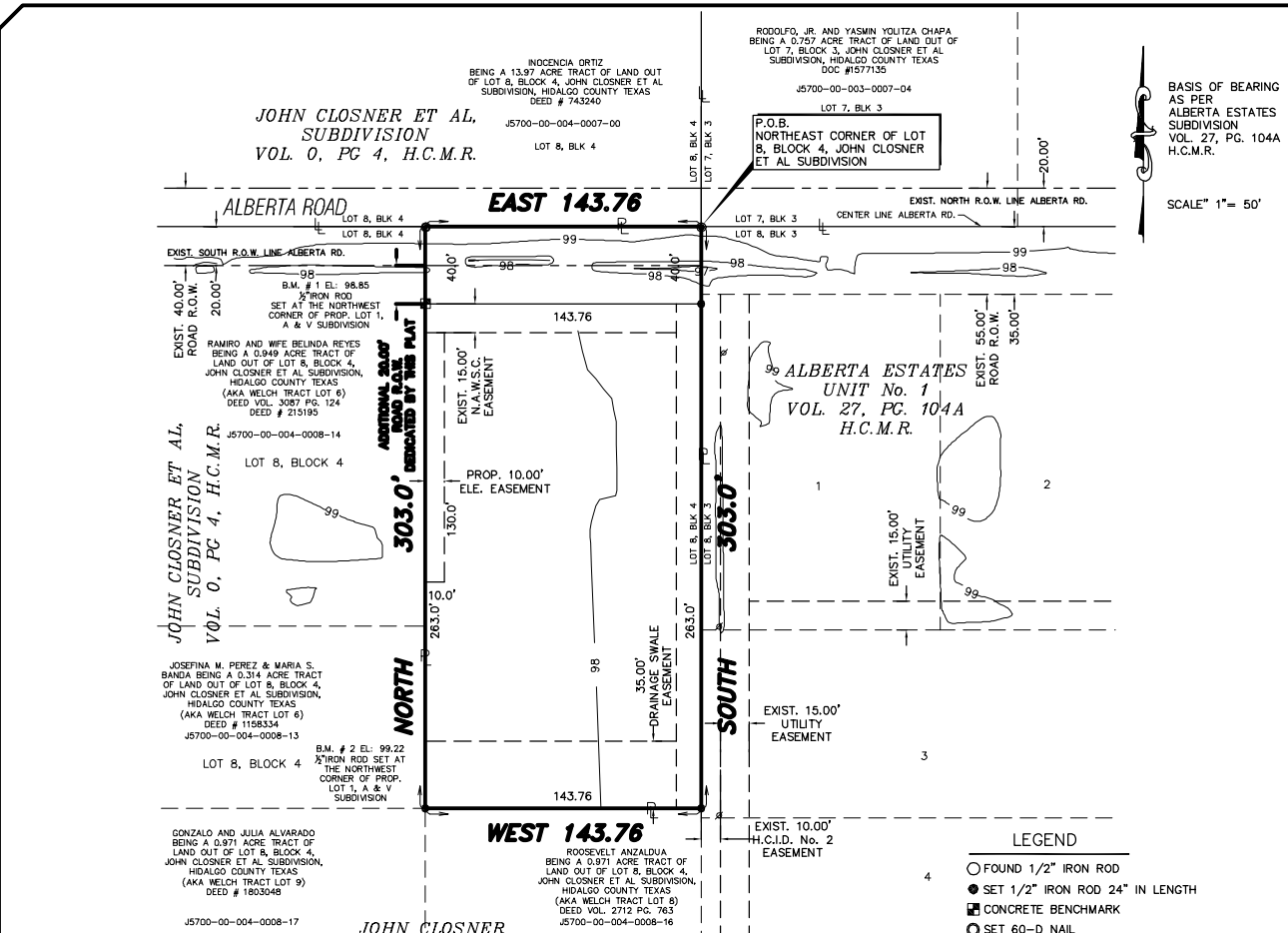

GENERAL SUBDIVISION PLAT NOTES

- FLOOD ZONE STATEMENT:
FLOOD ZONE DESIGNATION: ZONE "B" COMMUNITY-PANEL NUMBER: 480334 0425 C EFFECTIVE DATE: NOVEMBER 16, 1982 AREAS BETWEEN LIMITS OF 100-YEAR FLOOD AND 500-YEAR FLOOD, OR CERTAIN AREAS SUBJECT TO 100-YEAR FLOODING WITH AVERAGE DEPTHS LESS THAN ONE (1) FOOT OR WHERE THE CONTRIBUTING DRAINAGE AREA IS LESS THAN ONE SQUARE MILE; OR AREAS PROTECTED BY LEVEES FROM THE BASE FLOOD (MEDIUM SHADING).
- SETBACKS:
FRONT: 50.00 FEET
REAR: 30.00 FEET OR EASEMENT WHICHEVER IS GREATER
SIDE: 6.00 FEET OR EASEMENT WHICHEVER IS GREATER
- LOT 1 SHALL BE FOR MULTI-FAMILY USES. THE ENGINEER HAS SUBMITTED PLANNING MATERIAL FOR THIS PURPOSE AND NO ALTERATION OR CHANGES TO THE APPROVED DESIGN OF THIS MULTI-FAMILY PROPOSAL SHALL BE MADE UNLESS A RE-SUBDIVISION PLAT IS APPROVED BY THE COUNTY FOR SUCH CHANGES. THIS MUST BE STIPULATED ON ALL DEEDS AND CONTRACTS FOR DEEDS. APPLICATIONS FOR CONSTRUCTION ARE REQUIRED PRIOR TO OCCUPANCY A LOT.
- MINIMUM FINISH FLOOR ELEVATION SHALL BE 24" ABOVE THE CENTER LINE OF STREET OR 24" ABOVE NATURAL GROUND, WHICHEVER IS GREATER. ELEVATION CERTIFICATE MAY BE REQUIRED FOR LOTS LOCATED OUTSIDE A DESIGNATED FLOOD ZONE AT THE TIME FOR APPLICATION FOR CONSTRUCTION TO VERIFY PRE AND POST CONSTRUCTION FINISH FLOOR ELEVATIONS. AN ELEVATION CERTIFICATE SHALL BE REQUIRED FOR ALL LOTS WITHIN A DESIGNATED FLOOD ZONE AT THE TIME FOR A DEVELOPMENT PERMIT APPLICATION.
- THE FOLLOWING BENCHMARKS ARE IDENTIFIED ON THE FACE OF THE PLAT AND ON THE ATTACHED ENGINEERING PLANS.
--> B.M. NO. 1 - ELEV. 98.85 N.G.V.D. 29 DESCRIPTIONS: 2'X2' CONCRETE SLAB WITH A 1/2" SET AT THE NORTHWEST CORNER OF LOT 1, A & V SUBDIVISION.
B.M. NO. 2 - ELEV. 99.22 N.G.V.D. 29 DESCRIPTIONS: 1/2" IRON ROAD SET AT THE SOUTHWEST CORNER OF LOT 1, RE-PLAT OF A & V SUBDIVISION.
- IN ACCORDANCE WITH THE HIDALGO COUNTY DRAINAGE DISTRICT NO. 1 AND HIDALGO COUNTY REQUIREMENTS, THIS DEVELOPMENT WILL BE REQUIRED TO DETAIN A TOTAL OF 4,230.00 CUBIC-FEET (0.092 ACRE-FEET) OF STORM WATER PERMANENT.
- NO FILL OR PERMANENT STRUCTURES SHALL BE ALLOWED WITHIN ANY DRAINAGE SWALE EASEMENT. EACH DRAINAGE SWALE EASEMENT SHALL BE KEPT CLEAR OF FENCES, BUILDINGS, PLANTINGS, AND OTHER OBSTRUCTIONS THAT WOULD INTERFERE WITH THE OPERATION OF THE DRAINAGE SWALE EASEMENT. THE LOT OWNER SHALL BE RESPONSIBLE FOR THE MAINTENANCE OF THE SWALE.
- ONCE ANNEXED OR INCORPORATED TO THE CITY OF EDINBURG CITY LIMITS, SAID PROPERTY SHALL BE SUBJECT TO CITY OF EDINBURG'S REQUIREMENTS AND SPECIFICATIONS, SUCH REQUIREMENTS MAY INCLUDE, BUT NOT LIMITED TO THE UNIFIED DEVELOPMENT CODE, SETBACK BUFFER-YARDS, FLOOR AREA RATION, LANDSCAPING SURFACE RATIO, PARKING REQUIREMENTS, FIRE PROTECTION, BUILDING PERMIT REQUIREMENTS OR ANY OTHER REQUIREMENTS.
- ALL CONSTRUCTION SHALL COMPLY WITH STORM WATER POLLUTION PREVENTION PLAN (SW3P) REQUIREMENTS.
- ALL EXISTING FIRE HYDRANTS MAY BE REQUIRED AT THE BUILDING PERMIT AS PER COUNTY FIRE MARSHALL.
- A 5.0' SIDEWALK IS REQUIRED ALONG ALBERTA ROAD ROAD AT THE BUILDING PERMIT STAGE.
- NO STRUCTURE SHALL BE PERMITTED OVER ANY EASEMENT. EASEMENTS SHALL BE KEPT CLEAR OF FENCES, BUILDINGS, SHEDS, SHRUBS TREES, AND OTHER PLANTINGS (EXCEPT LOW, LESS THAN 18 INCHES MATURE HEIGHT, GROUND COVER, GRASS, OR FLOWERS) AND OTHER OBSTRUCTIONS THAT WOULD INTERFERE WITH THE OPERATIONS AND MAINTENANCE OF THE EASEMENT.
- EACH PURCHASED CONTRACT MADE BETWEEN A SUBDIVIDER AND PURCHASER OF A LOT IN THIS SUBDIVISION SHALL CONTAIN A STATEMENT DESCRIBING HOW AND WHEN WATER, SEWER, ELECTRICITY, AND GAS SERVICES WILL BE MADE AVAILABLE TO THE SUBDIVISION.
- ALL PUBLIC UTILITIES EASEMENTS DEDICATED BY THIS PLAT SHALL BE A MINIMUM WIDTH OF 15.00 FEET AS PER THE HIDALGO COUNTY MODEL SUBDIVISION RULES. BY SIGNING THIS PLAT DEVELOPER AND ENGINEER CERTIFY THAT ALL OTHER EASEMENTS SHOWN COMPLY WITH THE SIZE REQUIRED BY EACH UTILITY PROVIDER OCCUPYING AN EASEMENT.

BASIS OF BEARING AS PER ALBERTA ESTATES SUBDIVISION VOL. 27, PG. 104A H.C.M.R.

SCALE" 1"= 50'

LEGEND

- FOUND 1/2" IRON ROD
- SET 1/2" IRON ROD 24" IN LENGTH
- CONCRETE BENCHMARK
- SET 60-D NAIL
- FND 60-D NAIL

HIDALGO COUNTY CERTIFICATE OF PLAT APPROVAL

I, THE UNDERSIGNED CERTIFY THAT THIS PLAT OF RE-PLAT OF A & V SUBDIVISION WAS REVIEWED AND APPROVED BY THE HIDALGO COUNTY HEALTH DEPARTMENT ON _____ 2014.

ENVIRONMENTAL HEALTH DIVISION MANAGER. _____ DATE _____

HIDALGO COUNTY CERTIFICATE OF PLAT APPROVAL

HIDALGO COUNTY IRRIGATION DISTRICT # 2

THIS PLAT IS HEREBY APPROVED BY THE HIDALGO COUNTY IRRIGATION DISTRICT NO. 2 THIS THE _____ DAY OF _____ 2014.

NO IMPROVEMENTS OF ANY KIND (INCLUDING WITHOUT LIMITATION, TREES, FENCES, AND BUILDINGS) SHALL BE PLACED UPON HIDALGO COUNTY DISTRICT NO. 2 RIGHT OF WAYS EASEMENTS.

SECRETARY _____ DATE _____

PRESIDENT - H.C.I.D. NO. 2 _____ DATE _____



FILED FOR RECORD IN ARTURO GUAJARDO, JR. HIDALGO COUNTY CLERKS

ON _____ AM/PM INSTRUMENT NUMBER _____ RECORDED IN VOL. _____ PAGE _____ OF THE MAP RECORDS OF HIDALGO COUNTY, TEXAS

BY: _____ DEPUTY

I, LEO L. RODRIGUEZ, REGISTERED PROFESSIONAL LAND SURVEYOR IN THE STATE OF TEXAS, DO HEREBY CERTIFY THAT THIS PLAT IS TRUE AND CORRECTLY MADE FROM AN ACTUAL SURVEY MADE ON THE GROUND OF THE PROPERTY LEGALLY DESCRIBED HEREON, AND THAT THERE ARE NO APPARENT DISCREPANCIES, CONFLICTS, OR OVERLAPPING OF IMPROVEMENTS, VISIBLE UTILITY LINES OR ROADS IN PLACE, EXCEPT AS SHOWN ON THE ACCOMPANYING PLAT, AND THAT THE CORNER MONUMENTS SHOWN THEREON WERE PROPERLY PLACED UNDER MY SUPERVISION ON APRIL 1, 2013, IN ACCORDANCE WITH THE SUBDIVISION REGULATIONS OF THE CITY OF EDINBURG, TEXAS.

DATED THIS THE _____ DAY OF _____ 2014.

REGISTERED PROFESSIONAL SURVEYOR NO. 2448 STATE OF TEXAS

STATE OF TEXAS COUNTY OF HIDALGO

I, THE UNDERSIGNED, A REGISTERED PROFESSIONAL ENGINEER IN THE STATE OF TEXAS, HEREBY CERTIFY THAT PROPER ENGINEERING CONSIDERATION HAS BEEN GIVEN TO THIS PLAT.

I CERTIFY THAT THE WATER AND SEWER SERVICE FACILITIES FOR LOTS INTENDED FOR RESIDENTIAL PURPOSES DESCRIBED ABOVE ARE IN COMPLIANCE WITH THE MODEL RULES ADOPTED UNDER SECTION 16.343, WATER CODE. THE ESTIMATED COST TO INSTALL UNCONSTRUCTED WATER AND SEWERAGE FACILITIES DESCRIBED ABOVE ARE AS FOLLOWS: WATER FACILITIES: THESE FACILITIES WILL BE CONSTRUCTED.

SEWERAGE FACILITIES: (SEWER SERVICE CONNECTION/INSTALLATION OF SEPTIC SYSTEMS) ARE ESTIMATED TO COST \$ 1,500 PER LOT (ALL INCLUSIVE), FOR A TOTAL OF \$ 1,500.00 FOR THE SUBDIVISION. THE SUBDIVIDER HAS PAID A TOTAL OF \$ 1,500.00 TO COVER THE COST OF (SEWER SERVICE CONNECTION/INSTALLATION OF SEPTIC SYSTEMS).

DATED THIS THE _____ DAY OF _____ 2014.

REGISTERED PROFESSIONAL ENGINEER NO. 34928 STATE OF TEXAS

HIDALGO COUNTY CERTIFICATE OF PLAT APPROVAL UNDER LOCAL GOVERNMENT CODE S 232.028(A)

WE, THE UNDERSIGNED CERTIFY THAT THIS PLAT OF RE-PLAT OF A & V SUBDIVISION WAS REVIEWED AND APPROVED BY THE HIDALGO COUNTY COMMISSIONERS' COURT ON _____ 2014.

HIDALGO COUNTY JUDGE _____ DATE _____

ATTEST HIDALGO COUNTY CLERK _____ DATE _____

15. ON-SITE SEWAGE FACILITIES (OSSF) NOTE: THIS SUBDIVISION SHALL USE ON-SITE SEWAGE FACILITIES IN ACCORDANCE WITH TCEQ AND HIDALGO COUNTY REGULATIONS FOR SEWAGE DISPOSAL. THE SUBDIVIDER IS RESPONSIBLE FOR PROVIDING AN OSSF ON ALL LOTS.

- OSPF SYSTEM IS BEING DESIGNED FOR DISPOSAL OF DOMESTIC SEWERAGE ONLY. A SEPARATE DESIGN SHALL BE SUBMITTED FOR COMMERCIAL USE.
- EACH LOT ON THIS PLAT COMPLIES WITH THE MINIMUM 21,780 SQUARE FEET LOT AREA WITH POTABLE WATER SUPPLY.
- OSPF SYSTEM SHALL REQUIRE INSPECTION AND APPROVAL BY HIDALGO COUNTY AUTHORIZED DEPARTMENT
- SOIL ANALYSIS HAVE BEEN SUBMITTED TO THE AUTHORIZED HIDALGO COUNTY DEPARTMENT AND EXCERPTS MAY BE ALSO SEEN ON THE UTILITY LAYOUT FOR THIS SUBDIVISION AS SUBMITTED TO THE HIDALGO COUNTY PLANNING DEPARTMENT. THE ENGINEER HAS DETERMINED THAT THE SOIL IS SUITABLE FOR A STANDARD SEPTIC TANK AND ABSORPTIVE DRAIN FIELD SYSTEM.
- APPROVED "OSSF" PERMIT APPLICATION IS REQUIRED INCLUDING INDIVIDUAL LOT PLANNING MATERIALS PRIOR TO OCCUPANCY A LOT.

16. A SPECIAL DESIGN IS REQUIRED FOR ALL OSSF SYSTEMS LOCATED WITHIN A DESIGNATED FLOOD ZONE. THE DESIGN SHALL INCLUDE BUT NOT BE LIMITED TO THE FOLLOWING ITEMS:
1. ANCHORING OF SEPTIC TANK(S)
2. BACK FLOW VALVES
3. SEPTIC TANK COVER SHALL BE ABLE TO SEAL.

17. THERE ARE NO WATER WELLS WITHIN 150 FEET FROM THE BOUNDARIES OF THIS SUBDIVISION.

18. ALDO QUINTANILLA, THE OWNER & SUBDIVIDER OF RE-PLAT OF A & V SUBDIVISION, RETAINS AN EASEMENT UPON EACH LOT FOR THE PURPOSE OF INSTALLING AN APPROVED OSSF ON THE LOT AS DESCRIBED ON SHEET NO. 2 OF THIS PLAT.

19. ALL LOTS IN RE-PLAT OF A & V SUBDIVISION ARE HEREBY GRANTED A "DRAINAGE SWALE EASEMENT" WITH RESPECT TO SURFACE WATER RUN-OFF FROM ALL LOTS IN RE-PLAT OF A & V SUBDIVISION TO THE AREA DEPICTED ON THE SUBDIVISION PLAT AS THE "DRAINAGE SWALE" AREAS. LOT OWNERS OF A & V SUBDIVISION THEIR ASSIGNS AND ANY SUBSEQUENT OWNER OF THE REAL PROPERTY DESIGNATED ON THE SUBDIVISION PLAT ARE RESPONSIBLE FOR THE MAINTENANCE OF THE DRAINAGE SWALES. THE COUNTY OF HIDALGO, TEXAS (COUNTY), AND THE HIDALGO COUNTY DRAINAGE DISTRICT NUMBER 1 ("DRAINAGE DISTRICT") MAY ENFORCE THIS PLAT NOTE BY INJUNCTION OR ANY OTHER REMEDY PROVIDED BY LAW, AND THE COUNTY AND / OR THE DRAINAGE DISTRICT ARE ALSO ENTITLED TO RECOVER ALL ENFORCEMENT COSTS AND / OR MAINTENANCE COSTS FROM THE LOT OWNERS IN VIOLATION. IN THE EVENT THE DRAINAGE SWALES DEPICTED ON THE SUBDIVISION PLAT ARE NO LONGER NECESSARY FOR DRAINAGE OF THE LOTS COMPRISING RE-PLAT OF A & V SUBDIVISION BECAUSE AN ALTERNATE DRAINAGE SYSTEM, CONSTRUCTED BY A POLITICAL SUBDIVISION IN ACCORDANCE WITH ALL APPLICABLE STATE AND LOCAL LAWS AND REGULATIONS, IS FULLY OPERATIONAL AND ACTUALLY SERVING ALL THE LOTS IN RE-PLAT OF A & V SUBDIVISION, THE COUNTY AND THE DRAINAGE DISTRICT ARE HEREBY GRANTED THE RIGHT AND AUTHORITY (AND EACH LOT OWNER, BY THE ACCEPTANCE OF A DEED TO LOT IN RE-PLAT OF A & V SUBDIVISION ACKNOWLEDGES AND AGREES THAT THE COUNTY AND THE DRAINAGE DISTRICT HAS THE RIGHT AND AUTHORITY), TO RELEASE THE DRAINAGE EASEMENT BURDENING THE DRAINAGE SWALES PURSUANT TO THIS PLAT NOTE, BY AN INSTRUMENT IN WRITING RECORDED IN THE OFFICIAL RECORDS, HIDALGO COUNTY, TEXAS.

20. AN OFF-STREET PARKING LOT SITE PLAN & DRAINAGE PLAN APPROVAL BY THE HIDALGO COUNTY PLANNING DEPARTMENT SHALL BE REQUIRED FOR MULTI-FAMILY AND COMMERCIAL USE AT THE TIME OF APPLICATION FOR CONSTRUCTION, PRIOR TO THE BEGINNING AND/OR DEVELOPMENT PERMIT. NO WATER OR LIGHT CLEARANCES SHALL BE ISSUED UNTIL THE SITE PLAN, DRAINAGE PLAN AND OSSF PLAN ARE APPROVED AND PROPOSED IMPROVEMENTS ARE CONSTRUCTED IN ACCORDANCE WITH THE COUNTY AND STATE STANDARDS.

21. THE DEVELOPER SHALL BE RESPONSIBLE TO DETAIN AND ACCOMMODATE MORE THAN THE DETAINED VOLUME SHOW ABOVE IF IT DETERMINES AT THE DEVELOPMENT PERMIT STAGE THAT THE DETENTION REQUIREMENTS ARE GREATER THAN STATED ABOVE DUE TO THE IMPERVIOUS AREA BEING GREATER THAN PLAT ENGINEER CONSIDERED FOR THIS CALCULATIONS OF THIS SUBDIVISION.

22. A BUFFER FENCE IS REQUIRED BETWEEN COMMERCIAL AND RESIDENTIAL DEVELOPMENTS.

23. THE PURCHASER OF LOT 1 SHALL BE RESPONSIBLE TO INSTALL DRIVEWAY CULVERT REINFORCED CONCRETE PIPE OF NO LESS THAT 15" IN DIAMETER AND 24 FEET IN LENGTH.

24. ALL COMMON ACCESS, DETENTION AREAS, PARKING AND LANDSCAPING AREAS WILL BE MAINTAINED BY THE LOT OWNER.



PREPARED BY:
RODRIGUEZ ENGINEERING
CONSULTING ENGINEER & SURVEYOR
P.O. BOX 1830
EDINBURG, TEXAS 78540

DATE PREPARED: JANUARY 6, 2014
DATE SURVEYED: APRIL 1, 2013

RE-PLAT OF A & V SUBDIVISION IS LOCATED WITHIN HIDALGO COUNTY PRECINCT NO. 4 WITHIN THE COUNTY OF HIDALGO COUNTY, ON THE SOUTH SIDE OF ALBERTA ROAD APPROXIMATELY 1,086 FEET EAST FROM VETERANS ROAD (I ROAD). THE ONLY NEARBY MUNICIPALITY IS THE CITY OF EDINBURG, ACCORDING TO THE OFFICIAL MAP IN THE OFFICE OF THE SECRETARY OF THE CITY OF EDINBURG THE POPULATION IS 77,100. RE-PLAT OF A & V SUBDIVISION LIES ADJACENT TO THE CITY LIMITS OF THE CITY OF EDINBURG AND IS LOCATED WITHIN THE TWO MILE EXTRATERRITORIAL JURISDICTION (ETJ) UNDER LOCAL GOVERNMENT CODE 21.001.

MINOR SUBDIVISION PLAT OF RE-PLAT OF A & V SUBDIVISION

BEING A 0.999 ACRE TRACT OF LAND OUT OF LOT 8, BLOCK 4, JOHN CLOSNER ET AL, SUBDIVISION, AS PER MAP RECORDED IN VOLUME 0, PAGE 4, MAP RECORDS, HIDALGO COUNTY, TEXAS.

METES AND BOUNDS DESCRIPTION

BEING A 0.999 ACRE (43,558.28 SQ. FT.) TRACT OF LAND OUT OF LOT 8, BLOCK 4, JOHN CLOSNER ET AL SUBDIVISION, AS PER MAP RECORDED IN VOLUME 0, PAGE 4, MAP RECORDS, HIDALGO COUNTY, TEXAS. SAID 0.999 ACRE (43,558.28 SQ. FT.) TRACT OF LAND BEING MORE PARTICULARLY DESCRIBED BY METES AND BOUNDS AS FOLLOWS:

BEGINNING AT A 60-D NAIL FOUND AT THE NORTHEAST CORNER OF LOT 8, BLOCK 4, JOHN CLOSNER ET AL SUBDIVISION AS RECORDED IN VOL. 0, PG. 4, MAP RECORDS, HIDALGO COUNTY, TEXAS AND ALSO BEING THE NORTHEAST CORNER OF TRACT HEREIN DESCRIBED;

THENCE SOUTH, WITH AND ALONG THE EAST LOT LINE OF SAID LOT 8, BLOCK 4 AND THE WEST LINE OF SAID ALBERTA ESTATES UNIT NO. 1, A DISTANCE OF 20.0 FEET TO A POINT ON THE SOUTH AND CONTINUING ON THE SAME BEARING FOR A TOTAL DISTANCE OF 303.0 FEET TO A HALF INCH (1/2) IRON ROD SET FOR THE SOUTHEAST CORNER OF TRACT HEREIN DESCRIBED;

THENCE, WEST PARALLEL TO THE NORTH LOT LINE OF SAID LOT 8, BLOCK 4, A DISTANCE OF 143.76 TO A SET HALF INCH (1/2) IRON ROD FOR THE SOUTHWEST CORNER OF SAID TRACT HEREIN DESCRIBED;

THENCE, NORTH, PARALLEL TO THE EAST LOT LINE OF SAID LOT 8, BLOCK 4, AND THE WEST LINE OF SAID ALBERTA ESTATES UNIT NO. 1 SUBDIVISION, A DISTANCE OF 283.0 FEET TO A POINT ON THE SOUTH RIGHT-OF-WAY LINE OF ALBERTA ROAD AND CONTINUING ON THE SAME BEARING FOR A TOTAL DISTANCE OF 303.0 FEET TO A SET 60-D NAIL ON THE NORTH LOT LINE OF SAID LOT 8, BLOCK 4, FOR THE NORTHWEST CORNER OF SAID TRACT HEREIN DESCRIBED;

THENCE, EAST, WITH AND ALONG THE NORTH LOT LINE OF SAID LOT 8, BLOCK 4, A DISTANCE OF 143.76 FEET TO THE POINT OF BEGINNING, CONTAINING 0.999 ACRE (43,558.28 SQ. FT.) TRACT OF LAND MORE OR LESS.

INDEX TO SHEET FOR RE-PLAT OF A & V SUBDIVISION

1	LOCATION MAP AND ET, PRINCIPAL CONTACTS; PLAT WITH LOTS, STREETS, AND EASEMENT DESIGNATIONS; LEGAL DESCRIPTION (METES AND BOUNDS); SURVEYOR'S AND ENGINEER'S CERTIFICATION; PLAT NOTES AND RESTRICTIONS; OWNER'S DEDICATION, CERTIFICATION, AND ATTESTATION; CITY APPROVAL CERTIFICATE; COUNTY CLERK'S RECORDING CERTIFICATE; HIDALGO COUNTY CERTIFICATE OF PLAT APPROVAL; DESCRIPTION OF LOCATION OF SUBDIVISION WITH RESPECT TO THE ETJ OF A MUNICIPALITY AND DESIGNATE THE PRECINCT THE PROJECT IS SITUATED; H.C.D.D. NO. 1 CERTIFICATION; H.C.I.D. NO. 2 CERTIFICATION; RIGHT OF WAY CERTIFICATION; H.C.H.D. CERTIFICATION; REVISION NOTES.
2	WATER DISTRIBUTION AND SANITARY SEWER IMPROVEMENTS, ENGINEERING REPORT (ENGLISH AND SPANISH VERSION), INCLUDING DESCRIPTION OF WATER AND SANITARY SEWER AND ENGINEER'S CERTIFICATION (ENGLISH AND SPANISH VERSION); TYPICAL WATER SERVICE CONNECTION; DRAINAGE REPORT, SUB-DIVIDER CERTIFICATE AND STATEMENT; DRAINAGE REPORT INCLUDING DESCRIPTION OF DRAINAGE AND HOW IT WILL SERVE THIS DEVELOPMENT; MAP OF TOPOGRAPHY AND DRAINAGE, AND ENGINEER'S CERTIFICATION; REVISION NOTES.

RODRIGUEZ ENGINEERING
CONSULTING ENGINEER • SURVEYOR
P.O. BOX 1830 • EDINBURG, TEXAS • 78540
PHONE (956) 491-1013 • FIRM No. 101702-00

NO.	SHEET	REVISION	DATE	APPROVED

OWNER'S DEDICATION, CERTIFICATION, AND ATTESTATION:
ALDO QUINTANILLA, AS OWNER OF THE 0.999 ACRE TRACT OF LAND ENCOMPASSED WITHIN THE PROPOSED RE-PLAT OF A & V SUBDIVISION HEREBY SUBDIVIDE THE LAND AS DEPICTED IN THIS SUBDIVISION PLAT AND DEDICATED TO PUBLIC USE THE STREET, PARK, AND EASEMENTS SHOWN HEREIN.

I CERTIFY THAT I HAVE COMPLIED WITH THE REQUIREMENTS OF TEXAS LOCAL GOVERNMENT CODE 232.032 AND THAT:
(A) THE WATER QUALITY AND CONNECTIONS TO THE LOTS MEET, OR WILL MEET, THE MINIMUM STATE STANDARDS.
(B) SEWER CONNECTIONS TO THE LOTS MEET, OR WILL MEET, THE MINIMUM REQUIREMENTS OF THE STATE STANDARDS.
(C) ELECTRICAL CONNECTIONS PROVIDED TO THE LOTS MEET, OR WILL MEET, THE MINIMUM STATE STANDARDS; AND
(D) GAS CONNECTIONS, IF AVAILABLE, PROVIDED TO THE LOTS MEET, OR WILL MEET, THE MINIMUM STATE STANDARDS. I ATTEST THAT THE MATTERS ASSERTED IN THIS PLAT ARE TRUE AND COMPLETE.

ALDO QUINTANILLA _____ DATE _____
1707 WAYNE DR.
EDINBURG, TEXAS 78572

STATE OF TEXAS COUNTY OF HIDALGO:
BEFORE ME, THE UNDERSIGNED AUTHORITY, ON THIS DAY PERSONALLY APPEARED _____ KNOWN TO ME BY THE PERSON (S) WHOSE NAME (S) IS (ARE) SUBSCRIBED TO THE FOREGOING INSTRUMENT AND ACKNOWLEDGED TO ME THAT HE EXECUTED THE SAME FOR PURPOSED AND IN CONSIDERATION THEREIN STATED, GIVEN UNDER MY HAND AND SEAL OF OFFICE THIS THE _____ DAY OF _____ 2014.

NOTARY PUBLIC
MY COMMISSION EXPIRES ON _____

HIDALGO COUNTY DRAINAGE DISTRICT NO. 1
HIDALGO COUNTY DRAINAGE DISTRICT NO. 1 HEREBY CERTIFIES THAT THE DRAINAGE PLANS FOR THIS SUBDIVISION COMPLY WITH THE MINIMUM UTILITY OF THE DISTRICT ADOPTED UNDER TEXAS WATER CODE 49.211(C) THE DISTRICT HAS NOT REVIEWED AND DOES NOT CERTIFY THAT THE DRAINAGE STRUCTURES DESCRIBED ARE APPROPRIATE FOR THE SPECIFIC SUBDIVISION, BASED ON GENERALLY ACCEPTED ENGINEERING CRITERIA. IT IS THE RESPONSIBILITY OF DEVELOPER OF THE SUBDIVISION AND ITS ENGINEER TO MAKE THESE DETERMINATIONS.

DISTRICT MANAGER _____ DATE _____

STATE OF TEXAS COUNTY OF HIDALGO
I, _____ ADMINISTRATOR/DIRECTOR OF PLANNING AND ZONING DEPARTMENT OF THE CITY OF EDINBURG, TEXAS DO HEREBY CERTIFY THIS MINOR SUBDIVISION PLAT KNOWN AS RE-PLAT OF A & V SUBDIVISION CONFORMS TO ALL SUBDIVISION REQUIREMENTS OF THIS CITY WHEREIN MY APPROVAL IS REQUIRED AND HAS BEEN APPROVED FOR RECORDING ON THIS THE _____ DAY OF _____ 2014, WITH THE COUNTY CLERK OF HIDALGO COUNTY, TEXAS.

ADMINISTRATOR/PLANNING AND ZONING DEPARTMENT DIRECTOR

NAME	ADDRESS	PHONE NUMBER	FAX NUMBER
OWNER: ALDO QUINTANILLA	1707 WAYNE DRIVE, EDINBURG, TEXAS 78542	(956) 491-1013	N/A
ENGINEER: LEO RODRIGUEZ, JR., P.E.	P.O. BOX 1830, EDINBURG, TEXAS 78540	(956) 491-1013	(956) 381-2775
SURVEYOR: LEO L. RODRIGUEZ, JR., R.P.L.S.	P.O. BOX 1830, EDINBURG, TEXAS 78540	(956) 491-1013	(956) 381-2775

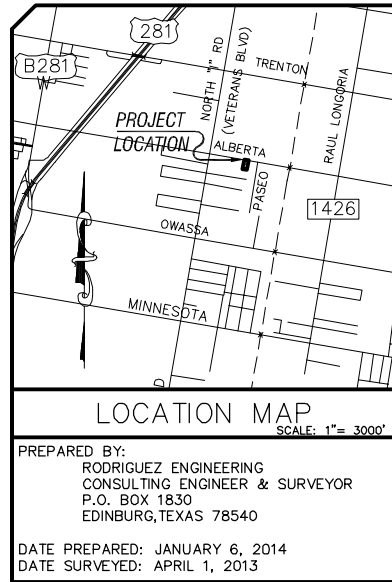

PREPARED BY:
RODRIGUEZ ENGINEERING
CONSULTING ENGINEER & SURVEYOR
P.O. BOX 1830
EDINBURG, TEXAS 78540

DATE PREPARED: JANUARY 6, 2014
DATE SURVEYED: APRIL 1, 2013

**MINOR
SUBDIVISION PLAT
OF
RE-PLAT OF A & V
SUBDIVISION
BEING A 0.999 ACRE TRACT OF
LAND OUT OF LOT 8, BLOCK 4,
JOHN CLOSNER ET AL, SUBDIVISION,
AS PER MAP RECORDED IN
VOL. 0, PG. 4, MAP RECORDS,
HIDALGO COUNTY, TEXAS.**

FINAL ENGINEERING REPORT
WATER SUPPLY, DESCRIPTION, COST, AND OPERABILITY DATE:

RE-PLAT OF A & V SUBDIVISION WILL BE PROVIDED WITH POTABLE WATER BY NORTH ALAMO WATER SUPPLY CORPORATION (N.A.W.S.C.). THE SUBDIVIDER AND N.A.W.S.C. HAVE ENTERED INTO A CONTRACT IN WHICH N.A.W.S.C. HAS PROMISED TO PROVIDE SUFFICIENT WATER TO THE SUBDIVISION FOR AT LEAST 30 YEARS AND N.A.W.S.C. HAS PROVIDED DOCUMENTATION TO SUFFICIENTLY ESTABLISH THE LONG TERM QUANTITY AND QUALITY OF THE AVAILABLE WATER SUPPLIES TO SERVE THE FULL DEVELOPMENT OF THIS SUBDIVISION.

N.A.W.S.C. HAS AN EXISTING 2" DIAMETER WATER LINE RUNNING ALONG THE SOUTH SIDE OF THE RIGHT-OF-WAY OF ALBERTA ROAD AND 8" WATER LINE ALONG THE NORTHSIDE. THE WATER SYSTEM FOR RE-PLAT OF A & V SUBDIVISION CONSIST OF ONE AND A HALF (1 1/2") DIAMETER SERVICE LINE THAT CONNECTS TO THE WATER METER BOX FOR THE LOT. THE SINGLE SERVICE AND THE METER BOX ARE EXISTING. IN ADDITION THE SUBDIVIDER WILL INSTALL A FIRE HYDRANT ALONG THE SOUTH SIDE OF ALBERTA ROAD. THE SUB-DIVIDER HAS PAID THE N.A.W.S.C. THE SUM OF \$ 1,960.00 WHICH COVERS THE COST FOR THE LOT AS STATED IN THE 30 YEAR WATER SERVICE AGREEMENT WHICH THE SUB-DIVIDER REPRESENTS THE TOTAL COST OF WATER SERVICE RIGHTS ACQUISITION FEES, AND ALL MEMBERSHIP DUES AND OTHER FEES ASSOCIATED WITH CONNECTING THE INDIVIDUAL LOTS IN THE SUBDIVISION TO N.A.W.S.C. THE ENTIRE WATER FACILITIES HAVE BEEN APPROVED AND ACCEPTED BY N.A.W.S.C. AND SAID DISTRIBUTION SYSTEM IS OPERABLE AS OF THE DATE OF THE RECORDING OF THE SUBDIVISION PLAT.

SEWAGE FACILITIES DESCRIPTION, COST AND OPERABILITY DATES UTILIZING PERSONAL CHECK:

SEWAGE FOR RE-PLAT OF A & V SUBDIVISION WILL BE TREATED BY INDIVIDUAL ON-SITE SEWAGE FACILITIES ("OSSF") CONSISTING OF A STANDARD DESIGN DUAL COMPARTMENTS SEPTIC TANK AND A DRAIN FIELD FOR THE LOT. JOSE ANGEL GONZALEZ, REGISTRATION NO. OS12258, HAS EVALUATED THE SUITABILITY OF THE SUBDIVISION SITE FOR OSSF AND SUBMITTED A REPORT CONCLUDING THAT THE SITE IS SUITABLE FOR OSSF. THE REPORT WAS REVIEWED AND APPROVED BY THE HIDALGO COUNTY HEALTH DEPARTMENT. THE LOT HAS ADEQUATE AREA FOR A REPLACEMENTS DRAINFIELD.

EACH LOT IN THE PROPOSED SUBDIVISION IS AT LEAST 1/2 ACRE IN SIZE. THE NATURAL RESOURCE CONSERVATION SERVICE SOIL SURVEY BOOK INDICATED A SANDY CLAY LOAM. TWO SOIL EXCAVATIONS WERE PERFORMED ON THE SITE, AT OPPOSITE ENDS OF THE PROPOSED DISPOSAL AREA. (ADDITIONAL BORINGS WERE UNNECESSARY BECAUSE THE SOILS ARE VERY UNIFORM WITHIN THIS LIMITS AREA). THE SOIL IS A UNIFORM SANDY CLAY LOAM EXTENDING UP TO 36" BELOW THE BOTTOM OF ANY PROPOSED EXCAVATIONS. THERE IS NO INDICATION OF GROUNDWATER OR A RESTRICTIVE LAYER WITHIN 24" OF BOTTOM OF THE PROPOSED EXCAVATIONS. THE SUBDIVISION DRAINS WELL.

THERE IS AN EXISTING SEWAGE SYSTEM THAT WILL BE REMOVED AND REPLACE IN ACCORDANCE TO HIDALGO COUNTY REQUIREMENTS AND SPECIFICATIONS. THE ESTIMATED COST TO INSTALL A NEW SEPTIC SYSTEM ON AN INDIVIDUAL LOT IS \$1,500.00, INCLUDING THE COSTS FOR THE REQUIRED PERMIT AND LICENSE. NO OSSF HAS BEEN INSTALLED AS OF THE TIME OF APPLICATION FOR FINAL PLAT APPROVAL. WITH THE FILING OF THIS FINAL PLAT, THE SUBDIVIDER IS PROVIDING ADEQUATE FINANCIAL GUARANTEES OF PERFORMANCE IN THE FORM OF A (CASHIERS CHECK OR PERSONAL CHECK) REPRESENTING A CASH DEPOSIT TO BE HELD BY THE COUNTY OF HIDALGO IN ESCROW IN THE AMOUNT OF (\$1,500.00), WHICH IS THE ESTIMATED TOTAL COST TO INSTALL A SEPTIC TANK SYSTEM ON EACH LOT. THE SUBDIVIDER WILL INCLUDE THE COST OF THE SEPTIC TANK SYSTEM IN THE SALE PRICE OF THE LOT. AT ANY TIME AFTER THE LOT IS SOLD, THE PURCHASER MAY INITIATE INSTALLATION OF A SEPTIC SYSTEM BY WRITING OR CALLING THE SUBDIVIDER AND THEN FILING WITH THE HIDALGO COUNTY HEALTH DEPARTMENT AN APPLICATION FOR A PERMIT TO CONSTRUCT A SEPTIC SYSTEM. SEPTIC TANK SYSTEMS SHALL BE INSTALLED ON THE LOT PRIOR TO THE COUNTY ISSUING A FINAL LIGHT AND WATER CLEARANCE.

WATER & SEWAGE ENGINEER CERTIFICATION:

BY MY SIGNATURE BELOW, I CERTIFY THAT THE WATER AND SEWAGE SERVICE FACILITIES DESCRIBED ABOVE ARE IN COMPLIANCE WITH THE MODEL RULES ADOPTED UNDER SECTION 16.243, WATER CODE. I CERTIFY THAT THE ESTIMATED COSTS TO INSTALL UNCONSTRUCTIVE WATER AND ON-SITE SEWAGE FACILITIES, DISCUSSED ABOVE, ARE AS FOLLOWS:

WATER FACILITIES - THESE FACILITIES ARE FULLY CONSTRUCTED. WITH THE INSTALLATION OF WATER METERS, WILL COST A GRAND TOTAL OF \$ 1,960.00.

SEWAGE FACILITIES - SEPTIC SYSTEMS HAVE BEEN INSTALLED AT A TOTAL COST OF \$1,500.00.

LEO L. RODRIGUEZ, R.P.L.S., P.E. REGISTERED PROFESSIONAL ENGINEER No. 34928

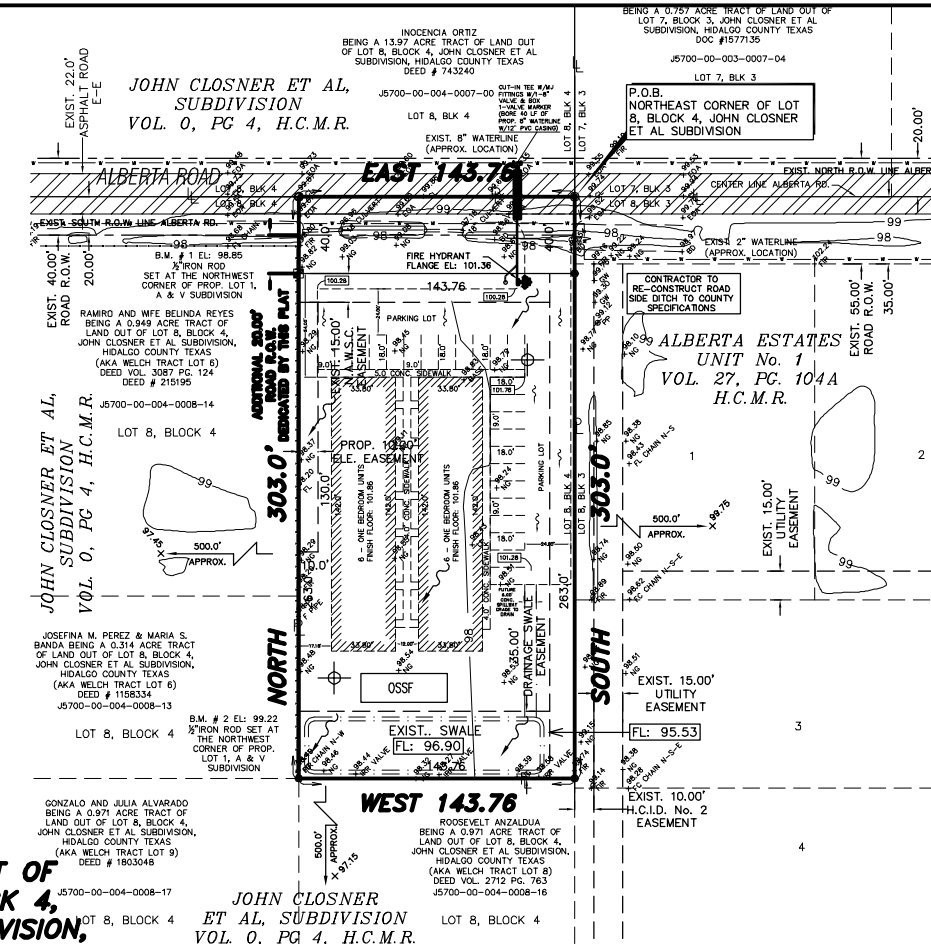

BASIS OF BEARING AS PER ALBERTA ESTATES SUBDIVISION VOL. 27, PG. 104A H.C.M.R.

SCALE 1" = 50'

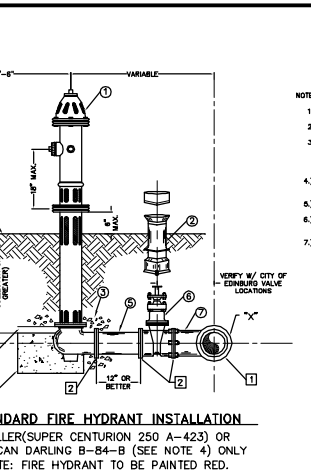
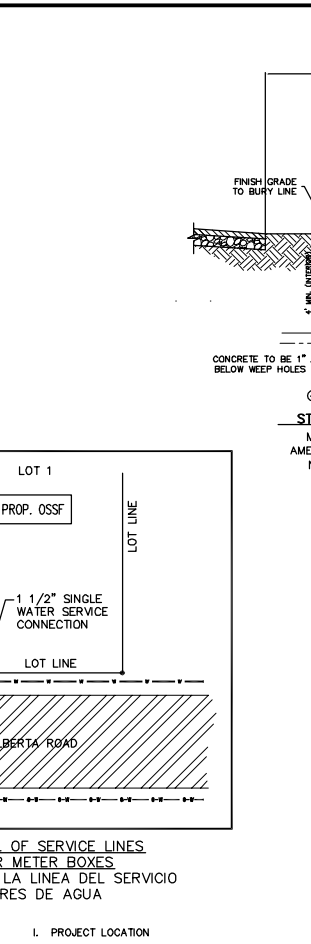

- NOTE:
- 1) OIL SHALL BE PLACED IN HYDRANT AT THE TIME OF INSTALLATION.
 - 2) PUMP NOZZLE SHALL FACE ROADWAY. (5 1/2" A.S.I.)
 - 3) IN CERTAIN INSTANCES, WHERE DISTANCES PERMIT, A PARALLEL, 180 DEGREE OR 90 DEGREE TURNING ADAPTER MAY BE USED IN PLACE OF A STANDARD TEE. FINAL APPROVAL BY THE CITY OF PHOENIX IS REQUIRED.
 - 4) IF AMERICAN CABLE IS USED MODEL B-84-B W/EPoxy COAT VALVE PLATE AND INTERIOR SIDE.
 - 5) TAPPING SLEEVES TO HAVE STAINLESS STEEL BOLTS AND NUTS.
 - 6) ALL VALVES, FITTINGS & ACCESSORIES TO BE GREASED WRAPPED IN PLASTIC.
 - 7) ALL VALVES, FITTINGS AND ACCESSORIES, VALVE BOXES, METER BOXES AND COVERS MUST BE APPROVED BY THE CITY OF PHOENIX.
- FIRE HYDRANT INSTALLATION CONSIST OF FIRE HYDRANT, VALVE AND VALVE BOX
- FIRE HYDRANT UNIT SHALL INCLUDE:
- 1) FIRE HYDRANT W/ (4 1/2" PUMP NOZZLE)
 - 2) VALVE BOX (EPOXY)
 - 3) 3 OIL FT. GRAVEL
 - 4) 3 OIL FT. CONCRETE 1" BELOW HYDRANT NEEP HOLES
 - 5) 1" OR METRIC PVC SPOOLS
 - 6) 4" RESILIENT SEAT GATE VALVE (FLANGED X M.A.)
 - 7) 4" CAST IRON TEE (FLANGED X M.A.)
 - 8) 1" WATER METER DIA.
- MECHANICAL JOINT
FLANGE

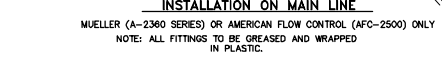

MUELLER (A-2300 SERIES) OR AMERICAN FLOW CONTROL (AFC-2500) ONLY
NOTE: ALL FITTINGS TO BE GREASED AND WRAPPED IN PLASTIC.

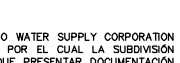

DETALLE TIPICO DE LA LINEA DEL SERVICIO Y MEDIDORES DE AGUA

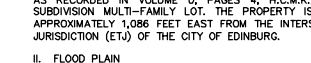

CONSTRUCTION COST ESTIMATE:
DRAINAGE = \$ 1,500.00
WATER = \$ 1,960.00
OSSF = \$ 1,500.00
TOTAL = \$ 4,960.00

2% INSPECTION FEE:
DRAINAGE = \$ 1,500.00
TOTAL = \$ 1,500.00
2% = \$ 30.00

DRAINAGE SWALE X-SECTION

SUBDIVIDER CERTIFICATION:

1.- BY COMPLETING THE IMPROVEMENTS DESCRIBED ON THE PLAT, SUBDIVIDER WILL COMPLY WITH MINIMUM STATE STANDARDS AND THAT (a) WATER QUALITY AND CONNECTIONS INCLUDING WATER METERS TO THE LOTS MEET SUCH STANDARDS AND (b) SEWER CONNECTIONS TO THE LOTS OR SEPTIC TANKS MEET OR WILL MEET SUCH STANDARDS AND WILL BE CONSTRUCTED IN ACCORDANCE WITH STATE AND COUNTY REGULATIONS.

SUBDIVIDER STATEMENT:

1.- I, ALDO QUINTANILLA, OWNER OF RE-PLAT OF A & V SUBDIVISION HEREBY CERTIFY SEWER PERMITS ARE REQUIRED PRIOR TO BUILDING ON THE LOT AND THAT AN ADEQUATE DRINKING WATER SOURCE IS IMMEDIATELY AVAILABLE TO EACH LOT OF THE TYPE, QUALITY & QUANTITY TO ENABLE EACH PERSON PURCHASING A LOT TO HAVE ADEQUATE WATER TO COMPLY WITH THE REGULATIONS AND THE LAWS OF THE STATE AS REQUIRED BY STATE AND COUNTY REGULATIONS.

STATE OF TEXAS
COUNTY OF HIDALGO:

BEFORE ME, THE UNDERSIGNED AUTHORITY, ON THIS DAY PERSONALLY APPEARED ALDO QUINTANILLA, KNOWN TO ME BY THE PERSON WHOSE NAME IS SUBSCRIBED TO THE FOREGOING INSTRUMENT AND ACKNOWLEDGED TO ME THAT HE EXECUTED THE SAME FOR PURPOSED AND CONSIDERATION THEREIN STATED, GIVEN UNDER MY HAND AND SEAL OF OFFICE THIS THE _____ DAY OF _____, 2014.

NOTARY PUBLIC
MY COMMISSION EXPIRES _____

**INDEX TO SHEET FOR
RE-PLAT OF A & V SUBDIVISION**

NO.	SHEET	REVISION	DATE	APPROVED

SOIL EVALUATION REPORT INFORMATION						BORES 01	
DEPTH (FEET)	TEXTURE CLASS	SOIL TEXTURE	STRUCTURE (FOR CLASS IS BLOCK, PLAT, OR MASSIVE)	DRAINAGE (DOTTED WATER TABLE)	RESTRICTIVE HORIZON	OBSERVATIONS	
0							
1		SANDY CLAY LOAM					
2		SANDY CLAY LOAM	N/A	NONE	NONE		SOIL IS SUITABLE FOR OSSF
3		SANDY CLAY LOAM					
4		SANDY CLAY LOAM					
5		SANDY CLAY LOAM					

SOIL EVALUATION REPORT INFORMATION						BORES 02	
DEPTH (FEET)	TEXTURE CLASS	SOIL TEXTURE	STRUCTURE (FOR CLASS IS BLOCK, PLAT, OR MASSIVE)	DRAINAGE (DOTTED WATER TABLE)	RESTRICTIVE HORIZON	OBSERVATIONS	
0							
1		SANDY CLAY LOAM					
2		SANDY CLAY LOAM	N/A	NONE	NONE		SOIL IS SUITABLE FOR OSSF
3		SANDY CLAY LOAM					
4		SANDY CLAY LOAM					
5		SANDY CLAY LOAM					

I. PROJECT LOCATION
RE-PLAT OF A & V SUBDIVISION IS A 0.999-ACRE TRACT OF LAND BEING OUT OF LOT 8, BLOCK 3, JOHN CLOSNER ET AL SUBDIVISION AS RECORDED IN VOLUME 0, PAGES 4, H.C.M.R., HIDALGO COUNTY, TEXAS. PROPOSED DEVELOPMENT WILL CONSIST OF A 1-LOT SUBDIVISION MULTI-FAMILY LOT. THE PROPERTY IS LOCATED IN HIDALGO COUNTY, TEXAS, ON THE SOUTH SIDE OF ALBERTA ROAD, APPROXIMATELY 1,086 FEET EAST FROM THE INTERSECTION OF VETERAN ROAD (SOUTH "I" ROAD) AND IS WITHIN THE EXTRATERRITORIAL JURISDICTION (ETJ) OF THE CITY OF EDINBURG.

II. FLOOD PLAIN
THE SUBJECT TRACT IS LOCATED IN ZONE B; AREAS BETWEEN LIMITS OF THE 100-YEAR AND 500-YEAR FLOOD; OR CERTAIN AREAS SUBJECT TO 100-YEAR FLOODING WITH AVERAGE DEPTHS OF LESS THAN 1 FOOT OR WHERE THE CONTRIBUTING DRAINAGE AREA IS LESS THAN ONE (1) SQUARE MILE; OR AREAS PROTECTED BY LEVEES FROM THE BASE FLOOD IN ACCORDANCE WITH FLOOD INSURANCE RATE MAP NO. 480334 0425 C, MAP REVISED NOVEMBER 16, 1982 (REFER TO EXHIBIT B).

III. SOIL CONDITIONS
A REVIEW OF THE SOIL SURVEY OF HIDALGO COUNTY (REFER TO EXHIBIT C) INDICATES THE SUBJECT TRACT LIES IN AN AREA OF PREDOMINANTLY RAYMONDVILLE CLAY LOAM (RAYMONDVILLE S2), A SOIL THAT IS WELL DRAINED, WITH SURFACE RUNOFF BEING SLOW AND THE AVAILABLE WATER IS HIGH. A FEW AREAS OF THIS SOIL HAVE BEEN ALTERED BY LAND LEVELING FOR IRRIGATION.

IV. EXISTING CONDITIONS
THE SUBJECT TRACT IS CURRENTLY UNDEVELOPED. THE EXISTING TERRAIN HAS A GRADE OF APPROXIMATELY 0.15 TO 0.20%. EXISTING RUNOFF IS BY SHEET FLOW GENERALLY TOWARDS THE SOUTHWEST OF THE TRACT, AND NATURALLY DRAINS OUT SURROUNDING LANDS. THE TOTAL CONTRIBUTING 10-YEAR EXISTING STORM WATER RUNOFF IS 0.87 CFS. (REFER TO EXHIBIT D)

V. PROPOSED CONDITIONS
THE PROPOSED CONDITIONS FOR THIS SUBJECT TRACT WILL CONSIST OF A 1-LOT SUBDIVISION MULTI-FAMILY LOT. THE DEVELOPMENT IN THE FORM OF IMPERVIOUS PAVEMENT, DRIVEWAYS AND STRUCTURE WILL NOT SIGNIFICANTLY INCREASE THE ULTIMATE STORM RUNOFF. DEVELOPMENT CONDITIONS WILL CONSIST OF RE-GRADING ONLY THE PAD SITES AND PROVIDING ON-SITE DETENTION AS REQUIRED BY HIDALGO COUNTY. RUNOFF WILL BE CONVEYED BY A COMBINATION OF LANDSCAPING AREAS TO DESIGNATED DETENTION SITES AS PART OF THE PROPOSED DRAINAGE PLAN. THE TOTAL CONTRIBUTING 10 YEAR DEVELOPED STORM WATER DISCHARGE WILL BE MAINTAINED AT 0.87 CFS. (REFER TO EXHIBIT D)

VI. DETENTION REQUIREMENTS
IN ACCORDANCE WITH THE HIDALGO COUNTY DRAINAGE DISTRICT NO 1 POLICY, THE PEAK RATE FOR RUNOFF FOR THIS DEVELOPMENT WILL BE LIMITED TO THE EXISTING 10-YEAR STORM WATER RUNOFF. IN ACCORDANCE WITH THE CITY OF EDINBURG REQUIREMENTS, THE DETENTION SHALL BE BASED ON A 10-YEAR FLOOD FOR A TOTAL OF 4,230.90 CUBIC FEET (0.097 AC-FT) OF ON-SITE DETENTION FOR THE ENTIRE SUBDIVISION.

LEO L. RODRIGUEZ, R.P.L.S., P.E. REGISTERED PROFESSIONAL ENGINEER No. 34928

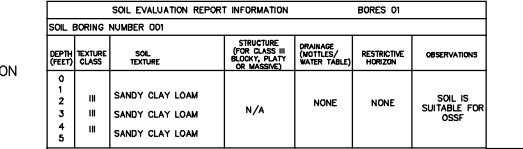

LEO L. RODRIGUEZ, R.P.L.S., P.E. REGISTERED PROFESSIONAL ENGINEER No. 34928

RODRIGUEZ ENGINEERING
CONSULTING ENGINEER • SURVEYOR
P.O. BOX 1830 • EDINBURG, TEXAS • 78540
PHONE (956) 491-1013 • FIRM NO. 101702-00

OWNER: ALDO QUINTANILLA
ENGINEER: LEO L. RODRIGUEZ, JR., P.E.
SURVEYOR: LEO L. RODRIGUEZ, JR., R.P.L.S.

ADDRESS: 1707 WAYNE DRIVE, EDINBURG, TEXAS 78542
P.O. BOX 1830, EDINBURG, TEXAS 78540
P.O. BOX 1830, EDINBURG, TEXAS 78540

PHONE NUMBER: (956) 491-1013
FAX NUMBER: (956) 381-2775

LEO L. RODRIGUEZ, R.P.L.S., P.E. REGISTERED PROFESSIONAL ENGINEER No. 34928

LEO L. RODRIGUEZ, R.P.L.S., P.E. REGISTERED PROFESSIONAL ENGINEER No. 34928