



# AIA<sup>®</sup> Document G714<sup>™</sup> – 2007

## Construction Change Directive

|   |  |  |
|---|--|--|
| <b>PROJECT:</b> <i>(Name and address)</i><br>Hidalgo County Remodel Old Admin Bldg<br>100 E Cano<br>Edinburg, Texas 78539 | <b>DIRECTIVE NUMBER:</b> 006<br><b>DATE:</b> August 1, 2014<br><b>CONTRACT FOR:</b><br>General Construction<br><b>CONTRACT DATED:</b> October 23, 2012<br><b>ARCHITECT'S PROJECT NUMBER:</b> | <b>OWNER</b> <input checked="" type="checkbox"/><br><b>ARCHITECT</b> <input checked="" type="checkbox"/><br><b>CONSULTANT</b> <input checked="" type="checkbox"/><br><b>CONTRACTOR</b> <input checked="" type="checkbox"/><br><b>FIELD</b> <input type="checkbox"/><br><b>OTHER</b> <input type="checkbox"/> |
| <b>TO CONTRACTOR:</b> <i>(Name and address)</i><br>D Wilson Construction<br>P.O. Box 3455<br>McAllen, Texas 78502         |  |  |

You are hereby directed to make the following change(s) in this Contract:

*(Describe briefly any proposed changes or list any attached information in the alternative.)*

- Change Request #52: \$5,080.00 : Provide L/M for the installation of new gypsum board with tape, float, texture along south wall of South Tower, 1st & 2nd Floors.
- Change Request #53: \$4,626.00: Re-do electrical/plumbing service lines for the installation of new structural steel members (Owner's request)
- Change Request #56: \$1,571.00 : Re-work new partitions at existing storefront.
- Change Request #57: \$486.00 : Additional Door Hardware Per Owner's Request

### PROPOSED ADJUSTMENTS

- The proposed basis of adjustment to the Contract Sum or Guaranteed Maximum Price:

- Lump Sum of \$ 11,763.00 (items 1,2,3,4 above)
- Unit Price of \$ per
- As provided in Section 7.3.3 of AIA Document A201<sup>™</sup>-2007
- As follows:

- The Contract Time is proposed to N/A . The proposed adjustment, if any, is N/A  
( 0 ) days.

When signed by the Owner and Architect and received by the Contractor, this document becomes effective IMMEDIATELY as a Construction Change Directive (CCD), and the Contractor shall proceed with the change(s) described above.

Contractor signature indicates agreement with the proposed adjustments in Contract Sum and Contract Time set forth in this CCD.

Alcocer Garcia Associates, Inc.  
ARCHITECT *(Firm name)*  
1333 E Jasmine  
McAllen, Texas 78501  
ADDRESS

County of Hidalgo  
OWNER *(Firm name)*  
2802 S Business Highway 281  
Edinburg, Texas 78539  
ADDRESS

D. Wilson Construction Company  
CONTRACTOR *(Firm name)*  
P.O. Box 3455  
McAllen, Texas 78502  
ADDRESS

BY *(Signature)*  
George A Garcia, Architect  
*(Typed name)*

BY *(Signature)*  
Ramon Garcia, County Judge  
*(Typed name)*

BY *(Signature)*  
Bill Wilson  
*(Typed name)*

DATE 8-1-14

DATE

DATE 8/2/14

D. Wilson Construction Company

P.O. Box 3455  
McAllen, TX 78502-3455  
Ph: (956) 686-9573

**Change Request**

To: George A. Garcia  
Alcocer Garcia Associates, Inc  
1333 E. Jasmine Ave.  
McAllen, TX 78501  
Ph: (956)618-2007 Fax: (956)618-2008

Number: 52  
Date: 7/13/14  
Job: 12-561 Remodel Administration Bldg  
Phone:

Description: Finishing out South wall both floors. NIC.

We are pleased to offer the following specifications and pricing to make the following changes:  
Insulate between furring strips, hang sheetrock, tape, float, & texture (no painting charged.. in original scope) South wall first & second floor. Reference RFI #45.

The total amount to provide this work is ..... \$5,080.00

The schedule will be impacted..

If you have any questions, please contact me at .

Submitted by: Manuel M. Ornelas, D. Wilson C

Approved by: \_\_\_\_\_  
Date: \_\_\_\_\_

Cc: Stan Ramos (Hidalgo County), Horacio Quintero (D. Wilson Construction Co.), valde.guerra@co.hidalgo.tx.us, Mateo Salazar (D. Wilson Construction Co.), apalacios@prodigycompany.com, Ed Alcocer, AGADC

HC Reno to Fmr Admin Bldg.

RFI #45

DATE: Sunday 7.13.2014

Completion February 3, 2015

#

Math Check

**12-000 Furnishings**

12-300 Educational Casework  
12-348 Laboratory Casework  
12-504 Horizontal Blinds

SUBTOTAL

**15-000 MEP**

15-100 Plumbing Contractor  
15-300 Fire Sprinkler System  
15-300 FM 200  
15-500 HVAC Contractor  
16-100 Electric Contractor/ Fire Alarm

SUBTOTAL

PROJECT SUBTOTAL

D. Wilson Construction Company fee

7.00%

322

322

4,922

322

91-871 1 Builder's Risk Policy (Hughston quote)  
91-874 Liability insurance

0.009%  
0.620%

0  
31

0  
31

INSURANCE SUBTOTAL

PROJECT SUBTOTAL

4,953

127

math is correct

91-870 Bond

127

127

PROJECT TOTAL:

5,080

127

math is correct

HC Reno to Fmr Admin Bldg.  
 Sunday 7.13.2014  
 February 3, 2015

RFI #45

#

Math Check

| <b>09-000 FINISHES</b> |  |       |
|------------------------|--|-------|
| 09-100                 | Gypsum Wall Board Systems                  | 4,200 |
| 09-200                 | Lath & Plaster                             | -     |
| 09-500                 | Acoustical Lay In Ceiling                  | -     |
| 09-310                 | Ceramic Tile                               | -     |
| 09-520                 | Acoustical Wall Panels, Fabrics, Diffusers | -     |
| 09-520                 | Acoustical Labor                           | -     |
| 09-670                 | Resinous Flooring                          | -     |
| 09-680                 | Carpet                                     | -     |
| 09-685                 | VCT  | -     |
| 09-629                 | Floor Protection Temporary                 | 400   |
| 09-900                 | Painting/VWC                               | 400   |
| SUBTOTAL:              |  | 4,600 |

| <b>10-000 SPECIALTIES: LABOR INCLUDED ON EACH LINE ITEM</b> |  |   |
|---|--|---|
| 10-100  | TV Mount Brackets (50)                       | - |
| 10-100  | TV Mount Brackets Labor                      | - |
| 10-100  | Maunal Projection Screens (52 & 1 Oversized) | - |
| 10-100  | Maunal Projection Screens Labor              | - |
| 10-100  | Motorized Projection Screens                 | - |
| 10-100  | Motorized Projection Screens Labor           | - |
| 10-100  | Curtain and Curtain Track (3 @ A115)         | - |
| 10-100  | Curtain and Curtain Track Labor              | - |
| 10-260  | Corner Guards                                | - |
| 10-260  | Corner Guards Labor                          | - |
| 10-100  | Library Security System                      | - |
| 10-100  | Library Security System Labor                | - |
| 10-100  | Ice Machine                                  | - |
| 10-100  | Ice Machine labor                            | - |

ERICO  
BUILDING SYSTEMS, LLC  
3714 W. Mile 17 ½  
Edinburg, Texas 78541

July 1, 2014

**PROPOSAL/CHANGE ORDER #7**

PROJECT: Hidalgo County Administration 1st & 2nd floor renovations (Edinburg, Texas)

Please find my proposed bid in the amount of FOUR THOUSAND TWO HUNDRED DOLLARS & NO/100 (\$4,200.00) for the extra work needed for completion of this project.

CHANGE ORDER #7: \$4,200.00

- Included: Provide and install 1" rigid board insulation
- Provide and Install 5/8" sheetrock on top of rigid board.

Should you have any questions concerning this proposal, please feel free to give me a call @ 789-0794. Thank you.

Eric R. Garcia  
ERICO BUILDING SYSTEMS, LLC

HC.  
RFI #45

# M & A Painting Service, Inc.

Miguel Barboza Jr.

3711 E. Main Ave.  
Alton, TX 78573

Phone:(956)585-6167

Fax: (956)583-3999

Email:mapaintingservice@att.net

**BASE BID: \$450.00**

AS PER PLANS & SPECS

**PROJECT:**

**HIDALGO COUNTY OLD ADMINISTRATION BUILDING  
EDINBURG, TEXAS**

**THIS BASE BID INCLUDES:**

RFI #45 TO PROVIDE A COST PROPOSAL FOR 220' SQUARE FEET TO TAPE, FLOAT AND TEXTURE ONLY. PAINT IS NOT INCLUDED AS THIS WALL WAS SUPPOSED TO BE EXISTING AND WAS SCHEDULED TO PAINT ALREADY BY ORIGINAL PLANS

**ACKNOWLEDGE OF ADDENDUMS:**

**PLEASE CALL MIKE IF YOU HAVE ANY QUESTIONS @ 956-605-5043**

|   |                      |           |  |
|---|----------------------|-----------|--|
|   | MIGUEL BARBOZA JR    | 7.10.2014 |  |
| X | _____                | DATE      | _____  |
|   | M & A REPRESENTATIVE |           | THIS BID IS GOOD FOR 30 DAYS FROM ABOVE DATE |

D. Wilson Construction Company

P.O. Box 3455  
McAllen, TX 78502-3455  
Ph : (956) 686-9573

**Change Request**

To: George A. Garcia  
Alcozer Garcia Associates, Inc  
1333 E. Jasmine Ave.  
McAllen, TX 78501  
Ph: (956)618-2007 Fax: (956)618-2008

Number: 53  
Date: 7/13/14  
Job: 12-561 Remodel Administration Bldg  
Phone:

Description: Remove, replace, re-route above ceiling utility lines.

We are pleased to offer the following specifications and pricing to make the following changes:  
Remove, replace, re-route above ceiling utility lines i.e plumbing, electrical & sprinkler lines in conflict with newly introduced structural steel. Reference RFP #27, RFI #21.

The total amount to provide this work is ..... \$4,626.00

The schedule will be impacted..

If you have any questions, please contact me at .

Submitted by: Manuel M. Ornelas, D. Wilson C

Approved by: \_\_\_\_\_  
Date: \_\_\_\_\_

Cc: Stan Ramos (Hidalgo County), valde.guerra@co.hidalgo.tx.us, Horacio Quintero (D. Wilson Construction Co.), Mateo Salazar (D. Wilson Construction Co.), apalacios@prodigycompany.com

HC Reno to Fmr Admin Bldg.  
 DATE: Sunday 7.13.2014  
 Completion February 3, 2015

RFP # 27

#

Math Check

|               |                      |          |       |
|---------------|----------------------|----------|-------|
| <b>12-000</b> | <b>Furnishings</b>   |          |       |
| 12-300        | Educational Casework |          | 1,730 |
| 12-348        | Laboratory Casework  |          | 1,430 |
| 12-504        | Horizontal Blinds    |          | -     |
|               |                      |          | 1,029 |
|               |                      | SUBTOTAL | 4,189 |

|               |                                 |          |       |
|---------------|---------------------------------|----------|-------|
| <b>15-000</b> | <b>MEP</b>                      |          |       |
| 15-100        | Plumbing Contractor             |          | 1,730 |
| 15-300        | Fire Sprinkler System           |          | 1,430 |
| 15-300        | FM 200                          |          | -     |
| 15-500        | HVAC Contractor                 |          | -     |
| 16-100        | Electric Contractor/ Fire Alarm |          | 1,029 |
|               |                                 | SUBTOTAL | 4,189 |

|  |                                    |       |              |
|--|------------------------------------|-------|--------------|
|  |                                    |       |              |
|  | <b>PROJECT SUBTOTAL</b>            |       | <b>4,189</b> |
|  | D. Wilson Construction Company fee | 7.00% | 293          |
|  |                                    |       | 4,482        |

|        |   |  |        |           |
|--------|---|--|--------|-----------|
| 91-871 | 1 | Builder's Risk Policy (Hughston quote) | 0.009% | 0         |
| 91-874 |   | Liability insurance                    | 0.620% | 28        |
|        |   | <b>INSURANCE SUBTOTAL</b>              |        | <b>28</b> |

|        |  |                         |  |              |
|--------|--|-------------------------|--|--------------|
| 91-870 |  | Bond                    |  | 4,510        |
|        |  | <b>PROJECT SUBTOTAL</b> |  | <b>116</b>   |
|        |  | <b>PROJECT TOTAL:</b>   |  | <b>4,626</b> |

*math is correct*  
*math is correct*



Faires Plumbing Co., Inc.

P. O. Box 1199

Edinburg, Texas 78540

Ph. 956-383-3221

Fax 956-383-7382

July 1, 2014

D. Wilson Construction

Re: Hidalgo County Renovation to Administration  
RFP #27 Relocate piping for structural beams

Attn.: Manny Ornelas

Dear Sir,

As per your request we submit a price of **\$1,730.00** to remove and reroute existing piping to accommodate structural changes at the project site. Please advise

Thank you,

Mike Fuentes



**Alliance Specialized Systems**

Fire Sprinkler Contractor

Texas SCR-0798

HUB Certified

E-Mail: [ederueda@alliance-fire.com](mailto:ederueda@alliance-fire.com)

602 North McColl Road

McAllen, Texas 78501

(956) 682-1602

(956) 682-1605

July 7, 2014

Attn: Manuel Ornelas  
***D. Wilson Construction***  
***1209 East Pecan***  
McAllen, Texas  
P. (956) 686-9573  
F. (956) 686-3270

RE: RFP-27  
Our Ref. #: ED77

Alliance Specialized Systems is pleased to provide our quotation of One Thousand Four Hundred Thirty Dollars (\$1,430.00) to provide material and labor to reroute the 3" sprinkler main and branch lines as needed per RFP-27.

Exclusions:

1. NA
2. Tax

THIS AGREEMENT CONSISTS OF THESE AGREEMENT PAGE AND THE TERMS AND CONDITIONS ATTACHED HERETO, and is the complete agreement between the parties. Customer acknowledges that he has read this agreement, understands it, and agrees to be bound by its terms and conditions. Neither party shall be bound by any statements or representations not contained in this agreement.

Respectfully submitted,

Ed De Rueda  
*Operations Manager*  
***Alliance Specialized Systems***



**METRO**  
ELECTRIC, INC.  
TECL# 17140

**MAIN OFFICE**  
1901 INDUSTRIAL DRIVE  
McALLEN, TX 78504-4015  
(956) 686-2323

**BRANCH OFFICE**  
5655 COMMERCIAL DRIVE  
P.O. BOX 4270  
BROWNSVILLE, TX 78523  
(956) 831-7801

HARLINGEN, TX 78550  
(956) 421-2800

WWW.METROELECTRIC-RGV.COM



June 24, 2014

D. Wilson Construction, Inc.  
1209 E Pecan Blvd.  
McAllen, TX 78501

Attn: Manuel Ornelas  
Re: Metro Electric, Inc.  
Hidalgo Administration Building Renovations – CPR #14

Please add \$1,029.00 from our base contract amount for the following changes.

SCOPE OF WORK

Furnish and install materials for RFP #27 revised, install and remove ¾" conduit.

Should you have any questions, please advise accordingly.

Sincerely,  
Metro Electric, Inc.

Jay Guajardo  
Sr. Project Manager

**COMMERCIAL • INDUSTRIAL**

Regulated by The Texas Department of Licensing and Regulation, P.O. Box 12157, Austin, Texas 78711,  
1-800-803-9202, 512-463-6599, website: [www.license.state.tx.us/complaints](http://www.license.state.tx.us/complaints)

### Change Price Request Cost Analysis

PROJECT: Hidalgo Administration Building Renovation Project  
 CONTRACTOR: D. Wilson Construction Company

DESCRIPTION OF CHANGE: Revise RFP #27

*Metro Electric, Inc. CPR #14*

| Description      | Quan. Req'd. | Material Cost | Unit | Material Total   | Labor Total      |
|------------------|--------------|---------------|------|------------------|------------------|
| ¼" EMT Conduit   | 160.00       | \$ 140.48     | C    | \$ 224.77        | \$ 326.27        |
| Remove Conduit   | 160.00       |               |      | \$ -             | \$ 210.50        |
| ¼" Couplings     | 16.00        | \$ 84.06      | C    | \$ 13.45         | \$ 31.57         |
|                  |              |               |      | \$ -             | \$ -             |
|                  |              |               |      | \$ -             | \$ -             |
|                  |              |               |      | \$ -             | \$ -             |
|                  |              |               |      | \$ -             | \$ -             |
|                  |              |               |      | \$ -             | \$ -             |
|                  |              |               |      | \$ -             | \$ -             |
|                  |              |               |      | \$ -             | \$ -             |
|                  |              |               |      | \$ -             | \$ -             |
|                  |              |               |      | \$ -             | \$ -             |
|                  |              |               |      | \$ -             | \$ -             |
|                  |              |               |      | \$ -             | \$ -             |
|                  |              |               |      | \$ -             | \$ -             |
|                  |              |               |      | \$ -             | \$ -             |
|                  |              |               |      | \$ -             | \$ -             |
| <b>Subtotals</b> |              |               |      | <b>\$ 238.22</b> | <b>\$ 568.34</b> |
| Sales Tax        |              |               |      | \$ -             |                  |
| Subtotal w/ Tax  |              |               |      | <b>\$ 238.22</b> |                  |

|  |                    |
|--|--------------------|
| Bond   | \$ -               |
| Subtotal (Material and Labor)                              | \$ 806.56          |
| Plus 15.00 % of (Material and Labor) For Overhead          | \$ 120.98          |
| <b>Subtotal (Material, Labor and Overhead)</b>             | <b>\$ 927.54</b>   |
| Plus 10.00 % of (Material, Labor, and Overhead) For Profit | \$ 92.75           |
| <b>Total (Material, Labor, Overhead, and Profit)</b>       | <b>\$ 1,020.29</b> |

D. Wilson Construction Company

P.O. Box 3455  
McAllen, TX 78502-3455  
Ph: (956) 686-9573

*Change Request*

To: George A. Garcia  
Alcocer Garcia Associates, Inc  
1333 E. Jasmine Ave.  
McAllen, TX 78501  
Ph: (956)618-2007 Fax: (956)618-2008

Number: 56  
Date: 7/25/14  
Job: 12-561 Remodel Administration Bldg  
Phone:

Description: Wall, window, T,F,T & P per RFP #008.

We are pleased to offer the following specifications and pricing to make the following changes:

New additional work as per RFP #008. Rework metal stud walls, install new window frame break metal mullions, T,F,T & P. As per RFP #008, 7.14.2014.

The total amount to provide this work is ..... \$1,571.00

The schedule will be impacted..

If you have any questions, please contact me at .

Submitted by: Manuel M. Ornelas, D. Wilson C

Approved by: \_\_\_\_\_  
Date: \_\_\_\_\_

Cc: Ed Alcocer, AGADC, Horacio Quintero (D. Wilson Construction Co.), Stan Ramos (Hidalgo County),  
apalacios@prodigycompany.com, valde.guerra@co.hidalgo.tx.us

HC Reno to fmr Admin Bldg.  
Friday 25, 2014

RFP 008

Alternates:

DATE:

Completion

Days

#

Months

February 18, 2014

Square Feet:

Math Check

SUBTOTAL:

06-000

**CARPENTRY**

06-050 Rough Carpenrty -Hang Chain Curtain  
06-410 Custom Cabinets

SUBTOTAL:

07-000

**MOISTURE PROTECTION**

07-115 Shower Stall Water Proofing  
07-160 Dampproofing Above Grade  
07-210 Building Insulation  
07-270 Firesopping and Firesafing  
07-402 Prefinished Metal Roofing  
07-525 Mod. Bit. Mem. Roofing  
07-620 Gutters/ Downspouts  
07-831 Roof Hatches and Heat/Smoke Vents  
07-900 Building Sealants

SUBTOTAL:

08-000

**DOORS & WINDOWS**

08-100 Hollow Metal Doors and Frames & HDW  
08-213 Plastic Laminate Faced Doors  
08-710 Finish Hardware  
88-100 Frame/Door/Hdwr Labor  
08-305 Access Doors  
08-332 Overhead Rolling Doors  
08-750 Glass & glazing  
08-950 Insulated Translucent Skylights

SUBTOTAL:

922

922

HC Reno to fmr Admin Bldg.

RFP 008

Friday 25, 2014

Alternates:

Completion

Days

# Months

February 18, 2014

Square Feet:

Math Check

**09-000 FINISHES**

|        |  |         |     |
|--------|--|---------|-----|
| 09-100 | Gypsum Wall Board Systems                  | Framing |     |
| 09-200 | Lath & Plaster                             |         |     |
| 09-500 | Acoustical Lay In Ceiling                  |         |     |
| 09-310 | Ceramic Tile                               |         |     |
| 09-520 | Acoustical Wall Panels, Fabrics, Diffusers |         |     |
| 09-520 | Acoustical Labor                           |         |     |
| 09-670 | Resinous Flooring                          |         |     |
| 09-680 | Carpet                                     |         |     |
| 09-685 | VCT  |         |     |
| 09-629 | Floor Protection Temporary                 |         |     |
| 09-900 | Painting and Staining                      |         | 500 |

SUBTOTAL:

**10-000 SPECIALTIES: LABOR INCLUDED ON EACH LINE ITEM**

|        |  |  |  |
|--------|--|--|--|
| 10-100 | TV Mount Brackets (50)                       |  |  |
| 10-100 | TV Mount Brackets Labor                      |  |  |
| 10-100 | Manual Projection Screens (52 & 1 Oversized) |  |  |
| 10-100 | Manual Projection Screens Labor              |  |  |
| 10-100 | Motorized Projection Screens                 |  |  |
| 10-100 | Motorized Projection Screens Labor           |  |  |
| 10-100 | Curtain and Curtain Track (3 @ A115)         |  |  |
| 10-100 | Curtain and Curtain Track Labor              |  |  |
| 10-260 | Corner Guards                                |  |  |
| 10-260 | Corner Guards Labor                          |  |  |
| 10-100 | Library Security System                      |  |  |
| 10-100 | Library Security System Labor                |  |  |
| 10-100 | Ice Machine                                  |  |  |
| 10-100 | Ice Machine labor                            |  |  |

HC Reno to fmr Admin Bldg.  
 Friday 25, 2014

RFP 008

Alternates:

DATE:  
 Completion

Days

# Months

February 18, 2014

Square Feet:

Math Check

**12-000**

**Furnishings**

12-300 Educational Casework  
 12-348 Laboratory Casework  
 12-504 Horizontal Blinds

SUBTOTAL

**15-000**

**MEP**

15-100 Plumbing Contractor  
 15-300 Fire Sprinkler System  
 15-300 FM 200  
 15-500 HVAC Contractor  
 16-100 Electric Contractor/ Fire Alarm

SUBTOTAL

PROJECT SUBTOTAL

D. Wilson Construction Company fee

7.00%

100

1,522

91-871

1 Builder's Risk Policy (Hughston quote)

0.009%

0

91-874

Liability insurance

0.620%

9

INSURANCE SUBTOTAL

10

PROJECT SUBTOTAL

1,532 math is correct

91-870 Bond

39

PROJECT TOTAL:

1,571 math is correct

39

39

G&S Glass, LLC  
 616 N. Closner Blvd.  
 Edinburg, TX 78541-3474

# Estimate

|           |            |
|-----------|------------|
| Date      | Estimate # |
| 7/23/2014 | 9709       |

|  |
|--|
| Name / Address   |
| D. WILSON CONSTRUCTION<br>1209 E. Pecan<br>P.O. Box 3455<br>McAllen, TX 78501<br>Phone: 686-9573 Fax: 686-3270 |

|         |
|---------|
| Project |
|---------|

| Description   | Qty | Rate   | Total  |
|---|-----|--------|--------|
| =====AGA RFP S=====   |     |        |        |
| 5 QTY--NEW BREAK MITAL ANCHORED TO EXISTING VERTICAL MULLION TO COVER DRYWALL PARTITION               |     | 686.25 | 686.25 |
| LABOR TO COMPLETE JOB   | 3   | 78.50  | 235.50 |
| FIRST FLOOR C-1-103, C-1-104, 175, 176, C-2-202 & C-2-203<br>SECOND FLOOR 261, 263, C-6-107 & C-6-108 |     |        |        |
| ESTIMATOR ROMAN V   |     |        |        |
| JOB LOCATION FORMER ADMIN BUILDING REMODEL<br>EDINBURG, HIDALGO COUNTY, TEXAS                         |     |        |        |

|                 |          |
|-----------------|----------|
| <b>Subtotal</b> | \$921.75 |
|-----------------|----------|

|                          |        |
|--------------------------|--------|
| <b>Sales Tax (8.25%)</b> | \$0.00 |
|--------------------------|--------|

|              |          |
|--------------|----------|
| <b>Total</b> | \$921.75 |
|--------------|----------|

|                |                |                  |
|----------------|----------------|------------------|
| Phone #        | Fax #          | E-mail           |
| (956) 287-1162 | (956) 287-1161 | gsfear@yahoo.com |

# M & A Painting Service, Inc.

Miguel Barboza Jr.

3711 E. Main Ave.  
Alton, TX 78573

Phone:(956)585-6167  
Fax: (956)583-3999

Email:mapaintingservice@att.net

---

**BASE BID: \$500.00**

AS PER PLANS & SPECS

---

**PROJECT:**

**HIDALGO COUNTY OLD ADMINISTRATION BUILDING  
EDINBURG, TEXAS**

---

**THIS BASE BID INCLUDES:**

RFP #008

PRICE FOR ADDITIONAL DRYWALL FINISHING AND PAINTING.

---

**ACKNOWLEDGE OF ADDENDUMS:**

**PLEASE CALL MIKE IF YOU HAVE ANY QUESTIONS @ 956-605-5043**

MIGUEL BARBOZA JR

7/17/2014

X

DATE

M & A REPRESENTATIVE

THIS BID IS GOOD  
FOR 30 DAYS FROM  
ABOVE DATE

July 16, 2014

**REQUEST FOR PROPOSAL  
008  
NEW WALL/CEILING TO  
EXISTING EXTERIOR GLAZING  
REVISED DETAILS RD-1, RD-2, RD-3**

Mr. Ornelas;

Provide costs, if applicable, at your earliest opportunity so that Owner may review.  
If accepted, a Construction Change Directive will be issued.

Alcocer Garcia Associates, Inc.

*Eduardo Alcocer*

Eduardo Alcocer

President

THE USE OF THESE  
 DRAWINGS IS RESTRICTED TO  
 THE ORIGINAL PURPOSE FOR  
 WHICH THEY WERE INTENDED.  
 ANY REUSE OR REPRODUCTION  
 WITHOUT PERMISSION FROM  
 THE OWNER IS PROHIBITED.

PROJECT #  
 ISSUED:  
 DRAWN BY: D.C.  
 CHECKED BY:  
 FILE NAME:  
 SHEET:

7.14.2014

FIRST FLOOR:  
 TYPICAL AT OFFICES:  
 C-1/103  
 C-1/104  
 175  
 176  
 C-2/202  
 C-2/203

SECOND FLOOR:  
 261  
 263  
 C-6/107  
 C-6/108



LICENSE EXPIRATION  
 DATE: 08.31.2014

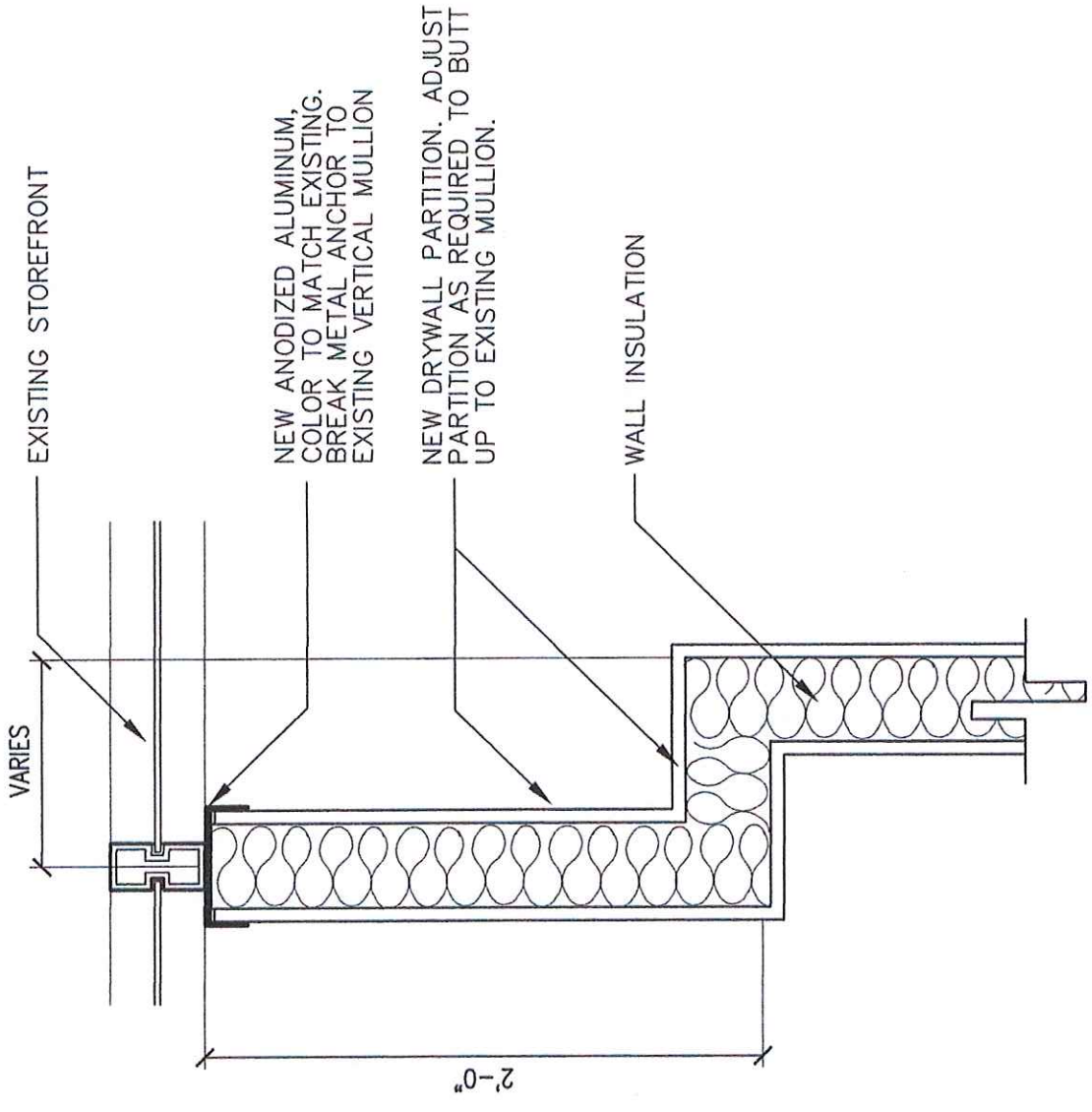

TYPICAL PLAN DETAIL  
 AT WALL TO EXISTING MULLION

SCALE: 1/2" = 1'-0"

REVISED DETAIL - RD1

FIRST FLOOR:  
TYPICAL AT OFFICES:

C-1/103  
C-1/104  
175  
176  
C-2/202  
C-2/203

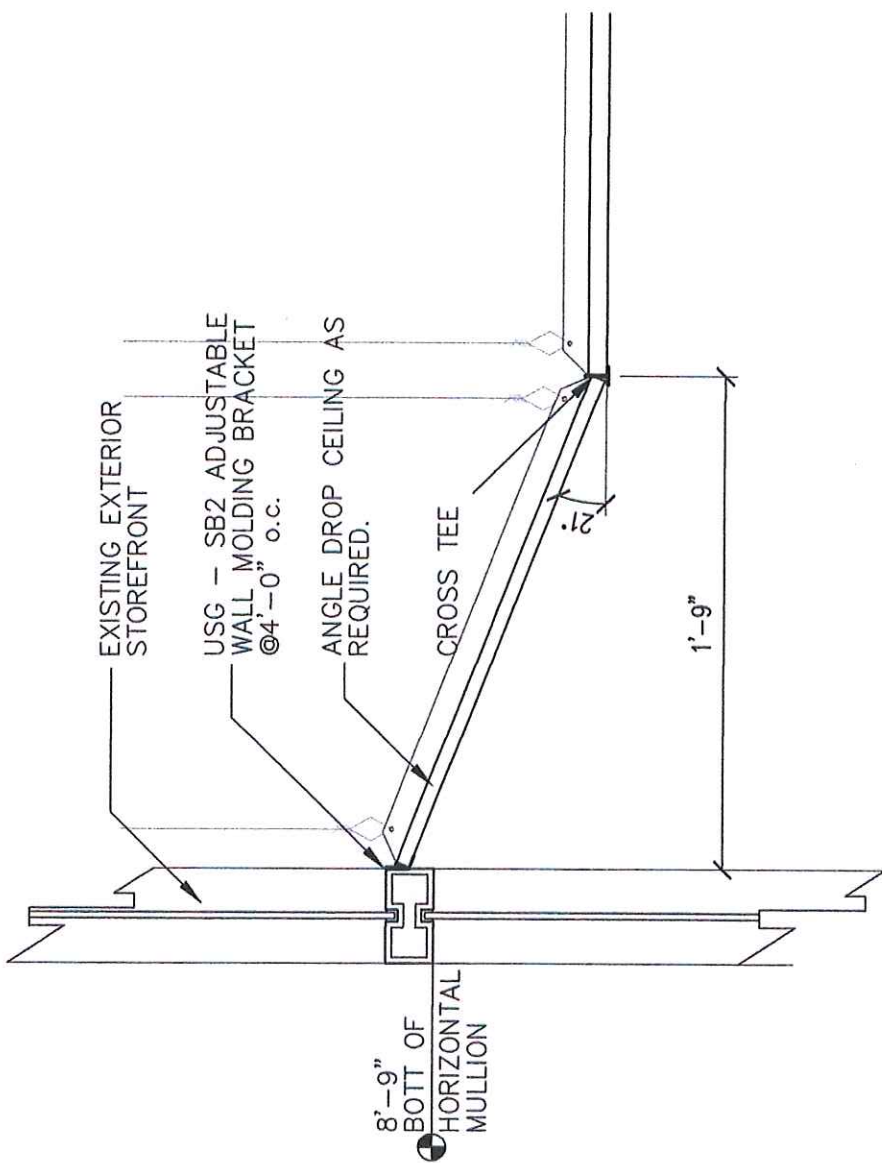

TYPICAL DETAIL  
AT CEILING TO EXISTING MULLION

SCALE: 1/2" = 1'-0"



LICENSE EXPIRATION  
DATE: 08.31.2014

AGA

Alcacer Garcia Associates, Inc.  
Design Consulting  
1333 E. Jasmine Ave.  
McAllen, Texas 78501  
Office: 956.618.2007  
Fax: 956.618.2008  
Web: WWW.AGADC.COM

1st AND 2nd FLOORS REMODEL  
FORMER ADMINISTRATION BUILDING  
HIDALGO COUNTY, TEXAS  
CITY OF EDINBURG, TEXAS

THE USE OF THESE  
DRAWINGS IS RESTRICTED TO  
THAT PROJECT AND NO OTHER  
REPRODUCTION WITHOUT  
WRITTEN PERMISSION FROM  
THE OWNER IS PERMITTED.

PROJECT #  
ISSUED:  
DRAWN BY: O.C.  
CHECKED BY:  
FILE NAME:  
SHEET:

7.14.2014

REVISED DETAIL - RD2

D. Wilson Construction Company

P.O. Box 3455  
McAllen, TX 78502-3455  
Ph : (956) 686-9573

*Change Request*

To: George A. Garcia  
Alcocer Garcia Associates, Inc  
1333 E. Jasmine Ave.  
McAllen, TX 78501  
Ph: (956)618-2007 Fax: (956)618-2008

Number: 57  
Date: 8/1/14  
Job: 12-561 Remodel Administration Bldg  
Phone:

Description: Change to Primus exterior cylinders.

We are pleased to offer the following specifications and pricing to make the following changes:  
At County's request change to Primus exterior cylinders on door HDW.

The total amount to provide this work is ..... \$486.00

The schedule will be Not Impacted..

If you have any questions, please contact me at .

Submitted by: Manuel M. Ornelas, D. Wilson C

Approved by: \_\_\_\_\_  
Date: \_\_\_\_\_

Cc: Horacio Quintero (D. Wilson Construction Co.), Stan Ramos (Hidalgo County), Mateo Salazar (D. Wilson Cons,  
apalacios@prodigycompany.com

HC Admin Bldg.  
Friday, August 01, 2014

CR Request

DATE:  
Completion

# Months

Math Check

SUBTOTAL: \_\_\_\_\_

**06-000 CARPENTRY**

06-050 Rough Carpentry /HDW Install  
06-420 Granite Counter Tops

SUBTOTAL: \_\_\_\_\_

**07-000 MOISTURE PROTECTION**

07-115 Shower Stall Water Proofing  
07-160 Dampproofing Above Grade  
07-210 Building Insulation  
07-270 Firesopping and Firesafing  
07-402 PreFinished Metal Roofing/Pavilion/Shed  
07-525 Mod. Bit. Mem. Roofing  
07-620 Gutters/ Downspouts  
07-831 Roof Hatches and Heat/Smoke Vents  
07-900 Building Sealants

SUBTOTAL: \_\_\_\_\_

**08-000 DOORS & WINDOWS**

08-100 Hollow Metal Door Frames & Wood Doors  
08-213 Plastic Laminate Faced Doors  
08-710 Finish Hardware  
88-100 Frame/Door/Hdwr Labor  
08-305 Access Doors  
08-332 Overhead Rolling Doors  
08-750 Glass & glazing  
08-950 Insulated Translucent Skylights

SUBTOTAL: \_\_\_\_\_

440

CR Request

HC Admin Bldg.

Friday, August 01, 2014

DATE:

Completion

# Months

Math Check

**12-000 Furnishings**

12-300 Educational Casework  
12-348 Laboratory Casework  
12-504 Horizontal Blinds

SUBTOTAL

—

**15-000 MEP**

15-100 Plumbing Contractor  
15-300 Fire Sprinkler System  
15-300 FM 200  
15-500 HVAC Contractor  
16-100 Electric Contractor/ Fire Alarm

SUBTOTAL

—

PROJECT SUBTOTAL

440

D. Wilson Construction Company fee

7.00%

31

31

91-871 1 Builder's Risk Policy (Hughston quote) 0.009% 0  
91-874 Liability insurance 0.620% 3

INSURANCE SUBTOTAL

3

PROJECT SUBTOTAL

474

math is correct

12

PROJECT TOTAL:

486

math is correct

12



**Project: 390165 - 1ST AND 2ND FLOOR RENOVATIONS TO ADMINISTRATION BLG  
 Contemplated Change Order # 6  
 Change to Primus Exterior Cylinders - Owner's request**

|    |                  |                       |  |    |  |         |
|----|------------------|-----------------------|--|----|--|---------|
| -1 | Pair Doors #E1   |                       | Exterior from Entry Vestibule 145      |    |  | RHRA    |
| 1  | Pair Doors #E1   |                       | Exterior from Entry Vestibule 145      |    |  | RHRA    |
| -1 | Mortise Cylinder | 987 #6 CAM 008876-001 | 613                                    | FL |  | (33.03) |
| 1  | Mortise Cylinder | 20-776 50-210-MK      | 613                                    | SC |  | 121.03  |
|    |                  |                       | Opening Total                          |    |  | 88.00   |
| -1 | Pair Doors #E2   |                       | Entry Vestibule 145 from Vestibule 146 |    |  | RHRA    |
| 1  | Pair Doors #E2   |                       | Entry Vestibule 145 from Vestibule 146 |    |  | RHRA    |
| -1 | Mortise Cylinder | 987 #6 CAM 008876-001 | 613                                    | FL |  | (33.03) |
| 1  | Mortise Cylinder | 20-776 50-210-MK      | 613                                    | SC |  | 121.03  |
|    |                  |                       | Opening Total                          |    |  | 88.00   |
| -1 | Pair Doors #E4   |                       | Exterior Canopy from Atrium 101        |    |  | RHRA    |
| 1  | Pair Doors #E4   |                       | Exterior Canopy from Atrium 101        |    |  | RHRA    |
| -1 | Mortise Cylinder | 987 #6 CAM 008876-001 | 613                                    | FL |  | (33.03) |
| 1  | Mortise Cylinder | 20-776 50-210-MK      | 613                                    | SC |  | 121.03  |
|    |                  |                       | Opening Total                          |    |  | 88.00   |
| -1 | Pair Doors #E10  |                       | Exterior from Hall - South Side        |    |  | RHRA    |
| 1  | Pair Doors #E10  |                       | Exterior from Hall - South Side        |    |  | RHRA    |
| -1 | Mortise Cylinder | 987 #6 CAM 008876-001 | 613                                    | FL |  | (33.03) |
| 1  | Mortise Cylinder | 20-776 50-210-MK      | 613                                    | SC |  | 121.03  |
|    |                  |                       | Opening Total                          |    |  | 88.00   |
| -1 | Pair Doors #E12  |                       | Exterior from Atrium 101               |    |  | RHRA    |
| 1  | Pair Doors #E12  |                       | Exterior from Atrium 101               |    |  | RHRA    |
| -1 | Mortise Cylinder | 987 #6 CAM 008876-001 | 613                                    | FL |  | (33.03) |
| 1  | Mortise Cylinder | 20-776 50-210-MK      | 613                                    | SC |  | 121.03  |
|    |                  |                       | Opening Total                          |    |  | 88.00   |

**Section Totals**

Finish Hardware 440.00

**Pre-Tax Total 440.00**

Owner has requested to change all exterior cylinders to Schlage Primus. This is a high security key system that will prevent unauthorized key duplication. The interior openings will remain on the Falcon Key System as originally scheduled.