



# AIA Document G701™ – 2001

## Change Order

<b>PROJECT</b> <i>(Name and address):</i> 1st and 2nd Flr Remodel Old Admin Bldg Edinburg, Hidalgo County, TX	<b>CHANGE ORDER NUMBER:</b> 003 <b>DATE:</b> August 19, 2014	<b>OWNER:</b> <input checked="" type="checkbox"/> <b>ARCHITECT:</b> <input checked="" type="checkbox"/> <b>CONTRACTOR:</b> <input checked="" type="checkbox"/> <b>FIELD:</b> <input type="checkbox"/> <b>OTHER:</b> <input type="checkbox"/>
<b>TO CONTRACTOR</b> <i>(Name and address):</i>	<b>ARCHITECT'S PROJECT NUMBER:</b> Alcocer Garcia Associates, Inc. <b>CONTRACT DATE:</b> October 23, 2012 <b>CONTRACT FOR:</b> General Construction	

**THE CONTRACT IS CHANGED AS FOLLOWS:**

*(Include, where applicable, any undisputed amount attributable to previously executed Construction Change Directives)*  
REFER TO ATTACHED COPY OF EXECUTED CONSTRUCTION CHANGE DIRECTIVE #006.

The original Contract Sum was	\$ 3,375,220.00
The net change by previously authorized Change Orders	\$ 239,351.00
The Contract Sum prior to this Change Order was	\$ 3,614,571.00
The Contract Sum will be increased by this Change Order in the amount of	\$ 11,763.00
The new Contract Sum including this Change Order will be	\$ 3,626,334.00

The Contract Time will be increased by Zero (0) days.

The date of Substantial Completion as of the date of this Change Order therefore is FEBRUARY 03, 2015

**NOTE:** This Change Order does not include changes in the Contract Sum, Contract Time or Guaranteed Maximum Price which have been authorized by Construction Change Directive until the cost and time have been agreed upon by both the Owner and Contractor, in which case a Change Order is executed to supersede the Construction Change Directive

**NOT VALID UNTIL SIGNED BY THE ARCHITECT, CONTRACTOR AND OWNER.**

Alcocer Garcia Associates, Inc.  
**ARCHITECT** *(Firm name)*

1333 E Jasmine  
McAllen, Texas 78501

**ADDRESS**

*George A Garcia*  
**BY** *(Signature)*

George A Garcia, Architect  
*(Typed name)*

*8-19-14*  
**DATE**

D Wilson Construction Company  
**CONTRACTOR** *(Firm name)*

P.O. Box 3455  
McAllen, Texas 78502-3455

**ADDRESS**

*[Signature]*  
**BY** *(Signature)*

Bill Wilson, Owner  
*(Typed name)*

*8/19/14*  
**DATE**

County of Hidalgo  
**OWNER** *(Firm name)*

2802 S Business 281  
Edinburg, Texas 78539

**ADDRESS**

*[Signature]*  
**BY** *(Signature)*

Ramon Garcia, County Judge  
*(Typed name)*

**DATE**



# AIA Document G714™ - 2007

## Construction Change Directive

**PROJECT: (Name and address)**

Hidalgo County Remodel Old Admin Bldg  
 100 E Cano  
 Edinburg, Texas 78539

**DIRECTIVE NUMBER:** 006**DATE:** August 1, 2014**CONTRACT FOR:**  
General Construction**CONTRACT DATED:** October 23, 2012**ARCHITECT'S PROJECT NUMBER:****TO CONTRACTOR: (Name and address)**

D Wilson Construction  
 P.O. Box 3455  
 McAllen, Texas 78502

OWNER ARCHITECT CONSULTANT CONTRACTOR FIELD OTHER 

You are hereby directed to make the following change(s) in this Contract:

(Describe briefly any proposed changes or list any attached information in the alternative.)

1. Change Request #52: \$5,080.00 : Provide L/M for the installation of new gypsum board with tape, float, texture along south wall of South Tower, 1st & 2nd Floors.
2. Change Request #53: \$4,626.00: Re-do electrical/plumbing service lines for the installation of new structural steel members (Owner's request)
3. Change Request #56: \$1,571.00 : Re-work new partitions at existing storefront.
4. Change Request #57: \$486.00 : Additional Door Hardware Per Owner's Request

**PROPOSED ADJUSTMENTS**

1. The proposed basis of adjustment to the Contract Sum or Guaranteed Maximum Price:

- Lump Sum of \$ 11,763.00 (items 1,2,3,4 above)  
 Unit Price of \$ per  
 As provided in Section 7.3.3 of AIA Document A201™-2007  
 As follows:

APPROVED BY  
 COMMISSIONERS' COURT  
 ON: 8/12/14

2. The Contract Time is proposed to N/A . The proposed adjustment, if any, is N/A  
 ( 0 ) days.

When signed by the Owner and Architect and received by the Contractor, this document becomes effective IMMEDIATELY as a Construction Change Directive (CCD), and the Contractor shall proceed with the change(s) described above.

Contractor signature indicates agreement with the proposed adjustments in Contract Sum and Contract Time set forth in this CCD.

Alcocer Garcia Associates, Inc.

ARCHITECT (Firm name)

1333 E Jasmine

McAllen, Texas 78501

ADDRESS

County of Hidalgo

OWNER (Firm name)

2802 S Business Highway 281

Edinburg, Texas 78539

ADDRESS

D. Wilson Construction Company

CONTRACTOR (Firm name)

P.O. Box 3455

McAllen, Texas 78502

ADDRESS

BY (Signature)

George A Garcia, Architect

(Typed name)

8-1-14

DATE

BY (Signature)

Ramon Garcia, County Judge

(Typed name)

8/12/14

DATE

BY (Signature)

Bill Wilson

(Typed name)

8/2/14

DATE

D. Wilson Construction Company

P.O. Box 3455  
McAllen, TX 78502-3455  
Ph: 356-688-9873

**Change Request**

To: George A. Garcia  
Alcega Garcia Associates, Inc.  
1333 E. Jasmine Ave.  
McAllen, TX 78501  
Ph: 356-618-2007 Fax: 356-618-2008

Number: 52  
Date: 7/13/14  
Job: 12-561 Remodel Administration Bldg  
Phone:

**Description:** Finishing out South wall bath floors, NIC

We are pleased to offer the following specifications and pricing to make the following changes:  
insulate between furring strips, hang sheetrock, tape, float & texture (no painting charged - in original scope) South wall first & second floor. Reference RFI #45

The total amount to provide this work is \$5,080.00

The schedule will be impacted

If you have any questions, please contact me at

Submitted by: Manuel M. Ornelas, D. Wilson Co.

Approved by: \_\_\_\_\_  
Date: \_\_\_\_\_

Cc: Stan Ramos (Hidalgo County), Horacio Quintero (D. Wilson Construction Co.), valde guerra@co.hidalgo.tx.us, Mateo Salazar (D. Wilson Construction Co.), apalacios@prodigycompany.com, Ed Alcega, AGADC

RFI #45

HC Reno to Fmr Admin Bldg.

DATE: Sunday 7.13.2014

Completion February 3, 2015

#

Build. cost

**12-000 Furnishings**

12-300 Educational Casework  
12-348 Laboratory Casework  
12-504 Horizontal Blinds

SUBTOTAL

**15-000 MEP**

15-100 Plumbing Contractor  
15-300 Fire Sprinkler System  
15-300 FM 200  
15-500 HVAC Contractor  
15-100 Electric Contractor/Fire Alarm

SUBTOTAL

PROJECT SUBTOTAL

D Wilson Construction Company fee

7.00% 322  
4,922

91-871 1 Builder's Risk Policy (Hughton quote)  
91-874 Liability Insurance

0.055% 0  
0.620% 31  
INSURANCE SUBTOTAL 31

PROJECT SUBTOTAL

4,953  
127

91-870 Bond

PROJECT TOTAL

5,080



ERICO  
BUILDING SYSTEMS, LLC  
3714 W. Mile 17 1/2  
Edinburg, Texas 78541

July 1, 2014

**PROPOSAL/CHANGE ORDER #7**

PROJECT: Hidalgo County Administration 1st & 2nd floor renovations (Edinburg, Texas)

Please find my proposed bid in the amount of FOUR THOUSAND TWO HUNDRED DOLLARS & NO 100 (\$4,200.00) for the extra work needed for completion of this project.

CHANGE ORDER #7: \$4,200.00

- Included: Provide and install 1" rigid board insulation
- Provide and Install 5' 8" sheetrock on top of rigid board.

Should you have any questions concerning this proposal, please feel free to give me a call at 789-0794. Thank you.

Eric R. Garcia  
ERICO BUILDING SYSTEMS, LLC

AC  
RFI #4

# M & A Painting Service, Inc.

Miguel Barboza Jr.

3711 E. Main Ave.  
Alton, TX 78575

Phone: (956) 585-6167  
Fax: (956) 583-3999

Email: [mapaintingsservice@att.net](mailto:mapaintingsservice@att.net)

BASE BID: \$450,000

AS PER PLANS & SPEC

**PROJECT:**

HIDALGO COUNTY OLD ADMINISTRATION BUILDING  
EDINBURG, TEXAS

THIS BASE BID INCLUDES:

RFI #45 TO PROVIDE A COST PROPOSAL FOR 2207 SQUARE FEET TO TAPE, FLOAT AND TEXTURE ONLY. PAINT IS NOT INCLUDED AS THIS WALL WAS SUPPOSED TO BE EXISTING AND WAS SCHEDULED TO PAINT ALREADY BY ORIGINAL PLANS

**ACKNOWLEDGE OF ADDENDUMS:**

PLEASE CALL MIKE IF YOU HAVE ANY QUESTIONS @ 956-605-5043

MIGUEL BARBOZA JR.  
M & A REPRESENTATIVE

DATE

7-10-2014

THIS BIDS GOOD  
FOR 50 DAYS FROM  
ABOVE DATE

D. Wilson Construction Company

P.O. Box 3455  
McAllen, TX 78502-3455  
Ph: (956) 666-9673

**Change Request**

To: George A. Garcia  
Alcoer Garcia Associates, Inc.  
1333 E. Jasmine Ave.  
McAllen, TX 78501  
Ph: (956) 618-2007 Fax: (956) 618-2008

Number: 53  
Date: 7/13/14  
Job: 12-561 Remodel Administration Bldg  
Phone:

Description: Remove, replace, re-route above ceiling utility lines

We are pleased to offer the following specifications and pricing to make the following changes:

Remove, replace, re-route above ceiling utility lines (i.e. plumbing, electrical & sprinkler lines) in contact with newly introduced structural steel. Reference RFP #27, RFI #21

The total amount to provide this work is:

\$4,626.00

The schedule will be impacted:

If you have any questions, please contact me at:

Submitted by: Manuel M. Ornelas, D. Wilson Co.

Approved by: \_\_\_\_\_  
Date: \_\_\_\_\_

Cc: Stan Ramos (Hidalgo County) valde.guerra@co.hidalgo.tx.us, Horacio Quintero (D. Wilson Construction Co.), Mateo Saizar (D. Wilson Construction Co.), apalacios@prodigycompany.com





Faires Plumbing Co., Inc.  
P. O. Box 1199  
Edinburg, Texas 78540  
Ph. 956-383-3221 Fax 956-383-7382

July 1, 2014

D. Wilson Construction

Re: Hidalgo County Renovation to Administration  
RFP #27 Relocate piping for structural beams

Attn.: Manny Ornelas

Dear Sir,

As per your request we submit a price of **\$1,730.00** to remove and reroute existing piping to accommodate structural changes at the project site. Please advise

Thank you.

*Mike Fuentes / C*  
Mike Fuentes



**Alliance Specialized Systems**

Fire Sprinkler Contractor

Texas SCR-0798

HUB Certified

E-Mail: [info@alliancespecialized.com](mailto:info@alliancespecialized.com)

602 North McColl Road

McAllen, Texas 78501

(956) 682-1602

(956) 682-1605

July 7, 2014

Attn: Manuel Ornelas  
**D. Wilson Construction**  
**1209 East Pecan**  
McAllen, Texas  
P: (956) 686-9573  
F: (956) 686-3273

RE: RFP-27  
Our Ref. #: ED77

Alliance Specialized Systems is pleased to provide our quotation of One Thousand Four Hundred Thirty Dollars (\$1,430.00) to provide material and labor to reroute the 3" sprinkler main and branch lines as needed per RFP-27.

Exclusions:

1. NA
2. Tax

THIS AGREEMENT CONSISTS OF THESE AGREEMENT PAGE AND THE TERMS AND CONDITIONS ATTACHED HERETO, and is the complete agreement between the parties. Customer acknowledges that he has read this agreement, understands it, and agrees to be bound by its terms and conditions. Neither party shall be bound by any statements or representations not contained in this agreement.

Respectfully submitted,

Ed De Rueda  
*Operations Manager*  
**Alliance Specialized Systems**



# METRO

INDUSTRIAL ELECTRIC SERVICE

MAIN OFFICE

1000 N. W. 10th St.  
Fort Lauderdale, FL 33304  
(954) 466-1111

BRANCH OFFICE

1000 N. W. 10th St.  
Fort Lauderdale, FL 33304  
(954) 466-1111

RECEIVED

BY: \_\_\_\_\_

04/24/2014

City of Fort Lauderdale  
1019 E. Ryder Blvd  
Weston, FL 33391

Attn: Walter Pittman  
Re: Metro Electric  
Indigo Administration Building Renovations - DPR #14

Please add \$1,029.00 from our base contract amount for the following changes

### SCOPE OF WORK

Furnish and install materials for RFP #21 revised, install and remove 74 conduit

and 210 cable trays. Please advise accordingly.

Sincerely,  
Metro Electric, Inc.

Jay S. Angelo  
Sr. Project Manager

### COMMERCIAL • INDUSTRIAL

Authorized by City of Fort Lauderdale and City of Weston, Florida. Project #14  
A valid 2014-2015 MEP RFP alternate bid contract system is in compliance

### Change Price Request Cost Analysis

PROJECT Hicago Administration Building Renovation Project  
 CONTRACTOR D. Wilson Construction Company

DESCRIPTION OF CHANGE Revise RFP #27

*Metro Electric, Inc. CPR #18*

Description	Quan. Req'd.	Material Cost	Unit	Material Total	Labor Total
REMOVE Circuit	60.00	\$ 140.48	C	\$ 224.77	\$ 328.27
Remove Conduct	51.00			\$ -	\$ 210.50
W/ Drawings	10.00	\$ 34.35	E	\$ 34.35	\$ 81.57
				\$ -	\$ -
				\$ -	\$ -
				\$ -	\$ -
				\$ -	\$ -
				\$ -	\$ -
				\$ -	\$ -
				\$ -	\$ -
				\$ -	\$ -
				\$ -	\$ -
				\$ -	\$ -
				\$ -	\$ -
				\$ -	\$ -
				\$ -	\$ -
				\$ -	\$ -
				\$ -	\$ -
<b>Subtotals</b>				<b>\$ 238.22</b>	<b>\$ 568.34</b>
Sales Tax				\$ -	
Subtotal w/ Tax				<b>\$ 238.22</b>	

Bond	\$ -
Subtotal (Material and Labor)	\$ 806.56
Plus 15.00 % of (Material and Labor) For Overhead	\$ 120.98
Subtotal (Material, Labor and Overhead)	\$ 927.54
Plus 10.00 % of (Material, Labor, and Overhead) For Profit	\$ 92.75
Total (Material, Labor, Overhead, and Profit)	\$ 1,020.29

D. Wilson Construction Company

P.O. Box 3455

McAllen, TX 78502-3455

Ph: (956) 686-9573

**Change Request**

To: George A. Garcia  
Alcocer Garcia Associates, Inc.  
1333 E. Jasmine Ave.  
McAllen, TX 78501  
Ph: (956) 618-2007 Fax: (956) 618-2008

Number: 56  
Date: 7/25/14  
Job: 12-561 Remodel Administration Bldg  
Phone:

Description: Wall, window T.F.T & P per RFP #008

We are pleased to offer the following specifications and pricing to make the following changes:  
New additional work as per RFP #008: Rework metal stud walls, install new window frame break metal mullions, T.F.T & P. As per RFP #008, 7/14/2014

The total amount to provide this work is \$1,571.00

The schedule will be impacted

If you have any questions, please contact me at

Submitted by: Manuel M. Ornelas, D. Wilson C

Approved by: \_\_\_\_\_  
Date: \_\_\_\_\_

Cc: Ed Alcocer, AGADC, Horacio Quintero (D. Wilson Construction Co.), Stan Ramos (Hidalgo County),  
apalacios@prodigycompany.com, valde.guerra@co.hidalgo.tx.us

HC Reno to fmr Admin Bldg.  
Friday 25. 2014

REF 008

Alternates

DATE:

Completion

Days

# Months

February 18, 2014

Square Feet:

SUBTOTAL

**06-000 CARPENTRY**

- 06-050 Rough Carpentry -Hang Chain Curtain
- 06-410 Custom Cabinets

SUBTOTAL

**07-000 MOISTURE PROTECTION**

- 07-115 Shower Stall Water Proofing
- 07-160 Dampproofing Above Grade
- 07-210 Building Insulation
- 07-270 Firesopping and Firesating
- 07-402 PreFinished Metal Roofing
- 07-525 Mod Bit Mem. Roofing
- 07-620 Gutters/ Downspouts
- 07-631 Roof Hatches and Heat/Smoke Vents
- 07-900 Building Sealants

SUBTOTAL

**08-000 DOORS & WINDOWS**

- 08-100 Hollow Metal Doors and Frames & HDW
- 08-213 Plastic Laminate Faced Doors
- 08-710 Finish Hardware
- 88-400 Frame/Door/Hdwr Labor
- 08-305 Access Doors
- 08-332 Overhead Rolling Doors
- 08-750 Glass & glazing
- 08-950 Insulated Translucent Skylights

SUBTOTAL

922

922

HC Reno to fmr Admin Bldg. RFP 078  
 Friday 25, 2014 Alternates

Completion

Days  
 # Months

February 18, 2014

Square Feet:

0.00

**09-000 FINISHES**

09-100	Gypsum Wall Board Systems	Framing	
09-200	Lath & Plaster		
09-500	Acoustical Lay in Ceiling		
09-310	Ceramic Tile		
09-520	Acoustical Wall Panels, Fabrics, Diffusers		
09-520	Acoustical Labor		
09-670	Resinous Flooring		
09-680	Carpet		
09-685	VCT		
09-629	Floor Protection Temporary		
09-600	Painting and Staining		510

SUBTOTAL

**10-000 SPECIALTIES: LABOR INCLUDED ON EACH LINE ITEM**

10-100	TV Mount Brackets (50)		
10-100	TV Mount Brackets Labor		
10-100	Manual Projection Screens (52 & 1 Oversized)		
10-100	Manual Projection Screens Labor		
10-100	Motorized Projection Screens		
10-100	Motorized Projection Screens Labor		
10-100	Curtain and Curtain Track (3 @ A115)		
10-100	Curtain and Curtain Track Labor		
10-260	Corner Guards		
10-260	Corner Guards Labor		
10-100	Library Security System		
10-100	Library Security System Labor		
10-100	Ice Machine		
10-100	Ice Machine labor		



G&S Glass, LLC  
 616 N. Closner Blvd.  
 Edinburg, TX 78541-3474

# Estimate

Date	Estimate #
03/23/2014	9709

Name	Address
D WILSON CONSTRUCTION	1209 E. Pecan P.O. Box 3455 McAllen, TX 78501 Phone: 686-9577 Fax: 686-8271

Project

Description	Qty	Rate	Total
COMPLETE 11/2" X 1/8" W BREAKMESH ANCHOR LUGS ASING OVER REINFORCING COVERED BY 1/2" GARDEN FABRIC - 1000000 FT LBS FIRST FLOOR 20' X 20' X 12' 6" (20' X 20' X 12' 6") SECOND FLOOR 20' X 20' X 12' 6" (20' X 20' X 12' 6") CONCRETE FORMS 10000' X 1000' FORMER ADMIN BLDG. INGRESS MODEL EDINBURG (HIDALGO COLONY) TEXAS	1	686.25	686.25
	1	215.50	215.50

<b>Subtotal</b>	8921.75
<b>Sales Tax (8.25%)</b>	80.60
<b>Total</b>	8921.75

Phone #	Fax #	E-mail
956-287-1162	956-287-1161	gs@ar@yahoo.com

# M & A Painting Service, Inc.

Miguel Barboza Jr.

3711 E. Main Ave.  
Alton, TX 78573

Phone: (956)585-6167  
Fax: (956)583-3999

E-mail: [mappingsservice@a.att.net](mailto:mappingsservice@a.att.net)

---

BASE BID: \$500,000

AS PER PLANS & SPECS

**PROJECT:**

HIDALGO COUNTY OLD ADMINISTRATION BUILDING  
EDINBURG, TEXAS

**THIS BASE BID INCLUDES:**

RFP #008

PRICE FOR ADDITIONAL DRYWALL FINISHING AND PAINTING.

---

**ACKNOWLEDGE OF ADDENDUMS:**

PLEASE CALL MIKE IF YOU HAVE ANY QUESTIONS @ 956-605-5043

X MIGUEL BARBOZA JR.  
M & A REPRESENTATIVE

DATE

7-17-2014

THIS BID IS GOOD  
FOR 30 DAYS FROM  
ABOVE DATE

July 16, 2014

**REQUEST FOR PROPOSAL  
008  
NEW WALL/CEILING TO  
EXISTING EXTERIOR GLAZING  
REVISED DETAILS RD-1, RD-2, RD-3**

Mr. Ornelas;

Provide costs, if applicable, at your earliest opportunity so that Owner may review.  
If accepted, a Construction Change Directive will be issued.

Alcocer Garcia Associates, Inc.

*Eduardo Alcocer*

Eduardo Alcocer

President

**AGA**  
 Alcega Garcia Associates, Inc.  
 Design Consulting  
 1333 E. 13th Ave.  
 McAllen, Texas 78501  
 Office: 956.618.2002  
 Fax: 956.618.2003  
 Web: www.agac.com

1st AND 2nd FLOORS REMODEL  
 FORMER ADMINISTRATION BUILDING  
 HIDALGO COUNTY, TEXAS  
 CITY OF EDINBURG, TEXAS

PROJECT # \_\_\_\_\_  
 REVISION \_\_\_\_\_  
 DRAWN BY: G.A.  
 CHECKED BY: \_\_\_\_\_  
 FILE NAME: \_\_\_\_\_  
 SHEET: \_\_\_\_\_  
 7.14.2014

**FIRST FLOOR:  
 TYPICAL AT OFFICES:**

C-1/103  
 C-1/104  
 175  
 176  
 C-2/202  
 C-2/203

**SECOND FLOOR:**

261  
 263  
 C-6/107  
 C-6/108



LICENSE EXPIRATION  
 DATE: 08.31.2014

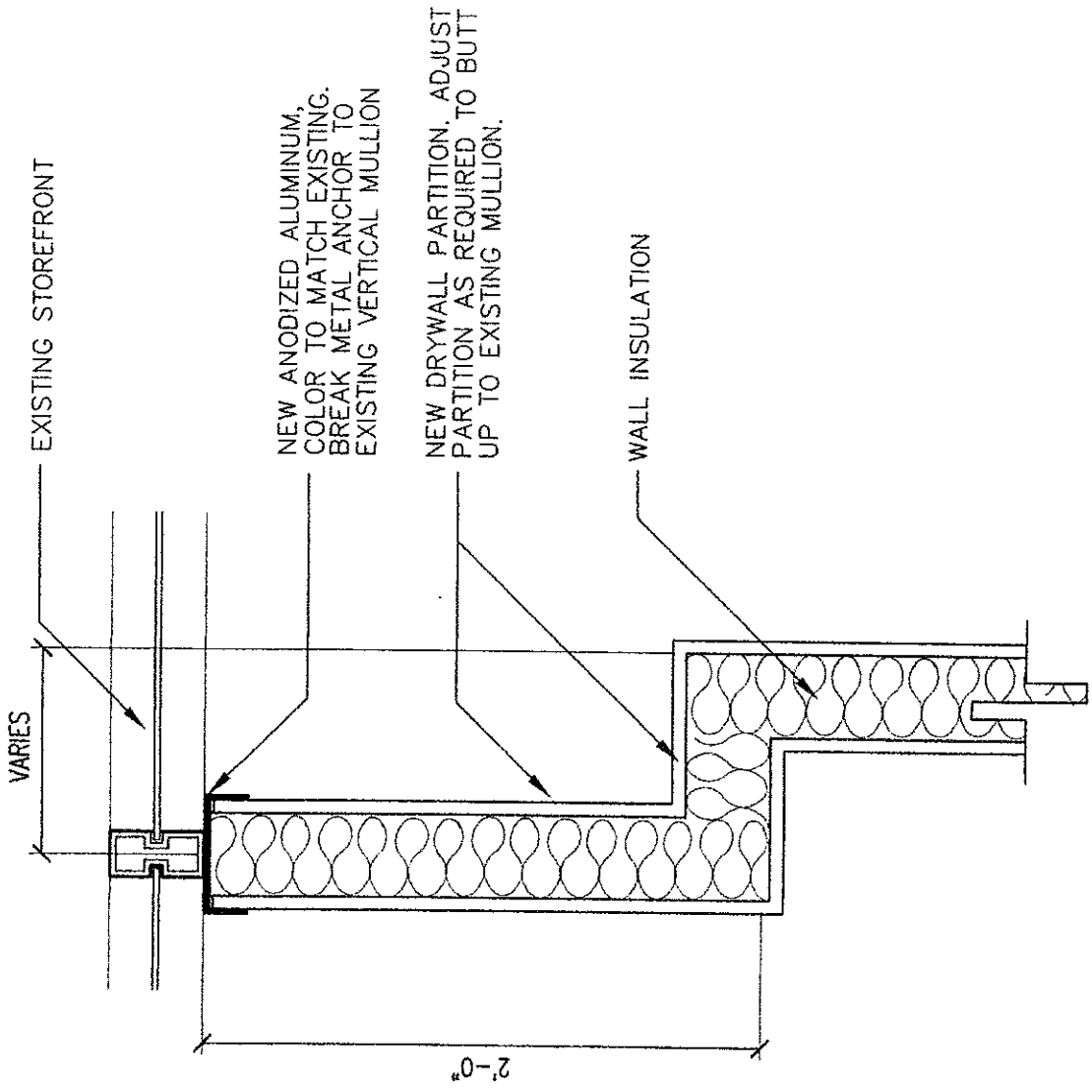

**TYPICAL PLAN DETAIL  
 AT WALL TO EXISTING MULLION**

SCALE: 1/2" = 1'-0"

**REVISED DETAIL - RD1**

AGA  
 Design Consulting  
 1331 Cassmore Ave.  
 Warren, Texas 75091  
 Office: 256.618.1202  
 Web: www.agaarch.com

1st AND 2nd FLOORS REMODEL  
 FORMER ADMINISTRATION BUILDING  
 HIDALGO COUNTY, TEXAS  
 CITY OF EDINBURG, TEXAS

THE USE OF THIS  
 DRAWING IS RESTRICTED TO  
 THE ORIGINAL PURPOSE FOR  
 WHICH IT WAS PREPARED.  
 ANY REUSE OF THIS DRAWING  
 FOR ANY OTHER PROJECT  
 WITHOUT PERMISSION FROM  
 THE OFFICE IS PROHIBITED.

PROJECT #  
 DRAWN BY: D.C.  
 CHECKED BY:  
 P.L. NAME:  
 SHEET:  
 7.14.2014

FIRST FLOOR:  
 TYPICAL AT OFFICES:

C-1/103  
 C-1/104  
 175  
 176  
 C-2/202  
 C-2/203

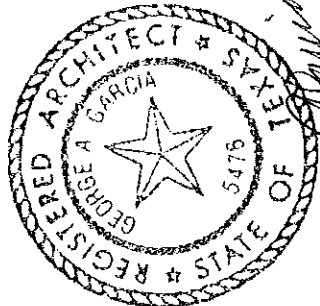
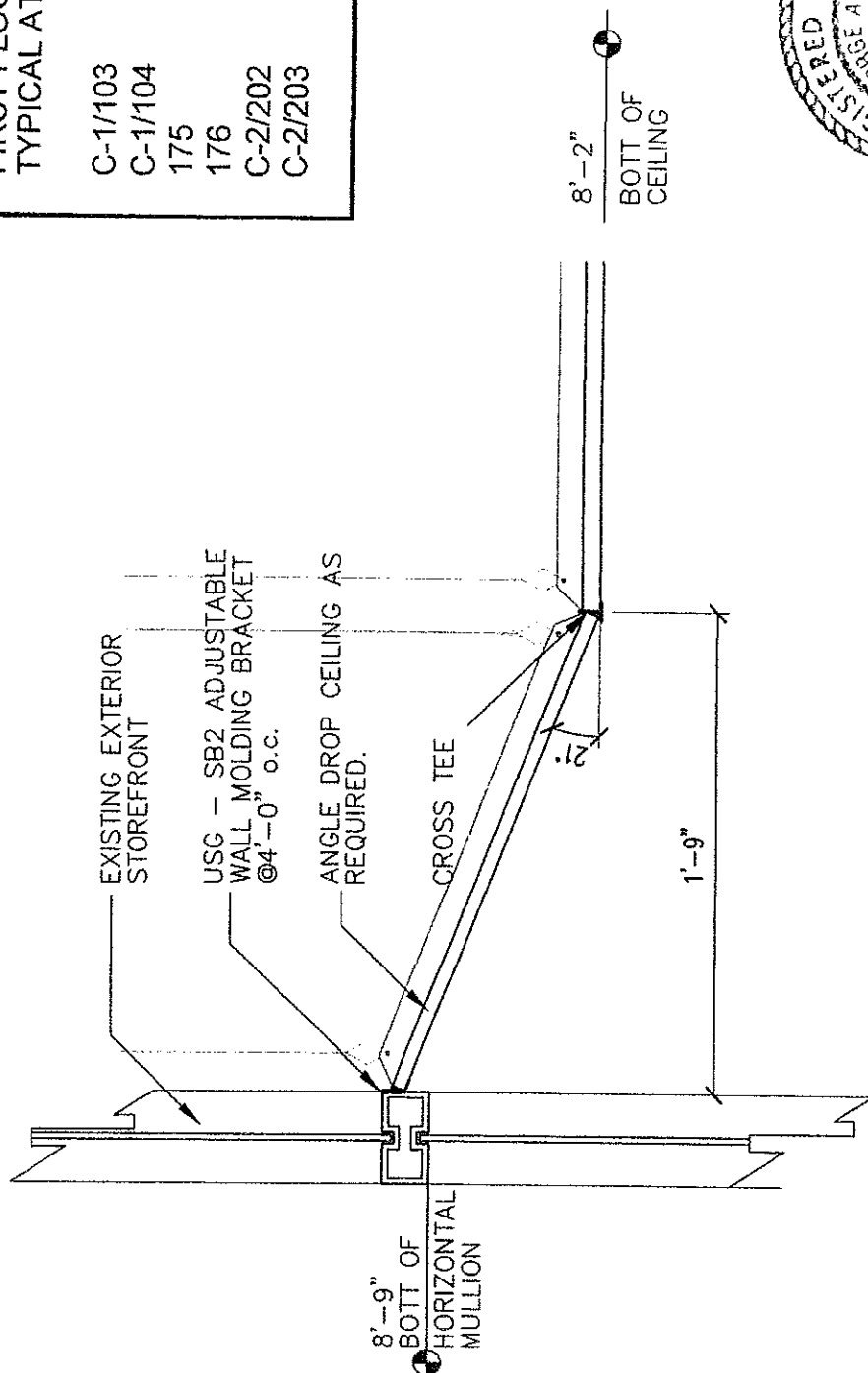

LICENSE EXPIRATION  
 DATE: 08.31.2014

TYPICAL DETAIL  
 AT CEILING TO EXISTING MULLION

SCALE: 1/4" = 1'-0"

REVISED DETAIL - RD2

D. Wilson Construction Comp /

P.O. Box 3455  
McAllen, TX 78502-3455  
Ph: (956) 686-9573

**Change Request**

To: George A. Garcia  
Alcocer Garcia Associates, Inc  
1333 E. Jasmine Ave.  
McAllen, TX 78501  
Ph: (956)618-2007 Fax: (956)618-2008

Number: 57  
Date: 8/1/14  
Job: 12-561 Remodel Administration Bldg  
Phone:

Description: Change to Primus exterior cylinders.

We are pleased to offer the following specifications and pricing to make the following changes:  
At County's request change to Primus exterior cylinders on door HDW.

The total amount to provide this work is ..... \$486.00

The schedule will be Not impacted..

If you have any questions, please contact me at .

Submitted by: Manuel M. Ornelas, D. Wilson C

Approved by: \_\_\_\_\_  
Date: \_\_\_\_\_

Cc: Horacio Quintero (D. Wilson Construction Co.), Stan Ramos (Hidalgo County), Mateo Salazar (D. Wilson Cons,  
apalacios@prodigycompany.com

CR Request

HC Admin Bldg

Friday, August 01, 2014

DATE:

Completion

# Months

Math Check

SUBTOTAL:

**06-000 CARPENTRY**

- 06-050 Rough Carpentry /HDW Install
- 06-420 Granite Counter Tops

SUBTOTAL:

**07-000 MOISTURE PROTECTION**

- 07-115 Shower Stall Water Proofing
- 07-160 Dampproofing Above Grade
- 07-210 Building Insulation
- 07-270 Firesopping and Firesafing
- 07-402 PreFinished Metal Roofing/Pavilion/Shed
- 07-525 Mod. Bit. Mem. Roofing
- 07-620 Gutters/ Downspouts
- 07-831 Roof Hatches and Heat/Smoke Vents
- 07-900 Building Sealants

SUBTOTAL:

**08-000 DOORS & WINDOWS**

- 08-100 Hollow Metal Door Frames & Wood Doors
- 08-213 Plastic Laminate Faced Doors
- 08-710 Finish Hardware
- 88-100 Frame/Door/Hdwr Labor
- 08-305 Access Doors
- 08-332 Overhead Rolling Doors
- 08-750 Glass & glazing
- 08-950 Insulated Translucent Skylights

SUBTOTAL:

CR Request

HC Admin Bldg.  
Friday, August 01, 2014

Completion

# Months

Main Check

<b>12-000</b>	<b>Furnishings</b>		
12-300	Educational Casework		
12-348	Laboratory Casework		
12-504	Horizontal Blinds		
	<b>SUBTOTAL</b>	<u>    </u>	<u>    </u>

<b>15-000</b>	<b>MEP</b>		
15-100	Plumbing Contractor		
15-300	Fire Sprinkler System		
15-300	FM 200		
15-500	HVAC Contractor		
16-100	Electric Contractor/ Fire Alarm		
	<b>SUBTOTAL</b>	<u>    </u>	<u>    </u>

	<b>PROJECT SUBTOTAL</b>	<u>440</u>	
	D. Wilson Construction Company fee	31	
		<u>471</u>	

91-871	1	Builder's Risk Policy (Hughtson quote)	0	0.009%	
91-874		Liability insurance	3	0.620%	
		<b>INSURANCE SUBTOTAL</b>	<u>3</u>		

91-870		Bond	474		math is correct
		<b>PROJECT SUBTOTAL</b>	<u>12</u>		
		<b>PROJECT TOTAL:</b>	<u>486</u>		math is correct

**Project: 390165 - 1ST AND 2ND FLOOR RENOVATIONS TO ADMINISTRATION BLG**  
**Contemplated Change Order # 6**  
**Change to Primus Exterior Cylinders - Owner's request**

-1	Pair Doors #E1		Exterior from Entry Vestibule 145			RHRA
1	Pair Doors #E1		Exterior from Entry Vestibule 145			RHRA
-1	Mortise Cylinder	987 #6 CAM 008876-001	613	FL		(33.03)
1	Mortise Cylinder	20-776 50-210-MK	613	SC		121.03
			Opening Total			88.00
-1	Pair Doors #E2		Entry Vestibule 145 from Vestibule 146			RHRA
1	Pair Doors #E2		Entry Vestibule 145 from Vestibule 146			RHRA
-1	Mortise Cylinder	987 #6 CAM 008876-001	613	FL		(33.03)
1	Mortise Cylinder	20-776 50-210-MK	613	SC		121.03
			Opening Total			88.00
-1	Pair Doors #E4		Exterior Canopy from Atrium 101			RHRA
1	Pair Doors #E4		Exterior Canopy from Atrium 101			RHRA
-1	Mortise Cylinder	987 #6 CAM 008876-001	613	FL		(33.03)
1	Mortise Cylinder	20-776 50-210-MK	613	SC		121.03
			Opening Total			88.00
-1	Pair Doors #E10		Exterior from Hall - South Side			RHRA
1	Pair Doors #E10		Exterior from Hall - South Side			RHRA
-1	Mortise Cylinder	987 #6 CAM 008876-001	613	FL		(33.03)
1	Mortise Cylinder	20-776 50-210-MK	613	SC		121.03
			Opening Total			88.00
-1	Pair Doors #E12		Exterior from Atrium 101			RHRA
1	Pair Doors #E12		Exterior from Atrium 101			RHRA
-1	Mortise Cylinder	987 #6 CAM 008876-001	613	FL		(33.03)
1	Mortise Cylinder	20-776 50-210-MK	613	SC		121.03
			Opening Total			88.00

**Section Totals**

Finish Hardware		440.00
	<b>Pre-Tax Total</b>	<b>440.00</b>

Owner has requested to change all exterior cylinders to Schlage Primus. This is a high security key system that will prevent unauthorized key duplication. The interior openings will remain on the Falcon Key System as originally scheduled.