

RECEIVED

ALCÓCER GARCIA ASSOCIATES, INC

Facilities Management

1333 EAST JASMINE AVENUE  
MCALLEN, TEXAS 78501

**INVOICE FOR PROFESSIONAL SERVICES**

INVOICE NUMBER : **23 - CHANGE IN SERVICES**  
(ADDITIONAL SERVICES, NOT PART OF BASIC A/E SERVICES)

DATE: NOVEMBER 21, 2014

PROJECT: REMODEL OF EXISTING FORMER ADMINISTRATION BUILDING, 1<sup>ST</sup> & 2<sup>ND</sup> FLOORS  
100 E. CANO ST., EDINBURG, TEXAS

TO: COUNTY OF HIDALGO, TEXAS  
C/O HIDALGO COUNTY PURCHASING DEPARTMENT  
2812 S. BUS. HWY 281  
EDINBURG, TEXAS

SUBMITTED UNDER THE OWNER-ARCHITECT CONTRACT, AIA STANDARD FORM OF AGREEMENT BETWEEN ARCHITECT AND OWNER, AND AMENDMENTS THERETO, AND ARTICLE 1.3.3, 'CHANGES IN SERVICES' OF SAID AGREEMENT.

**THIS INVOICE FOR FOLLOWING SERVICES**

ENGINEER'S PLUMBING DRAWINGS FOR REPLACEMENT OF DETERIORATED MAIN WATER DISTRIBUTION LINE WITHIN BUILDING AT 1<sup>ST</sup>FLOOR.

**BACKGROUND:**

REPLACEMENT WAS DISCOVERED BY THE CONTRACTOR AND INSPECTED AND RECOMMENDED BY THE PROJECT ENGINEER. THE COUNTY CONCURRED WITH THE REPLACEMENT AS A NECESSARY IMPROVEMENT AND AN UNFORESEEN CONDITION. WORK FOR THIS ITEM WAS INCLUDED IN EXECUTED CHANGE ORDER NO. 2 AND APPROVED BY COUNTY COMMISSIONERS COURT. (COPY OF ENGINEERING DRAWINGS ATTACHED).

THIS INVOICE FOR: COMPLETION AND DISTRIBUTION OF ADDITIONAL ENGINEERING PLANS

**FEE BREAKDOWN:**

ENGINEERING SERVICES, DIRECT COST (COPY OF MEP SOLUTIONS INVOICE # 588 ATTACHED) .....	\$ 1,500.00
ALCOCER GARCIA ASSOCIATES, INC. FEE (10%).....	<u>150.00</u>
<b>TOTAL DUE THIS INVOICE...</b>	<b>\$ 1,650.00</b>

PLEASE REMIT PAYMENT TO  
ALCÓCER GARCIA ASSOCIATES, INC.  
1333 E. JASMINE AVENUE  
MCALLEN, TEXAS 78501  
(EIN: 26 42 62 500)

THANK YOU,

  
George A. Garcia  
V.P., Project Architect



# Invoice

600 E. Beaumont Ave. Ste 2  
 McAllen, TX 78501  
 Phone # 956.664.2727

Date	Invoice #
10/6/2014	588

Bill To
Eduardo Alcocer AGA, Inc. 1333 E. Jasmine Ave. McAllen, Texas 78501

Project #	Description	Amount
08072	Hidalgo County 1st & 2nd Floor - MEP Sealed drawings for replacement of water line within building, drawings dated 02.10.2014.	1,500.00

<b>Total</b>	\$1,500.00
<b>Payments/Credits</b>	\$0.00
<b>Balance Due</b>	\$1,500.00

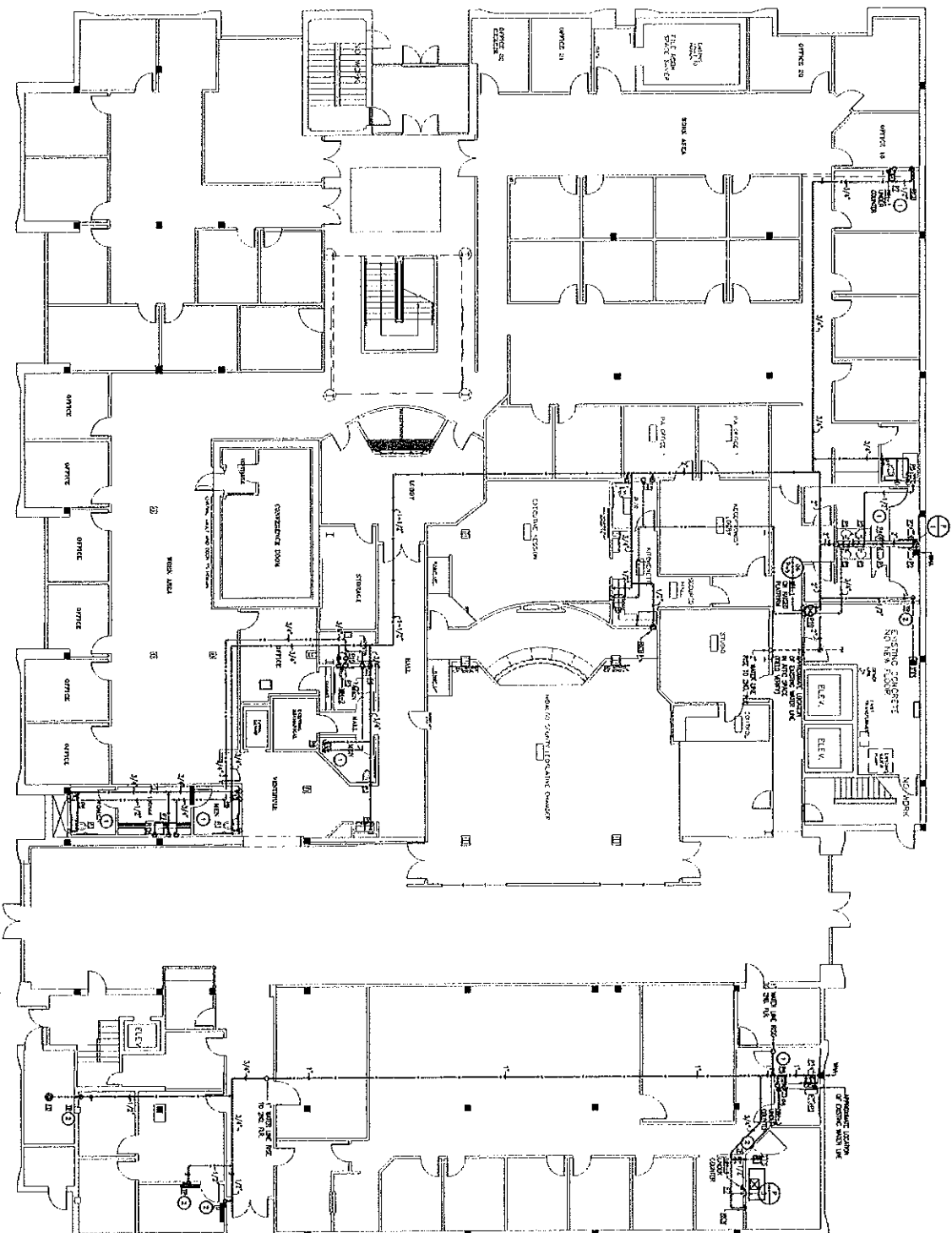

**FIRST FLOOR: PLUMBING DOMESTIC WATER IMPROVEMENT PLAN**

**GENERAL NOTES: (1)**

- 1) ALL WORK SHALL BE IN ACCORDANCE WITH THE CITY OF EDINBURG, TEXAS, PLUMBING CODE, THE TEXAS PLUMBING CODE, AND THE INTERNATIONAL PLUMBING CODE.
- 2) ALL WORK SHALL BE SUBJECT TO THE CITY OF EDINBURG, TEXAS, PLUMBING CODE, THE TEXAS PLUMBING CODE, AND THE INTERNATIONAL PLUMBING CODE.
- 3) ALL WORK SHALL BE SUBJECT TO THE CITY OF EDINBURG, TEXAS, PLUMBING CODE, THE TEXAS PLUMBING CODE, AND THE INTERNATIONAL PLUMBING CODE.
- 4) ALL WORK SHALL BE SUBJECT TO THE CITY OF EDINBURG, TEXAS, PLUMBING CODE, THE TEXAS PLUMBING CODE, AND THE INTERNATIONAL PLUMBING CODE.
- 5) ALL WORK SHALL BE SUBJECT TO THE CITY OF EDINBURG, TEXAS, PLUMBING CODE, THE TEXAS PLUMBING CODE, AND THE INTERNATIONAL PLUMBING CODE.
- 6) ALL WORK SHALL BE SUBJECT TO THE CITY OF EDINBURG, TEXAS, PLUMBING CODE, THE TEXAS PLUMBING CODE, AND THE INTERNATIONAL PLUMBING CODE.
- 7) ALL WORK SHALL BE SUBJECT TO THE CITY OF EDINBURG, TEXAS, PLUMBING CODE, THE TEXAS PLUMBING CODE, AND THE INTERNATIONAL PLUMBING CODE.
- 8) ALL WORK SHALL BE SUBJECT TO THE CITY OF EDINBURG, TEXAS, PLUMBING CODE, THE TEXAS PLUMBING CODE, AND THE INTERNATIONAL PLUMBING CODE.
- 9) ALL WORK SHALL BE SUBJECT TO THE CITY OF EDINBURG, TEXAS, PLUMBING CODE, THE TEXAS PLUMBING CODE, AND THE INTERNATIONAL PLUMBING CODE.
- 10) ALL WORK SHALL BE SUBJECT TO THE CITY OF EDINBURG, TEXAS, PLUMBING CODE, THE TEXAS PLUMBING CODE, AND THE INTERNATIONAL PLUMBING CODE.

**KEY NOTES:**

- 1) ALL WORK SHALL BE SUBJECT TO THE CITY OF EDINBURG, TEXAS, PLUMBING CODE, THE TEXAS PLUMBING CODE, AND THE INTERNATIONAL PLUMBING CODE.
- 2) ALL WORK SHALL BE SUBJECT TO THE CITY OF EDINBURG, TEXAS, PLUMBING CODE, THE TEXAS PLUMBING CODE, AND THE INTERNATIONAL PLUMBING CODE.
- 3) ALL WORK SHALL BE SUBJECT TO THE CITY OF EDINBURG, TEXAS, PLUMBING CODE, THE TEXAS PLUMBING CODE, AND THE INTERNATIONAL PLUMBING CODE.
- 4) ALL WORK SHALL BE SUBJECT TO THE CITY OF EDINBURG, TEXAS, PLUMBING CODE, THE TEXAS PLUMBING CODE, AND THE INTERNATIONAL PLUMBING CODE.
- 5) ALL WORK SHALL BE SUBJECT TO THE CITY OF EDINBURG, TEXAS, PLUMBING CODE, THE TEXAS PLUMBING CODE, AND THE INTERNATIONAL PLUMBING CODE.
- 6) ALL WORK SHALL BE SUBJECT TO THE CITY OF EDINBURG, TEXAS, PLUMBING CODE, THE TEXAS PLUMBING CODE, AND THE INTERNATIONAL PLUMBING CODE.
- 7) ALL WORK SHALL BE SUBJECT TO THE CITY OF EDINBURG, TEXAS, PLUMBING CODE, THE TEXAS PLUMBING CODE, AND THE INTERNATIONAL PLUMBING CODE.
- 8) ALL WORK SHALL BE SUBJECT TO THE CITY OF EDINBURG, TEXAS, PLUMBING CODE, THE TEXAS PLUMBING CODE, AND THE INTERNATIONAL PLUMBING CODE.
- 9) ALL WORK SHALL BE SUBJECT TO THE CITY OF EDINBURG, TEXAS, PLUMBING CODE, THE TEXAS PLUMBING CODE, AND THE INTERNATIONAL PLUMBING CODE.
- 10) ALL WORK SHALL BE SUBJECT TO THE CITY OF EDINBURG, TEXAS, PLUMBING CODE, THE TEXAS PLUMBING CODE, AND THE INTERNATIONAL PLUMBING CODE.

THE USER OF THESE DRAWINGS IS RESPONSIBLE FOR OBTAINING ALL NECESSARY PERMITS AND APPROVALS FROM THE CITY OF EDINBURG, TEXAS, PLUMBING CODE, THE TEXAS PLUMBING CODE, AND THE INTERNATIONAL PLUMBING CODE.

**MEP SOLUTIONS**  
MECHANICAL, ELECTRICAL, PLUMBING ENGINEERS

**1st AND 2nd FLOORS REMODEL  
FORMER ADMINISTRATION BUILDING  
HIDALGO COUNTY, TEXAS  
CITY OF EDINBURG, TEXAS**

**Alcázar García Associates**  
Design Consulting  
1333 E. JENNISON AVE.  
MCKINNEY, TEXAS 75001  
PHONE: 972.565.5555  
FAX: 972.565.5555  
WWW: WWW.AGAC.COM



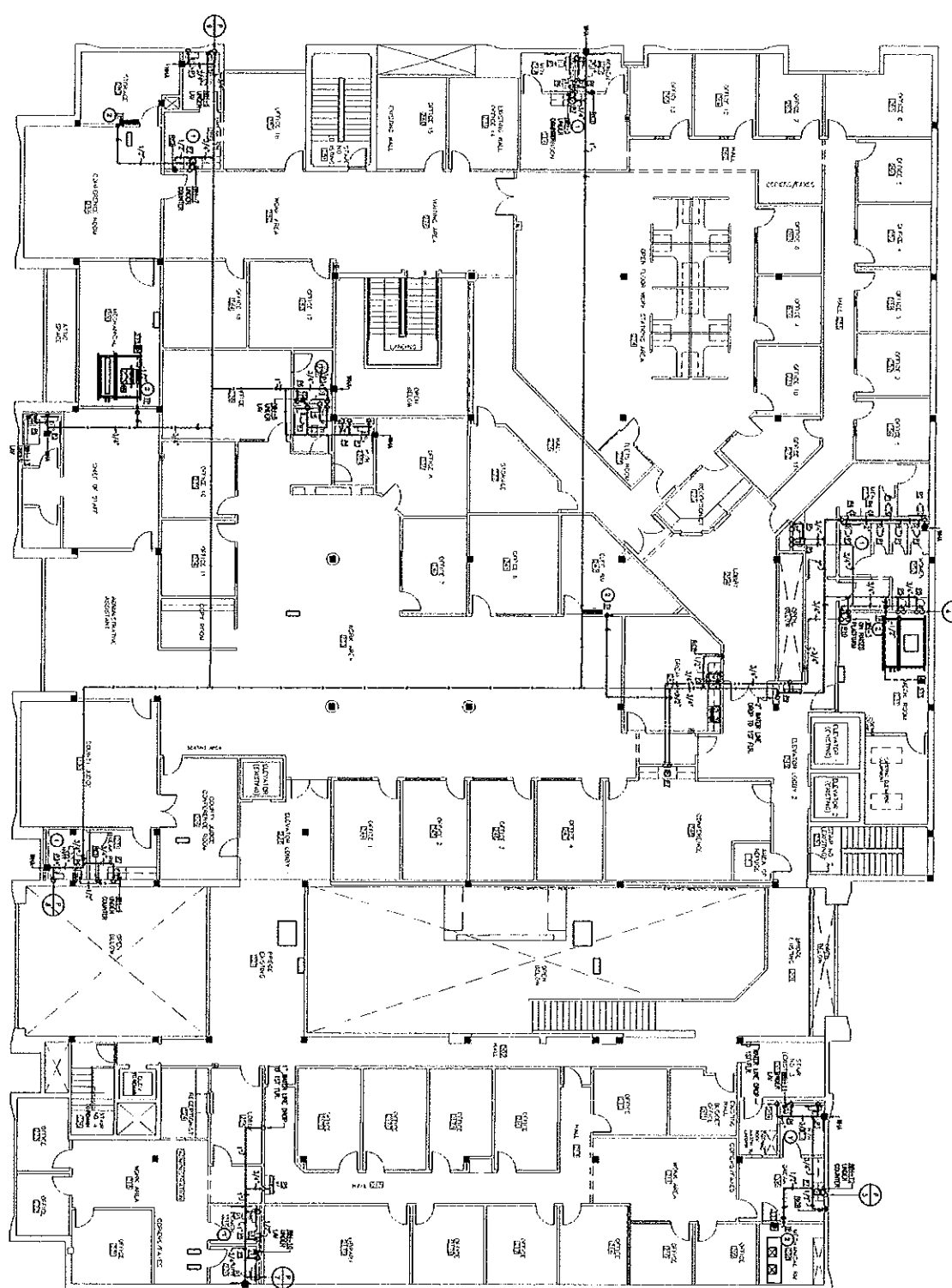

SECOND FLOOR PLUMBING DOMESTIC WATER IMPROVEMENT PLAN

GENERAL NOTES:  
 1) ALL WORK SHALL BE PERFORMED IN ACCORDANCE WITH THE CITY OF EDINBURG, TEXAS PLUMBING CODE AND THE TEXAS PLUMBING CODE.  
 2) ALL WORK SHALL BE PERFORMED IN ACCORDANCE WITH THE CITY OF EDINBURG, TEXAS PLUMBING CODE AND THE TEXAS PLUMBING CODE.  
 3) ALL WORK SHALL BE PERFORMED IN ACCORDANCE WITH THE CITY OF EDINBURG, TEXAS PLUMBING CODE AND THE TEXAS PLUMBING CODE.  
 4) ALL WORK SHALL BE PERFORMED IN ACCORDANCE WITH THE CITY OF EDINBURG, TEXAS PLUMBING CODE AND THE TEXAS PLUMBING CODE.  
 5) ALL WORK SHALL BE PERFORMED IN ACCORDANCE WITH THE CITY OF EDINBURG, TEXAS PLUMBING CODE AND THE TEXAS PLUMBING CODE.  
 6) ALL WORK SHALL BE PERFORMED IN ACCORDANCE WITH THE CITY OF EDINBURG, TEXAS PLUMBING CODE AND THE TEXAS PLUMBING CODE.  
 7) ALL WORK SHALL BE PERFORMED IN ACCORDANCE WITH THE CITY OF EDINBURG, TEXAS PLUMBING CODE AND THE TEXAS PLUMBING CODE.  
 8) ALL WORK SHALL BE PERFORMED IN ACCORDANCE WITH THE CITY OF EDINBURG, TEXAS PLUMBING CODE AND THE TEXAS PLUMBING CODE.  
 9) ALL WORK SHALL BE PERFORMED IN ACCORDANCE WITH THE CITY OF EDINBURG, TEXAS PLUMBING CODE AND THE TEXAS PLUMBING CODE.  
 10) ALL WORK SHALL BE PERFORMED IN ACCORDANCE WITH THE CITY OF EDINBURG, TEXAS PLUMBING CODE AND THE TEXAS PLUMBING CODE.

KEY NOTES:  
 1) ALL WORK SHALL BE PERFORMED IN ACCORDANCE WITH THE CITY OF EDINBURG, TEXAS PLUMBING CODE AND THE TEXAS PLUMBING CODE.  
 2) ALL WORK SHALL BE PERFORMED IN ACCORDANCE WITH THE CITY OF EDINBURG, TEXAS PLUMBING CODE AND THE TEXAS PLUMBING CODE.  
 3) ALL WORK SHALL BE PERFORMED IN ACCORDANCE WITH THE CITY OF EDINBURG, TEXAS PLUMBING CODE AND THE TEXAS PLUMBING CODE.  
 4) ALL WORK SHALL BE PERFORMED IN ACCORDANCE WITH THE CITY OF EDINBURG, TEXAS PLUMBING CODE AND THE TEXAS PLUMBING CODE.  
 5) ALL WORK SHALL BE PERFORMED IN ACCORDANCE WITH THE CITY OF EDINBURG, TEXAS PLUMBING CODE AND THE TEXAS PLUMBING CODE.  
 6) ALL WORK SHALL BE PERFORMED IN ACCORDANCE WITH THE CITY OF EDINBURG, TEXAS PLUMBING CODE AND THE TEXAS PLUMBING CODE.  
 7) ALL WORK SHALL BE PERFORMED IN ACCORDANCE WITH THE CITY OF EDINBURG, TEXAS PLUMBING CODE AND THE TEXAS PLUMBING CODE.  
 8) ALL WORK SHALL BE PERFORMED IN ACCORDANCE WITH THE CITY OF EDINBURG, TEXAS PLUMBING CODE AND THE TEXAS PLUMBING CODE.  
 9) ALL WORK SHALL BE PERFORMED IN ACCORDANCE WITH THE CITY OF EDINBURG, TEXAS PLUMBING CODE AND THE TEXAS PLUMBING CODE.  
 10) ALL WORK SHALL BE PERFORMED IN ACCORDANCE WITH THE CITY OF EDINBURG, TEXAS PLUMBING CODE AND THE TEXAS PLUMBING CODE.



MEP SOLUTIONS  
 ENGINEERING  
 1333 E. 54TH AVE.  
 MCKINNEY, TEXAS 75069  
 PHONE: 972-562-1111  
 FAX: 972-562-1112  
 WWW: WWW.MEPSOLUTIONS.COM

PROJECT: 1st AND 2nd FLOORS REMODEL  
 FORMER ADMINISTRATION BUILDING  
 Hidalgo County, Texas  
 City of Edinburg, Texas

DATE: 01/15/2014  
 DRAWN BY: J.C.  
 CHECKED BY: J.P.  
 PROJECT NO: 14-001  
 SHEET: P-4

AGCA  
 Design Consulting  
 1333 E. 54th Ave.  
 McKinney, Texas 75069  
 Phone: 972-562-1111  
 Fax: 972-562-1112  
 Web: www.agca.com

RECEIVED

Facilities Management

ALCÓCER GARCIA ASSOCIATES, INC  
1333 EAST JASMINE AVENUE  
MCALLEN, TEXAS 78501

**INVOICE FOR PROFESSIONAL SERVICES**

INVOICE NUMBER : 25 - **CHANGE IN SERVICES**  
(ADDITIONAL SERVICES, NOT PART OF BASIC A/E SERVICES)

DATE: NOVEMBER 21, 2014

PROJECT: REMODEL OF EXISTING FORMER ADMINISTRATION BUILDING, 1<sup>ST</sup> & 2<sup>ND</sup> FLOORS  
100 E. CANO ST., EDINBURG, TEXAS

TO: COUNTY OF HIDALGO, TEXAS  
C/O HIDALGO COUNTY PURCHASING DEPARTMENT  
2812 S. BUS. HWY 281  
EDINBURG, TEXAS

AS PER THE OWNER-ARCHITECT CONTRACT, AIA STANDARD FORM OF AGREEMENT BETWEEN ARCHITECT AND OWNER, AND AMENDMENTS THERETO, AND ARTICLE 3.1., 'CHANGES IN SERVICES' OF SAID AGREEMENT.

**THIS INVOICE FOR FOLLOWING SERVICES**

ENGINEERING DESIGNS FOR FAN - COIL AIR-CONDITIONING UNITS TO SERVE ELEVATOR EQUIPMENT ROOM 251.

**BACKGROUND:**

OWNER-REQUESTED DESIGNS FOR THE INSTALLATION OF TWO NEW FAN-COIL A/C UNITS TO PROVIDE PROPER OPERATING TEMPERATURE FOR ELEVATOR CONTROL EQUIPMENT THIS WORK INCLUDED IN CHANGE ORDER NO. 2 APPROVED BY COUNTY COMMISSIONER'S COURT. (COPY OF ENGINEERING DRAWINGS ATTACHED).

THIS INVOICE FOR COMPLETION AND DISTRIBUTION OF ENGINEERING PLANS

**FEE BREAKDOWN:**

ENGINEERING SERVICES, DIRECT COST (COPY OF MEP SOLUTIONS INVOICE # 590 ATTACHED).....	\$ 1,500.00
ALCOCER GARCIA, INC. FEE (10%).....	<u>150.00</u>
<b>TOTAL DUE THIS INVOICE.....</b>	<b>\$ 1,650.00</b>

PLEASE REMIT PAYMENT TO  
ALCÓCER GARCIA ASSOCIATES, INC.  
1333 E. JASMINE AVENUE  
MCALLEN, TEXAS 78501  
(EIN: 26 42 62 500)

THANK YOU,

  
George A. Garcia  
V.P., Project Architect



# Invoice

600 E. Beaumont Ave. Ste 2  
 McAllen, TX 78501  
 Phone # 956.664.2727

Date	Invoice #
10/6/2014	590

Bill To
Eduardo Alcocer AGA, Inc. 1333 E. Jasmine Ave. McAllen, Texas 78501

Project #	Description	Amount
08072	Hidalgo County 1st & 2nd Floor - MEP Scaled drawings for addition of Fan Coil Units located in Elevator Equipment Room <del>2nd</del> floor, drawings dated 06.09.2014.	1,500.00
<b>Total</b>		\$1,500.00
<b>Payments/Credits</b>		\$0.00
<b>Balance Due</b>		\$1,500.00

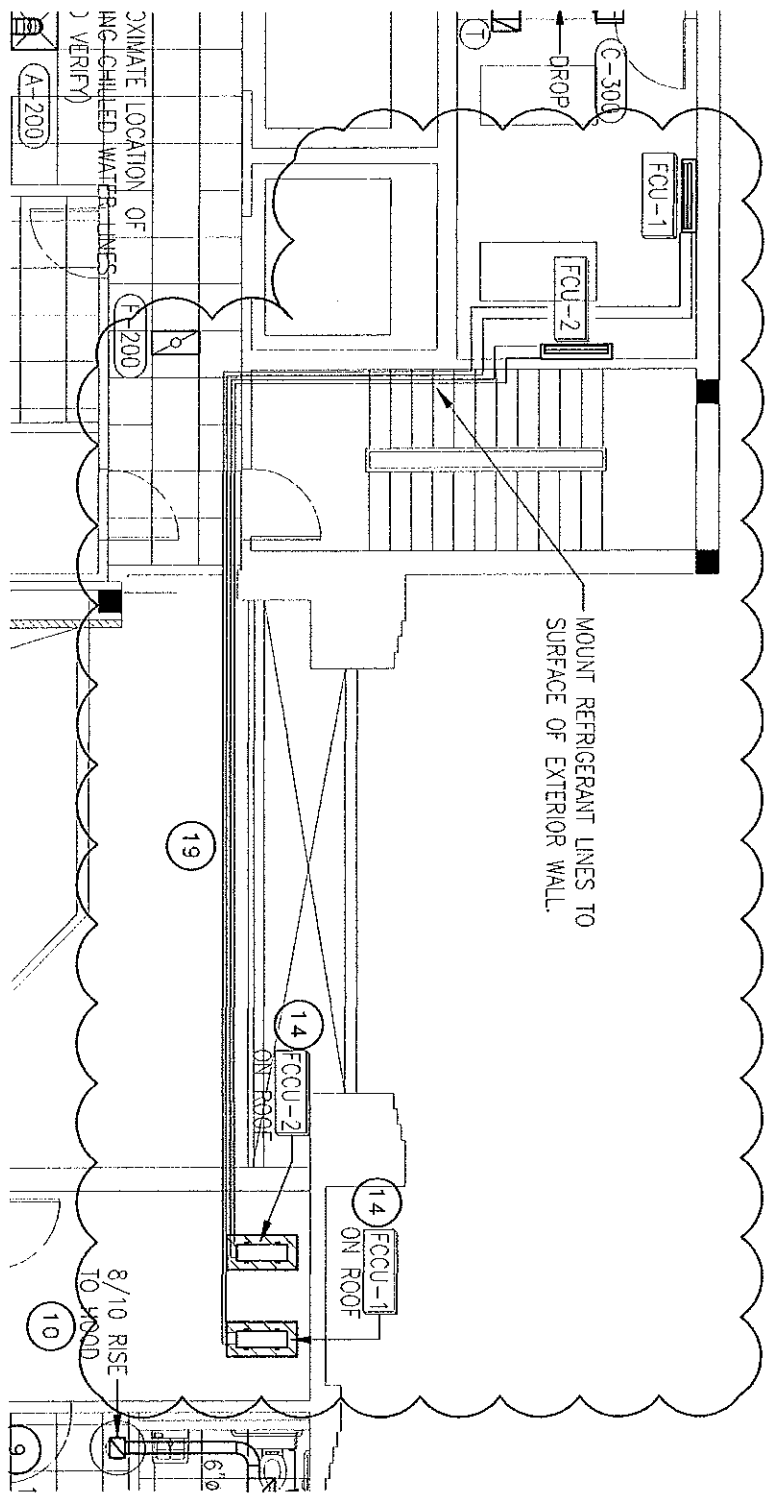

END GRAPHICS.

19 CONTRACTOR SHALL ROUTE REFRIGERANT LINES ALONG WALL THRU ARCHITECTURAL FURROUT.



SECOND FLOOR: MECHANICAL IMPROVEMENT PLAN

SCALE: 1/8" = 1'-0"

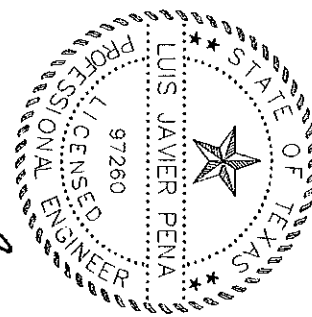

*Luis Javier Pena*  
08.09.2014

SHEET  
**M-2**

**MEP SOLUTIONS ENGINEERING**

MECHANICAL, ELECTRICAL, PLUMBING ENGINEERS  
600 E. BEAUMONT AVE. SUITE 2 McALLEN, TX 78501 (956) 664-2727  
TEXAS BOARD OF PROFESSIONAL ENGINEERS REGISTRATION # F-9748

1st AND 2nd FLOORS  
**REMODEL FORMER**  
ADMINISTRATION BUILDING  
HIDALGO COUNTY TEXAS  
CITY OF ENDINBURG, TEXAS

JOB NO.	08072
DATE	06-01-12
REVISIONS	06-09-14
DRAWN BY	J.P./L.S.

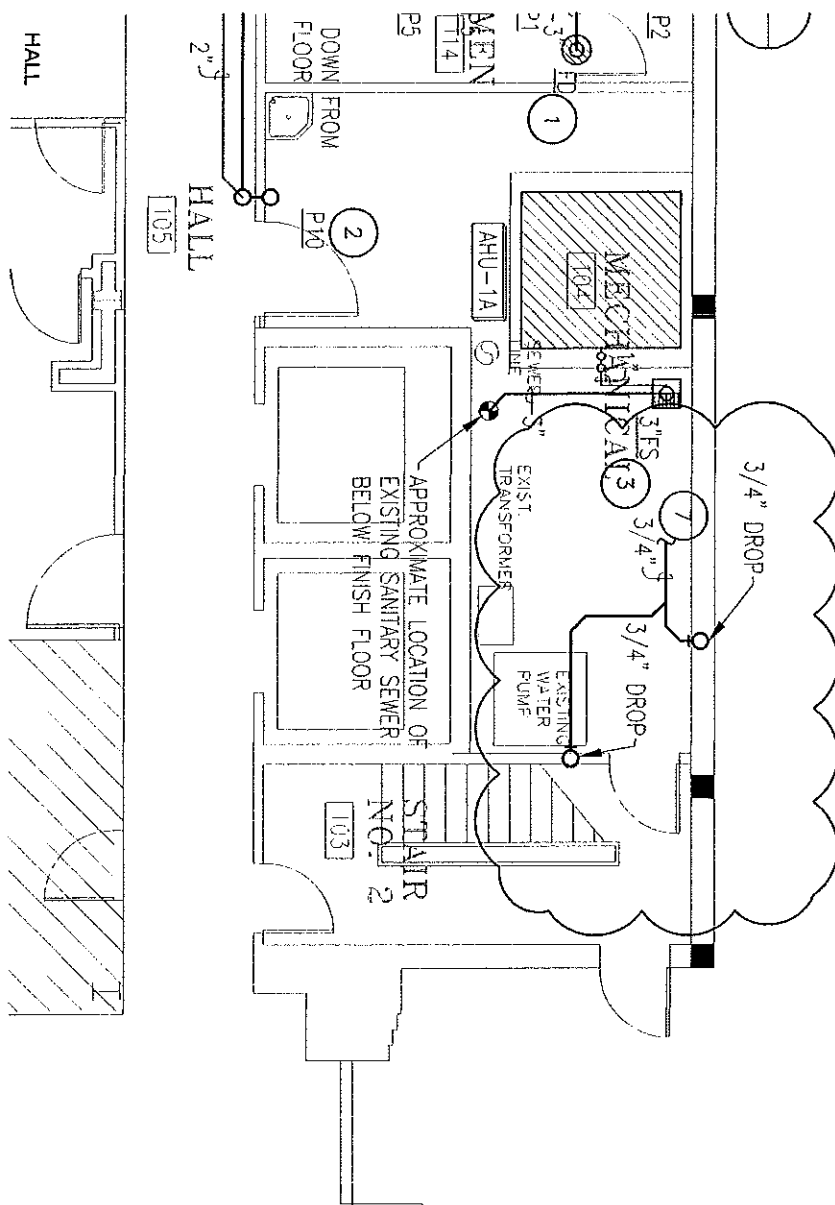

- (6) FLOOR DRAIN SHALL BE FINISHED FROM NEAREST WATER VALVE. FLUSH VALVE WITH 1/2" TRAP PRIMER LINE. REFER TO DETAIL.
- (7) ROUTE 3/4" CONDENSATE DRAIN LINE TO FLOOR SINK, FIELD VERIFY LOCATION OF FLOOR SINK PRIOR TO INSTALLATION.



**FIRST FLOOR: PLUMBING SANITARY SEWER IMPROVEMENT PLAN**

SCALE: 1/8" = 1'-0"

STATE OF TEXAS  
 LUIS JAVIER PENA  
 97260  
 LICENSED PROFESSIONAL ENGINEER

*Luis Javier Pena*  
 06.09.2014

SHEET  
**P-1**

**MEP SOLUTIONS**  
 ENGINEERING

MECHANICAL, ELECTRICAL, PLUMBING ENGINEERS  
 600 E. BEAUMONT AVE, SUITE 2 McALLEN, TX 78501 (956) 664-2727  
 TEXAS BOARD OF PROFESSIONAL ENGINEERS REGISTRATION # F-9748

**1st AND 2nd FLOORS**  
**REMODEL FORMER**  
 ADMINISTRATION BUILDING  
 HIDALGO COUNTY TEXAS  
 CITY OF ENDINBURG, TEXAS

JOB NO.	08072
DATE	06-01-12
REVISIONS	06-09-14
DRAWN BY	J.P./L.S.



SECOND FLOOR: PLUMBING SANITARY SEWER IMPROVEMENT PLAN

SCALE: 1/8" = 1'-0"

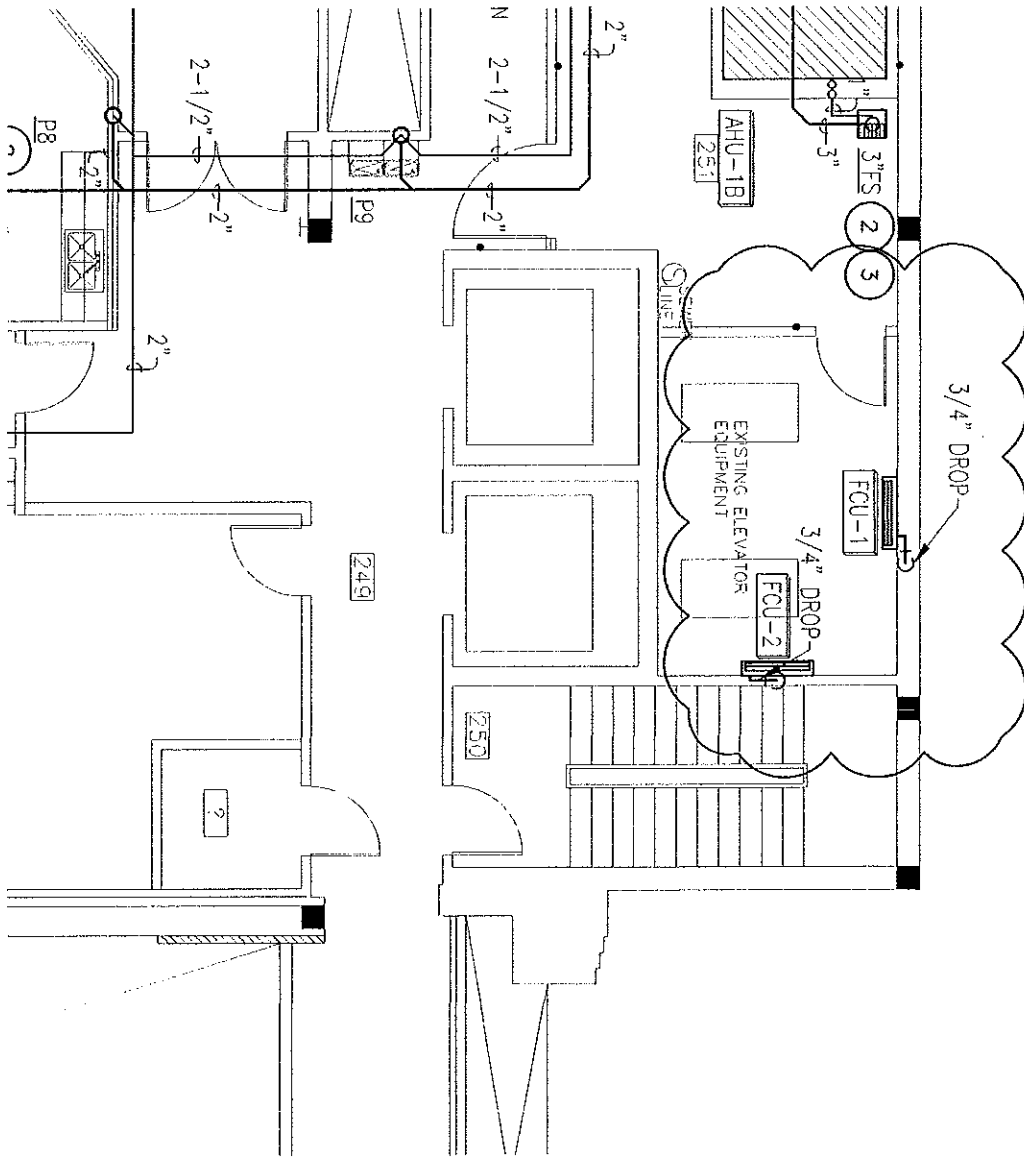

*Javier Pena*  
06.09.2014

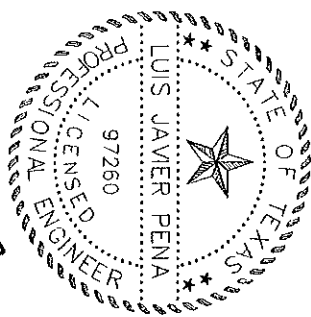

SHEET  
**P-2**

**MEP SOLUTIONS ENGINEERING**  
MECHANICAL, ELECTRICAL, PLUMBING ENGINEERS  
600 E. BEAUMONT AVE. SUITE 2 McALLEN, TX 78501 (956) 684-2727  
TEXAS BOARD OF PROFESSIONAL ENGINEERS REGISTRATION # F-9748

**1st AND 2nd FLOORS  
REMODEL FORMER**  
ADMINISTRATION BUILDING  
HIDALGO COUNTY TEXAS  
CITY OF ENDINBURG, TEXAS

JOB NO.	08072
DATE	06-01-12
REVISIONS	06-09-14
DRAWN BY	J.P./L.S.

RECEIVED

Facilities Management

ALCÓCER GARCIA ASSOCIATES, INC  
1333 EAST JASMINE AVENUE  
MCALLEN, TEXAS 78501

**INVOICE FOR PROFESSIONAL SERVICES**

INVOICE NUMBER : 26 - **CHANGE IN SERVICES**  
(ADDITIONAL SERVICES, NOT PART OF BASIC A/E SERVICES)

DATE: AUGUST , 2014

PROJECT: REMODEL OF EXISTING FORMER ADMINISTRATION BUILDING, 1<sup>ST</sup> & 2<sup>ND</sup> FLOORS  
100 E. CANO ST., EDINBURG, TEXAS

TO: COUNTY OF HIDALGO, TEXAS  
C/O HIDALGO COUNTY PURCHASING DEPARTMENT  
2812 S. BUS. HWY 281  
EDINBURG, TEXAS

AS PER THE OWNER-ARCHITECT CONTRACT, AIA STANDARD FORM OF AGREEMENT BETWEEN ARCHITECT AND OWNER, AND AMENDMENTS THERETO, AND ARTICLE 3.1., 'CHANGES IN SERVICES' OF SAID AGREEMENT.

**THIS INVOICE FOR FOLLOWING SERVICES**  
ENGINEERING DESIGNS FOR AIR-CONDITIONING UNITS IN MECHANICAL ROOM 208.

**BACKGROUND:**  
OWNER-REQUESTED ALTERNATE DESIGNS FOR THE INSTALLATION OF TWO NEW AIR HANDLING UNITS TO EVALUATE AGAINST KEEPING EXISTING SINGLE AIR HANDLING UNIT AND TO OBTAIN PRICEQUOTE FROM GENERAL CONTRACTOR (COPY OF ENGINEER'S DRAWINGS ATTACHED).

THIS INVOICE FOR COMPLETION AND DISTRIBUTION OF ENGINEERING PLANS

<b>FEE BREAKDOWN:</b>	
ENGINEERING SERVICES, DIRECT COST (COPY OF MEP SOLUTIONS INVOICE # 591 ATTACHED).....	\$ 1,500.00
ALCOCER GARCIA, INC. FEE (10%).....	<u>150.00</u>
<b>TOTAL DUE THIS INVOICE.....</b>	<b>\$ 1,650.00</b>

PLEASE REMIT PAYMENT TO  
ALCÓCER GARCIA ASSOCIATES, INC.  
1333 E. JASMINE AVENUE  
MCALLEN, TEXAS 78501  
(EIN: 26 42 62 500)

THANK YOU,

  
George A. Garcia  
V.P., Project Architect



# Invoice

Date	Invoice #
10/6/2014	591

600 E. Beaumont Ave. Ste 2  
 McAllen, TX 78501  
 Phone # 956.664.2727

Bill To
Eduardo Alcocer AGA, Inc. 1333 E. Jasmine Ave. McAllen, Texas 78501

Project #	Description	Amount
08072	Hidalgo County 1st & 2nd Floor - MEP Sealed drawings for addition of two new Air Handling Units located in Mechanical Room 208, drawings dated 07.11.2014.	1,500.00
<b>Total</b>		\$1,500.00
<b>Payments/Credits</b>		\$0.00
<b>Balance Due</b>		\$1,500.00

SECOND FLOOR MECHANICAL IMPROVEMENT PLAN

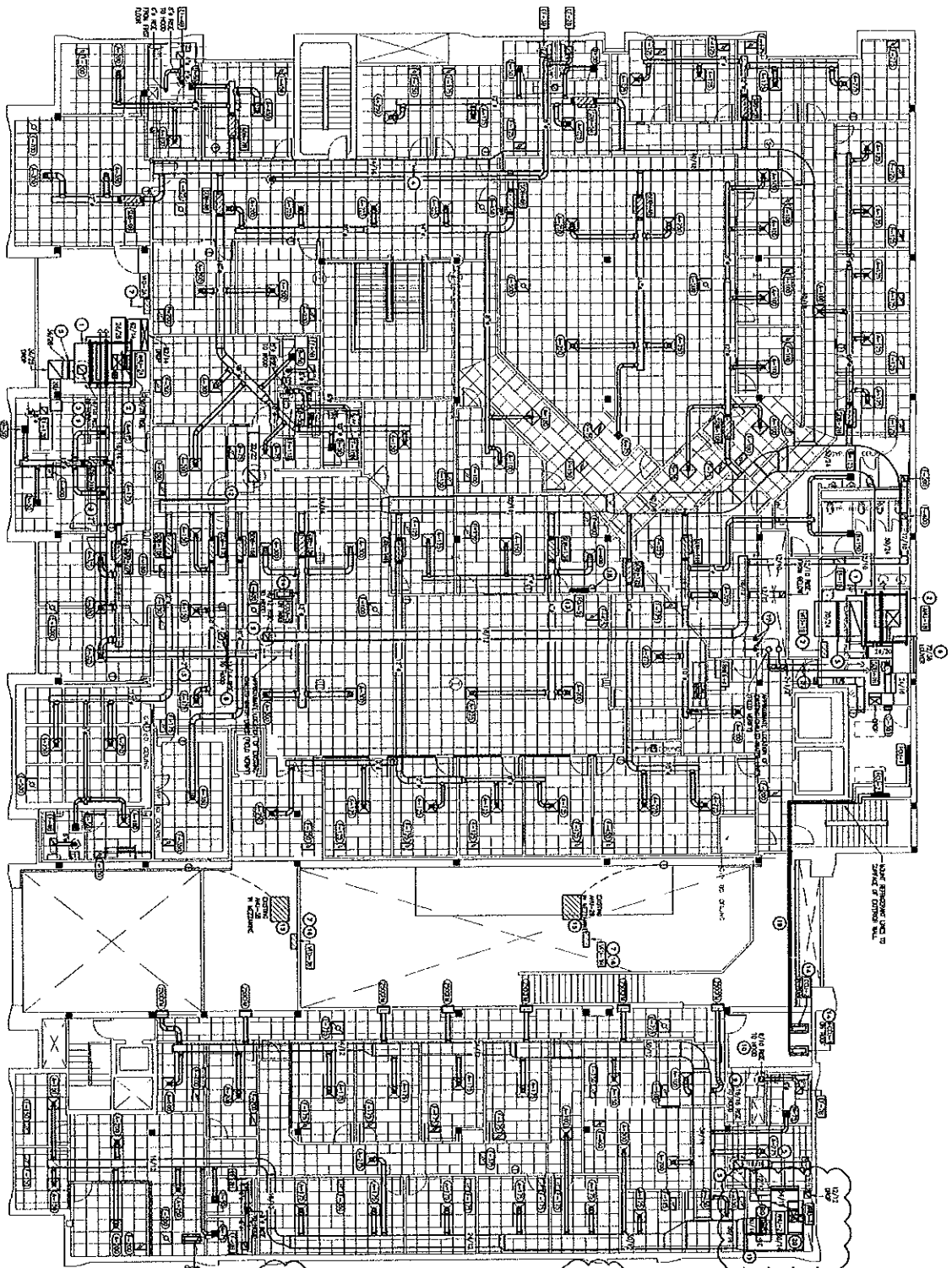

- GENERAL NOTES:**
1. REFER TO GENERAL NOTES FOR THE ORIGINAL PLAN.
  2. MECHANICAL EQUIPMENT SHALL BE INSTALLED IN THE MECHANICAL ROOMS UNLESS OTHERWISE INDICATED.
  3. ALL DUCT SHALL BE 18" MIN. INSULATION UNLESS OTHERWISE INDICATED.
- KEY NOTES:**
1. REMOVE AND RELOCATE EXISTING DUCT TO THE MECHANICAL ROOM AS SHOWN ON THIS PLAN.
  2. REMOVE EXISTING DUCT AND RELOCATE TO THE MECHANICAL ROOM AS SHOWN ON THIS PLAN.
  3. REMOVE EXISTING DUCT AND RELOCATE TO THE MECHANICAL ROOM AS SHOWN ON THIS PLAN.
  4. REMOVE EXISTING DUCT AND RELOCATE TO THE MECHANICAL ROOM AS SHOWN ON THIS PLAN.
  5. REMOVE EXISTING DUCT AND RELOCATE TO THE MECHANICAL ROOM AS SHOWN ON THIS PLAN.
  6. REMOVE EXISTING DUCT AND RELOCATE TO THE MECHANICAL ROOM AS SHOWN ON THIS PLAN.
  7. REMOVE EXISTING DUCT AND RELOCATE TO THE MECHANICAL ROOM AS SHOWN ON THIS PLAN.
  8. REMOVE EXISTING DUCT AND RELOCATE TO THE MECHANICAL ROOM AS SHOWN ON THIS PLAN.
  9. REMOVE EXISTING DUCT AND RELOCATE TO THE MECHANICAL ROOM AS SHOWN ON THIS PLAN.
  10. REMOVE EXISTING DUCT AND RELOCATE TO THE MECHANICAL ROOM AS SHOWN ON THIS PLAN.
  11. REMOVE EXISTING DUCT AND RELOCATE TO THE MECHANICAL ROOM AS SHOWN ON THIS PLAN.
  12. REMOVE EXISTING DUCT AND RELOCATE TO THE MECHANICAL ROOM AS SHOWN ON THIS PLAN.
  13. REMOVE EXISTING DUCT AND RELOCATE TO THE MECHANICAL ROOM AS SHOWN ON THIS PLAN.
  14. REMOVE EXISTING DUCT AND RELOCATE TO THE MECHANICAL ROOM AS SHOWN ON THIS PLAN.
  15. REMOVE EXISTING DUCT AND RELOCATE TO THE MECHANICAL ROOM AS SHOWN ON THIS PLAN.
  16. REMOVE EXISTING DUCT AND RELOCATE TO THE MECHANICAL ROOM AS SHOWN ON THIS PLAN.
  17. REMOVE EXISTING DUCT AND RELOCATE TO THE MECHANICAL ROOM AS SHOWN ON THIS PLAN.
  18. REMOVE EXISTING DUCT AND RELOCATE TO THE MECHANICAL ROOM AS SHOWN ON THIS PLAN.
  19. REMOVE EXISTING DUCT AND RELOCATE TO THE MECHANICAL ROOM AS SHOWN ON THIS PLAN.
  20. REMOVE EXISTING DUCT AND RELOCATE TO THE MECHANICAL ROOM AS SHOWN ON THIS PLAN.
  21. REMOVE EXISTING DUCT AND RELOCATE TO THE MECHANICAL ROOM AS SHOWN ON THIS PLAN.
  22. REMOVE EXISTING DUCT AND RELOCATE TO THE MECHANICAL ROOM AS SHOWN ON THIS PLAN.
  23. REMOVE EXISTING DUCT AND RELOCATE TO THE MECHANICAL ROOM AS SHOWN ON THIS PLAN.
  24. REMOVE EXISTING DUCT AND RELOCATE TO THE MECHANICAL ROOM AS SHOWN ON THIS PLAN.
  25. REMOVE EXISTING DUCT AND RELOCATE TO THE MECHANICAL ROOM AS SHOWN ON THIS PLAN.
  26. REMOVE EXISTING DUCT AND RELOCATE TO THE MECHANICAL ROOM AS SHOWN ON THIS PLAN.
  27. REMOVE EXISTING DUCT AND RELOCATE TO THE MECHANICAL ROOM AS SHOWN ON THIS PLAN.
  28. REMOVE EXISTING DUCT AND RELOCATE TO THE MECHANICAL ROOM AS SHOWN ON THIS PLAN.
  29. REMOVE EXISTING DUCT AND RELOCATE TO THE MECHANICAL ROOM AS SHOWN ON THIS PLAN.
  30. REMOVE EXISTING DUCT AND RELOCATE TO THE MECHANICAL ROOM AS SHOWN ON THIS PLAN.



M-2

1st AND 2nd FLOORS REMODEL  
FORMER ADMINISTRATION BUILDING  
HIDALGO COUNTY, TEXAS  
CITY OF EDINBURG, TEXAS

Alcócer García Associates  
Design Consulting  
1133 E. LINDBERG AVE.  
MCALLEN, TEXAS 78101  
PHONE 356.618.2009  
FAX 356.618.2008  
WEB WWW.AGACDC.COM



PROJECT # \_\_\_\_\_  
DATE \_\_\_\_\_  
DRAWN BY \_\_\_\_\_  
CHECKED BY \_\_\_\_\_  
DATE \_\_\_\_\_



THE USE OF INK IS REQUIRED FOR ALL DIMENSIONS AND NOTATION. THE ORIGINAL DRAWING SHALL BE KEPT IN THE OFFICE OF THE ARCHITECT. THE ARCHITECT SHALL BE RESPONSIBLE FOR THE PROTECTION OF THE ORIGINAL DRAWING.



**SECOND FLOOR ELECTRICAL POWER IMPROVEMENT PLAN**

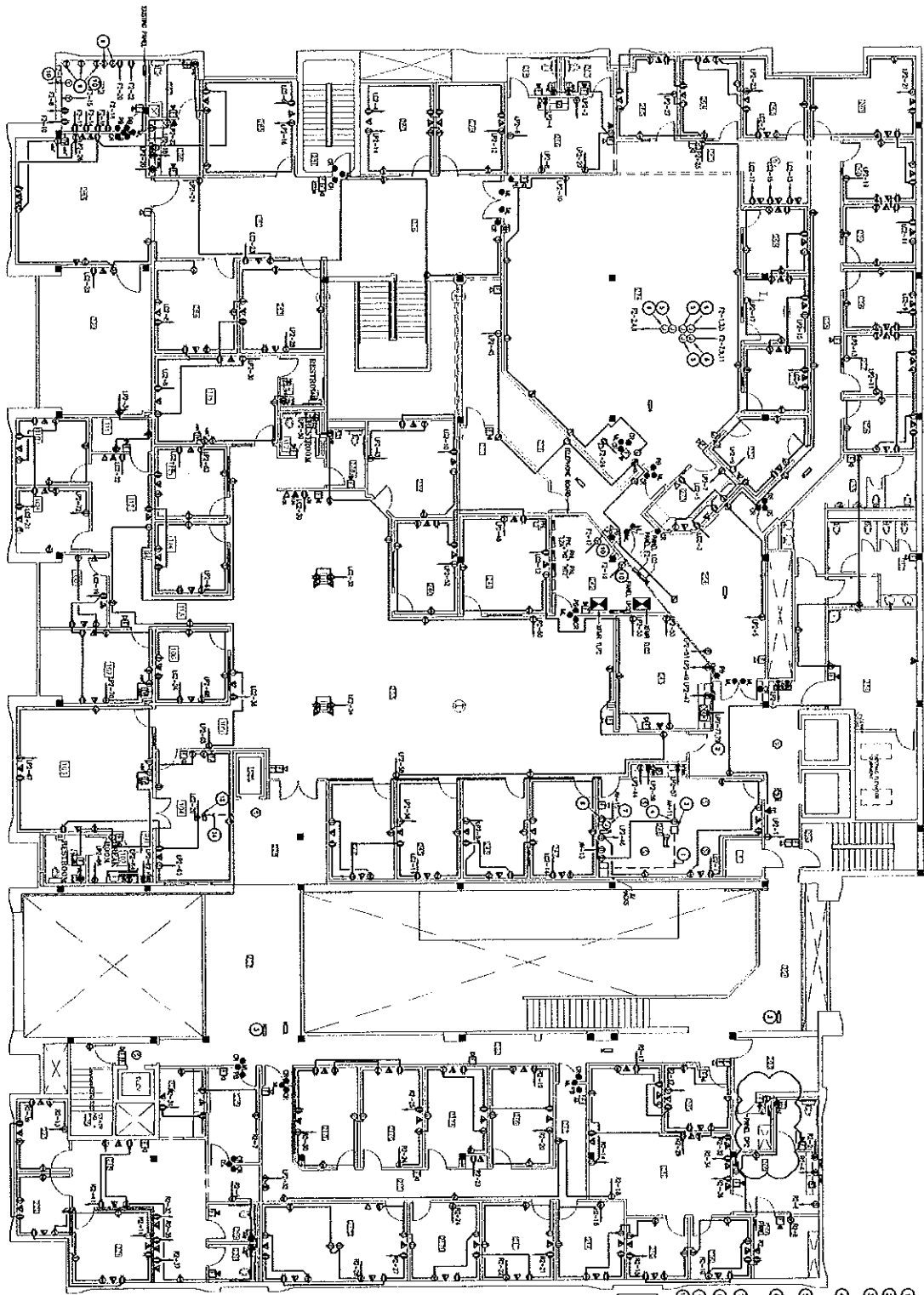

**GENERAL NOTES:**

1. EXISTING ROOMS TO REMAIN TO BE REMODELED.
2. ALL EXISTING ELECTRICAL SYMBOLS AND PANELS TO BE REMOVED AND REPLACED WITH NEW SYMBOLS AND PANELS.
3. REFER TO ALL SHEETS FOR MATERIAL, QUANTITY, AND REMARKS.

**KEY NOTES:**

1. REFER TO ALL SHEETS FOR MATERIAL, QUANTITY, AND REMARKS.
2. REFER TO ALL SHEETS FOR MATERIAL, QUANTITY, AND REMARKS.
3. REFER TO ALL SHEETS FOR MATERIAL, QUANTITY, AND REMARKS.
4. REFER TO ALL SHEETS FOR MATERIAL, QUANTITY, AND REMARKS.
5. REFER TO ALL SHEETS FOR MATERIAL, QUANTITY, AND REMARKS.
6. REFER TO ALL SHEETS FOR MATERIAL, QUANTITY, AND REMARKS.
7. REFER TO ALL SHEETS FOR MATERIAL, QUANTITY, AND REMARKS.
8. REFER TO ALL SHEETS FOR MATERIAL, QUANTITY, AND REMARKS.
9. REFER TO ALL SHEETS FOR MATERIAL, QUANTITY, AND REMARKS.
10. REFER TO ALL SHEETS FOR MATERIAL, QUANTITY, AND REMARKS.

LEGEND	
(Symbol)	NEW 1/2" CONDUIT
(Symbol)	NEW 3/4" CONDUIT
(Symbol)	NEW 1" CONDUIT
(Symbol)	NEW 1 1/2" CONDUIT
(Symbol)	NEW 2" CONDUIT
(Symbol)	NEW 3" CONDUIT
(Symbol)	NEW 4" CONDUIT
(Symbol)	NEW 6" CONDUIT
(Symbol)	NEW 8" CONDUIT
(Symbol)	NEW 10" CONDUIT
(Symbol)	NEW 12" CONDUIT
(Symbol)	NEW 14" CONDUIT
(Symbol)	NEW 16" CONDUIT
(Symbol)	NEW 18" CONDUIT
(Symbol)	NEW 20" CONDUIT
(Symbol)	NEW 24" CONDUIT
(Symbol)	NEW 30" CONDUIT
(Symbol)	NEW 36" CONDUIT
(Symbol)	NEW 42" CONDUIT
(Symbol)	NEW 48" CONDUIT
(Symbol)	NEW 54" CONDUIT
(Symbol)	NEW 60" CONDUIT
(Symbol)	NEW 66" CONDUIT
(Symbol)	NEW 72" CONDUIT
(Symbol)	NEW 78" CONDUIT
(Symbol)	NEW 84" CONDUIT
(Symbol)	NEW 90" CONDUIT
(Symbol)	NEW 96" CONDUIT
(Symbol)	NEW 102" CONDUIT
(Symbol)	NEW 108" CONDUIT
(Symbol)	NEW 114" CONDUIT
(Symbol)	NEW 120" CONDUIT

**MEP SOLUTIONS**  
 MECHANICAL, ELECTRICAL, PLUMBING  
 2500 W. UNIVERSITY BLVD. SUITE 100  
 EDINBURG, TEXAS 78541

**1st AND 2nd FLOORS REMODEL  
 FORMER ADMINISTRATION BUILDING  
 HIDALGO COUNTY, TEXAS  
 CITY OF EDINBURG, TEXAS**

**Alc6cer Garc3a Associates**  
 Design Consulting  
 1233 E. PARKWAY AVE.  
 EDINBURG, TEXAS 78541  
 OFFICE: 356.614.2007  
 FAX: 356.614.2008  
 WWW.AGACDC.COM



**E-4**

PROJECT # 2011-001  
 DESIGNED: JUNE 05, 2012  
 DRAWN BY: J.C. MC  
 CHECKED BY: J.C. MC  
 DATE: MAY 11, 2011

FOR THE USE OF THE CITY OF EDINBURG, TEXAS, THE CITY ENGINEER, HIDALGO COUNTY, TEXAS, HAS REVIEWED AND APPROVED THIS PLAN FOR THE CITY OF EDINBURG, TEXAS, AND THE CITY ENGINEER, HIDALGO COUNTY, TEXAS, HAS REVIEWED AND APPROVED THIS PLAN FOR THE CITY OF EDINBURG, TEXAS.

SECOND FLOOR MECHANICAL AND PLUMBING EQUIPMENT PLAN  
SCALE: 1/8" = 1'-0"

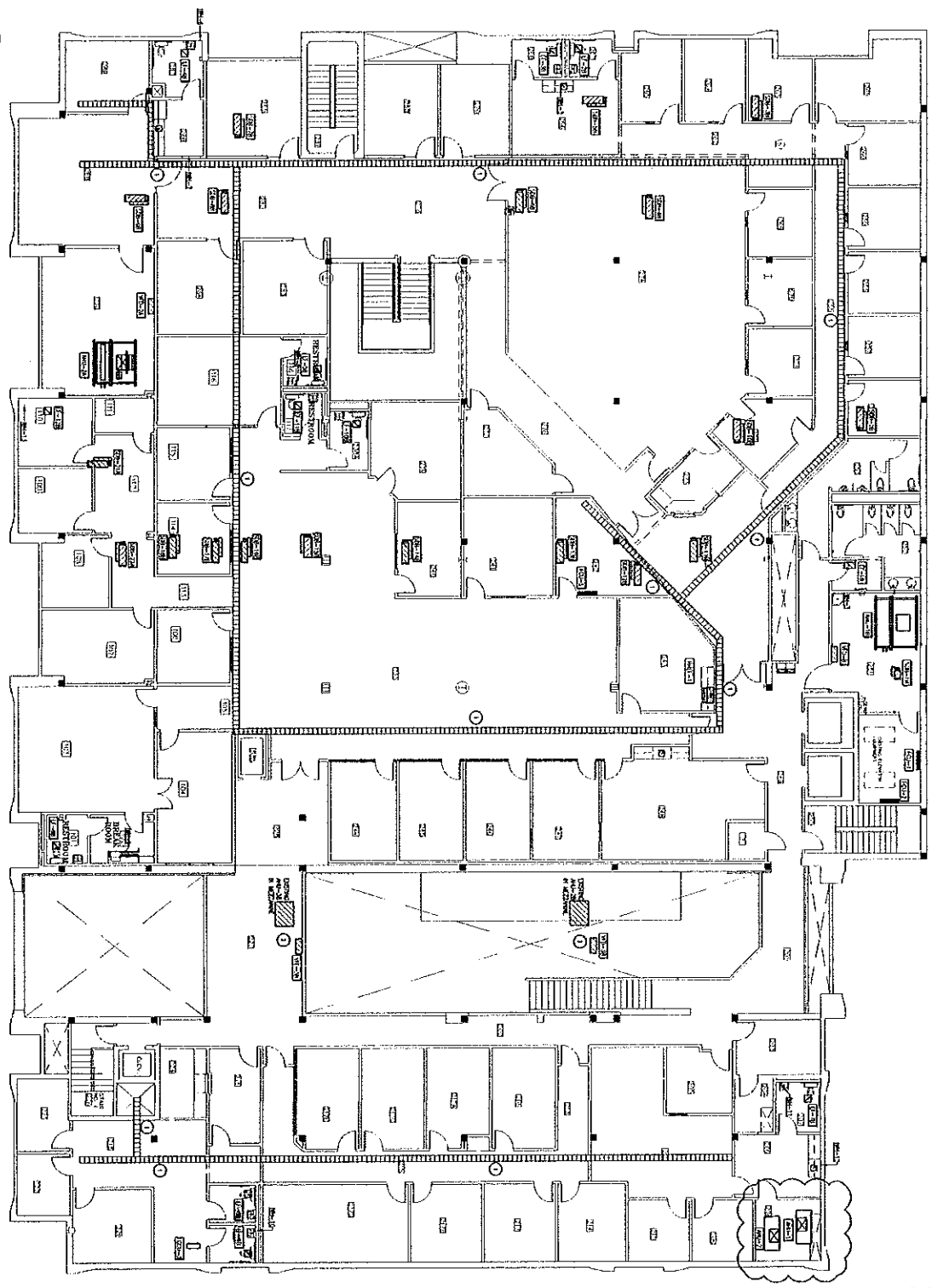

**GENERAL NOTES:**  
 1. GENERAL REMODEL WORK OF ALL TRADES PER ARCHITECTURAL DRAWINGS, SPECIFICATIONS AND NOTES.  
 2. THE MECHANICAL EQUIPMENT OPERATIONS SCHEDULE, REFER TO DRAWING SET.  
**KEY NOTES:**  
 1. FOR CHASE, REFER TO PERMITTING DRAWING 1104.  
 2. FOR FINISHES, REFER TO ARCHITECTURAL DRAWING 1104.  
 3. FOR MECHANICAL EQUIPMENT OPERATIONS SCHEDULE, REFER TO DRAWING SET.

**MEP SOLUTIONS**  
 ENGINEERING  
 ARCHITECTURAL  
 CONSULTING

PROJECT: 1st AND 2nd FLOOR REMODEL  
 ISSUED: JANUARY 2014  
 DRAWN BY: M.C.  
 CHECKED BY: M.C.  
 DATE: JANUARY 11, 2014  
 SHEET: E-6

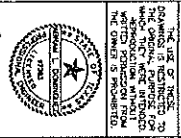

1st AND 2nd FLOOR REMODEL  
 FORMER ADMINISTRATION BUILDING  
 HIDALGO COUNTY, TEXAS  
 CITY OF EDINBURG, TEXAS

**Alcacer Garcia Associates**  
 Design Consulting  
 1333 E. JACOBY AVE.  
 SUITE 200, EDINBURG, TEXAS 78149  
 OFFICE: 356-618-2007  
 FAX: 356-618-2009  
 WEB: WWW.AGADC.COM





### FEEDER / BRANCH CIRCUIT SCHEDULE

LINE NO.	DESCRIPTION	CONDUIT	WIRE	TERMINALS	NOTES
101	300V 100A	1" EMT	3/0	10	
102	240V 100A	1" EMT	2/0	10	
103	208V 100A	1" EMT	1/0	10	
104	120V 100A	1" EMT	1/0	10	
105	300V 100A	1" EMT	3/0	10	
106	240V 100A	1" EMT	2/0	10	
107	208V 100A	1" EMT	1/0	10	
108	120V 100A	1" EMT	1/0	10	
109	300V 100A	1" EMT	3/0	10	
110	240V 100A	1" EMT	2/0	10	
111	208V 100A	1" EMT	1/0	10	
112	120V 100A	1" EMT	1/0	10	
113	300V 100A	1" EMT	3/0	10	
114	240V 100A	1" EMT	2/0	10	
115	208V 100A	1" EMT	1/0	10	
116	120V 100A	1" EMT	1/0	10	
117	300V 100A	1" EMT	3/0	10	
118	240V 100A	1" EMT	2/0	10	
119	208V 100A	1" EMT	1/0	10	
120	120V 100A	1" EMT	1/0	10	

A - FEEDER / BRANCH CIRCUIT SCHEDULE  
SCALE: N.T.S.

### TRANSFORMER SCHEDULE

LINE NO.	DESCRIPTION	POUNDS	REMARKS
101	300V 100A	100	
102	240V 100A	100	
103	208V 100A	100	
104	120V 100A	100	
105	300V 100A	100	
106	240V 100A	100	
107	208V 100A	100	
108	120V 100A	100	
109	300V 100A	100	
110	240V 100A	100	
111	208V 100A	100	
112	120V 100A	100	
113	300V 100A	100	
114	240V 100A	100	
115	208V 100A	100	
116	120V 100A	100	
117	300V 100A	100	
118	240V 100A	100	
119	208V 100A	100	
120	120V 100A	100	

B - ELECTRICAL TRANSFORMER SCHEDULE  
SCALE: N.T.S.

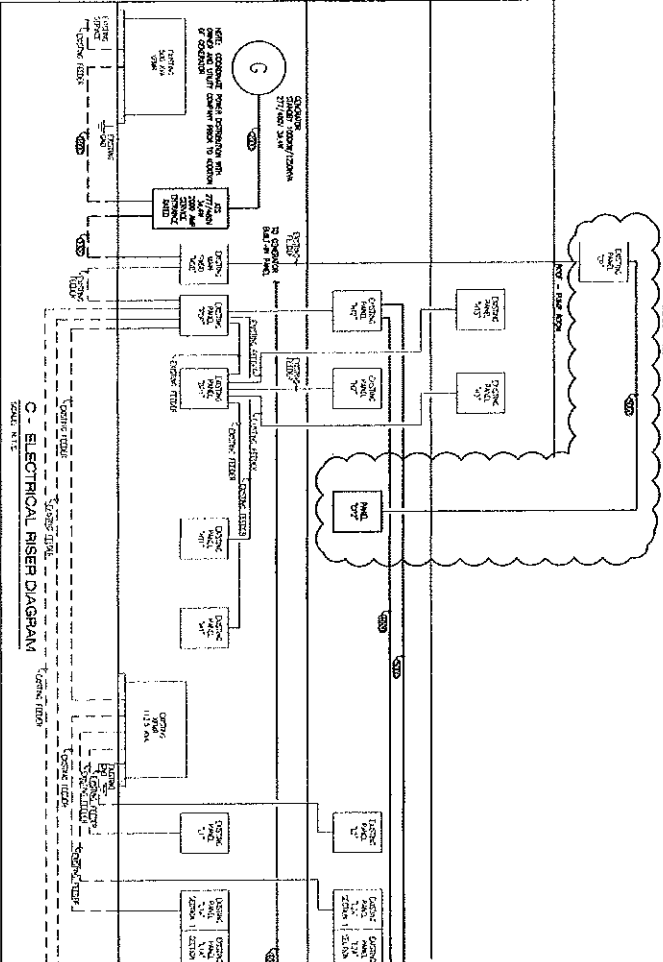

C - ELECTRICAL RISER DIAGRAM  
SCALE: N.T.S.

### ELECTRICAL LEGEND

SYMBOL	DESCRIPTION	SYMBOL	DESCRIPTION
1	300V 100A	1	300V 100A
2	240V 100A	2	240V 100A
3	208V 100A	3	208V 100A
4	120V 100A	4	120V 100A
5	300V 100A	5	300V 100A
6	240V 100A	6	240V 100A
7	208V 100A	7	208V 100A
8	120V 100A	8	120V 100A
9	300V 100A	9	300V 100A
10	240V 100A	10	240V 100A
11	208V 100A	11	208V 100A
12	120V 100A	12	120V 100A
13	300V 100A	13	300V 100A
14	240V 100A	14	240V 100A
15	208V 100A	15	208V 100A
16	120V 100A	16	120V 100A
17	300V 100A	17	300V 100A
18	240V 100A	18	240V 100A
19	208V 100A	19	208V 100A
20	120V 100A	20	120V 100A

D - ELECTRICAL LEGEND  
SCALE: N.T.S.

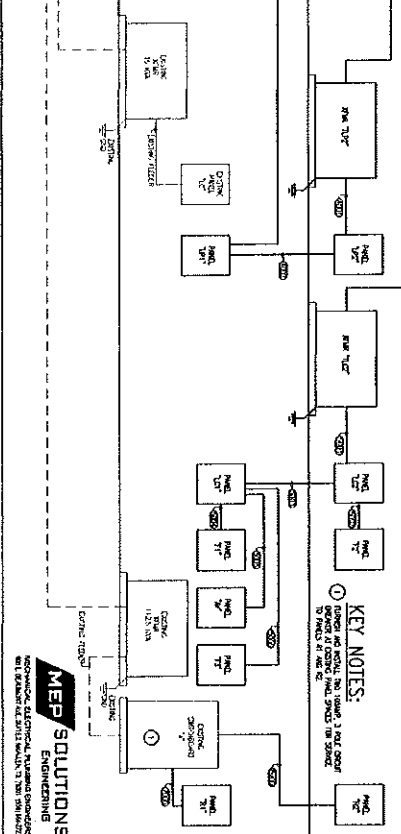

E - ELECTRICAL RISER DIAGRAM  
SCALE: N.T.S.

**MEP SOLUTIONS**  
ENGINEERING

1933 G. Jacobs Ave.  
McAllen, Texas 78501  
Office: 956.618.2007  
Fax: 956.618.2007  
Web: www.MEASDC.COM

1st AND 2nd FLOORS REMODEL  
FORMER ADMINISTRATION BUILDING  
HIDALGO COUNTY, TEXAS  
CITY OF EDINBURG, TEXAS

**AGA**

Alcorca Garcia Associates  
Design Consultant



RECEIVED

Facilities Management

ALCÓCER GARCIA ASSOCIATES, INC  
1333 EAST JASMINE AVENUE  
MCALLEN, TEXAS 78501

**INVOICE FOR PROFESSIONAL SERVICES**

INVOICE NUMBER : 27 - **CHANGE IN SERVICES**  
(ADDITIONAL SERVICES, NOT PART OF BASIC A/E SERVICES)

DATE: NOVEMBER 21, 2014

PROJECT: REMODEL OF EXISTING FORMER ADMINISTRATION BUILDING, 1<sup>ST</sup> & 2<sup>ND</sup> FLOORS  
100 E. CANO ST., EDINBURG, TEXAS

TO: COUNTY OF HIDALGO, TEXAS  
C/O HIDALGO COUNTY PURCHASING DEPARTMENT  
2812 S. BUS. HWY 281  
EDINBURG, TEXAS

AS PER THE OWNER-ARCHITECT CONTRACT, AIA STANDARD FORM OF AGREEMENT BETWEEN ARCHITECT AND OWNER, AND AMENDMENTS THERETO, AND ARTICLE 3.1., 'CHANGES IN SERVICES' OF SAID AGREEMENT.

**THIS INVOICE FOR FOLLOWING SERVICES**  
ENGINEERING DESIGNS FOR ADDITIONAL HVAC DUCT INSTALLATIONS.

**BACKGROUND:**  
CITY OF EDINBURG CODE ENFORCEMENT PLAN REVIEW REQUIRED ADDITIONS OF FIRE DAMPERS AT COUNTY COMMISSIONER'S MEETING ROOM AND SMOKE DAMPERS AT SMOKE COMPARTMENT AT 2<sup>ND</sup> FLOOR ELEVATOR LOBBY. ADDITIONS INCLUDED IN CHANGE ORDER NO. 2 APPROVED BY COUNTY COMMISSIONERS COURT. (COPY OF ENGINEER'S DRAWINGS ATTACHED).

THIS INVOICE FOR COMPLETION AND DISTRIBUTION OF ENGINEERING PLANS

<b>FEE BREAKDOWN:</b>	
ENGINEERING SERVICES, DIRECT COST (COPY OF MEP SOLUTIONS INVOICE # 592 ATTACHED).....	\$ 1,000.00
ALCOCER GARCIA, INC. FEE (10%).....	100.00
<b>TOTAL DUE THIS INVOICE.....</b>	<b>\$ 1,100.00</b>

PLEASE REMIT PAYMENT TO  
ALCÓCER GARCIA ASSOCIATES, INC.  
1333 E. JASMINE AVENUE  
MCALLEN, TEXAS 78501  
(EIN: 26 42 62 500)

THANK YOU,

  
George A. Garcia  
V.P., Project Architect



# Invoice

600 E. Beaumont Ave. Ste 2  
 McAllen, TX 78501  
 Phone # 956.664.2727

Date	Invoice #
10/6/2014	592

<b>Bill To</b>
Eduardo Alcocer AGA, Inc. 1333 E. Jasmine Ave. McAllen, Texas 78501

Project #	Description	Amount
08072	Hidalgo County 1st & 2nd Floor - MEP Sealed drawings for addition of Fire Dampers located in Meeting Room 101 and Elevator Lobby 2nd Floor, drawings dated 07.31.2014.	1,000.00

<b>Total</b>	\$1,000.00
<b>Payments/Credits</b>	\$0.00
<b>Balance Due</b>	\$1,000.00





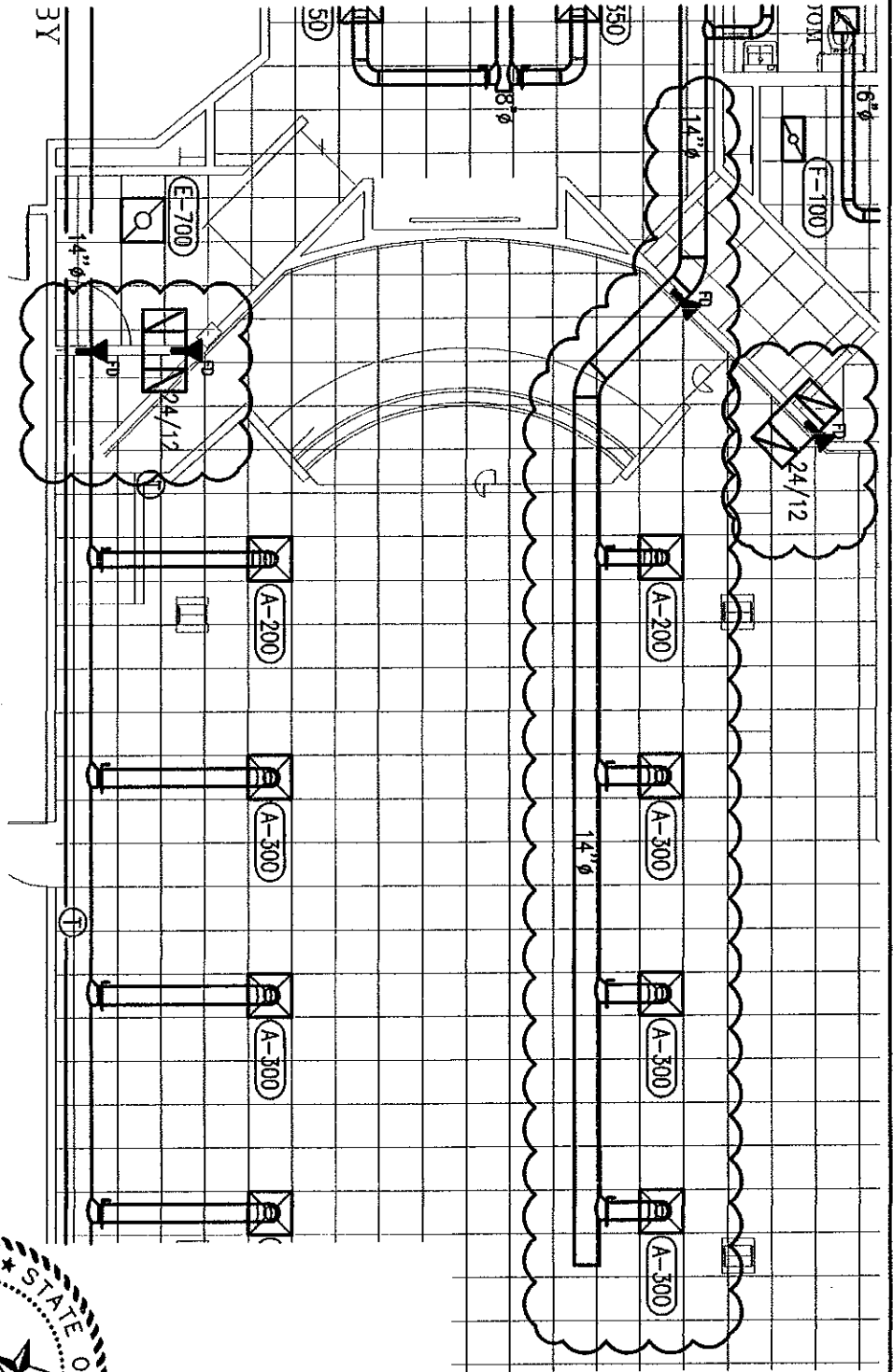

(A) PROVIDE AND INSTALL A FIRE DAMPER EQUAL TO A RUSKIN MODEL "DIBD2". FURNISH WITH DUCT ACCESS DOOR.



**FIRST FLOOR: MECHANICAL IMPROVEMENT PLAN**  
 SCALE: 1/8" = 1'-0"

PR#11

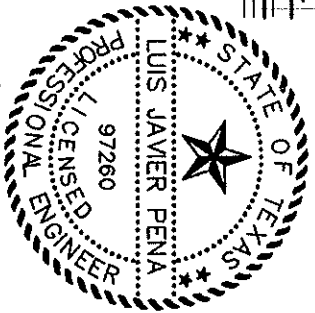

*Luis Javier Pena*  
 07.31.2014

SHEET  
**M-1**

**MEP SOLUTIONS ENGINEERING**  
 MECHANICAL, ELECTRICAL, PLUMBING ENGINEERS  
 600 E. BEAUMONT AVE. SUITE 2 McALLEN, TX 78501 (956) 664-2727  
 TEXAS BOARD OF PROFESSIONAL ENGINEERS REGISTRATION # F-9748

1st AND 2nd FLOORS  
 REMODEL FORMER  
 ADMINISTRATION BUILDING  
 HIDALGO COUNTY TEXAS  
 CITY OF ENDURBURG, TEXAS

JOB NO.	06072
DATE	06-01-12
REVISIONS	07-31-14
DRAWN BY	J.P.L.S.

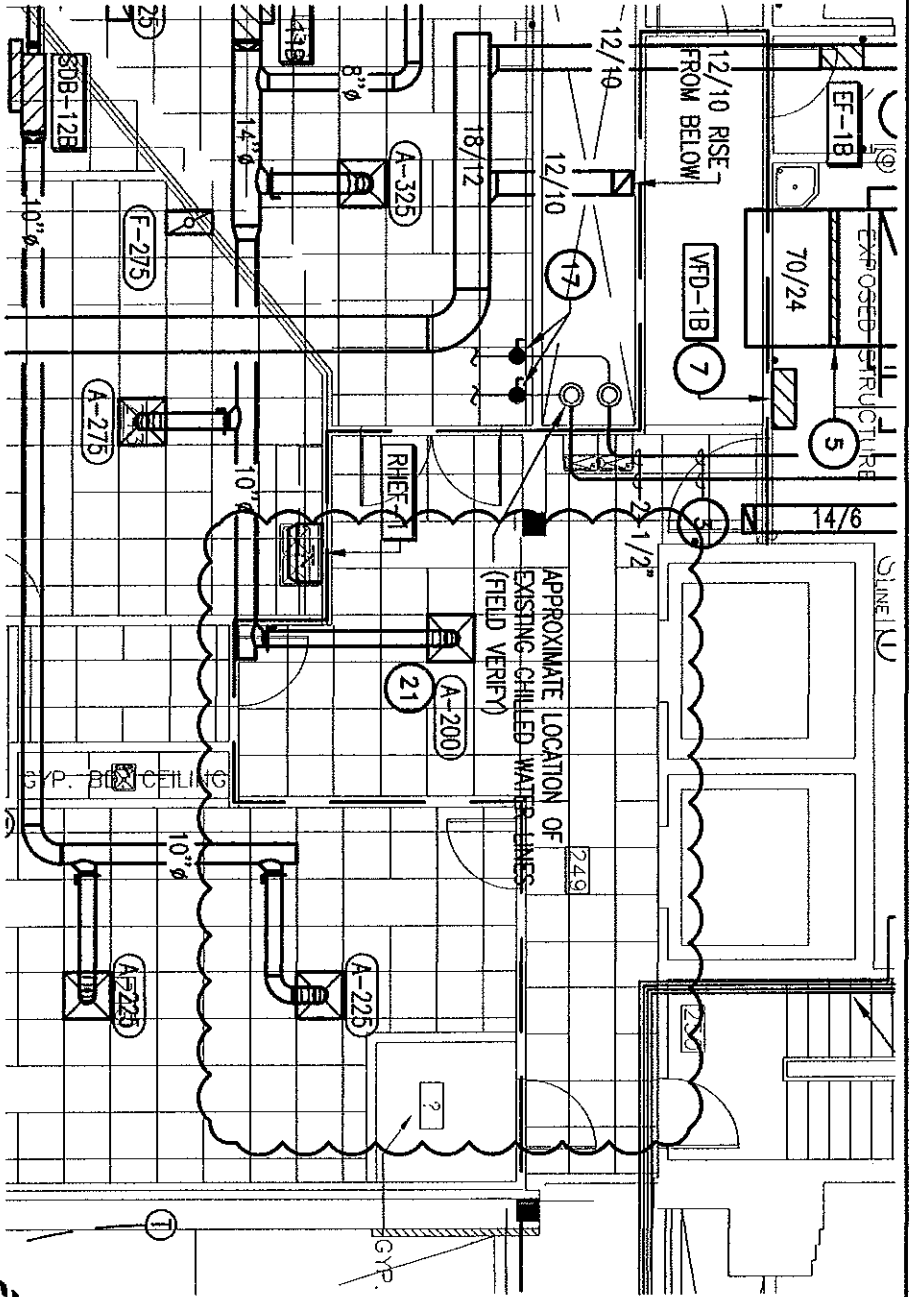

21 PROVIDE AND INSTALL STEEL AIR DEVICE EQUAL TO A TITUS MODEL "TMS" WITH AN 8" Ø NECK. FURNISH AIR DEVICE WITH FIRE/SMOKE DAMPER EQUAL TO A RUSKIN MODEL "DSFR1" AND MOUNT ON TO AIR DEVICE NECK.



SCALE: 1/8" = 1'-0"

SECOND FLOOR: MECHANICAL IMPROVEMENT PLAN



*Luis Javier Pena*  
07.31.2014

SHEET  
**M-2**

**MEP SOLUTIONS ENGINEERING**  
MECHANICAL, ELECTRICAL, PLUMBING ENGINEERS  
600 E. BEAUMONT AVE. SUITE 2 McALLEN, TX 78501 (956) 664-2727  
TEXAS BOARD OF PROFESSIONAL ENGINEERS REGISTRATION # F-9748

1st AND 2nd FLOORS  
REMODEL FORMER  
ADMINISTRATION BUILDING  
HIDALGO COUNTY TEXAS  
CITY OF ENDINBURG, TEXAS

JOB NO.	06072
DATE	08-01-12
REVISIONS	07-31-14
DRAWN BY	J.P.A.S.

RECEIVED

Facilities Management

ALCÓCER GARCIA ASSOCIATES, INC  
1333 EAST JASMINE AVENUE  
MCALLEN, TEXAS 78501

**INVOICE FOR PROFESSIONAL SERVICES**

INVOICE NUMBER : **28 - CHANGE IN SERVICES**  
(ADDITIONAL SERVICES, NOT PART OF BASIC A/E SERVICES)

DATE: NOVEMBER 21, 2014

PROJECT: REMODEL OF EXISTING FORMER ADMINISTRATION BUILDING, 1<sup>ST</sup> & 2<sup>ND</sup> FLOORS  
100 E. CANO ST., EDINBURG, TEXAS

TO: COUNTY OF HIDALGO, TEXAS  
C/O HIDALGO COUNTY PURCHASING DEPARTMENT  
2812 S. BUS. HWY 281  
EDINBURG, TEXAS

AS PER THE OWNER-ARCHITECT CONTRACT, AIA STANDARD FORM OF AGREEMENT BETWEEN ARCHITECT AND OWNER, AND AMENDMENTS THERETO, AND ARTICLE 3.1., 'CHANGES IN SERVICES' OF SAID AGREEMENT.

**THIS INVOICE FOR FOLLOWING SERVICES**  
ENGINEERING DESIGNS FOR PLUMBING AND ELECTRICAL INSTALLATIONS

**BACKGROUND:**  
OWNER-REQUESTED ENGINEERING DESIGNS FOR ADDING PLUMBING ROUGH - IN PIPING AND ELECTRICAL OUTLETS IN STORAGE ROOM 121 TO PROVIDE FOR FUTURE PLUMBING ELECTRICAL AND CABINETS INSTALLATIONS BY COUNTY. (COPY OF ENGINEER'S DRAWINGS ATTACHED).

THIS INVOICE FOR COMPLETION AND DISTRIBUTION OF ENGINEERING PLANS

<b>FEE BREAKDOWN:</b>	
ENGINEERING SERVICES, DIRECT COST (COPY OF MEP SOLUTIONS INVOICE # 589 ATTACHED).....	\$ 1,500.00
ALCOCER GARCIA, INC. FEE (10%).....	<u>150.00</u>
<b>TOTAL DUE THIS INVOICE.....</b>	<b>\$ 1,650.00</b>

PLEASE REMIT PAYMENT TO  
ALCÓCER GARCIA ASSOCIATES, INC.  
1333 E. JASMINE AVENUE  
MCALLEN, TEXAS 78501  
(EIN: 26 42 62 500)

THANK YOU,

  
George A. Garcia  
V.P., Project Architect



# Invoice

Date	Invoice #
10/6/2014	589

600 E. Beaumont Ave. Ste 2  
 McAllen, TX 78501  
 Phone # 956.664.2727

Bill To
Eduardo Alcocer AGA, Inc. 1333 E. Jasmine Ave. McAllen, Texas 78501

Project #	Description	Amount
08072	Hidalgo County 1st & 2nd Floor - MEP Sealed drawings for addition of plumbing and electrical for Storage Room 121, drawings dated 08.13.2014.	1,500.00
<b>Total</b>		\$1,500.00
<b>Payments/Credits</b>		\$0.00
<b>Balance Due</b>		\$1,500.00

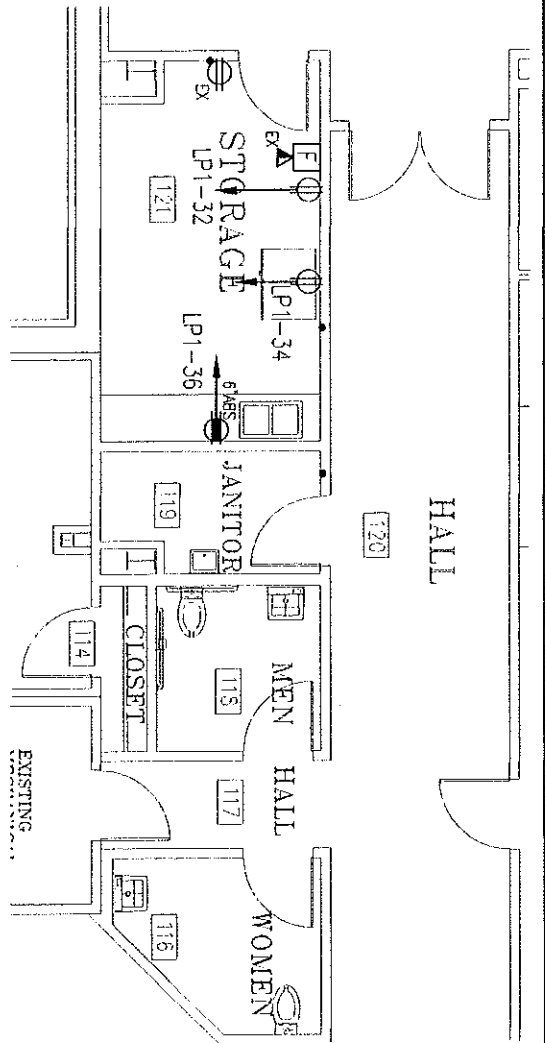

FIRST FLOOR: ELECTRICAL POWER IMPROVEMENT PLAN  
 SCALE: 1/8" = 1'-0"

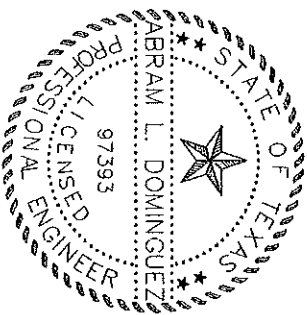

*Abram L. Dominguez*  
 08.13.2014

SHEET  
**E-3**

**MEP SOLUTIONS ENGINEERING**  
 MECHANICAL, ELECTRICAL, PLUMBING ENGINEERS  
 600 E. BEAUMONT AVE. SUITE 2 McALLEN, TX 78501 (956) 664-2727  
 TEXAS BOARD OF PROFESSIONAL ENGINEERS REGISTRATION # F-9748

1st AND 2nd FLOORS  
 REMODEL FORMER  
 ADMINISTRATION BUILDING  
 HIDALGO COUNTY TEXAS  
 CITY OF ENDINBURG, TEXAS

JOB NO.	08072
DATE	06-01-12
REVISIONS	08-13-14
DRAWN BY	A.D./M.G.

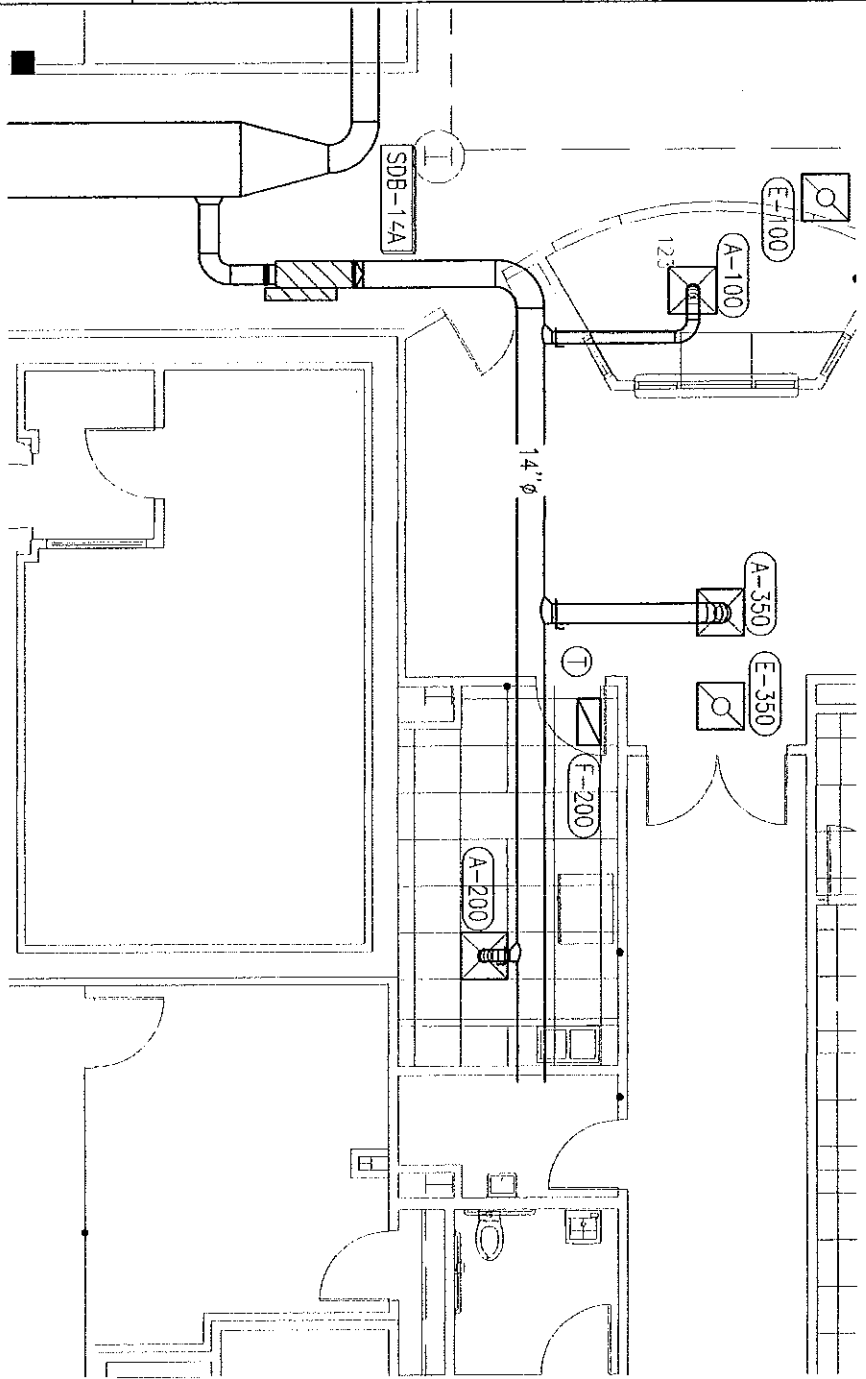

FIRST FLOOR: MECHANICAL IMPROVEMENT PLAN  
 SCALE: 1/8" = 1'-0"



*Luis J. Pena*  
 08.13.2014

SHEET  
**M-1**

**MEP SOLUTIONS ENGINEERING**  
 MECHANICAL, ELECTRICAL, PLUMBING ENGINEERS  
 600 E. BEAUMONT AVE. SUITE 2 McALLEN, TX 78501 (956) 664-2727  
 TEXAS BOARD OF PROFESSIONAL ENGINEERS REGISTRATION # F-9748

1st AND 2nd FLOORS  
 REMODEL FORMER  
 ADMINISTRATION BUILDING  
 HIDALGO COUNTY TEXAS  
 CITY OF ENDINBURG, TEXAS

JOB NO.	08072
DATE	06-01-12
REVISIONS	08-13-14
DRAWN BY	J.P./L.S.

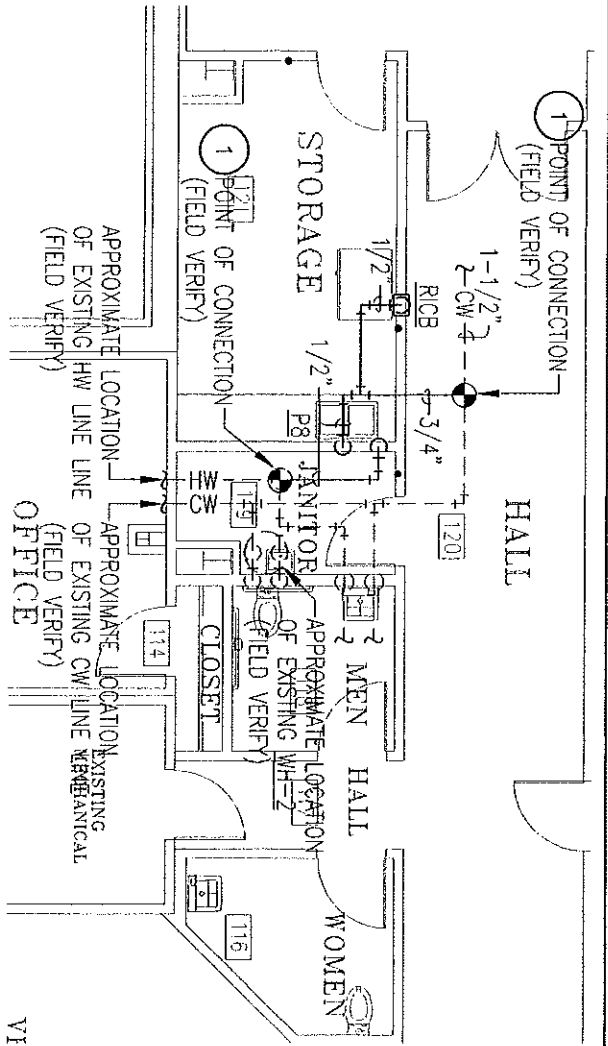

FIRST FLOOR PLUMBING HW/CW IMPROVEMENT PLAN

SCALE: 1/8" = 1'-0"

KEY NOTES: ○

- 1 PLUMBING CONTRACTOR SHALL VERIFY POINT OF CONNECTION TO BUILDING UTILITIES PRIOR TO BID TO AVOID CONFLICT. ANY DISCREPANCIES FOUND BY THE PLUMBING CONTRACTOR SHALL BE REPORTED TO THE ENGINEER/ARCHITECT IMMEDIATELY AND PRIOR TO ANY INSTALLATION. FAILURE TO COMPLY SHALL MAKE ALL CORRECTIONS AND/OR MODIFICATIONS THE FULL RESPONSIBILITY OF THE CONTRACTOR.

PLUMBING CONTRACTOR SHALL COORDINATE DOMESTIC WATER AND SANITARY SEWER LINE DIRECTION OF FLOW, SIZE, INVERT, AND POINT OF CONNECTION WITH EXISTING CONDITIONS PRIOR TO INSTALLATION OF ROUGH-IN TO AVOID CONFLICT. ANY DISCREPANCIES FOUND BY THE PLUMBING CONTRACTOR SHALL BE REPORTED TO THE ENGINEER/ARCHITECT IMMEDIATELY AND PRIOR TO ANY INSTALLATION. FAILURE TO COMPLY SHALL MAKE ALL CORRECTIONS AND/OR MODIFICATIONS THE FULL RESPONSIBILITY OF THE CONTRACTOR.

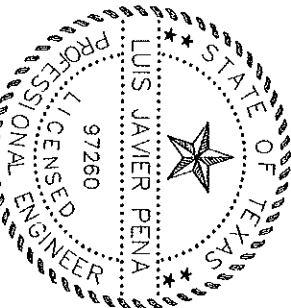

*Luis Javier Pena*  
08.13.2014

SHEET  
**P-1B**

**MEP SOLUTIONS ENGINEERING**  
MECHANICAL, ELECTRICAL, PLUMBING ENGINEERS  
600 E. BEAUMONT AVE. SUITE 2 McALLEN, TX 78501 (956) 664-2727  
TEXAS BOARD OF PROFESSIONAL ENGINEERS REGISTRATION # F-9748

1st AND 2nd FLOORS  
REMODEL FORMER  
ADMINISTRATION BUILDING  
HIDALGO COUNTY TEXAS  
CITY OF ENDINBURG, TEXAS

JOB NO.	08072
DATE	06-01-12
REVISIONS	08-13-14
DRAWN BY	JP./T.T.

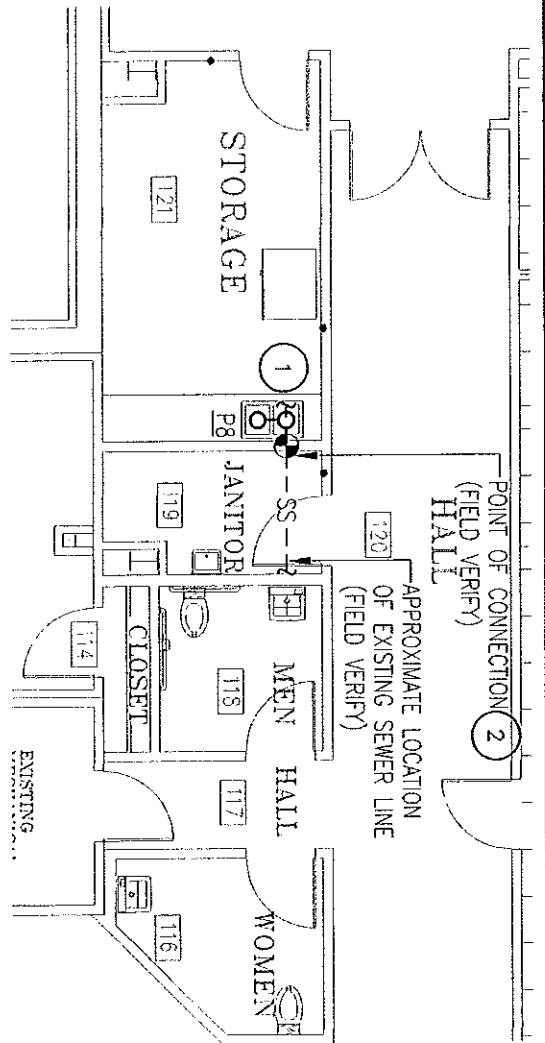

FIRST FLOOR: PLUMBING SEWER IMPROVEMENT PLAN



SCALE: 1/8" = 1'-0"

KEY NOTES: ○

- 1 CORE DRILL AND/OR SAW-CUT FINISH FLOOR AND WALLS AS REQUIRED TO PROVIDE NEW ROUGH-IN FOR PLUMBING FIXTURES. PATCH AND REPAIR AS PER ARCHITECTURAL REQUIREMENTS AND SPECIFICATIONS.
- 2 PLUMBING CONTRACTOR SHALL VERIFY POINT OF CONNECTION TO BUILDING UTILITIES PRIOR TO BID TO AVOID CONFLICT. ANY DISCREPANCIES FOUND BY THE PLUMBING CONTRACTOR SHALL BE REPORTED TO THE ENGINEER/ARCHITECT IMMEDIATELY AND PRIOR TO ANY INSTALLATION. FAILURE TO COMPLY SHALL MAKE ALL CORRECTIONS AND/OR MODIFICATIONS THE FULL RESPONSIBILITY OF THE CONTRACTOR.

PLUMBING CONTRACTOR SHALL COORDINATE DOMESTIC WATER AND SANITARY SEWER LINE DIRECTION OF FLOW, SIZE, INVERT, AND POINT OF CONNECTION WITH EXISTING CONDITIONS PRIOR TO INSTALLATION OF ROUGH-IN TO AVOID CONFLICT. ANY DISCREPANCIES FOUND BY THE PLUMBING CONTRACTOR SHALL BE REPORTED TO THE ENGINEER/ARCHITECT IMMEDIATELY AND PRIOR TO ANY INSTALLATION. FAILURE TO COMPLY SHALL MAKE ALL CORRECTIONS AND/OR MODIFICATIONS THE FULL RESPONSIBILITY OF THE CONTRACTOR.

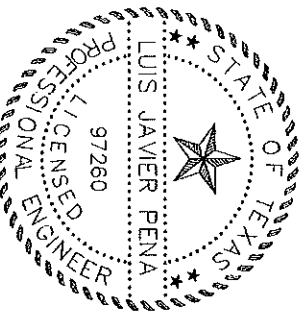

*Luis Javier Pena*  
08.13.2014

JOB NO.	O8072
DATE	06-01-12
REVISIONS	08-13-14
DRAWN BY	J.P./T.T.

1st AND 2nd FLOORS  
REMODEL FORMER  
ADMINISTRATION BUILDING  
HIDALGO COUNTY TEXAS  
CITY OF ENDINBURG, TEXAS

**MEP SOLUTIONS ENGINEERING**  
MECHANICAL, ELECTRICAL, PLUMBING ENGINEERS  
600 E. BEAUMONT AVE. SUITE 2 McALLEN, TX 78501 (956) 664-2727  
TEXAS BOARD OF PROFESSIONAL ENGINEERS REGISTRATION # F-9748

SHEET  
**P-1A**

RECEIVED

Facilities Management

ALCÓCER GARCIA ASSOCIATES, INC

1333 EAST JASMINE AVENUE  
MCALLEN, TEXAS 78501

**INVOICE FOR PROFESSIONAL SERVICES**

INVOICE NUMBER : **29** - **CHANGE IN SERVICES**  
(ADDITIONAL SERVICES, NOT PART OF BASIC A/E SERVICES)

DATE: NOVEMBER 21, 2014

PROJECT: REMODEL OF EXISTING FORMER ADMINISTRATION BUILDING, 1<sup>ST</sup> & 2<sup>ND</sup> FLOORS  
100 E. CANO ST., EDINBURG, TEXAS

TO: COUNTY OF HIDALGO, TEXAS  
C/O HIDALGO COUNTY PURCHASING DEPARTMENT  
2812 S. BUS. HWY 281  
EDINBURG, TEXAS

AS PER THE OWNER-ARCHITECT CONTRACT, AIA STANDARD FORM OF AGREEMENT BETWEEN ARCHITECT AND OWNER, AND AMENDMENTS THERETO, AND ARTICLE 3.1., 'CHANGES IN SERVICES' OF SAID AGREEMENT.

**THIS INVOICE FOR FOLLOWING SERVICES**

STRUCTURAL ENGINEERING DESIGNS FOR ADDING TWO STEEL BEAMS FOR ADDITIONAL SUPPORT FOR AIR HANDLING UNITS.

**BACKGROUND:**

THE CONTRACTOR REQUESTED THAT THE EXISTING STEEL FRAMING BE INSPECTED BENEATH THE LOCATION OF THE NEW AIR HANDLING UNITS AT MECHANICAL ROOM 251. THE STRUCTURAL ENGINEER DETERMINED THAT ADDITIONAL STEEL FLOOR SUPPORT NEEDED TO BE ADDED AT THAT LOCATION TO SUPPORT THE NEW EQUIPMENT LOADS (COPY OF ENGINEER'S DRAWINGS ATTACHED).

THIS INVOICE FOR COMPLETION AND DISTRIBUTION OF ENGINEERING PLANS

**FEE BREAKDOWN:**

ENGINEERING SERVICES, DIRECT COST (COPY OF HINOJOSA ENGINEERING, INC. INVOICE # 08-199 RFI#13 ATTACHED) .....	\$750.00
ALCOCER GARCIA, INC. FEE (10%).....	<u>75.00</u>
<b>TOTAL DUE THIS INVOICE..</b>	<b>\$ 825.00</b>

PLEASE REMIT PAYMENT TO  
ALCÓCER GARCIA ASSOCIATES, INC.  
1333 E. JASMINE AVENUE  
MCALLEN, TEXAS 78501  
(EIN: 26 42 62 500)

THANK YOU,

  
George A. Garcia  
V.P., Project Architect

# HINOJOSA ENGINEERING, INC.

Structural Engineering – Civil Engineering  
Land Surveying

108 WEST 18TH STREET MISSION, TEXAS 78572  
(956) 581-0143 OFFICE (956) 581-2074 FAX

**INVOICE # 08-199 RFI#13**

June 11, 2014

<b>CLIENT:</b> AGA Mr. Eduardo Alcocer 1333 East Jasmine Avenue McAllen, Texas 78501  Attn.: Mr. Eduardo Alcocer	<b>PROJECT # 08-199 RFI#13</b> Project Hidalgo County Administration Remodel (RFI#13 -2 <sup>nd</sup> Floor AHU Support)
------------------------------------------------------------------------------------------------------------------------------------	-----------------------------------------------------------------------------------------------------------------------------------

## FOR PROFESSIONAL SERVICES PERFORMED

### SCOPE OF WORK:

- 1 Site Observation & As-Built
- 2 Structural Design
2. Structural Plans/Details

## STRUCTURAL COST BREAKDOWN

A. Structural Engineering Fee	<b>\$750.00</b>
<b>B. Amount Due to This Invoice</b>	<b>\$ 750.00</b>

Please make check payable to **HINOJOSA ENGINEERING INC.** in the amount of **\$ 750.00**

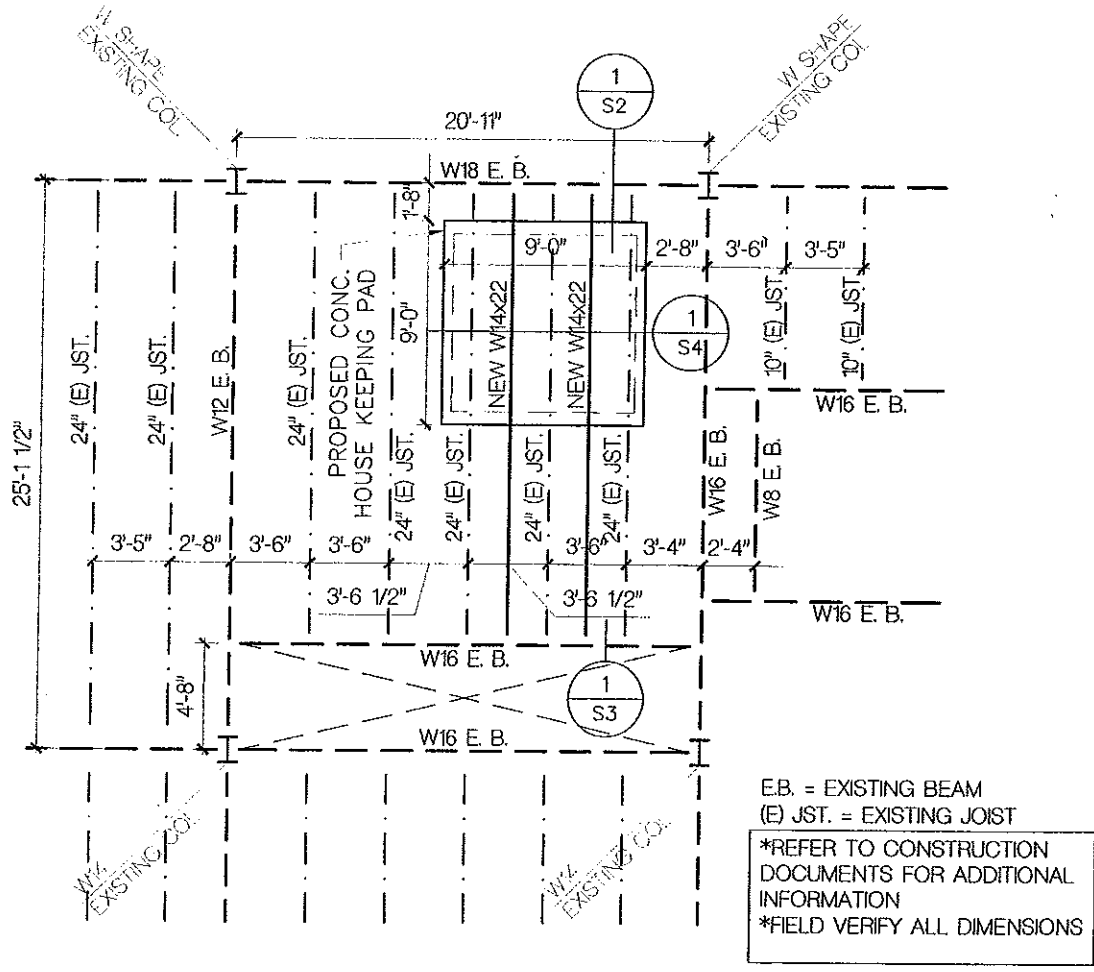

**HINOJOSA ENGINEERING, INC.**  
 STRUCTURAL ENGINEERING  
 CIVIL ENGINEERING LAND SURVEYING  
 108 W. 18TH ST. MISSION, TEXAS  
 (956) 581-0143 FAX: (956) 581-2074  
 E-MAIL: HinojosaEngInc@aol.com  
 REGISTRATION NUMBER: F-908 EXPIRATION DATE: 09/30/2014



1 PARTIAL EXISTING 2ND FLOOR FRAMING PLAN  
 Scale: 1/8"=1'-0"

Project : RE-MODEL FORMER ADMINISTRATION BLDG.  
 HIDALGO COUNTY, TEXAS

Drawing: RFI #13 (PART B)  
 Date : March 5, 2014

Project No. : 08-199

S1

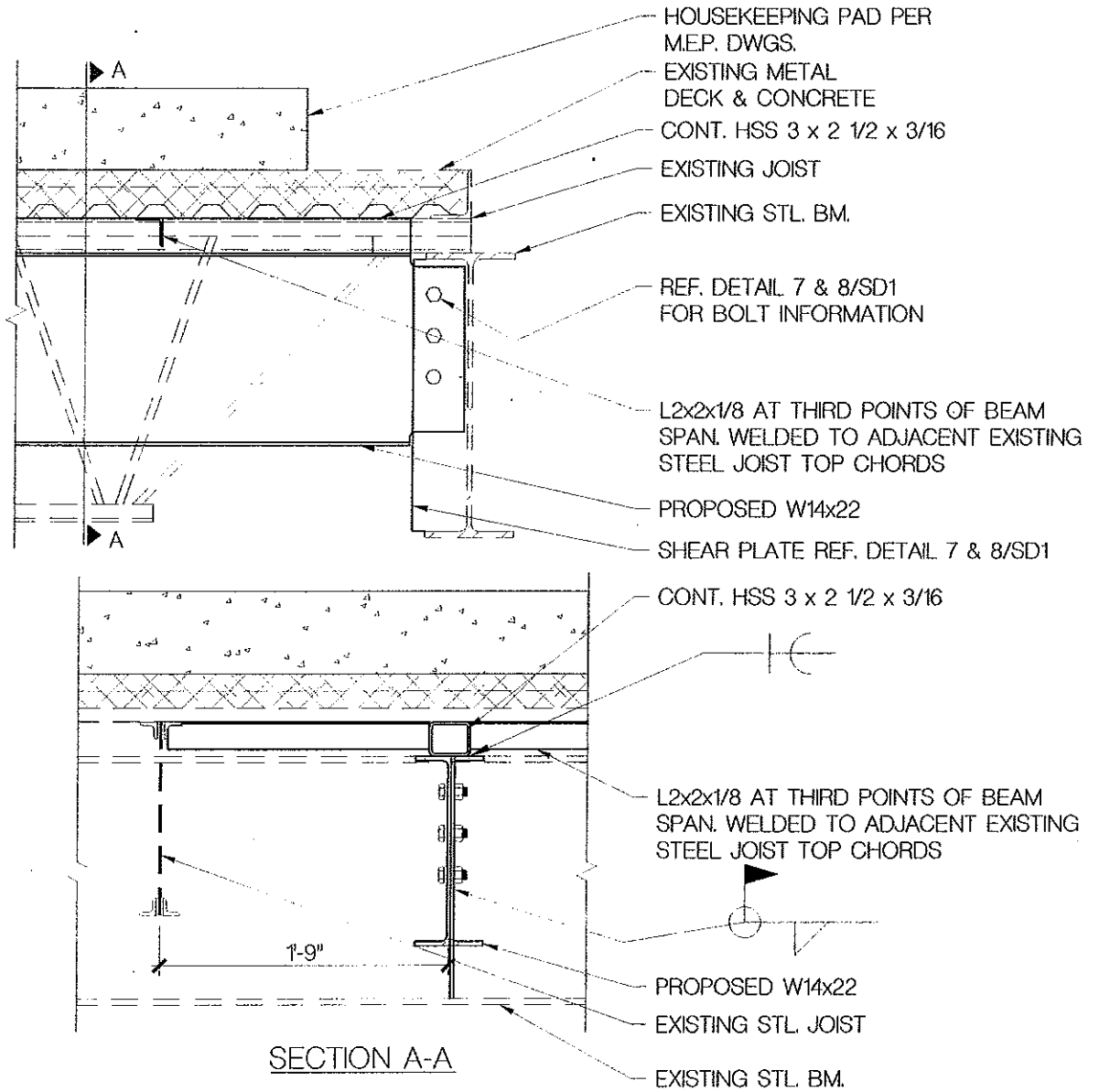

SECTION A-A



**HINOJOSA ENGINEERING, INC.**  
 STRUCTURAL ENGINEERING  
 CIVIL ENGINEERING LAND SURVEYING  
 108 W. 18TH ST. MISSION, TEXAS  
 (956) 581-0143 FAX: (956) 581-2074  
 E-MAIL: HinojosaEngInc@aol.com  
 REGISTRATION NUMBER: F-908 EXPIRATION DATE: 09/30/2014



STL. BM TO STL. BM.

Project : RE-MODEL FORMER ADMINISTRATION BLDG.  
 HIDALGO COUNTY, TEXAS

Drawing: RFI #13 (PART B)

Date : March 5, 2014

Project No. : 08-199

S2

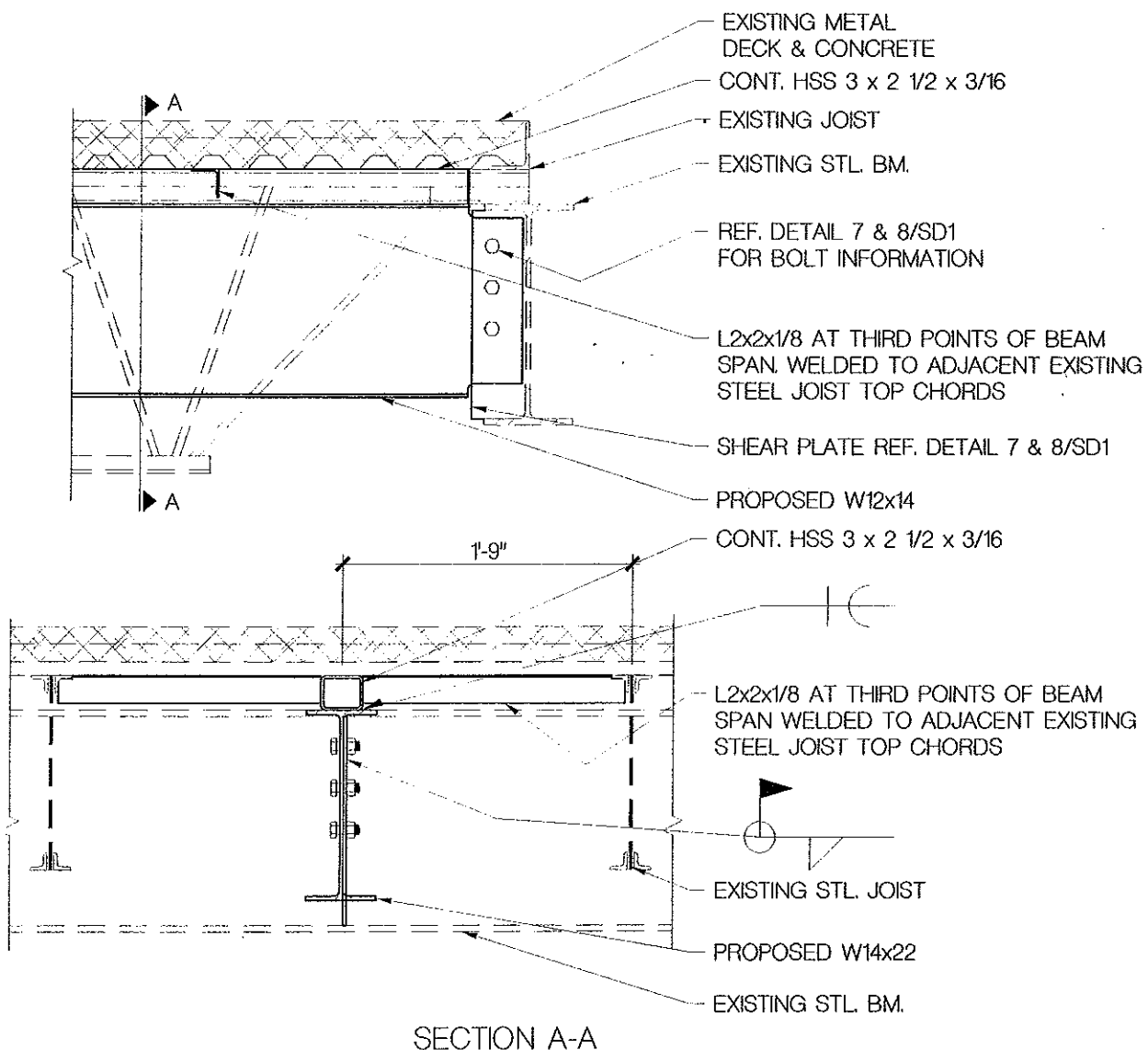

SECTION A-A



**HINOJOSA ENGINEERING, INC.**  
 STRUCTURAL ENGINEERING  
 CIVIL ENGINEERING LAND SURVEYING  
 108 W. 18TH ST. MISSION, TEXAS  
 (956) 581-0143 FAX: (956) 581-2074  
 E-MAIL: HinojosaEngInc@aol.com  
 REGISTRATION NUMBER: F-908 EXPIRATION DATE: 09/30/2014



1 STL. BM TO STL. BM.

Project : RE-MODEL FORMER ADMINISTRATION BLDG.  
 HIDALGO COUNTY, TEXAS

Drawing: RFI #13 (PART B)

Date : March 5, 2014

Project No. : 08-199

S3

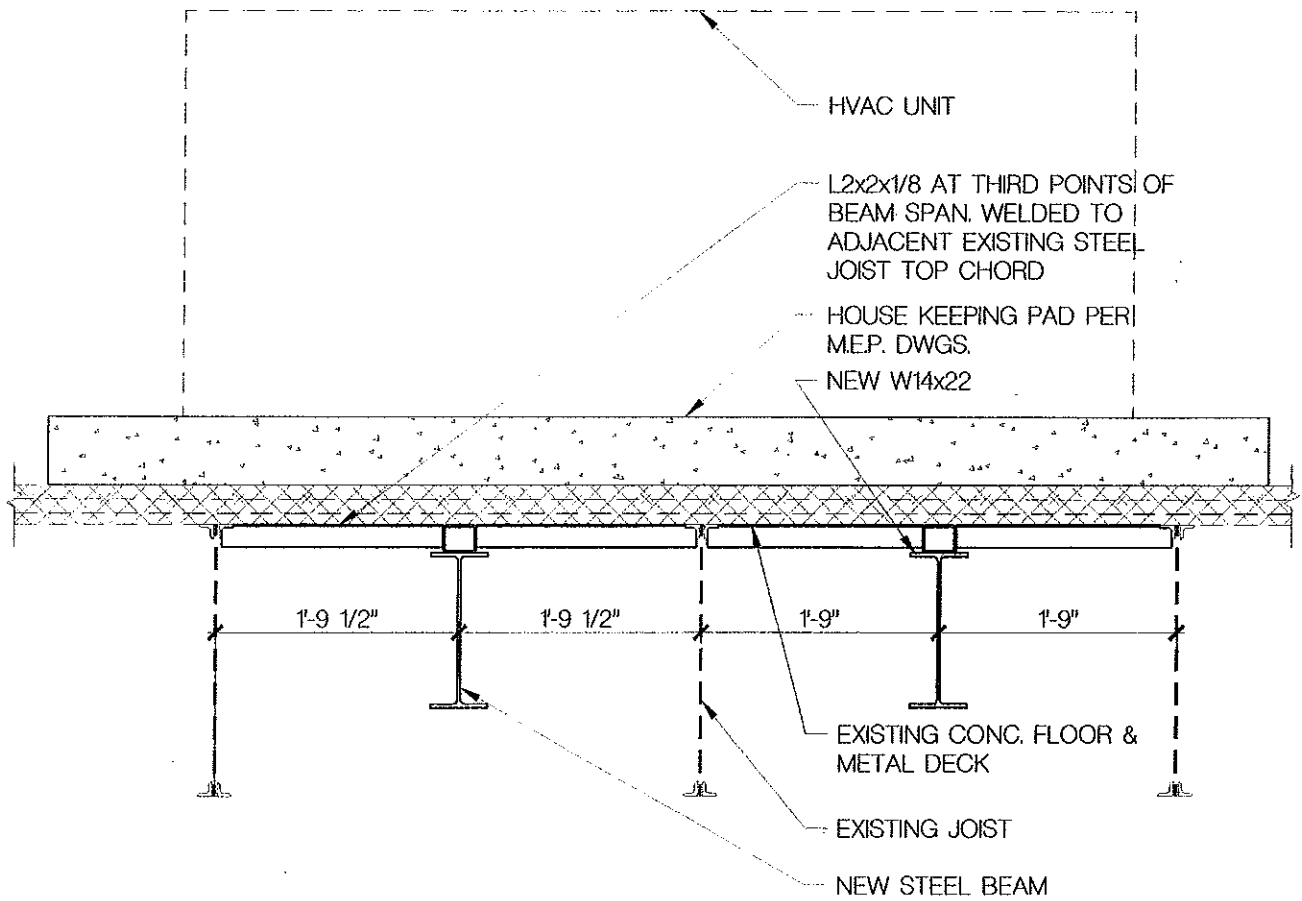

**HINOJOSA ENGINEERING, INC.**  
 STRUCTURAL ENGINEERING  
 CIVIL ENGINEERING LAND SURVEYING  
 108 W. 18TH ST. MISSION, TEXAS  
 (956) 581-0143 FAX: (956) 581-2074  
 E-MAIL: HinojosaEngInc@aol.com  
 REGISTRATION NUMBER: F-908 EXPIRATION DATE: 09/30/2014



1

STL. BM TO STL. BM.

Project : RE-MODEL FORMER ADMINISTRATION BLDG.  
 HIDALGO COUNTY, TEXAS

Drawing: RFI #13 (PART B)

Date : March 5, 2014

Project No. : 08-199

S4

RECEIVED

Facilities Management

ALCÓCER GARCIA ASSOCIATES, INC  
1333 EAST JASMINE AVENUE  
MCALLEN, TEXAS 78501

**INVOICE FOR PROFESSIONAL SERVICES**

INVOICE NUMBER : **30 - CHANGE IN SERVICES**  
(ADDITIONAL SERVICES, NOT PART OF BASIC A/E SERVICES)

DATE: NOVEMBER 21, 2014

PROJECT: REMODEL OF EXISTING FORMER ADMINISTRATION BUILDING, 1<sup>ST</sup> & 2<sup>ND</sup> FLOORS  
100 E. CANO ST., EDINBURG, TEXAS

TO: COUNTY OF HIDALGO, TEXAS  
C/O HIDALGO COUNTY PURCHASING DEPARTMENT  
2812 S. BUS. HWY 281  
EDINBURG, TEXAS

AS PER THE OWNER-ARCHITECT CONTRACT, AIA STANDARD FORM OF AGREEMENT BETWEEN ARCHITECT AND OWNER, AND AMENDMENTS THERETO, AND ARTICLE 3.1., 'CHANGES IN SERVICES' OF SAID AGREEMENT.

**THIS INVOICE FOR FOLLOWING SERVICES**

STRUCTURAL ENGINEERING DESIGNS FOR REPAIR AND ADDITION OF STEEL JOIST FRAMAING AT TOP OF 2<sup>ND</sup> FLOOR.

**BACKGROUND:**

THE CONTRACTOR REPORTED THAT SEVERAL EXISTING STEEL JOISTS AT THE EAST SIDE OF THE BUILDING NEAR MECHANICAL ROOM 251 HAD BEEN AFFECTED BY A WATER LEAK THAT HAD APPARENTLY EXISTED FOR QUITE SOME TIME. THE STRUCTURAL ENGINEER INSPECTED THE CONDITIONS AND RECOMMENDED THE REPAIR OF THE RUSTED JOISTS PLUS AND ADDITION OF ONE NEW JOIST (COPY OF ENGINEER'S DRAWINGS ATTACHED).

THIS INVOICE FOR COMPLETION AND DISTRIBUTION OF ENGINEERING PLANS

**FEE BREAKDOWN:**

ENGINEERING SERVICES, DIRECT COST (COPY OF HINOJOSA ENGINEERING, INC.

INVOICE # 08-199 RF121..... \$ 750.00

ALCOCER GARCIA, INC. FEE (10%)..... 75.00

**TOTAL DUE THIS INVOICE..... \$ 825.00**

PLEASE REMIT PAYMENT TO  
ALCÓCER GARCIA ASSOCIATES, INC.  
1333 E. JASMINE AVENUE  
MCALLEN, TEXAS 78501  
(EIN: 26 42 62 500)

THANK YOU,

  
George A. Garcia  
V.P., Project Architect

# HINOJOSA ENGINEERING, INC.

Structural Engineering – Civil Engineering  
Land Surveying

108 WEST 18TH STREET MISSION, TEXAS 78572  
(956) 581-0143 OFFICE (956) 581-2074 FAX

**INVOICE # 08-199 RFI#21**

June 11, 2014

<b>CLIENT:</b> AGA Mr. Eduardo Alcocer 1333 East Jasmine Avenue McAllen, Texas 78501  Attn.: Mr. Eduardo Alcocer	<b>PROJECT # 08-199 RFI#21</b> Project Hidalgo County Administration Remodel (RFI#21 -3 <sup>rd</sup> Floor Corroded Steel Joist)
------------------------------------------------------------------------------------------------------------------------------------	--------------------------------------------------------------------------------------------------------------------------------------------

## FOR PROFESSIONAL SERVICES PERFORMED

### SCOPE OF WORK:

- 1 Site Observation & As-Built
- 2 Structural Design
2. Structural Plans/Details

## STRUCTURAL COST BREAKDOWN

A. Structural Engineering Fee	<b>\$750.00</b>
<b>B. Amount Due to This Invoice</b>	<b>\$ 750.00</b>

Please make check payable to **HINOJOSA ENGINEERING INC.** in the amount of **\$ 750.00**

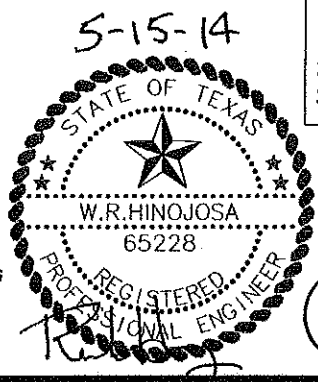
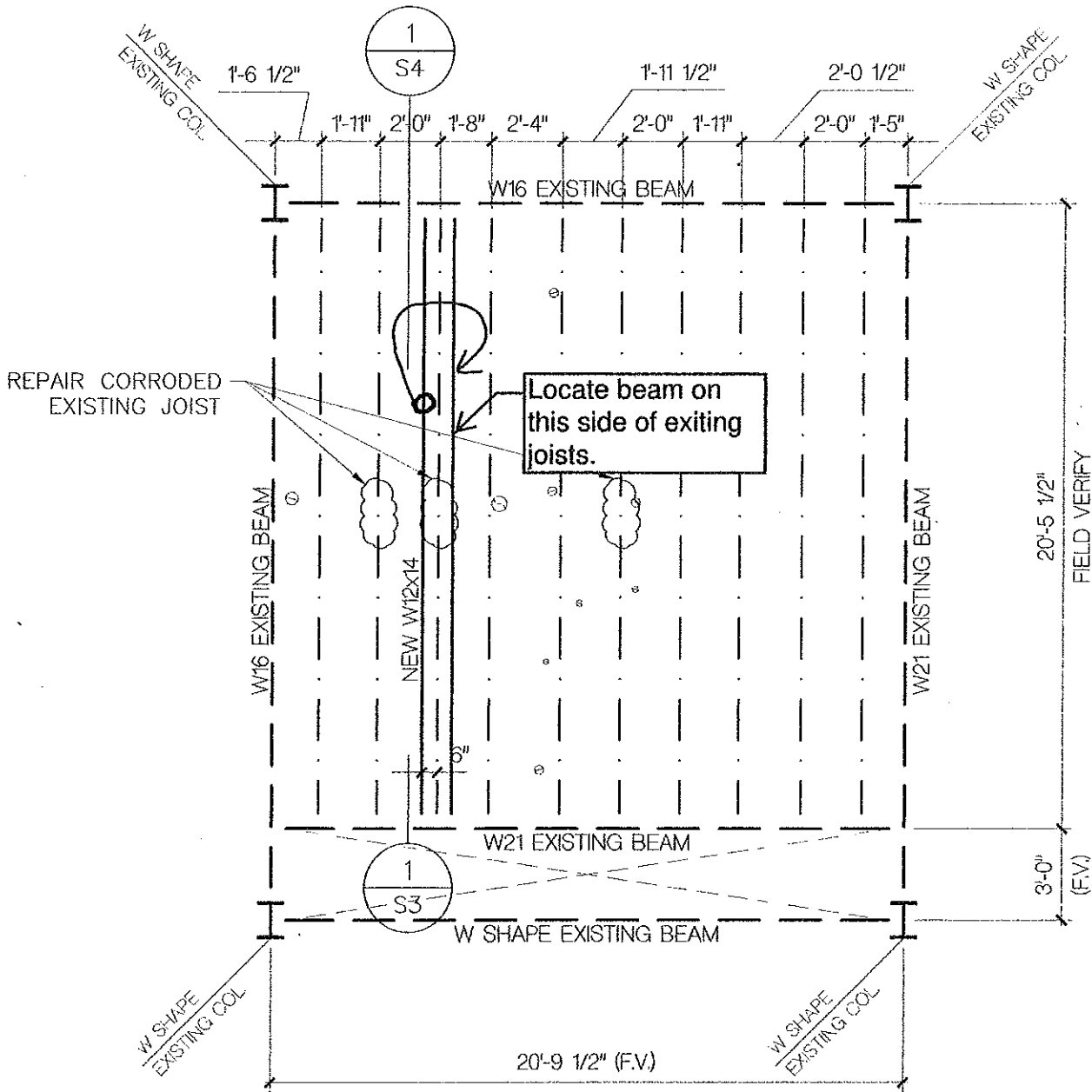

1. REFER TO CONSTRUCTION DOCUMENTS FOR ADDITIONAL INFORMATION.
2. FIELD VERIFY ALL DIMENSIONS.
3. REFER TO SHEET S2 FOR NOTES.

**HINOJOSA ENGINEERING, INC.**  
 STRUCTURAL ENGINEERING  
 CIVIL ENGINEERING LAND SURVEYING  
 108 W. 18TH ST. MISSION, TEXAS  
 (956) 581-0143 FAX: (956) 581-2074  
 E-MAIL: HinojosaEnginc@aol.com  
 REGISTRATION NUMBER: F-908 EXPIRATION DATE: 09/30/2014



**PARTIAL EXISTING 3RD FLOOR FRAMING**  
 Scale: 3/16"=1'-0"

Project : RE-MODEL FORMER ADMINISTRATION BLDG.  
 HIDALGO COUNTY, TEXAS

Drawing: RFI #21

Date : May 15, 2014

Project No. : 08-199

**S1**

## NOTES:

1. REMOVE ALL LOOSE MILL SCALE, LOOSE RUST, LOOSE PAINT, AND OTHER DETRIMENTAL FOREIGN MATTER FROM EXISTING OPEN WEB STEEL JOIST TOP CHORDS BY HAND CHIPPING, SCRAPING, SANDING, AND WIRE BRUSHING. THE EXTENT OF PREPARATION SHALL BE APPROXIMATELY 3'-0" IN LENGTH AT TOP CHORD CORRODED AREAS.
2. PROVIDE RUST-ANODE PRIMER ® AT THE EXISTING OPEN WEB STEEL JOIST PREP-AREAS. FOLLOW ALL MANUFACTURERS RECOMMENDATIONS ON PREPPING AND APPLYING PRODUCT.
3. INSTALL NEW BEAM. NEW STEEL BEAM SHALL BE PLACED SNUG TIGHT WITH EXISTING FLOOR METAL DECK OR EXPOSED CONCRETE.
4. WELD ALL EXISTING HORIZONTAL JOIST BRIDGING TO STEEL BEAM WHERE APPLICABLE.
5. REMOVE AND REINSTALL ALL ITEMS AFFECTED BY THE NEW BEAM INSTALLATION.



**HINOJOSA  
ENGINEERING, INC.**

STRUCTURAL ENGINEERING  
CIVIL ENGINEERING LAND SURVEYING  
108 W. 18TH ST. MISSION, TEXAS  
(956) 581-0143 FAX: (956) 581-2074  
E-MAIL: HinojosaEnginc@aol.com

REGISTRATION NUMBER: F-908

EXPIRATION DATE: 09/30/2014

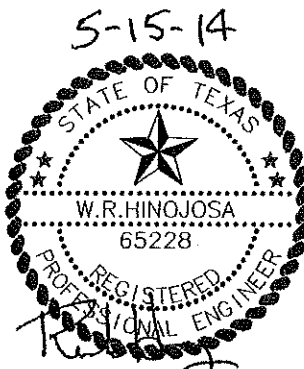

Project : RE-MODEL FORMER ADMINISTRATION BLDG.  
HIDALGO COUNTY, TEXAS

Drawing: RFI #21

Date : May 15, 2014

Project No. : 08-199

S2

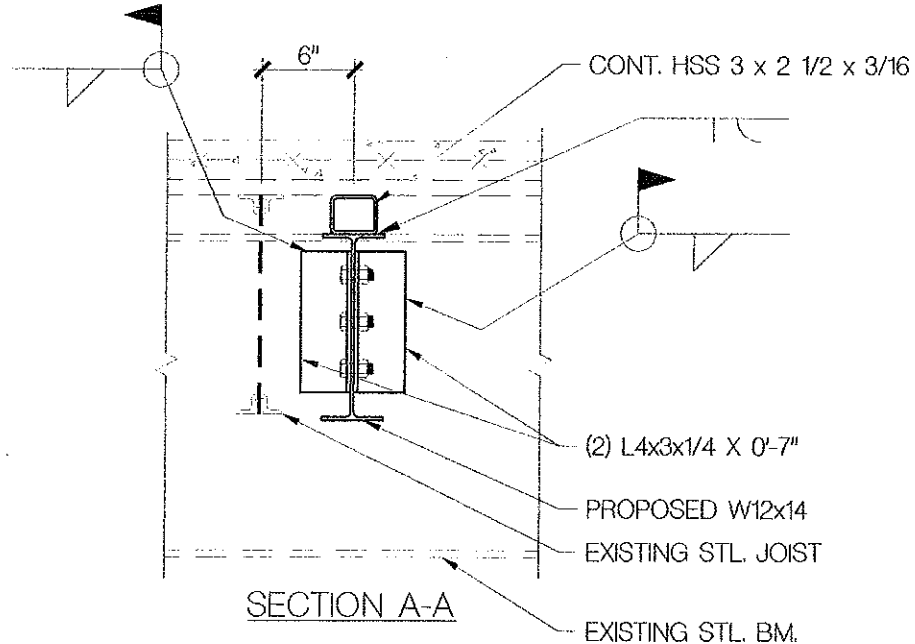
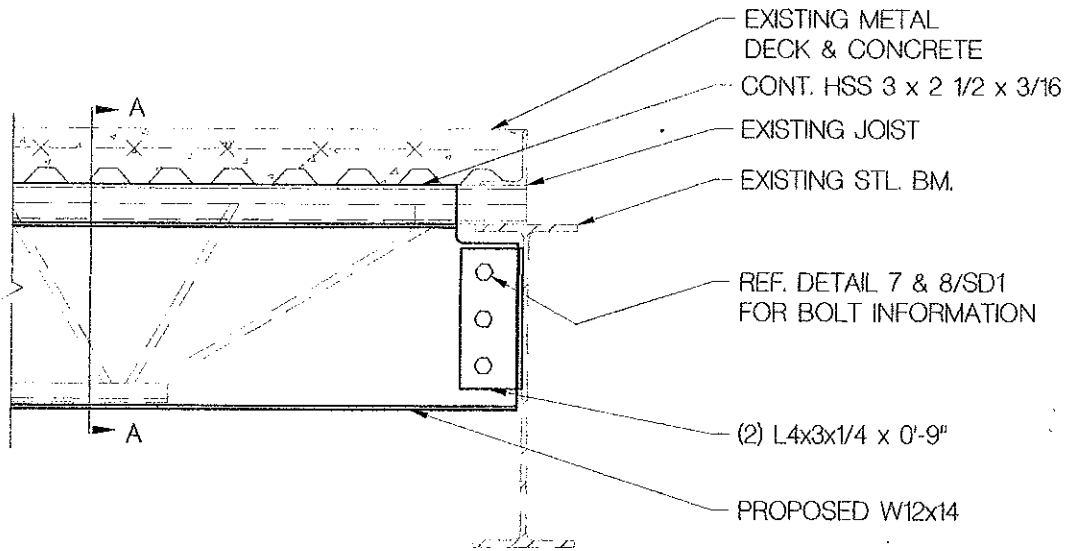

5-15-14



**HINOJOSA ENGINEERING, INC.**  
 STRUCTURAL ENGINEERING  
 CIVIL ENGINEERING LAND SURVEYING  
 108 W. 18TH ST. MISSION, TEXAS  
 (956) 581-0143 FAX: (956) 581-2074  
 E-MAIL: HinojosaEnginc@aol.com



1 STL. BM TO STL. BM.

REGISTRATION NUMBER: F-908

EXPIRATION DATE: 09/30/2014

Project : RE-MODEL FORMER ADMINISTRATION BLDG.  
 HIDALGO COUNTY, TEXAS

Drawing: RFI #21

Date : May 15, 2014

Project No. : 08-199

S3

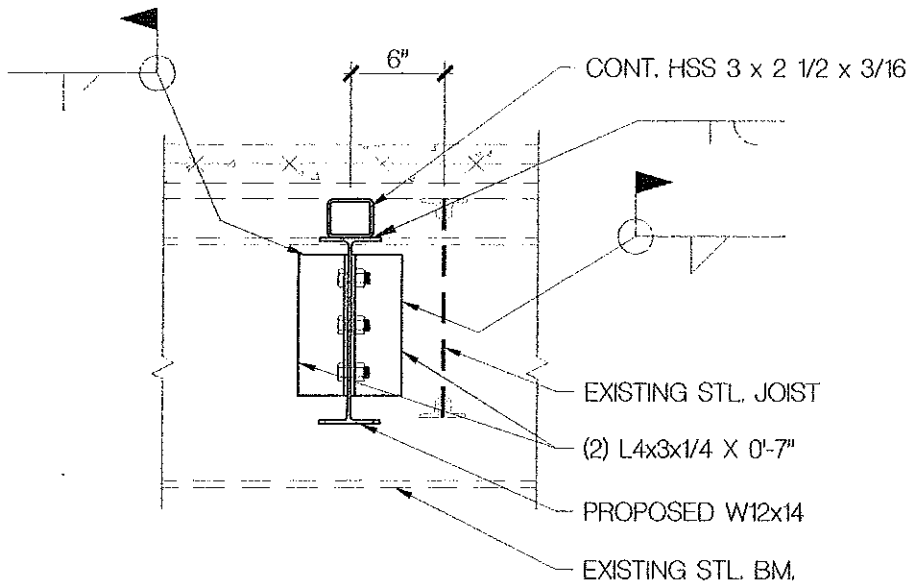
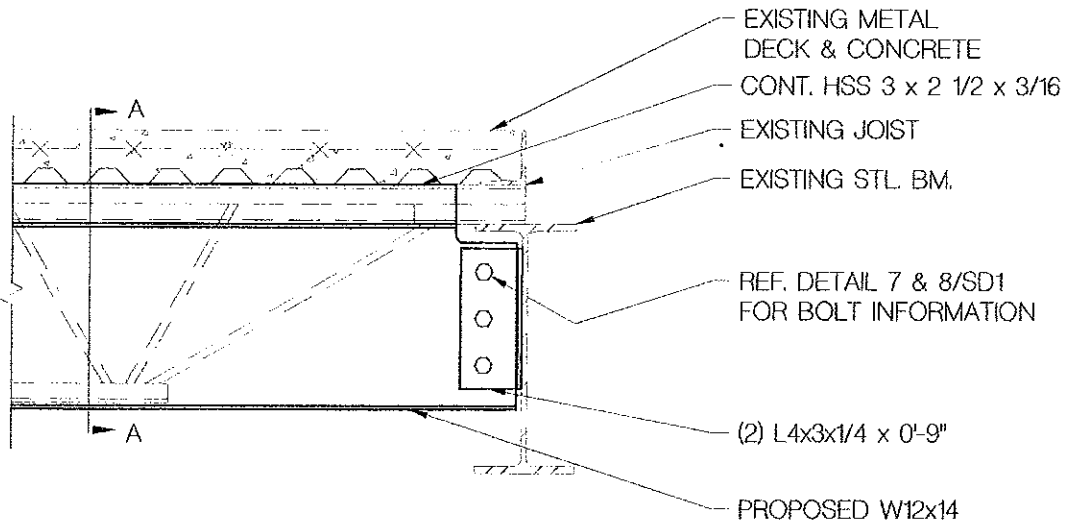

SECTION A-A

5-15-14



**HINOJOSA ENGINEERING, INC.**

STRUCTURAL ENGINEERING  
 CIVIL ENGINEERING LAND SURVEYING  
 108 W. 18TH ST. MISSION, TEXAS  
 (956) 581-0143 FAX: (956) 581-2074  
 E-MAIL: HinojosaEngInc@aol.com

REGISTRATION NUMBER: F-908

EXPIRATION DATE: 09/30/2014



STL. BM TO STL. BM.

Project : RE-MODEL FORMER ADMINISTRATION BLDG.  
 HIDALGO COUNTY, TEXAS

Drawing: RFI #21

Date : May 15, 2014

Project No. : 08-199

S4